



Stern Pod range

Product data sheet - Pod 165



Details:	24V
Product ref.:	MPSPC924 / POD
Typical boat size:	40 - 66'
Tunnel diameter (inside):	250mm
Tunnel thickness:	7 - 8mm
Nominal power voltage:	24V
Control system voltage:	24V
Weight:	61kg

Performance data:

Test power voltage:	22V
Amperage:	540 Amps
kW	11.88
Hp:	15.9
Thrust kg / lbs:	160 / 352
Duty Cycle [S2]:	3min

The POD 165 is part of Max Power's new Stern Pod range designed to simplify the traditionally problematic installation of stern thrusters in motor boats.

This single pre-assembled unit reduces potential installation errors, has twin propellers, a 250mm diameter stern tunnel complete with deflectors and a thrust rating of 160 / 352 (kg / lbs).

Unique Features:



Ignition Protected & Water Resistant



Composite drive legs
Zero maintenance



Line shields



High spec. DC contactors



High power connections



Purpose built DC motors



Unrivalled safety features



Case hardened spiro-conical gears

Stern Pod Installation:

Easy to install and requiring nothing other than simple electrical connections, the Stern Pod greatly reduces installation time.

The Stern Pod can be directly fitted from the outside of the boat thus requiring little or no work in the often inaccessible and cramped transom area.

Ignition protected and water resistant, the thruster's motor is protected from water and the corrosive atmosphere in the bilge.

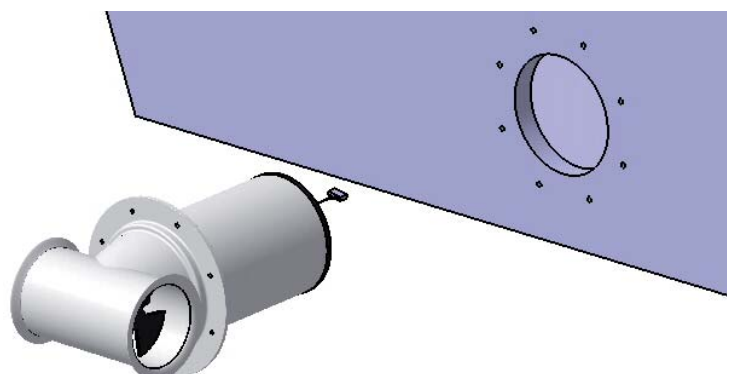

NB. Performance data is given for a thruster installed at one tunnel diameter immersion depth, in a tunnel no longer than twice the tunnel's diameter and this within a variation of + / - 6%. Higher voltages will result in higher thrust ratings, higher power consumption and a reduced duty cycle. Longer tunnels will result in lower thrust ratings and higher power consumption.