



## ALL-PURPOSE LASER SENSOR

Position, Contrast,  
& Transparency Detection

# TRUE DO-IT-ALL SENSOR



**SIMPLE SET UP**

## UNIVERSAL CHANGE DETECTION

(U.C.D. Function) LR-ZH Models

**DISTANCE**    **INTENSITY**

The LR-ZH models stand as the perfect combination of simplicity and performance. Simply press and hold the SET & UP buttons simultaneously to allow the sensor to detect any target that varies from the background. This is possible through the innovative U.C.D. Function, which monitors changes in both position and intensity to provide reliable and stable detection with ease.

### TRANSPARENT TARGETS



The image shows a close-up of the LR-ZH sensor's lens emitting a red laser beam that passes through a thin, transparent blue film. The sensor's display shows a green '0h'.

From clear bottles to plastic films, the LR-ZH models are able to easily detect transparent objects.

### CONTRAST CHANGES

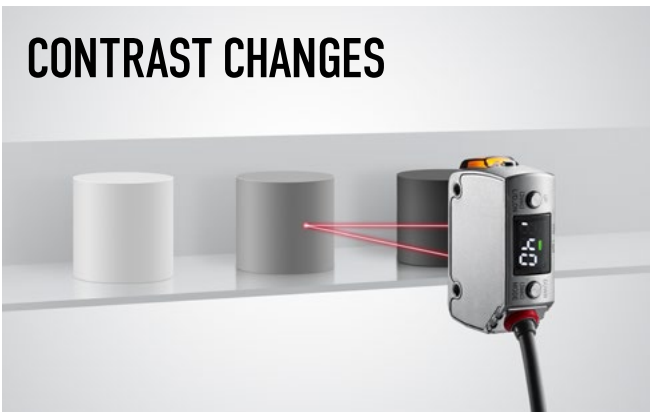

The image shows the LR-ZH sensor on a shelf with three cylindrical targets of different colors (white, grey, black). The sensor's red laser beam is directed at the black target, and its display shows a green '0h'.

The ability to detect contrast changes ensures detection of targets close to the background

# POSITION BASED DETECTION

DISTANCE

Position-based sensing, along with the diffuse sensor design, allow the LR-Z Series to dependably detect targets regardless of shape, color, or surface finish. All without the use of a cumbersome reflector.

Max.  
**500  
mm**  
19.69"  
RANGE



## DARK TARGETS



The Light Power Control Function adjusts light intensity to guarantee proper detection of dark and distant targets.

## METAL TARGETS

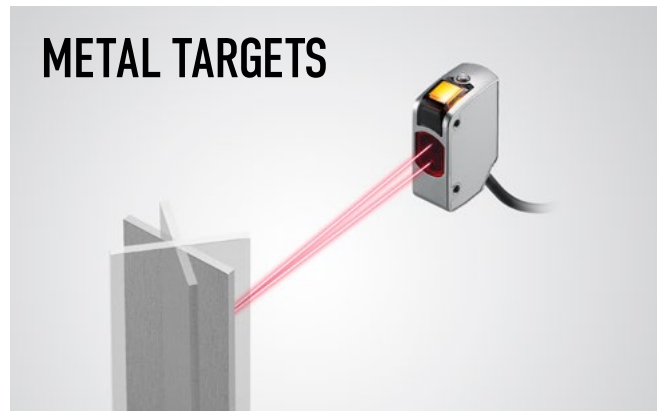

Even at extreme angles, shiny metal targets are stably detected with the versatile DATUM Calibration.

# ADDITIONAL FEATURES



## Rugged Metal Housing

The durable stainless steel housing provides increased longevity in rough factory environments.



## Water and Dust Resistance

The impressive IP68 & IP69K enclosure ratings ensure detection in both washdown and heavy buildup areas.



## 7-Segment LED Display

Installation, calibration, and monitoring are made easy with the intuitive LED display.



## Highly Visible Indicator

The sensor output status is easily recognized from a distance making troubleshooting a snap.



## Simplified Operation





















Three buttons is all it takes to fully utilize the innovative features of the LR-Z Series.







## Dynamic Stability Control

The D.S.C. function ensures stable detection by accounting for changes in the background due to dust or vibration.

Lineup





Type	Detecting distance	Spot diameter	Standard detectable deviation	Connection method	Output	Model	Weight
 M18 threaded mount w/ M12 connector	 25 to 490 mm 0.98" to 19.29"	Approx. $\phi 3$ mm $\phi 0.12$ " 	9 mm 0.35" (25 to 170 mm 0.98" to 6.69") 25 mm 0.98" (170 to 290 mm 6.69" to 11.42") 40 mm 1.57" (290 to 390 mm 11.42" to 15.35") 50 mm 1.97" (390 to 490 mm 15.35" to 19.29")	M12 4-pin	NPN/PNP selectable	<b>LR-ZH490CB</b> <small>(NEW) U.C.D. Function</small>	75 g
 M18 threaded mount w/ M12 connector	 25 to 240 mm 0.98" to 9.45"	Approx. 2.4 mm 0.09" Approx. 1.2 mm 0.05" At detecting distance of 240 mm 9.45"	9 mm 0.35" (25 to 170 mm 0.98" to 6.69") 25 mm 0.98" (170 to 240 mm 6.69" to 9.45")	M12 4-pin	Bipolar (NPN+ PNP)	<b>LR-ZB240CB</b>	
 M18 threaded mount w/ M12 connector	 25 to 90 mm 0.98" to 3.54"	Approx. 2 mm 0.08" Approx. 1 mm 0.04" At detecting distance of 90 mm 3.54"	1.5 mm 0.06" (25 to 40 mm 0.98" to 1.57") 3 mm 0.12" (40 to 90 mm 1.57" to 3.54")	M12 4-pin		<b>LR-ZB90CB</b>	
 Rectangular w/ cable	 35 to 500 mm 1.38" to 19.69"	Approx. $\phi 3$ mm $\phi 0.12$ " 	9 mm 0.35" (35 to 180 mm 1.38" to 7.09") 25 mm 0.98" (180 to 300 mm 7.09" to 11.81") 40 mm 1.57" (300 to 400 mm 11.81" to 15.75") 50 mm 1.97" (400 to 500 mm 15.75" to 19.69")	2 m cable	NPN	<b>LR-ZH500N</b> <small>(NEW) U.C.D. Function</small>	110 g
 Rectangular w/ M8 connector				M8 4-pin	NPN	<b>LR-ZH500CN</b> <small>(NEW) U.C.D. Function</small>	
	 Rectangular w/ M8 connector	35 to 500 mm 1.38" to 19.69"	Approx. $\phi 3$ mm $\phi 0.12$ " 	9 mm 0.35" (35 to 180 mm 1.38" to 7.09") 25 mm 0.98" (180 to 300 mm 7.09" to 11.81") 40 mm 1.57" (300 to 400 mm 11.81" to 15.75") 50 mm 1.97" (400 to 500 mm 15.75" to 19.69")	M8 3-pin	PNP	<b>LR-ZH500CP</b> <small>(NEW) U.C.D. Function</small>
						<b>LR-ZH500C3P</b> <small>(NEW) U.C.D. Function</small>	
 Rectangular w/ cable	 35 to 250 mm 1.38" to 9.84"	Approx. 2.4 mm 0.09" Approx. 1.2 mm 0.05" At detecting distance of 250 mm 9.84"	9 mm 0.35" (35 to 180 mm 1.38" to 7.09") 25 mm 0.98" (180 to 250 mm 7.09" to 9.84")	2 m cable	NPN	<b>LR-ZB250AN</b>	110 g
 Rectangular w/ M8 connector				M8 4-pin	NPN	<b>LR-ZB250CN</b>	
	 Rectangular w/ M8 connector	35 to 250 mm 1.38" to 9.84"	Approx. 2.4 mm 0.09" Approx. 1.2 mm 0.05" At detecting distance of 250 mm 9.84"	9 mm 0.35" (35 to 180 mm 1.38" to 7.09") 25 mm 0.98" (180 to 250 mm 7.09" to 9.84")	M8 3-pin	PNP	<b>LR-ZB250CP</b>
						<b>LR-ZB250C3P</b>	
 Rectangular w/ cable	 35 to 100 mm 1.38" to 3.94"	Approx. 2 mm 0.08" Approx. 1 mm 0.04" At detecting distance of 100 mm 3.94"	1.5 mm 0.06" (35 to 50 mm 1.38" to 1.97") 3 mm 0.12" (50 to 100 mm 1.97" to 3.94")	2 m cable	NPN	<b>LR-ZB100N</b>	110 g
 Rectangular w/ M8 connector				M8 4-pin	NPN	<b>LR-ZB100CN</b>	
	 Rectangular w/ M8 connector	35 to 100 mm 1.38" to 3.94"	Approx. 2 mm 0.08" Approx. 1 mm 0.04" At detecting distance of 100 mm 3.94"	1.5 mm 0.06" (35 to 50 mm 1.38" to 1.97") 3 mm 0.12" (50 to 100 mm 1.97" to 3.94")	M8 3-pin	PNP	<b>LR-ZB100CP</b>
						<b>LR-ZB100C3P</b>	

Mounting brackets



Type	Model	Compatible models	Material/Weight
 Standard mounting bracket (M3 screw x 2 supplied)	<b>OP-87408</b> <sup>1</sup>	Rectangular	SUS316L 30 g
 Rear mounting bracket (M3 screw x 2 supplied)	<b>OP-87409</b>	Rectangular	SUS316L 30 g
 Robust mounting bracket (t = 3) (M3 screw x 2 supplied)	<b>OP-87410</b> <sup>2</sup>	Rectangular	SUS316L 170 g
 M18 nut & Lock washer set	<b>OP-87413</b>	M18 Threaded Mount	M18 nut SUS316L 10 g Lock washer SUS304 5 g

<sup>1</sup> This bracket is dedicated to the cable type. Use OP-87409 or OP-87410, when installing the connector type.  
<sup>2</sup> This can be used only in combination with an L-shaped connector cable, when installing the connector type.

Mounting brackets [ adjustable brackets ]

Type	Model	Compatible models	Material/Weight
 Adjustable bracket (M3 screw x 2 supplied)	<b>OP-87404</b>	Rectangular	Zinc nickel plating 95 g
 Adjustable bracket	<b>OP-87405</b>	M18 Threaded Mount	Zinc nickel plating 100 g
 Screw length	Screw length: 45 mm 1.77" <b>OP-87406</b>	—	Iron nickel plating 70 g
 Locking screw for adjustable bracket	Screw length: 65 mm 2.56" <b>OP-87407</b>	—	Iron nickel plating 80 g

Reflectors (For U.C.D. function only)

Type	Model	Compatible models	Maximum detecting distance	Appearance
Reflector	<b>R-6L</b>	<b>LR-ZH models</b>	700 mm 27.56"	
Reflective tape	<b>OP-87123</b>		700 mm 27.56"	 25 x 25 mm 0.98" x 0.98"

\* When using the reflector or reflective tape, ensure that the spot from the sensor is stationary on the reflector.

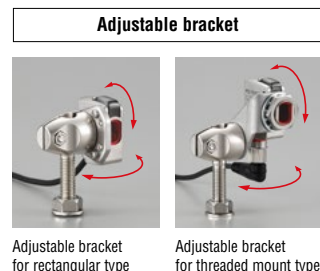

**Cables**

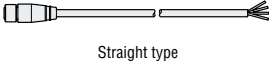
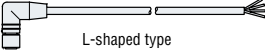
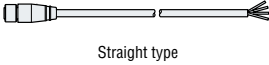
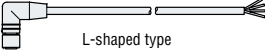
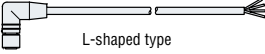
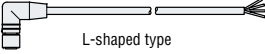
Specifications	Material	Appearance	Connection method	Length	Model	
Standard	Cable: PVC Connector: Brass Nickel Plating	 <p>Straight type</p>	M12 4-pin	2 m 6.56'	OP-75721	
				10 m 32.81'	OP-85502	
	Cable: PVC Connector: Zinc Nickel Plating		M8 4-pin	2 m 6.56'	OP-73864	
				10 m 32.81'	OP-73865	
Oil resistant	Cable: PUR Connector: Zinc Nickel Plating		 <p>L-shaped type</p>	M12 4-pin	2 m 6.56'	OP-87636
					10 m 32.81'	OP-87637
	Cable: PVC Connector: SUS316L			M8 4-pin	2 m 6.56'	OP-87628
					10 m 32.81'	OP-87629
Standard	Cable: PVC Connector: Brass Nickel Plating	 <p>Straight type</p>		M12 4-pin	2 m 6.56'	OP-87402
					10 m 32.81'	OP-87621
	Cable: PVC Connector: Zinc Nickel Plating			M8 4-pin	2 m 6.56'	OP-87622
					10 m 32.81'	OP-87622
Oil resistant	Cable: PUR Connector: Zinc Nickel Plating		 <p>L-shaped type</p>	M12 4-pin	2 m 6.56'	OP-75722
					10 m 32.81'	OP-87274
	Cable: PVC Connector: SUS316L			M8 4-pin	2 m 6.56'	OP-85497
					10 m 32.81'	OP-87631
Standard	Cable: PVC Connector: Brass Nickel Plating	 <p>L-shaped type</p>		M12 4-pin	2 m 6.56'	OP-87640
					10 m 32.81'	OP-87641
	Cable: PVC Connector: Zinc Nickel Plating			M8 4-pin	2 m 6.56'	OP-87632
					10 m 32.81'	OP-87633
Oil resistant	Cable: PUR Connector: Zinc Nickel Plating		 <p>L-shaped type</p>	M12 4-pin	2 m 6.56'	OP-87403
					10 m 32.81'	OP-87619
	Cable: PVC Connector: SUS316L			M8 4-pin	2 m 6.56'	OP-87619
					10 m 32.81'	OP-87620

**Enclosure ratings for each cable type**

Enclosure rating	Standard cable	Oil resistant cable	Chemical resistant cable
IP67 IEC60529	✓	✓	✓
IP68 IEC60529	-	✓	✓
IP69K DIN40050-9	-	-	✓
ECOLAB, Diversey	-	-	✓*

\* Have passed resistance tests with cleaning agents from multiple manufacturers.

**I/O circuit diagram**

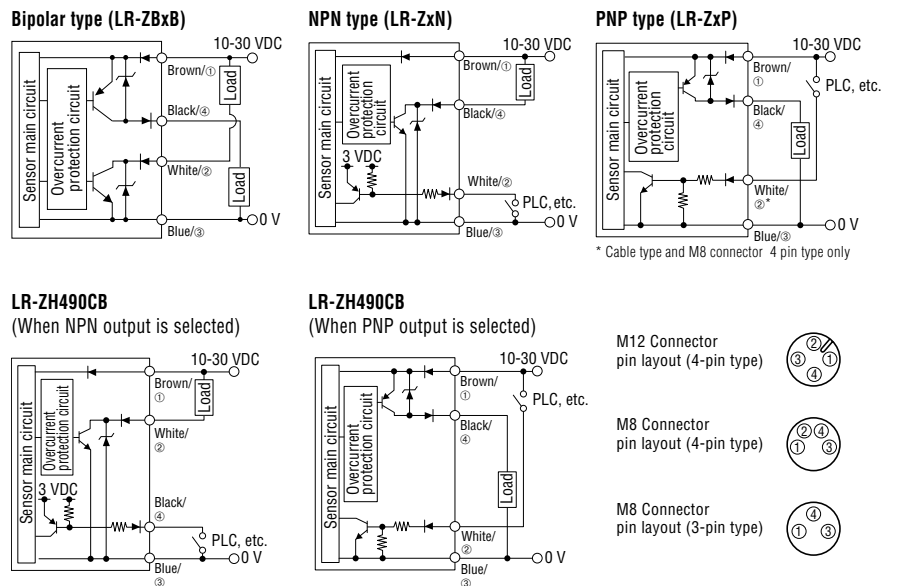

**Universal Change Detection:**

Universal Change Detection works by storing the light receiving pattern (distance and returned light intensity) associated with a set background or reference surface. From here, the sensor is able to detect any variations from the calibrated light receiving pattern (position changes and/or intensity changes).

**Background**

OFF

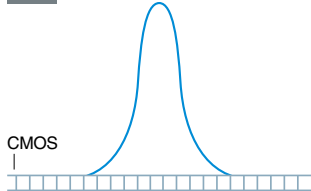

CMOS

SET + UP to register background

**Position Change**

ON

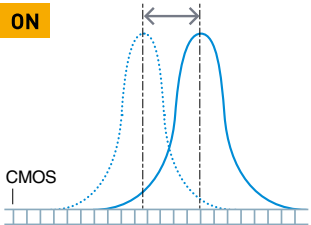

CMOS

**Intensity Change**

ON

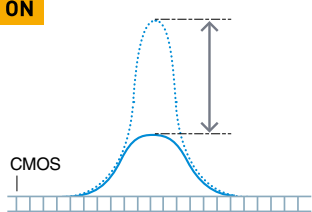

CMOS

# SPECIFICATIONS

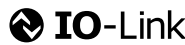

## Specifications

Type		Distance based laser sensor						
Appearance		M18 Threaded mount			Rectangular			
Model	Bipolar	M12 connector 4-pin	<b>LR-ZH490CB*1</b> <small>NEW U.C.D. Function</small>	<b>LR-ZB240CB</b>	<b>LR-ZB90CB</b>	—	—	—
	NPN	2 m 6.56' cable	—	—	—	<b>LR-ZH500N</b> <small>NEW U.C.D. Function</small>	<b>LR-ZB250AN</b>	<b>LR-ZB100N</b>
		M8 connector 4-pin	—	—	—	<b>LR-ZH500CN</b> <small>NEW U.C.D. Function</small>	<b>LR-ZB250CN</b>	<b>LR-ZB100CN</b>
	PNP	2 m 6.56' cable	—	—	—	<b>LR-ZH500P*1</b> <small>NEW U.C.D. Function</small>	<b>LR-ZB250AP</b>	<b>LR-ZB100P</b>
		M8 connector 4-pin	—	—	—	<b>LR-ZH500CP*1</b> <small>NEW U.C.D. Function</small>	<b>LR-ZB250CP</b>	<b>LR-ZB100CP</b>
		M8 connector 3-pin	—	—	—	<b>LR-ZH500C3P*1</b> <small>NEW U.C.D. Function</small>	<b>LR-ZB250C3P</b>	<b>LR-ZB100C3P</b>
Detectable distance		25 to 490 mm 0.98" to 19.29" (465 to 0)²	25 to 240 mm 0.98" to 9.45" (215 to 0)²	25 to 90 mm 0.98" to 3.54" (650 to 0)²	35 to 500 mm 1.38" to 19.69" (465 to 0)²	35 to 250 mm 1.38" to 9.84" (215 to 0)²	35 to 100 mm 1.38" to 3.94" (650 to 0)²	
Standard detectable deviation		25 to 170 mm 0.98" to 6.69" : 9 mm 0.35" 170 to 290 mm 6.69" to 11.42" : 25 mm 0.98" 290 to 390 mm 11.42" to 15.35" : 40 mm 1.57" 390 to 490 mm 15.35" to 19.29" : 50 mm 1.97"	25 to 170 mm 0.98" to 6.69" : 9 mm 0.35" 170 to 240 mm 6.69" to 9.45" : 25 mm 0.98"	25 to 40 mm 0.98" to 1.57" : 1.5 mm 0.06" 40 to 90 mm 1.57" to 3.54" : 3 mm 0.12"	35 to 180 mm 1.38" to 7.09" : 9 mm 0.35" 180 to 300 mm 7.09" to 11.81" : 25 mm 0.98" 300 to 400 mm 11.81" to 15.75" : 40 mm 1.57" 400 to 500 mm 15.75" to 19.69" : 50 mm 1.97"	35 to 180 mm 1.38" to 7.09" : 9 mm 0.35" 180 to 250 mm 7.09" to 9.84" : 25 mm 0.98"	35 to 50 mm 1.38" to 1.97" : 1.5 mm 0.06" 50 to 100 mm 1.97" to 3.94" : 3 mm 0.12"	
Display resolution		1 to 5 (1 to 5 mm 0.04" to 0.20")	1 to 3 (1 to 3 mm 0.04" to 0.12)	2 (0.2 mm 0.01")	1 to 5 (1 to 5 mm 0.04" to 0.20")	1 to 3 (1 to 3 mm 0.04" to 0.12")	2 (0.2 mm 0.01")	
Spot size		Approx. ø3 mm ø0.12"	Approx. 2.4 x 1.2 mm 0.09" x 0.05" at 240 mm 9.45"	Approx. 2 x 1 mm 0.08" x 0.04" at 90 mm 3.54"	Approx. ø3 mm ø0.12"	Approx. 2.4 x 1.2 mm 0.09" x 0.05" at 250 mm 9.84"	Approx. 2 x 1 mm 0.08" x 0.04" at 100 mm 3.94"	
Response time		1.5 ms / 10 ms / 50 ms selectable						
Light source	Type	Red laser (660 nm)						
	Laser class	Class 2 laser product (IEC60825-1) Class II Laser product (FDA(CDRH) Part1040.10)	Class 1 laser product (IEC60825-1, FDA (CDRH) Part1040.10 <sup>3</sup> )	Class 2 laser product (IEC60825-1) Class II Laser product (FDA(CDRH) Part1040.10)	Class 1 laser product (IEC60825-1, FDA (CDRH) Part1040.10 <sup>3</sup> )			
Function	Indicator	3-digit 7-segment display (white), output indicator (yellow), DATUM indicator (orange), 1 spot indicator (green)	3-digit 7-segment display (red), output indicator (yellow), DATUM indicator (orange), 1 spot indicator (green)	3-digit 7-segment display (white), output indicator (yellow), DATUM indicator (orange), 1 spot indicator (green)	3-digit 7-segment display (red), output indicator (yellow), DATUM indicator (orange), 1 spot indicator (green)			
	Timer	OFF/ON delay/OFF delay/One-shot						
Specifications	Power voltage	10 to 30 VDC, including 10% ripple (P-P), Class 2 or LPS						
	Power consumption	450 mW or less (18 mA or less at 24 V, 34 mA or less at 12 V)						
	Control output	LR-ZHxB: NPN Open collector/PNP Open collector selectable, LR-ZBxB: NPN+PNP Open collector, LR-ZxN: NPN Open collector, LR-ZxP: PNP Open collector, Applied voltage 30 VDC or less, Control current 100 mA or less, Residual voltage 1.2 V or less at 10 mA or less, 2 V or less at 10 to 100 mA						
	Protection circuit	Protection against reverse power connection, output overcurrent, output surge, reverse output connection						
	Output operation	Light-ON / Dark-ON selectable						
External input *4	Input time calibration: 35 ms or more ON, 35 ms or more OFF Laser emission stop: 2 ms or more ON, 20 ms or more OFF Short-circuit current NPN: 1 mA or less/PNP: 2 mA or less	None			Input time calibration: 35 ms or more ON, 35 ms or more OFF Laser emission stop: 2 ms or more ON, 20 ms or more OFF Short-circuit current NPN: 1 mA or less/PNP: 2 mA or less			
	Enclosure rating	IP68(IEC60529), IP69K(DIN40050-9), NEMA 4X, 6P, 13(NEMA250), ECOLAB <sup>15</sup> , Diversey <sup>5</sup>						
Environmental resistance	Ambient light *6	Incandescent lamp: 10000 lux or less Sunlight: 20000 lux or less at 240 mm 9.45" Incandescent lamp: 2000 lux or less Sunlight: 4000 lux or less at 490mm 19.29"	Incandescent lamp: 2000 lux or less Sunlight: 4000 lux or less	Incandescent lamp: 4000 lux or less Sunlight: 8000 lux or less	Incandescent lamp: 10000 lux or less Sunlight: 20000 lux or less at 250 mm 9.84" Incandescent lamp: 2000 lux or less Sunlight: 4000 lux or less at 500 mm 19.69"	Incandescent lamp: 2000 lux or less Sunlight: 4000 lux or less	Incandescent lamp: 4000 lux or less Sunlight: 8000 lux or less	
	Ambient temperature	-10 to +50°C 14 to 122°F (No freezing)						
	Storage temperature	-25 to +75°C -13 to 167°F (No freezing)						
	Ambient humidity	35 to 85%RH (No condensation)						
	Shock resistance	1000 m/s² in X, Y, Z axis directions respectively 6 times						
	Vibration resistance	10 to 55 Hz Double amplitude 1.5 mm 0.06" in the X, Y, Z axis directions respectively, 2 hours						
	Insulating resistance	20 MΩ or more (500 VDC)						
Withstand voltage	1000 VAC 50/60 Hz 1 min							
Material	Case: SUS316L, Display: PES, Lens cover: PMMA with scratch-resistant coating, Packing/Connector ring: FKM, Nut: SUS316L, Lock washer: SUS304 Case: SUS316L, Display: PES, Lens cover: PMMA with scratch-resistant coating, Packing/Connector ring: FKM							
Accompanying items	Instruction Manual, FDA warning/certification/identification label, Laser warning/explanation labels	Instruction Manual, Certification/identification label (FDA)			Instruction Manual, FDA warning/certification/identification label, Laser warning/explanation labels	Instruction Manual, Certification/identification label (FDA)		

\*1 IO-Link specification v.1.1/COM2 (38.4 kbps) is supported. (LR-ZH490CB: Only when PNP output is selected.) You can download a setup file from the KEYENCE website (<http://www.keyence.com>). If using the product in an environment in which downloading files over the internet is not possible, contact your nearest KEYENCE office. \*2 Display readings can be used as a guide for the detecting distance. When the setting value is turned, the readout shifts. When the value exceeds "99", "FF" is displayed. \*3 The laser classification for FDA (CDRH) is implemented based on IEC60825-1 in accordance with the requirements of Laser Notice No.50. \*4 M8 connector (3-pin) type does not include the external input function. \*5 Has passed resistance tests with cleaning agents from multiple manufacturers. \*6 When the response time is 10 ms

## Reference data

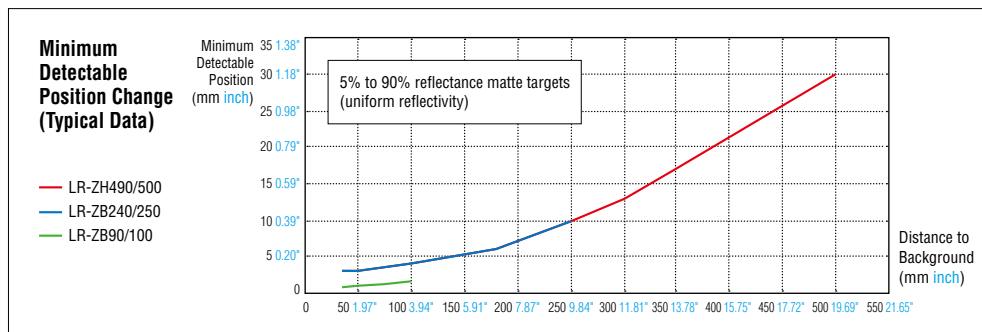

## Laser warning label (LR-ZH Models Only)

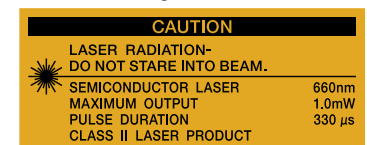

# DIMENSIONS

**LR-ZH490CB/  
ZB240CB/  
ZB90CB**

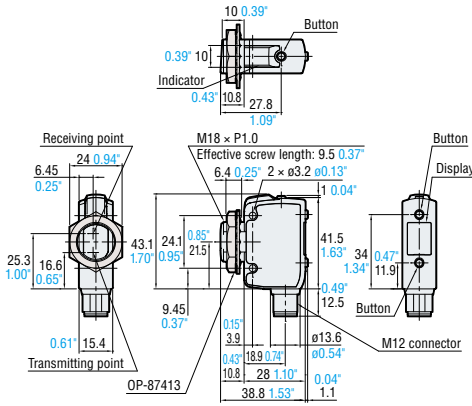

**LR-ZH500N/ZH500P/  
ZB250AN/ZB250AP/  
ZB100N/ZB100P**

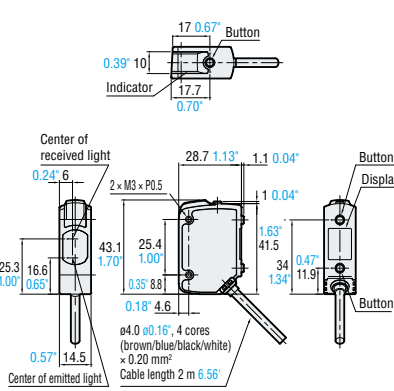

**LR-ZH500CN/ZH500CP/ZH500C3P/  
ZB250CN/ZB250CP/ZB250C3P/  
ZB100CN/ZB100CP/ZB100C3P**

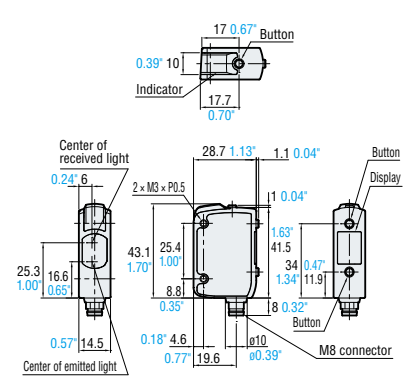

**OP-87408**

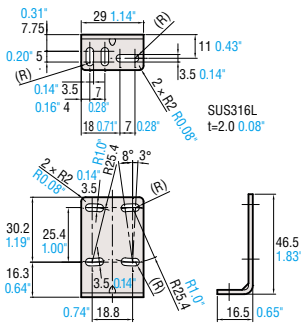

**OP-87410**

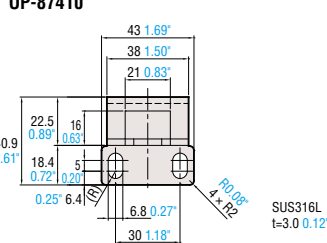

**OP-87413**

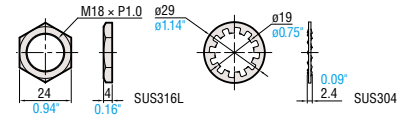

**OP-87406/87407**

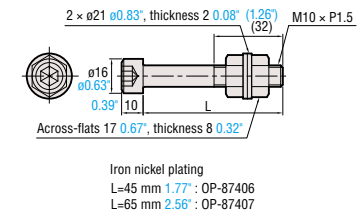

**OP-87409**

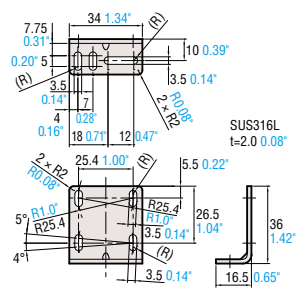

**OP-87404 + LR-ZH500N**

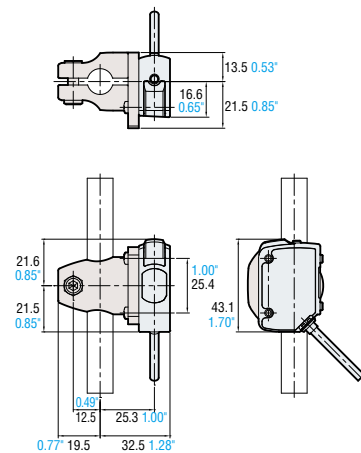

**OP-87406/87407 + OP-87404 + LR-ZH500N**

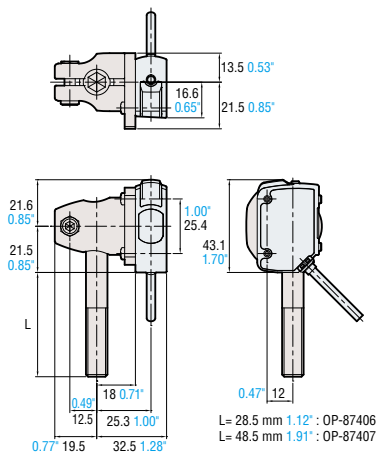

**OP-87404**

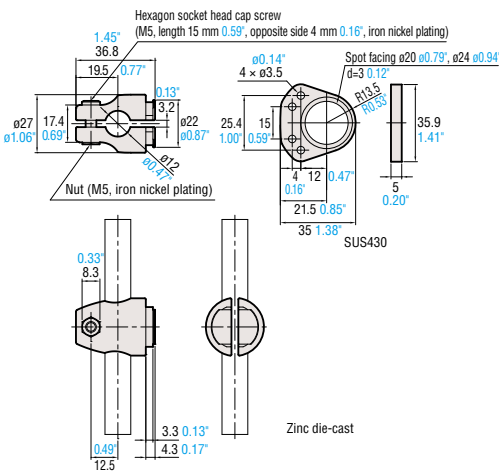



**OP-87405**

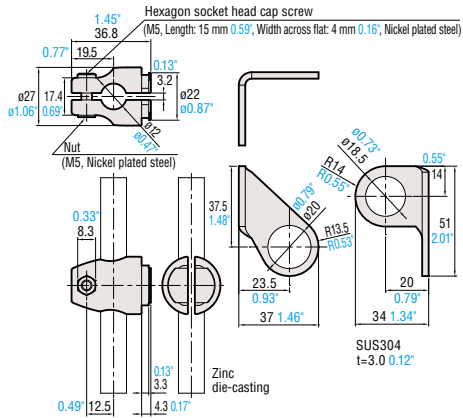

**OP-87405 + LR-ZH490CB**

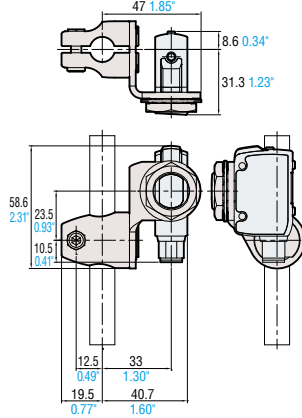

**OP-87406/87407 + OP-87405 + LR-ZH490CB**

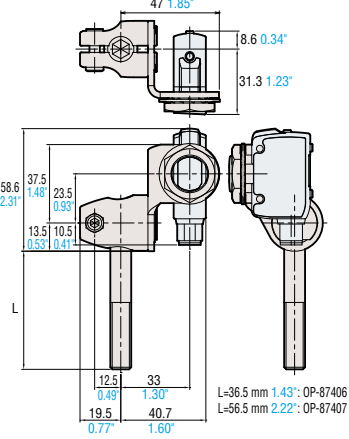

**Reflector R-6L**

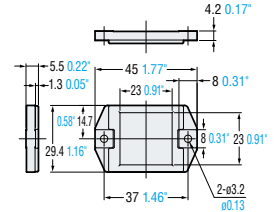

**OP-75721/85502**

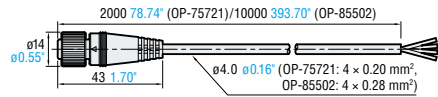

**OP-87636/ 87637**

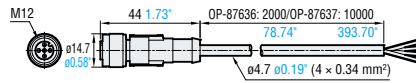

**OP-87402**

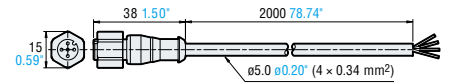

**OP-73864 / 73865**

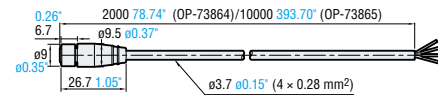

**OP-87627**

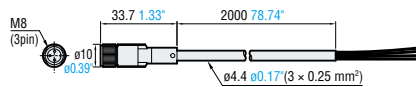

**OP-87628/87629**

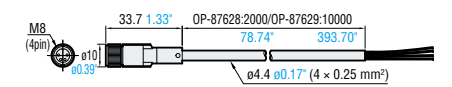

**OP-87621**

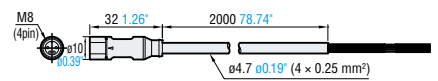

**OP-87622**

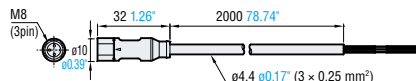

**OP-75722 / 87274**

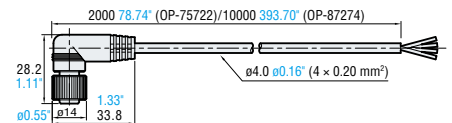

**OP-87640/87641**

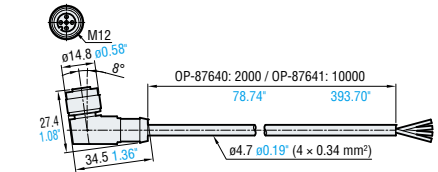

**OP-87403**

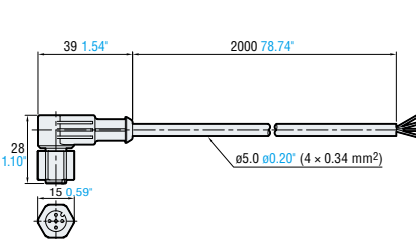

**OP-85497**

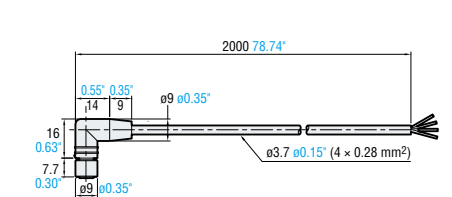

**OP-87631**

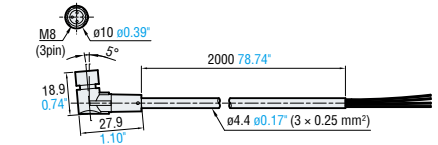

**OP-87632/87633**

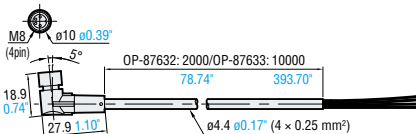

**OP-87619**

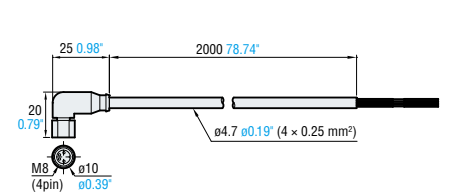

**OP-87620**

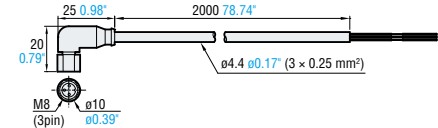

M12 Connector pin layout (4-pin type)



M8 Connector pin layout (4-pin type)



M8 Connector pin layout (3-pin type)



No.	Color
①	Brown
②	White
③	Blue
④	Black

**Note:**  
When the L-shaped connector is in use, the cable is fixed in the direction shown on the right. The connector is not rotatable.

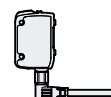

# RELATED PRODUCTS

## LR-T SERIES

TOF Laser Sensor



### Sensors

Type		Detecting distance	Features	Model
	Cable (2 m 6.56')	60 to 5000 mm 2.36' to 196.85'	Adjustable Spot Analog Output	LR-TB5000
	M12 connector (Cable sold separately)			LR-TB5000C/LR-TB5000CL
	Cable (2 m 6.56')	60 to 2000 mm 2.36' to 78.74'	Smaller Size	LR-TB2000
	M12 connector (Cable sold separately)			LR-TB2000C/LR-TB2000CL

### Brackets and Accessories

Type	Model	Type	Model	Type	Model
Adjustable angle bracket (For LR-TB5000 Series) (M4 screw × 2 supplied)	OP-87773	Adjustable bracket (For LR-TB5000 Series) (M4 screw × 2 supplied)	OP-87774	Front protection cover (For LR-TB5000 Series)	OP-87778
Adjustable angle bracket (For LR-TB2000 Series) (M3 screw × 2 supplied)	OP-87771	Adjustable bracket (For LR-TB2000 Series) (M3 screw × 2 supplied)	OP-87772	Front protection cover (For LR-TB2000 Series)	OP-87776
Small bracket (For LR-TB2000 Series) (M3 screw × 2 supplied)	OP-87770	Locking screw (For adjustable bracket) (85 mm 3.35")	OP-87775		

## LR-W SERIES

Full-Spectrum  
Sensor



### Sensors: Standard Models

Type		Detecting distance	Light source	Model
Cable (2 m 6.56')	Standard Type	30 to 500 mm 1.18' to 19.69'	White LED	LR-W500
M12 connector (Cable sold separately)				LR-W500C

### Sensors: Small/Dual Spot Models

Type		Detecting distance	Light source	Model
Cable (2 m 6.56')	Small/Dual Spot Type	30 to 70 mm 1.18' to 2.76'	White LED	LR-W70
M12 connector (Cable sold separately)				LR-W70C

### Sensors: Fiber Extension Models

Type		Detecting distance	Light source	Model
Cable (2 m 6.56')	Fiber Type	Detecting Distance and Min. Spot Diameter Based on Attached Fiber Head	White LED	LR-WF10
M12 connector (Cable sold separately)				LR-WF10C

### Brackets and Accessories

Type	Applicable Sensors	Model	Type	Applicable Sensors	Model
Standard mounting bracket (M3 screw × 2 supplied)	LR-W500/ W70/WF10	OP-88021*1	Luster canceling attachment	LR-W500(C)	LR-WA1*1*2
Small mounting bracket (M3 screw × 2 supplied)	LR-W70/ WF10	OP-88022*1	Luster canceling attachment	LR-W70(C)	LR-WA2*1*2
Adjustable bracket (M3 screw × 2 supplied)	LR-W500(C)/ W70(C)/ WF10(C)	OP-88023			
Adjustable bracket locking screw (105 mm 4.13')		OP-88024			

\*1 When using LR-WA1 or LR-WA2, detecting range may decrease on targets with low reflectance. Perform sufficient checks in the actual installation environment.

\*2 When using the LR-WA1 or LR-WA2, the enclosure rating (IP65/IP67) is not met.

\*1 The 4-pin M12 connector type may not be mounted in the orientation shown in the picture (connector downward). Confirm the dimensions and surroundings carefully.

# LR-T/LR-W SERIES

## Cables



### Cables

Cable Material	Type	Length	Compatible Model	Item
PVC	Straight	2 m 6.56'	LR-T	OP-87634
		5 m 16.40'	LR-W	OP-87272
		10 m 32.81'	LR-T	OP-87635
	L-Shape	2 m 6.56'	LR-W	OP-85502
		5 m 16.40'	LR-W	OP-87273
		10 m 32.81'	LR-W	OP-87274
PUR	Straight	2 m 6.56'	LR-T/LR-W	OP-87636
		10 m 32.81'	LR-T/LR-W	OP-87637
	L-Shape	2 m 6.56'	LR-W	OP-87640
		10 m 32.81'	LR-W	OP-87641

\* To ensure IP ratings are met, it is important to use cables specified for the particular sensor series and consult the sensor series brochure.

# MU-N SERIES

## Multi-Sensor Controller

Compatible Series  
LR-T/LR-W/FD-Q



### Controller

Type	Control output	External input	Analog output	Model
Main unit	4 standard outputs max.* (15 signal combinations available using binary logic)	5 inputs max.*	1 output max.*	MU-N11
Expansion unit			—	MU-N12

\* Specification when used with LR-W Series. For use with LR-T Series, contact KEYENCE for detail.

### Cables (MU-N Power Cable)

Appearance	Applicable unit	Cable material	Cable end	Controller side	Length	Model
	Main unit	PVC (Polyvinyl chloride)	8-core loose wires	Connector	2 m 6.56'	MU-CB8
			4-core loose wires			MU-CB4
	Expansion unit		6-core loose wires			MU-CB6
			2-core loose wires			MU-CB2
	Main unit		M12 4-pin straight	0.3 m 0.98'	MU-CC4	

### Cables (Sensor to Controller Cable)

Appearance	Cable material	Sensor side	Controller side	Length	Model
	PVC (Polyvinyl chloride)	M12 4-pin straight	Connector	2 m 6.56'	OP-88025
				10 m 32.81'	OP-88026*1
		M12 4-pin L-shape		2 m 6.56'	OP-88027
				10 m 32.81'	OP-88028*1

\*1 The 10 m 32.81' cable includes one spare connector for the controller side.

### Connectors

Appearance	Type	Applicable model	Model
	For PVC (Polyvinyl chloride) cable	Non-connector type LR-W and LR-T Series sensors OP-75721/87272/85502 OP-75722/87273/87274	OP-88029
	For PUR (Polyurethane) cable	OP-87636/87637 OP-87640/87641	OP-88030

## Additional Sensor Series

**KEYENCE offers a complete lineup of self-contained sensors**

### TOF LASER SENSORS LR-T Series

Detecting Distance [0.06 to 5 m 0.20' to 16.40']

Max. 5 m 16.40' detecting distance

Custom IC for superior detecting capabilities

Metal body with IP65/IP67 enclosure rating



### FULL-SPECTRUM SENSORS LR-W Series

Detect any changes in appearance

Innovative White LED Light Source

Long Range, Dual Spot, and Fiber Models

Controller Expansion for Increased Functionality



CALL  
TOLL  
FREE

TO CONTACT YOUR LOCAL OFFICE  
**1-888-KEYENCE**  
1 - 8 8 8 - 5 3 9 - 3 6 2 3

[www.keyence.com](http://www.keyence.com)



#### SAFETY INFORMATION

Please read the instruction manual carefully in order to safely operate any KEYENCE product.

CONTACT YOUR NEAREST OFFICE FOR RELEASE STATUS

#### KEYENCE CORPORATION OF AMERICA

**Head Office** 500 Park Boulevard, Suite 200, Itasca, IL 60143, U.S.A.

**PHONE:** +1-201-930-0100 **FAX:** +1-855-539-0123

**E-mail:** [keyence@keyence.com](mailto:keyence@keyence.com)

**AL** Birmingham

**CA** San Jose

**CO** Denver

**IL** Chicago

**MI** Detroit

**MO** St. Louis

**NC** Raleigh

**PA** Philadelphia

**TN** Nashville

**WI** Milwaukee

**AR** Little Rock

**CA** Cupertino

**FL** Tampa

**IN** Indianapolis

**MI** Grand Rapids

**NJ** Elmwood Park

**OH** Cincinnati

**PA** Pittsburgh

**TX** Austin

**AZ** Phoenix

**CA** Los Angeles

**GA** Atlanta

**KY** Louisville

**MN** Minneapolis

**NY** Rochester

**OH** Cleveland

**SC** Greenville

**TX** Dallas

**CA** San Francisco

**CA** Irvine

**IA** Iowa

**MA** Boston

**MO** Kansas City

**NC** Charlotte

**OR** Portland

**TN** Knoxville

**WA** Seattle

#### KEYENCE CANADA INC.

**Head Office** PHONE: +1-905-366-7655 FAX: +1-905-366-1122 E-mail: [keyencecanada@keyence.com](mailto:keyencecanada@keyence.com)

**Montreal** PHONE: +1-514-694-4740 FAX: +1-514-694-3206 Windsor PHONE: +1-905-366-7655 FAX: +1-905-366-1122

#### KEYENCE MEXICO S.A. DE C.V.

PHONE: +52-55-8850-0100 FAX: +52-81-8220-9097

E-mail: [keyencemexico@keyence.com](mailto:keyencemexico@keyence.com)

The information in this publication is based on KEYENCE's internal research/evaluation at the time of release and is subject to change without notice. Company and product names mentioned in this catalog are either trademarks or registered trademarks of their respective companies. The specifications are expressed in metric units. The English units have been converted from the original metric units.

Copyright (c) 2016 KEYENCE CORPORATION. All rights reserved.

KA1-1017

LRZ\_S-KA-C3-US 1116-2 **611C85**