

Montageanleitung

Nebelscheinwerfer FF40

Mounting instructions

Fog lamps FF40

Instructions de montage

Projecteur antibrouillard FF40

Monteringsanvisning

Dimstrålkastare FF40

Montagehandleiding

Mistlampen FF40

Instrucciones de montaje

Faros antiniebla FF40

Istruzioni di montaggio

Proiettori fendinebbia FF40

Asennusohje

Sumuvalonheittimet FF40

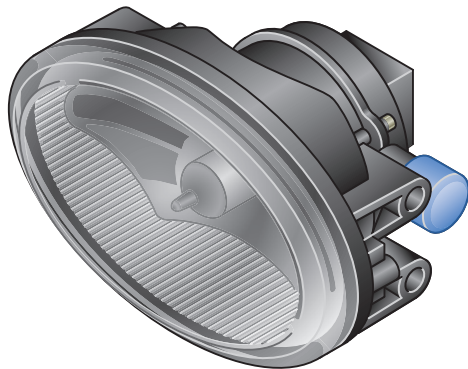

Lieferumfang
Kit includes
Fourniture

Leveransomfattning
Inhoud set
Volumen del suministro

Dotazione di fornitura
Osaluettelo

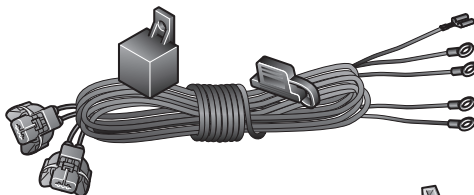
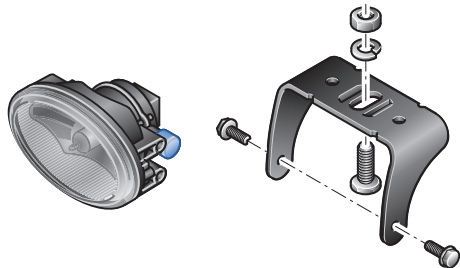
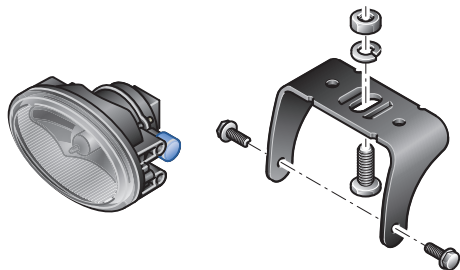

10x

DE Benötigte Montagewerkzeuge

EN Installation tools required

FR Outillage de montage requis

SV Nödvändiga monteringsverktyg

NL Benodigde montagewerktuigen

ES Herramientas de montaje necesarias

IT Attrezzi necessari per il montaggio

FI Tarvittavat asennustyökalut

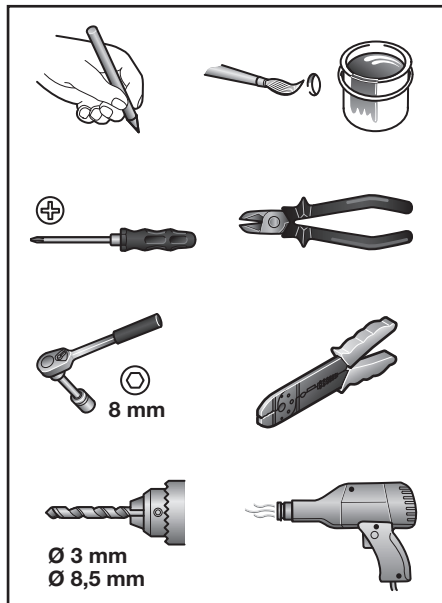

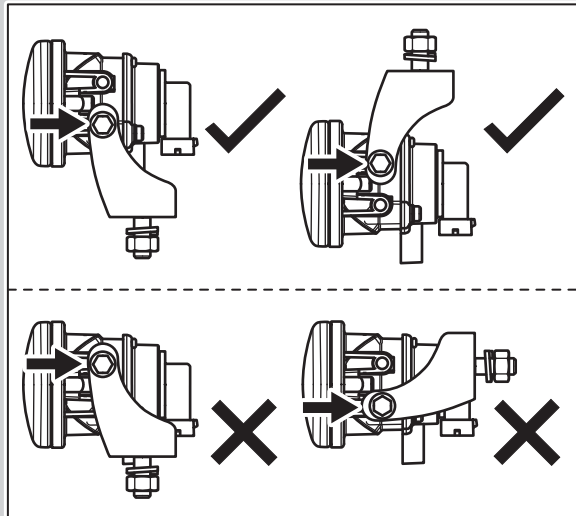
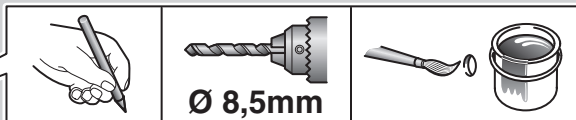
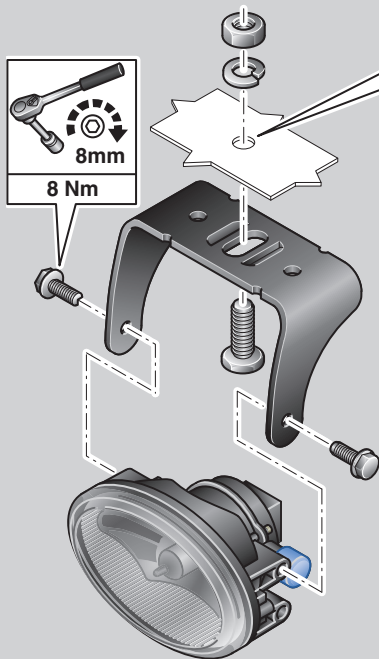

5

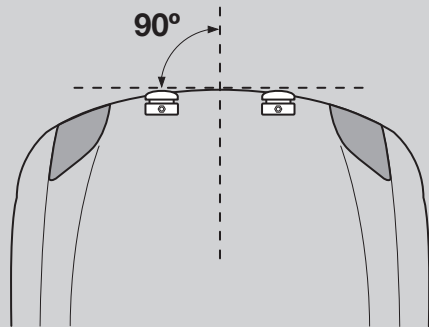
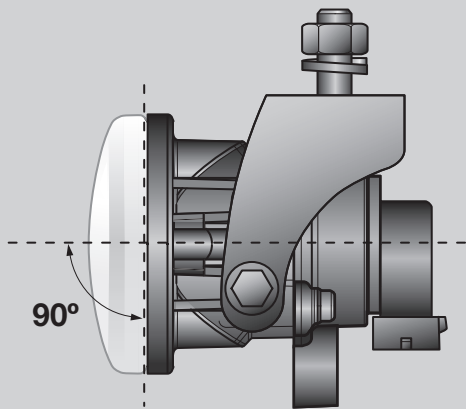

30rot
red
rouge
rödrood
rajo
rosso
punainen**85**braun
brown
marron
brunbruin
marrón
marrone
ruskea**86**gelb/grau
yellow/grey
jaune/gris
gul/grågeel/grijs
amarillo/gris
giallo/grigio
keltainen/harmaa**87**blau
blue
bleu
blåblauw
azul
blu
sininen

—

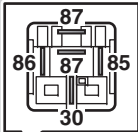
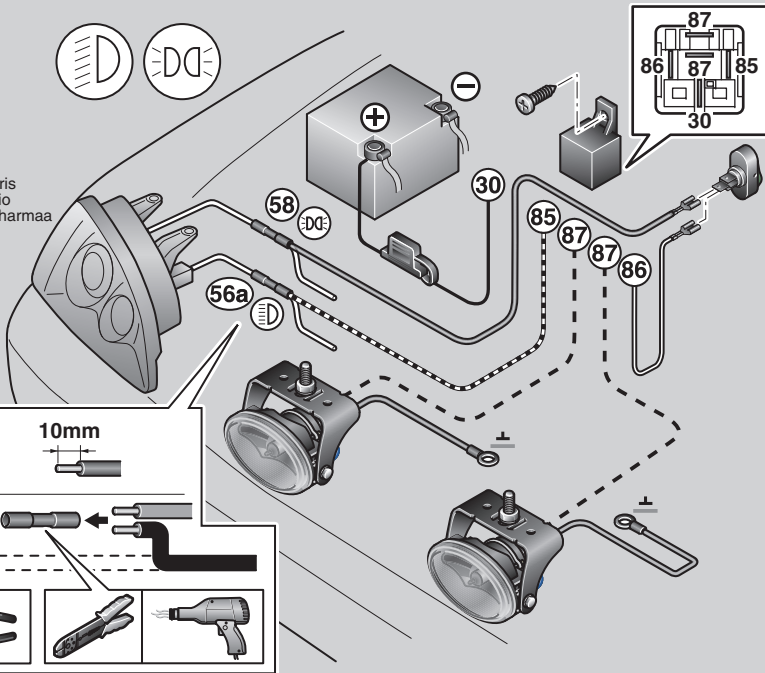
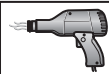
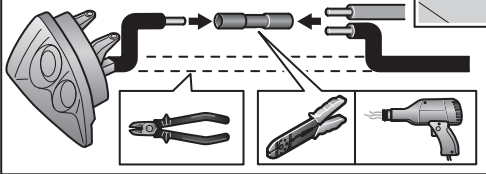
braun
brown
marron
brunbruin
marrón
marrone
ruskea**56a****58****30****85****87****87****86****10mm**

30 rot
red
rouge
röd

rood
rajo
rosso
punainen

85 braun
brown
marron
brun

bruin
marrón
marrone
ruskea

86 gelb/grau
yellow/grey
jaune/gris
gul/grå

geel/grijs
amarillo/gris
giallo/grigio
keltainen/harmaa

87 blau
blue
bleu
blå

blauw
azul
blu
sininen

braun
brown
marron
brun

bruin
marrón
marrone
ruskea

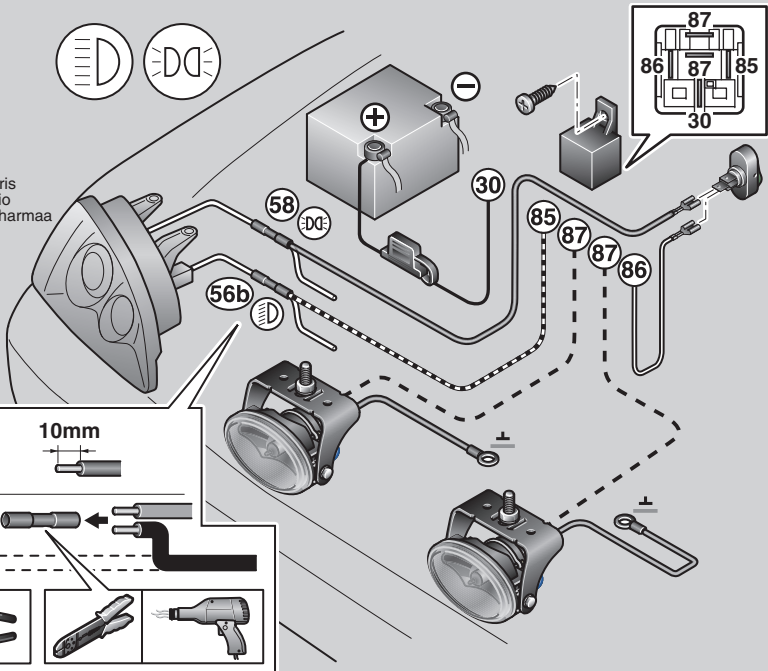

10mm

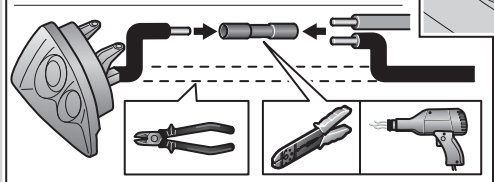

30 rot
red
rouge
röd

rood
rosso
punainen

85 braun
brown
marron
brun

bruin
marrón
marrone
ruskea

86 gelb/grau
yellow/grey
jaune/gris
gul/grå

geel/grijs
amarillo/gris
giallo/grigio
keltainen/harmaa

87 blau
blue
bleu
blå

blauw
azul
blu
sininen

braun
brown
marron
brun

bruin
marrón
marrone
ruskea

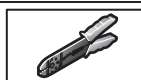
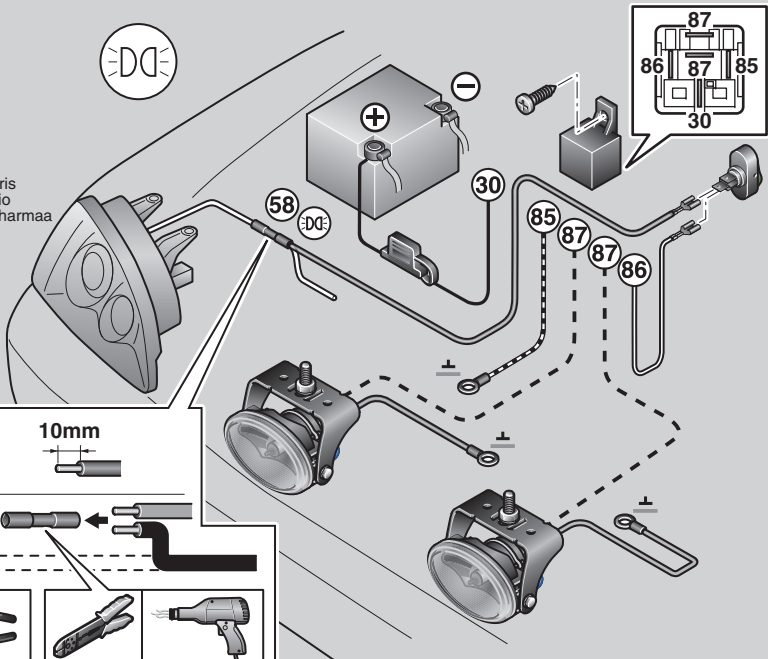

10mm

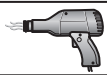
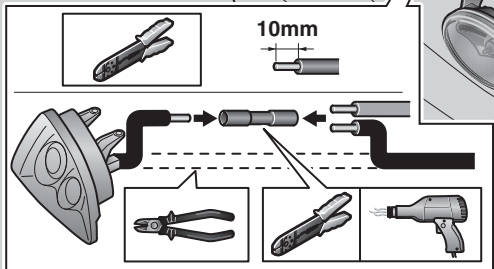

30

rot
red
rouge
röd

rood
rajo
rosso
punainen

85

braun
brown
marron
brun

bruin
marrón
marrone
ruskea

86

gelb/grau
yellow/grey
jaune/gris
gul/grå

geel/grijs
amarillo/gris
giallo/grigio
keltainen/harmaa

87

blau
blue
bleu
blå

blauw
azul
bleu
sininen

braun
brown
marron
brun

bruin
marrón
marrone
ruskea



56b



+

30

-

85

87

87

86

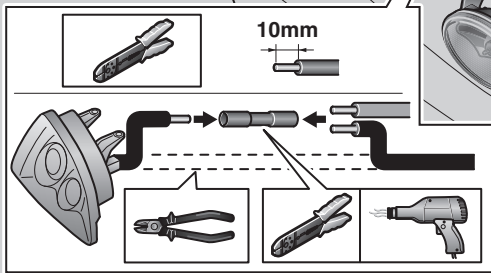
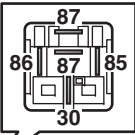

10mm

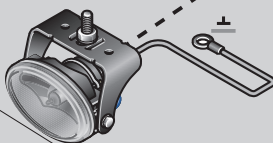
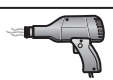

10

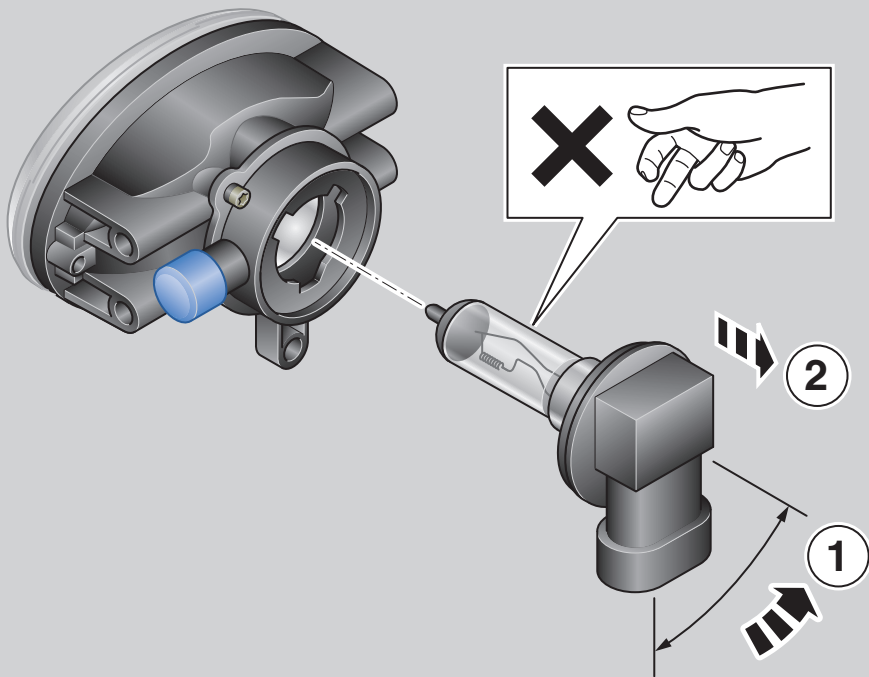

DE	DEUTSCH	Technische Änderungen vorbehalten	12-13
EN	ENGLISH	Subject to alteration without notice	14-15
FR	FRANÇAIS	Sous réserve de modifications techniques	16-17
SV	SVENSKA	Vi reserverar oss för tekniska ändringar	18-19
NL	NEDERLANDS	Technische wijzigingen voorbehouden	20-21
ES	ESPAÑOL	Reservadas modificaciones técnicas	22-23
IT	ITALIANO	Con riserva di modifiche tecniche	24-25
FI	SUOMI	Oikeus teknisiin muutoksiin pidätetään	26-27

Montage: Seite 4,5

Die Montage der Scheinwerfer ist stehend oder hängend möglich. Die Scheinwerfer dürfen nicht vibrieren, über die Motorhaube ragen und müssen symmetrisch angebracht sein. Bei der Montage sind die Anbaumaße in der aufgeführten Zeichnung zu beachten. Montageposition festlegen und Befestigungspunkte anzeichnen.

Mit 3 mm Bohrer vorbohren und 8,5 mm aufbohren.

Gebohrte Metallteile mit Rostschutz versiegeln.

Bei der Montage der Scheinwerfer darauf achten, dass die „TOP“-Markierung auf dem Gehäuse immer nach oben zeigt. Scheinwerfer nach oben zeigt. Scheinwerfer nach Zeichnung ausrichten und die Schrauben anziehen.

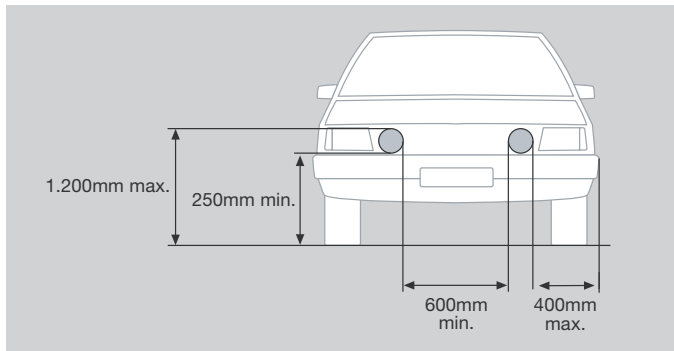

Glühlampe nach Zeichnung austauschen. Glühlampen nicht mit bloßen Fingern anfassen! Papier tuch oder ähnliches verwenden.

Elektrischer Anschluss: Ab Seite 6

Relais mit Anschlussklemmen spritzwassergeschützt nach unten einbauen.

Bei Bedarf einen Schalter (s. Zubehör) ins Armaturenbrett einbauen, oder einen, der speziell für Ihr Auto vorgesehen ist.

Leitungen nach einem der 4 Schaltpläne verlegen und anschließen.

Mit welchen Lichtfunktionen Nebelscheinwerfer kombiniert werden dürfen, soll die nachstehende Tabelle, beispielhaft für drei Länder zeigen.

Auf jeden Fall müssen aber die landesspezifischen Gesetze eingehalten werden.





Lichtanlage prüfen. Anschlussleitungen sicher befestigen.

Lassen Sie die Nebelscheinwerfer in der Fachwerkstatt einstellen.

Nur richtig eingestellte Scheinwerfer sorgen für optimales Licht.

Glühlampewechsel: Abb. Seite 10

Glühlampe nach Zeichnung austauschen. Glühlampen nicht mit bloßen Fingern anfassen! Papier tuch oder ähnliches verwenden.

		A	CH	D
Abblendlicht				●
Abblend- und Standlicht		●	●	● C max. 400 mm
Standlicht			●	● C max. 400 mm
Fern- und Standlicht			●	

Noch ein Tipp:

- Halten Sie die Scheinwerfer-Streuscheiben stets sauber. Schmutz kann bis zu 80% der Lichtleistung schlucken. Sie fahren sicher, wenn Sie gut sehen und somit auch gut gesehen werden.

Haben Sie Ersatz-Lampen und Sicherungen im Wagen?

Mounting steps: Page 4,5

It is possible to mount the lights in an upright or pendant position. The lights must not vibrate or jut out above the bonnet, and must be mounted symmetrically. When fitting, the attachment dimensions in the drawing listed are to be observed. Determine the mounting position and mark the fastening points. Drill using a 3 mm drill bit, and drill out to 8.5 mm. Seal drilled metal parts with rust protection 1.. When fitting the lights, ensure that the „TOP“ marking on the housing always points upwards. Light points upwards. Align the light in accordance with the drawing and tighten the screws.

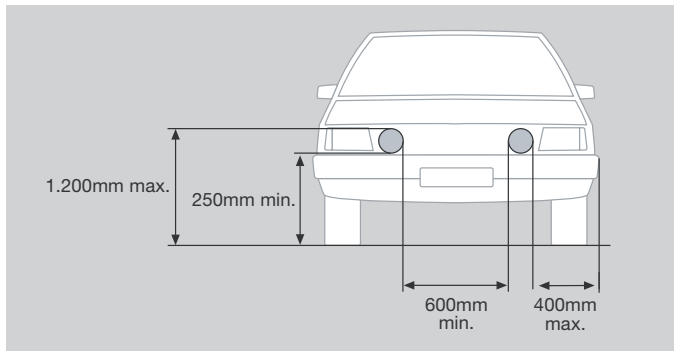

Electrical connection: From page 6

Fit the relay with the connection terminals pointing downwards in a waterproof manner.

If required, fit a switch (see Accessories) into the dashboard, or fit a switch which is intended specifically for your car.

Lay and connect the cables in accordance with one of the 4 circuit diagrams.

















By way of example for three countries, the following table is intended to show with which lighting functions fog lights may be combined.

It is however essential that country-specific laws are observed.

Check the lighting system.
Fasten the connection cables securely.

Have the fog lights adjusted at a specialist garage.

Only correctly adjusted lights

				
Dipped beam				
Dipped beam and position light	 			 C max. 400 mm
Position light				 C max. 400 mm
Main beam and position light	 			

provide optimum light.

Bulb replacement: Page 10

Replace bulb in accordance with the drawing. Do not touch bulbs with bare fingers! Use a paper towel or similar.

Another tip:

- Always keep the light lenses clean. Dirt can absorb more than 80% of the light output. You can drive safely if you can see well and therefore also be seen well.

Do you have spare bulbs and fuses in your car?

Montage: Page 4,5

Un montage vertical ou suspendu des projecteurs est possible. Les projecteurs ne doivent ni vibrer, ni dépasser la hauteur du capot moteur et doivent être montés de façon symétrique. Il convient, lors du montage, de respecter les cotes du plan mentionné. Définir la position de montage et repérer les points de fixation.

Effectuer un pré-perçage au foret de 3 mm et percer au foret de 8,5 mm.

Appliquer une protection antirouille sur les pièces métalliques percées. Lors du montage des projecteurs, - veiller à ce que le repère „TOP“ sur le boîtier soit dirigé vers le haut. Projecteur dirigé vers le haut. Orienter le projecteur suivant le plan et serrer les vis.

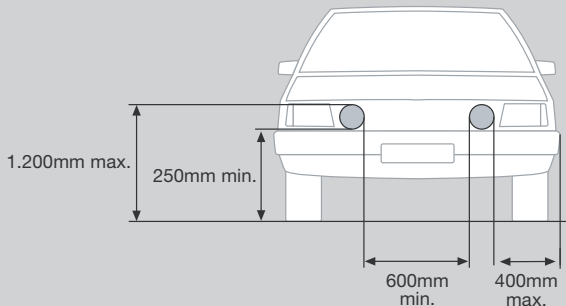

Branchement électrique: A partir de la page 6

Monter le relais avec les bornes orientées vers le bas, afin de le protéger des projections d'eau.

Si besoin, monter un commutateur (voir accessoires) dans la planche de bord, ou un commutateur prévu spécialement pour votre voiture.

Poser et raccorder les câbles suivant un des 4 schémas électriques.

Le tableau ci-après indique, avec l'exemple de trois pays à l'appui, avec quelles fonctions d'éclairage le projecteur antibrouillard peut être combiné.

Dans tous les cas, la législation spécifique à chaque pays doit être respectée.





Contrôler le système d'éclairage. Fixer les câbles de connexion de façon sûre.

Faites régler vos projecteurs antibrouillard dans un garage spécialisé.

Seuls des projecteurs correctement réglés garantissent un éclairage optimal.

Remplacement des lampes: Figure page 10

Remplacer les lampes suivant le plan. Ne pas prendre les lampes à mains nues ! Utiliser une serviette en papier ou autre semblable.

		A	CH	D
Feux de croisement				●
Feux de croisement et de position		●	●	● C max. 400 mm
Feux de position			●	● C max. 400 mm
Feux de route et de position			●	

Derniers conseils:

- Les glaces des projecteurs doivent toujours être propres. Les salissures peuvent absorber jusqu'à 80% de la puissance lumineuse. Vous roulez en toute sécurité si votre visibilité est bonne et si les autres usagers de la route vous voient bien.

Avez-vous des lampes de rechange et des fusibles dans votre voiture?

Montering: Sidan 4,5

Strålkastaren kan monteras stående eller hängande. Strålkastaren får inte utsättas för vibrationer eller sticka ut över motorhuven och måste monteras symmetriskt. Vid montering ska monteringsmåttet i bilden observeras. Fastställ monteringsläget och märk ut fästpunkterna.

Förborra med 3 mm borr och borra upp med 8,5 mm borr.

Försegla borrade metalldelar med rostskyddsmedel.

Se till att markeringen „TOP“ på strålkastarhuset alltid pekar uppåt vid montering av strålkastaren. Strålkastaren ska peka uppåt. Rikta in strålkastaren enligt bilden och dra åt skruvarna.

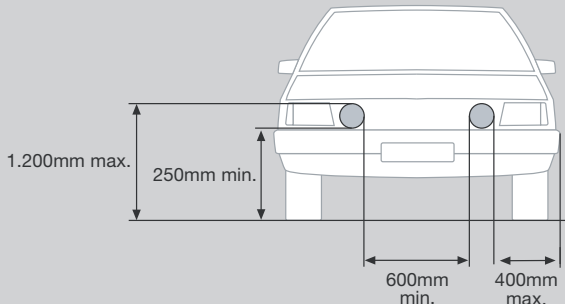

Elektrisk anslutning: Från sidan 6

Montera reläet med anslutningsklämmor nedtill så att det är skyddat mot stänkvatten.

Montera en strömställare (se tillbehör) i instrumentpanelen om det behövs eller montera en strömställare som är särskilt avsedd för din bil.

Dra ledningarna enligt något av de fyra kopplingsscheman som finns och anslut dem.

Nedanstående tabell visar exempel för tre olika länder på vilka ljusfunktioner som får kombineras.

Nationella lagar måste alltid följas.





Testa ljussystemet. Fäst anslutningsledningarna på ett säkert sätt.

Låt en fackverkstad ställa in dimljusstrålkastarna.

Endast rätt inställda strålkastare ger optimalt ljus.

Byte av glödlampa: Bild på sidan 10

Byt glödlampan enligt bilden. Ta inte i glödlampan med bara fingrar, använd pappersduk eller liknande.

		A	CH	D
Halvljus				●
Halv- och parkeringsljus		●	●	● C max. 400 mm
Parkeringsljus			●	● C max. 400 mm
Fjärr- och parkeringsljus			●	

Fler tips:

- Håll alltid strålkastarglasen rena. Smuts kan ta bort upp till 80 % av ljuseffekten. Du kör säkert när du ser bra och syns bra.

Har du med dig reservlampor och säkringar i bilen?

Montage: Pagina 4,5

De schijnwerpers kunnen staand of hangend worden gemonteerd. De schijnwerpers mogen niet trillen, boven de motorkap uitsteken en dienen symmetrisch te worden gemonteerd. Neem bij de montage de in de tekening aangegeven maten in acht. Bepaal de montagepositie en merk de bevestigingspunten. Met 3 mm voorboren en met 8,5 mm opboren.

Voorzie de geboorde metaaldelen van een roestwerend middel.

Let er bij het monteren van de schijnwerpers op dat de marking "TOP" op het lamphuis altijd naar boven wijst. Richt de schijnwerper uit zoals in de tekening is aangegeven en draai de schroeven vast.

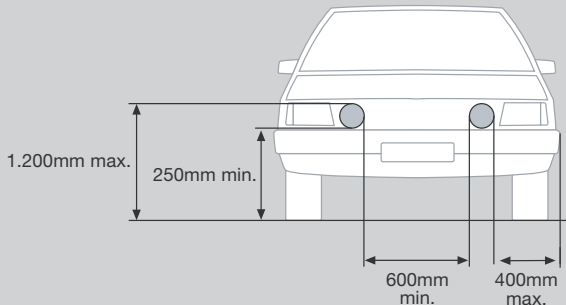

Elektrische aansluiting: Vanaf pagina 6

Relais met aansluitklemmen spatwaterdicht omlaag gericht monteren.

Monteer indien nodig een schakelaar (zie accessoires) in het dashboard. U kunt ook een schakelaar gebruiken die speciaal voor uw auto is ontwikkeld.

Leg de kabels en sluit ze aan zoals in een van de vier schakelschema's is aangegeven.

Met welke lichtfuncties mistlampen mogen worden gecombineerd, wordt in de volgende tabel als voorbeeld voor drie landen aangegeven.

Houd u te allen tijde aan de ter plaatse geldende wetgeving.

Verlichting controleren. Kabels goed bevestigen.

Laat de mistlampen in de werkplaats afstellen.

















Alleen goed afgestelde schijn-

werpers geven optimaal licht.

Gloeilamp vervangen: Afb. pagina 10

Vervang de gloeilamp zoals in de tekening is aangegeven. Raak de gloeilamp niet met blote vingers aan! Gebruik een papieren doekje of iets dergelijks.

21

				
Dimlicht				
Dim- en parkeerlicht	 			 C max. 400 mm
Parkeerlicht				 C max. 400 mm
Groot- en parkeerlicht	 			

Nog een tip:

- Houd het lampglas van de schijnwerpers schoon. Vuil kan tot 80% van de lichtopbrengst absorberen. U rijdt veilig wanneer u goed kunt zien en daardoor ook goed gezien wordt.

Heeft u reservelampen en -zekeringen bij u in de auto?

Montaje: Página 4,5

El montaje del faro puede realizarse en posición fija o suspendida. Los faros no pueden vibrar ni sobresalir del capó y deben montarse de forma simétrica. Durante el montaje deben tenerse en cuenta las medidas de instalación que se indican en el dibujo. Determinar la posición de montaje y marcar los puntos de fijación. Realizar una perforación previa con la broca de 3 mm y, a continuación, perforar con la de 8,5 mm. Es importante sellar con anticorrosivo las piezas metálicas que se hayan perforado. Durante el montaje del faro preste atención en que la marca "TOP" de la carcasa se encuentre siempre en la parte superior. El faro señala hacia arriba. Alinear el faro tal como indica el dibujo y apretar los tornillos.

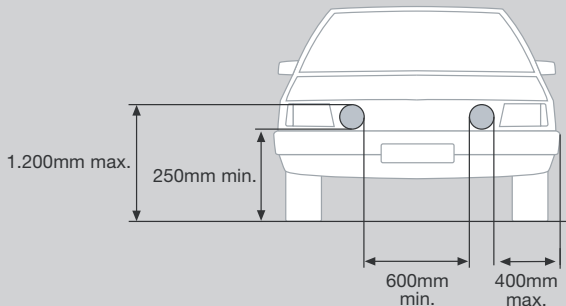

Conexión eléctrica: Página 6

Montar el relé con los bornes de conexión mirando hacia abajo para que estén protegidos de las salpicaduras de agua. En caso necesario y siempre que sea legal, puede montarse un conmutador (véase accesorios) en el cuadro de instrumentos o un conmutador que haya sido diseñado especialmente para su vehículo.

Tender los cables según uno de los 4 esquemas de conexiones y realizar las conexiones.

La siguiente tabla muestra las funciones de iluminación con las que pueden combinarse los faros antiniebla, tomando tres países como ejemplo.







En todos los casos deberán cumplirse las leyes específicas para cada país.

Comprobar el sistema de iluminación. Fijar los cables de conexión de forma segura.

Los faros de luz de carretera deberán ser ajustados por un taller especializado. Sólo los faros correctamente ajustados garantizan una iluminación óptima.

Cambio de lámparas: Fig. página 10

Sustituir la lámpara según el dibujo. No tocar la lámpara directamente con las manos; utilizar un trozo de papel o algo similar.

		A	CH	D
Luz de cruce				●
Luz de cruce y de posición	 	●	●	● C max. 400 mm
Luz de posición			●	● C max. 400 mm
Luz de carretera y de posición	 		●	

Un consejo más:

- Mantenga los cristales dispersores de los faros siempre limpios. La suciedad puede absorber hasta un 80% de la potencia luminosa. Conducirá de forma más segura si puede ver bien y también ser visto.

¿Lleva lámparas de repuesto y fusibles en su vehículo?

Montaggio: Pagine 4,5

Per i proiettori sono possibili sia il montaggio ritto che quello appeso. I proiettori non devono vibrare o sporgere dal cofano motore e devono essere montati in modo simmetrico. Durante il montaggio rispettare le misure di montaggio riportate nel disegno allegato. Determinare la posizione di montaggio e segnare i punti di fissaggio. Praticare un foro con la punta da 3 mm e allargarlo con quella da 8,5 mm.

Spalmare sulle parti in metallo forate la protezione antiruggine. Quando si montano i proiettori assicurarsi che il contrassegno „TOP“ sull'involucro esterno sia sempre rivolto verso l'alto. Il proiettore è rivolto verso l'alto. Allineare il proiettore in base al disegno e serrare le viti.

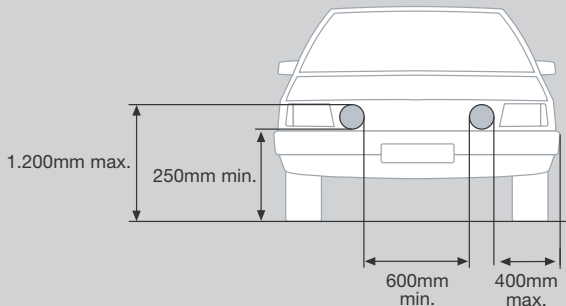

Collegamento elettrico: Da pagina 6

Montare il relè con i morsetti di collegamento rivolto verso il basso per proteggerlo dagli spruzzi d'acqua.

Se necessario montare un interruttore nel cruscotto (v. accessori) oppure montarne uno previsto appositamente per la vostra auto.

Montare e collegare i cavi in base a uno dei 4 schemi elettrici.

La seguente tabella indica le funzioni luminose con cui possono essere combinati i proiettori fendinebbia, portando l'esempio di tre Paesi.

In ogni caso bisogna rispettare le leggi specifiche del Paese.

Controllare l'impianto d'illuminazione. Fissare in modo sicuro i cavi di collegamento.

Far regolare i fendinebbia presso un'officina specializzata.

Solo proiettori regolati correttamente forniscono una luce ottimale.

Gloeilamp vervangen: Afb. pagina 10

Sostituire la lampadina in base al disegno. Non toccare le lampadine direttamente con le dita! Utilizzare fazzoletti di carta o simili.

		A	CH	D
Luce anabbagliante				●
Luce anabbagliante e di posizione		●	●	● C max. 400 mm
Luce di posizione			●	● C max. 400 mm
Luce di profondità e di posizione			●	

Ancora un consiglio:

- Tenere sempre puliti i trasparenti dei proiettori. La sporcizia può ridurre la potenza luminosa fino all'80%. Si viaggia più sicuri se si vede bene e si è ben visti.

Avete lampadine e fusibili di ricambio in auto?

Asennus: Sivu 4,5

Sumuvalot voidaan asentaa pysty- tai riippuasentoon.

Sumuvalot eivät saa täristä eikä ylettyä konepellin yli ja ne on sijoitettava symmetrisesti.

Asennuksessa on huomioitava piirroksessa ilmoitetut asennusmitat.

Valitse asennuspaikka ja piirrä kiinnityspisteet.

Poraa ensin 3 mm ja sitten läpi 8,5 mm poranterällä.

Ruostesuojaa poratut metalliosat.

Huomioi sumuvaloja asentaessasi, että kopan päällä oleva "TOP"-merkintä näyttää ylöspäin.

Asennoi sumuvalot piirroksen mukaan ja kiristä ruuvit.

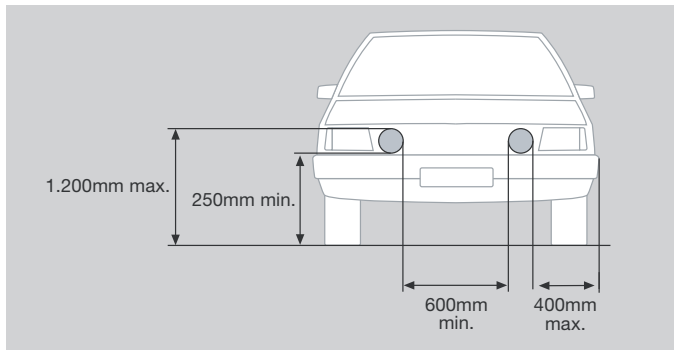

Sähköinen liitäntä: Sivu 6

Asenna releet liitospuristimilla alapuolelle siten, että ne ovat suo-
jassa roiskevedeltä.

Asenna tarvittaessa kojelautaan
katkaisija (katso tarvikkeet) tai
erityinen, Sinun autoosi suunniteltu
katkaisija.

Valitse neljästä kytkentäkaaviosta
oikea ja asenna johdot sen mukaan
ja liitä.

Alla olevassa taulukossa on esitetty
mitä valotoimintoja saa käyttää
yhdessä sumuvalojen kanssa
käyttämällä esimerkkinä kolmea eri
maata.

Maakohtaisia lakeja on nouda- tettava joka tapauksessa.

Testaa valolaitteisto. Kiinnitä liitos-
johdot huolellisesti.





Säädätä sumuvalot asiantunte- valla korjaamolla.

Vain oikein säädetyt sumuvalot

tuottavat ihanteellista valoa.

Polttimonvaihto: Kuva sivu 10

Vaihda polttimo piirroksen mukaan.
Älä koske polttimoon paljain sor-
min! Käytä paperiliinaa tai muuta
samantapaista.

		A	CH	D
Lähivalo				●
Lähi- ja seisontavalot		●	●	● C max. 400 mm
Seisontavalot			●	● C max. 400 mm
Kauko- ja seisontavalot			●	

Ohje:

- Pidä ajovalojen lasit puhtaina.
Lika voi siemaista valotehosta
jopa 80 %. Hyvä näkeminen ja
näkyminen liikenteessä lisäävät
turvallisuuttasi.

Onko ajoneuvossasi varalla poltti-
moita ja sulakkeita?

