



Pilot Operated Check Valves Catalog

Pilot to Open

RPC06

OPERATION

This is a pilot-to-open check valve.

Schematic

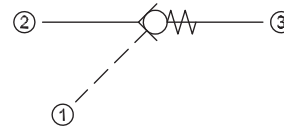

SPECIFICATIONS

Theoretical performance

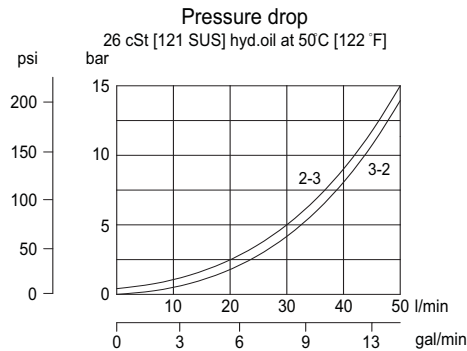

Specifications

Rated pressure*	350 bar [5075 psi]
Rated flow at 7 bar [100 psi]	35 l/min [9.25 US gal/min]
Weight	0.10 kg [0.22 lb]
Pilot ratio	3.4:1
Cavity	NCS06/3

*Rated pressure based on NFPA fatigue test standard (at 1 million cycles)

Note: A piston seal requires a 5 bar [72.5 psi] or greater return spring.

DIMENSIONS

mm [in]

Cross-sectional view

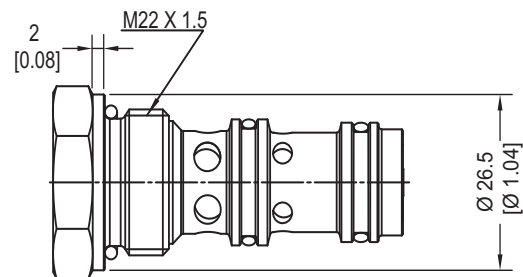
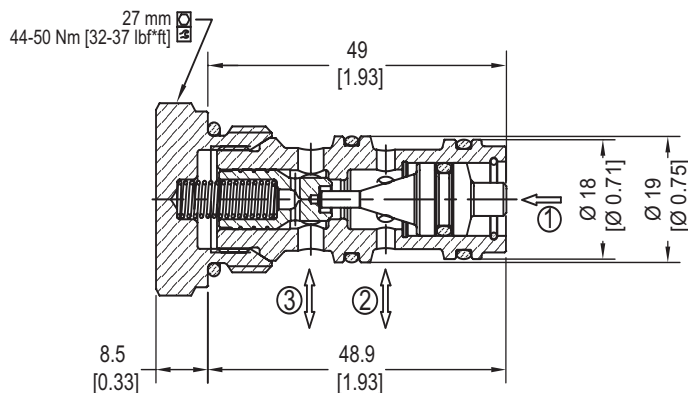

ORDERING INFORMATION

RPC06-5-OR-00-V

Pilot to Open

Crack Pressure	
0.5	0.5 bar [7 psi]
2	2 bar [30 psi]
5	5 bar [72.5 psi]
10	10 bar [145 psi]

Pilot Seal Option	
Omit	No seals
OR	Seals

Seal Option	Seal Kit
Omit = Buna-N	230000070
V = Viton	230000110

Code	Ports & Material	Body Nomenclature
00	00 = Cartridge only	No Housing
SE3/8	AL, 3/8 BSP	NCS06/3-SE-3/8
SE1/2	AL, 1/2 BSP	NCS06/3-SE-1/2
SE6S	AL, #6 SAE	NCS06/3-SE-6S
SE8S	AL, #8 SAE	NCS04/3-SE-8S

** Aluminum bodies are to be used for pressures less than 210 bar (3000 psi)
*** Other housings available

PO - Pilot Operated Check Valves
RPC 06