

REMEMBER TO INCLUDE **STAMPS** INFORMATION ABOUT YOUR SEALS: **SIZE, TEMPERATURE, APPLICATION, MEDIA, PRESSURE AND SPEED**

ROD SEALS

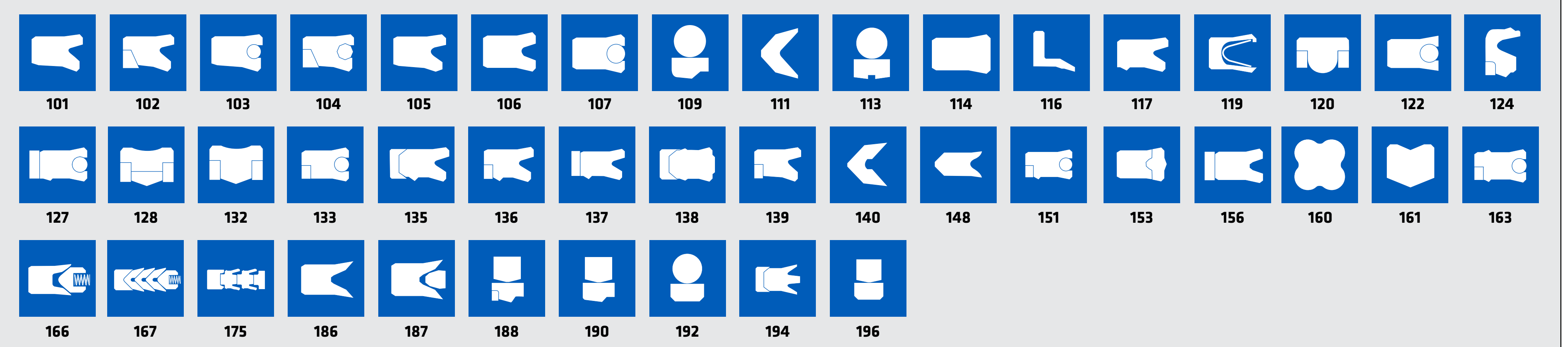

PISTON SEALS

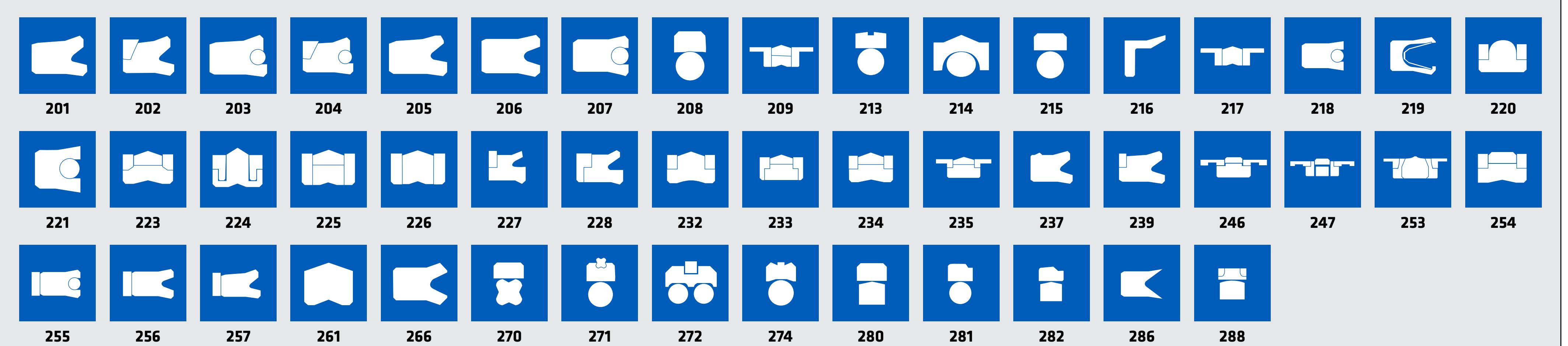

WIPERS

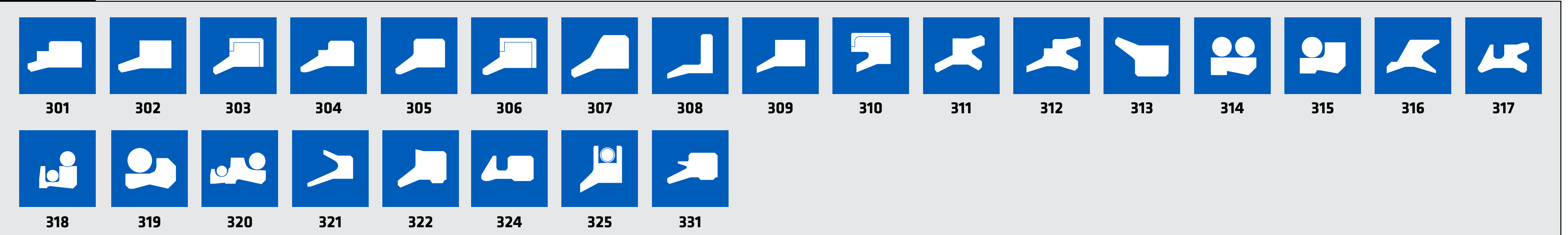

ROTARY SEALS

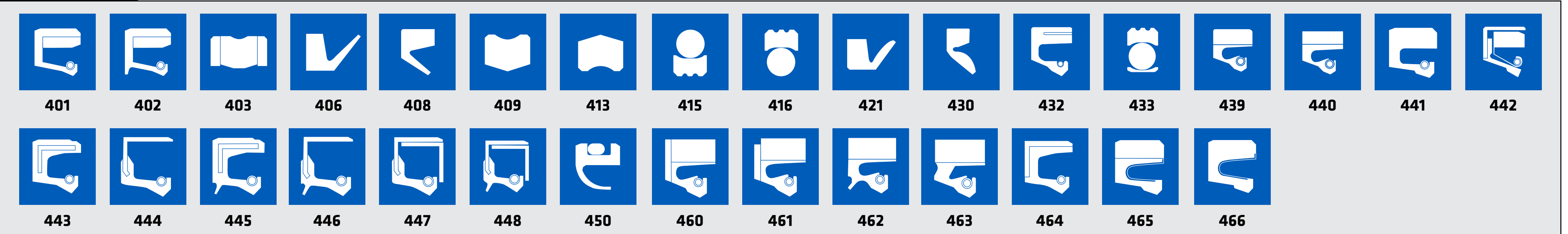

FACE SEALS

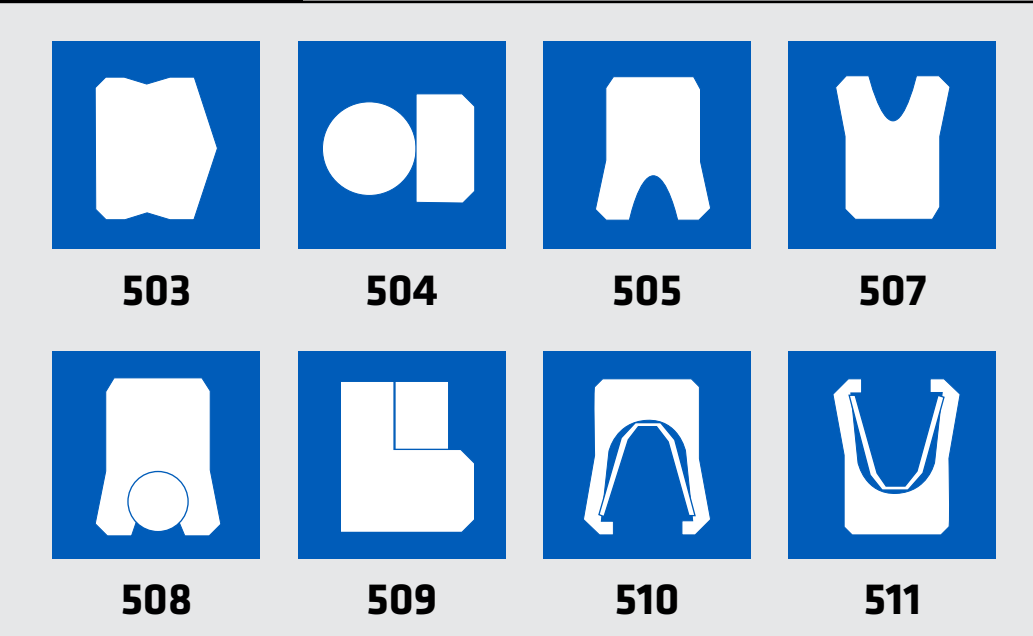

BACK-UPS

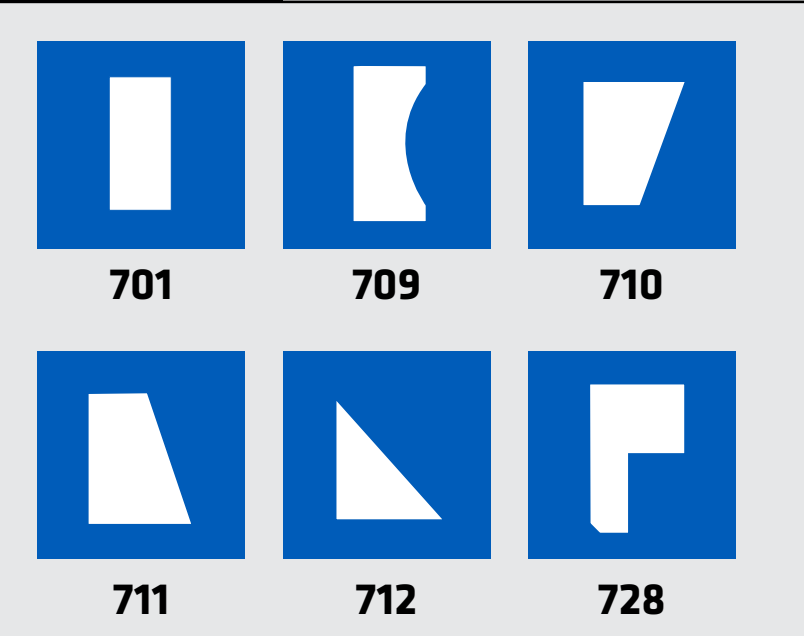

GUIDE WEAR BANDS

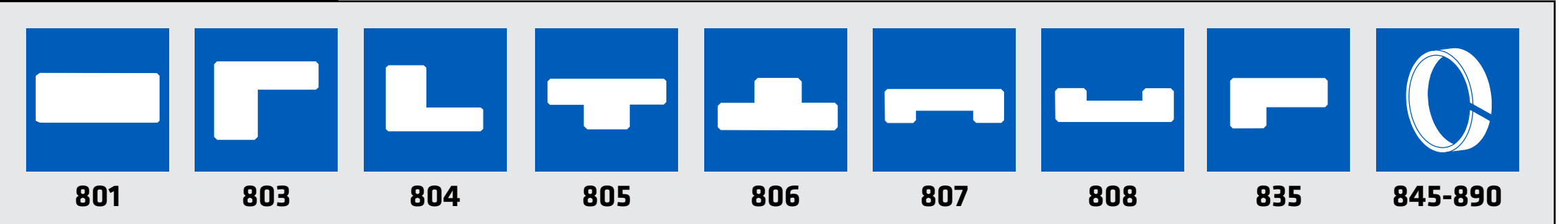

MATERIALS AVAILABLE • POLYURETHANE (PU) • NBR • HNBR • FPM (VITON) • EPDM
 SILICONE • PTFE COMPOUNDS • UHMWPE • ACETAL (POM) • POLYAMIDE (NYLON) • PEEK

PISTON

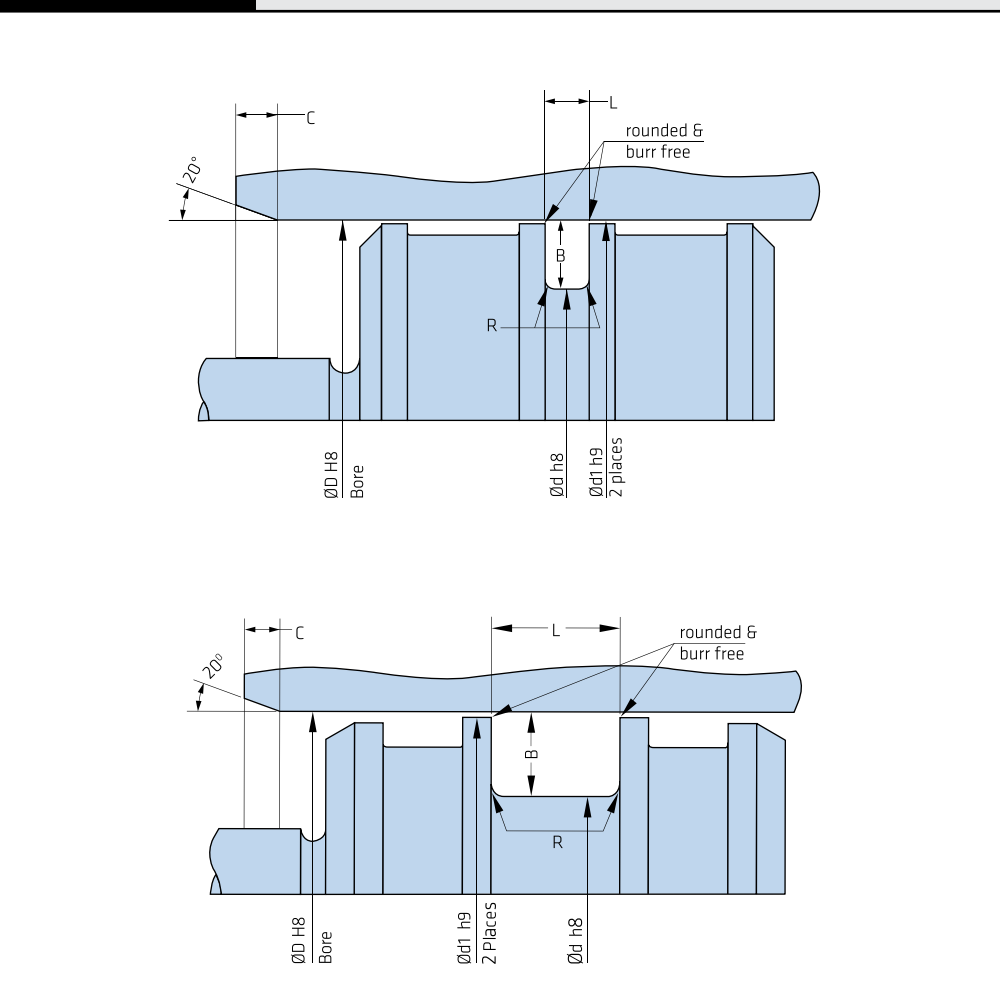

ROD

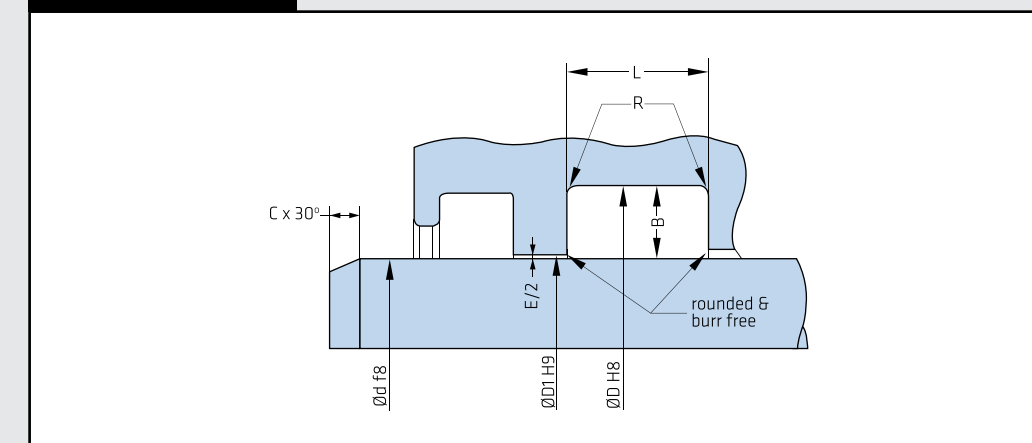

WIPER

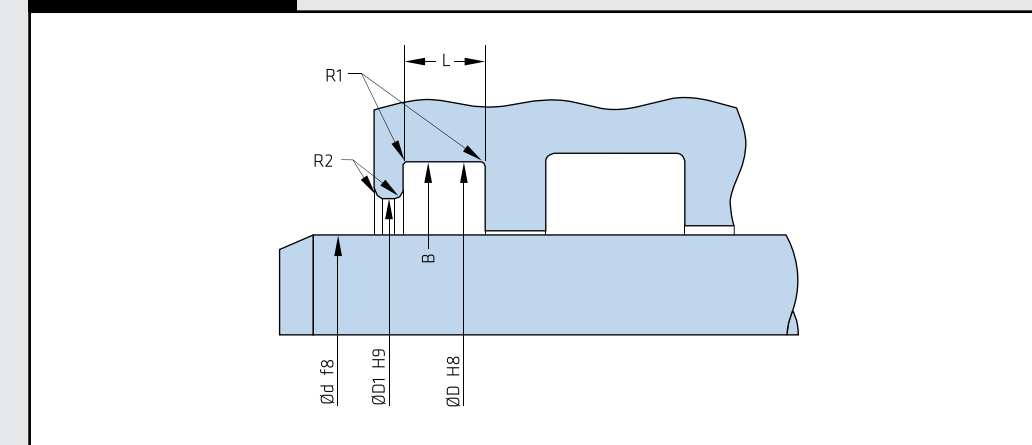

GUIDE BAND - PISTON

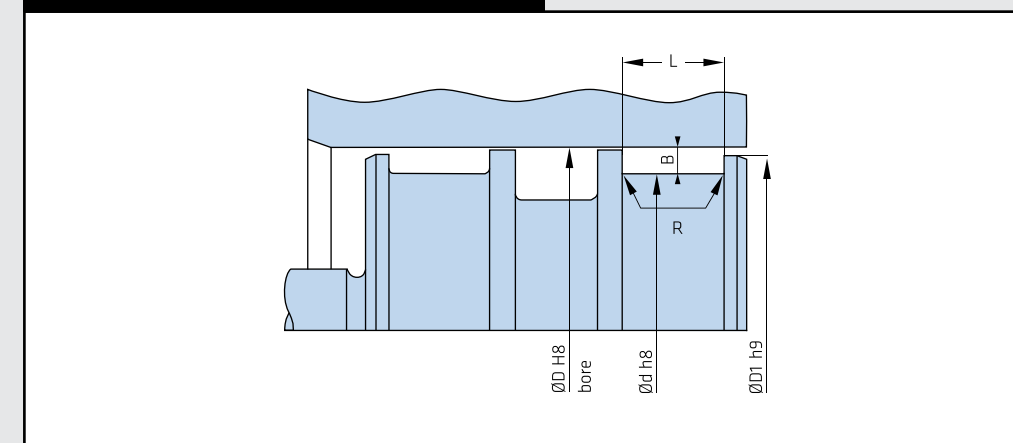

GUIDE BAND - ROD

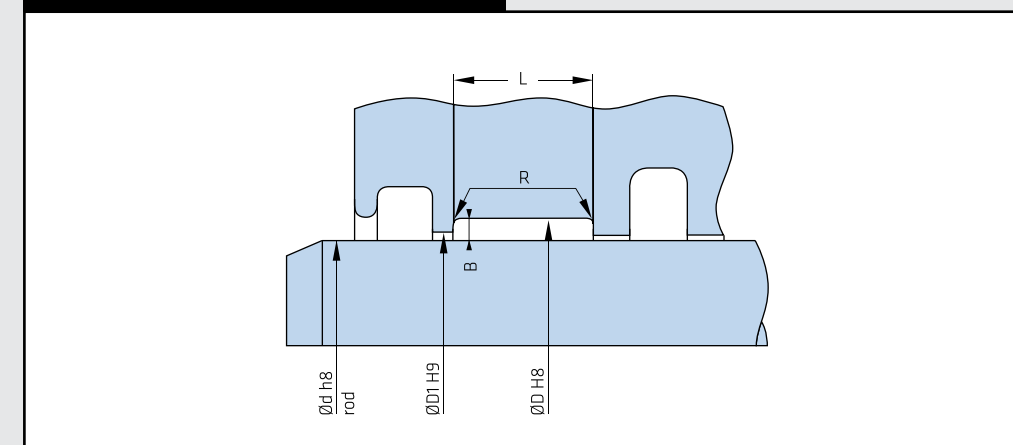

ROTARY

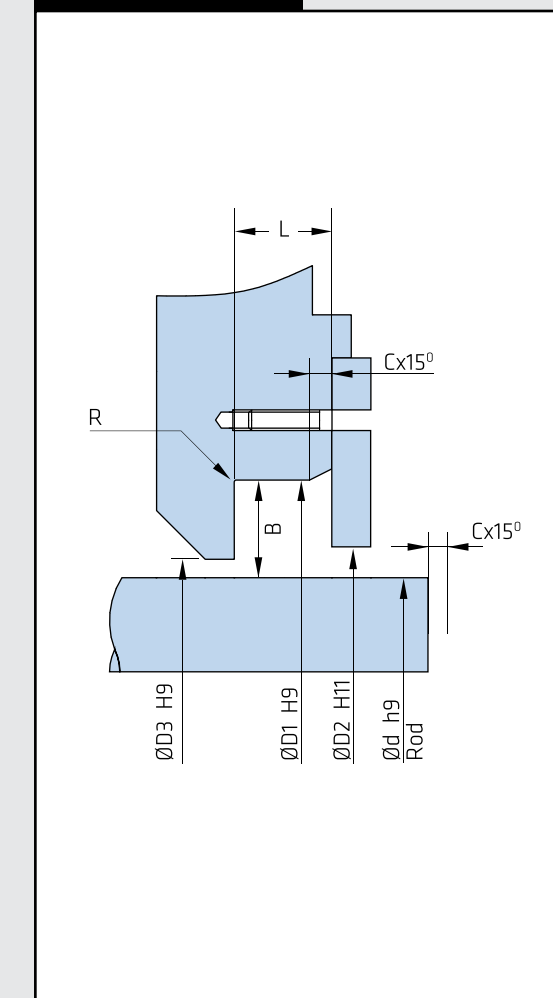

FACE SEAL

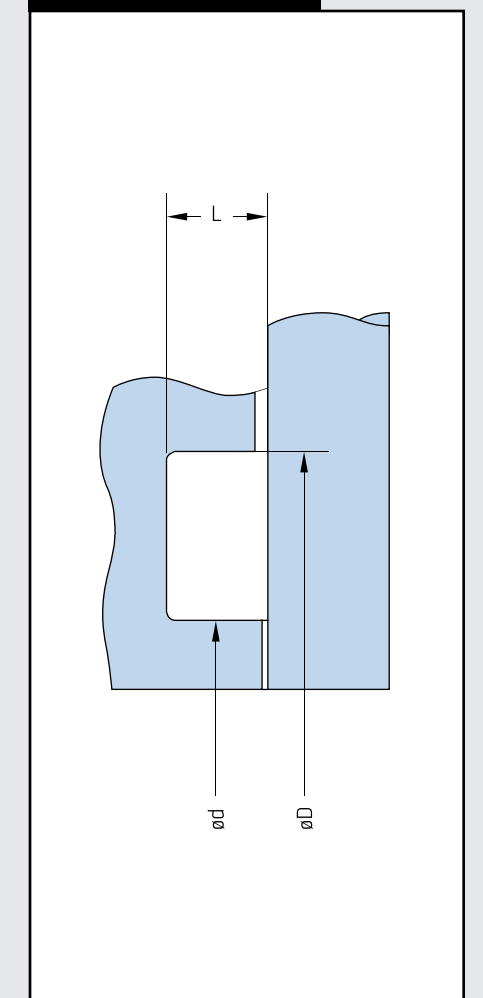

SEALS

HOUSING