



**PONGS**<sup>®</sup>  
walls ceilings & panels



# PEOPLE *search for?*

*innovation, change, inspiration, emotions,  
horizons, experiences, enjoyment,  
security, harmony.*

Contemporary architectural projects are more and more inspiring worlds on their own. Ideas and designs have to capture the past, tomorrow as well as they have to adapt to the ever changing contemporary taste the most possible flexibility.

Modularity and flexibility of the latest materials and their fresh new properties are in demand as never before. Our PONGS complete solution as a global high tech textile company: Building change by maintaining the value. This is done in line with the highest quality standards and with an excellent cost efficiency.





**PONGS<sup>®</sup>**

*It is that easy to let your visions become reality.*



## Walls, Ceilings & Panels



flexible, easy to replace...



...endless printing



ready-made...



...backlit

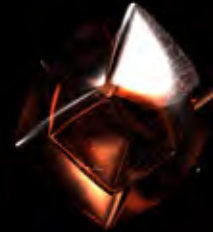

also sound-absorbing...



...spectacular design



everything by PONGS®.



*Walls, Ceilings, Panels*

*We* **HAVE**

*exactly the right material with the right system  
and the right digital printing.*

Interior design is extremely fast changing. Now rooms have concepts and the look conveys a certain lifestyle. They have to be as flexible as possible, easy to replace and with just the right design. Textile walls and ceilings make this possible and are also configured freely by the corresponding digital printing. And more, spacious modern rooms remain in balance with the background noise by using sound absorbing acoustic panels.

Project

Hôtel des Centraliens (Paris)  
Champs Elysées

Project management

Maison Margiella (Paris)



*High tech textile system. Simple, fast, fascinating ...*

Design with a lot of impact and completely fresh design possibilities.

Our DESCOR® system has the materials and the right accessories to even realize the most complicated shapes sensationally fast. Plus our PONGS® training center, which can be simple and technically implemented with the latest design looks for the professional.

Project: Design Loft Düsseldorf  
Project Management: Living Concept Consulting

DESCOR® Ceilings Led backlights.  
DESCOR® Walls and Video projection wall.





*design*





# INSTALLATION

*easy, quick, clean.*

Ready installed ceilings and walls without dirt in just one day? – That is not possible! But with PONGS® it is! Textile high tech walls and ceilings are easily fixed in a frame system that is very simple bolted to a wooden frame. The accompanying technology is taught by a skilled craftsman at our training center in just one day. By that one can trained professional creates an entirely new business area with booming growth potential.



# *No* **SURFACE**

*is as smooth and clean as a* **DESCOR®** *wall or ceiling.*

You do not have to think of how you might get your ceilings absolutely even over huge areas!

For PONGS® high tech materials absolutely straight, smooth and durably beautiful - this is our standard!

While others are still trying to paint their ceilings in a proper white - a DESCOR® ceiling is already installed and even refined individually with a spectacular digital printing.

Project: PONGS® Headquarter Stadtlohn, Germany.  
Interior redesign of our offices and representation areas.

Project Management: Living Concept Consulting

DESCOR® Ceilings Led backlights.

DESCOR® Ceilings with multiple Installations: light elements, aeration elements and smoke detectors. DESCOR® walls.

*Extremely flexible &* **TEMPERATURE**  
*independent installation.*

If top design works much better than the standard, then it has something to do with a superior system. Our DESCOR® system is simply thought through in every detail. For all structural contingencies, there are prefabricated elements and for all who still believe a textile cover can only be installed in a heated room, we have surprising news for you! DESCOR® and all other PONGS® materials are easily processed at room temperature - even in the ice cold.





*Ceilings get* **STYLISH**

DESCOR® textile ceilings can now be determined for a space experience, so rare and so exciting that the perfect embedded video projection screen just invites an experience that is exciting as the ceiling on top.



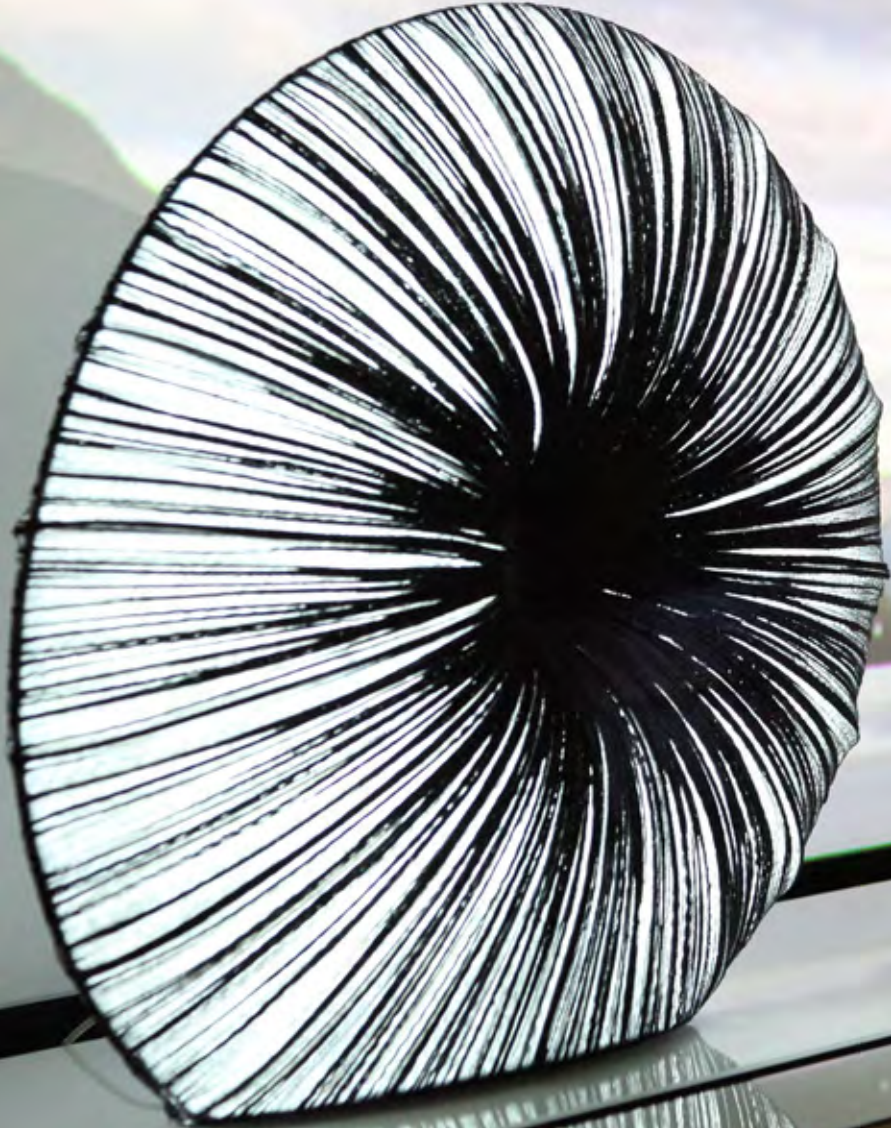

*projection screen en vogue.*



# ACOUSTIC *It is silent.*

Large, clear, stylish rooms with the corresponding glass fronts can now just be as they are – be acoustically in harmony with all who live and work there.

These materials are of high quality and of course, some of the most exciting new acoustic fabrics are made by PONGS®



**PONGS**<sup>®</sup>  
design

## PONGS Akutex<sup>®</sup>

A material with a fantastic design and acoustic properties. It is extremely sound-absorbing up to a  $\alpha_w$ -value of 0,90. It is very easy to handle as a 30 m roll weighs just 25 kg and it is permanently flame retardant. Additionally, it just feels very nice and has a huge creative potential when digitally printed or it's painted in trendy color versions like art canvas surfaces. Plus the material itself has a special weaving technique, no matter how you look at it, you face always the same homogeneous surface.



## **PONGS Silencio®**

*Function, design, aesthetics.*

PONGS Silencio® is the first acoustic fabric with a three-dimensional surface of permanently flame retardant fibers of the highest quality (Trevira CS).

Silencio®'s design possibilities are really exciting. The material looks spectacular in every color, is even digitally printable and mediates through its three-dimensionality a special motif depth.

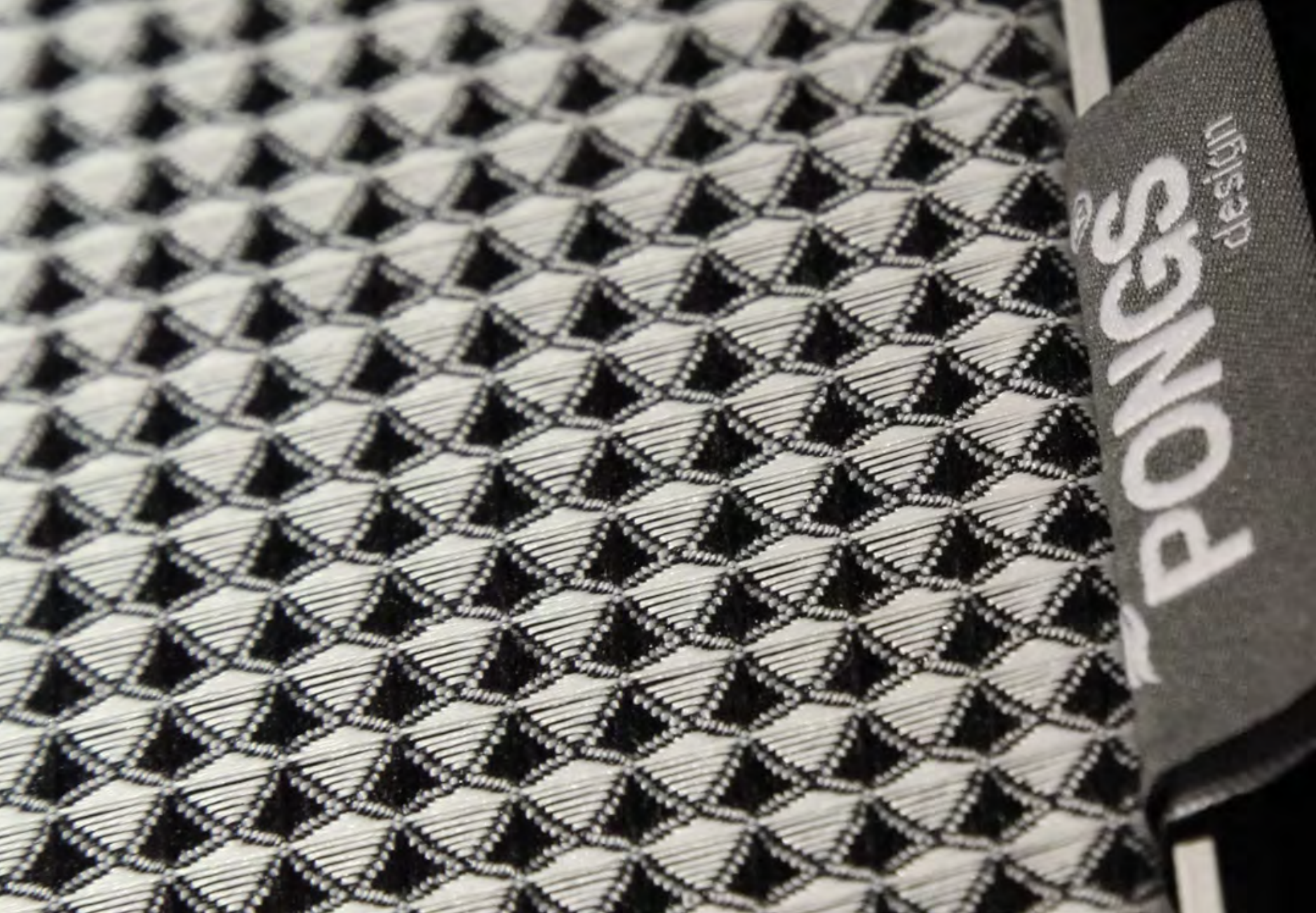

**PONGS**  
deslun



*High compatibility with all common printing systems  
max. print width of 500 cm, coating options  
such as washing, waterproofing, paints, coatings in 540 cm width*



# FORMAT

*printing sizes - there is nothing we can not print.*

Think XXXL. An artistic expression, perfection and a simply spectacular implementation of an overall concept of a leading architect in the town hall of Montpellier, France. Here it has been counted on PONGS® materials.





*let it be* LIGHT



# *lighting, dimming, coloring.*

A homogeneous ceiling or wall in itself already is a beautiful object. If you just „turn it on“ and see how they become a wide space and a dimmable light source, nothing is as it was before. The standard „wow moment“ can left behind, because the room just looks spectacular!

LED lights behind PONGS high tech textiles create such a modern new sense of space that you really have to see it. Change dimming and the color by using a slide rule on your tablet or smartphone.

By that visions of the future suddenly have a permanent place in the realization of conversions or in your latest projects. And this as easy to install as pulling a few stripes for a regular lamp.



# BACKLIGHTING

*with Softimage lightbox, Artist heavy & Artist Mambo*

Specially designed for backlighting, PONGS® textiles feature excellent digital printing quality. Best-sellers include Artist heavy or Softimage lightbox and Artist Mambo, both of which are crease-resistant and free of stress whitening. Add design highlights to your ambience. We guarantee that our products are free of hazardous substances and are therefore REACH-compliant. Made in Germany.



A microscopic view of several purple, spherical bacteria with numerous fine, hair-like projections (pili) extending from their surfaces. In the bottom left corner, a larger, more complex yellowish-green structure with several protruding, club-like appendages is visible. The background is a light, hazy white.

High-end textile for stretch wall and ceiling coverings with integrated Sanitized® hygiene technology: bonded silver ions safely combat multi-resistant bacteria, including MRSA, for the long term, ensuring an extended service life and improved functionality for the material. DESCOR® PREMIUM antibac offers protection, comfort and optimum hygiene for public buildings such as schools, hospitals and hotels.



# DESCOR<sup>®</sup> ANTIBAC

*Bacteria reduced by 99.99% thanks to Sanitized<sup>®</sup> silver ions*

A low-angle photograph of a tree with vibrant blue leaves against a cloudy sky. The image is overlaid with a semi-transparent hexagonal grid pattern. The text 'PRINTERIEUR®' is centered in the middle of the image in a white, bold, sans-serif font.

**PRINTERIEUR®**



*Print & wall* **ART** *editions*

Architects and real cool designers have rediscovered printed walls and ceilings.

The latest trend in digital printing is called „printerieur“ and it has become indispensable from contemporary interior design, because nothing else is so quick and easy in building spectacular rooms.

The easy interchangeability and flexibility of our PONGS® high tech materials combined with back lighting and large print sizes - blossom the ideas how walls and ceilings have to look like. As never been seen before and as individual as never before.

With designs that are especially developed for large-scale digital prints by artists and designers for our PONGS® Print Art Editions. Additional our PONGS® Wall Art Editions. These have been nominated materials at Heimtextil 2015 and stand for wall art creation in the highest level. Everything else is just wallpaper.

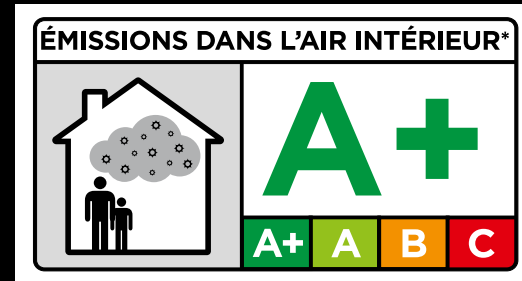

**PONGS®** - *We certificate all of our products.*

You find PONGS® high tech textiles within the largest construction projects up to the largest cruise liners.

A trust that is placed in us, we are worthy of - because of all the fantastic product properties some are particularly important:

Our products comply with all relevant building certificates worldwide.

This means that PONGS® customers are always safe when it comes to any major specifications.





*Our claim* **CERTIFICATES**  
*for all our products.*

Project

Restaurant Nabulione (Paris)

Stories can be written about outstanding German companies and even some of them make actual history. PONGS® is one such company. Owner-managed in the second generation PONGS® is the textile high tech company ever. A world leader of a proud weaving and knitting machines capacity of 1.9 million sqm per month, realizing the most impressive new material properties from the yarn to the finished fabric.

PONGS® is a complete textile concept and market leader in the development and sale of digital print media worldwide.

Our diverse product variants make the groundbreaking creations in visual merchandising, store design, as well as in exhibitions, stages and theaters. On top of that, we are the largest supplier in the textile interior design. We present, with DESCOR®, Suntex®, Akutex® and Silencio® a complete system that connects the textile indoor and outdoor installation with sound absorption, fire protection and sun protection. And this from the largest cruise ship to the spectacular large-scale projects of the most famous architects. Two large areas with one vision - demonstrate solutions and inspire our customers! With PONGS® cross selling all areas combined together and complement each other with a competence, product depth and innovation, you cannot find in any other company.

## *From filament to finished fabric.*

PONGS® Printerieur goes even further into the design detail. Using high resolution digital fabric printing, customized wholesale faces up to 5,05 m arise. This is the new trend future segment in interior design. We also present our Innovation Award nominated PONGS® wall art editions. Everything else is wallpaper.

PONGS® textil is the largest supplier of decorative materials and with the new PONGS® design brand one of the most innovative suppliers of textile lifestyle design objects, created entirely and exclusive of our finest and trendiest fabrics. This completes the textile concept PONGS® in very detail.

Be inspired and advised in everything we do, you are our main focus. Your vision is our driving force. With a great team and a diversified product portfolio, we are sure to be the best possible partner for you.

A close-up photograph of several identical bottles. The bottles have a golden, textured surface that looks like fine-grained metal or a special coating. They have a rounded, bulbous shape and a red, cylindrical cap on top. The lighting is dramatic, highlighting the texture and creating strong highlights and shadows. The background is blurred, showing more bottles in a row.

*overall* **CONCEPT**





 **PONGS**<sup>®</sup>

*Precedence is not enough for us - we are still there.*

PONGS<sup>®</sup> is worldwide one of the most modern textile production plant.

Weaving- and knitting machines capacity of 1.9 million sqm per month.

Gear system with considerable capacity of 2.5 million sqm per month.

Wide- and heavy fabrics up to 640 cm.

12.000 product descriptions.

Complete program for visual merchandising, advertising, events, exhibitions, stage, theater and interior design in the commercial sector and the interior design.

Continuous quality assurance of all stages of production.

Approx. 270 employees

4 subsidiaries:

Administrative center in Stadtlohn since 1967

Sales Office in New Jersey since 2014

Production plant in Mühltroff since 1992

Creative Center in Düsseldorf from summer 2015





**DESCOR<sup>®</sup>**  
Technical assembly instructions

#### **Welcome to the technical world of PONGS<sup>®</sup> walls, ceilings & panels**

The application, the processing, the installation, the accessories: Here you will easily find the right answer to all detailed technical questions related to the DESCOR<sup>®</sup> system, which is incredibly diverse, but still simple to process.

PONGS<sup>®</sup> produces and develops decorative and acoustic textile clamping systems for ceilings, walls and panels. The applications are universally usable both in new builds and in renovations. The installation of decorative elements as well as technical components such as e.g. lamps, spotlights, exhaust air systems and air handling units is simple to complete. The DESCOR<sup>®</sup> system is the ideal solution for all ceiling and wall coverings.

#### **Advantages at a glance**

DESCOR<sup>®</sup> is installed at room temperature and does not require the room to be additionally heated.

DESCOR<sup>®</sup> is multi-talented in this field: no other wall or ceiling is so harmonically smooth and simple to install and at the same time so clean and flexible to replace.

DESCOR<sup>®</sup> is a system that has proven itself 1,000 times and has applications from the largest construction projects, up to the largest cruise ships.

DESCOR<sup>®</sup> is high-resolution up to a width of 500 cm and is individually digitally printable. This means unlimited freedom for your ideas.

DESCOR<sup>®</sup> fulfils the CE and VOC standards and here achieves the highest possible emission requirement class: A+. The newly installed product smells similar to a freshly painted room for a few days.

#### **DESCOR<sup>®</sup> cleaning**

Every surface can get dirty.  
DESCOR<sup>®</sup> is just as easy to clean as it is to install.

The following procedure is recommended in this case:

##### *1. Clothes brush*

In most cases, light soiling can be removed by concentric movements while applying slight pressure with a clothes brush.

##### *2. Microfiber cloth*

The best way to remove dirt is using a damp microfiber cloth.

##### *3. Rubber eraser*

Some drugstores also offer relevant "dirt erasers". These can be used to remove a multitude of possible types of dirt.

#### **Allergens and micro-organisms**

The material is resistant to a multitude of pollen and microparticles due to its very fine textile structure. In addition, an antifungal layer provides a surface upon which fungi cannot reproduce.



<b>Introduction</b> .....	02	<b>4. Integration of technical elements</b> .....	16
<b>1. Preparation: Dimensions and ordering</b> .....	04	4.1 Selection of the supporting structure .....	16
1.1 The dimensions.....	04	4.2 Inspection cover .....	17
1.2 Assembly reserve/ handling reserve .....	04	4.3 Lighting and ventilation units .....	18
1.3 Ordering DESCOR <sup>®</sup> .....	05	4.4 Installation of spotlights .....	19
1.3.1 Material on reels .....	05	4.5 Use of a lamp .....	20
1.3.2 Cut .....	05	<b>5. The installation</b> .....	21
<b>2. The DESCOR<sup>®</sup> profile</b> .....	06	5.1 Fastening of a stretched ceiling.....	21
2.1 Explanation.....	06	5.2 Installation of a one-colored stretched ceiling .....	22
2.2 Types of profile .....	06	5.3 Installation of a DESCOR <sup>®</sup> ceiling (> 7 linear meters) .....	23
2.2.1 DESCOR <sup>®</sup> AM profile.....	07	5.4 Installation of complex ceiling systems.....	24
2.2.2 DESCOR <sup>®</sup> AP profile .....	07	5.5 Finishing of corners .....	25
2.3 Fastening options for a ceiling.....	08	<b>6. Acoustic solutions</b> .....	26
2.4 Fastening options for a wall .....	09	6.1 Acoustics and decoration for walls and ceilings. ....	26
2.5 Connecting of profiles.....	10	6.2 Fastening of acoustic materials .....	27
2.5.1 Connecting two profiles in corners .....	10	6.3 System structure for ceilings .....	28
2.5.2 Connecting more than two profiles .....	11	6.4 System structure for walls .....	28
2.6 DESCOR <sup>®</sup> APC profile.....	12	<b>Legal notice</b> .....	29
2.7 Installation situation for fireplaces .....	12		
2.8 Wall ledges and other decorative profiles.....	13		
<b>3. Double clamping</b> .....	14		
3.1 Explanation.....	14		
3.2 Running direction.....	14		

## 1. Preparation: Dimensions and ordering

### 1.1 The dimensions

The maximum width and length of the wall or ceiling area are required/ measured.

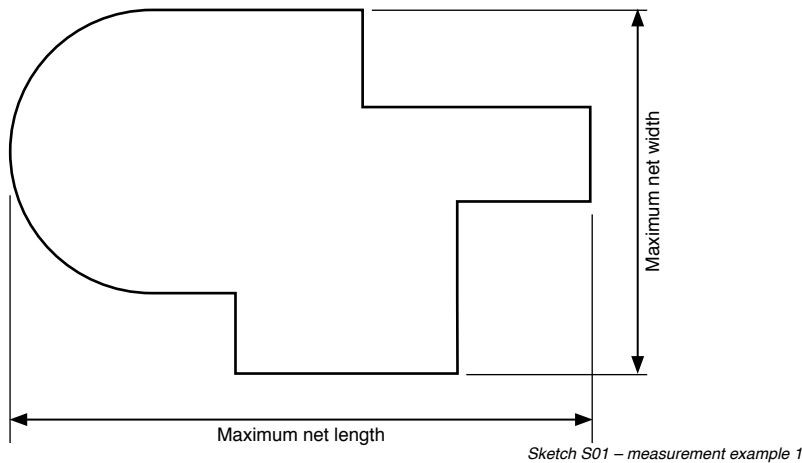

It is not necessary to measure the diagonals, intermediate dimensions and angles.

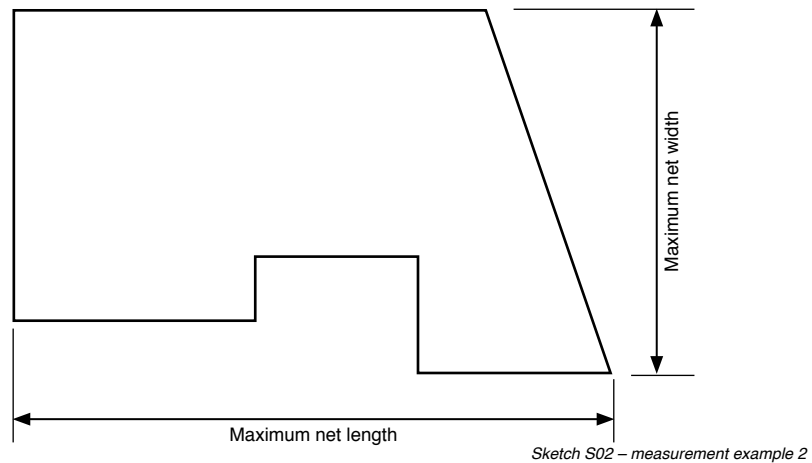

### 1.2 Assembly reserve/ handling reserve

For the installation an allowance is added all around to the measured dimensions of the ceiling or wall (this is hereinafter referred to as assembly reserve).

The following table serves as a guide:

The assembly reserve depends on the size of the area or on the largest measured value.

Maximum measured value (in m)	Assembly allowance required per side (in m)
< 3.00	0.10
3.01 to 5.00	0.15
5.01 to 6.00	0.20
6.01 to 10.00	0.30
> 10	> 0.50

*Table T01 – assembly reserve*

1. Preparation: Dimensions and ordering

1.3 Ordering DESCOR®

1.3.1 Material on reels

DESCOR® is available in different dimensions and can be ordered in the following standard widths. The relevant information can be viewed on the current price lists and sample cards. The standard length of a roll is 50 linear meters.

Gross width in m	Net width in m
3.20	3.10
3.60	3.50
4.20	4.10
4.60	4.50
5.20	5.05

Table T02 - standard widths of material on reels

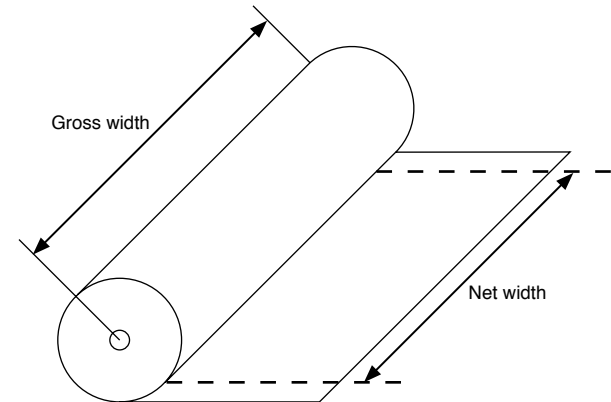

Sketch S03 - material on reels – gross/net

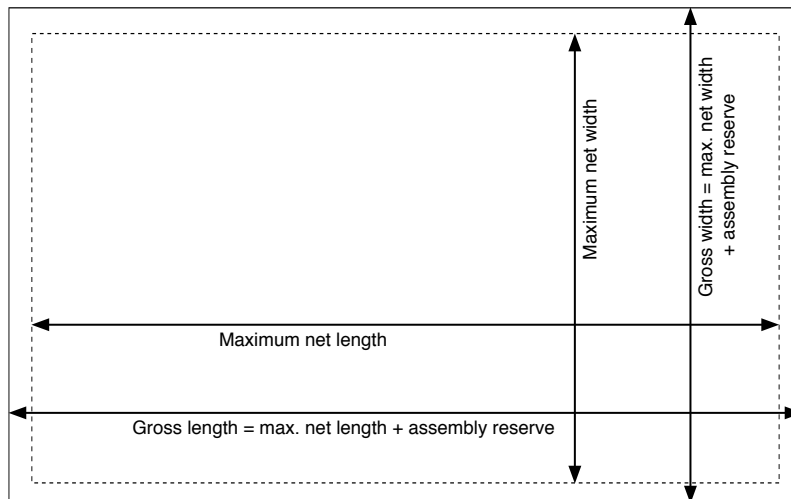

Sketch S04 - determining the right size to order

1.3.2 Cut

If the measurement (please see Item 1.1) is known, the required assembly reserve (please see Item 1.2) is added on. This is calculated from the cutting measurements to be ordered (please see ordering example).

The width dimension is adapted to the relevant available reel width of the required material.

Ordering example:

Net dimension of ceiling: 2.90 m × 6.20 m  
 Net dimension + assembly reserve: 2.90 m + 0.10 m + 0.10 m = 3.10 m  
 6.20 m + 0.30 m + 0.30 m = 6.80 m

Ordering: DESCOR® PR. 599130 320 450  
 3.20 m × 6.80 m Item No. Width Color

## 2. The DESCOR<sup>®</sup> profile

### 2.1 Explanation

The DESCOR<sup>®</sup> profiles are pre-drilled at a distance of 15 cm, whereby optimal installation is guaranteed through the use of screws. In addition, each of the profiles must be fastened to all joints/miters with a screw at the start and the end.

#### Chamfered edge (1)

The profile can be positioned better in corners thanks to chamfered edge.

#### Soft lip (2)

Due to a flawless finish the irregularities of the supporting surface are corrected.

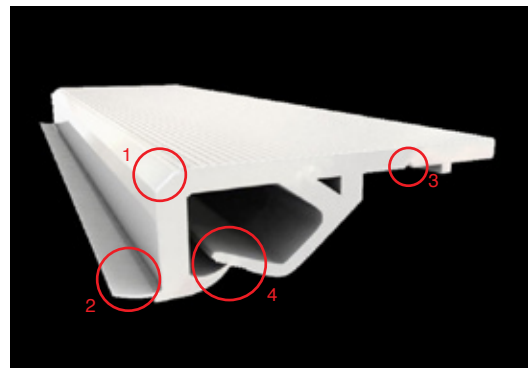

Image B01 – profile view

So that this work process can be completed without problems, the profile is provided with an integrated groove that simplifies the positioning of the screw.

#### Drill marking (3)

Thanks to drill markings, the fastening is simple and precise. It is therefore not necessary to remove the profile due to a screw that has been placed too far to the right. There is also no risk that the mounting clamp will squash the material due to a screw that is placed too far to the left.

#### Ribbed lip (4)

The ribbed lip ensures a safe support of the material and prevents it from slipping out after it has been grouted in.

### 2.2 Types of profile

Item number	Designation	Color	Length (in m)	Material	Feature	
098000 999	AP*	white	2.00	PVC	pre-drilled every 15 cm	
098001 999	AP*	black	2.00			
098002 999	AM**	white	2.00			
098003 999	AM**	black	2.00			
098004 999	AP*	white	3.00		pre-drilled every 15 cm, for curves	
098005 999	AP*	black	3.00			
098006 999	APC***	white	2.00			
098007 999	APC***	black	2.00			
098010 999	AP*	gray	2.00			pre-drilled every 15 cm

\* Please see Item 2.2.1; \*\* Please see Item 2.2.2; \*\*\* Please see Item 2.6

Table T03 - types of profile

### 2. The DESCOR<sup>®</sup> profile

If a direct fastening of the DESCOR<sup>®</sup> profile onto the supporting surface is not possible or a greater installation depth is required, then, for example, an additional wooden strip or a wall bracket can be fitted. The DESCOR<sup>®</sup> profile can be screwed onto the newly created supporting structure as usual (possibly also glued).

In every case the fastening must be completed carefully and every screw must be correctly in place, in order to guarantee a flawless result on the wall or ceiling. The correct screws/ screw lengths/ dowels and adhesive for the installation situation and supporting surface must be used. Further notes on possible fastenings are described under Item 2.3/ 2.4.

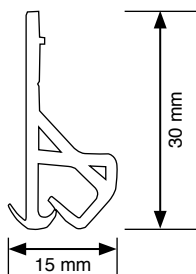

Sketch S05 - DESCOR<sup>®</sup> AM profile

#### 2.2.1 DESCOR<sup>®</sup> AM profile

The DESCOR<sup>®</sup> AM profile enables direct fastening onto the wall, in order to achieve the required suspension height (S07). This fastening profile is especially suitable for fastening onto plasterboards.

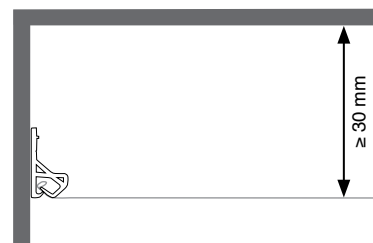

Sketch S07 - DESCOR<sup>®</sup> AM profile version

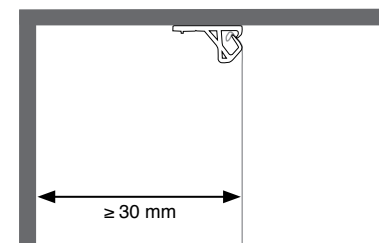

Sketch S08 - DESCOR<sup>®</sup> AM profile version

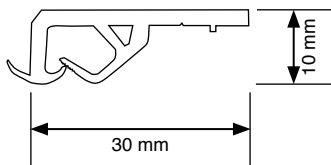

Sketch S06 - DESCOR<sup>®</sup> AP profile

#### 2.2.2 DESCOR<sup>®</sup> AP profile

In the case of direct fastening onto the existing wall/ ceiling the DESCOR<sup>®</sup> AP profile enables a minimum installation depth of 10 mm (which corresponds to the height of the profile).

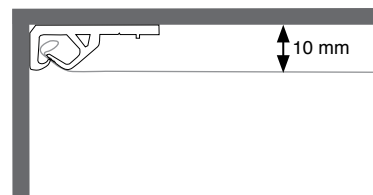

Sketch S09 - DESCOR<sup>®</sup> AP profile version

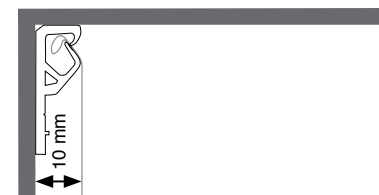

Sketch S10 - DESCOR<sup>®</sup> AP profile version

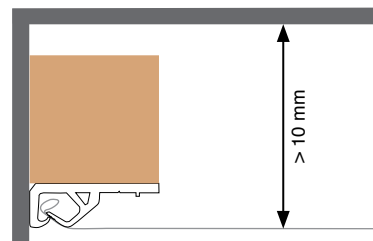

Sketch S11 - DESCOR<sup>®</sup> AP profile version

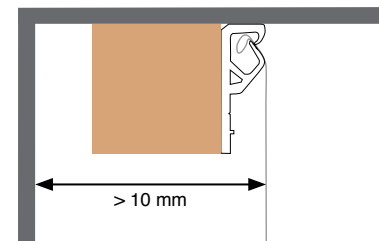

Sketch S12 - DESCOR<sup>®</sup> AP profile version

2.3 Fastening options for a ceiling

	Distance (in mm)	Profile	Supporting surface present	Supporting structure required	Fastening of DESCOR <sup>®</sup> profile onto supporting structure
	10	AP	Wood	no	round-head screws (4 x 20 mm)
			Plasterboard	no	contact adhesive + plasterboard screws (5.5 x 38 mm)
	≥ 40		Concrete	Wood/ wall angle	Wood: round-head screws (4 x 20 mm)
			Brick	Wood/ wall angle	Wall angle: pan head drilling screw (3.9 x 25 mm)
	≥ 40	AM	Wood	no	round-head screws (4 x 20 mm)
			Plasterboard	no	contact adhesive + plasterboard screws (5.5 x 38 mm)
			Concrete	Wood/ wall angle	Wood: round-head screws (4 x 20 mm)
			Brick	Wood/ wall angle	Wall angle: pan head drilling screw (3.9 x 25 mm)

Table T04 - ceiling fastening options

2.4 Fastening options for a wall

	Distance (in mm)	Profile	Supporting surface present	Supporting structure required	Fastening of DESCOR <sup>®</sup> profile onto supporting structure
	10	AP	Wood	no	round-head screws (4 × 20 mm)
			Plasterboard	no	contact adhesive + plasterboard screws (5.5 × 38 mm)
	≥ 40	AP	Concrete	Wood/ wall angle	Wood: round-head screws (4 × 20 mm)
			Brick	Wood/ wall angle	Wall angle: pan head drilling screw (3.9 × 25 mm)
	≥ 40	AM	Wood	no	round-head screws (4 × 20 mm)
			Plasterboard	no	contact adhesive + plasterboard screws (5.5 × 38 mm)
			Concrete	Wood/ wall angle	Wood: round-head screws (4 × 20 mm)
			Brick	Wood/ wall angle	Wall angle: pan head drilling screw (3.9 × 25 mm)

Table T05 - wall fastening options

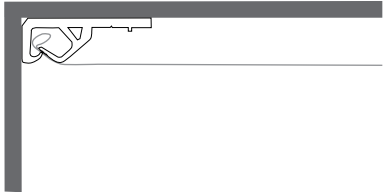
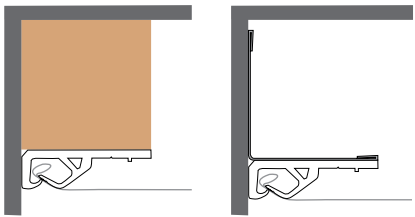
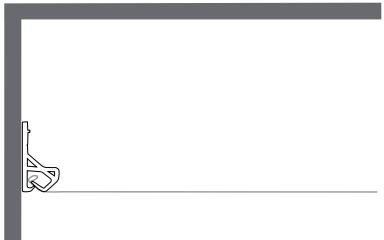
## 2. The DESCOR<sup>®</sup> profile

The alignment of the profiles can be simplified through the use of the DESCOR<sup>®</sup> assembly spatula.

### 2.5 Connecting of profiles

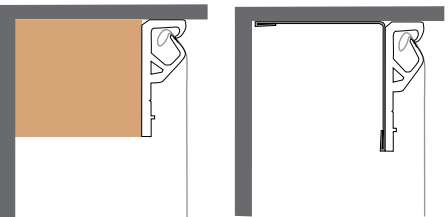
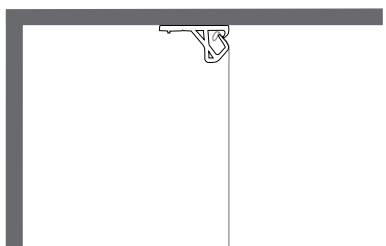
The connections between the profiles must be clean and carefully arranged, so that no distance is visible between the profiles. The profiles (please see Item 2.1) must additionally be fastened by screws.

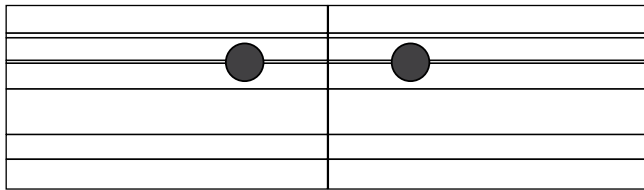

Sketch S13 - profile connection – top view

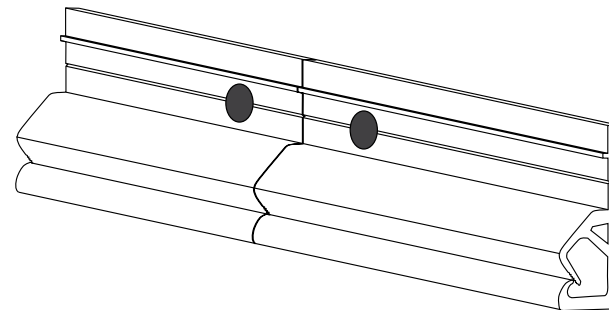

Sketch S14 - profile connection – diagonal view

### 2.5.1 Connecting two profiles in corners

The miters can be made using miter shears with lever transmission or a miter saw (alternatively, a saw with a miter gage).

In the case of miters the clean and careful arrangement must also be ensured. The area that is later visible (1) is important here. The inner area (2) does not require any particular care, because this will later be covered by the textile.



Image B02 - miter shears



Image B03 - miter saw



Image B04-B06 - corner assembly



2. The DESCOR<sup>®</sup> profile

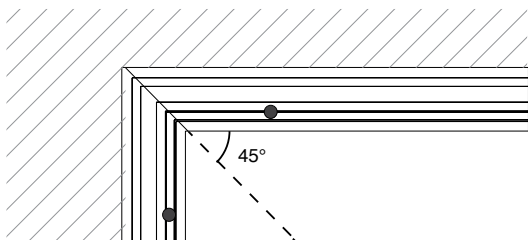

Sketch S15 - profile connection - top view



Image B07 - corner assembly - shell



Image B08 - corner assembly - with textile

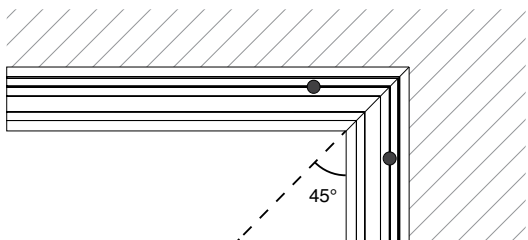

Sketch S16 - profile connection - top view



Image B09 - corner assembly - shell

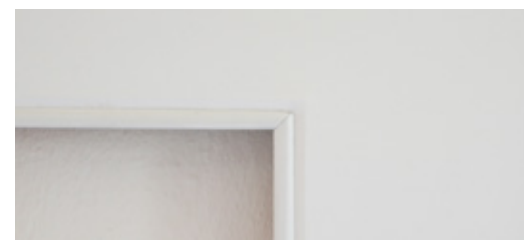
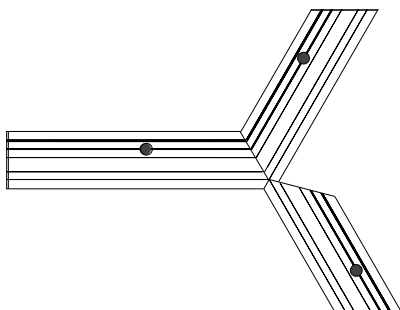

Image B10 - corner assembly - with textile

**2.5.2 Connecting more than two profiles**

Under consideration of the procedure named in Item 2.5.1, connections of several profile rails (e.g. in the case of gables/ the roof area) are possible.

In doing this, the miter angle must be adapted individually.



Sketch S17 - connection of three profiles



Image B11 - example of connection of three profiles - shell



Image B12 - example of connection of three profiles

## 2. The DESCOR<sup>®</sup> profile

### 2.6 DESCOR<sup>®</sup> APC profile

The DESCOR<sup>®</sup> APC profile enables the use and the realization of rounded forms and curves. The smallest possible radius is about 20 cm.

We recommend fastening the profiles with screws at a distance of 5 cm. For optimal support, an appropriate adhesive should also be used.

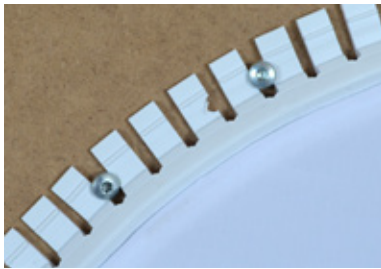

Image B13 - DESCOR<sup>®</sup> APC profile



Image B14 - DESCOR<sup>®</sup> APC profile

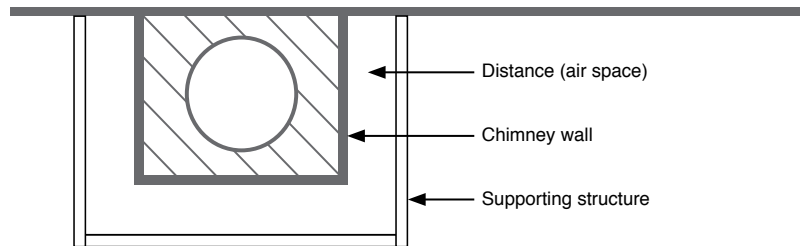

Image B15 - DESCOR<sup>®</sup> APC-profile – minimum bending radius = 20 cm

### 2.7 Installation situation for fireplaces

DESCOR<sup>®</sup> profiles are designed for use at normal room temperatures. A permanent temperature of 55°C on the profile should not be exceeded, in order to avoid the danger of the deformation of the profile (especially at the clamping lip). For temperature measurements it was determined that in the

case of different kinds of chimneys, atmospheric temperatures of around 70°C or more can arise. For the determination and definition of coverings and distances, a temperature measurement (actual temperature) should take place over several hours near the site of installation.



Sketch S18 - fireplace integration

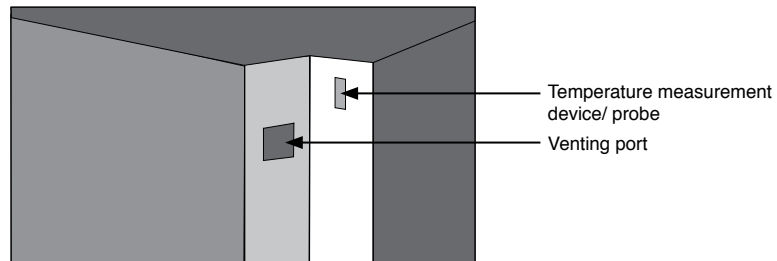

Image B19 - temperature control

## 2. The DESCOR<sup>®</sup> profile

### 2.8 Wall ledges and other decorative profiles

With the DESCOR<sup>®</sup> system, existing wall ledges and decorative profiles can be retained (in the case of the use of the DESCOR<sup>®</sup> AP profile with an installation depth of 10 mm).

For the assembly of new wall ledges/ decorative profiles there are several solutions, depending on the suspension height. In general, a wooden supporting structure should be worked with.

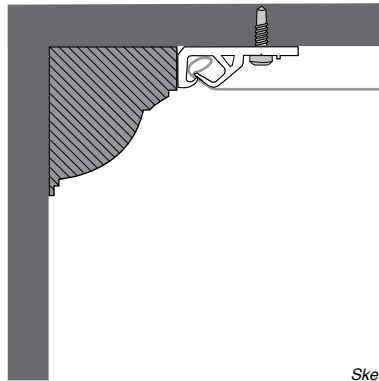

Sketch S20 - available wall ledges

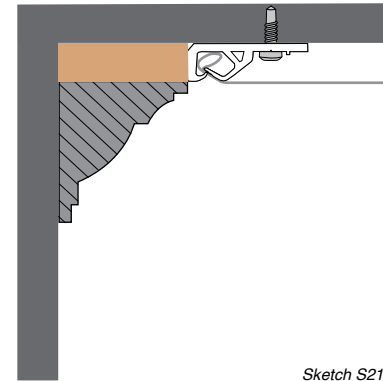

Sketch S21 - wooden support (h = 10 mm)

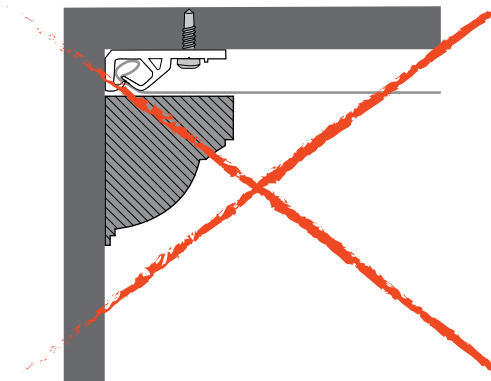

Sketch S22 - integration of wall ledge

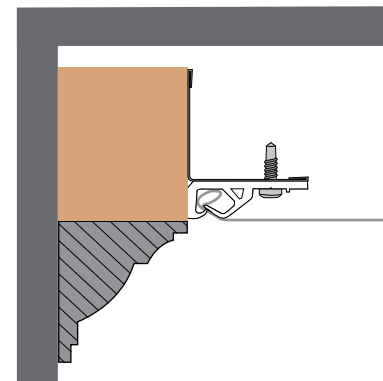

Sketch S23 - variable wooden support (h > 10 mm)

The DESCOR<sup>®</sup> profile should not be covered by the wall ledge, in order to ensure that the wall ledge is replaced quickly and in an uncomplicated way.

### 3. Double clamping

#### 3.1 Explanation

In the case of wall or ceiling areas that exceed 5 m both in their length and in their width, it is possible to make a double clamping. For this, two clamping surfaces made from the same batch of material (the same production) are connected to one another. At the crossover, one single profile is used.

At a crossover between a wall and a ceiling, a double clamping can also be completed in one profile.

#### 3.2 Running direction

In the case of a double clamping, account must always be taken of the running direction of the DESCOR<sup>®</sup> ceiling. This means the running direction of both surfaces must be aligned in the same way. Otherwise, depending on the structure, light reflection can cause a visible difference in color to result in the material.

If orders are for double clampings, this must always be specified.

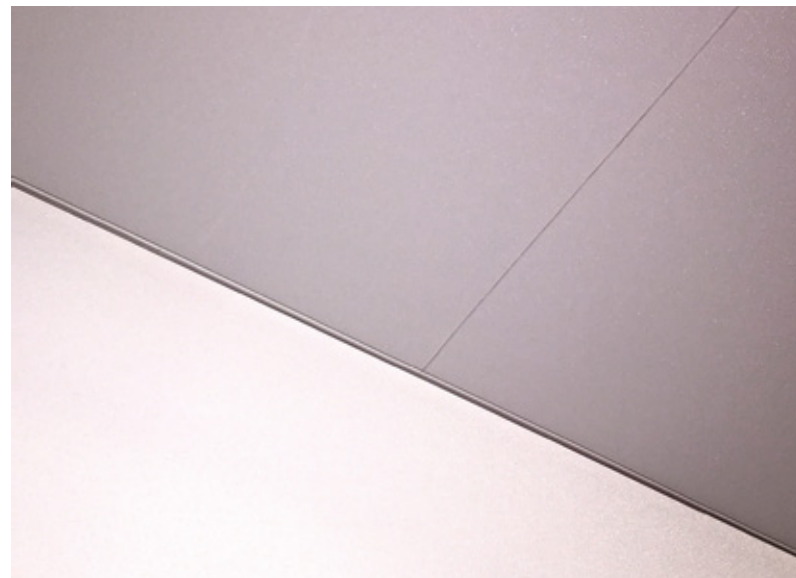
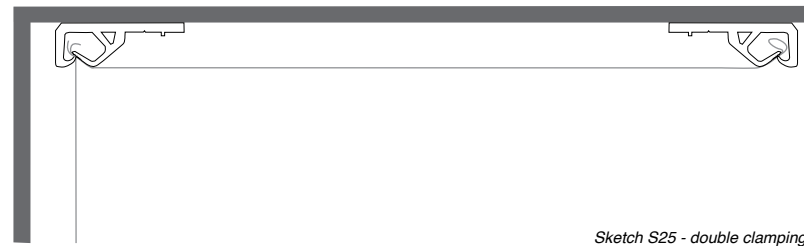
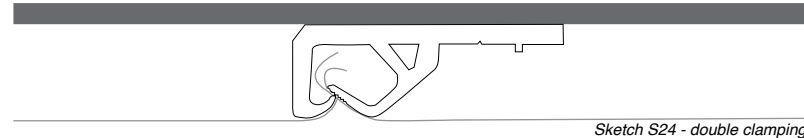

3. Double clamping

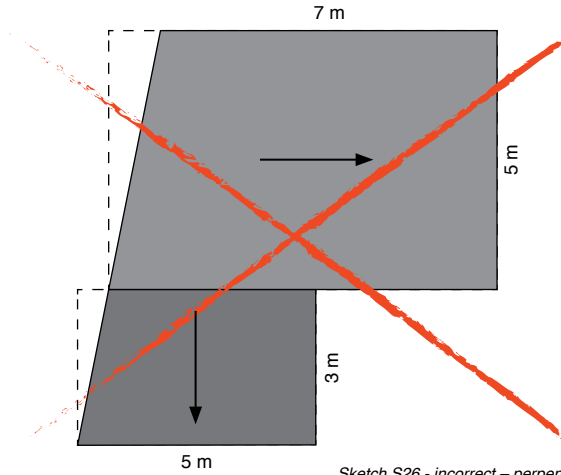

Sketch S26 - incorrect - perpendicular to one another

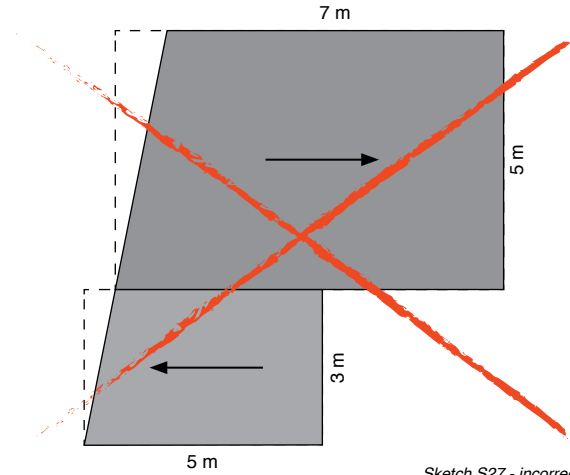

Sketch S27 - incorrect - opposite direction

Running direction →

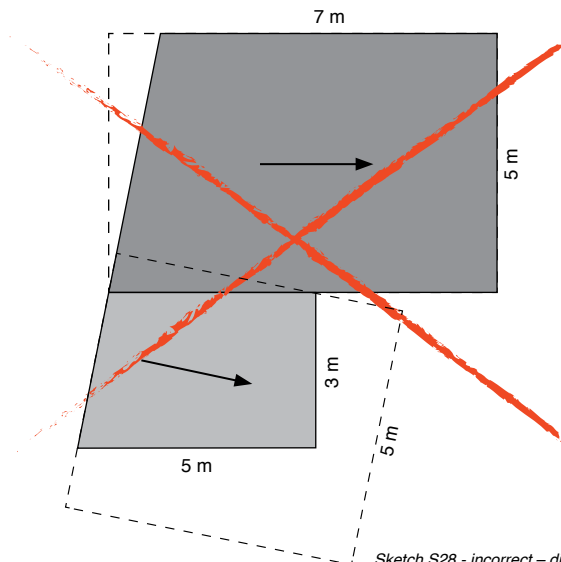

Sketch S28 - incorrect - diagonal to one another

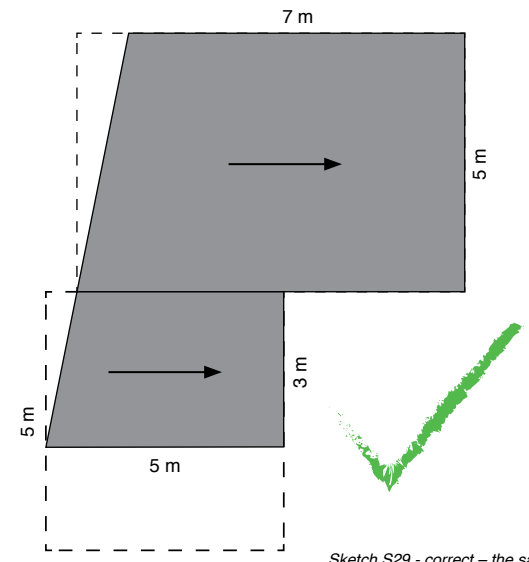

Sketch S29 - correct - the same, parallel direction

## 4. Integration of technical elements

### 4.1 Selection of the supporting structure

The integration of technical elements frequently requires the additional installation of a supporting structure. The selection of the correct material is very important in this. Thus it should be ensured that non-corrosive screws are used in the bathroom.

The installation of the supporting structure must be carried out with the greatest possible care. A poorly implemented supporting structure leads to considerable requirements for subsequent improvements that take a lot of time.

Also the selection of the correct color for the material used for the supporting structure is important here. Do not paint white under any circumstances!

If possible, use a paint color that corresponds to the surface to be covered or dark colors such as those from MDF, OSB or chipboards.

The smaller the distance between the supporting structure and the textile ceiling and the lighter the supporting structure, the greater is the danger that this poses to the textile ceiling by its outline through residual light and reflections after its installation.

Especially in the case of the DESCOR<sup>®</sup> PREMIUM acoustic attention must be paid to this, because it is particularly permeable to air. Also in the case of DESCOR<sup>®</sup> PREMIUM natural white, because no additional colour components are added

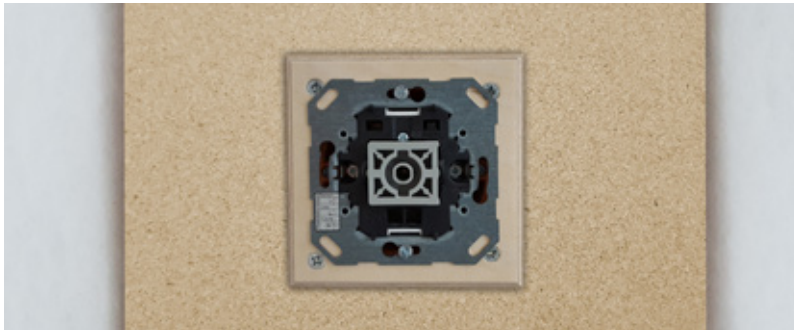

Image B17 - supporting structure - dark

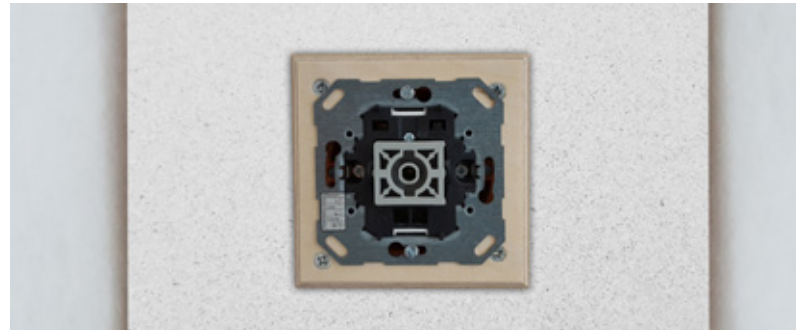

Image B18 - false supporting structure - light



Image B19 - completed final assembly



Image B20 - final assembly with visible supporting structure

## 4. Integration of technical elements

### 4.2 Inspection cover

Areas that often require maintenance must be provided with inspection openings. In the case of installation of inspection flaps the situation on site is always decisive.

The covering of the inspection cover with DESCOR<sup>®</sup> differs depending on the type of fastening:

Glues, tacks or the use of DESCOR<sup>®</sup> profiles.

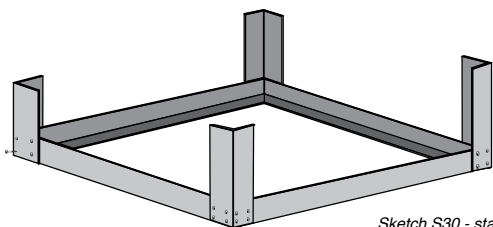

Sketch S30 - standard inspection cover 60 x 60 cm

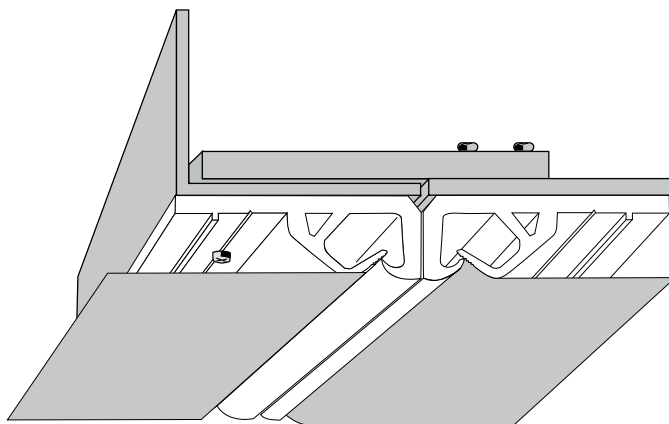

Sketch S31 - inspection cover with AP profile

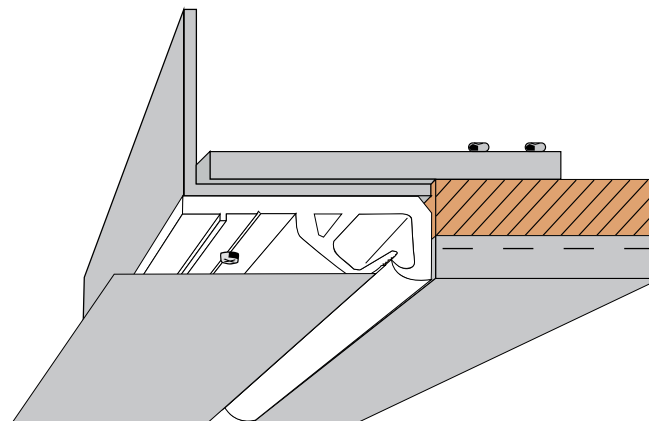

Sketch S32 - inspection cover fixed on

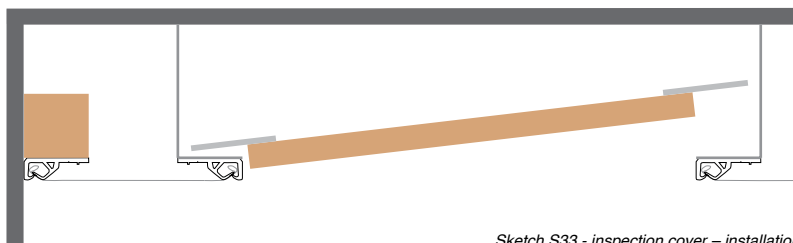

Sketch S33 - inspection cover - installation

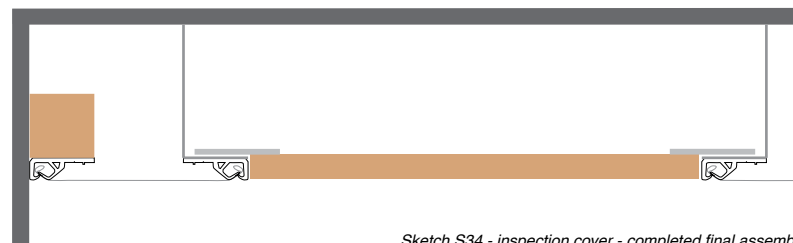

Sketch S34 - inspection cover - completed final assembly

## 4. Integration of technical elements

### 4.3 Lighting and ventilation units

After fastening of the DESCOR<sup>®</sup> profiles, a 10 mm wooden panel, for example, is fitted flush with the DESCOR<sup>®</sup> profiles on the existing ceiling. For an optimal adaptation to the height, a cord can be configured. The cord is stretched from profile to profile through the use of an assembly spatula and then the supporting structure/ spotlights are installed flush to the cord.

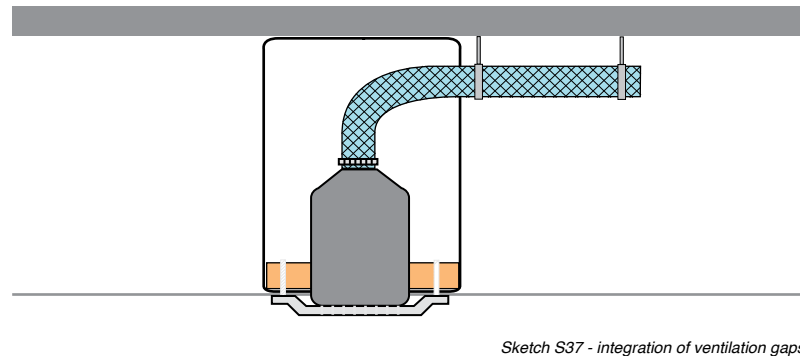
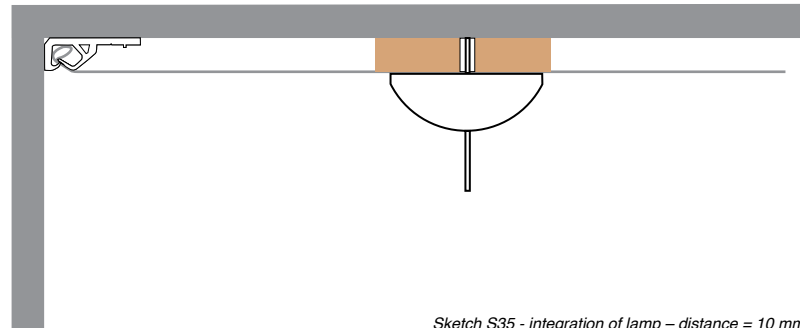

In order to compensate for small height differences, the edges on the wooden plate supporting structure are rounded. After assembly of the ceiling, the lamp is fastened onto the pre-assembled wood supporting structure through the ceiling. The location can be made visible with the help of a laser.

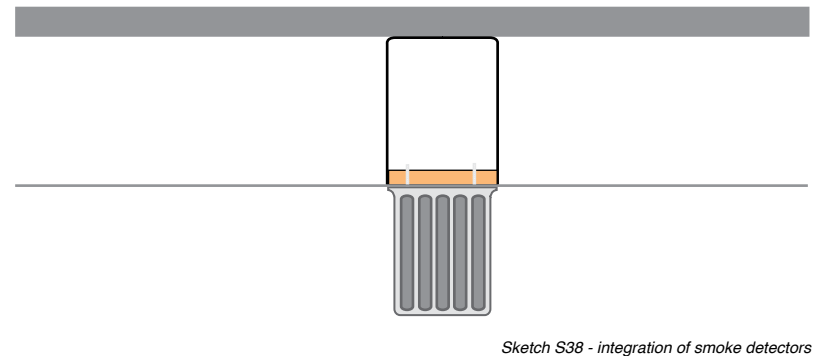
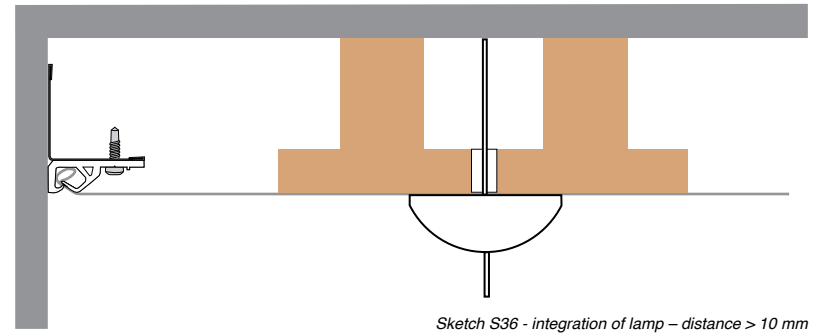

The DESCOR<sup>®</sup> ceiling can be cut into with a cutter knife. There is no danger that the place that has been cut into will tear further. It is not necessary to additionally stick in a safety ring (such as in the case of a vinyl ceiling).

All fittings/ supporting structures must be fastened in such a way that they do not become loose and/ or fall from behind onto the DESCOR<sup>®</sup> ceiling, or could touch this.



## 4. Integration of technical elements

### 4.4 Installation of spotlights

For the installation of standard spotlights, PONGS<sup>®</sup> offers a spotlight installation frame that makes installation simpler and shortens the installation time.

Properties/ Advantages:

- Removable ring for different diameters (70 and 80 mm)
- Contact between textile and spotlight installation frame max. on the lowest ring level (see sketch S40)
- Height regulation through later adjustment is possible
- Space for storage of transformers: This can also be removed through the opening of the spotlight for the purpose of maintenance or repair.
- Height regulation between 65-95 mm



Image B21 - spotlight installation frame

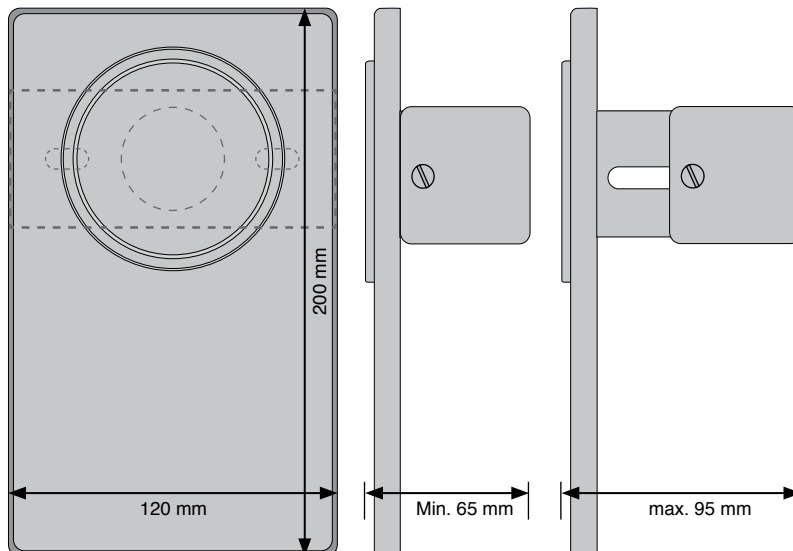

Sketch S39 - spotlight installation frame

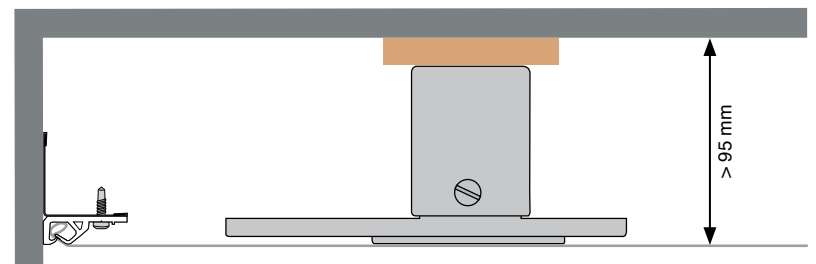
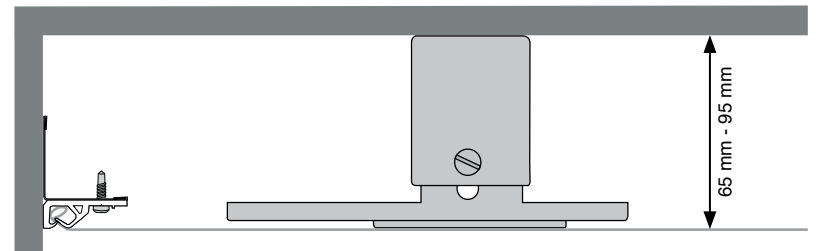

Sketch S40 - spotlight integration

## 4. Integration of technical elements

### 4.5 Use of a lamp

During installation it must be ensured that no openings arise that could allow light to shine into the space between the textile and the ceiling.

An example here is the use of LED spotlights (left image).

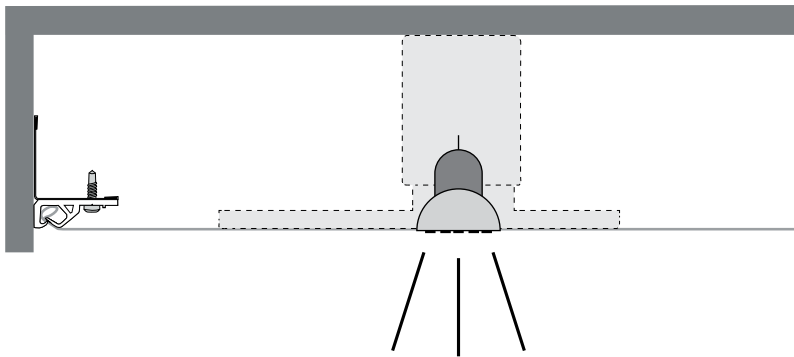

Sketch S41 - integration of spotlight

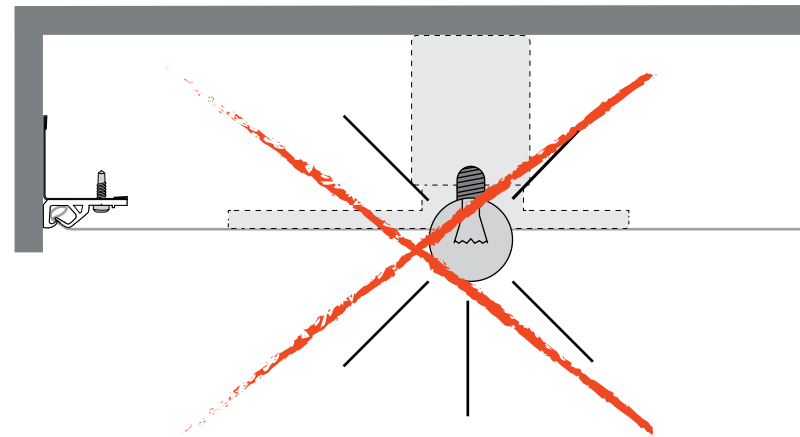

Sketch S42 - incorrect - integration of light bulb with light beams in the space

## 5. The installation

### 5.1 Special tools required

Two special tools are required for the installation:

- Assembly spatula
- Spatula for arranging the corners

Further important tools as well as accessories are listed in the current price lists.



Image B22 - spatula for corner processing and assembly spatula

5. The installation

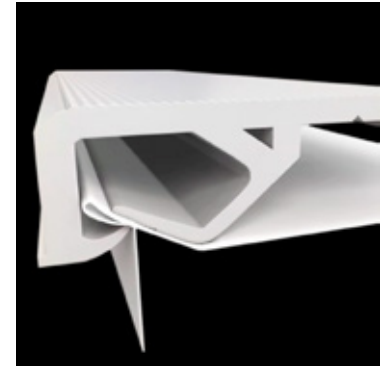
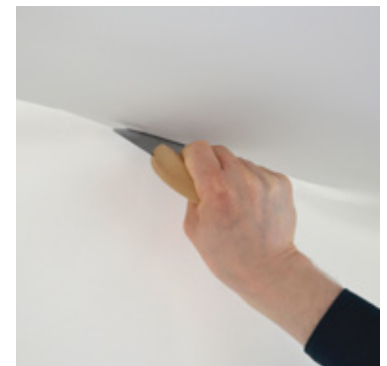

*Image B23-26 - fastening (schematic)*

**5.1 Fastening of a stretched ceiling**

The assembly spatula is placed/ pressed into the DESCOR<sup>®</sup> textile and unrolled to the side. Then the assembly spatula is pulled out. This process is repeated at regular intervals (see also item 5.2). The textile must be incorporated/ pushed in, between 0.8 and 1.0 cm into the profile.

During unrolling the spatula, attention must especially be paid to the tip of the spatula, so that the textile is not damaged. The tip of the spatula is only used for finishing the corners. After the complete stretching the protrusion is cut to about 1 cm before the profile. The excess material is then completely incorporated into the profile using the assembly spatula.



*Image B27-B30 - fastening*

## 5. The installation

### 5.2 Installation of a one-colored stretched ceiling

*Positioning, fastening, stretching*

Begin with the positioning about 20 cm before one corner (1). From there, the stretched ceiling is fastened into the DESCOR<sup>®</sup> profile (2) about every 40 cm. This process is repeated up to about 20 cm before the end of the next corner (3).  $\leftarrow 20 \cdot 40 \cdot 40 \cdot \dots \cdot 40 \cdot 40 \cdot 20 \rightarrow$

Now a triangle is formed and the tip that has been formed (4) is again fastened to the opposite side in the DESCOR<sup>®</sup> profile. From the position fastened in the middle, now, at a distance of 40 cm the stretched ceiling is fastened to the ends (5 and 6).  $\leftarrow 20 \cdot 40 \cdot \dots \cdot 40 \cdot 40 \cdot \dots \cdot 40 \cdot 20 \rightarrow$

The two other sides are fastened to the corners (7-12) in the same procedure from the middle (images of a triangle) and also at a distance of 40 cm in the DESCOR<sup>®</sup> profile.

Then the sides are retightened. A start is made in the middle of each side. To do this, the nearest fixation point is loosened and the material is then retensioned every 20 cm.  $\leftarrow 20 \cdot 20 \cdot \dots \cdot 20 \cdot 20 \cdot \dots \cdot 20 \cdot 20 \rightarrow$

If the ceiling now has enough tension and no folds can be seen, the complete clamping of the stretched ceiling in the profile can take place – starting in the middle.

#### 4.2.1 Installation of a digital print

During fastening, attention must be paid to the positioning of the pressure and its position in the room, if necessary a start must be made not at a corner but at a certain position (1); from there, proceed according to the points described previously.

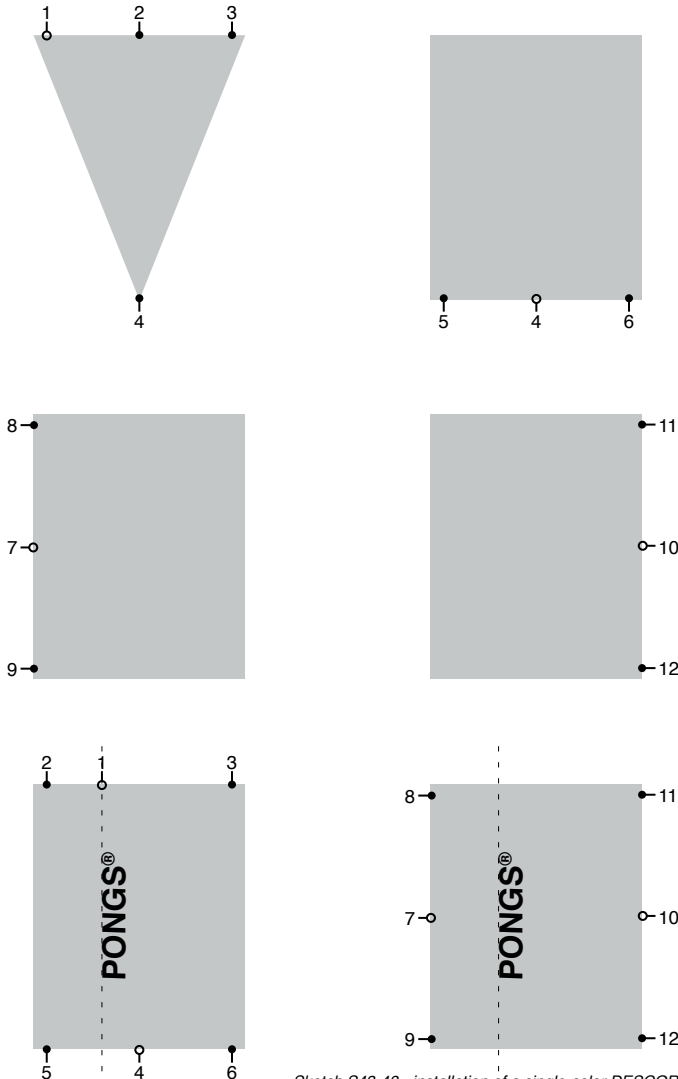

Sketch S43-48 - installation of a single-color DESCOR<sup>®</sup> ceiling

## 5. The installation

### 5.3 Installation of a DESCOR<sup>®</sup> ceiling (> 7 linear meters)

During the installation of stretched ceilings with a length of more than 7 linear meters, points are added during the completion, so that the stretched ceilings do not sag under their own weight during the installation.

#### *Positioning, fastening*

Starting with the narrow side (which corresponds to the DESCOR<sup>®</sup> fabric width; max. 5.20 m gross) the ceiling is fastened in accordance with Item 4.1 in the DESCOR<sup>®</sup> profile at a distance of 40 cm (1-3). For the easier installation of the opposite sides and in order to avoid a sagging of the ceiling, additional clamping points are added on the long sides depending on the length of the ceiling (for examples, please see: 4-7) Then the fastening to the second narrow side (opposite the starting point) takes place, starting in the middle (8-10).

#### *Pretensioning, tensioning*

Starting in the middle on one of the long sides, fastening to the corners takes place again with a distance of about 40 cm (1-5). Then the opposite long side is fastened analogously (6-10). 

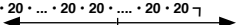
Then the sides are retightened. A start is made in the middle of each side. To do this, the nearest fixation point is loosened and the material is then retensioned every 20 cm. 

#### *Precision work*

If the ceiling now has enough tension and no folds can be seen, the complete clamping of the stretched ceiling in the profile can take place – starting in the middle.

Finally the protrusion is cut, up to about 1 cm before the profile. The excess material is completely worked into the profile using the assembly spatula.

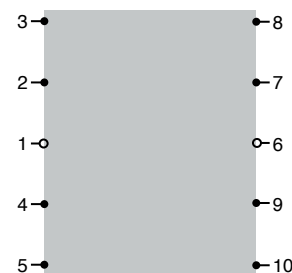
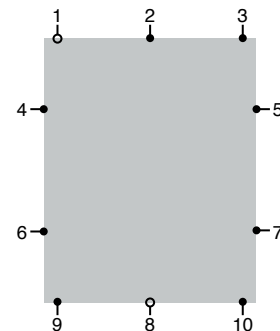

Sketch S49-50 - installation of a DESCOR<sup>®</sup> ceiling

### 5. The installation

#### 5.4 Installation of complex ceiling systems

In the case of complex ceiling systems, the assembly of a ceiling is split into several zones. Firstly, the larger zone is prepared.

##### *Positioning, fastening (Zone A)*

Begin with the positioning about 20 cm before one corner (1). From there, the stretched ceiling is again fastened into the DESCOR<sup>®</sup> profile at a distance of 40 cm. This work step is repeated up to about 20 cm before the end of the next corner (1-4).  $\leftarrow 20 \cdot 40 \cdot 40 \cdot \dots \cdot 40 \cdot 40 \cdot 20 \rightarrow$

Then the opposite side is fastened into the DESCOR<sup>®</sup> profile (5-8).

##### *Pretensioning, tensioning (Zone A)*

Then the starting side is retightened. A start is made in the middle of the side. For this, the nearest fixation point is loosened and the material is now retensioned every 20 cm (1-5).  $\leftarrow 20 \cdot 20 \cdot \dots \cdot 20 \cdot 20 \cdot \dots \cdot 20 \cdot 20 \rightarrow$

Then the opposite side is retightened in the DESCOR<sup>®</sup> profile (6-9).

These work steps are repeated on the narrow sides (10-15).

##### *Positioning, fastening, tensioning (Zone B)*

The ceiling is cut into up to the inner corner (1) (please see item P5.5). From there, the stretched ceiling is fastened into the DESCOR<sup>®</sup> profile at a distance of about 40 cm. This process is repeated up to about 20 cm before the end of the next corner (1-3).  $\leftarrow 20 \cdot 40 \cdot 40 \cdot \dots \cdot 40 \cdot 40 \cdot 20 \rightarrow$

Then the opposite side is fastened into the DESCOR<sup>®</sup> profile (4-6). The last side is tensioned starting from the middle in the same procedure and then retightened at a distance of 20 cm.

Then the complete clamping into the DESCOR<sup>®</sup> profile takes place.

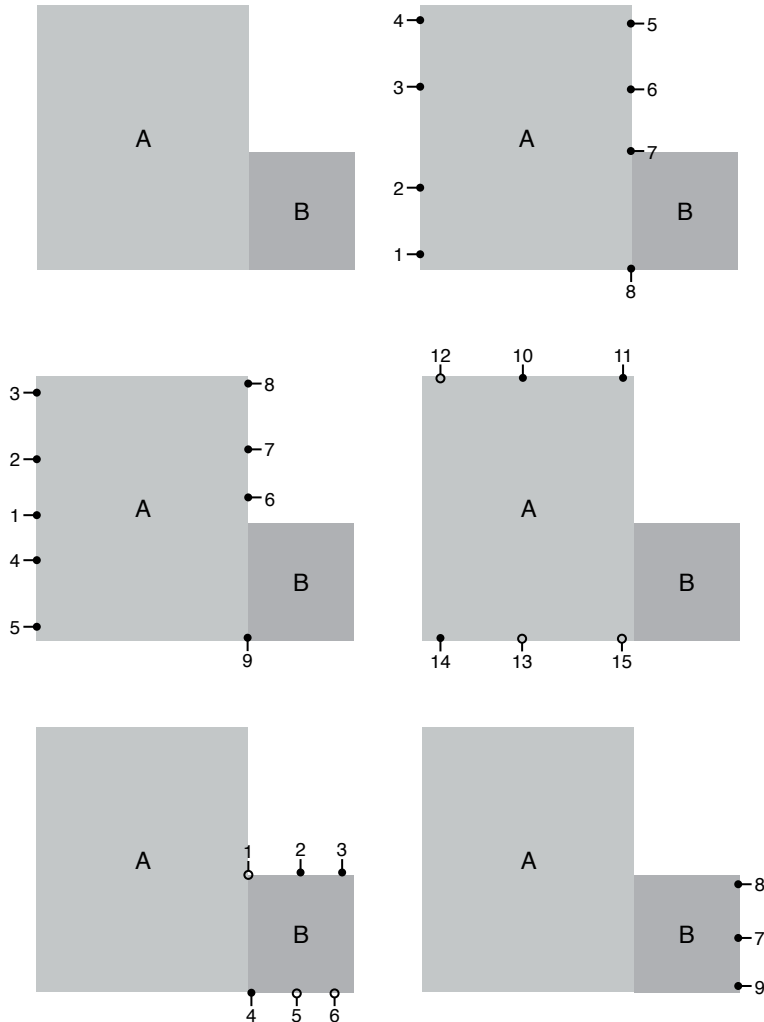

Sketch S51-S56 - installation of complex ceiling systems

5. The installation

**5.5 Finishing of corners**

Inner (1) and outer (2) corners are treated differently.

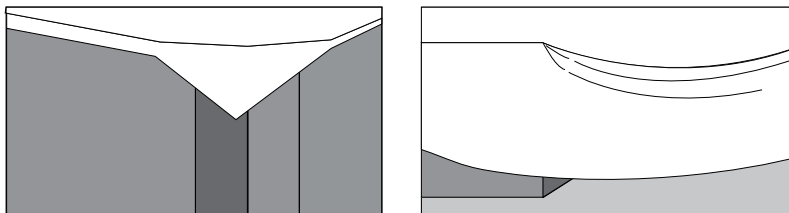
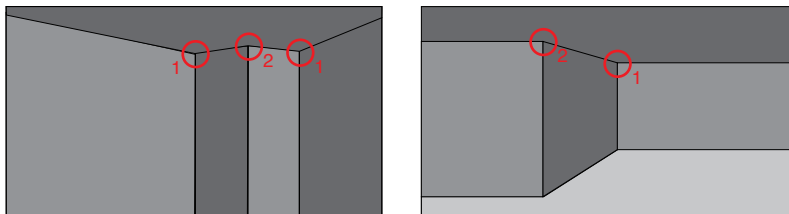

After the grouting in of the ceiling, a tension forms on the outer corners.

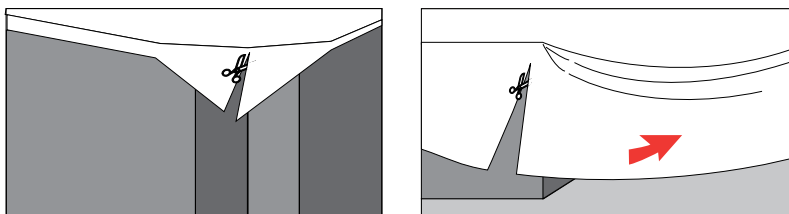

The textile is now cut into with the scissors, up to the inner lip.

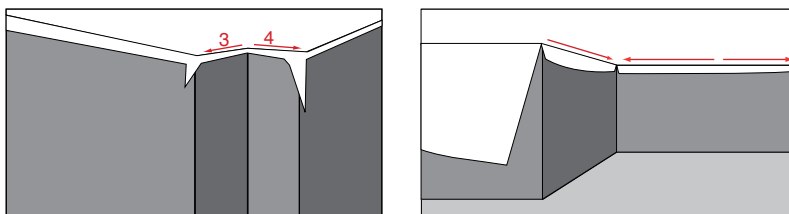

Starting at the outer corners, now the material is incorporated into the profile alternately to the left and the right (3-4).

When the whole ceiling has been tensioned, then the corners are carefully prepared.

Sketch S57-64 - corner preparation

## 6. Acoustic solutions

### 6.1 Acoustics and decoration for walls and ceilings

Through the use of DESCOR<sup>®</sup> PREMIUM acoustic a pleasant room atmosphere is created. This is achieved through an acoustic correction that results in improved room acoustics. The system contributes to a reduced sound transfer of airborne sound and structure-borne sound. Through the structure, the reverberation time in rooms is considerably reduced.

#### DESCOR<sup>®</sup> PREMIUM acoustic

The invisible microperforation in combination with further insulating material (e.g. PONGS<sup>®</sup> acoustic fleece) enhances the acoustic effect.

#### Acoustic correction

Great decrease of the sound level (acoustic correction) in reverberant spaces in connection with insulation panels.

Sound insulation in connection with a plasterboard and insulating material for noise barriers, separating walls etc.

#### Decoration

DESCOR<sup>®</sup> PREMIUM acoustic is available in the colors natural white and black, also customizable in individual UV digital printing procedure (images/ logos).

#### Structure

The system consists of an insulating material (absorber) and the micro-perforated acoustic paneling DESCOR<sup>®</sup> PREMIUM acoustic.

#### Fields of application

Living rooms, teaching rooms, business rooms and conference rooms, restaurants, sports centers, lobbies, in new builds, during renovation and for retrofitting

#### Improvement of acoustic conditions

With DESCOR<sup>®</sup> PREMIUM acoustic the acoustic conditions in rooms are considerably improved.

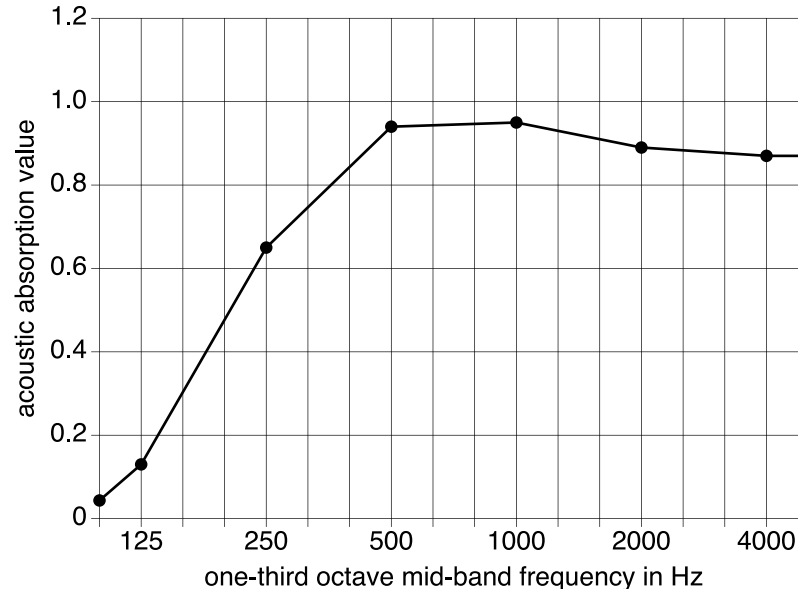

Design type E-50 in accordance with DIN EN ISO 354, lying on the echo chamber floor DESCOR<sup>®</sup> PREMIUM acoustic in front of 50 mm air space coated with 40 mm ISOVER SSP 2

weighted sound absorption coefficient  $\alpha_w$  0.90  
sound absorption class A

This procedure is about achieving good comprehensibility of the acoustic message, avoiding the "cocktail party effect", as well as guaranteeing an improved and corrected homogeneity of the sound field, with reference to level and frequency. Whereby the use of an acoustician is necessary in certain situations.

The perfect combination of acoustic performance and esthetics.



6.2 Fastening of acoustic materials

Type of insulation	Supporting surface	Type of fastening	Fastening of insulating materials
PONGS <sup>®</sup> acoustic fleece/ ISOVER SSP 2 panel	Wood	Insulation fixing with screw	 <p>The fastening must always be adapted to the insulation used. Possible varieties, depending on the supporting surface, are: Insulation fixing, assembly or spray adhesive</p>
	Hollow bricks	Insulation fixing with tensioner	
	Plasterboard		
	Plaster	Insulation holder with knock-in dowel	
	Concrete		

Table T06 - types of fastening

6.3 System structure for ceilings

	Distance (in mm)	Absorber(s)	Weighted sound absorption coefficient $\alpha_w$	Sound absorption class
	≥ 50	1x ISOVER SSP 2 (40 mm)  1x DESCOR <sup>®</sup> PREMIUM acoustic	0.90	A

Table T07 - system construction - ceiling

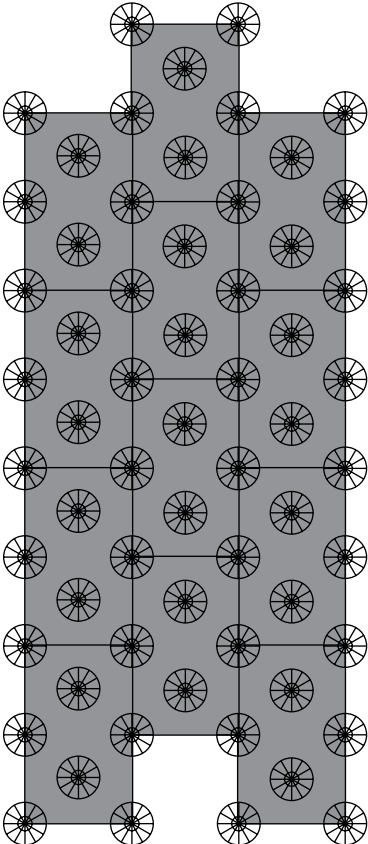
6.4 System structure for walls

	Distance (in mm)	Absorber(s)	Weighted sound absorption coefficient $\alpha_w$	Sound absorption class
	≥ 50	1x ISOVER SSP 2 (40 mm)  1x DESCOR <sup>®</sup> PREMIUM acoustic	0.90	A

Table T08 - system construction - wall

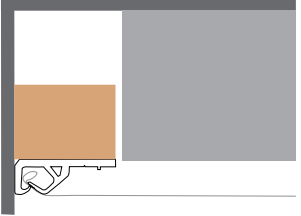

Technical assembly instructions

Editor

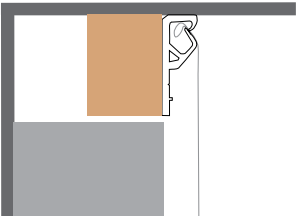
**PONGS Textil GmbH  
Head Office Stadtlohn**

Boschstraße 2  
48703 Stadtlohn  
Germany

phone +49 2563 405-01  
fax +49 2563 405-160  
mail info@pongs.de

**PONGS Technical Textiles GmbH  
Production Plant Mühltroff**

Bahnhofstraße 21  
07919 Pausa-Mühltroff  
Germany

phone +49 366 45 350-0  
fax +49 366 45 350-191  
mail technicaltextiles@pongs.de



[www.pinterest.com/PONGSdesign](http://www.pinterest.com/PONGSdesign)



[www.youtube.com/user/PONGSmedia](http://www.youtube.com/user/PONGSmedia)



[www.facebook.com/PONGSdesignchannel](http://www.facebook.com/PONGSdesignchannel)



[www.pongs.com](http://www.pongs.com)

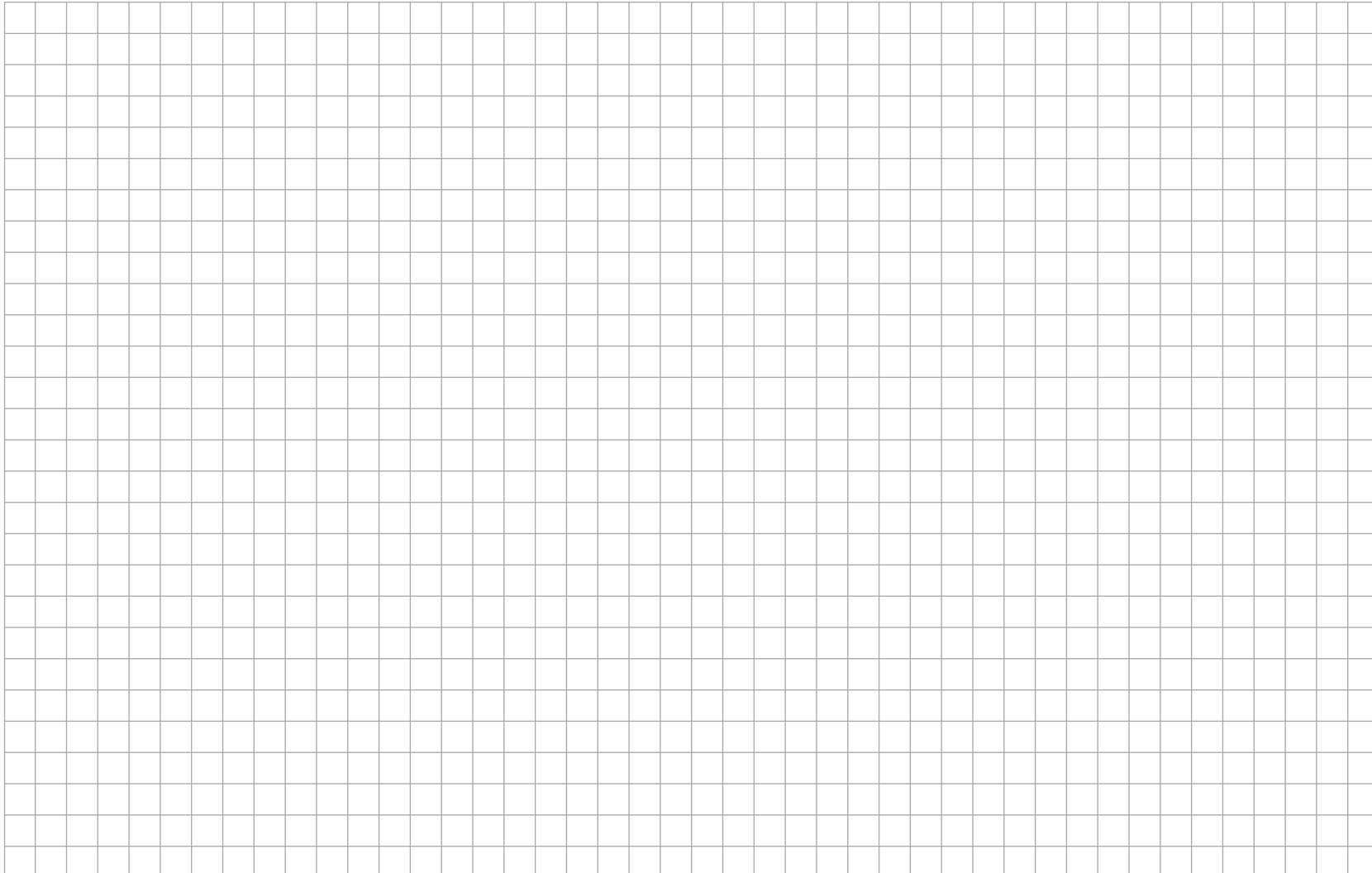



Technical assembly instructions

Notes

A large, empty grid of small squares, intended for taking notes or drawing technical diagrams.



DESCOR® PREMIUM

WEISS/ WHITE  
599130 - 00900 450

NATURWEISS/ NATURAL WHITE  
599130 - 00900 469

BEIGE  
599130 - 00900 451

GELB/ YELLOW  
599130 - 00900 457

SCHWARZ/ BLACK  
699148 - 00347 264

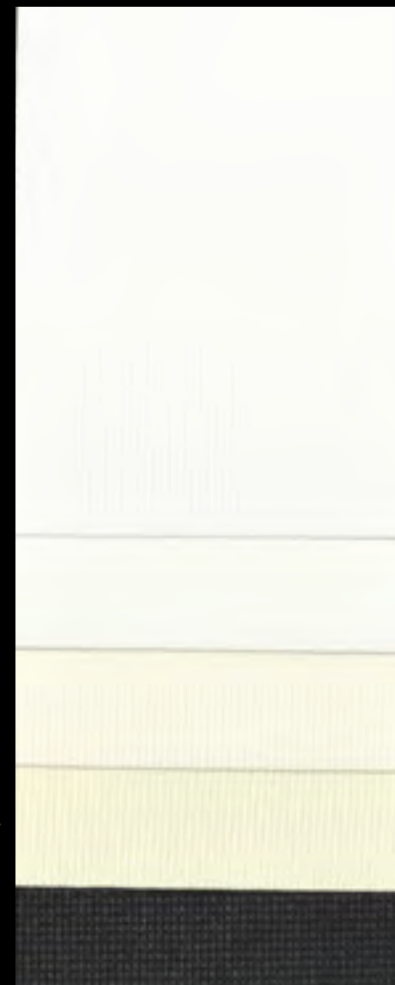

REF.

**DESCOR® PREMIUM**

Colour number  
599130 - 00900 - ###



polyester knitted fabric with polyurethane coating (PU)



**M1** **B1** **DIN EN 13501-1 B-s1, d0**



245 g/m<sup>2</sup> ± 5%



ca. 350 μm



**50m/55yrd**



15 x superior to PVC films

Specs



Gross in cm (inch)	320 (126)	360* (142)	420 (165)	460* (181)	520 (205)
Net in cm (inch)	310 (122)	350* (138)	410 (161)	450* (177)	505 (199)

\* on request

**DESCOR® PREMIUM**

Colour number  
699148 - 00347 264

polyester knitted fabric with polyurethane coating (PU)

**B1** **DIN EN 13501-1 B-s1, d0**

180 g/m<sup>2</sup> ± 5%

ca. 350 μm ± 10

**50m/55yrd**

15 x superior to PVC films

Gross in cm (inch)	320 (126)	420 (165)	520 (205)
Net in cm (inch)	310 (122)	410 (161)	505 (199)

DESCOR® PREMIUM solely applies to building professionals.  
The system is exclusively used by specialists trained in this technique.  
A list of recommended approved fitters is available on request.

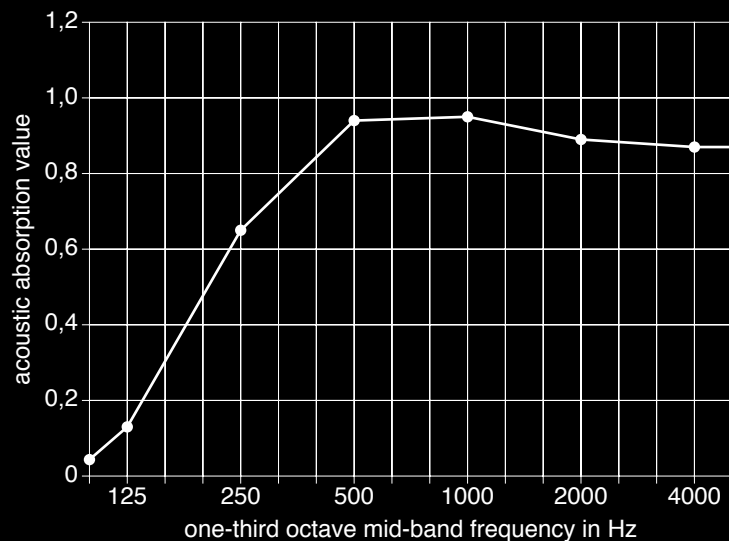

Acoustic absorption value $\alpha_w$	0,90
acoustic absorption class	A

Type of assembly E-50 according to DIN EN ISO 354 - lying on the ground  
DESCOR<sup>®</sup> PREMIUM acoustic in front of 40 mm airspace  
absorbed with 40 mm ISOVER SSP2

WEISS/ WHITE  
00900 - 085

SCHWARZ/ BLACK  
00347 - 086





REF.

**DESCOR® PREMIUM acoustic**

Colour number  
699144 - ##### - ###



polyester knitted fabric with polyurethane coating (PU)  
with micro-perforation (invisible)  
air permeable



**B1** **DIN EN**  
13501-1  
B-s1, d0



185 g/m<sup>2</sup> ± 5%



ca. 380 µm ± 10



  
50m/55yrd



15 x superior to PVC films

Specs



$\alpha_w$

DIN EN ISO 354 - test report no 086-12-G01 (Akustikbüro Krämer + Stegmeier)



Gross in cm (inch)	320 (126)	420 (165)	520 (205)
Net in cm (inch)	310 (122)	410 (161)	505 (199)

DESCOR® PREMIUM solely applies to building professionals.  
The system is exclusively used by specialists trained in this technique.  
A list of recommended approved fitters is available on request.



DESCOR® PREMIUM star

GRAU/ GRAY  
00900 - 167

DUNKELBEIGE/ DARK BEIGE  
00900 - 157

GRÜN/ GREEN  
00900 - 165

SCHWARZ/ BLACK  
00347 - 164



REF.

**DESCOR® PREMIUM star**

Colour number

699143 - ##### - ###



polyester knitted fabric with polyurethane coating (PU)



**B1** \* **DIN EN**  
13501-1  
B-s1, d0



250 g/m<sup>2</sup> ± 5%

185 g/m<sup>2</sup> ± 5% (black)



ca. 350 µm – 390 µm



15 x superior to PVC films



with aluminium pigment



Gross in cm (inch)	320 (126)	420 (165)	520 (205)
Net in cm (inch)	310 (122)	410 (161)	505 (199)

\* testing is instructed

DESCOR® PREMIUM solely applies to building professionals.  
The system is exclusively used by specialists trained in this technique.  
A list of recommended approved fitters is available on request.

  
**DESCOR®**  
WALL & CEILING SYSTEM

 **DESCOR**<sup>®</sup>  
WALL & CEILING SYSTEM

DESCOR<sup>®</sup> LIGHT

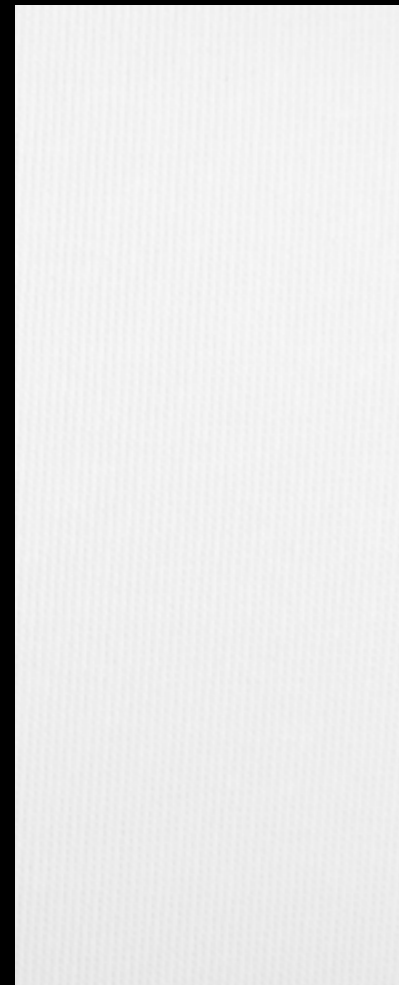

REF.

**DESCOR® LIGHT**  
Colour number  
599129 - 00900 - 369



polyester knitted fabric with polyurethane coating (PU)



**M1** **DIN EN 13501-1 B-s1, d0** **B1**



230 g/m<sup>2</sup> ± 5%



ca. 430 µm



15 × superior to PVC films



Gross in cm (inch)	320 (126)	420 (165)	520 (205)
Net in cm (inch)	310 (122)	410 (161)	505 (199)

DESCOR® PREMIUM solely applies to building professionals.  
The system is exclusively used by specialists trained in this technique.  
A list of recommended approved fitters is available on request.

  
**DESCOR®**  
WALL & CEILING SYSTEM

**DESCOR**<sup>®</sup>  
WALL & CEILING SYSTEM

DESCOR<sup>®</sup> PREMIUM colour



REF.

**DESCOR® PREMIUM colour**

Colour number  
699142 - 00900 - ###



polyester knitted fabric with polyurethane coating (PU)



**M1** **B1** **DIN EN 13501-1 B-s1, d0**



ca. 230 g/m<sup>2</sup> – 260 g/m<sup>2</sup> ± 5%



ca. 360 μm – 410 μm ± 10



15 x superior to PVC films

Specs



Gross in cm (inch)	315 (124)	510 (201)
Net in cm (inch)	310 (122)	505 (199)

DESCOR® PREMIUM solely applies to building professionals.  
The system is exclusively used by specialists trained in this technique.  
A list of recommended approved fitters is available on request.

  
**DESCOR®**  
WALL & CEILING SYSTEM

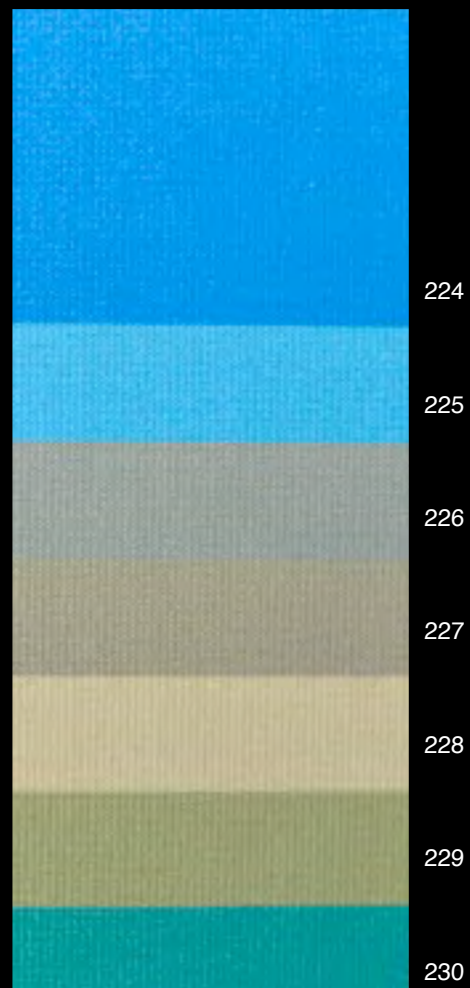
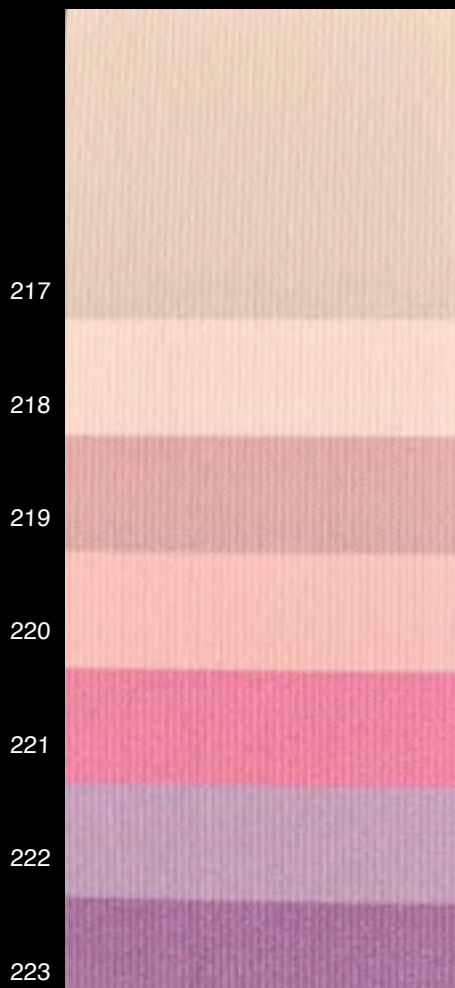



REF.

**DESCOR® PREMIUM colour**

Colour number  
699142 - 00900 - ###



polyester knitted fabric with polyurethane coating (PU)



**M1** **B1** **DIN EN 13501-1 B-s1, d0**



ca. 230 g/m<sup>2</sup> – 260 g/m<sup>2</sup> ± 5%



ca. 360 μm – 410 μm ± 10



15 x superior to PVC films

Specs



Gross in cm (inch)	315 (124)	510 (201)
Net in cm (inch)	310 (122)	505 (199)

DESCOR® PREMIUM solely applies to building professionals.  
The system is exclusively used by specialists trained in this technique.  
A list of recommended approved fitters is available on request.

  
**DESCOR®**  
WALL & CEILING SYSTEM

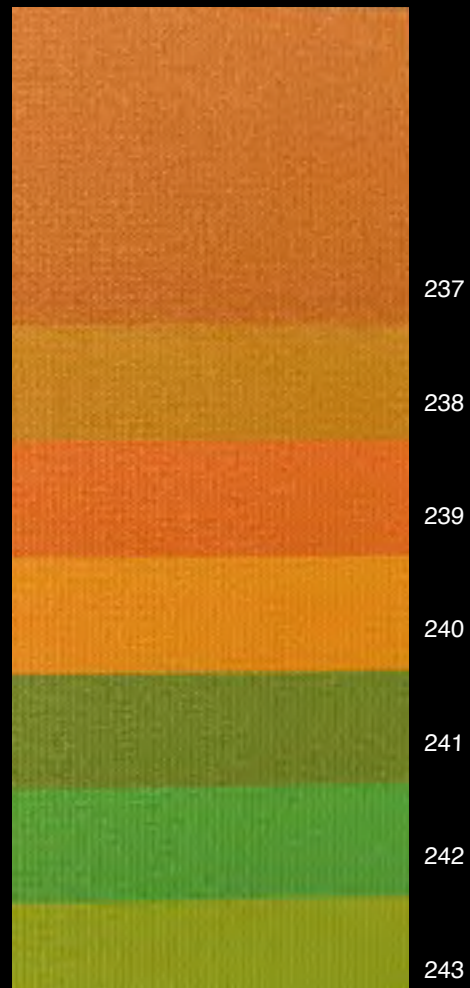
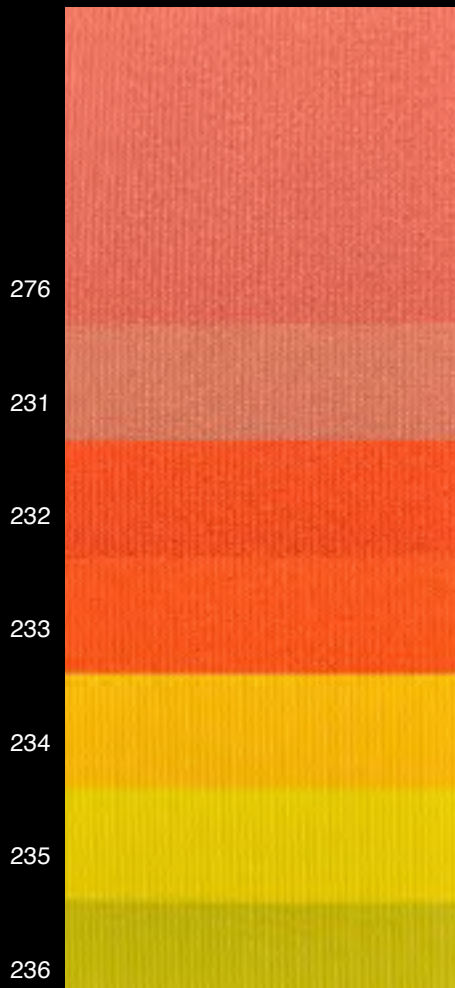

REF.

**DESCOR® PREMIUM colour**

Colour number  
699142 - 00900 - ###



polyester knitted fabric with polyurethane coating (PU)



**M1** **B1** **DIN EN 13501-1 B-s1, d0**



ca. 230 g/m<sup>2</sup> – 260 g/m<sup>2</sup> ± 5%



ca. 360 μm – 410 μm ± 10



15 x superior to PVC films

Specs



Gross in cm (inch)	315 (124)	510 (201)
Net in cm (inch)	310 (122)	505 (199)

DESCOR® PREMIUM solely applies to building professionals.  
The system is exclusively used by specialists trained in this technique.  
A list of recommended approved fitters is available on request.

  
**DESCOR®**  
WALL & CEILING SYSTEM

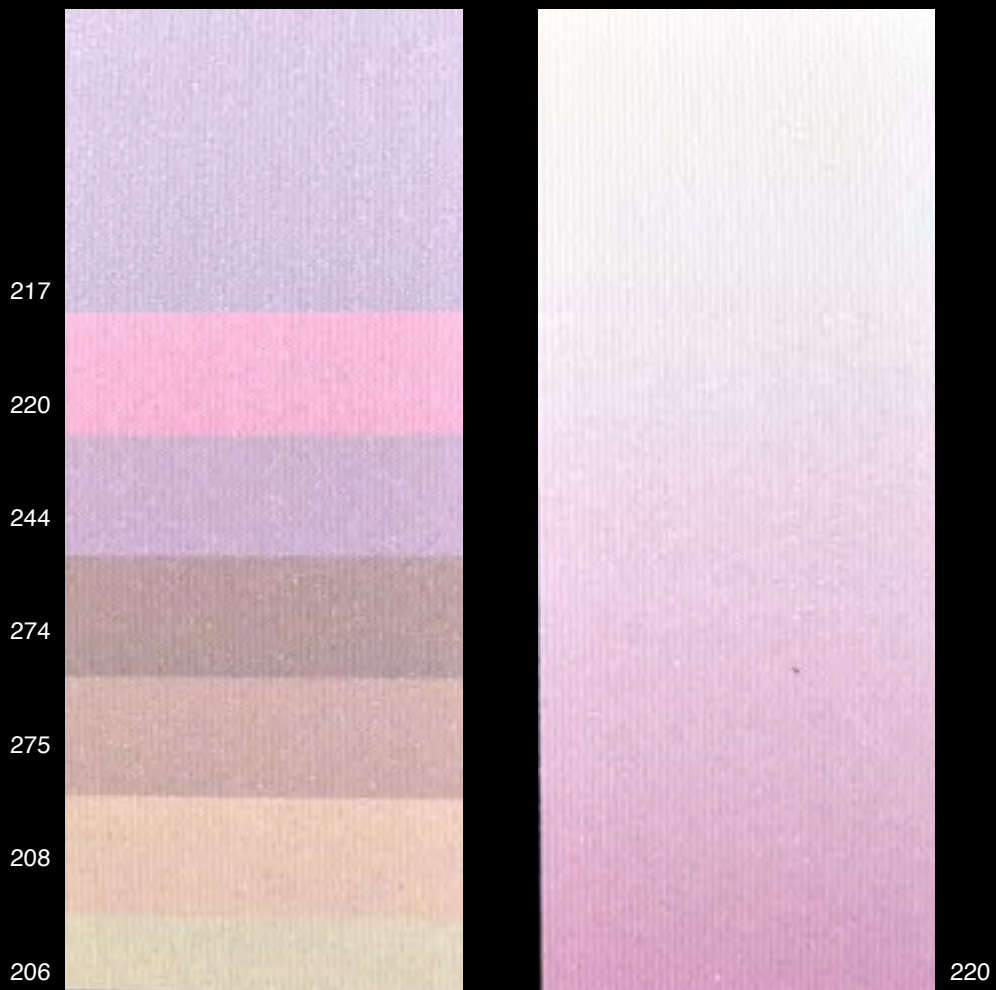

REF.

**DESCOR® PREMIUM gradient**

Colour number  
699149 - 00900 - ###



polyester knitted fabric with polyurethane coating (PU)



**B1** \* **DIN EN**  
13501-1  
B-s1, d0 \*



250 g/m<sup>2</sup> – 310 g/m<sup>2</sup> ± 5%



ca. 350 μm – 410 μm ± 10



15 × superior to PVC films



with aluminium pigment



Gross in cm (inch)	310 (122)	410 (161)	505 (199)
Net in cm (inch)	305 (120)	405 (159)	500 (197)

\* testing is instructed

DESCOR® PREMIUM solely applies to building professionals.  
The system is exclusively used by specialists trained in this technique.  
A list of recommended approved fitters is available on request.

  
**DESCOR®**  
WALL & CEILING SYSTEM



REF.

### DESCOR® PREMIUM gradient

Colour number

699149 - 00900 - ###



polyester knitted fabric with polyurethane coating (PU)



**B1** \* **DIN EN**  
13501-1  
B-s1, d0 \*



250 g/m<sup>2</sup> – 310 g/m<sup>2</sup> ± 5%



ca. 350 μm – 410 μm ± 10



15 × superior to PVC films



with aluminium pigment



Gross in cm (inch)	310 (122)	410 (161)	505 (199)
Net in cm (inch)	305 (120)	405 (159)	500 (197)

\* testing is instructed

DESCOR® PREMIUM solely applies to building professionals.  
The system is exclusively used by specialists trained in this technique.  
A list of recommended approved fitters is available on request.

  
**DESCOR®**  
WALL & CEILING SYSTEM

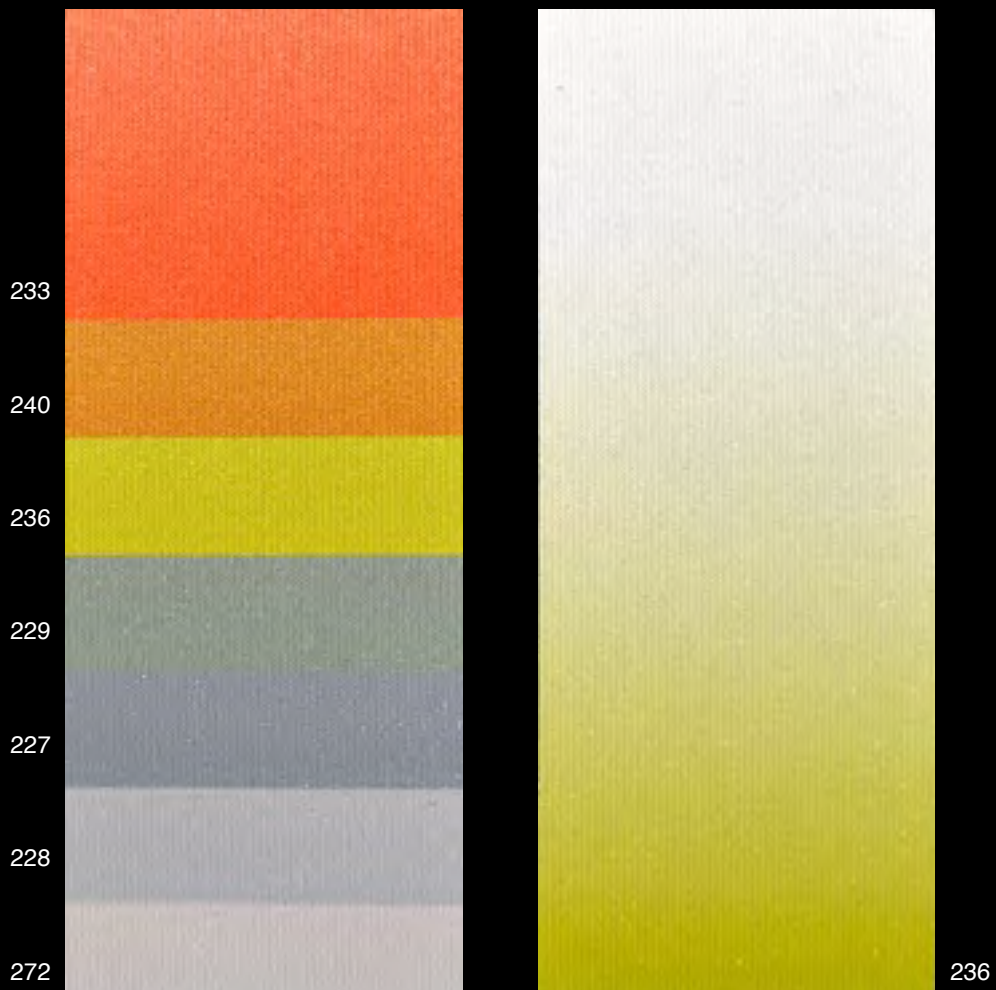



REF.

**DESCOR® PREMIUM gradient**

Colour number  
699149 - 00900 - ###



polyester knitted fabric with polyurethane coating (PU)



**B1** \* **DIN EN**  
13501-1  
B-s1, d0 \*



250 g/m<sup>2</sup> – 310 g/m<sup>2</sup> ± 5%



ca. 350 μm – 410 μm ± 10



15 × superior to PVC films



with aluminium pigment



Gross in cm (inch)	310 (122)	410 (161)	505 (199)
Net in cm (inch)	305 (120)	405 (159)	500 (197)

\* testing is instructed

DESCOR® PREMIUM solely applies to building professionals.  
The system is exclusively used by specialists trained in this technique.  
A list of recommended approved fitters is available on request.

  
**DESCOR®**  
WALL & CEILING SYSTEM

 **DESCOR**<sup>®</sup>  
WALL & CEILING SYSTEM

DESCOR<sup>®</sup> PREMIUM design



DESCOR PREMIUM design  
599130 - 00900 - 450



DESCOR PREMIUM star design  
699143 - 00900 - 157



DESCOR PREMIUM acoustic design  
699144 - 00900 - 085

REF.

**DESCOR® PREMIUM design**

Colour number  
599130 - 00900 - 450



polyester knitted fabric  
with polyurethane coating (PU)



245 g/m<sup>2</sup> – 315 g/m<sup>2</sup> ± 5%



ca. 350 μm – 410 μm ± 10



15 x superior to PVC films

Specs



Further  
Details

**DESCOR® PREMIUM star design**

Colour number  
699143 - 00900 - 157

polyester knitted fabric  
with polyurethane coating (PU)

250 g/m<sup>2</sup> – 310 g/m<sup>2</sup> ± 5%

ca. 350 μm – 410 μm

15 x superior to PVC films



**DESCOR® PREMIUM acoustic design**

Colour number  
699144 - 00900 - 085

polyester knitted fabric  
with polyurethane coating (PU) and  
micro-perforation (invisible); air permeable

185 g/m<sup>2</sup> – 245 g/m<sup>2</sup> ± 5%

ca. 380 μm – 440 μm ± 10

15 x superior to PVC films



All fabrics can be digital printed with individual images and sizes up to 5 m (small side).

DESCOR® PREMIUM solely applies to building professionals.  
The system is exclusively used by specialists trained in this technique.  
A list of recommended approved fitters is available on request.

# PONGS®

SILENCIO® Size 5

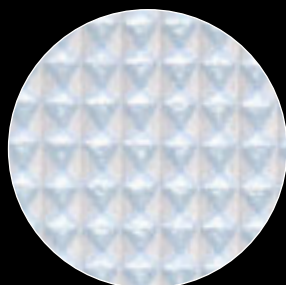

104  
Artic Ice

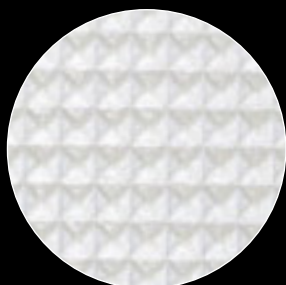

303  
Crystal

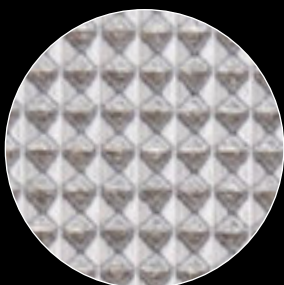

945  
Metal

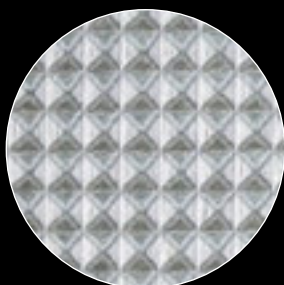

305  
Silver Grey

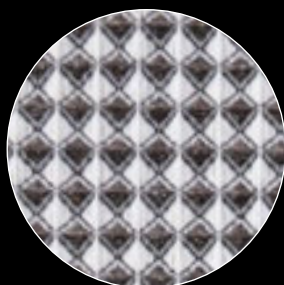

589  
Turkish Coffee

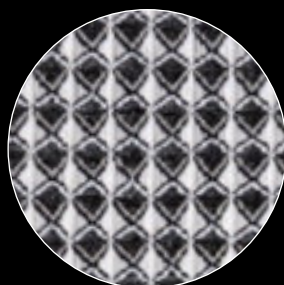

347  
Nero

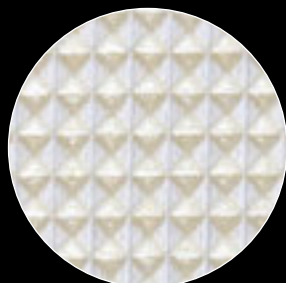

501  
Desert Sand

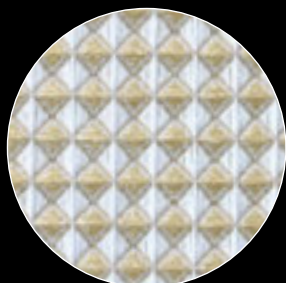

525  
Leaves

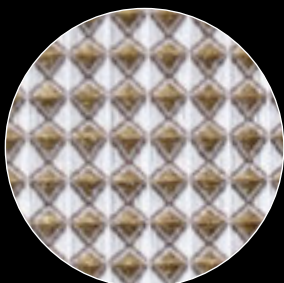

947  
Walnut

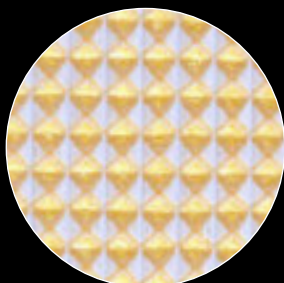

733  
Canary

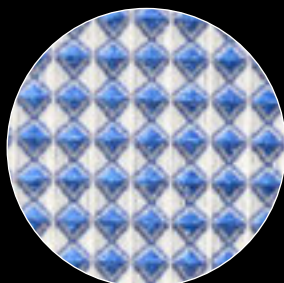

162  
Deep Water

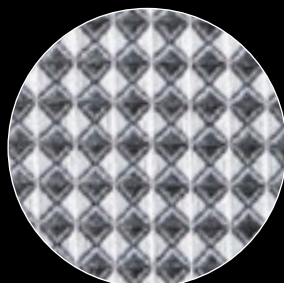

333  
Moskito

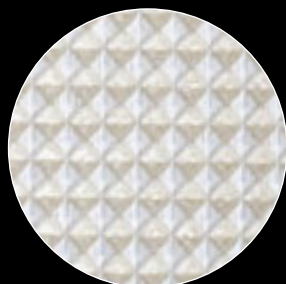

507  
Pearl

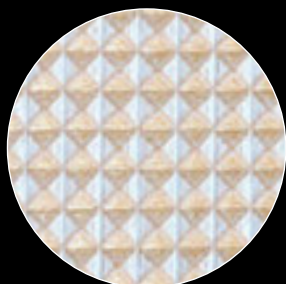

547  
Cinnamon

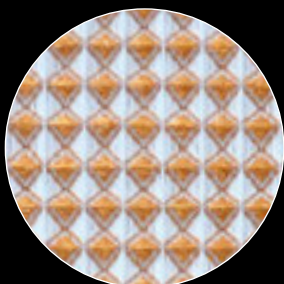

523  
Almond

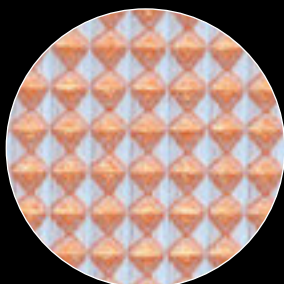

739  
Apricot

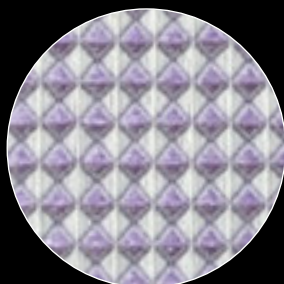

235  
Viola

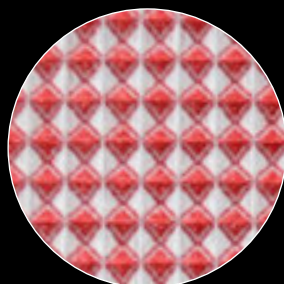

466  
Red Pepper

REF.

**SILENCIO® Size 5**  
Colour number  
687350 - 00900 - ###



100 % Trevira CS



DIN EN  
13501-1  
B-s1, d0



ca. 320 / 520 cm



350 g/m<sup>2</sup> ± 5%



ca. 2 mm



25m / 27yrd

Specs



Further Details

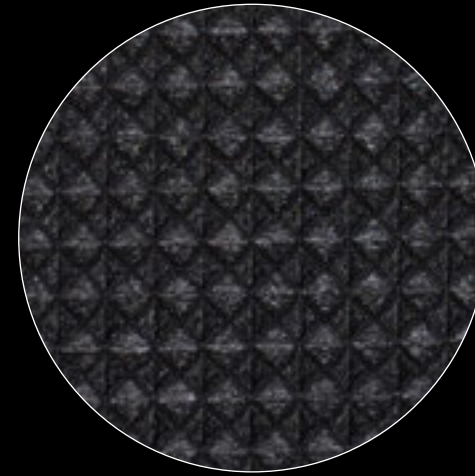

339  
Deep Black

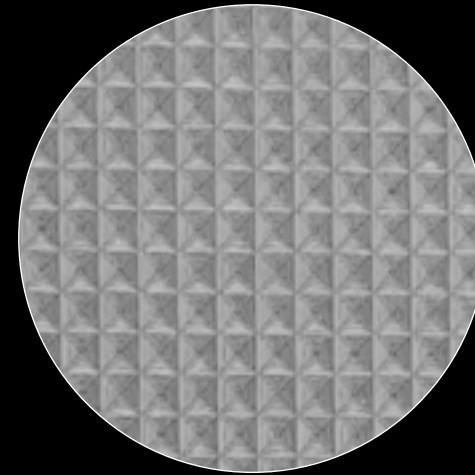

311  
Silver Grey

# PONGS®

SILENCIO® Size 10

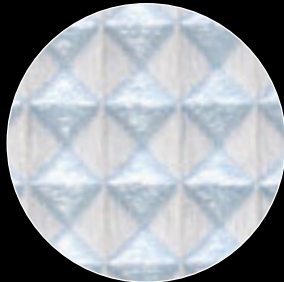

104  
Artic Ice



303  
Crystal

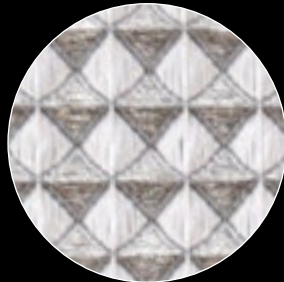

945  
Metal



305  
Silver Grey

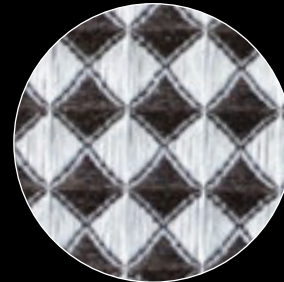

589  
Turkish Coffee

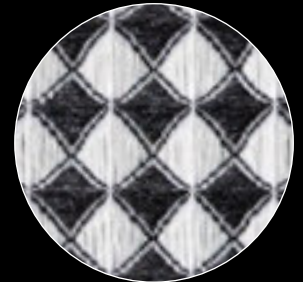

347  
Nero



501  
Desert Sand

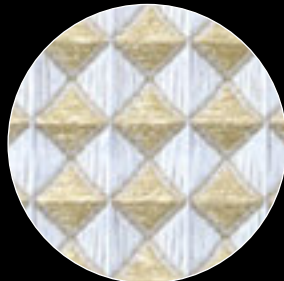

525  
Leaves

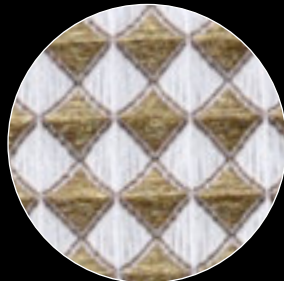

947  
Walnut

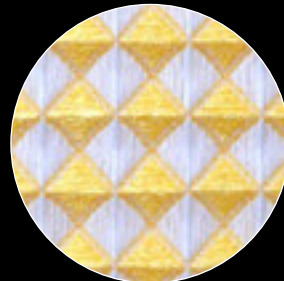

733  
Canary

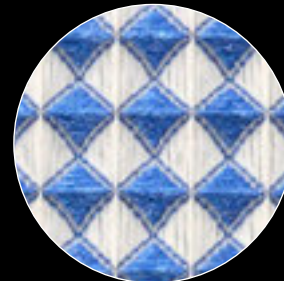

162  
Deep Water



333  
Moskito



507  
Pearl

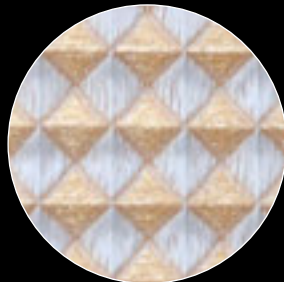

547  
Cinnamon

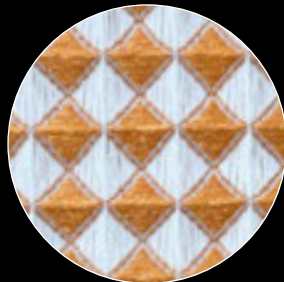

523  
Almond

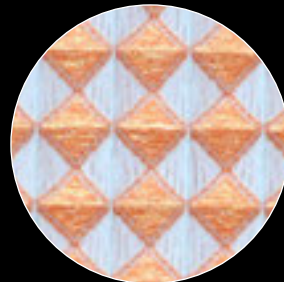

739  
Apricot

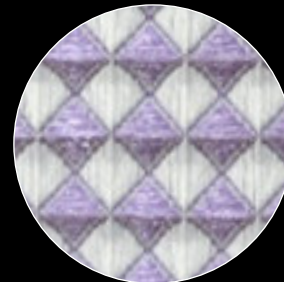

235  
Viola

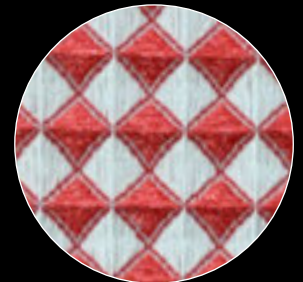

466  
Red Pepper

REF.

**SILENCIO® Size 10**  
Colour number  
687351 - 00900 - ###



100 % Trevira CS



DIN EN  
13501-1  
B-s1, d0



ca. 320 / 520 cm



350 g/m<sup>2</sup> ± 5%



ca. 4 mm



25m / 27yrd

Specs



Further Details

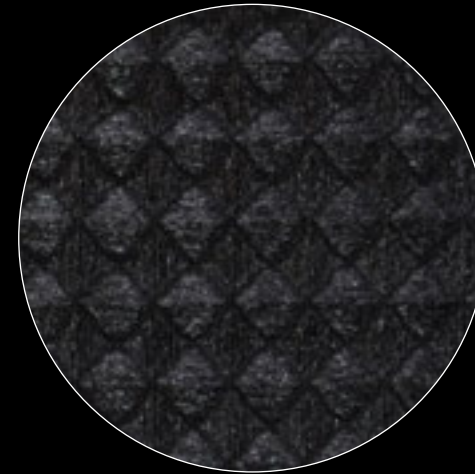

339  
Deep Black

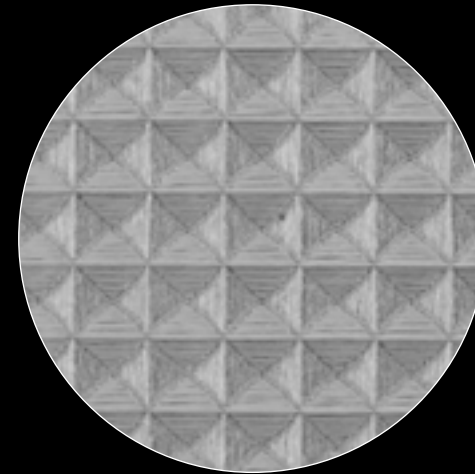

311  
Silver Grey

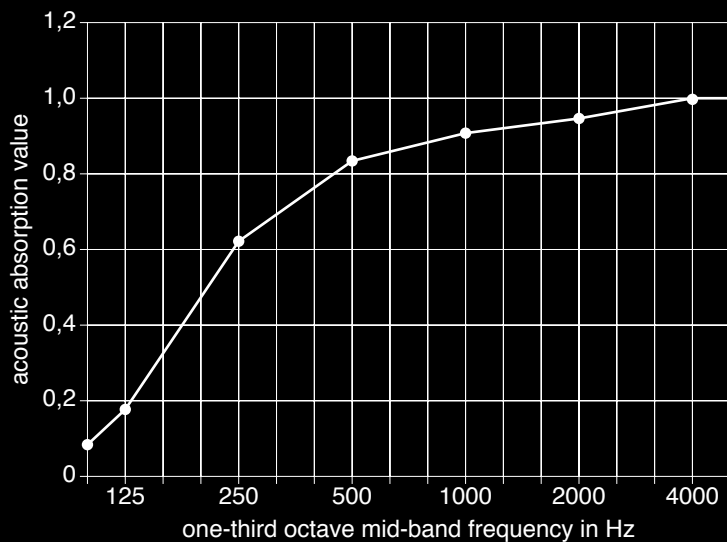

003  
White

Acoustic absorption value $\alpha_w$	0,85
acoustic absorption class	B

Type of assembly E-50 according to DIN EN ISO 354 - lying on the ground  
 SILENCIO® Size 5 in front of a cavity of 50 mm  
 with 2 x 20 mm ISOVER SSP2 insulation



REF.

**SILENCIO® Size 5**  
White  
687300 - 00900 - 003



100 % Trevira CS



DIN EN  
13501-1  
B-s1, d0



315 / 505 cm



300 g/m<sup>2</sup> ± 5%



ca. 2 mm



25m / 27yrd

Specs



Further  
Details



**PONGS®**

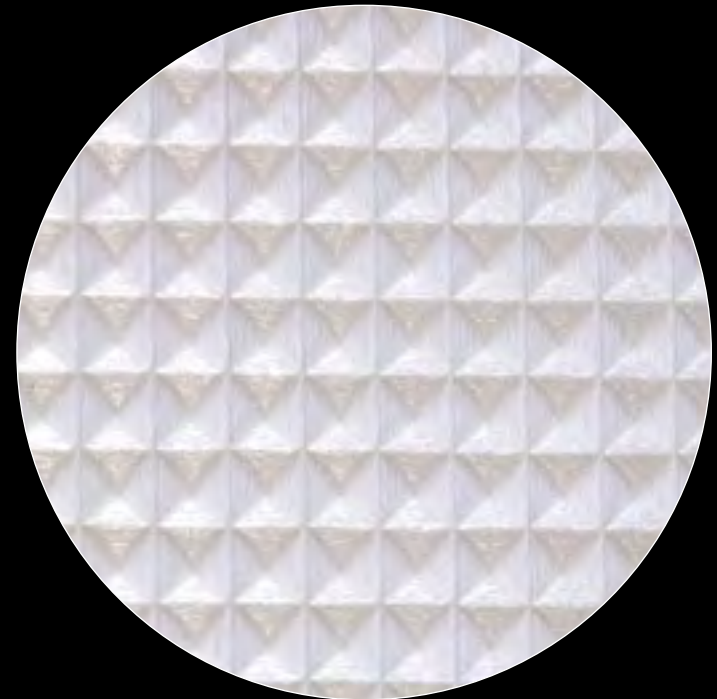
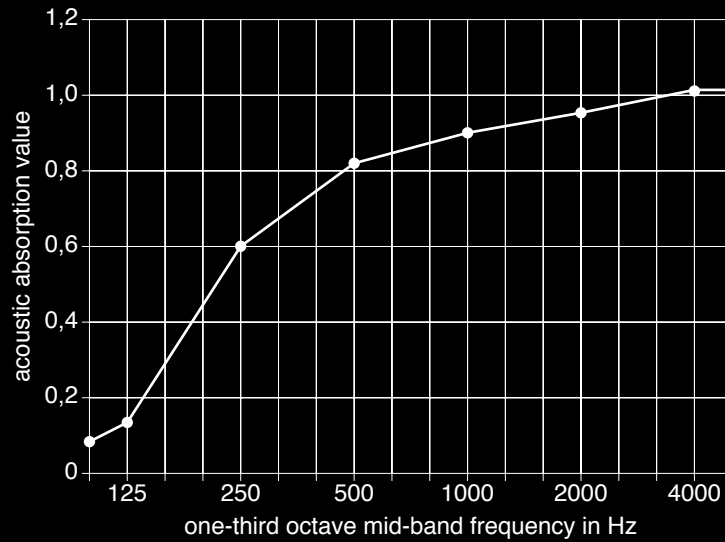

003  
White

Acoustic absorption value $\alpha_w$	0,85
acoustic absorption class	B

Type of assembly E-50 according to DIN EN ISO 354 - lying on the ground  
 SILENCIO® Size 10 in front of a cavity of 50 mm  
 with 2 x 20 mm ISOVER SSP2 insulation

REF.

**SILENCIO® Size 10**  
White  
687301 - 00900 - 003



100 % Trevira CS



DIN EN  
13501-1  
B-s1, d0



315 / 505 cm



300 g/m<sup>2</sup> ± 5%



ca. 4 mm



25m / 27yrd

Specs



Further  
Details



# PONGS® AKUTEX®

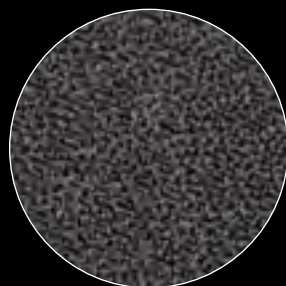

347

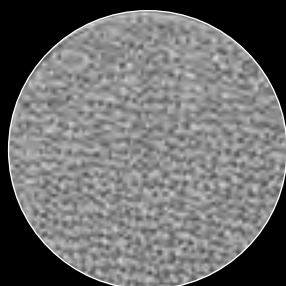

331

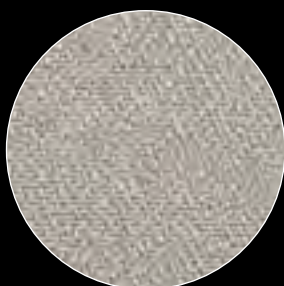

329

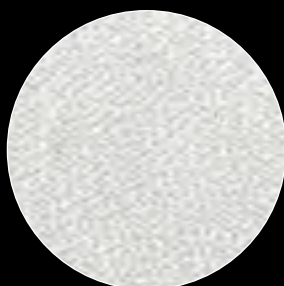

309



303

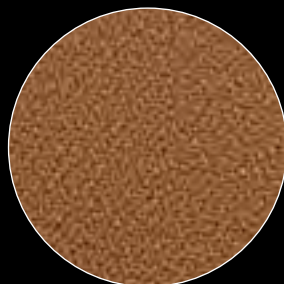

545

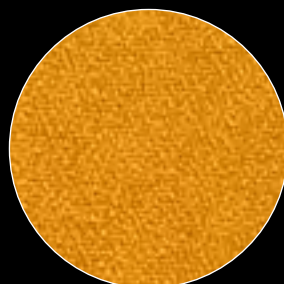

727

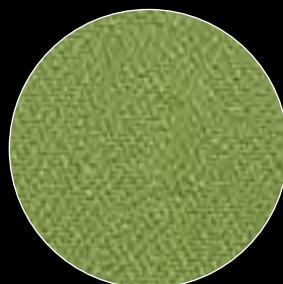

638

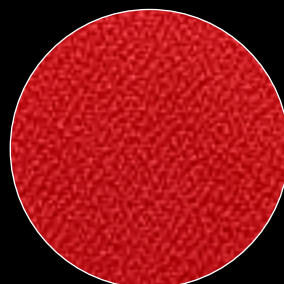

466

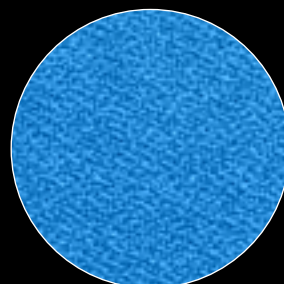

162

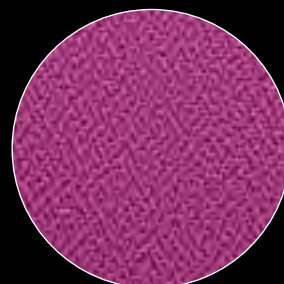

235



541



731

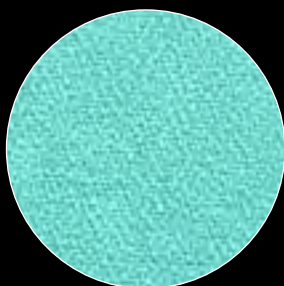

628

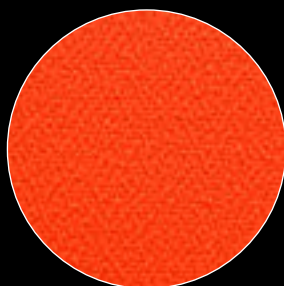

440

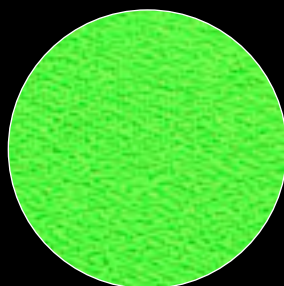

642

REF.

**AKUTEX®**  
Colour number  
506251 - ###



100 % Polyester



**B1** **DIN EN 13501-1** **M1**  
B-s1, d0



270 g/m<sup>2</sup> ± 5%



ca. 620 μm ± 10



30m/33yrd 60m/66yrd



ca. 308 cm



100 Pa: 192 l/(m<sup>2</sup>s)  
200 Pa: 342 l/(m<sup>2</sup>s)



warp: 107,5 N  
weft: 115,2 N



5-6

Specs



Further Details

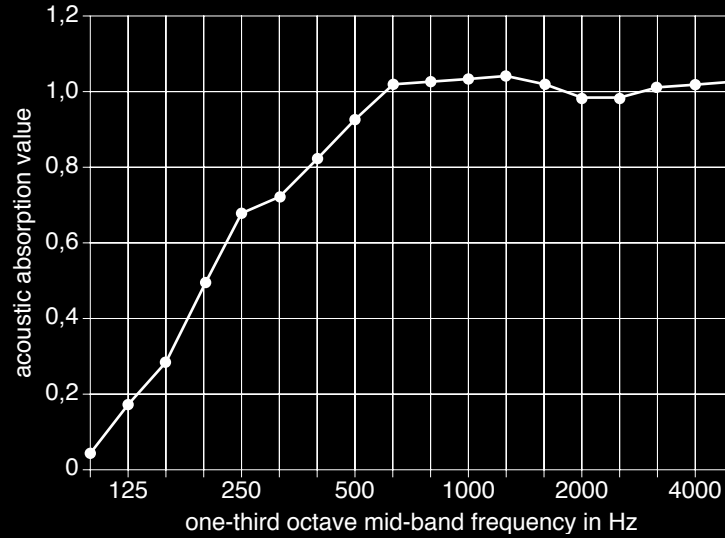

Acoustic absorption value $\alpha_w$	0,90
acoustic absorption class	A

Type of assembly E-50 according to DIN EN ISO 354 - lying on the ground  
AKUTEX® in front of 50 mm airspace absorbed with 40 mm ISOVER SSP2



# PONGS®

Akustikvlies



White

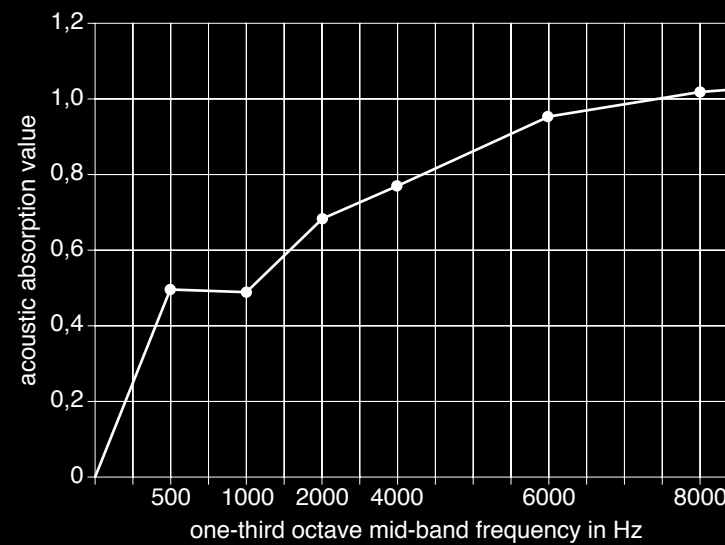

Type of assembly 20 mm Akustikvlies, no foil, in wooden frame

REF.

Akustikvlies  
White



100 % Polyester



DIN EN  
13501-1  
B-s1, d0

B1



400 g/m<sup>2</sup> ± 5%



ca. 20 mm



20m/ 22yrd



ca. 270 cm

Specs



Further  
Details





Artist heavy  
564250 - 00900 - 042

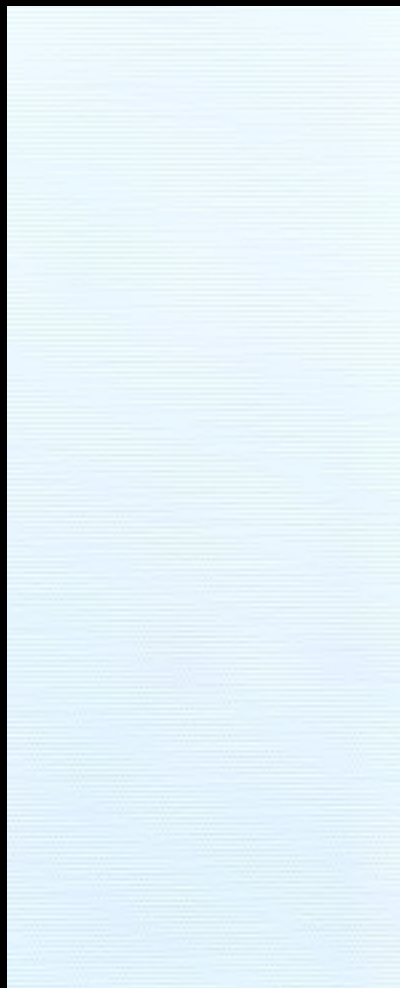

Artist Backlite  
564252 - 00900 - 083



Artist Mambo  
564160 - 00900 - 137



REF.

**Artist heavy**  
Colour number  
564250 - 00900 - 042

**Artist Backlite**  
Colour number  
564252 - 00900 - 083

**Artist Mambo**  
Colour number  
564160 - 00900 - 137



100 % Polyester

100 % Polyester

100 % Polyester



DIN EN  
13501-1  
B-s1, d0

DIN EN  
13501-1  
B-s1, d0

DIN EN  
13501-1 in testing  
B-s1, d0



280 g/m<sup>2</sup> ± 5%

250 g/m<sup>2</sup> ± 5%

170 g/m<sup>2</sup> ± 5%



103, 137, 155, 205,  
252, 310, 505 cm

103, 137, 155, 252, 310, 505 cm

103, 155, 310, 505 cm



26,9 % (DIN EN 410)

31,9 % (DIN EN 410)

26,9 % (DIN EN 410)

Specs



Further  
Details

All fabrics can be digital printed with individual images.

DESCOR® PREMIUM solely applies to building professionals.  
The system is exclusively used by specialists trained in this technique.  
A list of recommended approved fitters is available on request.



 **DESCOR**<sup>®</sup>  
WALL & CEILING SYSTEM

Backlit fabrics



Softimage lightbox  
599180 - 00900 - 173



Backlite Premium  
599280 - 00900 - 140

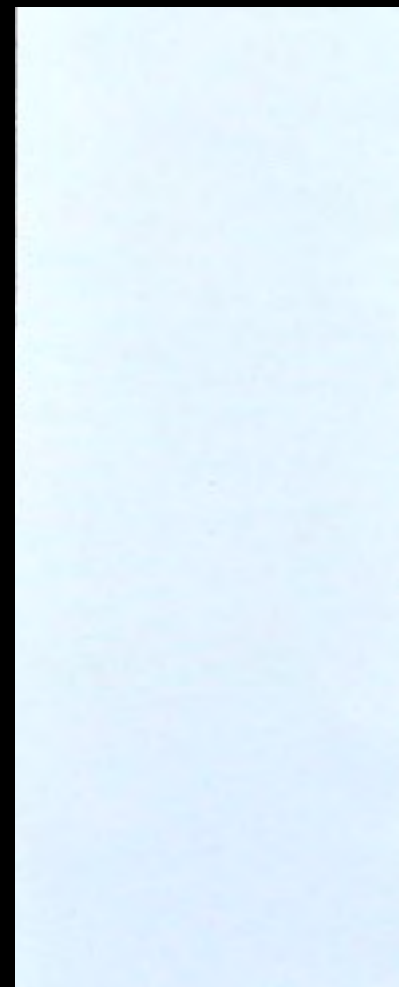

Stretch Twill Soft  
584097 - 00900 - 123

REF.

**Softimage lightbox**  
Colour number  
599180 - 00900 - 173

**Backlite Premium**  
Colour number  
599280 - 00900 - 140

**Stretch Twill Soft**  
Colour number  
584097 - 00900 - 123



100 % Polyester

100 % Polyester

100 % Polyester



DIN EN  
13501-1  
B-s1, d0

DIN EN  
13501-1  
B-s1, d0

DIN EN  
13501-1  
B-s1, d0

M1



205 g/m<sup>2</sup> ± 5%

280 g/m<sup>2</sup> ± 5%

115 g/m<sup>2</sup> ± 5%



103, 155, 252, 310, 505 cm

103, 155, 252, 310, 505 cm

103, 155, 310 cm



35,7 % (DIN EN 410)

14,5 % (DIN EN 410)

26,9 % (DIN EN 410)

Specs

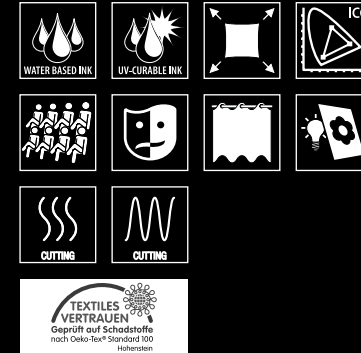
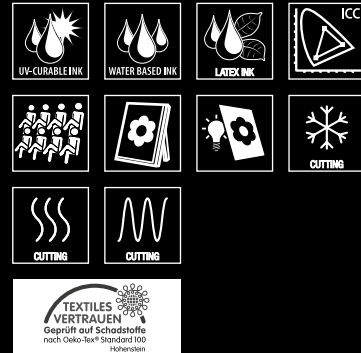
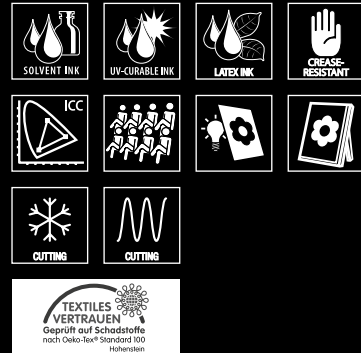

Further  
Details

All fabrics can be digital printed with individual images.

DESCOR® PREMIUM solely applies to building professionals.  
The system is exclusively used by specialists trained in this technique.  
A list of recommended approved fitters is available on request.

**DESCOR®**  
WALL & CEILING SYSTEM