

**FOR PUBLIC
RELEASE**

Wireless 200M HDMI Extender

DE/VK-W200

User manual

Thank you for purchasing this product. For optimum performance and safety, please read these instructions carefully before connecting, operating or adjusting this product. Please keep this manual for future reference.

1.0 Introduction

The Wireless HDMI Extender Kit 1080p - 200m extends high definition HDMI signals wirelessly from a source device to a display device up to 200 meters with the advanced application of transport protocol and wireless technology. It requires no cables between the transmitter (TX) and receiver (RX), making the installation easy and clean. Great for homes and offices.

2.0 Package Contents

HDMI Transmitter -----1pc
HDMI Receiver -----1pc
Windband IR Tx cable -----1pc
Windband IR Rx cable -----1pc
5V2A DC Power Supply Adaptor -----2pcs
Product Manual -----1pc

3.0 Features

- 1.Supports one to many without interference--Connect up to 4 wireless receivers within the same location. No line of sight placement required and no difficulties transmitting/receiving signals through walls, ceilings, and floors. Each transmitter will scan for surrounding Wi-Fi 2.4/5GHz channels, automatically selecting an unoccupied frequency to avoid interference.
- 2.Supports extend distance up to 200m--Separate your HDMI source from your HDMI display up to 200 meters away, transmitting wirelessly over 5GHz Wi-Fi bands, eliminating the need to run long cables through or around walls, ceilings or floors.
- 3.Supports 1080p@60HZ with low latency--With a virtually undetectable max latency of 200ms, or 0.20 seconds,it is great for live TV, video games and sports. Connect all your High Definition HDMI devices (cable box, computer, video game console, etc.) and enjoy 1080p@60Hz resolution.(When you displaying Videos,it even supports full 4K@30HZ resolution.)
- 4 Supports USB firmware update capabilities--Download Firmware updates via USB to improve the quality, functionality and usability of this extender.
- 5.Supports One-way IR control.

4.0 Specifications

HDMI Transmitter Input/Output Ports	1x HDMI port//1 x AUX 1x IR Transmitter/1 x HDMI port
HDMI Receiver Input/Output Ports	1x IR Receiver 1x HDMI port/1 x AUX
Wireless length between Rx and TX	200 meters
HDMI Input	1080p/720p/576p/576i/480p/480i
HDMI Output	1080p/720p/576p/576i/480p/480i
Power Supply	DC 5 V 2 A
ESD Protection Human Body Model:	± 8kV (air-gap discharge) ± 4kV (contact discharge)

Operating Temperature	0°C ~ 40°C / 32°F ~ 104°F
Storage Temperature	-20°C ~ 60°C / -4°F ~ 140°F
Relative Humidity	20 ~ 90% RH (Non-condensing)
Dimension (L x W x H)	221x70x25(mm)

5.0 Operation controls and Functions

Transmitter

FOR PUBLIC RELEASE

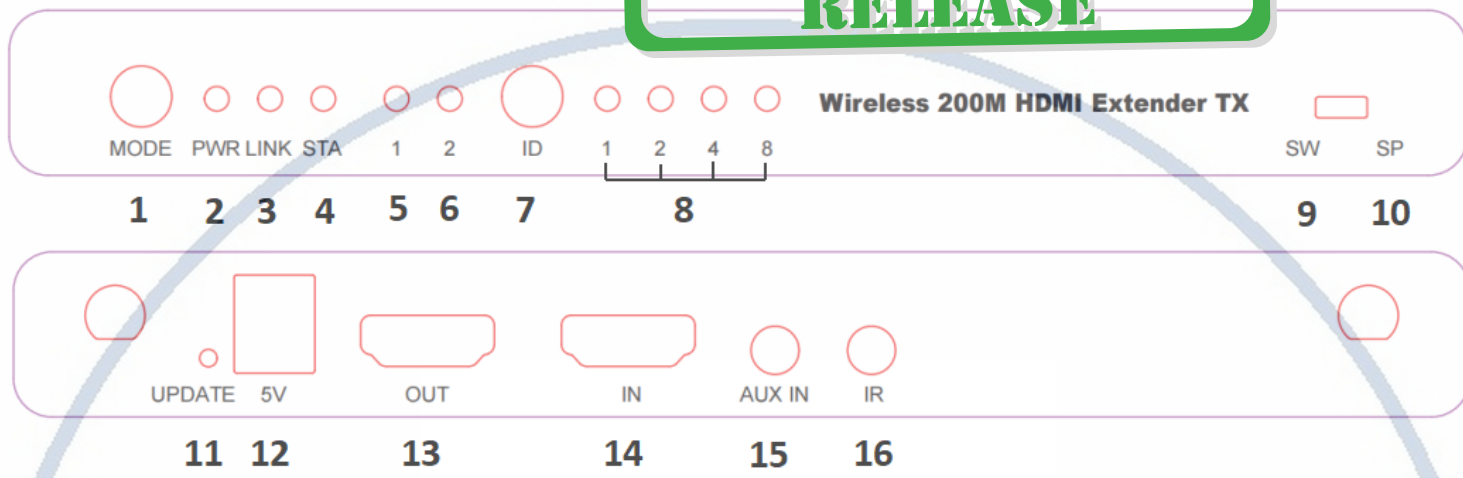

Light signal and button:

- 1 Mode button: Click to enable DHCP mode (lighting for mode 1), and long press to switch channel bit (lighting for mode 2).
- 2 Power light: Lighting when power is supplied.
- 3 Link (Ethernet) light: Lighting when Ethernet is connected.
- 4 STA (HDMI) light: Flashing when data is transmitting.
- 5 Mode 1 light (DHCP mode): Lighting on to enable DHCP when necessary. Please enable DHCP after LAN cable is connected to switch without DHCP embedded. It is possible to run DHCP on multiple TX at the same time, but only the one with stronger MAC ADDR hosts the DHCP.
- 6 Mode 2 light (Channel bit): Lighting on to adjust high-bit channel, and lighting off to adjust low-bit channel.
- 7 ID button: Click to switch channel ID.
- 8 Channel signal: Channel number is the total of what is light on.
- 9 Many-to-one mode: Display the screen of TX with the same channel ID, it supports to connect up to 8 wireless transmitters, and it needs to set channel ID and pair with HDMI cables.
- 10 One-to-one and one-to-many modes: Direct connection to TX for 1 to 1 extending display and connect up to 4 wireless receivers within the same location. No channel ID should be set but need to pair with HDMI cables.
- 11 UPDATE: upgrade software.

Port:

- 12 5V port: Requires 5V/2A power supply.
- 13 HDMI Output: Connects to monitor with HDMI port for loop back.
- 14 HDMI Input: Connects to your device (laptop or computer box).
- 15 AUX IN: Audio input to replace the audio from HDMI source.
- 16 IR out: Supports IR output for remote control.

Receiver

FOR PUBLIC RELEASE

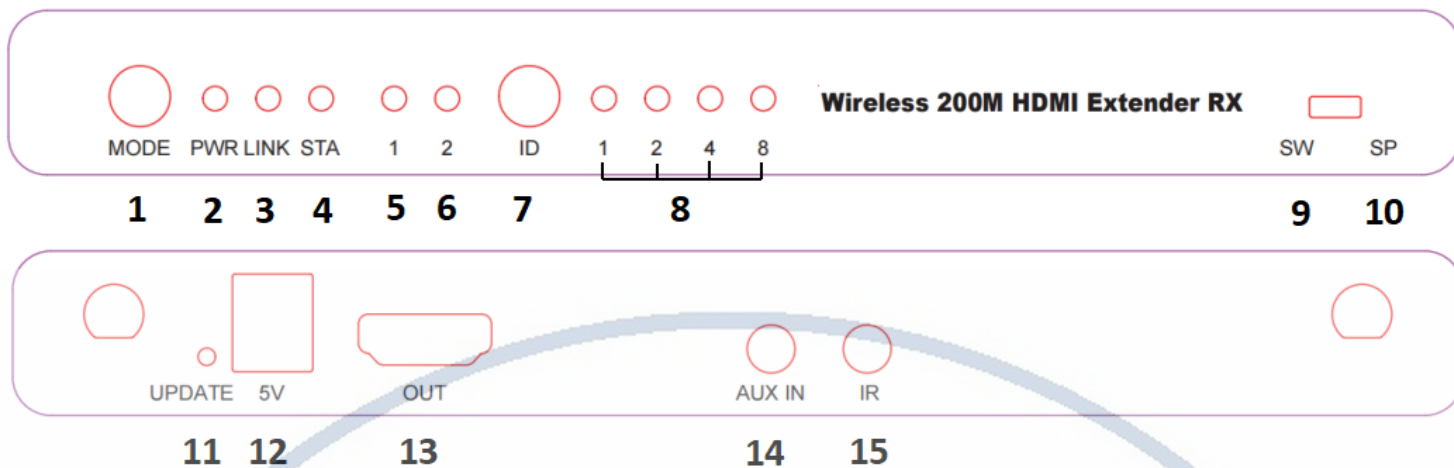

Light signal and button:

- 1 Mode button: Click to switch display mode (lighting for mode 1), and long press to switch channel bit (lighting for mode 2).
- 2 Power light:Lighting when power is supplied.
- 3 Link(Ethernet) light:Flashing when data is transmitting.
- 4 STA(HDMI) light: Lighting when HDMI cable is connected.
- 5 Mode 1 light (Display mode): Lighting off for Graphic Mode with shorter latency, and lighting on for Video mode with less package lost rate.
- 6 Mode 2 light (Channel bit): Lighting on to adjust high-bit channel, and lighting off to adjust low-bit channel.
- 7 Channel ID button: Click to switch channel ID.
- 8 Channel ID signal:Channel number is the total of what is light on.
- 9 Many-to-one mode: Display the screen of TX with the same channel ID,it supports to connect up to 8 wireless transmitters,and it needs to set channel ID and pair with HDMI cables
- 10 One-to-one and one-to-many modes:Direct connection to TX for 1 to 1 extending display and connect up to 4 wireless receivers within the same location. No channel ID should be set but need to pair with HDMI cables.
- 11 UPDATE: upgrade software.

Port:

- 12 5V port: Requires 5V/2A power supply.
- 13 HDMI Output: Connects to monitor with HDMI port for display
- 14 AUX OUT: Audio output to other speakers. Note that HDMI output port sends audio simultaneously.
- 15 IR IN: Supports IR input for remote control.

FOR PUBLIC RELEASE

6.0 Channel adjustment

- **Low-bit channel 1-15:** Press ID button to switch channel from 1 to 15.



- Advanced section for more channels

If 15 channels are not enough for your circumstances, up to 255 channels are provided.

The channel ID more than 15 is “high bits * 16 + low bits”.

1. High-bit channel adjustment

- (1) Long press MODE button to light on Mode 2 signal to adjust high-bit channel.
- (2) Press ID button to change high-bit channel, which defines the adjustment range of low-bit signals.

High-bit adjustment



FOR PUBLIC RELEASE

High-bit signals define the adjustment range of low-bit signals



2. Example for channel 16-32:

- (1) Long press MODE button to light on Mode 2 signal to adjust high-bit channel.
- (2) Click ID button to 1. High-bit channel 1 makes low-bit channel adjustment start from channel 16. (High-bit channel 2 makes low-bit channel adjustment start from 32. So as high-bit channel 3-15 adjust low-bit channel from 46-255.)
- (3) Long press MODE button again to switch to low-bit adjustment.
- (4) Click ID button to switch channel from 16-32.

To start low-bit channel from 16-31, switch to high-bit adjustment and press ID button to 1.



Switch back to low-bit adjustment and change channel ID by ID button

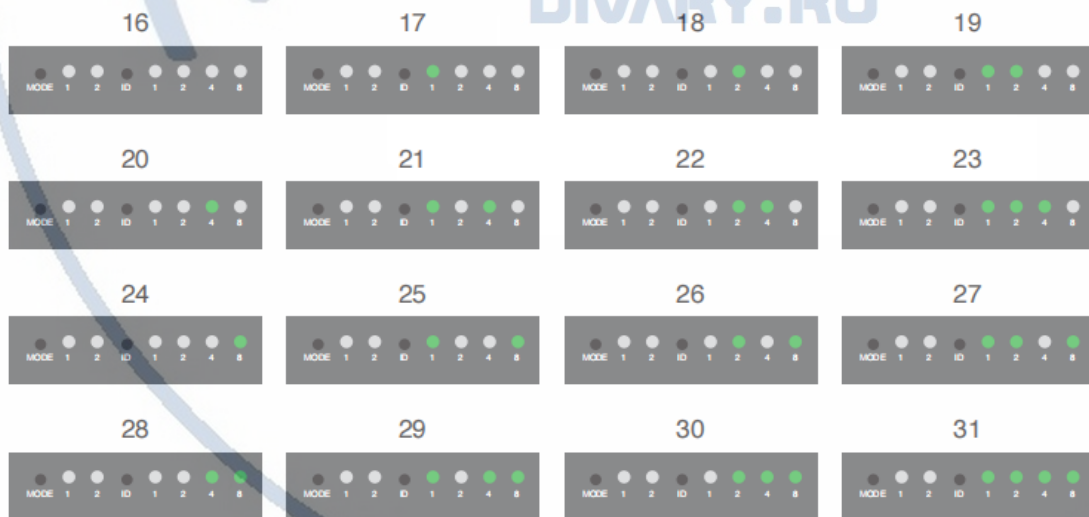

Note: Only channel 1-15 are adjustable when high-bit channel is 0, which means not allowing the adjustment of high-bit channel 0 and low-bit channel 0 simultaneously.

7.0 Installation

Splitter Mode Display (1 to 1):

1. Position the toggle switch to Splitter Mode on both RX and TX.
2. Connect power to 5V/2A and a monitor to display output on RX.
3. Connect RX and TX by the USB-A data cable to pair.
4. After pairing, connect power to 5V/2A, a monitor for loopback, and a device to input on TX.

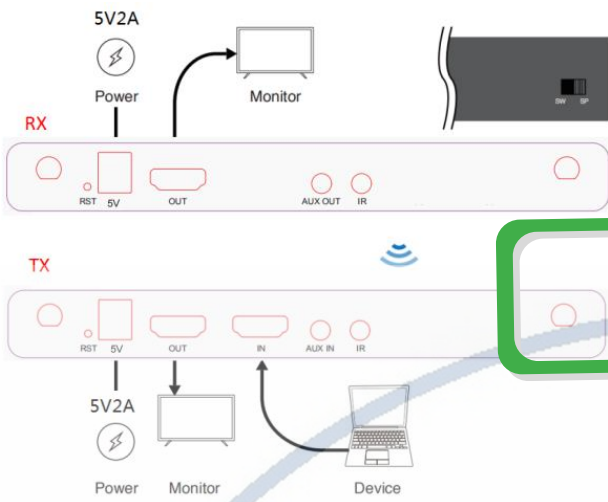

FOR PUBLIC RELEASE

*Troubleshooting guide: If there's no signal on the monitor connected to RX, please make sure RX and TX (1) are both switched to Splitter mode and (2) have been paired together.

Switch Mode Display (1 to N, N to 1):

1. Position the toggle switch to Switch Mode on both RX and TX.
2. Connect power to 5V/2A and a monitor to display output on RX.
3. Connect RX and TX by the USB-A data cable to pair.
4. After pairing, connect power to 5V/2A, a monitor for loop back, and a device to input on TX.
5. Set RX and TX to the same channel ID.

* Note: Every TX under the same network should be set to different channel ID.

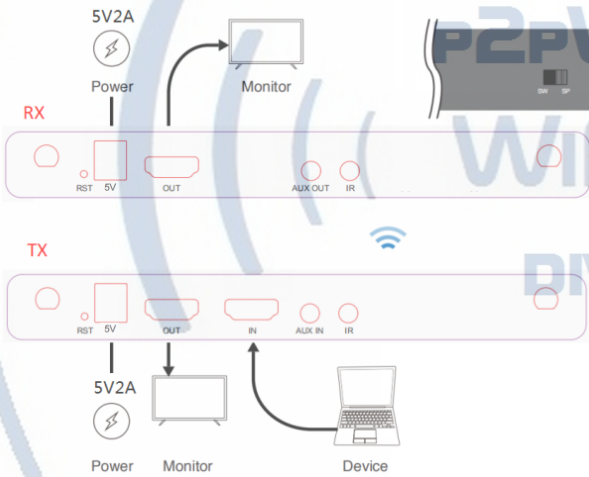

* Troubleshooting guide: If there's no signal on the monitor connected to RX, please make sure RX and TX (1) are both switched to Switch Mode, (2) have been paired together, and (3) are set to the same channel ID.

8.0 Installation of Remote Control

Flexible methods for remote control. The connection examples are only for the remote control function, please arrange other display kits depending on your needs.

Equip IR kit on RX and TX to control the device connected to TX from RX. The receiver is for IR input and the transmitter is for IR output.

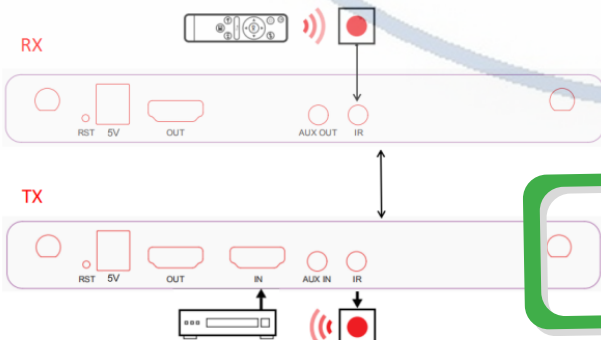

FOR PUBLIC RELEASE

9.0 Installation of Audio Input and Output

1. HDMI input and HDMI output

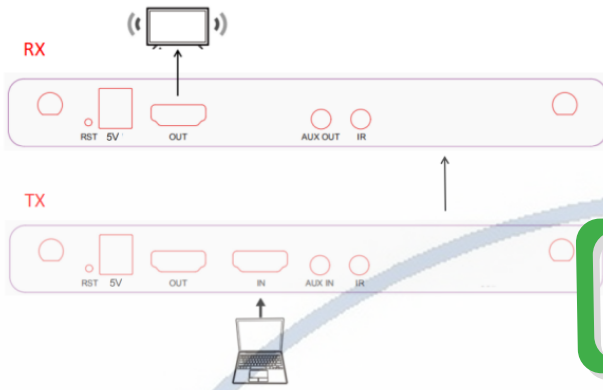

2. AUX input and HDMI output

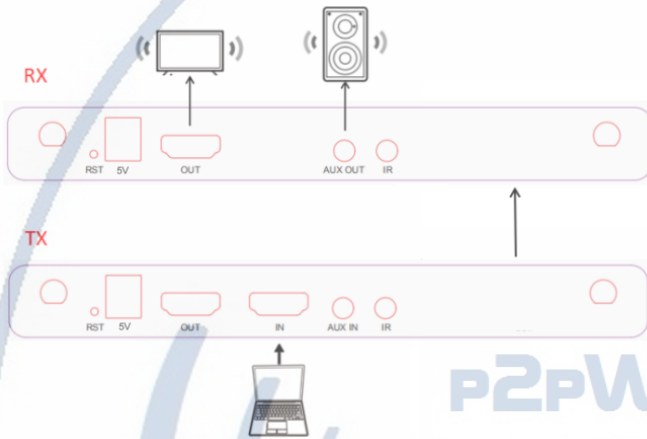

3. HDMI input and HDMI/ AUX output

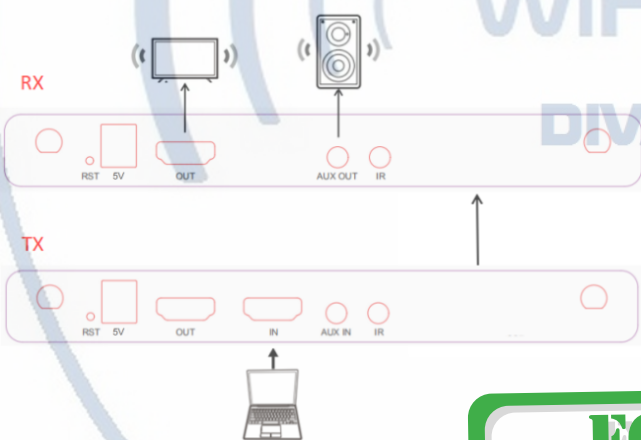

4. HDMI/ AUX input and HDMI/ AUX output

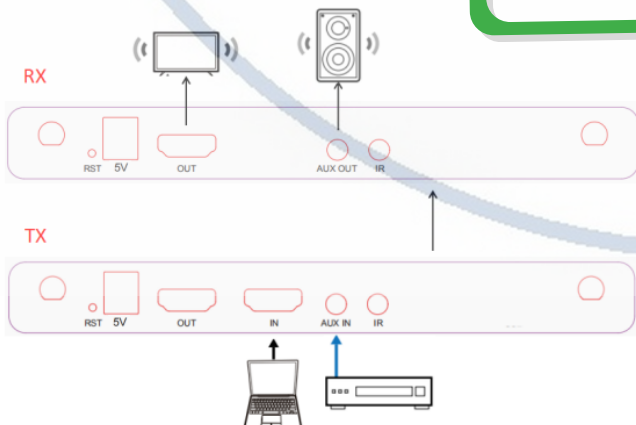

5. HDMI input and AUX output

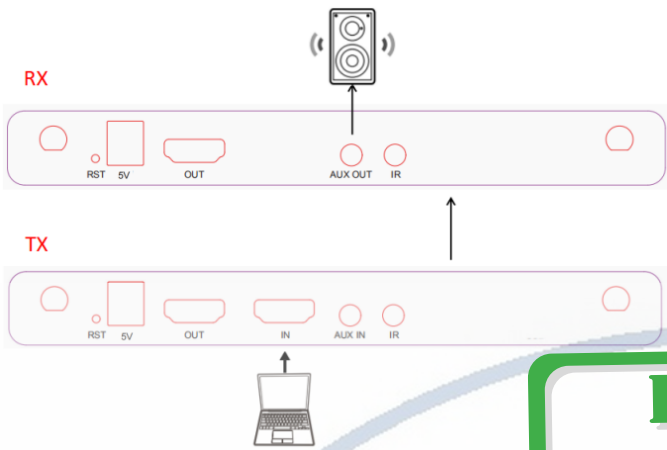

FOR PUBLIC RELEASE

6. AUX input and AUX output

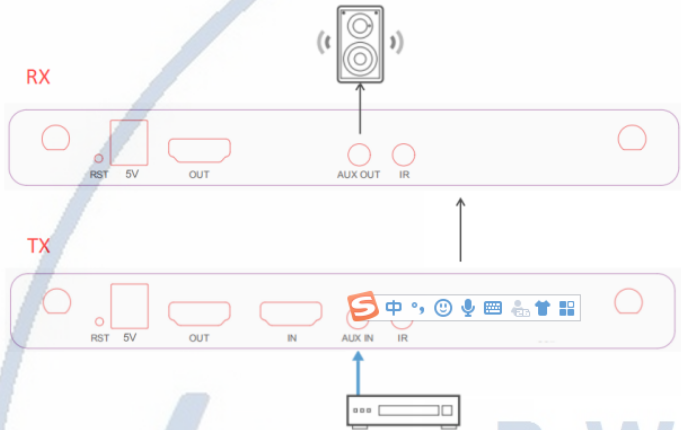

P2PWIFICAM.RU

WIFISEC.RU

DIVARY.RU

10.0 Configuration Examples

Extender (1 to 1)

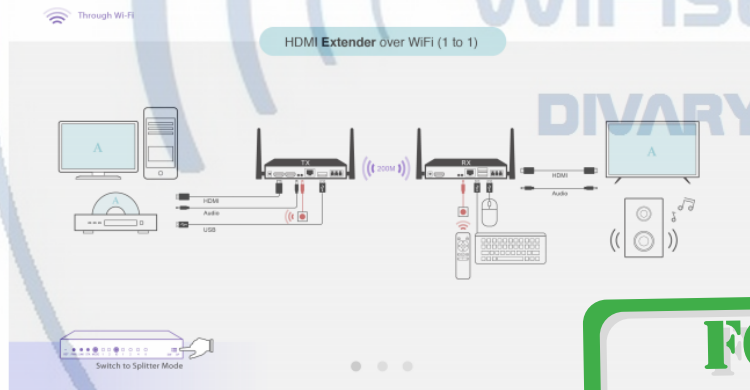

FOR PUBLIC RELEASE

Splitter (1 to N)

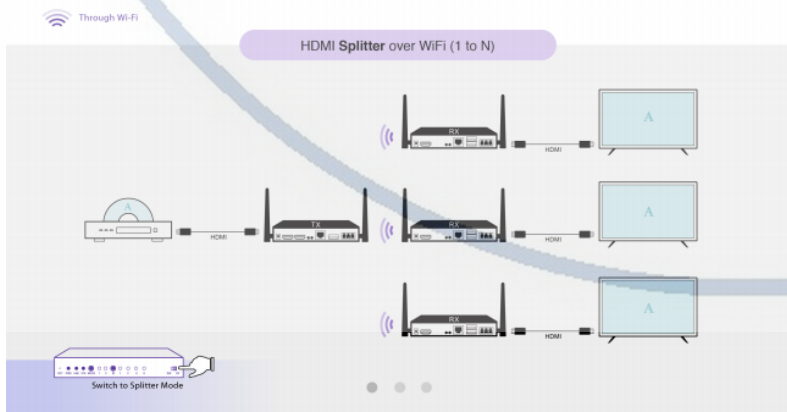

Switcher (1 to 1, N to 1)

HDMI KVM Switch over WiFi (1 to 1, N to 1)

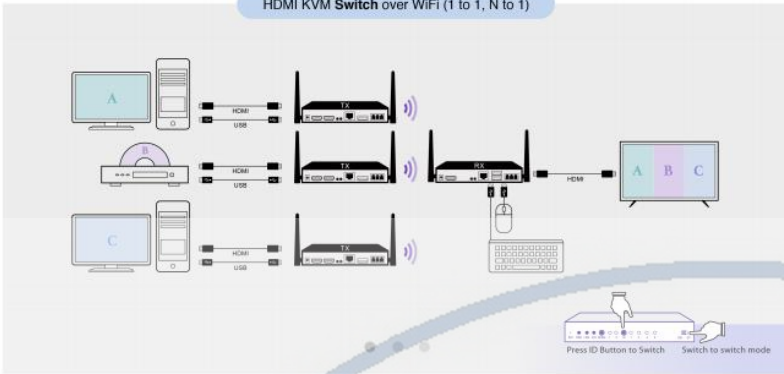

Wideband IR(30KHz---60KHz) introduction

FOR PUBLIC RELEASE



IR RECEIVER

IR BLASTER

IR BLASTER (TX)

To control the source: Plug IR Blaster into IR TX port of transmitter unit; place blaster in front of the IR eye of the source.

IR RECEIVER (RX)

To control the source: Plug IR Receiver into IR RX port of receiver unit; place receiver at or near display.

P2PWIFICAM.RU
 WIFISEC.RU
 DIVARY.RU

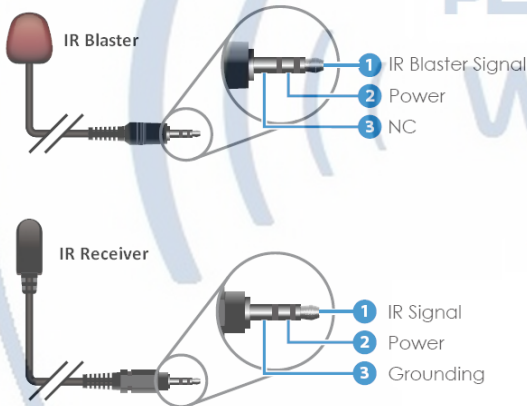

Appendix

FOR PUBLIC RELEASE

Support list of display input		4K Model
TX HDMI input and RX HDMI output		1.11534.0
TX HDMI input	RX HDMI output	HDMI loopback output
640x480 60Hz	800x600 60Hz	640x480 60Hz
800x600 60Hz	800x600 60Hz	800x600 60Hz
1024x768 60Hz	1024x768 60Hz	1024x768 60Hz
1280x720 60Hz	1280x720 60Hz	1280x720 60Hz
1280x720 50Hz	1280x720 60Hz	1280x720 50Hz
1280x768 60Hz	1280x768 60Hz	1280x768 60Hz
1280x800 60Hz	1280x800 60Hz	1280x800 60Hz
1280x960 60Hz	1280x960 60Hz	1280x960 60Hz
1280x1024 60Hz	1280x1024 60Hz	1280x1024 60Hz
1360x768 60Hz	1920x1080 60Hz	1360x768 60Hz
1400x1050 60Hz	1400x1050 60Hz	1400x1050 60Hz
1440x900 60Hz	1440x900 60Hz	1440x900 60Hz
1920x1200 60Hz	1920x1200 60Hz	1920x1200 60Hz
1600x1200 60Hz	1600x1200 60Hz	1600x1200 60Hz
1680x1050 60Hz	1680x1050 60Hz	1680x1050 60Hz
1920x1080 60Hz	1920x1080 60Hz	1920x1080 60Hz
1920x1080i 60Hz	1920x1080 60Hz	1920x1080i 60Hz
1920x1080 50Hz	1920x1080 60Hz	1920x1080 50Hz
1920x1080i 50Hz	1920x1080 60Hz	1920x1080i 50Hz
3840x2160 30Hz	1920x1080 60Hz	3840x2160 30Hz
4096x2160 30Hz	1920x1080 60Hz	4096x2160 30Hz

Support list of display input		1080P Model
TX HDMI input and RX HDMI output		1.11194.0
TX HDMI input	RX HDMI output	HDMI loopback output
640x480 60Hz	800x600 60Hz	800x600 60Hz
800x600 60Hz	800x600 60Hz	800x600 60Hz
1024x768 60Hz	1024x768 60Hz	1024x768 60Hz
1280x720 60Hz	1280x720 60Hz	1280x720 60Hz
1280x720 50Hz	1280x720 60Hz	1280x720 60Hz
1280x768 60Hz	1280x768 60Hz	1280x768 60Hz
1280x800 60Hz	1280x800 60Hz	1280x800 60Hz
1280x960 60Hz	1280x960 60Hz	1280x960 60Hz
1280x1024 60Hz	1280x1024 60Hz	1280x1024 60Hz
1360x768 60Hz	1920x1080 60Hz	1920x1080 60Hz
1400x1050 60Hz	1400x1050 60Hz	1400x1050 60Hz
1440x900 60Hz	1440x900 60Hz	1440x900 60Hz
1920x1200 60Hz	1920x1200 60Hz	1920x1200 60Hz
1600x1200 60Hz	1600x1200 60Hz	1600x1200 60Hz
1680x1050 60Hz	1680x1050 60Hz	1680x1050 60Hz
1920x1080 60Hz	1920x1080 60Hz	1920x1080 60Hz
1920x1080i 60Hz	1920x1080 60Hz	1920x1080i 60Hz
1920x1080 50Hz	1920x1080 60Hz	1920x1080 60Hz
1920x1080i 50Hz	1920x1080 60Hz	1920x1080 60Hz

P2PWIFICAM.RU

WIFISEC.RU

DIVARY.RU

**FOR PUBLIC
RELEASE**