

HC-2020

Serial Number

30000001-30999999

Last updated date

01/Apr/2021

TABLE OF CONTENTS

CYLINDER, PISTON, CRANKSHAFT	1
CRANKCASE	3
MAGNETO.....	5
AIR CLEANER, CARBURETOR.....	7
CARBURETOR.....	9
FUEL TANK	11
MUFFLER.....	13
RECOIL STARTER.....	15
GEAR CASE	17
CUTTING BLADE	19
HANDLE.....	21
ACCESSORIES	23

CYLINDER, PISTON, CRANKSHAFT

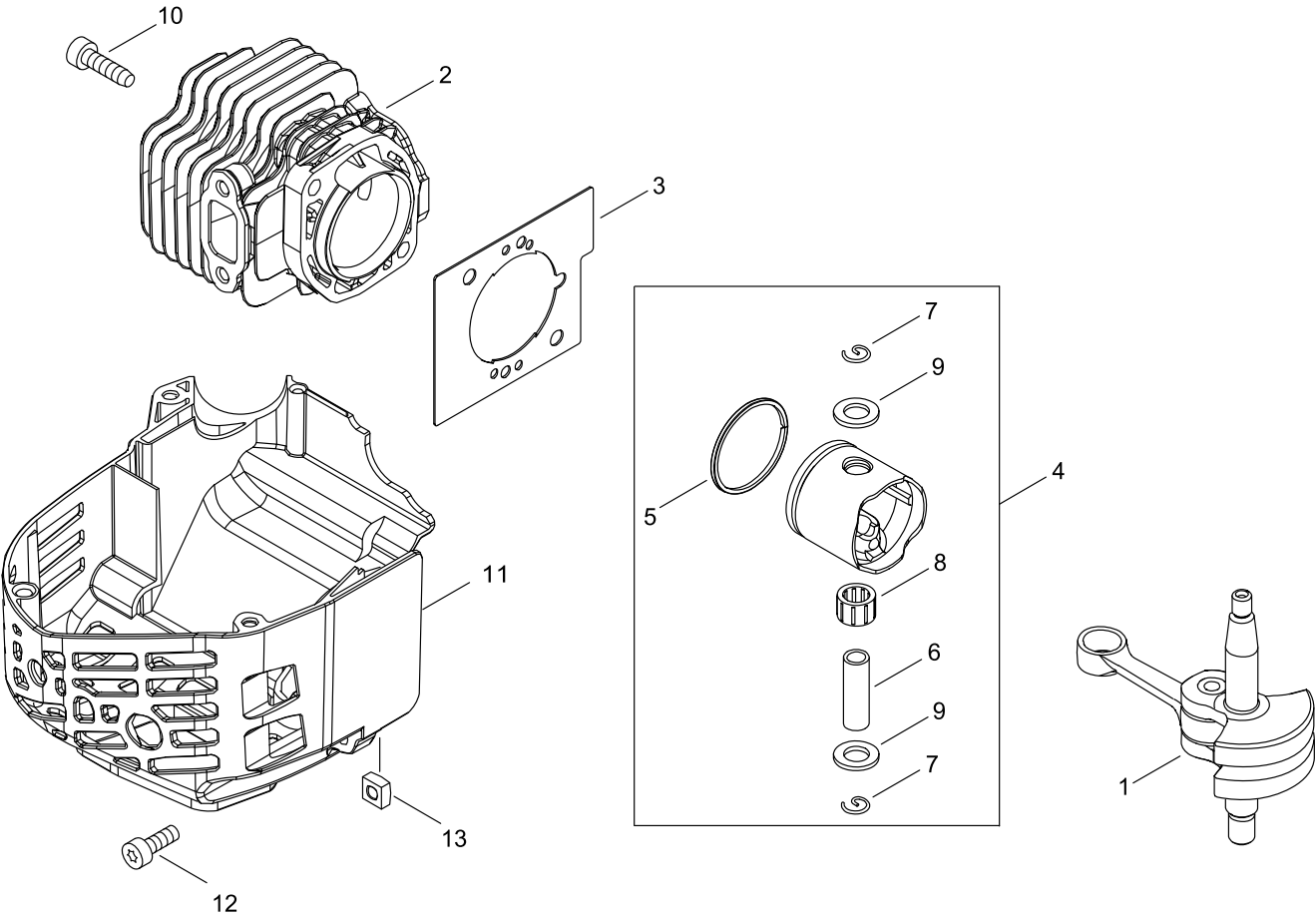

CYLINDER, PISTON, CRANKSHAFT

Key No.	LV (+)	Parts Number	Parts Description	Qty	Standard	Class
1		A011-001550	CRANKSHAFT,ASY	1		D
2		A130-001960	CYLINDER	1		D
3		V100-000720	GASKET,CYL	1		B
4		P021-007772	PISTON KIT	1		
5	+	A101-000090	RING,PISTON	1		B
6	+	100013-11520	PIN, PISTON	1		D
7	+	100015-04630	CIRCLIP, PISTON PIN	2		C
8	+	100113-05930	BEARING, NEEDLE	1	8*12*8	B
9	+	100014-08960	SPACER, PISTON PIN	2		C
10		V805-000210	BOLT, TORX 5	2	TB-5*20 12.9	C
11		A160-003580	COVER,CYLINDER	1	HC-2020	C
12		V805-000150	BOLT, TORX 5	1	TB-5*16 10.9	C
13		900565-00005	NUT, SQUARE	1	5	

Class : Consumable class

A:Fast moving parts B:Semi-fast moving parts C:Slow moving parts D:Order only as needed

CRANKCASE

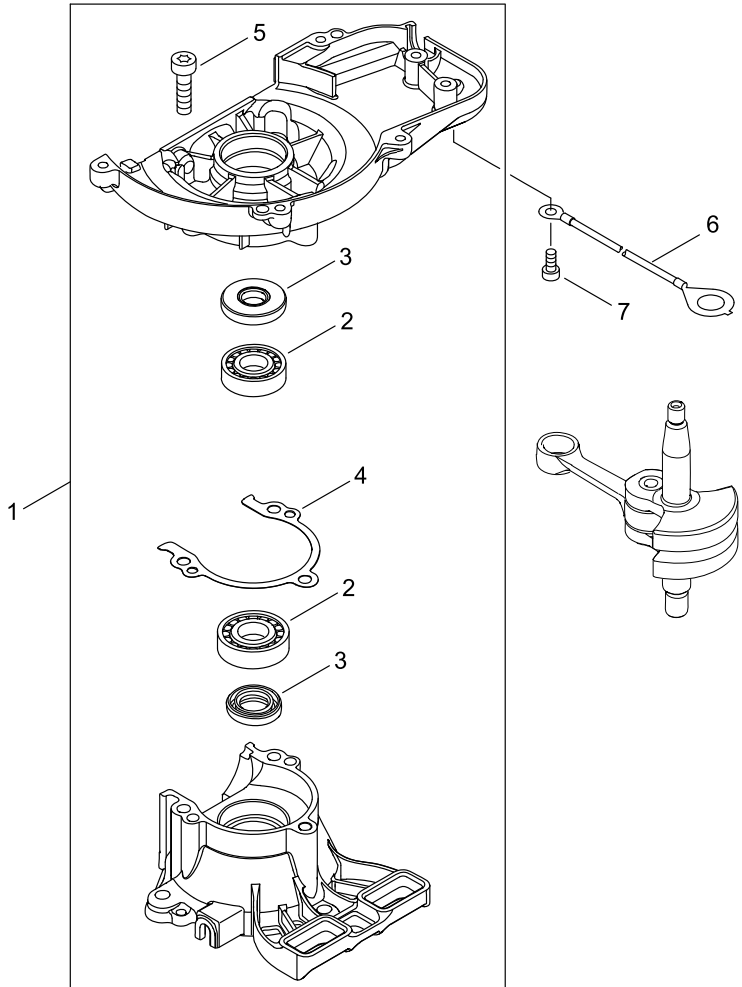

CRANKCASE

Key No.	LV (+)	Parts Number	Parts Description	Qty	Standard	Class
1		P100-006080	CRANKCASE SET	1		
2	+	900810-36000	BEARING, BALL	2	6000	
3	+	100212-61830	OILSEAL	2	ISCD 10*20*5	C
4	+	V102-000240	GASKET,CRANKCASE	1		B
5	+	V805-000220	BOLT, TORX 5	3	TB-5*25 12.9	C
6		V485-003140	LEAD	1		C
7		V804-000040	BOLT, TORX 4	1	TB-4*10 10.9	C

Class : Consumable class
 A:Fast moving parts B:Semi-fast moving parts C:Slow moving parts D:Order only as needed

MAGNETO

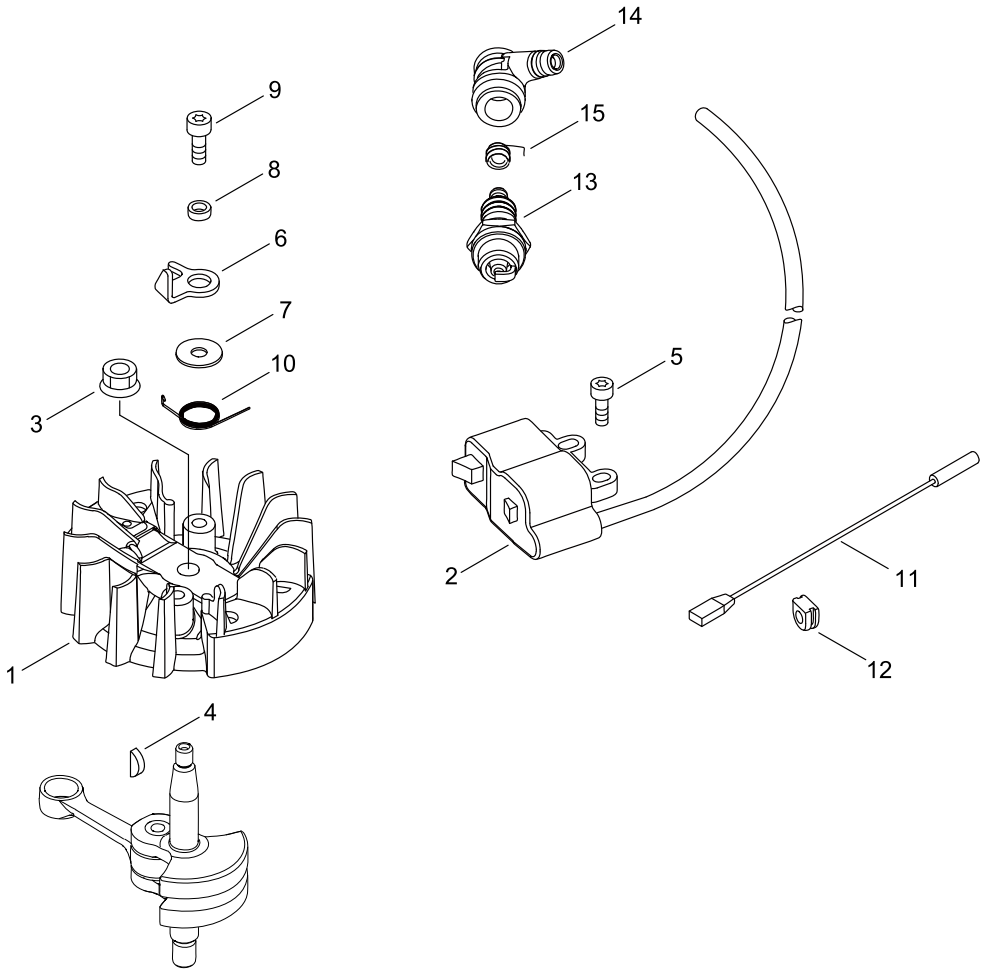

MAGNETO

Key No.	LV (+)	Parts Number	Parts Description	Qty	Standard	Class
1		A409-001360	ROTOR, MAGNETO	1	ID R10011	C
2		A411-001810	COIL, IGNITION	1	L200+10	C
3		92105-06000	NUT L, FLANGE	1	6	
4		100142-12330	KEY, WOODRUFF	1		C
5		V804-000060	BOLT, TORX 4	2	TB-4*16 10.9	C
6		A514-000260	PAWL	2		C
7		131911-03460	WASHER	2		C
8		178070-10860	SPACER	2		C
9		V805-000150	BOLT, TORX 5	2	TB-5*16 10.9	C
10		V452-001370	SPRING,TORSION	2		B
11		V485-001220	LEAD	1	L:85	C
12		V135-000150	GROMMET,HT CORD	1		C
13		A425-000000	SPARKPLUG	1	BPMR8Y	A
14		A427-000013	CAP,SPARK PLUG	1		C
15		A426-000010	TERMINAL,SPARKPLUG	1		C

Class : Consumable class

A:Fast moving parts B:Semi-fast moving parts C:Slow moving parts D:Order only as needed

AIR CLEANER, CARBURETOR

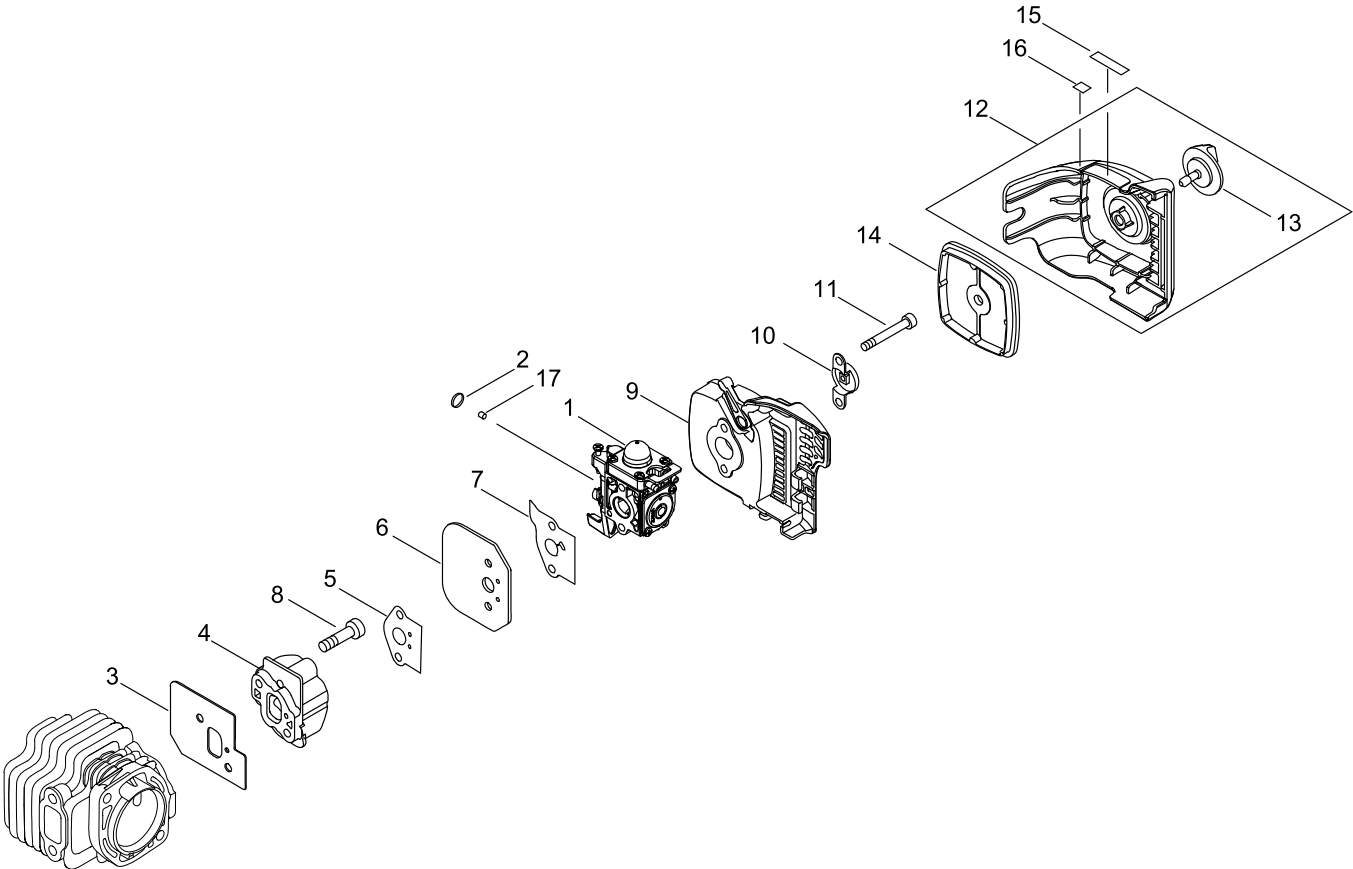

AIR CLEANER, CARBURETOR

Key No.	LV (+)	Parts Number	Parts Description	Qty	Standard	Class
1		A021-004900	CARBURETOR,DIAPHRAGM	1	ID:YZ0008	B
2		V490-001100	CLIP	1		C
3		V103-002030	GASKET,INTAKE	1	T1.0	A
4		A200-001200	INSULATOR, INTAKE	1		C
5		V103-002020	GASKET,INTAKE	1		A
6		A209-000610	PLATE, INSULATOR	1		C
7		V103-001740	GASKET,INTAKE	1		A
8		V805-000170	BOLT, TORX 5	2	TB-5*25 10.9	C
9		P021-049871	CASE,CLEANER	1		
10		A244-000070	PLATE,PREVENT	1		C
11		V805-000100	BOLT, TORX 5	2	TB-5*65 10.9	C
12		P021-049130	CLEANER COVER ASY	1		
13	+	V299-000610	KNOB,FASTENER	1		C
14		A226-001410	ELEMENT,AIR FILTER	1		A
15		890332-52730	LABEL, CHOKE	1		D
16		X524-001901	LABEL	1		D
17		A259-000010	CAP,LIMITER	1		B

Class : Consumable class

A:Fast moving parts B:Semi-fast moving parts C:Slow moving parts D:Order only as needed

CARBURETOR

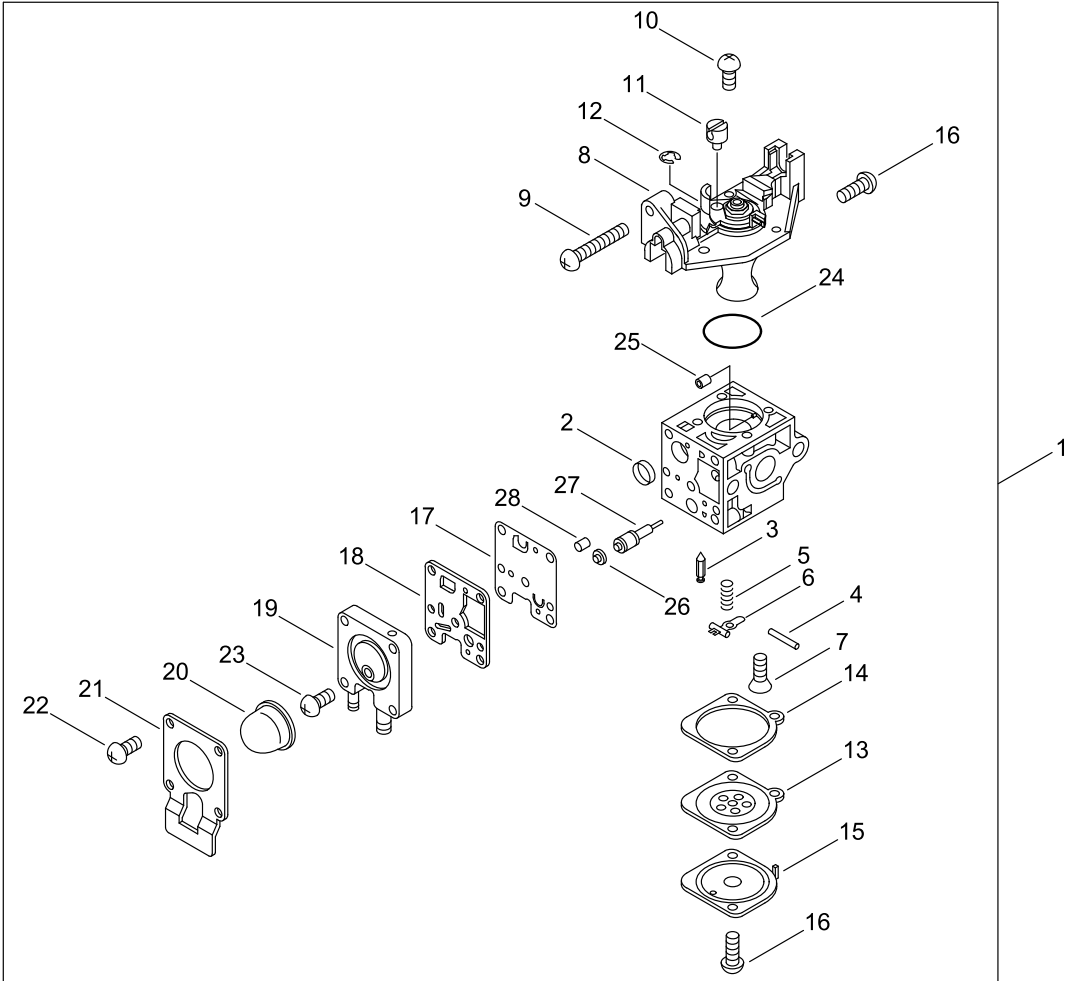

CARBURETOR

Key No.	LV (+)	Parts Number	Parts Description	Qty	Standard	Class
1		A021-004900	CARBURETOR,DIAPHRAGM	1	ID:YZ0008	B
2	+	P005-000010	STRAINER	1		
3	+	125337-08260	VALVE, INLET NEEDLE	1		D
4	+	125338-13930	PIN, METERING ARM	1		
5	+	P005-000940	SPRING, METER. LEVER	1		
6	+	125323-08260	ARM, VALVE	1		
7	+	125339-42030	SCREW	1		
8	+	P005-002050	COVER ASY, ROTOR	1		
9	+	P005-000100	SCREW,THROTTLEADJUST	1		
10	+	125344-13931	SCREW	3		D
11	+	P005-002200	POST	1		
12	+	P005-000190	E-RING	1		D
13	+	P005-003760	DIAPHRAGM ,METERING	1		
14	+	P005-000200	GASKET, METERING	1		A
15	+	125342-52130	COVER, DIAPHRAGM	1		D
16	+	125344-52130	SCREW	3		D
17	+	P005-000510	DIAPHRAGM, PUMP	1		A
18	+	P005-000520	GASKET, PUMP	1		A
19	+	P005-004240	BASE, ASY PRIMER	1		
20	+	P005-003110	PUMP, PRIMER	1		
21	+	P005-000250	RETAINER	1		
22	+	P005-001900	SCREW	4		D
23	+	P005-000270	SCREW	1		
24	+	P005-004260	RING,O	1		
25	+	P005-001000	ROLLER, GUIDE	1		D
26	+	P005-001250	RETAINER,PLUG BALL	1		
27	+	P005-001260	SCREW,MAINN MIXTURE	1		
28	+	P005-001270	PLUG, AJUST SCREW	1		

Class : Consumable class

A:Fast moving parts B:Semi-fast moving parts C:Slow moving parts D:Order only as needed

FUEL TANK

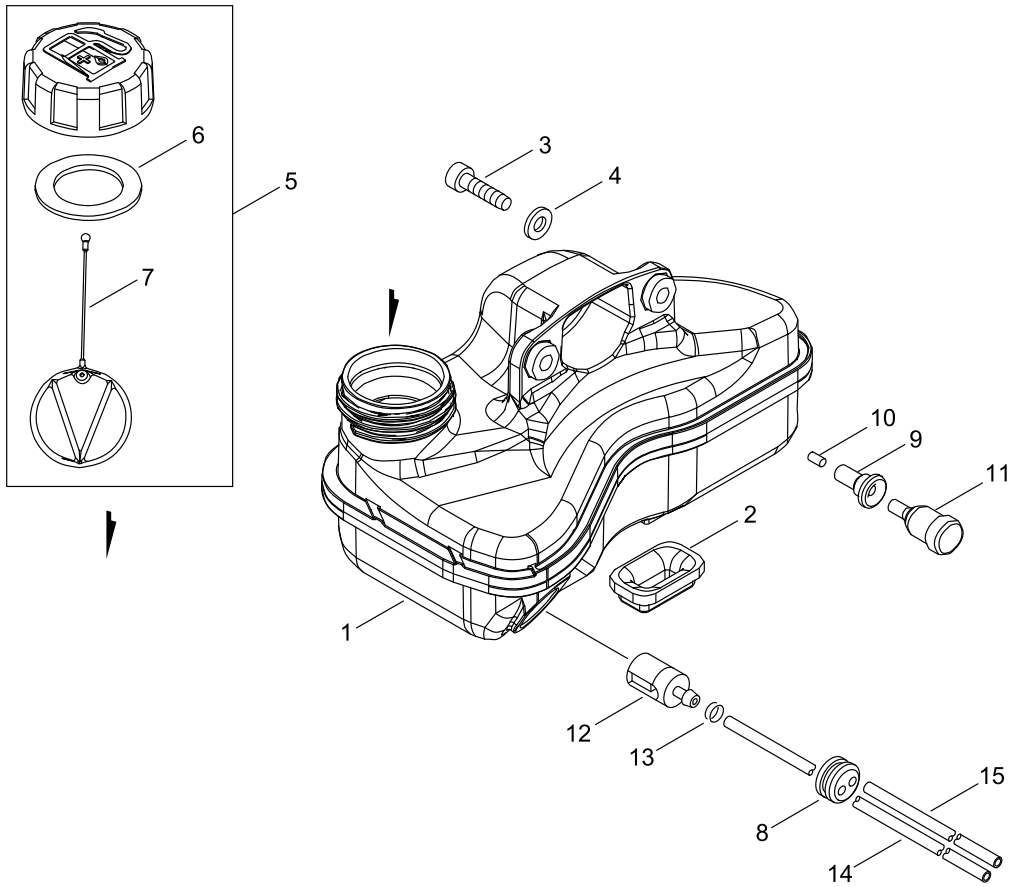

FUEL TANK

Key No.	LV (+)	Parts Number	Parts Description	Qty	Standard	Class
1		A350-002520	TANK, FUEL	1		C
2		V420-004490	CUSHION	2		B
3		V805-000160	BOLT, TORX 5	2	TB-5*20 10.9	C
4		900603-00005	WASHER	2	5	
5		P100-006051	FUEL CAP ASY	1		
6	+	V107-000190	GASKET,FUEL CAP	1	37.9* T2.2	A
7	+	A365-000050	CONNECTOR,CAP	1		B
8		132115-44331	GROMMET, FUEL	1		C
9		V137-000150	GROMMET,FUEL	1		C
10		131314-35430	VALVE, CHECK	1		C
11		A356-000031	VALVE,CHECK	1		B
12		A369-000480	STRAINER, FUEL	1	125-959	A
13		V490-001240	CLIP	1		C
14		V471-005540	PIPE	1	3*5*210	C
15		132010-56330	PIPE 3*6*90	1	3*6*90 YL	C

Class : Consumable class

A:Fast moving parts B:Semi-fast moving parts C:Slow moving parts D:Order only as needed

MUFFLER

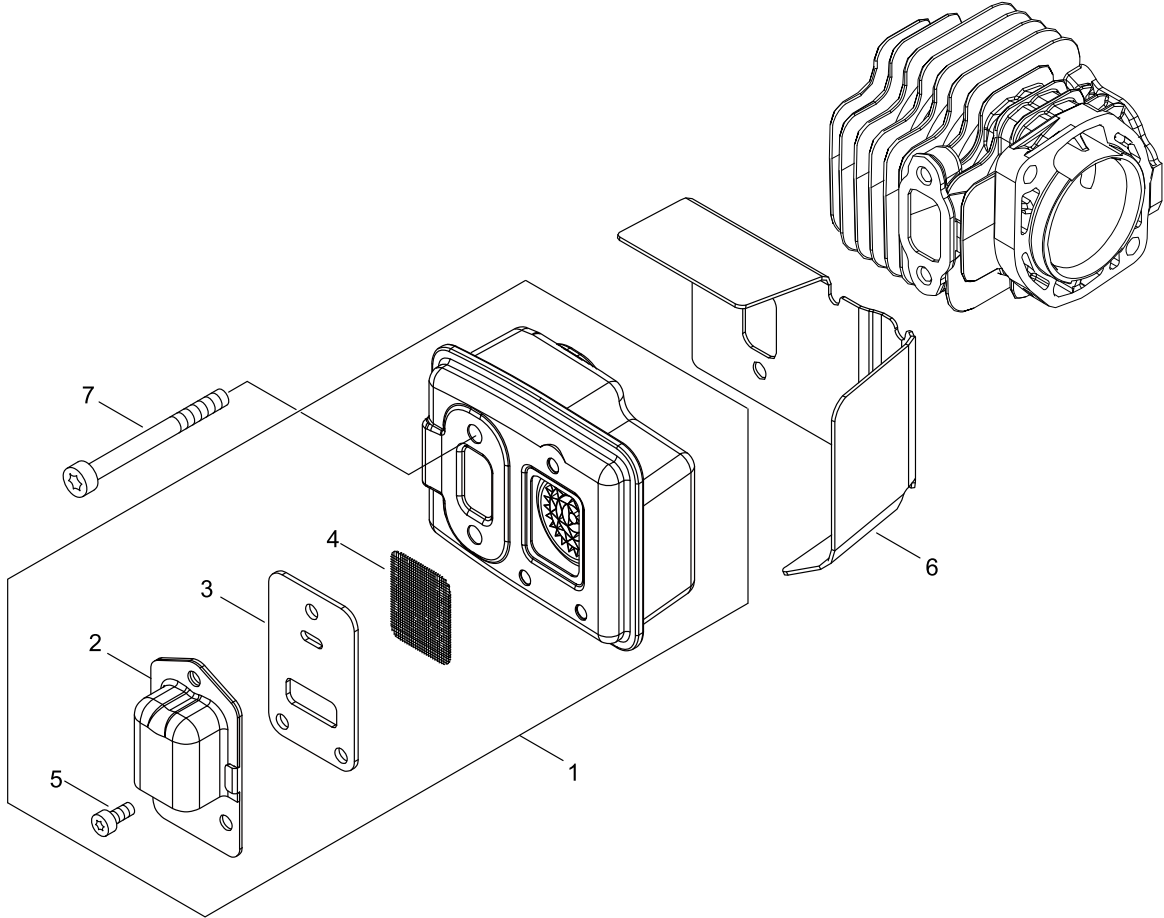

MUFFLER

Key No.	LV (+)	Parts Number	Parts Description	Qty	Standard	Class
1		P100-009110	MUFFLER ASY	1		
2	+	A313-002120	GUIDE, EXHAUST	1	ID#2920	C
3	+	V104-002530	GASKET,EXHAUST	1	T:1.5	A
4	+	145862-40630	SCREEN, MUFFLER	1		B
5	+	V804-000030	BOLT, TORX 4	3	TB-4*8 10.9	C
6		V104-002190	GASKET,EXHAUST	1		A
7		V805-000190	BOLT, TORX 5	2	TB-5*55 12.9	C

Class : Consumable class

A:Fast moving parts B:Semi-fast moving parts C:Slow moving parts D:Order only as needed

RECOIL STARTER

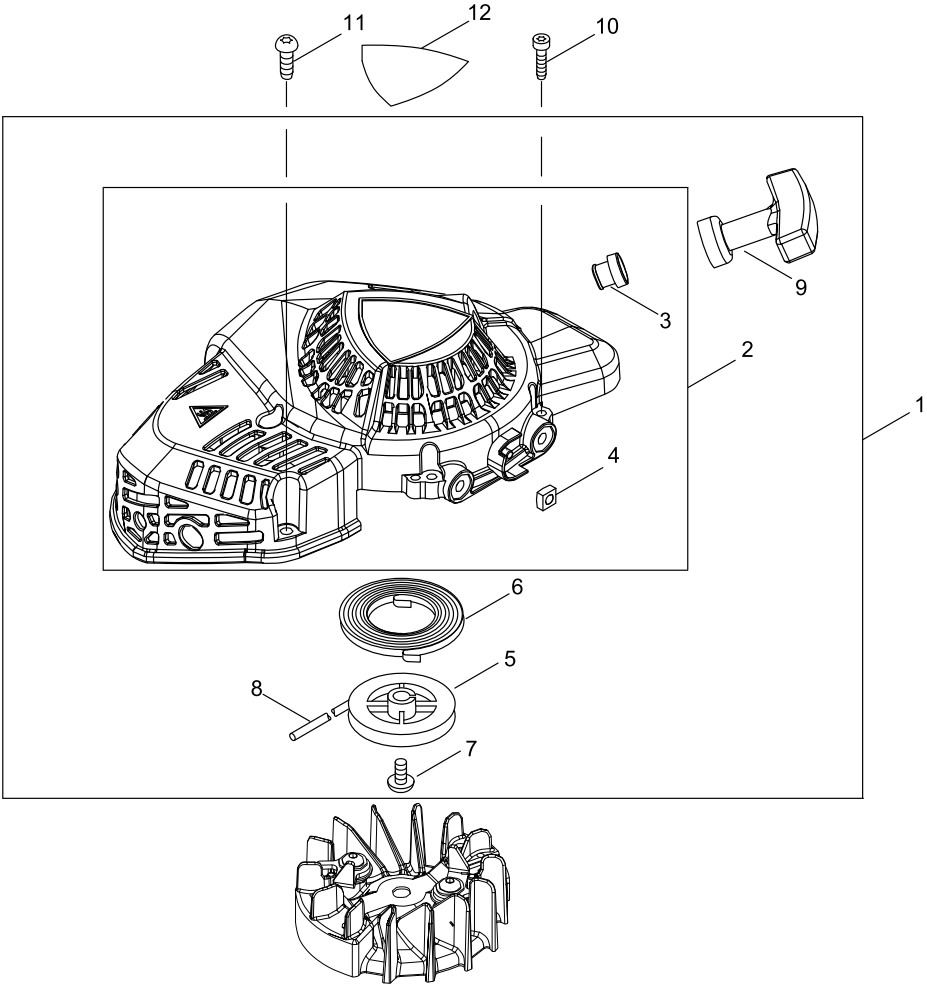

RECOIL STARTER

Key No.	LV (+)	Parts Number	Parts Description	Qty	Standard	Class
1		A051-003390	STARTER,RECOIL ASY	1		B
2	+	P022-051640	CASE, STARTER	1		
3	++	P022-045770	GUIDE, ROPE	1		
4	++	P022-022010	NUT	2		
5	+	P022-051650	DRUM, STARTER	1		
6	+	P022-019680	SPRING, SPIRAL	1		
7	+	177236-44330	SCREW	1		
8	+	P022-039290	ROPE, STARTER	1		
9	+	P022-051660	GRIP, STARTER	1		
10		V804-000060	BOLT, TORX 4	4	TB-4*16 10.9	C
11		V805-000000	BOLT, TORX 5	2	TT-5*16 DG 10.9	C
12		X502-001190	LABEL,ECHO	1	ECHO+HC-2020	D

Class : Consumable class

A:Fast moving parts B:Semi-fast moving parts C:Slow moving parts D:Order only as needed

GEAR CASE

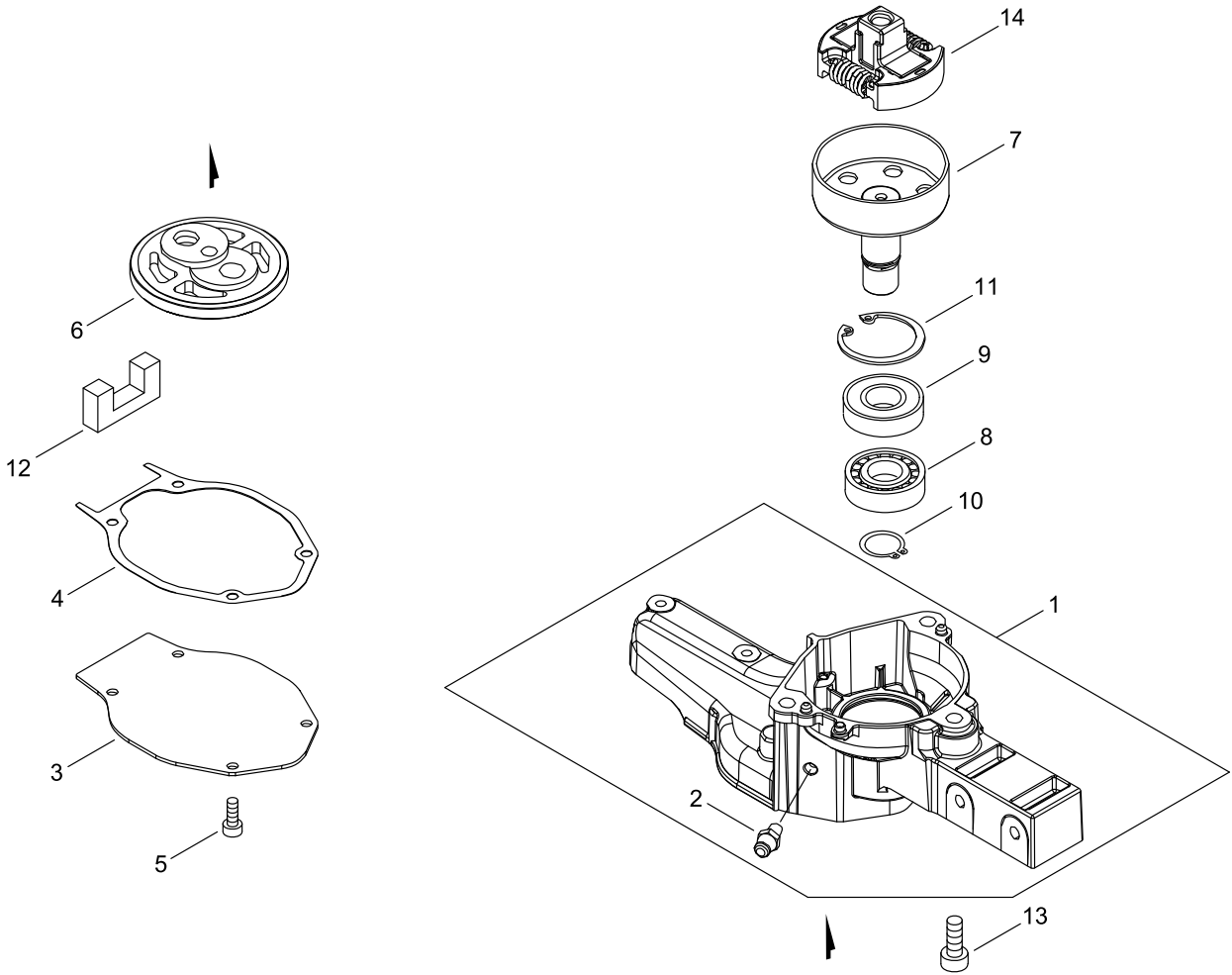

GEAR CASE

Key No.	LV (+)	Parts Number	Parts Description	Qty	Standard	Class
1		P100-006070	CASE,GEAR ASY	1		
2	+	880110-54230	NIPPLE, GREASE	1		
3		C539-000190	LID,GEARCASE	1	T1.6	D
4		V110-000230	GASKET,GEAR CASE	1	T0.3	A
5		V804-000050	BOLT, TORX 4	4	TB-4*12 10.9	C
6		V650-000740	GEAR,SPUR	1		C
7		A556-001840	DRUM, CLUTCH	1	50 T1.4	B
8		900800-06002	BEARING, BALL	1	6002	
9		900802-06002	BEARING, BALL	1	6002LLU(DDU)	
10		900701-00014	RETAINING RING, EXTERNAL	1	CS-14	
11		900702-00032	RETAINING RING, INTERNAL	1	CR-32	
12		V541-000750	SEAL	1		C
13		V806-000130	BOLT, TORX 6	3	TB-6*16 ALL 10.9	C
14		A056-000790	CLUTCH ASY	1		B

Class : Consumable class

A:Fast moving parts B:Semi-fast moving parts C:Slow moving parts D:Order only as needed

CUTTING BLADE

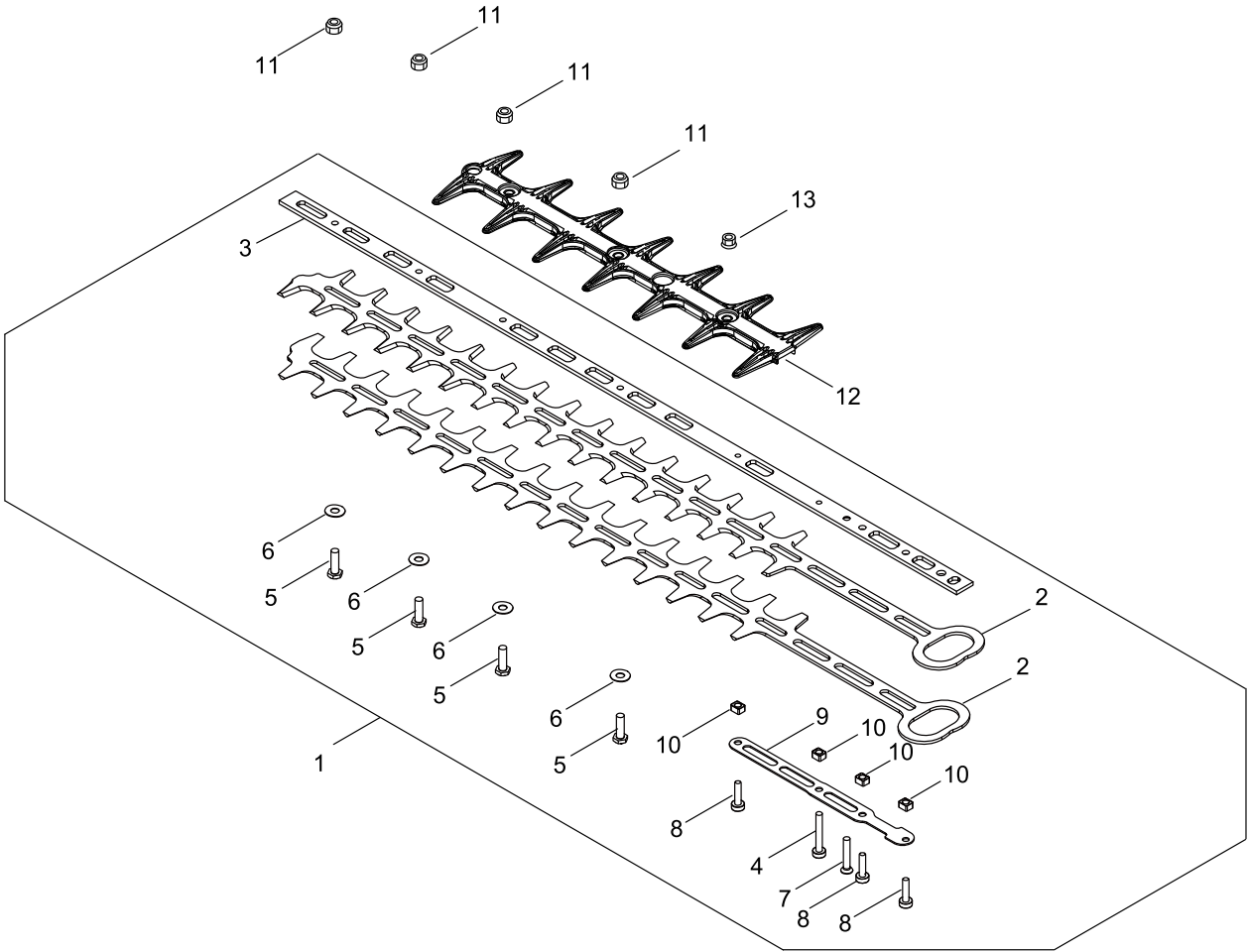

CUTTING BLADE

Key No.	LV (+)	Parts Number	Parts Description	Qty	Standard	Class
1		P100-008710	CUTTER SET	1		
2	+	X412-000850	CUTTER	2		A
3	+	X425-001150	SUPPORT,CUTTER	1		B
4	+	V805-000370	BOLT, TORX 5	1	TB-5*35 ALL 12.9	C
5	+	V204-000570	BOLT	4		C
6	+	699118-04560	WASHER	4		C
7	+	900212-05030	SCREW	1	5*30	
8	+	V805-000210	BOLT, TORX 5	3	TB-5*20 12.9	C
9	+	V150-004720	PLATE,EYE	1	T:1.2	C
10	+	V353-000250	COLLAR	4	9*7.45*5.3	C
11		433022-06460	NUT	4		C
12		X431-000200	BLUNT	1		C
13		92108-05000	NUT, FLANGE	1	5	

Class : Consumable class

A:Fast moving parts B:Semi-fast moving parts C:Slow moving parts D:Order only as needed

HANDLE

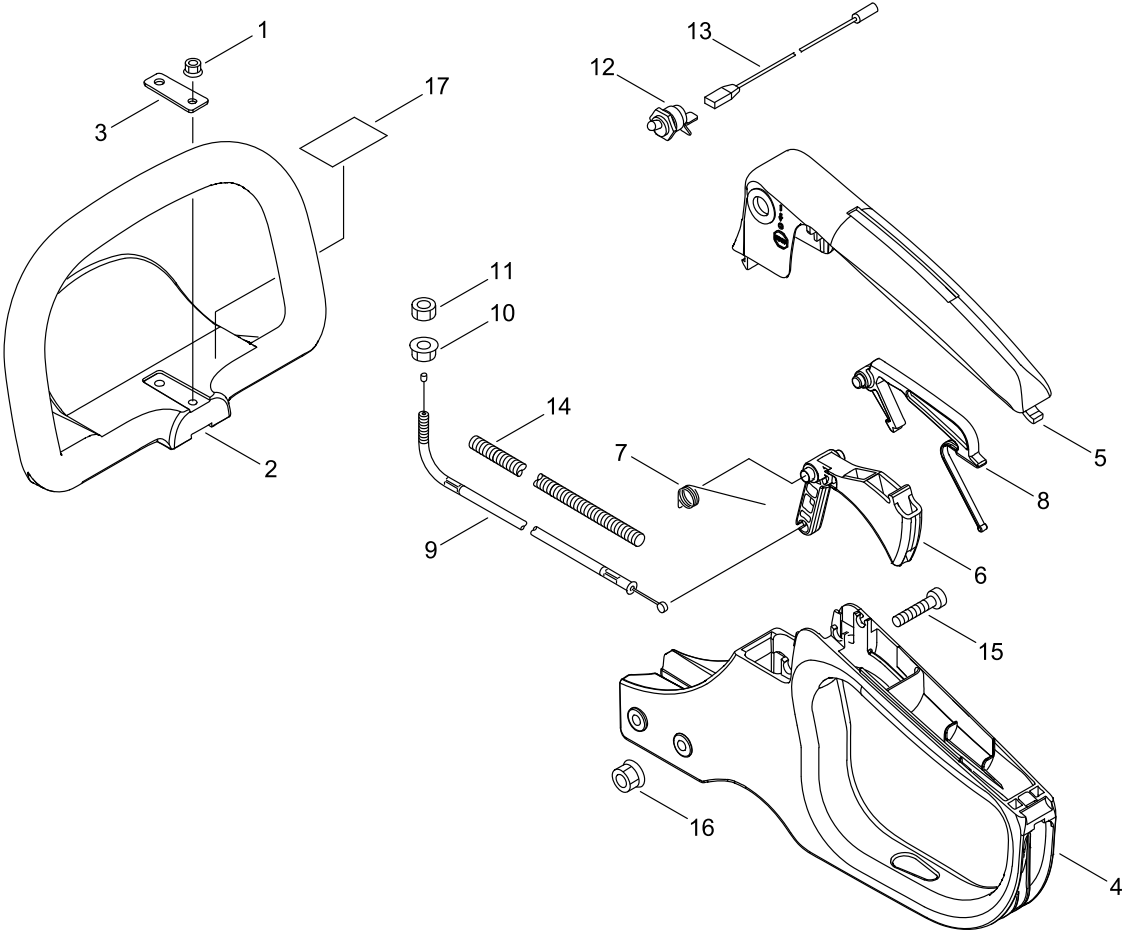

HANDLE

Key No.	LV (+)	Parts Number	Parts Description	Qty	Standard	Class
1		92108-05000	NUT, FLANGE	2	5	
2		C400-000533	HANDLE, FRONT	1		C
3		351611-05360	WASHER	1		C
4		C410-000431	HANDLE, REAR	1	HC-155/HC-2020	C
5		C411-000030	LID,HANDLE	1		C
6		C450-000750	TRIGGER,THROTTLE	1		C
7		V452-000392	SPRING,TORSION	1	11.5 ID	B
8		C460-000120	LOCKOUT, THROTTLE	1		C
9		V430-004670	CABLE,BOWDEN	1		B
10		900515-00006	NUT, FLANGE	1	6	
11		900502-00006	NUT	1	6	
12		163400-03460	SWITCH, IGNITION	1		C
13		V485-003150	LEAD	1	C2809 CA104 415	C
14		V475-007040	TUBE	1	7*210	C
15		V805-000280	BOLT, TORX 5	2	TB-5*45 10.9	C
16		92108-05000	NUT, FLANGE	2	5	
17		X505-002030	LABEL,CAUTION	1	37*35	D

Class : Consumable class

A:Fast moving parts B:Semi-fast moving parts C:Slow moving parts D:Order only as needed

ACCESSORIES

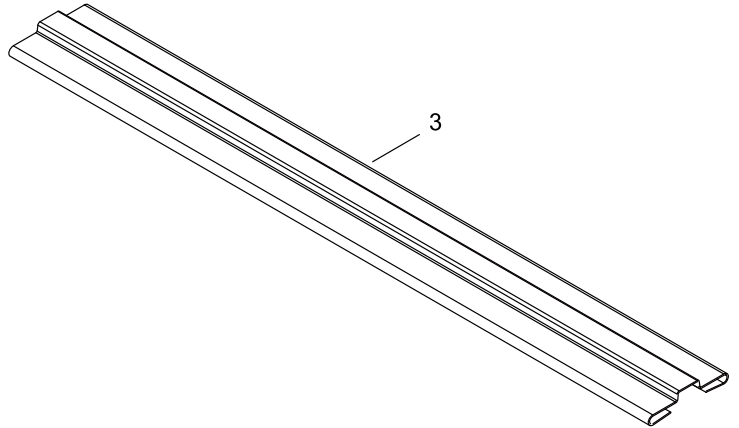
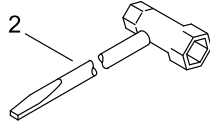
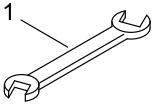

ACCESSORIES

Key No.	LV (+)	Parts Number	Parts Description	Qty	Standard	Class
1		895112-00330	SPANNER 8*10	1		D
2		895410-03930	WRENCH, W/S. DRIVER	1		D
3		X495-000630	SCABBARD, BLADE	1	L585	D

Class : Consumable class

A:Fast moving parts B:Semi-fast moving parts C:Slow moving parts D:Order only as needed

NUMERICAL PARTS INDEX

Part No	Part description	Page	Part No	Part description	Page	Part No	Part description	Page
100013-11520	PIN, PISTON	2	A021-004900	CARBURETOR, DIAPHRAGM	10	P005-002200	POST	10
100014-08960	SPACER, PISTON PIN	2	A051-003390	STARTER,RECOIL ASY	16	P005-003110	PUMP, PRIMER	10
100015-04630	CIRCLIP, PISTON PIN	2	A056-000790	CLUTCH ASY	18	P005-003760	DIAPHRAGM ,METERING	10
100113-05930	BEARING, NEEDLE	2	A101-000090	RING,PISTON	2	P005-004240	BASE, ASY PRIMER	10
100142-12330	KEY, WOODRUFF	6	A130-001960	CYLINDER	2	P005-004260	RING,O	10
100212-61830	OILSEAL	4	A160-003580	COVER,CYLINDER	2	P021-007772	PISTON KIT	2
125323-08260	ARM, VALVE	10	A200-001200	INSULATOR, INTAKE	8	P021-049130	CLEANER COVER ASY	8
125337-08260	VALVE, INLET NEEDLE	10	A209-000610	PLATE, INSULATOR	8	P021-049871	CASE,CLEANER	8
125338-13930	PIN, METERING ARM	10	A226-001410	ELEMENT,AIR FILTER	8	P022-019680	SPRING, SPIRAL	16
125339-42030	SCREW	10	A244-000070	PLATE,PREVENT	8	P022-022010	NUT	16
125342-52130	COVER, DIAPHRAGM	10	A259-000010	CAP,LIMITER	8	P022-039290	ROPE, STARTER	16
125344-13931	SCREW	10	A313-002120	GUIDE, EXHAUST	14	P022-045770	GUIDE, ROPE	16
125344-52130	SCREW	10	A350-002520	TANK, FUEL	12	P022-051640	CASE, STARTER	16
131314-35430	VALVE, CHECK	12	A356-000031	VALVE,CHECK	12	P022-051650	DRUM, STARTER	16
131911-03460	WASHER	6	A365-000050	CONNECTOR,CAP	12	P022-051660	GRIP, STARTER	16
132010-56330	PIPE 3*6*90	12	A369-000480	STRAINER, FUEL	12	P100-006051	FUEL CAP ASY	12
132115-44331	GROMMET, FUEL	12	A409-001360	ROTOR, MAGNETO	6	P100-006070	CASE,GEAR ASY	18
145862-40630	SCREEN, MUFFLER	14	A411-001810	COIL, IGNITION	6	P100-006080	CRANKCASE SET	4
163400-03460	SWITCH, IGNITION	22	A425-000000	SPARKPLUG	6	P100-008710	CUTTER SET	20
177236-44330	SCREW	16	A426-000010	TERMINAL,SPARKPLUG	6	P100-009110	MUFFLER ASY	14
178070-10860	SPACER	6	A427-000013	CAP,SPARK PLUG	6	V100-000720	GASKET,CYL	2
351611-05360	WASHER	22	A514-000260	PAWL	6	V102-000240	GASKET,CRANKCASE	4
433022-06460	NUT	20	A556-001840	DRUM, CLUTCH	18	V103-001740	GASKET,INTAKE	8
699118-04560	WASHER	20	C400-000533	HANDLE, FRONT	22	V103-002020	GASKET,INTAKE	8
880110-54230	NIPPLE, GREASE	18	C410-000431	HANDLE, REAR	22	V103-002030	GASKET,INTAKE	8
890332-52730	LABEL, CHOKE	8	C411-000030	LID,HANDLE	22	V104-002190	GASKET,EXHAUST	14
895112-00330	SPANNER 8*10	24	C450-000750	TRIGGER,THROTTLE	22	V104-002530	GASKET,EXHAUST	14
895410-03930	WRENCH, W/S. DRIVER	24	C460-000120	LOCKOUT, THROTTLE	22	V107-000190	GASKET,FUEL CAP	12
900212-05030	SCREW	20	C539-000190	LID,GEARCASE	18	V110-000230	GASKET,GEAR CASE	18
900502-00006	NUT	22	P005-000010	STRAINER	10	V135-000150	GROMMET,HT CORD	6
900515-00006	NUT, FLANGE	22	P005-000100	SCREW, THROTTLEADJUST	10	V137-000150	GROMMET,FUEL	12
900565-00005	NUT, SQUARE	2	P005-000190	E-RING	10	V150-004720	PLATE,EYE	20
900603-00005	WASHER	12	P005-000200	GASKET, METERING	10	V204-000570	BOLT	20
900701-00014	RETAINING RING, EXTERNAL	18	P005-000250	RETAINER	10	V299-000610	KNOB,FASTENER	8
900702-00032	RETAINING RING, INTERNAL	18	P005-000270	SCREW	10	V353-000250	COLLAR	20
900800-06002	BEARING, BALL	18	P005-000510	DIAPHRAGM, PUMP	10	V420-004490	CUSHION	12
900802-06002	BEARING, BALL	18	P005-000520	GASKET, PUMP	10	V430-004670	CABLE,BOWDEN	22
900810-36000	BEARING, BALL	4	P005-000940	SPRING, METER. LEVER	10	V452-000392	SPRING,TORSION	22
92105-06000	NUT L, FLANGE	6	P005-001000	ROLLER, GUIDE	10	V452-001370	SPRING,TORSION	6
92108-05000	NUT, FLANGE	20	P005-001250	RETAINER,PLUG BALL	10	V471-005540	PIPE	12
92108-05000	NUT, FLANGE	22	P005-001260	SCREW,MAINN MIXTURE	10	V475-007040	TUBE	22
A011-001550	CRANKSHAFT,ASY	2	P005-001270	PLUG, AJUST SCREW	10	V485-001220	LEAD	6
A021-004900	CARBURETOR, DIAPHRAGM	8	P005-001900	SCREW	10	V485-003140	LEAD	4
			P005-002050	COVER ASY, ROTOR	10	V485-003150	LEAD	22
						V490-001100	CLIP	8

NUMERICAL PARTS INDEX

Part No	Part description	Page
V490-001240	CLIP	12
V541-000750	SEAL	18
V650-000740	GEAR,SPUR	18
V804-000030	BOLT, TORX 4	14
V804-000040	BOLT, TORX 4	4
V804-000050	BOLT, TORX 4	18
V804-000060	BOLT, TORX 4	6
V804-000060	BOLT, TORX 4	16
V805-000000	BOLT, TORX 5	16
V805-000100	BOLT, TORX 5	8
V805-000150	BOLT, TORX 5	2
V805-000150	BOLT, TORX 5	6
V805-000160	BOLT, TORX 5	12
V805-000170	BOLT, TORX 5	8
V805-000190	BOLT, TORX 5	14
V805-000210	BOLT, TORX 5	2
V805-000210	BOLT, TORX 5	20
V805-000220	BOLT, TORX 5	4
V805-000280	BOLT, TORX 5	22
V805-000370	BOLT, TORX 5	20
V806-000130	BOLT, TORX 6	18
X412-000850	CUTTER	20
X425-001150	SUPPORT,CUTTER	20
X431-000200	BLUNT	20
X495-000630	SCABBARD,BLADE	24
X502-001190	LABEL,ECHO	16
X505-002030	LABEL,CAUTION	22
X524-001901	LABEL	8