

Geniox Go with control system Air handling unit

User Manual

GB

Document in original language | A006

Part number of this manual 211728



Detailed table of contents on the following pages

General description

- A Manufacturer
- B Name of machines
- C Declaration of Conformity
- D General descriptions, dangers and warnings
- E Drawings, diagrams, guides and instructions for the use, maintenance and repair
- F Employees in charge of operation/control/maintenance
- G Intended use and range of applications
- H Unintended use and misuse – inappropriate applications for the machine

Installation

- I Instructions for unloading and handling on site
- J Installation
- K Installation and assembly instructions for reduction of noise and vibration emissions

Start-up, adjustments and operation

- L Start-up, adjustments, use and commissioning
- M Information about the residual risks
- N Instructions on the protective measures during repair and maintenance
- O The essential characteristics of tools which may be fitted to the machinery

Machine stability

- P The conditions of stability during use, transportation, assembly, dismantling when out of service
- Q Instructions for machinery where these are regularly to be transported

Breakdown

- R The operating method to be followed in the event of breakdown. Safe restart.

Maintenance

- S Adjustment and maintenance operations
- T Instructions to enable adjustment and maintenance safely

Noise

- U Information on airborne noise emissions exceeding 70 dB(A)

Annexes

- 1 Technical data – unique data for every unit (in separate cover)
- 2 Assembly of base frame – height 118 mm or 218 mm for unit sizes 10 – 18
- 3 Assembly of base frame – height 118 mm or 218 mm for unit sizes 20 – 24
- 4 Installation of steel roof in the sizes 10 – 31
- 5 Speed control for rotor and assembly of divided rotor
- 6 Reversible heat pump unit (in separate cover, if heat pump was delivered)
- 7 Menu for internal controller in the heat pump unit (in separate cover, if heat pump was delivered)
- 8 Connection of fan motor and set-up manual for frequency converter
- 9 Commissioning protocol (in separate cover)
- 10 Report with data from final functional test on the Systemair factory
- 11 Short description of main components in the control system
- 12 Wiring diagram (in separate cover, if control system was delivered)
- 13 Operator's guide (How to use the Systemair control panel) (in separate cover)

Contents

A	Manufacturer.....	1
B	Name of machines.....	1
C	Declaration of Conformity.....	2
D	General descriptions, dangers and warnings.....	3
D.1	Overview via pictograms on the inspection side of the unit.....	3
D.1.1	Available pictograms and their placing on the units.....	3
D.1.2	Warnings about dangers.....	6
D.1.3	Machine card with unique data on every unit.....	7
D.2	Dimensions of the units.....	7
E	Drawings, diagrams, guides and instructions for the use, maintenance and repair.....	7
F	Employees in charge of operation/control/maintenance.....	8
G	Intended use and range of applications.....	8
H	Unintended use and misuse – inappropriate applications for the machine.....	8
H.1	Air handling unit in operation.....	8
I	Instructions for unloading and handling on site.....	8
I.1	Delivery types.....	8
I.2	Permissible handling methods and weight limits.....	8
I.3	Warnings.....	9
I.4	Handling examples.....	10
I.4.1	Handling sections which are delivered on pallets.....	10
I.4.2	Handling units/sections which are delivered on base frame.....	12
I.4.3	Additional information.....	15
J	Installation.....	16
J.1	Installation - mechanical.....	16
J.1.1	Free area in front of and above the unit.....	16
J.1.2	Supporting surface.....	16
J.1.3	Adjustable feet under legs or base frame and transport of sections.....	16
J.1.4	Base frame assembly.....	16
J.1.5	Base frames for outdoor units.....	16
J.1.6	Outdoor units – support under the base frame of the unit.....	16
J.1.7	Installation on the site of unit sections at the base frame when sections are delivered on pallets.....	17
J.1.8	Joining the unit sections.....	18
J.1.9	Fitting the ductwork.....	20
J.1.10	Risk of stack effect by vertical ducts and wind pressure on louvers.....	20
J.1.11	Lock the doors by using the key.....	21
J.2	Installation - electrical.....	21
J.2.1	Installation of cable sealing boxes (only in rotor sections of Geniox Go 27–31).....	21
J.2.2	Lock the doors by using the key.....	22
J.3	Installation – Pipes for water – hot and chilled, valves and drains.....	22
J.3.1	Description.....	22
J.3.2	Pipe connections.....	22
J.3.3	Possibility of extracting components from the unit.....	22
J.3.4	Pipe connections to batteries.....	23
J.3.5	Draining condensate water.....	24
J.3.6	Draining condensate water from plate heat exchanger.....	24
J.3.7	Draining condensate water from cooling battery.....	24
K	Installation and assembly instructions for reduction of noise and vibration emissions.....	25
L	Start-up, adjustments, use and commissioning.....	25
L.1	Print-outs on paper.....	25
L.2	Start-up by installer.....	25
L.2.1	Checklist, relevant values.....	25
L.3	Description of functions.....	26
L.3.1	Remote control.....	26
L.3.2	Extended operation and external start/stop (for example by presence detectors).....	26
L.3.3	Valve and valve motor for heating coil.....	26
L.3.4	Valve and valve motor for cooling coil.....	26
L.3.5	DX cooling.....	26

L.3.6	Circulation pump, heating	26
L.3.7	Fire alarm function	26
L.3.8	Electrical heater battery	27
L.3.9	Speed control of fans	27
L.3.10	Cabinet	27
L.3.11	Temperature sensors	27
L.3.12	Filter guards	28
L.3.13	Room temperature sensors	28
L.3.14	Frost protection	28
L.3.15	Cooling recovery	28
L.3.16	Free cooling	28
L.4	Commissioning	28
M	Information about the residual risks	28
M.1	Unit casing	28
M.1.1	Design of the machine to make transport safe	28
M.1.2	Common for all unit sections	29
M.1.3	Common for all unit sections by insufficient lighting	29
M.1.4	Dampers	29
M.1.5	Attenuators	30
M.1.6	Filters	30
M.1.7	Plug fans	30
M.1.8	Batteries for heating and cooling	31
M.1.9	Heat pump units	31
N	Instructions on the protective measures during repair and maintenance	32
O	The essential characteristics of tools which may be fitted to the machinery	32
P	The conditions of stability during use, transportation, assembly, dismantling when out of service	32
P.1	Installed reliable to avoid units to be tilted or moved by storm	32
P.2	Transport of section with heat pump unit	32
P.3	Disposal of the heat pump system	32
P.4	General disassembly – sharp edges	32
Q	Instructions for machinery where these are regularly to be transported	32
R	The operating method to be followed in the event of breakdown. Safe restart.	33
S	Adjustment and maintenance operations	33
S.1	Shutdown of the unit to a safe state	33
S.2	Unlock and lock the doors by using the key	33
S.3	Recommended maintenance intervals	33
S.4	Filters – always replace filters with new filters with the same characteristics to maintain SFP value	34
S.4.1	Bag filters – the number of filters and sizes of frames	35
S.4.2	Panel filters – the number of filters and the sizes of the frames	35
S.4.3	Bag filters	36
S.4.4	Panel filters	38
S.5	Changing the Internal Battery in the controller	38
S.6	Other functions to maintain	39
S.6.1	The unit	39
S.6.2	Dampers	40
S.6.3	Rotary heat exchanger	41
S.6.4	Cross flow and counter flow exchanger	41
S.6.5	Run-around heat exchanger	42
S.6.6	Heating coil	42
S.6.7	Plug fans	43
S.6.8	Silencer	43
S.6.9	Outdoor air section	43
S.6.10	Heat pump unit	43
T	Instructions to enable adjustment and maintenance safely	43
T.1	Protective measures and additional protective measures	43
T.1.1	Necessary protection measures prior to start-up	43
T.1.2	Safe adjustment and maintenance	44
T.1.3	Personal protective equipment for maintenance staff – health and safety	44
U	Information on airborne noise emissions exceeding 70 dB(A)	44
Annex 1	Technical data – unique data for every unit (in separate cover)	47
Annex 2	Assembly of base frame – height 118 mm or 218 mm for unit sizes 10 – 18	47
2.1	Components	47
2.2	Base frame length 482 – 2681 [mm] Unit size 10 – 18	48
2.3	Base frame length 2682 – 5081 [mm] Unit size 10 – 18	49

Contents

2.4	Base frame length 5082 – 6081 [mm] Unit size 10 – 18	50
Annex 3	Assembly of base frame – height 118 mm or 218 mm for unit sizes 20 – 24	51
3.1	Components	51
3.2	Base frame length 482 – 2681 [mm] Unit size 20 – 24	52
3.3	Base frame length 2681 – 5081 [mm] Unit size 20 – 24	53
3.4	Base frame length 5082 – 6081 [mm] Unit size 20 – 24	54
Annex 4	Installation of steel roof in the sizes 10 – 31	55
4.1	Warnings	55
4.1.1	Components	55
4.1.2	Mounting rails and roof sheets	56
4.1.3	Mounting roof side profiles and corners	61
Annex 5	Speed control for rotor and assembly of divided rotor	61
5.1	Speed control	61
5.1.1	Selection of correct signal via the 8 DIP switch levers	62
5.1.2	Indication of operation mode via red and green LED as well as test of motor	62
5.1.3	Copy of the label with information about connection of cables	63
5.2	Assemble of split rotor for Geniox Go 27, Geniox Go 29 and Geniox Go 31	63
5.2.1	Dimensions of split rotor sections	63
5.2.2	Assemble of rotor casing	64
5.2.3	Installation of rotation sensor, rotor magnet and belt	66
Annex 6	Reversible heat pump unit (in separate cover, if heat pump was delivered)	68
Annex 7	Menu for internal controller in the heat pump unit (in separate cover, if heat pump was delivered)	68
Annex 8	Connection of fan motor and set-up manual for frequency converter	68
Annex 9	Commissioning protocol (in separate cover)	68
Annex 10	Report with data from final functional test on the Systemair factory	68
Annex 11	Short description of main components in the control system	68
11.1	Geniox units delivered in one or several sections	68
11.1.1	External components	68
Annex 12	Wiring diagram (in separate cover, if control system was delivered)	68
Annex 13	Operator's guide (How to use the Systemair control panel) (in separate cover)	68

A Manufacturer

This User Manual covers all air handling units with control system delivered by Systemair A/S.

Manufacturer and supplier data:

Systemair UAB

Linq st. 101

LT-20174 Ukmergė, Lithuania

B Name of machines

This manual is about Systemair air handling units called Geniox Go 10, Geniox Go 11, Geniox Go 12, Geniox Go 14, Geniox Go 16, Geniox Go 18, Geniox Go 20, Geniox Go 22, Geniox Go 24, Geniox Go 27, Geniox Go 29, and Geniox Go 31.

C Declaration of Conformity

Manufacturer



Systemair UAB
 Linų st. 101
 LT-20174 Ukmergė, Lithuania
 Office: +370 340 60165 Fax: +37034060166
 www.systemair.com

hereby confirms that the following products:

Geniox GO 10-RDR/RDL/XDR/XDL/RADR/RADL/CXDR/CXDL/DXRDR/DXRDL, Geniox GO 11-RDR/RDL/XDR/XDL/RADR/RADL/CXDR/CXDL/DXRDR/DXRDL, Geniox GO 12-RDR/RDL/XDR/XDL/RADR/RADL/CXDR/CXDL/DXRDR/DXRDL, Geniox GO 14-RDR/RDL/XDR/XDL/RADR/RADL/CXDR/CXDL/DXRDR/DXRDL, Geniox GO 16-RDR/RDL/XDR/XDL/RADR/RADL/CXDR/CXDL/DXRDR/DXRDL, Geniox GO 18-RDR/RDL/XDR/XDL/RADR/RADL/CXDR/CXDL/DXRDR/DXRDL, Geniox GO 20-RDR/RDL/XDR/XDL/RADR/RADL/CXDR/CXDL/DXRDR/DXRDL, Geniox GO 22-RDR/RDL/XDR/XDL/RADR/RADL/DXRDR/DXRDL, Geniox GO 24-RDR/RDL/XDR/XDL/RADR/RADL/DXRDR/DXRDL, Geniox GO 27.13-RSR/RSL/XSR/XSL/RASR/RASL, Geniox GO 29.14-RSR/RSL/RASR/RASL, Geniox GO 31.15-RSR/RSL/RASR/RASL.

(The declaration applies only to product in the condition it was delivered in and installed in the facility in accordance with the included installation instructions. The insurance does not cover components that are added or actions carried out subsequently on the product)

Comply with all applicable requirements in the following directives

- Machinery Directive 2006/42/EC
- Ecodesign – Commission regulation 1253/2014
- EMC – directive 2014/30/EC
- Low Voltage Directive 2014/35/EU

The following regulations are applied in applicable parts:

327/2011	Requirements for fans
1253/2014	Requirements for ventilation units

The following harmonized standards are applied in applicable parts:

EN ISO 12100:2010	Safety of machinery - General principles for design - Risk assessment and risk reduction.
EN 13857	Safety of machinery - Safety distances to prevent hazard zones being reached by upper and lower limbs.
EN 60 335-1	Household and similar electrical appliances - Safety - Part 1: General requirements.
EN 60 335-2-80	Household and similar electrical appliances - Safety - Part 2-80: Particular requirements for fans.
EN 62233	Measurement methods for electromagnetic fields of household appliances and similar apparatus with regard to human exposure.
EN 50 106:2007	Safety of household and similar appliances – Particular rules for routine tests referring to appliances under the scope of EN 60-335-1 and EN 60967.
EN 60 529	Degrees of protection provided by enclosures (IP Code).
EN 60 204-1	Safety of machinery - Electrical equipment of machines - Part 1: General requirements.
EN 61000-6-2	Electromagnetic compatibility (EMC) - Part 6-2: Generic standards - Immunity for industrial environments.
EN 61000-6-3	Electromagnetic compatibility (EMC) - Part 6-3: Generic standards - Emission standard for residential, commercial and light-industrial environments.

The complete technical documentation is available.

Skinnskatteberg, 04-09-2017





Mats Sándor
 Technical Director

D General descriptions, dangers and warnings

Geniox Go air handling units are order specific machines available in many different configurations. Only a few examples of machine configurations are described below.

- The air handling units are intended for the transport and treatment of air between -40 °C and + 40 °C.
- The units are exclusively for comfort ventilation.
- Maintenance of the units must be carried out by skilled technicians.

On the drawing below, a right hand unit is shown because the inspection doors are mounted on the right hand side of the unit when looked in direction of **SUPPLY** airflow. The unit below is with rotary heat exchanger.

Position	Description	Symbol
A	Connection, supply air (to the rooms)	
B	Connection, exhaust air	
C	Connection, outdoor air in	
D	Connection, extract air (from the rooms)	



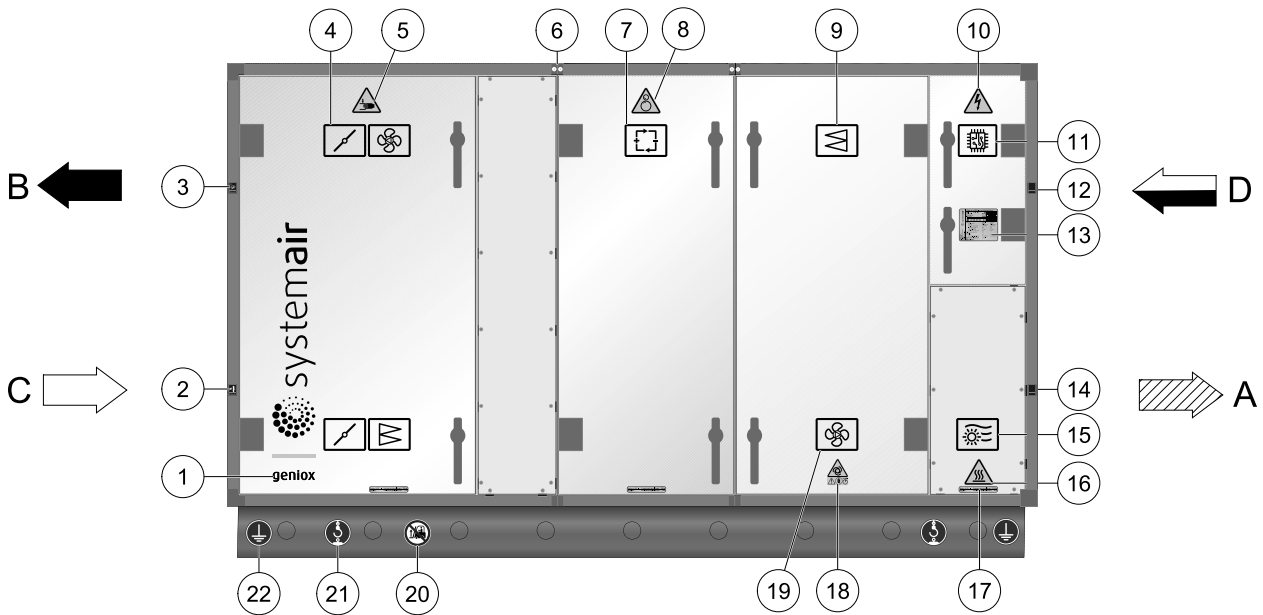





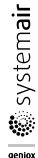

D.1 Overview via pictograms on the inspection side of the unit

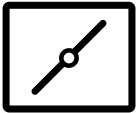

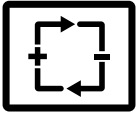

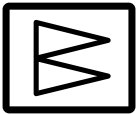

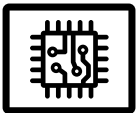



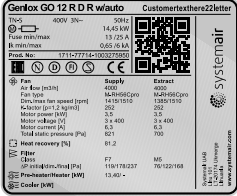





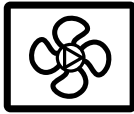

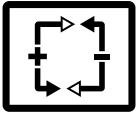
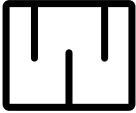

The unit above is a right version, because the supply air (C) from the outside flows to the right.

D.1.1 Available pictograms and their placing on the units

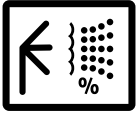
Example (Symbols and descriptions of functions for fast identification)

Position	Description	Symbol
1.	Branding sticker	
2.	Outdoor air duct connection sticker	
3.	Exhaust air duct connection sticker	
4.	Damper sticker	
5.	Risk of crushing sticker	
6.	Assembly number sticker	
7.	Energy recovery section sticker	
8.	Risk of moving parts sticker	
9.	Filter with an airflow direction sticker	
10.	Electricity warning sticker	
11.	Controller sticker	
12.	Extract air duct connection sticker	

Position	Description	Symbol
13.	Machinery card	
14.	Supply air duct connection sticker	
15.	Heater sticker	
16.	Hot surface warning sticker	
17.	Section ID sticker	
18.	Fan run down warning sticker	
19.	Fan with an airflow arrow sticker	
20.	Prohibited lifting sticker	
21.	Lifting point sticker	
22.	Grounding sticker	

Position	Description	Symbol
Other labels	Cooler sticker	
	Reversible heat pump sticker	
	Silencer sticker	
	Inspection sticker	
	Humidifier sticker	
	Mounting point sticker	
	Informative installation sticker	
	Component stickers	
		
		
		

D.1.2 Warnings about dangers

Pictograms according to EN1886



Warning

Warning about danger by rotating parts



Warning

Warning about danger by electricity



Warning

Warning about danger by heat



Warning

Disregards of instructions shown on warning signs are connected by risk for injury or damage on material.

D.1.3 Machine card with unique data on every unit

Machine card contains an important information about the unit. An example of a machine card is shown below.

Geniox GO 12 R D R w/auto Customertexthere22letter

TN-S	400V 3N~	50Hz
Fuse min/max		14,45 kW
lk min/max		13 /25 A
Prod. No:	1711-77714-1003275950	

	Supply	Extract
Fan	4000	4000
Air flow [m3/h]		
Fan type	M-RH56Cpro	M-RH56Cpro
Dim./max fan speed [rpm]	1415/1510	1385/1510
K-factor [p=1,2 kg/m3]	252	252
Motor power [kW]	3,5	3,5
Motor voltage [V]	3 x 400	3 x 400
Motor current [A]	6,3	6,3
Total static pressure [Pa]	821	700
Heat recovery [%]	81,2	
Filter		
Class	F7	M5
ΔP initial/dim./final [Pa]	119/178/237	76/122/168
Pre-heater/Heater [kW]	13,40/ -	
Cooler [kW]		

Systemair UAB
 Litu 101
 LT-20174 Ukmerge
 Lithuania
www.systemair.com

Product name informs about the unit size, heat exchanger type, the presence of automation. In this example product name is **Geniox Go12 R D R w/auto**, where 12 informs about the size of the unit, letter 'R' informs about the heat exchanger type, letter 'D' informs about the section type (in this example it is double height section), and the second letter 'R' informs about the unit version (in this example it is right). Production number (Prod. No.) for the complete unit consist of manufacturing date (YYMM), item number (xxxxx)and manufacturing number (yyyyyyyyyy).

D.2 Dimensions of the units

See Annex 1 with information about the exact dimensions.

E Drawings, diagrams, guides and instructions for the use, maintenance and repair

All Geniox Go units with integrated control system are manufactured in compliance with the EC Declaration of Conformity and they are CE marked as machines. Declaration is an integral part of the machine – enclosed as *C Declaration of Conformity* to this manual. If the buyer carries out changes or adds components in or on the machine, the buyer must issue a new *EC Declaration of Conformity* and a new CE marking of the machine.

To promote correct use of the machines, the below-mentioned instructions are an integral part of the machine:

- Unique drawings, data and description of functions for the delivered unit – Annex 1
- Wiring diagrams – Annex 12
- Operator’s Guide – Annex 13
- Instructions for use of the machine – chapter L in this manual
- Instructions about adjustment and maintenance – chapter S in this manual
- Safety during adjustment and maintenance – chapter T

F Employees in charge of operation/control/maintenance

The units are constructed and built with a fully integrated control system. After start-up and hand-over from installer to operators, the unit operates fully automatically.

Skilled technicians must carry care out maintenance as well as repairs.

G Intended use and range of applications

The air handling units are intended for the transport and treatment of air between -40 °C and + 40 °C The units are exclusively for comfort ventilation. The units are not for environments that exceed the corrosion class C4 according to EN ISO 12944-2.

Intended applications for the units are:

- Offices
- teaching rooms
- hotels
- shops
- homes and similar comfort zones

H Unintended use and misuse – inappropriate applications for the machine

Units for outdoor installation must be specified and ordered for outdoor installation. The units must not be used in environments that exceed corrosion class C4 according to EN ISO 12944-2, and for transport of solid particles.

Examples of not intended use:

- Kitchen extraction
- swimming pools
- off-shore
- Ex-areas
- drying of washed clothes.
- Do not use the unit with partly finished duct systems.
- Do not use the unit for ventilation of the building site until the unit is properly provided with guards.

H.1 Air handling unit in operation

The pressure difference between interior and exterior of the unit must not exceed 2000 Pa.

Before start-up of the unit all ducts, safety guards and all protective devices must be mounted to prevent any access to rotating fan impellers. All inspection doors must be closed and locked when the unit is in operation.

Do not use the unit without filters.

I Instructions for unloading and handling on site

I.1 Delivery types

The air handling unit (AHU) could be delivered attached to the base frame or split into separate sections which are delivered on pallets. If AHU is delivered in sections, it must be assembled on site. Loading and unloading as well as transport on the site is possible by forklift trucks, manual forklifts or crane. Systemair does not provide lifting equipment.

I.2 Permissible handling methods and weight limits

Permissible (✓) and forbidden (✗) handling methods are described in table bellow.

Delivery type	Handling option					
	Forklift	Straps	Brackets (optional)	Hoist holes	Side baseframe holes	Lifting corners
Sections placed on pallet	✓	✓	✗	✗	✗	✓
Sections attached onto base frame	✓	✓	✓	✓	✓	✓
Whole unit attached onto base frame	✓	✓	✓	✓	✓	✗



Warning

It is strictly forbidden to exceed the maximum permitted handling weight! Incorrect handling may cause that the unit is dropped, this could lead to property damage, irreversible injury or death.

I.3 Warnings



Danger

Do not walk, stay or work under suspended loads!



Caution

When unloading and transporting with forklift trucks, use forks which go fully underneath the unit. Only transport units on the base frame or on the pallet.

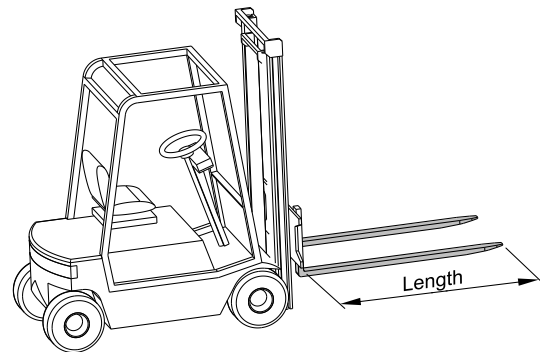

Caution

It is strictly forbidden to lift a section under the top of the section. The plastic corners and brackets are not at all reinforced for lifting the unit under the top. There is serious danger that the bottom with the heavy components will fall down with the risk of serious injury and damage to property.

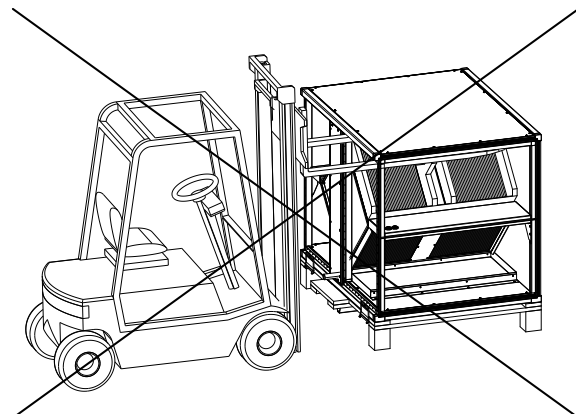

**Caution**

If base frame has 4 forklift holes section must be lifted evenly using two forklifts. There is a risk of overturning resulting serious injury and damage to property if section is lifted unevenly or only by one forklift.

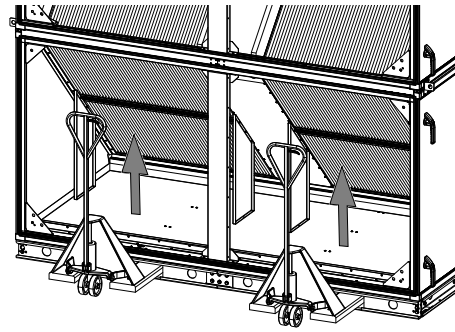
**Important**

- Transportation must be performed by specialised personnel (truck operators, hook-up personal), equipped with the necessary protection equipment.
- The AHU must be transported and stored in such a way that it is protected against physical damage.
- During transportation the unit must always be in the upright position and tilted less than 15°.
- If sections must be tilted more than 15 degrees, sections with fans or rotating exchangers that can be drawn out for service must be secured carefully.
- During transportation, suction pipe of the compressor must always point upwards to prevent the escape of oil from the compressor sump.
- Doors of the units must always be closed during transport.

Important

- Only approved hoisting equipment with sufficient load capacity must be used for lifting.
- All lifting devices, ropes, straps etc, must be selected by someone with the required knowledge and be fully responsible for the use.
- The hoisting equipment must be in perfect condition.
- Lifting gear must be checked for load capacity and damage before use.
- The overhanging drip edges must be safeguarded by additional measures during crane transport (e. g. traverses or wooden spacer beams).
- Even lifting of the unit/section must be assured.
- Lifting may only be performed using permitted attachment points.
- Ensure that the method of lifting does not allow the unit to slip from chains and slings and does not allow the unit to turn over or slide from lifting devices.

The manufacturer will not accept any responsibility in case of possible accidents due to the non-observance of these warnings

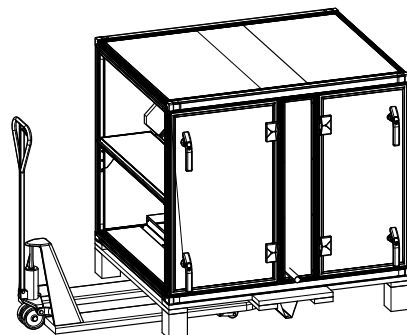
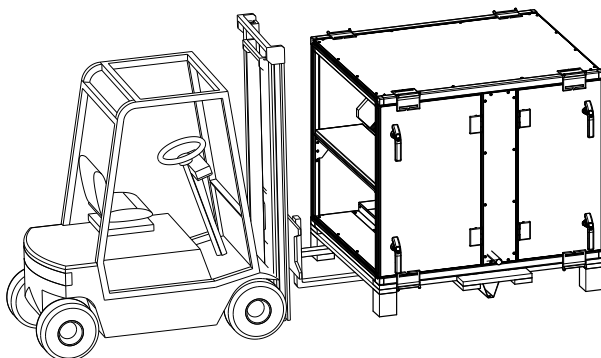
I.4 Handling examples**I.4.1 Handling sections which are delivered on pallets****I.4.1.1 Forklift**

Sections on a pallets could be lifted and transported on site by a forklift truck or manual forklift.

I.4.1.2 Straps

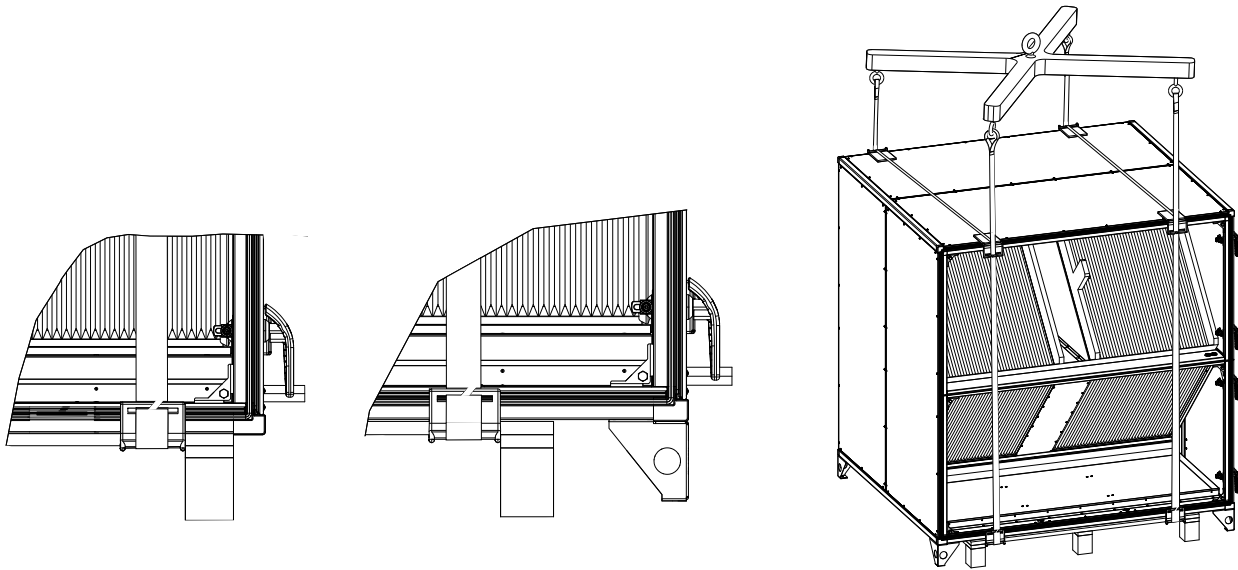

Lifting straps must be directed through the plastic corners. To avoid slipping, straps must be obtruded in notches of the plastic corners.



Caution

Use an appropriate lifting beam with a sufficient span to avoid that the straps touch and damage the drip nose profiles and the inspection side with handles, pipes and accessories – for example manometers, cabinets, tabs for measuring the pressure. Lifting brackets, beams and straps are not included in the delivery.

I.4.1.3 Lifting corners

Lifting corners are market with informative stickers. Mount a shackle in each of the four corners as shown in picture below. Ensure that lifting straps are directed upwards and upper profiles are safeguarded by additional measures during crane transport (e. g. traverses or wooden spacer beams).

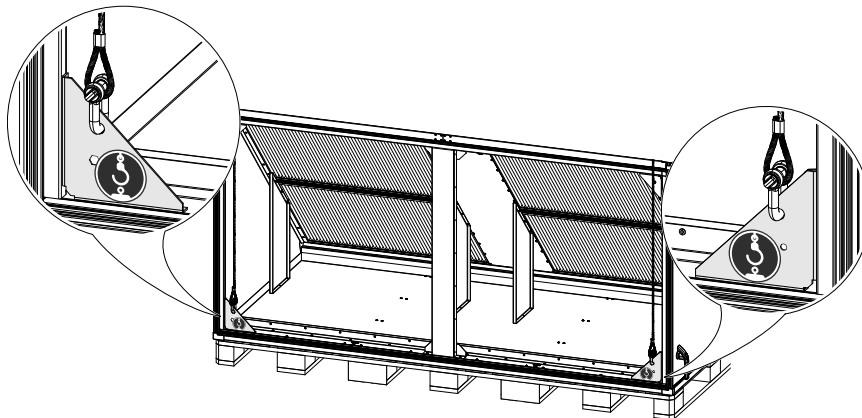

Danger

Do not lift the section using corners at the top as they are not designed to withstand the weight of the section. There is a potential risk that the bottom with the heavy components may fall down with serious risk of injury and damage to property.

I.4.2 Handling units/sections which are delivered on base frame

I.4.2.1 Forklift

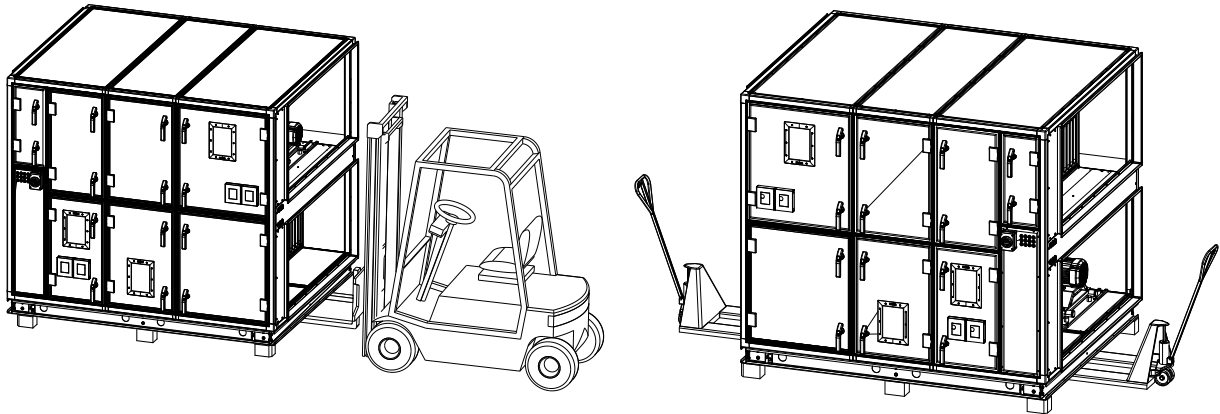

Unit or section placed on a base frame could be lifted and transported by a forklift truck or manual forklift.

In largerGeniox units base frame has 4 holes made for forklifts.

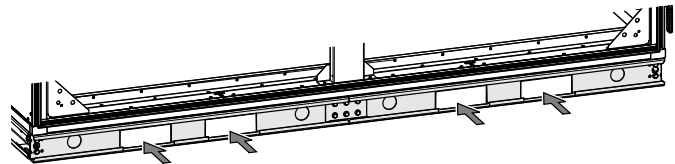

I.4.2.2 Straps

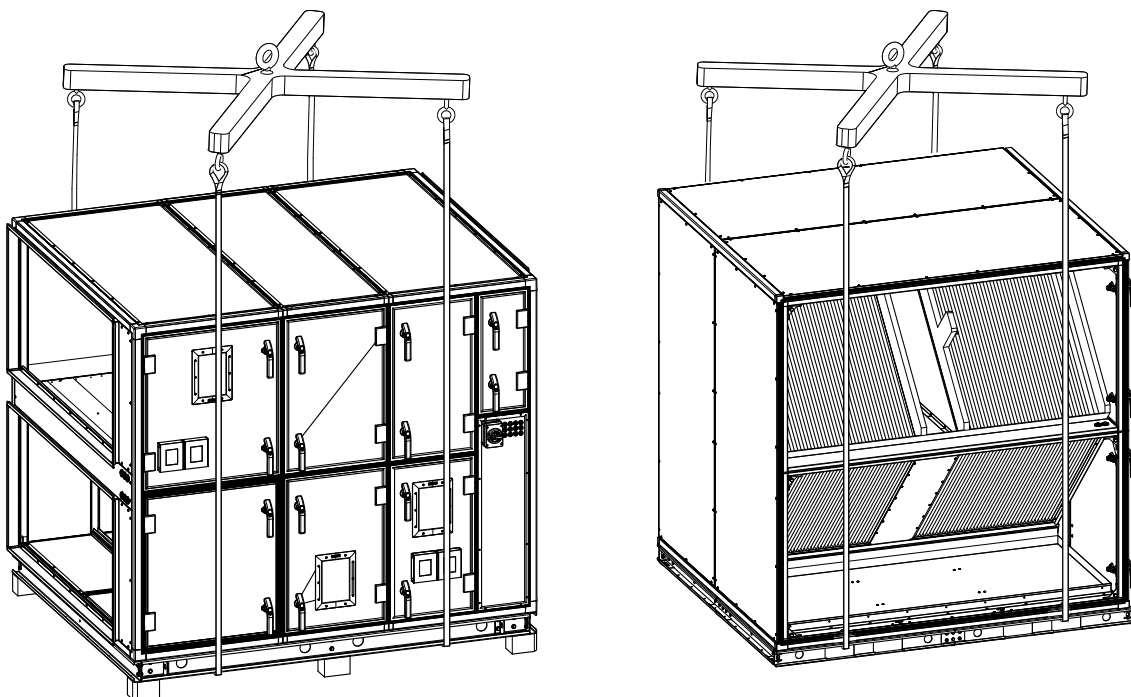

Caution

Use an appropriate lifting beam with a sufficient span to avoid that the straps touch and damage the drip nose profiles and the inspection side with handles, pipes and accessories – for example manometers, cabinets, tabs for measuring the pressure. Ensure that lifting straps are directed upwards and upper profiles are safeguarded by additional measures during crane transport (e. g. traverses or wooden spacer beams). Lifting beams and straps are not included in the delivery.

I.4.2.3 Brackets

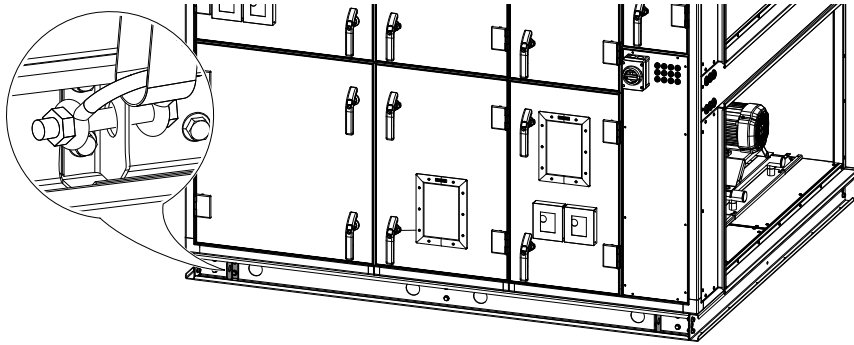

Brackets must be attached firmly to the base frame in places where steel corners are installed and fixed with M10 bolts. Mount a shackle in each bracket as shown in picture above.

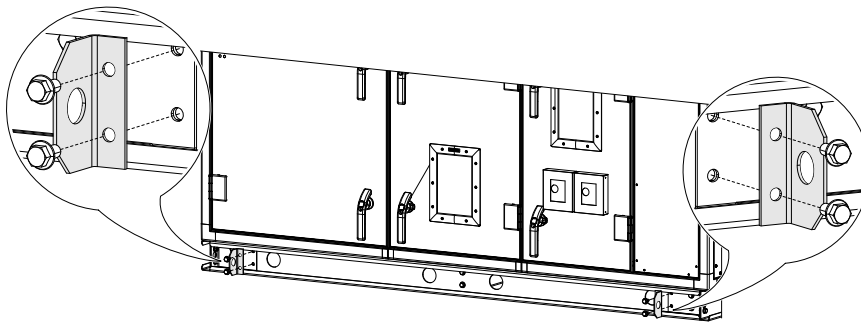

Caution

Use an appropriate lifting beam with a sufficient span to avoid that the straps touch and damage the drip nose profiles and the inspection side with handles, pipes and accessories – for example manometers, cabinets, tabs for measuring the pressure. Ensure that lifting straps are directed upwards and upper profiles are safeguarded by additional measures during crane transport (e. g. traverses or wooden spacer beams). Lifting brackets, beams and straps are not included in the delivery.

I.4.2.4 Hoist holes

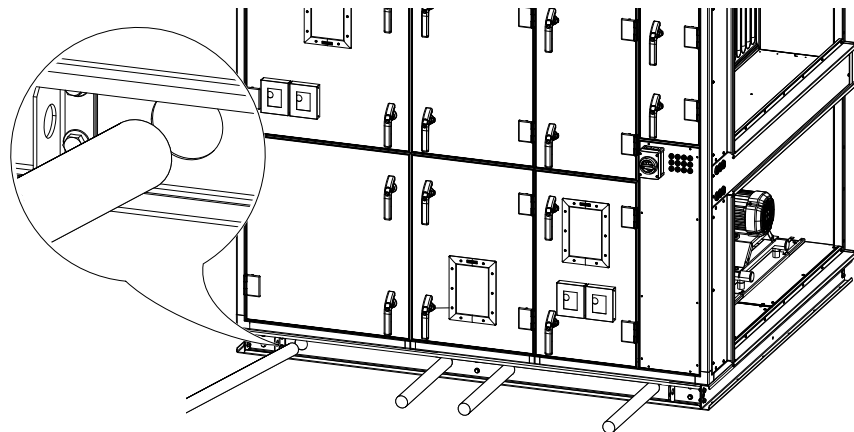

Hoisting pipes must be entered to a hoist holes and pushed all the way through the section. Ensure that lifting straps are directed upwards and upper profiles are safeguarded by additional measures during crane transport (e. g. traverses or wooden spacer beams). Hoisting equipment is not provided by Systemair.

I.4.2.5 Base frame side holes

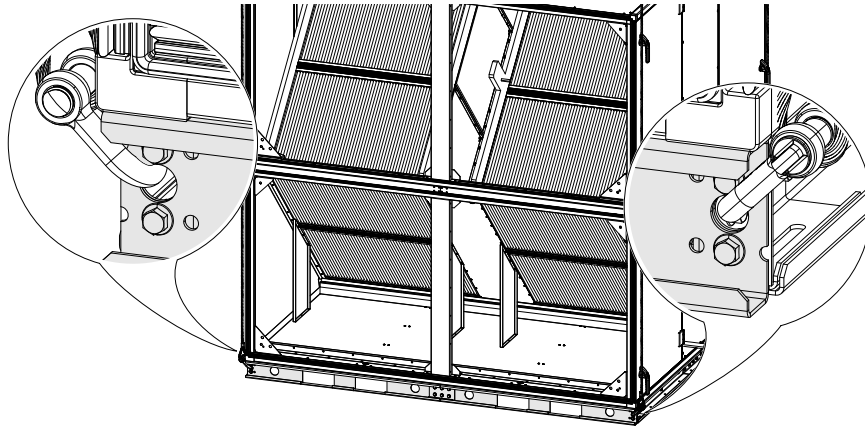

Unit or section placed on a base frame could be lifted using 4 base frame side holes. Mount a shackle in each as shown in picture above. Ensure that lifting straps are directed upwards and upper profiles are safeguarded by additional measures during crane transport (e. g. traverses or wooden spacer beams).

I.4.2.6 Lifting corners

Lifting corners are marked with informative stickers. Mount a shackle in each of the four corners as shown in picture below. Ensure that lifting straps are directed upwards and upper profiles are safeguarded by additional measures during crane transport (e. g. traverses or wooden spacer beams).

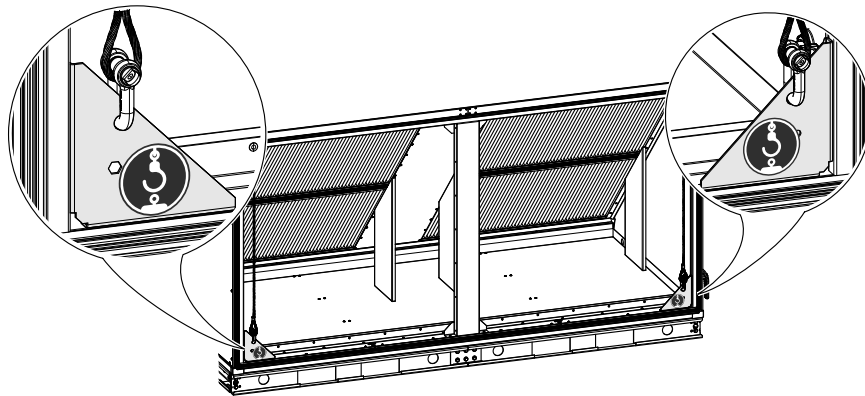

Caution

Do not lift the section using corners at the top as they are not designed to withstand the weight of the section. There is a potential risk that the bottom with the heavy components may fall down with serious risk of injury and damage to property.

I.4.3 Additional information

I.4.3.1 Available corners

Corner inside the unit for assembly of Geniox Go units in the sizes 16 – 20.



Caution

This type of corner is not reinforced and cannot be used for lifting the section.

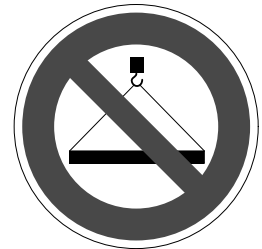
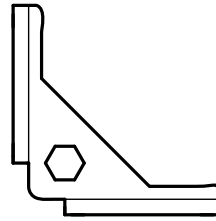

Corner inside the unit for assembly of Geniox Go units in the sizes 22 – 24. Top Corner inside the unit for assembly of Geniox Go units in sizes 27 – 31.



Caution

This type of corner is not reinforced and cannot be used for lifting the section.

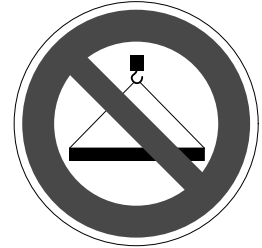
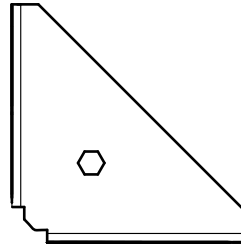

Bottom corner inside the unit for assembly of Geniox Go units in the sizes 27 – 31. This type of corner is reinforced and can be used for lifting the section.



Caution

Do not exceed the maximum permitted handling weight, described in chapter 1.2 *Permissible handling methods and weight limits*, page 8

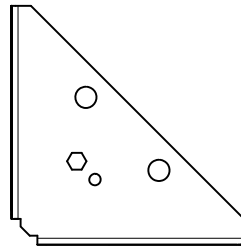

I.4.3.2 Roof unit with PVC roof

Avoid damaging the drip nose profiles along the PVC roof. Keep the protection profiles of Styrofoam on the unit until the installation has been completed. If the unit is lifted by straps, the straps must be kept away from the drip nose profiles by traverses or wooden spacer beams to avoid damage to roof profiles.

I.4.3.3 Roof unit with steel roof



Caution

For units with steel plate roof, the steel plates are delivered uninstalled on a separate pallet. Do **not** step or walk on the plates.

I.4.3.4 Pre-assembly storage

The unit must be protected from the weather and accidental impact. Plastic packaging **must** be removed and the unit covered with tarpaulin or similar materials. In order to minimize condensation, sufficient air circulation must be ensured between the covering and the unit.

I.4.3.5 Tilt less than 30° during transportation of the section with heat pump

During transportation, the unit section **must** always be in the upright position or tilted less than 30°. If it is necessary to tilt the unit more than 30°, the suction pipe of the compressor must point upwards to prevent the escape of oil from the compressor sump.

J Installation

J.1 Installation - mechanical

J.1.1 Free area in front of and above the unit

Important

When positioning the unit on the site, it must be ensured that an area with the same width as the unit is kept free for service and inspection and also for replacement of fans and exchanger, if needed. The width of the free area must be at least 900 mm.

Important

For safe access to the cabinet with electrical components, if the cabinet is placed on top of the unit, the free area from the upper edge of the cabinet to the ceiling must be at least 700 mm.

J.1.2 Supporting surface



Caution

Duct work must be sound insulated and must not be mounted directly on beams, trusses or other critical building parts.



Caution

The surface beneath the unit must be level, horizontal and vibration-free. The surface must be able to withstand the load of the unit. Weights of the sections are presented in AHU selection software and also printed on section ID labels attached to the unit sections.

J.1.3 Adjustable feet under legs or base frame and transport of sections

Adjustable feet are provided in a carton box placed inside the unit. Adjustable feet are delivered both for indoor and outdoor units.

Sections can be transported on the site by hand manual forklifts or similar. The frame profiles in the edges of the sections have carrying capacity for lifting by the hand manual forklifts.

J.1.4 Base frame assembly

Depending on the order, base frame could be factory attached to the unit or delivered unassembled.

Assembly of the base frame is available in this user manual in Annex 2 and Annex 3.

There are two types of base frames:

1. 118 mm high base frames
2. 218 mm high base frames

There are 2 different manuals and each of them illustrates the assembly of the 2 different types of base frames:

1. Assembly of base frame – height 118 mm or 218 mm for unit sizes 10 - 18 .
2. Assembly of base frame – height 118 mm or 218 mm for unit sizes 20 - 24 .

In Geniox Go sizes 27 to 31 each section has a separate base frame.

Adjustable feet with a distance of maximum 1500 mm between each feet must be fitted under the base frame. The base frame can be levelled by the adjustable feet.

J.1.5 Base frames for outdoor units

Outdoor units can be installed on both 118 mm and 218 mm high base frames. Hot-dip galvanized base frames are recommended for outdoor units. Systemair delivers these base frames with the above mentioned adjustable feet.

J.1.6 Outdoor units – support under the base frame of the unit

The installer must provide a frame that supports the base frame of the unit under the inspection side and under the back side of the unit. The frame must support the base frames of the unit under the entire length of the unit.



Caution

To avoid that the unit may tilt during storm the base frame of the unit must be properly fastened to the frame provided by the installer

J.1.7 Installation on the site of unit sections at the base frame when sections are delivered on pallets

1. Lift up the section by **hand manual forklifts** to the level where the underside of the section is even with the overside of the base frame.
2. Pull the section to the correct position on the base frame by lifting straps – it is maybe necessary to support the section by heavy duty furniture trolleys (see the photos below)



Example of heavy duty furniture trolley turned with the wheels upwards. Placed in this way on the forks of the hand manual forklifts the heavy duty furniture trolleys are suitable for safe and careful rolling of the unit sections over to the base frames.

Example of very heavy duty furniture trolleys. Turned with the wheels upwards and placed on the forks of hand manual forklifts these heavy duty furniture trolleys are very suitable for safe and careful rolling of the unit sections over to the base frames.

3. Pull sections together with straps. We recommend the shown type of straps because this type is not damaging the bottom frame profiles of the units. Place the strap on the bottom profiles of the unit to avoid any load and stress on the plastic corners created by the tensioner when sections are pulled together.

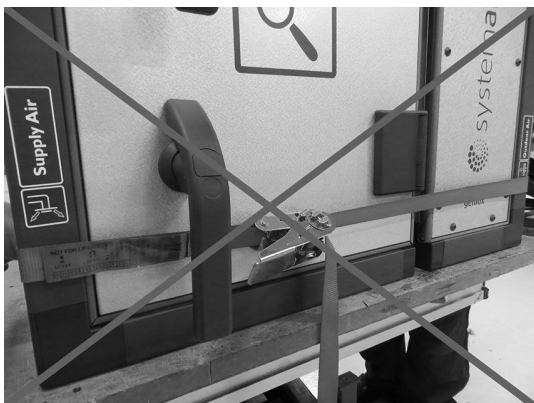
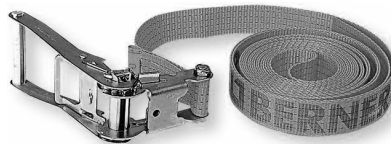

Note! Do not place the strap on the vertical profiles because the plastic corners and the profiles are not at all reinforced for the heavy load and stress that is created by the tensioner. To avoid any load and stress on the plastic corners the strap must be carefully placed on the bottom profiles of the unit when sections are pulled together.

Place the strap on the bottom profiles of the unit to avoid any load and stress on the plastic corners created by the tensioner when sections are pulled together.

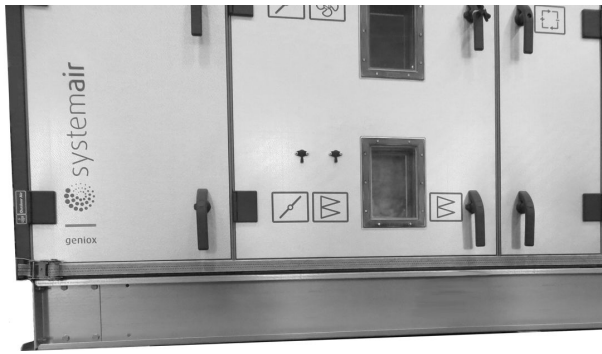

The sections must be pulled fully and tight together with the strap is placed on the bottom profiles. Do not pull and slide a section unless the strap is placed on the bottom profile.

When the sections are pulled fully together it may be helpful to place the strap halfway up on the unit to press the sections fully together so that the rubber seals are closing 100% tight. Only gentle tension is allowed because the vertical profiles are not reinforced for brutal stress in this direction and they may be bent. Instal delivered brackets before the strap is removed.

4. Sections are mounted to base frames with self-drilling screws. In the base frame you will find a sufficient number of 5 mm holes that are prepared for the self drilling screws.

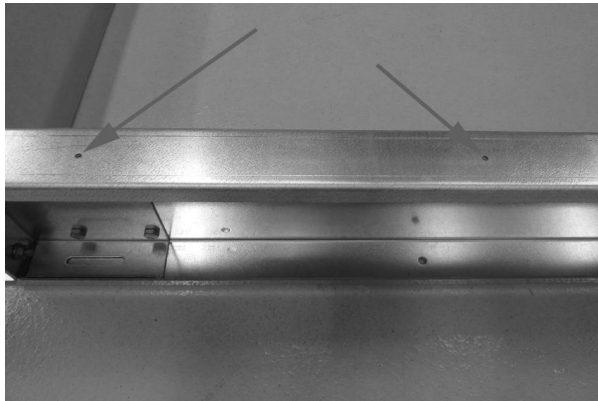

In this picture you are watching the assembled base frame from above.



In this picture you are looking upward under the base frame. The screws will not be visible while looking on the unit.

5. Use self-drilling screws – 4,8 X 16 mm – to be screwed upward through the holes into the bottom profile of the air handling unit. **Note! A screw must be placed in every hole to achieve the necessary strength.**

J.1.8 Joining the unit sections

1. Ensure that the internal factory-fitted rubber sealing is undamaged
2. Sections must be positioned directly opposite each other and aligned by two planes. The height of each section can be adjusted by adjustable feet.

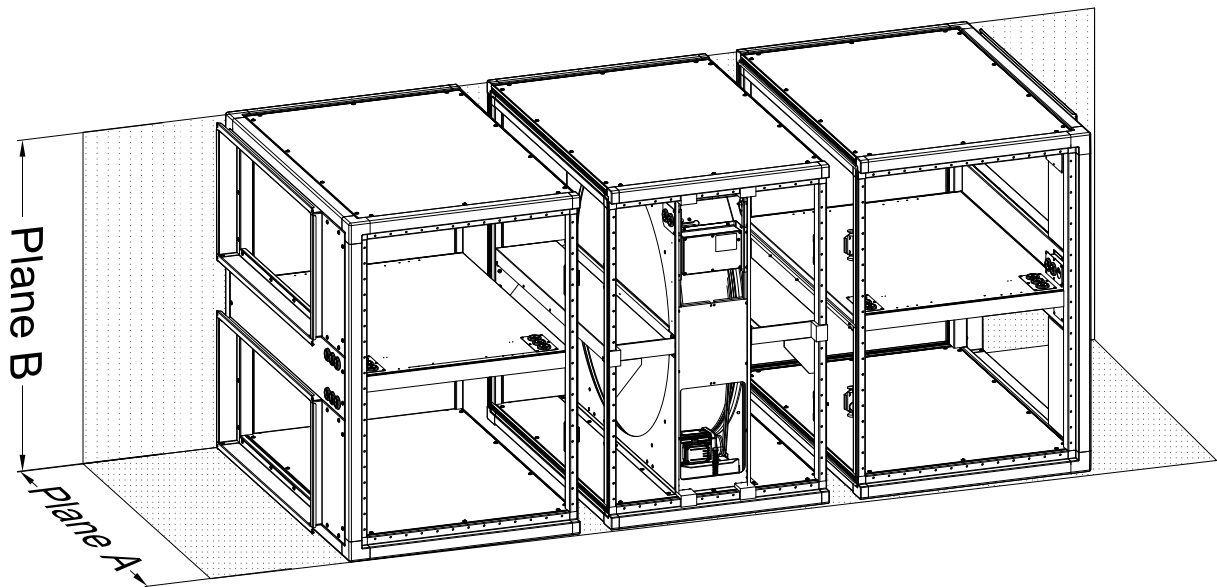
**Note:**

To achieve the best results, pull no more than two sections at a time!

3. Press the sections hard together so that the rubber profiles are so flat that the iron frames of the two sections are joined. Straps with tensioner are suitable for pressing the sections hard together. Place the strap on the bottom profiles (pos. A) and pull sections together. When sections are pulled fully together it may be helpful to place the strap halfway up on the unit (pos. B) to press the sections fully together so that the rubber seals are closing 100% tight.

**Caution**

Only gentle tension is allowed on vertical profiles because they are not reinforced for brutal stress in this direction and profiles may get bent.

**Caution**

Do not place the strap on the duct connectors !

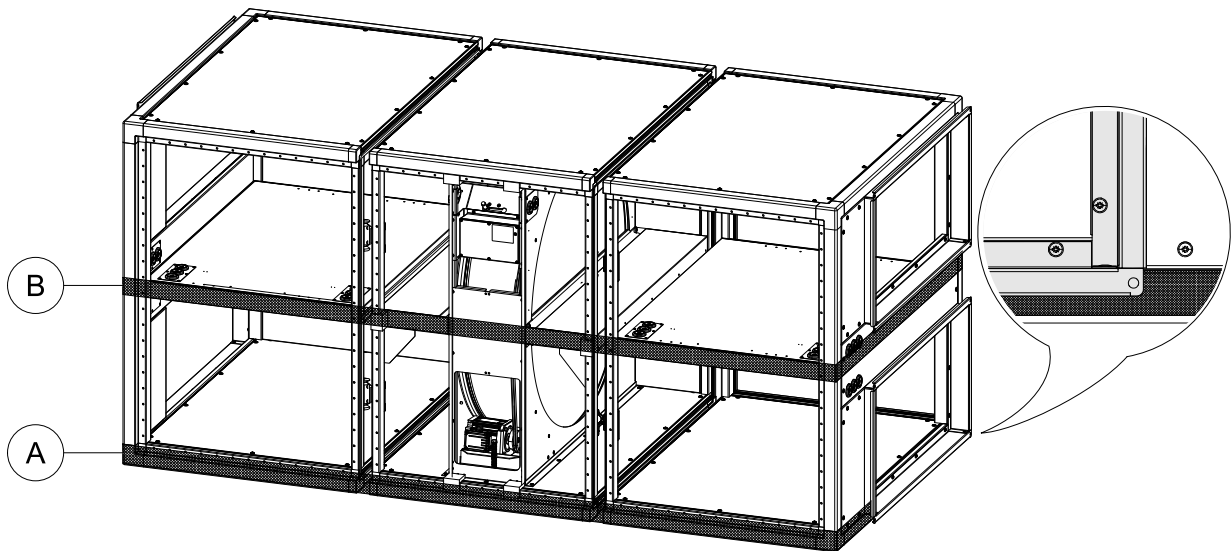

4. Geniox Go units have clamp locking system. Ensure that sections are aligned before trying to pull sections together. If there is a gap between the two clamps (fig. A), try pulling the sections further until both clamps gets fully locked together and fix them with 8 mm bolts (fig. B). Bolts are delivered.

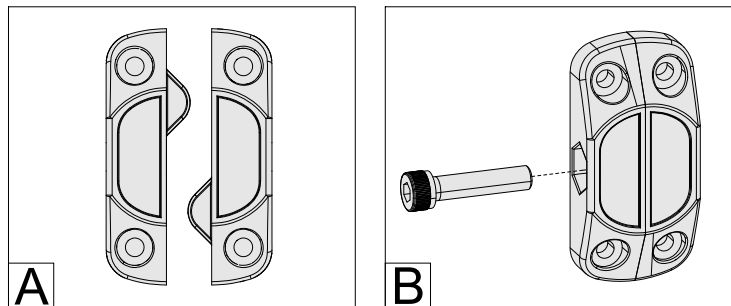

J.1.9 Fitting the ductwork

Flexible duct connections between unit and ductwork must always be installed. Be sure that flexible duct connections are almost fully stretched. (Flexible connections are ordered as accessories and they are packaged placed near the unit). At the fan outlet on a centrifugal fan, the duct size should be as close to the outlet size as possible. Avoid blockage and turbulence at the fan outlet.

J.1.10 Risk of stack effect by vertical ducts and wind pressure on louvers

Important

The Systemair air handling units can be ordered and delivered without dampers, and the installer/user must check that duct systems with the described risk of stack effect (chimney effect) will be provided with dampers and spring return motors.

On special occasions stack effect – also called chimney effect – in the ducts create airflows that drives the impellers by turned off motors.

A rotating impeller is a potential hazard during cleaning and maintenance of the unit. Eliminate this airflow by dampers with spring return motors for automatic closing of the dampers - even by power failure.

J.1.11 Lock the doors by using the key

Use the key to lock the doors. The doors are not locked automatically by turning the handle to the vertical position.



J.2 Installation - electrical

J.2.1 Installation of cable sealing boxes (only in rotor sections of Geniox Go 27–31)

In rotor sections of Geniox Go 27 –31 installers must assemble 4 cable sealing boxes. All required parts are included in accessories.

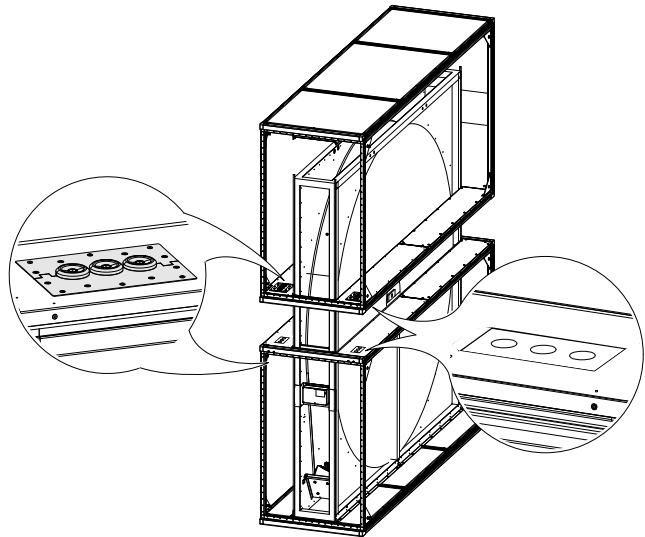

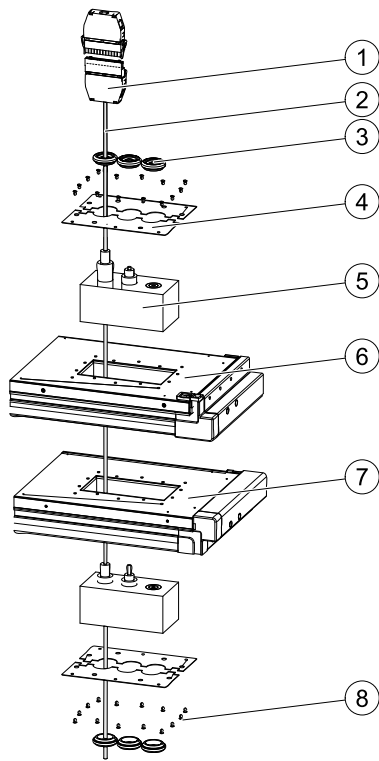

Part. No.	Name	Notes
1.	Cable connector	Connectors are factory preinstalled.
2.	Cable	Cables are factory preinstalled. During installation, cables must be routed through lower and upper section panels (pos. 6) .
3.	Cable-through sealing element	Cable-through sealing elements are factory preinstalled.
4.	Seal holding plate	Seal holding plates hold cable sealing blocks (pos. 5) in place. Those plates must be fixed to the panels using screws (pos. 7).
5.	Cable sealing block	Foam sealing blocks are used to enclose cables (pos. 2) and prevent air leakage between lower and upper sections. To enclose a cable, first remove a required thickness inner block tube. Ensure that there is no gap between the sealant and the cable before fixing it into the panel.
6.	Bottom panel of upper section	Cable sealing blocks must be installed into the panels (pos. 6 and pos. 7) and fixed with seal holding plates (pos. 4).
7.	Upper panel of bottom section	
8.	Screws	Screws are used to fix seal holding plates (pos. 4).

J.2.2 Lock the doors by using the key

Use the key to lock the doors. The doors are not locked automatically by turning the handle to the vertical position.

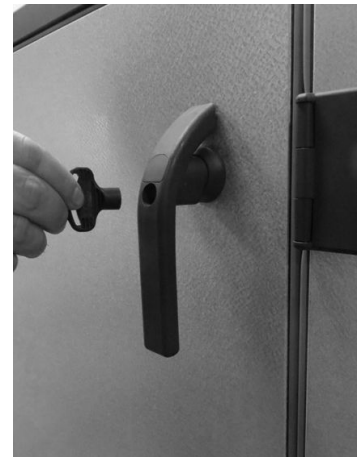

J.3 Installation – Pipes for water – hot and chilled, valves and drains

J.3.1 Description

If ordered with the unit, the valves and valve motors are factory installed. Factory installed water traps are optional. Water traps are necessary to prevent outside air coming into AHU via drainage.

J.3.2 Pipe connections

Connection pipes on heating- and cooling coils are provided with external thread. Drainage outlets on drip trays are provided with external thread.

J.3.3 Possibility of extracting components from the unit

Pipes and cables must not obstruct the inspection doors and components which can be extracted from the unit. Potential components for extraction are filters, fans and rotary heat exchanger.

J.3.4 Pipe connections to batteries

J.3.4.1 Heating coils

Pipes for hot water must be protected by insulation against frost and loss of heat. Further protection against frost can be obtained by installing electrical heating wires around the pipes and under the insulation combined with temperature sensors and a control system. Pipes, insulation, electrical heating wires, control system for heating wires and circulation pump are not delivered by Systemair.

J.3.4.2 Cooling coils

If ordered with the unit, the valves and valve motors are stored in a carton box placed inside the unit. Pipes for cooling must be protected by insulation against condensation on the pipes and loss of cooling in the summer. Pipes and insulation are not delivered by Systemair.

J.3.4.3 Rigid pipe mounting brackets for valves, circulation pumps and pipe system

The coil and pipes from the coil are not constructed to withstand the weight and stress from valves, circulation pumps, long pipes and insulation of pipes. The system must be supported carefully in rigid pipe mounting brackets to roof, floor and walls.

J.3.4.3.1 Pipe connection to heating coils

The heating capacity of the coil with only 2 rows is independent of the connection of the hot water in equal flow or in counter flow to the direction of the air, but connection of the hot water to the pipe marked for inlet and the return water to the pipe marked for outlet is very important to ensure that the sensor for transmission of the water temperature really will be placed in a return circuit of the coil (Screw-joint for the water temperature sensor is welded in the main collection pipe for return water).

For the frost protection of heating coil, the water temperature in the coil is transmitted to the controller. The controller always generates a signal to the valve motor that keeps a sufficient flow of hot water to protect the coil against frost. This frost protection is also activated when the running mode is "off".

Coils with 3 rows or more must always be connected in counter flow to the airflow.



Note:

If glycol is added, the glycol must be without additives and auto glycol must not be used. Automatic bleeding has to be installed at the highest point of the 2 pipes – supply or return pipe.

If the heating battery is built with 3 or more rows, the water flow must be in counter flow to the direction of the air.

To protect against frost a temperature sensor for the transmission of an analog signal to the controller is placed in a pipe on the collection pipe for return water. The sensor must be fitted water tight with a cap in the pipe before water under pressure is in the battery. The pipe for the sensor is soldered on the collection pipe and it is important to hold contra on the pipe, when the cap is tightened.

Battery seen from above. The sensor measures the water temperature of the water inside one of the small pipes for return water in the battery. The sensor reduces the area in this pipe and hereby also the flow of warm water in this pipe. The temperature in this pipe is reduced more than the temperature in all other pipes by the airflow through the battery. Because the lowest temperature in the battery probably is measured here, this system creates early and safe warning of frost.

It is important that the cap is tightened sufficient to keep the sensor system fully water tight.

J.3.4.3.2 Pipe connection to cooling coils for chilled water

Coils with 3 rows or more must always be connected in counter flow to the airflow.



Caution

The glycol must be without additives and auto glycol must not be used.
Automatic bleeding has to be installed at the highest point of the 2 pipes – supply or return pipe

J.3.4.3.3 Valve motor and valve for heating

The valve and valve motor are not installed. 2-way or 3-way valve is available.

J.3.4.3.4 Valve motor and valve for cooling

The valve and valve motor are not installed. 2-way or 3-way valve is available

J.3.5 Draining condensate water

Drip trays for collection of condensate water are installed under plate heat exchanger and cooling coil. Each drip tray is provided with a drainage outlet. A water trap is always necessary. To avoid freeze ups and frost bursts of water trap and pipes, sufficient insulation is recommended and installation of heating between the insulation and water trap/pipes could even be necessary (insulation, heating and controller for the heating are not delivered by Systemair).

J.3.6 Draining condensate water from plate heat exchanger

Condensate from the plate heat exchanger is collected in the drip tray. Heavy negative air pressure in this section prevents the water from flowing out of the drainpipe. A water trap with sufficient closing level of the water is essential to ensure that condensate water flows out of the unit. The closing level of the water trap must be estimated correctly to ensure safe escape of the water (see the illustration and estimate the minimum closing level according to the table). The pipe diameter of the water trap and sewage system must be identical to the pipe diameter of the drainage outlet from the tray.

A water trap is optional and installation of the water trap is not included.

Remember to check that there is water in the water trap.

Table 1 Negative pressure P (Pa)

P, Pa	H1 Minimum, mm	H2, mm
500	100	40
750	150	55
1.000	190	70

This type of water trap for sections with negative pressure and a ball that is sucked down into its seat for blockage of air flow into the section is available from Systemair. The above mentioned heights – H1 and H2 – are also valid for this type of water trap. The great advantage of this type of water trap for sections with negative pressure is that this type does not require water in the bottom to close for air flow backwards into the section. Condensate water will escape through this type of water trap – even after long periods without any water to close for air flow backwards through the trap.

This water trap is optional and must be ordered separately. Installation of water trap is not included.



J.3.7 Draining condensate water from cooling battery

If the cooling battery and the drip tray are placed in the unit where negative pressure (underpressure) occurs, the closing level of the water trap must be estimated correctly. See the above-mentioned information in J.3.6 *Draining condensate water from plate heat exchanger*. If the cooling battery and the drip tray are placed in the unit where positive pressure (overpressure) occurs, the closing level of the water trap must be estimated correctly as shown on the illustration below. A water trap is optional and installation of the water trap is not included.

Remember to check that there is water in the water trap.

Table 2 Positive pressure P(Pa)

P, Pa	H1, mm	H2, mm
500	90	65
750	120	90
1.000	150	120

K Installation and assembly instructions for reduction of noise and vibration emissions

Due to the design and construction of the units the (A) weighed sound pressure level from fans and other components do not exceed 70 dB (A) outside the units.

Installation of the units on rubber anti-vibration elements will reduce the transmission of noise and vibrations to the building. Systemair does not deliver anti-vibration elements for this purpose.

Flexible connections between the units and the ducts are available as accessories.

L Start-up, adjustments, use and commissioning

L.1 Print-outs on paper

The documents listed below are always printed on paper and delivered together with the units according to the Machinery Directive and the related national laws

This User Manual with:

- Declaration of incorporation – *C Declaration of Conformity*, page 2
- The unique technical data for this unit - Annex 1
- Installation instructions including instructions for the Danfoss frequency converter
- Printed form for Commissioning protocol – Annex 9.
- Test report – Annex 10
- Short description about the main components in the control system – Annex 11
- Wiring diagrams - Annex 12
- Operator's guide for the Systemair control panel - Annex 13

L.2 Start-up by installer

All protection and safety measures must be met before start-up of the unit. The mains supply voltage must also be checked too. The mains supply voltage must be measured at the supply terminals in the cabinet.

L.2.1 Checklist, relevant values

L.2.1.1 Checklist prior to start-up

- Is the unit assembled correctly with its functions in the correct order?
- Are the sections and ducts assembled correct?
- Check that fans and anti-vibration mounts are not damaged after transportation and installation.
- Is the rotary exchanger turning freely?
- Are doors locked?
- If the unit includes integrated heat pump, check whether it is installed and supervised by qualified service personnel.
- If the unit contains Electric air heater, make sure that the supply isolator disconnects with the unit.
- Ducts - are all ducts installed?
- External components - are the valve and valve motor installed correctly?
- Is the circulation pump installed correctly?
- Is water under pressure in the coil and circulation pump?

- Are the pressure transmitters installed and connected correctly? (If this is a system with pressure transmitters in the ducts)
- Main power supply:
 - Connected correctly?
 - Test of supply voltage for actuators and control signal!
 - Are control signals for actuators connected correctly?

L.2.1.2 Switch on power



Warning

Do not start until all safety procedures have been completed and ensure that inspection doors are closed and locked.

Switch on power and the unit should be ready for the start-up.

For start-up see the Operator's guide for the Systemair control panel - Annex 13 (this manual is delivered with the unit - printed on paper).

L.3 Description of functions

L.3.1 Remote control

Please aware that some options described below are optional and their presence depends on the order.

L.3.2 Extended operation and external start/stop (for example by presence detectors)

When the unit is running at reduced speed or is in shutdown mode, it can be forced up one step by using a Push button (impulse). The required number of minutes for the extended operation must be selected on the Systemair Control Panel. Button and cable are not delivered by Systemair. Furthermore when the unit is in shutdown mode it is possible to start/stop the unit by presence detectors. Presence detectors and cable are not delivered by Systemair.

L.3.3 Valve and valve motor for heating coil

The supply voltage for the water valve actuator is 24V DC, the control signal is 0-10 V. The sensor for water temperature has to be installed in the heating coil and the sensor is provided with cable and connected to the terminals in the cabinet. The cable between valve motor and terminals in the cabinet is not delivered by Systemair. Standard valves are available for 2 or 3-way connection.

L.3.4 Valve and valve motor for cooling coil

The supply voltage for the water valve actuator is 24V DC, the control signal is 0-10 V. Cables between valve motor and terminals in the cabinet are not delivered by Systemair. Standard valves are available for 2 or 3-way connection.

L.3.5 DX cooling

A DX-cooler can be connected to the controller. Input and output are available for:

Start cooling – Alarm cooling – Cooling Y3. Cables are not delivered by Systemair

L.3.6 Circulation pump, heating

Circulation pump is not included in the delivery from Systemair. If the pump has not been activated for 24 hours, the pump is exercised once daily for 1 minute to keep the pump in a good condition. Cables are not delivered by Systemair.

L.3.7 Fire alarm function

L.3.7.1 External fire signal that indicate block or run

The unit is available without components for this function. The controller is as standard configured for ordinary running when the contact is closed (NC). By open contacts the fans stop and the dampers close. If disconnected, fire is indicated and the unit will stop until the signal is re-connected. On the site qualified technicians are able to change the configuration.

L.3.7.2 External fire signal

The unit is delivered without components for this function. The controller is as standard configured for ordinary running when the contact is closed (NC). By open contacts the fans stop and the dampers close. When the unit has been shut down by a fire signal, the unit has to be restarted on the control panel. The unit is also available with 2 thermostats installed in the unit – 1 in the extract air and 1 in the supply air. The cut-off temperature in the thermostats is adjustable between 40 and 70°C. At the factory supply is set at 70°C and extract is set at 40°C. The controller is as standard configured to stop the fans and close the dampers if a thermostat is released. On the site qualified technicians are able to change the configuration.

L.3.7.3 One smoke detector in extract air

The smoke detector has been installed in extract air next to the fan. The controller is as standard configured to stop the fans and close the dampers if the detector is released by smoke. When the unit has been shut down by a fire signal, the unit has to be restarted on the control panel. On the site qualified technicians are able to change the configuration.

L.3.8 Electrical heater battery

L.3.8.1 Control of heating capacity connected to unit with Systemair control system

Electrical heater installed with separate controller beside the heater. The separate controller is designed for capacity conversion of the 0-10 V control signal from the main control system. The heating capacity is adapted in steps. The electric heater is not supplied from the air handling unit cabinet as the cabinet is not designed to supply the heater with power. No power supply cables are connected to the electric heater. The separate controller is without supply disconnecting device.

L.3.9 Speed control of fans

L.3.9.1 Geniox control system - frequency converters inside the unit are IP20 or IP54

Fan motor revolutions are controlled by frequency converters, and they are configured and tested to comply with the data for the unit. The frequency converter for each fan motor is installed inside the unit beside the fan motor with cables between motor and converter. In units with complete control system the frequency converters are delivered with system parameters adapted to the motors and the project.

L.3.9.2 Pressure transmitters

Separate control of the air flow or duct pressure for supply fan and for extract fan. The required air flow or duct pressures with normal as well as reduced capacity are selected on the Systemair Control Panel. The actual pressure is measured by pressure transmitters. PI calculation in the controller continuously transmits the necessary revolutions for the fans to the frequency converters to achieve the required pressure.

L.3.9.3 CO₂-dependent air flow

The air flow is controlled by a CO₂ sensor. High CO₂ concentration is equal to higher air flow. Low CO₂ concentration is equal to lower air flow. Based on the actual CO₂ level and a min/max level, the needed airflow is calculated. The speed of each fan is adjusted via frequency converter. Terminals in the cabinet are available for connection of the sensor.

L.3.9.4 Humidity dependent air flow

The air flow is controlled by the humidity sensor. High humidity is equal to higher air flow. Low humidity is equal to lower air flow. Based on the actual humidity level and a min/max level the needed airflow is calculated. The speed of each fan is adjusted via frequency converter. Terminals in the cabinet are available for connection of the sensor

L.3.10 Cabinet

Cabinet is integrated in the unit behind an inspection door. Terminals are installed in the cabinet for all external components. The number of terminals is always adapted to the individual order.

L.3.11 Temperature sensors

Four sensors are always delivered with each unit. See below where the sensors are placed;

- 1 sensor in the extract air, installed inside the unit
- 1 sensor in the outdoor air, installed inside the unit before the supply air filter on the cold side of the heat exchanger
- 1 sensor in the supply air to be placed in the supply air duct by the installer
- 1 sensor in the supply air installed inside the unit after the heat exchanger before coils

L.3.12 Filter guards

Filter guard over pre-filter and primary filter installed and connected to the controller for display of alarm when set limit is exceeded. Filter alarm will be displayed on the Systemair Control Panel.

L.3.13 Room temperature sensors

One or two external room temperature sensors are available. The cabinet has been prepared with additional terminals for connection of the room temperature sensors. The sensors are delivered without cable. The controller calculates an average of the value from the 2 sensors as input for the control.

L.3.14 Frost protection

For the frost protection of the heating coil, the water temperature in the coil is transmitted to the controller by a temperature sensor in a water return circuit of the coil. The controller always generates a signal to the valve motor that keeps a sufficient flow of hot water to protect the coil against frost. This frost protection is also activated when the running mode is "off".

If the water temperature falls below the set point temperature the fans stop, the dampers close, and an alarm is activated.

From Systemair every heating coil for hot water is provided with a little pipe at the collection pipe for the return water. This little pipe is prepared for the installation of the above mentioned temperature sensor for the transmission of the return water temperature to the controller.

L.3.15 Cooling recovery

If the extract air temperature is lower than the outdoor air temperature, and there is a cooling demand in the rooms, the cooling recovery will be activated by reversing the heat exchanger signal. The signal is increased to the cooling recovery by increasing cooling demand. On the site qualified technicians could enable this option.

L.3.16 Free cooling

A temperature sensor has been installed inside the unit in the outdoor air entrance. If the outdoor temperature after midnight is below the room temperature set point and the actual average room temperature is above the set point temperature, the fans start during the summer to cool down the building during night hours. On the site qualified technicians could enable this option.

L.4 Commissioning

When the installer has completed the installation and wants to hand over the finished installation to his customer for payment the commissioning protocol can be the written receipt for the full ended job. Fill in the blank spaces and sign the proposed commissioning protocol.

M Information about the residual risks

M.1 Unit casing

M.1.1 Design of the machine to make transport safe

Hazards/dangerous area:

- Incorrect handling during transportation may cause that the unit is dropped.

Dangerous incident:

- If a person is hit by a unit that is dropped, this could in unfortunate circumstances lead to irreversible injury or death.

Claim for reduction of danger:

- Correct handling during transportation is described in this manual. If lifted by **fork-lift truck** the forks of the truck must be sufficiently long. Safety measures are also described in this manual by use of crane. Information about weight of each section is also visible.

M.1.2 Common for all unit sections

M.1.2.1 Risk caused by lightning strike

Hazards/dangerous area:

- Lightning strike close to the machine.

Dangerous incident:

- Lightning strike can create flash over between phases and conductive parts. This can cause fire or the overvoltage can make injury on persons

Claim for reduction of danger:

- Installer and user must be aware of the fact that lightning makes a risk that requires installation of overvoltage protection devices to lead the lightning overvoltage to an earth lead on a safe way. The need for overvoltage protection devices depend on where the unit is placed in and on the building.
- Installer and user must take care of this according to local statutory requirements.

M.1.2.2 Risk caused by surfaces, edges and corners

Hazards/dangerous area:

- Sharp edges on plates might occur inside the machines as well as sharp edges on frames of dampers. No sharp edges on the outside of the units.

Hazards/dangerous area:

- Sharp edges on plates might occur inside the machines as well as sharp edges on frames of dampers. No sharp edges on the outside of the units.

Dangerous incident:

- Cut fingers/hands.

Claim for reduction of danger:

- Risk only exists during maintenance and cleaning. This takes place at least once every year. Use of gloves and helmet is described in this manual. Cut-resistant gloves for protection against injury from sharp metal plate edges. Use CE-marked gloves for this purpose. If ordered, lamps are mounted or packed inside the unit. Sufficient lighting reduce the risk of injury.

M.1.3 Common for all unit sections by insufficient lighting

M.1.3.1 Risk caused by insufficient lighting inside sections

Hazards/dangerous area:

- On the floors of the units there are handles to hold filters, profiles for the carrying of fan motors. Cables are between fan motors and frequency converters.

Dangerous incident:

- By insufficient lighting, the above-mentioned obstacles are not visible with the risk of stumbling that becomes a fall, leading in unfortunate circumstances to irreversible injury or death.

Claim for reduction of danger:

- Risk only exists during maintenance and cleaning. This takes place at least once every year. According to this manual and in the SystemairCAD software for configuration and selection of accessories, lamps for sufficient lighting inside the units are mandatory according to the latest interpretations of the Machinery Directive by the authorities. Use of helmets reduces the risk of injury.

M.1.4 Dampers

M.1.4.1 Risk caused by maintenance and cleaning of dampers

Hazards/dangerous area:

- Are between the damper blades and the system of bars and links between motor and damper blades.

Dangerous incident:

- Crushing of fingers.

Claim for reduction of danger:

- Examination is still under preparation in our own laboratory. Still no voluntary test persons are available.

M.1.5 Attenuators**M.1.5.1 Risk caused by maintenance and cleaning of attenuators****Hazards/dangerous area:**

- High concentration of dust on the surface of the baffles might be harmful to the health.

Dangerous incident:

- To breathe in particles that is harmful to the health.

Claim for reduction of danger:

- Risk only exists during maintenance and cleaning. This takes place at least one time every year. Use of particulate respirator is described in this manual. Particulate respirator – maintenance free including foam face-seal and adjustable pre-threaded headbands (same particulate respirator as recommended for change of filters).

M.1.6 Filters**M.1.6.1 Risk caused by missing change of filters****Hazards/dangerous area:**

- Missing change of filters and missing maintenance decrease the capacity and final consequence will be breakdown.

Dangerous incident:

- By extensive lack of filter change and maintenance the machine can break down.

Claim for reduction of danger:

- In the manual is the method and schedule for change of filters and maintenance specified.

M.1.6.2 Risk caused by the execution of filter change**Hazards/dangerous area:**

- Filter panels and filter bags

Dangerous incident:

- To breathe in particles that is harmful to the health.

Claim for reduction of danger:

- Use of particulate respirator – maintenance free including foam face-seal and adjustable pre-threaded headbands (same particulate respirator as recommended for cleaning of attenuators).

M.1.7 Plug fans**M.1.7.1 Risk caused by permanent magnet motor****Hazards/dangerous area:**

- Rotation of the shaft generates electricity. This danger is always visualized by a yellow warning label on the inspection door where permanent magnet motors are installed.



Dangerous incident:

- Persons touching conductive parts get electric shock, burns, heart flicker and so on.

Claim for reduction of danger:

- By installation or repairs of conductive components, the shaft must be blocked to prevent any rotation.

M.1.7.2 Risk of rotating impeller caused by stack effect (chimney effect).**Hazards/dangerous area:**

- On special occasions stack effect – also called chimney effect – in the ducts create airflows that drives the impellers by turned off motors.

Dangerous incident:

- Injury of fingers, hands and arms.

Claim for reduction of danger:

- Eliminate this airflow for supply air and exhaust air by dampers with spring return motors for automatic closing of the dampers by turned off fan motors and by power failure.

M.1.8 Batteries for heating and cooling**M.1.8.1 Extreme temperatures - heating****Hazards/dangerous area:**

- Electrical heating elements can achieve surface temperature of 500 degree Celsius.
- Batteries and pipes for hot water can achieve 95 degree Celsius.

Dangerous incident:

- According to ISO 13732-1:2006, here is no direct risk of burns. (short-time contact – lesser than 2,5 sec).

Claim for reduction of danger:

- No.

M.1.8.2 Extreme temperatures - cooling**Hazards/dangerous area:**

- Evaporator batteries and pipes connected to cooling compressor can achieve minus 10 degrees Celsius.

Dangerous incident:

- According to ISO 13732-1:2006, here is no direct risk of burns. (short-time contact – lesser than 2,5 sec).

Claim for reduction of danger:

- No.

M.1.9 Heat pump units**M.1.9.1 Risk of high temperature****Hazards/dangerous area:**

- Condenser batteries and pipes can achieve temperature of 60 degree Celsius.

Dangerous incident:

- According to ISO 13732-1:2006, here is no direct risk of burns. (short-time contact – lesser than 2,5 sec).

Claim for reduction of danger:

- No

N Instructions on the protective measures during repair and maintenance

Use the below-mentioned personal protective equipment for maintenance:

- Cut-resistant gloves for protection against injury from sharp metal plate edges. Use CE-marked gloves for this purpose.
- Helmet
- Particulate respirator – maintenance free including foam face-seal and adjustable pre-threaded headbands – for replacing filters.
- Permanent magnet motor. The shaft must be blocked during repairs and maintenance of the electric system (the motor generates electricity by rotation – for example that the wind and thermic drives the fan/motor).
- Lighting inside the units. According to the latest interpretations of the Machinery Directive by the authorities sufficient lighting inside the units is mandatory.
- Tools to block the impeller during repairs and maintenance if stack effect – also called chimney effect – in the ducts create airflows that drives the impellers by turned off motors

O The essential characteristics of tools which may be fitted to the machinery

The subject in the Machinery Directive about tools on the machine does not exist for the Geniox Go air handling units, because those tools does not exist.

P The conditions of stability during use, transportation, assembly, dismantling when out of service

The unit must always be handled in an upright position. Never tilt any section more than 15 degrees. If sections must be tilted more than 15 degrees, sections with fans or rotating exchangers that can be drawn out for service must be secured carefully.

During transportation, installation, dismantling or other handling, it must be secured that all components in the unit are properly fastened and with additional attention to the control of anti-vibration mounts under the fans that they are undamaged. The mounting and smooth running of the fans must be controlled and handled with great care.

P.1 Installed reliable to avoid units to be tilted or moved by storm

Units installed on roofs and other places with the risk of heavy winds must be installed reliable to avoid that they can be tilted or moved by the any storm. The base frame is provided with holes that are intended for fastening by sufficient bolts and fittings supplied by the installer.

P.2 Transport of section with heat pump unit



Warning

During transportation, the unit section with heat pump **must** always be in the upright position or tilted less than 30°. If it is necessary to tilt the unit more than 30°, the suction pipe of the compressor must point upwards to prevent the escape of oil from the compressor sump.

P.3 Disposal of the heat pump system

Prior to the disposal of the heat pump unit section, the refrigerant in the heat pump system must be drained off by a skilled technician from a certified company. After correct evacuation of the refrigerant, the disposal of the heat pump unit section is similar to the disposal of the rest of the air handling unit.

P.4 General disassembly – sharp edges

Pay attention to several sharp edges during dismantling and disposal of the unit. To avoid injury, CE-marked cut-resistant gloves as well as helmet must be used. The measures are described further in the Maintenance, Dismantling and Disposal Manual.

Q Instructions for machinery where these are regularly to be transported

The subject in the Machinery Directive about machinery that are regularly to be transported does not exist for the Geniox Go air handling units, because those units are for specially made for one intended application.

R The operating method to be followed in the event of breakdown. Safe restart.

Use the below mentioned procedure in the event of breakdown or blockage:

- Switch off the power and turn the main power switch to off position.
- Remove the reason for breakdown or blockage.
- Follow the start-up procedure described in chapter L.

S Adjustment and maintenance operations

Must be performed by skilled technicians.

In connection with demands for compensation, Systemair must have full and unhindered access to all relevant reporting on service, repair, modification and use since the unit was transferred from Systemair to a transport company at the Systemair factory. It is a condition for compensation that maintenance outlined on the following pages has as a minimum been performed.

S.1 Shutdown of the unit to a safe state

Switch the unit OFF on the Systemair Control Panel. Turn off the power by rotating the main unit power switch handle to OFF position.

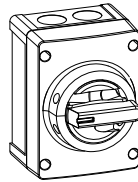

Use the start-up procedure described in chapter L, when the maintenance activities are completed.

S.2 Unlock and lock the doors by using the key

Use the key to lock the doors. The doors are not locked automatically by turning the handle to the vertical position.



S.3 Recommended maintenance intervals

Function	Maintenance	Number per year
Unit casing	Cleaning of the unit casing.	1
	Control of rubber seals on doors and between sections.	1
Filters	Change on demand by alarm and always minimum twice a year.	2
	Control of rubber seals.	2

Function	Maintenance	Number per year
Fans	Cleaning of all parts.	1
	Check motors and bearings	1
	Check that the impellers are rotating without dissonance.	1
	Check that anti-vibration mounts are intact.	1
	Check that the unit is operation without vibrations after the cleaning, overhaul and maintenance.	1
Rotary heat exchanger	Check that leakage and dirt accumulation is insignificant	1
	Check that the rotor can turn freely and easily manually with a hand when the belt is removed from the drive	1
Plate heat exchanger	Check bypass function and sequence for de-icing	1
Run-around heat exchanger	Check the exchanger function and test the frost protection. The glycol must be without additives and auto glycol must not be used.	1
Dampers	Test the operation.	1
	Visual inspection of seals and tightness when closed.	1
Hot water battery	Check the dirt accumulation and clean, if needed.	1
	Bleeding, if needed.	1
	Test of frost protection sequence	1
	Test of circulation pump	1
Electric heating battery	Check dirt accumulation and clean, if needed.	1
	Test the function of the system with the fuses for the safety.	1
Cooling battery	Check dirt accumulation and clean, if needed.	1
	Test the frost protection (glycol)	1
Heat pump unit	Mandatory annual control of the heat pump system. Must be done by certified technician from a certified company.	1
Condensate drain	Cleaning of tray, water trap and outlet. Check the electrical heating between insulation and pipes, if installed.	1
Saving- and comfort functions	Test of CO2 sensor, humidity sensor, motion sensor, pressure transmitters for air capacity control, extended operation via button, cooling recovery, free cooling	1
Fire alarm	Test of thermostats, smoke detectors and fire detection systems	1
Battery in controller	Change the battery on demand by alarm in the display and always change the battery as a minimum every 5 years.	1
Remote control	Test of Communications.	1

S.4 Filters – always replace filters with new filters with the same characteristics to maintain SFP value

Filters in supply air and in extract air always have the same sizes of frames and the number of filters for supply air and extract air are always the same. REMEMBER to order filters for supply air as well as for extract air.

To maintain the factory-calculated SFP values for the air-handling unit, it is very important that filters with the same characteristics for start pressure as well as lifetime replace factory-mounted filters.

To achieve the most favourable SFP values, the factory-mounted filters represent the lowest achievable start pressure as well as the longest achievable lifetime. If other filters with higher start pressure and shorter lifetime replace the factory-mounted filters, the user will experience smaller airflow and/or consumption of more electricity, and the SFPv value calculated by Systemair according to the Eurovent certification will not be achieved. Poor SFPv values will be detected by tests according to commissioning standards, DGNB, LEED or BREEAM sustainability standards and locally defined performance standards (the SFPv is with new clean filters).

Filter frame for bag filters must be of NON-PVC plastic to ensure safe disposal by incineration.

For each individual air handling unit you will find the data for the factory-mounted filters in attached technical documents which are packed inside the unit. Filter related information also written on the machinery card that is attached to the unit. You will find an example of the machinery card in D.1.3 *Machine card with unique data on every unit*, page 7 of this manual.

The factory-mounted filters comply with indoor air quality demands of customers and with the SFP values according to local legislation.

These air handling units are available with filters that comply with the below-mentioned filter classes:

- G4 – Coarse 65%
- M5 - ePM10 60%
- M6 - ePM2,5 50%
- F7 - ePM1 60%
- F7 - ePM1 60% CityFlo

S.4.1 Bag filters – the number of filters and sizes of frames

Filters in supply air and in extract air are always the same sizes and the same numbers. See the filters in supply or extract air below.

Size of unit	Numbers and sizes of frames for bag filters (WxH)
10	1x[792x392]
11	2x[490x490]
12	1x[592x490] + 1x[490x490]
14	2x[490x592] + 1x[287x592]
16	3x[490x592]
18	2x[490x392] + 4x[592x392]
20	3x[592x592] + 3x[592x287]
22	6x[592x490] + 2x[287x490]
24	3x[595x592] + 1x[490x592] + 3x[592x490] + 1x[490x490]
27	2x[592x592] + 8x[490x592]
29	6x[592x592] + 4x[490x592]
31	5x[592x592] + 5x[592x490] + 5x[592x287]



Note:

Special sizes of filters are available from Camfil.

S.4.2 Panel filters – the number of filters and the sizes of the frames

Size of unit	Numbers and sizes of frames for panel filters (WxHxD)
10	1x[494x394x48] + 1x[394x394x48]
11	2x[494x494x48]
12	1x[494x494x48] + 1x[622x494x48]
14	2x[394x622x48] + 1x[494x622x48]
16	3x[622x494x48]
18	2x[494x394x48] + 4x[622x394x48]
20	2x[494x494x48] + 2x[494x394x48] + 1x[622x494x48] + 1x[622x394x48] + 1x[287x494x48] + 1x[287x394x48]
22	2x[622x394x48] + 2x[622x622x48] + 1x[287x394x48] + 1x[592x622x48] + 1x[287x622x48] + 1x[592x394x48]
24	2x[592x622x48] + 2x[592x494x48] + 1x[494x494x48] + 1x[622x494x48] + 1x[494x622x48] + 1x[622x622x48]

Size of unit	Numbers and sizes of frames for panel filters (WxHxD)
27	8x[494x592x48] + 2x[592x592x48]
29	4x[494x494x48] + 6x[592x494x48] + 3x[592x287x48] + 2x[494x287x48]
31	4x[622x494x48] + 2x[622x394x48] + 3x[592x394x48] + 6x[592x494x48]

**Note:**

Special sizes of filters are available by Camfil.

S.4.3 Bag filters

Turn the unit off and wait for 2 minutes till unit completely stops. Used filters can be pulled out. Store the used filters immediately in plastic bags to avoid that dust pollutes the environment. Geniox Go units in the sizes 10 – 31 are provided with a very corrosive-resistant and reliable system, where filters are slid into the units in a lower and upper durable u-profile of plastic/rubber. Check the upper and lower U-profile for damage and check the vertical rubber profile on the back wall as well as the rubber profile on the inspection door for damage. The new filter bags must be pushed carefully into the unit in order to ensure that they are sealed properly. The filters must have vertical bags.

ONE self-adhesive foam strip must be placed on the vertical frame of EACH filter to avoid major air leakage through the vertical opening between 2 filters. Please note – only ONE self-adhesive foam strip must be placed on the vertical frame of EACH filter – Please establish the practical rule that the self-adhesive foam strip is placed on the vertical side that is visible from the inspection side. Those very important self-adhesive foam strips are usually not delivered by the suppliers of filters. The customer must order those self-adhesive foam strip from a supplier of foam strips. The foam strip must be wide enough to prevent air leakage between the filters but not too wide to allow closing the inspection door. **Note! The staff must have the self-adhesive foam strips available when they go to the air handling unit. Without those self-adhesive foam strips, any change of filters is impossible.**

Remove the protection from the self-adhesive side of the strip.

Place the self-adhesive strip on **one** vertical side of the filter frame

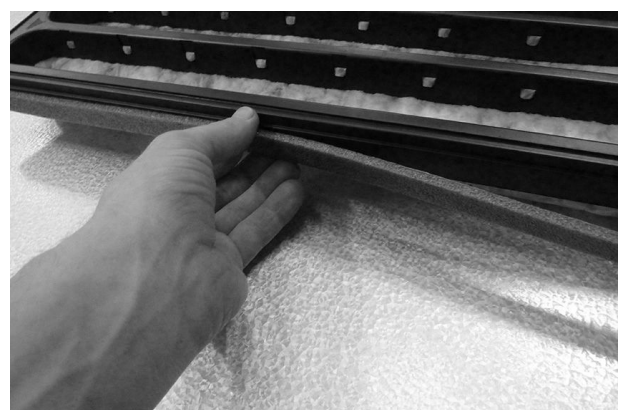
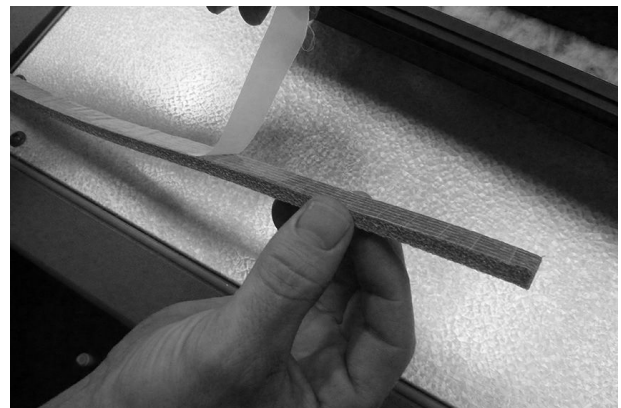
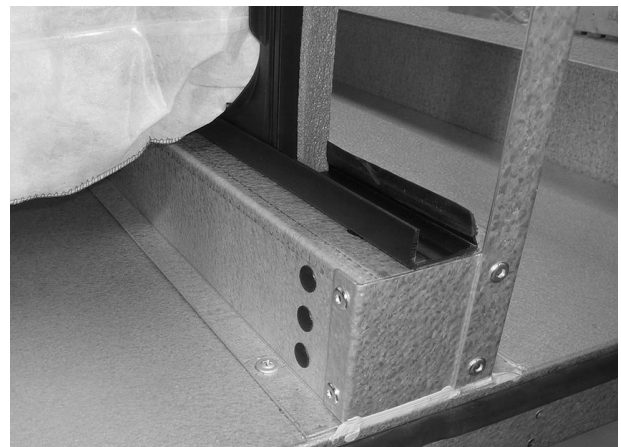

Check that the end of the strip is fully even with the horizontal side of the filter frame.



Remove excess of the strip. The end of the strip must be fully even with the horizontal side of the filter frame.



Push the filters carefully in the U-profile to be sure that there are no leakages between the filters. Check that the vertical side of the last filter in the U-profile is fully even with the end of the U-profile. If the end of the last filter is not fully even with the end of the U-profile an additional self-adhesive profile must be added to avoid any gap between the rubber profile on the inspection door and the last filter.



The end of the last filter is fully even with the end of the U-profile. The rubber profile on the inspection door will close the gap between inspection door and filter. Job is done.



Check that rubber profiles on the back panel as well as rubber profiles on the inspection door are without wear and damage – still sufficient for avoiding any air leakage.



S.4.4 Panel filters

The filter cell guide rails are to be cleaned before fitting the new filters.

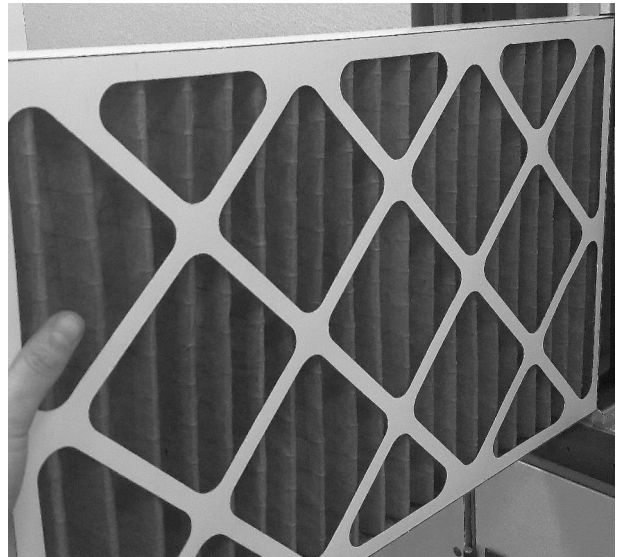

S.5 Changing the Internal Battery in the controller



Caution

This procedure requires knowledge of proper ESD protection; i.e. an earthed wristband must be used!

When the alarm "Internal Battery" is activated and the battery LED lights up red, the battery for backup of program memory and real-time clock has become too weak. The battery is replaced as described below. A backup capacitor saves the memory and keeps the clock running for at least 10 minutes after the power supply is removed. Therefore, if the battery replacement takes less than 10 minutes, there will be no need to reload the program, and the clock will continue to run normally.

The replacement battery must be of the type CR2032.

- 1 Remove the cover by pressing down the locking torques at the edge of the cover using a small screwdriver, and at the same time pulling the edges outwards.

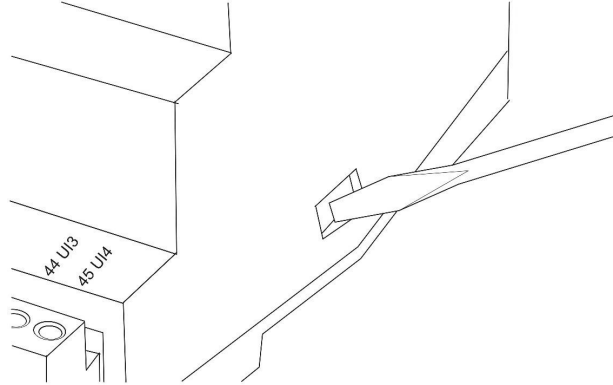

- 2 Grip the battery firmly with your fingers and lift it upwards until it rises from its holder. Press the new battery firmly down into place. Note that to preserve correct polarity; the battery can only be inserted the "right way round".

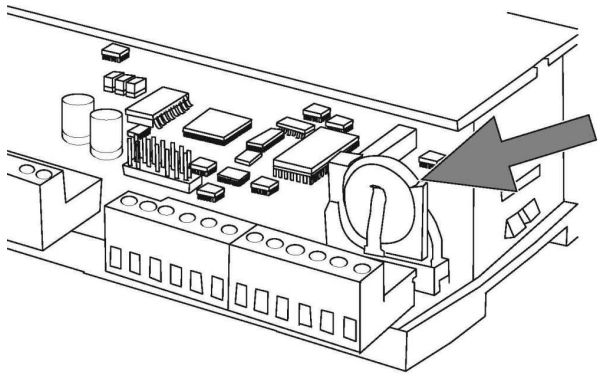

S.6 Other functions to maintain

S.6.1 The unit

It is very easy to remove inspection doors for extraordinary good access to cleaning, service, repairs and replacement of components in the unit. Lift the stainless steel shaft in the hinge to remove the door

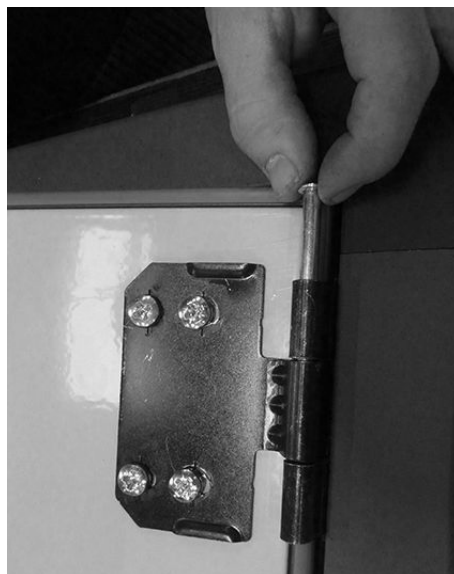

- The unit should be cleaned once a year when operating with normal air quality for comfort ventilation with no special hygiene requirements.
- To clean the unit, dry it off with a dry cloth, or use water mixed with a non-corrosive cleaning medium.

- Any corrosion – for example the bottom of the section for outdoor air intake and the bottom of the section for exhaust air outlet must be cleaned off immediately, and the surface treated.
- In special operating conditions, where the air is aggressive or very humid, for example, or where there are special hygiene requirements, the unit shall be cleaned more frequently as required.
- Cleaning medium and method should be adapted to the relevant conditions. Any corrosion should be cleaned off immediately, and the surface treated.
- Closing mechanisms are to be lubricated at least once a year. Synthetic door hinges are service free. Seals around inspection doors are to be cleaned at least once a year and are to be checked for leakage.
- It is recommended to treat the seals with a moisture repellent agent. Connecting pieces for the unit sections, including the Disc-Lock types, are to be checked for tightness at least once a year.
- All seals are to be inspected at least once a year and are to be repaired if necessary.
- Grilles for air intake and exhaust air outlet are to be cleaned at least once a year to prevent blockage.

S.6.2 Dampers

Rubber seals between the damper blades and the frame are to be checked once a year. These seals are not to be lubricated or treated in any other way.

Each damper blade is driven by a gear drive of a temperature-resistant, glass-fibre reinforced PA6 nylon composite. Gear-drive as well as bearings do not require lubrication.

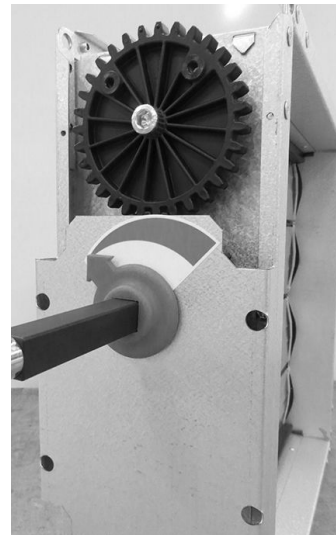
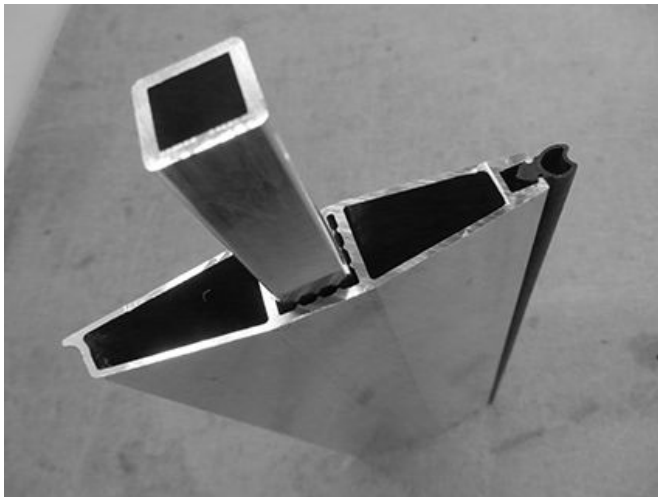

The damper blades are fitted with synthetic bearings requiring no lubrication. Air-tightness of the damper, when the damper motor is in the closed position, must be visually checked once a year. The damper motor is to be adjusted if the damper does not close tightly.

S.6.3 Rotary heat exchanger

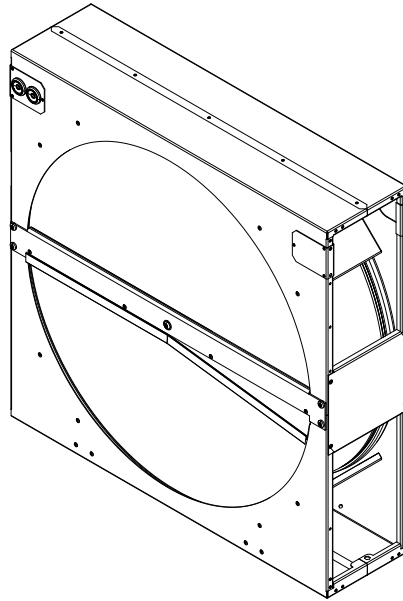

S.6.3.1 Rotor

The rotor is to be checked at least once a year to ensure that it can turn freely and easily. This can be done by removing the belt drive at the motor and then turning the rotor manually with a hand on the peripheral rotor casing. At the same time the brush seals are to be checked for damage. The bearings are factory lubricated and do not require any service lubrication. During operation the rotor can become dirty. The rotor can be cleaned by blowing through with compressed air.

S.6.3.2 Motor and belt drive

The bearings are factory lubricated and do not require any service lubrication. The belt drive is to be checked for correct tightness and that it is undamaged. On smaller units, the rotor is fitted with an elastic belt drive and supplied with a reserve belt on the rotor. This belt drive does not require service and cannot be shortened. A new belt can be fitted using specialist tools. On larger heat exchangers the rotor has a V-belt with a belt connector. If the belt is no longer tight, it must be shortened to a length which enables the motor base frame tightening spring to hold the belt tight. If new screws are used for the belt connector, they must not have a length which exceeds the thickness of the belt and connector. Remove the excess, if any, with a file.

S.6.4 Cross flow and counter flow exchanger

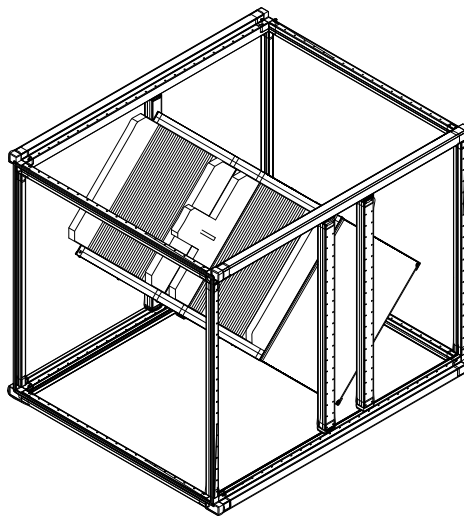

Note:

Once a year the edges of the heat exchanger plates are to be checked for cleanliness and damage.

If there is dust on the edges of the plates, remove it with a soft brush. If grease or other such substances are present, then the edges must be washed using grease dissolving detergents.

S.6.4.1 By-pass damper

The damper blades are fitted with synthetic bearings requiring no lubrication. Each damper blade is driven by a gear drive of a temperature resistant glass fibre reinforced PA6 nylon composite. The steel rods and brass bushes do not require lubrication. Air-tightness of the dampers, when the damper motor is in the closed position, must be visually checked once a year. The damper motor is to be adjusted if the damper does not close tightly.

S.6.4.2 Condensate water drain

Once a year clean the drip tray beneath the heat exchanger, as well as the drain and the water trap. Take care that there is sufficient water in the water trap. If a droplet eliminator has been fitted, this must be checked once a year and cleaned if necessary.

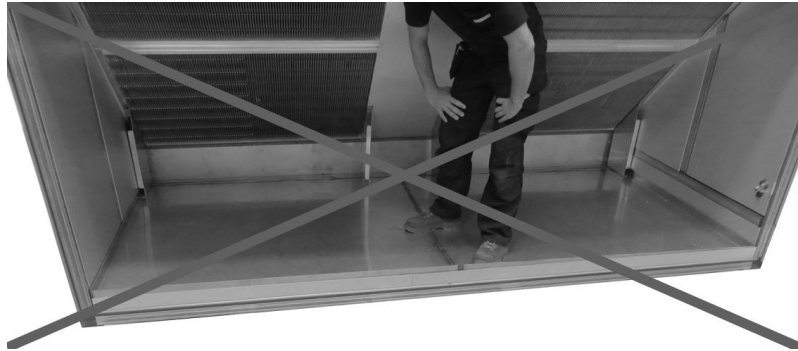

Drip tray with slope is not supported for the weight of persons. Do not walk or stay in the drip tray

This type of water trap is designed for negative pressure. Demount this type of water trap for careful cleaning.



S.6.5 Run-around heat exchanger

A heat recovery system of this type consists of a heating coil in the supply air- flow and a cooling coil in the exhaust air- flow. After an extended running period (normally a few years) dust particles can accumulate on the surface of the coils. This can reduce the efficiency of the coils. Cleaning must be carried out with the utmost care to ensure that the coil fins are not damaged.

The piping system must be vented once a year as air in the system can significantly reduce the capacity of the coils.

S.6.5.1 Pump and pressure expansion

The service instructions issued by the pump manufacturer must be followed. The pressure expansion system must be checked once a year. If necessary, the pressure must be increased to the correct level.

S.6.5.2 Condensate water drain

Once a year clean the drip tray beneath the heat exchanger, as well as the drain and the water trap. Take care that there is sufficient water in the water trap. If a droplet eliminator has been fitted to the cooling coil, this must be checked once a year and cleaned if necessary.

S.6.6 Heating coil

After an extended running period (normally a few years) dust particles can accumulate on the surface of the coil. This can reduce the efficiency of the coil. Cleaning must be carried out with the utmost care to ensure that the coil fins are

not damaged. The piping system must be vented once a year as air in the system can significantly reduce the capacity of the coil.

S.6.6.1 Heating battery

Check that the frost protection system is fully operational. A battery may burst due to frost if the frost protection system is not operational.

S.6.6.2 Cooling battery

Once a year clean the drip tray beneath the cooling coil, as well as the drain and the water trap. Take care that there is sufficient water in the water trap. If a droplet eliminator has been fitted to the cooling coil, this must be checked once a year and cleaned if necessary.

S.6.6.3 Electric heating battery

Check that the built-in safety thermostat with an automatic reset function and the overheat thermostat with manual re-setting are fully operational.

S.6.7 Plug fans

Dust can accumulate on the fan impeller which can cause imbalance and vibrations. The fan impeller must therefore be checked once a year and cleaned, if necessary. Anti-vibration mounts and flexible connections should be checked at the same time. If the anti-vibration mounts are damaged in any way they must be replaced.

S.6.7.1 Motor

The motor are usually fitted with factory lubricated bearings which require no further lubrication. Larger motors can be fitted with greasing nipples and bearings which require regular lubrication. Lubricating these types of bearings must be carried out according to the manufacturer's instructions.

S.6.8 Silencer

During operation dust particles can accumulate on the surface of the baffles. Silencers that are designed for dry and wet cleaning are fitted with baffles that can be extracted from the unit casing. Baffles designed for dry cleaning can be cleaned using a soft brush or they can be vacuum cleaned. Baffles designed for wet cleaning can be washed down using a soft brush and soapy water. The detergent used must be non-aggressive. After washing, the baffles must be wiped dry with a cloth. Remember to clean the inside surface of the unit casing before refitting the baffles.

S.6.9 Outdoor air section

Dust and dirt can accumulate in this section. Large inspection doors give access for cleaning.

S.6.10 Heat pump unit

Mandatory annual control must be done by certified technicians from a certified company. See further description in Annex 6 and 7.

T Instructions to enable adjustment and maintenance safely

T.1 Protective measures and additional protective measures

Adjustment and maintenance must be done by skilled technicians – usually based on service contracts for some years or long-term ESCO contracts.

The units are provided with lockable doors to avoid unintended hazards and injury because of rotating parts in the unit. The potential sources of harm are the fans with fast rotating impellers. Hazards from the impellers are obvious during operation, but when power is cut-off, the impellers are still potential hazards due to after-run for at least 20 seconds. Notice that even cut-off the impellers are still potential hazards.

Other motor-driven parts are dampers with damper motors and rotary heat exchangers, but the movement is so slow that guard measures are not necessary. Just keep your hands away from places with risk of injury.

Use particulate respirator when filters are replaced.

T.1.1 Necessary protection measures prior to start-up

Ensure that all protection measures are installed correct before start-up.

T.1.1.1 Design of protection measures

Lockable doors can be unlocked only by use of tools.

T.1.1.2 Configuration of frequency converters

A frequency converter is mounted beside the fan in some units. If the configuration of frequency is carried out with the fan in operation for safety reasons a long cable must be installed between the frequency converter inside the unit and the control panel outside the unit.

T.1.2 Safe adjustment and maintenance

Before maintenance and repair, the unit must be turned off by rotating the main power switch to **OFF** position. **Note that lamps must be switched on during maintenance** (lamps are an accessory – only installed, if ordered).

Use cut-resistant gloves for protection against injury from sharp metal plate edges. Use CE-marked gloves for this purpose. Use helmet during maintenance work in the unit.

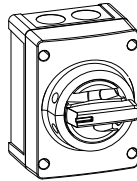

T.1.3 Personal protective equipment for maintenance staff – health and safety

Use the below-mentioned personal protective equipment for maintenance:

- Cut-resistant gloves for protection against injury from sharp metal plate edges. Use CE-marked gloves for this purpose.
- Helmet
- Particulate respirator – maintenance free including foam face-seal and adjustable pre-threaded headbands – for replacing filters.
- Permanent magnet motor. The shaft must be blocked during repairs and maintenance of the electric system (the motor generates electricity by rotation – for example that the wind and thermic drives the fan/motor).

U Information on airborne noise emissions exceeding 70 dB(A)

Due to the design and construction of the units the (A) weighed sound pressure level from fans and other components do not exceed 70 dB (A) outside the units.

Annex Geniox Go with control system Air handling unit

User Manual

GB

Document in original language | A006

Part number of this manual 211728



Contents

- Annex 1 Technical data – unique data for every unit (in separate cover)..... 47
- Annex 2 Assembly of base frame – height 118 mm or 218 mm for unit sizes 10 – 18..... 47
- Annex 3 Assembly of base frame – height 118 mm or 218 mm for unit sizes 20 – 24..... 51
- Annex 4 Installation of steel roof in the sizes 10 – 31..... 55
- Annex 5 Speed control for rotor and assembly of divided rotor 61
- Annex 6 Reversible heat pump unit (in separate cover, if heat pump was delivered) 68
- Annex 7 Menu for internal controller in the heat pump unit (in separate cover, if heat pump was delivered) 68
- Annex 8 Connection of fan motor and set-up manual for frequency converter..... 68
- Annex 9 Commissioning protocol (in separate cover)..... 68
- Annex 10 Report with data from final functional test on the Systemair factory 68
- Annex 11 Short description of main components in the control system..... 68
- Annex 12 Wiring diagram (in separate cover, if control system was delivered) 68
- Annex 13 Operator’s guide (How to use the Systemair control panel) (in separate cover) 68

Annex 1 Technical data – unique data for every unit (in separate cover)

Printed on separate pages and delivered with every unit. Enclosed in separate cover.

Annex 2 Assembly of base frame – height 118 mm or 218 mm for unit sizes 10 – 18

2.1 Components

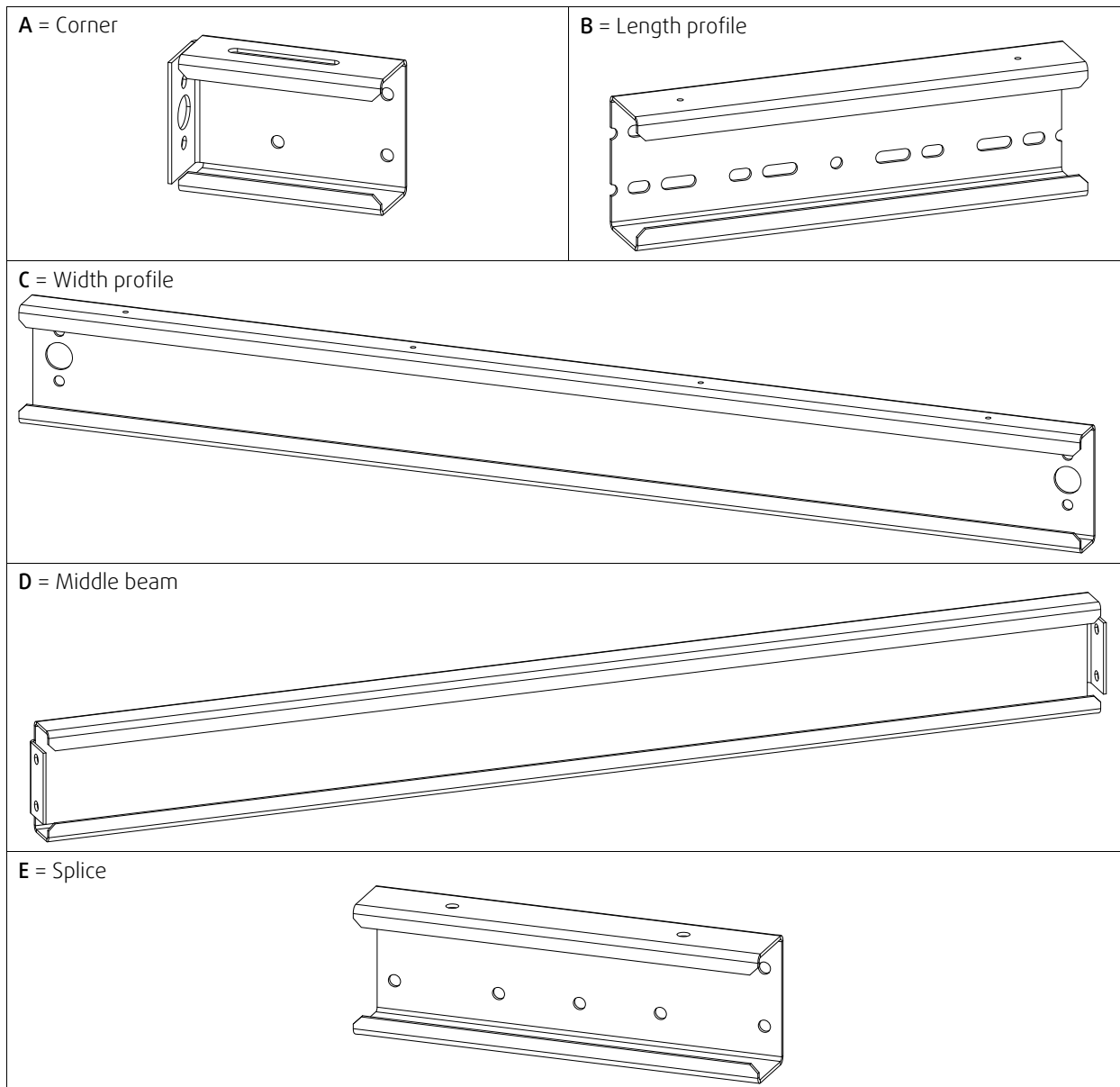

2.2 Base frame length 482 – 2681 [mm] Unit size 10 – 18

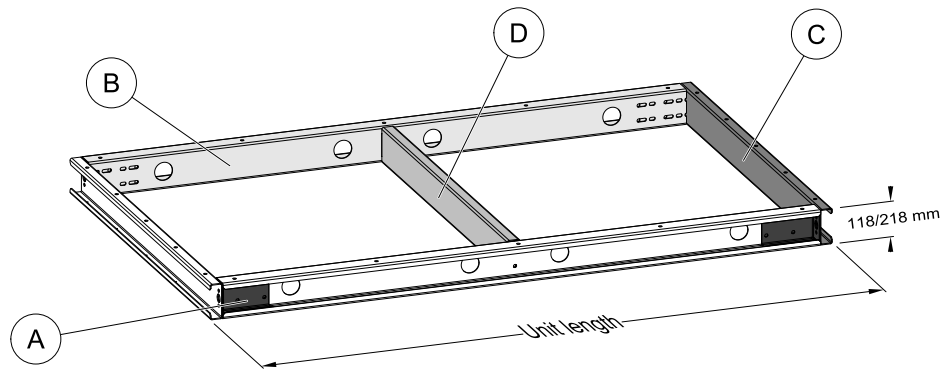

Width profile type C		
Unit size	Quantity	Length [mm]
Geniox10	2	1070
Geniox11	2	1170
Geniox12	2	1270
Geniox14	2	1470
Geniox16	2	1670
Geniox18	2	1870

Frame length [mm]	B		A	D
	Quantity	Length [mm]	Quantity	Quantity
482-581	2	400	4	0
582-681	2	500	4	0
682-781	2	600	4	1
782-881	2	700	4	1
882-981	2	800	4	1
982-1081	2	900	4	1
1082-1181	2	1000	4	1
1182-1281	2	1100	4	1
1282-1381	2	1200	4	1
1482-1581	2	1400	4	1
1582-1681	2	1500	4	1
1682-1781	2	1600	4	1
1782-1881	2	1700	4	1
1882-1981	2	1800	4	1
1982-2081	2	1900	4	1
2082-2181	2	2000	4	1
2182-2281	2	2100	4	1
2282-2381	2	2200	4	1
2382-2481	2	2300	4	1
2482-2581	2	2400	4	1
2582-2681	2	2500	4	1

2.3 Base frame length 2682 – 5081 [mm] Unit size 10 – 18

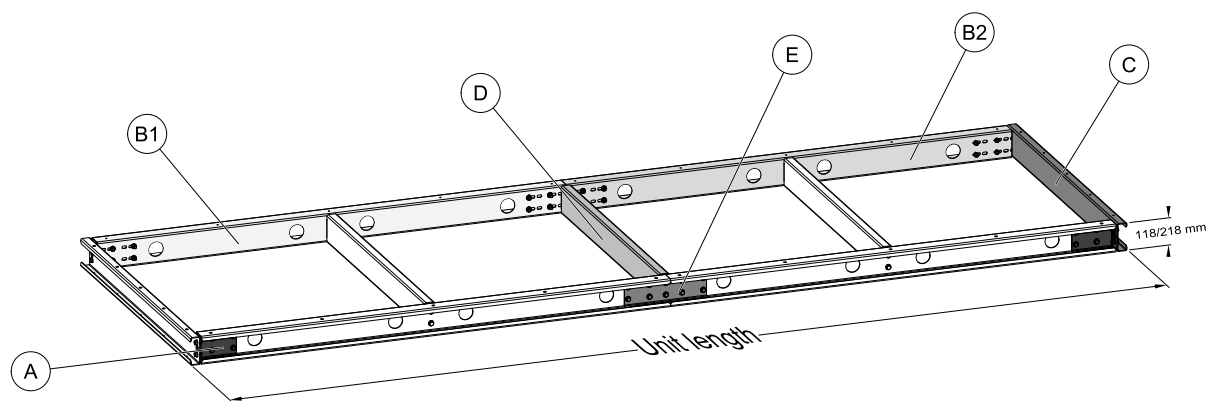

Width profile type C		
Unit size	Quantity	Length [mm]
Geniox10	2	1070
Geniox11	2	1170
Geniox12	2	1270
Geniox14	2	1470
Geniox16	2	1670
Geniox18	2	1870

Frame length [mm]	B1		B2		A	D	E
	Quantity	Length [mm]	Quantity	Length [mm]	Quantity	Quantity	Quantity
2682-2781	4	1300	0	0	4	3	2
2782-2881	2	1300	2	1400	4	3	2
2882-2981	4	1400	0	0	4	3	2
2982-3081	2	1400	2	1500	4	3	2
3082-3181	4	1500	0	0	4	3	2
3182-3281	2	1500	2	1600	4	3	2
3282-3381	4	1600	0	0	4	3	2
3382-3481	2	1600	2	1700	4	3	2
3482-3581	4	1700	0	0	4	3	2
3582-3681	2	1700	2	1800	4	3	2
3682-3781	4	1800	0	0	4	3	2
3782-3881	2	1800	2	1900	4	3	2
3882-3981	4	1900	0	0	4	3	2
3982-4081	2	1900	2	2000	4	3	2
4082-4181	4	2000	0	0	4	3	2
4182-4281	2	2000	2	2100	4	3	2
4282-4381	4	2100	0	0	4	3	2
4382-4481	2	2100	2	2200	4	3	2
4482-4581	4	2200	0	0	4	3	2
4582-4681	2	2200	2	2300	4	3	2
4682-4781	4	2300	0	0	4	3	2
4782-4881	2	2300	2	2400	4	3	2
4882-4981	4	2400	0	0	4	3	2
4982-5081	2	2400	2	2500	4	3	2

2.4 Base frame length 5082 – 6081 [mm] Unit size 10 – 18

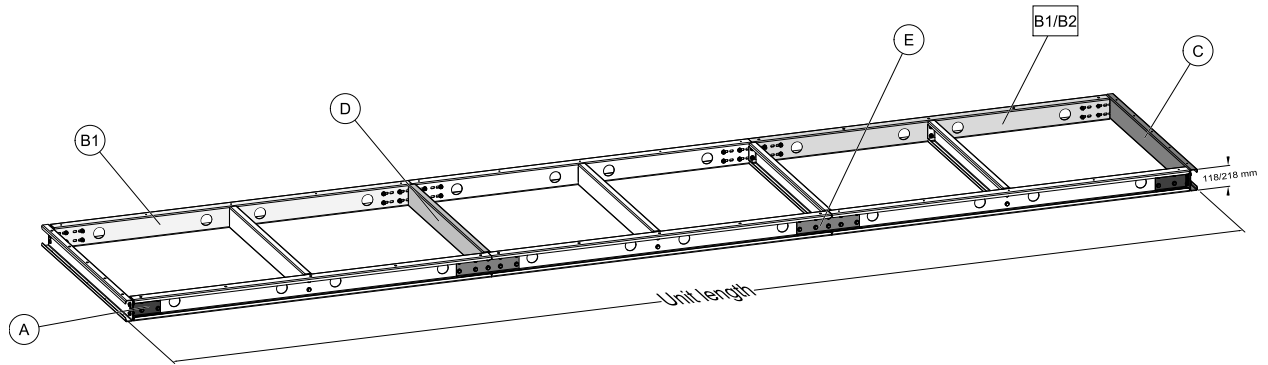

Width profile type C		
Unit size	Quantity	Length [mm]
Geniox10	2	1070
Geniox11	2	1170
Geniox12	2	1270
Geniox14	2	1470
Geniox16	2	1670
Geniox18	2	1870

Frame length [mm]	B1		B2		A	D	E
	Quantity	Length [mm]	Quantity	Length [mm]	Quantity	Quantity	Quantity
5082-5181	2	1600	4	1700	4	5	4
5182-5281	6	1700	0	0	4	5	4
5282-5381	4	1700	2	1800	4	5	4
5382-5481	2	1700	4	1800	4	5	4
5482-5581	6	1800	0	0	4	5	4
5582-5681	4	1800	2	1900	4	5	4
5682-5781	2	1800	4	1900	4	5	4
5782-5881	6	1900	0	0	4	5	4
5882-5981	4	1900	2	2000	4	5	4
5982-6081	2	1900	4	2000	4	5	4

Annex 3 Assembly of base frame – height 118 mm or 218 mm for unit sizes 20 – 24

3.1 Components

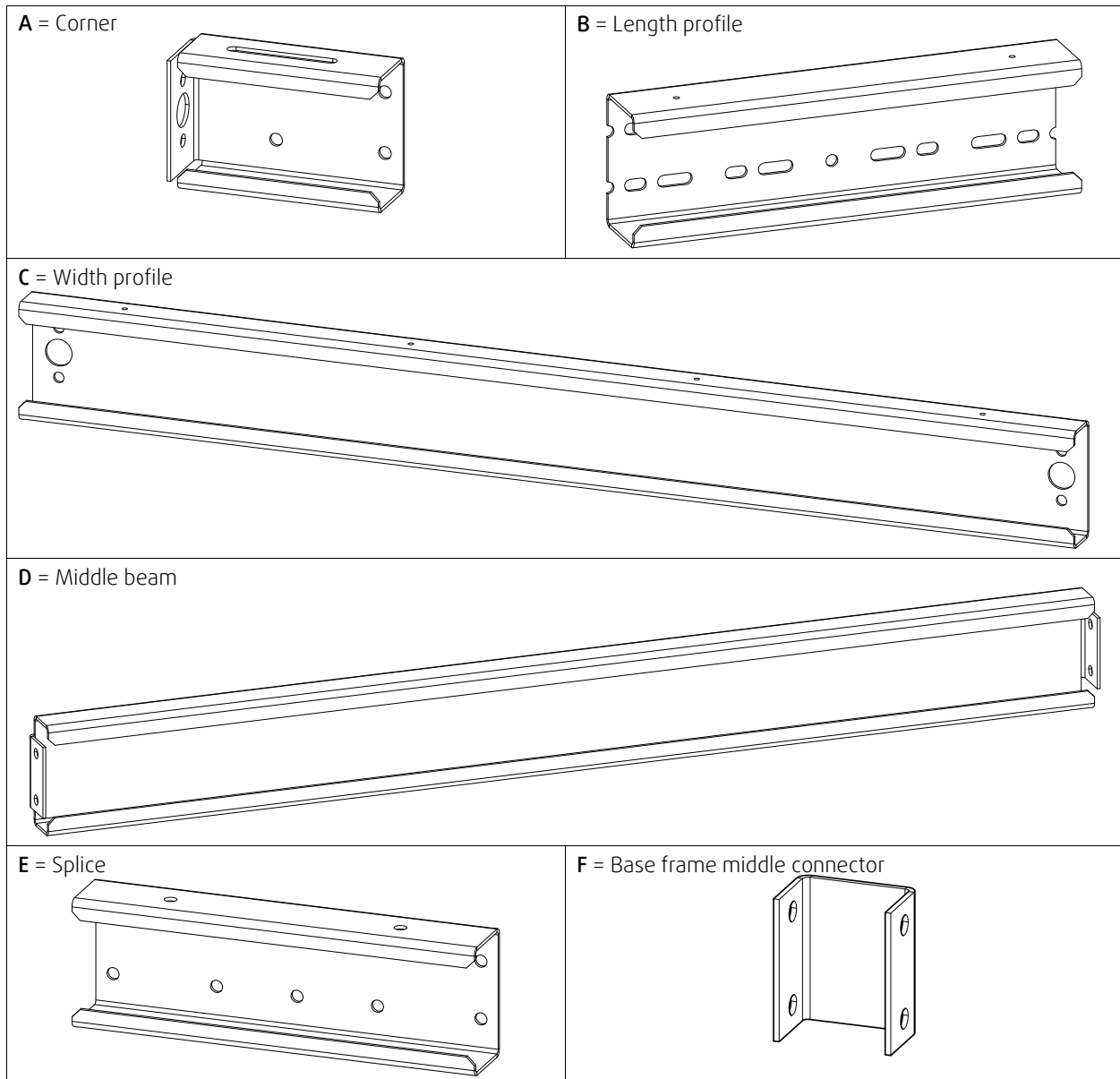

3.2 Base frame length 482 – 2681 [mm] Unit size 20 – 24

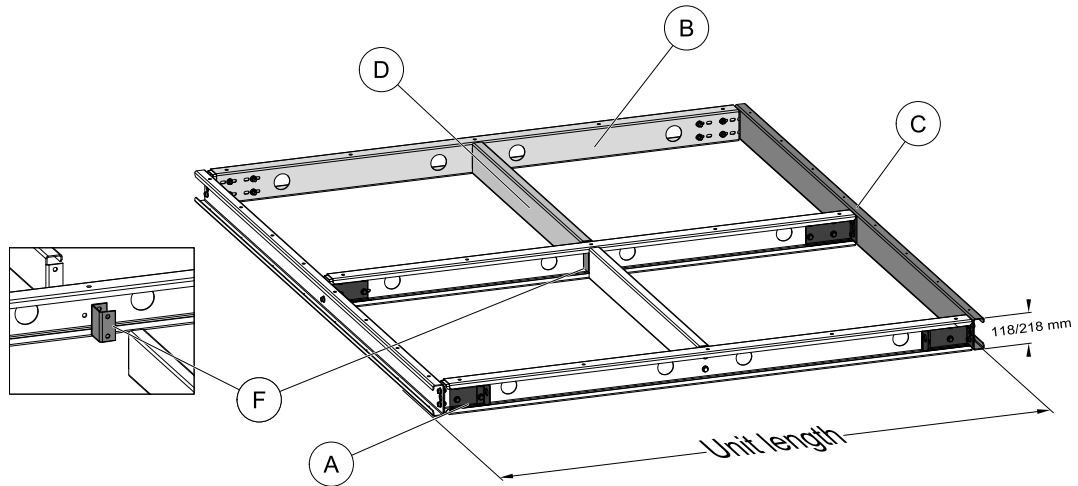

Width profile type C		
Unit size	Quantity	Length [mm]
Geniox20	2	2070
Geniox22	2	2270
Geniox24	2	2470

Frame length [mm]	B		A	D	F
	Quantity	Length [mm]	Quantity	Quantity	Quantity
482-581	3	400	6	0	1
582-681	3	500	6	0	1
682-781	3	600	6	2	1
782-881	3	700	6	2	1
882-981	3	800	6	2	1
982-1081	3	900	6	2	1
1082-1181	3	1000	6	2	1
1182-1281	3	1100	6	2	1
1282-1381	3	1200	6	2	1
1482-1581	3	1400	6	2	1
1582-1681	3	1500	6	2	1
1682-1781	3	1600	6	2	1
1782-1881	3	1700	6	2	1
1882-1981	3	1800	6	2	1
1982-2081	3	1900	6	2	1
2082-2181	3	2000	6	2	1
2182-2281	3	2100	6	2	1
2282-2381	3	2200	6	2	1
2382-2481	3	2300	6	2	1
2482-2581	3	2400	6	2	1
2582-2681	3	2500	6	2	1

3.3 Base frame length 2681 – 5081 [mm] Unit size 20 – 24

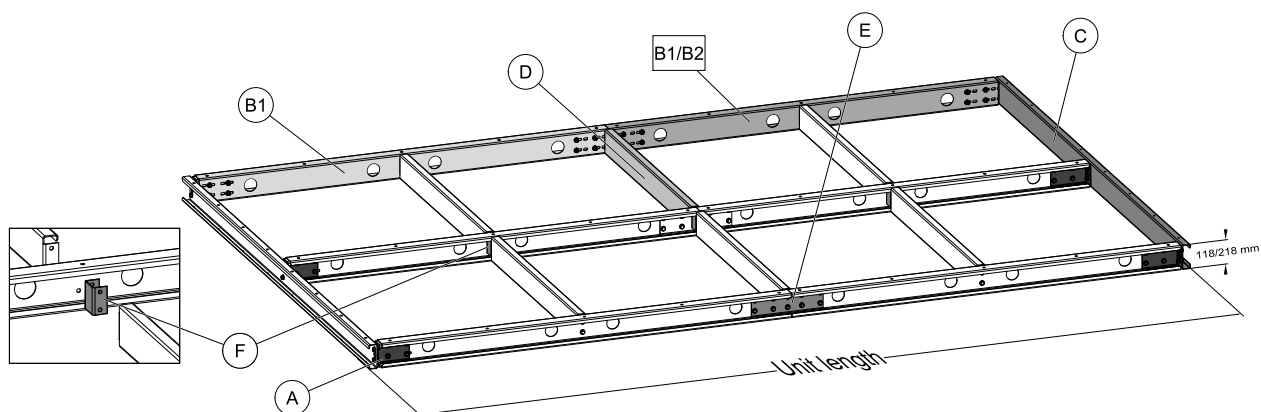

Width profile type C		
Unit size	Quantity	Length [mm]
Geniox20	2	2070
Geniox22	2	2270
Geniox24	2	2470

Frame length [mm]	B1		B2		A	D	E	F
	Quantity	Length [mm]	Quantity	Length [mm]	Quantity	Quantity	Quantity	Quantity
2682-2781	6	1300	0	0	6	6	3	3
2782-2881	3	1300	3	1400	6	6	3	3
2882-2981	6	1400	0	0	6	6	3	3
2982-3081	3	1400	3	1500	6	6	3	3
3082-3181	6	1500	0	0	6	6	3	3
3182-3281	3	1500	3	1600	6	6	3	3
3282-3381	6	1600	0	0	6	6	3	3
3382-3481	3	1600	3	1700	6	6	3	3
3482-3581	6	1700	0	0	6	6	3	3
3582-3681	3	1700	3	1800	6	6	3	3
3682-3781	6	1800	0	0	6	6	3	3
3782-3881	3	1800	3	1900	6	6	3	3
3882-3981	6	1900	0	0	6	6	3	3
3982-4081	3	1900	3	2000	6	6	3	3
4082-4181	6	2000	0	0	6	6	3	3
4182-4281	3	2000	3	2100	6	6	3	3
4282-4381	6	2100	0	0	6	6	3	3
4382-4481	3	2100	3	2200	6	6	3	3
4482-4581	6	2200	0	0	6	6	3	3
4582-4681	3	2200	3	2300	6	6	3	3
4682-4781	6	2300	0	0	6	6	3	3
4782-4881	3	2300	3	2400	6	6	3	3
4882-4981	6	2400	0	0	6	6	3	3
4982-5081	3	2400	3	2500	6	6	3	3

3.4 Base frame length 5082 – 6081 [mm] Unit size 20 - 24

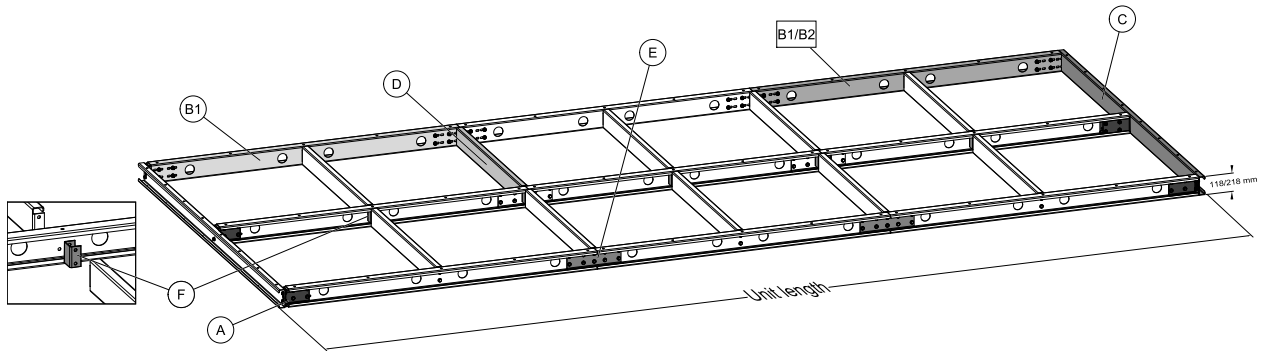

Width profile type C		
Unit size	Quantity	Length [mm]
Geniox20	2	2070
Geniox22	2	2270
Geniox24	2	2470

Frame length [mm]	B1		B2		A	D	E	F
	Quantity	Length [mm]	Quantity	Length [mm]	Quantity	Quantity	Quantity	Quantity
5082-5181	3	1600	6	1700	6	10	6	5
5182-5281	9	1700	0	0	6	10	6	5
5282-5381	6	1700	3	1800	6	10	6	5
5382-5481	3	1700	6	1800	6	10	6	5
5482-5581	9	1800	0	0	6	10	6	5
5582-5681	6	1800	3	1900	6	10	6	5
5682-5781	3	1800	6	1900	6	10	6	5
5782-5881	9	1900	0	0	6	10	6	5
5882-5981	6	1900	3	2000	6	10	6	5
5982-6081	3	1900	6	2000	6	10	6	5

Annex 4 Installation of steel roof in the sizes 10 – 31

4.1 Warnings





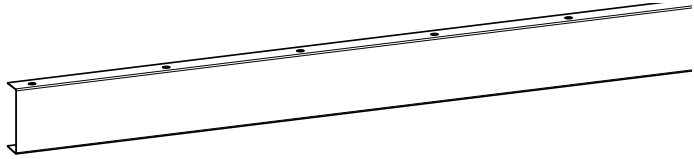
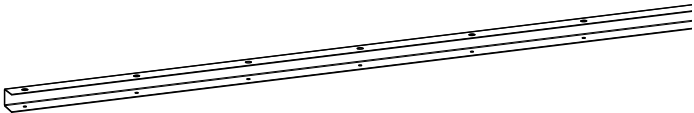
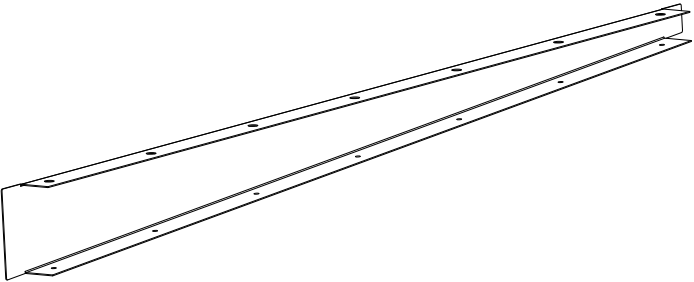
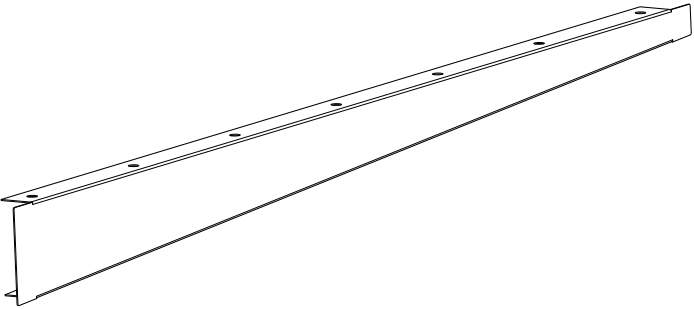
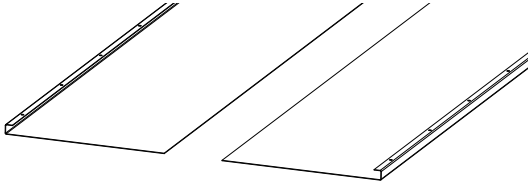
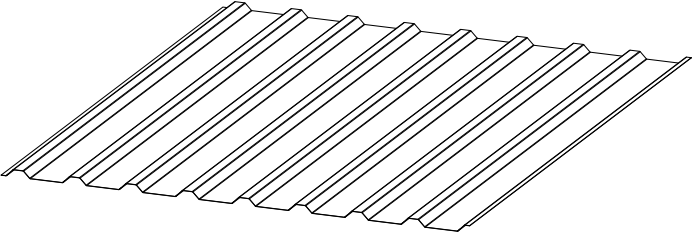

Warning

- Beware of sharp edges during the installation. Use protective gloves.
- This product must only be operated by a person which has suitable knowledge or education within this field or carried out with the supervision of a suitably qualified person.

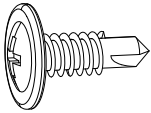
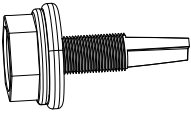
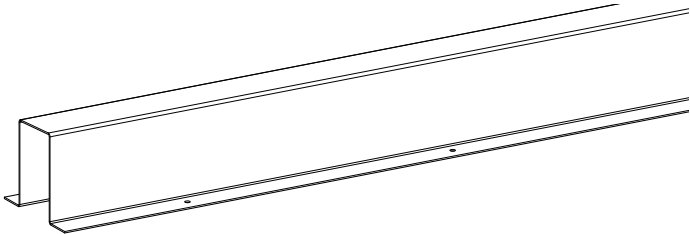
4.1.1 Components

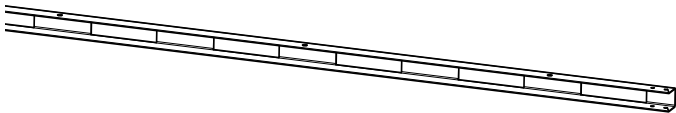
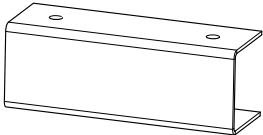
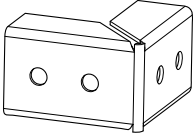
Part	Position	Description
	1	Front rail
	2	Back rail
	3	Left side rail with a slope
	4	Right side rail with a slope
	5	Left and right side overhang profiles
	6	Trapezoidal roof profile sheets

Part	Position	Description
	7	Self drilling screw
	8	Self drilling screw with sealing washer
	9	Middle rail (for units size 20 and higher)
	10	Roof profile front
	11	Roof profile back
	12	Roof profile connector
	13	Roof profile corner
	14	Foam band

4.1.2 Mounting rails and roof sheets

Important

- Place all screws in available screw holes. Stress on the roof during stormy weather is extremely high and a big amount of screws is needed to hold the roof safely.



Note:

- Roof profile sheets (pos 6) and roof overhang profiles (pos 5) do not have holes for screws. Calculate right positions before tightening screws.

1. Mount front rail (pos 1) on the front side with inspection doors and back rail (pos 2) on the back of the unit. Use self drilling screws (pos 7). The slope of the roof is 3%.

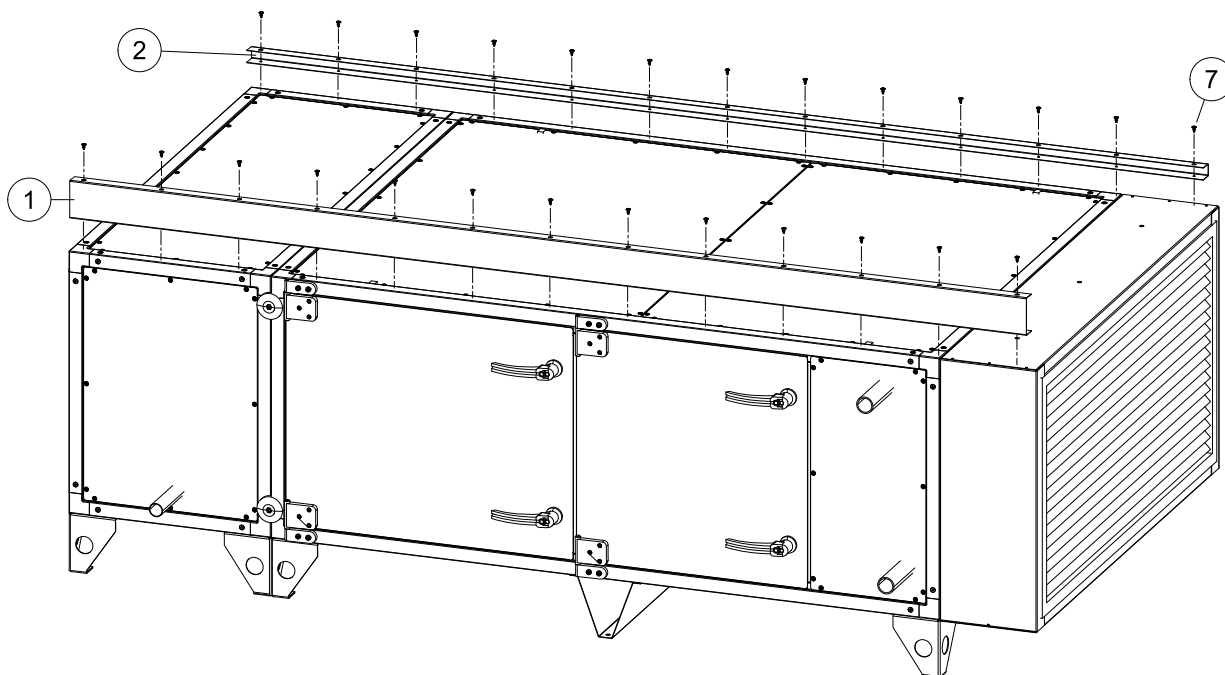

2. Some units can be delivered with rails split into several parts. In that case join these parts to match the length of the unit and secure them with screws as shown before.

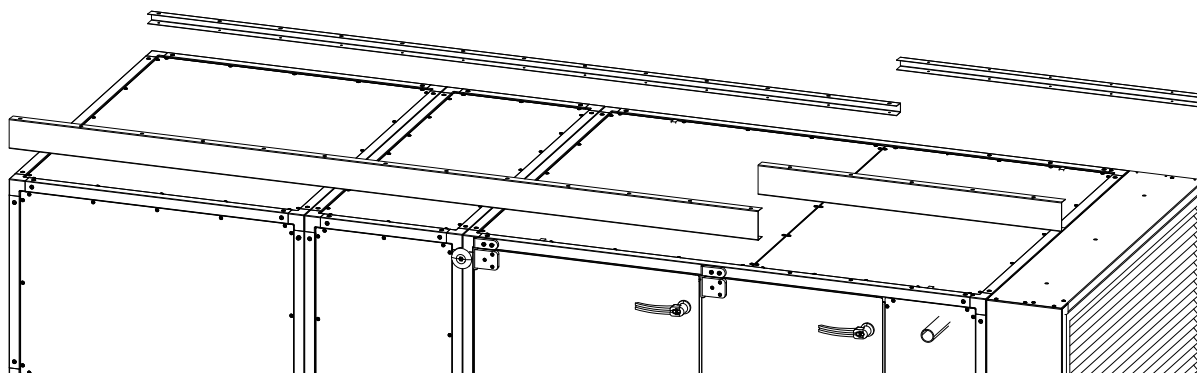

3. Mount left (pos 3) and right (pos 4) rails with the slope at each side of the unit. Use self drilling screws (pos 7).

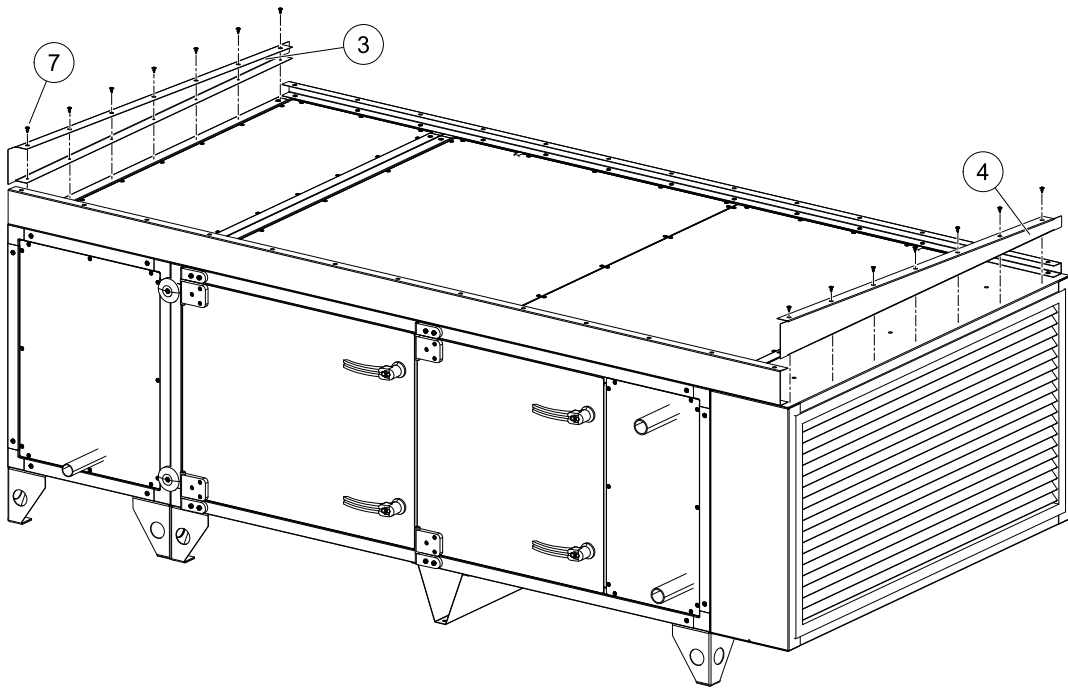

4. Mount the middle rail (pos 9) longitudinally at the centre-line of the unit with self drilling screws (pos 7). Middle rail is delivered only for units size 16 and higher.

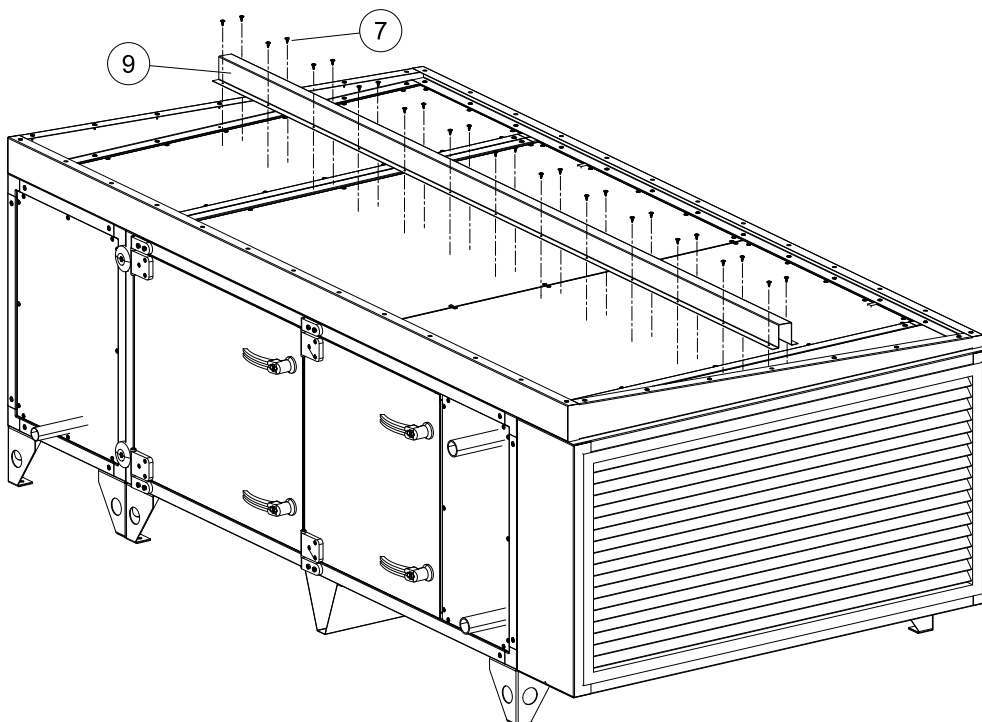

5. Place all trapezoidal roof sheets (pos 6) on rails, mount overhang plates (pos 5) under trapezoidal roof sheets at each end of the unit. Sheets have to be placed on top of each other by overlapping two crests (pos A). Last two sheets may overlap by more than two crests to match the length of the roof (pos B).

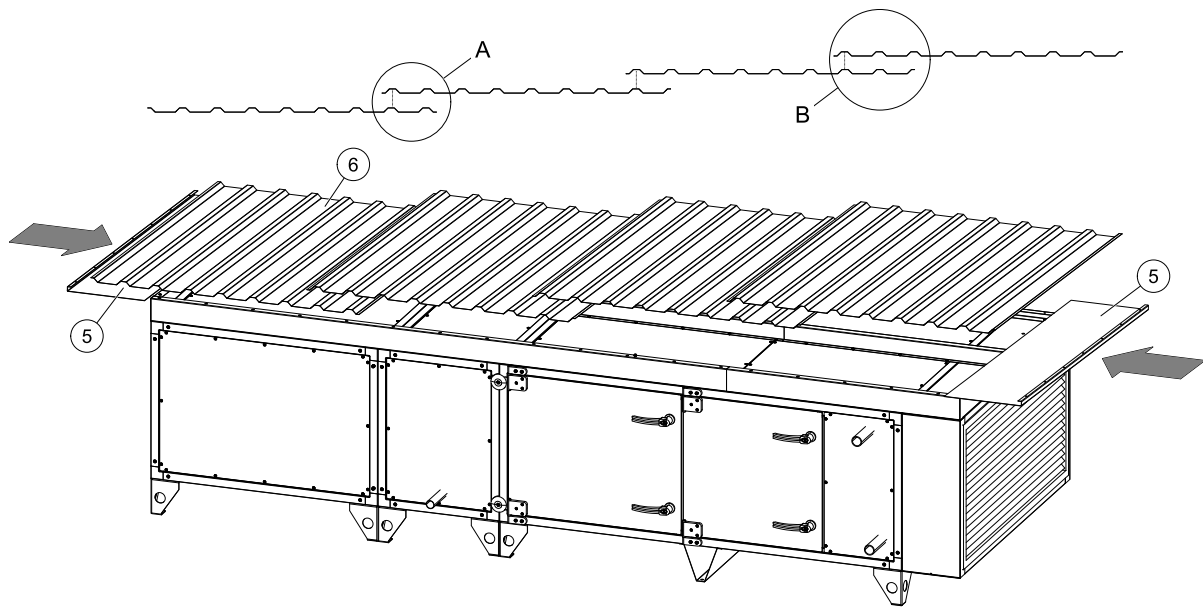

6. Position the roof so that the roof overhang profiles would be sticking out roughly 200 mm at sides and 100 mm at the front and back as show in the illustration bellow.

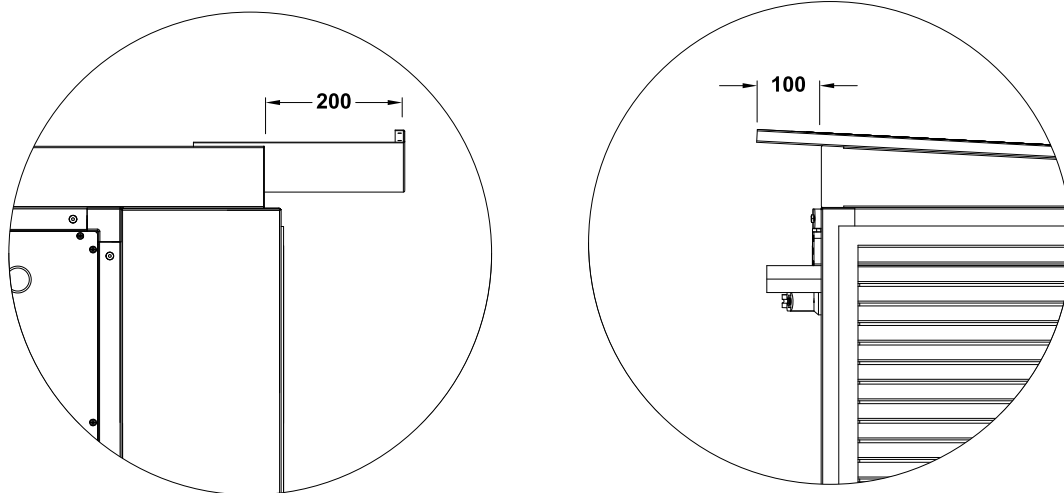

7. Once the roof is positioned correctly, secure roof overhang profiles (pos 5) with self drilling screws (pos 7).

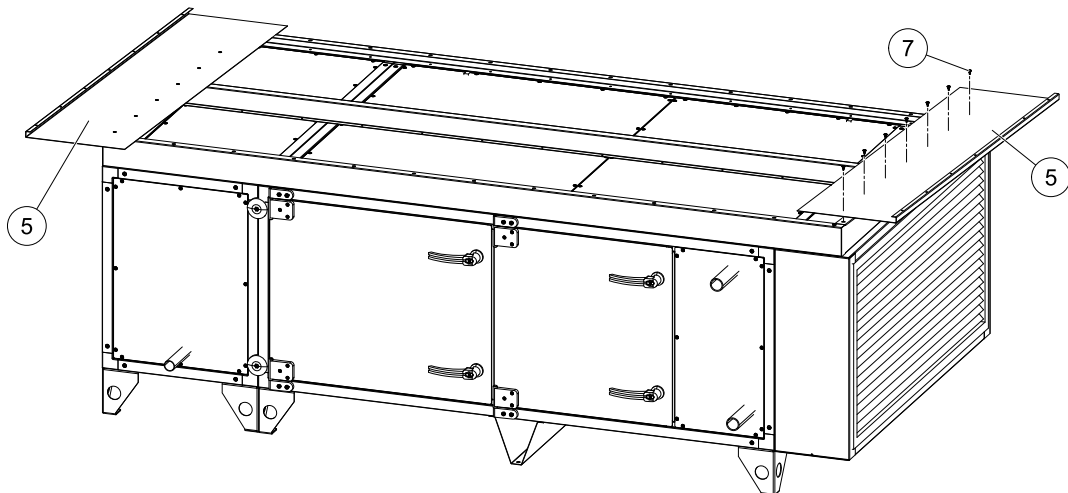

8. Then mount one of the trapezoidal roof sheets (pos 6) on the roof overhang profile (pos 5) with self drilling screws with sealing washer (pos 8). Mount the rest of trapezoidal roof sheets in the same way as the first. Last roof sheet must be mounted on the second roof overhang profile (pos 5) using self drilling screws with sealing washer (pos 8). Place two foam bands (pos 14) near the edges in both sides of recently installed trapezoidal roof sheets.

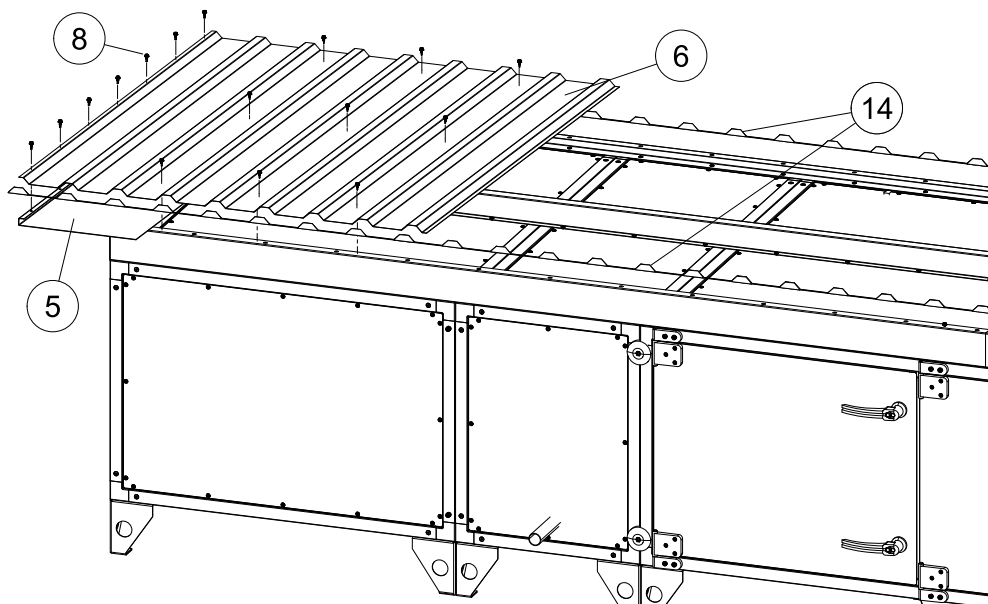

4.1.3 Mounting roof side profiles and corners

1. Mount front (pos 10) and back (pos 11) roof profiles to cover holes on the trapezoidal roof sheets. Use self drilling screws with sealing washer (pos 8). Roof profiles can be delivered split into several parts. In that case join these parts together with roof profile connectors (pos 12). Use self drilling screws (pos 7).

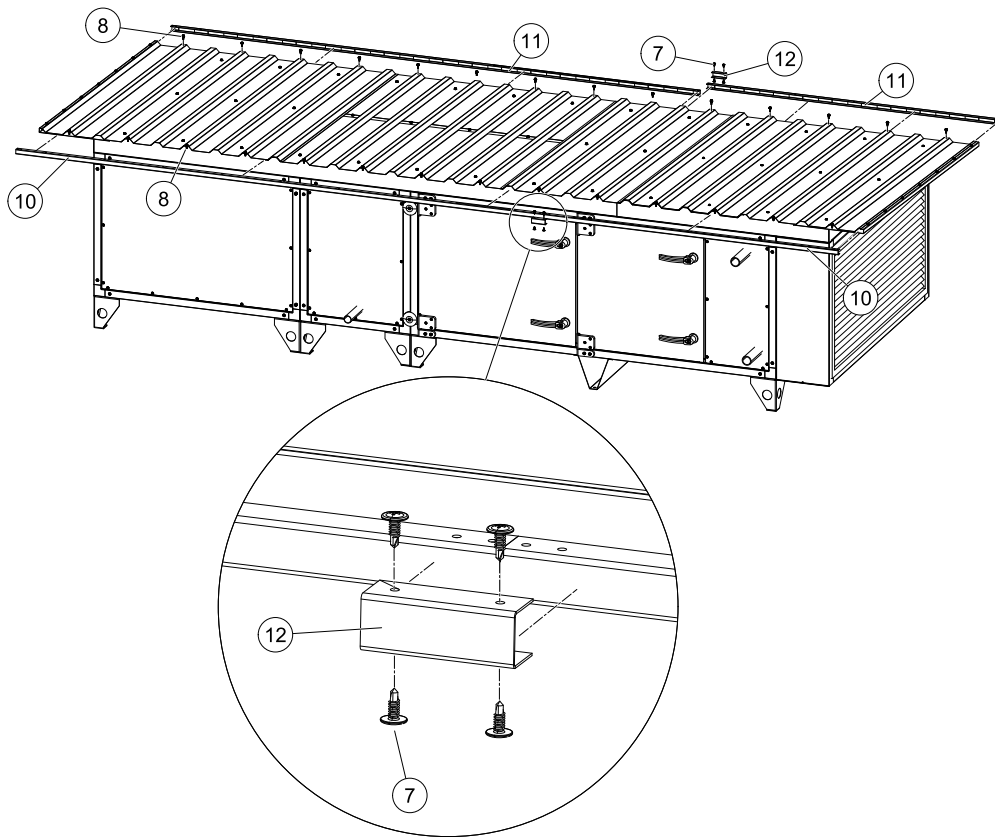

2. Mount 4 pieces of roof profile corners (pos 13) at each corner with self drilling screws (pos 7).

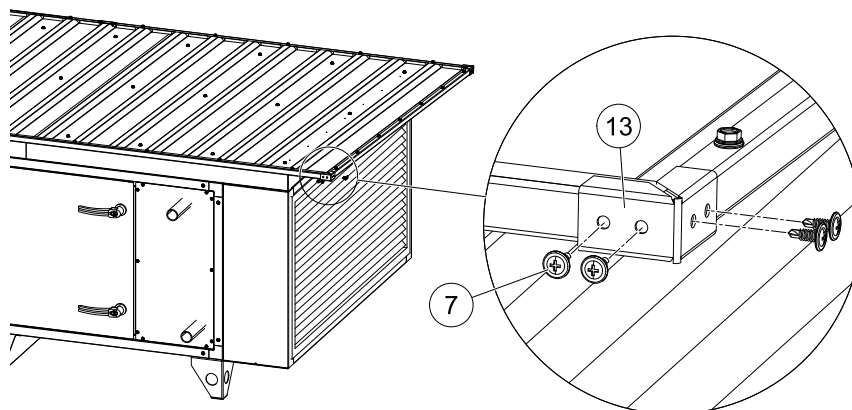

3. Finish installation of steel roof by sealing all sheet and rail joints with sealant to prevent rainwater from passing into the unit.

Annex 5 Speed control for rotor and assembly of divided rotor

5.1 Speed control

The cabinet with the speed control system for the rotor is installed behind the inspection door in the rotor section.

The cabinet contains the speed controller with all components, terminal blocks, LED displaying the operation mode, the dual position DIP switch with 8 sliding levers for programming the rotor motor signal and a button for the activation of the test mode.

5.1.1 Selection of correct signal via the 8 DIP switch levers

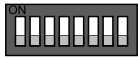

Position	Function	Code
Up	Active = ON	1
Down	Deactivated = OFF	0

The factory sets the positions of the 8 DIP switch levers for the maximum of 10 revolutions per minute for standard temperature exchangers and for hygroscopic exchangers. The position of each DIP switch lever is shown below.

Gen-iox Go size	Diameter of pulley	Diameter of pulley (Sorption)	DIP switch position	Motor	Motor (Sorption)
10	50	65	0000	90 TYD-S214-M	90TYD-S214-M
11	50	85			120 TYD-S214-M
12	50	85			
14	65	106			
16	65	106			
18	65	106	1000		
20	71	118	0100	120 TYD-S214-M	
22	80	140			120 TYD-S214-L
24	85	150			
27	95	150			
29	106	150			
31	112	160			

5.1.2 Indication of operation mode via red and green LED as well as test of motor

The LED is in the cover of the cabinet.

LED indication	Value
No indication	Power off
Green	Ordinary operation
Green – flashes	Ready for operation
Green/Red strobe	Rotary guard activated
Red	Rotor guard has not been activated
Red strobe in sequence	Alarm, rotary guard failure

Number of red flashes in series	Value
1	Output current limit
2	Over voltage
3	Under voltage
4	Failure in the controller
5	Communication failure

Restart of rotor:

- Switch off power and switch on power again
or
- Press the test button inside the cabinet

Table 3 Test of motor by checking the resistance in all 3 windings

Motor sizes	Ohm
90TYD-S214-M	40Ω
120TYD-S214-M	18Ω
120TYD-S214-L	10Ω

Setting of constant speed:

- Set fourth DIP switch lever in position - ON

Test:

- Set fourth DIP switch lever in position - ON
- Press the test button

5.1.3 Copy of the label with information about connection of cables

This self-adhesive label is always placed on the cover of the cabinet. The text is always in English.



Manual Setpoint



Test/Reset

9	10	11	12	13	14	15	16	17	18	19
Relay COM	Relay NC	Relay NO	Uin 0-10VDC	GND	Rotary Guard	GND	VCC (max 10mA)	RS485 A	RS485 B	GND
					Black	Blue	Brown			

Disable Rotary guard by connecting 14 and 16.

DIP SETTINGS:

DIP1	DIP2	DIP3	DIP4	DIP5	FUNCTION
OFF	OFF	OFF	--	--	90 TYD-S214-M 200RPM
ON	OFF	OFF	--	--	90 TYD-S214-M 250RPM
OFF	ON	OFF	--	--	120 TYD-S214-M 250RPM
ON	ON	OFF	--	--	120 TYD-S214-M 300RPM
OFF	OFF	ON	--	--	120 TYD-S214-L 270RPM
ON	OFF	ON	--	--	120 TYD-S214-L 300RPM
OFF	ON	ON	--	--	120 TYD-S214-M 350RPM
--	--	--	OFF	OFF	AI 0-10V CONTROL
--	--	--	ON	OFF	POTENTIOMETER CONTROL
--	--	--	OFF	ON	AI 0-10V CONTROL Potentiometer: max rpm limit 50-100%
--	--	--	ON	ON	NO FUNCTION

5.2 Assemble of split rotor for Geniox Go 27, Geniox Go 29 and Geniox Go 31

5.2.1 Dimensions of split rotor sections

For easier transportation, Systemair offers split rotor option. This type of rotor is divided into two sections – one is assembled in factory and contains half of the rotor, rotor controller and motor (pos. 1), another section is empty (pos. 2). Second half of the rotor is delivered in parts packed on a separate pallet. Rotor should be assembled following a manufacturer’s manual (provided in a separate cover). Split rotor option is available for Geniox Go sizes 27, 29 and 31. Dimensions of sections are shown below.

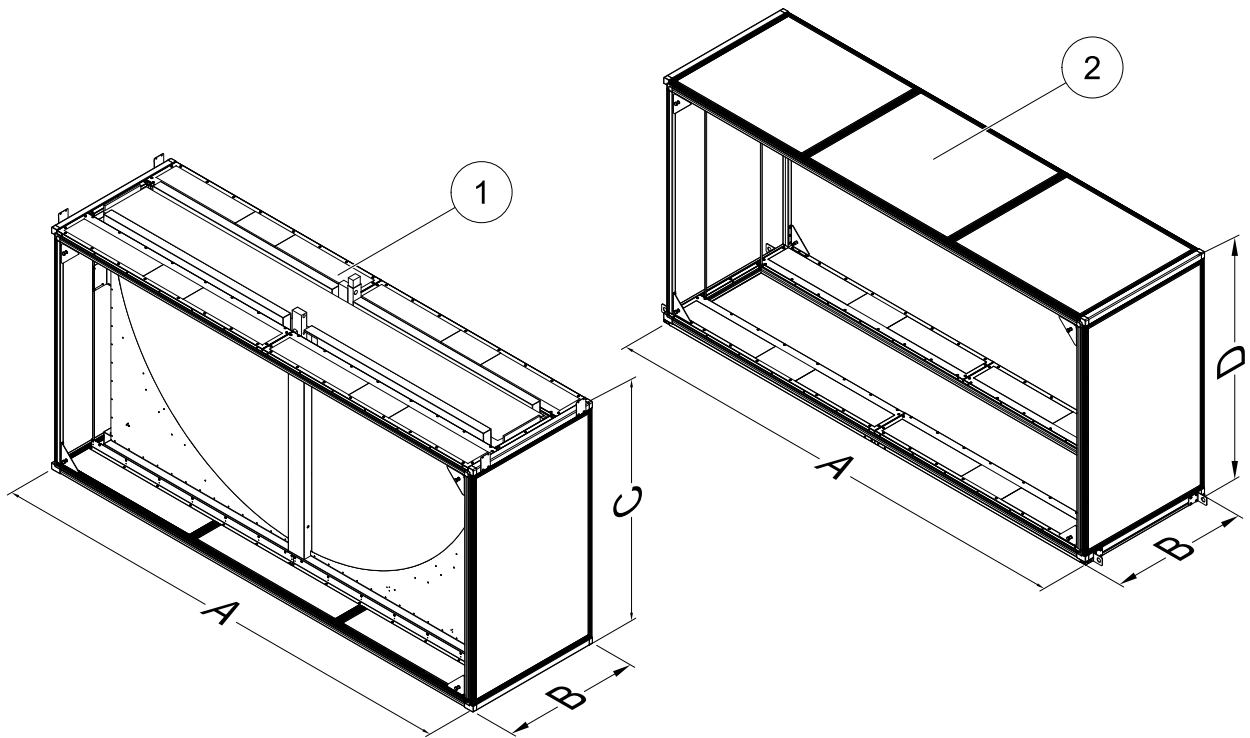

Size	A [mm]	B [mm]	C [mm]	D [mm]
Geniox Go 27	2782	800	1382	1403,2
Geniox Go 29	2982	900	1482	1503,2
Geniox Go 31	3182	900	1582	1603,2

5.2.2 Assemble of rotor casing

1. Assemble rest of the rotor (pos. 1) on top of the first section (pos. 2) by following a manufacturer's manual (provided in a separate cover if divided rotor option was ordered).

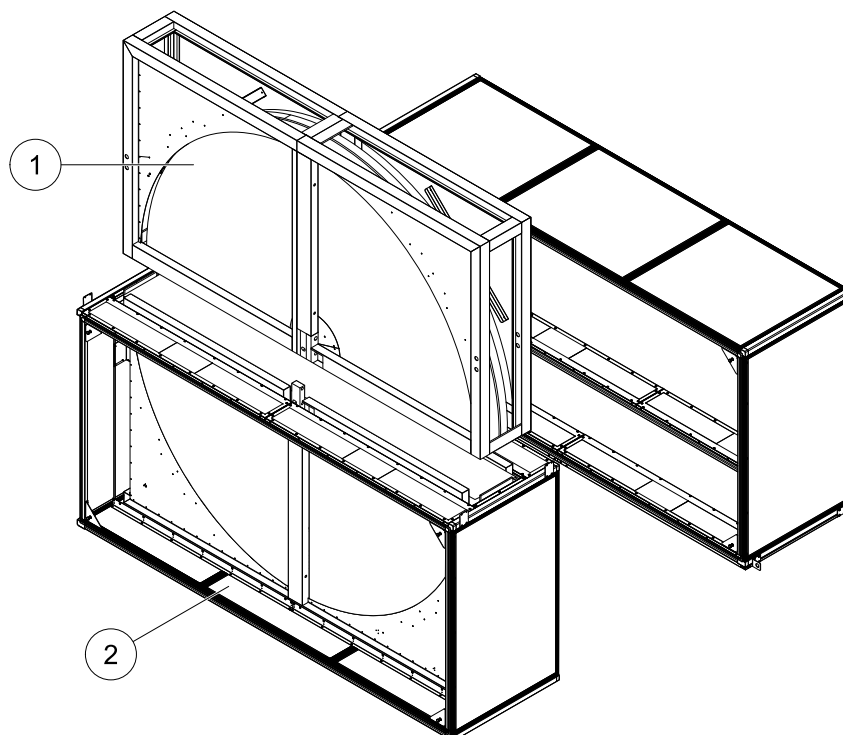

2. Lift empty section (pos. 2) and place it on top of assembled rotor and lower section (pos. 1).

Important

Make sure not to damage the rotor or sections during lifting procedure.

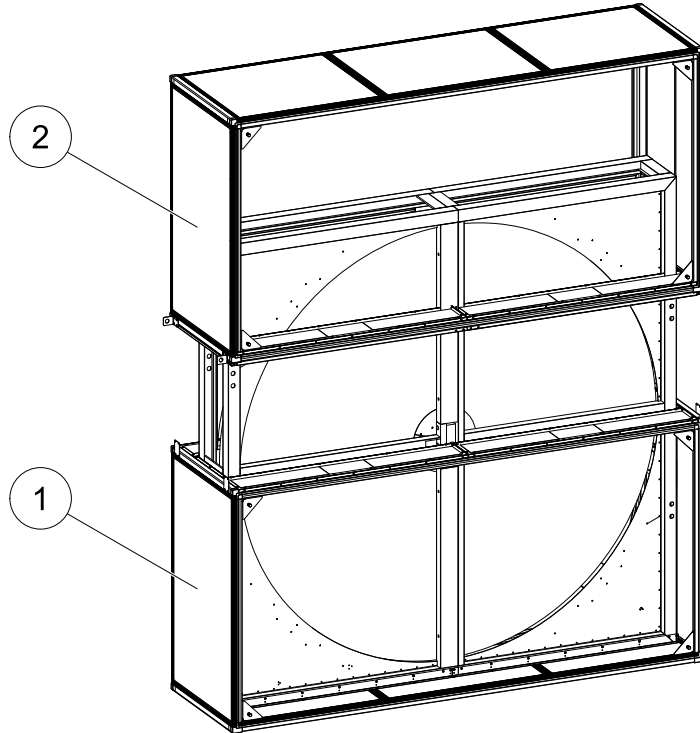

3. Finish the assembly by fixing 4 locking plates in both section sides (2 plates in front and 2 plates on the back).

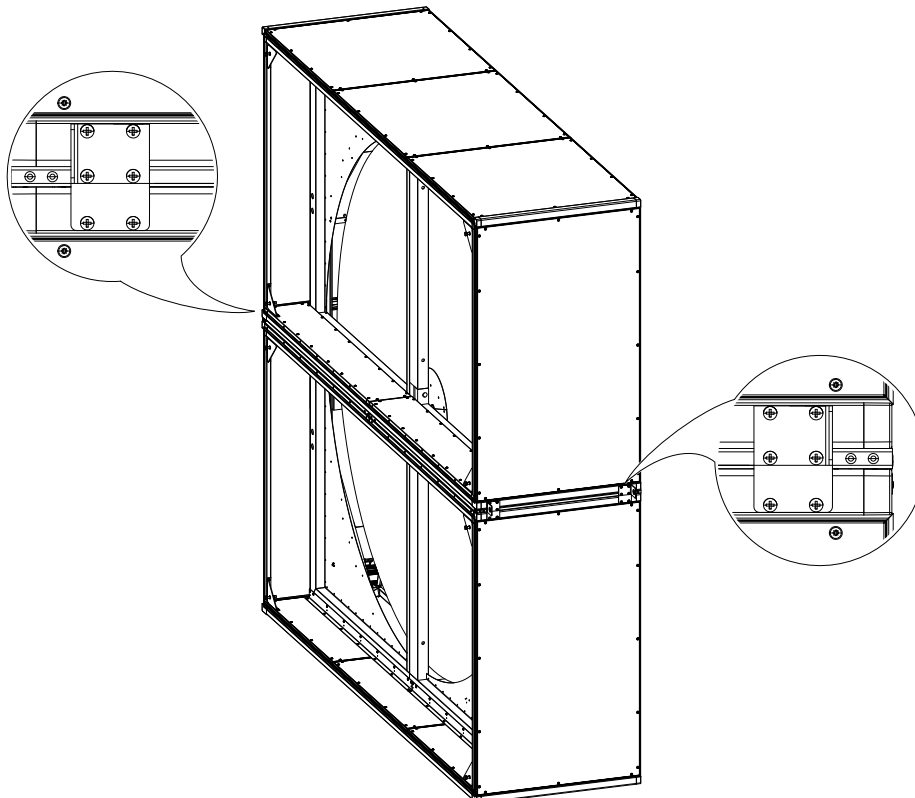

4. Dimensions of assembled rotor section are given in table bellow.

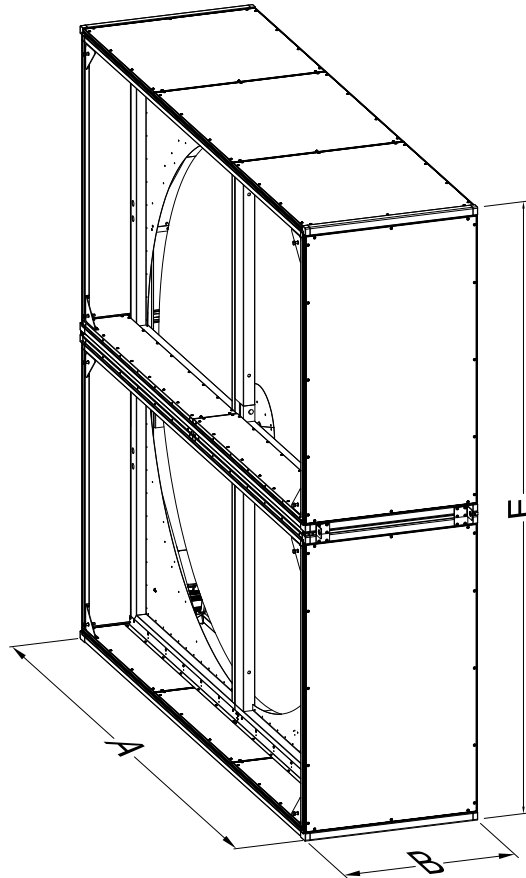

Size	A	B	E
Geniox Go 27	2782	800	2782
Geniox Go 29	2982	900	2982
Geniox Go 31	3182	900	3182

5.2.3 Installation of rotation sensor, rotor magnet and belt

1. Section with half of the rotor is delivered with rotor motor and controller factory preinstalled.

Rotor motor:

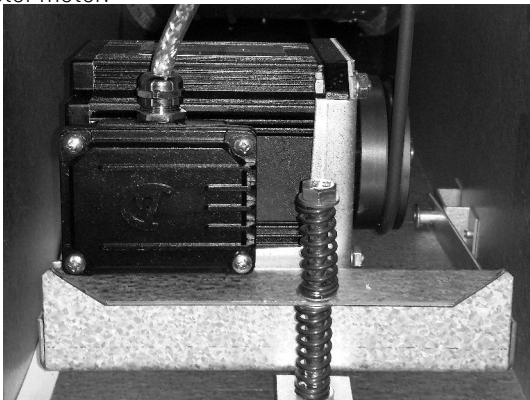

Controller:

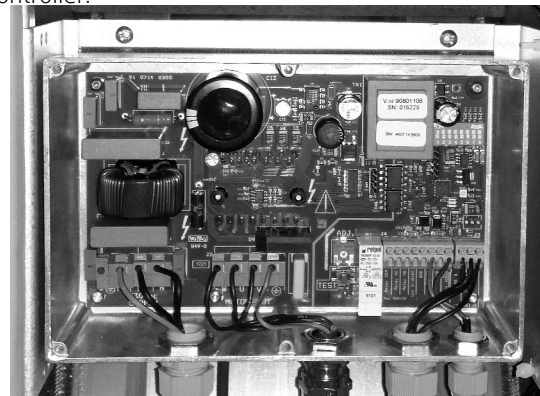

2. Attach the rotation sensor (pos. 1) to the holder (pos. 2) above the controller box (pos. 3). Note the distance from the sensor to the left holder side (pos. A).

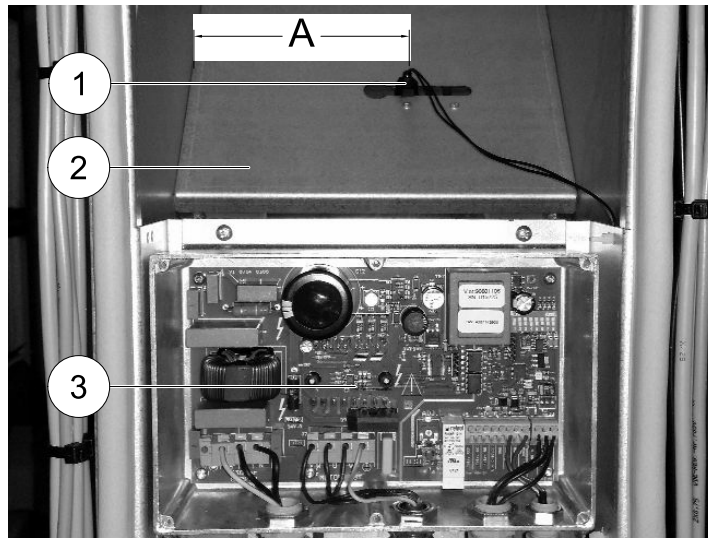

3. On the rotor, within the same distance (pos. A) as sensor (pos. 1) was placed drill a 2,5 mm hole. Attach magnet to the rotor (pos. 2) using a screw.

Rotor magnet placement:

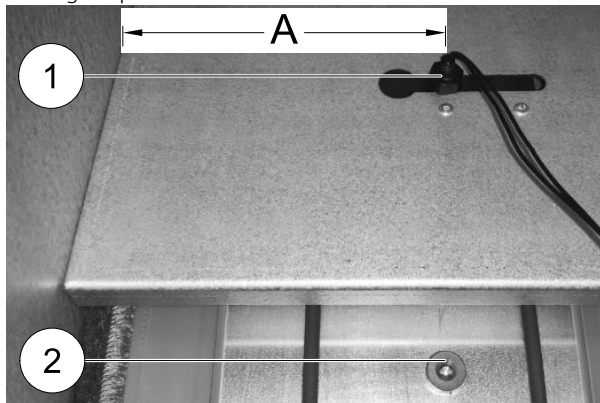

Rotor magnet with a screw:

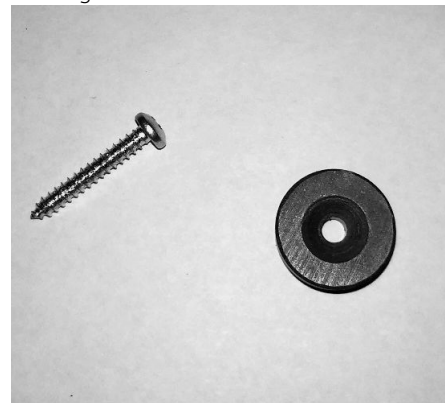

4. Put a V-belt around recently assembled rotor wheel. Use a beltlock with screws to fix both ends of the belt. Grind the ends of screws if they come to other side of the belt to have a flat surface. Spare belt lock is provided in a package attached on inner side of the rotor.

Belt lock mounting:



Grinded belt lock screws:



Spare belt lock:



5. Turn the rotor by hand to make sure it rotates freely.

Annex 6 Reversible heat pump unit (in separate cover, if heat pump was delivered)

Heat pump section is a separate section in the air handling unit, containing a complete stand-alone reversible heat pump system (heating and cooling). If the air handling unit was delivered with this section, a separate manual about the heat pump was enclosed in the separate cover.

Annex 7 Menu for internal controller in the heat pump unit (in separate cover, if heat pump was delivered)

If the air handling unit was delivered with this section, a separate manual about the heat pump was enclosed in the separate cover

Annex 8 Connection of fan motor and set-up manual for frequency converter

Connection of the fan motor is described in label attached to the frequency converter or 12 *Wiring diagram (in separate cover, if control system was delivered)* which is provided in separate cover. Frequency converter set-up, installation of ECblue and diagnostic information also is provided in separate cover.

Annex 9 Commissioning protocol (in separate cover)

Printed on separate pages and delivered with every unit. Enclosed in separate cover.

Annex 10 Report with data from final functional test on the Systemair factory

Provided on user demand.

Annex 11 Short description of main components in the control system

11.1 Geniox units delivered in one or several sections

Geniox units have an integrated control system and depending on the size, the cabinet is installed inside the unit. Systemair E283W-3 port controller is mounted in the cabinet, and all electrical connections between cabinet and components in the unit are installed. The control system is configured according to the customer's order – confirmed by the order confirmation - to promote easy start-up on the site. The unit is tested at the factory and all functions are confirmed by a final functional test and test report. The test report is available on user demand. After the final test the unit is delivered as one assembled section or divided in separate sections. If unit was shipped divided into sections, during reassembly on the site, all external components and the clearly marked cables with sockets must be reconnected in the marked cabinet terminals.

11.1.1 External components

External components are Systemair Control Panel, valves, valve motors, pressure transmitters, supply air temperature sensor, sensor for water temperature in the heating coil (if water heating coil was requested) and circulation pump (Systemair does not deliver the pump). Terminals are present in the cabinet for pressure transmitters, if it is a solution for constant pressure in the ducts, and terminals are present in the cabinet for valve motors, circulation pump, supply air temperature sensor and sensor for water temperature in the heating coil, but cables are not installed and not connected to terminals in the cabinet. The Systemair Control Panel with 10 meters of cable is connected to the controller in the cabinet. All external components delivered are packed in a cardboard box delivered together with the unit.

Annex 12 Wiring diagram (in separate cover, if control system was delivered)

The wiring diagram is in a separate cover

Annex 13 Operator's guide (How to use the Systemair control panel) (in separate cover)

A separate manual is delivered with every unit. This manual assists the everyday user/operator about how to control the unit by navigating the menus by the buttons and the display. Enclosed in separate cover.



Systemair UAB
Ling st. 101
LT-20174 Ukmergė, LITHUANIA

Phone +370 340 60165
Fax +370 340 60166

www.systemair.com