

Geniox Air handling unit

User Manual

GB

Document in original language |

Part number of this manual 90925520
Order number output



Only the English version is valid in case of a dispute. Translated versions are not valid in case of disputes.

Detailed table of contents on the following pages

General description

- A Manufacturer
- B Name of machines
- C Declaration of Conformity - example
- D General descriptions, dangers and warnings
- E Drawings, diagrams, guides and instructions for the use, maintenance and repair
- F Employees in charge of operation/control/maintenance
- G Intended use and range of applications
- H Unintended use and misuse – inappropriate applications for the machine

Installation

- I Instructions for unloading on the site as well as installation and connection
- J Installation and assembly instructions for reduction of noise and vibration emissions

Start-up, adjustments and operation

- K Start-up, adjustments, use, commissioning and unit in hibernation
- L Information about the residual risks
- M Instructions on the protective measures during repair and maintenance
- N The essential characteristics of tools which may be fitted to the machinery

Machine stability

- O The conditions of stability during use, transportation, assembly, dismantling when out of service
- P Instructions for machinery where these are regularly to be transported

Breakdown

- Q The operating method to be followed in the event of breakdown. Safe restart.

Maintenance

- R Adjustment and maintenance operations
- S Instructions to enable adjustment and maintenance safely
- T The specifications of the spare parts to be used, when these affect the health and safety of operators

Noise

- U Information on airborne noise emissions exceeding 70 dB(A)

Annexes

- 1 Declaration of conformity with production number (in separate cover)
- 2 Technical data – unique data for every unit (in separate cover)
- 3 Spare part list (in separate cover)
- 4 Assembly of base frame – height 118 mm for unit sizes 10 – 18
- 5 Assembly of base frame – height 118 mm for unit sizes 20 – 31
- 6 Assembly of base frame – height 218 mm for unit sizes 10 – 18
- 7 Assembly of base frame – height 218 mm for unit sizes 20 – 31
- 8 Installation of steel roof in the sizes 10 – 31
- 9 Speed control for rotor and assembly of divided rotor
- 10 Reversible heat pump unit (in separate cover, if heat pump was delivered)
- 11 Menu for internal controller in the heat pump unit (in separate cover, if heat pump was delivered)
- 12 Connection of fan motor and set-up manual for frequency converter
- 13 Commissioning protocol – proposal (in separate cover)
- 14 Report with data from final functional test on the Systemair factory (in separate cover, if control system was delivered)
- 15 Short description of main components in the control system
- 16 Wiring diagram (in separate cover, if control system was delivered)
- 17 Operator's guide (how to use the Systemair control panel) (in separate cover, if control system was delivered)

Contents

- A Manufacturer..... 1
- B Name of machines..... 1
- C Declaration of Conformity - example 2
- D General descriptions, dangers and warnings 3
 - D.1 Overview via pictograms on the inspection side of the unit 3
 - D.1.1 Where are pictograms placed on the units 3
 - D.1.2 Weight of each section and production number – example for the Geniox unit 6
 - D.1.3 CE label – example for the Geniox unit 6
 - D.1.4 Pictograms about warnings and dangers on the units 6
 - D.2 Data about the unit according to cards and labels in and on the unit 7
 - D.2.1 Example of Machine card with unique data on every unit 7
 - D.2.2 Label with data about the cabinet – example..... 7
 - D.2.3 Flowchart – example of the label placed on or with the cabinet 8
 - D.2.4 Symbols in the flowchart and explanation about the symbols 8
 - D.2.5 Example of label placed on or with the cabinet – Terminal plan for external components 9
 - D.2.6 Control board for Systemair Access control system..... 10
 - D.3 Hand terminal, if the unit is delivered with control system..... 11
 - D.4 Dimensions of the units 11
 - D.5 Ordinary automatically operation – only manual operation by new parameters..... 11
- E Drawings, diagrams, guides and instructions for the use, maintenance and repair 11
- F Employees in charge of operation/control/maintenance 11
- G Intended use and range of applications..... 12
- H Unintended use and misuse – inappropriate applications for the machine 12
 - H.1 Air handling unit in operation 12
- I Instructions for unloading on the site as well as installation and connection 12
 - I.1 Unloading on the site..... 12
 - I.1.1 Handling methods 12
 - I.1.2 Unloading by fork-lift truck 13
 - I.1.3 Unloading by crane 13
 - I.1.4 Transport of unit without base frame on the site..... 13
 - I.1.5 Lifting a unit with straps..... 13
 - I.1.6 Lifting a unit with installed brackets on the base frame for lifting..... 14
 - I.1.7 Lifting a unit without base frame and legs but with installed brackets for lifting. 14
 - I.1.8 Handling a unit with holes in base frame for forks 15
 - I.1.9 Roof unit with PVC or bitumen roof..... 17
 - I.1.10 Roof unit with steel roof 17
 - I.1.11 Pre-assembly storage..... 17
 - I.1.12 Tilt less than 30° during transportation of the section with heat pump 18
 - I.1.13 Transport and pre-installation storage of rotary heat exchanger – always in vertical position..... 18
 - I.2 Installation - mechanical 18
 - I.2.1 Free area in front of and above the unit 18
 - I.2.2 Supporting surface..... 18
 - I.2.3 Adjustable feet under legs or base frame and transport of sections..... 18
 - I.2.4 Base frame assembly 18
 - I.2.5 Base frames for outdoor units 19
 - I.2.6 Outdoor units – support under the base frame of the unit 19
 - I.2.7 Installation on the site of unit sections at the base frame when sections are delivered on pallets..... 19
 - I.2.8 Joining the AHU sections 21
 - I.2.9 Fitting the ductwork..... 24
 - I.2.10 Risk of stack effect by vertical ducts and wind pressure on louvers 25
 - I.2.11 Remove transport brackets – when spring mounts are installed..... 25
 - I.2.12 Refitting of guards 26
 - I.2.13 Lock the doors by using the key..... 27
 - I.3 Installation - electrical 27
 - I.3.1 Description..... 27
 - I.3.2 Wiring diagrams 27

I.3.3	Installation of mains power supply	27
I.3.4	Electrical connection of components and functions.....	28
I.3.5	Lock the doors by using the key.....	28
I.4	Installation – Pipes for water – hot and chilled, valves and drains	29
I.4.1	Description.....	29
I.4.2	Pipe connections.....	29
I.4.3	Possibility of extracting components from the unit	29
I.4.4	Pipe connections to batteries	29
I.4.5	Draining condensate water	30
I.4.6	Draining condensate water from heat exchanger.....	31
I.4.7	Draining condensate water from cooling battery –	32
J	Installation and assembly instructions for reduction of noise and vibration emissions	32
K	Start-up, adjustments, use, commissioning and unit in hibernation	33
K.1	Print-outs on paper	33
K.2	Documentation is available for download.....	33
K.3	Start-up by installer	34
K.3.1	Checklist, relevant values	34
K.4	Adjustments and use.....	34
K.5	Description of functions, if control system is delivered by Systemair	35
K.5.1	Remote control	35
K.5.2	Extended operation and external start/stop (for example by presence detectors).....	35
K.5.3	Valve and valve motor for heating coil.....	35
K.5.4	Valve and valve motor for cooling coil	35
K.5.5	DX cooling.....	35
K.5.6	Circulation pump, heating	35
K.5.7	Fire alarm function.....	35
K.5.8	Electrical heater battery	36
K.5.9	Speed control of fans	36
K.5.10	Cabinet	36
K.5.11	Temperature sensors	37
K.5.12	Damper motors.....	37
K.5.13	Filter guards	37
K.5.14	Room temperature sensors.....	37
K.5.15	Frost protection.....	37
K.5.16	Systemair Control Panel - NaviPad.....	37
K.5.17	Cooling recovery	37
K.5.18	Free cooling	37
K.5.19	Alarm signal	37
K.5.20	Heat recovery	37
K.5.21	Frost protection – plate heat exchanger	38
K.6	Commissioning	38
K.7	Unit in hibernation – not in regular operation for several months	38
L	Information about the residual risks.....	38
L.1	Unit casing	38
L.1.1	Design of the machine to make transport safe	38
L.1.2	Common for all unit sections	38
L.1.3	Common for all unit sections by insufficient lighting	38
L.1.4	Dampers.....	39
L.1.5	Attenuators.....	39
L.1.6	Filters	39
L.1.7	Plug fans	40
L.1.8	Batteries for heating	40
L.1.9	Heat pump units.....	41
M	Instructions on the protective measures during repair and maintenance	41
N	The essential characteristics of tools which may be fitted to the machinery	42
O	The conditions of stability during use, transportation, assembly, dismantling when out of service	42
O.1	Installed reliable to avoid units to be tilted or moved by storm.....	42
O.2	Transport of section with heat pump unit	42
O.3	Disposal of the heat pump system - type Geniox - HP.....	42
O.4	General disassembly – sharp edges.....	42
P	Instructions for machinery where these are regularly to be transported	42
Q	The operating method to be followed in the event of breakdown. Safe restart.	42
R	Adjustment and maintenance operations	42
R.1	Shutdown of the unit to a safe state	43
R.2	Unlock and lock the doors by using the key	43
R.3	Recommended maintenance intervals.....	43

Contents

R.4	Filters – always replace filters with new filters with the same characteristics to maintain SFP value	44
R.4.1	Bag filters – the number of filters and sizes of frames	45
R.4.2	Panel filters – the number of filters and the sizes of the frames	46
R.4.3	Bag filters	46
R.4.4	Panel filters	49
R.5	Changing the Internal Battery in the controller	49
R.6	Functions to maintain	50
R.6.1	The unit	50
R.6.2	Dampers	50
R.6.3	Rotary heat exchanger	51
R.6.4	Cross flow and counter flow exchanger	53
R.6.5	Run-around heat exchanger	55
R.6.6	Coils/batteries for heating and/or cooling	56
R.6.7	Plug fans	57
R.6.8	Silencer	57
R.6.9	Outdoor air section	58
R.6.10	Heat pump unit	58
S	Instructions to enable adjustment and maintenance safely	58
S.1	Protective measures and additional protective measures	58
S.1.1	Necessary protection measures prior to start-up	59
S.1.2	Safe adjustment and maintenance	59
S.1.3	Personal protective equipment for maintenance staff – health and safety	59
T	The specifications of the spare parts to be used, when these affect the health and safety of operators	59
T.1	Spare parts - Mechanical	59
T.2	Spare parts - Electrical	59
U	Information on airborne noise emissions exceeding 70 dB(A)	60
Annex 1	Declaration of conformity with production number (in separate cover)	1-1
Annex 2	Technical data – unique data for every unit (in separate cover)	2-1
Annex 3	Spare part list (in separate cover)	3-1
Annex 4	Assembly of base frame – height 118 mm for unit sizes 10 – 18	4-1
4.1	Base frame length 482 – 2564 [mm] Unit size 10 – 18	4-2
4.2	Base frame length 2582 – 4964 [mm] Unit size 10 – 18	4-3
4.3	Base frame length 4982 – 6164 [mm] Unit size 10 – 18	4-4
Annex 5	Assembly of base frame – height 118 mm for unit sizes 20 – 31	5-1
5.1	Base frame length 482– 2564 [mm] Unit size 20 – 31	5-1
5.2	Base frame length 2582 – 4964 [mm] Unit size 20 – 31	5-2
5.3	Base frame length 4982 – 6164 [mm] Unit size 20 – 31	5-3
Annex 6	Assembly of base frame – height 218 mm for unit sizes 10 – 18	6-1
6.1	Base frame length 482– 2564 [mm] Unit size 10 – 18	6-1
6.2	Base frame length 2582 – 4964 [mm] Unit size 10 – 18	6-2
6.3	Base frame length 4982 – 6164 [mm] Unit size 10 – 18	6-4
Annex 7	Assembly of base frame – height 218 mm for unit sizes 20 – 31	7-1
7.1	Base frame length 482– 2564 [mm] Unit size 20-31	7-1
7.2	Base frame length 2582 – 4964 [mm] Unit size 20 – 31	7-2
7.3	Base frame length 4982 – 6164 [mm] Unit size 20 – 31	7-3
Annex 8	Installation of steel roof in the sizes 10 – 31	8-1
8.1	Overview	8-1
8.1.1	Mount rails. Units of size 10, 11, 12, and 14	8-1
8.1.2	Mount rails. Units of size 16 and units larger than size 16	8-2
8.1.3	Roof overhang along the long sides of the unit	8-3
8.1.4	Calculation of the overhang at the ends of the unit. Mount overhang profile – G1	8-3
8.1.5	Foam bands between rails and roof plates – mount roof plates	8-5
8.1.6	Foam bands between roof plates	8-6
8.1.7	Mount roof plates – some of them are overlapping by 2 ribs	8-6
8.1.8	Mount overhang profile – G5 on the other end of the unit	8-6
8.1.9	Mount side profiles and corners along the edges of the roof to protect persons	8-7
8.1.10	Apply sealing on plate joints to ensure water resistance	8-7
Annex 9	Speed control for rotor and assembly of divided rotor	9-1
9.1	Speed control	9-1
9.1.1	Selection of correct signal via the 8DIP switch levers	9-1
9.1.2	Indication of operation mode via red and green LED as well as test of motor	9-2
9.1.3	The board for control of revolutions	9-3
9.1.4	Information about connection of cables to terminals on the control board	9-4
9.2	Assemble divided rotor and the Systemair casing	9-4

9.3	Assemble divided rotor from Hoval.....	9-5
9.3.1	Tools and aids.....	9-5
9.3.2	Lifting instruction for upper half of the Hoval CDS 290 mm rotor casing	9-5
9.3.3	Installation of upper half of the Hoval CDS 290 mm rotor casing.....	9-6
9.3.4	Installation of radial walls between segments.....	9-7
9.3.5	Adjusting clearance between radial walls and the casing.....	9-7
9.3.6	Installation of rotor segment and periphery plates	9-8
9.3.7	Installation, first periphery plate.....	9-9
9.3.8	Installation of next segment.....	9-10
9.3.9	Installation, next periphery plate.....	9-11
9.3.10	Final adjustment of segments and periphery plates.....	9-11
9.3.11	Installation of brush sealing and upper half of the Systemair	9-12
9.4	Installation of motor that turns rotor and sensor for control of rotation	9-14
Annex 10	Reversible heat pump unit (in separate cover, if heat pump was delivered)	10-1
10.1	Geniox-HP section (reversible heat pump unit)	10-1
Annex 11	Menu for internal controller in the heat pump unit (in separate cover, if heat pump was delivered)	11-1
Annex 12	Connection of fan motor and set-up manual for frequency converter.....	12-1
12.1	Connection of fan motor	12-1
12.2	Set-up for Danfoss FC101 for Geniox-units with AC motors.....	12-1
12.3	AC-fan operation without thermistor for Danfoss FC101.....	12-2
12.4	Set-up Danfoss FC101 for Geniox-units with PM motors.....	12-3
12.5	Installation ECblue	12-5
12.5.1	Connection.....	12-5
12.5.2	Diagnostic/faults.....	12-6
Annex 13	Commissioning protocol – proposal (in separate cover).....	13-1
Annex 14	Report with data from final functional test on the Systemair factory (in separate cover, if control system was delivered)	14-1
Annex 15	Short description of main components in the control system	15-1
15.1	Geniox units delivered in several sections	15-1
15.1.1	External components.....	15-1
15.2	Geniox unit delivered assembled on base frame.....	15-1
15.2.1	External components.....	15-1
Annex 16	Wiring diagram (in separate cover, if control system was delivered).....	16-1
Annex 17	Operator’s guide (how to use the Systemair control panel) (in separate cover, if control system was delivered).....	17-1

A Manufacturer

This User Manual covers all air handling units delivered by Systemair A/S.

Manufacturer and supplier data:

Systemair A/S

Ved Milepælen 7

DK-8361 Hasselager

Responsible for documentation: Ulf Bang

B Name of machines

This manual is about Systemair air handling units called Geniox 10, Geniox 11, Geniox 12, Geniox 14, Geniox 16, Geniox 18, Geniox 20, Geniox 22, Geniox 24, Geniox 27, Geniox 29 and Geniox 31.

C Declaration of Conformity - example



The manufacturer:
Systemair A/S
Ved Milepælen 7
DK - 8361 Hasselager

Hereby declares that, air handling units of the following types:

DANVENT DV10, DANVENT DV15, DANVENT DV20, DANVENT DV25, DANVENT DV30, DANVENT DV40,
DANVENT DV50, DANVENT DV60, DANVENT DV80, DANVENT DV100, DANVENT DV120, DANVENT
DV150, DANVENT DV190 and DANVENT DV240.
TIMEec 10, TIMEec 15, TIMEec 20, TIMEec 25, TIMEec 30, TIMEec 40
Geniox: 10, 11, 12, 14, 16, 18, 20, 22, 24, 27, 29, 31
Serial No: "YYMM-000XXXXXX-XX"

are manufactured and delivered in accordance with following directives:

Machinery directive 2006/42/EC
Ecodesign – Commission regulation 1253/2014
EMC – directive 2014/30/EC
Low voltage directive 2014/35/EC
Pressure equipment directive 2014/68/EC
European Standard EN378-1 & 2 – 2016, EN13053:2011, EN308:1997, EN1886:2008

Equipment type: **Heat pump Section – Geniox, DV and TIME units**

Consisting of: Compressor, evaporator and condenser
Verification and Assessment by:

Notified Body Bureau VERITAS CE0062 for PED
Bureau VERITAS SA, Newtime 52 Boulevard du Parc
Ile de la Jatte, FR-92200 Neuilly sur Seine

Module: A2
Certificate no:
CE-0062-PED-A2-SAI 001-19-DNK

The declaration is only valid, if the installation of the air handling unit is carried out according to the instructions delivered with the unit. The installer will be responsible for the CE marking and documentation, if any construction or functional changes are applied to the air handling unit.

Hasselager 27 January 2019







D General descriptions, dangers and warnings

Geniox air handling units are order specific machines available in thousands of different configurations. Only a few examples of machine configurations are described below. The air handling units are intended for the transport and treatment of air between -40 °C and + 40 °C.

The units are exclusively for comfort ventilation.

Maintenance of the units must be carried out by skilled technicians.

On the drawing below, a right hand unit is shown because the inspection doors are mounted on the right hand side of the unit when looked in direction of **SUPPLY** airflow. The unit below is with rotary heat exchanger.



Position	Description	Symbol
A	Connection, supply air (to the rooms)	
B	Connection, exhaust air	
C	Connection, outdoor air in	
D	Connection, extract air (from the rooms)	

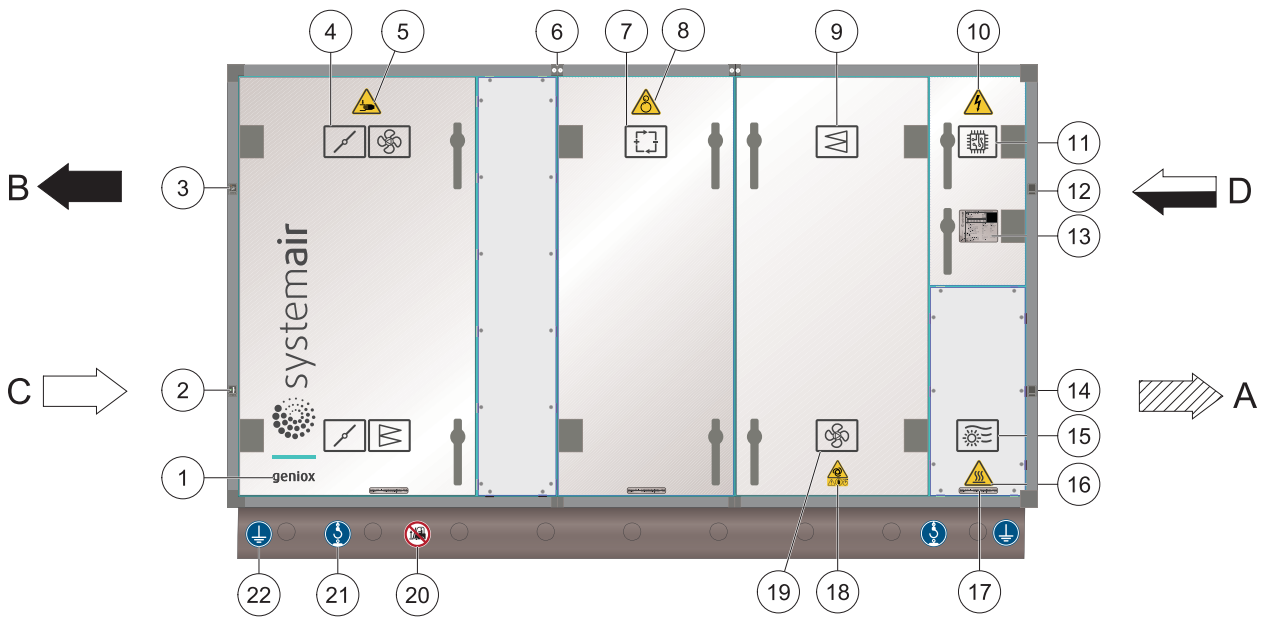





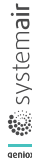



D.1 Overview via pictograms on the inspection side of the unit







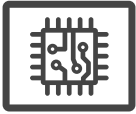

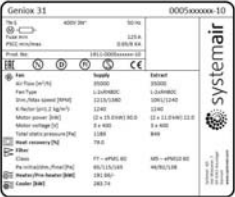

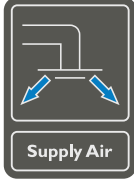



D.1.1 Where are pictograms placed on the units

Example (Pictograms and labels with descriptions of functions for fast identification)

Position	Description	Symbol
1.	Branding	
2.	Outdoor air duct connection	

Position	Description	Symbol
3.	Exhaust air duct connection	
4.	Damper	
5.	Warning about crushing	
6.	Connect sections with identical numbers	
7.	Energy recovery	
8.	Warning about danger by rotating parts	
9.	Filter with indication of airflow direction	
10.	Warning about danger by electricity	
11.	Controller in a cabinet behind this inspection door	
12.	Extract air duct connection	
13.	Machine card	

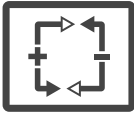
Position	Description	Symbol
14.	Supply air duct connection	
15.	Heating battery	
16.	Warning about danger by heat	
17.	Weight of the section, production number of the unit, number of the section.	
18.	Warning about danger by rotating fan during 4 minutes rundown period.	
19.	Fan with arrow for indication of airflow direction.	
20.	Lifting prohibited	
21.	Lifting permitted.	
22.	Grounding	

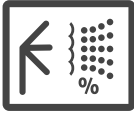
Position	Description	Symbol
Other labels	Cooling battery	
	Reversible heat pump	
	Silencer	
	Inspection	
	Humidifier	

D.1.2 Weight of each section and production number – example for the Geniox unit









Weight of the section. Production number of the unit.
Number of the section in the unit.

Product name in this example is Geniox 31, where 31 indicates the size of the unit. The unique production number for the complete unit in this example is – 0005xxxxxx-10 and – Section 1/6 indicates that this is section 1 out of the total of 6 sections.

Geniox 31		VE01A	
Prod. No:	0005xxxxxx-10	Weight:	576 kg
Section:	1/6		

D.1.3 CE label – example for the Geniox unit

CE marking is printed on the machine card.

Geniox 31		0005xxxxxx-10	
TN-S 400V 3N~ 50 Hz			
 Fuse min 125 A			
PSCC min/max: 0.65/6 kA			
Prod. No: 1911-0005xxxxxx-10			
			
 Fan	Supply	Extract	
Air flow [m³/h]	35000	35000	
Fan Type	L-2xRH80C	L-2xRH80C	
Dim./Max speed [RPM]	1213/1380	1061/1240	
K-factor (p=1.2 kg/m³)	1240	1240	
Motor power [kW]	(2 x 15.0 kW) 30.0	(2 x 11.0 kW) 22.0	
Motor voltage [V]	3 x 400	3 x 400	
Total static pressure [Pa]	1189	849	
 Heat recovery [%]	79.0		
 Filter			
Class	F7 – ePM1 60	M5 – ePM10 60	
Pa initial/dim./final [Pa]	65/115/165	46/92/138	
 Heater/Pre-heater [kW]	191.66/-		
 Cooler [kW]	283.74		
 Systemair AS Ved Moskanen 7 DK-8381 Harscoeger www.systemair.com			

D.1.4 Pictograms about warnings and dangers on the units

Pictograms according to EN1886 about



Warning

Warning about danger by rotating parts.



Warning
Warning about crushing.



Warning
Warning about danger by electricity.



Warning
Warning about danger by heat



Warning
Rotating fan during 4 minutes rundown period with risk of injury.



Warning
Attention – risk for injury or damage on material.

D.2 Data about the unit according to cards and labels in and on the unit

D.2.1 Example of Machine card with unique data on every unit

The unique production number for the complete unit in this example is 1911-0005xxxxx-10 where 19 indicates production year 2019 and 11 indicates production month at the Systemair factory in Denmark. With question about the unit please inform staff at Systemair of this unique production number from the factory in Denmark.

If the unit is not at a site in Denmark but at a site in any other country, please inform the staff at your local Systemair company of this unique production number from the factory in Denmark and please inform of the original order confirmation number from the Systemair company in your country with questions to your local Systemair company in your country. If the order confirmation number is not available, please inform that staff at the local Systemair company that detailed information about the unit through the above mentioned production number from the factory in Denmark is immediately available for Systemair staff from <https://techdoc.systemair.dk> through a personal password for each Systemair employee. The kind and extent of available information is listed in chapter K2 in this User Manual.

Geniox 31		0005xxxxx-10
TN-S	400V 3N~	50 Hz
Fuse min		125 A
PSCC min/max		0.65/6 KA
Prod. No:	1911-0005xxxxx-10	
	Fan	Supply Extract
	Air flow [m³/h]	35000 35000
	Fan Type	L-2xRH80C L-2xRH80C
	Dim./Max speed [RPM]	1213/1380 1061/1240
	K-factor (p=1.2 kg/m³)	1240 1240
	Motor power [kW]	(2 x 15.0 kW) 30.0 (2 x 11.0 kW) 22.0
	Motor voltage [V]	3 x 400 3 x 400
	Total static pressure [Pa]	1189 849
	Heat recovery [%]	79.0
	Filter	
	Class	F7 – ePM1 60 M5 – ePM10 60
	Pa initial/dim./final [Pa]	65/115/165 46/92/138
	Heater/Pre-heater [kW]	191.66/-
	Cooler [kW]	283.74
		 Systemair A/S DK-8381 Hørsholm Denmark www.systemair.com

D.2.2 Label with data about the cabinet – example.

An example of the label that is always placed on or with the cabinet

Systemair A/S	
Systemair declares hereby that the cabinet is in conformity with:	
SBB Low voltage panels:	N60439-1
Electrical material on machines:	EN60204-1
EMC-directive environment:	89/336/EOF
Diagram version	Geniox ver. X:XX
Systemair order number	72800-1
Unit size	10
Cabinet data:	



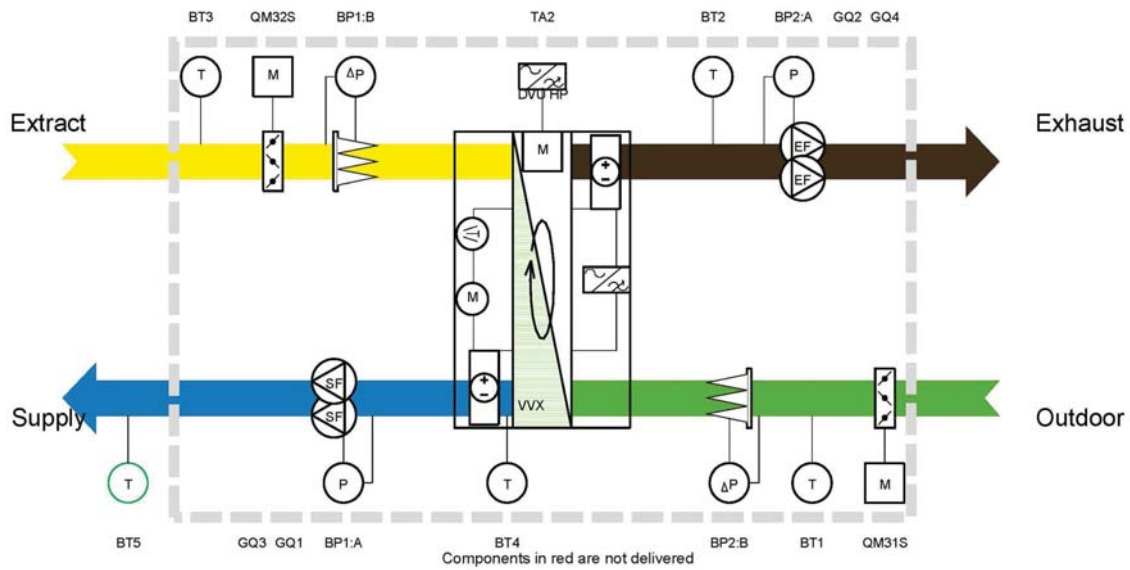

System ground	TN-S
Current type	AC
Frequency	50 HZ
Rated voltage	3*400 V+N+PE VAC
Control voltage	24 VDC
PSCC max	6 kA
PSCC min	650 A
Max fuse	25
Min fuse	10
Cable colors:	
Protection circuit	Green/yellow
230 VAC phase	Black
0 VAC neutral	Blue
24 VDC	Grey
0 VDC	Grey
Analog/digital	Grey

D.2.3 Flowchart – example of the label placed on or with the cabinet



D.2.4 Symbols in the flowchart and explanation about the symbols

Id	Description	Symbol
T	Temperature sensor - PT1000	
M	Damper motor – on/off or spring return	

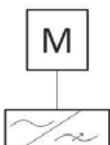
Id	Description	Symbol
M	Damper motor – modulating – 0-10V	
P	Filter guard - digital	
P	Pressure transmitter – 0-10V	
RH	Sensor for relative humidity – 0-10V	
CO2	Sensor for CO2 – 0-10V	
M	Controller and drive motor for rotary heat exchanger – modulating – 0-10V	

D.2.5 Example of label placed on or with the cabinet – Terminal plan for external components

External components	Symbol Name	Cable number	Page/ Column	Terminals	HW I/O
Supply air temperature	BT5	W355	14 : 3	X8:1-2	AI1
Normal speed	Ext. Sig.	W581	10 : 2	T31	DI2
Reduced speed		W580	10 : 1	T32	DI1
Unit stop		W583	10 : 4	T30	DI3
Internal components					
Rotor drive	TA2	W232	36 : 7	F3: L1-N	
		W642	36 : 8	Link 2	BUS Adr. 7
Temperature efficiency	BT4	W343	29 : 1	BP1	DPT BP1: In2
Damper motor on/off spring return, supply	QM31S	W631S	33 : 1	Link 1	BUS Adr. 21 (31)
Pressure over filter, supply		W662	30 : 2		DPT BP2: B
Outdoor air temperature	BT1	W341	30 : 1	BP2	DPT BP2: In1

D.2.6 Control board for Systemair Access control system

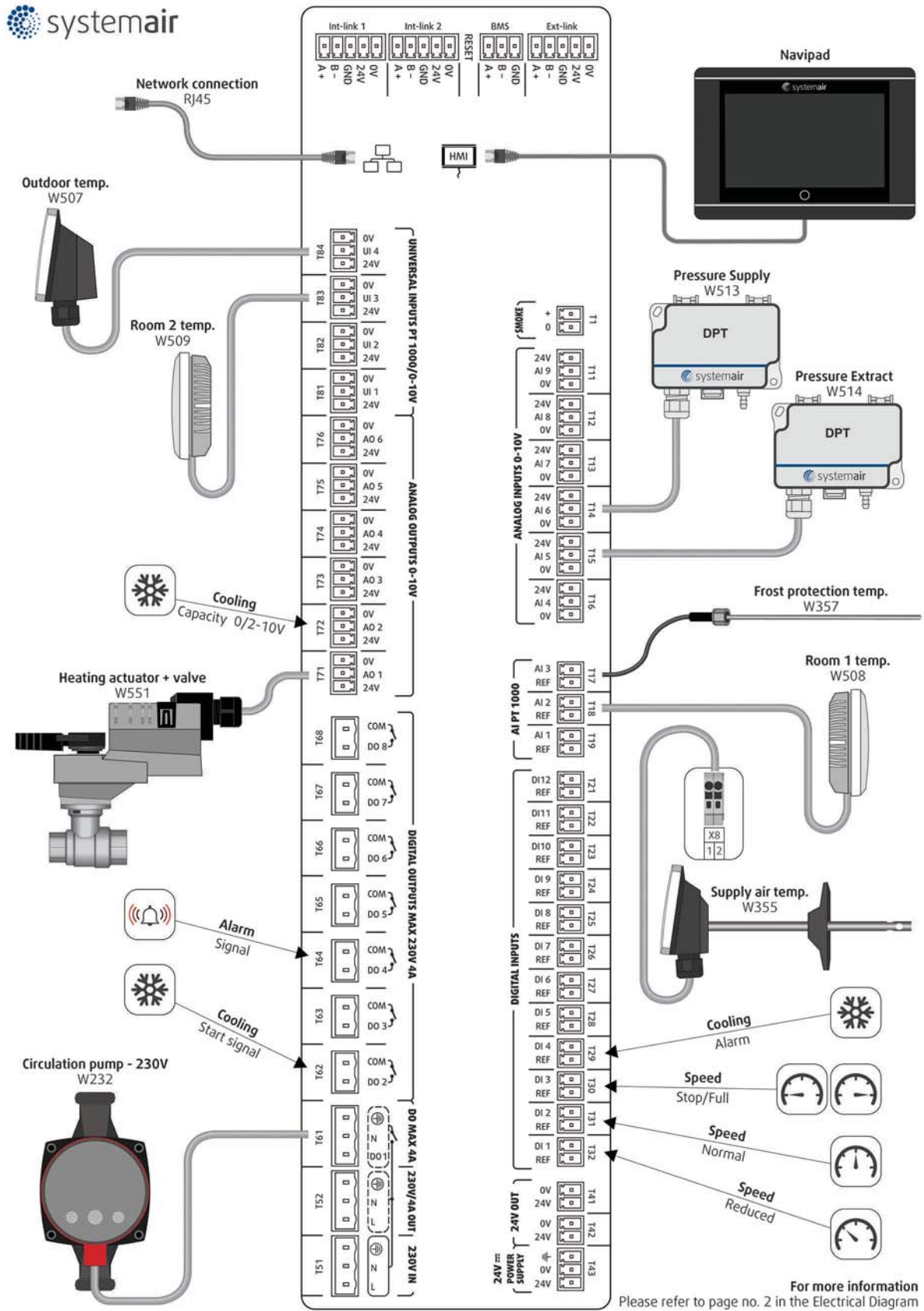

Terminals at the Access control board. The connected components is an example, and not unique for any order.

D.3 Hand terminal, if the unit is delivered with control system.

The hand terminal is delivered in a cardboard box containing the other external control components. This cardboard box is usually, but not always, placed in the section with the supply air fan. The Operator's Guide (also called The User's Guide) is one of the annexes delivered with this – User Manual.

This is the NaviPad control panel for the Access control system from Systemair.

The hand terminal is connected by a cable to the controller in the cabinet. 3 meters of cable is delivered with the unit and the customer has the possibility to replace this cable with an identical type of cable that is up to 100 meters long.



D.4 Dimensions of the units

See Annex 2 with information about the exact dimensions.

D.5 Ordinary automatically operation – only manual operation by new parameters

The unit is operating fully automatically and manual operation includes only selection of new parameters via a hand terminal. The alternative is that the controller is connected to a BMS system with the ability to select new parameters via PC, tablet or SmartPhone.

E Drawings, diagrams, guides and instructions for the use, maintenance and repair

All units are manufactured in compliance with the EC Declaration of Conformity and they are CE marked as machines. Unique Declaration with production number of the machine is an integral part of the machine – enclosed as Annex 1 to this manual. If the buyer carries out changes or adds components in or on the machine, the buyer must issue a new EC Declaration of Conformity and a new CE marking of the machine.

To promote correct use of the machines, the below-mentioned instructions are an integral part of the machine:

- Unique drawings, data and description of functions for the delivered unit – Annex 2
- Instructions for use of the machine – chapter K in this manual
- Instructions about adjustment and maintenance – chapter R in this manual
- Safety during adjustment and maintenance – chapter S
- Wiring diagram, if the unit is delivered with control system.
- Operator's Guide (also called User's Guide), if the unit is delivered with control system.

F Employees in charge of operation/control/maintenance

The units are constructed and built with a fully integrated control system. After start-up and hand-over from installer to operators/users, the unit operates fully automatically.

Indications of operating status as well as indication of faults are visible in the display at the hand terminal. The operators/users can enter new parameters in the controller via the hand terminal. Alternatively, the controller can be connected to a BMS system so that new parameters can be selected via PC, tablet or Smartphone. The operators/users do not need to open inspections doors for the operation.

Skilled technicians must carry care out maintenance as well as repairs.

G Intended use and range of applications

The air handling units are intended for transport and treatment of air between -40 °C and + 40 °C. The units are exclusively for comfort ventilation. The units are not for environments that exceed the corrosion class C4 according to EN ISO 12944-2 (motors are constructed for handling of air between -20 °C and + 60 °C).

Intended applications for the units are:

- Offices
- teaching rooms
- hotels
- shops
- homes and similar comfort zones

H Unintended use and misuse – inappropriate applications for the machine

Units for outdoor installation must be specified and ordered for outdoor installation. The units must not be used in environments that exceed corrosion class C4 according to EN ISO 12944-2, and for transport of solid particles.

Examples of not intended use:

- Kitchen extraction
- swimming pools
- off-shore
- Ex-areas
- drying of washed clothes.
- Do not use the unit with partly finished duct systems.
- Do not use the unit for ventilation of the building site until the unit is properly provided with guards.

H.1 Air handling unit in operation

The pressure difference between interior and exterior of the unit must not exceed 2000 Pa for the Geniox 10 and up to Geniox 31 (including Geniox 31).

Before start-up of the unit all ducts, safety guards and all protective devices must be mounted to prevent any access to rotating fan impellers. All inspection doors must be closed and locked when the unit is in operation.

Do not use the unit without filters.

I Instructions for unloading on the site as well as installation and connection

I.1 Unloading on the site

The air handling unit – AHU - is delivered as one section or in several sections, which are to be assembled on site. The AHU is delivered on transport pallets, legs, base frame with brackets for lifting or base frames with holes for forks on forklifts. Loading and unloading as well as transport on the site is possible by fork-lift truck or by crane using suitable lifting straps.

I.1.1 Handling methods

Possible (✓) and not possible (✗) handling methods are described in the table below.

Type	Handling methods					
	Forklift	Lifting by straps	Brackets at base frame for lifting	Hoist holes in base frames	Holes in base frames for forks (option)	Corners in sections for lifting
Sections on pallets	✓	✓	✗	✗	✗	✓
Sections on base frames	✓	✓	✓	✓	✓	✓
Unit on base frame	✓	✓	✓	✓	✓	✗

I.1.2 Unloading by fork-lift truck

The forks of the truck must be sufficiently long to avoid any damage to the AHU underside.

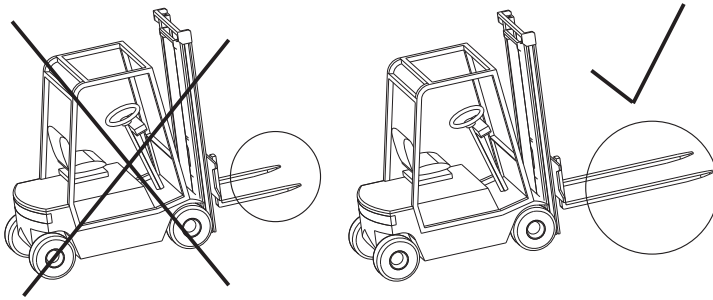

I.1.3 Unloading by crane

AHU delivered on transport pallet must be lifted by straps as shown in the illustration.

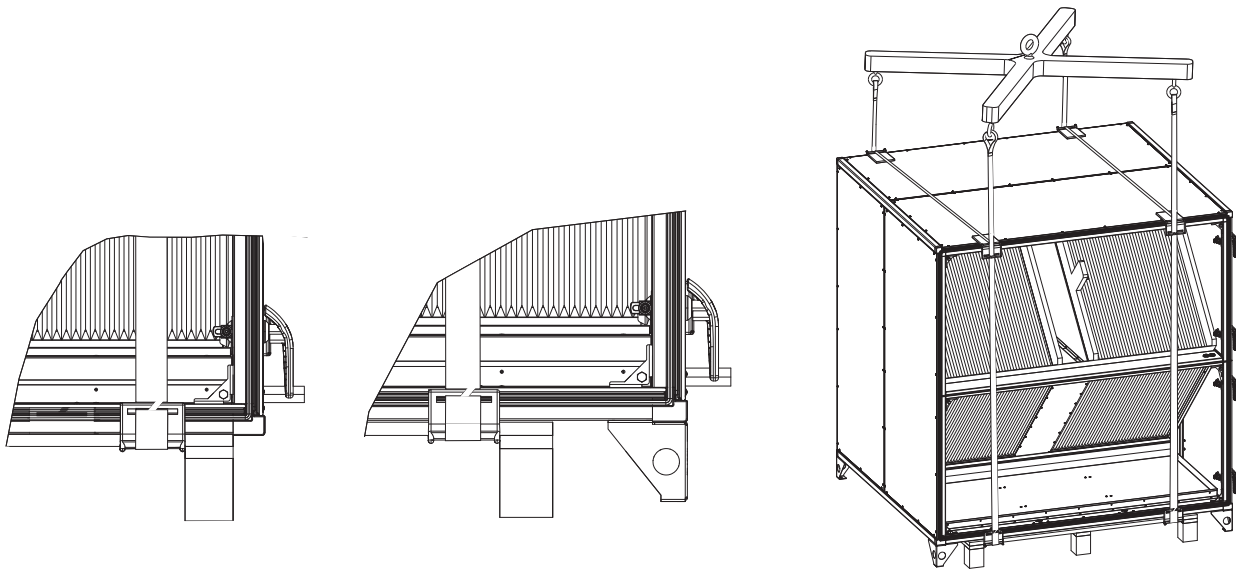

I.1.4 Transport of unit without base frame on the site

Units without base frame are always delivered in sections with each section on a pallet. Sections can be transported on the site by hand manual forklifts.

I.1.5 Lifting a unit with straps

Use an appropriate lifting beam with a sufficient span to avoid that the straps touch and damage the drip nose profiles and the inspection side with handles, pipes and accessories – for example manometers, cabinets, tabs for measuring the pressure.

I.1.6 Lifting a unit with installed brackets on the base frame for lifting.

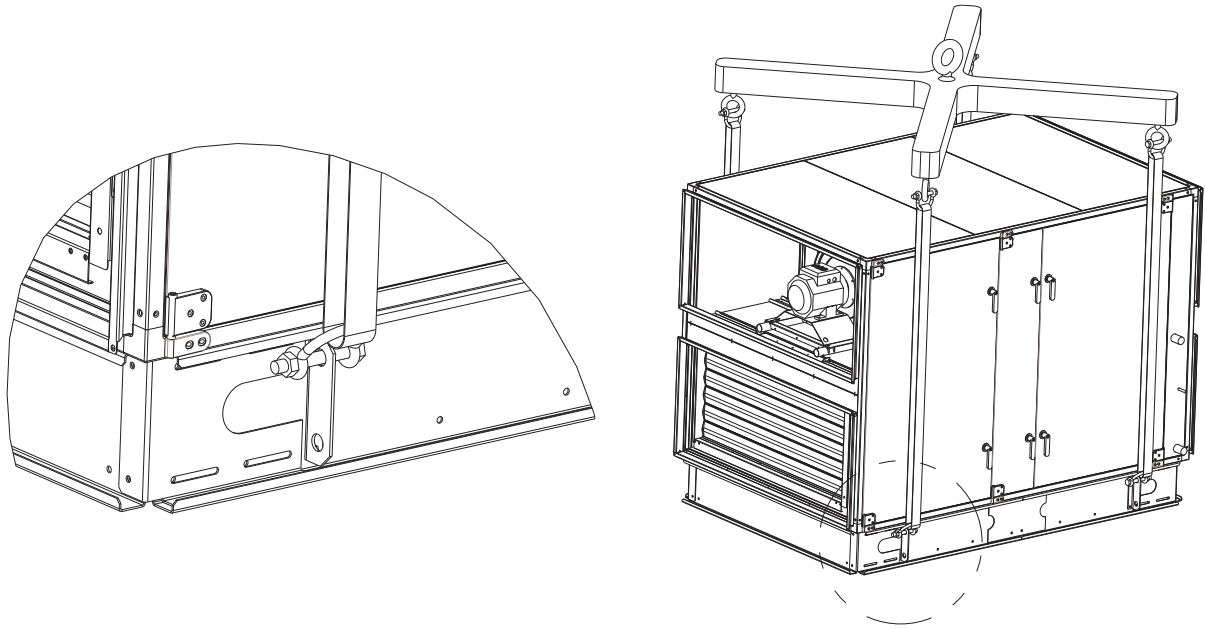

Lifting beam and straps are not included in the delivery.

I.1.7 Lifting a unit without base frame and legs but with installed brackets for lifting.

Attach straps carefully to the 4 brackets at the bottom of sections on Geniox units sizes 20 – 31 if the brackets are marked with the blue labels showing a hook, because these blue labels tell that those brackets are mounted to the profiles that are bearing the heavy components in the section



This type of bracket at the bottom of Geniox units in the sizes 20 – 31 is reinforced for lifting the unit. Mount a shackle in each of the 4 brackets that are suitable for lifting the weight of the section. The weight of the section is printed on the label placed on the inspection side of the unit.



The information about the weight of a section is very accurate and you must always be sure that the equipment intended for lifting the section is constructed and authorized for the task.

Geniox 31		VE01A	
Prod. No:	0005xxxxxx-10	Weight:	576 kg
		Section:	1/6



Caution

Do not lift a section in the 4 brackets that are marked with the label – lifting prohibited.

Lifting prohibited – in this bracket.



This bracket in Geniox units in the sizes 20 – 31 is not for lifting the unit. This bracket is for permanently holding 2 sections tight together with 8 mm bolts.



This bracket in Geniox units in the sizes 10 – 18 is not for lifting the unit. This bracket is for permanently holding two sections tight together with 8 mm bolts.

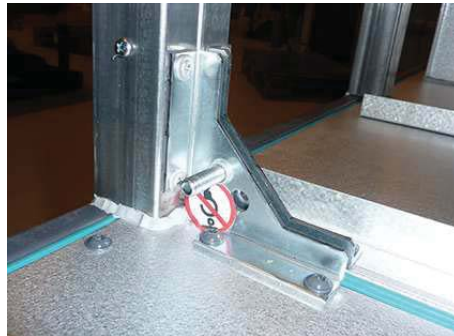

I.1.8 Handling a unit with holes in base frame for forks

Depending on the width or length of the section/unit there will be 1, 2 or more middle profiles.



Do not activate the wheels of forklift on the horizontal profile of a middle profile. Activation of the wheels on the horizontal profile might bend the profile.

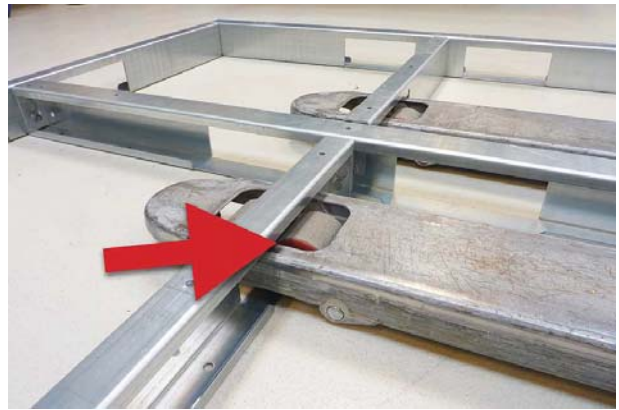

The forks of the forklift must be longer than the width or length of the section/unit to achieve safe transport of the section/unit.

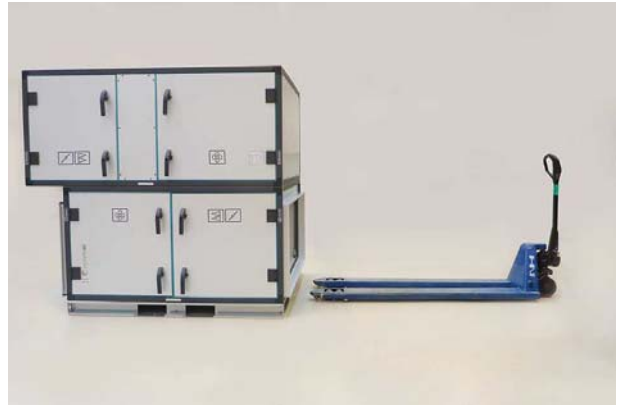

Very important to check that the wheels of the forklift are never activated on the horizontal profile of the base frame on the other side of the section/unit.



If only forklifts for Europallets with forks that are only 120 cm long are available, the alternative is to use 2 of those forklifts.



By lifting the section/unit with 2 or more forklifts it is important to avoid activation of wheels of any forklift on any horizontal profile the base frame.





Caution

If the base frame has 4 holes for forklifts as shown, the section/unit must be lifted evenly by 2 forklifts in each side. Hereby 4 forklifts must be used. There is a risk of overturning causing injury and damage to property if a section/unit is lifted unevenly or only by one forklift in each side.

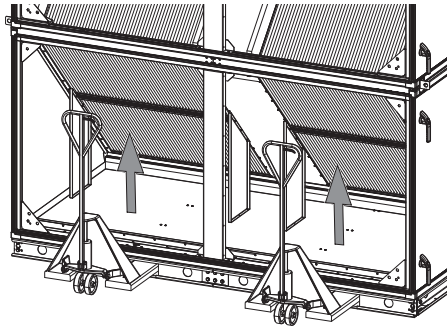

Caution

Avoid to activate the wheels on forklifts over horizontal profiles of base frames

I.1.9 Roof unit with PVC or bitumen roof

Avoid damaging the drip nose profiles along the PVC or bitumen roof. Keep the protection profiles of Styrofoam on the unit until the installation has been completed. If the unit is lifted by straps, the straps must be kept away from the drip nose profiles by bars to avoid damage to roofing profiles.

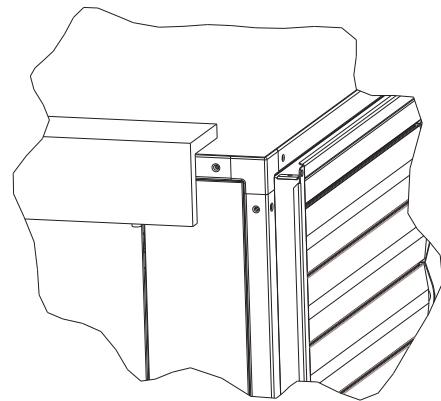
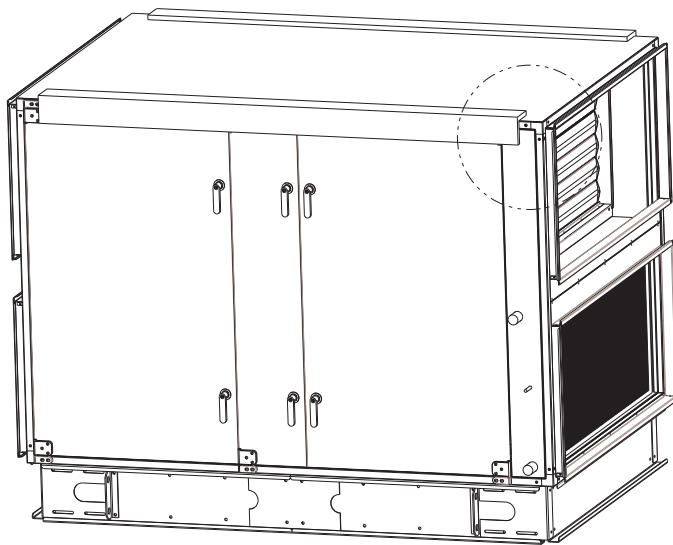

I.1.10 Roof unit with steel roof



Caution

For units with steel plate roof, the steel plates are delivered uninstalled on a separate pallet. Do **not** step or walk on the plates.

I.1.11 Pre-assembly storage

The AHU must be protected from the weather and accidental impact. Plastic packaging **must** be removed and the unit covered with tarpaulin or similar materials. In order to minimize condensation, sufficient air circulation must be ensured between the covering and the unit.

I.1.12 Tilt less than 30° during transportation of the section with heat pump

During transportation, the unit section **must** always be in the upright position or tilted less than 30°. If it is necessary to tilt the unit more than 30°, the suction pipe of the compressor must point upwards to prevent the escape of oil from the compressor sump.

I.1.13 Transport and pre-installation storage of rotary heat exchanger – always in vertical position

During transportation, the unit section **must** always be in the upright vertical position and never in a horizontal or tilted position. During pre-installation storage the unit section **must** always be in the upright vertical position. The rotary heat exchanger is not constructed for transportation and storage in a horizontal or tilted position.

I.2 Installation - mechanical

I.2.1 Free area in front of and above the unit

Important

When positioning the unit on the site, it must be ensured that an area with the same width as the unit is kept free for service and inspection and also for replacement of fans and exchanger, if needed. The width of the free area must be at least 900 mm.

Important

For safe access to the cabinet with electrical components, if the cabinet is placed on top of the unit, the free area from the upper edge of the cabinet to the ceiling must be at least 700 mm.

I.2.2 Supporting surface



Caution

Duct work must be sound insulated and must not be mounted directly on beams, trusses or other critical building parts.



Caution

The surface beneath the unit must be level, horizontal and vibration-free. The surface must be able to withstand the load of the AHU. Weights of the sections are written in Annex 2.

I.2.3 Adjustable feet under legs or base frame and transport of sections

Adjustable feet are provided in a carton box placed inside the unit. Adjustable feet are delivered for indoor units and not for outdoor units.

Sections can be transported on the site by hand manual forklifts or similar. The frame profiles in the edges of the sections have carrying capacity for lifting by the hand manual forklifts.

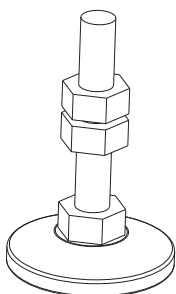

I.2.4 Base frame assembly

Base frame is delivered unassembled for the indoor units that are delivered in sections on pallets. Assembly of the base frame is illustrated on 4 pages in a manual in a plastic bag which is attached to one of the large base frame parts.

The 4 pages with the illustration regarding the assembly of the base frame are also available in this user manual in Annex 4, 5, 6 or 7.

There are two types of base frames:

1. 118 mm high base frames
2. 218 mm high base frames

There are 4 different manuals and each of them illustrates the assembly of the 4 different types of base frames:

1. Manual about the 118 mm high base frames for AHUs in the sizes from Geniox 10 to Geniox 18. The name of this manual is – **Base frame 118 sizes 10 - 18**
2. Manual about the 118 mm high base frames for AHUs in the sizes from Geniox 20 to Geniox 31. The name of the manual is – **Base frame 118 sizes 20 - 31**
3. Manual about the 218 mm high base frames for AHUs in the sizes from Geniox 10 to Geniox 18. The name of the manual is – **Base frame 218 sizes 10 - 18**
4. Manual about the 218 mm high base frames for AHUs in the sizes from Geniox 20 to Geniox 31. The name of the manual is – **Base frame 218 sizes 20 - 31**

Mount adjustable feet with a distance of maximum 1500 mm between each foot under the base frame. The base frame can now be levelled by the adjustable feet. The next step is to place and assemble AHU sections on the base frame.

1.2.5 Base frames for outdoor units

Outdoor units must be installed on 218 mm high base frames and are always fitted to the AHU sections. Hot-dip galvanized base frames are recommended for outdoor units. Systemair delivers these base frames without the above mentioned adjustable feet.

1.2.6 Outdoor units – support under the base frame of the unit

The installer must provide a frame that supports the base frame of the unit under the inspection side and under the back side of the unit. The frame must support the base frames of the unit under the entire length of the unit.



Caution

To avoid that the unit may tilt during storm the base frame of the unit must be properly fastened to the frame provided by the installer

1.2.7 Installation on the site of unit sections at the base frame when sections are delivered on pallets

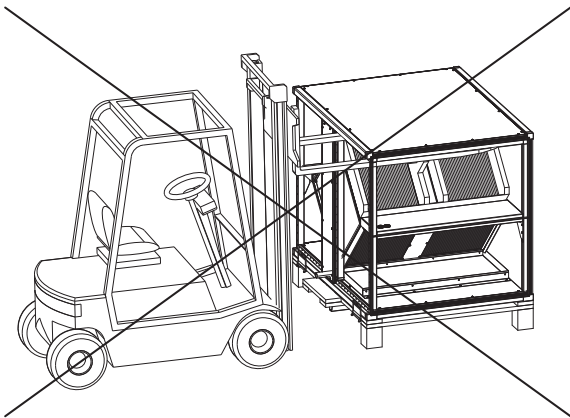

Caution

It is strictly forbidden to lift a section under the top of the section. The plastic corners and brackets are not at all reinforced for lifting the unit under the top. There is serious danger that the bottom with the heavy components will fall down with the risk of serious injury and damage to property.

Lift up the section by **forklifts** to the level where the underside of the section is even with the overside of the base frame. Pull the section to the correct position on the base frame by straps – it is maybe necessary to support the section by heavy duty trolleys (see the photos below).

Example of heavy duty trolleys. The trolleys – with the wheels downwards – placed **under the profiles** of the unit section and with a plate placed on the forks of a fork-lift these heavy duty trolleys are suitable for safe rolling of a unit section over to the base frames.



Pull sections together with a strap. We recommend the shown type of strap because this type is not damaging the frame profiles in the bottom of the units. An example of strap is shown to the right. **Note! To avoid any load and stress on the vertical profiles the strap must be carefully placed on the bottom profiles of the unit when sections are pulled together.**

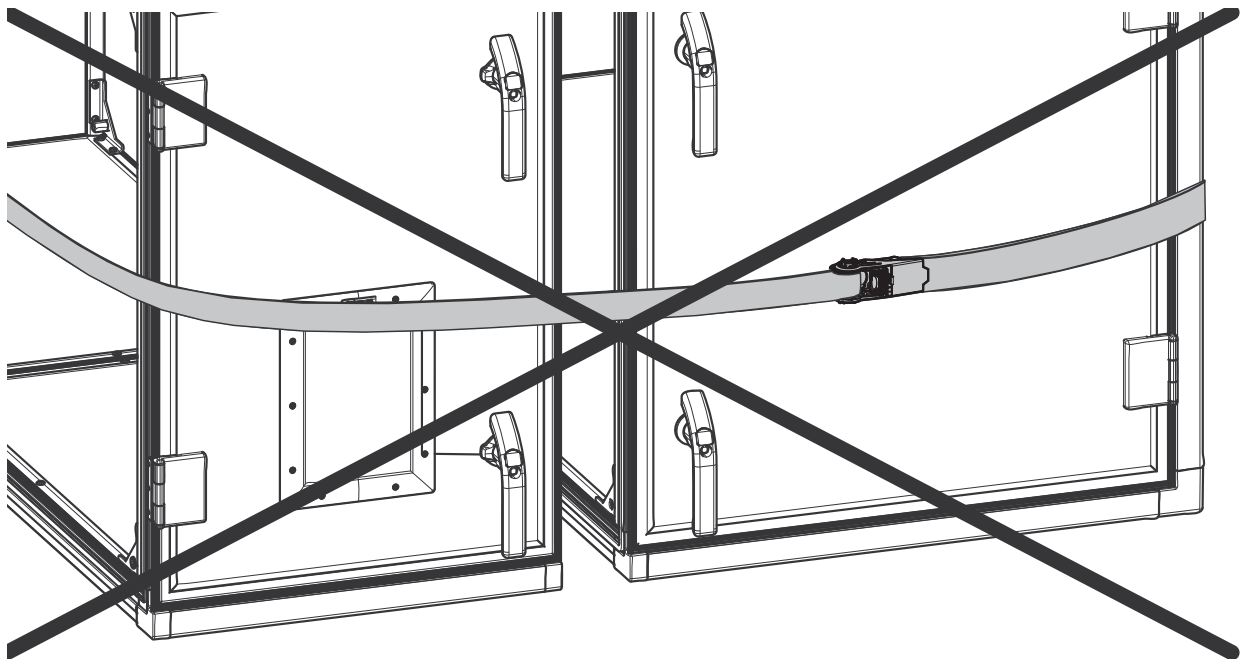
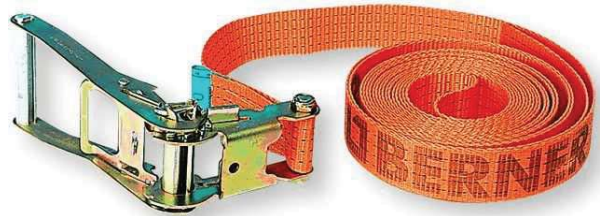

Note! Never – place the strap on the vertical profile when a section is pulled along the base frame or on the floor.

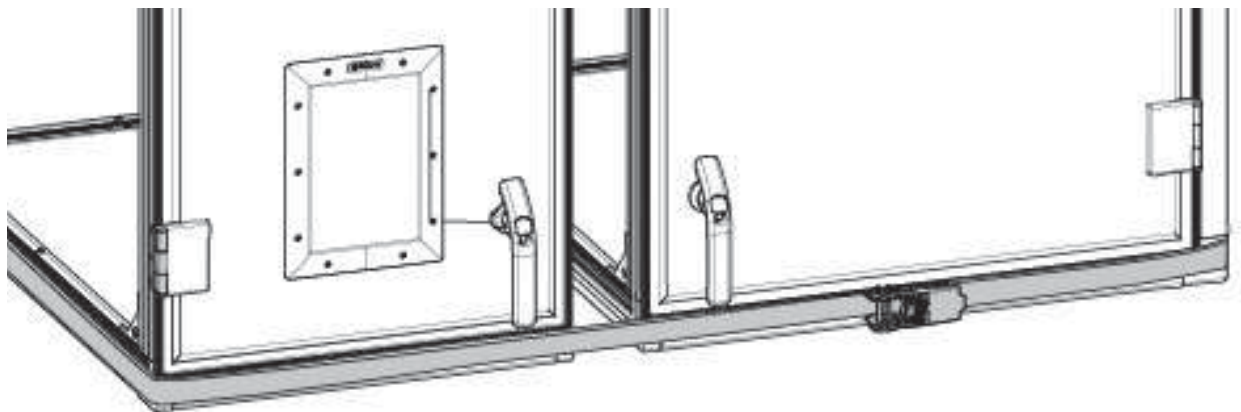

Note! Place the strap on the bottom profiles of the unit to avoid any load and stress on the vertical profiles when sections are pulled together along the base frame or on the floor. The sections must be pulled fully and tight together with the strap placed on the bottom profiles.



Sections are mounted to base frames with self-drilling screws. In the base frame you will find a sufficient number of 5 mm holes that are prepared for the self drilling screws. In this picture you are standing and you are watching the assembled base frame on the floor or roof.

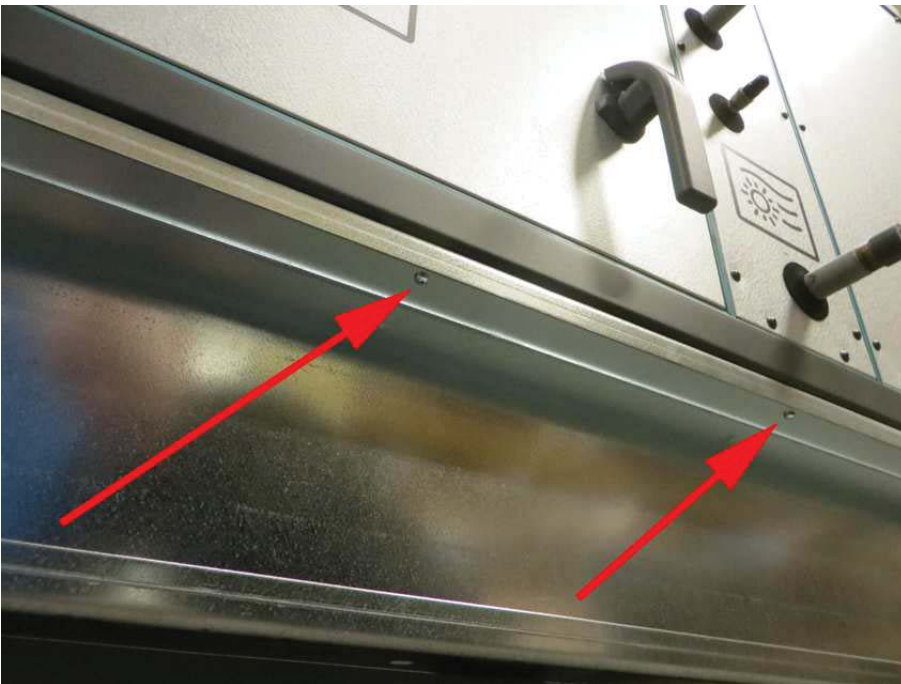

Use self-drilling screws – 4,8 X 18 mm – to be screwed upward through the holes into the bottom profile of the air handling unit **Note! A screw must be placed in every hole to achieve the necessary strength.** In this picture you are lying on the floor or roof looking upward under the base frame. The screws will not be visible, when you are standing beside the unit looking at the unit

1.2.8 Joining the AHU sections

The sections must be placed on the base frame and if the unit is delivered with 150 mm legs, the sections must be positioned directly in line with each other.

Ensure that the internal factory-fitted rubber sealing is undamaged

The sections are then to be positioned directly opposite each other. If the sections are built with legs, the adjustable feet can be used to get the sections in line and at the same height.



Press the sections hard together so that the rubber profiles are so flat that the iron frames of the two sections are joined. Strap with tensioner is suitable for pressing the sections hard together.. **Note! Do not place the strap on the vertical profiles. The strap must be carefully placed on the bottom profiles of the unit.**

The sections must then be locked permanently together with 8 mm bolts and nuts through the grey guiding and connection blocks. Systemair have provided you the 8 mm bolts with round heads and nuts required to carry this task out. An Allen key – size 6 – will be required.



Assembly has been completed successfully



The grey guiding and connection blocks might be installed inside the units on the vertical profiles. Press the sections hard together so that the rubber profiles are so flat that the iron frames of the two sections are joined. Strap with tensioner is suitable for pressing the sections hard together.. **Note! Do not place the strap on the vertical profiles. To avoid any load and stress on the profiles the strap must be carefully placed on the bottom profiles of the unit.**

The sections must then be locked permanently together with 8 mm bolts and nuts through the grey guiding and connection blocks. Systemair have provided you the 8 mm bolts with round heads and nuts required to carry this task out. An Allen key – size 6 – will be required.

Note! Do not move the sections together by tensioning the 8 mm bolts and nuts. Tighten the straps for this purpose.

If none of the above mentioned grey guiding and connection blocks are installed this alternative method must be used. Demount the doors and lock the two sections permanently together with self-drilling screws. Self-drilling screws are delivered with the unit. It might be necessary to use clamps to hold the sections fully together prior to tightening the screws.

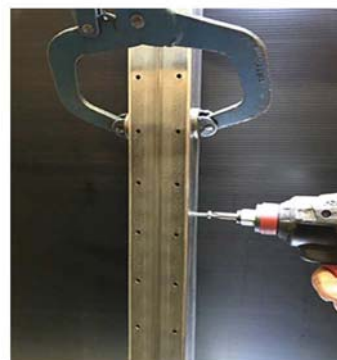

Bracket inside a section. A similar bracket is installed in the next section. This is the bracket in the Geniox sizes 10 and 18

Press the sections hard together so that the rubber profiles are so flat that the iron frames of the two sections are joined. Strap with tensioner is suitable for pressing the sections hard together.. **Note! Do not place the strap on the vertical profiles. To avoid any load and stress on the vertical profiles the strap must be carefully placed on the bottom profiles of the unit.**

The sections must then be locked permanently together with 8 mm bolts. Nut with thread is installed from the factory in one of the brackets

Note! Do not pull the sections together by tensioning the 8 mm bolts. Use the strap for this purpose.

Brackets inside a section. Similar brackets are installed in the next section. These are the brackets in the Geniox sizes 20 to 31

Press the sections hard together so that the rubber profiles are so flat that the iron frames of the two sections are joined. Strap with tensioner is suitable for pressing the sections hard together.. **Note! Do not place the strap on the vertical profiles. To avoid any load and stress on the profiles the strap must be carefully placed on the bottom profiles of the unit.**

The sections must then be locked permanently together with 8 mm bolts. Nut with thread is installed from the factory in one of the brackets

Note! Do not pull the sections together by tensioning the 8 mm bolts. Use a strap for this pupose.

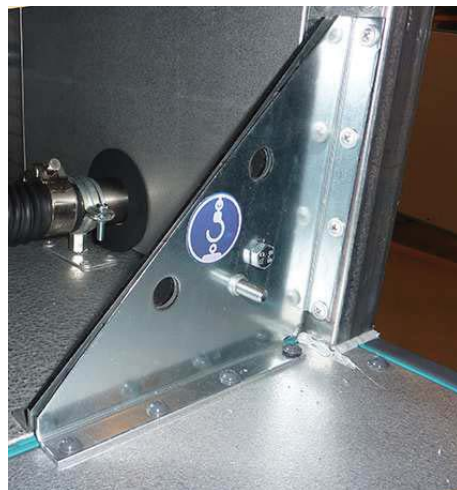
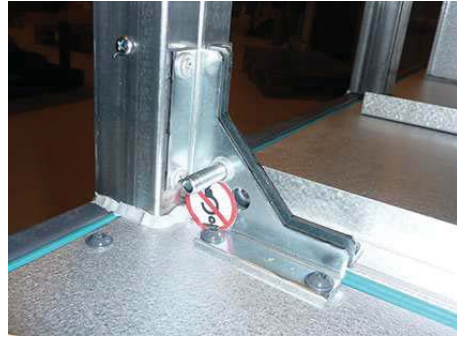

I.2.9 Fitting the ductwork

Flexible duct connections between AHU and ductwork must always be installed. Be sure that flexible duct connections are almost fully stretched. (Flexible connections are ordered as accessories and they are placed inside the unit). At the fan outlet on a centrifugal fan, the duct size should be as close to the outlet size as possible. Avoid blockage and turbulence at the fan outlet.

1.2.10 Risk of stack effect by vertical ducts and wind pressure on louvers

Important

The Systemair air handling units can be ordered and delivered without dampers, and the installer/user must check that duct systems with the described risk of stack effect (chimney effect) will be provided with dampers and spring return motors.

On special occasions stack effect – also called chimney effect – in the ducts create airflows that drives the impellers by turned off motors.

A rotating impeller is a potential hazard during cleaning and maintenance of the unit. Eliminate this airflow by dampers with spring return motors for automatic closing of the dampers - even by power failure.

1.2.11 Remove transport brackets – when spring mounts are installed

1.2.11.1 Impeller diameters 220 – 560 mm

If the fans are installed on spring mounts the transport brackets must be removed after the installation of the air handling unit. Two transport brackets are fitted to the coil springs during transport and installation. Both transport brackets must all be removed to give the full anti-vibration function to the coil springs. The transport brackets are made more visible with yellow labels. After removal of the transport brackets they must be disposed of safely.

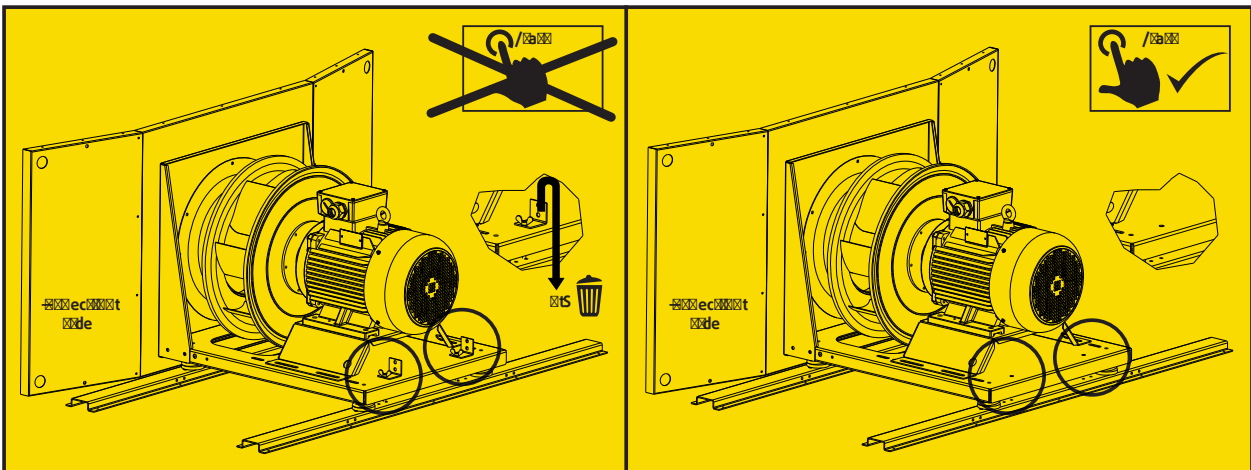

After disposal of the transport brackets the yellow label on the outside of the fan inspection door has no function and should be removed.

1.2.11.2 Impeller diameters 630 – 1.000 mm

If the fans are installed on spring mounts the transport brackets must be removed after the installation of the air handling unit. Four transport brackets are fitted to the coil springs during transport and installation. The four transport brackets must all be removed to give the full anti-vibration function to the coil springs. The transport brackets are made more visible with yellow labels, as shown in the picture below. After removal of the transport brackets they must be disposed of safely.

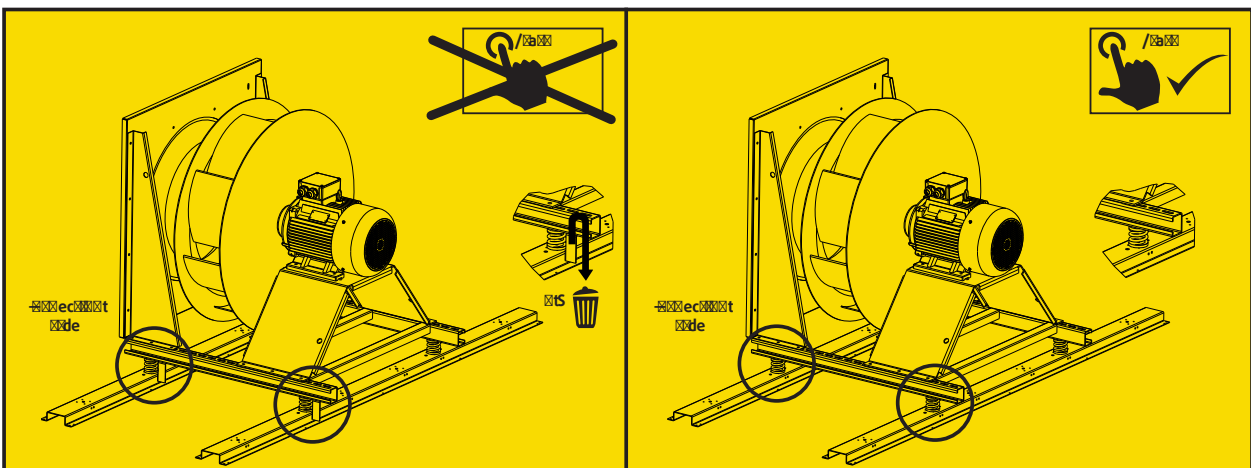

After disposal of the transport brackets the yellow label on the outside of the fan inspection door has no function and should be removed.

I.2.12 Refitting of guards

The guard is a safety guard installed inside the door. The safety guard show on the illustration below is optional from Systemair. According to Machinery Directive guidelines, tools are necessary for the removal of the guard. If the guard has been demounted during the installation on the site, the guard must be refitted before startup of the unit.

If the optional guard from Systemair has not been ordered, the installer, that starts-up the unit, must make and install a guard, where a guard is necessary according to Machinery Directive guidelines.

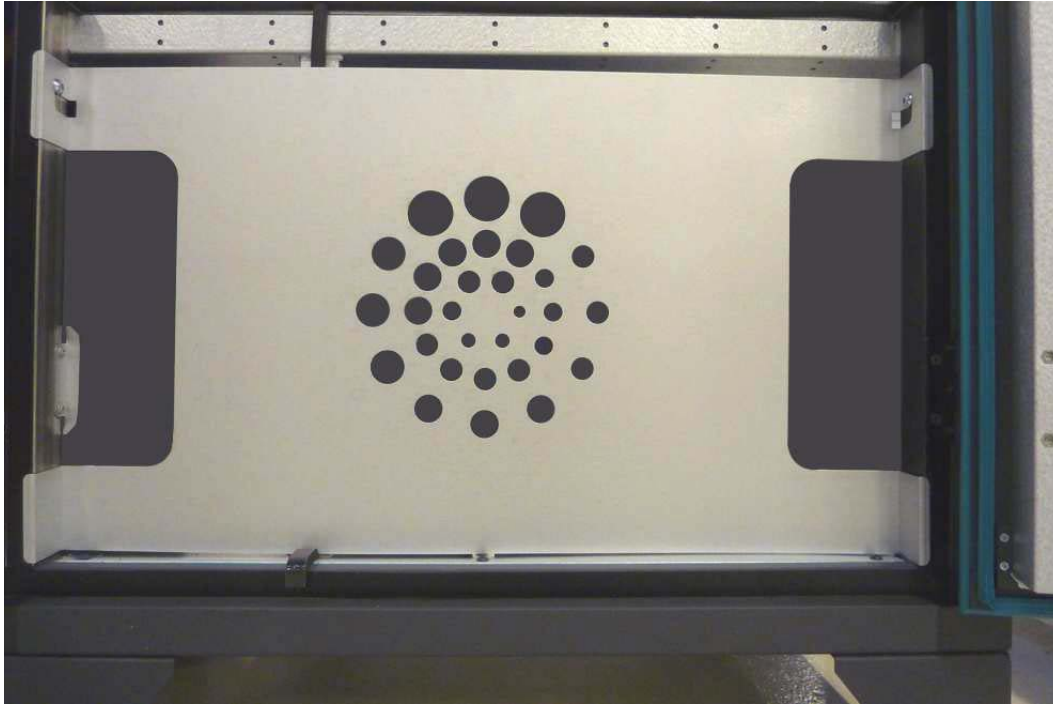

Use an Allan key – size 6 or size 8 – for refitting the safety guard from Systemair. Replace the vibration damping rubber list if it is damaged.



I.2.13 Lock the doors by using the key

Use the key to lock the doors. The doors are not locked automatically by turning the handle to the vertical position.



I.3 Installation - electrical

I.3.1 Description

The position of components is shown and described in Annex 2.

Connections to terminals are shown in the wiring diagram.

When control of constant pressure in the ducts (also called demand controlled capacity) is required, the pressure transmitters must measure in the duct system at places where all pressure changes can be registered accurately for reliable pressure control. This placement is left to the customer's free choice.

It is important to achieve a constant pressure – also for the most faraway diffusers.

I.3.2 Wiring diagrams

The wiring diagrams are printed in separate manuals delivered with the units.

The wiring diagrams are not unique for the order specific units, but it is standard wiring diagrams with data about all configurations of the units. Hereby the wiring diagrams will inform about components that are not ordered and delivered. See the order confirmation and Annex 2 with exact information about the accessory components that are ordered and delivered.

The wiring diagram includes:

- General description, Circuit diagrams, Cabinet layout, Terminal matrix and Cable plan.
- The wiring diagrams are on the DVD delivered with every unit.

I.3.2.1 Labels on or with the cabinet

- Label with data about the cabinet – including data about fuses – see chapter D.2.2
- Flowchart – see the example in chapter D.2.3 – unique flowchart for the order specific unit is shown in annex 2 with the unique production number of the unit
- Label with an example of the terminal plan for external components is shown in chapter D.2.5 – the unique terminal plan for external components for the order specific unit is shown in annex 2 with the unique production number of the unit.

In chapter D.2.5 is for the Access control board shown a drawing of the control board with the terminals and this is just an example, and not unique for the order specific unit.

I.3.3 Installation of mains power supply

An AC/DC residual current device must be installed in the power supply. The power supply for the units is 3*400 V + N + PE - 50 Hz. Protection of the units in accordance with the local statutory requirements for the additional protection of

systems with frequency converters and EC fans. The operator is responsible for the installation of the necessary protection equipment (supply disconnecting device is not delivered by Systemair).

I.3.3.1 Necessary mains power supply for units with cabinet/control system

Necessary mains power supply is printed on the unique machine card placed on the front of every unit (see example of a machine card in chapter D.2.1).

I.3.3.2 Necessary overvoltage protection device, that leads lightning overvoltage to an earth lead on a safe way.

The Installer and user must be aware of the fact that lightning strikes make a risk that requires installation of overvoltage protection devices to lead the lightning overvoltage to an earth lead in a safe way. Installer and user must take care of this according to local statutory requirements.

I.3.4 Electrical connection of components and functions

External components and functions are delivered according to the order confirmation. Cable numbers appear from the label inside or on the cabinet, and cable numbers appear from the wiring diagrams.

I.3.4.1 Connection of the Systemair NaviPad control panel to the Access controller

The NaviPad control panel with touch screen is provided with 3 metres of cable for connection to the Access controller inside the cabinet. Up to 100 m of cable between the Systemair NaviPad control panel and the Access controller is possible. Place the Systemair NaviPad control panel on the outer side of the unit or on a wall.

Connection and start-up of the Access control system with the NaviPad control panel is described in:

Quick guide NaviPad — on 16 pages. This information is delivered with the unit in a booklet.



I.3.5 Lock the doors by using the key

Use the key to lock the doors. The doors are not locked automatically by turning the handle to the vertical position.



I.4 Installation – Pipes for water – hot and chilled, valves and drains

I.4.1 Description

If ordered with the unit, the valves and valve motors are stored in a carton box placed inside the unit. Water trap(s) – standard or optional - is (are) necessary to ensure escape of water from the tray under plate heat exchanger and (or) cooling coil. Water trap(s) is (are) stored in a carton box placed inside the unit.

I.4.2 Pipe connections

Connection pipes on heating- and cooling coils are provided with external thread. Drainage outlets on drip trays are provided with straight pipe for quick connect fittings on the pipe with the water trap.

I.4.3 Possibility of extracting components from the unit

Pipes and cables must not obstruct the inspection doors and components which can be extracted from the unit. Potential components for extraction are filters, fans and rotary heat exchanger.

I.4.4 Pipe connections to batteries

I.4.4.1 Heating coils

Pipes for hot water must be protected by insulation against frost and loss of heat. Further protection against frost can be obtained by installing electrical heating wires around the pipes and under the insulation combined with temperature sensors and a control system. Pipes, insulation, electrical heating wires, control system for heating wires and circulation pump are not delivered by Systemair.

I.4.4.2 Cooling coils

If ordered with the unit, the valves and valve motors are stored in a carton box placed inside the unit. Pipes for cooling must be protected by insulation against condensation on the pipes and loss of cooling in the summer. Pipes and insulation are not delivered by Systemair.

I.4.4.3 Rigid pipe mounting brackets for valves, circulation pumps and pipe system

The coil and pipes from the coil are not constructed to withstand the weight and stress from valves, circulation pumps, long pipes and insulation of pipes. The system must be supported carefully in rigid pipe mounting brackets to roof, floor and walls.

I.4.4.3.1 Pipe connection to heating coils

The heating capacity of the coil with only 2 rows is independent of the connection of the hot water in equal flow or in counter flow to the direction of the air, but connection of the hot water to the pipe marked for inlet and the return water to the pipe marked for outlet is very important to ensure that the sensor for transmission of the water temperature really will be placed in a return circuit of the coil (Screw-joint for the water temperature sensor is welded in the main collection pipe for return water).

For the frost protection of heating coil, the water temperature in the coil is transmitted to the controller. The controller always generates a signal to the valve motor that keeps a sufficient flow of hot water to protect the coil against frost. This frost protection is also activated when the running mode is "off".

Coils with 3 rows or more must always be connected in counter flow to the airflow.



Note:

If glycol is added, the glycol must be without additives and auto glycol must not be used. Automatic bleeding has to be installed at the highest point of the 2 pipes – supply or return pipe.

If the heating coil is built with 3 or more rows, the water flow must be in counter flow to the direction of the air.

To protect against frost a temperature sensor for the transmission of an analog signal to the controller is placed in a pipe on the collection pipe for return water. The sensor must be fitted water tight with a cap in the pipe before water under pressure is in the coil. The pipe for the sensor is soldered on the collection pipe and it is important to hold contra on the pipe, when the cap is tightened.

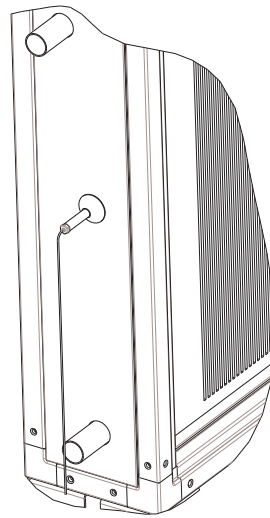

Coil seen from above. The sensor measures the water temperature of the water inside one of the small pipes for return water in the coil. The sensor reduces the area in this pipe and hereby also the flow of warm water in this pipe. The temperature in this pipe is reduced more than the temperature in all other pipes by the airflow through the battery. Because the lowest temperature in the battery probably is measured here, this system creates early and safe warning of frost.

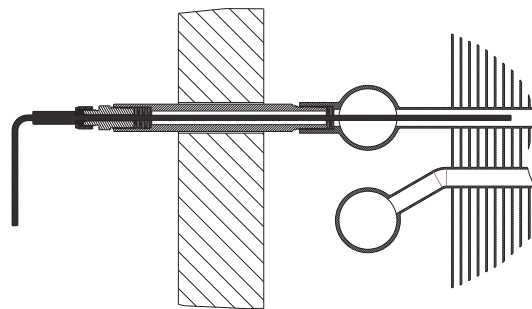

It is important that the cap is tightened sufficient to keep the sensor system fully water tight.

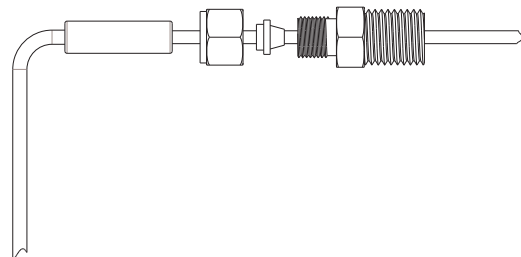

I.4.4.3.2 Pipe connection to cooling coils for chilled water

Coils with 3 rows or more must always be connected in counter flow to the airflow.



Caution

The glycol must be without additives and auto glycol must not be used. Automatic bleeding has to be installed at the highest point of the 2 pipes – supply or return pipe

I.4.4.3.3 Valve motor and valve for heating

The valve and valve motor are not installed. 2-way or 3-way valve is available.

I.4.4.3.4 Valve motor and valve for cooling

The valve and valve motor are not installed. 2-way or 3-way valve is available

I.4.5 Draining condensate water

Drip trays for collection of condensate water are installed under plate heat exchanger, run-around coil and cooling coil. Each drip tray is provided with a drainage outlet. A water trap is always necessary. To avoid freeze ups and frost bursts of water trap and pipes, sufficient insulation is recommended and installation of heating between the insulation and water trap/pipes could even be necessary (insulation, heating and controller for the heating are not delivered by Systemair).

I.4.6 Draining condensate water from heat exchanger

Condensate from the plate heat exchanger or run-around-coil is collected in the drip tray. Heavy negative air pressure in this section prevents the water from flowing out of the drainpipe. A water trap with sufficient closing level of the water is essential to ensure that condensate water flows out of the unit. The closing level of the water trap must be estimated correctly to ensure safe escape of the water (see the illustration and estimate the minimum closing level according to the table). The pipe diameter of the water trap and sewage system must be identical to the pipe diameter of the drainage outlet from the tray.

Remember to check that there is water in the water trap.

Table 1 Negative pressure P (Pa)

P	H1 Minimum	H2	H1 minus H2 Closing level	Excess height for flow
500 Pa	100 mm	40 mm	60 mm	10 mm
750 Pa	150 mm	55 mm	95 mm	20 mm
1.000 Pa	190 mm	70 mm	120 mm	20 mm

Necessary closing level that is H1 minus H2 – for example for the negative pressure 500 Pa – equal to 50 mm of water column is 60 mm because the 50 mm corresponds to the negative pressure is lifting the water 50 mm and an excess height of 10 mm enables the water to flow out through the water trap into the sewage system.

With the negative pressure at 750 Pa, an excess height of 20 mm enables the water to flow out through the water trap into the sewage system.

This type of water trap for sections with negative pressure and a ball that is sucked down into its seat for blockage of air flow into the section is available from Systemair. The above-mentioned heights – H1 and H2 – also apply to this type of water trap. The great advantage of this type of water trap for sections with negative pressure is that this type does not require water at the bottom to close for air flow backwards into the section. Condensate water will escape through this type of water trap – even after long periods without any water to close for air flow backwards through the trap.

This water trap is optional and must be ordered separately. Installation of water trap is not included.

The water trap in this picture has the delivered standard length of H1 of 150 mm and with the adjustable length of H2 adjusted to 55 mm, this set-up allows water to flow out at a negative pressure of 750 Pa, because the closing level that is H1 minus H2 is 95 mm and with 75 mm corresponding to the negative pressure lifting the water 75 mm and an excess height of 20 mm that enables the water to lift the ball and to flow out through the water trap into the sewage system..

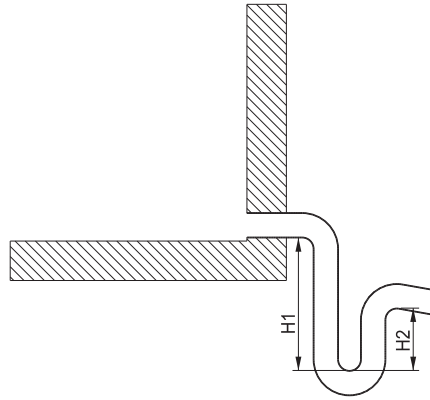

H1 must be shortened on the site by the installer – sometimes to only 100 mm – because the height of the low version of the base frame is only 118 mm. The adjustable length of H2 must be reduced to the minimum of 40 mm. According to the values in the above table, this allows Water to flow out at a negative pressure up to 500 Pa because the closing level that is H1 minus H2 is 60 mm with 50 mm corresponding to the negative pressure lifting the water 50 mm and an excess height of 10 mm that enables the water to lift the ball and to flow out through the water trap into the sewage system.

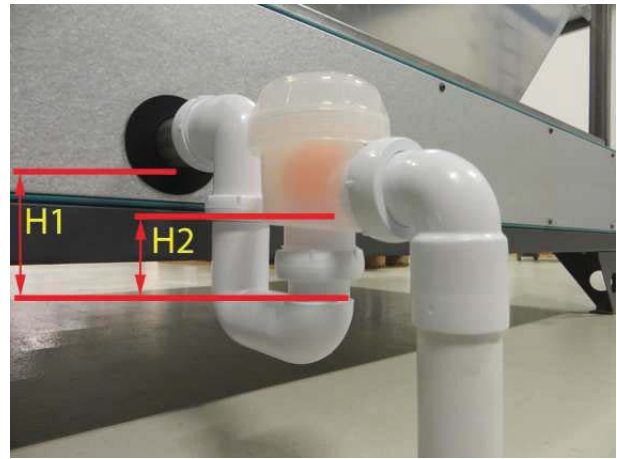

To avoid freeze ups and frost bursts of water trap and pipes, sufficient insulation is recommended and installation of heating between the insulation and water trap/ pipes could even be necessary (insulation, heating and controller for the heating are not delivered by Systemair).

The insulation must be easy to remove above the cap, because the ball and the seat for the ball must be cleaned regularly to allow the ball to close air-tight to the seat.



1.4.7 Draining condensate water from cooling battery –

If the cooling battery and the drip tray are placed in the unit where negative pressure (underpressure) occurs, the closing level of the water trap must be estimated correctly. See the above-mentioned information in 1.4.6 *Draining condensate water from heat exchanger*. If the cooling battery and the drip tray are placed in the unit where positive pressure (overpressure) occurs, the closing level of the water trap must be estimated correctly as shown on the illustration below. A water trap is optional and installation of the water trap is not included.

Remember to check that there is water in the water trap.

Table 2 Positive pressure P (Pa)

P	H1 Minimum	H2
500 Pa	90 mm	65 mm
750 Pa	120 mm	90 mm
1.000 Pa	150 mm	120 mm

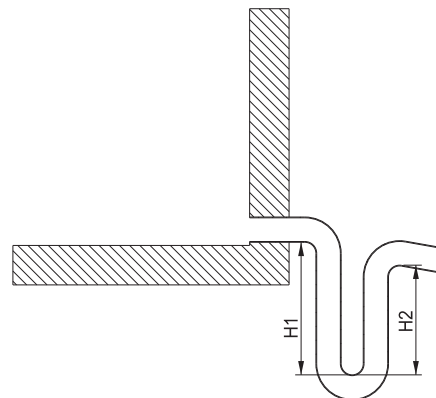

J Installation and assembly instructions for reduction of noise and vibration emissions

Due to the design and construction of the units the (A) weighed sound pressure level from fans and other components do not exceed 70 dB (A) outside the units.

Data about sound in Annex 2.

Installation of the units on springs will reduce the transmission of noise and vibrations to the building. Systemair does not deliver springs for this purpose.

Flexible connections between the units and the ducts are available as accessories.

K Start-up, adjustments, use, commissioning and unit in hibernation

K.1 Print-outs on paper

The documents listed below are always printed on paper and delivered together with the units according to the Machinery Directive and the related national laws

This User Manual with:

- Declaration of conformity with production number for this unit– annex 1
- The unique technical data with production number for this unit - Annex 2
- Installation instructions for assembling of base frame. – Annex 4
- Installation instructions for assembling of base frame. – Annex 5
- Installation instructions for assembling of base frame. – Annex 6
- Installation instructions for assembling of base frame. – Annex 7
- Installation instructions for assembling of steel roof. – Annex 8
- Speed control for rotor and assembly of divided rotor. – Annex 9
- Instructions for the Danfoss frequency converter if the unit was delivered with Danfoss frequency converters – 12
- Instructions for the Danfoss frequency converter if the unit was delivered with Danfoss frequency converters – 12
- Printed form for Commissioning protocol - Annex 13
- Test report if the unit was delivered with Systemair control system – Annex 14
- Short description about the main components in the control system if the unit was delivered with Systemair control system – Annex 15
- Wiring diagrams if the unit was delivered with Systemair control system - Annex 16
- Operator’s guide for the Systemair control panel - Annex 17

K.2 Documentation is available for download

From <https://techdoc.systemair.dk>

Your local Systemair company is able to provide the below-mentioned documents and data.

Common

- This User Manual in an order specific version
- Declaration of conformity with production number for this unit and the unique technical data with production number for this unit
- Commissioning Protocol as a Word-file for modification by the installer
- Wiring diagrams – if Systemair control system was delivered
- Operator’s Guide for the Systemair control system – Access controller – if Systemair control system was delivered

Components in the air handling unit

- Control system for rotary heat exchanger
- Danfoss frequency converter
- EC motors
- Damper motors
- Filter guards
- Temperature sensors
- Fire thermostats
- Smoke detectors
- Pressure transmitters
- Valves
- Valve motors
- Humidity sensors

- CO2 sensor
- Control panel
- Humidifier
- Manuals about configuration of Systemair control systems— Access
- Information about connection of Systemair control systems to Building Management Systems
- Other

K.3 Start-up by installer

All protection and safety measures must be met before start-up of the unit. The mains supply voltage must also be checked too. The mains supply voltage must be measured at the supply terminals in the cabinet.

K.3.1 Checklist, relevant values

K.3.1.1 Checklist prior to start-up

- Is the unit assembled correctly with its functions in the correct order? See Annex 2.
- Are the sections and ducts assembled correct? See annex i.
- Check that fans and anti-vibration mounts are not damaged after transportation and installation.
- Is the rotary exchanger turning freely?
- Are safety guards installed correctly?
- If the unit includes integrated heat pump, check whether it is installed and supervised by qualified service personnel.
- If the unit contains Electric air heater, make sure that the supply isolator disconnects with the unit.
- Ducts - are all ducts installed?
- External components - are the valve and valve motor installed correctly?
- Is the circulation pump installed correctly?
- Is water under pressure in the coil and circulation pump?
- Are the pressure transmitters installed and connected correctly? (If this is a system with pressure transmitters in the ducts)
- Main power supply:
 - Connected correctly? (3x400 V + N + PE)
 - Test of supply voltage for actuators and control signal!
 - Are control signals for actuators connected correctly?

K.3.1.2 Switch on power



Warning

Do not start until all safety procedures have been completed and ensure that inspection doors are closed and locked.

Switch on power and the unit should be ready for the start-up.

For start-up see the Operator's guide (also called User's Guide) for the Systemair control panel, if the unit was delivered with control system from Systemair - Annex 17 (this manual is delivered with the unit – printed on paper).

K.4 Adjustments and use

Adjust the factory set values for parameters on the Systemair Control panel if the unit was delivered with Systemair control system. See the Operator's guide for the Systemair control panel - Annex 17.

K.5 Description of functions, if control system is delivered by Systemair

K.5.1 Remote control

K.5.1.1 Communication to BMS systems with MODBUS

The controller has been prepared for communication via RS485 communication port to a MODBUS based BMS system (Building Management System).

The controller can work as a stand-alone system without any support from other controllers.

K.5.1.2 Communication to BMS systems via BACnet

The controller has been prepared for BACnet TCP/IP interface. This can be used for communication with a BMS system (Building Management System).

The controller can work as a stand-alone system without any support from other controllers.

K.5.2 Extended operation and external start/stop (for example by presence detectors)

When the unit is running at reduced speed or is in shutdown mode, it can be forced up one step by using a Push button (impulse). The required number of minutes for the extended operation must be selected on the Systemair Control Panel. Button and cable are not delivered by Systemair. Furthermore when the unit is in shutdown mode it is possible to start/stop the unit by presence detectors. Presence detectors and cable are not delivered by Systemair.

K.5.3 Valve and valve motor for heating coil

The supply voltage for the water valve actuator is 24V AC, the control signal is 0-10 V. The sensor for water temperature has to be installed in the heating coil and the sensor is provided with cable but not connected to the terminals in the cabinet. The cable between valve motor and terminals in the cabinet is not delivered by Systemair. Standard valves are available for 2 or 3-way connection.

K.5.4 Valve and valve motor for cooling coil

The supply voltage for the water valve actuator is 24V AC, the control signal is 0-10 V. Cables between valve motor and terminals in the cabinet are not delivered by Systemair. Standard valves are available for 2 or 3-way connection.

K.5.5 Da cooling

A DX-cooler can be connected to the controller. Input and output are available for:

Start cooling – Alarm cooling – Cooling Y3. Cables are not delivered by Systemair

K.5.6 Circulation pump, heating

Circulation pump is not included in the delivery from Systemair. If the pump has not been activated for 24 hours, the pump is exercised once daily for 1 minute to keep the pump in a good condition. Cables are not delivered by Systemair.

K.5.7 Fire alarm function

K.5.7.1 External fire signal that indicate block or run

The unit is available without components for this function. The controller is as standard configured for ordinary running when the contact is closed (NC). By open contacts the fans stop and the dampers close. If disconnected, fire is indicated and the unit will stop until the signal is re-connected. On the site qualified technicians are able to change the configuration.

K.5.7.2 External fire signal

The unit is delivered without components for this function. The controller is as standard configured for ordinary running when the contact is closed (NC). By open contacts the fans stop and the dampers close. When the unit has been shut down by a fire signal, the unit has to be restarted on the control panel. On the site qualified technicians are able to change the configuration.

K.5.7.3 Two fire thermostats

The unit is available with 2 thermostats installed in the unit – 1 in the extract air and 1 in the supply air. The cut-off temperature in the thermostats is adjustable between 40 and 70°C. At the factory supply is set at 70°C and extract is set at

40°C. The controller is as standard configured to stop the fans and close the dampers if a thermostat is released. On the site qualified technicians are able to change the configuration.

K.5.7.4 One smoke detector in extract air

The smoke detector has been installed in extract air next to the fan. The controller is as standard configured to stop the fans and close the dampers if the detector is released by smoke. When the unit has been shut down by a fire signal, the unit has to be restarted on the control panel. On the site qualified technicians are able to change the configuration.

K.5.8 Electrical heater battery

K.5.8.1 Control of heating capacity connected to unit with Systemair control system

Electrical heater installed with separate controller beside the heater. The separate controller is designed for capacity conversion of the 0-10 V control signal from the main control system. The electric heater is not supplied from the air handling unit cabinet as the cabinet is not designed to supply the heater with power. No power supply cables are connected to the electric heater. The separate controller is without supply disconnecting device.

K.5.8.2 Control of heating capacity connected to unit without Systemair control system

Electrical heater installed with separate controller beside the heater. The separate controller is designed for capacity conversion of the 0-10 V control signal from the main control system. The heating capacity is adapted in steps.

The electric heater is not supplied from the air handling unit cabinet as the cabinet is not designed to supply the heater with power. No power supply cables are connected to the electric heater. The separate controller is without supply disconnecting device.

K.5.9 Speed control of fans

K.5.9.1 Control system - frequency converters inside the unit are IP 20

Fan motor revolutions are controlled by frequency converters, and they are configured and tested to comply with the data for the unit. The frequency converter for each fan motor is installed inside the unit beside the fan motor with cables between motor and converter. In units with complete control system the frequency converters are delivered with system parameters adapted to the motors and the project.

K.5.9.2 Pressure transmitters

Separate control of the air flow or duct pressure for supply fan and for extract fan. The required air flow or duct pressures with normal as well as reduced capacity are selected on the Systemair Control Panel. The actual pressure is measured by pressure transmitters. PI calculation in the controller continuously transmits the necessary revolutions for the fans to the frequency converters to achieve the required pressure.

K.5.9.3 CO₂-dependent air flow

The air flow is controlled by a CO₂ sensor. High CO₂ concentration is equal to higher air flow. Low CO₂ concentration is equal to lower air flow. Based on the actual CO₂ level and a min/max level, the needed airflow is calculated. The speed of each fan is adjusted via frequency converter. Terminals in the cabinet are available for connection of the sensor.

K.5.9.4 Humidity dependent air flow

The air flow is controlled by the humidity sensor. High humidity is equal to higher air flow. Low humidity is equal to lower air flow. Based on the actual humidity level and a min/max level the needed airflow is calculated. The speed of each fan is adjusted via frequency converter. Terminals in the cabinet are available for connection of the sensor

K.5.10 Cabinet

K.5.10.1 Integrated cabinet in units with control system

Cabinet is integrated in the unit behind an inspection door. Terminals are installed in the cabinet for all external components. The number of terminals is always adapted to the individual order.

K.5.10.2 Cabinet placed on the unit with control system

The models with the cabinet on the unit are exclusively for indoor installation. Terminals are installed in the cabinet for all external components. The number of terminals is always adapted to the individual order.

K.5.11 Temperature sensors

Four sensors are always delivered with each unit. See below where the sensors are placed;

- 1 sensor in the extract air, installed inside the unit
- 1 sensor in the outdoor air, installed inside the unit before the supply air filter on the cold side of the heat exchanger
- 1 sensor in the supply air to be placed in the supply air duct by the installer
- 1 sensor in the exhaust, installed inside the unit

K.5.12 Damper motors

Four different types of damper motors are available;

- On/off damper motor, without spring return function. Torque is 20 Nm and run time is 150 seconds
- Modulating damper motor, without spring return function. Torque is 20 Nm and run time is 150 seconds
- On/off damper motor, with spring return function. Torque is 20 Nm and run time is 150/16 seconds
- Modulating damper motor, with spring return function. Torque is 20 Nm and run time is 150/16 seconds

K.5.13 Filter guards

Filter guard over pre-filter and primary filter installed and connected to the controller for display of alarm when the mechanically set limit is exceeded. Filter alarm will be displayed on the Systemair Control Panel.

K.5.14 Room temperature sensors

One or two external room temperature sensors are available. The cabinet has been prepared with additional terminals for connection of the room temperature sensors. The sensors are delivered without cable. The controller calculates an average of the value from the 2 sensors as input for the control.

K.5.15 Frost protection

For the frost protection of the heating coil, the water temperature in the coil is transmitted to the controller by a temperature sensor in a water return circuit of the coil. The controller always generates a signal to the valve motor that keeps a sufficient flow of hot water to protect the coil against frost. This frost protection is also activated when the running mode is "off".

If the water temperature falls below the set point temperature the fans stop, the dampers close, and an alarm is activated.

From Systemair every heating coil for hot water is provided with a little pipe at the collection pipe for the return water. This little pipe is prepared for the installation of the above mentioned temperature sensor for the transmission of the return water temperature to the controller.

K.5.16 Systemair Control Panel - NaviPad

The separate cable-connected (3m) hand terminal with touch screen — the NaviPad is always necessary for the normal handling and programming, because the main controller — Access — is without display and buttons.

K.5.17 Cooling recovery

If the extract air temperature is lower than the outdoor air temperature, and there is a cooling demand in the rooms, the cooling recovery will be activated by reversing the heat exchanger signal. The signal is increased to the cooling recovery by increasing cooling demand.

K.5.18 Free cooling

A temperature sensor has been installed inside the unit in the outdoor air entrance. If the outdoor temperature after midnight is below the room temperature set point and the actual average room temperature is above the set point temperature, the fans start during the summer to cool down the building during night hours.

K.5.19 Alarm signal

By alarm there are 24 V DC on terminals in the cabinet. Lamps and cables are not available from Systemair.

K.5.20 Heat recovery

The heat recovery capacity is controlled by modulating speed of the rotor.

K.5.21 Frost protection – plate heat exchanger

Signals from a temperature sensor mounted in the airflow after the plate heat exchanger are transmitted to the controller for frost protection of the plate heat exchanger.

K.6 Commissioning

When the installer has completed the installation and wants to hand over the finished installation to his customer for payment the commissioning protocol can be the written receipt for the full ended job. Fill in the blank spaces and sign the proposed commissioning protocol that is Annex 13, or fill in the Word-file with a Commissioning Protocol that is available from your local Systemair office.

K.7 Unit in hibernation – not in regular operation for several months

When the unit is in hibernation (is not in regular operation for several months) after the installer has completed the installation, the unit must be in operation for 10 – 15 minutes every day.

L Information about the residual risks

L.1 Unit casing

L.1.1 Design of the machine to make transport safe

Hazards/dangerous area:

- Incorrect handling during transportation may cause that the unit is dropped.

Dangerous incident:

- If a person is hit by a unit that is dropped, this could in unfortunate circumstances lead to irreversible injury or death.

Claim for reduction of danger:

- Correct handling during transportation is described in this manual. If lifted by **fork-lift truck** the forks of the truck must be sufficiently long. Safety measures are also described in this manual by use of crane. Information about weight of each section is also visible.

L.1.2 Common for all unit sections

L.1.2.1 Risk caused by surfaces, edges and corners

Hazards/dangerous area:

- Sharp edges on plates might occur inside the machines as well as sharp edges on frames of dampers. No sharp edges on the outside of the units.

Hazards/dangerous area:

- Sharp edges on plates might occur inside the machines as well as sharp edges on frames of dampers. No sharp edges on the outside of the units.

Dangerous incident:

- Cut fingers/hands.

Claim for reduction of danger:

- Risk only exists during maintenance and cleaning. This takes place at least once every year. Use of gloves and helmet is described in this manual. Cut-resistant gloves for protection against injury from sharp metal plate edges. Use CE-marked gloves for this purpose. Lamps mounted inside the unit with sufficient lighting reduce the risk of injury.

L.1.3 Common for all unit sections by insufficient lighting

L.1.3.1 Risk caused by insufficient lighting inside sections

Hazards/dangerous area:

- On the floors of the units there are handles to hold filters, profiles for the carrying of fan motors. Cables are between fan motors and frequency converters.

Dangerous incident:

- By insufficient lighting, the above-mentioned obstacles are not visible with the risk of stumbling that becomes a fall, leading in unfortunate circumstances to irreversible injury or death.

Claim for reduction of danger:

- Risk only exists during maintenance and cleaning. This takes place at least once every year. According to this manual and in the SystemairCAD software for configuration and selection of accessories, lamps for sufficient lighting inside the units are mandatory according to the latest interpretations of the Machinery Directive by the authorities. Use of helmets reduces the risk of injury.

L.1.4 Dampers**L.1.4.1 Risk caused by maintenance and cleaning of dampers****Hazards/dangerous area:**

- Are between the damper blades and the system of bars and links between motor and damper blades.

Dangerous incident:

- Crushing of fingers.

Claim for reduction of danger:

- Risk only exists during maintenance and cleaning. This task must be done by skilled technicians that are aware of this risk.

L.1.5 Attenuators**L.1.5.1 Risk caused by maintenance and cleaning of attenuators****Hazards/dangerous area:**

- High concentration of dust on the surface of the baffles might be harmful to the health.

Dangerous incident:

- To breathe in particles that is harmful to the health.

Claim for reduction of danger:

- Risk only exists during maintenance and cleaning. This takes place at least one time every year. Use of particulate respirator is described in this manual. Particulate respirator – maintenance free including foam face-seal and adjustable pre-threaded headbands (same particulate respirator as recommended for change of filters).

L.1.6 Filters**L.1.6.1 Risk caused by missing change of filters****Hazards/dangerous area:**

- Missing change of filters and missing maintenance decrease the capacity and final consequence will be breakdown.

Dangerous incident:

- By extensive lack of of filter change and maintenance the machine can break down.

Claim for reduction of danger:

- In the manual is the method and schedule for change of filters and maintenance specified.

L.1.6.2 Risk caused by the execution of filter change**Hazards/dangerous area:**

- Filter panels and filter bags

Dangerous incident:

- To breathe in particles that is harmful to the health.

Claim for reduction of danger:

- Use of particulate respirator – maintenance free including foam face-seal and adjustable pre-threaded headbands (same particulate respirator as recommended for cleaning of attenuators).

L.1.7 Plug fans**L.1.7.1 Risk caused by lightning strike****Hazards/dangerous area:**

- Lightning strike close to the machine.

Dangerous incident:

- Lightning strike can create flash over between phases and conductive parts. This can cause fire or the overvoltage can make injury on persons

Claim for reduction of danger:

- Installer and user must be aware of the fact that lightning makes a risk that requires installation of overvoltage protection devices to lead the lightning overvoltage to an earth lead on a safe way. The need for overvoltage protection devices depend on where the unit is placed in and on the building.
- Installer and user must take care of this according to local statutory requirements. Overvoltage protection devices are also described in chapter I.3.3.2 of this manual.

L.1.7.2 Risk caused by permanent magnet motor**Hazards/dangerous area:**

- Rotation of the shaft generates electricity. This danger is always visualized by a yellow warning label on the inspection door where permanent magnet motors are installed.

**Dangerous incident:**

- Persons touching conductive parts get electric shock, burns, heart flicker and so on.

Claim for reduction of danger:

- By installation or repairs of conductive components, the shaft must be blocked to prevent any rotation.

L.1.7.3 Risk of rotating impeller caused by stack effect (chimney effect).**Hazards/dangerous area:**

- On special occasions stack effect – also called chimney effect – in the ducts create airflows that drives the impellers by turned off motors.

Dangerous incident:

- Injury of fingers, hands and arms.

Claim for reduction of danger:

- Eliminate this airflow for supply air and exhaust air by dampers with spring return motors for automatic closing of the dampers by turned off fan motors and by power failure.

L.1.8 Batteries for heating**L.1.8.1 Extreme temperatures - heating****Hazards/dangerous area:**

- Electrical heating elements can achieve surface temperature of 500 degree Celsius.
- Batteries and pipes for hot water can achieve 95 degree Celsius.

Dangerous incident:

- According to ISO 13732-1:2006, here is no direct risk of burns. (short-time contact – lesser than 2,5 sec).

Claim for reduction of danger:

- No.

L.1.8.2 Extreme temperatures - cooling**Hazards/dangerous area:**

- Evaporator batteries and pipes connected to cooling compressor can achieve minus 10 degrees Celsius.

Dangerous incident:

- According to ISO 13732-1:2006, here is no direct risk of burns. (short-time contact – lesser than 2,5 sec).

Claim for reduction of danger:

- No.

L.1.9 Heat pump units**L.1.9.1 Risk of high temperature****Hazards/dangerous area:**

- Condenser batteries and pipes can achieve temperature of 60 degree Celsius.

Dangerous incident:

- Vurderet ud fra ISO 13732-1:2006, der er umiddelbart ikke risiko for forbrændinger. (berøringstid 2,5 sek).

Claim for reduction of danger:

- No

L.1.9.2 Risk caused by lightning strike**Hazards/dangerous area:**

- Lightning strike close to the machine.

Dangerous incident:

- Lightning strike can create flash over between phases and conductive parts. This can cause fire or the overvoltage can make injury on persons

Claim for reduction of danger:

- Installer and user must be aware of the fact that lightning makes a risk that requires installation of overvoltage protection devices to lead the lightning overvoltage to an earth lead on a safe way. The need for overvoltage protection devices depend on where the unit is placed in and on the building.
- Installer and user must take care of this according to local statutory requirements. Overvoltage protection devices are also described in chapter I.3.3.2 of this manual

M Instructions on the protective measures during repair and maintenance

Use the below-mentioned personal protective equipment for maintenance:

- Cut-resistant gloves for protection against injury from sharp metal plate edges. Use CE-marked gloves for this purpose.
- Helmet
- Particulate respirator – maintenance free including foam face-seal and adjustable pre-threaded headbands – for replacing filters.
- Padlock for locking the automatic circuit breakers in off position
- Permanent magnet motor. The shaft must be blocked during repairs and maintenance of the electric system (the motor generates electricity by rotation – for example that the wind and thermic drives the fan/motor).
- Lighting inside the units. According to the latest interpretations of the Machinery Directive by the authorities sufficient lighting inside the units is mandatory.

- Tools to block the impeller during repairs and maintenance if stack effect – also called chimney effect – in the ducts create airflows that drives the impellers by turned off motors

N The essential characteristics of tools which may be fitted to the machinery

The subject in the Machinery Directive about tools on the machine does not exist for the Geniox air handling units, because those tools does not exist.

O The conditions of stability during use, transportation, assembly, dismantling when out of service

The unit must always be handled in an upright position. Never tilt any section more than 15 degrees. If sections must be tilted more than 15 degrees, sections with fans or rotating exchangers that can be drawn out for service must be secured carefully.

During transportation, installation, dismantling or other handling, it must be secured that all components in the unit are properly fastened and with additional attention to the control of anti-vibration mounts under the fans that they are undamaged. The mounting and smooth running of the fans must be controlled and handled with great care.

0.1 Installed reliable to avoid units to be tilted or moved by storm

Units installed on roofs and other places with the risk of heavy winds must be installed reliable to avoid that they can be tilted or moved by the any storm. The base frame is provided with holes that are intended for fastening by sufficient bolts and fittings supplied by the installer.

0.2 Transport of section with heat pump unit



Warning

During transportation, the unit section – Geniox – HP **must** always be in the upright position or tilted less than 30°. If it is necessary to tilt the unit more than 30°, the suction pipe of the compressor must point upwards to prevent the escape of oil from the compressor sump.

0.3 Disposal of the heat pump system - type Geniox - HP

Prior to the disposal of the Geniox – HP unit section, the refrigerant in the heat pump system must be drained off by a skilled technician from a certified company. After correct evacuation of the refrigerant, the disposal of the Geniox – HP unit section is similar to the disposal of the rest of the air handling unit.

0.4 General disassembly – sharp edges

Pay attention to several sharp edges during dismantling and disposal of the unit. To avoid injury, CE-marked cut-resistant gloves as well as helmet must be used. The measures are described further in the Maintenance, Dismantling and Disposal Manual.

P Instructions for machinery where these are regularly to be transported

The subject in the Machinery Directive about machinery that are regularly to be transported does not exist for the Geniox air handling units, because those units are specially made for one intended application.

Q The operating method to be followed in the event of breakdown. Safe restart.

Use the below mentioned procedure in the event of breakdown or blockage:

- Switch off the power and lock the automatic circuit breaker by padlocks in the off position.
- Remove the reason for breakdown or blockage.
- Follow the start-up procedure described in chapter K.

R Adjustment and maintenance operations

Must be performed by skilled technicians.

In connection with demands for compensation, Systemair must have full and unhindered access to all relevant reporting on service, repair, modification and use since the unit was transferred from Systemair to a transport company at the

Systemair factory. It is a condition for compensation that maintenance outlined on the following pages has as a minimum been performed.

R.1 Shutdown of the unit to a safe state

Switch the unit to OFF on the Systemair Control Panel. See the - Operator’s Guide – if the unit was delivered with control system from SystemairAnnex 17. Switch off the automatic disconnecting device and block them by padlocks. The automatic disconnecting device are marked F1 to F4. See the illustration below about how to place a padlock on each disconnecting device.

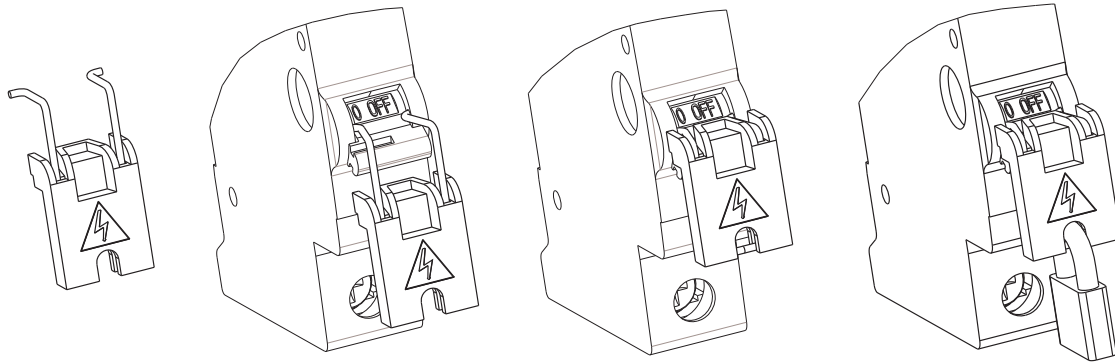

Check that the disconnecting device marked F5 is still switched on because the lamps inside the unit, and only those lamps, are connected to this switch. Switch on the lamps for light during the maintenance activities.

Use the start-up procedure described in chapter K, when the maintenance activities are completed.

R.2 Unlock and lock the doors by using the key

Use the key to lock the doors. The doors are not locked automatically by turning the handle to the vertical position.



R.3 Recommended maintenance intervals

Function	Maintenance	Number per year
Unit casing	Cleaning of the unit casing.	1
	Control of rubber seals on doors and between sections.	1
Filters	Change on demand by alarm and always minimum twice a year.	2
	Control of rubber seals. Control of the system on Geniox10 – Geniox31.	2

Function	Maintenance	Number per year
Fans	Cleaning of all parts.	1
	Check motors and bearings	1
	Check that the impellers are rotating without dissonance.	1
	Check that anti-vibration mounts are intact.	1
	Check that the unit is operating without vibrations after the cleaning, overhaul and maintenance.	1
Rotary heat exchanger	Check that leakage is insignificant. By significant leakage brush seals must be replaced.	1
	Check that the rotor can turn freely and easily manually with a hand when the belt is removed from the drive	1
	Check that dirt accumulation is insignificant. The rotor can only be cleaned by gentle vacuum cleaning.	1
	Check drive belt, motor and the speed control system. Check and repair immediately by alarm for malfunction.	1
Plate heat exchanger	Check bypass function and sequence for de-icing. Check and repair immediately by alarm for malfunction.	1
Run-around heat exchanger	Check the exchanger function and test the frost protection. The glycol must be without additives and auto glycol must not be used. Check and repair immediately by alarm for malfunction.	1
Dampers	Test the operation.	1
	Visual inspection of seals and tightness when closed.	1
Hot water battery	Check the dirt accumulation and clean, if needed.	1
	Bleeding, if needed.	1
	Test of frost protection sequence	1
	Test of circulation pump	1
Electric heating battery	Check dirt accumulation and clean, if needed.	1
	Test the function of the system with the fuses for the safety.	1
Cooling battery	Check dirt accumulation and clean, if needed.	1
	Test the frost protection (glycol)	1
Heat pump unit	Mandatory annual control of the heat pump system. Must be done by certified technician from a certified company.	1
Condensate drain	Cleaning of tray, water trap and outlet. Check the electrical heating between insulation and pipes, if installed. Check and clean on demand and always minimum twice a year.	2
Saving- and comfort functions	Test of CO2 sensor, humidity sensor, motion sensor, pressure transmitters for air capacity control, extended operation via button, cooling recovery, free cooling	1
Fire alarm	Test of thermostats, smoke detectors and fire detection systems	1
Battery in controller	Change the battery on demand by alarm in the display and always change the battery as a minimum every 5. Year.	1
Remote control	Test of Communications.	1

R.4 Filters – always replace filters with new filters with the same characteristics to maintain SFP value

Filters in supply air and in extract air always have the same sizes of frames and the number of filters for supply air and extract air are always the same. REMEMBER to order filters for supply air as well as for extract air.

To maintain the factory-calculated SFP values for the air-handling unit, it is very important that filters with the same characteristics for start pressure as well as lifetime replace factory-mounted filters.

To achieve the most favourable SFP values, the factory-mounted filters represent the lowest achievable start pressure as well as the longest achievable lifetime. If other filters with higher start pressure and shorter lifetime replace the factory-mounted filters, the user will experience smaller airflow and/or consumption of more electricity, and the SFPv value calculated by Systemair according to the Eurovent certification will not be achieved. Poor SFPv values will be detected by tests according to commissioning standards, DGNB, LEED or BREEAM sustainability standards and locally defined performance standards (the SFPv is with new clean filters).

Filter frame for bag filters must be of NON-PVC plastic to ensure safe disposal by incineration.

For each individual air handling unit you will find the data for the factory-mounted filters in Annex 2 that is always provided in a cover placed inside the air handling unit when the air handling unit is delivered to the final site. Annex 2 is also always available from Systemair if you can inform us of the production number of the air handling unit. The production number is always printed on the so-called machine card that is attached to the unit. You will find an example of this machine card in section d.2.1 of this manual.

The factory-mounted filters comply with indoor air quality demands of customers and with the SFP values according to local legislation.

The filters comply with the filter classes according to the new test standard EN ISO 16890:2016 valid from 1 January 2019.

Filter classes according to the old test standard EN 779:2012 and the new test standard EN ISO 16890:2016 are listed below:

G4 – coarse 60%
M5 – ePM10 60%
M6 – ePM2,5 50%
F7 – ePM1 60%
F7 CityFlo – ePM1 60%
F8 – ePM1 75%
F9 – ePM1 85%

R.4.1 Bag filters – the number of filters and sizes of frames

Filters in supply air and in extract air are always the same sizes and the same numbers. See the filters in supply or extract air below.

Size of unit	Numbers and sizes of frames for bag filters (WxH)
10	1x[792x392]
11	2x[490x490]
12	1x[592x490] + 1x[490x490]
14	2x[490x592] + 1x[287x592]
16	3x[490x592]
18	2x[490x392] + 4x[592x392]
20	3x[592x592] + 3x[287x592]
22	6x[592x490] + 2x[287x490]
24	3x[592x592] + 1x[490x592] + 3x[592x490] + 1x[490x490]
27	2x[592x592] + 8x[490x592]
29	6x[592x592] + 4x[490x592]
31	5x[592x592] + 5x[490x490] + 5x[592x287]



Note:

Special sizes of filters are available from Camfil.

Dept of filter frame must be 25 mm to ensure a complete airtight sealing around the AHU filter frame

R.4.2 Panel filters – the number of filters and the sizes of the frames

Size of unit	Numbers and sizes of frames for panel filters (WxHxD)
10	1x[792x392x48]
11	2x[490x392x48]
12	1x[490x490x48] + 1x[592x490x48]
14	2x[490x592x48] + 1x[287x592x48]
16	3x[490x592x48]
18	2x[490x392x48] + 4x[592x392x48]
20	3x[592x592x48] + 3x[592x287x48]
22	6x[592x490x48] + 2x[287x490x48]
24	3x[592x592x48] 4x[490x592x48] + 1x[490x490x48]
27	2x[592x592x48] + 8x[490x592x48]
29	6x[592x592x48] + 4x[490x592x48]
31	5x[592x592x48] + 5x[592x490x48] + 5x[592x287x48]



Note:

Special sizes of filters are available by Camfil.

R.4.3 Bag filters

Turn the unit off and wait for 2 minutes till unit completely stops. Used filters can be pulled out. Store the used filters immediately in plastic bags to avoid that dust pollutes the environment. Geniox units in the sizes 10 – 31 are provided with a very corrosive-resistant and reliable system, where filters are slid into the units in a lower and upper durable u-profile of plastic/rubber. Check the upper and lower U-profile for damage and check the vertical rubber profile on the back wall as well as the rubber profile on the inspection door for damage. The new filter bags must be pushed carefully into the unit in order to ensure that they are sealed properly. The filters must have vertical bags.



Note:

Instructions about easy, quick and safe change of filters are displayed in a 2-minutes video. The video is available on YouTube.

https://youtu.be/w2yP5_770fc

ONE self-adhesive foam strip must be placed on the vertical frame of EACH filter to avoid major air leakage through the vertical opening between 2 filters. Please note – only ONE self-adhesive foam strip must be placed on the vertical frame of EACH filter – Please establish the practical rule that the self-adhesive foam strip is placed on the vertical side that is visible from the inspection side. Those very important self-adhesive foam strips are usually not delivered by the suppliers of filters. The customer must order those self-adhesive foam strip from a supplier of foam strips. Width of the foam strip is about 15 mm and thickness of foam strip must be exactly 8 mm. If the thickness of the foam strip is less than 8 mm, there will be a gap for leakage between the filters. If the foam strip is more than 8 mm the row of filters in the U-profile will be too wide making it impossible to close the inspection door. **Note! The staff must have the self-adhesive foam strips available when they go to the air handling unit. Without those self-adhesive foam strips, any change of filters is impossible.**



Remove the protection from the self-adhesive side of the strip.



Place the self-adhesive strip on **one** vertical side of the filter frame



Check that the end of the strip is fully even with the horizontal side of the filter frame.



Remove excess of the strip. The end of the strip must be fully even with the horizontal side of the filter frame.



Push the filters carefully in the U-profile to be sure that there are no leakages between the filters. Check that the vertical side of the last filter in the U-profile is fully even with the end of the U-profile. If the end of the last filter is not fully even with the end of the U-profile an additional self-adhesive profile must be added to avoid any gap between the rubber profile on the inspection door and the last filter.



The end of the last filter is fully even with the end of the U-profile. The rubber profile on the inspection door will close the gap between inspection door and filter. Job is done.



Check that rubber profiles on the back panel as well as rubber profiles on the inspection door are without wear and damage – still sufficient for avoiding any air leakage.



R.4.4 Panel filters

The filter cell guide rails are to be cleaned before fitting the new filters.



R.5 Changing the Internal Battery in the controller



Caution

This procedure requires knowledge of proper ESD protection; i.e. an earthed wristband must be used!

When the alarm "Internal Battery" is activated and the battery LED lights up red, the battery for backup of program memory and real-time clock has become too weak. The battery is replaced as described below. A backup capacitor saves the memory and keeps the clock running for at least 10 minutes after the power supply is removed. Therefore, if the battery replacement takes less than 10 minutes, there will be no need to reload the program, and the clock will continue to run normally.

The replacement battery must be of the type CR2032.

- 1 Remove the cover by pressing down the locking torques at the edge of the cover using a small screwdriver, and at the same time pulling the edges outwards.
- 2 Grip the battery firmly with your fingers and lift it upwards until it rises from its holder. Press the new battery firmly down into place. Note that to preserve correct polarity; the battery can only be inserted the "right way round".

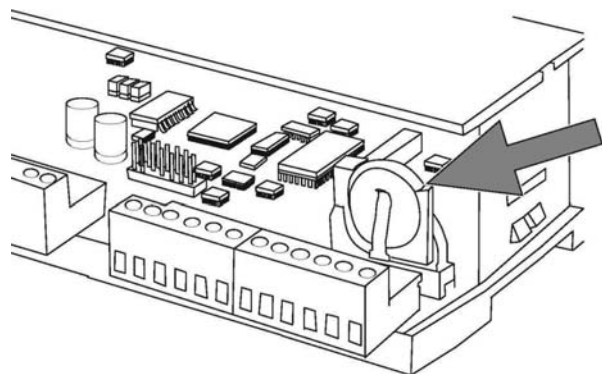

R.6 Functions to maintain

R.6.1 The unit

It is very easy to remove inspection doors for extraordinary good access to cleaning, service, repairs and replacement of components in the unit. Lift the stainless steel shaft in the hinge to remove the door



The unit should be cleaned once a year when operating with normal air quality for comfort ventilation with no special hygiene requirements.

To clean the unit, dry it off with a dry cloth, or use water mixed with a non-corrosive cleaning medium.

Any corrosion – for example the bottom of the section for outdoor air intake and the bottom of the section for exhaust air outlet must be cleaned off immediately, and the surface treated.

In special operating conditions, where the air is aggressive or very humid, for example, or where there are special hygiene requirements, the unit shall be cleaned more frequently as required.

Cleaning medium and method should be adapted to the relevant conditions. Any corrosion should be cleaned off immediately, and the surface treated.

Closing mechanisms are to be lubricated at least once a year. Synthetic door hinges are service free. Seals around inspection doors are to be cleaned at least once a year and are to be checked for leakage.

It is recommended to treat the seals with a moisture repellent agent.

All seals are to be inspected at least once a year and are to be repaired if necessary.

Grilles for air intake and exhaust air outlet are to be cleaned at least once a year to prevent blockage.

R.6.2 Dampers

Rubber seals between the damper blades and the frame are to be checked once a year. These seals are not to be lubricated or treated in any other way.



Each damper blade is driven by a gear drive of a temperature-resistant, glass-fibre reinforced PA6 nylon composite. Gear-drive as well as bearings do not require lubrication

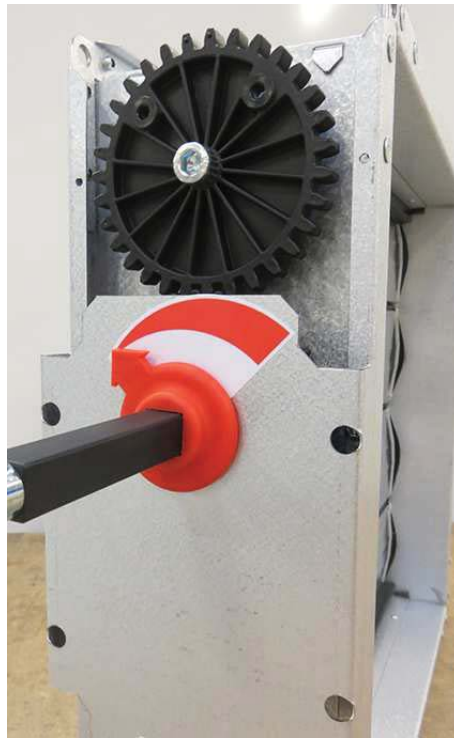

The damper blades are fitted with synthetic bearings requiring no lubrication. Air-tightness of the damper, when the damper motor is in the closed position, must be visually checked once a year. The damper motor is to be adjusted if the damper does not close tightly.

R.6.3 Rotary heat exchanger



R.6.3.1 Rotor

The rotor is to be checked at least once a year to ensure that it can turn freely and easily. This can be done by removing the belt drive at the motor and then turning the rotor manually with a hand on the peripheral rotor casing. At the same time the brush seals are to be checked for damage. The bearings are factory lubricated and do not require any service lubrication. During operation the rotor can become dirty.



Note:

The rotor can be cleaned by gentle vacuum cleaning and not with compressed air or water.

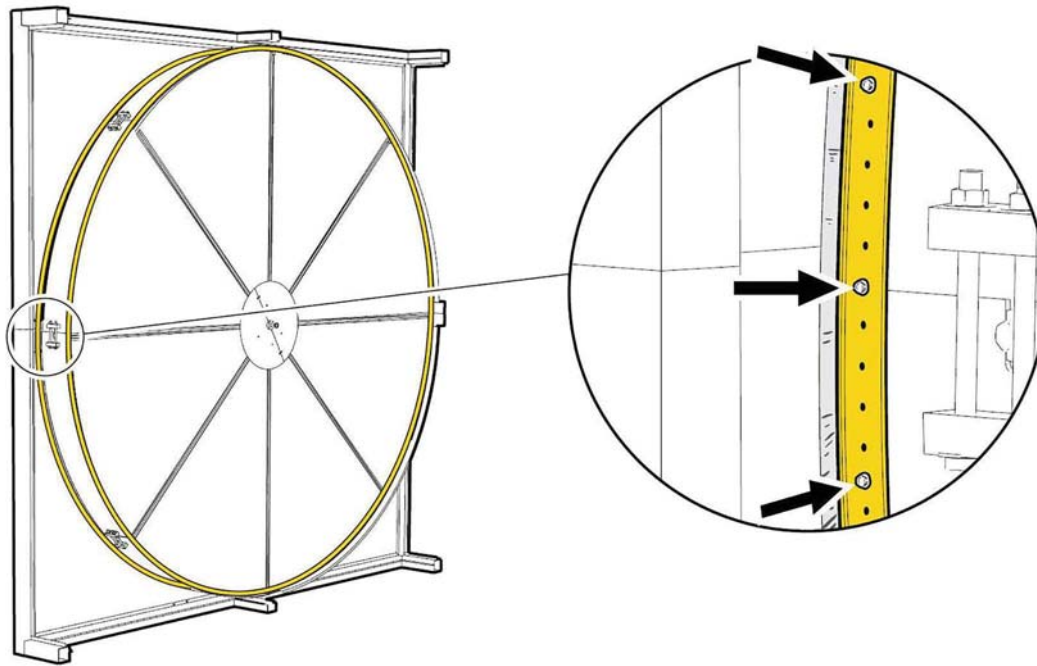

Check annually that the brush lists close well. Expect that brush lists should be changed every 5 years – maybe more often – if necessary.

To ease inspection and service the rotor can be pulled out of the sizes 10, 11, 12, 14 and 16.

R.6.3.2 Motor and belt drive

The bearings are factory lubricated and do not require any service lubrication. The belt drive is to be checked for correct tightness and that it is undamaged. On smaller AHU, the rotor is fitted with an elastic belt drive and supplied with a reserve belt on the rotor. This belt drive does not require service and cannot be shortened. A new belt can be fitted using specialist tools. On larger heat exchangers the rotor has a V-belt with a belt connector. If the belt is no longer tight, it must be shortened to a length which enables the motor base frame tightening spring to hold the belt tight. If new screws are used for the belt connector, they must not have a length which exceeds the thickness of the belt and connector. Remove the excess, if any, with a file.

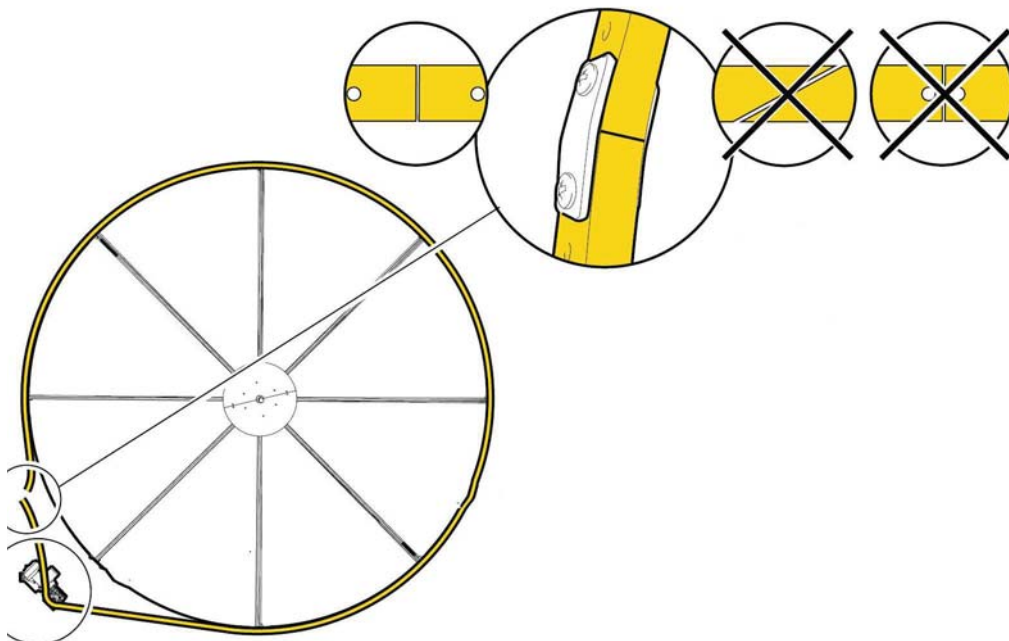

Check the drive belt annually. Replace if necessary. Reuse both brackets. If new screws are needed do not hesitate to make the screws even with the surface of the inner bracket.

R.6.4 Cross flow and counter flow exchanger



Note:

Once a year the edges of the heat exchanger plates are to be checked for cleanliness and damage.

If there is dust on the edges of the plates, remove it with a soft brush. The thin plates are not constructed for cleaning with compressed air or water.

R.6.4.1 By-pass damper

The damper blades are fitted with synthetic bearings requiring no lubrication. Each damper blade is driven by a gear drive of a temperature resistant glass fibre reinforced PA6 nylon composite. The steel rods and brass bushes do not require lubrication. Air-tightness of the dampers, when the damper motor is in the closed position, must be visually checked once a year. The damper motor is to be adjusted if the damper does not close tightly.

R.6.4.2 Condensate water drain

At least once a year the drip tray beneath the heat exchanger, as well as the drain and the water trap must be cleaned. Take care that there is sufficient water in the water trap. If a droplet eliminator has been fitted, this must be checked once a year and cleaned if necessary.



Note:

Instructions about easy, quick and safe cleaning of water trap is displayed in a 2-minutes video. The video is available on YouTube.

<https://youtu.be/5qMswv2c0SQ>



Drip tray with slope is not supported for the weight of a person. Do not walk or stay in the drip tray.

Demount this type of water trap regularly for careful cleaning.



Note:

Information about disassembly, cleaning and reassembly is available in a 2-minutes video on YouTube.

<https://youtu.be/5qMswv2c0SQ>



R.6.5 Run-around heat exchanger

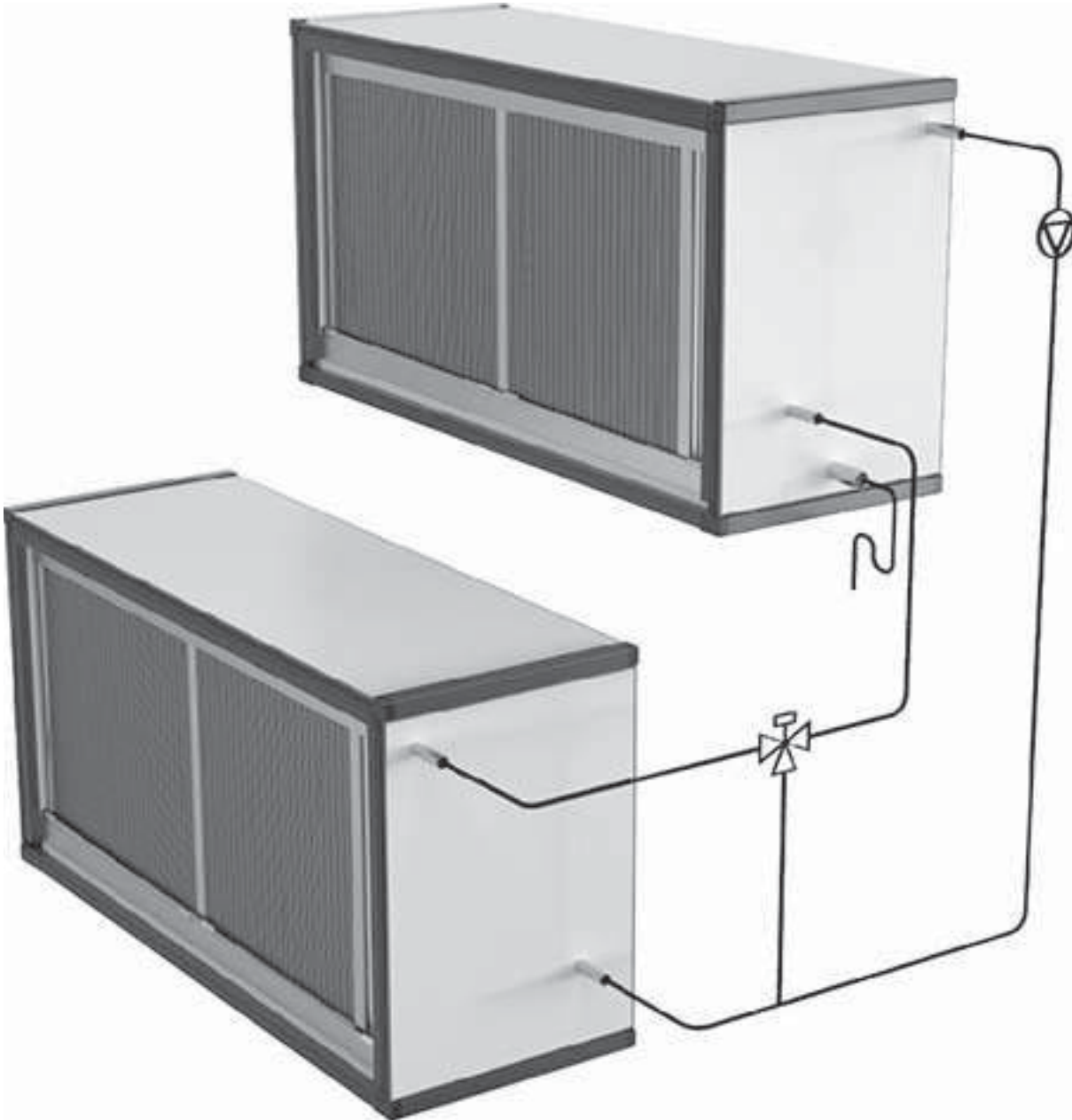

A heat recovery system of this type consists of a heating coil in the supply air-flow and a cooling coil in the exhaust air-flow. After an extended running period (normally a few years) dust particles can accumulate on the surface of the coils. This can reduce the efficiency of the coils. Cleaning must be carried out with the utmost care to ensure that the coil fins are not damaged.

The piping system must be vented once a year as air in the system can significantly reduce the capacity of the coils.

R.6.5.1 Pump and pressure expansion

The service instructions issued by the pump manufacturer must be followed. The pressure expansion system must be checked once a year. If necessary, the pressure must be increased to the correct level.

R.6.5.2 Condensate water drain

Once a year clean the drip tray beneath the heat exchanger, as well as the drain and the water trap. Take care that there is sufficient water in the water trap. See the explanation above.

If a droplet eliminator has been fitted, this must be checked once a year and cleaned if necessary.

R.6.6 Coils/batteries for heating and/or cooling

After an extended running period (normally a few years) dust particles can accumulate on the surface of the coil. This can reduce the efficiency of the coil. Cleaning must be carried out with the utmost care to ensure that the coil fins are not damaged. The piping system must be vented once a year as air in the system can significantly reduce the capacity of the coil.

R.6.6.1 Heating battery



Check that the frost protection system is fully operational. A battery may burst due to frost if the frost protection system is not operational.

R.6.6.2 Cooling battery



Once a year clean the drip tray beneath the cooling coil, as well as the drain and the water trap. Take care that there is sufficient water in the water trap. If a droplet eliminator has been fitted to the cooling coil, this must be checked once a year and cleaned if necessary.



Droplet eliminator must be checked once a year and cleaned if necessary.

R.6.6.3 Electric heating battery

Check that the built-in safety thermostat with an automatic reset function and the overheat thermostat with manual re-setting are fully operational.

R.6.7 Plug fans



Dust can accumulate on the fan impeller which can cause imbalance and vibrations. The fan impeller must therefore be checked once a year and cleaned, if necessary. Anti-vibration mounts and flexible connections should be checked at the same time. If the anti-vibration mounts are damaged in any way they must be replaced.

R.6.7.1 Motor

The motor are usually fitted with factory lubricated bearings which require no further lubrication. Larger motors can be fitted with greasing nipples and bearings which require regular lubrication. Lubricating these types of bearings must be carried out according to the manufacturer's instructions.

R.6.8 Silencer

During operation dust particles can accumulate on the surface of the baffles. Silencers that are designed for dry and wet cleaning are fitted with baffles that can be extracted from the unit casing. Large inspection doors give access to easily extraction of the baffles. Baffles designed for dry cleaning can be vacuum cleaned. Baffles designed for wet cleaning can be washed down using a soft brush and soapy water. The detergent used must be non-aggressive. After washing, the baffles must be wiped dry with a cloth. Remember to clean the inside surface of the unit casing before re-fitting the baffles.

R.6.9 Outdoor air section

Dust and dirt can accumulate in this section. Large inspection doors give access for cleaning.

R.6.10 Heat pump unit

Mandatory annual control must be done by certified technicians from a certified company. See further description in Annex 10 and 11.

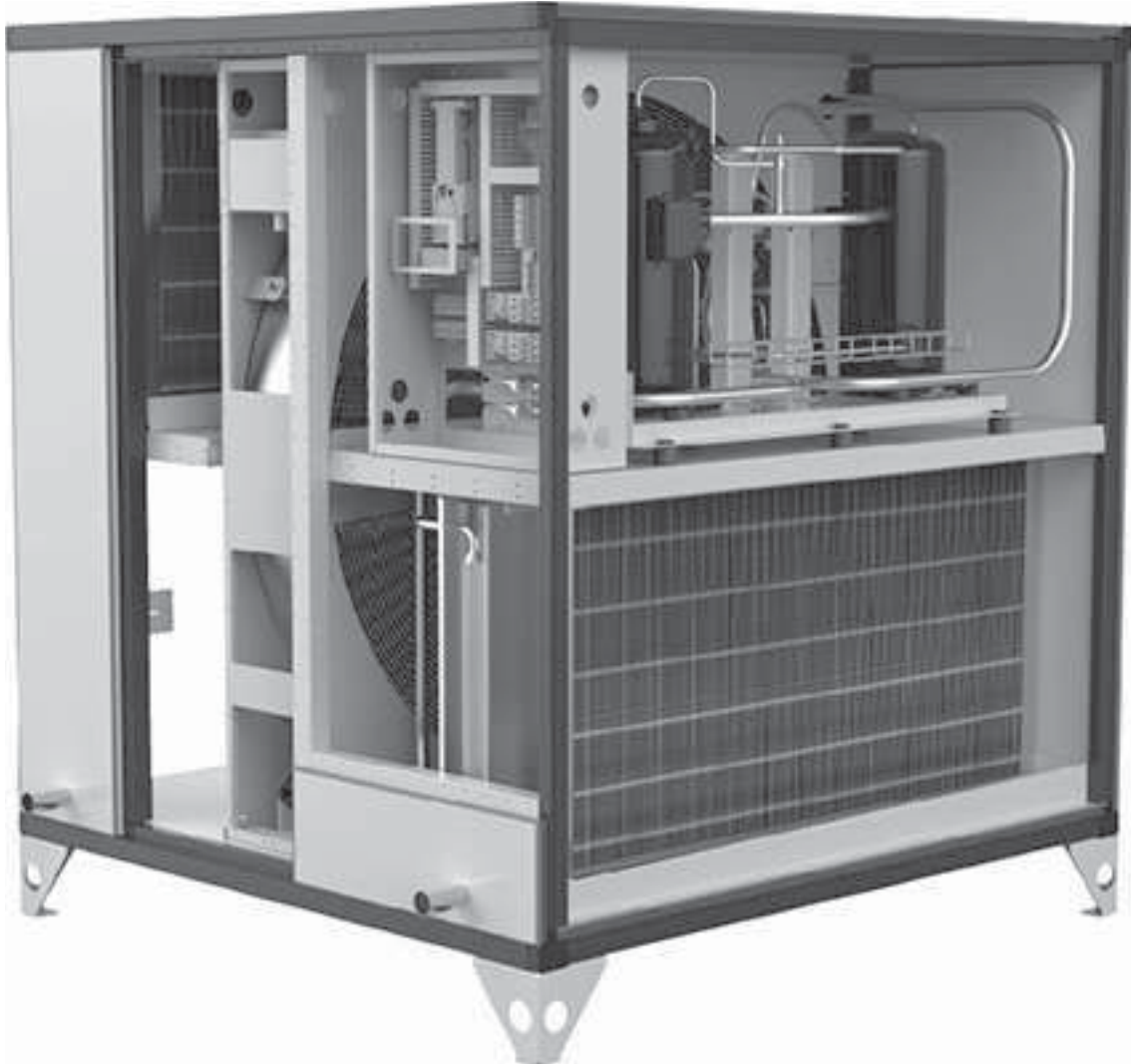

S Instructions to enable adjustment and maintenance safely

S.1 Protective measures and additional protective measures

Adjustment and maintenance must be done by skilled technicians – usually based on service contracts for some years or long-term ESCO contracts.

The units are provided with guards to avoid unintended hazards and injury because of rotating parts in the unit. The potential sources of harm are the fans with fast rotating impellers. Hazards from the impellers are obvious during operation, but when power is cut-off, the impellers are still potential hazards due to after-run for at least 20 seconds. Notice that even cut-off the impellers are still potential hazards.

The fan guard's are the inspection doors and the doors are provided with locks. Inside the doors are additional protection installed – guards that only can be removed by use of tools.

Other motor-driven parts are dampers with damper motors and rotary heat exchangers, but the movement is so slow that guard measures are not necessary. Just keep your hands away from places with risk of injury.

Use particulate respirator when filters are replaced.

S.1.1 Necessary protection measures prior to start-up

Ensure that all protection measures are installed correct before start-up.

S.1.1.1 Design of protection measures

Inside the doors are additional protection installed – guards that only can be removed by use of tools.

S.1.1.2 Configuration of frequency converters with installed guard

A frequency converter is mounted beside the fan in some units. If the configuration of frequency is carried out with the fan in operation, the guard must be installed for safety reasons and a long cable must be installed between the frequency converter inside the unit and the control panel outside the unit.

S.1.2 Safe adjustment and maintenance

Before maintenance and repair, the unit must be switched off by switching off the disconnecting device and block them by padlocks. **Note that lamps must be switched on during maintenance** (lamps are an accessory – only installed, if ordered).

Use cut-resistant gloves for protection against injury from sharp metal plate edges. Use CE-marked gloves for this purpose. Use helmet during maintenance work in the unit.

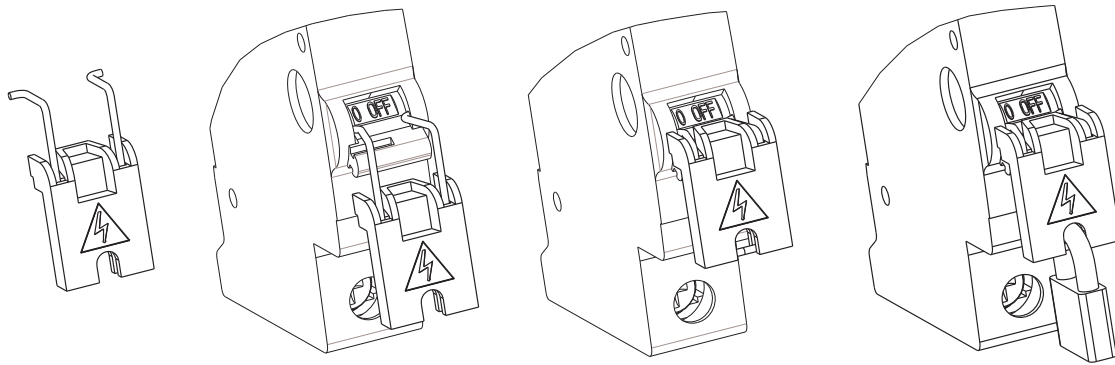

S.1.3 Personal protective equipment for maintenance staff – health and safety

Use the below-mentioned personal protective equipment for maintenance:

- Cut-resistant gloves for protection against injury from sharp metal plate edges. Use CE-marked gloves for this purpose.
- Helmet
- Particulate respirator – maintenance free including foam face-seal and adjustable pre-threaded headbands – for replacing filters.
- Padlock for locking the above mentioned automatic circuit breakers.
- Permanent magnet motor. The shaft must be blocked during repairs and maintenance of the electric system (the motor generates electricity by rotation – for example that the wind and thermic drives the fan/motor).

T The specifications of the spare parts to be used, when these affect the health and safety of operators

Geniox air handling units are operating automatically. Operators can control the unit by the Systemair control panel

T.1 Spare parts - Mechanical

Annex 3 - available on demand

T.2 Spare parts - Electrical

Annex 3 - available on demand

U Information on airborne noise emissions exceeding 70 dB(A)

Due to the design and construction of the units the (A) weighed sound pressure level from fans and other components do not exceed 70 dB (A) outside the units.

Annex Geniox Air handling unit

User Manual

GB

Document in original language |

Part number of this manual 90925520
Order number output



Only the English version is valid in case of a dispute. Translated versions are not valid in case of disputes.

Contents

Annex 1	Declaration of conformity with production number (in separate cover)	1-1
Annex 2	Technical data – unique data for every unit (in separate cover)	2-1
Annex 3	Spare part list (in separate cover)	3-1
Annex 4	Assembly of base frame – height 118 mm for unit sizes 10 – 18	4-1
Annex 5	Assembly of base frame – height 118 mm for unit sizes 20 – 31	5-1
Annex 6	Assembly of base frame – height 218 mm for unit sizes 10 – 18	6-1
Annex 7	Assembly of base frame – height 218 mm for unit sizes 20 – 31	7-1
Annex 8	Installation of steel roof in the sizes 10 – 31	8-1
Annex 9	Speed control for rotor and assembly of divided rotor	9-1
Annex 10	Reversible heat pump unit (in separate cover, if heat pump was delivered)	10-1
Annex 11	Menu for internal controller in the heat pump unit (in separate cover, if heat pump was delivered)	11-1
Annex 12	Connection of fan motor and set-up manual for frequency converter	12-1
Annex 13	Commissioning protocol – proposal (in separate cover)	13-1
Annex 14	Report with data from final functional test on the Systemair factory (in separate cover, if control system was delivered)	14-1
Annex 15	Short description of main components in the control system	15-1
Annex 16	Wiring diagram (in separate cover, if control system was delivered)	16-1
Annex 17	Operator’s guide (how to use the Systemair control panel) (in separate cover, if control system was delivered)	17-1

1-1 | Declaration of conformity with production number (in separate cover)

Annex 1 Declaration of conformity with production number (in separate cover)

Printed on separate page and delivered with every unit. Enclosed in separate cover.

Annex 2 Technical data – unique data for every unit (in separate cover)

Printed on separate pages and delivered with every unit. Enclosed in separate cover.

3-1 | Spare part list (in separate cover)

Annex 3 Spare part list (in separate cover)

Printed on separate pages but not delivered with every unit. Available on demand.





Annex 4 Assembly of base frame – height 118 mm for unit sizes 10 – 18



Note:

Information about assembly is available in a 2-minutes video on YouTube.

<https://youtu.be/B3nX-x7KnrQ>

<p>A = Corner</p> 	<p>B = Splice</p> 
<p>C = Length profile</p> 	
<p>D = End profile (width of base frame)</p> 	
<p>D1 = Middle profile</p> 	

4.1 Base frame length 482 - 2564 dnmeUnit size 10 - 18

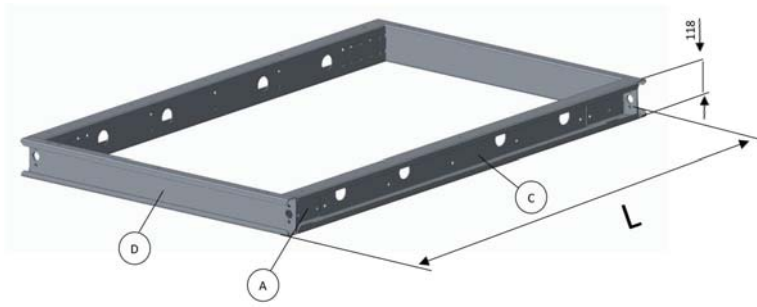

End profile type D (width of base frame)		
Unit size	Quantity	Length of endprofile (width of base frame) [mm]
Geniox10	2	1070
Geniox11	2	1170
Geniox12	2	1270
Geniox14	2	1470
Geniox16	2	1670
Geniox18	2	1870

Adjustable length of frame - L [mm]	Length profile type C		Corner A
	Quantity	Length of profile [mm]	Quantity
482 - 564	2	400	4
582 - 664	2	500	4
682 - 764	2	600	4
782 - 864	2	700	4
882 - 964	2	800	4
982 - 1064	2	900	4
1082 - 1164	2	1000	4
1182 - 1264	2	1100	4
1282 - 1364	2	1200	4
1382 - 1464	2	1300	4
1482 - 1564	2	1400	4
1582 - 1664	2	1500	4
1682 - 1764	2	1600	4
1782 - 1864	2	1700	4
1882 - 1964	2	1800	4
1982 - 2064	2	1900	4
2082 - 2164	2	2000	4
2182 - 2264	2	2100	4
2282 - 2364	2	2200	4
2382 - 2464	2	2300	4
2482 - 2564	2	2400	4

4.2 Base frame length 2582 – 4964 mm Unit size 10 – 18

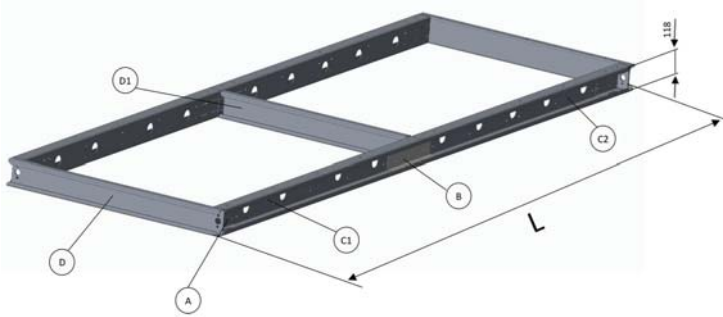

End profile type D (width of base frame)			Middle profile type D1	
Unit size	Quantity	width of base frame [mm]	Quantity	Length [mm]
Geniox10	2	1070	1	950
Geniox11	2	1170	1	1050
Geniox12	2	1270	1	1150
Geniox14	2	1470	1	1350
Geniox16	2	1670	1	1550
Geniox18	2	1870	1	1750

Adjustable length of frame – L [mm]	Length profile C1		Length profile C2		Corner A	Splice B
	Quantity	Length [mm]	Quantity	Length [mm]	Quantity	Quantity
2582-2664	2	1200	2	1300	4	2
2682-2764	2	1300	2	1300	4	2
2782-2864	2	1300	2	1400	4	2
2882-2964	2	1400	2	1400	4	2
2982-3064	2	1400	2	1500	4	2
3082-3164	2	1500	2	1500	4	2
3182-3264	2	1500	2	1600	4	2
3282-3364	2	1600	2	1600	4	2
3382-3464	2	1600	2	1700	4	2
3482-3564	2	1700	2	1700	4	2
3582-3664	2	1700	2	1800	4	2
3682-3764	2	1800	2	1800	4	2
3782-3864	2	1800	2	1900	4	2
3882-3964	2	1900	2	1900	4	2
3982-4064	2	1900	2	2000	4	2
4082-4164	2	2000	2	2000	4	2
4182-4264	2	2000	2	2100	4	2
4282-4364	2	2100	2	2100	4	2
4382-4464	2	2100	2	2200	4	2
4482-4564	2	2200	2	2200	4	2
4582-4664	2	2200	2	2300	4	2
4682-4764	2	2300	2	2300	4	2
4782-4864	2	2300	2	2400	4	2
4882-4964	2	2100	2	2100	4	2

4.3 Base frame length 4982 – 6164 dmmeUnit size 10 – 18

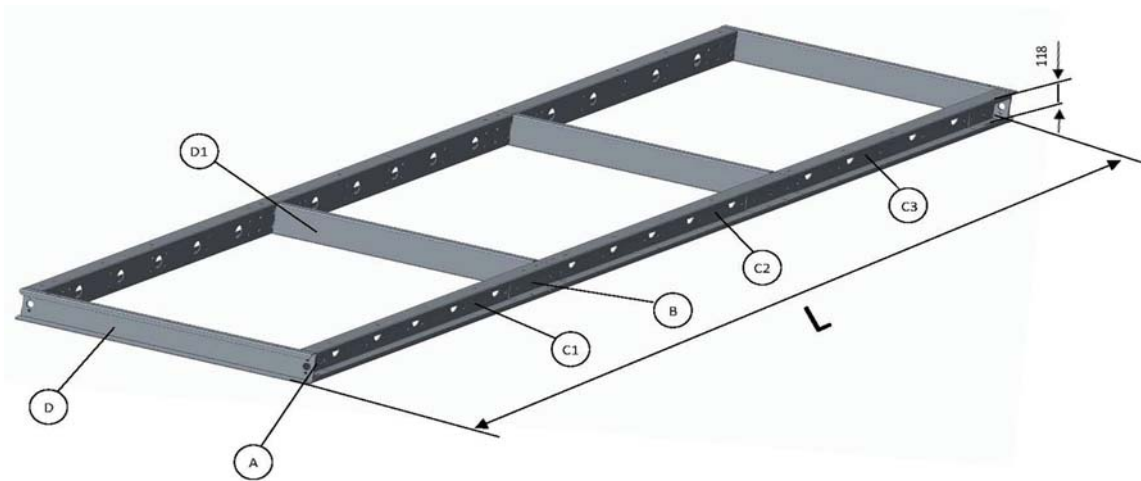

End profile type D (width of base frame)			Middle profile type D1	
Unit size	Quantity	width of base frame [mm]	Quantity	Length [mm]
Geniox10	2	1070	2	950
Geniox11	2	1170	2	1050
Geniox12	2	1270	2	1150
Geniox14	2	1470	2	1350
Geniox16	2	1670	2	1550
Geniox18	2	1870	2	1750





Adjustable length of frame – L [mm]	Length profile C1		Length profile C2		Length profile C3		A	B
	Quantity	Length [mm]	Quantity	Length [mm]	Quantity	Length [mm]	Qty	Qty
4982-5064	2	1600	2	1600	2	1700	4	4
5082-5164	2	1600	2	1700	2	1700	4	4
5182-5264	2	1700	2	1700	2	1700	4	4
5282-5364	2	1700	2	1700	2	1800	4	4
5382-5464	2	1700	2	1800	2	1800	4	4
5482-5564	2	1800	2	1800	2	1800	4	4
5582-5664	2	1800	2	1800	2	1900	4	4
5682-5764	2	1800	2	1900	2	1900	4	4
5782-5864	2	1900	2	1900	2	1900	4	4
5882-5964	2	1900	2	1900	2	2000	4	4
5982-6064	2	1900	2	2000	2	2000	4	4
6082-6164	2	2000	2	2000	2	2000	4	4

Annex 5 Assembly of base frame – height 118 mm for unit sizes 20 – 31

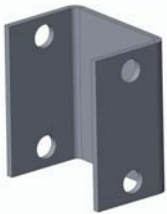

Note:

Information about assembly is available in a 2-minutes video on YouTube.
<https://youtu.be/N-oaYpwsAlo>

<p>A = Corner</p> 	<p>B = Splice</p> 	<p>C = Spacer</p> 
<p>C = Length profile</p> 		
<p>D = End profile (width of base frame)</p> 		
<p>D1 = Middle profile</p> 		

5.1 Base frame length 482– 2564 dmmeUnit size 20 – 31

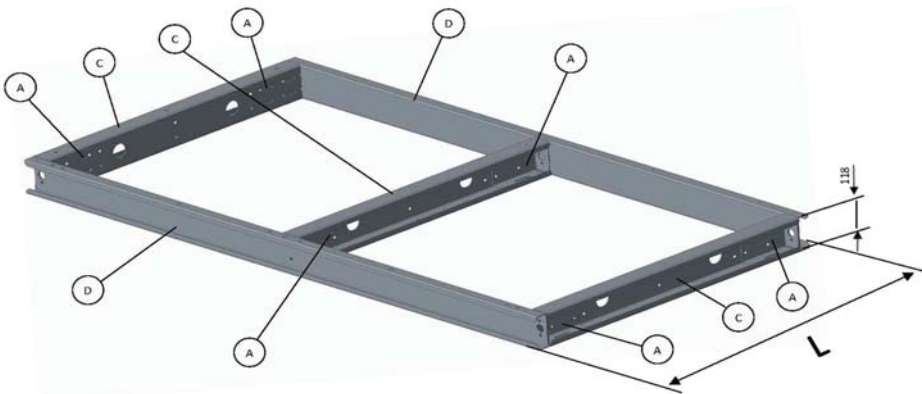

End profile type D (width of base frame)		
Unit size	Quantity	Length [mm]
Geniox20	2	2070
Geniox22	2	2270
Geniox24	2	2470
Geniox27	2	2770
Geniox29	2	2970
Geniox31	4	1585

Adjustable length of frame – L [mm]	Length profile type C		Corner A
	Quantity	Length of profile [mm]	Quantity
482-564	3	400	6
582-664	3	500	6
682-764	3	600	6
782-864	3	700	6
882-964	3	800	6
982-1064	3	900	6
1082-1164	3	1000	6
1182-1264	3	1100	6
1282-1364	3	1200	6
1382-1464	3	1300	6
1482-1564	3	1400	6
1582-1664	3	1500	6
1682-1764	3	1600	6
1782-1864	3	1700	6
1882-1964	3	1800	6
1982-2064	3	1900	6
2082-2164	3	2000	6
2182-2264	3	2100	6
2282-2364	3	2200	6
2382-2464	3	2300	6
2482-2564	3	2400	6

5.2 Base frame length 2582 - 4964 dnmeUnit size 20 - 31

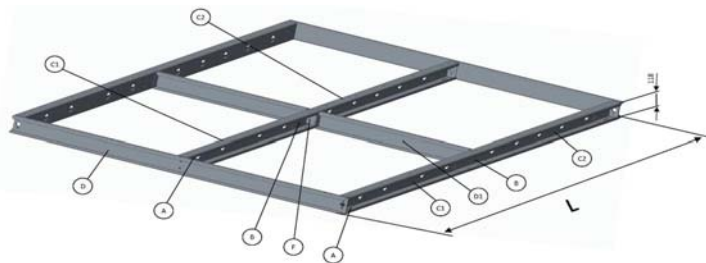

End profile type D (width of base frame)			Middle profile type D1		Spacer F
Unit size	Quantity	Length [mm]	Quantity	Length [mm]	Quantity
Geniox20	2	2070	2	941	1
Geniox22	2	2270	2	1041	1
Geniox24	2	2470	2	1141	1
Geniox27	2	2770	2	1291	1

End profile type D (width of base frame)			Middle profile type D1		Spacer F
Unit size	Quantity	Length [mm]	Quantity	Length [mm]	Quantity
Geniox29	2	2970	2	1391	1
Geniox31	4	1585	2	1491	1

Adjustable length of frame – L [mm]	Length profile type C1		Length profile type C2		Corner A	Splice B
	Quantity	Length [mm]	Quantity	Length [mm]	Quantity	Quantity
2582-2664	3	1200	3	1300	6	3
2682-2764	3	1300	3	1300	6	3
2782-2864	3	1300	3	1400	6	3
2882-2964	3	1400	3	1400	6	3
2982-3064	3	1400	3	1500	6	3
3082-3164	3	1500	3	1500	6	3
3182-3264	3	1500	3	1600	6	3
3282-3364	3	1600	3	1600	6	3
3382-3464	3	1600	3	1700	6	3
3482-3564	3	1700	3	1700	6	3
3582-3664	3	1700	3	1800	6	3
3682-3764	3	1800	3	1800	6	3
3782-3864	3	1800	3	1900	6	3
3882-3964	3	1900	3	1900	6	3
3982-4064	3	1900	3	2000	6	3
4082-4164	3	2000	3	2000	6	3
4182-4264	3	2000	3	2100	6	3
4282-4364	3	2100	3	2100	6	3
4382-4464	3	2100	3	2200	6	3
4482-4564	3	2200	3	2200	6	3
4582-4664	3	2200	3	2300	6	3
4682-4764	3	2300	3	2300	6	3
4782-4864	3	2300	3	2400	6	3
4882-4964	3	2400	3	2400	6	3

5.3 Base frame length 4982 – 6164 dnm Unit size 20 – 31

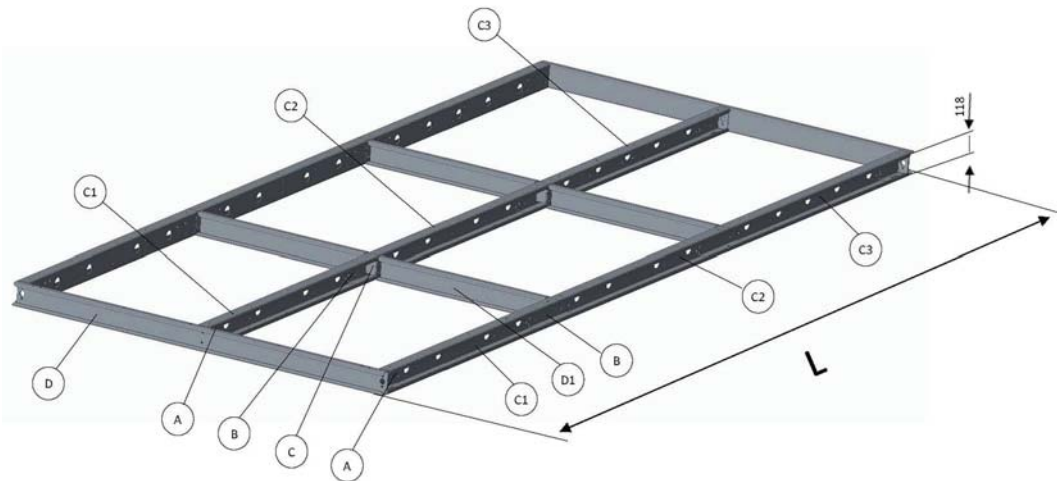

End profile type D (width of base frame)			Middle profile type D1		Spacer F
Unit size	Quantity	Length [mm]	Quantity	Length [mm]	Quantity
Geniox20	2	2070	4	941	2
Geniox22	2	2270	4	1041	2
Geniox24	2	2470	4	1141	2
Geniox27	2	2770	4	1291	2
Geniox29	2	2970	4	1391	2
Geniox31	4	1585	4	1491	2





Adjustable length of frame – L [mm]	Length profile type C1		Length profile type C2		Length profile type C3		A	B
	Qty	Length [mm]	Qty	Length [mm]	Qty	Length [mm]	Qty	Qty
4982-5064	3	1600	3	1600	3	1700	6	6
5082-5164	3	1600	3	1700	3	1700	6	6
5182-5264	3	1700	3	1700	3	1700	6	6
5282-5364	3	1700	3	1700	3	1800	6	6
5382-5464	3	1700	3	1800	3	1800	6	6
5482-5564	3	1800	3	1800	3	1800	6	6
5582-5664	3	1800	3	1800	3	1900	6	6
5682-5764	3	1800	3	1900	3	1900	6	6
5782-5864	3	1900	3	1900	3	1900	6	6
5882-5964	3	1900	3	1900	3	2000	6	6
5982-6064	3	1900	3	2000	3	2000	6	6
6082-6164	3	2000	3	2000	3	2000	6	6

Annex 6 Assembly of base frame – height 218 mm for unit sizes 10 – 18

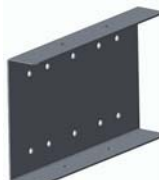

Note:

Information about assembly is available in a 2-minutes video on YouTube.
<https://youtu.be/B3nX-x7KnrQ>

<p>A = Corner</p> 	<p>B = Splice</p> 
<p>C = Length profile</p> 	
<p>D = End profile (width of base frame)</p> 	
<p>D1 = Middle profile</p> 	

6.1 Base frame length 482- 2564 dmmeUnit size 10 – 18

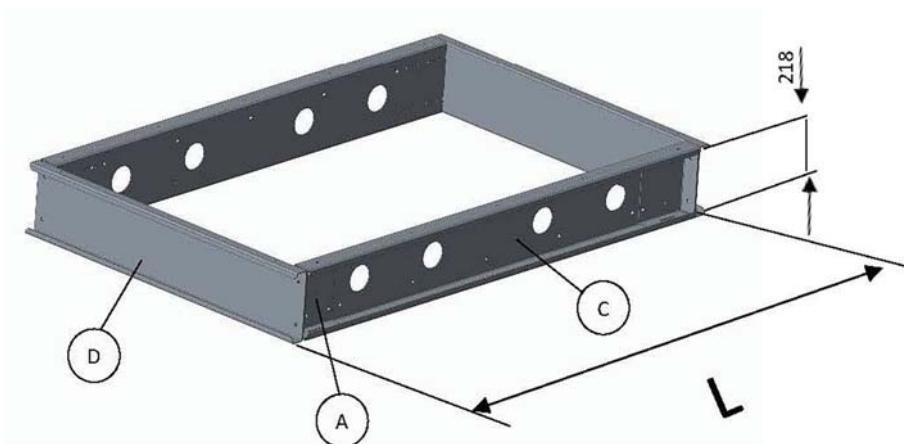

End profile type D (width of base frame)		
Unit size	Quantity	Length of endprofile (width of base frame) [mm]
Geniox10	2	1070
Geniox11	2	1170
Geniox12	2	1270
Geniox14	2	1470
Geniox16	2	1670
Geniox18	2	1870

Adjustable length of frame – L [mm]	Length profile type C		Corner A
	Quantity	Length of profile [mm]	Quantity
482 – 564	2	400	4
582 – 664	2	500	4
682 – 764	2	600	4
782 – 864	2	700	4
882 – 964	2	800	4
982 – 1064	2	900	4
1082 – 1164	2	1000	4
1182 – 1264	2	1100	4
1282 – 1364	2	1200	4
1382 – 1464	2	1300	4
1482 – 1564	2	1400	4
1582 – 1664	2	1500	4
1682 – 1764	2	1600	4
1782 – 1864	2	1700	4
1882 – 1964	2	1800	4
1982 – 2064	2	1900	4
2082 – 2164	2	2000	4
2182 – 2264	2	2100	4
2282 – 2364	2	2200	4
2382 – 2464	2	2300	4
2482 – 2564	2	2400	4

6.2 Base frame length 2582 – 4964 dmmeUnit size 10 – 18

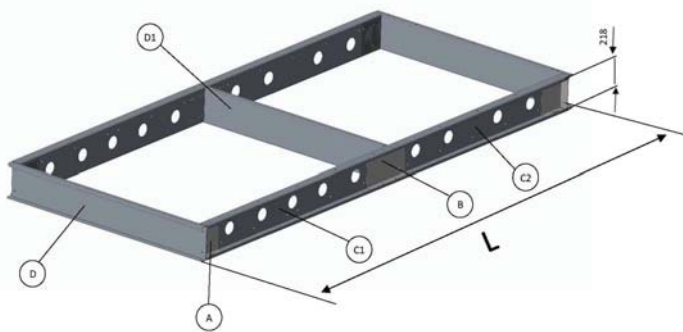

End profile type D (width of base frame)			Middle profile type D1	
Unit size	Quantity	width of base frame [mm]	Quantity	Length [mm]
Geniox10	2	1070	1	950
Geniox11	2	1170	1	1050
Geniox12	2	1270	1	1150
Geniox14	2	1470	1	1350
Geniox16	2	1670	1	1550
Geniox18	2	1870	1	1750

Adjustable length of frame – L [mm]	Length profile C1		Length profile C2		Corner A	Splice B
	Quantity	Length [mm]	Quantity	Length [mm]	Quantity	Quantity
2582-2664	2	1200	2	1300	4	2
2682-2764	2	1300	2	1300	4	2
2782-2864	2	1300	2	1400	4	2
2882-2964	2	1400	2	1400	4	2
2982-3064	2	1400	2	1500	4	2
3082-3164	2	1500	2	1500	4	2
3182-3264	2	1500	2	1600	4	2
3282-3364	2	1600	2	1600	4	2
3382-3464	2	1600	2	1700	4	2
3482-3564	2	1700	2	1700	4	2
3582-3664	2	1700	2	1800	4	2
3682-3764	2	1800	2	1800	4	2
3782-3864	2	1800	2	1900	4	2
3882-3964	2	1900	2	1900	4	2
3982-4064	2	1900	2	2000	4	2
4082-4164	2	2000	2	2000	4	2
4182-4264	2	2000	2	2100	4	2
4282-4364	2	2100	2	2100	4	2
4382-4464	2	2100	2	2200	4	2
4482-4564	2	2200	2	2200	4	2
4582-4664	2	2200	2	2300	4	2
4682-4764	2	2300	2	2300	4	2
4782-4864	2	2300	2	2400	4	2
4882-4964	2	2400	2	2400	4	2

6.3 Base frame length 4982 - 6164 dmmeUnit size 10 - 18

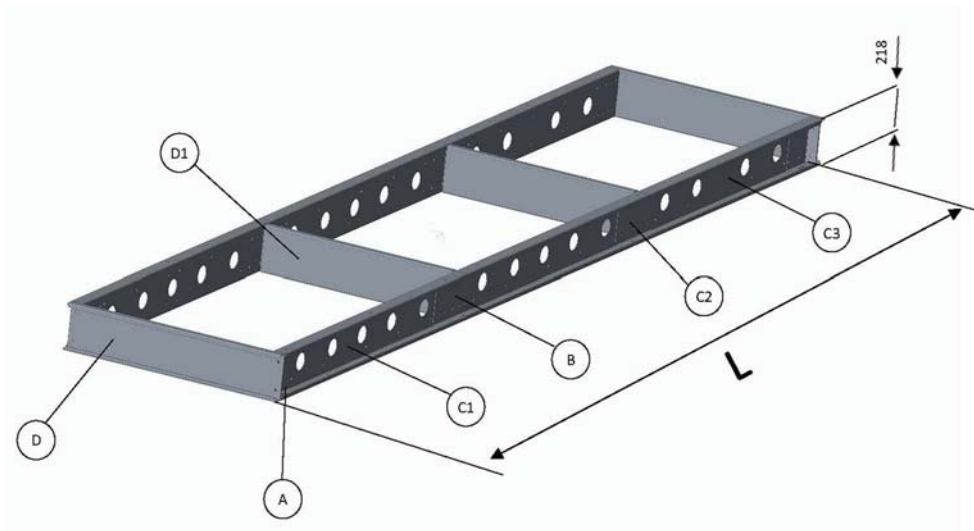

End profile type D (width of base frame)			Middle profile type D1	
Unit size	Quantity	width of base frame [mm]	Quantity	Length [mm]
Geniox10	2	1070	2	950
Geniox11	2	1170	2	1050
Geniox12	2	1270	2	1150
Geniox14	2	1470	2	1350
Geniox16	2	1670	2	1550
Geniox18	2	1870	2	1750







Adjustable length of frame – L [mm]	Length profile C1		Length profile C2		Length profile C3		A	B
	Quantity	Length [mm]	Quantity	Length [mm]	Quantity	Length [mm]	Qty	Qty
4982-5064	2	1600	2	1600	2	1700	4	4
5082-5164	2	1600	2	1700	2	1700	4	4
5182-5264	2	1700	2	1700	2	1700	4	4
5282-5364	2	1700	2	1700	2	1800	4	4
5382-5464	2	1700	2	1800	2	1800	4	4
5482-5564	2	1800	2	1800	2	1800	4	4
5582-5664	2	1800	2	1800	2	1900	4	4
5682-5764	2	1800	2	1900	2	1900	4	4
5782-5864	2	1900	2	1900	2	1900	4	4
5882-5964	2	1900	2	1900	2	2000	4	4
5982-6064	2	1900	2	2000	2	2000	4	4
6082-6164	2	2000	2	2000	2	2000	4	4

Annex 7 Assembly of base frame – height 218 mm for unit sizes 20 – 31



Note:

Information about assembly is available in a 2-minutes video on YouTube.
<https://youtu.be/N-oaYpwsAlo>

<p>A = Corner</p> 	<p>B = Splice</p> 	<p>F = Spacer</p> 
<p>C = Length profile</p> 		
<p>D = End profile (width of base frame)</p> 		
<p>D1 = Middle profile</p> 		

7.1 Base frame length 482– 2564 dmmeUnit size 20-31

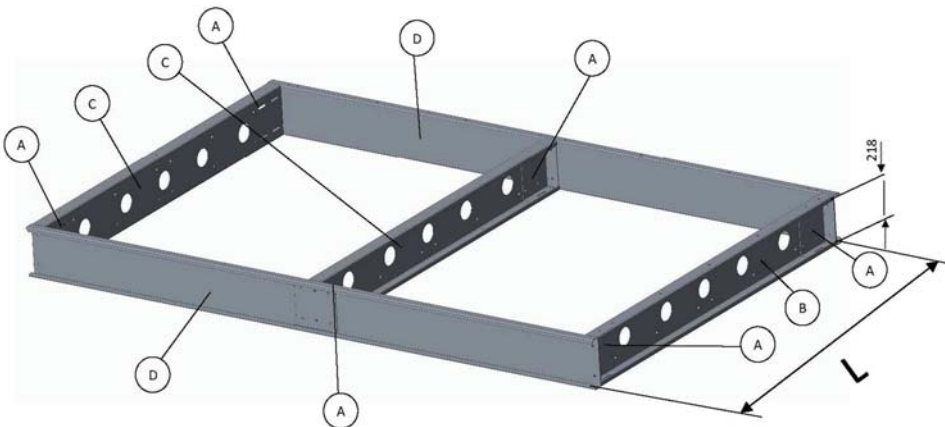

End profile type D (width of base frame)		
Unit size	Quantity	Length [mm]
Geniox20	2	2070
Geniox22	2	2270
Geniox24	2	2470
Geniox27	2	2770
Geniox29	2	2970
Geniox31	4	1585

Adjustable length of frame – L [mm]	Length profile type C		Corner A
	Quantity	Length of profile [mm]	Quantity
482-564	3	400	6
582-664	3	500	6
682-764	3	600	6
782-864	3	700	6
882-964	3	800	6
982-1064	3	900	6
1082-1164	3	1000	6
1182-1264	3	1100	6
1282-1364	3	1200	6
1382-1464	3	1300	6
1482-1564	3	1400	6
1582-1664	3	1500	6
1682-1764	3	1600	6
1782-1864	3	1700	6
1882-1964	3	1800	6
1982-2064	3	1900	6
2082-2164	3	2000	6
2182-2264	3	2100	6
2282-2364	3	2200	6
2382-2464	3	2300	6
2482-2564	3	2400	6

7.2 Base frame length 2582 - 4964 dnmeUnit size 20 - 31

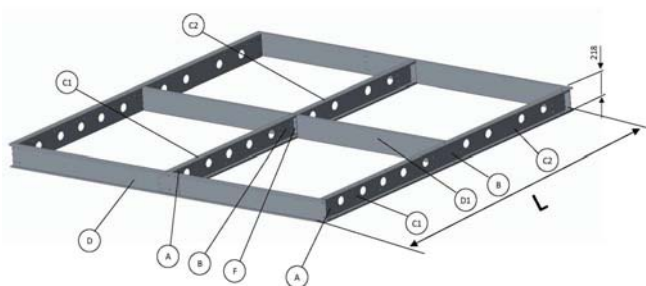

End profile type D (width of base frame)			Middle profile type D1		Spacer F
Unit size	Quantity	Length [mm]	Quantity	Length [mm]	Quantity
Geniox20	2	2070	2	941	1
Geniox22	2	2270	2	1041	1
Geniox24	2	2470	2	1141	1
Geniox27	2	2770	2	1291	1

End profile type D (width of base frame)			Middle profile type D1		Spacer F
Unit size	Quantity	Length [mm]	Quantity	Length [mm]	Quantity
Geniox29	2	2970	2	1391	1
Geniox31	4	1585	2	1491	1

Adjustable length of frame – L [mm]	Length profile type C1		Length profile type C2		Corner A	Splice B
	Quantity	Length [mm]	Quantity	Length [mm]	Quantity	Quantity
2582-2664	3	1200	3	1300	6	3
2682-2764	3	1300	3	1300	6	3
2782-2864	3	1300	3	1400	6	3
2882-2964	3	1400	3	1400	6	3
2982-3064	3	1400	3	1500	6	3
3082-3164	3	1500	3	1500	6	3
3182-3264	3	1500	3	1600	6	3
3282-3364	3	1600	3	1600	6	3
3382-3464	3	1600	3	1700	6	3
3482-3564	3	1700	3	1700	6	3
3582-3664	3	1700	3	1800	6	3
3682-3764	3	1800	3	1800	6	3
3782-3864	3	1800	3	1900	6	3
3882-3964	3	1900	3	1900	6	3
3982-4064	3	1900	3	2000	6	3
4082-4164	3	2000	3	2000	6	3
4182-4264	3	2000	3	2100	6	3
4282-4364	3	2100	3	2100	6	3
4382-4464	3	2100	3	2200	6	3
4482-4564	3	2200	3	2200	6	3
4582-4664	3	2200	3	2300	6	3
4682-4764	3	2300	3	2300	6	3
4782-4864	3	2300	3	2400	6	3
4882-4964	3	2400	3	2400	6	3

7.3 Base frame length 4982 – 6164 dmm Unit size 20 – 31

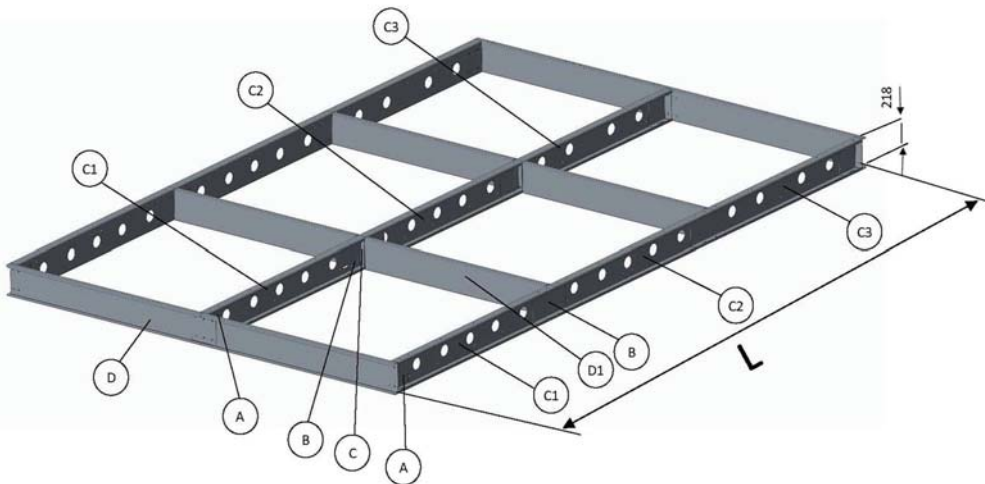

End profile type D (width of base frame)			Middle profile type D1		Spacer F
Unit size	Quantity	Length [mm]	Quantity	Length [mm]	Quantity
Geniox20	2	2070	4	941	2
Geniox22	2	2270	4	1041	2
Geniox24	2	2470	4	1141	2
Geniox27	2	2770	4	1291	2
Geniox29	2	2970	4	1391	2
Geniox31	4	1585	4	1491	2

Adjustable length of frame – L [mm]	Length profile type C1		Length profile type C2		Length profile type C3		A	B
	Qty	Length [mm]	Qty	Length [mm]	Qty	Length [mm]	Qty	Qty
4982-5064	3	1600	3	1600	3	1700	6	6
5082-5164	3	1600	3	1700	3	1700	6	6
5182-5264	3	1700	3	1700	3	1700	6	6
5282-5364	3	1700	3	1700	3	1800	6	6
5382-5464	3	1700	3	1800	3	1800	6	6
5482-5564	3	1800	3	1800	3	1800	6	6
5582-5664	3	1800	3	1800	3	1900	6	6
5682-5764	3	1800	3	1900	3	1900	6	6
5782-5864	3	1900	3	1900	3	1900	6	6
5882-5964	3	1900	3	1900	3	2000	6	6
5982-6064	3	1900	3	2000	3	2000	6	6
6082-6164	3	2000	3	2000	3	2000	6	6

Annex 8 Installation of steel roof in the sizes 10 – 31

8.1 Overview

- Mount rails A1, B2, C3, D4, E5 on the unit for support of trapezoidal roof plates (mount also rails Y and Z on units of the size 30 and on units that are larger than size 30 longitudinally at the centre- line of the units).
- Place foam bands – P – on the horizontal rails A1, B2, C3 and D4 for support of roof plates.
- Calculate overhang of the roof at both ends of the unit and mount roof overhang profile – G1 on the first trapezoidal roof plate – F1 before the roof plate is mounted.
- Place and mount roof plates F1, F2, F3 and so on.
- Remember foam bands on the side laps between roof plates to prevent rainwater from passing through.
- Place roof overhang profile – G5 at the other end of the unit before the last roof plate is mounted.
- Mount sides and corners on the roof.
- Apply sealing where plates are joined to ensure water resistance - even in stormy weather.

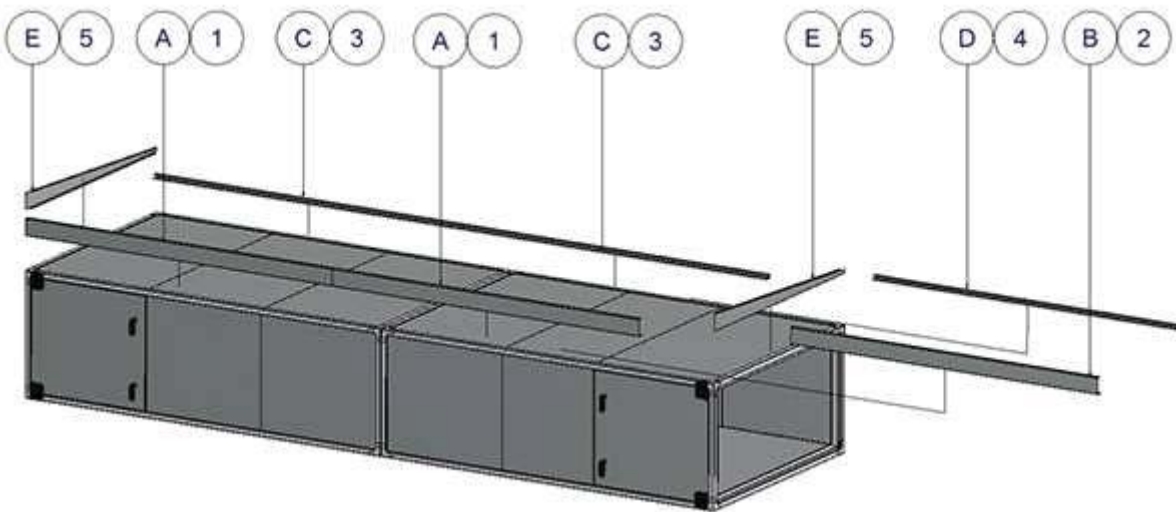

8.1.1 Mount rails. Units of size 10, 11, 12, and 14

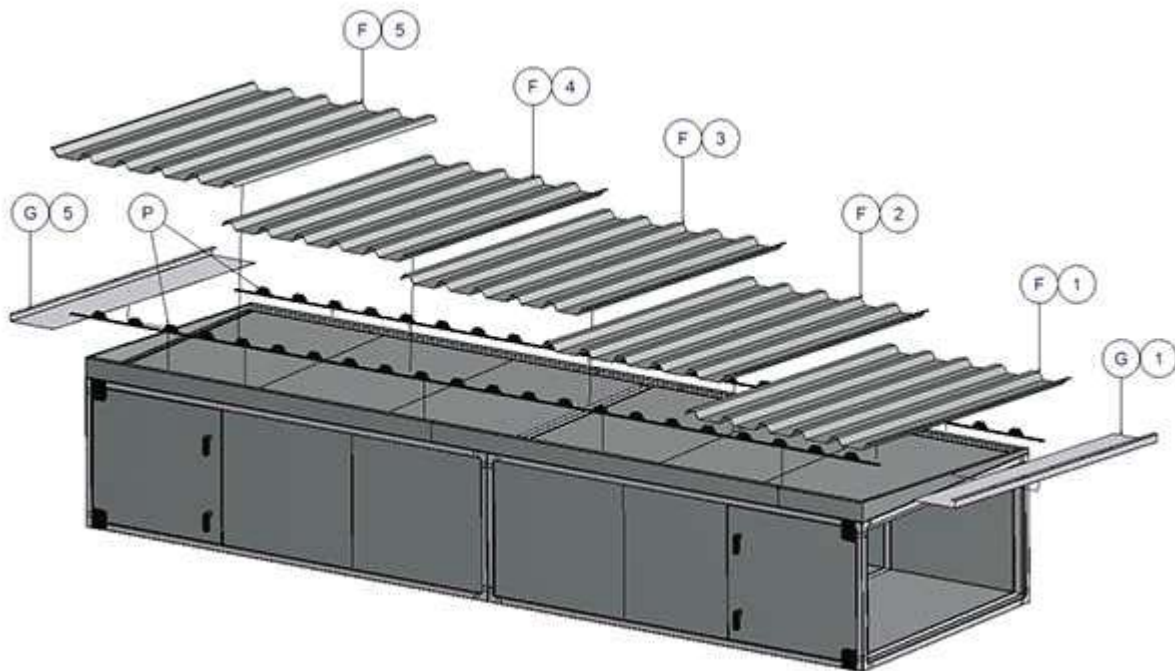

Squeeze sealant in sufficient quantity between the underside of the rails A1, B2, C3, D4, E5 and the horizontal top side of the unit before the rails are mounted. This means that the rails are standing on sealant to achieve the tightest

connection between rails and unit to prevent rainwater from passing under the rails and into the unit. Mount the rails A1 and B2 on the front side (the side with the inspection doors) – use the simple self-drilling screws without the sealing washer – see the illustration of the screw below.



Note:

Rail B2 fits into the rail A1, and this offers the advantage that the rail B2 can be slid inside the rail A1 to adjust the length of rail B2 accurately to the length of the unit. In this way it is not necessary to spend time and effort cutting the rail B2

Mount the lower rails C3 and D4 on the back side of the unit.



Note:

Rail D4 fits into the rail C3, and this offers the advantage that the rail D4 can be slid inside the rail C3 to adjust the length of rail D4 accurately to the length of the unit. In this way it is not necessary to spend time and effort on cutting the rail D4.

Mount vertical rail – E5 – with the roof slope at each end of the unit



Caution

It is important to place a screw in each hole – even though the number of holes for screws seems to be very large, a screw in each hole is necessary as the stress on the roof during stormy weather is extremely high.

8.1.2 Mount rails. Units of size 16 and units larger than size 16.

On units of size 16 and on units that are larger than size 16, rails A1, B2, C3, D4, E5 must be mounted on the unit for support of trapezoidal roof plates, but also rails Y and Z must be mounted longitudinally at the centre-line of the units to hold the trapezoidal roof plates.

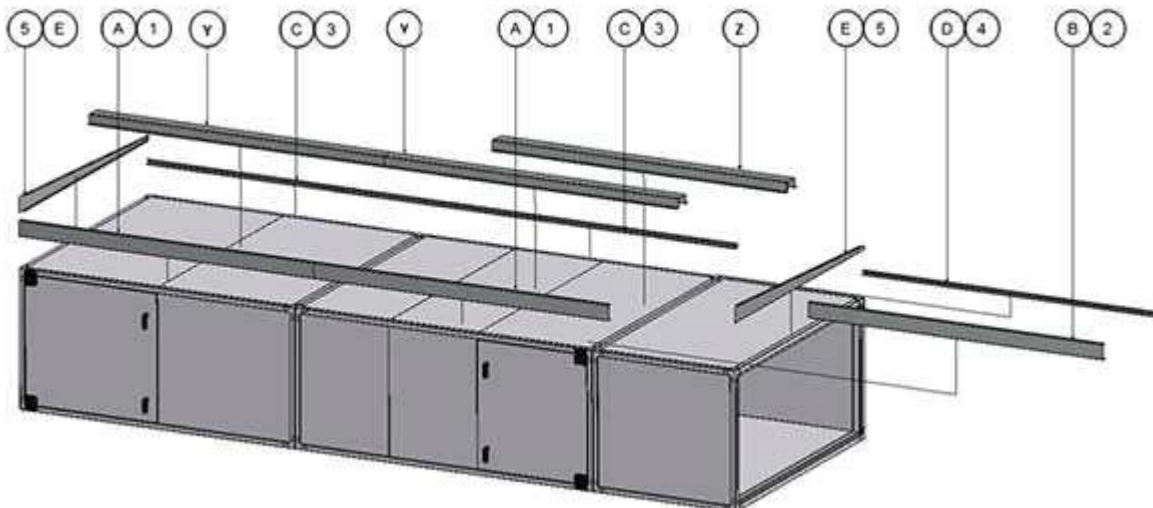

Squeeze sealant in sufficient quantity between the underside of the rails A1, B2, C3, D4, E5 and the horizontal top side of the unit before the rails are mounted. This means that the rails are standing on sealant to achieve the tightest connection between rails and unit to prevent rainwater from passing under the rails and into the unit. Mount the rails A1 and B2 on the front side (the side with the inspection doors) – use the simple self drilling screws without the sealing washer – see the illustration of the screw below.

**Note:**

Rail B2 fits into the rail A1, and this offers the advantage that the rail B2 can be slid inside the rail A1 to adjust the length of rail B2 accurately to the length of the unit. In this way it is not necessary to spend time and effort cutting the rail B2.

Mount the lower rails C3 and D4 on the back side of the unit.

**Note:**

Rail D4 fits into the rail C3, and this offers the advantage that the rail D4 can be slid inside the rail C3 to adjust the length of rail D4 accurately to the length of the unit. In this way it is not necessary to spend time and effort cutting the rail D4.

Mount vertical rail – E5 - with the roof slope at each end of the unit.

Mount the rails Y and Z on the unit with the centre-line of the rails exactly over the centre-line of the unit. It is longitudinal on the middle of the units to hold the trapezoidal roof plates.

**Note:**

Rail Z fits over the lower rail Y, and this offers the advantage that the rail Z can be slid on the rail Y to adjust the length of rail Z accurately to the length of the unit. In this way it is not necessary to spend time and effort on cutting the rail Z.

**Caution**

It is important to place a screw in each hole – even though the number of holes for screws seems to be very large, a screw in each hole is necessary as the stress on the roof during stormy weather is extremely high.

8.1.3 Roof overhang along the long sides of the unit

The roof plates are longer than the width of the unit to ensure sufficient overhang along the sides of the unit.

The overhang is 100 mm along each side of the smallest unit – size 10.

The overhang is 150 mm along each side of the units – size 11, 12, 14.

The overhang is 175 mm along each side of the biggest units – including size 16.

8.1.4 Calculation of the overhang at the ends of the unit. Mount overhang profile – G1.

The roof must be between 200 and 400 mm longer than the length of the unit to secure a roof overhang between 100 mm and 200 mm at the each of the 2 ends of the unit, and the length of this overhang must be calculated before the first roof plate is mounted.

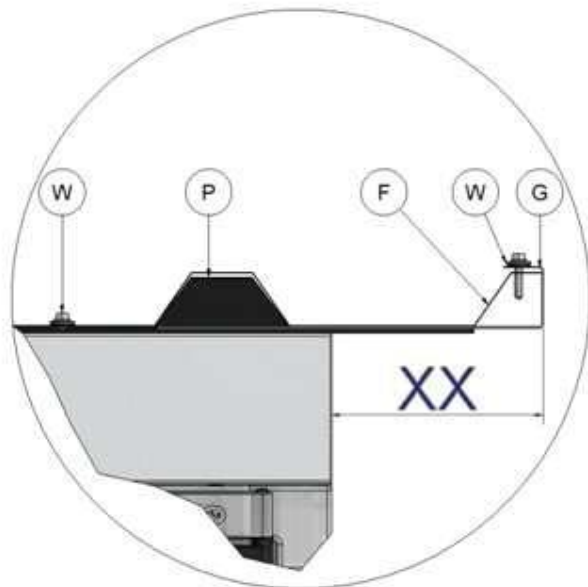
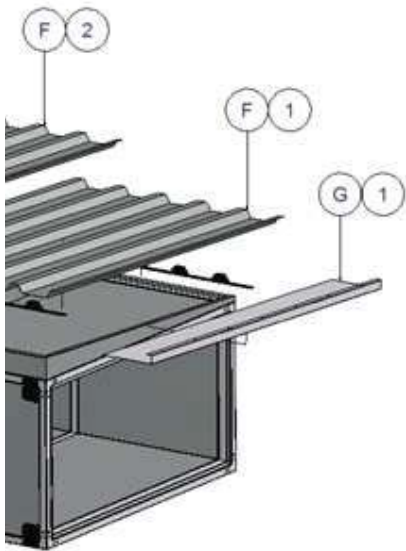

The unit is delivered with 2 similar overhang profiles - G1 and G5 - one for each end of the roof. Mount one of the 2 roof overhang profiles - G on a trapezoidal roof plate. Use the self drilling, painted screws with sealing washers - W - see the illustration.



Note:

Foam bands - P - are necessary between the overhang profile G1 and the roof plate F1. See the illustration.



Self-drilling, painted screws supplied with sealing washer for the mounting of the trapezoidal plate to the roof overhang profile.

The total cover width of the trapezoidal roof plates always changes with the pitch of 205 mm between the trapezoidal ribs, making up a total length of the complete roof of - for example 2100 mm, 2305 mm, 2510 mm and so on. We call

this length of the total roof for RL and we call the total length of the complete unit for AL. The trapezoidal roof must always be longer than the unit, to obtain a reasonable overhang called – XX - of the roof at both ends.

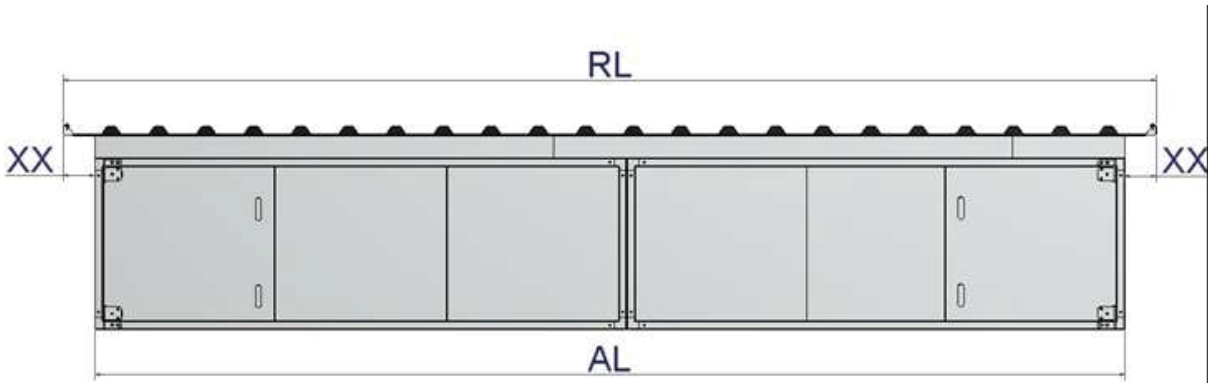

In the table below you will find 40 different lengths of roofs (always changing with the 205 mm) and the lengths of units that are ideal for each of the 40 alternative roof lengths.

Measure the total length – AL of the unit – for example 5000 mm between the 4982 and 5182 mm mentioned in the table below.

AHU length AL	Roof length RL		AHU length AL	Roof length RL		AHU length AL	Roof length RL
1670 - 1870	2100		4568 - 4768	4970		7466 - 7666	7840
1877 - 2077	2305		4775 - 4975	5175		7673 - 7873	8045
2084 - 2284	2510		4982 - 5182	5380		7880 - 8080	8250
2291 - 2491	2715		5189 - 5389	5585		8087 - 8287	8455
2498 - 2698	2920		5396 - 5596	5790		8294 - 8494	8660
2705 - 2905	3125		5603 - 5803	5995		8501 - 8701	8865
2912 - 3112	3330		5810 - 6010	6200		8708 - 8908	9070
3119 - 3319	3535		6017 - 6217	6405		8915 - 9115	9275
3326 - 3526	3740		6224 - 6424	6610		9122 - 9322	9480
3533 - 3733	3945		6431 - 6631	6815		9329 - 9529	9685
3740 - 3940	4150		6638 - 6838	7020		9536 - 9736	9890
3947 - 4147	4355		6845 - 7045	7225		9743 - 9943	10095
4154 - 4354	4560		7052 - 7252	7430			
4361 - 4561	4765		7259 - 7459	7635			

The mentioned length of roof – RL - for this length of unit is 5380 mm (the delivered trapezoidal plates can be combined to this length - RL = 5380 mm). 5380 mm minus 5000 mm is 380 mm overhang for both ends, and 380/2 mm = 190 mm is the overhang for each end. Place the trapezoidal roof plate F1 with the roof overhang profile G1 on rail E with an overhang of 190 mm.

8.1.5 Foam bands between rails and roof plates – mount roof plates.

Place foam bands P between profiles A1, B2, C3, D4 and roof plates.

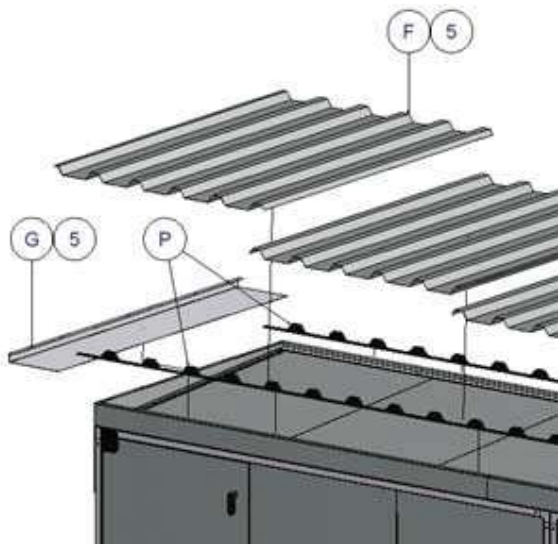

The trapezoidal roof plates are mounted with the self-drilling, painted screws supplied with sealing washer.

8.1.6 Foam bands between roof plates

Mount the self-adhesive foam band - O - on the underlapping rib for water resistant and effective sealing due to the small slope of the roof.

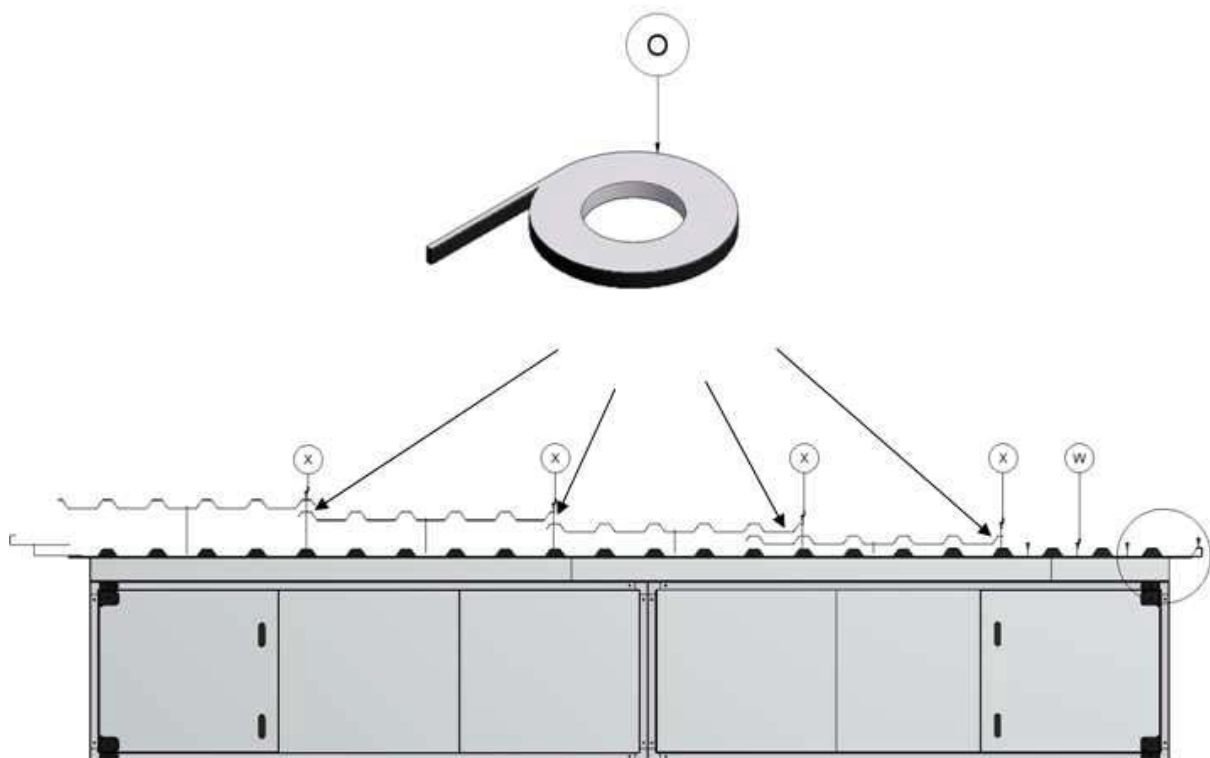

8.1.7 Mount roof plates – some of them are overlapping by 2 ribs

The width of each plate is always 1025 mm and some of the plates have to overlap by 2 ribs to achieve the optimal total length of the whole roof – see the illustration above.

8.1.8 Mount overhang profile – G5 on the other end of the unit.

When the last trapezoidal plate (in this example F5) has been placed on the unit, the second roof overhang profile G5 must be pushed under the trapezoidal roof plate and mounted with the self-drilling, painted screw with sealing washer. Mounting must be similar to the mounting of roof overhang profile under the trapezoidal roof plate at the other end of the unit.

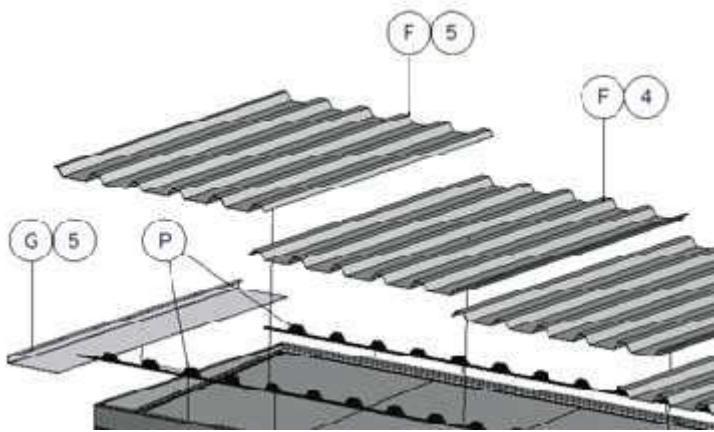

8.1.9 Mount side profiles and corners along the edges of the roof to protect persons

Profiles N and O with the rectangular holes are for the long and lower side of the roof because rain can escape through the holes. Mount the profiles type N first and the profile O last because the profile O goes over the profile N. Mounted in this order, the profile O can match the end of the roof and the surplus length of the profile O will just cover part of the previous profile N. Mount the profiles L and M along the long and higher front side of the roof. Mount the 4 protection corners.

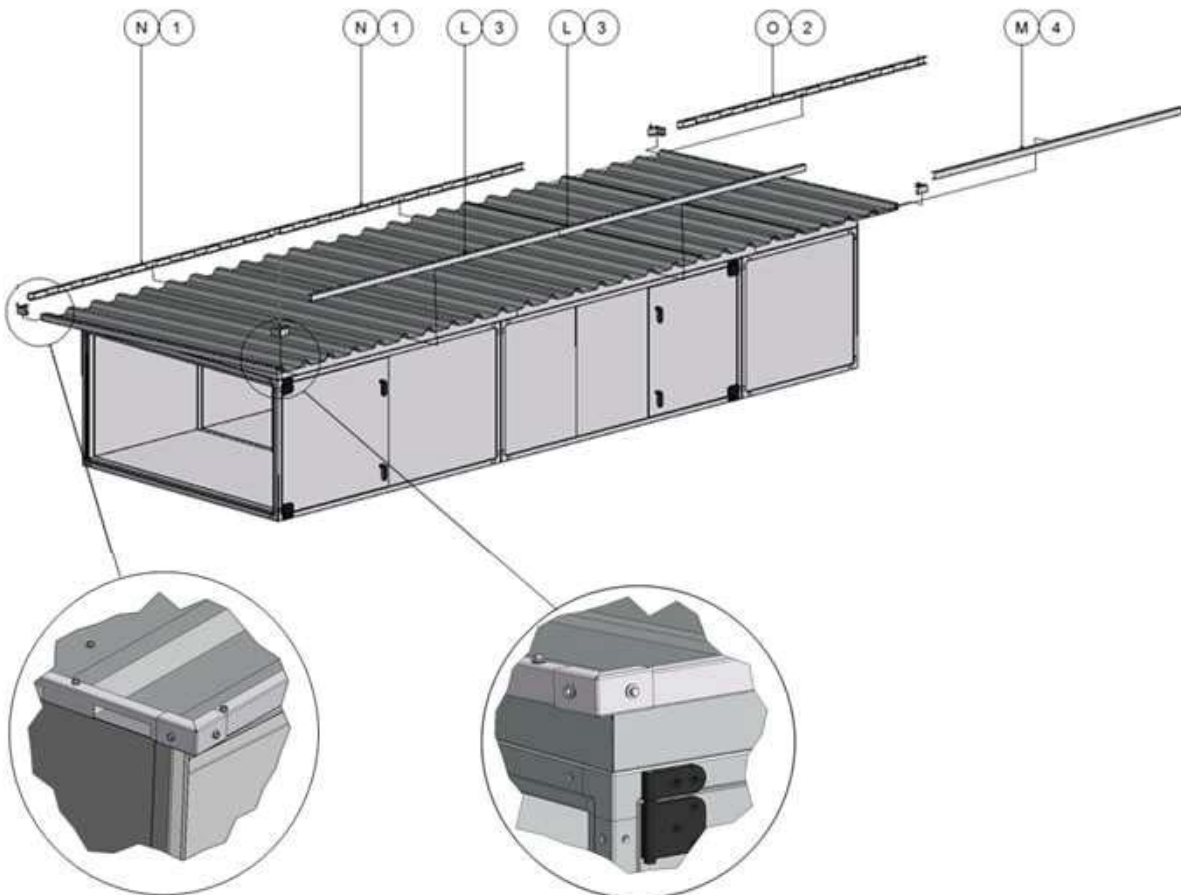

8.1.10 Apply sealing on plate joints to ensure water resistance.

Finish installation of the steel roof by sealing all plate joints with silicone to prevent rainwater from passing into the unit. See examples below of joints to be sealed.

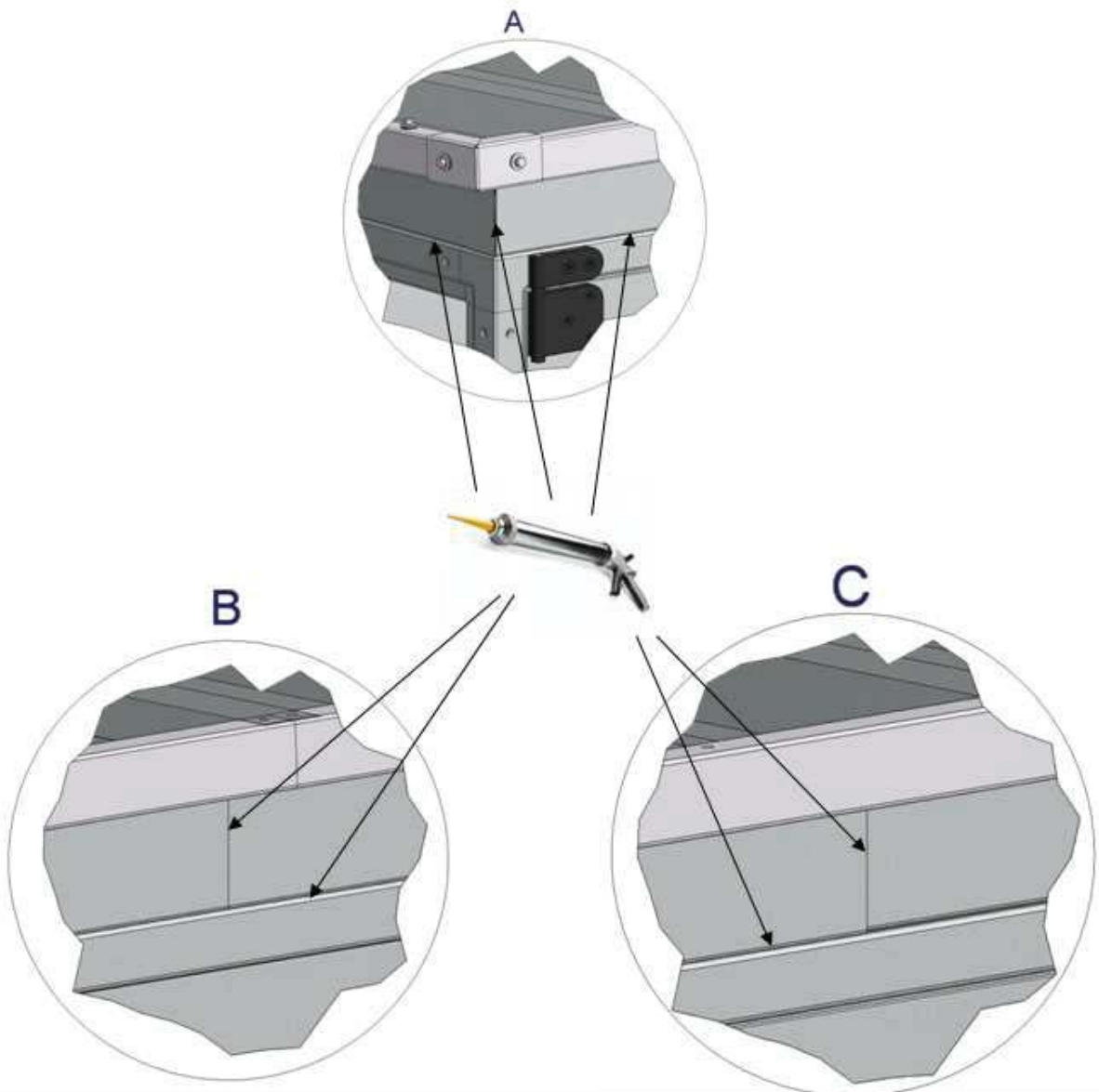

Annex 9 Speed control for rotor and assembly of divided rotor

9.1 Speed control

The cabinet with the speed control system for the rotor is installed behind the inspection door in the rotor section.

The cabinet contains the speed controller with all components, terminal blocks, LED displaying the operation mode, the dual position DIP switch with 8 sliding levers for programming the rotor motor signal and a button for the activation of the test mode.

Through the different combinations of the 8 sliding levers of this dual position DIP switch, the correct signal is available for the 3 different motors used for the 12 sizes of air handling units. The sliding levers are set and the function is checked at the factory. The positions of the levers appear from the tables below.

9.1.1 Selection of correct signal via the 8DIP switch levers

Position	Function	Code
Up	Active = ON	1
Down	Deactivated = OFF	0

The factory sets the positions of the 8 DIP switch levers for the maximum of 12 revolutions per minute for standard temperature exchangers and for sorption-hybrid exchangers. The position of each of the 4 DIP switches to the left is shown below.

Geniox	Pulley	Position for DIP switches to the left	Motor
10	54	0000	90TYD-S214-M 2.8Nm
11	54	0000	
12	54	1000	
14	77	0000	
16	77	1000	
18	77	1000	
20	85	0100	120TYD-S214-M 5.5Nm
22	95	0100	
24	106	0100	
27	118	0100	
29	106	1100	
31	112	1100	

The factory sets the positions of the 8 DIP switch levers for the maximum of 20 revolutions per minute for sorption exchangers. The position of each of the 4 DIP switches to the left is shown below.

Geniox	Pulley	Position for DIP switches to the left	Motor
10	70	1000	90TYD-S214-M
11	77	1000	
12	95	1000	
14	95	1000	
16	118	0100	120TYD-S214-M
18	112	1100	
20	118	1100	
22	132	1100	
24	132	0110	
27	160	1010	
29	160	0110	
31	150	0110	

9.1.2 Indication of operation mode via red and green LED as well as test of motor

The LED is in the cover of the cabinet.

LED indication	Value
No indication	Power off
Green	Ordinary operation
Green - flashes	Ready for operation
Green/redstrobe,slow	Magnet on the rotor has activated rotor guard
Green/red strobe, fast	Restart sequence active
Red	Rotor guard has not been activated

Number of red flashes in series	Value
1	Output current limit
2	Over voltage
3	Under voltage
4	Failure in the controller
5	Communication failure

Restart of rotor:

- Switch off power and switch on power again
or
- Press the test button inside the cabinet

Table 3 Test of motor by checking the resistance in all 3 windings

Motor sizes	Ohm
90TYD-S214-M	40Ω
120TYD-S214-M	18Ω
120TYD-S214-L	10Ω

Setting of constant speed:

- Set fourth DIP switch lever in position - ON

Test:

- Set fourth DIP switch lever in position - ON
- Press the test button

9.1.3 The board for control of revolutions.



9.1.4 Information about connection of cables to terminals on the control board.

Connection of cables to the terminals on the board		
Terminal	Connection	
1	Earth – supply	
2	Earth – supply	
3	Fase – supply	
4	Neutral – supply	
5	Rotor turns upwards seen from inspection side	Rotor turns downwards seen from inspection side
6	Terminal 5 = wire 1	Terminal 5 = wire 2
7	Terminal 6 = wire 2	Terminal 6 = wire 1
	Terminal 7 = wire 3	Terminal 7 = wire 3
8	Earth for rotor motor	
Test	Set DIP switch 4 in position – ON – and press the button for test. The signal is controlled by the potentiometer at constant speed and not by any signal from the control system.	
Adjust	Is activated by setting DIP switch 4 at OFF and DIP switch 5 at ON. Hereby the maximum revolutions can be adjusted between 50 and 100 % by the potentiometer. Usually, the factory setting is OK, but with this potentiometer the maximum revolutions can be reduced or increased.	
9	Alarm signal – COM (common)	
10	Alarm signal – Relay is normally closed (this is used by the control system from Systemair)	
11	Alarm signal – Relay is normally open (this is not used by the control system from Systemair)	
12	Control system input is 0 – 10 volt DC	
13	Control system input – ground	
14	Rotor guard – (black cable from rotor guard from Systemair)	
15	Rotor guard – (blue cable from rotor guard from Systemair)	
16	Rotor guard – (brown cable from rotor guard from Systemair)	
17	For BUS signal – RS485 – A (green wire from Systemair control system)	
18	For BUS signal – RS485 – B (yellow wire from Systemair control system)	
19	For BUS signal – ground (white wire from Systemair control system)	

9.2 Assemble divided rotor and the Systemair casing

Half of the rotary heat exchanger is pre-assembled from Sytemair with centre of the rotor as well as bearings in the centre installed in the lower half of the unit section.

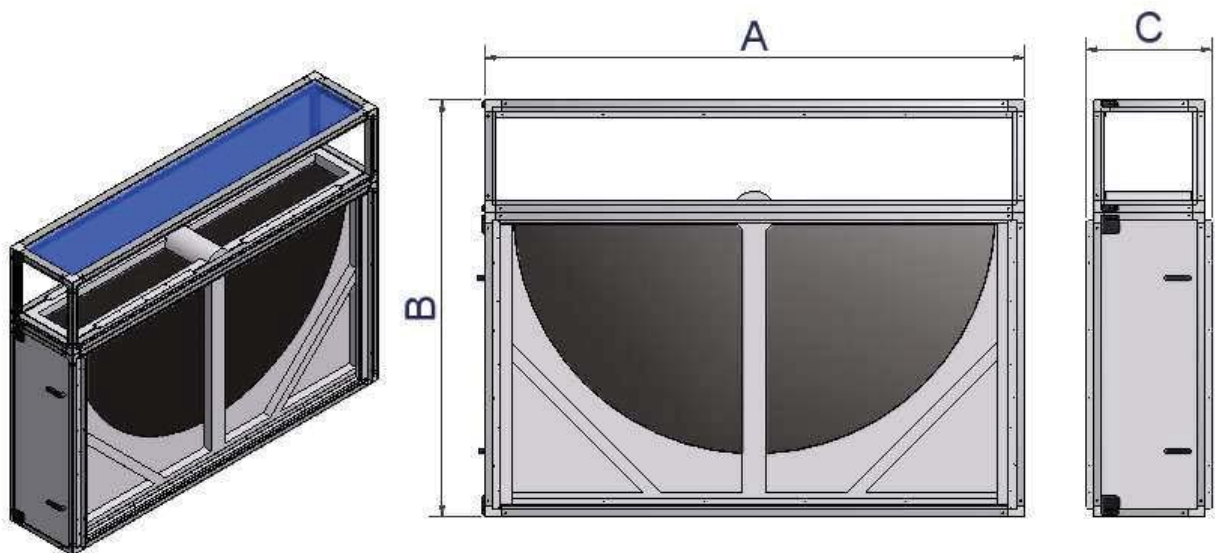

Size	A	B	C
Geniox 22	2282	1764	500
Geniox 24	2482	1864	500
Geniox 27	2782	1964	500
Geniox 29	2982	2064	500
Geniox 31	3182	2164	500

Remove the Systemair ceiling panel from the lower half of the Systemair unit section for free access to mount the upper half of rotor casing from Hoval. With the upper half of the rotor casing from Hoval properly mounted, the next step is to mount the radial walls to the flanges on the center. The radial walls that are between the rotor segments.

9.3 Assemble divided rotor from Hoval

9.3.1 Tools and aids

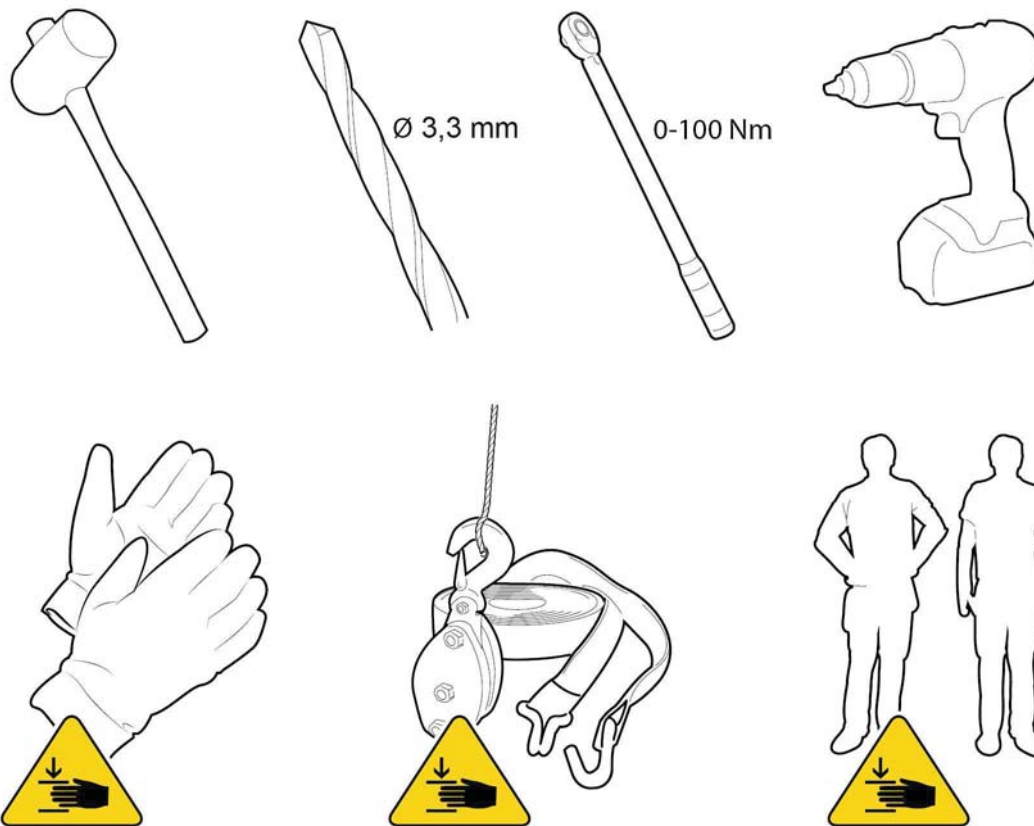

9.3.2 Lifting instruction for upper half of the Hoval CDS 290 mm rotor casing



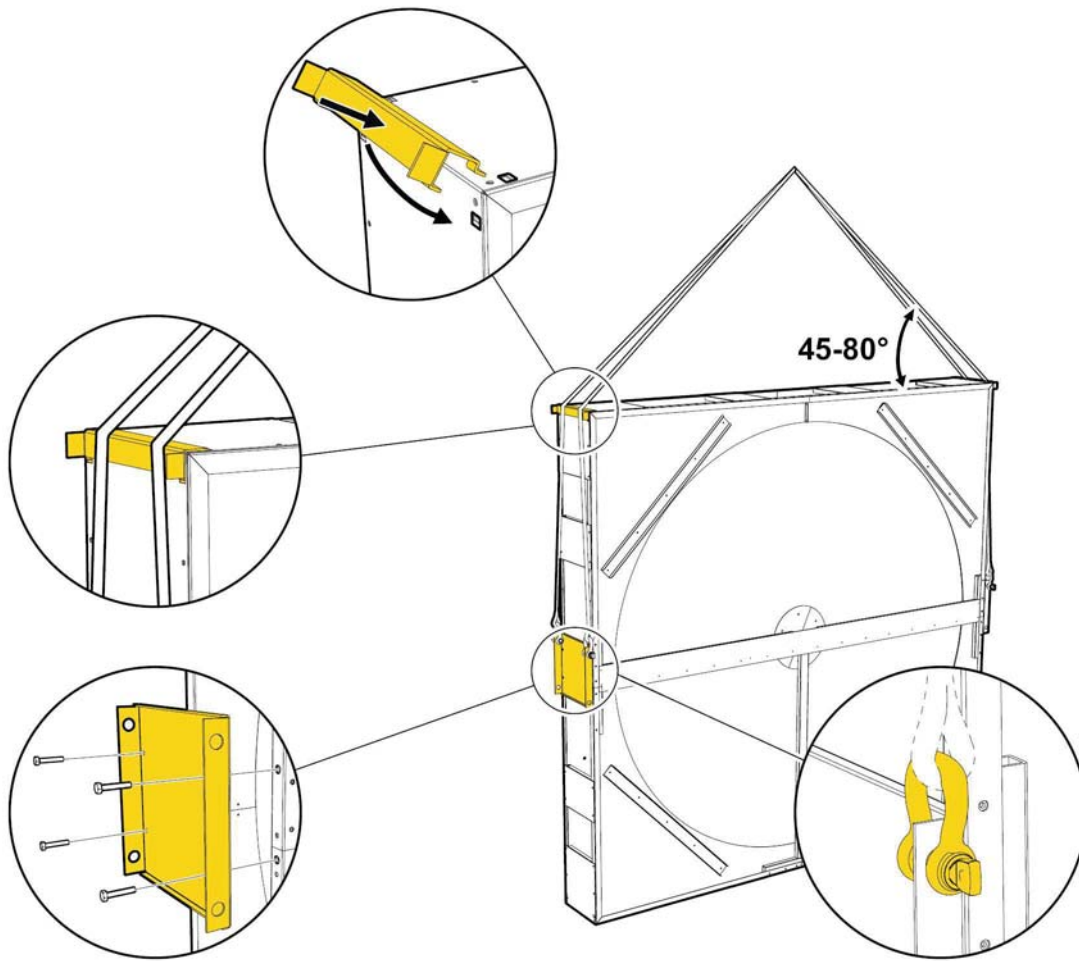

9.3.3 Installation of upper half of the Hoval CDS 290 mm rotor casing

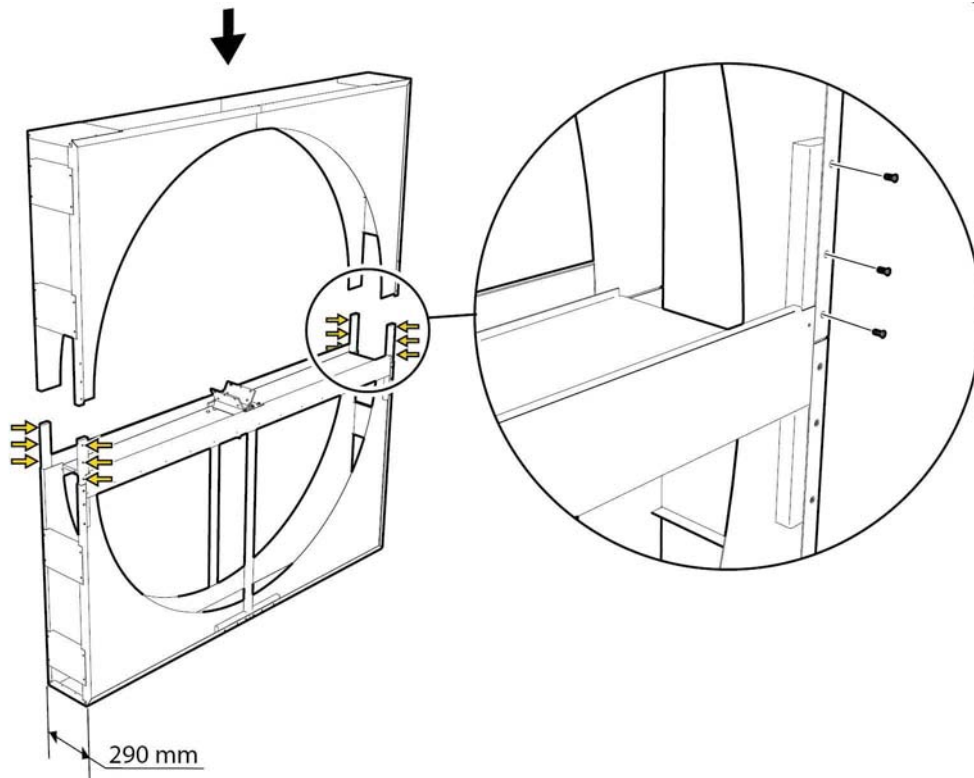

9.3.4 Installation of radial walls between segments



9.3.5 Adjusting clearance between radial walls and the casing

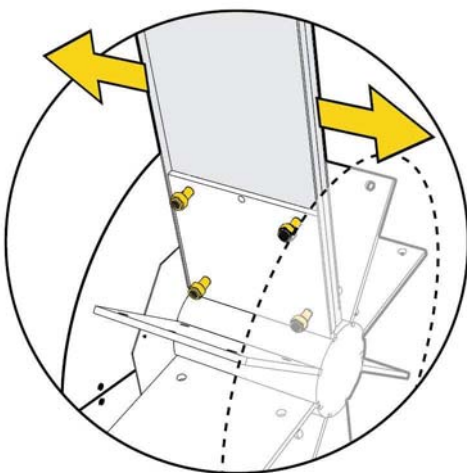
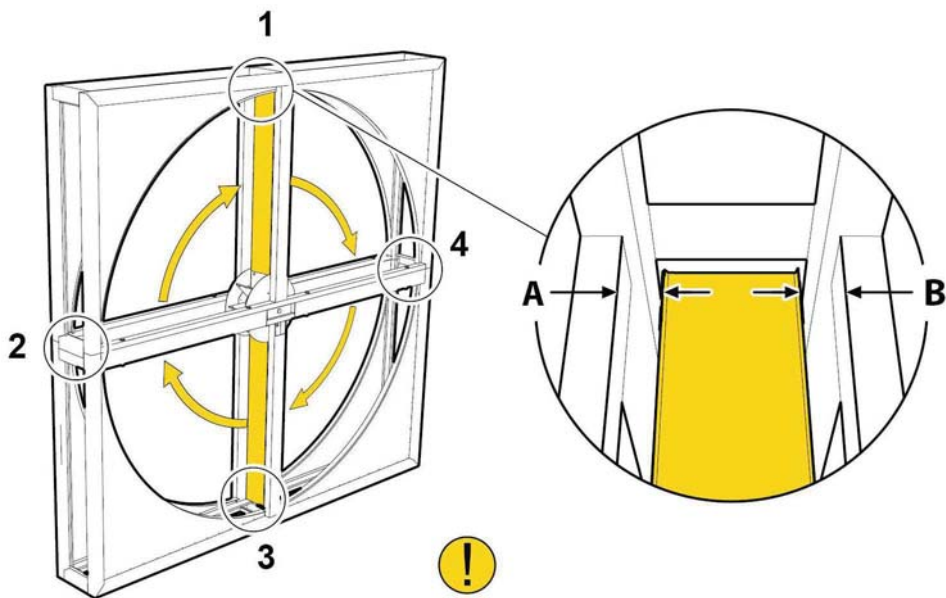

9.3.6 Installation of rotor segment and periphery plates

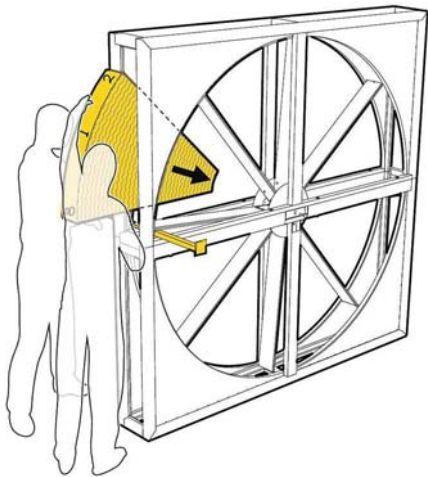
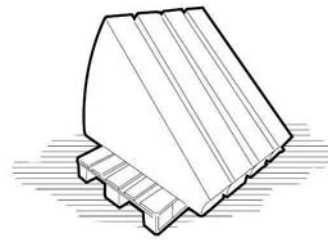
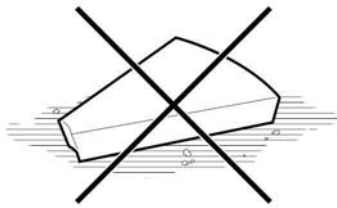
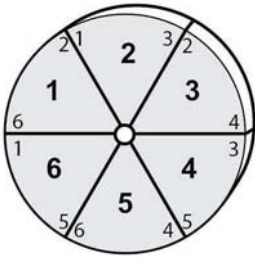
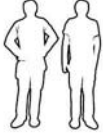

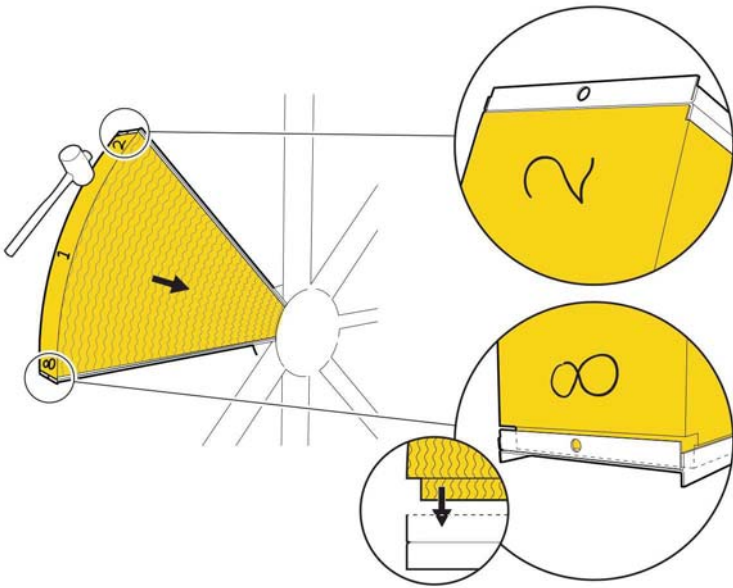

9.3.7 Installation, first periphery plate

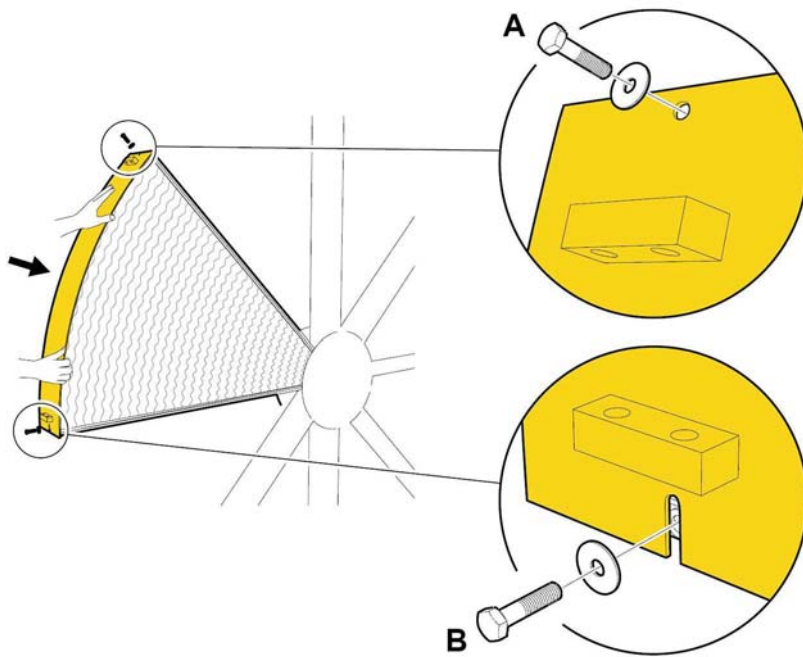

9.3.8 Installation of next segment

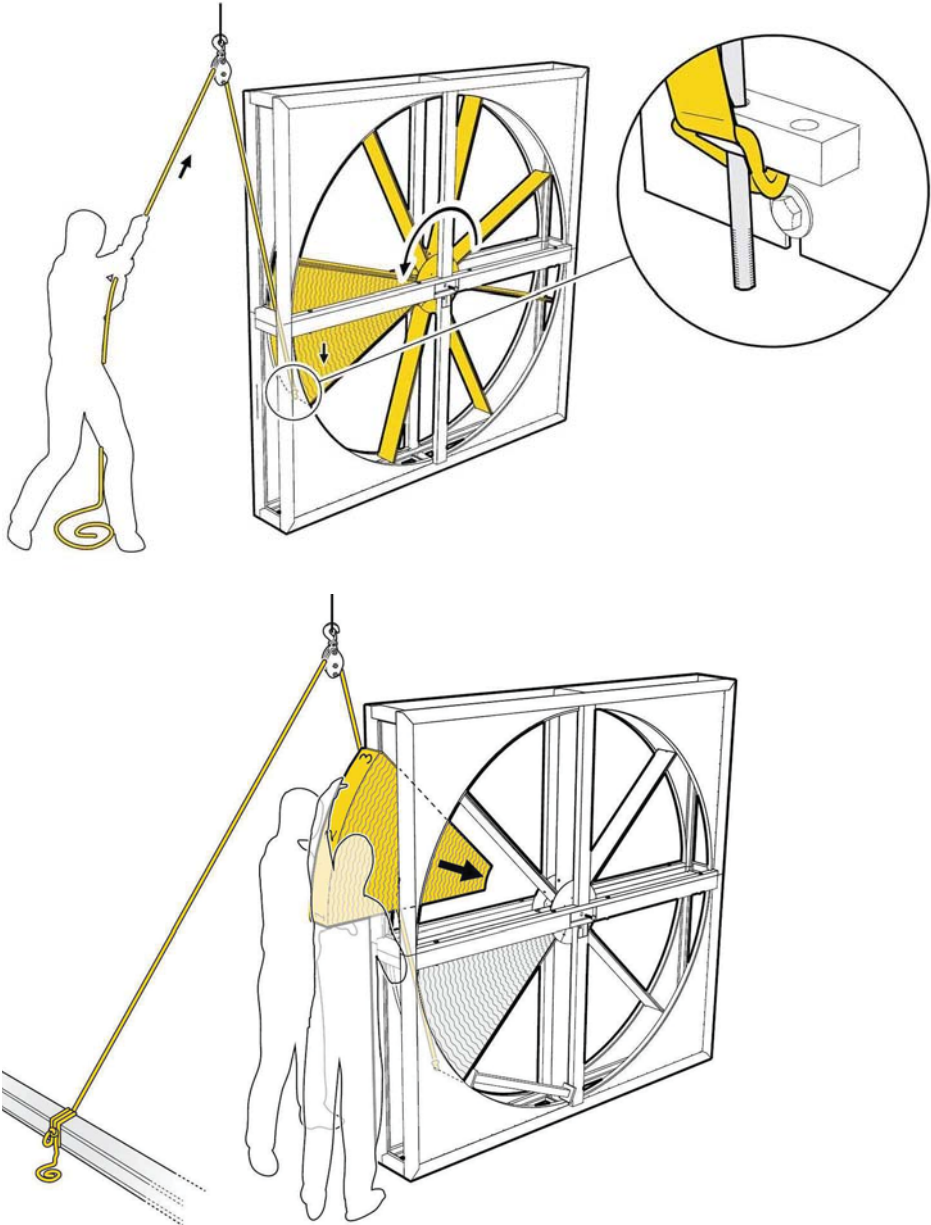

9.3.9 Installation, next periphery plate

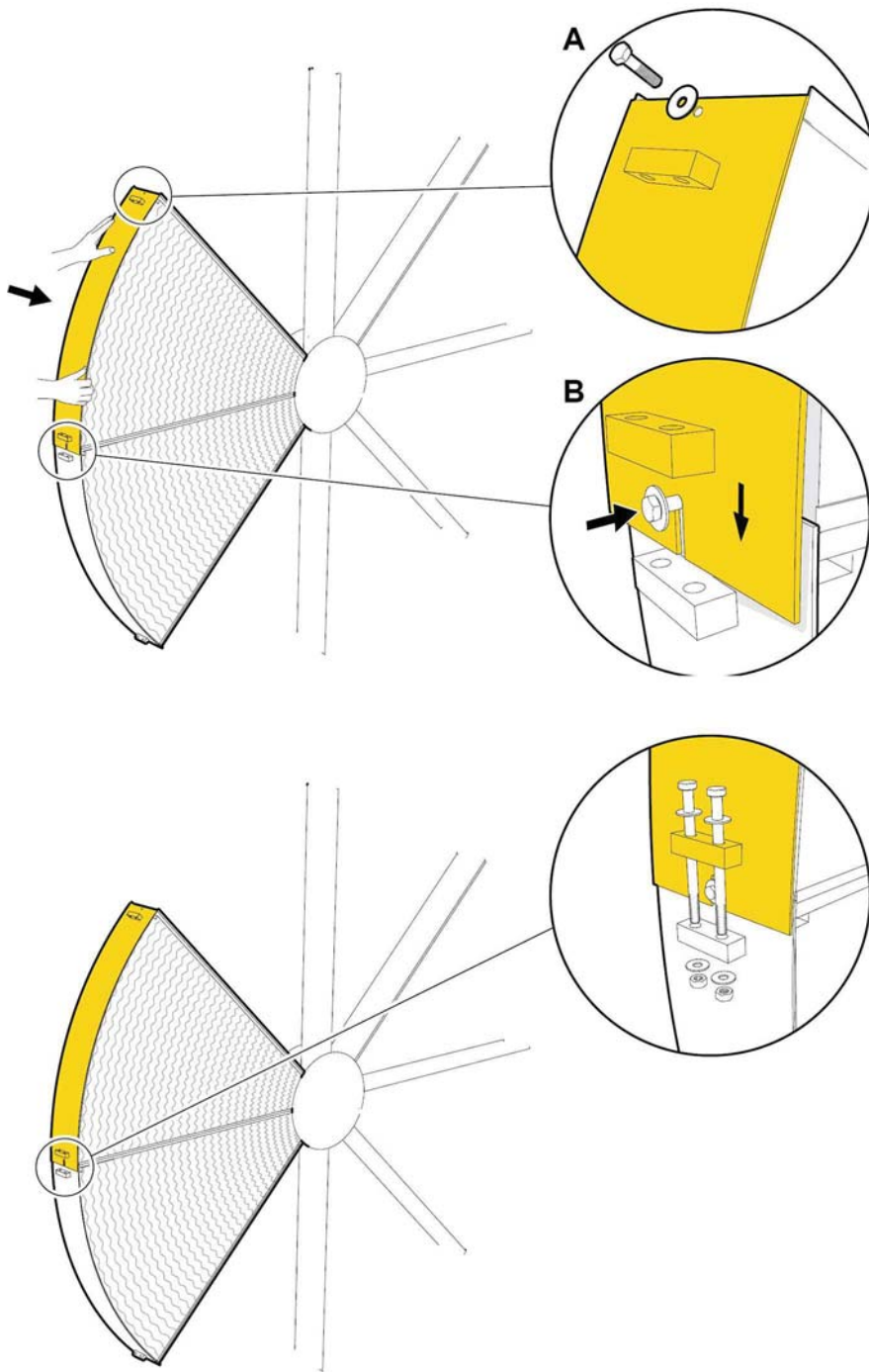

9.3.10 Final adjustment of segments and periphery plates

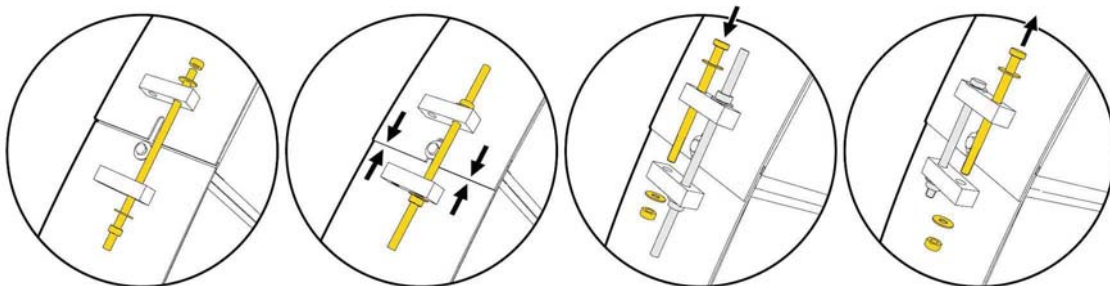

9.3.11 Installation of brush sealing and upper half of the Systemair

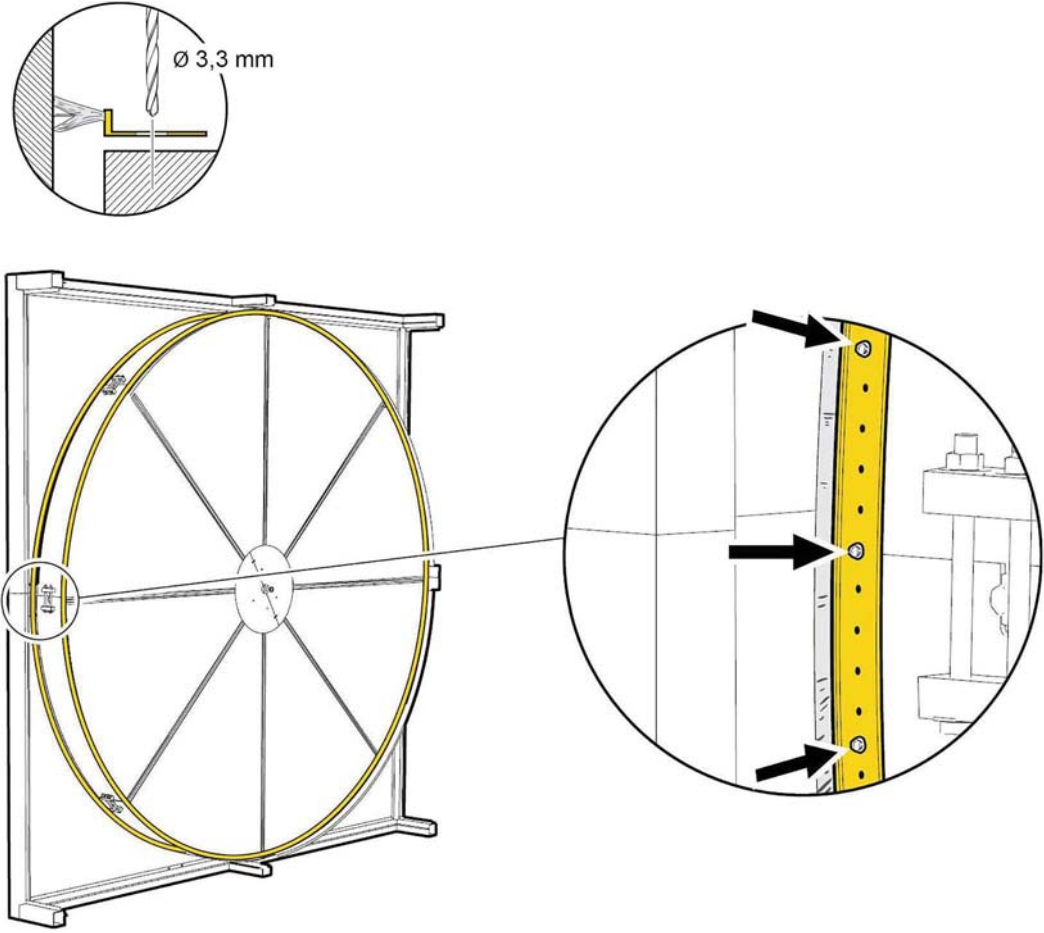

The next step is to mount the upper half of the Systemair unit casing consisting of 4 vertical profiles and the horizontal roof panel

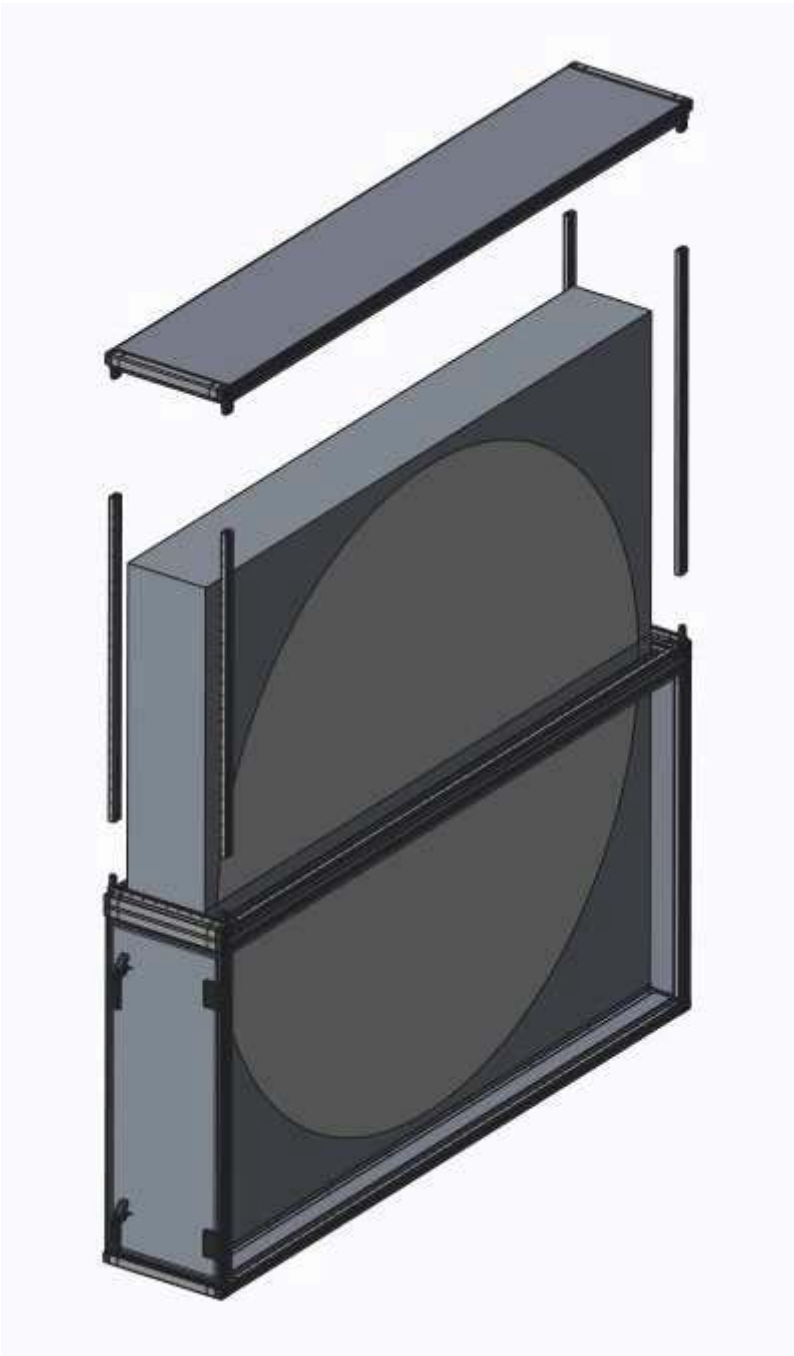

Final step is to mount two panels.

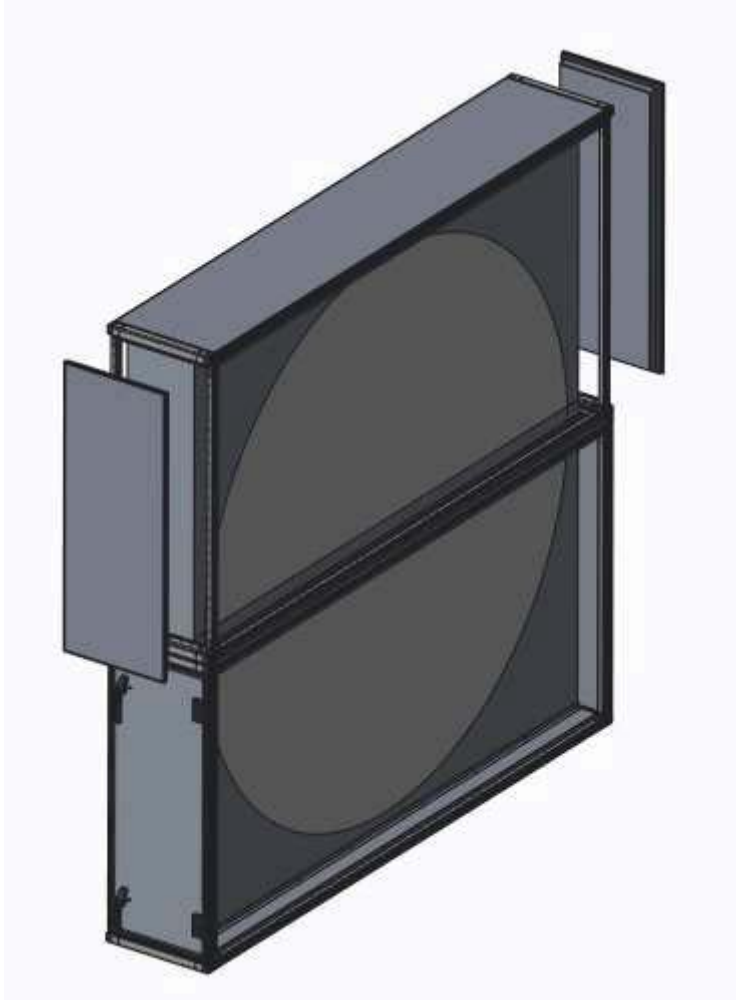

9.4 Installation of motor that turns rotor and sensor for control of rotation

After assembly of divided rotor drive belt between rotor and rotor motor as well as sensor for control of rotation must be installed.

The rotor motor is installed by Systemair before delivery.

The rotor motor is mounted on a motor console plate.

Sensor for control of rotation must be installed by the installer. On the rotor the installer must mount the screw that activates signal from the sensor. Distance between sensor and screw for activation of signal must **not** exceed 2mm.

Pay attention to the heights of the brackets which are used for the assembly of the rotor segments. Check that collision between brackets and sensor is impossible. Please turn the rotor by hand in order to verify that the sensor will not be hit by the brackets.



Note:

To activate the signal from the sensor during rotation of the rotor it is necessary to install a screw on the rotor. The distance from the screw to the sensor must **not** exceed 2 mm.

Check that collision between belt and bracket at the rotor is impossible. Adjust position of rotor motor if necessary.



Install sensor for registration of rotation. The sensor must be installed to the right seen from the inspection side of the unit. Check that collision between sensor and brackets at the rotor is impossible. Adjust position of sensor if necessary.



Mount the illustrated screw on the rotor for activation of signal from the sensor.



Note:

The distance from the screw to the sensor must **not** exceed 2 mm.



Annex 10 Reversible heat pump unit (in separate cover, if heat pump was delivered)

10.1 Geniox-HP section (reversible heat pump unit)

The air handling unit section – Geniox-HP – is a separate section in the air handling unit, containing a complete stand-alone reversible heat pump system (heating and cooling). If the air handling unit was delivered with this section, a separate manual about the heat pump was enclosed in the separate cover.

Annex 11 Menu for internal controller in the heat pump unit (in separate cover, if heat pump was delivered)

If the air handling unit was delivered with this section, a separate manual about the heat pump was enclosed in the separate cover

Annex 12 Connection of fan motor and set-up manual for frequency converter

12.1 Connection of fan motor

Delta connection is shown to the left, and star connection is shown to the right.

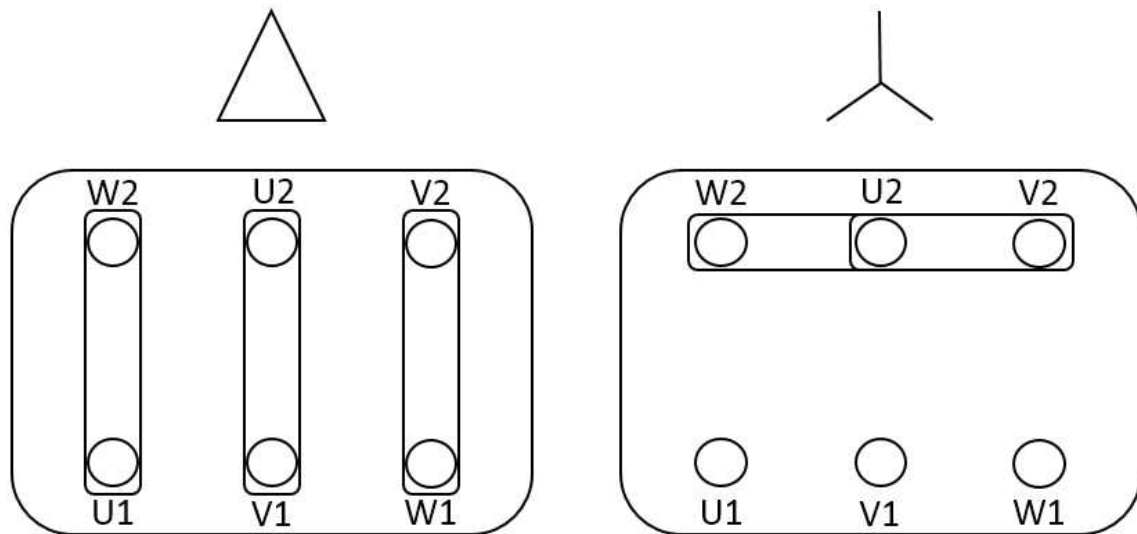

12.2 Set-up for Danfoss FC101 for Geniox-units with AC motors

SETUP IS DONE IN FACTORY BEFORE DELIVERY

To reload Systemair factory settings from the control panel:

0-50: LCP Copy: [2]

Systemair factory set-up is based on Danfoss initialization.

14-22: **Operation mode:** [2] Initialisation (Danfoss Initialisation)

Turn power off and on.

Systemair factory set-up:

0-01: Language selection:

1-03: **Torque characteristic:** Single fan: [3] Auto-Energy optim.

With twin fan set-up: [1] Variable Torque

1-20: **Motor Power:** According to motor plate / order papers

With twin fan set-up total power must be used

1-24: **Motor Current:** According to motor plate / order papers

With twin fan set-up total current must be used

1-25: **Motor Nominal Speed:** According to motor plate / order papers

1-42: **Motor Cable Length:** 3m

1-50: **Motor Magnetisation at zero speed.:** 0 %

1-52: **Min. Speed Normal Magnetisation:** 10 Hz

1-73: **Flying Start:** [0] Disabled

1-90: **Motor Thermal Protection:** [2] Thermistor trip

3-15: **Reference 1 Source:** [2] Analog input AI54

1-93: **Thermistor Source:** [1] Analog input AI53

- 3-03: **Maximum Reference:** Max. Hz from order papers
- 3-16 + 3-17: **Reference 2- and 3 Source:** [0] No function
- 3-41 + 342: **Ramp 1 up and down:** 20 Sec.
- 4-19: **Max. Output Frequency:** 90Hz
- 4-14: **Motor Speed High Limit:** 90Hz
- 4-18: **Current limit:** 100 %
- 5-12: **Terminal 27 Digital input:** [0] No operation
- 5-40.0: **Function Relay:** [3] Drive ready/remote
- 5-40.1: **Function Relay:** [3] Drive ready/remote
- 6-25: **Terminal 54 High Reference:** Max. Hz from order papers
- 14-03: **Over modulation:** [1] Active
- 14-20: **Reset Mode:** [2] Automatic reset x 2
- 0-50: **LCP Copy:** [1] All to LCP (Copy of Systemair factory settings to panel)

Connections:

0-10V: terminal 54-55

Start: terminal 12-18

Thermistor: terminal 50-53

Drive ready: terminal 1-2

12.3 AC-fan operation without thermistor for Danfoss FC101

Systemair factory set-up is based on Danfoss initialization.

14-22: **Operation mode:** [2] Initialisation (Danfoss Initialisation)

Turn power off and on.

Systemair factory set-up:

0-01: Language selection:

1-03: **Torque characteristic:** [3] Auto-Energy optim.

1-20: **Motor power:** According to motor plate

1-24: **Motor Current:** According to motor plate

1-25: **Motor Nominal Speed:** According to motor plate

1-29: **Automatic motor adaption (AMA):** [1] Compl.motor adaption to (Turn power off and on.)

1-42: **Motor Cable Length:** Order specific

1-50: **Motor Magnetisation at zero speed.:** 0 %

1-52: **Min. Speed Normal Magnetisation:** 10 Hz

1-73: **Flying start:** [0] Deactivated

5-40.0: Function Relay: [3] Drive ready/remote

14-03: Over modulation: [1] Active

14-20: Reset Mode: [2] Automatic reset x 2

0-50: LCP Copy: [1] All to LCP (Copy of Systemair factory settings to panel)

Connections:

0-10V: terminal 54-55

Start: terminal 12-18

Drive ready: terminal 1-2

Jumper terminal 12-27

12.4 Set-up Danfoss FC101 for Geniox-units with PM motors

SETUP IS DONE IN FACTORY BEFORE DELIVERY

To reload Systemair factory settings from the control panel:

0-50: LCP Copy: [2]

Systemair factory set-up is based on Danfoss initialization.

14-22: **Operation mode:**[2] Initialisation (Danfoss Initialisation)

Turn power off and on.

Systemair factory set-up:

0-01: Language selection:

1-06: Clockwise Direction: [1] Inverse

1-10: Motor Construction: [1] PM, non-salient SPM

1-24: Motor Current: According to motor plate / Schedule

1-25: Motor Nominal Speed: According to motor plate / Schedule

1-26: Motor Cont. Rated torque: According to motor plate / Schedule

1-30: Stator Resistance (Rs): According to motor plate / Schedule

1-37: d-axis inductance (Ld): According to motor plate / Schedule

1-39: Motor Poles: According to motor plate / Schedule

1-40: Back EMF at 1000 RPM: According to motor plate / Schedule

1-42: Motor Cable Length: 3m

1-90: Motor Thermal Protection: [2] Thermistor trip

3-15: Reference 1 Source: [2] Analog input AI54

1-93: Thermistor Source: [1] Analog input AI53

3-03: Maximum Reference: According to motor plate / Schedule

3-16 + 3-17: Reference 2- and 3 Source: [0] No function

3-41 + 3-42: Ramp 1 Up and down: 30 sec.

4-19: Max. Output Frequency: According to motor plate / Schedule

4-14: Motor Speed High Limit: According to motor plate / Schedule

4-18: Current limit: 115 %

5-12: Terminal 27 Digital input: [0] No operation

5-40.0: Function Relay: [3] Drive ready/remote

5-40.1: Function Relay: [3] Drive ready/remote

6-25: Terminal 54 High Reference: According to motor plate / Schedule

14-03: Over modulation: [1] Active

14-20: Reset Mode: [2] Automatic reset x 2

0-50: LCP Copy: [1] All to LCP (Copy of Systemair factory settings to panel)

Connections:

0-10V: terminal 54-55

Start: terminal 12-18

Thermistor: terminal 50-53

Drive ready: terminal 1-2

Schedule for PM motor parameters

12.5 Installation ECblue

12.5.1 Connection

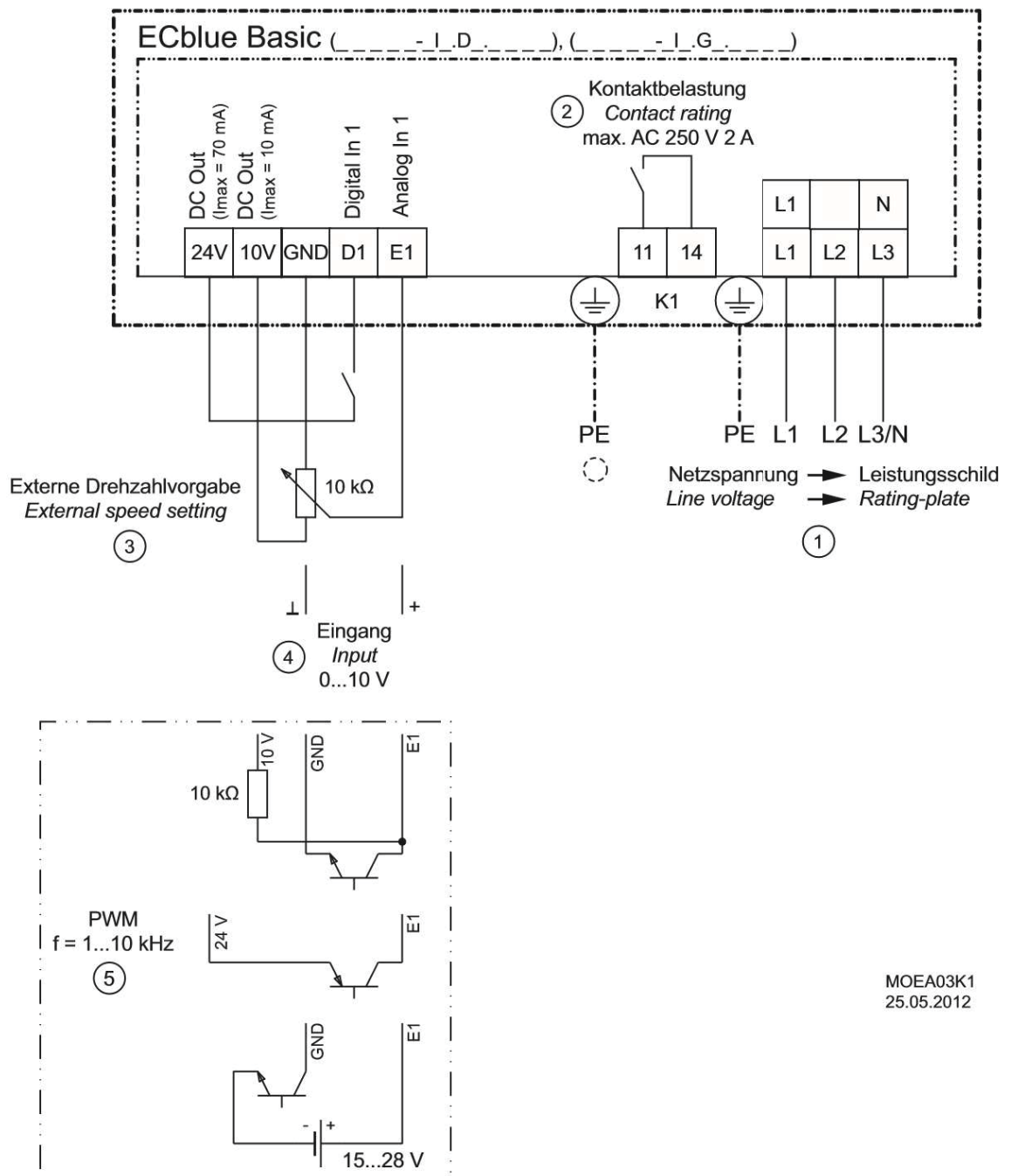



MOEA03K1
25.05.2012

- 1 Line voltage → rating plate
- 2 Contact rating max. AC 250 V 2 A
- 3 External speed setting

1. Line voltage rating plate
2. Contact rating max AC 250 V 2 A
3. External speed setting
4. Input 0...10 V
5. PWM input, f = 1...10 kHz

For ECblue 3 ~ types and when connecting 1 ~ types between two outer conductors, only all-current sensitive fault current circuit breakers (type B) are allowed (→ EN 50 178, Art. 5.2).

Residual-current-operated protective devices

Terminal	Function / connection
L1, N, PE	Mains connection for 1 ~ types (observe the line voltage indicated  rating plate).
L1, L2, L3, PE	Mains connection for 3 ~ types (observe the line voltage indicated  rating plate).
11, 14	Relay output "K1" for fault indication. ¹ <ul style="list-style-type: none">  For operation the relay is energized, connections "11" and "14" are bridged. For fault the relay is de-energized (Diagnostics / faults). When switching off via enable (D1 = Digital In 1), the relay remains energized.
E1, GND	Analog input for setting speed via 0 - 10 V or PWM signal*
10V	Voltage supply for speed setting by 10 kΩ potentiometer.
24V	Voltage supply for external devices.
D1, +24V	Digital input for enable. ¹ <ul style="list-style-type: none"> Device "ON" for closed contact. Controller "OFF" with opened contact.

¹ Function for standard factory setting, different presetting possible

UL: Input (Line)

- Cu connection leads with the following specifications must be employed:
 - Minimum insulation temperature of 80 °C
 - Terminal tightening torque for field block (L1, N, and/or L1, L2, L3) of 5 - 7 Lb In.
(Exception: spring-cage terminal for motor size "G" @ line voltage 3 ~ 200...240 V) – Terminal tightening torque of 4.5 Lb In for field block (K1).
 - Terminal tightening torque of 4.5 Lb In for all other field blocks.
 - Terminal tightening torque of 2.2 Lb In for add-on modules.

12.5.2 Diagnostic/faults

Status Out with flash code

LED Code	Relays K1 ¹	Cause
OFF	de-energized, 11 - 14 interrupted	No line voltage
ON	energized, 11 - 14 bridged	Normal operation without fault
1 x	energized, 11 - 14 bridged	No enable = OFF
2 x	energized, 11 - 14 bridged	Temperature management active
3 x	de-energized, 11 - 14 interrupted	HALL-IC error
4 x	de-energized, 11 - 14 interrupted	Line failure (only for 3 ~ types)
5 x	de-energized, 11 - 14 interrupted	Motor blocked
6 x	de-energized, 11 - 14 interrupted	IGBT Fault
7 x	de-energized, 11 - 14 interrupted	Intermediate circuit undervoltage
8 x	de-energized, 11 - 14 interrupted	Intermediate circuit overvoltage
9 x	energized, 11 - 14 bridged	IGBT cooling down period
11 x	de-energized, 11 - 14 interrupted	Error motor start
12 x	de-energized, 11 - 14 interrupted	Line voltage too low
13 x	de-energized, 11 - 14 interrupted	Line voltage too high

LED Code	Relays K1 ¹	Cause
14 x	de-energized, 11 - 14 interrupted	Error Peak current
17 x	de-energized, 11 - 14 interrupted	Temperature alarm

¹ K1: programmed function at factory: Fault indication not inverted

Annex 13 Commissioning protocol – proposal (in separate cover)

Printed on separate pages and delivered with every unit. Enclosed in separate cover.

14-1 | Report with data from final functional test on the Systemair factory (in separate cover, if control system was delivered)

Annex 14 Report with data from final functional test on the Systemair factory (in separate cover, if control system was delivered)

Printed on separate pages and delivered with every unit. Enclosed in separate cover.

Annex 15 Short description of main components in the control system

15.1 Geniox units delivered in several sections

This model of the Geniox unit has an integrated control system and depending on the size of the unit, the cabinet is installed in the unit, on the unit or on the front of the unit. The controller is mounted in the cabinet, and all electrical connections between cabinet and components in the unit are installed. The control system is configured according to the customer's order – confirmed by the order confirmation – to promote easy start-up on the site. The unit is tested at the factory and all functions are confirmed by a final functional test and test report that is delivered with the unit. After the final test the unit is divided in sections to facilitate the transport. After reassembly of the unit on the site, the clearly marked cables with sockets must be reconnected in the marked terminals. Cable strips are preinstalled for installation of the cables between the components in the unit-sections and the cabinet. Cables installed on the unit-sections in the preinstalled strips are protected by metal covers. The covers have been removed before installation of the unit on the final site and must be replaced after installation of the cables. Cables with the mains power supply must be installed in the automatic circuit breakers belonging to fans, heat pump unit Geniox-HP (if delivered). All external components must be connected on the site.

15.1.1 External components

External components are Systemair control panel, valves, valve motors, pressure transmitters, supply air temperature sensor, sensor for water temperature in the heating coil (if water heating coil was requested) and circulation pump (Systemair does not deliver the pump). Terminals are present in the cabinet for pressure transmitters, if it is a solution for constant pressure in the ducts, and terminals are present in the cabinet for valve motors, circulation pump, supply air temperature sensor and sensor for water temperature in the heating coil, but cables are not installed and not connected to terminals in the cabinet. The Systemair control panel with cable is not connected to the controller in the cabinet. All external components delivered are packed in a cardboard box delivered together with the unit.

15.2 Geniox unit delivered assembled on base frame

This model of the Geniox unit has an integrated control system and the cabinet mounted inside the unit. The cabinet is always mounted in the unit section with the heat exchanger and the cabinet is always placed at the warm side of the heat exchanger. The intelligent controller is mounted in the cabinet, and all electrical connections between cabinet and components in the unit are installed. The control system is configured according to the customer's order – confirmed by the order confirmation – to promote easy start-up on the site. The unit is tested at the factory and all functions are confirmed by a final functional test and test report that is delivered with the unit. The unit is delivered as one assembled section on base frame. Cables with the mains power supply must be installed in the automatic circuit breakers belonging to fans, heat pump unit Geniox-HP (if delivered). All external components must be connected on the site.

15.2.1 External components

External components are Systemair control panel, valves, valve motors, pressure transmitters, supply air temperature sensor, sensor for water temperature in the heating coil (if water heating coil was requested) and circulation pump (Systemair does not deliver the pump). Terminals are present in the cabinet for pressure transmitters, if it is a solution for constant pressure in the ducts, and terminals are present in the cabinet for valve motors, circulation pump, supply air temperature sensor and sensor for water temperature in the heating coil, but cables are not installed and not connected to terminals in the cabinet. The Systemair control panel with cable is not connected to the controller in the cabinet. All external components delivered are packed in a cardboard box delivered together with the unit.

16-1 | Wiring diagram (in separate cover, if control system was delivered)

Annex 16 Wiring diagram (in separate cover, if control system was delivered)

The wiring diagram is in a separate cover

Annex 17 Operator's guide (how to use the Systemair control panel) (in separate cover, if control system was delivered)

A separate manual is delivered with every unit. This manual assists the everyday user/operator about how to control the unit by navigating the menus by the buttons and the display. Enclosed in separate cover.



Systemair
Unit 28, Gravelly Industrial Park
Birmingham, B24 8HZ

Tel.: +44 (0)121 322 0200

info@systemair.co.uk

www.systemair.co.uk

Systemair
Unit 02 Furry Park
Santry Dublin 9

Tel.: +353 1 86 24 544

sales@systemair.ie

www.systemair.co.uk

Systemair A/S
Ved Milepælen 7
DK-8361 Hasselager

Tel.: +45 8738 7500

mail@systemair.dk

www.systemair.dk