

Geniox/DV Control system 04.04

Documents listed on pages below:

- Project cover sheet: page 1
- Quick Guide: page 2
- General Description: page 3-4
- External connections: page 10-18
- Circuit Diagram: page 19-36
- Modbus Guide: page 28
- Modbus address list: page 40
- VLT guide: page 41-42
- Cable plan: page 100-133

Units with external cabinet:

Geniox 10-18 are placed on top of the unit.
Geniox 20-31 are placed on front of the unit

Units with internal cabinet:

Cabinet is always inside the unit.

Data over AHU unit.

Heat exchanger type:

See data in the attached annex - Technical data

Heat coil type:

See data in the attached annex - Technical data

Cooling coil type:

See data in the attached annex - Technical data

Heat pump type:

See data in the attached annex - Technical data

Electrical data:

Total consumed power:	Watch printed order
Fan fuse size:	Watch printed order
Supply air fan cable resistance:	Watch printed order
Extract air fan cable resistance:	Watch printed order
Max pre-fuse:	Watch printed order
1k max on fuse in unit:	10 kAmps

Manufacturer:

Systemair A/S, Denmark
Ved Milepælen 7
8361 Hasselager



Geniox
Access CU 40-C

Frontpage

Project:	Geniox-DV Control system 04.04		Rev.:	01.00	Sheet:	1	
Date:	27-11-2018	initials:	MIKE	Total sheets:	4	Next sheet:	2

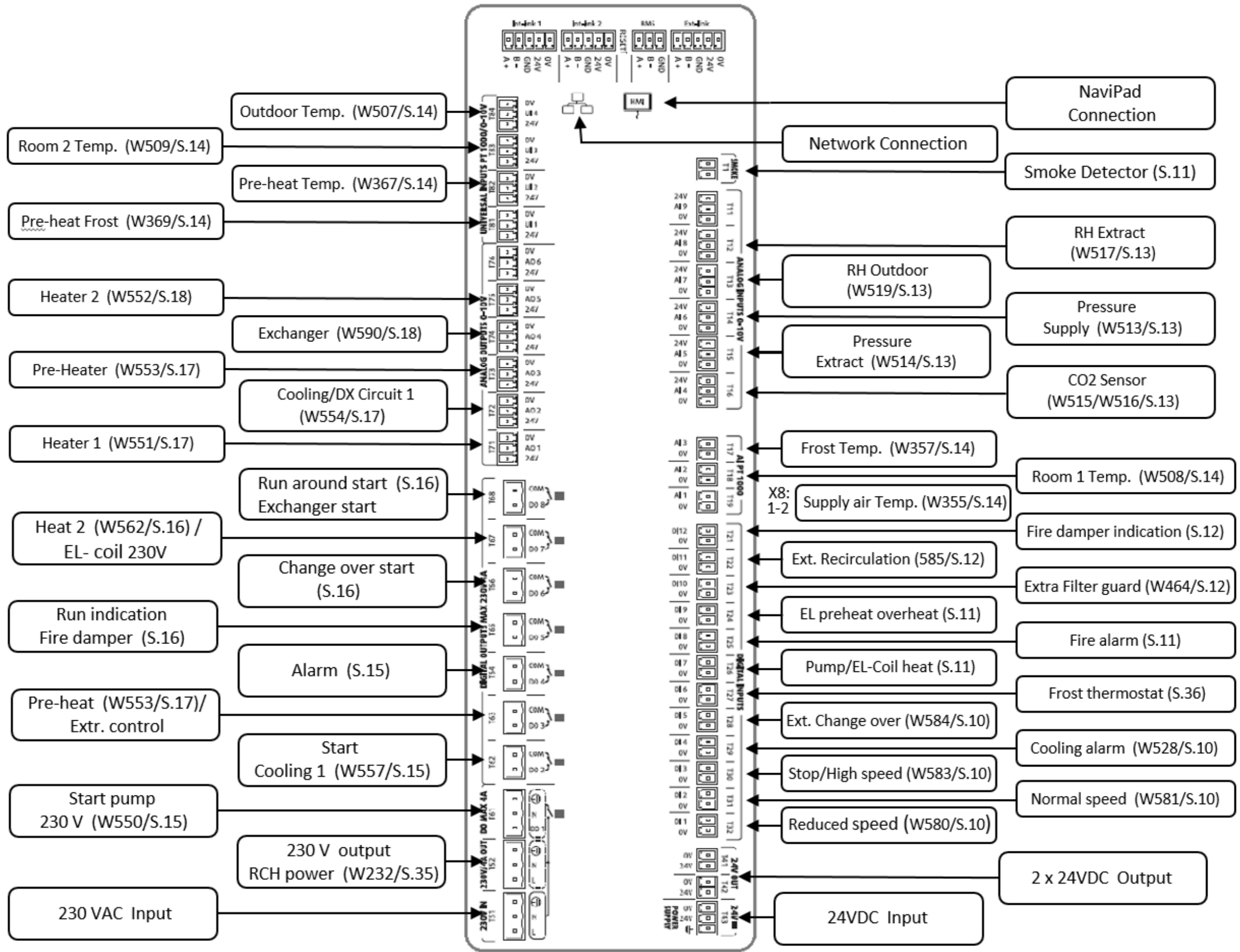

Symbols are according to IEC 60617.
 On the following 2 pages there are descriptions of used symbols in the project.

Wire Colour code

Black - BK
 Brown - BN
 Red - RD
 Yellow - YE
 Green - GN
 Blue - BU
 Violet - VT
 Gray - GY
 White - WH
 Pink - PK
 Transparent - TP
 Green/Yellow - PE

L1:1 > References

-X2:1  Terminal

-EA  Lamp

-SF  Switchgear

-BQ  Pressure transmitter

-BP  Pressure Switch

-F  Automatic tripping,

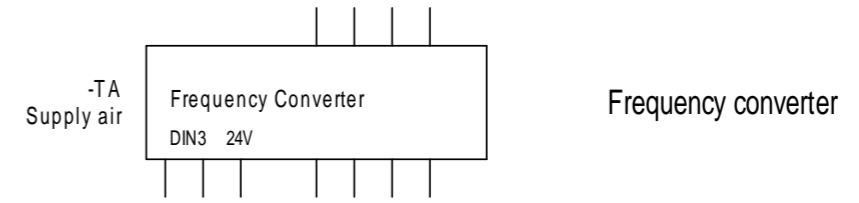

Frequency converter

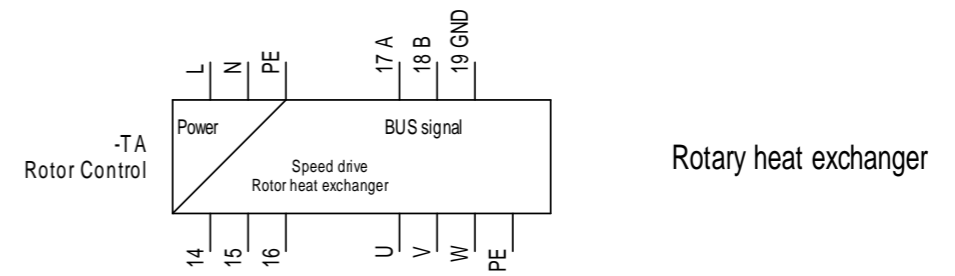

Rotary heat exchanger

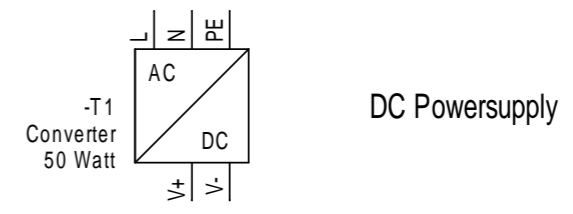

DC Powersupply

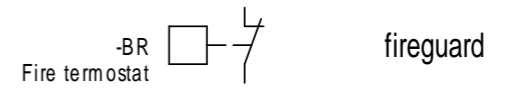

fireguard



Temperature (measuring)

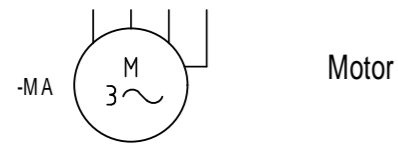

Motor

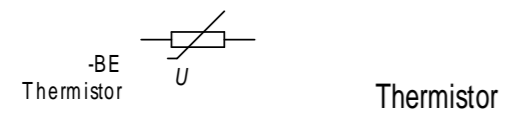

Thermistor

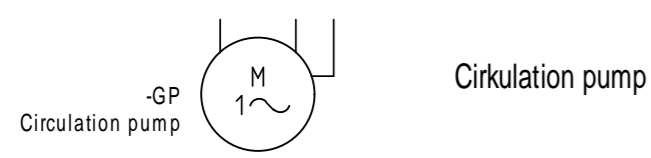

Cirkulation pump

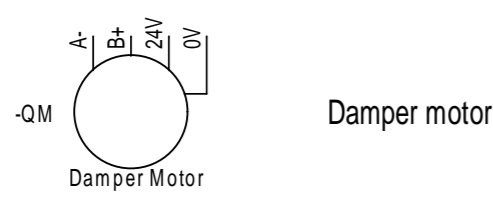

Damper motor

Labeling of wires
Cables are marked with terminal name

Components are marked with component codes followed by a number according to IEC 61346-1 Chart 1

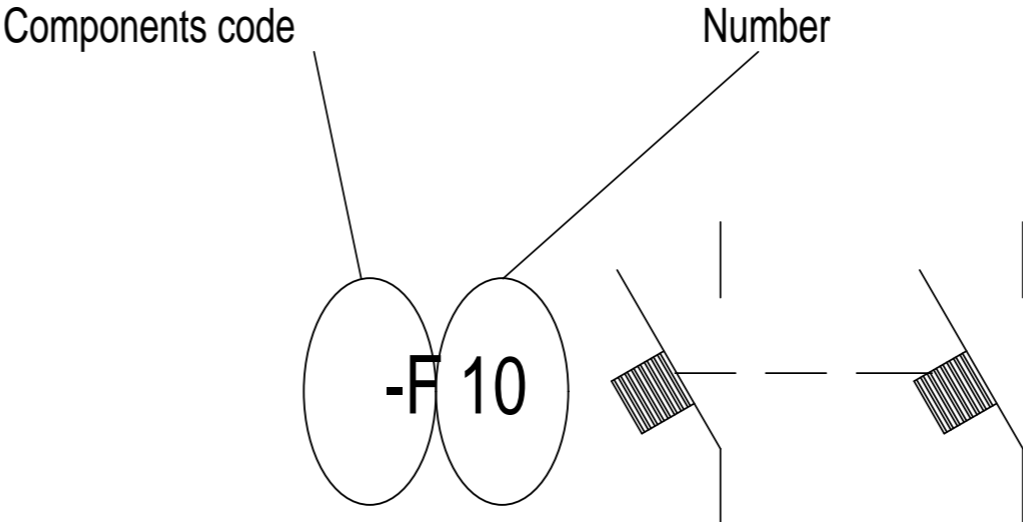
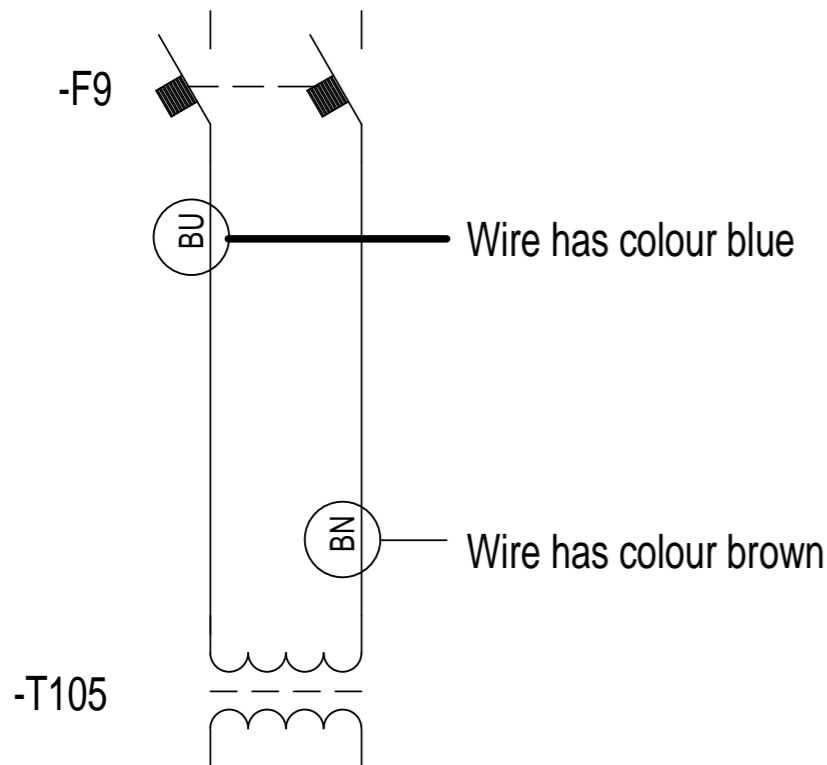

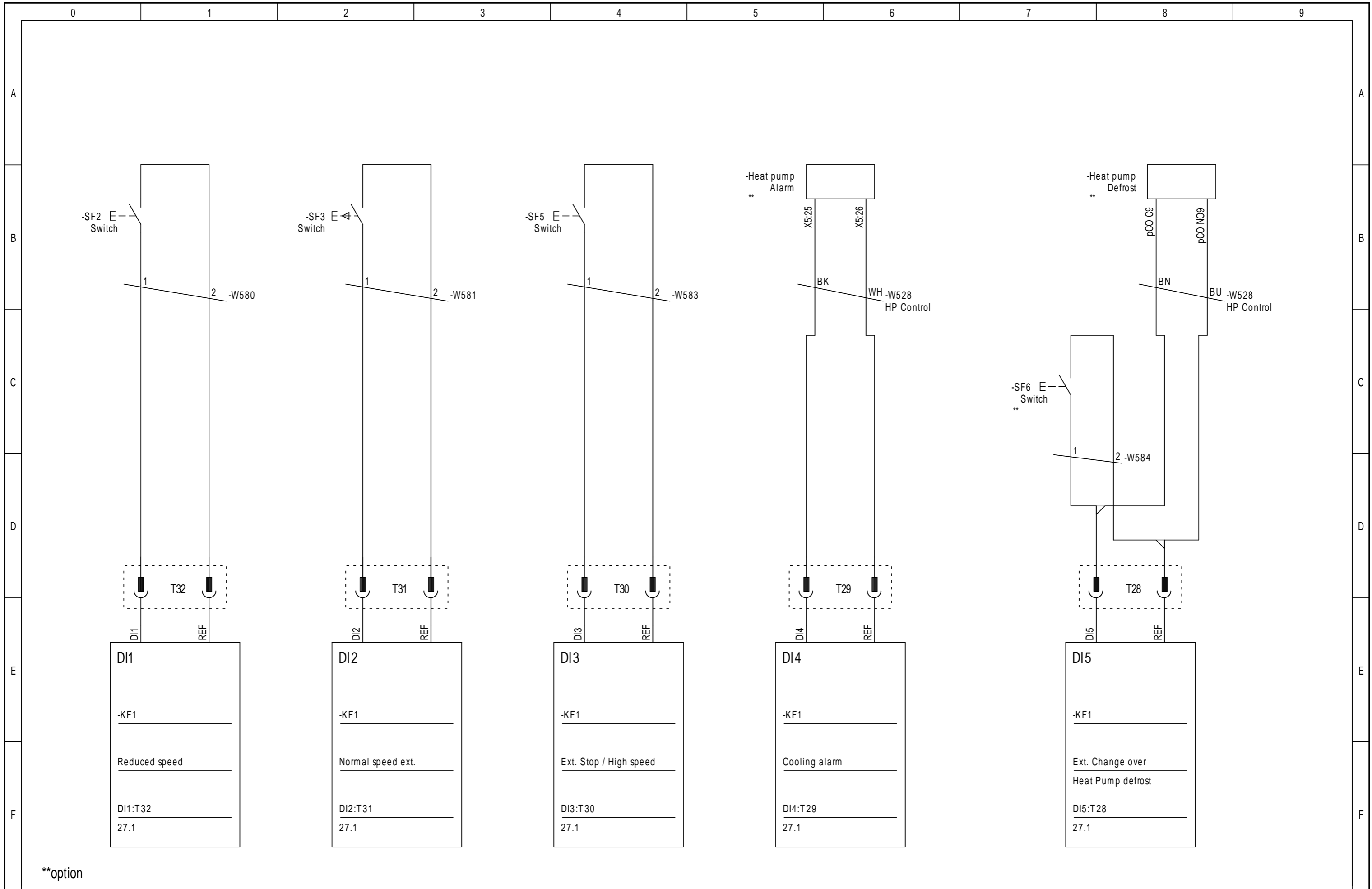

**option

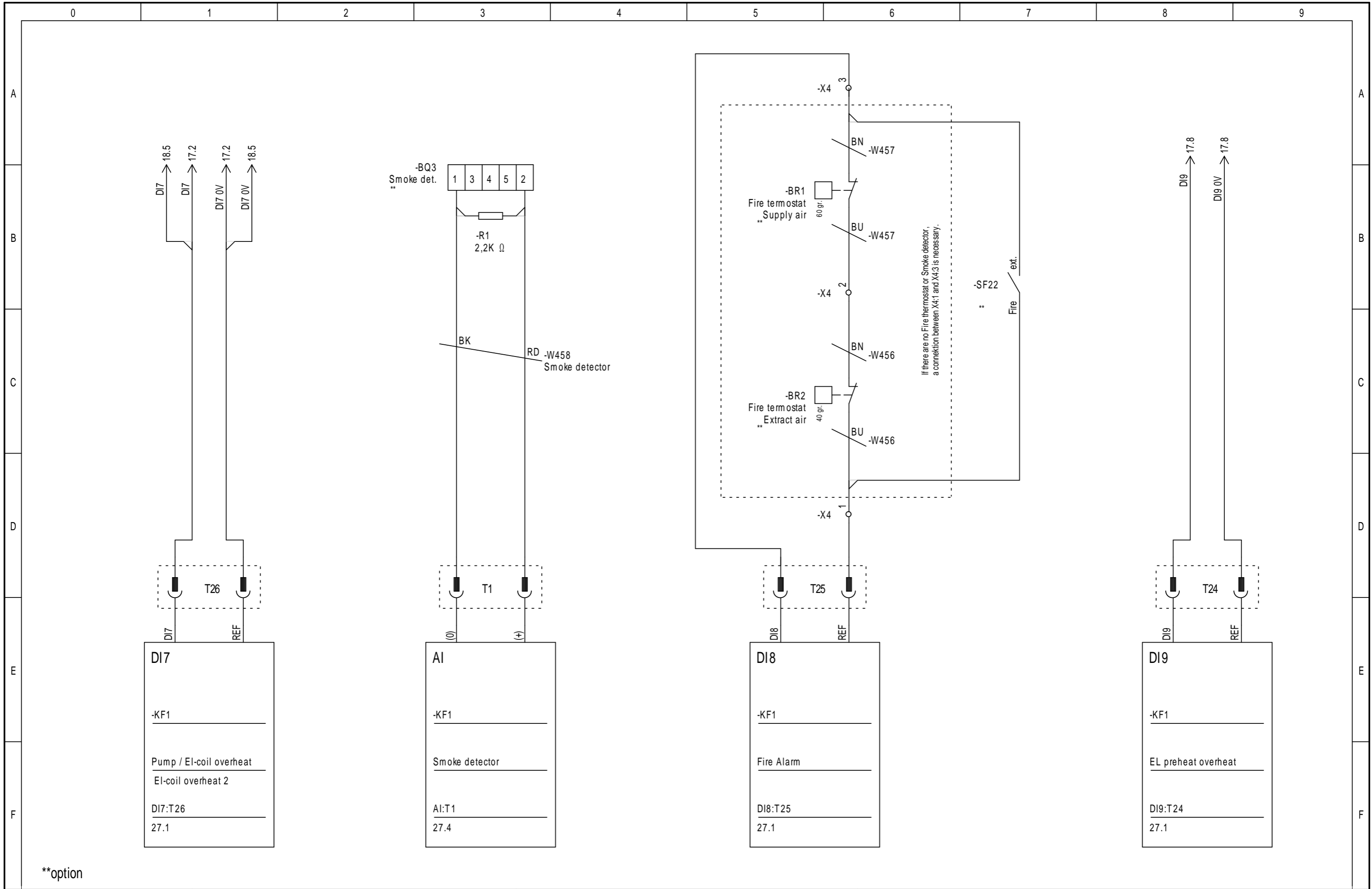

**option

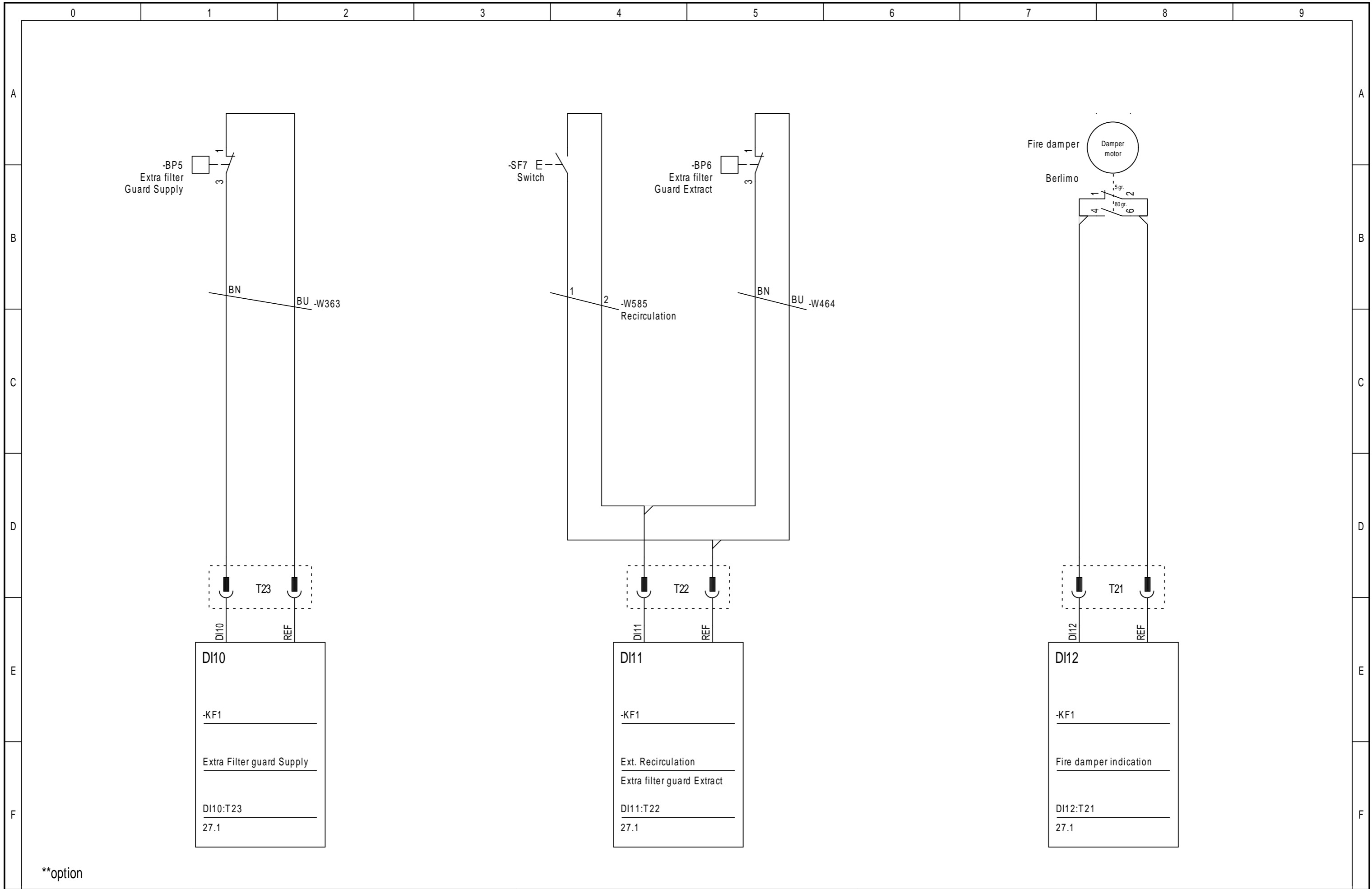

**option

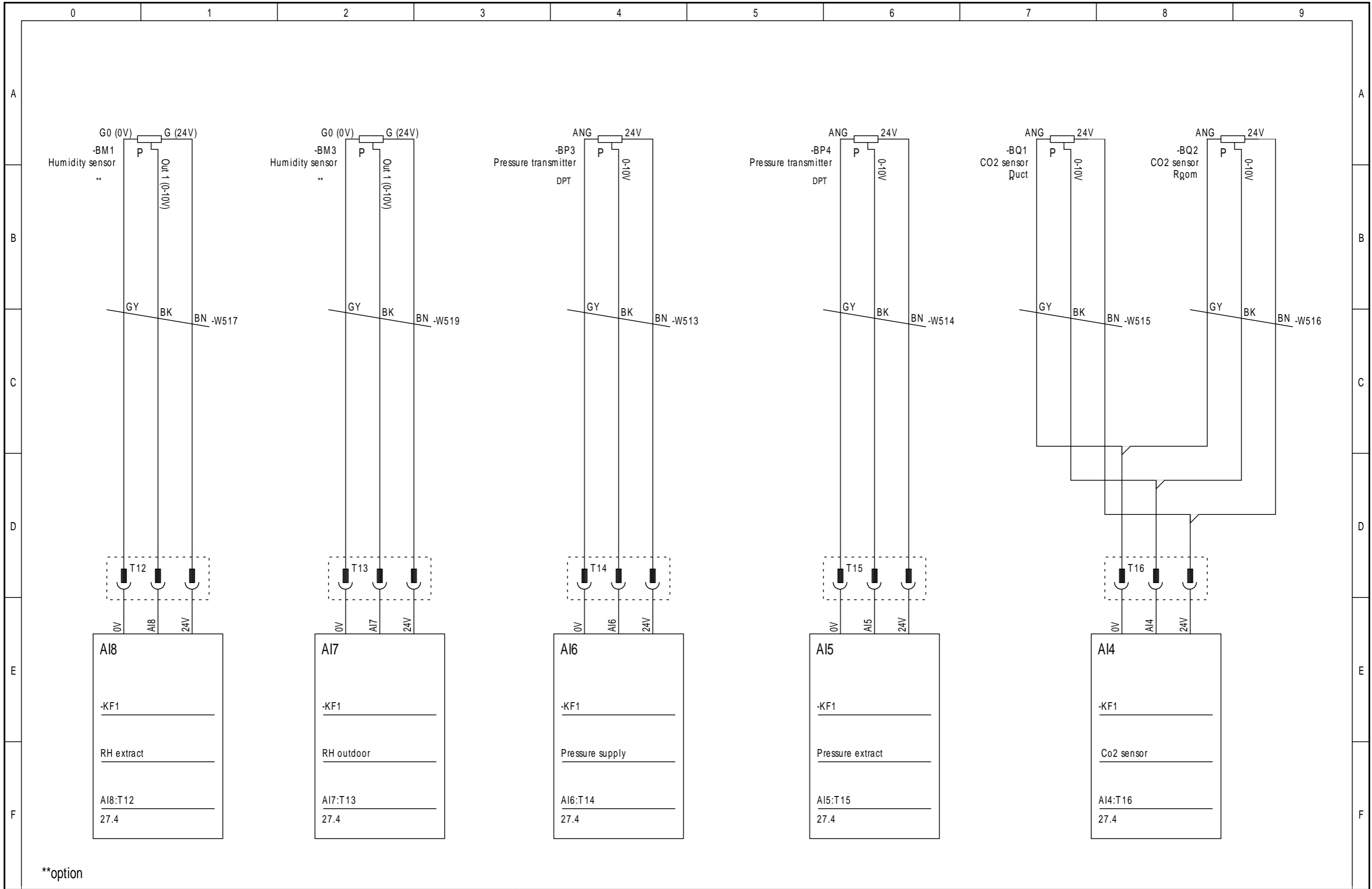

**option



Geniox
Access CU 40-C

External connections AI

Project:	Geniox-DV Control system 04.04		Rev.:	01.00	Sheet:	13	
Date:	30-05-2018	initials:	MIKE	Total sheets:	30	Next sheet:	14

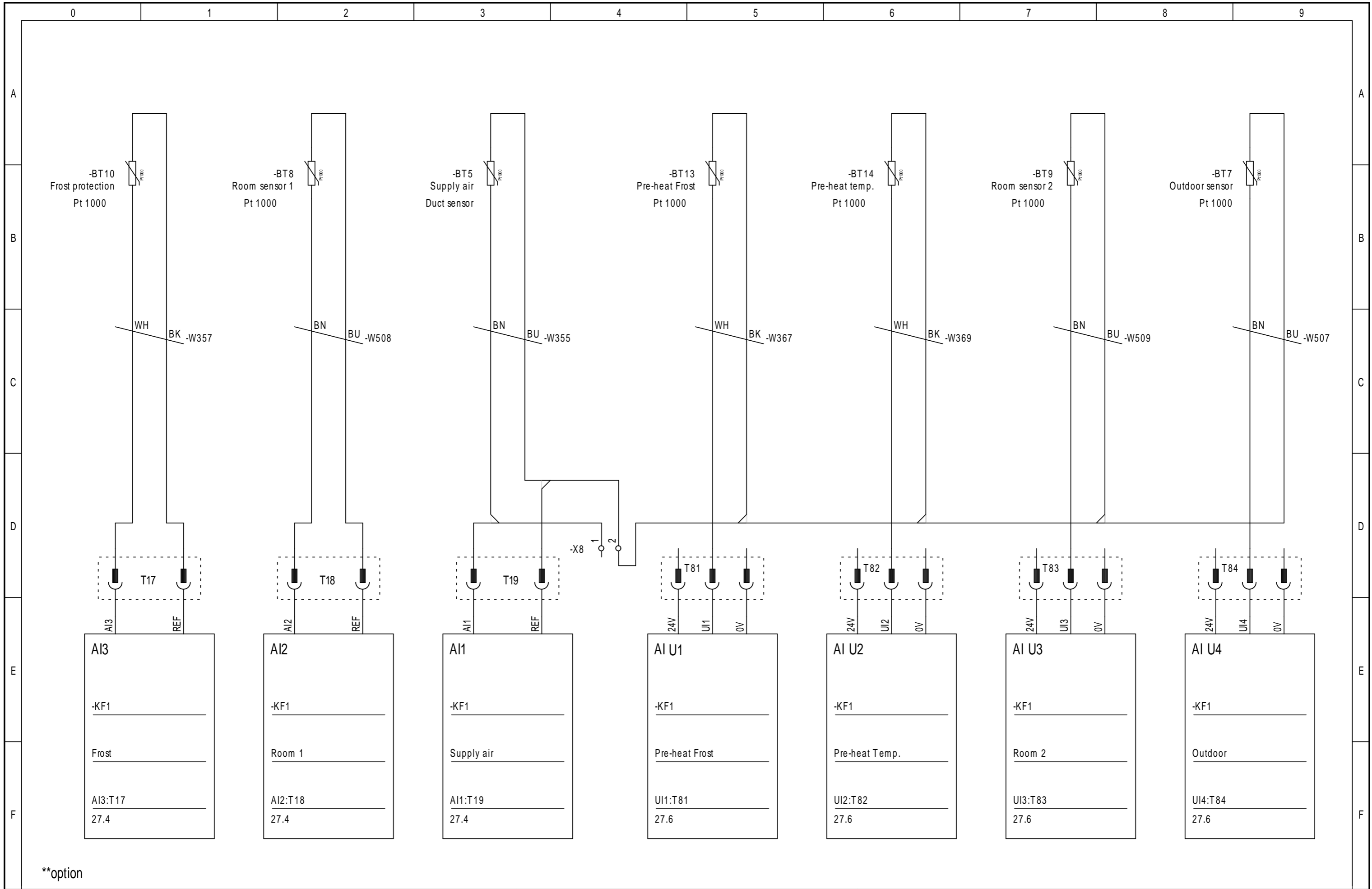

**option

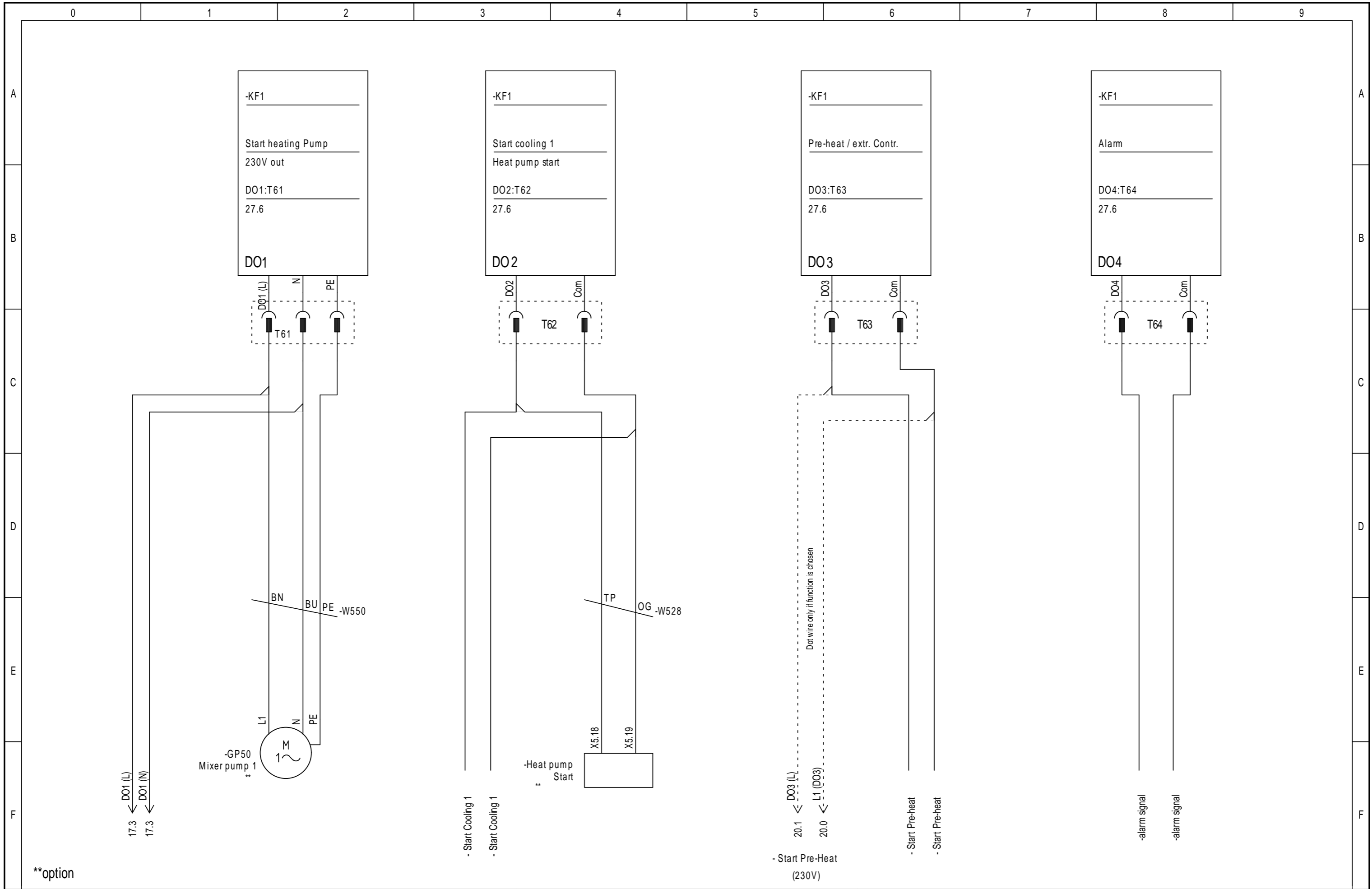

**option

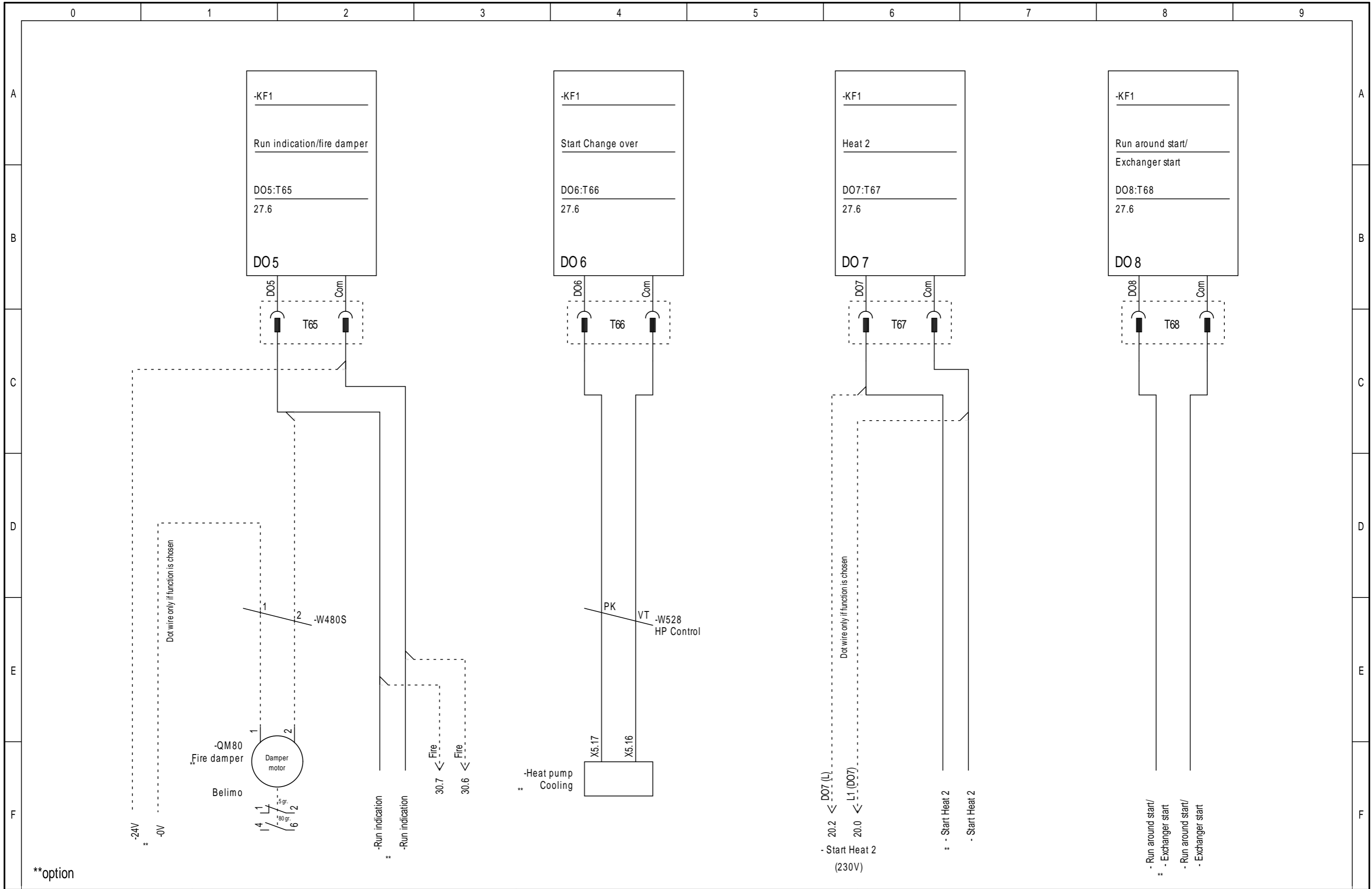

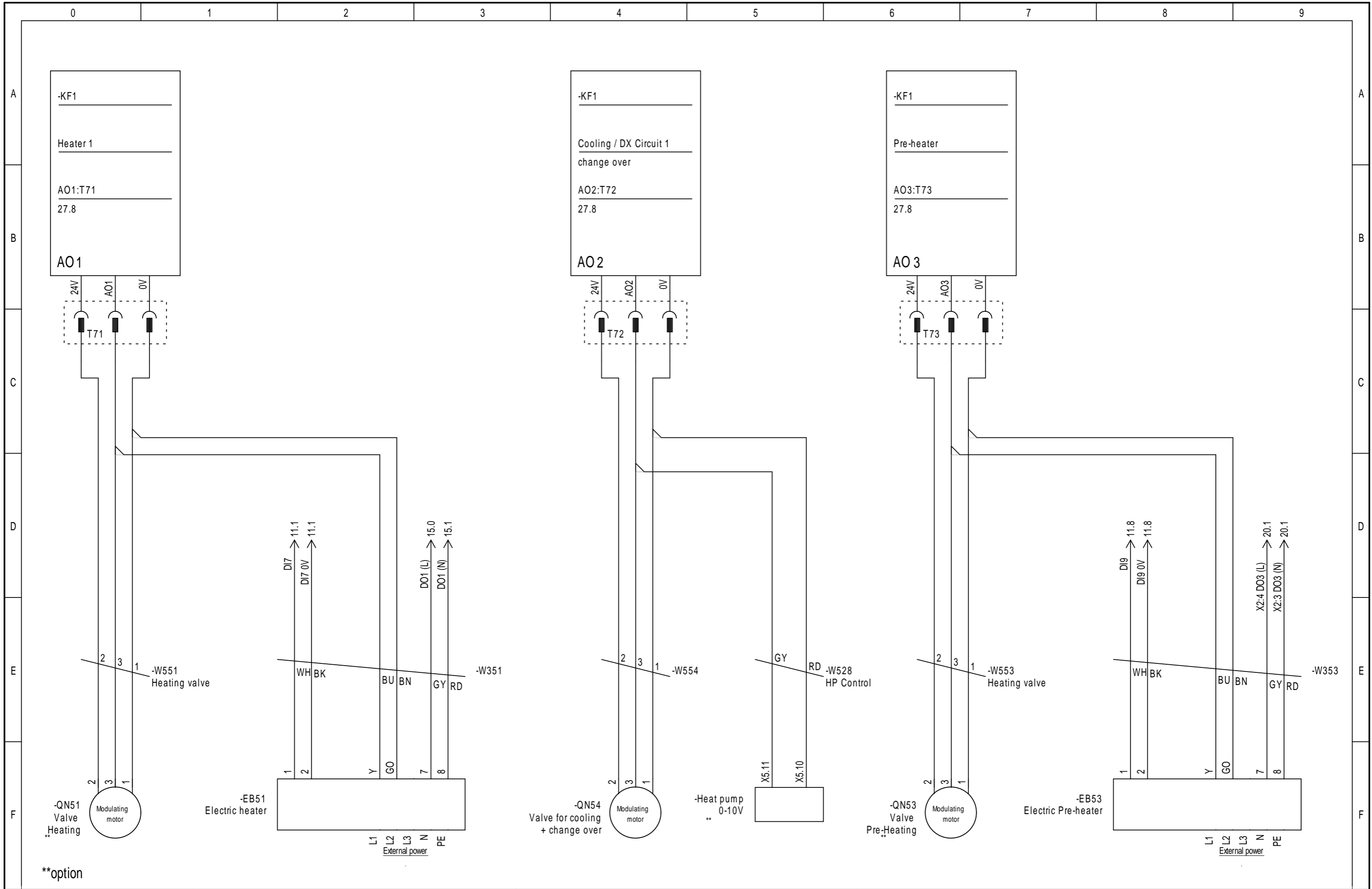

**option

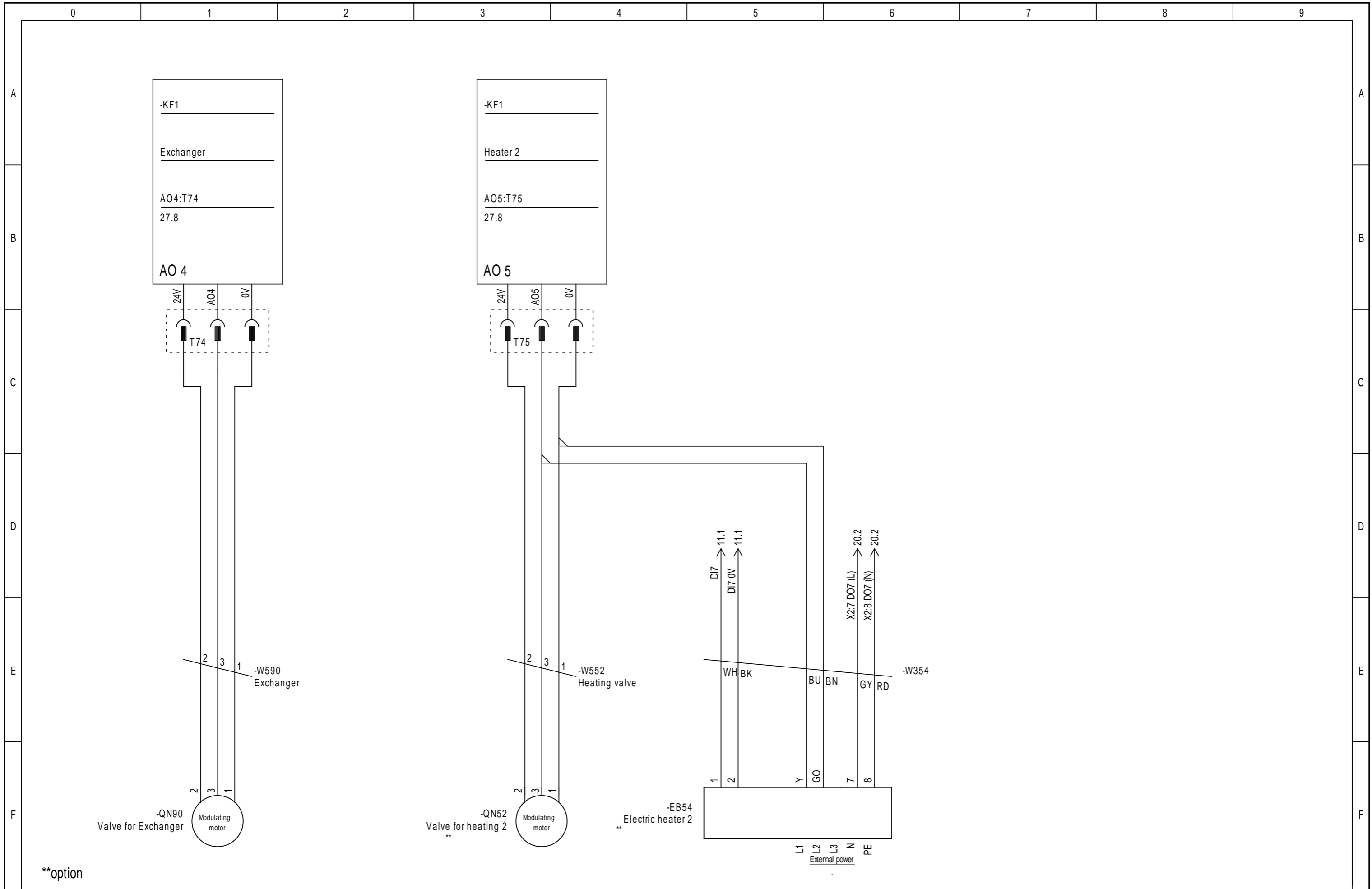

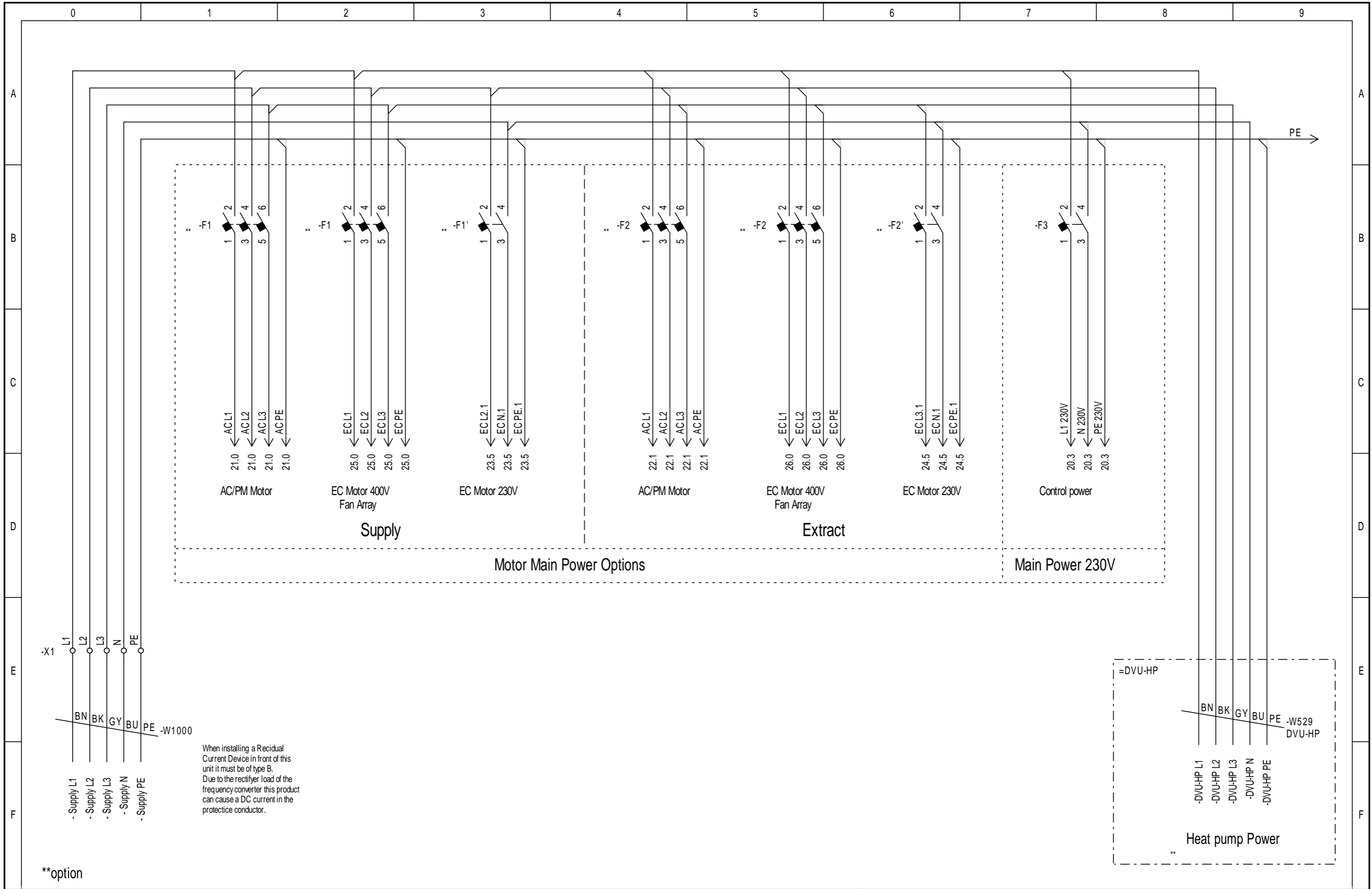

**option

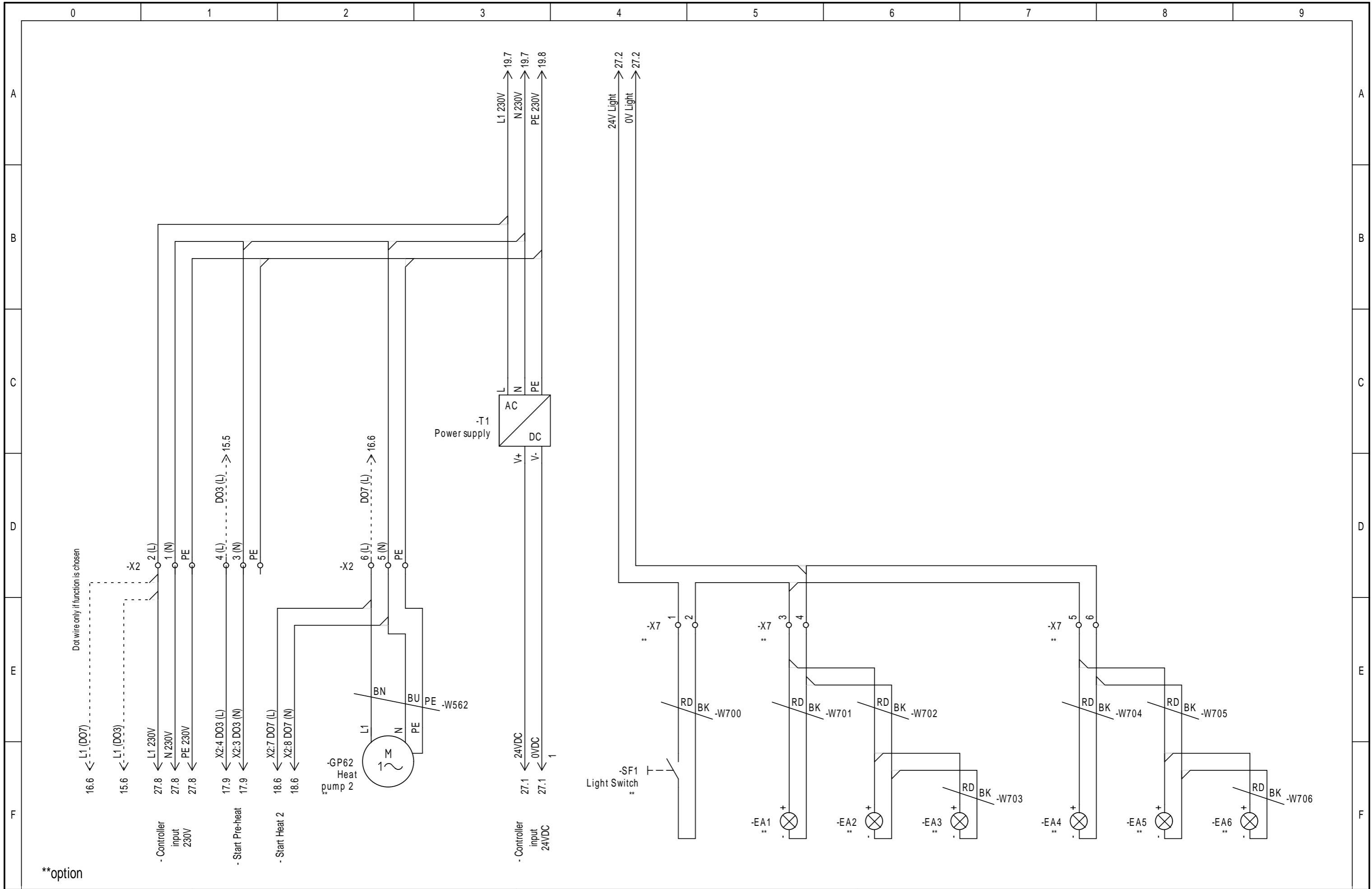

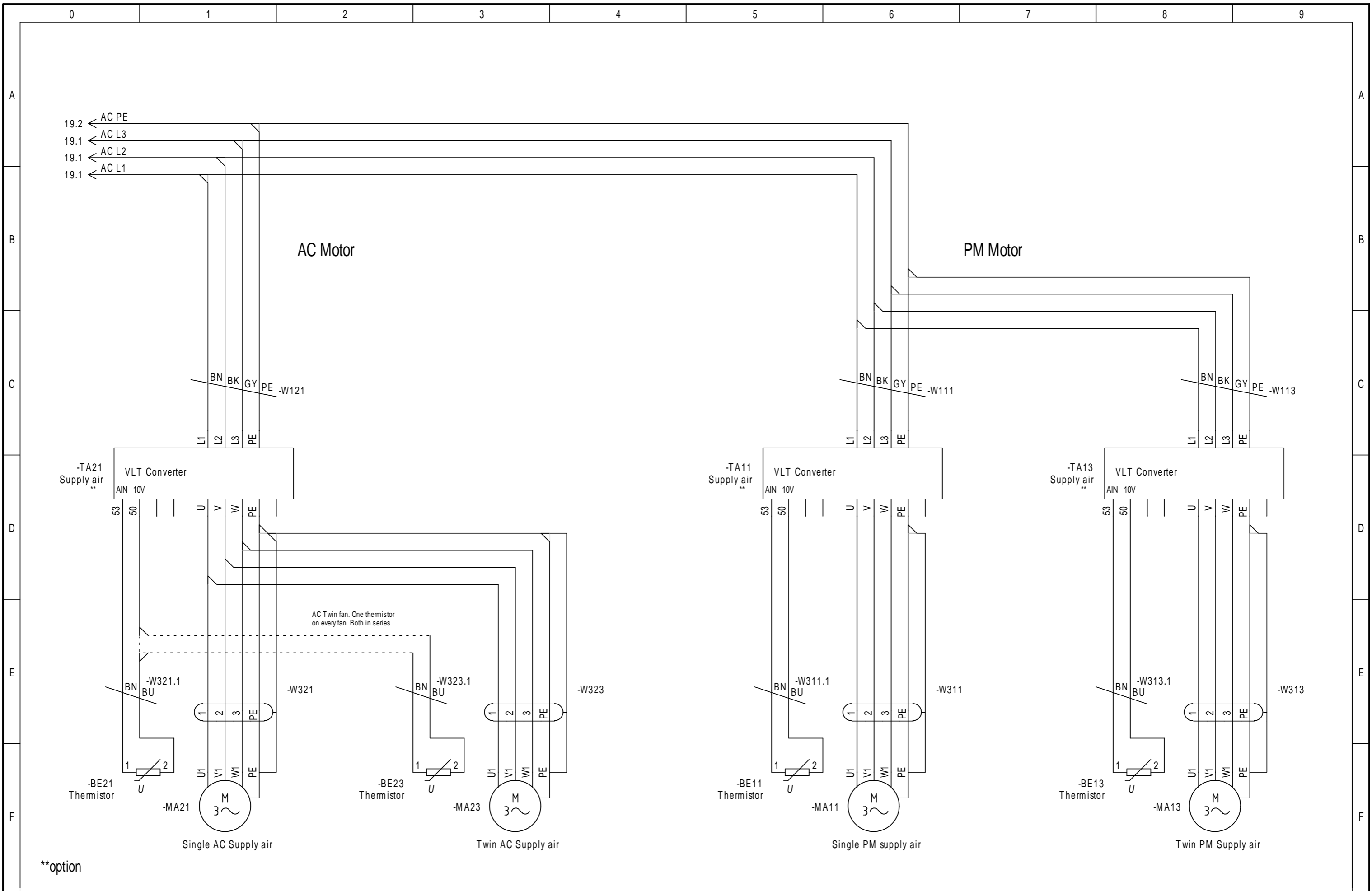

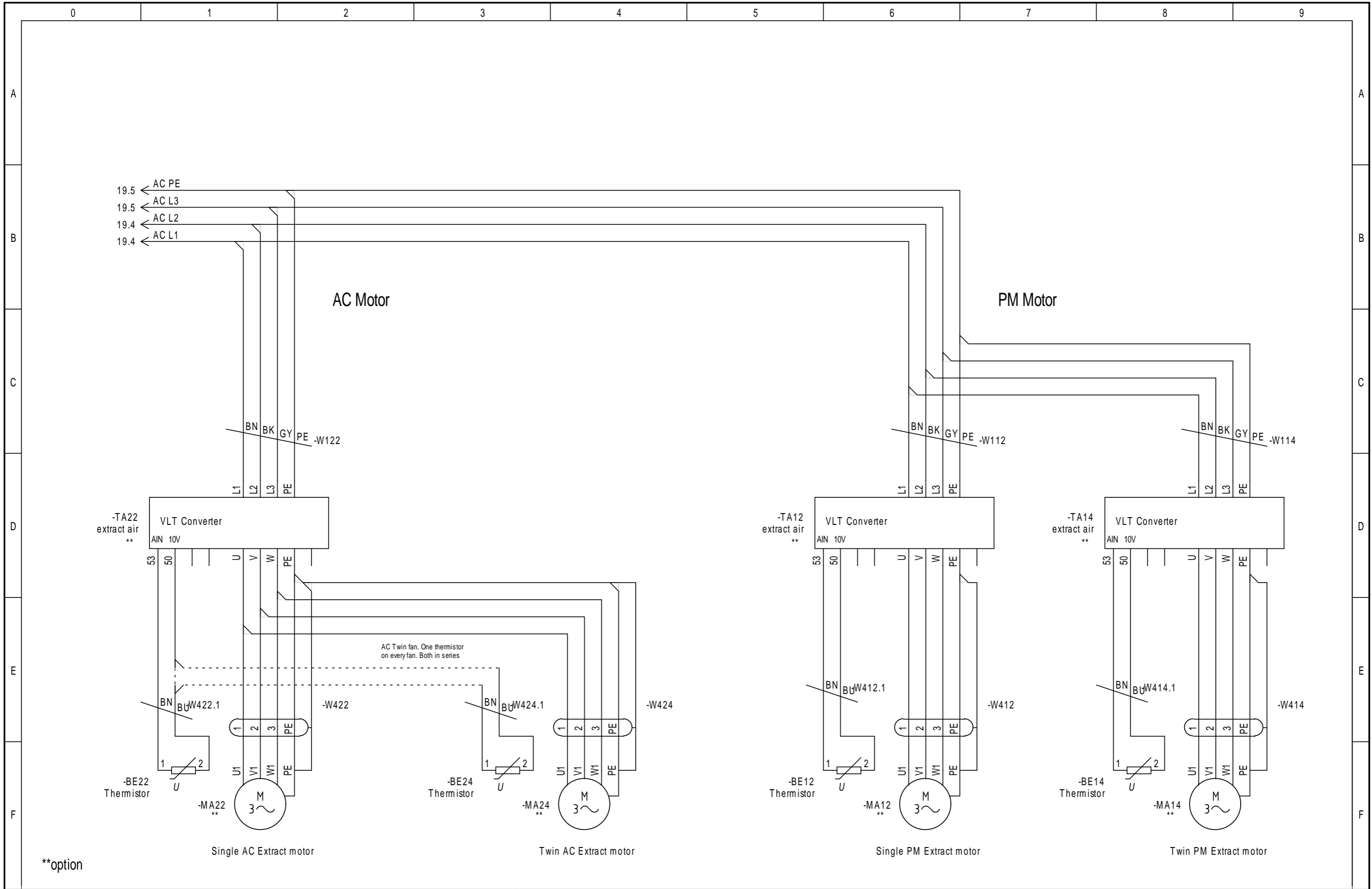

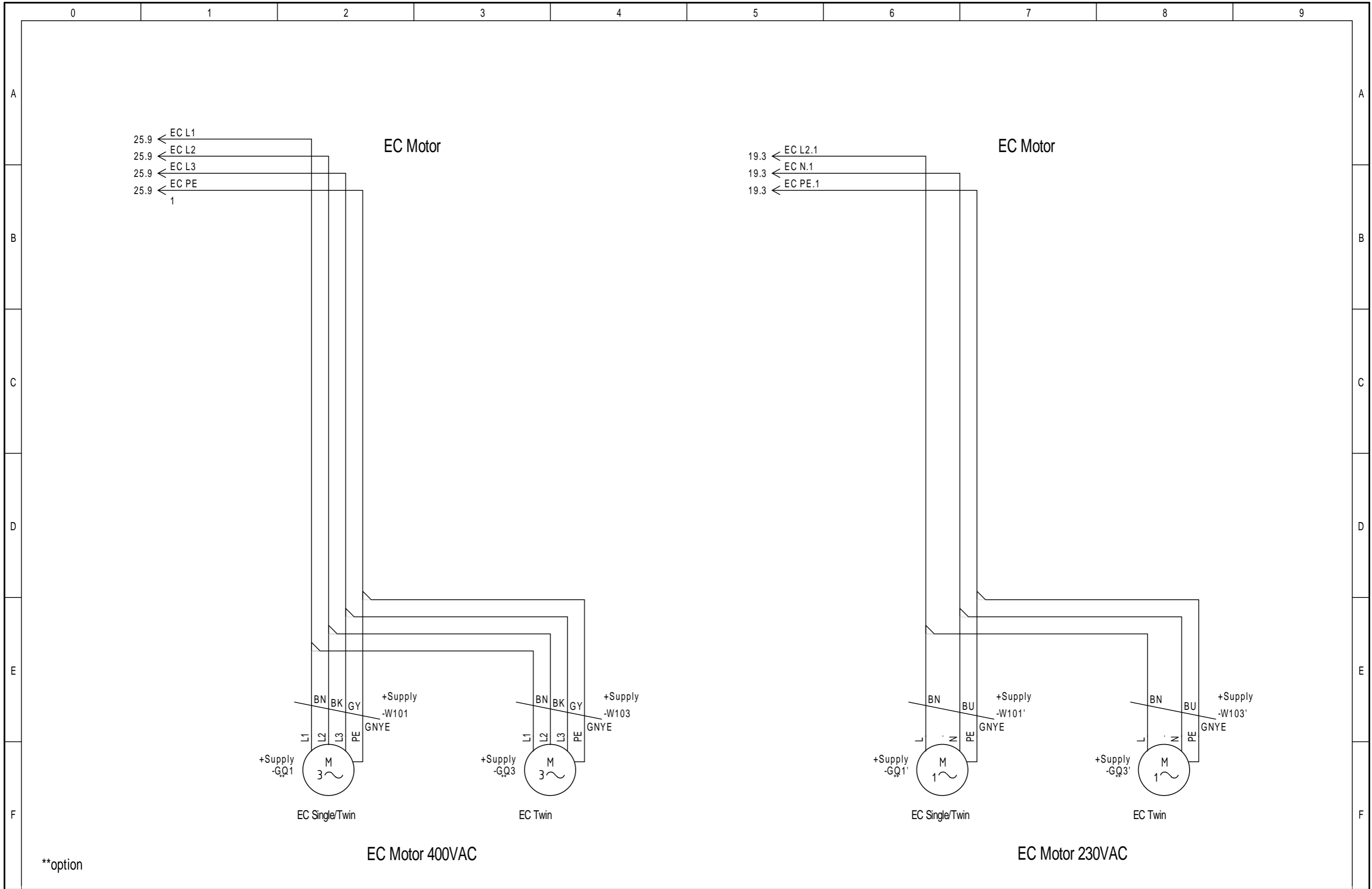

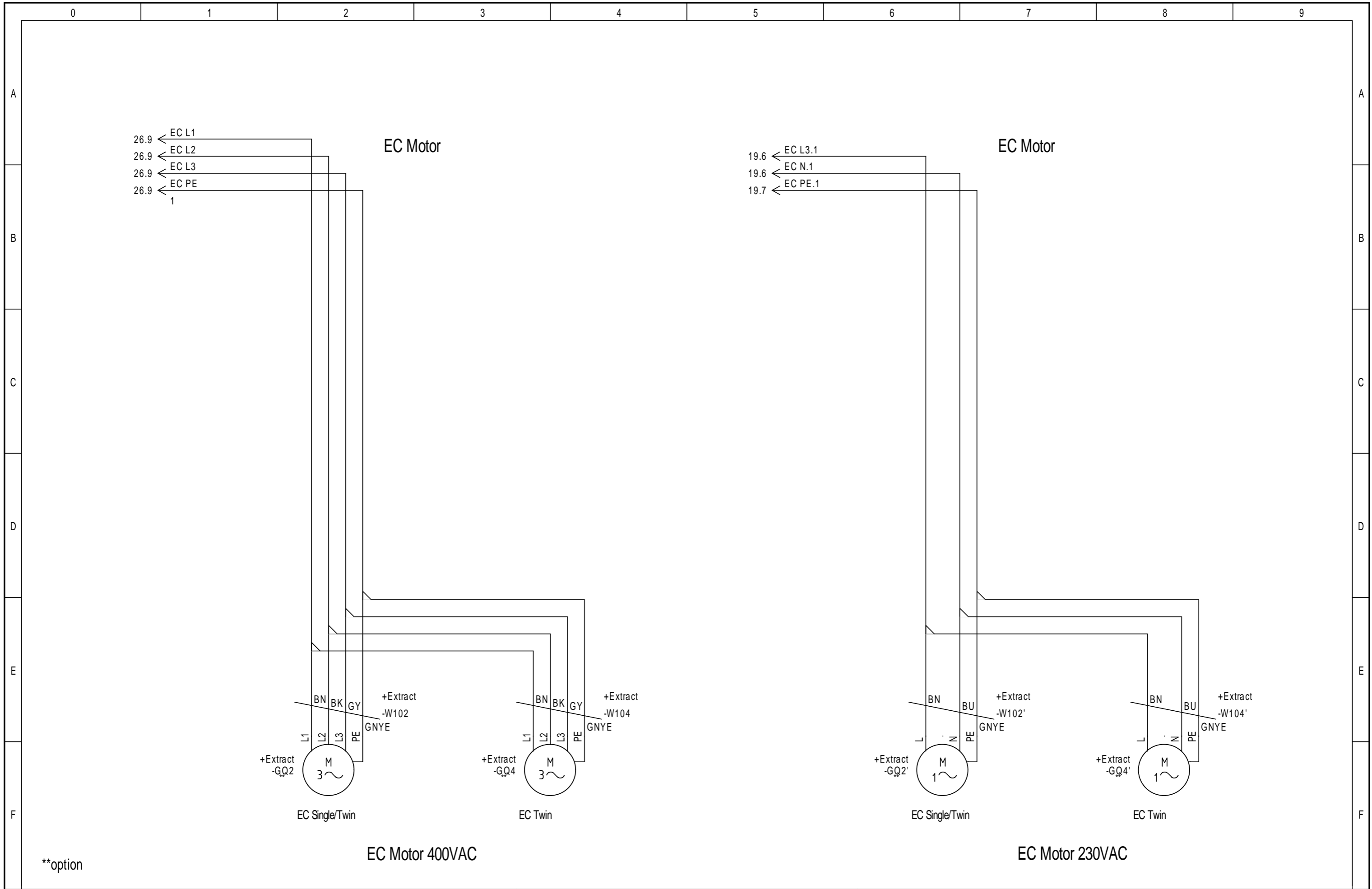

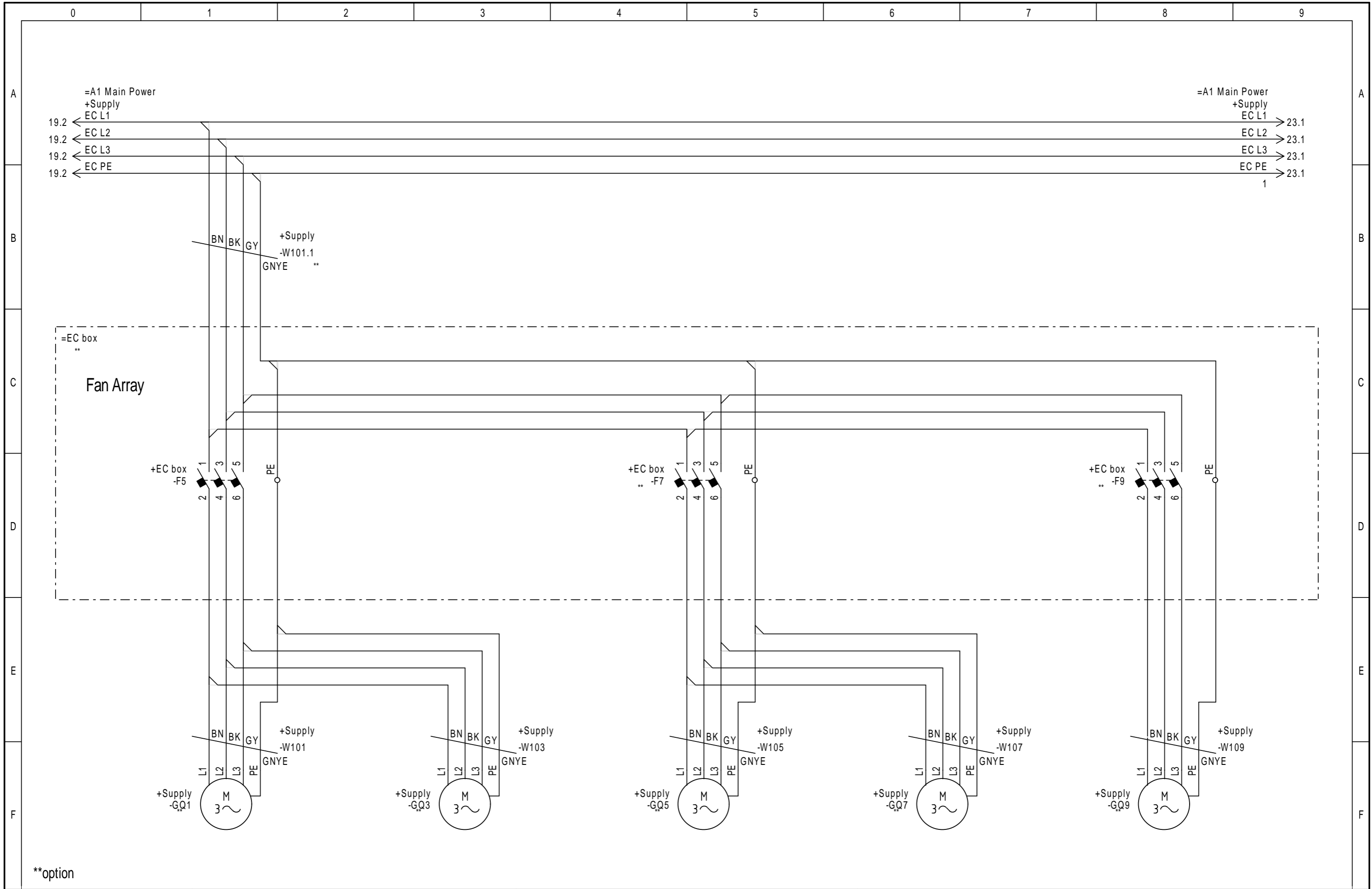

**option

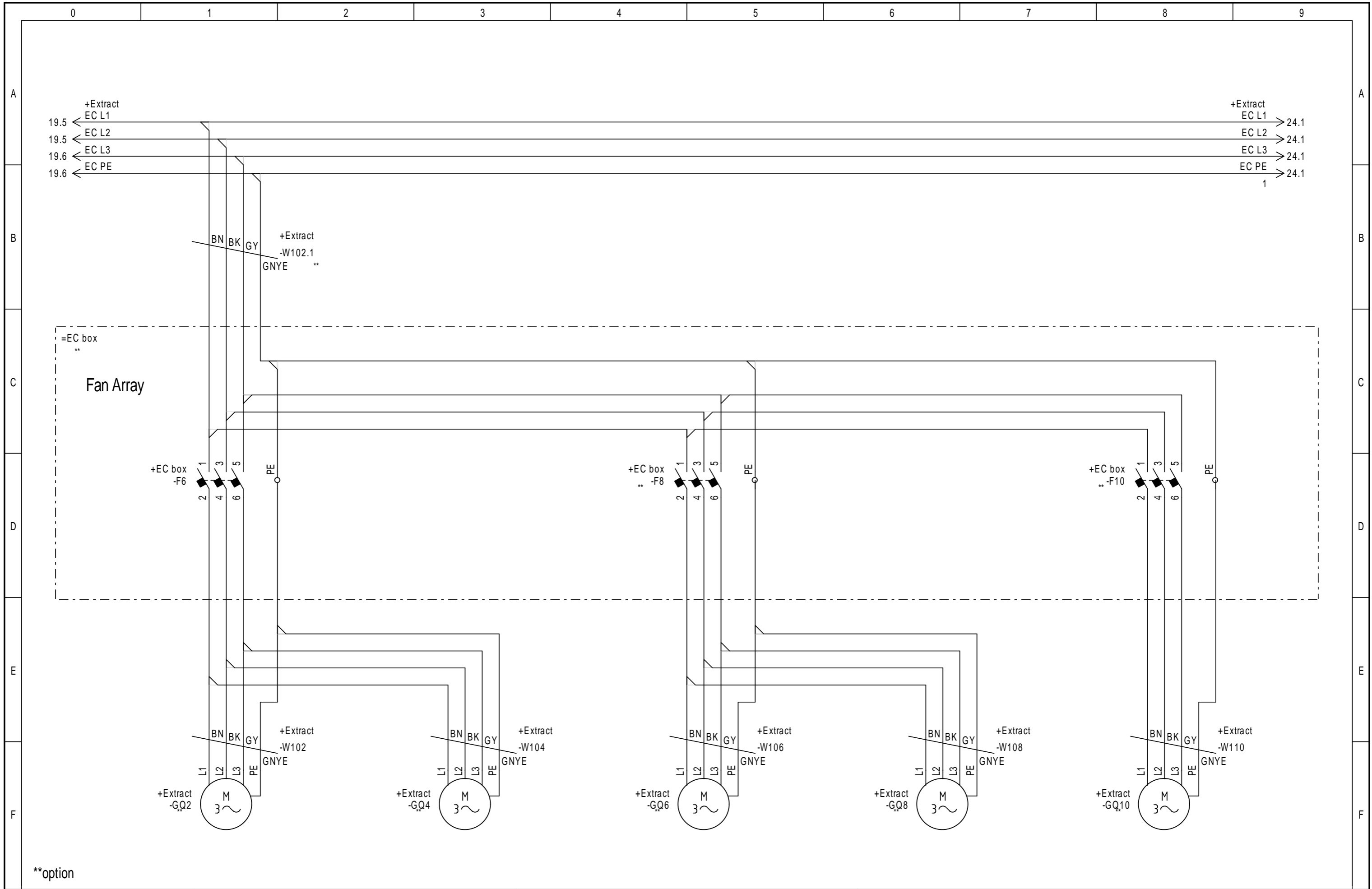

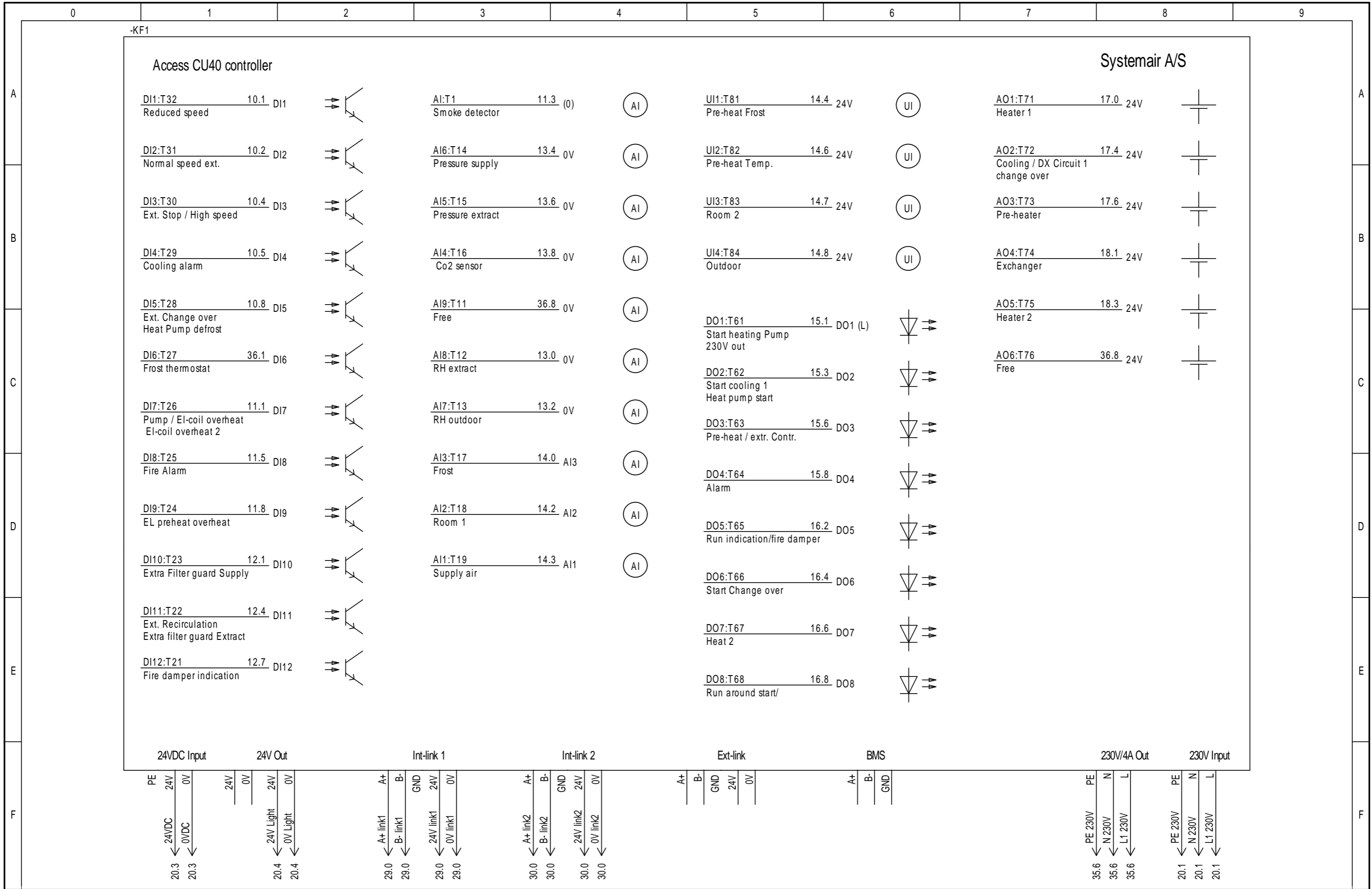

Geniox
Access CU 40-C

Access controller

Project:	Geniox-DV Control system 04.04		Rev.:	01.00	Sheet:	27	
Date:	01-06-2017	initials:	MIKE	Total sheets:	30	Next sheet:	28

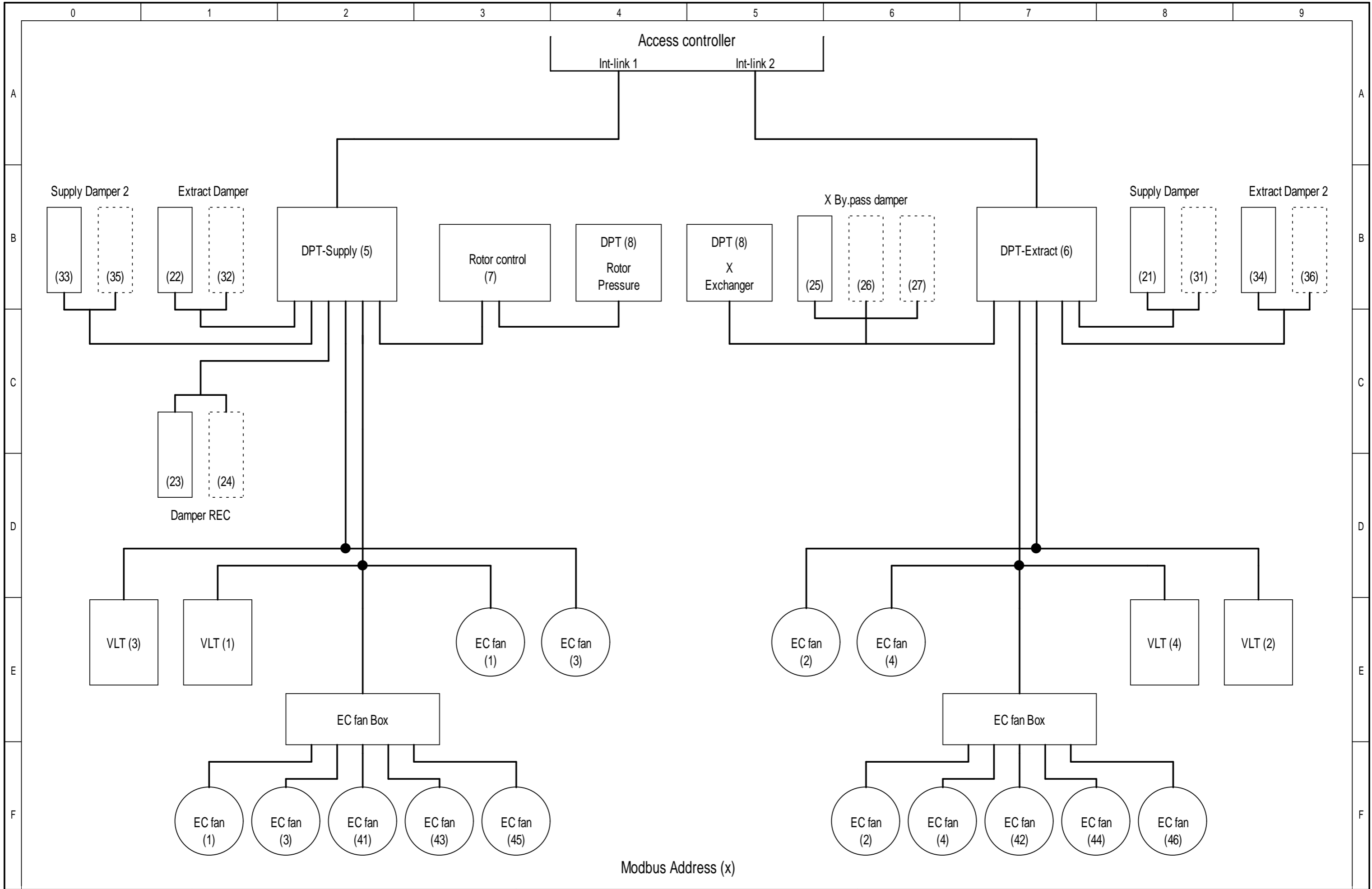

Modbus Address (x)

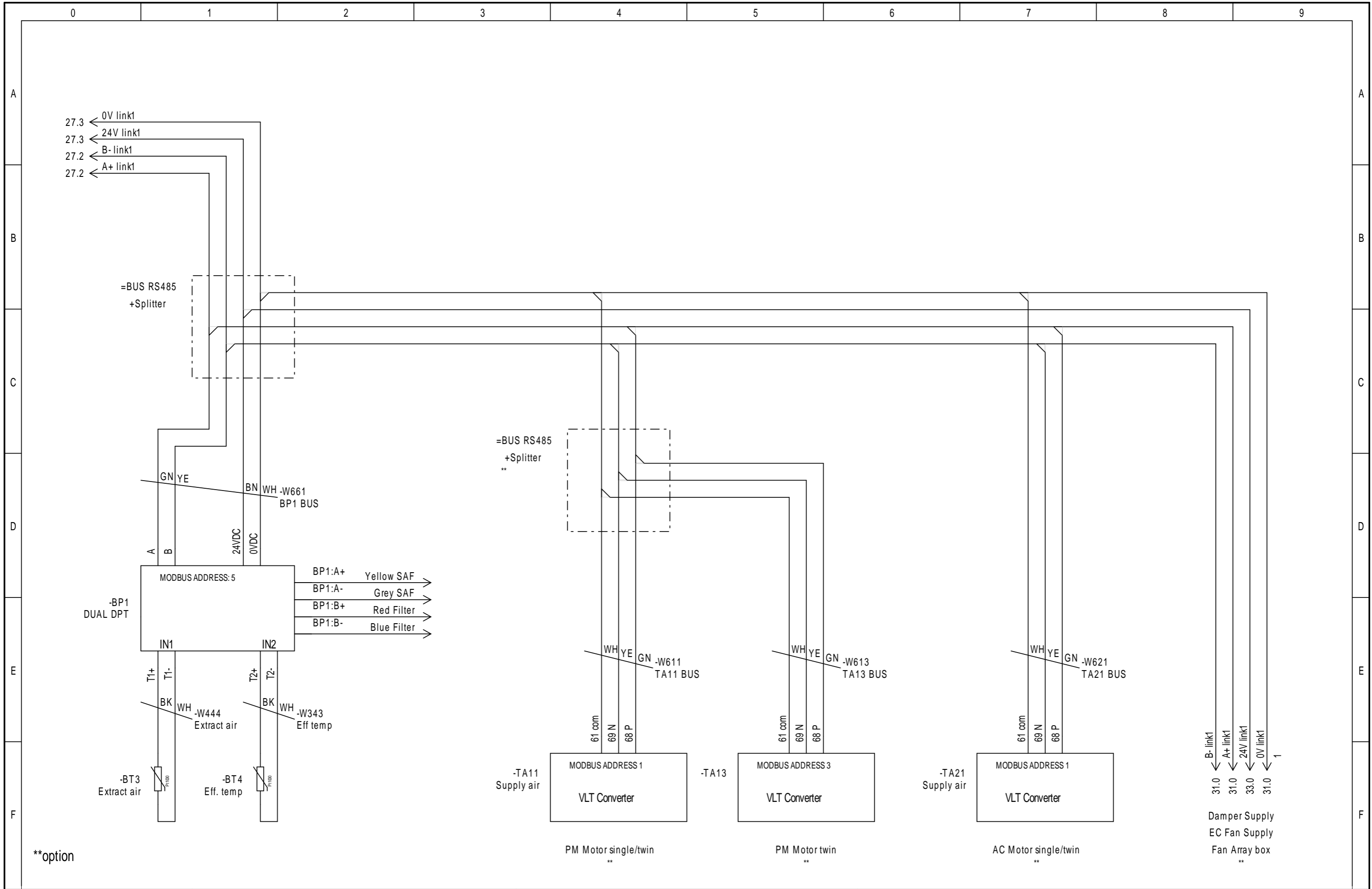

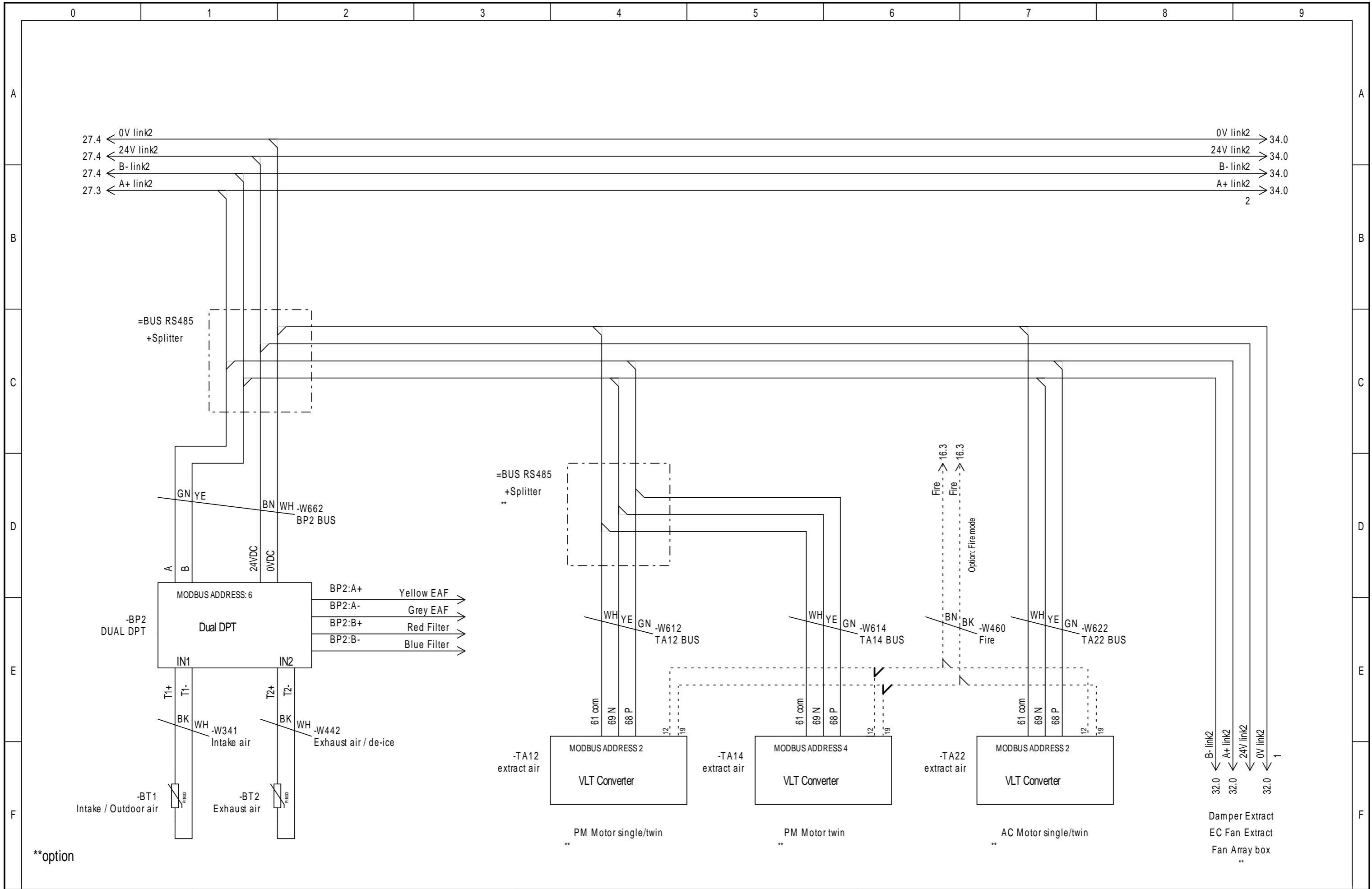

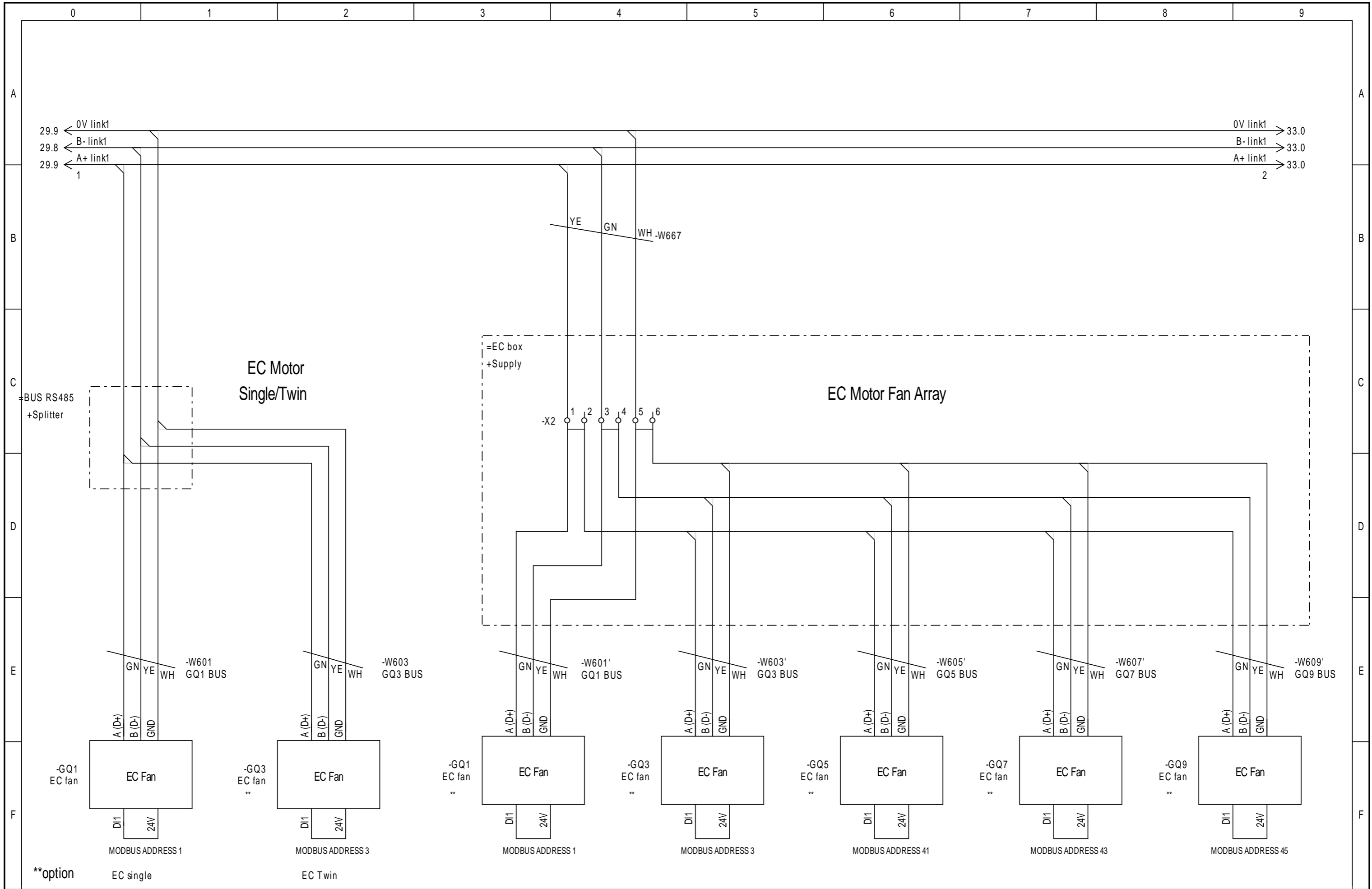

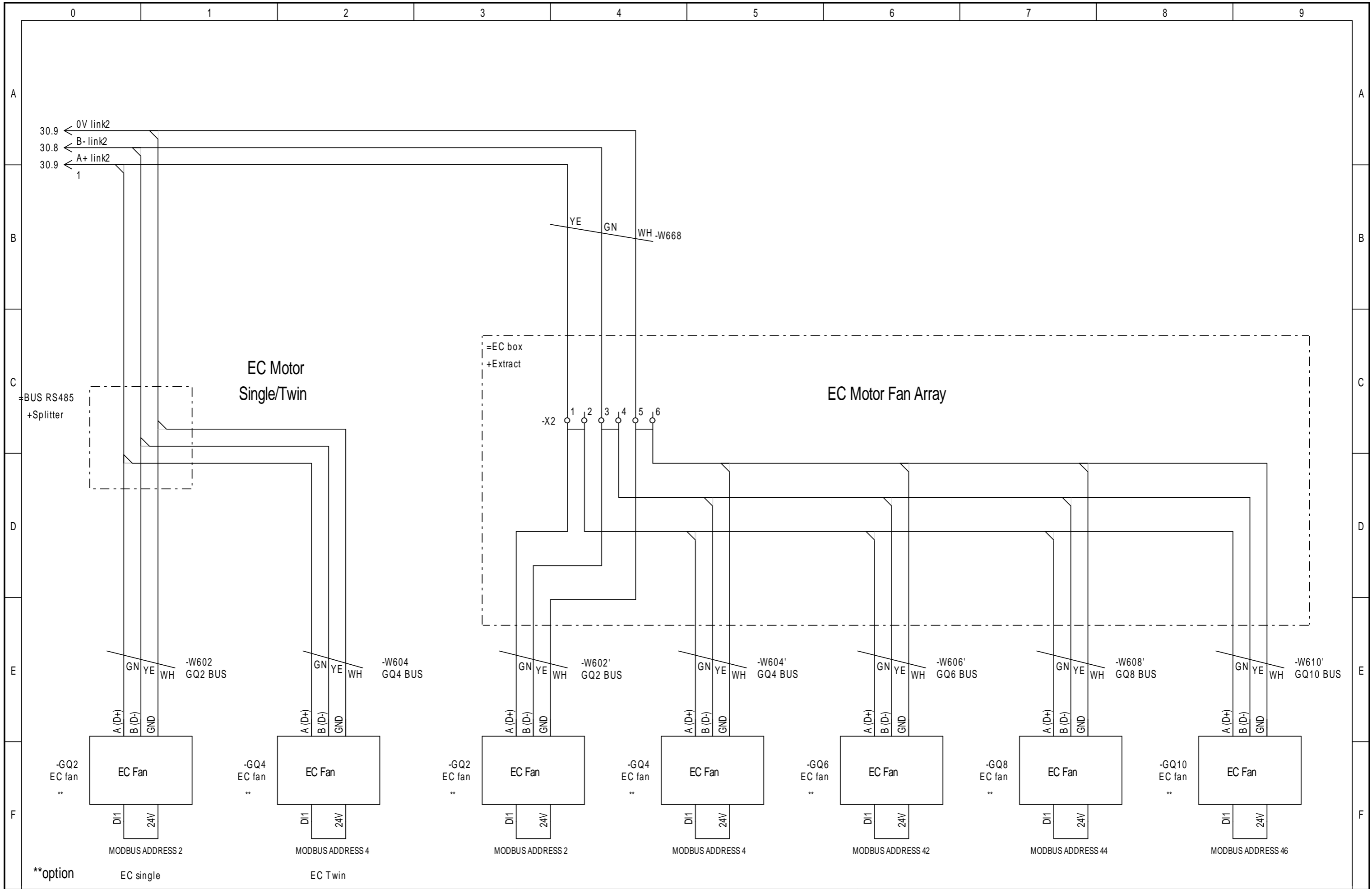

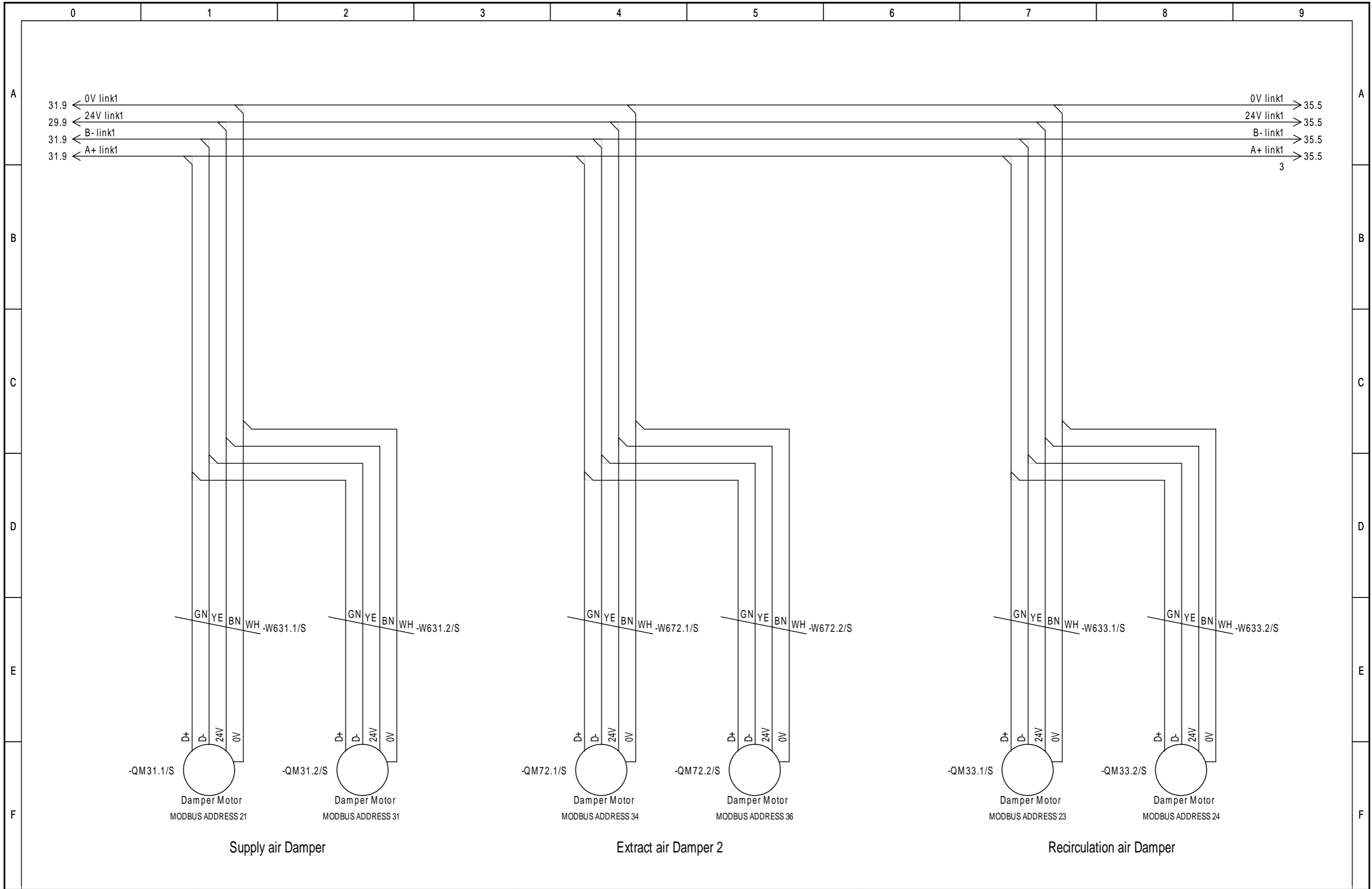

Geniox
Access CU 40-C

RS485 Damper Supply
Supply-Recirculation

Project:	Geniox-DV Control system 04.04		Rev.:	01.00	Sheet:	33	
Date:	11-06-2018	initials:	MIKE	Total sheets:	30	Next sheet:	34

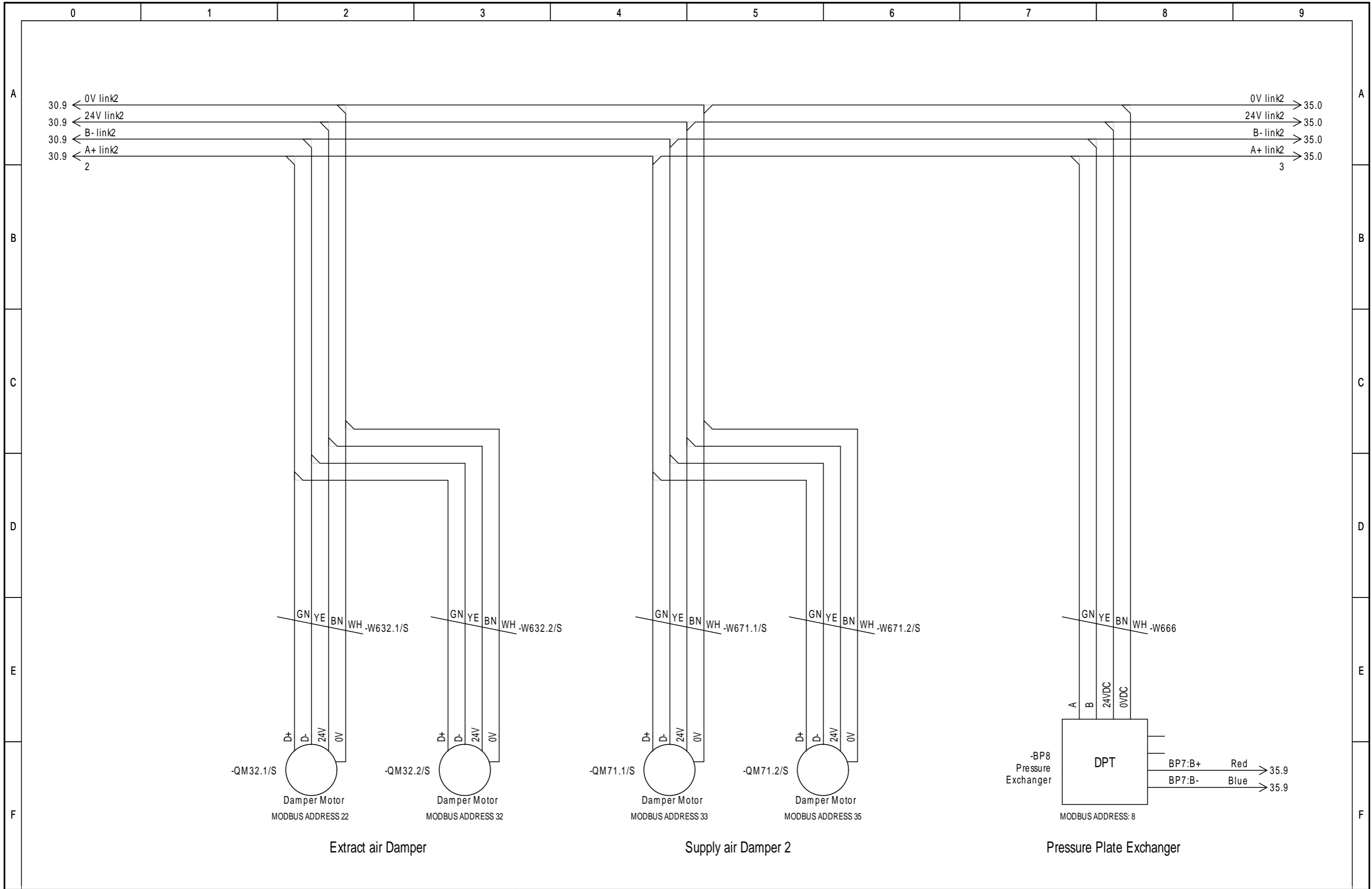

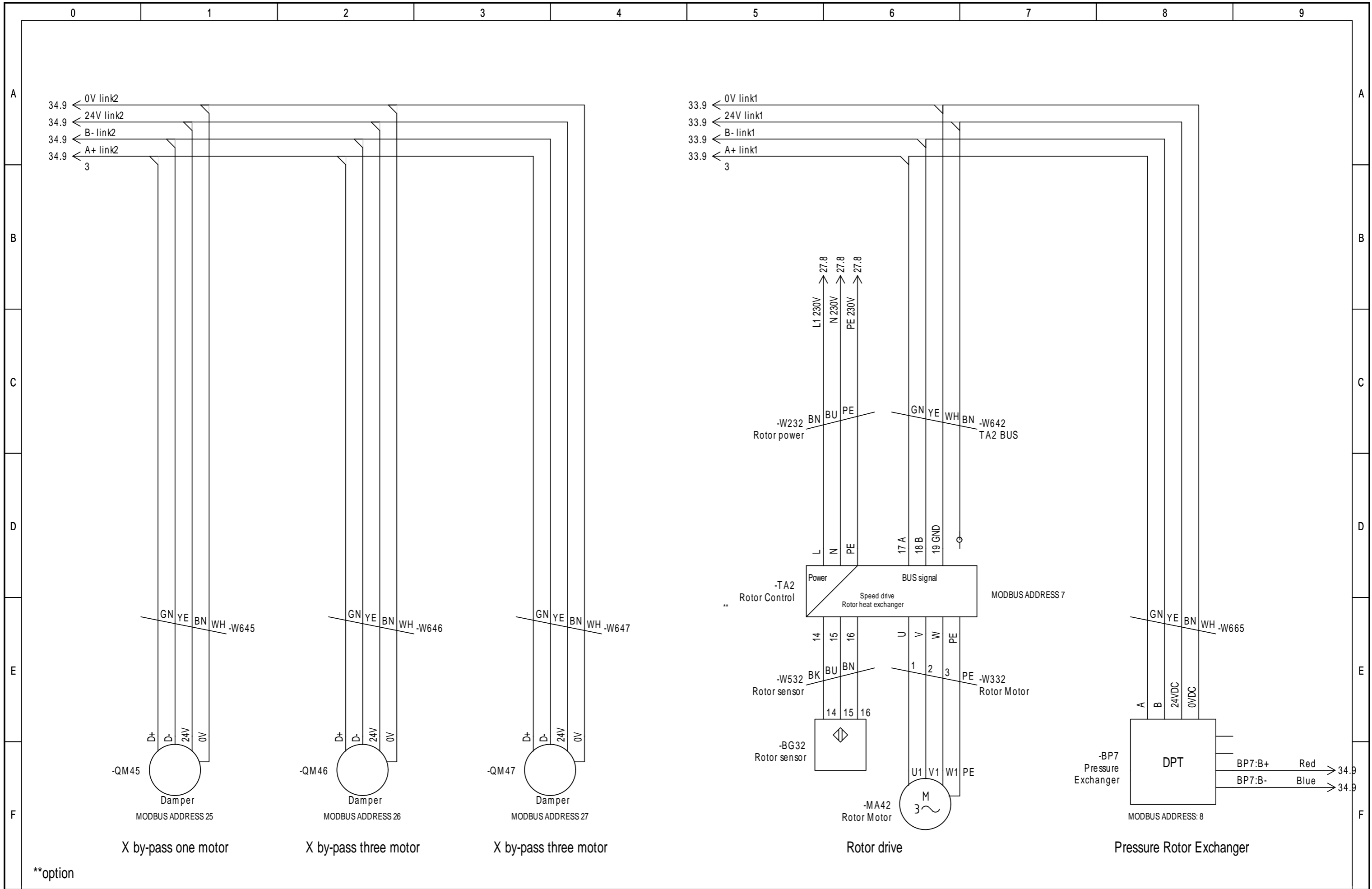

**option

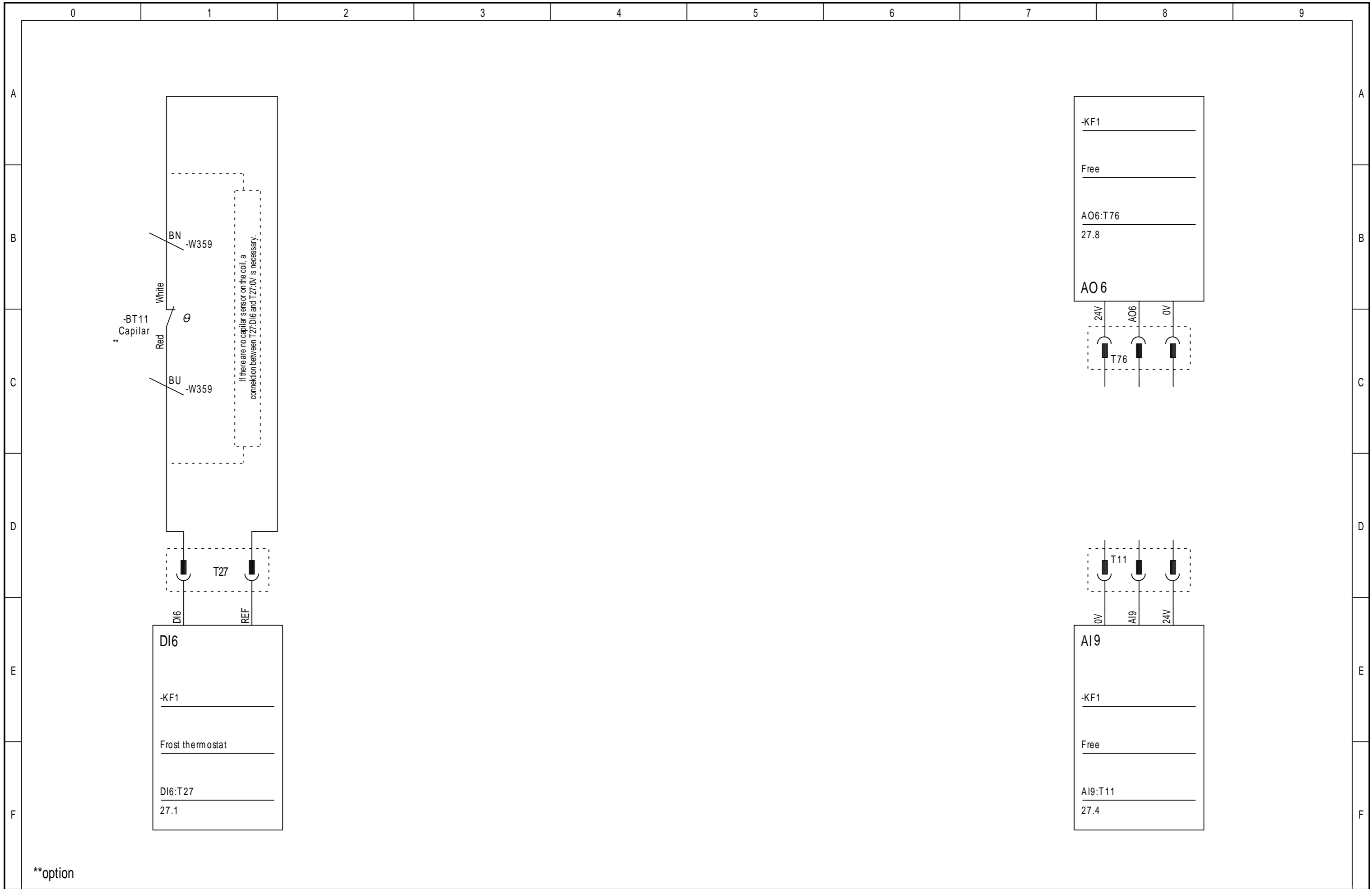

**option

Address list		Systemair settings of ECblue Modbus
1	Supply air fan 1: GQ1 - TA11 - TA21	COM Baudrate: 9600Bd
2	Extract air fan 1: GQ2 - TA12 - TA22	
3	Supply air fan 2: GQ3 - TA13 - TA21	COM Mode: 8N1
4	Extract air fan 2: GQ4 - TA14 - TA22	
5	Dual pressure transmitter supply: BP1	BUS Address: Supply air, 1 and (3, Twin fans)
6	Dual pressure transmitter extract: BP2	
7	RHC (Rotor drive system): TA2	Extract air, 2 and (4, Twin fans)
8	Pressure Exchanger: BP7	
21	Supply air damper 1: QM31.1/S	
22	Extract air damper 1: QM32.1/S	
23	Recirculation damper 1: QM33.1/S	D1: 19D
24	Recirculation damper 2: QM33.2/S	D1 is set to disable internal safety functions that protects the motor (fire mode)
25	Plate exchanger by-pass: QM45	Normal speed control of the fan is possible in this mode.
26	Plate exchanger "by-pass" 2: QM46	Function is active if D1 is open = no signal.
27	Plate exchanger "by-pass" 3: QM47	
29	VVX by-pass supply: QM38	
30	VVX by-pass extract: QM39	
31	Supply damper 2: QM31.2/S	
32	Extract damper 2: QM32.2/S	
33	Supply damper 3: QM71.1/S	
34	Extract damper 3: QM72.1/S	
35	Supply damper 4: QM71.2/S	
36	Extract damper 4: QM72.2/S	
41	Supply fan 3: GQ5	
42	Extract fan 3: GQ6	
43	Supply fan 4: GQ7	
44	Extract fan 4: GQ8	
45	Supply fan 5: GQ9	
46	Extract fan 5: GQ10	

	0	1	2	3	4	5	6	7	8	9	
A	<h2>Set-up Danfoss FC101 for Geniox-units with AC motors</h2> <p>Connections:</p> <p>Modbus Terminal 61(N) - 68(B) - 69(A) Thermistor: Terminal 50-53 Wire jumper: Terminal 12-19 (no fire)</p> <p>Systemair factory set-up is based on Danfoss initialisation.</p> <p>14-22: Operation mode: [2] Initialisation (Danfoss Initialisation)</p> <p>Systemair factory set-up:</p> <p>0-01: Language selection: 1-03: Torque characteristic: 1-20: Motor Power: 1-24: Motor Current: 1-25: Motor Nominal Speed: 1-42: Motor Cable Length: 1-50: Motor Magnetisation at zero speed.: 1-52: Min. Speed Normal Magnetisation: 1-73: Flying Start: 1-90: Motor Thermal Protection: 1-93: Thermistor Source: 3-03: Maximum Reference: 3-15: Reference Resource 1: 3-16 + 3-17: Reference 2- and 3 Source: 3-41: Ramp 1 up and down: 3-42: Ramp 1 Down time: 4-14: Motor Speed High Limit: 4-19: Max. Output Frequency: 5-10: Terminal 18 Digital Input 5-11: Terminal 19 Digital Input 5-12: Terminal 27 Digital input: 5-40.0: Function Relay: 5-40.1: Function Relay: 6-25: Terminal 54 High Reference: 8-01: Control Site 8-02: Control Source 8-03: Control Timeout Time 8-04: Control Timeout Function 8-30: Protocol 8-31: Address: 8-32: FC Port Baud Rate 8-33: FC Port Parity 14-20: Reset Mode: 24-00: Fire mode function 24-05: Fire mode Preset Reference 24-09: Fire mode Alarm Handling 0-50: LCP Copy:</p> <p>To store Systemair factory settings from the control panel: 0-50: LCP Copy:</p>					<h2>Set-up Danfoss FC101 for Geniox-units with PM motors</h2> <p>Connections:</p> <p>Modbus Terminal 61(N) - 68(B) - 69(A) Thermistor: Terminal 50-53 Wire jumper: Terminal 12-19 (no fire)</p> <p>Systemair factory set-up is based on Danfoss initialisation.</p> <p>14-22: Operation mode: [2] Initialisation (Danfoss Initialisation)</p> <p>Systemair factory set-up:</p> <p>0-01: Language selection: 1-06: Clockwise Direction: [1] Inverse 1-10: Motor Construction: [1] PM, non salient SPM 1-24: Motor Current: According to motor plate / Schedule 1-25: Motor Nominal Speed: According to motor plate / Schedule 1-26: Motor Cont. Rated torque: According to motor plate / Schedule 1-30: Stator Resistance (Rs): According to motor plate / Schedule 1-37: d-axis inductance (Ld): According to motor plate / Schedule 1-39: Motor Poles: According to motor plate / Schedule 1-40: Back EMF at 1000 RPM: According to motor plate / Schedule 1-42: Motor Cable Length: 3m 1-73: Flying start [1] Enabled 1-90: Motor Thermal Protection: [2] Thermistor trip 1-93: Thermistor Source: [1] Analog input AI53 2-01: DC brake Current: 100 % 2-02: DC braking Time: 20.0 Sec. 2-07: Parking time: 10.0 Sec. 3-03: Maximum Reference: According to motor plate / Schedule 3-15: Reference Resource 1: [11] Local bus reference 3-16 + 3-17: Reference 2- and 3 Source: [0] No function 3-41: Ramp 1 Up Time: According to PM Schedule 3-42: Ramp 1 Down Time: According to PM Schedule 4-14: Motor Speed High Limit: According to motor plate / Schedule 4-19: Max. Output Frequency: According to motor plate / Schedule 5-10: Terminal 18 Digital Input [0] No operation 5-11: Terminal 19 Digital Input [37] Fire mode 5-12: Terminal 27 Digital input: [0] No operation 5-40.0: Function Relay: [3] Drive ready/remote 5-40.1: Function Relay: [3] Drive ready/remote 6-25: Terminal 54 High Reference: According to motor plate / Schedule 8-01: Control Site [0] Digital and ctrl.word 8-02: Control Source [1] FC Port 8-03: Control Timeout Time 20 sec. 8-04: Control Timeout Function [2] Stop 8-30: Protocol [2] Modbus RTU 8-31: Address: 1-Supply #1. 3-Supply #2. 2-Extract #1. 4-Extract #2. 8-32: FC Port Baud Rate [2] 9600 Baud 8-33: FC Port Parity [2] No Parity, 1 stop Bit 14-20: Reset Mode: [2] Automatic reset x 2 24-00: Fire mode function [1] Enabled run forward 24-05: Fire mode Preset Reference 50% 24-09: Fire mode Alarm Handling [1] Trip, Critical Alarms 0-50: LCP Copy: [1] All to LCP (Copy of settings to panel)</p> <p>To store Systemair factory settings from the control panel: 0-50: LCP Copy: [2] All from LCP</p>					A
B											B
C											C
D											D
E											E
F											F



Geniox
Access CU 40-C

VLT guide

Project:	Geniox-DV Control system 04.04		Rev.:	01.00	Sheet:	41	
Date:	18-07-2018	initials:	MIKE	Total sheets:	30	Next sheet:	42

Menu:	3-41	3-42	1-24	1-25	1-26	1-30	1-37	1-39	1-40	3-03	4-14	4-19	6-25
Motor Type	Ramp up	Ramp Down	Amp Name plate	Motor RPM rated	Nm Name plate	Ohm [Rf-0]	mH [Lf-0]	Poles	Bemf @ 1000	Max Hz	Max motor Hz	Max motor Hz	Max Hz
HPS 71 3800 18	30	20	1,9	3800	2,0	3,900	11,75	6	67	196	200	200	196
HPS 71 3700 28	30	20	3,0	3700	3,6	2,100	8,25	6	79	191	194	194	191
HPS 71 3300 18	30	20	1,9	3300	2,6	6,250	19,25	6	85	170	173	173	170
HPS 71 3200 30	30	20	3,2	3200	4,2	2,000	8,05	6	84	161	168	168	161
HPS 71 2900 21	30	20	2,4	2900	3,3	4,550	15,40	6	91	143	152	152	143
HPS 71 2800 40	30	20	4,1	2800	6,1	1,750	7,15	6	100	144	147	147	144
HPS 71 2500 29	30	20	3,1	2500	5,0	3,700	13,00	6	105	129	131	131	129
HPS 71 2350 38	30	20	4,2	2350	7,3	2,400	10,85	6	115	120	123	123	120
HPS 90 2650 64	30	30	7,0	2650	9,6	1,150	11,40	8	89	182	186	186	182
HPS 90 2350 76	30	30	8,1	2350	13,0	0,800	10,00	8	103	159	165	165	159
HPS 90 2100 63	30	30	6,7	2100	10,5	1,500	14,75	8	100	142	147	147	142
HPS 90 2050 100	30	30	10,7	2050	19,0	0,700	8,50	8	115	140	144	144	140
HPS 90 1850 84	30	30	8,9	1850	16,0	0,875	11,50	8	117	127	130	130	127
HPS 90 1900 136	30	30	15,3	1900	26,0	0,575	7,25	8	110	127	133	133	127
HPS 90 1700 106	30	30	11,3	1700	22,0	0,575	7,25	8	121	116	119	119	116
HPS 112 1550 108	30	60	11,7	1550	32,0	0,750	8,75	6	178	80	81	81	80
HPS 112 1700 145	30	60	15,5	1700	39,0	0,465	5,45	6	162	88	89	89	88
HPS 112 1350 135	60	60	14,8	1350	44,0	0,570	6,95	6	206	69	71	71	69
HPS 112 1500 187	60	60	19,2	1500	54,0	0,350	5,00	6	182	76	79	79	76
HPS 112 1000 140	60	60	15,0	1000	51,0	0,520	7,75	6	220	54	53	65	54
HPS 132 1250 199	60	60	21,3	1250	69,0	0,320	7,60	6	210	65	66	66	65
HPS 132 1000 202	60	60	21,6	1000	77,0	0,375	9,25	6	230	51	53	53	51
HPS 132 1150 300	60	60	32,1	1150	104,0	0,235	8,00	6	230	58	60	60	58
HPS 132 930 273	60	60	29,4	930	118,0	0,280	9,75	6	261	46	49	49	46



Geniox
Access CU 40-C

VLT guide

Project:

Geniox-DV Control system 04.04

Rev.:

01.00

Sheet:

42

Date:

15-08-2018

initials:

MIKE

Total sheets:

30

Next sheet:

Cable Plan

Path
Sheet

Remark: Rotor power
Cable-type:

-W232

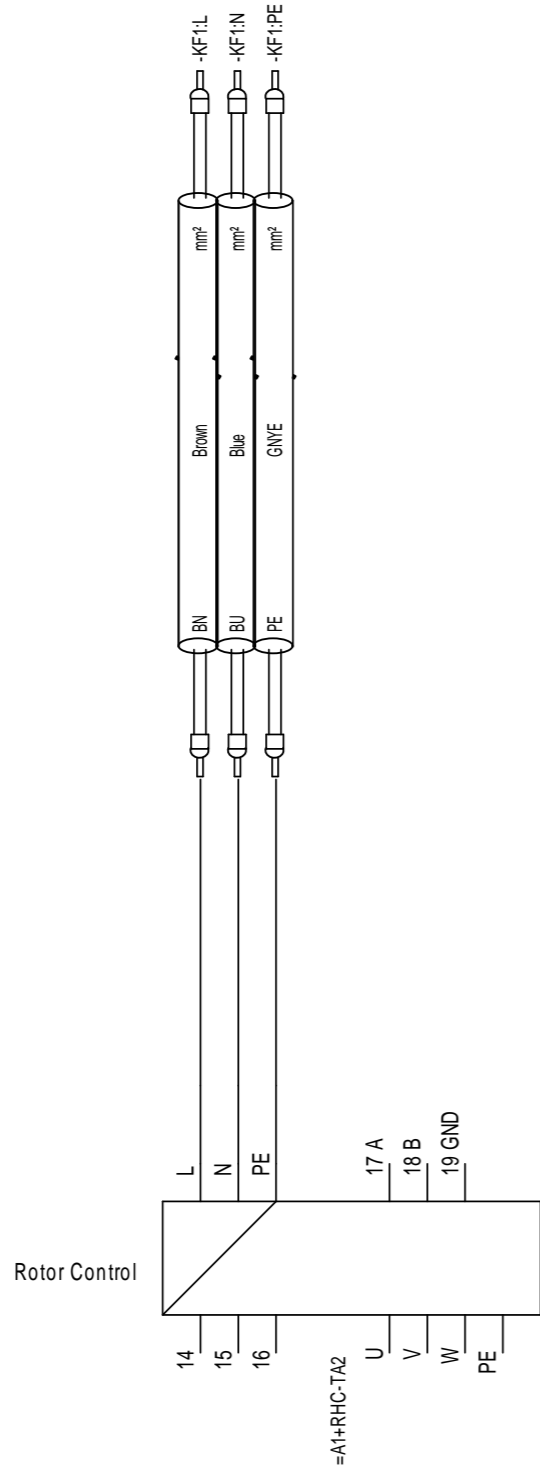

-W351

Remark: Electric heater
Cable-type:

Electric heater

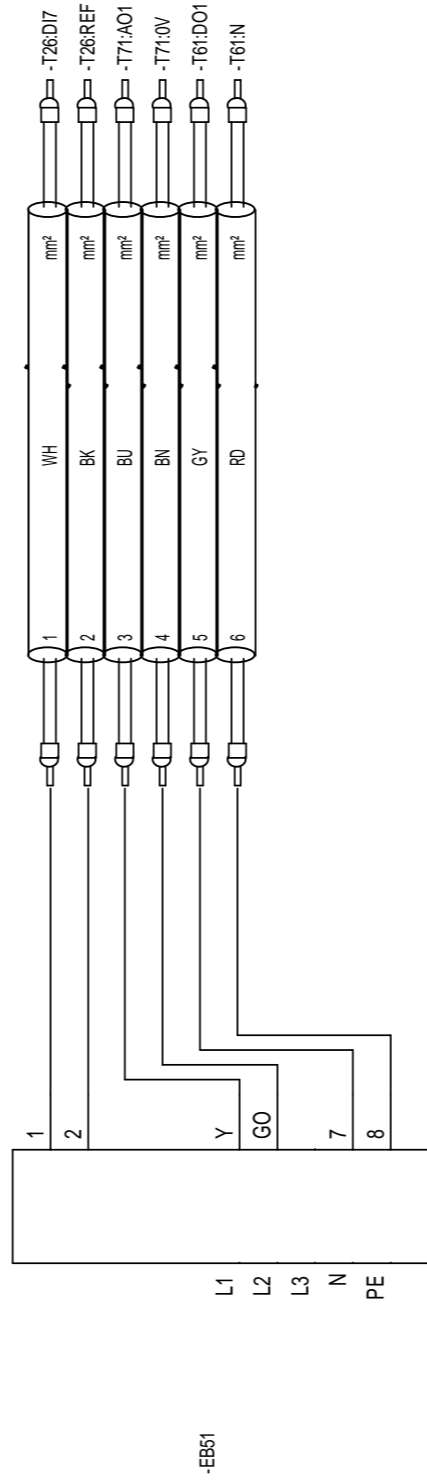

-W353

Remark: Electric pre-heater
Cable-type:

Electric Pre-heater

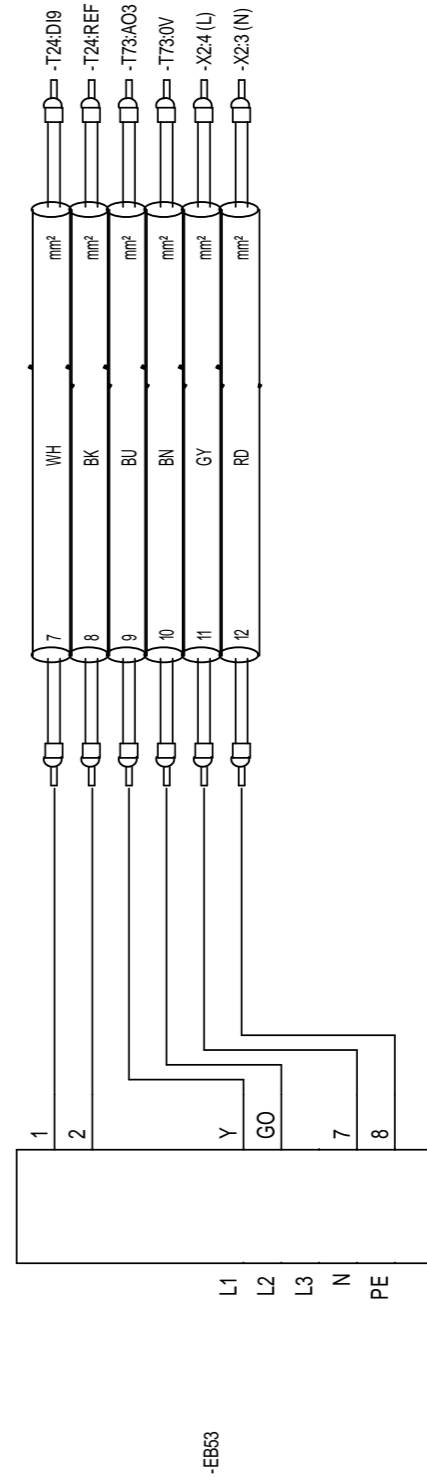

6
35
6
35
6
35

2
17
2
17
2
17
2
17
3
17
3
17

8
17
8
17
8
17
9
17
9
17
9
17

Cable Plan

Remark: Electric heater 2
Cable-type:

-W354

Electric heater 2

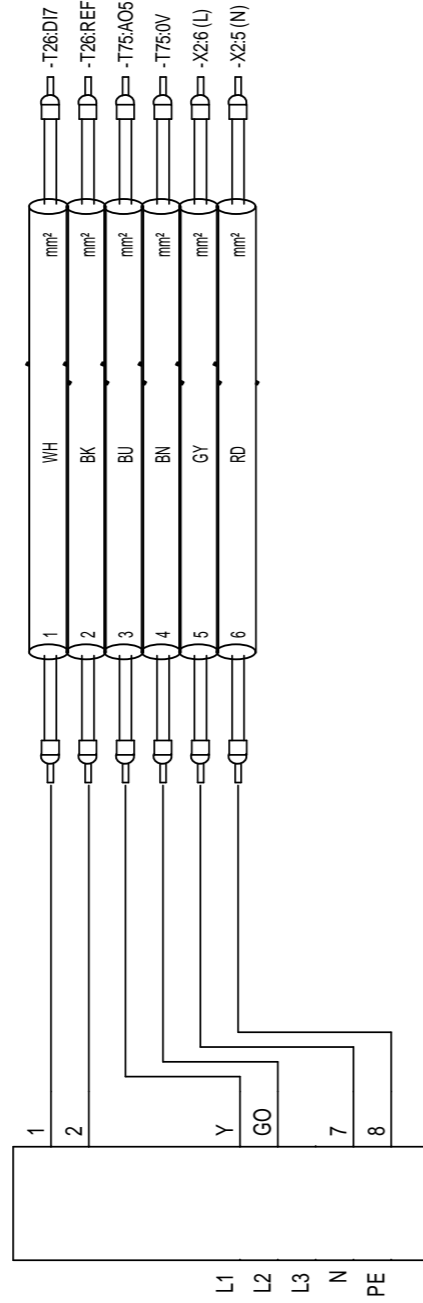

-EB54

Remark: Temperatur sensor supply air
Cable-type:

-W355

Supply air
Duct sensor

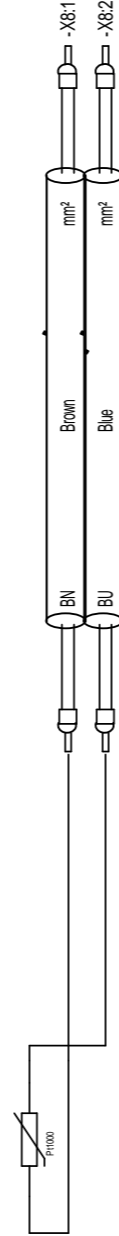

-BT5

Remark: Frost protection heating coil
Cable-type:

-W357

Frost protection
Pt 1000

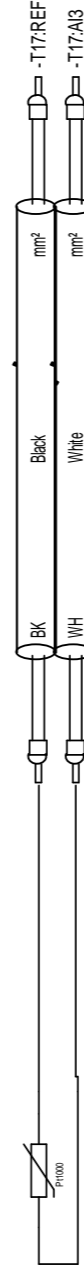

-BT10

Remark: Extra filter guard
Cable-type:

-W363

Extra filter
Guard Supply

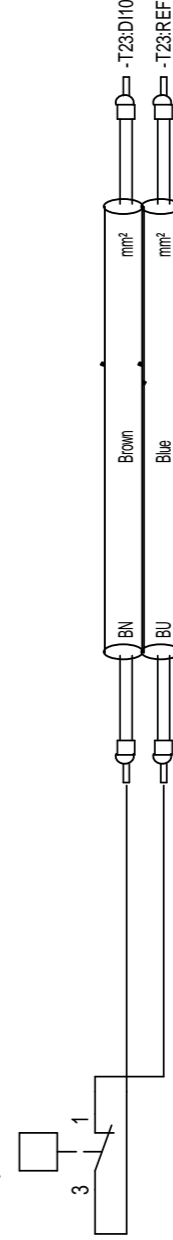

-BP5

Path
Sheet

5
18
5
18
5
18
6
18
6
18
6
18

3
14
3
14

1
14
0
14

1
12
2
12

Cable Plan

Path
Sheet

Remark: Pre-heat Temp.
Cable-type:

-W367

Pre-heat Frost
Pt 1000

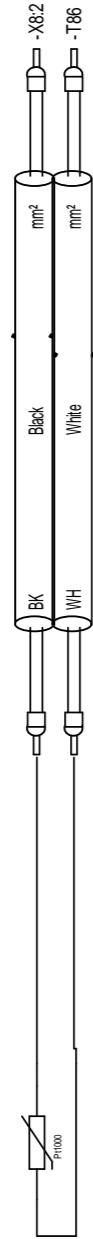

-BT13

5
5

14
14

Remark: Pre-heat Temp.
Cable-type:

-W369

Pre-heat temp.
Pt 1000

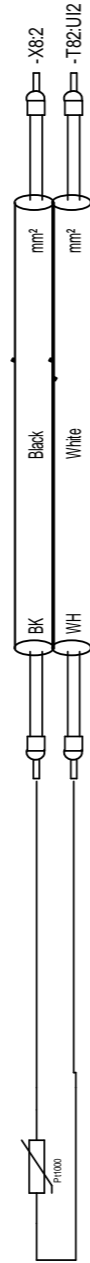

-BT14

6
6

14
14

Remark: Fire thermostat extract air
Cable-type:

-W456

Fire thermostat
Extract air

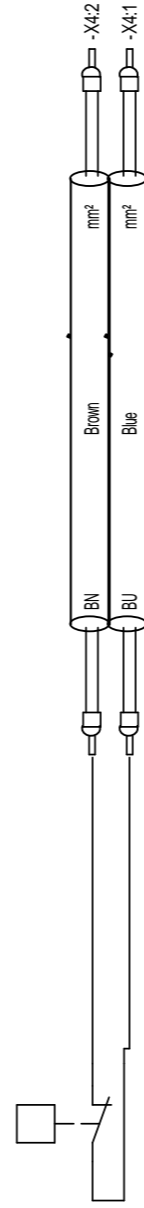

-BR2

6
6

11
11

Remark: Fire thermostat
Cable-type: 2x0,75mm2

-W457

Fire thermostat
Supply air

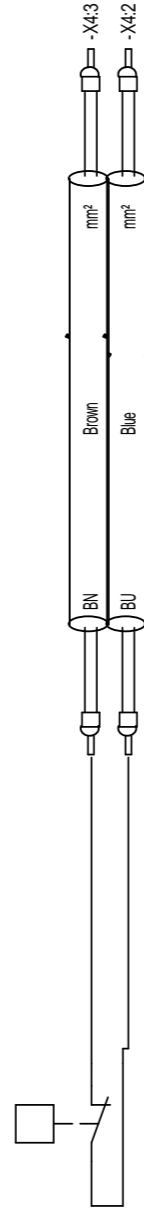

-BR1

6
6

11
11

Cable Plan

Path
Sheet

Remark: Smoke detector
Cable-type:

-W458

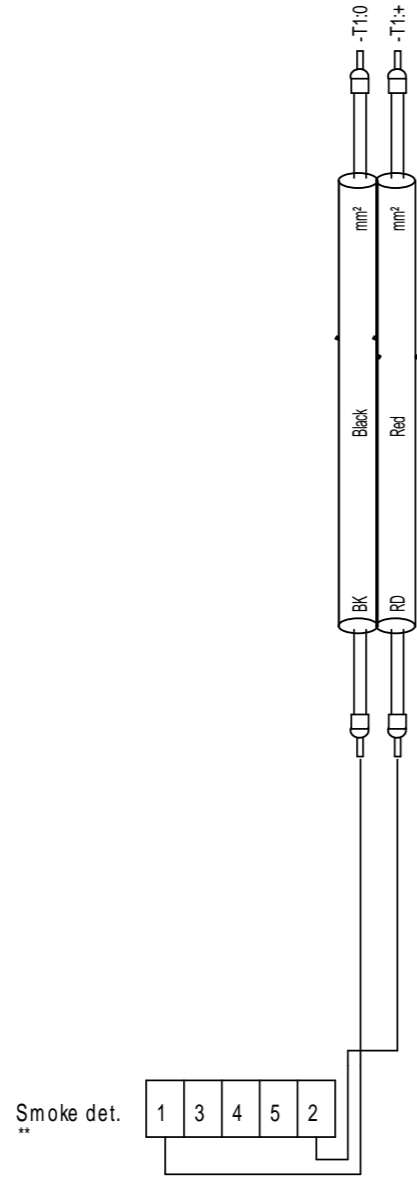

-B03

Remark: Extra filter guard Extract
Cable-type:

-W464

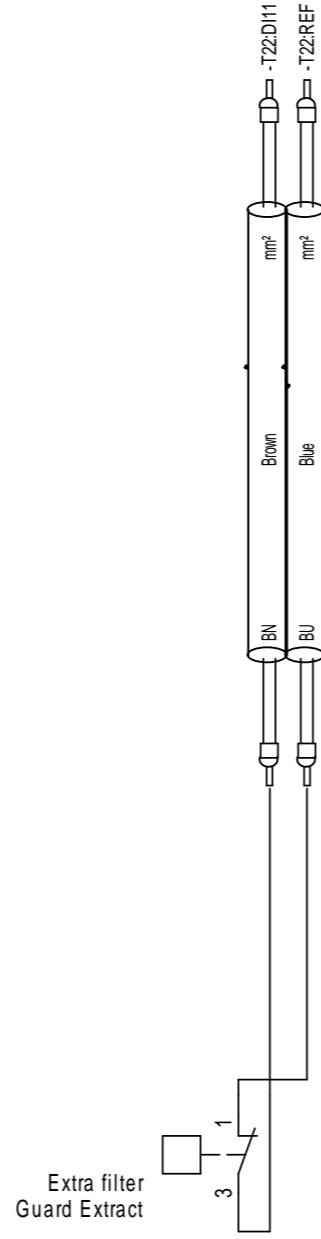

-BP6

Remark:
Cable-type:

-W480S

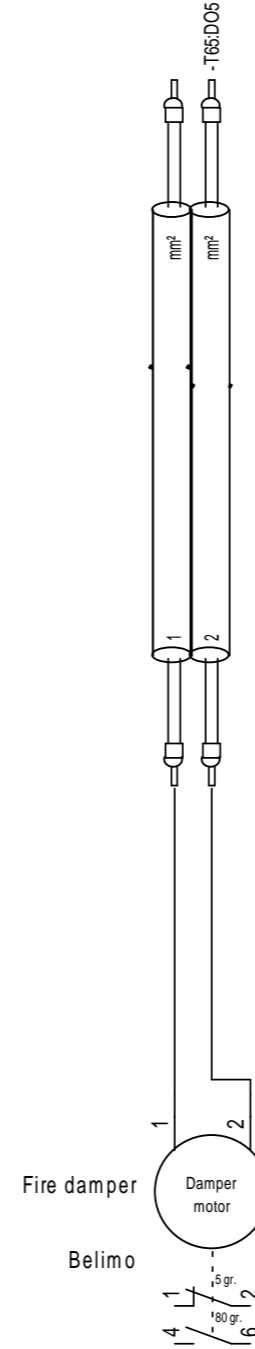

-QM80

Remark: Outdoor sensor
Cable-type:

-W507

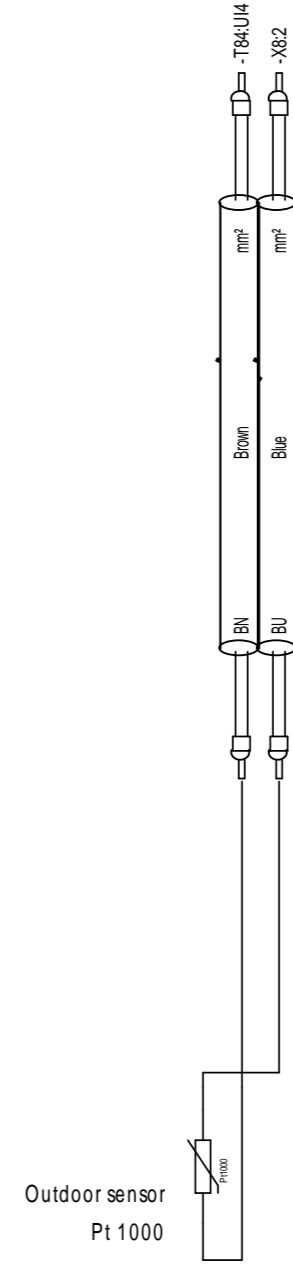

-BT7

3
11

5
12

1
16

9
14

3
11

5
12

2
16

9
14

Cable Plan

Path
Sheet

Remark: Room sensor 1
Cable-type:

-W508

Room sensor 1
Pt 1000

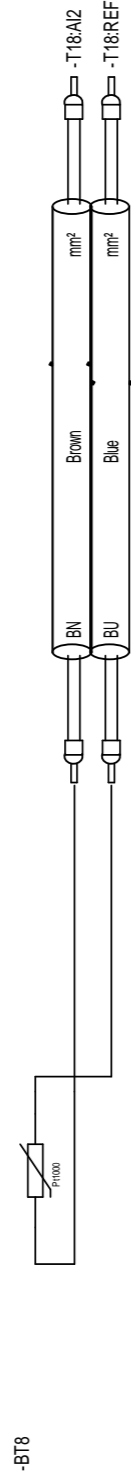

-BT8

Remark: Room sensor 2
Cable-type:

-W509

Room sensor 2
Pt 1000

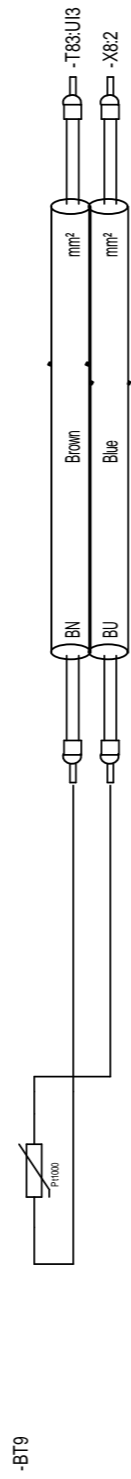

-BT9

Remark: Pressure Supply air external
Cable-type:

-W513

Pressure transmitter
DPT

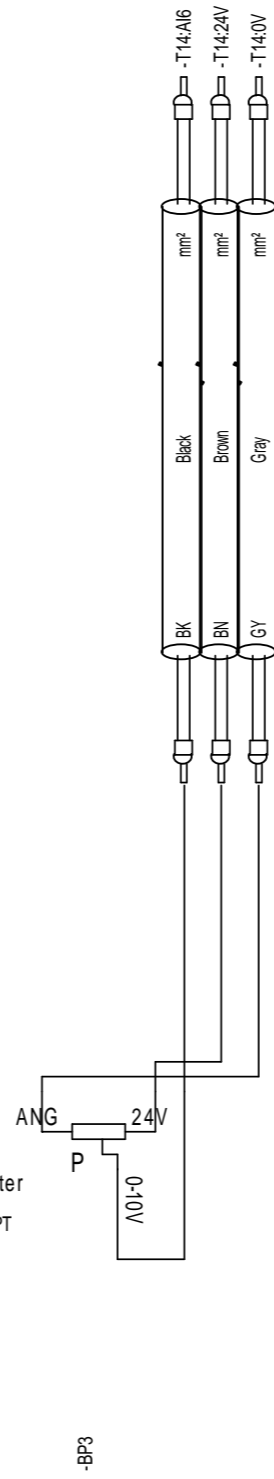

-BP3

Remark: Pressure Extract air external
Cable-type:

-W514

Pressure transmitter
DPT

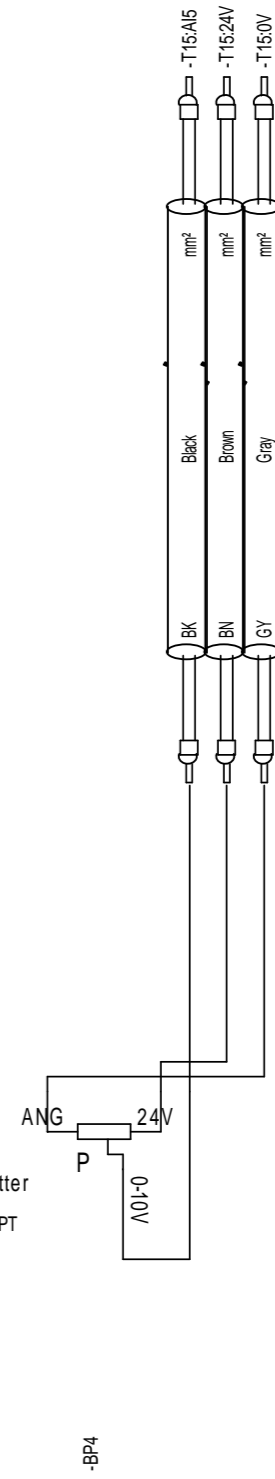

-BP4

Cable Plan

Path
Sheet

7	13
8	13
7	13
9	13
9	13
8	13
1	13
1	13
0	13

Remark: CO2 Sensor
Cable-type:

-W515

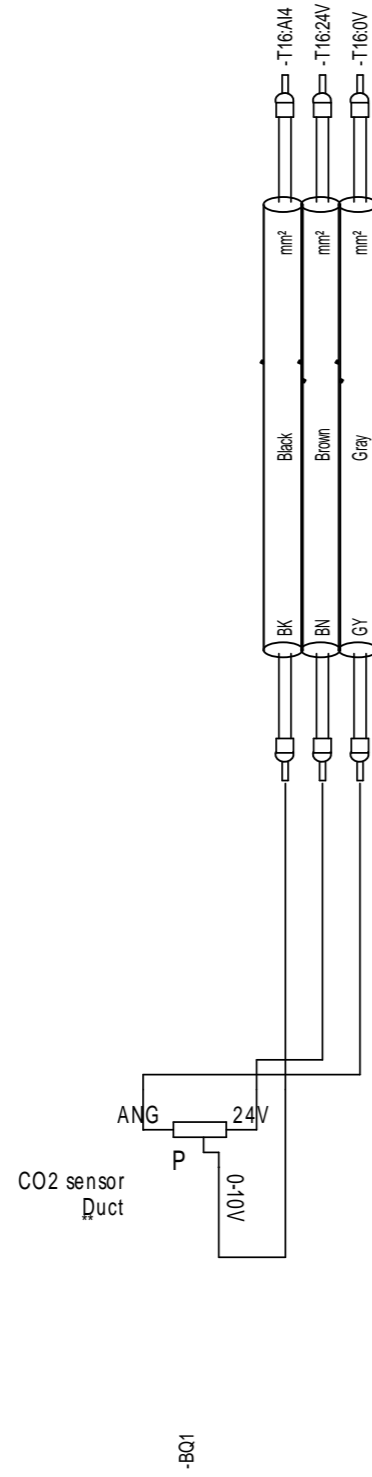

Remark: CO2 Sensor
Cable-type:

-W516

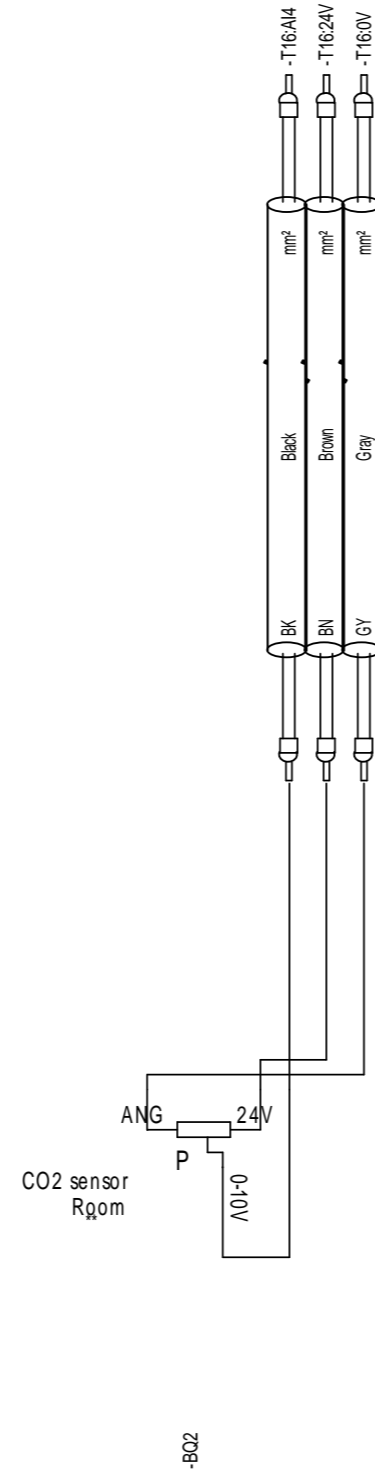

Remark: Humidity sensor external
Cable-type:

-W517

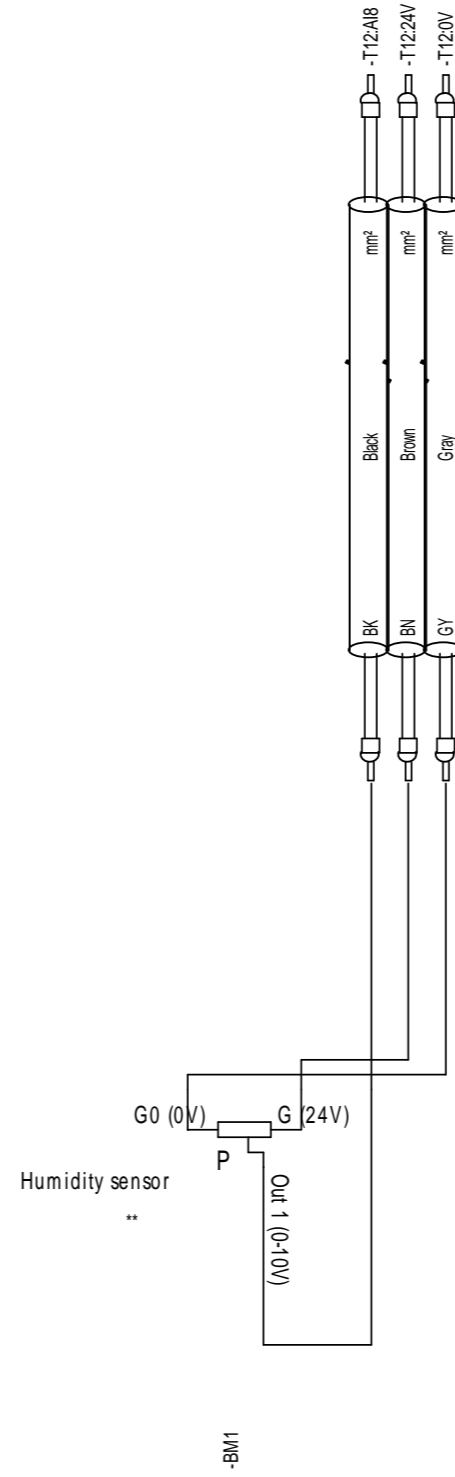

Cable Plan

Path
Sheet

Remark: Humidity sensor
Cable-type:

-W519

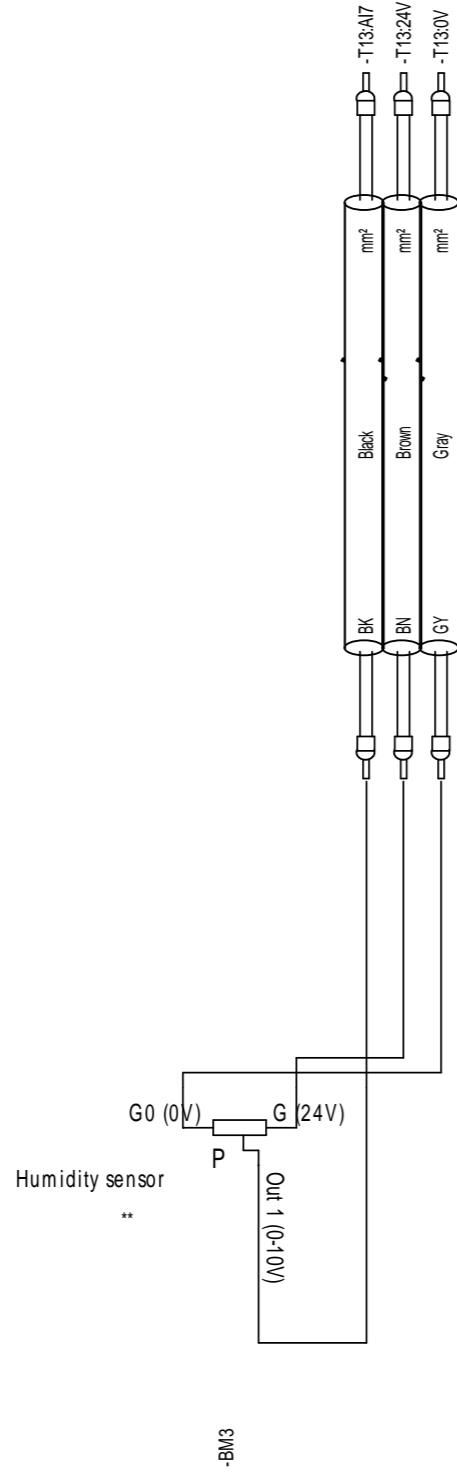

-W528

Remark: HP Control
Cable-type:

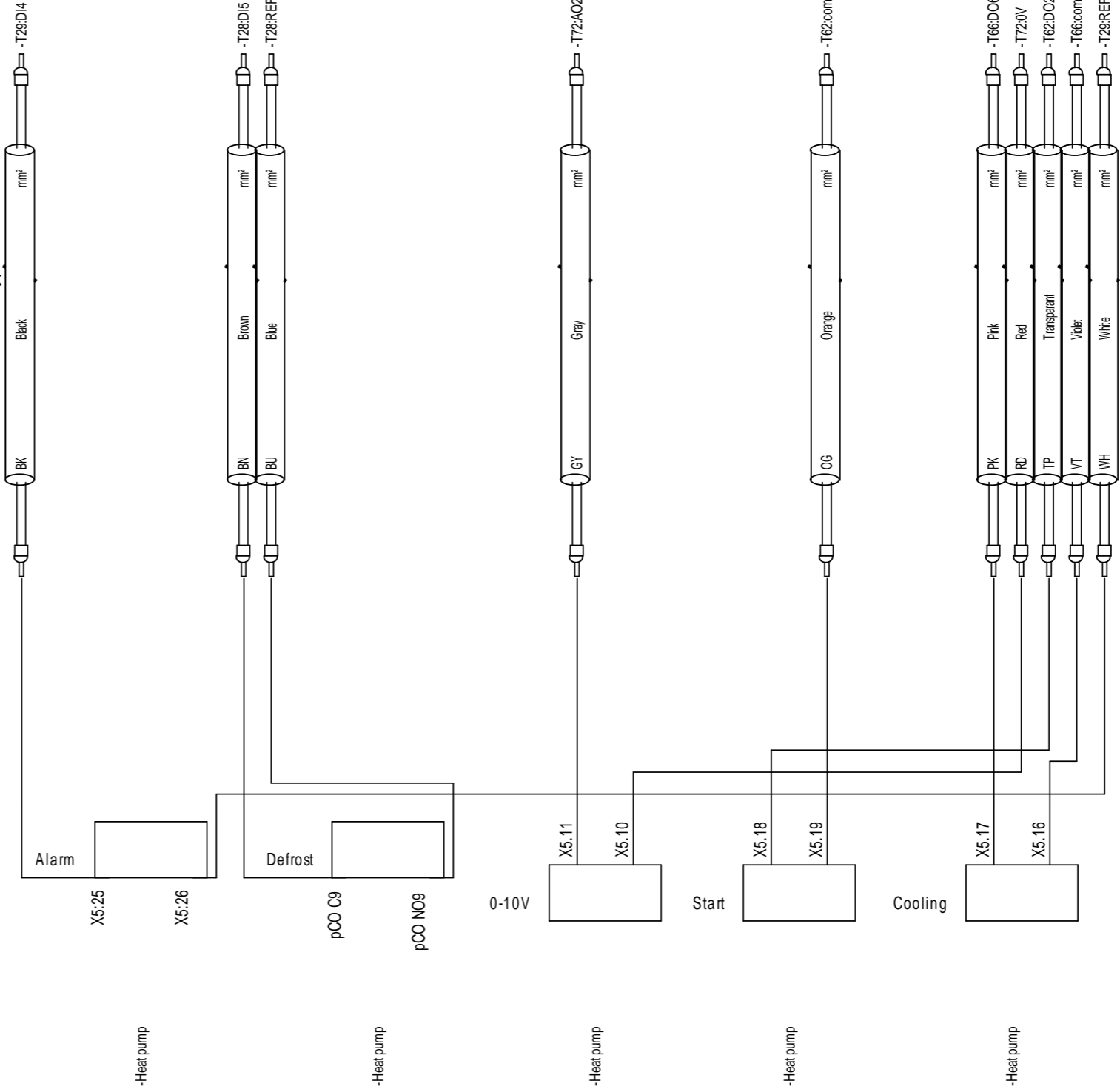

2	3	2	5	8	8	5	4	4	5	4	4	6
13	13	13	10	10	10	17	15	16	17	15	16	10

Cable Plan

Path
Sheet

	0	4	7	1	2
	0	3	6	1	3
	0	3	6	1	1
17	17	17	10	10	10

Remark: Heating valve
Cable-type:

-W551

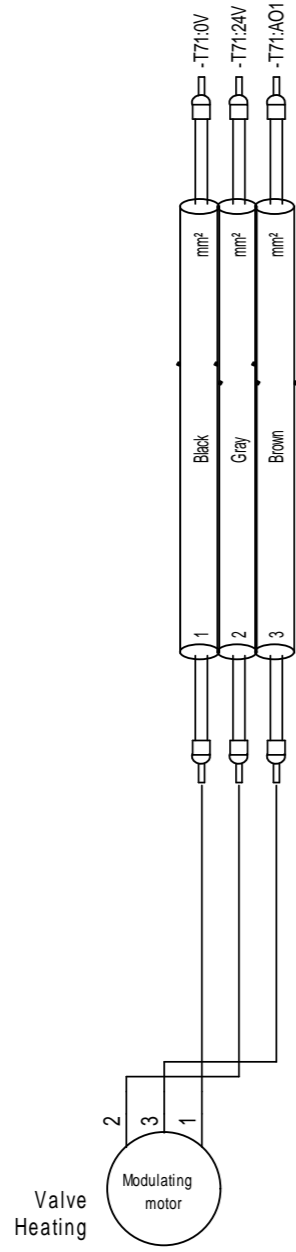

-QN51

Remark: Heating valve
Cable-type:

-W552

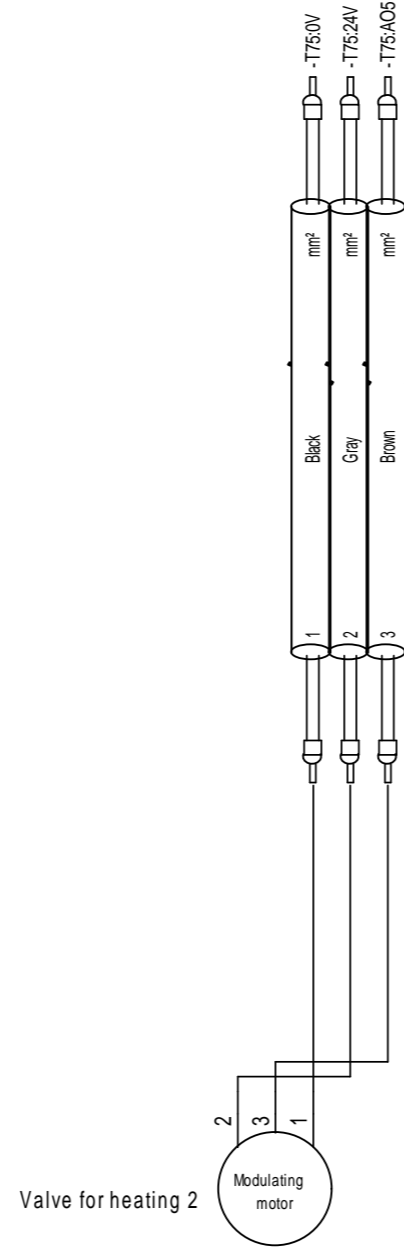

-QN52

Remark: Heating valve
Cable-type:

-W553

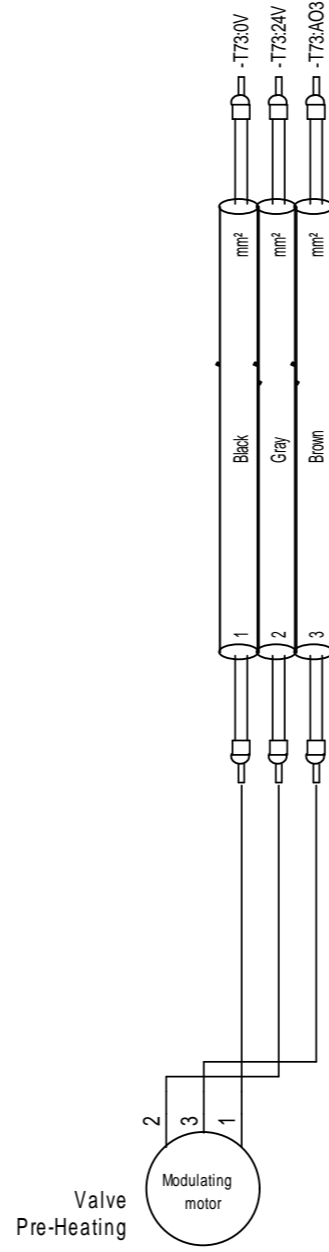

-QN53

Remark: Reduced speed
Cable-type: 2x0,75mm2

-W580

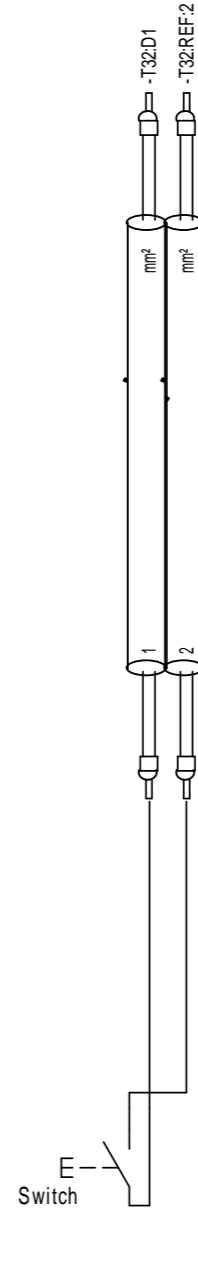

-SF2

Remark: Normal speed-ext.
Cable-type:

-W581

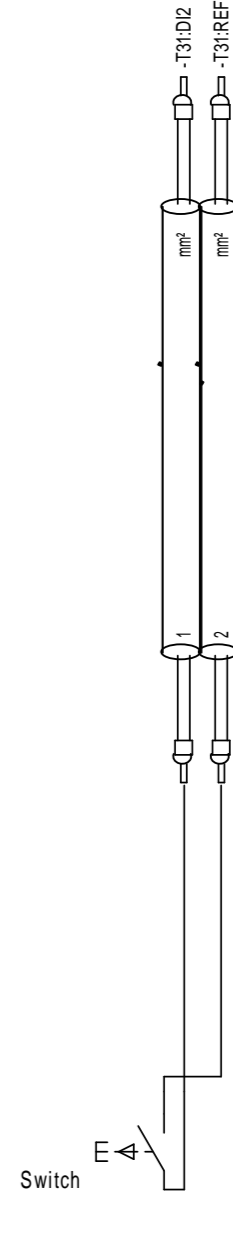

-SF3

Cable Plan

Path	4	4	7	8	4	4	0	1	1	3	3	4
Sheet	10	10	10	10	12	12	31	31	31	31	31	31

Remark: Ext. stop
Cable-type: 2x0,75mm²

-W583

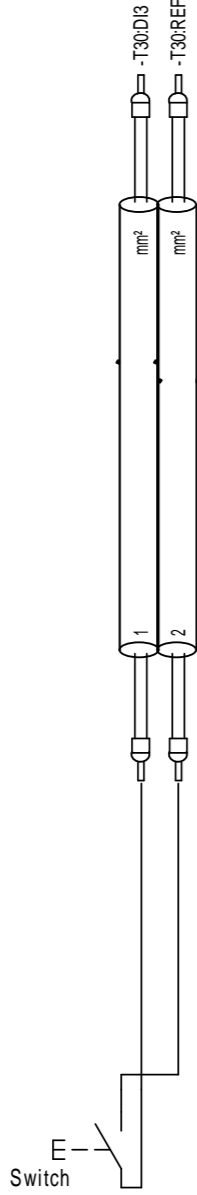

-SF5

Remark: Change over
Cable-type:

-W584

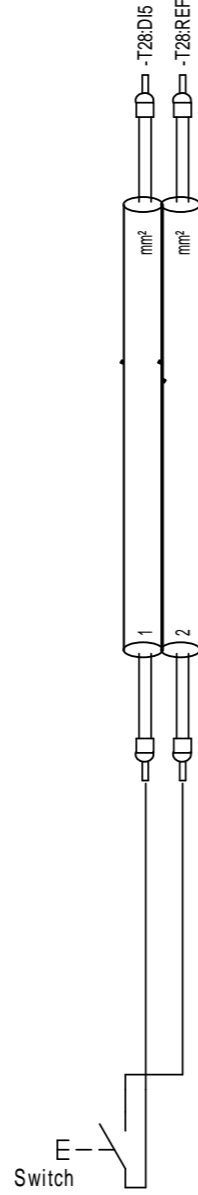

-SF6

Remark: Recirculation
Cable-type:

-W585

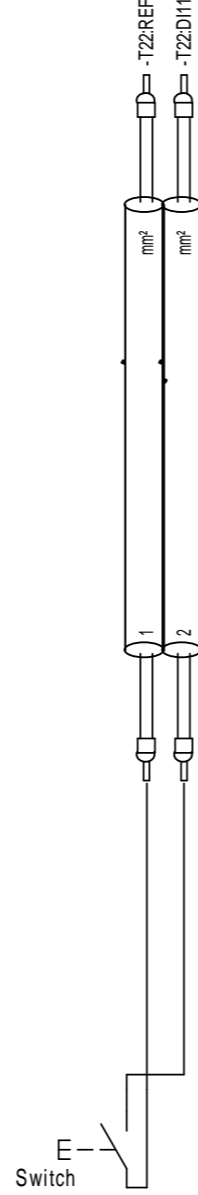

-SF7

Remark: GQ1 BUS
Cable-type: 4x0,6mm²

-W601

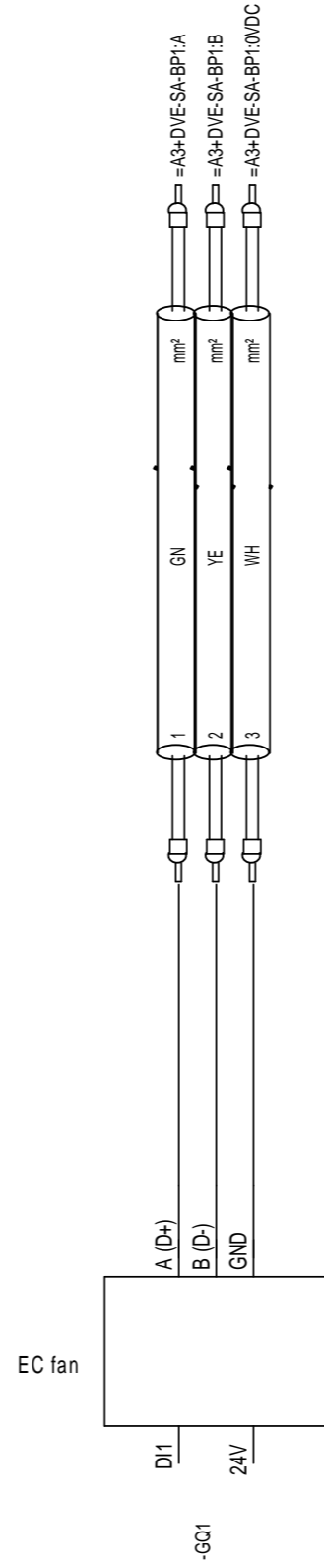

-GQ1

Remark: GQ1 BUS
Cable-type: 4x0,6mm²

-W601'

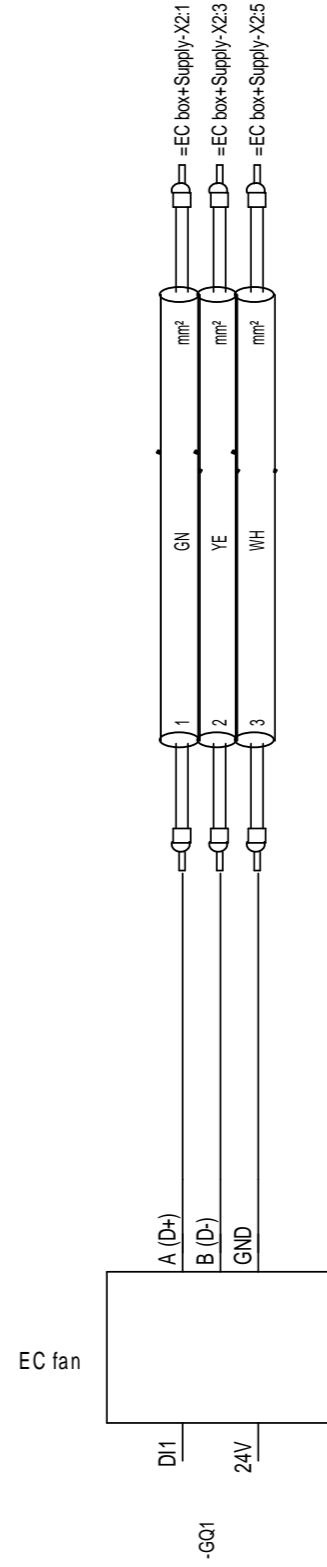

-GQ1

Cable Plan

-W602

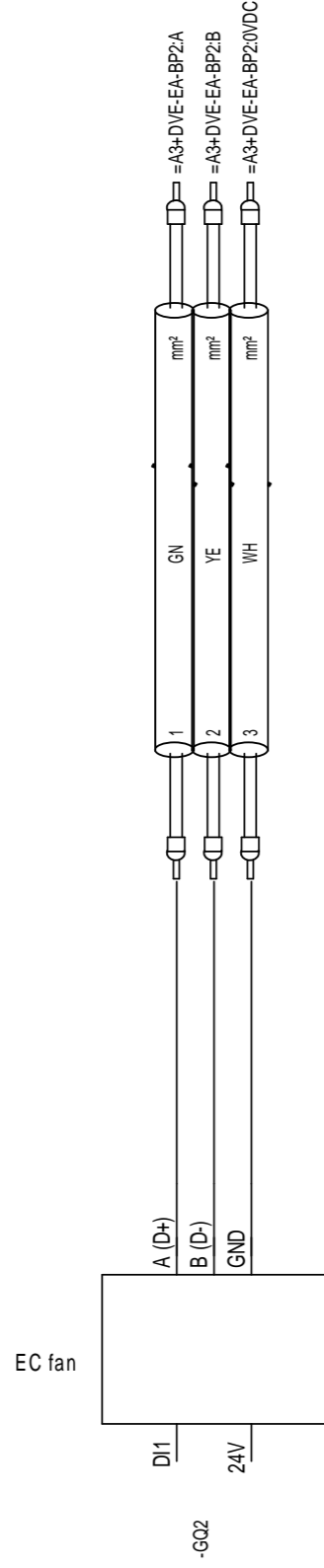

-W602'

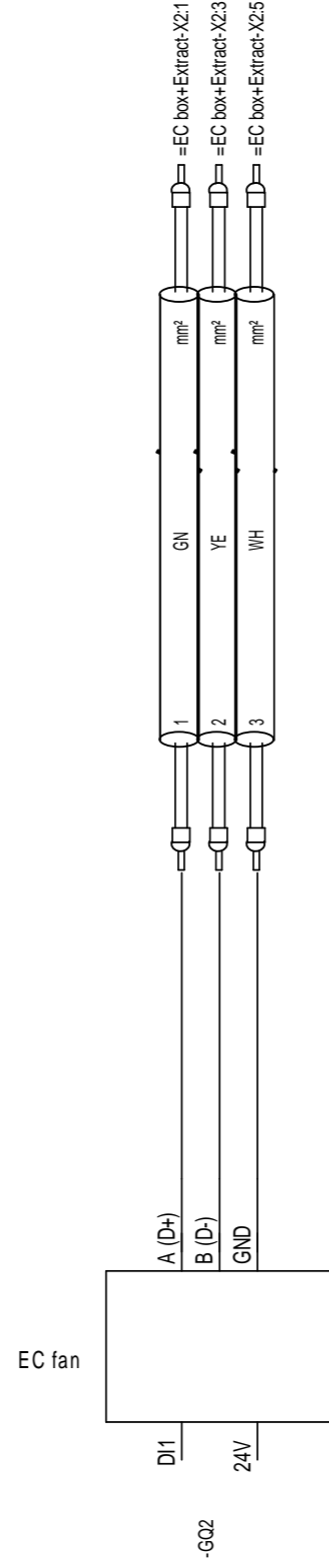

-W603

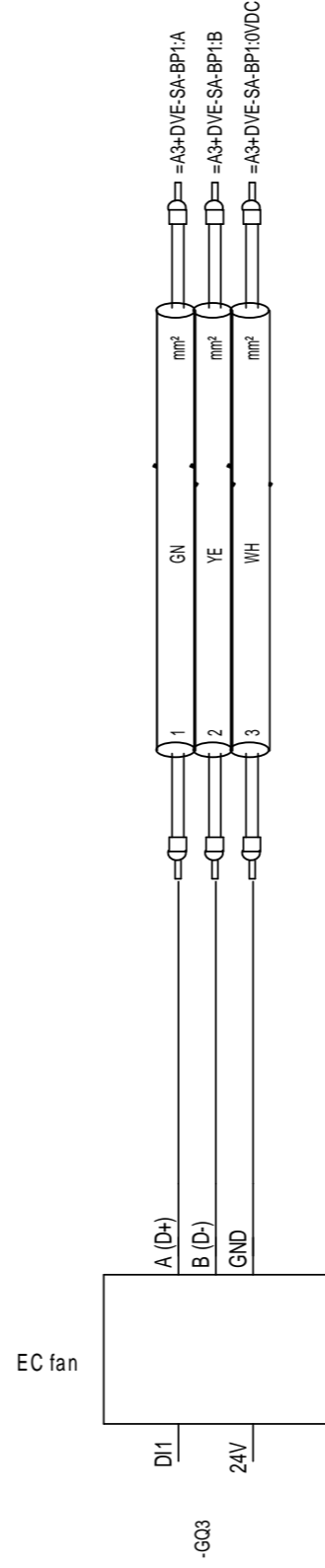

-W603'

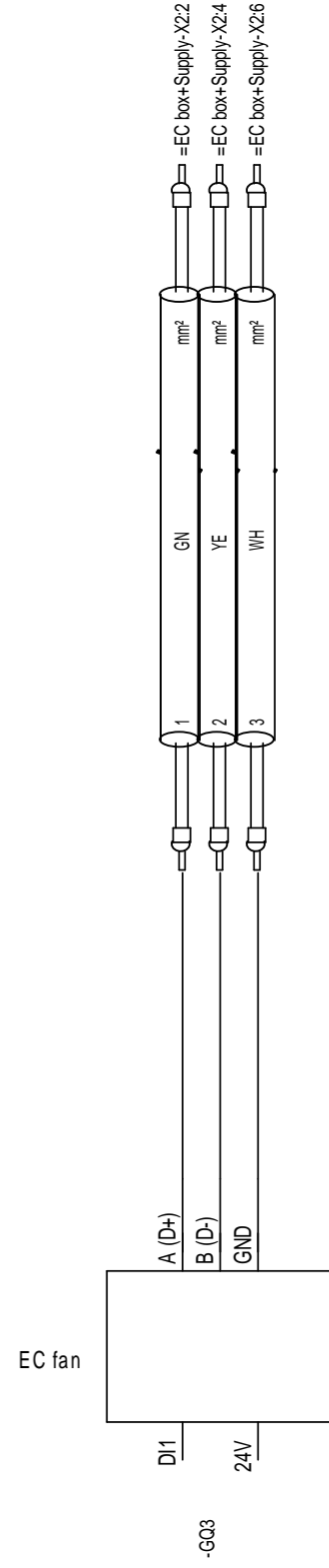

Cable Plan

Remark: GQ4 BUS
Cable-type: 4x0,6mm²

-W604

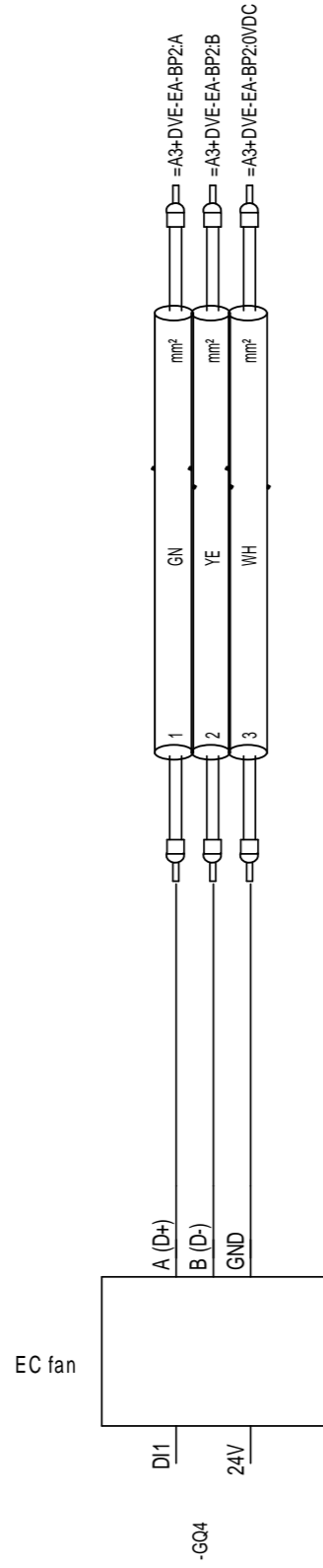

Path
Sheet

2
32
2
32
2
32

Remark: GQ4 BUS
Cable-type: 4x0,6mm²

-W604'

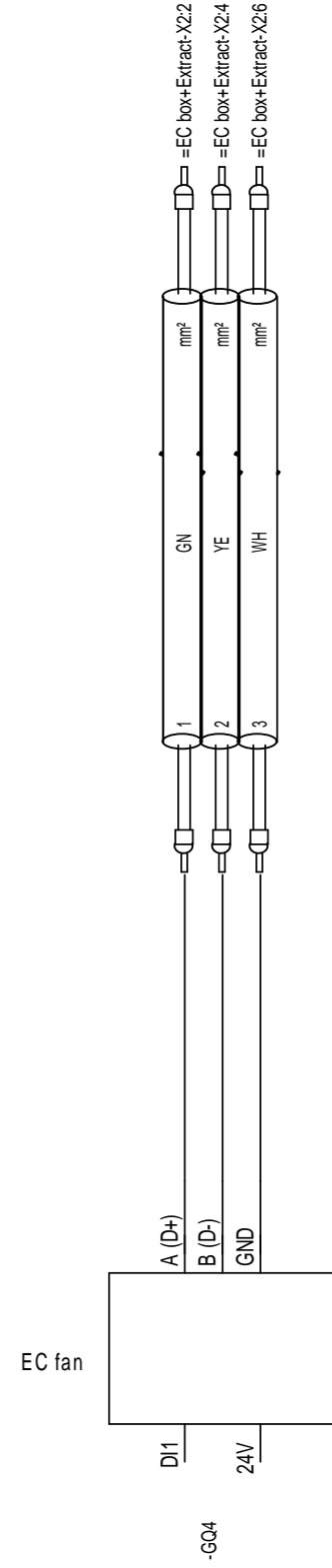

5
32
5
32
5
32

Remark: GQ5 BUS
Cable-type: 4x0,6mm²

-W605

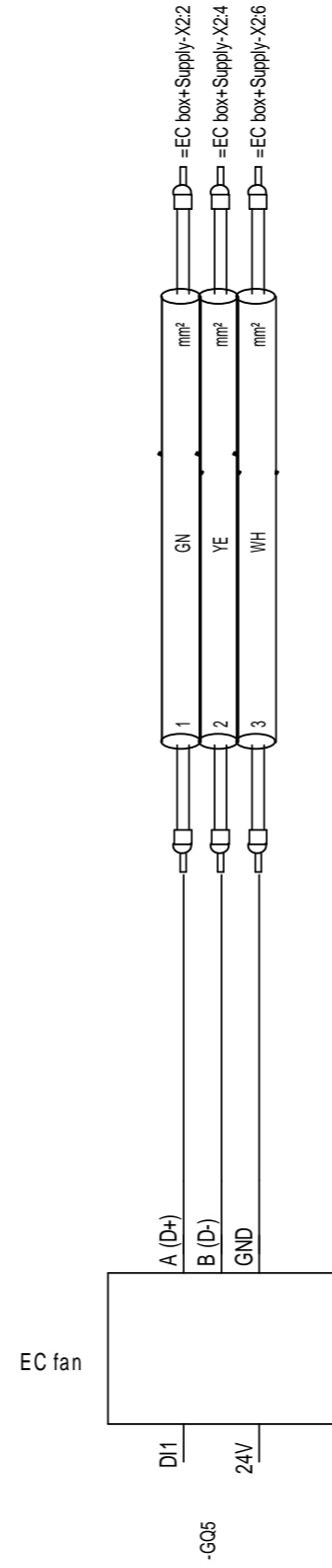

6
31
6
31
6
31

Remark: GQ6 BUS
Cable-type: 4x0,6mm²

-W606

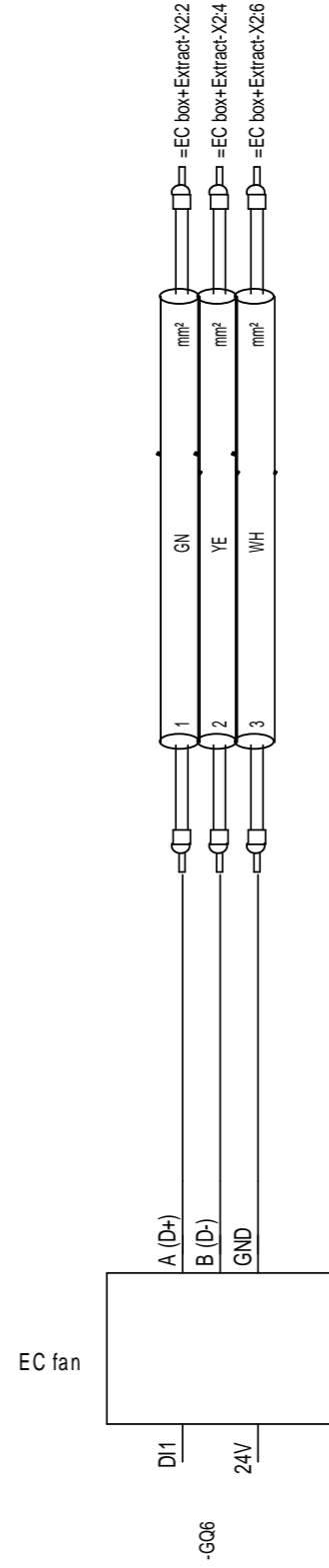

6
32
6
32
6
32

Cable Plan

Remark: GQ7 BUS
Cable-type: 4x0,6mm²

-W607'

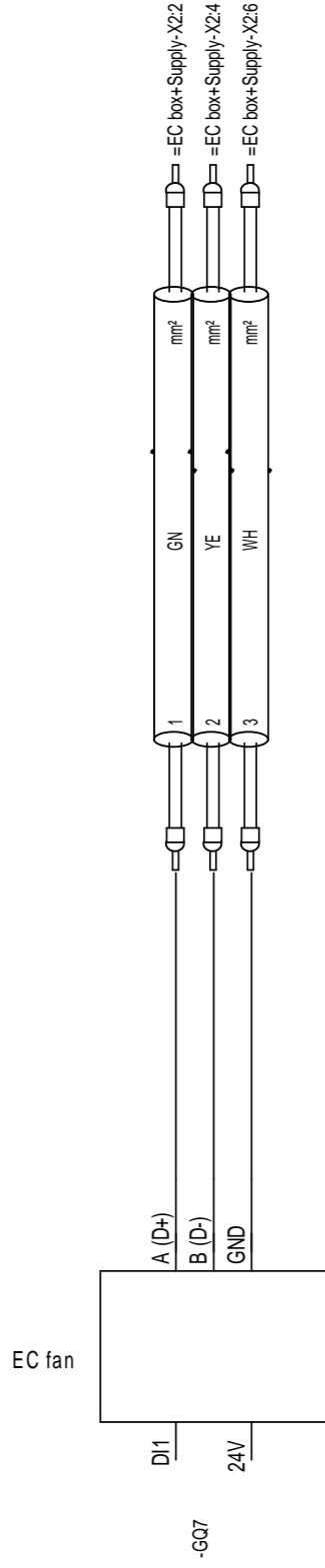

-W608'

Remark: GQ8 BUS
Cable-type: 4x0,6mm²

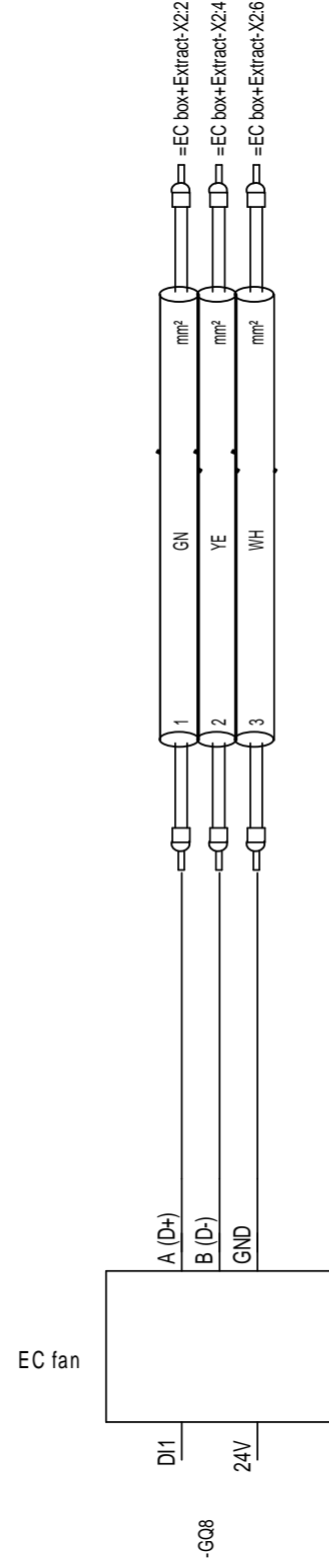

-W609'

Remark: GQ9 BUS
Cable-type: 4x0,6mm²

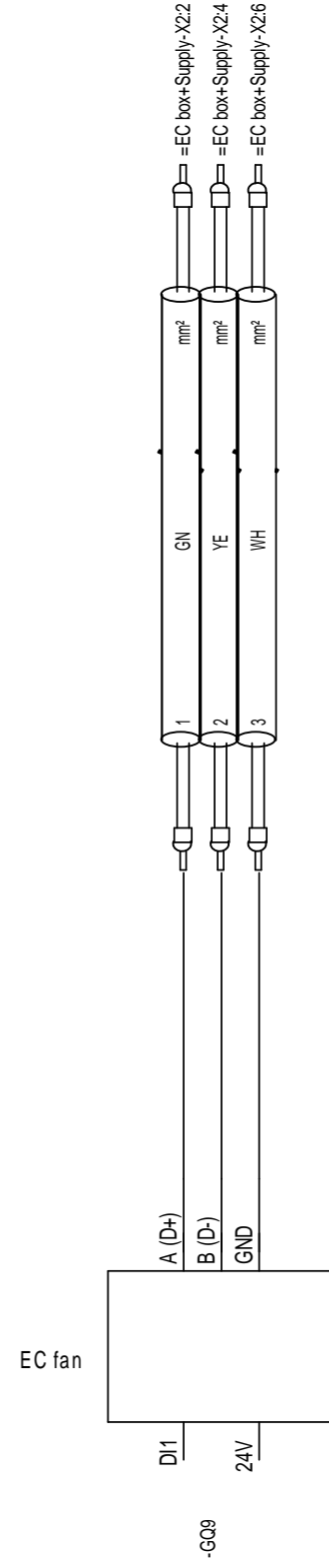

-W610'

Remark: GQ10 BUS
Cable-type: 4x0,6mm²

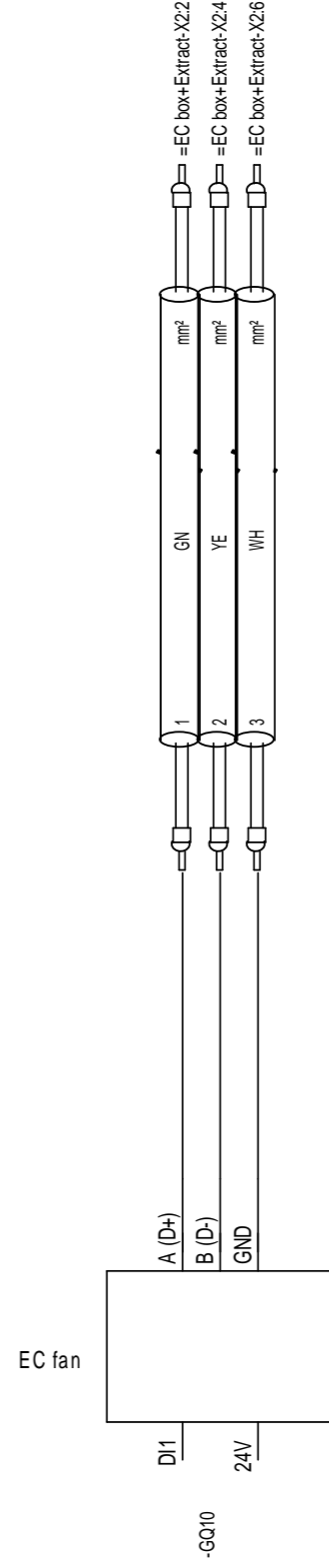

-W631.1/S

Remark: Supply
Cable-type:

Path
Sheet

7
31
31
31

7
32
32
32

9
31
31
31

9
32
32
32

Cable Plan

Sheet	Path
33	1
33	1
33	1
33	1
33	1
33	2
33	2
33	2
33	2
34	2
34	2
34	2
34	2

-W631.1/S

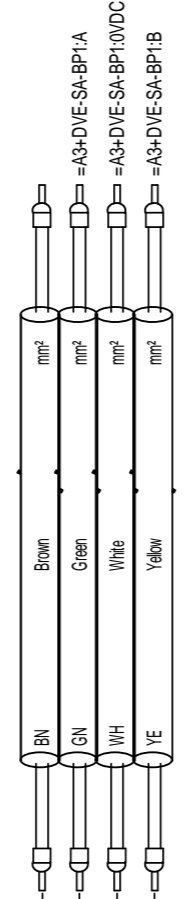
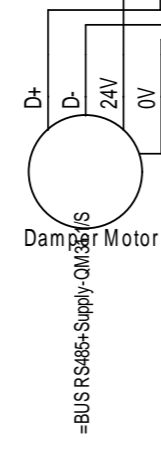
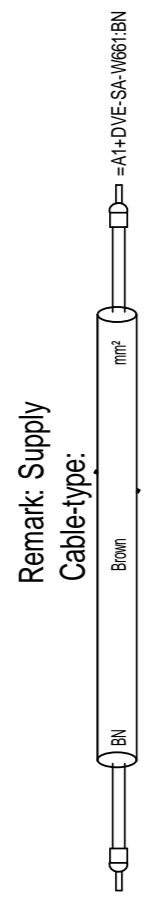

-W631.2/S

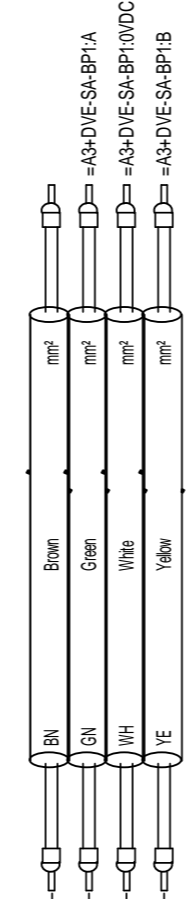
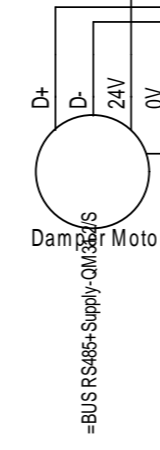
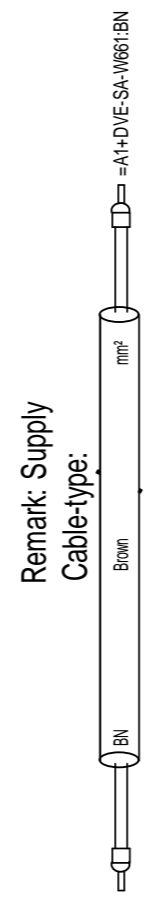

-W632.1/S

Remark: Extract
Cable-type:

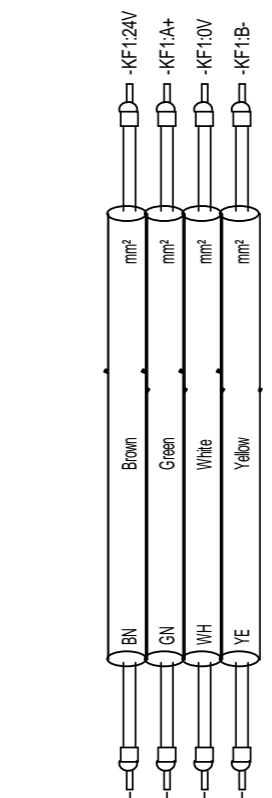
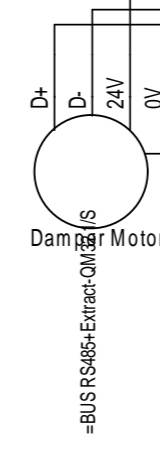

Cable Plan

Path
Sheet

-W632.2/S

Remark: Extract
Cable-type:

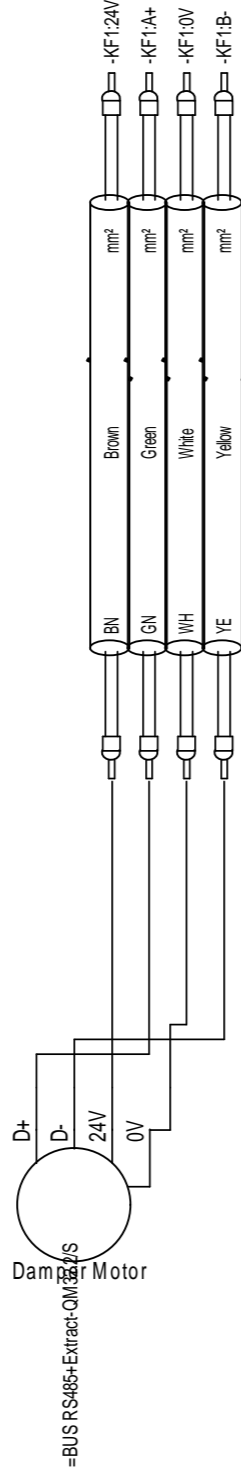

-W633.1/S

Remark: REC
Cable-type:

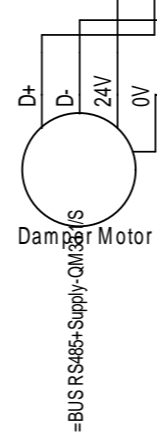

-W633.2/S

Remark: REC
Cable-type:

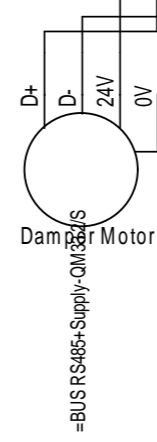

34
34
34
34

33

33
33
33
33

33

33
33
33
33

8
8
8
8

Cable Plan

Path	Sheet
7	35
7	35
6	35
6	35
6	35
1	35
1	35
1	35
1	35
2	35
2	35
2	35
2	35

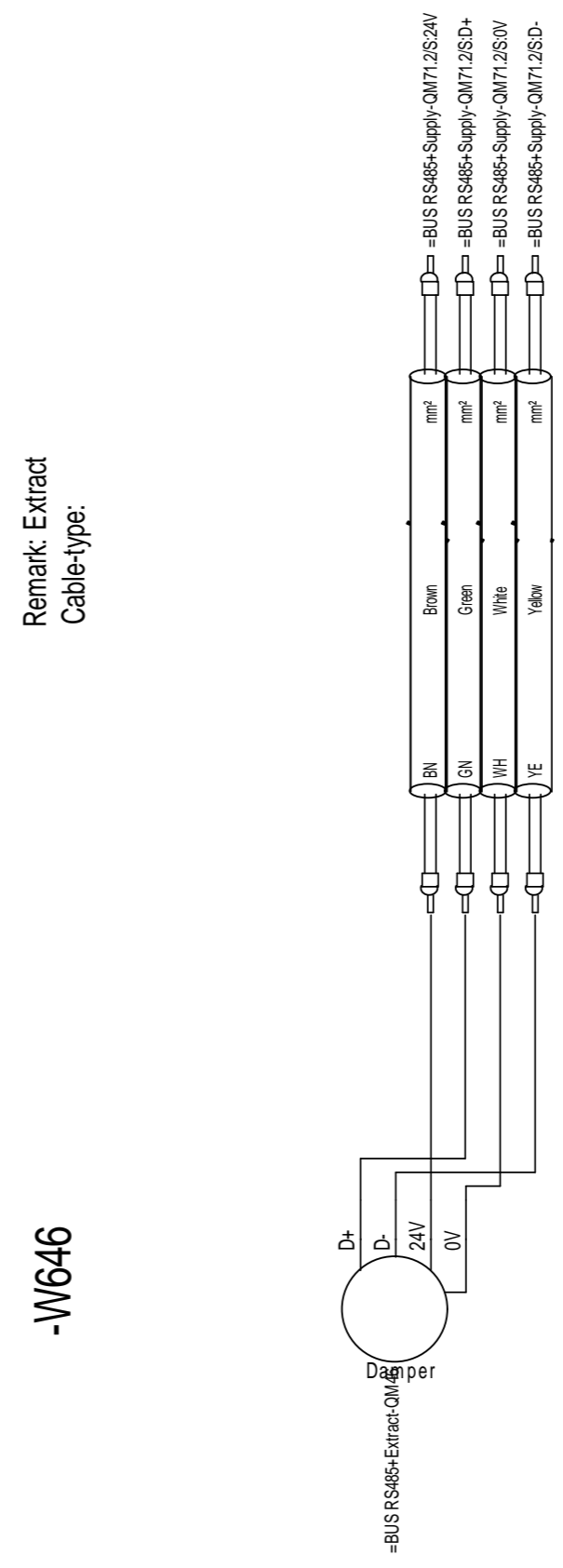
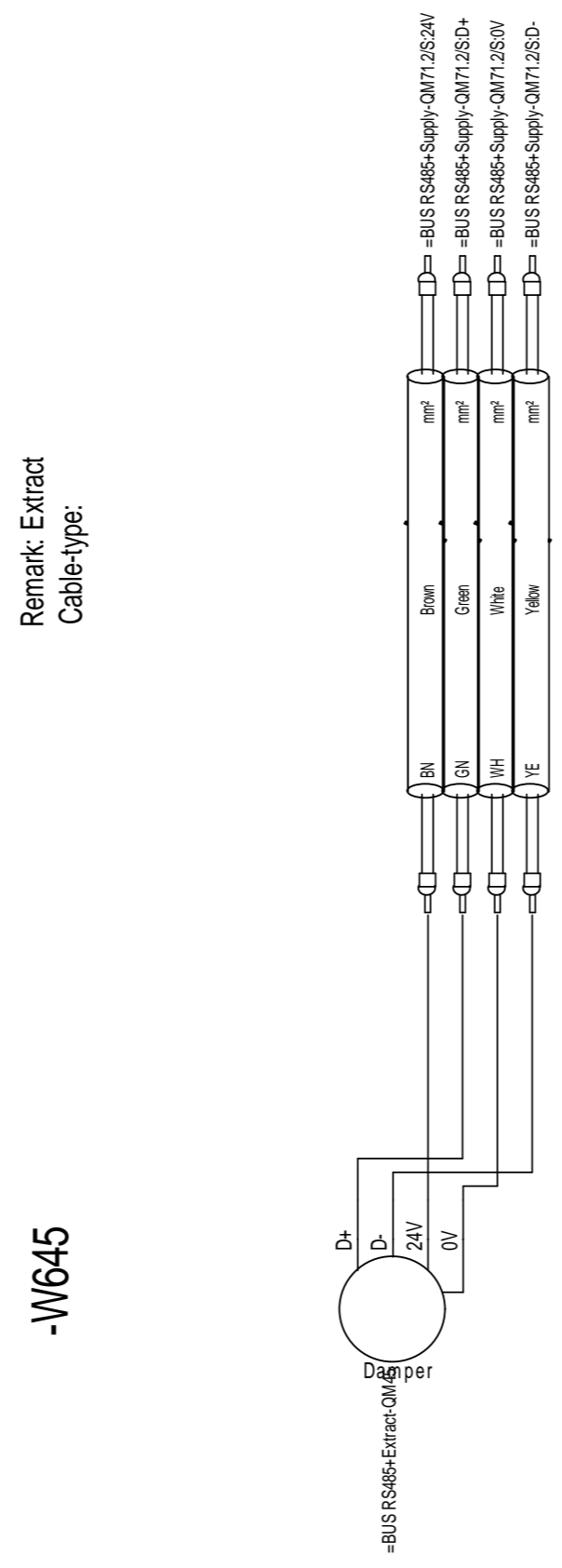
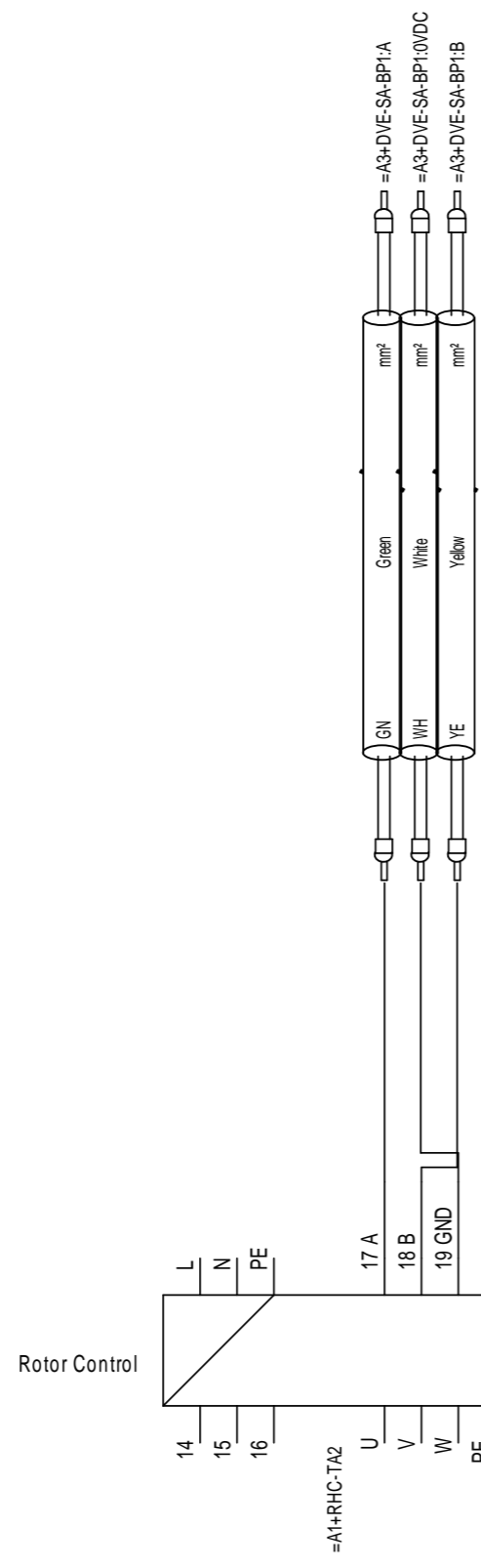
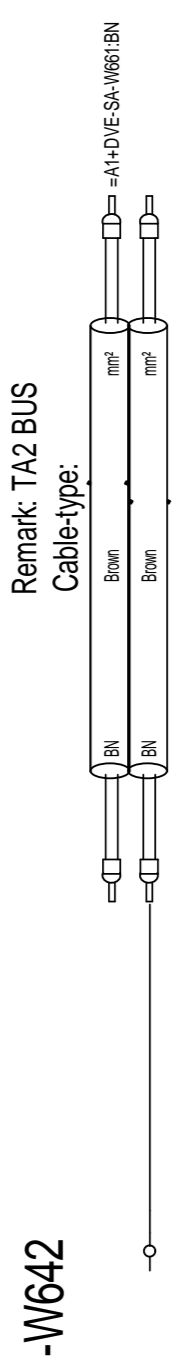

Cable Plan

-W647

Remark: Extract
Cable-type:

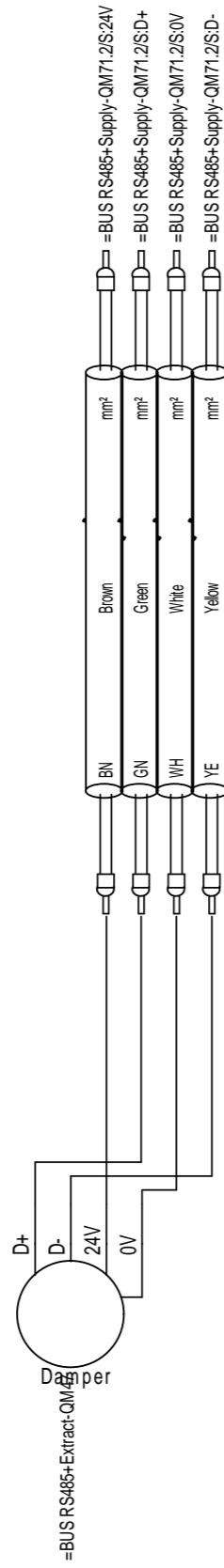

-W665

Remark: Pressure Rotor
Cable-type:

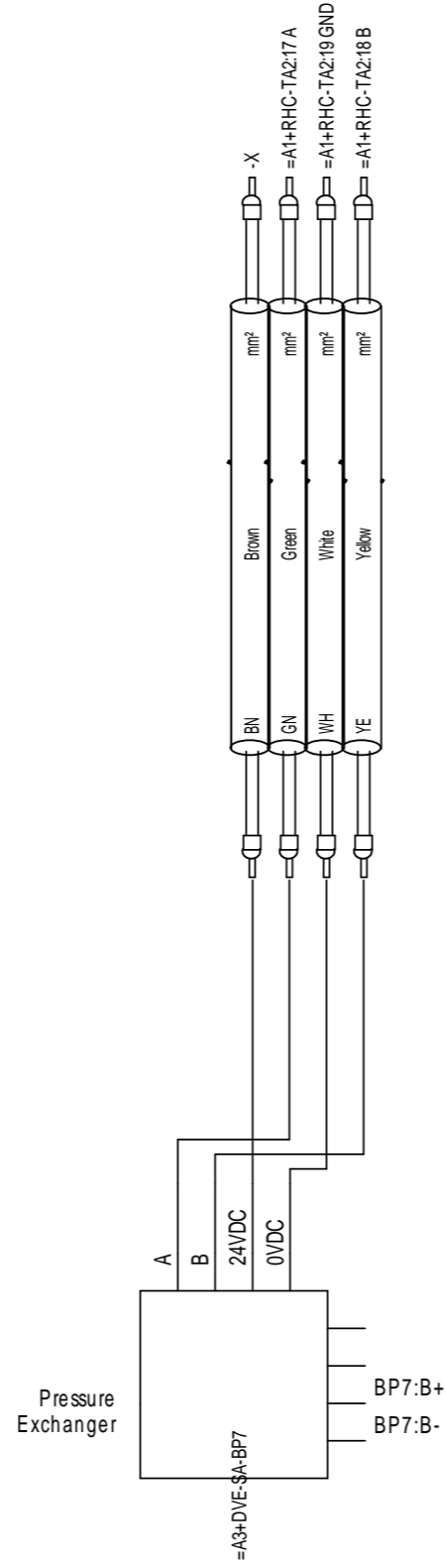

-W666

Remark: Pressure Plate
Cable-type:

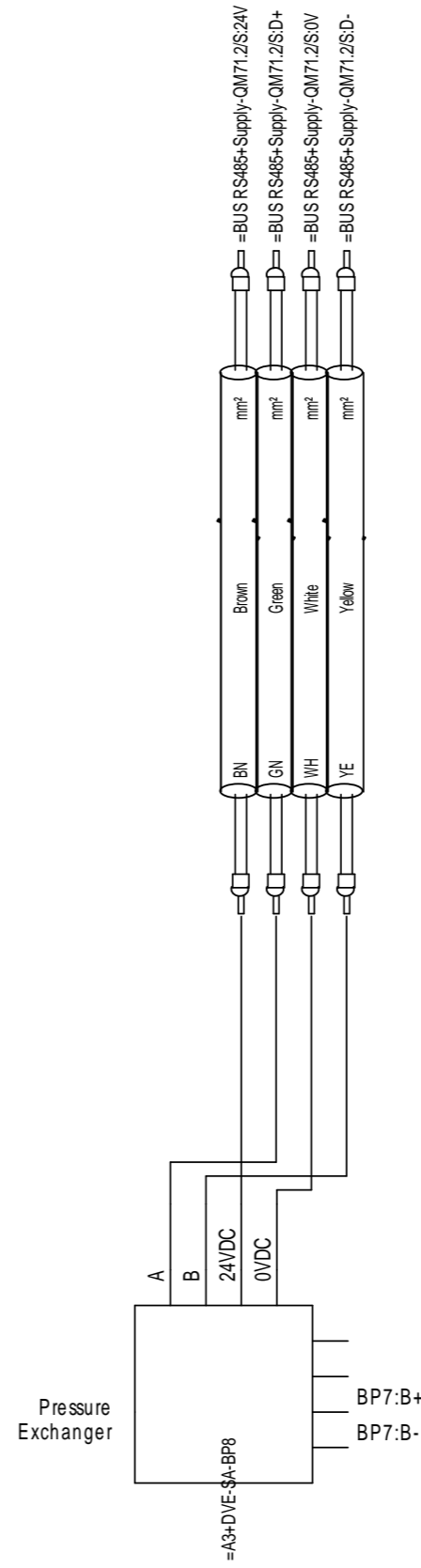

-W667

Remark: Supply
Cable-type:

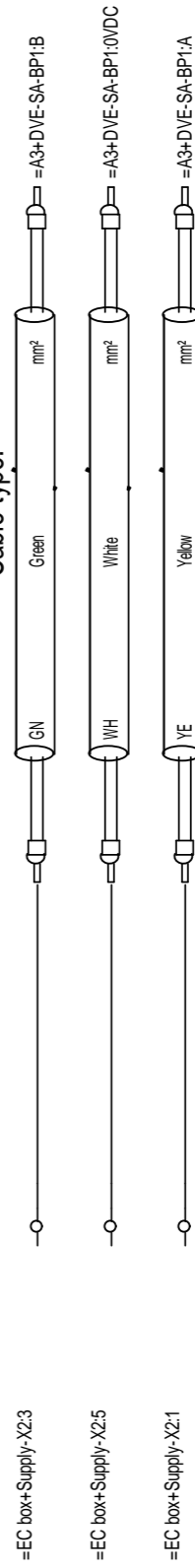

Path
Sheet

35	4
35	3
35	4
35	4

35	8
35	8
35	8
35	8

34	8
34	7
34	8
34	8

31	4
31	4
31	4

Cable Plan

-W668

Remark: Extract
Cable-type:

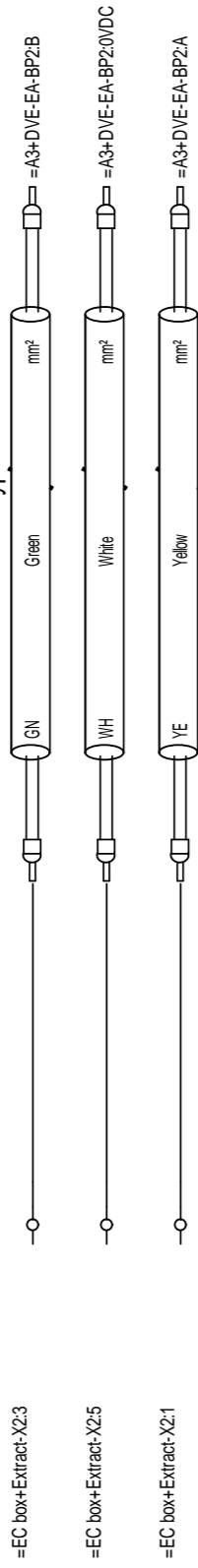

-W671.1/S

Remark: Supply 2
Cable-type:

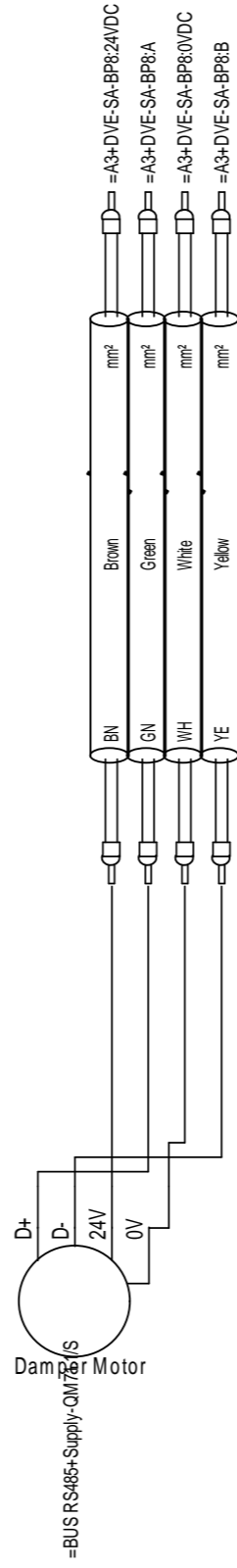

-W671.2/S

Remark: Supply 2
Cable-type:

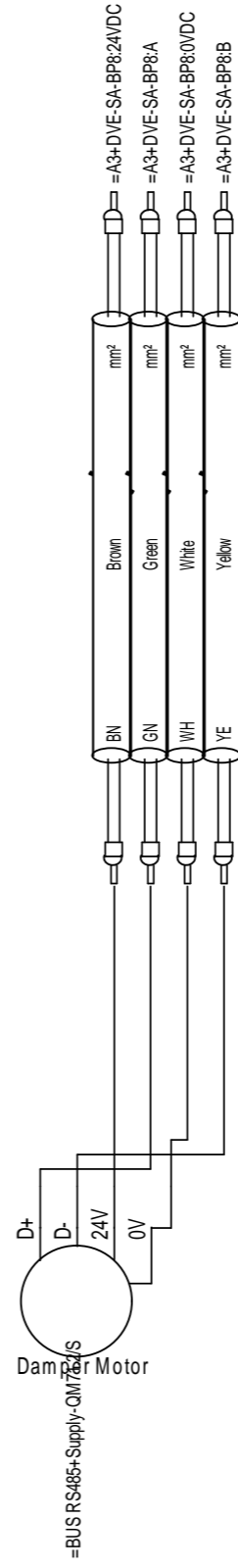

Sheet Path

32 4

32 4

32 4

34 5

34 4

34 5

34 4

34 6

34 5

34 6

34 6

Cable Plan

-W672.1/S

Remark: Extract 2
Cable-type:

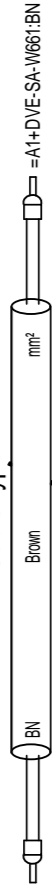

Sheet 33
Path 4

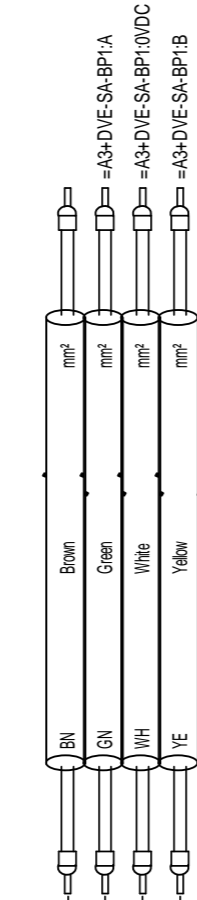
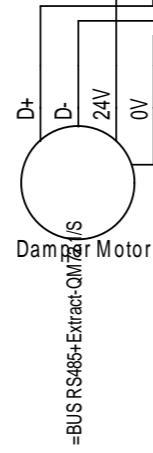

Sheet 33
Path 4
33
33
33
33

-W672.2/S

Remark: Extract 2
Cable-type:

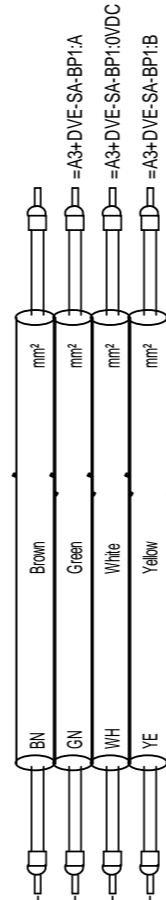
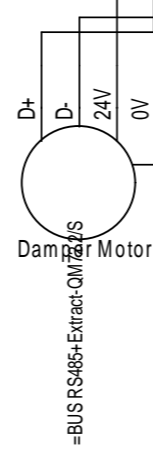

Sheet 33
Path 5
33
33
33
33

=A1-W111

Remark: VLT Supplyair
Cable-type:

Supply air

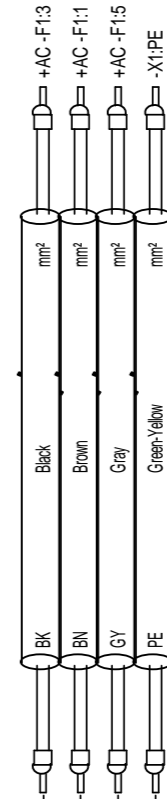
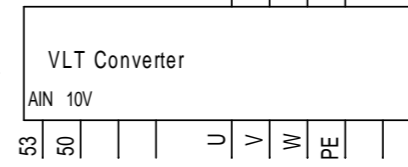

Sheet 21
Path 6
21
21
21
21

Cable Plan

Remark: VLT extract power
Cable-type:

=A1-W112

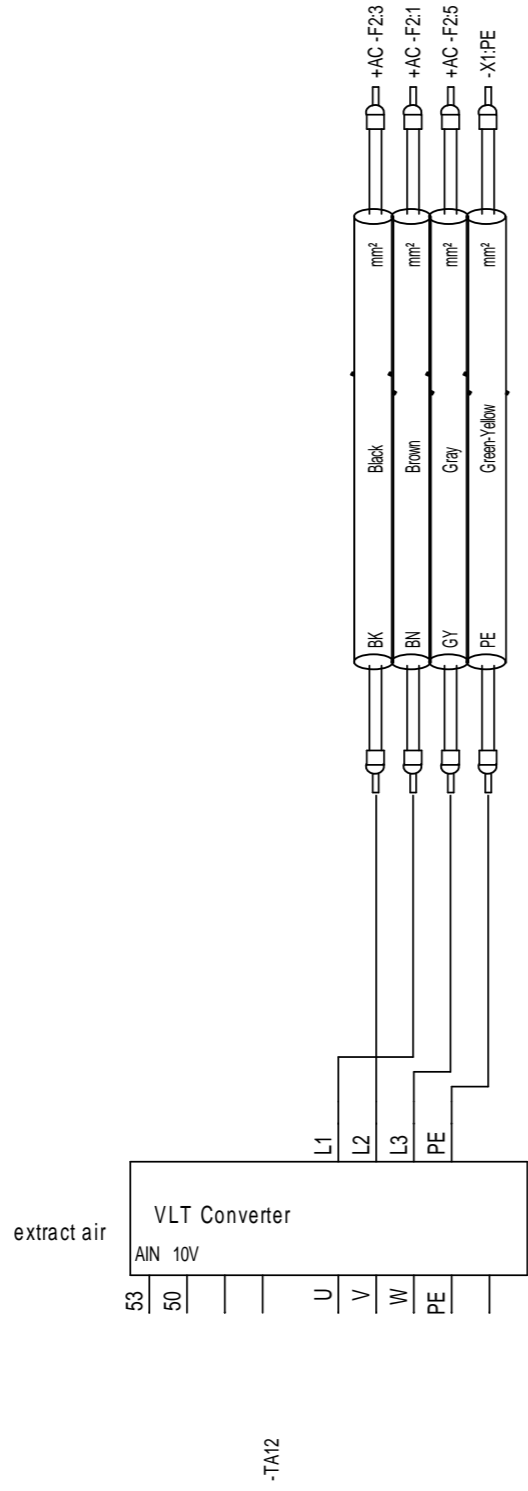

Remark: VLT Supplyair
Cable-type:

=A1-W113

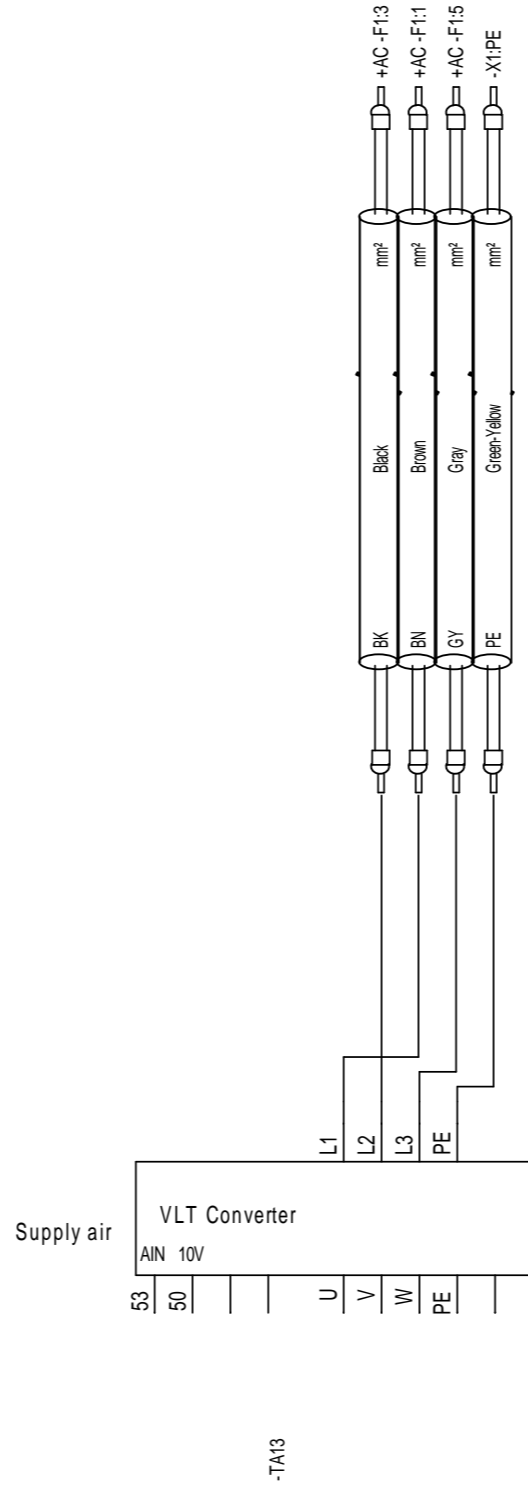

Remark: VLT extract power
Cable-type:

=A1-W114

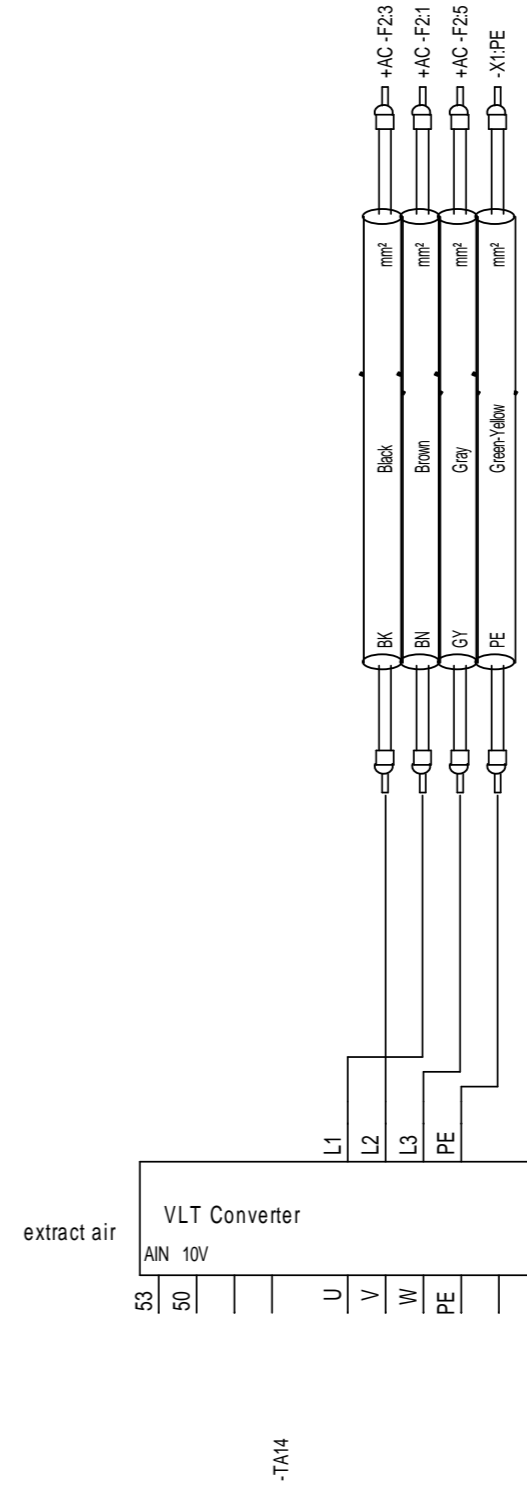

Path	6	6	6	7	8	8	9	9	8	8	9	9
Sheet	22	22	22	22	21	21	21	21	22	22	22	22

Cable Plan

Path
Sheet

Remark: VLT Supplyair
Cable-type:

=A1-W121

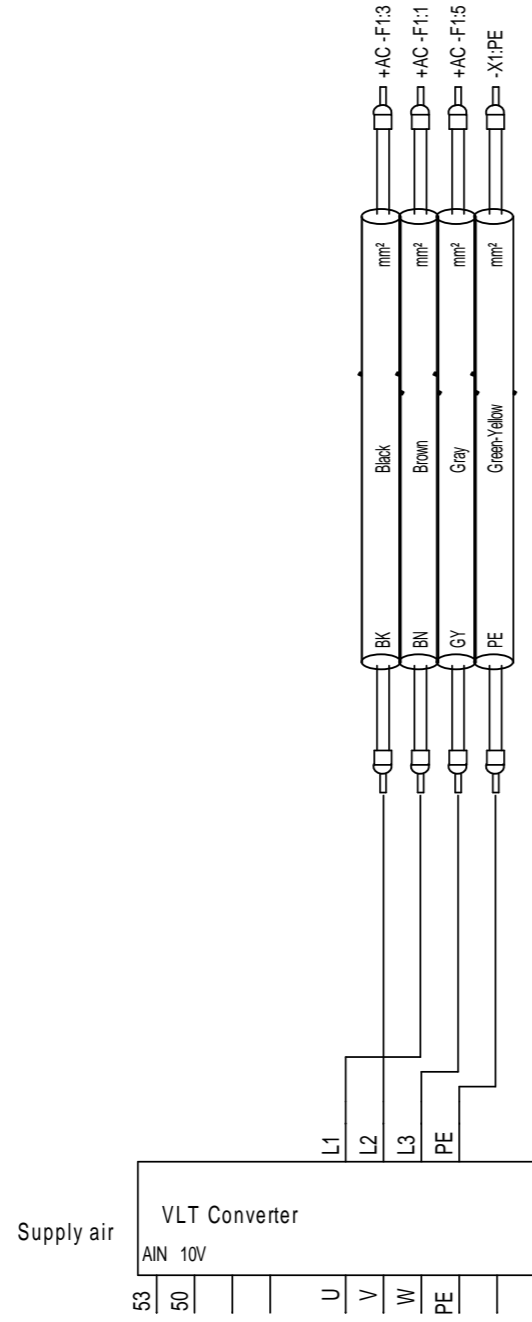

-TA21

Remark: VLT extract power
Cable-type:

=A1-W122

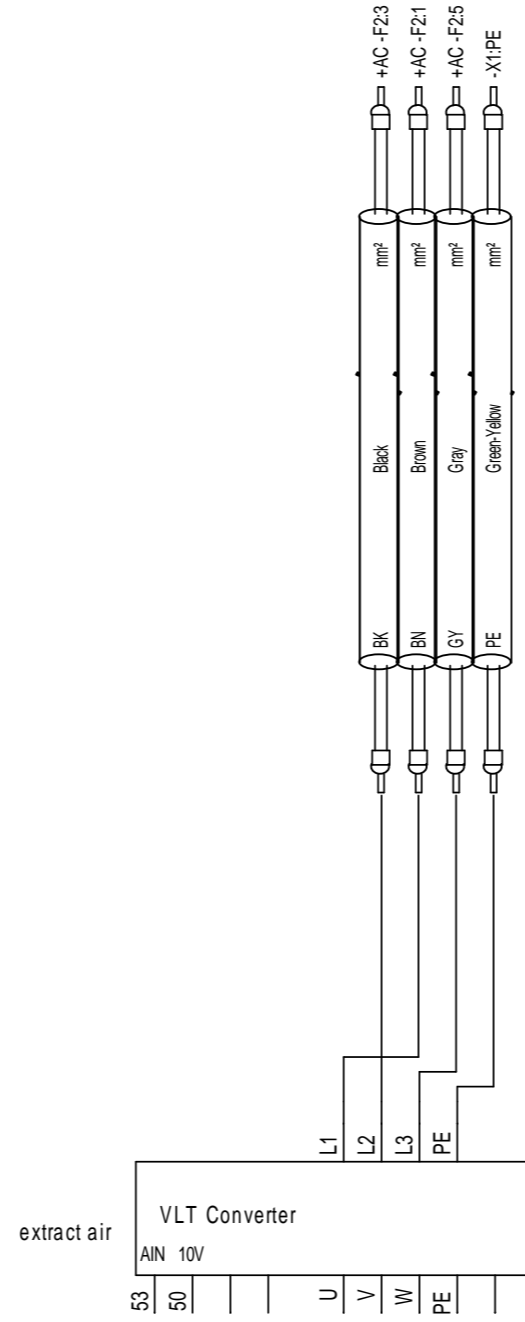

-TA22

Remark: motor supplyair
Cable-type:

=A1-W311

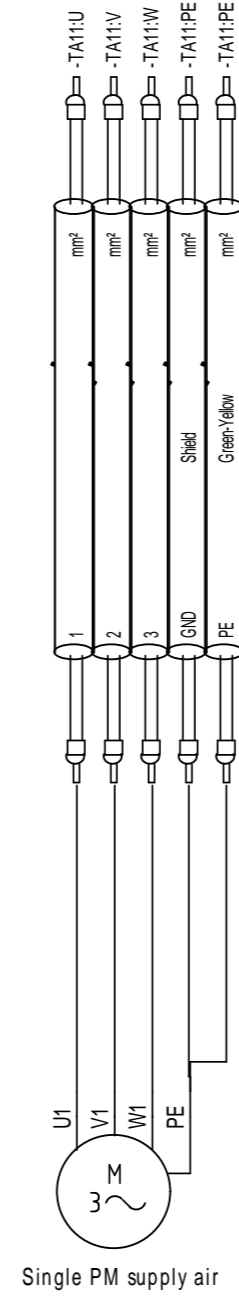

-MA11

Remark: Supply thermistor
Cable-type:

=A1-W311.1

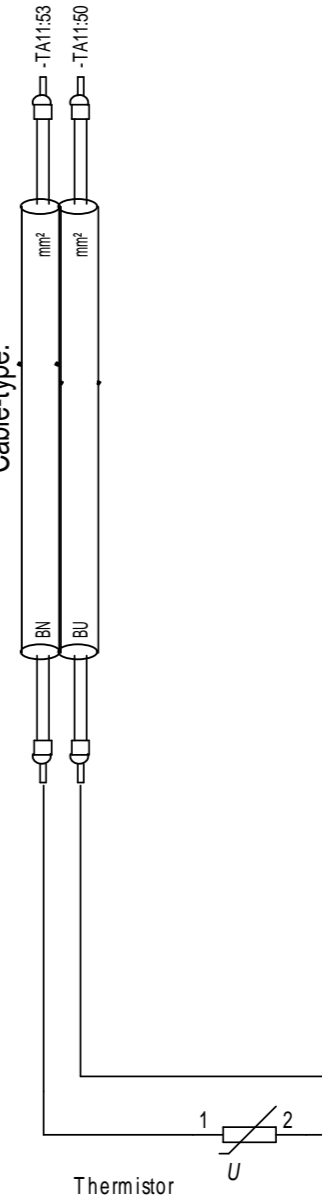

-BE11

1
21

1
21

1
21

1
21

1
22

1
22

2
22

2
22

6
21

6
21

6
21

6
21

6
21

5
21

5
21

Cable Plan

Path
Sheet

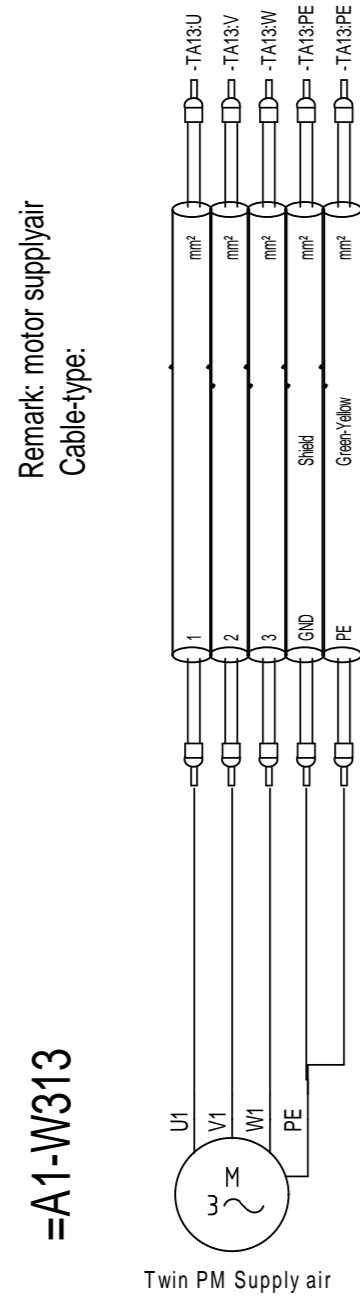

8
21
8
21
9
21
9
21
9
21

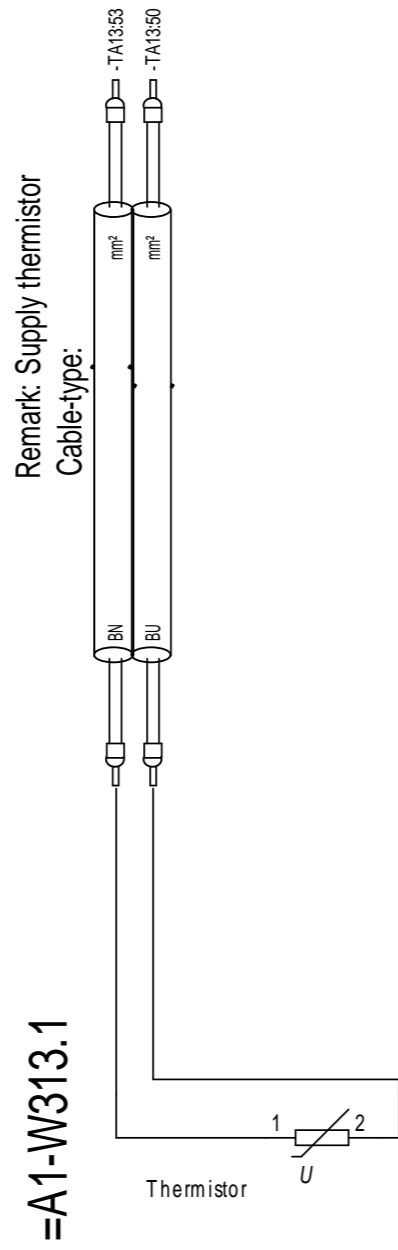

8
21
8
21

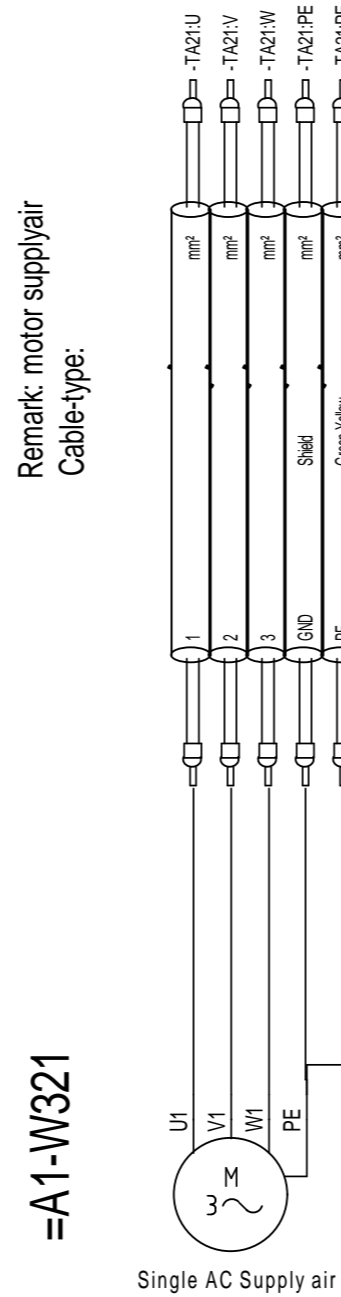

1
21
1
21
1
21
2
21
1
21

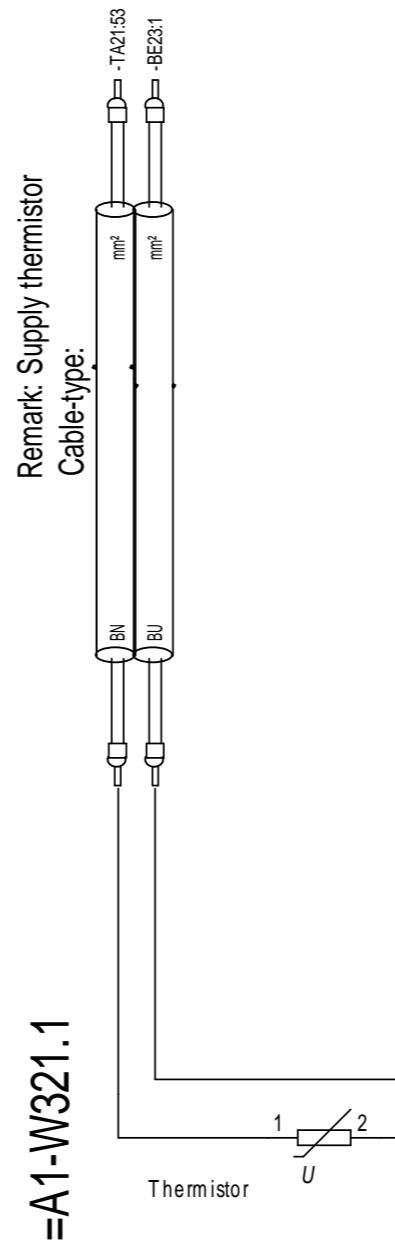

0
21
1
21

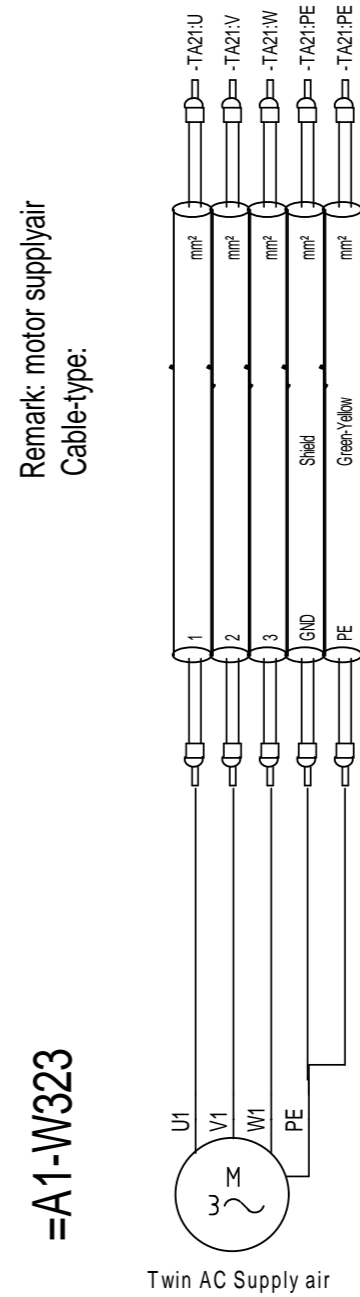

3
21
3
21
3
21
4
21
4
21

Cable Plan

Sheet	Path
21	3
21	3
35	6
35	6
35	6
35	7
36	1
36	1
22	6
22	6
22	6
22	7
22	7
22	6
22	6

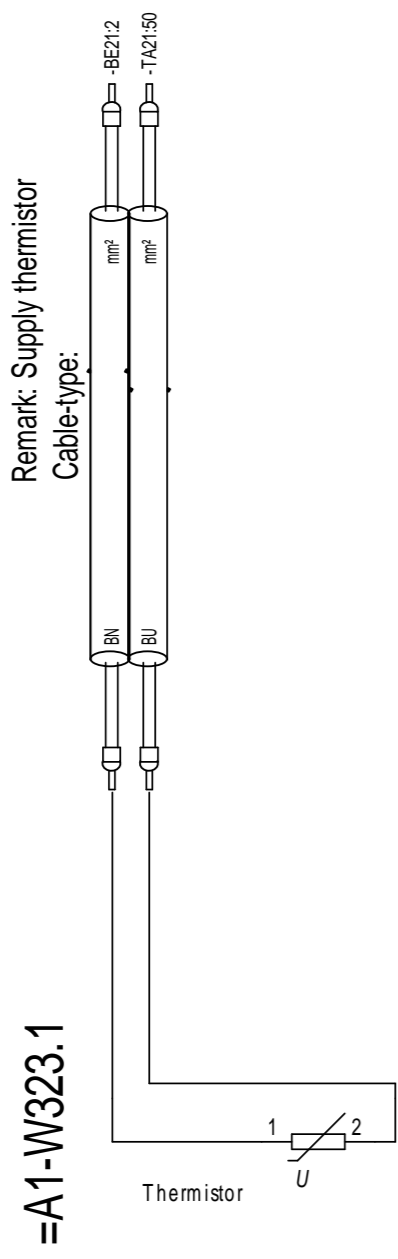

-BE23

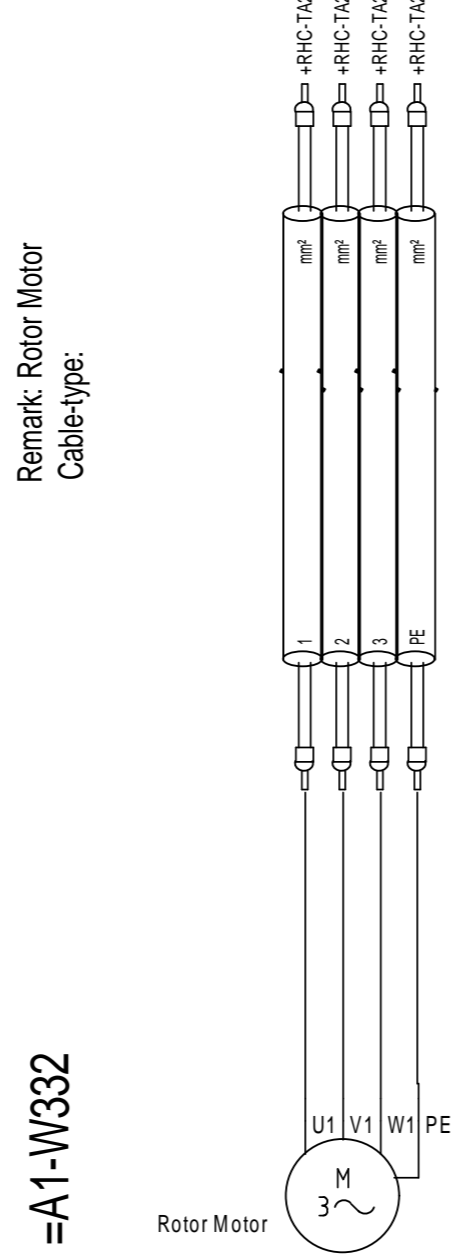

+RHC-MA42

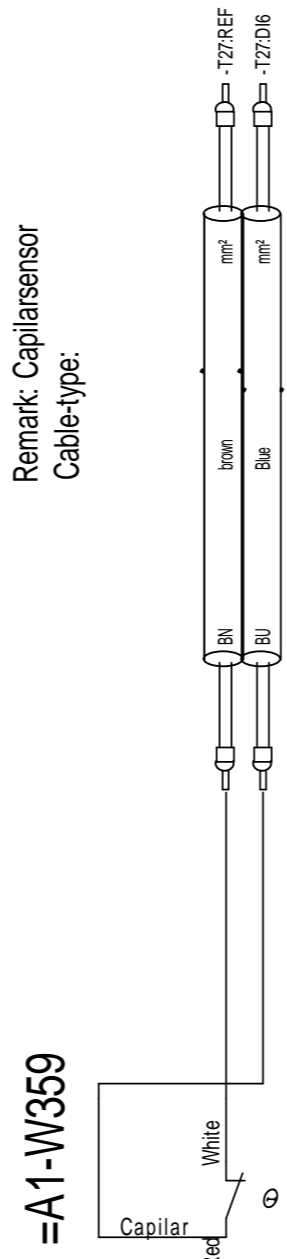

-BT11

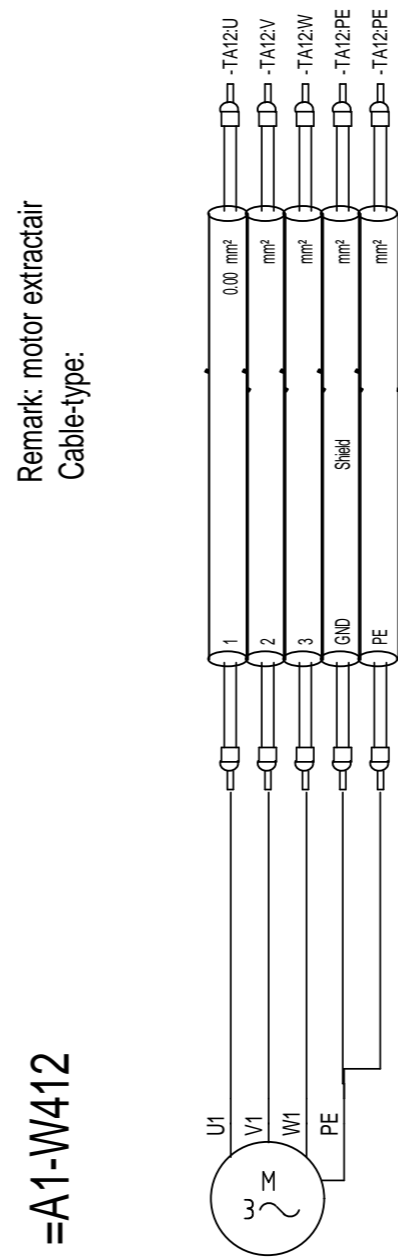

-MA12

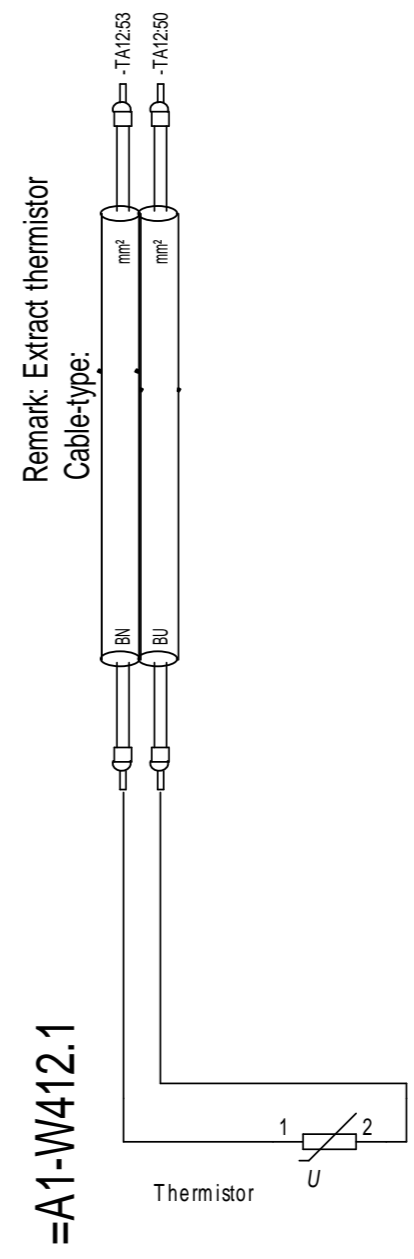

-BE12

Cable Plan

Path
Sheet

Remark: motor extractair
Cable-type:

=A1-W414

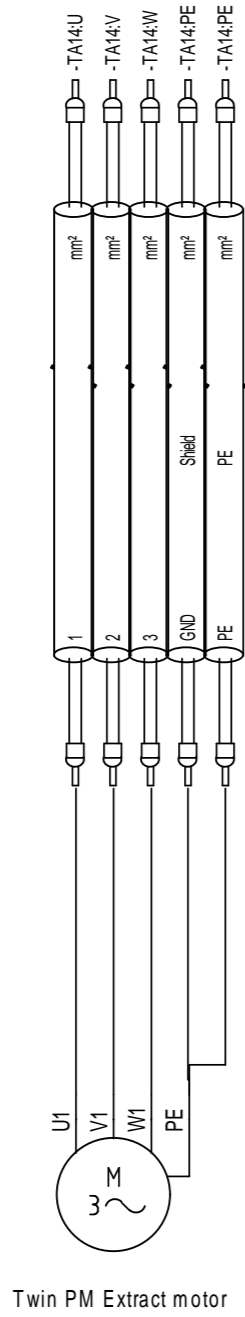

-MA14

=A1-W414.1

Remark: Extract thermistor
Cable-type:

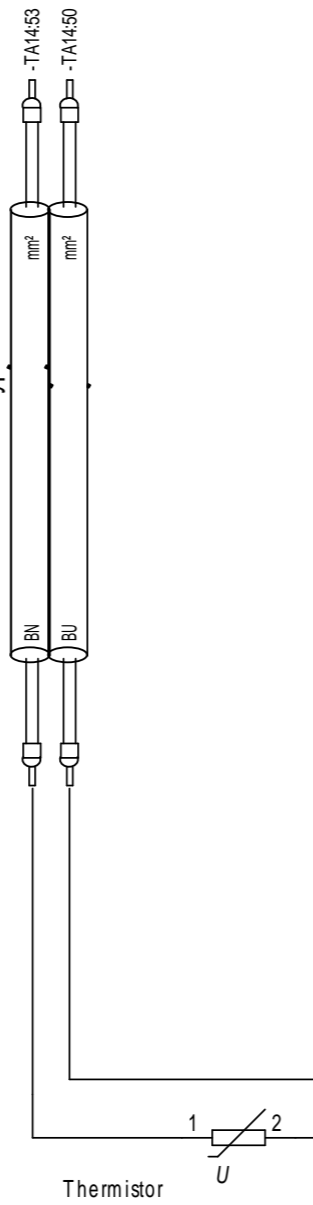

-BE14

=A1-W422

Remark: motor extractair
Cable-type:

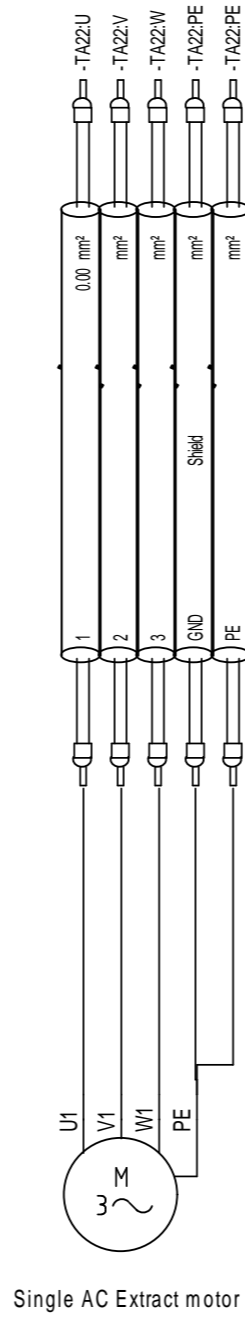

-MA22

=A1-W422.1

Remark: Extract thermistor
Cable-type:

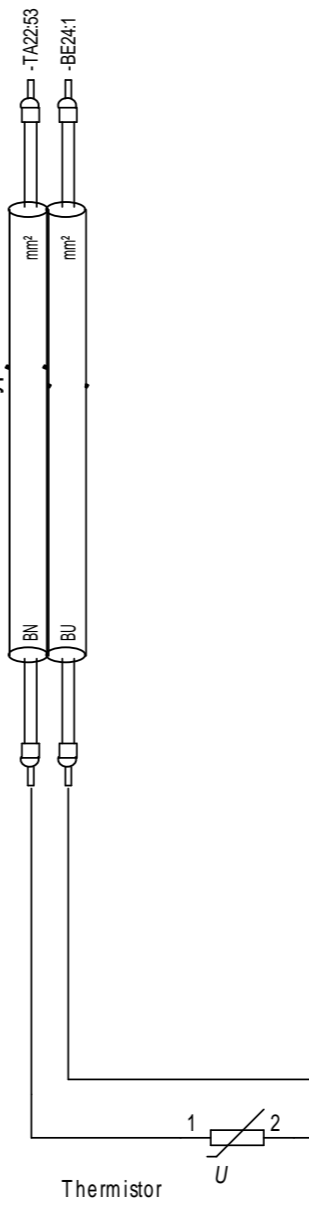

-BE22

=A1-W424

Remark: motor extractair
Cable-type:

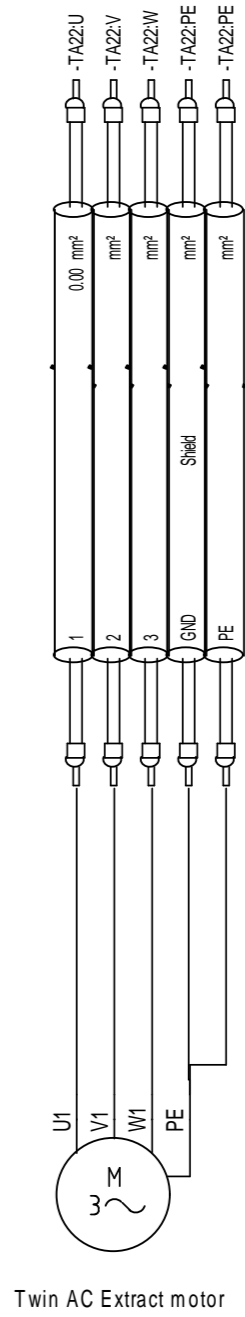

-MA24

Cable Plan

=A1-W424.1

Remark: Extract thermistor
Cable-type:

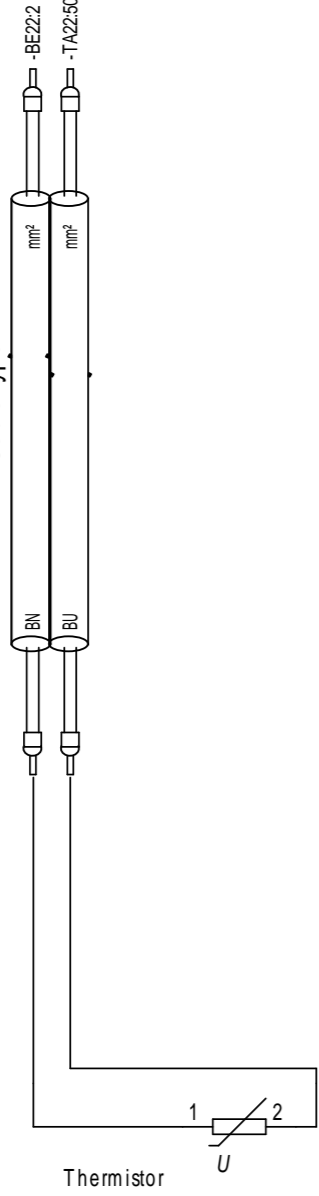

Sheet 22
Path 3

=A1-W460

Remark: Fire
Cable-type:

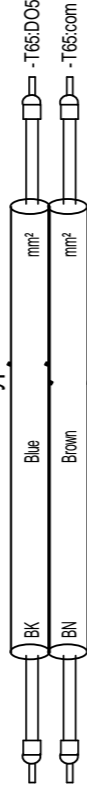

Sheet 30
Path 7

=A1-W529

Remark: DVU-HP
Cable-type:

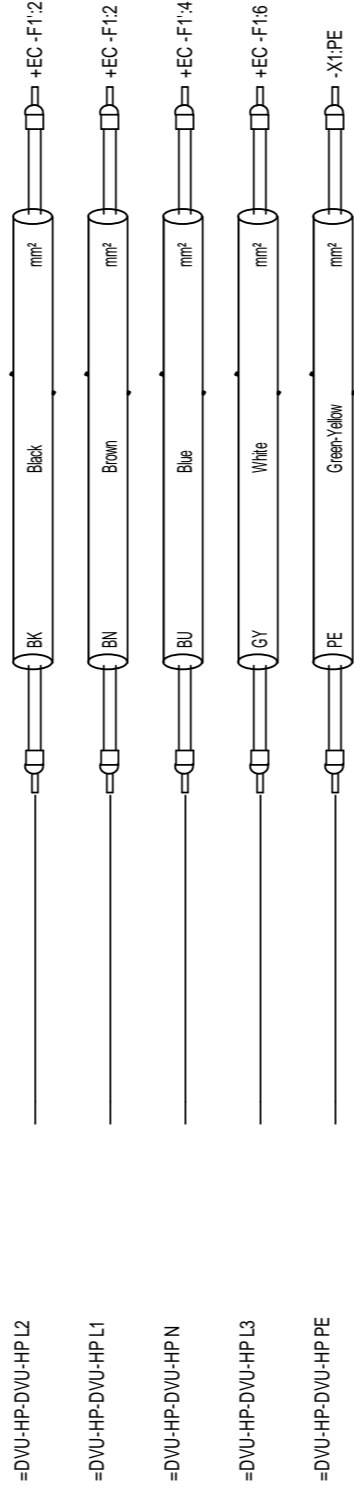

Sheet 19
Path 8

=A1-W532

Remark: Rotor sensor
Cable-type:

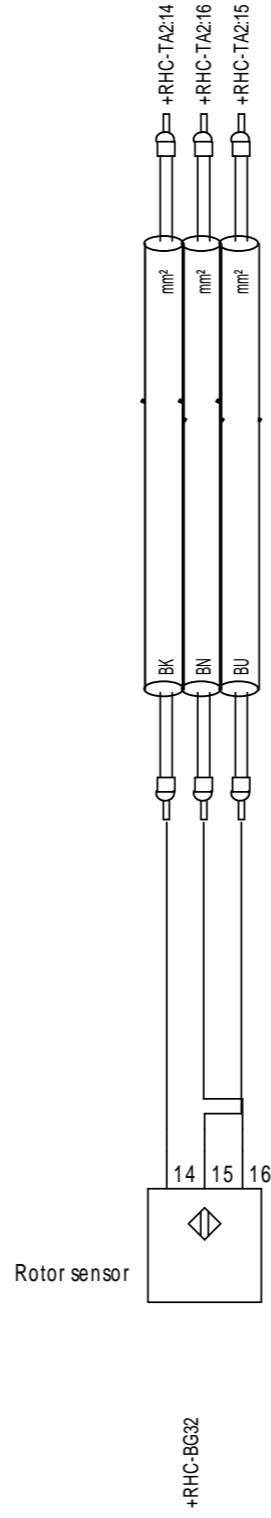

Sheet 35
Path 6

=A1-W550

Remark: Mixing pump
Cable-type:

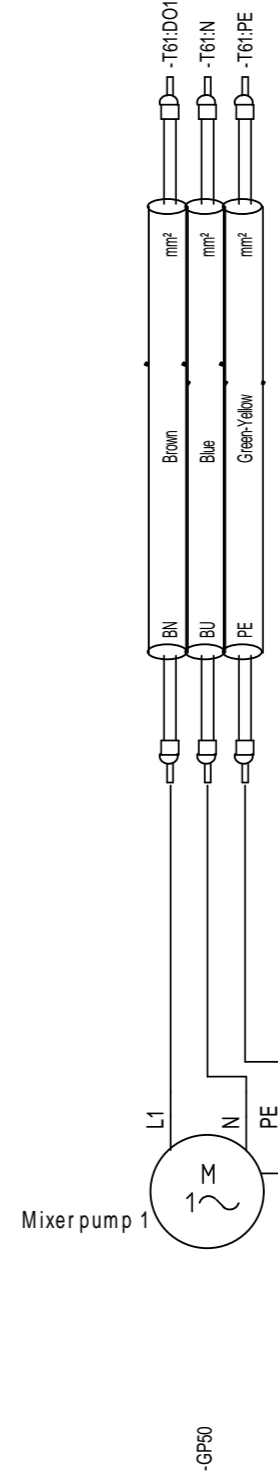

Sheet 15
Path 1

Cable Plan

Sheet	Path
17	4
17	4
17	4
20	2
20	2
20	3
18	1
18	1
18	1
29	4
29	4
29	4

=A1-W554

Remark: Cooling valve
Cable-type:

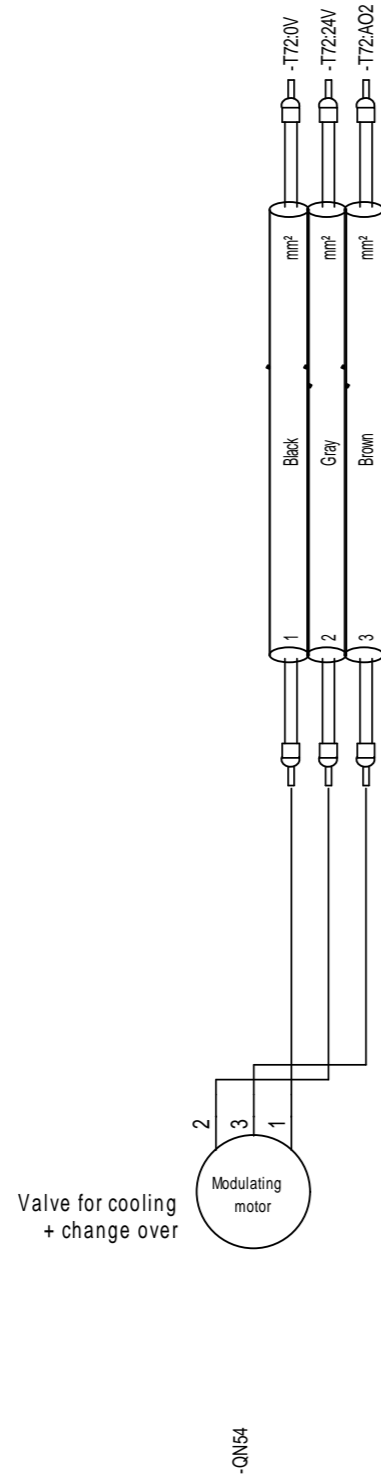

-QN54

=A1-W562

Remark: Mixing pump heater 2
Cable-type:

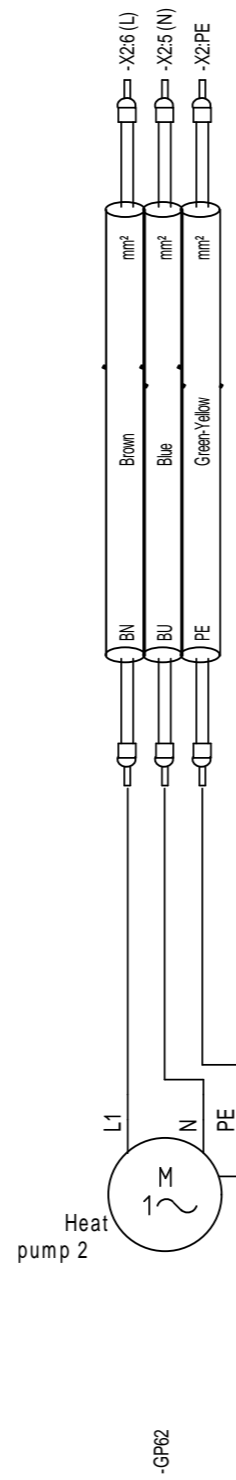

-GR62

=A1-W590

Remark: Exchanger
Cable-type:

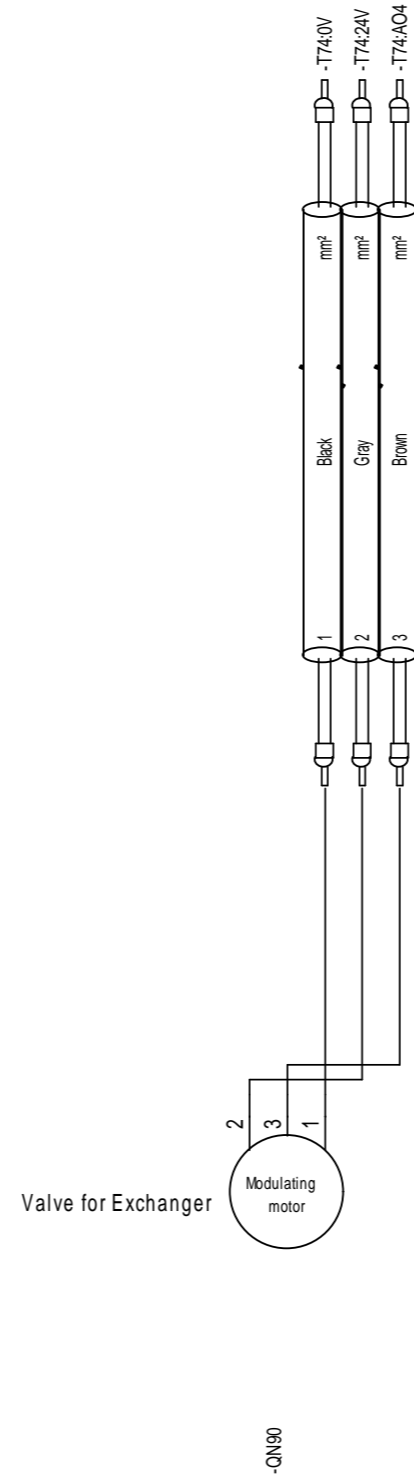

-QN90

=A1-W611

Remark: TA11 BUS
Cable-type: 4x0,6mm2

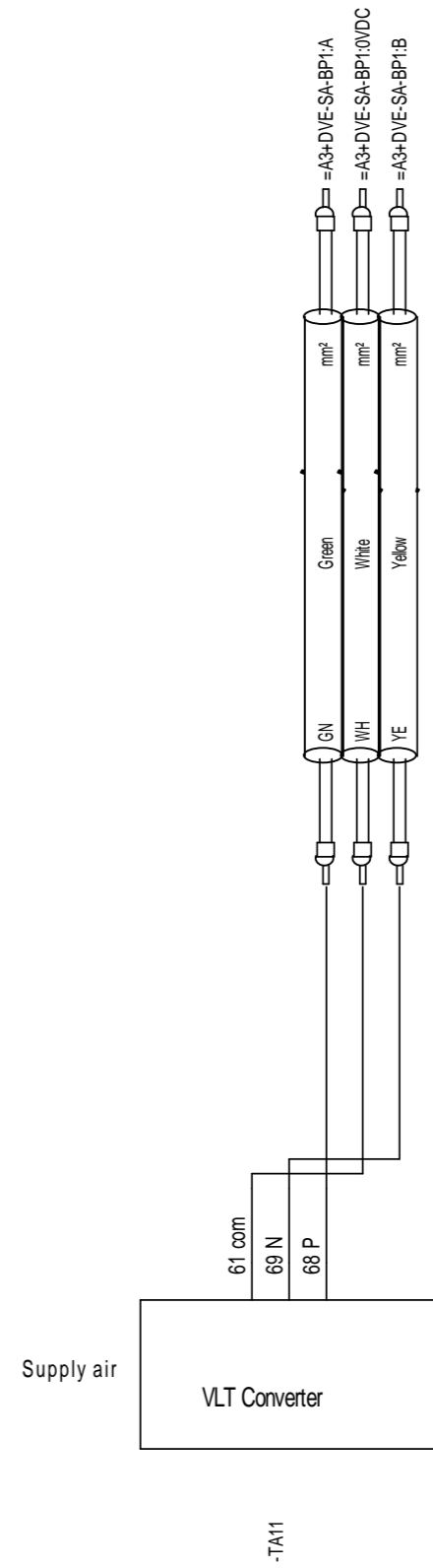

-TA11

Cable Plan

Path		4	4	4	6	5	5	6	5	6	7	7	7
Sheet		30	30	30	29	29	29	30	30	30	29	29	29

Remark: TA12 BUS
Cable-type: 4x0,6mm²

=A1-W612

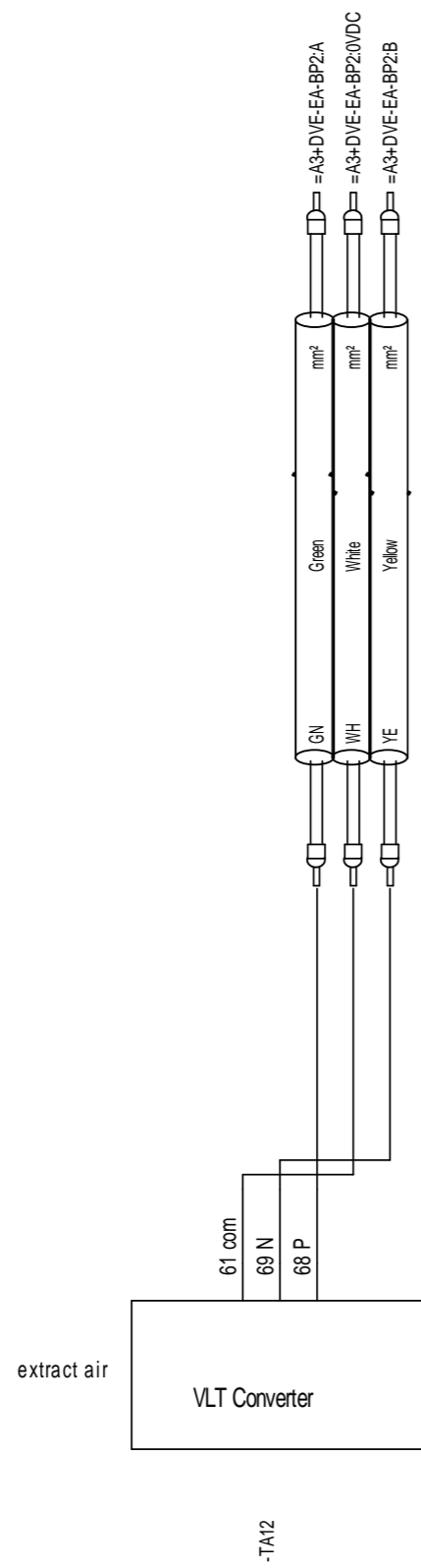

Remark: TA13 BUS
Cable-type: 4x0,6mm²

=A1-W613

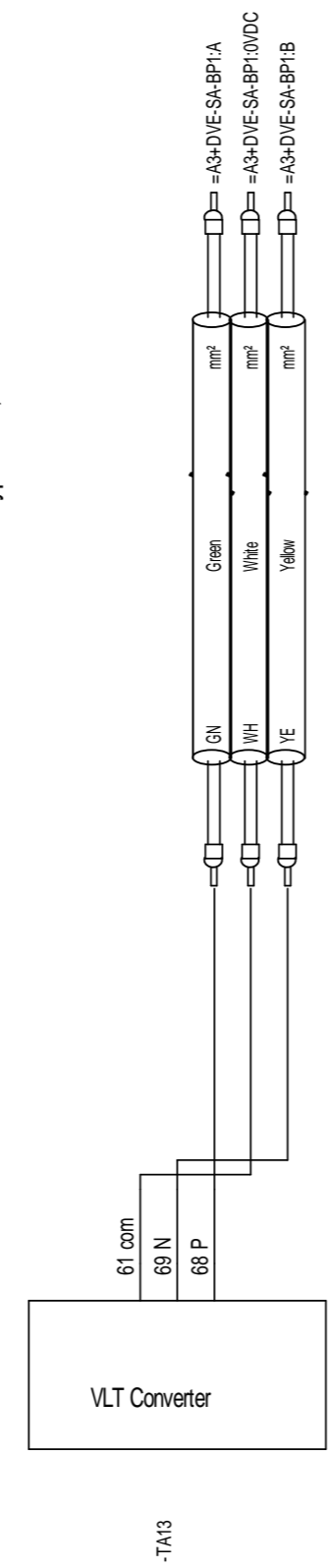

Remark: TA14 BUS
Cable-type: 4x0,6mm²

=A1-W614

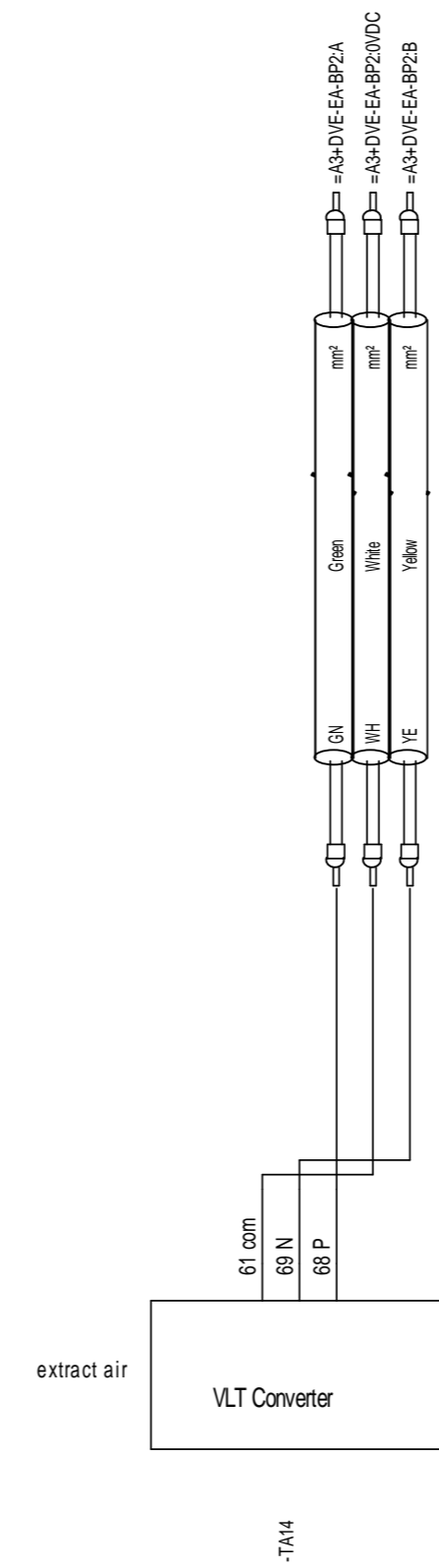

Remark: TA21 BUS
Cable-type: 4x0,6mm²

=A1-W621

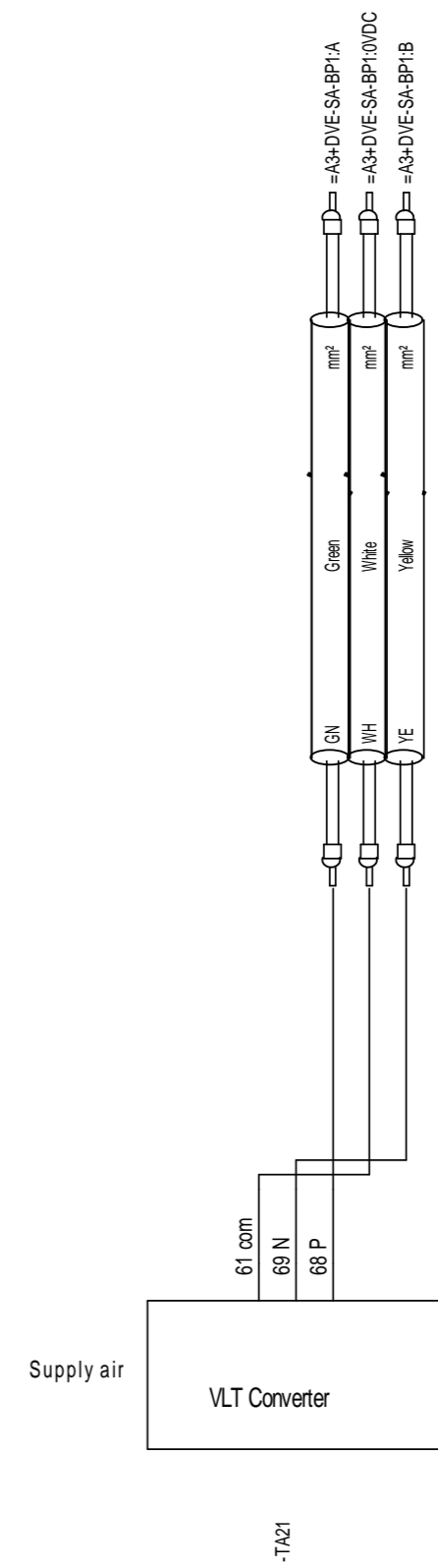

Cable Plan

Path	Sheet
7	30
7	30
7	30
5	20
4	20
5	20
5	20
6	20
6	20
7	20
7	20
8	20
7	20

Remark: TA22 BUS
Cable-type:

=A1-W622

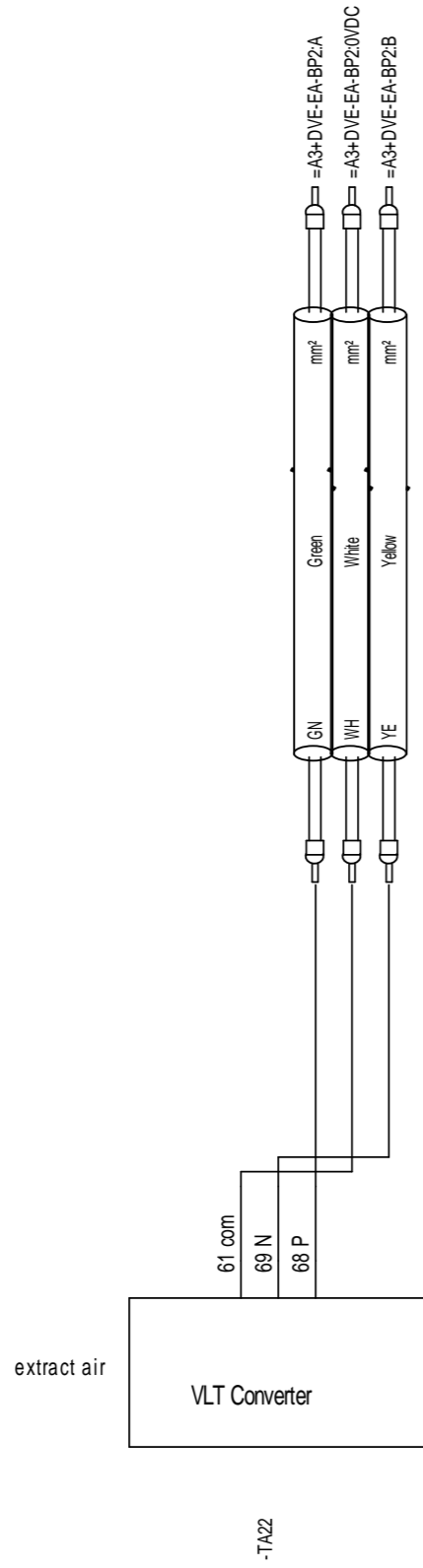

Remark: Light switch
Cable-type:

=A1-W700

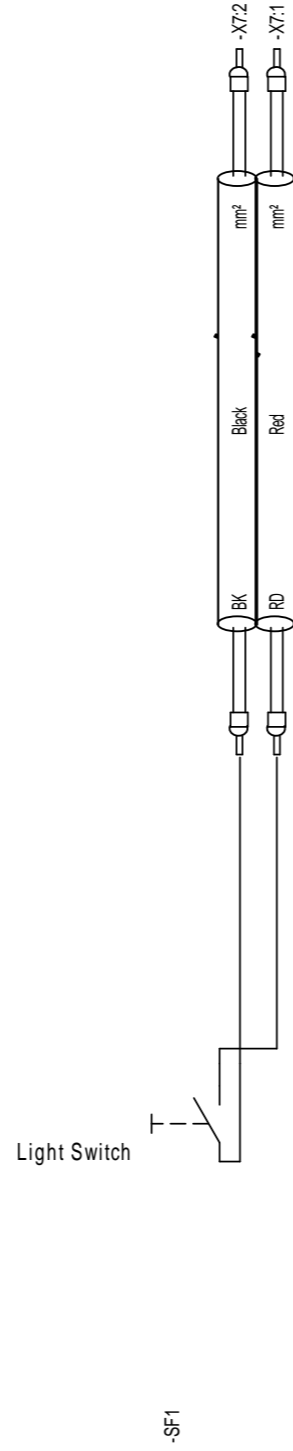

Remark: Light P20
Cable-type:

=A1-W701

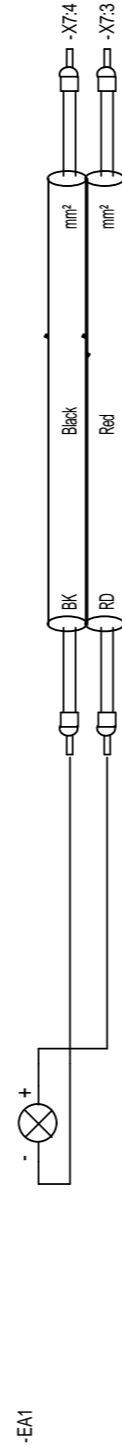

Remark: Light P20
Cable-type:

=A1-W702

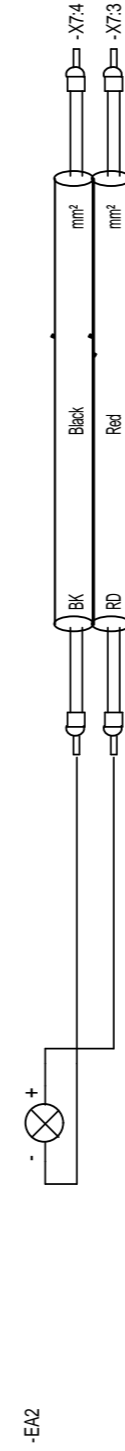

Remark: Light P20
Cable-type:

=A1-W703

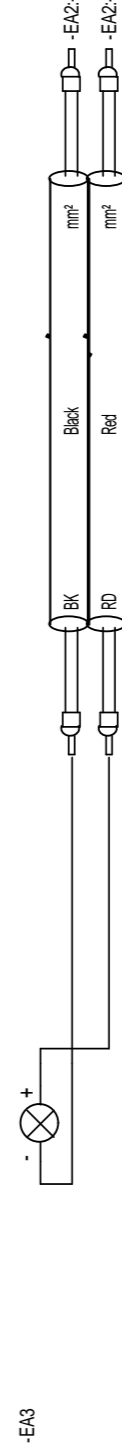

Remark: Light P21
Cable-type:

=A1-W704

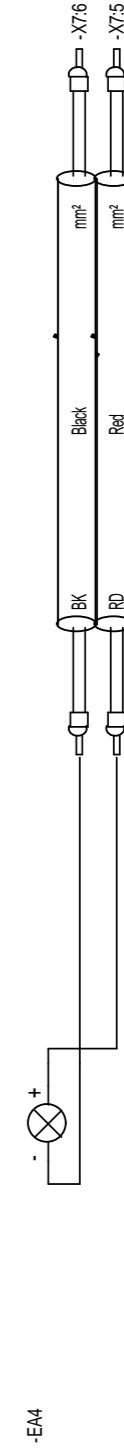

Cable Plan

=A1-W705

Remark:
Cable-type:

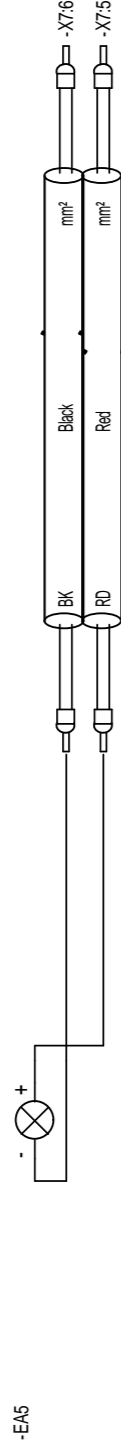

Sheet	20	20
Path	8	8

=A1-W706

Remark:
Cable-type:

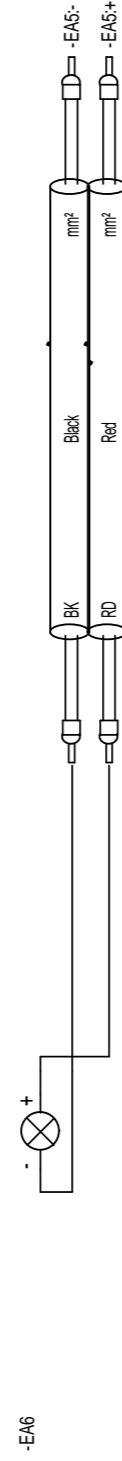

Sheet	20	20
Path	9	9

=A1-W1000

Remark: Main supply
Cable-type:

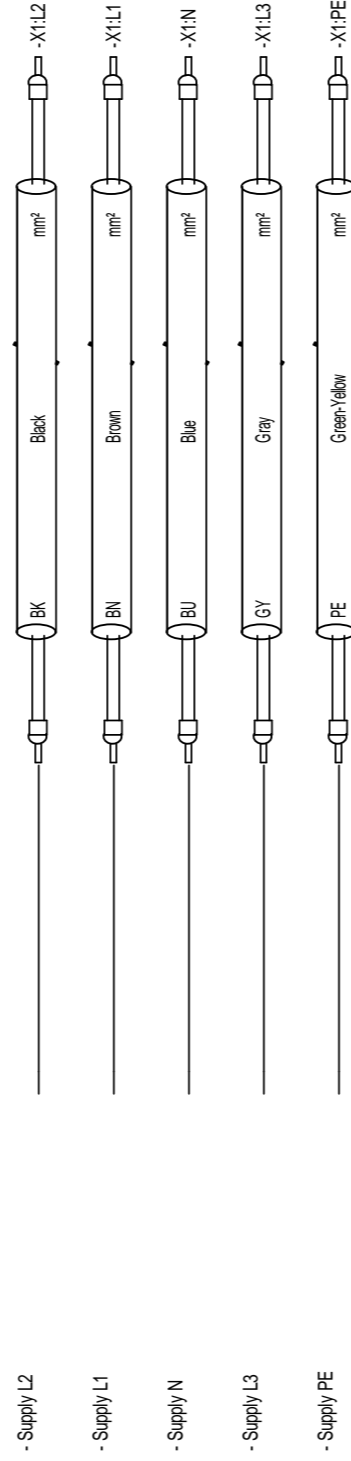

Sheet	19	19	19	19	19
Path	0	0	0	0	1

=A1+DVE-EA-W662

Remark: BP2 BUS
Cable-type: 2x0,6mm+2x0,5mm2

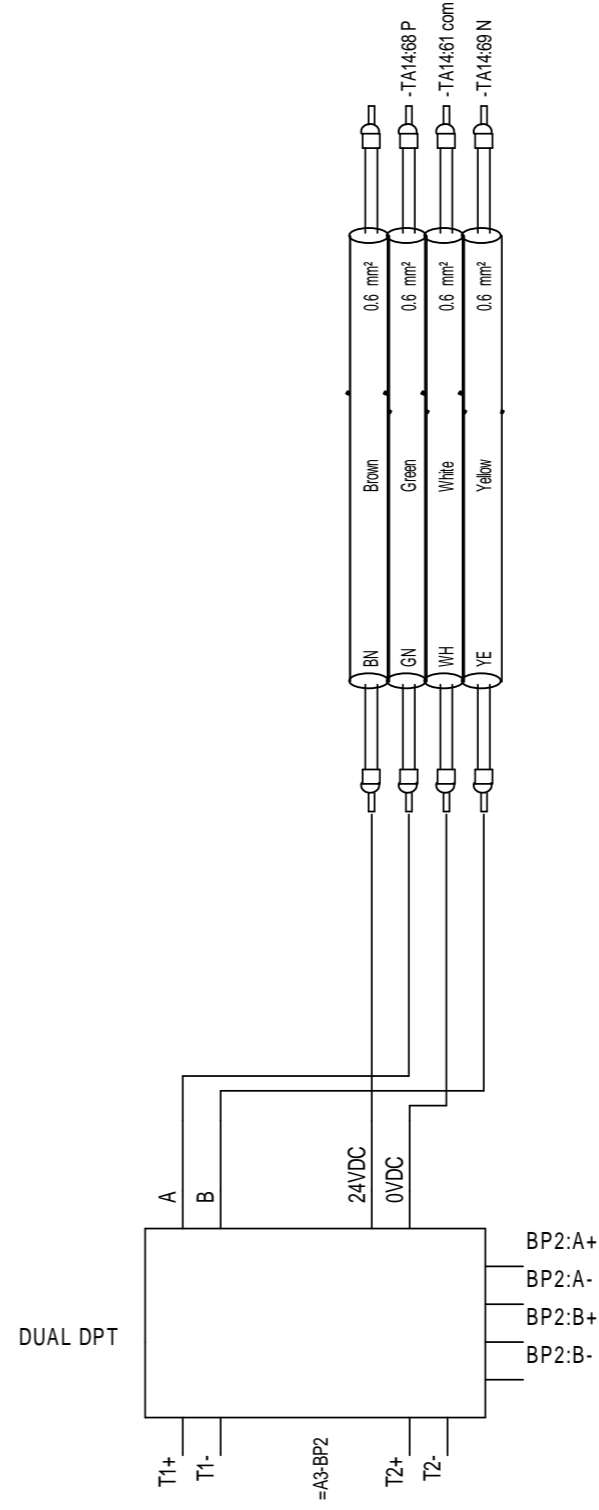

Sheet	30	30	30	30
Path	1	1	2	1

=A1+DVE-SA-W661

Remark: BP1 BUS
Cable-type: 2x0,6mm+2x0,5mm2

Cable Plan

=A1+DVE-SA-W661

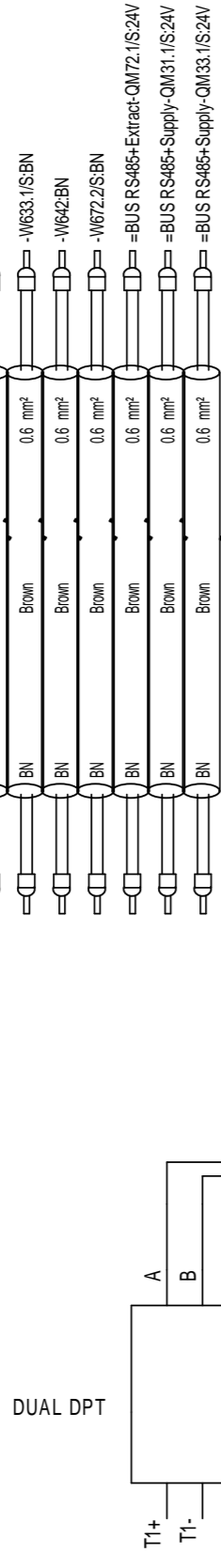

Remark: BP1 BUS
Cable-type: 2x0,6mm+2x0,5mm2

Sheet	Path
29	1
29	1
29	1
29	1
29	1
29	1
29	1
29	1

=A3-W341

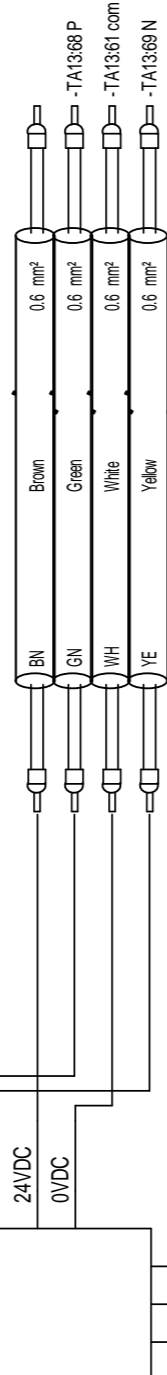

=A3-W341

Remark: Intake air
Cable-type: 2x0,25mm2

Intake / Outdoor air

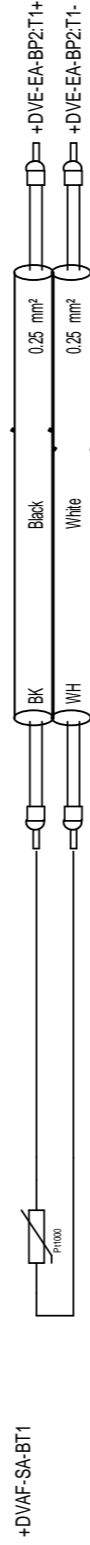

=A3-W343

Remark: Eff temp
Cable-type: 2x0,25mm2

Eff. temp

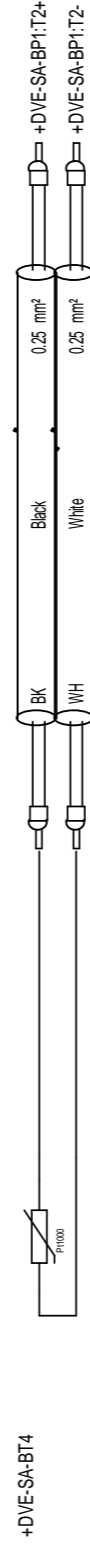

=A3-W442

Remark: Exhaust air / de-ice
Cable-type: 2x0,25mm2

Exhaust air

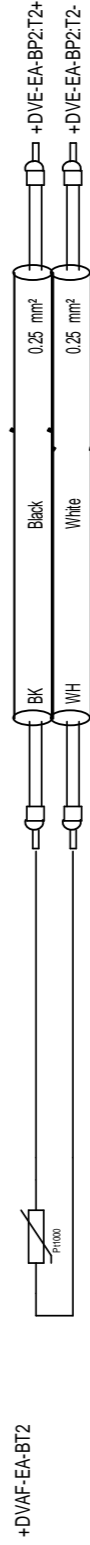

Sheet	Path
30	2
30	2

Cable Plan

=A3-W444

Remark: Extract air
Cable-type: 2x0,25mm²

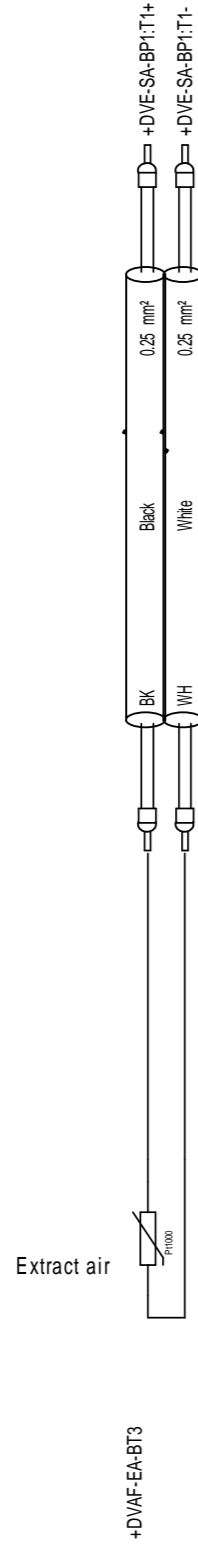

+D/VE-SA-BT3

=EC box+Extract-W102

Remark:
Cable-type:

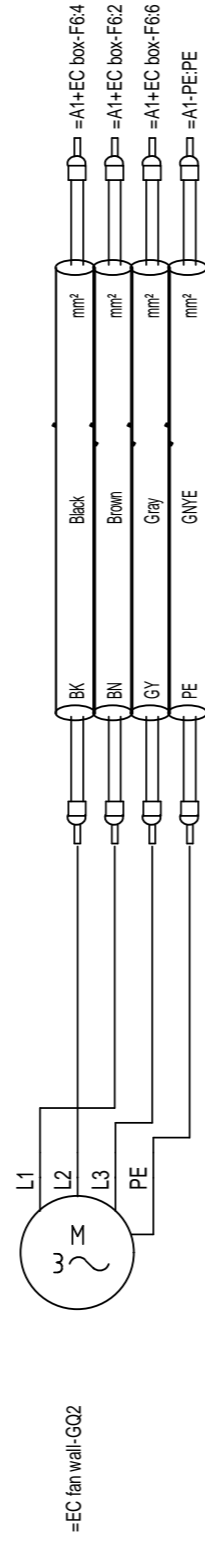

=EC fan wall-G02

=EC box+Extract-W104

Remark:
Cable-type:

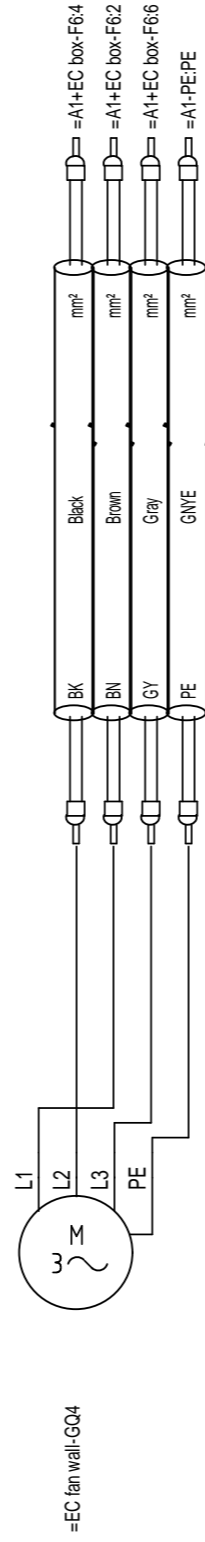

=EC fan wall-G04

=EC box+Extract-W106

Remark:
Cable-type:

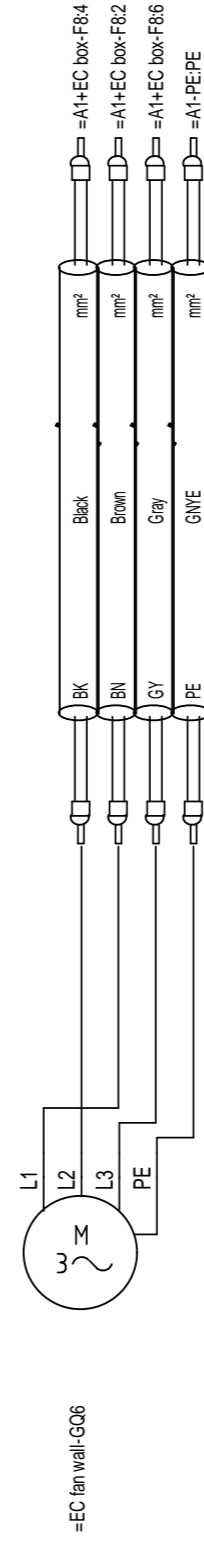

=EC fan wall-G06

=EC box+Extract-W108

Remark:
Cable-type:

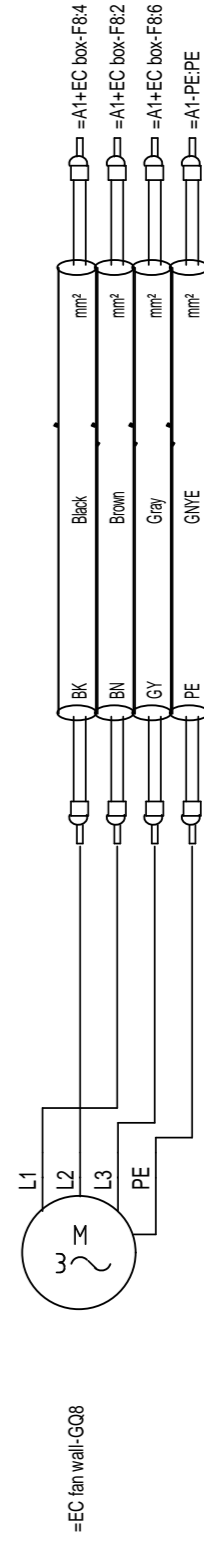

=EC fan wall-G08

Sheet

29
29

26
26
26
26

26
26
26
26

26
26
26
26

26
26
26
26

Path

1
1

1
1
1
1

3
3
3
3

5
5
5
5

6
6
7
7

Cable Plan

=EC box+Extract-W110

Remark:
Cable-type:

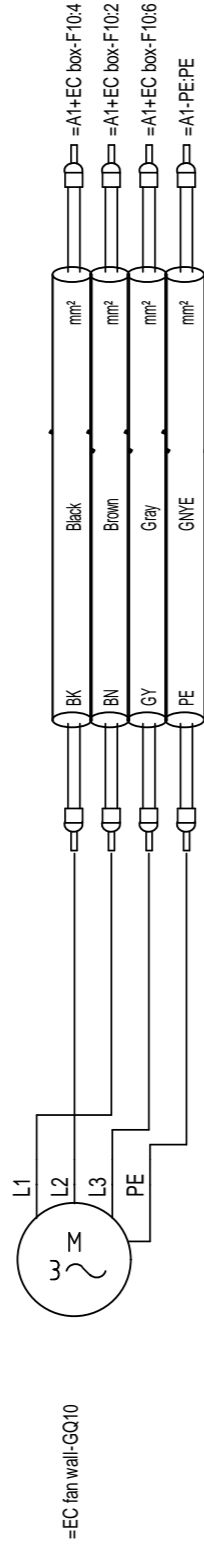

=EC box+Supply-W101

Remark: EC Power
Cable-type:

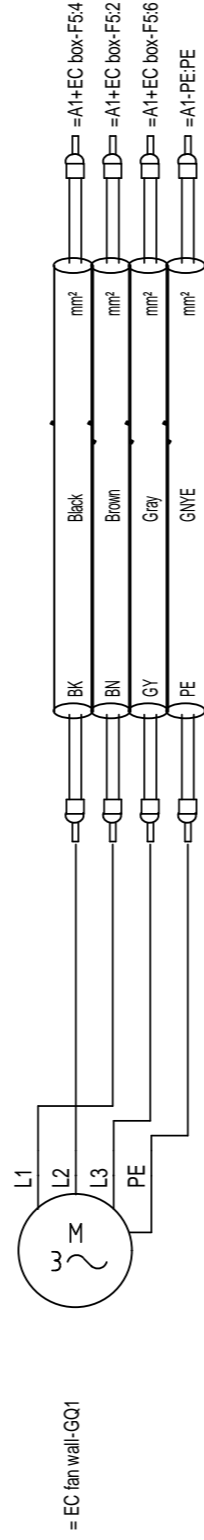

=EC box+Supply-W103

Remark: EC Power
Cable-type:

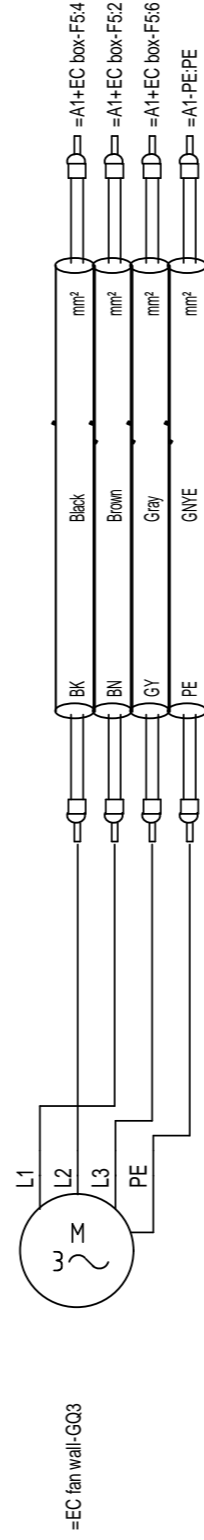

=EC box+Supply-W105

Remark: EC Power
Cable-type:

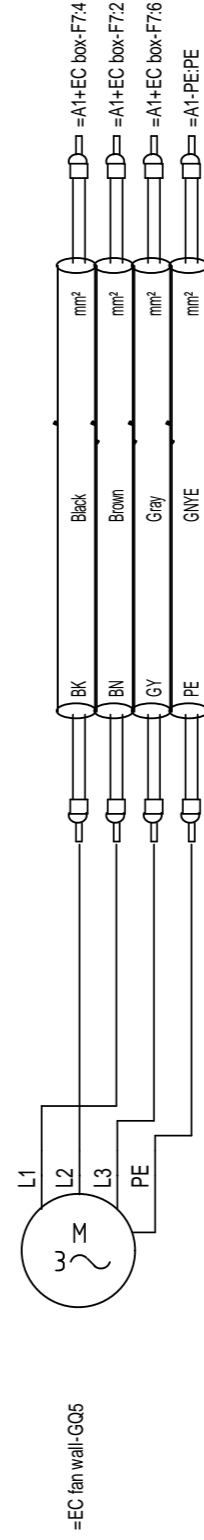

Path
Sheet

8
8
8
8
26
26
26
26

1
1
1
1
25
25
25
25

3
3
3
3
25
25
25
25

5
5
5
5
25
25
25
25

Cable Plan

=EC box+Supply-W107

Remark: EC Power
Cable-type:

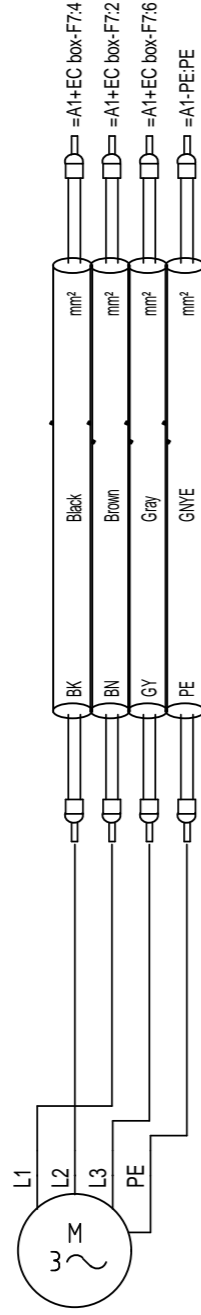

=EC fan wall-GQ7

=EC box+Supply-W109

Remark: EC Power
Cable-type:

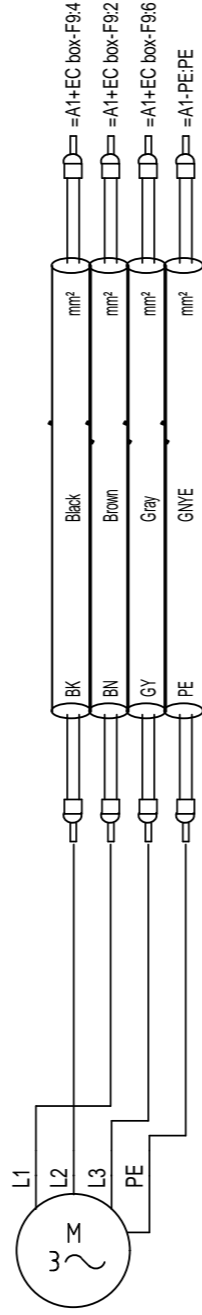

=EC fan wall-GQ8

=EC fan Array+Extract-W102.1

Remark:
Cable-type:



=A1+EC box-F6

=A1-PE:PE

=EC fan Array+Supply-W101.1

Remark:
Cable-type:



=A1+EC box-F5

=A1-PE:PE

=EC Single/Twin+Extract-W102

Remark:
Cable-type:

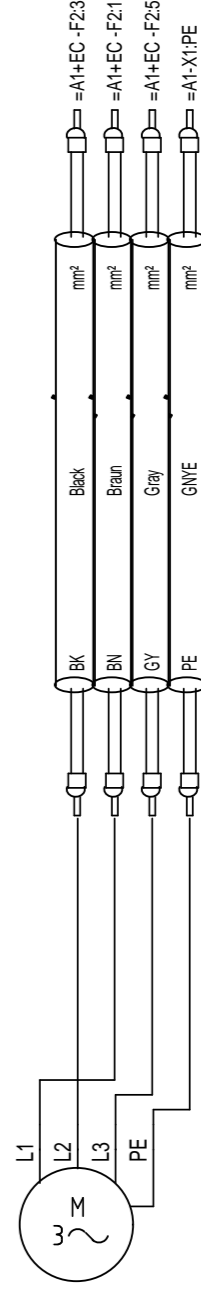

-GQ2

Sheet Path

25 6
25 6
25 7
25 7

25 8
25 8
25 8
25 8

26 1
26 1
26 1
26 1

25 1
25 1
25 1
25 1

24 2
24 2
24 2
24 2

Cable Plan

=EC Single/Twin+Extract-W102'

Remark:
Cable-type:

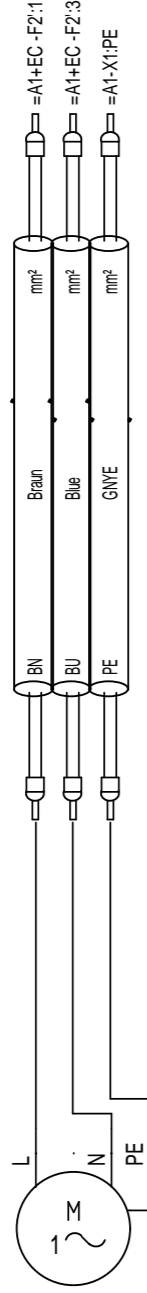

-GQ2

Path
Sheet

6
24
7
24
7
24

=EC Single/Twin+Supply-W101

Remark: EC Power
Cable-type:

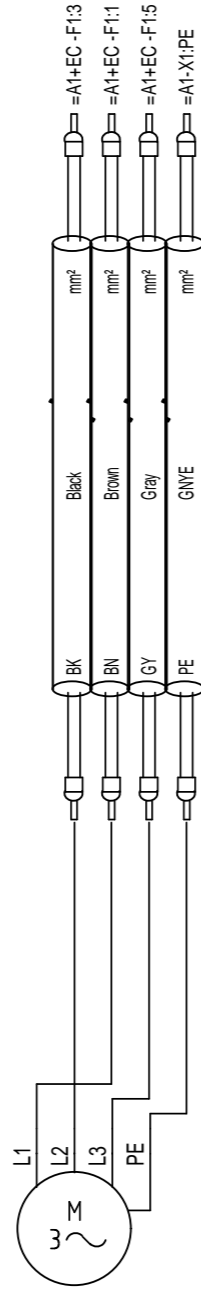

-GQ1

2
23
2
23
2
23
2
23

=EC Single/Twin+Supply-W101'

Remark: EC Power
Cable-type:

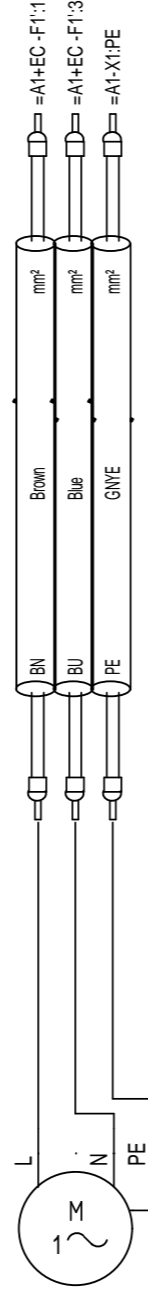

-GQ1'

6
23
7
23
7
23

=EC Twin+Extract-W104

Remark:
Cable-type:

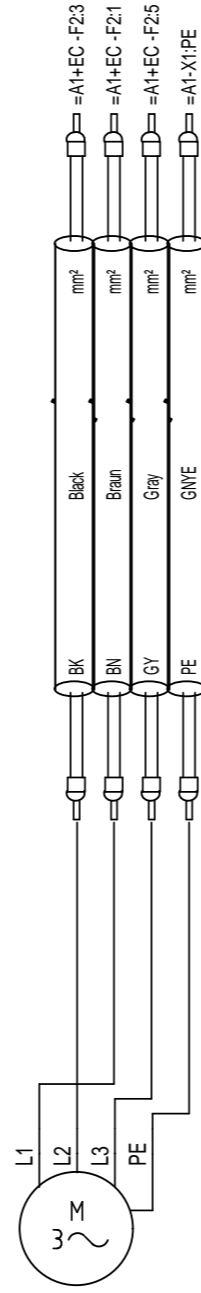

-GQ4

4
24
3
24
4
24
4
24

=EC Twin+Extract-W104'

Remark:
Cable-type:

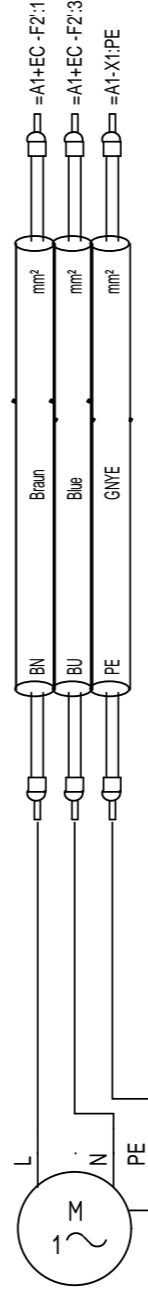

-GQ4'

8
24
8
24
8
24

=EC Twin+Supply-W103

Remark: EC Power
Cable-type:

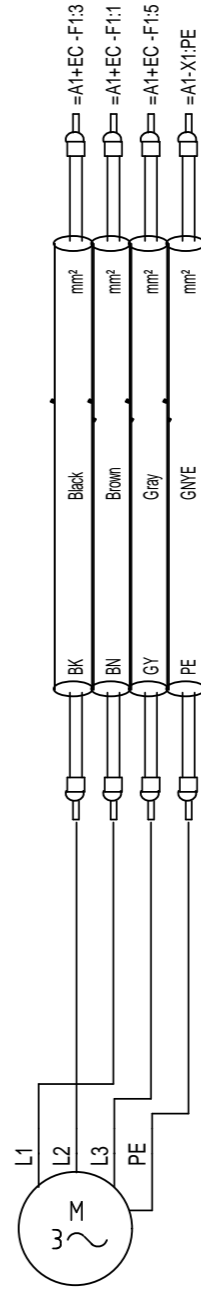

-GQ3

4
23
3
23
4
23
4
23

=EC Twin+Supply-W103'

Remark: EC Power
Cable-type:

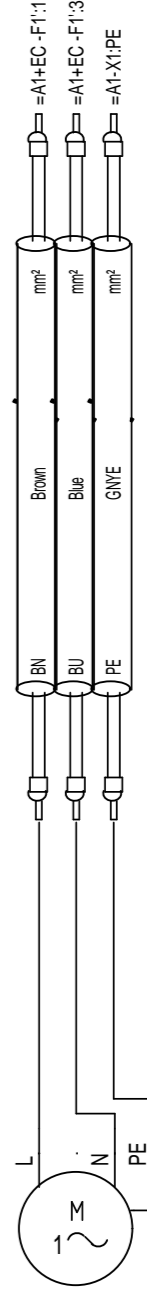

-GQ3'

8
23
8
23
8
23

