

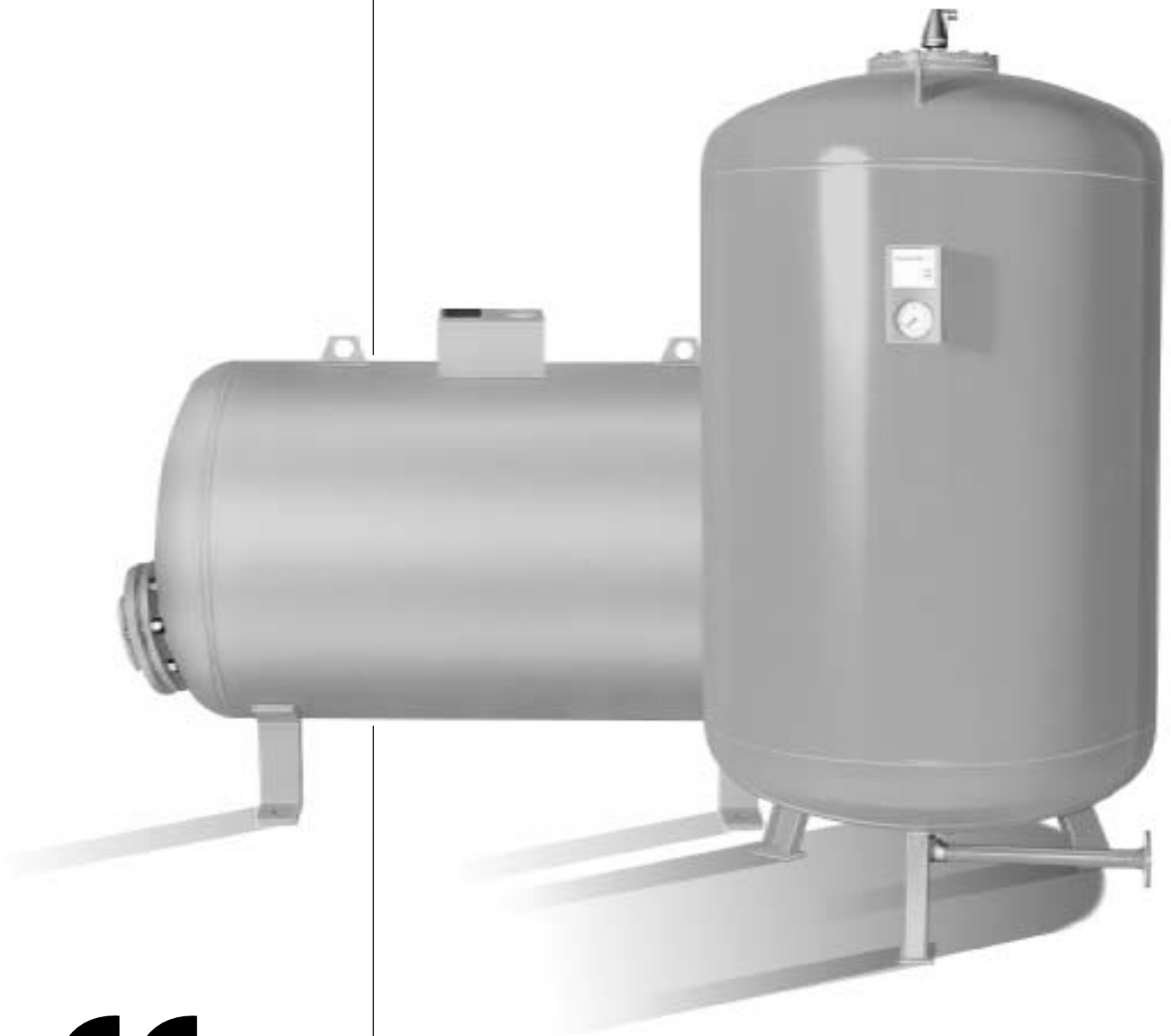

# Flamco Flexcon<sup>®</sup> M



© 2002 Flamco 18501067



Installation and operating instructions



# Flamco

## Flamco b.v.

P.O. Box 115  
2800 AC Gouda - Holland  
Industriestraat 6  
2802 AC Gouda - Holland  
Tel.: +31(0)182 591800  
Fax: +31(0)182 522557  
E-mail: info@flamco.nl  
Internet: www.flamco.nl

## Flamco

Buro & Design Center  
Heizel Esplanade B 31  
1020 Brussels - Belgium  
Tel.: +32(0)2 4760101  
Fax: +32(0)2 4760199  
E-mail: info@flamco.be  
Internet: www.flamco.be

## Flexcon M installation and operating instructions

With the Flexcon M pressure expansion vessel, you have acquired a Flamco quality product.

The Flexcon M pressure expansion vessel offers you a combination of tried-and-trusted technology, operating safety and ease of use.

This operating manual has been put together to allow you to profit to the fullest extent from the quality of this Flexcon M pressure expansion vessel.

In the following text, you will find instructions and directions on the installation and functioning of the Flexcon M pressure expansion vessel.

Should you have any other questions arising from the instructions for the Flexcon M diaphragm pressure expansion vessel, we will be glad to answer them.

## Contents

Section	Page
1. General	3
2. Function, method of working and equipment	4
3. Installation and fitting	6
4. Initial operation, subsequent operation	7
5. Servicing – periodic inspections	8



## 1. General

Flexcon M pressure expansion vessels with an exchangeable diaphragm are steel vessels in which a diaphragm in the form of bellows is fitted. The flange construction makes it possible to replace the diaphragm. The diaphragm forms the division between the expansion water and the gas area filled with nitrogen. The gas cushion can be compressed, allowing the storage of the central heating water that increases in volume. The gas cushion can be compressed to the maximum permissible pressure at the point the Flexcon M vessel is reached. The maximum installation pressure is limited by the Prescor safety valve.

1) To make an effective calculation of the necessary capacity of the expansion vessel, you can obtain the **Flamco Calculation Disk** for expansion vessels, which is available from the Flamco sales office on request.

### 1.1. Area of application

The Flexcon M pressure expansion vessel may be used in closed heating installations and in closed cooling and air-conditioning installations. Particularly advantageous use is achieved in installations with large pressure variations between the static pressure and the safety valve set pressure. A high useful effect uses the capacity of the vessel to its fullest.

The Flexcon M pressure expansion vessel is constructed for:

- DIN 4807 part 3-compliant maximum continuous temperature load of 70 °C

Should the temperature in the expansion line be able to rise to more than 70 °C, a Flexcon intermediate vessel should be used to let the expansion water cool. Flexcon VSV and V-B intermediate vessels are available from 200 litres.

### 1.2. Programme overview

The standard models below are available:

- Flexcon M 80 – 8,000 litres, upright model, maximum permissible operating pressure 6 and 10 bars;  
maximum operating temperature: 120 °C

Flexcon M pressure expansion vessels, horizontal model or with an operating pressure of more than 10 bars available on request.

### 1.3. Definitions and regulations

Flexcon M pressure expansion vessels are approved, with reference to construction, subject to Directive 97/23/EEC. The configuration of the vessels was made in compliance with the European Pressure Equipment Directive (97/23/EG) and in observance of the German AD information sheets. For special usage conditions, a corrosion number in the strength calculation for standard models smaller than 1 mm has been chosen. If the corrosion number needs to be equal to or greater than 1 mm, it should be noted separately on ordering.

The EU sample testing certificate for Flexcon M pressure expansion vessels is available for scrutiny at the offices of the manufacturer. The type plates of the individual vessels bear the mark of the appointed body, CE 0045, which shows that the vessels are subject to a consistency check in compliance with Section 10 of the European Pressure Equipment Directive (97/23/EG) prescribed by the European Parliament and the Commission on amendment of legislation of the member states in terms of equipment working under high pressure. The member states of the EU may not forbid, limit or hinder the marketing and commissioning of pressure equipment under the conditions laid down by the manufacturer on account of pressure-related risks. The parameters for use supplied by the manufacturer must be adhered to: exceeding the parameters is not permitted.



## 2. Function, method of working and equipment

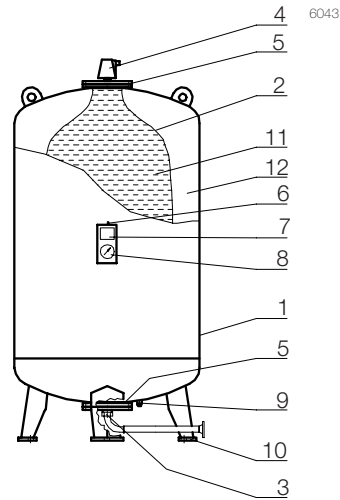

Figure 1

1. Steel vessel
2. Exchangeable butyl rubber diaphragm (DIN 4807 part 3-compliant)
3. System connection (adapter for a flange connector optional)
4. Float vent (optional)
5. Inspection port
6. Nitrogen filler valve
7. Type plate
8. Pressure gauge with protective collar
9. Drain nipple
10. Foot (from 2,800 litres available with height-adjustment facility)
11. Expansion water
12. Nitrogen cushion

Figure 1 shows the Flexcon M pressure expansion vessel as an upright model. The diaphragm (2) fitted in the vessel (1) is for the absorption and storage of the expansion water.

Flexcon M pressure expansion vessels are designed for use in closed heating systems and in closed cooling and air-conditioning installations. The vessels are for the intake and storage of expansion water.

Flexcon M pressure expansion vessels are equipped with a diaphragm that separates the nitrogen cushion from the water. Butyl rubber is used as the material for the diaphragm, as it has a very low permeability (does not let gas through). The diaphragms are tested to DIN 4807 part 3 standard.

### They work as follows:

On warming, the water in the heating installation expands and is pressed into the diaphragm via the system connection on the underside. This action compresses the nitrogen cushion. On cooling, the opposite happens. This means that the nitrogen cushion compresses the diaphragm and the water that is stored in the diaphragm flows back into the installation.



## Flexcon M – upright model

With the exception of the M 80 type, the connection on the system is located on the underside of the expansion vessel near the inspection port.

Vessel capacity	Connection to the system	
	Screw thread DIN 2999-1	Flange PN16/DIN 2633
80 litres	1"	-
400 to 800 litres	1 1/4"/DN 32	-
1,000 to 1,600 litres	1 1/2"/DN 40	-
2,000 litres	2" /DN 50	-
2,800 to 5,200 litres	2 1/2"/DN 65	-
6,700 to 8,000 litres	-	DN 100

## Options for Flexcon M – upright model

At the customer's request, an adapter with flange connection PN16 (DIN 2633-compliant) may be supplied for expansion vessels from 400 to 5,200 litres. Moreover, the Flexcon M can be supplied with a 'diaphragm rupture sensor', so that any damage to the diaphragm will be indicated.

## Flexcon M – horizontal model

The connection to the system on the horizontal model is near the inspection port on the side of the expansion vessel.

Vessel capacity	Connection to the system with a PN16/DIN 2633 compliant flange
400 to 800 litres	DN 32
1,000 to 2,000 litres	DN 40
2,000 litres	DN 50
2,800 to 5,200 litres	DN 65
6,700 to 12,500 litres	DN 100



## 3. Installation and fitting

The Flexcon M pressure expansion vessel is supplied horizontally, completely assembled on disposable pallets.

The Flexcon M pressure expansion vessel should be set up in an enclosed area (ambient temperature 5 - 40 °C), so that it can always be used, serviced and inspected without problems.

The sketches and diagrams below show the minimum distances:

### Flexcon M – upright model

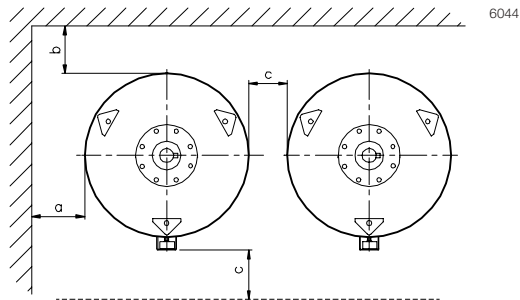

Vessel capacity (l)	a (mm)	b (mm)	c (mm)
≤ 1,600	500	650	800
> 1,600	500	1,000	800

Above the inspection port at the top, clearance of:

- a minimum of 650 mm for pressure vessels with a capacity of 1,600 litres or less
- a minimum of 1,000 mm for pressure vessels with a capacity of more than 1,600 litres.

### Flexcon M – horizontal model

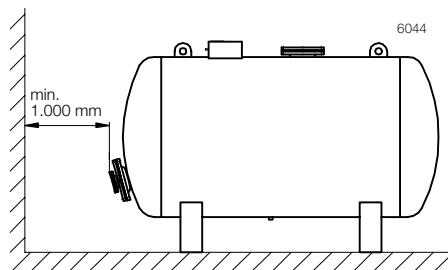

The location for set-up must be chosen in such a way that the installation's stability is guaranteed.

Connect the installation via the return line, taking into account the fact that there is a direct connection with the boiler.

#### In addition, please be aware of the following when connecting to the system:

- You must be able to shut off the connection between the expansion vessel and the boiler. The shut-off provision must be protected, so that unintentional shut-off can be avoided.
- A facility for draining must be fitted between the shut-off valve and the expansion vessel.
- Welding must be carried out in such a way that no welding slag can get on or into the expansion vessel.
- The operating temperature at the system connection may not exceed 70 °C. (A full insulation of the expansion line increases the temperature load of the diaphragm.)



## Other dangers

Fitting and servicing carried out on the pressure expansion vessels must be carried out solely when the gas and water areas of the vessel are pressure-free.

**Note:** the water in the vessel, under normal circumstances, can reach 70 °C; if the operating instructions are not followed, it can rise higher. This carries the danger of fire! Do not touch an operating vessel without taking adequate precautions: the wall temperature is higher than 50 °C.

## Advice on fitting Flexcon M pressure expansion vessels

One or more boilers may be linked to one or more pressure vessels. Domestic/European standards apply to the design, installation and use of heating systems.

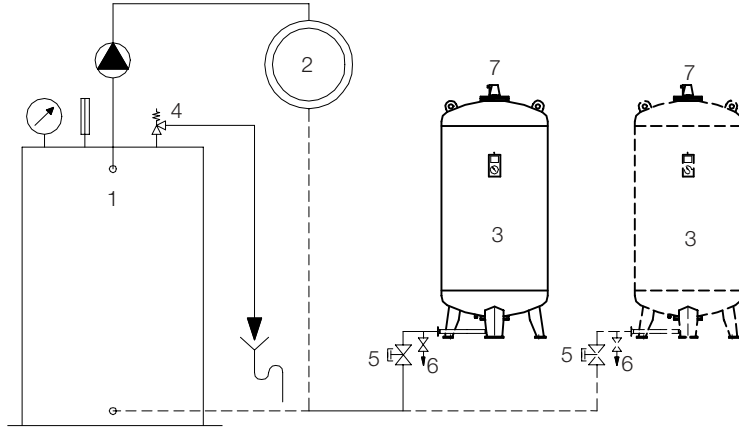

Figure 2

## Heating installation without mixing provision/variable boiler temperature valve (e.g. in the NT sector)

1. Boiler
2. Heat consumers (heating circuit)
3. Flexcon M pressure expansion vessel
4. Prescor safety valve
5. Shut-off valve (protected)
6. Draining valve
7. Venting valve

## 4. Initial operation, subsequent operation

The use of Flexcon M pressure expansion vessels can prove dangerous if fitted by unqualified personnel, the parameters for use are not observed, the vessels are used for purposes other than those for which they are intended, or the safety regulations when using heat-producing installations are not complied with.

To use Flexcon M pressure expansion vessels in existing installations for heat production, the vessels are required to be sufficiently protected against exceeding the permitted supply temperature and the permitted operating pressure. The most important requirements for this are:

- Each heat-producing installation must be equipped with a suitable temperature controller to adjust the heating to the heat consumption.
- Each indirect heat-producing installation must be equipped with a suitable temperature-monitoring system with an independent sensor.
- Each heat-producing installation must be equipped with a suitable temperature limiter with an independent sensor.
- The existing heat-producing installations must be equipped with a safety valve to prevent exceeding the permitted pressure. To this end, each heat-producing installation may be fitted with a maximum of three safety valves.

The safety valves must be fitted in an easily accessible place, in compliance with local regulations, at the highest point of the heat-producing installation or in the immediate vicinity thereof in the lead line.

- Supplementary national rules and regulations regarding temperature and pressure-limiting when using Flexcon M pressure expansion vessels must be observed.



Heat-producing installations may only be constructed by qualified personnel. Prior to initial operation, the heat-producing installation must be checked in detail in respect of the prescribed state of the heat-producing elements and the heater and in respect of the technical safety equipment with a view to complying with the requirements in line with national rules and regulations (E.B.I.). This check must be carried out by qualified personnel or a specialist in the field.

The manufacturer and user respectively shall be liable for delivery and commissioning of the installation in accordance with the rules and regulations.

#### **Other instructions:**

- Before the Flexcon M pressure expansion vessel is used for the first time, it may not be filled with water or have the connection with the rest of the installation interrupted (i.e. with the shut-off valve closed).
- The gas pressure is factory-set as per the specification on the order. If no specification is given, the factory-set gas pressure is:

- 6-bar version = max. 4 bars
- 10-bar version = max. 6 bars

This gas pressure must be adjusted to the required level.

#### **Too high or too low a gas pressure impairs the function of the Flexcon M pressure expansion vessel.**

- After inspection of the gas pressure with the shut-off valve closed (protected), fill and vent the heating installation.
- Open the shut-off valve (protected).
- Vent the Flexcon M pressure expansion vessel using the valve on the vessel. (Not applicable if a float is fitted for venting).

#### **Important information for vessels over 6 bars:**

In this event, the pre-pressure in relation to the backpressure caused by the use of nitrogen must be adjusted. When increasing the gas pressure from 6 bars, the pressure difference should be at most 3 bars. The filler mechanism must be provided with a tested and suitable safety valve.

## **5. Servicing – periodic inspections**

In compliance with European Pressure Equipment Directive (97/23/EG), diaphragm pressure vessels require annual servicing and inspection. Apart from the external appearance of the expansion vessel and the functional operation of various components, the pre-pressure must above all also be inspected. An inspection of the nitrogen cushion is possible solely on expansion vessels without water pressure. After the water has been discharged, check the pre-pressure and, if necessary, top up.

If there is no water pressure in the vessel, the pressure gauge on the vessel will show the nitrogen pre-pressure. The nitrogen valve is behind the pressure gauge.

#### **Venting**

During operation air may amass in the waterside part of the diaphragm; this is particularly the case with roof units. To vent this air, Flexcon pressure expansion vessels of 400 litres and over have the following function on the top of the vessel:

400 – 1,000 litres: At the head of the diaphragm attachment, there is an M12 x 6 nut. Loosening this 1 – 2 turns may allow the air to escape.

**NOTE:** do not fully loosen the nut. Escaping water may cause burning or scalding.

1,200 – 8,000 litres: under the cap nut, which can be removed, there is a VG-8 valve. Depressing its pin will allow the air to escape.

#### **Fitting a Flexvent Super Float Vent:**

On Flexcon M pressure expansion vessels from 400 litres, a Flexvent Super float vent may be fitted. This must be done with a vessel which has been shut off from the installation and emptied/drained. The M12 x 6 nut/VG8 valve must be removed. The Flexvent Super float vent can be fitted to the diaphragm attachment with a 1/2" ex. / 3/8" int. reducing nipple. For the best results use a liquid gasket as a seal to prevent force being transferred to the diaphragm attachment.





# Flamco

**Note:** only nitrogen may be used to refill the nitrogen cushion!

A manufacturer of heat-producing installations must provide an operation and servicing manual for the installation in question including the information necessary for reliable operation of the technical safety equipment and specifications, and sign the original along with the customer carrying out commissioning.

The intervals for periodic inspections on Flexcon M pressure expansion vessels are as follows:

- external inspection: annually
- internal inspection: every 5 years
- water pressure inspection: every 10 years

The inspection must be carried out by the bodies or persons appointed: observe and give priority to national rules and regulations at all times.

**We advise you to use Flamco's service organisation for maintenance.**