



MERCEDES X-CLASS

TAIL LOCK

FITTING INSTRUCTIONS

—GENERAL NOTES

- Read through the fitting instructions prior to installation of accessory.
- Ensure all recyclable components and packaging are discarded and recycled following local recycling regulations.
- Safely store and protect any removed vehicle components.

—SAFETY NOTES

- Check that all work practices comply with safety standards.
- Please wear appropriate clothing and use safety equipment.

—FITTING TIME



45mins

—PARTS SUPPLIED

Part Description	Part Number	Quality/ Length	CHECK LIST
TAIL LOCK ASSEMBLY			
Main Bracket	NP18-A	1	
Rod	NP18-B	1	
Lever	NP18-C	1	
Actuator	ACT-01	1	
Wiring	CL-LOOM-SHORT	1	
Patch Wiring	MX-PATCH	1	
FASTENERS			
Spacer	39	1	
Actuator Screws	36	2	
M6 x 16mm	44	1	
OTHER			
Cable Ties		5	
Rod Clips	37	2	
Fitting Instruction		1	

— STEP 1 —

Fit rod into actuator as shown.

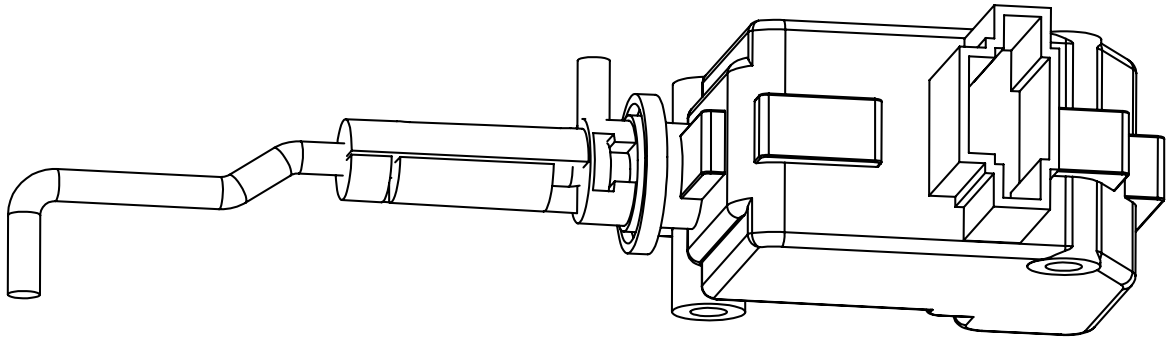

— STEP 2 —

Fit actuator to TailLock bracket as shown.

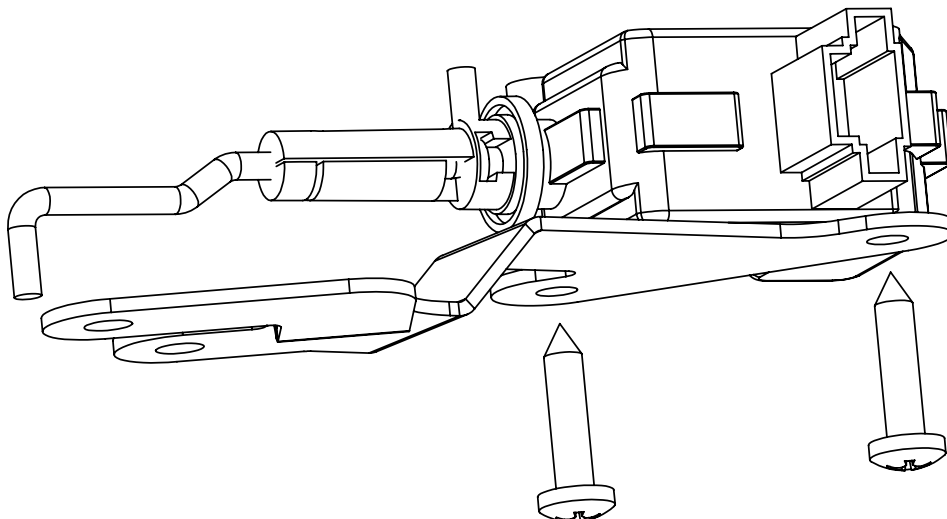

— STEP 3 —

Fit actuator to TailLock bracket as shown.

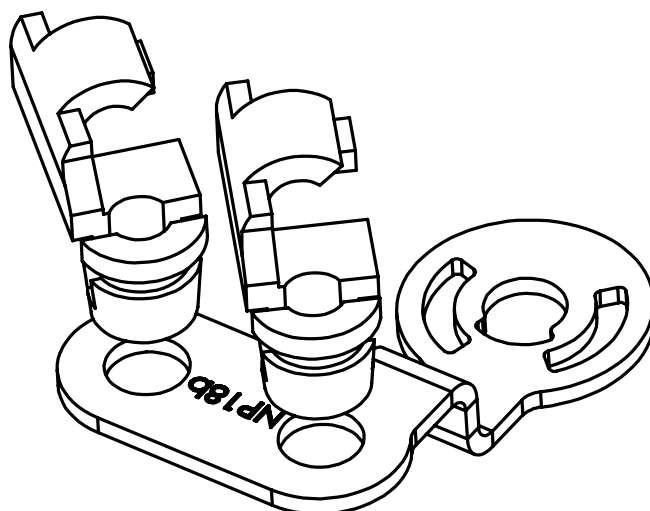

— STEP 4 —

Remove tail gate cover.

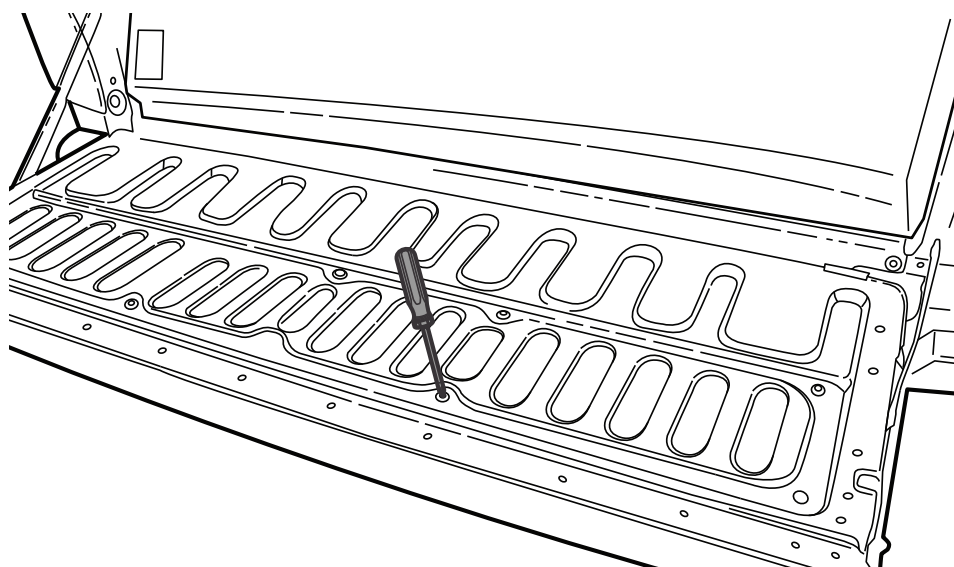

— STEP 5 —

Standard assembly.

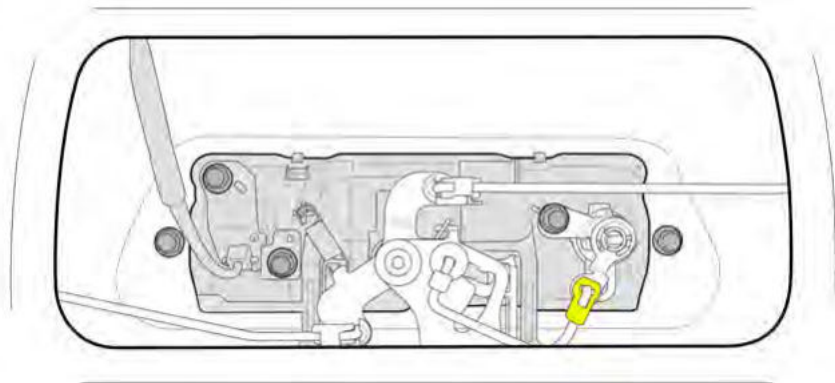

— STEP 6 —

Remove rod as shown.

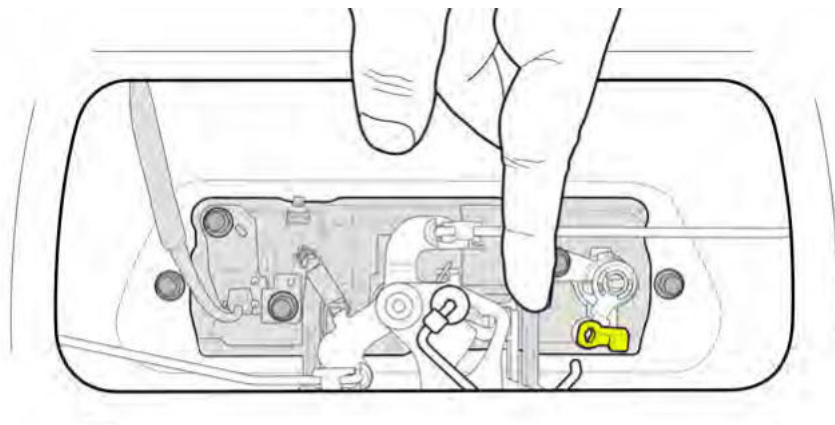

— STEP 7 —

Remove the cam as shown and by carefully removing the cert clip.

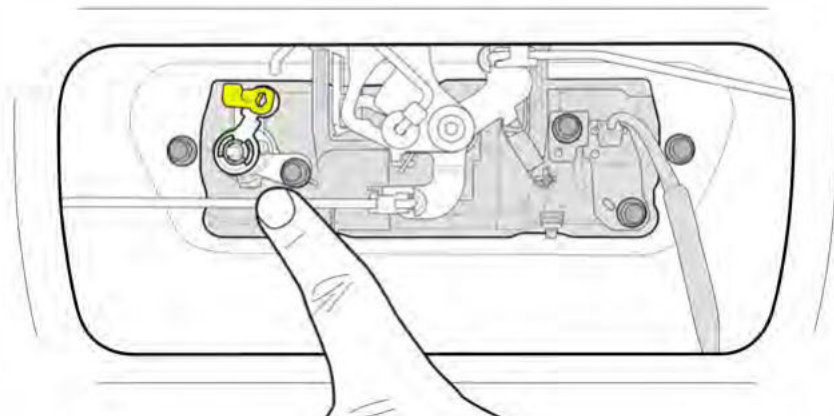

— STEP 8 —

Fasten the 2 bolts shown.

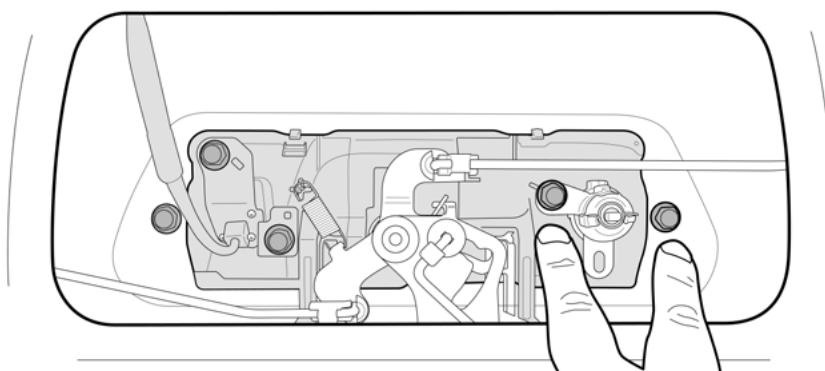

— STEP 9 —

Install TailLock assembly as shown. Use cert clip removed from original cam to secure the new cam in place. Plug actuator rod as shown.

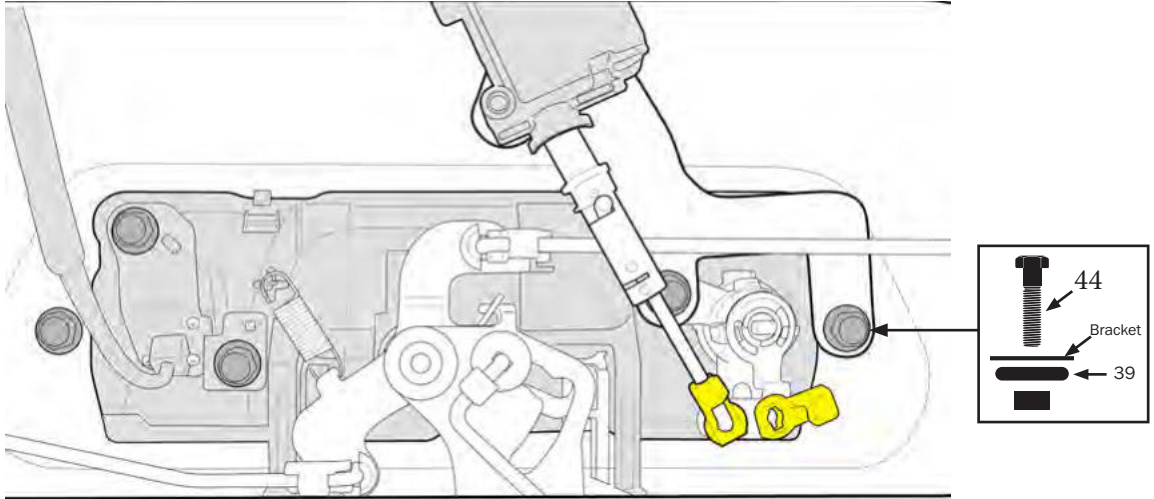

— STEP 10 —

Attach rod to the new cam as shown.

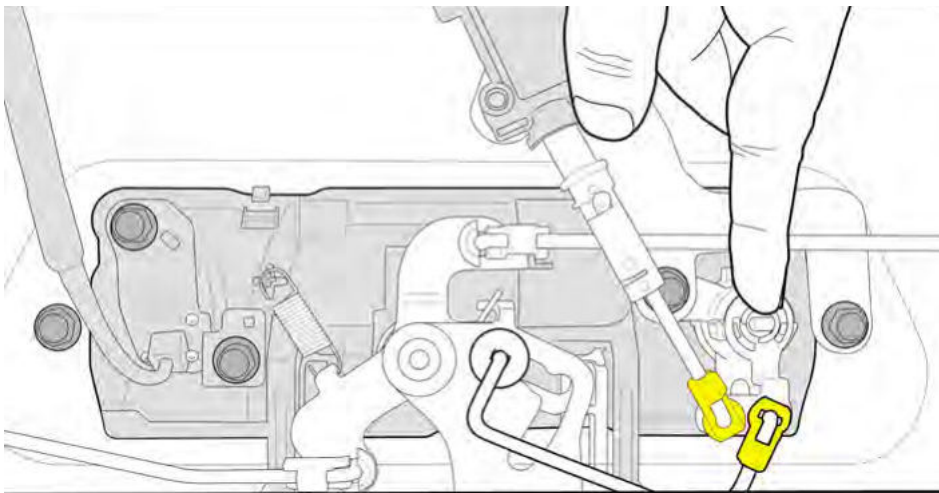

— STEP 11 —

Plug wiring to the actuator end.

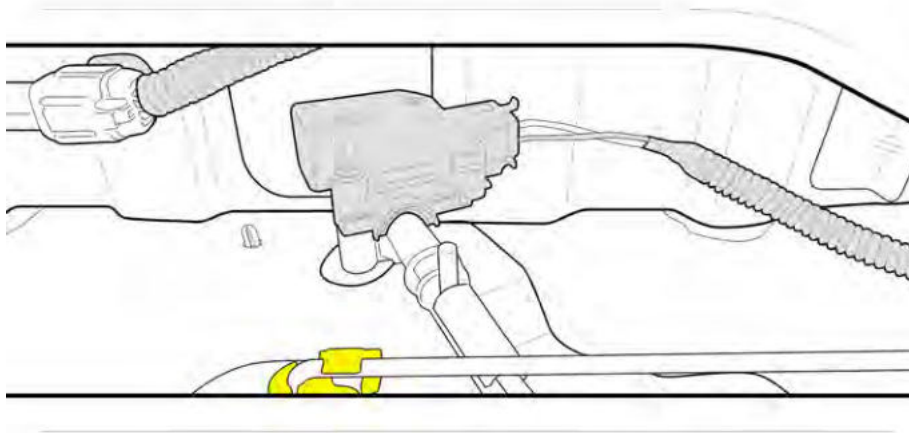

— STEP 12 —

Connect the wiring to the actuator then route the actuator wiring harness (1) out of the tailgate and underneath the vehicle.

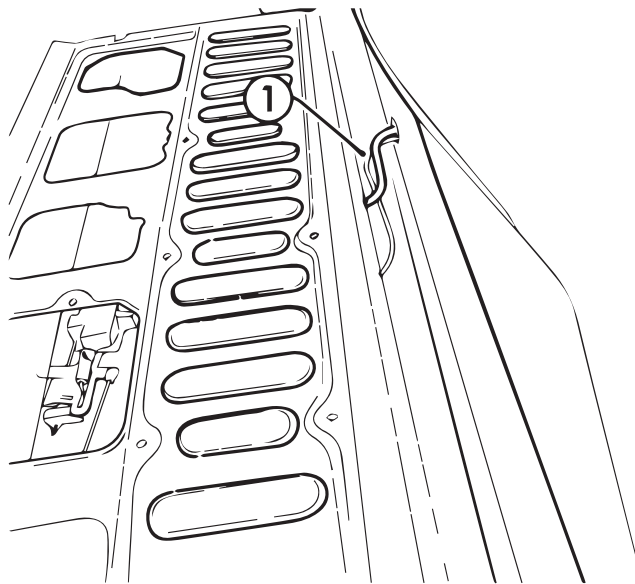

— STEP 13 —

Run wiring from tailgate to fuel cap. Use cable ties every 400mm.

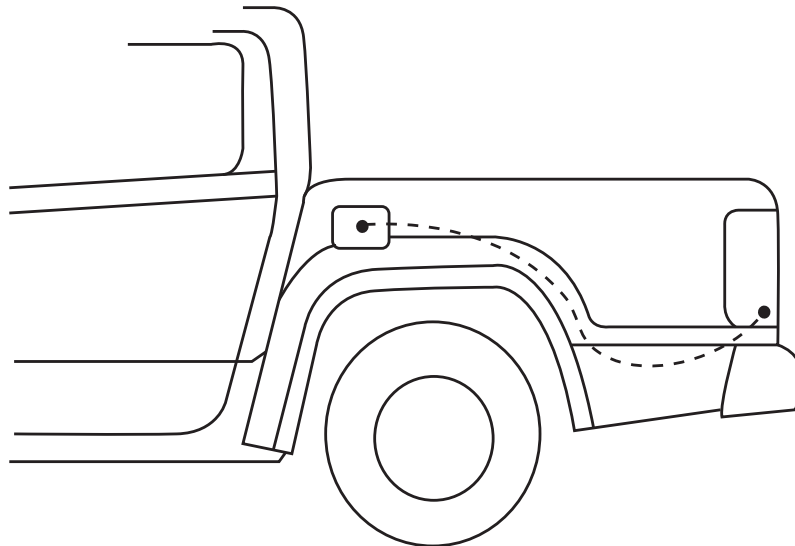

— STEP 14 —

Remove indicated fuel cap wiring cover.

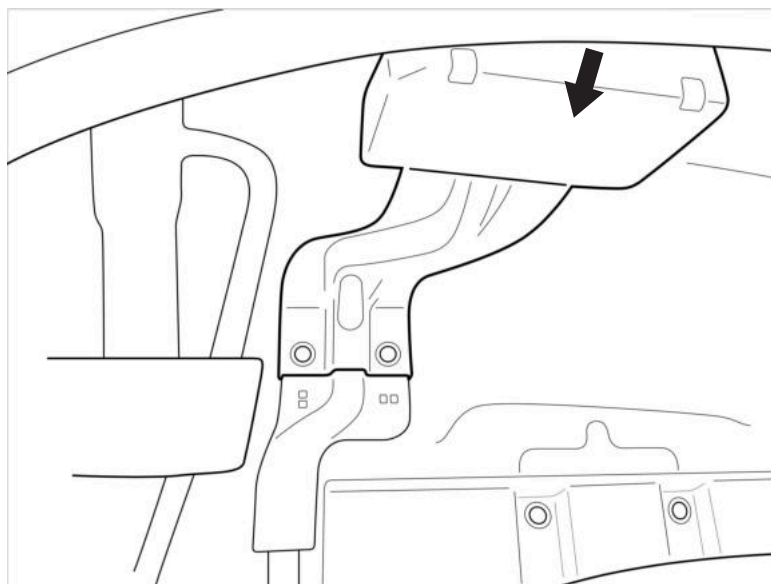

— STEP 15 —

Unplug fuel cap wiring.

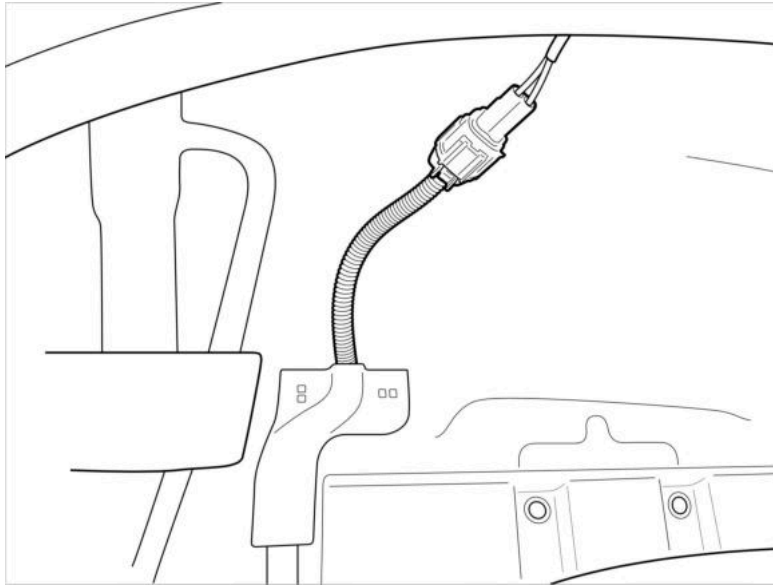

— STEP 16 —

- 1) Plug MX-PATCH wiring.
- 2) Plug CL-LOOM-SHORT wiring.

Cable tie overhang of wiring and place the cover removed earlier.

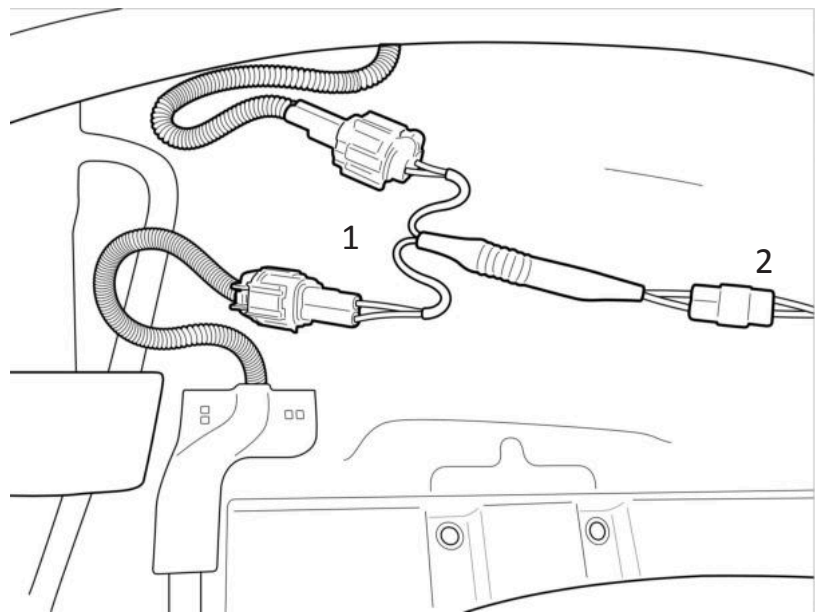

STEP 17

Re-fasten the tailgate cover.

