



ISUZU D-MAX

TAIL LOCK

---

FITTING INSTRUCTIONS

## —GENERAL NOTES

---

- Read through the fitting instructions prior to installation of accessory.
- Ensure all recyclable components and packaging are discarded and recycled following local recycling regulations.
- Safely store and protect any removed vehicle components.

## —SAFETY NOTES

---

- Check that all work practices comply with safety standards.
- Please wear appropriate clothing and use safety equipment.

## —FITTING TIME

---



45mins

## —PARTS SUPPLIED

---

Part Description	Part Number	Quality/ Length	CHECK LIST
<b>TAIL LOCK ASSEMBLY</b>			
Main Bracket	X18-A	1	
Tube	X18-B	1	
Actuator	ACT-01	1	
Wiring	CL-LOOM-LONG	1	
Patch Wiring	X-PATCH	1	
Lever	X18-C	1	
<b>FASTENERS</b>			
Actuator Screws	36	2	
Lever Bolt	32	1	
20mm M6 Bolt	16	1	
<b>OTHER</b>			
Cable Ties		5	
Fitting Instruction		1	

## — STEP 1 —

Fit the lever through main bracket bend as shown.

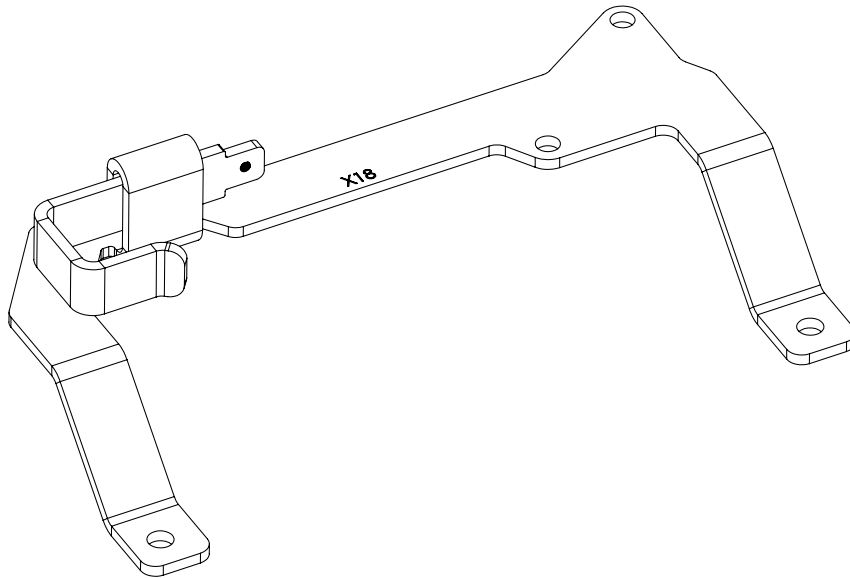

## — STEP 2 —

Fit tube to lever and fasten the bolt as shown.

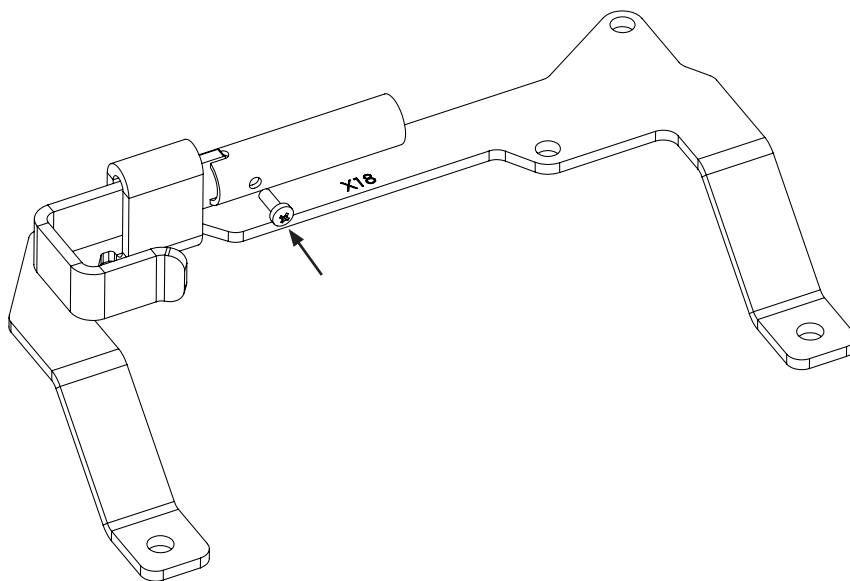

— STEP 3 —

Fit actuator to main bracket as shown.

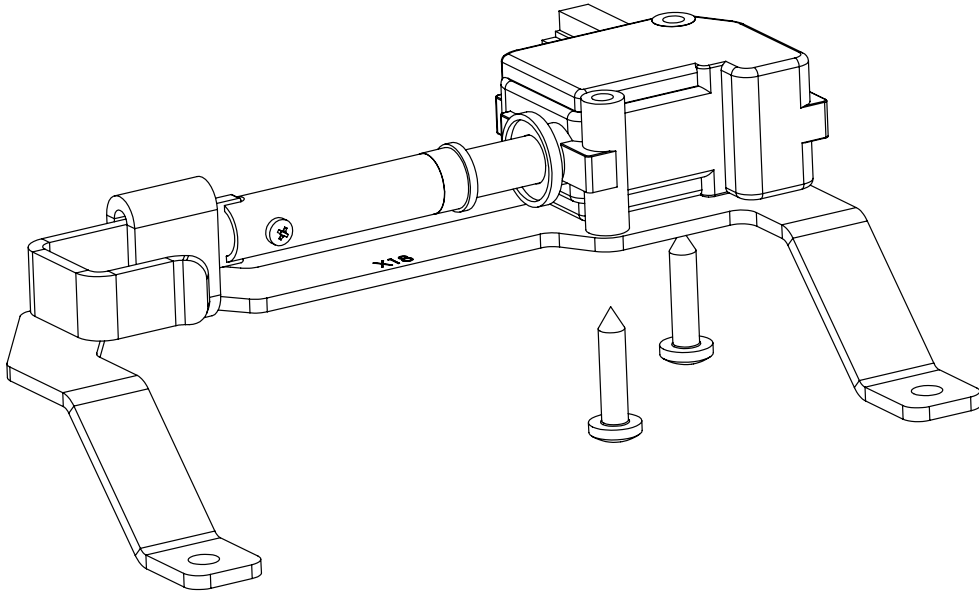

— STEP 4 —

Plug wiring to actuator.

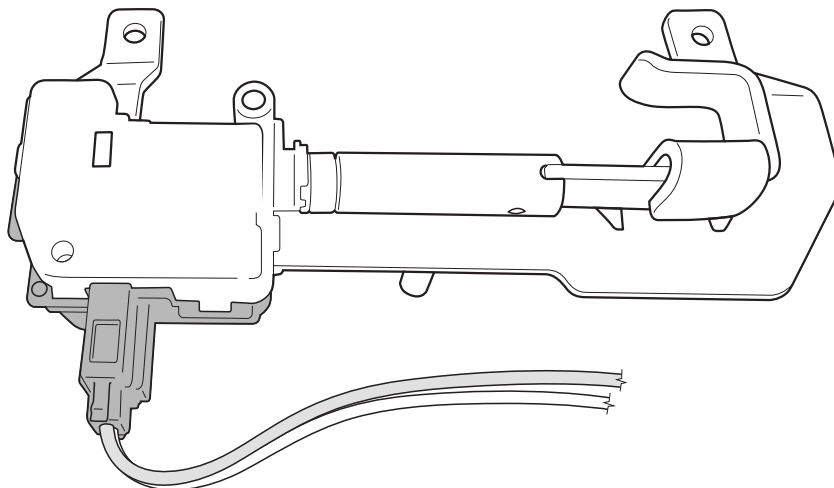

— STEP 5 —

Remove tail gate cover.

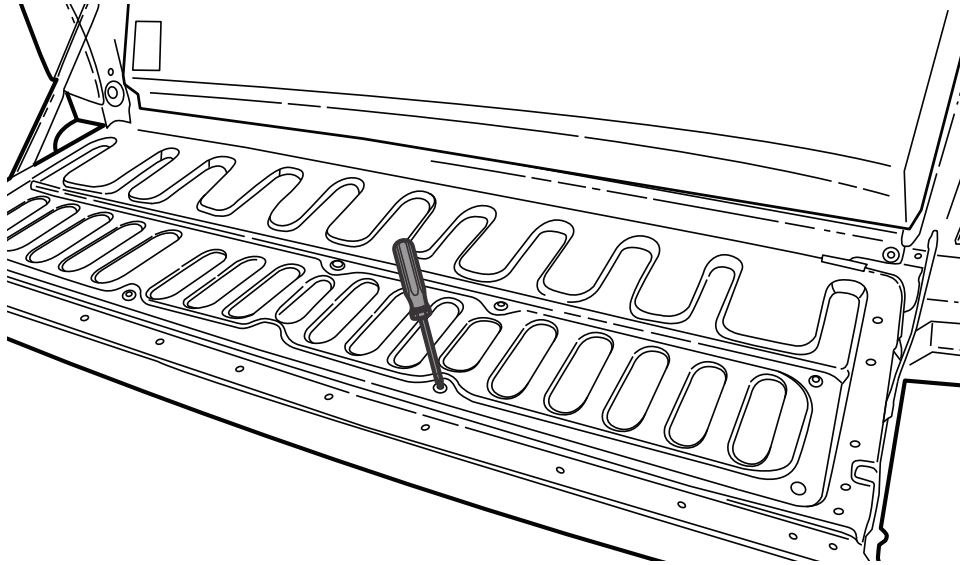

— STEP 6 —

Remove cover then remove the indicated bolts and rod as shown.

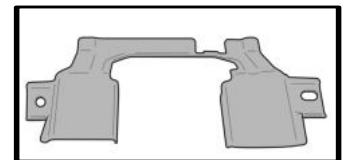

Dispose cover

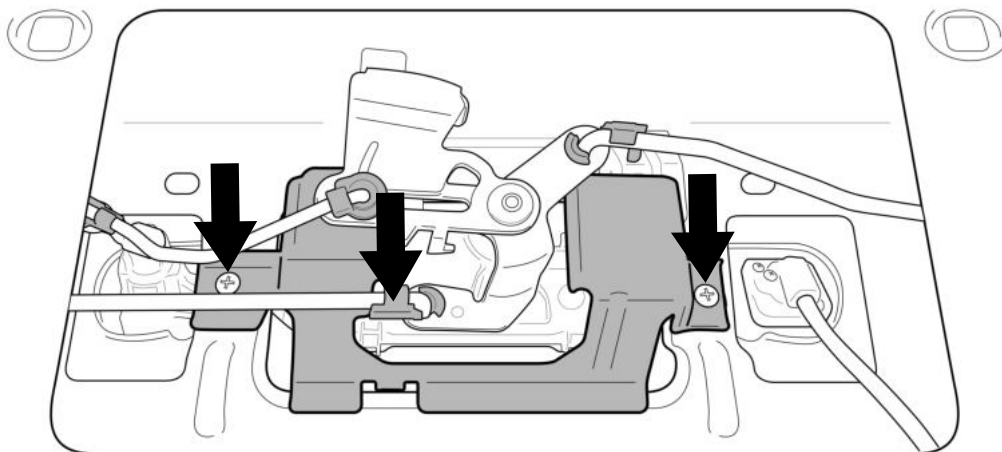

## — STEP 7 —

Fit Tail Lock bracket and indicated bolts and rod as shown.

- 1) Use the longer of the two bolts removed earlier to fasten.
- 2) Use the included 20mm M6 Bolt to fasten.

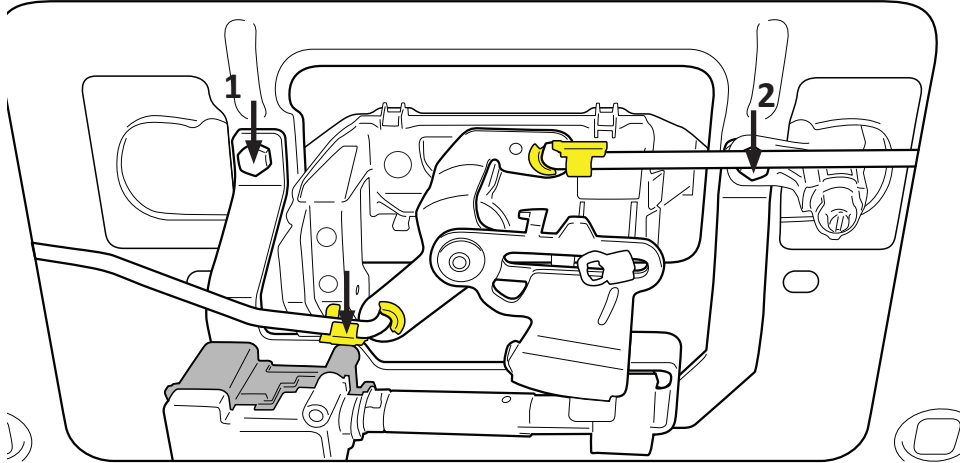

## — STEP 8 —

Run wiring from tailgate unde the car

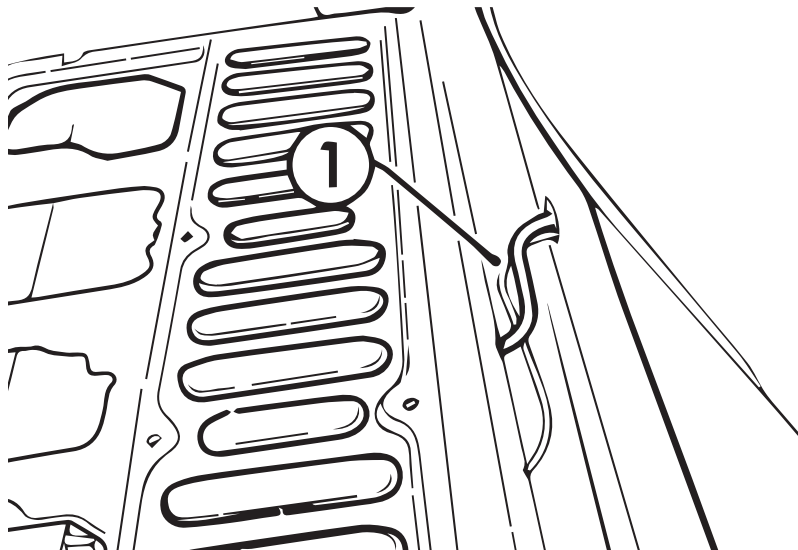

— STEP 9 —

Run wiring from tailgate to front passenger door over chassis rail. Cable tie wiring every 500mm.

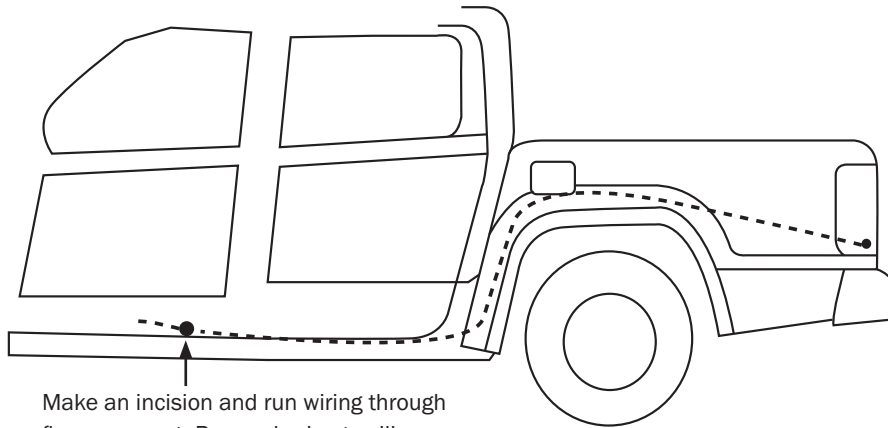

Make an incision and run wiring through floor grommet. Remembering to silicon when finished.

— STEP 10 —

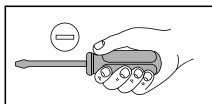

**REMOVE  
SCUFF PLATE**

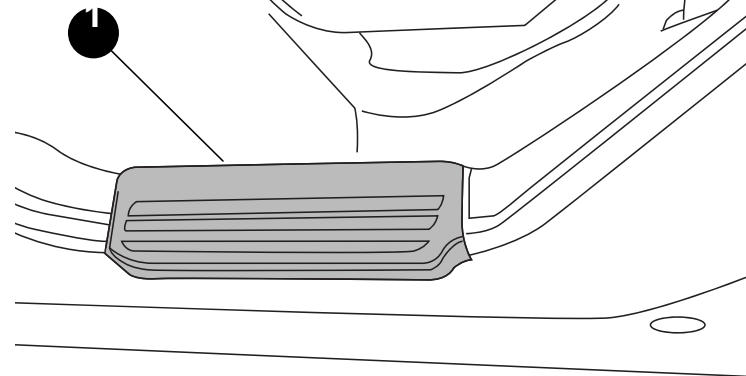

—STEP 11—

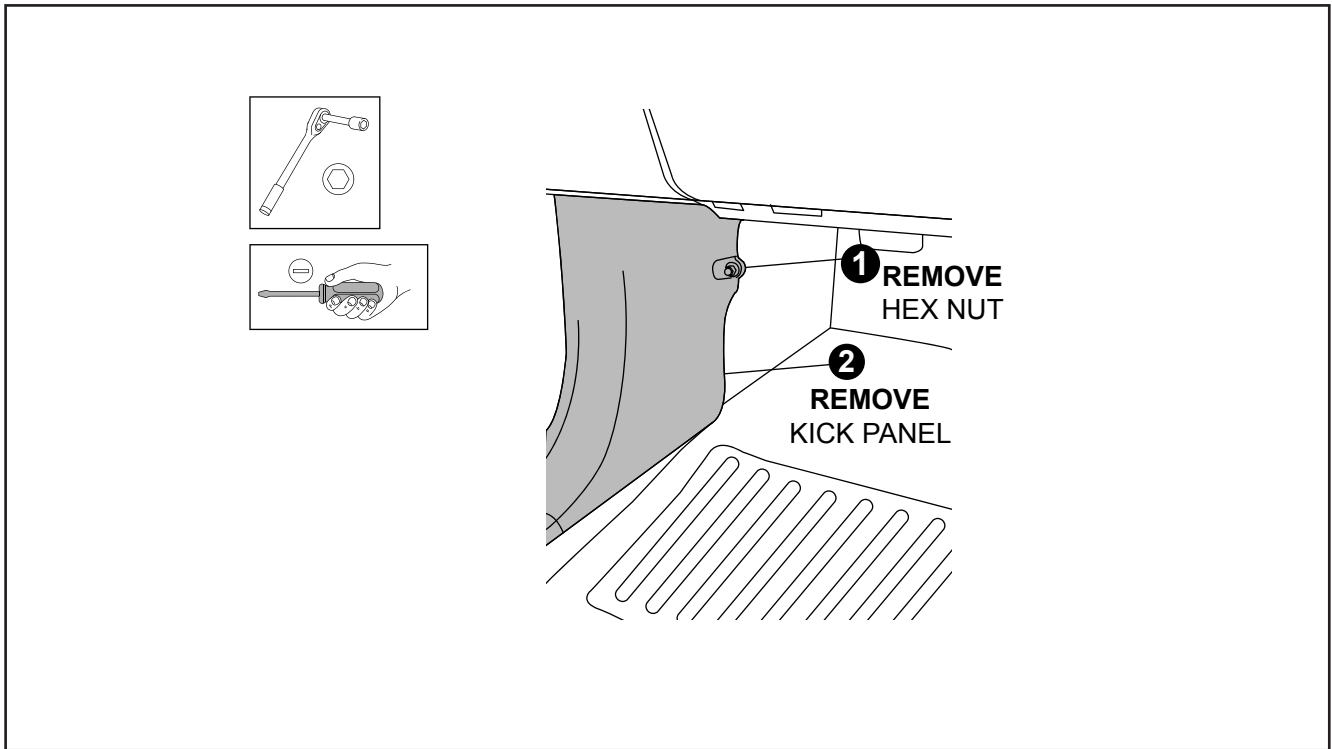

—STEP 12—

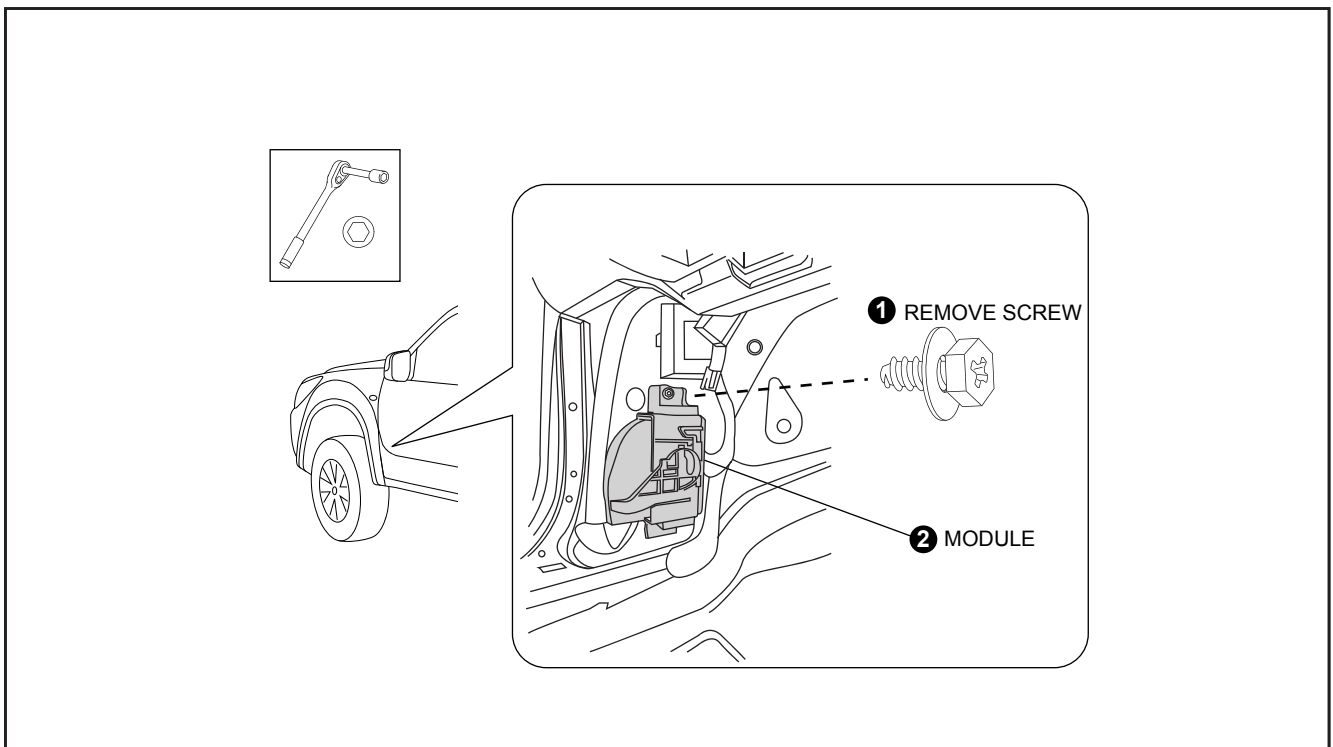



— STEP 13 —

Release the lever and unplug wiring.

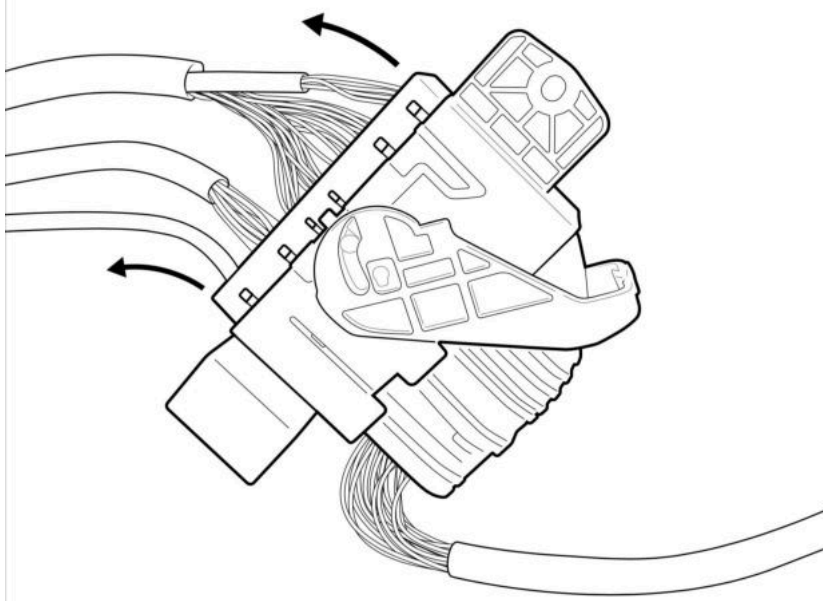

— STEP 14 —

Remove indicated section.

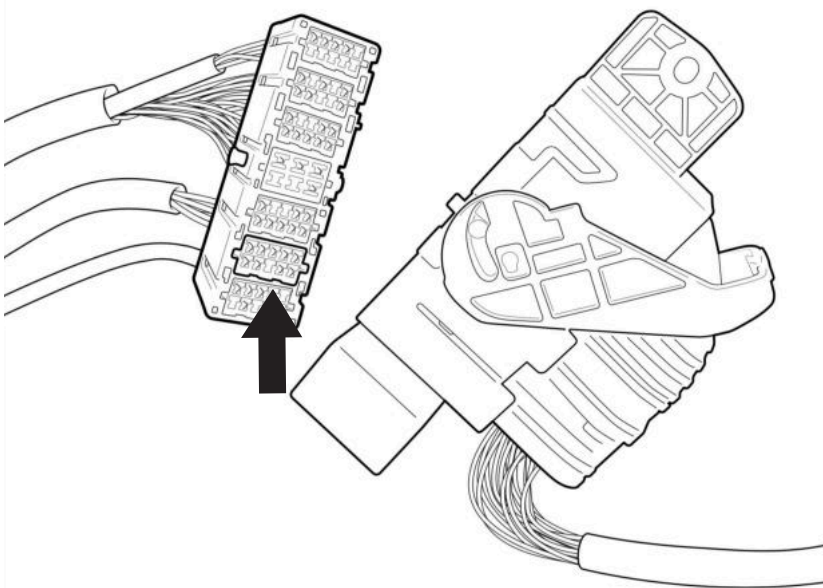

—STEP 15—

Remove wire blue, replace with wire blue from X-PATCH loom.  
Remove wire blue with red trace, replace with wire red from X-PATCH loom

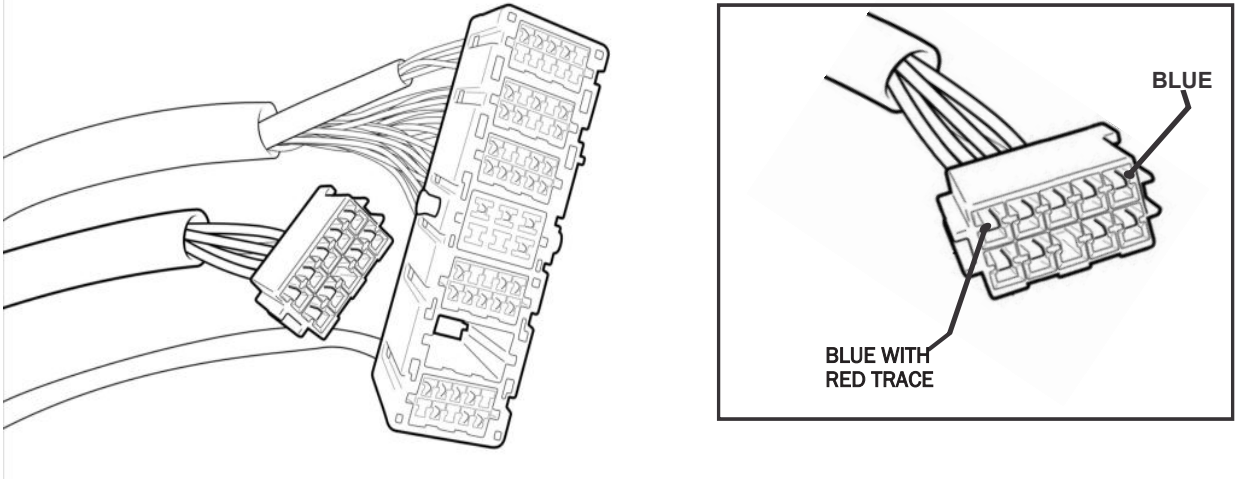

—STEP 16—

House the lock/unlock wiring terminals, previously removed from the vehicle harness (1) into the supplied 2-way male connector (2) as shown, now Connect the actuator wiring harness to the vehicle patch harness 2-way connector (3).

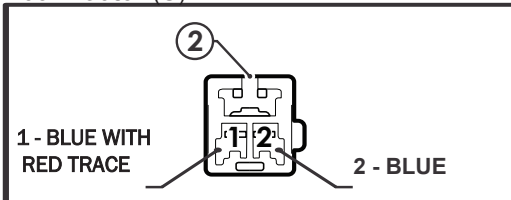

Rear view of 2-way connector

Check the wiring harness and vehicle patch harness are securely attached to the main vehicle harnesses.

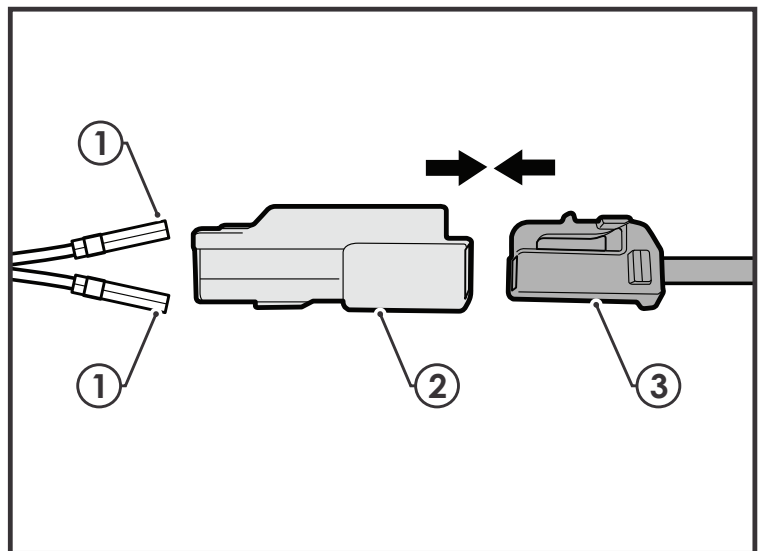

—STEP 17—

Connect X-PATCH loom to CL-LOOM-LONG

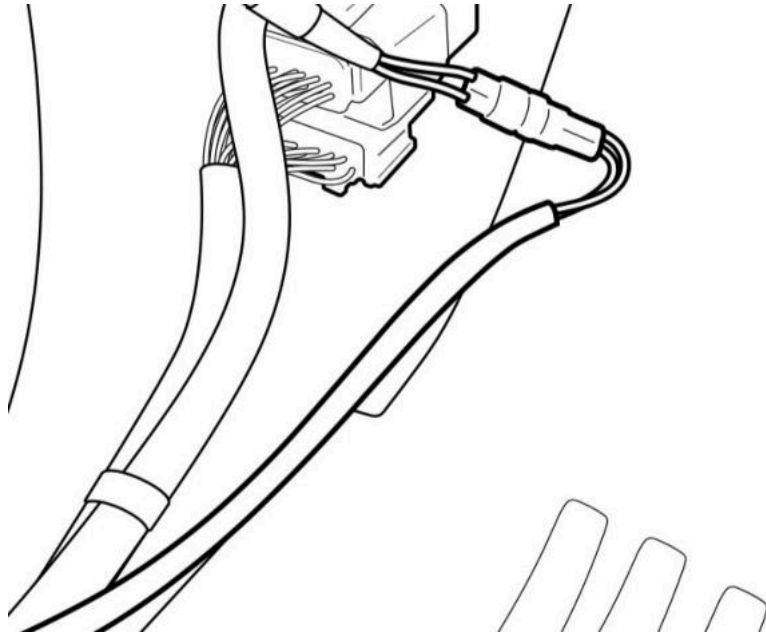

—STEP 18—

Plug all connectors removed earlier inside kicker panel. Then assemble kicker panel.

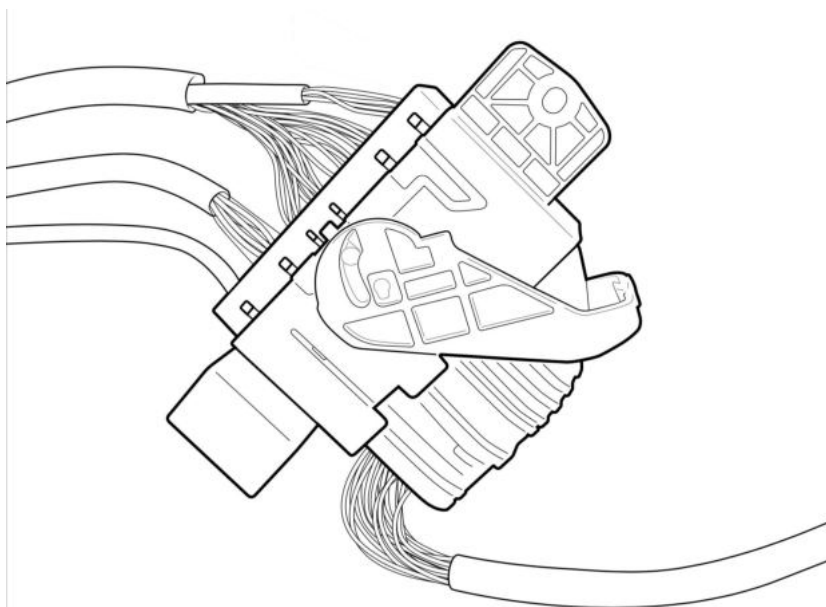

—STEP 19—

---

Place and fasten tail gate cover.

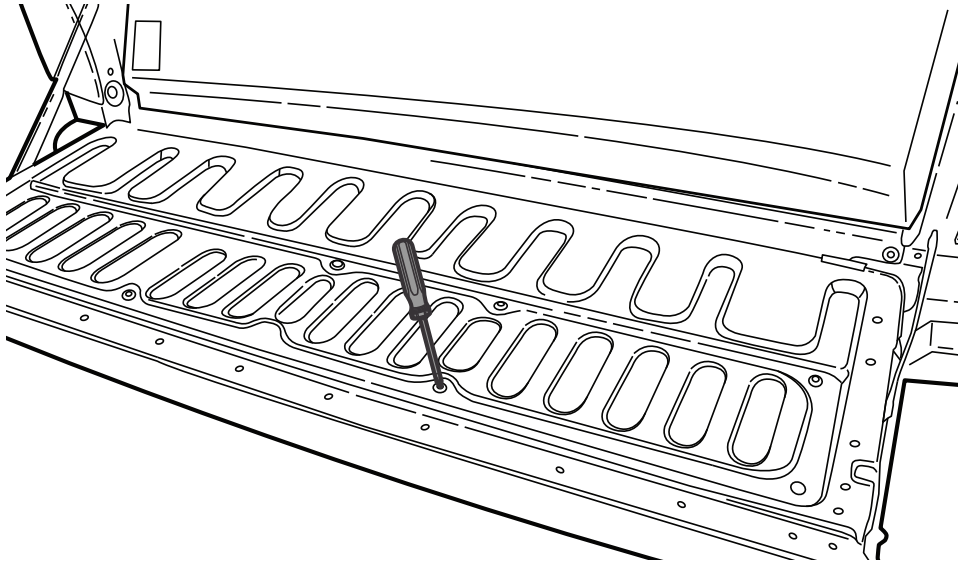

—FITTING COMPLETED—

---