

Air Cylinder New

Large Bore Sizes $\varnothing 125, \varnothing 140, \varnothing 160$

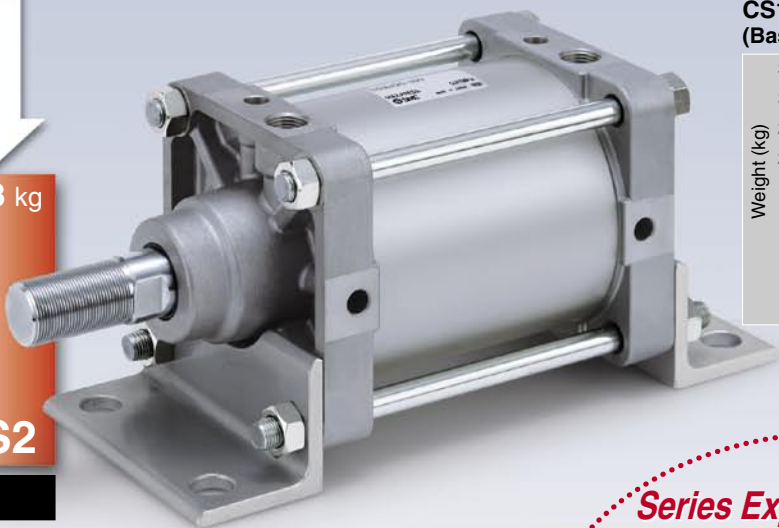

- Lighter installation achieved by reducing weight.
- Die cast rod cover and head cover are used in order to achieve greater weight reduction.
- Rod bore size changed to suit uses, achieving greater weight reduction.

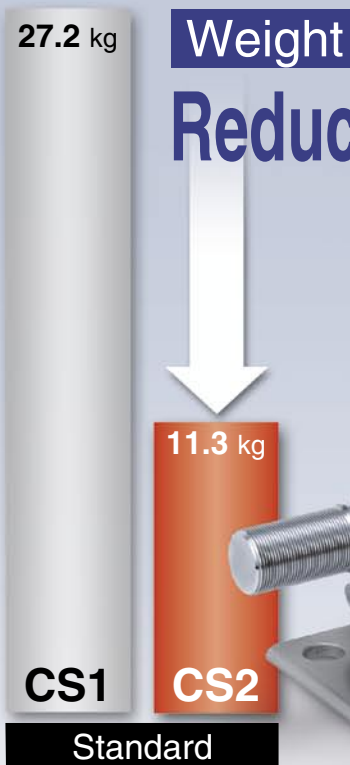
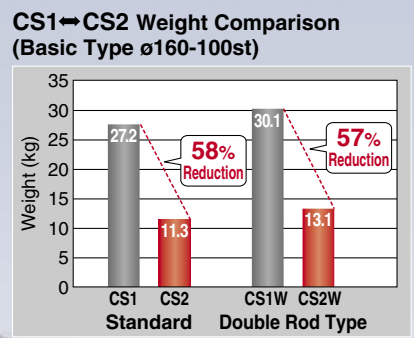

Maximum stroke when using rotating bracket

Expanded by **1.6 times** (compared to series CS1)

Lighter cylinder reduces self-weight deflection.
Stroke range extended to widen use.

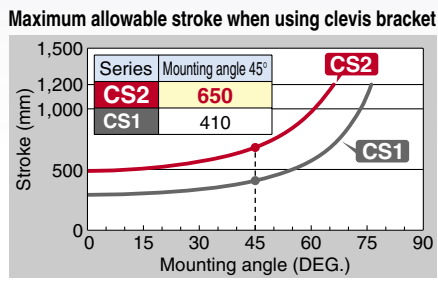
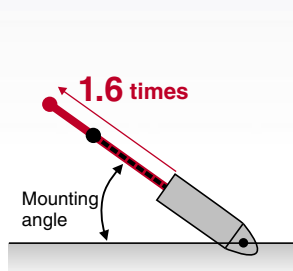

Allowable lateral load equal to Series CS1

Even if the rod diameter is changed to suit various needs, the function remains equal to Series CS1.

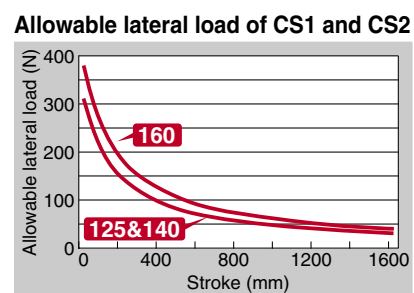

Series Expanded **NEW**

Double Rod Type, Smooth Cylinder added to Series CS2!

9 Made to Order types added!

Double Rod Type

Smooth Cylinder

Series CS2

Improved operability after installation

Operability has been improved by placing the piping port and cushion valve operation position on the same side.

Compact auto switches can be mounted

2-colour display auto switches can be mounted, enabling precise determination of mounting position, without error.

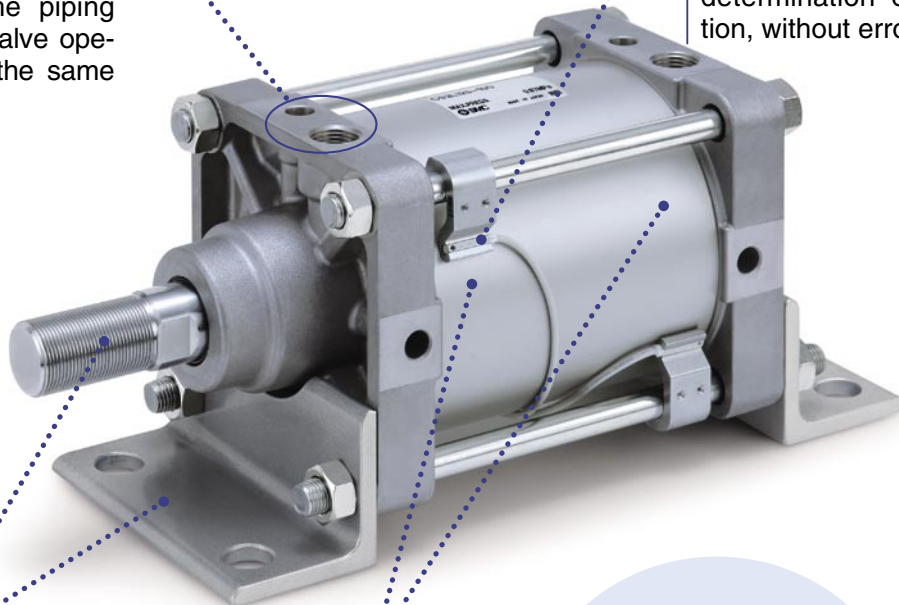

Interchangeability with Series CS1

Cylinder mounting dimensions and rod end thread sizes are interchangeable with Series CS1.

Cushion seals are now replaceable



Maintenance improved by making cushion seals replaceable.

Smooth Cylinder

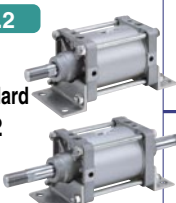

- Minimum operating pressure **0.005**
- Realise stable, low speed operation at even **5 mm/s**

Series Variations

Series	Action	Type	Standard variations		Bore size (mm)	Made to Order
			With rod boot	Copper-free		
P.2 Standard CS2 	Double acting	Single rod	●	●	125 140 160	<ul style="list-style-type: none"> • Change of rod end shape NEW • Special port positions • Change of trunnion bracket mounting position • Change of tie-rod length • Double clevis pin and double knuckle pin with split pin and flat washer • Double clevis pin and double knuckle pin made of stainless steel • Rod side trunnion mounted on the front of the rod cover • Made of stainless steel (Piston rod is hard chrome plated) • With rod end bracket
		NEW Double rod	●	●		
P.17 Smooth Cylinder CS2Y NEW 	Double acting	Single rod	●			

Combination of Standard Products and Made to Order Specifications

Series CS2

- : Standard
- ◎ : Made to Order specifications
- : Special product (Contact SMC for details)
- : Not available

Symbol	Specification	Applicable bore size	Series		CS2 (Standard)	CS2Y (Smooth Cylinder)
			Action/Type	Double acting		Double acting
				Single rod	Double rod	Single rod
				Non-lube		Non-lube
			ø125 to ø160		ø125 to ø160	
Standard	Standard	ø125 to ø160		●	●	●
CDS2	Built-in magnet			●	●	●
CS2□-□ ^J _K	With rod boot			●	●	●
20-	Copper and Fluorine-free	ø125 to ø160		◎	◎	—
-XA□	Change of rod end shape			◎	◎	◎
-XB5	Oversized rod cylinder			○	○	○
-XB6	Heat-resistant cylinder (-10 to 150°C)			○	○	—
-XB7	Cold-resistant cylinder			○	○	—
-XB9	Low speed cylinder (5 to 50 mm/s)			○	○	○
-XC3	Special port position			◎	◎	◎
-XC4	With heavy duty scraper			○	○	—
-XC5	Heat resistant cylinder (0 to 110°C)			○	○	—
-XC6	Made of stainless steel			—	—	—
-XC7	Tie-rod, cushion valve, tie-rod nut, etc. made of stainless steel			○	○	○
-XC8	Adjustable stroke cylinder/Adjustable extension type			○	—	—
-XC9	Adjustable stroke cylinder/Adjustable retraction type			○	—	○
-XC10	Dual stroke cylinder/Double rod type			○	—	○
-XC11	Dual stroke cylinder/Single rod type			○	—	○
-XC12	Tandem cylinder		ø125 to ø160	○	—	—
-XC14	Change of trunnion bracket mounting position			◎	◎	◎
-XC15	Change of tie-rod length			◎	◎	◎
-XC22	Fluororubber seal			○	○	—
-XC26	Double clevis pin/Double knuckle pin with split pin and flat washer			◎	—	◎
-XC27	Double clevis pin and double knuckle pin made of stainless steel			◎	—	◎
-XC30	Rod side trunnion mounted on the front of the rod cover			◎	◎	◎
-XC35	With coil scraper			○	○	—
-XC39	Special trunnion bearing			○	○	○
-XC40	Clevis hole with bushing			○	—	○
-XC50	Knuckle fixed with nut			○	○	○
-XC68	Made of stainless steel (With hard chrome plated piston rod)			◎	◎	◎
-XC86	With rod end bracket		◎	○	◎	

Basic

Double Rod Type

Smooth Cylinder

Auto Switch

Made to Order

- Присоединительные, габаритные и установочные размеры, такие же, как у CS1, что обеспечивает взаимозаменяемость пневмоцилиндров
- Характеристики давления и скорости хода аналогичны CS1
- Значительное снижение веса по сравнению с CS1 благодаря использованию крышек из алюминия (например в исполнении Ø125 с ходом 100 мм вес уменьшен более чем на 50%)
- В стандартном исполнении предусмотрено пневм. демпфирование конечных положений.
- Более рациональная компоновка: регулировочный винт пневматического демпфера расположен рядом с присоединительным отверстием
- Смазка не требуется
- Возможность установки датчиков положения



Условное обозначение



Технические характеристики

Диаметр поршня, мм	125	140	160
Диаметр поршневого штока, мм	32		38
Резьба поршневого штока	M30x1.5		M36x1.5
Присоединительная резьба	Rc 1/2, G1/2		Rc 3/4, G1/2
Среда	Очищенный сжатый воздух с содержанием масла или без него		
Испытательное давление, МПа	1.57		
Диапазон рабочих давлений, МПа	0.05 ~ 0.97		
Скорость хода поршня, мм/с	50 ~ 500		
Демпфирование	Пневматическое		
Температура рабочей и окружающей среды, °C	0 ~ 70 (не допускать замерзания) 0 ~ 60 – для исполнений с датчиками положения		

Максимальная длина хода цилиндра, мм

Ø поршня, мм	Тип крепления	
	B, G, C, D, T	L, F
125	1000	1600
140		
160	1200	

Допуск по длине хода

Длина хода, мм	До 250	251~1000	1001~1200	1201~1400	1401~1600
Допуск по длине хода, мм	+1,0 / 0	+1,2 / 0	+1,4 / 0	+1,6 / 0	+1,8 / 0

Способ крепления			Обознач.	Рабочее давление (МПа)	Макс. допустимая длина хода, см		
Схема нагружения		L, F, G			125	140	160
L	F		G	L, F	0.3	103	92
			0.5		79	70	86
			0.7		66	58	72
		C, D	0.3		96	83	106
			0.5		71	61	76
			0.7		59	50	62
		L, F	0.3	135	119	147	
			0.5	101	89	111	
			0.7	84	74	91	
		L, F	0.3	301	267	330	
			0.5	231	207	253	
			0.7	193	172	212	
			G	0.3	144	126	156
				0.5	109	94	118
				0.7	90	78	97
		L, F	0.3	433	386	476	
			0.5	334	297	367	
			0.7	281	250	309	
			G	0.3	210	185	229
				0.5	160	141	175
				0.7	134	117	129

Вес пневмоцилиндра и крепежных элементов, кг

Ø поршня, мм		125	140	160
Базовый вес	Базовое крепление	5,46	6,50	9,07
	На лапах	7,49	9,50	12,45
	Передний фланец	8,51	12,03	15,80
	Задний фланец	8,51	12,03	15,80
	Одинарная опора сзади	8,53	10,79	14,56
	Двойная опора сзади	8,99	11,54	15,41
	Центральная опора	9,59	12,23	15,47
Вес магнитного кольца и датчика положения		0,07	0,07	0,08
Дополнительный вес на каждые 100 мм хода		1,55	1,67	2,23
Крепежные элементы	Шарнирный наконечник	0,91	1,16	1,56
	Наконечник-вилка (с учетом веса штифта и шплинта)	1,37	1,81	2,48
	Гайка штока	0,16	0,16	0,23

Характеристики продольной устойчивости пневмоцилиндра

В приведенной таблице указаны максимальные длины хода, при которых пневмоцилиндр сохраняет устойчивость к продольному изгибу. Устойчивость определяется не только длиной хода и диаметром штока, но и способом крепления корпуса цилиндра и характером нагружения.

Схемы, показанные на рисунке, разделены на 4 группы, расположенные в порядке возрастания устойчивости:

- 1 – цилиндр жестко зафиксирован с одной стороны и свободен с другой
- 2 – шарниры с обеих сторон
- 3 – цилиндр жестко зафиксирован с одной стороны и закреплен на шарнире с другой
- 4 – цилиндр жестко зафиксирован с обеих сторон

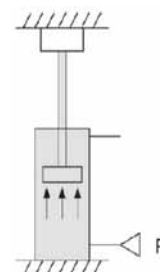

Пневматический цилиндр Серия CS2

Номер для заказа

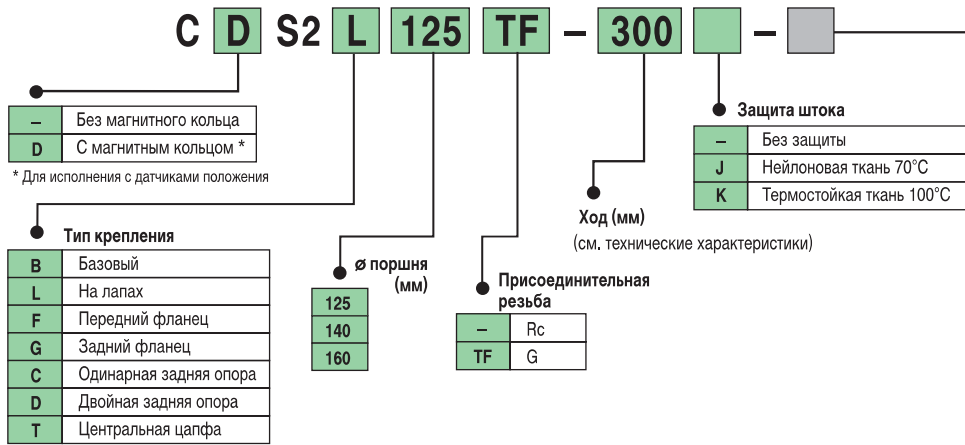

Теоретическое усилие, Н

Диаметр, мм поршня	Направление действия штока	S поршня, мм ²	Рабочее давление, МПа									
			0,2	0,3	0,4	0,5	0,6	0,7	0,8	0,9	1,0	
125	Выдвижение	12300	2460	3690	4920	6150	7380	8610	9840	11100	12300	
	Втягивание	11500	2300	3450	4600	5750	6900	8050	9200	10400	11500	
140	Выдвижение	15400	3080	4620	6160	7700	9240	10800	12300	13900	15400	
	Втягивание	14600	2920	4380	5840	7300	8760	10200	11700	13100	14600	
160	Выдвижение	20100	4020	6030	8040	10100	12100	14100	16100	18100	20100	
	Втягивание	19000	3800	5700	7600	9500	11400	13300	15200	17100	19000	

Датчики положения и элементы крепления датчиков заказываются отдельно. (см. раздел "датчики положения")

Номер для заказа принадлежностей

Номер для заказа ремкомплекта (комплекта уплотнений)

Ø поршня, мм	Ремкомплект
125	CS2-125A-PS
140	CS2-140A-PS
160	CS2-160A-PS

Уплотнения

Наименование	Материал
Уплотнение штока	NBR
Демпфирующее кольцо	Уретан
Уплотнение поршня	NBR
Уплотнение пневм. демпфера	
Прокладка гильзы	
Прокладка поршня	

Шарнирный наконечник

Номер для заказа	Ø поршня
I-12A	125
I-14A	140
I-16A	160

Наконечник-вилка

Номер для заказа	Ø поршня
Y-12A	125
Y-14A	140
Y-16A	160

Штифт

(для наконечников и двойной опоры)

Номер для заказа	Ø поршня	Шплинт (в комплекте)
IY-12	125	Ø4x40
IY-14	140	Ø4x40
IY-16	160	Ø4x40

Гайка штока

Номер для заказа	Ø поршня
NT-12	125 / 140
NT-16	160

* Штифт и шплинт в комплекте

Датчики положения

Для цилиндров серии CS2 используются электронные датчики положения D-M9NL, D-M9PL, D-M9BL и герконовые датчики положения D-A90L и D-A93L. Технические характеристики датчиков - см. раздел "универсальные датчики положения"

Ø поршня	Гистерезис		Зона переключения			
			D-A9*L		D-M9*L	
	D-A9*L	D-M9*L	A	B	A	B
125	12	4	9	8	13	12
140	12,5	4,5	9	8	13	12
160	11,5	4,5	9	8	13	12

Элементы крепления для датчиков положения



Минимальная длина хода при использовании датчиков положения

Тип датчика	Кол-во датчиков	Тип крепления B, L, F, G, C, D	Тип крепления T		
			Ø125	Ø140	Ø160
Герконовый D-A9*L	1, 2	15	100	105	110
	n	$15 + 35 \frac{n-2}{2}$ (n = 2, 4, 6, 8...)	$100 + 35 \frac{n-4}{2}$ (n = 4, 8, 12...)	$105 + 35 \frac{n-4}{2}$ (n = 4, 8, 12...)	$110 + 35 \frac{n-4}{2}$ (n = 4, 8, 12...)
Электронный D-M9*L	1, 2	15	105	110	115
	n	$15 + 35 \frac{n-2}{2}$ (n = 2, 4, 6, 8...)	$105 + 35 \frac{n-4}{2}$ (n = 4, 8, 12...)	$110 + 35 \frac{n-4}{2}$ (n = 4, 8, 12...)	$115 + 35 \frac{n-4}{2}$ (n = 4, 8, 12...)

Скоба крепления на шпильке цилиндра

Ø поршня	Номер для заказа
125	BS5-125
140	
160	BS5-160

Конструкция

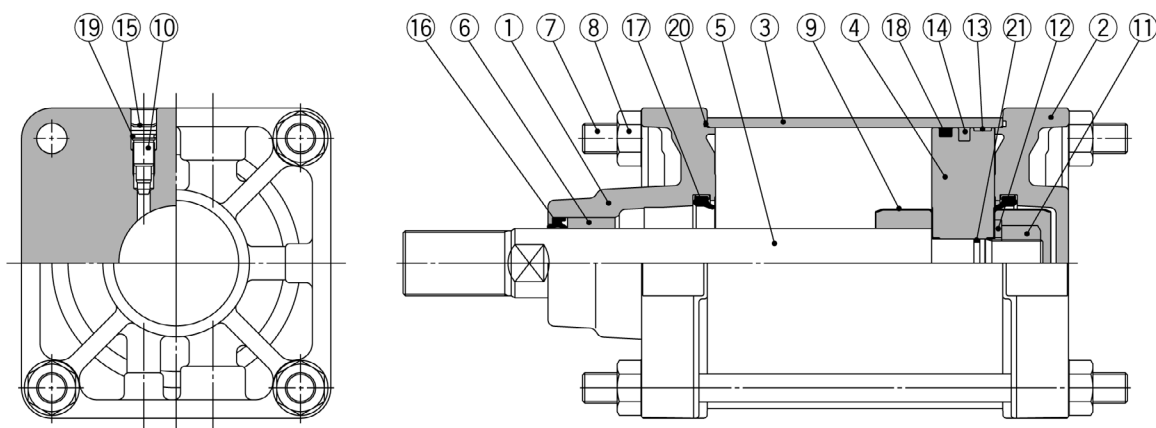

Спецификация

Поз.	Наименование	Материал	Примечание
1	Штоковая крышка	Алюминий	–
2	Задняя крышка	(литье под давлением)	–
3	Гильза цилиндра	Алюминиевый сплав	Анодирование
4	Поршень		Хроматирование
5	Шток	Углеродистая сталь	Твердое хроматирование
6	Направляющее кольцо штока	Спеченный металлический порошок, пропитанный маслом	–
7	Стяжная шпилька	Углеродистая сталь	Хроматирование
8	Гайка	Сталь	Никелевое покрытие
9	Втулка	Нерж. сталь	–
10	Клапан пневм. демпфера	Сталь	Никелевое покрытие
11	Гайка поршня		
12	Шайба	Углеродистая сталь	–
13	Кольцо		
14	Магнит	Магнитный материал	–
15	Стопорное кольцо	Пружинная сталь	Фосфатирование

Уплотнения

Поз.	Наименование	Материал
16	Уплотнение штока	NBR
17	Демпфирующее кольцо	Уретан
18	Уплотнение поршня	NBR
19	Уплотнение пневм. демпфера	
20	Прокладка гильзы	
21	Прокладка поршня	

Номер для заказа ремкомплекта (комплекта уплотнений)

Ø поршня, мм	Ремкомплект
125	CS2-125A-PS
140	CS2-140A-PS
160	CS2-160A-PS

Пневматический цилиндр CS2

Размеры

Базовое исполнение

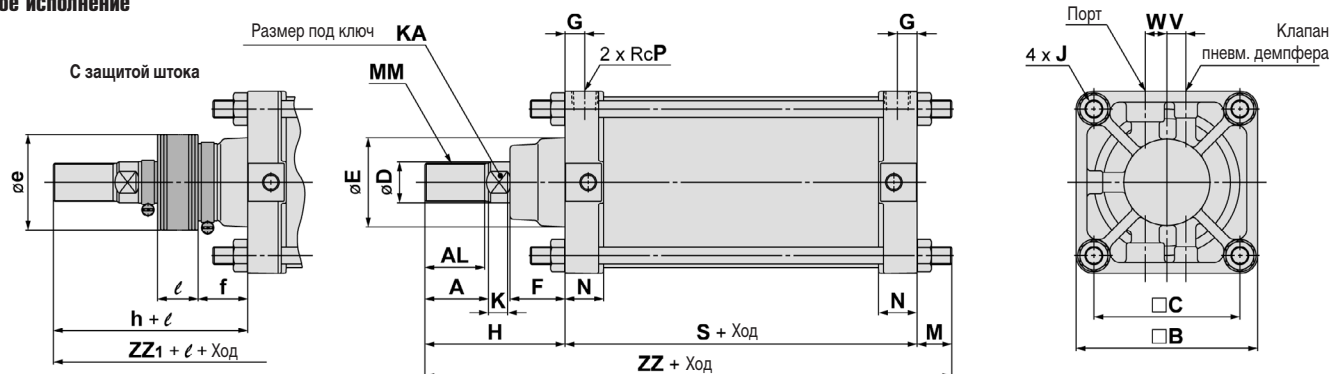

ø поршня	Ход	A	AL	B	C	D	E	F	G	J	V	W	K	KA	M
125	До 1000	50	47	143	115	32	71	43	15	M14x1.5	15	17	15	27	27
140	До 1000	50	47	157	128	32	71	43	15	M14x1.5	15	17	15	27	27
160	До 1200	56	53	177	144	38	78.5	42	18	M16x1.5	15	20	17	34	30.5

ø поршня	MM	N	P	S	Без защиты штока		С защитой штока				
					H	ZZ	e	f	h	l	ZZ1
125	M30x1.5	30.5	1/2	98	110	235	75	40	133	0.2 хода	258
140	M30x1.5	30.5	1/2	98	110	235	75	40	133		258
160	M36x1.5	34.5	3/4	106	120	256.5	75	40	141		277.5

* Минимальный ход для исполнения с защитой штока 30 мм

Тип крепления L (на лапах)

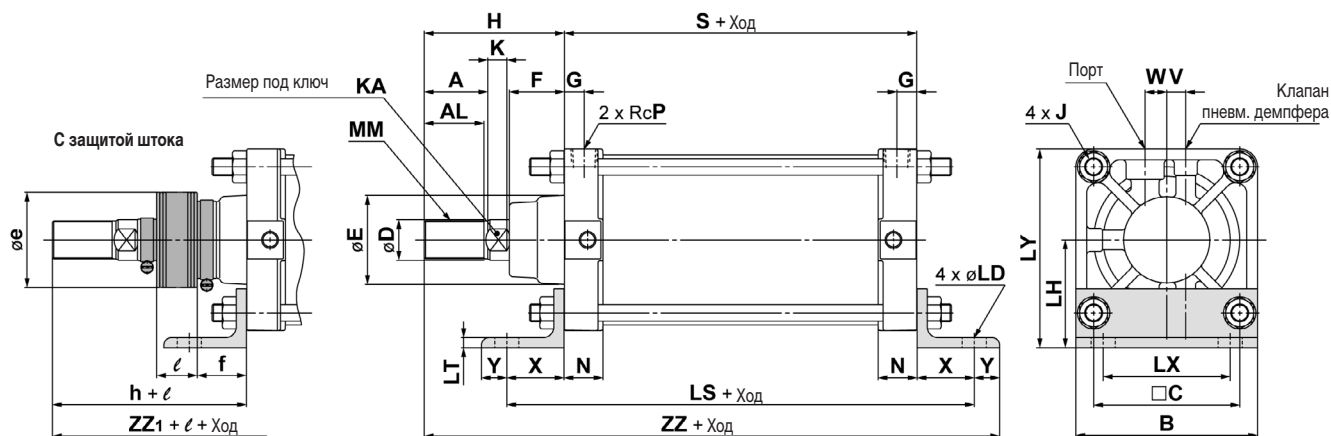

ø поршня	Ход	A	AL	B	C	D	E	F	G	J	V	W	K	KA	LD	LH
125	До 1600	50	47	145	115	32	71	43	15	M14x1.5	15	17	15	27	19	85
140	До 1600	50	47	161	128	32	71	43	15	M14x1.5	15	17	15	27	19	100
160	До 1600	56	53	182	144	38	78.5	42	18	M16x1.5	15	20	17	34	19	106

ø поршня	LS	LT	LX	LY	MM	N	P	S	X	Y	Без защиты штока		С защитой штока				
											H	ZZ	e	f	h	l	ZZ1
125	188	8	100	156.5	M30x1.5	30.5	1/2	98	45	20	110	273	75	40	133	0.2 хода	296
140	188	8	112	178.5	M30x1.5	30.5	1/2	98	45	30	110	283	75	40	133		306
160	206	9	118	194.5	M36x1.5	34.5	3/4	106	50	25	120	301	75	40	141		322

* Минимальный ход для исполнения с защитой штока 30 мм

Размеры

Тип крепления F (передний фланец)

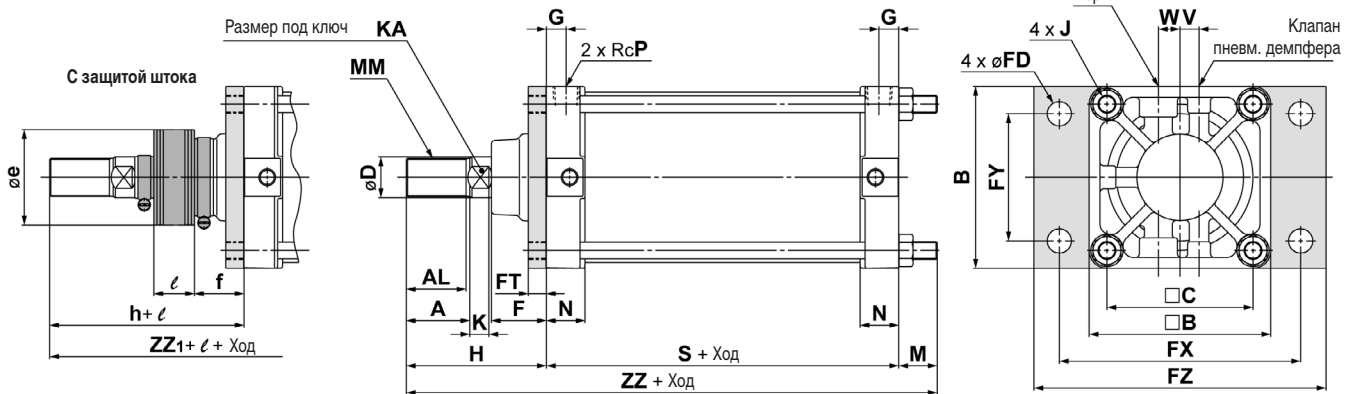

ø поршня	Ход	A	AL	□B	B	□C	D	E	F	FD	FT	FX	FY	FZ	G	J
125	До 1600	50	47	143	145	115	32	71	43	19	14	190	100	230	15	M14x1.5
140	До 1600	50	47	157	160	128	32	71	43	19	20	212	112	255	15	M14x1.5
160	До 1600	56	53	177	180	144	38	78.5	42	19	20	236	118	275	18	M16x1.5

ø поршня	V	W	K	KA	M	MM	N	P	S	Без защиты штока		С защитой штока				
										H	ZZ	e	f	h	l	ZZ1
125	15	17	15	27	13	M30x1.5	30.5	1/2	98	110	221	75	40	133	0.2 хода	244
140	15	17	15	27	13	M30x1.5	30.5	1/2	98	110	221	75	40	133		244
160	15	20	17	34	15	M36x1.5	34.5	3/4	106	120	241	75	40	141		262

* Минимальный ход для исполнения с защитой штока 30 мм

Тип крепления G (задний фланец)

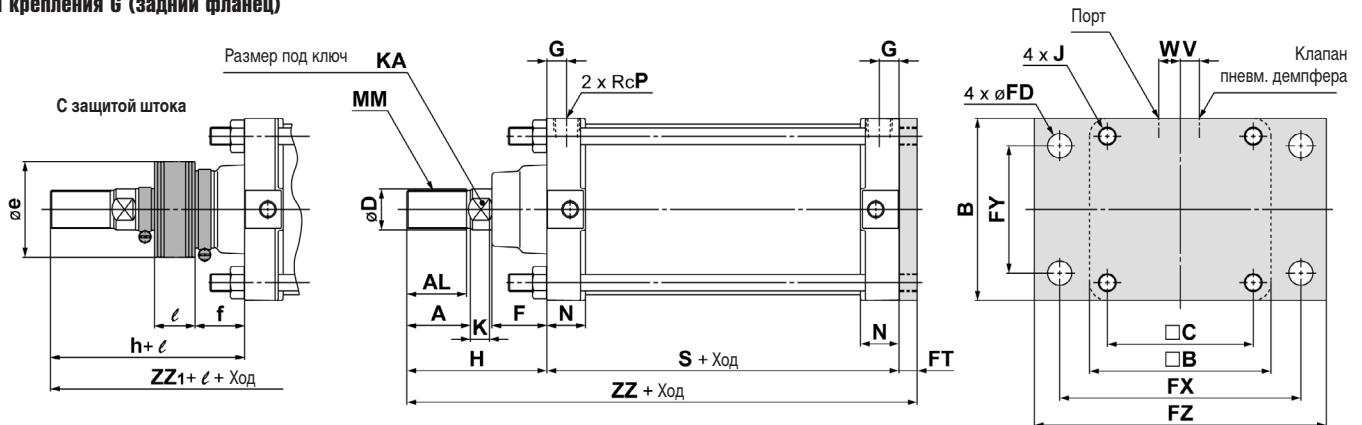

ø поршня	Ход	A	AL	□B	B	□C	D	E	F	FD	FT	FX	FY	FZ	G	J
125	До 1000	50	47	143	145	115	32	71	43	19	14	190	100	230	15	M14x1.5
140	До 1000	50	47	157	160	128	32	71	43	19	20	212	112	255	15	M14x1.5
160	До 1200	56	53	177	180	144	38	78.5	42	19	20	236	118	275	18	M16x1.5

ø поршня	V	W	K	KA	MM	N	P	S	Без защиты штока		С защитой штока				
									H	ZZ	e	f	h	l	ZZ1
125	15	17	15	27	M30x1.5	30.5	1/2	98	110	222	75	40	133	0.2 хода	245
140	15	17	15	27	M30x1.5	30.5	1/2	98	110	228	75	40	133		251
160	15	20	17	34	M36x1.5	34.5	3/4	106	120	246	75	40	141		267

* Минимальный ход для исполнения с защитой штока 30 мм

Пневматический цилиндр CS2

Размеры

Тип крепления С (одинарная задняя опора)

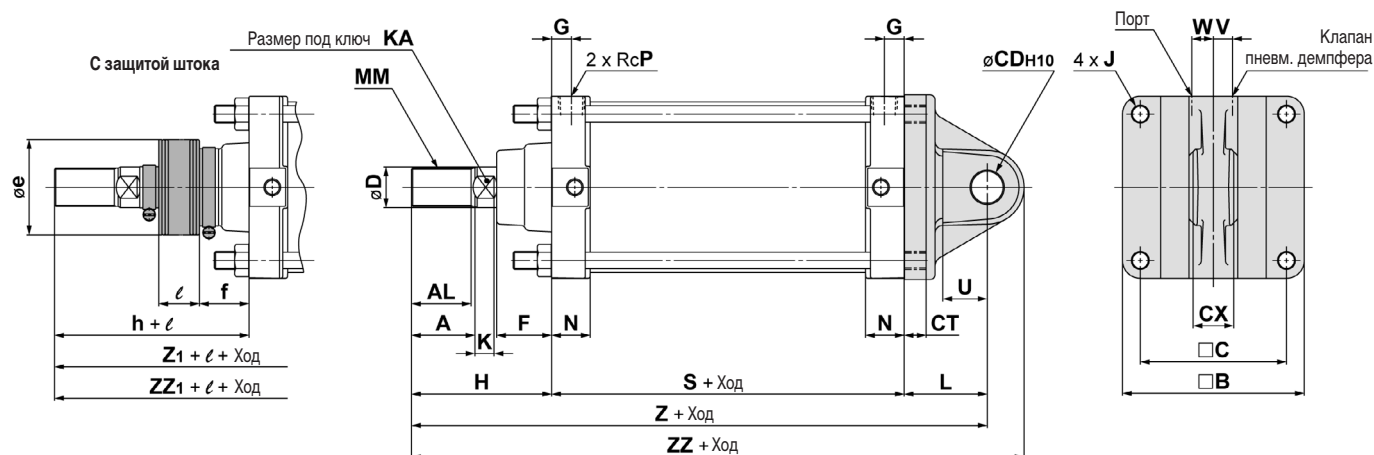

Тип крепления D (двойная задняя опора)

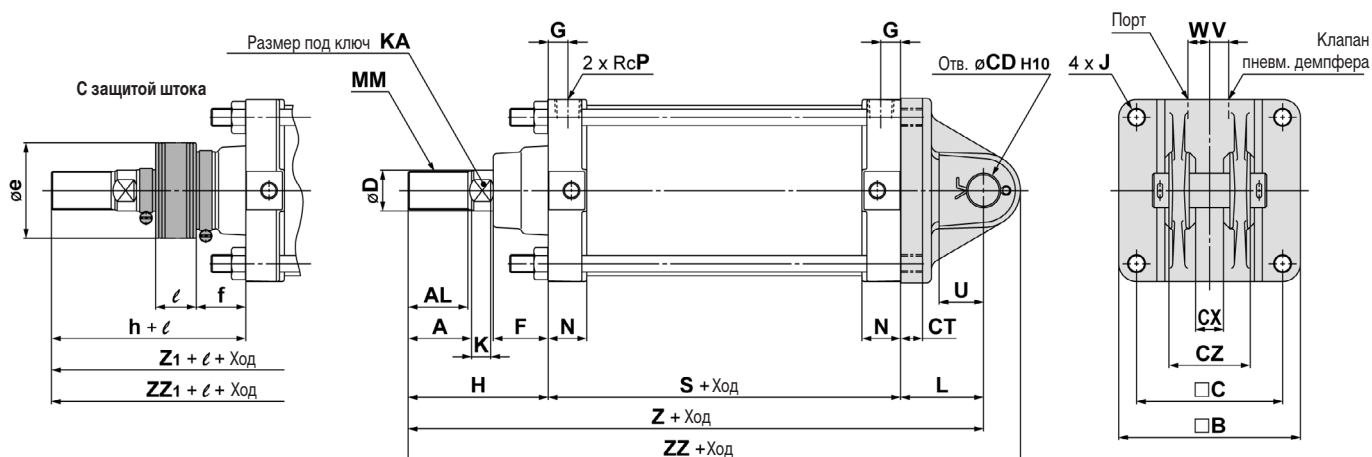

ø поршня	Ход	A	AL	B	C	CDH10	CT	Один. опора			D	E	F	G
								CX	CX	CZ				
125	До 1000	50	47	143	115	25 ^{+0.084} ₀	17	32 ^{-0.1} _{-0.3}	32 ^{+0.3} _{+0.1}	64 ⁰ _{-0.2}	32	71	43	15
140	До 1200	50	47	157	128	28 ^{+0.084} ₀	17	36 ^{-0.1} _{-0.3}	36 ^{+0.3} _{+0.1}	72 ⁰ _{-0.2}	32	71	43	15
160	До 1200	56	53	177	144	32 ^{+0.100} ₀	20	40 ^{-0.1} _{-0.3}	40 ^{+0.3} _{+0.1}	80 ⁰ _{-0.2}	38	78.5	42	18

ø поршня	J	V	W	K	KA	L	MM	N	P	S	U	PR
125	M14x1.5	15	17	15	27	65	M30x1.5	30.5	1/2	98	35	29
140	M14x1.5	15	17	15	27	75	M30x1.5	30.5	1/2	98	40	32
160	M16x1.5	15	20	17	34	80	M36x1.5	34.5	3/4	106	45	36

ø поршня	Без защиты штока			С защитой штока				l	Z1	ZZ1
	H	Z	ZZ	e	f	h				
125	110	273	302	75	40	133	0.2 хода	296	325	
140	110	283	315	75	40	133		306	338	
160	120	306	342	75	40	141		327	363	

* Минимальный ход для исполнения с защитой штока 30 мм

Размеры

Тип крепления Т (центральная цапфа)

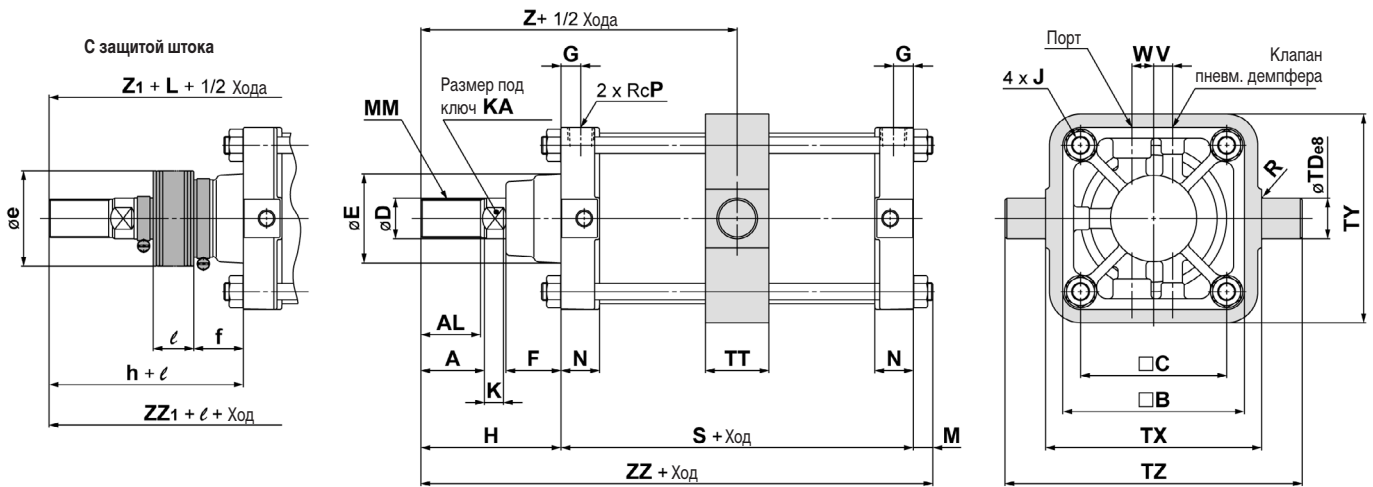

Ø порш.	Ход	A	AL	□B	□C	D	E	F	G	J	V	W	K	KA	M	MM
125	25 ~ 1000	50	47	143	115	32	71	43	15	M14x1.5	15	17	15	27	13	M30x1.5
140	30 ~ 1000	50	47	157	128	32	71	43	15	M14x1.5	15	17	15	27	13	M30x1.5
160	35 ~ 1200	56	53	177	144	38	78.5	42	18	M16x1.5	15	20	17	34	15	M36x1.5

Ø порш.	N	P	R	S	TDeв	TT	TX	TY	TZ	Без защиты штока			С защитой штока					
										H	Z	ZZ	e	f	h	l	Z1	ZZ1
125	30.5	1/2	1	98	32 ^{-0.050} _{-0.089}	50	170	164	234	110	159	221	75	40	133	0.2 хода	182	244
140	30.5	1/2	1.5	98	36 ^{-0.050} _{-0.089}	55	190	184	262	110	159	221	75	40	133		182	244
160	34.5	3/4	1.5	106	40 ^{-0.050} _{-0.089}	60	212	204	292	120	173	241	75	40	141		194	262

* Минимальный ход для исполнения с защитой штока 30 мм – для типоразмеров Ø125 и Ø140,
35 мм – для типоразмера Ø160

Пневматический цилиндр CS2

Размеры и номер для заказа принадлежностей

Шарнирный наконечник

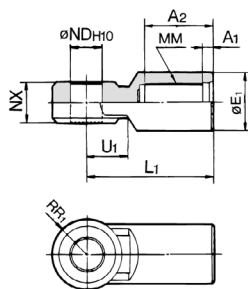

Номер для заказа	\varnothing поршня	A1	A2	E1	L1	MM
I-12A	125	8	54	46	100	M30x1.5
I-14A	140	8	54	48	105	M30x1.5
I-16A	160	8	60	55	110	M36x1.5

Номер для заказа	\varnothing поршня	ND _{H10}	NX	RR1	U1
I-12A	125	25 ^{+0.084} ₀	32 ^{-0.1} _{0.3}	27	33
I-14A	140	28 ^{+0.084} ₀	36 ^{-0.1} _{0.3}	30	39
I-16A	160	32 ^{+0.100} ₀	40 ^{-0.1} _{0.3}	34	39

* При установке совместно с гайкой штока, размеры А и Н возрастают (см. подраздел «Размеры в сборе с наконечниками»)

Наконечник-вилка

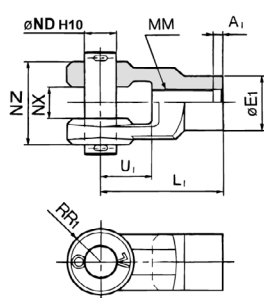

Номер для заказа	\varnothing поршня	A1	E1	L1	MM
Y-12A	125	8	46	100	M30x1.5
Y-14A	140	8	48	105	M30x1.5
Y-16A	160	8	55	110	M36x1.5

Номер для заказа	\varnothing поршня	ND _{H10}	NX	NZ	RR1	U1
Y-12A	125	25 ^{+0.084} ₀	32 ^{+0.3} _{+0.1}	64 ^{-0.1} _{0.3}	27	42
Y-14A	140	28 ^{+0.084} ₀	36 ^{+0.3} _{+0.1}	72 ^{-0.1} _{0.3}	30	47
Y-16A	160	32 ^{+0.100} ₀	40 ^{+0.3} _{+0.1}	80 ^{-0.1} _{0.3}	34	46

* Штифт и шплинт в комплекте

** При установке совместно с гайкой штока, размеры А и Н возрастают (см. подраздел «Размеры в сборе с наконечниками»)

Штифт (для наконечников и двойной опоры)

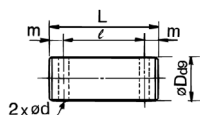

Номер для заказа	\varnothing поршня	D _{д9}	L	l	m	d	Шплинт (в комплекте)
IY-12	125	25 ^{-0.065} _{-0.117}	79.5	69.5	5	4	$\varnothing 4 \times 40$
IY-14	140	28 ^{-0.065} _{-0.117}	86.5	76.5	5	4	$\varnothing 4 \times 40$
IY-16	160	32 ^{-0.080} _{-0.142}	94.5	84.5	5	4	$\varnothing 4 \times 40$

Гайка штока

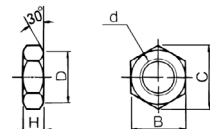

Номер для заказа	\varnothing поршня	d	H	B	C	D
NT-12	125 / 140	M30x1.5	18	46	53.1	44
NT-16	160	M36x1.5	21	55	63.5	53

Размеры в сборе с наконечниками

Шарнирный наконечник / наконечник-вилка

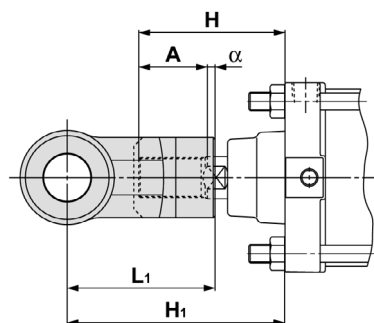

\varnothing поршня	H	A	α	L1	H1
125	110	50	3.5	100	156.5
140	110	50	3.5	105	161.5
160	120	56	3.5	110	170.5

Размеры А, Н при совместной установке наконечника с гайкой штока

\varnothing поршня	A	H
125	65	125
140	65	125
160	76	140

Air Cylinder, Double Rod

Series CS2W

ø125, ø140, ø160

How to Order

CS2W **L** **125** **-** **100** **-** **-**

With auto switch **CDS2W** **L** **125** **-** **100** **-** **M9BW** **-** **-**

• **With auto switch (Built-in magnet)**

• **Double rod type**

• **Mounting**

B	Basic
L	Foot
F	Rod flange
T	Centre trunnion

• **Bore size**

125	125 mm
140	140 mm
160	160 mm

• **Port thread type**

-	Rc
TN	NPT
TF	G

• **Cylinder stroke (mm)**
Refer to the next page for the "Maximum Stroke" table.

• **Made to Order**
For details, refer to the next page.

• **Number of auto switches**

-	2 pcs.
3	3 pcs.
S	1 pc.
n	"n" pcs.

• **Auto switch**

-	Without auto switch
----------	---------------------

* Refer to the table below for the applicable auto switch model.

• **Suffix for cylinder**

Single side rod boot	J	Nylon tarpaulin
Single side rod boot	K	Heat resistant tarpaulin
Both side rod boot	JJ	Nylon tarpaulin
Both side rod boot	KK	Heat resistant tarpaulin

Built-in Magnet Cylinder Model

If a built-in magnet cylinder without auto switch is required, there is no need to enter the symbol for auto switch.
(Example) CDS2WB125-100

Applicable Auto Switches / For detailed auto switch specifications, refer to Best Pneumatics No. 2.

Type	Special function	Electrical entry	Indicator light	Wiring (Output)	Load voltage		Auto switch model		Lead wire length (m)				Pre-wired connector	Applicable load			
					DC	AC	Tie-rod mounting	Band mounting	0.5 (-)	1 (M)	3 (L)	5 (Z)		IC circuit	Relay, PLC		
Solid state switch	—	Grommet	No	3-wire (NPN)	24 V	5 V, 12 V	—	M9N	—	●	●	●	○	○	IC circuit	Relay, PLC	
				3-wire (PNP)				M9P	—	●	●	●	○	○			
		2-wire		—	—	100 V, 200 V	M9B	—	●	●	●	○	○	—			
		2-wire		—	—	100 V, 200 V	J51	—	●	●	○	○	—				
	Diagnostic indication (2-colour indication)	Terminal conduit	Yes	No	3-wire (NPN)	24 V	5 V, 12 V	—	—	G39	—	—	—	—	—	IC circuit	Relay, PLC
					2-wire				—	K39	—	—	—	—	—		
		3-wire (NPN)			—	M9NW	—	●	●	●	○	○	IC circuit				
		3-wire (PNP)			—	M9PW	—	●	●	●	○	○	IC circuit				
		2-wire			—	M9BW	—	●	●	●	○	○	—				
		2-wire			—	M9NA	—	○	○	●	○	○	IC circuit				
Water resistant (2-colour indication)	Grommet	Yes	No	3-wire (NPN)	24 V	5 V, 12 V	—	M9PA	—	○	○	●	○	○	—		
				3-wire (PNP)				M9BA	—	○	○	●	○	○	—		
Diagnostic indication (2-colour indication)	Grommet	Yes	No	2-wire	24 V	12 V	—	M9BA	—	○	○	●	○	○	—		
				4-wire (NPN)				F59F	—	●	—	●	○	○	IC circuit		
Reed switch	—	Grommet	Yes	3-wire (NPN equivalent)	24 V	5 V	—	A96	—	●	—	●	—	—	IC circuit	—	
								12 V	A93	—	●	—	●	—	—		—
								5 V, 12 V	A90	—	●	—	●	—	—		IC circuit
								100 V, 200 V	A54	—	●	—	●	—	—		—
		Terminal conduit	No	2-wire	24 V	12 V	—	100 V, 200 V	200 V or less	A64	—	●	—	●	—	—	—
										—	A33	—	—	—	—	—	
										—	A34	—	—	—	—	—	
										—	A44	—	—	—	—	—	
DIN terminal	Yes	2-wire	24 V	12 V	—	100 V, 200 V	—	—	—	—	—	—	—	—			
								—	A59W	—	●	—	●		—	—	
Diagnostic indication (2-colour indication)	Grommet	Yes	No	3-wire (NPN equivalent)	24 V	5 V	—	A59W	—	●	—	●	—	—	—		
								12 V	A93	—	●	—	●	—		—	

* Lead wire length symbols: 0.5 m — (Example) M9NW
 1 m M (Example) M9NWM
 3 m L (Example) M9NWL
 5 m Z (Example) M9NWX

* Solid state auto switches marked with "○" are produced upon receipt of order.

* Since there are applicable auto switches other than listed, refer to page 23 for details.

* For details about auto switches with pre-wired connector, refer to Best Pneumatics No. 2.

* D-A9□, M9□, M9□W, M9□AL are shipped together (but not assembled). (Only auto switch mounting bracket is assembled at the time of shipment.)



JIS Symbol
Double acting

Rod Boot Material

Symbol	Material	Max. ambient temperature
J	Nylon tarpaulin	70°C
K	Heat resistant tarpaulin	110°C*

* Maximum ambient temperature for the rod boot itself.

Minimum Stroke for Auto Switch Mounting

For details on the minimum number of strokes required for mounting, please refer to the "Minimum Stroke for Auto Switch Mounting" table on page 22.

Made to Order Specifications (For details, refer to pages 25 to 29.)

Symbol	Specifications
-XA□	Change of rod end shape
-XC14	Change of trunnion bracket mounting positions
-XC15	Change of tie-rod length
-XC30	Rod side trunnion mounted on the front of the rod cover
-XC68	Made of stainless steel (With hard chrome plated piston rod)

For the specifications of cylinders with auto-switch, please refer to pages 21 to 24.

- Minimum stroke for auto switch mounting
- Auto switch proper mounting position (detection at stroke end) and its mounting height
- Operating range
- Auto switch mounting bracket part no.

Specifications

Bore size (mm)	125	140	160
Action	Double acting, Double rod		
Fluid	Air		
Proof pressure	1.57 MPa		
Maximum operating pressure	0.97 MPa		
Minimum operating pressure	0.05 MPa		
Piston speed	50 to 500 mm/s		
Cushion	Air cushion		
Ambient and fluid temperature	Without auto switch	0 to 70°C (No freezing)	
	With auto switch	0 to 60°C (No freezing)	
Lubrication	Not required (Non-lube)		
Stroke length tolerance	250 or less st : $^{+1.0}_0$, 251 to 1,000 st : $^{+1.4}_0$, 1,001 to 1,200 st : $^{+1.8}_0$		
Mounting	Basic, Foot, Rod flange, Head flange, Centre trunnion		

Maximum Stroke

Bore size	Maximum stroke (mm)
125	1000 or less
140	
160	1200 or less

Accessory

Mounting		Basic	Foot	Rod flange	Centre trunnion
Option	Rod end nut	●	●	●	●
	Single knuckle joint	●	●	●	●
	Double knuckle joint (Knuckle pin, Split pin)	●	●	●	●
	Rod boot	●	●	●	●

* If using the rod end nut together with a single knuckle joint and a double knuckle joint, please refer to page 11.

Mounting Bracket Part No.

Bore size (mm)	125	140	160
Foot*	CS2-L12	CS2-L14	CS2-L16
Flange	CS2-F12	CS2-F14	CS2-F16

* Order two foot brackets per cylinder.

Weight / Aluminum tube: lube type

Bore size (mm)		125	140	160
Basic weight	Basic	6.36	7.54	9.93
	Foot	8.39	10.54	13.31
	Rod flange	9.41	13.07	16.66
	Trunnion	10.49	13.27	16.33
Additional weight with magnet (With built-in magnet and auto switch)		0.07	0.07	0.08
Additional weight per 100 mm of stroke		2.18	2.30	3.11
Accessory bracket	Single knuckle	0.91	1.16	1.56
	Double knuckle joint (Knuckle pin, Split pin)	1.37	1.81	2.48
	Rod end nut	0.16	0.16	0.23

Calculation: (Example) **CS2WL160-500**

- Basic weight 13.31 (kg)
 - Additional weight 3.11 (kg/100 mm)
 - Cylinder stroke 500 (mm)
- 13.31 + 3.11 x 500/100 = 28.86 (kg)

Series CS2W

Construction

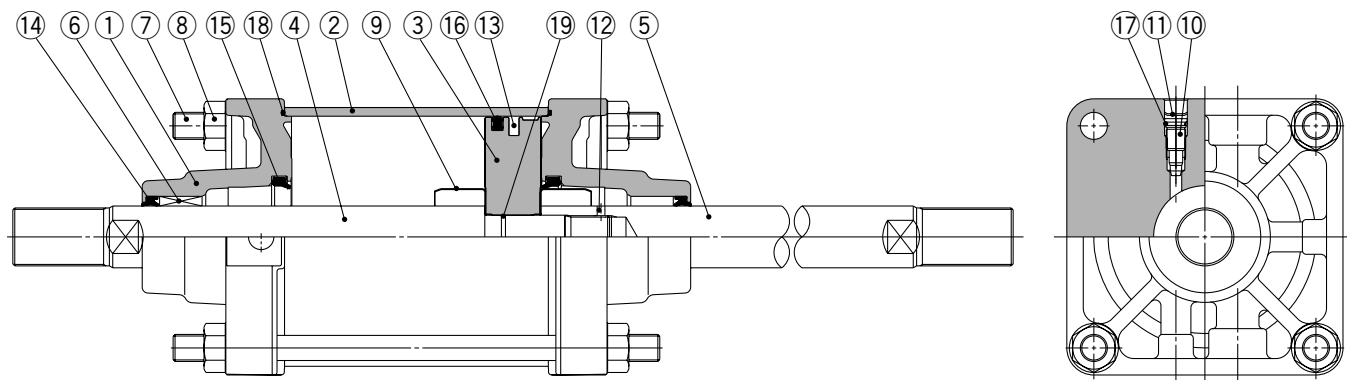

Component Parts

No.	Description	Material	Note
1	Rod cover	Aluminum die-cast	Chromated
2	Cylinder tube	Aluminum alloy	Hard anodized
3	Piston	Aluminum alloy	Chromated
4	Piston rod A	Carbon steel	Hard chrome plated
5	Piston rod B	Carbon steel	Hard chrome plated
6	Bushing	Oil-impregnated sintered alloy	
7	Tie-rod	Carbon steel	Zinc chromated
8	Tie-rod nut	Rolled steel	Nickel plated
9	Cushion ring	Stainless steel	
10	Cushion valve	Rolled steel	Nickel plated
11	Retaining ring	Spring steel	Phosphate coated
12	Pin	Spring steel	Phosphate coated
13	Magnet*	—	

* Built-in magnet type with auto switch

Component Parts

No.	Description	Material	Note
14	Rod seal	NBR	
15	Cushion seal	Urethane	
16	Piston seal	NBR	
17	Valve seal	NBR	
18	Tube gasket	NBR	
19	Piston gasket	NBR	

Replacement Parts: Seal Kit

Bore size (mm)	Kit no.	Content
125	CS2W125A-PS	Set of nos. above 14, 15, 16, 18.
140	CS2W140A-PS	
160	CS2W160A-PS	

* Seal kit includes a grease pack (40 g).
Order with the following part number when only the grease pack is needed.
Grease pack part number: GR-S-010 (10 g), GR-S-020 (20 g)

Dimensions

Basic: CS2WB

With rod boot (One side)

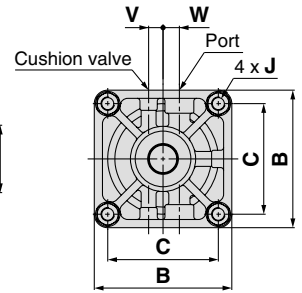
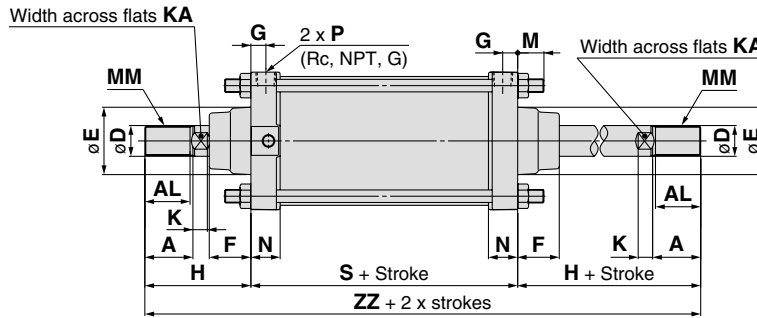
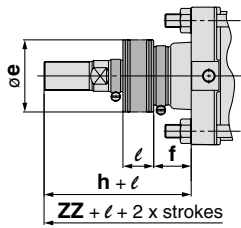

With rod boot (Both sides)

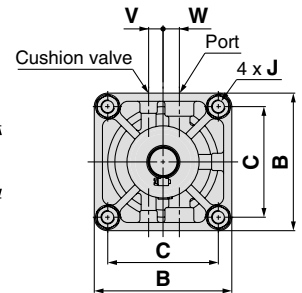
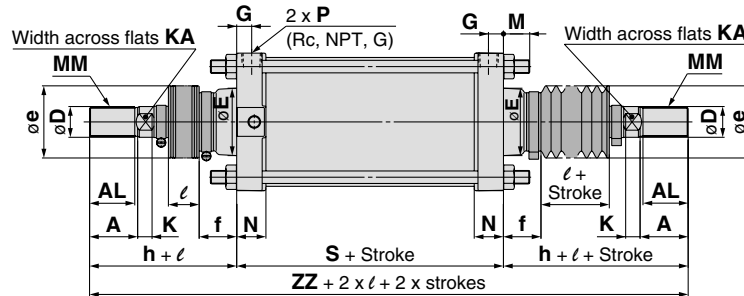

Bore size (mm)	Stroke range (mm)	A	AL	B	C	D	E	F	G	J	V	W	K	KA	M	MM	N	P	S
ø125	Up to 1000	50	47	143	115	32	71	43	15	M14 x 1.5	15	17	15	27	27	M30 x 1.5	30.5	1/2	98
ø140	Up to 1000	50	47	157	128	32	71	43	15	M14 x 1.5	15	17	15	27	27	M30 x 1.5	30.5	1/2	98
ø160	Up to 1200	56	53	177	144	38	78.5	42	18	M16 x 1.5	15	20	17	34	30.5	M36 x 1.5	34.5	3/4	106

Bore size (mm)	Without rod boot		With rod boot (single side)					(Both sides)	
	H	ZZ	e	f	h	l	ZZ	ZZ	
ø125	110	318	75	40	133	1/5 stroke	341	364	
ø140	110	318	75	40	133	1/5 stroke	341	364	
ø160	120	346	75	40	141	1/5 stroke	367	388	

* The minimum stroke with rod boot is 30 mm or more.
 ** For auto switch mounting position and its mounting height, refer to page 21.
 *** Refer to "Minimum Stroke for Auto Switch Mounting" on page 22.

Foot: CS2WL

With rod boot

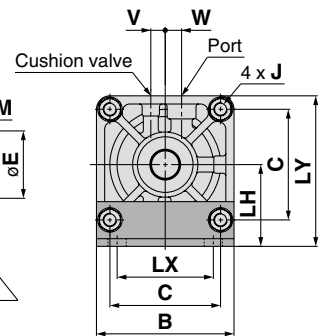
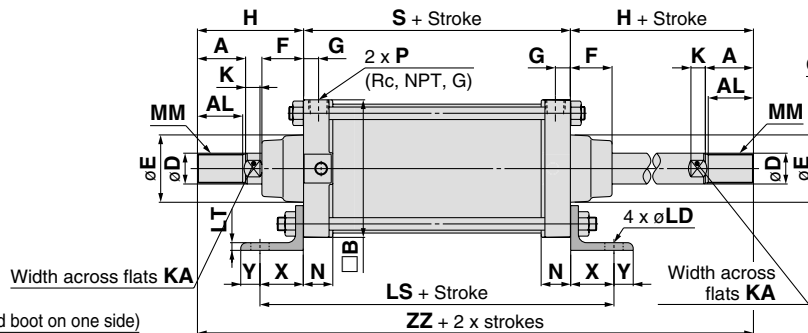
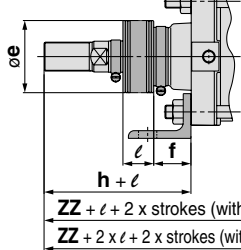

Bore size (mm)	Stroke range (mm)	A	AL	B	B	C	D	E	F	G	J	V	W	K	KA	LD	LH	LS	LT	LX	LY
ø125	Up to 1000	50	47	143	143	115	32	71	43	15	M14 x 1.5	15	17	15	27	19	85	188	8	100	156.5
ø140	Up to 1000	50	47	157	157	128	32	71	43	15	M14 x 1.5	15	17	15	27	19	100	188	9	112	178.5
ø160	Up to 1200	56	53	177	177	144	38	78.5	42	18	M16 x 1.5	15	20	17	34	19	106	206	9	118	194.5

Bore size (mm)	MM	N	P	S	X	Y	Without rod boot		With rod boot (Single side)					(Both sides)	
							H	ZZ	e	f	h	l	ZZ	ZZ	
ø125	M30 x 1.5	30.5	1/2	98	45	20	110	318	75	40	133	1/5 stroke	341	364	
ø140	M30 x 1.5	30.5	1/2	98	45	30	110	318	75	40	133	1/5 stroke	341	364	
ø160	M36 x 1.5	34.5	3/4	106	50	25	120	346	75	40	141	1/5 stroke	367	388	

* The minimum stroke with rod boot is 30 mm or more.
 ** For auto switch mounting position and its mounting height, refer to page 21.
 *** Refer to "Minimum Stroke for Auto Switch Mounting" on page 22.

Series CS2W

Dimensions

Rod flange: CS2WF

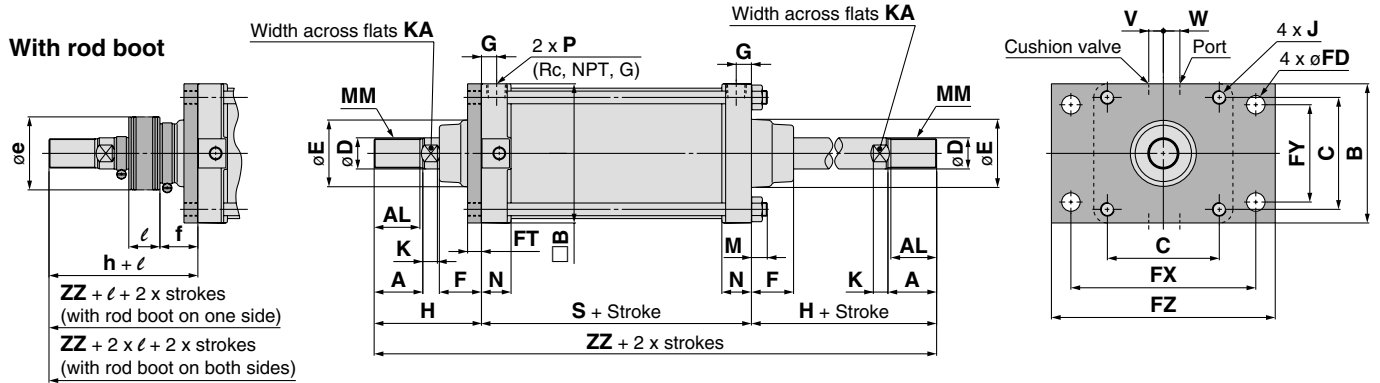

Bore size (mm)	Stroke range (mm)	A	AL	\square B	B	C	D	E	F	FD	FT	FX	FY	FZ	G	J	V	W	K	KA	M
ϕ 125	Up to 1000	50	47	143	145	115	32	71	43	19	14	190	100	230	15	M14 x 1.5	15	17	15	27	13
ϕ 140	Up to 1000	50	47	157	160	128	32	71	43	19	20	212	112	255	15	M14 x 1.5	15	17	15	27	13
ϕ 160	Up to 1200	56	53	177	180	144	38	78.5	42	19	20	236	118	275	18	M16 x 1.5	15	20	17	34	15

Bore size (mm)	MM	N	P	S	Without rod boot		With rod boot (Single side)					(Both sides)	
					H	ZZ	e	f	h	ℓ	ZZ	ZZ	
ϕ 125	M30 x 1.5	30.5	1/2	98	110	318	75	40	133	$\frac{1}{2}$ stroke	341	364	
ϕ 140	M30 x 1.5	30.5	1/2	98	110	318	75	40	133	$\frac{1}{2}$ stroke	341	364	
ϕ 160	M36 x 1.5	34.5	3/4	106	120	346	75	40	141	$\frac{1}{2}$ stroke	367	388	

* The minimum stroke with rod boot is 30 mm or more.
 ** For auto switch mounting position and its mounting height, refer to page 21.
 *** Refer to "Minimum Stroke for Auto Switch Mounting" on page 22.

Centre trunnion: CS2WT

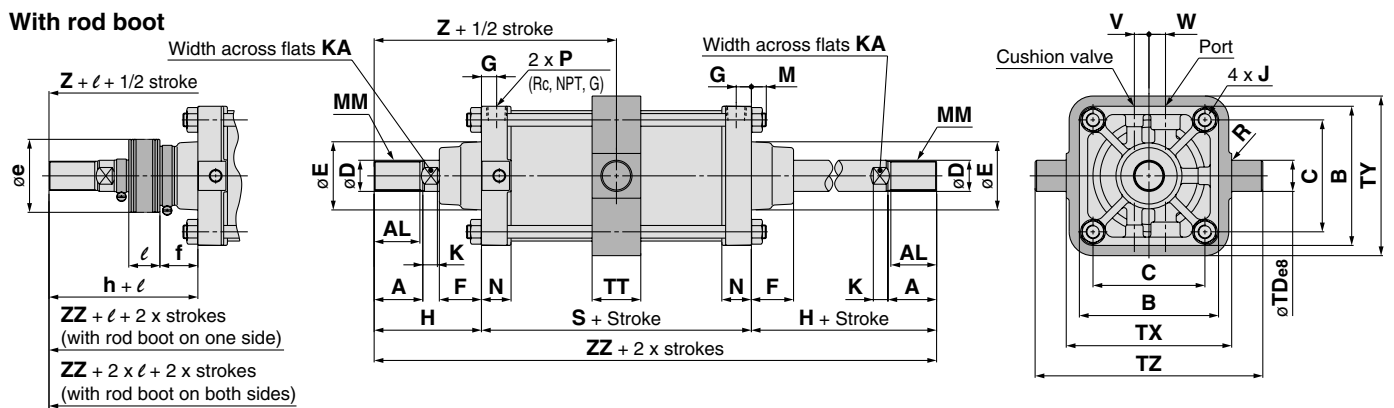

Bore size (mm)	Stroke range (mm)	A	AL	B	C	D	E	F	G	J	V	W	K	KA	M	MM	N	P	R	S
ϕ 125	25 to 1000	50	47	143	115	32	71	43	15	M14 x 1.5	15	17	15	27	13	M30 x 1.5	30.5	1/2	1	98
ϕ 140	30 to 1000	50	47	157	128	32	71	43	15	M14 x 1.5	15	17	15	27	13	M30 x 1.5	30.5	1/2	1.5	98
ϕ 160	35 to 1200	56	53	177	144	38	78.5	42	18	M16 x 1.5	15	20	17	34	15	M36 x 1.5	34.5	3/4	1.5	106

Bore size (mm)	TD ϕ es	TT	TX	TY	TZ	Without rod boot		With rod boot (Single side)					(Both sides)		
						H	Z	ZZ	e	f	h	ℓ	Z	ZZ	ZZ
ϕ 125	32 ^{-0.050} _{-0.089}	50	170	164	234	110	159	318	75	40	133	$\frac{1}{2}$ stroke	182	341	364
ϕ 140	36 ^{-0.050} _{-0.089}	55	190	184	262	110	159	318	75	40	133	$\frac{1}{2}$ stroke	182	341	364
ϕ 160	40 ^{-0.050} _{-0.089}	60	212	204	292	120	173	346	75	40	141	$\frac{1}{2}$ stroke	194	367	388

* The minimum stroke with rod boot is 30 mm or more for ϕ 125, ϕ 140, and 35 mm or more for ϕ 160.
 ** For auto switch mounting position and its mounting height, refer to page 21.
 *** Refer to "Minimum Stroke for Auto Switch Mounting" on page 22.

Smooth Cylinder

Series CS2Y

ø125, ø140, ø160

How to Order

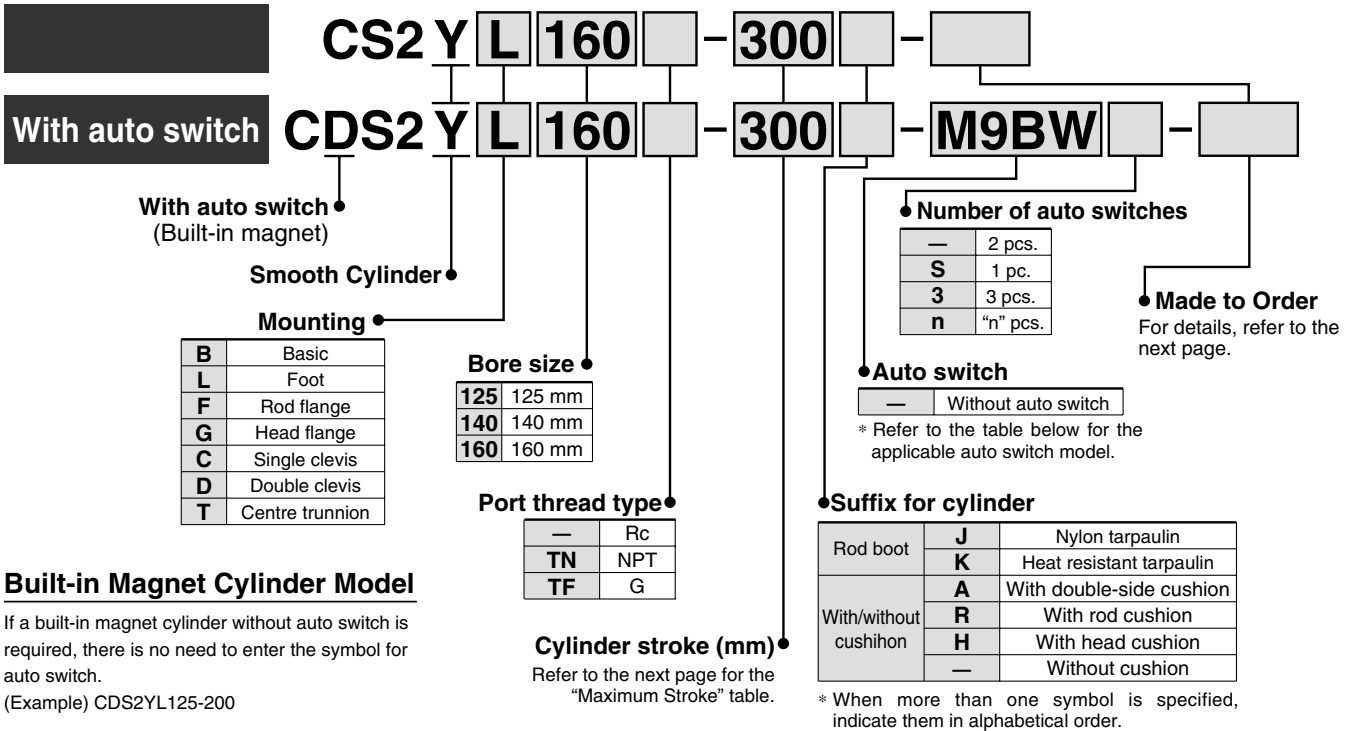

Built-in Magnet Cylinder Model

If a built-in magnet cylinder without auto switch is required, there is no need to enter the symbol for auto switch.

(Example) CDS2YL125-200

Applicable Auto Switches / For detailed auto switch specifications, refer to Best Pneumatics No. 2.

Type	Special function	Electrical entry	Indicator/light	Wiring (Output)	Load voltage		Auto switch model		Lead wire length (m)				Pre-wired connector	Applicable load			
					DC	AC	Tie-rod mounting	Band mounting	0.5 (-)	1 (M)	3 (L)	5 (Z)		IC circuit	Relay, PLC		
Solid state switch	—	Grommet	—	3-wire (NPN)	24 V	5 V, 12 V	—	M9N	●	●	●	○	—	—	—		
				3-wire (PNP)				M9P	●	●	●	○					
		2-wire		—	—	100 V, 200 V	M9B	●	●	●	○	—	—				
		—					J51	●	—	●	○						
	Terminal conduit	—	—	—	3-wire (NPN)	24 V	5 V, 12 V	—	—	—	—	—	—	—	—		
					2-wire				G39	—	—	—				—	
	Diagnostic indication (2-colour indication)	—	Grommet	Yes	3-wire (NPN)	24 V	5 V, 12 V	—	M9NW	●	●	●	○	—	—	—	
					3-wire (PNP)				M9PW	●	●	●	○				
					2-wire				M9BW	●	●	●	○				
					3-wire (NPN)				M9NA	—	○	○	●				○
3-wire (PNP)					M9PA				—	○	○	●	○				
2-wire					M9BA				—	○	○	●	○				
Diagnostic indication (2-colour indication)	—	—	—	4-wire (NPN)	—	5 V, 12 V	—	F59F	●	—	●	○	—	—			
Reed switch	—	Grommet	Yes	3-wire (NPN equivalent)	24 V	5 V	—	A96	●	—	●	—	—	—	—		
				—				12 V	100 V	A93	●	—				●	—
				—						5 V, 12 V	100 V or less	A90				●	—
				No				2-wire	12 V			200 V or less				A54	●
		Yes	—	—	—	—	—			—	—						
		Terminal conduit	—	—	—	—	—	—	—	—	—	—	—	—	—		
		DIN terminal	Yes	—	—	—	—	100 V, 200 V	—	—	A33	—	—	—	—	—	
										—	A34	—	—	—			—
Diagnostic indication (2-colour indication)	—	—	—	—	—	—	—	A59W	●	—	●	—	—	—			

* Lead wire length symbols: 0.5 m — (Example) M9NW
 1 m M (Example) M9NWM
 3 m L (Example) M9NWL
 5 m Z (Example) M9NWZ

* Solid state auto switches marked with "○" are produced upon receipt of order.

* Since there are applicable auto switches other than listed, refer to page 23 for details.

* For details about auto switches with pre-wired connector, refer to Best Pneumatics No. 2.

* D-A9□, M9□, M9□W, M9□AL are shipped together (but not assembled). (Only auto switch mounting bracket is assembled at the time of shipment.)

Series CS2Y

Designed with a low sliding resistance of the piston, this air cylinder is ideal for applications such as contact pressure control, which requires smooth movements at low pressure.

Low sliding resistance

Min. operating pressure — 0.005 MPa

Auto switch mounting is possible



JIS Symbol

Double acting

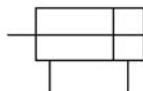

Made to Order specifications
(For details, refer to pages 25 to 29.)

Symbol	Specifications
-XA□	Change of rod end shape
-XC3	Special port position
-XC14	Change of trunnion bracket mounting position
-XC15	Change of tie-rod length
-XC26	Double clevis pin/Double knuckle pin with split pin and flat washer
-XC27	Double clevis pin and double knuckle pin made of stainless steel
-XC30	Rod side trunnion mounted on the front of the rod cover
-XC68	Made of stainless steel (With hard chrome plated piston rod)
-XC86	With rod end bracket

For the specifications of cylinders with auto-switch, please refer to pages 21 to 24.

- Minimum stroke for auto switch mounting
- Auto switch proper mounting position (detection at stroke end) and its mounting height
- Operating range
- Auto switch mounting bracket part no.

Application Example

Low friction cylinder is used in combination with precision regulator (Series IR).

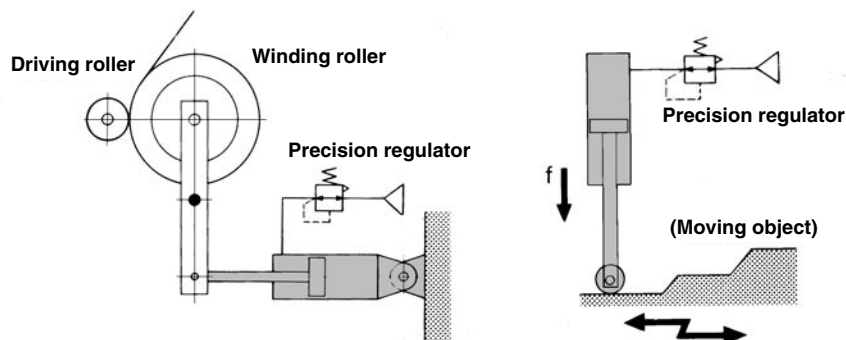

Specifications

Bore size (mm)	125	140	160
Action	Double acting, Single rod		
Direction of low friction	Both directions		
Fluid	Air		
Proof pressure	1.05 MPa		
Maximum operating pressure	0.7 MPa		
Minimum operating pressure	0.005 MPa*		
Ambient and fluid temperature	Without auto switch	0 to 70°C (No freezing)	
	With auto switch	0 to 60°C (No freezing)	
Allowable leakage	Less than 0.5 ℓ/min (ANR)		
Cushion	Without cushion** (manufacturable with cushion)		
Lubrication	Not required (Non-lube)		
Mounting	Basic, Foot, Rod flange, Head flange, Single clevis, Double clevis, Centre trunnion		

- * If a cushion is used, this value will not include the operating pressure within the cushion stroke.
- ** If an air cushion is not used, set the energy at the stroke end to 0.36J or less.

Maximum Stroke

		(mm)		
Tube material	Aluminum alloy	Carbon steel tube		
Mounting bracket	Basic, Head flange, Single clevis, Double clevis, Centre trunnion Rod flange	Basic, Head flange, Single clevis, Double clevis, Centre trunnion	Foot, Rod flange	
				Bore size (mm)
125	1000 or less	1000 or less	1600 or less	
140	1000 or less	1000 or less	1600 or less	
160	1200 or less	1200 or less	1600 or less	

Accessory

Mounting		Basic	Foot	Rod flange	Head flange	Single clevis	Double clevis	Centre trunnion
Standard equipment	Clevis pin	—	—	—	—	—	●	—
	Rod end nut	●	●	●	●	●	●	●
Option	Single knuckle joint	●	●	●	●	●	●	●
	Double knuckle joint (Knuckle pin, Split pin)	●	●	●	●	●	●	●
	Rod boot	●	●	●	●	●	●	●

Mounting Bracket Part No.

Bore size (mm)	125	140	160
Foot*	CS2-L12	CS2-L14	CS2-L16
Flange	CS2-F12	CS2-F14	CS2-F16
Single clevis	CS2-C12	CS2-C14	CS2-C16
Double clevis**	CS2-D12	CS2-D14	CS2-D16

* Order two foot brackets per cylinder.

** When ordering the double clevis style, the clevis pin and 2 split pins are included as accessories.

Rod Boot Material

Symbol	Material	Max. ambient temperature
J	Nylon tarpaulin	70°C
K	Heat resistant tarpaulin	110°C*

* Maximum ambient temperature for the rod boot itself.

Weight

Bore size (mm)		125	140	160
Basic weight	Basic	5.46	6.50	9.07
	Foot	7.49	9.50	12.45
	Rod flange	8.51	12.03	15.80
	Head flange	8.51	12.03	15.80
	Single clevis	8.53	10.79	14.56
	Double clevis	8.99	11.54	15.41
	Trunnion	9.59	12.23	15.47
Additional weight with magnet (With built-in magnet and auto switch)		0.07	0.07	0.08
Additional weight per each 100 mm of stroke		1.55	1.67	2.23
Accessory bracket	Single knuckle	0.91	1.16	1.56
	Double knuckle (With Knuckle pin, Split pin)	1.37	1.81	2.48
	Rod end nut	0.16	0.16	0.23

Calculation: (Example) **CS2Y160-500**

- Basic weight 12.45 (kg)
- Additional weight 2.23 (kg/100 mm)
- Cylinder stroke 500 (mm)
- $12.45 + 2.23 \times 500/100 = 23.60$ (kg)

Sliding Resistance

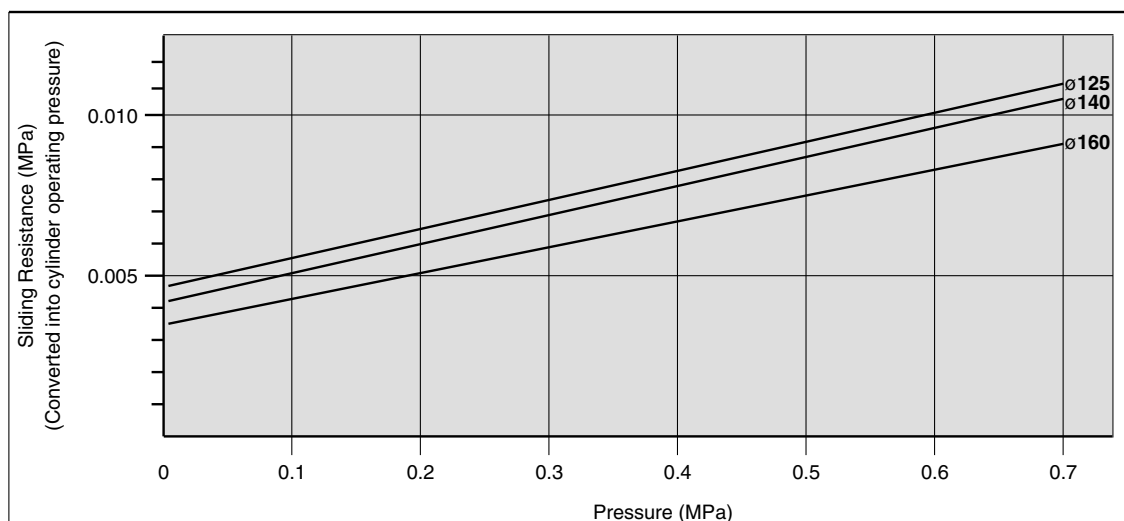

Basic

Double Rod Type

Smooth Cylinder

Auto Switch

Made to Order

Series CS2Y

Construction

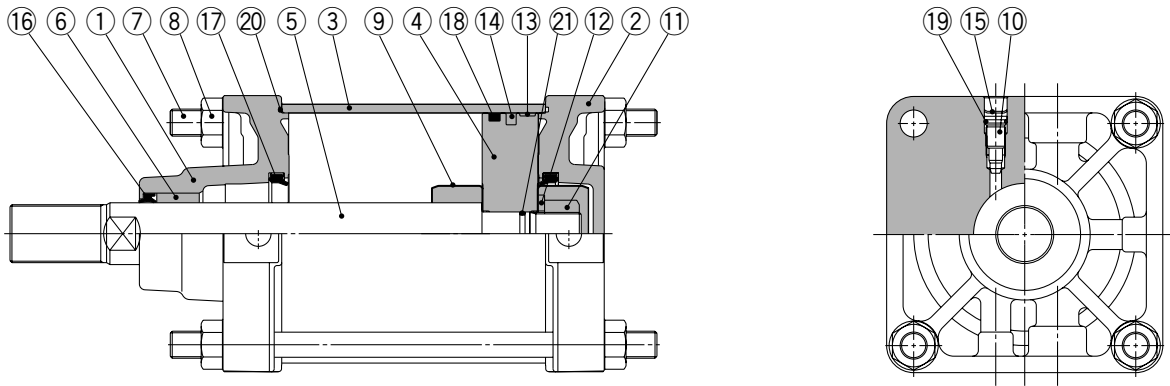

Component Parts

No.	Description	Material	Note
1	Rod cover	Aluminum die-cast	Chromated
2	Head cover	Aluminum die-cast	Chromated
3	Cylinder tube	Aluminum alloy	Hard anodized
4	Piston	Aluminum alloy	Chromated
5	Piston rod	Carbon steel	Hard chrome plated
6	Bushing	Sintered alloy	
7	Tie-rod	Carbon steel	Zinc chromated
8	Tie-rod nut	Rolled steel	Nickel plated
9	Cushion ring	Stainless steel	
10	Cushion valve	Rolled steel	Nickel plated
11	Piston nut	Carbon steel	Nickel plated
12	Flat washer	Carbon steel	Nickel plated
13	Wear ring	Resin	
14	Magnet*	—	
15	Retaining ring	Spring steel	Phosphate coded.
16	Rod seal	NBR	
17	Cushion seal**	Urethane	
18	Piston seal	NBR	
19	Valve seal	NBR	
20	Tube gasket	NBR	
21	Piston gasket	NBR	

* For types with built-in magnet or with auto switch.
 ** Used with cushion only.

Replacement Parts: Seal kit.

Bore size (mm)	Kit no.	Content
125	CS2Y125A-PS	Without cushion
140	CS2Y140A-PS	Consists of Component Part
160	CS2Y160A-PS	Numbers 16, 18, and 20
125	CS2Y125AA-PS	With single-side cushion
140	CS2Y140AA-PS	Consists of Component Part
160	CS2Y160AA-PS	Numbers 16, 17 (two), 18, and 20
125	CS2Y125AR-PS	With single-side cushion
140	CS2Y140AR-PS	Consists of Component Part
160	CS2Y160AR-PS	Numbers 16, 17 (one), 18 and 20.

* Seal kit does not include a grease pack.
 Order with the following part number when only the grease pack is needed.
Grease pack part number: GR-L-005 (5 g), GR-L-010 (10 g), GR-L-150 (150g)

Dimensions

External dimensions are the same as the CS2 standard type. Refer to pages 7 to 10.

Auto Switch Proper Mounting Position (Detection at stroke end) and Its Mounting Height

<Band mounting>

D-A3□ type
D-G3/K3 type

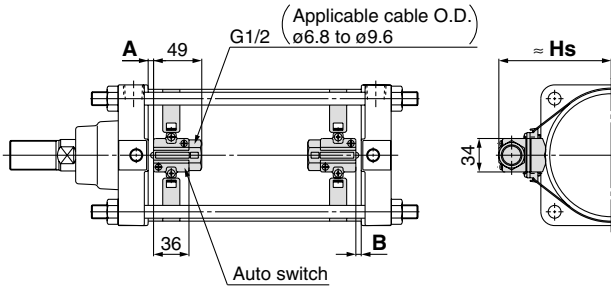

D-A44 type

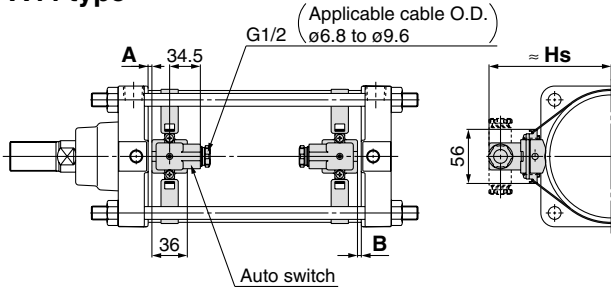

* The indicator light faces the inside.

<Tie-rod mounting>

D-A9□/A9□V type D-Z7□/Z80 type
D-M9□/M9□V type D-Y59□/Y69□/Y7P/Y7PV type
D-M9□W/M9□WV type D-Y7□W/Y7□WV type
D-M9□AL/M9□AVL type D-Y7BAL type

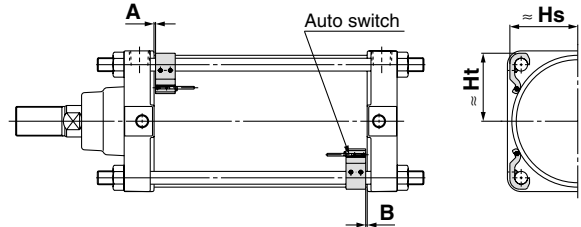

D-A5□/A6□ type

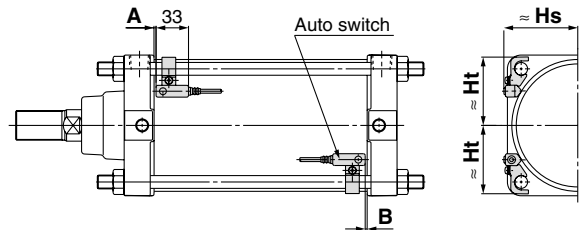

D-F5□/J5□/D-F5NTL type
D-F5BAL/F59F type
D-F5□W/J59W type

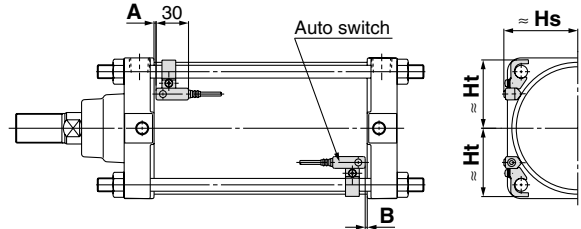

Auto Switch Proper Mounting Position

Auto switch model	(mm)													
	D-A9□ D-A9□V		D-M9□ D-M9□V D-M9□W D-M9□WV D-M9□AL D-M9□AVL		D-Z7□/Z80 D-Y5□/Y6□ D-Y7P/Y7PV D-Y7□W D-Y7□WV D-Y7BAL		D-A5□ D-A6□ D-A3□ D-A44 D-G39 D-K39		D-A59W		D-F5□W D-J59W D-F5BAL D-F5□ D-J5□ D-F59F		D-F5NTL	
Bore size	A	B	A	B	A	B	A	B	A	B	A	B	A	B
125	9	8	13	12	6.5	5.5	3	2	7	6	9.5	8.5	14.5	13.5
140	9	8	13	12	6.5	5.5	3	2	7	6	9.5	8.5	14.5	13.5
160	9	8	13	12	6.5	5.5	3	2	7	6	9.5	8.5	14.5	13.5

* Provided as guidelines for auto switch proper mounting position (detection at stroke end). When setting an auto switch, confirm the operation and adjust its mounting position.

Auto Switch Mounting Height

Auto switch model	(mm)													
	D-A9□ D-A9□V D-M9□ D-M9□W D-M9□AL		D-M9□V D-M9□WV D-M9□AVL		D-Z7□/Z80 D-Y5□/Y6□ D-Y7P D-Y7PV D-Y7□W D-Y7□WV D-Y7BAL		D-A3□ D-G39 D-K39	D-A44	D-A5□ D-A6□ D-A59W		D-F5□ D-J5□ D-F5□W D-J59W D-F5BAL D-F59F D-F5NTL			
Bore size	Hs	Ht	Hs	Ht	Hs	Ht	Hs	Hs	Hs	Ht	Hs	Ht	Hs	Ht
125	69	69.5	71.5	69.5	69	69.5	116	126	75.5	69.5	74.5	70		
140	76	76	77.5	76	76	76	124	134	81	76.5	80	76.5		
160	85	85	86	85	85	85	134.5	144.5	89	87.5	88	87.5		

Minimum Stroke for Auto Switch Mounting

n: Number of auto switches (mm)

Auto switch model	Number of auto switches mounted	Mounting brackets other than centre trunnion	Centre trunnion			
			ø125	ø140	ø160	
D-A9□	With 2 pcs. (Different surfaces, Same surface), With 1 pc.	15	100	105	110	
	With n pcs.	$15 + 40 \frac{(n-2)}{2}$ (n = 2, 4, 6, 8...)	$100 + 40 \frac{(n-4)}{2}$ (n = 4, 8, 12, 16...)	$105 + 40 \frac{(n-4)}{2}$ (n = 4, 8, 12, 16...)	$110 + 40 \frac{(n-4)}{2}$ (n = 4, 8, 12, 16...)	
D-A9□V	With 2 pcs. (Different surfaces, Same surface), With 1 pc.	10	75	80	85	
	With n pcs.	$10 + 30 \frac{(n-2)}{2}$ (n = 2, 4, 6, 8...)	$75 + 30 \frac{(n-4)}{2}$ (n = 4, 8, 12, 16...)	$80 + 30 \frac{(n-4)}{2}$ (n = 4, 8, 12, 16...)	$85 + 30 \frac{(n-4)}{2}$ (n = 4, 8, 12, 16...)	
D-M9□ D-M9□W	With 2 pcs. (Different surfaces, Same surface), With 1 pc.	15	105	110	115	
	With n pcs.	$15 + 40 \frac{(n-2)}{2}$ (n = 2, 4, 6, 8...)	$105 + 40 \frac{(n-4)}{2}$ (n = 4, 8, 12, 16...)	$110 + 40 \frac{(n-4)}{2}$ (n = 4, 8, 12, 16...)	$115 + 40 \frac{(n-4)}{2}$ (n = 4, 8, 12, 16...)	
D-M9□V D-M9□WV	With 2 pcs. (Different surfaces, Same surface), With 1 pc.	10	80	85	90	
	With n pcs.	$10 + 30 \frac{(n-2)}{2}$ (n = 2, 4, 6, 8...)	$80 + 30 \frac{(n-4)}{2}$ (n = 4, 8, 12, 16...)	$85 + 30 \frac{(n-4)}{2}$ (n = 4, 8, 12, 16...)	$90 + 30 \frac{(n-4)}{2}$ (n = 4, 8, 12, 16...)	
D-M9□AL	With 2 pcs. (Different surfaces, Same surface), With 1 pc.	20	115	120		
	With n pcs.	$20 + 40 \frac{(n-2)}{2}$ (n = 2, 4, 6, 8...)	$115 + 40 \frac{(n-4)}{2}$ (n = 4, 8, 12, 16...)	$120 + 40 \frac{(n-4)}{2}$ (n = 4, 8, 12, 16...)		
D-M9□AVL	With 2 pcs. (Different surfaces, Same surface), With 1 pc.	15	90	95		
	With n pcs.	$15 + 30 \frac{(n-2)}{2}$ (n = 2, 4, 6, 8...)	$90 + 30 \frac{(n-4)}{2}$ (n = 4, 8, 12, 16...)	$95 + 30 \frac{(n-4)}{2}$ (n = 4, 8, 12, 16...)		
D-A5□/A6□ D-A59W D-F5□/J5□ D-F5□W D-J59W D-F5BAL D-F59F	With 2 pcs. (Different surfaces, Same surface), With 1 pc.	25	125	135		
	With n pcs. (Same surface)	$25 + 55 \frac{(n-2)}{2}$ (n = 2, 4, 6, 8...)	$125 + 55 \frac{(n-4)}{2}$ (n = 4, 8, 12, 16...)	$135 + 55 \frac{(n-4)}{2}$ (n = 4, 8, 12, 16...)		
D-F5NTL	With 2 pcs. (Different surfaces, Same surface), With 1 pc.	35	145	155		
	With n pcs. (Same surface)	$35 + 55 \frac{(n-2)}{2}$ (n = 2, 4, 6, 8...)	$145 + 55 \frac{(n-4)}{2}$ (n = 4, 8, 12, 16...)	$155 + 55 \frac{(n-4)}{2}$ (n = 4, 8, 12, 16...)		
D-A3□ D-G39 D-K39	With 2 pcs. Different surfaces	35	110			
		Same surface				100
	With n pcs.	Different surfaces	$35 + 30(n-2)$	$110 + 30(n-2)$ (n = 2, 4, 6, 8...)		
		Same surface	$100 + 100(n-2)$	$110 + 100(n-2)$ (n = 2, 4, 6, 8...)		
With 1 pc.		15	110			
D-A44	With 2 pcs. Different surfaces	35	110			
		Same surface				55
	With n pcs.	Different surfaces	$35 + 30(n-2)$	$110 + 30(n-2)$ (n = 2, 4, 6, 8...)		
		Same surface	$55 + 55(n-2)$	$110 + 50(n-2)$ (n = 2, 4, 6, 8...)		
	With 1 pc.		15	110		
D-Z7□ D-Z80 D-Y59□ D-Y7P D-Y7□W	With 2 pcs. (Different surfaces, Same surface), With 1 pc.	15	105	110	115	
	With n pcs.	$15 + 40 \frac{(n-2)}{2}$ (n = 2, 4, 6, 8...)	$105 + 40 \frac{(n-4)}{2}$ (n = 4, 8, 12, 16...)	$110 + 40 \frac{(n-4)}{2}$ (n = 4, 8, 12, 16...)	$115 + 40 \frac{(n-4)}{2}$ (n = 4, 8, 12, 16...)	
D-Y69□ D-Y7PV D-Y7□WV	With 2 pcs. (Different surfaces, Same surface), With 1 pc.	10	90	95	100	
	With n pcs.	$10 + 30 \frac{(n-2)}{2}$ (n = 2, 4, 6, 8...)	$90 + 30 \frac{(n-4)}{2}$ (n = 4, 8, 12, 16...)	$95 + 30 \frac{(n-4)}{2}$ (n = 4, 8, 12, 16...)	$100 + 30 \frac{(n-4)}{2}$ (n = 4, 8, 12, 16...)	
D-Y7BAL	With 2 pcs. (Different surfaces, Same surface), With 1 pc.	20	115	120	125	
	With n pcs.	$20 + 45 \frac{(n-2)}{2}$ (n = 2, 4, 6, 8...)	$115 + 45 \frac{(n-4)}{2}$ (n = 4, 8, 12, 16...)	$120 + 45 \frac{(n-4)}{2}$ (n = 4, 8, 12, 16...)	$125 + 45 \frac{(n-4)}{2}$ (n = 4, 8, 12, 16...)	

Operating Range

Auto switch model	Bore size (mm)		
	125	140	160
D-A9□/A9□V	12	12.5	11.5
D-M9□/M9□V D-M9□W/M9□WV D-M9□AL/M9□AVL	6	6.5	6.5
D-Z7□/Z80	14	14.5	13
D-A3□/A44 D-A5□/A6□	10	10	10
D-A59W	17	17	17
D-Y59□/Y69□ D-Y7P/Y7PV D-Y7□W/Y7□WV D-Y7BAL	12	13	7
D-F5□/J5□/F5□W D-J59W/F5BAL D-F5NTL/F59F	5	5	5.5
D-G39/K39	11	11	10

* Since this is a guideline including hysteresis, not meant to be guaranteed.
(Assuming approximately ±30% dispersion.)
There may be the case it will vary substantially depending on an ambient environment.

Auto Switch Mounting Bracket Part No.

Auto switch model	Bore size (mm)		
	ø125	ø140	ø160
D-A9□/A9□V D-M9□/M9□V D-M9□W/M9□WV D-M9□AL/M9□AVL	BS5-125	BS5-125	BS5-160
D-A5□/A6□ D-A59W D-F5□/J5□ D-F5NTL D-F5□W/J59W D-F5BAL/F59F	BT-12	BT-12	BT-16
D-A3□/A44 D-G39/K39	BS1-125	BS1-140	BS1-160
D-Z7□/Z80 D-Y59□/Y69□ D-Y7P/Y7PV D-Y7□W/Y7□WV D-Y7BAL	BS4-125	BS4-125	BS4-160

[Mounting screws set made of stainless steel]

The following set of mounting screws made of stainless steel (including set screws) is also available. Use it in accordance with the operating environment. (Please order the auto switch mounting bracket separately, since it is not included.)

BBA1: For D-A5, A6, F5, J5 type

“D-F5BAL” auto switch is set on the cylinder with the stainless steel screws above when shipped.

When only an auto switch is shipped independently, “BBA1” screws are attached.

Note) When using the D-M9□AL/M9□AVL or Y7BAL model, do not use the steel set screw which is included with the auto switch mounting bracket in the above table (BS5-□□□, BS4-□□□). Please separately prepare the stainless steel screw set (BBA1), and select and use the M4 x 8L stainless steel set screw included in BBA1.

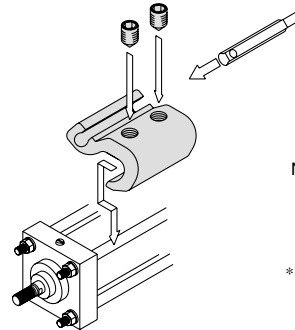

Note 1) Refer to Best Pneumatics No. 2 for the details of BBA1 screws.

* Shows an example of mounting the D-A9□(V), M9□(V), M9□W(V), M9□A(V)L model.

Other than the applicable auto switches listed in “How to Order”, the following auto switches can be mounted. For detailed specifications, refer to Best Pneumatics No. 2.

Type	Model	Electrical entry (Direction)	Features
Reed auto switch	D-A90V	Grommet (Perpendicular)	Without indicator light
	D-A93V, A96V		—
	D-Z73, Z76	Grommet (in-line)	Without indicator light
	D-A53, A56		—
	D-A67		Without indicator light
	D-Z80		—
Solid state auto switch	D-F59, F5P, J59	Grommet (in-line)	—
	D-Y59A, Y59B, Y7P		2-colour indication
	D-F59W, F5PW, J59W		Water resistant (2-colour indication)
	D-Y7NW, Y7PW, Y7BW		With timer
	D-F5BAL, Y7BAL		—
	D-F5NTL	Grommet (Perpendicular)	2-colour indication
	D-M9NV, M9PV, M9BV		—
	D-Y69A, Y69B, Y7PV		2-colour indication
	D-M9NWV, M9PWV, M9BWV		Water resistant (2-colour indication)
	D-Y7NWV, Y7PWV, Y7BWV		—
	D-M9NAVL, M9PAVL, M9BAVL		Water resistant (2-colour indication)

* With pre-wired connector is available for solid state auto switches. For details, refer to Best Pneumatics No. 2.

* Normally closed (NC = b contact), solid state switches (D-F9G, F9H, Y7G, Y7H type) are also available. For details, refer to Best Pneumatics No. 2.

Auto Switch Connections and Examples

Basic Wiring

Solid state 3-wire, NPN

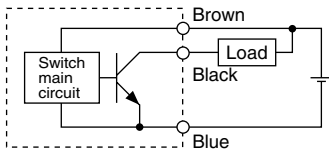

Solid state 3-wire, PNP

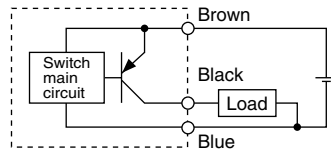

2-wire (Solid state)

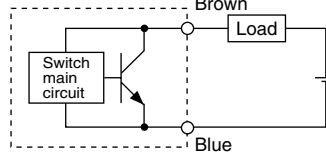

2-wire (Reed)

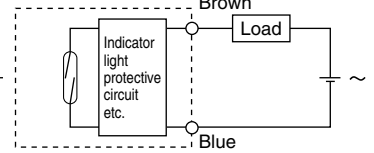

(Power supplies for switch and load are separate.)

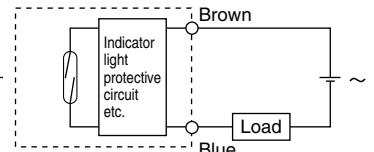
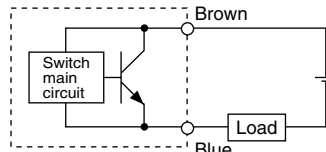
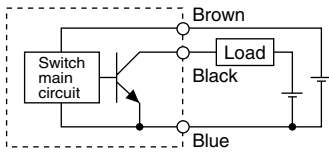

Example of Connection to PLC (Programmable Logic Controller)

• Sink input specification 3-wire, NPN

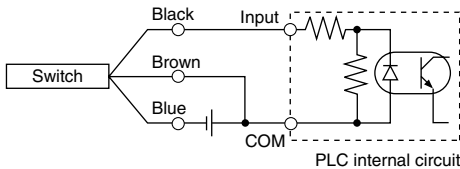

• Source input specification 3-wire, PNP

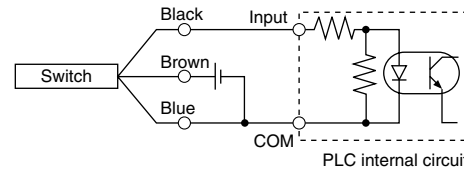

Connect according to the applicable PLC input specifications, since the connection method will vary depending on the PLC input specifications.

2-wire

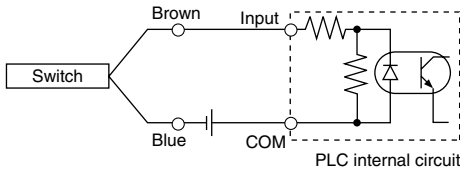

2-wire

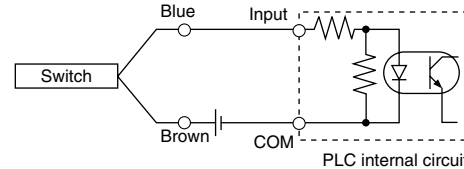

Example of AND (Serial) and OR (Parallel) Connection

• 3-wire

AND connection for NPN output (using relays)

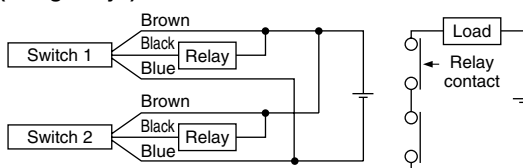

AND connection for NPN output (performed with switches only)

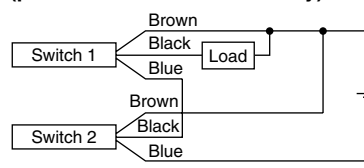

OR connection for NPN output

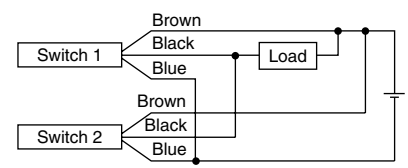

The indicator lights will illuminate when both switches are turned ON.

2-wire with 2-switch AND connection

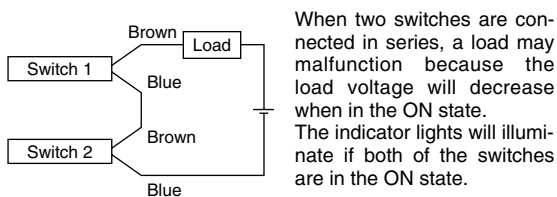

When two switches are connected in series, a load may malfunction because the load voltage will decrease when in the ON state. The indicator lights will illuminate if both of the switches are in the ON state.

$$\begin{aligned} \text{Load voltage at ON} &= \text{Power supply} - \frac{\text{Residual voltage}}{\text{Load impedance}} \times 2 \text{ pcs.} \\ &= 24 \text{ V} - 4 \text{ V} \times 2 \text{ pcs.} \\ &= 16 \text{ V} \end{aligned}$$

Example: Power supply is 24 VDC.
Internal voltage drop in switch is 4 V.

2-wire with 2-switch OR connection

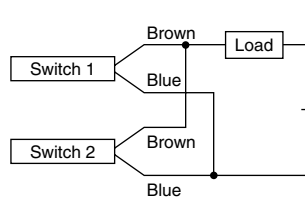

(Solid state)

When two switches are connected in parallel, a malfunction may occur because the load voltage will increase when in the OFF state.

$$\begin{aligned} \text{Load voltage at OFF} &= \text{Leakage current} \times 2 \text{ pcs.} \times \text{Load impedance} \\ &= 1 \text{ mA} \times 2 \text{ pcs.} \times 3 \text{ k}\Omega \\ &= 6 \text{ V} \end{aligned}$$

Example: Load impedance is 3 kΩ.
Leakage current from switch is 1 mA.

(Reed)

Because there is no current leakage, the load voltage will not increase when turned OFF. However, depending on the number of switches in the ON state, the indicator lights may sometimes dim or not light because of the dispersion and reduction of the current flowing to the switches.

Air Cylinder / Series CS2 Simple Specials

Please order through the Simple Specials system.

1 Change of Rod End Shape Symbol -XA0 to XA30

Applicable Series

Series	Description	Model	Action	Symbol for applicable patterns
CS2	Standard type	CS2	Double acting single rod	XA0 to 30
		CS2W	Double acting double rod	XA0 to 30
	Smooth cylinder	CS2Y	Double acting single rod	XA0 to 30

Precautions

- 1) Dimensions, tolerance and finish that are not displayed here are the same as standard types, or set at the discretion of SMC.
- 2) The standard dimensions with * will be as follows to the following rod diameter (D).
Please specify if changing the dimensions.
D ≤ 6 → D - 1 mm 6 < D ≤ 25 → D - 2 mm D > 25 → D - 4 mm
- 3) In the case of double rod type and single acting retraction type, enter the dimensions for when the rod is retracted.
- 4) Only the single side of a double rod is able to manufacture.

Symbol: A0 	Symbol: A1 	Symbol: A2 	Symbol: A3 	Symbol: A4
Symbol: A5 	Symbol: A6 	Symbol: A7 	Symbol: A8 	Symbol: A9
Symbol: A10 	Symbol: A11 	Symbol: A12 	Symbol: A13 	Symbol: A14
Symbol: A15 	Symbol: A16 	Symbol: A17 	Symbol: A18 	Symbol: A19
Symbol: A20 	Symbol: A21 	Symbol: A22 	Symbol: A23 	Symbol: A24
Symbol: A25 	Symbol: A26 	Symbol: A27 	Symbol: A28 	Symbol: A29
Symbol: A30 				

Basic

Double Rod Type

Smooth Cylinder

Auto Switch

Made to Order

Air Cylinder / Series CS2

Made to Order Specifications 1

Contact SMC for detailed dimensions, specifications, and lead times.



2 Special Port Positions

Symbol
-XC3

The positions of ports and cushion valves on the rod cover and head cover are changed from those of the standard type.

Applicable Series

Series	Description	Model	Action
CS2	Standard type	CS2	Double acting single rod
	Smooth cylinder	CS2Y	Double acting single rod

How to Order

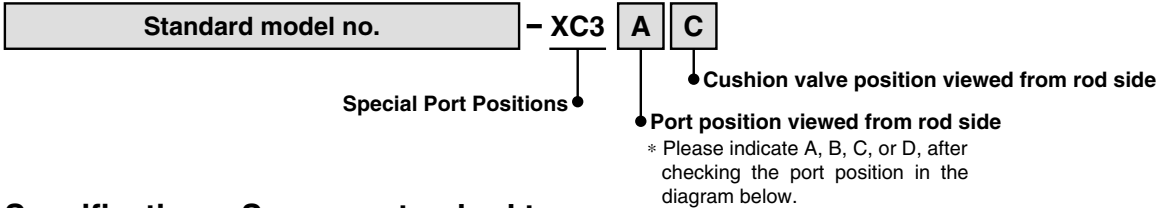

Specifications: Same as standard type

Relation between Port Positions and Cushion Valve Positions (Rod chamfer)

Series	Symbols according to mounting bracket (relation of positions)						
CS2							
	Basic	Foot	Rod flange	Head flange	Single clevis	Double clevis	Centre trunnion
<p>(1) The symbol A indicating the port or cushion valve position is assigned to the top position viewed from the rod side, with B, C, and D to the other positions in order when rotating clockwise.</p> <p>(2) The optional combination of the port and cushion valve is available only when the same positional change is applied to the rod cover and head cover.</p> <p>(3) The symbol -XC3AA indicates the standard specification so an optional specification with this part number does not exist.</p>							

3 Change of Trunnion Bracket Mounting Position

Symbol
-XC14

The position for mounting the trunnion bracket on the cylinder can be moved from the standard mounting position to any desired position.

Applicable Series

Series	Description	Model	Action
CS2	Standard type	CS2	Double acting single rod
		CS2W	Double acting double rod
	Smooth cylinder	CS2Y	Double acting single rod

Precautions

- Specify "Z + 1/2 stroke" in case the trunnion bracket position is not -XC14A, -XC14B or trunnion is not a centre trunnion.
- SMC will make appropriate arrangements if no dimensions, tolerance, or finish instructions are given in the diagram.
- The possible range of trunnion bracket mounting positions is indicated in the table below.
- Some trunnion mounting positions do not allow auto switch mounting. Consult SMC for more information.
- Series CS2 has a greater range of trunnion bracket mounting positions than Series CS1, so the value of "Z + 1/2 stroke" at -XC14A and -XC14B is different.

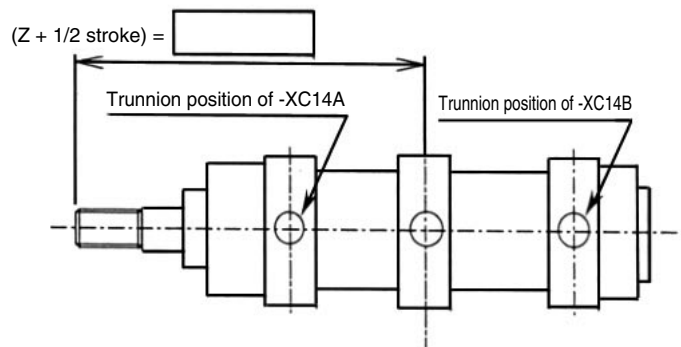

Series CS2

Bore Size	Symbol		Z + 1/2 stroke (mm)			
	For -XC14A	For -XC14B	For -XC14		Reference for standard (centre trunnion)	Minimum Stroke
			Minimum	Maximum		
125	165.5	152.5 + Stroke	166	152 + Stroke	159 + 1/2 stroke	25
140	168	150 + Stroke	168.5	149.5 + Stroke	159 + 1/2 stroke	30
160	186	160 + Stroke	186.5	159.5 + Stroke	173 + 1/2 stroke	35

4 Change of Tie Rod Length Symbol **-XC15**

Standard M dimension, the tie rod length of the air cylinder, is changed.

Applicable Series

Series	Description	Model	Action
CS2	Standard type	CS2	Double acting single rod
		CS2W	Double acting double rod
	Smooth cylinder	CS2Y	Double acting single rod

Precautions

- 1) When ordering, specify the required M dimension with the part number.
- 2) SMC will make appropriate arrangements if no dimensions, tolerance, or finish instructions are given in the diagram.
- 3) The possible range of tie-rod length is listed in the table below.
- 4) The M dimension of the bracket mounting side of Flange (F, G), Clevis (C, D) types cannot be specified.

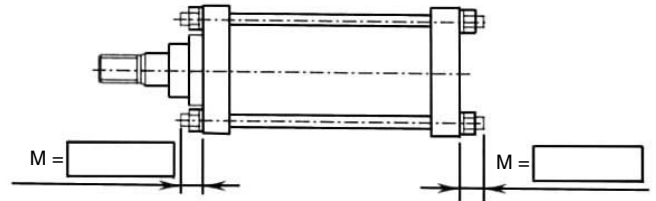

Changeable Range of Tie Rod Length (mm)

Model	CS2								
	125			140			160		
Bore size	L	B, F, G, C, D, T	L	B, F, G, C, D, T	L	B, F, G, C, D, T	L	B, F, G, C, D, T	L
M minimum	20	12	21	12	23	14			
M maximum	270								

5 Double Clevis Pin/Double Knuckle Pin with Split Pin and Flat Washer Symbol **-XC26**

Flat washer was added to the double clevis type (a mounting type) or the double knuckle joint (an accessory).

Applicable Series

Series	Description	Model	Action
CS2	Standard type	CS2	Double acting single rod
	Smooth cylinder	CS2Y	Double acting single rod

Specification

Mounting bracket	Double clevis type (D), double knuckle joint only
Changed parts	Clevis pin, knuckle pin, flat washer
Other specifications	Same as standard type

Dimensions (Dimensions not listed below are the same as those of the standard type.)

Double clevis

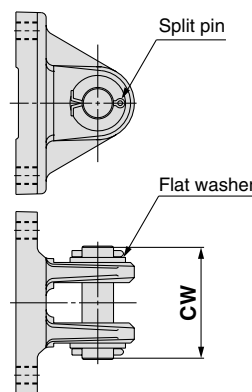

- * The mounting bracket itself will be shipped together with the split pin, clevis pin and flat washer (but not assembled).
- * Mounting is the same as standard types.

Bore size (mm)	CW
ø125	90
ø140	104
ø160	113

Double Knuckle Joint

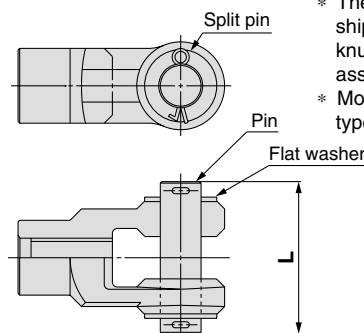

- * The mounting bracket itself will be shipped together with the split pin, knuckle pin and flat washer (but not assembled).
- * Mounting is the same as standard types.

Bore size (mm)	L
ø125	90
ø140	104
ø160	113

How to Order

Product

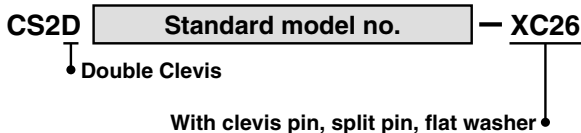

Parts Ass'y

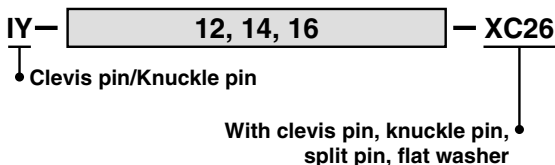
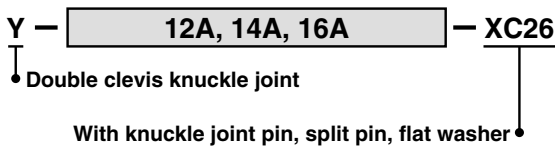
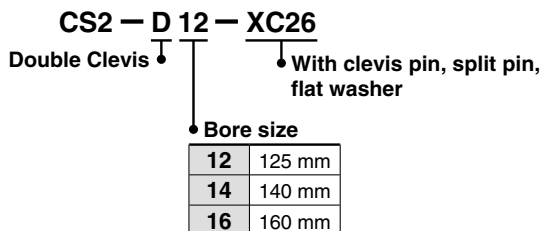

Air Cylinder / Series CS2

Made to Order Specifications 2

Contact SMC for detailed dimensions, specifications, and lead times.



6 Double Clevis Pin and Double Knuckle Pin Made of Stainless Steel Symbol **-XC27**

To prevent the rotating part of a double clevis, which is a bracket, or double knuckle joint, which is an accessory, from rusting the materials of the pin and the retaining ring (split pin) have been changed to stainless steel.

Applicable Series

Series	Description	Model	Action
CS2	Standard type	CS2	Double acting single rod
	Smooth cylinder	CS2Y	Double acting single rod

How to Order

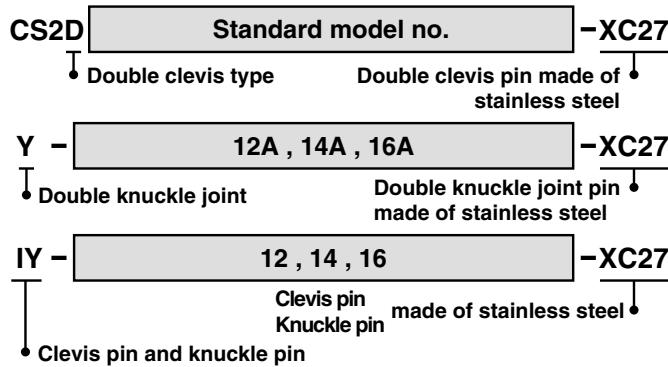

Specification

Mounting bracket	Double clevis type (D), double knuckle joint only
Changed parts	Clevis pin, knuckle pin, split pin
Other specifications	Same as standard type

Dimensions: Same as standard type

* The mounting bracket itself will be shipped together with the split pin, clevis pin, and knuckle joint pin.

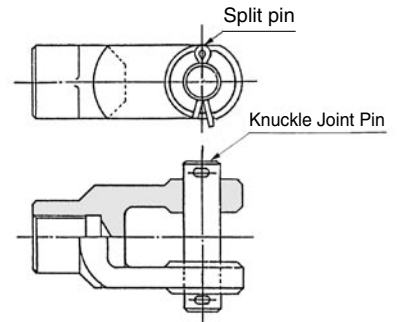

* Mounting as the same as standard size.

7 Rod Side Trunnion Mounted on the Front of the Rod Cover. Symbol **-XC30**

A cylinder with a reduced distance between the fulcrum and the rod end, which has been realised by mounting the trunnion bracket on the front of the cylinder's rod cover.

Applicable Series

Series	Description	Model	Action
CS2	Standard type	CS2	Double acting single rod
		CS2W	Double acting double rod
	Smooth cylinder	CS2Y	Double acting single rod

How to Order

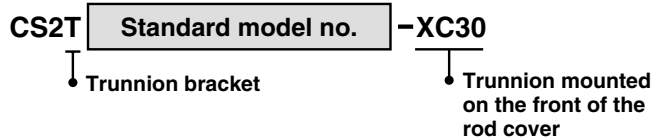

Specifications: Same as standard type

Dimensions (Dimensions other than below are the same as standard type)

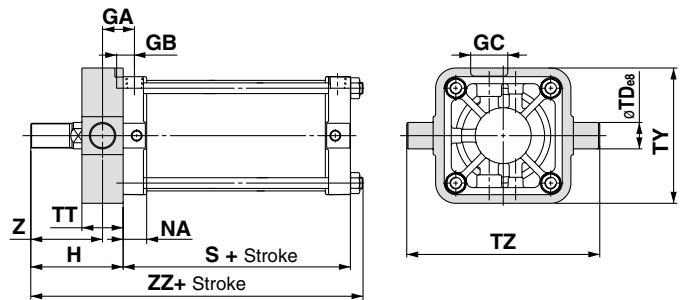

(mm)

Bore size (mm)	GA	GB	GC	NA	S	TDe8	TT	TY	TZ	H	Z	ZZ
ø125	38	23	45	28.5	96	32 ^{-0.050} _{-0.089}	50	164	234	112	87	221
ø140	40.5	23	45	28.5	96	36 ^{-0.050} _{-0.089}	55	184	262	112	84.5	221
ø160	46	26	50	32.5	104	40 ^{-0.050} _{-0.089}	60	204	292	122	92	241

8 Made of Stainless Steel (With hard chrome plated piston rod) Symbol **-XC68**

Applicable for uses where rust and corrosion are expected, such as by immersing in water.

Applicable Series

Series	Description	Model	Action
CS2	Standard type	CS2	Double acting single rod
		CS2W	Double acting double rod
	Smooth cylinder	CS2Y	Double acting single rod

How to Order

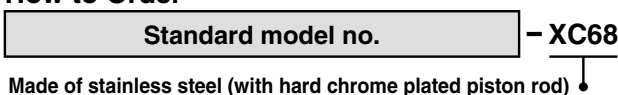

Specifications

Parts changed to stainless steel	Piston rod
Other specifications and dimensions	Same as standard type

Maximum Stroke (mm)

Series	Double functioning single rod	Double functioning single rod with rod boot
CS2	1600	1400

9 With Rod End Bracket Symbol **-XC86**

The rod end bracket has been included to simplify the ordering procedure.

Applicable Series

Series	Description	Model	Action
CS2	Standard type	CS2	Double acting single rod
	Smooth cylinder	CS2Y	Double acting single rod

How to Order

Standard no. for each series **-XC86 A**

With rod end bracket

Suffix

A	With rod end bracket
B	With double knuckle joint
C	With single knuckle joint
D	With double knuckle joint and rod end bracket
E	With single knuckle joint and rod end bracket

Note 1) The rod end bracket will be shipped together.
 Note 2) 1 pin and 2 split pins will be shipped as accessories to the double knuckle joint.

Dimensions (Dimensions other than below are the same as standard type.)

**Series CS2
XC86B, XC86C**

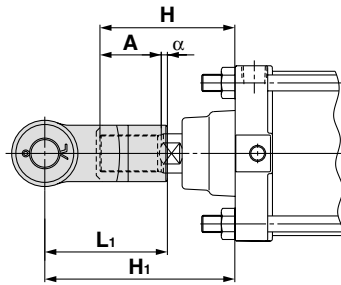

Symbol Bore size (mm)	H	A	α	L ₁	H ₁	Applicable knuckle joint part number	
						I type single knuckle	Y type double knuckle
125	110	50	3.5	100	156.5	I-12A	Y-12A
140	110	50	3.5	105	161.5	I-14A	Y-14A
160	120	56	3.5	110	170.5	I-16A	Y-16A

**Series CS2
XC86D, XC86E**

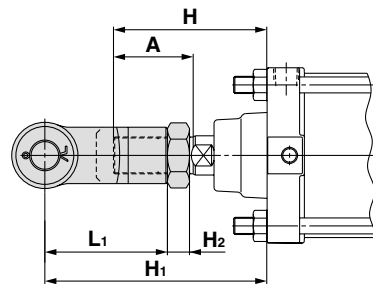

Symbol Bore size (mm)	H	A	L ₁	H ₁	H ₂	Applicable knuckle joint part number		Applicable rod end nut
						I type single knuckle	Y type double knuckle	
125	125	65	100	181	18	I-12A	Y-12A	NT-12
140	125	65	105	186	18	I-14A	Y-14A	NT-12
160	140	76	110	198	21	I-16A	Y-16A	NT-16

Safety Instructions

These safety instructions are intended to prevent hazardous situations and/or equipment damage. These instructions indicate the level of potential hazard with the labels of “**Caution**,” “**Warning**” or “**Danger**.” They are all important notes for safety and must be followed in addition to International Standards (ISO/IEC)*1, and other safety regulations.

Caution:

Caution indicates a hazard with a low level of risk which, if not avoided, could result in minor or moderate injury.

Warning:

Warning indicates a hazard with a medium level of risk which, if not avoided, could result in death or serious injury.

Danger:

Danger indicates a hazard with a high level of risk which, if not avoided, will result in death or serious injury.

- *1) ISO 4414: Pneumatic fluid power – General rules relating to systems.
ISO 4413: Hydraulic fluid power – General rules relating to systems.
IEC 60204-1: Safety of machinery – Electrical equipment of machines.
(Part 1: General requirements)
ISO 10218-1: Manipulating industrial robots - Safety.
etc.

Warning

1. The compatibility of the product is the responsibility of the person who designs the equipment or decides its specifications.

Since the product specified here is used under various operating conditions, its compatibility with specific equipment must be decided by the person who designs the equipment or decides its specifications based on necessary analysis and test results. The expected performance and safety assurance of the equipment will be the responsibility of the person who has determined its compatibility with the product. This person should also continuously review all specifications of the product referring to its latest catalogue information, with a view to giving due consideration to any possibility of equipment failure when configuring the equipment.

2. Only personnel with appropriate training should operate machinery and equipment.

The product specified here may become unsafe if handled incorrectly. The assembly, operation and maintenance of machines or equipment including our products must be performed by an operator who is appropriately trained and experienced.

3. Do not service or attempt to remove product and machinery/equipment until safety is confirmed.

- The inspection and maintenance of machinery/equipment should only be performed after measures to prevent falling or runaway of the driven objects have been confirmed.
- When the product is to be removed, confirm that the safety measures as mentioned above are implemented and the power from any appropriate source is cut, and read and understand the specific product precautions of all relevant products carefully.
- Before machinery/equipment is restarted, take measures to prevent unexpected operation and malfunction.

4. Contact SMC beforehand and take special consideration of safety measures if the product is to be used in any of the following conditions.

- Conditions and environments outside of the given specifications, or use outdoors or in a place exposed to direct sunlight.
- Installation on equipment in conjunction with atomic energy, railways, air navigation, space, shipping, vehicles, military, medical treatment, combustion and recreation, or equipment in contact with food and beverages, emergency stop circuits, clutch and brake circuits in press applications, safety equipment or other applications unsuitable for the standard specifications described in the product catalogue.
- An application which could have negative effects on people, property, or animals requiring special safety analysis.
- Use in an interlock circuit, which requires the provision of double interlock for possible failure by using a mechanical protective function, and periodical checks to confirm proper operation.

Caution

1. The product is provided for use in manufacturing industries.

The product herein described is basically provided for peaceful use in manufacturing industries.

If considering using the product in other industries, consult SMC beforehand and exchange specifications or a contract if necessary.

If anything is unclear, contact your nearest sales branch.

Limited warranty and Disclaimer/ Compliance Requirements

The product used is subject to the following “Limited warranty and Disclaimer” and “Compliance Requirements”.

Read and accept them before using the product.

Limited warranty and Disclaimer

- The warranty period of the product is 1 year in service or 1.5 years after the product is delivered.*2)
Also, the product may have specified durability, running distance or replacement parts. Please consult your nearest sales branch.
- For any failure or damage reported within the warranty period which is clearly our responsibility, a replacement product or necessary parts will be provided.
This limited warranty applies only to our product independently, and not to any other damage incurred due to the failure of the product.
- Prior to using SMC products, please read and understand the warranty terms and disclaimers noted in the specified catalogue for the particular products.

*2) Vacuum pads are excluded from this 1 year warranty.

A vacuum pad is a consumable part, so it is warranted for a year after it is delivered. Also, even within the warranty period, the wear of a product due to the use of the vacuum pad or failure due to the deterioration of rubber material are not covered by the limited warranty.

Compliance Requirements

- The use of SMC products with production equipment for the manufacture of weapons of mass destruction (WMD) or any other weapon is strictly prohibited.
- The exports of SMC products or technology from one country to another are governed by the relevant security laws and regulations of the countries involved in the transaction. Prior to the shipment of a SMC product to another country, assure that all local rules governing that export are known and followed.

Safety Instructions

Be sure to read “Handling Precautions for SMC Products” (M-E03-3) before using.

SMC Corporation (Europe)

Austria	☎ +43 2262622800	www.smc.at	office@smc.at
Belgium	☎ +32 (0)33551464	www.smc-pneumatics.be	info@smc-pneumatics.be
Bulgaria	☎ +359 29744492	www.smc.bg	office@smc.bg
Croatia	☎ +385 13776674	www.smc.hr	office@smc.hr
Czech Republic	☎ +420 541424611	www.smc.cz	office@smc.cz
Denmark	☎ +45 70252900	www.smc.dk.com	smc@smcdk.com
Estonia	☎ +372 6510370	www.smc-pneumatics.ee	smc@smc-pneumatics.ee
Finland	☎ +358 207513513	www.smc.fi	smc.fi@smc.fi
France	☎ +33 (0)164761000	www.smc-france.fr	contact@smc-france.fr
Germany	☎ +49 (0)61034020	www.smc-pneumatik.de	info@smc-pneumatik.de
Greece	☎ +30 210 2717265	www.smchellas.gr	sales@smchellas.gr
Hungary	☎ +36 23511390	www.smc.hu	office@smc.hu
Ireland	☎ +353 (0)14039000	www.smc-pneumatics.ie	sales@smc-pneumatics.ie
Italy	☎ +39 (0)292711	www.smcitalia.it	mailbox@smcitalia.it
Latvia	☎ +371 67817700	www.smc.lv	info@smclv.lv

Lithuania	☎ +370 5 2308118	www.smclt.lt	info@smclt.lt
Netherlands	☎ +31 (0)205318888	www.smc-pneumatics.nl	info@smc-pneumatics.nl
Norway	☎ +47 67129020	www.smc-norge.no	post@smc-norge.no
Poland	☎ +48 222119600	www.smc.pl	office@smc.pl
Portugal	☎ +351 226166570	www.smc.eu	postpt@smc.smces.es
Romania	☎ +40 213205111	www.smcromania.ro	smcromania@smcromania.ro
Russia	☎ +7 8127185445	www.smc-pneumatik.ru	info@smc-pneumatik.ru
Slovakia	☎ +421 413213212	www.smc.sk	office@smc.sk
Slovenia	☎ +386 73885412	www.smc.si	office@smc.si
Spain	☎ +34 945184100	www.smc.eu	post@smc.smces.es
Sweden	☎ +46 (0)86031200	www.smc.nu	post@smc-pneumatics.se
Switzerland	☎ +41 (0)523963131	www.smc.ch	info@smc.ch
Turkey	☎ +90 (0)2124440762	www.entek.com.tr	smc@entek.com.tr
UK	☎ +44 (0)845 121 5122	www.smc-pneumatics.co.uk	sales@smc-pneumatics.co.uk