

Предназначен для удаления из сжатого воздуха механических загрязнений и конденсата

- Фильтрующий элемент, изготовленный из пластика, обеспечивает увеличенный расход воздуха при высокой степени очистки (5 мкм)
- Легкая замена фильтрующего элемента
- Пригоден для модульного монтажа

Технические характеристики

Типоразмер	AF10	AF20	AF30	AF40	AF50	AF60
Присоединительная резьба	M5	G1/8, G1/4	G1/4, G3/8	G1/4, G3/8, G1/2	G3/4, G1	G1
Номинальный расход ¹⁾ (н. л/мин)	150	1100	2600	4100	8000	9000
Испытательное давление (МПа)	1.5 (3.0 спец.исполнение)					
Макс. рабочее давление (МПа)	1.0 (2.0 спец.исполнение)					
Мин. рабочее давление с автоматич. отводом (МПа)	Н.О.	0.1 МПа				
	Н.З.	0.1 МПа	0.15 МПа			
Диапазон рабочих температур (°C)	-5 ~ 60 ²⁾					
Тонкость фильтрации (мкм)	5					
Материал резервуара	Поликарбонат ³⁾					
Объем резервуара (см ³)	2.5	8	25	45	45	45
Вес (кг)	0.06	0.08	0.18	0.36	0.87	1.00
Защитный колпак	-	По запросу (сталь)	Стандарт (кожух из поликарбоната)			

1) При давлении на входе 0.7 МПа и перепаде давлений 0.05 МПа

2) Исполнения для более высоких (-5 ~ 80) и более низких (-30 ~ 60) температур – по запросу.

3) Металл или нейлон – по запросу.

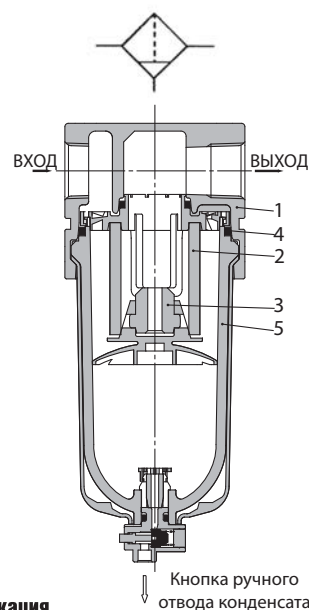

Спецификация

Поз.	Обозначение	Материал
1	Корпус	Алюминий
2	Фильтрующий элемент	Нетканый матер.
3	Разделительная перегородка	PBT
4	Кольцевое уплотнение	NBR
5	Резервуар	Поликарбонат

Номер для заказа

Типоразмер	Присоединительная резьба	Номер для заказа		
		Отвод конденсата вручную	Автоматический отвод	Исполнение для раб. давления 2.0 МПа
10	M5	AF10-M5-A	AF10-M5C-A	-
20	G1/8	AF20-F01-A	AF20-F01C-A	AF20-F01-X425
	G1/4	AF20-F02-A	AF20-F02C-A	AF20-F02-X425
30	G1/4	AF30-F02-A	AF30-F02D-A	AF30-F02-X425
	G3/8	AF30-F03-A	AF30-F03D-A	AF30-F03-X425
40	G1/4	AF40-F02-A	AF40-F02D-A	AF40-F02-X425
	G3/8	AF40-F03-A	AF40-F03D-A	AF40-F03-X425
	G1/2	AF40-F04-A	AF40-F04D-A	AF40-F04-X425
50	G3/4	AF50-F06-A	AF50-F06D-A	AF50-F06-X425
	G1	AF50-F10-A	AF50-F10D-A	AF50-F10-X425
60	G1	AF60-F10-A	AF60-F10D-A	AF60-F10-X425

Принадлежности (заказываются отдельно)

Типоразмер	10	20	30	40	50	60
Крепежный угольник ¹⁾	-	AF22P-050AS	AF32P-050AS	AF42P-050AS	AF52P-050AS	AF52P-050AS
Стакан с автомат. отводом конденсата ²⁾	Н.О.	-	AD38-A	AD48-A	AD48-A	AD48-A
	Н.З.	AD17-A	AD27-A	AD37-A	AD47-A	AD47-A
Сменный фильтрующий элемент	AF10P-060S	AF20P-060S	AF30P-060S	AF40P-060S	AF50P-060S	AF60P-060S

1) Комплект включает угольник и два установочных винта

2) Минимальное рабочее давление: Н.О. – 0.1 МПа; Н.З. – 0.1 МПа (AD17/27) и 0.15 МПа (AD37/47)

Микрофильтр / Субмикрофильтр

AFM/AFD20-40

G1/8 ~ G1/2

Предназначен для защиты оборудования / прецизионного оборудования.

- Удаляет из сжатого воздуха механические частицы размером свыше 0.3 / 0.01 мкм, и масляный туман
- Легкая замена фильтрующего элемента
- Пригоден для модульного монтажа

Технические характеристики

Типоразмер		20	30	40
Присоединительная резьба		G1/8, G1/4	G1/4, G3/8	G1/4, G3/8, G1/2
Номинальный расход воздуха ¹⁾ (норм. л/мин)	Микрофильтр AFM	200	450	1100
	Субмикрофильтр AFD	120	240	600
Испытательное давление (МПа)		1.5		
Макс. рабочее давление (МПа)		1.0		
Мин. рабочее давление (МПа)		0.05		
Диапазон рабочих температур ²⁾ (°C)		-5 ~ 60		
Тонкость фильтрации (мкм)	Микрофильтр AFM	0.3 (99.9% фильтрация частиц)		
	Субмикрофильтр AFD	0.01 (99.9% фильтрация частиц)		
Материал резервуара		Поликарбонат		
Вес (кг)		0.09	0.19	0.38
Защитный колпак		По запросу (сталь)	Стандарт (кожух из поликарбоната)	
Объем резервуара (см ³)		8	25	45

1) При давлении на входе P=0.7 МПа. Расход зависит от давления на входе.

2) При низких температурах применять сухой воздух.

Номер для заказа

Типоразмер	Присоед. резьба	Микрофильтр		Микрофильтр	
		Ручной отвод конденсата	Автомат. отвод конденсата	Ручной отвод конденсата	Автомат. отвод конденсата
20	G1/8	AFM20-F01-A	AFM20-F01C-A	AFD20-F01-A	AFD20-F01C-A
	G1/4	AFM20-F02-A	AFM20-F02C-A	AFD20-F02-A	AFD20-F02C-A
30	G1/4	AFM30-F02-A	AFM30-F02D-A	AFD30-F02-A	AFD30-F02D-A
	G3/8	AFM30-F03-A	AFM30-F03D-A	AFD30-F03-A	AFD30-F03D-A
40	G1/4	AFM40-F02-A	AFM40-F02D-A	AFD40-F02-A	AFD40-F02D-A
	G3/8	AFM40-F03-A	AFM40-F03D-A	AFD40-F03-A	AFD40-F03D-A
	G1/2	AFM40-F04-A	AFM40-F04D-A	AFD40-F04-A	AFD40-F04D-A

Принадлежности (заказываются отдельно)

Типоразмер		20	30	40
Крепежный угольник ¹⁾		AF22P-050AS	AF32P-050AS	AF42P-050AS
Стакан с автомат. отводом конденсата ²⁾	Н.О.	—	AD38-A	AD48-A
	Н.З.	AD27-A	AD37-A	AD47-A
Сменный фильтрующий элемент	AFD	AFD20P-060AS	AFD30P-060AS	AFD40P-060AS
	AFM	AFM20P-060AS	AFM30P-060AS	AFM40P-060AS

1) Комплект включает угольник и два установочных винта

2) Минимальное рабочее давление: Н.О. – 0,1 МПа, Н.З. – 0,1 МПа (AD17/27) и 0,15 МПа (AD37/47)



Предназначен для понижения давления сжатого воздуха и поддержания его на заданном уровне

- Пригоден для модульного монтажа

Технические характеристики

Конструктивное исполнение	Поршневые или мембранные регуляторы						
Типоразмер	10	20	25	30	40	50	60
Присоединительная резьба	M5	G1/8, G1/4	G1/4, G3/8	G1/4, G3/8	G1/4, G3/8, G1/2	G3/4, G1	G1
Номинальный расход ¹⁾ (н. л/мин)	125	800	1100	1500	3000	8000	10000
Диапазон рабочих температур (°C)	-5 ~ 60 ²⁾						
Испытательное давление (МПа)	1.5 (3.0 спец. исполнение)						
Макс. рабочее давление (МПа)	1.0 (2.0 спец. исполнение)						
Диапазон регулирования (МПа)	0.02 ~ 0.2 (по запросу)						
	0.05 ~ 0.7	0.05 ~ 0.7, 0.05 ~ 0.85 (0.1 ~ 1.6 спец. исполнение)					
Резьба для присоедин. манометра ³⁾	Rc1/16 ⁴⁾	G1/8	G1/8	G1/8	G1/4	G1/4	G1/4
Сброс давления	Установленное вых. давление + 0.05МПа ⁵⁾ (расход сброса 0.1 л/мин)						
Вес (кг)	0.06	0.17	0.19	0.34	0.58	1.17	1.22

- 1) При давлении на входе 0.7 МПа, давлении на выходе при нулевом расходе 0.5 МПа и снижении давления на выходе при изменении расхода от нуля до номинального равном 0.1 МПа
- 2) Исполнения для более высоких (-5 ~ 80) и более низких (-30 ~ 60) температур – по запросу.
- 3) Не требуется для блоков со встраиваемым квадратным манометром (AR20 – AR60)
- 4) Для подсоединения манометра с резьбой 1/8 к отверстию с резьбой 1/16 используйте специальный переходник (арт. 131168)
- 5) Неприменимо к AR10

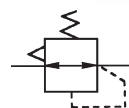

Пример: обеспечение различных давлений для выдвигания и втягивания штока пневмоцилиндра

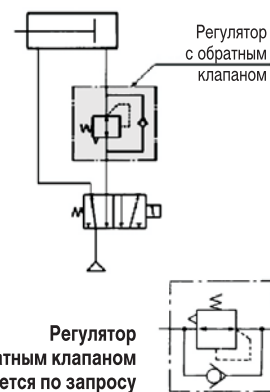

Регулятор с обратным клапаном поставляется по запросу

Номер для заказа

Типоразмер	Присоед. резьба	Номер для заказа				
		Стандарт. исполнение		Спец. исполнение		
		0.05 ~ 0.7 МПа	0.05 ~ 0.85 МПа	0.02 ~ 0.2 МПа	0.1 ~ 1.6 МПа ¹⁾	Обезжиренное
10	M5	AR10-M5-A	-	AR10-M5-1-A	-	-
20	G1/8	AR20-F01-A	AR20-F01-B	AR20-F01-1-A	AR20-F01-X425	AR20-F01-X2400
	G1/4	AR20-F02-A	AR20-F02-B	AR20-F02-1-A	AR20-F02-X425	AR20-F02-X2400
25	G1/4	AR25-F02-A	AR25-F02-B	AR25-F02-1-A	AR25-F02-X425	AR25-F02-X2400
	G3/8	AR25-F03-A	AR25-F03-B	AR25-F03-1-A	AR25-F03-X425	AR25-F03-X2400
30	G1/4	AR30-F02-A	AR30-F02-B	AR30-F02-1-A	AR30-F02-X425	AR30-F02-X2400
	G3/8	AR30-F03-A	AR30-F03-B	AR30-F03-1-A	AR30-F03-X425	AR30-F03-X2400
40	G1/4	AR40-F02-A	AR40-F02-B	AR40-F02-1-A	AR40-F02-X425	AR40-F02-X2400
	G3/8	AR40-F03-A	AR40-F03-B	AR40-F03-1-A	AR40-F03-X425	AR40-F03-X2400
	G1/2	AR40-F04-A	AR40-F04-B	AR40-F04-1-A	AR40-F04-X425	AR40-F04-X2400
50	G3/4	-	AR50-F06-B	AR50-F06-1-B	AR50-F06-X425	AR50-F06-X2400
	G1	-	AR50-F10-B	AR50-F10-1-B	AR50-F10-X425	AR50-F10-X2400
60	G1	-	AR60-F10-B	AR60-F10-1-B	AR60-F10-X425	AR60-F10-X2400

1) Манометры поставляются по запросу

Принадлежности (заказываются отдельно)

Типоразмер		10	20	25	30	40	50	60
Крепежный угольник ¹⁾	для исполнения А	AR12P-270AS	AR22P-270AS	AR27P-270AS	AR32P-270AS	AR42P-270AS	-	-
	для исполнения В	-	AR23P-270AS	AR28P-270AS	AR33P-270AS	AR43P-270AS	AR52P-270AS	
Гайка для панельного монтажа	для исполнения А	AR12P-260S	AR22P-260S	AR22P-260S	AR32P-260S	AR42P-260S	-	-
	для исполнения В	-	AR23P-260S	AR28P-260S	AR33P-260S	AR43P-260S	-	-
Манометр	1.0 МПа	Круглый	G27-10-R1	G36-10-01			G46-10-01	
		Квадратн. встраив. ³⁾	-	GC3-10AS				
	0.2 МПа	Круглый	G27-10-R1 ⁴⁾	G36-4-01			G46-4-01	
		Квадратн. встраив. ³⁾	-	GC3-2AS				
Реле давления с цифровой индикацией ⁵⁾	NPN выход / разъем снизу	ISE35-N-25-MLA						
	NPN выход / разъем сверху	ISE35-R-25-MLA						
	PNP выход / разъем снизу	ISE35-N-65-MLA						
	PNP выход / разъем сверху	ISE35-R-65-MLA						

- 1) Комплект включает угольник и установочную гайку
- 2) Комплект включает угольник и два установочных винта
- 3) Только для исполнения В. Уплотнительное кольцо и два установочных винта в комплекте.
- 4) Для 1 МПа

- 5) Только для исполнения В. Комплект включает кабель (2 м) с разъемом, адаптер, фиксатор, кольцевую прокладку (1 шт.) и монтажные винты (2 шт.)

Для всех исполнений манометры заказываются отдельно

Предназначен для подачи масла в пневмосистему пропорционально расходу сжатого воздуха в случаях когда это необходимо (пневмоинструмент и т.д.)

- Пригоден для модульного монтажа

Технические характеристики

Типоразмер	AL10	AL20	AL30	AL40	AL50	AL60
Присоединительная резьба	M5	G1/8, G1/4	G1/4, G3/8	G1/4, G3/8, G1/2	G3/4, G1	G1
Испытательное давление (МПа)	1.5					
Макс. рабочее давление (МПа)	1.0					
Мин. расход, при котором возможно маслораспыление ¹⁾ (норм.л/мин)	4	15	1/4: 30 3/8: 40	1/4: 30 3/8: 40 1/2: 50	190	220
Объем резервуара (см ³)	7	25	55	135	135	135
Диапазон рабочих температур (°C) ²⁾	-5 ~ 60					
Рекомендуемое качество масла	ISO VG32, Класс 1					
Материал резервуара	Поликарбонат					
Вес (кг)	0.07	0.10	0.20	0.38	0.94	1.09
Защитный колпак	-	По запросу (сталь)	Стандарт (кожух из поликарбоната)			



1) Расход масла 5 капель в минуту при следующих условиях: давление на входе 0.5 МПа, масло ISO VG32 Класс 1, температура масла 20 °C, винт регулировки подачи масла полностью открыт.

2) При низких температурах применять сухой воздух

Для заказа маслораспылителей большого расхода см. серию AL800-900

Номер для заказа

Типоразмер	Присоединительная резьба	Номер для заказа
10	M5	AL10-M5-A
20	G1/8	AL20-F01-A
	G1/4	AL20-F02-A
30	G1/4	AL30-F02-A
	G3/8	AL30-F03-A
40	G1/4	AL40-F02-A
	G3/8	AL40-F03-A
	G1/2	AL40-F04-A
50	G3/4	AL50-F06-A
	G1	AL50-F10-A
60	G1	AL60-F10-A

Принадлежности (заказываются отдельно)

Типоразмер	10	20	30	40	50	60
Крепежный угольник ¹⁾	-	AF22P-050AS	AF32P-050AS	AF42P-050AS	AF52P-050AS	AF52P-050AS
Резервуар ²⁾	C1SL-3-A	C2SL-3C-A ³⁾	C3SL-3-A	C4SL-3-A	C4SL-3-A	C4SL-3-A

1) Комплект включает угольник и 2 установочных винта

2) Комплект включает уплотнительное кольцо

3) Поставляется со стальным защитным колпаком

Фильтр/регулятор

AW10-60

M5 ~ G1

Комбинация двух устройств – воздушного фильтра и регулятора давления в одном корпусе, что позволяет экономить рабочее пространство. Предназначен для удаления из сжатого воздуха механических загрязнений и конденсата, а также для понижения давления сжатого воздуха и поддержания его на заданном уровне.

- Фильтрующий элемент, изготовленный из пластика, обеспечивает увеличенный расход воздуха при высокой степени очистки (5 мкм)
- Легкая замена фильтрующего элемента. Пригоден для модульного монтажа
- Высокотемпературные (до +80) и низкотемпературные (от -30) исполнения

Технические характеристики

Конструктивное исполнение	Поршневой и мембранный регулятор				
Типоразмер	10	20	30	40	60
Присоединительная резьба	M5	G1/8, 1/4	G1/4, 3/8	G1/4, 3/8, 1/2, 3/4	G3/4, 1
Номинальный расход ¹⁾ (н. л/мин)	125	550	1500	2400	10000
Испытательное давление (МПа)	1.5 (3.0 спец. исполнение)				
Макс. рабочее давление (МПа)	1.0 (2.0 спец. исполнение)				
Диапазон регулирования (МПа)	0.05 ~ 0.7, 0.05 ~ 0.7, 0.05 ~ 0.85 (специполн. 0.02 ~ 0.2, 0.1 ~ 1.6)				
Резьба для присоедин. манометра ²⁾	Rc 1/16 ³⁾	G1/8	G1/8	G1/8	G1/4
Сброс давления	Установленное вых. давление + 0.05 МПа ⁴⁾ (расход сброса 0.1 л/мин)				
Рабочая температура ⁵⁾ (°C)	-30 ~ 80				
Тонкость фильтрации (мкм)	5				
Материал резервуара	Поликарбонат				
Объем резервуара (см ³)	2.5	8	25	45	
Защитный колпак	-	По запросу (сталь)	Стандарт (кожух из поликарбоната)		
Вес (кг)	0.09	0.21	0.41	0.75	2

1) При давлении на входе 0.7 МПа, давлении на выходе при нулевом расходе 0.5 МПа и снижении давления на выходе при изменении расхода от нуля до номинального равном 0.1 МПа

2) Не требуется для блоков со встраиваемым квадратным манометром (AW20 – AW60)

3) Для подсоединения манометра с резьбой 1/8 к отверстию с резьбой 1/16 используйте специальный переходник

4) Неприменимо к AW10 5) Исполнения для температур (-40 ~ 80) – по запросу



Номер для заказа

Для всех исполнений манометры заказываются отдельно

Типоразмер	Присоед. резьба	Номер для заказа							
		Отвод конденсата вручную		Стандартное исполнение		Спец. исполнения		-30 ~ 60°C	-5 ~ 80°C
		0.05 ~ 0.7 МПа	0.05 ~ 0.85 МПа	0.05 ~ 0.7 МПа	0.05 ~ 0.85 МПа	0.02 ~ 0.2 МПа	0.1 ~ 1.6 МПа ¹⁾		
10	M5	AW10-M5-A	-	AW10-M5C-A	-	AW10-M5-1-A	-	-	-
20	G1/8	AW20-F01-A	AW20-F01-B	AW20-F01C-A	AW20-F01C-B	AW20-F01-1-A	AW20-F01-2-X425	-	-
	G1/4	AW20-F02-A	AW20-F02-B	AW20-F02C-A	AW20-F02C-B	AW20-F02-1-A	AW20-F02-2-X425	-	-
30	G1/4	AW30-F02-A	AW30-F02-B	AW30-F02D-A	AW30-F02D-B	AW30-F02-1-A	AW30-F02-2-X425	AW30-F02-2-X430	AW30-F02-2-X440
	G3/8	AW30-F03-A	AW30-F03-B	AW30-F03D-A	AW30-F03D-B	AW30-F03-1-A	AW30-F03-2-X425	AW30-F03-2-X430	AW30-F03-2-X440
40	G1/4	AW40-F02-A	AW40-F02-B	AW40-F02D-A	AW40-F02D-B	AW40-F02-1-A	AW40-F02-2-X425	AW40-F02-2-X430	AW40-F02-2-X440
	G3/8	AW40-F03-A	AW40-F03-B	AW40-F03D-A	AW40-F03D-B	AW40-F03-1-A	AW40-F03-2-X425	AW40-F03-2-X430	AW40-F03-2-X440
	G1/2	AW40-F04-A	AW40-F04-B	AW40-F04D-A	AW40-F04D-B	AW40-F04-1-A	AW40-F04-2-X425	AW40-F04-2-X430	AW40-F04-2-X440
	G3/4	AW40-F06-A	AW40-F06-B	AW40-F06D-A	AW40-F06D-B	AW40-F06-1-A	AW40-F06-2-X425	AW40-F06-2-X430	AW40-F06-2-X440
60	G3/4	-	AW60-F06-B	-	AW60-F06D-B	AW60-F06-1-B	AW60-F06-2-X425	AW60-F06-2-X430	AW60-F06-2-X440
	G 1	-	AW60-F10-B	-	AW60-F10D-B	AW60-F10-1-B	AW60-F10-2-X425	AW60-F10-2-X430	AW60-F10-2-X440

1) Манометры поставляются по запросу

Принадлежности (заказываются отдельно)

Типоразмер		10	20	30	40	60
Крепежный угольник ¹⁾	для исполнения А	AR12P-270AS	AR22P-270AS	AR32P-270AS	AR42P-270AS	--
	для исполнения В	-	AW23P-270AS	AR33P-270AS	AR43P-270AS	AW62P-270AS
Гайка для панельного монтажа	для исполнения А	AR12P-260S	AR22P-260S	AR32P-260S	AR42P-260S	--
	для исполнения В	-	AR23P-260S	AR33P-260S	AR43P-260S	--
Манометр	1.0 МПа	Круглый	G27-10-R1	G36-10-01	G46-10-01	
		Квадратн. встраиваемый ²⁾	-	GC3-10AS		
	0.2 МПа	Круглый	G27-10-R1 ³⁾	G36-4-01	G46-4-01	
		Квадратн. встраиваемый ²⁾	-	GC3-2AS		
Стакан с автомат. отводом конденсата ⁴⁾	Н.О.	-	-	AD38-A	AD48-A	
	Н.З.	AD17-A	AD27-A	AD37-A	AD47-A	
Алюмин. стакан для исполнения Х430		-	-	C3SF-2-X430	C4SF-2-X430	
Алюмин. стакан с фитингом G1/4 для исп-я Х430		-	-	C3SFF-2J-X430	C4SFF-2J-X430	
Алюмин. стакан для исполнения Х440		-	-	C3SF-2-X440	C4SF-2-X440	
Алюмин. стакан с фитингом G1/4 для исп-я Х440		-	-	C3SFF-2J-X440	C4SFF-2J-X440	
Сменный фильтрующий элемент		AF10P-060S	AF20P-060S	AF30P-060S	AF40P-060S	AW60P-060S
Реле давления с цифр. индикацией ⁵⁾	NPN выход, разъем снизу / сверху	ISE35-N-25-MLA / ISE35-R-25-MLA				
	PNP выход, разъем снизу / сверху	ISE35-N-65-MLA / ISE35-R-65-MLA				

- 1) Комплект включает угольник и установочные гайки
- 2) Только для исполнения В. Прилагаются одно уплотнительное кольцо и два установочных винта
- 3) Для давления 1.0 МПа
- 4) Минимальное рабочее давление: Н.О. – 0.1 МПа, Н.З. – 0.1 МПа (AD17/27) и 0.15 МПа (AD37/47)
- 5) Только для исполнения В. Включает кабель (2 м) с разъемом, адаптер, фиксатор, кольцевую прокладку (1 шт.) и монтажные винты (2 шт.)

Фильтр-регулятор-маслораспылитель

AC10-60

M5 ~ G1

Комбинация фильтра, регулятора и маслораспылителя с крепежными деталями

Технические характеристики

Комбинация	AC	10	20	30	40	50	60
Фильтр	AF	10	20	30	40	50	60
Регулятор давления	AR	10	20	30	40	50	60
Маслораспылитель	AL	10	20	30	40	50	60
Переходная деталь (2 шт. в комплекте)	Y100T-A	Y200T-A	Y300T-A	Y400T-A	Y500T-A	Y600T-A	
Присоединительная резьба	M5	G1/8, G1/4	G1/4, G3/8	G1/4, G3/8, G1/2	G3/4, G1	G1	
Резьба для присоединения манометра ¹⁾	Rc1/16	G1/8	G1/8	G1/8	G1/4	G1/4	
Испытательное давление (МПа)	1.5						
Макс. давление на входе (МПа)	1.0						
Диапазон давлений на выходе (МПа)	0.05 ~ 0.7, 0.05 ~ 0.85, 0.05 ~ 0.7						
Сброс давления	Установленное вых. давление + 0.05МПа ²⁾ (расход сброса 0.1 л/мин)						
Рабочая температура (°C)	-5 ~ 60						
Тонкость фильтрации (мкм)	5						
Рекомендуемое масло	ISO VG32						
Материал резервуара	поликарбонат						
Защитный колпак	-	По запросу (сталь)	Стандарт (кожух из поликарбоната)				
Вес (кг)	0.27	0.39	0.78	1.39	3.43	3.76	

1) Резьба для присоединения манометра не требуется для блоков со встраиваемым квадратным манометром (AC20 – AC60)

2) Неприменимо к AC10

AC40



AC20

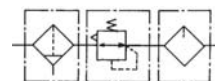

Номер для заказа

Манометры

заказываются отдельно

Типоразмер	Присоед. резьба	Отвод конденсата вручную		Автоматич. отвод конденсата	
		0.05 ~ 0.7 МПа	0.05 ~ 0.85 МПа	0.05 ~ 0.7 МПа	0.05 ~ 0.85 МПа
10	M5	AC10-M5-A	-	AC10-M5C-A	-
20	G1/8	AC20-F01-A	AC20-F01-B	AC20-F01C-A	AC20-F01C-B
	G1/4	AC20-F02-A	AC20-F02-B	AC20-F02C-A	AC20-F02C-B
30	G1/4	AC30-F02-A	AC30-F02-B	AC30-F02D-A	AC30-F02D-B
	G3/8	AC30-F03-A	AC30-F03-B	AC30-F03D-A	AC30-F03D-B
40	G1/4	AC40-F02-A	AC40-F02-B	AC40-F02D-A	AC40-F02D-B
	G3/8	AC40-F03-A	AC40-F03-B	AC40-F03D-A	AC40-F03D-B
	G1/2	AC40-F04-A	AC40-F04-B	AC40-F04D-A	AC40-F04D-B
50	G3/4	-	AC50-F06-B	-	AC50-F06D-B
	G1	-	AC50-F10-B	-	AC50-F10D-B
60	G1	-	AC60-F10-B	-	AC60-F10D-B

Принадлежности

(заказываются отдельно)

Обозначение		Типоразмер / Номер для заказа					
		10	20	30	40	50	60
Промежуточный отвод с обрат. клапаном ¹⁾		-	AKM2000-F01-A	AKM3000-F02-A	AKM4000-F03-A	-	-
Переходная деталь		Y100-A	Y200-A	Y300-A	Y400-A	Y600-A	Y600-A
Промежуточный отвод ¹⁾		Y110-M5-A	Y210-F01-A	Y310-F02-A	Y410-F03-A	Y610-F03-A	Y610-F04-A
Промежуточный отвод с 4 выходами ¹⁾		Y14-M5-A	Y24-F01-A, Y24-F02-A	Y34-F01-A, Y34-F02-A	Y44-F02-A, Y44-F03-A	-	-
Ручной запорный клапан ¹⁾		-	VHS20-F01A VHS20-F02A	VHS30-F02A VHS30-F03A	VHS40-F02A VHS40-F03A VHS40-F04A	VHS50-F06A	-
Реле давления	IS10M	-	IS10M-20-6L-A	IS10M-30-6L-A	IS10M-40-6L-A	IS10M-60-6L-A	IS10M-60-6L-A
	IS10E	-	IS10E-20F01-6L-A IS10E-20F02-6L-A IS10E-20F03-6L-A	IS10E-30F02-6L-A IS10E-30F03-6L-A IS10E-30F04-6L-A	IS10E-40F02-6L-A IS10E-40F03-6L-A IS10E-40F04-6L-A IS10E-40F06-6L-A	-	-
Реле давления с цифровой индикацией ⁴⁾	NPN выход / разъем снизу	ISE35-N-25-MLA					
	NPN выход / разъем сверху	ISE35-R-25-MLA					
	PNP выход / разъем снизу	ISE35-N-65-MLA					
	PNP выход / разъем сверху	ISE35-R-65-MLA					
Стакан с автомат. Н.О. отводом конденсата ²⁾	Н.О.	-	-	AD38-A	AD48-A	AD48-A	AD48-A
	Н.З.	AD17-A	AD27-A	AD37-A	AD47-A	AD47-A	AD47-A
Переходник ¹⁾		E100-M5-A	E200-F01-A E200-F02-A E200-F03-A	E300-F02-A E300-F03-A E300-F04-A	E400-F02-A E400-F03-A E400-F04-A E400-F06-A	E600-F06-A E600-F10-A	E600-F06-A E600-F10-A
Манометр	1.0 МПа	Круглый	G27-10-R1	G36-10-01		G46-10-01	
		Встраив. квадрат. ³⁾	-	GC3-10AS			
	0.2МПа	Круглый	G27-10-R1	G36-4-01		G46-4-01	
		Встраив. квадрат. ³⁾	-	GC3-2AS			

Примечания: 1) Для монтажа требуются отдельные переходные детали

2) Минимальное рабочее давление: Н.О. – 0,1 МПа, Н.З. – 0,15 МПа (AD17/27)

3) Только для исполнения В. Прилагаются одно уплотнительное кольцо и два установочных винта

4) Только для исполнения В. Комплект включает кабель (2 м) с разъемом, адаптер, фиксатор, кольцевую прокладку (1 шт.) и монтажные винты (2 шт.)

Комбинация фильтра/регулятора и маслораспылителя с крепежными деталями

Технические характеристики

Комбинация	АСПА	10	20	30	40
Фильтр/регулятор	AW	10	20	30	40
Маслораспылитель	AL	10	20	30	40
Переходная деталь		Y100T-A	Y200T-A	Y300T-A	Y400T-A
Присоединительная резьба		M5	G1/8, G1/4	G1/4, G3/8	G1/4, G3/8, G1/2
Резьба для присоединения манометра ¹⁾		Rc1/16	G1/8	G1/8	G1/4
Испытательное давление (МПа)		1.5			
Макс. давление на входе (МПа)		1.0			
Диапазон давлений на выходе (МПа)		0.05 ~ 0.7 (0.05 ~ 0.85 по запросу)			
Сброс давления		Установленное вых. давление + 0.05 МПа ²⁾ (расход сброса 0.1 л/мин)			
Рабочая температура (°C)		-5 ~ 60			
Тонкость фильтрации (мкм)		5			
Рекомендуемое масло		ISO VG32			
Материал резервуара		Поликарбонат			
Защитный колпак		-	По запросу (сталь)	Стандарт (кожух из поликарбоната)	
Вес (кг)		0.20	0.33	0.66	1.22

1) Не требуется для блоков со встраиваемым квадратным манометром (AC20A AC40A)

2) Неприменимо к AC10A



Номер для заказа

Типоразмер	Присоединительная резьба	Номер для заказа	
		Отвод конденсата вручную	Автоматический отвод конденсата
10	M5	AC10A-M5-A	AC10A-M5C-A
20	G1/8	AC20A-F01-A	AC20A-F01C-A
	G1/4	AC20A-F02-A	AC20A-F02C-A
30	G1/4	AC30A-F02-A	AC30A-F02D-A
	G3/8	AC30A-F03-A	AC30A-F03D-A
40	G1/4	AC40A-F02-A	AC40A-F02D-A
	G3/8	AC40A-F03-A	AC40A-F03D-A
	G1/2	AC40A-F04-A	AC40A-F04D-A

Манометры заказываются отдельно

Принадлежности (заказываются отдельно)

Типоразмер	10	20	30	40	
Промежуточный отвод с обрат. клапаном ¹⁾	-	AKM2000-F01-A	AKM3000-F02-A	AKM4000-F03-A	
Переходная деталь	Y100-A	Y200-A	Y300-A	Y400-A	
Промежуточный отвод ¹⁾	Y110-M5-A	Y210-F01-A	Y310-F02-A	Y410-F03-A	
Промежуточный отвод с 4 выходами ¹⁾	Y14-M5-A	Y24-F01-A, Y24-F02-A	Y34-F01-A, Y34-F02-A	Y44-F02-A, Y44-F03-A	
Ручной запорный клапан ¹⁾	-	VHS20-F01A, VHS20-F02A	VHS30-F02A, VHS30-F03A	VHS40-F02A, VHS40-F03A, VHS40-F04A	
Реле давления	IS10M	-	IS10M-20-6L-A	IS10M-30-6L-A	
	IS10E	-	IS10E-20F01-6L-A IS10E-20F02-6L-A IS10E-20F03-6L-A	IS10E-30F02-6L-A IS10E-30F03-6L-A IS10E-30F04-6L-A	
Стакан с автоматическим отводом конденсата ²⁾	H.O.	-	-	AD38-A	
	H.3.	AD17-A	AD27-A	AD37-A	
Переходник ¹⁾	E100-M5-A	E200-F01-A, E200-F02-A, E200-F03-A	E300-F02-A, E300-F03-A, E300-F04-A	E400-F02-A, E400-F03-A, E400-F04-A, E400-F06-A	
Манометры	1.0 МПа	Круглый	G27-10-R1	G36-10-01	
		Встраив. квадрат. ³⁾	-	GC3-10AS	
	0.2 МПа	Круглый	G27-10-R1	G36-4-01	G46-4-01
		Встраив. квадрат. ³⁾	-	GC3-2AS	

1) Для монтажа требуются отдельные переходные детали

2) Минимальное рабочее давление: H.O. – 0.1 МПа, H.3. – 0.15 МПа (AD17/27)

3) Прилагаются одно уплотнительное кольцо и два установочных винта

Принадлежности для модульного монтажа

Переходная деталь



Номер для заказа	Для типоразмера
Y100-A	AC10, AC10A
Y200-A	AC20, AC20A
Y300-A	AC30, AC30A
Y400-A	AC40, AC40A
Y600-A	AC60, AC50

Переходная деталь с крепежным угольником формы Т

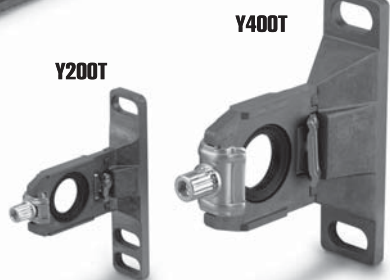

Номер для заказа	Для типоразмера
Y100T-A	AC10, AC10A
Y200T-A	AC20, AC20A
Y300T-A	AC30, AC30A
Y400T-A	AC40, AC40A
Y600T-A	AC50, AC60

Ремкомплекты

Наименование	Материал	Номер для заказа				
		Y100, Y100T	Y200, Y200T	Y300, Y300T	Y400, Y400T	Y600, Y600T
Уплотнение	HNBR	По запросу	Y220P-050S	Y320P-050S	Y420P-050S	По запросу

Промежуточный отвод

Y110 - Y610



Номер для заказа	Присоединительная резьба	Для типоразмера
Y110-M5-A	M5	AC10, AC10A
Y210-F01-A	G1/8	AC20, AC20A
Y210-F02-A	G1/4	
Y310-F01-A	G1/8	AC30, AC30A
Y310-F02-A	G1/4	AC40, AC40A
Y410-F02-A	G1/4	
Y410-F03-A	G3/8	AC50, AC60
Y610-F03-A	G3/8	
Y610-F04-A	G1/2	

Промежуточный отвод с четырьмя выходами

Y14 - Y44



Промежуточный отвод с четырьмя выходами

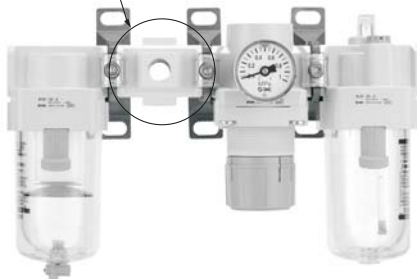

Номер для заказа	Присоединительная резьба	Для типоразмера
Y14-M5-A	M5	AC10, AC10A
Y24-F01-A	G1/8	AC20, AC20A
Y24-F02-A	G1/4	
Y34-F01-A	G1/8	AC30, AC30A
Y34-F02-A	G1/4	AC40, AC40A
Y44-F02-A	G1/4	
Y44-F03-A	G3/8	

Переходник

E100 - E600



Переходник трубный



Номер для заказа	Присоединительная резьба	Для устройств
E100-M5-A	M5	AC10, AC10A
E200-F01-A	G1/8	AC20, AC20A
E200-F02-A	G1/4	
E200-F03-A	G3/8	AC30, AC30A
E300-F02-A	G1/4	
E300-F03-A	G3/8	AC40, AC40A
E300-F04-A	G1/2	
E400-F02-A	G1/4	AC40, AC40A
E400-F03-A	G3/8	
E400-F04-A	G1/2	AC50, AC60
E400-F06-A	G3/4	
E600-F06-A	G3/4	AC50, AC60
E600-F10-A	G1	

Резьбовой переходник E210, E310, E410

Предназначен для присоединения изделий с внутренней резьбой к устройствам модульной системы

- Соединяет устройства разных типоразмеров, например, AF30 и ARG20
- Позволяет варьировать угол установки



Номер для заказа	Типоразмер изделий модульной серии	Присоединение (универсальная резьба)	Типоразмер клапана / пневмораспределителя
E210-U01	20	1/8	VP344, VX21
E210-U02		1/4	VP344/544, VX21/22/23, VXD213, VXZ22
E310-U02	30	1/4	VP344/544, VX21/22/23, VXD213, VXZ22
E310-U03		3/8	VP544/744, VX22/23, VXD214
E410-U02	40	1/4	VP344/544, VX21/22/23, VXD213, VXZ22
E410-U03		3/8	VP544/744, VX22/23, VXD214
E410-U04		1/2	VX22/23, VXD213/214, VXZ22

Рекомендации

Наименование	Материал	Номер для заказа				
		E210-U01	E210-U02	E310-U02 E410-U02	E310-U03 E410-U03	E410-U04
Уплотнение	NBR	E210P-040S -	E210P-030S E210P-050S	E210P-030S -	E310P-030S -	E410P-030S -

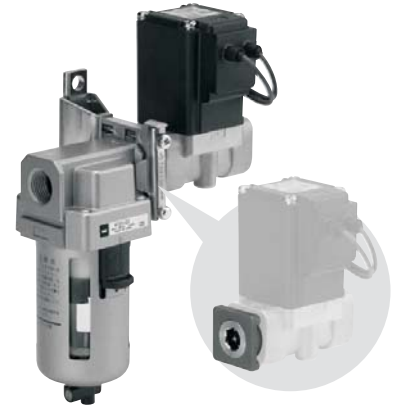

Реле давления IS10

Реле давления IS10 применяется для контроля давления сжатого воздуха

- Ресурс 5 млн циклов
- Пригодно для модульного монтажа
- Варианты монтажа: на выходе блока подготовки сжатого воздуха, между устройствами подготовки сжатого воздуха, самостоятельный монтаж
- Исполнения с диапазоном срабатывания (0.1 ~ 0.4) МПа, с кабелем 0.5 м или 5 м - по запросу

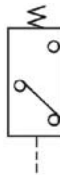

Технические характеристики

Рабочая среда	Сжатый воздух	
Испытательное давление (МПа)	1.0	
Макс. рабочее давление (МПа)	0.7	
Давление срабатывания (МПа)	0.1 ~ 0.6	
Гистерезис (МПа)	0.08	
Воспроизводимость (МПа)	0.05	
Тип коммутации	Нормально-разомкнутый *	
Рабочее напряжение, ток	12 ~ 100 В (AC/DC), 50 мА	
Максимальная нагрузка	постоянный ток (Вт)	2
	переменный ток (ВА)	2
Время переключения (мс)	1.2	
Стойкость к ударным нагрузкам (G)	30	
Соединительный кабель	двухпроводной, длина 3 м	
Диапазон рабочих температур (°C)	-5 ~ 60	
Присоединение	R 1/8	
Степень защиты	IP40	

* при отсутствии давления электрическая цепь размыкается

Реле давления IS10M

Монтируется между двумя устройствами



Реле давления IS10E

Монтируется на выходе устройства подготовки сжатого воздуха



Номер для заказа	Типоразмер для модульного монтажа
IS10M-20-6L-A	AC20, AC20A
IS10M-30-6L-A	AC30, AC30A
IS10M-40-6L-A	AC40, AC40A
IS10M-60-6L-A	AC50, AC60

Номер для заказа		Типоразмер для модульного монтажа
Монтаж справа	Монтаж слева	
IS10E-20F01-6L-A	IS10E-20F01-6LR-A	AC20, AC20A
IS10E-20F02-6L-A	IS10E-20F02-6LR-A	
IS10E-20F03-6L-A	IS10E-20F03-6LR-A	
IS10E-30F02-6L-A	IS10E-30F02-6LR-A	AC30, AC30A
IS10E-30F03-6L-A	IS10E-30F03-6LR-A	
IS10E-30F04-6L-A	IS10E-30F04-6LR-A	
IS10E-40F02-6L-A	IS10E-40F02-6LR-A	AC40, AC40A
IS10E-40F03-6L-A	IS10E-40F03-6LR-A	
IS10E-40F04-6L-A	IS10E-40F04-6LR-A	
IS10E-40F06-6L-A	IS10E-40F06-6LR-A	

Примечание: для монтажа требуются отдельные переходные детали.

Реле давления IS10-01



Номер для заказа	Присоед. резьба
IS10-01-6L	R1/8

Примечание: для монтажа требуется отдельная переходная деталь

Принадлежности для модульного монтажа

Ручной запорный клапан VHS20–50

Предназначен для подачи и выпуска сжатого воздуха из пневмосистемы

- Визуальный контроль состояния SUP/EXH (Вкл./Выкл.)
- Пригоден для модульного монтажа



Показатели расхода

Типоразмер	Эквивалентное сечение (мм ²)	
	ВКЛ. - ВЫКЛ.	ВЫКЛ. - ВКЛ.
VHS20-F01	10	11
VHS20-F02	14	16
VHS30-F02	16	14
VHS30-F03	31	29
VHS40-F02	27	36
VHS40-F03	38	40
VHS40-F04	55	42
VHS50-F06	82	50
VHS50-F10	125	53

Типоразмер для модульного монтажа	Номер для заказа	Присоединительная резьба	Принадлежности (заказываются отдельно)	
			Варианты крепежа для модульного монтажа	Пневмоглушитель
20	VHS20-F01A	G1/8	Y200-A, Y200T-A	AN10-01
	VHS20-F02A	G1/4		
30	VHS30-F02A	G1/4	Y300-A, Y300T-A	AN20-02
	VHS30-F03A	G3/8		
40	VHS40-F02A	G1/4	Y400-A, Y400T-A	AN30-03
	VHS40-F03A	G3/8		
	VHS40-F04A	G1/2		
50	VHS50-F06A	G3/4	Y300-A, Y300T-A	AN40-04
	VHS50-F10A	G1		

Промежуточный отвод с обратным клапаном АКМ2000–4000

Применяется для предотвращения обратного течения маслосодержащего воздуха из маслораспылителя в промежуточный отвод

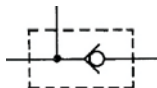

Показатели расхода

Тип	Эквивалентное сечение (мм ²)
AKM2000	28
AKM3000	55
AKM4000	111

Номер для заказа	Присоединительная резьба	Типоразмер для модульного монтажа
AKM2000-F01-A	G1/8	AC20, AC20A
AKM2000-F02-A	G1/4	
AKM3000-F01-A	G1/8	AC30, AC30A
AKM3000-F02-A	G1/4	
AKM4000-F02-A	G1/4	AC40, AC40A
AKM4000-F03-A	G3/8	



Блокиратор установочной ручки регулятора давления

Предотвращает несанкционированное изменение настройки регулятора давления

Совместим только с регуляторами серии В (с выходным давлением 0.05 ~ 0.85 МПа)



Замок
не входит
в комплект поставки

Номер для заказа	Совместимые серии регуляторов давления
AR20P-580AS	AC20□, AR20, AR20K, ARP20, ARP20K, AW20, AW20K, AWM20, AWD20
AR25P-580AS	AC25□, AR25, AR25K
AR30P-580AS	AC30□, AR30, AR30K, ARP30, ARP30K, AW30, AW30K, AWM30, AWD30
AR40P-580AS	AC40□(-06), AR40(-06), AR40K(-06), ARP40, ARP40K, AW40(-06), AW40K(-06), AWM40(-06), AWD40(-06)

Modular F.R.L. Units

RoHS

Better visibility & environmental resistance

Double layer design

The bowl is covered with a transparent bowl guard!

- The inside is visible from 360°.
- The bowl is completely protected from the environment. Safety improved

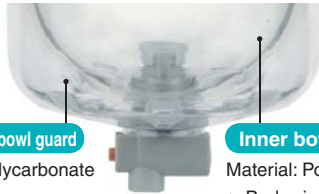

Transparent bowl guard
Material: Polycarbonate

Inner bowl
Material: Polycarbonate
* Body size: 30 or more

Selection of pressure gauges



Square embedded type pressure gauge



Round type pressure gauge



Digital pressure switch

Interchangeability

Interchangeable with the previous AR series by panel mounting

Easy replacement of the element

The element and the bowl are in one piece. Replacement can be done in hand.

Replacement in hand!

Previous model



New



* AF-A only
(Except AF10-A, AF50-A, AF60-A)

Reduced required maintenance space

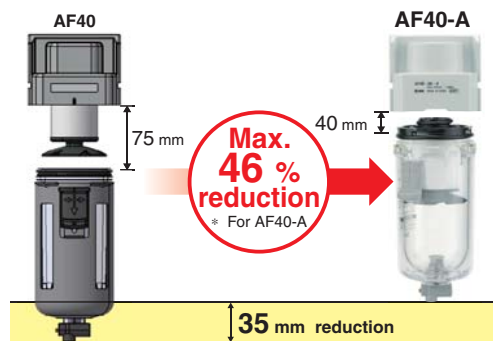

Set pressure: 0.05 to 0.85 MPa
0.02 to 0.2 MPa

AR-K regulator with backflow function added.

New Made to order added.

- Long bowl (-X64)
- 0.4 MPa setting (-X406)
- With element service indicator (-X2141)
- High pressure (-X425)
- Low temperature (-X430)
- High temperature (-X440)
- Clean series (10-)
- Copper, fluorine and silicone-free + Low particle generation (21-)



AC Series



CAT.EUS40-60B-UK

▶ Transparent bowl guard

Better environmental resistance:
Transparent bowl guard can protect the inner bowl!

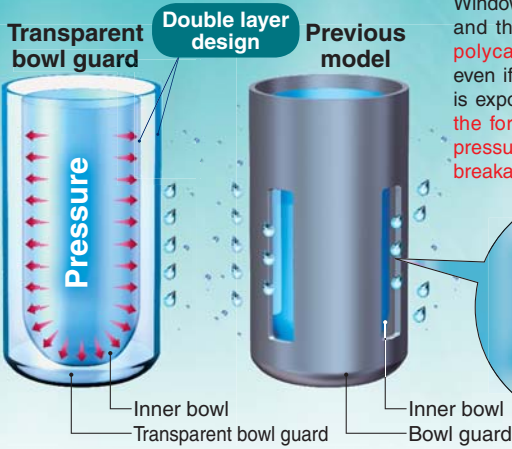

Windows on the bowl guard have been removed and the inner bowl is instead covered with a polycarbonate transparent bowl guard. Now, even if the environment changes and the bowl is exposed to corrosive chemical or oil splash, the foreign matter will not stick directly to the pressurized bowl. This can reduce risk of bowl breakage.

Applicable model

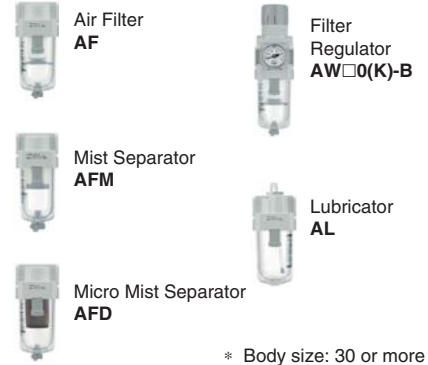

Better visibility: 360°

Use of transparent bowl guard makes it possible to check the condensate inside the filter bowl and the remaining oil amount in the lubricator from the entire periphery.

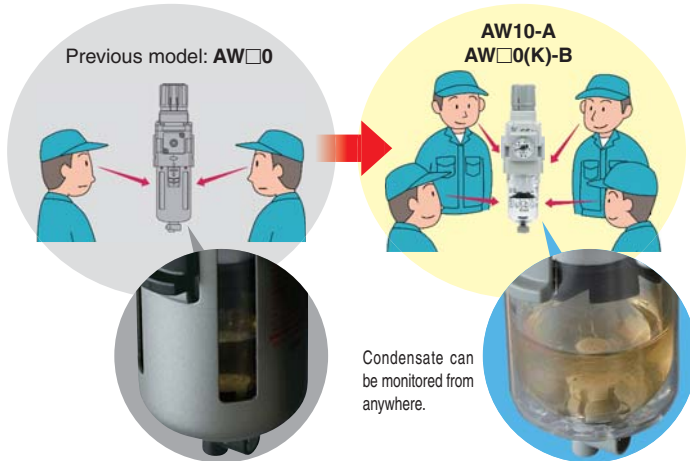

Light weight: Max. 90 g reduction

* Except AW

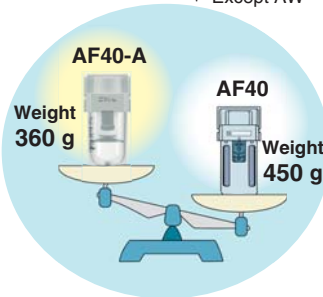

Metal related corrosion does not occur.



New Spacer

Modular connection

Step ①

- Mount the product by lining up the mating surface of the new spacer with bracket.
- Insert the retainer into the spacer bolt and tighten the nut. (temporary assembling)

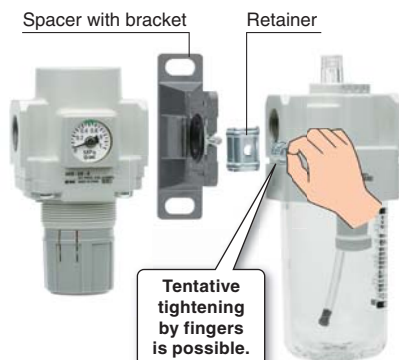

Step ②

- Tighten the nut with the hexagon wrench.

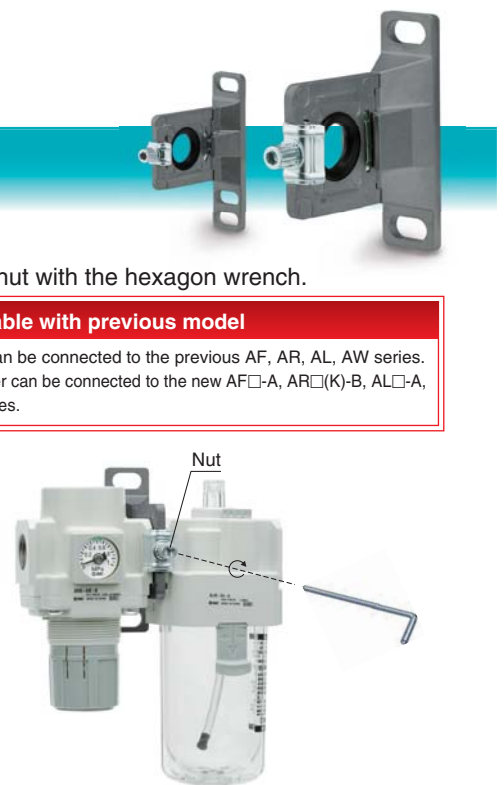

Interchangeable with previous model

- New spacer can be connected to the previous AF, AR, AL, AW series.
- Previous spacer can be connected to the new AF□-A, AR□(K)-B, AL□-A, AW□(K)-B series.



AC Series

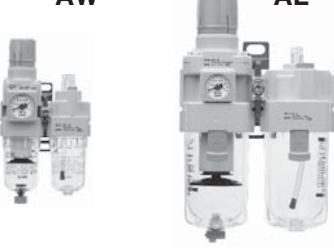

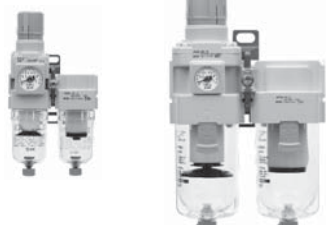

Series Configuration



Product	Model	Port size							INDEX
		M5	1/8	1/4	3/8	1/2	3/4	1	
<p>Air Filter + Regulator + Lubricator</p> <p>AF AR AL</p> 	AC10-A	●							P. 7
	AC20-B		●	●					
	AC25-B			●	●				
	AC30-B			●	●				
	AC40-B			●	●	●			
	AC40-06-B						●		
	AC50-B						●	●	
	AC60-B							●	
<p>Filter Regulator + Lubricator</p> <p>AW AL</p> 	AC10A-A	●						P. 15	
	AC20A-B		●	●					
	AC30A-B			●	●				
	AC40A-B			●	●	●			
	AC40A-06-B						●		
	AC50A-B						●		●
AC60A-B							●		
<p>Air Filter + Regulator</p> <p>AF AR</p> 	AC10B-A	●						P. 21	
	AC20B-B		●	●					
	AC25B-B			●	●				
	AC30B-B			●	●				
	AC40B-B			●	●	●			
	AC40B-06-B						●		
	AC50B-B						●		●
	AC60B-B								●
<p>Air Filter + Mist Separator + Regulator</p> <p>AF AFM AR</p> 	AC20C-B		●	●				P. 27	
	AC25C-B			●	●				
	AC30C-B			●	●				
	AC40C-B			●	●	●			
	AC40C-06-B						●		
<p>Filter Regulator + Mist Separator</p> <p>AW AFM</p> 	AC20D-B		●	●				P. 31	
	AC30D-B			●	●				
	AC40D-B			●	●	●			
	AC40D-06-B						●		

Air Combination

AC
AF+AR+AL
AW+AL
AF+AR
AF+AFM+AR
AW+AFM
Attachment
AF
AFM/AFD
AR
AL
AW

Series Configuration

	Product	Model	Port size						INDEX	
			M5	1/8	1/4	3/8	1/2	3/4		1
Air Filter		AF10-A	●						P. 43	
		AF20-A		●	●					
		AF30-A			●	●				
		AF40-A			●	●	●			
		AF40-06-A						●		
		AF50-A						●		●
		AF60-A								●
Mist Separator		AFM20-A		●	●				P. 55	
		AFM30-A			●	●				
		AFM40-A			●	●	●			
		AFM40-06-A						●		
Micro Mist Separator		AFD20-A		●	●				P. 55	
		AFD30-A			●	●				
		AFD40-A			●	●	●			
		AFD40-06-A						●		
Regulator		AR10-A	●						P.64	
		AR20-B		●	●					
		AR25-B			●	●				
		AR30-B			●	●				
		AR40-B			●	●	●			
		AR40-06-B						●		
		AR50-B						●		●
		AR60-B								●
Regulator with Backflow Function		AR20K-B		●	●				P.67	
		AR25K-B			●	●				
		AR30K-B			●	●				
		AR40K-B			●	●	●			
		AR40K-06-B						●		
		AR50K-B						●		●
		AR60K-B								●

Product	Model	Port size							INDEX
		M5	1/8	1/4	3/8	1/2	3/4	1	
Lubricator 	AL								P. 82
	AL10-A	●							
	AL20-A		●	●					
	AL30-A			●	●				
	AL40-A			●	●	●			
	AL40-06-A						●		
	AL50-A						●	●	
AL60-A							●		
Filter Regulator 	AW								P. 92
	AW10-A	●							
	AW20-B		●	●					
	AW30-B			●	●				
	AW40-B			●	●	●			
	AW40-06-B						●		
AW60-B						●	●		
Filter Regulator with Backflow Function 	AW□K								P. 95
	AW20K-B		●	●					
	AW30K-B			●	●				
	AW40K-B			●	●	●			
	AW40K-06-B						●		
AW60K-B						●	●		

- AC
- AF+AR+AL
- AW+AL
- AF+AR
- AF+AFM+AR
- AW+AFM
- Attachment
- AF
- AFM / AFD
- AR
- AL
- AW

Simple Specials System

A system designed to respond quickly and easily to your special ordering needs



Short lead times

This system enables us to respond to your special needs, such as additional machining, accessory assembly, or modular unit, and deliver such special products as quickly as standard products.

Repeat orders

Once we receive a Simple Special part number from your previous order, we will process the order, manufacture the product, and deliver it to you.

Please contact your local sales representative for more details.

Attachment List

Check valve

Page 34

■ A check valve with intermediate branch port can be easily installed to prevent a backflow of lubricant when branching the air flow and releasing the air on the outlet side of the regulator.

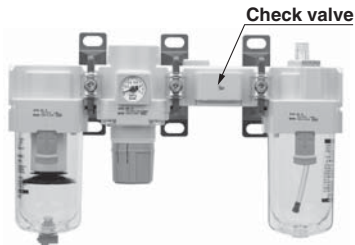

- Applicable series
- Air Filter + Regulator + Lubricator (AC20-B to AC40-B)
 - Filter Regulator + Lubricator (AC20A-B to AC40A-B)
 - * Port size: Except 06

Pressure switch

Page 35

■ A compact integrated pressure switch can be easily installed and facilitates the pressure detection of the line.

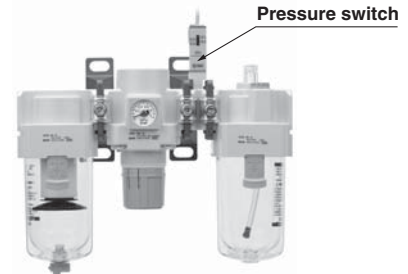

- Applicable series
- Air Filter + Regulator + Lubricator (AC20-B to AC60-B)
 - Filter Regulator + Lubricator (AC20A-B to AC60A-B)
 - Air Filter + Regulator (AC20B-B to AC60B-B)
 - Air Filter + Mist Separator + Regulator (AC20C-B to AC60C-B)
 - Filter Regulator + Mist Separator (AC20D-B to AC60D-B)

T-spacer

Page 35

■ Using a T-shaped spacer facilitates the branching of air flow.

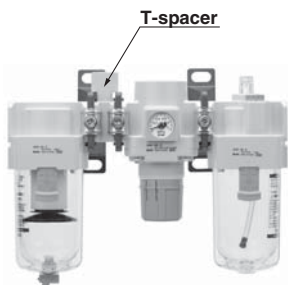

- Applicable series
- Air Filter + Regulator + Lubricator (AC10-A to AC60-B)
 - Air Filter + Regulator (AC10B-A to AC60B-B)
 - Air Filter + Mist Separator + Regulator (AC20C-B to AC40C-B)

Pressure relief 3 port valve

Page 36

■ With the use of a pressure relief 3 port valve, pressure left in the line can be easily exhausted.



- Applicable series
- Air Filter + Regulator + Lubricator (AC20-B to AC50-B)
 - Filter Regulator + Lubricator (AC20A-B to AC50A-B)
 - Air Filter + Regulator (AC20B-B to AC50B-B)
 - Air Filter + Mist Separator + Regulator (AC20C-B to AC40C-B)
 - Filter Regulator + Mist Separator (AC20D-B to AC40D-B)

Cross spacer

Page 36

■ Piping are possible in all 4 directions.

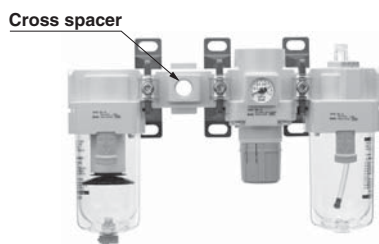

* Needs to be ordered separately.

Piping adapter

Page 37

■ A piping adapter allows installation/removal of the component without removing the piping and thus makes maintenance easier.

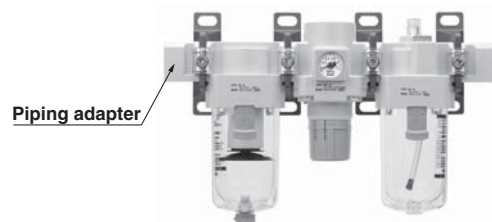

* Needs to be ordered separately.

Pressure switch with piping adapter Page 37

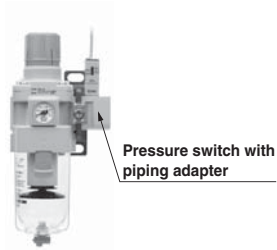

Pressure switch with piping adapter

* Needs to be ordered separately.

Accessories (Spacer/Spacer with bracket) Page 38

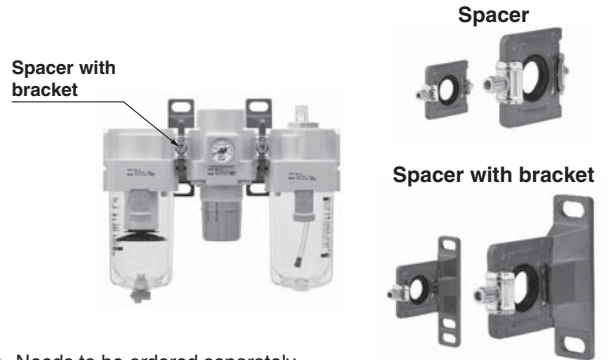

* Needs to be ordered separately.

Made-to-Order List

	Air Filter AF Series	Mist Separator/ Micro Mist Separator AFM/AFD Series	Regulator AR Series	Regulator with Backflow Function AR□K Series	Filter Regulator AW Series	Filter Regulator with Backflow Function AW□K Series
Long bowl (-X64)	● P.51	● P.61			● From P.108	● From P.109
0.4 MPa setting (-X406)			● From P.78	● P.79	● From P.108	● From P.109
With element service indicator (-X2141)	● P.52	● P.62				
High pressure 2.0 MPa (-X425)	● P.53		● P.77		● P.107	
Low temperature -30 to 60 °C (-X430)	● P.53		● P.77		● P.106	
High temperature -5 to 80 °C (-X440)	● P.53		● P.77		● P.106	
Clean series (10-)	● P.54	● P.63	● P.80	● P.80	● P.111	● P.111
Copper, fluorine and silicone-free + Low particle generation (21-)	● P.54	● P.63	● P.80	● P.80	● P.111	● P.111

Related Product

Modular adapter

Easy modular connections for all equipment!

Example) Air filter + 3 port valve

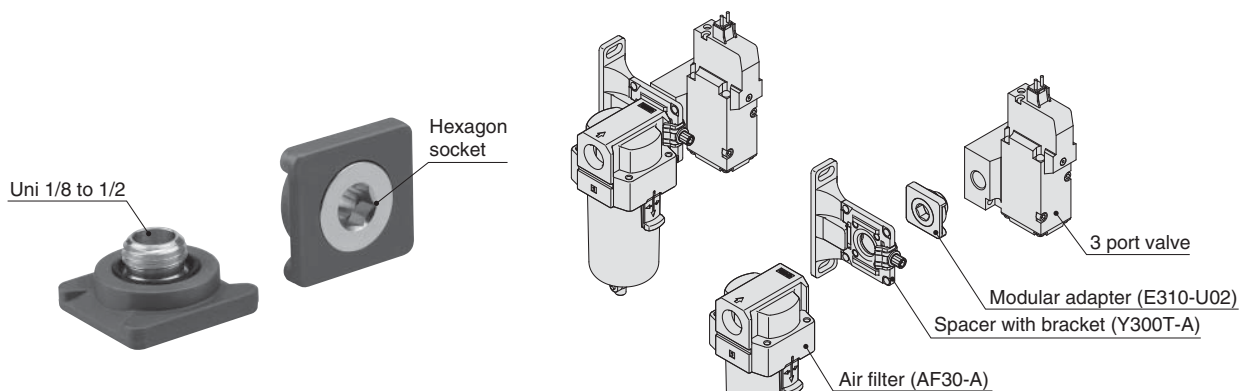

AC
AF+AR+AL
AF+AR
AW+AL
AF+AR
AF+AFM+AR
AW+AFM
Attachment
AF
AFM/AFD
AR
AL
AW

AC10-A

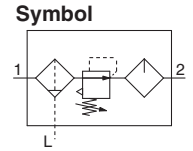

How to Order

Refer to page 9 for size 20 to 60.

AC10-M5 - - - A

1
 2
 3

- Option/Semi-standard: Select one each for **a** to **h**.
- Option/Semi-standard symbol: When more than one specification is required, indicate in alphanumeric order.
Example) AC10-M5CG-T-12NR-A

		Symbol	Description	
1	Option	a	Float type auto drain	— Without auto drain
			C *1 N.C. (Normally closed) Drain port is closed when pressure is not applied.	
		b	Pressure gauge	— Without pressure gauge
				G *2 Round type pressure gauge (without limit indicator)
+				
2	Attachment (T-spacer) *3	— Without attachment		
		T Mounting position: AF+ T +AR+AL		
+				
3	Semi-standard	c	Set pressure *4	— 0.05 to 0.7 MPa setting
			1 0.02 to 0.2 MPa setting	
		+		
		d	Bowl *5	— Polycarbonate bowl
				2 Metal bowl
				6 Nylon bowl
		+		
		e	Lubricator lubricant exhaust port	— Without drain cock
				3 Lubricator with drain cock
		+		
		f	Exhaust mechanism	— Relieving type
				N Non-relieving type
+				
g	Flow direction	— Flow direction: Left to right		
		R Flow direction: Right to left		
+				
h	Pressure unit	— Name plate, caution plate for bowl, and pressure gauge in SI units: MPa		
		Z Name plate, caution plate for bowl, and pressure gauge in imperial units: psi, °F		

*1 When pressure is not applied, condensate which does not start the auto drain mechanism will be left in the bowl. Releasing the residual condensate before ending operations for the day is recommended.

*2 A 1.0 MPa pressure gauge will be fitted. It is not assembled and supplied loose at the time of shipment.

*3 The bracket position varies depending on the T-spacer mounting.

*4 Pressure can be set higher than the specification pressure in some cases, but use pressure within the specification range.

*5 Refer to chemical data on page 46 for chemical resistance of the bowl.



AC10-A

Standard Specifications

Component	Air Filter [AF]	AF10-A
	Regulator [AR]	AR10-A
	Lubricator [AL]	AL10-A
Port size		M5 x 0.8
Pressure gauge port size [AR]		1/16
Fluid		Air
Ambient and fluid temperature		-5 to 60 °C (with no freezing)
Proof pressure		1.5 MPa
Maximum operating pressure		1.0 MPa
Set pressure range [AR]		0.05 to 0.7 MPa
Nominal filtration rating [AF]		5 μm
Recommended lubricant [AL]		Class 1 turbine oil (ISO VG32)
Bowl material [AF/AL]		Polycarbonate
Construction [AR]		Relieving type
Weight [kg]		0.27

⚠ Specific Product Precautions

Be sure to read this before handling the products. Refer to the back cover for safety instructions. For F.R.L. units precautions, refer to the “Handling Precautions for SMC Products” and the “Operation Manual”, <http://www.smc.eu>

Selection

⚠ Caution

1. When releasing air at the intermediate position using a T-spacer on the inlet side of the lubricator, lubricant may back flow. Therefore, releasing air that does not contain traces of lubricant is not possible.
2. An F.R.L. unit shipped from the plant has its model number labelled. However, components that are combined together during the distribution process do not have a label on them.

AC
AF+AR+AL
AW+AL
AF+AR
AF+AFM+AR
AW+AFM
Attachment
AF
AFM / AFD
AR
AL
AW

AC20-B to AC60-B

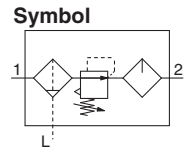

How to Order

Refer to page 7 for size 10.

AC **30** - **03** **DE** - **1** - **6** - B

1
2
3
4
5
6

- Option/Semi-standard: Select one each for **a** to **m**.
- Option/Attachment/Semi-standard symbol: When more than one specification is required, indicate in alphanumeric order. Example) AC30-F03DE1-KSTV-136NR-B

		Symbol	Description	1							
				Body size							
				20	25	30	40	50	55	60	
2	Pipe thread type	—	Rc	●	●	●	●	●	●	●	
		N*1	NPT	●	●	●	●	●	●	●	
		F*2	G	●	●	●	●	●	●	●	
+											
3	Port size	01	1/8	●	—	—	—	—	—	—	
		02	1/4	●	●	●	●	—	—	—	
		03	3/8	—	●	●	●	—	—	—	
		04	1/2	—	—	—	●	—	—	—	
		06	3/4	—	—	—	●	●	—	—	
		10	1	—	—	—	—	●	●	●	
+											
4	a	Float type auto drain	—	Without auto drain	●	●	●	●	●	●	
			C*4	N.C. (Normally closed) Drain port is closed when pressure is not applied.	●	●	●	●	●	●	●
			D*5	N.O. (Normally open) Drain port is open when pressure is not applied.	—	●	●	●	●	●	●
	+										
	b	Pressure gauge *6	—	Without pressure gauge	●	●	●	●	●	●	●
			E	Square embedded type pressure gauge (with limit indicator)	●	●	●	●	●	●	●
			G	Round type pressure gauge (with limit indicator)	●	●	●	●	●	●	●
			M	Round type pressure gauge (with colour zone)	●	●	●	●	●	●	●
		Digital pressure switch	E1	Output: NPN output, Electrical entry: Wiring bottom entry	●	●	●	●	●	●	●
			E2	Output: NPN output, Electrical entry: Wiring top entry	●	●	●	●	●	●	●
E3			Output: PNP output, Electrical entry: Wiring bottom entry	●	●	●	●	●	●	●	
E4	Output: PNP output, Electrical entry: Wiring top entry	●	●	●	●	●	●	●			
+											
5	c	Check valve	—	Without attachment	●	●	●	●	●	●	
			K	Mounting position: AF+AR+K+AL	●	●	●	●*7	—	—	—
	+										
	d	Pressure switch	—	Without attachment	●	●	●	●	●	●	●
			S*8	Mounting position: AF+AR+S+AL	●	●	●	●	●	●	●
	+										
	e	T-spacer	—	Without attachment	●	●	●	●	●	●	●
			T*8	Mounting position: AF+T+AR+AL	●	●	●	●	●	●	●
+											
f	Pressure relief 3 port valve	—	Without attachment	●	●	●	●	●	●	●	
		V	Mounting position: AF+AR+AL+V	●	●	●	●	●	—	—	
+											
6	g	Set pressure *9	—	0.05 to 0.85 MPa setting	●	●	●	●	●	●	●
			1	0.02 to 0.2 MPa setting	●	●	●	●	●	●	●
	+										
	h	Bowl *10	—	Polycarbonate bowl	●	●	●	●	●	●	●
			2	Metal bowl	●	●	●	●	●	●	●
			6	Nylon bowl	●	●	●	●	●	●	●
			8	Metal bowl with level gauge	—	—	—	—	—	—	—
			C	With bowl guard	●	—*11	—*11	—*11	—*11	—*11	—*11
			6C	With bowl guard (Nylon bowl)	●	—*12	—*12	—*12	—*12	—*12	—*12

Air Combination **AC20-B to AC60-B Series**

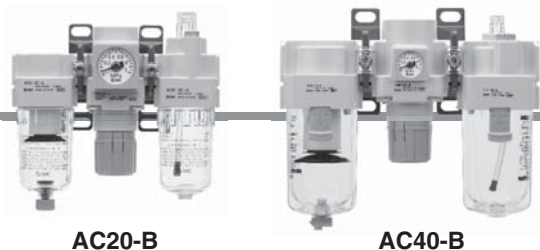

		Symbol	Description	①							
				Body size							
				20	25	30	40	50	55	60	
⑥	i	Air filter drain port *13	—	With drain cock	●	●	●	●	●	●	●
			J*14	Drain guide 1/8	●	—	—	—	—	—	—
				Drain guide 1/4	—	●	●	●	●	●	●
			W*15	Drain cock with barb fitting (for Ø 6 x Ø 4 nylon tube)	—	●	●	●	●	●	●
	+										
	j	Lubricator lubricant exhaust port	—	Without drain cock	●	●	●	●	●	●	●
			3*16	Lubricator with drain cock	●	●	●	●	●	●	●
	+										
	k	Exhaust mechanism	—	Relieving type	●	●	●	●	●	●	●
			N	Non-relieving type	●	●	●	●	●	●	●
+											
l	Flow direction	—	Flow direction: Left to right	●	●	●	●	●	●	●	
		R	Flow direction: Right to left	●	●	●	●	●	●	●	
+											
m	Pressure unit	—	Name plate, caution plate for bowl, and pressure gauge in SI units: MPa	●	●	●	●	●	●	●	
		Z*17	Name plate, caution plate for bowl, and pressure gauge in imperial units: psi, °F	○*19	○*19	○*19	○*19	○*19	○*19	○*19	
		ZA*18	Digital pressure switch: With unit selection function	△*20	△*20	△*20	△*20	△*20	△*20	△*20	

- *1 Drain guide is NPT 1/8 (applicable to the AC20-B) and NPT 1/4 (applicable to the AC25-B to AC60-B).
The auto drain port comes with Ø 3/8" One-touch fitting (applicable to the AC25-B to AC60-B).
- *2 Drain guide is G 1/8 (applicable to the AC20-B) and G 1/4 (applicable to the AC25-B to AC60-B).
- *3 Options G, M are not assembled and supplied loose at the time of shipment.
- *4 When pressure is not applied, condensate which does not start the auto drain mechanism will be left in the bowl. Releasing the residual condensate before ending operations for the day is recommended.
- *5 If the compressor is small (0.75 kW, discharge flow is less than 100 l/min[ANR]), air leakage from the drain cock may occur during start of operations. N.C. type is recommended.
- *6 When the pressure gauge is attached, a 1.0 MPa

- pressure gauge will be fitted for standard (0.85 MPa) type. 0.4 MPa pressure gauge for 0.2 MPa type.
- *7 Not available with piping port size: 06
- *8 The bracket position varies depending on the T-spacer or pressure switch mounting.
- *9 Pressure can be set higher than the specification pressure in some cases, but use pressure within the specification range.
- *10 Refer to chemical data on page 46 for chemical resistance of the bowl.
- *11 A bowl guard is provided as standard equipment (polycarbonate).
- *12 A bowl guard is provided as standard equipment (nylon).
- *13 The combination of float type auto drain: C and D is not available.
- *14 Without a valve function

- *15 The combination of metal bowl: 2 and 8 is not available.
- *16 When choosing with W: Filter drain port, the drain cock of a lubricator will be with barb fittings.
- *17 For pipe thread type: NPT.
Cannot be used with M: Round type pressure gauge (with colour zone). Available by request for special.
The digital pressure switch will be equipped with the unit selection function, setting to psi initially.
- *18 For options: E1, E2, E3, E4.
- *19 ○: For pipe thread type: NPT only
- *20 △: Select with options: E1, E2, E3, E4.

Standard Specifications

Model		AC20-B	AC25-B	AC30-B	AC40-B	AC40-06-B	AC50-B	AC55-B	AC60-B
Component	Air Filter [AF]	AF20-A	AF30-A	AF30-A	AF40-A	AF40-06-A	AF50-A	AF60-A	AF60-A
	Regulator [AR]	AR20-B	AR25-B	AR30-B	AR40-B	AR40-06-B	AR50-B	AR50-B	AR60-B
	Lubricator [AL]	AL20-A	AL30-A	AL30-A	AL40-A	AL40-06-A	AL50-A	AL60-A	AL60-A
Port size		1/8, 1/4	1/4, 3/8	1/4, 3/8	1/4, 3/8, 1/2	3/4	3/4, 1	1	1
Pressure gauge port size [AR] *1		1/8							
Fluid		Air							
Ambient and fluid temperature *2		-5 to 60 °C (with no freezing)							
Proof pressure		1.5 MPa							
Maximum operating pressure		1.0 MPa							
Set pressure range [AR]		0.05 to 0.85 MPa							
Nominal filtration rating [AF]		5 µm							
Recommended lubricant [AL]		Class 1 turbine oil (ISO VG32)							
Bowl material [AF/AL]		Polycarbonate							
Bowl guard [AF/AL]		Semi-standard (Steel)		Standard (Polycarbonate)					
Construction [AR]		Relieving type							
Weight [kg]		0.39	0.70	0.78	1.39	1.53	3.43	3.71	3.76

- *1 Pressure gauge connection threads are not available for F.R.L. unit with a square embedded type pressure gauge or with a digital pressure switch.
- *2 -5 to 50 °C for the products with the digital pressure switch.

AC
 AF+AR+AL
 AW+AL
 AF+AR
 AF+AFM+AR
 AW+AFM
 Attachment
 AF
 AFM/AFD
 AR
 AL
 AW

AC10-A Series

AC20-B to AC60-B Series

Flow Rate Characteristics (Representative values)

Condition: Inlet pressure of 0.7 MPa

AC10-A M5 x 0.8

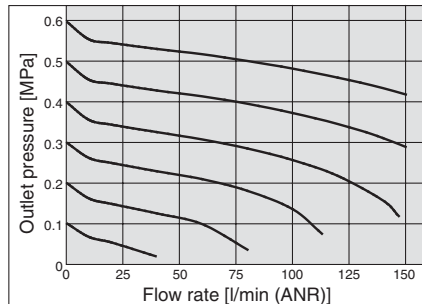

AC20-B Rc 1/4

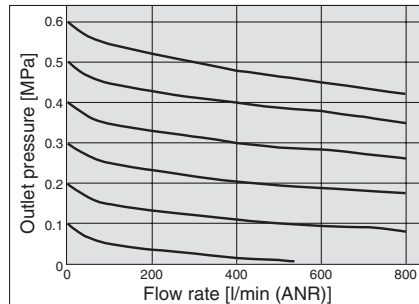

AC25-B Rc 3/8

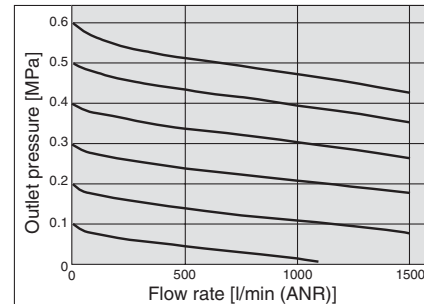

AC30-B Rc 3/8

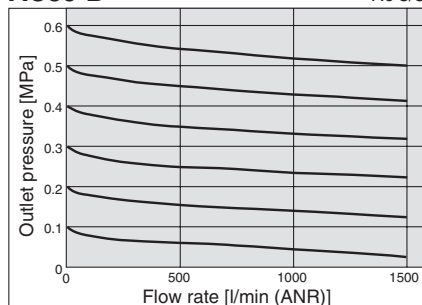

AC40-B Rc 1/2

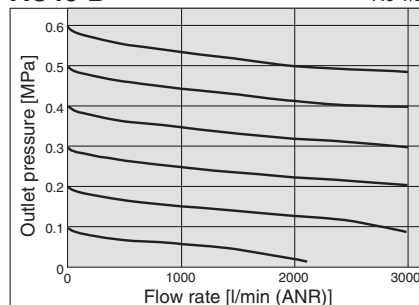

AC40-06-B Rc 3/4

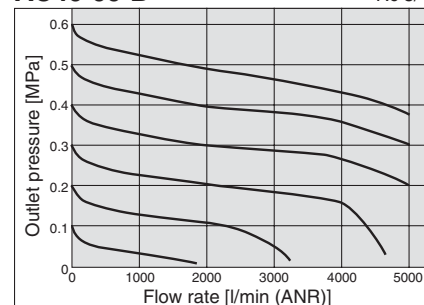

AC50-B Rc 1

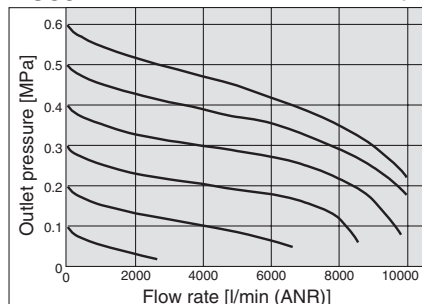

AC55-B Rc 1

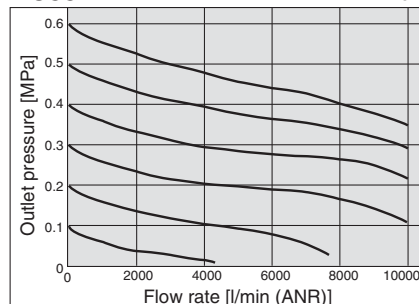

AC60-B Rc 1

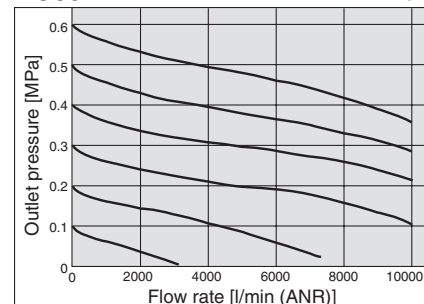

Pressure Characteristics (Representative values)

Conditions: Inlet pressure of 0.7 MPa, Outlet pressure of 0.2 MPa, Flow rate 20 l/min (ANR)

AC10-A

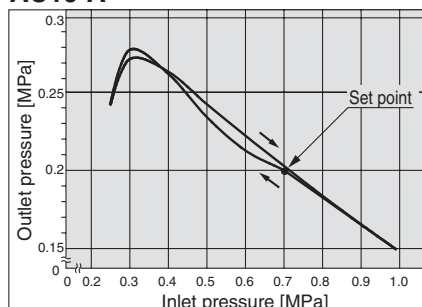

AC20-B

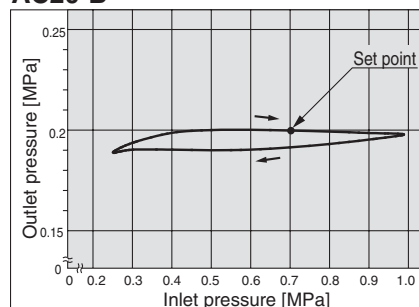

AC25-B

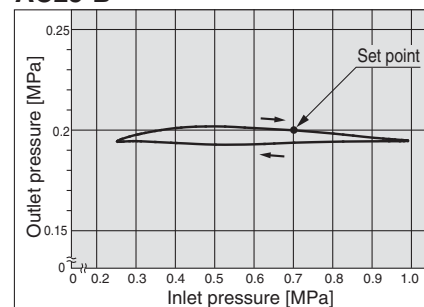

AC30-B

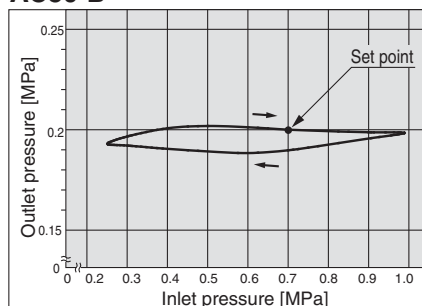

AC40-B

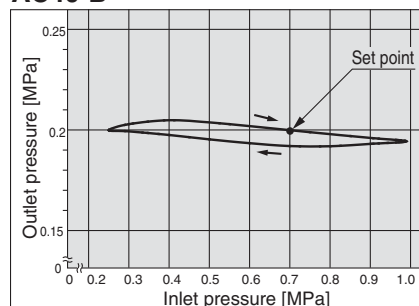

AC40-06-B

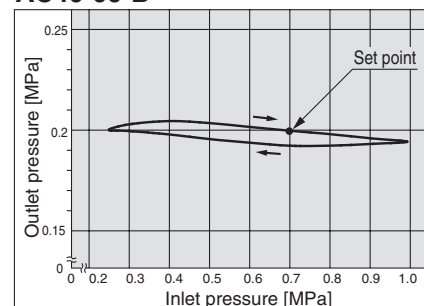

Air Combination **AC10-A Series**

Air Combination **AC20-B to AC60-B Series**

Pressure Characteristics (Representative values)

Conditions: Inlet pressure of 0.7 MPa, Outlet pressure of 0.2 MPa, Flow rate 20 l/min (ANR)

AC50-B

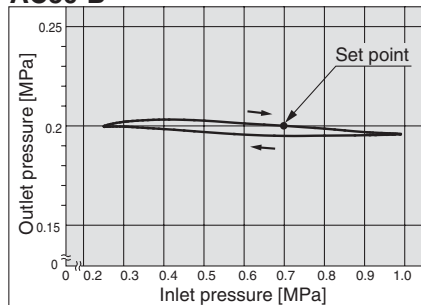

AC55-B

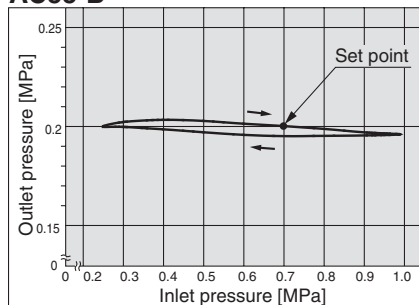

AC60-B

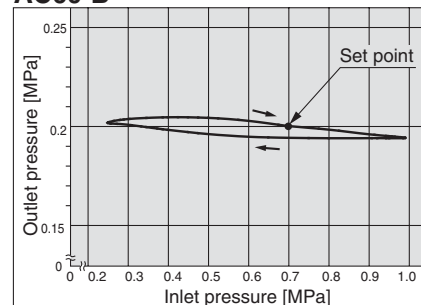

⚠ Specific Product Precautions

Be sure to read this before handling the products. Refer to the back cover for safety instructions. For F.R.L. units precautions, refer to the "Handling Precautions for SMC Products" and the "Operation Manual", <http://www.smc.eu>

Mounting/Adjustment

⚠ Caution

1. A knob cover is available to prevent careless operation of the knob. Refer to page 112 for details.

Piping

⚠ Warning

1. When mounting a check valve, make sure the arrow (IN side) points in the correct direction of air flow.

Air Supply

⚠ Caution

1. Use an air filter with 5 μm or less filtration rating on the inlet side of the valve to avoid any damage to the seat caused by dust when mounting a pressure relief 3 port valve on the inlet side.

Mounting/Adjustment

⚠ Caution

1. When the bowl is installed on the air filter, filter regulator, lubricator, mist separator, or micro mist separator (AC25-B to AC60-B), install them so that the lock button lines up to the groove of the front (or the back) of the body to avoid drop or damage of the bowl.



Selection

⚠ Warning

1. Float type auto drain
 - Operate under the following conditions to avoid malfunction.
 - <N.O. type>
 - Operating compressor: 0.75 kW (100 l/min (ANR)) or more.
 - When using 2 or more auto drains, multiply the value above by the number of auto drains to find the capacity of the compressors you will need.
 - For example, when using 2 auto drains, 1.5 kW (200 l/min (ANR)) of the compressor capacity is required.
 - Operating pressure: 0.1 MPa or more
- <N.C. type>
 - Operating pressure for AD27-A: 0.1 MPa or more
 - Operating pressure for AD37-A/AD47-A: 0.15 MPa or more
2. Use a regulator or filter regulator with backflow function when mounting a pressure release 3 port valve on the inlet side to ensure the release of the residual pressure. Otherwise, residual pressure will not be fully released.

⚠ Caution

1. When releasing air at the intermediate position using a T-spacer on the inlet side of the lubricator, lubricant may back flow. Therefore, releasing air that does not contain traces of lubricant is not possible.
 - To release air that does not contain traces of lubricant, use a check valve (AKM series) on the inlet side of the lubricator to prevent a backflow of the lubricant.
2. If a pressure relief 3 port valve is mounted on the inlet side of the lubricator, causing a backflow of air, it can result in a backflow of oil or damage to internal parts. Do not use it in this fashion.
3. An F.R.L. unit shipped from the plant has its model number labeled. However, components that are combined together during the distribution process do not have a label on them.

AC
AF+AR+AL
AW+AL
AF+AR
AF+AFM+AR
AW+AFM
Attachment
AF
AFM/AFD
AR
AL
AW

AC10-A Series

AC20-B to AC60-B Series

Dimensions

AC10-A

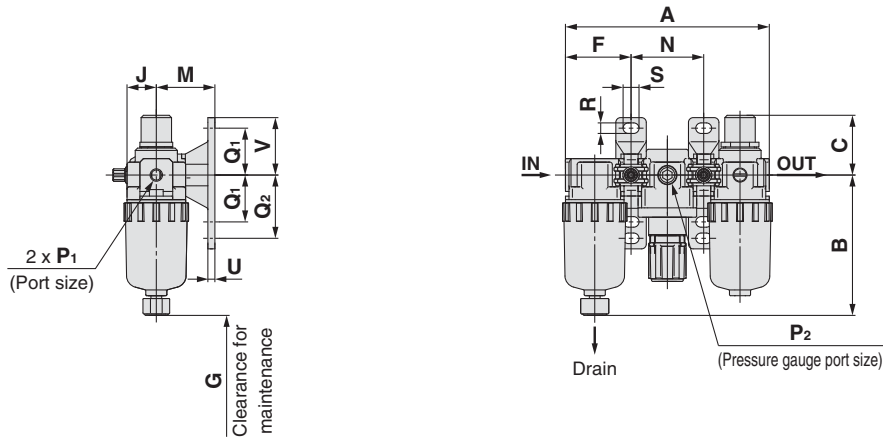

AC20-B

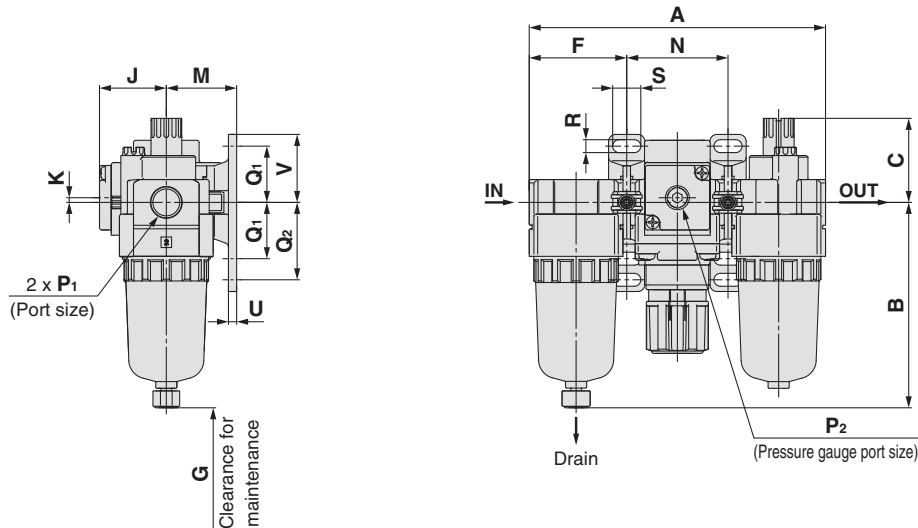

AC25-B to AC60-B

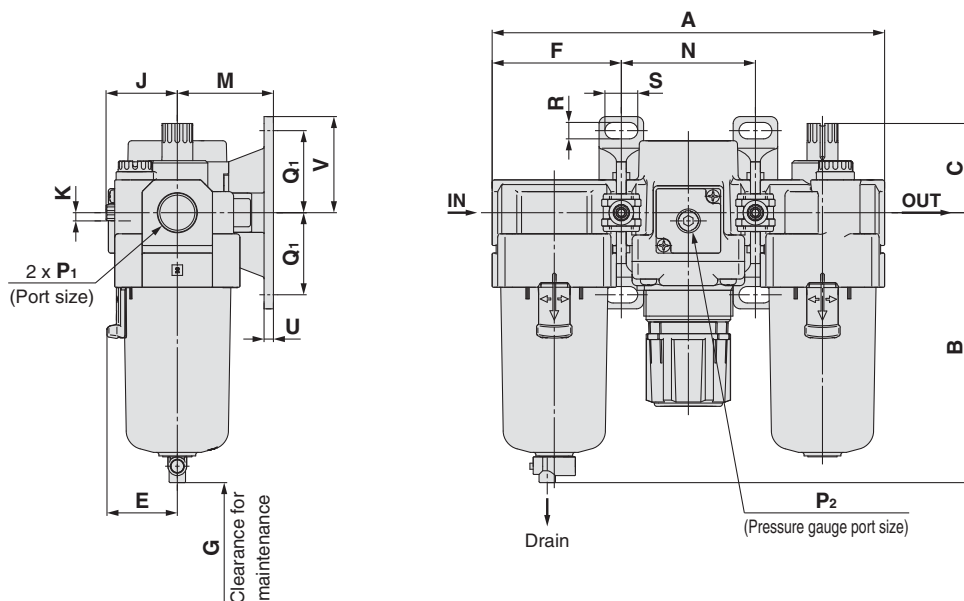

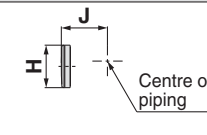
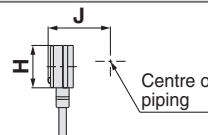
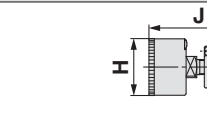
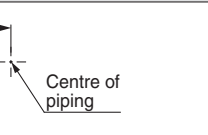

Air Combination **AC10-A Series**

Air Combination **AC20-B to AC60-B Series**

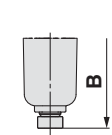
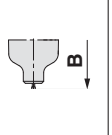
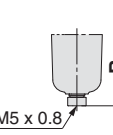
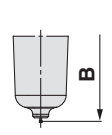
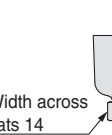
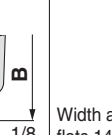
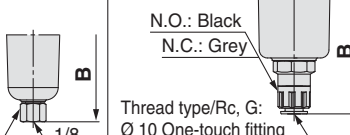
Option	Square embedded type pressure gauge	Digital pressure switch	Round type pressure gauge	Round type pressure gauge (with colour zone)
Dimensions				

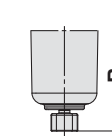
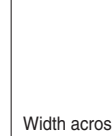
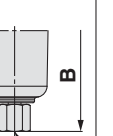
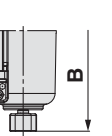
Applicable model	AC10-A		AC20-B				AC25-B to AC60-B
	With auto drain	Metal bowl	With auto drain	Metal bowl	With drain guide	Metal bowl with drain guide	With auto drain (N.O./N.C.)
Dimensions							

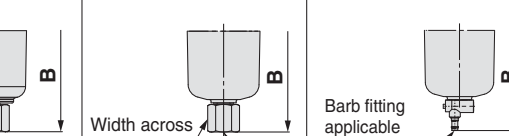
Applicable model	AC25-B to AC60-B					
	Metal bowl	Metal bowl with drain guide	Metal bowl with level gauge	Metal bowl with level gauge, with drain guide	With drain guide	Drain cock with barb fitting
Dimensions						

Model	Standard specifications																	
	P ₁	P ₂	A	B	C	E	F	G	J	K	Bracket mount							
											M	N	Q ₁	Q ₂	R	S	U	V
AC10-A	M5 x 0.8	1/16	87	59.9	25.5	—	28	35	12.5	—	25	31	20	27	4.5	6.8	3	24.5
AC20-B	1/8, 1/4	1/8	126.4	87.6	35.9	—	41.6	60	28.5	2 * ¹	30	43.2	24	33	5.5	12	3.5	29
AC25-B	1/4, 3/8	1/8	167.4	115.1	38.1	30	55.1	80	27.5	0	41	57.2	35	—	7	14	4	41
AC30-B	1/4, 3/8	1/8	167.4	115.1	38.1	30	55.1	80	29.4	3.5	41	57.2	35	—	7	14	4	41
AC40-B	1/4, 3/8, 1/2	1/8	220.4	147.1	39.8	38.4	72.6	110	33.8	3.5	50	75.2	40	—	9	18	5	48
AC40-06-B	3/4	1/8	235.4	149.1	37.8	38.4	77.6	110	33.8	3	50	80.2	40	—	9	18	5	48
AC50-B	3/4, 1	1/8	282.4	220.1	41.2	—	93.1	110	43.3	3.2	70	96.2	50	—	11	20	6	60
AC55-B	1	1/8	292.4	234.1	44.7	—	98.1	110	43.3	3.2	70	96.2	50	—	11	20	6	60
AC60-B	1	1/8	297.4	234.1	44.7	—	98.1	110	43.3	3.2	70	101.2	50	—	11	20	6	60

Model	Optional specifications								Semi-standard specifications							
	Square embedded type pressure gauge		Digital pressure switch		Round type pressure gauge		Round type pressure gauge (with colour zone)		With auto drain	With barb fitting	With drain guide	Metal bowl	Metal bowl with drain guide	Metal bowl with level gauge	Metal bowl with level gauge, with drain guide	
	H	J	H	J	H	J	H	J	B	B	B	B	B	B	B	
AC10-A	—	—	—	—	∅ 26	26	—	—	77.9	—	—	59.3	—	—	—	
AC20-B	∅28	29.5	∅27.8	40	∅ 37.5	65	∅ 37.5	66	104.9	—	91.4	87.4	93.9	—	—	
AC25-B	∅28	28.5	∅27.8	39	∅ 37.5	64	∅ 37.5	65	156.8	123.6	121.9	117.6	122.1	137.6	142.1	
AC30-B	∅28	30.4	∅27.8	40.9	∅ 37.5	65.9	∅ 37.5	66.9	156.8	123.6	121.9	117.6	122.1	137.6	142.1	
AC40-B	∅28	34.8	∅27.8	45.3	∅ 42.5	71.3	∅ 42.5	71.3	186.9	155.6	153.9	149.6	154.1	169.6	174.1	
AC40-06-B	∅28	34.8	∅27.8	45.3	∅ 42.5	71.3	∅ 42.5	71.3	188.9	157.6	155.9	151.6	156.1	171.6	176.1	
AC50-B	∅28	44.3	∅27.8	54.8	∅ 42.5	80.8	∅ 42.5	80.8	259.9	228.6	226.9	222.6	227.1	242.6	247.1	
AC55-B	∅28	44.3	∅27.8	54.8	∅ 42.5	80.8	∅ 42.5	80.8	273.9	242.6	240.9	236.6	241.1	256.6	261.1	
AC60-B	∅28	44.3	∅27.8	54.8	∅ 42.5	80.8	∅ 42.5	80.8	273.9	242.6	240.9	236.6	241.1	256.6	261.1	

*1 For the AC20-B only, the position of the pressure gauge is above the centre of the piping.

AC
 AF+AR+AL
 AW+AL
 AF+AR
 AF+AFM+AR
 AW+AFM
 Attachment
 AF
 AFM / AFD
 AR
 AL
 AW

AC10A-A

Symbol

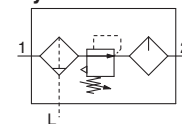

How to Order

Refer to page 17 for size 20 to 60.

AC10A-M5 - - - A

1
 2
 3

- Option/Semi-standard: Select one each for **a** to **h**.
- Option/Semi-standard symbol: When more than one specification is required, indicate in alphanumeric order.
Example) AC10-M5CG-T-12NR-A

		Symbol	Description		
1	Option	a	Float type auto drain	— Without auto drain	
			C *1 N.C. (Normally closed) Drain port is closed when pressure is not applied.		
		b	Pressure gauge	— Without pressure gauge	
			G *2 Round type pressure gauge (without limit indicator)		
+					
2	Attachment (T-spacer) *3	—	Without attachment		
		T	Mounting position: AW+ T +AL		
+					
3	Semi-standard	c	Set pressure *4	— 0.05 to 0.7 MPa setting	
			1 0.02 to 0.2 MPa setting		
		+			
		d	Bowl *5	— Polycarbonate bowl	
			2 Metal bowl		
			6 Nylon bowl		
		+			
		e	Lubricator lubricant exhaust port	— Without drain cock	
			3 Lubricator with drain cock		
		+			
		f	Exhaust mechanism	— Relieving type	
			N Non-relieving type		
+					
g	Flow direction	— Flow direction: Left to right			
	R Flow direction: Right to left				
+					
h	Pressure unit	— Name plate, caution plate for bowl, and pressure gauge in SI units: MPa			
	Z Name plate, caution plate for bowl, and pressure gauge in imperial units: psi, °F				

*1 When pressure is not applied, condensate which does not start the auto drain mechanism will be left in the bowl.

Releasing the residual condensate before ending operations for the day is recommended.

*2 A 1.0 MPa pressure gauge will be fitted. It is not assembled and supplied loose at the time of shipment.

*3 The bracket position varies depending on the T-spacer mounting.

*4 Pressure can be set higher than the specification pressure in some cases, but use pressure within the specification range.

*5 Refer to chemical data on page 46 for chemical resistance of the bowl.



AC10A-A

Standard Specifications

Component	Filter Regulator [AW]	AW10-A
	Lubricator [AL]	AL10-A
Port size		M5 x 0.8
Pressure gauge port size [AW]		1/16
Fluid		Air
Ambient and fluid temperature		-5 to 60 °C (with no freezing)
Proof pressure		1.5 MPa
Maximum operating pressure		1.0 MPa
Set pressure range [AW]		0.05 to 0.7 MPa
Nominal filtration rating [AW]		5 μm
Recommended lubricant [AL]		Class 1 turbine oil (ISO VG32)
Bowl material [AW/AL]		Polycarbonate
Construction [AW]		Relieving type
Weight [kg]		0.2

AC
AF+AR+AL
AW+AL
AF+AR
AF+AFM+AR
AW+AFM
Attachment
AF
AFM / AFD
AR
AL
AW

AC20A-B to AC60A-B

Symbol

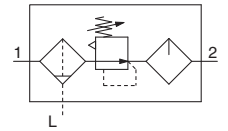

How to Order

Refer to page 15 for size 10.

AC **30** A- **03** **DE** - - - B

1
2
3
4
5
6

- Option/Semi-standard: Select one each for a to l.
- Option/Attachment/Semi-standard symbol: When more than one specification is required, indicate in alphanumeric order.
Example) AC30A-F03DE1-KSV-136NR-B

		Symbol	Description	1					
				Body size					
				20	30	40	50	60	
2	Pipe thread type	—	Rc	●	●	●	●	●	
		N*1	NPT	●	●	●	●	●	
		F*2	G	●	●	●	●	●	
+									
3	Port size	01	1/8	●	—	—	—	—	
		02	1/4	●	●	●	—	—	
		03	3/8	—	●	●	—	—	
		04	1/2	—	—	●	—	—	
		06	3/4	—	—	●	●	—	
		10	1	—	—	—	●	●	
+									
4	a	Float type auto drain	—	Without auto drain	●	●	●	●	●
			C*4	N.C. (Normally closed) Drain port is closed when pressure is not applied.	●	●	●	●	●
			D*5	N.O. (Normally open) Drain port is open when pressure is not applied.	—	●	●	●	●
	+								
	b	Pressure gauge *6	—	Without pressure gauge	●	●	●	●	●
			E	Square embedded type pressure gauge (with limit indicator)	●	●	●	●	●
			G	Round type pressure gauge (with limit indicator)	●	●	●	●	●
			M	Round type pressure gauge (with colour zone)	●	●	●	●	●
		Digital pressure switch	E1	Output: NPN output, Electrical entry: Wiring bottom entry	●	●	●	●	●
			E2	Output: NPN output, Electrical entry: Wiring top entry	●	●	●	●	●
	+								
	5	c	Check valve	—	Without attachment	●	●	●	●
K				Mounting position: AW+K+AL	●	●	●*7	—	—
+									
d		Pressure switch	—	Without attachment	●	●	●	●	●
			S*8	Mounting position: AW+S+AL	●	●	●	●	●
+									
e	Pressure relief 3 port valve	—	Without attachment	●	●	●	●	●	
		V	Mounting position: AW+AL+V	●	●	●	●	—	
+									
6	f	Set pressure *9	—	0.05 to 0.85 MPa setting	●	●	●	●	●
			1	0.02 to 0.2 MPa setting	●	●	●	●	●
	+								
	g	Bowl *10	—	Polycarbonate bowl	●	●	●	●	●
			2	Metal bowl	●	●	●	●	●
			6	Nylon bowl	●	●	●	●	●
			8	Metal bowl with level gauge	—	●	●	●	●
			C	With bowl guard	●	—*11	—*11	—*11	—*11
			6C	With bowl guard (Nylon bowl)	●	—*12	—*12	—*12	—*12
	+								
	h	Filter regulator drain port *13	—	With drain cock	●	●	●	●	●
			J*14	Drain guide 1/8	●	—	—	—	—
J*14			Drain guide 1/4	—	●	●	●	●	
W*15			Drain cock with barb fitting: For Ø 6 x Ø 4 nylon tube	—	●	●	●	●	

Air Combination **AC20A-B to AC60A-B Series**

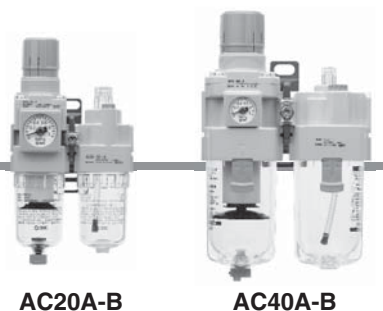

AC20A-B

AC40A-B

		Symbol	Description	① Body size					
				20	30	40	50	60	
⑥	Semi-standard	i	—	Without drain cock	●	●	●	●	●
			3*16	Lubricator with drain cock	●	●	●	●	●
		j	—	Relieving type	●	●	●	●	●
			N	Non-relieving type	●	●	●	●	●
	k	—	Flow direction: Left to right	●	●	●	●	●	
		R	Flow direction: Right to left	●	●	●	●	●	
	l	—	Name plate, caution plate for bowl, and pressure gauge in SI units: MPa	●	●	●	●	●	
		Z*17	Name plate, caution plate for bowl, and pressure gauge in imperial units: psi, °F	○*19	○*19	○*19	○*19	○*19	
		ZA*18	Digital pressure switch: With unit selection function	△*20	△*20	△*20	△*20	△*20	

*1 Drain guide is NPT 1/8 (applicable to the AC20A-B) and NPT 1/4 (applicable to the AC30A-B to AC60A-B).

The auto drain port comes with Ø 3/8" One-touch fitting (applicable to the AC30A-B to AC60A-B).

*2 Drain guide is G 1/8 (applicable to the AC20A-B) and G 1/4 (applicable to the AC30A-B to AC60A-B).

*3 Options G, M are not assembled and supplied loose at the time of shipment.

*4 When pressure is not applied, condensate which does not start the auto drain mechanism will be left in the bowl. Releasing the residual condensate before ending operations for the day is recommended.

*5 If the compressor is small (0.75 kW, discharge flow is less than 100 l/min[ANR]), air leakage from the drain cock may occur during start of operations. N.C. type is recommended.

*6 When the pressure gauge is attached, a 1.0 MPa

pressure gauge will be fitted for standard (0.85 MPa) type. 0.4 MPa pressure gauge for 0.2 MPa type.

*7 Not available with piping port size: 06

*8 The bracket position varies depending on the pressure switch mounting.

*9 Pressure can be set higher than the specification pressure in some cases, but use pressure within the specification range.

*10 Refer to chemical data on page 46 for chemical resistance of the bowl.

*11 A bowl guard is provided as standard equipment (polycarbonate).

*12 A bowl guard is provided as standard equipment (nylon).

*13 The combination of float type auto drain: C and D is not available.

*14 Without a valve function

*15 The combination of metal bowl: 2 and 8 is not available.

*16 When choosing with W: Filter drain port, the drain cock of a lubricator will be with barb fittings.

*17 For pipe thread type: NPT.

Cannot be used with M: Round type pressure gauge (with colour zone). Available by request for special. The digital pressure switch will be equipped with the unit selection function, setting to psi initially.

*18 For options: E1, E2, E3, E4.

*19 ○: For pipe thread type: NPT only

*20 △: Select with options: E1, E2, E3, E4.

Standard Specifications

Model		AC20A-B	AC30A-B	AC40A-B	AC40A-06-B	AC50A-B	AC60A-B
Component	Filter Regulator [AW]	AW20-B	AW30-B	AW40-B	AW40-06-B	AW60-B	AW60-B
	Lubricator [AL]	AL20-A	AL30-A	AL40-A	AL40-06-A	AL50-A	AL60-A
Port size		1/8, 1/4	1/4, 3/8	1/4, 3/8, 1/2	3/4	3/4, 1	1
Pressure gauge port size [AW] *1		1/8					
Fluid		Air					
Ambient and fluid temperature *2		-5 to 60 °C (with no freezing)					
Proof pressure		1.5 MPa					
Maximum operating pressure		1.0 MPa					
Set pressure range [AW]		0.05 to 0.85 MPa					
Nominal filtration rating [AW]		5 µm					
Recommended lubricant [AL]		Class 1 turbine oil (ISO VG32)					
Bowl material [AW/AL]		Polycarbonate					
Bowl guard [AW/AL]		Semi-standard (Steel)	Standard (Polycarbonate)				
Construction [AW]		Relieving type					
Weight [kg]		0.33	0.63	1.15	1.25	3.21	3.36

*1 Pressure gauge connection threads are not available for F.R.L. unit with a square embedded type pressure gauge or with a digital pressure switch.

*2 -5 to 50 °C for the products with the digital pressure switch.

AC
AF+AR+AL
AW+AL
AF+AR
AF+AFM+AR
AF+AFM
AW+AFM
Attachment
AF
AFM/AFD
AR
AL
AW

AC10A-A Series

AC20A-B to AC60A-B Series

Dimensions

AC10A-A

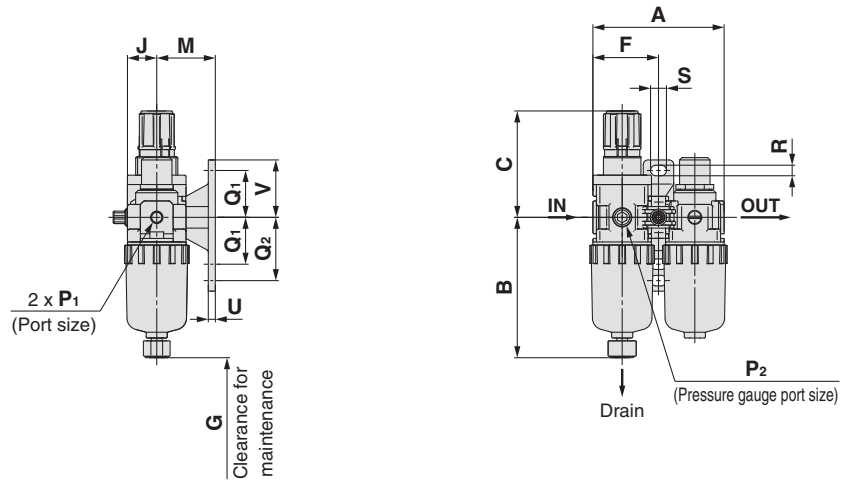

AC20A-B

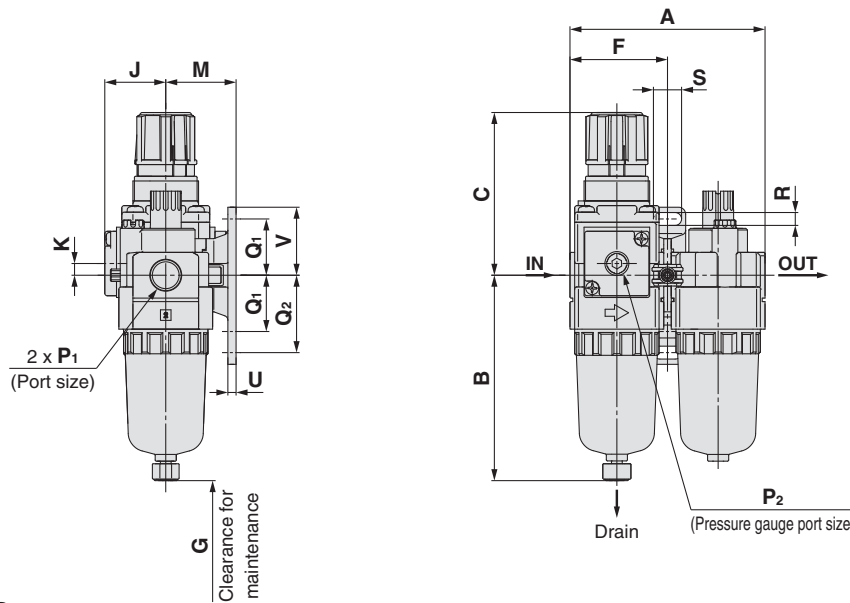



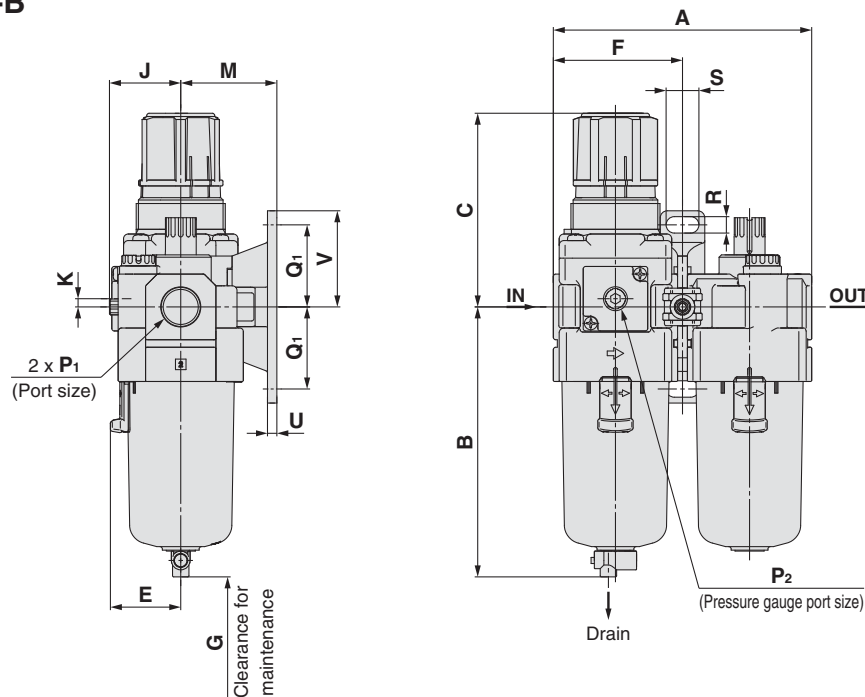

AC30A-B to AC60A-B

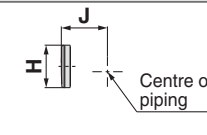
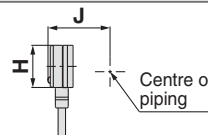
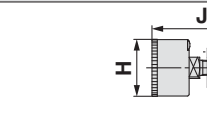
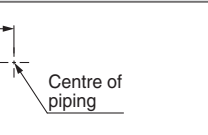

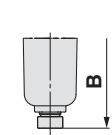
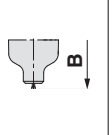
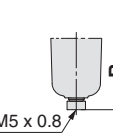
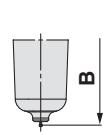
Air Combination **AC10A-A Series** Air Combination **AC20A-B to AC60A-B Series**

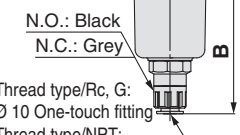
Option	Square embedded type pressure gauge	Digital pressure switch	Round type pressure gauge	Round type pressure gauge (with colour zone)
Dimensions				

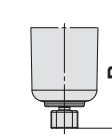
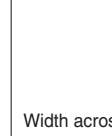
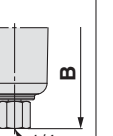
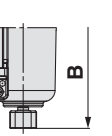
Applicable model	AC10A-A		AC20A-B				AC30A-B to AC60A-B	
Optional/Semi-standard specifications	With auto drain	Metal bowl	With auto drain	Metal bowl	With drain guide	Metal bowl with drain guide	With auto drain (N.O./N.C.)	
Dimensions							 N.O.: Black N.C.: Grey Thread type/Rc, G: Ø 10 One-touch fitting Thread type/NPT: Ø 3/8" One-touch fitting	

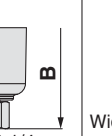
Applicable model	AC30A-B to AC60A-B					
Optional/Semi-standard specifications	Metal bowl	Metal bowl with drain guide	Metal bowl with level gauge	Metal bowl with level gauge, with drain guide	With drain guide	Drain cock with barb fitting
Dimensions						

Model	Standard specifications																
	P ₁	P ₂	A	B	C*1	E	F	G	J	K	Bracket mount						
											M	Q ₁	Q ₂	R	S	U	V
AC10A-A	M5 x 0.8	1/16	56	59.9	47.4	—	28	25	12.5	—	25	20	27	4.5	6.8	3	24.5
AC20A-B	1/8, 1/4	1/8	83.2	87.6	72.4	—	41.6	60	28.5	5	30	24	33	5.5	12	3.5	29
AC30A-B	1/4, 3/8	1/8	110.2	115.1	85.6	30	55.1	80	29.4	3.5	41	35	—	7	14	4	41
AC40A-B	1/4, 3/8, 1/2	1/8	145.2	147.1	91.7	38.4	72.6	110	33.8	1.5	50	40	—	9	18	5	48
AC40A-06-B	3/4	1/8	155.2	149.1	93.2	38.4	77.6	110	33.8	1.2	50	40	—	9	18	5	48
AC50A-B	3/4, 1	1/8	191.2	220.1	175.5	—	93.1	110	43.3	3.2	70	50	—	11	20	6	60
AC60A-B	1	1/8	196.2	234.1	175.5	—	98.1	110	43.3	3.2	70	50	—	11	20	6	60

Model	Optional specifications								Semi-standard specifications							
	Square embedded type pressure gauge		Digital pressure switch		Round type pressure gauge		Round type pressure gauge (with colour zone)		With auto drain	With barb fitting	With drain guide	Metal bowl	Metal bowl with drain guide	Metal bowl with level gauge	Metal bowl with level gauge, with drain guide	
	H	J	H	J	H	J	H	J	B	B	B	B	B	B	B	
AC10A-A	—	—	—	—	Ø 26	26	—	—	77.9	—	—	59.3	—	—	—	
AC20A-B	□28	27	□27.8	37.5	Ø 37.5	62.5	Ø 37.5	63.5	104.9	—	91.4	87.4	93.9	—	—	
AC30A-B	□28	30	□27.8	40.9	Ø 37.5	66.9	Ø 37.5	67.9	156.8	123.6	121.9	117.6	122.1	137.6	142.1	
AC40A-B	□28	38.4	□27.8	48.8	Ø 42.5	75.7	Ø 42.5	75.7	186.9	155.6	153.9	149.6	154.1	169.6	174.1	
AC40A-06-B	□28	38.4	□27.8	48.8	Ø 42.5	75.7	Ø 42.5	75.7	188.9	157.6	155.9	151.6	156.1	171.6	176.1	
AC50A-B	□28	44.3	□27.8	61.3	Ø 42.5	80.8	Ø 42.5	80.8	259.9	228.6	226.9	222.6	227.1	242.6	247.1	
AC60A-B	□28	44.3	□27.8	61.3	Ø 42.5	80.8	Ø 42.5	80.8	273.9	242.6	240.9	236.6	241.1	256.6	261.1	

*1 The dimension of C is the length when the filter regulator knob is unlocked.

AC
 AF+AR+AL
 AW+AL
 AF+AR
 AF+AFM+AR
 AW+AFM
 Attachment
 AF
 AFM / AFD
 AR
 AL
 AW

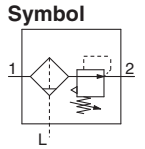

How to Order

Refer to page 23 for size 20 to 60.

AC10B-M5 - - - A

1
 2
 3

- Option/Semi-standard: Select one each for a to g.
- Option/Semi-standard symbol: When more than one specification is required, indicate in alphanumeric order.
Example) AC10B-M5CG-T-12NR-A

		Symbol	Description
1	Option	a	Float type auto drain
			Without auto drain
		b	Pressure gauge
			Without pressure gauge
		+	
		C* ¹	N.C. (Normally closed) Drain port is closed when pressure is not applied.
		G* ²	Round type pressure gauge (without limit indicator)
		+	
2	Attachment (T-spacer) * ³	—	Without attachment
		T	Mounting position: AF+T+AR
		+	
3	Semi-standard	c	Set pressure * ⁴
			0.05 to 0.7 MPa setting
		d	Bowl * ⁵
			Polycarbonate bowl
			Metal bowl
		e	Exhaust mechanism
			Relieving type
		f	Flow direction
			Flow direction: Right to left
		g	Pressure unit
			Name plate, caution plate for bowl, and pressure gauge in SI units: MPa
		N	Non-relieving type
		+	
		R	Flow direction: Right to left
		+	
		Z	Name plate, caution plate for bowl, and pressure gauge in imperial units: psi, °F

*1 When pressure is not applied, condensate which does not start the auto drain mechanism will be left in the bowl.
Releasing the residual condensate before ending operations for the day is recommended.

*2 A 1.0 MPa pressure gauge will be fitted. It is not assembled and supplied loose at the time of shipment.

*3 The bracket position varies depending on the T-spacer mounting.

*4 Pressure can be set higher than the specification pressure in some cases, but use pressure within the specification range.

*5 Refer to chemical data on page 46 for chemical resistance of the bowl.



AC10B-A

Standard Specifications

Component	Air Filter [AF]	AF10-A
	Regulator [AR]	AR10-A
Port size		M5 x 0.8
Pressure gauge port size [AR]		1/16
Fluid		Air
Ambient and fluid temperature		-5 to 60 °C (with no freezing)
Proof pressure		1.5 MPa
Maximum operating pressure		1.0 MPa
Set pressure range [AR]		0.05 to 0.7 MPa
Nominal filtration rating [AF]		5 μm
Bowl material [AF]		Polycarbonate
Construction [AR]		Relieving type
Weight [kg]		0.16

AC
AF+AR+AL
AW+AL
AF+AR
AF+AFM+AR
AW+AFM
Attachment
AF
AFM / AFD
AR
AL
AW

AC20B-B to AC60B-B

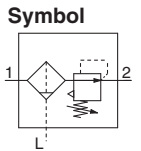

How to Order

Refer to page 21 for size 10.

AC **30** B - **03** **DE** - **01** - **01** - B

1
2
3
4
5
6

- Option/Semi-standard: Select one each for a to j.
- Option/Attachment/Semi-standard symbol: When more than one specification is required, indicate in alphanumeric order.
Example) AC30B-F03DE1-SV-16NR-B

	Symbol	Description	1								
			Body size								
			20	25	30	40	50	55	60		
2	Pipe thread type	—	Rc	●	●	●	●	●	●	●	
		N*1	NPT	●	●	●	●	●	●	●	
		F*2	G	●	●	●	●	●	●	●	
+											
3	Port size	01	1/8	●	—	—	—	—	—	—	
		02	1/4	●	●	●	●	—	—	—	
		03	3/8	—	●	●	●	—	—	—	
		04	1/2	—	—	—	●	—	—	—	
		06	3/4	—	—	—	●	●	—	—	
		10	1	—	—	—	—	●	●	●	
+											
4	a	Float type auto drain	—	Without auto drain	●	●	●	●	●	●	●
			C*4	N.C. (Normally closed) Drain port is closed when pressure is not applied.	●	●	●	●	●	●	●
			D*5	N.O. (Normally open) Drain port is open when pressure is not applied.	—	●	●	●	●	●	●
	+										
	b	Pressure gauge *6	—	Without pressure gauge	●	●	●	●	●	●	●
			E	Square embedded type pressure gauge (with limit indicator)	●	●	●	●	●	●	●
			G	Round type pressure gauge (with limit indicator)	●	●	●	●	●	●	●
			M	Round type pressure gauge (with colour zone)	●	●	●	●	●	●	●
		Digital pressure switch	E1	Output: NPN output, Electrical entry: Wiring bottom entry	●	●	●	●	●	●	●
			E2	Output: NPN output, Electrical entry: Wiring top entry	●	●	●	●	●	●	●
			E3	Output: PNP output, Electrical entry: Wiring bottom entry	●	●	●	●	●	●	●
	E4	Output: PNP output, Electrical entry: Wiring top entry	●	●	●	●	●	●	●		
+											
5	c	Pressure switch	—	Without attachment	●	●	●	●	●	●	●
			S*7	Mounting position: AF+S+AR	●	●	●	●	●	●	●
			T*7	Mounting position: AF+T+AR	●	●	●	●	●	●	●
+											
d	Pressure relief 3 port valve	—	Without attachment	●	●	●	●	●	●	●	
		V	Mounting position: AF+AR+V	●	●	●	●	●	—	—	
		V1*8	Mounting position: V+AF+AR□K	●	●	●	●	●	—	—	
+											
6	e	Set pressure *9	—	0.05 to 0.85 MPa setting	●	●	●	●	●	●	●
			1	0.02 to 0.2 MPa setting	●	●	●	●	●	●	●
	+										
	f	Bowl *10	—	Polycarbonate bowl	●	●	●	●	●	●	●
			2	Metal bowl	●	●	●	●	●	●	●
			6	Nylon bowl	●	●	●	●	●	●	●
			8	Metal bowl with level gauge	—	●	●	●	●	●	●
			C	With bowl guard	●	—*11	—*11	—*11	—*11	—*11	—*11
			6C	With bowl guard (Nylon bowl)	●	—*12	—*12	—*12	—*12	—*12	—*12
	+										
	g	Air filter drain port *13	—	With drain cock	●	●	●	●	●	●	●
			J*14	Drain guide 1/8	●	—	—	—	—	—	—
J*14			Drain guide 1/4	—	●	●	●	●	●	●	
W*15			Drain cock with barb fitting: For Ø 6 x Ø 4 nylon tube	—	●	●	●	●	●	●	

Air Combination **AC20B-B to AC60B-B Series**

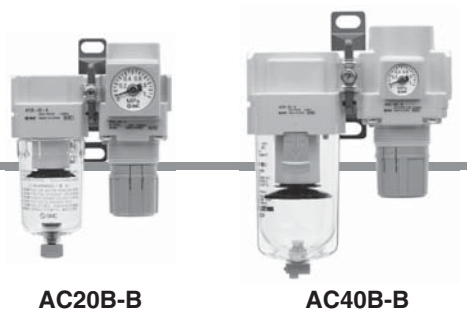

		Symbol	Description	①							
				Body size							
				20	25	30	40	50	55	60	
⑥	h	Exhaust mechanism	—	Relieving type	●	●	●	●	●	●	●
			N	Non-relieving type	●	●	●	●	●	●	●
				+							
	i	Flow direction	—	Flow direction: Left to right	●	●	●	●	●	●	●
			R	Flow direction: Right to left	●	●	●	●	●	●	●
				+							
j	Pressure unit	—	Name plate, caution plate for bowl, and pressure gauge in SI units: MPa	●	●	●	●	●	●	●	
		Z*16	Name plate, caution plate for bowl, and pressure gauge in imperial units: psi, °F	○*18	○*18	○*18	○*18	○*18	○*18	○*18	
		ZA*17	Digital pressure switch: With unit selection function	△*19	△*19	△*19	△*19	△*19	△*19	△*19	

- *1 Drain guide is NPT 1/8 (applicable to the AC20B-B) and NPT 1/4 (applicable to the AC25B-B to AC60B-B). The auto drain port comes with Ø 3/8" One-touch fitting (applicable to the AC25B-B to AC60B-B).
- *2 Drain guide is G 1/8 (applicable to the AC20B-B) and G 1/4 (applicable to the AC25B-B to AC60B-B).
- *3 Options G, M are not assembled and supplied loose at the time of shipment.
- *4 When pressure is not applied, condensate which does not start the auto drain mechanism will be left in the bowl. Releasing the residual condensate before ending operations for the day is recommended.
- *5 If the compressor is small (0.75 kW, discharge flow is less than 100 l/min[ANR]), air leakage from the drain cock may occur during start of operations. N.C. type is recommended.

- *6 When the pressure gauge is attached, a 1.0 MPa pressure gauge will be fitted for standard (0.85 MPa) type. 0.4 MPa pressure gauge for 0.2 MPa type.
- *7 The bracket position varies depending on the T-spacer or pressure switch mounting.
- *8 Make sure that the outlet pressure is released to atmospheric pressure using a pressure gauge.
- *9 Pressure can be set higher than the specification pressure in some cases, but use pressure within the specification range.
- *10 Refer to chemical data on page 46 for chemical resistance of the bowl.
- *11 A bowl guard is provided as standard equipment (polycarbonate).
- *12 A bowl guard is provided as standard equipment (nylon).

- *13 The combination of float type auto drain: C and D is not available.
- *14 Without a valve function
- *15 The combination of metal bowl: 2 and 8 is not available.
- *16 For pipe thread type: NPT. Cannot be used with M: Round pressure gauge (with colour zone). Available by request for special. The digital pressure switch will be equipped with the unit selection function, setting to psi initially.
- *17 For options: E1, E2, E3, E4.
- *18 ○: For pipe thread type: NPT only
- *19 △: Select with options: E1, E2, E3, E4.

Standard Specifications

Model		AC20B-B	AC25B-B	AC30B-B	AC40B-B	AC40B-06-B	AC50B-B	AC55B-B	AC60B-B
Component	Air Filter [AF]	AF20-A	AF30-A	AF30-A	AF40-A	AF40-06-A	AF50-A	AF60-A	AF60-A
	Regulator [AR]	AR20-B	AR25-B	AR30-B	AR40-B	AR40-06-B	AR50-B	AR50-B	AR60-B
Port size		1/8, 1/4	1/4, 3/8	1/4, 3/8	1/4, 3/8, 1/2	3/4	3/4, 1	1	1
Pressure gauge port size [AR] *1		1/8							
Fluid		Air							
Ambient and fluid temperature *2		-5 to 60 °C (with no freezing)							
Proof pressure		1.5 MPa							
Maximum operating pressure		1.0 MPa							
Set pressure range [AR]		0.05 to 0.85 MPa							
Nominal filtration rating [AF]		5 µm							
Bowl material [AF]		Polycarbonate							
Bowl guard [AF]		Semi-standard (Steel)	Standard (Polycarbonate)						
Construction [AR]		Relieving type							
Weight [kg]		0.27	0.45	0.53	0.91	0.99	2.27	2.40	2.45

- *1 Pressure gauge connection threads are not available for F.R.L. unit with a square embedded type pressure gauge or with a digital pressure switch.
- *2 -5 to 50 °C for the products with the digital pressure switch.

AC
 AF+AR+AL
 AW+AL
 AF+AR
 AF+AFM+AR
 AW+AFM
 Attachment
 AF
 AFM/AFD
 AR
 AL
 AW

AC10B-A Series

AC20B-B to AC60B-B Series

Dimensions

AC10B-A

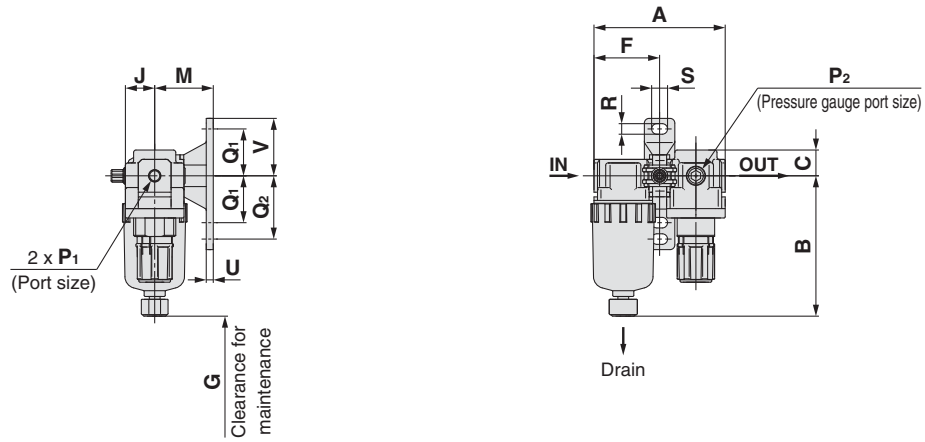

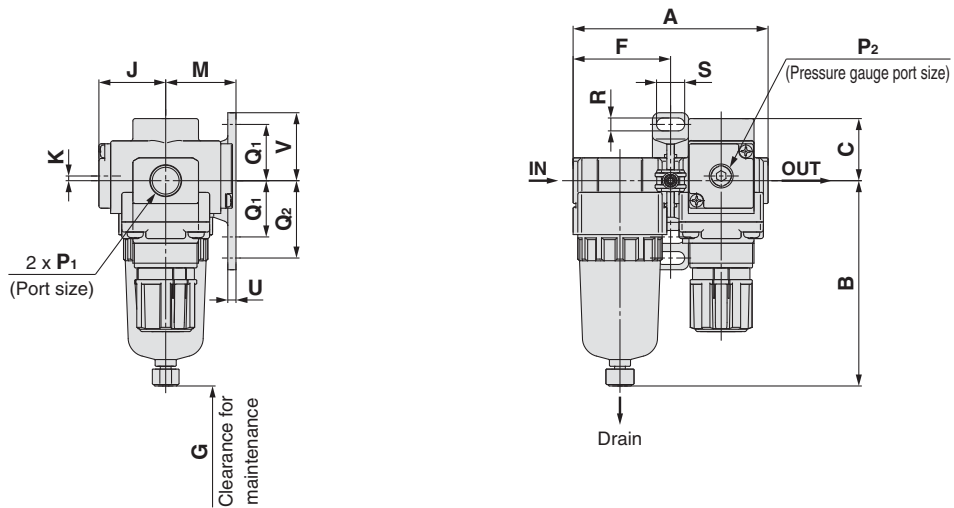

AC20B-B



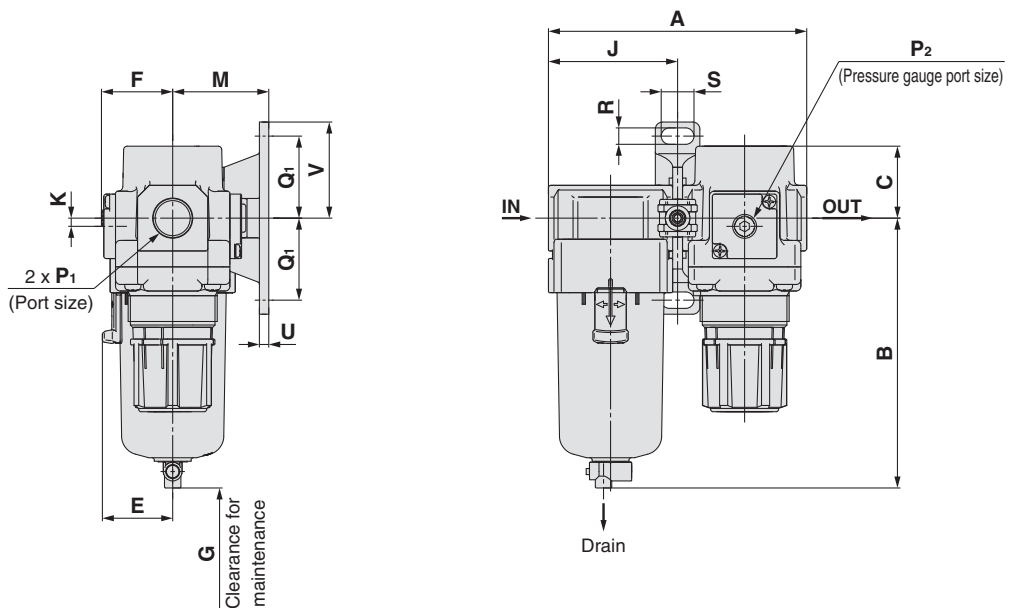



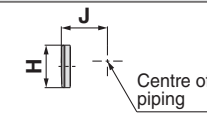
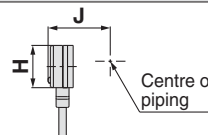
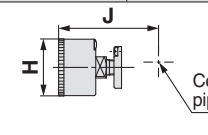

AC25B-B to AC60B-B

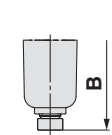
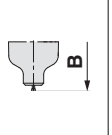
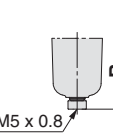
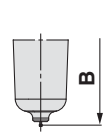

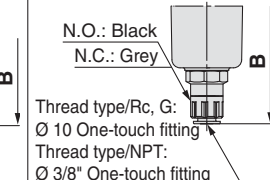
Air Combination **AC10B-A Series** Air Combination **AC20B-B to AC60B-B Series**

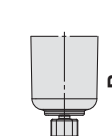
Option	Square embedded type pressure gauge	Digital pressure switch	Round type pressure gauge	Round type pressure gauge (with colour zone)
Dimensions				

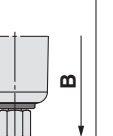
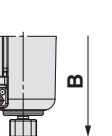
Applicable model	AC10B-A		AC20B-B				AC25B-B to AC60B-B	
	Optional/Semi-standard specifications	With auto drain	Metal bowl	With auto drain	Metal bowl	With drain guide	Metal bowl with drain guide	With auto drain (N.O./N.C.)
Dimensions								N.O.: Black N.C.: Grey Thread type/Rc, G: Ø 10 One-touch fitting Thread type/NPT: Ø 3/8" One-touch fitting

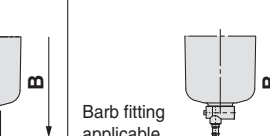
Applicable model	AC25B-B to AC60B-B						
	Optional/Semi-standard specifications	Metal bowl	Metal bowl with drain guide	Metal bowl with level gauge	Metal bowl with level gauge, with drain guide	With drain guide	Drain cock with barb fitting
Dimensions							Barb fitting applicable tubing: T0604

Model	Standard specifications																
	P ₁	P ₂	A	B	C	E	F	G	J	K	Bracket mount						
											M	Q ₁	Q ₂	R	S	U	V
AC10B-A	M5 x 0.8	1/16	56	59.9	11	—	28	25	12.5	—	25	20	27	4.5	6.8	3	24.5
AC20B-B	1/8, 1/4	1/8	83.2	87.6	26.5	—	41.6	25	28.5	2 ^{*1}	30	24	33	5.5	12	3.5	29
AC25B-B	1/4, 3/8	1/8	110.2	115.1	28	30	55.1	35	27.5	0	41	35	—	7	14	4	41
AC30B-B	1/4, 3/8	1/8	110.2	115.1	30.7	30	55.1	35	29.4	3.5	41	35	—	7	14	4	41
AC40B-B	1/4, 3/8, 1/2	1/8	145.2	147.1	35.8	38.4	72.6	40	33.8	3.5	50	40	—	9	18	5	48
AC40B-06-B	3/4	1/8	155.2	149.1	35.8	38.4	77.6	40	33.8	3	50	40	—	9	18	5	48
AC50B-B	3/4, 1	1/8	186.2	220.1	43	—	93.1	30	43.3	3.2	70	50	—	11	20	6	60
AC55B-B	1	1/8	191.2	234.1	43	—	98.1	30	43.3	3.2	70	50	—	11	20	6	60
AC60B-B	1	1/8	196.2	234.1	46	—	98.1	30	43.3	3.2	70	50	—	11	20	6	60

Model	Optional specifications								Semi-standard specifications							
	Square embedded type pressure gauge		Digital pressure switch		Round type pressure gauge		Round type pressure gauge (with colour zone)		With auto drain	With barb fitting	With drain guide	Metal bowl	Metal bowl with drain guide	Metal bowl with level gauge	Metal bowl with level gauge, with drain guide	
	H	J	H	J	H	J	H	J	B	B	B	B	B	B	B	
AC10B-A	—	—	—	—	Ø 26	26	—	—	77.9	—	—	59.3	—	—	—	
AC20B-B	□28	29.5	□27.8	40	Ø 37.5	65	Ø 37.5	66	104.9	—	91.4	87.4	93.9	—	—	
AC25B-B	□28	28.5	□27.8	39	Ø 37.5	64	Ø 37.5	65	156.8	123.6	121.9	117.6	122.1	137.6	142.1	
AC30B-B	□28	30.4	□27.8	40.9	Ø 37.5	65.9	Ø 37.5	66.9	156.8	123.6	121.9	117.6	122.1	137.6	142.1	
AC40B-B	□28	34.8	□27.8	45.3	Ø 42.5	71.3	Ø 42.5	71.3	186.9	155.6	153.9	149.6	154.1	169.6	174.1	
AC40B-06-B	□28	34.8	□27.8	45.3	Ø 42.5	71.3	Ø 42.5	71.3	188.9	157.6	155.9	151.6	156.1	171.6	176.1	
AC50B-B	□28	44.3	□27.8	54.8	Ø 42.5	80.8	Ø 42.5	80.8	259.9	228.6	226.9	222.6	227.1	242.6	247.1	
AC55B-B	□28	44.3	□27.8	54.8	Ø 42.5	80.8	Ø 42.5	80.8	273.9	242.6	240.9	236.6	241.1	256.6	261.1	
AC60B-B	□28	44.3	□27.8	54.8	Ø 42.5	80.8	Ø 42.5	80.8	273.9	242.6	240.9	236.6	241.1	256.6	261.1	

*1 For the AC20B-B only, the position of the pressure gauge is above the centre of the piping.

AC
 AF+AR+AL
 AW+AL
 AF+AR
 AF+AFM+AR
 AW+AFM
 Attachment
 AF
 AFM / AFD
 AR
 AL
 AW

AC20C-B to AC40C-B

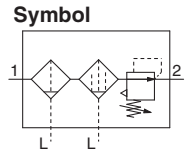

How to Order

AC **30** C - **03** **DE** - **01** - **01** - **01** - B

① ② ③ ④ ⑤ ⑥

- Option/Semi-standard: Select one each for a to j.
- Option/Attachment/Semi-standard symbol: When more than one specification is required, indicate in alphanumeric order.
Example) AC30C-F03DE1-SV-16NR-B

		Symbol	Description	①					
				Body size					
				20	25	30	40		
②	Pipe thread type	—	Rc	●	●	●	●		
		N*1	NPT	●	●	●	●		
		F*2	G	●	●	●	●		
+									
③	Port size	01	1/8	●	—	—	—		
		02	1/4	●	●	●	●		
		03	3/8	—	●	●	●		
		04	1/2	—	—	—	●		
		06	3/4	—	—	—	●		
+									
④	a	Float type auto drain	—	Without auto drain	●	●	●	●	
			C*4	N.C. (Normally closed) Drain port is closed when pressure is not applied.	●	●	●	●	
			D*5	N.O. (Normally open) Drain port is open when pressure is not applied.	—	●	●	●	
	+								
	b	Pressure gauge *6	—	Without pressure gauge	●	●	●	●	
			E	Square embedded type pressure gauge (with limit indicator)	●	●	●	●	
			G	Round type pressure gauge (with limit indicator)	●	●	●	●	
			M	Round type pressure gauge (with colour zone)	●	●	●	●	
		Digital pressure switch	E1	Output: NPN output, Electrical entry: Wiring bottom entry	●	●	●	●	
			E2	Output: NPN output, Electrical entry: Wiring top entry	●	●	●	●	
			E3	Output: PNP output, Electrical entry: Wiring bottom entry	●	●	●	●	
	E4	Output: PNP output, Electrical entry: Wiring top entry	●	●	●	●			
	+								
	⑤	c	Pressure switch	—	Without attachment	●	●	●	●
				S*7	Mounting position: AF+AFM+S+AR	●	●	●	●
T-spacer			T*7	Mounting position: AF+AFM+T+AR	●	●	●	●	
+									
d	Pressure relief 3 port valve	—	Without attachment	●	●	●	●		
		V	Mounting position: AF+AFM+AR+V	●	●	●	●		
		V1*8	Mounting position: V+AF+AFM+AR□K	●	●	●	●		
+									
⑥	e	Set pressure *9	—	0.05 to 0.85 MPa setting	●	●	●	●	
			1	0.02 to 0.2 MPa setting	●	●	●	●	
	+								
	f	Bowl *10	—	Polycarbonate bowl	●	●	●	●	
			2	Metal bowl	●	●	●	●	
			6	Nylon bowl	●	●	●	●	
			8	Metal bowl with level gauge	—	●	●	●	
			C	With bowl guard	●	—*11	—*11	—*11	
	6C	With bowl guard (Nylon bowl)	●	—*12	—*12	—*12			
	+								
	g	Air filter Mist separator drain port *13	—	With drain cock	●	●	●	●	
			J*14	Drain guide 1/8	●	—	—	—	
			J*14	Drain guide 1/4	—	●	●	●	
			W*15	Drain cock with barb fitting: For Ø 6 x Ø 4 nylon tube	—	●	●	●	
	+								
h	Exhaust mechanism	—	Relieving type	●	●	●	●		
		N	Non-relieving type	●	●	●	●		

Air Combination **AC20C-B to AC40C-B Series**

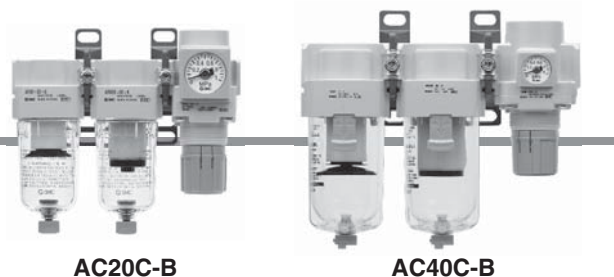

		Symbol	Description	① Body size			
				20	25	30	40
⑥	i	Flow direction	—	Flow direction: Left to right			
			R	Flow direction: Right to left			
		+					
	j	Pressure unit	—	Name plate, caution plate for bowl, and pressure gauge in SI units: MPa			
			Z*16	Name plate, caution plate for bowl, and pressure gauge in imperial units: psi, °F			
			ZA*17	Digital pressure switch: With unit selection function			
			●	●	●	●	
			○*18	○*18	○*18	○*18	
			△*19	△*19	△*19	△*19	

- *1 Drain guide is NPT 1/8 (applicable to the AC20C-B) and NPT 1/4 (applicable to the AC25C-B to AC40C-B). The auto drain port comes with Ø 3/8" One-touch fitting (applicable to the AC25C-B to AC40C-B).
- *2 Drain guide is G 1/8 (applicable to the AC20C-B) and G 1/4 (applicable to the AC25C-B to AC40C-B).
- *3 Options G, M are not assembled and supplied loose at the time of shipment.
- *4 When pressure is not applied, condensate which does not start the auto drain mechanism will be left in the bowl. Releasing the residual condensate before ending operations for the day is recommended.
- *5 If the compressor is small (0.75 kW, discharge flow is less than 100 l/min [ANR]), air leakage from the drain cock may occur during start of operations. N.C. type is recommended.

- *6 When the pressure gauge is attached, a 1.0 MPa pressure gauge will be fitted for standard (0.85 MPa) type. 0.4 MPa pressure gauge for 0.2 MPa type.
- *7 The bracket position varies depending on the T-spacer or pressure switch mounting.
- *8 Make sure that the outlet pressure is released to atmospheric pressure using a pressure gauge.
- *9 Pressure can be set higher than the specification pressure in some cases, but use pressure within the specification range.
- *10 Refer to chemical data on page 46 for chemical resistance of the bowl.
- *11 A bowl guard is provided as standard equipment (polycarbonate).
- *12 A bowl guard is provided as standard equipment (nylon).

- *13 The combination of float type auto drain: C and D is not available.
- *14 Without a valve function
- *15 The combination of metal bowl: 2 and 8 is not available.
- *16 For pipe thread type: NPT.
Cannot be used with M: Round type pressure gauge (with colour zone). Available by request for special. The digital pressure switch will be equipped with the unit selection function, setting to psi initially.
- *17 For options: E1, E2, E3, E4.
- *18 ○: For pipe thread type: NPT only
- *19 △: Select with options: E1, E2, E3, E4.

Standard Specifications

Model		AC20C-B	AC25C-B	AC30C-B	AC40C-B	AC40C-06-B
Component	Air Filter [AF]	AF20-A	AF30-A	AF30-A	AF40-A	AF40-06-A
	Mist Separator [AFM]	AFM20-A	AFM30-A	AFM30-A	AFM40-A	AFM40-06-A
	Regulator [AR]	AR20-B	AR25-B	AR30-B	AR40-B	AR40-06-B
Port size		1/8, 1/4	1/4, 3/8	1/4, 3/8	1/4, 3/8, 1/2	3/4
Pressure gauge port size [AR] *1		1/8				
Fluid		Air				
Ambient and fluid temperature *2		-5 to 60 °C (with no freezing)				
Proof pressure		1.5 MPa				
Maximum operating pressure		1.0 MPa				
Set pressure range [AR]		0.05 to 0.85 MPa				
Nominal filtration rating [AF/AFM]		AF: 5 µm, AFM: 0.3 µm (99.9 % filtered particle size)				
Rated flow [l/min(ANR)] [AFM] *3		200	450	450	1100	1100
Outlet side oil mist concentration [AFM] *4 *5		Max. 1.0 mg/m ³ (ANR) (≈0.8 ppm)				
Bowl material [AF/AFM]		Polycarbonate				
Bowl guard [AF/AFM]		Semi-standard (Steel)	Standard (Polycarbonate)			
Construction [AR]		Relieving type				
Weight [kg]		0.38	0.69	0.77	1.39	1.53

- *1 Pressure gauge connection threads are not available for F.R.L. unit with a square embedded type pressure gauge or with a digital pressure switch.
- *2 -5 to 50 °C for the products with the digital pressure switch.
- *3 Conditions: Mist separator inlet pressure: 0.7 MPa; The rated flow varies depending on the inlet pressure. Keep the air flow within the rated flow to prevent an outflow of lubricant to the outlet side.
- *4 When the compressor oil mist discharge concentration is 30 mg/m³ (ANR).
- *5 Bowl seal and other O-rings are slightly lubricated.

AC
 AF+AR+AL
 AW+AL
 AF+AR
 AF+AFM+AR
 AW+AFM
 Attachment
 AF
 AFM/AFD
 AR
 AL
 AW

AC20C-B to AC40C-B Series

Dimensions

AC20C-B

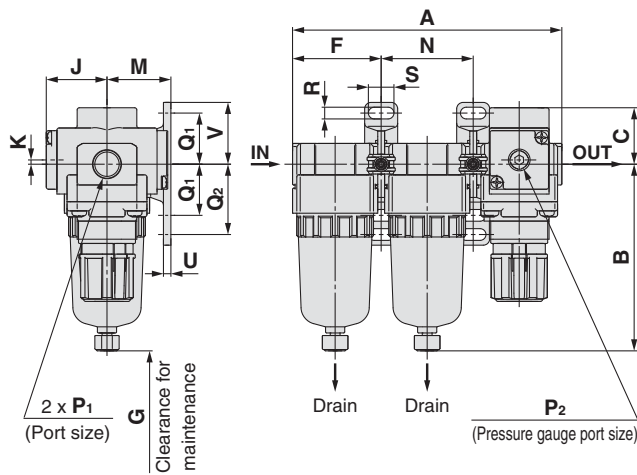

AC25C-B to AC40C-06-B

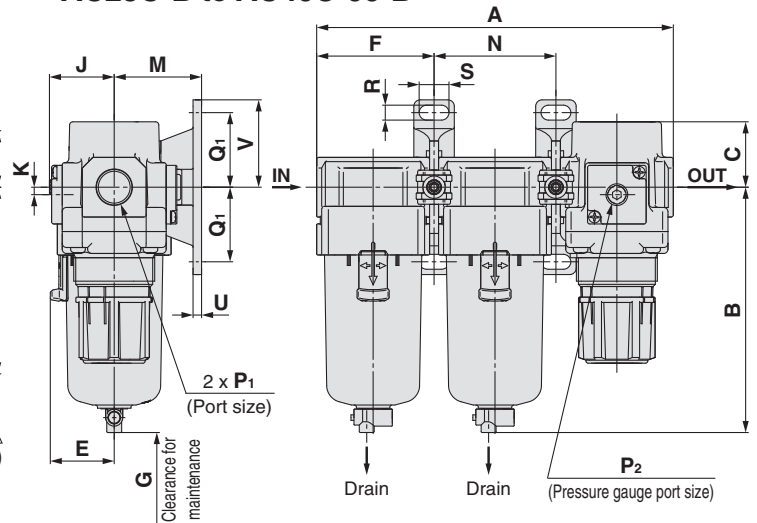

Option	Square embedded type pressure gauge	Digital pressure switch	Round type pressure gauge	Round type pressure gauge (with colour zone)
Dimensions				

Applicable model	AC20C-B				AC25C-B to AC40C-06-B	
Optional/Semi-standard specifications	With auto drain (N.C.)	With drain guide	Metal bowl	Metal bowl with drain guide	With auto drain (N.O./N.C.)	
Dimensions						

Applicable model	AC25C-B to AC40C-06-B					
Optional/Semi-standard specifications	Metal bowl	Metal bowl with drain guide	Metal bowl with level gauge	Metal bowl with level gauge, with drain guide	With drain guide	Drain cock with barb fitting
Dimensions						

Model	Standard specifications																	
	P ₁		P ₂	A	B	C	E	F	G	J	K	Bracket mount						
	M	N	Q ₁	Q ₂	R	S	U	V										
AC20C-B	1/8, 1/4	1/8	126.4	87.6	26.5	—	41.6	40	28.5	2 *1	30	43.2	24	33	5.5	12	3.5	29
AC25C-B	1/4, 3/8	1/8	167.4	115.1	28	30	55.1	50	27.5	0	41	57.2	35	—	7	14	4	41
AC30C-B	1/4, 3/8	1/8	167.4	115.1	30.7	30	55.1	50	29.4	3.5	41	57.2	35	—	7	14	4	41
AC40C-B	1/4, 3/8, 1/2	1/8	220.4	147.1	35.8	38.4	72.6	75	33.8	3.5	50	75.2	40	—	9	18	5	48
AC40C-06-B	3/4	1/8	235.4	149.1	35.8	38.4	77.6	75	33.8	3	50	80.2	40	—	9	18	5	48

Model	Optional specifications										Semi-standard specifications					
	Square embedded type pressure gauge		Digital pressure switch		Round type pressure gauge		Round type pressure gauge (with colour zone)		With auto drain	With barb fitting	With drain guide	Metal bowl	Metal bowl with drain guide	Metal bowl with level gauge	Metal bowl with level gauge, with drain guide	
	H	J	H	J	H	J	H	J	B	B	B	B	B	B	B	
AC20C-B	□28	29.5	□27.8	40	Ø 37.5	65	Ø 37.5	66	104.9	—	91.4	87.4	93.9	—	—	
AC25C-B	□28	28.5	□27.8	39	Ø 37.5	64	Ø 37.5	65	156.8	123.6	121.9	117.6	122.1	137.6	142.1	
AC30C-B	□28	30.4	□27.8	40.9	Ø 37.5	65.9	Ø 37.5	66.9	156.8	123.6	121.9	117.6	122.1	137.6	142.1	
AC40C-B	□28	34.8	□27.8	45.3	Ø 42.5	71.3	Ø 42.5	71.3	186.9	155.6	153.9	149.6	154.1	169.6	174.1	
AC40C-06-B	□28	34.8	□27.8	45.3	Ø 42.5	71.3	Ø 42.5	71.3	188.9	157.6	155.9	151.6	156.1	171.6	176.1	

*1 For the AC20C-B only, the position of the pressure gauge is above the centre of the piping.

AW

AL

AR

AFM / AFD

AF

Attachment

AW+AFM

AF+AFM+AR

AF+AR

AW+AL

AF+AR+AL

AC

AC20D-B to AC40D-B

Symbol

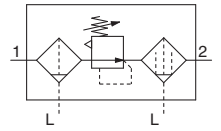

How to Order

AC **30** D - **03** DE - **01** - **03** - B

① ② ③ ④ ⑤ ⑥

- Option/Semi-standard: Select one each for a to j.
- Option/Attachment/Semi-standard symbol: When more than one specification is required, indicate in alphanumeric order.
Example) AC30D-F03DE1-SV-16NR-B

	Symbol	Description	① Body size				
			20	30	40		
② Pipe thread type	—	Rc	●	●	●		
	N*1	NPT	●	●	●		
	F*2	G	●	●	●		
+							
③ Port size	01	1/8	●	—	—		
	02	1/4	●	●	●		
	03	3/8	—	●	●		
	04	1/2	—	—	●		
	06	3/4	—	—	●		
+							
④ Option*3	a Float type auto drain	—	Without auto drain	●	●	●	
		C*4	N.C. (Normally closed) Drain port is closed when pressure is not applied.	●	●	●	
		D*5	N.O. (Normally open) Drain port is open when pressure is not applied.	—	●	●	
	+						
	b Pressure gauge*6	—	Without pressure gauge	●	●	●	
		E	Square embedded type pressure gauge (with limit indicator)	●	●	●	
		G	Round type pressure gauge (with limit indicator)	●	●	●	
		M	Round type pressure gauge (with colour zone)	●	●	●	
		Digital pressure switch	E1	Output: NPN output, Electrical entry: Wiring bottom entry	●	●	●
			E2	Output: NPN output, Electrical entry: Wiring top entry	●	●	●
	E3		Output: PNP output, Electrical entry: Wiring bottom entry	●	●	●	
	E4	Output: PNP output, Electrical entry: Wiring top entry	●	●	●		
+							
⑤ Attachment	c Pressure switch	—	Without attachment	●	●	●	
		S*7	Mounting position: AW+S+AFM	●	●	●	
	+						
	d Pressure relief 3 port valve	—	Without attachment	●	●	●	
V		Mounting position: AW+AFM+V	●	●	●		
V1*8		Mounting position: V+AW□K+AFM	●	●	●		
+							
⑥ Semi-standard	e Set pressure*9	—	0.05 to 0.85 MPa setting	●	●	●	
		1	0.02 to 0.2 MPa setting	●	●	●	
	+						
	f Bowl*10	—	Polycarbonate bowl	●	●	●	
		2	Metal bowl	●	●	●	
		6	Nylon bowl	●	●	●	
		8	Metal bowl with level gauge	—	●	●	
		C	With bowl guard	●	—*11	—*11	
		6C	With bowl guard (Nylon bowl)	●	—*12	—*12	
	+						
	g Filter regulator Mist separator drain port*13	—	With drain cock	●	●	●	
		J*14	Drain guide 1/8	●	—	—	
			Drain guide 1/4	—	●	●	
		W*15	Drain cock with barb fitting: For Ø 6 x Ø 4 nylon tube	—	●	●	
	+						
h Exhaust mechanism	—	Relieving type	●	●	●		
	N	Non-relieving type	●	●	●		
+							
i Flow direction	—	Flow direction: Left to right	●	●	●		
	R	Flow direction: Right to left	●	●	●		

Air Combination **AC20D-B to AC40D-B Series**

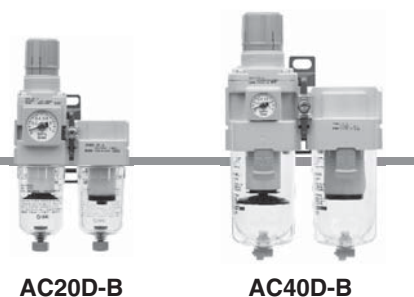

		Symbol	Description	①			
				Body size			
				20	30	40	
⑥	Semi-standard	j	Pressure unit	—	●	●	●
				Z*16	○*18	○*18	○*18
				ZA*17	△*19	△*19	△*19

- *1 Drain guide is NPT 1/8 (applicable to the AC20D-B) and NPT 1/4 (applicable to the AC30D-B/AC40D-B).
The auto drain port comes with Ø 3/8" One-touch fitting (applicable to the AC30D-B/AC40D-B).
- *2 Drain guide is G 1/8 (applicable to the AC20D-B) and G 1/4 (applicable to the AC30D-B/AC40D-B).
- *3 Options G, M are not assembled and supplied loose at the time of shipment.
- *4 When pressure is not applied, condensate which does not start the auto drain mechanism will be left in the bowl. Releasing the residual condensate before ending operations for the day is recommended.
- *5 If the compressor is small (0.75 kW, discharge flow is less than 100 l/min [ANR]), air leakage from the drain cock may occur during start of operations. N.C. type is recommended.

- *6 When the pressure gauge is attached, a 1.0 MPa pressure gauge will be fitted for standard (0.85 MPa) type. 0.4 MPa pressure gauge for 0.2 MPa type.
- *7 The bracket position varies depending on the pressure switch mounting.
- *8 Make sure that the outlet pressure is released to atmospheric pressure using a pressure gauge.
- *9 Pressure can be set higher than the specification pressure in some cases, but use pressure within the specification range.
- *10 Refer to chemical data on page 46 for chemical resistance of the bowl.
- *11 A bowl guard is provided as standard equipment (polycarbonate).
- *12 A bowl guard is provided as standard equipment (nylon).

- *13 The combination of float type auto drain: C and D is not available.
- *14 Without a valve function
- *15 The combination of metal bowl: 2 and 8 is not available.
- *16 For pipe thread type: NPT.
Cannot be used with M: Round type pressure gauge (with colour zone). Available by request for special.
The digital pressure switch will be equipped with the unit selection function, setting to psi initially.
- *17 For options: E1, E2, E3, E4.
- *18 ○: For pipe thread type: NPT only
- *19 △: Select with options: E1, E2, E3, E4.

Standard Specifications

Model		AC20D-B	AC30D-B	AC40D-B	AC40D-06-B
Component	Filter Regulator [AW]	AW20-B	AW30-B	AW40-B	AW40-06-B
	Mist Separator [AFM]	AFM20-A	AFM30-A	AFM40-A	AFM40-06-A
Port size		1/8, 1/4	1/4, 3/8	1/4, 3/8, 1/2	3/4
Pressure gauge port size [AW] *1		1/8			
Fluid		Air			
Ambient and fluid temperature *2		-5 to 60 °C (with no freezing)			
Proof pressure		1.5 MPa			
Maximum operating pressure		1.0 MPa			
Set pressure range [AW]		0.05 to 0.85 MPa			
Nominal filtration rating [AW/AFM]		AW: 5 µm, AFM: 0.3 µm (99.9 % filtered particle size)			
Rated flow [l/min(ANR)] [AFM] *3		150	330	800	800
Outlet side oil mist concentration [AFM] *4 *5		Max.1.0 mg/m ³ (ANR) (≈0.8 ppm)			
Bowl material [AW/AFM]		Polycarbonate			
Bowl guard [AW/AFM]		Semi-standard (Steel)	Standard (Polycarbonate)		
Construction [AW]		Relieving type			
Weight [kg]		0.32	0.62	1.15	1.25

- *1 Pressure gauge connection threads are not available for F.R.L. unit with a square embedded type pressure gauge or with a digital pressure switch.
- *2 -5 to 50 °C for the products with the digital pressure switch.
- *3 Conditions: Mist separator inlet pressure: 0.5 MPa; The rated flow varies depending on the inlet pressure.
Keep the air flow within the rated flow to prevent an outflow of lubricant to the outlet side.
- *4 When the compressor oil mist discharge concentration is 30 mg/m³ (ANR).
- *5 Bowl seal and other O-rings are slightly lubricated.

AC
 AF+AR+AL
 AW+AL
 AF+AR
 AF+AFM+AR
 AW+AFM
 Attachment
 AF
 AFM/AFD
 AR
 AL
 AW

AC20D-B to AC40D-B Series

Dimensions

AC20D-B

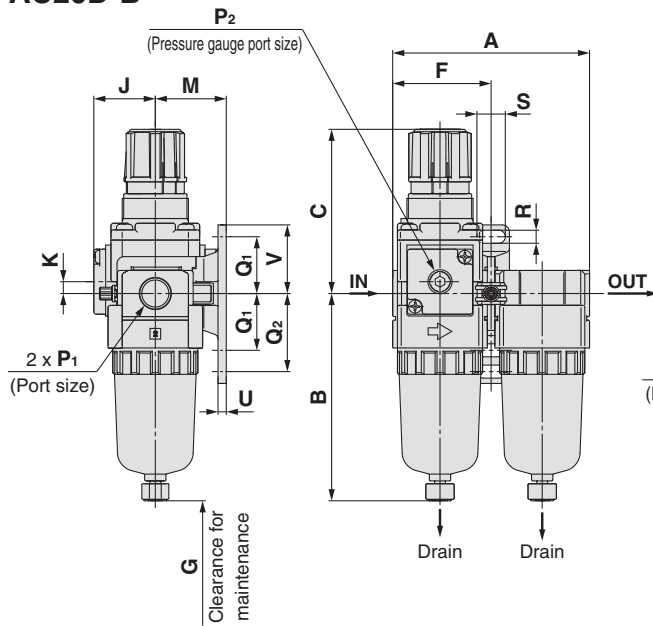

AC30D-B to AC40D-06-B

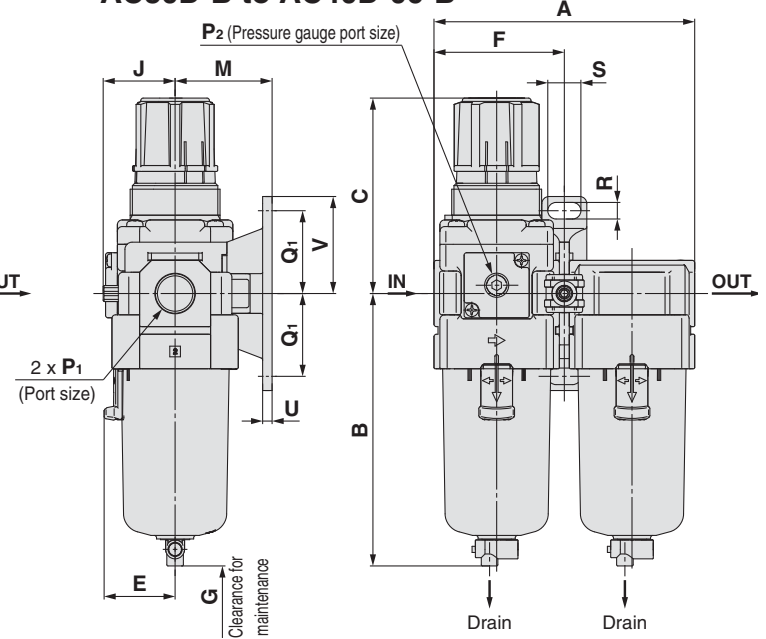

Option	Square embedded type pressure gauge	Digital pressure switch	Round type pressure gauge	Round type pressure gauge (with colour zone)
Dimensions	Centre of piping	Centre of piping	Centre of piping	

Applicable model	AC20D-B				AC30D-B to AC40D-06-B
Optional/Semi-standard specification	With auto drain (N.C.)	With drain guide	Metal bowl	Metal bowl with drain guide	With auto drain (N.O./N.C.)
Dimensions	M5 x 0.8	Width across flats 14 1/8	B	Width across flats 14 1/8	N.O.: Black N.C.: Grey Thread type/Rc, G: Ø 10 One-touch fitting Thread type/NPT: Ø 3/8" One-touch fitting

Applicable model	AC30D-B to AC40D-06-B					
Optional/Semi-standard specification	Metal bowl	Metal bowl with drain guide	Metal bowl with level gauge	Metal bowl with level gauge, with drain guide	With drain guide	Drain cock with barb fitting
Dimensions	B	Width across flats 17 1/4	B	Width across flats 17 1/4	Width across flats 17 1/4	Barb fitting applicable tubing: T0604

Model	Standard specifications																
	P ₁	P ₂	A	B	C*1	E	F	G	J	K	Bracket mount						
											M	Q ₁	Q ₂	R	S	U	V
AC20D-B	1/8, 1/4	1/8	83.2	87.6	72.4	—	41.6	40	28.5	5	30	24	33	5.5	12	3.5	29
AC30D-B	1/4, 3/8	1/8	110.2	115.1	85.6	30	55.1	50	29.4	3.5	41	35	—	7	14	4	41
AC40D-B	1/4, 3/8, 1/2	1/8	145.2	147.1	91.7	38.4	72.6	75	33.8	1.5	50	40	—	9	18	5	48
AC40D-06-B	3/4	1/8	155.2	149.1	93.2	38.4	77.6	75	33.8	1.2	50	40	—	9	18	5	48

Model	Optional specifications						Semi-standard specifications							
	Square embedded type pressure gauge		Digital pressure switch		Round type pressure gauge		Round type pressure gauge (with colour zone)	With auto drain	With barb fitting	With drain guide	Metal bowl	Metal bowl with drain guide	Metal bowl with level gauge	Metal bowl with level gauge, with drain guide
	H	J	H	J	H	J	H	J	B	B	B	B	B	B
AC20D-B	□28	27	□27.8	37.5	Ø 37.5	62.5	Ø 37.5	63.5	104.9	—	91.4	87.4	93.9	—
AC30D-B	□28	30	□27.8	40.9	Ø 37.5	66.9	Ø 37.5	67.9	156.8	123.6	121.9	117.6	122.1	137.6
AC40D-B	□28	38.4	□27.8	48.8	Ø 42.5	75.7	Ø 42.5	75.7	186.9	155.6	153.9	149.6	154.1	169.6
AC40D-06-B	□28	38.4	□27.8	48.8	Ø 42.5	75.7	Ø 42.5	75.7	188.9	157.6	155.9	151.6	156.1	171.6

*1 The dimension of C is the length when the filter regulator knob is unlocked.

Air Combination AC Series Options/Attachments

Options/Attachments/Part No.

Section	Model		Part no.									
			For AC10-A	For AC20-B	For AC25-B	For AC30-B	For AC40-B	For AC40-06-B	For AC50-B	For AC55-B	For AC60-B	
			For AC10A-A	For AC20A-B	—	For AC30A-B	For AC40A-B	For AC40A-06-B	For AC50A-B	—	For AC60A-B	
			For AC10B-A	For AC20B-B	For AC25C-B	For AC30B-B	For AC40B-B	For AC40B-06-B	For AC50B-B	For AC55B-B	For AC60B-B	
Option	Pressure gauge ^{*1}	Round type	Standard	G27-10-R1	G36-10-□01			G46-10-□01				
		0.02 to 0.2 MPa setting	G27-10-R1	G36-4-□01			G46-4-□01					
	Round type (with colour zone)	Standard	—	G36-10-□01-L			G46-10-□01-L					
		0.02 to 0.2 MPa setting	—	G36-4-□01-L			G46-4-□01-L					
	Square embedded type ^{*2}	Standard	—	GC3-10AS [GC3P-010AS (Pressure gauge cover only)]								
		0.02 to 0.2 MPa setting	—	GC3-4AS [GC3P-010AS (Pressure gauge cover only)]								
	Digital pressure switch	NPN output, Wiring bottom entry	—	ISE35-N-25-MLA [ISE35-N-25-M (Switch body only)] ^{*3}								
		NPN output, Wiring top entry	—	ISE35-R-25-MLA [ISE35-R-25-M (Switch body only)] ^{*3}								
		PNP output, Wiring bottom entry	—	ISE35-N-65-MLA [ISE35-N-65-M (Switch body only)] ^{*3}								
		PNP output, Wiring top entry	—	ISE35-R-65-MLA [ISE35-R-65-M (Switch body only)] ^{*3}								
Float type auto drain ^{*4}	N.O.	—	—	AD38-A			AD48-A					
	N.C.	AD17-A	AD27-A	AD37-A			AD47-A					
Attachment	Spacer		Y100-A	Y200-A	Y300-A		Y400-A	Y500-A	Y600-A			
	Spacer with bracket		Y100T-A	Y200T-A	Y300T-A		Y400T-A	Y500T-A	Y600T-A			
	Check valve ^{*5} ^{*6}		—	AKM2000-□01-A (□02-A)	AKM3000-(□01)-A (□02-A)		AKM4000-(□02)-A (□03-A)		—	—	—	
	Pressure switch ^{*6}		—	IS10M-20-A	IS10M-30-A		IS10M-40-A		IS10M-50-A		IS10M-60-A	
	T-spacer ^{*5} ^{*6}		Y110-M5-A	Y210-□01-A (□02-A)	Y310-(□01)-A (□02-A)		Y410-(□02)-A (□03-A)		Y510-(□02)-A (□03-A)		Y610-□03-A (□04-A)	Y610-(□03)-A (□04-A)
	Pressure relief 3 port valve ^{*6}		—	VHS20-□01A (□02A)	VHS30-□02A (□03A)		VHS40-□03A (□04A)		VHS50-□06A (□10A)		—	—
	Piping adapter ^{*6}		E100-M5-A	□01-A (□02-A) (□03-A)	□02-A (□03-A) (□04-A)		E400-□03-A (□04-A) (□06-A)		E500-□06-A		E600-□06-A (□10-A)	
	Pressure switch with piping adapter ^{*6}		—	□01-A (IS10E-20□02-A) (□03-A)	□02-A (IS10E-30□03-A) (□04-A)		□02-A (IS10E-40□03-A) (□04-A) (□06-A)		—	—	—	—
	Cross spacer ^{*6}		Y14-M5-A	Y24-□01-A (□02-A)	Y34-□01-A (□02-A)		Y44-□02-A (□03-A)		Y54-□03-A (□04-A)		—	—

*1 □ in part numbers for a round type pressure gauge indicates a pipe thread type. No indication is necessary for R; however, indicate N for NPT. Please contact SMC regarding the connection thread NPT and pressure gauge supply for psi unit specifications.

*2 Including one O-ring and 2 mounting screws

*3 Lead wire with connector (2 m), adapter, lock pin, O-ring (1 pc.), mounting screw (2 pcs.) are attached. []: Switch body only.

Regarding how to order the digital pressure switch, refer to the **Web Catalogue**.

*4 Minimum operating pressure: N.O. type—0.1 MPa; N.C. type—0.1 MPa (AD27-A) and 0.15 MPa (AD37-A/AD47-A). Please consult with SMC separately for psi and °F unit display specifications.

*5 For F.R.L. units, port sizes without () are standard specifications.

*6 Separate spacers are required for modular unit.

Check Valve: (K) 1/8, 1/4, 3/8

A check valve with intermediate air release port can be easily installed to prevent a backflow of lubricant when redirecting the air flow and releasing the air on the outlet side of the regulator.

AKM 30 00 - □ 01 - A

① ② ③

Symbol

Symbol	Description	① Body size		
		20	30	40
② Pipe thread type	—	Rc	●	●
	N	NPT	●	●
	F	G	●	●
③ By-pass port size	+	1/8	●	●
	01	1/8	●	●
	02	1/4	●	●
		3/8	—	●

By-pass port size for redirecting air flow

Model	By-pass port size	A	B	C	D	E	Applicable model
AKM2000-A	1/8, 1/4	40	28	11	40	11	AC20-B, AC20A-B
AKM3000-A	1/8, 1/4	53	34	14	48	13	AC25-B AC30-B, AC30A-B
AKM4000-A	1/4, 3/8	70	42	18	54	15	AC40-B, AC40A-B ^{*1}

Specifications

Model	Effective area [mm ²]
AKM2000-A	28
AKM3000-A	55
AKM4000-A	111

Be sure to use above check valves when redirecting the air flow on the inlet side of the lubricator. Threads for IN and OUT ports are not machined.

*1 Cannot be mounted on the AC40□-06-B.
* Refer to the attachment table above for standard by-pass port sizes applicable to the AC.

AC Series

Pressure Switch: (S)

A compact integrated pressure switch can be easily installed and facilitates the pressure detection of the line.

IS10M-30-□-A

① ②

- Semi-standard: Select one each for **a** to **c**.
- Semi-standard symbol: When more than one specification is required, indicate in alphanumeric order.
Example) IS10M-30-6LP

		Symbol	Description	① Body size				
				20	30	40	50	60
② Semi-standard	a	Set pressure range	—	0.1 to 0.4 MPa				
			6*1	0.1 to 0.6 MPa				
	b	Lead wire length	—	0.5 m				
			L	3 m				
			Z	5 m				
	c	Pressure unit of the scale plate	—	MPa				
P*2			MPa/psi dual scale					

*1 Set pressure range of 6P (L, Z) is 0.2 to 0.6 MPa (30 to 90 psi).

Specifications

Fluid	Air
Ambient and fluid temperature	-5 to 60 °C (with no freezing)
Proof pressure	1.0 MPa
Maximum operating pressure	0.7 MPa
Set pressure range (when OFF)	0.1 to 0.4 MPa
Hysteresis	0.08 MPa or less

Switch Characteristics

Contact point configuration	1a
Maximum contact point capacity	2 VA (AC), 2 W (DC)
Operating voltage: AC, DC	100 V or less
Maximum operating current	12 V to 24 V AC, DC: 50 mA 48 V AC, DC: 40 mA 100 V AC, DC: 20 mA

* For detailed specifications on the IS10 series, refer to the IS10 series section of the SMC website: <http://www.smc.eu>

T-Spacer: (T) M5 x 0.8, 1/8, 1/4, 3/8, 1/2

Using a T-spacer facilitates the branching of air flow.

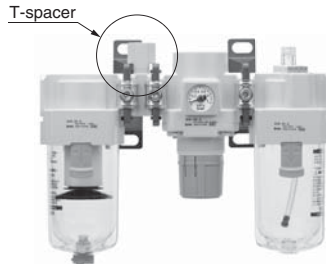
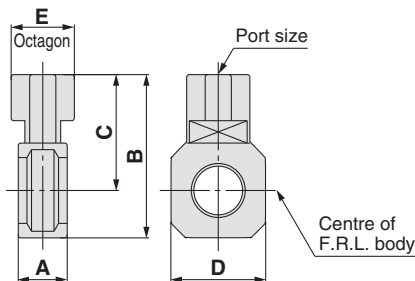

Symbol



Pressure switch

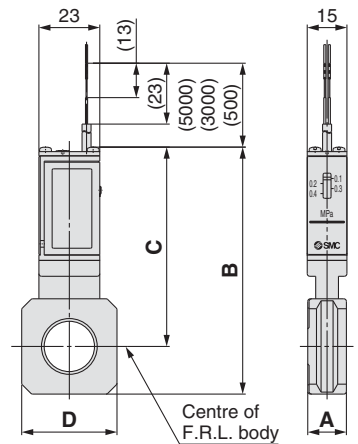

Model	A	B	C	D	Applicable model
IS10M-20-A	10.6	74.2	64.4	28	AC20□-B
IS10M-30-A	12.6	84.5	70.5	30	AC25□-B, AC30□-B
IS10M-40-A	14.6	93.3	75.3	36	AC40□-B
IS10M-50-A	16.6	97.3	77.3	44	AC40□-06-B
IS10M-60-A	22	92.5	68.5	53	AC50□-B, AC55□-B, AC60□-B

* Separate spacers are required for modular unit.

Model *1	Port size	A	B	C	D	E	Applicable model
Y110-M5-A	M5 x 0.8	11.2	19	12	14	8	AC10-A, AC10B-A
Y210-□01-A	1/8	14.6	41.8	32	28	19	AC20-B, AC20B-B AC20C-B
Y210-□02-A	1/4						
Y310-□01-A	1/8	14.6	52.7	38.7	30	19	AC25-B, AC25B-B AC25C-B, AC30C-B
Y310-□02-A	1/4						
Y410-□02-A	1/4	18.6	62	44	36	24	AC40-B, AC40B-B AC40C-B
Y410-□03-A	3/8						
Y510-□02-A	1/4	18.6	66	46	44	24	AC40-06-B, AC40B-06-B AC40C-06-B
Y510-□03-A	3/8						
Y610-□03-A	3/8	22	81	57	53	30	AC50-B, AC55-B, AC60-B, AC50B-B, AC55B-B, AC60B-B
Y610-□04-A	1/2						

*1 □ in model numbers indicates a pipe thread type. No indication is necessary for Rc; however, indicate N for NPT, and F for G.

* Separate spacers are required for modular unit.

* Refer to the attachment table on page 34 for standard port sizes when using with the AC.

Caution on Mounting

If a T-spacer is used on the inlet side of the lubricator, lubricant may be mixed. Use the AKM series check valve to avoid such possibility.

Pressure Relief 3 Port Valve: (V)

With the use of a pressure relief 3 port valve, pressure left in the line can be easily exhausted.

VHS 30 - **03** **A** -

1
 2
 3
 4

<ul style="list-style-type: none"> Semi-standard: Select one each for a to b. Semi-standard symbol: When more than one specification is required, indicate in alphanumeric order. Example) VHS30-03A-RZ						
Symbol	Description	1				
		Body size				
		20	30	40	50	
2	Pipe thread type	—	Rc			
		N*1	NPT			
		F*1	G			
		+				
3	Port size	01	1/8			
		02	1/4			
		03	3/8			
		04	1/2			
		06	3/4			
		+				
4	a	Flow direction	—	Flow direction: Left to right		
		R	Flow direction: Right to left			
			+			
	b	Pressure unit	—	Name plate in SI units: MPa		
Z*1		Name plate in imperial units: psi				

*1 For pipe thread type: NPT only.

Flow Rate Characteristics

Model	Port size		Flow rate characteristics					
	IN, OUT	EXH	IN → OUT			OUT → EXH		
			C(dm ³ /s·bar)	b	Cv	C(dm ³ /s·bar)	b	Cv
VHS20	1/8	1/8	2.4	0.43	0.65	2.5	0.39	0.69
	1/4		3.3	0.40	0.88	3.1	0.51	0.84
VHS30	1/4	1/4	6.4	0.45	1.7	6.2	0.38	1.7
	3/8		8.3	0.41	2.3	7.0	0.41	1.9
VHS40	1/4	3/8	7.3	0.49	2.0	8.5	0.35	2.3
	3/8		10.9	0.45	3.0	11.6	0.40	3.1
	1/2		14.2	0.39	3.8	13.3	0.43	3.6
VHS40-06	3/4	1/2	18.3	0.31	5.0	17.7	0.37	4.8
VHS50	3/4	1/2	23.8	0.41	6.4	21.8	0.41	5.9
	1		31.9	0.33	8.6	23.5	0.44	6.4

Cross Spacer: M5 x 0.8, 1/8, 1/4, 3/8, 1/2

Pipings are possible in all 4 directions.
 IN/OUT ports are not machined for threads.
 Please contact SMC if threaded (machined) ports are required.

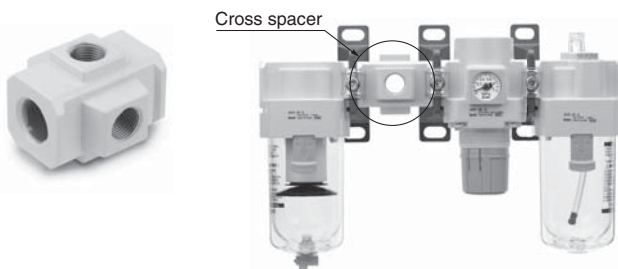

Caution on Mounting

- When mounting a cross spacer directly on the IN side of the lubricator, be sure to use the AKM series check valve between the lubricator and cross spacer.
- Factory mounting of a cross spacer on the AC model is available as a special order.

Pressure relief 3 port valve

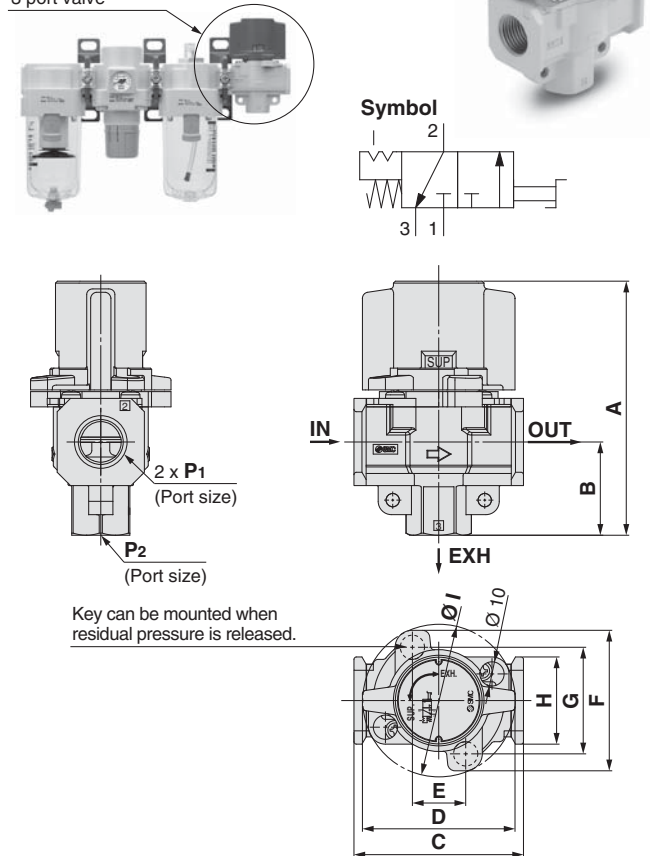

Model	Standard specifications										
	P ₁	P ₂	A	B	C	D	E	F	G	H	I
VHS20	1/8, 1/4	1/8	66.4	22.3	40	37.5	14	46.6	33.6	28	43
VHS30	1/4, 3/8	1/4	80.3	29.4	53	49	19	52	38	30	49
VHS40	1/4, 3/8, 1/2	3/8	104.9	38.5	70	63	22	58	44	36	63
VHS40-06	3/4	1/2	110.4	42	75	63	22	58	44	44	63
VHS50	3/4, 1	1/2	134.3	53	90	76	26	76	61	53	81

* Use an air filter on the inlet side for operating protection.

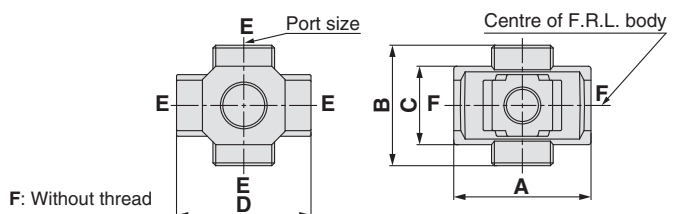

Model *1	E (Port size)	A	B	C	D	Applicable model
Y14-M5-A	M5	23	16	14	25	AC10□-A
Y24-□01-A	1/8	40	40	22	40	AC20□-B
Y24-□02-A	1/4					
Y34-□01-A	1/8	49	43	28	48	AC25□-B, AC30□-B
Y34-□02-A	1/4					
Y44-□02-A	1/4	60	48	36	54	AC40□-B
Y44-□03-A	3/8					
Y54-□03-A	3/8	72	62	40	62	AC40□-06-B
Y54-□04-A	1/2					

- *1 □ in model numbers indicates a pipe thread type. No indication is necessary for Rc; however, indicate N for NPT, and F for G.
- * If threaded IN/OUT ports are required, they are available as a special order. Please contact SMC.
- * Two hexagon socket head plugs are included in the package.

AC
 AF+AR+AL
 AW+AL
 AF+AR
 AF+AFM+AR
 AW+AFM
 Attachment
 AF
 AFM/AFD
 AR
 AL
 AW

AC Series

Piping Adapter: M5 x 0.8, 1/8, 1/4, 3/8, 1/2, 3/4, 1

A piping adapter allows installation/removal of the component without removing the piping and thus makes maintenance easier.

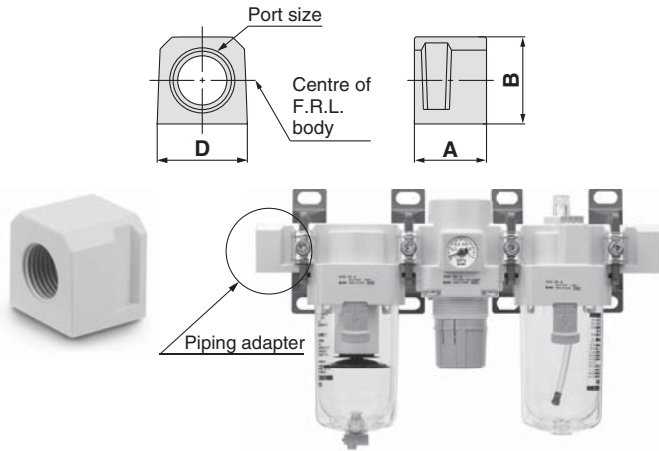

Model *1	Port size	A	B	D	Applicable model
E100-M5-A	M5 x 0.8	10	14	14	AC10□-A
E200-□01-A	1/8	29.8	23.5	28	AC20□-B
E200-□02-A	1/4				
E200-□03-A	3/8				
E300-□02-A	1/4	31.8	30	30	AC25□-B, AC30□-B
E300-□03-A	3/8				
E300-□04-A	1/2				
E400-□02-A	1/4	31.8	36	36	AC40□-B
E400-□03-A	3/8				
E400-□04-A	1/2				
E400-□06-A	3/4	31.8	40	44	AC40□-06-B
E500-□06-A	3/4				
E600-□06-A	3/4	35	48	53	AC50-B, AC55-B, AC60-B, AC50A-B, AC60A-B, AC50B-B, AC55B-B, AC60B-B
E600-□10-A	1				

*1 □ in model numbers indicates a pipe thread type. No indication is necessary for Rc; however, indicate N for NPT, and F for G.

* Separate spacers are required for modular unit.

* Factory mounting of a piping adapter on the AC models is available as a special order.

Pressure Switch with Piping Adapter

IS10E - **30** - **03** - **□** - **A**

① ② ③ ④

- Semi-standard: Select one each for a to d.
- Semi-standard symbol: When more than one specification is required, indicate in alphanumeric order. Example) IS10E-30N03-6PRZ

	Symbol	Description	①			
			20	30	40	
② Pipe thread type	—	Rc	●	●	●	
	N*2	NPT	●	●	●	
	F*2	G	●	●	●	
③ Port size	+ 01	1/8	●	—	—	
	02	1/4	●	●	●	
	03	3/8	●	●	●	
	04	1/2	—	●	●	
	06	3/4	—	—	●	
④ Semi-standard	a Set pressure range	— 0.1 to 0.4 MPa	●	●	●	
		+ 6*1 0.1 to 0.6 MPa	●	●	●	
	b Lead wire length	—	0.5 m	●	●	●
		L	3 m	●	●	●
		Z	5 m	●	●	●
	c Pressure unit of the scale plate	—	MPa	●	●	●
		P*2	MPa/psi dual scale	●	●	●
	d Mounting position	—	Right	●	●	●
		R	Left	●	●	●

*1 Set pressure range of 6P (L, R, Z) is 0.2 to 0.6 MPa (30 to 90 psi).

*2 For pipe thread type: NPT only.

Specifications

Fluid	Air
Ambient and fluid temperature	-5 to 60 °C (with no freezing)
Proof pressure	1.0 MPa
Maximum operating pressure	0.7 MPa
Set pressure range (when OFF)	0.1 to 0.4 MPa
Hysteresis	0.08 MPa or less

Switch Characteristics

Contact point configuration	1a
Maximum contact point capacity	2 VA (AC), 2 W (DC)
Operating voltage: AC, DC	100 V or less
Maximum operating current	12 V to 24 V AC, DC: 50 mA 48 V AC, DC: 40 mA 100 V AC, DC: 20 mA

Symbol

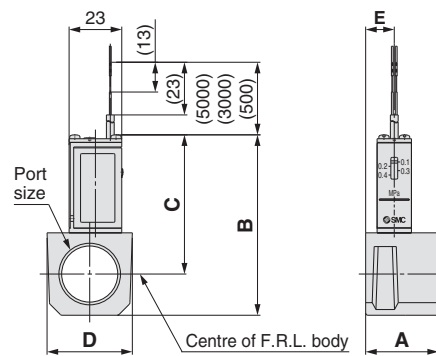
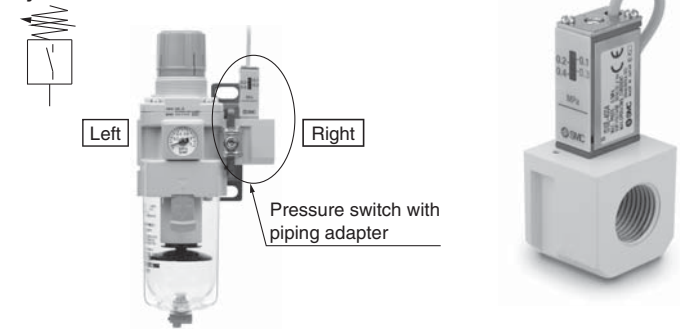

Model *1	Port size	A	B	C	D	E	Applicable model
IS10E-20□01-A	1/8	29.8	66.3	55.3	28	16	AC20□-B
IS10E-20□02-A	1/4						
IS10E-20□03-A	3/8						
IS10E-30□02-A	1/4	31.8	72.8	58.8	30	13	AC25□-B, AC30□-B
IS10E-30□03-A	3/8						
IS10E-30□04-A	1/2						
IS10E-40□02-A	1/4	31.8	78.8	60.8	37	12.5	*2 AC40□-B
IS10E-40□03-A	3/8						
IS10E-40□04-A	1/2						
IS10E-40□06-A	3/4						

*1 □ in the model numbers indicates a pipe thread type. No indication is necessary for Rc; however, indicate N for NPT, and F for G.

*2 Cannot be mounted on the AC40□-06-B.

* Separate spacers are required for modular unit.

* The pressure switch on the AC40□-06-B can be mounted by screwing IS10-01S into the piping adapter E500-□06-A-X501 (with top-face thread Rc 1/8). Products with a premounted switch are available as a special order. Please contact SMC regarding their availability.

AC Series Accessories (Spacers/Brackets)

Spacer

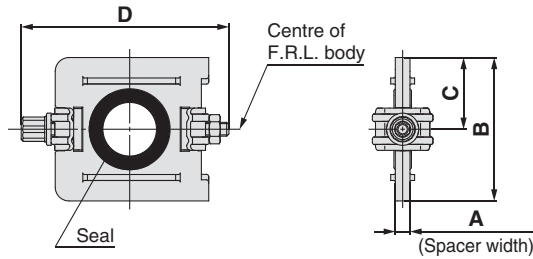

Model	A	B	C	D	Applicable model
Y100-A	6	17.9	9	35.4	AC10□-A
Y200-A	3.2	31.2	15.6	44.9	AC20□-B
Y300-A	4.2	43.4	21.7	57.9	AC25□-B, AC30□-B
Y400-A	5.2	53	26.5	68.5	AC40□-B
Y500-A	5.2	57	28.5	75.6	AC40□-06-B
Y600-A	6.2	67.6	33.8	92.5	AC50□-B, AC55□-B, AC60□-B

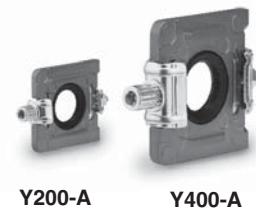

Replacement Parts

Description	Material	Part no.					
		Y100-A	Y200-A	Y300-A	Y400-A	Y500-A	Y600-A
Seal	HNBR (NBR) *1	Y120P-050AS *2	Y220P-050S	Y320P-050S	Y420P-050S	Y520P-050S	Y620P-050S

*1 (): Size 10

*2 Assembly of 2 O-rings

Spacer with Bracket

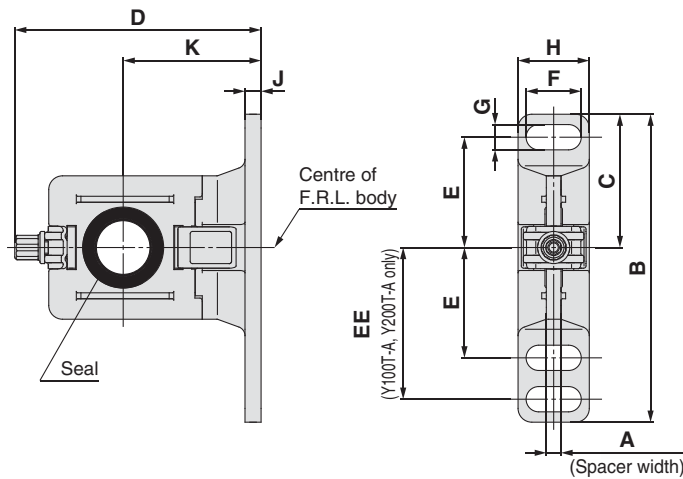

Model	A	B	C	D	E	EE	F	G	H	J	K	Applicable model
Y100T-A	6	56	24.5	43.6	20	27	6.8	4.5	13	3	25	AC10□-A
Y200T-A	3.2	67	29	53.4	24	33	12	5.5	15.5	3.5	30	AC20□-B
Y300T-A	4.2	82	41	71.5	35	—	14	7	19	4	41	AC25□-B, AC30□-B
Y400T-A	5.2	96	48	86.1	40	—	18	9	26	5	50	AC40□-B
Y500T-A	5.2	96	48	89.6	40	—	18	9	26	5	50	AC40□-06-B
Y600T-A	6.2	120	60	118	50	—	20	11	31.2	6	70	AC50□-B, AC55□-B, AC60□-B

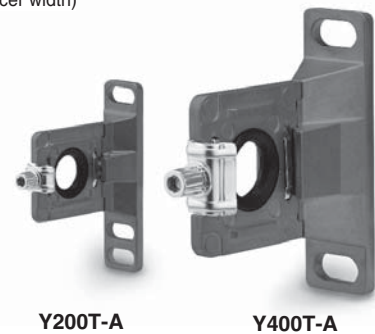

Replacement Parts

Description	Material	Part no.					
		Y100T-A	Y200T-A	Y300T-A	Y400T-A	Y500T-A	Y600T-A
Seal	HNBR (NBR) *1	Y120P-050AS *2	Y220P-050S	Y320P-050S	Y420P-050S	Y520P-050S	Y620P-050S

*1 (): Size 10

*2 Assembly of 2 O-rings

Mounting Position for Spacer with Bracket

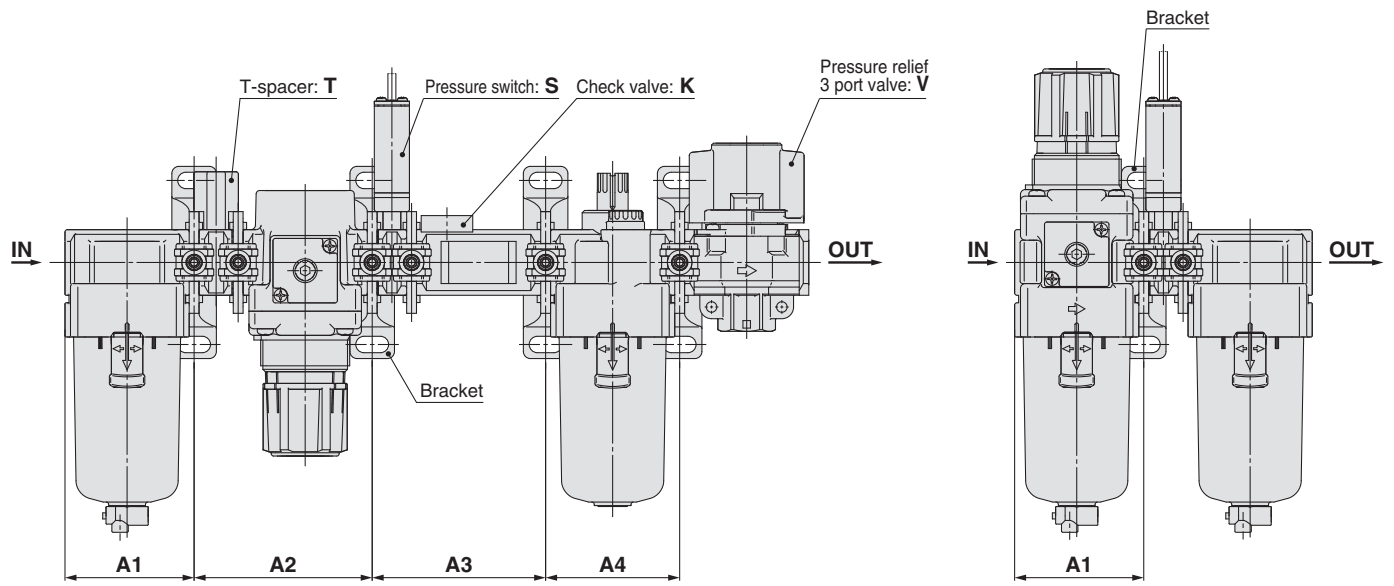

Attachment Model	K			S		T		V			KS			KT			KV				KST		
	A1	A2	A3	A1	A2	A1	A2	A1	A2	A3	A1	A2	A3	A1	A2	A3	A1	A2	A3	A4	A1	A2	A3
AC10-A	—	—	—	—	—	28	48.2	—	—	—	—	—	—	—	—	—	—	—	—	—	—	—	—
AC20-B	41.6	43.2	43.2	41.6	43.2	41.6	61	41.6	43.2	43.2	41.6	43.2	57	41.6	61	43.2	41.6	43.2	43.2	43.2	41.6	61	57
AC25-B	55.1	57.2	57.2	55.1	57.2	55.1	76	55.1	57.2	57.2	55.1	57.2	74	55.1	76	57.2	55.1	57.2	57.2	57.2	55.1	76	74
AC30-B	55.1	57.2	57.2	55.1	57.2	55.1	76	55.1	57.2	57.2	55.1	57.2	74	55.1	76	57.2	55.1	57.2	57.2	57.2	55.1	76	74
AC40-B	72.6	75.2	75.2	72.6	75.2	72.6	99	72.6	75.2	75.2	72.6	75.2	95	72.6	99	75.2	72.6	75.2	75.2	75.2	72.6	99	95
AC40-06-B	—	—	—	77.6	80.2	77.6	104	77.6	80.2	80.2	—	—	—	—	—	—	—	—	—	—	—	—	—
AC50-B	—	—	—	93.1	96.2	93.1	124	—	—	—	—	—	—	—	—	—	—	—	—	—	—	—	—
AC55-B	—	—	—	98.1	96.2	98.1	124	—	—	—	—	—	—	—	—	—	—	—	—	—	—	—	—
AC60-B	—	—	—	98.1	101.2	98.1	129	—	—	—	—	—	—	—	—	—	—	—	—	—	—	—	—

Attachment Model	KSV				KTV				KSTV				ST		SV			STV			TV		
	A1	A2	A3	A4	A1	A2	A3	A4	A1	A2	A3	A4	A1	A2	A1	A2	A3	A1	A2	A3	A1	A2	A3
AC10-A	—	—	—	—	—	—	—	—	—	—	—	—	—	—	—	—	—	—	—	—	—	—	—
AC20-B	41.6	43.2	57	43.2	41.6	61	43.2	43.2	41.6	61	57	43.2	41.6	61	41.6	43.2	57	41.6	61	57	41.6	61	57
AC25-B	55.1	57.2	74	57.2	55.1	76	57.2	57.2	55.1	76	74	57.2	55.1	76	55.1	57.2	74	55.1	76	74	55.1	76	74
AC30-B	55.1	57.2	74	57.2	55.1	76	57.2	57.2	55.1	76	74	57.2	55.1	76	55.1	57.2	74	55.1	76	74	55.1	76	74
AC40-B	72.6	75.2	95	75.2	72.6	99	75.2	75.2	72.6	99	95	75.2	72.6	99	72.6	75.2	95	72.6	99	95	72.6	99	95
AC40-06-B	—	—	—	—	—	—	—	—	—	—	—	—	77.6	104	77.6	80.2	102	77.6	104	102	77.6	104	80.2
AC50-B	—	—	—	—	—	—	—	—	—	—	—	—	93.1	124	93.1	189.3	124	93.1	124	124	93.1	124	96.2
AC55-B	—	—	—	—	—	—	—	—	—	—	—	—	98.1	124	—	—	—	—	—	—	—	—	—
AC60-B	—	—	—	—	—	—	—	—	—	—	—	—	98.1	129	—	—	—	—	—	—	—	—	—

Attachment Model	K		S		V		KS		KV			KSV			SV	
	A1	A2	A1	A2	A1	A2	A1	A2	A1	A2	A3	A1	A2	A3	A1	A2
AC20A-B	41.6	43.2	41.6	41.6	43.2	41.6	41.6	57	41.6	43.2	43.2	41.6	57	43.2	41.6	57
AC30A-B	55.1	57.2	55.1	55.1	57.2	55.1	55.1	74	55.1	57.2	57.2	55.1	74	57.2	55.1	74
AC40A-B	72.6	75.2	72.6	72.6	75.2	72.6	72.6	95	72.6	75.2	75.2	72.6	95	75.2	72.6	95
AC40A-06-B	—	—	77.6	77.6	80.2	—	—	—	—	—	—	—	—	—	77.6	102
AC50A-B	—	—	93.1	93.1	96.2	—	—	—	—	—	—	—	—	—	93.1	124
AC60A-B	—	—	98.1	—	—	—	—	—	—	—	—	—	—	—	—	—

Attachment Model	S		T		V		V1		SV		SV1		TV		TV1	
	A1	A1	A1	A2	A1	A2	A1	A2	A1	A2	A1	A2	A1	A2	A1	A2
AC10B-A	—	28	—	—	—	—	—	—	—	—	—	—	—	—	—	—
AC20B-B	41.6	41.6	41.6	43.2	41.6	43.2	41.6	57	41.6	43.2	41.6	61	41.6	43.2	41.6	43.2
AC25B-B	55.1	55.1	55.1	57.2	55.1	57.2	55.1	74	55.1	57.2	55.1	76	55.1	57.2	55.1	57.2
AC30B-B	55.1	55.1	55.1	57.2	55.1	57.2	55.1	74	55.1	57.2	55.1	76	55.1	57.2	55.1	57.2
AC40B-B	72.6	72.6	72.6	75.2	72.6	75.2	72.6	95	72.6	75.2	72.6	99	72.6	75.2	72.6	75.2
AC40B-06-B	77.6	77.6	77.6	80.2	77.6	80.2	77.6	102	77.6	80.2	77.6	104	77.6	80.2	77.6	80.2
AC50B-B	93.1	93.1	93.1	189.3	93.1	96.2	93.1	124	93.1	96.2	93.1	124	93.1	124	93.1	96.2
AC55B-B	98.1	98.1	—	—	—	—	—	—	—	—	—	—	—	—	—	—
AC60B-B	98.1	98.1	—	—	—	—	—	—	—	—	—	—	—	—	—	—

Attachment Model	S		T		V			V1			SV			SV1			TV			TV1		
	A1	A2	A1	A2	A1	A2	A3	A1	A2	A3	A1	A2	A3	A1	A2	A3	A1	A2	A3	A1	A2	A3
AC20C-B	41.6	43.2	41.6	43.2	41.6	43.2	43.2	41.6	43.2	43.2	41.6	43.2	57	41.6	43.2	43.2	41.6	43.2	61	41.6	43.2	43.2
AC25C-B	55.1	57.2	55.1	57.2	55.1	57.2	57.2	55.1	57.2	57.2	55.1	57.2	74	55.1	57.2	57.2	55.1	57.2	76	55.1	57.2	57.2
AC30C-B	55.1	57.2	55.1	57.2	55.1	57.2	57.2	55.1	57.2	57.2	55.1	57.2	74	55.1	57.2	57.2	55.1	57.2	76	55.1	57.2	57.2
AC40C-B	72.6	75.2	72.6	75.2	72.6	75.2	75.2	72.6	75.2	75.2	72.6	75.2	95	72.6	75.2	75.2	72.6	75.2	99	72.6	75.2	75.2
AC40C-06-B	77.6	80.2	77.6	80.2	77.6	80.2	80.2	77.6	80.2	80.2	77.6	80.2	102	77.6	80.2	80.2	77.6	80.2	104	77.6	80.2	80.2

Attachment Model	S		V		V1		SV		SV1	
	A1	A1	A1	A2	A1	A2	A1	A2	A1	A2
AC20D-B	41.6	41.6	43.2	41.6	43.2	41.6	57	41.6	43.2	43.2
AC30D-B	55.1	55.1	57.2	55.1	57.2	55.1	74	55.1	57.2	57.2
AC40D-B	72.6	72.6	75.2	72.6	75.2	95	72.6	75.2	75.2	75.2
AC40D-06-B	77.6	77.6	80.2	77.6	80.2	102	77.6	80.2	80.2	80.2

A1: Dimension from the end of the IN side to the centre of the mounting hole for the first bracket.

A2: Mounting hole pitch between the first and the second brackets.

A3: Mounting hole pitch between the second and the third brackets.

A4: Mounting hole pitch between the third and the fourth brackets.

AC

AF+AR+AL

AW+AL

AF+AR

AF+AFM+AR

AW+AFM

Attachment

AF

AFM / AFD

AR



AL

AW

Modular Type

Air Filters

AF/AFM/AFD Series

Air Filter AF Series	Model	Port size	Filtration μm	Options
 <p data-bbox="134 891 343 929">Pages 43 to 54</p>	AF10-A	M5 x 0.8	5	Bracket (Except AF10-A) Float type auto drain
	AF20-A	1/8, 1/4		
	AF30-A	1/4, 3/8		
	AF40-A	1/4, 3/8, 1/2		
	AF40-06-A	3/4		
	AF50-A	3/4, 1		
	AF60-A	1		
 <p data-bbox="134 1220 343 1258">Pages 55 to 63</p>	AFM20-A	1/8, 1/4	0.3	Bracket Float type auto drain
	AFM30-A	1/4, 3/8		
	AFM40-A	1/4, 3/8, 1/2		
	AFM40-06-A	3/4		
 <p data-bbox="134 1550 343 1588">Pages 55 to 63</p>	AFD20-A	1/8, 1/4	0.01	Bracket Float type auto drain
	AFD30-A	1/4, 3/8		
	AFD40-A	1/4, 3/8, 1/2		
	AFD40-06-A	3/4		

- AC
- AF+AR+AL
- AW+AL
- AF+AR
- AF+AFM+AR
- AW+AFM
- Attachment
- AF
- AFM / AFD
- AR
- AL
- AW

Air Filter

AF10-A to AF60-A

Symbol
Air Filter

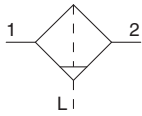

Air Filter with Auto Drain

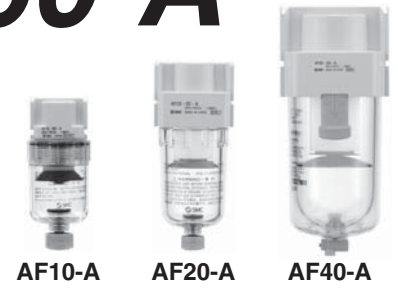
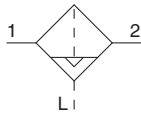

How to Order

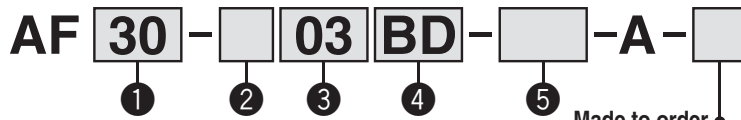

Made to order

(Refer to pages 51 to 53 for details.)

- Option/Semi-standard: Select one each for a to f.
- Option/Semi-standard symbol: When more than one specification is required, indicate in alphanumeric order.
Example) AF30-03BD-R-A

	Symbol	Description	① Body size					
			10	20	30	40	50	60
②	Pipe thread type	—	Metric thread (M5)					
		N*1	●	—	—	—	—	—
		F*2	—	●	●	●	●	●
		+	—	●	●	●	●	●
③	Port size	M5	●	—	—	—	—	—
		01	—	●	—	—	—	—
		02	—	●	●	—	—	—
		03	—	—	●	●	—	—
		04	—	—	—	●	—	—
		06	—	—	—	●	●	—
		10	—	—	—	—	●	●
④	a	—	●	●	●	●	●	●
		B*3	—	●	●	●	●	●
	b	—	●	●	●	●	●	●
		C*4	●	●	●	●	●	●
		D*5	—	—	●	●	●	●
		+	—	—	—	—	—	—
⑤	c	—	●	●	●	●	●	●
		2	●	●	●	●	●	●
		6	●	●	●	●	●	●
		8	●	●	●	●	●	●
		C	—	—	—	—	—	—
		6C	—	●	—*7	—*7	—*7	—*7
	d	—	●	●	●	●	●	●
		J*10	—	●	—	—	—	—
		W*11	—	—	●	●	●	●
	e	—	●	●	●	●	●	●
		R	●	●	●	●	●	●
f	—	●	●	●	●	●	●	
	Z*12	○*13	○*13	○*13	○*13	○*13	○*13	

- *1 Drain guide is NPT 1/8 (applicable to the AF20-A) and NPT 1/4 (applicable to the AF30-A to AF60-A). The auto drain port comes with Ø 3/8" One-touch fitting (applicable to the AF30-A to AF60-A).
- *2 Drain guide is G 1/8 (applicable to the AF20-A) and G 1/4 (applicable to the AF30-A to AF60-A). The auto drain port comes with Ø 10 One-touch fitting (applicable to the AF30-A to AF60-A).
- *3 Option B is not assembled and supplied loose at the time of shipment. Assembly of a bracket and 2 mounting screws.
- *4 When pressure is not applied, condensate which does not start the auto drain mechanism will be left in the bowl. Releasing the residual condensate before ending operations for the day is recommended.
- *5 If the compressor is small (0.75 kW, discharge flow is less than 100 l/min [ANR]), air leakage from the drain cock may occur during start of operations. N.C. type is recommended.
- *6 Refer to chemical data on page 46 for chemical resistance of the bowl.
- *7 A bowl guard is provided as standard equipment (polycarbonate).
- *8 A bowl guard is provided as standard equipment (nylon).
- *9 The combination of float type auto drain: C and D is not available.
- *10 Without a valve function
- *11 The combination of metal bowl: 2 and 8 is not available.
- *12 For pipe thread type: M5, NPT.
- *13 ○: For pipe thread type: M5, NPT only

Standard Specifications

Model	AF10-A	AF20-A	AF30-A	AF40-A	AF40-06-A	AF50-A	AF60-A
Port size	M5 x 0.8	1/8, 1/4	1/4, 3/8	1/4, 3/8, 1/2	3/4	3/4, 1	1
Fluid	Air						
Ambient and fluid temperature	-5 to 60 °C (with no freezing)						
Proof pressure	1.5 MPa						
Maximum operating pressure	1.0 MPa						
Nominal filtration rating	5 μm						
Drain capacity [cm ³]	2.5	8	25	45			
Bowl material	Polycarbonate						
Bowl guard	—	Semi-standard (Steel)	Standard (Polycarbonate)				
Weight [kg]	0.06	0.08	0.18	0.36	0.41	0.87	1.00

Option/Part No.

Optional specifications	Model						
	AF10-A	AF20-A	AF30-A	AF40-A	AF40-06-A	AF50-A	AF60-A
Bracket assembly *1	—	AF22P-050AS	AF32P-050AS	AF42P-050AS	AF42P-070AS	AF52P-050AS	

*1 Assembly of a bracket and 2 mounting screws

Bowl Assembly/Part No.

Bowl material	Drain discharge mechanism	Drain port	Other	Model							
				AF10-A	AF20-A	AF30-A	AF40-A	AF40-06-A	AF50-A	AF60-A	
Polycarbonate	Manual	With drain cock	—	C1SF-A	C2SF-A	—	—				
		With bowl guard	—	—	C2SF-C-A	C3SF-A	C4SF-A				
		Drain cock with barb fitting	With bowl guard	—	—	C3SF-W-A	C4SF-W-A				
		With drain guide (without valve function)	With bowl guard	—	—	C2SF□-J-A	—	—			
	Automatic *1 (Auto drain)	Normally closed (N.C.)	—	AD17-A	AD27-A	—	—				
		With bowl guard	—	—	AD27-C-A	AD37□-A	AD47□-A				
Nylon	Manual	Normally open (N.O.)	With bowl guard	—	—	AD38□-A	AD48□-A				
		With drain cock	—	C1SF-6-A	C2SF-6-A	—	—				
		With bowl guard	—	—	C2SF-6C-A	C3SF-6-A	C4SF-6-A				
		Drain cock with barb fitting	With bowl guard	—	—	C3SF-6W-A	C4SF-6W-A				
	Automatic *1 (Auto drain)	With drain guide (without valve function)	With bowl guard	—	—	C2SF□-6J-A	—	—			
		With bowl guard	—	—	C2SF□-6CJ-A	C3SF□-6J-A	C4SF□-6J-A				
Metal	Manual	Normally closed (N.C.)	—	AD17-6-A	AD27-6-A	—	—				
		With bowl guard	—	—	AD27-6C-A	AD37□-6-A	AD47□-6-A				
		Normally open (N.O.)	With bowl guard	—	—	AD38□-6-A	AD48□-6-A				
		With drain cock	—	C1SF-2-A	C2SF-2-A	C3SF-2-A	C4SF-2-A				
	Automatic *1 (Auto drain)	With drain guide (without valve function)	With level gauge	—	—	C3LF-8-A	C4LF-8-A				
		With bowl guard	—	—	C2SF□-2J-A	C3SF□-2J-A	C4SF□-2J-A				
Metal	Manual	With level gauge	—	—	C3LF□-8J-A	C4LF□-8J-A					
		Normally closed (N.C.)	—	AD17-2-A	AD27-2-A	AD37□-2-A	AD47□-2-A				
	Automatic *1 (Auto drain)	With level gauge	—	—	AD37□-8-A	AD47□-8-A					
		Normally open (N.O.)	With level gauge	—	—	AD38□-2-A	AD48□-2-A				
Metal	Automatic *1 (Auto drain)	With level gauge	—	—	AD38□-8-A	AD48□-8-A					

*1 Minimum operating pressure: N.O. type—0.1 MPa (AD38-A, AD48-A); N.C. type—0.1 MPa (AD17-A, AD27-A) and 0.15 MPa (AD37-A, AD47-A).

Bowl assembly for the AF20-A to AF60-A models comes with a bowl seal.

□ in bowl assembly part numbers indicates a pipe thread type (applicable tubing for auto drain).

No indication is necessary for Rc thread; however, indicate N for NPT thread, and F for G thread. (For auto drain, —: Ø 10, N: Ø 3/8")

Please consult with SMC separately for psi and °F unit display specifications.

AC
 AF+AR+AL
 AW+AL
 AF+AR
 AF+AFM+AR
 AW+AFM
 Attachment
 AF
 AFM / AFD
 AR
 AL
 AW

AF10-A to AF60-A Series

Flow Rate Characteristics (Representative values)

AF10-A

M5

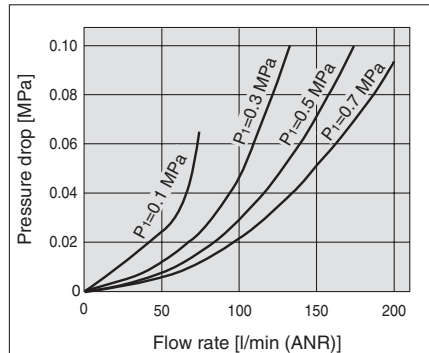

AF20-A

Rc 1/4

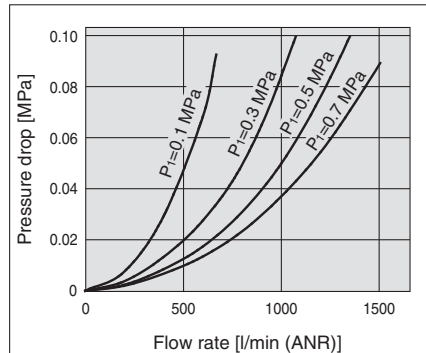

AF30-A

Rc 3/8

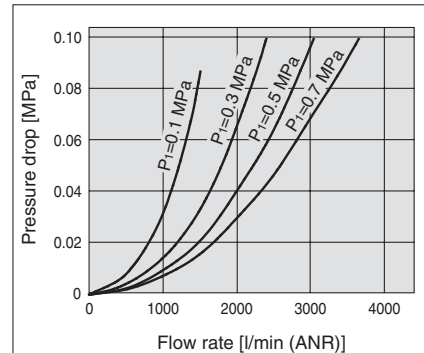

AF40-A

Rc 1/2

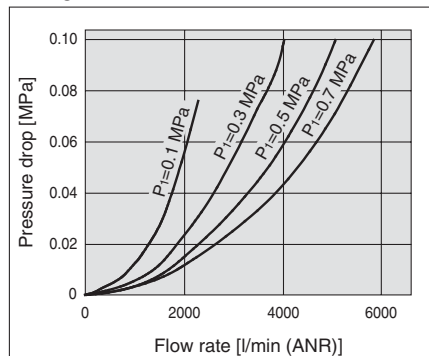

AF40-06-A

Rc 3/4

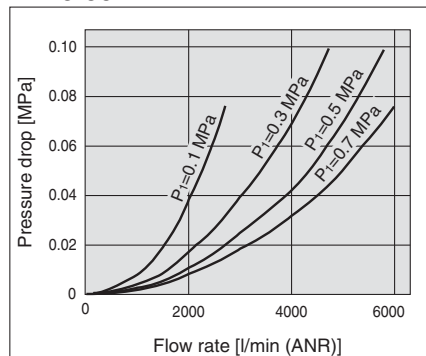

AF50-A

Rc 1

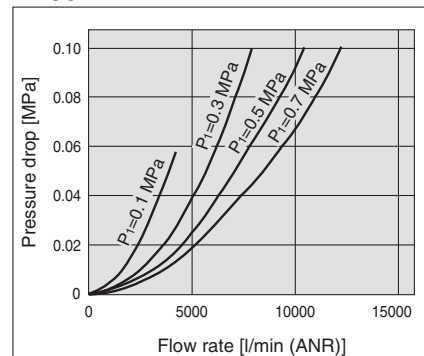

AF60-A

Rc 1

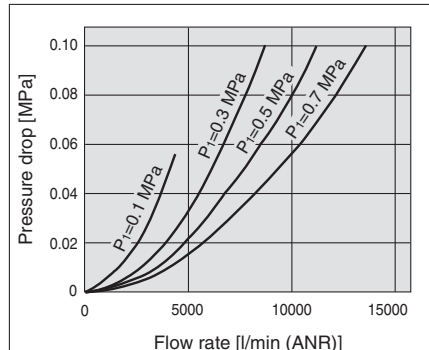

⚠ Specific Product Precautions

Be sure to read this before handling the products. Refer to the back cover for safety instructions. For F.R.L. units precautions, refer to the “Handling Precautions for SMC Products” and the “Operation Manual”, <http://www.smc.eu>

Design/Selection

⚠ Warning

- The standard bowl for the air filter, filter regulator, and lubricator, as well as the sight dome for the lubricator are made of polycarbonate. Do not use in an environment where they are exposed to or come in contact with organic solvents, chemicals, cutting oil, synthetic oil, alkali, and thread lock solutions.

Effects of atmosphere of organic solvents and chemicals, and where these elements are likely to adhere to the equipment.

Chemical data for substances causing degradation (Reference)

Type	Chemical name	Application examples	Material	
			Polycarbonate	Nylon
Acid	Hydrochloric acid Sulfuric acid, Phosphoric acid Chromic acid	Acid washing liquid for metals	△	×
Alkaline	Sodium hydroxide (Caustic soda) Potash Calcium hydroxide (Slack lime) Ammonia water Carbonate of soda	Degreasing of metals Industrial salts Water-soluble cutting oil	×	○
Inorganic salts	Sodium sulfide Potassium nitrate Sulfate of soda	—	×	△
Chlorine solvents	Carbon tetrachloride Chloroform Ethylene chloride Methylene chloride	Cleansing liquid for metals Printing ink Dilution	×	△
Aromatic series	Benzene Toluene Paint thinner	Coatings Dry cleaning	×	△
Ketone	Acetone Methyl ethyl ketone Cyclohexane	Photographic film Dry cleaning Textile industries	×	×
Alcohol	Ethyl alcohol IPA Methyl alcohol	Antifreeze Adhesives	△	×
Oil	Gasoline Kerosene	—	×	○
Ester	Phthalic acid dimethyl Phthalic acid diethyl Acetic acid	Synthetic oil Anti-rust additives	×	○
Ether	Methyl ether Ethyl ether	Brake oil additives	×	○
Amino	Methyl amino	Cutting oil Brake oil additives Rubber accelerator	×	×
Others	Thread-lock fluid Seawater Leak tester	—	×	△

○: Essentially safe △: Some effects may occur. ×: Effects will occur.

When the above factors are present, or there is some doubt, use a metal bowl for safety.

Maintenance

⚠ Warning

- Replace the element every 2 years or when the pressure drop becomes 0.1 MPa, whichever comes first, to prevent damage to the element.

Mounting/Adjustment

⚠ Caution

- When the bowl is installed on the air filter (AF30-A to AF60-A), install them so that the lock button lines up to the groove of the front (or the back) of the body to avoid drop or damage of the bowl.



AC

AF+AR+AL

AW+AL

AF+AR

AF+AFM+AR

AW+AFM

Attachment

AF

AFM / AFD

AR

AL

AW

AF10-A to AF60-A Series

Working Principle: Float Type Auto Drain

N.O. type: AD38-A, AD48-A

N.C. type: AD37-A, AD47-A

Compact auto drain N.C. type:
AD17-A, AD27-A

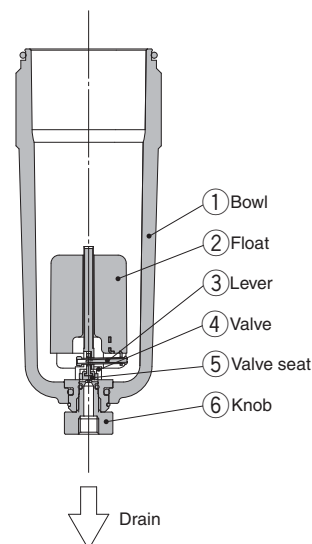
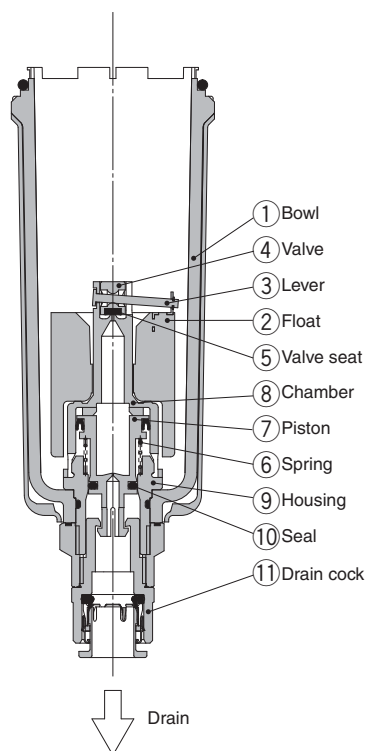
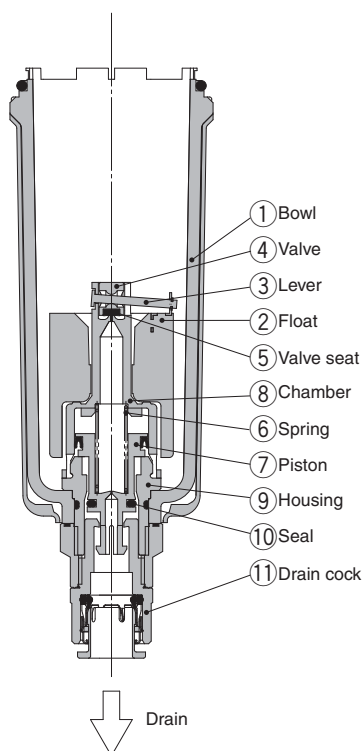

• **When pressure inside the bowl is released:**

When pressure is released from the bowl ①, the piston ⑦ is lowered by the spring ⑥. The sealing action of the seal ⑩ is interrupted, and the outside air flows inside the bowl ① through the housing hole ⑨ and the drain cock ⑪.

Therefore, if there is an accumulation of condensate in the bowl ①, it will drain out through the drain cock.

• **When pressure is applied inside the bowl:**

When pressure is 0.1 MPa or more, the force of the piston ⑦ surpasses the force of the spring ⑥, and the piston goes up. This pushes seal ⑩ up so that it creates a seal, and the inside of the bowl ①, is shut off from the outside air.

If there is no accumulation of condensate in the bowl ① at this time, the float ② will be pulled down by its own weight, causing the valve ④, which is connected to the lever ③, to seal the valve seat ⑤.

• **When there is an accumulation of condensate in the bowl:**

The float ② rises due to its own buoyancy and the seal at the valve seat ⑤ is interrupted. This allows the pressure inside the bowl ① to enter the chamber ⑧. The result is that the combined pressure inside the chamber ⑧ and the force of the spring ⑥ lowers the piston ⑦. This causes the sealing action of the seal ⑩ to be interrupted, and the accumulated condensate in the bowl ① drains out through the drain cock ⑪.

Turning the drain cock ⑪ manually counterclockwise lowers the piston ⑦, and causes the seal created by the seal ⑩ to be interrupted, thus allowing the condensate to drain out.

• **When pressure inside the bowl is released:**

Even when pressure inside the bowl ① is released, spring ⑥ keeps the piston ⑦ in its upward position.

This keeps the seal created by the seal ⑩ in place; thus, the inside of the bowl ① is shut off from the outside air.

Therefore, even if there is an accumulation of condensate in the bowl ①, it will not drain out.

• **When pressure is applied inside the bowl:**

Even when pressure is applied inside the bowl ①, the combined force of the spring ⑥ and the pressure inside the bowl ① keeps the piston ⑦ in its upward position.

This maintains the seal created by the seal ⑩ in place; thus, the inside of the bowl ① is shut off from the outside air.

If there is no accumulation of condensate in the bowl ① at this time, the float ② will be pulled down by its own weight, causing the valve ④, which is connected to the lever ③, to seal the valve seat ⑤.

• **When there is an accumulation of condensate in the bowl:**

The float ② rises due to its own buoyancy and the seal at the valve seat ⑤ is interrupted. This allows the pressure inside the bowl ① to enter the chamber ⑧.

The result is that the pressure inside the chamber ⑧ surpasses the force of the spring ⑥ and pushes the piston ⑦ downward.

This causes the sealing action of the seal ⑩ to be interrupted and the accumulated condensate in the bowl ① drains out through the drain cock ⑪.

Turning the drain cock ⑪ manually counterclockwise lowers the piston ⑦, and causes the seal created by the seal ⑩ to be interrupted, thus allowing the condensate to drain out.

• **When pressure inside the bowl is released:**

Even when pressure inside the bowl ① is released, the weight of the float ② causes the valve ④, which is connected to the lever ③, to seal the valve seat ⑤. As a result, the inside of the bowl ① is shut off from the outside air.

Therefore, even if there is an accumulation of condensate in the bowl ①, it will not drain out.

• **When pressure is applied inside the bowl:**

Even when pressure is applied inside the bowl ①, the weight of the float ② and the differential pressure that is applied to the valve ④ cause the valve ④ to seal the valve seat ⑤, and the outside air is shut off from the inside of the bowl ①.

• **When there is an accumulation of condensate in the bowl:**

The float ② rises due to its own buoyancy and the seal at the valve seat ⑤ is interrupted.

The condensate inside the bowl ① drains out through the knob ⑥.

Turning the knob ⑥ manually counterclockwise lowers it and causes the sealing action of the valve seat ⑤ to be interrupted, which allows the condensate to drain out.

Operating State and Proper Use of Float Type Auto Drain

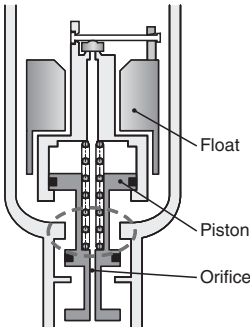
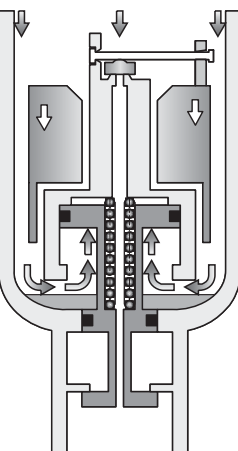
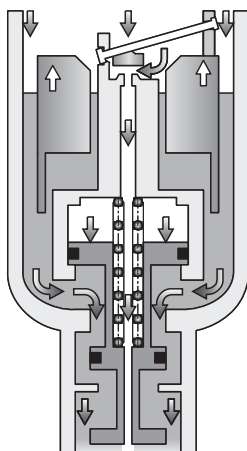
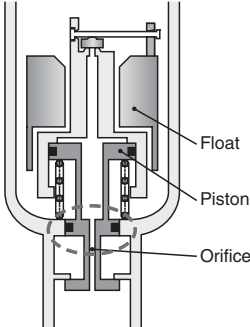
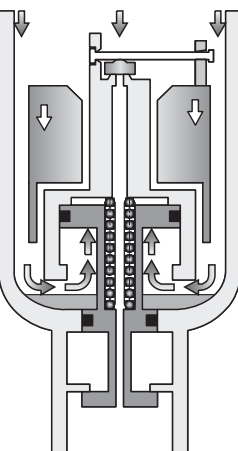
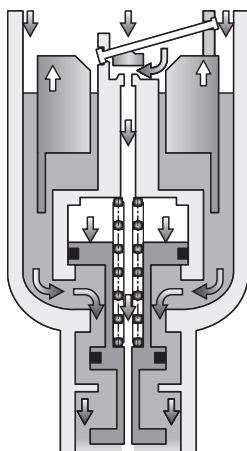
Auto drain	When pressure is not applied (After exhausting residual pressure)	When pressure is applied		Minimum operating pressure (Outlet pressure)
		Before drain accumulates	When drain accumulates	
N.O. Normally open	Drain discharged (Open) 	Drain not discharged (Close) 	Drain discharged (Open) 	0.1 MPa or more AF30-A to AF60-A
N.C. Normally closed	Drain not discharged (Close) 			0.1 MPa or more AF10-A to AF20-A 0.15 MPa or more AF30-A to AF60-A

◆ For both N.O. and N.C., the drain can be discharged manually by turning the drain cock to the “O” position.
(Except for medium air pressure, AFF75B, AM□850, and free standing type)

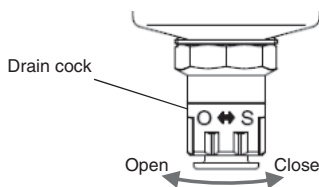

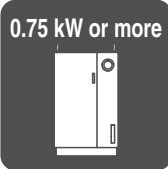
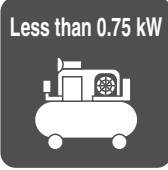
Proper Use			Recommended auto drain
Compressor	When pressure is not applied (After exhausting residual pressure)	Cold climates	
0.75 kW or more 	Drain not accumulated Do not want to accumulate drain generated at the inlet side when pressure is not applied.	Want to prevent troubles caused by freezing.	N.O. ^{Note)} Normally open
Less than 0.75 kW 	Drain accumulated	—	N.C. Normally closed

Note) For N.O. (Normally open) type, the drain discharge passage is open when pressure is not applied. For this reason, the drain exhaust port is not closed completely in a compressor with a small supply amount (less than 0.75 kW) and the air will ceaselessly blow out.

AC
 AF+AR+AL
 AW+AL
 AF+AR
 AF+AFM+AR
 AW+AFM
 Attachment
 AF
 AFM/AFD
 AR
 AL
 AW

AF10-A to AF60-A Series

Construction

AF10-A/AF20-A

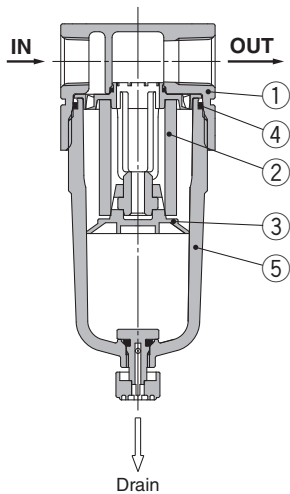

AF30-A to AF40-06-A

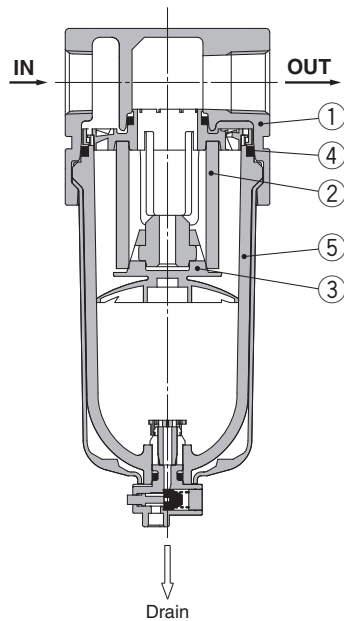

AF50-A/AF60-A

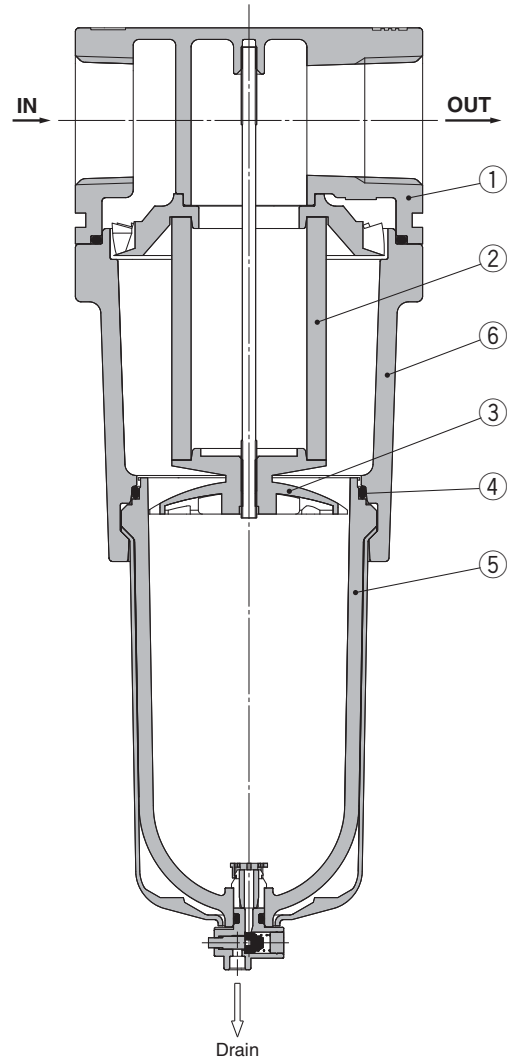

Component Parts

No.	Description	Material	Model	Colour
1	Body	Zinc die-cast	AF10-A	White
		Aluminium die-cast	AF20-A to AF60-A	
6	Housing	Aluminium die-cast	AF50-A/AF60-A	White

Replacement Parts

No.	Description	Material	Part no.						
			AF10-A	AF20-A	AF30-A	AF40-A	AF40-06-A	AF50-A	AF60-A
2	Filter element	Non-woven fabric	AF10P-060S	AF20P-060S	AF30P-060S	AF40P-060S		AF50P-060S	AF60P-060S
3	Baffle	PBT	AF10P-040S *2	AF22P-040S	AF32P-040S	AF42P-040S		AF50P-040S	AF60P-040S
4	Bowl seal	NBR	C1SFP-260S	C2SFP-260S	C32FP-260S	C42FP-260S			
5	Bowl assembly *1	Polycarbonate	C1SF-A	C2SF-A	C3SF-A	C4SF-A			

*1 Bowl seal is included for the AF20-A to AF60-A. Please contact SMC regarding the supply of bowl assembly with psi and °F unit specifications.

*2 The baffle material for the AF10-A (AF10P-040S) only is polyacetal.

Dimensions

AF10-A/AF20-A

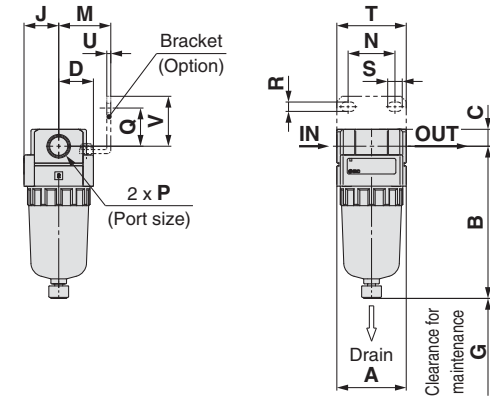

AF50-A/AF60-A

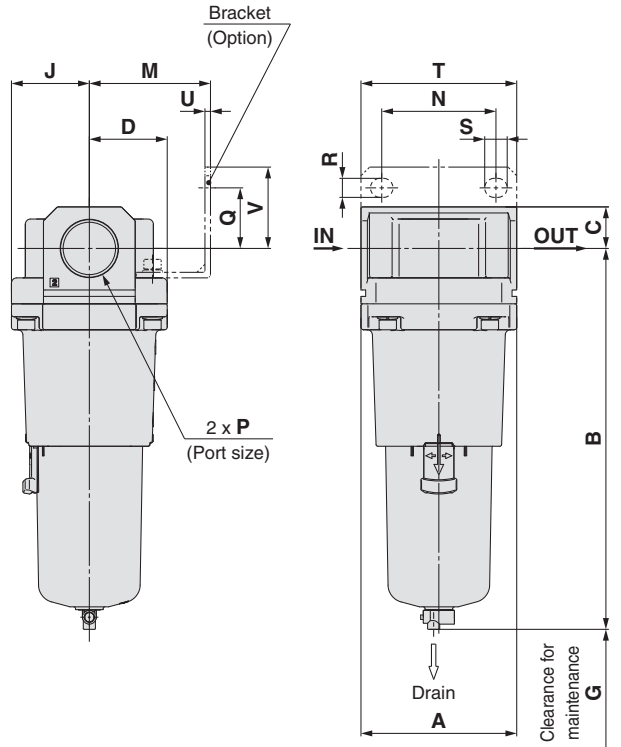

AF30-A to AF40-06-A

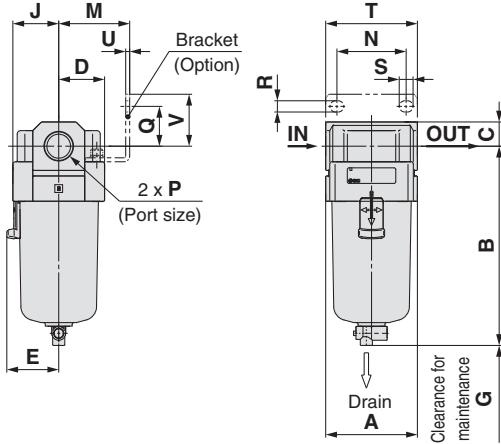

Applicable model	AF10-A/AF20-A		AF20-A		AF30-A to AF60-A
Optional/Semi-standard specifications	With auto drain (N.C.)	Metal bowl	With drain guide	Metal bowl with drain guide	With auto drain (N.O./N.C.)
Dimensions					

Applicable model	AF30-A to AF60-A					
Optional/Semi-standard specifications	Metal bowl	Metal bowl with drain guide	Metal bowl with level gauge	Metal bowl with level gauge, with drain guide	With drain guide	Drain cock with barb fitting
Dimensions						

Model	Standard specifications																Optional specifications				Semi-standard specifications						
																	Bracket mount				With auto drain	With barb fitting	With drain guide	Metal bowl	Metal bowl with drain guide	Metal bowl with level gauge	Metal bowl with level gauge, with drain guide
	P	A	B	C	D	E	G	J	M	N	Q	R	S	T	U	V	B	B	B	B	B	B	B	B			
AF10-A	M5 x 0.8	25	59.9	7	12.5	—	25	12.5	—	—	—	—	—	—	—	—	77.9	—	—	—	59.3	—	—	—			
AF20-A	1/8, 1/4	40	87.6	9.8	20	—	25	20	30	27	22	5.4	8.4	40	2.3	28	104.9	—	—	—	87.4	93.9	—	—			
AF30-A	1/4, 3/8	53	115.1	14	26.7	30	35	26.7	41	35	23	6.5	13	53	2.3	30	156.8	123.6	—	—	117.6	122.1	137.6	142.1			
AF40-A	1/4, 3/8, 1/2	70	147.1	18	35.5	38.4	40	35.5	50	52	26	8.5	12.5	70	2.3	35	186.9	155.6	153.9	—	149.6	154.1	169.6	174.1			
AF40-06-A	3/4	75	149.1	20	35.5	38.4	40	35.5	50	52	25	8.5	12.5	70	2.3	34	188.9	157.6	155.9	—	151.6	156.1	171.6	176.1			
AF50-A	3/4, 1	90	220.1	24	45	—	30	45	70	66	35	11	13	90	3.2	47	259.9	228.6	226.9	—	222.6	227.1	242.6	247.1			
AF60-A	1	95	234.1	24	47.5	—	30	47.5	70	66	35	11	13	90	3.2	47	273.9	242.6	240.9	—	236.6	241.1	256.6	261.1			

AC
 AF+AR+AL
 AW+AL
 AF+AR
 AF+AFM+AR
 AW+AFM
 Attachment
 AF
 AFM / AFD
 AR
 AL
 AW

AF10-A to AF60-A Air Filter

Made to Order

Please contact SMC for detailed dimensions, specifications and lead times.



① Long Bowl

Drain capacity is greater than that of standard models.

Applicable Model/Drain Capacity

Model	AF10-A	AF20-A	AF30-A	AF40-A	AF40-06-A	AF50-A	AF60-A
Port size	M5	1/8, 1/4	1/4, 3/8	1/4, 3/8, 1/2	3/4	3/4, 1	1
Drain capacity [cm ³]	9	19	43	88			
B dimension [mm] *1	81.6	108.6	137.1	167.2	169.2	240.2	254.2

*1 For polycarbonate bowls. Please contact SMC for other bowl materials.

AF **30** - **03** - **A** - **X64**

① ② ③ ④ ⑤ • Long bowl

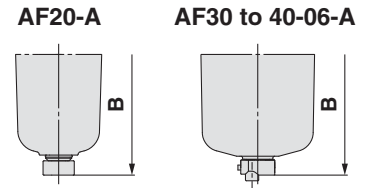

- Semi-standard: Select one each for **a** to **d**.
- Option/Semi-standard symbol: When more than one specification is required, indicate in alphanumeric order.
Example) AF30-03B-2R-A-X64

		Symbol	Description	① Body size						
				10	20	30	40	50	60	
②	Pipe thread type	—	Metric thread (M5)	●	—	—	—	—	—	
		N*1	NPT	—	●	●	●	●	●	
		F*2	G	—	●	●	●	●	●	
		+								
③	Port size	M5	M5	●	—	—	—	—	—	
		01	1/8	—	●	—	—	—	—	
		02	1/4	—	●	●	—	—	—	
		03	3/8	—	—	●	●	—	—	
		04	1/2	—	—	—	●	—	—	
		06	3/4	—	—	—	●	●	—	
		10	1	—	—	—	—	●	●	
④	Option (Mounting)	—	Without mounting option	●	●	●	●	●	●	
		B*3	With bracket	—	●	●	●	●	●	
⑤	a	Bowl *4	—	Polycarbonate bowl	●	●	●	●	●	●
			2	Metal bowl	●	●	●	●	●	●
			6	Nylon bowl	●	●	●	●	●	●
			C	With bowl guard	—	●	—*5	—*5	—*5	—*5
			6C	With bowl guard (Nylon bowl)	—	●	—*6	—*6	—*6	—*6
	b	Drain port	—	With drain cock	●	●	●	●	●	●
			J*7	Drain guide 1/8	—	●	—	—	—	—
				Drain guide 1/4	—	—	●	●	●	●
			W*8	Drain cock with barb fitting (for Ø 6 x Ø 4 nylon tube)	—	—	●	●	●	●
	c	Flow direction	—	Flow direction: Left to right	●	●	●	●	●	●
			R	Flow direction: Right to left	●	●	●	●	●	●
	d	Pressure unit	—	Name plate and caution plate for bowl in SI units: MPa	●	●	●	●	●	●
			Z*9	Name plate and caution plate for bowl in imperial units: psi, °F	○*10	○*10	○*10	○*10	○*10	○*10

*1 Drain guide is NPT 1/8 (applicable to the AF20-A) and NPT 1/4 (applicable to the AF30-A to AF60-A).

The auto drain port comes with Ø 3/8" One-touch fitting (applicable to the AF30-A to AF60-A).

*2 Drain guide is G 1/8 (applicable to the AF20-A) and G 1/4 (applicable to the AF30-A to AF60-A).

*3 Option B is not assembled and supplied loose at the time of shipment. Assembly of a bracket and 2 mounting screws.

*4 Refer to chemical data on page 46 for chemical resistance of the bowl.

*5 A bowl guard is provided as standard equipment (polycarbonate).

*6 A bowl guard is provided as standard equipment (nylon).

*7 Without a valve function

*8 The combination of metal bowl: 2 is not available.

*9 For pipe thread type: NPT.

*10 ○: For pipe thread type: NPT only

AF20-A to AF60-A Air Filter

Made to Order

Please contact SMC for detailed dimensions, specifications and lead times.



② With Element Service Indicator

Clogging status of elements can be checked visually.

Applicable Model

Model	AF20-A	AF30-A	AF40-A	AF40-06-A	AF50-A	AF60-A
Port size	1/8, 1/4	1/4, 3/8	1/4, 3/8, 1/2	3/4	3/4, 1	1

AF **30** - **03** - **03** - **A** - **X2141**

① ② ③ ④ ⑤

- Option/Semi-standard: Select one each for a to f.
 - Option/Semi-standard symbol: When more than one specification is required, indicate in alphanumeric order.
- Example) AF30-03BD-2R-A-X2141

• With element service indicator

A special body type is required to mount the element service indicator. It cannot be mounted on a standard body.

	Symbol	Description	① Body size					
			20	30	40	50	60	
② Pipe thread type	—	Rc	●	●	●	●	●	
	N*1	NPT	●	●	●	●	●	
	F*2	G	●	●	●	●	●	
③ Port size	+							
	01	1/8	●	—	—	—	—	
	02	1/4	●	●	—	—	—	
	03	3/8	—	●	●	—	—	
	04	1/2	—	—	●	—	—	
	06	3/4	—	—	●	●	—	
④ Option	+							
	a Mounting	—	Without mounting option	●	●	●	●	●
		B*3	With bracket	●	●	●	●	●
	b Float type auto drain	—	Without auto drain	●	●	●	●	●
C*4		N.C. (Normally closed) Drain port is closed when pressure is not applied.	●	●	●	●	●	
D*5		N.O. (Normally open) Drain port is open when pressure is not applied.	—	●	●	●	●	
⑤ Semi-standard	+							
	c Bowl*6	—	Polycarbonate bowl	●	●	●	●	●
		2	Metal bowl	●	●	●	●	●
		6	Nylon bowl	●	●	●	●	●
		8	Metal bowl with level gauge	—	●	●	●	●
	d Drain port*7	—	With drain cock	—	●	●	●	●
		J*8	Drain guide 1/8	●	—	—	—	—
			Drain guide 1/4	—	●	●	●	●
	W*9	Drain cock with barb fitting (for Ø 6 x Ø 4 nylon tube)	—	●	●	●	●	
	e Flow direction	+						
—		Flow direction: Left to right	●	●	●	●	●	
R	Flow direction: Right to left	●	●	●	●	●		
f Pressure unit	+							
	—	Name plate and caution plate for bowl in SI units: MPa	●	●	●	●	●	
Z*10	Name plate and caution plate for bowl in imperial units: psi, °F	○*11	○*11	○*11	○*11	○*11		

*1 Drain guide is NPT 1/8 (applicable to the AF20-A) and NPT 1/4 (applicable to the AF30-A to AF60-A).

The auto drain port comes with Ø 3/8" One-touch fitting (applicable to the AF30-A to AF60-A).

*2 Drain guide is G 1/8 (applicable to the AF20-A) and G 1/4 (applicable to the AF30-A to AF60-A).

*3 Option B is not assembled and supplied loose at the time of shipment. Assembly of a bracket and 2 mounting screws.

*4 When pressure is not applied, condensate which does not start the auto drain mechanism will be left in the bowl.

Releasing the residual condensate before ending operations for the day is recommended.

*5 If the compressor is small (0.75 kW, discharge flow is less than 100 l/min [ANR]), air leakage from the drain cock may occur during start of operations. N.C. type is recommended.

*6 Refer to chemical data on page 46 for chemical resistance of the bowl.

*7 The combination of float type auto drain: C and D is not available.

*8 Without a valve function

*9 The combination of metal bowl: 2 and 8 is not available.

*10 For pipe thread type: NPT.

*11 ○: For pipe thread type: NPT only

AC
AF+AR+AL
AW+AL
AF+AR
AF+AFM+AR
AW+AFM
Attachment
AF
AFM / AFD
AR
AL
AW

AF20-A to AF60-A Air Filter

Made to Order

Please contact SMC for detailed dimensions, specifications and lead times.



③ Special Temperature Environment

Special materials are used in the manufacturing of seals and resin parts to allow them to withstand various temperature conditions in cold or tropical (hot) climates.

Specifications

Made-to-order part no.	-X430	-X440
Environment	Low temperature	High temperature
Ambient temperature [°C]	-30 to 60	-5 to 80
Fluid temperature [°C]	-5 to 60 (with no freezing)	
Material	Rubber parts Special NBR	FKM
	Main parts	Metal (Aluminium die-cast, etc.)

Applicable Model

Model	AF30-A	AF40-A	AF40-06-A	AF50-A	AF60-A
Port size	1/4, 3/8	1/4, 3/8, 1/2	3/4	3/4, 1	1

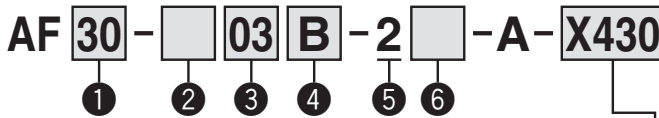

- Semi-standard: Select one each for **a** to **c**.
 - Semi-standard symbol: When more than one specification is required, indicate in alphabetic order.
- Example) AF30-03B-2R-A-X430

For high/low temperature

X430	Low temperature
X440	High temperature

	Symbol	Description	① Body size				
			30	40	50	60	
② Pipe thread type	—	Rc	●	●	●	●	
	N *1	NPT	●	●	●	●	
	F *2	G	●	●	●	●	
③ Port size	02	1/4	●	●	—	—	
	03	3/8	●	●	—	—	
	04	1/2	—	●	—	—	
	06	3/4	—	●	●	—	
	10	1	—	—	●	●	
④ Option (Mounting)	—	Without mounting option	●	●	●	●	
	B *3	With bracket	●	●	●	●	
⑤ Bowl*4	2	Metal bowl	●	●	●	●	
⑥ Semi-standard	a Drain port	—	With drain cock	●	●	●	●
		J *5	Drain guide 1/4	●	●	●	●
	b Flow direction	—	Flow direction: Left to right	●	●	●	●
		R	Flow direction: Right to left	●	●	●	●
c Pressure unit	—	Name plate and caution plate for bowl in SI units: MPa	●	●	●	●	
	Z *6	Name plate and caution plate for bowl in imperial units: psi, °F	○*7	○*7	○*7	○*7	

- *1 Drain guide is NPT 1/4.
- *2 Drain guide is G 1/4.
- *3 A bracket is not assembled and supplied loose at the time of shipment. Including 2 mounting screws
- *4 Only metal bowl 2 is available.
- *5 Without a valve function
- *6 For pipe thread type: NPT.
- *7 ○: For pipe thread type: NPT only

④ High Pressure

Strong materials are used in the manufacturing of air filters intended for high pressure operation.

Specifications

Made-to-order part no.	-X425
Proof pressure [MPa]	3.0
Maximum operating pressure [MPa]	2.0
Ambient and fluid temperature [°C]	-5 to 60 (with no freezing)

Applicable Model

Model	AF20-A	AF30-A	AF40-A	AF40-06-A	AF50-A	AF60-A
Port size	1/8, 1/4	1/4, 3/8	1/4, 3/8, 1/2	3/4	3/4, 1	1

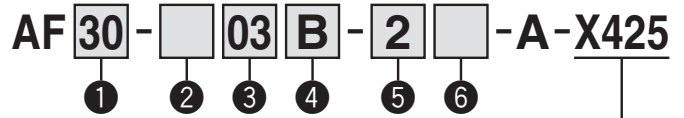

For high pressure

- Semi-standard: Select one each for **a** to **c**.
 - Semi-standard symbol: When more than one specification is required, indicate in alphabetic order.
- Example) AF30-03B-2R-A-X425

	Symbol	Description	① Body size				
			20	30	40	50	60
② Pipe thread type	—	Rc	●	●	●	●	●
	N *1	NPT	●	●	●	●	●
	F *2	G	●	●	●	●	●
③ Port size	01	1/8	●	—	—	—	—
	02	1/4	●	●	—	—	—
	03	3/8	—	●	—	—	—
	04	1/2	—	—	●	—	—
	06	3/4	—	—	●	●	—
	10	1	—	—	—	●	●
④ Option (Mounting)	—	Without mounting option	●	●	●	●	●
	B *3	With bracket	●	●	●	●	●
⑤ Bowl*4	2	Metal bowl	●	●	●	●	●
	8	Metal bowl with level gauge	—	●	●	●	●
⑥ Semi-standard	a Drain port	—	With drain cock	●	●	●	●
		J *5	Drain guide 1/8 Drain guide 1/4	●	—	—	—
	b Flow direction	—	Flow direction: Left to right	●	●	●	●
		R	Flow direction: Right to left	●	●	●	●
c Pressure unit	—	Name plate and caution plate for bowl in SI units: MPa	●	●	●	●	
	Z *6	Name plate and caution plate for bowl in imperial units: psi, °F	○*7	○*7	○*7	○*7	

- *1 Drain guide is NPT 1/8 (applicable to the AF20-A) and NPT 1/4 (applicable to the AF30-A to AF60-A).
- *2 Drain guide is G 1/8 (applicable to the AF20-A) and G 1/4 (applicable to the AF30-A to AF60-A).
- *3 A bracket is not assembled and supplied loose at the time of shipment. Including 2 mounting screws
- *4 Only metal bowl 2 and 8 are available.
- *5 Without a valve function
- *6 For pipe thread type: NPT.
- *7 ○: For pipe thread type: NPT only

AF20-A to AF60-A Air Filter Made to Order

Please contact SMC for detailed dimensions, specifications and lead times.



⑤ Clean Series

For details, refer to the Clean Series/Low Particle Generation section of the **Web Catalogue**.

10 - Standard model no.

* Please contact SMC if a product with pressure gauge is desired.

- Clean series

⑥ Copper, Fluorine and Silicone-free + Low Particle Generation

For details, refer to the Clean Series/Low Particle Generation section of the **Web Catalogue**.

21 - Standard model no.

- Copper, fluorine and silicone-free + Low particle generation

AC
AF+AR+AL
AW+AL
AF+AR
AF+AFM+AR
AW+AFM
Attachment
AF
AFM / AFD
AR
AL
AW

Mist Separator

AFM20-A to AFM40-A

Micro Mist Separator

AFD20-A to AFD40-A

Symbol
Mist Separator

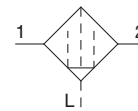

Symbol
Micro Mist Separator

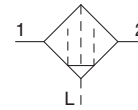

AFM20-A

AFD40-A

- AFM Series Nominal filtration rating: 0.3 μm
- AFD Series Nominal filtration rating: 0.01 μm

How to Order

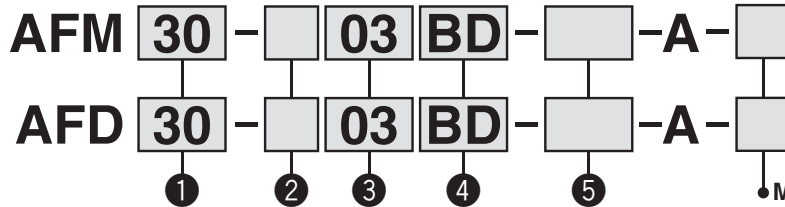

- Option/Semi-standard: Select one each for a to f.
- Option/Semi-standard symbol: When more than one specification is required, indicate in alphanumeric order. Example) AFM30-03BD-R-A

• Made to order
(Refer to pages 61 and 62 for details.)

		Symbol	Description	①				
				Body size				
				20	30	40		
②	Pipe thread type	—	Rc	●	●	●		
		N*1	NPT	●	●	●		
		F*2	G	●	●	●		
+								
③	Port size	01	1/8	●	—	—		
		02	1/4	●	●	●		
		03	3/8	—	●	●		
		04	1/2	—	—	●		
		06	3/4	—	—	●		
+								
④	Option	a	Mounting	—	Without mounting option	●	●	●
				B*3	With bracket	●	●	●
+								
④	Option	b	Float type auto drain	—	Without auto drain	●	●	●
				C*4	N.C. (Normally closed) Drain port is closed when pressure is not applied.	●	●	●
				D*5	N.O. (Normally open) Drain port is open when pressure is not applied.	—	●	●
+								
⑤	Semi-standard	c	Bowl *6	—	Polycarbonate bowl	●	●	●
				2	Metal bowl	●	●	●
				6	Nylon bowl	●	●	●
				8	Metal bowl with level gauge	—	●	●
				C	With bowl guard	●	—*7	—*7
				6C	With bowl guard (Nylon bowl)	●	—*8	—*8
		+						
		d	Drain port *12	—	With drain cock	●	●	●
				J*9	Drain guide 1/8	●	—	—
				W*13	Drain cock with barb fitting (for Ø 6 x Ø 4 nylon tube)	—	●	●
		+						
		e	Flow direction	—	Flow direction: Left to right	●	●	●
R	Flow direction: Right to left			●	●	●		
+								
f	Pressure unit	—	Name plate and caution plate for bowl in SI units: MPa	●	●	●		
		Z*10	Name plate and caution plate for bowl in imperial units: psi, °F	○*11	○*11	○*11		

*1 Drain guide is NPT 1/8 (applicable to the AFM20-A, AFD20-A) and NPT 1/4 (applicable to the AFM30-A/40-A, AFD30-A/40-A).

The auto drain port comes with Ø 3/8" One-touch fitting (applicable to the AFM30-A/40-A, AFD30-A/40-A).

*2 Drain guide is G 1/8 (applicable to the AFM20-A, AFD20-A) and G 1/4 (applicable to the AFM30-A/40-A, AFD30-A/40-A).

*3 A bracket is not assembled and supplied loose at the time of shipment. Including 2 mounting screws

*4 When pressure is not applied, condensate which does not start the auto drain mechanism will be left in the bowl.

Releasing the residual condensate before ending operations for the day is recommended.

*5 If the compressor is small (0.75 kW, discharge flow is less than 100 l/min [ANR]), air leakage from the drain cock may occur during start of operations. N.C. type is recommended.

*6 Refer to chemical data on page 58 for chemical resistance of the bowl.

*7 A bowl guard is provided as standard equipment (polycarbonate).

*8 A bowl guard is provided as standard equipment (nylon).

*9 Without a valve function

*10 For pipe thread type: NPT.

*11 ○: For pipe thread type: NPT only

*12 The combination of float type auto drain: C and D is not available.

*13 The combination of metal bowl: 2 and 8 is not available.

Mist Separator **AFM20-A to AFM40-A Series**

Micro Mist Separator **AFD20-A to AFD40-A Series**

Standard Specifications

Model	AFM20-A AFD20-A	AFM30-A AFD30-A	AFM40-A AFD40-A	AFM40-06-A AFD40-06-A
Port size	1/8, 1/4	1/4, 3/8	1/4, 3/8, 1/2	3/4
Fluid	Air			
Ambient and fluid temperature	-5 to 60 °C (with no freezing)			
Proof pressure	1.5 MPa			
Maximum operating pressure	1.0 MPa			
Minimum operating pressure	0.05 MPa			
Nominal filtration rating	AFM20-A to AFM40-06-A	0.3 μm (99.9 % filtered particle size)		
	AFD20-A to AFD40-06-A	0.01 μm (99.9 % filtered particle size)		
Outlet side oil mist concentration	AFM20-A to AFM40-06-A	Max. 1.0 mg/m ³ (ANR) (≈ 0.8 ppm) *2 *3		
	AFD20-A to AFD40-06-A	Max. 0.1 mg/m ³ (ANR) (Before saturated with oil 0.01 mg/m ³ (ANR) or less ≈ 0.008 ppm) *2 *3		
Rated flow [l/min (ANR)] *1	AFM20-A to AFM40-06-A	200	450	1100
	AFD20-A to AFD40-06-A	120	240	600
Drain capacity [cm ³]	8	25	45	
Bowl material	Polycarbonate			
Bowl guard	Semi-standard (Steel)		Standard (Polycarbonate)	
Weight [kg]	0.09	0.19	0.38	0.43

*1 Conditions: Inlet pressure: 0.7 MPa; The rated flow varies depending on the inlet pressure.

Keep the air flow within the rated flow to prevent an outflow of lubricant to the outlet side.

*2 When the compressor oil mist discharge concentration is 30 mg/m³ (ANR).

*3 Bowl seal and other O-rings are slightly lubricated.

Options/Part No.

Optional specifications	Model			
	AFM20-A AFD20-A	AFM30-A AFD30-A	AFM40-A AFD40-A	AFM40-06-A AFD40-06-A
Bracket assembly *1	AF22P-050AS	AF32P-050AS	AF42P-050AS	AF42P-070AS
Float type auto drain *2 *3	N.C.	AD27-A	AD37-A	AD47-A
	N.O.	—	AD38-A	AD48-A

*1 Assembly of a bracket and 2 mounting screws

*2 Minimum operating pressure: N.O. type—0.1 MPa; N.C. type—0.1 MPa (AD27-A) and 0.15 MPa (AD37-A/AD47-A).

Please consult with SMC separately for psi and °F unit display specifications.

*3 Please consult with SMC for details on drain piping to fit NPT or G port sizes.

Bowl Assembly/Part No.

Bowl material	Drain discharge mechanism	Drain port	Other	Model				
				AFM20-A AFD20-A	AFM30-A AFD30-A	AFM40-A AFD40-A	AFM40-06-A AFD40-06-A	
Polycarbonate	Manual	With drain cock	—	C2SF-A	—	—	—	
		With bowl guard	—	C2SF-C-A	C3SF-A	—	C4SF-A	
		Drain cock with barb fitting	With bowl guard	—	—	C3SF-W-A	—	C4SF-W-A
		With drain guide (without valve function)	—	C2SF□-J-A	—	—	—	—
	Automatic *1 (Auto drain)	Normally closed (N.C.)	—	—	AD27-A	—	—	—
			With bowl guard	—	AD27-C-A	AD37□-A	—	AD47□-A
		Normally open (N.O.)	—	—	—	AD38□-A	—	AD48□-A
			With bowl guard	—	—	—	—	—
Nylon	Manual	With drain cock	—	C2SF-6-A	—	—	—	
		With bowl guard	—	C2SF-6C-A	C3SF-6-A	—	C4SF-6-A	
		Drain cock with barb fitting	With bowl guard	—	—	C3SF-6W-A	—	C4SF-6W-A
		With drain guide (without valve function)	—	C2SF□-6J-A	—	—	—	—
	Automatic *1 (Auto drain)	Normally closed (N.C.)	—	—	AD27-6-A	—	—	—
			With bowl guard	—	AD27-6C-A	AD37□-6-A	—	AD47□-6-A
		Normally open (N.O.)	—	—	—	AD38□-6-A	—	AD48□-6-A
			With bowl guard	—	—	—	—	—
Metal	Manual	With drain cock	—	C2SF-2-A	C3SF-2-A	—	C4SF-2-A	
		With level gauge	—	—	C3LF-8-A	—	C4LF-8-A	
		With drain guide (without valve function)	—	C2SF□-2J-A	C3SF□-2J-A	—	C4SF□-2J-A	
		With level gauge	—	—	C3LF□-8J-A	—	C4LF□-8J-A	
	Automatic *1 (Auto drain)	Normally closed (N.C.)	—	—	AD27-2-A	AD37□-2-A	—	AD47□-2-A
			With level gauge	—	—	AD37□-8-A	—	AD47□-8-A
		Normally open (N.O.)	—	—	—	AD38□-2-A	—	AD48□-2-A
			With level gauge	—	—	AD38□-8-A	—	AD48□-8-A

*1 Minimum operating pressure: N.O. type—0.1 MPa (AD38-A, AD48-A); N.C. type—0.1 MPa (AD17-A, AD27-A) and 0.15 MPa (AD37-A, AD47-A).

Bowl assembly for the AFM20-A to AFM40-06-A, AFD20-A to AFD40-06-A models comes with a bowl seal.

□ in bowl assembly part numbers indicates a pipe thread type (applicable tubing for auto drain). No indication is necessary for Rc thread; however, indicate N for NPT thread, and F for G thread. (For auto drain, —: Ø 10, N: Ø 3/8")

Please consult with SMC separately for psi and °F unit display specifications.

AC
 AF+AR+AL
 AW+AL
 AF+AR
 AF+AFM+AR
 AW+AFM
 Attachment
 AF
 AFM / AFD
 AR
 AL
 AW

AFM20-A to AFM40-A Series

AFD20-A to AFD40-A Series

Flow Rate Characteristics (Representative values)

— When saturated with oil
 - - - Initial state

AFM20-A

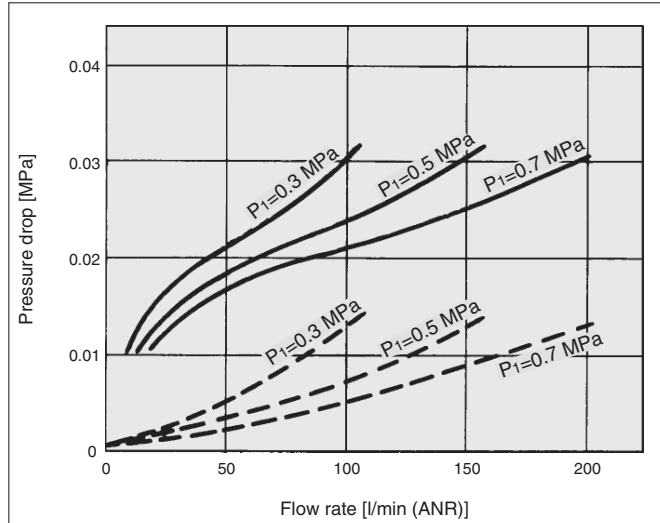

AFD20-A

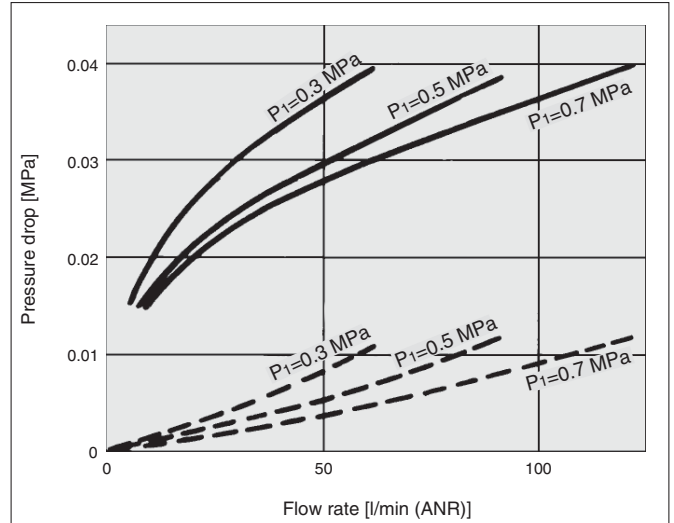

AFM30-A

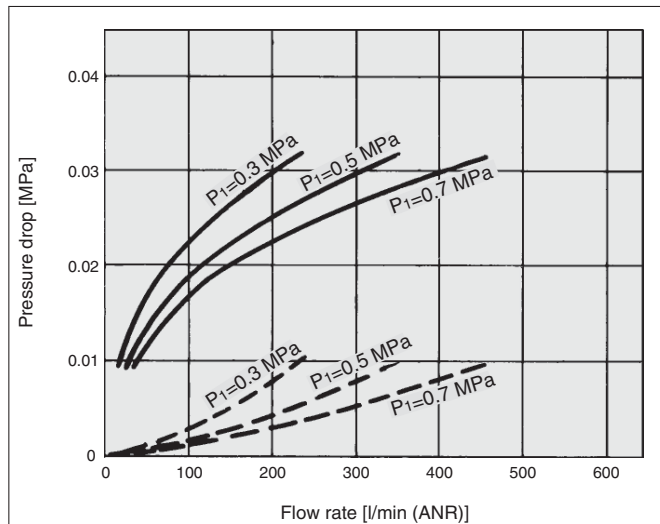

AFD30-A

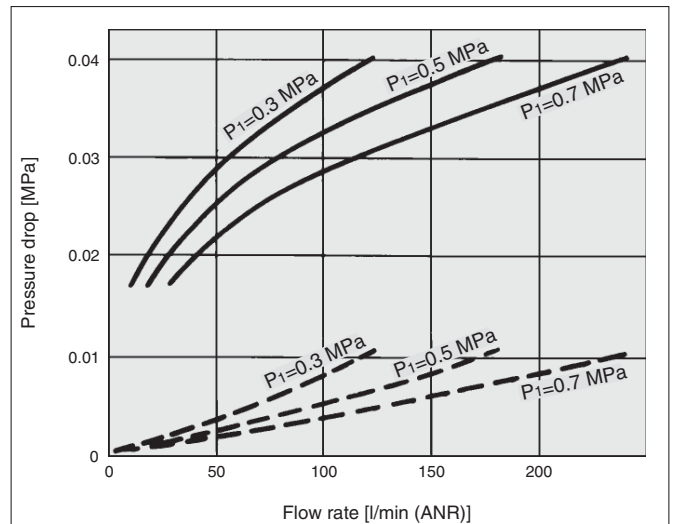

AFM40-A

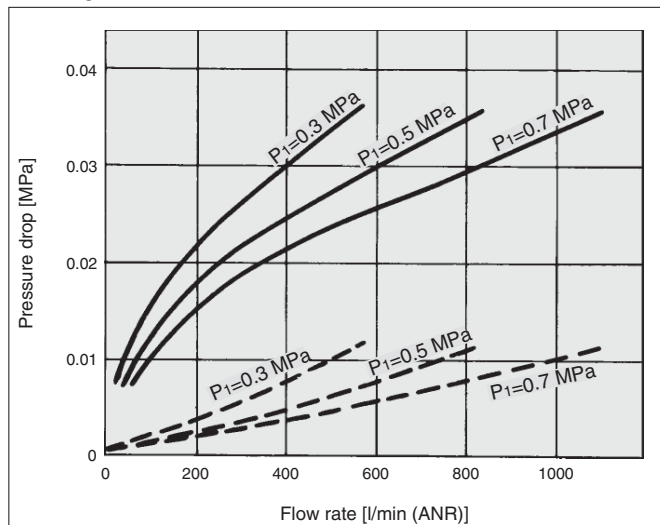

AFD40-A

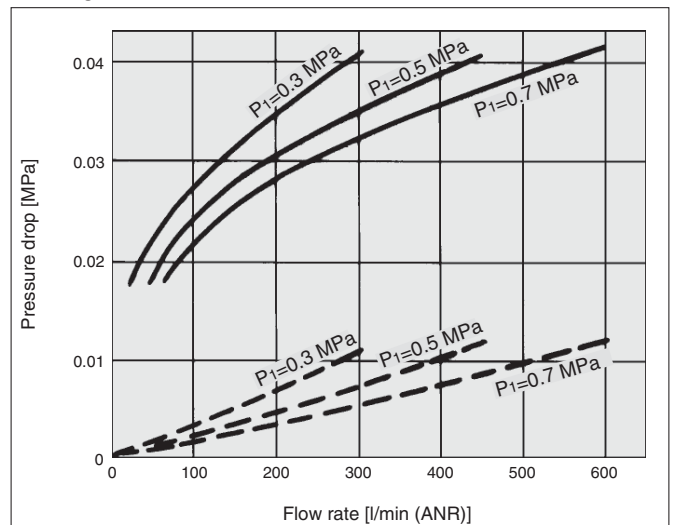

⚠ Specific Product Precautions

Be sure to read this before handling the products. Refer to the back cover for safety instructions. For F.R.L. units precautions, refer to the "Handling Precautions for SMC Products" and the "Operation Manual", <http://www.smc.eu>

Design/Selection

⚠ Warning

- The standard bowl for the air filter, filter regulator, and lubricator, as well as the sight dome for the lubricator are made of polycarbonate. Do not use in an environment where they are exposed to or come in contact with organic solvents, chemicals, cutting oil, synthetic oil, alkali, and thread lock solutions.

Effects of atmosphere of organic solvents and chemicals, and where these elements are likely to adhere to the equipment.
 Chemical data for substances causing degradation (Reference)

Type	Chemical name	Application examples	Material	
			Polycarbonate	Nylon
Acid	Hydrochloric acid Sulfuric acid, Phosphoric acid Chromic acid	Acid washing liquid for metals	△	×
Alkaline	Sodium hydroxide (Caustic soda) Potash Calcium hydroxide (Slack lime) Ammonia water Carbonate of soda	Degreasing of metals Industrial salts Water-soluble cutting oil	×	○
Inorganic salts	Sodium sulfide Potassium nitrate Sulfate of soda	—	×	△
Chlorine solvents	Carbon tetrachloride Chloroform Ethylene chloride Methylene chloride	Cleansing liquid for metals Printing ink Dilution	×	△
Aromatic series	Benzene Toluene Paint thinner	Coatings Dry cleaning	×	△
Ketone	Acetone Methyl ethyl ketone Cyclohexane	Photographic film Dry cleaning Textile industries	×	×
Alcohol	Ethyl alcohol IPA Methyl alcohol	Antifreeze Adhesives	△	×
Oil	Gasoline Kerosene	—	×	○
Ester	Phthalic acid dimethyl Phthalic acid diethyl Acetic acid	Synthetic oil Anti-rust additives	×	○
Ether	Methyl ether Ethyl ether	Brake oil additives	×	○
Amino	Methyl amino	Cutting oil Brake oil additives Rubber accelerator	×	×
Others	Thread-lock fluid Seawater Leak tester	—	×	△

○: Essentially safe △: Some effects may occur. ×: Effects will occur.

When the above factors are present, or there is some doubt, use a metal bowl for safety.

Air Supply

⚠ Caution

- Install an air filter (AF series) as a pre-filter on the inlet side of the mist separator to prevent premature clogging.
- Install a mist separator (AFM series) as a pre-filter on the inlet side of the micro mist separator to prevent premature clogging.
- Do not install on the inlet side of the dryer as this can cause premature clogging of the element.

Maintenance

⚠ Warning

- Replace the element every 2 years or when the pressure drop becomes 0.1 MPa, whichever comes first, to prevent damage to the element.

Mounting/Adjustment

⚠ Caution

- When the bowl is installed on the mist separator (AFM30-A/AFM40-A), or micro mist separator (AFD30-A/AFD40-A), install them so that the lock button lines up to the groove of the front (or the back) of the body to avoid drop or damage of the bowl.



Design

⚠ Caution

- Design the system so that the mist separator is installed in a pulsation-free location. The difference between internal and external pressure inside the element should be kept within 0.1 MPa, as exceeding this value could cause damage.

Selection

⚠ Caution

- Do not allow air flow that exceeds the rated flow. If the air flow is allowed outside the range of the rated flow even momentarily, drainage and lubricant may splash at the outlet side or cause damage to the component.
- Do not use in a low pressure application (such as a blower). An F.R.L. unit has its own minimum operating pressure depending on the equipment and is designed specifically to function with compressed air. If used below the minimum operating pressure, a loss of performance and malfunction can occur. Please contact SMC if an application under such conditions cannot be avoided.

AC

AF+AR+AL

AW+AL

AF+AR

AF+AFM+AR

AW+AFM

Attachment

AF

AFM / AFD

AR

AL

AW

AFM20-A to AFM40-A Series

AFD20-A to AFD40-A Series

Construction

AFM20-A
AFD20-A

AFM30-A to AFM40-06-A
AFD30-A to AFD40-06-A

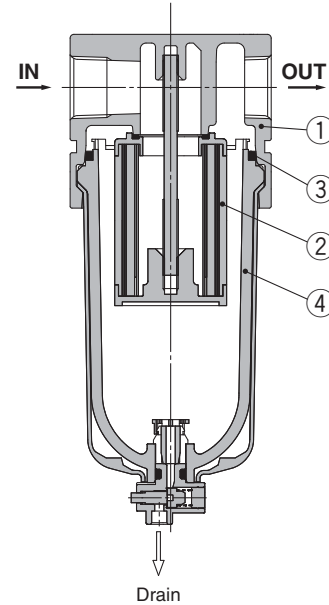
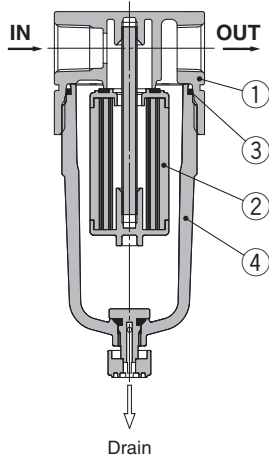

Component Parts

No.	Description	Material	Model	Colour
1	Body	Aluminium die-cast	AFM20-A to AFM40-06-A AFD20-A to AFD40-06-A	White

Replacement Parts

No.	Description	Material	Part no.			
			AFM20-A AFD20-A	AFM30-A AFD30-A	AFM40-A AFD40-A	AFM40-06-A AFD40-06-A
2	Element assembly	AFM20 to 40	—	AFM20P-060AS	AFM30P-060AS	AFM40P-060AS
		AFD20 to 40	—	AFD20P-060AS	AFD30P-060AS	AFD40P-060AS
3	Bowl seal	NBR	C2SFP-260S	C32FP-260S	C42FP-260S	
4	Bowl assembly *1	Polycarbonate	C2SF-A	C3SF-A	C4SF-A	

*1 Bowl seal is included. Please contact SMC regarding the supply of bowl assembly with psi and °F unit display specifications.

Mist Separator **AFM20-A to AFM40-A Series** Micro Mist Separator **AFD20-A to AFD40-A Series**

Dimensions

**AFM20-A
AFD20-A**

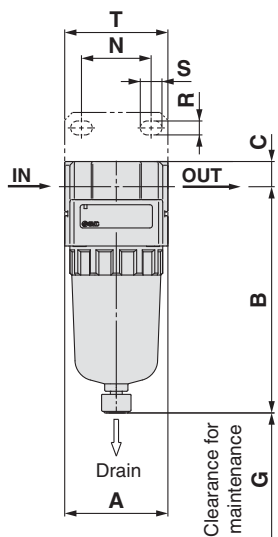
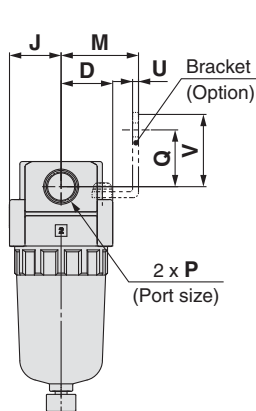

**AFM30-A to AFM40-06-A
AFD30-A to AFD40-06-A**

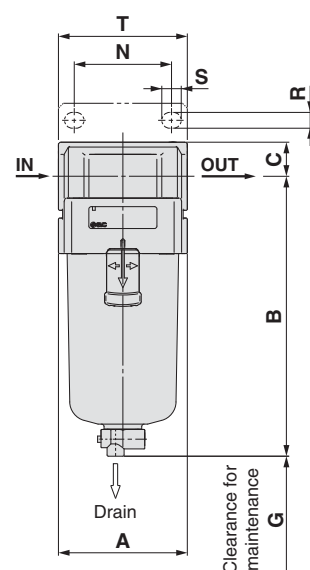
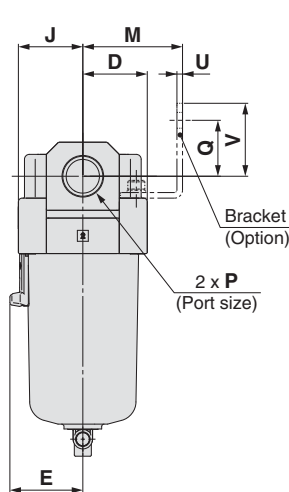

Applicable model	AFM20-A/AFD20-A				AFM30-A to AFM40-06-A/AFD30-A to AFD40-06-A
Optional/Semi-standard specifications	With auto drain (N.C.)	With drain guide	Metal bowl	Metal bowl with drain guide	With auto drain (N.O./N.C.)
Dimensions	 M5 x 0.8 B	 Width across flats 14 1/8 B	 B	 Width across flats 14 1/8 B	 N.O.: Black N.C.: Grey Thread type/Rc, G: Ø 10 One-touch fitting Thread type/NPT: Ø 3/8" One-touch fitting B

Applicable model	AFM30-A to AFM40-06-A/AFD30-A to AFD40-06-A					
Optional/Semi-standard specifications	Metal bowl	Metal bowl with drain guide	Metal bowl with level gauge	Metal bowl with level gauge, with drain guide	With drain guide	Drain cock with barb fitting
Dimensions	 B	 Width across flats 17 1/4 B	 B	 Width across flats 17 1/4 B	 Width across flats 17 1/4 B	 Barb fitting applicable tubing: T0604 B

Model	Standard specifications																Optional specifications	
	P	A	B	C	D	E	G	J	M	N	Q	R	S	T	U	V	With auto drain	B
AFM20-A/AFD20-A	1/8, 1/4	40	87.6	9.8	20	—	40	20	30	27	22	5.4	8.4	40	2.3	28	104.9	
AFM30-A/AFD30-A	1/4, 3/8	53	115.1	14	26.7	30	50	26.7	41	35	23	6.5	13	53	2.3	30	156.8	
AFM40-A/AFD40-A	1/4, 3/8, 1/2	70	147.1	18	35.5	38.4	75	35.5	50	52	26	8.5	12.5	70	2.3	35	186.9	
AFM40-06-A/AFD40-06-A	3/4	75	149.1	20	35.5	38.4	75	35.5	50	52	25	8.5	12.5	70	2.3	34	188.9	

Model	Semi-standard specifications					
	With barb fitting	With drain guide	Metal bowl	Metal bowl with drain guide	Metal bowl with level gauge	Metal bowl with level gauge, with drain guide
AFM20-A/AFD20-A	—	91.4	87.4	93.9	—	—
AFM30-A/AFD30-A	123.6	121.9	117.6	122.1	137.6	142.1
AFM40-A/AFD40-A	155.6	153.9	149.6	154.1	169.6	174.1
AFM40-06-A/AFD40-06-A	157.6	155.9	151.6	156.1	171.6	176.1

AC
 AF+AR+AL
 AW+AL
 AF+AR
 AF+AFM+AR
 AW+AFM
 Attachment
 AF
 AFM / AFD
 AR
 AL
 AW

AFM20-A to AFM40-06-A Mist Separator AFD20-A to AFD40-06-A Micro Mist Separator Made to Order

Please contact SMC for detailed dimensions, specifications and lead times.



① Long Bowl

Drain capacity is greater than that of standard models.

Applicable Model/Drain Capacity

Model	AFM20-A, AFD20-A	AFM30-A, AFD30-A	AFM40-A, AFD40-A	AFM40-06-A, AFD40-06-A
Port size	1/8, 1/4	1/4, 3/8	1/4, 3/8, 1/2	3/4
Drain capacity [cm ³]	19	43		88
B dimension [mm]*1	108.6	137.1	167.2	169.2

*1 For polycarbonate bowls. Please contact SMC for other bowl materials.

AFM **30** - **03** - **A** - **X64**

AFD **30** - **03** - **A** - **X64**

① ② ③ ④ ⑤ •Long bowl

AFM20-A
AFD20-A

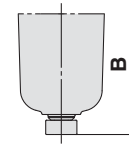

AFM30 to 40-06-A
AFD30 to 40-06-A

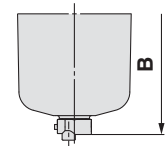

- Semi-standard: Select one each for a to d.
- Option/Semi-standard symbol: When more than one specification is required, indicate in alphanumeric order.
Example) AFM30-03B-2R-A-X64

		Symbol	Description	① Body size		
				20	30	40
②	Pipe thread type	—	Rc	●	●	●
		N*1	NPT	●	●	●
		F*2	G	●	●	●
③	Port size	01	1/8	●	—	—
		02	1/4	●	●	●
		03	3/8	—	●	●
		04	1/2	—	—	●
		06	3/4	—	—	●
④	Option (Mounting)	—	Without mounting option	●	●	●
		B*3	With bracket	●	●	●
⑤ Semi-standard	a Bowl *4	—	Polycarbonate bowl	●	●	●
		2	Metal bowl	●	●	●
		6	Nylon bowl	●	●	●
		C	With bowl guard	●	—*5	—*5
	b Drain port	—	With drain cock	●	●	●
		J*7	Drain guide 1/8	●	—	—
		J*7	Drain guide 1/4	—	●	●
		W*8	Drain cock with barb fitting (for Ø 6 x Ø 4 nylon tube)	—	●	●
	c Flow direction	—	Flow direction: Left to right	●	●	●
		R	Flow direction: Right to left	●	●	●
	d Pressure unit	—	Name plate and caution plate for bowl in SI units: MPa	●	●	●
		Z*9	Name plate and caution plate for bowl in imperial units: psi, °F	○*10	○*10	○*10

*1 Drain guide is NPT 1/8 (applicable to the AFM20-A, AFD20-A) and NPT 1/4 (applicable to the AFM30-A to AFM40-06-A, AFD30-A to AFD40-06-A).

*2 Drain guide is G 1/8 (applicable to the AFM20-A, AFD20-A) and G 1/4 (applicable to the AFM30-A to AFM40-06-A, AFD30-A to AFD40-06-A).

*3 A bracket is not assembled and supplied loose at the time of shipment. Including 2 mounting screws.

*4 Refer to chemical data on page 58 for chemical resistance of the bowl.

*5 A bowl guard is provided as standard equipment (polycarbonate).

*6 A bowl guard is provided as standard equipment (nylon).

*7 Without a valve function

*8 The combination of metal bowl: 2 is not available.

*9 For pipe thread type: NPT.

*10 ○: For pipe thread type: NPT only

AFM20-A to AFM40-06-A Mist Separator AFD20-A to AFD40-06-A Micro Mist Separator Made to Order



Please contact SMC for detailed dimensions, specifications and lead times.

② With Element Service Indicator

Clogging status of elements can be checked visually.

Applicable Model

Model	AFM20-A, AFD20-A	AFM30-A, AFD30-A	AFM40-A, AFD40-A	AFM40-06-A, AFD40-06-A
Port size	1/8, 1/4	1/4, 3/8	1/4, 3/8, 1/2	3/4

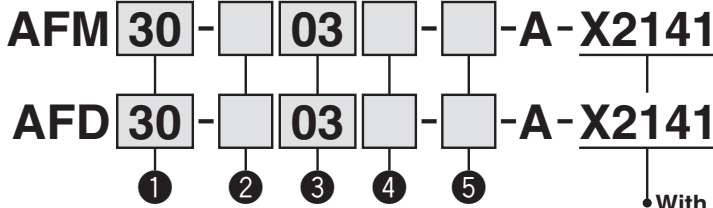

- Option/Semi-standard: Select one each for a to f.
- Option/Semi-standard symbol: When more than one specification is required, indicate in alphanumeric order.
Example) AFM30-03BD-2R-A-X2141

A special body type is required to mount the element service indicator. It cannot be mounted on a standard body.

	Symbol	Description	① Body size			
			20	30	40	
② Pipe thread type	—	Rc	●	●	●	
	N*1	NPT	●	●	●	
	F*2	G	●	●	●	
③ Port size	01	1/8	●	—	—	
	02	1/4	●	●	●	
	03	3/8	—	●	●	
	04	1/2	—	—	●	
	06	3/4	—	—	●	
④ Option	a Mounting	—	Without mounting option	●	●	●
		B*3	With bracket	●	●	●
	b Float type auto drain	—	Without auto drain	●	●	●
		C*4	N.C. (Normally closed) Drain port is closed when pressure is not applied.	●	●	●
		D*5	N.O. (Normally open) Drain port is open when pressure is not applied.	—	●	●
		—	—	—	—	—
⑤ Semi-standard	c Bowl*6	—	Polycarbonate bowl	●	●	●
		2	Metal bowl	●	●	●
		6	Nylon bowl	●	●	●
		8	Metal bowl with level gauge	—	●	●
		C	With bowl guard	●	—*7	—*7
		6C	With bowl guard (Nylon bowl)	●	—*8	—*8
	d Drain port*12	—	With drain cock	●	●	●
		J*9	Drain guide 1/4	●	●	●
		W*13	Drain cock with barb fitting (for Ø 6 x Ø 4 nylon tube)	—	●	●
	e Flow direction	—	Flow direction: Left to right	●	●	●
R		Flow direction: Right to left	●	●	●	
f Pressure unit	—	Name plate and caution plate for bowl in SI units: MPa	●	●	●	
	Z*10	Name plate and caution plate for bowl in imperial units: psi, °F	●	○*11	○*11	

*1 Drain guide is NPT 1/8 (applicable to the AFM20-A, AFD20-A) and NPT 1/4 (applicable to the AFM30-A/40-A, AFD30-A/40-A).

The auto drain port comes with Ø 3/8" One-touch fitting (applicable to the AFM30-A/40-A, AFD30-A/40-A).

*2 Drain guide is G 1/8 (applicable to the AFM20-A, AFD20-A) and G 1/4 (applicable to the AFM30-A/40-A, AFD30-A/40-A).

*3 A bracket is not assembled and supplied loose at the time of shipment. Including 2 mounting screws

*4 When pressure is not applied, condensate which does not start the auto drain mechanism will be left in the bowl. Releasing the residual condensate before ending operations for the day is recommended.

*5 If the compressor is small (0.75 kW, discharge flow is less than 100 l/min [ANR]), air leakage from the drain cock may occur during start of operations. N.C. type is recommended.

*6 Refer to chemical data on page 58 for chemical resistance of the bowl.

*7 A bowl guard is provided as standard equipment (polycarbonate).

*8 A bowl guard is provided as standard equipment (nylon).

*9 Without a valve function

*10 For pipe thread type: NPT.

*11 ○: For pipe thread type: NPT only

*12 The combination of float type auto drain: C and D is not available.

*13 The combination of metal bowl: 2 and 8 is not available.

AC
AF+AR+AL
AW+AL
AF+AR
AF+AR
AF+AFM+AR
AW+AFM
Attachment
AF
AFM / AFD
AR
AL
AW

AFM20-A to AFM40-06-A Mist Separator AFD20-A to AFD40-06-A Micro Mist Separator Made to Order

Please contact SMC for detailed dimensions, specifications and lead times.



③ Clean Series

For details, refer to the Clean Series/Low Particle Generation section of the **Web Catalogue**.

10 - **Standard model no.**

* Please contact SMC if a product with pressure gauge is desired.

- Clean series

④ Copper, Fluorine and Silicone-free + Low Particle Generation

For details, refer to the Clean Series/Low Particle Generation section of the **Web Catalogue**.

21 - **Standard model no.**

- Copper, fluorine and silicone-free + Low particle generation

Modular Type Regulator *AR Series*

Regulator AR Series 	Model	Port size	Set pressure	Options
	AR10-A	M5 x 0.8	0.05 to 0.7 MPa 0.02 to 0.2 MPa	Bracket Round type pressure gauge Set nut (for panel mount) *1
	AR20(K)-B	1/8, 1/4	0.05 to 0.85 MPa 0.02 to 0.2 MPa	Bracket
	AR25(K)-B	1/4, 3/8		Set nut (for panel mount) *1
	AR30(K)-B			Square embedded type pressure gauge
	AR40(K)-B	1/4, 3/8, 1/2		Digital pressure switch
	AR40(K)-06-B	3/4		Round type pressure gauge
	AR50(K)-B	3/4, 1		Bracket Square embedded type pressure gauge
	AR60(K)-B	1		Digital pressure switch
Round type pressure gauge				

Pages 65 to 80

*1 Interchangeable with the previous AR series and panel mounting dimensions.

AC

AF+AR+AL

AW+AL

AF+AR

AF+AFM+AR

AW+AFM

Attachment

AF

AFM / AFD

AR

AL

AW

Regulator AR10-A

Symbol
Regulator

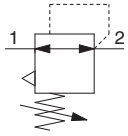

AR10-A

How to Order

Refer to page 67 for size 20 to 60.

AR10-M5 - -A

- Option/Semi-standard: Select one each for **a** to **g**.
- Option/Semi-standard symbol: When more than one specification is required, indicate in alphanumeric order.
Example) AR10-M5BG-1NR-A

		Symbol	Description		
1	Option *1	a	Mounting	—	Without mounting option
				B *2	With bracket
				H	With set nut (for panel mount)
	+				
	b	Pressure gauge	—	Without pressure gauge	
			G *3	Round type pressure gauge (without limit indicator)	
+					
2	Semi-standard	c	Set pressure *4	—	0.05 to 0.7 MPa setting
				1	0.02 to 0.2 MPa setting
		+			
		d	Exhaust mechanism	—	Relieving type
				N	Non-relieving type
		+			
	e	Flow direction	—	Flow direction: Left to right	
			R	Flow direction: Right to left	
	+				
	f	Knob	—	Downward	
			Y	Upward	
	+				
g	Pressure unit	—	Name plate and pressure gauge in SI units: MPa		
		Z	Name plate and pressure gauge in imperial units: psi		

*1 Options are not assembled and supplied loose at the time of shipment.

*2 Assembly of a bracket and set nuts

*3 A 1.0 MPa pressure gauge will be fitted. It is not assembled and supplied loose at the time of shipment.

*4 Pressure can be set higher than the specification pressure in some cases, but use pressure within the specification range.

Standard Specifications

Port size	M5 x 0.8
Pressure gauge port size *1	1/16
Fluid	Air
Ambient and fluid temperature	-5 to 60 °C (with no freezing)
Proof pressure	1.5 MPa
Maximum operating pressure	1.0 MPa
Set pressure range	0.05 to 0.7 MPa
Construction	Relieving type
Weight [kg]	0.06

*1 Use a bushing (part no.: 131368) when connecting the R 1/8 pressure gauge to the Rc 1/16.

Options/Part No.

Bracket assembly *1	AR12P-270AS
Set nut	AR12P-260S
Round type pressure gauge *2	G27-10-R1

*1 Assembly of a bracket and set nuts

*2 1.0 MPa pressure gauge

⚠ Specific Product Precautions

Be sure to read this before handling the products. Refer to the back cover for safety instructions. For F.R.L. units precautions, refer to the "Handling Precautions for SMC Products" and the "Operation Manual", <http://www.smc.eu>

Selection

⚠ Warning

- Although exhaust of the residual pressure to the inlet side is possible when eliminating the inlet pressure, exhaust is not possible when the set pressure is 0.15 MPa or less.

Maintenance

⚠ Warning

- When using the regulator between a solenoid valve and an actuator, check the pressure gauge periodically. Sudden pressure fluctuations may shorten the durability of the pressure gauge. A digital pressure gauge is recommended for such situation or as deemed necessary.

Mounting/Adjustment

⚠ Warning

- Set the regulator while verifying the displayed values of the inlet and outlet pressure gauges. Turning the regulator knob excessively can cause damage to the internal parts.
- Do not use tools on the pressure regulator knob as this may cause damage. It must be operated manually.

⚠ Caution

- Be sure to unlock the knob before adjusting the pressure and lock it after setting the pressure. Failure to follow this procedure can cause damage to the knob and the outlet pressure may fluctuate.
 - Pull the pressure regulator knob to unlock. (You can visually verify this with the "orange mark" that appears in the gap.)
 - Push the pressure regulator knob to lock. When the knob is not easily locked, turn it left and right a little and then push it (when the knob is locked, the "orange mark", i.e., the gap will disappear).
- Pulsation will be generated when the difference between the inlet and the outlet pressure is large. In this case, reduce the pressure difference between the inlet and the outlet. Please consult with SMC if the pulsation problem is not resolved.

AC
 AF+AR+AL
 AW+AL
 AF+AR
 AF+AFM+AR
 AW+AFM
 Attachment
 AF
 AFM / AFD
 AR
 AL
 AW

Regulator

AR20-B to AR60-B

Regulator with Backflow Function

AR20K-B to AR60K-B

Symbol
Regulator

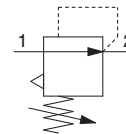

Regulator with
Backflow Function

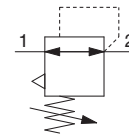

- With the backflow function, it incorporates a mechanism to exhaust the air pressure in the outlet side reliably and quickly.

Example 1)

When the pressure in the rear and the front of the cylinder differs:

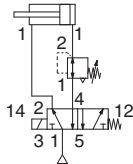

Example 2)

When the air supply is cut off and releasing the inlet pressure to the atmosphere, the residual pressure release of the outlet side can be ensured for a safety purpose.

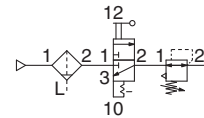

How to Order

Refer to page 65 for size 10.

AR **30** **K** - **03** **BE** - **B** - **10**

① ② ③ ④ ⑤ ⑥

- Option/Semi-standard: Select one each for a to g.
- Option/Semi-standard symbol: When more than one specification is required, indicate in alphanumeric order.
Example) AR30K-03BE-1NR-B

• Made to order

(Refer to pages 77 to 79 for details.)

	Symbol	Description	① Body size							
			20	25	30	40	50	60		
② With backflow function	—	Without backflow function	●	●	●	●	●	●		
	K*1	With backflow function	●	●	●	●	●	●		
③ Pipe thread type	+	Rc	●	●	●	●	●	●		
	N	NPT	●	●	●	●	●	●		
	F	G	●	●	●	●	●	●		
④ Port size	+	01 1/8	●	—	—	—	—	—		
	02 1/4	●	●	●	●	—	—			
	03 3/8	—	●	●	●	—	—			
	04 1/2	—	—	—	●	—	—			
	06 3/4	—	—	—	●	●	—			
	10 1	—	—	—	—	●	●			
⑤ Option *2	a Mounting	—	Without mounting option	●	●	●	●	●	●	
		B*3	With bracket	●	●	●	●	●	●	
		H	With set nut (for panel mount)	●	●	●	●	—	—	
	b	Pressure gauge *4	—	Without pressure gauge	●	●	●	●	●	●
			E	Square embedded type pressure gauge (with limit indicator)	●	●	●	●	●	●
			G	Round type pressure gauge (with limit indicator)	●	●	●	●	●	●
			M	Round type pressure gauge (with colour zone)	●	●	●	●	●	●
		Digital pressure switch *5	E1	Output: NPN output, Electrical entry: Wiring bottom entry	●	●	●	●	●	●
			E2	Output: NPN output, Electrical entry: Wiring top entry	●	●	●	●	●	●
			E3	Output: PNP output, Electrical entry: Wiring bottom entry	●	●	●	●	●	●
			E4	Output: PNP output, Electrical entry: Wiring top entry	●	●	●	●	●	●

Regulator **AR20-B to AR60-B Series** Regulator with Backflow Function **AR20K-B to AR60K-B Series**



AR20-B, AR20K-B AR40-B, AR40K-B

AC
AF+AR+AL
AW+AL
AF+AR
AF+AFM+AR
AW+AFM
Attachment
AF
AFM / AFD
AR
AL
AW

	Symbol	Description	①							
			Body size							
			20	25	30	40	50	60		
6 Semi-standard	c Set pressure *6	—	0.05 to 0.85 MPa setting	●	●	●	●	●	●	
		1	0.02 to 0.2 MPa setting	●	●	●	●	●	●	
	+									
	d Exhaust mechanism	—	Relieving type	●	●	●	●	●	●	
		N	Non-relieving type	●	●	●	●	●	●	
	+									
	e Flow direction	—	Flow direction: Left to right	●	●	●	●	●	●	
		R	Flow direction: Right to left	●	●	●	●	●	●	
	+									
	f Knob	—	Downward	●	●	●	●	●	●	
		Y	Upward	●	●	●	●	●	●	
	+									
g Pressure unit	—	Name plate and pressure gauge in SI units: MPa	●	●	●	●	●	●		
	Z*7	Name plate and pressure gauge in imperial units: psi	○*9	○*9	○*9	○*9	○*9	○*9		
	ZA*8	Digital pressure switch: With unit selection function	△*10	△*10	△*10	△*10	△*10	△*10		

- *1 Set the inlet pressure to at least 0.05 MPa higher than the set pressure.
- *2 Options B, G, H, M are not assembled and supplied loose at the time of shipment.
- *3 Assembly of a bracket and set nuts (applicable to the AR20(K)-B to AR40(K)-B). Including 2 mounting screws for the AR50(K)-B and AR60(K)-B.
- *4 When the pressure gauge is attached, a 1.0 MPa pressure gauge will be fitted for standard (0.85 MPa) type. 0.4 MPa pressure gauge for 0.2 MPa type.
- *5 When choosing with H (panel mount), the installation space for lead wires will not be secured. In this case, select "wiring top entry" for the electrical entry. (Select "wiring bottom entry" when the semi-standard Y is chosen simultaneously.)
- *6 Pressure can be set higher than the specification pressure in some cases, but use pressure within the specification range.
- *7 For pipe thread type: NPT.
Cannot be used with M: Round type pressure gauge (with colour zone). Available by request for special.
The digital pressure switch will be equipped with the unit selection function, setting to psi initially.
- *8 For options: E1, E2, E3, E4.
- *9 ○: For pipe thread type: NPT only
- *10 △: Select with options: E1, E2, E3, E4.

Standard Specifications

Model	AR20-B	AR25-B	AR30-B	AR40-B	AR40-06-B	AR50-B	AR60-B
Port size	1/8, 1/4	1/4, 3/8	1/4, 3/8	1/4, 3/8, 1/2	3/4	3/4, 1	1
Pressure gauge port size *1	1/8						
Fluid	Air						
Ambient and fluid temperature *2	-5 to 60 °C (with no freezing)						
Proof pressure	1.5 MPa						
Maximum operating pressure	1.0 MPa						
Set pressure range	0.05 to 0.85 MPa						
Construction	Relieving type						
Weight [kg]	0.16	0.21	0.29	0.44	0.47	1.17	1.22

*1 Pressure gauge connection threads are not available for F.R.L. unit with a square embedded type pressure gauge or with a digital pressure switch.
*2 -5 to 50 °C for the products with the digital pressure switch.

AR20-B to AR60-B Series

AR20K-B to AR60K-B Series

Options/Part No.

Option		Model	AR20(K)-B	AR25(K)-B	AR30(K)-B	AR40(K)-B	AR40(K)-06-B	AR50(K)-B	AR60(K)-B
Bracket assembly *1			AR23P-270AS	AR28P-270AS	AR33P-270AS	AR43P-270AS		AR52P-270AS	
Set nut			AR23P-260S	AR28P-260S	AR33P-260S	AR43P-260S		—*2	
Pressure gauge	Round type *3	Standard	G36-10-□01			G46-10-□01			
		0.02 to 0.2 MPa setting	G36-4-□01			G46-4-□01			
	Round type *3 (with colour zone)	Standard	G36-10-□01-L			G46-10-□01-L			
		0.02 to 0.2 MPa setting	G36-4-□01-L			G46-4-□01-L			
Square *4 embedded type	Standard	GC3-10AS [GC3P-010AS (Pressure gauge cover only)]							
	0.02 to 0.2 MPa setting	GC3-4AS [GC3P-010AS (Pressure gauge cover only)]							
Digital pressure switch *5	NPN output, Wiring bottom entry		ISE35-N-25-MLA [ISE35-N-25-M (Switch body only)]						
	NPN output, Wiring top entry		ISE35-R-25-MLA [ISE35-R-25-M (Switch body only)]						
	PNP output, Wiring bottom entry		ISE35-N-65-MLA [ISE35-N-65-M (Switch body only)]						
	PNP output, Wiring top entry		ISE35-R-65-MLA [ISE35-R-65-M (Switch body only)]						

*1 Assembly of a bracket and set nuts. Including 2 mounting screws for the AR50(K)-B and AR60(K)-B

*2 Please consult with SMC regarding the set nuts for the AR50(K)-B and AR60(K)-B.

*3 □ in part numbers for a round pressure gauge indicates a pipe thread type. No indication is necessary for R; however, indicate N for NPT. Please contact SMC regarding the pressure gauge supply for psi unit specifications.

*4 Including one O-ring and 2 mounting screws. []: Pressure gauge cover only

*5 In addition to the pressure switch body, lead wire with connector (2 m), adapter, lock pin, O-ring (1 pc.), mounting screw (2 pcs.) are attached. []: Switch body only. (Regarding how to order the digital pressure switch, refer to the **Web Catalogue**.)

⚠ Specific Product Precautions

Be sure to read this before handling the products. Refer to the back cover for safety instructions. For F.R.L. units precautions, refer to the “Handling Precautions for SMC Products” and the “Operation Manual”, <http://www.smc.eu>

Selection

⚠ Warning

- Residual pressure disposal (outlet pressure removal) is not possible for the AR20-B to AR60-B even though the inlet pressure is exhausted. When the residual pressure disposal is performed, use the regulator with a backflow function (AR20K-B to AR60K-B).

Maintenance

⚠ Warning

- When using the regulator with backflow function between a solenoid valve and an actuator, check the pressure gauge periodically. Sudden pressure fluctuations may shorten the durability of the pressure gauge. A digital pressure gauge is recommended for such situation or as deemed necessary.

Mounting/Adjustment

⚠ Warning

- Set the regulator while verifying the displayed values of the inlet and outlet pressure gauges. Turning the regulator knob excessively can cause damage to the internal parts.
- Do not use tools on the pressure regulator knob as this may cause damage. It must be operated manually.

⚠ Caution

- Be sure to unlock the knob before adjusting the pressure and lock it after setting the pressure. Failure to follow this procedure can cause damage to the knob and the outlet pressure may fluctuate.
 - Pull the pressure regulator knob to unlock. (You can visually verify this with the “orange mark” that appears in the gap.)
 - Push the pressure regulator knob to lock. When the knob is not easily locked, turn it left and right a little and then push it (when the knob is locked, the “orange mark”, i.e., the gap will disappear).

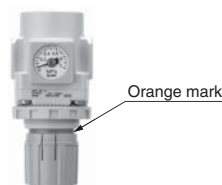

- A knob cover is available to prevent careless operation of the knob. Refer to page 112 for details.

Regulator **AR10-A Series**
 Regulator **AR20-B to AR60-B Series**
 Regulator with Backflow Function **AR20K-B to AR60K-B Series**

Flow Rate Characteristics (Representative values)

Condition: Inlet pressure of 0.7 MPa

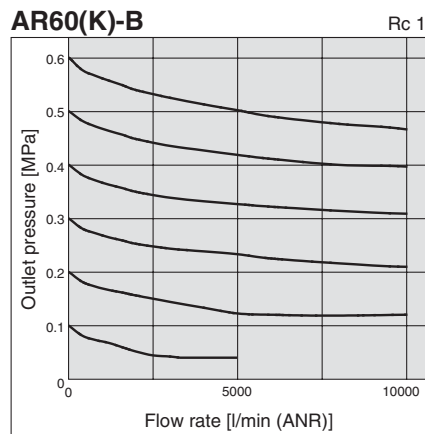
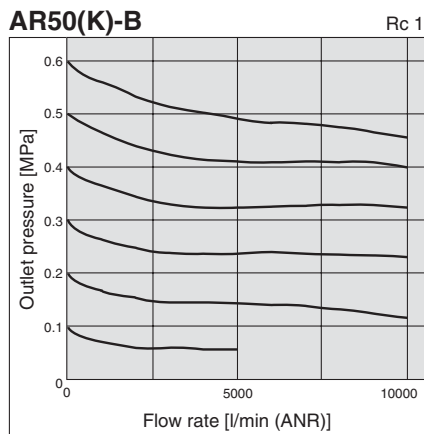
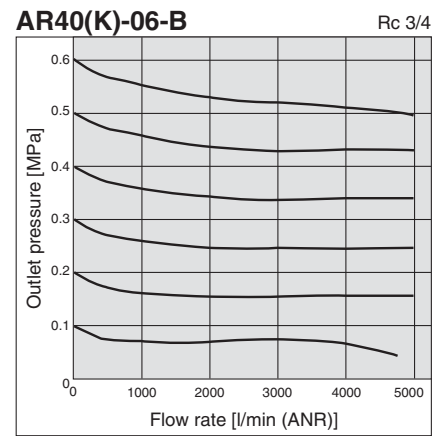
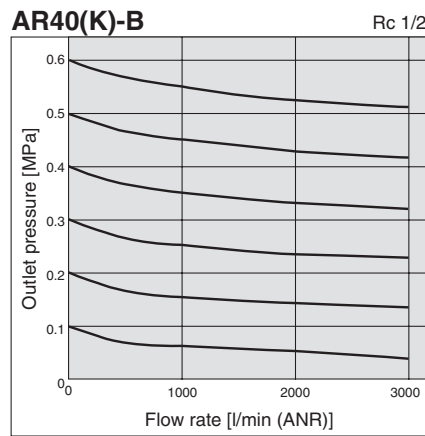
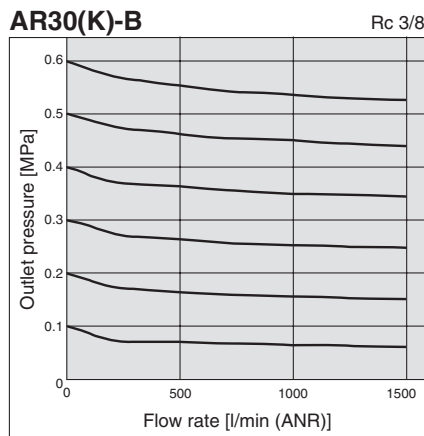
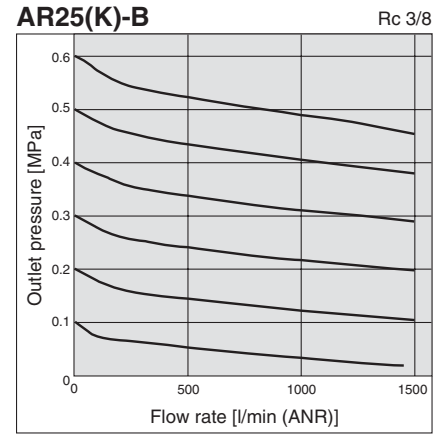
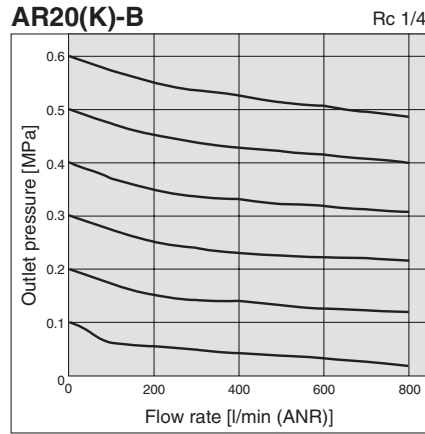
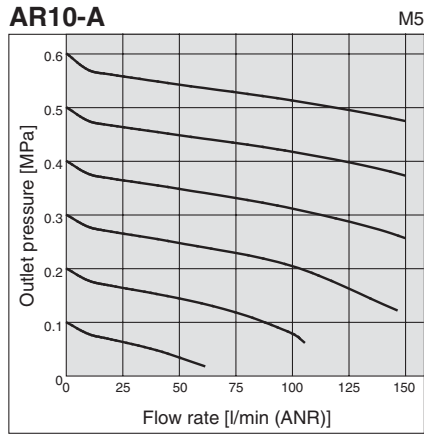

AC

AF+AR+AL

AW+AL

AF+AR

AF+AFM+AR

AW+AFM

Attachment

AF

AFM / AFD

AR

AL

AW

AR10-A Series

AR20-B to AR60-B Series

AR20K-B to AR60K-B Series

Pressure Characteristics (Representative values)

Conditions: Inlet pressure of 0.7 MPa, Outlet pressure of 0.2 MPa, Flow rate 20 l/min (ANR)

AR10-A

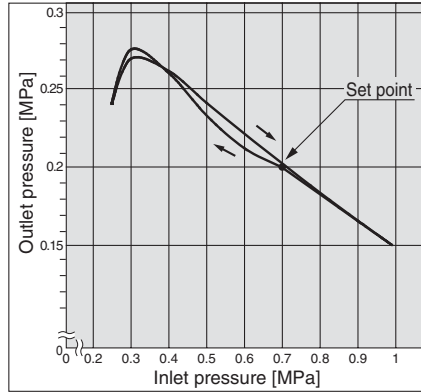

AR20(K)-B

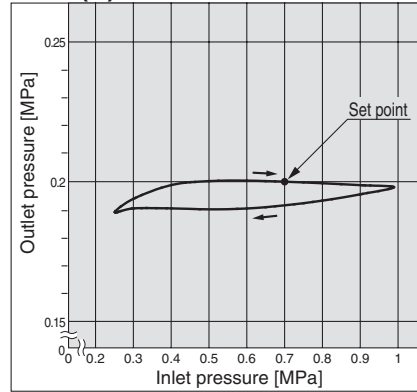

AR25(K)-B

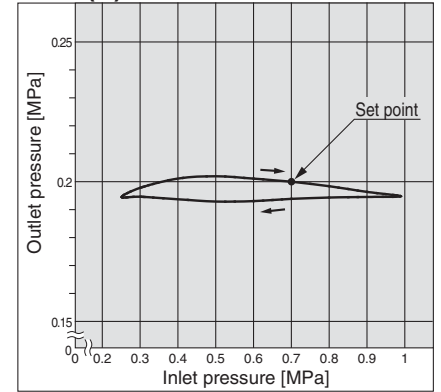

AR30(K)-B

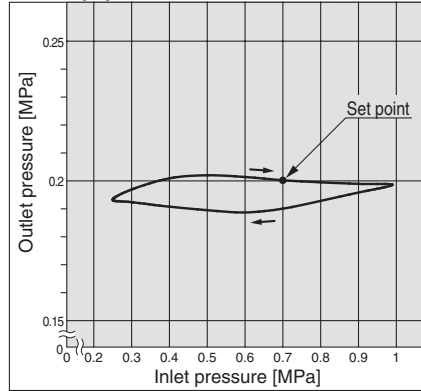

AR40(K)-B

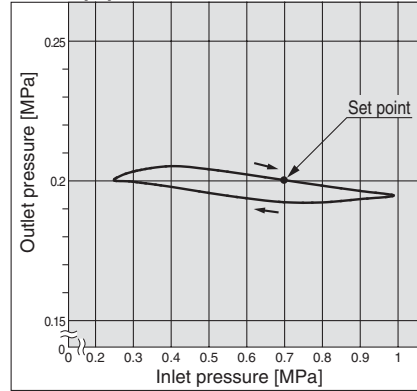

AR40(K)-06-B

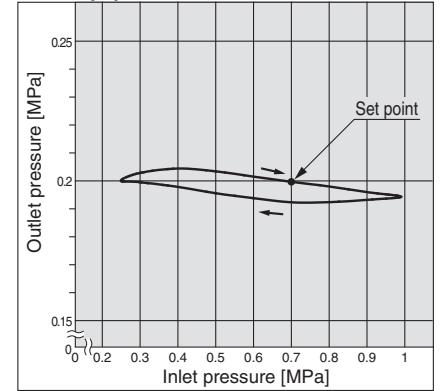

AR50(K)-B

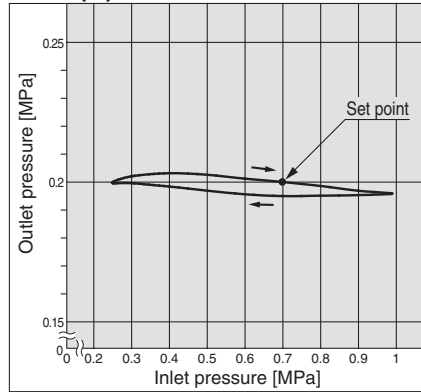

AR60(K)-B

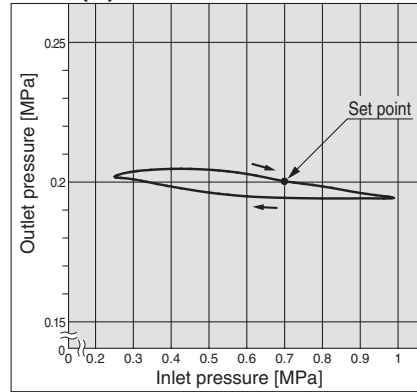

Regulator **AR10-A Series**
 Regulator **AR20-B to AR60-B Series**
 Regulator with Backflow Function **AR20K-B to AR60K-B Series**

Construction

AR10-A

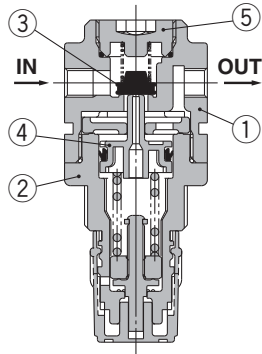

AR20(K)-B/AR25(K)-B

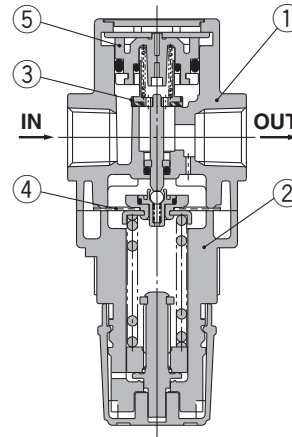

AR30(K)-B/AR40(K)-B

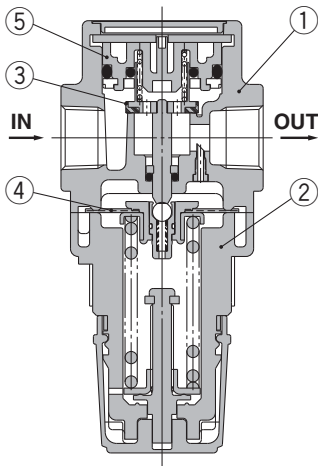

AR50(K)-B/AR60(K)-B

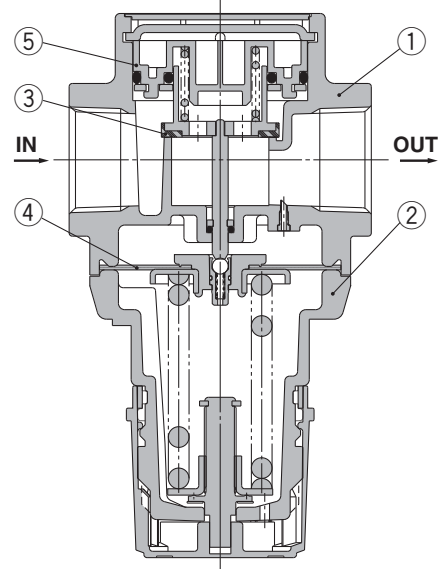

Component Parts

No.	Description	Material	Model	Colour
1	Body	Zinc die-cast	AR10-A	White
		Aluminium die-cast	AR20(K)-B to AR60(K)-B	
2	Bonnet	Polyacetal	AR10-A	White
			AR20(K)-B to AR40(K)-B	
		Aluminium die-cast	AR50(K)-B/AR60(K)-B	

Replacement Parts

[AR10-A]

No.	Description	Material	Part no.
3	Valve	HNBR	AR10P-090S
4	Piston assembly	Polyacetal	AR10P-150AS
5	Valve guide assembly	Polyacetal	131329

[AR20(K)-B to AR60(K)-B]

No.	Description	Material	Part no.					
			AR20(K)-B	AR25(K)-B	AR30(K)-B	AR40(K)-B	AR40(K)-06-B	AR50(K)-B
3	Valve	Brass, HNBR	AR20P-410S	AR25P-410S	AR30P-410S	AR40P-410S	AR50P-410S	AR60P-410S
4	Diaphragm assembly	Weatherable NBR	AR20P-150AS	AR25P-150AS	AR30P-150AS	AR40P-150AS	AR50P-150AS	
5	Valve guide assembly	Polyacetal	AR20P-050AS	AR25P-050AS	AR30P-050AS	AR40P-050AS	AR50P-050AS	AR60P-050AS
6	Check valve assembly *1	—	AR23KP-020AS					

*1 Check valve assembly is applicable for a regulator with backflow function (AR20K-B to AR60K-B) only.
 Assembly of a check valve cover, check valve body assembly and 2 mounting screws

AR20K-B to AR60K-B
 (Regulator with Backflow Function)

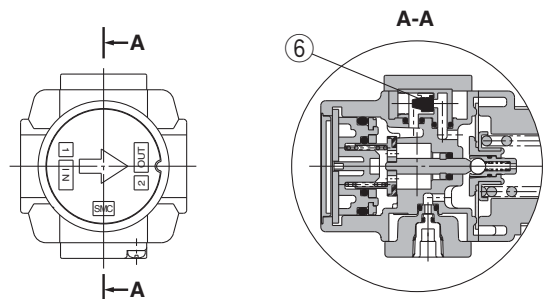

AC
AF+AR+AL
AW+AL
AF+AR
AF+AFM+AR
AW+AFM
Attachment
AF
AFM / AFD
AR
AL
AW

AR10-A Series

AR20K-B to AR60K-B Series

Working Principle (Regulator with Backflow Function)

AR10-A

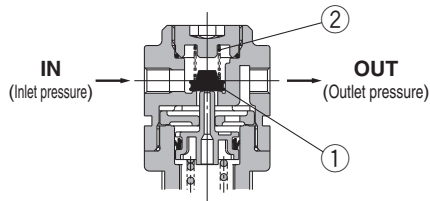

Figure 1

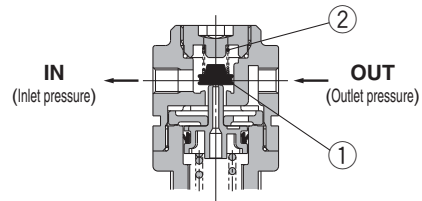

Figure 2

When the inlet pressure is higher than the regulating pressure, the check valve operates as a normal regulator (Figure 1). When the inlet pressure is shut off and exhausted, any inlet pressure applied to the valve ① will be lost. The force for seating the valve ① is the valve spring force ② only. When the valve ① is opened using the outlet force, the outlet pressure will be exhausted at the inlet side (Figure 2). When the set pressure is 0.15 MPa or less, the valve ① may not open due to the valve spring ② force.

AR20K-B to AR60K-B

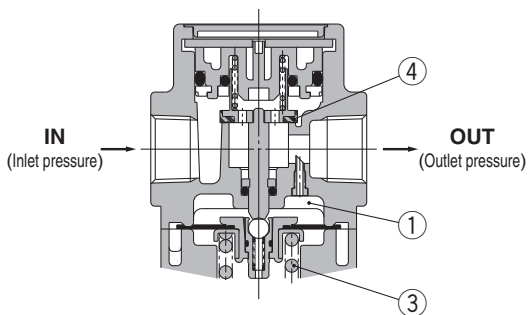
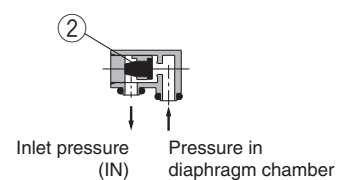
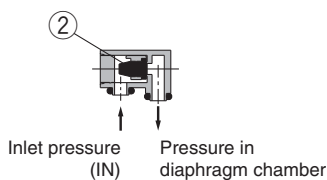
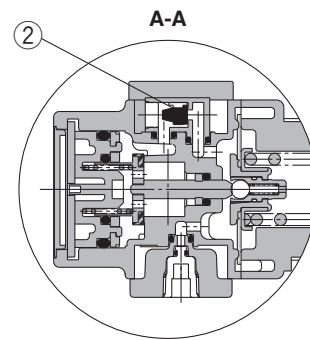
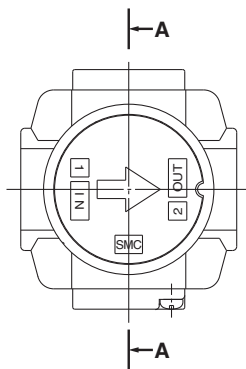

Figure 1 Normal

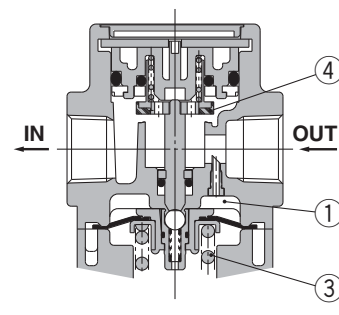

Figure 2 Backflow

When the inlet pressure is higher than the regulating pressure, the check valve ② closes and operates as a normal regulator (Figure 1). When the inlet pressure is shut off and released, the check valve ② opens and the pressure in the diaphragm chamber ① is released into the inlet side (Figure 2). This lowers the pressure in the diaphragm chamber ① and the force generated by the spring ③ lifts the diaphragm. The valve ④ opens through the stem, and the outlet pressure is released to the inlet side (Figure 2).

AC

AF+AR+AL

AW+AL

AF+AR

AF+AFM+AR

AW+AFM

Attachment

AF

AFM / AFD

AR

AL

AW

AR10-A Series AR20-B to AR60-B Series AR20K-B to AR60K-B Series

Dimensions

AR10-A

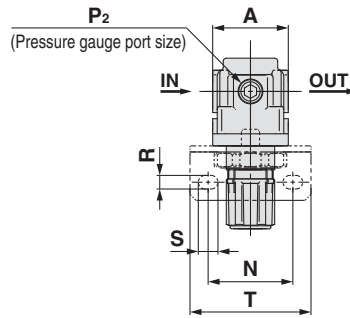
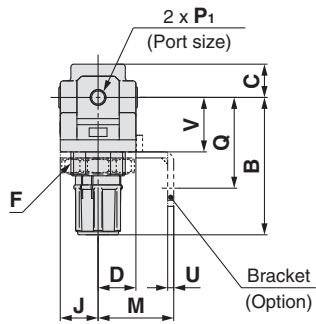

Panel mounting dimensions

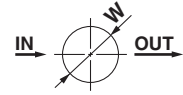
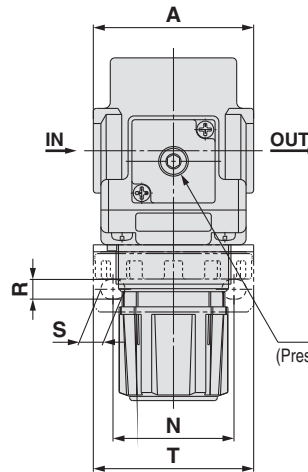
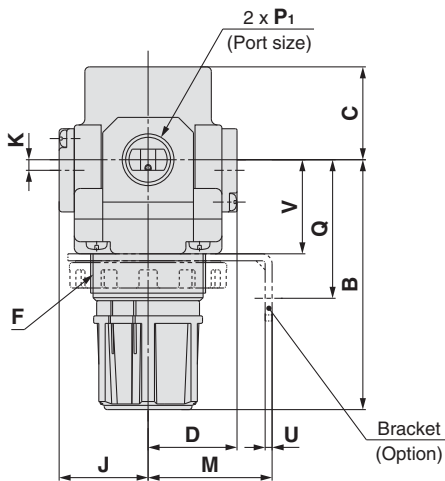

Plate thickness
AR10-A: Max. 3.5

AR20(K)-B to AR40(K)-06-B



Panel mounting dimensions

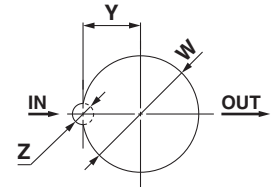
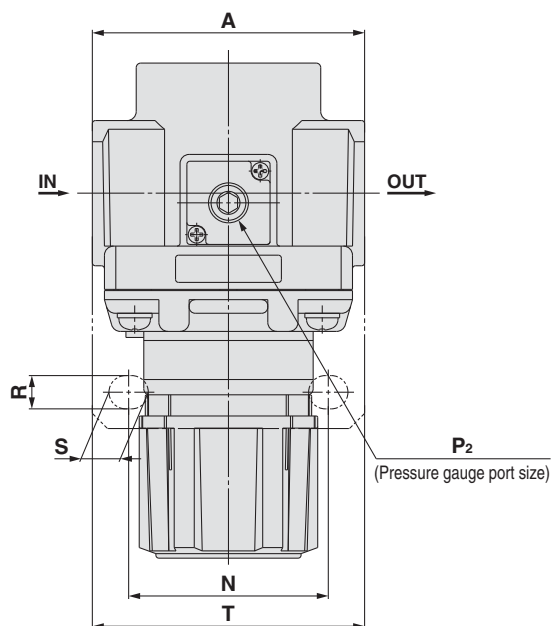
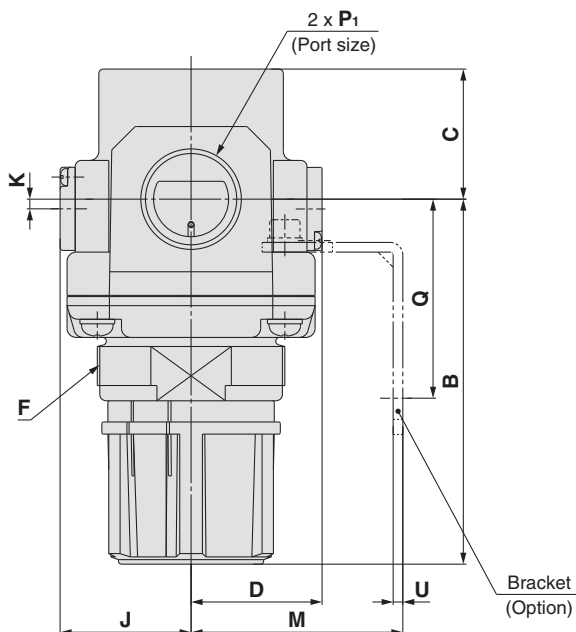
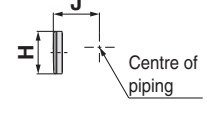
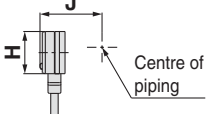
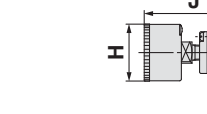



Plate thickness
AR20(K)-B to AR30(K)-B: Max. 3.5
AR40(K)-B : Max. 5

AR50(K)-B/AR60(K)-B



Regulator **AR10-A Series**
 Regulator **AR20-B to AR60-B Series**
 Regulator with Backflow Function **AR20K-B to AR60K-B Series**

Option	Square embedded type pressure gauge	Digital pressure switch	Round type pressure gauge	Round type pressure gauge (with colour zone)
Dimensions				

Model	Standard specifications										Optional specifications						
	P ₁	P ₂	A	B* ¹	C	D	F	J	K	H	J	H	J	H	J	H	J
AR10-A	M5 x 0.8	1/16	25	47.4	11	12.5	M18 x 1	12.5	—	—	—	—	—	∅ 26	26	—	—
AR20(K)-B	1/8, 1/4	1/8	40	67.4	26.5	28.5	M28 x 1	28.5	2* ²	□28	29.5	□27.8	40	∅ 37.5	65	∅ 37.5	66
AR25(K)-B	1/4, 3/8	1/8	53	71.9	28	27.5	M32 x 1.5	27.5	0	□28	28.5	□27.8	39	∅ 37.5	64	∅ 37.5	65
AR30(K)-B	1/4, 3/8	1/8	53	85.6	30.7	29.4	M38 x 1.5	29.4	3.5	□28	30.4	□27.8	40.9	∅ 37.5	65.9	∅ 37.5	66.9
AR40(K)-B	1/4, 3/8, 1/2	1/8	70	91.7	35.8	33.8	M42 x 1.5	33.8	3.5	□28	34.8	□27.8	45.3	∅ 42.5	71.3	∅ 42.5	71.3
AR40(K)-06-B	3/4	1/8	75	93.2	35.8	33.8	M42 x 1.5	33.8	3	□28	34.8	□27.8	45.3	∅ 42.5	71.3	∅ 42.5	71.3
AR50(K)-B	3/4, 1	1/8	90	125.2	43	43.3	M62 x 1.5	43.3	3.2	□28	44.3	□27.8	54.8	∅ 42.5	80.8	∅ 42.5	80.8
AR60(K)-B	1	1/8	95	129.6	46	43.3	M62 x 1.5	43.3	3.2	□28	44.3	□27.8	54.8	∅ 42.5	80.8	∅ 42.5	80.8

Model	Optional specifications										
	Bracket mount							Panel mount			
	M	N	Q	R	S	T	U	V	W	Y	Z
AR10-A	25	28	30	4.5	6.5	40	2	18	18.5	—	—
AR20(K)-B	30	34	43.9	5.4	15.4	55	2.3	24.7	28.5	14	6
AR25(K)-B	30	34	43.9	5.4	15.4	55	2.3	25.7	32.5	16	6
AR30(K)-B	41	40	45.8	6.5	8	53	2.3	31.1	38.5	19	7
AR40(K)-B	50	54	54	8.5	10.5	70	2.3	35.5	42.5	21	7
AR40(K)-06-B	50	54	55.5	8.5	10.5	70	2.3	37	42.5	21	7
AR50(K)-B	70	66	65.8	11	13	90	3.2	—	—	—	—
AR60(K)-B	70	66	65.8	11	13	90	3.2	—	—	—	—

*1 The dimension of B is the length when the filter regulator knob is unlocked.
 *2 For the AR20(K)-B only, the position of the pressure gauge is above the centre of the piping.

AC
 AF+AR+AL
 AW+AL
 AF+AR
 AF+AFM+AR
 AW+AFM
 Attachment
 AF
 AFM / AFD
 AR
 AL
 AW

AR20-B to AR60-B Regulator Made to Order

Please contact SMC for detailed dimensions, specifications and lead times.



AR30-03-B-X430/440/425

① Special Temperature Environment

Special materials are used in the manufacturing of seals and resin parts to allow them to withstand various temperature conditions in cold or tropical (hot) climates.

Specifications

Made-to-order part no.	-X430	-X440
Environment	Low temperature	High temperature
Ambient temperature [°C]	-30 to 60	-5 to 80
Fluid temperature [°C]	-5 to 60 (with no freezing)	
Material	Rubber parts	Special NBR
	Main parts	FKM Metal (Aluminium die-cast, etc.)

Applicable Model

Model	AR25-B	AR30-B	AR40-B	AR40-06-B	AR50-B	AR60-B
Port size	1/4, 3/8	1/4, 3/8	1/4, 3/8, 1/2	3/4	3/4, 1	1

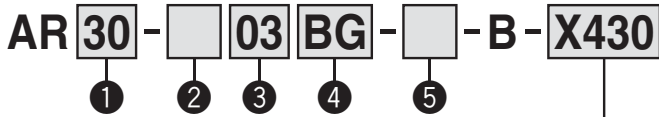

- Option/Semi-standard: Select one each for a to g.
- Option/Semi-standard symbol: When more than one specification is required, indicate in alphanumeric order.
Example) AR30-03BG-1NR-B-X430

For high/low temperature

X430	Low temperature
X440	High temperature

	Symbol	Description	① Body size					
			25	30	40	50	60	
② Pipe thread type	—	Rc	●	●	●	●	●	
	N	NPT	●	●	●	●	●	
	F	G	●	●	●	●	●	
③ Port size	02	1/4	●	●	●	—	—	
	03	3/8	●	●	●	—	—	
	04	1/2	—	—	●	—	—	
	06	3/4	—	—	●	●	—	
	10	1	—	—	—	●	●	
④ Option #1	a Mounting	—	Without mounting option	●	●	●	●	●
		B*2	With bracket	●	●	●	●	●
		H	With set nut (for panel mount)	●	●	●	—	—
④ Option #1	b Pressure gauge	G*3	Round type pressure gauge (without limit indicator)	●	●	●	●	●
		—	—	●	●	●	●	●
⑤ Semi-standard	c Set pressure	—	0.05 to 0.85 MPa setting	●	●	●	●	●
		1*4	0.02 to 0.2 MPa setting	●	●	●	●	●
	d Exhaust mechanism	—	Relieving type	●	●	●	●	●
		N	Non-relieving type	●	●	●	●	●
	e Flow direction	—	Flow direction: Left to right	●	●	●	●	●
R		Flow direction: Right to left	●	●	●	●	●	
f Knob	—	Downward	●	●	●	●	●	
	Y	Upward	●	●	●	●	●	
g Pressure unit	—	Name plate and pressure gauge in SI units: MPa	●	●	●	●	●	
	Z*5	Name plate and pressure gauge in imperial units: psi	○*6	○*6	○*6	○*6	○*6	

- *1 Options B, G, H are not assembled and supplied loose at the time of shipment.
- *2 Assembly of a bracket and set nuts (AR25-B to AR40-B) Including 2 mounting screws for the AR50-B and AR60-B
- *3 Mounting thread for pressure gauge: 1/8, Pressure gauge type: G43
- *4 The only difference from the standard specifications is the spring for the regulator. It does not restrict the setting of 0.2 MPa or more. When the pressure gauge is attached, a 0.4 MPa pressure gauge will be fitted.
- *5 For pipe thread type: NPT.
- *6 ○: For pipe thread type: NPT only

② High Pressure

Strong materials are used in the manufacturing of regulators intended for high pressure operation. Also, construction modification allows a wider set pressure range.

Specifications

Made-to-order part no.	-X425
Proof pressure [MPa]	3.0
Maximum operating pressure [MPa]	2.0
Set pressure range [MPa]	0.1 to 1.7
Ambient and fluid temperature [°C]	-5 to 60 (with no freezing)

Applicable Model

Model	AR20-B	AR25-B	AR30-B	AR40-B	AR40-06-B	AR50-B	AR60-B
Port size	1/8, 1/4	1/4, 3/8	1/4, 3/8	1/4, 3/8, 1/2	3/4	3/4, 1	1

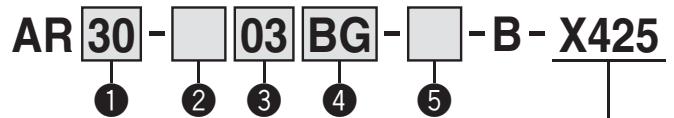

- Option/Semi-standard: Select one each for a to f.
- Option/Semi-standard symbol: When more than one specification is required, indicate in alphabetic order.
Example) AR30-03BG-NR-B-X425

	Symbol	Description	① Body size					
			20	25	30	40	50	60
② Pipe thread type	—	Rc	●	●	●	●	●	●
	N	NPT	●	●	●	●	●	●
	F	G	●	●	●	●	●	●
③ Port size	01	1/8	●	—	—	—	—	—
	02	1/4	●	●	●	—	—	—
	03	3/8	—	●	●	—	—	—
	04	1/2	—	—	●	—	—	—
	06	3/4	—	—	—	●	●	—
④ Option #1	a Mounting	—	Without mounting option	●	●	●	●	●
		B*2	With bracket	●	●	●	●	●
		H	With set nut (for panel mount)	●	●	●	—	—
④ Option #1	b Pressure gauge	G*3	Round type pressure switch (with limit indicator)	●	●	●	●	●
		—	—	●	●	●	●	●
⑤ Semi-standard	c Exhaust mechanism	—	Relieving type	●	●	●	●	●
		N	Non-relieving type	●	●	●	●	●
⑤ Semi-standard	d Flow direction	—	Flow direction: Left to right	●	●	●	●	●
		R	Flow direction: Right to left	●	●	●	●	●
⑤ Semi-standard	e Knob	—	Downward	●	●	●	●	●
		Y	Upward	●	●	●	●	●
f Pressure unit	—	Name plate and pressure gauge in SI units: MPa	●	●	●	●	●	
	Z*4	Name plate and pressure gauge in imperial units: psi	○*5	○*5	○*5	○*5	○*5	

- *1 Options B, G, H are not assembled and supplied loose at the time of shipment.
- *2 Assembly of a bracket and set nuts (AR20-B to AR40-B) Including 2 mounting screws for the AR50-B and AR60-B
- *3 Mounting thread for pressure gauge: 1/8, Pressure gauge type: G46-20-□
- *4 For pipe thread type: NPT.
- *5 ○: For pipe thread type: NPT only

AR10 Regulator Made to Order

Please contact SMC for detailed dimensions, specifications and lead times.



③ 0.4 MPa Setting

The maximum set pressure is 0.4 MPa. When a pressure gauge is included, the display will show a range from 0 to 0.4 MPa.

Specifications

Made-to-order part no.	-X406
Proof pressure [MPa]	1.5
Maximum operating pressure [MPa]	1.0
Set pressure range [MPa]	0.05 to 0.4

⚠ Caution

- The AR10 comes with a backflow function as a standard feature. When using the AR10 as with backflow function, backflow may not occur with the set pressure of 0.15 MPa or less.

Applicable Model

Model	AR10
Port size	M5

AR 10 - M5 - - A - X406

① ② •0.4 MPa setting

- Option/Semi-standard: Select one each for a to f.
- Option/Semi-standard symbol: When more than one specification is required, indicate in alphabetic order. Example) AR10-M5BG-NR-A-X406

		Symbol	Description	Body size	
				10	
①	Option *1	a	—	Without mounting option	●
			B*2	With bracket	●
			H	With set nut (for panel mount)	●
			+		
	b	Pressure gauge *3	—	Without pressure gauge	●
			G	Round type pressure gauge (without limit indicator)	●
		+			
②	Semi-standard	c	—	Relieving type	●
			N	Non-relieving type	●
			+		
	d	Flow direction	—	Flow direction: Left to right	●
			R	Flow direction: Right to left	●
			+		
	e	Knob	—	Downward	●
			Y	Upward	●
			+		
	f	Pressure unit	—	Name plate and pressure gauge in SI units: MPa	●
Z			Name plate and pressure gauge in imperial units: psi	●	

*1 Options B, G, H are not assembled and supplied loose at the time of shipment.

*2 Assembly of a bracket and set nuts.

*3 A 1.0 MPa pressure gauge will be fitted.

- AC
- AF+AR+AL
- AW+AL
- AF+AR
- AF+AFM+AR
- AW+AFM
- Attachment
- AF
- AFM / AFD
- AR
- AL
- AW

AR20-B to AR60-B Regulator AR20K-B to AR60K-B Regulator with Backflow Function Made to Order

Please contact SMC for detailed dimensions, specifications and lead times.



③ 0.4 MPa Setting

The maximum set pressure is 0.4 MPa. When a pressure gauge is included, the display will show a range from 0 to 0.4 MPa.

Specifications

Made-to-order part no.	-X406
Proof pressure [MPa]	1.5
Maximum operating pressure [MPa]	1.0
Set pressure range [MPa]	0.05 to 0.4

Applicable Model

Model	AR20(K)-B	AR25(K)-B	AR30(K)-B	AR40(K)-B	AR40(K)-06-B	AR50(K)-B	AR60(K)-B
Port size	1/8, 1/4	1/4, 3/8	1/4, 3/8	1/4, 3/8, 1/2	3/4	3/4, 1	1

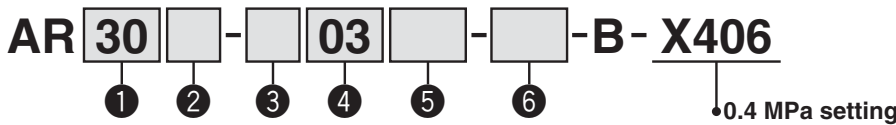

- Option/Semi-standard: Select one each for a to f.
- Option/Semi-standard symbol: When more than one specification is required, indicate in alphabetic order.
Example) AR30K-03BE-NR-B-X406

	Symbol	Description	① Body size							
			20	25	30	40	50	60		
② With backflow function	—	Without backflow function	●	●	●	●	●	●		
	K*1	With backflow function	●	●	●	●	●	●		
③ Pipe thread type	—	Rc	●	●	●	●	●	●		
	N	NPT	●	●	●	●	●	●		
	F	G	●	●	●	●	●	●		
④ Port size	01	1/8	●	—	—	—	—	—		
	02	1/4	●	●	●	●	—	—		
	03	3/8	—	●	●	●	—	—		
	04	1/2	—	—	—	●	—	—		
	06	3/4	—	—	—	●	●	—		
	10	1	—	—	—	—	●	●		
⑤ Option *2	a Mounting	—	Without mounting option	●	●	●	●	●	●	
		B*3	With bracket	●	●	●	●	●	●	
		H	With set nut (for panel mount)	●	●	●	●	—	—	
	b Pressure gauge*4	—	Without pressure gauge	●	●	●	●	●	●	
		E	Square embedded type pressure gauge (with limit indicator)	●	●	●	●	●	●	
		G	Round type pressure gauge (with limit indicator)	●	●	●	●	●	●	
		M	Round type pressure gauge (with colour zone)	●	●	●	●	●	●	
		Digital pressure switch	E1*5	Output: NPN output, Electrical entry: Wiring bottom entry	●	●	●	●	●	●
			E2*5	Output: NPN output, Electrical entry: Wiring top entry	●	●	●	●	●	●
			E3*5	Output: PNP output, Electrical entry: Wiring bottom entry	●	●	●	●	●	●
E4*5	Output: PNP output, Electrical entry: Wiring top entry		●	●	●	●	●	●		
⑥ Semi-standard	c Exhaust mechanism	—	Relieving type	●	●	●	●	●	●	
		N	Non-relieving type	●	●	●	●	●	●	
	d Flow direction	—	Flow direction: Left to right	●	●	●	●	●	●	
		R	Flow direction: Right to left	●	●	●	●	●	●	
	e Knob	—	Downward	●	●	●	●	●	●	
		Y	Upward	●	●	●	●	●	●	
f Pressure unit	—	Name plate and pressure gauge in SI units: MPa	●	●	●	●	●	●		
	Z*6	Name plate and pressure gauge in imperial units: psi	○*8	○*8	○*8	○*8	○*8	○*8		
	ZA*7	Digital pressure switch: With unit selection function	△*9	△*9	△*9	△*9	△*9	△*9		

*1 Please set the inlet pressure to at least 0.05 MPa higher than the set pressure.

*2 Options B, G, H are not assembled and supplied loose at the time of shipment.

*3 Assembly of a bracket and set nuts. (AR20(K)-B to AR40(K)-B). Including 2 mounting screws for the AR50(K)-B and AR60(K)-B

*4 A 0.7 MPa pressure gauge will be fitted.

*5 When choosing with H (panel mount), the installation space for lead wires will not be secured. In this case, select "wiring top entry" for the electrical entry. (Select "wiring bottom entry" when the semi-standard Y is chosen simultaneously.)

*6 For pipe thread type: NPT. The digital pressure switch will be equipped with the unit selection function, setting to psi initially.

*7 For options: E1, E2, E3, E4.

*8 ○: For pipe thread type: NPT only

*9 △: Select with options: E1, E2, E3, E4.

AR20-B to AR60-B Regulator AR20K-B to AR60K-B Regulator with Backflow Function Made to Order

Please contact SMC for detailed dimensions, specifications and lead times.



④ Clean Series

For details, refer to the Clean Series/Low Particle Generation section of the **Web Catalogue**.

10 - Standard model no.

* Please contact SMC if a product with pressure gauge is desired.

- Clean series

⑤ Copper, Fluorine and Silicone-free + Low Particle Generation

For details, refer to the Clean Series/Low Particle Generation section of the **Web Catalogue**.

21 - Standard model no.

- Copper, fluorine and silicone-free + Low particle generation

AC

AF+AR+AL

AW+AL

AF+AR

AF+AFM+AR

AW+AFM

Attachment

AF

AFM / AFD

AR

AL

AW

Modular Type Lubricator *AL Series*

Lubricator AL Series 	Model	Port size	Option
	AL10-A	M5 x 0.8	Bracket (Except AL10-A)
	AL20-A	1/8, 1/4	
	AL30-A	1/4, 3/8	
	AL40-A	1/4, 3/8, 1/2	
	AL40-06-A	3/4	
	AL50-A	3/4, 1	
	AL60-A	1	
Pages 83 to 90			

AC

AF+AR+AL

AW+AL

AF+AR

AF+AFM+AR

AW+AFM

Attachment

AF

AFM / AFD

AR

AL

AW

Lubricator

AL10-A to AL60-A

Symbol



How to Order

AL **30** - **03** **B** - **A**

① ② ③ ④ ⑤

- Option/Semi-standard: Select one each for a to d.
- Option/Semi-standard symbol: When more than one specification is required, indicate in alphanumeric order.
Example) AL30-03B-3RW-A

	Symbol	Description	①						
			Body size						
			10	20	30	40	50	60	
②	Pipe thread type	—	Metric thread (M5)						
		Rc	●	—	—	—	—	—	
		NPT	—	●	●	●	●	●	
		G	—	●	●	●	●	●	
+									
③	Port size	M5	M5 x 0.8						
		01	●	—	—	—	—	—	
		02	—	●	—	—	—	—	
		03	—	—	●	●	—	—	
		04	—	—	—	●	—	—	
		06	—	—	—	—	●	●	
		10	—	—	—	—	—	●	●
+									
④	Option (Mounting)	—	Without mounting option						
		B*1	●	●	●	●	●	●	
+									
⑤	a	Bowl *2 *3	—	Polycarbonate bowl					
			2	●	●	●	●	●	●
			6	●	●	●	●	●	●
			8	●	●	●	●	●	●
			C	—	—	●	●	●	●
			6C	—	●	—*4	—*4	—*4	—*4
	+								
	b	Lubricant exhaust port	—	Without drain cock					
			3	●	●	●	●	●	●
			3W*6	—	—	●	●	●	●
	+								
	c	Flow direction	—	Flow direction: Left to right					
			R	●	●	●	●	●	●
+									
d	Pressure unit	—	Name plate and caution plate: MPa						
		Z*7	○*8	○*8	○*8	○*8	○*8	○*8	

- *1 Option is not assembled and supplied loose at the time of shipment.
- *2 Refer to chemical data on page 86 for chemical resistance of the bowl.
- *3 Refer to page 89 for 1000 cm³ tanks.
- *4 A bowl guard is provided as standard equipment (polycarbonate).
- *5 A bowl guard is provided as standard equipment (nylon).
- *6 The combination of metal bowl: 2 and 8 is not available.
- *7 For pipe thread type: M5, NPT.
- *8 ○: For pipe thread type: M5, NPT only

Lubricator *AL10-A to AL60-A Series*

Standard Specifications

Model	AL10-A	AL20-A	AL30-A	AL40-A	AL40-06-A	AL50-A	AL60-A
Port size	M5 x 0.8	1/8, 1/4	1/4, 3/8	1/4, 3/8, 1/2	3/4	3/4, 1	1
Fluid	Air						
Ambient and fluid temperature	-5 to 60 °C (with no freezing)						
Proof pressure	1.5 MPa						
Maximum operating pressure	1.0 MPa						
Minimum dripping flow rate [l/min (ANR)]*1	4	15	1/4: 30 3/8: 40	1/4: 30 3/8: 40 1/2: 50	50	190	220
Oil capacity [cm ³]	7	25	55	135			
Recommended lubricant	Class 1 turbine oil (ISO VG32)						
Bowl material	Polycarbonate						
Bowl guard	—	Semi-standard (Steel)	Standard (Polycarbonate)				
Weight [kg]	0.07	0.10	0.20	0.38	0.43	0.94	1.09

- *1 · The flow rate is 5 drops or greater/min under the following conditions: Inlet pressure of 0.5 MPa; Class 1 turbine oil (ISO VG32); Temperature at 20 °C; Oil adjustment valve fully open.
 · For a circuit that repeatedly turns ON and OFF on the outlet side, make the adjustment so that the average air consumption per minute becomes the minimum dripping flow rate or more.

Option/Part No.

Optional specifications	Model						
	AL10-A	AL20-A	AL30-A	AL40-A	AL40-06-A	AL50-A	AL60-A
Bracket assembly *1	—	AF22P-050AS	AF32P-050AS	AF42P-050AS	AF42P-070AS	AF52P-050AS	

- *1 Assembly of a bracket and 2 mounting screws

Bowl Assembly/Part No.

Bowl material	Lubricant exhaust port	Other	Model						
			AL10-A	AL20-A	AL30-A	AL40-A	AL40-06-A	AL50-A	AL60-A
Polycarbonate	Without drain cock	—	C1SL-A	C2SL-A	—	—			
		With bowl guard	—	C2SL-C-A	C3SL-A	C4SL-A			
	With drain cock	—	C1SL-3-A	C2SL-3-A	—	—			
		With bowl guard	—	C2SL-3C-A	C3SL-3-A	C4SL-3-A			
Drain cock with barb fitting	With bowl guard	—	—	C3SL-3W-A	C4SL-3W-A				
Nylon	Without drain cock	—	C1SL-6-A	C2SL-6-A	—	—			
		With bowl guard	—	C2SL-6C-A	C3SL-6-A	C4SL-6-A			
	With drain cock	—	C1SL-36-A	C2SL-36-A	—	—			
		With bowl guard	—	C2SL-36C-A	C3SL-36-A	C4SL-36-A			
Drain cock with barb fitting	With bowl guard	—	—	C3SL-36W-A	C4SL-36W-A				
Metal	Without drain cock	—	C1SL-2-A	C2SL-2-A	C3SL-2-A	C4SL-2-A			
		With level gauge	—	—	C3LL-8-A	C4LL-8-A			
	With drain cock	—	C1SL-23-A	C2SL-23-A	C3SL-23-A	C4SL-23-A			
		With level gauge	—	—	C3LL-38-A	C4LL-38-A			

- * · Bowl seal is included for the AL20-A to AL60-A.
 · Please consult with SMC separately for psi and °F unit display specifications.

AC
 AF+AR+AL
 AW+AL
 AF+AR
 AF+AFM+AR
 AW+AFM
 Attachment
 AF
 AFM/AFD
 AR
 AL
 AW

AL10-A to AL60-A Series

Flow Rate Characteristics (Representative values)

AL10-A M5

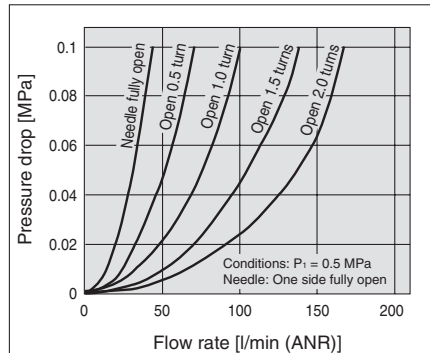

AL20-A Rc 1/4

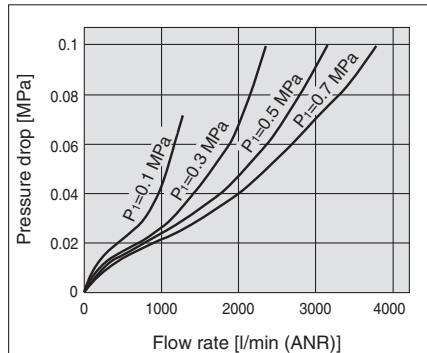

AL30-A Rc 3/8

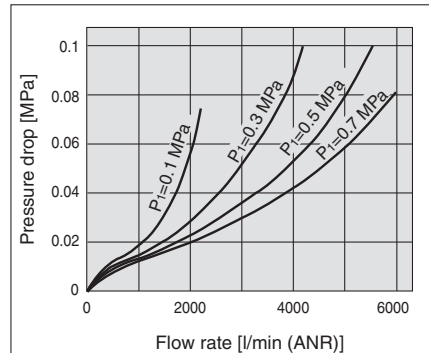

AL40-A Rc 1/2

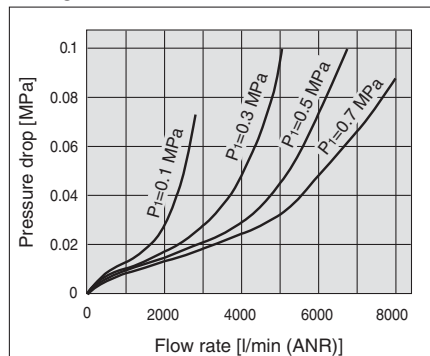

AL40-06-A Rc 3/4

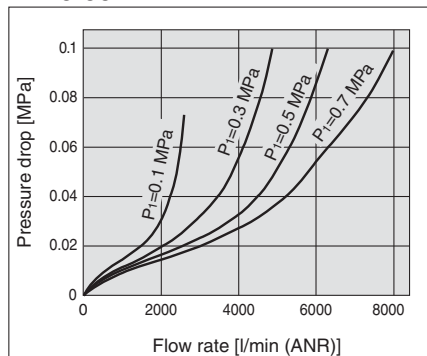

AL50-A Rc 1

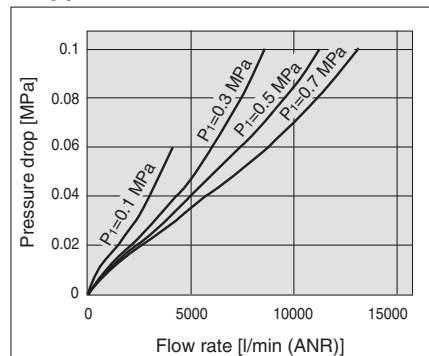

AL60-A Rc 1

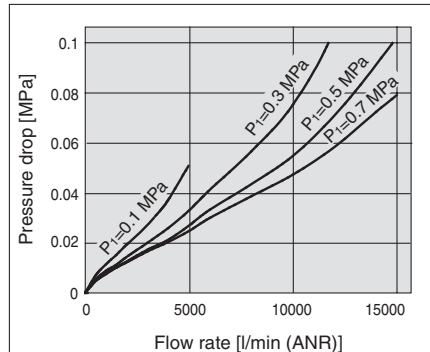

Working Principle: AL10

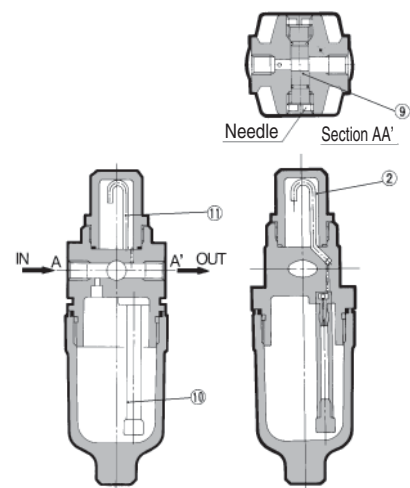

A portion of the air introduced from the IN side pressurises the lubricant inside the bowl. The remainder of the air passes through the needle (9), and flows to the OUT side. The differential pressure between the inside of the bowl and the inside of the sight dome (2), causes the lubricant inside the bowl into the oil passage (10). The lubricant drips from the dripping tube (11), and lubricates the OUT side. The amount of lubricant is adjusted by the needle (9) on the front face. Turning the needle clockwise increases the amount of the lubricant, and turning it counterclockwise until fully open shuts off the lubricant. The needle on the side that is not used should be left fully open.

⚠ Specific Product Precautions

Be sure to read this before handling the products. Refer to the back cover for safety instructions. For F.R.L. units precautions, refer to the "Handling Precautions for SMC Products" and the "Operation Manual", <http://www.smc.eu>

Selection

⚠ Warning

- Do not introduce air from the outlet side as this can damage the bumper.
- The standard bowl for the air filter, filter regulator, and lubricator, as well as the sight dome for the lubricator are made of polycarbonate. Do not use in an environment where they are exposed to or come in contact with organic solvents, chemicals, cutting oil, synthetic oil, alkali, and thread lock solutions.

Effects of atmosphere of organic solvents and chemicals, and where these elements are likely to adhere to the equipment.
Chemical data for substances causing degradation (Reference)

Type	Chemical name	Application examples	Material	
			Polycarbonate	Nylon
Acid	Hydrochloric acid Sulfuric acid, Phosphoric acid Chromic acid	Acid washing liquid for metals	△	×
Alkaline	Sodium hydroxide (Caustic soda) Potash Calcium hydroxide (Slack lime) Ammonia water Carbonate of soda	Degreasing of metals Industrial salts Water-soluble cutting oil	×	○
Inorganic salts	Sodium sulfide Potassium nitrate Sulfate of soda	—	×	△
Chlorine solvents	Carbon tetrachloride Chloroform Ethylene chloride Methylene chloride	Cleansing liquid for metals Printing ink Dilution	×	△
Aromatic series	Benzene Toluene Paint thinner	Coatings Dry cleaning	×	△
Ketone	Acetone Methyl ethyl ketone Cyclohexane	Photographic film Dry cleaning Textile industries	×	×
Alcohol	Ethyl alcohol IPA Methyl alcohol	Antifreeze Adhesives	△	×
Oil	Gasoline Kerosene	—	×	○
Ester	Phthalic acid dimethyl Phthalic acid diethyl Acetic acid	Synthetic oil Anti-rust additives	×	○
Ether	Methyl ether Ethyl ether	Brake oil additives	×	○
Amino	Methyl amino	Cutting oil Brake oil additives Rubber accelerator	×	×
Others	Thread-lock fluid Seawater Leak tester	—	×	△

○: Essentially safe △: Some effects may occur. ×: Effects will occur.

When the above factors are present, or there is some doubt, use a metal bowl for safety.

Selection

⚠ Caution

- Use a check valve (AKM series) to prevent back flow of the lubricant when redirecting the air flow before the lubricator.

Maintenance

⚠ Warning

- For the AL10-A/AL20-A, replenish the lubricant after releasing the inlet pressure. Lubrication cannot take place under a pressurised condition.
- Adjustment of the oil regulating valve for models from the AL20-A to AL60-A should be carried out manually. Turning it counterclockwise increases the dripping amount, and turning it clockwise reduces the dripping amount. The use of tools etc. can result in damage to the unit. From the fully closed position, three rotations will bring it to the fully open position. Do not rotate it any further than this. Note that the numbered scale markings are guidelines for adjusting the position, and not indicators of the dripping amount.

⚠ Caution

- Check the dripping amount once a day. Drip failure can cause damage to the components that need lubrication.

Mounting/Adjustment

⚠ Caution

- When the bowl is installed on the AL30-A to AL60-A, install them so that the lock button lines up to the groove of the front (or the back) of the body to avoid drop or damage of the bowl.



AC

AF+AR+AL

AW+AL

AF+AR

AF+AFM+AR

AW+AFM

Attachment

AF

AFM / AFD

AR

AL

AW

AL10-A to AL60-A Series

Construction

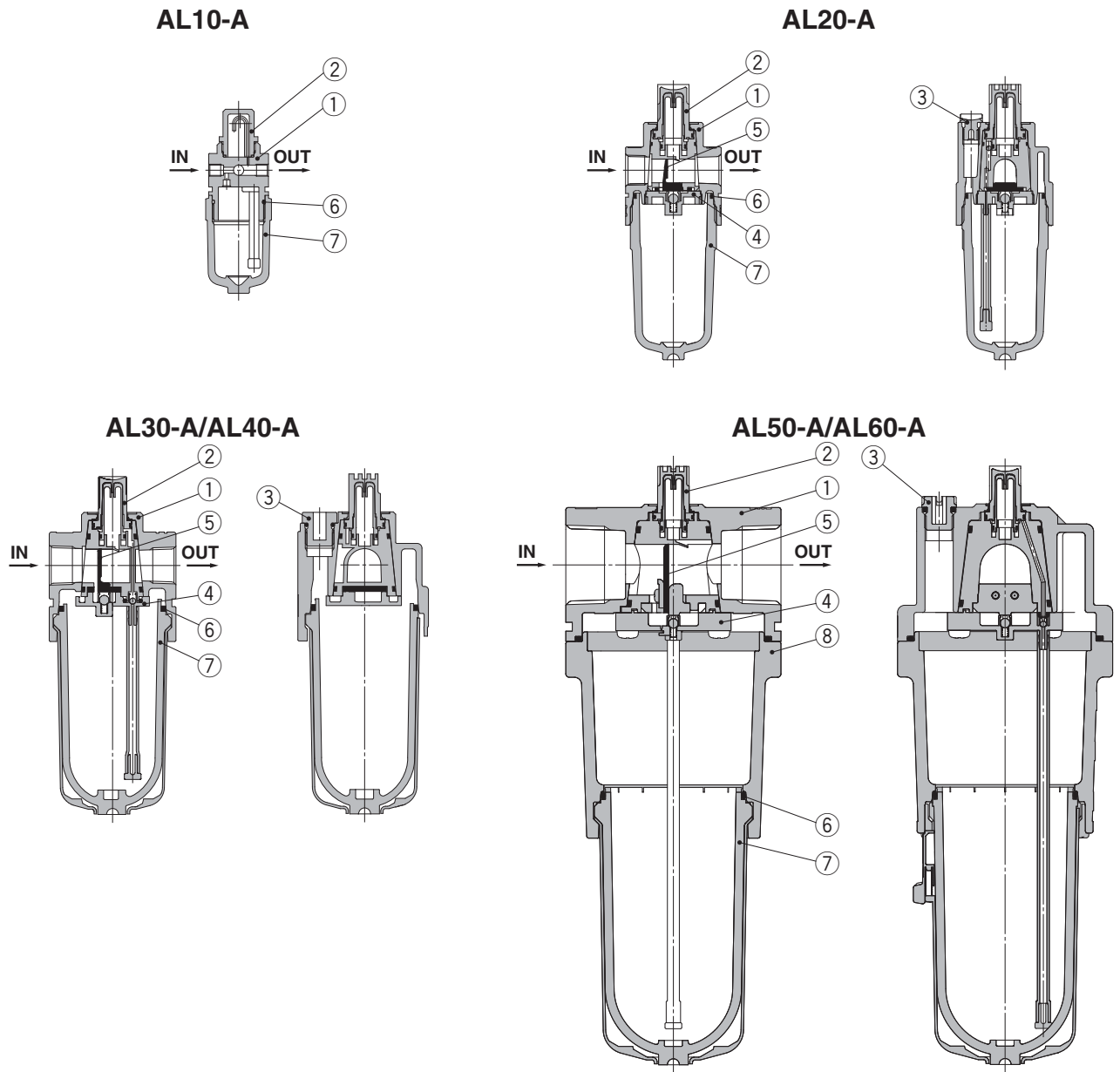

Component Parts

No.	Description	Material	Model	Colour
1	Body	Zinc die-cast	AL10-A	White
		Aluminium die-cast	AL20-A to AL60-A	
8	Housing	Aluminium die-cast	AL50-A/AL60-A	White

Replacement Parts

No.	Description	Material	Part no.						
			AL10-A	AL20-A	AL30-A	AL40-A	AL40-06-A	AL50-A	AL60-A
2	Sight dome assembly	Polycarbonate	AL10P-080AS			AL20P-080AS			
3	Lubrication plug assembly	—	—	AL22P-060AS	AL32P-060AS		AL42P-060AS		
4	Bumper retainer assembly	—	—	AL20P-030AS	AL30P-030AS		AL40P-030AS	AL50P-030AS	AL60P-030AS
5	Bumper (assembly)	Synthetic resin	—	AL20P-040S	AL30P-040S		AL40P-040S	AL50P-040AS	AL60P-040AS
6	Bowl seal	NBR	C1SFP-260S	C2SFP-260S	C32FP-260S		C42FP-260S		
7	Bowl assembly *1	Polycarbonate	C1SL-A	C2SL-A	C3SL-A		C4SL-A		

*1 · Bowl seal is included for the AL20-A to AL60-A. Please consult with SMC separately for psi and °F unit display specifications.
 · Bowl assembly for the AL30-A to AL60-A models comes with a bowl guard (Material: Polycarbonate).

Dimensions

AL10-A

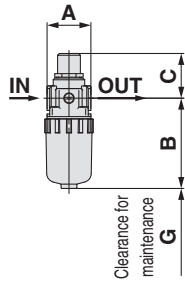
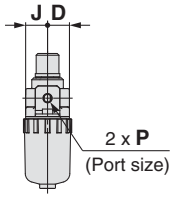

AL20-A

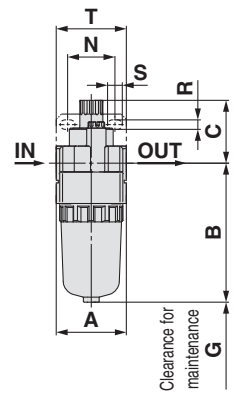
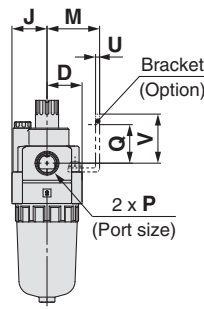

AL30-A to AL40-06-A

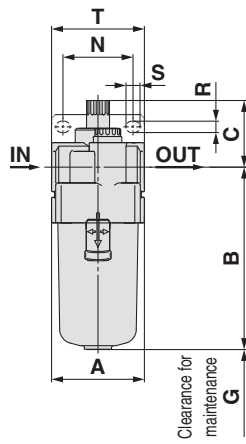
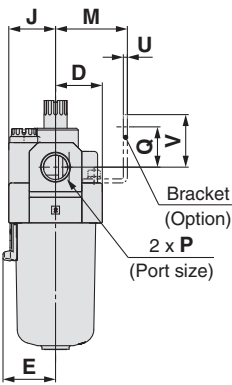

AL50-A AL60-A

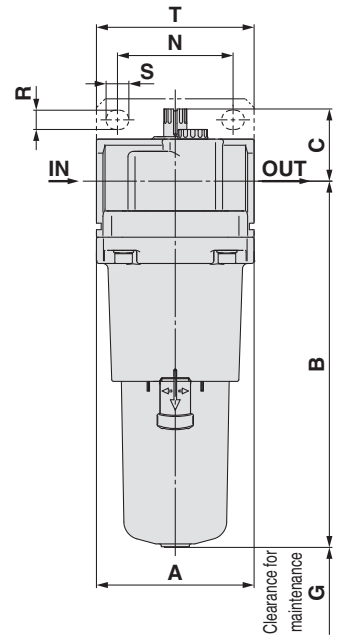
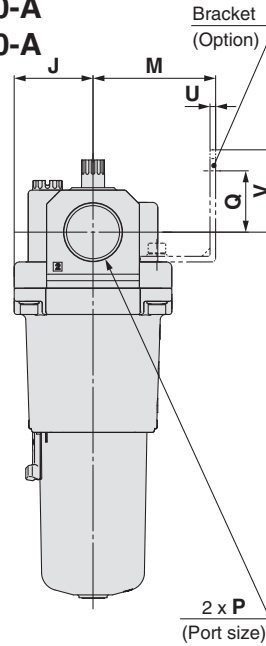

Applicable model	AL10-A/AL20-A			AL30-A to AL60-A
Optional/Semi-standard specifications	With drain cock	Metal bowl	Metal bowl with drain cock	Metal bowl
Dimensions				

Applicable model	AL30-A to AL60-A				
Optional/Semi-standard specifications	With drain cock	Metal bowl with level gauge	Metal bowl with drain cock	Metal bowl with level gauge, with drain cock	Drain cock with barb fitting
Dimensions					

Model	Standard specifications														Optional specifications				Semi-standard specifications			
	P	A	B	C	D	E	G	J	M	N	Q	R	S	T	U	V	Bracket mount					
																	With drain cock	With barb fitting	Metal bowl	Metal bowl with drain cock	Metal bowl with level gauge	Metal bowl with level gauge, with drain cock
AL10-A	M5 x 0.8	25	51.5	25.5	12.5	—	35	12.5	—	—	—	—	—	—	—	—	59.9	—	56.3	59.3	—	—
AL20-A	1/8, 1/4	40	79.3	35.9	20	—	60	20	30	27	22	5.4	8.4	40	2.3	28	87.7	—	84.5	87.5	—	—
AL30-A	1/4, 3/8	53	104.1	38.1	26.7	30	80	26.7	41	35	23	6.5	13	53	2.3	30	115.1	123.6	104.1	117.6	124.1	137.6
AL40-A	1/4, 3/8, 1/2	70	136.1	39.8	35.5	38.4	110	35.5	50	52	26	8.5	12.5	70	2.3	35	147.1	155.6	136.1	149.6	156.1	169.6
AL40-06-A	3/4	75	138.1	37.8	35.5	38.4	110	35.5	50	52	25	8.5	12.5	70	2.3	34	149.1	157.6	138.1	151.6	158.1	171.6
AL50-A	3/4, 1	90	209.1	41.2	45	—	110	45	70	66	35	11	13	90	3.2	47	220.1	228.6	209.1	222.6	229.1	246.2
AL60-A	1	95	223.1	44.7	47.5	—	110	47.5	70	66	35	11	13	90	3.2	47	234.1	242.6	223.1	236.6	243.1	256.6

AC
AF+AR+AL
AW+AL
AF+AR
AF+AFM+AR
AW+AFM
Attachment
AF
AFM / AFD
AR
AL
AW

Semi-standard Specifications: 1000 cm³ Tank Lubricator

AL30 to AL60

Available for previous models (AL30 to 60).

Symbol



How to Order

AL **30** - **03** **B** - **1**

① ② ③ ④ ⑤

- Option/Semi-standard: Select one each for **a** to **c**.
- Option/Semi-standard symbol: When more than one specification is required, indicate in alphanumeric order.
Example) AL30-03B-1R

	Symbol	Description	① Body size				
			30	40	50	60	
② Pipe thread type	—	Rc	●	●	●	●	
	N	NPT	●	●	●	●	
	F	G	●	●	●	●	
+							
③ Port size	02	1/4	●	●	—	—	
	03	3/8	●	●	—	—	
	04	1/2	—	●	—	—	
	06	3/4	—	●	●	—	
	10	1	—	—	●	●	
+							
④ Option (Mounting)	—	Without mounting option	●	●	●	●	
	B *1	With bracket	●	●	●	●	
+							
⑤	a Bowl*2	1 1000 cm ³ tank	●	●	●	●	
	+						
	b Flow direction	—	Flow direction: Left to right	●	●	●	●
		R	Flow direction: Right to left	●	●	●	●
	+						
	c Pressure unit	—	Name plate in SI units: MPa	●	●	●	●
Z *3		Name plate in imperial units: psi	○*4	○*4	○*4	○*4	

*1 Option B is not assembled and supplied loose at the time of shipment.

*2 The standard bowl is a metal bowl with level gauge and lubricant discharge function. The material of the sight dome is polycarbonate resin. For chemical resistance, refer to the chemical data on page 463.

*3 For pipe thread type: M5, NPT. This product is for overseas use only according to the new Measurement Act. (The SI unit type is provided for use in Japan.)

*4 ○: For pipe thread type: M5, NPT only

Semi-standard/Bowl Assembly Part No.

Semi-standard specifications			Model				
Bowl material	With switch		AL30	AL40	AL40-06	AL50	AL60
	Lowest limit ON	Lowest limit OFF					
1000 cm ³ tank (Metal bowl with level gauge)	—	—	121538-1A				

· It is not possible to switch from a polycarbonate, nylon or metal bowl, or from a metal bowl with a level gauge to a 1000 cm³ tank. Please order the product separately.

· When adding a float switch to the 1000 cm³ tank, select IS400-1 or IS400-2.

· For other replacement parts, refer to the Operation Manual.

Dimensions

Semi-standard specifications: 1000 cm³ tank

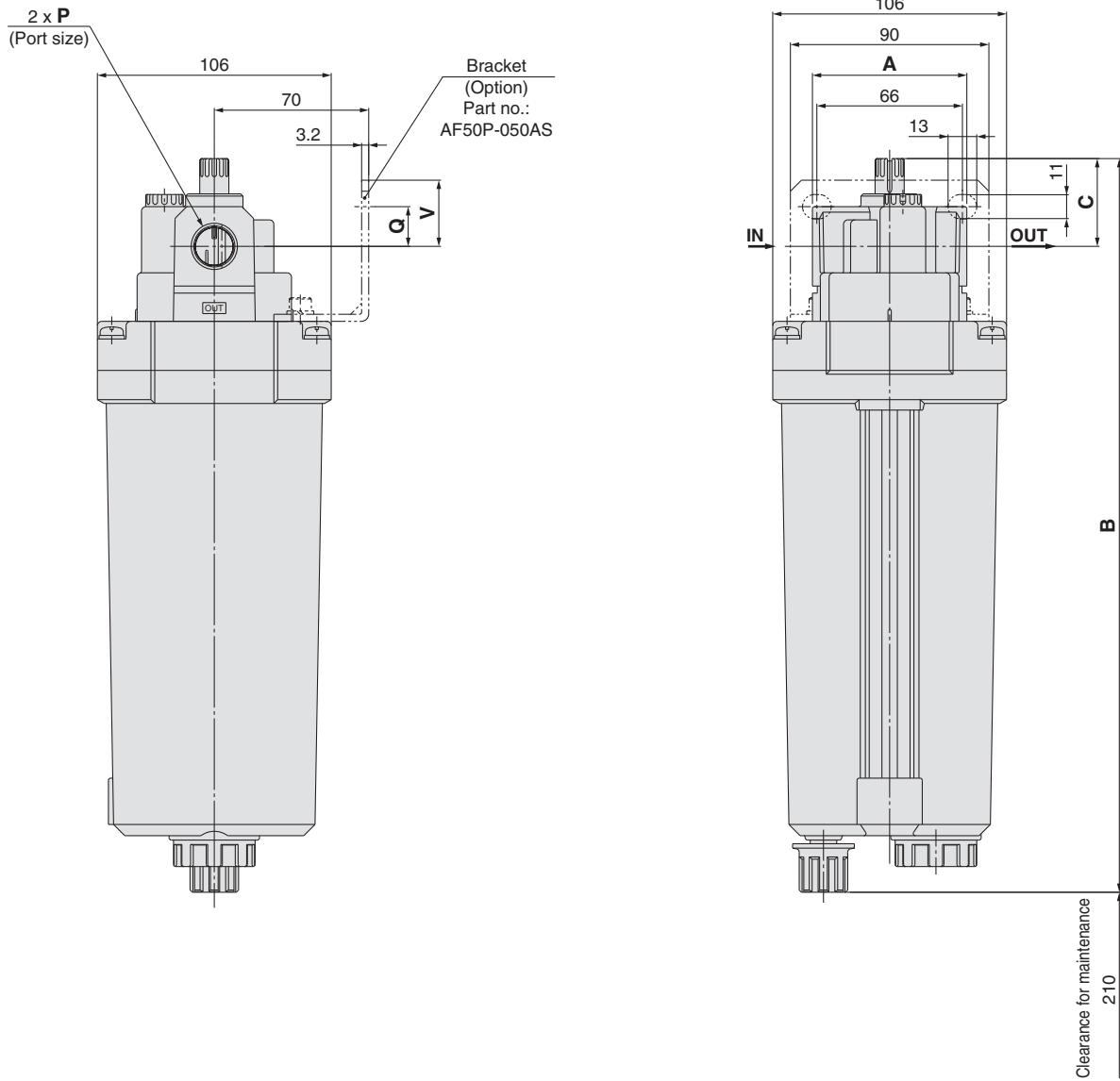

Model	P	A	B	C	Bracket mount		Float switch
					Q	V	B
AL30	1/4, 3/8	53	324	38	25	—	374
AL40	1/4, 3/8, 1/2	70	333	40	18	—	383
AL40-06	3/4	75	333	38	16	—	383
AL50	3/4, 1	90	332	41	35	47	382
AL60	1	95	335	45	35	47	385

AC

AF+AR+AL

AW+AL

AF+AR

AF+AFM+AR

AW+AFM

Attachment

AF

AFM / AFD

AR

AL

AW

Modular Type Filter Regulator **AW Series**

Filter Regulator AW Series 	Model	Port size	Set pressure	Options
	AW10-A	M5 x 0.8	0.05 to 0.7 MPa 0.02 to 0.2 MPa	Bracket Round type pressure gauge Set nut (for panel mount)*1
	AW20-B	1/8, 1/4	0.05 to 0.85 MPa 0.02 to 0.2 MPa	Bracket Set nut (for panel mount)*1
	AW30-B	1/4, 3/8		Float type auto drain
	AW40-B	1/4, 3/8, 1/2		Square embedded type pressure gauge Digital pressure switch
	AW40-06-B	3/4		Round type pressure gauge
	AW60-B	3/4, 1		Bracket Square embedded type pressure gauge Digital pressure switch
Round type pressure gauge				

Pages 93 to 111

***1 Interchangeable with the previous AW series and panel mounting dimensions.**

AC

AF+AR+AL

AW+AL

AF+AR

AF+AFM+AR

AW+AFM

Attachment

AF

AFM / AFD

AR

AL

AW

Filter Regulator AW10-A

Symbol
Filter Regulator

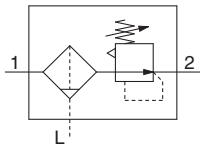

- Integrated filter and regulator units save space and require less piping.

How to Order

Refer to page 95 for size 20 to 60.

AW10-M5 - - A -

① ②

- Option/Semi-standard: Select one each for **a** to **h**.
- Option/Semi-standard symbol: When more than one specification is required, indicate in alphanumeric order.
Example) AW10-M5CG-12NR-A

- **Made to order**
(Refer to page 108 for details.)

		Symbol	Description		
1	Option #1	a	Mounting	—	Without mounting option
				B	With bracket
				H	With set nut (for panel mount)
		+			
		b	Float type auto drain	—	Without auto drain
				C*2	N.C. (Normally closed) Drain port is closed when pressure is not applied.
+					
c	Pressure gauge	—	Without pressure gauge		
		G*3	Round type pressure gauge (without limit indicator)		
+					
2	Semi-standard	d	Set pressure *4	—	0.05 to 0.7 MPa setting
				1	0.02 to 0.2 MPa setting
		+			
		e	Bowl *5	—	Polycarbonate bowl
				2	Metal bowl
				6	Nylon bowl
		+			
		f	Exhaust mechanism	—	Relieving type
				N	Non-relieving type
		+			
g	Flow direction	—	Flow direction: Left to right		
		R	Flow direction: Right to left		
+					
h	Pressure unit	—	Name plate, caution plate, and pressure gauge in SI units: MPa		
		Z	Name plate, caution plate, and pressure gauge in imperial units: psi, °F		

*1 Options B, G, H are not assembled and supplied loose at the time of shipment.

*2 When pressure is not applied, condensate which does not start the auto drain mechanism will be left in the bowl.

Releasing the residual condensate before ending operations for the day is recommended.

*3 A 1.0 MPa pressure gauge will be fitted. It is not assembled and supplied loose at the time of shipment.

*4 Pressure can be set higher than the specification pressure in some cases, but use pressure within the specification range.

*5 Refer to chemical data on page 98 for chemical resistance of the bowl.



AW10-A

Standard Specifications

Port size	M5 x 0.8
Pressure gauge port size	1/16
Fluid	Air
Ambient and fluid temperature	-5 to 60 °C (with no freezing)
Proof pressure	1.5 MPa
Maximum operating pressure	1.0 MPa
Set pressure range	0.05 to 0.7 MPa
Nominal filtration rating	5 μm
Drain capacity [cm ³]	2.5
Bowl material	Polycarbonate
Construction	Relieving type
Weight [kg]	0.09

Options/Part No.

Bracket assembly *1	AR12P-270AS
Set nut	AR12P-260S
Round type pressure gauge *2	G27-10-R1

*1 Assembly of a bracket and set nuts

*2 1.0 MPa pressure gauge

Bowl Assembly/Part No.

Bowl material	Drain discharge mechanism	Drain port	Bowl part no.
Polycarbonate	Manual	With drain cock	C1SF-A
	Automatic (Auto drain) *1	Normally closed (N.C.)	AD17-A
Nylon	Manual	With drain cock	C1SF-6-A
	Automatic (Auto drain) *1	Normally closed (N.C.)	AD27-6-A
Metal	Manual	With drain cock	C1SF-2-A
	Automatic (Auto drain) *1	Normally closed (N.C.)	AD17-2-A

*1 Minimum operating pressure: 0.1 MPa

* Please consult with SMC separately for psi and °F unit display specifications.

AC

AF+AR+AL

AW+AL

AF+AR

AF+AFM+AR

AW+AFM

Attachment

AF

AFM / AFD

AR

AL

AW

Filter Regulator

AW20-B to AW60-B

Filter Regulator with Backflow Function

AW20K-B to AW60K-B

Symbol
Filter Regulator

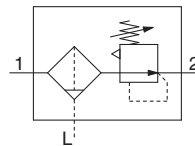

Filter Regulator with
Backflow Function

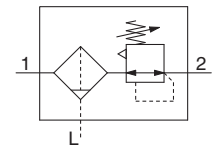

- Integrated filter and regulator units save space and require less piping.
- With the backflow function, it incorporates a mechanism to exhaust the air pressure in the outlet side reliably and quickly.

Example)

When the air supply is cut off and releasing the inlet pressure to the atmosphere, the residual pressure release of the outlet side can be ensured for a safety purpose.

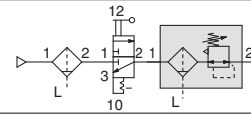

How to Order

Refer to page 93 for size 10.

AW 30 K - 03 BE - - B -

1
 2
 3
 4
 5
 6

- Option/Semi-standard: Select one each for a to i.
- Option/Semi-standard symbol: When more than one specification is required, indicate in alphanumeric order.
Example) AW30K-03BE-1N-B

• Made to order

(Refer to pages 106 to 110 for details.)

	Symbol	Description	① Body size					
			20	30	40	60		
② With backflow function	—	Without backflow function	●	●	●	●		
	K*1	With backflow function	●	●	●	●		
+								
③ Pipe thread type	—	Rc	●	●	●	●		
	N*2	NPT	●	●	●	●		
	F*3	G	●	●	●	●		
+								
④ Port size	01	1/8	●	—	—	—		
	02	1/4	●	●	●	—		
	03	3/8	—	●	●	—		
	04	1/2	—	—	●	—		
	06	3/4	—	—	●	●		
	10	1	—	—	—	●		
+								
⑤ Option *4	a Mounting	—	Without mounting option	●	●	●	●	
		B*5	With bracket	●	●	●	●	
		H	With set nut (for panel mount)	●	●	●	—	
	+							
	b Float type auto drain	—	Without auto drain	●	●	●	●	
		C*6	N.C. (Normally closed) Drain port is closed when pressure is not applied.	●	●	●	●	
		D*7	N.O. (Normally open) Drain port is open when pressure is not applied.	—	—	●	●	
	+							
	c Pressure gauge *8	—	Without pressure gauge	●	●	●	●	
		E	Square embedded type pressure gauge (with limit indicator)	●	●	●	●	
		G	Round type pressure gauge (with limit indicator)	●	●	●	●	
		M	Round type pressure gauge (with colour zone)	●	●	●	●	
		Digital pressure switch *9	E1	Output: NPN output, Electrical entry: Wiring bottom entry	●	●	●	●
			E2	Output: NPN output, Electrical entry: Wiring top entry	●	●	●	●
			E3	Output: PNP output, Electrical entry: Wiring bottom entry	●	●	●	●
E4	Output: PNP output, Electrical entry: Wiring top entry		●	●	●	●		
+								
⑥ Semi-standard	d Set pressure *10	—	0.05 to 0.85 MPa setting	●	●	●	●	
		1	0.02 to 0.2 MPa setting	●	●	●	●	
+								
e Bowl *11	—	Polycarbonate bowl	●	●	●	●		
	2	Metal bowl	●	●	●	●		
	6	Nylon bowl	●	●	●	●		
	8	Metal bowl with level gauge	—	●	●	●		
	C	With bowl guard	●	—*12	—*12	—*12		
	6C	With bowl guard (Nylon bowl)	●	—*13	—*13	—*13		
+								
f Drain port *14	—	With drain cock	●	●	●	●		
	J*15	Drain guide 1/8	●	—	—	—		
		Drain guide 1/4	—	●	●	●		
	W*16	Drain cock with barb fitting	—	●	●	●		

Filter Regulator **AW20-B to AW60-B Series**

Filter Regulator with Backflow Function **AW20K-B to AW60K-B Series**



AW20-B, AW20K-B AW40-B, AW40K-B

		Symbol	Description	①				
				Body size				
				20	30	40	60	
6	g	Exhaust mechanism	—	Relieving type	●	●	●	●
			N	Non-relieving type	●	●	●	●
			+					
	h	Flow direction	—	Flow direction: Left to right	●	●	●	●
			R	Flow direction: Right to left	●	●	●	●
			+					
i	Pressure unit	—	Name plate, caution plate for bowl, and pressure gauge in SI units: MPa	●	●	●	●	
		Z*17	Name plate, caution plate for bowl, and pressure gauge in imperial units: psi, °F	○*19	○*19	○*19	○*19	
		ZA*18	Digital pressure switch: With unit selection function	△*20	△*20	△*20	△*20	

- *1 Set the inlet pressure to at least 0.05 MPa higher than the set pressure.
- *2 Drain guide is NPT 1/8 (applicable to the AW20(K)-B) and NPT 1/4 (applicable to the AW30(K)-B to AW60(K)-B). The auto drain port comes with Ø 3/8" One-touch fitting (applicable to the AW30(K)-B to AW60(K)-B).
- *3 Drain guide is G 1/8 (applicable to the AW20(K)-B) and G 1/4 (applicable to the AW30(K)-B to AW60(K)-B).
- *4 Options B, G, H, M are not assembled and supplied loose at the time of shipment.
- *5 Assembly of a bracket and set nuts (applicable to the AW20(K)-B to AW40(K)-B). Including 2 mounting screws for the AW60(K)-B
- *6 When pressure is not applied, condensate which does not start the auto drain mechanism will be left in the bowl. Releasing the residual condensate before ending operations for the day is recommended.

- *7 If the compressor is small (0.75 kW, discharge flow is less than 100 l/min[ANR]), air leakage from the drain cock may occur during start of operations. N.C. type is recommended.
- *8 When the pressure gauge is attached, a 1.0 MPa pressure gauge will be fitted for standard (0.85 MPa) type. 0.4 MPa pressure gauge for 0.2 MPa type.
- *9 When choosing with H (panel mount), the installation space for lead wires will not be secured. In this case, select "wiring top entry" for the electrical entry.
- *10 Pressure can be set higher than the specification pressure in some cases, but use pressure within the specification range.
- *11 Refer to chemical data on page 98 for chemical resistance of the bowl.
- *12 A bowl guard is provided as standard equipment (polycarbonate).
- *13 A bowl guard is provided as standard equipment (nylon).

- *14 The combination of float type auto drain: C and D is not available.
- *15 Without a valve function
- *16 The combination of metal bowl: 2 and 8 is not available.
- *17 For pipe thread type: NPT. Cannot be used with M: Round type pressure gauge (with colour zone). Available by request for special. The digital pressure switch will be equipped with the unit selection function, setting to psi initially.
- *18 For options: E1, E2, E3, E4.
- *19 ○: For pipe thread type: NPT only
- *20 △: Select with options: E1, E2, E3, E4.

Standard Specifications

Model	AW20-B	AW30-B	AW40-B	AW40-06-B	AW60-B
Port size	1/8, 1/4	1/4, 3/8	1/4, 3/8, 1/2	3/4	3/4, 1
Pressure gauge port size *1	1/8				
Fluid	Air				
Ambient and fluid temperature *2	-5 to 60 °C (with no freezing)				
Proof pressure	1.5 MPa				
Maximum operating pressure	1.0 MPa				
Set pressure range	0.05 to 0.85 MPa				
Nominal filtration rating	5 µm				
Drain capacity [cm³]	8	25	45		
Bowl material	Polycarbonate				
Bowl guard	Semi-standard (Steel)	Standard (Polycarbonate)			
Construction	Relieving type				
Weight [kg]	0.20	0.36	0.66	0.72	2.05

- *1 Pressure gauge connection threads are not available for F.R.L. unit with a square embedded type pressure gauge or with a digital pressure switch.
- *2 -5 to 50 °C for the products with the digital pressure switch.

AC
AF+AR+AL
AW+AL
AF+AR
AF+AFM+AR
AW+AFM
Attachment
AF
AFM / AFD
AR
AL
AW

AW20-B to AW60-B Series

AW20K-B to AW60K-B Series

Options/Part No.

Optional specifications		Model				
		AW20(K)-B	AW30(K)-B	AW40(K)-B	AW40(K)-06-B	AW60(K)-B
Bracket assembly *1		AW23P-270AS	AR33P-270AS	AR43P-270AS		AW62P-270AS
Set nut		AR23P-260S	AR33P-260S	AR43P-260S		—*2
Pressure gauge	Round type *3	Standard	G36-10-□01		G46-10-□01	
		0.02 to 0.2 MPa setting	G36-4-□01		G46-4-□01	
	Round type *3 (with colour zone)	Standard	G36-10-□01-L		G46-10-□01-L	
		0.02 to 0.2 MPa setting	G36-4-□01-L		G46-4-□01-L	
Square embedded type *4	Standard	GC3-10AS [GC3P-010AS (Pressure gauge cover only)]				
	0.02 to 0.2 MPa setting	GC3-4AS [GC3P-010AS (Pressure gauge cover only)]				
Digital pressure switch *5		NPN output, Wiring bottom entry	ISE35-N-25-MLA [ISE35-N-25-M (Switch body only)]			
		NPN output, Wiring top entry	ISE35-R-25-MLA [ISE35-R-25-M (Switch body only)]			
		PNP output, Wiring bottom entry	ISE35-N-65-MLA [ISE35-N-65-M (Switch body only)]			
		PNP output, Wiring top entry	ISE35-R-65-MLA [ISE35-R-65-M (Switch body only)]			

*1 Assembly of a bracket and set nuts. Including 2 mounting screws for the AW60(K)-B

*2 Please consult with SMC regarding the set nuts for the AW60(K)-B.

*3 □ in part numbers for a round type pressure gauge indicates a pipe thread type.

No indication is necessary for R; however, indicate N for NPT.

Please contact SMC regarding the pressure gauge supply for psi unit specifications.

*4 Including one O-ring and 2 mounting screws.

[]: Pressure gauge cover only

*5 In addition to the pressure switch body, lead wire with connector (2 m), adapter, lock pin, O-ring (1 pc.), mounting screw (2 pcs.) are attached.

[]: Switch body only. (Regarding how to order the digital pressure switch, refer to the **Web Catalogue**.)

A pressure switch can be mounted on the AW60(K)-B, with a special mounting adapter (Pressure switch adapter assembly: AW63P-310AS) and mounting screws (M3 x 0.5 x 14) which are delivered with the mounting adapter.

Bowl Assembly/Part No.

Bowl material	Drain discharge mechanism	Drain port	Other	Model				
				AW20-B	AW30-B	AW40-B	AW40-06-B	AW60-B
Polycarbonate	Manual	With drain cock	—	C2SF-A	—	—		
		With bowl guard	—	C2SF-C-A	C3SF-A	C4SF-A		
		Drain cock with barb fitting	With bowl guard	—	C3SF-W-A	C4SF-W-A		
	Automatic *1 (Auto drain)	With drain guide (without valve function)	—	C2SF□-J-A	—	—		
		With bowl guard	—	C2SF□-CJ-A	C3SF□-J-A	C4SF□-J-A		
		Normally closed (N.C.)	—	AD27-A	—	—		
Normally open (N.O.)	With bowl guard	—	AD27-C-A	AD37□-A	AD47□-A			
	With bowl guard	—	AD38□-A	—	AD48□-A			
Nylon	Manual	With drain cock	—	C2SF-6-A	—	—		
		With bowl guard	—	C2SF-6C-A	C3SF-6-A	C4SF-6-A		
		Drain cock with barb fitting	With bowl guard	—	C3SF-6W-A	C4SF-6W-A		
	Automatic *1 (Auto drain)	With drain guide (without valve function)	—	C2SF□-6J-A	—	—		
		With bowl guard	—	C2SF□-6CJ-A	C3SF□-6J-A	C4SF□-6J-A		
		Normally closed (N.C.)	—	AD27-6-A	—	—		
Normally open (N.O.)	With bowl guard	—	AD27-6C-A	AD37□-6-A	AD47□-6-A			
	With bowl guard	—	AD38□-6-A	—	AD48□-6-A			
Metal	Manual	With drain cock	—	C2SF-2-A	C3SF-2-A	C4SF-2-A		
		With level gauge	—	—	C3LF-8-A	C4LF-8-A		
		With drain guide (without valve function)	—	C2SF□-2J-A	C3SF□-2J-A	C4SF□-2J-A		
	Automatic *1 (Auto drain)	With level gauge	—	—	C3LF□-8J-A	C4LF□-8J-A		
		Normally closed (N.C.)	—	AD27-2-A	AD37□-2-A	AD47□-2-A		
		With level gauge	—	—	AD37□-8-A	AD47□-8-A		
Normally open (N.O.)	—	—	AD38□-2-A	—	AD48□-2-A			
	With level gauge	—	—	AD38□-8-A	AD48□-8-A			

*1 Minimum operating pressure: N.O. type—0.1 MPa (AD38-A, AD48-A); N.C. type—0.1 MPa (AD27-A) and 0.15 MPa (AD37-A, AD47-A).

Bowl assembly comes with a bowl seal.

□ in bowl assembly part numbers indicates a pipe thread type (applicable tubing for auto drain).

No indication is necessary for Rc thread; however, indicate N for NPT thread, and F for G thread. (For auto drain, —: Ø 10, N: Ø 3/8")

Please consult with SMC separately for psi and °F unit display specifications.

⚠ Specific Product Precautions

Be sure to read this before handling the products. Refer to the back cover for safety instructions. For F.R.L. units precautions, refer to the “Handling Precautions for SMC Products” and the “Operation Manual”, <http://www.smc.eu>

Design/Selection

⚠ Warning

- Residual pressure disposal (outlet pressure removal) is not possible for the AW20-B to AW60-B even though the inlet pressure is exhausted. When the residual pressure disposal is performed, use the filter regulator with backflow function (AW20K-B to AW60K-B).
- The standard bowl for the air filter, filter regulator, and lubricator, as well as the sight dome for the lubricator are made of polycarbonate. Do not use in an environment where they are exposed to or come in contact with organic solvents, chemicals, cutting oil, synthetic oil, alkali, and thread lock solutions.

Effects of atmosphere of organic solvents and chemicals, and where these elements are likely to adhere to the equipment.
Chemical data for substances causing degradation (Reference)

Type	Chemical name	Application examples	Material	
			Polycarbonate	Nylon
Acid	Hydrochloric acid Sulfuric acid, Phosphoric acid Chromic acid	Acid washing liquid for metals	△	×
Alkaline	Sodium hydroxide (Caustic soda) Potash Calcium hydroxide (Slack lime) Ammonia water Carbonate of soda	Degreasing of metals Industrial salts Water-soluble cutting oil	×	○
Inorganic salts	Sodium sulfide Potassium nitrate Sulfate of soda	—	×	△
Chlorine solvents	Carbon tetrachloride Chloroform Ethylene chloride Methylene chloride	Cleansing liquid for metals Printing ink Dilution	×	△
Aromatic series	Benzene Toluene Paint thinner	Coatings Dry cleaning	×	△
Ketone	Acetone Methyl ethyl ketone Cyclohexane	Photographic film Dry cleaning Textile industries	×	×
Alcohol	Ethyl alcohol IPA Methyl alcohol	Antifreeze Adhesives	△	×
Oil	Gasoline Kerosene	—	×	○
Ester	Phthalic acid dimethyl Phthalic acid diethyl Acetic acid	Synthetic oil Anti-rust additives	×	○
Ether	Methyl ether Ethyl ether	Brake oil additives	×	○
Amino	Methyl amino	Cutting oil Brake oil additives Rubber accelerator	×	×
Others	Thread-lock fluid Seawater Leak tester	—	×	△

○: Essentially safe △: Some effects may occur. ×: Effects will occur.

When the above factors are present, or there is some doubt, use a metal bowl for safety.

Maintenance

⚠ Warning

- Replace the element every 2 years or when the pressure drop becomes 0.1 MPa, whichever comes first, to prevent damage to the element.

Mounting/Adjustment

⚠ Warning

- Set the regulator while verifying the displayed values of the inlet and outlet pressure gauges. Turning the regulator knob excessively can cause damage to the internal parts.
- Do not use tools on the pressure regulator knob as this may cause damage. It must be operated manually.

⚠ Caution

- Be sure to unlock the knob before adjusting the pressure and lock it after setting the pressure. Failure to follow this procedure can cause damage to the knob and the outlet pressure may fluctuate.
 - Pull the pressure regulator knob to unlock. (You can visually verify this with the “orange mark” that appears in the gap.)
 - Push the pressure regulator knob to lock. When the knob is not easily locked, turn it left and right a little and then push it (when the knob is locked, the “orange mark”, i.e., the gap will disappear).
- A knob cover is available to prevent careless operation of the knob. Refer to page 112 for details.
- When the bowl is installed on the AW30-B to AW60-B, install them so that the lock button lines up to the groove of the front (or the back) of the body to avoid drop or damage of the bowl.



AC

AF+AR+AL

AW+AL

AF+AR

AF+AFM+AR

AW+AFM

Attachment

AF

AFM / AFD

AR

AL

AW

AW10-A Series

AW20-B to AW60-B Series

AW20K-B to AW60K-B Series

Flow Rate Characteristics (Representative values)

Condition: Inlet pressure of 0.7 MPa

AW10-A M5

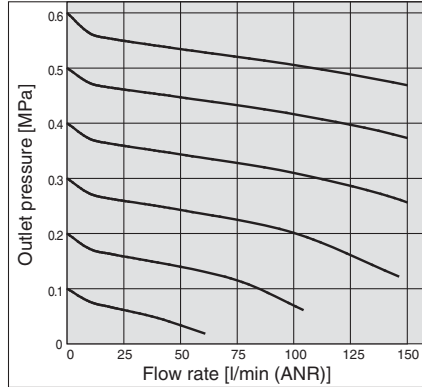

AW20(K)-B Rc 1/4

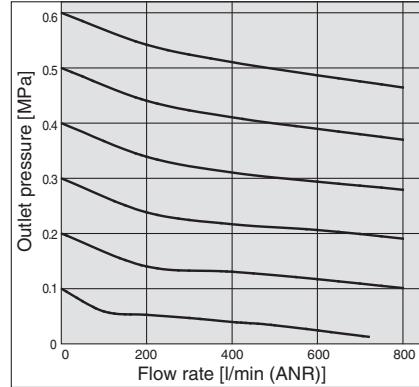

AW30(K)-B Rc 3/8

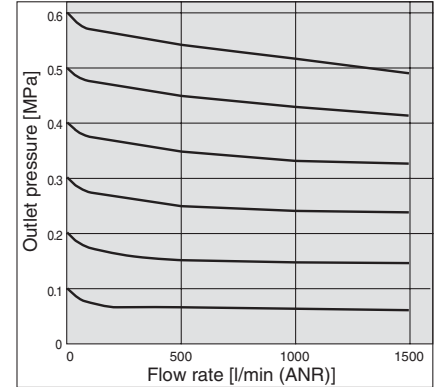

AW40(K)-B Rc 1/2

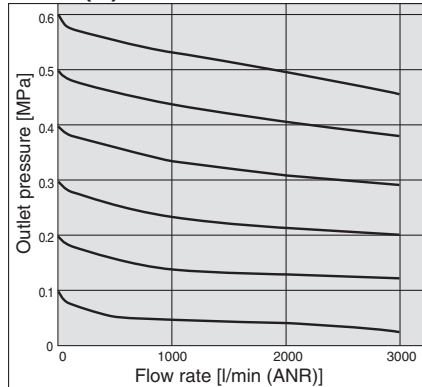

AW40(K)-06-B Rc 3/4

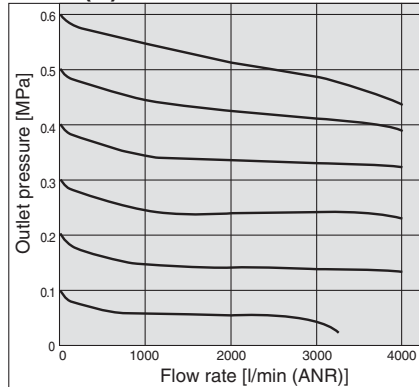

AW60(K)-B Rc 1

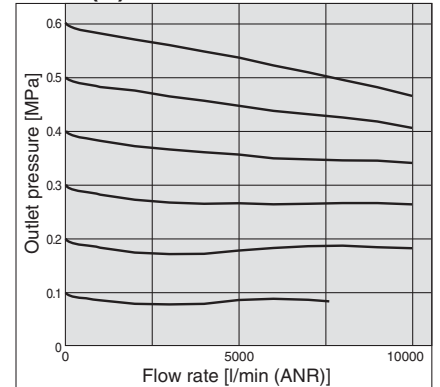

Pressure Characteristics (Representative values)

Conditions: Inlet pressure of 0.7 MPa, Outlet pressure of 0.2 MPa, Flow rate 20 l/min (ANR)

AW10-A

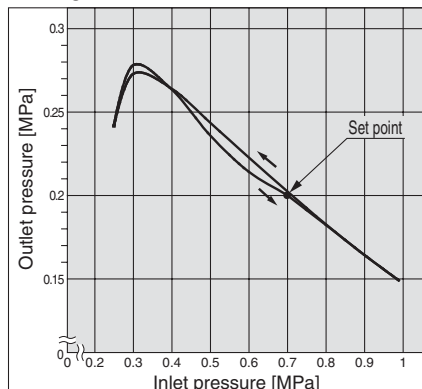

AW20(K)-B

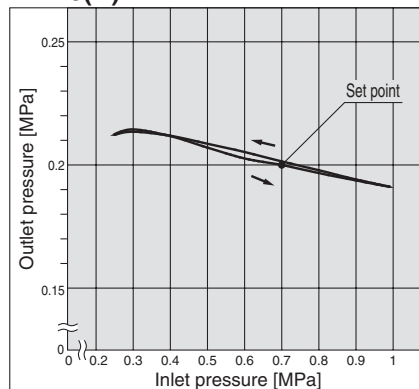

AW30(K)-B

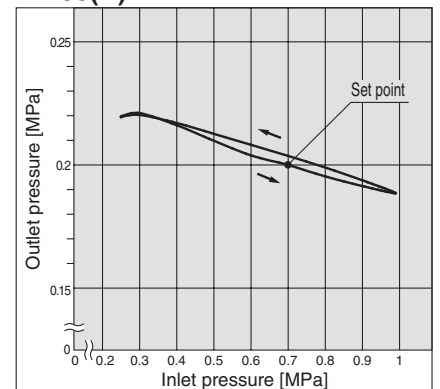

AW40(K)-B

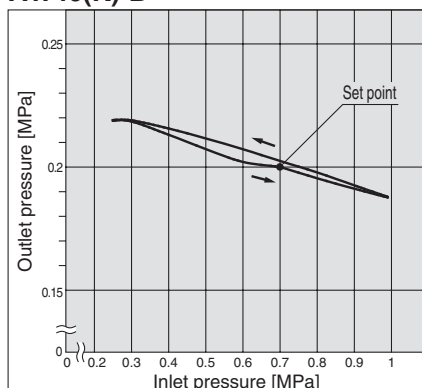

AW40(K)-06-B

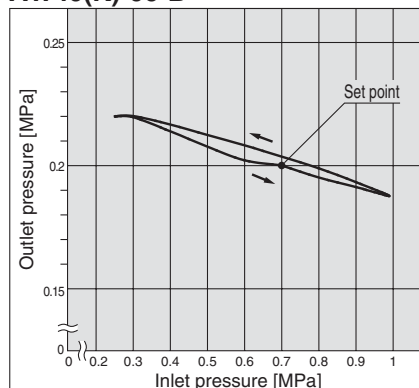

AW60(K)-B

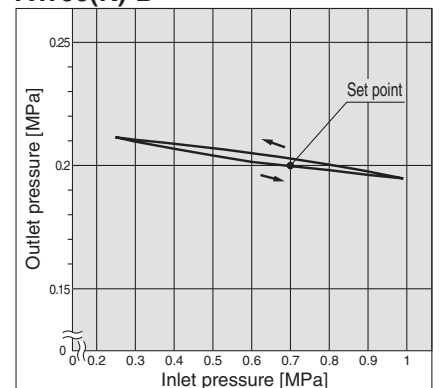

Construction

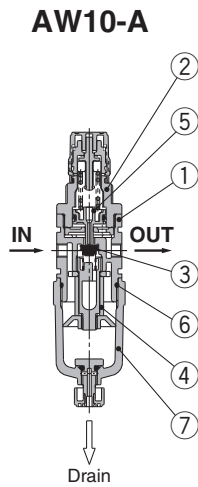

Component Parts

No.	Description	Material	Colour
1	Body	Zinc die-cast	White
2	Bonnet	Polyacetal	White

Replacement Parts

No.	Description	Material	Part no.
3	Valve	HNBR	AR10P-090S
4	Filter element	Non-woven fabric	AF10P-060S
5	Piston assembly	Polyacetal	AR10P-150AS
6	Bowl O-ring	NBR	C1SFP-260S
7	Bowl assembly	Polycarbonate	C1SF-A

Working Principle (Filter Regulator with Backflow Function)

AW10-A

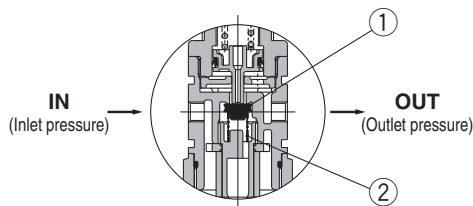

Figure 1

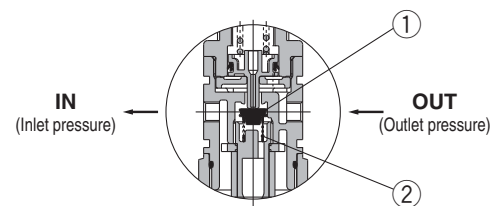

Figure 2

When the inlet pressure is higher than the regulating pressure, the check valve operates as a normal regulator (Figure 1).

When the inlet pressure is shut off and exhausted, any inlet pressure applied to the valve ① will be lost. The force for seating the valve ① is the valve spring force ② only. When the valve ① is opened using the outlet force, the outlet pressure will be exhausted at the inlet side (Figure 2). When the set pressure is 0.15 MPa or less, the valve ① may not open due to the valve spring ② force.

AC
AF+AR+AL
AW+AL
AF+AR
AF+AFM+AR
AW+AFM
Attachment
AF
AFM / AFD
AR
AL
AW

AW20-B to AW60-B Series

AW20K-B to AW60K-B Series

Construction

AW20(K)-B

AW30(K)-B/AW40(K)-B

AW60(K)-B

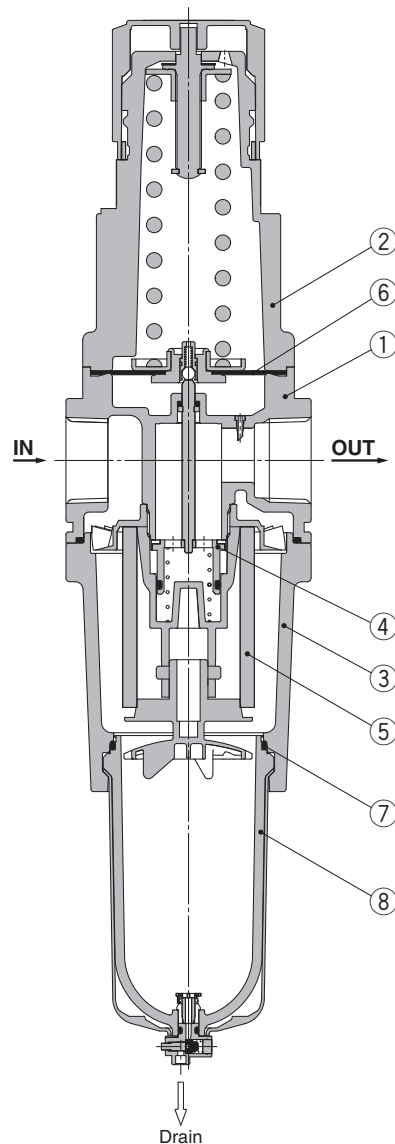
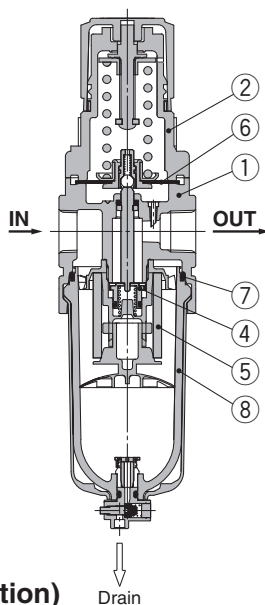
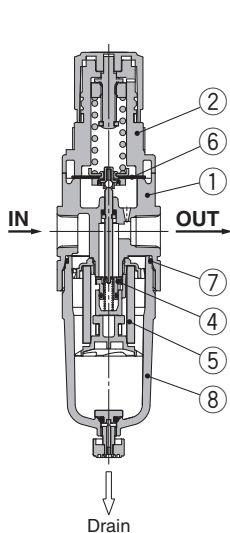

AW20K-B to AW60K-B
(Filter Regulator with Backflow Function)

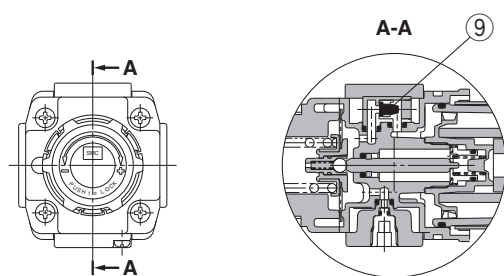

Component Parts

No.	Description	Material	Model	Colour
1	Body	Aluminium die-cast	AW20-B to AW60-B	White
2	Bonnet	Polyacetal	AW20-B to AW40-B	White
		Aluminium die-cast	AW60-B	White
3	Housing	Aluminium die-cast	AW60-B	White

Replacement Parts

No.	Description	Material	Part no.				
			AW20(K)-B	AW30(K)-B	AW40(K)-B	AW40(K)-06-B	AW60(K)-B
4	Valve assembly	Brass, HNBR	AW20P-340AS	AW30P-340AS	AW40P-340AS	AW40P-340AS	AW60P-090AS
5	Filter element	Non-woven fabric	AF20P-060S	AF30P-060S	AF40P-060S	AF40P-060S	AW60P-060S
6	Diaphragm assembly	Weatherable NBR	AR20P-150AS	AR30P-150AS	AR40P-150AS	AR40P-150AS	AR50P-150AS
7	Bowl seal	NBR	C2SFP-260S	C32FP-260S	C42FP-260S		
8	Bowl assembly *1	Polycarbonate	C2SF-A	C3SF-A*2	C4SF-A*2		
9	Check valve assembly *3	—	AR23KP-020AS				

*1 Bowl assembly includes the bowl O-ring.

Please consult with SMC separately for psi and °F unit display specifications.

*2 Bowl assembly for the AW30(K)-B to AW60(K)-B models comes with a bowl guard (Material: Polycarbonate).

*3 Check valve assembly is applicable for a filter regulator with backflow function (AW20(K)-B to AW60(K)-B) only.

Assembly of a check valve cover, check valve body assembly and 2 mounting screws

Working Principle (Filter Regulator with Backflow Function)

AW20K-B to AW60K-B

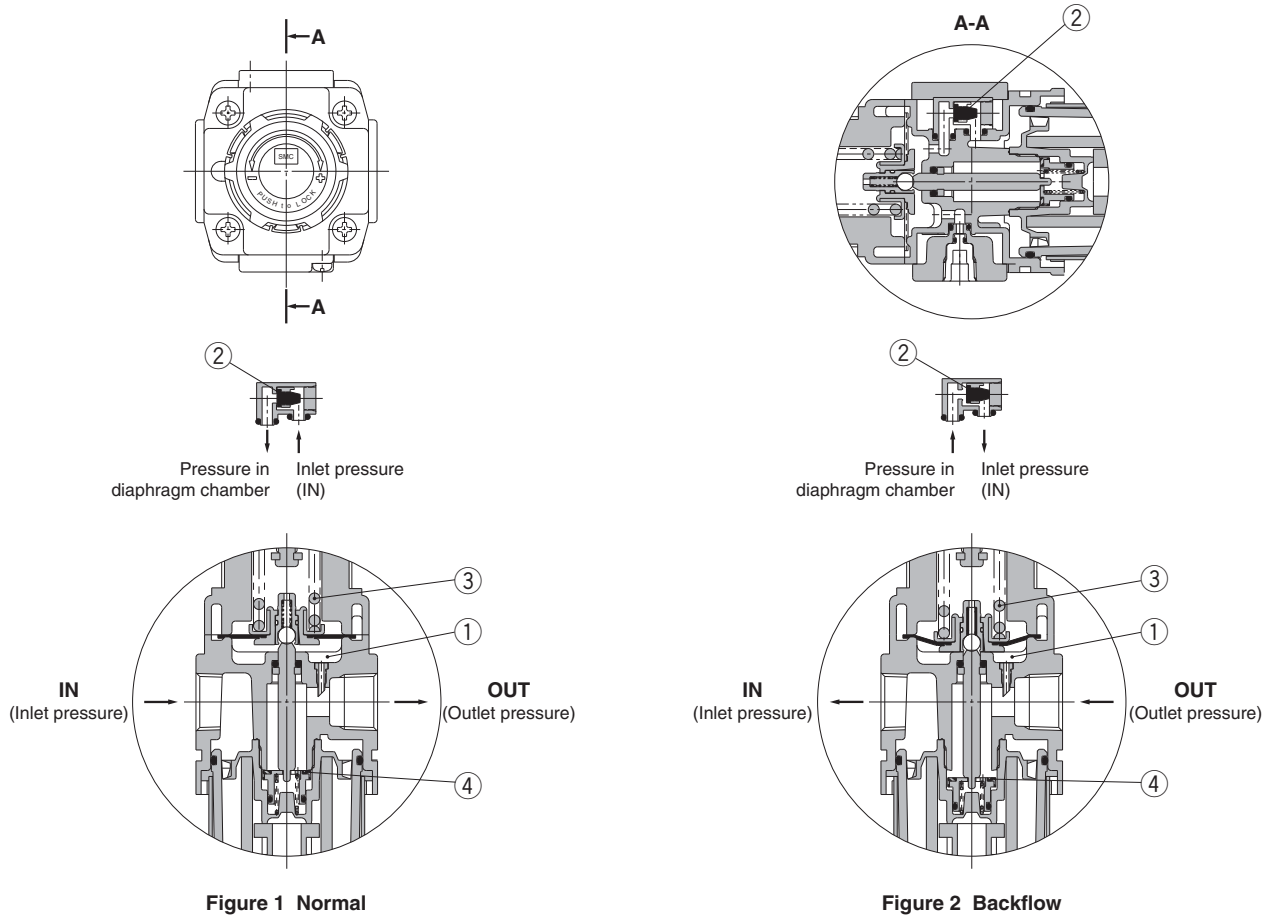

When the inlet pressure is higher than the regulating pressure, the check valve ② closes and operates as a normal regulator (Figure 1). When the inlet pressure is shut off and released, the check valve ② opens and the pressure in the diaphragm chamber ① is released into the inlet side (Figure 2). This lowers the pressure in the diaphragm chamber ① and the force generated by the spring ③ lifts the diaphragm. The valve ④ opens through the stem, and the outlet pressure is released to the inlet side (Figure 2).

AC
AF+AR+AL
AW+AL
AF+AR
AF+AFM+AR
AW+AFM
Attachment
AF
AFM / AFD
AR
AL
AW

AW10-A Series

AW20-B to AW60-B Series

AW20K-B to AW60K-B Series

Dimensions

AW10-A

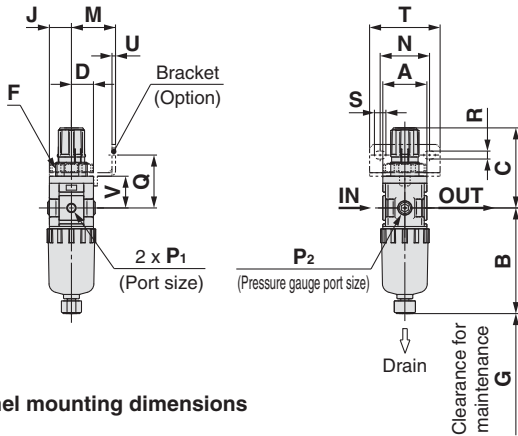

Panel mounting dimensions



Plate thickness
AW10-A: Max. 3.5

AW20(K)-B

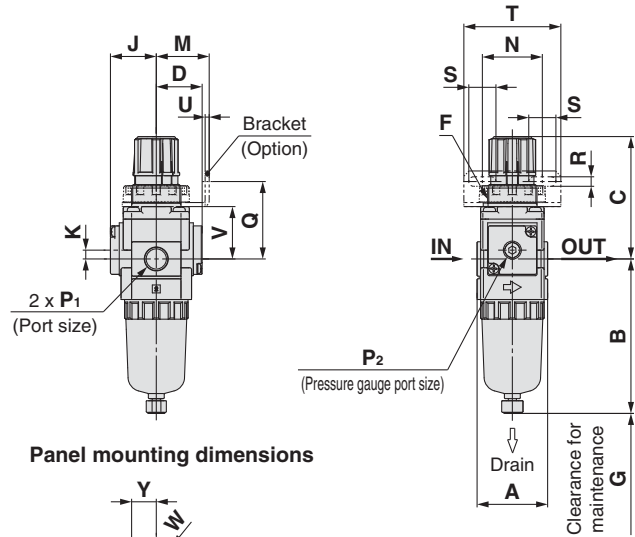

Panel mounting dimensions

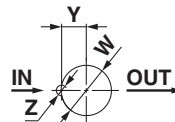
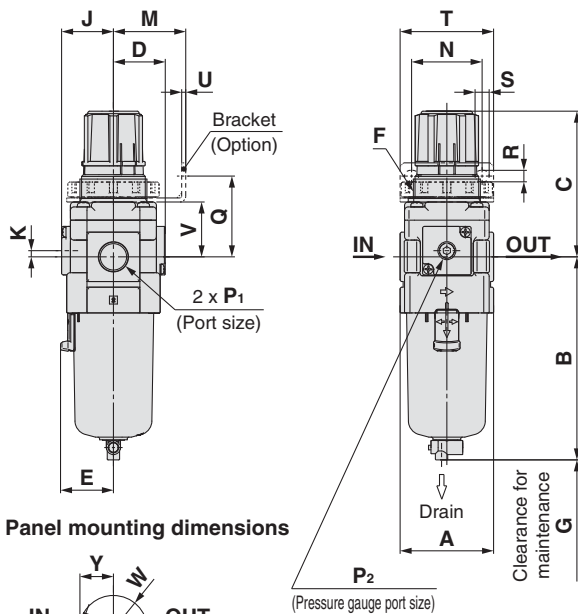

Plate thickness
AW20(K)-B: Max. 3.5

AW30(K)-B to AW40(K)-06-B



Panel mounting dimensions

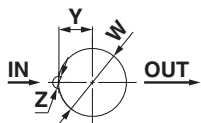
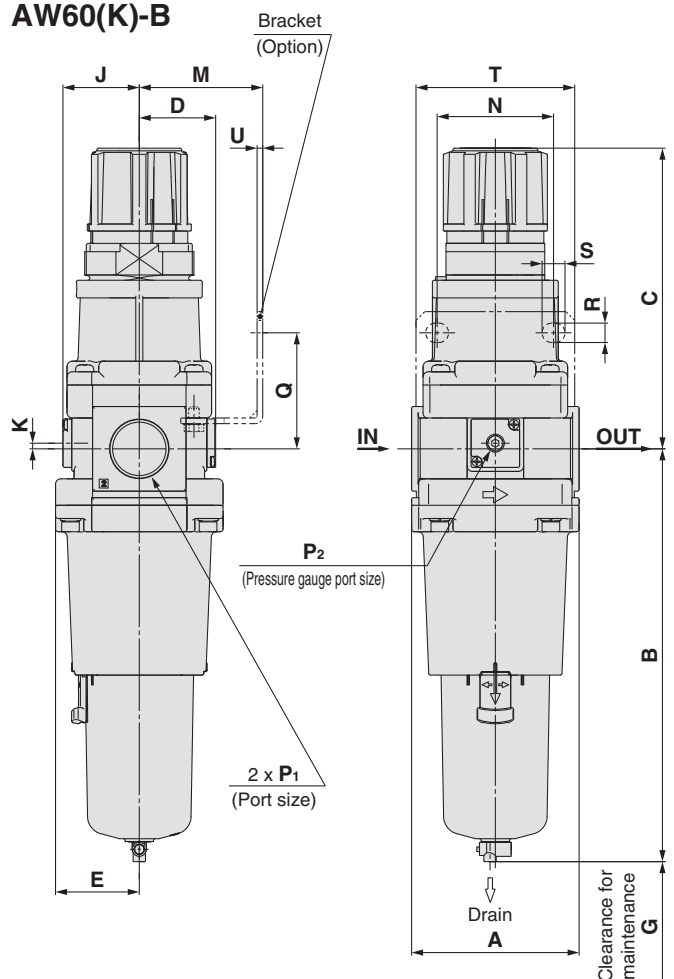

Plate thickness
AW30(K)-B: Max. 3.5
AW40(K)-B: Max. 5

AW60(K)-B



Filter Regulator **AW10-A Series**

Filter Regulator **AW20-B to AW60-B Series**

Filter Regulator with Backflow Function **AW20K-B to AW60K-B Series**

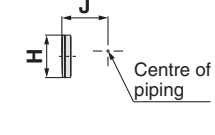
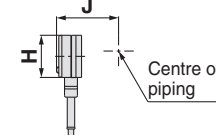
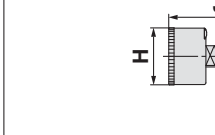
Option	Square embedded type pressure gauge	Digital pressure switch	Round type pressure gauge	Round type pressure gauge (with colour zone)
Dimensions				

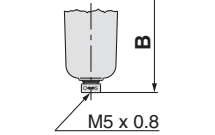
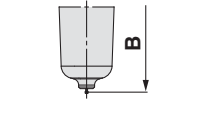
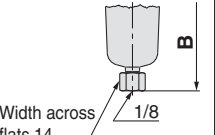
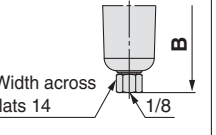
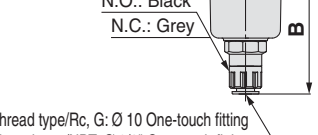
Applicable model	AW10-A/AW20(K)-B		AW20(K)-B		AW30(K)-B to AW60(K)-B
Optional/Semi-standard specifications	With auto drain (N.C.)	Metal bowl	With drain guide	Metal bowl with drain guide	With auto drain (N.O./N.C.)
Dimensions					

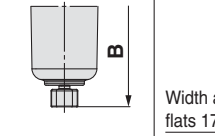
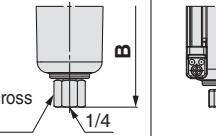
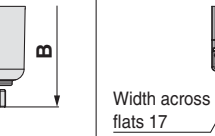
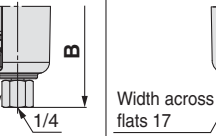
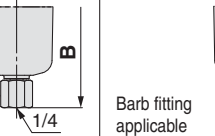
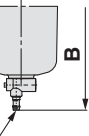
Applicable model	AW30(K)-B to AW60(K)-B					
Optional/Semi-standard specifications	Metal bowl	Metal bowl with drain guide	Metal bowl with level gauge	Metal bowl with level gauge, with drain guide	With drain guide	Drain cock with barb fitting
Dimensions						

Model	Standard specifications											Optional specifications							
												Square embedded type pressure gauge	Digital pressure switch		Round type pressure gauge		Round type pressure gauge (with colour zone)		
	P ₁	P ₂	A	B	C*1	D	E	F	G	J	K	H	J	H	J	H	J	H	J
AW10-A	M5 x 0.8	1/16	25	59.9	47.4	12.5	—	M18 x 1	25	12.5	—	—	—	—	—	Ø 26	26	—	—
AW20(K)-B	1/8, 1/4	1/8	40	87.6	72.4	26	—	M28 x 1	40	26	5	□28	27	□27.8	37.5	Ø 37.5	62.5	Ø 37.5	63.5
AW30(K)-B	1/4, 3/8	1/8	53	115.1	85.6	29.4	30	M38 x 1.5	55	29.4	3.5	□28	30.4	□27.8	40.9	Ø 37.5	65.9	Ø 37.5	66.9
AW40(K)-B	1/4, 3/8, 1/2	1/8	70	147.1	91.7	37.3	38.4	M42 x 1.5	80	37.3	1.5	□28	38.3	□27.8	48.8	Ø 42.5	74.8	Ø 42.5	74.8
AW40(K)-06-B	3/4	1/8	75	149.1	93.2	37.3	38.4	M42 x 1.5	80	37.3	1.2	□28	38.3	□27.8	48.8	Ø 42.5	74.8	Ø 42.5	74.8
AW60(K)-B	3/4, 1	1/8	95	234.1	175.5	43.3	47.5	—	20	43.3	3.2	□28	44.3	□27.8	61.3	Ø 42.5	80.8	Ø 42.5	80.8

Model	Optional specifications											Semi-standard specifications							
	Bracket mount						Panel mount					With auto drain	With barb fitting	With drain guide	Metal bowl	Metal bowl with drain guide	Metal bowl with level gauge	Metal bowl with level gauge, with drain guide	
	M	N	Q	R	S	T	U	V	W	Y	Z	B	B	B	B	B	B	B	
AW10-A	25	28	30	4.5	6.5	40	2	18	18.5	—	—	77.9	—	—	59.3	—	—	—	
AW20(K)-B	30	34	43.9	5.4	15.4	55	2.3	29.7	28.5	14	6	104.9	—	91.4	87.4	93.9	—	—	
AW30(K)-B	41	40	45.8	6.5	8	53	2.3	31.1	38.5	19	7	156.8	123.6	121.9	117.6	122.1	137.6	142.1	
AW40(K)-B	50	54	54	8.5	10.5	70	2.3	35.5	42.5	21	7	186.9	155.6	153.9	149.6	154.1	169.6	174.1	
AW40(K)-06-B	50	54	55.5	8.5	10.5	70	2.3	37	42.5	21	7	188.9	157.6	155.9	151.6	156.1	171.6	176.1	
AW60(K)-B	70	66	65.8	11	13	90	3.2	—	—	—	—	273.9	240.9	242.6	236.6	241.1	256.6	261.1	

*1 The dimension of C is the length when the filter regulator knob is unlocked.

AC
 AF+AR+AL
 AW+AL
 AF+AR
 AF+AFM+AR
 AW+AFM
 Attachment
 AF
 AFM/AFD
 AR
 AL
 AW

AW30-B to AW60-B Filter Regulator

Made to Order



Please contact SMC for detailed dimensions, specifications and lead times.

① Special Temperature Environment

Special materials are used in the manufacturing of seals and resin parts to allow them to withstand various temperature conditions in cold or tropical (hot) climates.

Specifications

Made-to-order part no.	-X430	-X440
Environment	Low temperature	High temperature
Ambient temperature [°C]	-30 to 60	-5 to 80
Fluid temperature [°C]	-5 to 60 (with no freezing)	
Material	Rubber parts	Special NBR
	Main parts	Metal (Aluminium die-cast, etc.)



AW30-03-2-B-X440

Applicable Model

Model	AW30-B	AW40-B	AW40-06-B	AW60-B
Port size	1/4, 3/8	1/4, 3/8, 1/2	3/4	3/4, 1

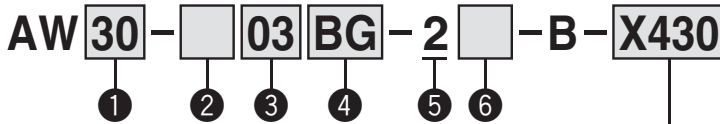

For high/low temperature

X430	Low temperature
X440	High temperature

- Option/Semi-standard: Select one each for **a** to **g**.
- Option/Semi-standard symbol: When more than one specification is required, indicate in alphanumeric order.
Example) AW30-03BG-2N-B-X430

	Symbol	Description	① Body size			
			30	40	60	
② Pipe thread type	—	Rc	●	●	●	
	N	NPT	●	●	●	
	F	G	●	●	●	
③ Port size	02	1/4	●	●	—	
	03	3/8	●	●	—	
	04	1/2	—	●	—	
	06	3/4	—	●	●	
	10	1	—	—	●	
④ Option*1	a Mounting	—	Without mounting option	●	●	●
		B *2	With bracket	●	●	●
		H	With set nut (for panel mount)	●	●	—
b Pressure gauge	—	Without pressure gauge	●	●	●	
	G *3	Round type pressure gauge (without limit indicator)	●	●	●	
⑤ Bowl *4	2	Metal bowl	●	●	●	
⑥ Semi-standard	c Set pressure	—	0.05 to 0.85 MPa setting	●	●	●
		1 *5	0.02 to 0.2 MPa setting	●	●	●
	d Drain port	—	With drain cock	●	●	●
		J *6	Drain guide 1/4	●	●	●
	e Exhaust mechanism	—	Relieving type	●	●	●
		N	Non-relieving type	●	●	●
	f Flow direction	—	Flow direction: Left to right	●	●	●
		R	Flow direction: Right to left	●	●	●
g Pressure unit	—	Name plate, caution plate for bowl, and pressure gauge in SI units: MPa	●	●	●	
	Z *7	Name plate, caution plate for bowl, and pressure gauge in imperial units: psi, °F	○*8	○*8	○*8	

*1 Options B, G, H are not assembled and supplied loose at the time of shipment.

*2 Assembly of a bracket and set nuts (AW30-B to AW40-B)
Including 2 mounting screws for the AW60-B

*3 Mounting thread for pressure gauge: 1/8, Pressure gauge type: G43

*4 Only metal bowl 2 is available.

*5 The only difference from the standard specifications is the spring for the regulator. It does not restrict the setting of 0.2 MPa or more. When the pressure gauge is attached, a 0.4 MPa pressure gauge will be fitted.

*6 Without a valve function

*7 For pipe thread type: NPT.

*8 ○: For pipe thread type: NPT only

AW20-B to AW60-B Filter Regulator

Made to Order

Please contact SMC for detailed dimensions, specifications and lead times.



② High Pressure

Strong materials are used in the manufacturing of filter regulators intended for high pressure operation. Also, construction modification allows a wider set pressure range.

Specifications

Made-to-order part no.	-X425
Proof pressure [MPa]	3.0
Maximum operating pressure [MPa]	2.0
Set pressure range [MPa]	0.1 to 1.7
Ambient and fluid temperature [°C]	-5 to 60 °C (with no freezing)



AW30-03-2-B-X425

Applicable Model

Model	AW20-B	AW30-B	AW40-B	AW40-06-B	AW60-B
Port size	1/8, 1/4	1/4, 3/8	1/4, 3/8, 1/2	3/4	3/4, 1

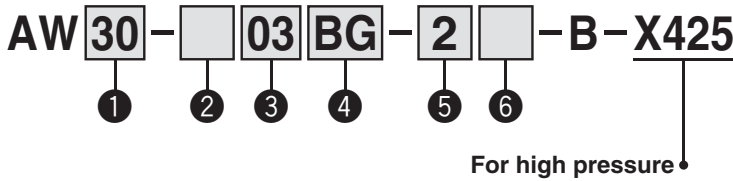

- Option/Semi-standard: Select one each for a to f.
- Option/Semi-standard symbol: When more than one specification is required, indicate in alphanumeric order.
Example) AW30-03BG-2N-B-X425

	Symbol	Description	① Body size				
			20	30	40	60	
② Pipe thread type	—	Rc	●	●	●	●	
	N	NPT	●	●	●	●	
	F	G	●	●	●	●	
③ Port size	01	1/8	●	—	—	—	
	02	1/4	●	●	—	—	
	03	3/8	—	●	●	—	
	04	1/2	—	—	●	—	
	06	3/4	—	—	●	●	
	10	1	—	—	—	●	
④ Option *1	a Mounting	—	Without mounting option	●	●	●	●
		B*2	With bracket	●	●	●	●
		H	With set nut (for panel mount)	●	●	●	—
	b Pressure gauge	—	Without pressure gauge	●	●	●	●
G*3		Round type pressure gauge (with limit indicator)	●	●	●	●	
⑤ Bowl *4	2	Metal bowl	●	●	●	●	
	8	Metal bowl with level gauge	—	●	●	●	
⑥ Semi-standard	c Exhaust mechanism	—	Relieving type	●	●	●	●
		N	Non-relieving type	●	●	●	●
	d Drain port	—	With drain cock	●	●	●	●
		J*5	Drain guide 1/8	●	—	—	—
		J*5	Drain guide 1/4	—	●	●	●
	e Flow direction	—	Flow direction: Left to right	●	●	●	●
		R	Flow direction: Right to left	●	●	●	●
	f Pressure unit	—	Name plate, caution plate for bowl, and pressure gauge in SI units: MPa	●	●	●	●
Z*6		Name plate, caution plate for bowl, and pressure gauge in imperial units: psi, °F	○*7	○*7	○*7	○*7	

*1 Options B, G, H are not assembled and supplied loose at the time of shipment.

*2 Assembly of a bracket and set nuts (AW20-B to AW40-B)
Including 2 mounting screws for the AW60-B

*3 Mounting thread for pressure gauge: 1/8, Pressure gauge type: G46-20-□

*4 Only metal bowl 2 and 8 are available.

*5 Without a valve function

*6 For pipe thread type: NPT.

*7 ○: For pipe thread type: NPT only

AW10 Filter Regulator Made to Order

Please contact SMC for detailed dimensions, specifications and lead times.



Refer to page 109 and after for size 20 or more.

③ 0.4 MPa Setting

The maximum set pressure is 0.4 MPa. When a pressure gauge is included, the display will show a range from 0 to 0.4 MPa.

Specifications

Made-to-order part no.	-X406
Proof pressure [MPa]	1.5
Maximum operating pressure [MPa]	1.0
Set pressure range [MPa]	0.05 to 0.4

Applicable Model

Model	AW10
Port size	M5

④ Long Bowl

Drain capacity is greater than that of standard models.

Applicable Model/Drain Capacity

Model	AW10
Port size	M5
Drain capacity [cm ³]	9
B dimension [mm] *1	81.6

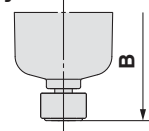

*1 For polycarbonate bowls. Please contact SMC for other bowl materials.

How to Order

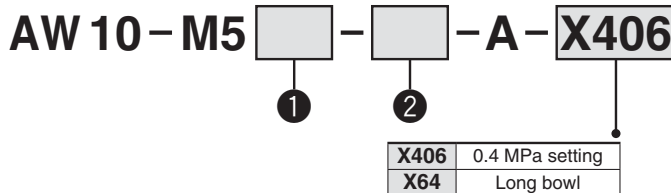

- Option/Semi-standard: Select one each for a to g.
 - Option/Semi-standard symbol: When more than one specification is required, indicate in alphanumeric order.
- Example) AW10-M5BG-NR-A-X406

		Symbol	Description	
①	Option *1	a	Mounting	
		—	Without mounting option	
		B *2	With bracket	
			H	With set nut (for panel mount)
			+	
			b	Float type auto drain
		—	Without auto drain	
		C	Float type auto drain (N.C.)	
		+		
		c	Pressure gauge *3	
		—	Without pressure gauge	
		G	Round type pressure gauge (without limit indicator)	
		+		
②	Semi-standard	d	Bowl *4	
		—	Polycarbonate bowl	
		2	Metal bowl	
			6	Nylon bowl
			+	
			e	Exhaust mechanism
		—	Relieving type	
		N	Non-relieving type	
		+		
		f	Flow direction	
		—	Flow direction: Left to right	
		R	Flow direction: Right to left	
		+		
		g	Pressure unit	
		—	Name plate, caution plate for bowl, and pressure gauge in SI units: MPa	
		Z	Name plate, caution plate for bowl, and pressure gauge in imperial units: psi, °F	

- *1 Options B, G, H are not assembled and supplied loose at the time of shipment.
- *2 Assembly of a bracket and set nuts.
- *3 A 1.0 MPa pressure gauge will be fitted.
- *4 Refer to chemical data on page 98 when selecting a bowl material.

⚠ Caution

- The AW10 comes with a backflow function as a standard feature. When using the AW10 as with backflow function, backflow may not occur with the set pressure of 0.15 MPa or less. Please set the inlet pressure to at least 0.05 MPa higher than the set pressure.

	0.4 MPa Setting	Long Bowl
	Body size	Body size
	10	10
	●	●
	●	●
	●	●
	●	—
	●	—
	●	●
	●	●
	●	●
	●	●
	●	●
	●	●
	●	●
	●	●

AC
AF+AR+AL
AW+AL
AF+AR
AF+AFM+AR
AW+AFM
Attachment
AF
AFM/AFD
AR
AL
AW

AW20-B to AW60-B Filter Regulator AW20K-B to AW60K-B Filter Regulator with Backflow Function Made to Order

Please contact SMC for detailed dimensions, specifications and lead times.



③ 0.4 MPa Setting

The maximum set pressure is 0.4 MPa. When a pressure gauge is included, the display will show a range from 0 to 0.4 MPa.

Specifications

Made-to-order part no.	-X406
Proof pressure [MPa]	1.5
Maximum operating pressure [MPa]	1.0
Set pressure range [MPa]	0.05 to 0.4

Applicable Model

Model	AW20(K)-B	AW30(K)-B	AW40(K)-B	AW40(K)-06-B	AW60(K)-B
Port size	1/8, 1/4	1/4, 3/8	1/4, 3/8, 1/2	3/4	3/4, 1

④ Long Bowl

Drain capacity is greater than that of standard models.

Applicable Model/Drain Capacity

Model	AW20(K)-B	AW30(K)-B	AW40(K)-B	AW40(K)-06-B	AW60(K)-B
Port size	1/8, 1/4	1/4, 3/8	1/4, 3/8, 1/2	3/4	3/4, 1
Drain capacity [cm ³]	19	43	88		
B dimension [mm]*1	108.6	137.1	167.2	169.2	254.2

*1 For polycarbonate bowls. Please contact SMC for other bowl materials.

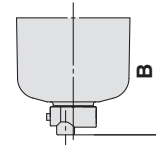

How to Order

AW **30** **□** - **□** **03** **□** - **□** - B - **X406**

① ② ③ ④ ⑤ ⑥

X406	0.4 MPa setting
X64	Long bowl

- Option/Semi-standard: Select one each for **a** to **h**.
- Option/Semi-standard symbol: When more than one specification is required, indicate in alphanumeric order.
Example) AW30K-03BE-2N-B-X406

	Symbol	Description
--	--------	-------------

②	With backflow function	—	Without backflow function
		K	With backflow function

③	Pipe thread type	—	Rc
		N *1	NPT
		F *2	G

④	Port size	01	1/8
		02	1/4
		03	3/8
		04	1/2
		06	3/4
		10	1

⑤	a	Mounting	—	Without mounting option
			B *4	With bracket
			H	With set nut (for panel mount)

⑤	b	Float type auto drain	—	Without auto drain
			C	Float type auto drain (N.C.)
			D	Float type auto drain (N.O.)

⑤	c	Pressure gauge*5	—	Without pressure gauge
			E	Square embedded type pressure gauge (with limit indicator)
			G	Round type pressure gauge (with limit indicator)
			M	Round type pressure gauge (with colour zone)
	Digital pressure switch	E1 *6	Output: NPN output, Electrical entry: Wiring bottom entry	
		E2 *6	Output: NPN output, Electrical entry: Wiring top entry	
		E3 *6	Output: PNP output, Electrical entry: Wiring bottom entry	
		E4 *6	Output: PNP output, Electrical entry: Wiring top entry	

0.4 MPa Setting				Long Bowl			
① Body size				① Body size			
20	30	40	60	20	30	40	60

●	●	●	●	●	●	●	●
●	●	●	●	●	●	●	●

●	●	●	●	●	●	●	●
●	●	●	●	●	●	●	●
●	●	●	●	●	●	●	●

●	—	—	—	●	—	—	—
●	●	—	—	●	●	—	—
—	●	●	—	—	●	●	—
—	—	●	—	—	—	●	—
—	—	●	●	—	—	●	●
—	—	—	●	—	—	—	●

●	●	●	●	●	●	●	●
●	●	●	●	●	●	●	●
●	●	●	—	●	●	●	—

●	●	●	●	—	—	—	—
●	●	●	●	—	—	—	—
—	●	●	●	—	—	—	—

●	●	●	●	●	●	●	●
●	●	●	●	●	●	●	●
●	●	●	●	●	●	●	●
●	●	●	●	●	●	●	●
●	●	●	●	●	●	●	●
●	●	●	●	●	●	●	●
●	●	●	●	●	●	●	●

*1 Drain guide is NPT 1/8 (applicable to the AW20(K)-B) and NPT 1/4 (applicable to the AW30(K)-B to AW60(K)-B). The auto drain port comes with Ø 3/8" One-touch fitting (applicable to the AW30(K)-B to AW60(K)-B).
*2 Drain guide is G 1/8 (applicable to the AW20(K)-B) and G 1/4 (applicable to the AW30(K)-B to AW60(K)-B).
*3 Options B, G, H, M are not assembled and supplied loose at the time of shipment.

*4 Assembly of a bracket and set nuts. (AW20(K)-B to AW40(K)-B). Including 2 mounting screws for the AW60(K)-B.
*5 A 0.7 MPa pressure gauge will be fitted for a 0.4 MPa setting (-X406).
*6 When choosing with H (panel mount), the installation space for lead wires will not be secured. In this case, select "wiring down entry" for the electrical entry.

AC

AF+AR+AL

AW+AL

AF+AR

AF+AFM+AR

AW+AFM

Attachment

AF

AFM / AFD

AR

AL

AW

			0.4 MPa Setting				Long Bowl								
			①				①								
			Body size				Body size								
			20	30	40	60	20	30	40	60					
6	d	Set pressure	—	0.05 to 0.85 MPa setting			—	—	—	—	●	●	●	●	
			1*7	0.02 to 0.2 MPa setting			—	—	—	—	●	●	●	●	
	e	Bowl *8		—	Polycarbonate bowl			●	●	●	●	●	●	●	●
				2	Metal bowl			●	●	●	●	●	●	●	●
				6	Nylon bowl			●	●	●	●	●	●	●	●
				8	Metal bowl with level gauge			—	●	●	●	—	—	—	—
				C	With bowl guard			●	—	—	—	●	—	—	—
				6C	With bowl guard (Nylon bowl)			●	—	—	—	●	—	—	—
	f	Drain port *9		—	With drain cock			●	●	●	●	●	●	●	●
				J*10	Drain guide 1/8			—	—	—	—	●	—	—	—
				W*11	Drain cock with barb fitting: For Ø 6 x Ø 4 nylon tube			—	●	●	●	—	●	●	●
	g	Exhaust mechanism		—	Relieving type			●	●	●	●	●	●	●	
				N	Non-relieving type			●	●	●	●	●	●	●	
	h	Flow direction		—	Flow direction: Left to right			●	●	●	●	●	●	●	
				R	Flow direction: Right to left			●	●	●	●	●	●	●	
i	Pressure unit		—	Name plate, caution plate for bowl, and pressure gauge in SI units: MPa			●	●	●	●	●	●	●	●	
			Z*12	Name plate, caution plate for bowl, and pressure gauge in imperial units: psi, °F			○*14	○*14	○*14	○*14	○*14	○*14	○*14	○*14	
			ZA*13	Digital pressure switch: With unit selection function			△*15	△*15	△*15	△*15	△*15	△*15	△*15	△*15	

*7 The only difference from the standard specifications is the adjusting spring for the regulator. It does not restrict the setting of 0.2 MPa or more. When the pressure gauge is attached, a 0.4 MPa pressure gauge will be fitted.
 *8 Refer to chemical Data on page 98 when selecting a bowl material.
 *9 Float type auto drain: The combination of C and D is not possible.
 *10 Without a valve function
 *11 Metal bowl: The combination of 2 and 8 is not possible.
 *12 For pipe thread type: NPT. The digital pressure switch will be equipped with the unit selection function, setting to psi initially.
 *13 For options: E1, E2, E3, E4.
 *14 ○: For pipe thread type: NPT only
 *15 △: Select with options: E1, E2, E3, E4.

AW20-B to AW60-B Filter Regulator AW20K-B to AW60K-B Filter Regulator with Backflow Function Made to Order

Please contact SMC for detailed dimensions, specifications and lead times.



⑤ Clean Series

For details, refer to the Clean Series/Low Particle Generation section of the **Web Catalogue**.

10 - **Standard model no.**

* Please contact SMC if a product with pressure gauge is desired.

• Clean Series



⑥ Copper, Fluorine and Silicone-free + Low Particle Generation

For details, refer to the Clean Series/Low Particle Generation section of the **Web Catalogue**.

21 - **Standard model no.**

• Copper, fluorine and silicone-free + Low particle generation

Option Knob Cover

Prevents careless knob operation.

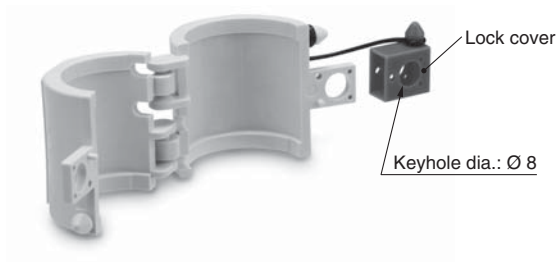

Part no.	Applicable model
AR20P-580AS	AC20□-B, AR20(K)-B, AW20(K)-B
AR25P-580AS	AC25□-B, AR25(K)-B
AR30P-580AS	AC30□-B, AR30(K)-B, AW30(K)-B
AR40P-580AS	AC40□(-06)-B, AR40(K)(-06)-B, AW40(K)(-06)-B

AC

AF+AR+AL

AW+AL

AF+AR

AF+AFM+AR

AW+AFM

Attachment

AF

AFM / AFD



AR

AL

AW

Safety Instructions

These safety instructions are intended to prevent hazardous situations and/or equipment damage. These instructions indicate the level of potential hazard with the labels of “Caution,” “Warning” or “Danger.” They are all important notes for safety and must be followed in addition to International Standards (ISO/IEC)*1), and other safety regulations.

-  **Caution:** Caution indicates a hazard with a low level of risk which, if not avoided, could result in minor or moderate injury.
-  **Warning:** Warning indicates a hazard with a medium level of risk which, if not avoided, could result in death or serious injury.
-  **Danger:** Danger indicates a hazard with a high level of risk which, if not avoided, will result in death or serious injury.

- *1) ISO 4414: Pneumatic fluid power – General rules relating to systems.
- ISO 4413: Hydraulic fluid power – General rules relating to systems.
- IEC 60204-1: Safety of machinery – Electrical equipment of machines. (Part 1: General requirements)
- ISO 10218-1: Manipulating industrial robots - Safety. etc.

Warning

- 1. The compatibility of the product is the responsibility of the person who designs the equipment or decides its specifications.**
Since the product specified here is used under various operating conditions, its compatibility with specific equipment must be decided by the person who designs the equipment or decides its specifications based on necessary analysis and test results. The expected performance and safety assurance of the equipment will be the responsibility of the person who has determined its compatibility with the product. This person should also continuously review all specifications of the product referring to its latest catalogue information, with a view to giving due consideration to any possibility of equipment failure when configuring the equipment.
- 2. Only personnel with appropriate training should operate machinery and equipment.**
The product specified here may become unsafe if handled incorrectly. The assembly, operation and maintenance of machines or equipment including our products must be performed by an operator who is appropriately trained and experienced.
- 3. Do not service or attempt to remove product and machinery/equipment until safety is confirmed.**
 1. The inspection and maintenance of machinery/equipment should only be performed after measures to prevent falling or runaway of the driven objects have been confirmed.
 2. When the product is to be removed, confirm that the safety measures as mentioned above are implemented and the power from any appropriate source is cut, and read and understand the specific product precautions of all relevant products carefully.
 3. Before machinery/equipment is restarted, take measures to prevent unexpected operation and malfunction.
- 4. Contact SMC beforehand and take special consideration of safety measures if the product is to be used in any of the following conditions.**
 1. Conditions and environments outside of the given specifications, or use outdoors or in a place exposed to direct sunlight.
 2. Installation on equipment in conjunction with atomic energy, railways, air navigation, space, shipping, vehicles, military, medical treatment, combustion and recreation, or equipment in contact with food and beverages, emergency stop circuits, clutch and brake circuits in press applications, safety equipment or other applications unsuitable for the standard specifications described in the product catalogue.
 3. An application which could have negative effects on people, property, or animals requiring special safety analysis.
 4. Use in an interlock circuit, which requires the provision of double interlock for possible failure by using a mechanical protective function, and periodical checks to confirm proper operation.

Limited warranty and Disclaimer/ Compliance Requirements

The product used is subject to the following “Limited warranty and Disclaimer” and “Compliance Requirements”.
Read and accept them before using the product.

Limited warranty and Disclaimer

1. The warranty period of the product is 1 year in service or 1.5 years after the product is delivered, whichever is first.*2)
Also, the product may have specified durability, running distance or replacement parts. Please consult your nearest sales branch.
2. For any failure or damage reported within the warranty period which is clearly our responsibility, a replacement product or necessary parts will be provided. This limited warranty applies only to our product independently, and not to any other damage incurred due to the failure of the product.
3. Prior to using SMC products, please read and understand the warranty terms and disclaimers noted in the specified catalogue for the particular products.

*2) Vacuum pads are excluded from this 1 year warranty.

A vacuum pad is a consumable part, so it is warranted for a year after it is delivered. Also, even within the warranty period, the wear of a product due to the use of the vacuum pad or failure due to the deterioration of rubber material are not covered by the limited warranty.

Compliance Requirements

1. The use of SMC products with production equipment for the manufacture of weapons of mass destruction (WMD) or any other weapon is strictly prohibited.
2. The exports of SMC products or technology from one country to another are governed by the relevant security laws and regulations of the countries involved in the transaction. Prior to the shipment of a SMC product to another country, assure that all local rules governing that export are known and followed.

Caution

- 1. The product is provided for use in manufacturing industries.**
The product herein described is basically provided for peaceful use in manufacturing industries.
If considering using the product in other industries, consult SMC beforehand and exchange specifications or a contract if necessary.
If anything is unclear, contact your nearest sales branch.

Caution

SMC products are not intended for use as instruments for legal metrology.
Measurement instruments that SMC manufactures or sells have not been qualified by type approval tests relevant to the metrology (measurement) laws of each country. Therefore, SMC products cannot be used for business or certification ordained by the metrology (measurement) laws of each country.

Safety Instructions

Be sure to read “Handling Precautions for SMC Products” (M-E03-3) before using.

SMC Corporation (Europe)

Austria	☎ +43 (0)2262622800	www.smc.at	office@smc.at	Lithuania	☎ +370 5 2308118	www.smclt.lt	info@smclt.lt
Belgium	☎ +32 (0)33551464	www.smcpnematics.be	info@smcpneumatics.be	Netherlands	☎ +31 (0)205318888	www.smcpnematics.nl	info@smcpneumatics.nl
Bulgaria	☎ +359 (0)2807670	www.smc.bg	office@smc.bg	Norway	☎ +47 67129020	www.smc-norge.no	post@smc-norge.no
Croatia	☎ +385 (0)13707288	www.smc.hr	office@smc.hr	Poland	☎ +48 222119600	www.smc.pl	office@smc.pl
Czech Republic	☎ +420 541424611	www.smc.cz	office@smc.cz	Portugal	☎ +351 226166570	www.smc.eu	postpt@smc.smces.es
Denmark	☎ +45 70252900	www.smcdk.com	smc@smcdk.com	Romania	☎ +40 213205111	www.smcromania.ro	smcromania@smcromania.ro
Estonia	☎ +372 6510370	www.smcpnematics.ee	smc@smcpneumatics.ee	Russia	☎ +7 8127185445	www.smc-pneumatik.ru	info@smc-pneumatik.ru
Finland	☎ +358 207513513	www.smc.fi	smc@smc.fi	Slovakia	☎ +421 (0)413213212	www.smc.sk	office@smc.sk
France	☎ +33 (0)164761000	www.smc-france.fr	info@smc-france.fr	Slovenia	☎ +386 (0)73885412	www.smc.si	office@smc.si
Germany	☎ +49 (0)61034020	www.smc.de	info@smc.de	Spain	☎ +34 902184100	www.smc.eu	post@smc.smces.es
Greece	☎ +30 210 2717265	www.smchellas.gr	sales@smchellas.gr	Sweden	☎ +46 (0)86031200	www.smc.nu	post@smc.nu
Hungary	☎ +36 23511390	www.smc.hu	office@smc.hu	Switzerland	☎ +41 (0)523963131	www.smc.ch	info@smc.ch
Ireland	☎ +353 (0)14039000	www.smcpnematics.ie	sales@smcpneumatics.ie	Turkey	☎ +90 212 489 0 440	www.smcpnomatik.com.tr	info@smcpnomatik.com.tr
Italy	☎ +39 0292711	www.smcitalia.it	mailbox@smcitalia.it	UK	☎ +44 (0)845 121 5122	www.smcpnematics.co.uk	sales@smcpneumatics.co.uk
Latvia	☎ +371 67817700	www.smc.lv	info@smclv.lv				

SMC CORPORATION Akihbara UDX 15F, 4-14-1, Sotokanda, Chiyoda-ku, Tokyo 101-0021, JAPAN Phone: 03-5207-8249 FAX: 03-5298-5362