

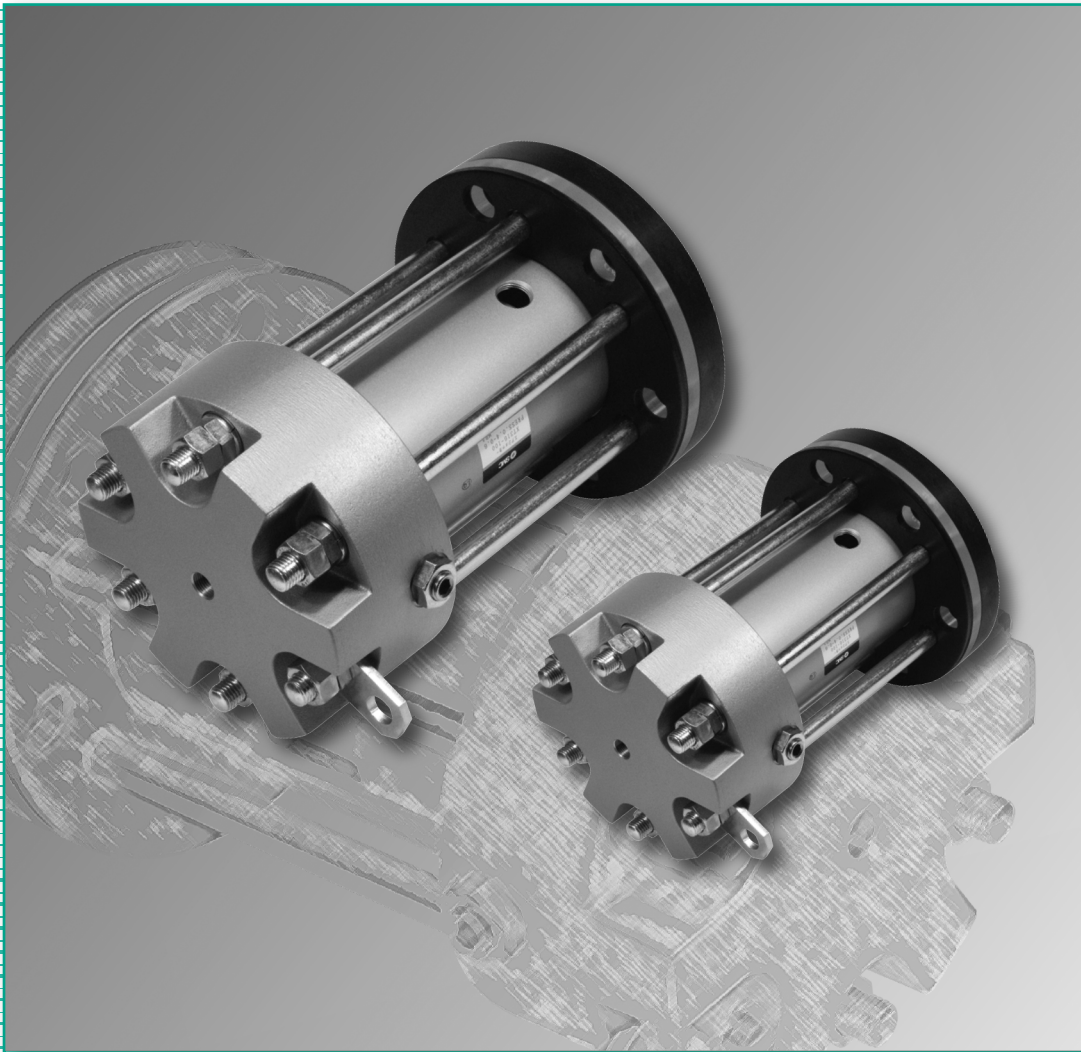

Air Shocker
Series XT316



The air shocker is a pneumatic piston type shock generator.

Removes plugging due to bridging or adhesion of bulk material inside a hopper or chute.

- Variable impact force
- Strong, stable impact force
- No lubrication required

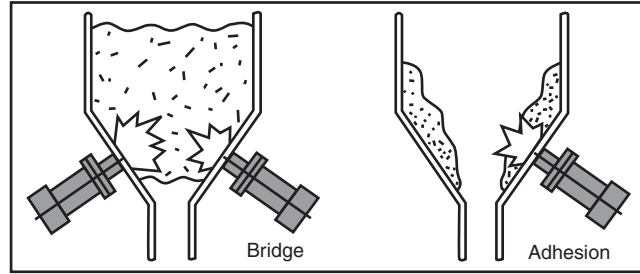

Specifications

Model	XT316-30B	XT316-40B	XT316-63B	XT316-80B	XT316-100B
Bore size	Ø30	Ø40	Ø63	Ø80	Ø100
Operating pressure MPa (kgf/cm ²)	0.4 - 0.6 (4.1 - 6.1)				
Impact cycle (cycles/min)	MAX. 15				
Air consumption (ℓ/cycles)	0.33	0.75	1.29	1.91	4
(Note 1) Impact energy (kgm)	0.05 - 0.07	0.17 - 0.31	0.45 - 0.75	1.0 - 1.8	2.2 - 4.0
(Note 2) Weight (kg)	2.5	4.4	11.2	15	33.5
Ambient and fluid temperature	32 - 140 °F (0 - 60 °C)				
Port size (PT)	1/8				3/8
Lubrication	Not lubricated				

(Note 1) Change in potential energy applied to a pendulum
 (Note 2) Total weight including the mounting base and bolts

How to Order

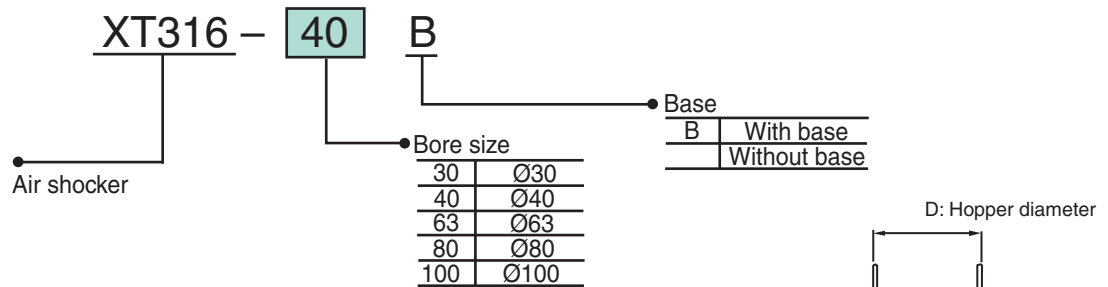

Model Selection

The model of an air shocker to be selected depends on the type, shape, and size of the machine on which the air shocker is mounted, as well as the degree of adhesion and plugging. However, the following diagram will provide a guideline on selection of the type and number of air shockers.

Example) Suppose the diameter and thickness of the hopper are 500mm and 4mm, respectively. According to the intersection of the lines representing the diameter and thickness, one XT316-63B should be selected.

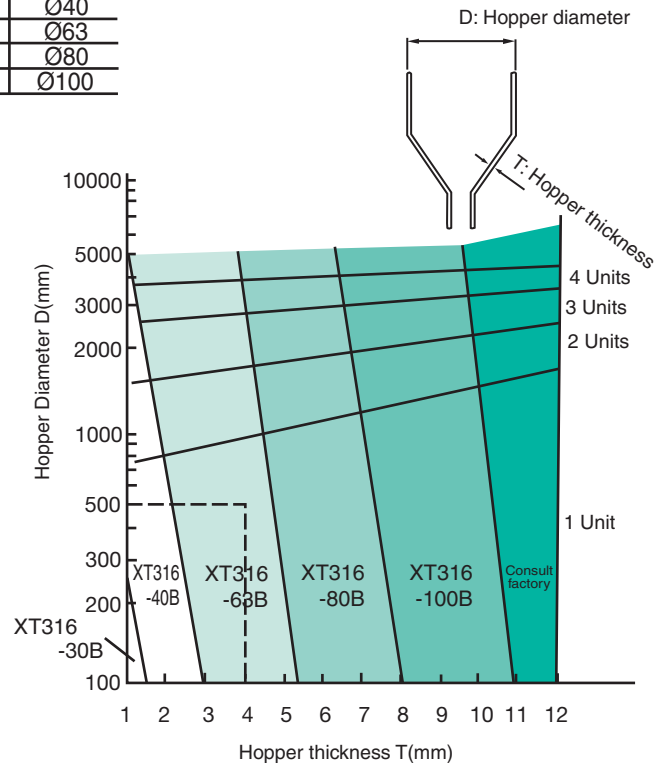

Construction and Working Principle

1) Initial condition

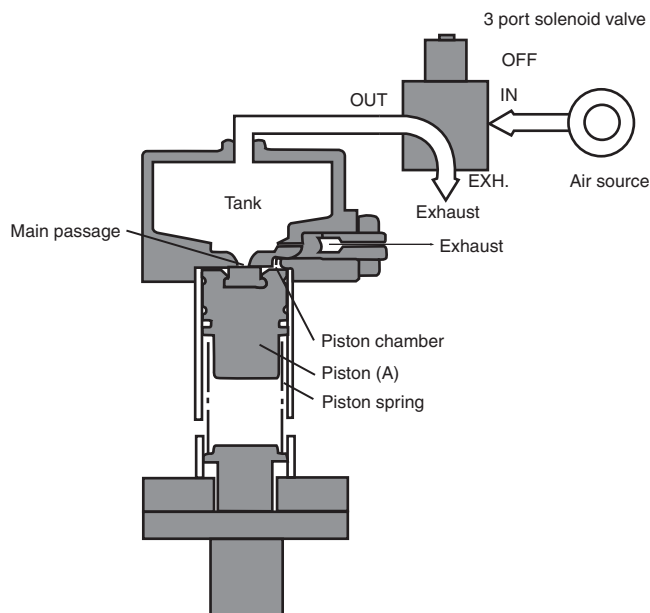

When the 3-port solenoid valve remains OFF, the tank and piston chamber are under atmospheric pressure, piston (A) is locked by a spring, and thus the main passage is closed.

2) Piston begins to move

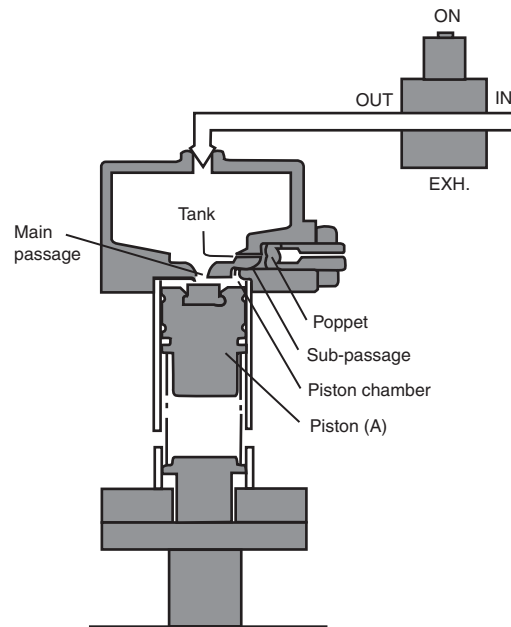

When the 3-port solenoid valve remains ON, air flows into the tank. When the pressure reaches the specified value, the poppet opens, the air passes through the sub-passage and flows into the piston chamber to move piston (A), and thus the main passage opens.

3) Impact

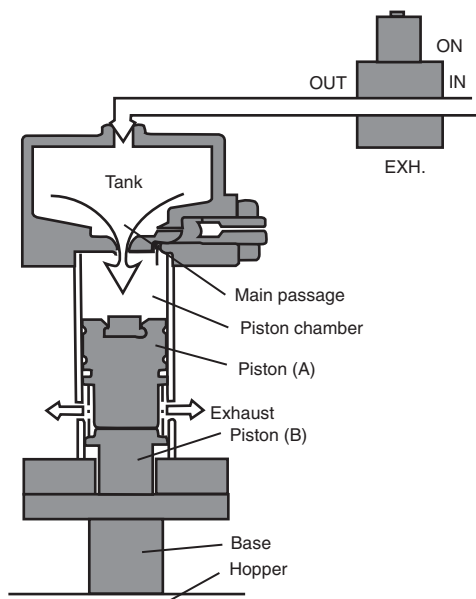

A large quantity of air accumulated in the tank flows through the main passage into the piston chamber. Then piston (A) moves at high speed to strike against piston (B), and thus vibration is transmitted through the base to the hopper.

4) Return

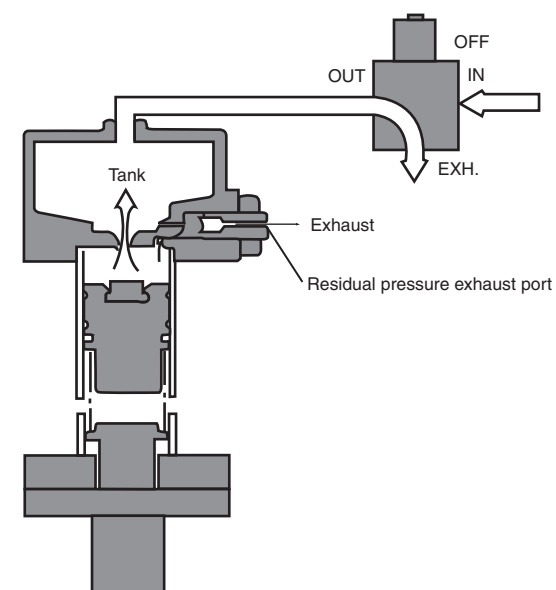

When the 3-port solenoid valve is turned OFF, the air inside the tank and cylinder is exhausted through the exhaust port of the solenoid valve and residual pressure exhaust port. Then piston (A) and poppet return to their initial condition.

Mounting Position

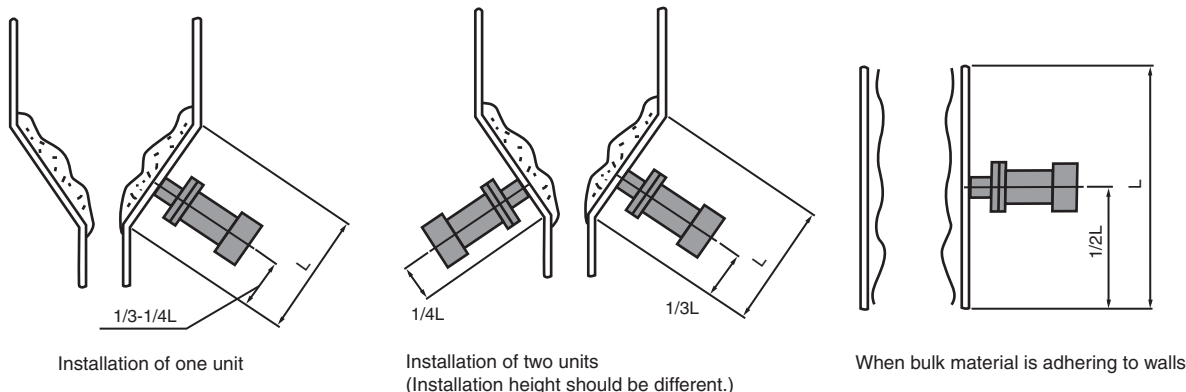

Mounting Method

1. The base is subjected to repeated impact load of the air shocker, so weld all the periphery completely. Installation of a stiffening rib is recommended.
2. When the mounting section is thin, install a stiffening plate and weld all its periphery completely.
3. Securely tighten the air shocker with the attached bolts, spring washers, and hard-locknuts.
4. Apply wire or chain to the hook to fix the air shocker and prevent it from falling.

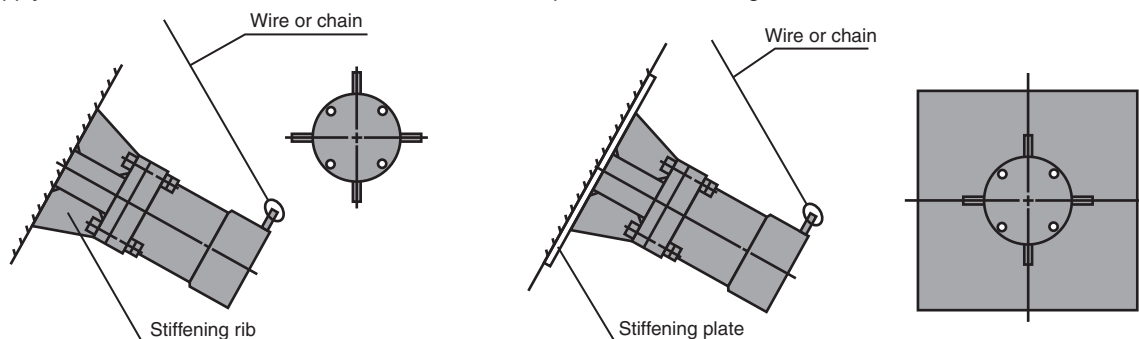

Dimensions

(mm)

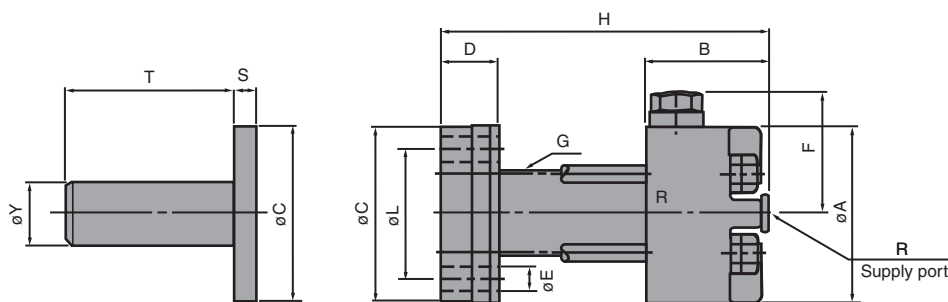

Model	Bore Size	øA	B	øC	D	øE	F	G	H	øL	S	T	øY	R
XT316-30B	ø30	70	51	70	13	9	58	M8x1	134	55	7	41	27.2	1/8
XT316-40B	ø40	95	66	95	30.5	13.5	67	M10x1	175	70	12	90	34	1/8
XT316-63B	ø63	140	61	140	31.5	15.5	80	M12x1.5	215	110	12	100	76.3	1/8
XT316-80B	ø80	150	76	150	36	17.5	86	M16x1.5	250	120	14	110	76.3	1/8
XT316-100B	ø100	190	88	210	41	22	105	M20x1.5	306	170	22	145	114.3	3/8