

5 YEAR WARRANTY



## V-INSP-L

Maturing cabinet

Built-in and Flush-fitted – Full Glass door

1-temperature



Sliding shelf  
(6 bottles)

ACMSIW / ACMSIB



Wine service area  
(11 bottles)

ACMSERVW / ACMSERVB



Storage shelf  
(up to 22 bottles)

AXIHW / AXIHB



Half shelf  
(5 bottles)

ACMSI-DEMI

ORIGINE FRANCE GARANTIE

BVCon. 6010761

### CONFIGURATIONS

Premium Pack bottle capacity <sup>1</sup>	Service Pack bottle capacity <sup>1</sup>	Access Pack bottle capacity <sup>1</sup>
89	88	89
14 sliding shelves (+grid)	12 sliding shelves 1 half shelf 1 Wine service area	3 sliding shelves 3 storage shelves (+grid)

### TECHNICAL FEATURES

#### REGULATION

- On/Off/Standby of the display button
- Electronic regulation
- Temperature setting range between 5°C and 20°C
- Electronic external display and settings
- LED screen
- Backlit capacitive keys
- Visual and/or sound alarms in case of:
  - Temperature dysfunction (sound and visual)
  - Hygrometry dysfunction (visual)
  - Sensor fault (sound and visual)
  - Hygrometry limit (visual)
  - Open door (sound and visual)
  - Need to replace charcoal filter (visual)
- Automatic defrost
- Frost protection thermostat (double protection)

#### HOT – COLD – INSULATION TECHNOLOGIES

Cold production:	<ul style="list-style-type: none"> <li>• Ventilated</li> <li>• Compressor R600a</li> </ul>
Cords:	<ul style="list-style-type: none"> <li>• CE/UK/AU/CH/US</li> </ul>
Heat production:	<ul style="list-style-type: none"> <li>• Heating element</li> </ul>
Heat release:	<ul style="list-style-type: none"> <li>• Automatic, adjustable threshold</li> </ul>
Inner material:	<ul style="list-style-type: none"> <li>• Stucco aluminum</li> </ul>
Exterior coating material:	<ul style="list-style-type: none"> <li>• HDF (High Density Fiber) melamine-faced panels</li> </ul>
Insulation type:	<ul style="list-style-type: none"> <li>• Injected polyurethane foam (59mm)</li> </ul>

### GENERAL FEATURES

	Full Glass door
Gross weight packaged (kg)	102,3
Empty net weight (kg)	91,3
Dimensions H x W x D (mm)	1820-1890 x 594 <sup>2</sup> x 597
Dimensions packaged H x W x D (mm)	1980 x 645 x 630

### EQUIPMENT & ACCESSORIES

#### EQUIPMENT

- Reversible Full Glass door with soft close and door stop
- Inner lighting : light strip and 2 LED (3 options: permanent, open door, disabled)
- Charcoal filter
- 4 adjustable feet
- Humidity cartridge
- Lock

#### ACCESSORIES

- Sliding shelves with Mains du Sommelier, open / close locking notch, setting of the Main du Sommelier at the front of the shelf
- 6 removable bottles identifiers per sliding shelf
- 1 erasable felt-tip marker
- 1 microfiber cloth
- 1 EuroCave key ring

### ENERGY EFFICIENCY & CONSUMPTION

Cords	230V-50Hz (R600a)
Type of door	Full Glass
Energy efficiency class	A
Annual energy consumption AEC <sup>3</sup> (Kwh/year)	165
Useful volume (liters)	285
Sound emission (dB(A))	38
Ambient temperature range (°C)	12-35

<sup>1</sup> Traditional Bordeaux bottles

<sup>2</sup> With fillers

<sup>3</sup> Calculation based on the result obtained over 24 hrs in standard conditions (25°C / 77°F)

## Installation diagrams

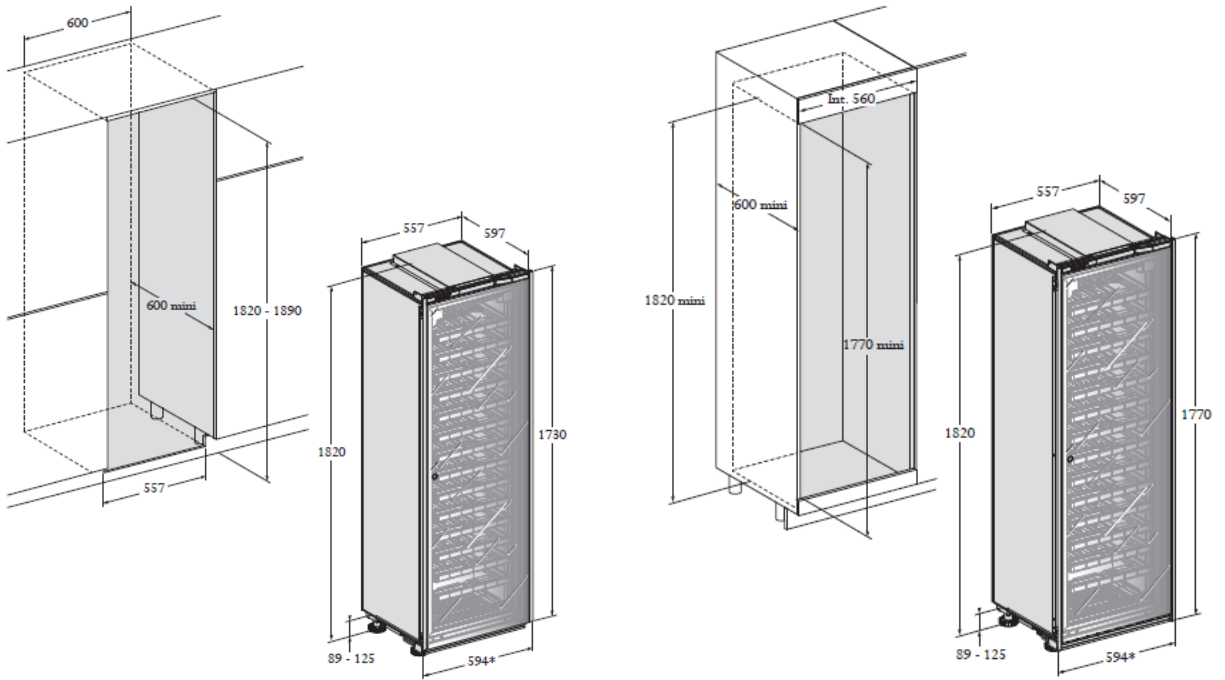

Built-in

Flush-fitted

## Storage layouts

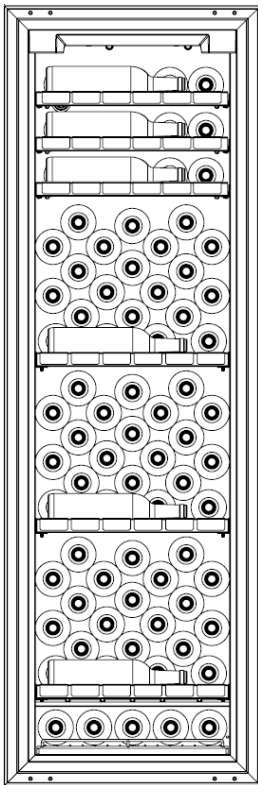

Access  
Pack

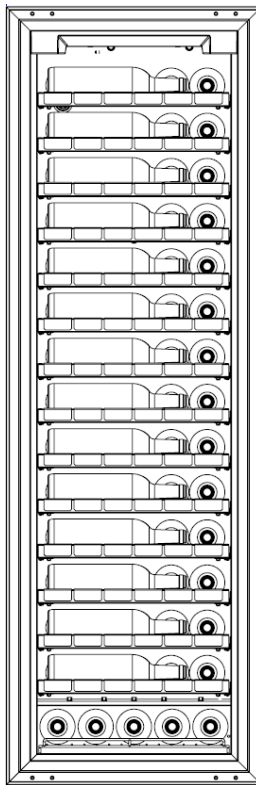

Premium  
Pack

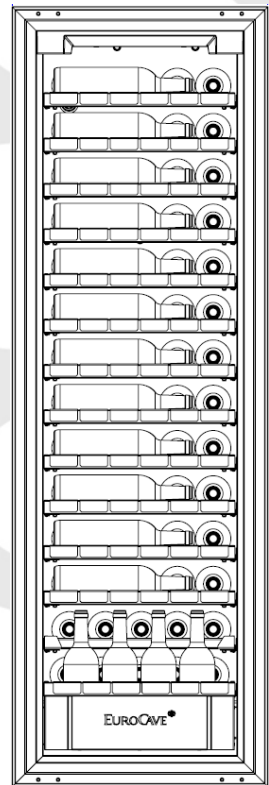

Service  
Pack