



Xinrui Industry Co., Ltd.

















Professional manufacturer of carbide cutting tools











сайт: <http://www.imperial-tools.ru>

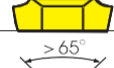



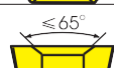
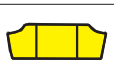
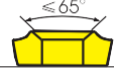
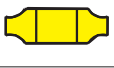
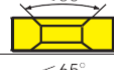
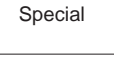



e-mail: info@imperial-tools.ru

тел: 8(423) 2-72-64-51

| Insert Shape / Code | | |
|---|---|---|
|  A |  B |  C |
|  D |  E |  H |
|  K |  L |  M |
|  O |  P |  R |
|  S |  T |  V |
|  W | Others | Z |
| Insert shape | | |

| Metric | | | | | | | |
|--|-------------------|--------------------------|---|------|-------------------|--------------------------|---|
| Code | With/Without hole | With/Without chipbreaker | Sadrplaned insert | Code | With/Without hole | With/Without chipbreaker | Sadrplaned insert |
| B | With | Without |  | N | Without | Without |  |
| H | With | Single-side |  | R | Without | Single-side |  |
| C | With | Without |  | F | Without | Double-side |  |
| J | With | Double-side |  | A | With | Without |  |
| W | With | Without |  | M | With | Single-side |  |
| T | With | Single-side |  | G | With | Double-side |  |
| Q | With | Without |  | X | --- | --- | Special |
| U | With | Double-side |  | | | | |
| Chipbreaker and clamping system | | | | | | | |

T P K N

| Clearance angle of main cutting edge | | | |
|--------------------------------------|---|------|---|
| Code | Clearance angle | Code | Clearance angle |
| A |  3° | B |  5° |
| C |  7° | D |  15° |
| E |  20° | F |  25° |
| G |  30° | N |  0° |
| P |  11° | O | Other clearance angle |

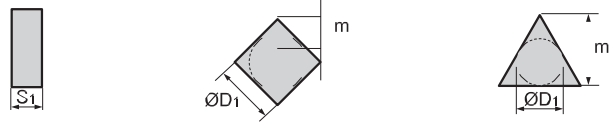
| Tolerance | | | | | | | | | | |
|--|------------------------------|-------------------------------------|----------------------------|---|------------------|--------|------------------|------------------|------------------|-------|
|  | | | | | | | | | | |
| Code | Nose height M Tolerance (mm) | Inscribed circle ØD1 Tolerance (mm) | Thickness S Tolerance (mm) | (Reference) details of M-class tolerance (identified by shape and size) | | | | | | |
| | | | | · Nose height tolerance (mm) | | | | | | |
| A | ±0.005 | ±0.025 | ±0.025 | Inscribed circle | Regular triangle | Square | Diamond with 80° | Diamond with 55° | Diamond with 35° | Round |
| F | ±0.005 | ±0.013 | ±0.025 | 6.35 | ±0.08 | ±0.08 | ±0.08 | ±0.11 | ±0.16 | --- |
| C | ±0.013 | ±0.025 | ±0.025 | 9.525 | ±0.08 | ±0.08 | ±0.08 | ±0.11 | ±0.16 | --- |
| H | ±0.013 | ±0.013 | ±0.025 | 12.7 | ±0.13 | ±0.13 | ±0.13 | ±0.15 | --- | --- |
| E | ±0.025 | ±0.025 | ±0.025 | 15.875 | +0.15 | +0.15 | +0.15 | +0.18 | --- | --- |
| G | ±0.025 | ±0.025 | ±0.13 | 19.05 | ±0.15 | ±0.15 | ±0.15 | ±0.18 | --- | --- |
| J | ±0.005 | ±0.05±0.13 | ±0.025 | 25.4 | --- | ±0.18 | --- | --- | --- | --- |
| | | | | · Tolerance of Inscribed Circle ØD1 (mm) | | | | | | |
| J | ±0.005 | ±0.05±0.13 | ±0.025 | Inscribed circle | Regular triangle | Square | Diamond with 80° | Diamond with 55° | Diamond with 35° | Round |
| K | ±0.013 | ±0.05±0.13 | ±0.025 | 6.35 | ±0.05 | ±0.05 | ±0.05 | ±0.05 | ±0.05 | --- |
| L | ±0.025 | ±0.05±0.13 | ±0.025 | 9.525 | ±0.05 | ±0.05 | ±0.05 | ±0.05 | ±0.05 | ±0.05 |
| M | ±0.08±0.18 | ±0.05±0.13 | ±0.13 | 12.7 | ±0.08 | ±0.08 | ±0.08 | ±0.08 | --- | ±0.08 |
| N | ±0.08±0.18 | ±0.05±0.13 | ±0.025 | 15.875 | ±0.10 | ±0.10 | ±0.10 | ±0.10 | --- | ±0.10 |
| U | ±0.13±0.38 | ±0.08±0.25 | ±0.13 | 19.05 | ±0.10 | ±0.10 | ±0.10 | ±0.10 | --- | ±0.10 |
| | | | | 25.4 | --- | ±0.13 | --- | --- | --- | ±0.13 |

сайт: <http://www.imperial-tools.ru>

e-mail: info@imperial-tools.ru

тел: 8(423) 2-72-64-51

| Diameter of IC | Insert shape | | | | | | |
|----------------|--------------|----|----|----|----|----|----|
| | C | D | R | S | T | V | W |
| 3.97 | | | | | 06 | | |
| 5.0 | | | 05 | | | | |
| 5.56 | | | | | 09 | | |
| 6.0 | | | 06 | | | | |
| 6.35 | 06 | 07 | | | 11 | 11 | |
| 8.0 | | | 08 | | | | |
| 9.525 | 09 | 11 | 09 | 09 | 16 | 16 | 06 |
| 10.0 | | | 10 | | | | |
| 12.0 | | | 12 | | | | |
| 12.7 | 12 | 15 | 12 | 12 | 22 | 22 | 08 |
| 15.875 | 16 | | 15 | 15 | 27 | | |
| 16.0 | | 19 | 16 | | | | |
| 19.05 | 19 | | 19 | 19 | 33 | | |
| 20.0 | | | 20 | | | | |
| 25.0 | 25 | 25 | 25 | | | | |
| 25.4 | | | 25 | 25 | | | |
| 31.75 | | | 31 | | | | |
| 32 | | | 32 | | | | |

Length of cutting edge

Thickness is defined as height from bottom of insert to the highest part of cutting edge.

| Code | Insert thickness(mm) |
|------|----------------------|
| 00 | 0.79 |
| T0 | 0.99 |
| 01 | 1.59 |
| T1 | 1.98 |
| 02 | 2.38 |
| T2 | 2.58 |
| 03 | 3.18 |
| T3 | 3.97 |
| 04 | 4.76 |
| T4 | 4.96 |
| 05 | 5.96 |
| T5 | 5.95 |
| 06 | 6.35 |
| T6 | 6.75 |
| 07 | 7.94 |
| 09 | 9.52 |
| T9 | 9.72 |
| 11 | 11.11 |
| 12 | 12.70 |

Insert thickness

22 04 PD F R ISO

| Wiper | | | |
|----------|--------|----------|--------|
| | | | |
| A | 45° | A | 3° |
| D | 60° | B | 5° |
| E | 75° | C | 7° |
| F | 85° | D | 15° |
| P | 90° | E | 20° |
| Z | Others | F | 25° |
| | | G | 30° |
| | | N | 0° |
| | | P | 11° |
| | | Z | Others |

| Chamfer (mm) | | | |
|--------------|--------|--------|--------|
| F | | | |
| | 0-5° | 0-0.10 | |
| E | | 1-10° | 1-0.15 |
| | 2-15° | 2-0.20 | |
| T | | 3-20° | 3-0.25 |
| | 4-25° | 4-0.30 | |
| | 5-30° | 5-0.35 | |
| S | | 6-0.40 | |
| | 7-0.45 | 7-0.45 | |

| Cutting direction | |
|-------------------|------------|
| R | Right hand |
| L | Left hand |
| N | Neutral |

сайт: <http://www.imperial-tools.ru>

e-mail: info@imperial-tools.ru

тел: 8(423) 2-72-64-51

APKT

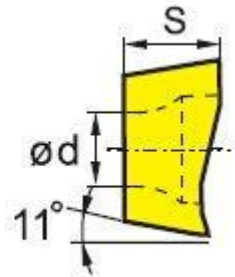
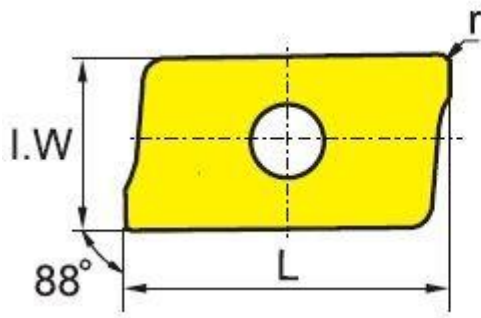

| commodity | Item no. | Dimension(mm)基本尺寸 | | | | |
|-----------------|------------|-------------------|------|------|-----|-----|
| | | L | I.W | S | d | r |
| milling inserts | APKT1135 | 11.24 | 6.2 | 3.6 | 2.8 | 0.8 |
| | APKT11T304 | 12.24 | 6.5 | 3.6 | 2.8 | 0.4 |
| | APKT11T308 | 12.24 | 6.5 | 3.6 | 2.8 | 0.8 |
| | APKT11T312 | 12.24 | 6.5 | 3.6 | 2.8 | 1.2 |
| | APKT160408 | 17.877 | 9.33 | 5.76 | 4.4 | 0.8 |

APKT150412

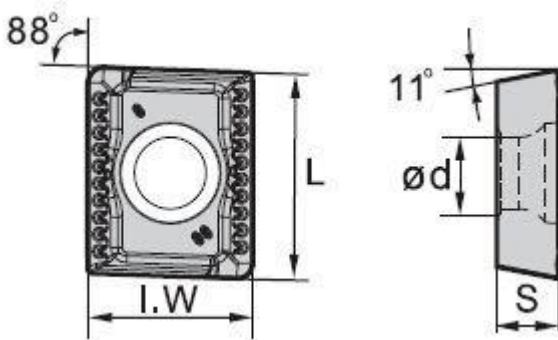

| commodity | Item no. | Dimension(mm)基本尺寸 | | | | |
|-----------------|------------|-------------------|------|------|-----|-----|
| | | L | I.W | S | d | r |
| milling inserts | APKT150412 | 16.33 | 12.7 | 4.76 | 5.4 | 1.2 |

сайт: <http://www.imperial-tools.ru>

e-mail: info@imperial-tools.ru

тел: 8(423) 2-72-64-51

APMT

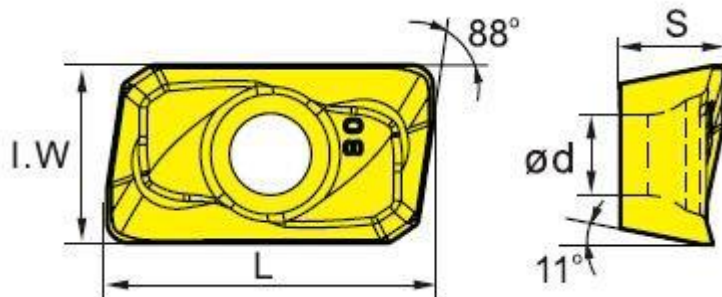

| commodity | item no. | Dimension(mm)基本尺寸 | | | | |
|-----------------|----------------|-------------------|------|------|-----|-----|
| | | L | I.W | S | d | r |
| milling inserts | APMT1135PDR | 11.25 | 6.2 | 3.5 | 2.8 | 0.8 |
| | APMT160408PDER | 17.25 | 9.25 | 4.76 | 4.4 | 0.8 |

сайт: <http://www.imperial-tools.ru>

e-mail: info@imperial-tools.ru

тел: 8(423) 2-72-64-51

MPHT

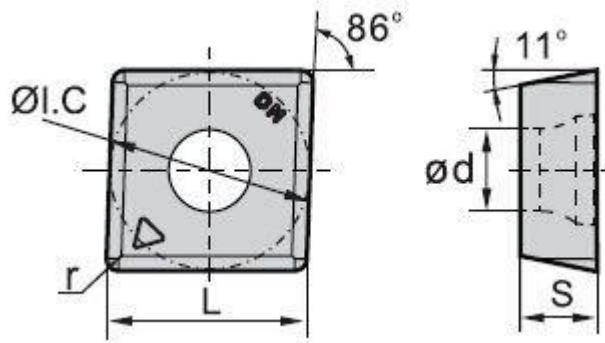

| commodity | item no. | Dimension(mm)基本尺寸 | | | | |
|-----------------|------------|-------------------|------|------|------|-----|
| | | I.C | L | S | d | r |
| milling inserts | MPHT060304 | 6.35 | 6.35 | 3.18 | 2.8 | 0.4 |
| | MPHT080305 | 8.3 | 8.3 | 3.18 | 3.4 | 0.5 |
| | MPHT120408 | 12.7 | 12.7 | 4.76 | 5.56 | 0.8 |

сайт: <http://www.imperial-tools.ru>

e-mail: info@imperial-tools.ru

тел: 8(423) 2-72-64-51

RCKT

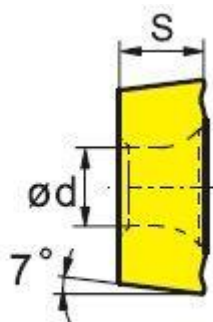
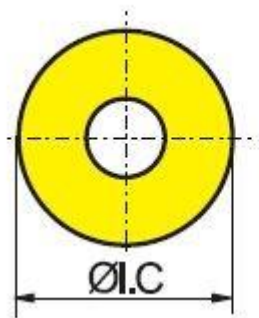

| commodity | item no. | Dimension(mm)基本尺寸 | | | | |
|-----------------|-------------|-------------------|------|------|------|--|
| | | R | I.C | S | d | |
| Milling inserts | RCKT10T3MO | 5 | 10.0 | 3.97 | 4.4 | |
| | RCKT1204MO | 5 | 12.0 | 4.76 | 4.0 | |
| | RCKT1204MO- | 6 | 12.0 | 4.76 | 4.0 | |
| | RCKT1606MO | 8 | 16 | 6.35 | 5.56 | |
| | RCKT2006MO | 10 | 20 | 6.35 | 5.56 | |

сайт: <http://www.imperial-tools.ru>

e-mail: info@imperial-tools.ru

тел: 8(423) 2-72-64-51

RDKW

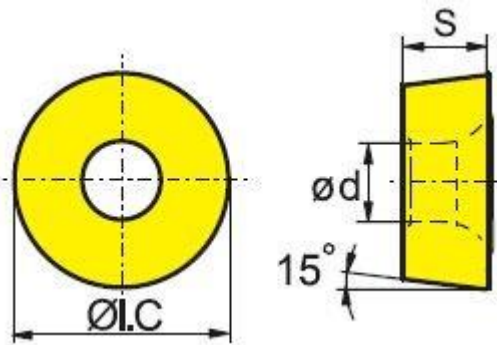

| commodity | item no. | Dimension(mm)基本尺寸 | | | | |
|-----------------|------------|-------------------|------|------|-----|--|
| | | R | I.C | S | D | |
| Milling inserts | RDKW0803MO | 4 | 8 | 3.18 | 3.4 | |
| | RDKW10T3MO | 5 | 10 | 3.97 | 4.4 | |
| | RDKW1204MO | 6 | 12 | 4.76 | 4.4 | |
| | RDKW1605MO | 8 | 16.0 | 5.56 | 5.5 | |
| | RDKW2006MO | 10 | 20.0 | 6.35 | 6.5 | |

сайт: <http://www.imperial-tools.ru>

e-mail: info@imperial-tools.ru

тел: 8(423) 2-72-64-51

SDMT09T308

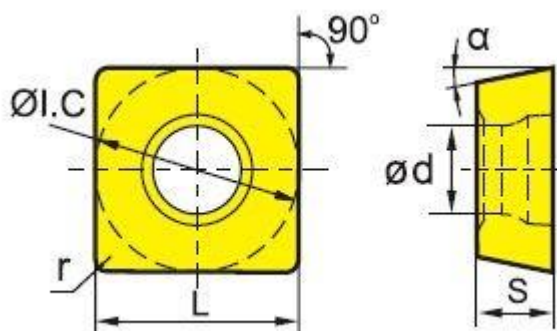

| commodity | item no. | Dimension(mm)基本尺寸 | | | | | |
|-----------------|------------|-------------------|-------|-------|------|-----|-----|
| | | r | L | I.C | S | d | a |
| Milling inserts | SDMT090308 | 0.8 | 9.525 | 9.525 | 3.18 | 4.4 | 15° |

сайт: <http://www.imperial-tools.ru>

e-mail: info@imperial-tools.ru

тел: 8(423) 2-72-64-51

SDMT

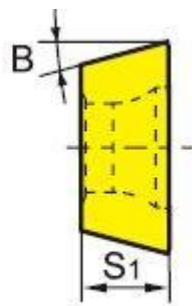
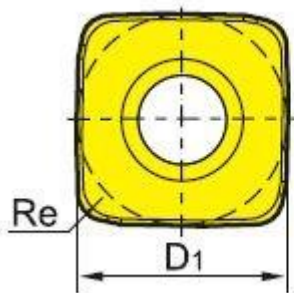

| commodity | item no. | Dimension(mm)基本尺寸 | | | | |
|-----------------|------------|-------------------|-----|----------------|----------------|--|
| | | B | Re | S ₁ | D ₁ | |
| Milling inserts | SDMT09T312 | 15° | 1.2 | 3.97 | 9.525 | |
| | SDMT120408 | 15° | 2.0 | 4.76 | 12.7 | |

сайт: <http://www.imperial-tools.ru>

e-mail: info@imperial-tools.ru

тел: 8(423) 2-72-64-51

SEET12T3

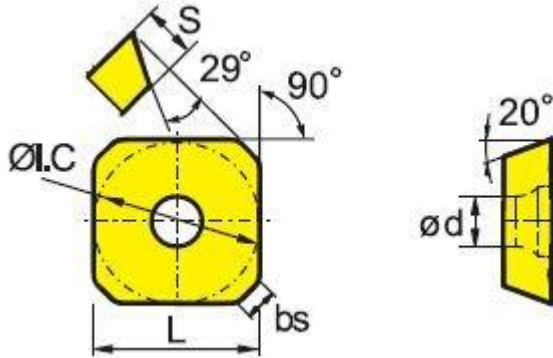

| commodity | item no. | Dimension(mm)基本尺寸 | | | | | |
|-----------------|----------|-------------------|-------|------|-----|------|---|
| | | L | I.C | S | d | BS | R |
| Milling inserts | SEET12T3 | 12.40 | 13.40 | 3.97 | 4.1 | 2.55 | |

сайт: <http://www.imperial-tools.ru>

e-mail: info@imperial-tools.ru

тел: 8(423) 2-72-64-51

SEET

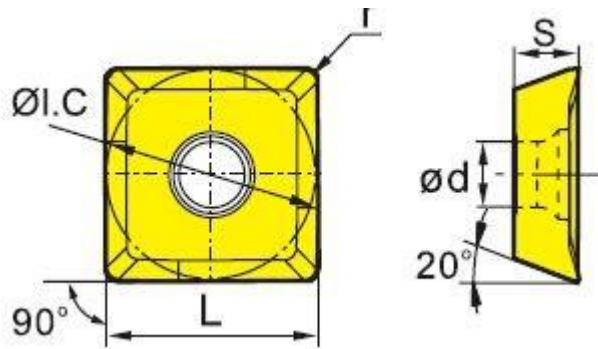

| commodity | item no. | Dimension(mm)基本尺寸 | | | | |
|-----------------|---------------|-------------------|--------|------|-----|-----|
| | | L | I.C | S | D | r |
| Milling inserts | SEET09T308PER | 9.525 | 9.525 | 4.01 | 3.3 | 0.8 |
| | SEET120308PER | 13.308 | 13.308 | 4.04 | 4.1 | 0.8 |

сайт: <http://www.imperial-tools.ru>

e-mail: info@imperial-tools.ru

тел: 8(423) 2-72-64-51

SEKN

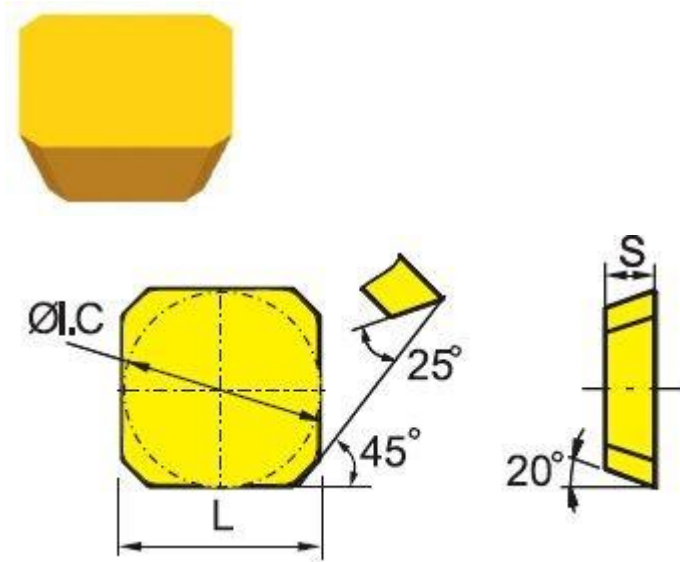

| Commodity | item no. | Dimension(mm)基本尺寸 | | |
|-----------------|--------------|-------------------|--------|------|
| | | L | I.C | S |
| Milling inserts | SEEN1203AFTN | 12.7 | 12.7 | 3.18 |
| | SEKN1203AFFN | 12.7 | 12.7 | 3.18 |
| | SEKN1203AFN | 12.7 | 12.7 | 3.18 |
| | SEKN1203AFTN | 12.7 | 12.7 | 3.18 |
| | SEKN1504AFN | 15.875 | 15.875 | 4.76 |
| | SEKN1504AFTN | 15.875 | 15.875 | 4.76 |

сайт: <http://www.imperial-tools.ru>

e-mail: info@imperial-tools.ru

тел: 8(423) 2-72-64-51

SEKR

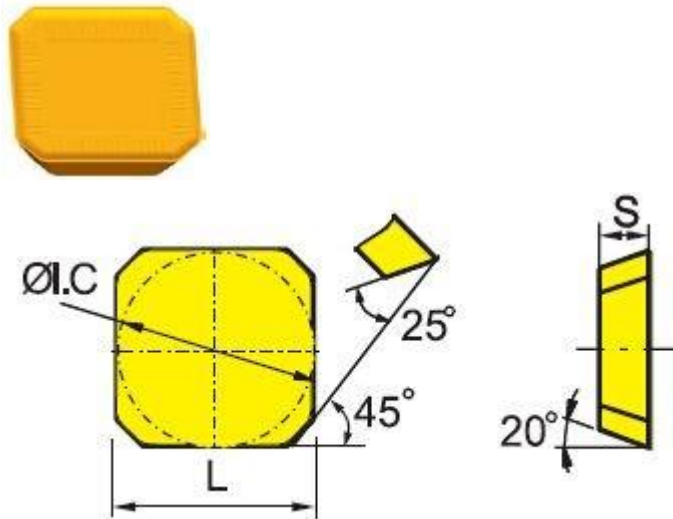

| Commodity | item no. | Dimension(mm)基本尺寸 | | |
|-----------------|-------------|-------------------|--------|------|
| | | L | I.C | S |
| Milling inserts | SEKR1203AFN | 12.7 | 12.7 | 3.18 |
| | SEKR1504AFN | 15.875 | 15.875 | 4.76 |

сайт: <http://www.imperial-tools.ru>

e-mail: info@imperial-tools.ru

тел: 8(423) 2-72-64-51

SPMT-SPKT

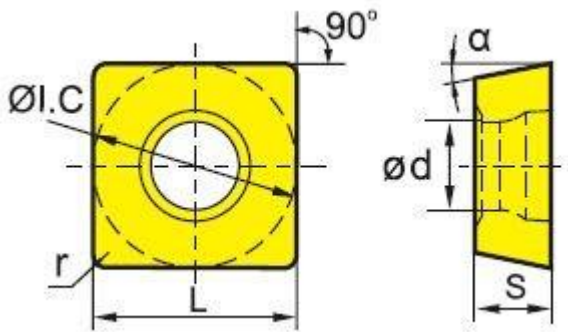

| commodity | item no. | Dimension(mm)基本尺寸 | | | | | |
|-----------------|-------------|-------------------|------|------|------|------|-----|
| | | r | L | I.C | S | d | a |
| Milling inserts | SPMT060304 | 0.4 | 6.35 | 6.35 | 3.18 | 2.8 | 11° |
| | SPMT120408 | 0.8 | 12.7 | 12.7 | 4.76 | 5.5 | 11° |
| | SPKT1204EDR | | 12.7 | 12.7 | 4.76 | 5.56 | 11° |

сайт: <http://www.imperial-tools.ru>

e-mail: info@imperial-tools.ru

тел: 8(423) 2-72-64-51

SPKW

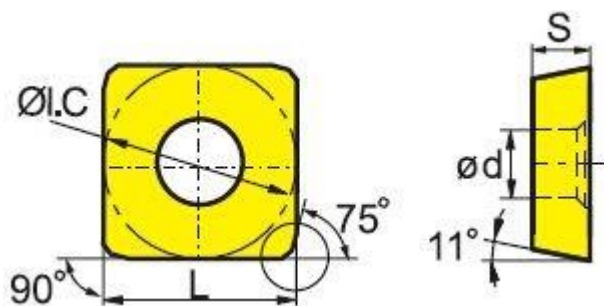

| commodity | item no. | Dimension(mm)基本尺寸 | | | | | |
|-----------------|--------------|-------------------|------|------|------|------|-----|
| | | r | L | I.C | S | d | a |
| Milling inserts | SPKW1204EDFR | | 12.7 | 12.7 | 4.76 | 5.65 | 11° |
| | SPKW1204EDSR | | 12.7 | 12.7 | 4.76 | 5.65 | 11° |

сайт: <http://www.imperial-tools.ru>

e-mail: info@imperial-tools.ru

тел: 8(423) 2-72-64-51

SPKR-A

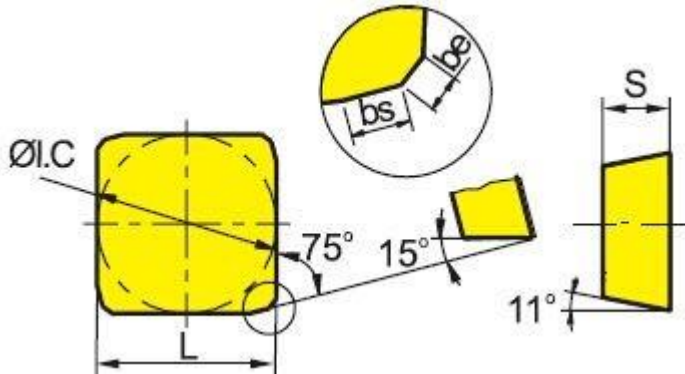

| commodity | item no. | Dimension(mm)基本尺寸 | | | | |
|-----------------|-------------|-------------------|--------|------|----|-----|
| | | L | I.C | S | Be | bs |
| Milling inserts | SPKR1203EDR | 12.7 | 12.7 | 3.18 | 1 | 1.4 |
| | SPKR1203EDL | 12.7 | 12.7 | 3.18 | 1 | 1.4 |
| | SPKR1504EDR | 15.875 | 15.875 | 4.76 | 1 | 1.4 |
| | SPKR1504EDL | 15.875 | 15.875 | 4.76 | 1 | 1.4 |

сайт: <http://www.imperial-tools.ru>

e-mail: info@imperial-tools.ru

тел: 8(423) 2-72-64-51

SPMR

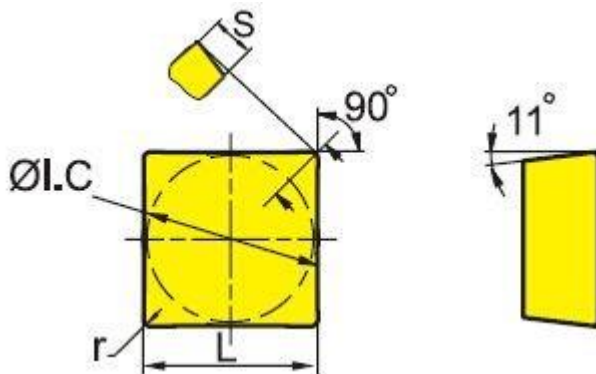

| commodity | item no. | Dimension(mm)基本尺寸 | | | |
|-----------------|------------|-------------------|-------|------|-----|
| | | L | I.C | S | r |
| Milling inserts | SPMR090304 | 9.525 | 9.525 | 3.18 | 0.4 |
| | SPMR09T304 | 9.525 | 9.525 | 3.97 | 0.4 |
| | SPMR090308 | 9.525 | 9.525 | 3.18 | 0.8 |
| | SPMR120304 | 12.7 | 12.7 | 3.18 | 0.4 |
| | SPMR120308 | 12.7 | 12.7 | 3.18 | 0.8 |
| | SPMR120312 | 12.7 | 12.7 | 3.18 | 1.2 |

сайт: <http://www.imperial-tools.ru>

e-mail: info@imperial-tools.ru

тел: 8(423) 2-72-64-51

SPUN-SPGN

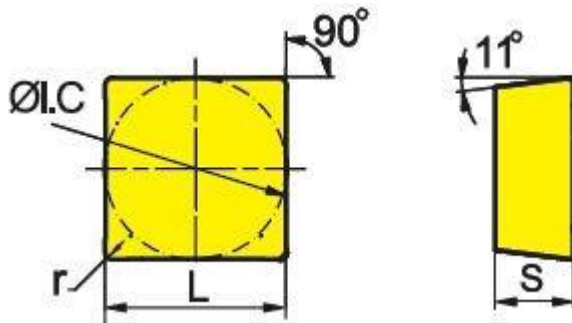

| commodity | item no. | Dimension(mm)基本尺寸 | | | |
|-----------------|------------|-------------------|--------|------|-----|
| | | L | I.C | S | r |
| Milling inserts | SPUN090304 | 9.525 | 9.525 | 3.18 | 0.4 |
| | SPUN090308 | 9.525 | 9.525 | 3.18 | 0.8 |
| | SPUN120304 | 12.7 | 12.7 | 3.18 | 0.4 |
| | SPUN120308 | 12.7 | 12.7 | 3.18 | 0.8 |
| | SPUN120312 | 12.7 | 12.7 | 3.18 | 1.2 |
| | SPUN150408 | 15.875 | 15.875 | 4.76 | 0.8 |
| | SPUN150412 | 15.875 | 15.875 | 4.76 | 1.2 |
| | SPUN190408 | 19.05 | 19.05 | 4.76 | 0.8 |
| | SPUN190412 | 19.05 | 19.05 | 4.76 | 1.2 |
| | SPUN190416 | 19.05 | 19.05 | 4.76 | 1.6 |
| Milling inserts | SPGN090304 | 9.525 | 9.525 | 3.18 | 0.4 |
| | SPGN090308 | 9.525 | 9.525 | 3.18 | 0.8 |
| | SPGN120308 | 12.7 | 12.7 | 3.18 | 0.8 |
| | SPGN120404 | 12.7 | 12.7 | 4.76 | 0.4 |
| | SPGN120408 | 12.7 | 12.7 | 4.76 | 0.8 |
| | SPGN120412 | 12.7 | 12.7 | 4.76 | 1.2 |
| | SPGN150404 | 15.875 | 15.875 | 4.76 | 0.4 |
| | SPGN150408 | 15.875 | 15.875 | 4.76 | 0.8 |
| | SPGN190408 | 19.05 | 19.05 | 4.76 | 0.8 |
| | SPGN190416 | 19.05 | 19.05 | 4.76 | 1.6 |

сайт: <http://www.imperial-tools.ru>

e-mail: info@imperial-tools.ru

тел: 8(423) 2-72-64-51

SNKN

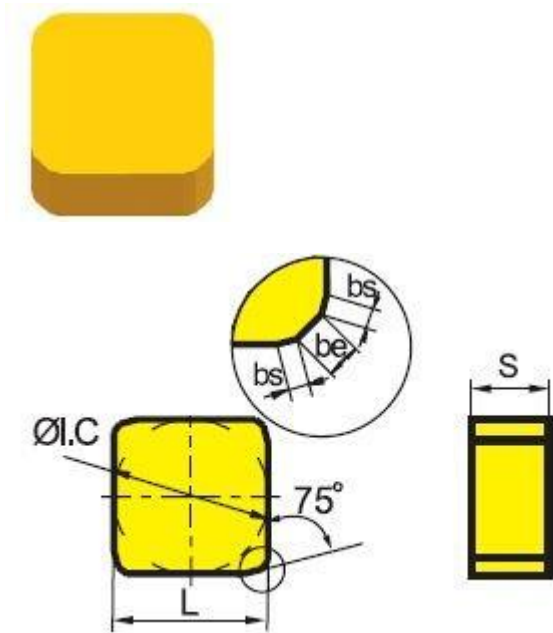

| commodity | item no. | Dimension(mm)基本尺寸 | | | | |
|-----------------|-------------|-------------------|--------|------|-----|-----|
| | | L | I.C | S | be | bs |
| Milling inserts | SNKN1204ENN | 12.7 | 12.7 | 4.76 | 0.9 | 1.5 |
| | SNKN1504ENN | 15.875 | 15.875 | 4.76 | 0.9 | 1.5 |
| | SNKN1904ENN | 19.05 | 19.05 | 4.76 | 1.0 | 1.5 |

сайт: <http://www.imperial-tools.ru>

e-mail: info@imperial-tools.ru

тел: 8(423) 2-72-64-51

TPKN

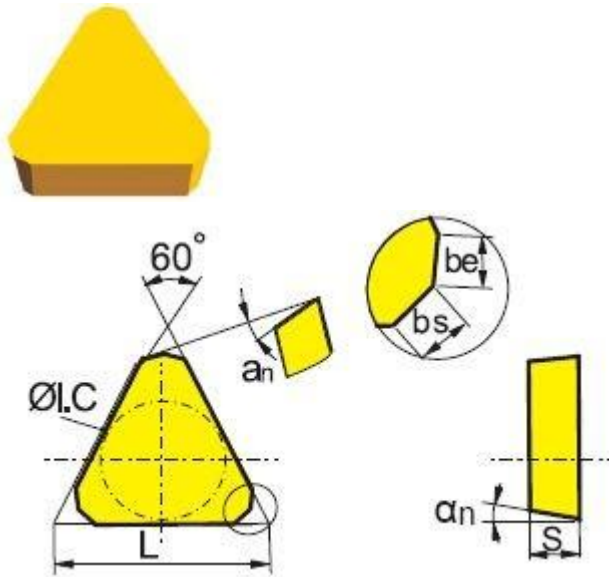

| commodity | item no. | Dimension(mm)基本尺寸 | | | | |
|-----------------|--------------|-------------------|------|-----|-----|------------|
| | | L | I.C | be | bs | α_n |
| Milling inserts | TPKN2204PDFR | 22 | 12.7 | 1.4 | 0.7 | 11° |
| | TPKN2204PDFL | 22 | 12.7 | 1.4 | 0.7 | 11° |
| | TPKN2204PDR | 22 | 12.7 | 1.4 | 0.7 | 11° |
| | TPKN2204PDL | 22 | 12.7 | 1.4 | 0.7 | 11° |
| | TPKN2204PDTR | 22 | 12.7 | 1.4 | 0.7 | 11° |
| | TPKN2204PDTL | 22 | 12.7 | 1.4 | 0.7 | 11° |

сайт: <http://www.imperial-tools.ru>

e-mail: info@imperial-tools.ru

тел: 8(423) 2-72-64-51

TPGN

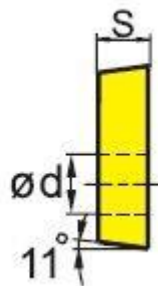
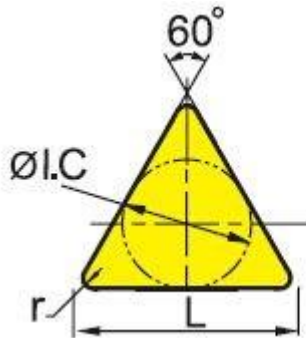
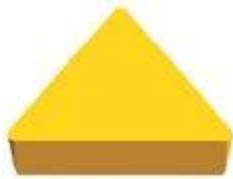

| commodity | item no. | Dimension(mm)基本尺寸 | | | |
|-----------------|------------|-------------------|--------|------|-----|
| | | L | I.C | S | r |
| Milling inserts | TPGN090204 | 9.6 | 5.56 | 2.38 | 0.4 |
| | TPGN090208 | 9.6 | 5.56 | 2.38 | 0.8 |
| | TPGN110204 | 11 | 6.35 | 2.38 | 0.4 |
| | TPGN110304 | 11 | 6.35 | 3.18 | 0.4 |
| | TPGN110308 | 11 | 6.35 | 3.18 | 0.8 |
| | TPGN160304 | 16.5 | 9.525 | 3.18 | 0.4 |
| | TPGN160308 | 16.5 | 9.525 | 3.18 | 0.8 |
| | TPGN160312 | 16.5 | 9.525 | 3.18 | 1.2 |
| | TPGN160316 | 16.5 | 9.525 | 3.18 | 1.6 |
| | TPGN220308 | 22 | 12.7 | 4.76 | 0.8 |
| | TPGN220404 | 22 | 12.7 | 4.76 | 0.4 |
| | TPGN220408 | 22 | 12.7 | 4.76 | 0.8 |
| | TPGN220412 | 22 | 12.7 | 4.76 | 1.2 |
| | TPGN270408 | 27.5 | 15.875 | 4.76 | 0.8 |

сайт: <http://www.imperial-tools.ru>

e-mail: info@imperial-tools.ru

тел: 8(423) 2-72-64-51

TPUN

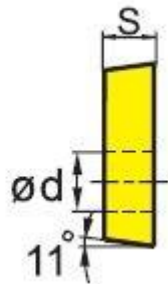
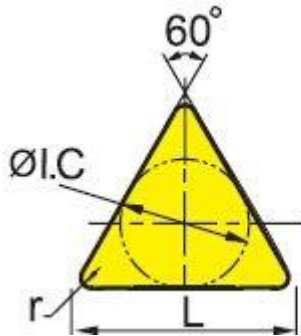

| commodity | item no. | Dimension(mm)基本尺寸 | | | |
|-----------------|------------|-------------------|-------|------|-----|
| | | L | I.C | S | r |
| Milling inserts | TPUN110208 | 11 | 6.35 | 2.38 | 0.8 |
| | TPUN110304 | 11 | 6.35 | 3.18 | 0.4 |
| | TPUN110308 | 11 | 6.35 | 3.18 | 0.8 |
| | TPUN160304 | 16.5 | 9.525 | 3.18 | 0.4 |
| | TPUN160308 | 16.5 | 9.525 | 3.18 | 0.8 |
| | TPUN160312 | 16.5 | 9.525 | 3.18 | 1.2 |
| | TPUN160408 | 16.5 | 9.525 | 4.76 | 0.8 |
| | TPUN160412 | 16.5 | 9.525 | 4.76 | 1.2 |
| | TPUN220404 | 22 | 12.7 | 4.76 | 0.4 |
| | TPUN220408 | 22 | 12.7 | 4.76 | 0.8 |
| | TPUN220412 | 22 | 12.7 | 4.76 | 1.2 |
| | TPUN220416 | 22 | 12.7 | 4.76 | 1.6 |

сайт: <http://www.imperial-tools.ru>

e-mail: info@imperial-tools.ru

тел: 8(423) 2-72-64-51

TPMR

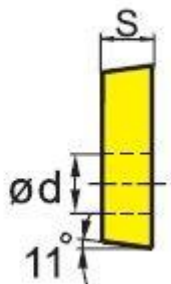
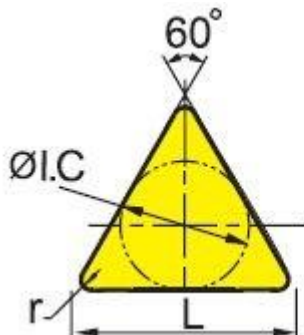

| commodity | item no. | Dimension(mm)基本尺寸 | | | |
|-----------------|------------|-------------------|-------|------|-----|
| | | L | I.C | S | r |
| Milling inserts | TPMR090204 | 9.6 | 5.56 | 2.38 | 0.4 |
| | TPMR110304 | 11 | 6.35 | 3.18 | 0.4 |
| | TPMR110308 | 11 | 6.35 | 3.18 | 0.8 |
| | TPMR160304 | 16.5 | 9.525 | 3.18 | 0.4 |
| | TPMR160308 | 16.5 | 9.525 | 3.18 | 0.8 |
| | TPMR160312 | 16.55 | 9.525 | 3.18 | 1.2 |
| | TPMR220412 | 22 | 12.7 | 4.76 | 1.2 |

сайт: <http://www.imperial-tools.ru>

e-mail: info@imperial-tools.ru

тел: 8(423) 2-72-64-51

Milling insert grades

| Workpiece material | ISO code | Coating | | Cermet | Cemented carbide | PCBN and PCD material |
|---|----------|----------------|----------------|--------|------------------|-----------------------|
| | | CVD | PVD | | | |
| P Steel | P01 | | | | | |
| | P10 | | XRG202, XRG252 | | | |
| | P20 | XRC301, XRM251 | XRG202, XRG252 | | | |
| | P30 | XRM351 | XRG202, XRG302 | | | |
| | P40 | | | | | |
| M Stainless steel | M01 | | | | | |
| | M10 | XRM251 | XRG202, XRG252 | | | |
| | M20 | XRM351 | XRG202, XRG302 | | | |
| | M30 | | | | | |
| | M40 | | | | | |
| K Cast iron | K01 | | | | | |
| | K10 | XRD152 | XRG102, XRG252 | | | |
| | K20 | XRD252 | XRG152 | | | |
| | K30 | | | | | |
| | K40 | | | | | |
| N Non ferrous metal | N01 | | | | | |
| | N10 | | | | | |
| | N20 | | | | | |
| | N30 | | | | | |
| S Heat resistant alloy & Ti alloy | S01 | | | | | |
| | S10 | | XRG202 | | | |
| | S20 | | | | | |
| | S30 | | | | | |
| H Super hard material | H01 | | | | | |
| | H10 | | | | | |
| | H20 | | | | | |
| | H30 | | | | | |

сайт: <http://www.imperial-tools.ru>

e-mail: info@imperial-tools.ru

тел: 8(423) 2-72-64-51