

Solid carbide end mills code key

HT	General machining
HG	Machining hardened material
HL	Machining aluminum
HN	Machining materials hard to cut
HO	Other series
End mills category	

E	Flattened
B	Ball nose
R	Radius
W	Corrugated edge
End mills type	

Radius or radius of ball nose end mills

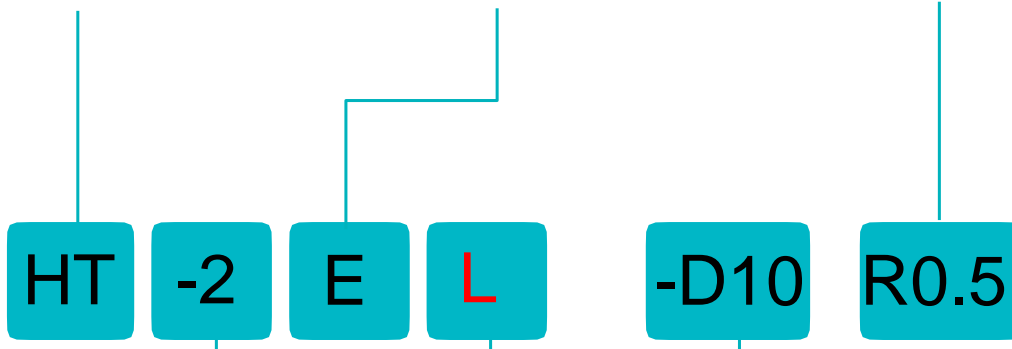

Number of teeth

Length category

L	Long series
S	Tiny diameter
F	Short cutting edge
Defaulted	Series of standard length

Diameter

сайт: <http://www.imperial-tools.ru>

e-mail: info@imperial-tools.ru

тел: 8(423) 2-72-64-51

HT series general machining end mills

2-flute flattened end mills with straight shank

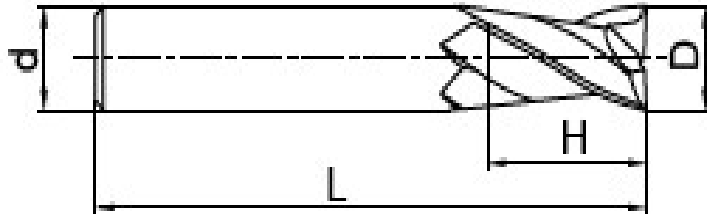
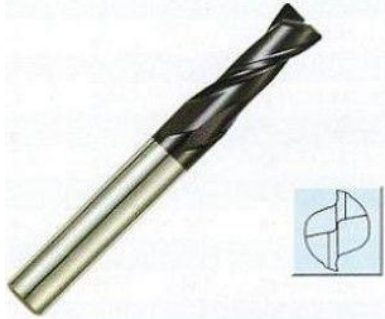

item no.	Dimension(mm)				
	D	H	d	L	Z
HT-2E-D1.0	1	3	4	50	2
HT-2E-D1.5	1.5	4	4	50	2
HT-2E-D2.0	2	6	4	50	2
HT-2E-D2.5	2.5	7	4	50	2
HT-2E-D3.0	3.0	8	4	50	2
HT-2E-D3.5	3.5	11	4	50	2
HT-2E-D4.0	4	12	4	50	2
HT-2E-D4.5	4.5	12	4	50	2
HT-2E-D5.0	5.0	15	6	50	2
HT-2E-D6.0	6	16	6	50	2
HT-2E-D7.0	7	18	8	60	2
HT-2E-D8.0	8	20	8	60	2
HT-2E-D9.0	9	22	10	75	2
HT-2E-D10.0	10	25	10	75	2
HT-2E-D11.0	11	25	11	75	2
HT-2E-D12.0	12	25	12	75	2
HT-2E-D14.0	14	45	14	100	2
HT-2E-D16.0	16	45	16	100	2
HT-2E-D18.0	18	45	18	100	2
HT-2E-D20.0	20	45	20	100	2

сайт: <http://www.imperial-tools.ru>

e-mail: info@imperial-tools.ru

тел: 8(423) 2-72-64-51

3-flute flattened end mills with straight shank

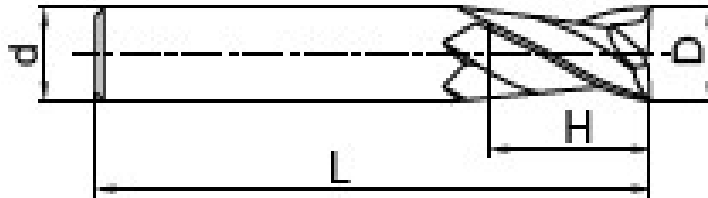

item no.	Dimension(mm)				
	D	d	H	L	Z
HT-3E-D3.0	3	4	8	50	3
HT-3E-D4.0	4	4	12	50	3
HT-3E-D5.0	5	6	15	50	3
HT-3E-D6.0	6	6	16	50	3
HT-3E-D8.0	8	8	20	60	3
HT-3E-D10.0	10	10	25	75	3
HT-3E-D12.0	12	12	25	75	3
HT-3E-D14.0	14	14	45	100	3
HT-3E-D16.0	16	16	45	100	3
HT-3E-D18.0	18	18	45	100	3
HT-3E-D20.0	20	20	45	100	3

сайт: <http://www.imperial-tools.ru>

e-mail: info@imperial-tools.ru

тел: 8(423) 2-72-64-51

4-flute flattened end mills with straight shank

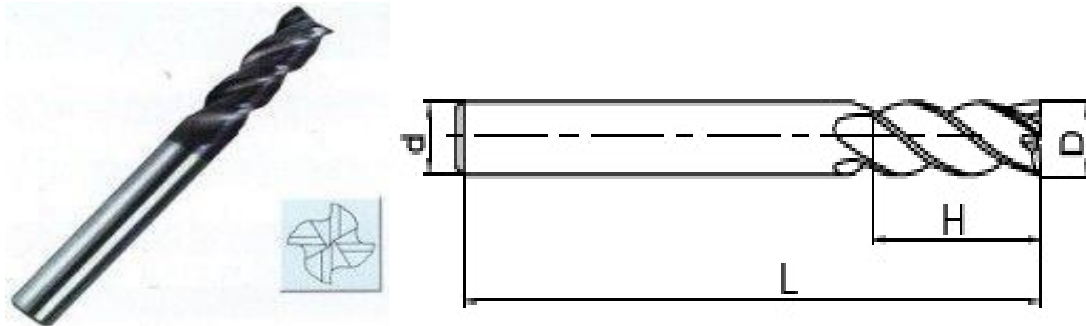

item no.	Dimension(mm)				
	D	H	d	L	Z
HT-4E-D1.0	1	3	4	50	4
HT-4E-D2.0	2	6	4	50	4
HT-4E-D2.5	2.5	7	4	50	4
HT-4E-D3.0	3	8	4	50	4
HT-4E-D4.0	4	12	4	50	4
HT-4E-D5.0	5	15	6	50	4
HT-4E-D6.0	6	16	6	50	4
HT-4E-D8.0	8	20	8	60	4
HT-4E-D10.0	10	25	10	75	4
HT-4E-D12.0	12	25	12	75	4
HT-4E-D14.0	14	45	14	100	4
HT-4E-D16.0	16	45	16	100	4
HT-4E-D18.0	18	45	18	100	4
HT-4E-D20.0	20	45	20	100	4
HT-2E-D14.0	14	45	14	100	2
HT-2E-D16.0	16	45	16	100	2
HT-2E-D18.0	18	45	18	100	2
HT-2E-D20.0	20	45	20	100	2

сайт: <http://www.imperial-tools.ru>

e-mail: info@imperial-tools.ru

тел: 8(423) 2-72-64-51

6-flute flattened end mills with straight shank

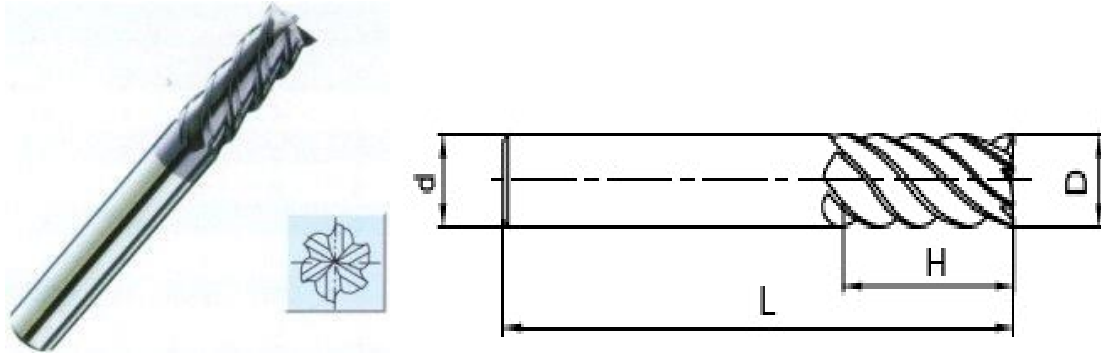

item no.	Dimension(mm)				
	D	d	H	L	Z
HT-6E-D6.0	6	6	16	60	6
HT-6E-D8.0	8	8	20	60	6
HT-6E-D10.0	10	10	25	75	6
HT-6E-D12.0	12	12	25	75	6
HT-6E-D16.0	16	16	45	100	6
HT-6E-D20.0	20	20	45	100	6
HT-6E-D25.0	25	25	45	100	6

сайт: <http://www.imperial-tools.ru>

e-mail: info@imperial-tools.ru

тел: 8(423) 2-72-64-51

2-flute ball nose end mills with straight shank

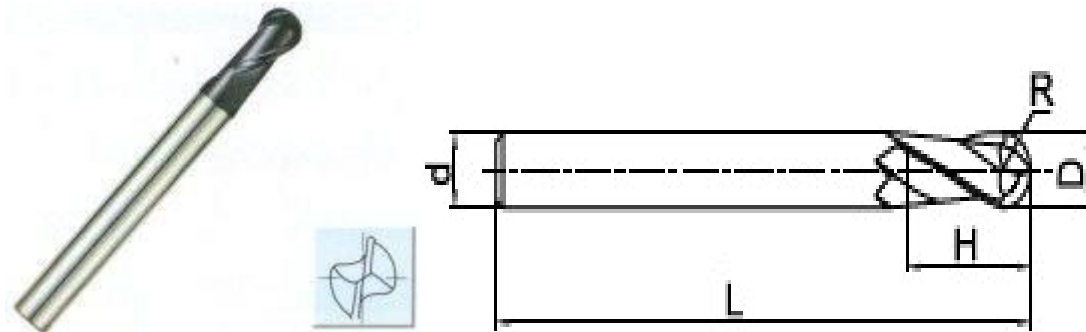

item no.	Dimension(mm)					
	D	H	d	L	R	Z
HT-2B-D3R1.5	3	6	4	50	1.5	2
HT-2B-D4R2.0	4	8	4	50	2.0	2
HT-2B-D5R2.5	5	10	6	50	2.5	2
HT-2B-D6R3.0	6	12	6	50	3.0	2
HT-2B-D7R3.5	7	16	8	60	3.5	2
HT-2B-D8R4.0	8	16	8	60	4.0	2
HT-2B-D9R4.5	9	20	10	75	4.5	2
HT-2B-D10R5.0	10	20	10	75	5.0	2
HT-2B-D12R6.0	12	20	12	75	6.0	2
HT-2B-D14R7.0	14	40	14	100	7.0	2
HT-2B-D16R8.0	16	40	16	100	8.0	2
HT-2B-D18R9.0	18	40	18	100	9.0	2
HT-2B-D20R10.0	20	40	20	100	10.0	2

сайт: <http://www.imperial-tools.ru>

e-mail: info@imperial-tools.ru

тел: 8(423) 2-72-64-51

3-flute ball nose end mills with straight shank

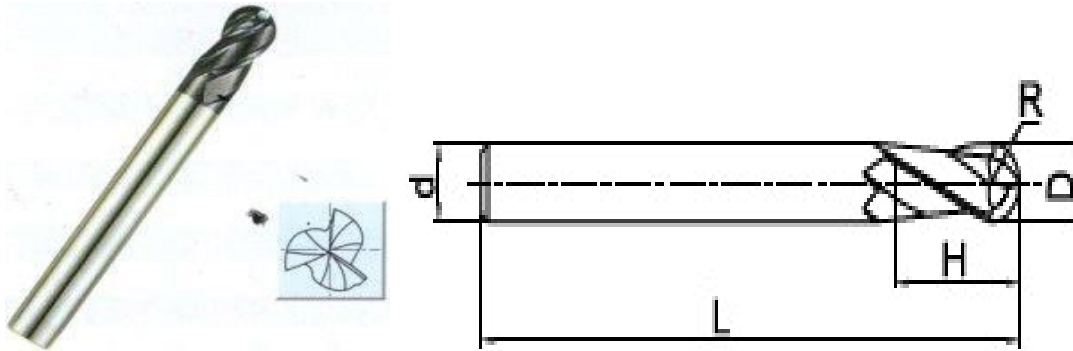

item no.	Dimension(mm)					
	D	H	d	L	R	Z
HT-3B-D3R1.5	3	6	4	50	1.5	3
HT-3B-D4R2.0	4	8	4	50	2.0	3
HT-3B-D5R2.5	5	10	6	50	2.5	3
HT-3B-D6R3.0	6	12	6	50	3.0	3
HT-3B-D7R3.5	7	16	8	60	3.5	3
HT-3B-D8R4.0	8	16	8	60	4.0	3
HT-3B-D9R4.5	9	20	10	75	4.5	3
HT-3B-D10R5.0	10	20	10	75	5.0	3
HT-3B-D12R6.0	12	20	12	75	6.0	3
HT-3B-D14R7.0	14	40	14	100	7.0	3
HT-3B-D16R8.0	16	40	16	100	8.0	3
HT-3B-D18R9.0	18	40	18	100	9.0	3
HT-3B-D20R10.0	20	40	20	100	10.0	3

сайт: <http://www.imperial-tools.ru>

e-mail: info@imperial-tools.ru

тел: 8(423) 2-72-64-51

4-flute ball nose end mills with straight shank

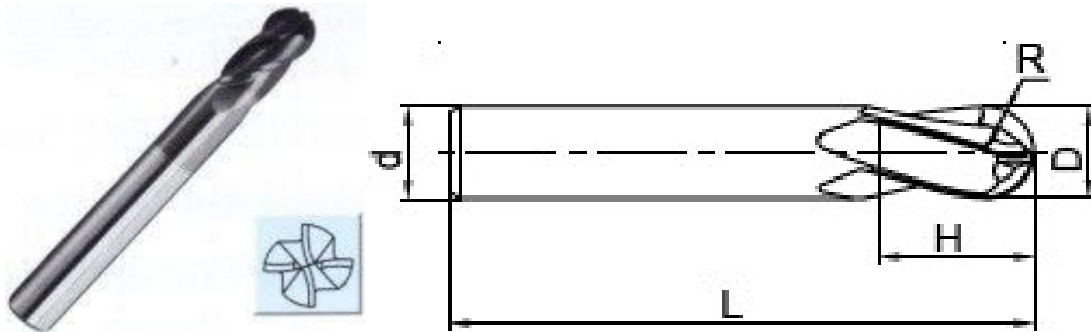

item no.	Dimension(mm)					
	D	H	d	L	R	Z
HT-4B-D3R1.5	3	6	4	50	1.5	4
HT-4B-D4R2.0	4	8	4	50	2.0	4
HT-4B-D5R2.5	5	10	6	50	2.5	4
HT-4B-D6R3.0	6	12	6	50	3.0	4
HT-4B-D7R3.5	7	16	8	60	3.5	4
HT-4B-D8R4.0	8	16	8	60	4.0	4
HT-4B-D9R4.5	9	20	10	75	4.5	4
HT-4B-D10R5.0	10	20	10	75	5.0	4
HT-4B-D12R6.0	12	20	12	75	6.0	4
HT-4B-D14R7.0	14	40	14	100	7.0	4
HT-4B-D16R8.0	16	40	16	100	8.0	4
HT-4B-D18R9.0	18	40	18	100	9.0	4
HT-4B-D20R10.0	20	40	20	100	10.0	4

сайт: <http://www.imperial-tools.ru>

e-mail: info@imperial-tools.ru

тел: 8(423) 2-72-64-51

2 and 4-flute R end mills with straight shank

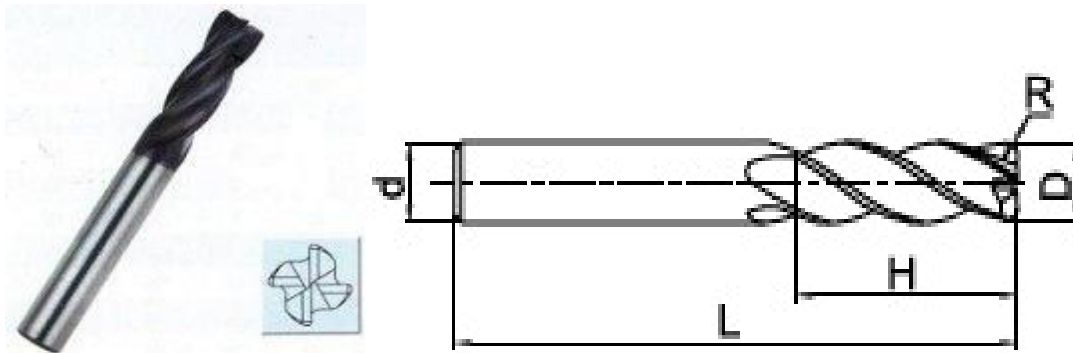

item no.	Dimension(mm)					
	D	H	d	L	R	Z
HT-2R-D3R0.5	3	6	4	50	0.5	2
HT-2R-D4R0.5	4	8	4	50	0.5	2
HT-4R-D5R0.5	5	15	6	50	0.5	4
HT-4R-D6R1.0	6	15	6	50	1.0	4
HT-4R-D8R1.0	8	20	8	60	1.0	4
HT-4R-D8R2.0	8	20	8	60	2.0	4
HT-4R-D10R1.5	10	25	10	75	1.5	4
HT-4R-D10R2.0	10	25	10	75	2.0	4
HT-4R-D12R1.0	12	25	12	75	1.0	4
HT-4R-D12R2.0	12	25	12	75	2.0	4
HT-4R-D16R2.0	16	40	16	100	2.0	4
HT-4R-D20R1.0	20	40	20	100	1.0	4
HT-4R-D20R2.0	20	40	20	100	2.0	4

сайт: <http://www.imperial-tools.ru>

e-mail: info@imperial-tools.ru

тел: 8(423) 2-72-64-51

HG series end mills for machining high hardness steel

2-flute flattened end mills with straight shank

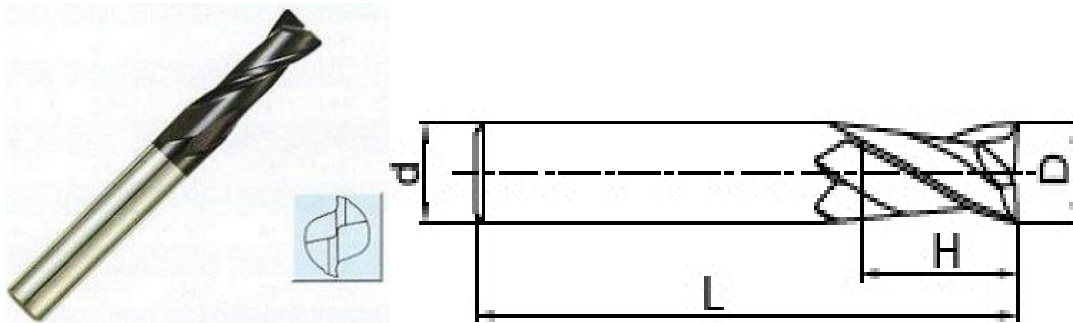

item no.	Dimension(mm)				
	D	H	d	L	Z
HG-2E-D1.0	1	3	4	50	2
HG-2E-D1.5	1.5	4	4	50	2
HG-2E-D2.0	2	6	4	50	2
HG-2E-D2.5	2.5	7	4	50	2
HG-2E-D3.0	3.0	8	4	50	2
HG-2E-D3.5	3.5	11	4	50	2
HG-2E-D4.0	4	12	4	50	2
HG-2E-D4.5	4.5	12	4	50	2
HG-2E-D5.0	5.0	15	6	50	2
HG-2E-D6.0	6	16	6	50	2
HG-2E-D7.0	7	18	8	60	2
HG-2E-D8.0	8	20	8	60	2
HG-2E-D9.0	9	22	10	75	2
HG-2E-D10.0	10	25	10	75	2
HG-2E-D11.0	11	25	11	75	2
HG-2E-D12.0	12	25	12	75	2
HG-2E-D14.0	14	45	14	100	2
HG-2E-D16.0	16	45	16	100	2
HG-2E-D18.0	18	45	18	100	2
HG-2E-D20.0	20	45	20	100	2

сайт: <http://www.imperial-tools.ru>

e-mail: info@imperial-tools.ru

тел: 8(423) 2-72-64-51

3-flute flattened end mills with straight shank

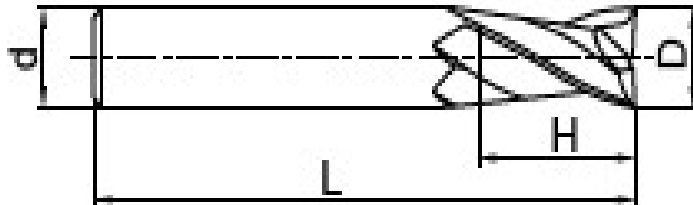

item no.	Dimension(mm)				
	D	d	H	L	Z
HG-3E-D3.0	3	4	8	50	3
HG-3E-D4.0	4	4	12	50	3
HG-3E-D5.0	5	6	15	50	3
HG-3E-D6.0	6	6	16	50	3
HG-3E-D8.0	8	8	20	60	3
HG-3E-D10.0	10	10	25	75	3
HG-3E-D12.0	12	12	25	75	3
HG-3E-D14.0	14	14	45	100	3
HG-3E-D16.0	16	16	45	100	3
HG-3E-D18.0	18	18	45	100	3
HG-3E-D20.0	20	20	45	100	3

сайт: <http://www.imperial-tools.ru>

e-mail: info@imperial-tools.ru

тел: 8(423) 2-72-64-51

4-flute flattened end mills with straight shank

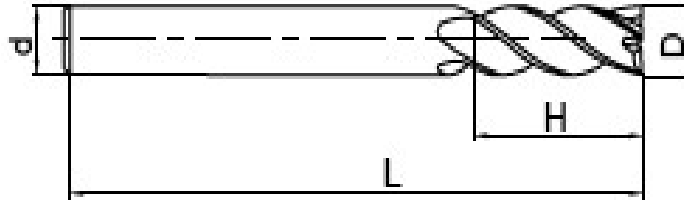

item no.	Dimension(mm)				
	D	H	d	L	Z
HG-4E-D1.0	1	3	4	50	4
HG-4E-D2.0	2	6	4	50	4
HG-4E-D2.5	2.5	7	4	50	4
HG-4E-D3.0	3	8	4	50	4
HG-4E-D4.0	4	12	4	50	4
HG-4E-D5.0	5	15	6	50	4
HG-4E-D6.0	6	16	6	50	4
HG-4E-D8.0	8	20	8	60	4
HG-4E-D10.0	10	25	10	75	4
HG-4E-D12.0	12	25	12	75	4
HG-4E-D14.0	14	45	14	100	4
HG-4E-D16.0	16	45	16	100	4
HG-4E-D18.0	18	45	18	100	4
HG-4E-D20.0	20	45	20	100	4
HG-2E-D14.0	14	45	14	100	2
HG-2E-D16.0	16	45	16	100	2
HG-2E-D18.0	18	45	18	100	2
HG-2E-D20.0	20	45	20	100	2

сайт: <http://www.imperial-tools.ru>

e-mail: info@imperial-tools.ru

тел: 8(423) 2-72-64-51

6-flute flattened end mills with straight shank

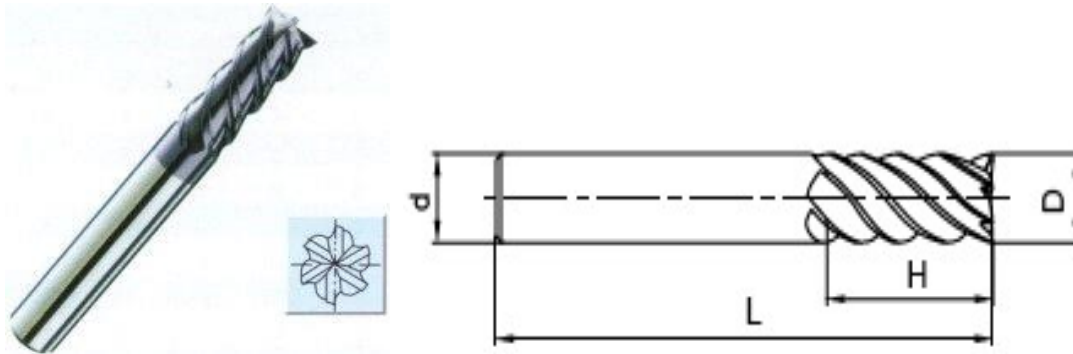

item no.	Dimension(mm)				
	D	d	H	L	Z
HG-6E-D6.0	6	6	16	60	6
HG-6E-D8.0	8	8	20	60	6
HG-6E-D10.0	10	10	25	75	6
HG-6E-D12.0	12	12	25	75	6
HG-6E-D16.0	16	16	45	100	6
HG-6E-D20.0	20	20	45	100	6
HG-6E-D25.0	25	25	45	100	6

сайт: <http://www.imperial-tools.ru>

e-mail: info@imperial-tools.ru

тел: 8(423) 2-72-64-51

2-flute ball nose end mills with straight shank

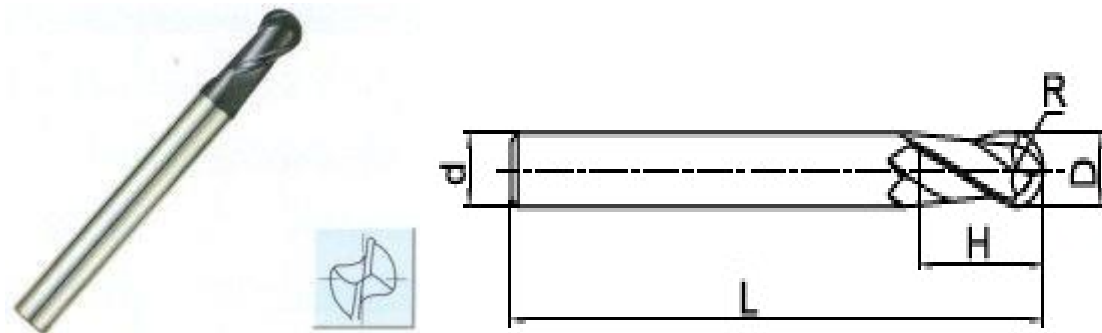

item no.	Dimension(mm)					
	D	H	d	L	R	Z
HG-2B-D3R1.5	3	6	4	50	1.5	2
HG-2B-D4R2.0	4	8	4	50	2.0	2
HG-2B-D5R2.5	5	10	6	50	2.5	2
HG-2B-D6R3.0	6	12	6	50	3.0	2
HG-2B-D7R3.5	7	16	8	60	3.5	2
HG-2B-D8R4.0	8	16	8	60	4.0	2
HG-2B-D9R4.5	9	20	10	75	4.5	2
HG-2B-D10R5.0	10	20	10	75	5.0	2
HG-2B-D12R6.0	12	20	12	75	6.0	2
HG-2B-D14R7.0	14	40	14	100	7.0	2
HG-2B-D16R8.0	16	40	16	100	8.0	2
HG-2B-D18R9.0	18	40	18	100	9.0	2
HG-2B-D20R10.0	20	40	20	100	10.0	2

сайт: <http://www.imperial-tools.ru>

e-mail: info@imperial-tools.ru

тел: 8(423) 2-72-64-51

3-flute ball nose end mills with straight shank

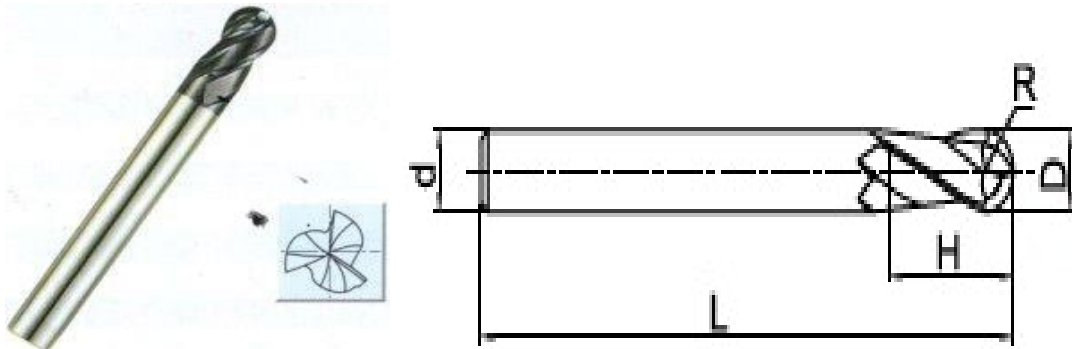

item no.	Dimension(mm)					
	D	H	d	L	R	Z
HG-3B-D3R1.5	3	6	4	50	1.5	3
HG-3B-D4R2.0	4	8	4	50	2.0	3
HG-3B-D5R2.5	5	10	6	50	2.5	3
HG-3B-D6R3.0	6	12	6	50	3.0	3
HG-3B-D7R3.5	7	16	8	60	3.5	3
HG-3B-D8R4.0	8	16	8	60	4.0	3
HG-3B-D9R4.5	9	20	10	75	4.5	3
HG-3B-D10R5.0	10	20	10	75	5.0	3
HG-3B-D12R6.0	12	20	12	75	6.0	3
HG-3B-D14R7.0	14	40	14	100	7.0	3
HG-3B-D16R8.0	16	40	16	100	8.0	3
HG-3B-D18R9.0	18	40	18	100	9.0	3
HG-3B-D20R10.0	20	40	20	100	10.0	3

сайт: <http://www.imperial-tools.ru>

e-mail: info@imperial-tools.ru

тел: 8(423) 2-72-64-51

4-flute ball nose end mills with straight shank

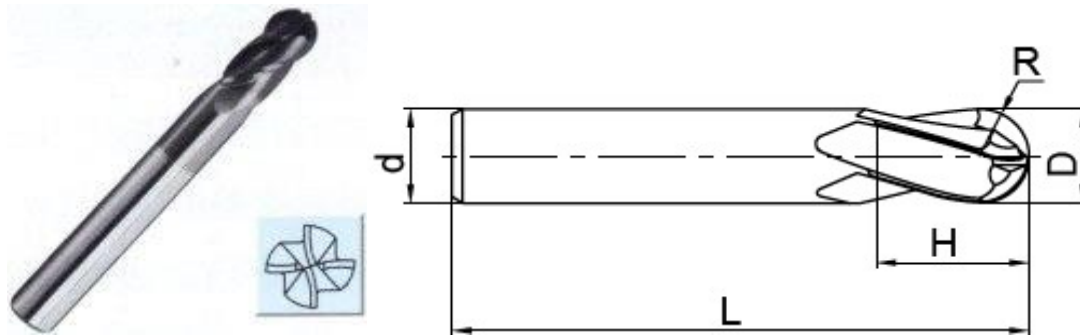

item no.	Dimension(mm)					
	D	H	d	L	R	Z
HG-4B-D3R1.5	3	6	4	50	1.5	4
HG-4B-D4R2.0	4	8	4	50	2.0	4
HG-4B-D5R2.5	5	10	6	50	2.5	4
HG-4B-D6R3.0	6	12	6	50	3.0	4
HG-4B-D7R3.5	7	16	8	60	3.5	4
HG-4B-D8R4.0	8	16	8	60	4.0	4
HG-4B-D9R4.5	9	20	10	75	4.5	4
HG-4B-D10R5.0	10	20	10	75	5.0	4
HG-4B-D12R6.0	12	20	12	75	6.0	4
HG-4B-D14R7.0	14	40	14	100	7.0	4
HG-4B-D16R8.0	16	40	16	100	8.0	4
HG-4B-D18R9.0	18	40	18	100	9.0	4
HG-4B-D20R10.0	20	40	20	100	10.0	4

сайт: <http://www.imperial-tools.ru>

e-mail: info@imperial-tools.ru

тел: 8(423) 2-72-64-51

2 and 4-flute R end mills with straight shank

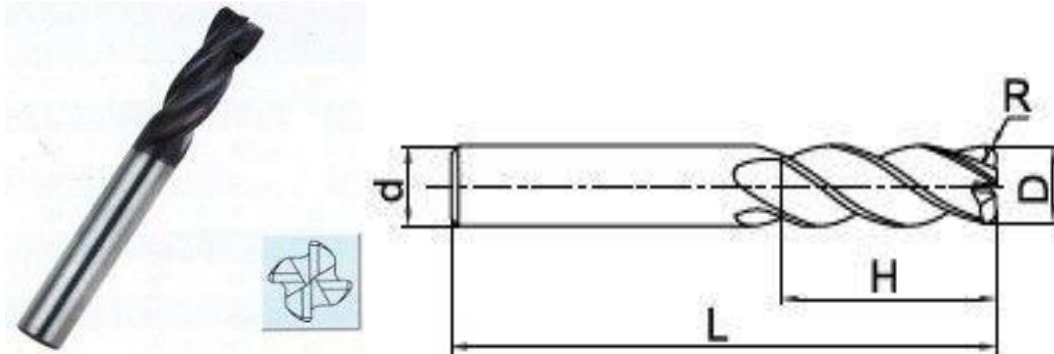

item no.	Dimension(mm)					
	D	H	d	L	R	Z
HG-2R-D3R0.5	3	6	4	50	0.5	2
HG-2R-D4R0.5	4	8	4	50	0.5	2
HG-4R-D5R0.5	5	15	6	50	0.5	4
HG-4R-D6R1.0	6	15	6	50	1.0	4
HG-4R-D8R1.0	8	20	8	60	1.0	4
HG-4R-D8R2.0	8	20	8	60	2.0	4
HG-4R-D10R1.5	10	25	10	75	1.5	4
HG-4R-D10R2.0	10	25	10	75	2.0	4
HG-4R-D12R1.0	12	25	12	75	1.0	4
HG-4R-D12R2.0	12	25	12	75	2.0	4
HG-4R-D16R2.0	16	40	16	100	2.0	4
HG-4R-D20R1.0	20	40	20	100	1.0	4
HG-4R-D20R2.0	20	40	20	100	2.0	4

HL series end mills for machining aluminum

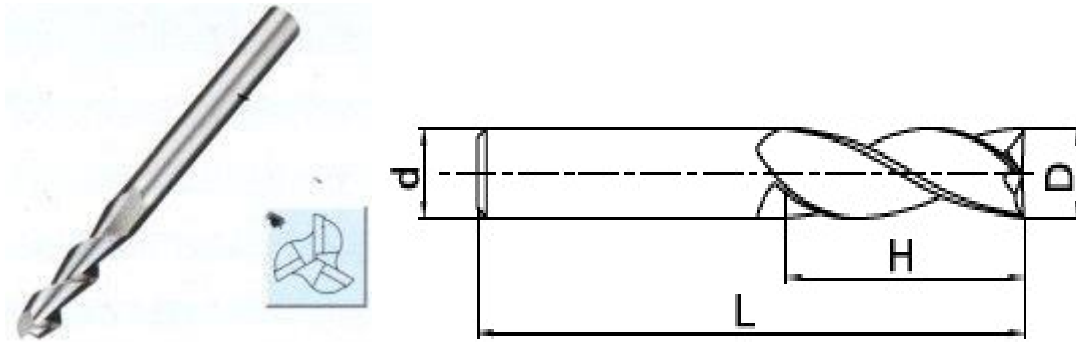

item no.	Dimension(mm)				
	D	H	d	L	Z
HL-3E-D5.0	5	15	6	50	3
HL-3E-D6.0	6	16	6	50	3
HL-3E-D7.0	7	18	8	60	3
HL-3E-D8.0	8	20	8	60	3
HL-3E-D9.0	9	25	10	75	3
HL-3E-D10.0	10	30	10	75	3
HL-3E-D11.0	11	30	12	75	3
HL-3E-D12.0	12	30	12	75	3
HL-3E-D13.0	13	40	14	100	3
HL-3E-D14.0	14	40	14	100	3
HL-3E-D15.0	15	45	16	100	3
HL-3E-D16.0	16	45	16	100	3
HL-3E-D18.0	18	45	18	100	3
HL-3E-D20.0	20	45	20	100	3
HL-3E-D25.0	25	45	25	100	3