

The STAPLE anchor for brick linings

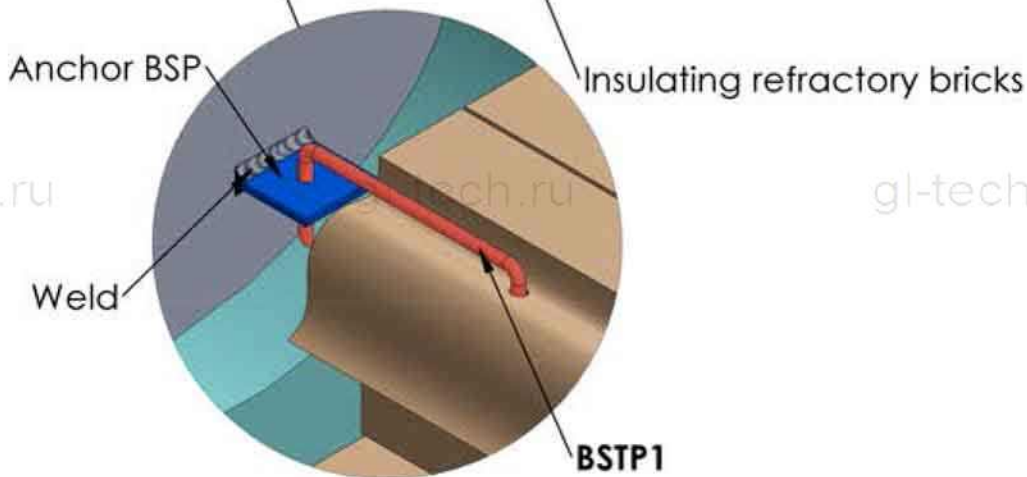
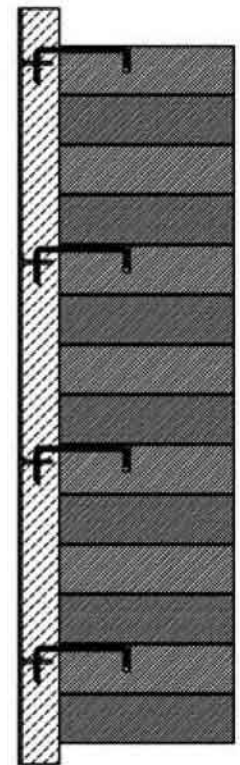
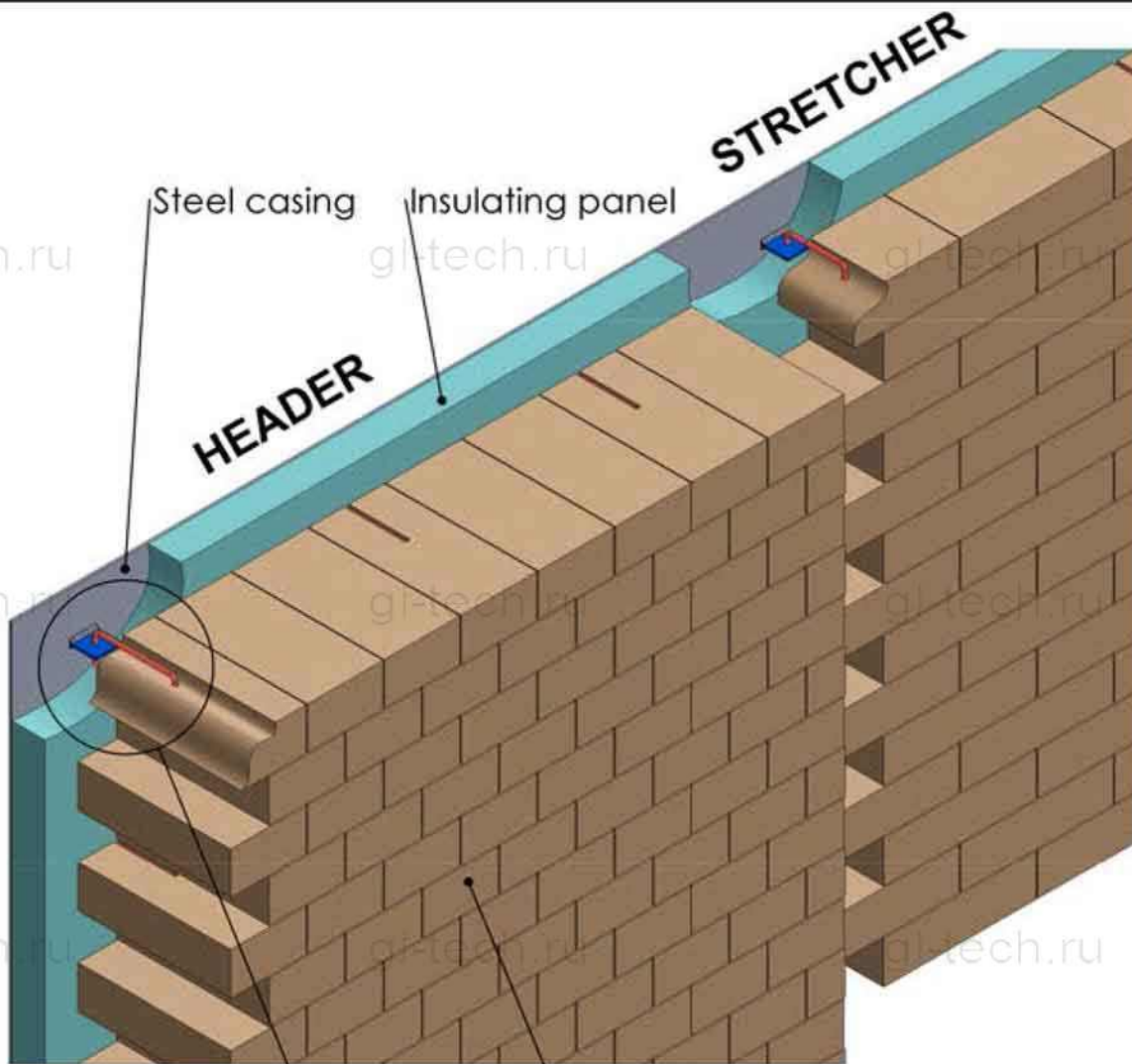

IRIS - Industrial Refractories & Insulating Specialities
 Parc d'Activités Aéroport Ouest - Rouvignies - F - 59328 VALENCIENNES Cedex (France)

Tél : +33 (0)3.27.21.52.80
 E-mail: contact@irisfrance.com

Fax : +33 (0)3.27.21.52.99
 Web: www.irisfrance.com

This drawing is the property of IRIS. Unauthorised use of patented features and/or reproduction of this drawing is strictly prohibited

DESIGNATION EXAMPLE

BS1 .6(50-30)125 - 304

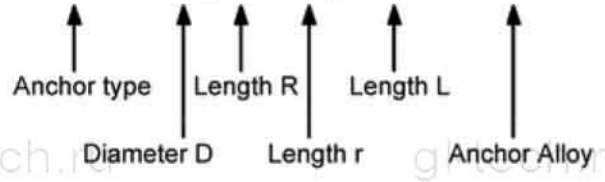

BS1

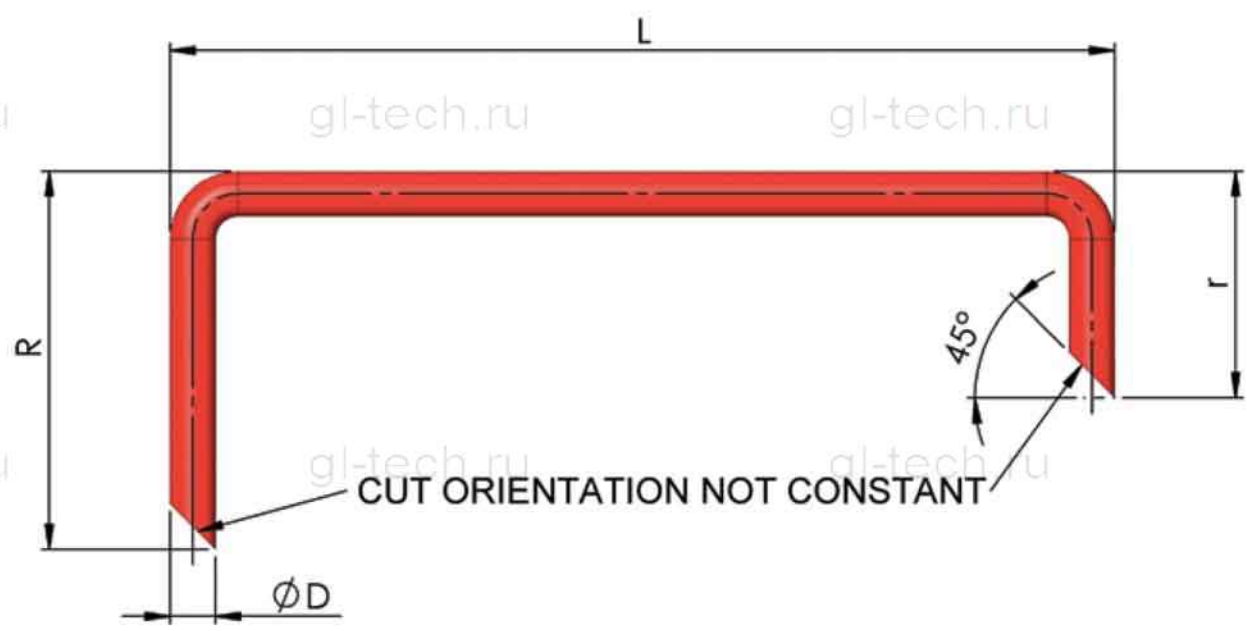

IRIS manufactures anchors from cold drawn wires, with a specific tensile strength, using a "soft bending technique", utilizing robotic machines. This "in house" developed technology, reduces mechanical stress in the steel structure and avoids the formation of micro cracks, through which corrosion can accelerate and damage the anchors. Due to the advanced bending methods developed by IRIS, there are mostly no bending marks in our metal anchors

*Sketch not contractual

OPTIONS

Angle

IN.BSP.040.040.8(10) - 304

Alloy and length to detail.

OPTION: BSP .50 .35 .10 (14-13) .310-BV

HOLE: STANDARD POSITION & CENTER
"A" to be mentioned if hole not in the center

OPTIONAL:
Reveled edges for welding

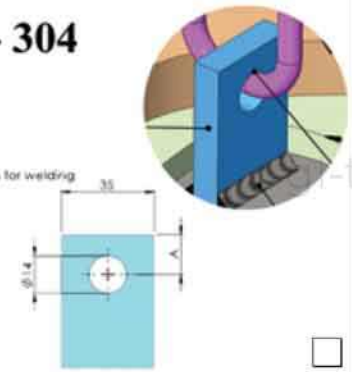

BS 1/2/3

BS1

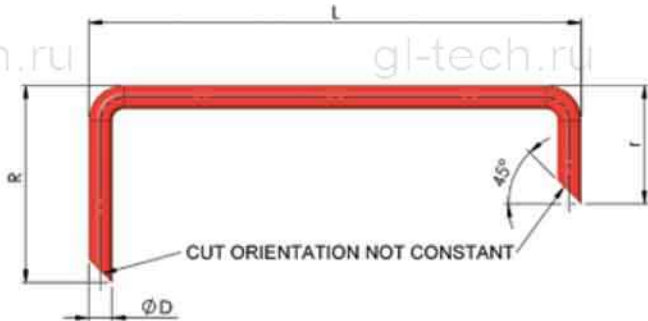

BS2

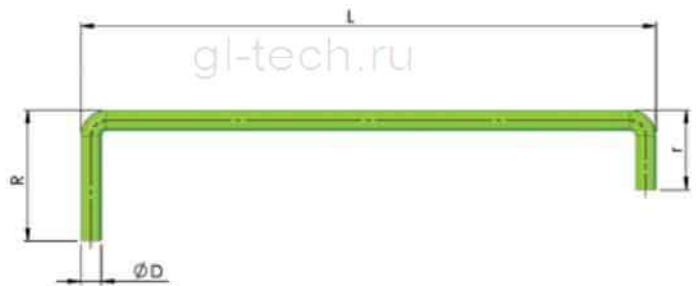

BS3

OPTIONS

Angle

IN.BSP.040.040.8(10) - 304

Alloy and length to detail.

OPTION: BSP - 50 - 35 - 10 (14 - 13) - 310 - BV

HOLE: STANDARD POSITION & CENTER
"A" to be mentioned if hole
not in the center

OPTIONAL:
Bevelled edges for welding

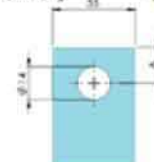

IRIS - Industrial Refractories & Insulating Specialities

Parc d'Activités Aéroport Ouest - Rouvignies - F - 59328 VALENCIENNES Cedex (France)

Tél : +33 (0)3.27.21.52.80

E-mail: contact@irisfrance.com

Fax : +33 (0)3.27.21.52.99

Web: www.irisfrance.com

DESIGNATION EXAMPLE

BS2 .8(50-30)225 - 310

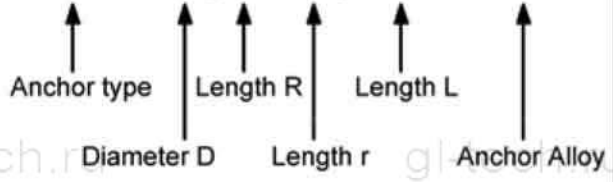

BS2

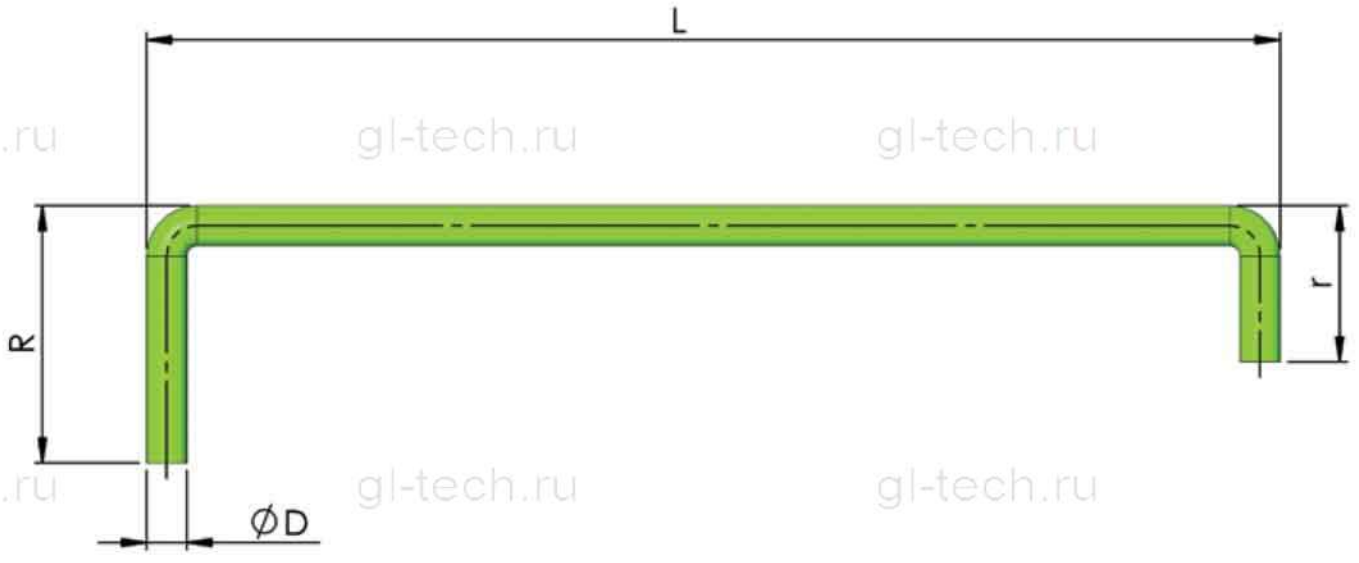

IRIS manufactures anchors from cold drawn wires, with a specific tensile strength, using a "soft bending technique", utilizing robotic machines. This "in house" developed technology, reduces mechanical stress in the steel structure and avoids the formation of micro cracks, through which corrosion can accelerate and damage the anchors. Due to the advanced bending methods developed by IRIS, there are mostly no bending marks in our metal anchors

*Sketch not contractual

OPTIONS

Angle

IN.BSP.040.040.8(10) - 304

Alloy and length to detail.

OPTION: BSP . 50 . 35 . 10 (14-13) . 310-BV

HOLE: STANDARD POSITION & CENTER "A" to be mentioned if hole not in the center

OPTIONAL: Beveled edges for welding

