

# iPECS

## LDP-9200 series

---

### Quick Guide

Please read this user guide carefully before operating your set.  
Retain it for future reference.

iPECS is an Ericsson-LG Brand



## Revision History

Issue	Date	Remark
1.0	Jan, 2016	Initial release

**Copyright© 2015 Ericsson-LG Enterprise Co., Ltd. All Rights Reserved.**

This material is copyrighted by Ericsson-LG Enterprise Co., Ltd. Any unauthorized reproductions, use or disclosure of this material, or any part thereof, is strictly prohibited and is a violation of Copyright Laws. Ericsson-LG Enterprise reserves the right to make changes in specifications at any time without notice. The information furnished by Ericsson-LG Enterprise in this material is believed to be accurate and reliable, but is not warranted to be true in all cases.

## Important Safety Information

To prevent unexpected danger or damage please read this information before installing or attempting to repair your phone. Warning and Caution information is provided to alert the consumer of known dangers:



**Warning:** To reduce the possibility of electric shock, do not expose your phone to high humidity areas, such as a bathroom, swimming area, etc.



**Caution:** Use only Ericsson-LG Enterprise approved batteries and desktop chargers to avoid the damage to the phone. Using other batteries or chargers voids your warranty and may cause an explosion.



### Warning

1. Only trained and qualified service personnel shall install, replace or service the phone.
2. Do not spill liquid life water on the phone. If so, call the service center as this may result in fire or electric shock.
3. If you see smoke or smell something during use, unplug the power cord and the phone line. Call the service center immediately.
4. If the power adapter is used, do not touch the plug with wet hands. This may result in a fire or an electric shock or equipment damage.
5. Do not use the phone during a thunderstorm. Lightning strike may result in fire, severe electrical or acoustic shock.
6. Do not use the power adapter if the power cord or wall outlet is damaged. This may result in fire or an electric shock.



### Caution

1. Ensure that children do not pull on phone cords. This may injure children or result in equipment damage.
2. The ear-piece houses a magnetic device which may attract pins or small metal objects. Keep headset clear of such objects and check before use.
3. Avoid placing the phone in an area that is excessively dusty, damp or subject to vibration.
4. Choose a site for the phone that is well-ventilated and dry.
5. Do not plug multiple plug-packs into one power outlet. This may result in the plug overheating and may result in a fire or plug pack failure.
6. Do not put heavy things on the phone.
7. Do not drop or throw the phone.
8. Static electricity discharge will damage electronic components.
9. Keep out of direct sunlight and away from heat.
10. No user-serviceable parts inside. Do not insert a screwdriver or any metal objects into the phone. This may cause electric shock or damage the equipment and will render the warranty void.
11. Clean the phone with a soft, dry cloth only. Do not use volatile liquids such as petrol, alcohol, or acetone as this may cause a fire or result in discoloration or damage to plastics. Do not clean with wax or silicon products as these may enter the equipment and cause operation to become unstable.

## [EU]

### European Union Declarations of Conformity

Ericsson-LG Enterprise Co.,Ltd. declare that the equipment specified in this document bearing the “CE” mark conforms to the European Union Radio and Telecommunications Terminal Equipment Directive(R&TTE 1999/5/EC), including the Electromagnetic Compatibility Directive(2004/108/EC) and Low Voltage Directive(2006/95/EC).

Copies of these Declarations of Conformity (DoCs) can be obtained by contacting your local sales representative.

## [USA/CSA]

### FCC/IC Interference Statement

This equipment has been tested and found to comply with the limits for a Class B digital device, pursuant to part 15 of the FCC Rules.

These limits are designed to provide reasonable protection against harmful interference in a residential

installation.

This equipment generates, uses and can radiate radio frequency energy and, if not installed and used in accordance with the instructions, may cause harmful interference to radio communications. However, there is no guarantee that interference will not occur in a particular installation. If this equipment does cause harmful interference to radio or television reception, which can be determined by turning the equipment off and on, the user is encouraged to try to correct the interference by one or more of the following measures:

- Reorient or relocate the receiving antenna.
- Increase the separation between the equipment and receiver.
- Connect the equipment into an outlet on a circuit different from that to which the receiver is connected.
- Consult the dealer or an experienced radio/TV technician for help.

This device complies with part 15 /RSS-GEN of the FCC/IC rules. Operation is subject to the following two conditions:

(1) This device may not cause harmful interference; and (2) This device must accept any interference received, including interference that may cause undesired operation.

- (1) l'appareil ne doit pas produire de brouillage, et  
(2) l'utilisateur de l'appareil doit accepter tout brouillage radioélectrique subi, même si le brouillage est susceptible d'en compromettre le fonctionnement.

This Class B digital apparatus meets the requirements of the Canadian Interference-Causing Equipment Regulations, CAN ICES-3(B)NMB-3(B)

Cet appareil numérique de la classe B respecte toutes les exigences du Règlement sur le matériel brouilleur du Canada.

The use of this device in a system operating either partially or completely outdoors may require the user to obtain a license for the system according to the Canadian regulations.

**CAUTION:** Any changes or modifications in construction of this device which are not expressly approved by the party responsible for compliance could void the user's authority to operate the equipment.

**ATTENTION:** Tout changement ou modification dans la construction de cet appareil qui ne sont pas expressément approuvés par la partie responsable de la conformité pourraient annuler l'autorité de l'utilisateur à utiliser l'équipement.

### Disposal of your old appliance



1. When the crossed-out wheeled bin symbol is attached to a product, it means the product is covered by the European Directive 2012/19/EC.

2. All electrical and electronic products should be disposed of separately from the municipal waste stream via designated collection facilities appointed by government or the local authorities.

The correct disposal of your old appliance will help prevent potential negative consequences for the environment and human health.

4. For more detailed information about disposal of your old appliance, please contact your city office, waste disposal service or the shop where you purchased the product.

# 1. Introduction

## 1.1 General

Your telephone is connected to an advanced-technology, highly-versatile, fully-featured telecom system designed to make office communications easy and productive.

LDP-9200 series (shown) incorporate user interface to provide you with a cost effective, simple to use, productive communications tool. For the detailed specification, refer to the below table.

Features and functions of your Phone are accessed either using the Fixed or Flexible buttons or by selecting a menu item using the Soft buttons. In the remainder of this Quick Guide, the Fixed or Flexible buttons are shown with a box surrounding the **BUTTON** designation while Soft button menu selections are shown with a double underline. Some buttons have to be programmed on the flexible button by using the user program code. It is called 'programmed xxxx' button.

LDP-9208D does not support Soft button menu. So you have to assign the Flexible button using Feature code if you need to be operated.

Model	LDP-9208D	LDP-9224D	LDP-9224DF	LDP-9240D
Design				
Display	2-Line 24Character	3-Line 24Character	192x36 Graphic	320x144 Graphic
LCD Backlit	No	No	Yes	Yes
Desk mount tilt	No	Yes	Yes	Yes
Wall mount	Optional	Optional	Optional	Optional
Speaker Phone	Half duplex	Half duplex	Full duplex	Full duplex
Headset	Yes(RJ-9)	Yes(RJ-9)	Yes(RJ-9)	Yes(RJ-9)
EHS Support	No	Yes(Optional)	Yes(Optional)	Yes(Optional)
Program. Keys	8	24	24	12(x2)-Paperless
DSS Support	No	Yes(48DSS)	Yes(12/24/48DSS)	Yes(12/24/48DSS)

## 1.2 Phone Layout and Functions

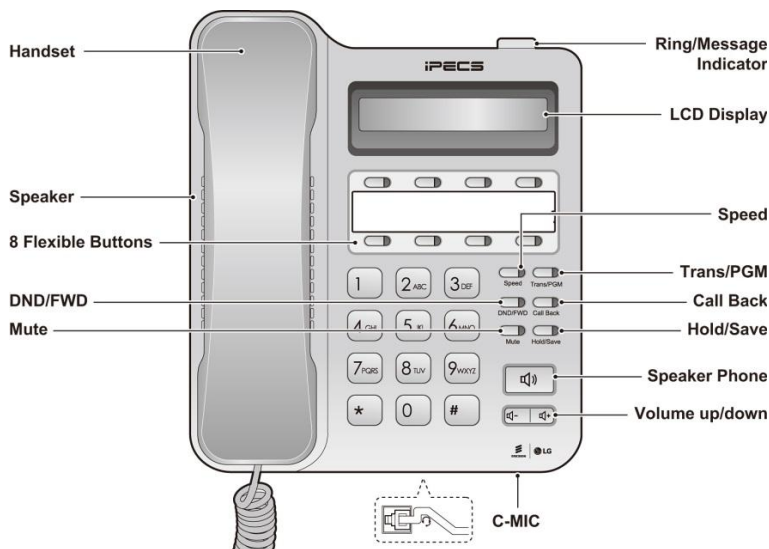

Figure 1 LDP-9208D button naming

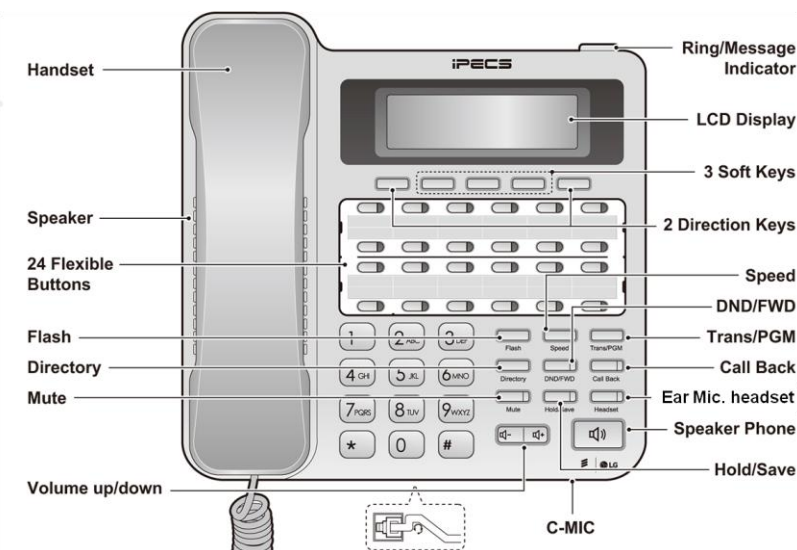

Figure 2 LDP-9224D button naming

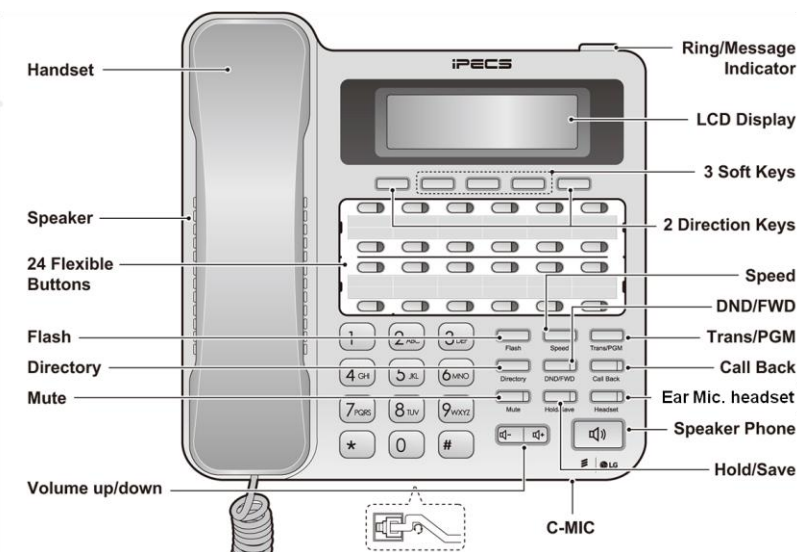

Figure 3 LDP-9224DF button naming

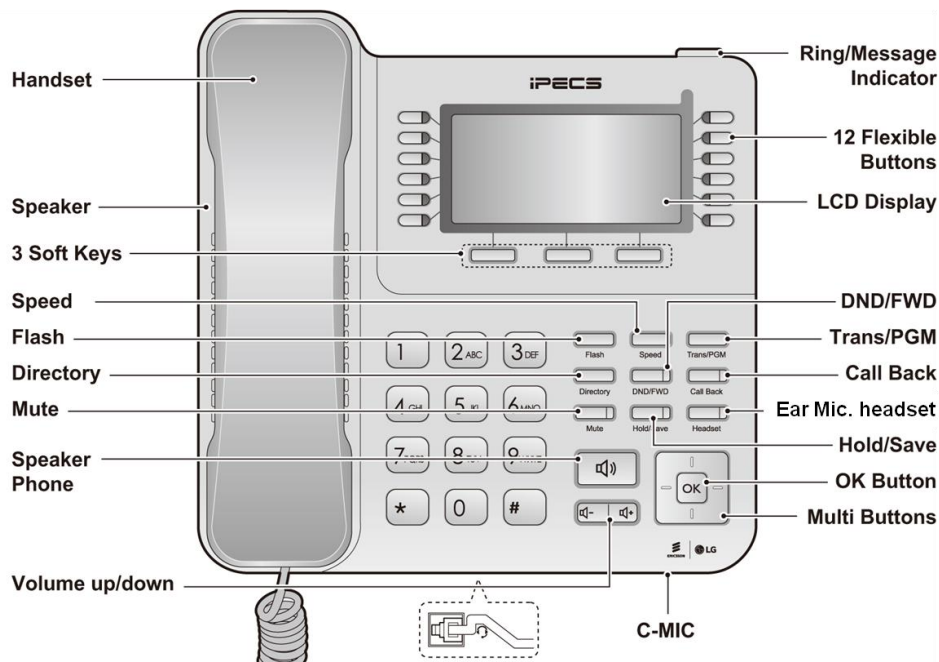

Figure 4 LDP-9240D button naming

## The functions of button

Below is a brief description of the elements called out in the above LDP-9200 series Phone diagrams.

1. **Ring/Message Indicator:** Flashes when receiving a new call or you have a new message waiting.
2. **LCD Display:** Displays your phones status, dialing directories, and text message information.
3. **Handset:** Use to answer a call using the handset.
4. **Speaker:** Delivers ringing and other signals, and lets you hear the caller's voice in speakerphone mode.
5. **Dial pad buttons:** Use to dial a number, select a menu item, or input a value.
6. **Speakerphone button:** Toggles the phone speakerphone on and off. The button illuminates when the speakerphone is active or the phone is in menu mode.
7. **Volume control button:** Use to adjust Ring, Headset, Handset, and Speaker volume.
8. **Flexible buttons:** Assigned as Line or feature access button.
  - LDP-9208D has 8 flexible buttons.
  - LDP-9224D has 24 flexible buttons.
  - LDP-9224DF has 24 flexible buttons.
  - LDP-9240D has 24 (2\*12) flexible buttons.
9. **Soft keys:** Soft keys are interactive, changing function based on the status of LDP-9224D & LDP-9224DF, and LDP-9240D. LDP-9208D does not support Soft keys.
10. **Navigation key for LDP-9240D**
  - **Left:** Use to select the previous group of soft keys when ◀ appears in the bottom-left of the LCD.
  - **Right:** Use to select the next group of soft keys when ▶ appears in the bottom-right of the LCD.
  - **Up:** Scrolls through the phone's menu options upward.
  - **Down:** Scrolls through the phone's menu options downward.

- **OK**: Selects the highlighted choice when navigating through a menu.

### 11. Fixed buttons

LDP-9208D does not support some buttons: Flash, Directory, and Headset among the below buttons.

- **Flash** button: Use to seize the new line without on-hook. So you can make a call by dialing the desired number.
- **Speed** button: Use to assign your speed dial numbers. The button also deletes the last character of an input in the menu mode such as registering Station name.
- **Transfer/PGM** button: Transfers the current active call or to enter programming mode.
- **Directory** button: Accesses your private or public directory for speed dialing.
- **DND (Do Not Disturb)/FWD** button: Use to activate DND so that your phone will not ring. Use to allow you to forward all calls to another number by setting the call forward type (1~4).
- **Call Back** button: When the MWI LED indicates you have a message, use to access your Voice Mailbox.
- **Mute** button: Toggles audio from the microphone to the connected party on and off.
- **Hold/Save** button: Use to place a call on Hold. Also, use to access a held call. In menu mode, it saves your inputs.

**Ear Mic. Headset** button: When using a Ear Mic. headset, this button toggles the Ear Mic. headset state. When the Ear Mic. headset is active, the button LED illuminates red.Or, press [PGM] +19 and then set ON.

## 1.3 DSS Console

The available DSS are shown in figure below and described as follows:

- LIP-9012DSS has 12 flexible buttons with tri-color LED. The DSS button kit uses a paper label for the button designations.
- LIP-9024DSS has 24 flexible buttons with tri-color LED. The DSS button kit uses a paper label for the button designations.
- LDP-9248DSS has 48 flexible buttons with tri-color LED. The DSS uses a paper label for the button designations.

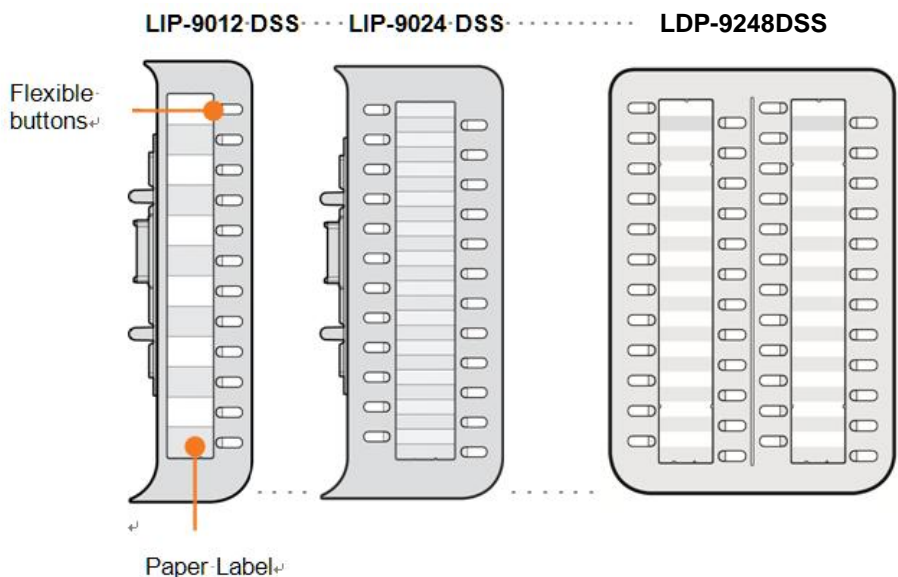

Figure 5 DSS console



## 2. Installation Connecting the Phone

LDP-9200 series have 3 connection ports (refer to following figure). Each port is for connecting to: Handset, Ear Mic. headset, and the line cable.

- Connect the telephone cord (curly cord) to the handset and the other end to the handset jack at the bottom of the telephone.
- Connect the line cable to the port at the bottom of telephone and the other end to the wall socket.
- Connect the Ear Mic. headset to the jack at the bottom of the telephone. To use Ear Mic. function, press [PGM] +19 and then set ON.

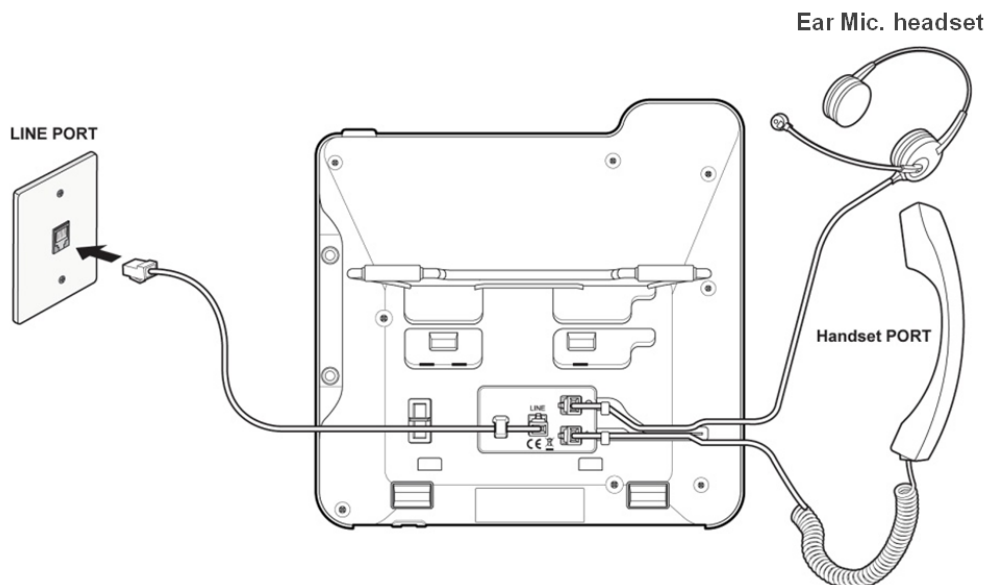

Figure 6 LDP-9200 series Connections

### Information about compatibility headset

- We can't guarantee other headsets except the headset list posted on the web site.
- Regarding Headset compatibility, refer to "Headset list for IP phone" on the web site.
- We will update the compatibility list if we finish testing the new one anytime.

### 2.1 Wall Mount

LDP-9200 series phones can be mounted on the wall as needed. The following instructions describe the wall mount installation. Note the foot-stand must be removed.

1. If installed, remove the foot-stand from the Phone and DSS.
2. Connect all wiring to the phone as described in "Phone connection". Connect the phone side wiring only.
3. If required, install the DSS console.
4. Align the wall-mount bracket (ordered separately) over the back of the phone, then press the bracket onto the phone applying steady pressure until it clicks into place.
5. Install the DSS console wall-mount bracket if required, in the same way as the bracket for the phone.
6. Mark and drill two 7mm holes for plastic wall anchors (not included).
7. Insert the two anchors into the holes, and insert and tighten the two screws (not included)

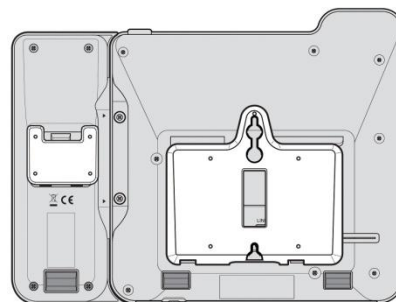

- leaving about 2.5 mm (1/8-inch) exposed.
- 8. Align the key holes in the bracket over the screws and slide the phone down assuring the phone is secure.
- 9. Remove, reverse and re-install the handset hook so that the hook catches the groove in the handset receiver.
- 10. Hang the handset up on the handset hook.
- 11. Complete all wiring connections as described in "Phone connection".

**NOTE**

**It may be necessary to remove the phone and tighten or loosen the screws for a secure mounting.**

## 2.2 DSS (Direct Station Select) Console Installation

A DSS console can be installed with LDP-9200 series phone.

As we described the available DSS for each phone, the available DSS is as below:

- ✓ LDP-9208D: no DSS
- ✓ LDP-9224D: LDP-9248DSS
- ✓ LDP-9224DF: LIP-9012DSS, LIP-9024DSS, and LDP-9248DSS
- ✓ LDP-9240D: LIP-9012DSS, LIP-9024DSS, and LDP-9248DSS

The DSS console should be installed on the phone prior to making any connections to the phone. This simplifies the installation.

To install DSS console:

1. First, assure the phone is NOT connected to power. For convenience, you may wish to remove the handset and foot-stand; this simplifies the Button kit installation.

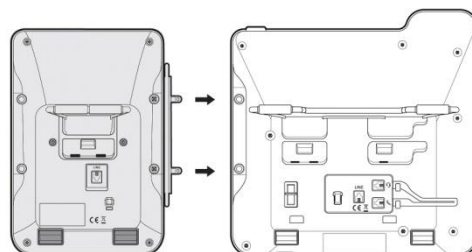

2. On the right side of the phone, remove the Button kit cover.

3. Align the Button kit and phone as shown in the drawing.

4. Push the Button kit into the phone until the button kit is fully engaged.

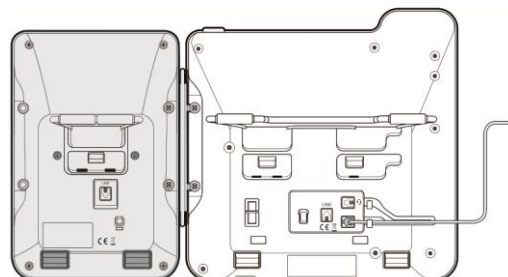

5. Insert the screws provided through the screw tabs in the Button kit and tighten the screws into the phone. Do not over-tighten.

## 3. User Operation

The following is provided as quick reference for commonly used features / functions. Complete instructions are included in *LDP-9200 Series User Guide*.

### Placing a Call:

#### Internal Station to Station Call

- Lift the handset, or press the **SPEAKER** button.
- Dial the extension number of the desired station.
- When the call is answered or the Splash tone is heard, begin speaking with the called party.

#### External Call

- Lift the handset, or press the **SPEAKER** button.
- Press the **CO/IP** line, or dial the access number.
- Dial the desired number.

### Using Camp-On (Call-Wait):

- Press \* and await an answer for a busy station.

### Using ACNR (Auto Call Number Redial):

#### To set up ACNR, while on an outgoing call:

- Select the **ACNR** Soft button.
- Hang-up handset.

#### To cancel the ACNR request:

- Press the **Stop** Soft button.

### Answering a Call while idle:

#### To answer a call ringing at your phone:

- Lift the handset or press the **SPEAKER** button, or press the flashing Flex button (if the number was assigned), the call will be connected.

#### To respond to an Intercom Voice Announce call:

- In HF (Hands-Free) mode, simply speak as normal into the microphone.  
Or,
- In PV (Private) mode, lift the handset to respond.

### Answering a Call while busy:

#### To answer a Call Waiting:

- Press **HOLD/SAVE** and/or,
- Press the flashing **CO/IP** line button.

**To activate One-time DND:**

- Press the **DND** button.

**To activate Text message forward:**

- Press the **TRANS/PGM** button.
- Dial the User Program feature code 51.
- Dial the two-digit text Message code (00-20).  
For reference, the message 00 is as the below and the message 11-20 are edited only Attendant (PGM + 0 + 5 + 3) or Web admin 'System Data: Custom message'.
- Dial any auxiliary input for messages of 01-04 and 06-08.
- Press the **HOLD/SAVE** button, you will receive confirmation tone.

**To program the Station Custom Message (00) at your station:**

- Press **PGM**,
- Dial User Program feature code 52.
- Enter Message contents, up to 24 characters.
- Press the **HOLD/SAVE** button to save the message.

**Using Do Not Disturb (DND):**

- Press the **DND** button (toggles ON and OFF).

**Pickup a Call to another Station:**

- Lift handset.
- Dial the directed Call Pick-up Code (the direct call pick-up code is different according to Numbering plan, refer to 'Flexible Numbering Plan (106~109)').
- Dial the intercom number of the ringing station.

**Pickup a Call from another Station in your Group:**

- Lift the handset.
- Dial the Group Call Pickup code (the group call pick-up code is different according to Numbering plan, refer to 'Flexible Numbering Plan (106~109)').

**Conference:**

To make Conference button on Flexible button for LDP-9208, press **TRANS/PGM** + the empty Flexible button+ **TRANS/PGM** + 91 (Conference User Program code) + **HOLD/SAVE**.

**To establish a Conference:**

- Establish call with one of the desired conference parties.
- Select the **Conf** soft button or press the programmed **Conf** button (LDP-9208D).
- Establish call with the other conference party.
- Select the **Conf** soft button or press the programmed **Conf** button (LDP-9208D).
- Select the **Conf** soft button or press the programmed **Conf** button (LDP-9208D) again to establish the conference.

**To place a Conference on Hold:**

- Press the **HOLD/SAVE** button.

**To retrieve the Conference from Hold:**

- Select the Conf soft button or press the programmed Conf button (LDP-9208D).

**To establish an Unsupervised Conference:**

- Establish conference with two external parties.
- Select the Conf soft button or press the programmed Conf button (LDP-9208D).
- Hand-up handset.

**To retrieve an Unsupervised Conference:**

- Lift the handset.
- Select the Conf soft button or press the programmed Conf button (LDP-9208D).

**Call Hold: Placing a call in a waiting state**

- Press the HOLD/SAVE button.

**Call Forward:**

You may define the conditions or 'type of forward' as below:

- 0: **Remote**—activate Call Forward for your phone from a different phone within the System.
- 1: **Unconditional**—all calls to the station, except recalls, are forwarded.
- 2: **Busy**—Immediately forwards all calls, except recalls, when the station is busy.
- 3: **No Answer**—forwards all calls to the station, except recalls, when the station does not answer within the No Answer timer.
- 4: **Busy/No Answer**—forwards calls if the station is busy or does not answer within the No Answer timer.
- 5: Incoming CO Off-net: Forward calls to an external destination; calls can be forwarded from an internal station or a remote location.

**To activate Call Forward from your phone to another phone or internal system resource:**

- Lift the handset.
- Press the Fwd soft button or FORWARD button.
- Dial the type of forward code 1-4.
- Dial the destination number.

**To deactivate Call Forward from your phone:**

- Lift the handset.
- Press the Fwd Soft button or FORWARD button.
- Dial #.

**To activate Call Forward for your phone from a different phone within the System (Call Forward, Remote):**

- Lift the handset.
- Press the Fwd soft button or FORWARD button.
- Dial 0 (Remote Call Forward code).
- Dial your Authorization code (Station number & Password).
- Dial the 'type of forward' code 1-4.
- Dial the destination number.

**To deactivate Call Forward, Remote:**

- Lift the handset.
- Press the Fwd soft button or **FORWARD** button.
- Dial 0 (Remote Call Forward code).
- Dial your Authorization code (Station number & Password).
- Press the # key.

**Call Transfer: Sending a call to a different destination**

- Press the TRANS soft button or **TRANS/PGM** button.
- Dial the number of the transfer party.
- Unscreened Call Transfer- Hang-up.
- Screened Call Transfer– When call is answered or Splash tone is heard, announce the call and hang-up.

**Using Call Log:****To access the Call Log menu:**

- Press the programmed CALL LOG button.
- Using the Volume up/down (Navigation Up/Down) keys, to view items (Received, Dialed or Lost).

**To assign your Call Log to Flex button:**

- Press the **TRANS/PGM** button.
- Press the desired Flex button.
- Press the **TRANS/PGM** button.
- Dial 57.
- Press the **HOLD/SAVE** button.

**To place a call using numbers stored in the Call Log:**

- From the Call Log, use the Volume up/down (Navigation Up/Down) keys, to view items (Called, Dialed, or Lost).
- Press the Ok soft button or **HOLD/SAVE** button to place the call. For LDP-9208D, press the **HOLD/SAVE** button to place the call.

**Save Caller information to Directory:**

- Press the programmed CALL LOG button to access Call History.
- Use the Volume up/down (Navigation Up/Down) keys to select a listing.
- Press the Select soft button until showing the Save on the right, and the Save soft button to add the party's information to the directory.

\*LDP-9208D does not support this feature.

**Request a Callback (wait off-hook) for a busy station:**

- Press the MSG Soft button or the **CALL BACK** button and hang-up.

**Activate a queue if the selected/dialed line is busy:**

- Select the desired CO/IP line button; when the busy notification is returned, press the **CALL BACK** button.
- Return to an idle state by going on-hook; when the line is available, the station will be notified (ringing).

**Respond to Station Message Waiting Indication:**

- Press the **CALL BACK** button, the message contents summary is shown.
- Dial 1 to select ICM MWI (Station Message Wait).
- Press the **CALL BACK** button to return a call for the station message.

**Respond to CLI Message Waiting Indication:**

- Press the **CALL BACK** button, the message contents summary is shown.
- Dial 2 to select CLI MSG (Absent CLI Message Wait).
- Press the **HOLD/SAVE** button to call back for absent CLI.

**Retrieve Voice Mail:**

- Press the **CALL BACK** button, the message contents summary is shown,
- Dial 3 for VSF, 4 for external VM, 5 for Feature Server Voice Mail, etc.
- Follow each voice mail retrieve process.

**View received Short text messages:**

- Press the **CALL BACK** button, the message contents summary is shown.
- Dial 6; SMS message list is shown.
- Dial the Message number to view the entire SMS message.

**Last Number Redial (LNR):**

- Lift the handset.
- Press the **SPEED** button.
- Dial \*.
- Press the volume up/down keys to select from the last numbers dialed or received.
- Press the **HOLD/SAVE** button.

**Saved Number Redial (SNR):**

- Lift the handset.
- Press the **SPEED** button.
- Dial #, then outgoing call is made directly with the latest saved number.
- To store a number at the SNR memory, while on an outgoing call, press **SPEED** button twice.

## Using System Speed Dial:

- Lift the handset.
- Press the **SPEED** button.
- Dial the desired system speed number.

## Using Station Speed Dial:

- Lift the handset.
- Press the **SPEED** button.
- Dial the desired station speed number.

## Using Dial By Name:

### To place a call using Dial by Name:

- Press **SPEED** button twice.
- Select the desired menu as the below table and press the **HOLD/SAVE** button: LCD will display the names in alphabetical order.
  - 1) LDP-9208D
 

ICM:1	U_SPD:2	S_SPD:3
-------	---------	---------
  - 2) LDP-9224D/9224DF
 

1.DIAL BY ICM NAME
2.DIAL BY STA SPD NAME
3.DIAL BY SYS SPD NAME
  - 3) LDP-9240D
 

1.PRIVATE DIRECTORY
2.PUBLIC DIRECTORY
3.VIEW STATION NAME
- Scroll using the Volume up/down keys, or enter search characters.
- Press **HOLD/SAVE** to place the call.

### To enter your station user name:

- Press the **TRANS/PGM** button.
- Dial 74.
- Enter the Name, up to 12 characters (press **SPEED** button to delete a character and Use the Volume up/down keys to move to next or previous character or make Space).

Go to the next page for entering the Station User Name



In case of LDP-9208D and LDP-9224D, use the following table and press the OK Soft button or SAVE button.

**LDP-9208D/9224D Character Entry Chart** (D1: 1<sup>st</sup> Digit, D2: 2<sup>nd</sup> Digit)

Char	D1	D2	Char	D1	D2	Char	D1	D2
A	2	1	T	8	1	1	1	0
B	2	2	U	8	2	2	2	0
C	2	3	V	8	3	3	3	0
D	3	1	W	9	1	4	4	0
E	3	2	X	9	2	5	5	0
F	3	3	Y	9	3	6	6	0
G	4	1	Z	9	#	7	7	0
H	4	2	Q	1	1	8	8	0
I	4	3	Z	1	2	9	9	0
J	5	1	.	1	3	0	0	0
K	5	2	SPC	*	1			
L	5	3	:	*	2			
M	6	1	,	*	3			
N	6	2	(	#	1			
O	6	3	)	#	2			
P	7	1	-	#	3			
Q	7	*	*	0	*			
R	7	2						
S	7	3						

(SPC: Space)

In case of LDP-9224DF and LDP-9240D, use the following table and press the OK Soft button or SAVE button.

**To input characters:**

- Press the second Soft button to select ABC> or abc> mode.
- To input the first character of a button, press the button 1 time (ex., for 'a', press 2 button once).
- To input the second character of a button, press the button 2 times (ex., for 'b', press the 2 button twice).
- To input the third character of a button, press the button 3 times (ex., for 'f', press the 3 button three times).
- Press HOLD/SAVE button.

**LDP-9224DF/9240D Character Entry Chart** (SPC: Space)

Dial Pad button	Letter Type												
	Upper case (ABC)				Lower case (abc)				Num	Symbol			
	Button depressions												
	1	2	3	4	1	2	3	4		1	2	3	4
1	@	:	/		@	:	/		1	@	:	/	
2	A	B	C		a	b	c		2		\$	%	
3	D	E	F		d	e	f		3	^	&	_	
4	G	H	I		g	h	i		4	(	)	?	
5	J	K	L		j	k	l		5	-	+	/	
6	M	N	O		m	n	o		6	<	>	=	
7	P	Q	R	S	p	q	r	s	7	;	:		
8	T	U	V		t	u	v		8	'	"	`	
9	W	X	Y	Z	w	x	y	z	9	{	}		
0	.	,	?	!	.	,	?	!	0	.	,	?	!
*	*	.			*	.			*	*	.		
#	#	SPC			#	SPC			#	#	[	]	

### 3.1 Flex Button Program

1. Press the **TRANS/PGM** button.
2. Press the flexible button to be programmed.
3. Press the **TRANS/PGM** button and User Program Code (refer to the below table).
4. Press the **HOLD/SAVE** button.

### 3.2 Station User Program Codes

CODE	FUNCTION
10	En-block Dialing (1: ON, 2: OFF)
11X	Intercom Differential Ring ( X = 1-15 )
12X	CO Line Differential Ring ( X = 1-15 )
13	Intercom Answer Mode (1: HF/2: TONE/3: PV)
14X	Call Coverage Attribute (1: On/Off, 2: Ring Delay)
15X	Station Ring download (Not available)
19	Ear Mic. Headset (1: ON, 2: OFF)
21	Knock Down Station COS (ICM only mode)
22	Restore Station COS (Enter Station No. & Password)
23	Walking COS
24	ICR scenario (0-9)
25	LIP Keypad Stat (Not available)
26	Call profile (Table index (0-3))
30	VM Mobile Notify (1: ON, 2: OFF)
31	Message Retrieve Method (9240D is not available)
32	Message Retrieve Example (9240D is not available)
33	User Authorization Code Registration (Station No. & Password)
34	Call Wait (0: OFF, 1: ALL, 2: External, 3: Internal)
35	Message Wait in Executive/Secretary pair (1: ON, 2: OFF)
36	Send SMS Message (1: Resend, 2: Edit)
37	Register Mobile Extension (via Web admin)
38	Make Mobile Extension active (via Web admin)
39	Register Mobile Extension CLI (via Web admin)
41	Set Wake-Up Time (HH:MM)
42	Wake-Up Time Disable (Press [Save] button to erase)
51XX	Custom/Pre-select Message Display (XX = 00-20, 00: User Custom message, 01-10: Fixed message, 11-20: Unregister Message (Attendant station: PGM +0+5+3) or Web Admin: System Data > Custom message on Web or System Attendant keyset), #: Cancel)
52	Register Custom Message (Message 00)
53	Active Conference Room (Create Conference room 1-9, enter Room No. and 5 digits password)
54	Deactive Conference Room (Delete Conference room by entering Room No. and 5digits password)
55X	Conference Group (1: Monitor Conf. Group, 2: Active Conf. group, 3: Deactive Conf. group)
56	User Greeting (1:Unconditional, 2: Busy, 3: DND, 4: No Answer, 0:All)
61	Headset/Speakerphone Mode (1: Speaker, 2: Headset)
62	Change Headset Ring type (1:Speaker, 2:Headset, 3:Both)
71	LCD Display Mode (language)
72	MFIM Version Display
73	Background Music (00-10, 00: No music)
74	Station User Name Registration
75	Display Phone IP Address (DTIM or DSIB)
77	Display MAC Address (DTIM or DSIB MAC Address)

<b>CODE</b>	<b>FUNCTION</b>
78	Network configuration (Not available)
79	Display Phone Version
7*	Display Serial number & license status
*#	Enter Admin (Only Attendant is available)
*6	Set Forced Forward Dest
*7	Forced Forward to Dest
*8	Register Bluetooth (Not available)
*9	Bluetooth Usage (Not available)