

PHANTOM 4 PRO/PRO⁺

DISCLAIMER AND SAFETY GUIDELINES

V1.0 2016.10



Contents

Safety At a Glance	2
NOTICE	5
Glossary	5
Pre-flight Checklist	5
Disclaimer and Warning	6
Before You Begin	8
Individual Parts	8
Regarding Genuine and Functional Parts	8
Remote Controller	8
Camera	9
Gimbal	9
Compass	9
Propulsion Systems	10
DJI GO 4 App	11
Firmware	11
Product Care	12
Storage and Transportation	12
Maintenance and Upkeep	12
Flight Condition Requirements	13
Weather Conditions and Surrounding Environment	13
Interference with Flight Controller, Communications, and Positioning Systems	13
Operating the Aircraft Responsibly	13
Flight Modes, Functions and Warnings	14
Flight Modes	14
Failsafe and Return-to-Home	15
Low Battery	15
Vision System and Infrared Sensing System	15
TapFly™	17
ActiveTrack™	17
Compliance with Regulations & No Fly Zones	18
Regulations	18
No Fly Zones	19
Compliance Information	19

Safety At a Glance

1. Environmental Consideration

- Always fly at locations that are clear of building and other obstacles.
- DO NOT fly above or near large crowds.
- Avoid flying at altitudes above 400 feet (120 m).
- Be very careful when flying 19,600 feet (6,000 m) or more above sea level.
- Fly in moderate weather conditions with temperatures between 32° to 104° F (0° to 40° C).
- Please take additional caution while flying indoors because the aircraft stabilization features may be interfered.



The DJI™ PHANTOM™ 4 Pro/Pro+ is NOT a toy and is NOT suitable for children under the age of 18.

Note that 'Safety at a Glance' only provides a quick overview of the safety tips. Make sure you read and understand the remaining sections of the Phantom 4 Pro/Pro+ Disclaimer and Safety Guidelines.

2. Pre-flight Checklist

- Ensure the remote controller and aircraft batteries are fully charged.
- Ensure the propellers are in good condition and securely tightened before each flight.
- Ensure there is nothing obstructing the motors.
- Only calibrate the compass when the DJI GO™ 4 app or the status indicator prompt you to do so.
- Check that the camera lens is clean and free of stains.
- DO NOT temper (cover or otherwise interfere) with onboard sensors.
- Altering or modifying the aircraft may impact its stability.

3. Operation

- Stay away from the rotating propellers and motors.
- Maintain visual line of sight of your aircraft at all times.
- DO NOT pull the left stick to the bottom inside corner and press the Return-to-Home (RTH) button at the same time when the aircraft is airborne unless in an emergency situation.
- DO NOT answer incoming calls during flight.
- DO NOT fly under the influence of alcohols or drugs.
- During the Return-to-Home procedure, you can adjust the altitude to avoid obstacles.
- DO NOT fly closely above reflective surfaces such as water or snow, as these terrain may affect the performance of the Vision Positioning System.
- In the instance of a Low Battery Warning, land the aircraft at a safe location.
- After landing, first stop the motor, then turn off the Intelligent Flight Battery, and then turn off the remote controller.
- When using TapFly™ and ActiveTrack™ features, be prepared to take control of the aircraft or press the "STOP" button on the screen at all times, in case of an emergency.
- While with advanced technology, the pilot's sound discretion is required during the flight. Safety and flight assistance features such as obstacle avoidance and precise landing are designed to assist your operation, not to replace it.
- Environmental conditions including lighting and obstacle's texture may impact the performance of the Vision System.
- The aircraft is not able to automatically break and stop at a safe distance from an obstacle if the aircraft speed exceeds 14m/s (31.3 mph).

- The binocular sensor contrary to the flight direction and the infrared modules are disabled in certain situations. Please refer to the Phantom 4 Pro/Pro+ User Manual for more information.
- Please set the Return to Home flight height higher than surrounding obstacles.
- The RTH feature does not enable the aircraft to automatically return to a moving home point.

4. Maintenance and Upkeep

- DO NOT use aged, chipped or broken propellers.
- Recommended storage temperature: between 71° and 82° F (22° and 28° C).
- Refer to the *Phantom 4 series Intelligent Flight Battery Safety Guidelines* for more information about the safe use of the battery.

5. Observe Local Laws and Regulations

- DO NOT fly in the No Fly Zones. You can find a complete list of these areas at <http://fllysafe.dji.com/>
- The DJI No Fly Zone is not a replacement for **local government regulations** or **good judgment**.
- Avoid flying in areas where rescue teams are actively using the airspace.

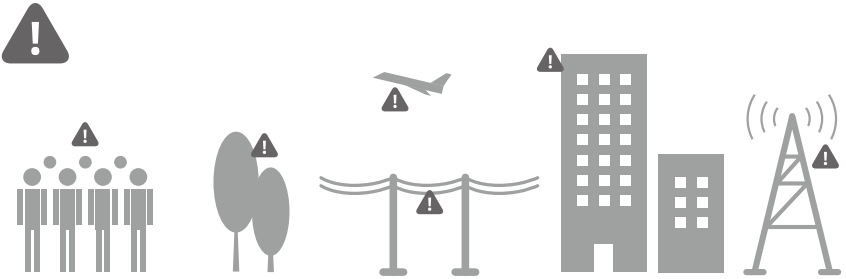

Avoid flying over or near obstacles, crowds, high voltage power lines, trees or bodies of water. **DO NOT** fly near strong electromagnetic sources such as power lines and base stations as it may affect the onboard compass.



DO NOT use the aircraft in adverse weather conditions such as rain, snow, fog and wind speeds exceeding 10 m/s or 22 mph.

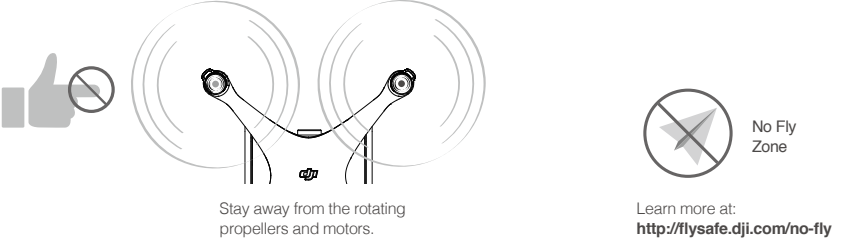

NOTICE

All instructions and other collateral documents are subject to change at the sole discretion of SZ DJI TECHNOLOGY CO., LTD. For up-to-date product information, visit <http://www.dji.com> and click on the Phantom 4 Pro/Pro+ product page.

Glossary

The following terms are used throughout the product literature to indicate various levels of potential harm when operating this product:

NOTICE NOTICE: Procedures, which if not properly followed, create a possibility of physical property damage AND a little or no possibility of injury.

CAUTION CAUTION: Procedures, which if not properly followed, create the probability of physical property damage AND a possibility of serious injury.

WARNING WARNING: Procedures, which if not properly followed, create the probability of property damage, collateral damage, and serious injury OR create a high probability of superficial injury.



WARNING

Read the **ENTIRE** user manual to become familiar with the features of this product before operating. Failure to operate the product correctly

can result in damage to the product or personal property and cause serious injury.

This is a sophisticated product. It must be operated with caution and common sense and requires some basic mechanical ability. Failure to operate this product in a safe and responsible manner could result in injury or damage to the product or other property. This product is not intended for use by children without direct adult supervision. **DO NOT** use with incompatible components or alter this product in any way outside of the documents provided by SZ DJI TECHNOLOGY CO., LTD. These Safety Guidelines contain instructions for safety, operation and maintenance. It is essential to read and follow all of the instructions and warnings in the user manual, prior to assembly, setup or use, in order to operate the product correctly and avoid damage or serious injury.

AGE RECOMMENDATION: NOT FOR CHILDREN UNDER THE AGE OF 18. THIS IS NOT A TOY.

Pre-flight Checklist

1. Ensure that you are using only genuine parts and that all parts are in mint condition.
2. Ensure the remote controller, Intelligent Flight Battery, and mobile device are fully charged.
3. Ensure that there is no foreign object stuck to the camera lens, the Micro SD card has been inserted into the camera, and the gimbal can rotate freely before powering it on.
4. Ensure the propellers are securely mounted and tightened onto the motors, and the motors can start and function normally.
5. Follow the on-screen instructions to calibrate the compass.
6. Ensure the app and aircraft's firmware have been upgraded to the latest version.
7. Ensure that your flight area is outside the No Fly Zones and flight conditions are suitable for flying the aircraft.
8. Be sure that you are NOT flying under the influence of alcohol, drugs or any substance that may impair your cognitive abilities.
9. Be familiar with the selected flight mode and understand all safety functions and warnings.

10. Be sure to observe all local regulations, obtain appropriate authorizations, and understand the risks. REMEMBER: It is solely your responsibility to comply with all flight regulations.
11. Please MAINTAIN LINE OF SIGHT (WITH YOUR EYES) OF YOUR AIRCRAFT AT ALL TIMES . Please do not only rely on first person view camera to control your aircraft.
12. Ensure the DJI GO 4 App is properly launched to assist your operation of the aircraft. WITHOUT THE FLIGHT DATA RECORDED BY THE DJI GO 4 App, IN CERTAIN SITUATIONS (INCLUDING THE LOSS OF YOUR AIRCRAFT) DJI MAY NOT BE ABLE TO PROVIDE AFTERSALES SUPPORT TO YOU OR ASSUME LIABILITY.

Disclaimer and Warning

This product is NOT a toy and is not suitable for children under the age of 18. Adults should keep the Phantom 4 Pro/Pro+ out of the reach of children and exercise caution when operating this aircraft in the presence of children.

While the product adopts advanced technology, inappropriate use of the Product could result in personal injury or property damages. Please read the materials associated with the product before your first use of the product. These documents are included in the product package and are also available online on the DJI product page at <http://www.dji.com>.

This product is a flying camera that offers easy flight when in good working order as set forth below. Visit <http://www.dji.com> for the most current instructions and warnings and <http://knowbeforeyoufly.org/> for more information about flight safety and compliance.

The information in this document affects your safety and your legal rights and responsibilities. Read this entire document carefully to ensure proper configuration before use. Failure to read and follow the instructions and warnings in this document may result in product loss, serious injury to you, or damage to your aircraft.

By using this product, you hereby signify that you have read this disclaimer carefully and that you understand and agree to abide by the terms and conditions herein. EXCEPT AS EXPRESSLY PROVIDED IN DJI LIMITED WARRANTY (POLICY AVAILABLE AT ([HTTP://WWW.DJI.COM/SERVICE](http://www.dji.com/service)), THE PRODUCT AND ALL MATERIALS, AND CONTENT AVAILABLE THROUGH THE PRODUCT ARE PROVIDED "AS IS" AND ON AN "AS AVAILABLE" BASIS, WITHOUT WARRANTY OR CONDITION OF ANY KIND, EITHER EXPRESS OR IMPLIED. DJI DISCLAIMS ALL WARRANTIES OF ANY KIND, EXCEPT AS EXPRESSLY PROVIDED IN DJI LIMITED WARRANTY, WHETHER EXPRESS OR IMPLIED, RELATING TO THE PRODUCT, PRODUCT ACCESSORIES, AND ALL MATERIALS, INCLUDING: (A) ANY IMPLIED WARRANTY OF MERCHANTABILITY, FITNESS FOR A PARTICULAR PURPOSE, TITLE, QUIET ENJOYMENT, OR NON-INFRINGEMENT; AND (B) ANY WARRANTY ARISING OUT OF COURSE OF DEALING, USAGE, OR TRADE. DJI DOES NOT WARRANT, EXCEPT AS EXPRESSLY PROVIDED IN DJI LIMITED WARRANTY, THAT THE PRODUCT, PRODUCT ACCESSORIES, OR ANY PORTION OF THE PRODUCT, OR ANY MATERIALS, WILL BE UNINTERRUPTED, SECURE, OR FREE OF ERRORS, VIRUSES, OR OTHER HARMFUL COMPONENTS, AND DO NOT WARRANT THAT ANY OF THOSE ISSUES WILL BE CORRECTED.

NO ADVICE OR INFORMATION, WHETHER ORAL OR WRITTEN, OBTAINED BY YOU FROM THE PRODUCT, PRODUCT ACCESSORIES, OR ANY MATERIALS WILL CREATE ANY WARRANTY REGARDING DJI OR THE PRODUCT THAT IS NOT EXPRESSLY STATED IN THESE TERMS. YOU ASSUME ALL RISK FOR ANY DAMAGE THAT MAY RESULT FROM YOUR USE OF OR ACCESS TO THE PRODUCT, PRODUCT

ACCESSORIES, AND ANY MATERIALS. YOU UNDERSTAND AND AGREE THAT YOU USE THE PRODUCT AT YOUR OWN DISCRETION AND RISK, AND THAT YOU ARE SOLELY RESPONSIBLE FOR ANY PERSONAL INJURY, DEATH, DAMAGE TO YOUR PROPERTY (INCLUDING YOUR COMPUTER SYSTEM OR MOBILE DEVICE OR DJI HARDWARE USED IN CONNECTION WITH THE PRODUCT) OR THIRD PARTY PROPERTY, OR THE LOSS OF DATA THAT RESULTS FROM YOUR USE OF OR INABILITY TO USE THE PRODUCT.

SOME JURISDICTIONS MAY PROHIBIT A DISCLAIMER OF WARRANTIES AND YOU MAY HAVE OTHER RIGHTS THAT VARY FROM JURISDICTION TO JURISDICTION.

DJI accepts no liability for damage, injury or any legal responsibility incurred directly or indirectly from the use of this product. The user shall observe safe and lawful practices including, but not limited to, those set forth in these Safety Guidelines.

Data Storage and Usage

When you use our mobile app or our products or other software, data regarding the use and operation of the product, such as flight telemetry data (e.g., speed, altitude, battery life, and information about the gimbal and camera) and operations records, may be automatically or manually uploaded to and maintained on a DJI-designated server. The internal storage device incorporated into the product stores various types of data, including flight telemetry data. You may also provide flight telemetry data and other data to us when you manually transmit that information from the internal storage device to us.

The information that is automatically uploaded or manually uploaded to us include personal data, such as your user name, may become associated with, used to identify, or tagged to such uploaded information when we store it. We separately describe how we use your user name and other personal data on our privacy policy at <http://www.dji.com/policy>. By using the product, the mobile app or other software we distribute, or by manually providing data to us, you consent to the following:

- Our storage of any flight telemetry data and other data uploaded or provided to us, including in combination with your user name;
- Our use of any such data uploaded or provided (including your user name) in connection providing support and services to you and to improve our products;
- Our disclosure of such data uploaded or provided (including your user name) to our agents and/or contractors who may use it on our behalf or in connection with their relationship with us; and
- Our disclosure of such uploaded or provided data (including your user name) as required by law, in a matter of public safety or policy, as needed in connection with the transfer of our business assets, or if we believe in good faith that sharing the data is necessary to protect our rights or property.

DJI reserves the right to update this disclaimer and the safety guidelines. Please visit www.dji.com and check your email periodically for the latest version. This disclaimer is made in various language versions; in the event of divergence among different versions, the English version shall prevail.

Before You Begin

The following documents have been produced to help you safely operate and make full use of your Phantom 4 Pro/Pro+:

In the Box

Disclaimer and Safety Guidelines

Intelligent Flight Battery Safety Guidelines

Quick Start Guide

User Manual

Check all of the included parts listed in the *In the Box* document and read the *Safety Guidelines* before flight. Then prepare for your first flight by using the *Quick Start Guide* and watching all of the tutorial videos on DJI's official website (<http://www.dji.com>). If you have questions, refer to the *User Manual* in the app or on DJI's official website for more comprehensive information. Make sure you fully understand the functionality of each individual part, the flight condition requirements, the key contingency warning functions/systems, and all government regulations before each flight. If you have any questions or problems during the assembly, maintenance or use of this product, please contact DJI or a DJI authorized dealer.

Individual Parts

Regarding Genuine and Functional Parts

WARNING

To avoid component malfunction, serious injury, and property damage, observe the following rules:

1. Use only genuine DJI parts or parts certified by DJI. Unauthorized parts or parts from non-DJI certified manufacturers may cause system malfunctions and compromise safety.
2. Ensure there are no foreign objects (such as water, oil, soil, sand, etc.) inside of the aircraft or its components.
3. Ensure the aircraft and its components – including but not limited to the remote controller, camera, gimbal, compass, propulsion system, and battery – are all in good working order, damage-free, and functioning well. Refer to the remaining sections in this document for more details on how to ensure the functionality of these components.
4. Do not modify or alter the aircraft, its components, and parts. Unauthorized modification may cause malfunctions and affect the aircraft's functionality and safety.

Remote Controller

NOTICE

1. Ensure the remote controller is fully charged before each flight.
2. If the remote controller is powered on and has NOT been used for 5 minutes, it will sound an alert. After 10 minutes it will automatically power off. Move the sticks or perform some other action to cancel the alert.
3. Adjust the clamp of the mobile device holder to allow a firm grip on your mobile device.
4. Ensure the mobile device holder is firmly in place and does not slip.

5. Ensure the antennas of the remote controller are unfolded and adjusted to the proper position to achieve optimal transmission quality.
6. Repair or replace the remote controller if damaged. A damaged remote controller antenna will greatly decrease performance.
7. Linking is required if you wish to replace your remote controller or receiver or add a new remote controller. Refer to the User Manual for details.
8. Make Sure that you first switch off the aircraft (after it is safe to do so), then switch off the Remote Controller. Otherwise it may cause the lost of control of the aircraft.

Camera

CAUTION

To avoid possible serious injury and property damage, observe the following rule:

1. DO NOT block any ventilation holes on the camera as the heat generated may hurt you and damage the device.

NOTICE

1. Check camera settings before use to make sure you can adjust them to fit your needs.
2. Test the camera by shooting a few test images and check that it is operating correctly before shooting important pictures or videos.
3. DO NOT remove the Micro SD card from the camera when it is powered on.
4. Photos or videos cannot be transmitted or copied from the camera if the Intelligent Flight Battery is powered off.
5. Be sure to power off the Intelligent Flight Battery correctly, otherwise your camera parameters will NOT be saved and any recorded videos may be damaged. NOTE: Regardless of the reason, DJI will not be responsible for any failure of an image or video to be recorded or having been recorded in a way that is not machine readable.

Gimbal

NOTICE

1. Precision elements in the gimbal may be damaged in a collision or impact, which may cause the gimbal to function abnormally.
2. DO NOT apply external force to the gimbal after the gimbal is powered on.
3. DO NOT add any payloads to the gimbal, as this may cause the gimbal to function abnormally or even lead to motor damage.
4. Remove the gimbal clamp before powering on the gimbal. Re-install the gimbal clamp to secure the gimbal's position if you are going to store the aircraft for an extended period.

Compass

CAUTION

To avoid possible serious injury and property damage, observe the following rule:

1. Land immediately when severe drifting occurs in flight, i.e., the aircraft does NOT fly in straight lines.

NOTICE

Only calibrate the compass when the DJI GO 4 App or the status indicator prompt you to do so. Observe the following rules when calibrating your compass:

1. DO NOT calibrate your compass where there is a chance of strong magnetic interference, such as magnetite, parking structures, and steel reinforcements underground.
2. DO NOT carry ferromagnetic materials with you during calibration such as cellular phones.
3. The DJI GO 4 App will prompt you to resolve the compass issue if the compass is affected by strong interference after calibration is complete. Follow the prompted instructions to resolve the compass issue.

Propulsion Systems

WARNING

To avoid serious injury to yourself or others, which may be caused by the rotating propellers and motors, observe the following rules:

Propellers

1. DO NOT use aged, chipped, or broken propellers.
2. Always power off the aircraft before touching the propellers.
3. Be aware of the sharp edges of the propellers when mounting or removing the propellers. Wear gloves or take other protective measures when touching the propellers.
4. Whenever necessary, use tools (e.g., wrench, screwdriver, pliers, etc.) to remove or install the propellers.
5. Ensure the propellers are securely mounted and tightened to prevent them from falling off the motors.
6. DO NOT turn on the motors when propellers are mounted and there are other people or animals in the immediate vicinity.
7. Using third-party propellers may compromise the aerodynamics of the aircraft. For a better and safer flight experience, we recommend you to use original DJI propellers only.

Motors

1. Ensure the motors are securely mounted and rotating smoothly.
2. DO NOT attempt to modify the structure of the motors.
3. DO NOT touch or let your hands or body come in contact with the motors after flight as they may be hot.

CAUTION

To avoid possible serious injury and property damage, observe the following rules:

1. DO NOT block any of the ventilation holes on the motors.
2. DO NOT block any of the ventilation holes on the body of the aircraft.

NOTICE

Motors

1. Keep the motors free of dust.
2. If a motor is stuck and unable to rotate freely, execute the CSC (Combination Stick Command) to stop the motors immediately.

Electronic Speed Controllers

1. Ensure the ESCs sound normal when powered on.

DJI GO 4 App

NOTICE

1. Be sure to fully charge your tablet or mobile device before launching the app (DJI GO 4 App). A tablet is recommended for a better user experience.
2. If you are using a phone as your mobile display device, be sure to continue flying safely when the phone receives an incoming call. DO NOT accept phone calls or use the texting features during flight.
3. Read all prompted safety tips, warning messages, and disclaimers carefully. Be familiar with the related regulations in your area. You are solely responsible for being aware of all relevant regulations and flying in a way that is compliant.
 - a. Read and understand the warning messages before using the Auto-take off and Auto-landing features.
 - b. Read and understand the warning message and disclaimer before setting the altitude beyond the default limit.
 - c. Read and understand the warning messages and disclaimer before switching between flight modes.
4. Land your aircraft immediately if there is an alert shown on the app.
5. Examine and check all warning messages on the checklist displayed in the app prior to each flight.
6. Use the in-app simulator to practice your flight skills if you have never operated the aircraft or if you do not have sufficient experience to be comfortable operating the aircraft.
7. Beginner Mode is enabled by default when you launch the app for the first time. The aircraft's altitude and flight distance is restricted when flying in Beginner Mode. We recommend you fly in Beginner Mode to perfect your flight skills. Operate the actual aircraft only after you are confident that you have mastered adequate flight skills.
8. Cache the map data of the area where you intend to fly the aircraft by connecting to the Internet before each flight.
9. The app is designed to assist your operation. Please use your sound discretion and DO NOT rely on the app to control your aircraft.
10. Your use of the app is subject to the DJI GO 4 App Terms of Use and DJI Privacy Policy. Please read them carefully in the app.

Firmware

WARNING

To avoid serious injury to children and animals, observe the following rule:

1. **Keep children and animals at a safe distance during any firmware upgrade, system calibration, and parameter setting procedures.**

NOTICE

1. For safety, always update the firmware to the latest version when an upgrade notification is shown in the app.
2. Firmware upgrade notifications will prompt you to proceed with an update immediately or to update the firmware within three days. If you choose to ignore the current firmware update, you are required to accept the prompted disclaimer. You further understand and agree that the data including but not limited to flight telemetry data and user selection records may be uploaded to and maintained on a DJI-designated server.

3. Be sure to download the firmware package file from the official DJI website. Verify the firmware package file's integrity before upgrading.
4. Be sure to update the remote controller's firmware to the latest version after you update the aircraft's firmware.
5. The remote controller may become unlinked from the aircraft after updating. Re-link the remote controller and aircraft.
6. Be sure to check all connections and remove the propellers from the motors before performing the firmware update.

Product Care

Storage and Transportation

WARNING

To avoid serious injury to children and animals, observe the following rule:

1. **Small parts, such as cables and straps, are dangerous if swallowed. Keep all parts out of reach of children and animals.**

NOTICE

1. Store the Intelligent Flight Battery and remote controller in a cool, dry place away from direct sunlight to ensure the built-in LiPo battery does NOT overheat. Recommended storage temperature: between 71° and 82° F (22° and 28° C) for storage periods of more than three months. Never store in environments outside the temperature range of -68° to 113° F (-20° to 45° C).
2. DO NOT allow the camera to come into contact with, or become immersed in, water or other liquids. If it gets wet, wipe dry with a soft, absorbent cloth. Turning on an aircraft that has fallen into water may cause permanent component damage. DO NOT use substances containing alcohol, benzene, thinners or other flammable substances to clean or maintain the camera. DO NOT store the camera in humid or dusty areas.
3. DO NOT connect this product to any USB interface that is older than version 2.0. DO NOT connect this product to any "power USB" or similar devices.

Maintenance and Upkeep

NOTICE

1. Check every part of the aircraft after any crash or violent impact. If you have any problems or questions, please contact a DJI authorized dealer.
2. Regularly check the Battery Level Indicators to see the current battery level and overall battery life. When the battery life reaches 0%, it can no longer be used.
3. Please refer to the Phantom 4 series Intelligent Flight Battery Safety Guidelines for more information on battery maintenance and upkeep.

Flight Condition Requirements

Weather Conditions and Surrounding Environment

WARNING

The aircraft is designed to operate in good to moderate weather conditions. To avoid collision, serious injury and property damage, observe the following rules:

1. **DO NOT** use the aircraft in severe weather conditions. These include wind speeds exceeding 10 m/s (22.4 mph) , snow, rain, smog, heavy wind, hail, lightning, tornadoes or hurricanes.
2. **Keep the aircraft at least 10 meters (30 feet) away from obstacles, people, animals, buildings, public infrastructure, trees, and bodies of water when in flight. As the aircraft's altitude increases, keep an even further distance away from the aforementioned objects or obstacles.**
3. **Be EXTRA cautious when operating the aircraft indoors. Some features of the aircraft, especially the stabilization feature, may be impacted.**

NOTICE

1. Aircraft and battery performance is subject to environmental factors such as air density and temperature.
 - a. Be very careful when flying 20,000 feet (6,000 meters) or more above sea level as battery and aircraft performance may be reduced.
2. **DO NOT** use the aircraft near accidents, fire, explosions, floods, tsunamis, avalanches, landslides, earthquakes, dust, or sandstorms.

Interference with Flight Controller, Communications, and Positioning Systems

NOTICE

1. Fly in open areas. Tall buildings or steel structures may affect the accuracy of the on-board compass and block the GPS signal.
2. Avoid interference from other wireless equipment, because it may affect the remote controller. Make sure to turn off the Wi-Fi on your mobile device.
3. **DO NOT** fly near areas with magnetic or radio interference. These include but are NOT limited to: high voltage lines, large scale power transmission stations or mobile base stations and broadcasting towers. Failing to do so may compromise the transmission quality of this product or cause remote controller and video transmission errors which may affect flight orientation and location accuracy. The aircraft may behave abnormally or go out of control in areas with too much interference.

Operating the Aircraft Responsibly

WARNING

To avoid serious injury and property damage, observe the following rules:

1. Make sure you are NOT drunk, taking drugs, under the influence of anesthesia, or suffering from dizziness, fatigue, nausea or any other conditions, whether physical or mental, that could impair your ability to operate the aircraft safely.
2. Pulling the left stick to the bottom inside corners and pressing the RTH button at the same time will stop the motor when the aircraft is airborne. The landing function of the aircraft will not be triggered. DO NOT perform the aforementioned combination command unless in an emergency situation. You may turn off this combination command feature via the DJI GO 4 App.
3. Upon landing, power off the aircraft first, then switch off the remote controller.
4. DO NOT drop, launch, fire or otherwise project any dangerous payloads on or at any buildings, persons or animals, or which could cause personal injury or property damage.

NOTICE

1. Make sure you have been sufficiently trained and have contingency plans for emergency situations or for when accidents occur.
2. Make sure you have a flight plan and never fly the aircraft recklessly.
3. Respect the privacy of others when using the camera. Make sure you comply with local privacy laws, regulations, and moral standards.
4. DO NOT use this product for any reason other than general personal use. DO NOT use it for any illegal or inappropriate purpose (such as spying, military operations, or unauthorized investigations).
5. DO NOT use this product to defame, abuse, harass, stalk, threaten or otherwise violate the legal rights (such as the right of privacy and publicity) of others.
6. DO NOT trespass onto private property of others.

Flight Modes, Functions and Warnings

Flight Modes

WARNING

To avoid serious injury and property damage, observe the following rule:

1. DO NOT switch from P-mode to either A-mode or S-mode unless you are sufficiently familiar with the aircraft's behavior for each flight mode, since disabling GPS may result in being unable to land the aircraft safely.

NOTICE

P-mode or S-mode is preferred for most flight scenarios. Users can switch to A-mode if P-mode or S-mode is unavailable. When flying in A-mode, take EXTRA precautions because some features are NOT available in A-mode.

1. P-mode (Positioning): P-mode works best when the GPS signal is strong. The aircraft utilizes the GPS and Vision System to automatically stabilize itself, navigate between obstacles or track a moving object. Advanced features such as TapFly and ActiveTrack are enabled in this mode.
2. S-mode (Sports): S-mode is identical to P-mode in terms of flight controller settings, except that the handling gain values of the aircraft are adjusted in order to enhance the maneuverability of the aircraft. The maximum flight speed of the aircraft is increased in this mode.
3. A-mode (Attitude): When neither the GPS nor the Vision System is available, the aircraft will only use its barometer for positioning to control the altitude.

If you intend to switch to modes that disable GPS assistance (e.g., Atti mode), you are required to accept the prompted disclaimer to enable this function. If this function is enabled, you further understand and agree that data including but not limited to flight telemetry data and function records could be uploaded to and maintained on a DJI designated server.

Failsafe and Return-to-Home

NOTICE

1. The Return-to-Home feature will NOT work if the GPS signal is insufficient or if GPS is not active.
2. Press the RTH (Return-to-Home) Button on the remote controller to bring the aircraft back to the Home Point. DO NOT resort to turning off the remote controller to force the aircraft to return to Home Point.
3. Tall buildings may adversely affect the Failsafe function. Please adjust the aircraft location, altitude and speed while returning home to avoid obstacles.
4. Make sure to always fly the aircraft within the transmission range of the remote controller.
5. Only use the Failsafe and Return-to-Home functions in emergency cases, as they may be affected by the weather, the environment, or any nearby magnetic fields.
6. The aircraft cannot avoid obstacles during the Failsafe RTH when lighting condition is not ideal, or if the Visual System is otherwise disabled. Therefore, it is important to set an appropriate Failsafe altitude before each flight.
7. When flying indoors, the aircraft cannot perform precision hovering when flying above certain surfaces. Refer to the "Vision Positioning System" section for complete indoor flying criteria.
8. During the Failsafe RTH, the pilot may regain control of the aircraft if the remote controller signal is re-established. Moving the left stick when the aircraft reaches 20 meters (65 feet) altitudes or beyond will cancel the ascending process and command the aircraft to return to the home point immediately. Pressing the RTH button once during the Failsafe RTH will cancel the RTH process immediately.
9. If the battery life so allows, the aircraft may first return to the last position where it had connection with the remote controller during the Failsafe RTH. As a result, you may observe the aircraft first flying away from you, then returning to the home point.

Low Battery

NOTICE

1. When the Critical Battery Level Warning activates and the aircraft is descending automatically, you may push the throttle up to maintain the aircraft's altitude and navigate it to a more appropriate location for landing.
2. When battery warnings are triggered, promptly bring the aircraft back to the Home Point or land to avoid losing power during flight and causing damage to the aircraft, property, animals, and people.

Vision System and Infrared Sensing System

NOTICE

1. The Vision System cannot work properly over surfaces that do NOT have clear pattern variations. The Vision System is only effective when the aircraft is at altitudes of 0.3 to 10 meters.
2. The Vision System may NOT function properly when the aircraft is flying over water or snow-covered areas.

3. Keep your pets away from the aircraft when the Vision System is activated, as the sonar sensors emit a high frequency sound that is only audible to some pets.
4. Note that the Vision System may NOT function properly when the aircraft is flying too fast or too low.
5. Operate the aircraft cautiously when in any of the following situations:
 - a. Flying over monochrome surfaces (e.g., pure black, pure white, pure red, pure green).
 - b. Flying over highly reflective surfaces;
 - c. Flying at high speeds (over 10m/s (32.8 feet/s) at 2 meters (6.6 feet) or over 5m/s (16.4 feet) at 1 meter (3.3 feet));
 - d. Flying over water or transparent surfaces;
 - e. Flying over moving surfaces or objects;
 - f. Flying in an area where the lighting changes frequently or drastically;
 - g. Flying over extremely dark (< 10 lux) or bright ($> 10,000$ lux) surfaces;
 - h. Flying over surfaces that can absorb sound waves (e.g., thick carpet).
 - i. Flying over surfaces without clear patterns or texture;
 - j. Flying over surfaces with identical repeating patterns or textures (e.g. tiles with same design);
 - k. Flying over inclined surfaces that will deflect sound waves away from the aircraft.
6. Camera calibration is required if the aircraft suffers from crashing. Calibrate the front cameras if the DJI GO 4 App prompts you to do so.
7. Keep the sensors clean and at all times. DO NOT temper with the sensors.
8. The Vision System may not be able to recognize pattern on the ground in low light conditions (less than 100 lux).
9. Do not use other ultrasonic devices with frequency of 40 KHz when Vision System is in operation.
10. Infrared Sensing System is enabled only in the Beginner Mode, Tapfly and ActiveTrack mode.
11. Binocular sensor contrary to the flight direction is enabled only in the P-mode, Tapfly, and ActiveTrack mode when the aircraft speed is less than 6m/s (13.4 mph).
12. The Vision System and Infrared Sensing System are not able to brake and stop the aircraft at a safe distance from an obstacle if the aircraft speed exceeds 14m/s (31.3 mph).
13. Please be mindful of blind spots of the Vision System and Infrared Sensing System, as shown below.

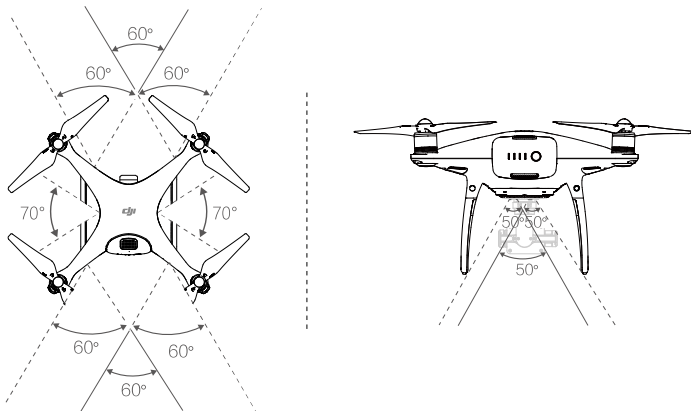

TapFly™

CAUTION

To prevent serious injury or property damage, observe the following guidelines:

1. DO NOT instruct the aircraft to fly towards people, animals, small and fine objects (e.g. tree branches and power lines) or transparent objects (e.g. glass and water).
2. Watch out for potential obstacles in your surrounding area (especially on the rear, left, and right sides of the aircraft) and stay clear of them to avoid accidents.
3. Be prepared to take control of the aircraft or press the "STOP" button on the screen at all times, in case of an emergency.

NOTICE

1. There may be deviations between the expected and actual paths for your TapFly selection.
2. The selectable range on the screen is limited. You cannot make TapFly selections near the upper or lower edges of the screen.
3. The TapFly mode may NOT function properly when the aircraft is flying over water or snow covered area.
4. Be extra cautious when flying in extremely dark (< 300 lux) or bright (> 10,000 lux) environments.

ActiveTrack™

CAUTION

To prevent serious injury or property damage, observe the following guidelines:

1. Ensure there are no people, animals, small and fine objects (e.g. tree branches and power lines) or transparent objects (e.g. glass and water) along the desired tracking path.
2. Watch out for potential obstacles in your surrounding area (especially on the rear, left, and right sides of the aircraft) and stay clear of them to avoid accidents.
3. Be prepared to take control of the aircraft or press the "STOP" button on the screen at all times, in case of an emergency.
4. Ensure there are no obstacles behind the aircraft when it performs ActiveTrack in the reverse direction.

NOTICE

1. Be extra cautious when using ActiveTrack in any of the following situations:
 - a. The movement of the tracked subject is not on a level plane;
 - b. The tracked subject changes shape drastically while moving;
 - c. The tracked subject could be blocked or out of sight for a long time;
 - d. When the tracked object is in a snow-covered area;
 - e. The lighting is extremely low (< 300 lux) or high (> 10,000 lux); and
 - f. The tracked subject has a similar color or pattern as the surrounding environment.
2. You must follow local privacy laws and regulations when using ActiveTrack.

Compliance with Regulations & No Fly Zones

Regulations

WARNING

To avoid non-compliant behavior, serious injury and property damage, observe the following rules:

1. **DO NOT** operate in the vicinity of manned aircraft, regardless of altitude. (Land immediately if necessary)
2. **DO NOT** fly the aircraft in densely populated areas, including cities, sporting events, exhibitions, performances, etc.
3. **DO NOT** fly the aircraft above the authorized altitude. Remain well clear of and **DO NOT** interfere with manned aircraft operations. Be aware of and avoid other aircraft and obstacles at all times.

CAUTION

To avoid non-compliant behavior, serious injury and property damage, observe the following rules:

1. **DO NOT** fly the aircraft near or inside no fly zones specified by local laws and regulations. The no fly zone list includes: airports, borders between two sovereign countries or regions, major cities/regions, etc., and is continuously updated.
2. **DO NOT** fly the aircraft above the authorized altitude
3. **ALWAYS** keep your aircraft within visual line of sight (VLOS), and use an observer to assist if needed.
4. **NEVER** use the aircraft to carry illegal or dangerous goods/payloads.

NOTICE

1. Make sure you understand the nature/type of your flight operation (such as for recreation, for public use, or for commercial use) and have obtained corresponding approval and clearance from the related government agencies before flight. Consult with your local regulators for comprehensive definitions and specific requirements. For users operating their aircraft in the United States, please first visit <http://www.knowbeforeyoufly.org/> and take the most appropriate action that suits your circumstances.
2. Please note that remote controlled aircraft may be banned from conducting commercial activities in certain countries and regions. Check and follow all local laws and ordinances before flying as those rules may differ from those stated here.
3. **DO NOT** fly around sensitive infrastructure or property such as power stations, water treatment facilities, correctional facilities, heavily traveled roadways, government facilities, military zones, etc.
4. Respect the privacy of others when using the camera. **DO NOT** conduct surveillance operations such as image capture or video recording on any person, entity, event, performance, exhibition, and property without authorization or where there is an expectation of privacy, even if the image or video is captured for personal use.
5. Please be advised that in certain areas, the recording of images and videos from events, performances, exhibitions, or commercial properties by means of a camera may contravene copyright or other legal rights, even if the image or video was shot for personal use.

No Fly Zones

NOTICE

DJI always stresses safety during flight, and has therefore developed various aids to help users comply with local rules and regulations while flying. We strongly recommend that you update the firmware to the latest version to ensure the following features are fully updated:

No Fly Zones

1. No Fly Zones include but are not limited to major airports around world, borders between two sovereign countries or regions, major cities/regions, etc.
2. The complete list of No Fly Zones is listed on the official DJI website at <http://flysafe.dji.com/no-fly> and is subject to periodic updates in line with the latest regulatory requirements without prior notice.
3. Some No Fly Zones are comprised of several zones. Each zone features circles of various sizes. The aircraft will NOT be able to take off in the inner most zone of the No Fly Zone, and will descend to the specified altitude when it approaches the edge of the inner most zone. Ground station functionality is disabled when the aircraft is within a No Fly Zone.
4. Users are NOT able to set up waypoints within No Fly Zones.

Altitude Limit

1. Fly NO higher than 120 meters (400 feet) above ground level and stay away from any surrounding obstacles.
2. If you intend to fly above the default altitude limit, you are required to accept the prompted disclaimer to enable the new altitude limit. If a new altitude limit is set, you further understand and agree that data including but not limited to flight telemetry data and altitude limit changes could be uploaded to and maintained on a DJI-designated server.

Compliance Information

FCC Compliance Notice

This device complies with Part 15 of the FCC Rules. Operation is subject to the following two conditions: (1) This device may not cause harmful interference, and (2) This device must accept any interference received, including interference that may cause undesired operation.

Any changes or modifications not expressly approved by the party responsible for compliance could void the user's authority to operate the equipment.

This equipment has been tested and found to comply with the limits for a Class B digital device, pursuant to part 15 of the FCC Rules. These limits are designed to provide reasonable protection against harmful interference in a residential installation. This equipment generates, uses and can radiate radio frequency energy and, if not installed and used in accordance with the instructions, may cause harmful interference to radio communications. However, there is no guarantee that interference will not occur in a particular installation. If this equipment does cause harmful interference to radio or television reception, which can be determined by turning the equipment off and on, the user is encouraged to try to correct the interference by one or more of the following measures:

- Reorient or relocate the receiving antenna.
- Increase the separation between the equipment and receiver.
- Connect the equipment into an outlet on a circuit different from that to which the receiver is connected.
- Consult the dealer or an experienced radio/TV technician for help.

RF Exposure Information

This equipment complies with FCC radiation exposure limits set forth for an uncontrolled environment. In order to avoid the possibility of exceeding the FCC radio frequency exposure limits, human proximity to the antenna shall not be less than 20cm during normal operation.

IC RSS Warning

This device complies with Industry Canada licence-exempt RSS standard (s). Operation is subject to the following two conditions: (1) this device may not cause interference, and (2) this device must accept any interference, including interference that may cause undesired operation of the device.

Le présent appareil est conforme aux CNR d'Industrie Canada applicables aux appareils radio exempts de licence.

L'exploitation est autorisée aux deux conditions suivantes:

(1) l'appareil ne doit pas produire de brouillage, et

(2) l'utilisateur de l'appareil doit accepter tout brouillage radioélectrique subi, même si le brouillage est susceptible d'en compromettre le fonctionnement.

IC Radiation Exposure Statement:

This equipment complies with IC RF radiation exposure limits set forth for an uncontrolled environment. This transmitter must not be co-located or operating in conjunction with any other antenna or transmitter.

This equipment should be installed and operated with minimum distance 20cm between the radiator & your body.

Any Changes or modifications not expressly approved by the party responsible for compliance could void the user's authority to operate the equipment.

KCC Warning Message

"해당 무선설비는 운용 중 전파혼신 가능성이 있으므로 인명안전과 관련된 서비스는 할 수 없습니다."

"해당 무선설비는 운용 중 전파혼신 가능성이 있음"

NCC Warning Message

低功率電波輻射性電機管理辦法

第十二條 經型式認證合格之低功率射頻電機，非經許可，公司、商號或使用者均不得擅自變更頻率、加大功率或變更原設計之特性及功能。

第十四條 低功率射頻電機之使用不得影響飛航安全及干擾合法通信；經發現有干擾現象時，應改善至無干擾時方得繼續使用。前項合法通信，指依電信法規定作業之無線電通信。低功率射頻電機須忍受合法通信或工業、科學及醫療用電波輻射性電機設備之干擾。

EU Compliance Statement: SZ DJI TECHNOLOGY CO., LTD. hereby declares that this device is in compliance with the essential requirements and other relevant provisions of the Directive 1999/5/EC.

A copy of the EU Declaration of Conformity is available online at www.dji.com/euro-compliance

Declaración de cumplimiento UE: SZ DJI TECHNOLOGY CO., LTD. por la presente declara que este dispositivo cumple los requisitos básicos y el resto de provisiones relevantes de la Directiva 1999/5/EC.

Hay disponible online una copia de la Declaración de conformidad UE en www.dji.com/euro-compliance

EU-verklaring van overeenstemming: SZ DJI TECHNOLOGY CO., LTD. verklaart hierbij dat dit apparaat voldoet aan de essentiële vereisten en andere relevante bepalingen van Richtlijn 1999/5/EC.

De EU-verklaring van overeenstemming is online beschikbaar op www.dji.com/euro-compliance

Declaração de conformidade da UE: A SZ DJI TECHNOLOGY CO., LTD. declara, através deste documento, que este dispositivo está em conformidade com os requisitos essenciais e outras disposições relevantes da Diretiva 1999/5/EC.

Existe uma cópia da Declaração de conformidade da UE disponível online em www.dji.com/euro-compliance

Dichiarazione di conformità UE: SZ DJI TECHNOLOGY CO., LTD. dichiara che il presente dispositivo è conforme ai requisiti essenziali e alle altre disposizioni rilevanti della direttiva 1999/5/EC.

Una copia della dichiarazione di conformità UE è disponibile online all'indirizzo Web www.dji.com/euro-compliance

Déclaration de conformité UE : Par la présente, SZ DJI TECHNOLOGY CO., LTD déclare que cet appareil est conforme aux principales exigences et autres clauses pertinentes de la directive européenne 1999/5/EC.

Une copie de la déclaration de conformité UE est disponible sur le site www.dji.com/euro-compliance

EU-Compliance: Hiermit erklärt SZ DJI TECHNOLOGY CO., LTD., dass dieses Gerät den wesentlichen Anforderungen und anderen einschlägigen Bestimmungen der EU-Richtlinie 1999/5/EC entspricht.

Eine Kopie der EU-Konformitätserklärung finden Sie online auf www.dji.com/euro-compliance.

CE 1313

EU contact address: DJI GmbH, Industrie Strasse. 12, 97618, Niederlauer, Germany

CAUTION: RISK OF EXPLOSION IF BATTERY IS REPLACED BY AN INCORRECT TYPE. DISPOSE OF USED BATTERIES ACCORDING TO THE INSTRUCTIONS

Environmentally friendly disposal



Old electrical appliances must not be disposed of together with the residual waste, but have to be disposed of separately. The disposal at the communal collecting point via private persons is for free. The owner of old appliances is responsible to bring the appliances to these collecting points or to similar collection points. With this little personal effort, you contribute to recycle valuable raw materials and the treatment of toxic substances.

Thailand Warning message

เครื่องใช้ทางคมนาคมและอุปกรณ์นี้ มีความเสี่ยงที่ต้องตามข้อกำหนดของ กทช.

This content is subject to change.

**Download the latest version from
www.dji.com/support**

If you have any questions about this document, please contact DJI by sending a message to DocSupport@dji.com.

PHANTOM™ is a trademark of DJI.
Copyright © 2016 DJI All Rights Reserved.



Printed in China.