

**A16 S**



### **Macchina Bordatrice**

Macchine bordatrici per pannelli con forme diritte, rotonde o curve: si propongono alle esigenze di aziende industriali o artigianali. Permettono l'applicazione di bordi in impiallaccatura, melaminico, PVC, ABS fino a 3 mm di spessore e massello fino a 4 mm, sia in strisce che in rotolo. Le macchine dispongono di accessori, in particolare per bordi da 2-3 mm in PVC-ABS, attia a facilitare la produzione, come indicato nei vari accessori da impiegare.

### **Edging machine**

Edging machines for streight, rounded or curved panels designed for industrial or artisan use. They permit the application of veneer, melamine, PVC and ABS edges up to 3 mm thick and solid wood edges up to 4 mm in strips or reels. Accessories can be used, in particular for 2-3 mm PVC-ABS, to facilitate production. Information is given with each accessory.

**Frevol**

Ø 500 mm



Max.  
0,8 mm



0°-45°



## **Máquina chapeadora**

Maquinas chapeadoras de cantos para tableros rectos, en curva o con perfiles redondeados; adecuado para las exigencias tanto de epresas industriales como artesanales. Permite la aplicacion de cantos en chapa, melamina, PVC, ABS hasta 3 mm de espesor y macizo hasta 4 mm de espesor, ya sea en tiras o en rollos. La maquina dispone de diversos accesorios especialmente para cantos de 2-3 mm en PVC a fin de facilitar la produccion.



**A16 W**



## **Machine encolleuse**

Machines encolleuses de chant pour les panneaux avec formes droites, arrondies ou courbes; s'applique aux exigences des entreprises industrielles ou artisanales. Permet l'application des bords en plaqué, mélaminé, PVC, ABS jusqu'à 3 mm d'épaisseur et maximum jusqu'à 4 mm, aussi bien en que en rouleau. La machine dispose pour bords de 2-3 mm en la production, comme accessoires à utiliser.

**A16 NV**



## **Kantenanleimmaschine**

Kantenanleimmaschinen für Werkstücke mit geraden, gerundeten oder frei geformten Kanten für die industrielle und handwerkliche Fertigung. Die Maschinen erlauben das Aufbringen von Kanten mittels Schmelzkleber als Rollen- oder Streifenware in Furnier, Kunststoff, Melamin, PVC, ABS bis zu einer Kantenstärke von 3 mm und Massivholzkanten bis 4 mm Stärke. Zur Erleichterung und Vereinfachung der Produktion können die Maschinen speziell für die Verarbeitung von PVC u. ABS-knten, Stärke 2-3 mm mit entsprechenden. Zubehöreinrichtungen ausgestattet werden.

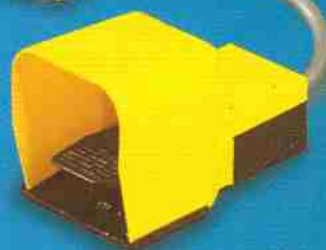



- 3)** Spalla di contrasto (in posizione d'appoggio)  
 Contrast shoulder (on support position)  
 Support de contraste (en position d'appui)  
 Gegenleiste (auflegeposition)  
 Apoyo (en posición de apoyo)



- 4)** Intestatore laterale di bordi con lama circolare  
 End cut off lateral saw of edges with circular blade  
 Coupe en boutte laterale des chants avec lame circulaire  
 Seitliche Schnittvorrichtung für umleimer mit schneidblatt  
 Retestador lateral de cantos con sierra circular



- 14)** Soffiatore riscaldante - Heating blower - Groupe de soufflage chauffant  
 Heizgebläse - Soplador de calentamiento.  
**15)** Trascinatore motorizzato - Motorized conveyor belt  
 Dispositif d'entraînement motorisé - Motorisierte zugvorrichtung  
 Arrastador motorizado.

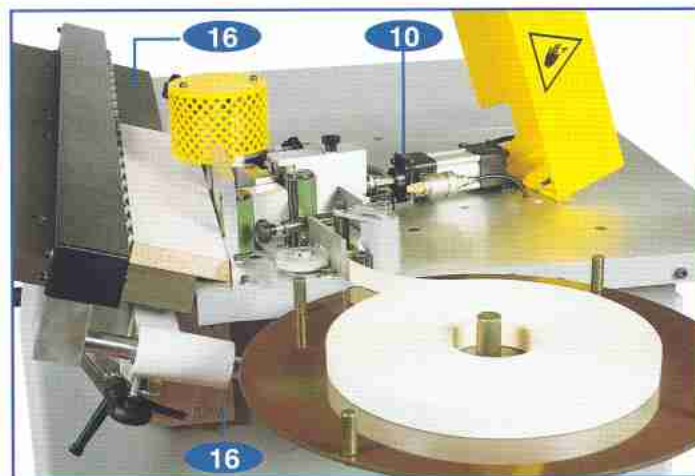

- 10)** Trancia PVC-ABS 3mm - PVC-ABS Schear  
 Cisaille PVC-ABS - PVC-ABS Klinge - Cortadora PVC-ABS  
**16)** Piani di lavoro inclinabile 0°-45° - Tilting work surface from 0°-45°  
 Plans de travail inclinables de 0°-45° - Kippbare arbeitsflächen: von 0° bis 45°  
 Planos inclinables de trabajo desde 0° hasta 45°



- 1)** Gruppo rifilatore (pezzi dritti)  
 Trimmer unit (right pieces)  
 Groupe affeurteur (pieces droites)  
 Abkantaggregat (gerade werkstücke)  
 Grupo perfilador (piezas rectas)  
**2)** Contamillimetri elettronico digitale  
 Electronic digital millimeter counter  
 Compte-millimetres electronique digital  
 Digitaler millimeterzhähler  
 Cuentamilímetros electrónico digital



- 1)** Gruppo rifilatore (pezzi curvi) - Trimmer unit (curved pieces)  
 Groupe affeurteur (pieces courbes) - Abkantaggregat (geformte werkstücke)  
 Grupo perfilador (piezas curvas)  
**19)** Piatto porta rotolo girevole ø 800 - Revolving roll-holder plate ø 800  
 Plateau porte-rouleau tournant ø 800 - Drehbare rollenträgerplatte ø 800  
 Disco giratorio portarollo y ø 800

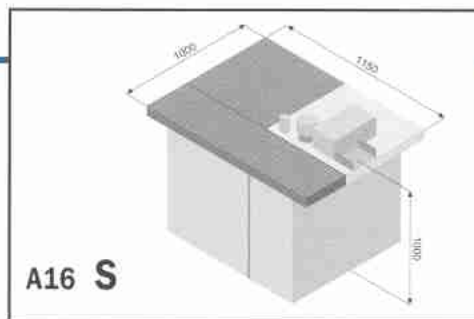

**A16 S**

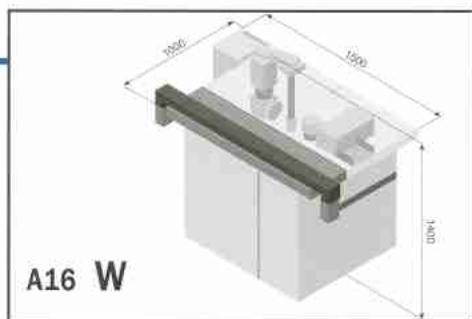

**A16 W**

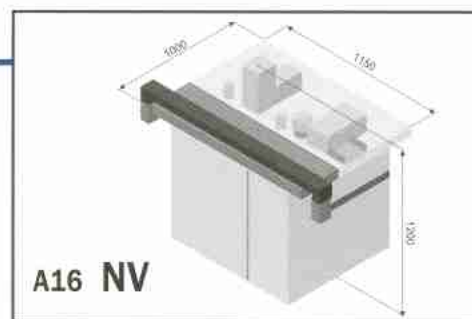

**A16 NV**

**DATI TECNICI - SPECIFICATIONS - DONNES TECHNIQUES - TECHNISCHE ANGABEN - DATOS TECNICOS**

Modello - Model - Modèle Modell - Modelo	Serie A16 S		Serie A16 W		Serie A16 NV	
	Min	Max	Min	Max	Min	Max
Altezza del pannello Panel height - Hauteur du panneau Werkstückstärke - Altura tablero	10 mm	÷ 60 mm	10 mm	÷ 60 mm	10 mm	÷ 60 mm
Spessore bordo Edge thickness - Epaisseur du chant Kantenmaterial-Stärke - Altura del canto	0,4 mm	÷ 3 mm	0,4 mm	÷ 3 mm	0,4 mm	÷ 3 mm
Raggio min. bordatura Min. edging radius - Rayon min. d'encollage Mindestradius Umrandung - Radio min. encolado	20 mm		20 mm		20 mm	
Avanzamento variabile - Variable feed speeds Avancement variable - Stufenloser Vorschub Anleimmaschine - Velocidad de avance variable	2,5 ÷ 12 mt/min		2,5 ÷ 12 mt/min		2,5 ÷ 12 mt/min	
Spalmatura Spreading - Encollage Umrandung - Encolado	1 rullo 1 roll - 1 rouleau 1 walze - 1 rulo		2 rullo 2 roll - 2 rouleau 2 walze - 2 rulo		2 rullo 2 roll - 2 rouleau 2 walze - 2 rulo	
Altezza di rifilatura - Trimming height Hauteur d'affleurement - Kantennhoehe Beim Buendigfraesen - Altura de perfilado	16 mm ÷ 50 mm optional acc. 1		16 mm ÷ 50 mm optional acc. 1		10 mm ÷ 50 mm standard	
Raggio min. rifilatura - Min. trimming radius Hauteur min. d'affleurement - Mindestradius beim Buendigfraesen - Radio minimo perfilado	25 mm optional acc. 1		25 mm optional acc. 1		25 mm standard	
Giri al rifilatore min. - Trimming device approx. min Tours de l'affleureuse, par minute - Drehzahl Buendigfraese/min. - Velocidad del perfilador	12.000 r.p.m. optional acc. 1		12.000 r.p.m. optional acc. 1		12.000 r.p.m. standard	
Potenza installata Installed power - Puissance installée Leistung installierte - Potencia instalada	2470 W		2470 W		3470 W	
Voltaggi e frequenze Voltages and cycles - Voltages et frequences Spannung, Frequenz - Voltaje y frecuencias	220-380 V 50/60 Hz 3 Ph		220-380 V 50/60 Hz 3 Ph		220-380 V 50/60 Hz 3 Ph	
Pressione d'aria Air pressure - Pression de l'aire Druck - Presión	6 bar		6 bar		6 bar	
Peso Weight - Poids Gewicht - Peso	300 Kg		320 Kg		350 Kg	

La Ditta si riserva di apportare qualsiasi modifica senza preavviso. - The Company reserves the right to alter any detail with no forewarning. - La maison réserve le droit d'apporter les modifications jugées utiles sans préavis. - Die Firma behält sich das Recht für Änderungen ohne Voranzeige vor. - La empresa se reserva cualquier modificación sin preavisar a los clientes.

# Fravol

**MACCHINE PER LA LAVORAZIONE DEL LEGNO  
MANUFACTURE OF WOODWORKING MACHINES**

Uff. e Dep.: Via A. Niedda, 5-7 - 35010 PERAGA di Vigonza - (PD) - Italy  
Tel. +39 - 049 725085 - 725888 - Fax +39 - 049 8931635  
e-mail: fravolexport@tin.it - fravol.export@tiscalinet.it

DEALER