



Datasheet

GUARDWALL ANTENNA

READER ANTENNA DATASHEET

Version 6.0

© 2018, Impinj, Inc.

www.impinj.com

TABLE OF CONTENTS

1	Overview	1
1.1	Features	1
2	Read Zone Characteristics	1
3	Specifications	2
3.1	Electrical Specifications.....	2
3.1.1	Field Plots	3
3.2	Environmental Specifications	4
3.3	Mechanical Specifications	5
3.3.1	Mechanical Drawings.....	5
4	Ordering Information	6
5	Notices	6

1 OVERVIEW

The Impinj Guardwall RAIN RFID antenna, deployed in pairs, provides a tightly controlled read zone designed to integrate into conveyor systems. The antenna provides a tightly controlled read zone and intense RF field for item-level reading of packed goods, critical to penetrating deep into packed cases. When used as a pair, the Guardwall antenna absorbs energy from its opposing mate so that very little passes beyond the exterior face. This configuration maximizes stray read rejection by constraining the read zone to the area within the two antennas. It also increases read reliability by maximizing the intensity within the read zone.

Figure 1: Antenna Picture



1.1 Features

- A pair of Guardwall antennas creates a tightly controlled read zone and intense RF field to penetrate boxes and cases of items
- Designed to smoothly integrate into conveyor systems
- FCC and ETSI versions available
- Designed to be used in a pair

2 READ ZONE CHARACTERISTICS

A pair of Guardwall antennas used together creates an intense, well-contained read zone, with little spillover beyond the exterior faces.

Figure 2: Guardwall Read Zone Diagram



3 SPECIFICATIONS

3.1 Electrical Specifications

Table 1: Electrical Specifications

PARAMETER	VALUE
Frequency Range	FCC: 902-928 MHz
	ETSI: 865-868MHz
Polarization	RH Circular & LH Circular (Dual Elements)
Input Power	30 dBm
3 dB Beamwidth	55°
Far-Field Gain	6 dBi
VSWR Across Frequency Range	1.5:1
Front-to-Back Ratio	22 dB
Axial Ratio	3 dB
Nominal Impedance	50Ω

3.1.1 Field Plots

Figure 3: Guardwall Radiation Pattern (x-z plane)

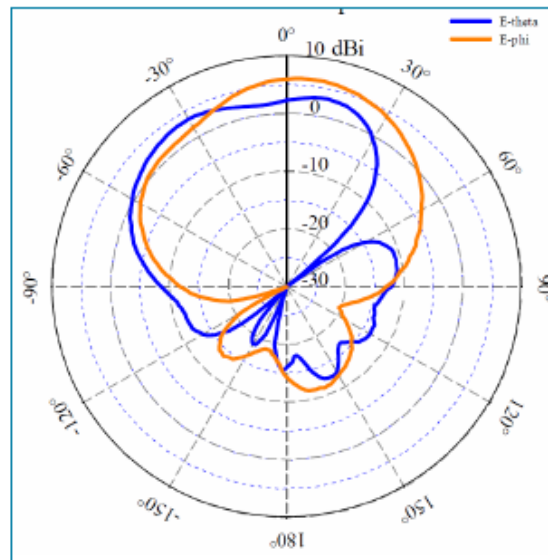

Figure 4: Guardwall Radiation Pattern at 915 MHz (y-z plane)

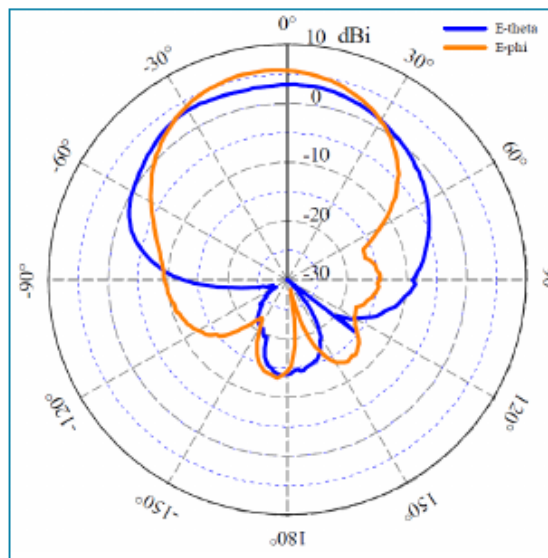
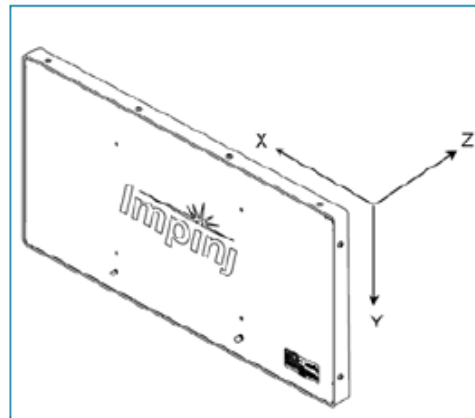

Figure 5: Guardwall Plane Coordinate Key



3.2 Environmental Specifications

Table 2: Environmental Specifications

PARAMETER	VALUE
Environmental Rating	IP51 (Indoor Use Only)
Operating & Storage Temperature	0 °C to 40 °C (32 °F to 104 °F)
Humidity	5% to 95% (Relative, Non-Condensing)

3.3 Mechanical Specifications

Table 3: Mechanical Specifications

PARAMETER	VALUE
Dimensions (L x W x D)	27.6 x 15.8 x 2.9 in
	70.2 x 40.2 x 7.3 cm
Weight	11 lbs (5 kgs)
Mounting	2X SMA female*
RoHS	RoHS Compliant
Radome	ABS
Enclosure	Aluminum
Mounting	Brackets sold separately
Connector Type	SMA Female (x2)

*Requires accessory cable to connect to reader's RP-TNC connector

3.3.1 Mechanical Drawings

Figure 6: Guardwall Mechanical Drawings

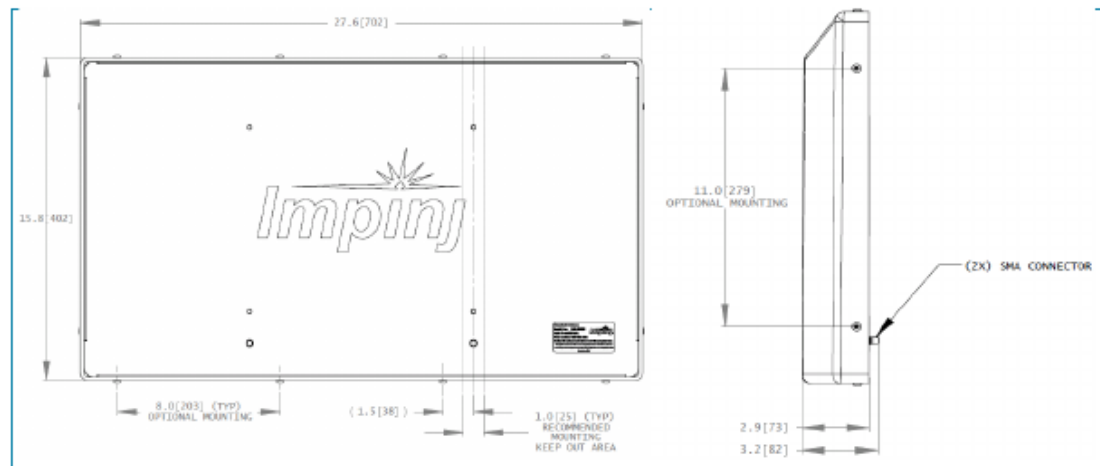

Included with the antenna are two cables and their connectors: 2x Cable, Male RP-TNC / Male SMA, RG58 (6.2 ft / 2 m)

4 ORDERING INFORMATION

Table 4: Ordering Information

PART NUMBER	DESCRIPTION
IPJ-A0402-USA	Guardwall (FCC) (70 x 40 x 10 cm)
IPJ-A0402-EU1	Guardwall (ETSI) (70 x 40 x 10 cm)

5 NOTICES

Copyright © 2018, Impinj, Inc. All rights reserved.

Impinj gives no representation or warranty, express or implied, for accuracy or reliability of information in this document. Impinj reserves the right to change its products and services and this information at any time without notice.

EXCEPT AS PROVIDED IN IMPINJ'S TERMS AND CONDITIONS OF SALE (OR AS OTHERWISE AGREED IN A VALID WRITTEN INDIVIDUAL AGREEMENT WITH IMPINJ), IMPINJ ASSUMES NO LIABILITY WHATSOEVER AND IMPINJ DISCLAIMS ANY EXPRESS OR IMPLIED WARRANTY, RELATED TO SALE AND/OR USE OF IMPINJ PRODUCTS INCLUDING LIABILITY OR WARRANTIES RELATING TO FITNESS FOR A PARTICULAR PURPOSE, MERCHANTABILITY, OR INFRINGEMENT.

NO LICENSE, EXPRESS OR IMPLIED, BY ESTOPPEL OR OTHERWISE, TO ANY PATENT, COPYRIGHT, MASKWORK RIGHT, OR OTHER INTELLECTUAL PROPERTY RIGHT IS GRANTED BY THIS DOCUMENT.

Impinj assumes no liability for applications assistance or customer product design. Customers should provide adequate design and operating safeguards to minimize risks.

Impinj products are not designed, warranted or authorized for use in any product or application where a malfunction may reasonably be expected to cause personal injury or death, or property or environmental damage ("hazardous uses"), including but not limited to military applications; life-support systems; aircraft control, navigation or communication; air-traffic management; or in the design, construction, operation, or maintenance of a nuclear facility. Customers must indemnify Impinj against any damages arising out of the use of Impinj products in any hazardous uses.

Impinj, and Impinj products and features are trademarks or registered trademarks of Impinj, Inc. For a complete list of Impinj Trademarks, visit www.impinj.com/trademarks. All other product or service names may be trademarks of their respective companies.

The products referenced in this document may be covered by one or more U.S. patents. See www.impinj.com/patents for details.