



THE SATO TH2 RETAIL LABEL PRINTER



USER GUIDE

Help & Service for your SATO Printer	2
Setting up your Printer	3
The Keypad	6
Loading the Label Roll	7
Using the Dispenser	9
Label Formats	11
Printing Labels	13
Charging the Battery	15
Cleaning Procedures	16



About your SATO Retail Printer

Your SATO TH2 printer will immediately provide professional labels with the simplest of operation.

Being designed using the most up-to-date technology, the printer is fully future-proofed and can be programmed to take care of any labelling requirements that your business may need.

If you should wish to upgrade your printer a number of enhancements are available:

High Capacity Rechargeable Battery

The High-capacity rechargeable battery makes the TH2 fully portable and can print up to 5,000 labels without re-charging. The battery can be fully recharged in the printer in about 6 hours or even faster when using the optional charging unit.

Barcode Scanner

Adding a Barcode Scanner enables you to scan an existing product barcode and produce a new label without manual entry of the product details.

Anti-Microbial Keypad Cover

The casing of your TH2 is manufactured from anti-microbial material which discourages the growth of bacteria. A keypad cover with the same properties can be added to prevent ingress of food and dust into the keypad.

Automatic Calculations

Automatic calculation of percentage reductions can be added as well as Best Before date printing and product database options . Indeed, The TH" can be programmed to perform almost any business function. Please do not hesitate to contact us with your requirements.









Assistance for your SATO Printer

You should find that your SATO printer is straightforward to operate. However, if you should experience any difficulty, please contact our Helpdesk for assistance:

Call: 01255 252828
or
e-mail: techsupport@satouk.com

Ordering more labels

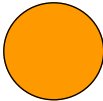
The high quality TH2 labels are manufactured by SATO in the UK and have been especially developed to give the best results in the TH2 printer. These labels are relied upon by many household name stores in UK retail.

Label Type	Size	SATO Product Code
Yellow 	45 X 34.925mm	P70011017451 Permanent Adhesive
White 	32x 25.4mm	P70010101601 Peel adhesive
Red & White Reduced 	28 x 33mm	P70010109921 Peel adhesive
Red & White Sale 	28 x 33mm	P70010109961 Peel adhesive
Orange 	40mm circular	P70011014331 Peel adhesive
Red 	23mm circular	P70010144861 Peel adhesive
White 	45 X 47.625mm	P70010101571 Peel adhesive



Setting up your SATO Printer (1)

Inside the box:

- TH2 Retail Label Printer
- Quick Guide
- Mains AC Adaptor
- Mains Cable

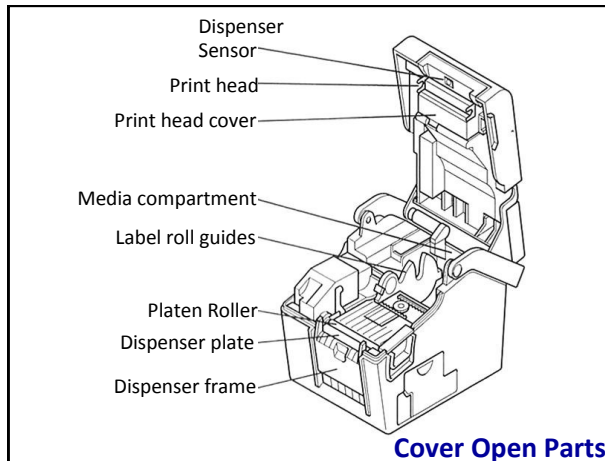
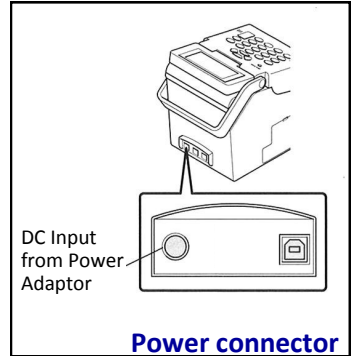
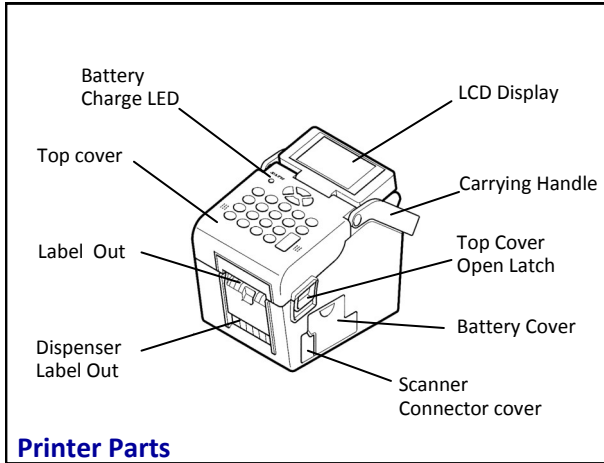



Setting up your SATO Printer (2)

Power Connection

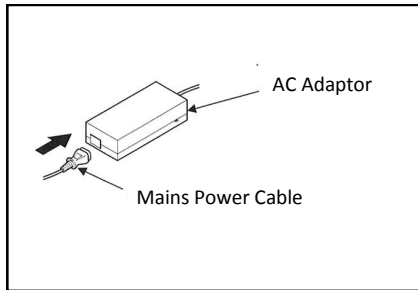

1. Plug the Mains Power Cable into the AC Adaptor

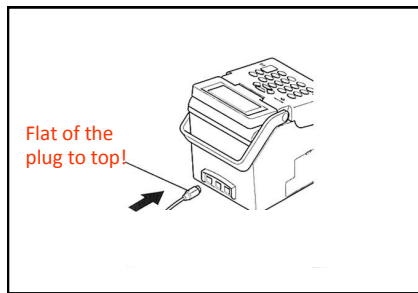

2. Plug the DC Output plug into it's socket at the rear of the printer.

THIS PLUG ONLY FITS ONE WAY ROUND! The flat area of the plastic plug should be upwards.

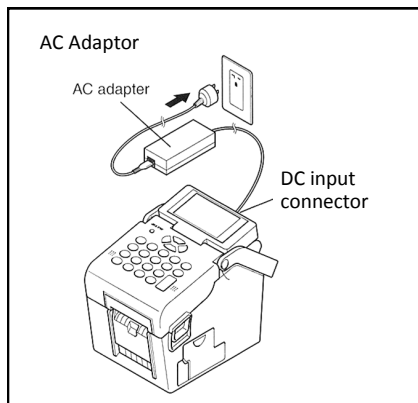

3. Plug the Mains Power Cable into the Mains supply socket.

Notes:



The Printer Keypad

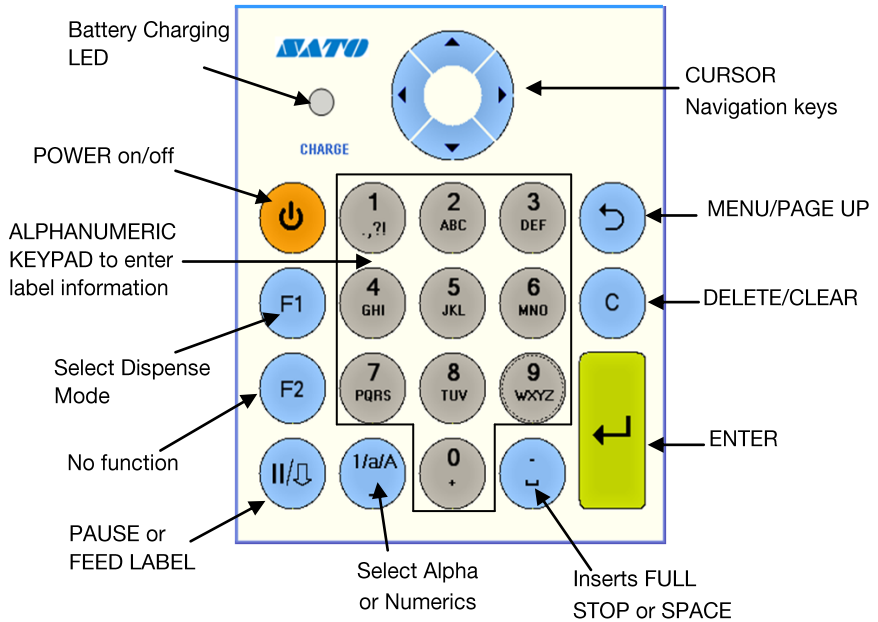

Power	Power On: Press for 1 second Power Off: Press for 3 seconds
Menu/Page Up	Menu: Press for more than 1 second Up 1 level: Press once
Delete	Deletes/Clears characters to the left of the cursor. Hold for 2 seconds to delete all input data
Select Dispense Mode	Switches to label dispense mode
Pause/Feed	In Print Mode: Pauses and re-starts printing Feed Mode: Feeds one label
Select Alphanumerics	Press to select numbers/lower case/upper case
Full Stop/Space	Enters space or full stop



Loading the Label Roll



SELECT THE TYPE OF LABEL THAT YOU WISH TO PRINT AND INSTALL INTO THE PRINTER AS FOLLOWS:

1. Push the handle fully back. Press the Cover Open Latch (1) and lift up the cover (2). Ensure that the cover is in the “up” position.

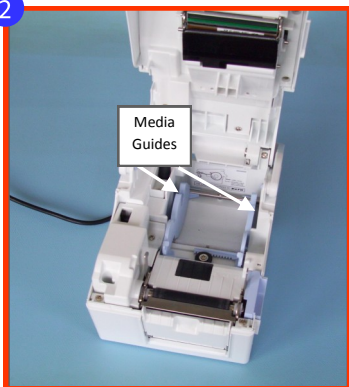

2. Adjust the spacing of the Media Guides to the widest position.

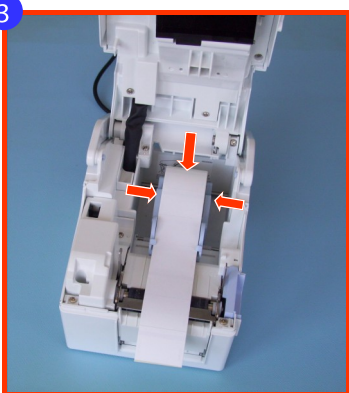

3. Place the new label roll into the Media Compartment. Labels upwards. Adjust the Media Guides inwards until the Guides press lightly against the roll.



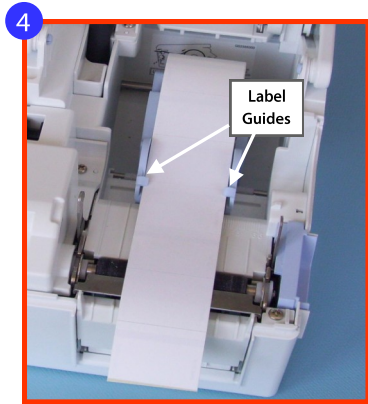

4. Position the edges of the labels under the Label Guides and pull the end of the roll out of the front of the printer.



5. Close the top cover until it clicks into position.



6. Press the Power key for 1 second if the printer is turned off. 

Press <Enter> then the <Feed> key to feed and align the first label. 





Using the Label Dispenser

This feature will print and dispense a single label. As soon as the label is removed the printer will issue the next label. This procedure will set up the printer for dispenser use.

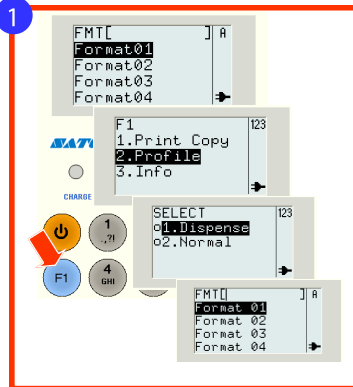

1. SWITCH TO THE DISPENSE MODE:
 - Press the <F1> key.
 - Select **2. Profile** and press <Enter>.
 - Select **1. Dispense** and Press <Enter> to return to the Format menu .
 - The printer is now set to Label dispensing

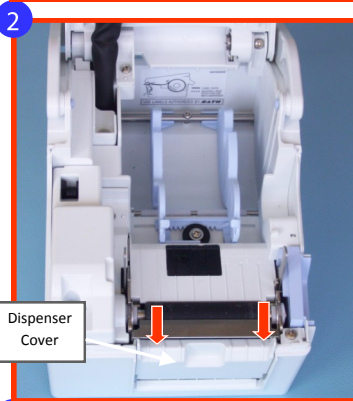

2. Open the printer Top Cover.
Place two fingers at the top of the Dispenser Cover and pull forward to release the cover.

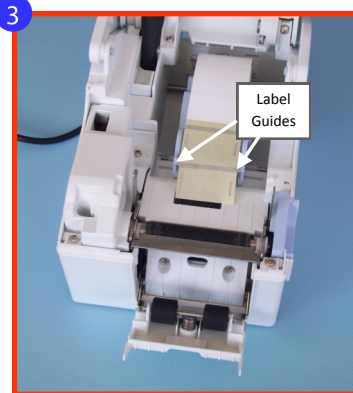

3. Fit the label roll into the printer and remove the first few labels from the backing paper.
Position the edges of the roll underneath the two label guides.

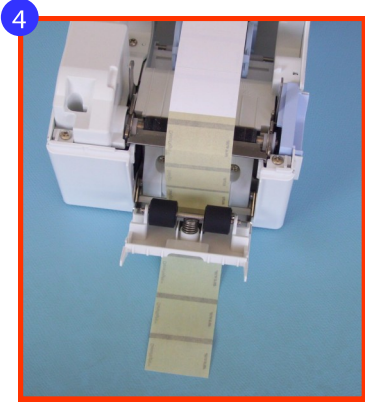

4. Thread the label backing paper underneath the black rollers and out of the front of the printer.

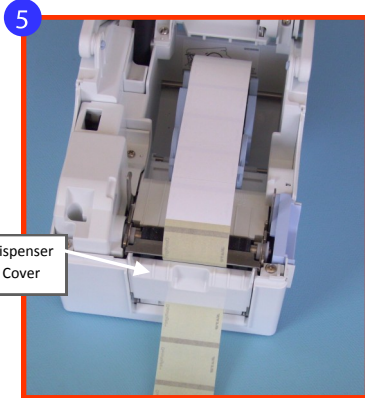

5. Close the Dispenser Cover until it locks into position.
Tighten the label roll if it is slack.

6. Firmly close the Top Cover until it clicks into position.
Switch the printer on and press the <FEED> key until the first label is dispensed.
You are now ready to print your labels.

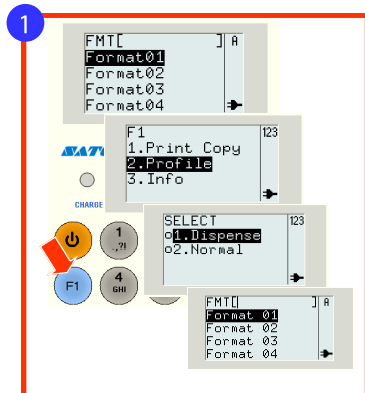

To return to Normal label mode

1. SWITCH TO THE NORMAL MODE:
- Press the <F1> key.
 - Select *2. Profile* and press <Enter>.
 - Select *2. Normal* and Press <Enter> to return to the Format menu .
 - The printer is now set to output labels on the backing paper
- ENSURE THAT THE LABELS ARE LOADED AS SHOWN ON PAGES 8 & 9**



Printing Labels

There are 13 common label formats provided with your TH2 printer. Select the function and label required from the table below.

Label Formats

Label Format No.	Function	Label Type	Label Re-order Code
1	Price, VAT & 1 x Description field		P70010101601 32x25
2	Price, VAT & 2 x Item Code		P70010101571 45x47
3	Price, VAT & Item Code		P70011017451 45x35
4	Price Only		P70010101601 32x25
5	Price Only, rotated		P70010101571 45 x 47
6	Price Only		P70011017451 45x35



Printer Format No.	Function	Label Type	Label Re-order Code
7	Price, Description & Barcode		P7001010160 1 32 x 25
8	Price, Description & Barcode		P70010101571 45 x 47
9	Price, Description & Barcode		P70011017451 45x35
10	Was/Now pricing		P70010144711 28X33
11	Was/Now pricing		P70010109961 28X33
12	Price Only		P70010144861 23X23
13	Was/Now pricing		P70011014331 40X40



Printing Labels

Printing labels is done by selection of the required label format and following the on-screen prompts. Label Format 9, text, price and barcode is used in this example.

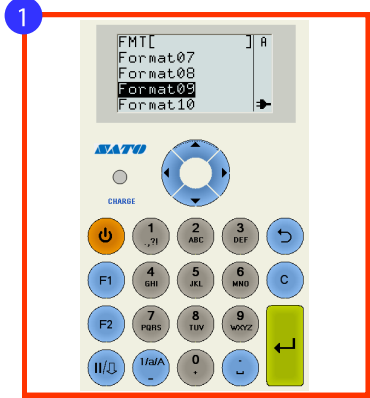

1. Ensure that the printer is switched ON.
(Hold the Power key for 1 second).

Select the required label format number by scrolling the list or by entering the Format number.
Press <ENTER>

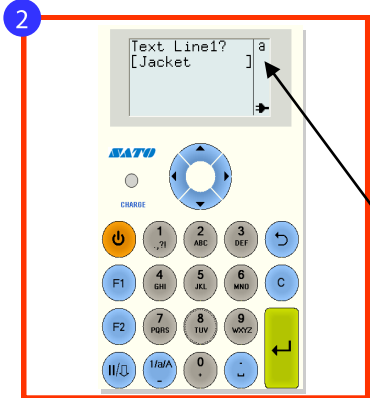

2. Input the first line of text as requested. This may be a code or a description etc. The maximum numbers of characters is 10.
Use the <Select Alphanumerics > key to choose either upper or lower case letters, or numbers. The type of character selected is shown in the top right corner of the display.
Press ENTER>

Indicates Selection:

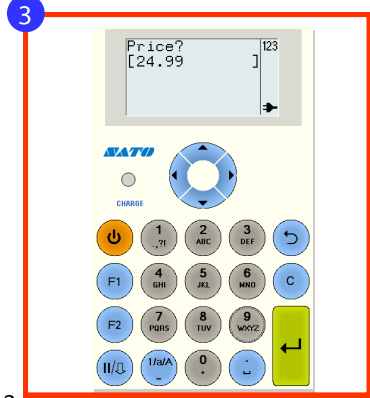

3. Enter the article price using the <FULL STOP> key to input the decimal point.

Press <ENTER>

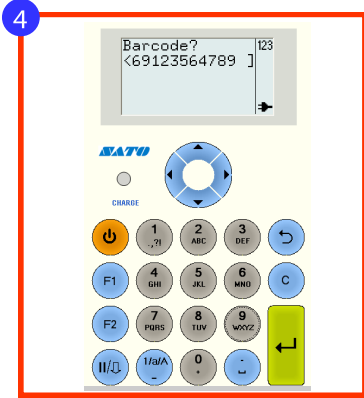

4. Input the Barcode data. The standard EAN13 code requires 12 digits. Press <ENTER>

The 13th digit is calculated automatically.

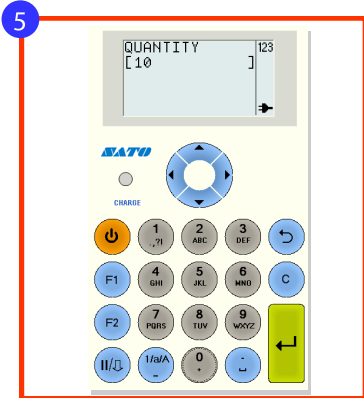

5. Enter the required number of labels and press <ENTER>. Your labels will be printed immediately.



NOTE that for safety reasons, there is no serrated edge to tear your labels. Tear off the labels using a downwards and sideways motion.

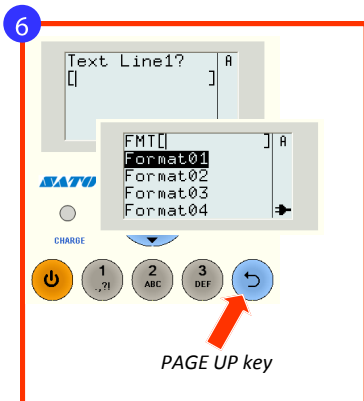

6. The printer will returns to screen 1 of the selected format. If you wish to select a new label format press the <Page Up> key to return to the Label Format0 selection screen.

PAGE UP key



Optional Battery Installation & Charging

Fitting the Battery

1



Put the terminal end of the battery into the compartment first. Push the battery inwards until it is locked in place by the Blue Locking Tab. Close the battery cover.

2



The battery can now be removed.

Removing the Battery

3



Lower the Battery Compartment Cover on the right-hand side of the printer. Slide the Blue Locking Tab to release the battery.

Charging the Battery

4



Connect the AC Power Adaptor to the printer and to the mains power supply. The charge LED will illuminate to indicate charging and go out when the battery is fully charged.

AN EXHAUSTED BATTERY WILL NEED ABOUT 6 HOURS TO ACHIEVE FULL CHARGE.



Cleaning Procedures

Regular cleaning will ensure that your SATO printer always produces high quality labels. Please follow the procedure below each month.

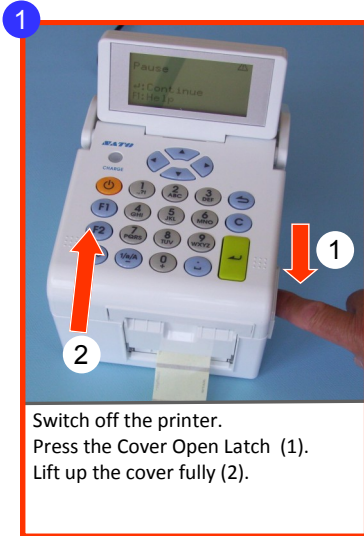

Switch off the printer.
Press the Cover Open Latch (1).
Lift up the cover fully (2).

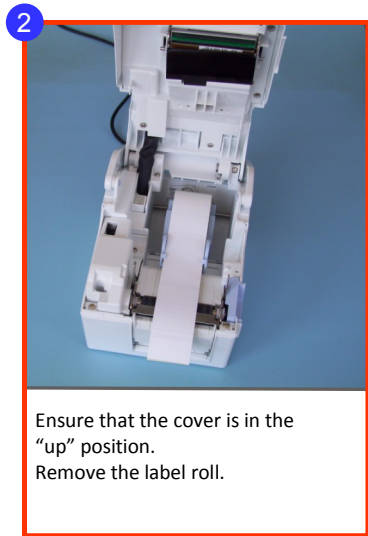

Ensure that the cover is in the "up" position.
Remove the label roll.

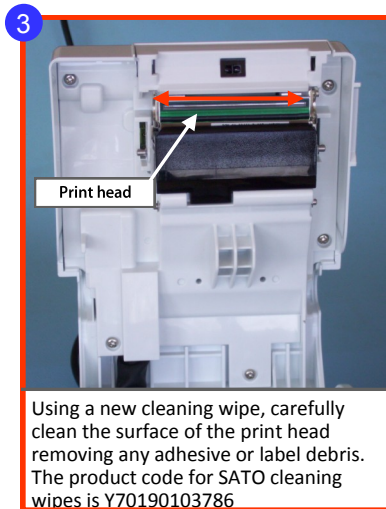

Using a new cleaning wipe, carefully clean the surface of the print head removing any adhesive or label debris. The product code for SATO cleaning wipes is Y70190103786

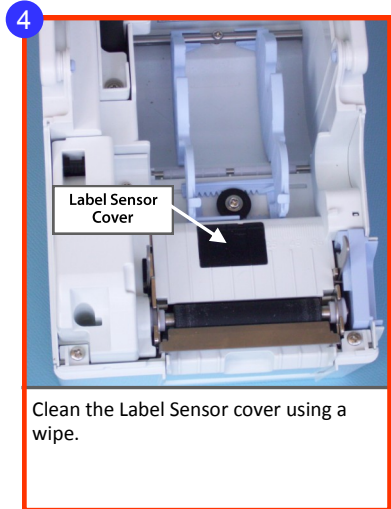

Clean the Label Sensor cover using a wipe.



Cleaning Procedures continued

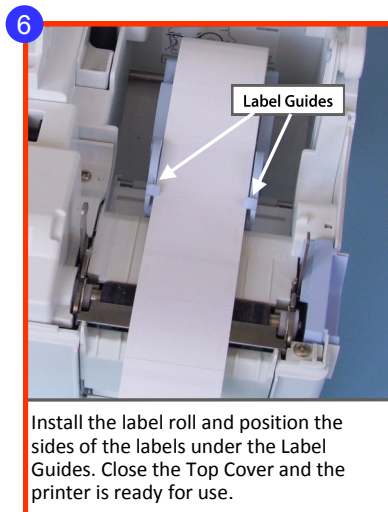
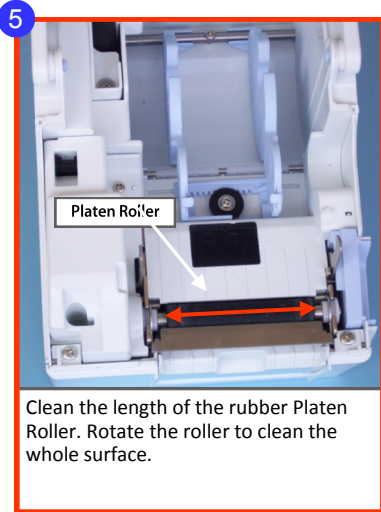

For effective cleaning use SATO Cleaning wipes,
Product Code Y70190103786

Assistance for your SATO Printer

Call: 01255 252828
or
e-mail: techsupport@satouk.com

