

# MICRO SEIKI®

## DYNAMIC BALANCE TONEARM MA-505 (DD-40's TONEARM)

### SERVICE MANUAL

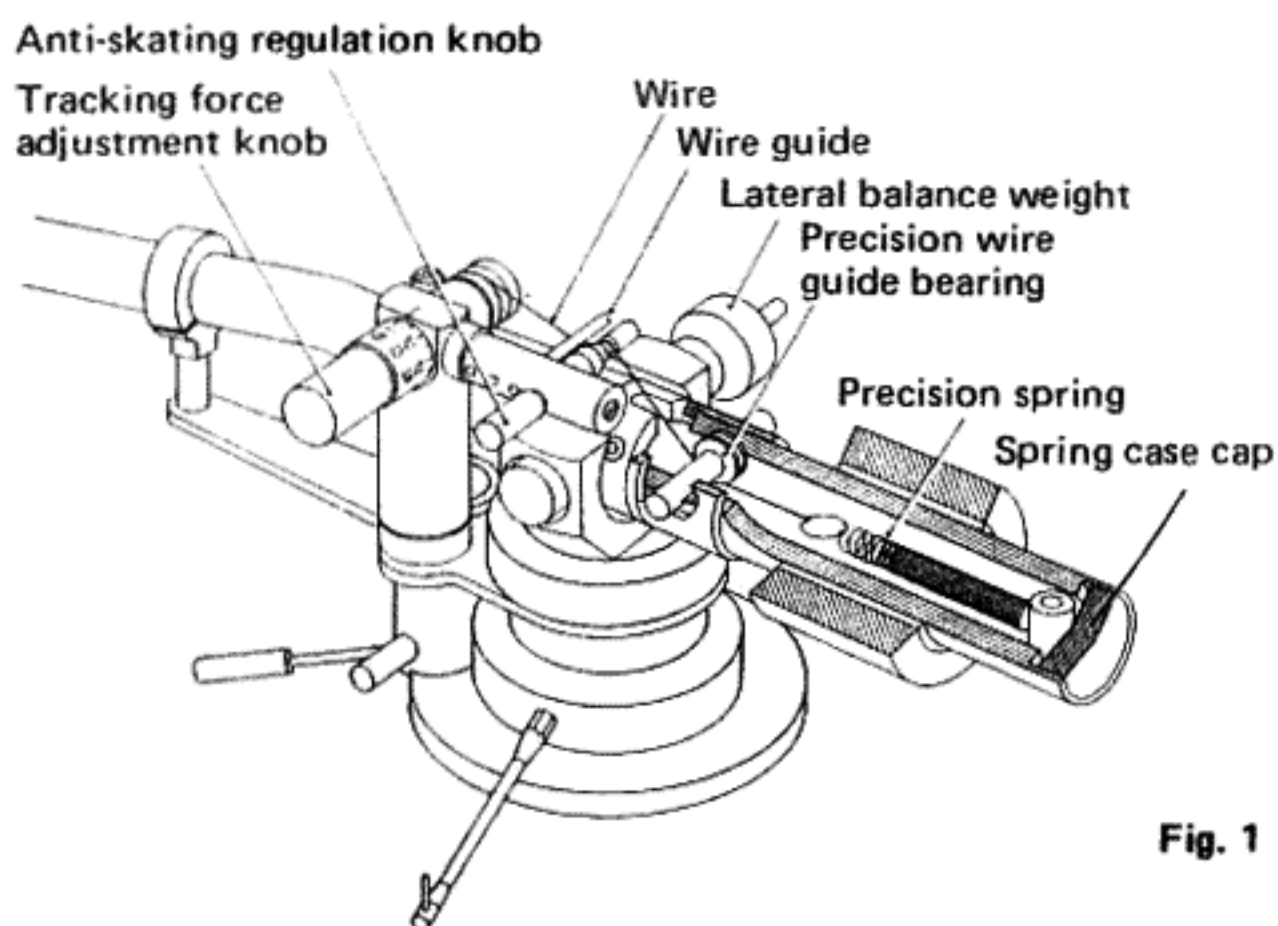

Fig. 1

#### ● WIRE REPLACEMENT

- 1) Prepare 10 inches or so of string for leading the new wire through the spring case of the tonearm.
- 2) Remove the headshell from the tonearm.
- 3) Loosen the set screw securing the wire to the tracking force adjustment reel. (photo 1)

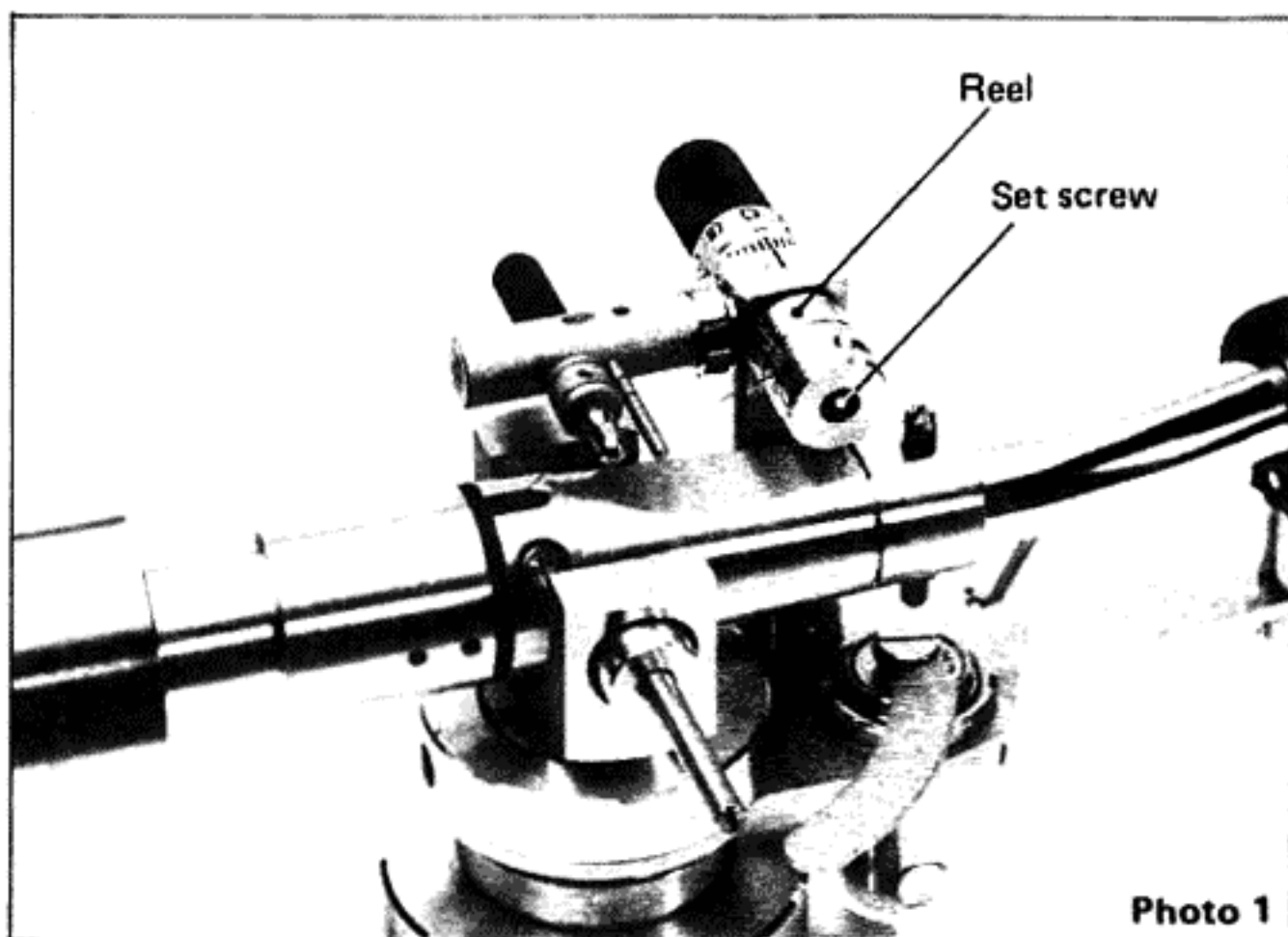

Photo 1

- 4) Remove the wire from the reel.
- 5) Remove the cap of the spring case by rotating it counter-clockwise with a two-pin screw driver. (fig. 1)  
If the cap is not remove easily, melt adhesives on internal threads by using a solvent such as toluol around outside edge of cap.
- 6) Link the string to the end of the wire.
- 7) Pull the spring retaining pin and withdraw the spring-wire assembly. (fig. 2)

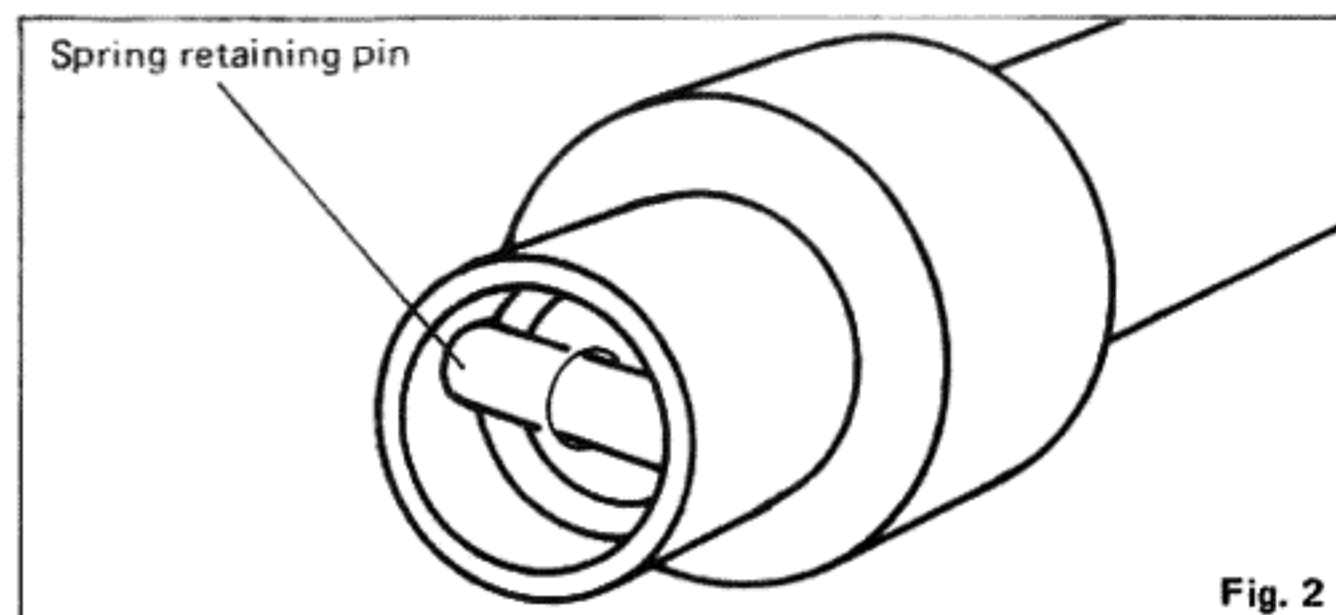

Fig. 2

- 8) Remove the string from the wire.
- 9) Remove the wire from the spring.
- 10) Connect the new wire to the spring and the string to the other end of the new wire. (fig. 3)

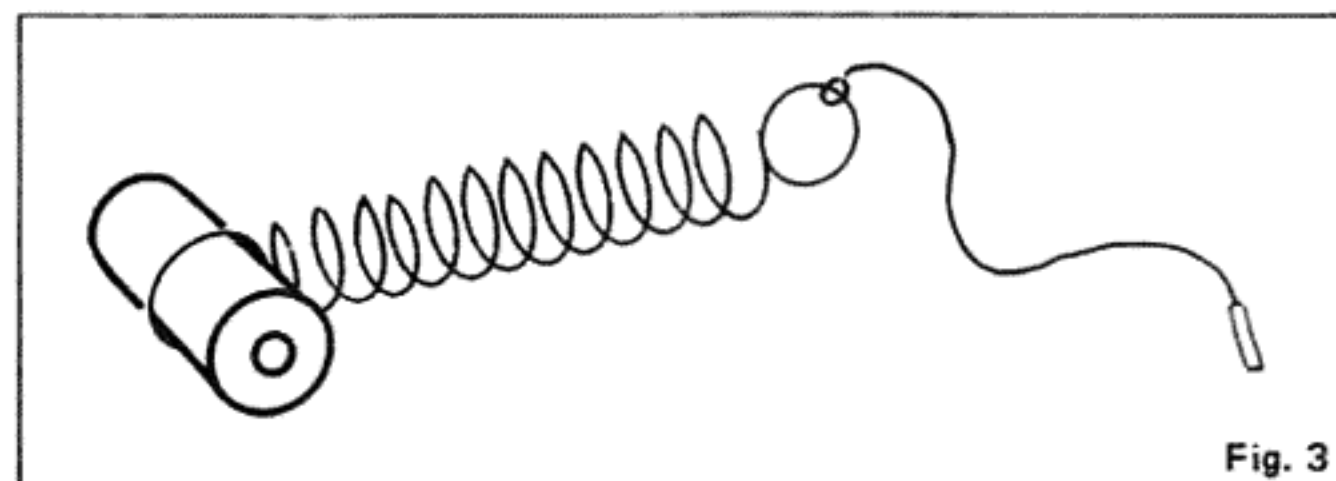

Fig. 3

- 11) Pull the string and the spring-wire assembly back into the spring case, so that the new wire appears out of the tonearm.
- 12) Remount the spring retaining pin and attached spring. Confirm that the pin is lying horizontally and that the spring is not touching the inner wall of the spring case.
- 13) Remount the cap to the spring case using a small amount of adhesive or locking compound.
- 14) Remove the string from the new wire.
- 15) Loosen the set screw retaining the tracking force dial to the shaft.
- 16) Align the tracking force adjustment reel and the tracking force dial as showing Fig 4.

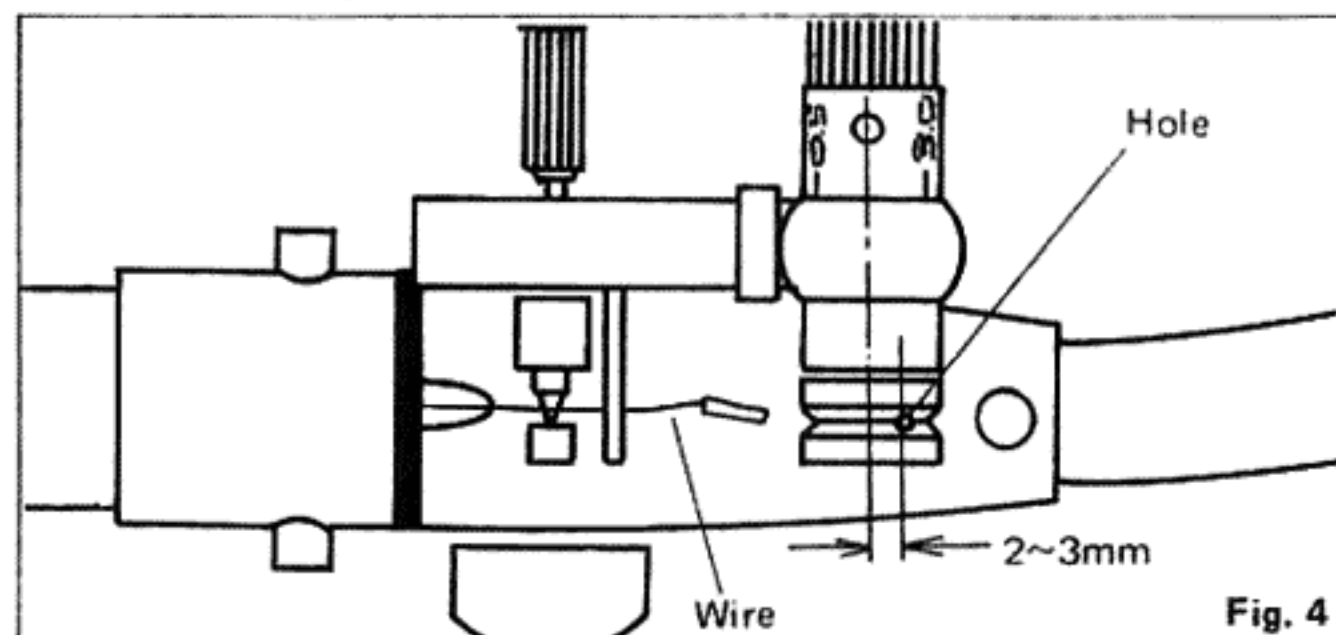

Fig. 4

- 17) Turn the anti-skating regulation knob counter-clockwise until it stops.
- 18) Thread the wire through as shown in Fig. 5 and insert the end pipe of the wire into the hole on the tracking force adjustment reel and secure it with the set screw. Confirm that the end pipe of the wire does not appear out of the hole.

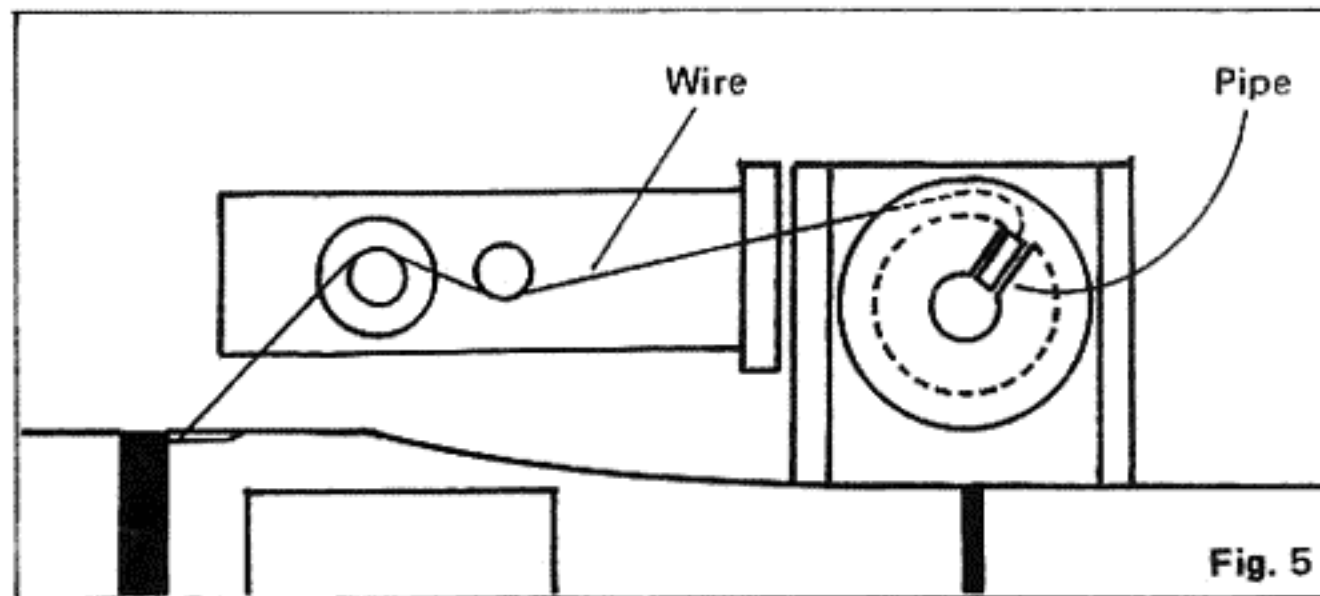

Fig. 5

### ● TRACKING FORCE CALIBRATION

Using a balance (a beam and scales), calibrate the tracking force dial as following procedures;

- 1) Remount the headshell with the cartridge to the tonearm, but to prevent damaging the stylus, remove the stylus by pulling it forward out of the cartridge.
- 2) Turn the counterweight of the tonearm until the tonearm balance is achieved.
- 3) Place the cartridge on one side of the scale and a 1 gram weight on the other side. If the cartridge body does not rest on the scale due to the tonearm pipe touching the scale edge, mount a suitable flat plate on the scale as shown in Fig. 6 and balance it again, before weighing 1 gram.

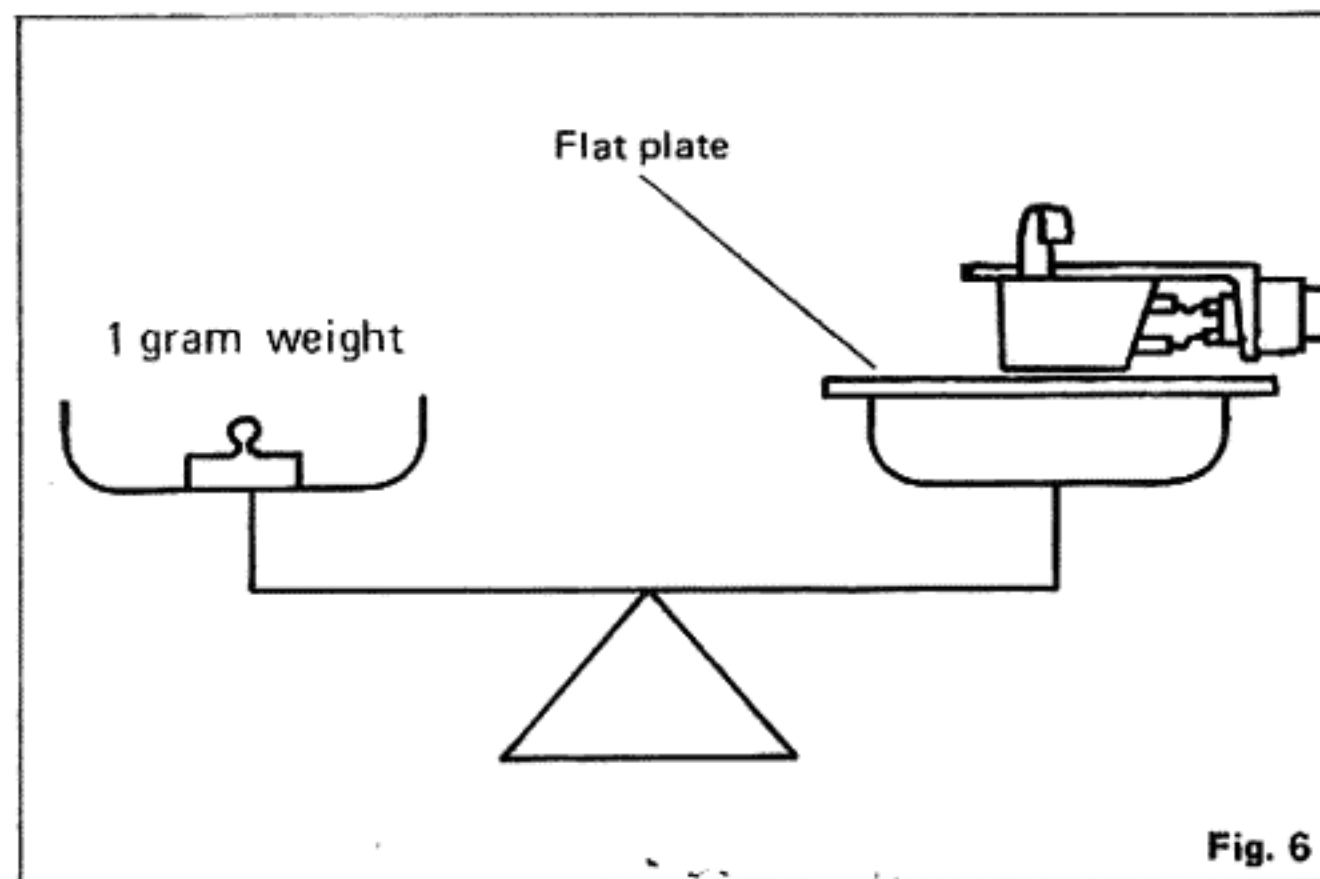

Fig. 6

- 4) Turn the tracking force adjustment knob until the balance keeps level.
- 5) Align the 1 mark on the dial with the reference line after loosening set screw. During the alignment hold the reel so that the wire does not get loose.

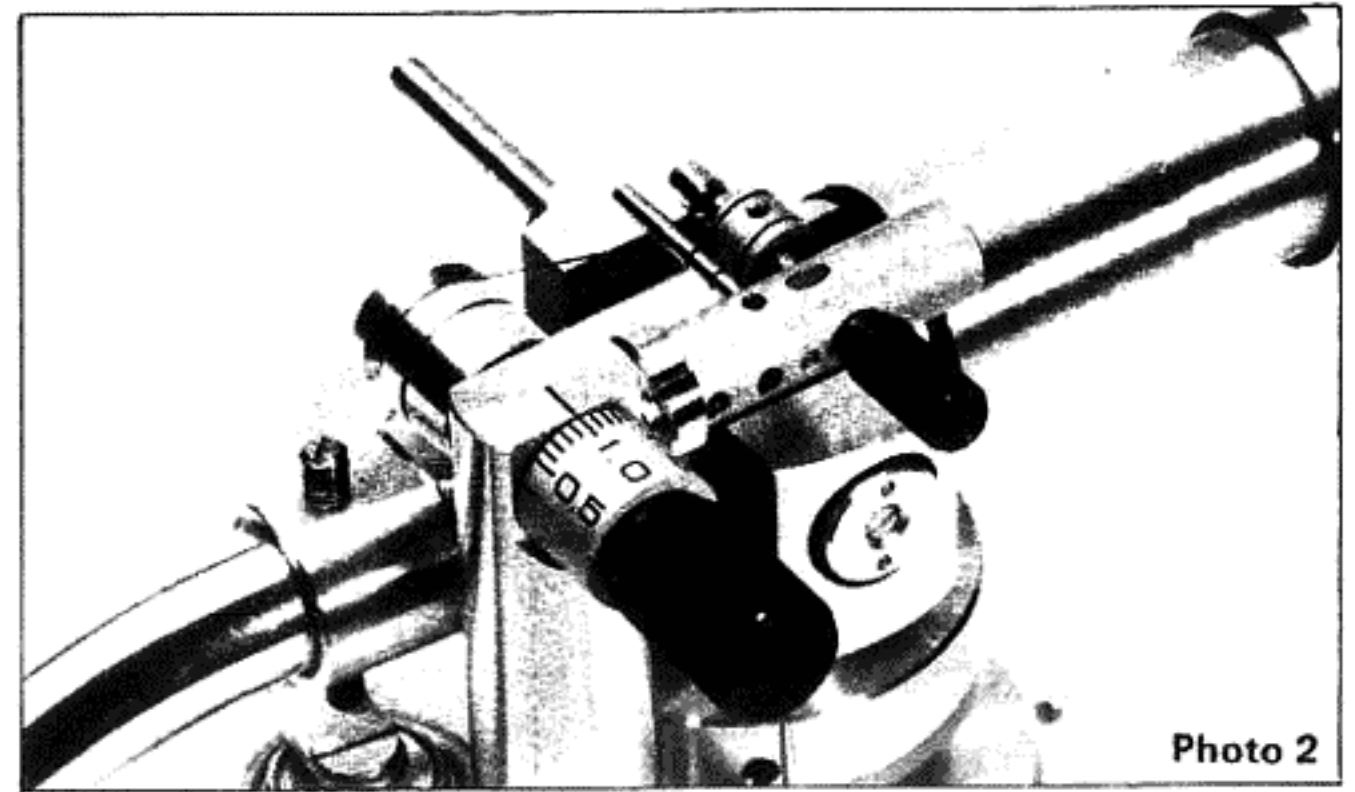

Photo 2

- 6) Secure the tracking force dial to the shaft with the set screw.

### ● SPECIFICATION

Model	Dynamic balance type universal tone arm
Total length	322 mm (12-11/16")
Working length	237 mm ( 9-5/16")
Overhang	15 mm (19/32")
Offset angle	21° 50'
Angle of tracking error	Less than 1.5°
Height adjustment range	42-86 mm (1-5/8"~3-3/8") (measured from the motor board to the cartridge installation surface)
Height adjustment range achieved by lever operation	6 mm (1/4")
Suitable cartridge weight	4-10 g (0.14~0.35 oz)
Using sub-weight (large)	9.5-16 g (0.34~0.56 oz)
Horizontal movement sensitivity	25 mg
Vertical movement sensitivity	25 mg
Tracking force regulation range	0-3 g scale
Anti-skating device	Spring tension system regulated according to tracking force
Arm lifter	Built-in shock absorber for raising Slow return type Headshell turning mechanism installed
Output lead	Low capacity 5P plug in (55 pF/m) shielded cord
Headshell weight	9.7 g (0.34 oz)
Head connector	SME type 4P connector
Connector	Electroplated in hard metal