

Technics

QUARTZ Direct Drive
Turntable System

SL-M3

Operating Instructions

T4P is the standard mark for the "P-mount" plug-in-connector system. Products carrying this mark are interchangeable and compatible with each other.



The model number of this product is found on the back of the unit, and the serial number either on the back or on the bottom. Please note the model and serial numbers of this unit in the space provided below and retain this booklet as a permanent record of your purchase to aid identification in the event of theft.

MODEL NUMBER **SL-M3**

SERIAL NUMBER

Contents

Before use.....	2
Parts identification	3
Parts identification and their functions	4
Set-up.....	5
Placement	5
Connections	5
Operation	6 ~ 7
Adjustments	7
Notes and maintenance	7 ~ 8
Suggestions for safety	8
Specifications	9
Features.....	9

Before operating this product, please read these instructions completely.

We want to thank you for selecting the SL-M3. For optimum performance, we recommend that you read these instructions carefully.



Dear Stereo Fan

Technics. The science of sound. Our name represents over 100 high quality audio products, in every price range.

From our revolutionary direct drive turntables to our highly acclaimed linear phase speakers, Technics quality and value have become almost legendary among audio enthusiasts.

Our truly complete selection of turntables (including belt-drive and quartz-locked, direct drive models with varying degrees of automation) now includes an exciting line of linear tracking turntables with zero tracking error. Another innovation, direct drive cassette decks, is available in both slim and micro formats. In fact, with Technics micro series, you can assemble an entire system of the highest quality with truly compact dimensions. Features like our new computer-drive new class-A amplification and quartz-synthesizer tuning have created tremendous excitement among reviewers and customers alike.

Amplifiers, tuners, headphones, microphones, cartridges, open reel decks, sound processors—we are proud of all our high quality equipment and we are constantly seeking to improve our products, in terms of performance and handling ease. In addition, our confidence in the reliability of our merchandise (demonstrated by our warranties) and the reasons for our enormous and rapid growth become obvious.

	CAUTION RISK OF ELECTRIC SHOCK DO NOT OPEN	
<p>CAUTION: TO REDUCE THE RISK OF ELECTRIC SHOCK, DO NOT REMOVE SCREWS. NO USER-SERVICEABLE PARTS INSIDE. REFER SERVICING TO QUALIFIED SERVICE PERSONNEL.</p>		

 The lightning flash with arrowhead symbol, within an equilateral triangle, is intended to alert the user to the presence of uninsulated "dangerous voltage" within the product's enclosure that may be of sufficient magnitude to constitute a risk of electric shock to persons.

 The exclamation point within an equilateral triangle is intended to alert the user to the presence of important operating and maintenance (servicing) instructions in the literature accompanying the appliance.

WARNING: To reduce the risk of fire or electric shock, do not expose this appliance to rain or moisture.

Before use

Caution:

- Remove the transport spacers of the tonearm.
- Never connect the AC power plug before assembly has been completed.
- Attach the dust cover last, so that assembly and adjustments can be made most conveniently.

■ Remove protective transport items and assemble turntable.

To avoid damage caused by vibrations and shocks occurring during shipment, the tonearm is held in place by two screws, a counterweight clamp and an tonearm protective spacer. Note that some turntable parts are packed separately in the carton. Perform the following steps to remove the transport materials and assemble the turntable. Store the materials in a safe place so that you can replace them if the unit is ever shipped again.

1. Remove the two tonearm counterweight locking screws and pull out the clamp.

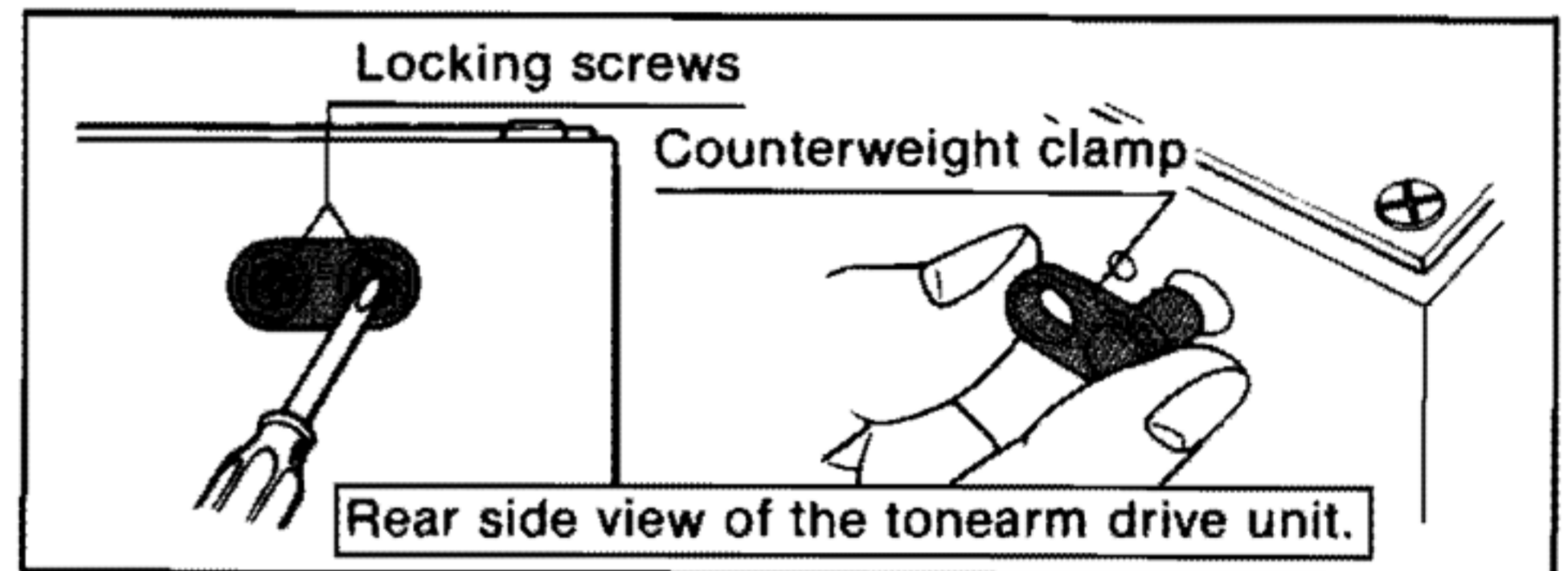

2. Pull out the tonearm spacer in the direction of the arrow.

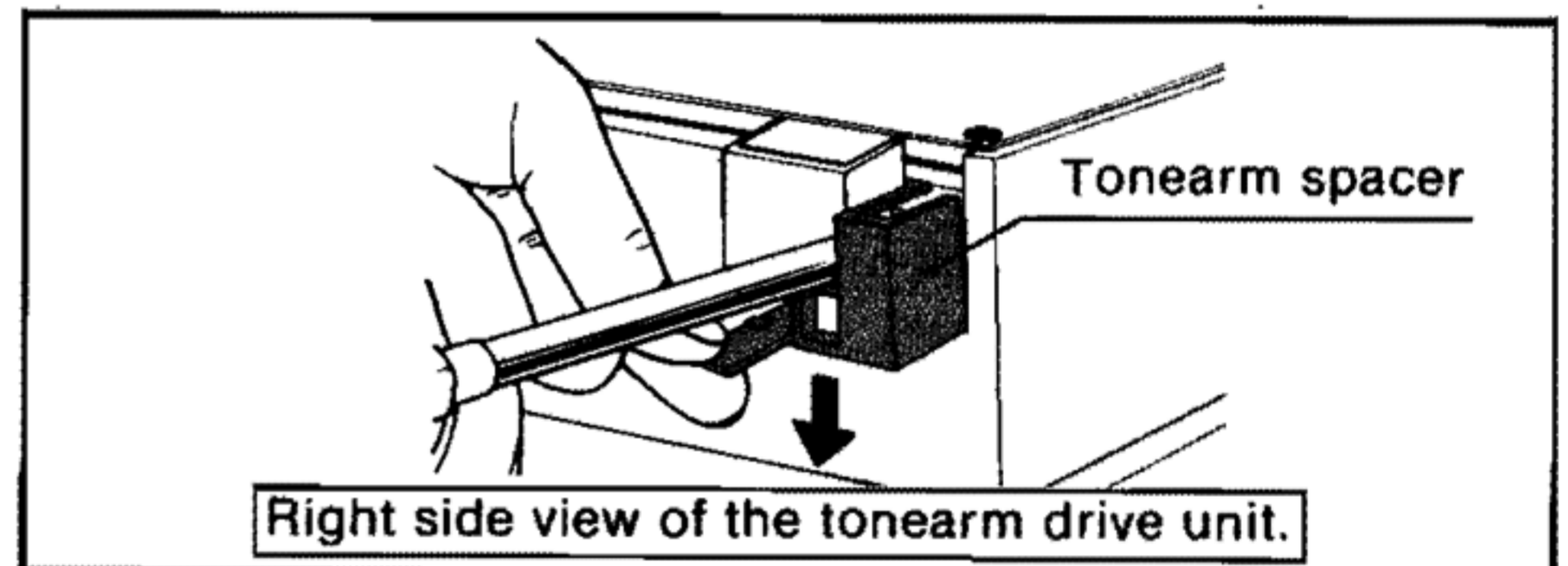

3. Place the platter over the center spindle while holding the platter at a slight angle. Be careful not to hit the tonearm with the platter.

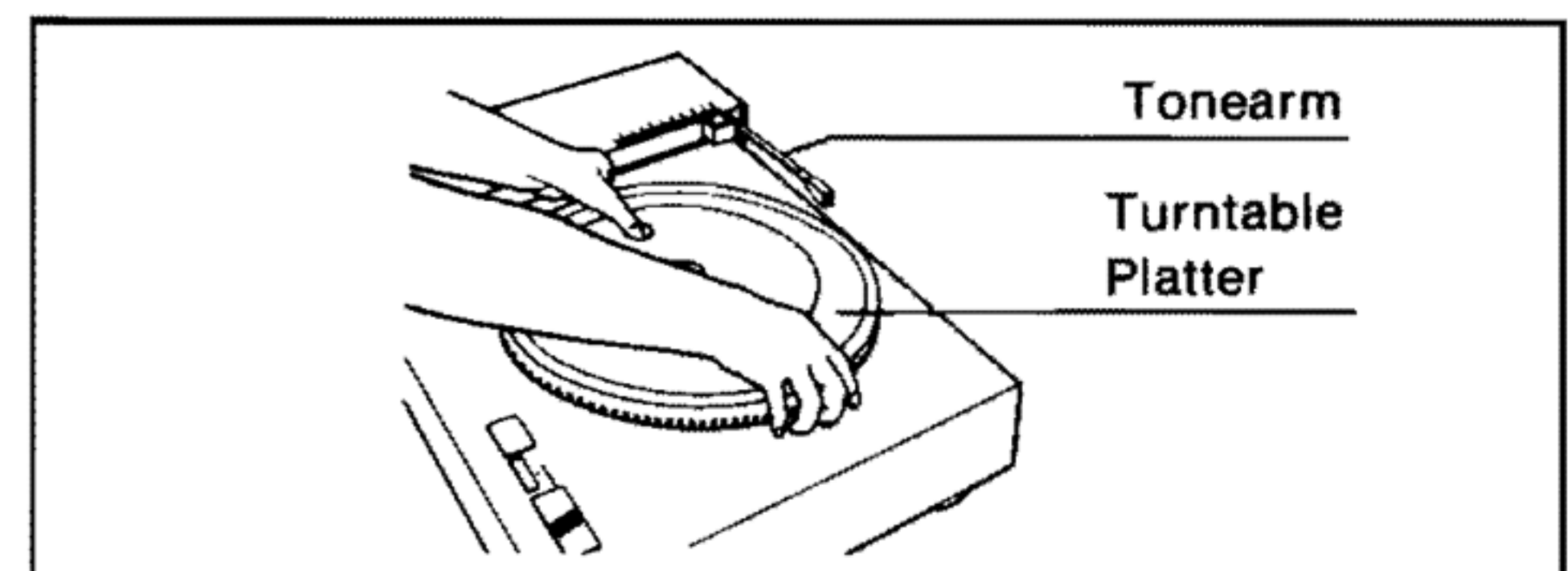

4. Place the mat on the platter.
5. Attach the stylus guard by inserting the two guard pins in the holes in the cabinet.

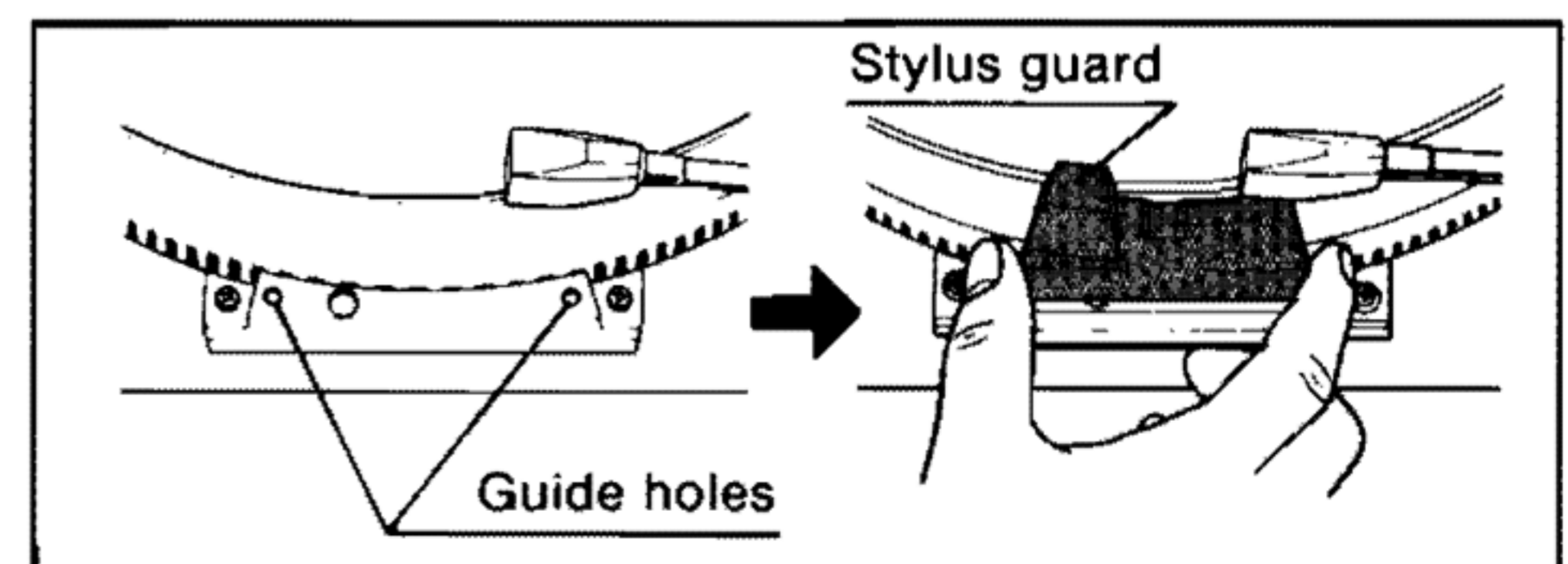

Parts identification

Leave page 3 folded out to quickly locate specific sections at any time.

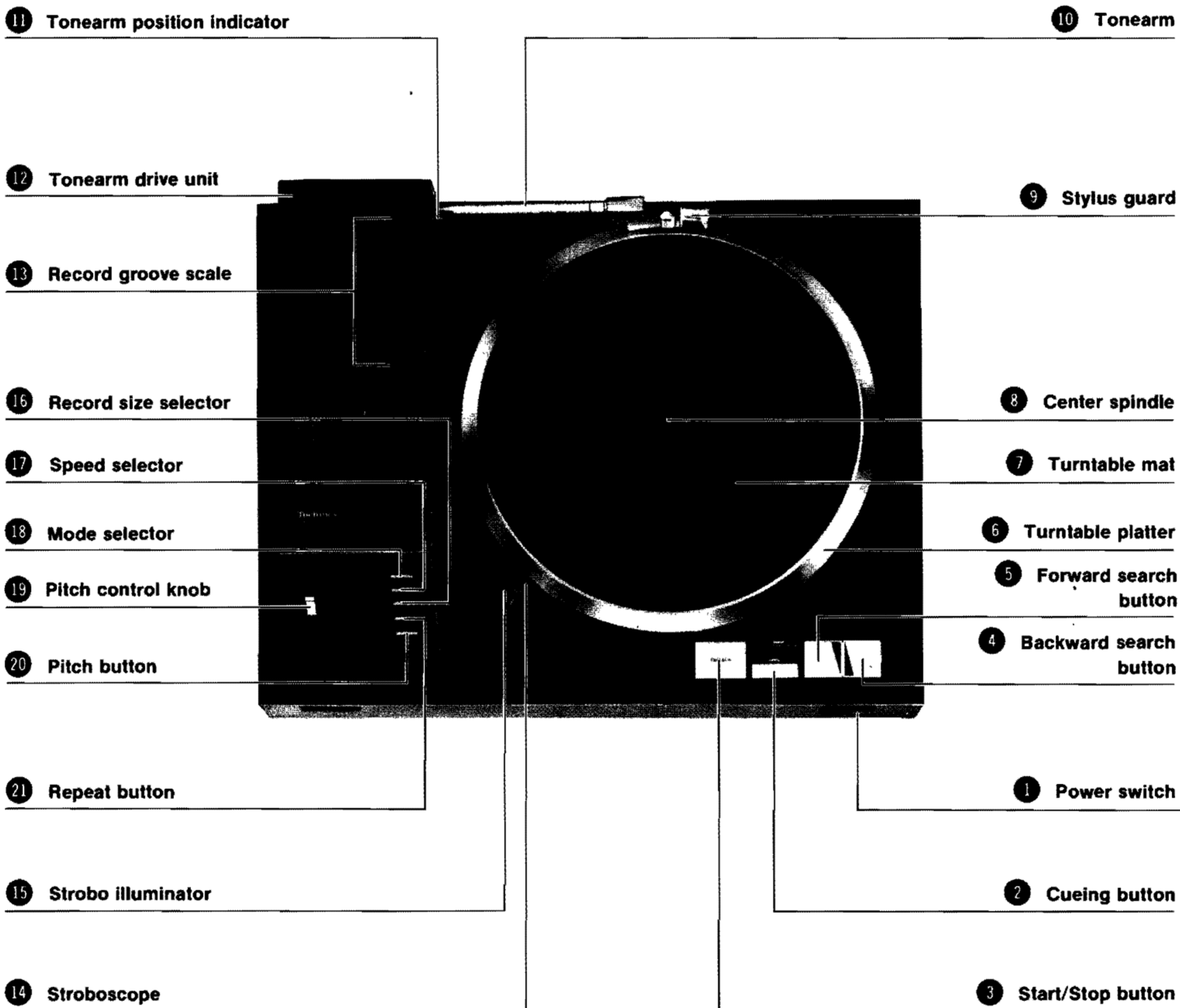

Parts identification and their functions

1 Power switch:

Press once to turn power on and again to turn power off. When power is turned on, the stylus illuminator, strobo illuminator, pitch indicator and auto, 33 and 30 indicators light. If power is switched off during record play, the tonearm will stop at that point on the record. Record play will then be resumed from that point when power is switched on again.

2 Cueing button:

Use this button to raise and lower the tonearm. During record play, pressing this button causes the tonearm to rise. If the tonearm is in the up position, pressing this button causes the tonearm to lower to the record surface. If the tonearm is at the starting position and the unit is in the auto mode, pressing this button causes the tonearm to move to the beginning of the record (for the record size set) and begin record play.

3 Start/Stop button:

Use this button to start and stop record play and platter rotations. The position of the mode switch on the tonearm drive unit determines the effect of pressing this button. When the auto indicator is lit:

Pressing the start/stop button causes record play to begin (auto start, auto lead-in). If this button is pressed again, record play is stopped and the tonearm returns to the starting position (auto return, auto stop) and the platter stops rotating.

When the manual indicator is lit:

Pressing the start/stop button causes the platter to begin rotating and pressing the button again causes the platter to stop rotating.

Never press the start/stop button when there is no record on the platter. The stylus may be lowered onto the platter itself and be seriously damaged.

4 Backward search button:

Press this button to move the tonearm backward (manual play). When this button is held down, the tonearm moves slowly outward for about 1 second and then moves more faster.

5 Forward search button:

Press this button to move the tonearm forward (manual play). When this button is held down, the tonearm moves slowly inward for about 1 second and then moves more faster.

6 Turntable platter:

7 Turntable mat:

8 Center spindle:

9 Stylus guard:

This guard prevents the stylus from being hit when placing 30 cm records on the platter.

10 Tonearm:

11 Tonearm position indicator:

12 Tonearm drive unit:

13 Record groove scale:

The approximate location of the tonearm is shown on this scale (1 mm graduations).

14 Stroboscope:

When the platter is rotating at the rated speed, the strobolines appear to be standing still.

15 Strobe illuminator:

This illuminates the strobolines. The illuminator is synchronized with a quartz generated frequency. When the pitch switch is off or the pitch control is set to 0 (even when the pitch switch is on), this illuminator is synchronized with the set speed of the platter to make the strobolines appear to be standing still when the platter rotates at the precise rated speed.

This light is not synchronized with fluorescent lighting; if the stroboscope is viewed under fluorescent lighting, the lines will appear to be moving even though the platter speed is at the precise rated speed.

16 Record size selector:

Set this selector to the correct position for the size of the record to be played. This switch is always set to 30 (12") when the power is switched on. Press this selector once to change the setting to 17 (7") if necessary (17 (7") indicator lights).

Do not change the setting of this selector during record play or when the tonearm is not in the starting position.

17 Speed selector:

Set this selector to the correct position for the record to be played. This selector is always set to 33 (actually 33-1/3) when power is switched on. Press this selector once to change the setting to 45 if necessary (45 indicator lights). Do not change the setting of this selector during record play or when the tonearm is not in the starting position.

18 Mode selector:

Use this switch to select the auto or manual operating modes. The mode is always set to auto when power is switched on. Press this switch once to change the mode to manual if desired (manual indicator lights).

Do not change the setting of this switch during record play or when the tonearm is not in the starting position.

19 Pitch control knob:

Use this to adjust the pitch. Pitch is continuously adjustable over a range of $\pm 6\%$ from either of the two rated speeds (33-1/3 and 45). When this knob is in the 0 position, the platter rotates at exactly the rated speed set by the speed switch.

20 Pitch button:

Press this switch to perform pitch adjustment. When this switch is pressed, the pitch indicator goes out to show that the pitch control knob can be used. Press this switch again to deactivate the pitch control function (indicator lights and platter returns to rated speed).

21 Repeat button:

Press this switch to activate the repeat mode (repeat indicator lights) and press once again to deactivate the repeat mode (indicator goes out). The repeat switch can be used during record play if the unit is in the auto mode.

Set-up

Checklist of parts

Turntable unit	1
Turntable platter	1
Turntable mat	1
Dust cover	1
45-rpm adaptor	1
AC power cord	1
Stereo connection cable	1
Ground wire	1
Stylus guard	1
Cartridge mounting screw	1
Driver	1

Attach the cartridge

(An example of cartridge installation is shown in figures. When installing a cartridge, follow the instructions that came with the cartridge.)

1. Press the power switch to switch power on.
2. Press the forward search button to move the tonearm to the innermost section of the platter.
3. Press the power switch to switch power off.
4. Firmly insert the cartridge in the tonearm connector.
5. Tighten the connection screw using the accessory screwdriver. (large)
6. Switch power on again the tonearm will return to the starting position.

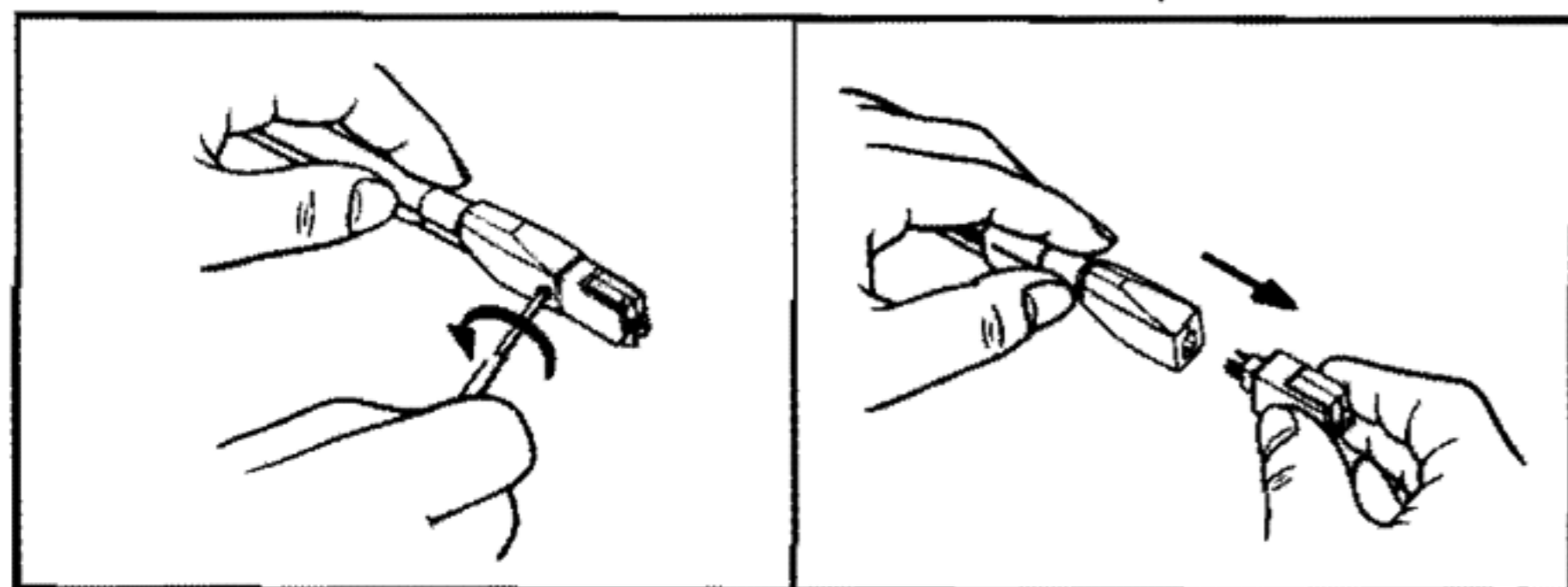

Plug-in cartridges are now available from Technics and many other of the world's top cartridge manufacturers. All compatible cartridges are identified by the **TAP** mark. These cartridges are designed for perfect matching with this turntable in all areas including weight, tracking force, stylus tip position, and center of gravity. The plug-in cartridge design eliminates the trouble of lead wire connections and tracking force adjustments.

Installation of dust cover

Place the dust cover in position from directly above, holding it at both sides. For detaching the dust cover, be certain first to raise it as illustrated before removal.

Note:

Opening or closing of the dust cover during play should be avoided. This may not only cause undesired vibrations, but also result in skipping of the stylus. If you must open the dust cover during play, do so as gently as possible.

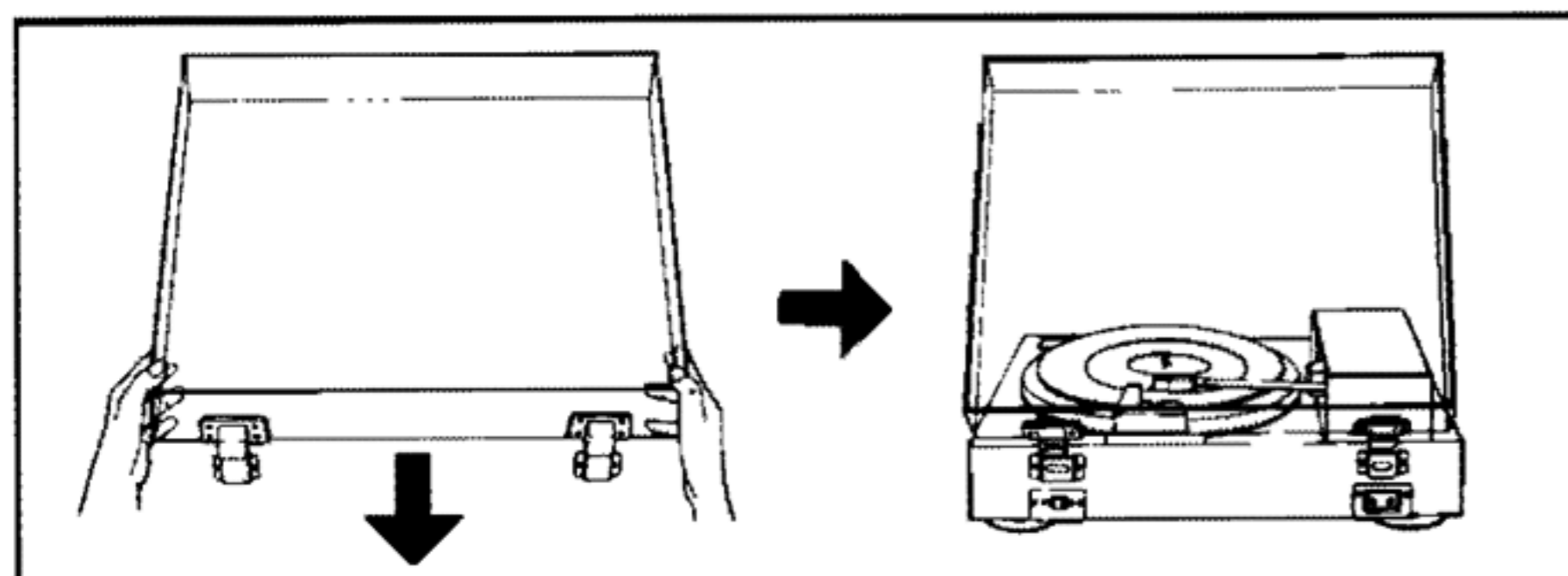

Placement

- Place the unit in a stable and horizontal position where there is little or no vibration.
- Place the unit away from the speakers so that it will be subject to as little direct sound radiation as possible.
- Do not place the unit where it will be exposed to direct sunlight, dust, moisture or heat.
- Keep it in a well ventilated location.
- If you try to listen to a radio near the turntable while it is turning, you may hear some interference.

Connections

Connect the output terminals

Output terminals	Amplifier or Receiver
L (White) →	L Channel
R (Red) →	R Channel
GND (Spade lug) →	GND

Note that hum may occur if you neglect to connect the ground wire.

Connect the AC power plug

Plug the female end into the turntable AC jack and plug the other end into an AC wall socket.

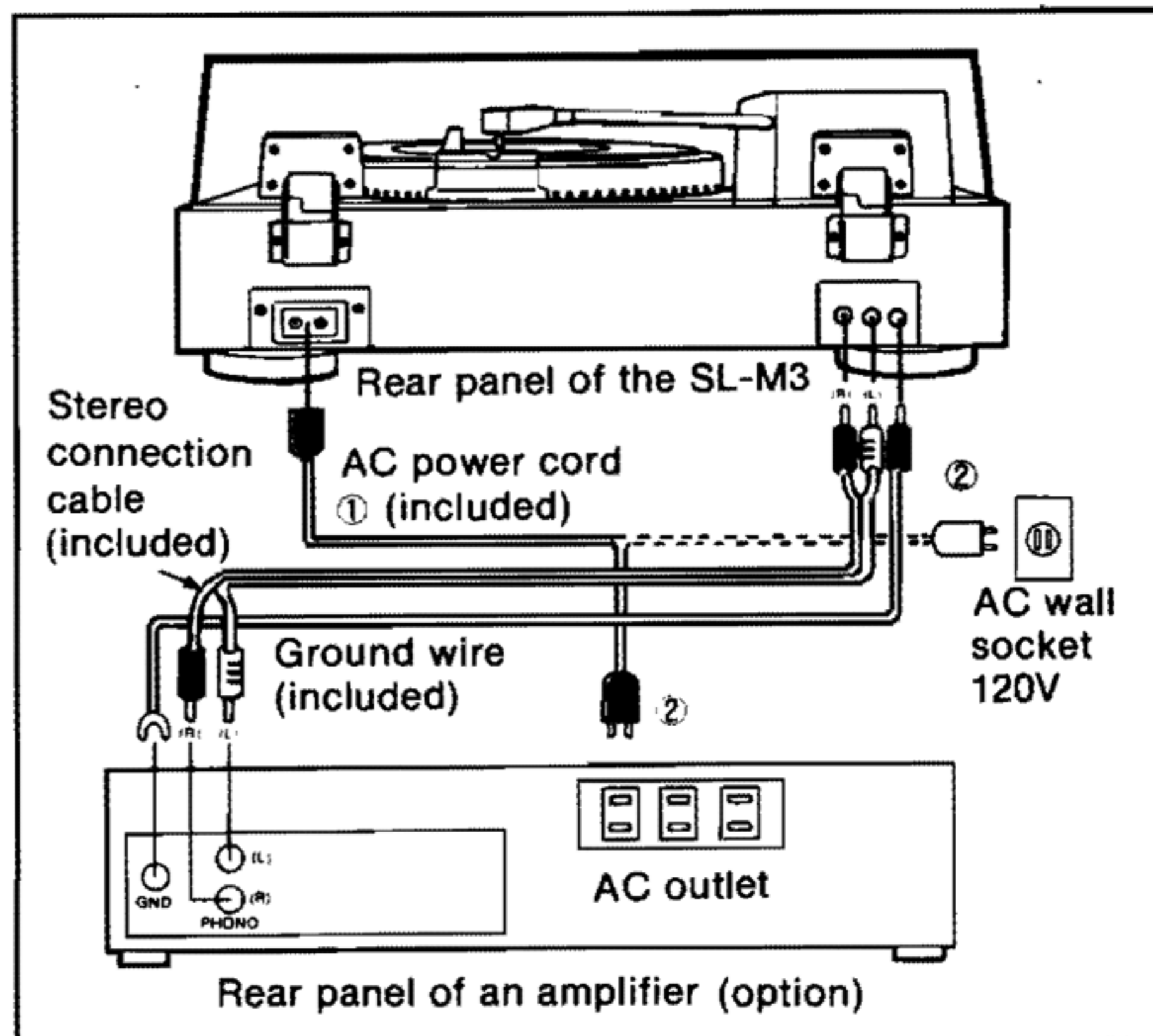

Operation

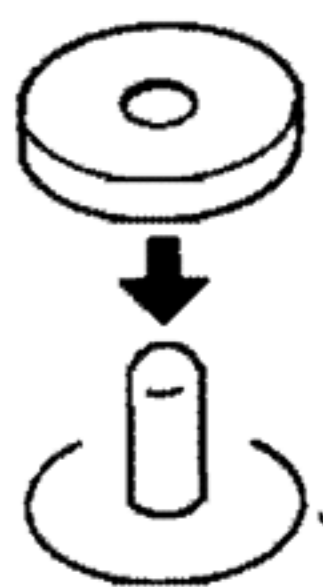
Procedure	Remarks/Notes
<p>■ Automatic operation For LP records (30 cm, 33-1/3 rpm)</p> <ol style="list-style-type: none"> Place a record on the platter. Remove the stylus cover. Press the power switch to switch power on. <p>4. Press the start/stop button. (Record play can also be started by pressing the cueing button. This is possible only for automatic play of 30 cm LP records.)</p> <p>After the play has finished...</p> <ol style="list-style-type: none"> Switch power off if the unit is not going to be used for a while. 	<ul style="list-style-type: none"> Be careful not to touch the stylus itself. The speed is automatically set to 33-1/3 and the record size to 30 cm. Wait about two seconds after switching power on before using any controls. Record play begins. When the end of the record is reached, the tonearm returns to the starting position and the platter stops rotating. If the unit is not going to be used for a long time, replace the stylus cover.
<p>■ For 45-rpm 17 cm records Perform steps 1, 2 and 3 of the above section first.</p> <ol style="list-style-type: none"> Place the 45-rpm adapter over the center spindle. Press the speed selector. Press the record size selector. <p>4. Press the start/stop button. After the play has finished...</p> <p>Perform step 5 of the automatic operation section.</p>	<ul style="list-style-type: none"> Speed indication switches from 33 to 45. Size indication switches from 30 to 17. Record play begins. When the end of the record is reached, the tonearm returns to the starting position and the platter stops rotating. 
<p>■ Manual operation</p> <ol style="list-style-type: none"> Press the mode selector. Press the speed selector to set the correct speed. Press the record size selector to set the correct record size. Press the start/stop button. Hold down the forward search button. (If the tonearm goes too far, use the backward search button to return to the desired location.) Release the forward search button when the tonearm has reached the desired location. Press the cueing button. <p>After the play has finished...</p> <p>Perform step 5 of the automatic operation section.</p>	<p>Indication switches from <input type="checkbox"/> auto to <input type="checkbox"/> manual</p> <ul style="list-style-type: none"> The platter begins rotating. The tonearm moves forward slowly at first (about 3.2 mm) and then more quickly. The tonearm lowers and record play begins. When the end of the record is reached, the tonearm returns to the starting position and the platter stops rotating.
<p>■ Repeat play (only for 30 cm and 17 cm records)</p> <ul style="list-style-type: none"> Press the repeat button before or during record play. Press the repeat button again to cancel repeat play. 	<ul style="list-style-type: none"> The repeat indicator lights to show the repeat mode has been activated. The record is now played repeatedly until the repeat mode is cancelled. The repeat indicator goes out. The repeat mode can also be cancelled by pressing the start/stop button.

Procedure	Remarks/Notes
<p>■ To stop record play</p> <p>During the auto mode</p> <ul style="list-style-type: none"> • Press the start/stop button. <p>During the manual mode</p> <ul style="list-style-type: none"> • Press the backward search button to return the tonearm to the starting position. 	<ul style="list-style-type: none"> • The tonearm returns to the starting position and the platter stops rotating. • If you mistakenly press the start/stop button, the platter will stop rotating, causing the stylus to stop in the record groove, possibly damaging the stylus and record.
<p>■ To briefly interrupt record play</p> <ul style="list-style-type: none"> • Press the cueing button • Press again to resume record play. 	<ul style="list-style-type: none"> • The tonearm rises.

Adjustments

■ Pitch adjustment

This unit employs a quartz linear synthesizer pitch control system to permit continuous adjustment of pitch by up to $\pm 6\%$ from the rated platter speed.

1. Press the pitch button (pitch indicator goes out).
2. Slide the pitch control knob up or down to the desired position.

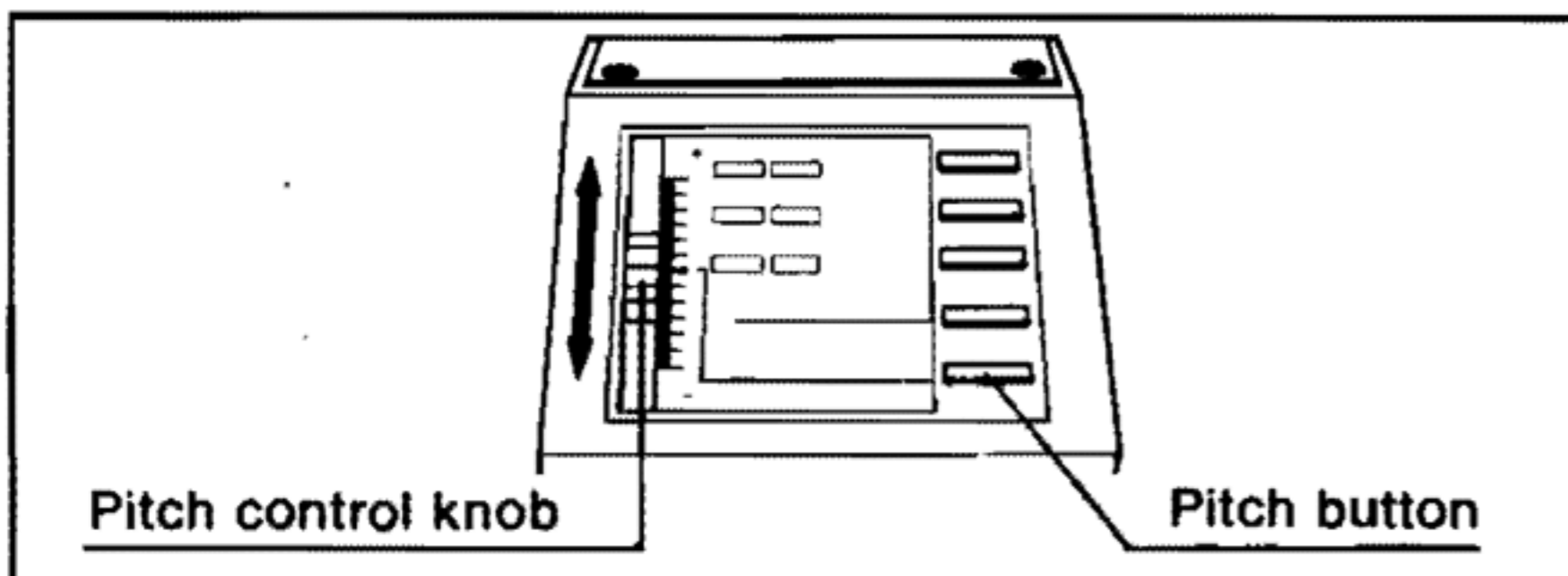

When the pitch control knob is moved in the + direction, the strobolines will appear to be moving forward. When moved in the - directions, the strobolines will appear to be moving backward.

- Set the pitch control knob to 0 to obtain precisely the rated platter speed (33-1/3 or 45 rpm).
- When the pitch function is not longer needed, press the pitch button again (pitch indicator lights).

Notes:

- The strobolines appear to be moving even when the platter is rotating at a rated speed when viewed under fluorescent lighting.
- Standard record playing should always be done with the pitch indicator out.

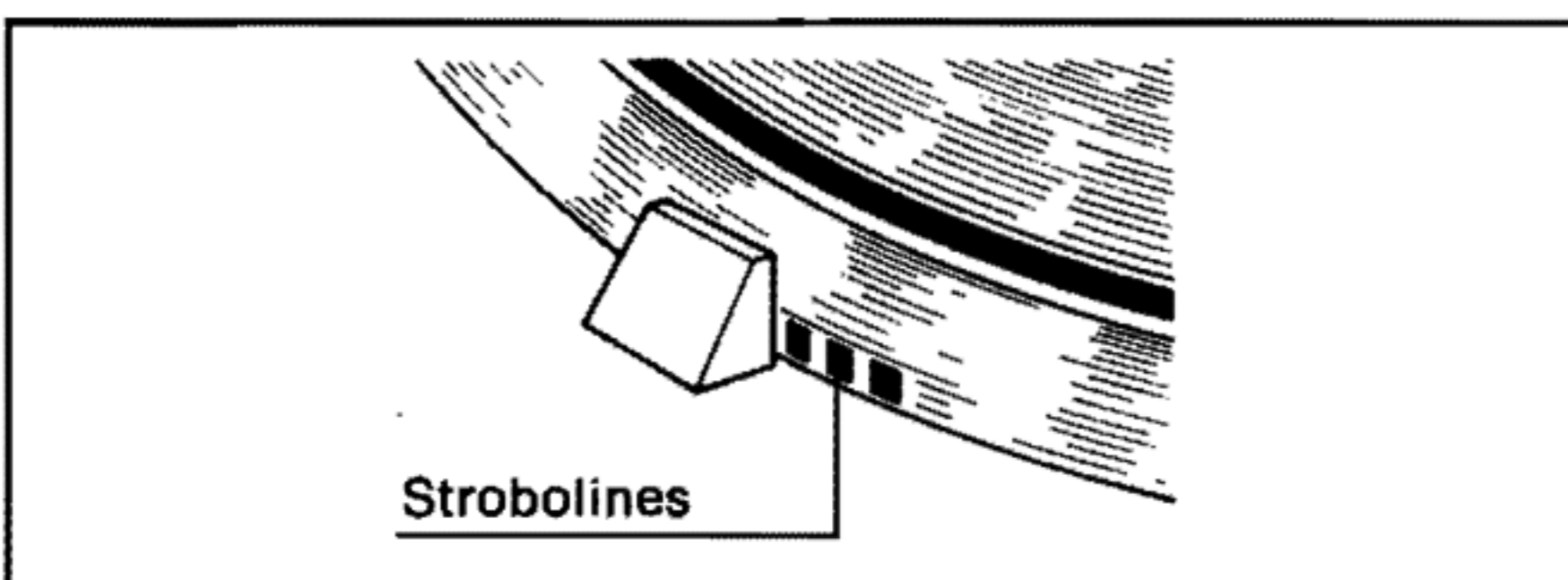

Notes and maintenance

- **Carefully remove dust and dirt from records and stylus.** Dust and dirt degrade sound quality and cause excessive wear of the stylus and grooves.
- **Do not loosen any screws on the arm drive unit.**
- **Do not press the start/stop button when there is no record on the platter (when unit is in auto mode).**
- **Wipe the dust cover and turntable base with a soft, dry cloth.** Never use volatile cleaners such as alcohol, benzene or thinner. Do not use chemically treated dust cloths. Do not expose the cover to insecticide spray. To remove stubborn spots, first pull out the AC plug and detach the cover. Then wipe the cover with a soft cloth slightly moistened with a mild soap and water solution. Do not wipe the cover during play, or the tonearm may be attracted toward the cover due to the generation of static electricity.
- **Be sure to remove all dirt and dust from the stylus tip and the record.** The cartridge stylus is an extremely delicate and precisely manufactured device designed for picking up the subtle nuances of the record grooves. Therefore, be very careful not to touch it, push on it, or apply excessive force in any way. The stylus tip cannot retain proper groove contact when it is dirty. This causes bad sound reproduction and excess wear on the stylus tip and grooves. Therefore, use a brush to remove dust and dirt by brushing upward. Also, use a good record cleaner to remove dust and dirt from the grooves.

Even when the tonearm seems to be at the starting position, mode selector may fail to switch from **manual** to **auto**. In such a case, turn off the power and then on to reset to **auto**.

■ Lubricating the motor shaft

Apply 2 or 3 drops of oil after every 2000 hours of operation. Note that the interval between lubrication is much longer than for conventional motors (200—500 hours).

Be sure to use only special oil (part number SFWO 010) available from your audio dealer.

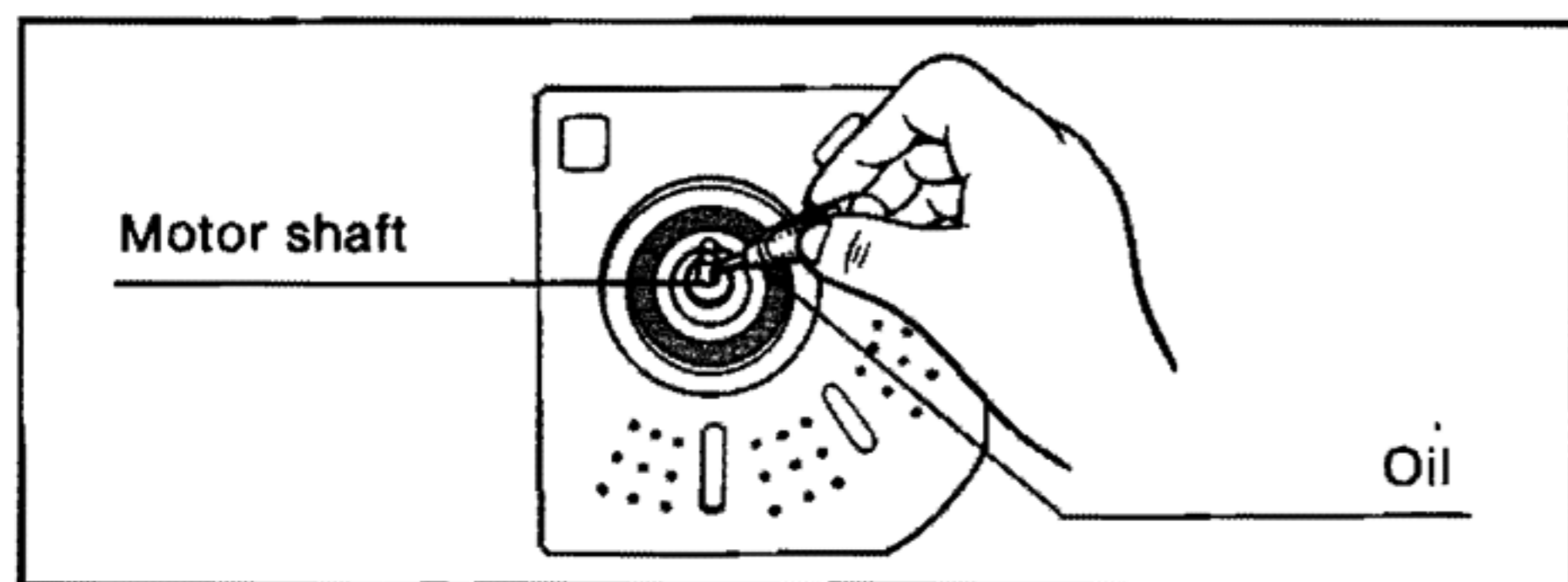

■ When the unit is transported

Before transporting this unit, attach the protective packing materials described at the beginning of this manual and repack the unit in the original carton. If this is not possible, perform the following steps.

- Unplug the cartridge from the tonearm, attach the stylus cover and pack the cartridge so that it is protected from bumps.
- Remove the dust cover and wrap it in soft paper, cloth or other protective materials to protect it from bumps.
- Reverse the assembly procedure to remove the platter mat and platter from the cabinet. Then pack both items so that they will not be damaged.
- Remove the stylus guard and pack it together with other turntable parts so that it will not be misplaced.
- Be sure to replace the tonearm spacer and counterweight clamber.
- Wrap the turntable cabinet in a blanket or other soft cloth before packing it.

■ Unplug from AC outlet if unit will not be used for an extended period of time.

Note:

The rotor is connected to the underside of the turntable platter. (The magnet of the motor is attached to the turntable platter.) To maintain optimum performance, extra care should be taken to prevent adhesion of dust or iron filings to the magnet and not to damage the magnet by dropping it.

Do not remove or loosen the screws. Should the position of the fixed magnet be altered by loosening the securing screws, the rated performance of the unit cannot be guaranteed.

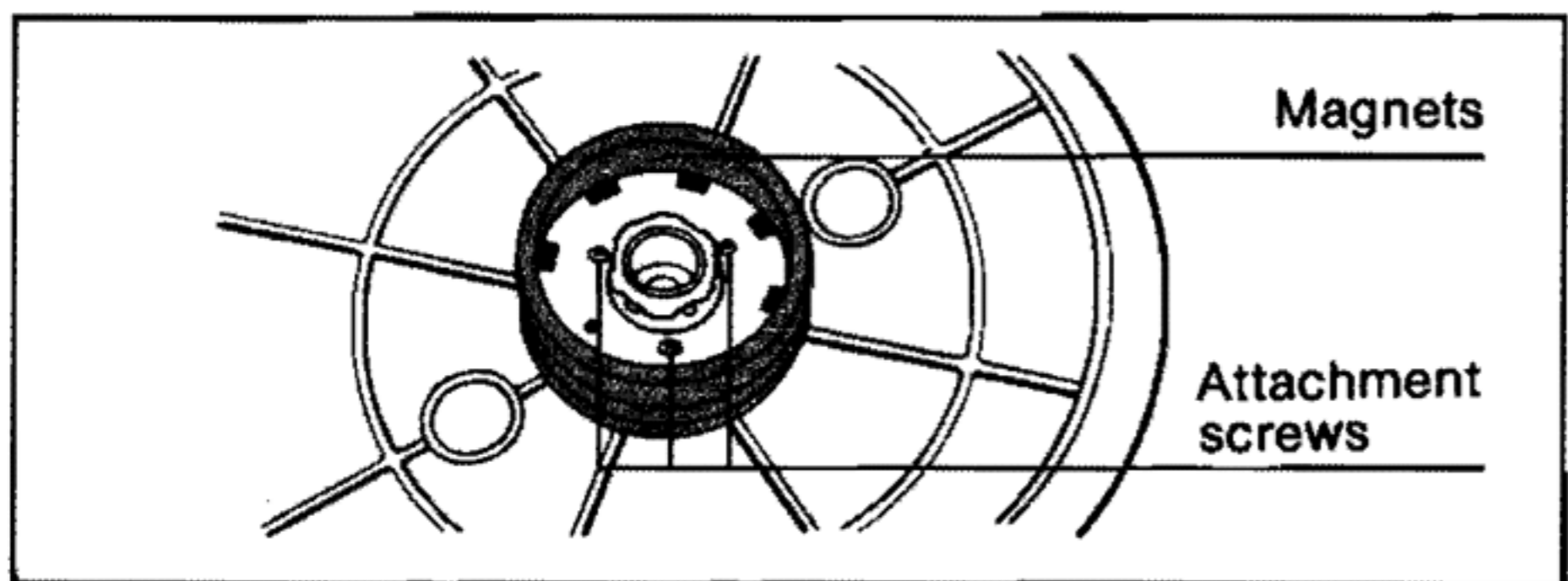

Suggestions for safety

Before using this unit, be sure to read applicable items of the operating instructions and these safety suggestions carefully; and afterwards keep them handy for future reference. Take special care to follow the warnings indicated on the unit itself as well as in the operating instructions.

1. Avoid places where there is water or humidity.

Do not use this unit near a bathtub, washbasin, swimming pool, or the like. Damp basements should also be avoided.

2. Do not allow water or any foreign object to get inside this unit.

Do not place small metal objects or anything containing liquid on or near the unit.

3. Avoid placement of the unit where it will be exposed to the direct rays of the sun, or where ventilation is inadequate.

Do not place this unit in a bookcase or between cabinets, unless proper ventilation is provided, or where curtains or furniture may obstruct the ventilation holes.

4. Place this unit away from heat-emitting appliances.

Never place this unit on or near a radiator, heat register, stove, or any other heat-emitting equipment (including amplifiers).

5. Placement

Place the unit on a stable, vibration-free, level shelf or stand.

6. Use of a cart or stand.

When deciding on a cart or stand, be sure to use only with the cart or stand recommended by the manufacturer.

7. Wall or ceiling installation.

If the unit is to be mounted on a wall or ceiling, be sure to do so only as recommended by the manufacturer.

8. Check the voltage rating of this unit before connecting the unit to a power source.

Be sure to connect the unit only to the type of power source indicated in the operating instructions, or as indicated on the unit itself.

9. Care of the power cord and plug.

Take care that the cord is not bent sharply (especially near its connection to the unit or near the plug), that nothing is placed on it, and that it is not pinched, crushed or frayed. Never take hold of the plug or cord if your hand is wet, and always be sure to grasp the plug body when connecting or disconnecting it.

10. If the unit will not be used for an extended period of time:

Be sure to disconnect the power cord from the wall outlet.

11. Maintenance

Refer to the operating instructions for details.

12. Never attempt repairs yourself:

- (a) If the power cord or plug is damaged.
- (b) If a foreign object has fallen or liquid has spilled into it.
- (c) If the unit is exposed to rain.
- (d) If the unit does not function normally, or if operation shows a distinct change in performance.
- (e) If the unit has been dropped and the cabinet or chassis are damaged... etc.

Unplug the power cord and have it checked by a qualified technician (or the dealer from whom the unit was purchased or the nearest servicenter).

13. Repairs

Except for adjustments explained in the operating instructions, do not attempt any repairs yourself. Be sure to request service from a qualified technician (or your dealer or nearest servicenter).

Specifications

■ General

Power supply:	120 V AC, 60 Hz
Power consumption:	27 W
Dimensions:	52.6 × 20.5 × 42.5 cm Maximum height when dust cover is open. 52.6 × 52 × 50 cm
Weight:	15 kg (33 lb.)

■ Turntable section

Type:	Quartz direct drive Fully automatic turntable
Features:	Auto start/Auto lead-in Auto return/Auto stop Repeat play 2 speed search play
Drive method:	Direct drive
Motor:	Brushless DC motor
Drive control method:	Quartz-phase-locked control
Turntable platter:	Aluminum die-cast Diameter 32.5 cm (12-13/16") Weight 2.5 kg (including turntable mat)
Turntable speeds:	33-1/3 rpm and 45 rpm Auto speed select (Manual selection possible)
Pitch control:	±6% range
Starting torque:	1.6 kg·cm
Build-up characteristics:	0.9 second to 33-1/3 rpm
Speed change due to load torque:	0% within 1 kg·cm
Wow and flutter:	0.008% WRMS* 0.022% WRMS (JIS C5521) ±0.031% peak (IEC 98A Weighted)

*Measured by obtaining signal from built-in frequency generator of motor assembly.

Rumble:	-70 dB (IEC 98A Unweighted) -82 dB (IEC 98A Weighted)
----------------	----------------------------------------------------------

■ Tonearm section

Type:	Dynamically-balanced type Linear tracking tonearm 4-pivot gimbal suspension
Effective length:	23.8 cm (9-3/8")
Tracking error angle:	Within ±0.5°
Effective mass:	13 g (including cartridge)
Resonance frequency:	10 Hz
Tonearm drive motor:	DC motor
Phono cable capacitance:	100 pF

Specifications subject to change without notice.
Weight and dimensions shown are approximate.

CAUTION

This equipment has been tested and found to comply with the limits for a Class B computing device in accordance with the specifications set forth in Subpart J of Part 15 of the FCC Rules. If this equipment does cause interference to radio or television reception which can be determined by turning the equipment on and off, use the equipment in another location and/or utilize an electrical outlet different from that used by the receiver.

Features

1. Precision-made natural wood cabinet that prevents harmful resonances.

The cabinet is made of natural wood that has been pulverized using a special process. The wood particles were then used to create a high-pressure particleboard that is extremely resistant to resonances.

2. 2.5 kg platter reaches rated speed (33-1/3 rpm) in just 0.9 sec. thanks to use of high torque direct-drive motor

The platter is driven by a powerful heteropole direct-drive motor having a very high start-up torque of 1.6 kg·cm. That means the massive 2.5 kg platter reaches the 33-1/3 rpm rated speed in only 0.9 seconds. Another advantage of using this powerful motor is that variations in platter speed are zero for changes in the fixed load of up to 1 kg·cm. (In other words, the correct platter speed would be maintained even a tracking force of 200 grams were used.)

3. Fully automatic operation with dynamically balanced linear tracking tonearm

To play a 30 cm, 33-1/3 rpm record, simply place it on the platter and press the start/stop button. When the end of the record is reached, the tonearm automatically returns to the starting position. For manual operation in which specific record locations can be manually pinpointed, simply press the mode switch.

■ Other features

- **Full cycle detection frequency generator for extremely reliable and accurate monitoring of platter speed.**
This system reduces wow and flutter to 0.008 % and raises the S/N ratio to 82 dB.
- **Repeat play function**
- **Pitch control capability (up to ± 6 %)**
- **Electronic platter brake**

Panasonic Company
Division of Matsushita Electric
Corporation of America
One Panasonic Way, Secaucus,
New Jersey 07094

Panasonic Hawaii, Inc. ("PHI")
91-238, Kauhi St. Ewa Beach P.O. Box 774
Honolulu, Hawaii 96808-0774

Panasonic Sales Company,
Division of Matsushita Electric
of Puerto Rico, Inc.
Ave. 65 De Infanteria, KM 9.7
Victoria Industrial Park
Carolina, Puerto Rico 00630

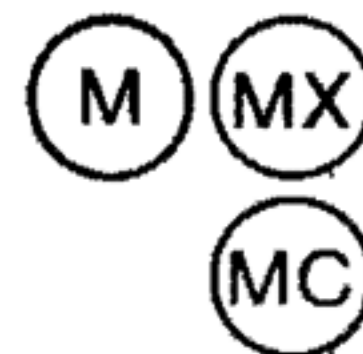

Matsushita Electric of Canada Limited
5770 Ambler Drive, Mississauga, Ontario
L4W 2T3

Printed in Japan

SFNUM03M01
S0984D0