

Service Manual

Turtable System SL-M3



* Sets for [M] and [MC] areas are not provided with cartridge.
 is the standard mark for the "P-mount" plug-in-connector system. Products carrying this mark are inter-changeable and compatible with each other.

Area
* [M] U.S.A.
* [MC] ... Canada
* [E] Switzerland and Scandinavia.
* [EK] United Kingdom
* [XL] Australia
* [EG] F.R. Germany
* [EB] Belgium
* [EH] Holland
* [EF] France
* [Ei] Italy
* [EC] Czechoslovakia
* [XA] Southeast Asia, Oceania, Africa, Middle Near East and Central South America
* [XM] Central South America
* [PA] far East PX
* [PE] European Military
* [PC] European Audio Club
* [XZ] New Zealand

English

Specifications

Specifications subject to change without notice.
 Weight and dimensions shown are approximate.

■ General

Power supply:	For U.S.A. and Canada: 120 V AC, 60 Hz For others: ~ 110-120/220-240 V, 50 or 60 Hz
Power consumption:	For U.S.A. and Canada: 27 W For others: 25 W
Dimensions:	52.6 X 20.5 X 42.5 cm Maximum height when dust cover is open. 52.6 X 52 X 50 cm
Weight:	15 kg

■ Turntable section

Type:	Quartz direct drive Fully automatic turntable
Features:	Auto start/Auto lead-in Auto return/Auto stop Repeat play 2 speed search play
Drive method:	Direct drive

Motor:	Brushless DC motor
Drive control method:	Quartz-phase-locked control
Turntable platter:	Aluminum die-cast Diameter 32.5 cm (12-13/16") Weight 2.5 kg (including turntable mat)

Turntable speeds:	33-1/3 rpm and 45 rpm Auto speed select (Manual selection possible)
--------------------------	---

Pitch control:	±6% range
Starting torque:	1.6 kg·cm
Build-up characteristics:	0.9 second to 33-1/3 rpm

Speed change due to load torque:	0% within 1 kg·cm
Wow and flutter:	0.008% WRMS* 0.022% WRMS (JIS C5521) ±0.031% peak (IEC 98A Weighted)

*Measured by obtaining signal from built-in frequency generator of motor assembly.

Rumble:	-70 dB (IEC 98A Unweighted) -82 dB (IEC 98A Weighted)
----------------	--

Matsushita Engineering and Service Company
 50 Meadowland Parkway,
 Secaucus, New Jersey 07094

Panasonic Hawaii Inc.
 91-238 Kauhū St. Ewa Beach
 P.O. Box 774
 Honolulu, Hawaii 96808-0774

Panasonic Sales Company,
 Division of Matsushita Electric of Puerto Rico, Inc.
 Ave. 65 De Infantaria, KM 9.7
 Victoria, Industrial Park
 Carolina, Puerto Rico 00630

Matsushita Electric of Canada Limited
 5770 Ambler Drive, Mississauga,
 Ontario, M4W 1G7

Technics

Panasonic Tokyo
 Matsushita Electric Industrial Co., Ltd.
 1-1-2 Shiba-koen Minato-ku Tokyo 105, Japan
 Tel: (03) 437-1121

■ Tonearm section

Type:	Dynamically-balanced type Linear tracking tonearm 4-pivot gimbal suspension
Effective length:	23.8 cm
Tracking error angle:	Within $\pm 0.5^\circ$
Effective mass:	13 g (including cartridge)
Resonance frequency:	10 Hz
Tonearm drive motor:	DC motor
Phono cable capacitance:	100 pF

■ Cartridge section

Type:	Moving magnet stereo cartridge
Magnetic circuit:	All laminated core

Frequency response:	10 Hz ~ 50 kHz 20 Hz ~ 10 kHz ± 1 dB
Output voltage:	2.5 mV at 1 kHz, 5 cm/s. zero to peak lateral velocity; (7 mV at 1 kHz, 10 cm/s. zero to peak 45° velocity [DIN 45 500])
Channel separation:	More than 22 dB at 1 kHz
Channel balance:	Within 1.8 dB at 1 kHz
Recommended load impedance:	47 k Ω ~ 100 k Ω
Compliance (dynamic):	12×10^{-8} cm/dyne at 100 Hz
Stylus pressure range:	1.25 \pm 0.25 g (12.5 \pm 2.5 mN)
Weight:	6 g (cartridge only)
Replacement stylus:	EPS-33ES

- The power supply for this unit varies depending upon the areas. Also, the parts used for power supply are different. So, refer to the circuit diagram and the replacement parts list.
- ★ 120V (60 Hz) for U.S.A. and Canada.
- ★ 220V (50 Hz) for Continental Europe.
- ★ 240V (50 Hz) for United Kingdom and Australia.
- ★ 110V—120V/220V—240V (50/60 Hz) for other areas.
- ★ Except for [M] and [MC] areas are provided with voltage selector.

Deutsch

TECHNISCHE DATEN

Änderungen der technischen Daten vorbehalten.
Die angegebenen Gewichts- und Abmessungsdaten sind
ungefähre Werte.

■ Allgemeine Daten

Stromversorgung:	—110-120/220-240 V, 50/60 Hz
Leistungsaufnahme:	25 W
Abmessungen: (B×H×T)	52,6 × 20,5 × 42,5 cm 52,6 × 52 × 50 cm (Maximale Höhe bei vollständig geöffnetem Gehäuseoberteil)
Gewicht:	15 kg

■ Plattenteller

Typ:	Vollautomatischer Plattenspieler mit Quarz-Direktantrieb
Eigenschaften:	Auto-Start/Auto-Zuführung Rückführautomatik Stopautomatik Wiederholtes Abspielen Suchabspiel mit 2 Geschwindigkeiten Direktantrieb Kollektorloser Gleichstrommotor
Antrieb: Motor:	Phasenverriegelte Quarzsteuerung
Antriebsregelungsmethode:	Aluminium-Druckguß Durchmesser 32,5 cm Gewicht 2,5 kg (einschließlich Plattentellermatte)
Plattenteller: Drehzahlen:	33-1/3 und 45 U./min. Automatische Drehzahlwahl (manuelle Wahl möglich)
Drehzahlregelung:	$\pm 6\%$ Bereich
Anlaufdrehmoment:	1,6 kg·cm
Beschleunigung:	in 0,9 Sekunden auf 33-1/3 U./min

Drehzahländerung

Wegen Lastmoment:	0% Innerhalb 1 kg·cm
Gleichlaufschwankungen:	0,008% WRMS* 0,022% WRMS (JIS C5521) $\pm 0,031\%$ Spitze (IEC 98A bewertet)
*Gemessen anhand von Signalen vom eingebauten Frequenzgenerator des Motorteils.	
Rumpeln:	—70 dB (IEC 98A unbewertet) —82 dB (IEC 98A bewertet)

■ Tonarm

Typ:	Linearabtastungs-Tonarm mit 4-Punkt-Kardanaufhängung
Effektive Länge:	23,8 cm
Spurfehlwinkel:	Innerhalb $\pm 0,5^\circ$
Effektive Masse:	13 g (einschließlich Tonabnehmer)
Resonanzfrequenz:	10 Hz
Tonarm-Antriebsmotor:	Gleichstrommotor

■ Tonabnehmer

Typ:	Beweglicher Magnet- Stereo-Tonabnehmer
Magnetkreis:	Ganzlamellenkern
Frequenzgang:	10 Hz bis 50 kHz 20 Hz bis 10 kHz ± 1 dB
Ausgangsspannung:	2,5 mV bei 1 kHz 5 cm/s. Null-zu-Spitze, lateral [7 mV bei 1 kHz 10 cm/s. Null- zu-Spitze, 45° (DIN 45 500)]
Kanaltrennung:	22 dB bei 1 kHz
Kanalabweichung:	Innerhalb 1,8 dB bei 1 kHz

Empfohlene
Endimpedanz: 47 k Ω ~ 100 k Ω
Nachgiebigkeit
(dynamisch): 12 x 10⁻⁶ cm/dyn bei 100 Hz

Auflagekraft-
Einstellbereich: 1,25 \pm 0,25 g (12,5 \pm 2,5 mN)
Gewicht: 6 g (nur Tonabnehmer)
Ersatznadel: EPS-33ES

Français

CARACTERISTIQUES

Les spécifications sont susceptibles d'être modifiées sans avertissement préalable.

Le poids et les dimensions donnés sont approximatifs.

■ Généralités

Allimentation: ~ 110-120/220-240 V, 50 ou 60 Hz
Consommation: 25 W
Dimensions: 52,6 x 20,5 x 42,5 cm
(LxHxP) 52,6 x 52 x 50 cm
(Hauteur maximum lorsque le couvercle protège-poussière est ouvert.)
Poids: 15 kg

■ Plateau de lecture

Type: Entraînement direct par quartz
Platine entièrement automatique
Caractéristiques: Démarrage automatique/Entrée automatique
Retour automatique/Arrêt automatique
Audition répétée
Audition de recherche sur 2 vitesses
Système d'entraînement: Entraînement direct
Moteur: Moteur C.C. sans balai
Système de commande d'entraînement: Réglage d'accrochage de phase par quartz
Plateau de lecture: Aluminium moulé sous pression
Diamètre 32,5 cm
Vitesses de la platine: 33-1/3 et 45 t/p.m.
Sélecteur de vitesse automatique (Sélection manuelle possible)
Réglage d'écart: Plage de \pm 6%
Couple de démarrage: 1,6 kg · cm
Caractéristiques d'accélération: 0,9 seconde à 33-1/3 t/p.m.
Changement de vitesse dû à un changement de couple: 0% en deçà de 1 kg · cm
Pleurage et scintillement: 0,008% de valeur efficace*
0,022% de valeur efficace (JIS C5521)
 \pm 0,031% de crête (IEC 98A Pondéré)
*Mesuré par l'obtention d'un signal provenant du générateur de fréquences incorporé de l'ensemble du moteur.
Ronflement: -70 dB (IEC 98A Non pondéré)
-82 dB (IEC 98A Pondéré)

■ Bras de lecture

Type: Bras de lecture à alignement linéaire de type dynamiquement équilibré
Longueur effective: 23,8 cm
Angle d'erreur de piste: En deçà de \pm 0,5°
Masse réelle: 13 g (y compris la cellule pick-up)
Fréquence de résonance: 10 Hz
Moteur d'entraînement du bras de lecture: Moteur C.C.

■ Cellule pick-up

Type: Cellule pick-up stéréo à aimant mobile
Circuit magnétique: Noyau entièrement feuilleté
Réponse en fréquence: 10 Hz à 50 kHz
20 Hz à 10 kHz \pm 1 dB
Tension de sortie: 2,5 mV à 1 kHz; 5 cm/s., zéro à vitesse latérale de crête
(7 mV à 1 kHz; 10 cm/s., zéro à vitesse 45° de crête [DIN 45 500])
Séparation des canaux: 22 dB à 1 kHz
Équilibrage des canaux: En deçà de 1,8 dB à 1 kHz
Impédance de charge recommandée: 47 k Ω ~ 100 k Ω
Elasticité (dynamique): 12 x 10⁻⁶ cm/dyne à 100 Hz
Plage de la force verticale d'appui: 1,25 \pm 0,25 g (12,5 \pm 2,5 mN)
Poids: 6 g (cellule seule)
Pointe de lecture de remplacement: EPS-33ES

ESPECIFICACIONES

Las especificaciones quedan sujetas a cambios sin aviso previo.
El peso y las dimensiones indicados son aproximados.

■ En general

Alimentación de corriente:	-110-120/220-240 V, 50 ó 60 Hz
Consumo de corriente:	25 W
Dimensiones: (Ancho×Alto×Prof.)	52,6 × 20,5 × 42,5 cm Altura máxima cuando la tapa contra el polvo está abierta. 52,6 × 52 × 50 cm
Peso:	15 kg

■ Sección del plato giratorio

Tipo:	Plato giratorio totalmente automático con accionamiento directo por cuarzo.
Ventajas:	Arranque/descenso automáticos Retorno automático Parada automática Ejecución repetida Ejecución con búsqueda con 2 velocidades
Método de accionamiento:	Accionamiento directo
Motor:	Motor de C.C. sin escobillas
Método de control de accionamiento:	Control enclavado de fase de cuarzo
Platillo del palto giratorio:	Aluminio fundido 32,5 cm de diámetro
Peso:	2,5 kg (incluyendo la almohadilla del plato giratorio)
Velocidades del plato giratorio:	33-1/3 y 45 rpm Selección automática de la velocidad (También posibilidad de seleccionar a mano)
Control de altura de sonido:	En un ámbito aproxim. de 6%
Par de arranque:	1,6 kg · cm
Características de establecimiento:	0,9 de segundo a 33-1/3 rpm
Cambio de velocidad debido al par de carga:	0% en menos de 1 kg · cm
Ululaciones y trémolo:	0,008% WRMS* 0,022% WRMS (JIS C5521) ±0,031% cresta (IEC 98A Ponderado)

*Medido obteniendo una señal proveniente del generador de frecuencias incorporado del conjunto del motor.

Ruido de rodadura:	-70 dB (IEC 98A No ponderado) -82 dB (IEC 98A Ponderado)
---------------------------	---

■ Sección del brazo sonoro

Tipo:	Brazo sonoro de seguimiento lineal con suspensión cardánica de 4 pivotes
Longitud efectiva:	23,8 cm
Angulo de error de seguimiento:	Inferior a 0,5° aproxim.
Masa efectiva:	13 g (incluyendo el cartucho)
Frecuencia de resonancia:	10 Hz
Motor de accionamiento del brazo sonoro:	Motor de corriente continua

■ Sección del cartucho

Tipo:	Cartucho estereofónico de imán móvil
Circuito magnético:	Núcleo totalmente laminado
Respuesta de frecuencia:	10 Hz a 50 kHz 20 Hz a 10 kHz ±1 dB
Voltaje de salida:	2,5 mV a 1 kHz, velocidad lateral de cero a cresta de 5 cm/s. [7 mV a 1 kHz, velocidad de 45° de cero a cresta de 10 cm/s. (DIN 45 500)]
Separación de canales:	22 dB a 1 kHz
Equilibrio de canales:	Inferior a 1,8 dB a 1 kHz
Impedancia de carga recomendada:	47 kΩ a 100 kΩ
Elasticidad (dinámica):	12 × 10 ⁻⁵ cm/dina a 100 Hz
Radio de presión de la aguja:	1,25 ±0,25 g (12,5±2,5 mN)
Peso:	6 g (cartucho solamente)
Replacement stylus:	EPS-33ES

■ CONTENTS

	Page		Page
SAFETY PRECAUTION	5	MEDICIONES Y AJUSTE (Español)	13
LOCATION OF CONTROLS	6	ADJUSTMENT POINTS	14
OPERATION	6, 7	TROUBLE SHOOTING	14~17
DISASSEMBLY INSTRUCTIONS	8, 9	REPLACEMENT PARTS LIST	18, 22
HOW TO SET THE TONEARM DRIVE ROPE	10	EXPLODED VIEWS	19~22
PITCH ADJUSTMENT	10	RESISTORS AND CAPACITORS	23
MEASUREMENTS AND		CIRCUIT BOARD AND WIRING	
ADJUSTMENT (English)	11	CONNECTION DIAGRAM	24~27
MESSUNGEN UND		SCHEMATIC DIAGRAM	28~34
JUSTIERUNGEN (Deutsch)	11, 12	BLOCK DIAGRAM	35~37
MESURAGES ET RÉGLAGES (Français)	12, 13	PACKING	38

■ SAFETY PRECAUTION

1. Before servicing, unplug the power cord to prevent an electric shock.
2. When replacing parts, use only manufacturer's recommended components for safety.
3. Check the condition of the power cord. Replace if wear or damage is evident.
4. After servicing, be sure to restore the lead dress, insulation barriers, insulation papers, shields, etc.
5. Before returning the serviced equipment to the customer, be sure to make the following insulation resistance test to prevent the customer from being exposed to a shock hazard.

● INSULATION RESISTANCE TEST

1. Unplug the power cord and short the two prongs of the plug with a jumper wire.
2. Turn on the power switch.
3. Measure the resistance value with ohmmeter between the jumpered AC plug and each exposed metal cabinet part, such as screwheads antenna, control shafts, handle brackets, etc. Equipment with antenna terminals should read between $3M\Omega$ and $5.2M\Omega$ to all exposed parts. (Fig. A) Equipment without antenna terminals should read approximately infinity to all exposed parts. (Fig. B)

Note: Some exposed parts may be isolated from the chassis by design. These will read infinity.

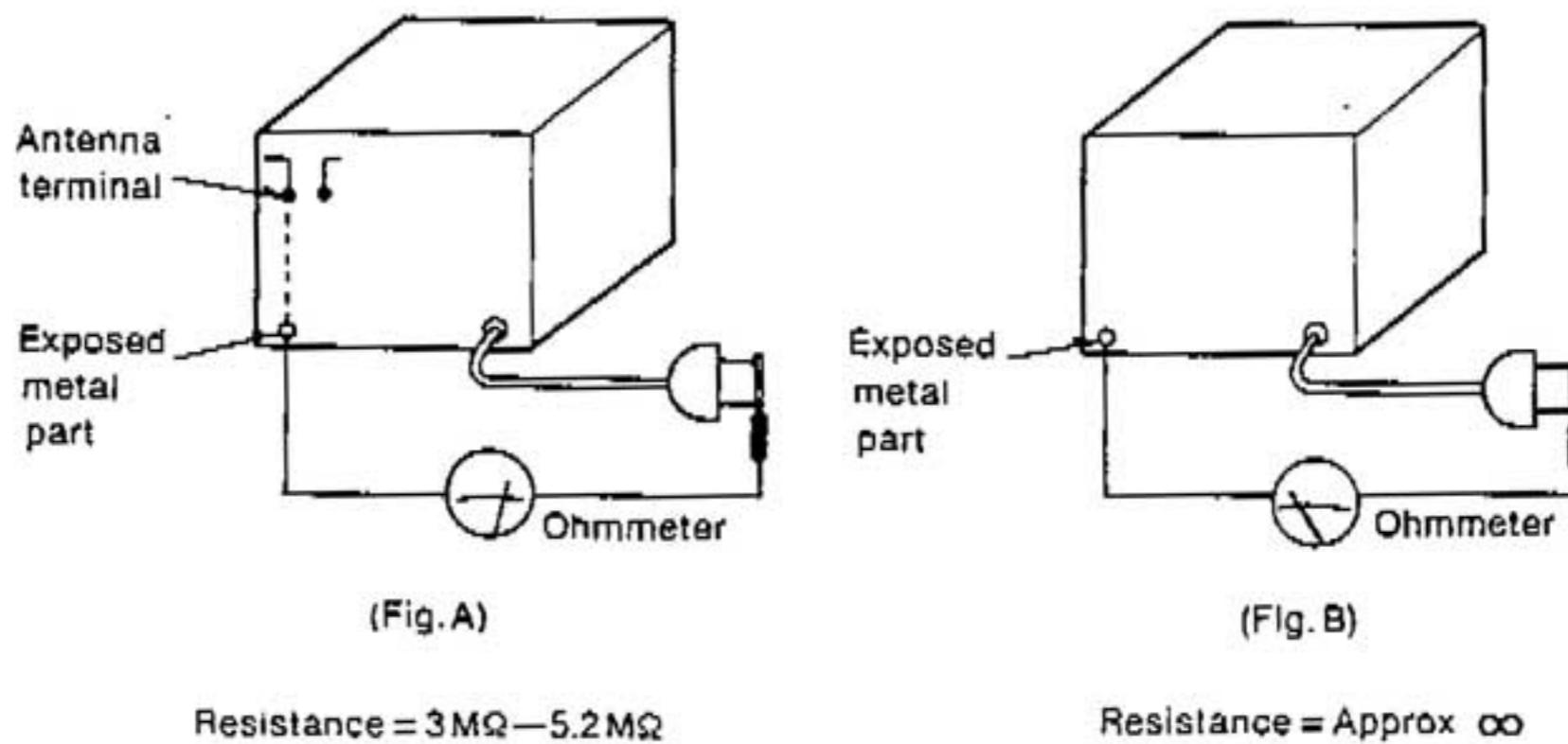

4. If the measurement is outside the specified limits, there is a possibility of a shock hazard. The equipment should be repaired and rechecked before it is returned to the customer.

■ LOCATION OF CONTROLS

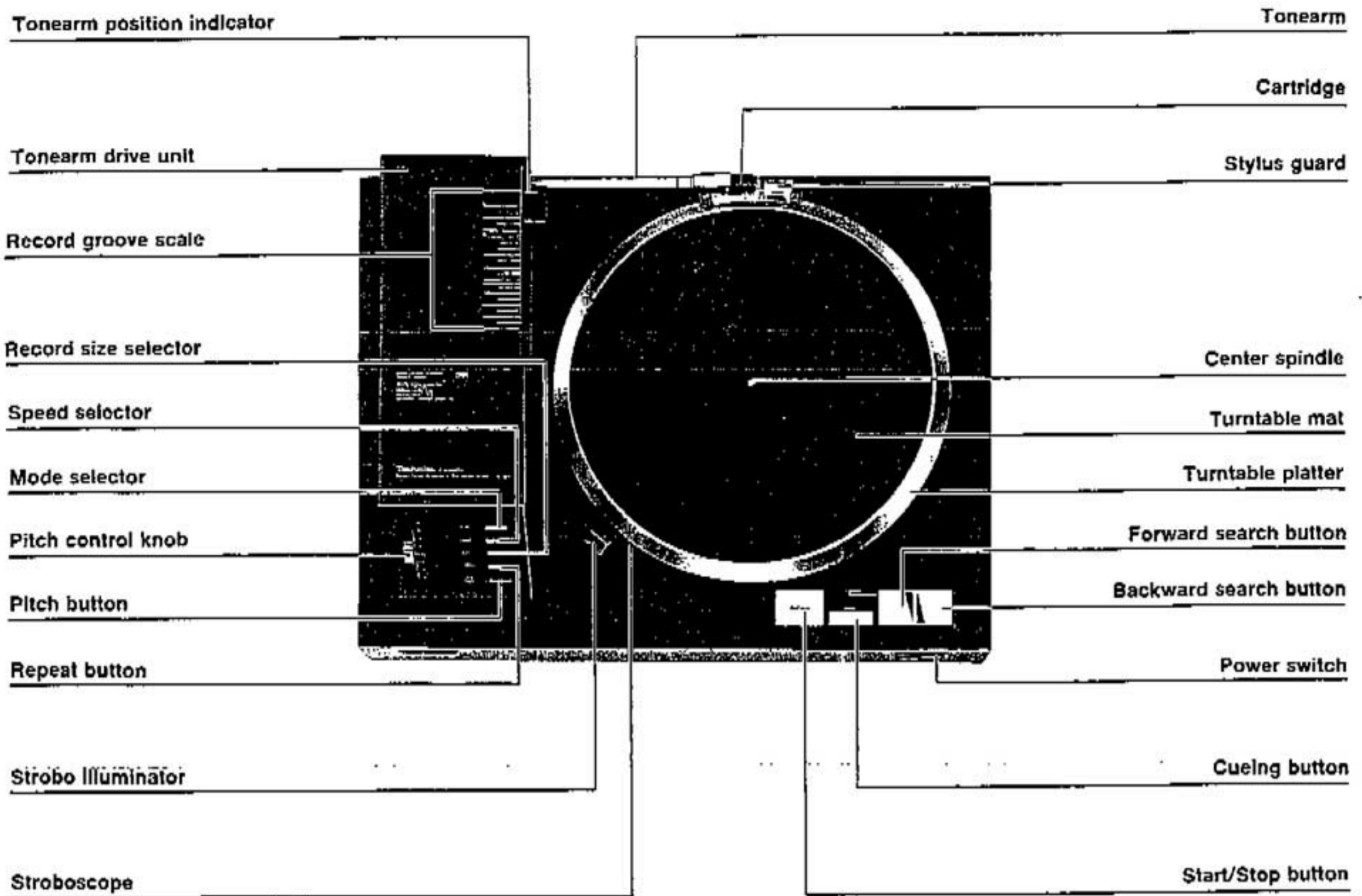

■ OPERATION

Procedure	Remarks/Notes
<p>■ To stop record play</p> <p>During the auto mode</p> <ul style="list-style-type: none"> • Press the start/stop button. <p>During the manual mode</p> <ul style="list-style-type: none"> • Press the backward search button to return the tonearm to the starting position. 	<ul style="list-style-type: none"> • The tonearm returns to the starting position and the platter stops rotating. • If you mistakenly press the start/stop button, the platter will stop rotating, causing the stylus to stop in the record groove, possibly damaging the stylus and record.
<p>■ To briefly interrupt record play</p> <ul style="list-style-type: none"> • Press the cueing button • Press again to resume record play. 	<ul style="list-style-type: none"> • The tonearm rises.

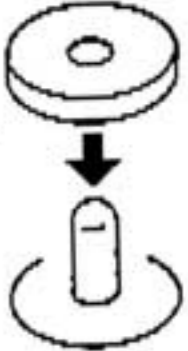
Procedure	Remarks/Notes
<p>■ Automatic operation For LP records (30 cm, 33-1/3 rpm)</p> <ol style="list-style-type: none"> Place a record on the platter. Remove the stylus cover. Press the power switch to switch power on. <p>4. Press the start/stop button. (Record play can also be started by pressing the cueing button. This is possible only for automatic play of 30 cm LP records.)</p> <p>After the play has finished...</p> <p>5. Switch power off if the unit is not going to be used for a while.</p>	<ul style="list-style-type: none"> Be careful not to touch the stylus itself. The speed is automatically set to 33-1/3 and the record size to 30 cm. Wait about two seconds after switching power on before using any controls. Record play begins. When the end of the record is reached, the tonearm returns to the starting position and the platter stops rotating. If the unit is not going to be used for a long time, replace the stylus cover.
<p>■ For 45-rpm 17 cm records Perform steps 1, 2 and 3 of the above section first.</p> <ol style="list-style-type: none"> Place the 45-rpm adapter over the center spindle. Press the speed selector. Press the record size selector. <p>4. Press the start/stop button. After the play has finished...</p> <p>Perform step 5 of the automatic operation section.</p>	<ul style="list-style-type: none"> Speed indication switches from 33 to 45. Size indication switches from 30 to 17. Record play begins. When the end of the record is reached, the tonearm returns to the starting position and the platter stops rotating. 
<p>■ Manual operation</p> <ol style="list-style-type: none"> Press the mode selector. Press the speed selector to set the correct speed. Press the record size selector to set the correct record size. Press the start/stop button. Hold down the forward search button. (If the tonearm goes too far, use the backward search button to return to the desired location.) Release the forward search button when the tonearm has reached the desired location. Press the cueing button. <p>After the play has finished...</p> <p>Perform step 5 of the automatic operation section.</p>	<p>Indication switches from <input type="checkbox"/> auto to <input type="checkbox"/> manual.</p> <ul style="list-style-type: none"> The platter begins rotating. The tonearm moves forward slowly at first (about 3.2 mm) and then more quickly. The tonearm lowers and record play begins. When the end of the record is reached, the tonearm returns to the starting position and the platter stops rotating.
<p>■ Repeat play (only for 30 cm and 17 cm records)</p> <ul style="list-style-type: none"> Press the repeat button before or during record play. Press the repeat button again to cancel repeat play. 	<ul style="list-style-type: none"> The repeat indicator lights to show the repeat mode has been activated. The record is now played repeatedly until the repeat mode is cancelled. The repeat indicator goes out. The repeat mode can also be cancelled by pressing the start/stop button.

■ DISASSEMBLY INSTRUCTIONS

• How to remove the drive circuit P.C.B.

1. Remove the cartridge.

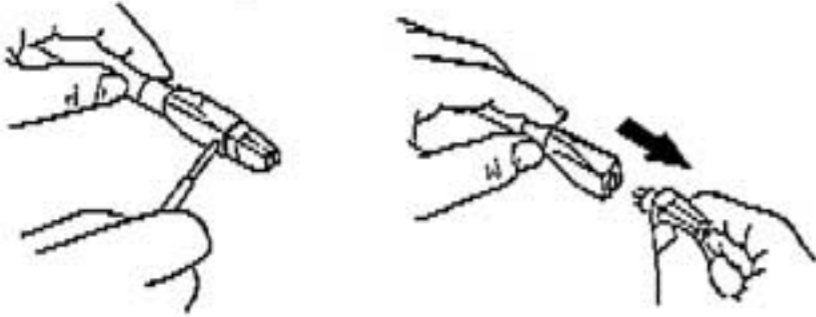

2. Remove the stylus guard.

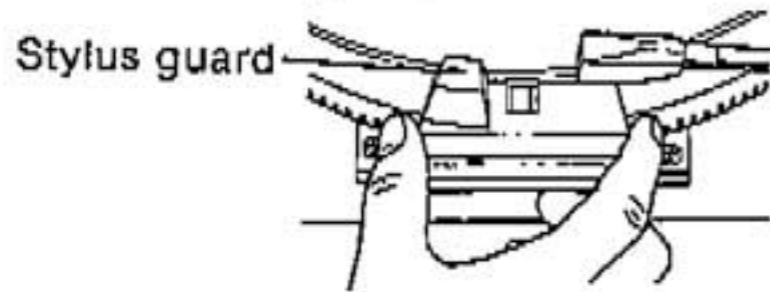

3. Remove the turntable platter.

* Lift it up with care not to touch the tonearm.

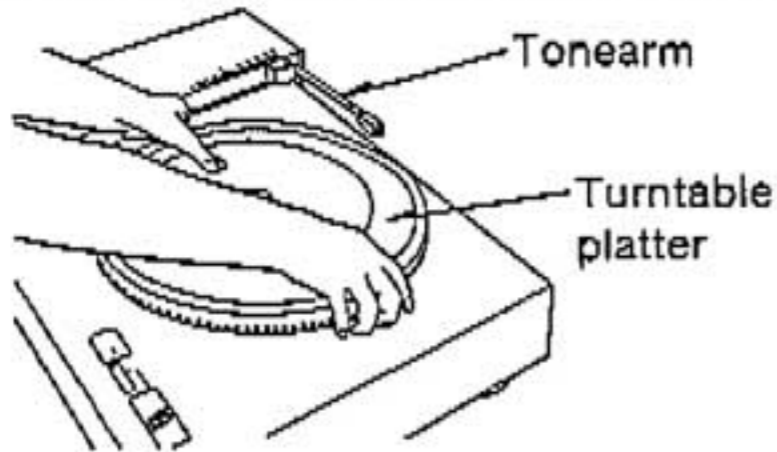

4. Remove the bottom board. (4 setscrews)

* Drive circuit can be checked without removing the bottom board.

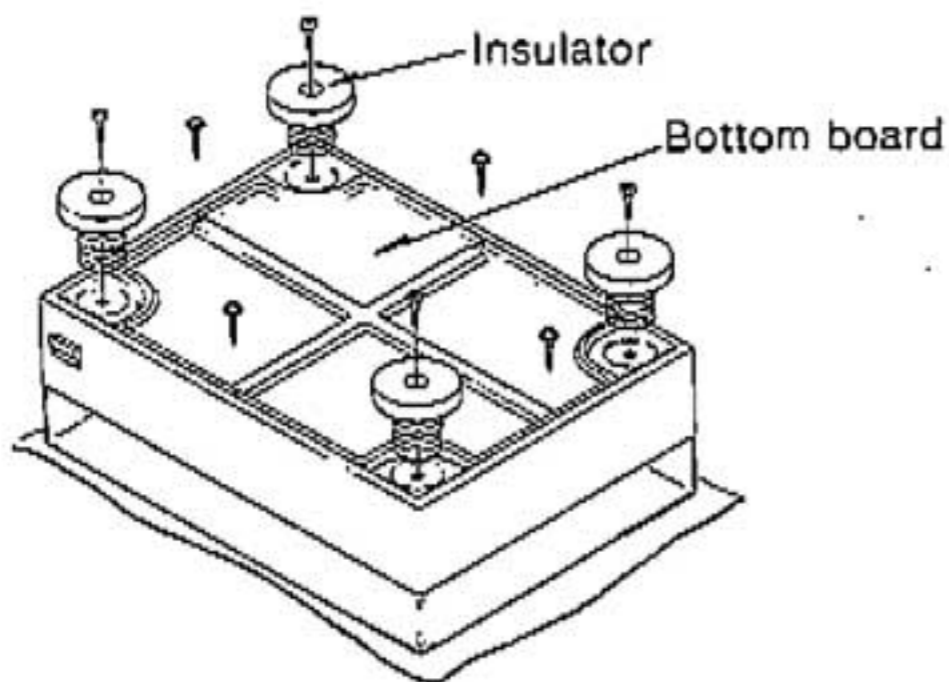

Insulator can be removed by removing 4 setscrews.
* Note that the front and rear insulators are different.

5. Remove the connector, transistor and setscrew of grounding lead on the control P.C.B.

* Do not remove these connector, transistor and ground lead when checking the drive circuit.

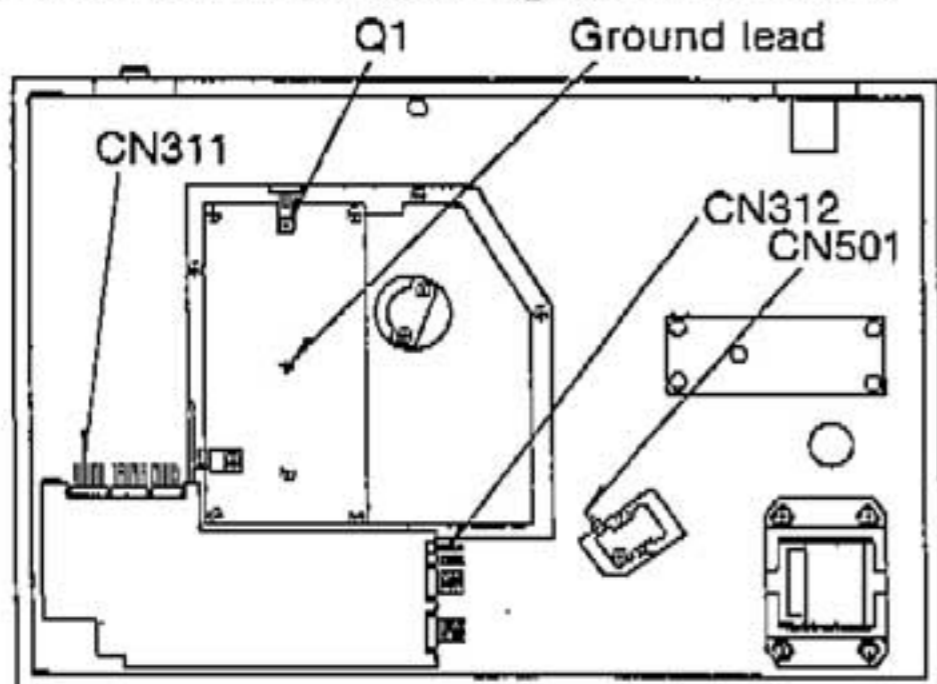

6. Remove the panel cover. (4 setscrews)

* Drive circuit can be checked in this condition.

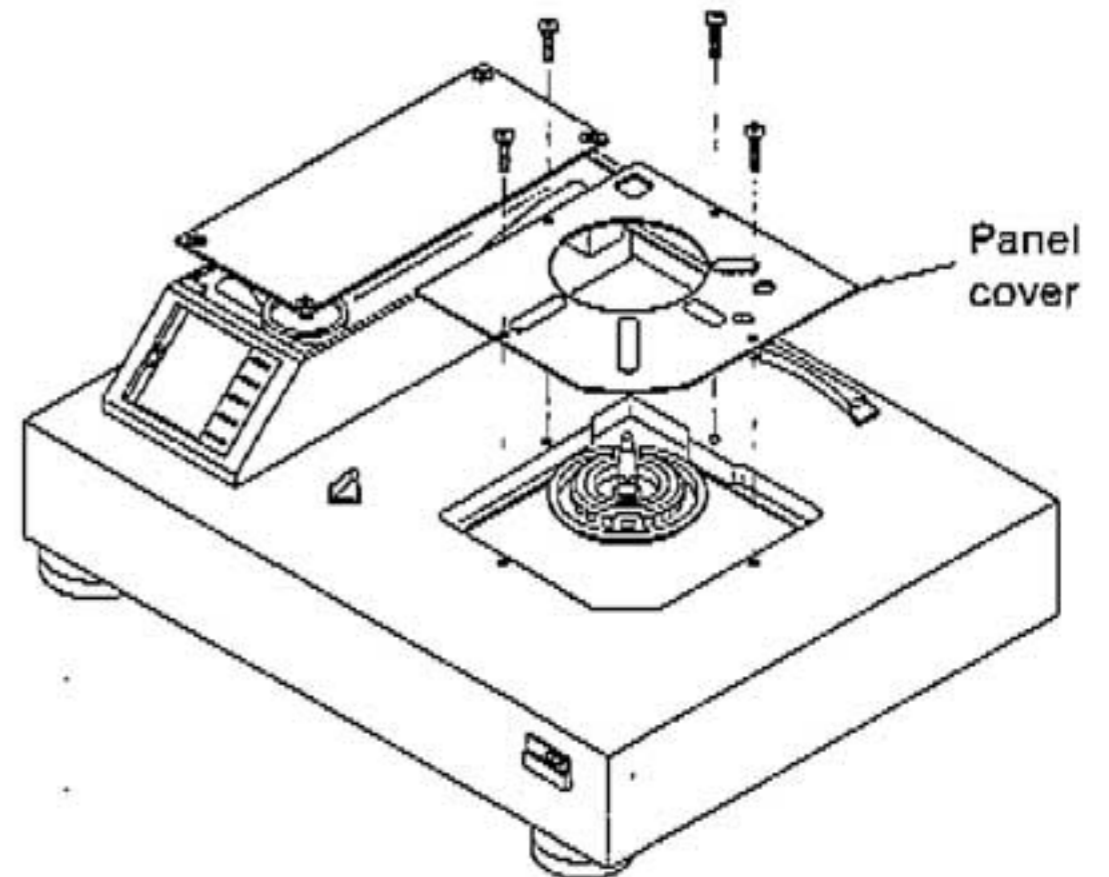

7. Remove the 6 setscrews of drive circuit P.C.B.

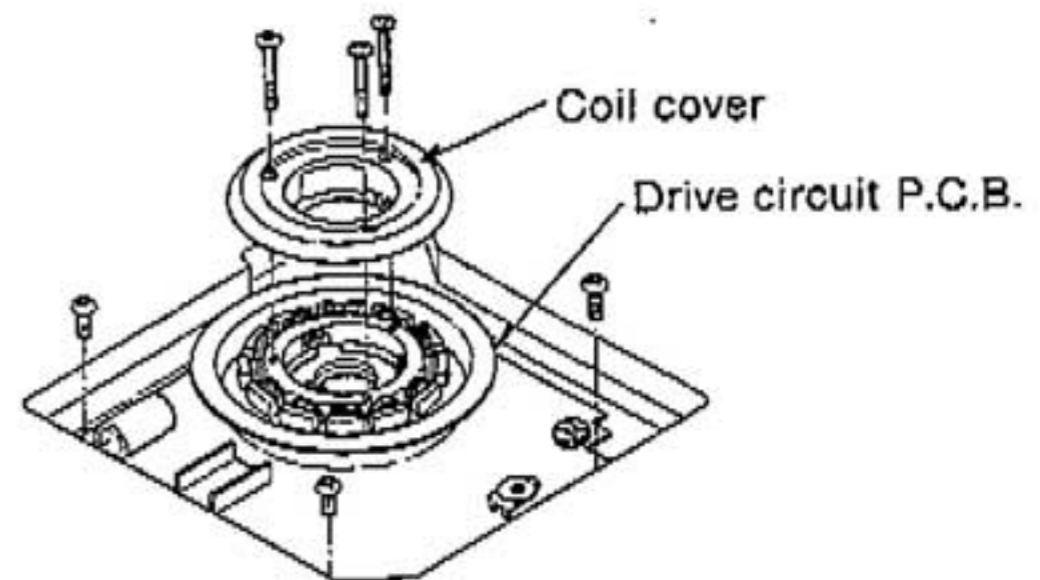

• How to remove the tonearm

1. Remove the top panel of arm drive unit. (4 setscrews)

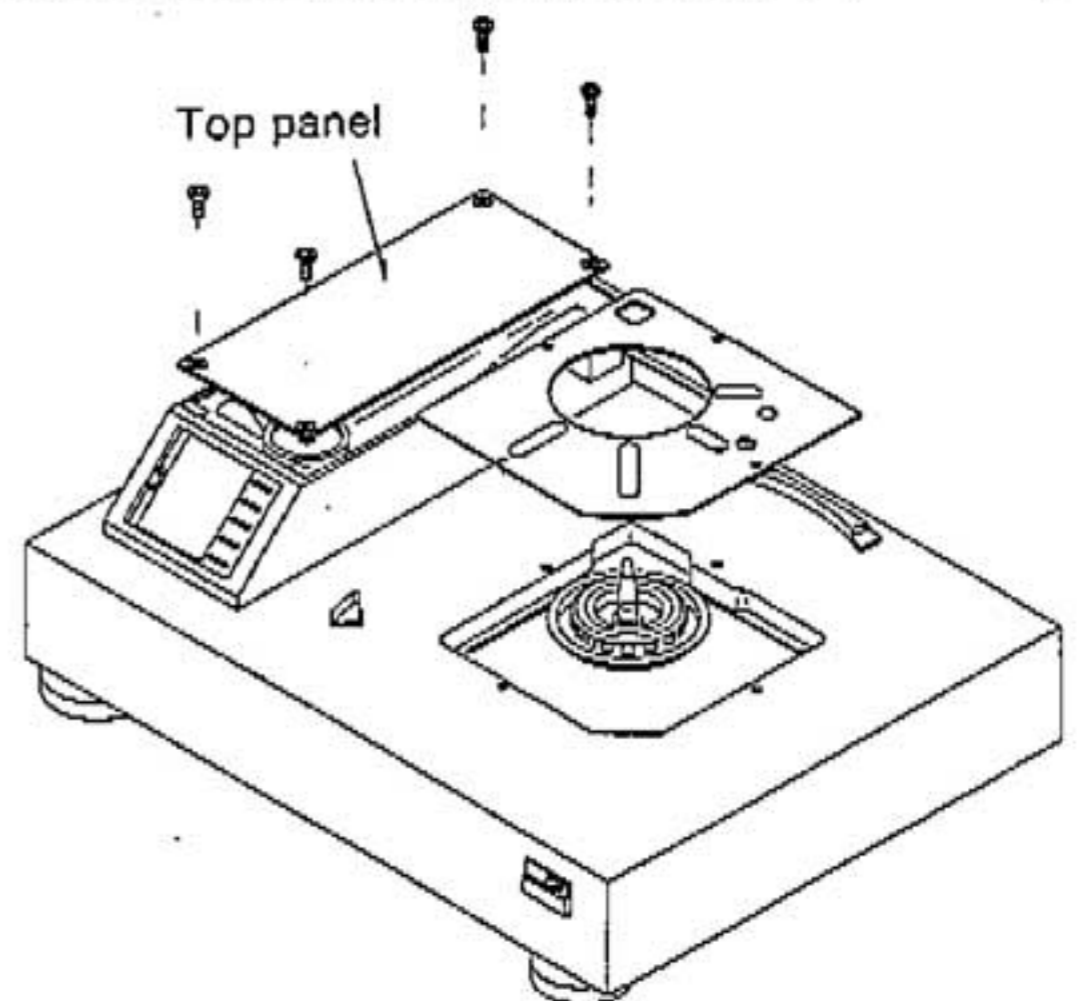

2. Remove the shield cover and unsolder the output lead.
3. Turn the drive motor by hand to shift the tonearm inside.
4. To remove the tonearm only, remove the setscrew.
5. Remove the rope fitting and the retaining plate.
6. Remove the stopper and rest switch rod.
7. Remove the tonearm unit from the guide rail.

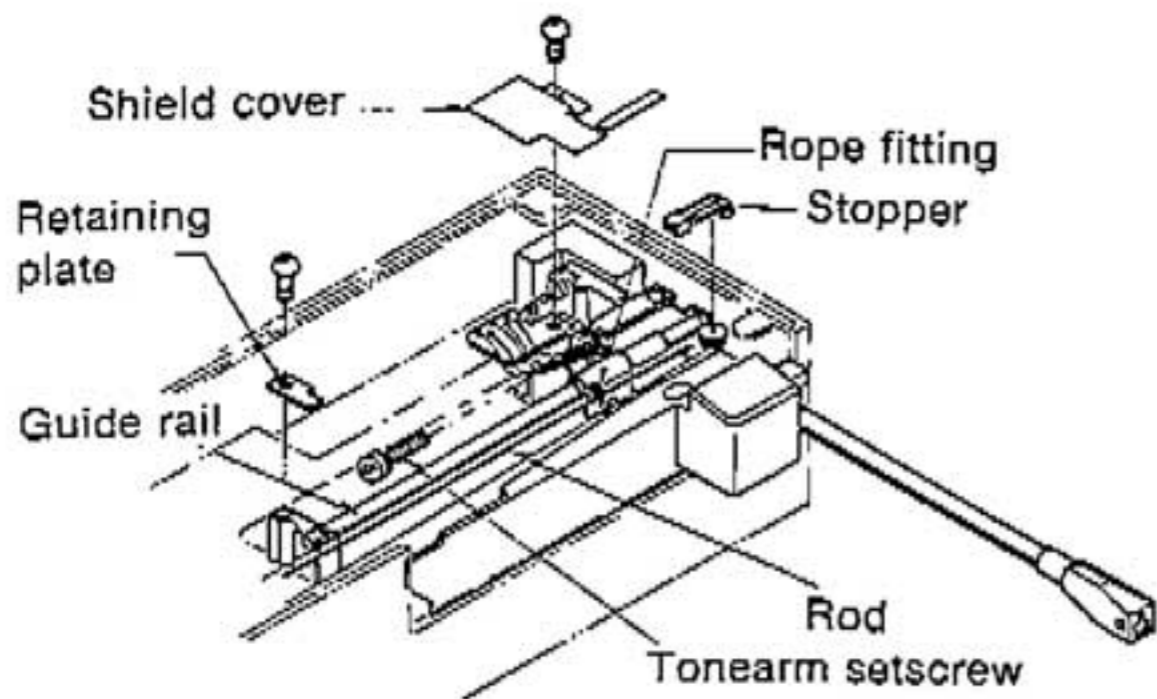

• **How to remove the cueing plunger**

1. Remove the tonearm unit.
2. Remove the plunger setscrew.

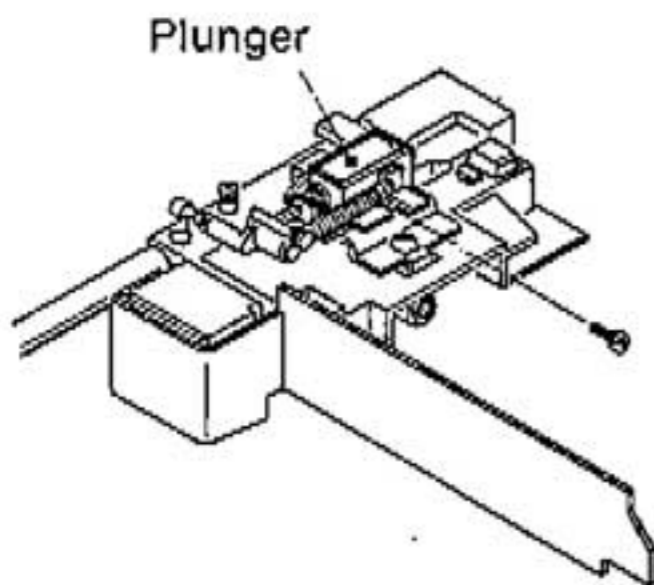

• **How to remove the control button**

1. Remove the bottom board.
2. Remove the control P.C.B. setscrews. (5 setscrews)
3. Unfasten the 2 claws.

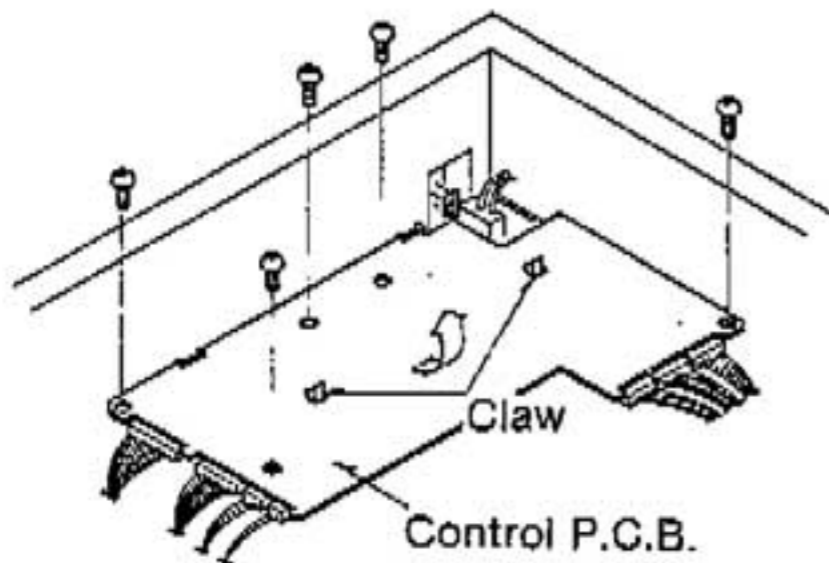

4. Remove the badge and power switch knob.

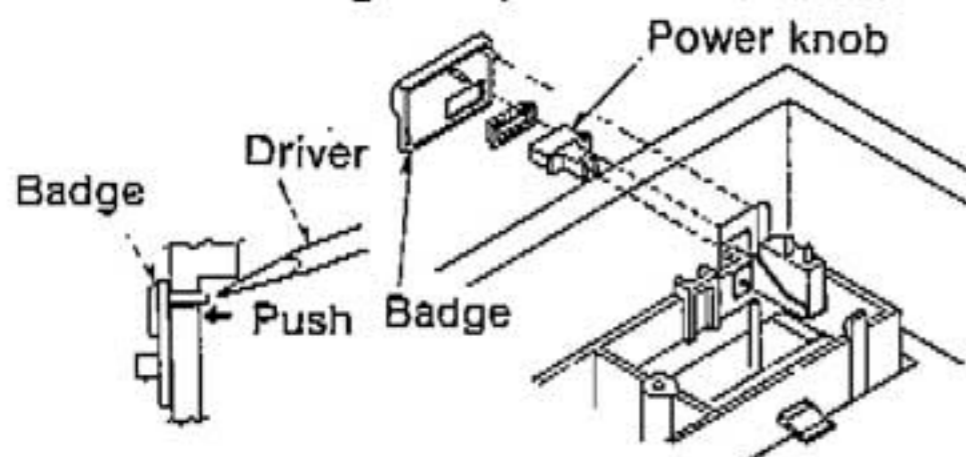

5. Unfasten the claw of guide frame.

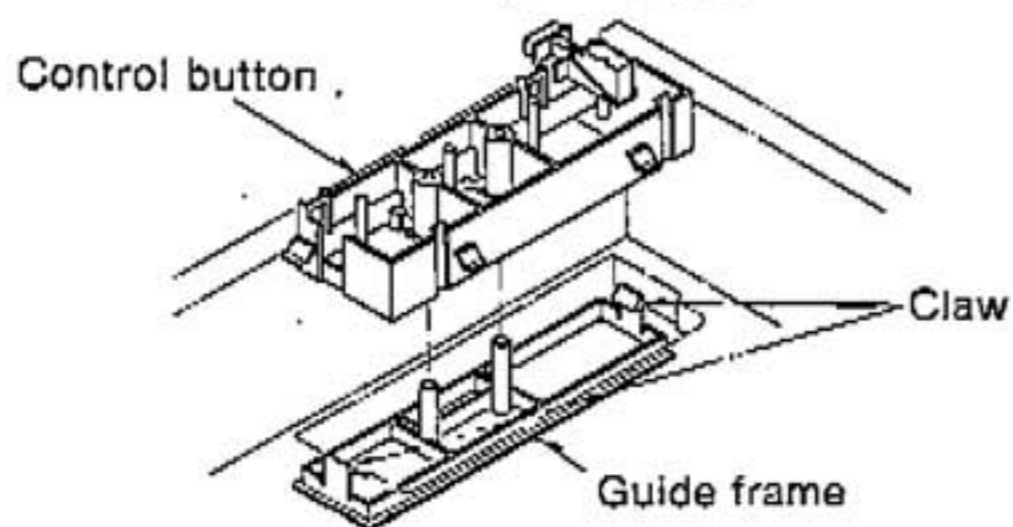

• **How to remove the switch P.C.B.**

1. Remove the bottom board.
2. Remove each connector.

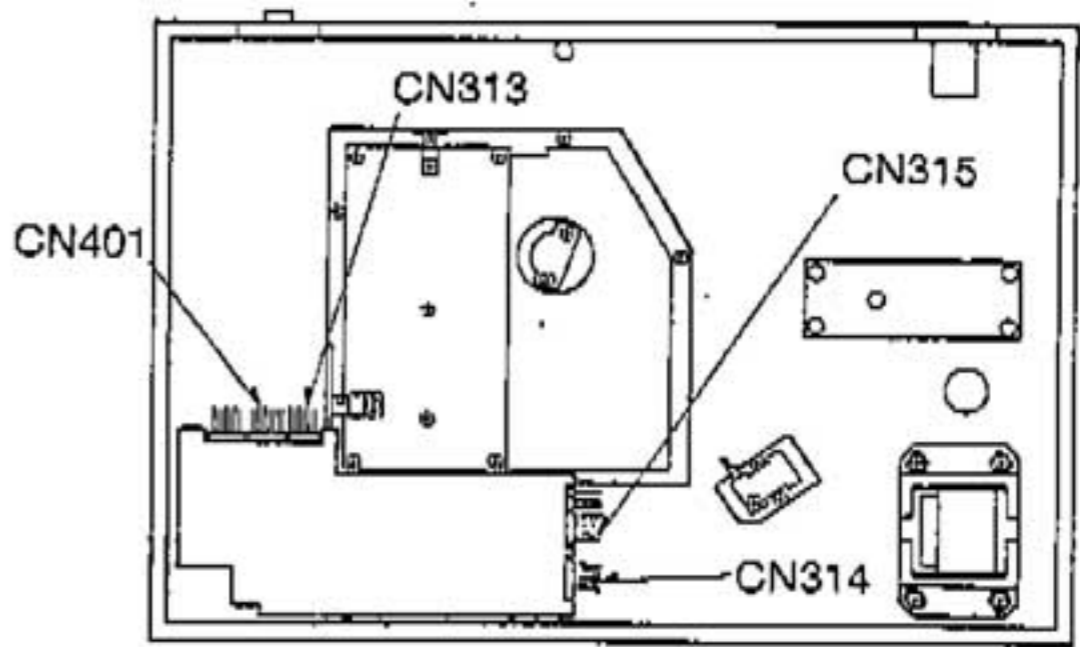

3. Remove the panel of arm drive unit.
4. Remove the setscrews. (3 setscrews)

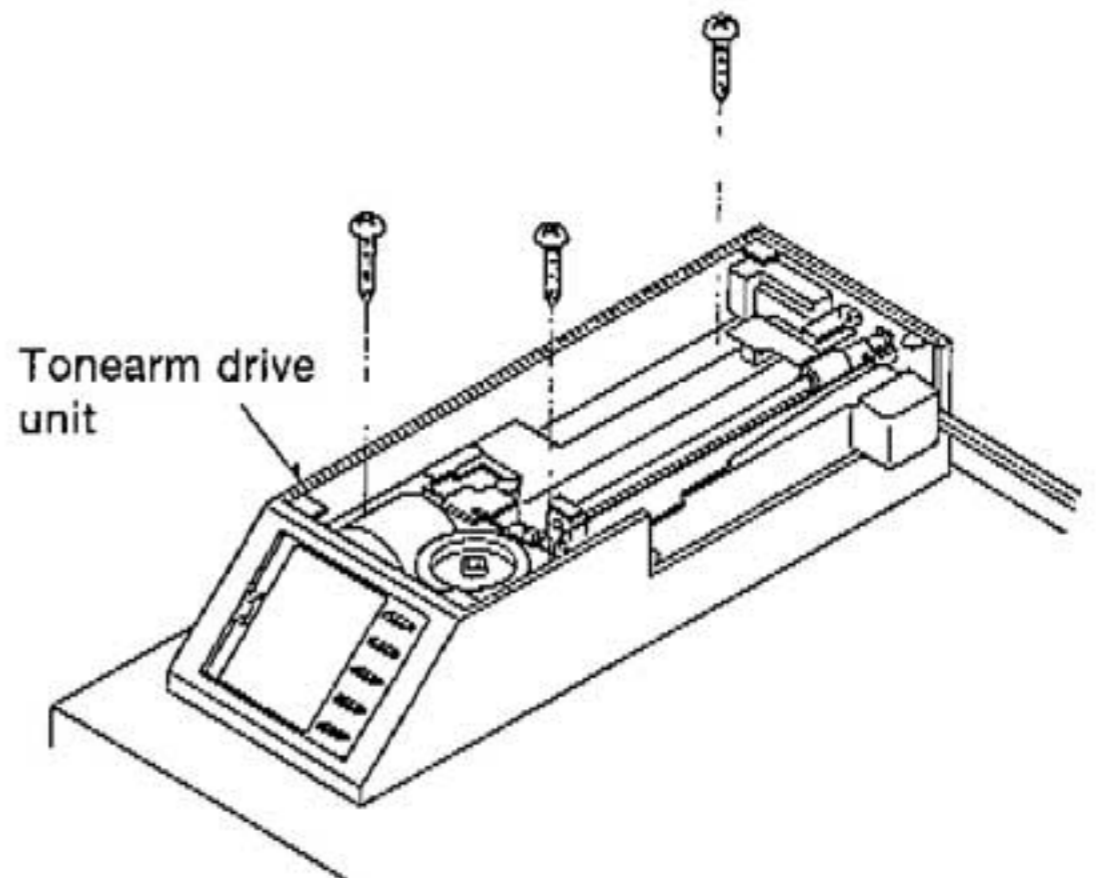

5. Remove the control button frame setscrews and unfasten the claws.

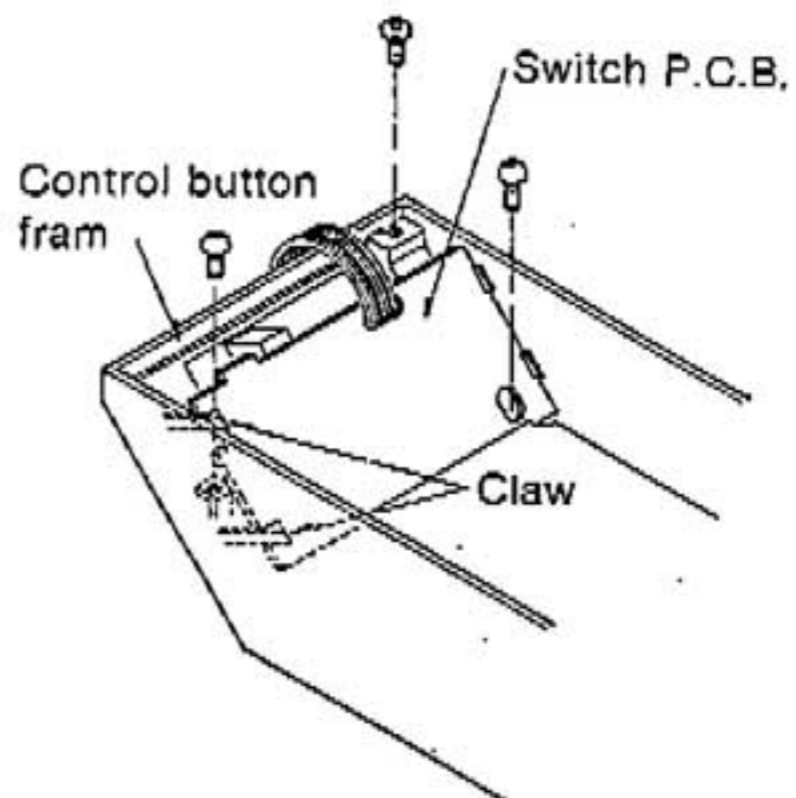

■ HOW TO SET THE TONEARM DRIVE ROPE

When setting the rope, follow the procedure given below.

1. Remove the top panel of tonearm drive unit.
2. Remove the stopper.
3. Set the rope in the order of 1 ~ 5.
4. Fit the rope connector to the tonearm.
5. Set the roller cover and turn the worm gear by hand to see that the tonearm moves.

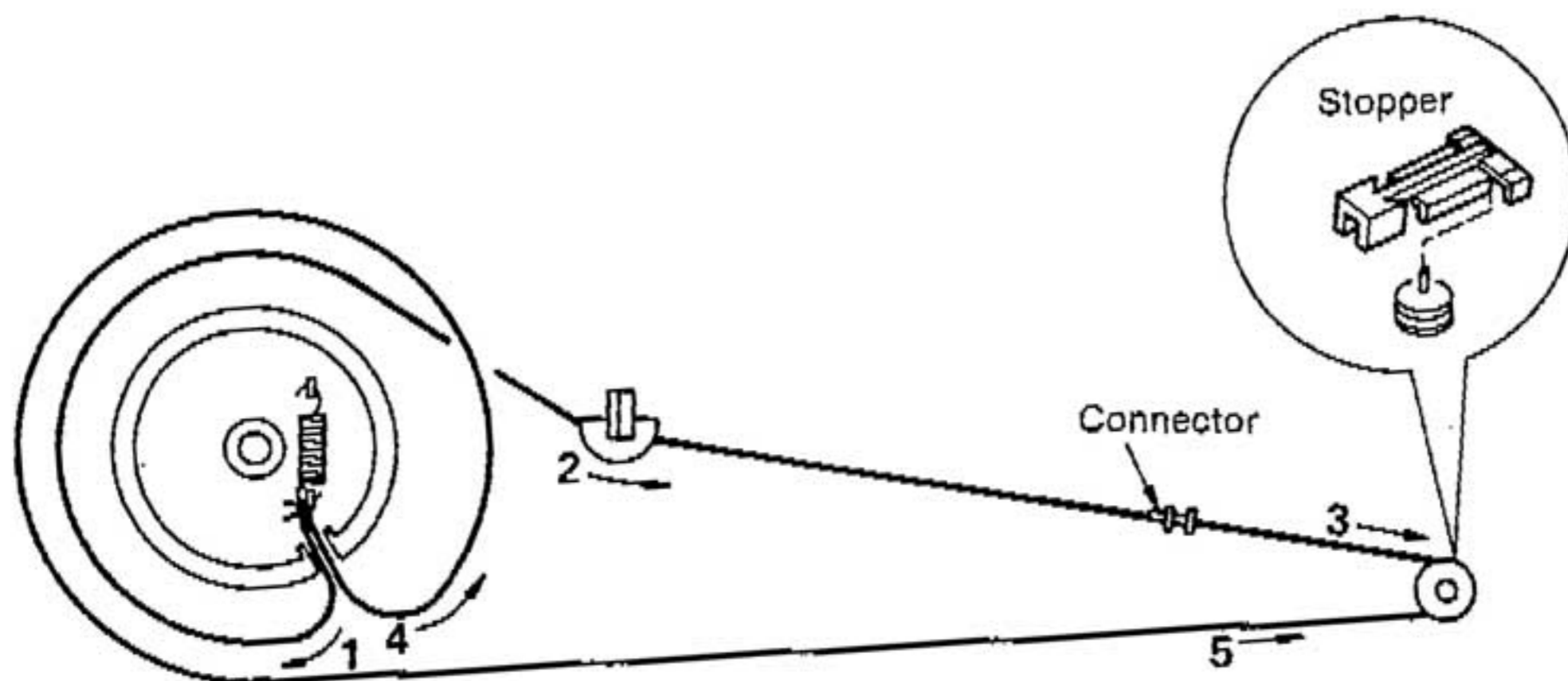

■ PITCH ADJUSTMENT

This unit employs a quartz linear synthesizer pitch control system to permit continuous adjustment of pitch by up to $\pm 6\%$ from the rated platter speed while still maintaining quartz control.

1. Press the pitch button (pitch indicator goes out).
2. Slide the pitch control knob up or down to the desired position.

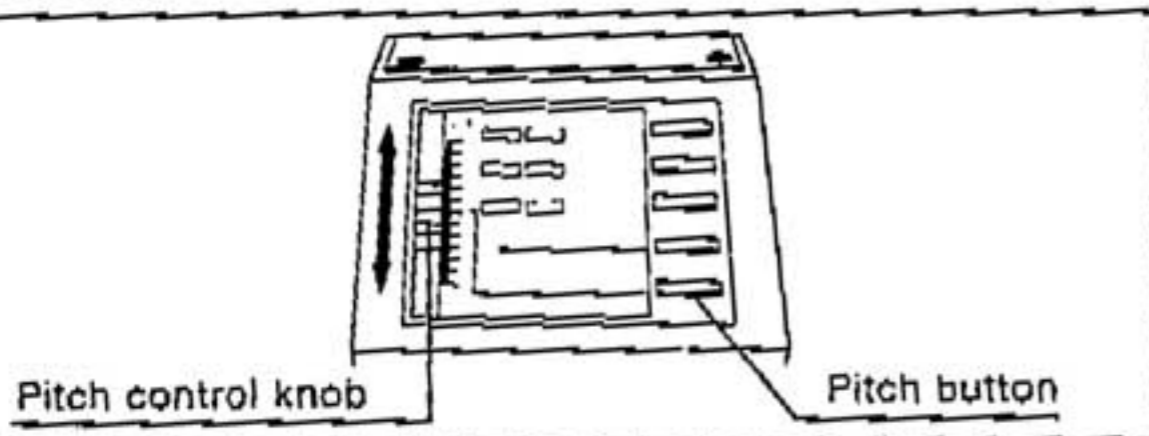

When the pitch control knob is moved in the + direction, the strobolines will appear to be moving forward. When moved in the - directions, the strobolines will appear to be moving backward.

- Set the pitch control knob to 0 to obtain precisely the rated platter speed (33-1/3 or 45 rpm).
- When the pitch function is not longer needed, press the pitch button again (pitch indicator lights).

Notes:

- The strobolines appear to be moving even when the platter is rotating at a rated speed when viewed under fluorescent lighting.
- Standard record playing should always be done with the pitch indicator out.

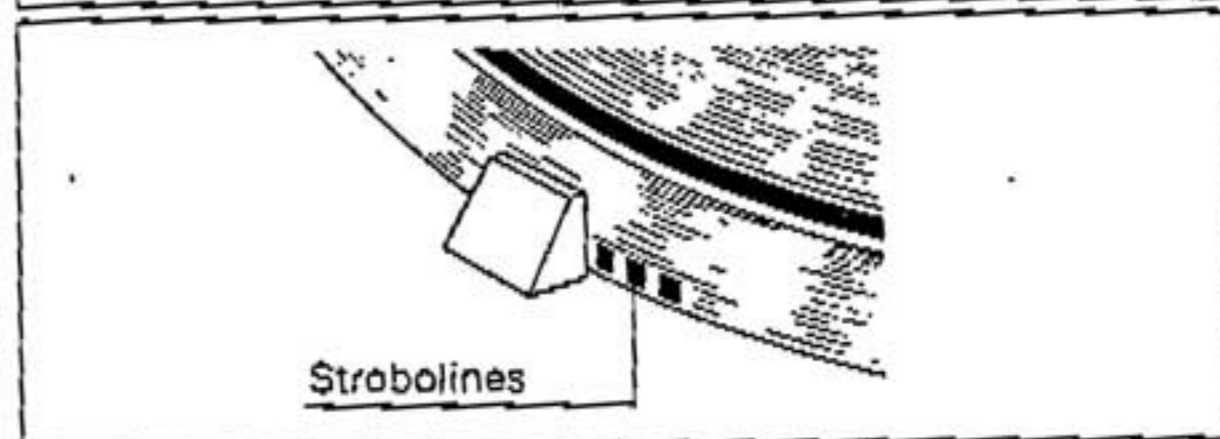

MEASUREMENTS AND ADJUSTMENT English

• Instruments used

1. Oscilloscope
2. Frequency counter
3. DC voltmeter

4. 30 cm record
5. Screwdriver

Step	Item	Preparations	Portion adjusted	Adjustment procedure
1	Brake	<ol style="list-style-type: none"> 1. Turn power switch "on". 2. Set mode selector to "manual". 3. Set speed selector to "33". 4. Press start button. 	VR201 (Fig. 1)	<ul style="list-style-type: none"> • Adjust VR201 so that turntable platter stops within the angle of $90^\circ \sim 120^\circ$ when the stop button is pressed during rotation. • Remove the turntable mat. It can be adjusted from the hole in the turntable platter.
2	Reference frequency	<ol style="list-style-type: none"> 1. Remove the turntable platter and panel cover. 2. Connect the frequency counter between TP27 and GND. (Fig. 1) 3. Turn power switch "on". 4. Set pitch control knob to "0" and press pitch button so that pitch indicator goes out. 	VR301 (Fig. 1)	<ul style="list-style-type: none"> • Adjust VR301 so that the frequency counter shows $262.075 \sim 262.085$ kHz.
3	Start position	<ol style="list-style-type: none"> 1. Put 30 cm record on. 2. Turn power switch "on". 3. Set mode selector to "auto". 4. Set size selector to "30". 5. Press start button. 	Start position adjust screw (Fig. 2)	<ul style="list-style-type: none"> • If stylus moves down too much inside, adjust it by turning the screw.
4	Clock frequency	<ol style="list-style-type: none"> 1. Remove bottom board. 2. Connect IC312 pins ⑦ ~ ⑩ to pin ⑰ (+5 V). 3. Connect oscilloscope to IC312 pin ④. 	VR311 (Fig. 3)	<ol style="list-style-type: none"> 1. Turn power switch "on". 2. Adjust VR311 so that output waveform cycle is $33 \pm 1 \mu s$.
5	Servo gain and offset voltage	<ol style="list-style-type: none"> 1. Remove top panel and pointer cover of arm drive unit. 2. Remove bottom board and connect DC voltmeter to CN313 pin ③ and ground. 	VR501 (Fig. 4) Offset voltage adjust screw (Fig. 4)	<ol style="list-style-type: none"> 1. Turn power switch "on". 2. Set mode selector to "manual". 3. Press the search button to move tonearm inside. 4. Completely shift the tonearm clockwise. 5. Adjust VR501 so that output voltage is 6.0 V. (Servo gain adjustment) 6. Adjust tonearm to the center position. Make sure that output voltage is 3.0 V. 7. If the voltage is not 3.0 V, turn an adjust screw. (Offset voltage adjustment)

MESSUNGEN UND JUSTIERUNGEN Deutsch

• Zu verwendende Instrumente

1. Oszilloskop
2. Frequenzzähler
3. Gleichstrom-Voltmeter

4. 30 cm-Platte
5. Schraubenzieher

Schritt	Abgleich	Vorbereitungen	Zu justierende Punkte	Justiermethode
1	Bremse	<ol style="list-style-type: none"> 1. Den Netzschalter auf "on" stellen. 2. Den Betriebsart-Wahlschalter auf "manual" stellen. 3. Den Drehzahl-Wahlschalter auf "33" stellen. 4. Die Starttaste drücken. 	VR201 (Abb. 1)	<ul style="list-style-type: none"> • VR201 so justieren, daß der Plattenteller innerhalb $90^\circ \sim 120^\circ$ stoppt, wenn die Stoptaste bei der Drehung gedrückt wird. • Die Plattentellerauflage abnehmen. Die Justierung kann durch das Loch im Plattenteller vorgenommen werden.
2	Referenzfrequenz	<ol style="list-style-type: none"> 1. Den Plattenteller und die Abdeckplatte entfernen. 2. Den Frequenzzähler zwischen TP27 und Masse anschließen. (Abb. 1) 3. Den Netzschalter auf "on" stellen. 4. Den Drehzahlregler auf "0" stellen und die Drehzahl-taste drücken, so daß die Drehzahl-anzeige erlöscht. 	VR301 (Abb. 1)	<ul style="list-style-type: none"> • VR301 so justieren, daß der Frequenzzähler $262.075 \sim 262.085$ kHz anzeigt.

3	Startposition	<ol style="list-style-type: none"> 1. Eine 30 cm-Platte auflegen. 2. Den Netzschalter auf "on" stellen. 3. Den Betriebsart-Wahlschalter auf "auto" stellen. 4. Den Plattengröße-Wahlschalter auf "30" stellen. 5. Die Starttaste drücken. 	Startposition-Justierschraube (Abb. 2)	<ul style="list-style-type: none"> • Falls die Nadel zu weit innen absenkt, ist durch Drehen der Schraube zu justieren.
4	Taktgeber-Frequenz	<ol style="list-style-type: none"> 1. Bodenabdeckung entfernen. 2. Die Stifte ⑦ ~ ⑩ von IC312 an Stift ⑫ (+5 V) anschließen. 3. Oszilloskop an Stift ④ von IC312 anschließen. 	VR311 (Abb. 3)	<ol style="list-style-type: none"> 1. Den Netzschalter auf "on" stellen. 2. VR311 so justieren, daß der Zyklus der Ausgangswellenform $33 \pm 1 \mu s$ beträgt.
5	Servo-Verstärkung und Offsetspannung	<ol style="list-style-type: none"> 1. Die obere Abdeckung und Zeigerabdeckung der Tonarm-Antriebsbox entfernen. 2. Die Bodenabdeckung entfernen und Gleichstrom-Voltmeter an Stift ③ von CN313 und an Masse anschließen. 	VR501 (Abb. 4) Offsetwinkel-Justierschraube (Abb. 4)	<ol style="list-style-type: none"> 1. Den Netzschalter auf "on" stellen. 2. Den Betriebsart-Wahlschalter auf "manual" stellen. 3. Die Suchlauf-taste drücken, um den Tonarm nach innen zu bewegen. 4. Den Tonarm vollständig im Uhrzeigersinn bewegen. 5. VR501 so justieren, daß die Ausgangsspannung 6,0 V beträgt. (Servo-Verstärkungs-Justierung) 6. Den Tonarm in die Mittenposition justieren. Überprüfen, daß die Ausgangsspannung 3,0 V beträgt. 7. Falls die Spannung nicht 3,0 V beträgt, durch Drehen der Schraube justieren. (Offsetspannung-Justierung)

■ MESURAGES ET RÉGLAGES Français

• Equipement utilisé

- | | |
|---------------------------|--------------------|
| 1. Oscilloscope | 4. Disque de 30 cm |
| 2. Compteur de fréquences | 5. Tournevis |
| 3. Voltmètre à C.C. | |

Etape	Article	Préparatifs	Partie à régler	Procédure de réglage
1	Frein	<ol style="list-style-type: none"> 1. Tourner l'interrupteur d'alimentation sur "on" (en circuit). 2. Régler le sélecteur de mode sur "manual". 3. Régler le sélecteur de vitesse sur "33". 4. Appuyer sur la touche de mise en marche. 	VR201 (Fig. 1)	<ul style="list-style-type: none"> • Ajuster VR201 de telle sorte que le plateau de lecture s'arrête en deçà d'un angle de $90^\circ - 120^\circ$ lorsque l'on appuie sur la touche d'arrêt pendant la rotation. * Retirer le tapis de la platine. Il peut être ajusté à partir de l'orifice se trouvant dans le plateau de lecture.
2	Fréquence de référence	<ol style="list-style-type: none"> 1. Retirer le plateau de lecture et le panneau de protection. 2. Raccorder le compteur de fréquences entre TP27 et la masse (GND). (Fig. 1) 3. Tourner l'interrupteur d'alimentation sur "on" (en circuit). 4. Régler la manette de réglage d'écart sur "0" et appuyer sur la touche d'écart de telle sorte que l'indicateur d'écart s'éteigne. 	VR301 (Fig. 1)	<ul style="list-style-type: none"> • Ajuster VR301 de telle sorte que le compteur de fréquences indique $262,075 \sim 262,085$ kHz.
3	Position de démarrage	<ol style="list-style-type: none"> 1. Installer un disque de 30 cm. 2. Tourner l'interrupteur d'alimentation sur "on" (en circuit). 3. Régler le sélecteur de mode sur "auto". 4. Régler le sélecteur de diamètre des disques sur "30". 5. Appuyer sur la touche de mise en marche. 	Vis de réglage du positionnement de démarrage. (Fig. 2)	<ul style="list-style-type: none"> • Si la pointe de lecture s'abaisse trop à l'intérieur, l'ajuster en tournant la vis.
4	Fréquence de rythme	<ol style="list-style-type: none"> 1. Retirer la plaque de la face inférieure. 2. Raccorder les broches ⑦ ~ ⑩ IC312 à la broche ⑫ (+5 V). 3. Brancher l'oscilloscope à la broche ④ IC312. 	VR311 (Fig. 3)	<ol style="list-style-type: none"> 1. Tourner l'interrupteur d'alimentation sur "on" (en circuit). 2. Ajuster VR311 de telle sorte que le cycle de la forme d'onde de sorte soit de $33 \pm 1 \mu s$.

Identificación Función Nombre de ajuste	<ol style="list-style-type: none"> Retirar el panel superior y la cubierta protectora de la aguja del botlero de arrastre del brazo. Retirar la placa de la cara inferior y conectar el voltmetro a C.C. a la brocha ③ CN313 y a la masa. 	VR501 (Fig. 4) Vis de ajuste de tensión de desviación (Fig. 4)	<ol style="list-style-type: none"> Rotar el interruptor de alimentación a "on" (en circuito). Ajustar el selector de modo a "manual". Presionar la tecla de búsqueda para mover el brazo de lectura hacia el interior. Desplazar completamente el brazo de lectura en el sentido de las agujas del reloj. Ajustar VR501 de tal modo que la tensión de salida sea de 6,0 V. (Ajuste de la amplificación servomecánica.) Desplazar el brazo de lectura hacia la posición central. Asegurarse de que la tensión de salida sea de 3,0 V. Si la tensión no es de 3,0 V, girar la vis de ajuste. (Ajuste de desviación)
--	---	---	--

ADJUSTES Y AJUSTE Español

Herramientas usadas

Copio
 Voltmetro
 Fuente de CC

4. Disco de 30 cm
 5. Destornillador

Nombre	Preparaciones	Porción ajustada	Procedimiento de ajuste
	<ol style="list-style-type: none"> Conectar el interruptor de alimentación. Poner el selector de modalidad en "manual". Poner el selector de velocidad en "33". Presionar el botón de arranque. 	VR201 (Fig. 1)	<ul style="list-style-type: none"> Ajustar VR201 de tal modo que el mecanismo del plato giradiscos se para dentro de un ángulo de $90^\circ \rightarrow 120^\circ$ cuando se presiona el botón de parada durante la rotación. Remover la esterilla del plato giradiscos. Puede ajustarse desde el agujero en el mecanismo del plato giradiscos.
Función de frecuencia	<ol style="list-style-type: none"> Remover el mecanismo del plato giradiscos y la cubierta del panel. Conectar el frecuencímetro entre TP27 y Tierra (GND) (Fig. 1) Conectar el interruptor de alimentación. Poner la perilla de control de saltos de aguja en "0" y presionar el botón de tono de tal modo que el indicador de tono se apaga. 	VR301 (Fig. 1)	<ul style="list-style-type: none"> Ajustar VR301 de tal modo que el frecuencímetro muestra $262,075 \sim 262,085$ kHz.
Función de ajuste	<ol style="list-style-type: none"> Colocar el disco de 30 cm Conectar el interruptor de alimentación. Poner el selector de modalidad en "auto". Poner el selector de tamaño en "30". Presionar el botón de arranque. 	Tornillo de ajuste de posición de arranque (Fig. 2)	<ul style="list-style-type: none"> Si la aguja cae demasiado adentro, ajustarla girando el tornillo.
Función de frecuencia de onda	<ol style="list-style-type: none"> Remover la placa inferior. Conectar pines ⑦ ~ ⑩ de IC312 a pino ⑫ (+5 V). Conectar osciloscopio a pino ④ de IC312. 	VR311 (Fig. 3)	<ol style="list-style-type: none"> Conectar el interruptor de alimentación. Ajustar VR311 de tal modo que el ciclo de forma de onda de salida sea $33 \pm 1 \mu s$.
Función de ajuste de voltaje	<ol style="list-style-type: none"> Remover el panel superior y cubierta de aguja de caja de accionamiento de brazo. Remover la placa inferior y conectar voltmetro de CC a pino ③ de CN313 y tierra. 	VR501 (Fig. 4) Tornillo de ajuste de voltaje de desviación (fonocaptor) (Fig. 4)	<ol style="list-style-type: none"> Conectar el interruptor de alimentación. Poner el selector de modalidad en "manual". Presionar el botón de exploración para mover el interior del brazo de fonocaptor. Mover completamente el brazo de fonocaptor a la derecha. Ajustar VR501 de tal modo que el voltaje de salida sea 6,0 V. (Ajuste de servogancia) Ajustar el brazo de fonocaptor a la posición central. Asegurarse de que el voltaje de salida sea 3,0 V. Si el voltaje no es 3,0 V, girar un tornillo de ajuste. (Ajuste de voltaje de desviación)

■ ADJUSTMENT POINTS

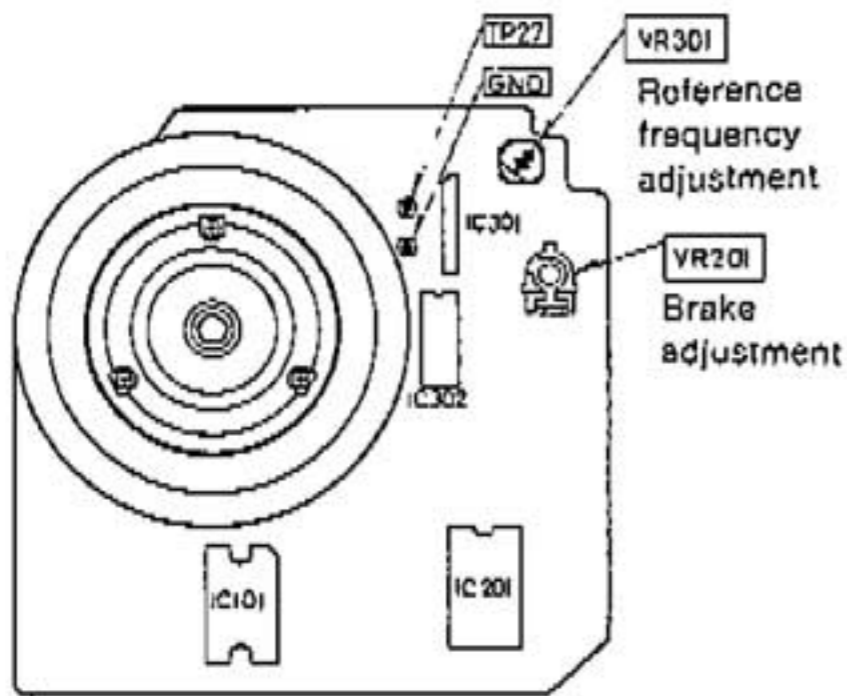

(Fig. 1)
(Abb. 1)

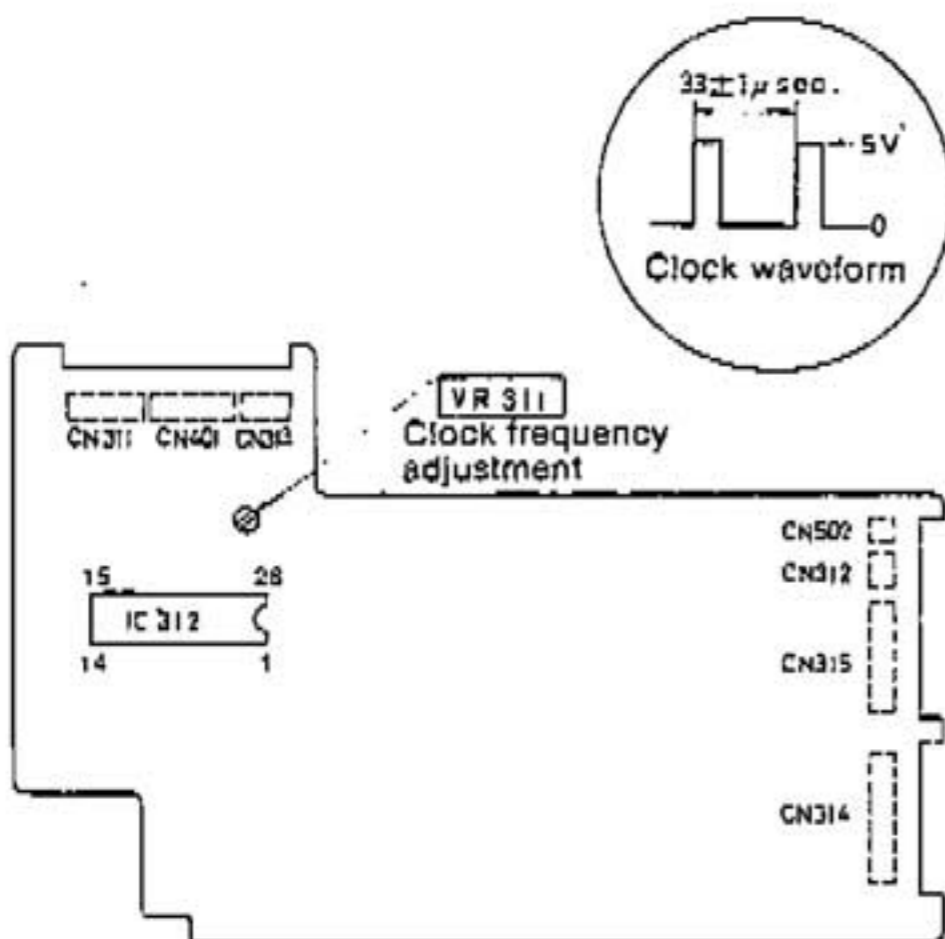

(Fig. 3)
(Abb. 3)

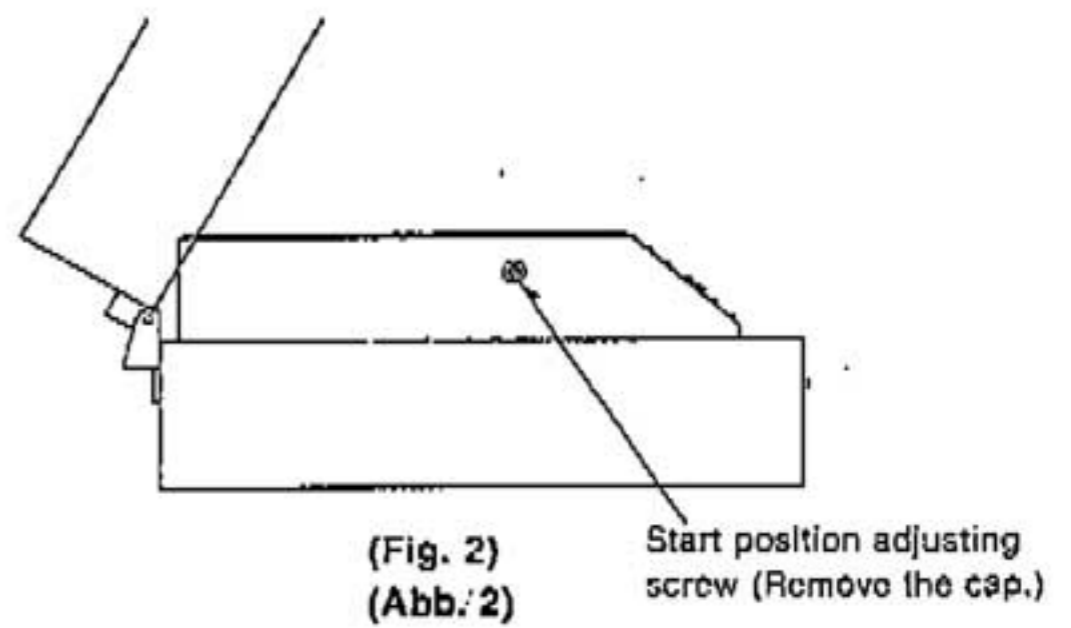

(Fig. 2)
(Abb. 2) Start position adjusting screw (Remove the cap.)

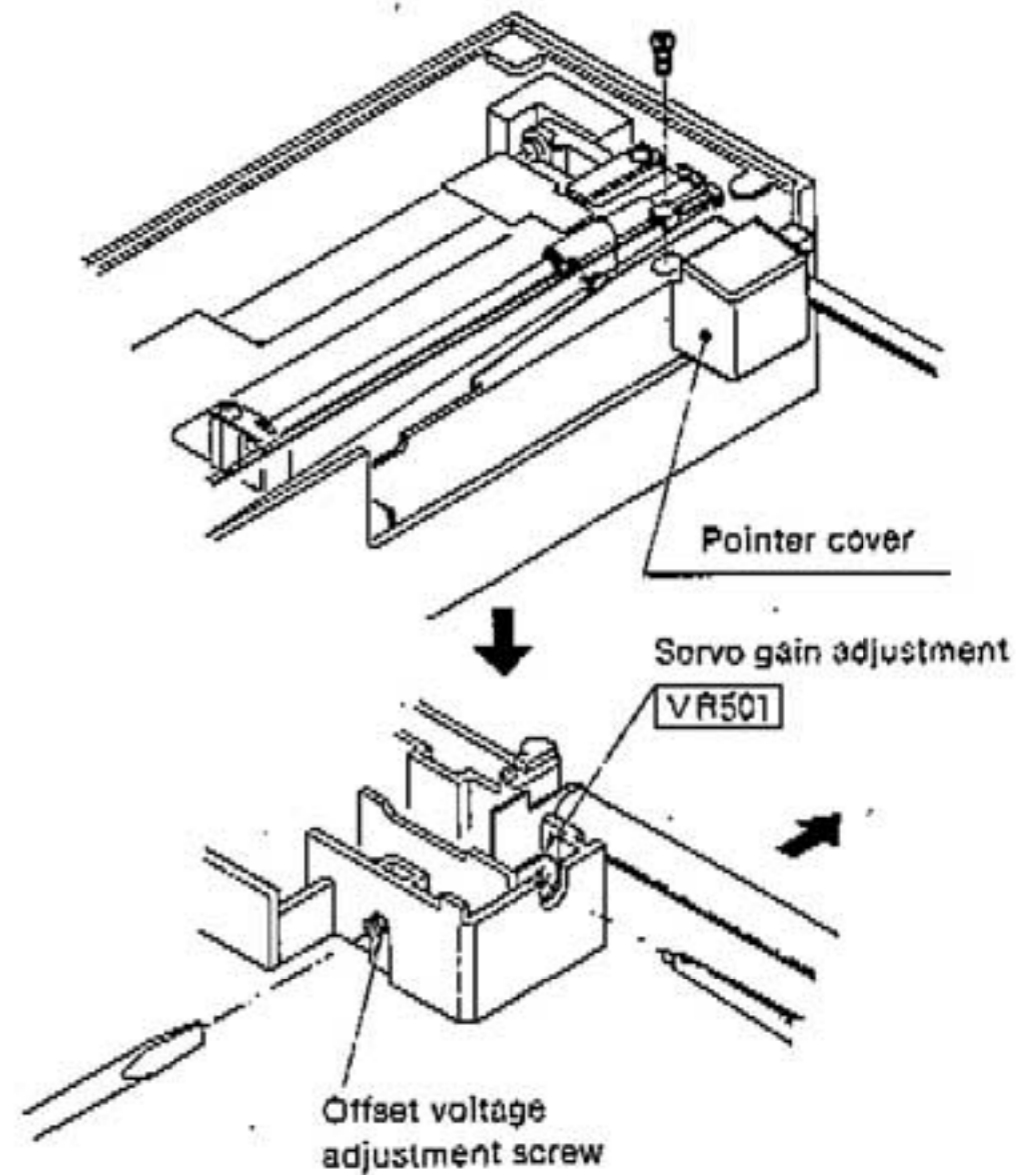

(Fig. 4)
(Abb. 4)

■ TROUBLE SHOOTING

• State of setting

1. Remove the cartridge. (Be sure to remove it for protection of stylus tip.)
2. Remove the turntable platter and panel cover.
3. Remove the bottom board.
4. Remove the control circuit P.C.B.
5. Put the set on the repair table.
6. When checking the drive circuit in rotation mode, pass the lead wire from the cabinet bottom and put on the turntable platter.

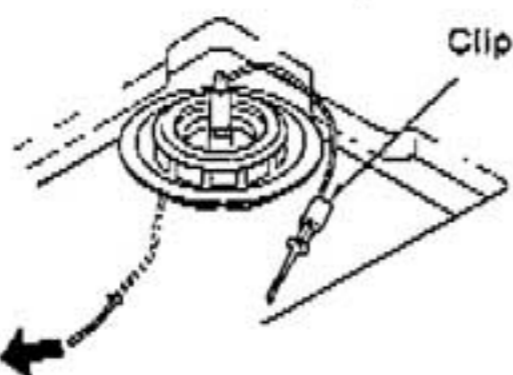

To voltmeter and oscilloscope

• Caution for check

With mode selector in auto position, the arm operates when the start/stop button is pressed. In manual position, however, the arm does not operate unless the search button is pressed.

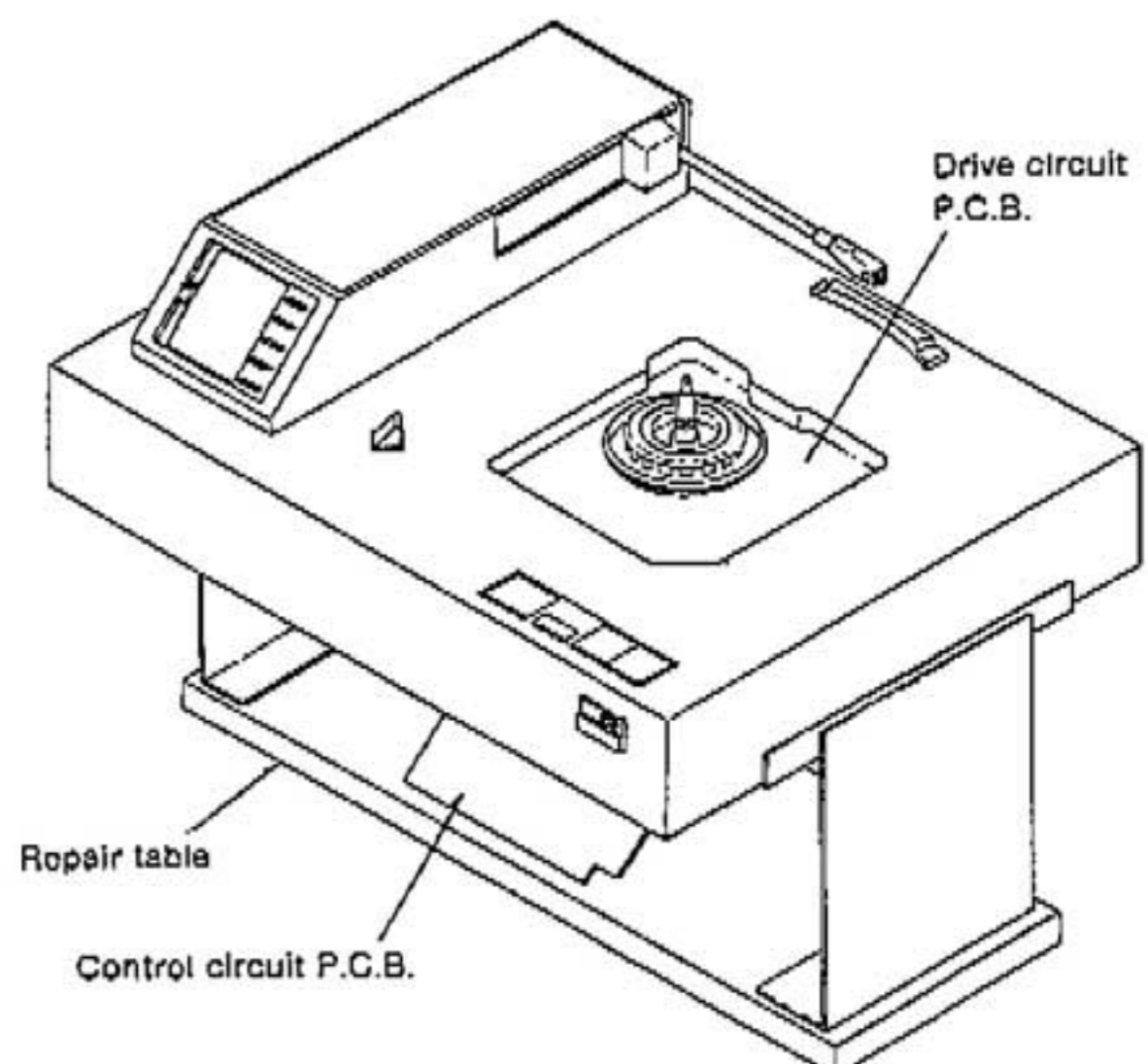

★ Turntable drive circuit

Turntable does not rotate.

Power source circuit

1. AC voltage of power transformer secondary side 30 V
2. DC voltage of regulator transistor Q1
Ⓒ 35.8 V Ⓓ 20.6 V Ⓔ 20 V
3. DC voltage of regulator transistor Q201
Ⓒ 20 V Ⓓ 10 V Ⓔ 9.4 V
4. DC voltage of drive IC (IC101) terminal Ⓓ 20 V
5. DC voltage of control IC (IC201) terminal Ⓓ 9.4 V

1. Power transformer, AC cord, S1
2. Q1~3, D1, C1~6, R1~5.
3. Q201, R202
4. IC101
5. IC201

NO

Press start/stop button (S305).

Turntable control circuit

- DC voltage at each terminal of IC201

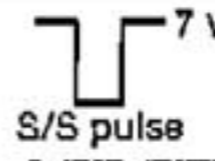
Pin No.	Stop	Start
Ⓓ	7 V	 7 V S/S pulse
Ⓔ	5.9 V	0.3 V
Ⓕ	0.2 V	2.8 V

IC201

NO

Press start/stop button (S305).

Turntable drive circuit

- DC voltage and waveform at each terminal of IC101

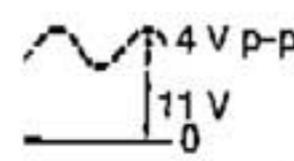
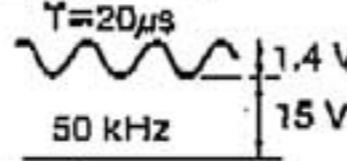
Pin No.	Stop	Start
Ⓐ	2 V	 4 V p-p 11 V 0
Ⓑ	2.9 V	
Ⓒ	2 V	
Ⓓ Ⓔ Ⓕ	 1.4 V 50 kHz 15 V	

IC101 drive coil

NO

Note: The waveform at start is measured with the turntable platter on.

★ Operation circuit

Power source circuit

1. DC voltage of regulator IC (IC311)
Ⓐ 20 V Ⓑ 0 V Ⓒ 12 V
2. DC voltage of regulator transistor (Q311)
Ⓒ 12 V Ⓓ 5.6 V Ⓔ 5 V
3. DC voltage of IC312 terminal Ⓓ 5 V

1. IC311, C311, 312
2. Q311, RF1, R311, 312, C313, D311
3. IC312

NO

Press start/stop button (S305).

Clock frequency

- Waveform of IC312 terminal Ⓓ, when connect the IC312 terminal Ⓔ ~ Ⓕ and Ⓓ (+5 V).

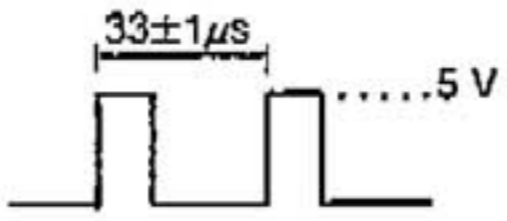

IC312, VR311, C322

NO

Start/stop select circuit

1. DC voltage of IC312 terminal Ⓓ 5 V with S/S switch (S305) pressed.
2. DC voltage of IC312 terminal Ⓒ at stop 0.8 V, at start 0.2 V

IC312, S305, Q321

NO

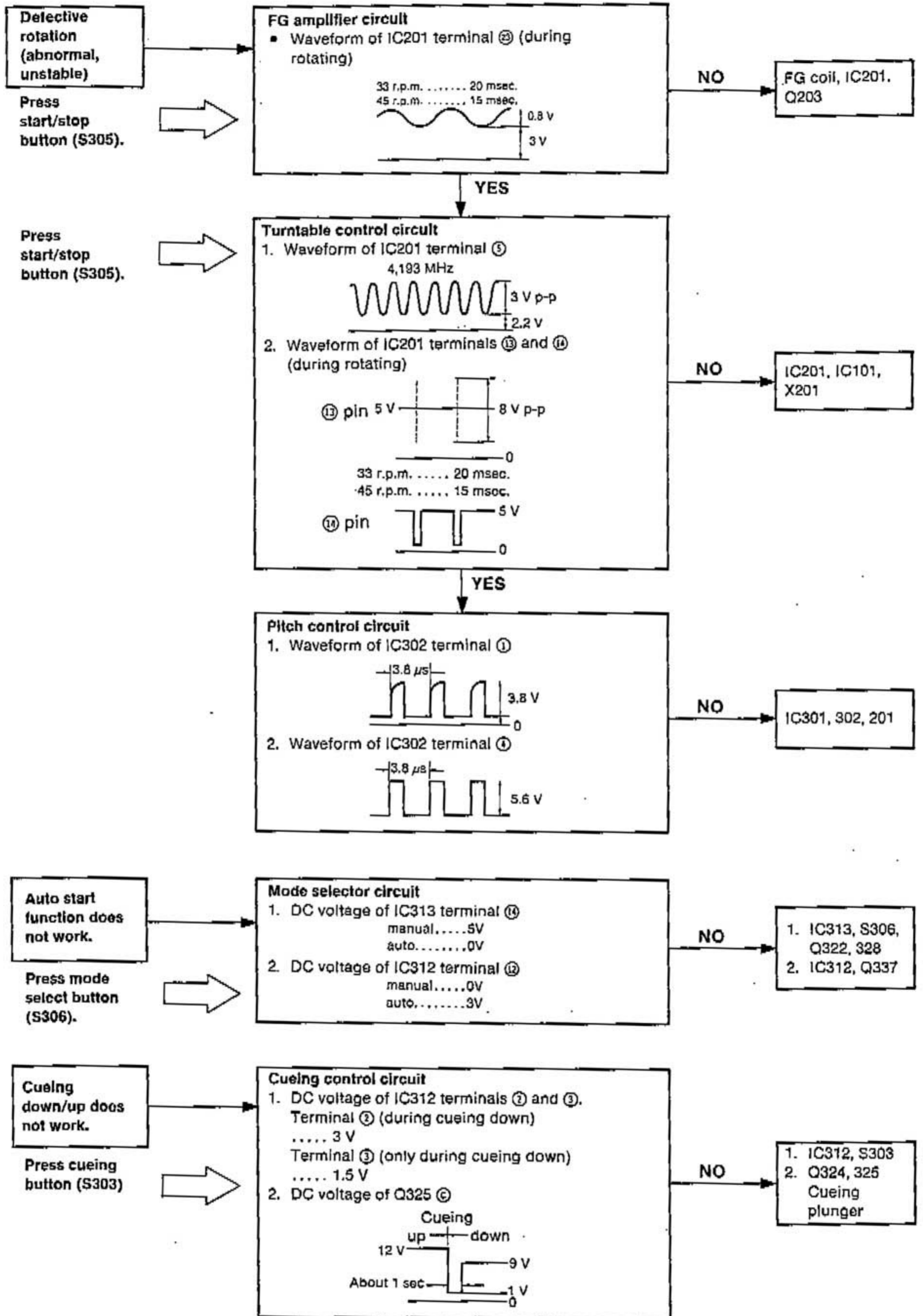

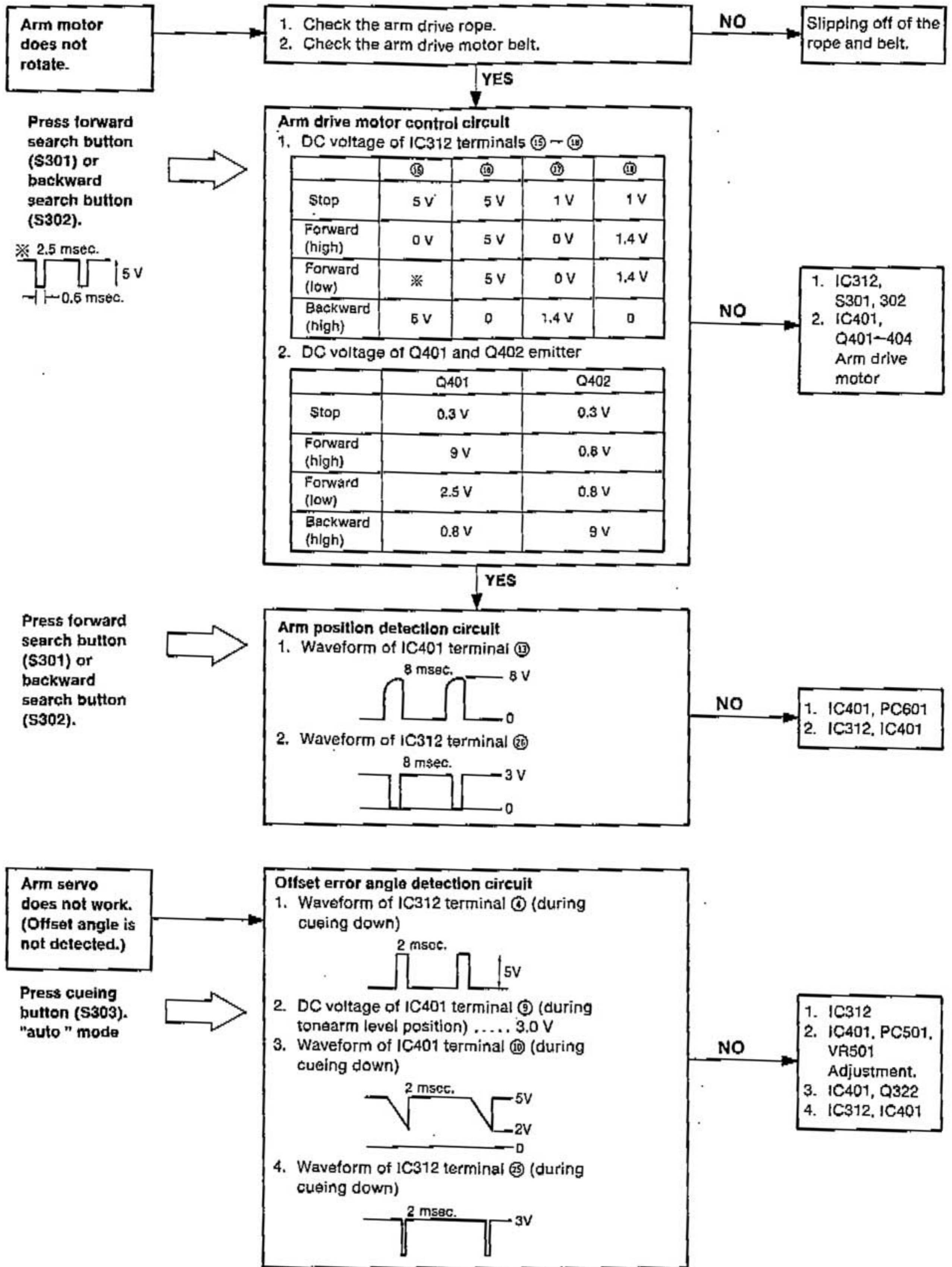

I REPLACEMENT PARTS LIST

- Notes: 1. Part numbers are indicated on most mechanical parts. Please use this part number for parts orders.
2. Important safety notice: Components identified by Δ mark have special characteristics important for safety. When replacing any of these components, use only manufacturer's specified parts.
3. Bracketed indications in Ref. No. columns specify the area. Parts without these indications can be used for all areas.
4. The "Ⓢ" mark is service standard parts and may differ from production parts.
5. The parenthesized numbers in the columns of description stand for the quantity per set.

Area
* [M] U.S.A.
* [MC] ... Canada
* [E] Switzerland and Scandinavia.
* [EK] United Kingdom
* [XL] Australia
* [EG] F.R. Germany
* [EB] Belgium
* [EH] Holland
* [EF] France
* [Ei] Italy
* [EC] Czechoslovakia
* [XA] Southeast Asia, Oceania, Africa, Middle Near East and Central South America
* [XM] Central South America
* [PA] far East PX
* [PE] European Military
* [PC] European Audio Club
* [XZ] New Zealand

Ref. No.	Part No.	Description
INTEGRATED CIRCUITS		
101	AN6875	Turntable Drive
201	AN6680	Turntable Control
301	AN6682	Pitch Control
302	MN4011B	NAND Gate
311	AN78M12	Regulator
312	MN1402FPK	Micro Computer
313, 314	MN4027B	J-K Flip Flop
401	AN6554	Comparator

Ref. No.	Part No.	Description
TRANSISTORS		
1	2SD1285	Regulator
2, 3	2SD637	Regulator
201	Ⓢ 2SC1846-R	Regulator
202	2SD637	Strobe Drive
203	Ⓢ 2SC1328-Y	FG Amp.
311	2SC1383	Regulator
321	2SD636	Start/Stop Select
322	2SB641	Switching
323, 324	2SD638	Muting Drive & Cueing Control
325	2SD892	Cueing Control
328~340	2SD636	Switching, Size Select & Mode Select
401, 402	2SD973	Arm Motor Control
403, 404	2SD892	Arm Motor Control

Ref. No.	Part No.	Description
DIODES		
11	Δ SVD51RBA20Z	Rectifier
12	MA1051M	5.1V, Zener
1204	Ⓢ MA162A	Switching
1301	MA1051M	5.1V, Zener
1311	MA4056M	5.8V, Zener
1321	MA4082M	6.2V, Zener
1322	MA185	Switching
1323~330	SVD5LV31VC3	Mode, Speed, Size, Repeat & Pitch Indicator
1501 ~ 503	SVD5LH54DC3	Strobe Indicator
1511	Ⓢ MA162A	Switching
1701	MA185	Switching

Ref. No.	Part No.	Description
SWITCHES		
11	Δ ESB8213V	Power Switch
12 Except for [M, MC]	Δ SFD5HXW01317	Voltage Selector
1301 ~ 309	EVOQS405K	F-search, B-search, Cueing, Repeat, Start/Stop, Mode, Size, Speed & Pitch
3601	SFDSC02N03	Rest Switch

Ref. No.	Part No.	Description
VARIABLE RESISTORS		
1R201	EVT53MA00B54	Brake Adjustment, 50 k Ω (B)

Ref. No.	Part No.	Description
VR301	Ⓢ EVMH9GA00B53	Pitch Control Adjustment, 5 k Ω (B)
VR311	EVN61AAC0B24	Clock Frequency Adjustment, 20 k Ω (B)
VR312	EWAPF5X05AU4	Pitch Control
VR501	Ⓢ EVNK0AA00B14	Servo Gain Adjustment, 10 k Ω (B)

Ref. No.	Part No.	Description
RELAY		
RL701	SFDYG5A237P	Muting

Ref. No.	Part No.	Description
CRYSTAL		
X201	SVQMS4193	Crystal OSC, 4.193 MHz

Ref. No.	Part No.	Description
PHOTO INTERRUPTERS		
PC501	ON1195	Offset Angle Sensor
PC601	ON1181	Arm Position Sensor

Ref. No.	Part No.	Description
LAMP		
PL1	SFDNM03N01E	Stylus Illuminator

Ref. No.	Part No.	Description
FUSES		
F1 [MC] only	Δ XBA1F16NU14	1.6 A, 250V
F1 Except for [M, MC]	Δ XBA2C031TR0	T310 mA, 250 V

Ref. No.	Part No.	Description
POWER TRANSFORMER		
T1 [M]	Δ SLT55DTL3A	Power Source
T1 [MC]	Δ SLT55DT15D	Power Source
T1 [Other Areas]	Δ SLT88DTE13F	Power Source

Ref. No.	Part No.	Description
CABINET AND CHASSIS PARTS		
1	SFADM03N01E	Dust Cover (1)
2	SFATM03N01A	Hinge (2)
3	SFTGM01N01	Turntable Mat (1)
4	SFTEM01N01Z	Turntable Platter (1)
5	SFAUM03N01	Bottom Board (1)
6	SFGAM02N01E	Insulator Ass'y (4)
7	SFOAM03N01	Spring (A), Insulator (2)
8	SFOAM03N02	Spring (B), Insulator (2)
9	SFGCM01N01	Cushion Rubber, Power Transformer (2)
10	SFGCM01N02	Cushion Rubber, Power Transformer (4)
11	SFUMM03N02R	Operation Button Ass'y (1)

Ref. No.	Part No.	Description
12	SFUMM03N01	Guide, Operation Button (1)
13	SFKTM02N02	Button, Power Switch (1)
14	SFUM130-01	Strobe Cover (1)
15	SFGZM02N02	Spacer, Strobe (1)
16	SFUMM02N05	Guide, Strobe Cover (1)
17	SFUPM02N04	Cover, Cabinet (1)
18 [M]	SFNNM03M01	Name Plate (1)
18 [MC]	SFNNM03C01	Name Plate (1)
18 [E, EC]	SFNNM03S01	Name Plate (1)
18 [EK, XL, XZ]	SFNNM03G01	Name Plate (1)
18 [XA, XM]	SFNNM03X01	Name Plate (1)
18 [PA, PE]	SFNNM03P01	Name Plate (1)
18 [PC]	SFNNM03P02	Name Plate (1)
18 [Other Areas]	SFNNM03R01	Name Plate (1)
19	SFUPM03N01	Cover, Phono Output (1)
20	SFUPM03N02	Holder, Phono Output (1)
21	SFUMM03N03	Stylus Guard (1)
22	SFUMM03N04	Base, Stylus Guard (1)
23	SFUPM01N07	Holder, AC Socket (1)
24 [M, MC]	Δ SFDJHSC049T	AC Socket (1)
24 [XL, XA, XM, PA, PE, PC]	Δ SFDJHSC049T	AC Socket (1)
24 [XZ]	Δ SFDJHSC516-1	AC Socket (1)
24 [Other Areas]	Δ SFDJHSC049B	AC Socket (1)
25	SFACM03N01R	Cabinet (1)
26	SFUP116-05	Case, Hinge (2)
27	SFKBM03N01	Badge (Quartz) (1)
28	SFUMM02N05	Guide, Power Switch (1)
29	SFKBM03N02	Badge (Technics) (1)
30	SFMGQ20-01	Cover, Starter Frame (1)
31	SFMG520-31A	Drive Coil Ass'y (1)
32	SFMZ172-01E	FG Coil Ass'y (1)
33	SFMZM01N01A	Shaft Ass'y, Turntable Drive (1)
34 [M]	SFUMM02M03	Base, Drive Circuit Board (1)
34 [Other Areas]	SFUMM02ND3	Base, Drive Circuit Board (1)
35	SFDJM03N03	Jack, Phono Out (1)
36	SFUZM02N02	Tape, Bdgo (1)
37	SFUZM02N06	Spacer (6)
38	SFGZM03N01	Spacer (2)
39	SFUMQ06N22	Latch (1)

■ EXPLODED VIEWS

• Cabinet and chassis parts

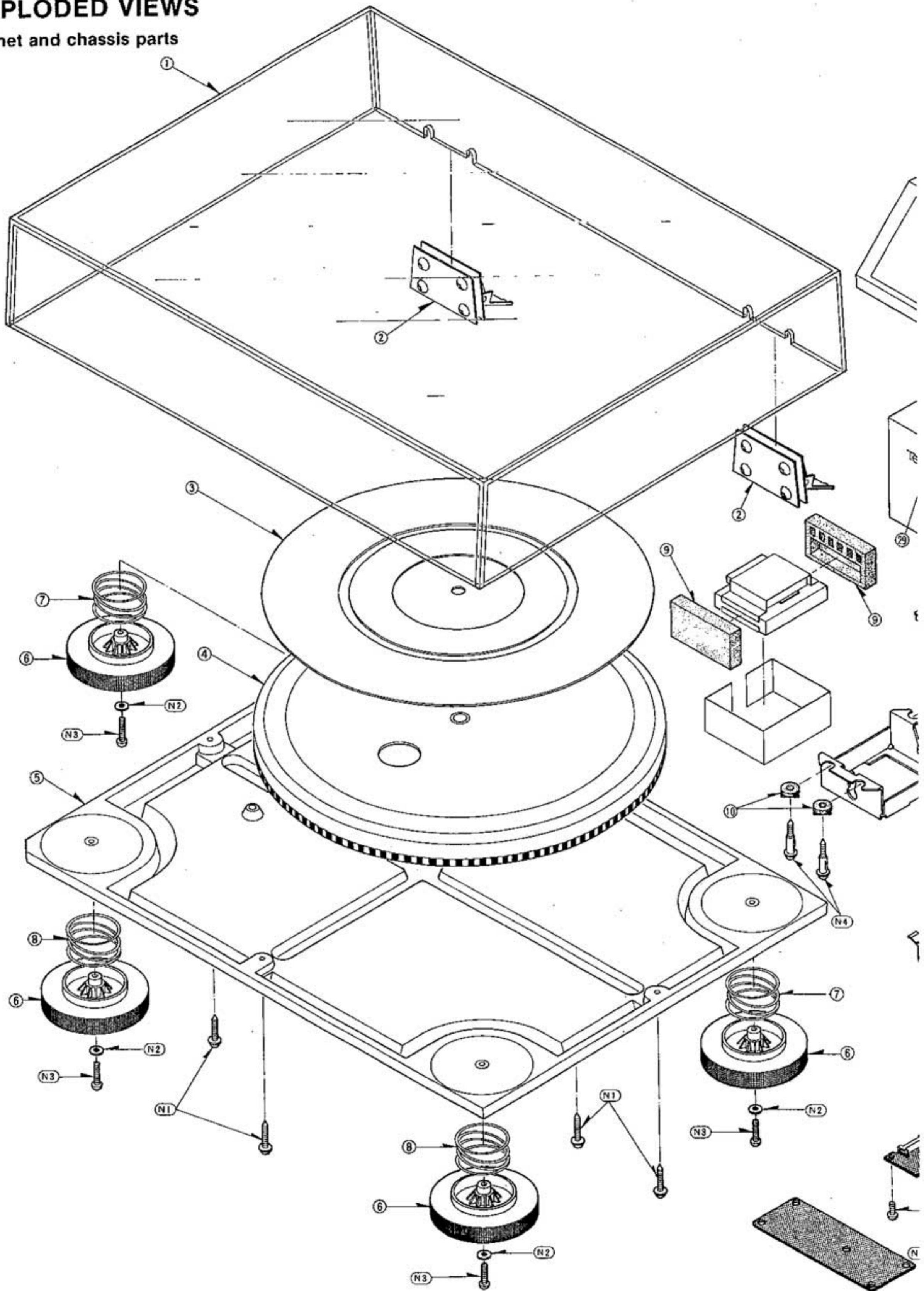

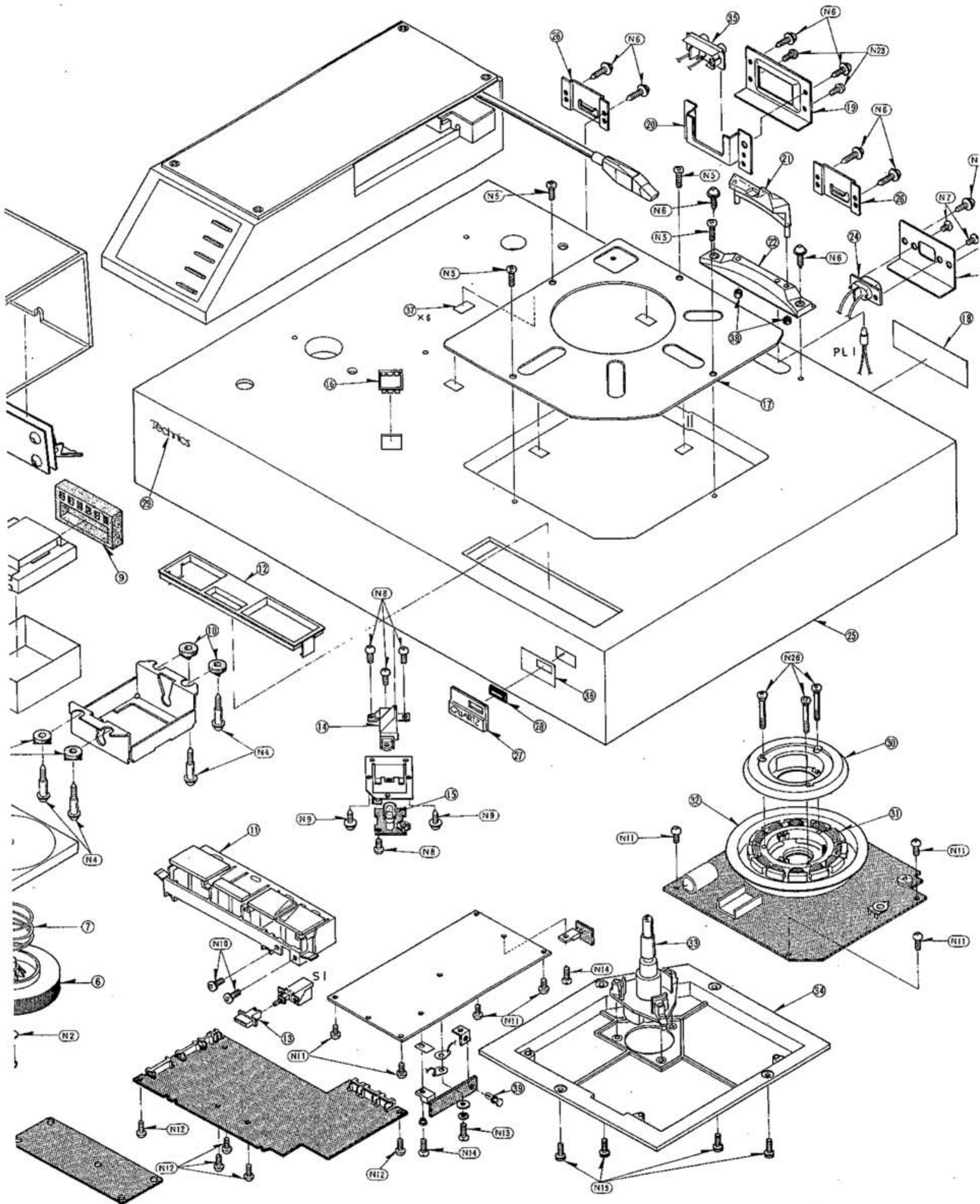

• Tonearm drive unit parts

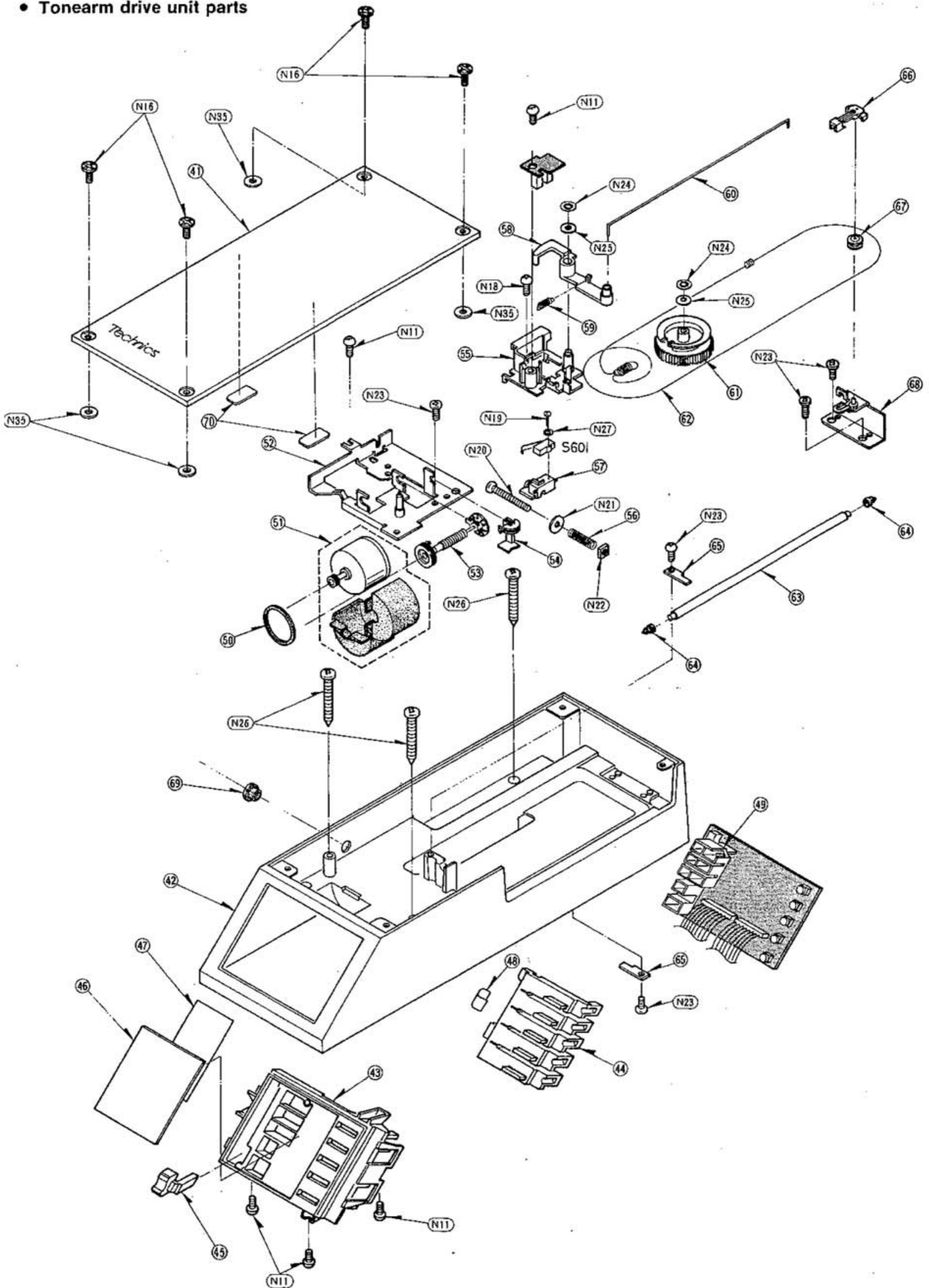

• Tonearm parts

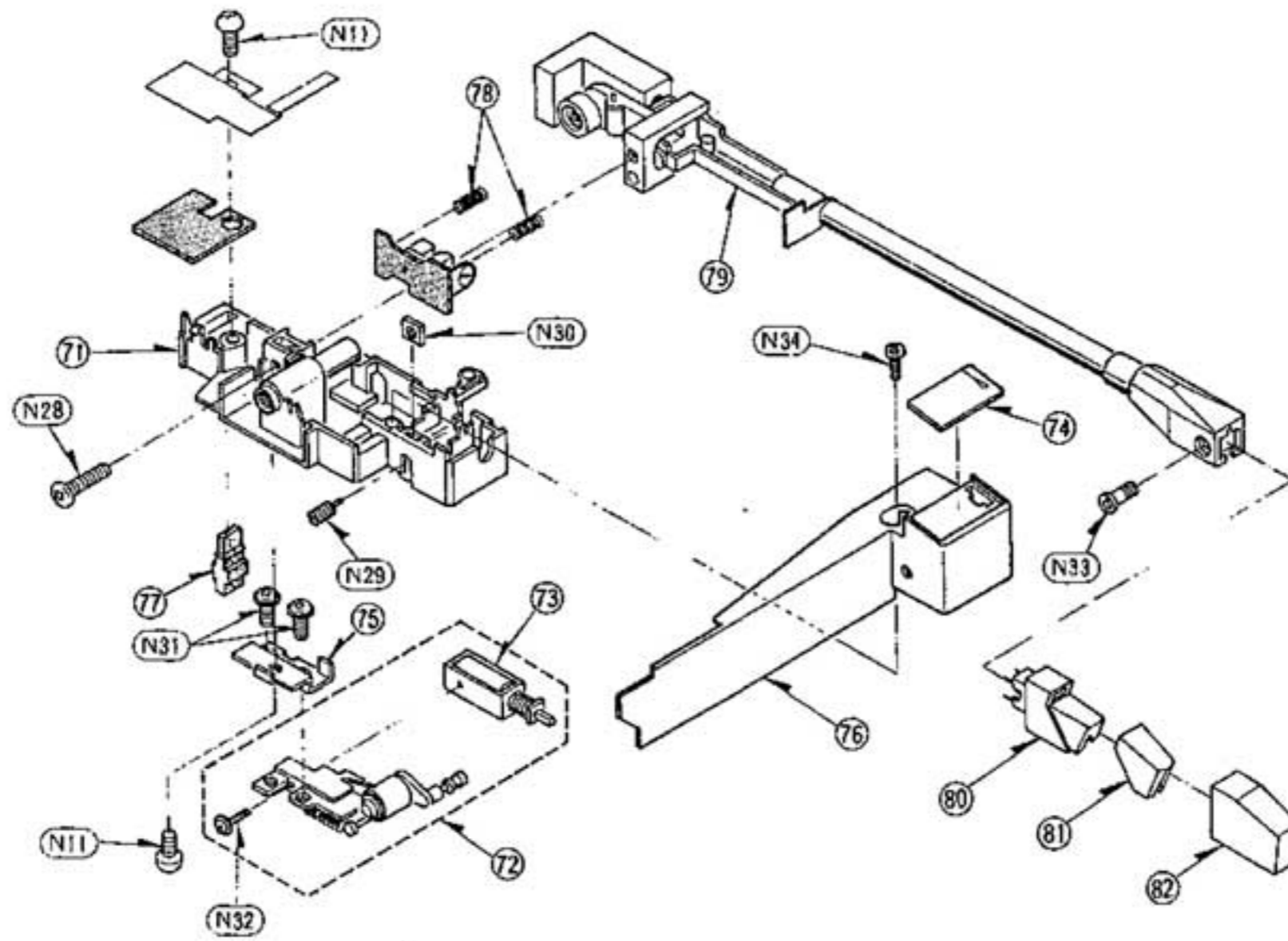

Ref. No.	Part No.	Description
TONEARM DRIVE UNIT PARTS		
41	SFKKM03N02	Cover, Tonearm Box (1)
42	SFUMM03N09E	Tonearm Box (1)
43	SFUMM03N05	Frame, Operation Button (1)
44	SFUMM03N08E	Operation Button Ass'y (1)
45	SFKTM03N03E	Knob, Pitch (1)
46	SFKKM03N01	Ornament Plate (1)
47	SFUZM03N02	Sheet, Ornament Plate (1)
48	SFNZM03N03	Sheet, Ornament Plate (1)
49	SFUMM03N11	Holder, LED (1)
50	SFGBC10-01	Belt, Tonearm (1)
51	SFMHJ02N01E	Motor Ass'y, Tonearm Drive (1)
52	SFUPBL3N11E	Base, Tonearm Drive Motor (1)
53	SFUMQ06N06A	Worm Gear Ass'y (1)
54	SFUMC02N10	Rope Guide (1)
55	SFUMQ06N09	Holder, Rest Switch (1)
56	SFQA913-01	Spring, Adjustment Screw (1)
57	SFUMC02N06	Base, Rest Switch (1)
58	SFUMC02N05	Lever, Rest Switch (1)
59	SFOHQ34N22	Spring, Rest Switch Lever (1)
60	SFUZM03N04	Rod, Rest Switch (1)

Ref. No.	Part No.	Description
61	SFUML11R03	Wheel, Tonearm Drive (1)
62	SFUZM03N03E	Rope Ass'y, Tonearm Drive (1)
63	SFXJM03N01	Guide Rail, Tonearm Drive (1)
64	SFGCC05N05	Cushion Rubber, Guide Rail (2)
65	SFUPM03N03	Holder, Guide Rail (1)
66	SFUMV05N23	Cap, Pulley (1)
67	SFUMC05N22	Pulley (1)
68	SFUPM03N02E	Bracket, Guide Rail (1)
69	SFGK171F01	Cap (1)
70	SFGCC07-08	Spacer (2)
TONEARM PARTS		
71	SFPKD0M301E	Base, Tonearm (1)
72	SFPZB0M302E	Tonearm Lift Ass'y (1)
73	SFDZM03N01E	Solenoid Ass'y (1)
74	SFPAK0M301	Pointer (1)
75	SFPZB0M301	Holder (1)
76	SFPCS0M301	Cover, Tonearm Base (1)
77	SFPGML1101	Cushion Rubber, Tonearm (1)
78	SFPSP00302	Spring, Adjustment (2)
79	SFPAM0M301A	Tonearm Ass'y (1)
80	EPC-P33	*Cartridge (1)
81	EPS-33ES	*Stylus (1)
82	SFCNC03301	Cover, Stylus (1)

Ref. No.	Part No.	Description
SCREWS, WASHERS AND NUTS		
N1	XTWS3+25QFZ	Screw, ⊕3X25 (4)
N2	Ⓢ XWA3BFZ	Washer, φ3 (4)
N3	Ⓢ XSN3+16BVS	Screw, ⊕3X16 (4)
N4	SFXGM02N02	Screw (4)
N5	XYM3+C12FZ	Screw, ⊕3X12 (4)
N6	XTWS3+14QFZ	Screw, ⊕3X14 (10)
N7	XTV4+8GFZ	Screw, ⊕4X6 (2)
N8	Ⓢ XTN3+8B	Screw, ⊕3X8 (4)
N9	XTWS3+12QFZ	Screw, ⊕3X12 (2)
N10	XYN3+F8	Screw, ⊕3X8 (2)
N11	Ⓢ XTV3+8BFN	Screw, ⊕3X8 (17)
N12	Ⓢ XTV3+10BFN	Screw, ⊕3X10 (2)
N13	XYE3+EJ8	Screw, ⊕3X8 (1)
N14	XYN3+C6S	Screw, ⊕3X6 (1)
N15	SFXGM02N03	Screw (4)
N16	SFXGM03N01	Screw (4)
N17	SFXGM02N01	Screw (3)
N18	Ⓢ XTN3+6B	Screw, ⊕3X6 (1)
N19	XTN16+10G	Screw, ⊕1.6X10 (1)
N20	Ⓢ XSN3+30S	Screw, ⊕3X30 (1)
N21	Ⓢ XWE3D10	Washer, φ3 (1)
N22	XNC3HS	Nut, φ3 (1)
N23	Ⓢ XTV3+8BFZ	Screw, ⊕3X6 (1)
N24	CSTW3	Washer, φ3 (2)
N25	Ⓢ XWE3A8BW	Washer, φ3 (2)
N26	XTN5+30AFZ	Screw, ⊕5X30 (3)
N27	XWE2C4BN	Washer, φ2 (1)
N28	XYN3+F12S	Screw, ⊕3X12 (1)
N29	SFPTN00301	Screw (1)
N30	SFXN623-1	Nut (1)
N31	XTN26+6JFZ	Screw, ⊕2.6X6 (2)
N32	XYN2+C4	Screw, ⊕2X4 (2)
N33	SFPEV08001	Screw (1)
N34	XTN23+6JFZ	Screw, ⊕2.3X6 (1)
N35	SFXWM03N01	Washer (4)

RESISTORS AND CAPACITORS

Notes:

- Part numbers are indicated on most mechanical parts. Please use this part number for parts orders.
- Important safety notice: Components identified by Δ mark have special characteristics important for safety. When replacing any of these components use only manufacturer's specified parts.
- This "Ⓢ" mark is service standard parts and may differ from production parts.
- Unless otherwise specified. All resistors are in OHMS (Ω) K = 1000 Ω , M = 1000k Ω . All capacitors are in MICROFARADS (μ F), P = 10⁻⁵ μ F.

Numbering System of Resistor

Example

ERD 25 F J 101
Type Wattage Shape Tolerance Value

ERG 1 AN J 2R2
Type Wattage Shape Tolerance Value

Numbering System of Capacitor

Example

ECKD 1H 102 Z F
Type Voltage Value Tolerance Peculiarity

ECEA 50 M R47 R
Type Voltage Peculiarity use Value Special use

Resistor Type	Wattage	Tolerance
ERD: Carbon	25 : 1/4 W	F : \pm 1%
ERG: Metal Oxide	S2 : 1/4 W	J : \pm 5%
ERX: Metal Film	50 : 1/2 W 1 : 1 W	G : \pm 2%
ERO: Metal Film		

Capacitor Type	Voltage	Tolerance
ECEA : Electrolytic	1A : 10 V	J : \pm 5%
ECEB : Electrolytic	1C : 16 V	K : \pm 10%
ECKD : Ceramic	1E : 25 V	Z : +80%, -20%
ECQM : Polyester	1V : 35 V	P : +100%, -0%
ECCD : Ceramic	1H : 50 V	M : \pm 20%
ECKR : Ceramic	1J : 63 V	
ECQP : Polypropylene	50 : 50 V	
ECFR : Ceramic	1 : 100 V	
ECQU : Polyester	2 : 250 V	
ECQE : Polyester		

ERD2FCG $\square\square\square$ \longrightarrow Fuse type carbon (1/4 W)
ERDS2TJ $\square\square\square$ \longrightarrow Small type carbon (1/4 W)

Ref. No.	Part No.	Value	Ref. No.	Part No.	Value	Ref. No.	Part No.	Value	Ref. No.	Part No.	Value
RESISTORS											
RF1	Δ ERD2FCG120P	12	R303	Ⓢ ERD25FJ822	8.2K	R367	ERDS2TJ333	33K	C202, 203	Ⓢ ECEA1HU010	1
RF2	Δ ERD2FCG180P	18	R304	Ⓢ ERD25FJ561	560	R369	ERDS2TJ101	100	C204	Ⓢ ECOM1H473JZ	0.047
R1	Ⓢ ERD25FJ562	5.6K	R306	Ⓢ ERD25TJ223	22K	R370	ERDS2TJ104	100K	C205	Ⓢ ECEA0JU221	220
R2	Ⓢ ERD25FJ682	6.8K	R311	ERDS2TJ581	680	R371	ERDS2TJ103	10K	C206	Ⓢ ECEA1HU010	1
R3	Ⓢ ERD25FJ272	2.7K	R312	ERDS2TJ221	220	R373	ERDS2TJ101	100	C207	Ⓢ ECCD1H101K	100P
R4, 5	Ⓢ ERD25FJ471	470	R321	ERDS2TJ103	10K	R374	ERDS2TJ104	100K	C208	Ⓢ ECCD1H220K	22P
R101	Ⓢ ERD25FJ103	10K	R322	ERDS2TJ561	560	R375	ERDS2TJ103	10K	C209	Ⓢ ECEA1CU101	100
R102	Ⓢ ERX1ANJ4R7	4.7	R323	ERDS2TJ271	270	R377 ~ 384	ERDS2TJ223	22K	C210, 211	Ⓢ ECQM1H224JZ	0.22
R103	Ⓢ ERD25FJ472	4.7K	R324	ERDS2TJ821	820	R385	ERDS2TJ153	15K	C212	Ⓢ ECEA1HU3R3	3.3
R104	Ⓢ ERD25TJ473	47K	R325	ERDS2TJ102	1K	R386	ERDS2TJ333	33K	C213	Ⓢ ECCD1H471K	470P
R105	Ⓢ ERD25FJ103	10K	R326	ERDS2TJ103	10K	R387, 388	Ⓢ ERD25FJ151	150	C214	Ⓢ ECEA1CU101	100
R106	Ⓢ ERD25FJ150	15	R327	ERDS2TJ472	4.7K	R390 ~ 392	Ⓢ ERD25FJ151	150	C215	Ⓢ ECEA1HU010	1
R107	Ⓢ ERX1ANJ1R5	1.5	R328	ERDS2TJ682	6.8K	R393, 394	Ⓢ ERD25FJ221	220	C216	Ⓢ ECEA1CU470	47
R108	Ⓢ ERD25FJ103	10K	R329	ERDS2TJ104	100K	R401, 402	ERDS2TJ823	82K	C217 ~ 219	Ⓢ ECKD1H104ZF	0.1
R109, 110	Ⓢ ERX1ANJ4R7	4.7	R330	ERDS2TJ103	10K	R403	ERDS2TJ182	1.8K	C301	ECQP1153JZ	0.015
R201	Ⓢ ERG1ANJ561	560	R331	ERDS2TJ333	33K	R404	ERDS2TJ822	8.2K	C302	Ⓢ ECOM1H153JZ	0.015
R202	Ⓢ ERD25FJ103	10K	R332	ERDS2TJ153	15K	R405	ERDS2TJ152	1.5K	C303	Ⓢ ECEA1HU010	1
R203	Ⓢ ERD25FJ470	47	R333	ERDS2TJ223	22K	R406	ERDS2TJ102	1K	C304	Ⓢ ECEA1CU100	10
R204	Ⓢ ERD25FJ272	2.7K	R334 ~ 339	ERDS2TJ272	2.7K	R407	ERDS2TJ224	220K	C305	Ⓢ ECQM1H122JZ	0.0012
R205	Ⓢ ERD25TJ124	120K	R340 ~ 342	ERDS2TJ562	5.6K	R408	ERDS2TJ152	1.5K	C306	Ⓢ ECEA1HU010	1
R206	Ⓢ ERD25TJ183	18K	R343, 344	ERDS2TJ222	2.2K	R409	ERDS2TJ102	1K	C311, 312	Ⓢ ECEA1EU470	47
R207	Ⓢ ERD25TJ563	56K	R345	ERDS2TJ272	2.7K	R410	ERDS2TJ224	220K	C313	Ⓢ ECEA0JU330	33
R208	Ⓢ ERD25TJ224	220K	R346	ERDS2TJ562	5.6K	R411	ERDS2TJ822	8.2K	C321	Ⓢ ECQM1H104JZ	0.1
R209	Ⓢ ERD25TJ124	120K	R347	ERDS2TJ152	1.5K	R501	Ⓢ ERD25FJ681	680	C322	Ⓢ ECCD1H680K	68P
R210	Ⓢ ERD25TJ123	12K	R348	ERDS2TJ223	22K	R502	Ⓢ ERD25FJ391	390	C323	Ⓢ ECEA1HU010	1
R211	Ⓢ ERD25FJ103	10K	R349 ~ 351	ERDS2TJ272	2.7K	R601	Δ Ⓢ ERD50FJ4R7	4.7	C324	ECFR1H104ZFM	0.1
R212	Ⓢ ERD25FJ271	270	R352	ERDS2TJ472	4.7K	CAPACITORS					
R214	Ⓢ ERD25TJ223	22K	R353, 354	ERDS2TJ331	330	C1	Ⓢ ECEB1HU102	1000	C325 ~ 330	Ⓢ ECEA1HU010	1
R215	Ⓢ ERD25FJ472	4.7K	R355	ERDS2TJ152	1.5K	C2	Ⓢ ECEA1EU330	33	C331 ~ 333	ECFR1H104ZFM	0.1
R216	Ⓢ ERD25TJ154	150K	R356	ERDS2TJ562	5.6K	C3	Ⓢ ECEA1EU220	22	C334	ECKR1H222KB	0.0022
R217	Ⓢ ERD25TJ223	22K	R357	ERDS2TJ103	10K	C5, 6	ECQM1223KZ	0.022	C335 ~ 339	ECKR1H102KB	0.001
R218	Ⓢ ERD25FJ102	1K	R358	ERDS2TJ104	100K	C101 ~ 103	Ⓢ ECEA1EU330	33	C340	Ⓢ ECEA0JU470	47
R219	Ⓢ ERD25FJ332	3.3K	R359	ERDS2TJ103	10K	C104 ~ 107	Ⓢ ECQM1H104JZ	0.1	C341	ECKR1H102KB	0.1
R220	Ⓢ ERD25FJ221	220	R360	ERDS2TJ104	100K	C108	Ⓢ ECEA1EU101	100	C401, 402	Ⓢ ECQM1H223JZ	0.022
R221	Ⓢ ERD25FJ471	470	R361	ERDS2TJ101	100	C109, 110	Ⓢ ECQM1H104JZ	0.1	C601(M,MC) Δ	ECQU1A473ME	0.047
R222	Ⓢ ERD25FJ391	390	R362	ERDS2TJ104	100K	C111	Ⓢ ECQM1H562JZ	0.0056	C601(XA, XM, PA, PE, PC) Δ	ECQE2A223ME	0.022
R301	Ⓢ ER025CKF1501	1.5K	R363	ERDS2TJ333	33K	C112	Ⓢ ECEA1HU4R7	4.7	C601[Other][Areas] Δ	ECQU2A223MF	0.022
R302	Ⓢ ERD25FJ471	470	R365	ERDS2TJ101	100	C201	Ⓢ ECEA1CU330	33	C611	ECFB1B104ZM	0.1
			R366	ERDS2TJ104	100K				C701	Ⓢ ECEA1CU101	100

■ CIRCUIT BOARD AND WIRING CONNECTION DIAGRAM

• Power source circuit

★ Product for Canada.

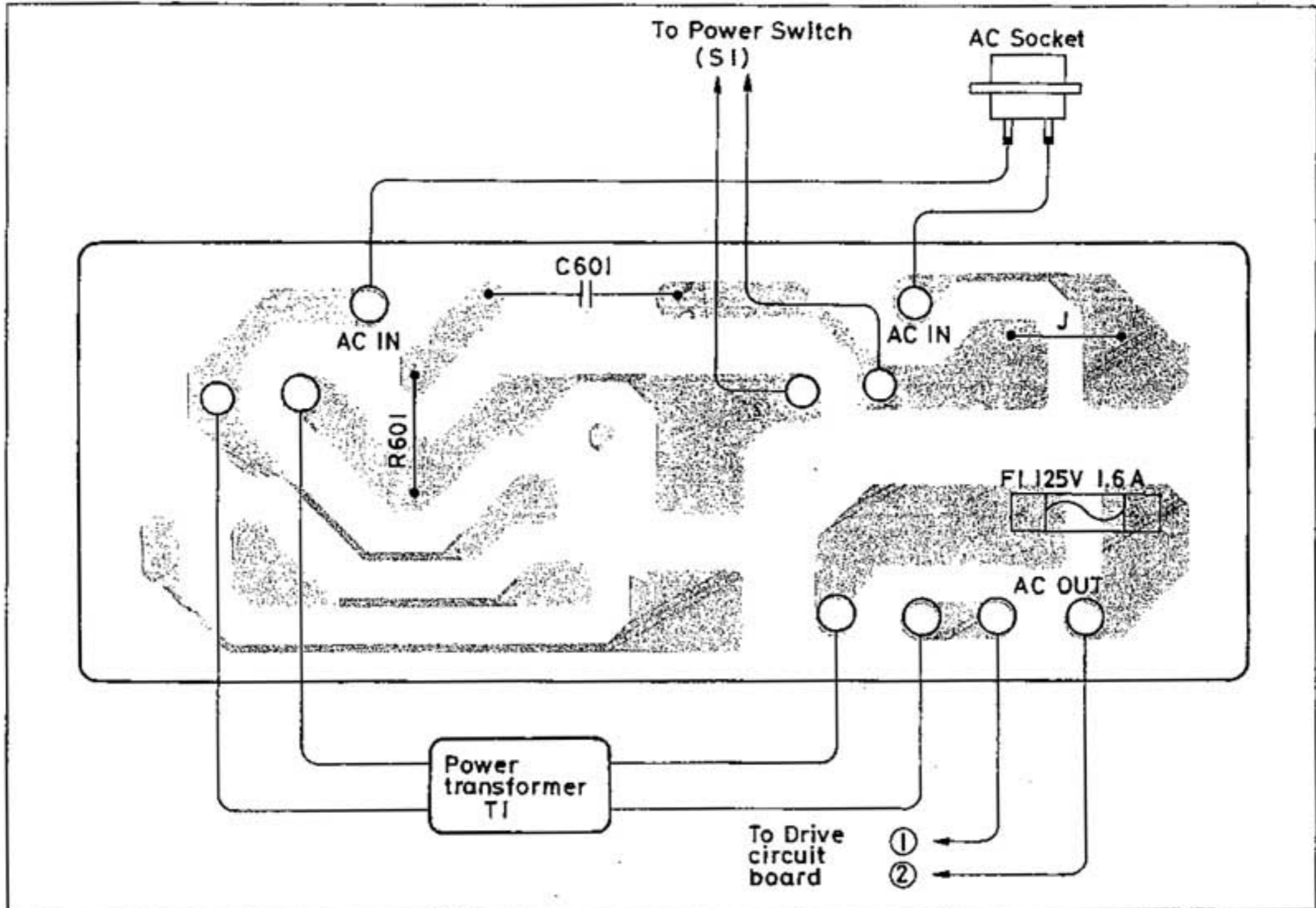

★ Product for other areas

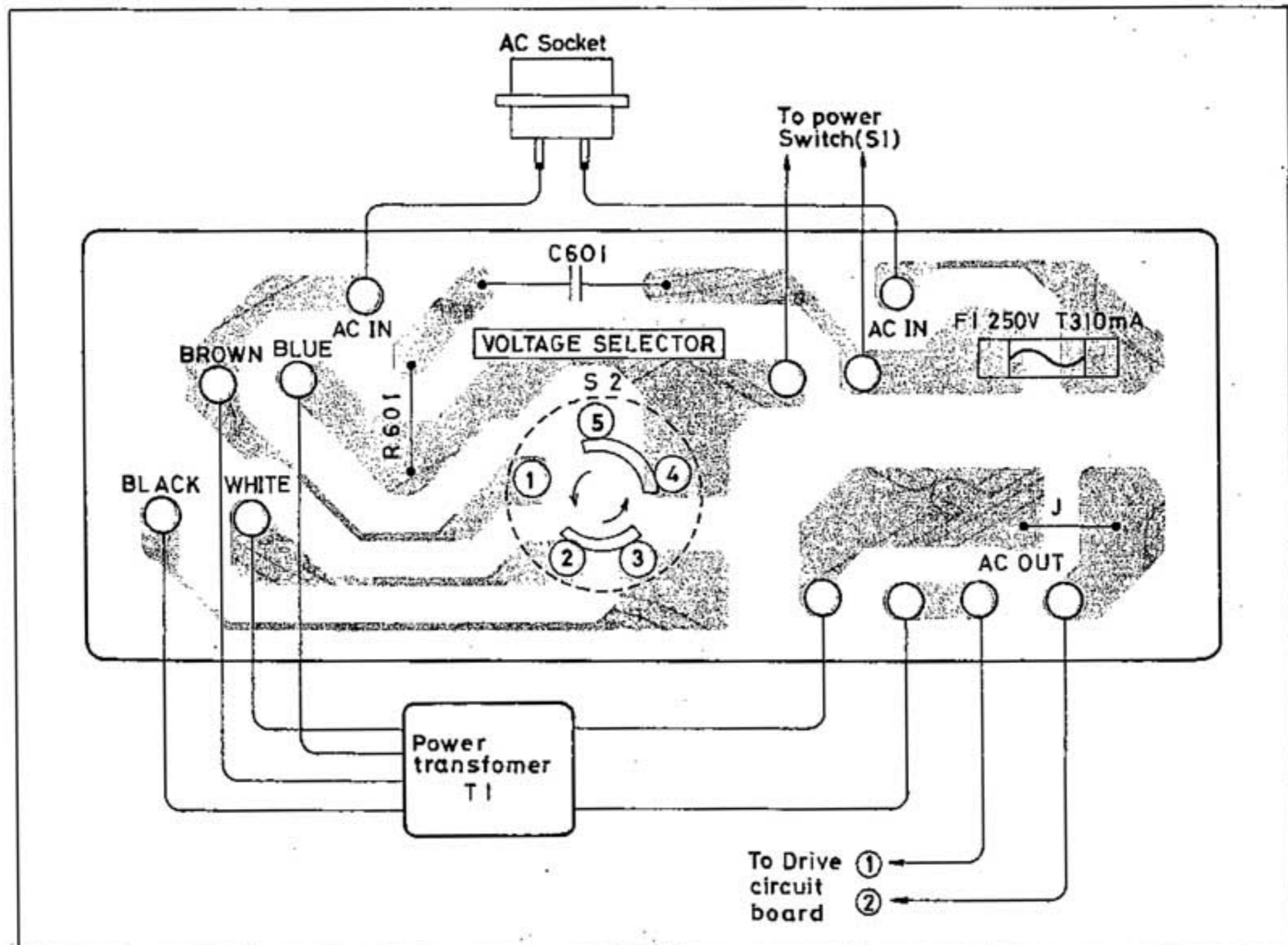

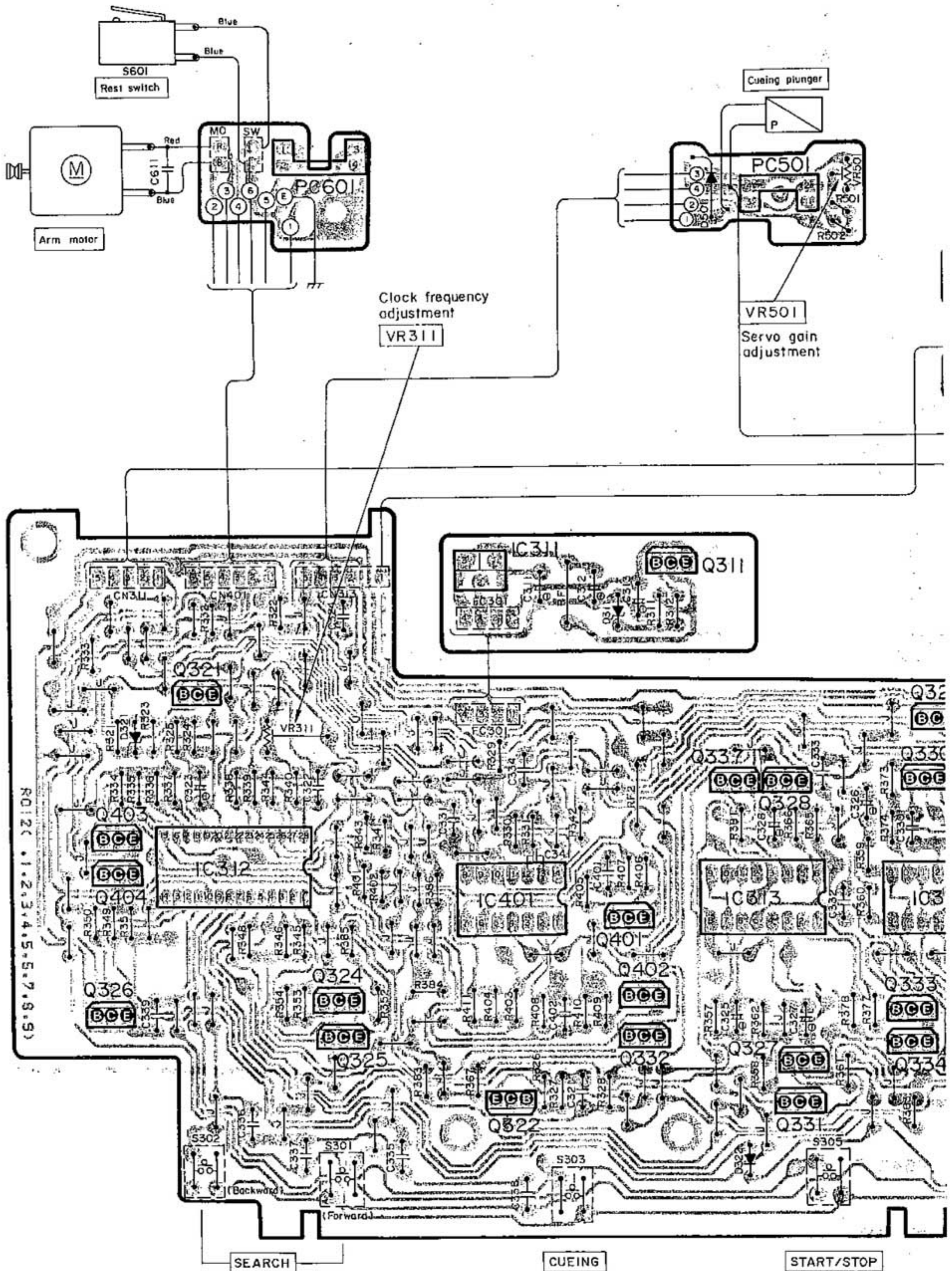

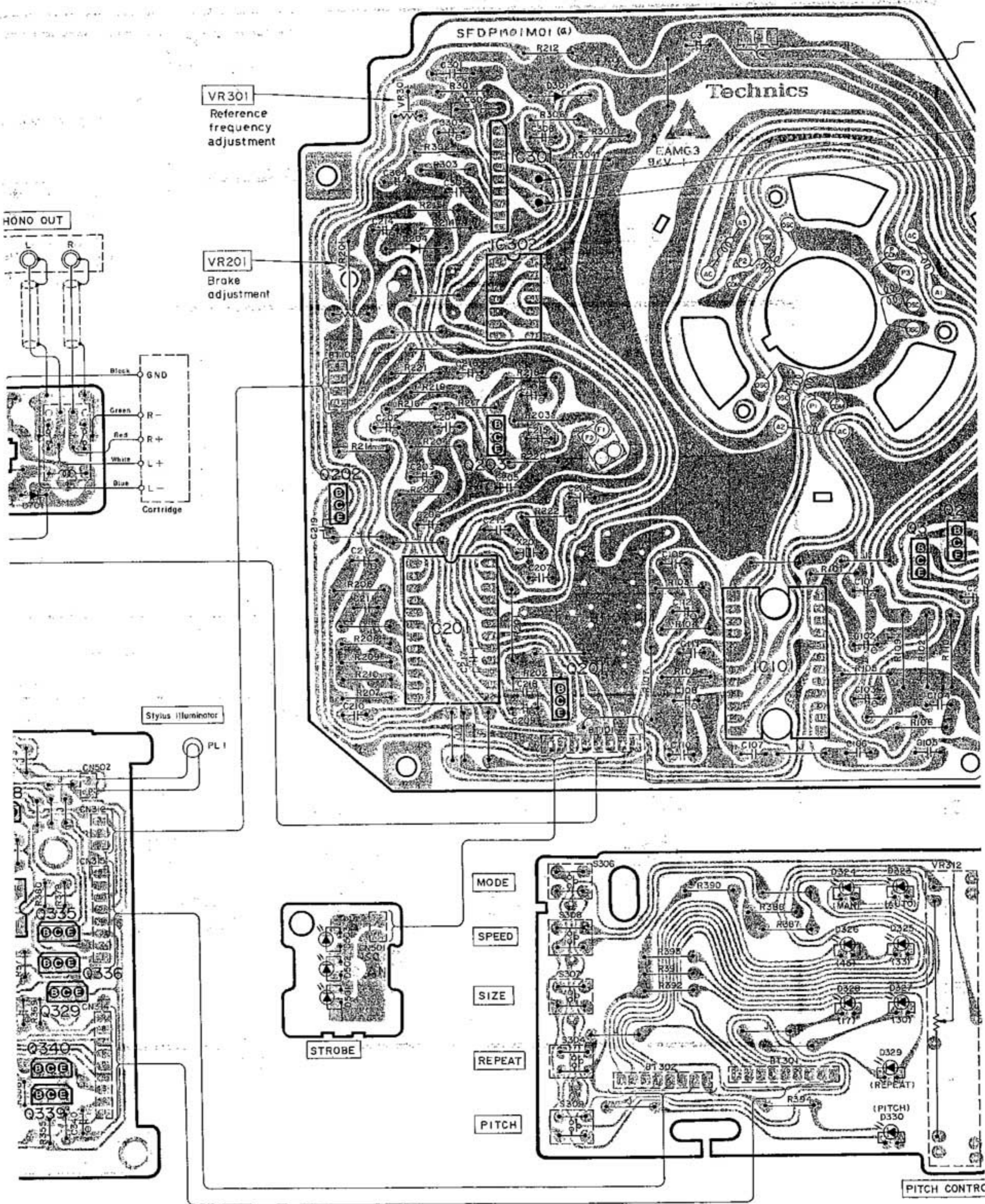

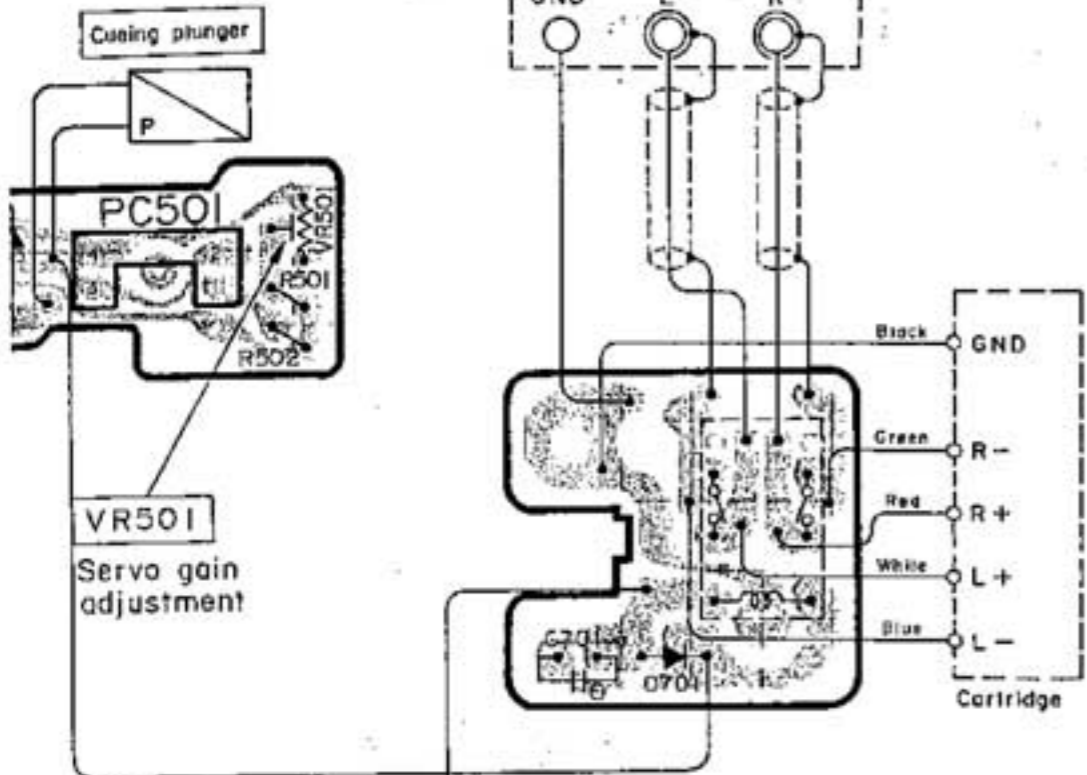

VR 301
Reference frequency adjustment

VR 201
Broke adjustment

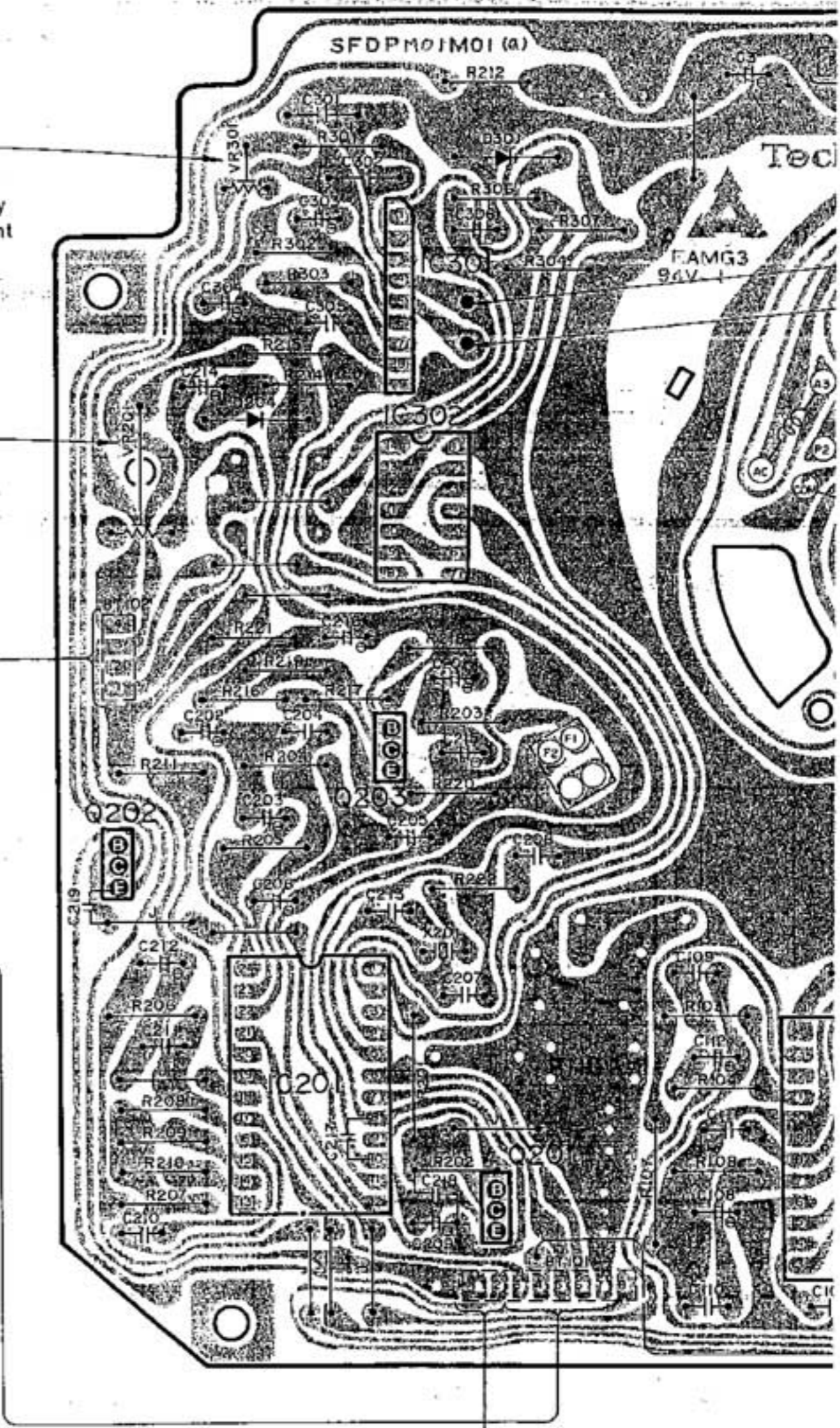

1311

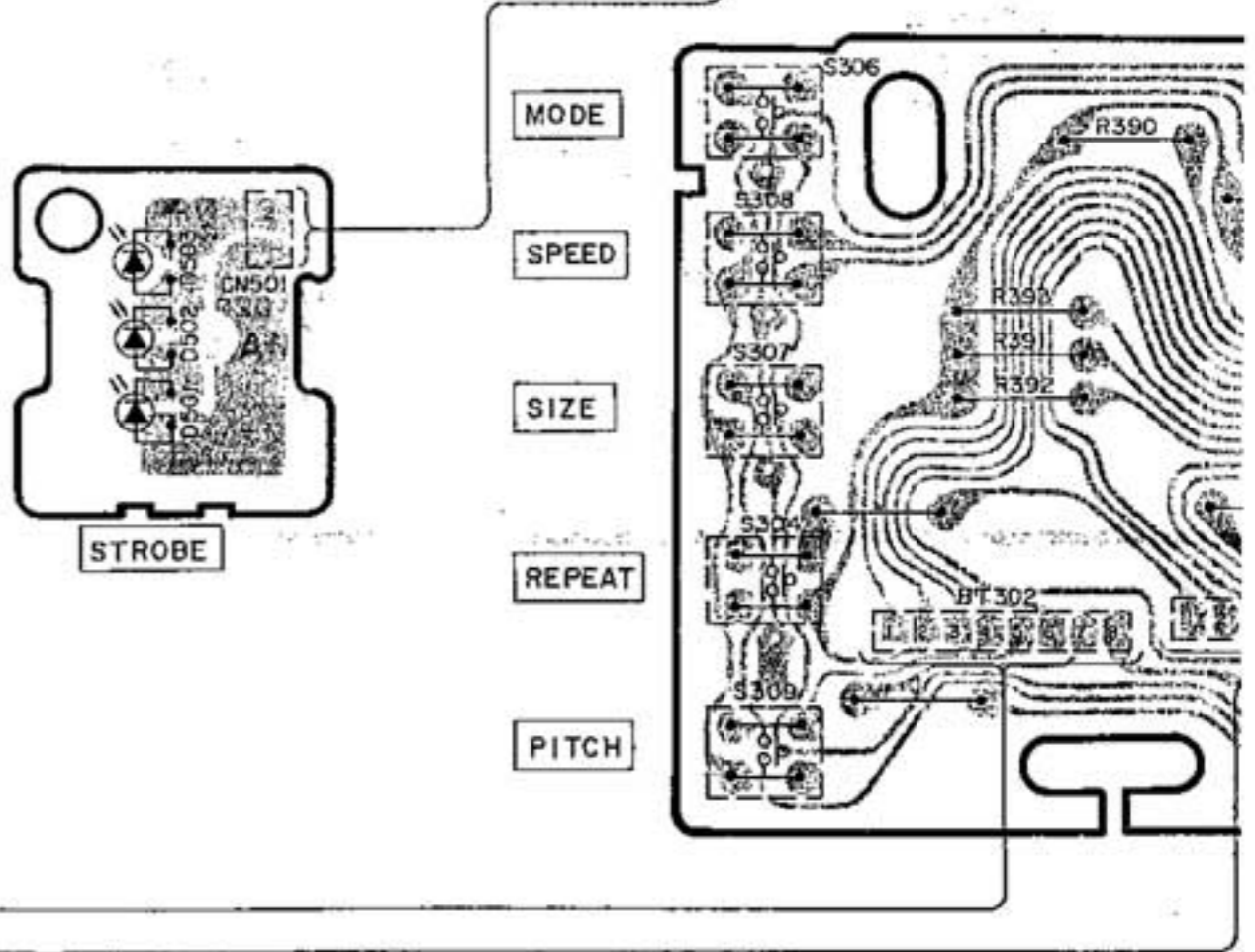
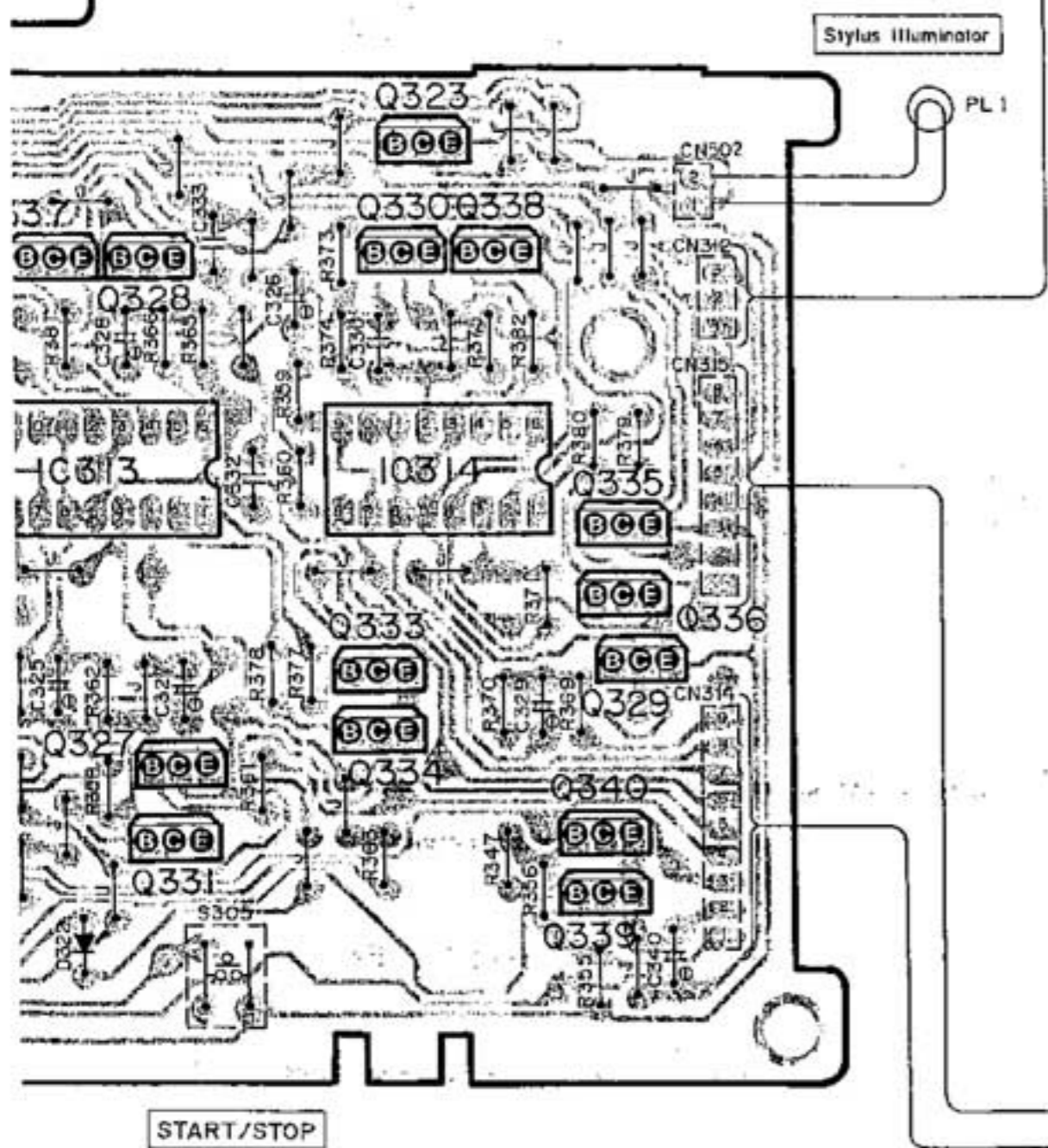

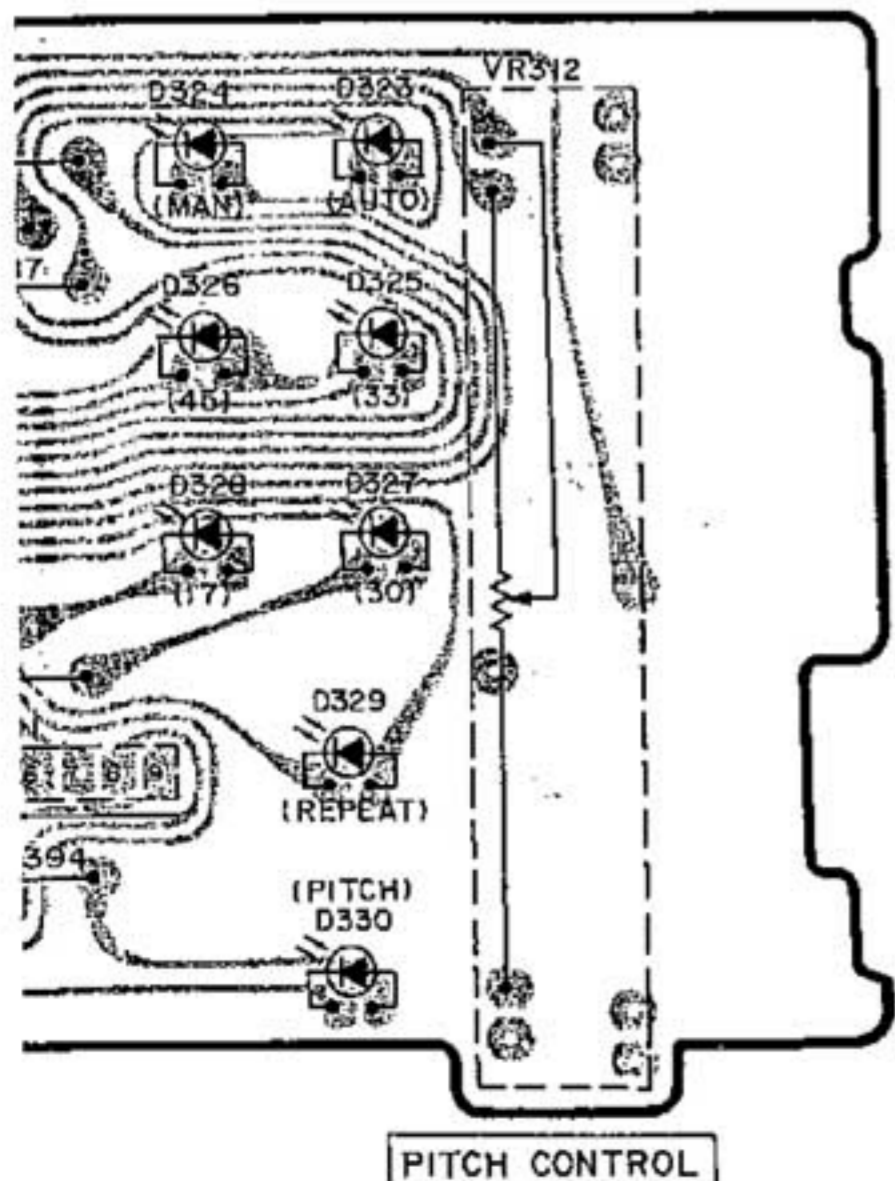
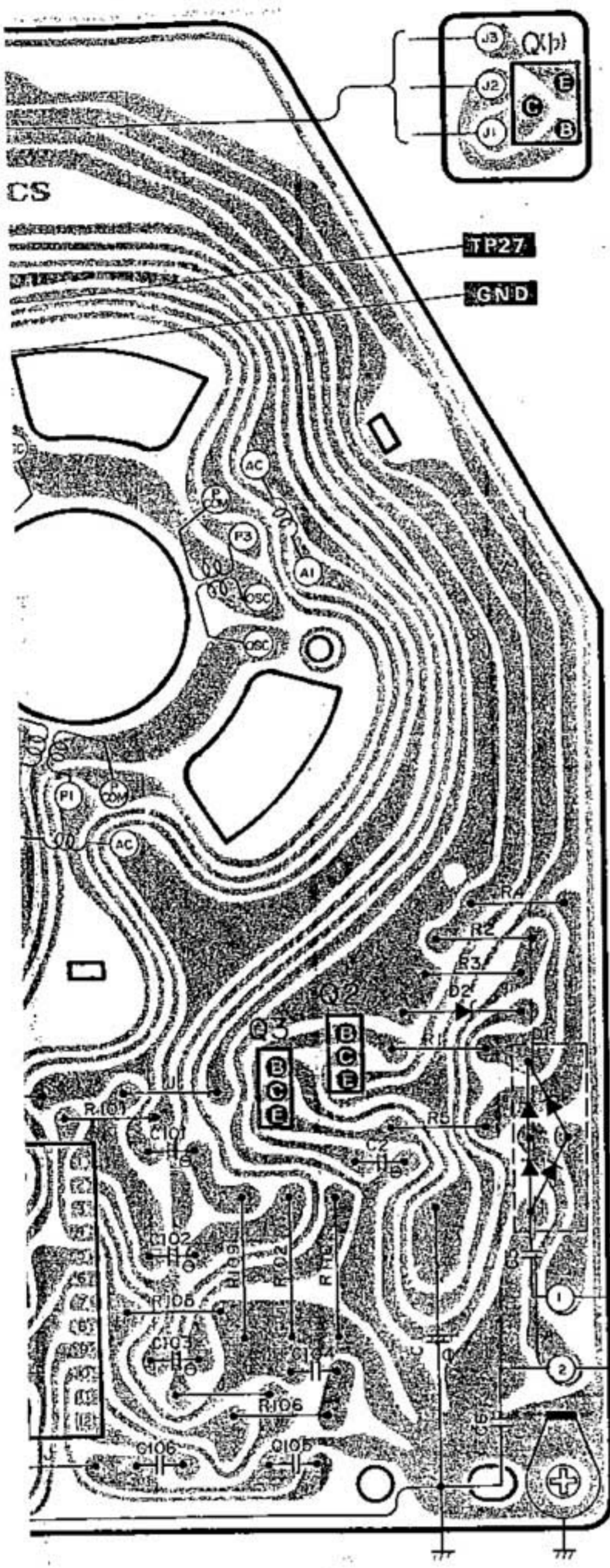

★ Power source circuit for U.S.A.

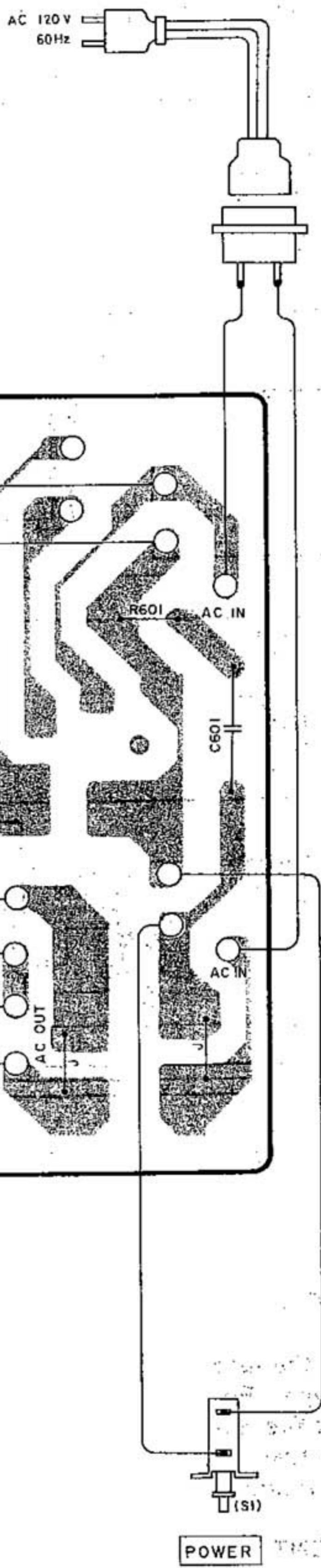

■ SCHEMATIC DIAGRAM

(This schematic diagram may be modified at any time with the development of new technology)

● Power source circuit

★ Product for Canada.

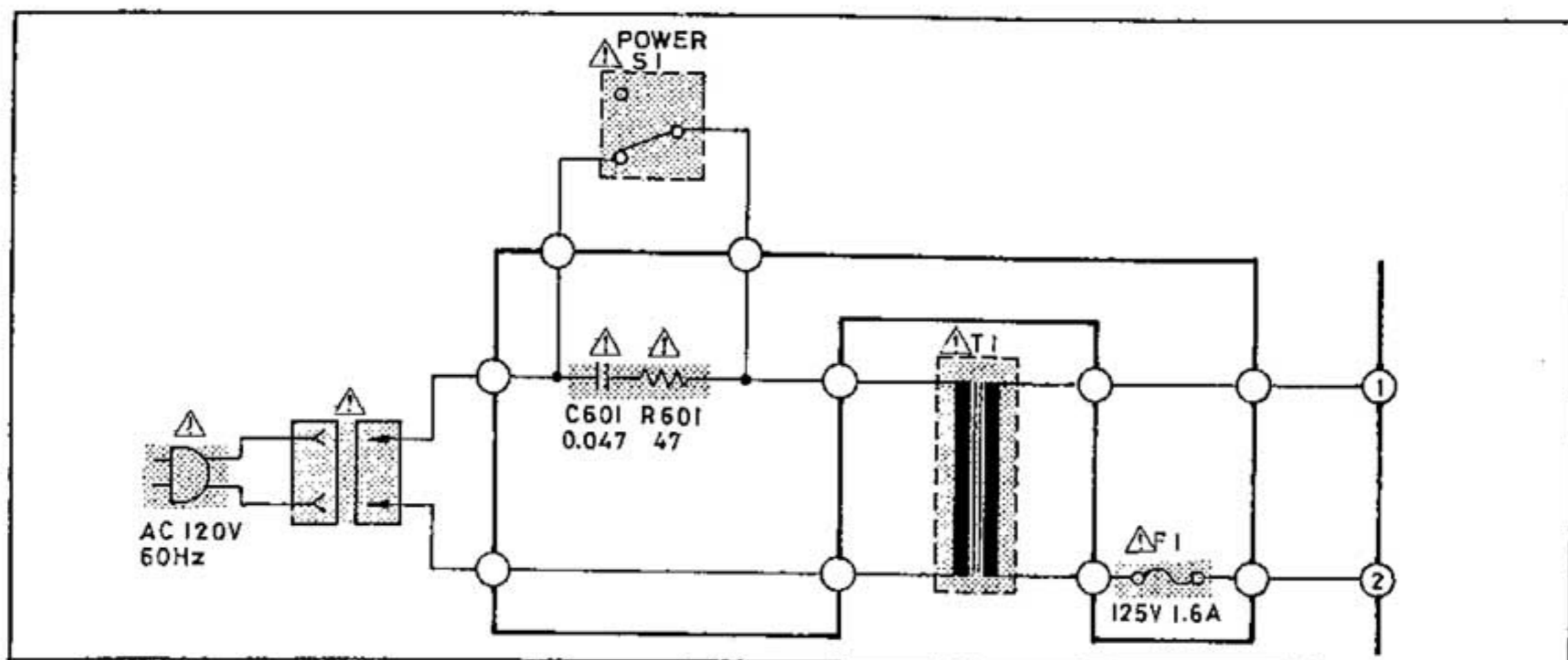

★ Product for other areas

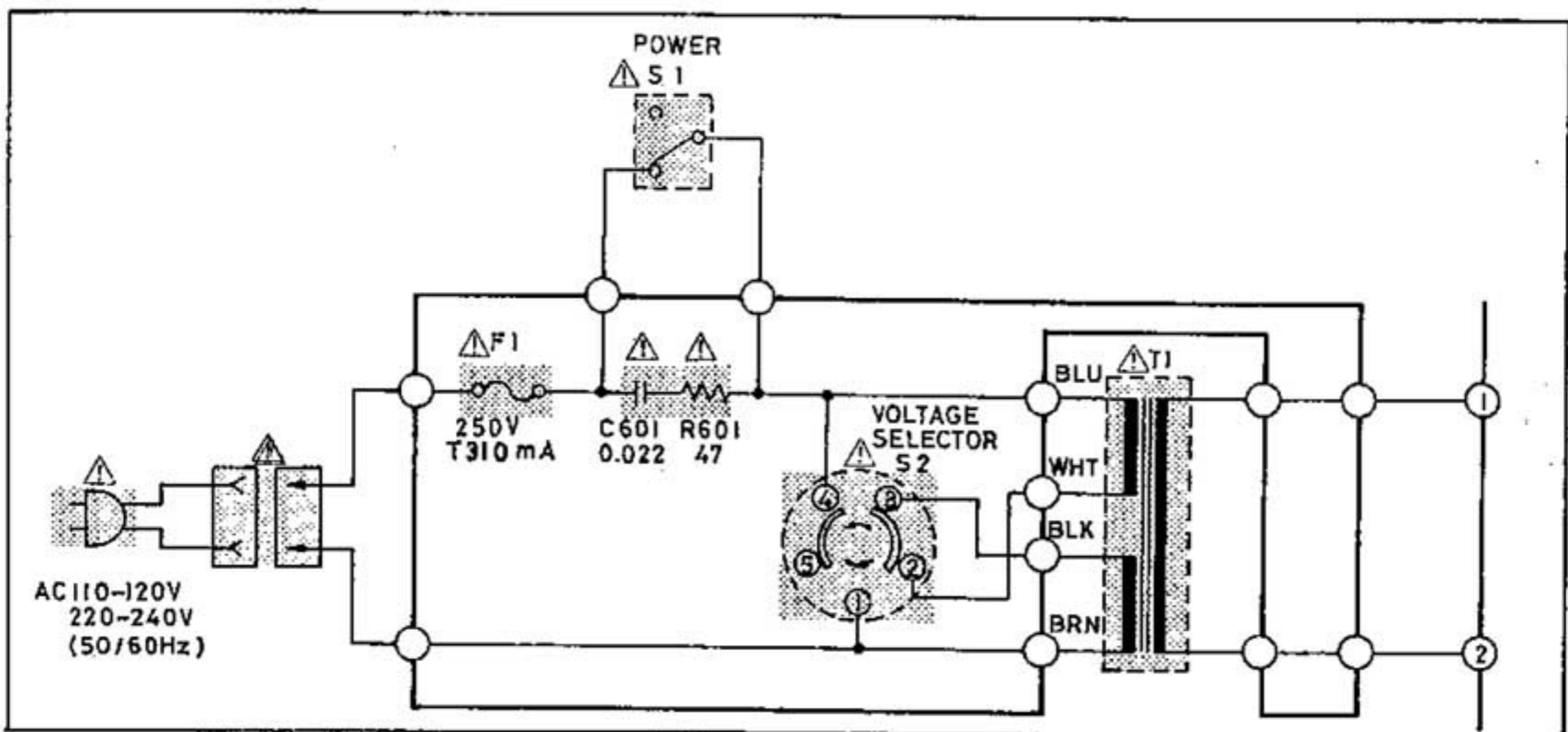

● Product for MC only

FUSE REPLACEMENT

 Symbol located near the fuse indicates fast operating type. For continued protection against fire hazard, replace with same type fuse. Refer to the symbol for fuse rating.

FUSIBLE REMPLACEMENT

 Le symbole qui se trouve près du fusible signifie un fusible à action rapide. Pour une protection continue contre les risques d'incendie, n'utiliser que des fusibles du même type. Se rapporter au symbole pour la valeur des fusibles.

★ Power source circuit for U.S.A.

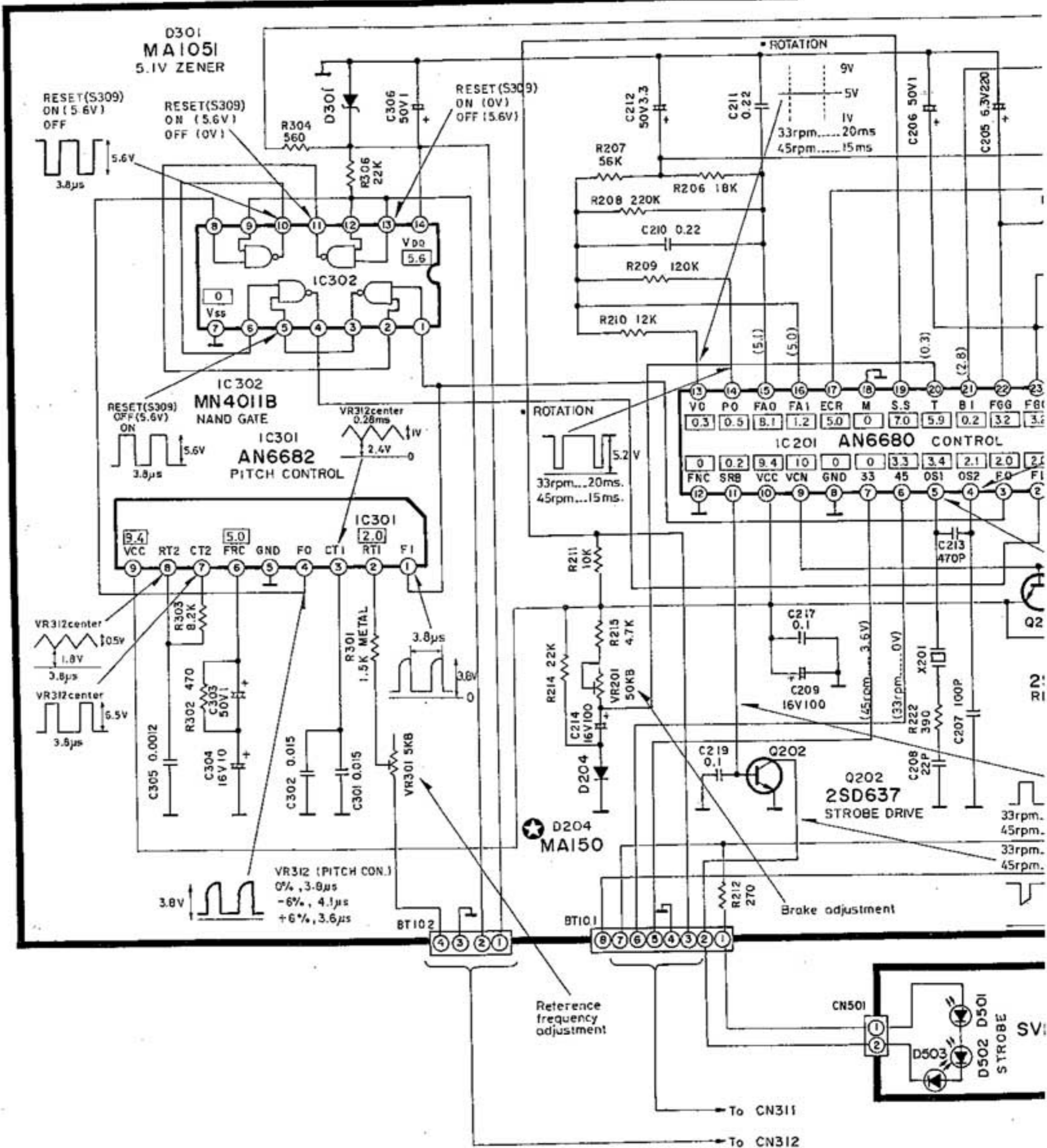
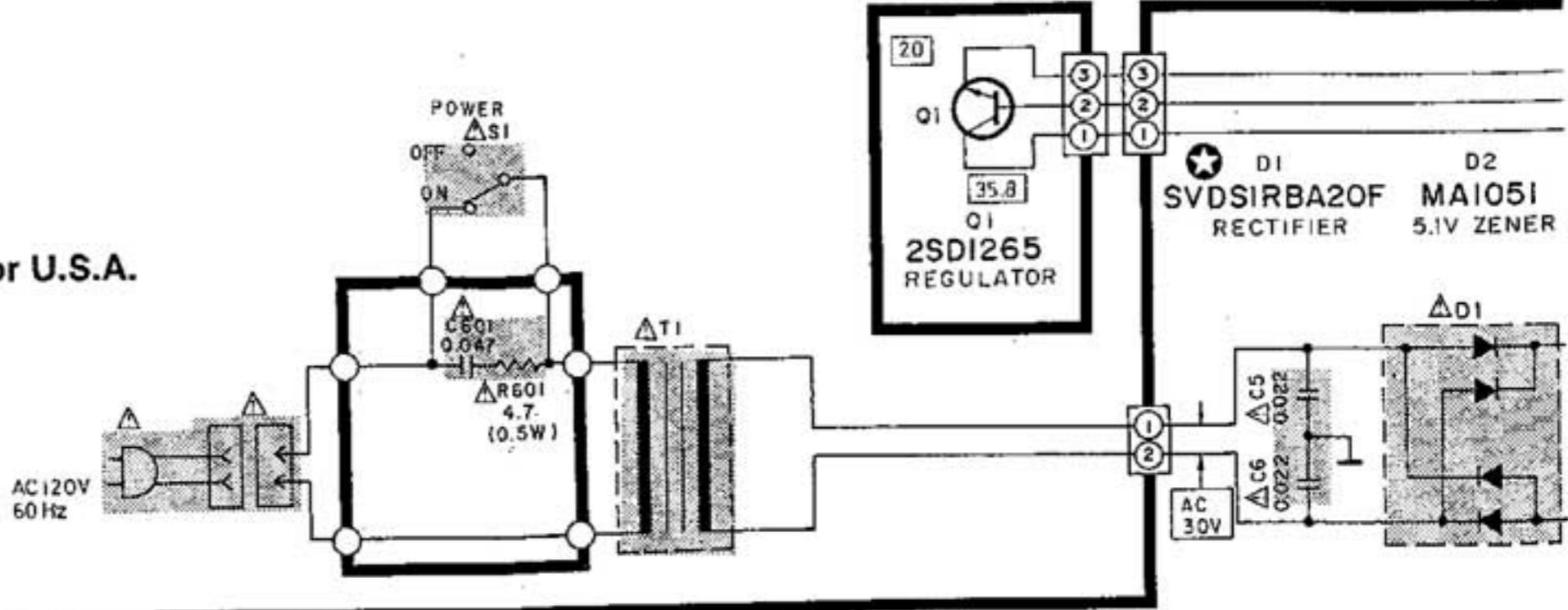

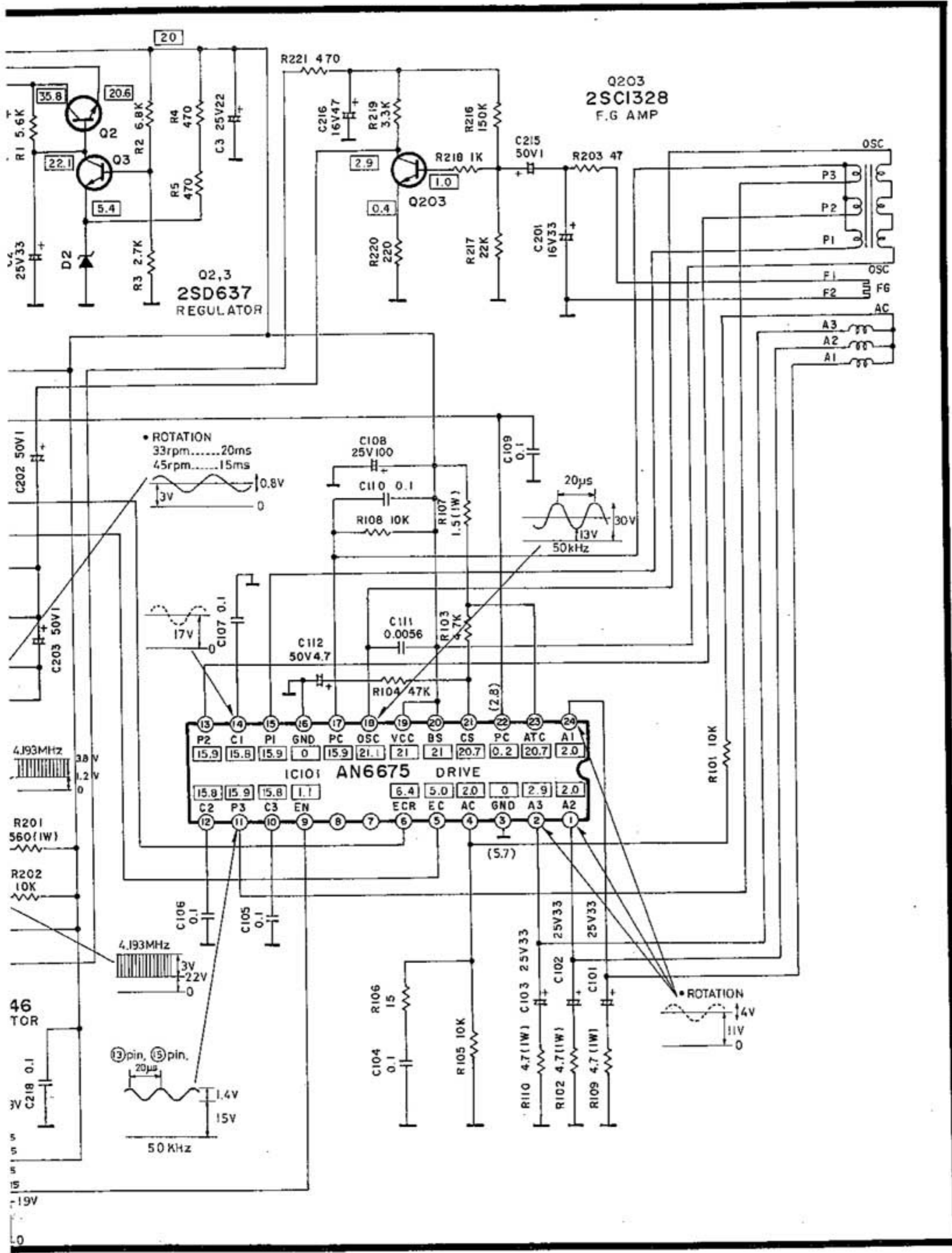

503
54DC3
3E IND.

1

2

3

4

5

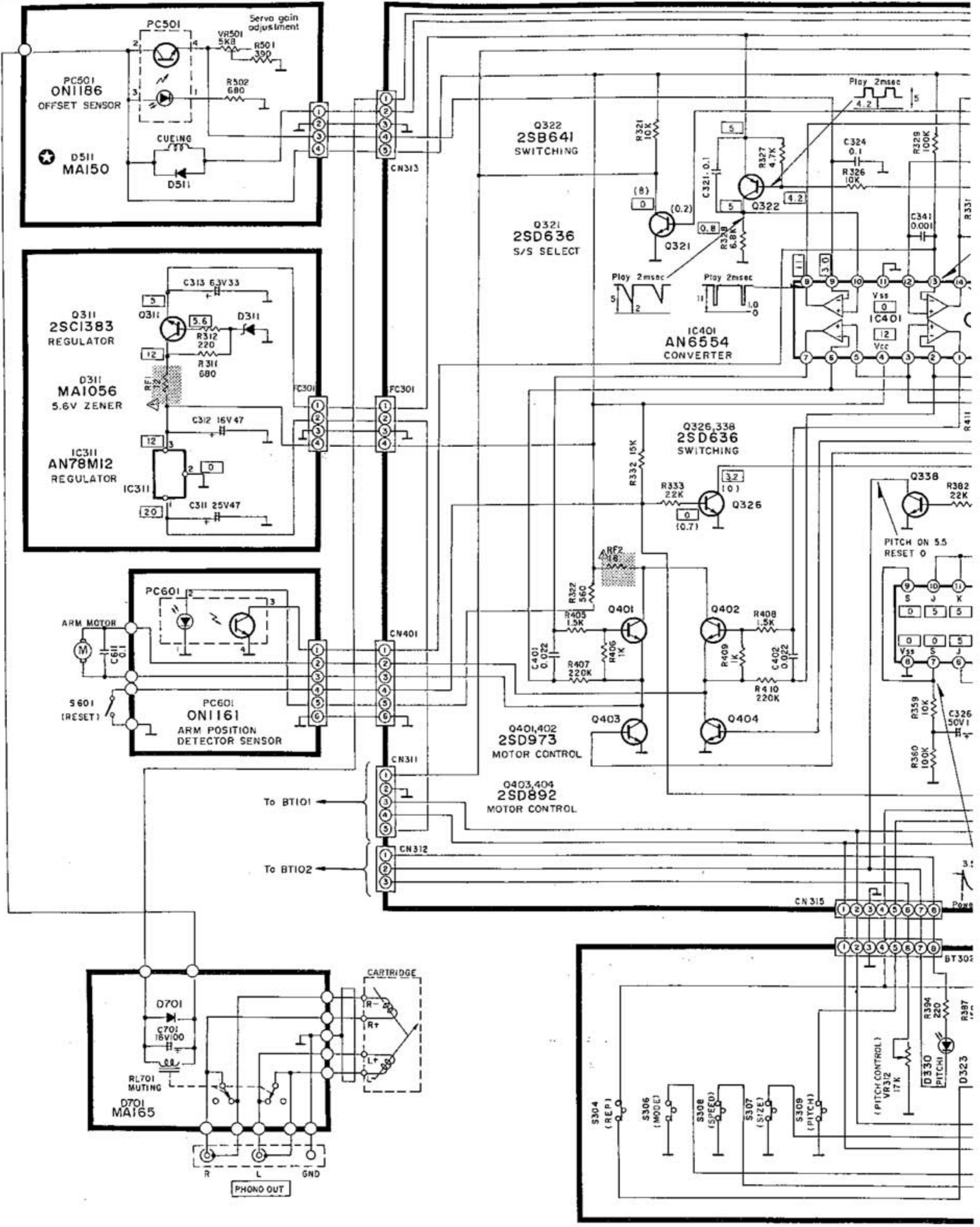

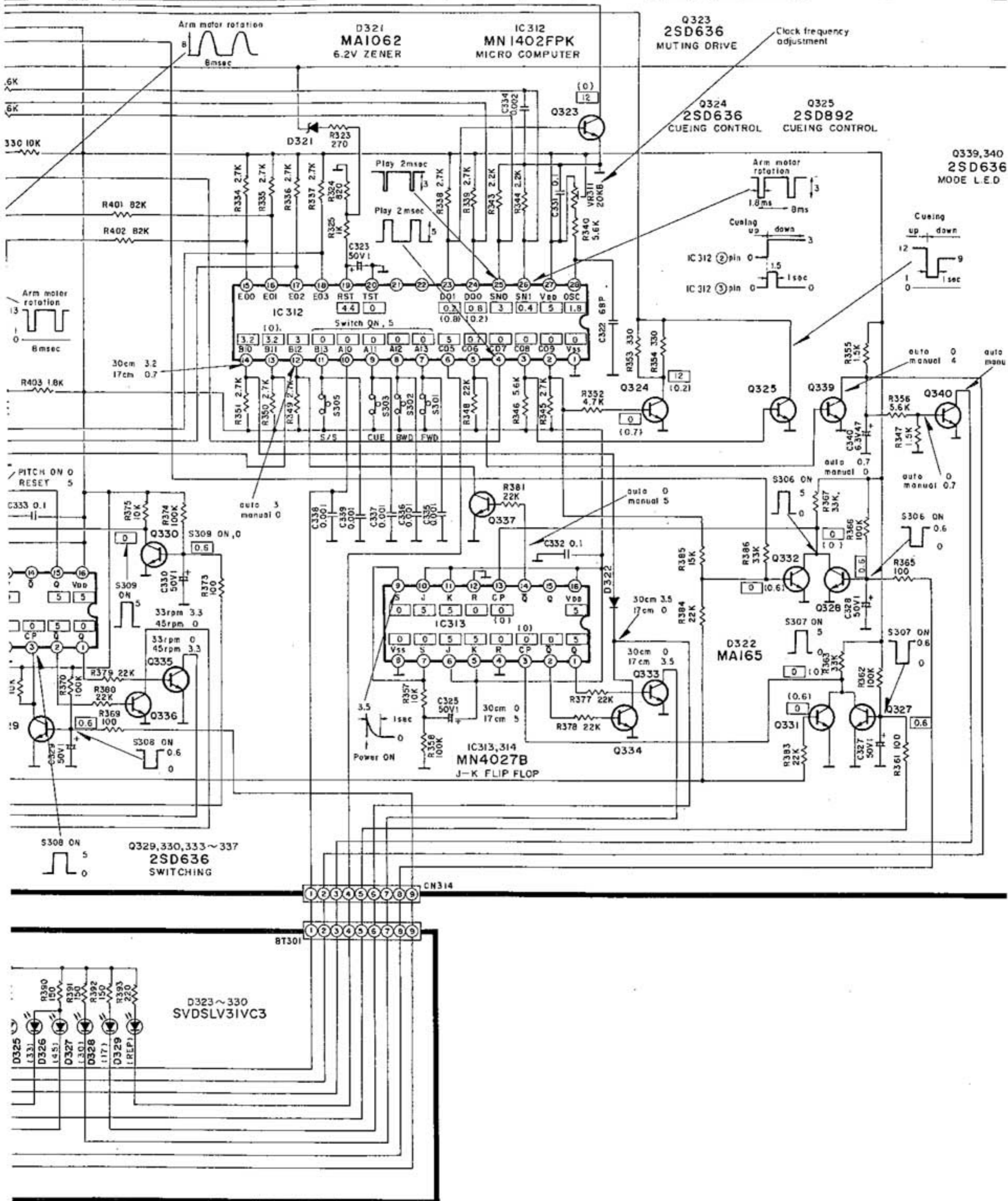

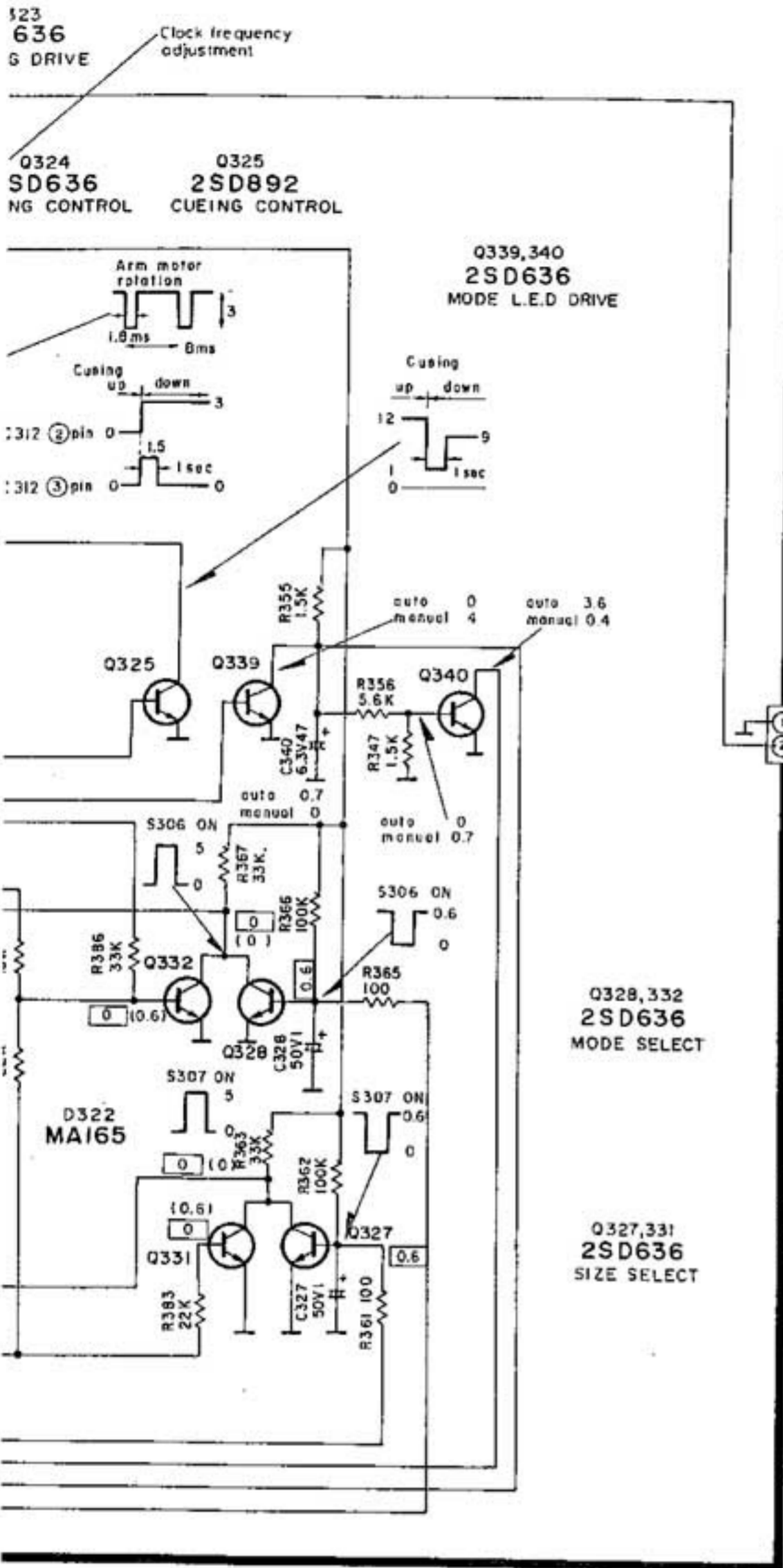

A

• Terminal guide of transistors and IC's

<p>2SC1846</p>	<p>2SC1328 2SD892 2SD1383</p>	<p>AN6682</p>										
<p>2SD637 2SB641 2SD636 2SD973</p>	<p>AN6675</p>											
<p>2SD1265</p>	<p>AN78M12</p>	<table border="1"> <tr><td>AN6554</td><td>14 Pin</td></tr> <tr><td>MN4011B</td><td>14 Pin</td></tr> <tr><td>MN4027B</td><td>16 Pin</td></tr> <tr><td>AN6680</td><td>24 Pin</td></tr> <tr><td>MN1402</td><td>28 Pin</td></tr> </table>	AN6554	14 Pin	MN4011B	14 Pin	MN4027B	16 Pin	AN6680	24 Pin	MN1402	28 Pin
AN6554	14 Pin											
MN4011B	14 Pin											
MN4027B	16 Pin											
AN6680	24 Pin											
MN1402	28 Pin											

B

C

D

E

F

G

• Voltage of tonearm motor control circuit



Mode	Pin No.	Stop	Forward (High Speed)	Forward (Low speed)	Backward (High speed)	Backward (Low speed)
IC 312	15	5	0	*	5	5
	16	5	5	5	0	*
	17	1	0	0	1.4	1.4
	18	1	1.4	1.4	0	0
IC 401	1	1.4	1.4	1.4	11	4.5
	2	3.6	3.7	3.7	2.6	3.7
	3	3.4	3.4	3.4	3.4	3.4
	5	3.4	3.4	3.4	3.4	3.4
	6	3.6	2.6	3.4	3.7	3.7
	7	1.4	11	4.5	1.4	1.4
	Q401	E	0.3	9	2.5	0.8
C		12	12	12	12	12
B		0.7	10	3	1	1
Q402	E	0.3	0.8	0.8	9	2.5
	C	12	12	12	12	12
Q403	B	0.7	1	1	10	3
	E	0	0	0	0	0
Q404	C	0.3	9	2.5	0.8	0.8
	B	1	0.2	0.2	1.5	1.5
	E	0	0	0	0	0

■ SCHEMATIC DIAGRAM

(This schematic diagram may be modified at any time with the development of new technology.)

Notes:

1. **S1** : Power switch in "on" position.
2. **S2** : Voltage selector in "220-240 V" position.
3. **S301** : Forward search switch.
4. **S302** : Backward search switch.
5. **S303** : Cueing switch.
6. **S304** : Repeat switch.
7. **S305** : Start/stop switch.
8. **S306** : Mode selector switch.
9. **S307** : Size selector switch.
10. **S308** : Speed selector switch.
11. **S309** : Pitch switch.
12. **S601** : Rest switch in "off" position.
13. The voltage value, and waveforms are the reference voltage values of this unit measured by DC electronic voltmeter (high impedance) and oscilloscope on the basis of chassis. Therefore, the voltage value and waveform may include some error due to the internal impedance of the tester or the measuring set.
 * \square is the voltage when turntable is in stop.
 * (\quad) is the voltage when turntable is in rotation. (at 33 rpm)
14. —+B Voltage lines

15. Important safety notice:

Components identified by Δ mark have special characteristics important for safety.

When replacing any of these components, use only manufacturer's specified parts.

16. The part No. of diodes mentioned in the schematic diagram stand for production part No. Regarding the part No. with \odot mark the production part No. are different from the replacement part No. Therefore, when placing an order for replacement part, please use the part No. in the replacement parts list.

IMPORTANT SAFETY NOTICE

The shaded area on this schematic diagram incorporates special features important for protection from fire and electrical shock hazards.

When servicing it is essential that only manufacturer's specified parts be used for the critical components in the shaded areas of the schematic.

• Function of terminal (MN1402FPK)

Pin No.	Symbol	Description	Pin No.	Symbol	Description																										
1	VSS	Ground terminal	15	E00	 Arm drive motor control terminal	<table border="1"> <tr> <td></td> <td>15</td> <td>16</td> <td>17</td> <td>18</td> </tr> <tr> <td>Stop</td> <td>H</td> <td>H</td> <td>H</td> <td>H</td> </tr> <tr> <td>Forward (High speed)</td> <td>L</td> <td>H</td> <td>L</td> <td>H</td> </tr> <tr> <td>Forward (Low speed)</td> <td>*</td> <td>H</td> <td>L</td> <td>H</td> </tr> <tr> <td>Backward (High speed)</td> <td>H</td> <td>L</td> <td>H</td> <td>L</td> </tr> </table>		15	16	17	18	Stop	H	H	H	H	Forward (High speed)	L	H	L	H	Forward (Low speed)	*	H	L	H	Backward (High speed)	H	L	H	L
	15	16					17	18																							
Stop	H	H					H	H																							
Forward (High speed)	L	H					L	H																							
Forward (Low speed)	*	H					L	H																							
Backward (High speed)	H	L					H	L																							
2	C09	Cueing control terminal ("H" during cueing down)					16	E01																							
3	C08	Cueing control terminal ("H" only for about 1 sec. during cueing down)	17	E02																											
4	C07	Offset error angle reading strove			18	E03																									
5	C06	Mode select indication terminal ("H" in auto and "L" in manual)																													
6	C05	Repeat indicator terminal (ON at "L")																													
7	A13	Forward search key input																													
8	A12	Backward search key input	19	RST	Reset terminal (Microcomputer is reset at "L")																										
9	A11	Cueing key input	20	TEST	Test terminal																										
10	A10	Repeat key input	21	D03	} Not used																										
			22	D02																											
11	BI3	Start/stop key input	23	D01		Muting control terminal ("H" when muting "off")																									
12	BI2	Operation mode detection ("L" in manual and "H" in auto)	24	D00	Turntable platter start/stop control terminal ("L" at start and "H" at stop)																										
13	BI1	Rest position detection terminal ("H" when tonearm is at rest position)	25	SNS0	Offset angle detection input terminal																										
			26	SNS1	Arm position detection input terminal																										
14	BI0	Record size detection terminal (30 cm "H", 17 cm "L")	27	VDD	Power supply (+5 V)																										
			28	OSC	Oscillation circuit (clock frequency adjusted to $33 \pm 1 \mu s$)																										

■ BLOCK DIAGRAM

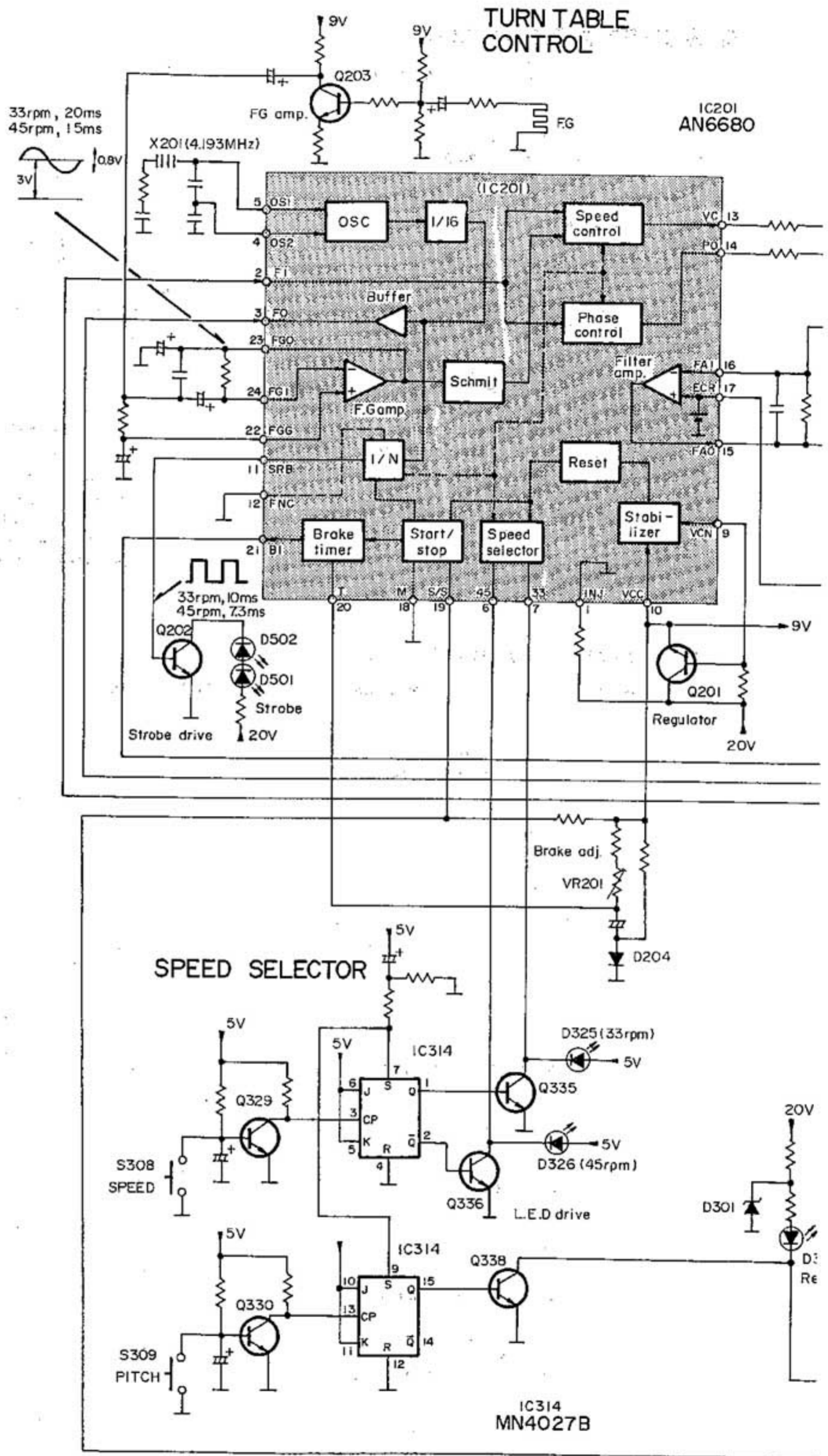

TURNTABLE DRIVE

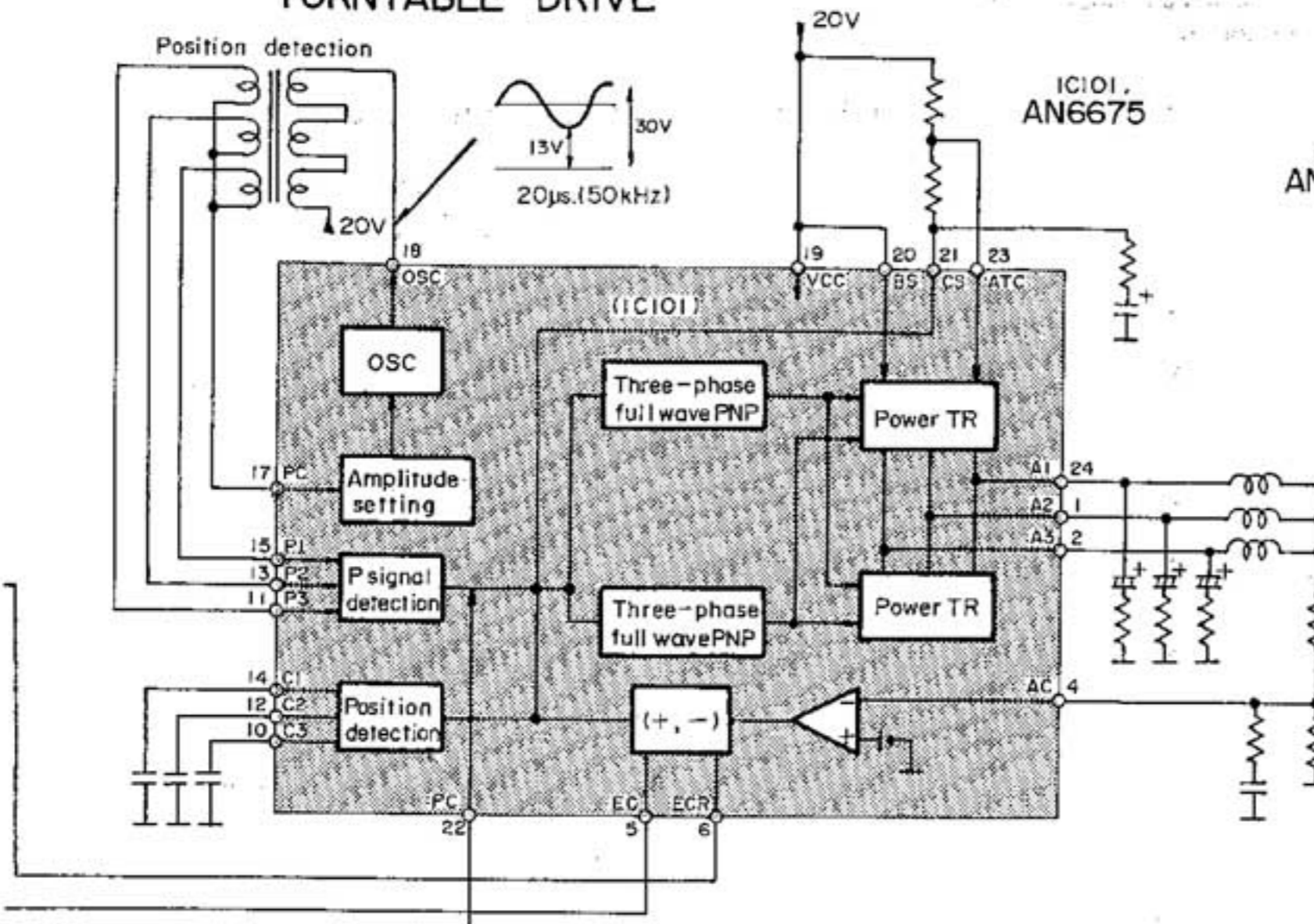

TONEARM MOTOR CONT

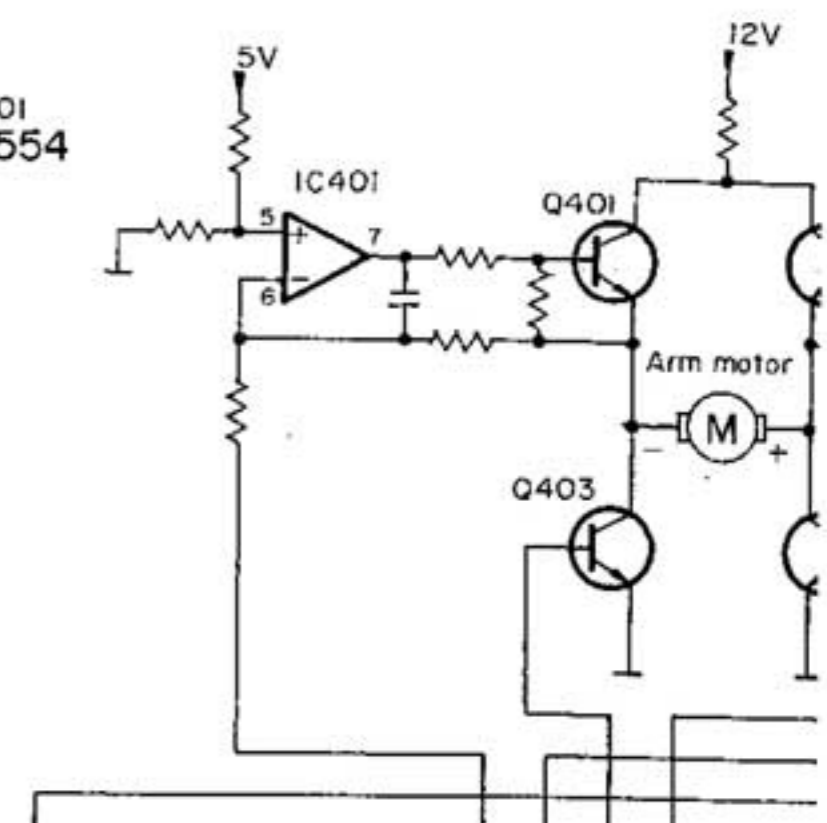

PITCH CONTROL

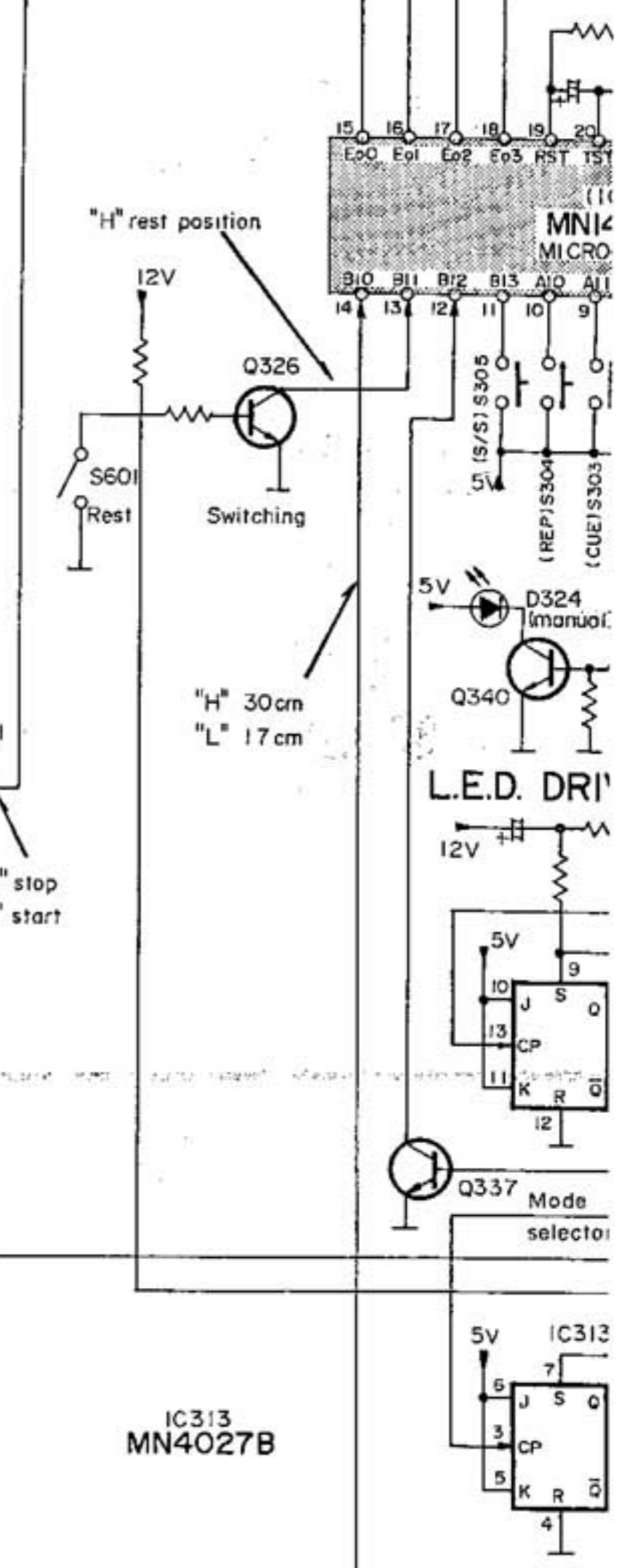
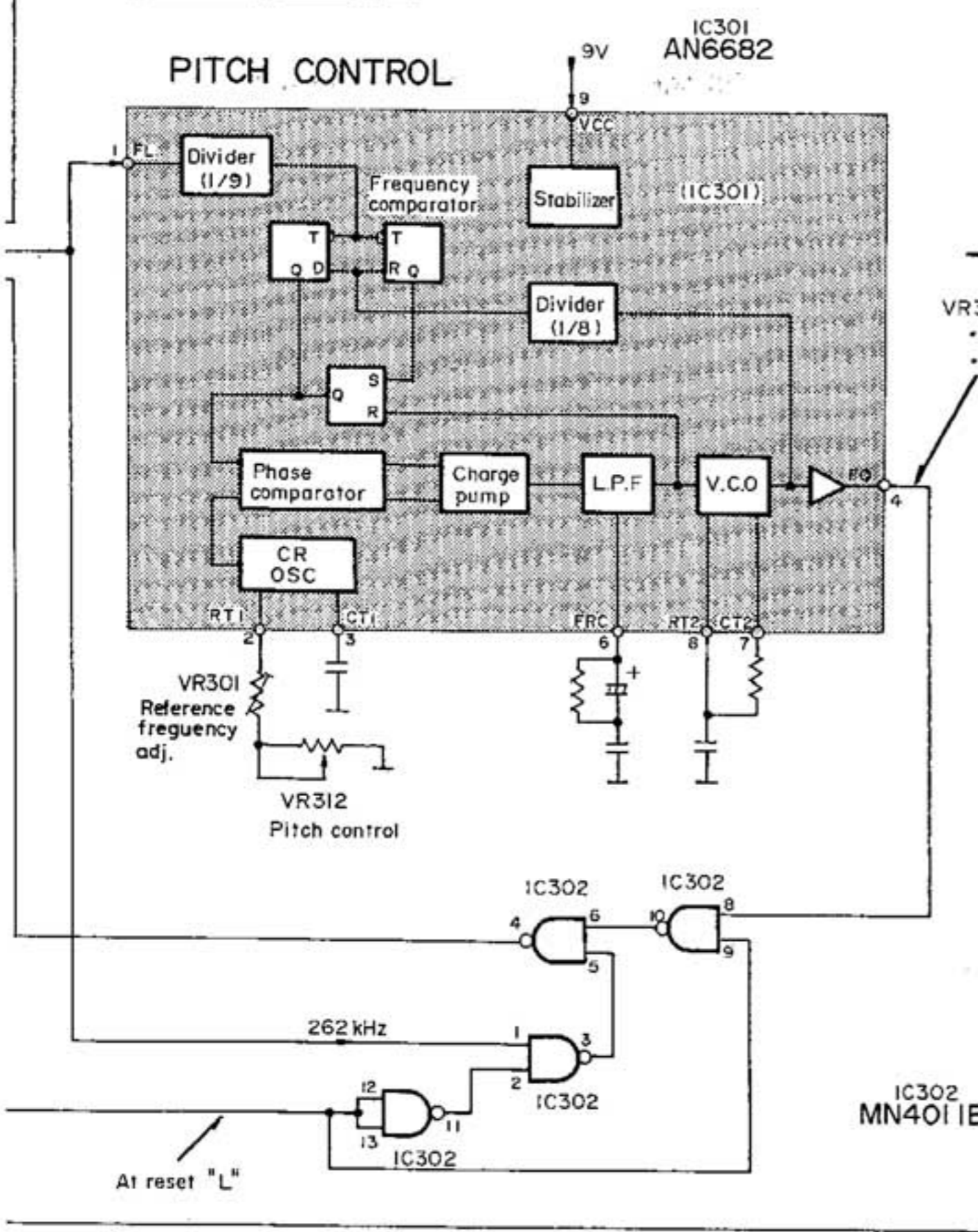

SIZE L.E.D. C

TO NEARM MOTOR CONTROL

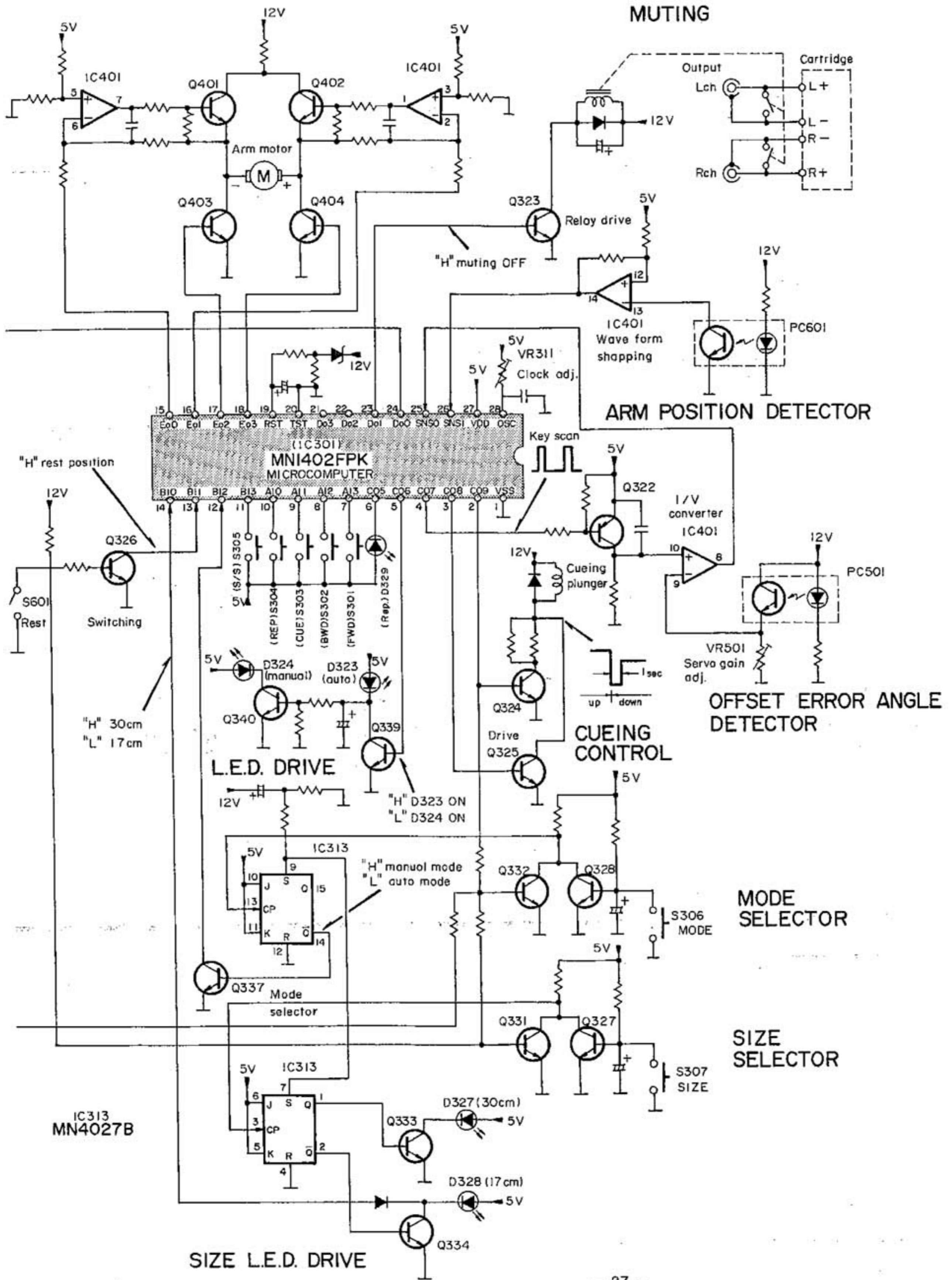

PACKING

1. Fit the clamber in place.

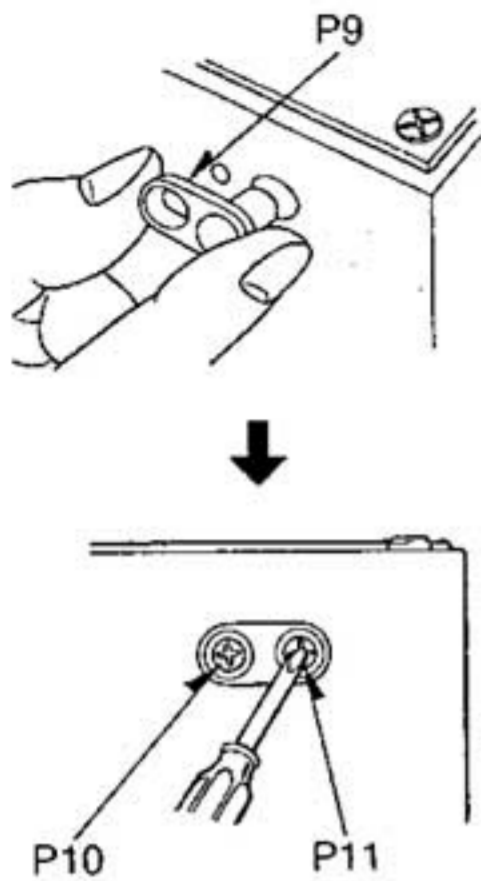

2. Fit the spacer in place.

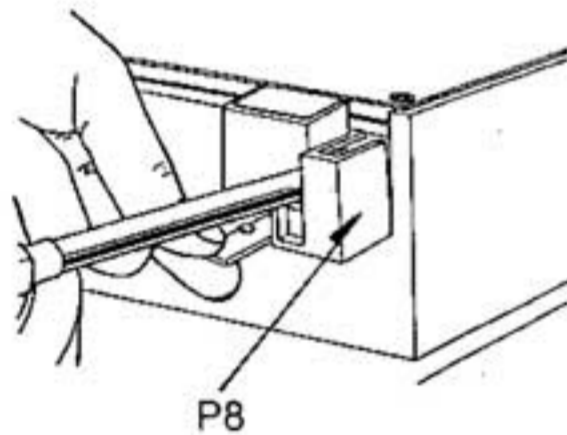

3. Pack the components according to the following procedure.

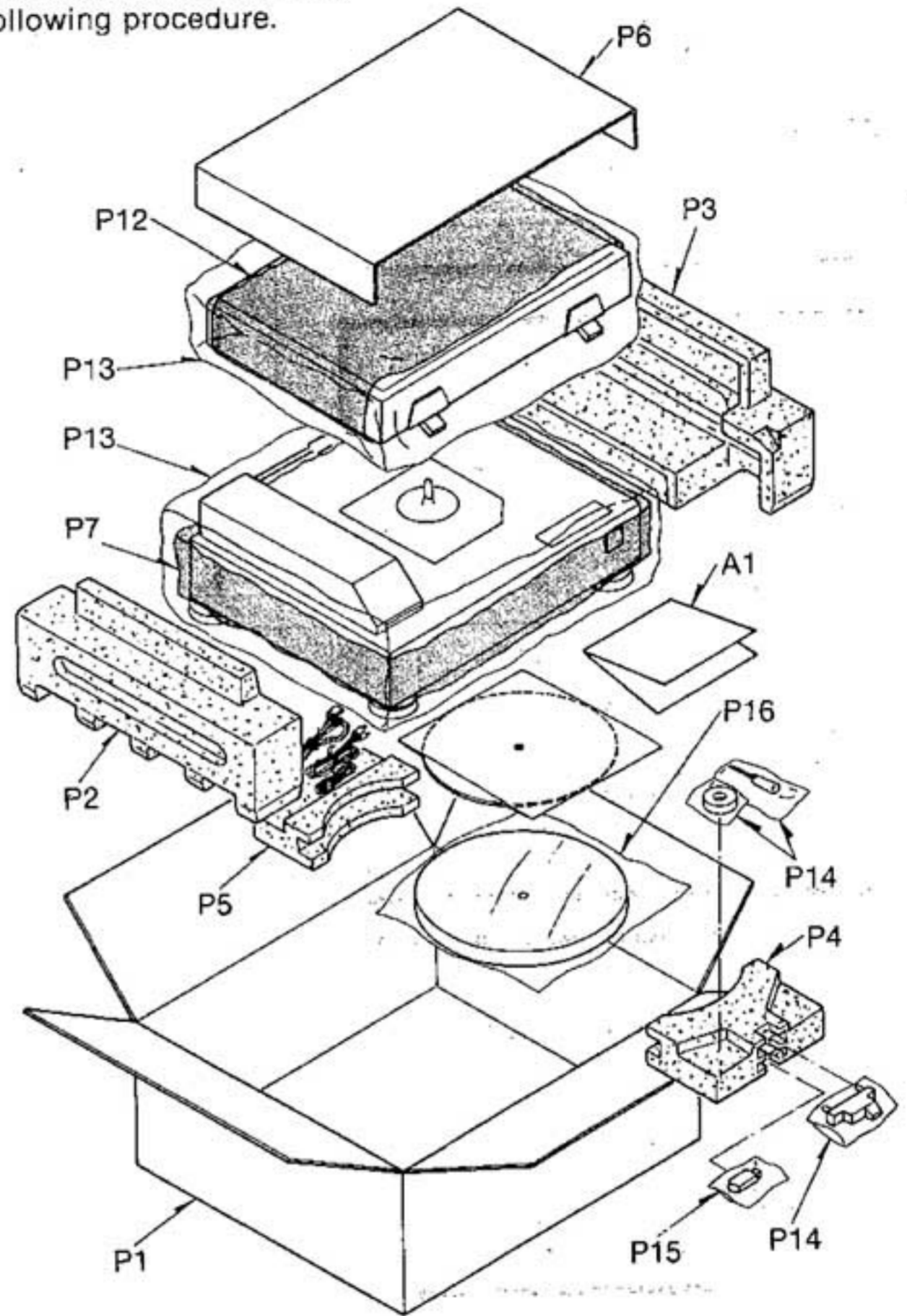

Ref. No.	Part No.	Description
ACCESSORIES		
A1 [M]	SFNUM03M01	Instruction Book (1)
A1 [MC]	SFNUM03C01E	Instruction Book (1)
A1 [EK]	SFNUM03G01	Instruction Book (1)
A1 [EI]	SFNUM03I01	Instruction Book (1)
A1 [PA, PE] [PC]	SFNUM03P01E	Instruction Book (1)
A1 [Other] [Areas]	SFNUM03S01	Instruction Book (1)
A2 [M, MC]	△ SFDAC05M01	AC Cord (1)
A2 [XL]	△ SFDAC05L01	AC Cord (1)
A2 [EK]	△ SFDAC05G02	AC Cord (1)
A2 [XZ]	△ SRDA007L01	AC Cord (1)
A2 [XA, XM]	△ SFDAC05X02	AC Cord (1)
A2 [PA, PE] [PC]	△ SFDAC05N01	AC Cord (1)

Ref. No.	Part No.	Description
A2 [Other] [Areas]	△ SFDAC05E02	AC Cord (1)
A3	SFDHM03N02	Phono Cord (1)
A4	SFDLJ02N01	Ground Wire (1)
A5	SFWE010	45 rpm Adaptor (1)
A6	SFCFB20502	Driver (1)
A7 [XA, XM] only	△ SFDK119118	2 Pin Plug (1)
A8 [PA, PE] [PC] only	△ QJP0603S	Adaptor (1)
PACKING PARTS		
P1 [MC, EF]	SFHPM03C01	Carton Box (1)
P1 [Other] [Areas]	SFHPM03M01	Carton Box (1)
P2	SFHMM03N01	Pad (L), Unit (1)
P3	SFHMM03N02	Pad (R), Unit (1)

Ref. No.	Part No.	Description
P4	SFHMM03N03	Pad (A), Turntable Platter (1)
P5	SFHMM03N04	Pad (B), Turntable Platter (1)
P6	SFHDM03N01	Pad, Top (1)
P7	SFHZM03N01	Sheet, Side (1)
P8	SFHKM03N01	Spacer, Tonearm (1)
P9	SFHKM03N02	Clamper, Weight (1)
P10	XSN4D8FYBS	Screw, Clamp (1)
P11	XSN4D14FYBS	Screw, Clamp (1)
P12	SFYF100A40	Sheet (1)
P13	SFYF60A80	Polyethylene Bag, Unit & Dust Cover (2)
P14	SFYF09A15	Polyethylene Bag, Accessories (3)
P15 Except for [M, MC]	SFYF05A06	Polyethylene Bag, Cartridge (1)
P16	SFYF40X45	Polyethylene Bag, Turntable (1)