

Quartz PLL DIRECT DRIVE 2-motor
FULL AUTOMATIC TURNTABLE

PL-570

HGT

< ART-222-0 >

Additional

Service Manual

This leaflet provides the description of the parts applied only HGT type.
For detailed instructions on adjustments, description, etc., please refer to the Service Manual of PL-570/KCT.

 **PIONEER**

MODEL PL-570 COMES IN DISTINGUISHED AS FOLLOWS:

Type	Voltage	Remarks
HGT	220V and 240V (Switchable)	Europe or Oceania model without phono cartridge

1. SPECIFICATIONS

Motor and Turntable

Motor	Quartz PLL Hall motor
Turntable Platter	324mm diam. aluminum alloy die-cast
Internal Mass	340kg-cm ² (including platter mat mass)
Speeds	33-1/3 and 45rpm
Speeds Control Range	±6%
Wow and Flutter	Less than 0.025% (WRMS)
Signal-to-Noise Ratio	More than 70dB (DIN-B)

Rotational Characteristics

Build-up Time	Within 240° rotation at 33-1/3rpm
Speed Deviation	Less than 0.003%
Speed vs. Load Characteristics	Stable up to 120 grams drag load
Speed Drift	Less than 0.0003%/h at 33-1/3rpm Less than 0.00004%/ C° change at 33-1/3rpm

Tonearm

Type	Static-balance type, S-shaped pipe arm
Effective Arm Length	237mm
Overhang	15mm
Usable Cartridge Weight	4g (min.) to 13.5g (max.) (For cartridge weighing over 9 grams, attach the sub-weight)
Arm Height Adjust Range	±5mm

Subfunctions

Warren motor for automatic functions, Anti-skating force control, Lateral balancer, Stylus pressure direct-readout counterweight, Arm height adjusting device, Cueing device, Headshell stand, Strobe light, Insulator feet, Free stop hinges

Semiconductors

ICs	4
Transistors	9
Diodes	12
Hall elements	3
LED	1
Photo Transistor	1

Miscellaneous

Power Requirement

PL-570/HGT 220-240V, 50/60Hz

Power Consumption

PL-570/HGT 11W

Dimensions 490(W) x 200(H) x 390(D)mm
19-5/16(W) x 7-7/8(H) x 15-3/8(D)in.

Weight 13.5kg/29 lb 11 oz

Accessories

45rpm adaptor	1
Overhang gauge	1
Screwdriver	1
Sub weight	1
Cartridge mounting screws	6
Cartridge mounting nuts	2
Cartridge mounting washers	2
Operating instructions	1

NOTES:

- *Specifications and design subject to possible modification without notice, due to improvements.*

2. SCHEMATIC DIAGRAMS

DRIVE CONTROL ASS'y PWG-011

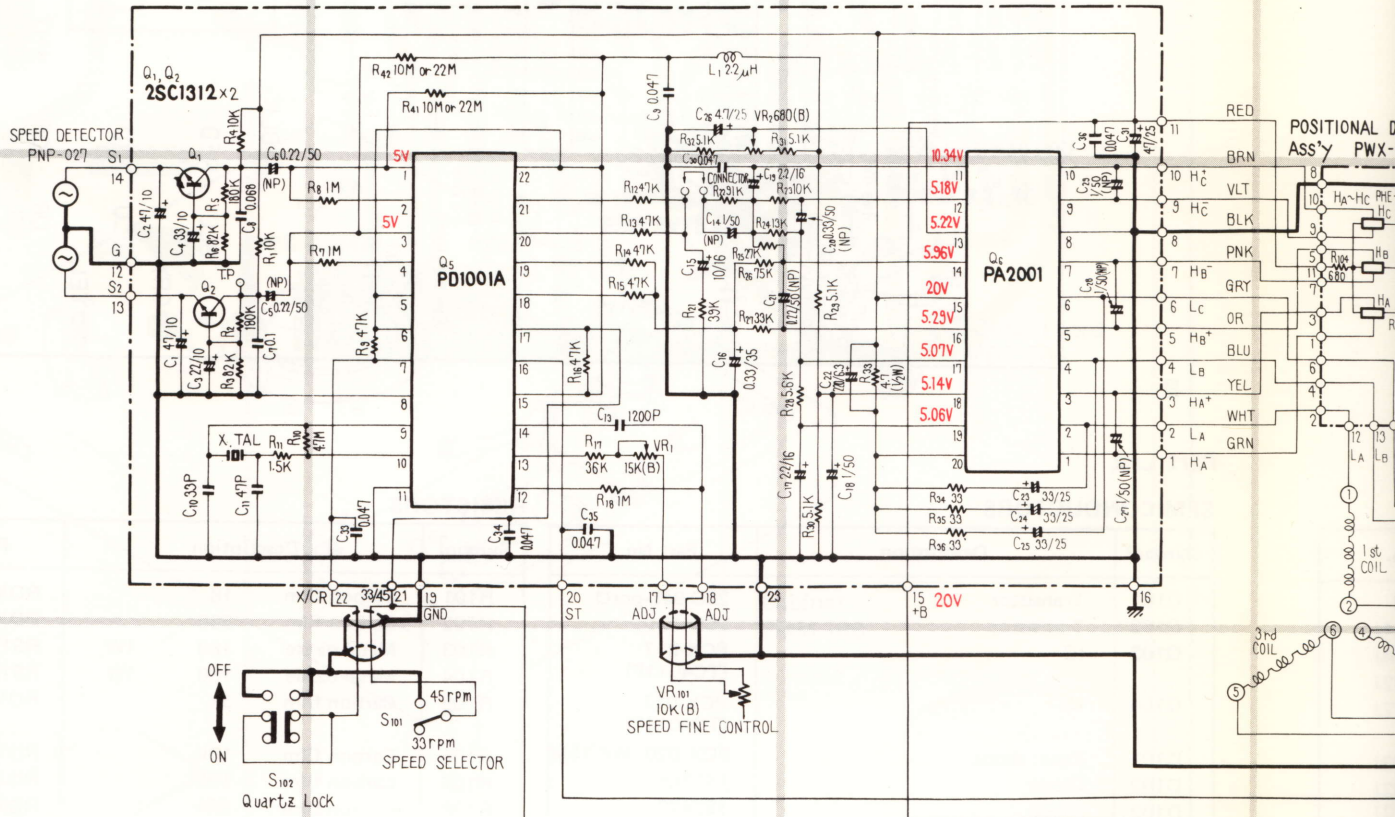

DETECTOR ASS'y PWX-011

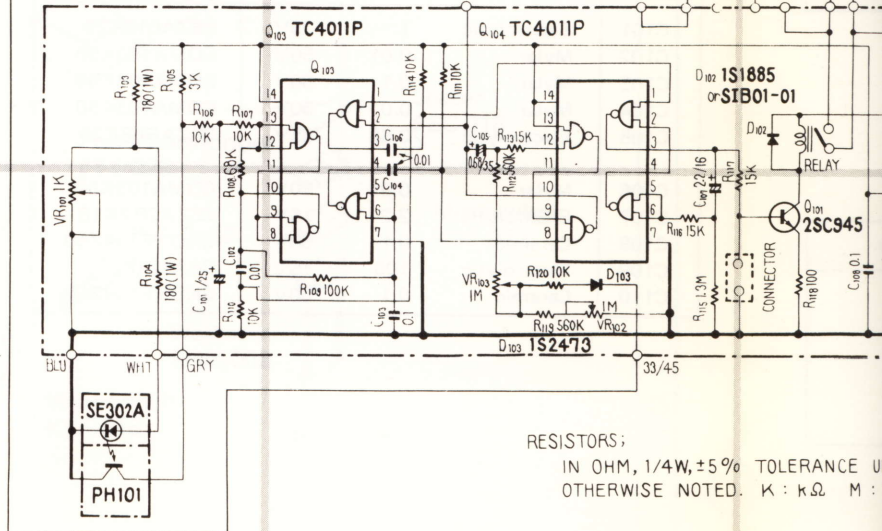

RESISTORS:
IN OHM, 1/4W, ±5% TOLERANCE U
OTHERWISE NOTED. K: K.Ω M: M.Ω

4

5

6

NOTE:

The indicated semiconductors are representative ones only. Other alternative semiconductors may be used and are listed in the parts list.

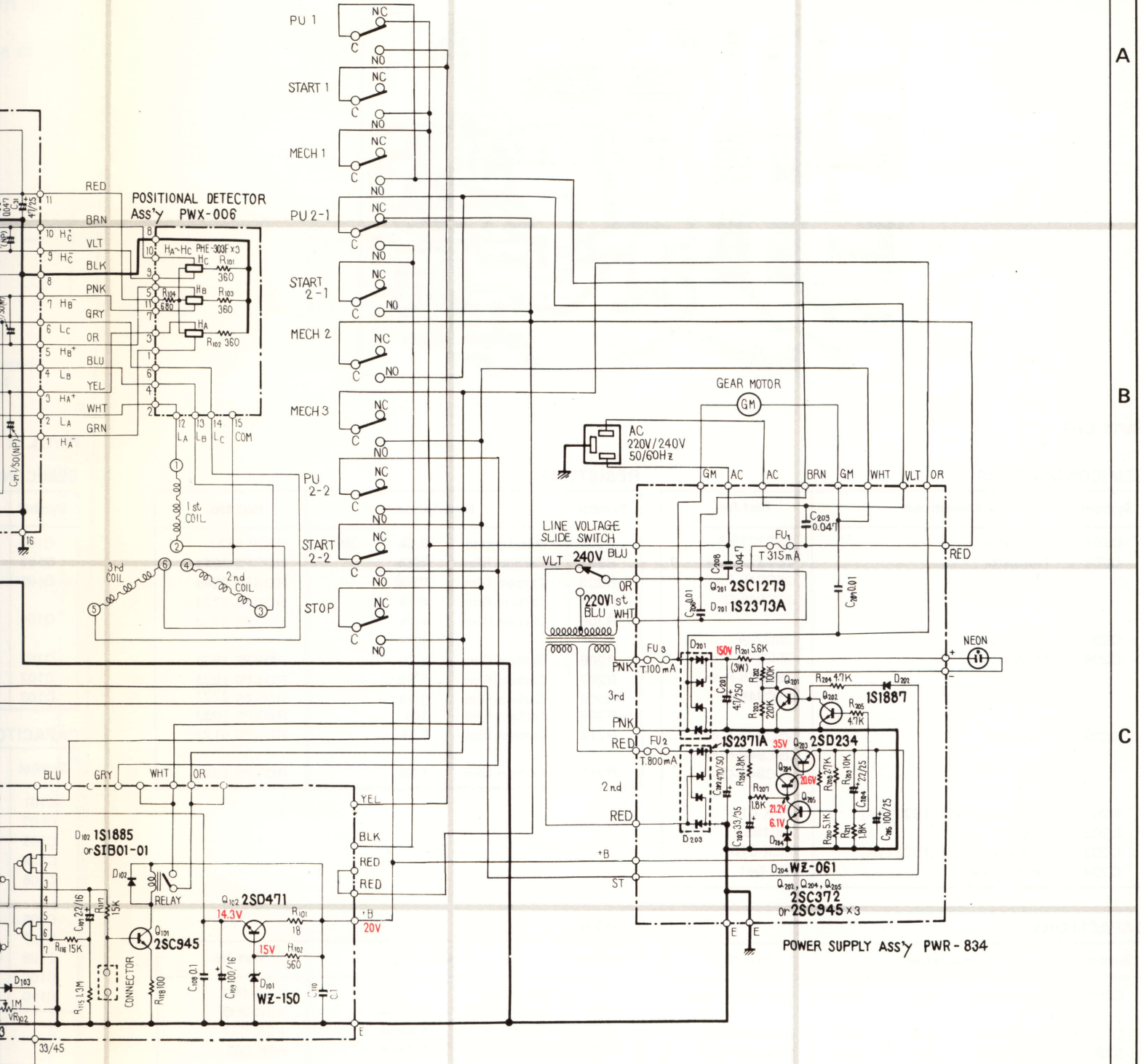

RESISTORS;
 1/4W, ±5% TOLERANCE UNLESS
 OTHERWISE NOTED. K : kΩ M : MΩ

CAPACITORS;
 IN μF UNLESS OTHERWISE NOTED P : pF

4

5

6

2.1 POWER SUPPLY ASSEMBLY (PWR-834)

P.C. Board

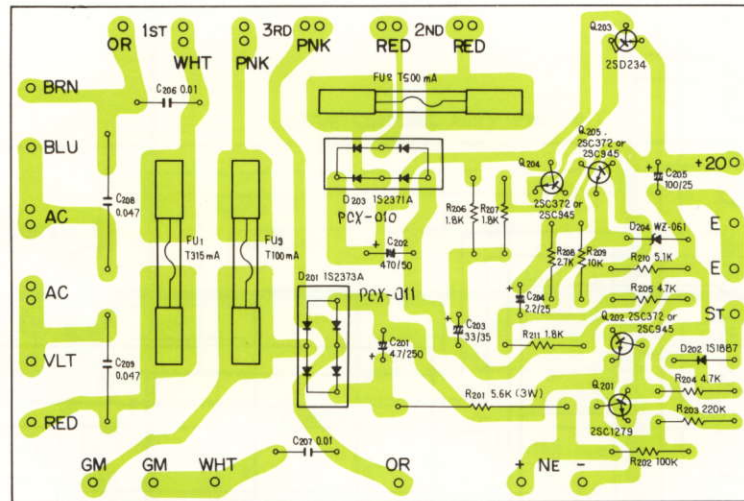

Parts List

SEMICONDUCTORS

Symbol	Description	Part No.
Q201	Transistor	2SC1279-S
Q202	Transistor	2SC372-Y or 2SC945-P or 2SC945-Q
Q203	Transistor	2SD234
Q204	Transistor	2SC372-Y or 2SC945-P or 2SC945-Q
Q205	Transistor	2SC372-Y or 2SC945-P or 2SC945-Q
D201	Bridge rectifiers (1S2373A)	PCX-011
D202	Diode	1S-1887
D203	Bridge rectifiers (1S2371A)	PCX-010
D204	Zener diode	WZ-061

RESISTORS

Symbol	Description	Part No.
R201	Metal oxide 5.6k 3W	RS3P 562J
R202	Carbon film 100k	RD¼PS 104J
R203	Carbon film 220k	RD¼PS 224J
R204	Carbon film 4.7k	RD¼PS 472J
R205	Carbon film 4.7k	RD¼PS 472J
R206	Carbon film 1.8k	RD¼PS 182J
R207	Carbon film 1.8k	RD¼PS 182J
R208	Carbon film 2.7k	RD¼PS 272J
R209	Carbon film 10k	RD¼PS 103J
R210	Carbon film 5.1k	RD¼PS 512J
R211	Carbon film 1.8k	RD¼PS 182J

CAPACITORS

Symbol	Description	Part No.
C201	Electrolytic 4.7 250V	CEA 4R7P 250
C202	Electrolytic 470 50V	CEA 471P 50
C203	Electrolytic 33 35V	CEA 330P 35
C204	Electrolytic 2.2 25V	CEB 2R2P 25
C205	Electrolytic 100 25V	CEA 101P 25
C206	Ceramic 0.01	ACG-001
C207	Ceramic 0.01	ACG-001
C208	Myler 0.047	PCL-014
C209	Myler 0.047	PCL-014

OTHERS

Symbol	Description	Part No.
	Fuse clip	KKR-001
FU1	Fuse 315mA	KEK-008
FU2	Fuse 500mA	PEK-007
FU3	Fuse 100mA	PEK-008
	Heat sink	PNS-001

2.2 AUTO RETURN DETECTOR ASSEMBLY (PWX-011)

P.C. Board

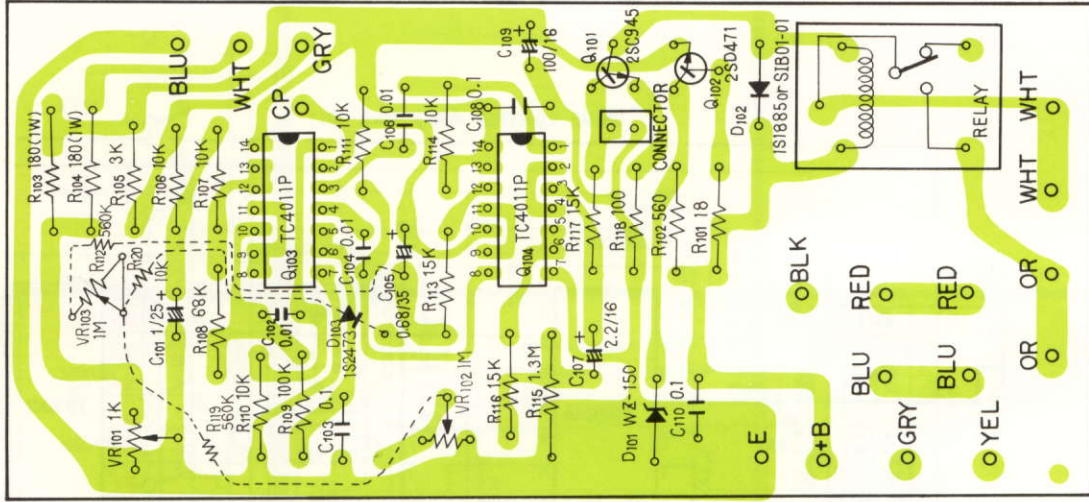

Part List

SEMICONDUCTORS

Symbol	Description	Part No.
Q101	Transistor	2SC 945-porQ
Q102	Transistor	2SD 471
Q103	IC	PCX-017 (TC4011P)
Q104	IC	PCX-017 (TC4011P)
D101	Zener diode	PCX-020 (WZ-150)
D102	Diode	1S1885
D103	Diode	1S2473

RESISTORS

Symbol	Description	Part No.
R101	Carbon film 18	RD¼PS 180J
R102	Carbon film 560	RD¼PS 561J
R103	Metal oxide 180 1W	RS1P 181J
R104	Metal oxide 180 1W	RS1P 181J
R105	Carbon film 3k	RD¼PS 302J
R106	Carbon film 10k	RD¼PS 103J
R107	Carbon film 10k	RD¼PS 103J
R108	Carbon film 68k	RD¼PS 683J
R109	Carbon film 100k	RD¼PS 104J
R110	Carbon film 10k	RD¼PS 103J
R111	Carbon film 10k	RD¼PS 103J
R112	Carbon film 560k	RD¼PS 564J
R113	Carbon film 15k	RD¼PS 153J
R114	Carbon film 10k	RD¼PS 103J
R115	Metal film 1.3M	RN½SS 1304G
R116	Carbon film 15k	RD¼PS 153J
R117	Carbon film 15k	RD¼PS 153J
R118	Carbon film 100	RD¼PS 101J
R119	Carbon film 560k	RD¼PS 564J
R120	Carbon film 10k	RD¼PS 103J
VR101	Semi-fixed 470-B	PCP-010
VR102	Semi-fixed 1M-B	PCP-008
VR103	Semi-fixed 1M-B	PCP-008

CAPACITORS

Symbol	Description	Part No.
C101	Electrolytic 1 25V	CSZA010K25
C102	Mylar 0.01 50V	CQMA103K50
C103	Mylar 0.1 50V	CQMA104K50
C104	Mylar 0.01 50V	CQMA103K50
C105	Electrolytic 0.68 35V	CSZAR68K35
C106	Mylar 0.01 50V	CQMA103K50
C107	Electrolytic 2.2 16V	CSZA2R2K16
C108	Ceramic 0.1 50V	CKDYF104Z50
C109	Electrolytic 100 16V	CEA101P16
C110	Ceramic 0.1 50V	CKDYF104Z50

3. EXPLODED VIEW

NOTE: Parts indicated in green type cannot be supplied. The parts indicated the designation and part number are newly-employed as HGT type. The parts without description are the same as the part in the KCT type.

A

A

B

B

C

C

D

D

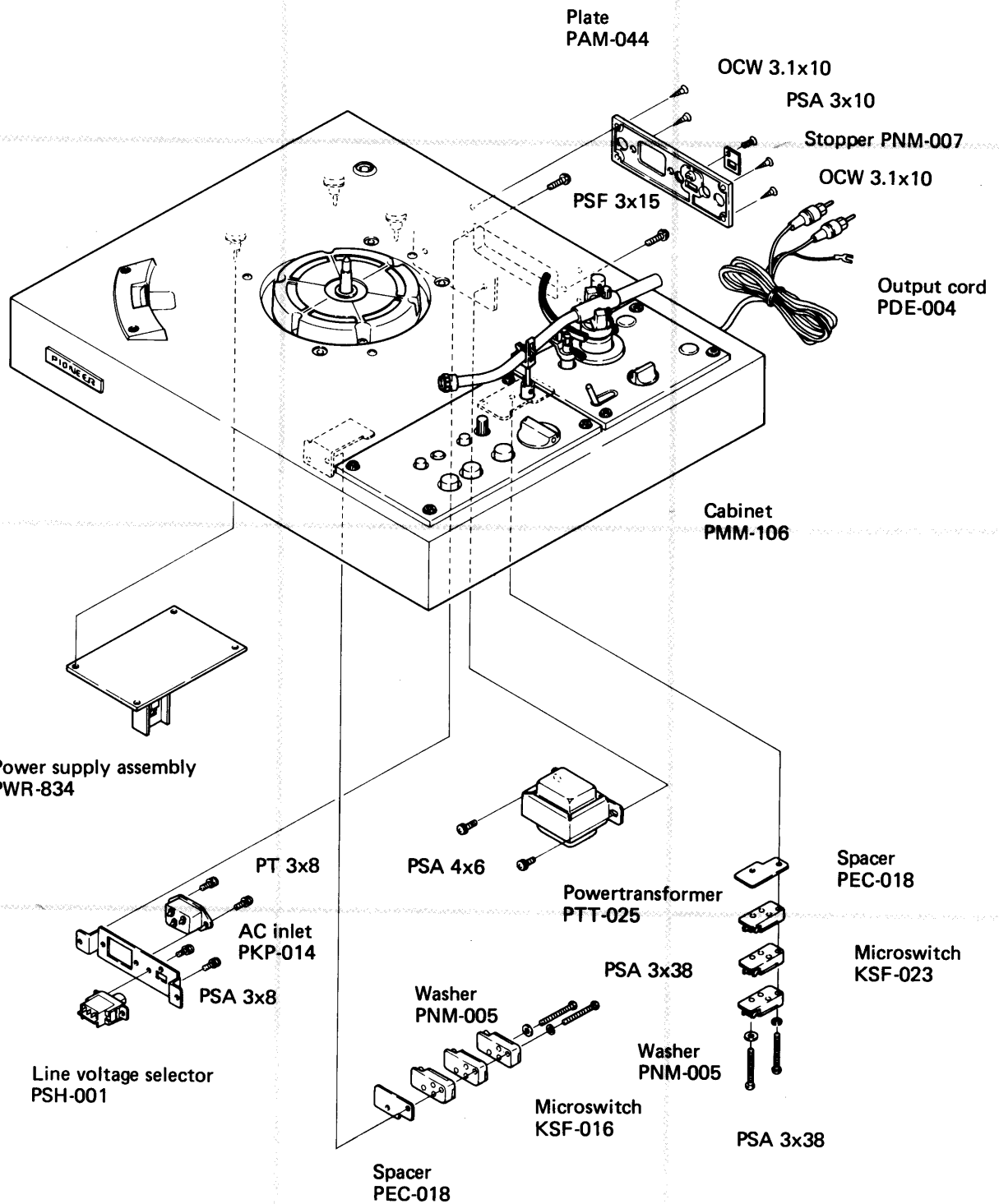

1

2

3

3.1 SUB PANEL-1

NOTE:

The parts indicated the designation and part number are newly-employed as HGT type.

The parts without description are the same as the part in the KCT type.

A

A

B

B

C

C

D

D

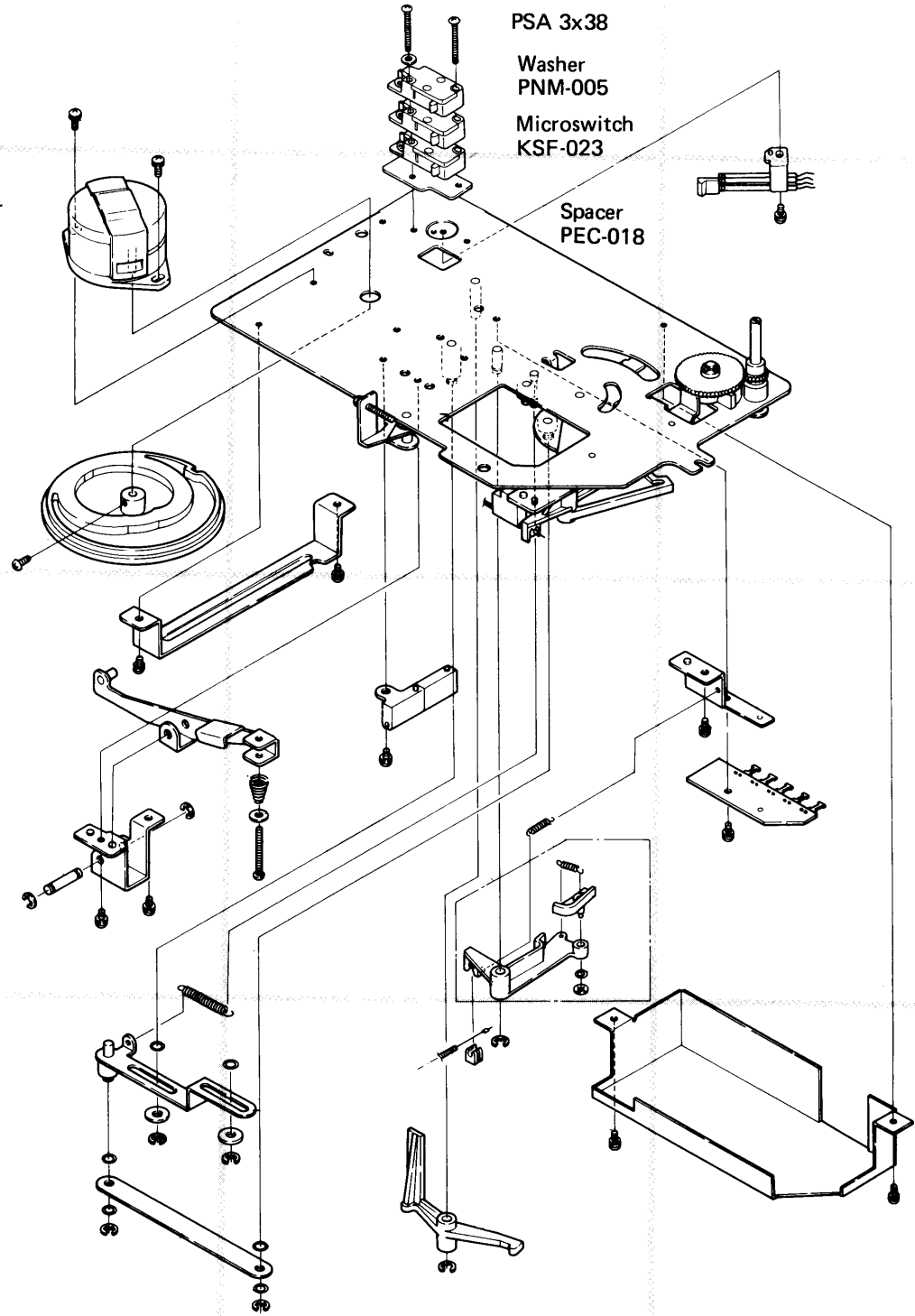

1

2

3

5. ADJUSTMENT OF REFERENCE TIME

1. Connect oscilloscope to CP pin of detection circuit ass'y PWX-011. Set scope sweep time at 0.2cm/sec.
2. Briefly short-circuit pins BR and BL on detection circuit ass'y.

45 Prm Adjustment

3. Oscilloscope should show a trace of 2.4cm (475msec \pm 15msec)

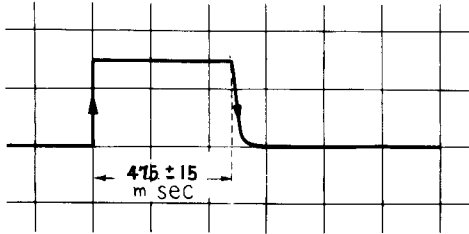

Fig. 1

4. If trace is longer or shorter, adjust VR₁₀₃ on detection circuit ass'y PWX-011.

NOTE:

Always ensure that the 45rpm adjustment is performed correctly before making the 33rpm adjustment. Failure to do this will result in impaired performance.

33 Rpm Adjustment

5. Oscilloscope should show a trace of 4.5cm (900msec \pm 50msec)

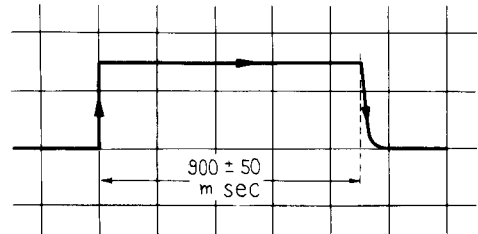

Fig. 2

6. If trace is longer or shorter, adjust VR₁₀₂ on detection circuit ass'y PWX-011.

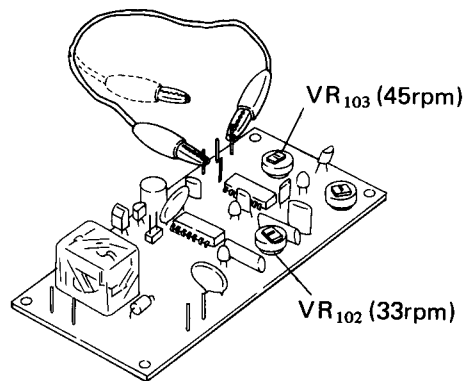

Fig. 3