

SERVICE MANUAL
TURNTABLE
MODEL LT-30

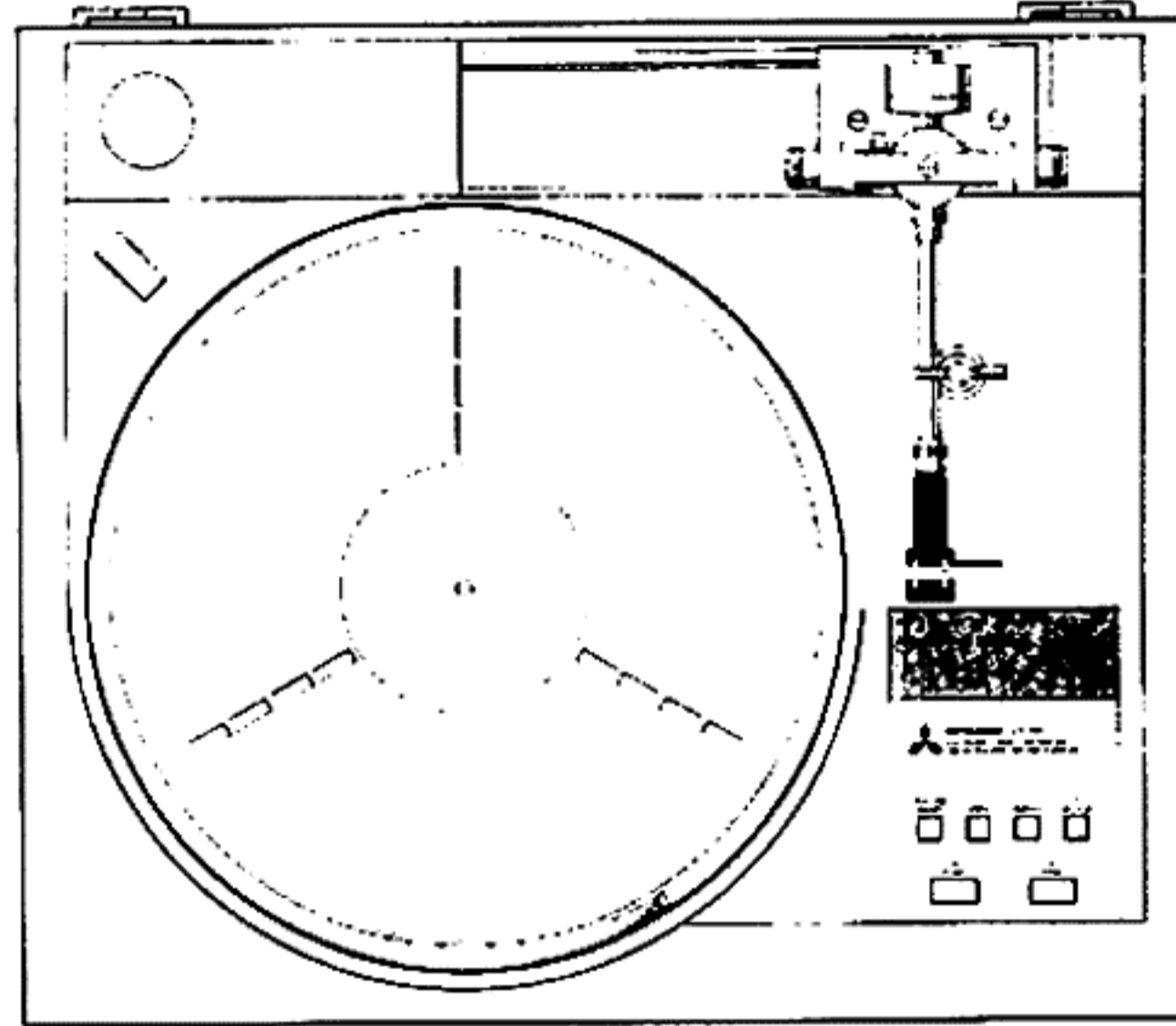

CONTENTS

SPECIFICATIONS	2
DISCRIPTION AND FUNCTION	2
CARTRIDGE INSTALLATION	4
DISASSEMBLY	4
ASSEMBLY PRECAUTIONS	6
ADJUSTMENTS	8
PRINTED CIRCUIT BOARDS	11
SCHEMATIC DIAGRAM	13
WIRING DIAGRAM	15
PARTS LIST	17
EXPLODED VIEW	19
MECHANICAL PARTS DESCRIPTION	21
PACKING INSTRUCTION	23

MELCO SALES INC.

3030 East Victoria Street Compton, California 90221

SPECIFICATIONS

1. PHONO MOTOR SECTION

Type Electronically controlled
 fully automatic operation
 Drive mechanism Direct drive
 Motor Quartz PLL DC servo motor
 Platter Diameter 312 mm (12-5/16")
 Weight 1.5 kg (3.3 lbs)
 Material Aluminum die-cast
 Platter speed 33-1/3, 45 r.p.m.
 Wow and flutter 0.025% (Wrms)
 ±0.04% (Wp-p, DIN 45-507)
 Signal to noise ratio 65 dB (IEC-B)
 78 dB (DIN 450539)

Overall length 225 mm (8-7/8")
 Effective length 175 mm (6-7/8")
 Tracking error Less than 0.05°
 Head shell Material Magnesium die-cast
 Weight 6g
 Possible cartridge weight 10g to 16g
 (with head shell) (16g to 20g with sub-weight)

2. TONEARM SECTION

Type Straight type universal static
 balanced

3. GENERAL

Power consumption 15W
 Dimensions (W x H x D) 485 x 177 x 413 mm
 (19-1/8 x 7 x 16-1/4")
 Weight 15 kg (33 lbs)

Design and specifications are subject to change without notice for improvement.

DISCRIPTION AND FUNCTION

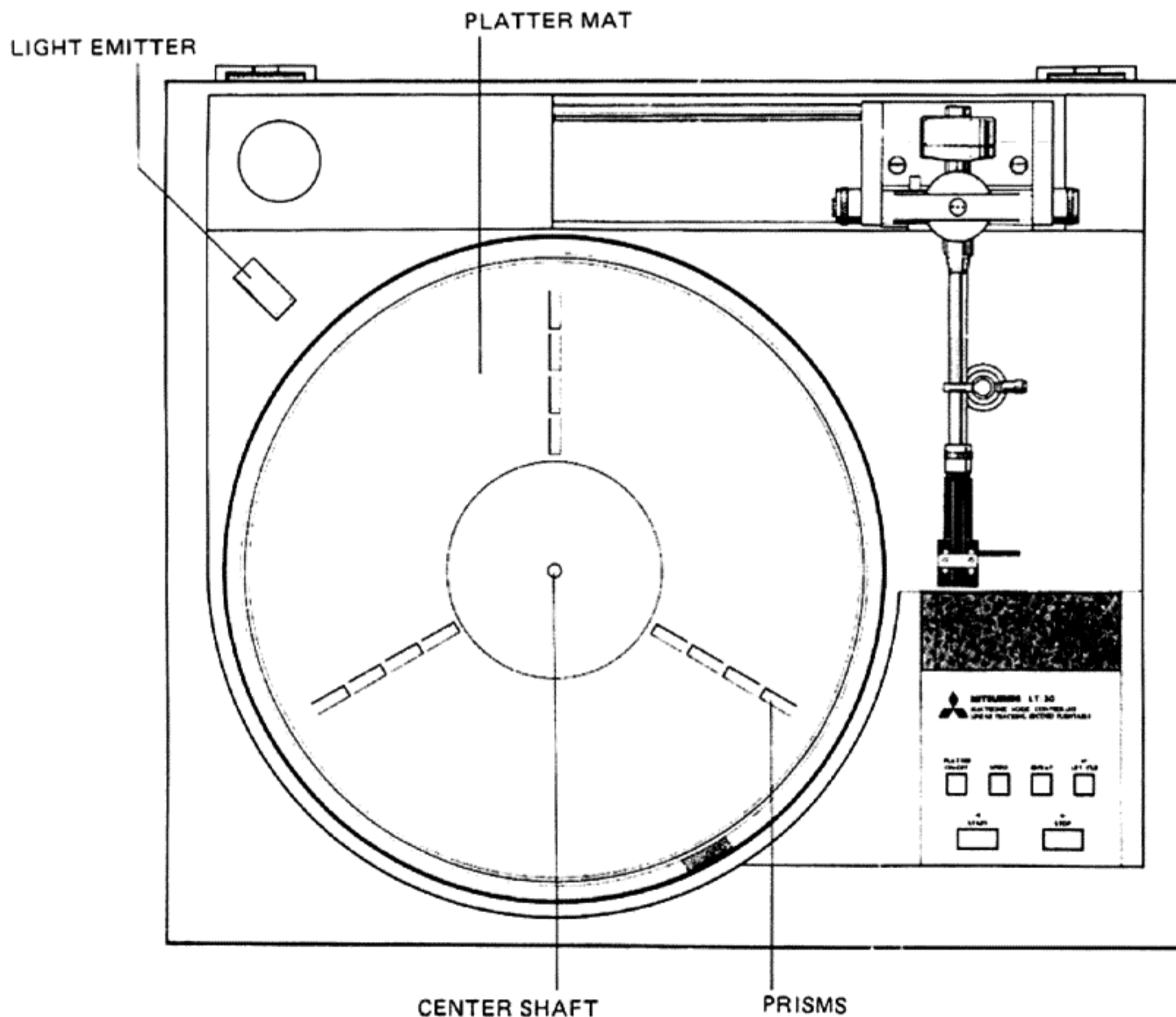

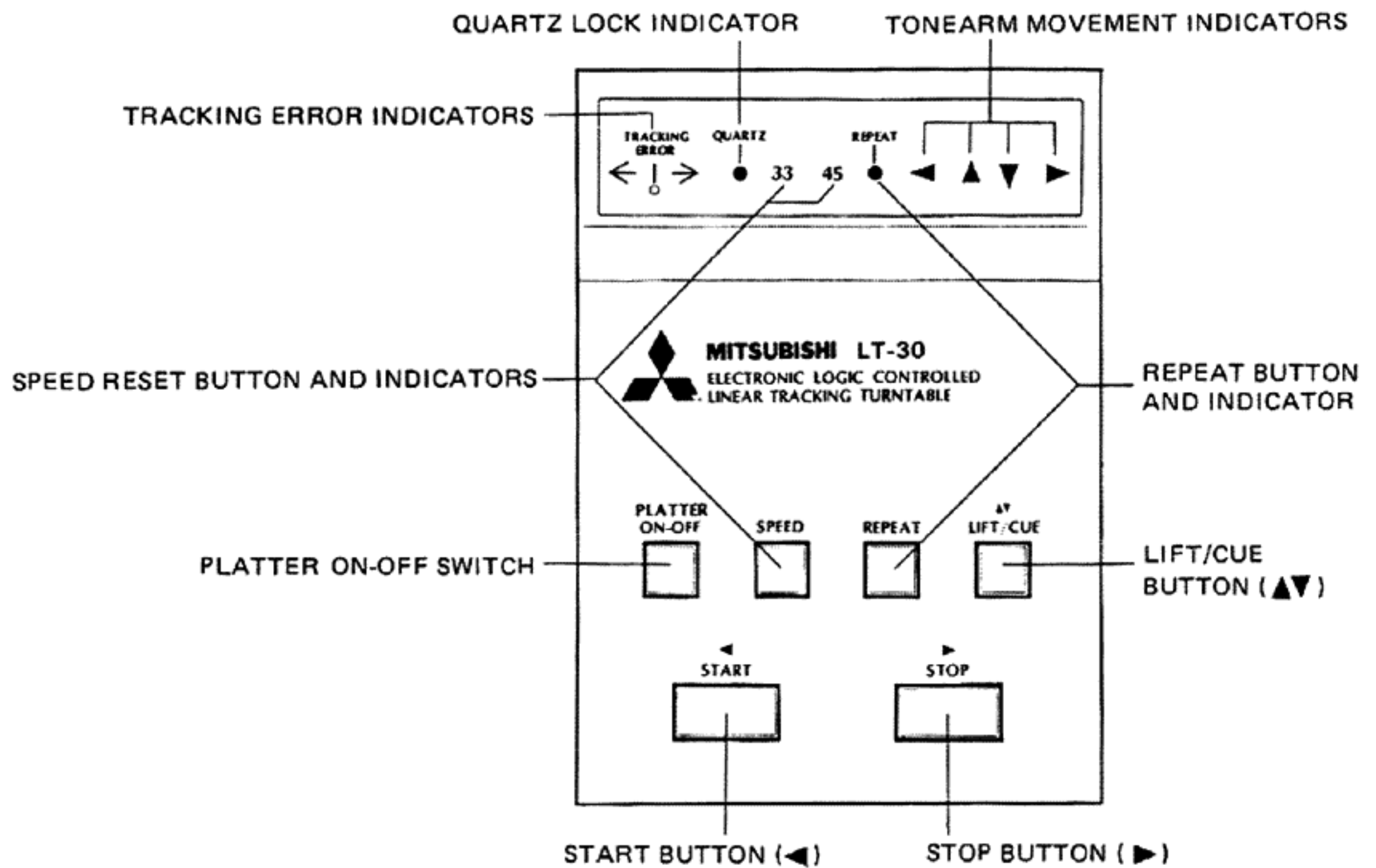
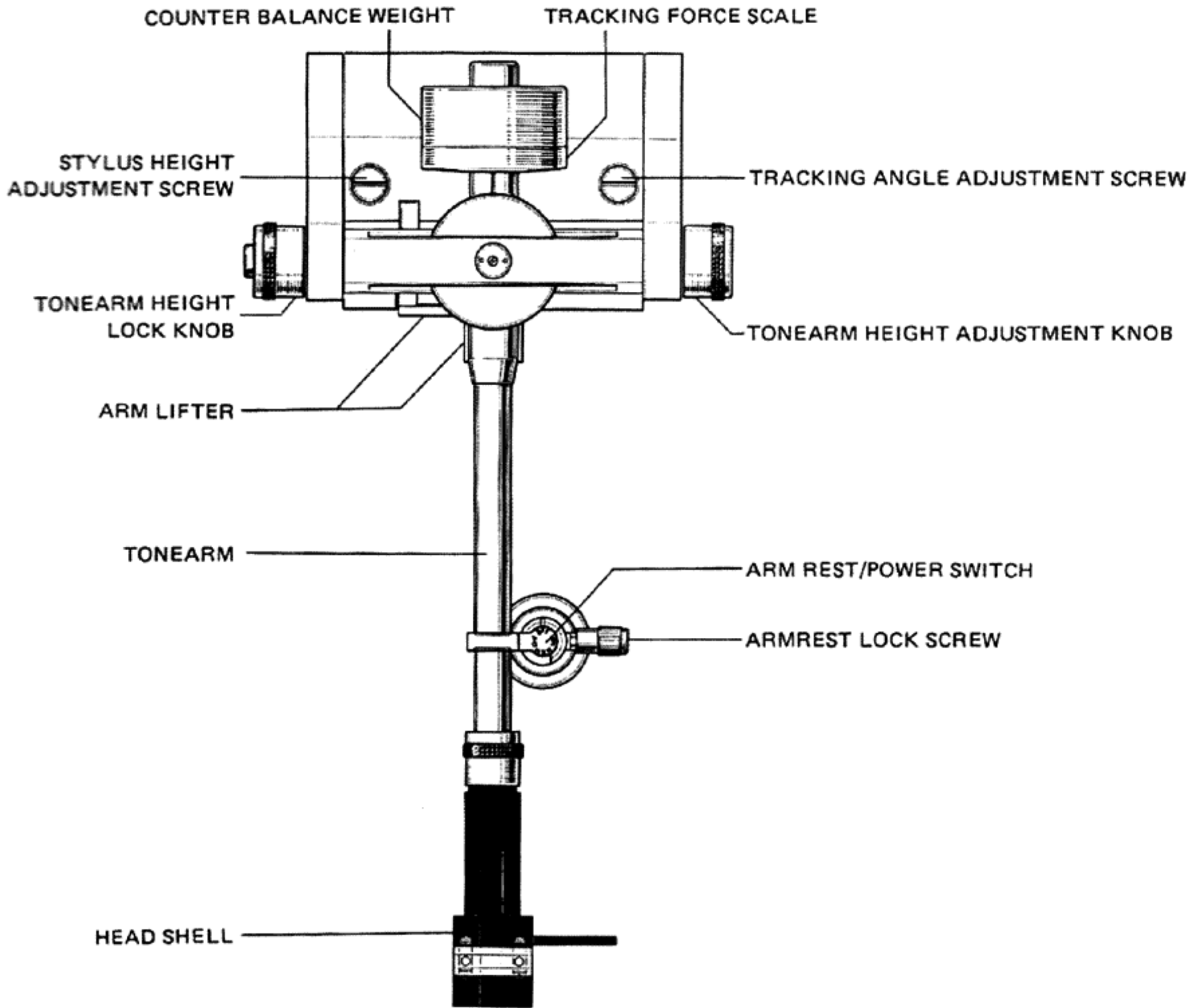

CARTRIDGE INSTALLATION:

The cartridge is not supplied with this unit.

1. LEAD CONNECTIONS

Attach the lead wires to the proper terminals on the cartridge.

- White Lead L (+)
- Blue Lead L (-)
- Red Lead R (+)
- Green Lead R (-) (G) (E)

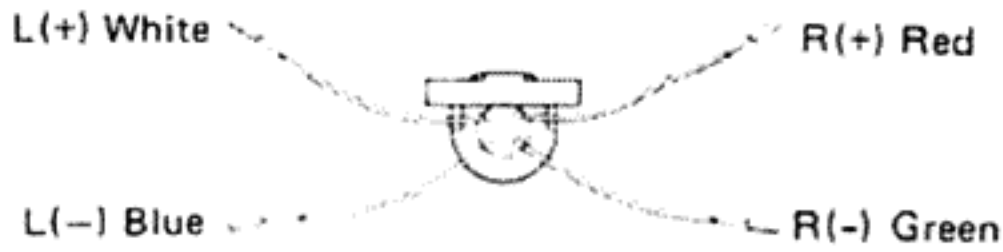

2. Choose the proper length screws from those supplied and attach the cartridge to the head shell as shown below.

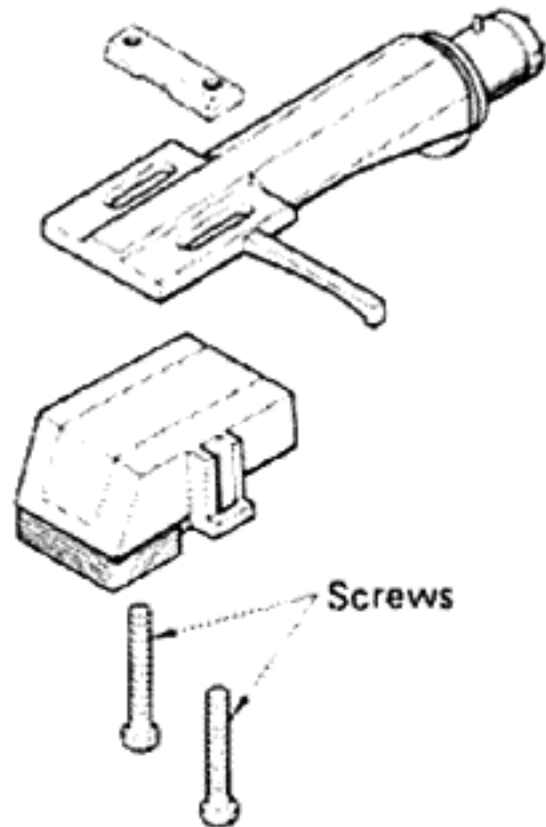

3. STYLUS TIP ADJUSTMENT

Using the supplied overhang gauge, adjust the stylus tip so that it comes just to the positioning line (◀) on the gauge and fasten it in place.

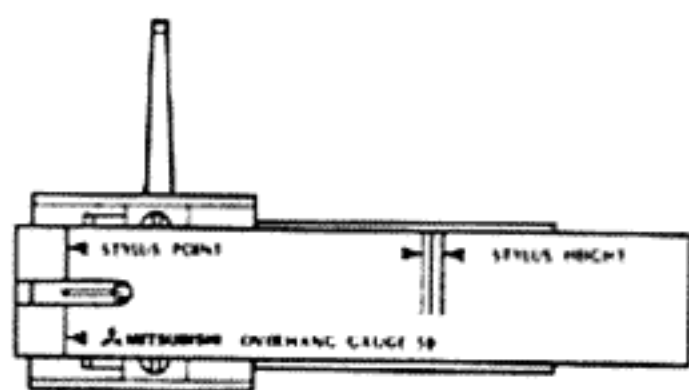
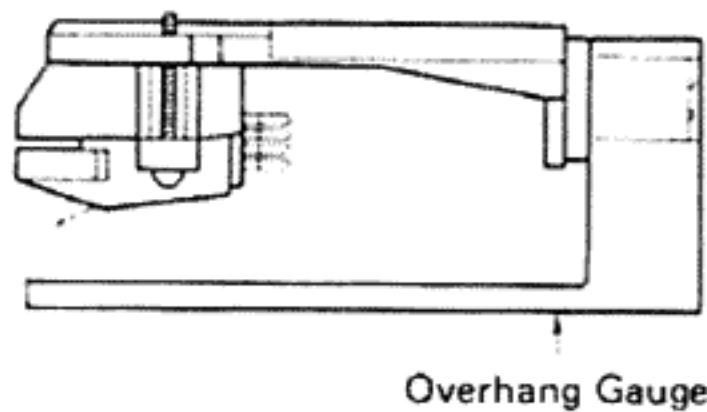

DISASSEMBLY:

1. REMOVAL OF TONEARM ASS'Y

- 1) Turn the set over and remove the bottom plate.
- 2) Disconnect clampers A and B shown in Fig. 1 and remove connectors CONN-5 and CONN-6.
- 3) Using a soldering iron, disconnect the following wires from the tonearm base: lead wires (red and black) leading to terminals ④ and ⑤ of the logic P. C. board, and the shield wires (red and white) and the black wire leading to the relay terminal P. C. board.

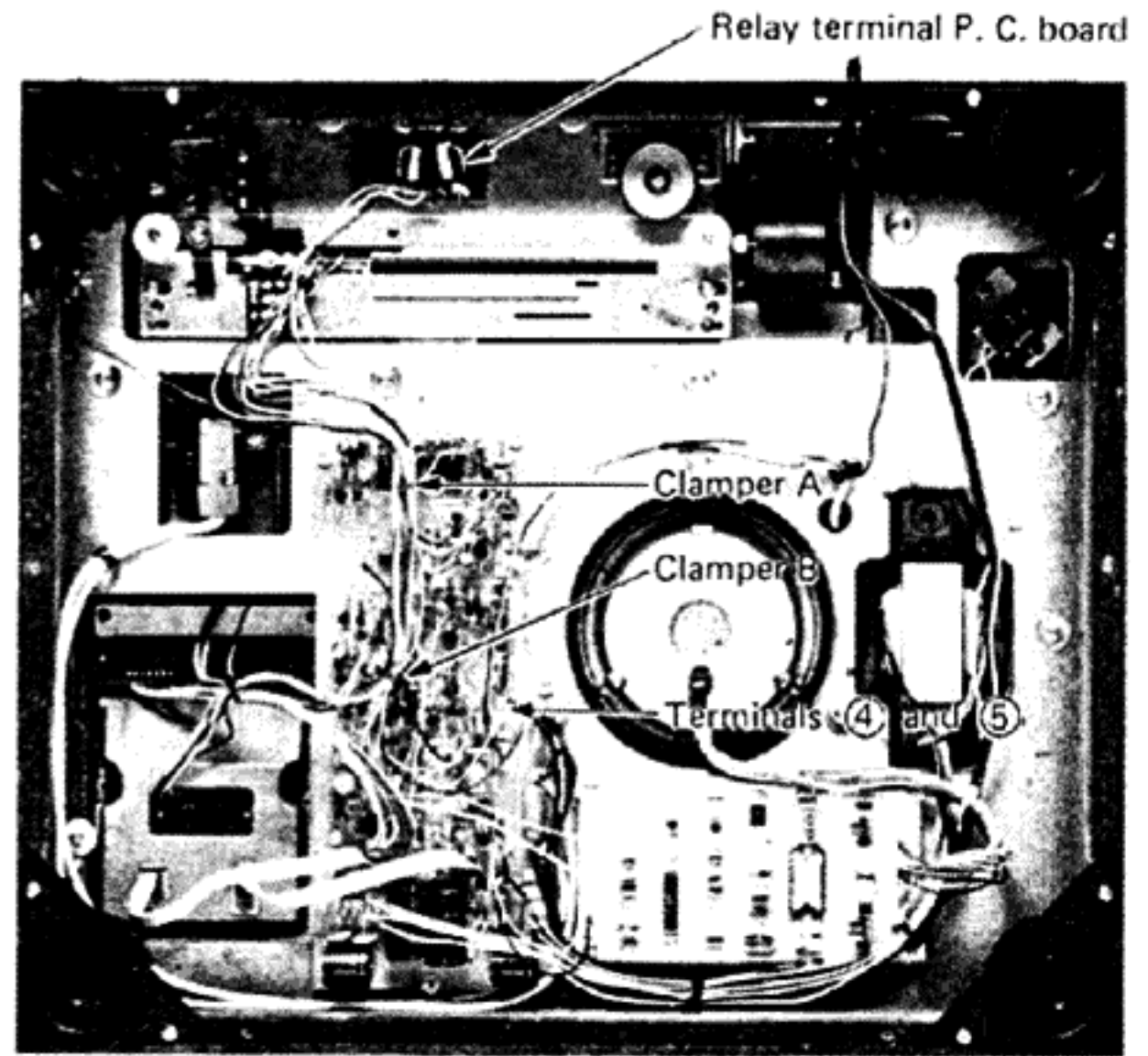

Fig. 1

- 4) Remove the two screws ③ shown in Fig. 2 and take off the lamp P. C. board's holder. As a wire used for driving the tonearm base is stretched across the area above the screws, keep this wire out of the way with your fingers.
- 5) Remove screw ④ shown in Fig. 2 and detach the LEAD-IN-POSITION adjusting plate.
- 6) The slit plate's spring, which is fixed to the body by a gear-shaped washer, is removed by removing the washer first.
- 7) Remove the two screws ⑤ shown in Fig. 2 and remove the slit plate.

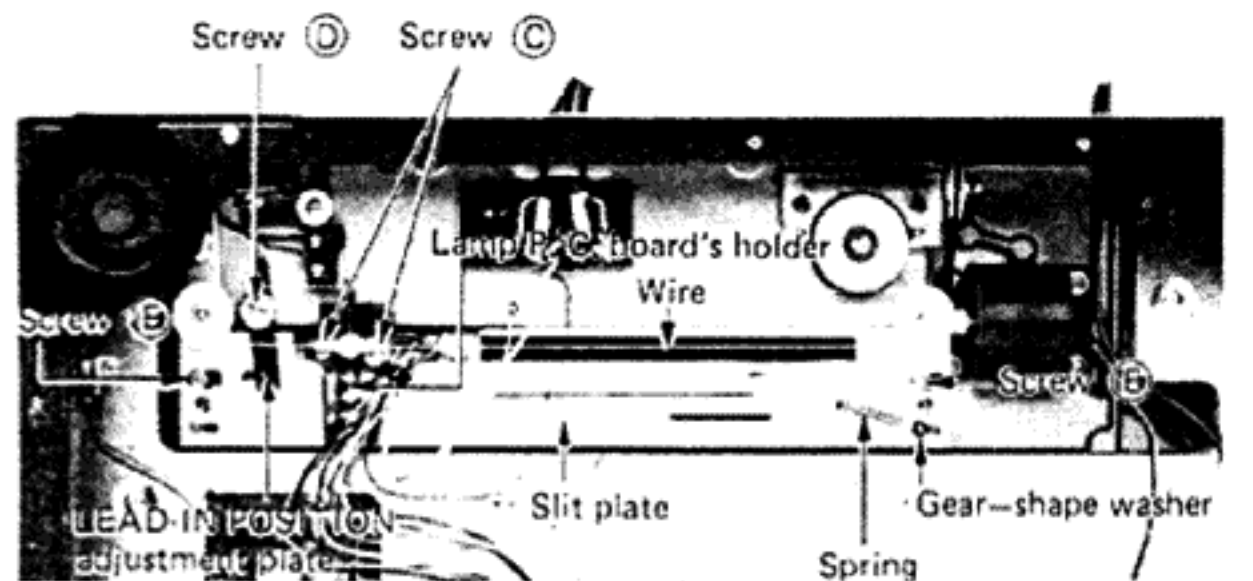

Fig. 2

- 8) Unscrew screw (F) shown in Fig. 3 and detach the sensor P. C. board's holder. (For assembly, refer to "ASSEMBLY PRECAUTIONS - 4".)
- 9) Using a hexagon wrench (1.5mm) loosen the two screws (G) shown in Fig. 3, and draw the tonearm base moving shaft to the extreme right.

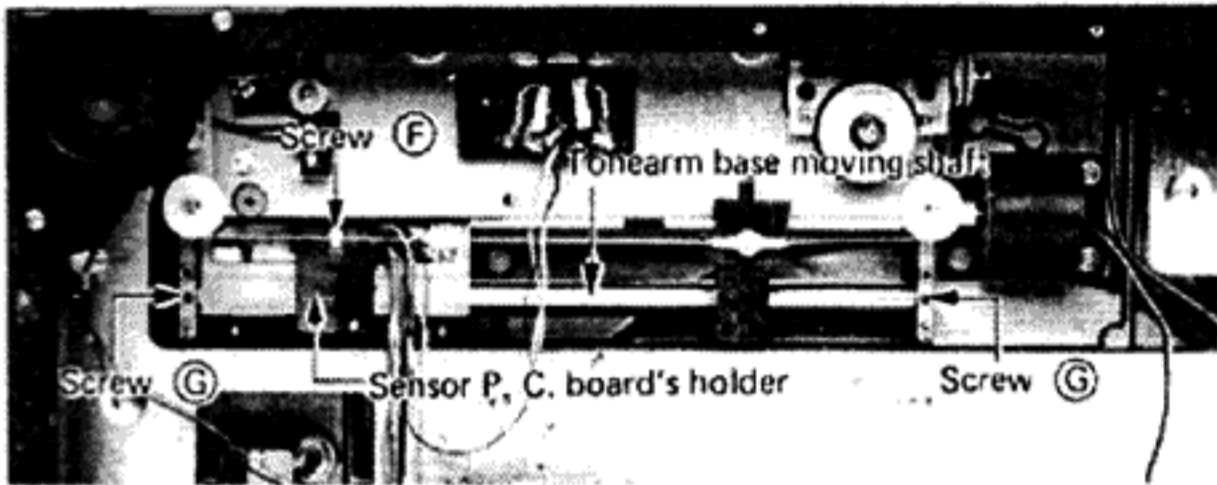

Fig. 3

- 10) With the set placed in its normal position, remove the two screws (H) and detach the L-shape holder. (Refer to Fig. 4)
- 11) Now, the tonearm ass'y can be removed in the following manner. Dismount the tonearm from the arm rest and remove the ass'y by lifting up the tonearm base diagonally toward the back.

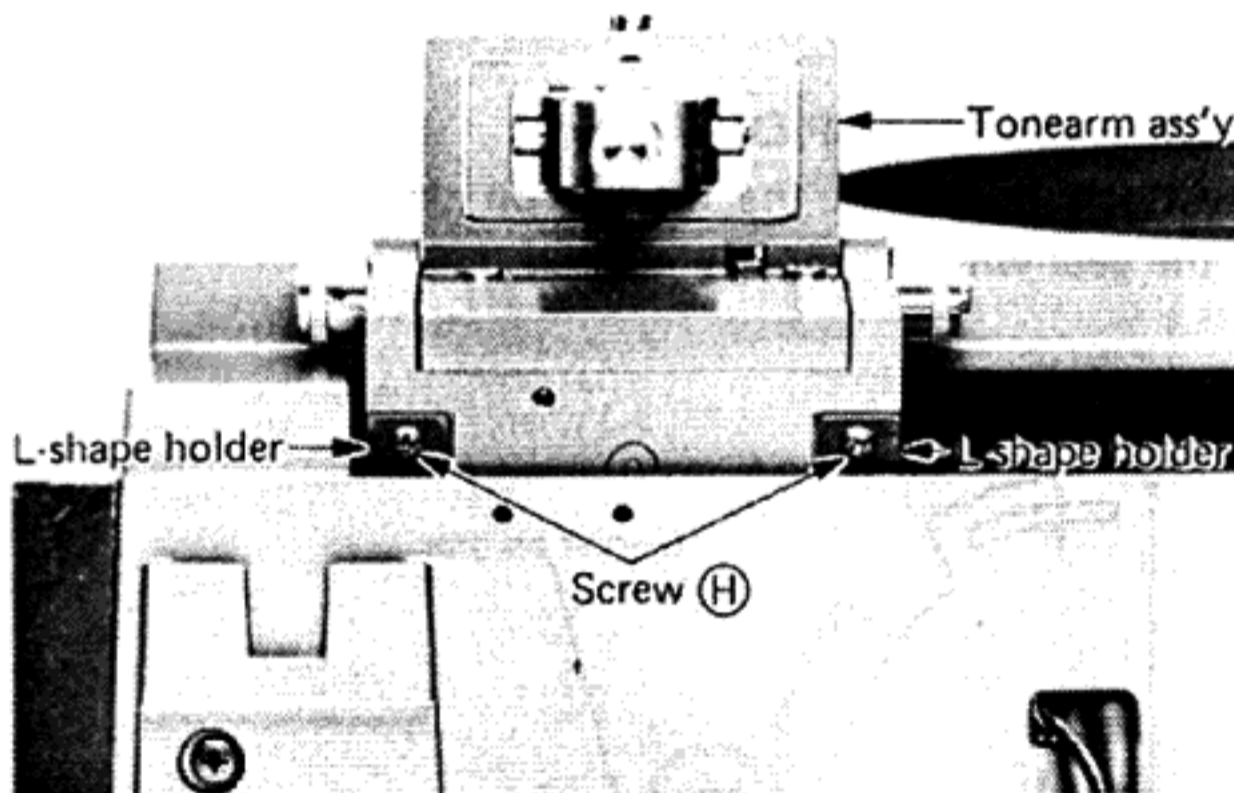

Fig. 4

2. REMOVAL OF VERTICAL DRIVE MOTOR AND TONEARM

- 1) Following the instructions given in Step 1, remove the tonearm ass'y from the body.
- 2) Using a soldering iron, disconnect the five lead wires connected to the muting switch P. C. board from the tonearm. (Refer to Fig. 5)
- 3) After removing the two E-rings shown in Fig. 5, pull out the UP/DOWN cam. (for assembly, refer to "ASSEMBLY PRECAUTIONS - 2".)
- 4) In this condition, the tonearm can be removed together with the base. (For assembly, refer to "ASSEMBLY PRECAUTIONS-1".)

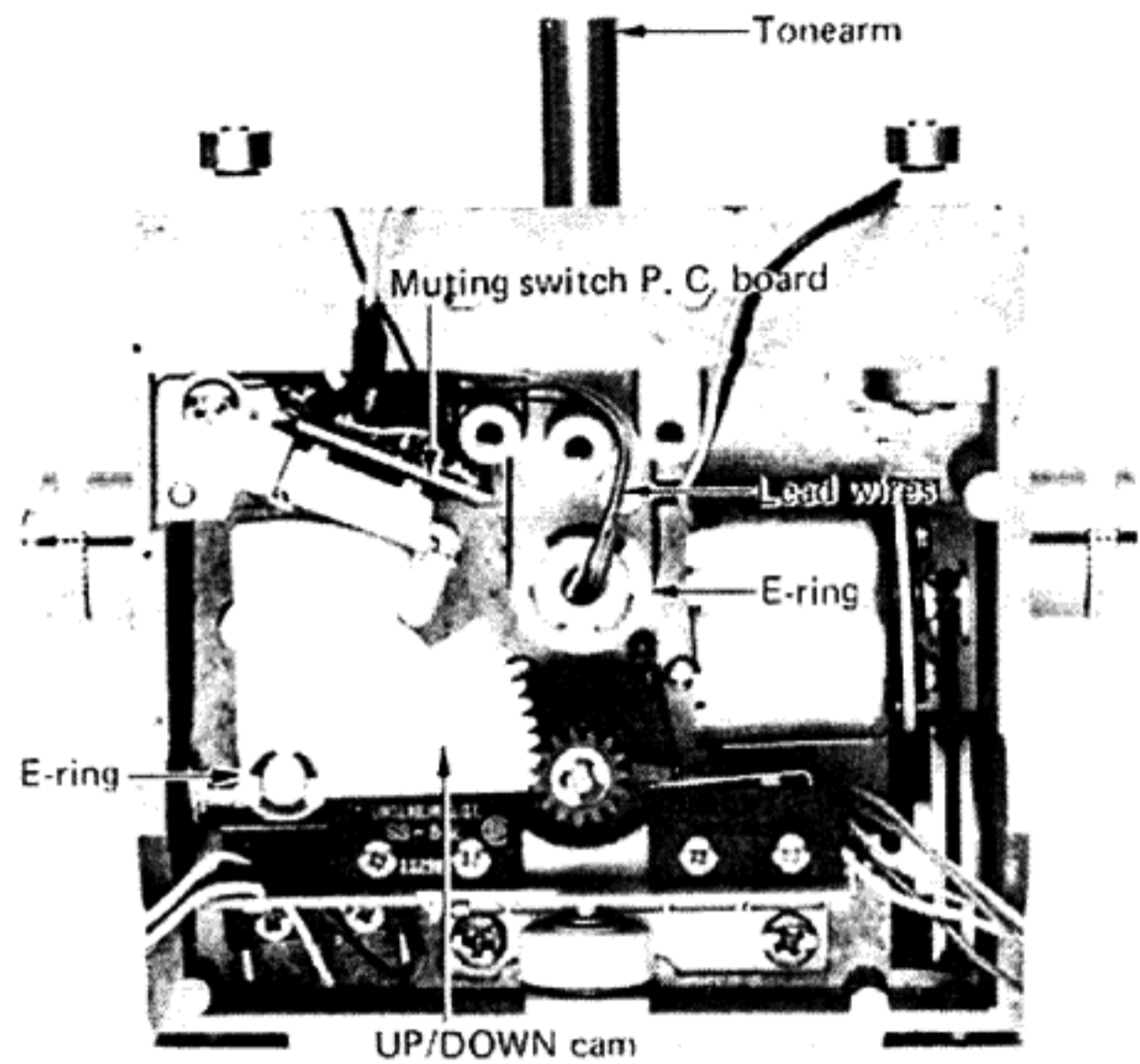

Fig. 5

- 5) The vertical drive motor can now be removed by removing screws (I) shown in Fig. 6.

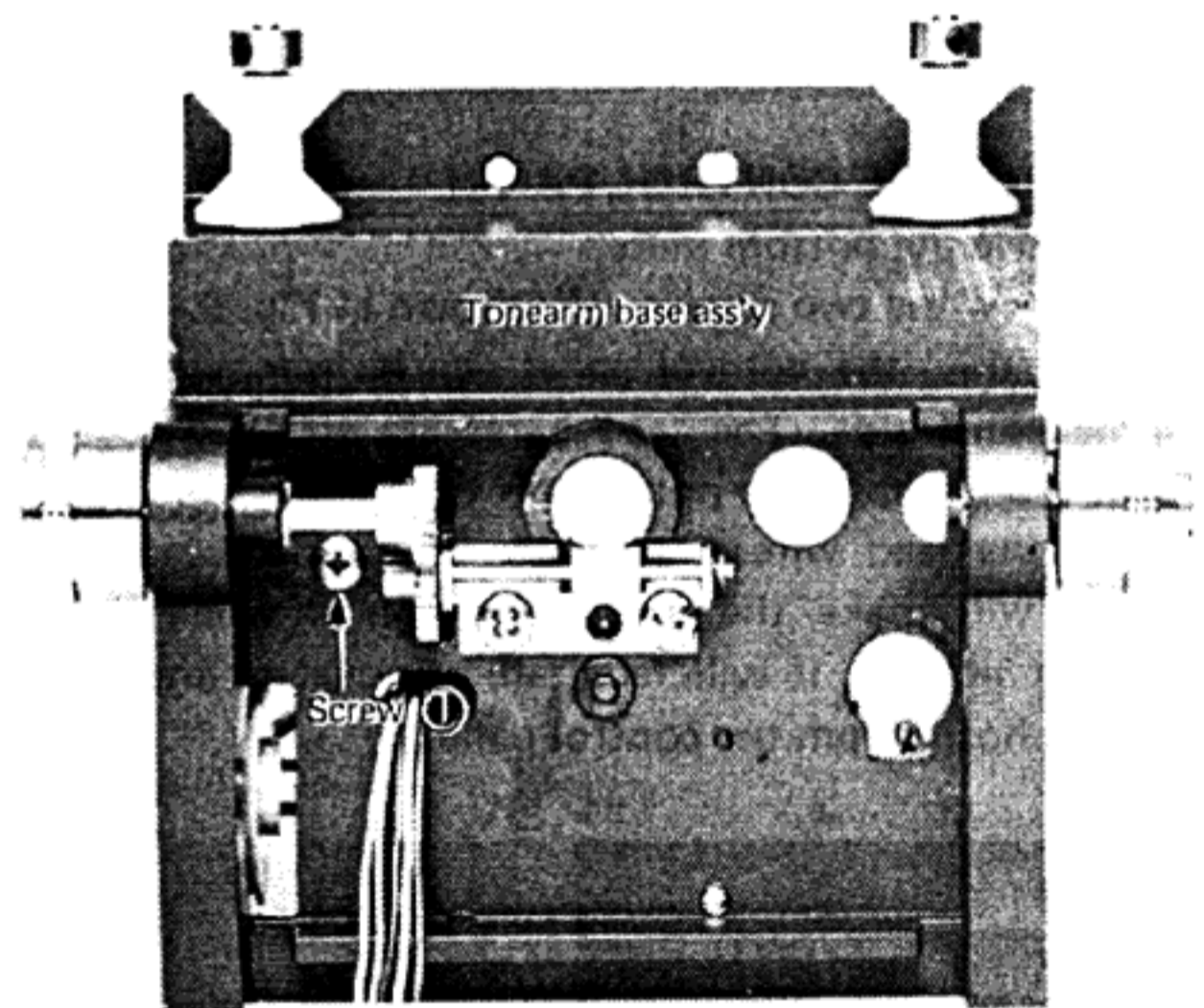

Fig. 6

- 6) Remove the E-ring, two screws (J) and two screws (K) and (L), referring to Fig. 7. Now, the tonearm can be taken off.

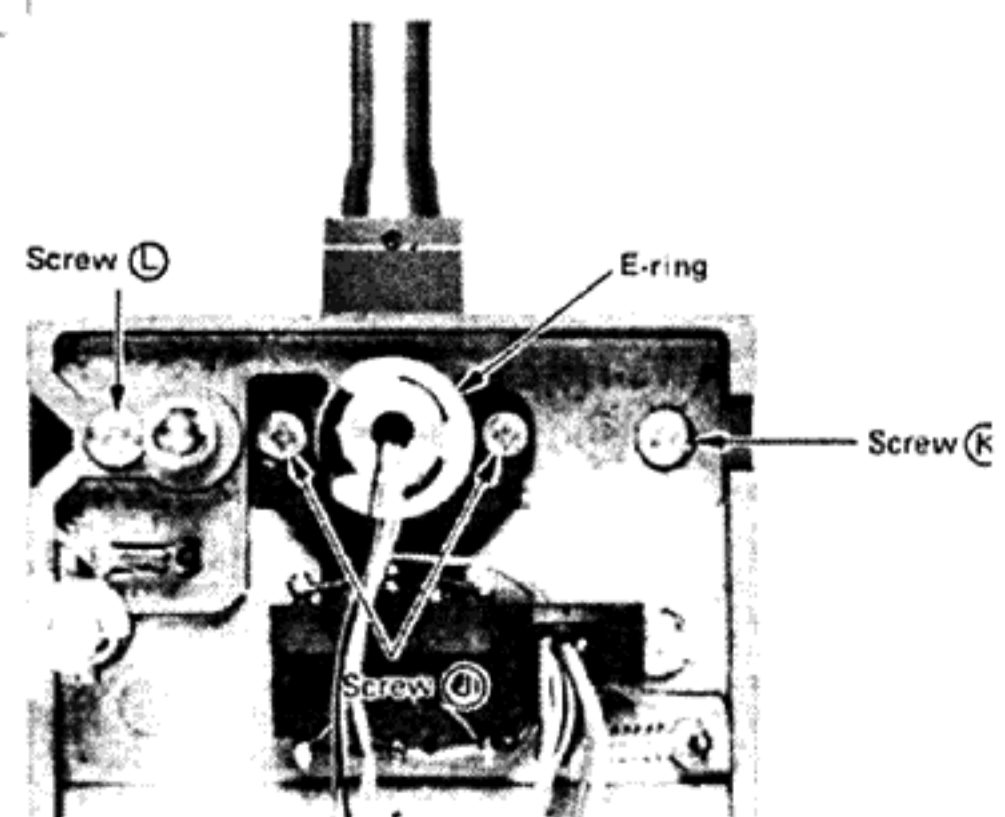

Fig. 7

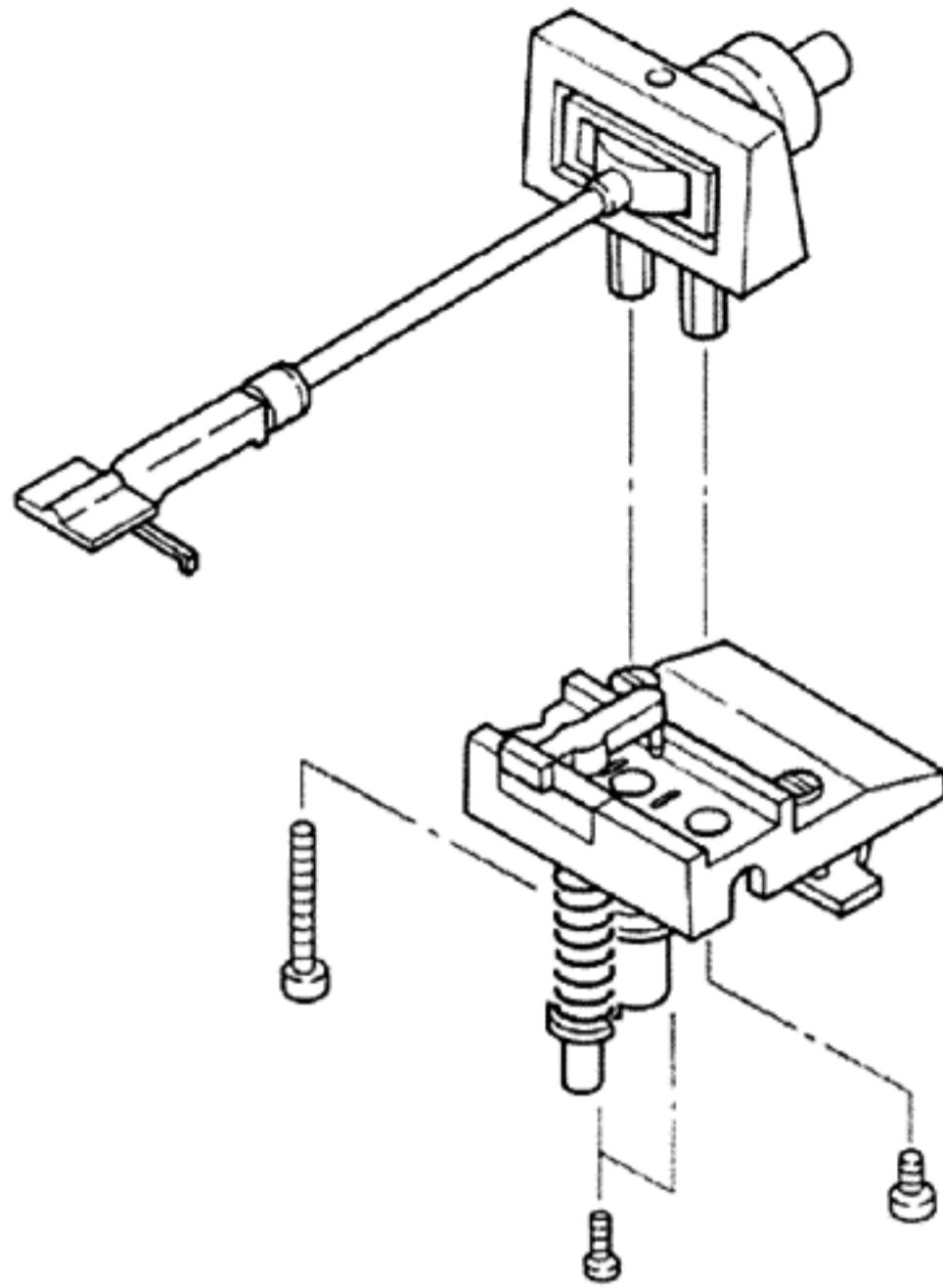

Fig. 8

3. REMOVAL OF CONTROL PANEL

- 1) Remove the bottom plate.
- 2) Unscrew the two screws (M) shown in Fig. 9.
- 3) With this, the control panel can be removed toward the panel side. The lead wires are clamped together with a clasper. Do not cut off this clasper but stretch out the lead wires leading to the control panel. As this will make the lead wires longer when the set is set upright, it will facilitate removal of the switch P. C. board from the control panel.

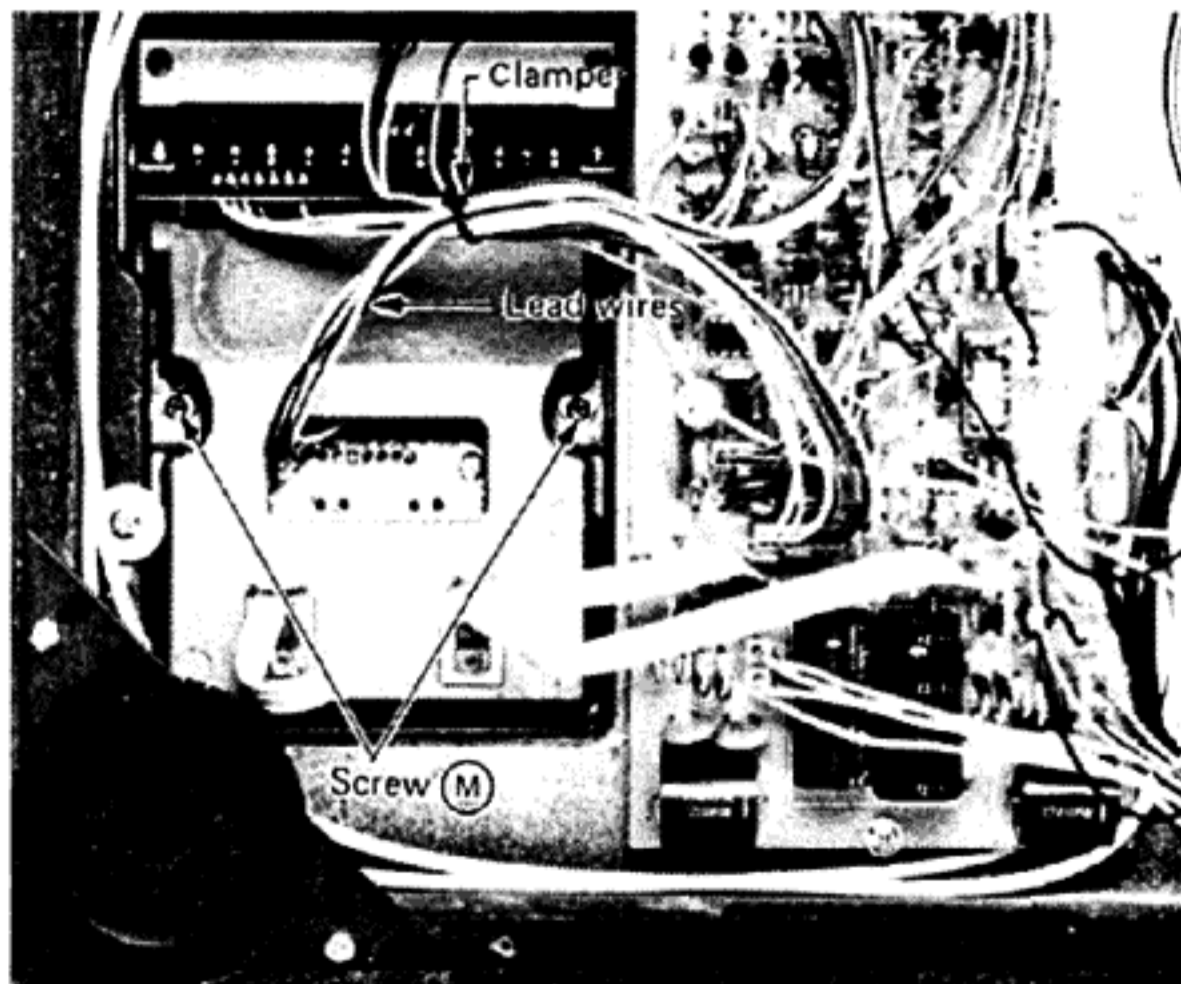

Fig. 9

ASSEMBLY PRECAUTIONS:

Assembly is performed by reversing the sequence of disassembly. In assembly, particular attention should be paid to the following points.

1. When assembling tonearm into tonearm base ass'y

When assembling the tonearm into the tonearm base ass'y, you will touch a projection which is a lock used for the tonearm height adjustment. Keep this lock pushed outward (in arrow direction) when assembling the tonearm.

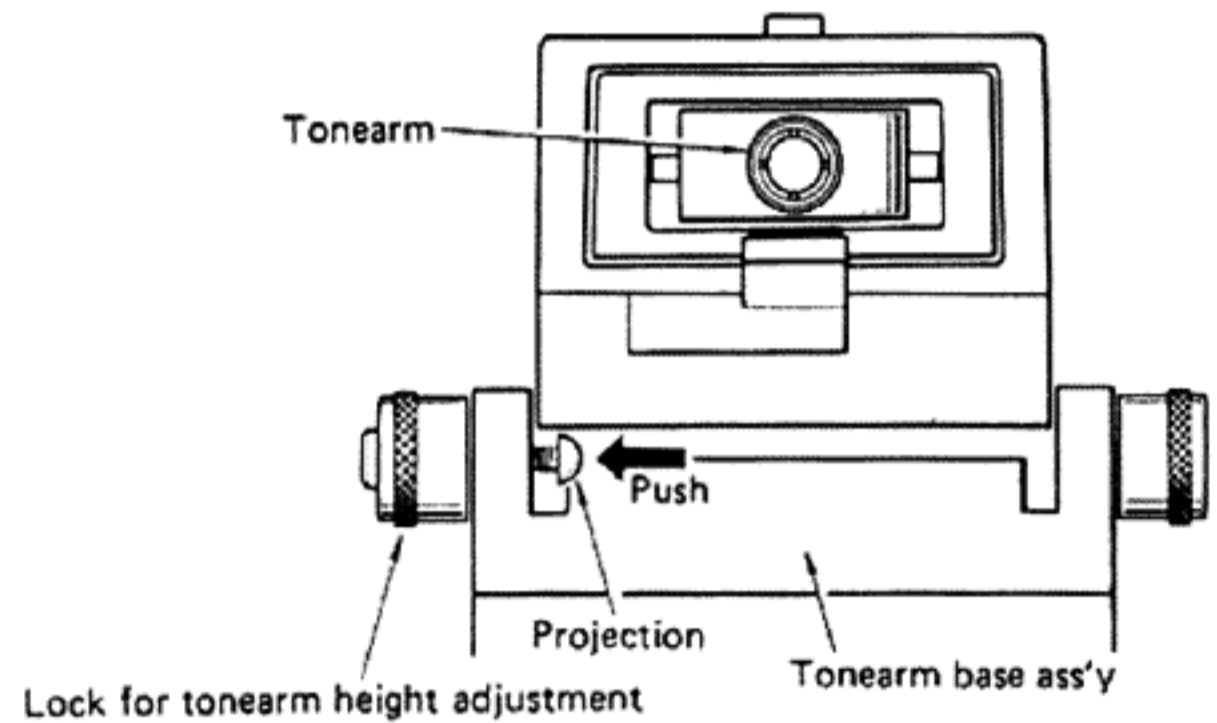

Fig. 10

2. When attaching UP/DOWN cam

Attach it so that the marker on the cam and that on the gear will be properly aligned.

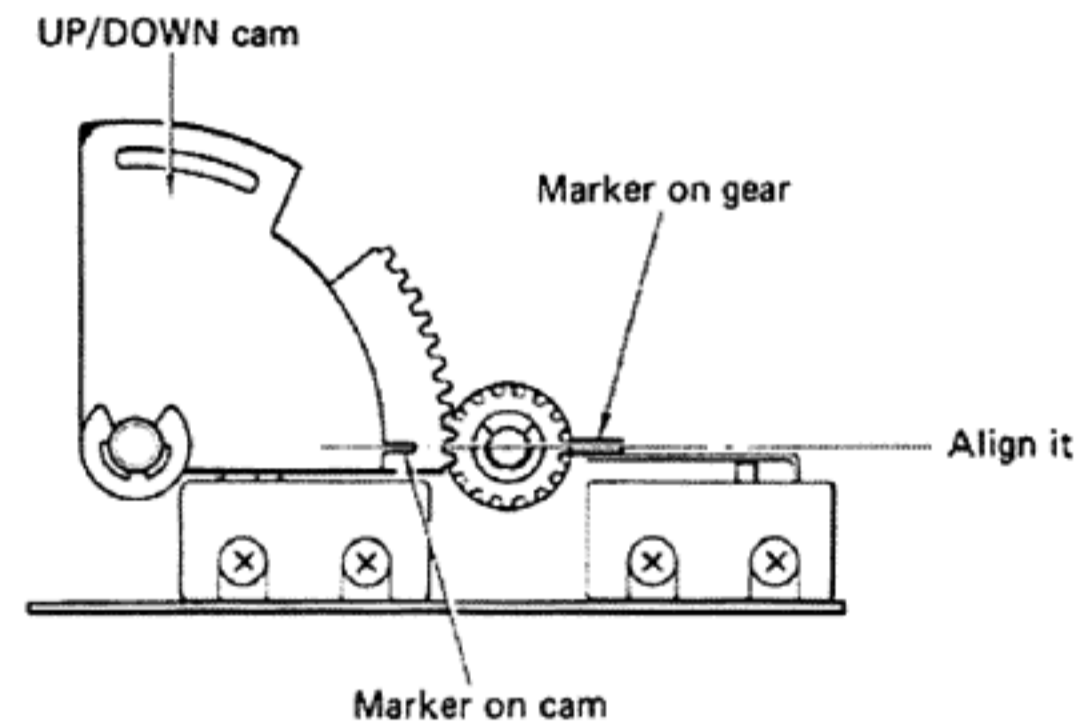

Fig. 11

3. When attaching tonearm ass'y to body

After attaching the tonearm ass'y to the body with the set positioned upright so that the REST position will be at the lower side of the set, insert the tonearm base moving shaft into its regular position. Fix the shaft in place by means of a hexagon wrench (1.5mm). Turn over the set.

4. When attaching the sensor P. C. board's holder

As there is a large number of lead wires coming from the tonearm base, refer to Fig. 12 and pay special attention in handling them.

- 1) Bunch the lead wires together using the sensor P. C. board's holder.
- 2) Attach the sensor P. C. board's holder, referring to Fig. 12, taking care not to let the lead wires get pinched between the tonearm base and sensor P. C. board's holder.

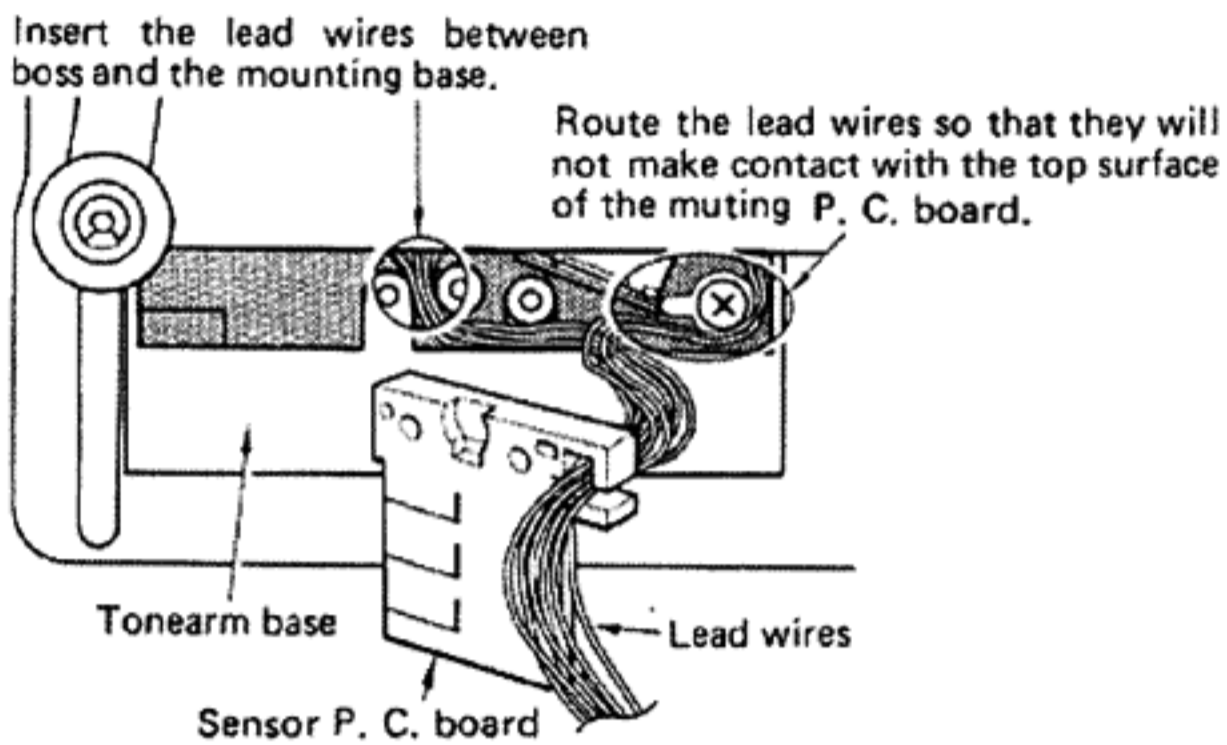
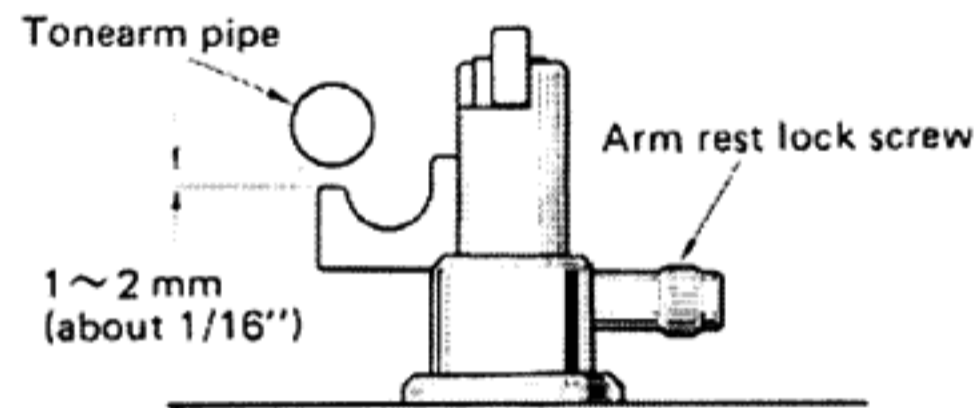

Fig. 12

- 3) The proper distance between the stylus and the record in the UP position is 5mm (3/16"). If this distance is different from the above value, adjust by turning the stylus height adjustment screw.
- 4) The stylus will be raised by turning this screw in a clockwise direction and lowered by turning in a counter-clockwise direction.

ARM REST HEIGHT ADJUSTMENT

- 1) After the stylus height adjustment, loosen the arm rest lock screw and set the arm rest to the lower position.
- 2) When the tonearm is in the UP position above a record, press the lift/cue button and then press the stop button.
- 3) The tonearm will return to the arm rest.
- 4) Press the lift/cue button again and set the tonearm in the UP position.
- 5) The proper space between the arm pipe and the arm rest is 1 to 2 mm (about 1/16"). Adjust the height of the arm rest so as to get the proper space and then turn the arm rest lock screw in a clockwise direction to lock the arm rest.
- 6) Press the lift/cue button again.



ADJUSTMENTS:

STYLUS HEIGHT ADJUSTMENT

- 1) After the tonearm height adjustment, press the lift/cue button when playing a record.
- 2) The tonearm will lift itself and will be in the UP position.

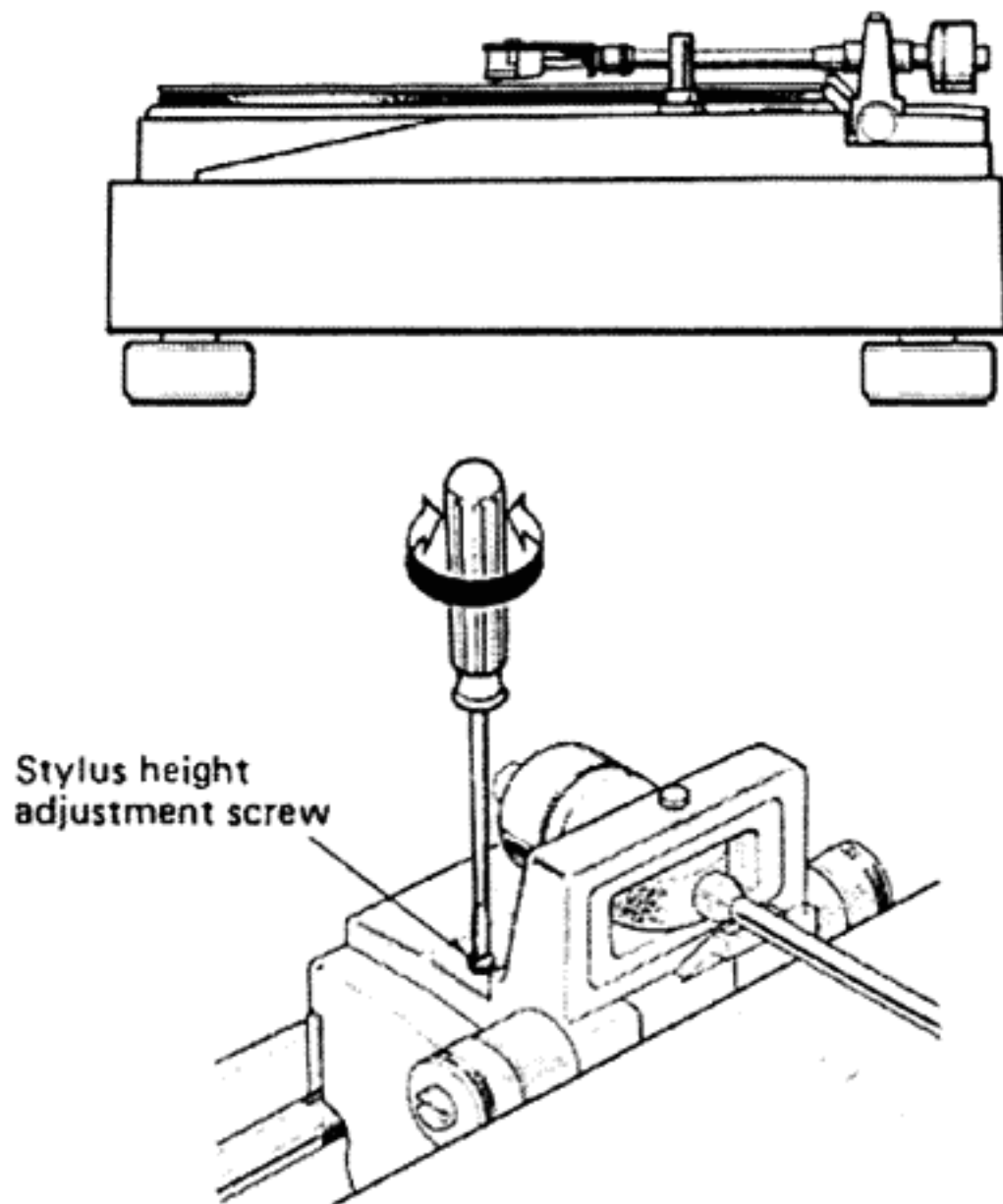

LEAD-IN POSITION ADJUSTMENT

When the stylus does not set down on the record at the correct position in automatic play, adjust the lead-in position of the tonearm by using a screwdriver to turn the lead-in adjustment screw.

- 1) Place a 30cm (12 in.) record on the platter.
- 2) Press the start button (◀) to play the record and check the lead-in position.
- 3) Turn the lead-in position adjustment screw either clockwise to move the lead-in position toward the outside or counterclockwise to move the lead-in position toward the inside and then press the stop button (▶).

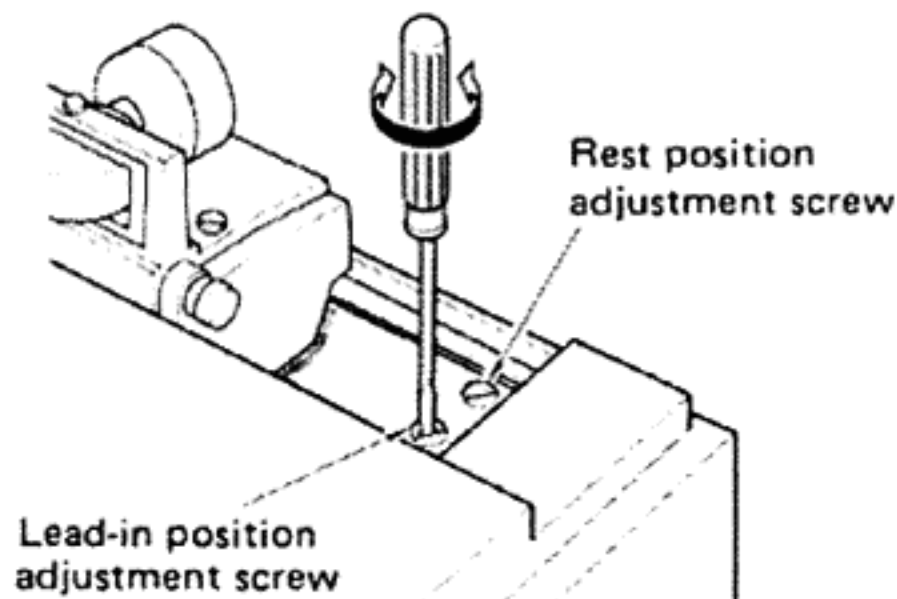

- 4) The tonearm will return to the arm rest.
- 5) Press the start button (◀) again to play the record and check the lead-in position. If the lead-in position is not correct, repeat procedures 3) to 5) until the correct lead-in position is obtained.

TRACKING ANGLE ADJUSTMENT

The tracking angle has been adjusted at the factory. But when the " ← " or " → " mark of the tracking error indicators are illuminated while playing a record, adjust the tracking angle as follows.

- 1) Place a 30 cm (12 in.) record on the platter.
- 2) Place the gauge for the tracking angle adjustment on the record as shown. The gauge is packed with the instruction book.

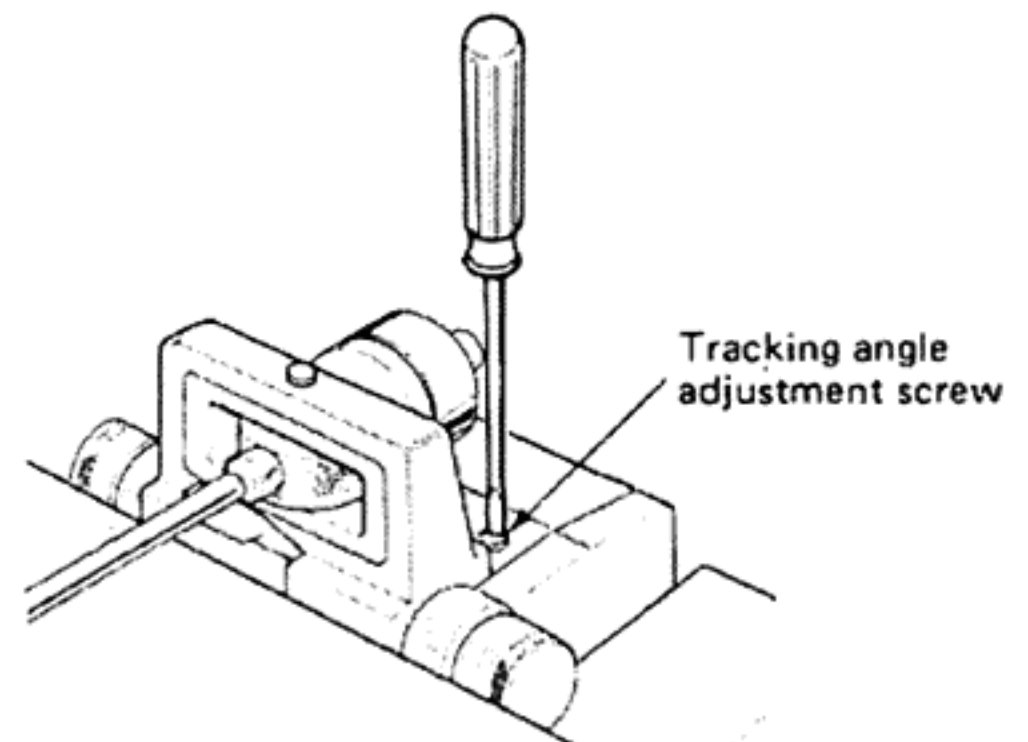
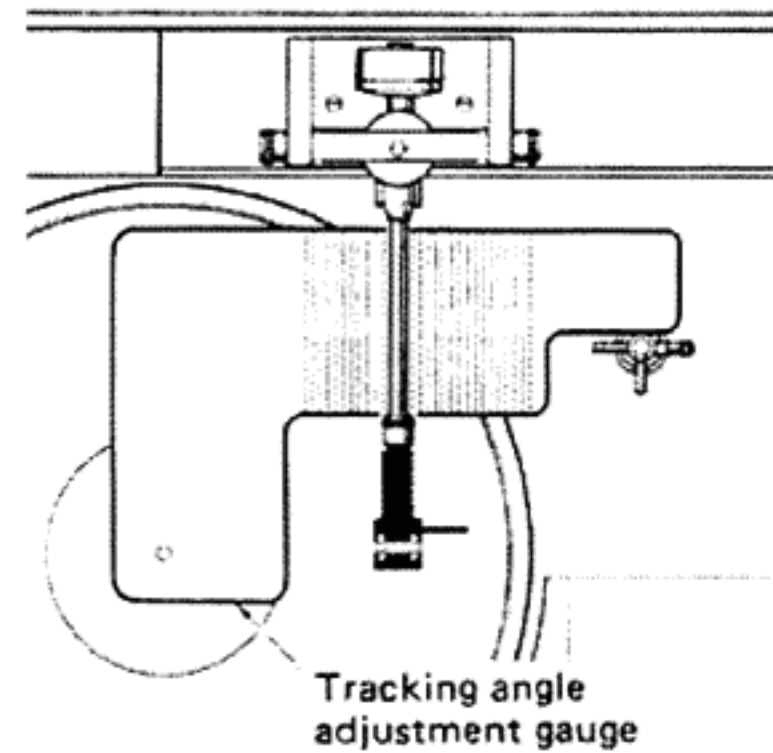

- 3) Press the start button (◀) and continue to press. When the stylus reaches the spot which is 10 to 20 mm (3/8" to 3/4") from the outer groove of the record, release the start button (◀) and press the lift/cue button (▼) to play the record.
- 4) Press the T/T ON-OFF switch to stop the rotation of the platter.
- 5) After ensuring that the edge of the gauge is contacting the arm rest, observe the parallel lines on the gauge and arm pipe from above.
- 6) If the lines on the gauge and arm pipe are not parallel, adjust the tracking angle by turning the tracking angle adjustment screw carefully with a screwdriver.
- 7) Press the stop button (▶) after adjustment.
- 8) Remove the gauge for the tracking angle adjustment.

REST POSITION ADJUSTMENT

If the tonearm does not descend to the arm rest in returning, adjustment is needed. Adjustment procedure are as follows:

- 1) Place a record on the platter.
- 2) Press the start button (◀) to play the record.
- 3) Turn the rest position adjustment screw clockwise to adjust the rest position to the right or counterclockwise to adjust the rest position to the left with a screwdriver.

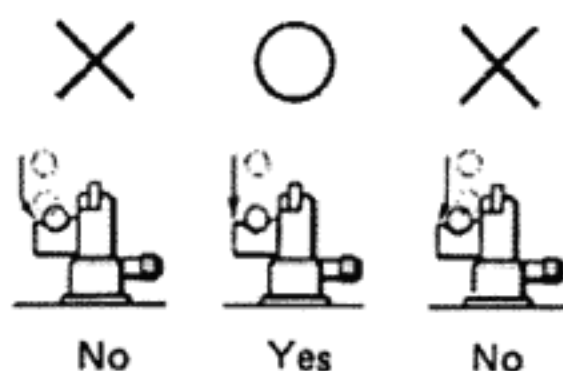
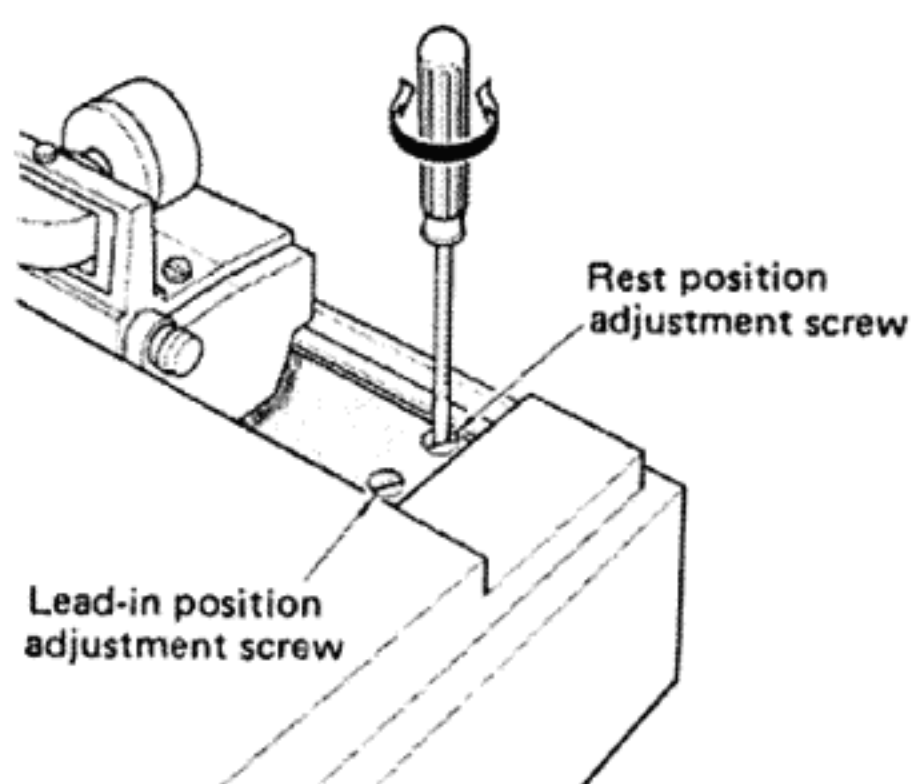

- 4) Press the stop button (▶) to return the tonearm to the arm rest.
- 5) Check the lowering position of the tonearm to ensure whether it is just on the hollow of the arm rest or not. If not, repeat the procedures 1) to 5) until the correct rest position can be obtained.

Note: When this adjustment has been performed re-adjustment of the lead-in position is necessary.

ON-OFF ADJUSTMENT OF TRACKING SERVO

This adjustment should be carried out when the tracking servo fails to turn on, or when it turns on before it should, when the stylus drops onto the disc surface, or when it fails to turn off at the tonearm's "UP" position. The following describes the adjusting procedures.

- 1) When the tracking servo fails to turn on (ON-timing is too slow) when the stylus drops onto the disc surface, turn the tracking servo ON-OFF adjustment screw counterclockwise by 90 degrees (for a quarter turn).
- 2) When it fails to turn off at the tonearm's "UP" position, or when the ON-timing is too fast at the "DOWN" position, turn the ON-OFF adjustment screw clockwise by 90 degrees (for a quarter turn).
- 3) With a disc placed on the platter, depress the START (◀) button and effect LEAD-IN of tonearm.
- 4) Check the ON-OFF timing of the tracking servo.
- 5) Lift the tonearm by depressing the LIFT/CUE (▲▼) button. If the ON-OFF timing is too fast, turn the ON-OFF adjustment screw counterclockwise. If it is too slow, turn the screw clockwise. Then, depress the LIFT/CUE (▲▼) button and lower the tonearm.
- 6) Repeat steps 4) and 5) so that the tracking servo will turn on at an exact timing with the drop of the stylus onto the disc surface.

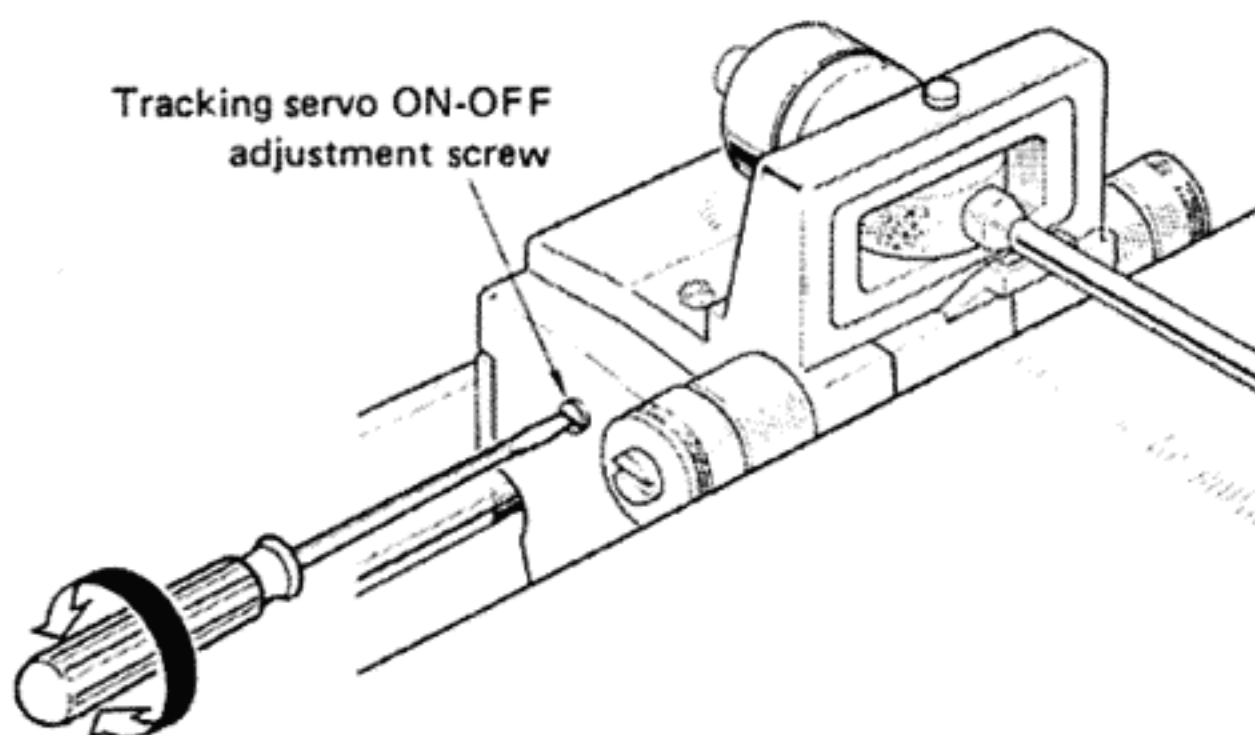

CONFIRMATION OF SYNCHRONIZING PHASE PULSE WIDTH (Motor Servo P. C. Board)

By observing the output waveform of the TP2 terminal of the Motor Servo P. C. Board by way of the buffer amplifier as shown in the following drawing, confirm that it is within the range of $T=9 \sim 17\text{ms}$.

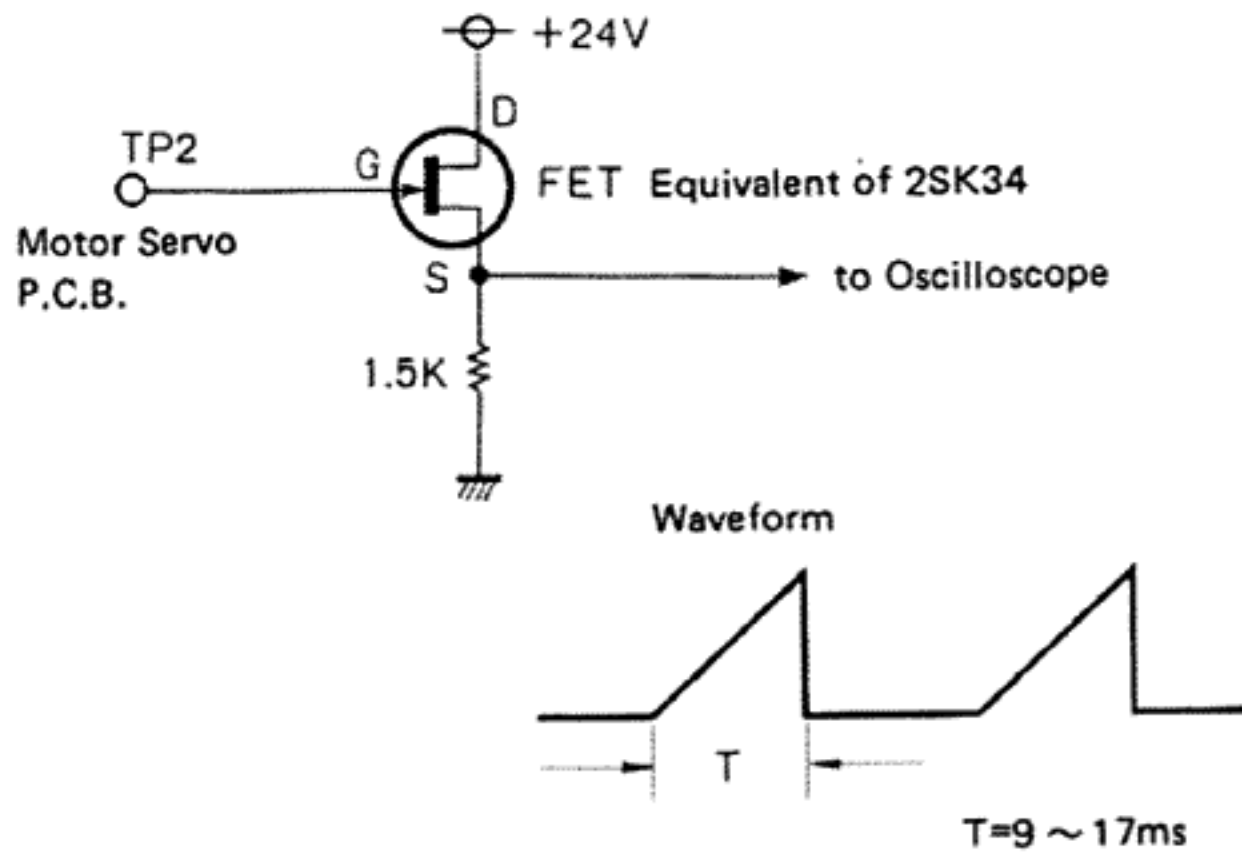

LOGIC P. C. BOARD

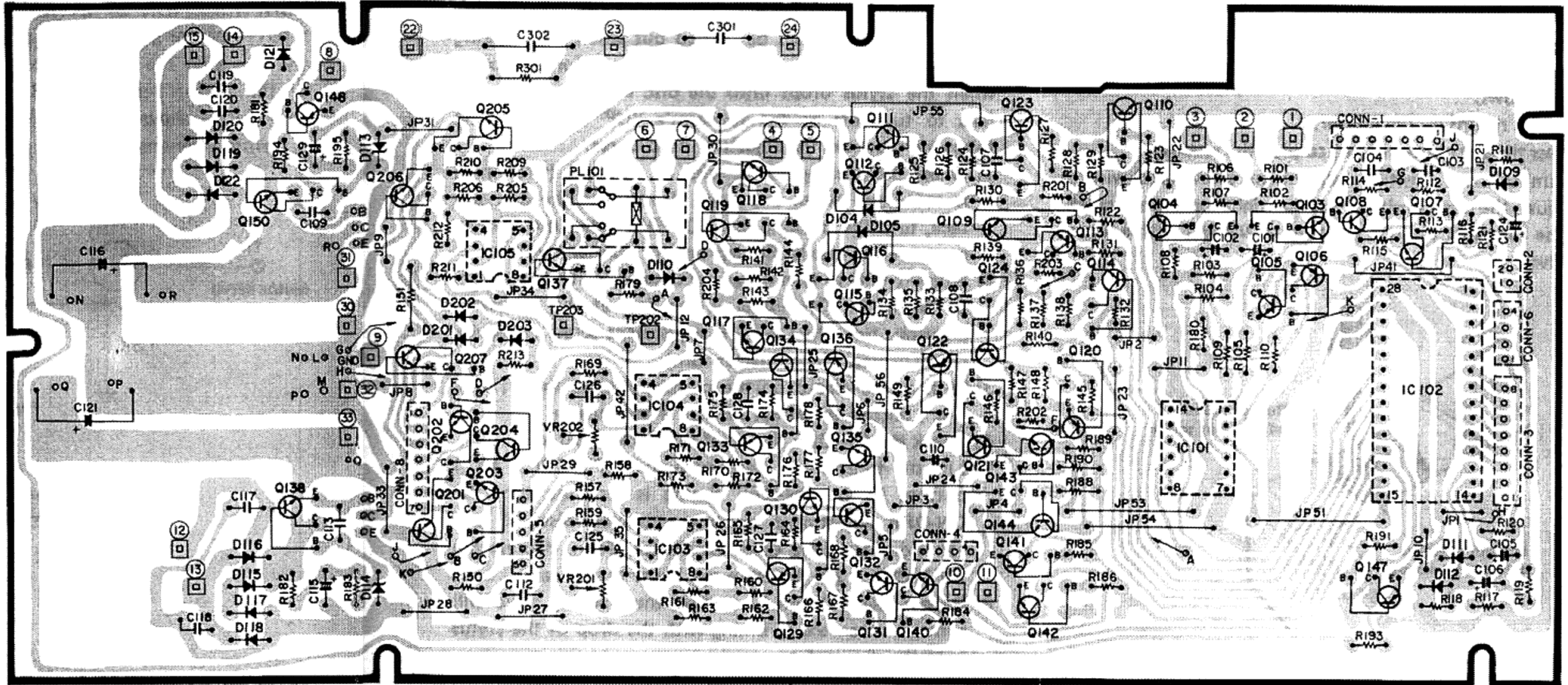

MOTOR SERVO P. C. BOARD

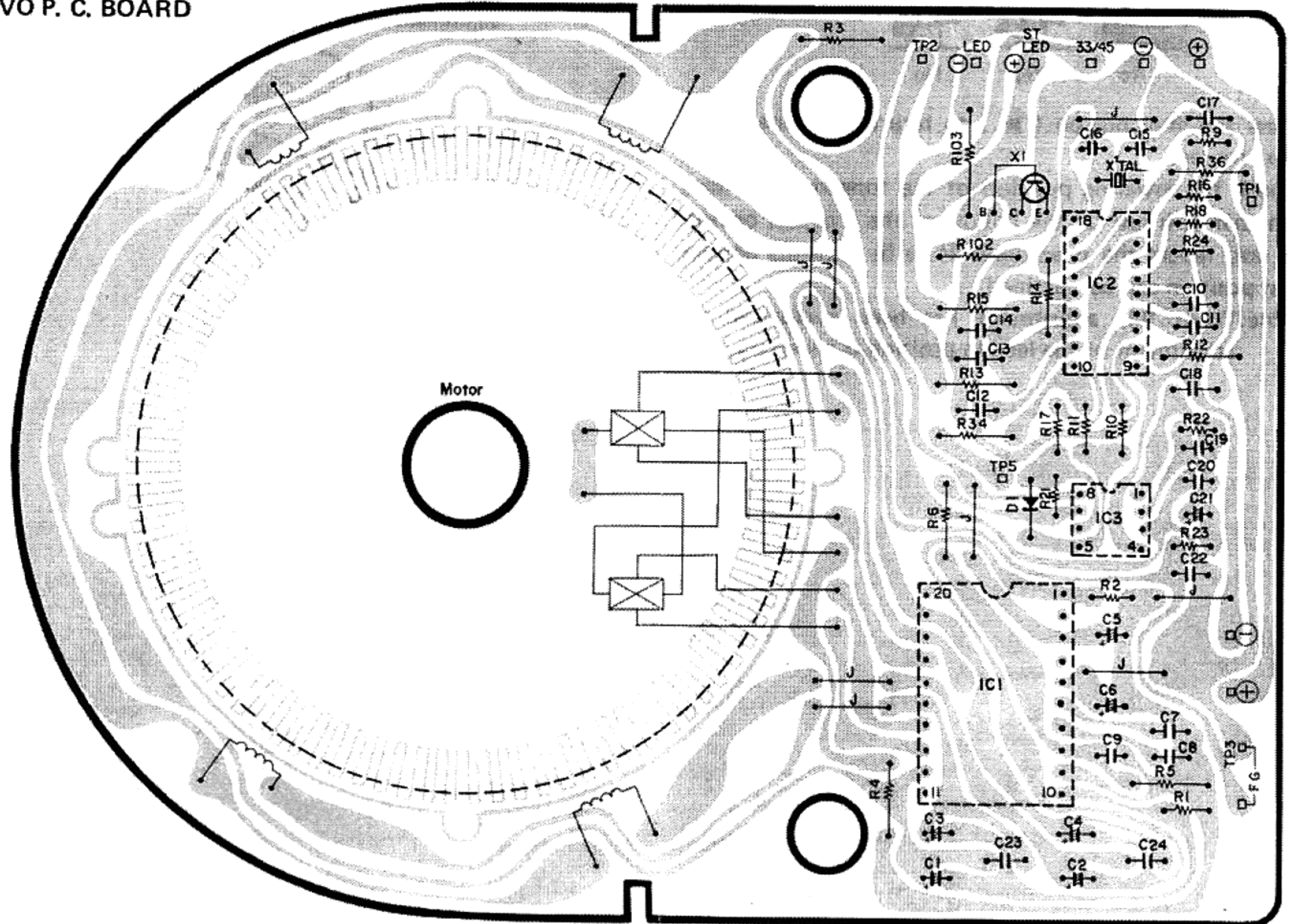

SCHEMATIC DIAGRAM

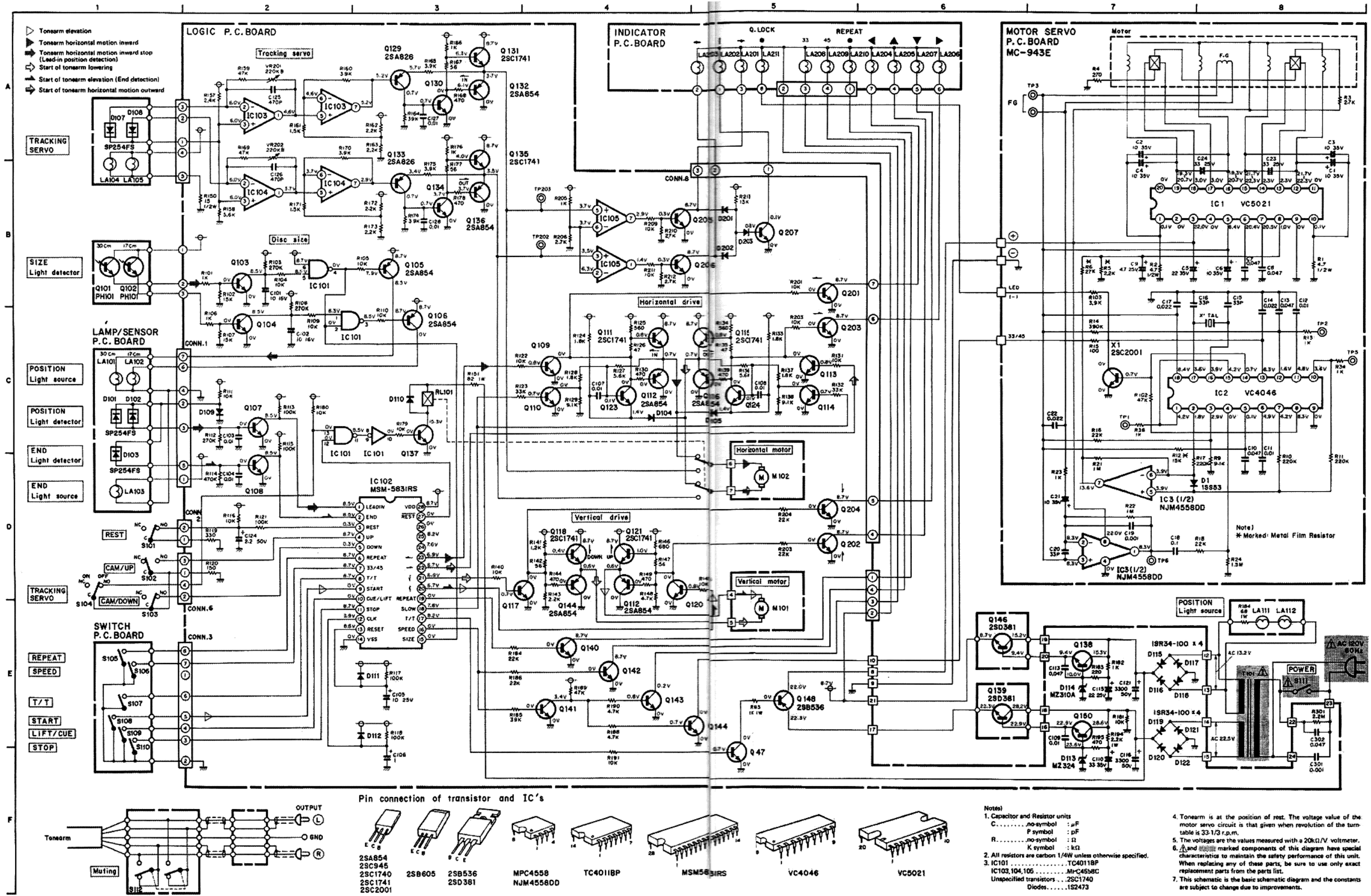

WIRING DIAGRAM

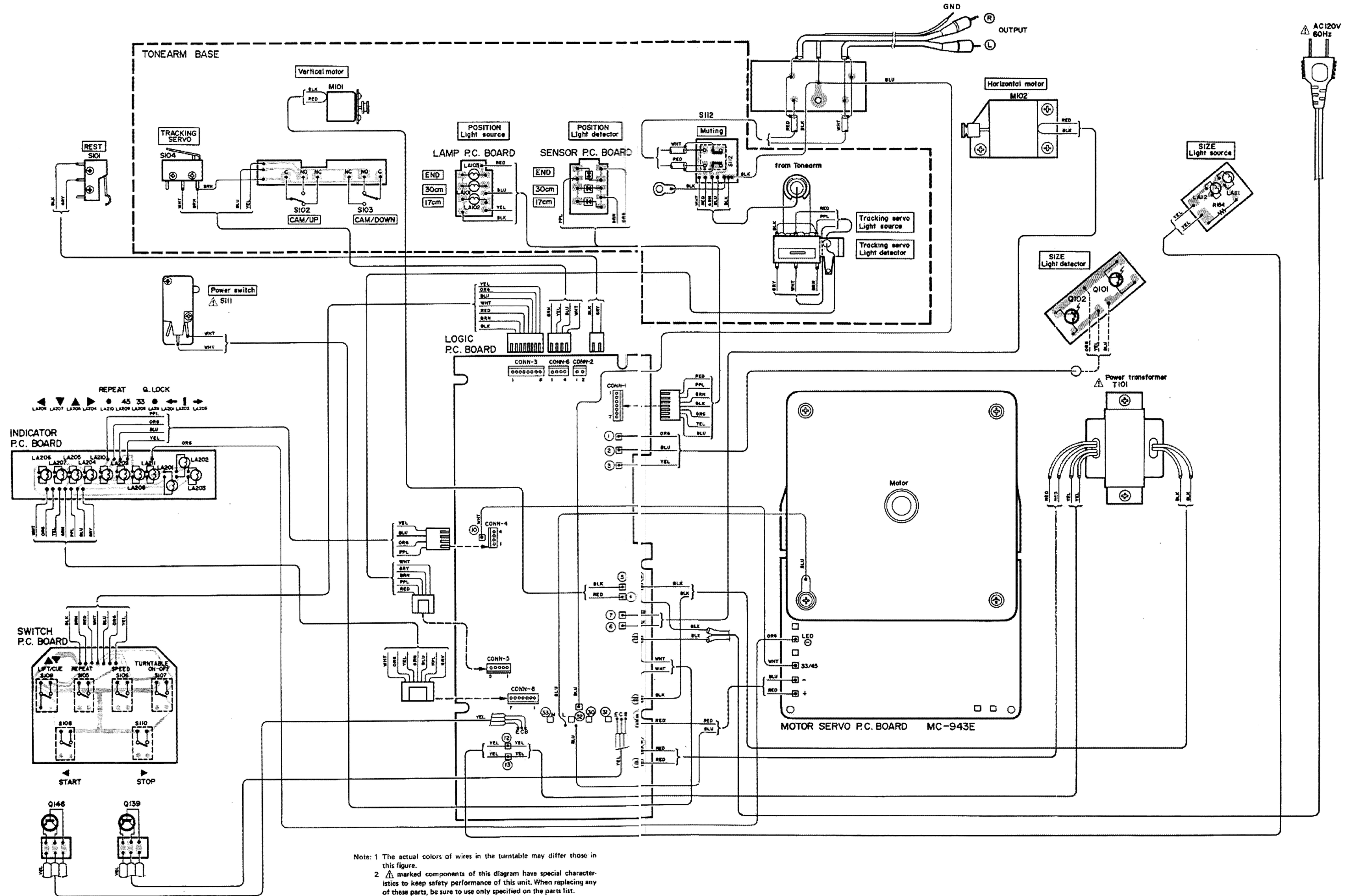

PARTS LIST

NOTE: ⚠ and █████ marked components on parts list have special characteristics to keep safety performance of this unit. When replacing any of these parts, be sure to use only specified parts.

Symbol No.	Parts No.	Description
Transistors		
Q101	M07137303	PH-101
Q102	M07137303	PH-101
Q103	M05104313	2SC1740
Q104	M05104313	2SC1740
Q105	M07137308	2SA854
Q106	M07137308	2SA854
Q107	M05104313	2SC1740
Q108	M05104313	2SC1740
Q109	M05104313	2SC1740
Q110	M05104313	2SC1740
Q111	M07137307	2SC1741
Q112	M07137308	2SA854
Q113	M05104313	2SC1740
Q114	M05104313	2SC1740
Q115	M07137307	2SC1741
Q116	M07137308	2SA854
Q117	M05104313	2SC1740
Q118	M07137307	2SC1741
Q119	M07137308	2SA854
Q120	M05104313	2SC1740
Q121	M07137307	2SC1741
Q122	M07137308	2SA854
Q123	M05104313	2SC1740
Q124	M05104313	2SC1740
Q129	M07137306	2SA826
Q130	M05104313	2SC1740
Q131	M07137307	2SC1741
Q132	M07137308	2SA854
Q133	M07137306	2SA826
Q134	M05104313	2SC1740
Q135	M07137307	2SC1741
Q136	M07137308	2SA854
Q137	M05104313	2SC1740
Q138	M05104313	2SC1740
Q139	M07462303	2SD381
Q140	M05104313	2SC1740
Q141	M05104313	2SC1740
Q142	M05104313	2SC1740
Q143	M05104313	2SC1740
Q144	M05104313	2SC1740
Q146	M07462303	2SD381
Q147	M05104313	2SC1740
Q148	M07462304	2SB536
Q150	M05104313	2SC1740
Q201	M05104313	2SC1740
Q202	M05104313	2SC1740
Q203	M05104313	2SC1740
Q204	M05104313	2SC1740
Q205	M05104313	2SC1740

Symbol No.	Parts No.	Description
Q206	M05104313	2SC1740
Q207	M05104313	2SC1740
X 1	M07299301	2SC2001
Diodes		
D 1	M07297323	1SS53
D101	M07297320	SP254FS
D102	M07297320	SP254FS
D103	M07297320	SP254FS
D104	M07060320	1S2473VE
D105	M07060320	1S2473VE
D107	M07297320	SP254FS
D108	M07297320	SP254FS
D109	M07060320	1S2473VE
D110	M07060320	1S2473VE
D111	M07060320	1S2473VE
D112	M07060320	1S2473VE
D113	M07288320	MZ324
D114	M07171322	MZ310
D115	M07391320	1SR34-100
D116	M07391320	1SR34-100
D117	M07391320	1SR34-100
D118	M07391320	1SR34-100
D119	M07391320	1SR34-100
D120	M07391320	1SR34-100
D121	M07391320	1SR34-100
D122	M07391320	1SR34-100
D201	M07060320	1S2473VE
D202	M07060320	1S2473VE
D203	M07060320	1S2473VE
ICs		
IC 1	M07437344	VC5021
IC 2	M07437346	VC4046
IC 3	M07314313	NJM4558DD
IC101	M07297343	TC4011BP
IC102	M07437343	MSM-5831RS
IC103	M07370343	MPC4558C
IC104	M07370343	MPC4558C
IC105	M07370343	MPC4558C
Miscellaneous		
S101	M07297450	Micro switch (Rest)
S102	M05129431	Micro switch (Cam/up)
S103	M05129431	Micro switch (Cam/down)

Symbol No.	Parts No.	Description
S104	M05129431	Micro switch (Tracking servo)
S105	M07445660	Push switch (Repeat)
S106	M07445660	Push switch (speed)
S107	M07445660	Push switch (T/T ON-OFF)
S108	M07445660	Push switch (Start)
S109	M07445660	Push switch (Lift/Cue)
S110	M07445660	Push switch (Stop)
S112	M07445661	Slide switch (Muting)
VR201	M05104360	Variable resistor (220kΩ-B)
VR202	M05104360	Variable resistor (220kΩ-B)
LA101	M07374251	Lamp 12V 0.05A
LA102	M07374251	Lamp 12V 0.05A
LA103	M07374251	Lamp 12V 0.05A
LA104	M07374251	Lamp 12V 0.05A
LA105	M07374251	Lamp 12V 0.05A
LA111	M07297250	Lamp 5V 0.06A
LA112	M07297250	Lamp 5V 0.06A
LA201	M07374251	Lamp 12V 0.05A
LA202	M07374251	Lamp 12V 0.05A
LA203	M07374251	Lamp 12V 0.05A
LA204	M07374251	Lamp 12V 0.05A
LA205	M07374251	Lamp 12V 0.05A
LA206	M07374251	Lamp 12V 0.05A
LA207	M07374251	Lamp 12V 0.05A
LA208	M07374251	Lamp 12V 0.05A
LA209	M07374251	Lamp 12V 0.05A
LA210	M07374251	Lamp 12V 0.05A
LA211	M07374251	Lamp 12V 0.05A
RL101	M07215465	Relay
201	M07469931	Parts bag (For dust cover)
202	M07469910	Cushion-mold
203	M07486930	Packing bag
204	M07490900	Packing box
205	M07469911	Cushion-Assy
	M07137603	Adapter (Accessory)
	M07137011	Driver (Accessory)
	M07490012	Stylus gauge (Accessory)
	M07469013	Tracking angle gauge (Accessory)
206	U871B005H36	Instruction book (I/B)

EXPLODED VIEW
CABINET

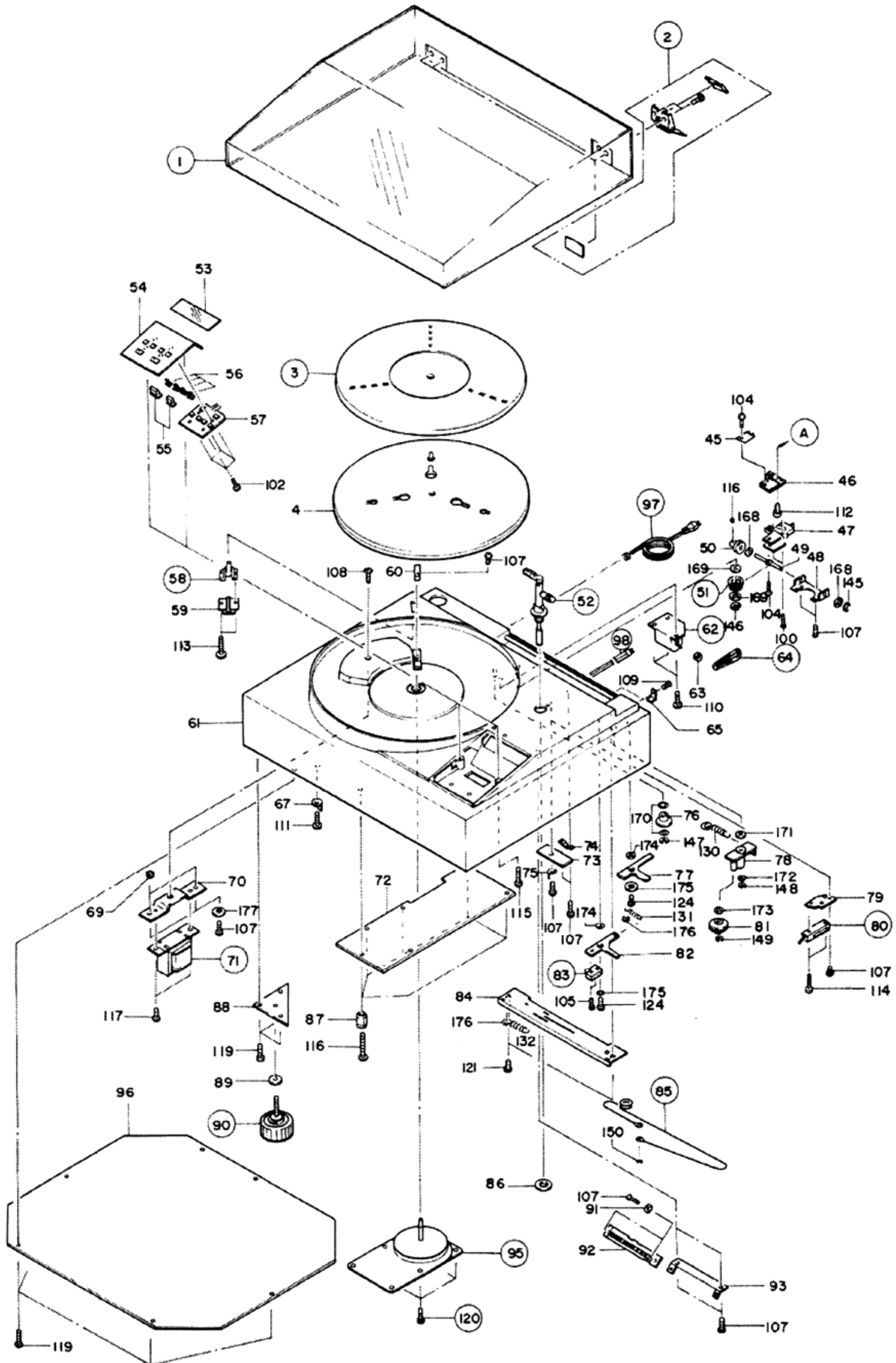

EXPLODED VIEW
TONEARM

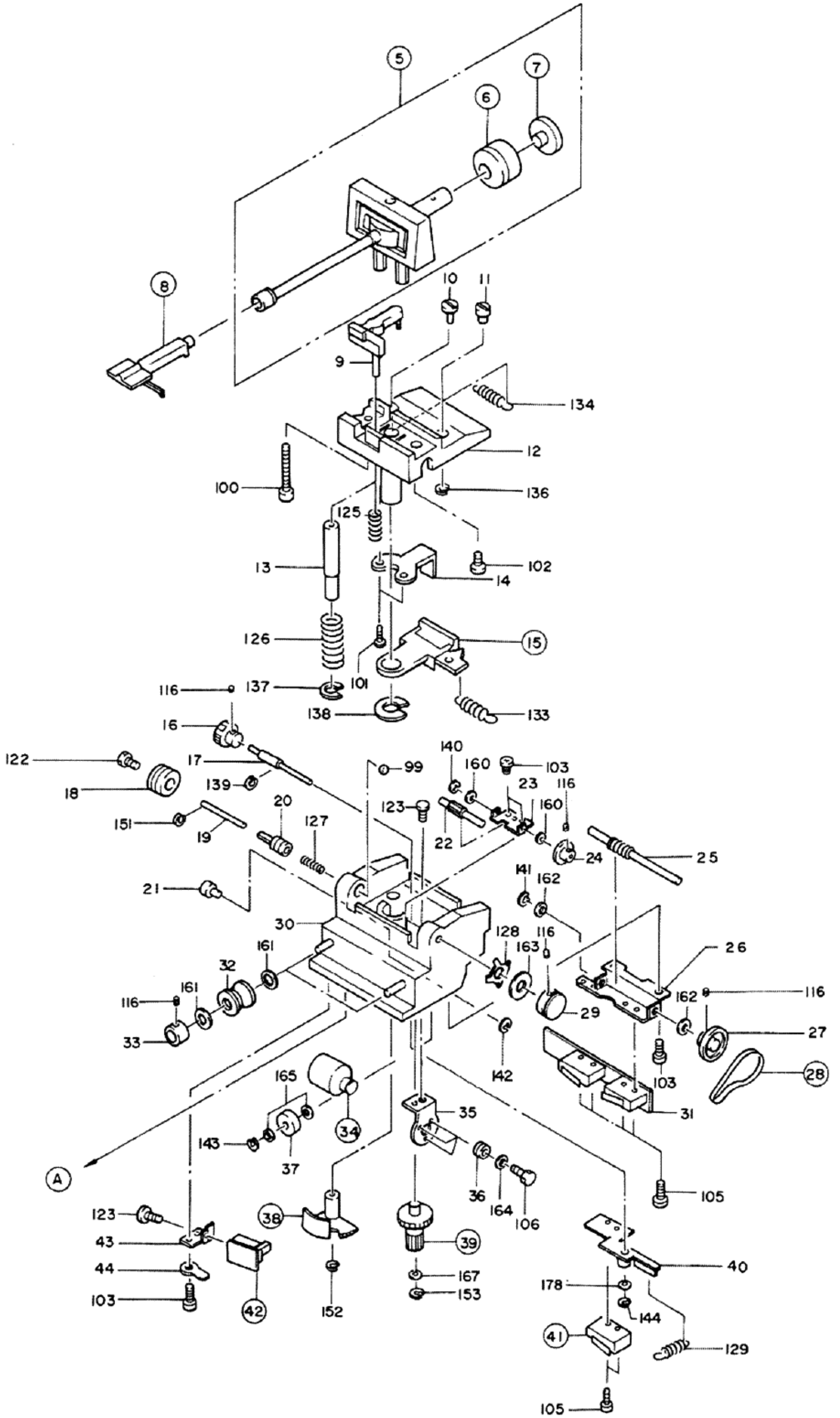

MECHANICAL PARTS DESCRIPTION

NOTE: Encircled parts are prepared as a servicing parts.

Symbol No.	Parts No.	Description
①	M07486690	Dust cover
②	M07469772	Hinge-Assy
③	M07490757	Platter mat
4		Platter
⑤	M07486610	Tonearm (With main weight and sub weight)
⑥	M07469635	Main weight
⑦	M07469936	Sub weight
⑧	M07490734	Head shell-Assy
9		Arm lifter
10		Screw
11		Pin
12		Arm base (Upper)
13		Post
14		Holder-L
⑮	M07490320	Diode-Assy (For tonearm)
16		Gear
17		Shaft
18		Knob
19		Shaft
20		Screw
21		Pin
22		Gear
23		Holder
24		Pulley
25		Shaft-Assy
26		Holder
27		Pulley
⑳	M07496629	Belt (For Tonearm)
29		Knob
30		Arm base (Lower)
31		P.C.B.-Assy
32		Pulley
33		Boss
⑳	M07496638	Motor (M101: Vertical drive)
35		Holder
36		Rubber bush
37		Pulley
⑳	M07469647	Cam (Vertical drive)
㉑	M07469646	Gear (Vertical drive)
40		Holder
⑳	M05129431	Micro switch (S104)
42		P.C.B.-Assy (Muting SW.)
43		Holder
44		Lug terminal
45		P.C.B.-Assy (Lamp P.C.B.)
46		Holder
47		Holder
48		Holder
49		Shaft-Assy
50		Pulley

Symbol No.	Parts No.	Description
⑤①	M07469645	Gear (Horizontal drive)
⑤②	M07469618	Arm rest-Assy
53		Cover
54	U712C187G02	Panel-Assy
55		Knob
56		Knob
57		P.C.B.-Assy (Switch P.C.B.)
⑤⑧	M07469605	Reflector
59		Holder
60		P.C.B.-Assy
61		Cabinet
⑥②	M07469639	Motor (Horizontal drive)
63		Pulley
⑥④	M07469628	Belt
65		Holder-L
66		—
67		Lug terminal
68		—
69		Rubber bush
70		Holder
⑦①	M07490549	Trans-power
72		P.C.B.-Assy (Logic P.C.B.)
73		P.C.B.-Assy (Output P.C.B.)
74		Holder
75		Lug terminal
76		Pulley
77		Lever
78		Lever-Assy
79		Holder
⑧①	M07179660	Micro switch (S111: Power)
81		Pulley
82		Lever
⑧③	M07297450	Micro switch (S101)
84		Slit plate
⑧⑤	M07490686	Wire
86		Nut
87		Boss
88		Holder-F
89		Rubber washer
⑨①	M08486694	Leg
91		Washer
92		P.C.B.-Assy (Indicator P.C.B.)
93		Holder
94		—
⑨⑤	M07486637	Phono motor (MC-943E)
96		Bottom plate
⑨⑦	M07475440	Power cord
⑨⑧	M07490680	Output cord
99		Pointer
100		Bind head screw M3 x 20
101		Bind head screw M2 x 3

Symbol No.	Parts No.	Description
102		Bind head screw M3 x 6
103		Bind head screw M3 x 5
104		Bind head screw M2.6 x 4
105		Bind head screw M2 x 8
106		Bind head screw M2 x 5
107		Tapping-screw 2 - 3 x 8
108		Bind head screw M4 x 12
109		Screw-F M3 x 6
110		Screw-metal
111		Tapping-screw 1 - 3 x 14
112		Bind head screw M3 x 8
113		Screw-metal 3 x 16
114		Bind head screw M3 x 16
115		Screw-metal
116		Screw M2.6 x 3
117		Bind head screw M4 x 6
118		—
119		Tapping-screw 1 - 3 x 16
120		Bind head screw M5 x 8
121		Screw-metal M3 x 6
122		Screw-metal
123		Bind head screw M2.6 x 5
124		Screw-metal M3 x 5
125		Spring
126		Spring
127		Spring
128		Spring
129		Spring
130		Spring
131		Spring
132		Spring
133		Spring
134		Spring
135		—
136		E-ring
137		E-ring
138		E-ring
139		E-ring
140		E-ring
141		E-ring
142		E-ring
143		E-ring 2.4
144		E-ring
145		E-ring 1.5
146		E-ring
147		E-ring
148		E-ring
149		E-ring
150		E-ring
151		E-ring 1.2
152		E-ring

Symbol No.	Parts No.	Description
153		E-ring 2.4
154		—
155		—
156		—
157		—
158		—
159		—
160		Washer
161		Washer
162		Washer
163		Washer
164		Washer
165		Washer-PL 3.1Φ
166		Washer
167		Washer-PL 3.1Φ
168		Washer-PL 2.1Φ
169		Washer-PL 2.1Φ
170		Washer-PL 2.1Φ
171		Washer-PL 2.1Φ
172		Washer-PL 2.1Φ
173		Washer-PL 2.1Φ
174		Washer-PL 2.1Φ
175		Washer-PL 2.1Φ
176		Toothed lock washer
177		Washer
178		Washer
179		—
180		—

PACKING INSTRUCTION

- Fasten the tonearm in place following the instructions given below.

- 1) Place the tonearm in the REST position.
- 2) After switching off the power switch, tie the tonearm with the binder. Lock the tonearm height adjusting lock at the tonearm's lowest position.
- 3) Insert the cushion underneath the tonearm base and fasten the base with the clampers A and B. (Clamper A is fastened on by pushing it downward and seeing to it that the forward end of the metal makes contact with the tonearm base.)

