

# INSTALLATION INSTRUCTIONS WAINSCOTING WITH 3D WALL COVERING

ORAC<sup>®</sup>  
DECOR

INSTALLATIE VAN LAMBRISERING MET 3D WALL COVERING | INSTALLATION  
DES LAMBRIS AVEC 3D WALL COVERING | INSTALLATION VON LAMBRISIERUNG  
MIT 3D WALL COVERING | INSTALACIÓN ARRIMADERO CON 3D WALL COVERING |  
УСТАНОВКА 3D НАСТЕННЫХ ПОКРЫТИЙ

UM405 - 08/2019

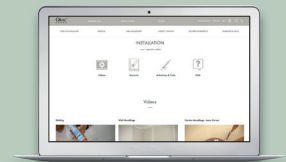
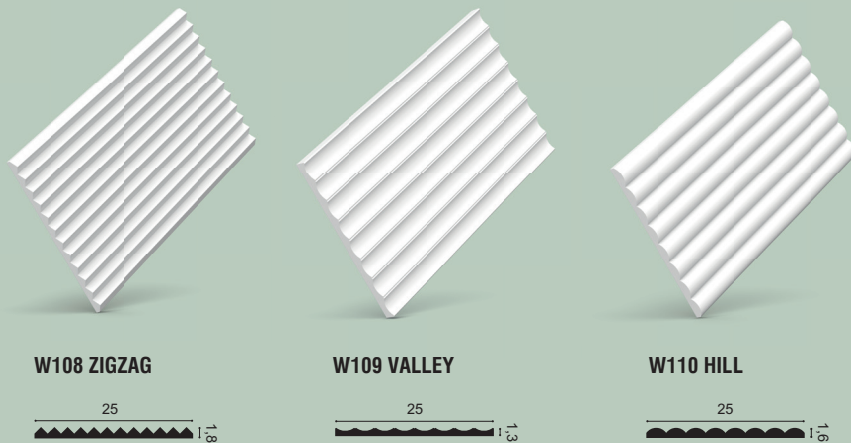

WWW.ORACDECOR.COM  
>> INSTALLATION

## 1 Ready?

### ATMOSPHERE & SURFACE

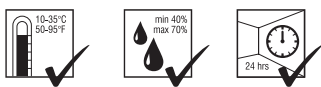

**Storage and installation conditions: Store profiles and adhesives at room temperature and wait 24 hours before installing.**

Opslag- en plaatsingsvoorwaarden: Plaats profielen en lijmen 24 uur vóór de installatie op kamertemperatuur.

Conditions d'installation et de stockage: Stockez les profils et les colles à température ambiante 24 heures avant la pose.

Lager- und Installationsbedingungen: Profile und Kleber 24 Stunden vor Verlegung bei Zimmertemperatur lagern.

Condiciones de almacenamiento y de instalación: Colocar molduras y adhesivos en el lugar 24 horas antes de la aplicación.

Условия хранения и монтажа: Оставьте профили и клей в комнате, которой планируется монтаж, на 24 часа.



Dust free  
Stofvrij  
Sans poussière  
Staubfrei  
Libre de polvo  
Удалите пыль



Sand and wash surface  
Schuur en reinig de ondergrond  
Poncez et nettoyez la surface  
Schleifen und reinigen Sie den Untergrund  
Superficie lisa y limpia  
Очистите поверхность



Flat wall & ceilings  
Vlakte wand en plafond  
Mur et plafond plats  
Plane Wand und Decke  
Paredes y techos lisos  
Выровняйте стены и потолки



Dry  
Droog  
Sec  
Trocken  
Seco  
Высушите



No grease  
Vetvrij  
Sans graisse  
Fettfrei  
Sin grasa  
Обезжирьте

## Ready? Set? Go!

INSTALLATION  
GUARANTEE

## 2 Set?

### DECOFIX ADHESIVES



**Interior, porous and dry surface**  
Binnen, poreuze en droge ondergronden  
Pose à l'intérieur, surfaces poreuses, pièces non humides  
Innen, poröse/saugfähig, und trockene Untergründe  
Interior, superficies porosas y secas  
Для внутренних работ, пористых и сухих поверхностей



**Heavy profile**  
Zware lijsten  
Grandes mouylures  
Grosse Profilen  
Perfiles Pesados  
Тяжёлые профили



**Exterior, non-porous or humid surface**  
Buiten, niet-poreuze of vochtige ondergronden  
Pose à l'extérieur, surfaces non poreuses ou environnement humide  
Außen, nicht-poröser/saugfähige Untergrund oder Feuchträume  
Exterior, superficies no porosas o ambientes húmedos  
Для внешних работ, непористых или влажных профилей



**Seal wall/ceiling**  
Verbinding muur/plafond  
Collage mur/plafond  
Verbindung Wand/Decke  
Adherencia techos/paredes  
Стены/потолки



### DecoFix Pro

Strong, water-based acrylic installation adhesive

FDP500 310ml | 7 > 8m  
FDP600 4200ml | 65 > 110m



### DecoFix Power

Very strong MS-Polymer-based installation adhesive

FDP700 290 ml | 7 > 8m



**\* Joints between mouldings**  
Verbinding tussen profielen  
Joints entre les profils  
Nahtverbindungen zwischen Profilen  
Uniones de los perfiles  
Стыки между профилями



### DecoFix Extra

Polyurethane-based adhesive

FX200 310ml | min. 80m  
FX210 tube 80ml | min. 20m



**\* The finished lateral sides on W108/W109/W110 don't require joint glue**  
De afgewerkte zijkanten van W108/W109/W110 vereisen geen voeglijm  
Les côtés finis des références W108 /W109/ W110 n'exigent pas la colle pour joints  
Für die fertigen Seiten der W108/W109/W110 brauchen Sie keinen Nahtkleber.  
Los laterales acabados de la W108 / W109 / W110 no requieren adhesivo para juntas  
Боковые стороны панелей W108/W109/W110 не нужно склеивать между собой

3

Go!

INSTALLATION



## W110 + CX190



**Install CX190 as skirting board\*** | Installeer de CX190 als plint | Installez la CX190 comme plinthe\* | Installieren Sie die CX190 als Sockelleiste\* | Instale la CX190 como rodapié\* | Установите CX190 в качестве плинтуса\*

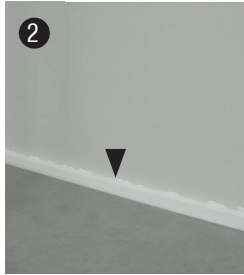

**Apply DecoFix to the length of the first and last rib** | Breng DecoFix aan op de lengte van de eerste en laatste rib | Appliquez la DecoFix sur chaque côté du profil | DecoFix der ersten und letzten Rippe entlang auftragen | Aplicar DecoFix a lo largo del primer y último saliente | Нанесите DecoFix по длине первого и последнего ребра

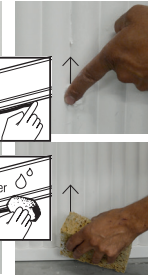
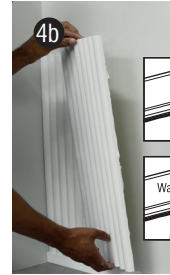

**Push firmly and remove excess glue** | Duw stevig aan en verwijder overtollige lijm | Poussez fermement et retirez l'excès de colle | Fest andrücken und überschüssigen Kleber entfernen | Presione firmemente y retire el exceso de pegamento | Сильно нажмите, чтобы удалить лишний клей



**Install the CX190 as a top rail\*** | Installeer de CX190 als afwerkingsrand\* | Installez la CX190 comme bord de finition\* | Installieren Sie die CX190 als Oberschiene\* | Instale la CX190 en la parte superior\* | Установите CX190 в качестве верхней направляющей\*

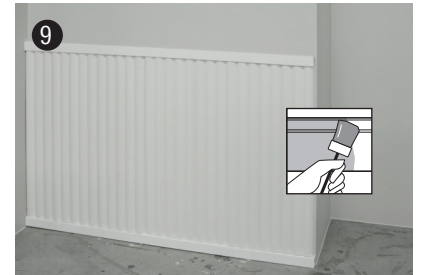
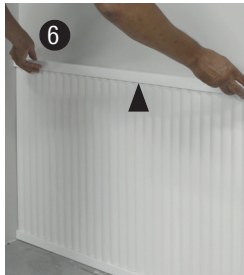

**\*Also see general instructions for mounting** | Zie ook de algemene instructies voor montage | Voir aussi les instructions générales pour montage | Siehe auch allgemeine Instruktionen für Montage | Ver instrucciones generales para montaje | Также смотрите общие инструкции по установке

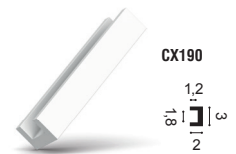

## W109 + CX190

**Follow the same steps as above** | Volg dezelfde stappen als hierboven | Suivez les mêmes étapes comme ci-dessus | Folgen Sie den gleichen Schritten wie oben beschrieben | Siga los mismos pasos arriba mencionados | Выполните те же действия, что и выше



## W108 + CX190

**Follow the same steps as above** | Volg dezelfde stappen als hierboven | Suivez les mêmes étapes comme ci-dessus | Folgen Sie den gleichen Schritten wie oben beschrieben | Siga los mismos pasos arriba mencionados | Выполните те же действия, что и выше



# INSTALLATION INSTRUCTIONS WAINSCOTING WITH PROFILES

ORAC<sup>®</sup>  
DECOR

INSTALLATIE VAN LAMBRISERING MET WANDLIJSTEN | INSTALLATION DES  
LAMBRIS AVEC CIMAISES | INSTALLATION VON LAMBRISIERUNG MIT LEISTEN |  
INSTALACIÓN ARRIMADERO CON MOLDURAS | ОБШИВКА ПАНЕЛЯМИ



SX157 + SX162 + SX163 + PX164

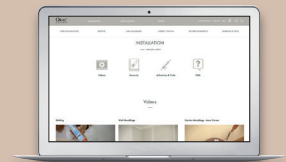

WWW.ORACDECOR.COM  
>> INSTALLATION

UM404 - 08/2019

## 1 Ready?

### ATMOSPHERE & SURFACE



**Storage and installation conditions: Store profiles and adhesives at room temperature and wait 24 hours before installing.**

Opslag- en plaatsingsvoorwaarden: Plaats profielen en lijmen 24 uur vóór de installatie op kamertemperatuur.

Conditions d'installation et de stockage: Stockez les profils et les colles à température ambiante 24 heures avant la pose.

Lager- und Installationsbedingungen: Profile und Kleber 24 Stunden vor Verlegung bei Zimmertemperatur lagern.

Condiciones de almacenamiento y de instalación: Colocar molduras y adhesivos en el lugar 24 horas antes de la aplicación.

Условия хранения и монтажа: Оставьте профили и клей в комнате, которой планируется монтаж, на 24 часа.



Dust free  
Stofvrij  
Sans poussière  
Staubfrei  
Libre de polvo  
Удалите пыль



**Sand and wash surface**

Schuur en reinig de ondergrond  
Poncez et nettoyez la surface  
Schleifen und reinigen Sie den Untergrund  
Superficie lisa y limpia  
Очистите поверхность



**Flat wall & ceilings**

Vlakke wand en plafond  
Mur et plafond plats  
Plane Wand und Decke  
Paredes y techos lisos  
Выровняйте стены и потолки



**Dry**

Droog  
Sec  
Trocken  
Seco  
Высушите



**No grease**

Vetvrij  
Sans graisse  
Fettfrei  
Sin grasa  
Обезжирьте

## Ready? Set? Go!

✓ **INSTALLATION  
GUARANTEE**

## 2 Set?

### DECOFIX ADHESIVES



**Interior, porous and dry surface**

Binnen, poreuze en droge ondergronden  
Pose à l'intérieur, surfaces poreuses, pièces non humides  
Innen, poröse/saugfähig, und trockene Untergründe  
Interior, superficies porosas y secas  
Для внутренних работ, пористых и сухих поверхностей



**Heavy profile**

Zware lijsten  
Grandes moulyures  
Grosse Profilen  
Perfiles Pesados  
Тяжёлые профили



**Exterior, non-porous or humid surface**

Buiten, niet-poreuze of vochtige ondergronden  
Pose à l'extérieur, surfaces non poreuses ou environnement humide  
Außen, nicht-poröse/saugfähige Untergrund oder Feuchträume  
Exterior, superficies no porosas o ambientes húmedos  
Для внешних работ, непористых или влажных профилей



**Seal wall/ceiling**

Verbinding muur/plafond  
Collage mur/plafond  
Verbindung Wand/Decke  
Adherencia techos/paredes  
Стены/потолки



**DecoFix Pro**

**Strong, water-based acrylic installation adhesive**

FDP500 310ml | 7 > 8m  
FDP600 4200ml | 65 > 110m



or  
of  
ou  
oder  
или



**DecoFix Power**

**Very strong MS-Polymer-based installation adhesive**

FDP700 290 ml | 7 > 8m



**\* Joints between mouldings**

Verbinding tussen profielen  
Joints entre les profils  
Nahtverbindungen zwischen Profilen  
Uniones de los perfiles  
Стыки между профилями

**\* For Durofoam®: Use DecoFix Pro (or DecoFix Power) for joints**

Voor Durofoam®: gebruik DecoFix Pro (of DecoFix Power) voor de naden  
Pour Durofoam®: utilisez DecoFix Pro (ou DecoFix Power) pour les joints  
Für Durofoam®: verwenden Sie DecoFix Pro (oder DecoFix Power) für die Stoßstellen  
Para Durofoam®: utilice DecoFix Pro (o DecoFix Power) para las uniones entre piezas  
Для Durofoam®: используйте монтажный клей DecoFix Pro / DecoFix Power для стыков



**DecoFix Extra**

**Polyurethane-based adhesive**

FX200 310ml | min. 80m  
FX210 tube 80ml | min. 20m





# 3

Go!

INSTALLATION

# INSTALLATION INSTRUCTIONS WAINSCOTING WITH PROFILES

Also see general instructions for mounting | Zie ook de algemene instructies voor montage | Voir aussi les instructions générales pour montage | Siehe auch allgemeine Instruktionen für Montage | Ver instrucciones generales para montaje | Также смотрите общие инструкции по установке

ONLY FULL GUARANTEE WITH DECOFIX  
VOLLEDIGE GARANTIE ENKEL BIJ GEBRUIK VAN DECOFIX  
GARANTIE TOTALE UNIQUEMENT AVEC COLLE DECOFIX  
VOLLSTÄNDIGE GARANTIE NUR BEI DER VERWENDUNG VON DECOFIX  
GARANTÍA COMPLETA SÓLO SI SE UTILIZA DECOFIX  
ГАРАНТИЯ НА ПРОДУКЦИЮ ДЕЙСТВУЕТ ТОЛЬКО ПРИ ИСПОЛЬЗОВАНИИ КЛЕЯ DECOFIX

Installatie van lambrisering met (multifunctionele) lijsten | Installation des lambris avec des profils (multifonctionelles) | Installation von Lambrisierung mit (multifunktionelle) Leisten | Instalación de arrimadero con molduras | Обшивка панелями

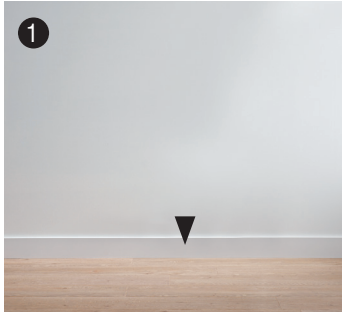

SX163 1,3  
10,2



SX157 1,3  
6,6



SX163 1,3  
10,2



SX162 1  
4



PX164 2,4  
3



SX157 1,3  
6,6



MORE INSPIRATION? | MEER INSPIRATIE? | PLUS D'INSPIRATION? | MEHR INSPIRATION? | ¿MÁS INSPIRACIÓN? | БОЛЬШЕ ВДОХНОВЕНИЯ?



# INSTALLATION INSTRUCTIONS WAINSCOTING WITH PANELS

ORAC<sup>®</sup>  
DECOR

INSTALLATIE VAN LAMBRISERING MET PANELEN | INSTALLATION DES LAMBRIS  
AVEC PANNEAUX | INSTALLATION VON LAMBRISIERUNG MIT PANEELN |  
INSTALACIÓN CON PANELES | УСТАНОВКА ПАНЕЛЕЙ СО ВСТАВКАМИ



**D503**  
43 x 43 x 1,7 cm

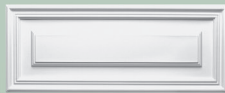

**D504**  
55 x 22 x 1,7 cm



**D506**  
55 x 55 x 1,7 cm



**D507**  
55 x 90,5 x 1,7 cm

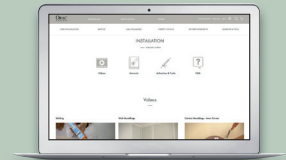

WWW.ORACDECOR.COM  
>> INSTALLATION

UM403 - 08/2019

## 1 Ready?

### ATMOSPHERE & SURFACE



**Storage and installation conditions: Store profiles and adhesives at room temperature and wait 24 hours before installing.**

Opslag- en plaatsingsvoorwaarden: Plaats profielen en lijmen 24 uur vóór de installatie op kamertemperatuur.

Conditions d'installation et de stockage: Stockez les profils et les colles à température ambiante 24 heures avant la pose.

Lager- und Installationsbedingungen: Profile und Kleber 24 Stunden vor Verlegung bei Zimmertemperatur lagern.

Condiciones de almacenamiento y de instalación: Colocar molduras y adhesivos en el lugar 24 horas antes de la aplicación.

Условия хранения и монтажа: Оставьте профили и клей в комнате, которой планируется монтаж, на 24 часа.



Dust free  
Stofvrij  
Sans poussière  
Staubfrei  
Libre de polvo  
Удалите пыль



**Sand and wash surface**  
Schoor en reinig de ondergrond  
Poncez et nettoyez la surface  
Schleifen und reinigen Sie den Untergrund  
Superficie lisa y limpia  
Очистите поверхность



**Flat wall & ceilings**  
Vlakte wand en plafond  
Mur et plafond plats  
Plane Wand und Decke  
Paredes y techos lisos  
Выровняйте стены и потолки



**Dry**  
Droog  
Sec  
Trocken  
Seco  
Высушите



**No grease**  
Vetvrij  
Sans graisse  
Fettfrei  
Sin grasa  
Обезжирьте

Ready? Set? Go!



INSTALLATION  
GUARANTEE

## 2 Set?

### DECOFIX ADHESIVES



**Interior, porous and dry surface**  
Binnen, poreuze en droge ondergronden  
Pose à l'intérieur, surfaces poreuses, pièces non humides  
Innen, poröse/saugfähig, und trockene Untergründe  
Interior, superficies porosas y secas  
Для внутренних работ, пористых и сухих поверхностей



**Heavy profiles**  
Zware lijsten  
Grandes moulures  
Grosse Profilen  
Perfiles pesados  
Тяжёлые профили



**Exterior, non-porous or humid surface**  
Buiten, niet-poreuze of vochtige ondergronden  
Pose à l'extérieur, surfaces non poreuses ou environnement humide  
Außen, nicht-poröser/saugfähige Untergrund oder Feuchträume  
Exterior, superficies no porosas o ambientes húmedos  
Для внешних работ, непористых или влажных профилей



**Seal wall/ceiling**  
Verbinding muur/plafond  
Collage mur/plafond  
Verbindung Wand/Decke  
Adherencia techos/paredes  
Стены/потолки



### DecoFix Pro

Strong, water-based acrylic installation adhesive

FDP500 310ml | 7 > 8m  
FDP600 4200ml | 65 > 110m



or  
of  
ou  
oder  
или



### DecoFix Power

Very strong MS-Polymer-based installation adhesive

FDP700 290 ml | 7 > 8m



**Joints between mouldings**  
Verbinding tussen profielen  
Verbindung zwischen Profilen  
Uniones de los perfiles  
Стыки между профилями



### DecoFix Extra

Polyurethane-based adhesive

FX200 310ml | min. 80m  
FX210 tube 80ml | min. 20m



# INSTALLATION INSTRUCTIONS

## WAINSCOTING WITH PANELS

Also see general instructions for mounting | Zie ook de algemene instructies voor montage | Voir aussi les instructions générales pour montage | Siehe auch allgemeine Instruktionen für Montage | Ver instrucciones generales para montaje | Также смотрите общие инструкции по установке

### ONLY FULL GUARANTEE WITH DECOFIX

VOLEDIGE GARANTIE ENKEL BIJ GEBRUIK VAN DECOFIX  
 GARANTIE TOTALE UNIQUEMENT AVEC COLLE DECOFIX  
 VOLLSTÄNDIGE GARANTIE NUR BEI DER VERWENDUNG VON DECOFIX  
 GARANTÍA COMPLETA SÓLO SI SE UTILIZA DECOFIX  
 ГАРАНТИЯ НА ПРОДУКЦИЮ ДЕЙСТВУЕТ ТОЛЬКО ПРИ ИСПОЛЬЗОВАНИИ КЛЕЯ DECOFIX

Installatie van lambrisering met panelen | Installation des lambris avec des panneaux |  
 Installation von Lambris mit Paneele | Instalación de arrimadero con paneles | Установка панелей со вставками

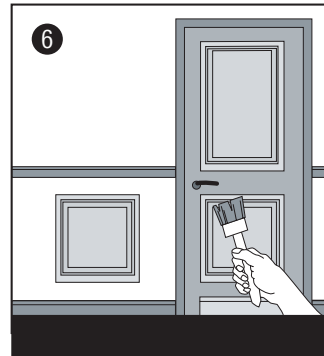
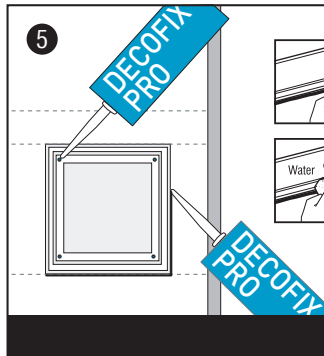
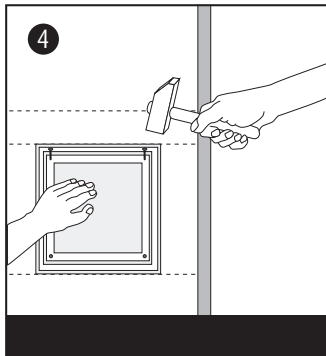
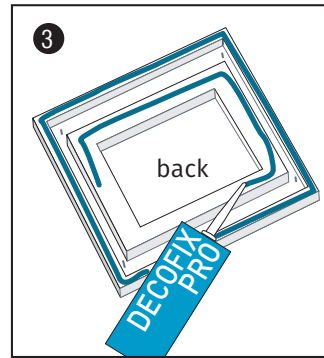
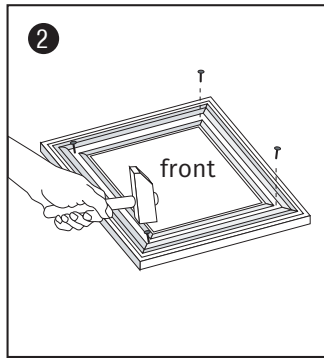
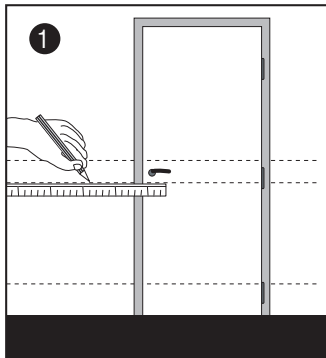
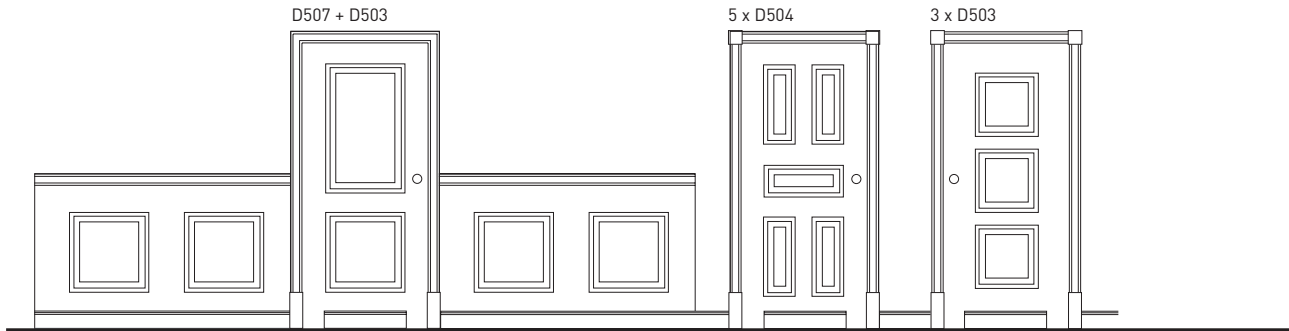

MORE INSPIRATION? | MEER INSPIRATIE? | PLUS D'INSPIRATION? | MEHR INSPIRATION? | ¿MÁS INSPIRACIÓN? | БОЛЬШЕ ВДОХНОВЕНИЯ?

