

PUNTE A COLTELLINI PER SMUSSI VARIABILI **0470**

VARI-ANGLE BEVELLING INSERT ROUTER CUTTERS



Z=2 / HW			
Cod.	D	B	Att
001	100	40	D=20 x 50
002	100	50	D=20 x 50

B = spessore in mm. - cutting height in mm. D = diametro in mm - diameter in mm.
Z = numero dei taglienti - number of cutting edges Att = attacco in mm. - shank in mm.

RICAMBI - SPARE PARTS			
Art.	Cod.	Descrizione - Description	
0520	006	coltellini reversibili - reversible inserts	40 x 12 x 1,5
0520	012	coltellini reversibili - reversible inserts	50 x 12 x 1,5

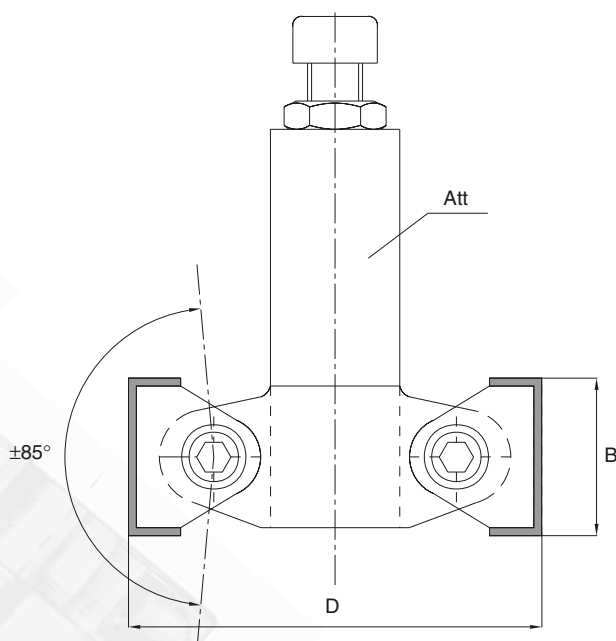

CARATTERISTICHE TECNICHE

Punta Z=2 per smussi variabili da 0°;+85°;-85° con coltellini reversibili in HW (HM integrale), spessore 1,5 mm.
Utensile adatto per lavorazione su tutti i tipi di legno, truciolari, M.D.F. ecc...

IMPIEGO

PANTOGRAFO

TECHNICAL SPECIFICATIONS

Z=2 insert cutters for adjustable bevels angle from 0°;+85°;-85°, with HW (integral tungsten carbide) reversible inserts, 1,5 mm thickness.
Suitable for all type of wood, chipboard, M.D.F. etc...

APPLICATION

ROUTER

