

0070 GRUPPO FRESE PER PARCHETTI E PERLINE

PANELLING AND FLOORING CUTTER SET

Z=4 / Hc - HS				
Cod. ▼	Fig. ▼	D	S	
001	1	140	12÷23	
002	2	140	12÷23	
003	3	140	12÷23	
004	4	140	17÷29	
005	5	140	8÷23	

S = Spessore del legno in mm. - thickness of wood in mm. D = diametro in mm. - diameter in mm.
d = foro in mm - bore in mm. Z = numero dei taglienti- number of cutting edges

Esecuzione frese: Z=6 incremento 20% - For Z=6 execution, 20% price increase

- SPECIFICARE IL MATERIALE Hc O HS NELL'ORDINE
- SPECIFY Hc OR HS EXECUTION WHEN ORDERING

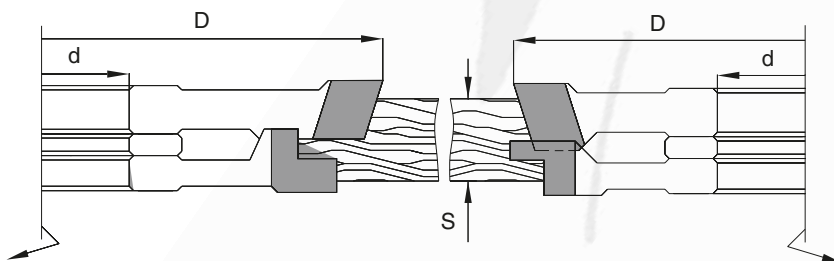

CARATTERISTICHE TECNICHE

Hc (HM riportato) per legni abrasivi, teneri, duri, incollati, MDF, multistrati e truciolari.
HS (HSS) per legni teneri e duri non incollati.

IMPIEGO

SCORNICIATRICE, TOUPIE,
SQUADRATRICE

TECHNICAL SPECIFICATIONS

Hc (brazed tungsten carbide) execution for abrasive, hard, soft and glued woods, MDF, plywood and chipboard.
HS (HSS) for all non - glued soft and hard woods.

APPLICATION

MOULDER, SPINDLE MOULDER,
DOUBLE TENONER

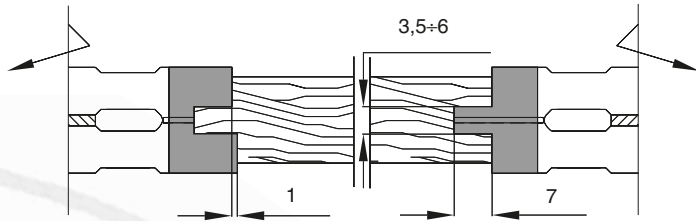

fig. 1

12+23

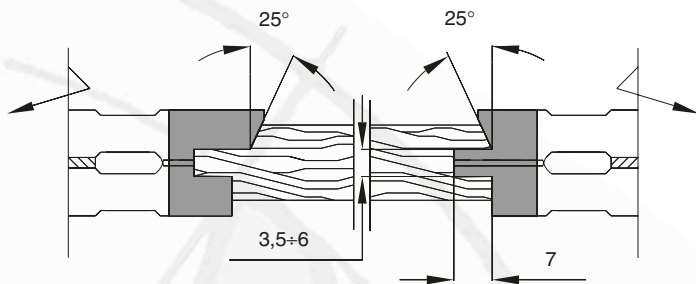
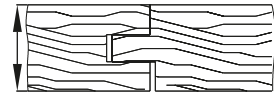

fig. 2

12+23

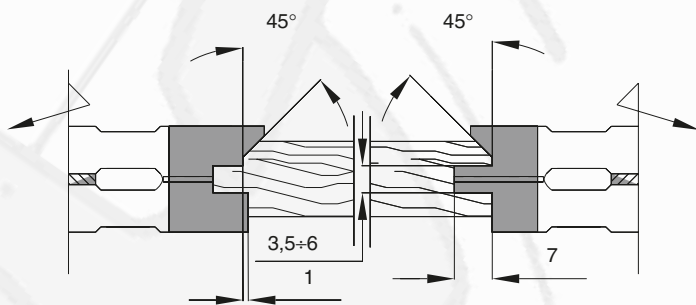
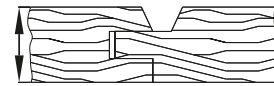

fig. 3

12+23

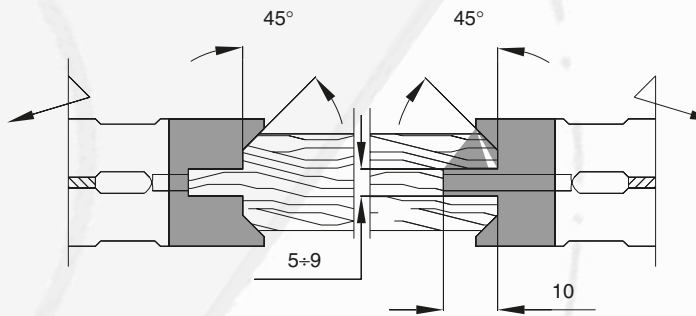

fig. 4

17+29

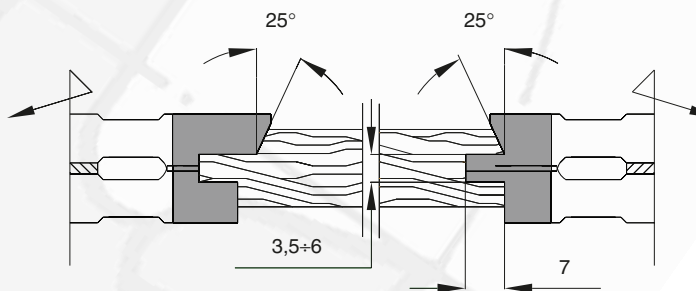
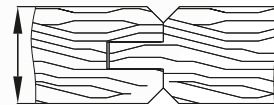

fig. 5

8+23

