

Lenkung und Aufhängung
Direction et Suspension
Dirección y Suspensión
Рулевое управление и подвеска



Steering and Suspension

Modelle N-Z
Models N-Z



Edition
2016

Content · Inhalt

bilstein group	I
Best Choice for Spare Parts	II
Catalogue Guide · Katalogleitfaden	IV
Page Overview · Seitenübersicht	VIII
Index · Register	XIII
Catalogues, Flyers and more · Kataloge, Flyer und mehr	XIV
Your Advantages at a glance · Ihre Vorteile auf einen Blick	XVI
Front axle applications · Verwendung Vorderachse	1 - 637
Rear axle applications · Verwendung Hinterachse	638 - 755
Ref. number > SWAG number · Ref.-Nr. > SWAG Nr.	756 - 846
SWAG number > ref. number · SWAG Nr. > Ref.-Nr.	847 - 886

ALLEINE STARK, IM TEAM UNSCHLAGBAR

Die bilstein group ist eine familiengeführte, konzernunabhängige Unternehmensgruppe, unter deren starkem Dach die renommierten Produktmarken febi, SWAG und Blue Print vereint werden.

Als führender Spezialist im weltweiten Automotive Aftermarket bietet die bilstein group Verschleißteile und Reparaturlösungen für alle gängigen Fahrzeugtypen der Bereiche PKW und NKW.

Das in Breite und Tiefe außergewöhnliche Sortiment umfasst rund 47.000 verschiedene Produkte und wird durch praxisorientierte Serviceleistungen ergänzt. Damit wird die bilstein group selbst höchsten Ansprüchen gerecht.

Weitere Informationen erhalten Sie unter:
www.bilsteingroup.com

INDIVIDUALLY STRONG, UNBEATABLE AS A TEAM

The bilstein group is a family-run, independent group of companies providing a single strong umbrella under which the prestigious product brands febi, SWAG and Blue Print are united.

As a leading specialist in the global automotive aftermarket, the bilstein group offers spare parts and repair solutions to fit all popular makes of cars and commercial vehicles.

The range, which is exceptional in its breadth and depth, comprises approximately 47,000 different products and is supplemented by practice-oriented services. The bilstein group can therefore meet even the highest requirements.

Get more information at: www.bilsteingroup.com

Best Choice for Spare Parts



Best Choice for Spare Parts

We are committed to this motto – to your benefit. Because SWAG stands for more than 22,000 popular parts for all German and other European vehicle types, for the product groups engine, steering, chassis and brake technology as well as electrics, fluids and SWAG Extra. An always up-to-date range of professional vehicle repair products for all popular vehicle types. Of course in OE-matching quality.

More than 60 years of experience in the IAM

SWAG is one of the leading global partners to the wholesale with manufacturing competence for automotive spare parts in the independent aftermarket. SWAG has been a synonym for high quality with extremely short delivery times since 1954. The company, which is located in Germany, is a strategic partner of leading manufacturers of the automotive supplier industry as well as a distributor of high-quality spare parts for motor vehicles.

Planning for the future

We are a member of the bilstein group, a family-run, independent group of companies with know-how acquired over many years and state-of-the-art manufacturing technologies. In order to meet the growing expectations of the market at all times, the group is continually investing in the expansion of production, testing equipment and machinery.

SWAG advantages at a glance

- OE-matching quality
- Variety in range
- Manufacturing expertise
- Triple-Checking-System
- A strong brand from Germany
- Just-in-time delivery in 140 countries



Best Choice for Spare Parts

Dieses Motto ist für uns eine Verpflichtung – und Ihr Vorteil. Denn SWAG bietet über 22.000 gängige Verschleißteile für alle deutschen sowie zahlreiche andere europäische Fahrzeugtypen an und deckt die Produktgruppen Motor-, Lenkungs-, Fahrwerks- und Bremstechnik sowie Elektrik, Flüssigkeiten und SWAG Extra ab. Ein stets aktuelles Programm für die professionelle Fahrzeugreparatur aller gängigen Modelle! Natürlich in Erstausrüstungsqualität.

Über 60 Jahre Erfahrung im freien Ersatzteilmarkt

SWAG gehört zu den weltweit führenden Großhandelspartnern mit Herstellerkompetenz für automotive Verschleißteile im freien Ersatzteilmarkt. Bereits seit 1954 steht SWAG für hochwertige Qualität bei kürzesten Lieferzeiten. Wir sind strategischer Partner führender Hersteller der Automobilzulieferindustrie und Distributor hochwertiger Ersatzteile für Kraftfahrzeuge.

Zukunft im Blick

Als Lieferant von Autoersatzteilen gehören wir zur bilstein group, einer deutschen Unternehmensgruppe mit langjährigem Know-how und modernster Fertigungstechnik. Um den steigenden Erwartungen des Marktes jederzeit zu entsprechen, wird kontinuierlich in den Ausbau der Logistik, in Prüfeinrichtungen und den Maschinenpark der Fertigung investiert.

SWAG Vorteile auf einen Blick

- Erstausrüstungsqualität
- Produktvielfalt
- Herstellerkompetenz
- Triple-Checking-System
- Eine starke Marke aus Deutschland
- Lieferung „Just-in-time“ in 140 Länder



Best Choice for Spare Parts

Nous avons adopté la devise – à votre avantage. SWAG est synonyme de plus de 22.000 pièces courantes, pour tous types de véhicules allemands et européens dans les groupes de produits technologies de moteur, de direction, de châssis et de freinage, mais aussi électricité, fluides et SWAG Extra. Une gamme constamment réactualisée de produits de réparation automobile professionnelle, tous types de véhicules courants confondus. Et bien sûr, pour une qualité équipement d'origine !

Plus de 60 ans d'expérience dans le secteur automobile

SWAG est un des partenaires de commerce en gros leaders dans le monde entier et compétent en matière de fabrication de pièces d'usure automobiles sur le marché libre des pièces de rechange. Depuis 1954, la société SWAG est réputée pour sa qualité haut de gamme avec de brefs délais de livraison. Nous sommes le partenaire stratégique pour les fabricants leaders dans le secteur de l'industrie des matériels automobiles additionnels et le distributeur de pièces de rechange de qualité élevée pour automobiles.

Regard vers l'avenir

Nous sommes membres du bilstein group d'entreprises familiales, indépendantes, disposant de nombreuses années de savoir-faire et maîtrisant parfaitement les techniques de fabrication à la pointe des connaissances. Soucieux de toujours satisfaire les attentes évolutives de ses marchés, le groupe investit continuellement dans l'expansion de ses moyens de production, équipements d'essai et machines.

Avantages SWAG en bref.

- Qualité de premier équipementier
- Multiplicité des produits
- Compétence de constructeur
- Le système Triple-Checking
- Une enseigne de renom
- Livraison „just-in-time“ dans 140 pays



Best Choice for Spare Parts

Este lema es nuestra obligación... y su ventaja. SWAG ofrece más de 22.000 referencias para todo tipo de vehículos alemanes y europeos, para familias de productos como motor, dirección, rodaje y frenado, más electricidad, líquidos y SWAG Extra. Un programa en continua actualización para la reparación profesional de vehículos de todos los modelos convencionales. Y, por supuesto, con calidad equivalente OE.

Más de 60 años de experiencia en el sector del automóvil

SWAG es uno de los mayoristas líderes a escala internacional de piezas de desgaste para el automóvil dentro del mercado libre de las piezas de repuesto. Además, su grado de competencia y conocimientos es igual al de los propios fabricantes. Ya desde 1954, SWAG es símbolo de alta calidad con reducidos plazos de entrega. Somos socios estratégicos de los fabricantes líderes del sector de suministros para el automóvil y distribuidores de piezas de repuesto de alta calidad para automóviles.

Planeando el futuro

Somos miembros de bilstein group, una empresa familiar, un grupo de empresas independientes, con conocimientos adquiridos a través de muchos años, con conocimiento tecnológicos y de fabricación. En orden a responder a las necesidades de crecimiento de los mercados en todo momento, el grupo está continuamente invirtiendo en el desarrollo de la producción, equipamiento tecnológico y maquinaria.

Ventajas de SWAG en un vistazo

- Calidad de equipo original
- Gran variedad de productos
- Competencia de fabricación
- Triple Checking System
- Marca potente
- Suministro „justo a tiempo“ a 140 países



Лучший выбор запасных частей

Для нас этот девиз – обязательство, для нас этот девиз – обязательство, для Вас – преимущество. Ведь марка SWAG – это синоним более 22 000 наиболее распространённых расходных деталей для всех типов немецких и других европейских транспортных средств с распределением по следующим товарным группам: детали двигателя, рулевого управления, ходовой части, тормозной системы, а также

электрика и детали категории SWAG Extra. Постоянно обновляемая программа для профессионального ремонта автомобилей всех основных моделей! Только настоящее качество оригинального производителя

Более чем 60-летний опыт в автомобильной промышленности

SWAG – один из мировых лидеров в области оптовой торговли с опытом производства изнашиваемых автомобильных запасных частей на свободном рынке запасных деталей. С 1954 SWAG ручается за высокое качество при кратчайших сроках поставки. Мы являемся стратегическим партнером ведущих производителей индустрии автомобильных комплектующих и дистрибьютором высококачественных запасных частей для автомобилей.

Курс на будущее

Являясь поставщиком запасных частей для автомобилей, мы принадлежим к немецкой группе производителей, обладающей с многолетним „ноу-хау“ и современной производственной технологией. Для того чтобы соответствовать постоянно растущим требованиям современных рынков, наша компания осуществляет последовательные инвестиции в расширение производственных мощностей, а также в испытательное оборудование и машинный парк.

Преимущества компании SWAG:

- Заводское качество
- Разнообразный ассортимент
- Компетентность производителя
- Тройная система контроля
- Сильная марка
- Поставки „Just-in-time“ в 140 стран

Catalogue Guide

Katalogleitfaden Manuel du catalogue Guía del catálogo Руководство по работе с каталогом



Find every part:
quick and convenient

You know the vehicle type and the
vehicle manufacturer's reference number:

Reference number → SWAG number
→ Page number

The positioning of the reference numbers
corresponds to the vehicle manufactur-
ers' sorting sequence:

SWAG number → Reference number
→ Page number

This list is sorted by SWAG number in
ascending order.

Note: On the catalogue cover, you
will find a list of symbols and abbrevi-
ations with explanations in different
languages.



Ersatzteile finden:
komfortabel und schnell

Sie kennen den Fahrzeugtyp und haben
eine Referenznummer des Fahrzeugher-
stellers:

Referenz-Nr. → SWAG-Nr. → Seiten-
zahl

Die Anordnung der Referenznummern
entspricht der Sortierreihenfolge der
Fahrzeughersteller:

SWAG-Nr. → Referenz-Nr. → Seiten-
zahl

Diese Liste ist nach SWAG-Nr. aufstei-
gend sortiert.

Hinweis: Eine Liste der Symbole und
Abkürzungen mit Erklärungen in ver-
schiedenen Sprachen finden Sie auf
den letzten Katalogseiten.

Ref. - No. → **SWAG**
GERMANY

Ref. - No. **SWAG**
GERMANY

passend für / to fit:
NISSAN

D8521-JD00B	82 93 4614	20, 27
D8521-JG00A	82 93 4614	20, 27
40110-B9500	99 78 0002	5, 23, 25
40110-T3060	99 78 0002	5, 23, 25
40110-T6000	99 78 0002	5, 23, 25
40110-T6025	99 78 0002	5, 23, 25
40110-T6000	60 93 1847	4
40110-T6025	60 93 1847	4
40110-T6000	60 93 4104	4
40110-T6025	60 92 2265	15
40110-T6000	82 78 0011	5, 23
40110-T6025	82 78 0011	5, 23
40110-T6000	82 78 0011	5, 23
40110-T6025	82 78 0011	5, 23
40110-T6000	60 92 7128	15
40110-T6025	84 93 3510	13
40110-T6000	82 93 0528	9
40110-T6025	82 93 2023	2
40110-T6000	82 93 2023	2
40110-T6025	82 92 6536	26
40110-T6000	60 92 1284	15
40110-T6025	60 92 1493	4
40110-T6000	60 93 7625	4
40110-T6025	60 92 1494	4
40110-T6000	60 93 7626	4
40110-T6025	60 92 1283	15
40110-T6000	60 92 1284	15
40110-T6025	60 92 7303	15
40110-T6000	60 92 7301	15
40110-T6025	60 93 7627	15
40110-T6000	60 93 7628	15
40110-T6025	60 91 9605	6, 14
40110-T6000	60 91 9604	6, 14
40110-T6025	60 94 3618	11
40110-T6000	60 94 3688	11
40110-T6025	60 94 3617	11

756 Die von uns gelieferten Produkte sind ausschließlich dem bestimmungsgemäßen Gebrauch zuzuführen. / The products delivered by us are to be put exclusively to the intended use.



Trouvez vos pièces facilement et rapidement

Vous connaissez le type du véhicule et avez la référence de son constructeur:

Référence → N° SWAG → Numéro de page

Le classement des références correspond à l'ordre de classement du constructeur de véhicules:

N° SWAG → Référence → Numéro de page

Cette liste est triée par référence SWAG, en ordre croissant.

Note: Sur la dernière page de catalogue, vous trouverez la liste des symboles et des abréviations avec les explications dans différentes langues.



Búsqueda de cualquier recambio: rápida y cómoda

Sabe usted cuál es el tipo de vehículo y tiene un número de referencia del fabricante del vehículo:

N° de referencia → N° de SWAG → N° de página

La clasificación de los números de referencia corresponden al orden de clasificación de los fabricantes de vehículos:

N° de SWAG → N° de referencia → N° de página

En esta lista se indican las referencias de SWAG en orden ascendente.

Nota: En la última página del catálogo usted encuentra un listado de todos los símbolos y las abreviaciones respectivamente, en los idiomas.



Поиск запасных частей: комфорт и скорость

Вы знаете тип транспортного средства и референсный номер автопроизводителя:

Референс-№ → SWAG-№ → Число страниц

Структура референсных номеров соответствует сортировочной последовательности автопроизводителей:

SWAG-№ → Референс-№ → Число страниц

Данный перечень рассортирован по номерам SWAG возрастающим порядком.

Указание: перечень символов и сокращений с объяснениями на различных языках Вы найдёте на странице обложки каталога.

Catalogue Guide

Katalogleitfaden Manuel du catalogue Guía del catálogo Руководство по работе с каталогом



User notes: clear and simple

The SWAG catalogue contains the following information:

- 1 Vehicle type (alphabetical order)
- 2 Model (alphabetical order)
- 3 Model year
- 4 Photo with SWAG number
- 5 Front / rear axle
- 6 SWAG number
- 7 Reference number
- 8 Part description in German and English
- 9 Restrictions and exceptions (in general, the parts shown apply to all engine and design variants; exceptions are highlighted in this list)
- 10 Dimensions



Benutzerhinweise: übersichtlich und einfach

Im SWAG Katalog befinden sich folgende Angaben:

- 1 Fahrzeugtyp (alphabetische Reihenfolge)
- 2 Modell (alphabetische Reihenfolge)
- 3 Modelljahr
- 4 Foto mit SWAG Nr.
- 5 Vorder- / Hinterachse
- 6 SWAG Nr.
- 7 Referenznummer
- 8 Artikelbezeichnung in Deutsch und Englisch
- 9 Ausnahmen und Abgrenzungen (grundsätzlich gelten die hier abgebildeten Teile für alle Motor- und Ausstattungsvarianten; Ausnahmen werden in dieser Liste hervorgehoben)
- 10 Abmessungen

passend für / to fit

OPEL

Movano B
(2010 →)

SWAG GERMANY

60 94 3617, 60 93 9444, 60 93 9444, 60 94 3618, 60 94 3687, 60 94 3688, 60 94 2634, 60 94 2634, 40 94 4428, 60 94 4728, 60 94 4728, 60 93 7309, 60 93 7309

alle mit Heckantrieb in Verbindung mit Doppelbereifung / all with rear drive combined with double tires
(1) EVD, FVD, HVD, UVV, JVO
Nur Fahrzeuge mit Frontantrieb mit einem Gesamtgewicht von 3300 u. 3500 kg / only vehicles with front wheel drive combined with a total weight of 3300 u. 3500 kg
(2) Vorderradantrieb oder Heckantrieb ohne Doppelbereifung / front-wheel drive or rear-wheel drive without double tires
(3)

SWAG	Ref.-No.				
60 93 7309	4419 291	Verbindungsstange / stabilizer link	(3)	L 330	
60 93 9444	4420 098 SK	Axialgelenk / axial joint		L 253	
60 94 2634	4419 219	Traggelenk / ball joint	→ 22.07.10	M18 x 1,5	
60 94 3617	4420 097	Spurstangenendstück / tie rod end		M18 x 1,5	
60 94 3618	4420 098	Spurstangenendstück / tie rod end		M18 x 1,5	
60 94 3687	4420 097 S1	Rep. Satz Spurstange / rep. kit tie rod			
60 94 3688	4420 098 S1	Rep. Satz Spurstange / rep. kit tie rod			
40 94 4428	4420 954	Verbindungsstange / stabilizer link	(1)	L 166	
60 94 4728	4419 323	Stabilisatorlager / stabilizer mount	(2)	Ø I 25,4	

70 Der Einbau darf nur durch geschultes Fachpersonal erfolgen. / The installation may exclusively be performed by trained specialist staff.

10



Information utilisateur: claire et simple

Les indications suivantes se trouvent dans le catalogue SWAG:

- 1 Type de véhicule (ordre alphabétique)
- 2 Modèle (ordre alphabétique)
- 3 Année de fabrication
- 4 Photo avec N° SWAG
- 5 L'essieu avant et arrière
- 6 N° SWAG
- 7 N° de référence
- 8 Désignation de pièce en allemand et en français
- 9 Limitations et exceptions (les pièces représentées sont en principe valables pour toutes les variantes de motorisations et d'équipements; les exceptions sont mises en évidence dans cette liste)
- 10 Dimensions



Para el usuario: claro y simple

En el catálogo SWAG se encuentran los siguientes datos:

- 1 Tipo de vehículo (orden alfabético)
- 2 Modelo (orden alfabético)
- 3 Año de fabricación
- 4 Foto con N° de SWAG
- 5 Ejes delantero y trasero
- 6 N° de SWAG
- 7 Número de referencia
- 8 Denominación de pieza en alemán e inglés
- 9 Delimitaciones y excepciones (generalmente, las piezas visualizadas son válidas para todas las variantes de motor y equipamiento; las excepciones están resaltadas en esta lista)
- 10 Dimensiones



Указания для пользователя отличаются ясностью и простотой

В каталоге SWAG содержатся следующие данные:

- 1 Марка автомобиля
- 2 Модель автомобиля (числовой/ алфавитный порядок, по возрастающей)
- 3 Год выпуска
- 4 Фото с SWAG номер
- 5 Передняя / задняя ось
- 6 SWAG номер
- 7 Оригинальный номер
- 8 Наименование изделия в немецкий и английский
- 9 Ограничения и исключения (в основном все представляемые запасные части действительны для любых моторов и различных соотношений; исключения будут показаны в этой колонке; перечень сокращений Вы найдёте на последней странице каталога).
- 10 размеры

Page Overview

to fit / passend für:

NISSAN

	front axle Vorderachse	rear axle Hinterachse
100 NX (B13)	1	-
Almera (N15) / (N16)	2	-
Almera Tino (V10)	3	-
Interstar (X70)	4	-
Juke (F15E)/King Cab/Pick Up (D21)	5	-
Kubistar (X76)	6	-
Maxima (A32) / (CA33)	7	-
Micra (K10) / (K11)	8	638
Micra (K12) / Micra C+C (CK12E)	9	-
Murano (Z50)	-	638
Murano (Z51)	10	638
Navara (D40M)	10	-
Note (E11)	11	-
NV400 (X62)	11	639
Pathfinder (R50)	12	639
Pathfinder (R51)	12	640
Patrol (Y60)	13	640
Pixo	13	-
Platina	14	-
Primastar (X83)	15	-
Primera Limousine (P10E)	16	-
Primera Wagon (W10)	17	-
Primera (P10 / W10)	-	640
Primera (P11 / WP11)	18	-
Primera (P12 / WP12)	19	640
Qashqai (J10E / +2 / JJ10E)	20	641
Serena (C23M)	20	-
Sunny (N14 / Y10)	21	-
Teana (J31)	-	641
Teana (J32) / (J32R)	22	641
Terrano I (WD21)	23	-
Terrano II (R20)	24	642
Urvan (E23/E24)	25	-
Vanette Cargo (HC23)	26	-
X-Trail (T30)	26	642
X-Trail (T31) / (T31R)	27	642

to fit / passend für:

OPEL

Adam	28	-
Agila A / Agila B	29-30	-
Antara	31	643
Ampera / Arena	32	-
Ascona C	33-34	-
Astra F	35-37	-
Astra G	38-39	-

to fit / passend für:

OPEL

	front axle Vorderachse	rear axle Hinterachse
Astra H	40-41	-
Astra J	42-44	-
Calibra	45-46	644
Cascada / Combo C	47	-
Combo D / Commodore C	48	-
Corsa A	49	-
Corsa B	50-51	-
Corsa C	52-53	-
Corsa D	54	-
Corsa E	55	-
Frontera A / Frontera B	56-57	-
Insignia	58	644
Kadett C	59	-
Kadett D	59-60	-
Kadett E	61-62	-
Manta B	63	-
Meriva A / Meriva B	64-65	-
Mokka	66	-
Monterey A / Monterey B	67	-
Movano A	68-69	-
Movano B	70	645
Monza	71	-
Omega A	72-73	645
Omega B	74	646
Rekord E	75	-
Senator A	76	-
Senator B	77	647
Signum	78	648
Tigra A	79-80	-
Tigra B TwinTop	81	-
Vectra A	82-85	649
Vectra B	86	650
Vectra C	87	651
Vivaro A	88-89	-
Zafira A	90-91	-
Zafira B	92-93	-
Zafira C	94	-

to fit / passend für:

PEUGEOT

106	95-96	-
107	97	-
205	98-99	-
206	100-101	-
206 SW	102-103	-
206 CC	104-105	-

to fit / passend für:

PEUGEOT

	front axle Vorderachse	rear axle Hinterachse
206 +	106	-
207 / CC / SW	107	-
208	108-109	-
301	110	-
306	111-113	-
307 / CC / SW	114-115	-
308 / CC / SW	116-117	-
308 II	118	-
309	119-120	-
405	121-122	-
406	123	652
407 / Coupé	124-125	653
504	126	-
505	127	-
508	128-129	653
604	130	-
605	131	654
607	132	654
806	133	-
807	134	-
1007	135	-
2008	136	-
3008	137	655
4007	138	655
4008	139	655
5008	140-141	-
Bipper / Tepee	142	-
Boxer I + II	143	-
Boxer III	144	656
Expert I + II	145	-
Expert III / Tepee	146	-
J5	147	656
Partner I	148-151	-
Partner II	152-153	-
Partner III / Tepee	154	-
RCZ	155	-

to fit / passend für:

PORSCHE

911 Carrera / Turbo (996)	156	659
911 Carrera 2 / 2-S (997)	157	659
924	158	-
Boxster (986) / (987)	159	657
Cayenne (955) S / GTS / Turbo	160	-
Cayenne (958) S / GTS / Turbo S	161	-
Cayenne S/Turbo S (A2)/Cayenne (9P)	161	-

to fit / passend für:

PORSCHE

	front axle Vorderachse	rear axle Hinterachse
Cayenne (9P)	161	-
Cayman (987)	162	658
Panamera (970)	162	-

to fit / passend für:

RENAULT

R5	163	-
R9 / R11	164	-
R12	165	-
R15 / R17 / R18	166	-
R19	167	-
R20 / R30	168	-
R21	169-170	-
R25	171	-
Avantime	172	-
Clio 1	173-174	-
Clio 2 / Symbol	175-176	660
Clio 3	177	-
Clio 4	178	-
Duster	178	661
Espace 1 / Espace 2	179-180	-
Espace 3 / Espace 4	181-182	-
Fluence	183	-
Kangoo 1	184	-
Kangoo 2	185	-
Koleos	186	660
Laguna 1	187	-
Laguna 2	188-189	-
Laguna 3	190	-
Logan 1	191	-
Master 2	192-193	-
Master 1	194	-
Master 3	195	662
Megane 1 / Coupé	196-197	-
Megane 1 / Scenic	198-199	-
Megane 2	200-201	-
Megane 3	202-203	-
Megane Generation	204	-
Modus	205	-
Rapid	206	-
Safrane	207	-
Sandero 1	208	-
Scenic 2	209	-
Scenic 3	210	-
Thalia	211	-
Trafic 1	212	662

Page Overview

to fit / passend für:

RENAULT

	front axle Vorderachse	rear axle Hinterachse
Trafic 2	213	-
Twingo 1	214	-
Twingo 2	215	-
Twizy	216	-
Vel Satis	217	-
Wind / Zoe	218	-

to fit / passend für:

ROVER

	front axle Vorderachse	rear axle Hinterachse
25	219	-
75 (RJ)	219	663
200 (3+5 Türen/3+5 door saloons)	220	663
200 (Coupé / Cabrio)	220	-
400	221	663
600 / Austin Metro	222	-
MG ZR/ZT	223	663
Mini	223	-

to fit / passend für:

SAAB

	front axle Vorderachse	rear axle Hinterachse
9-3 I	224	-
9-3 II	225	664
9-5 I	226	665
9-5 II	227	-
90 / 99 / 900 I	228	-
900 II	229	-
9000	230	-

to fit / passend für:

SEAT

	front axle Vorderachse	rear axle Hinterachse
Alhambra (7V8)	231	666
Alhambra (7V9)	232-233	666
Alhambra (710)	234-235	667
Altea (5P)	236-237	668-669
Arosa (6H)	238-241	-
Cordoba (6K)	242-244	-
Cordoba / Vario (6K)	245-247	-
Cordoba / Vario (6L)	248-251	-
Exeo (3R)	252-253	670
Ibiza (6K)	254-258	-
Ibiza (6L)	259-261	-
Ibiza (6J)	262-263	-
Inca (9K)	264	-
Leon (1M)	265-267	671
Leon (1P)	268-271	672-673
Leon (5F)	272-273	674
Marbella	274	-
Mii (KF)	275	-

to fit / passend für:

SEAT

	front axle Vorderachse	rear axle Hinterachse
Toledo (1L)	276-282	-
Toledo (1M)	283-285	-
Toledo (5P)	286-287	672-673
Toledo (KG3)	288-289	-

to fit / passend für:

ŠKODA

	front axle Vorderachse	rear axle Hinterachse
Citigo (NF)	290-291	-
Fabia (6Y)	292-295	-
Fabia II (5J)	296-297	-
Fabia III (NJ) / Favorit 785 Forman	298	-
Felicia (4X) (6X)	299	-
Octavia (1U)	300-303	675
Octavia (1Z)	304-305	676-677
Octavia (5E / NL3 / NR3)	306	675
Pick-Up (6U)	307	-
Rapid (NH / NK)	308-309	-
Roomster (5J)	310-313	-
Superb (3U)	314-315	-
Superb (3T)	316-317	678-679
Yeti 4x4 (5L)	318-319	678-679

to fit / passend für:

SMART

	front axle Vorderachse	rear axle Hinterachse
City Coupé / Cabrio	320	-
Crossblade / Forfour (BM 454)	321	-
Fortwo / Cabrio (BM 450)	322	680
Fortwo / Cabrio / Coupé (BM 451)	323	-
Roadster (BM 452)	324	-

to fit / passend für:

SUBARU

	front axle Vorderachse	rear axle Hinterachse
E 12 (D11)	325	-
Forester (S10) / (S11)	325, 326	681
Forester (S12)	327	-
Impreza (G10)	327	682
Impreza (G11) / (G12)	328	682
Justy IV (M300) / Legacy I (B10)	329	-
Legacy II (B11)	329	683
Legacy III (B12) / Legacy IV (B13)	330	684

to fit / passend für:

SUZUKI

	front axle Vorderachse	rear axle Hinterachse
Alto / Alto V	331	-
Baleno	332	-
Carry	332	-
Grand Vitara / Grand Vitara / XL	333	-
Ignis	334	-
Jimny	334	-

to fit / passend für:

SUZUKI

	front axle Vorderachse	rear axle Hinterachse
Splash	335	-
Swift I	336	-
Swift II	336	685
Swift III	337	-
SX-4 / Vitara	338	-
Wagon R+	339	685
Wagon R+ II	339	-
X-90	339	-

to fit / passend für:

TOYOTA

Alphard (GGH20)	340	-
Auris (_E15_) / (_X10_)	341	-
Avalon (_X20_) / (_X30_)	342	-
Avensis (_T22_)	343	687
Avensis (_T25_) / (_T27_)	344	687
Avensis Verso (ACM/20)	344	-
Aygo (WNB10)	345	-
Camry (_V2_)	346	688
Camry (_V10_)	346	-
Camry (_V20_)	347	-
Camry (_V30/31_)	348	688
Camry (_V36_)	349	688
Camry (_V40_)	349	-
Carina (_T15_)	350	-
Carina (_T17_)	350	689
Carina (_T19_)	351	689
Celica (_T16_) / (_T18_)	352	690
Celica (_T20_)	353	690
Celica (ZZT23)	353	-
Corolla (_E8_) / (_E9_)	354	-
Corolla (_E10_)	355	-
Corolla (_E11_)	356	691
Corolla (_E12_)	357	691
Corolla (_E15_)	357	-
Corolla Verso (_E12_)	358	-
Corona (AT190/210ST191/210)	359	-
Corona (AT220/CT220/ST210)	359	691
Corona (AT151/CT150/ST15)	360	-
Crown (GS151/JZS155)	360	-
Dyna (LY100/YY100)	361	-
Echo / Verso (NCP 12/13/20)	362	-
Hiace III (_H10_)	362	-
Hiace IV (_H1_H2_)	363	-
Hilux 2WD (N5)	363	-
Highlander (U20)	364	692

to fit / passend für:

TOYOTA

	front axle Vorderachse	rear axle Hinterachse
Hilux (RN 125)	364	-
Land Cruiser (J7_J8)	365	693
Land Cruiser (J9)	365	694
Land Cruiser (J10)	366	694
Land Cruiser (J12)	366	694
MR 2 (ZZW20) / (ZZW30)	367	-
Noah (ZRR70)	367	-
Paseo (EL44)	368	-
Picnic (_XM10_)	368	-
Previa (R1) / (R3)	369	-
Previa (_R5_)	369	-
Prius (NHW11) / (NHW20)	370	-
RAV 4 I (_SXA1/10/11/16_)	371	-
RAV 4 I (_BEA11_)	372	-
RAV 4 II (_XA2_)	372	695
RAV 4 III (_A3_)	373	695
Rukus	374	-
Scion (_10_)	375	-
Scion XA/XB (_NCP_)	375	-
Scion XB (_AZE_)	375	-
Sienna (_L_)	376	-
Solara	377	-
Spacio (AE111)	378	-
Starlet (_P7 / P8 / P9_)	379	-
Supra (MA70) / (JZA80)	380	-
Tacoma (_RN22_) / (_RZ/VZ_)	381	-
Tarago (_R1_) / (_R3_) / (_R5_)	382	-
Tercel (_EL31_) / (_EL40/42/53_)	383	-
Tundra (_CK30/40_)	383	-
4 Runner	384	697
Vios / Soluna Vios	385	-
Wish (_ANE11_) / (_ZNE10_)	386	-
Wish (_ZGE10_)	386	-
Yaris / Yaris Verso	387	-
Auris (ADE157)	-	686
Avalon (MCX10)	-	686
Corolla	-	690
FJ Cruiser (US) / Highlander (U25)	-	692
Kluger (_U28_)	-	693
MR 2 (_W2_) / (_W3_)	-	695
Scion TC / Solara (_V20_)	-	696

to fit / passend für:

VAUXHALL

Adam	388	-
Agila Mk I / Mk II	389	-

Page Overview

to fit / passend für: VAUXHALL	front axle Vorderachse	rear axle Hinterachse
Antara	390	698
Ampera / Arena	391	-
Astra Mk I	391	-
Astra Mk II	391-393	-
Astra Mk III	394-397	-
Astra Mk IV	398-399	-
Astra Mk V	400-401	-
Astra Mk VI	402-404	-
Calibra	405-406	699
Carlton	407-408	700
Cascada / Cavalier Mk II	409	-
Cavalier Mk III	410-415	701
Corsa Mk I	416-417	-
Corsa Mk II	418-419	-
Corsa Mk III	420	-
Corsa Mk IV	421	-
Combo Mk II	422	-
Combo Mk III / Frontera Mk I	423	-
Frontera Mk II	424	-
Insignia	425	701
Meriva Mk I	426	-
Meriva Mk II	427	-
Movano Mk I	428-429	-
Movano Mk II	430	702
Mokka	431	-
Nova	432	-
Omega	433-434	702
Royale	435	-
Senator Mk II	436	703
Signum	437	704
Tigra	438-439	-
Tigra TwinTop	440	-
Vectra Mk I	441	705
Vectra Mk II	442-443	706
Viceroy	444	-
Vivaro A	444-445	-
Zafira Mk I	446-447	-
Zafira Mk II	448-449	-
Zafira Mk III	450	-

to fit / passend für: VOLKSWAGEN	front axle Vorderachse	rear axle Hinterachse
Amarok (2H)	451	-
Bora (1J)	452-455	707
Caddy (14)	457	-
Caddy (9K)	458-459	-

to fit / passend für: VOLKSWAGEN	front axle Vorderachse	rear axle Hinterachse
Caddy (2K)	460-461	708
Caddy (2C)	462-463	707
Caddy Pickup (9U)	464	-
CC (3C)	465	710
Corrado (50)	466-468	-
Crafter (2E)	469	709
Derby 1 / Derby 2	469	-
Eos (1F)	470-471	712-713
Fox (5Z)	472-474	-
Golf 1 (17) / Cabrio (15)	475-476	-
Golf 2 (19/1G)	477-478	-
Golf 3 (1H)	479-482	-
Golf 3 Variant (1H)	483-486	-
Golf 3 Cabrio (1E)	487-489	-
Golf 4 (ex.) 4 Motion (1J)	490-491	-
Golf 4 4 Motion (1J)	492-495	711
Golf 5 / Plus (1K)	496-497	714-715
Golf 6 / Plus (1K)	498-499	716-717
Golf 7 (5G)	500	718
Golf 7 Sportsvan	501	-
Jetta 1 (16)	502-503	-
Jetta 2 (16/1G)	504-507	-
Jetta 2 Syncro	508	-
Jetta (16)	509	722
Jetta (1K)	510-511	719-721
Käfer	512-513	-
LT (28/29) (21)	514-516	-
LT 28 / LT 35	517-518	723
LT 46	518	723
Lupo (6x)	519-521	-
New Beetle (1C/9C)	522-525	723
New Beetle Cabrio (1Y)	526	-
New Beetle (5C1)	527	724
New Beetle (5C7)	528	-
Passat 1 (32)	529	-
Passat 2 (32)	530-534	-
Passat 3 (31/3A)	535-540	-
Passat 4 4motion	541	725
Passat 4 (3B)	542-543	725
Passat 5	544-545	726-727
Passat CC (3C)	544-545	730-731
Passat (Typ 36)	546	-
Passat 6 (A32)	547	728-729
Phaeton (3D)	548	732
Polo 1 / 2 (80/86/87)	549	-

to fit / passend für: VOLKSWAGEN	front axle Vorderachse	rear axle Hinterachse
Polo 3 (6N1)	550-551	-
Polo 3 (6N2)	552-553	-
Polo 4 (9N)	554-558	-
Polo (6C)	559	-
Polo Classic / Variant (6K)	560-563	-
Polo (6R)	564-565	-
Santana (32)	566-569	-
Scirocco 1+2 (53)	570-571	-
Scirocco 3 (13)	572-573	730-731
Sharan (7M8/7M9/7M6)	574	732
Sharan (7N)	575	733
Tiguan (5N)	576-577	734-735
Touareg (7L)	578-579	736
Touran (1T)	580-581	738-739
Touareg (7P)	582	737
Transporter Typ 3 (24)	583-584	740
Transporter T4 (70)	585-586	-
Transporter T4 (7D)	587-588	-
Transporter T5 (7H/7J)	589	740
Typ 3 (1500 / 1600)	590	-
up! (121) / e-up! (BL1)	591	-
Vento (1H)	592-596	-
Bora 4 4motion (1J)	-	711
Golf 6 Cabrio (51)	-	718
Transporter T4 / Multivan	-	740

to fit / passend für:

VOLVO

240 → 260	597-599	741
340 → 360	600	-
440 → 460	601	742
480	602	742
740 → 760	603-604	743
780	605	-
850	605-606	744
940 → 960	607-609	745
C 30	610-611	747
C 70 I	612-613	745
C 70 II	614-615	747
S 40 I	616-617	746
S 40 II	618-619	747
S 60 I	620-621	748
S 60 II	622-623	749
S 70 I	624-625	749
S 80 I	633	753
S 80 II	634	754

to fit / passend für: VOLVO	front axle Vorderachse	rear axle Hinterachse
S 90	635	754
V 40 II	626	750
V 40 Cross Country	627	750
V 40 I	616-617	746
V 50	618-619	747
V 60	622-623	749
V 70 I	624-625	-
V 70 II	628-629	751
V 70 III	632	752
V 70 XC , XC 70 II	630-631	751
V 90	635	754
XC 60	636	755
XC 70 III	632	752
XC 90 I	637	755

Catalogues, Flyers and more

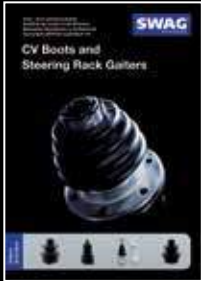

CV Boots and Steering Rack Gaiters

Achs- und Lenkmanschetten
Soufflets de Cardan et de Direction
Manguitos Guardapolvo y de Dirección
Осевые манжеты и манжеты рулевого управления

8 00 1019



Steering and Suspension

Lenkung und Aufhängung
Direction et Suspension
Dirección y Suspensión
Рулевое управление и подвеска

8 00 1013



Engine and Transmission Mountings

Motorlager/Getriebelager
Support de Moteur/Support de Boîte
Soportes de Motor/Soportes de Caja
Опора двигателя/коробки передач

8 00 1007



Electric 'Engine/Gearbox'

Elektrik 'Motor/Getriebe'
Electrique 'Moteur/Boîte à vitesses'
Sistema Eléctrico 'Motor/Caja de cambio'
Электрооборудование 'Двигатель/Коробка передач'

8 00 1050

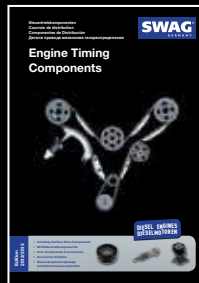

Engine Timing Components/Diesel Engines

Steuertriebkomponenten/Dieselmotoren
Courroie de distribution/véhicules diesel
Componentes de Distribución/motores diésel
Детали привода механизма газораспределения и вспомогательных агрегатов Для дизельных двигателей

8 00 1012



Propeller Shaft Accessories

Kardanwellenzubehör
Accessoires de Transmission
Accesorios para los Árboles de Cardán
Арматура карданного Вала

8 00 1017



Electric 'Heating/Climate Control'

Elektrik 'Heizung/Klima'
Electrique 'Chauffage/Climatisation'
Sistema Eléctrico 'Calefacción/Climatización'
Электрооборудование 'Система отопления/Кондиционер'

8 00 1051



Engine Timing Components/Petrol Engines

Steuertriebkomponenten/Benzinmotoren
Courroie de distribution/véhicules essence
Componentes de Distribución/motores gasolina
Детали привода механизма газораспределения и вспомогательных агрегатов Для бензиновых двигателей

8 00 1014



Rubber-Metal-Parts for Suspension

Gummimetallteile für Fahrwerke
Pièces Caoutchouc-Métal pour Suspension
Piezas de Caucho-Metal para Chasis
Резинометаллические детали для ходовой части

8 00 1006



Electric 'Brake'

Elektrik 'Bremse'
Electrique 'Frein'
Sistema Eléctrico 'Frenos'
Электрооборудование 'Тормозная система'

8 00 1052



Pulleys

Riemenscheiben
Poulies
Poleas
Ременной шкив

8 00 1066



Gas Pressure Springs

Gasdruckfedern
Ressort pneumatique
Molle pressione gas
газовые пружины

8 00 1054

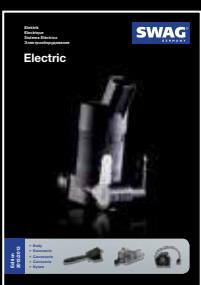

Electric 'Body'

Elektrik 'Karosserie'
Electrique 'Carrosserie'
Sistema Eléctrico 'Carrocería'
Электрооборудование 'Кузов'

8 00 1053



Wheel Bearing/Wheel Hubs

Radlager/Radnaben
Roulements de Roue/Moyeux de Roue
Rudamiento de la Rueda/Cubos de Rueda
Подшипник колеса / ступицы колёс

PDF file only!



Spare Parts to fit VW

98 00 1035

These catalogues are only available as pdf files:

Spare Parts to fit

- Asian Cars
- Audi
- BMW
- Ford
- French Cars
- Italian Cars
- LCV
- Mercedes-Benz
- Opel
- Porsche
- Scandinavian Cars
- Seat
- Škoda
- Smart
- Volkswagen



All Type Catalogues are available on
www.swag.de/service/downloads



Cabin Air Filters

Innenraumlufffilter
 Filtres à air d'habitacle
 Filtri abitacolo
 Filtros de aire del habitáculo
 внутренний воздушный фильтр

8 00 1043



Fluids

Технические жидкости

GB
 8 00 1040

RUS
 8 00 1042



Wheel Fastening

Radbefestigung
 Fixation de Roue
 Fissaggio Ruota
 Fijación de Ruedas
 Колесное крепление

8 00 1037

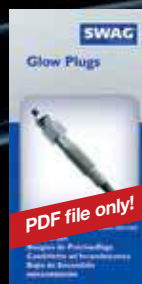

Glow Plugs

Glühkerzen
 Bougies de Préchauffage
 Candelette ad Incandescenza
 Bujía de Encendido
 Свечи накаливания



SWAG Extra

8 00 1032



Your advantages at a glance

Our special catalogue service for you!

- Clear layout allows quick parts identification.
- Picture, description, reference number and SWAG part number at a glance.
- The complete chassis at a glance.

Ihre Vorteile auf einen Blick

Unser spezieller Katalog-Service für Sie!

- Schnelle Teilefindung durch klare und übersichtliche Darstellungen.
- Abbildung, Referenznummer, SWAG Nummer und Eigenschaften auf einen Blick.
- Das komplette Fahrwerk auf einen Blick.

Vos avantages en un coup d'œil

Notre catalogue: conçu spécialement pour vous

- À travers une conception claire, trouvez rapidement et simplement les pièces..
- Photo, description, référence, informations, référence SWAG d'un seul coup d'œil.
- Le châssis complet d'un seul coup d'œil.

Sus ventajas en un solo vistazo

¡Nuestro servicio de catálogo especial para usted!

- Con esquema detallado para una búsqueda rápida y segura.
- Foto, descripción, referencia, número y referencia SWAG de un vistazo.
- El chasis al completo de un vistazo.

Все Ваши преимущества здесь и сейчас

Наш специальный сервис каталогов для Вас!

- Быстрое нахождение запчастей благодаря чётким и наглядным изображениям.
- Иллюстрация, оригинальный номер, номер SWAG и характеристики с первого взгляда.
- вся ходовая часть в одном месте.



100 NX (B13)
(10/90 → 10/94)

82 73 0012



82 73 0011



Vorderachse / Front axle



Almera (N15)

(1995 → 2000)

Vorderachse / Front axle

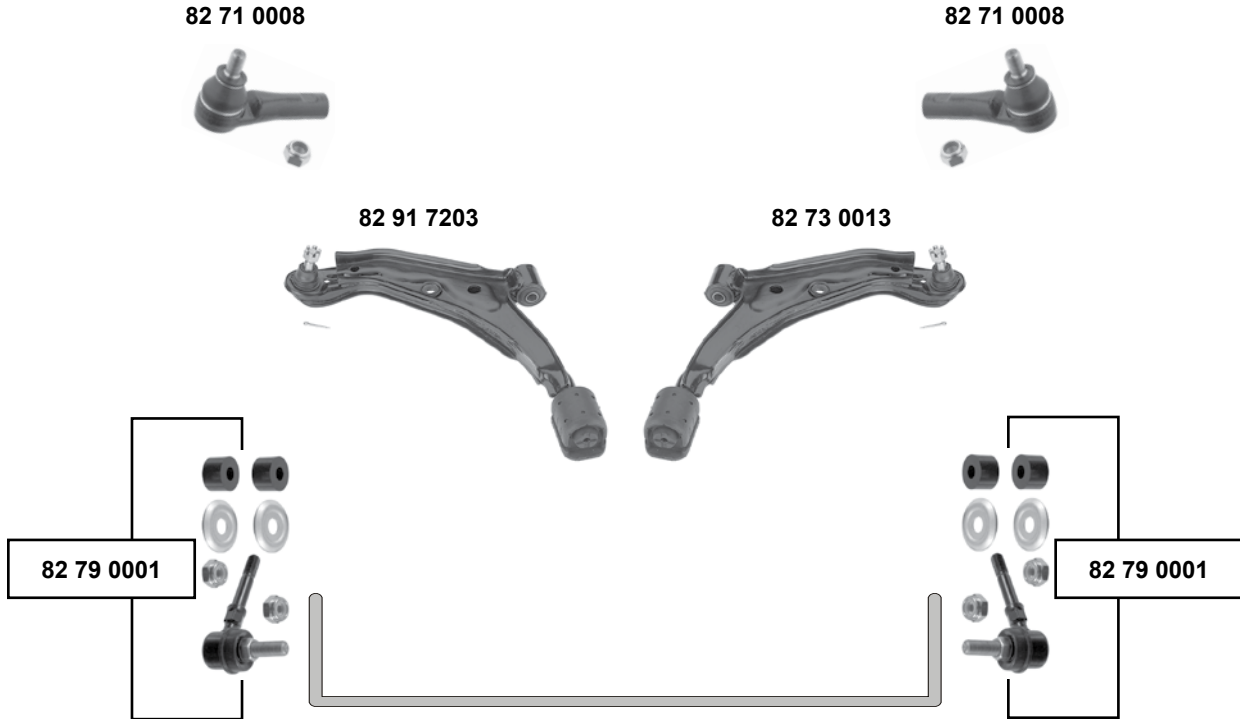

Almera (N16)

(2000 →)

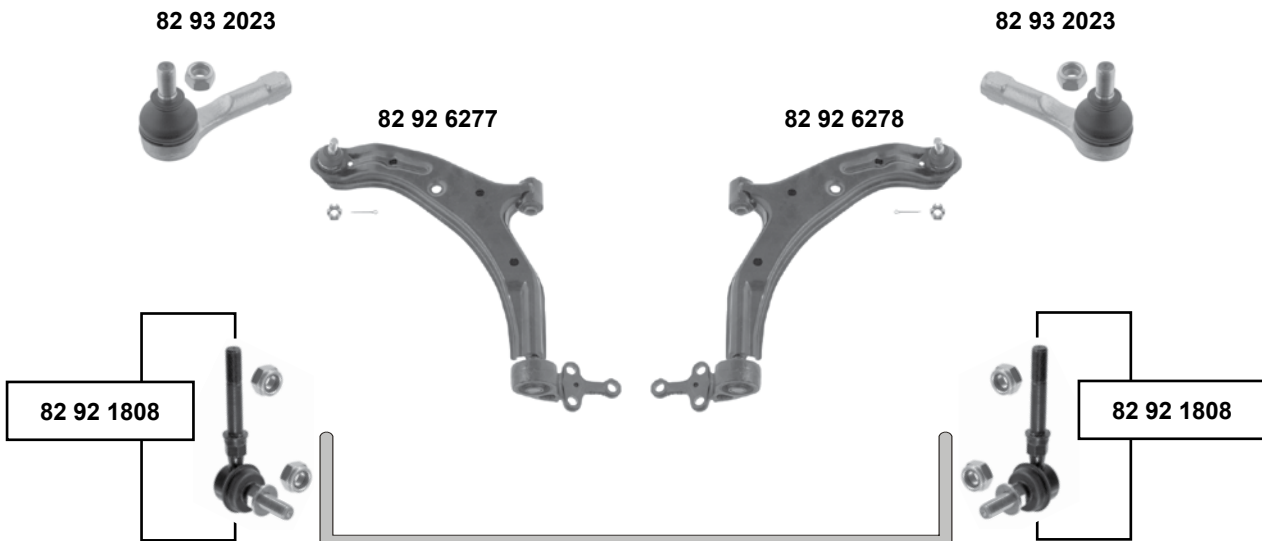

SWAG GERMANY	Ref. - No.			
82 71 0008	48520-73J25	Spurstangenendstück / tie rod end		M10 x 1,25
82 73 0013	54500-0M060	Querlenker / control arm		
82 79 0001	54618-50Y00	Verbindungsstange / stabilizer link		M10 x 1,25
82 91 7203	54501-0M060	Querlenker / control arm		
82 92 1808	54618-4M400	Verbindungsstange / stabilizer link		M10 x 1,25
82 92 6277	54501-4M410	Querlenker / control arm		
82 92 6278	54500-4M410	Querlenker / control arm		
82 93 2023	48520-BM425	Spurstangenendstück / tie rod end		M12 x 1,25



Almera Tino (V10)
(05/00 →)

Vorderachse / Front axle





Interstar (X70)

(2002 →)

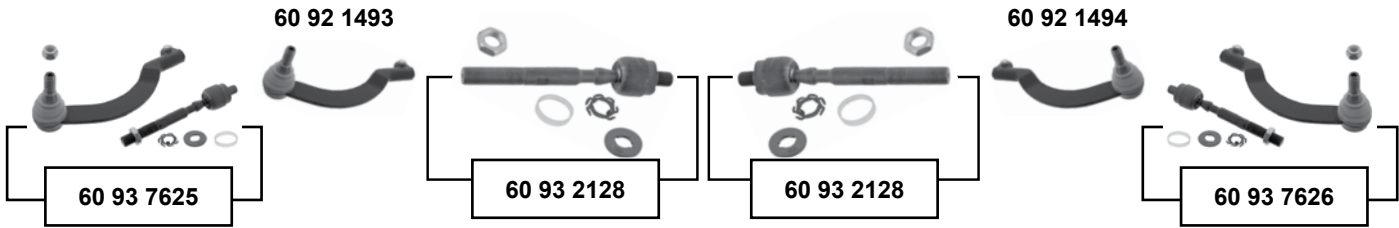

oben / upper

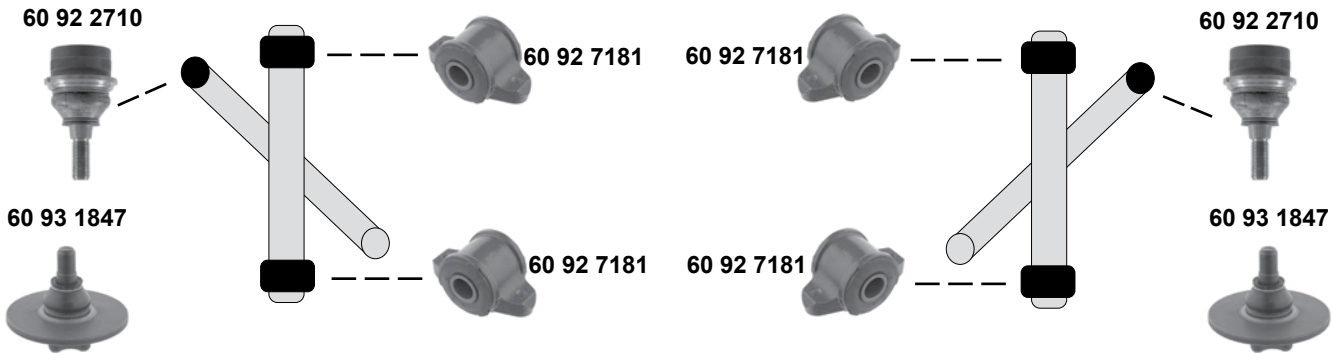

unten / lower

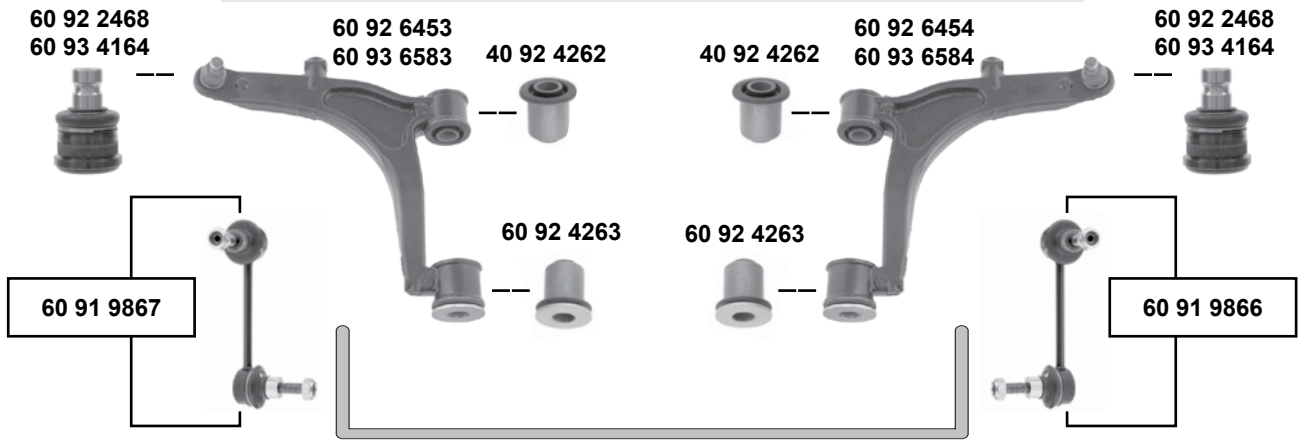

SWAG GERMANY	Ref. - No.			
40 92 4262	54570-00QAA	Querlenkerlager / control arm mount		
60 91 9866	54618-00QAA	Verbindungsstange / stabilizer link		L 130
60 91 9867	54618-00QAB	Verbindungsstange / stabilizer link		L 130
60 92 1493	48520-00QAH	Spurstangenendstück / tie rod end		L 225
60 92 1494	48520-00QAJ	Spurstangenendstück / tie rod end		L 225
60 92 2468	40160-00QAD	Traggelenk / ball joint	→ 07	Ø A 22
60 92 2710	40160-00QAB	Traggelenk / ball joint		Ø A 22
60 92 4263	54423-00QAA	Querlenkerlager / control arm mount		
60 92 6453	54501-00QAE	Querlenker / control arm	→ 06	
60 92 6454	54500-00QAE	Querlenker / control arm	→ 06	
60 92 7181	54450-00QAA	Querlenkerlager / control arm mount		
60 93 1847	40110-00QAB	Traggelenk / ball joint		ØA 15/101
60 93 2128	48521-00Q0B SK	Spurstange / tie rod		L 174,5
60 93 4164	40160-00Q0B	Traggelenk / ball joint	09.07 →	Ø A 24
60 93 6583	54501-00Q0E	Querlenker / control arm	07 →	
60 93 6584	54500-00Q0E	Querlenker / control arm	07 →	
60 93 7625	48520-00QAH S1	Rep. Satz Spurstange / rep. kit tie rod		
60 93 7626	48520-00QAJ S1	Rep. Satz Spurstange / rep. kit tie rod		



Juke (F15E)
(2010 →)

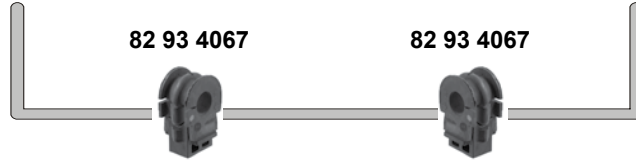

King Cab / Pick Up (D21)
(1985 → 1998)



oben / upper

99 78 0002

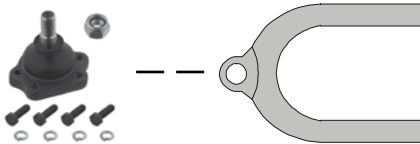

99 78 0002

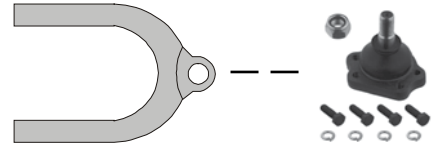

unten / lower

82 78 0011

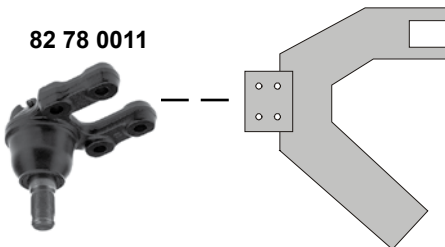

82 78 0011

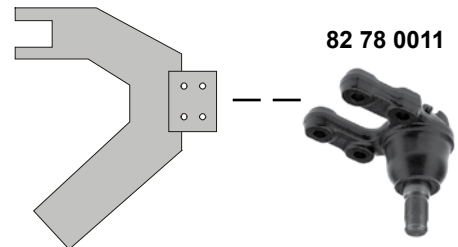



Kubistar (X76)

(2003 →)

Vorderachse / Front axle

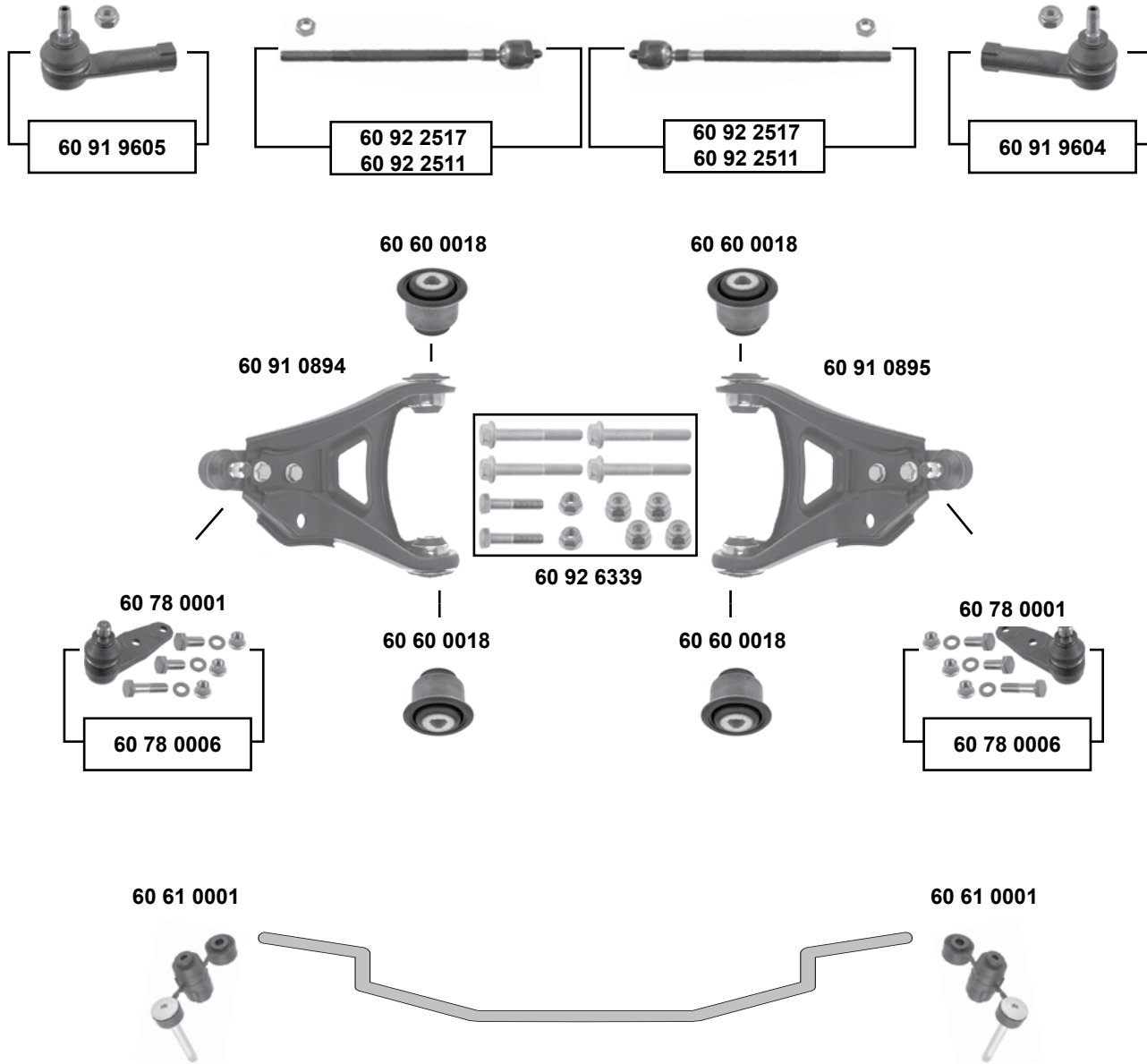

SWAG	Ref. - No.			
60 60 0018	54560-00QAB	Querlenkerlager / control arm mount		45,5x46
60 61 0001	54616-00QAA	Stabilisatorlager außen / stabilizer mount outer	gelb / yellow	
60 78 0001	54501-00QAH S2	Traggelenk / ball joint		
60 78 0006	54501-00QAH S1	Rep. Satz Traggelenk / rep. kit ball joint		
60 91 0894	54501-00QAH	Querlenker / control arm		
60 91 0895	54500-00QAH	Querlenker / control arm		
60 91 9604	48520-00QAP	Spurstangenendstück / tie rod end		
60 91 9605	48520-00QAN	Spurstangenendstück / tie rod end		
60 92 2511	48521-00QAA SK	Spurstange / tie rod	man.	
60 92 2517	48521-00QAG SK	Spurstange / tie rod	servo	
60 92 6339	54500-00QAH S1	Schraubensatz / screw kit		



Maxima (A32)
(1995 → 2000)

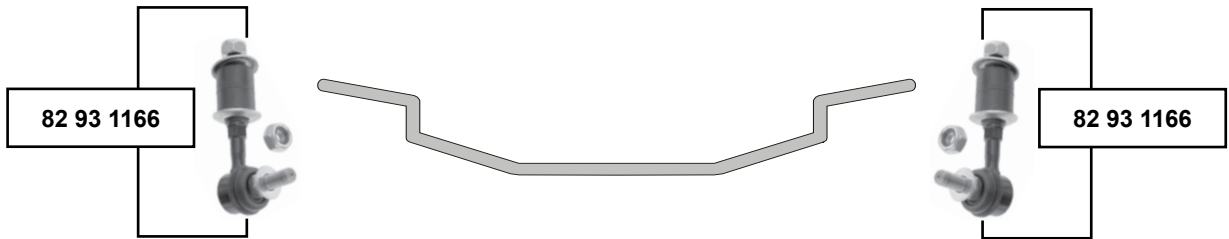

Vorderachse / Front axle

Maxima (CA33)
(2000 →)

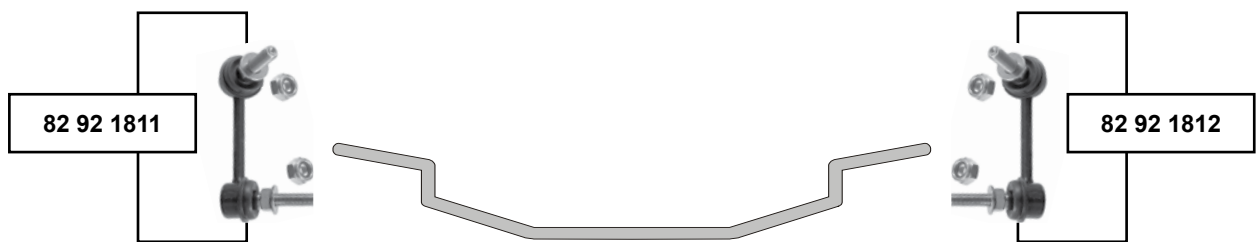

passend für / to fit

NISSAN

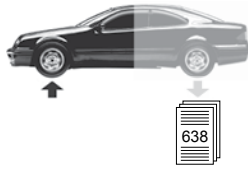

Micra (K10)
(1982 → 1992)

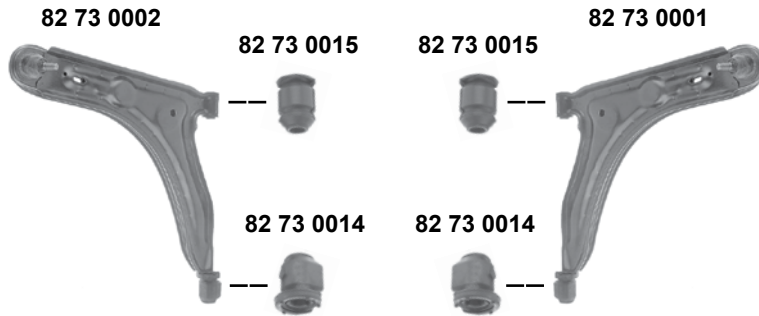
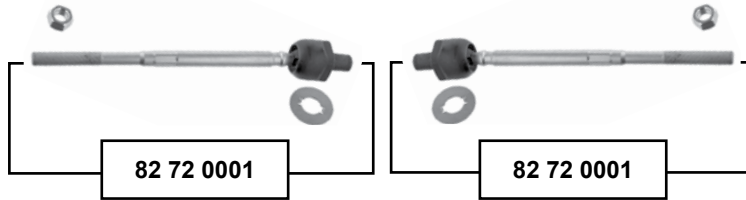

Vorderachse / Front axle

Micra (K11)
(1992 → 2003)

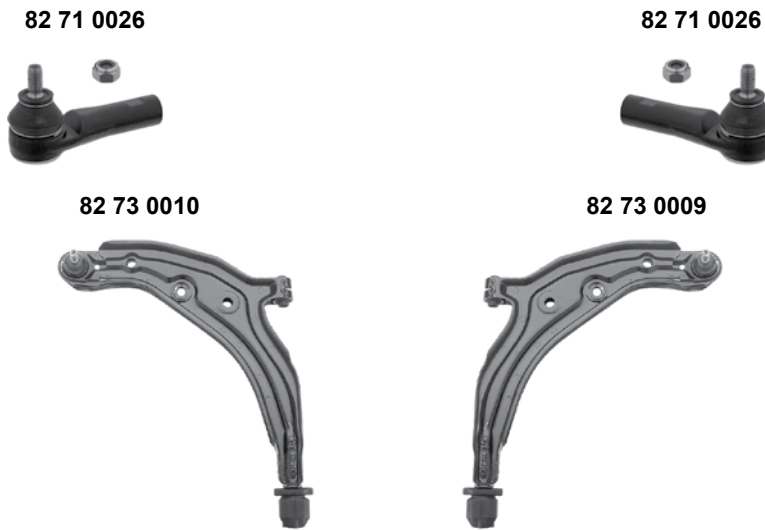

(1) 1,0 (Benzin, CG10DE), 1,3 (Benzin, CG13DE)

SWAG GERMANY	Ref. - No.			
82 71 0025	48520-17B25	Spurstangenendstück / tie rod end		M10 x 1,25
82 71 0026	48520-6F625	Spurstangenendstück / tie rod end		M10 x 1,25
82 72 0001	48521-70A06	Spurstange / tie rod	02/85 →	L 280
82 73 0001	54500-21B00	Querlenker / control arm		
82 73 0002	54501-21B00	Querlenker / control arm		
82 73 0009	54500-4F105	Querlenker / control arm	08/92 → 02/98 / (1)	
82 73 0010	54501-4F105	Querlenker / control arm	08/92 → 02/98 / (1)	
82 73 0014	54476-01B00	Querlenkerlager / control arm mount		
82 73 0015	54535-01B00	Querlenkerlager / control arm mount		



Micra (K12) (2003 →)

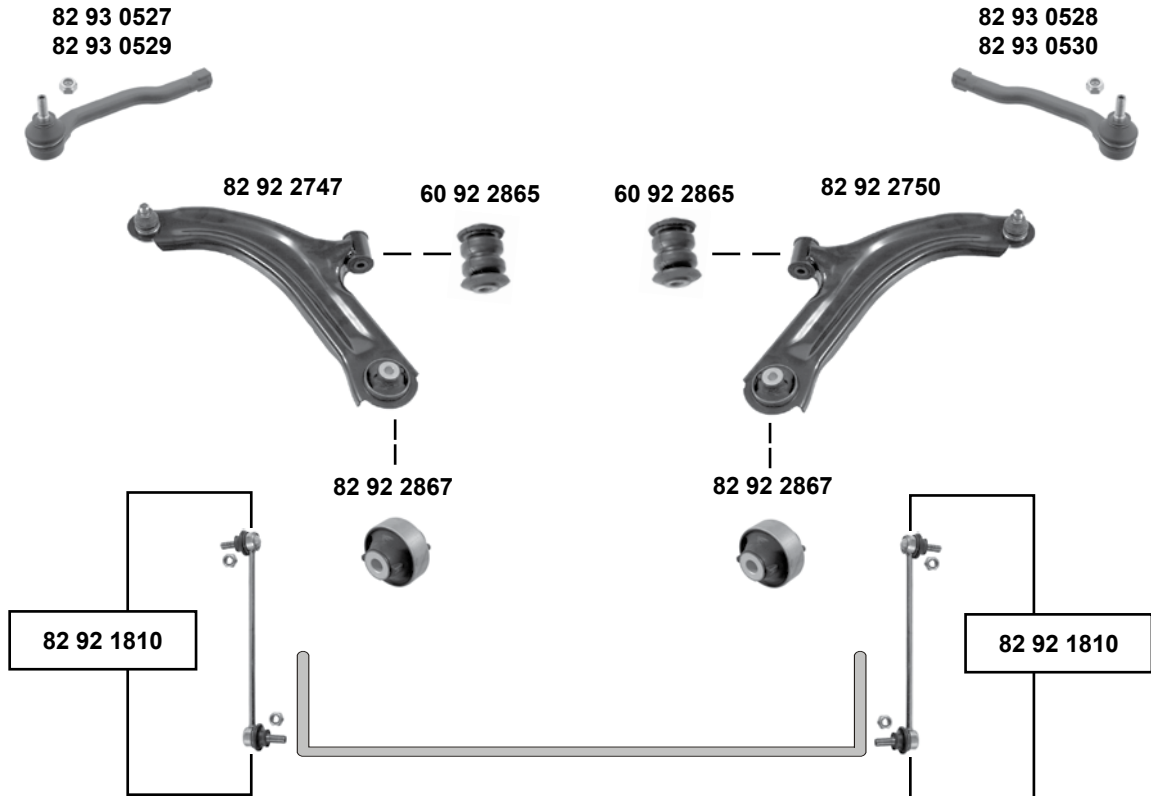

Vorderachse / Front axle

Micra C+C (CK12E) (2005 →)



Ref. - No.

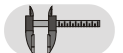

60 92 2865	54560-AX600	Querlenkerlager / control arm mount		Ø A 40
82 92 1810	54618-AX600	Verbindungsstange / stabilizer link		L 248
82 92 2747	54501-AX600	Querlenker / control arm		
82 92 2750	54500-AX600	Querlenker / control arm		
82 92 2867	54570-AX600	Querlenkerlager / control arm mount		Ø A 58
82 93 0527	48640-AX600	Spurstangenendstück / tie rod end	→ 04	
82 93 0528	48520-AX600	Spurstangenendstück / tie rod end	→ 04	
82 93 0529	48647-1U61A	Spurstangenendstück / tie rod end	07 →	
82 93 0530	48527-1U61A	Spurstangenendstück / tie rod end	07 →	

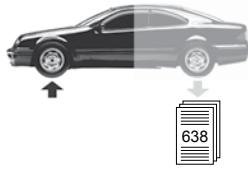

Murano (Z51)

(2008 →)

Vorderachse / Front axle



Navara (D40M)

(05/05 →)

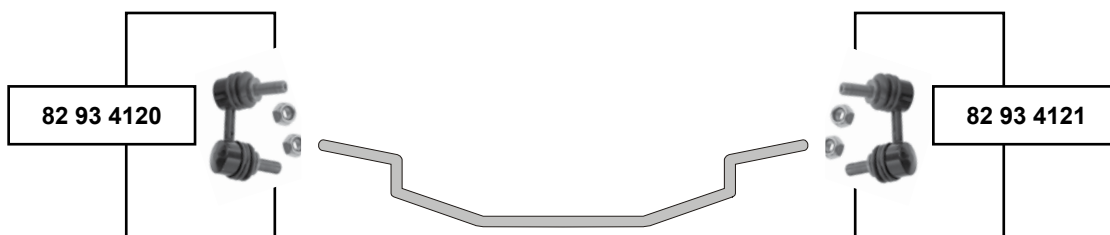
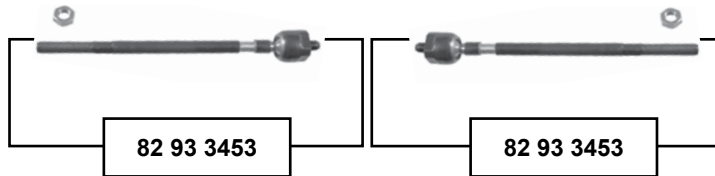

(1) (D40M) 05/05 → 2,5 D (YD25DDTi)
01/10 → 3,0 D (V9X)



Ref. - No.



82 93 0985	54668-JD00A	Verbindungsstange / stabilizer link		L 300
82 93 0986	54618-JD00A	Verbindungsstange / stabilizer link		L 300
82 93 3453	48521-EA000	Axialgelenk / axial joint	2,5 (Diesel, YD25DDTi)	L 203
82 93 4120	54668-EA010	Verbindungsstange / stabilizer link	(1)	L 64,5
82 93 4121	54618-EA010	Verbindungsstange / stabilizer link	(1)	L 64,5

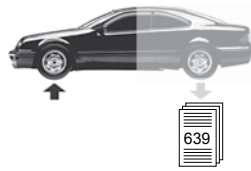

Note (E11)
(2006 →)

82 93 0529



82 93 0530



NV400 (X62)
(2011 →)

Vorderachse / Front axle

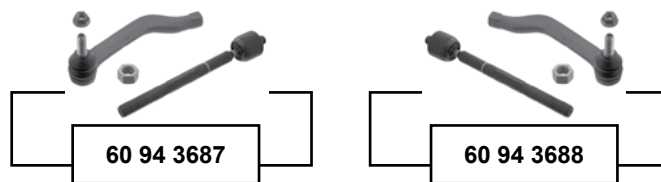
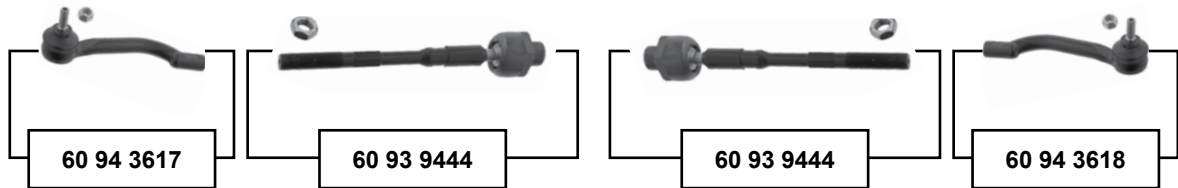

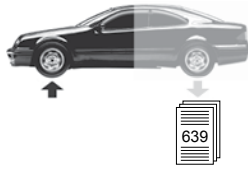

Pathfinder (R50)

(1997 → 2004)

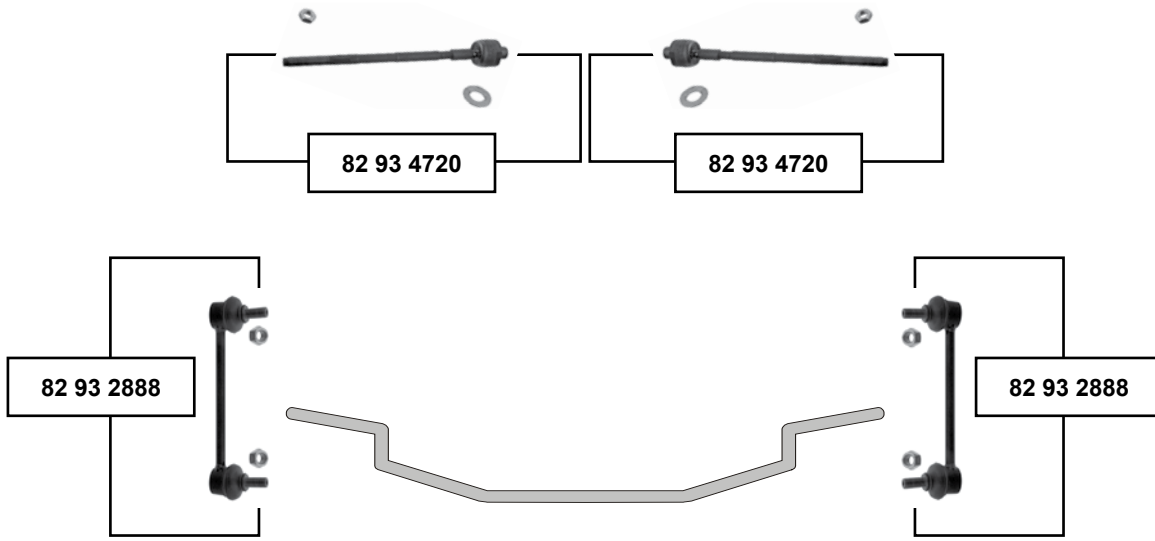

Vorderachse / Front axle

Pathfinder (R51)

(2005 →)

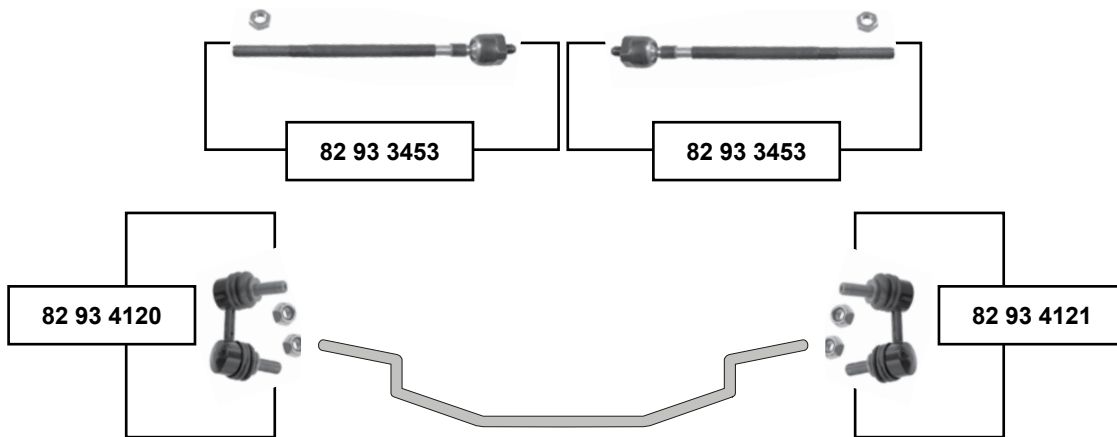

(1) (R50) 10/97 → 07/00 / 3,3 (Benzin, VG33E)
07/00 → / 3,5 (Benzin, VQ35DE)

(2) (R51M) 06/05 → 2,5 D (YD25DDTi), 4,0 B (VQ40DE)
01/10 → 3,0 D (V9X)

(3) (R50) 10/97 → 07/00 (mot.) VG33E
07/00 → 08/02 (mot.) VQ35DE



Ref. - No.



82 93 2888	54618-0W001
82 93 3453	48521-EA000
82 93 4120	54668-EA010
82 93 4121	54618-EA010
82 93 4720	48521-0W025

Verbindungsstange / stabilizer link
Axialgelenk / axial joint
Verbindungsstange / stabilizer link
Verbindungsstange / stabilizer link
Axialgelenk / axial joint

(1)
4,0 (Benzin, VQ40DE)
(2)
(2)
(3)

L 190
L 203
L 64,5
L 64,5
L 328

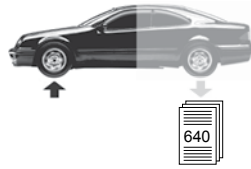

Patrol (Y60)
(1987 → 1997)



Pixo
(2009 →)

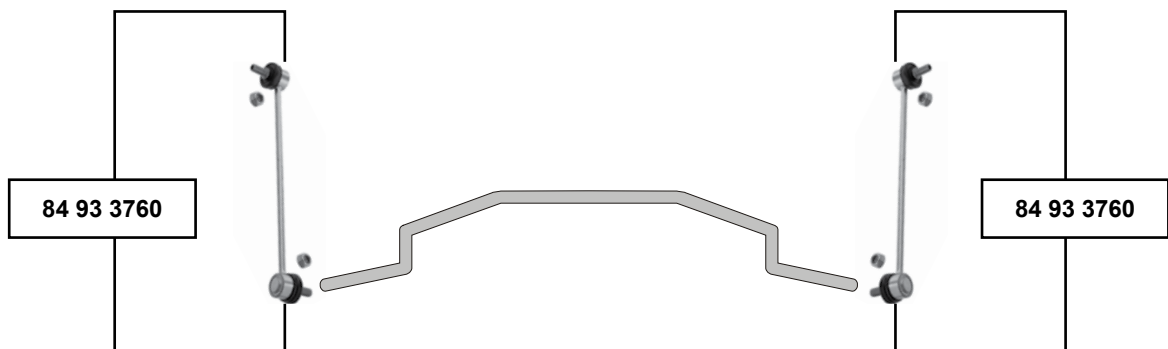
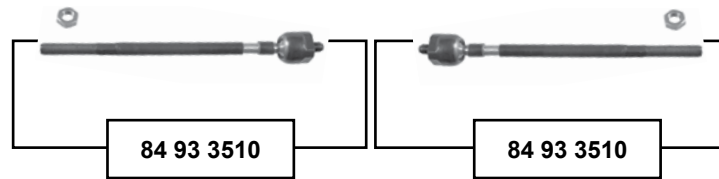

Vorderachse / Front axle



Platina (1998 →)

Vorderachse / Front axle

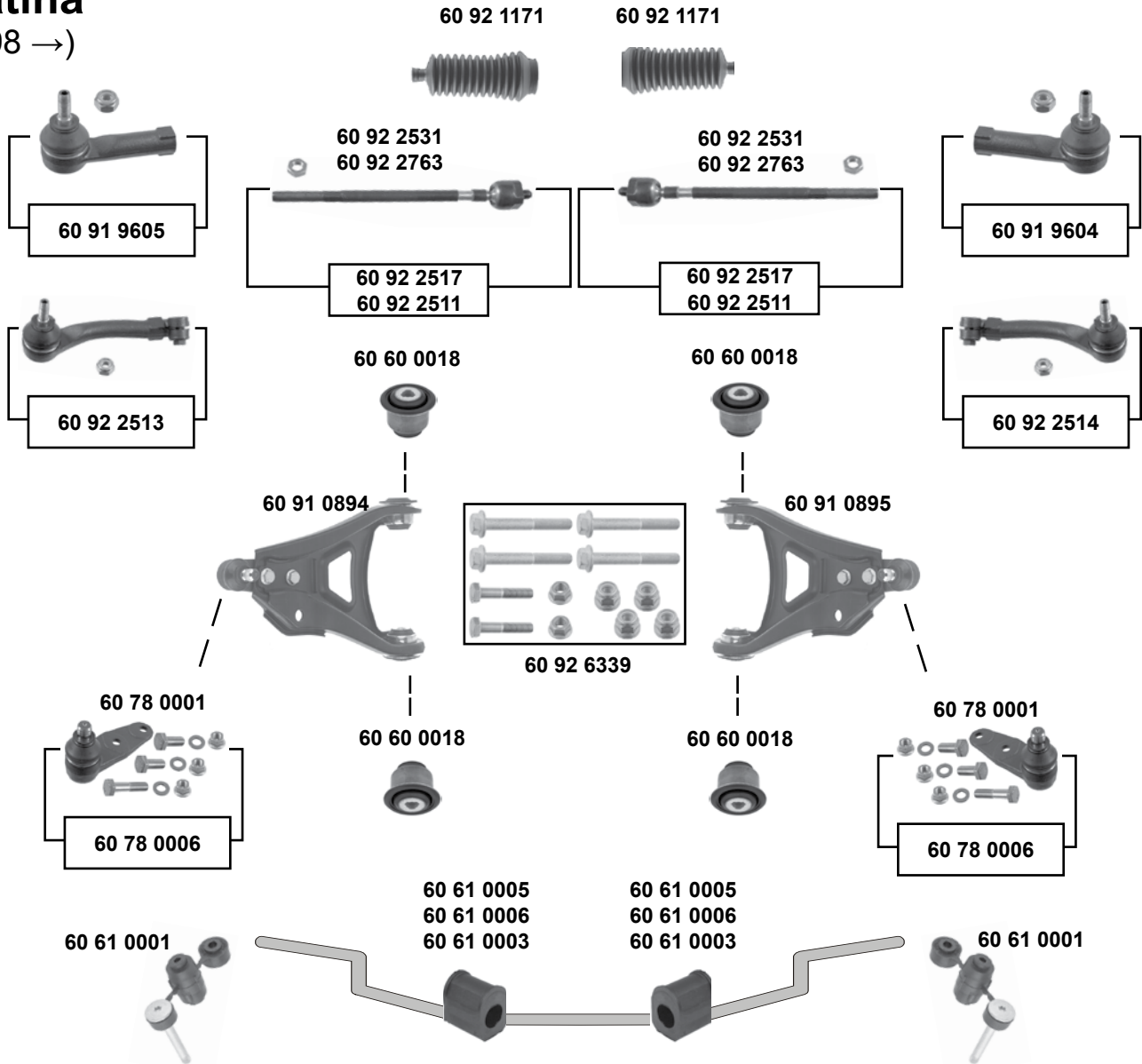

SWAG GERMANY	Ref. - No.			
60 60 0018	54560-00QAB	Querlenkerlager / control arm mount		45,5x46
60 61 0001	54616-00QAA	Stabilisatorlager / stabilizer mount	(ex.) RS V6	
60 61 0003	77 00 785 788	Stabilisatorlager / stabilizer mount		Ø I 23
60 61 0005	77 00 798 053	Stabilisatorlager / stabilizer mount		Ø I 22
60 61 0006	77 00 835 929	Stabilisatorlager / stabilizer mount		Ø I 24
60 78 0001	54501-00QAH S2	Traggelenk / ball joint		Ø A 16
60 78 0006	54501-00QAH S1	Rep. Satz Traggelenk / rep. kit ball joint		
60 91 0894	54501-00QAH	Querlenker / control arm		
60 91 0895	54500-00QAH	Querlenker / control arm		
60 91 9604	48520-00QAP	Spurstangenendstück / tie rod end	12/99 →	M10 x 1,25
60 91 9605	48520-00QAN	Spurstangenendstück / tie rod end	12/99 →	M10 x 1,25
60 92 1171	77 01 469 496	Lenkmanschette / steering boot	SMI servo	
60 92 2511	48521-00QAA SK	Spurstange / tie rod	man. 12/99 →	
60 92 2513	77 01 471 145	Spurstangenendstück / tie rod end	→ 12/99	
60 92 2514	77 01 471 146	Spurstangenendstück / tie rod end	→ 12/99	
60 92 2517	48521-00QAG SK	Spurstange / tie rod	SMI servo 12/99 →	
60 92 2531	77 01 471 145	Spurstange / tie rod	servo → 12/99	
60 92 2763	77 01 472 734 SK	Spurstange / tie rod	TRW servo 12/99 →	
60 92 6339	54500-00QAH S1	Schraubensatz / screw kit	(ex.) RS V6	



Primastar (X83) (2001 →)

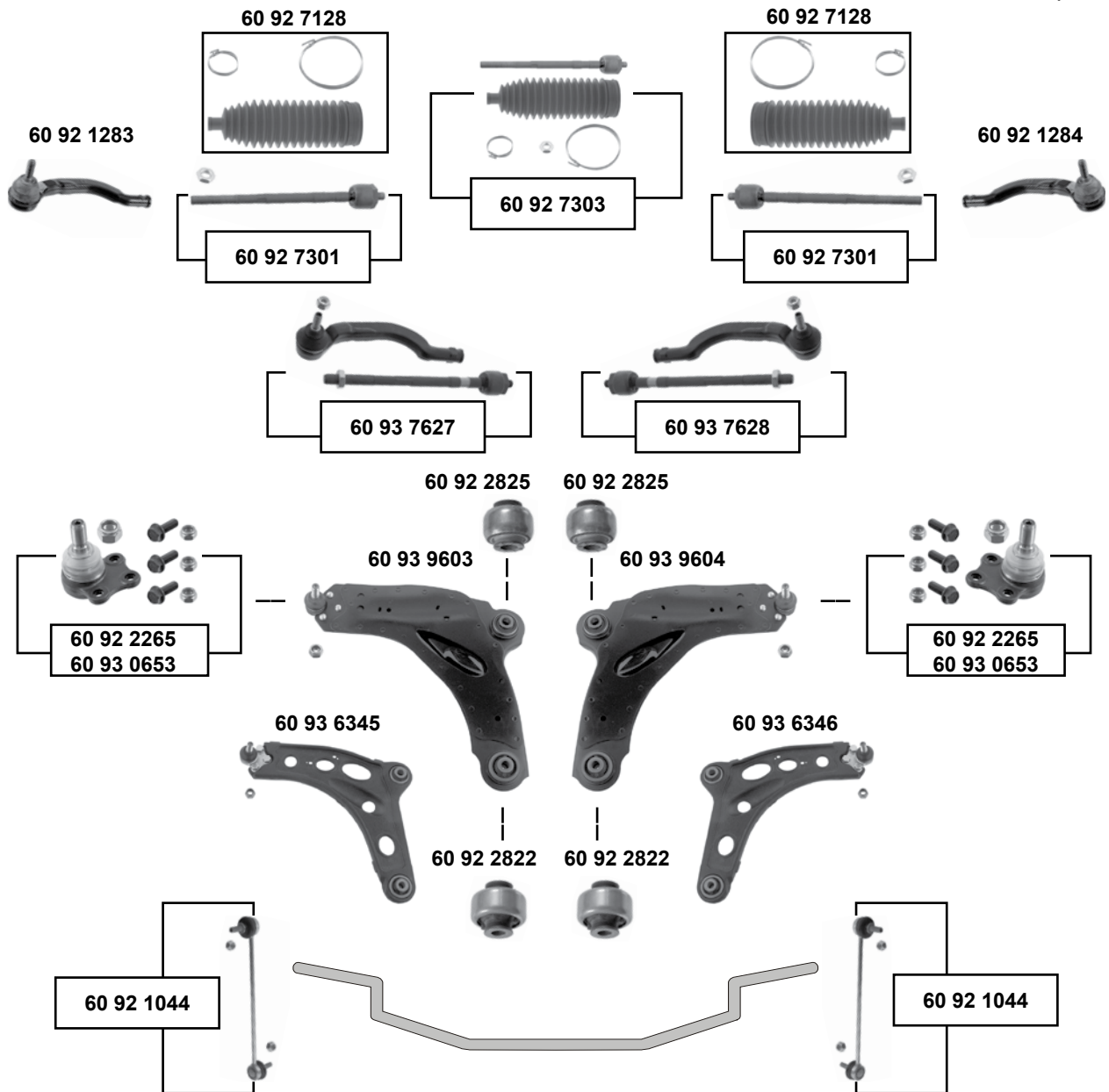

Vorderachse / Front axle



Ref. - No.



60 92 1044	54616-00QAC	Verbindungsstange / stabilizer link		L 280
60 92 1283	48520-00QAK	Spurstangenendstück / tie rod end		M14 x 1,5
60 92 1284	48520-00QAL	Spurstangenendstück / tie rod end		M14 x 1,5
60 92 2265	40160-00Q0C	Traggelenk / ball joint	07/02 → 10/06	M16 x 1,5 Ø A 58/27
60 92 2822	54503-00Q0B SK3	Querlenkerlager / control arm mount		
60 92 2825	54503-00Q0B SK2	Querlenkerlager / control arm mount		
60 92 7128	48203-00QAE	Rep. Satz Lenkmanschette / rep. kit steering boot	03 →	L 205
60 92 7301	48520-00QAM SK	Spurstange / tie rod	03 →	L 245
60 92 7303	48520-00QAM	Rep. Satz Spurstange beidseitig / rep. kit tie rod both sides	03 →	
60 93 0653	40160-00Q0A	Traggelenk / ball joint	10/06 →	M16 x 1,5
60 93 6345	54503-00Q0E	Querlenker / control arm	12/06 →	
60 93 6346	54502-00Q0E	Querlenker / control arm	12/06 →	
60 93 7627	48520-00QAM S1	Rep. Satz Spurstange / rep. kit tie rod	→ 12/06	
60 93 7628	48520-00QAM S2	Rep. Satz Spurstange / rep. kit tie rod	→ 12/06	
60 93 9603	54503-00Q0B	Querlenker / control arm		
60 93 9604	54502-00Q0B	Querlenker / control arm		



Primera Limousine (P10E)

(1990 → 1996)

82 71 0008



82 71 0008



oben / upper

82 73 0006



82 73 0005



unten / lower

82 73 0004



82 73 0003



Ref. - No.



82 71 0008	48520-73J25	Spurstangenendstück / tie rod end			M10 x 1,25
82 73 0003	54500-86J00	Querlenker / control arm	(ex.) 4WD		
82 73 0004	54501-86J00	Querlenker / control arm	(ex.) 4WD		
82 73 0005	54524-2F010	Querlenker / control arm	94 →		
82 73 0006	54525-2F010	Querlenker / control arm	94 →		
82 79 0001	54618-50Y00	Verbindungsstange / stabilizer link	(mot.) 1.6		M10 x 1,25
82 92 3724	54618-86J25	Verbindungsstange / stabilizer link	(ex.) (mot.) 1.6		L 165

Vorderachse / Front axle



Primera Wagon (W10)
(1990 → 1998)

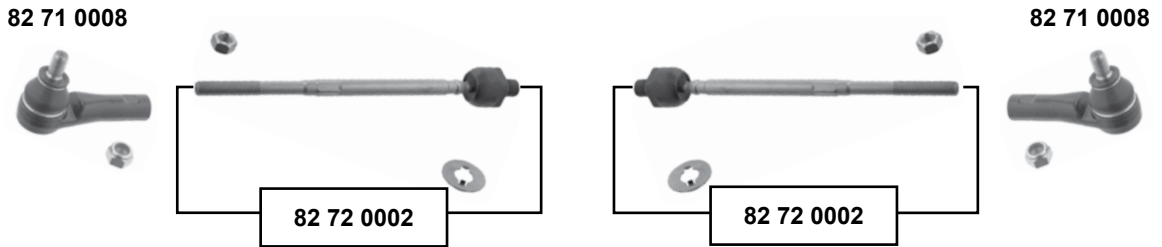

Vorderachse / Front axle





Primera (P11 / WP11)

(1996 → 2002)

82 71 0008



82 71 0008



oben / upper

82 73 0006



82 73 0005



unten / lower

82 73 0008



82 73 0007



82 92 3724

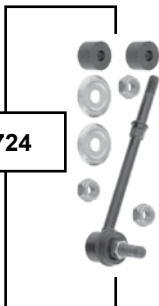

82 92 3724

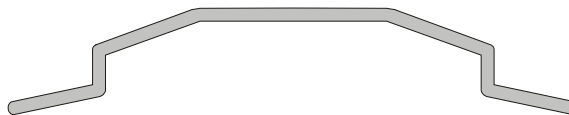

82 71 0008	48520-73J25	Spurstangenendstück / tie rod end
82 73 0005	54524-2F010	Querlenker / control arm
82 73 0006	54525-2F010	Querlenker / control arm
82 73 0007	54500-2F500	Querlenker / control arm
82 73 0008	54501-2F500	Querlenker / control arm
82 92 3724	54618-86J25	Verbindungsstange / stabilizer link

Vorderachse / Front axle

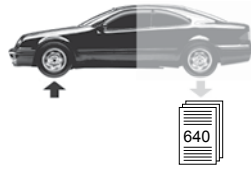

Primera (P12 / WP12)
(2002 →)

82 71 0008



82 71 0008



82 92 4417



82 92 4418

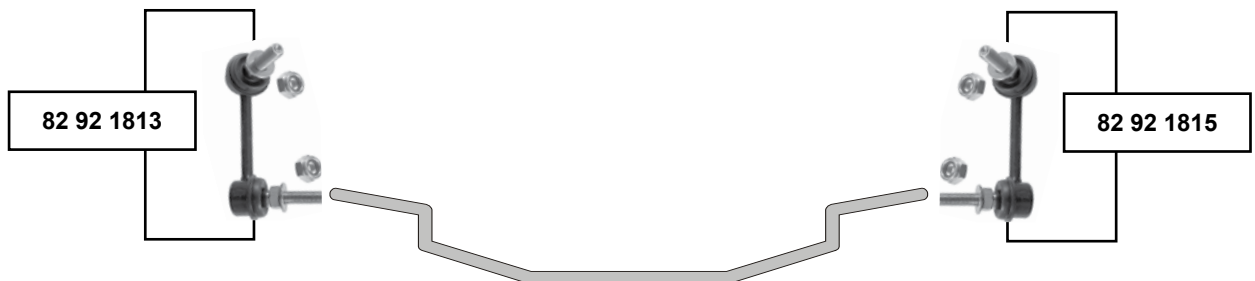

82 71 0008	48520-73J25
82 92 1813	54668-AU000
82 92 1815	54618-AU000
82 92 4417	54525-AV601
82 92 4418	54524-AV601

Spurstangenendstück / tie rod end
Verbindungsstange / stabilizer link
Verbindungsstange / stabilizer link
Querlenker links / control arm left
Querlenker rechts / control arm right

03/02 →
03/02 →

M10 x 1,25
L 65
L 65

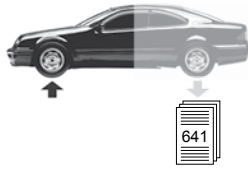

Qashqai (J10E / +2 / JJ10E)

(2006 →)

Vorderachse / Front axle

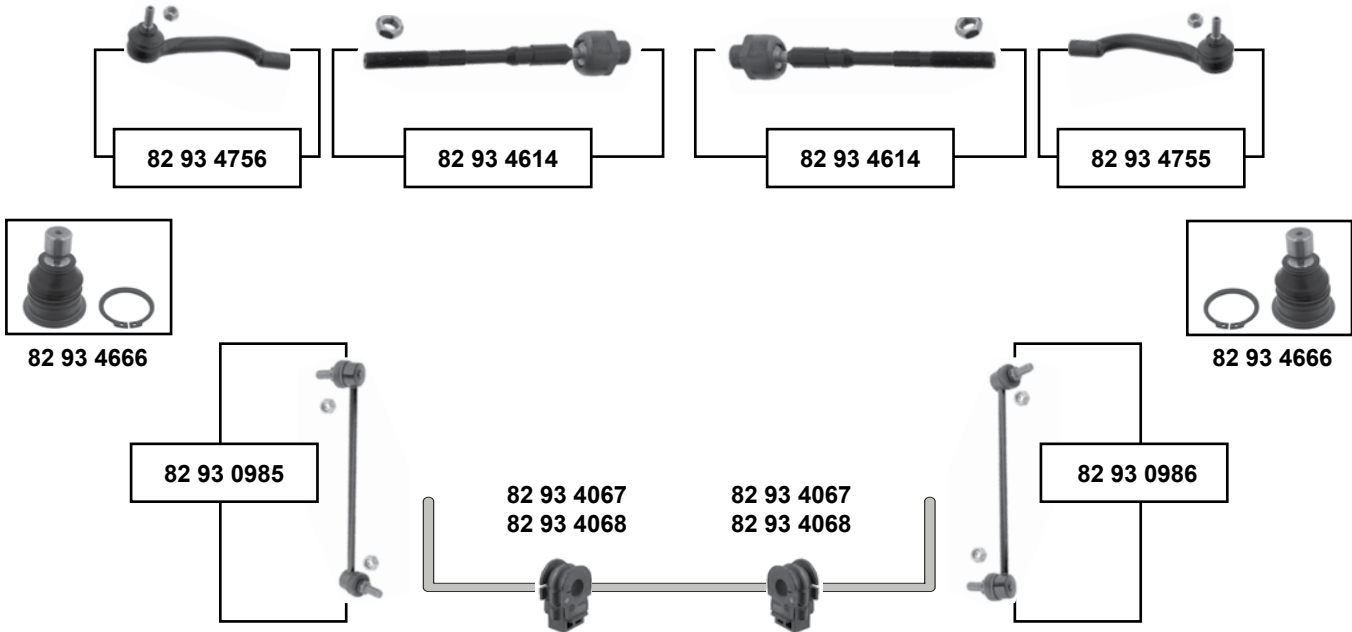

Serena (C23M)

(1992 →)



- (1) Qashqai (J10E) : 12/06 → (mot.) 1,6 / 1,5 / 2,0
- Qashqai +2 (JJ10E) : 08/08 → (mot.) 1,6 / 1,5 / 2,0
- (2) Qashqai (J10E) : 04/07 → (mot.) 2,0



- (3) Qashqai (J10E) 04/07 → (mot.) 2,0 Diesel M9R, (mot.) 1,6 Benzin HR16DE, (mot.) 2,0 Benzin (MR20DE)
- Qashqai (JJ10E) 08/08 → (mot.) 1,6 Benzin HR16DE, (mot.) 2,0 Benzin MR20DE, (mot.) 1,5 Diesel K9K

- (4) Qashqai (J10E) 12/06 → (mot.) HR16DE, MR20DE, K9K, M9R
- Qashqai (JJ10E) 08/08 → (mot.) HR16DE, MR20DE, K9K, M9R



Ref. - No.



Ref. - No.	Description	Notes	Dimensions
82 71 0008	Spurstangenendstück / tie rod end		M10 x 1,25
82 92 3515	Verbindungsstange / stabilizer link		L 131 12x1,5
82 92 3516	Verbindungsstange / stabilizer link		L 131 12x1,5
82 93 0985	Verbindungsstange / stabilizer link	(1)	L 300
82 93 0986	Verbindungsstange / stabilizer link	(1)	L 300
82 93 4067	Stabilisatorlager / stabilizer mount	(2)	Ø I 21
82 93 4068	Stabilisatorlager / stabilizer mount	(3)	Ø I 17
82 93 4614	Axialgelenk / axial joint	J10, JJ10 02/07 →	L 233
82 93 4666	Traggelenk / ball joint	(4)	
82 93 4755	Spurstangenendstück / tie rod end	(4)	M10 x 1,25
82 93 4756	Spurstangenendstück / tie rod end	(4)	M10 x 1,25



Sunny (N14 / Y10)
(1990 → 1998)

82 71 0008

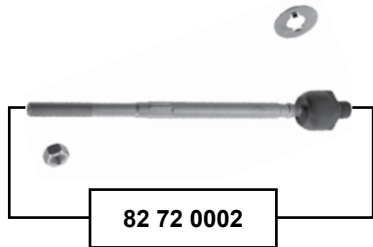

82 72 0002



82 72 0002

82 71 0008



82 73 0012



82 73 0011



82 79 0001

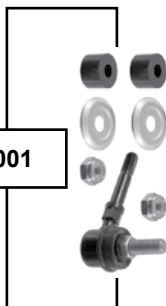

82 79 0001



Vorderachse / Front axle



82 71 0008	48520-73J25
82 72 0002	48521-50Y00
82 73 0011	54500-52Y70
82 73 0012	54501-52Y70
82 79 0001	54618-50Y00

Spurstangenendstück / tie rod end
Spurstange / tie rod
Querlenker / control arm
Querlenker / control arm
Verbindungsstange / stabilizer link

(ex.) 4WD
(ex.) 2.0 GTI-R
(ex.) 2.0 GTI-R

M10 x 1,25 L 290
M10 x 1,25

passend für / to fit

NISSAN

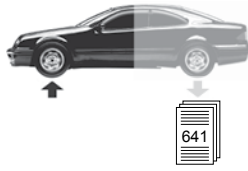

Teana (J32)

(2008 →)

Vorderachse / Front axle



Teana (J32R)

(2009 →)



Ref. - No.



82 93 0985	54668-JD00A
82 93 0986	54618-JD00A

Verbindungsstange / stabilizer link
Verbindungsstange / stabilizer link

L 300
L 300



Terrano I (WD21)
(1987 → 1997)



oben / upper

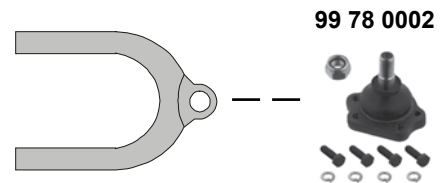
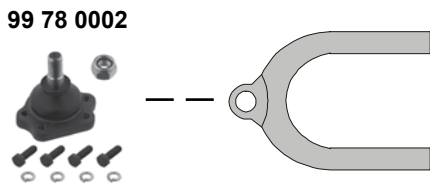

unten / lower

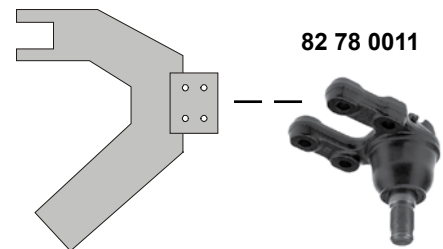
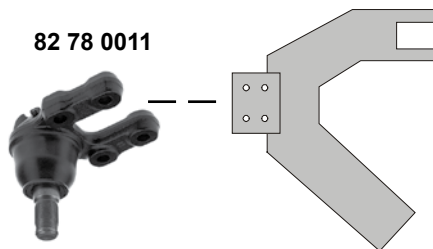

Vorderachse / Front axle

	Ref. - No.			
82 71 0012	48520-7F000	Spurstangenendstück / tie rod end		M12 x 1,25
82 78 0011	40160-93G25	Traggelenk / ball joint		M18 x 1,5
99 78 0002	40110-01G25	Traggelenk / ball joint		M14 x 1,5

passend für / to fit

NISSAN

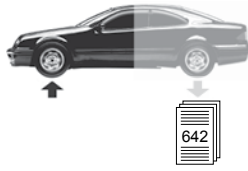

Terrano II (R20)

(1993 →)

Vorderachse / Front axle

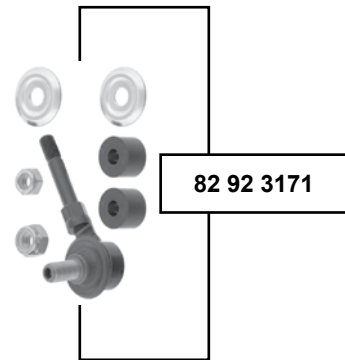
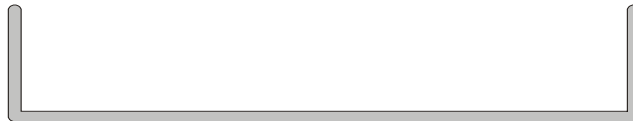
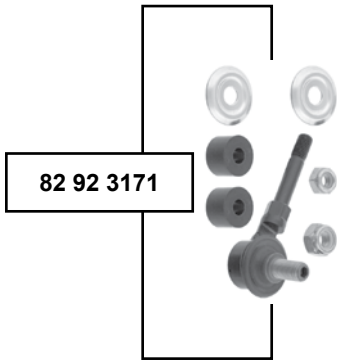

Ref. - No.



82 71 0012 48520-7F000
82 92 3171 54618-0F000

Spurstangenendstück / tie rod end
Verbindungsstange / stabilizer link

M12 x 1,25
M12/10x1,25



Urvan (E23/E24)
(1986 → 1995)

oben / upper

99 78 0002

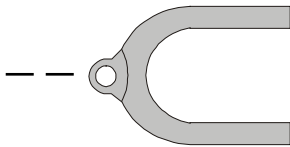

99 78 0002

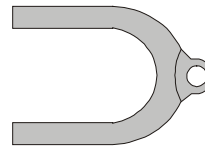

Vorderachse / Front axle

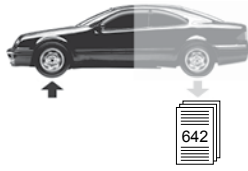

Vanette Cargo (HC23)

(1995 →)



X-Trail (T30)

(2001 →)

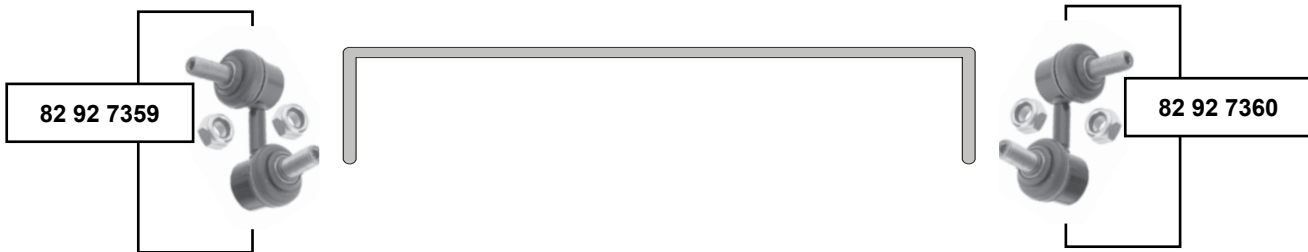
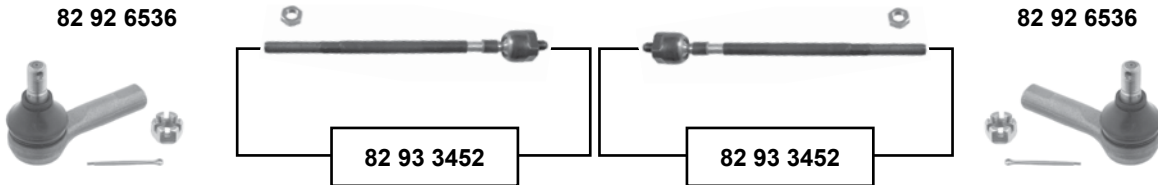

82 71 0008	48520-73J25	Spurstangenendstück / tie rod end			M10 x 1,25
82 92 3515	54618-9C002	Verbindungsstange / stabilizer link			L 131
82 92 3516	54668-9C000	Verbindungsstange / stabilizer link		06/01 →	L 65 M12x1,25
82 92 6536	48520-0P725	Spurstangenendstück / tie rod end			L 95
82 92 7359	54668-8H300	Verbindungsstange / stabilizer link		06/01 →	L 65 M12x1,25
82 92 7360	54618-8H300	Verbindungsstange / stabilizer link		06/01 →	L 65 M12x1,25
82 93 3452	48521-8H386	Axialgelenk / axial joint			L 287

Vorderachse / Front axle

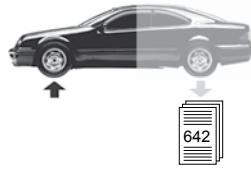

X-Trail (T31)
(2007 →)

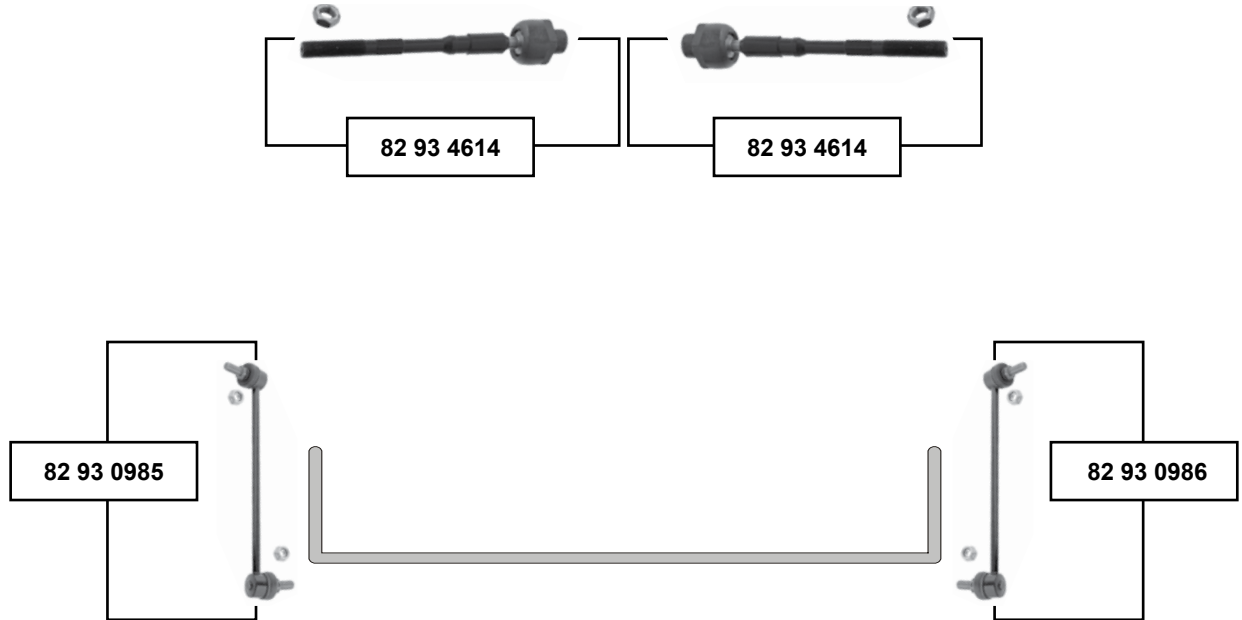

Vorderachse / Front axle

X-Trail (T31R)
(2009 →)



(1) 03/07 → (mot.) 2,0 Benzin (MR20DE), (mot.) 2,5 Benzin (QR25DE), (mot.) Diesel (M9R)



Ref. - No.



82 93 0985	54668-JD00A	Verbindungsstange / stabilizer link	(mot.) 2,0 / 2,5	L 300
82 93 0986	54618-JD00A	Verbindungsstange / stabilizer link	(mot.) 2,0 / 2,5	L 300
82 93 4614	D8521-JD00B	Axialgelenk / axial joint	(1)	L 233



Adam
(2013 →)

Vorderachse / Front axle

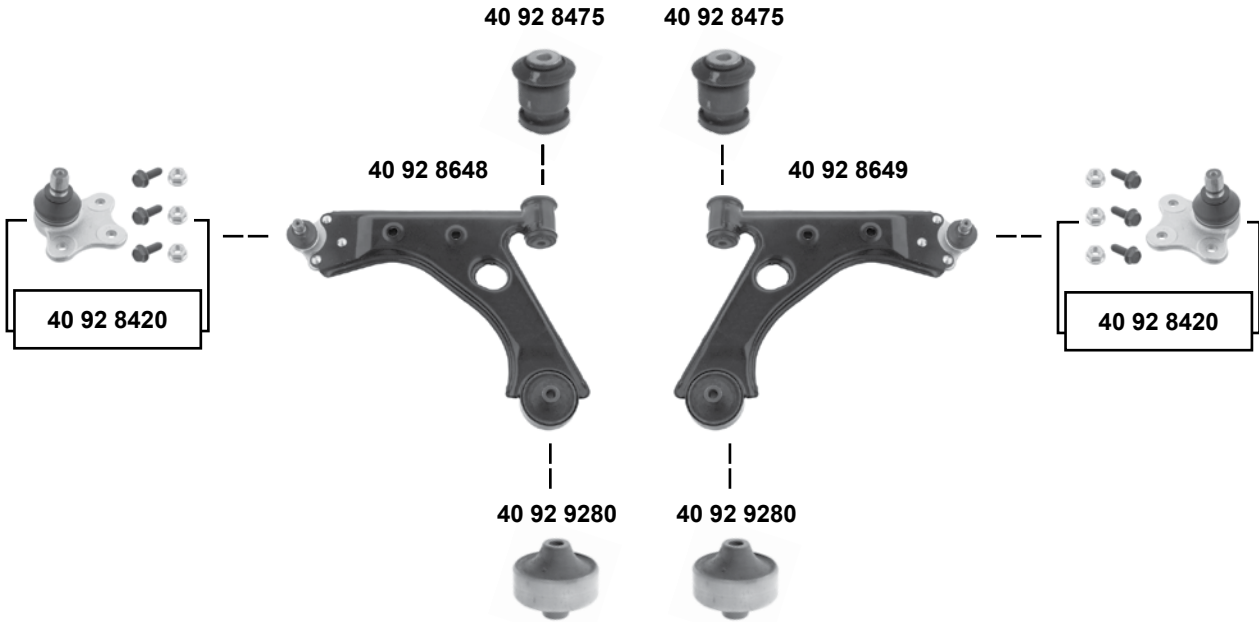

(1) (ex.) B1,4NEH / LPG **Sport**



Ref. - No.



40 92 8420	0352 087	Traggelenk / ball joint	
40 92 8475	0352 380	Querlenkerlager / control arm mount	Ø 16/12x52x68
40 92 8648	5352 039	Querlenker / control arm	
40 92 8649	5352 038	Querlenker / control arm	
40 92 9280	0352 864	Querlenkerlager / control arm mount	12x72x66
40 94 5219	0350 233	Verbindungsstange / stabilizer link	L 310
70 93 8586	0350 181	Stabilisatorsatz / stabilizer kit	L 1045

(1)



Agila A
(2000 → 2008)

84 94 2318

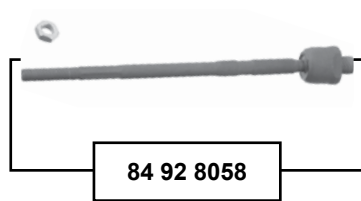

84 92 8058

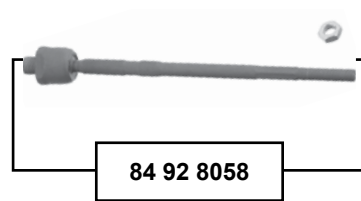

84 92 8058

84 94 2318

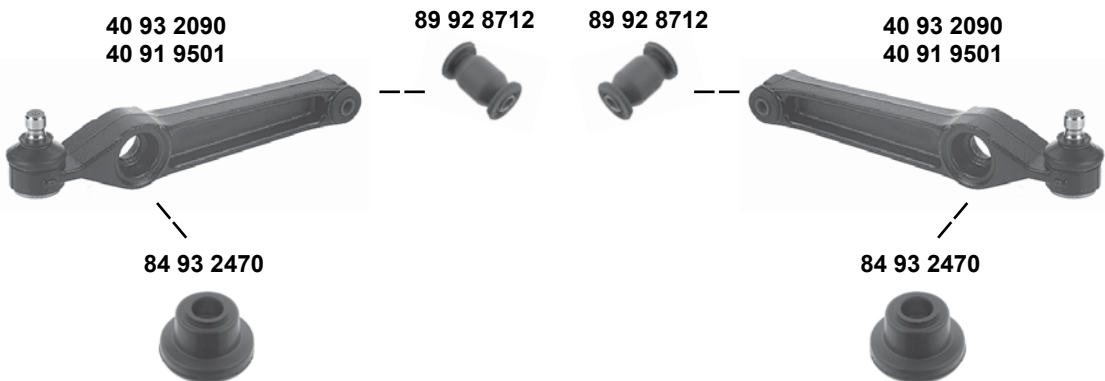

40 93 2090
40 91 9501

89 92 8712

89 92 8712

40 93 2090
40 91 9501

84 93 2470

84 93 2470





Agila B
(2008 →)

Vorderachse / Front axle

84 92 9830

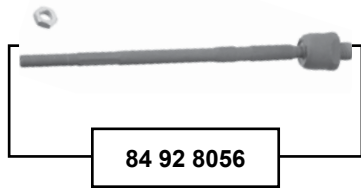

84 92 8056

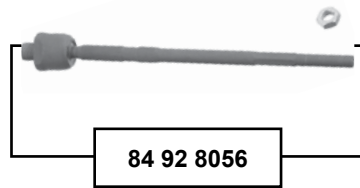

84 92 8056

84 92 9830



84 92 9826



84 93 2140



84 93 2141



84 92 9826



84 92 9827



84 92 9827



84 92 8000

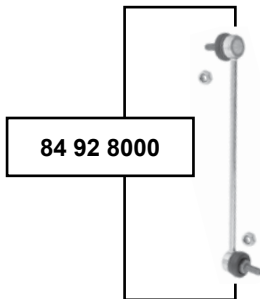

84 92 8000

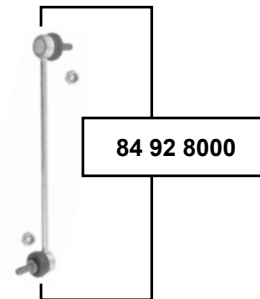

Ref. - No.



84 92 8000	4709 702
84 92 8056	4709 161
84 92 9826	4708 299 S1
84 92 9827	4708 299 S2
84 92 9830	4709 195
84 93 2140	4708 300
84 93 2141	4708 299

Verbindungsstange / stabilizer link
Spurstange / tie rod
Traggelenk / ball joint
Querlenkerlager / control arm mount
Spurstangenendstück / tie rod end
Querlenker / control arm
Querlenker / control arm

L 300
L 306
60x50
M12 x 1,25

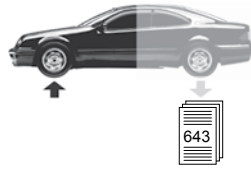

Antara
(2006 →)

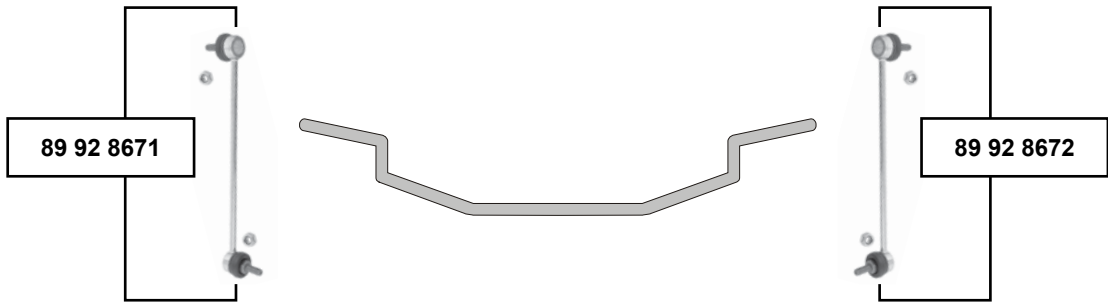
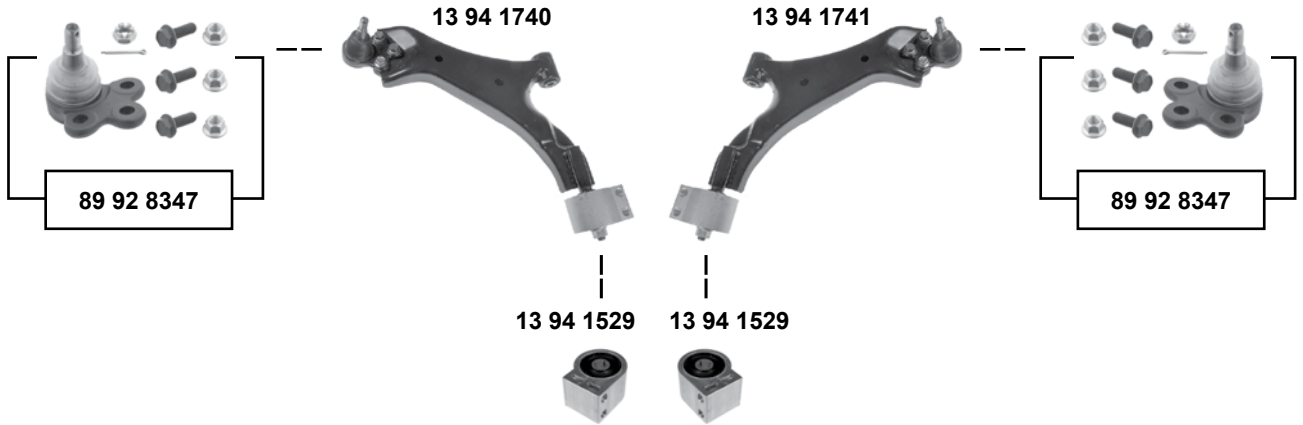

Vorderachse / Front axle



(1) (ch.) → AB999999, → A3999999

(2) (ch.) → 80999999, → AB999999, → A3999999



Ref. - No.



13 94 1529	4817 869	Querlenkerlager / control arm mount	(2)	
13 94 1740	4810 831	Querlenker / control arm		
13 94 1741	4812 870	Querlenker / control arm		
13 94 1929	4803 429	Spurstangenendstück / tie rod end		
89 92 8347	4810 831 SK	Traggelenk / ball joint	(2)	
89 92 8671	4817 516	Verbindungsstange / stabilizer link	(1)	L 286
89 92 8672	4817 515	Verbindungsstange / stabilizer link	(1)	L 286





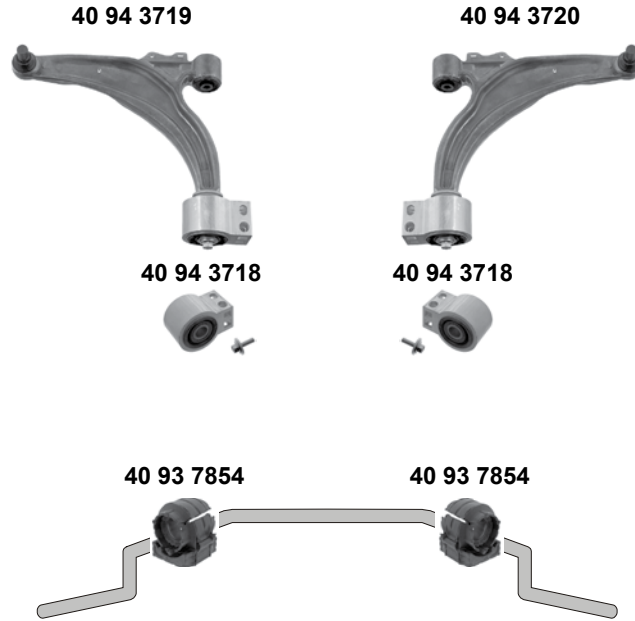

Ampera
(2011 →)

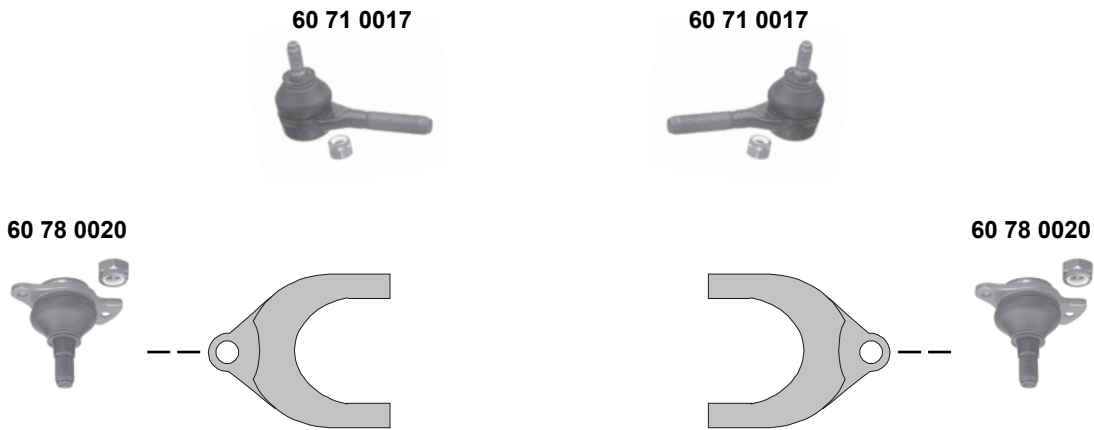

Arena
(1997 → 2001)



	Ref. - No.			
40 93 7854	0350 621	Stabilisatorlager / stabilizer mount	servo 	Ø 25
40 94 3718	0352 491	Querlenkerlager / control arm mount		106 x80 x65
40 94 3719	0352 492	Querlenker / control arm		
40 94 3720	0352 493	Querlenker / control arm		
60 71 0017	4403 661	Spurstangenendstück / tie rod end		
60 78 0020	4403 641	Traggelenk / ball joint		M14 x 1,5

Vorderachse / Front axle



Ascona C (1981 → 1988)

man.

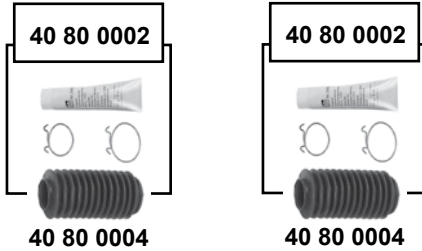

servo

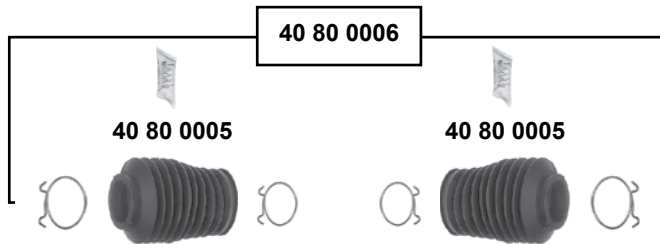

Vorderachse / Front axle

SWAG	Ref. - No.			
40 71 0006	0324 038	Spurstangenendstück / tie rod end		M16x1,5 LHT
40 71 0007	0324 039	Spurstangenendstück / tie rod end		M16x1,5 RHT
40 72 0006	0322 126	Spurstange / tie rod		L 429
40 72 0007	0322 125	Spurstange / tie rod		L 429
40 76 0001	0322 575	Einstellbolzen / adjusting bolt		M16 x 1,5
40 80 0002	0902 828 S1	Rep. Satz Lenkmanschette / rep. kit steering boot		
40 80 0004	0902 828	Lenkmanschette / steering boot		
40 80 0005	1609 073 S1	Lenkmanschette / steering boot		
40 80 0006	1609 073 SK	Lenkmanschette / steering boot		



Ascona C (1981 → 1988)

Vorderachse / Front axle

40 78 0006

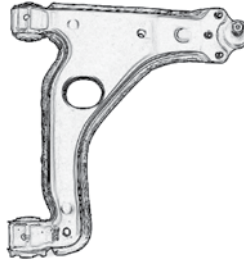
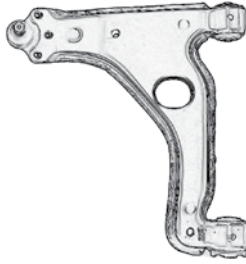

40 78 0006

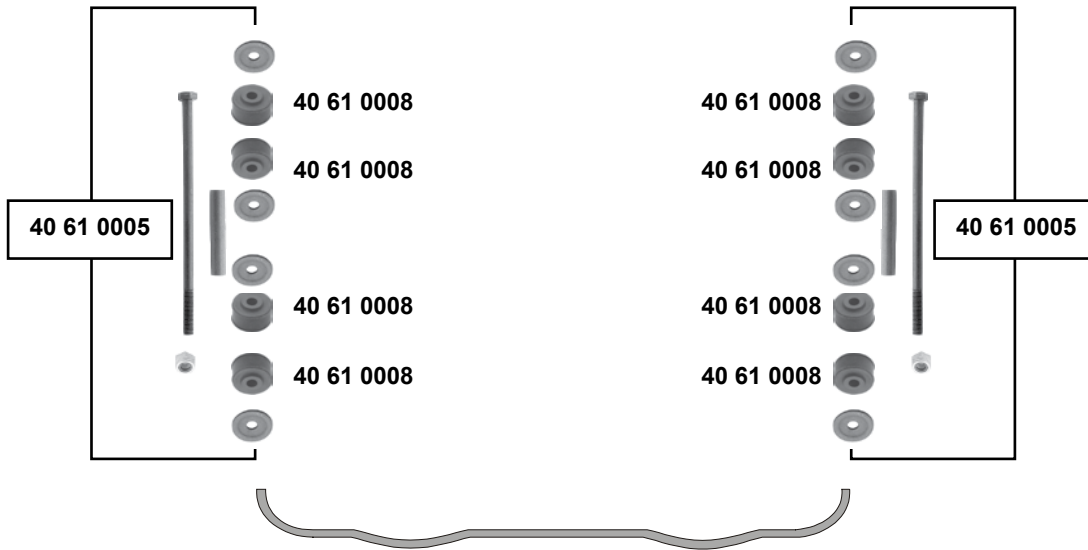



Astra F (1991 → 1998)

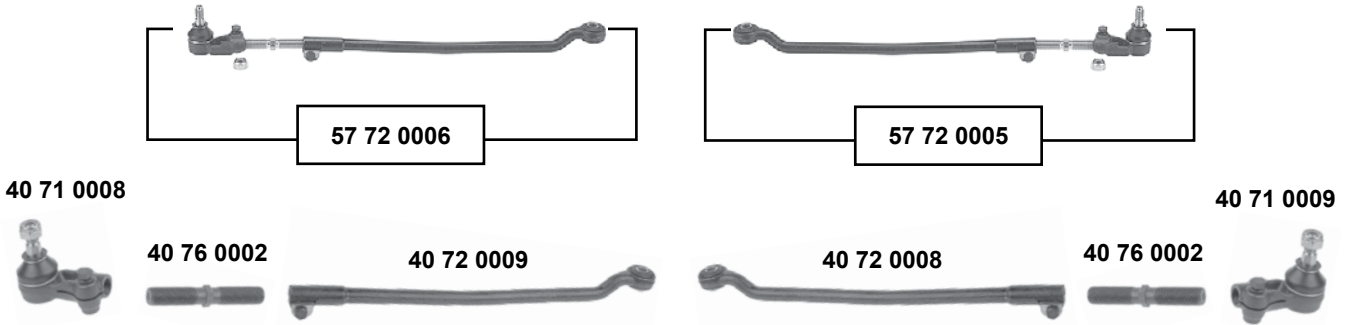

(ch.) → R 2595225, R 5111734, R 8145949

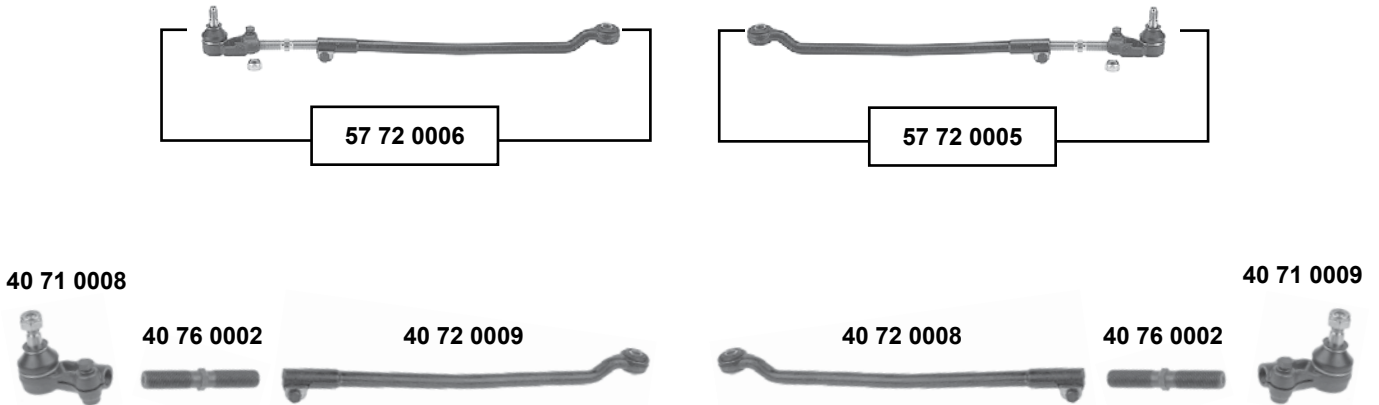

(ch.) R 2595226, R 5111735, R 8145950 →



Vorderachse / Front axle

SWAG®	Ref. - No.			
40 71 0008	0324 055	Spurstangenendstück / tie rod end		M16x1,5 RHT
40 71 0009	0324 056	Spurstangenendstück / tie rod end		M16x1,5 LHT
40 72 0008	0322 146	Spurstange / tie rod		L 434
40 72 0009	0322 147	Spurstange / tie rod		L 434
40 76 0002	0322 577	Einstellbolzen / adjusting bolt		M16x2x105,5
57 72 0005	0322 146 S1	Spurstange / tie rod		
57 72 0006	0322 147 S1	Spurstange / tie rod		



OPEL

Astra F (1991 → 1998)

(ch.) → R 2595225, R 5111734, R 8145949

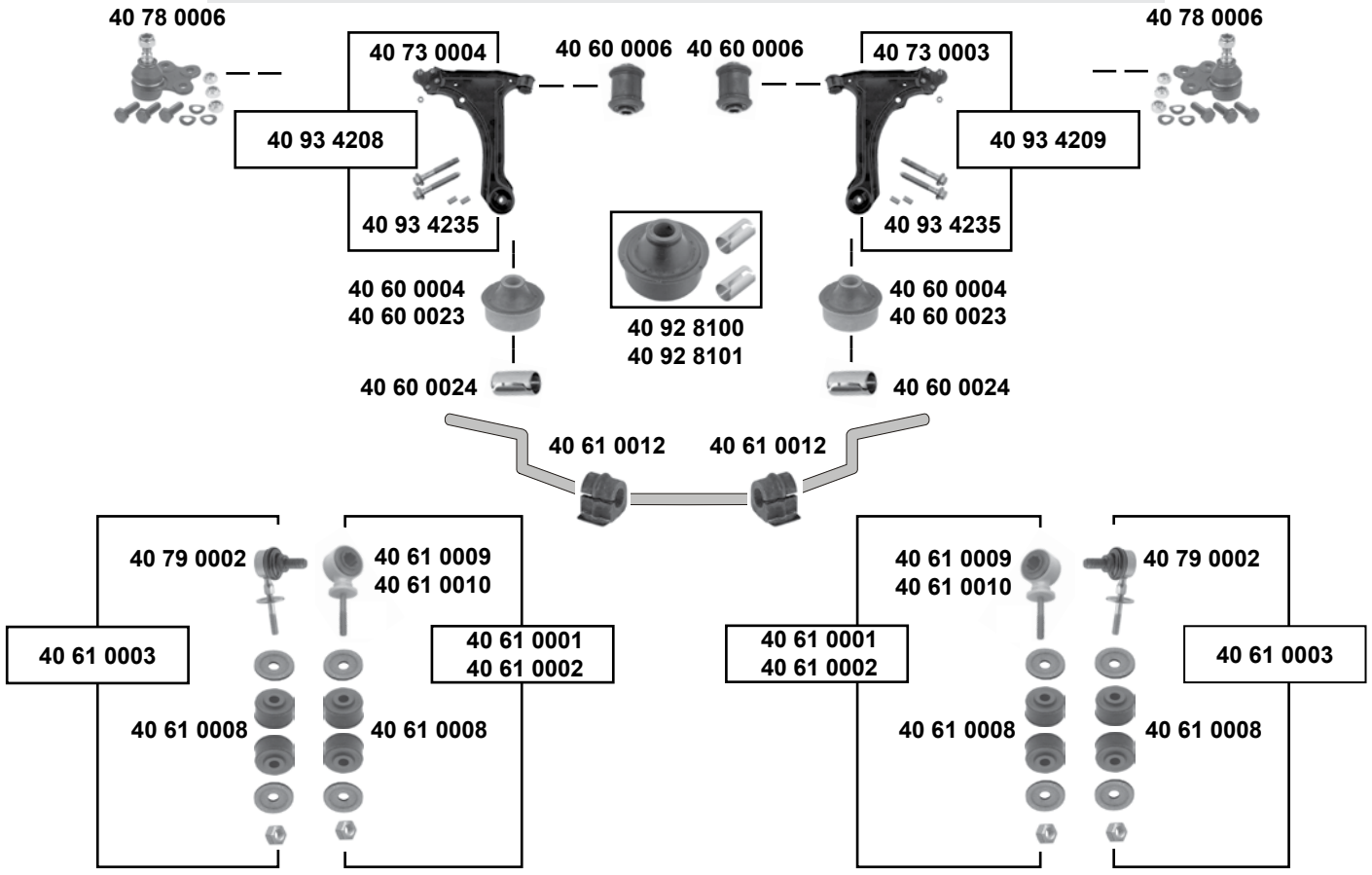

- | | | | | |
|--|---------------------------------|--|--|--|
| | (1) (ch.) → P 2603822 | | | |
| | (ch.) → P 8146889 | | | |
| | (2) (ch.) P 2603823 → R 2595225 | | | |
| | (ch.) P 5000000 → R 5111734 | | | |
| | (ch.) P 8146890 → R 8145949 | | | |

Ref. - No.			
40 60 0004	0352 348	Querlenkerlager / control arm mount	(1) 16x60x58
40 60 0006	0352 300	Querlenkerlager / control arm mount	(1) 12x39x60
40 60 0023	0352 352	Querlenkerlager / control arm mount	(2)
40 60 0024	0353 460	Hülse / sleeve	16,3x30
40 61 0001	0350 260 S1	Rep. Satz Verbindungsstange / rep. kit stabilizer link	
40 61 0002	0350 261 S1	Rep. Satz Verbindungsstange / rep. kit stabilizer link	
40 61 0003	0350 263 S1	Rep. Satz Verbindungsstange / rep. kit stabilizer link	
40 61 0008	0350 153	Verbindungsstangenlager / stabilizer link bush	L 86
40 61 0009	0350 260	Verbindungsstange / stabilizer link	8,5x30x19
40 61 0010	0350 261	Verbindungsstange / stabilizer link	Ø I 22
40 61 0012	0350 078	Stabilisatorlager / stabilizer mount	Ø I 18
40 73 0003	0352 192	Querlenker / control arm	Ø I 20
40 73 0004	0352 193	Querlenker / control arm	
40 78 0006	1603 167	Traggelenk / ball joint	inkl. 2x40600024 (ex.) GSI
40 79 0002	0350 263	Verbindungsstange / stabilizer link	inkl. 2x40600024 (ex.) GSI
40 92 8100	0352 348 S1	Querlenkerlager / control arm mount	(1) 16x60x58
40 92 8101	0352 352 S1	Querlenkerlager / control arm mount	(2) 16x60x58
40 93 4208	0352 193 S1	Rep. Satz Querlenker / rep. kit control arm	(ex.) GSI
40 93 4209	0352 192 S1	Rep. Satz Querlenker / rep. kit control arm	(ex.) GSI
40 93 4235	2026 745 S1	Schraubensatz für Querlenker / screw kit for control arm	



Astra F (1991 → 1998)

(ch.) R 2595226, R 5111735, R 8145950 →

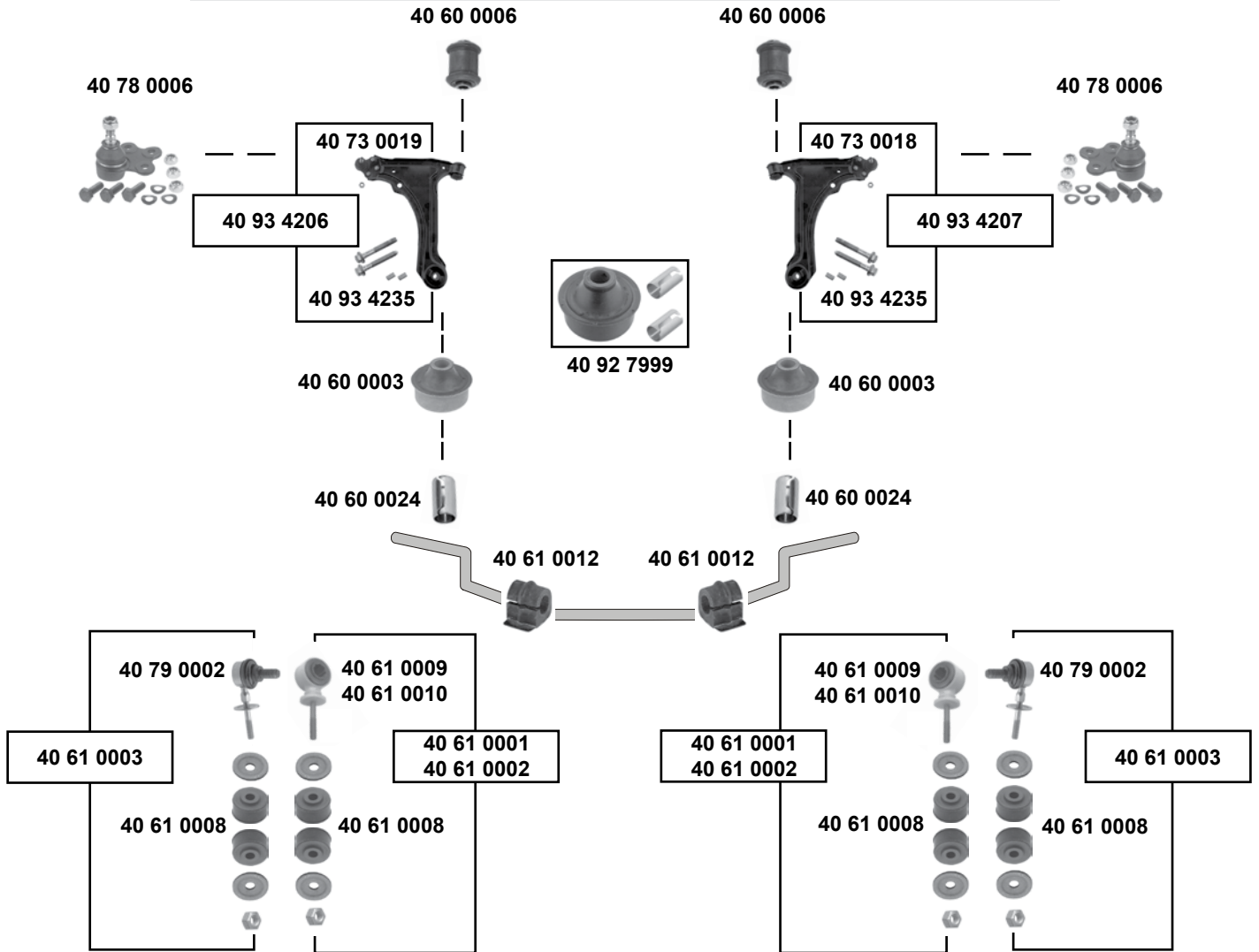

Vorderachse / Front axle



Ref. - No.

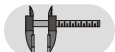

Part No.	Ref. - No.	Description	Notes	Dimensions
40 60 0003	0352 356	Querlenkerlager / control arm mount		16x60x58
40 60 0006	0352 300	Querlenkerlager / control arm mount		12x39x60
40 60 0024	0353 460	Hülse / sleeve		16,3x30
40 61 0001	0350 260 S1	Rep. Satz Verbindungsstange / rep. kit stabilizer link		
40 61 0002	0350 261 S1	Rep. Satz Verbindungsstange / rep. kit stabilizer link		
40 61 0003	0350 263 S1	Rep. Satz Verbindungsstange / rep. kit stabilizer link		L 86
40 61 0008	0350 153	Verbindungsstangenlager / stabilizer link bush		8,5x30x19
40 61 0009	0350 260	Verbindungsstange / stabilizer link		Ø 22
40 61 0010	0350 261	Verbindungsstange / stabilizer link		Ø 18
40 61 0012	0350 078	Stabilisatorlager / stabilizer mount		Ø 22
40 73 0018	5352 000	Querlenker / control arm	inkl. 2x40600024 (ex.) GSI	
40 73 0019	5352 001	Querlenker / control arm	inkl. 2x40600024 (ex.) GSI	
40 78 0006	1603 167	Traggelenk / ball joint		M12 x 1,5
40 79 0002	0350 263	Verbindungsstange / stabilizer link		L 86
40 92 7999	0352 356 S1	Querlenkerlager / control arm mount		16x60x58
40 93 4206	5352 001 S1	Rep. Satz Querlenker / rep. kit control arm	(ex.) GSI	
40 93 4207	5352 000 S1	Rep. Satz Querlenker / rep. kit control arm	(ex.) GSI	
40 93 4235	2026 745 S1	Schraubensatz für Querlenker / screw kit for control arm		



Astra G

(1998 → 2004)

Vorderachse / Front axle

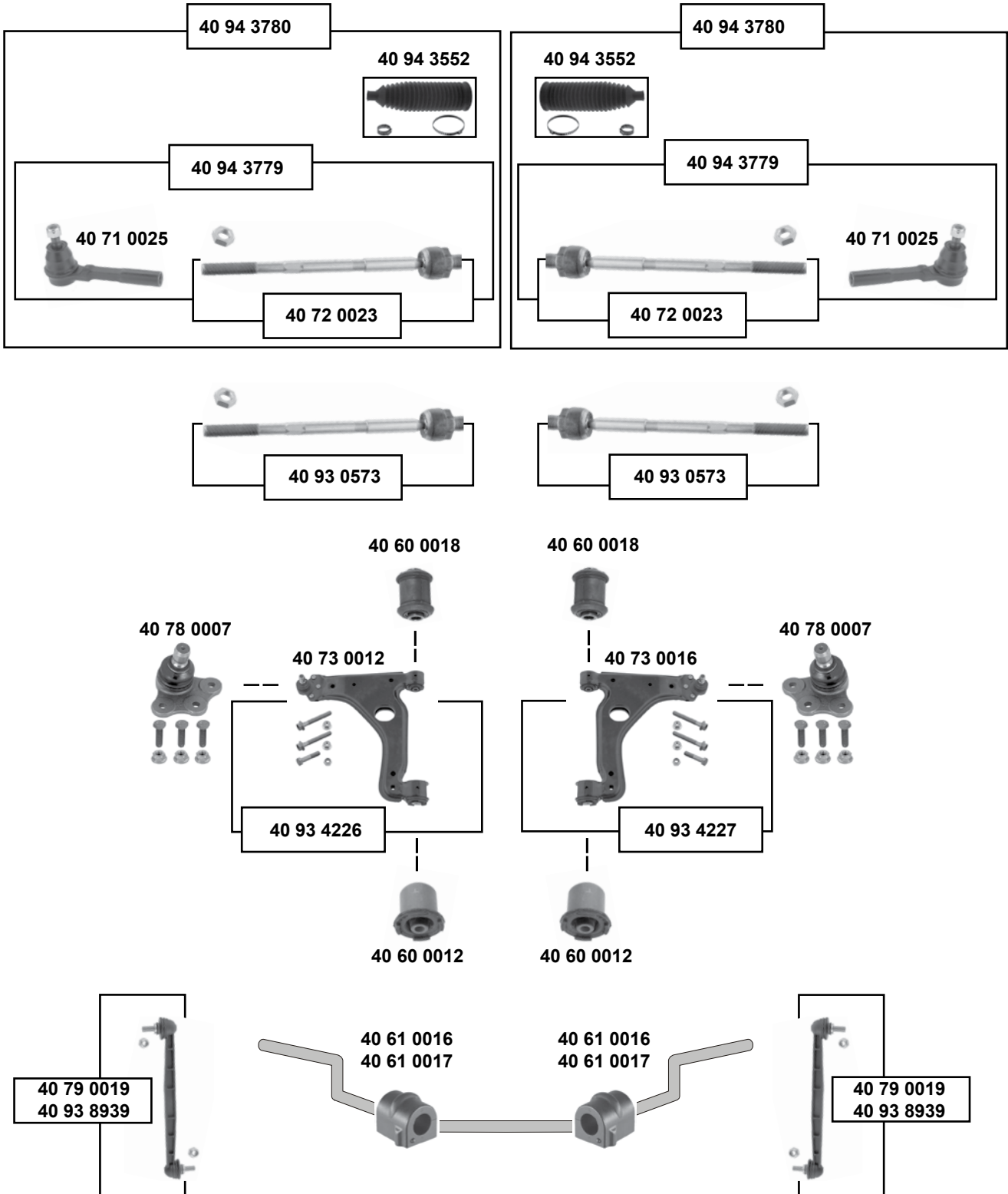



Astra G

(1998 → 2004)



- (1) 1.2 (ch.) → X 2999999 / X 5999999 / X 6999999 / X 8999999
- (2) 1.2 (ch.) Y 2000001 / Y 5000001 / Y 6000001 / Y 8000001 →
1.4 / 1.6 / 1.8 / 2.0 / 1.7 TD / DTI / 2.0 DI / DTI
- (3) Z1,4 XEP + servo elektronisch / electronic // Coupe/Cabrio + servo TRW
- (4) Nur für TRW-Lenkung / TRW-steering only

	Ref. - No.			
40 60 0012	0352 365	Querlenkerlager / control arm mount		12x45/48x60
40 60 0018	0352 364	Querlenkerlager / control arm mount		12x36,5x60
40 61 0016	0350 130	Stabilisatorlager / stabilizer mount	(1)	Ø I 16
40 61 0017	0350 138	Stabilisatorlager / stabilizer mount	(2)	Ø I 18
40 71 0025	1603 542	Spurstangenendstück / tie rod end	(ex.) OPC	M14x1,5 RHT
40 72 0023	1603 213	Spurstange / tie rod	(ex.) OPC	L 300
40 73 0012	5352 016	Querlenker / control arm		
40 73 0016	5352 017	Querlenker / control arm		
40 78 0007	0352 800	Traggelenk / ball joint		Ø A 18
40 79 0019	0350 614	Verbindungsstange / stabilizer link	OLD	L 300
40 93 0573	1603 644 SK	Spurstange / tie rod	(3)	L 304
40 93 4226	5352 016 S1	Rep. Satz Querlenker / rep. kit control arm		
40 93 4227	5352 017 S1	Rep. Satz Querlenker / rep. kit control arm		
40 93 8939	0350 176	Verbindungsstange / stabilizer link	NEW	L 350
40 94 3552	1609 356	Lenkmanschettensatz / steering boot set	(4)	L 211
40 94 3779	1603 643 S5	Spurstange / tie rod	(4)	M18 x 1,5
40 94 3780	1603 643 S6	Spurstange / tie rod	(4)	M18 x 1,5



Astra H

(2004 → 2009)

Vorderachse / Front axle

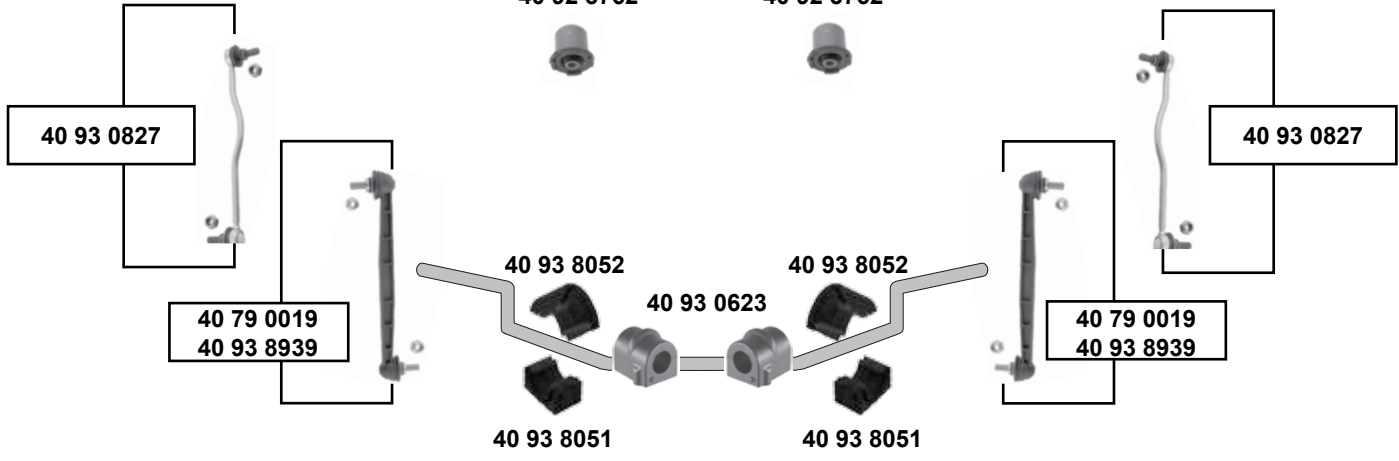
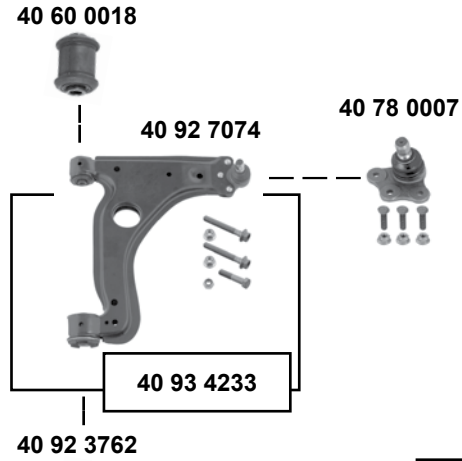
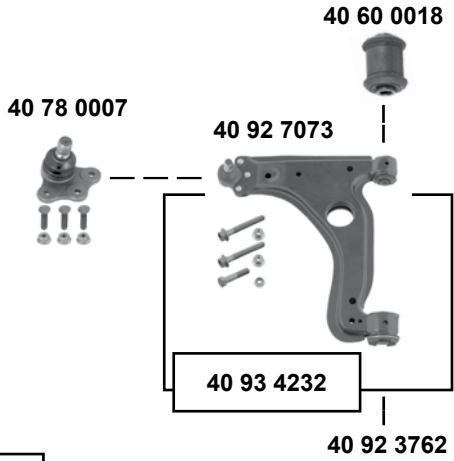
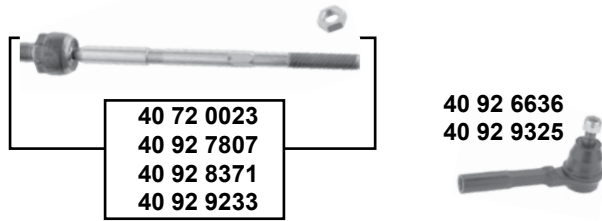
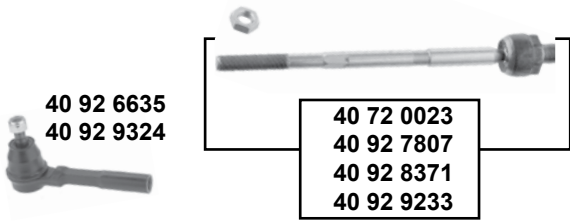
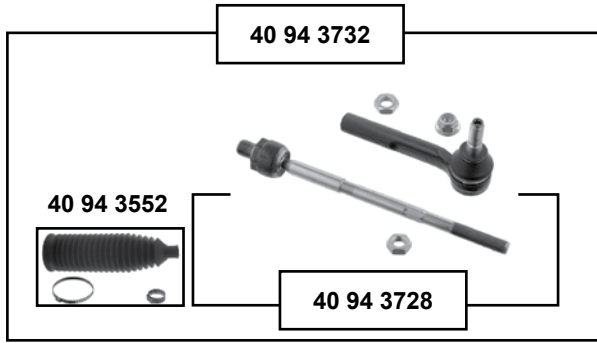
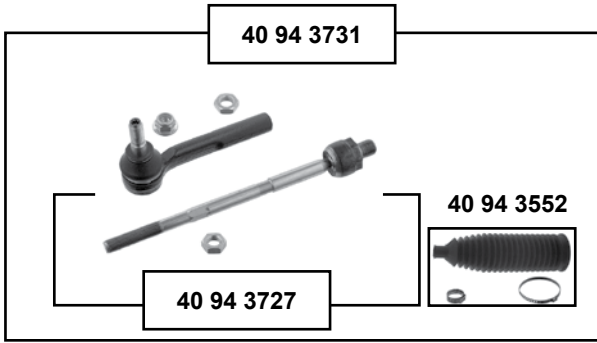



Astra H

(2004 → 2009)



(1) servo ZF (ex.) Sport	(3) servo ZF Sport , (ex.) 18/19"
(2) servo ZF Sport (ex.) 18/19"	(4) TRW Generation II
(5) Schrägheck/Hatchback (ch.) → 52999999, 55999999, 58999999	
(6) Nur für TRW-Lenkung / TRW-steering only (ch.) 72094720 , (ch.) 75080481 , (ch.) 78048189 , (ch.) 8B000001, (ch.) 7G-	
(7) (ch.) 72094720 - , (ch.) 75080481 - , (ch.) 78048189 - , (ch.) 8B000001 - , (ch.) 7G -	

	Ref. - No.			
40 60 0018	0352 364	Querlenkerlager / control arm mount		12x36,5x60
40 72 0023	1603 213	Spurstange / tie rod	(4) servo	L 283
40 78 0007	0352 800	Traggelenk / ball joint		
40 79 0019	0350 614	Verbindungsstange / stabilizer link	(ex.) IDS+ / OLD	L 300
40 92 3762	0352 324	Querlenkerlager / control arm mount		12x46x60
40 92 6635	1603 266	Spurstangenendstück / tie rod end	servo ZF	M14 x 1,5
40 92 6636	1603 267	Spurstangenendstück / tie rod end	servo ZF	M14 x 1,5
40 92 7073	5352 029	Querlenker / control arm		
40 92 7074	5352 030	Querlenker / control arm		
40 92 7807	1603 357 SK	Spurstange / tie rod	(1)	L 295
40 92 8371	1603 358 SK	Spurstange / tie rod	(2)	L 279
40 92 9233	1603 359 SK	Spurstange / tie rod	(3)	L 279
40 92 9324	1603 289	Spurstangenendstück / tie rod end	servo TRW	M14 x 1,5
40 92 9325	1603 288	Spurstangenendstück / tie rod end	servo TRW	M14 x 1,5
40 93 0623	0350 161	Stabilisatorlager / stabilizer mount	(5)	Ø I 21
40 93 0827	0350 613	Verbindungsstange / stabilizer link	IDS+	
40 93 4232	5352 029 S1	Rep. Satz Querlenker links / rep. kit control arm left		
40 93 4233	5352 030 S1	Rep. Satz Querlenker rechts / rep. kit control arm right		
40 93 8051	0350 391	Stabilisatorlager, unten / stabilizer mount, lower	nur/only Cabrio	Ø I 24
40 93 8052	0350 390	Stabilisatorlager, oben / stabilizer mount, upper	nur/only Cabrio	Ø I 24
40 93 8939	0350 176	Verbindungsstange / stabilizer link	(ex.) IDS+ / NEW	L 350
40 94 3552	1609 356	Lenkmanschettensatz / steering boot set	(6)	L 211
40 94 3727	1603 643 S1	Spurstange / tie rod	(4)	M18 x 1,5
40 94 3728	1603 643 S2	Spurstange / tie rod	(4)	M18 x 1,5
40 94 3731	1603 643 S3	Spurstange / tie rod	(4) (7)	M18 x 1,5
40 94 3732	1603 643 S4	Spurstange / tie rod	(4) (7)	M18 x 1,5



Astra J (2009 → 2015)

Vorderachse / Front axle

40 94 5095



40 94 5095



40 94 5096



40 94 5096



40 94 4424



40 94 4424



40 94 4446



40 94 4338



40 94 4446



40 94 4156



40 94 4434



40 94 4156



40 94 4249



40 94 4447



40 94 4250



Astra J (2009 → 2015)

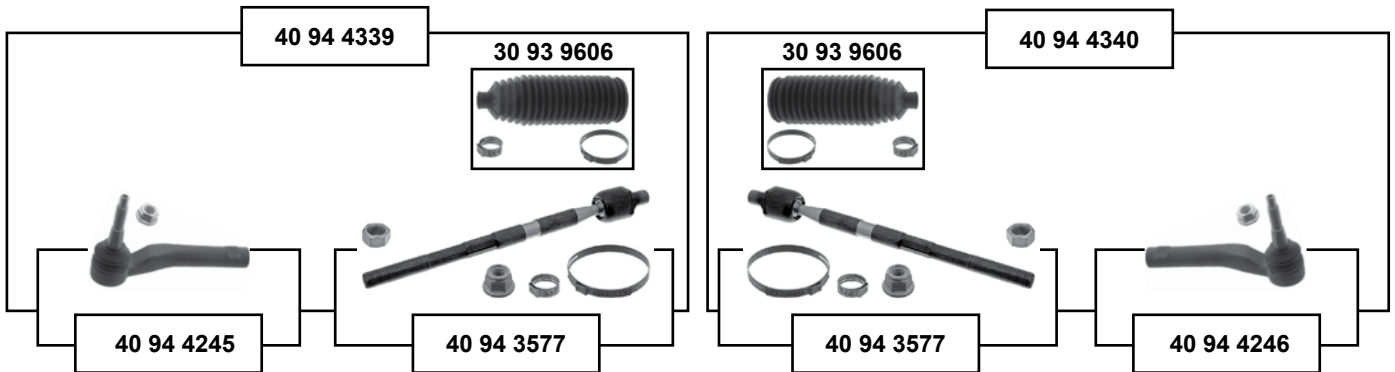

Vorderachse / Front axle

- (1) (ch.) → A3999999 / A8999999 / AG999999
- (2) 3-türer / doors mit / with servo
- (3) Coupe : Nur mit hydraulischer servo / combined with hydraulic servo
- (4) 5-türer / doors / servo / (ch.) C1000001 → , (ch.) B3000001 → , (ch.) B8000001 → , (ch.) BG000001 →
- (5) → (ch.) A3999999 / → (ch.) A8999999 / → (ch.) AG999999
- (6) 3-türer / doors E - servo
- (7) 5-türer / doors E - servo



Ref. - No.



SWAG	Ref. - No.			
30 93 9606	0902 010	Rep. Satz Lenkmanschette / rep. kit steering boot	servo	
40 94 3577	0920 005	Rep. Satz Axialgelenk / rep. kit axial joint	(1) servo	L 294
40 94 4156	1609 187	Rep. Satz Axialgelenk / rep. kit axial joint	Coupe E - servo	L 223
40 94 4245	1609 185	Spurstangenendstück / tie rod end	(2)	M12 x 1,75
40 94 4246	1609 186	Spurstangenendstück / tie rod end	(2)	M12 x 1,75
40 94 4249	1609 187 S1	Spurstange / tie rod	(6)	
40 94 4250	1609 187 S2	Spurstange / tie rod	(6)	
40 94 4338	0920 005 S1	Spurstange / tie rod	(5) (7)	
40 94 4339	0920 005 S2	Spurstange / tie rod	(2) (5)	L 396
40 94 4340	0920 005 S3	Spurstange / tie rod	(2) (5)	L 396
40 94 4424	1609 169	Rep. Satz Axialgelenk / rep. kit axial joint	(3)	L 228
40 94 4434	1609 169 S1	Spurstange / tie rod	(3)	
40 94 4446	0920 007	Rep. Satz Axialgelenk / rep. kit axial joint	(4)	L284
40 94 4447	0920 007 S1	Spurstange / tie rod	servo	
40 94 5095	1609 182 SK1	Lenkmanschette / steering boot	E - servo	
40 94 5096	1609 182	Lenkmanschettensatz / steering boot set	E - servo	



Astra J
(2009 → 2015)

Vorderachse / Front axle

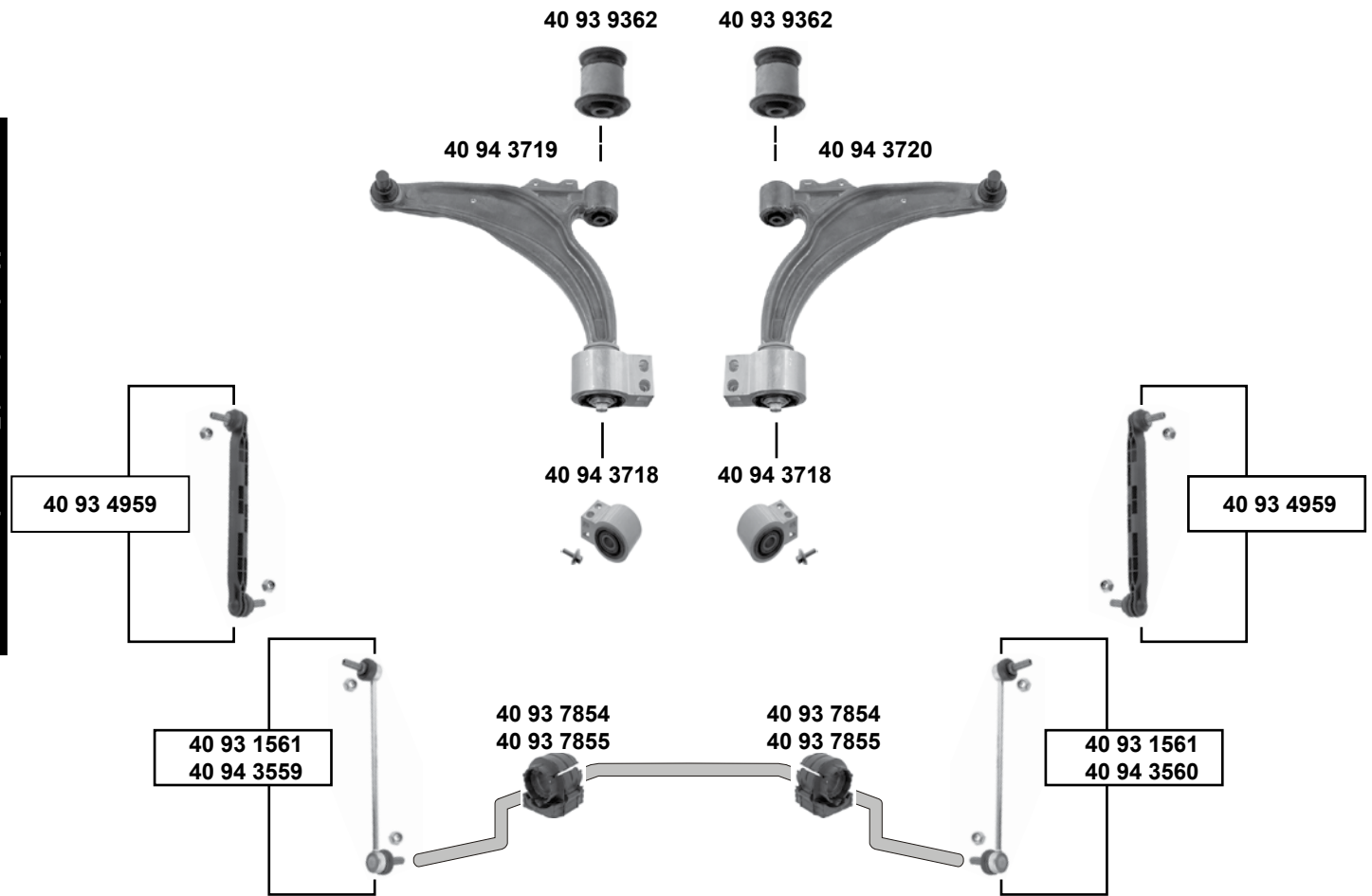

- (1) Für Fahrzeuge mit Flexride Fahrwerk (aktives Fahrwerk) / for vehicles with flexride chassis only
- (2) alle (ex.) Flexride Fahrwerk / all (ex.) flexride chassis
- (3) (ch.) B8106940 - B8999999 / (ch.) BG140001 - BG999999
(ch.) C0000001 → / (ch.) C1000001 → / (ch.) C3000001 → / (ch.) C8000001 / → (ch.) CG000001 →
(ex.) Biturbo
- (4) (mot.) A 2,0 NFT 3-türer // alle / all 5-türer
- (5) A2,0DTR , A2,0DTH , Y2,0DTJ , Z2,0DTC nur 3-türer / 3-doors only
- (6) (5-türer / doors Schrägheck / Sufenheck / Caravan) außer / except Biturbo



SWAG	Ref. - No.			
40 93 1561	0350 618	Verbindungsstange / stabilizer link	(1)	L 303,5
40 93 4959	0350 617	Verbindungsstange / stabilizer link	(2)	L 304
40 93 7854	0350 621	Stabilisatorlager / stabilizer mount	(4)	Ø 1 25
40 93 7855	0350 622	Stabilisatorlager / stabilizer mount	(5)	Ø 1 23
40 93 9362	0352 866	Querlenkerlager / control arm mount	(6)	12x52x60
40 94 3559	0350 192	Verbindungsstange / stabilizer link	3-türer / doors	L 290
40 94 3560	0350 193	Verbindungsstange / stabilizer link	3-türer / doors	L 290
40 94 3718	0352 491	Querlenkerlager / control arm mount	(6)	106x80x65
40 94 3719	0352 492	Querlenker / control arm	(3)	
40 94 3720	0352 493	Querlenker / control arm	(3)	

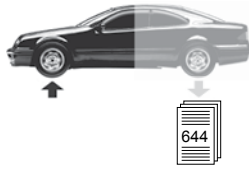

Calibra (1990 → 1997)

man.

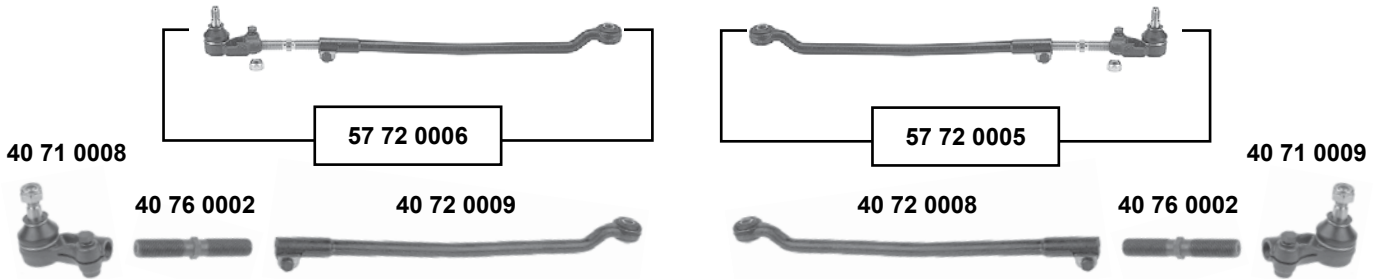

servo

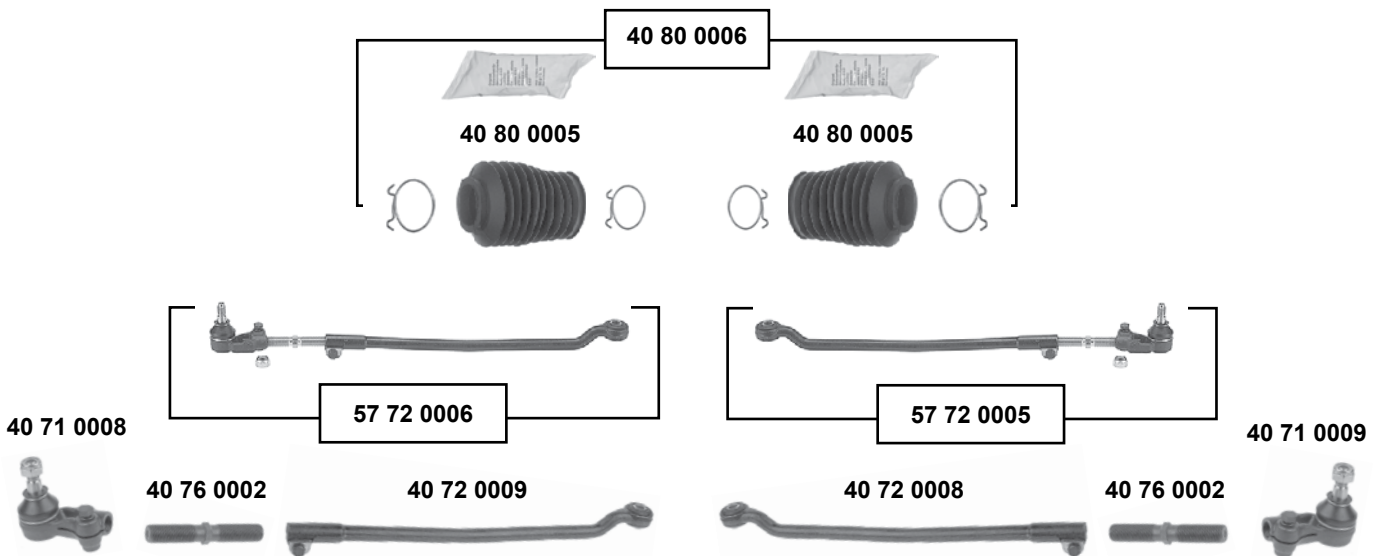

Vorderachse / Front axle

SWAG	Ref. - No.			
40 71 0008	0324 055	Spurstangenendstück / tie rod end		M16x1,5 RHT
40 71 0009	0324 056	Spurstangenendstück / tie rod end		M16x1,5 LHT
40 72 0008	0322 146	Spurstange / tie rod		L 434
40 72 0009	0322 147	Spurstange / tie rod		L 434
40 76 0002	0322 577	Einstellbolzen / adjusting bolt		M16x2x105,5
40 80 0005	1609 073 S1	Lenkmanschette / steering boot	LHD / für/to fit servo	ZF
40 80 0006	1609 073 SK	Lenkmanschette / steering boot	LHD / für/to fit servo	ZF
57 72 0005	0322 146 S1	Spurstange / tie rod		
57 72 0006	0322 147 S1	Spurstange / tie rod		

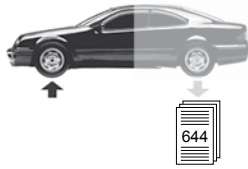

Calibra
(1990 → 1997)

Vorderachse / Front axle

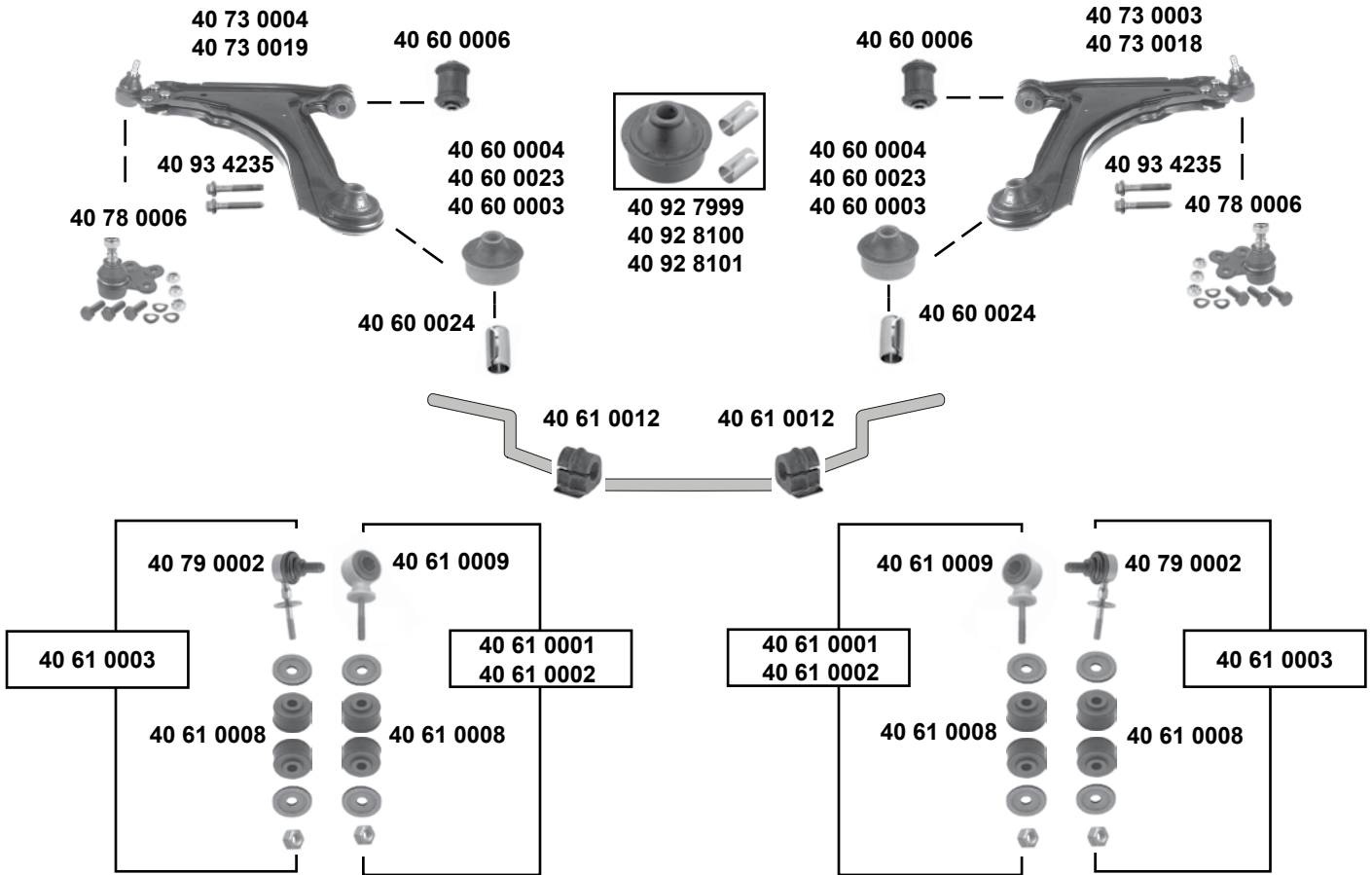

	(1) 2.0 i (85kW)	(ch.) → R 9003127	(3) 2.0 i (85kW)	(ch.) R 9003128 →
			2.0 i 16V → 2.5 V6	(ch.) R 9003175 →
	(2) 2.0 i 16V → 2.5 V6	(ch.) → R 9003174	(4) 2.0 i (85kW) / 2.0 i 16V	(ch.) R 9003128 →

	Ref. - No.			
40 60 0003	0352 356	Querlenkerlager / control arm mount	(3)	16x60x58
40 60 0004	0352 348	Querlenkerlager / control arm mount	(1)	16x60x58
40 60 0006	0352 300	Querlenkerlager / control arm mount	2.0 i (85 kW)	12x39x60
40 60 0023	0352 352	Querlenkerlager / control arm mount	(2)	
40 60 0024	0353 460	Hülse / sleeve		16,3x30
40 61 0001	0350 260 S1	Rep. Satz Verbindungsstange / rep. kit stabilizer link		
40 61 0002	0350 261 S1	Rep. Satz Verbindungsstange / rep. kit stabilizer link		
40 61 0003	0350 263 S1	Rep. Satz rep. kit Verbindungsstange / stabilizer link		L 86
40 61 0008	0350 153	Verbindungsstangenlager / stabilizer link bush		8,5x30x19
40 61 0009	0350 260	Verbindungsstange / stabilizer link		Ø I 22
40 61 0012	0350 078	Stabilisatorlager / stabilizer mount		Ø I 22
40 73 0003	0352 192	Querlenker / control arm	(1) inkl. 2x40600024	
40 73 0004	0352 193	Querlenker / control arm	(1) inkl. 2x40600024	
40 73 0018	5352 000	Querlenker / control arm	(4) inkl. 2x40600024	
40 73 0019	5352 000	Querlenker / control arm	(4) inkl. 2x40600024	
40 78 0006	1603 167	Traggelenk / ball joint	(ex.) 2.5 V6	M12 x 1,5
40 79 0002	0350 263	Verbindungsstange / stabilizer link		L 86
40 92 7999	0352 356 S1	Querlenkerlager / control arm mount	(3)	16x60x58
40 92 8100	0352 348 S1	Querlenkerlager / control arm mount	(1)	16x60x58
40 92 8101	0352 352 S1	Querlenkerlager / control arm mount	(2)	
40 93 4235	2026 745 S1	Schraubensatz für Querlenker / screw kit for control arm		



Cascade (2013 →)

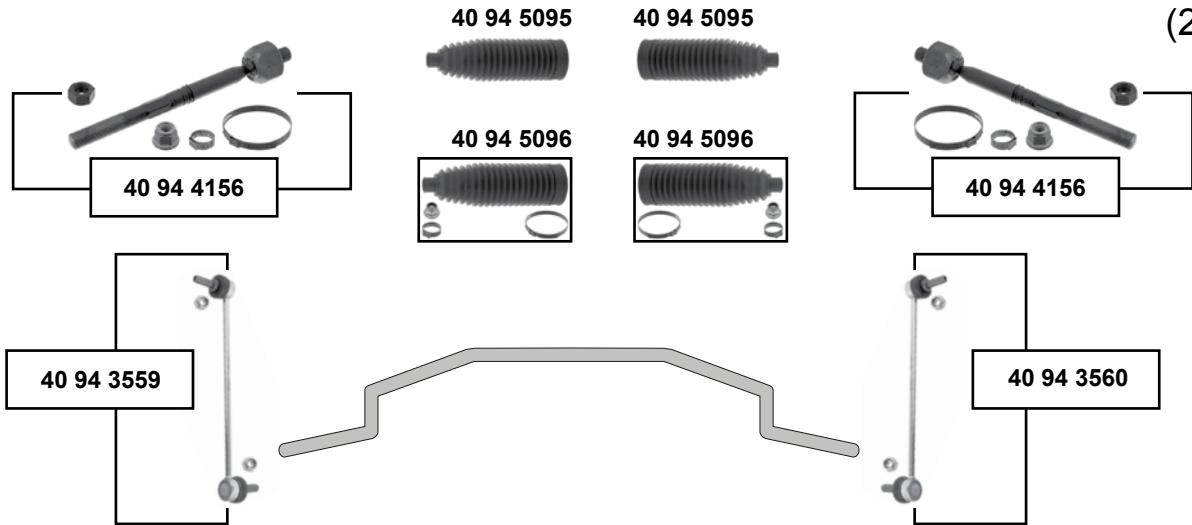

Combo C (2001 → 2010)

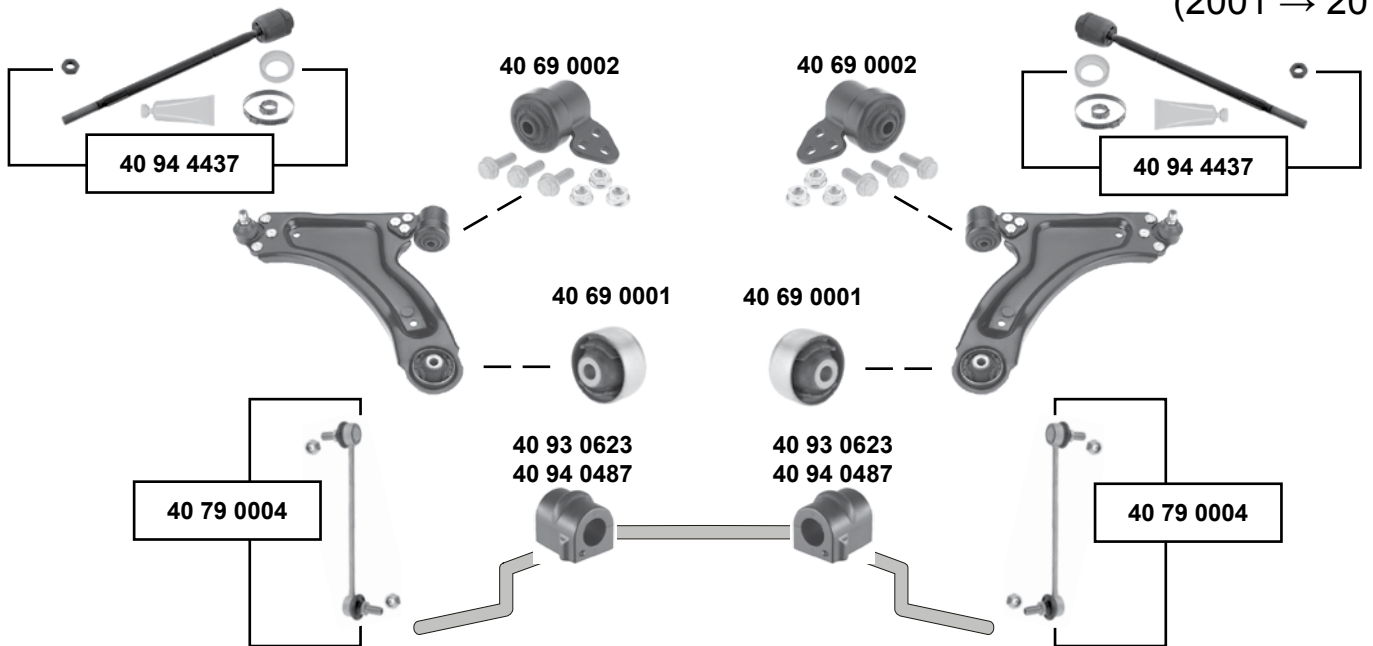

- (1) F06 → (ch.) 33999999 / F25 alle / all
- (2) F06 (ch.) 43000001 →, 74000001 →
- (3) (ex.) Z13DTJ / servo



Ref. - No.



Ref. - No.	Description	Notes	Dimensions
40 69 0001	Querlenkerlager / control arm mount		13x61x46
40 69 0002	Querlenkerlager / control arm mount		12x59x70
40 79 0004	Rep. Satz Verbindungsstange / rep. kit connecting rod		L 243,5
40 93 0623	Stabilisatorlager / stabilizer mount	(2)	
40 94 0487	Stabilisatorlager / stabilizer mount	(1)	Ø 22
40 94 3559	Verbindungsstange / stabilizer link		L 290
40 94 3560	Verbindungsstange / stabilizer link		L 290
40 94 4156	Rep. Satz Axialgelenk / rep. kit axial joint	E - servo	L 223
40 94 4437	Rep. Satz Axialgelenk / rep. kit axial joint	(3)	L 317
40 94 5095	Lenkmanschette / steering boot	E - servo	
40 94 5096	Lenkmanschettensatz / steering boot set	E - servo	



OPEL

Combo D

(2011 →)

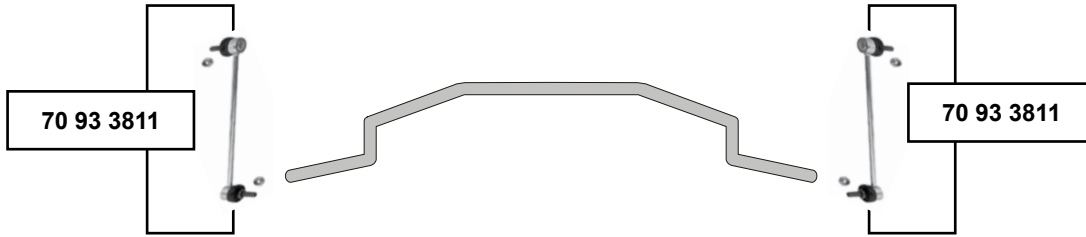

Commodore C

(1978 → 1982)

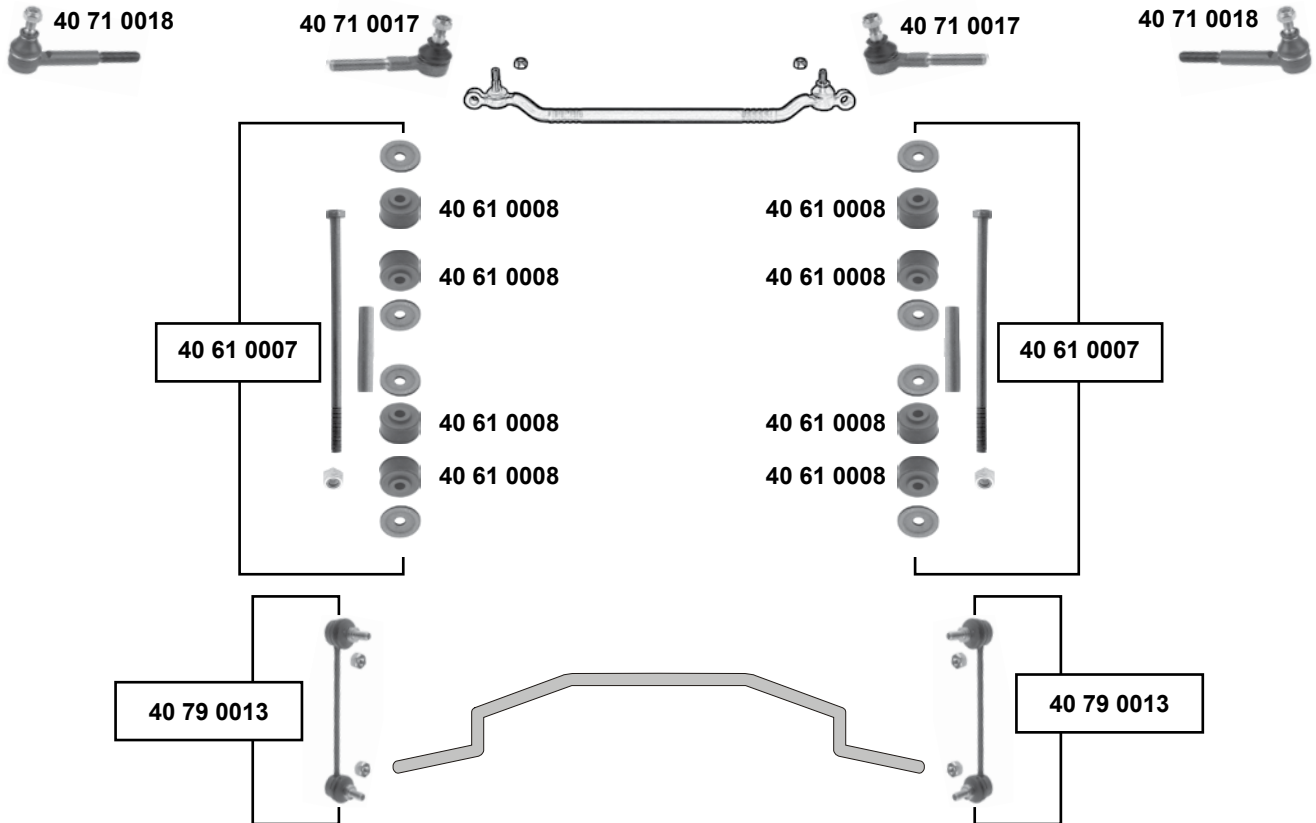

Ref. - No.



40 61 0007	1603 147
40 61 0008	0350 153
40 71 0017	0324 045
40 71 0018	0324 044
40 79 0013	0350 602
70 93 3811	0350 198

Rep. Satz Stabilisatorlager / rep. kit stabilizer mount
Verbindungsstangenlager / stabilizer link bush
Spurstangenendstück / tie rod end
Spurstangenendstück / tie rod end
Verbindungsstange / stabilizer link
Verbindungsstange / stabilizer link

8,5x30x19
M14x1,5 RHT
M14x1,5 LHT
L 195
L 297



Corso A (1982 → 1993)



40 60 0002	0352 327
40 60 0019	0353 560
40 71 0001	1603 645
40 73 0001	0352 043
40 73 0002	0352 044
40 74 0001	0322 149
40 78 0003	1603 187
40 80 0001	0902 826

Querlenkerlager / control arm mount
Zugstrebenlager / tension rod mount
Spurstangenendstück / tie rod end
Querlenker / control arm
Querlenker / control arm
Spurstange / tie rod
Traggelenk / ball joint
Rep. Satz Lenkmanschette / rep. kit steering boot

10x35x52
14x32/45x36
M12x1,5 RHT
L 300
Ø A 15



Corsa B (1993 → 2001)

(ch.) → V 3023597, V 4166925, V 6066279

Vorderachse / Front axle

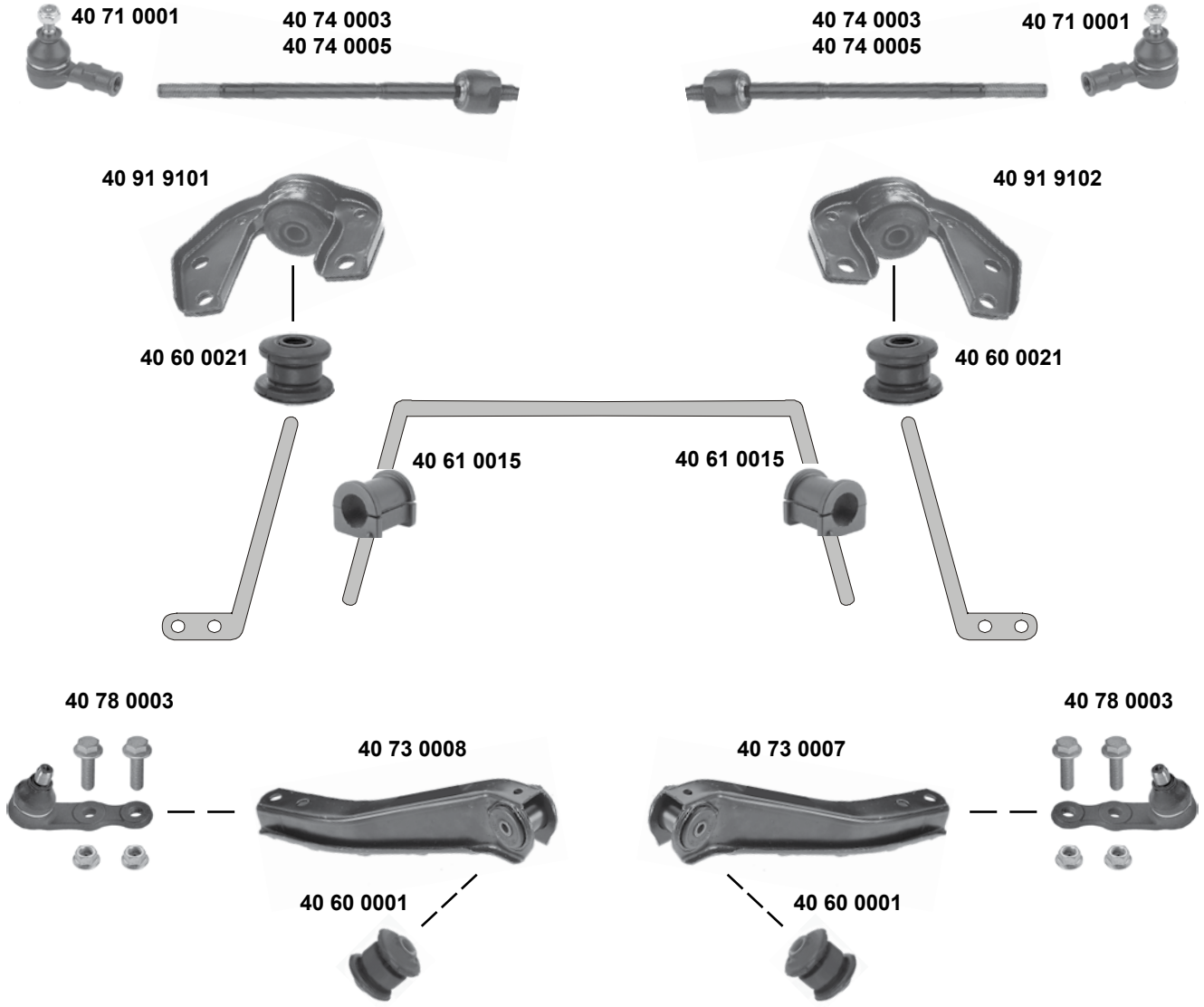

i (1) Combo (ch.) V 3037204 →

SWAG GERMANY	Ref. - No.		i	
40 60 0001	0352 301	Querlenkerlager / control arm mount		10x35x52
40 60 0021	0353 561	Zugstrebenlager / tension rod mount		14x36/50x40
40 61 0015	0350 127	Stabilisatorlager / stabilizer mount		Ø 21,5
40 71 0001	1603 645	Spurstangenendstück / tie rod end		M12x1,5 RHT
40 73 0007	0352 002	Querlenker / control arm		
40 73 0008	0352 003	Querlenker / control arm		
40 74 0003	1603 453 SK	Spurstange / tie rod		
40 74 0005	0322 158	Spurstange / tie rod		
40 78 0003	1603 187	Traggelenk / ball joint		
40 91 9101	0353 281	Halter / mount	(1)	
40 91 9102	0353 280	Halter / mount	(1)	
			man. / E - servo	L 325 L 290 Ø A 15



Corso B (1993 → 2001)

(ch.) V 3023598, V 4166926, V 6066280 →

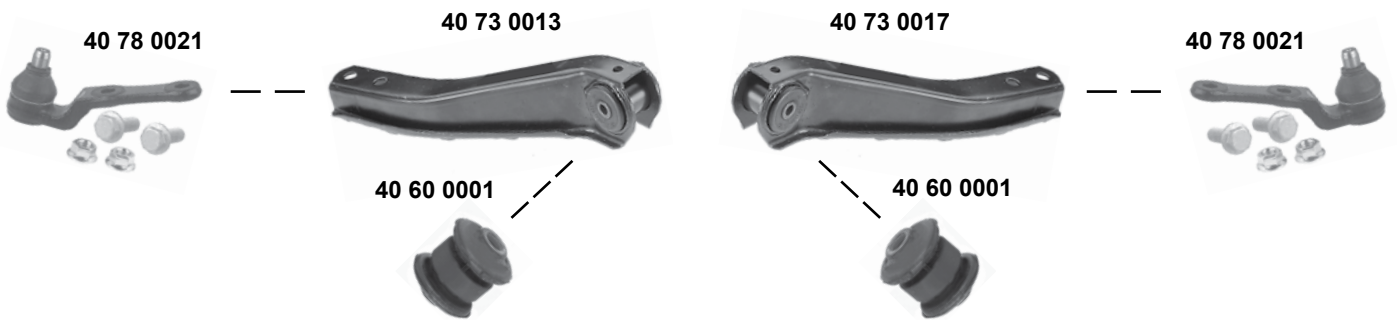
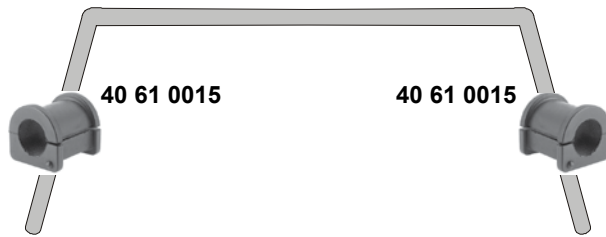

Vorderachse / Front axle

SWAG	Ref. - No.			
40 60 0001	0352 301	Querlenkerlager / control arm mount		10x35x52
40 61 0015	0350 127	Stabilisatorlager / stabilizer mount		Ø 1 21,5
40 71 0024	1603 455	Spurstangenendstück / tie rod end		M12x1,5 RHT
40 73 0013	5352 011	Querlenker / control arm		
40 73 0017	5352 012	Querlenker / control arm		
40 74 0003	1603 453 SK	Spurstange / tie rod	man. / E - servo	L 325
40 74 0005	0322 158	Spurstange / tie rod	servo	
40 78 0021	1603 202	Traggelenk / ball joint		Ø A 15



OPEL

Corsa C (2001 → 2006)

Vorderachse / Front axle

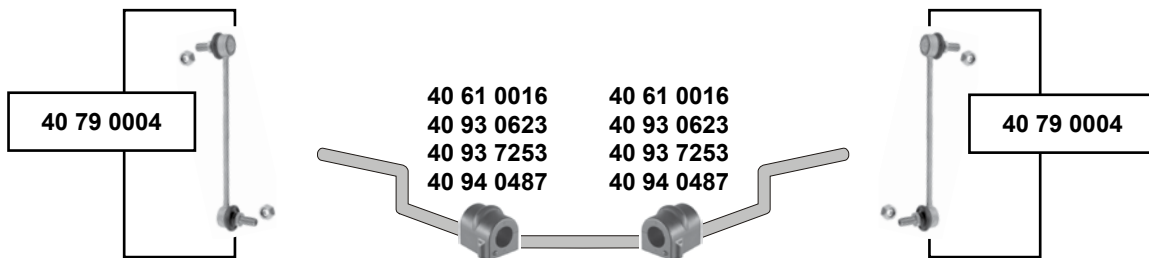
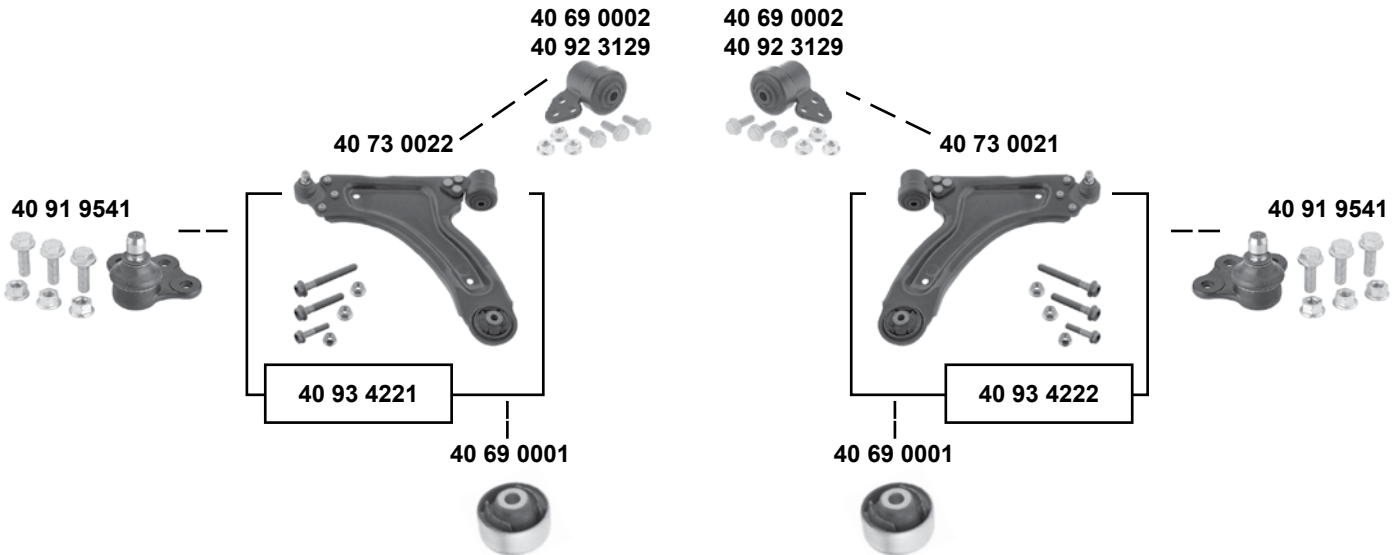
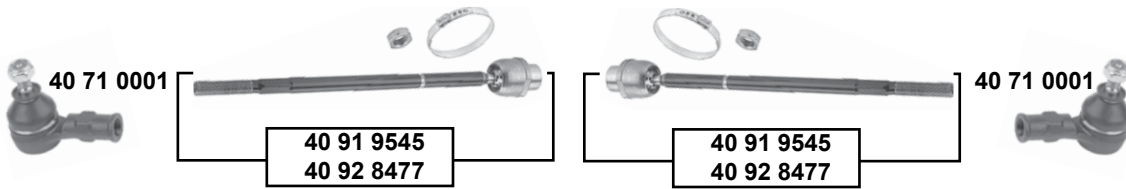







Corса C

(2001 → 2006)

- | | |
|---|--|
| (1) (ch.) 33999999 → ,(ch.) 34999999 →
(ch.) 36999999 → | (2) (ch.) 43000001 →, (ch.) 44000001 →
(ch.) 46000001 → |
| (3) (ex.) Combo (mot.) 1,0 / 1,2 / Y 1,3 DT / Z 1,3 DT / 1,4 / Z 1,7 DTH alle / all (ex.) Sport / (ex.) HD | |
| (4) (ex.) Combo (mot.) Z 1,0 XE / Z 1,2 XE /
für Fahrzeuge mit / for cars with HD (ex.) Sport → (ch.) 14999999, 16999999 | |
| (5) (ex.) Combo (mot.) Z 1,4 XE
für Fahrzeuge mit / for cars with Sport oder /or HD → (ch.) 14999999, 16999999 | |
| (6) Combo für alle Fahrzeuge (ex.) / Combo for all cars (ex.) HD | |

	Ref. - No.			
40 61 0016	0350 130	Stabilisatorlager / stabilizer mount		Ø I 16
40 69 0001	0352 320	Querlenkerlager / control arm mount		Ø A 59,5
40 69 0002	0352 309	Querlenkerlager / control arm mount		Ø A 60/49
40 71 0001	1603 645	Spurstangenendstück / tie rod end	(ex.) HD	M12x1,5 RHT
40 73 0021	0352 063	Querlenker / control arm	(1)	
40 73 0022	0352 061	Querlenker / control arm	(ex.) Sport / HD	
40 79 0004	0350 610	Verbindungsstange / stabilizer link	(ex.) Sport / HD	L 243,5
40 91 9541	0352 803	Traggelenk / ball joint	(ex.) Combo	
40 91 9545	1603 845	Spurstange / tie rod	(1)	L 315
40 92 3129	0352 377	Querlenkerlager / control arm mount	HD	Ø A60/49
40 92 8477	1603 844	Spurstange / tie rod	(2)	L 318
40 93 0623	0350 161	Stabilisatorlager / stabilizer mount	(2)	Ø I 21
40 93 4221	0352 061 S1	Rep. Satz Querlenker / rep. kit control arm	(3) (4) (5) (6)	
40 93 4222	0352 063 S1	Rep. Satz Querlenker / rep. kit control arm	(3) (4) (5) (6)	
40 93 7253	0350 104	Stabilisatorlager / stabilizer mount	(ex.) HD	Ø I 15 L 43,5
40 94 0487	0350 143	Stabilisatorlager / stabilizer mount		Ø 22



OPEL

Corsa D (2006 → 2014)

Vorderachse / Front axle

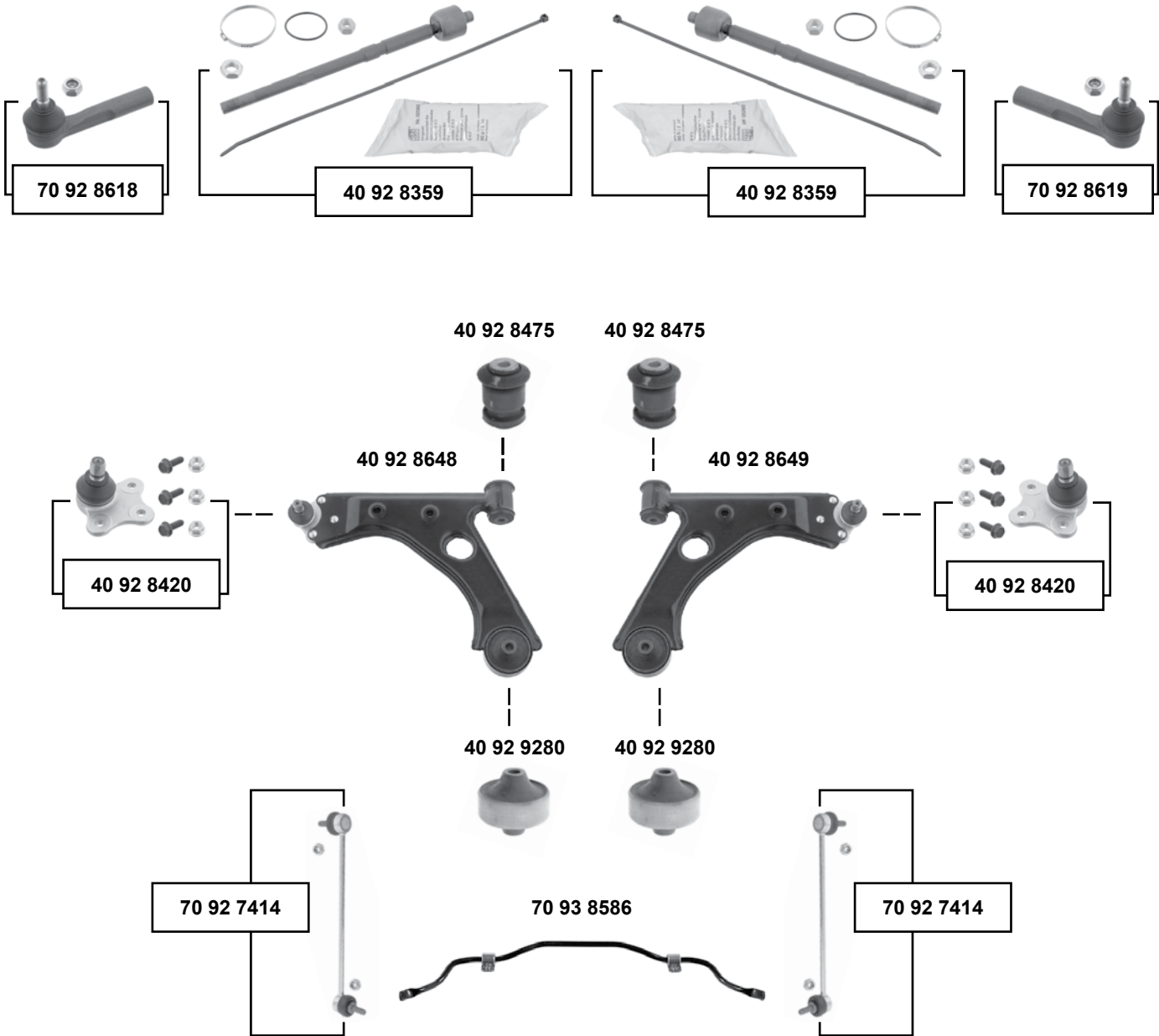

(1) (ch.) → 94170397, 96065974

	Ref. - No.			
40 92 8359	1603 543	Spurstange / tie rod		L 305
40 92 8420	0352 087	Traggelenk / ball joint		Ø A 16
40 92 8475	0352 380	Querlenkerlager / control arm mount		12x52x68
40 92 8648	5352 039	Querlenker / control arm		
40 92 8649	5352 038	Querlenker / control arm		
40 92 9280	0352 864	Querlenkerlager / control arm mount		12x72x66
70 92 7414	0350 175	Verbindungsstange / stabilizer link		L 301
70 92 8618	1603 544	Spurstangenendstück / tie rod end	(1)	M14 x 1,5
70 92 8619	1603 545	Spurstangenendstück / tie rod end	(1)	M14 x 1,5
70 93 8586	0350 181	Stabilisatorsatz / stabilizer set		L 1045



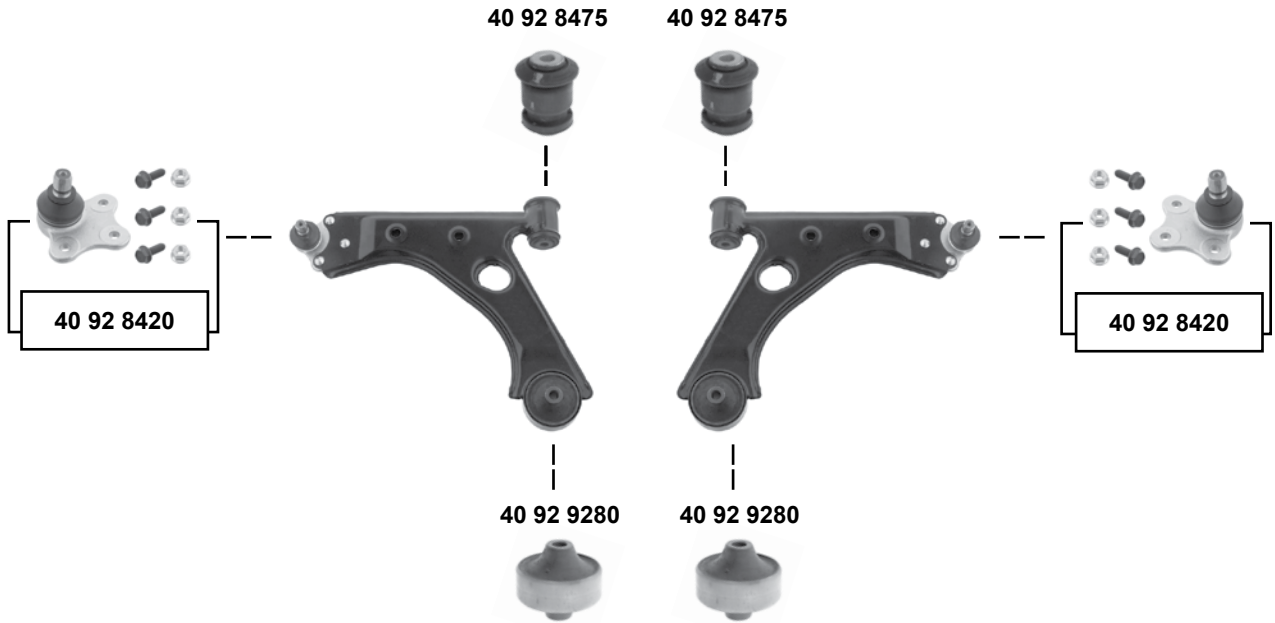

Corса E
(2014 →)

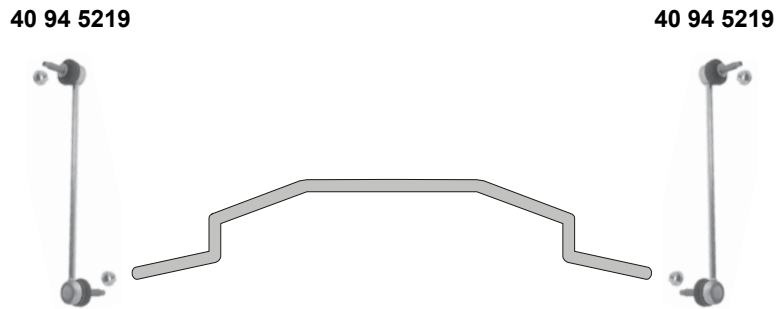

Vorderachse / Front axle



SWAG [®]	Ref. - No.			
40 92 8420	0352 087	Traggelenk / ball joint		Ø A 16
40 92 8475	0352 380	Querlenkerlager / control arm mount		12x52x68
40 92 9280	0352 864	Querlenkerlager / control arm mount		12x72x66
40 94 5219	0350 233	Verbindungsstange / stabilizer link		L 310



OPEL

Frontera A (1992 → 1998)

Vorderachse / Front axle

40 71 0016



40 71 0015



oben / upper

40 78 0009
40 92 6125

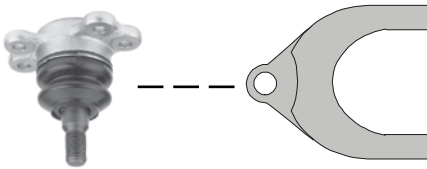

40 78 0009
40 92 6125

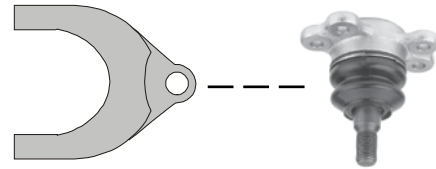

unten / lower

40 78 0008

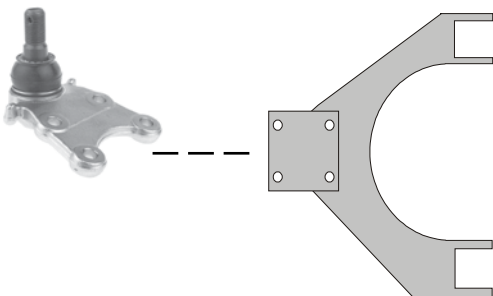

40 78 0008

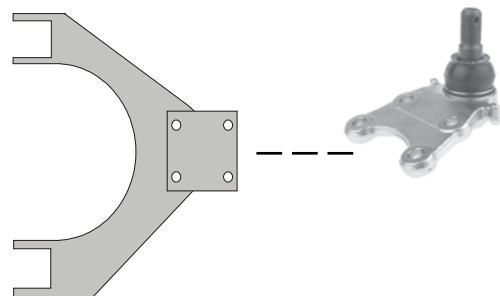

Ref. - No.



40 71 0015	0324 058	Spurstangenendstück / tie rod end		M14 x 1,5
40 71 0016	0324 057	Spurstangenendstück / tie rod end		M14 x 1,5
40 78 0008	0352 828	Traggelenk / ball joint		M18 x 1,5
40 78 0009	0310 821	Traggelenk / ball joint	(ch.) → SV 720102	M18 x 1,5
40 92 3687	0350 608	Verbindungsstange / stabilizer link	(ch.) SV 720103 →	L 150
40 92 3688	0350 607	Verbindungsstange / stabilizer link	(ch.) SV 720103 →	L 150
40 92 6125	0310 823	Traggelenk / ball joint	(ch.) SV 720103 →	M14 x 1,5



Frontera B
(1998 → 2004)

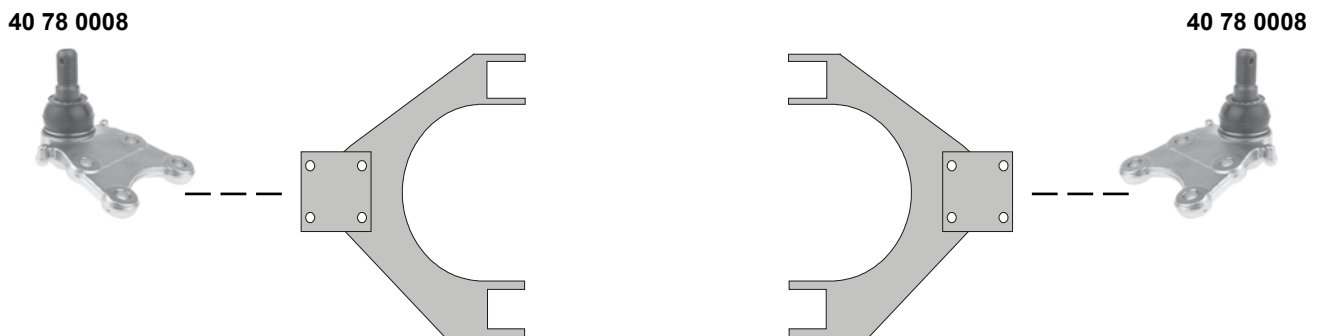
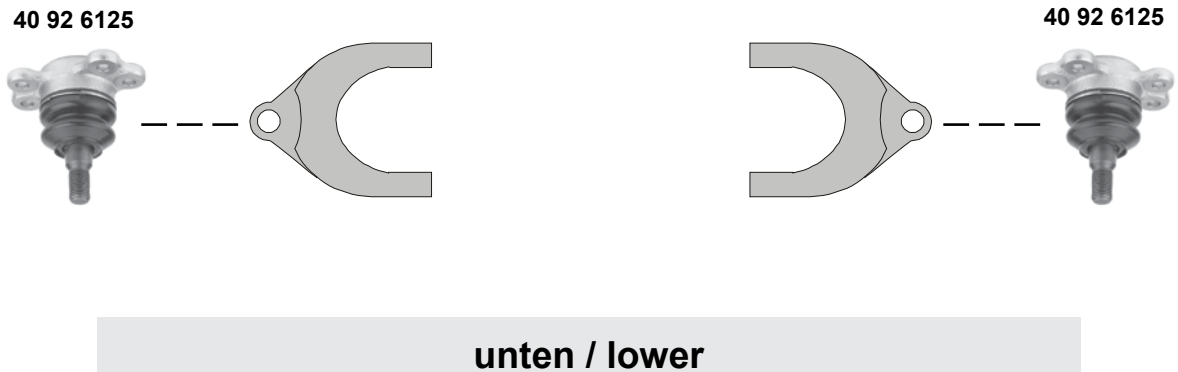
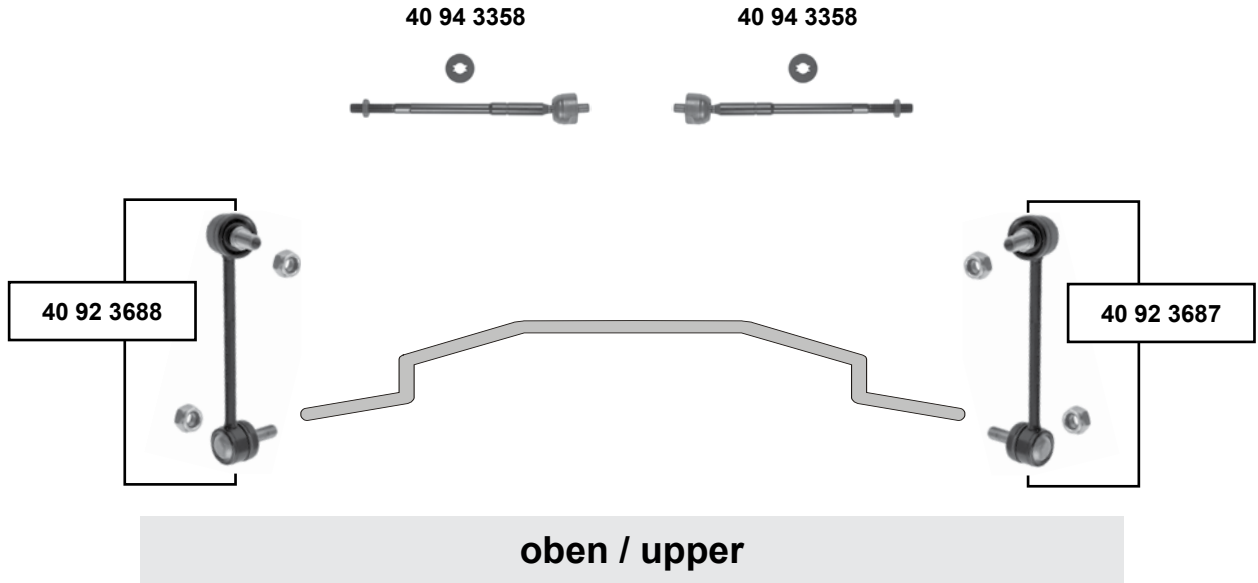

Vorderachse / Front axle

SWAG [®]	Ref. - No.			
40 78 0008	0352 828	Traggelenk / ball joint		M18 x 1,5
40 92 3687	0350 608	Verbindungsstange / stabilizer link		L 150
40 92 3688	0350 607	Verbindungsstange / stabilizer link		L 150
40 92 6125	0310 823	Traggelenk / ball joint		M14 x 1,5
40 94 3358	0900 905	Axialgelenk / axial joint		L 312

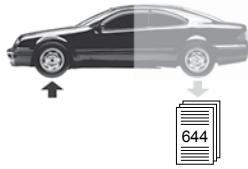

Insignia
(2008 →)

Vorderachse / Front axle

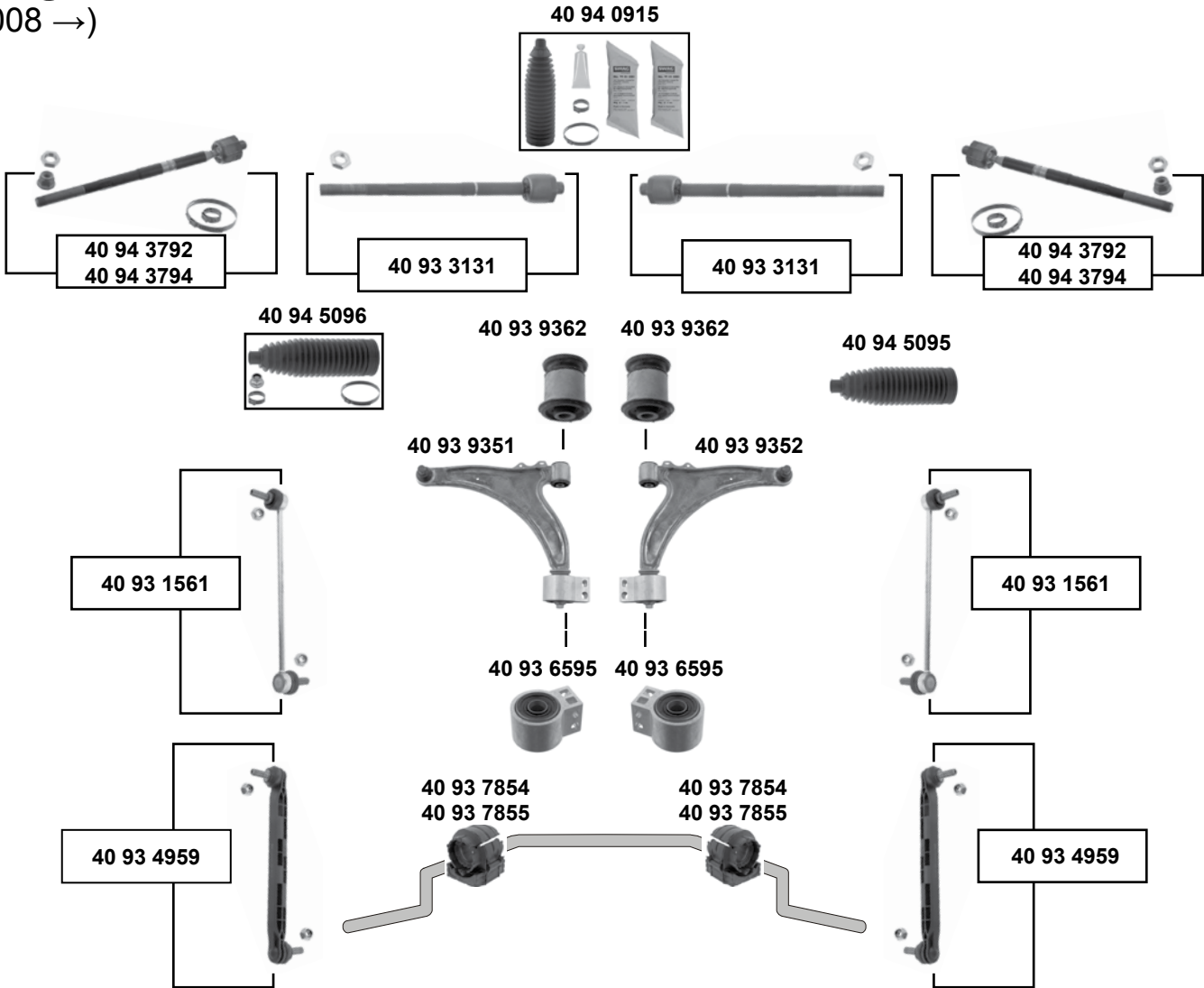

- (1) Für Fahrzeuge mit Flexride Fahrwerk (aktives Fahrwerk) / for vehicles with flexride chassis only
- (2) alle (ex.) Flexride Fahrwerk / all (ex.) flexride chassis
- (3) für reduzierten Stellweg der Zahnstange / for reduced range of the steering rack POC / NJ0
- (4) für normalen Stellweg der Zahnstange / for normal range of the steering rack POC / NJ1
- (5) (ex.) 4x4 / (ch.) POC XJ6 / (ch.) POC XJ2 / (ch.) POC XJ4



Ref. - No.



Ref. - No.				
40 93 1561	0350 618	Verbindungsstange / stabilizer link	(1)	L 303,5
40 93 3131	6606 030 SK	Axialgelenk ohne Endstück / axial joint without end		L 209
40 93 4959	0350 617	Verbindungsstange / stabilizer link	(2)	L 304
40 93 6595	0352 868	Querlenkerlager / control arm mount		Ø I 22
40 93 7854	0350 621	Stabilisatorlager / stabilizer mount		Ø I 25
40 93 7855	0350 622	Stabilisatorlager / stabilizer mount		Ø I 23
40 93 9351	0352 520	Querlenker / control arm	(5)	
40 93 9352	0352 521	Querlenker / control arm	(5)	
40 93 9362	0352 866	Querlenkerlager / control arm mount		12x52x60
40 94 0915	1609 357	Lenkmanschettenatz / steering boot set	servo	
40 94 3792	1609 183	Axialgelenk ohne Endstück / axial joint without end	(3) E - servo	L 314
40 94 3794	1609 181	Axialgelenk ohne Endstück / axial joint without end	(4) E - servo	L 311
40 94 5095	1609 182 SK1	Lenkmanschette / steering boot	E - servo	
40 94 5096	1609 182	Lenkmanschettenatz / steering boot set	E - servo	



Kadett C
(1973 → 1979)

40 61 0008



40 61 0008



Vorderachse / Front axle

Kadett D
(1979 → 1982)

(ch.) → C 2500000, C 5000090

40 76 0001



40 80 0002



40 80 0004

40 80 0002



40 80 0004

40 76 0001





Kadett D (1979 → 1984)

(ch.) C 2500001, C 5000091 →

Vorderachse / Front axle

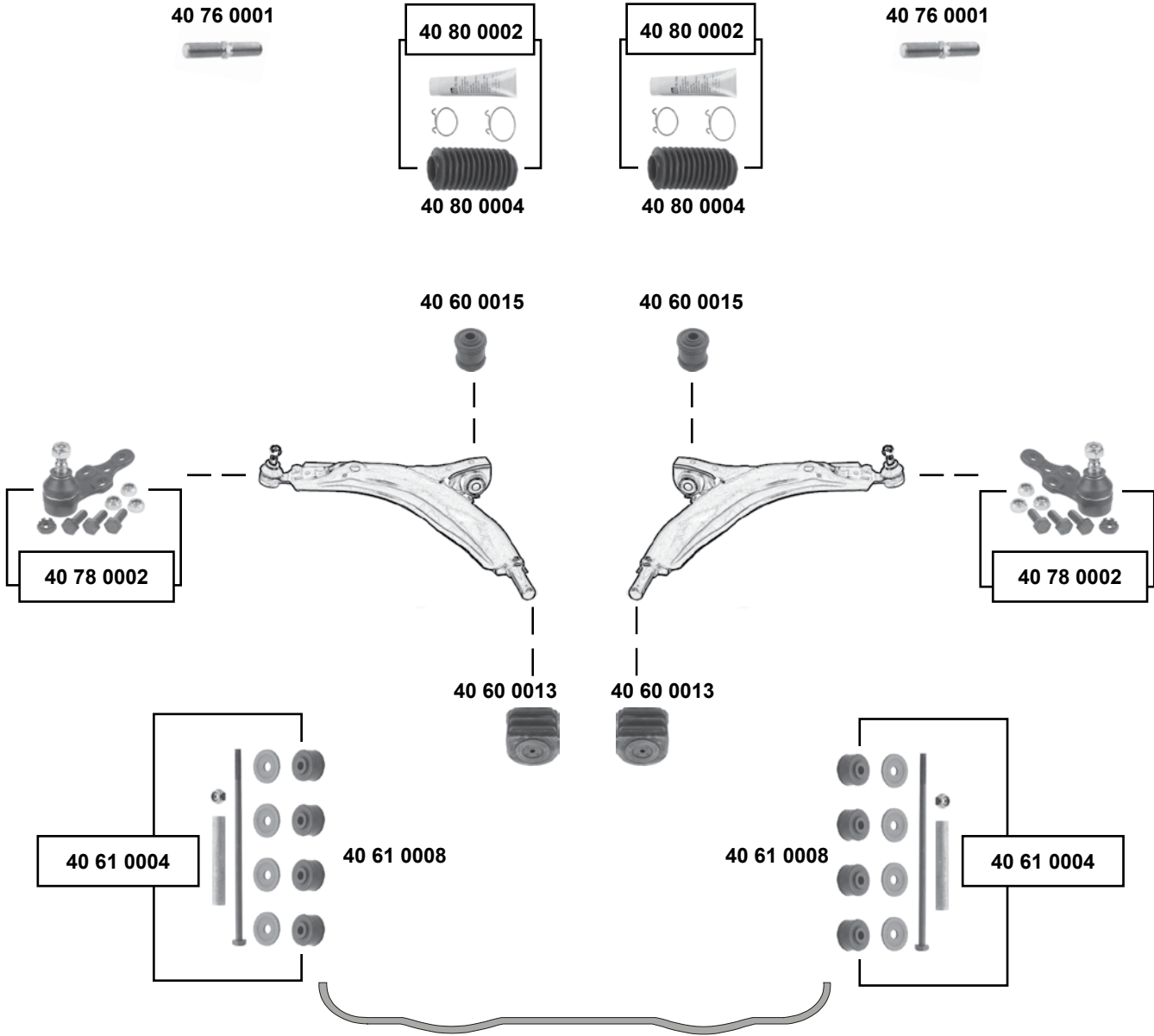

(1) (ch.) FD 2630572 / D 5109110 / CE 173724 →

SWAG GERMANY	Ref. - No.			
40 60 0013	0352 335	Querlenkerlager / control arm mount	für / to fit Caravan für / to fit Caravan (1)	21x56x54,5
40 60 0015	0352 349	Querlenkerlager / control arm mount		14,5x46x59
40 61 0004	1603 148	Stabilisatorlager / stabilizer mount		8,5x30x19
40 61 0008	0350 153	Verbindungsstangenlager / stabilizer link bush		M16x1,5x98,5
40 76 0001	0322 575	Einstellbolzen / adjusting bolt		M12 x 1,5
40 78 0002	1603 164	Traggelenk / ball joint		
40 80 0002	0902 828 S1	Rep. Satz Lenkmanschette / rep. kit steering boot		
40 80 0004	0902 828	Lenkmanschette / steering boot		



Kadett E (1984 → 1994)

man.

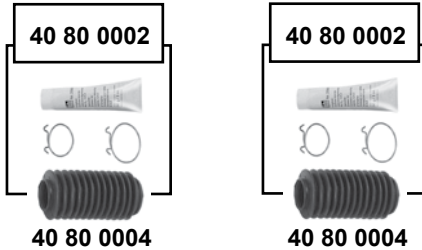

servo

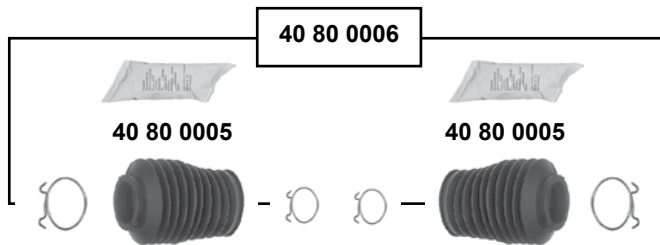

Vorderachse / Front axle

SWAG	Ref. - No.			
40 71 0006	0324 038	Spurstangenendstück / tie rod end		M16x1,5 LHT
40 71 0007	0324 039	Spurstangenendstück / tie rod end		M16x1,5 RHT
40 72 0006	0322 126	Spurstange / tie rod		L 429
40 72 0007	0322 125	Spurstange / tie rod		L 429
40 76 0001	0322 575	Einstellbolzen / adjusting bolt		M16x1,5x98,5
40 80 0002	0902 828 S1	Rep. Satz Lenkmanschette / rep. kit steering boot		
40 80 0004	0902 828	Lenkmanschette / steering boot		
40 80 0005	1609 073 S1	Lenkmanschette / steering boot	LHD / für/to fit servo	ZF
40 80 0006	1609 073 SK	Lenkmanschette / steering boot	LHD / für/to fit servo	ZF



OPEL

Kadett E
(1984 → 1994)

Vorderachse / Front axle

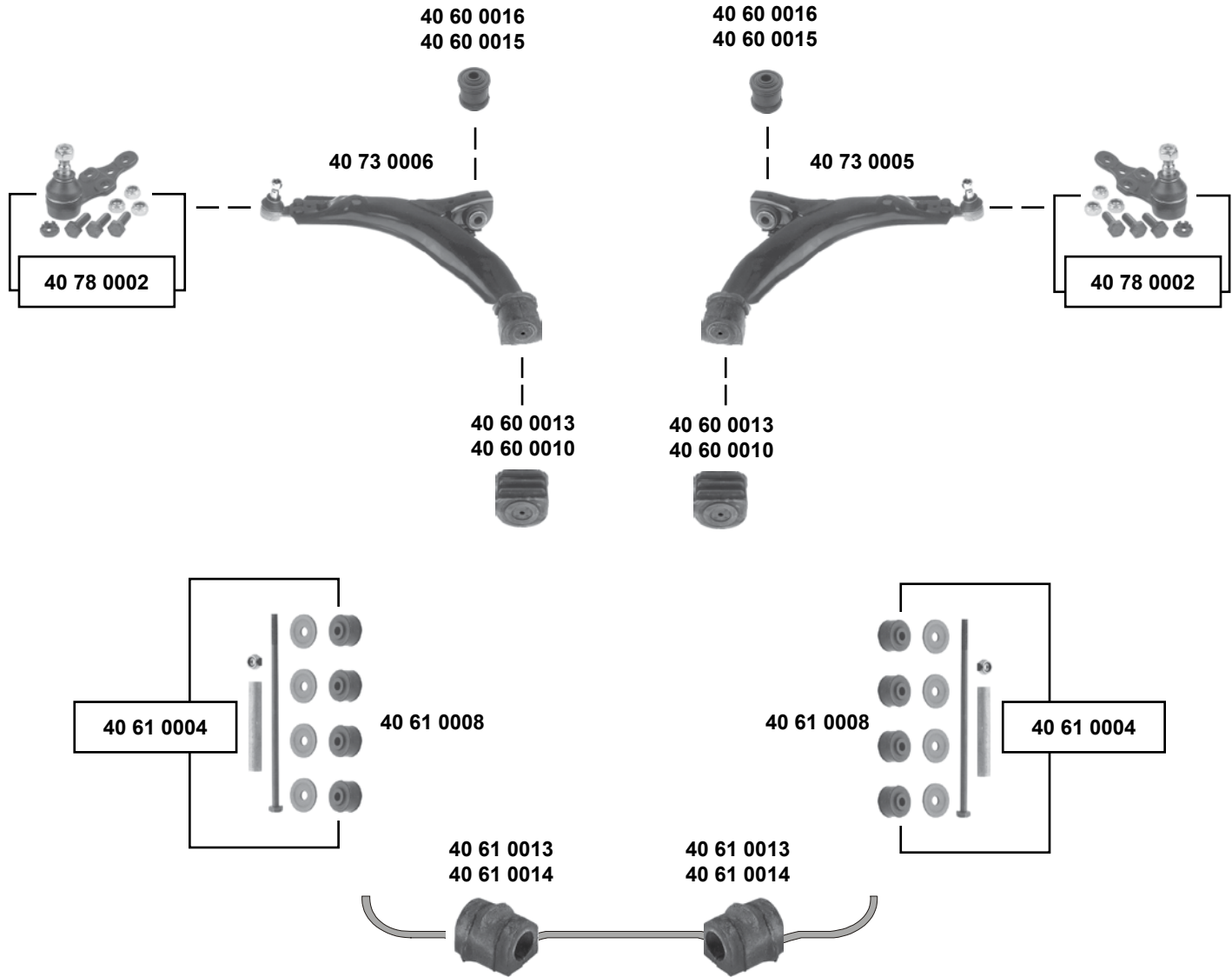

- (1) 1.8 E / SE Caravan, 2.0 Cabrio / Stufenheck / GSi / GTE
- (2) (ex.) 1.8 E / SE Caravan, 2.0 Cabrio / Stufenheck / GSi / GTE



Ref. - No.

40 60 0010	0352 338	Querlenkerlager / control arm mount	(1)	21x56x54,5
40 60 0013	0352 335	Querlenkerlager / control arm mount	(2)	21x56x54,5
40 60 0015	0352 349	Querlenkerlager / control arm mount	(2)	59x46x14,5
40 60 0016	0352 330	Querlenkerlager / control arm mount	(1)	59x43,5x14,5
40 61 0004	1603 148	Stabilisatorlager / stabilizer mount		
40 61 0008	0350 153	Verbindungsstangenlager / stabilizer link bush		8,5x30x19
40 61 0013	0350 113	Stabilisatorlager / stabilizer mount		Ø 20
40 61 0014	0350 112	Stabilisatorlager / stabilizer mount		Ø 17,5
40 73 0005	0352 172	Querlenker / control arm	(2)	
40 73 0006	5352 014	Querlenker / control arm	(2)	
40 78 0002	1603 164	Traggelenk / ball joint		M12 x 1,5



Manta B
(1975 → 1981)

Vorderachse / Front axle

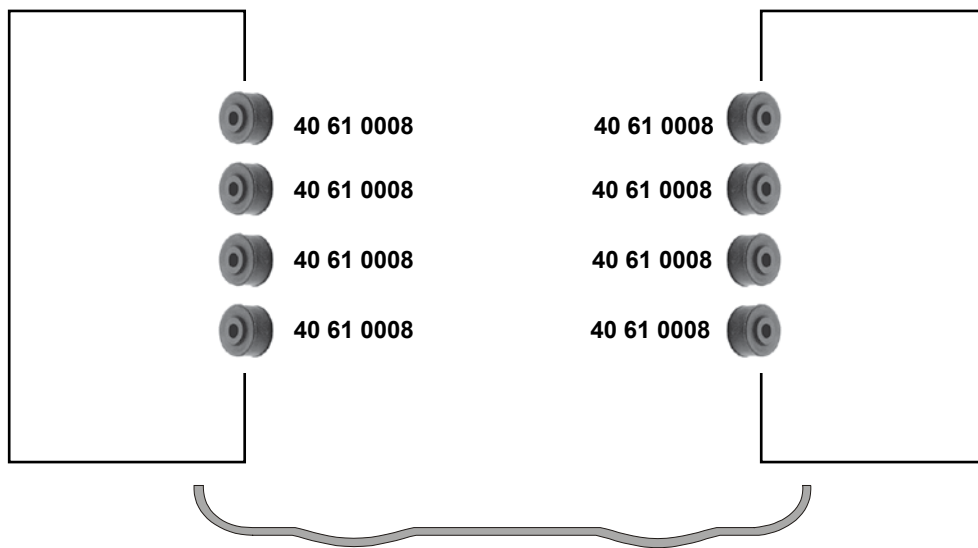



OPEL

Meriva A
(2003 → 2010)

Vorderachse / Front axle

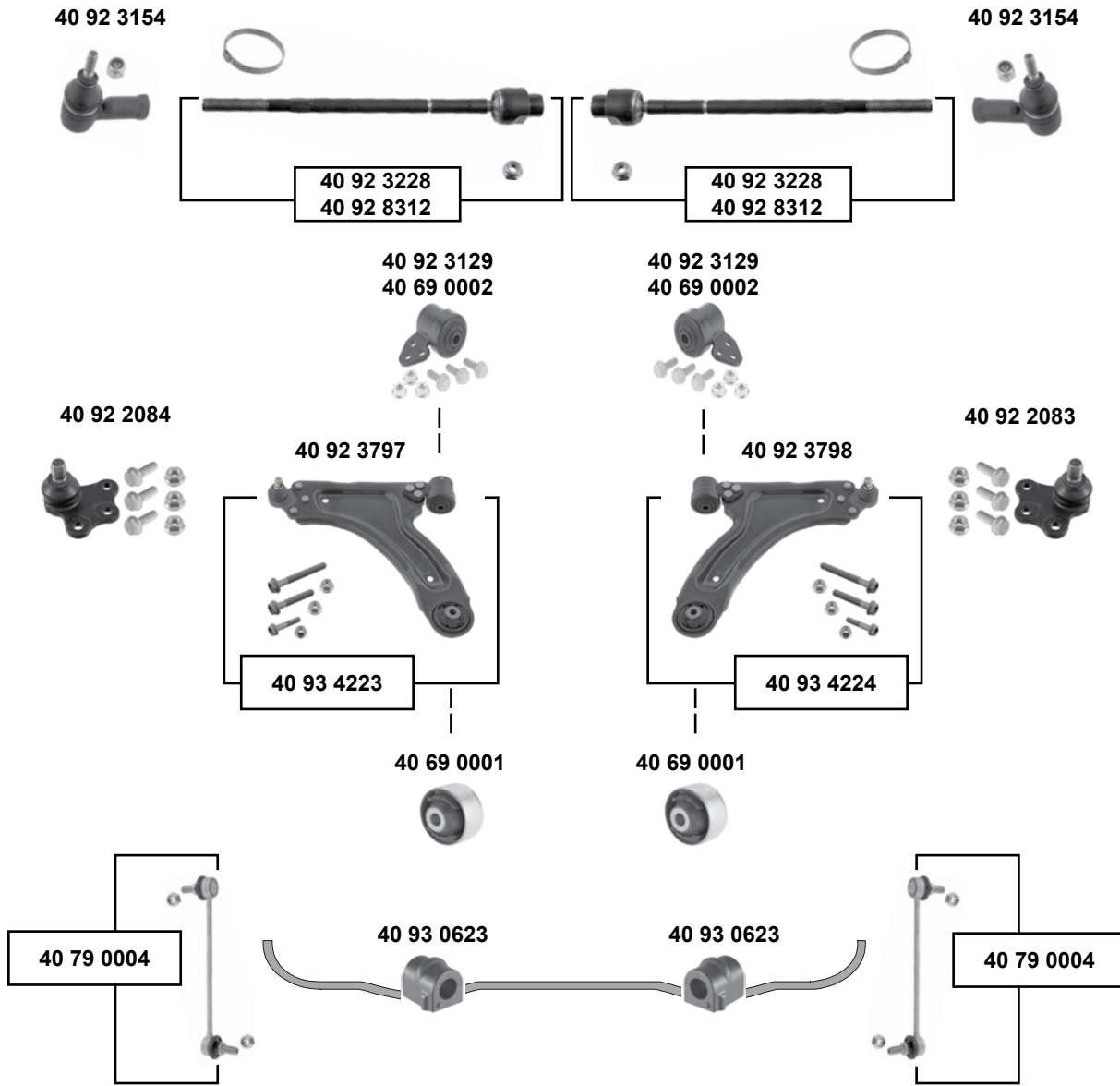

Ref. - No.			
40 69 0001	0352 320	Gummilager / rubber mounting	12x60x27/46
40 69 0002	0352 378	Querlenkerlagersatz / control arm mount kit	12x59x70
40 79 0004	0350 610	Verbindungsstange / stabilizer link	L 243,5
40 92 2083	5352 026	Traggelenk / ball joint	Ø A 16
40 92 2084	5352 025	Traggelenk / ball joint	Ø A 16
40 92 3129	0352 377	Gummilager / rubber mounting	12x49/50x70
40 92 3154	1603 240 SK	Spurstangenendstück / tie rod end	M14 x 1,5
40 92 3228	1603 240	Spurstange / tie rod	L 333
40 92 3797	5352 027	Querlenker / control arm	(ex.) OPC
40 92 3798	5352 028	Querlenker / control arm	(ex.) OPC
40 92 8312	1603 428	Spurstange / tie rod	(ex.) servo
40 93 0623	0350 161	Stabilisatorlager / stabilizer mount	L 332
40 93 4223	5352 027 S1	Rep. Satz Querlenker links / rep. kit control arm left	(ex.) OPC + VXR
40 93 4224	5352 028 S1	Rep. Satz Querlenker rechts / rep. kit control arm right	(ex.) OPC + VXR



Meriva B (2010 →)

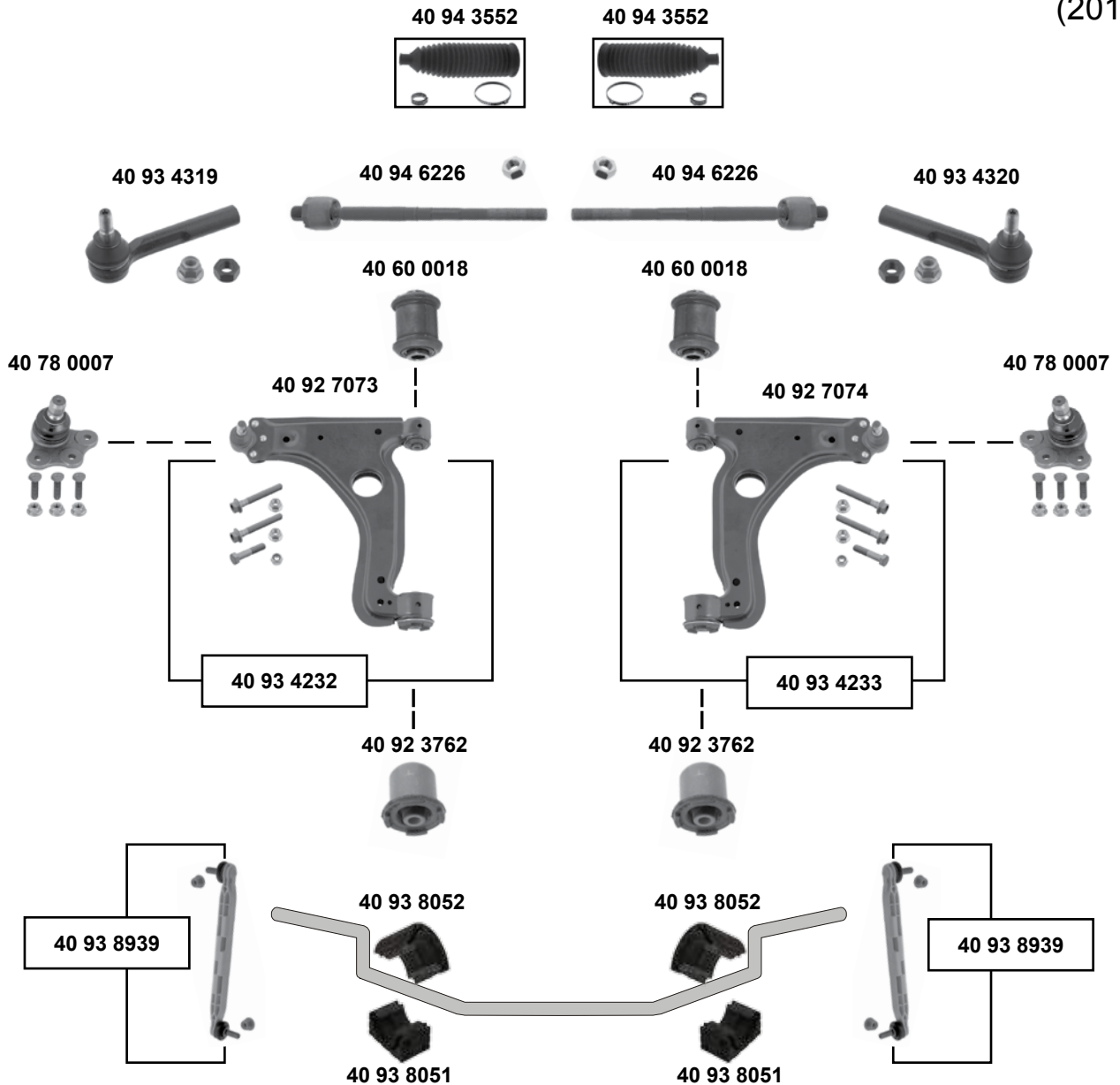

Vorderachse / Front axle



(1) Nur für TRW-Lenkung / TRW-steering only



Ref. - No.



40 60 0018	0352 364	Querlenkerlager / control arm mount		12x36,5x60
40 78 0007	0352 800	Traggelenk / ball joint		
40 92 3762	0352 324	Querlenkerlager / control arm mount		12x46x60
40 92 7073	5352 029	Querlenker / control arm		
40 92 7074	5352 030	Querlenker / control arm		
40 93 4232	5352 029 S1	Rep. Satz Querlenker links / rep. kit control arm left		
40 93 4233	5352 030 S1	Rep. Satz Querlenker rechts / rep. kit control arm right		
40 93 4319	1609 013	Spurstangenendstück / tie rod end		
40 93 4320	1609 012	Spurstangenendstück / tie rod end		
40 93 8051	0350 391	Stabilisatorlager, unten / stabilizer mount, lower		Ø 24-25,5
40 93 8052	0350 390	Stabilisatorlager, oben / stabilizer mount, upper		Ø 24-25,5
40 93 8939	0350 176	Rep. Satz Verbindungsstange / rep. kit stabilizer link		L 350
40 94 3552	1609 356	Lenkmanschettensatz / steering boot set	(1)	L 211
40 94 6226	1609 011 SK1	Axialgelenk / axial joint	POC 1	L276



Mokka (2013 →)

Vorderachse / Front axle

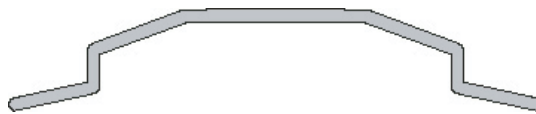
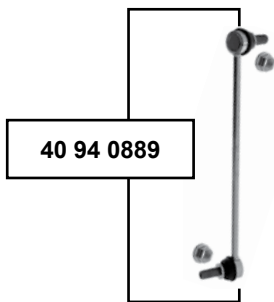
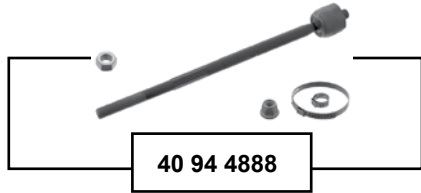

	Ref. - No.			
40 94 0889	0350 231	Verbindungsstange / stabilizer link		L 286
40 94 0890	0350 232	Verbindungsstange / stabilizer link		L 286
40 94 4888	1609 213	Rep. Satz Axialgelenk / rep. kit axial joint	E - servo	L 334



Monterey A
(1992 → 1997)

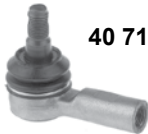

40 71 0016



40 71 0015



40 78 0008

Vorderachse / Front axle

Monterey B
(1998 → 2000)



40 71 0016



40 71 0015



Movano A (1998 → 2010)

Vorderachse / Front axle

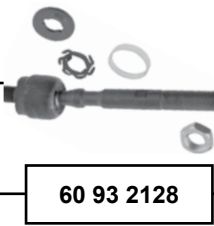
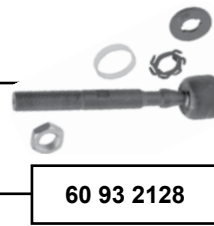
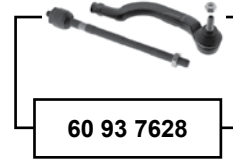

oben / upper

60 93 1847



60 92 7181



60 92 7181



60 92 7181



60 92 7181



60 93 1847



60 92 2710



unten / lower

60 92 2468
60 93 4164



60 92 6453
60 93 6583



40 92 4262



60 92 4263



40 92 4262



60 92 4263



60 92 6454
60 93 6584



60 92 2468
60 93 4164

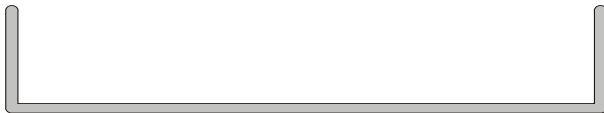
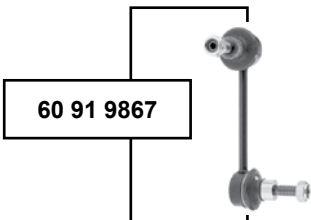



Movano A





(1998 → 2010)



(1) ED (ch.) B809446 → / FD (ch.) BB35303 → / FD (ch.) J023003 →
 HD (ch.) B784591 → / JD (ch.) B794054 → / UD (ch.) B822153 →
 außer Fahrzeuge mit erhöhtem Bodenabstand / except vehicles with increased ground distance

(2) ED (ch.) → B810866 / FD (ch.) → BB57431 / HD (ch.) → B785825 / JD (ch.) → B794913 /
 UD (ch.) → B825494

(3) (ch.) → B810866 (ED) / (ch.) → BB57431 (ED) / (ch.) → B785825 (ED) / (ch.) → B794913 (ED) /
 (ch.) → B825494 (ED)

	Ref. - No.			
40 92 4262	4500 094	Querlenkerlager / control arm mount		
60 91 9866	4500 199	Verbindungsstange / stabilizer link		L 130
60 91 9867	4500 198	Verbindungsstange / stabilizer link		L 130
60 92 1493	4501 262	Spurstangenendstück / tie rod end		L 225
60 92 1494	4501 263	Spurstangenendstück / tie rod end		L 225
60 92 2468	4401 909	Traggelenk / ball joint		Ø A 22
60 92 2710	4500 254	Traggelenk / ball joint	→ 09/02	
60 92 4263	4500 095	Querlenkerlager / control arm mount		
60 92 6453	4418 212	Querlenker / control arm		
60 92 6454	4418 213	Querlenker / control arm		
60 92 7181	4500 091	Querlenkerlager oben / upper control arm mount		M10 x 1,5
60 93 1847	4401 910	Traggelenk / ball joint		Ø A15/101
60 93 2128	4501 261 SK	Spurstange / tie rod		L 174,5
60 93 4164	4418 631	Traggelenk / ball joint	(1)	Ø A 24
60 93 6583	4418 629	Querlenker / control arm	07 → 10 (1)	
60 93 6584	4418 630	Querlenker / control arm	07 → 10 (1)	
60 93 7625	4501 261 S1	Spurstange / tie rod	(3)	
60 93 7626	4501 261 S2	Spurstange / tie rod	(3)	
60 93 7627	4408 474 S1	Spurstange / tie rod	(2)	
60 93 7628	4408 474 S2	Spurstange / tie rod	(2)	

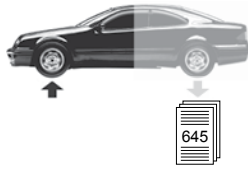

Movano B

(2010 →)

Vorderachse / Front axle

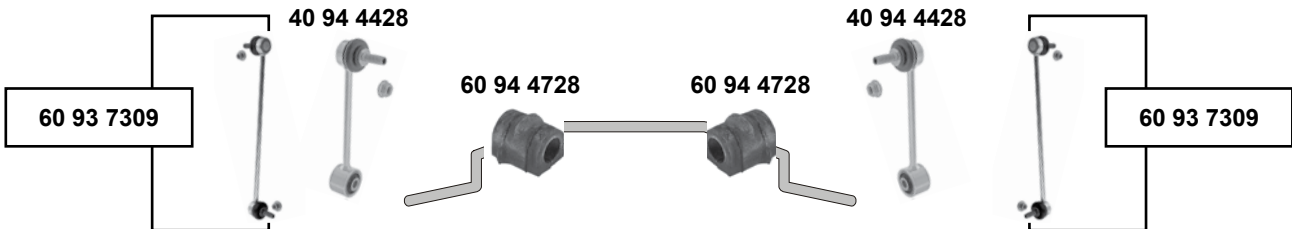
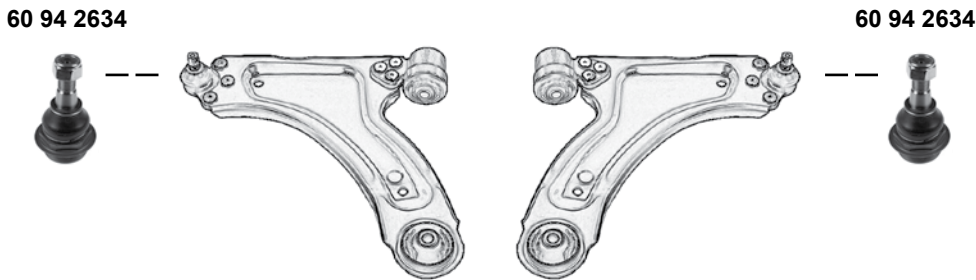
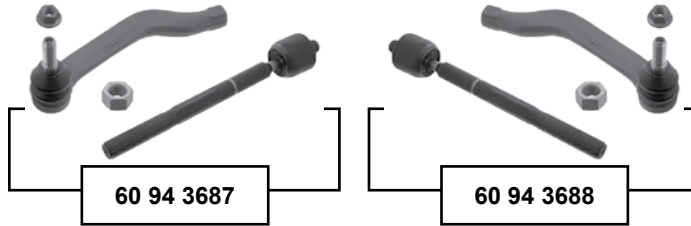
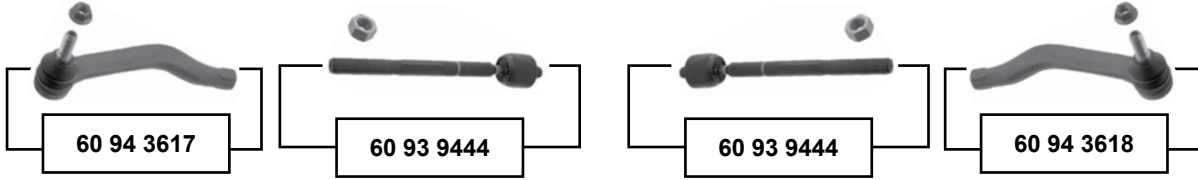

- (1) alle mit Heckantrieb in Verbindung mit Doppelbereifung / all with rear drive combined with double tires
- (2) EV0 , FV0 , HV0 , UV0 , JV0
Nur Fahrzeuge mit Frontantrieb mit einem Gesamtgewicht von 3300 u. 3500 kg / only vehicles with front wheel drive combined with a total weight of 3300 a. 3500 kg
- (3) Vorderradantrieb oder Heckantrieb ohne Doppelbereifung / front-wheel drive or rear-wheel drive without double tires



Ref. - No.



60 93 7309	4419 291	Verbindungsstange / stabilizer link	(3)	L 330
60 93 9444	4420 098 SK	Axialgelenk / axial joint		L 253
60 94 2634	4419 219	Traggelenk / ball joint	→ 22.07.10	
60 94 3617	4420 097	Spurstangenendstück / tie rod end		M18 x 1,5
60 94 3618	4420 098	Spurstangenendstück / tie rod end		M18 x 1,5
60 94 3687	4420 097 S1	Rep. Satz Spurstange / rep. kit tie rod		
60 94 3688	4420 098 S1	Rep. Satz Spurstange / rep. kit tie rod		
40 94 4428	4420 954	Verbindungsstange / stabilizer link	(1)	L 166
60 94 4728	4419 323	Stabilisatorlager / stabilizer mount	(2)	Ø I 25,4



Monza
(1978 → 1987)

Vorderachse / Front axle

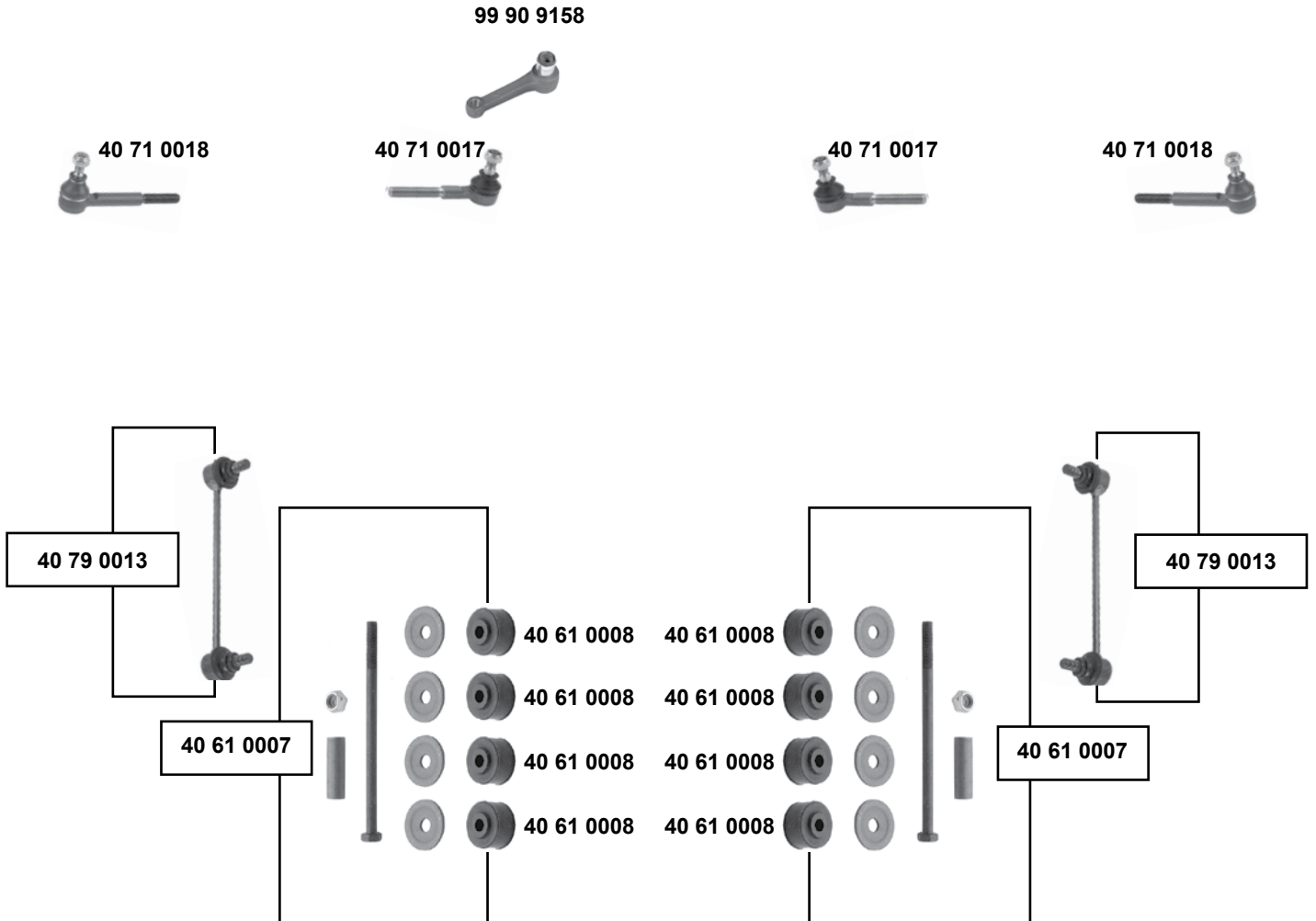

SWAG GERMANY	Ref. - No.			
40 61 0007	1603 147	Rep. Satz Stabilisatorlager / rep. kit stabilizer		
40 61 0008	0350 153	Verbindungsstangenlager / stabilizer link bush		8,5x30x19
40 71 0017	0324 045	Spurstangenendstück / tie rod end		M14x1,5 RHT
40 71 0018	0324 044	Spurstangenendstück / tie rod end		M14x1,5 LHT
40 79 0013	0350 602	Verbindungsstange / stabilizer link		L 195
99 90 9158	0920 367	Lenkhebel / steering arm		L 121 Ø I 18

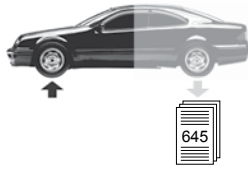

Omega A
(1986 → 1994)

Vorderachse / Front axle

99 90 9158
40 92 2099



40 72 0003

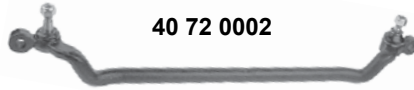

40 72 0002

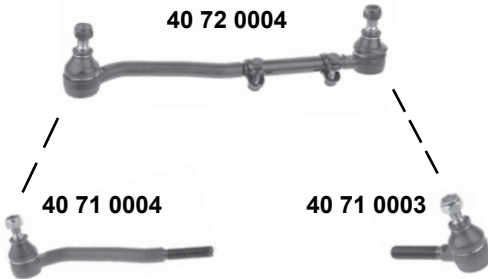

40 72 0004

40 71 0004

40 71 0003

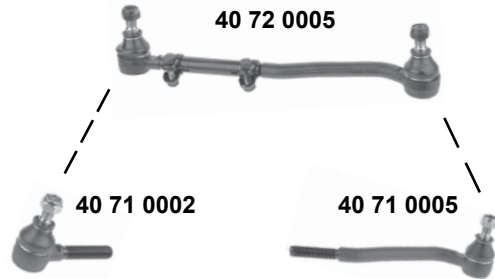

40 72 0005

40 71 0002

40 71 0005



- (1) Omega 1.8, 2.0, 2.6, 3.0
- (2) Omega 2.3D, 2.3TD, 2.4
- (3) Omega 1.8, 2.0, 2.4



Ref. - No.



Ref. - No.	Description	Notes	Dimensions
40 71 0002	Spurstangenendstück / tie rod end	(ch.) H 1169261 →	M14x1,5 RHT
40 71 0003	Spurstangenendstück / tie rod end	(ch.) H 1169261 →	M14x1,5 LHT
40 71 0004	Spurstangenendstück / tie rod end	(ch.) H 1169261 →	M14x1,5 RHT
40 71 0005	Spurstangenendstück / tie rod end	(ch.) H 1169261 →	M14x1,5 LHT
40 72 0002	Spurstange / tie rod	(2) LHD	L 572
40 72 0003	Spurstange / tie rod	(1) LHD	L 572
40 72 0004	Spurstange / tie rod		L 347
40 72 0005	Spurstange / tie rod		L 347
40 92 2099	Lenkhebel / steering arm	(3)	L 110 Ø 18
99 90 9158	Lenkhebel / steering arm		L 121 Ø 18

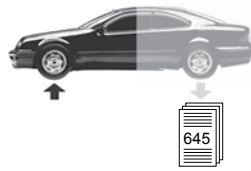

Omega A
(1986 → 1994)

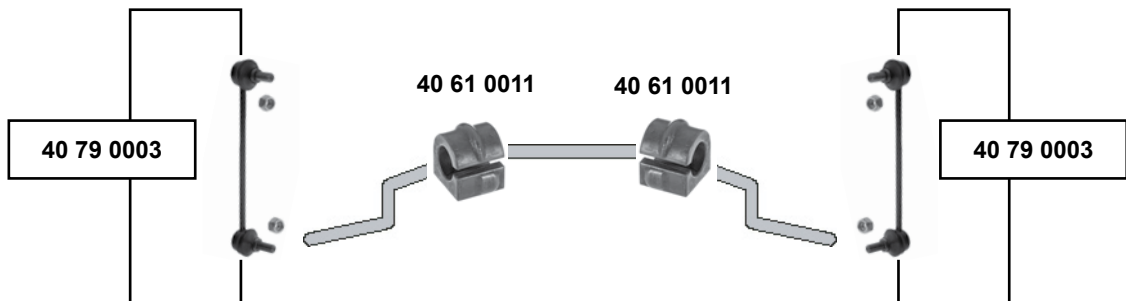
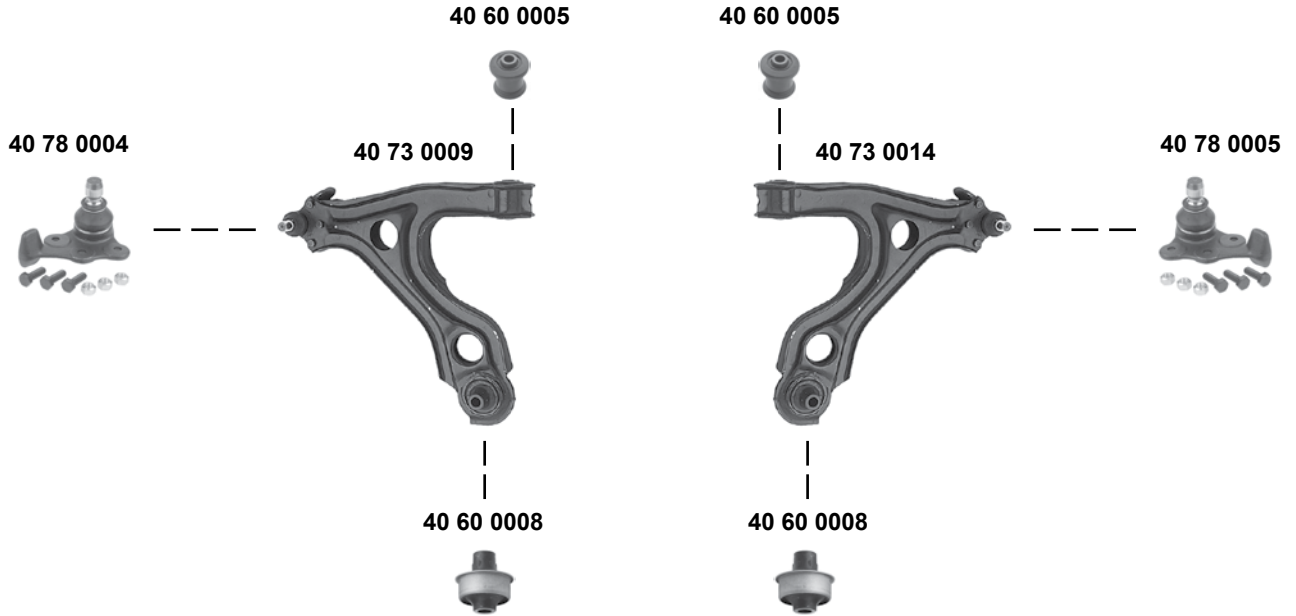

Vorderachse / Front axle

SWAG GERMANY	Ref. - No.			
40 60 0005	0352 341	Querlenkerlager / control arm mount		12x41/47x60
40 60 0008	0352 355	Querlenkerlager / control arm mount		16x60x69,5
40 61 0011	0350 116	Stabilisatorlager / stabilizer mount		Ø 22
40 73 0009	0352 135	Querlenker / control arm		
40 73 0014	0352 136	Querlenker / control arm		
40 78 0004	0352 826	Traggelenk / ball joint		Ø A 18
40 78 0005	0352 827	Traggelenk / ball joint		Ø A 18
40 79 0003	0350 609	Verbindungsstange / stabilizer link		L 225

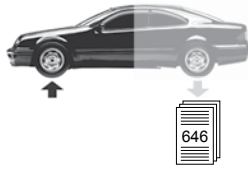

Omega B
(1994 → 2003)

Vorderachse / Front axle

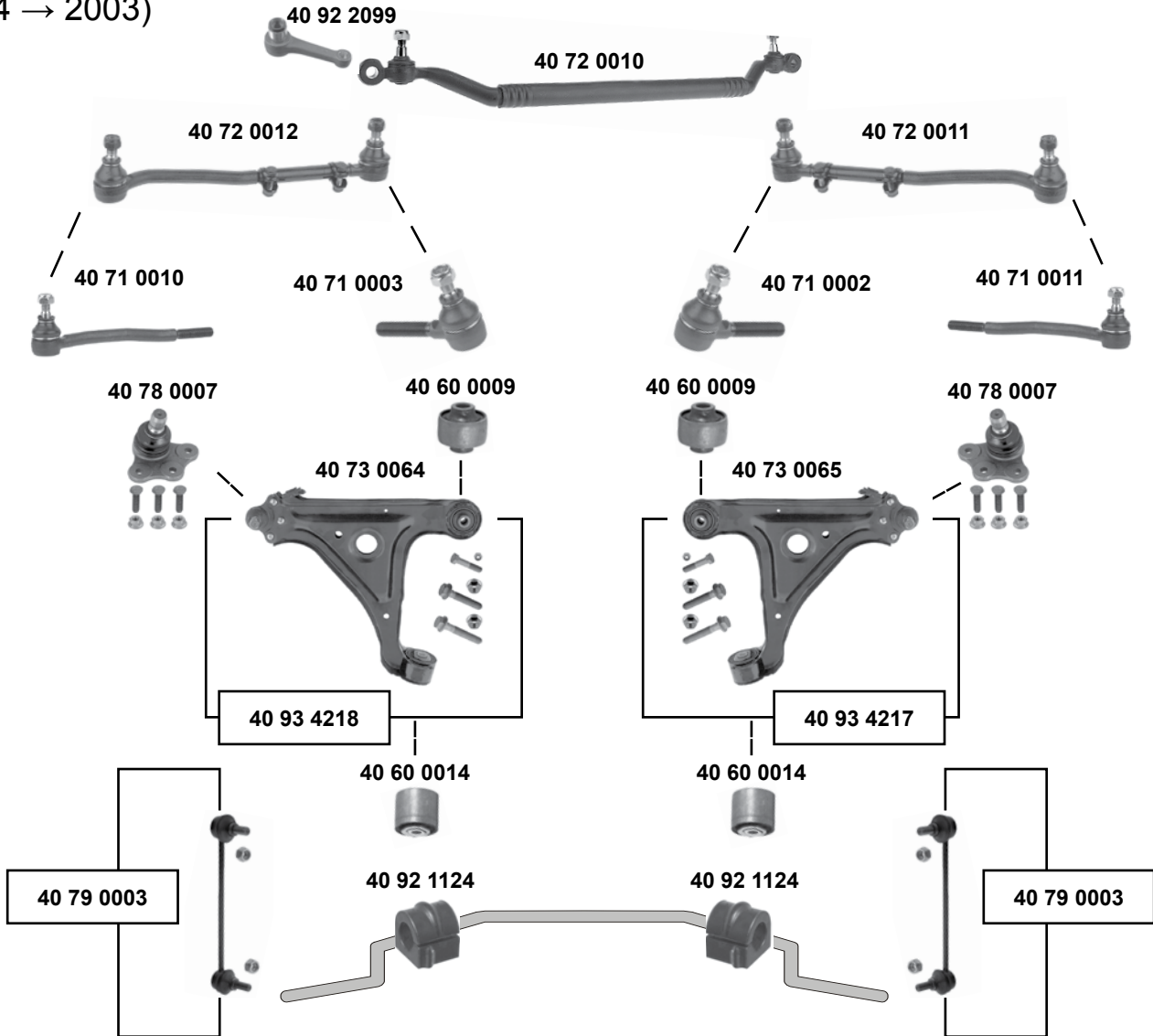

i (1) (ch.) → X 1999999 alle / all
(ch.) Y 2000000 → (ex.) Sport

SWAG	Ref. - No.		i	
40 60 0009	0352 303	Querlenkerlager / control arm mount		14x49x45,5
40 60 0014	0352 302	Querlenkerlager / control arm mount		14x58,5x56
40 71 0002	0322 172	Spurstangenendstück / tie rod end		M14x1,5 RHT
40 71 0003	0322 171	Spurstangenendstück / tie rod end		M14x1,5 LHT
40 71 0010	0322 179	Spurstangenendstück / tie rod end	(ch.) → X 1999999	M14x1,5 RHT
40 71 0011	0324 155	Spurstangenendstück / tie rod end	(ch.) → X 1999999	M14 x1,5 LHT
40 72 0010	0322 166	Spurstange / tie rod	(1) LHD	L 605
40 72 0011	0322 168	Spurstange / tie rod	(ch.) → X 1999999	L 354
40 72 0012	0322 194	Spurstange / tie rod	(ch.) → X 1999999	L 354
40 73 0064	0352 029	Querlenker / control arm		
40 73 0065	0352 028	Querlenker / control arm		
40 78 0007	0352 800	Traggelenk / ball joint	(ch.) → W 1172238	Ø A 18
40 79 0003	0350 609	Verbindungsstange / stabilizer link		L 225
40 92 1124	0350 147	Stabilisatorlager / stabilizer mount		Ø I 23
40 92 2099	0920 355	Lenkhebel / steering arm		L 110 / Ø I 18
40 93 4217	0352 028 S1	Rep. Satz Querlenker / rep. kit control arm		
40 93 4218	0352 029 S1	Rep. Satz Querlenker / rep. kit control arm		



Rekord E (1977 → 1986)

Vorderachse / Front axle

99 90 9158



40 71 0018

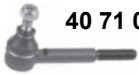

40 71 0017



40 71 0017



40 71 0018

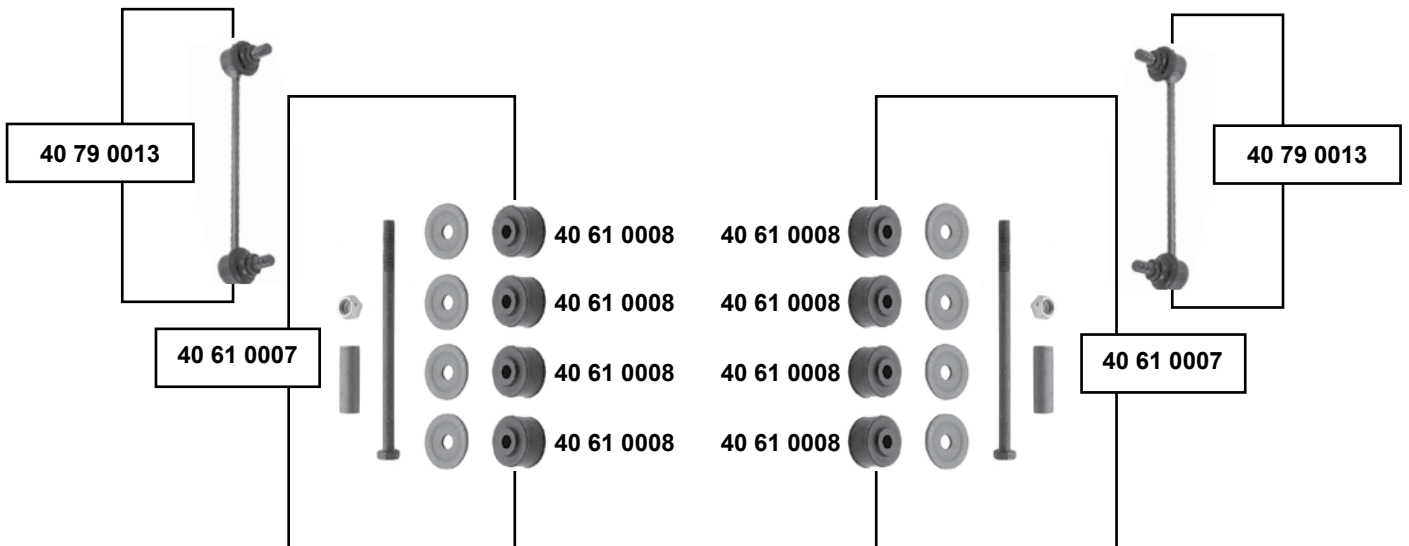

40 61 0007	1603 147
40 61 0008	0350 153
40 71 0017	0324 045
40 71 0018	0324 044
40 79 0013	0350 602
99 90 9158	0920 367

Rep. Satz Stabilisatorlager / rep. kit stabilizer
Verbindungsstangenlager / stabilizer link bush
Spurstangenendstück / tie rod end
Spurstangenendstück / tie rod end
Verbindungsstange / stabilizer link
Lenkhebel / steering arm

8,5x30x19
M14x1,5 RHT
M14x1,5 LHT
L 195
L 121



Senator A
(1978 → 1987)

Vorderachse / Front axle

99 90 9158



40 71 0018



40 71 0017



40 71 0017



40 71 0018

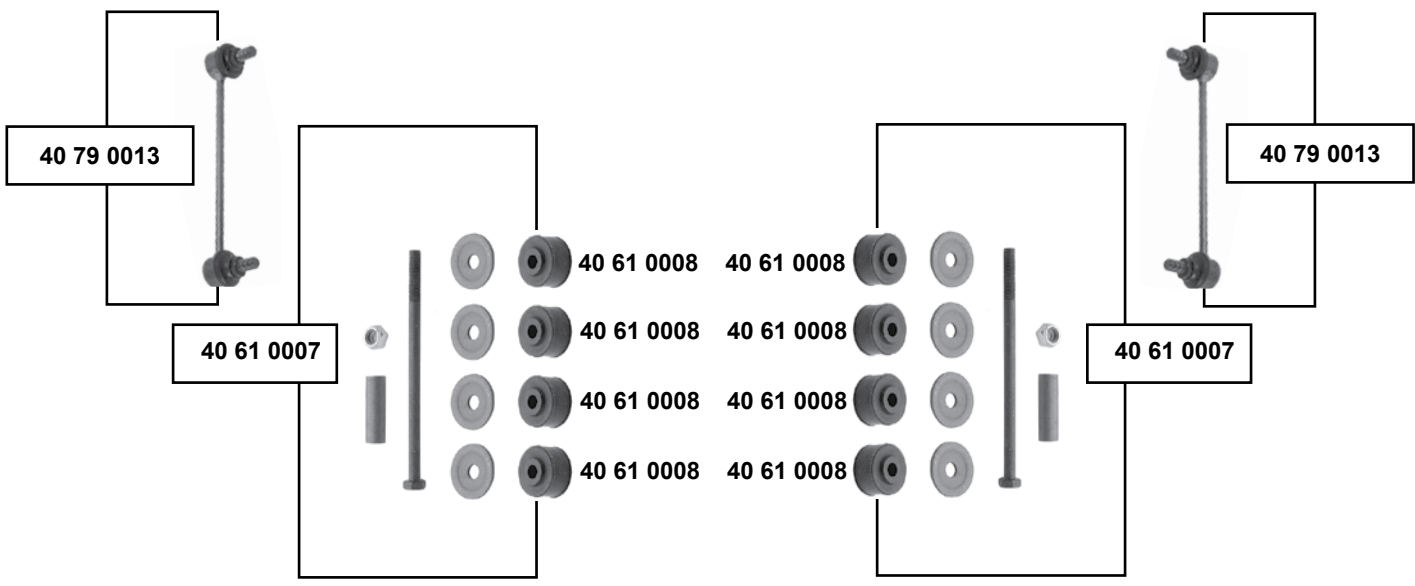

SWAG GERMANY	Ref. - No.			
40 61 0007	1603 147	Rep. Satz Stabilisatorlager / rep. kit stabilizer		
40 61 0008	0350 153	Verbindungsstangenlager / stabilizer link bush		8,5x30x19
40 71 0017	0324 045	Spurstangenendstück / tie rod end		M14x1,5 RHT
40 71 0018	0324 044	Spurstangenendstück / tie rod end		M14x1,5 LHT
40 79 0013	0350 602	Verbindungsstange / stabilizer link		L 195
99 90 9158	0920 367	Lenkhebel / steering arm		L 121

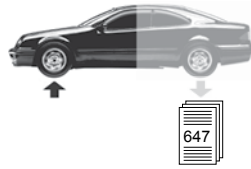

Senator B (1986 → 1994)

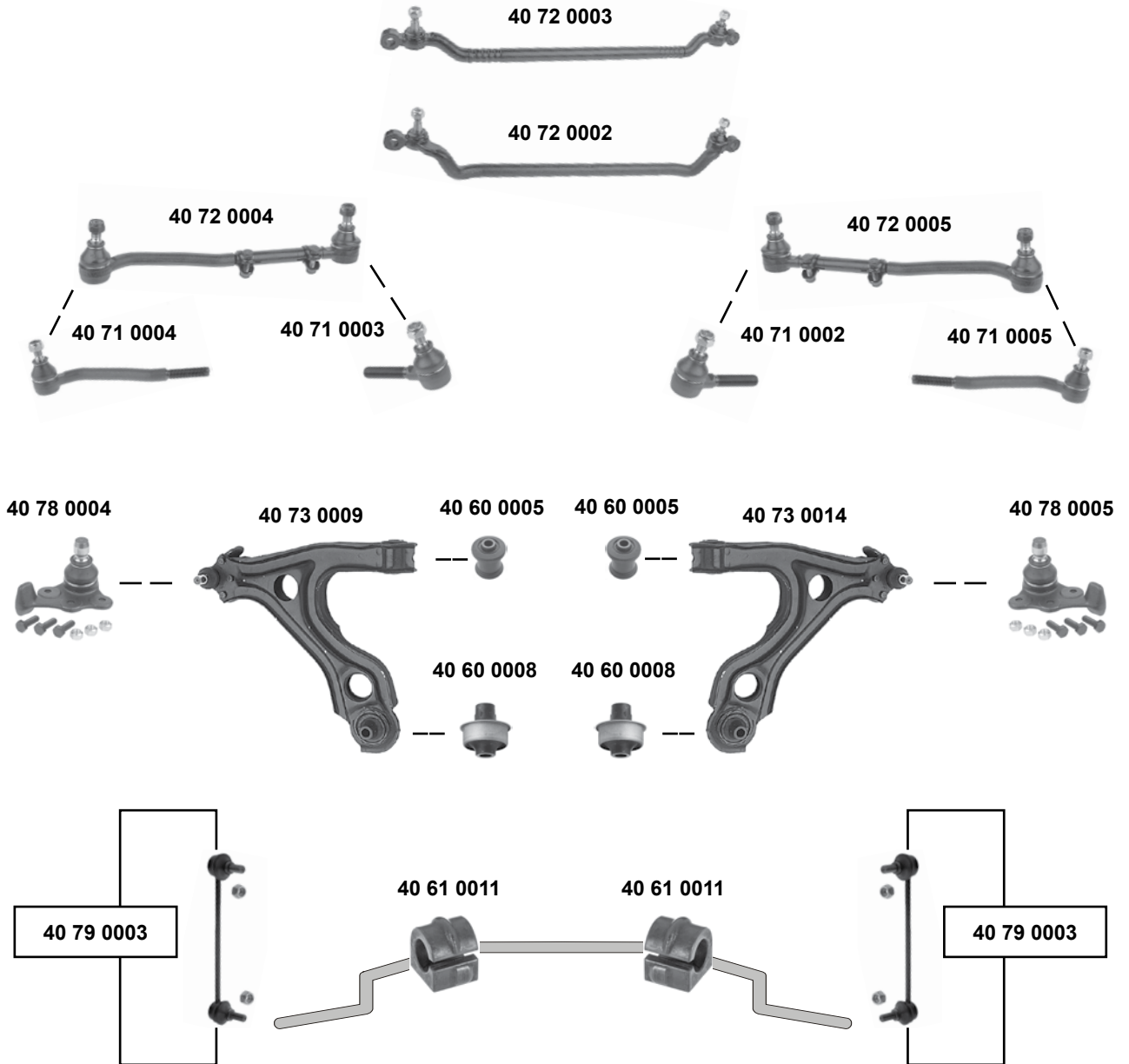

Vorderachse / Front axle

SWAG	Ref. - No.			
40 60 0005	0352 341	Querlenkerlager / control arm mount		12x41/47x60
40 60 0008	0352 355	Querlenkerlager / control arm mount		16x60x69,5
40 61 0011	0350 116	Stabilisatorlager / stabilizer mount		Ø I 22
40 71 0002	0322 172	Spurstangenendstück / tie rod end	(ch.) H 1169261 →	M14x1,5 RHT
40 71 0003	0322 171	Spurstangenendstück / tie rod end	(ch.) H 1169261 →	M14x1,5 LHT
40 71 0004	0322 175	Spurstangenendstück / tie rod end	(ch.) H 1169261 →	M14x1,5 RHT
40 71 0005	0322 176	Spurstangenendstück / tie rod end	(ch.) H 1169261 →	M14x1,5 LHT
40 72 0002	0322 145	Spurstange / tie rod	LHD	L 572
40 72 0003	0322 148	Spurstange / tie rod	LHD	L 572
40 72 0004	0322 173	Spurstange / tie rod		L 347
40 72 0005	0322 174	Spurstange / tie rod		L 347
40 73 0009	0352 135	Querlenker / control arm		
40 73 0014	0352 136	Querlenker / control arm		
40 78 0004	0352 826	Traggelenk / ball joint		Ø A 18
40 78 0005	0352 827	Traggelenk / ball joint		Ø A 18
40 79 0003	0350 609	Verbindungsstange / stabilizer link		L 225

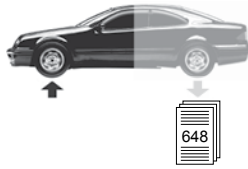

Signum
(2003 → 2008)

Vorderachse / Front axle

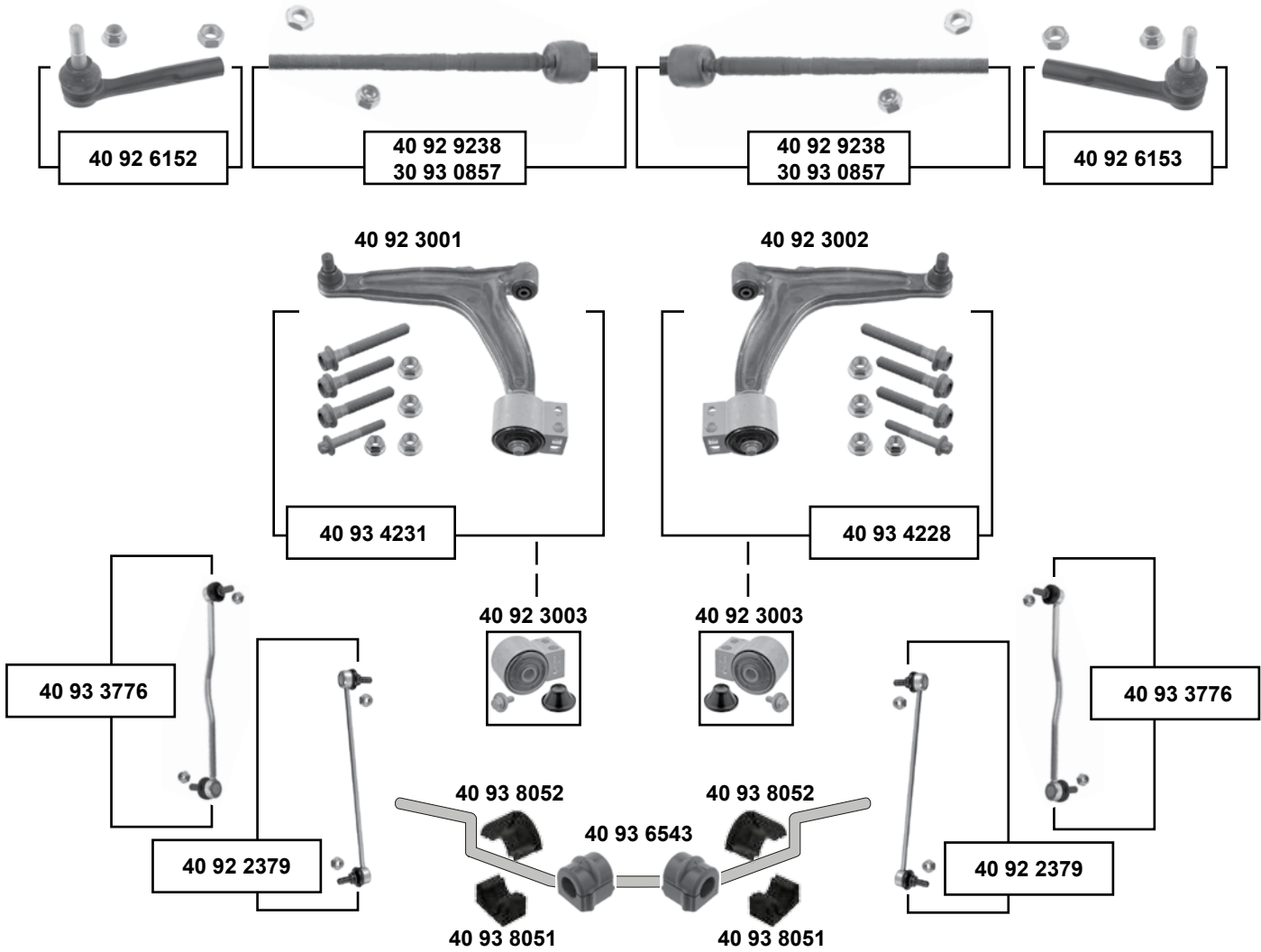

- (1) 18" → (ch.) 41000001 → 61039489 (2) (ex.) IDS+ alle/ all / IDS+ (ch.) → 31999999
- (3) nur Fahrzeuge mit IDS + Fahrwerk / vehicles with IDS + chassis only / (ch.) 41000001 →
- (4) → 05 / (ch.) → 51999999

SWAG	Ref. - No.			
30 93 0857	1603 417 SK	Spurstange / tie rod	(1)	L 305
40 92 2379	0350 615	Verbindungsstange / stabilizer link	(2)	L 355
40 92 3001	0352 051	Querlenker / control arm	Alu / alloy	
40 92 3002	0352 052	Querlenker / control arm	Alu / alloy	
40 92 3003	0352 319	Rep. Satz Querlenker / rep. kit control arm		
40 92 6152	1603 227	Spurstangenendstück / tie rod end		M14 x 1,5
40 92 6153	1603 228	Spurstangenendstück / tie rod end		M14 x 1,5
40 92 9238	1603 416 SK	Spurstange / tie rod	→ 17"	L 284
40 93 3776	0350 612	Verbindungsstange / stabilizer link	(3)	L 395
40 93 4228	0352 052 S1	Rep. Satz Querlenker rechts / rep. kit control arm right	(ex.) OPC/VXR	
40 93 4231	0352 051 S1	Rep. Satz Querlenker links / rep. kit control arm left	(ex.) OPC/VXR	
40 93 6543	0350 145	Stabilisatorlager / stabilizer mount	(4)	Ø 23,3
40 93 8051	0350 391	Stabilisatorlager, unten / stabilizer mount, lower	(ch.) 61000001 →	Ø 24
40 93 8052	0350 390	Stabilisatorlager, oben / stabilizer mount, upper	(ch.) 61000001 →	Ø 24



Tigra A (1994 → 2000)

(ch.) → V 3023597, V 4166925, V 6066279

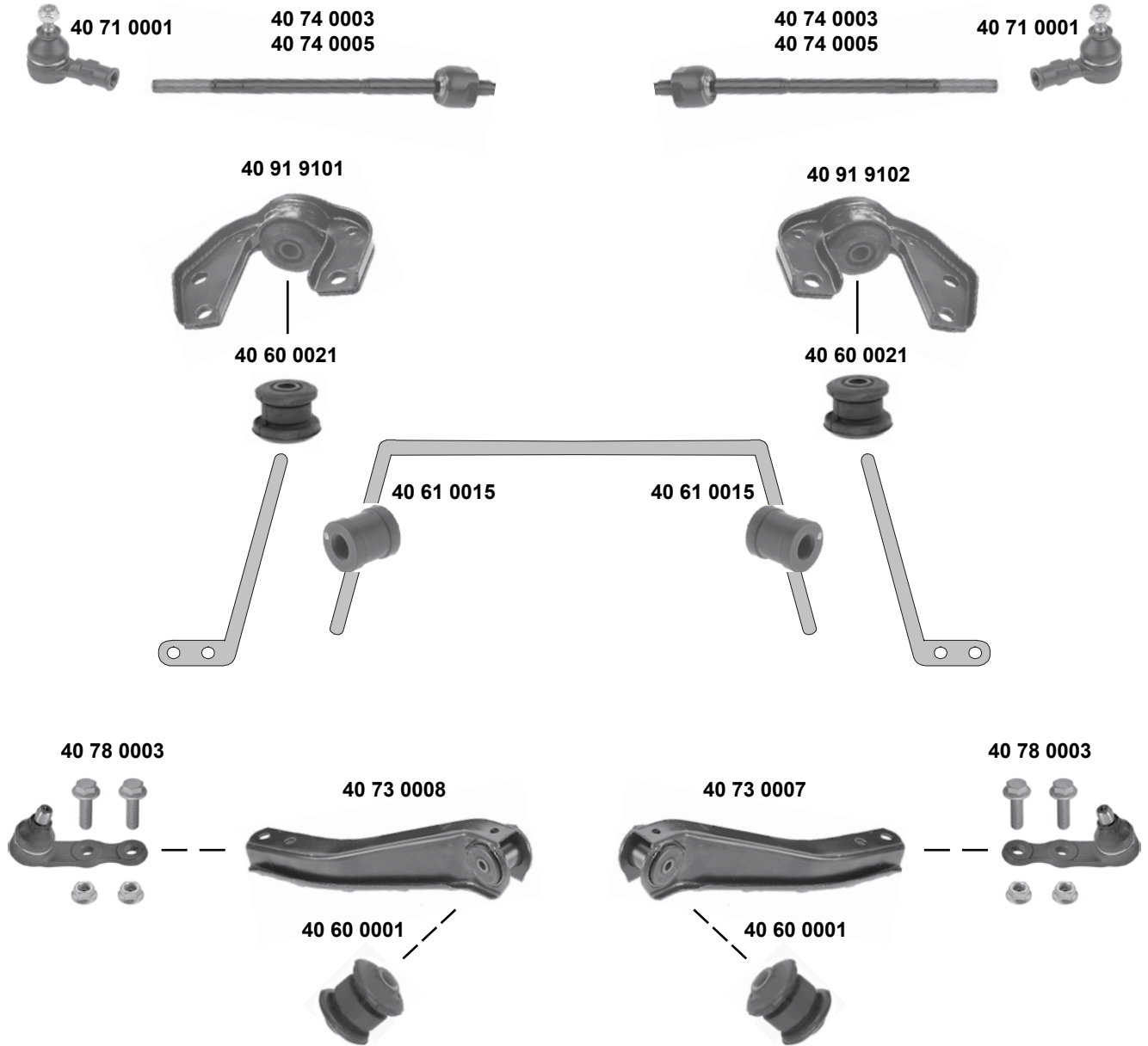

Vorderachse / Front axle

SWAG	Ref. - No.			
40 60 0001	0352 301	Querlenkerlager / control arm mount	man. / E - servo	10x35x52
40 60 0021	0353 561	Zugstrebenlager / tension rod mount		14x36/50x40
40 61 0015	0350 127	Stabilisatorlager / stabilizer mount		Ø I 21,5
40 71 0001	1603 645	Spurstangenendstück / tie rod end		M12x1,5 RHT
40 73 0007	0352 002	Querlenker / control arm		
40 73 0008	0352 003	Querlenker / control arm		
40 74 0003	1603 453 SK	Spurstange / tie rod		L 325
40 74 0005	0322 158	Spurstange / tie rod		L 290
40 78 0003	1603 187	Traggelenk / ball joint		Ø A 15
40 91 9101	0353 281	Halter / mount		
40 91 9102	0353 280	Halter / mount		



OPEL

Tigra A (1994 → 2000)

(ch.) V 3023598, V 4166926, V 6066280 →

Vorderachse / Front axle

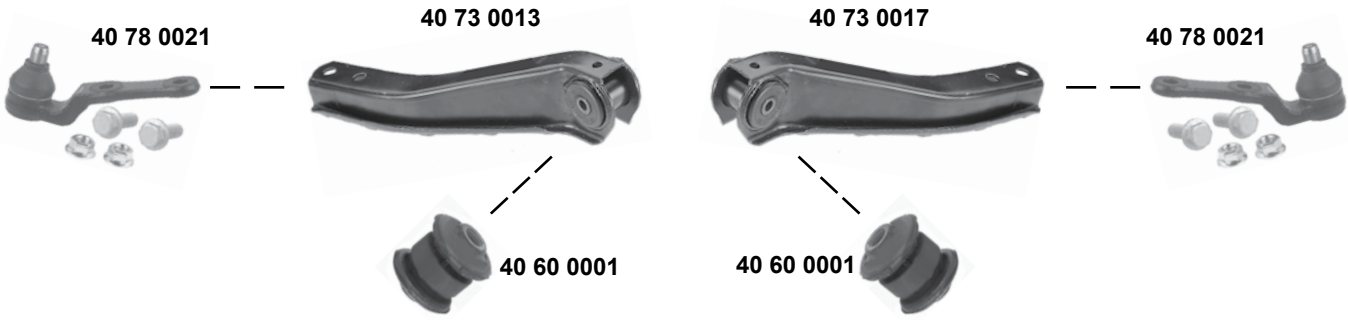
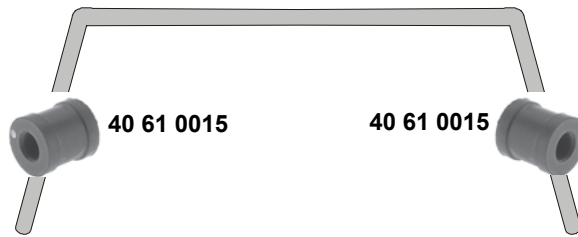

SWAG GERMANY	Ref. - No.			
40 60 0001	0352 301	Querlenkerlager / control arm mount		10x35x52
40 61 0015	0350 127	Stabilisatorlager / stabilizer mount		Ø 21,5
40 71 0024	1603 455	Spurstangenendstück / tie rod end		M12x1,5 RHT
40 73 0013	5352 011	Querlenker / control arm		
40 73 0017	5352 012	Querlenker / control arm		
40 74 0003	1603 453 SK	Spurstange / tie rod	man.	L 325
40 74 0005	0322 158	Spurstange / tie rod	servo	L 300
40 78 0021	1603 202	Traggelenk / ball joint		Ø A 15



Tigra B TwinTop (2004 → 2009)

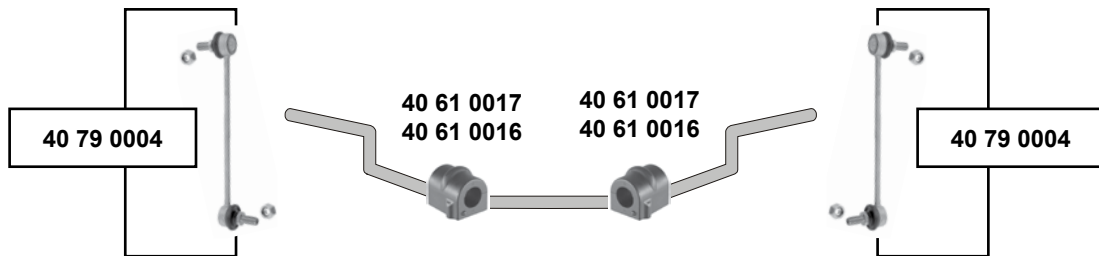
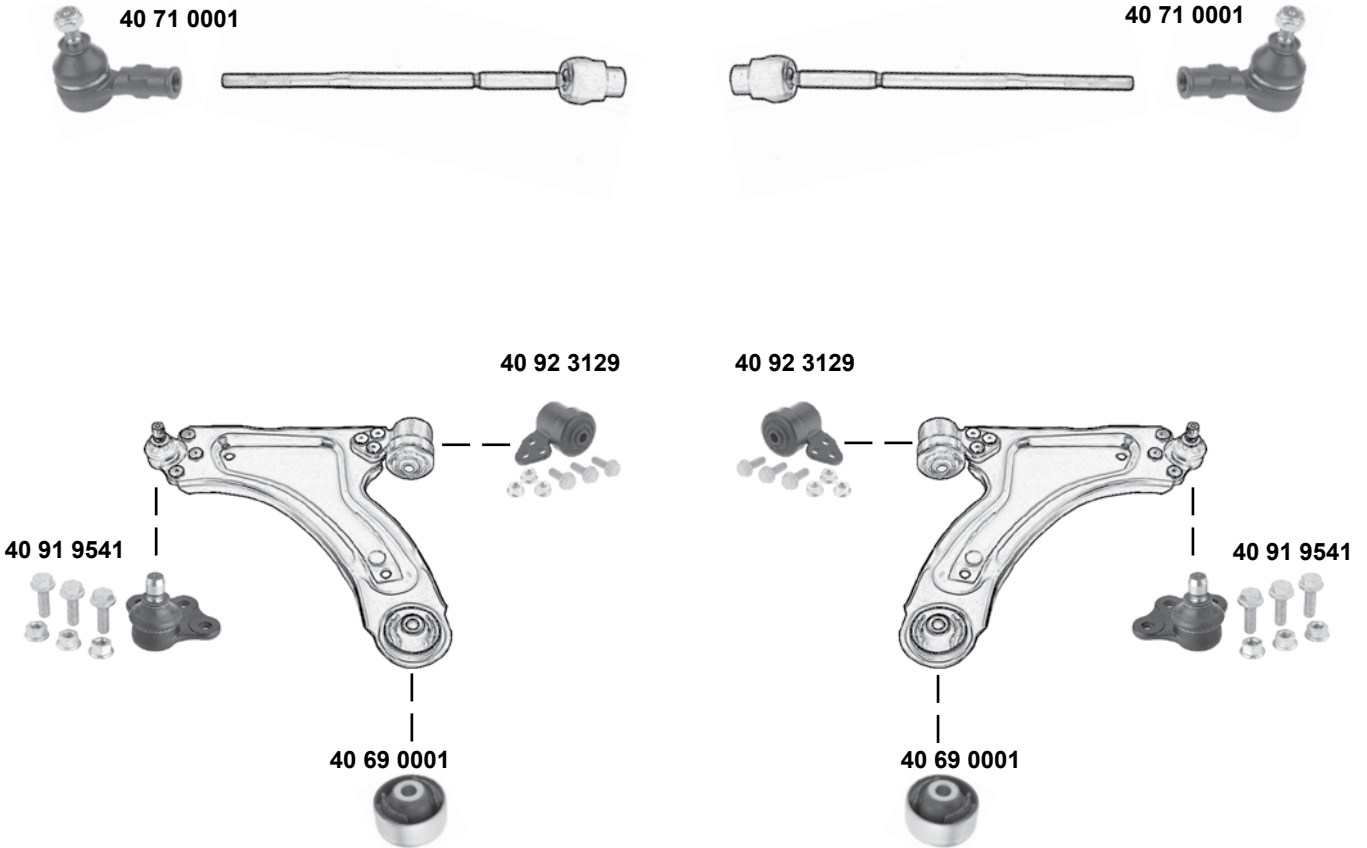

Vorderachse / Front axle



40 61 0016	0350 130	Stabilisatorlager / stabilizer mount		Ø I 16
40 61 0017	0350 138	Stabilisatorlager / stabilizer mount		Ø I 18
40 69 0001	0352 320	Querlenkerlager / control arm mount		Ø A 59,5
40 71 0001	1603 645	Spurstangenendstück / tie rod end		M12 x 1,5
40 79 0004	0350 610	Verbindungsstange / stabilizer link		L 243,5
40 91 9541	0352 803	Traggelenk / ball joint		
40 92 3129	0352 377	Querlenkerlager / control arm mount	(ch.) → 5E999999	

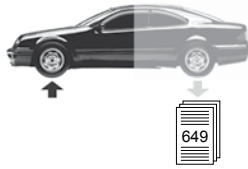

Vectra A

(1988 → 1995)

1.4 → 2.0 i (ex.)16 V

1.7 D / TD

man.

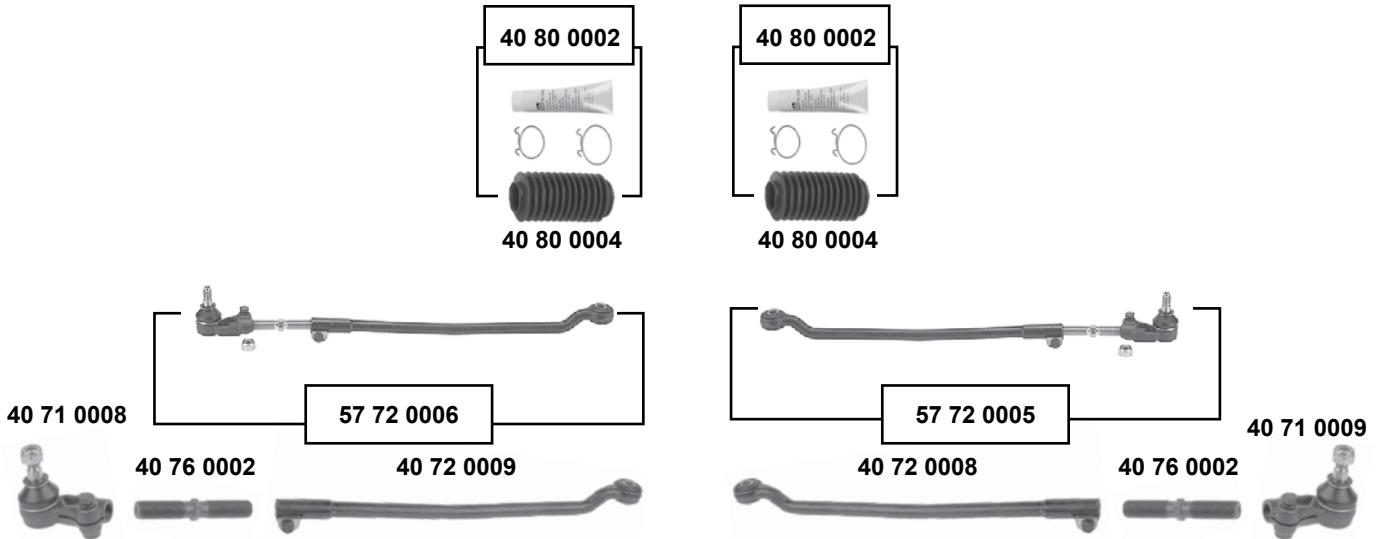

servo

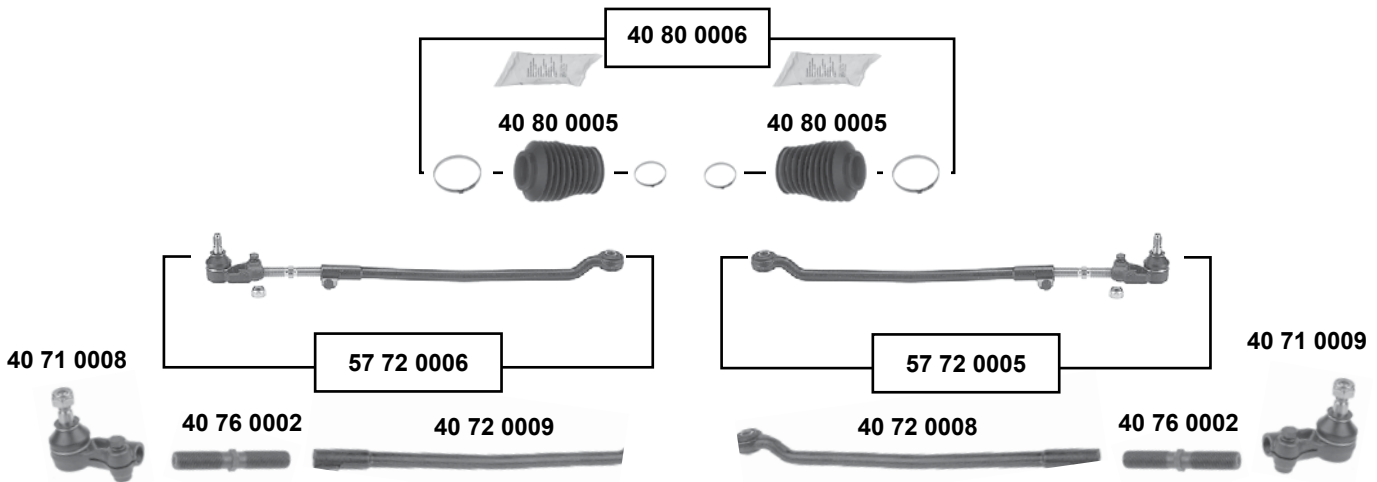

- (1) (ch.) → M 1300367
- (ch.) → M 5396085
- (ch.) → NV 102027



Ref. - No.

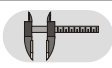

40 71 0008	0324 055	Spurstangenendstück / tie rod end			M16x2 RHT
40 71 0009	0324 056	Spurstangenendstück / tie rod end			M16x2 LHT
40 72 0008	0322 146	Spurstange / tie rod			L 434
40 72 0009	0322 147	Spurstange / tie rod			L 434
40 76 0002	0322 577	Einstellbolzen / adjusting bolt			M16x2x105,5
40 80 0002	0902 828 S1	Rep. Satz Lenkmanschette / rep. kit steering boot	(1)		
40 80 0004	0902 828	Lenkmanschette / steering boot	(1)		
40 80 0005	1609 073 S1	Lenkmanschette / steering boot		LHD / für/to fit servo	ZF
40 80 0006	1609 073 SK	Lenkmanschette / steering boot		LHD / für/to fit servo	ZF
57 72 0005	0322 146 S1	Spurstange / tie rod			M16 x 2
57 72 0006	0322 147 S1	Spurstange / tie rod			M16 x 2

Vorderachse / Front axle

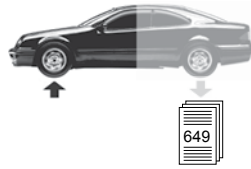

Vectra A

(1988 → 1995)

1.4 → 2.0 i (ex.) 16 V

1.7 D / TD

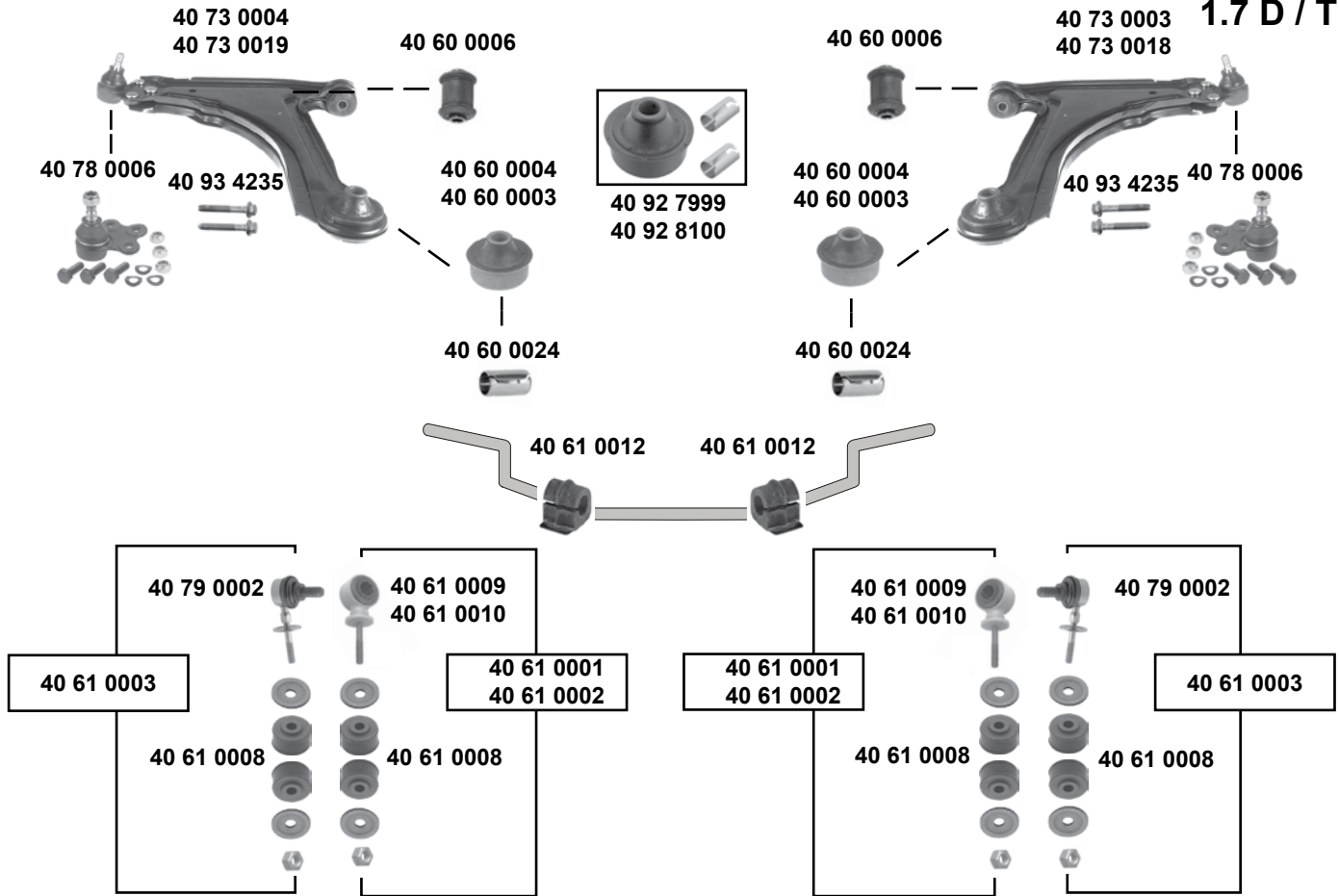

Vorderachse / Front axle

	(1) (ch.) → R 1049313	(2) (ch.) R 1049314 →
	(ch.) → R 5112256	(ch.) R 5112257 →
	(ch.) → R 7540515	(ch.) R 7540516 →

	Ref. - No.			
40 60 0003	0352 356	Querlenkerlager / control arm mount	(2)	16x60x58
40 60 0004	0352 348	Querlenkerlager / control arm mount	(1)	16x60x58
40 60 0006	0352 300	Querlenkerlager / control arm mount		12x39x60
40 60 0024	0353 460	Hülse / sleeve		16,3x30
40 61 0001	0350 260 S1	Rep. Satz Verbindungsstange / rep. kit stabilizer link		
40 61 0002	0350 261 S1	Rep. Satz Verbindungsstange / rep. kit stabilizer link		
40 61 0003	0350 263 S1	Rep. Satz Verbindungsstange / rep. kit stabilizer link		L 86
40 61 0008	0350 153	Verbindungsstangenlager / stabilizer link bush		8,5x30x19
40 61 0009	0350 260	Verbindungsstange / stabilizer link		Ø 22
40 61 0010	0350 261	Verbindungsstange / stabilizer link		Ø 18
40 61 0012	0350 078	Stabilisatorlager / stabilizer mount		Ø 20
40 73 0003	0352 192	Querlenker / control arm	(1) inkl. 2x40600024	
40 73 0004	0352 193	Querlenker / control arm	(1) inkl. 2x40600024	
40 73 0018	5352 000	Querlenker / control arm	(2) inkl. 2x40600024	
40 73 0019	5352 001	Querlenker / control arm	(2) inkl. 2x40600024	
40 78 0006	1603 167	Traggelenk / ball joint		M12 x 1,5
40 79 0002	0350 263	Verbindungsstange / stabilizer link		L 86
40 92 7999	0352 356 S1	Querlenkerlager / control arm mount	(2)	16x60x58
40 92 8100	0352 348 S1	Querlenkerlager / control arm mount	(1)	16x60x58
40 93 4235	2026 745 S1	Schraubensatz für Querlenker / screw kit for control arm		

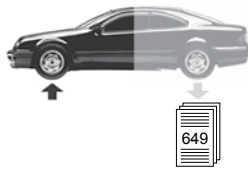

Vectra A

(1988 → 1995)

2.0 i 16V → 2.5 V6

man.

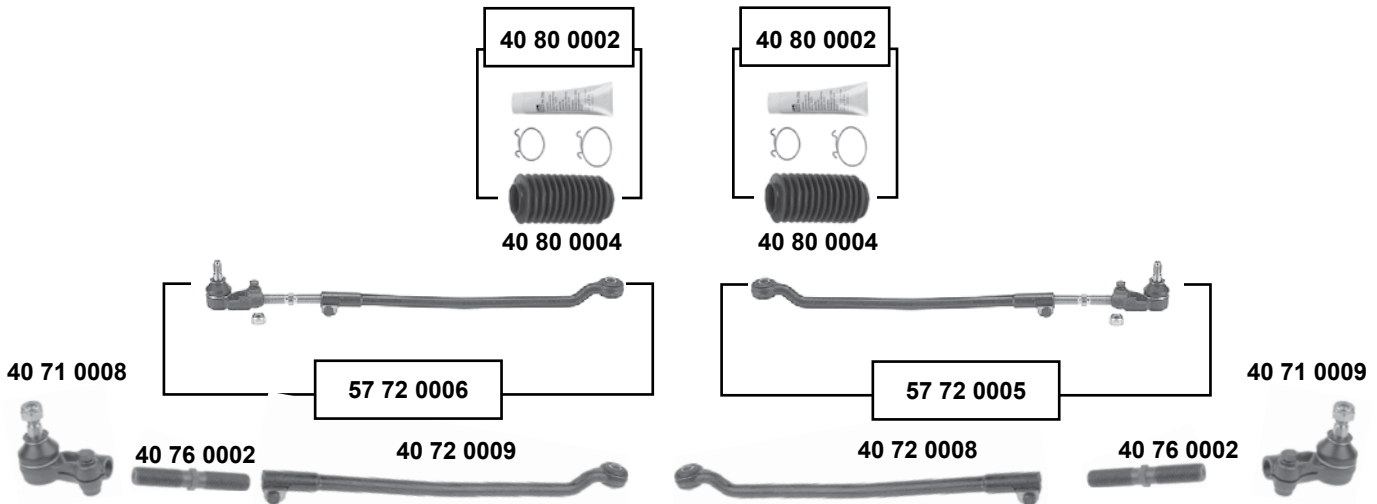

servo

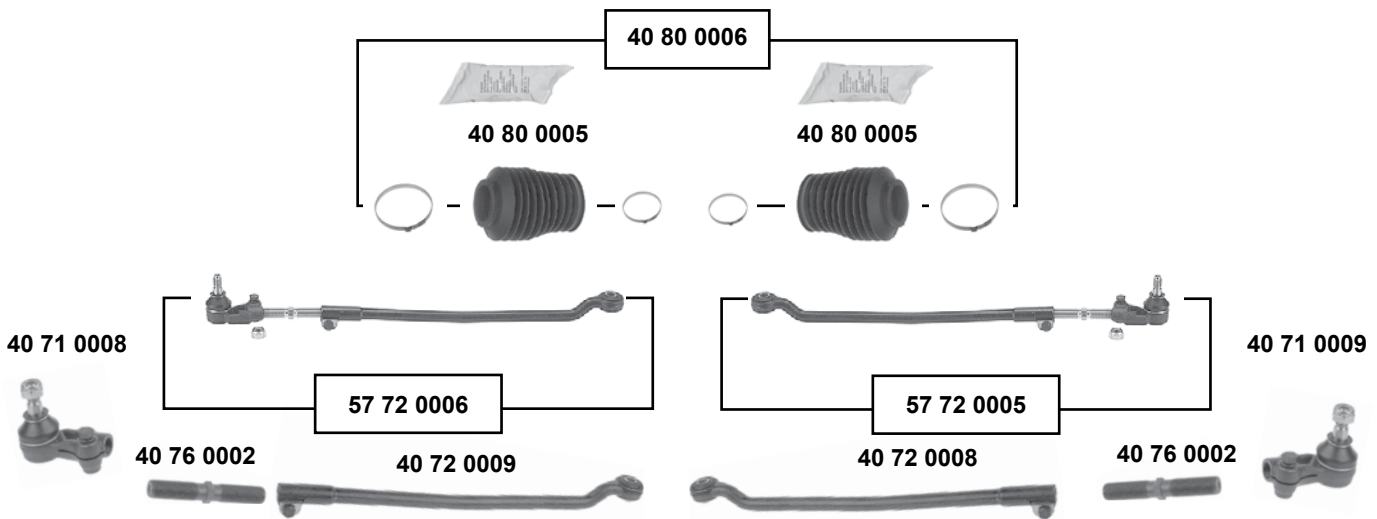

- (1) (ch.) → M 1300367
- (ch.) → M 5396085
- (ch.) → NV 102027



Ref. - No.



40 71 0008	0324 055	Spurstangenendstück / tie rod end		M16x1,5 RHT
40 71 0009	0324 056	Spurstangenendstück / tie rod end		M16x1,5 LHT
40 72 0008	0322 146	Spurstange / tie rod		L 434
40 72 0009	0322 147	Spurstange / tie rod		L 434
40 76 0002	0322 577	Einstellbolzen / adjusting bolt		M16x2x105,5
40 80 0002	0902 828 S1	Rep. Satz Lenkmanschette / rep. kit steering boot	(1)	
40 80 0004	0902 828	Lenkmanschette / steering boot	(1)	
40 80 0005	1609 073 S1	Lenkmanschette / steering boot	LHD / für/to fit servo	ZF
40 80 0006	1609 073 SK	Lenkmanschette / steering boot	LHD / für/to fit servo	ZF
57 72 0005	0322 146 S1	Spurstange / tie rod		M16 x 2
57 72 0006	0322 147 S1	Spurstange / tie rod		M16 x 2

Vorderachse / Front axle

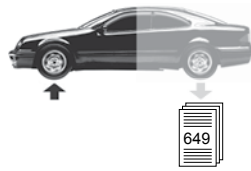

Vectra A

(1988 → 1995)

2.0 i 16V → 2.5 V6

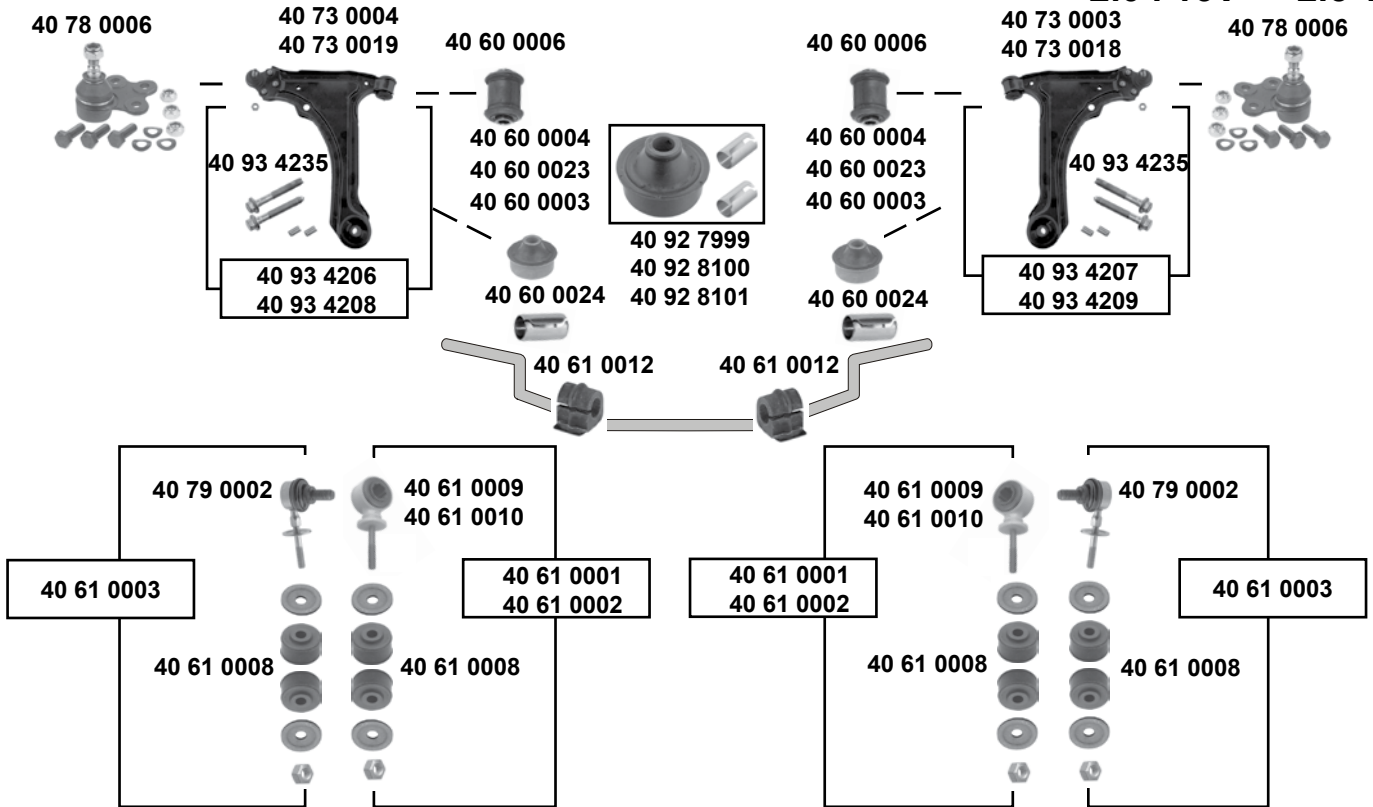

Vorderachse / Front axle



(1) (ch.) → NV 535971 / P 1001687 / P 5004910

(3) (ch.) NV 535972 / P 1001688 / P 5004911 →

(2) (ch.) R 75440516 / R 1049315 / R 5112257 →

(4) (ch.) → R 75440515 / R 1049314 / R 5112256



Ref. - No.



Ref. - No.	Description	Notes	Dimensions
40 60 0003	Querlenkerlager / control arm mount	(2) (ex.) 2.5 V6	16x60x58
40 60 0004	Querlenkerlager / control arm mount	(1) (ex.) 2.5 V6	16x60x58
40 60 0006	Querlenkerlager / control arm mount	(1) (ex.) 2.5 V6	12x39x60
40 60 0023	Querlenkerlager / control arm mount	(3) (4) (ex.) 2.5 V6	Ø I 12
40 60 0024	Hülse / sleeve		16,3x30
40 61 0001	Rep. Satz Verbindungsstange / rep. kit stabilizer link		
40 61 0002	Rep. Satz Verbindungsstange / rep. kit stabilizer link		
40 61 0008	Verbindungsstangenlager / stabilizer link bush		8,5x30x19
40 61 0009	Verbindungsstange / stabilizer link		Ø I 22
40 61 0010	Verbindungsstange / stabilizer link		Ø I 18
40 61 0012	Stabilisatorlager / stabilizer mount		Ø I 20
40 73 0003	Querlenker / control arm	(4) (ex.) 2.5 V6	
40 73 0004	Querlenker / control arm	(4) (ex.) 2.5 V6	
40 73 0018	Querlenker / control arm	(2) (ex.) 2.5 V6	
40 73 0019	Querlenker / control arm	(2) (ex.) 2.5 V6	
40 78 0006	Traggelenk / ball joint	(ex.) 2.5 V6	M12 x 1,5
40 79 0002	Verbindungsstange / stabilizer link		
40 61 0003	Rep. Satz Verbindungsstange / rep. kit stabilizer link		
40 92 7999	Querlenkerlager / control arm mount	(2) (ex.) 2.5 V6	16x60x58
40 92 8100	Querlenkerlager / control arm mount	(1) (ex.) 2.5 V6	16x60x58
40 92 8101	Querlenkerlager / control arm mount	(3) (4) (ex.) 2.5 V6	
40 93 4206	Rep. Satz Querlenker links / rep. kit control arm left	(2)	
40 93 4207	Rep. Satz Querlenker rechts / rep. kit control arm right	(2)	
40 93 4208	Rep. Satz Querlenker links / rep. kit control arm left	(4)	
40 93 4209	Rep. Satz Querlenker rechts / rep. kit control arm right	(4)	
40 93 4235	Schraubensatz für Querlenker / screw kit for control arm		

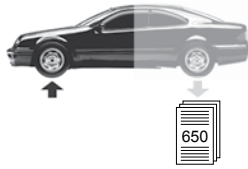

Vectra B
(1995 → 2002)

Vorderachse / Front axle

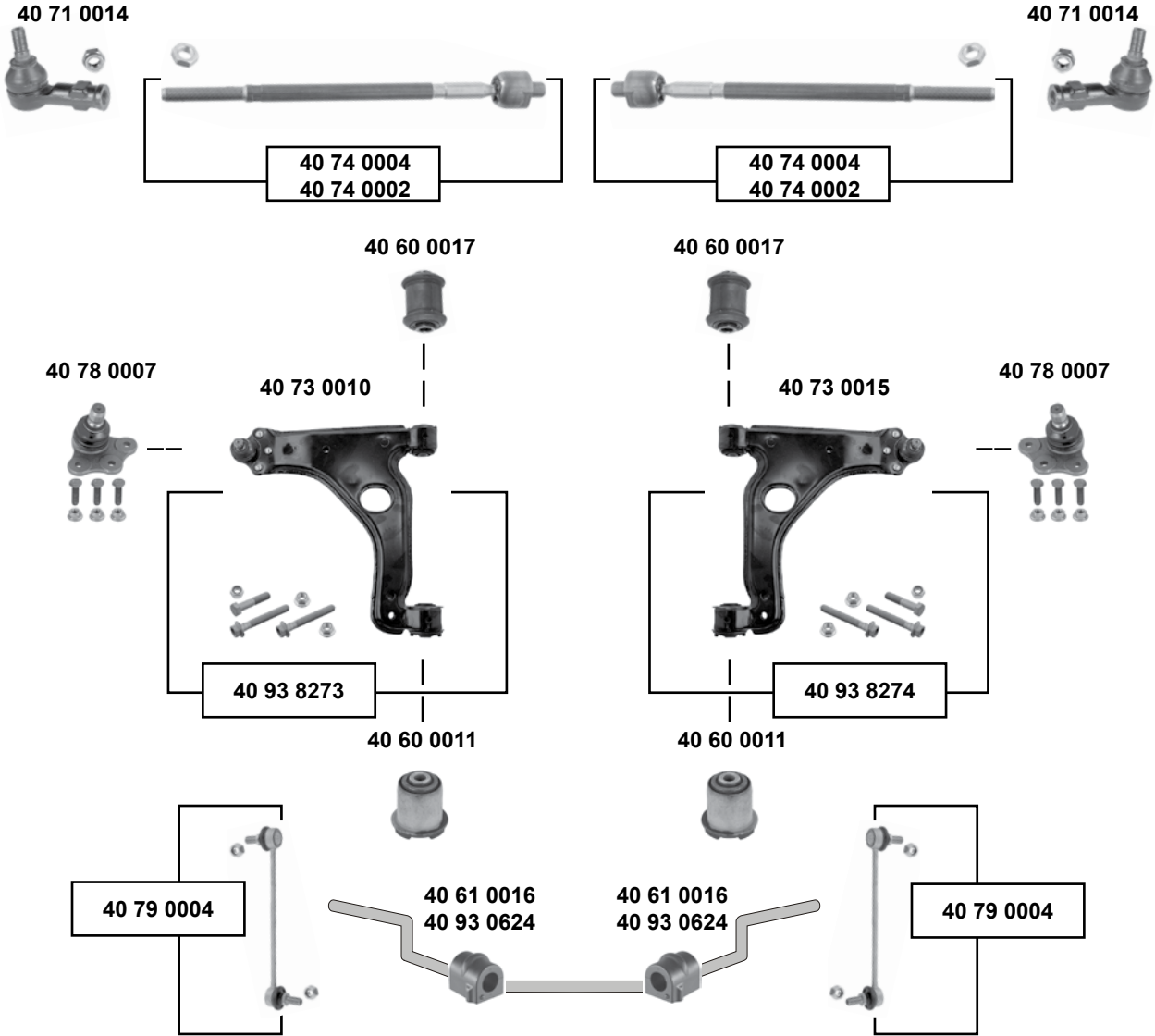

(1) (ch.) → W 1999999 / W 5999999 / W 7999999
(ch.) XL 00001 → XL 99999

(2) (ex.) Sport (ch.) X 1000001, X 7000001 YL 00001 → // Sport (ch.) Y 1000001, Y 7000001 →



Ref. - No.



Ref. - No.	Description	Notes	Dimensions
40 60 0011	Querlenkerlager / control arm mount		12x47,5x60
40 60 0017	Querlenkerlager / control arm mount		12x36,5x60
40 61 0016	Stabilisatorlager / stabilizer mount		Ø I 16
40 71 0014	Spurstangenendstück / tie rod end		M14 x 1,5
40 73 0010	Querlenker / control arm		
40 73 0015	Querlenker / control arm		
40 74 0002	Spurstange / tie rod		L 360
40 74 0004	Spurstange / tie rod		L 360
40 78 0007	Traggelenk / ball joint		Ø A 18
40 79 0004	Verbindungsstange / stabilizer link		L 243,5
40 93 0624	Stabilisatorlager / stabilizer mount		Ø I 17
40 93 8273	Rep. Satz Querlenker / rep. kit control arm		
40 93 8274	Rep. Satz Querlenker / rep. kit control arm		

(1) (ex.) Sport

servo ZF
servo Saginaw

(2)

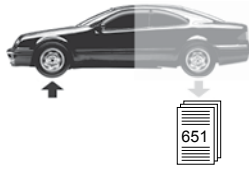

Vectra C (2002 → 2008)

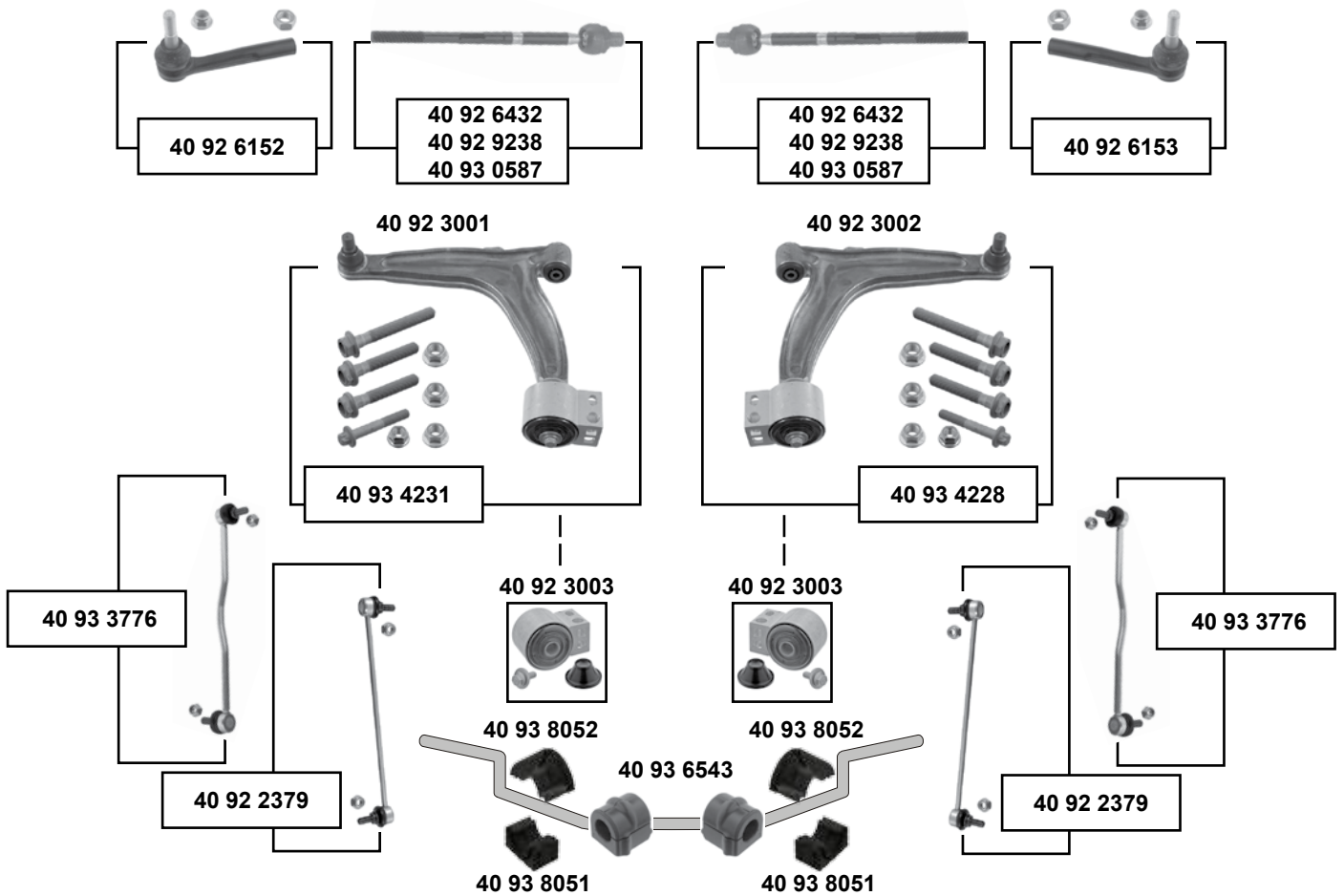

Vorderachse / Front axle

- | | |
|--|---|
| (1) Limousine: → 17" / (ch.) 31032141, 3804656 →
Caravan : → 17" alle / all | (3) Limousine: 18" → / (ch.) → 61039489
Caravan : 18" → alle / all |
| (2) → (ch.) 31032140, 38040655 / (ex.) Caravan | (4) (ex.) IDS+ alle/ all // IDS+
(ch.) → 31999999, 38999999 / Caravan: → 17" |
| (5) nur Fahrzeuge mit IDS + Fahrwerk / only vehicles with IDS + chassis / (ch.) 41000001,48000001 → | |
| (6) → 05 / (ch.) → 410105077, 48008980
→ 05 / (ch.) 41010578 → 51999999, 48008981 → 58999999 / (ex.) HD | |

SWAG [®]	Ref. - No.			
40 92 2379	0350 615	Verbindungsstange / connecting rod	(4)	L 355
40 92 3001	0352 051	Querlenker / control arm	Alu / alloy	
40 92 3002	0352 052	Querlenker / control arm	Alu / alloy	
40 92 3003	0352 319	Rep. Satz Querlenker / rep. kit control arm		
40 92 6152	1603 227	Spurstangenendstück / tie rod end		M14 x 1,5
40 92 6153	1603 228	Spurstangenendstück / tie rod end		M14 x 1,5
40 92 6432	1603 415 SK	Spurstange / tie rod	(2)	L 300
40 92 9238	1603 416 SK	Spurstange / tie rod	(1)	L 300
40 93 0587	1603 417 SK	Spurstange / tie rod	(3)	L 305
40 93 3776	0350 612	Verbindungsstange / stabilizer link	(5)	L 395
40 93 4228	0352 052 S1	Rep. Satz Querlenker rechts / rep. kit control arm right	(ex.) OPC / VXR	
40 93 4231	0352 051 S1	Rep. Satz Querlenker links / rep. kit control arm left	(ex.) OPC / VXR	
40 93 6543	0350 145	Stabilisatorlager / stabilizer mount	(6)	Ø 23,3
40 93 8051	0350 391	Stabilisatorlager, unten / stabilizer mount, lower	(ch.) 61000001 →	Ø 24
40 93 8052	0350 390	Stabilisatorlager, oben / stabilizer mount, upper	(ch.) 61000001 →	Ø 24



OPEL

Vivaro A
(2001 → 2014)

Vorderachse / Front axle

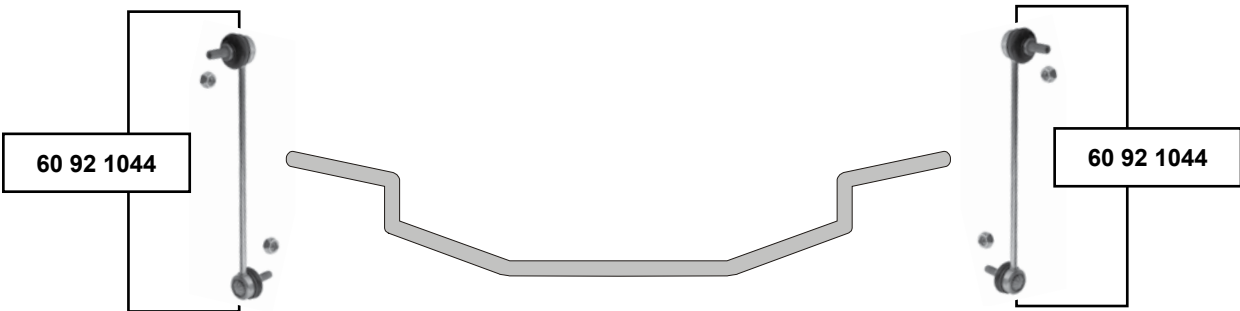
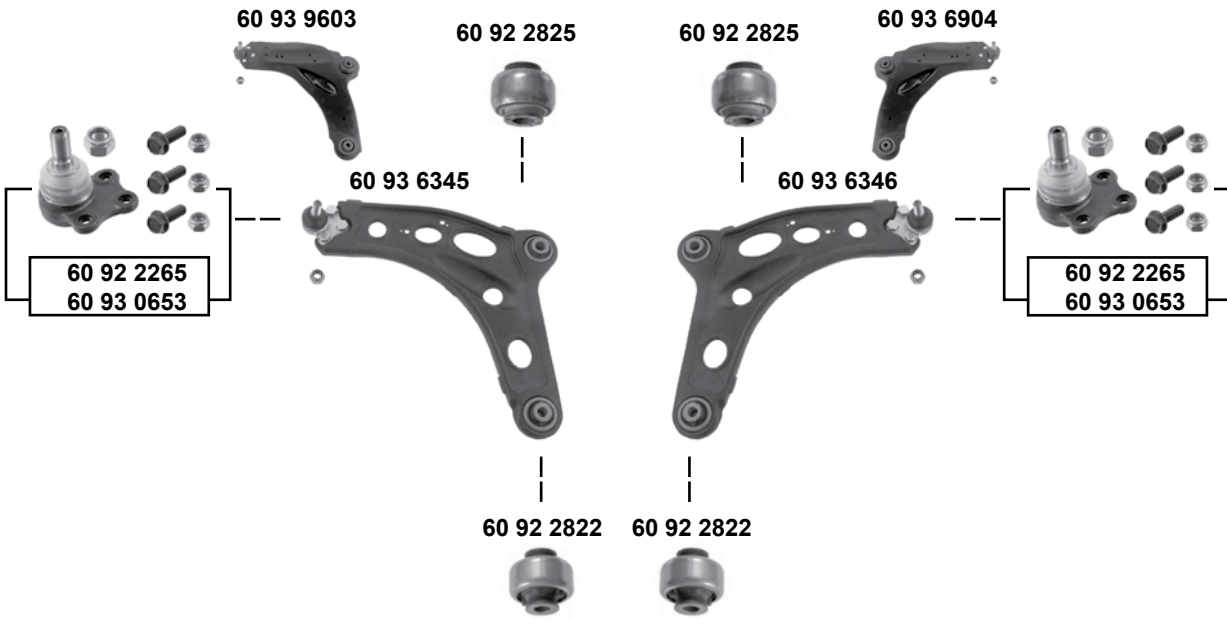
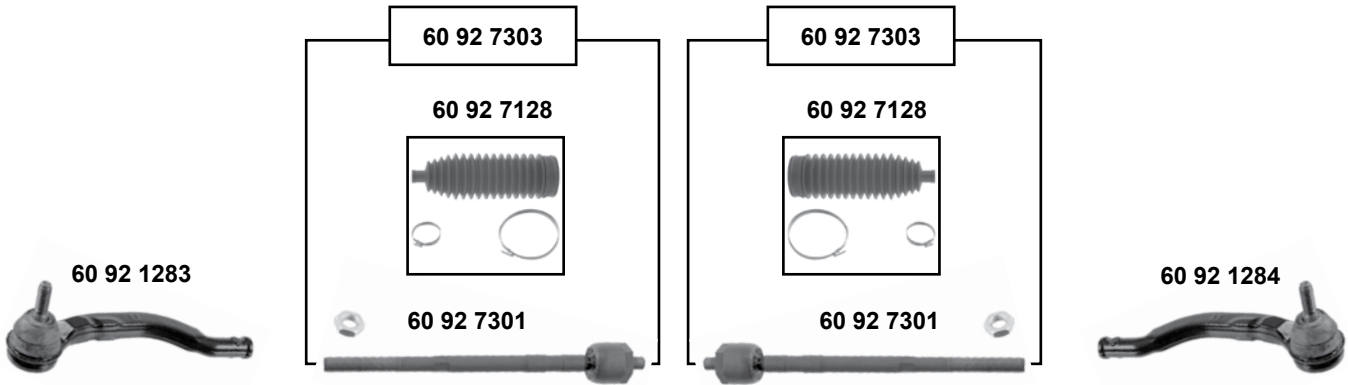



Vivaro A

(2001 → 2014)



(1) (ch.) C 7V621198, C 7V721613 →

(3) 07 → / (ch.) 7V600001 → / 7Y000001 →

(2) (ch.) → C 7V621197, C 7V721612

(4) Blech / metal sheet ; → (ch.) 6V999999, 6Y699999



Ref. - No.



60 92 1044	4417 973	Verbindungsstange / stabilizer link		L 280
60 92 1283	4408 510	Spurstangenendstück / tie rod end		L 230
60 92 1284	4408 511	Spurstangenendstück / tie rod end		L 230
60 92 2265	4419 075	Traggelenk / ball joint	(2)	Ø I 10
60 92 2822	4418 223 SK3	Querlenkerlager / control arm mount		Ø A 58
60 92 2825	4418 223 SK2	Querlenkerlager / control arm mount		Ø A 55
60 92 7128	4408 476	Lenkmanschettensatz		L 205
60 92 7301	4408 474 SK	Spurstange / tie rod		L 265
60 92 7303	4408 474	Rep. Satz Lenkmanschette / rep. kit steering boot		
60 93 0653	4431 869	Traggelenk / ball joint	(1)	Ø I 12
60 93 6345	4421 647	Querlenker / control arm	(3)	
60 93 6346	4421 646	Querlenker / control arm	(3)	
60 93 9603	4418 223	Querlenker / control arm	(4)	
60 93 6904	4418 224	Querlenker / control arm	(4)	



Zafira A (1998 → 2005)

Vorderachse / Front axle

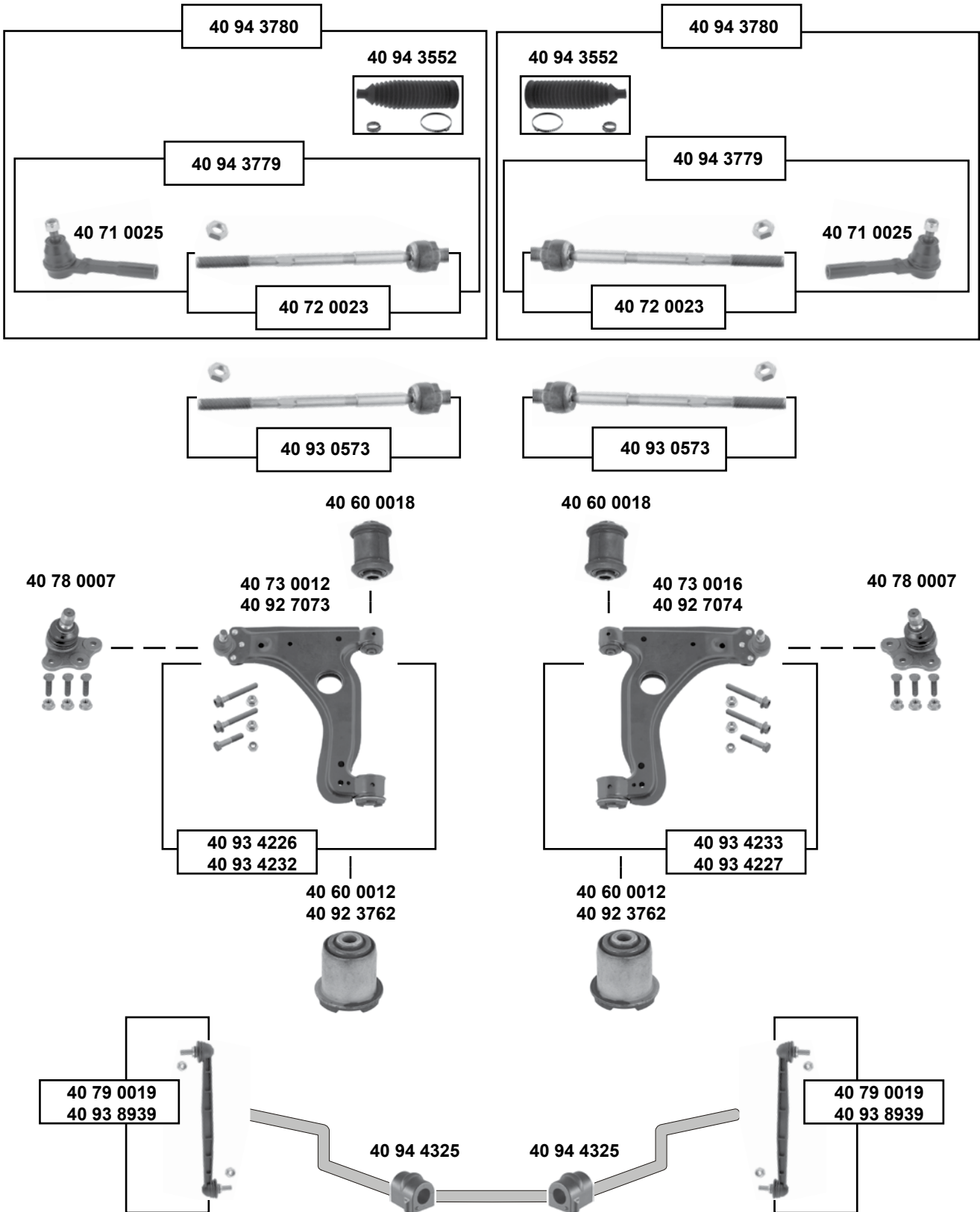







Zafira A

(1998 → 2005)



(1) Nur für TRW-Lenkung / TRW-steering only

	Ref. - No.			
40 60 0012	0352 365	Querlenkerlager / control arm mount	(ch.) → 42125089	12x45/48x60
40 60 0018	0352 364	Querlenkerlager / control arm mount	(ch.) 42125090, 4G000001→	12x36,5x60
40 71 0025	1603 542	Spurstangenendstück / tie rod end		M14x1,5 RHT
40 72 0023	1603 213	Spurstange / tie rod		L 300
40 73 0012	5352 016	Querlenker / control arm	(ch.) → 42125089	
40 73 0016	5352 017	Querlenker / control arm	(ch.) → 42125089	
40 78 0007	0352 800	Traggelenk / ball joint	(ch.) 42125090, 4G000001→	Ø A 18
40 79 0019	0350 614	Verbindungsstange / stabilizer link	OLD	L 300
40 92 3762	0352 324	Querlenker / control arm	(ch.) 42125090 →	12x46x60
40 92 7073	5352 029	Querlenker / control arm	(ch.) 42125090, 4G000001→	
40 92 7074	5352 030	Querlenker / control arm	(ch.) 42125090, 4G000001→	
40 93 0573	1603 644 SK	Spurstange / tie rod	(mot.) Z 2,0 LET	L 304
40 93 4226	5352 016 S1	Rep. Satz Querlenker / rep. kit control arm	→ (ch.) 42125089	
40 93 4227	5352 017 S1	Rep. Satz Querlenker / rep. kit control arm	→ (ch.) 42125089	
40 93 4232	5352 029 S1	Rep. Satz Querlenker / rep. kit control arm	(ch.) 42125090, 4G000001 →	
40 93 4233	5352 030 S1	Rep. Satz Querlenker / rep. kit control arm	(ch.) 42125090, 4G000001 →	
40 93 8939	0350 176	Verbindungsstange / stabilizer link	NEW	L 350
40 94 3552	1609 356	Lenkmanschettensatz / steering boot set	(1)	L 211
40 94 3779	1603 643 S5	Spurstange / tie rod	(1)	M18 x 1,5
40 94 3780	1603 643 S6	Spurstange / tie rod	(1)	M18 x 1,5
40 94 4325	0350 093	Stabilisatorlager / stabilizer mount	(1)	ØI 24



Zafira B (2005 → 2011)

Vorderachse / Front axle

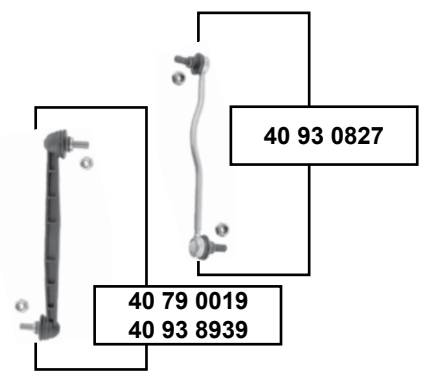
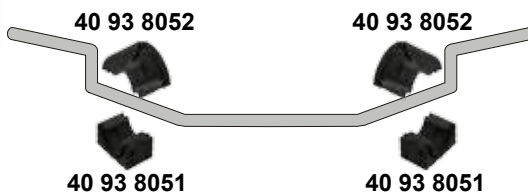
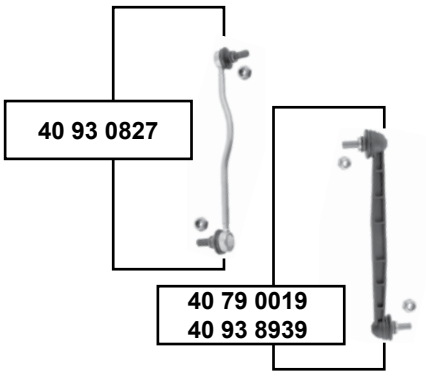
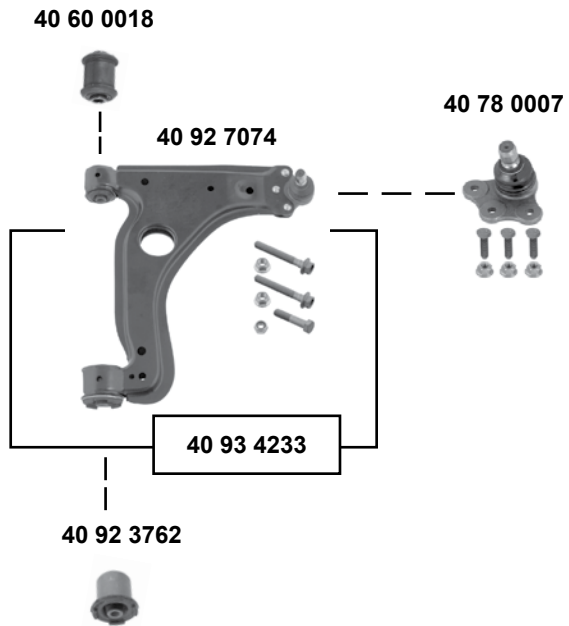
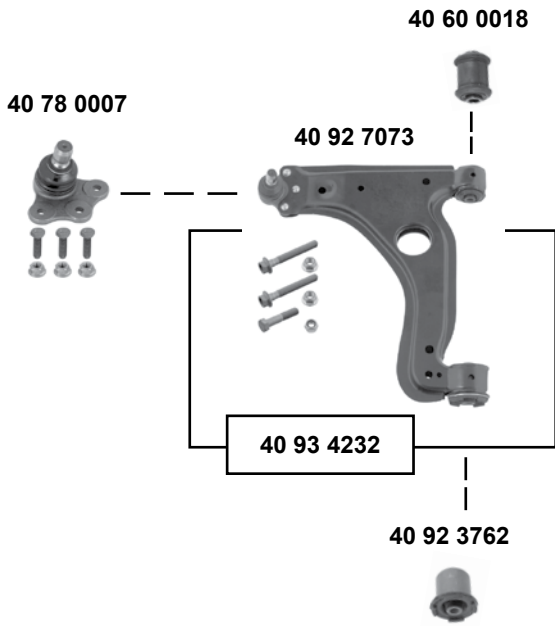
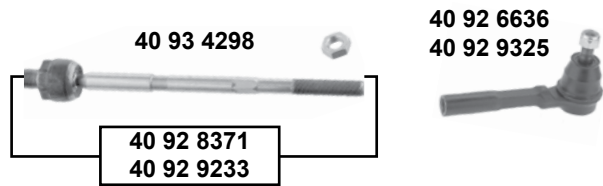
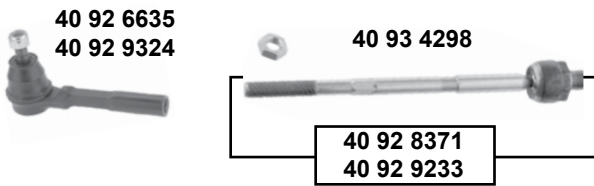
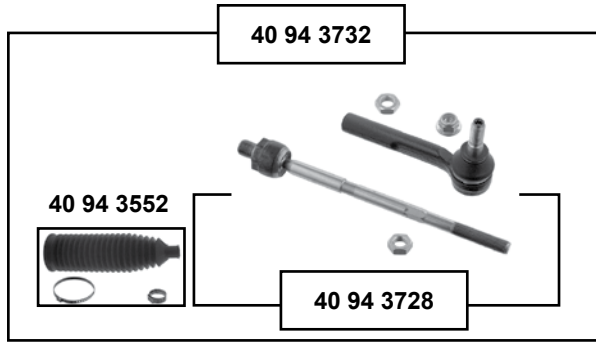
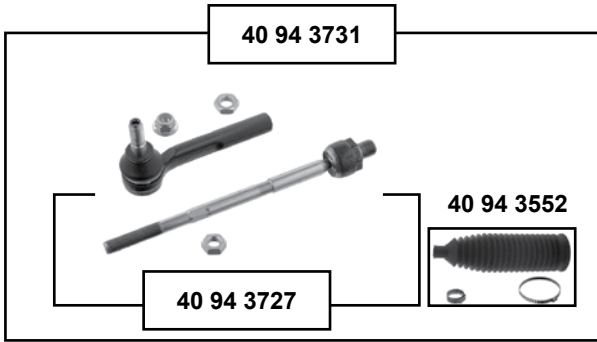



Zafira B (2005 → 2011)

- (1)** servo TRW // Z1,6 XEP, XER, XE1 alle/ all
Z1,8 XER (ex.) ESP
- (2)** Fahrzeuge mit TRW 2. Generation Lenkung /
vehicles with TRW 2. generation steering
- (3)** servo ZF, (ex.) 18" / (mot.) Y 1,6YNG / Z16YNG / Z16XNT / A16XNT / Z 1,7 DTR / Z17DTJ / A17DTJ /
A17DTR / Z 1,8 XER / A18XER / Z 1,9 DT / Z 1,9 DTL / Z 1,9 DTH / Z 2,0 LER / Z 2,0 LEH
- (4)** Nur für TRW-Lenkung / TRW-steering only // (ch.) 72095157- (ch.) 7G066982-
- (5)** Z1,6 XEP, XER, XE1, A16XER alle/ all // Z1,8XER, A18XER (ex.) ESP
- (6)** (ch.) 72095157 - , (ch.) 7G066982 - Z1,6 XEP, XER, XE1, A16XER alle/ all // Z1,8XER, A18XER (ex.) ESP

	Ref. - No.			
40 60 0018	0352 364	Querlenkerlager / control arm mount		12x36,5x60
40 78 0007	0352 800	Traggelenk / ball joint		Ø A 18
40 79 0019	0350 614	Verbindungsstange / stabilizer link	(ex.) IDS+ / OLD	L 300
40 92 3762	0352 324	Querlenker / control arm		12x46x60
40 92 6635	1603 266	Spurstangenendstück / tie rod end	servo ZF	M14 x 1,5
40 92 6636	1603 267	Spurstangenendstück / tie rod end	servo ZF	M14 x 1,5
40 92 7073	5352 029	Querlenker / control arm		
40 92 7074	5352 030	Querlenker / control arm		
40 92 8371	1603 358 SK	Spurstange / tie rod	(3)	L 279
40 92 9233	1603 359 SK	Spurstange / tie rod	18"	L 279
40 92 9324	1603 289	Spurstangenendstück / tie rod end	(1) servo TRW	M14 x 1,5
40 92 9325	1603 288	Spurstangenendstück / tie rod end	(1) servo TRW	M14 x 1,5
40 93 0827	0350 613	Verbindungsstange / stabilizer link	IDS+	
40 93 4232	5352 029 S1	Rep. Satz Querlenker links / rep. kit control arm left		
40 93 4233	5352 030 S1	Rep. Satz Querlenker rechts / rep. kit control arm right		
40 93 4298	1603 642 SK	Spurstange / tie rod	(2)	
40 93 8051	0350 391	Stabilisatorlager, unten / stabilizer mount, lower		Ø I 24
40 93 8052	0350 390	Stabilisatorlager, oben / stabilizer mount, upper		Ø I 24
40 93 8939	0350 176	Verbindungsstange / stabilizer link	(ex.) IDS+ / NEW	L 350
40 94 3552	1609 356	Lenkmanschettensatz / steering boot set	(4)	L 211
40 94 3727	1603 643 S1	Spurstange / tie rod	(2) (5)	M18 x 1,5
40 94 3728	1603 643 S2	Spurstange / tie rod	(2) (5)	M18 x 1,5
40 94 3731	1603 643 S3	Spurstange / tie rod	(2) (6)	M18 x 1,5
40 94 3732	1603 643 S4	Spurstange / tie rod	(2) (6)	M18 x 1,5



OPEL

Zafira C (2012 →)

Vorderachse / Front axle

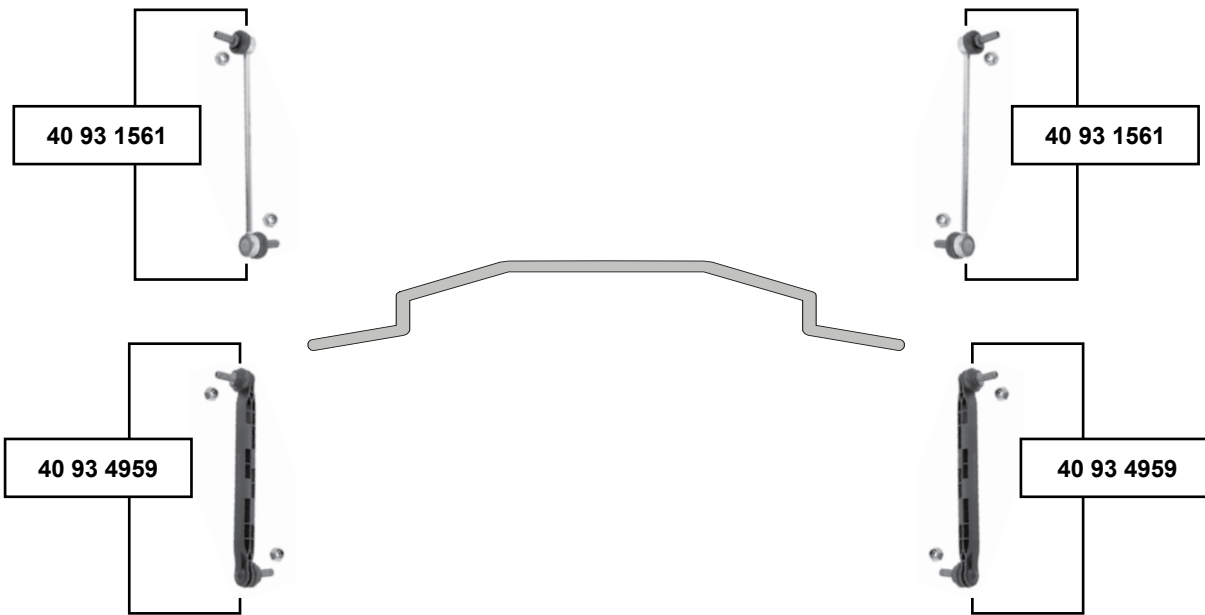
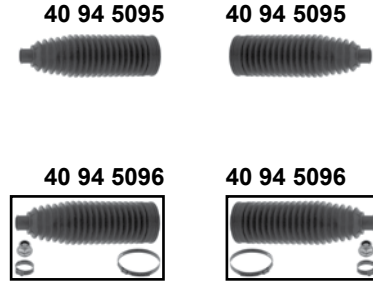

(1) Für Fahrzeuge mit Flexride Fahrwerk (aktives Fahrwerk) / for vehicles with flexride chassis only

(2) alle (ex.) Flexride Fahrwerk / all (ex.) flexride chassis



Ref. - No.



40 93 1561	0350 618
40 93 4959	0350 617
40 94 5095	1609 182 SK1
40 94 5096	1609 182

Verbindungsstange / stabilizer link
Verbindungsstange / stabilizer link
Lenkmanschette / steering boot
Lenkmanschettensatz / steering boot set

(1)
(2)
E - servo
E - servo

L 303,5
L 304



LHD



62 91 9917



62 93 0876

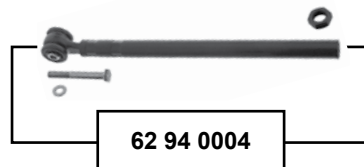

RHD



62 93 0876



62 91 9917

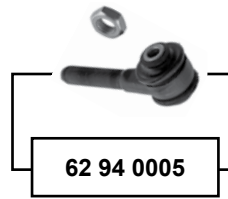
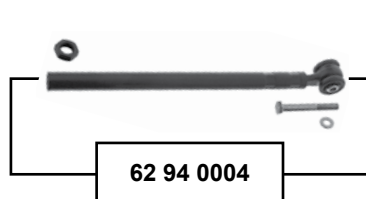

(1) RHD (ex.) servo O 07233 →
servo alle / all

LHD (ex.) servo O 07141 →
servo O 07112 →

(2) RHD (ex.) servo → O 07232
servo alle / all

LHD (ex.) servo → O 07140
servo → O 07111



62 71 0002	3817.42	Spurstangenendstück / tie rod end		M10 x 1,25
62 71 0003	3817.41	Spurstangenendstück / tie rod end		M10 x 1,25
62 91 9917	4066.32	Lenkmanschette / steering boot		
62 93 0876	3817.47	Spurstange / tie rod	(1)	L 215
62 94 0004	3817.36 S1	Axialgelenk / axial joint	(2)	L 350
62 94 0005	3817.33	Spurstangenendstück / tie rod end	(2)	M14 x 1,5



106 (1991 → 2005)

→ 55 kW (75 PS) (ex.) Sport

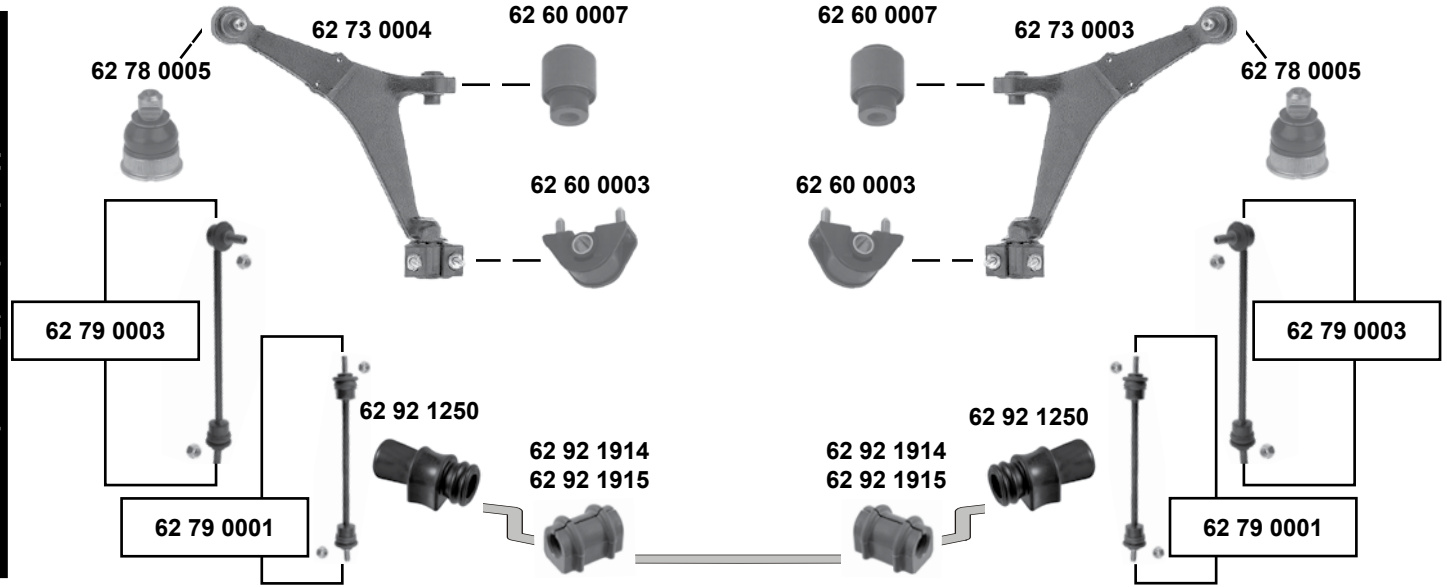

→ 55 kW (75 PS) Sport
65 kW (88 PS) → alle/all

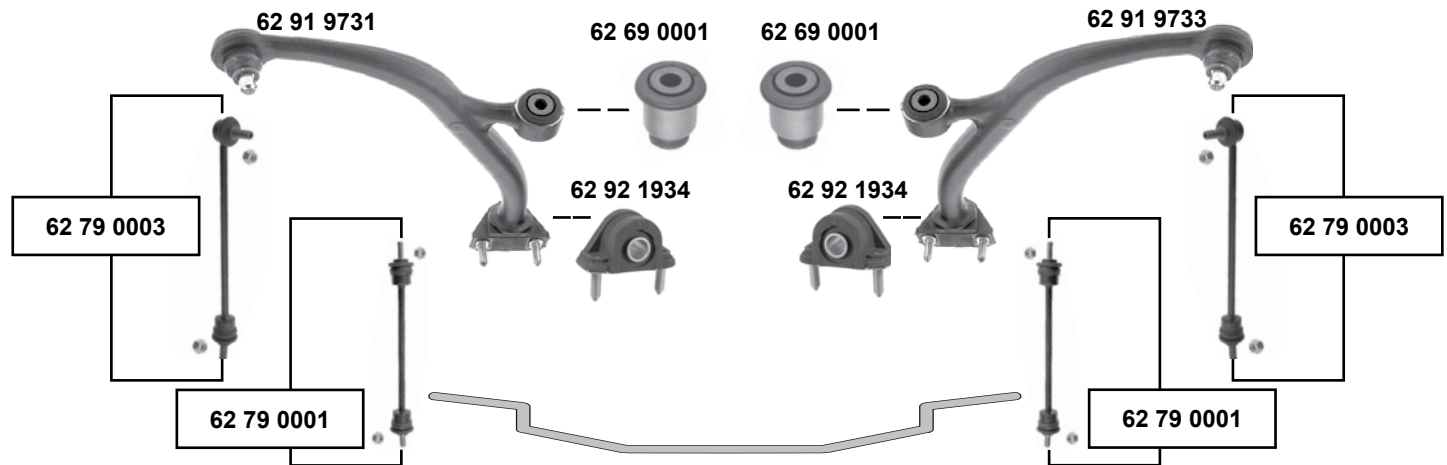

Ref. - No.



62 60 0003	3523.51	Querlenkerlager / control arm mount		
62 60 0007	3523.50	Querlenkerlager / control arm mount		
62 69 0001	3523.52	Querlenkerlager / control arm mount		12x34x48 12x34x48
62 73 0003	3520.79	Querlenker / control arm		
62 73 0004	3520.78	Querlenker / control arm		
62 78 0005	3640.36	Traggelenk / ball joint		Ø A 16
62 79 0001	5087.33	Verbindungsstange / connecting rod	→ 05/95	L 300
62 79 0003	5087.40	Verbindungsstange / connecting rod	05/95 →	L 300
62 91 9731	3520.92	Querlenker / control arm		
62 91 9733	3520.93	Querlenker / control arm		
62 92 1250	5094.59	Stabilisatorlager / stabilizer mount		Ø I 19
62 92 1914	5094.56	Stabilisatorlager / stabilizer mount		Ø I 19
62 92 1915	5094.57	Stabilisatorlager / stabilizer mount		Ø I 21
62 92 1934	3523.53	Querlenkerlager / control arm mount		



107
(2005 →)

Vorderachse / Front axle

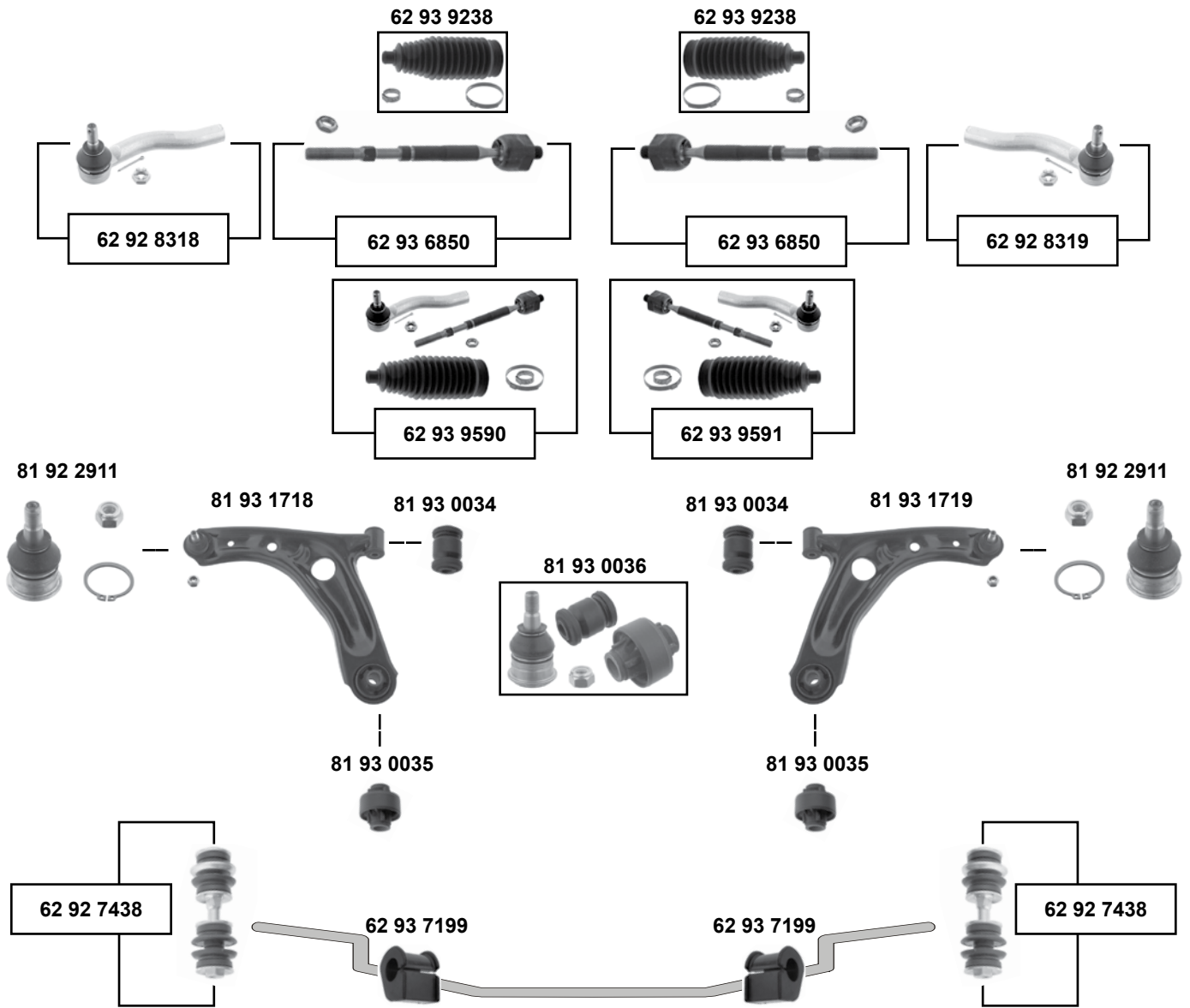

Ref. - No.



62 92 7438	5091.10 S1	Verbindungsstange / connecting rod	L 92
62 92 8318	3817.63	Spurstangenendstück / tie rod end	M12 x 1,25
62 92 8319	3817.64	Spurstangenendstück / tie rod end	M12 x 1,25
62 93 6850	4001.33 S1	Axialgelenk / axial joint	L 223
62 93 7199	5094.A8	Stabilisatorlager / stabilizer mount	Ø 122
62 93 9238	4066.A3	Rep. Satz Lenkmanschette / rep. kit steering boot	L 170
62 93 9590	4001.33 S2	Rep. Satz Spurstange / rep. kit tie rod	
62 93 9591	4001.33 S3	Rep. Satz Spurstange / rep. kit tie rod	
81 92 2911	3520.QS S1	Traggelenk / ball joint	M12 x 1,25
81 93 0034	3520.Q2 S2	Querlenkerlager / control arm mount	A Ø 33
81 93 0035	3520.Q2 S3	Querlenkerlager / control arm mount	A Ø 57,3
81 93 0036	3520.Q2 S4	Rep. Satz Querlenker / rep. kit control arm	
81 93 1718	3520.Q2	Querlenker / control arm	M12 x 1,25
81 93 1719	3521.L3	Querlenker / control arm	M12 x 1,25



205
(1983 → 1996)

Vorderachse / Front axle

man.

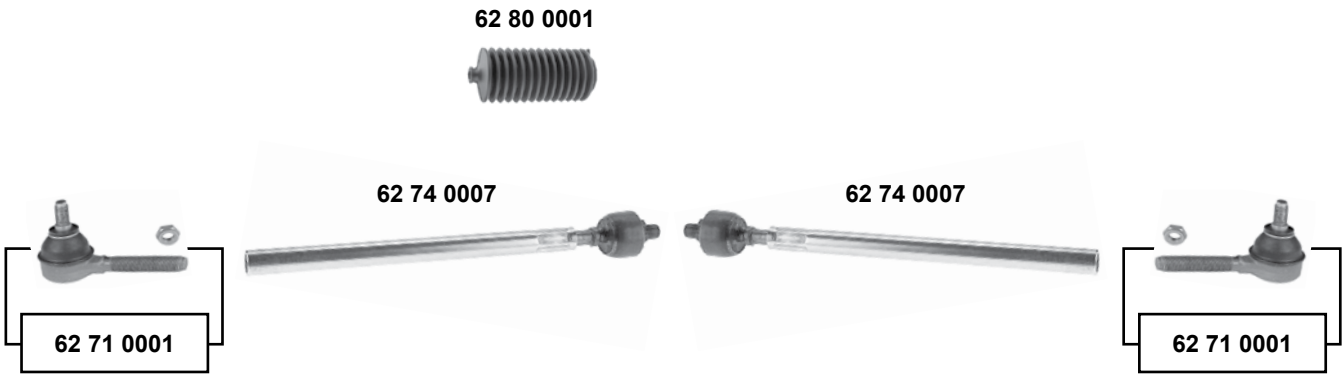

servo

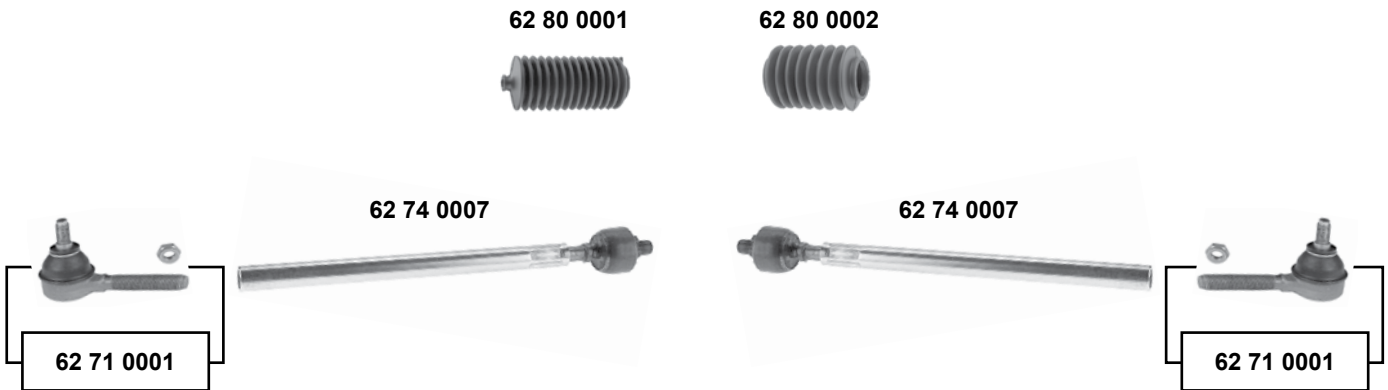

	Ref. - No.			
62 71 0001	3817.50	Spurstangenendstück / tie rod end		M10 x 1,25
62 74 0007	3812.95	Spurstange / tie rod		M14 x 1,5
62 80 0001	4066.20	Lenkmanschette / steering boot		
62 80 0002	4066.22	Lenkmanschette / steering boot		



(ex.) Rallye / GTI / Turbo - Diesel

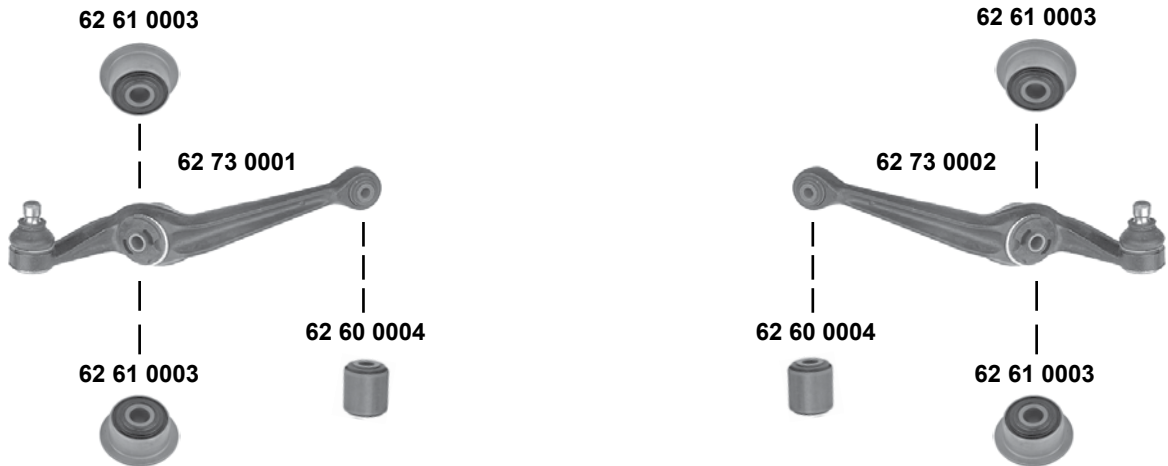

Rallye / GTI / Turbo - Diesel

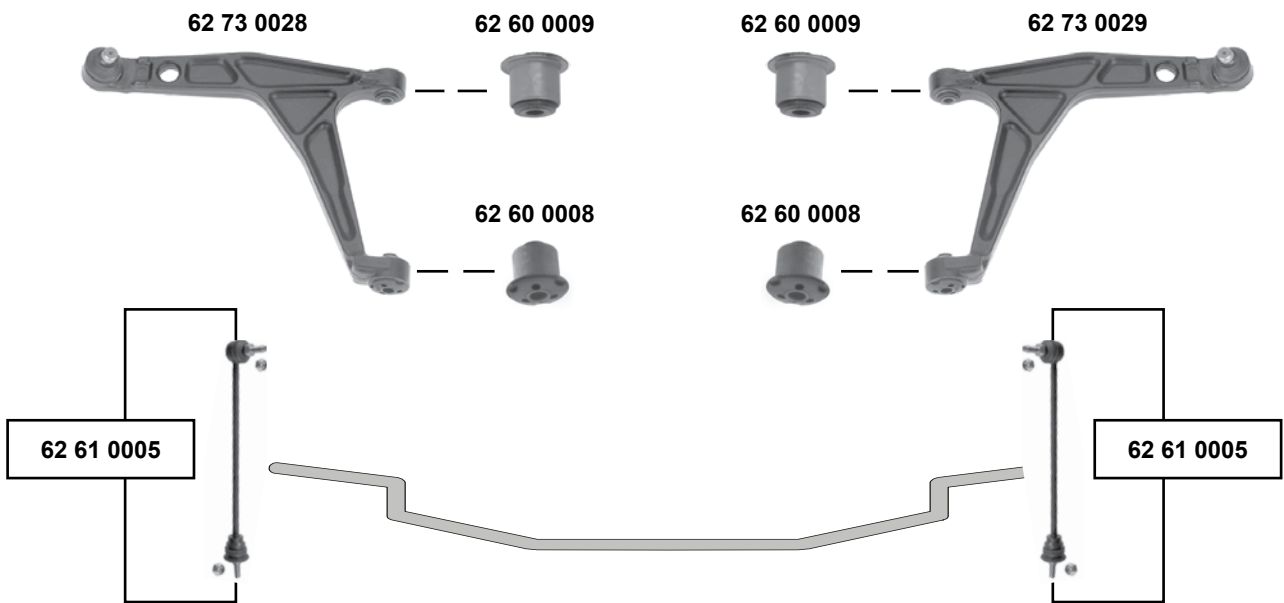

Vorderachse / Front axle

SWAG	Ref. - No.			
62 60 0004	3523.20	Querlenkerlager / control arm mount		10x28x34
62 60 0008	3523.23	Querlenkerlager / control arm mount		31/42x12x38
62 60 0009	3523.31	Querlenkerlager / control arm mount		10x28x34
62 61 0003	3523.49	Stabilisatorlager / stabilizer mount		36x12x25
62 61 0005	5087.32	Verbindungsstange / connecting rod		L 312
62 73 0001	3520.51	Querlenker / control arm		
62 73 0002	3521.34	Querlenker / control arm		
62 73 0028	3520.54	Querlenker / control arm		
62 73 0029	3521.37	Querlenker / control arm		



206
(1998 → 2006)

Vorderachse / Front axle

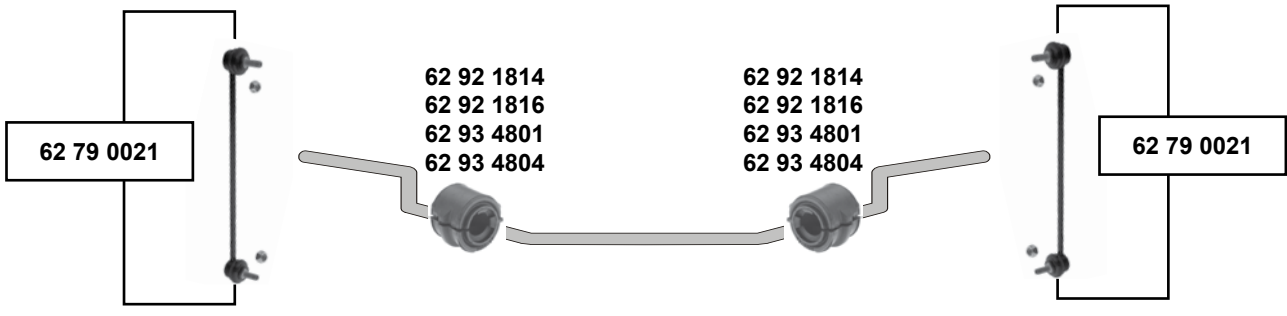
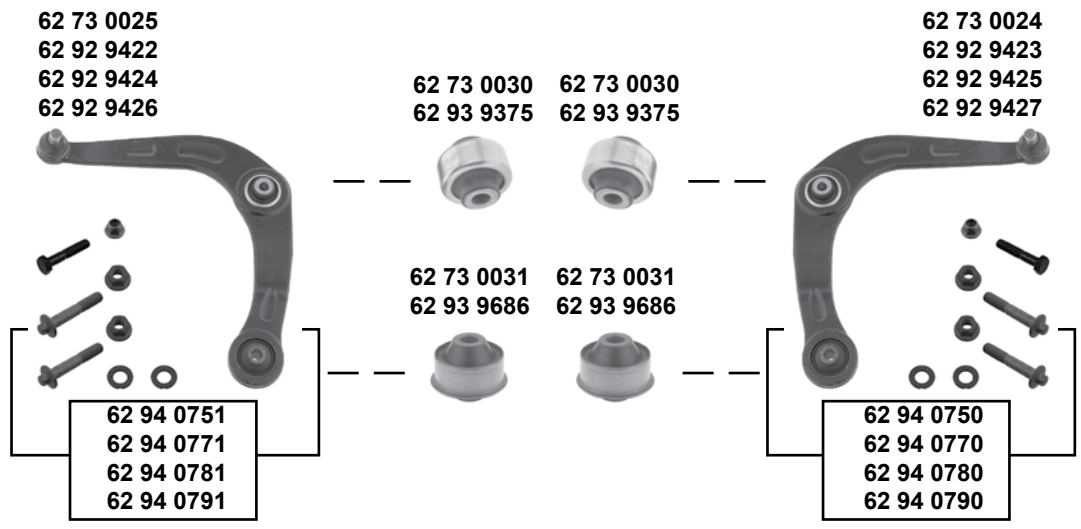
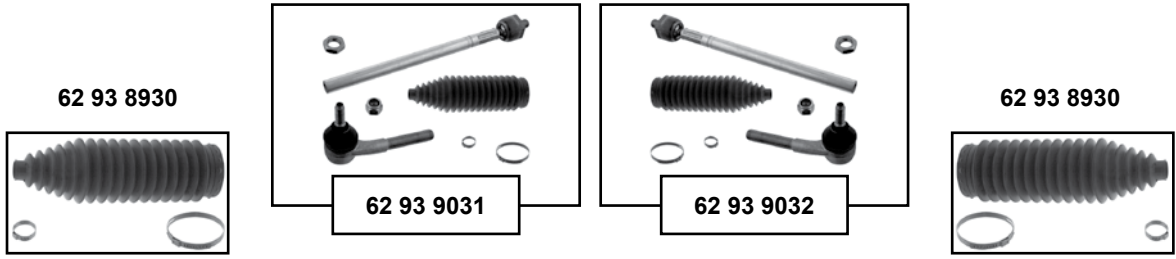
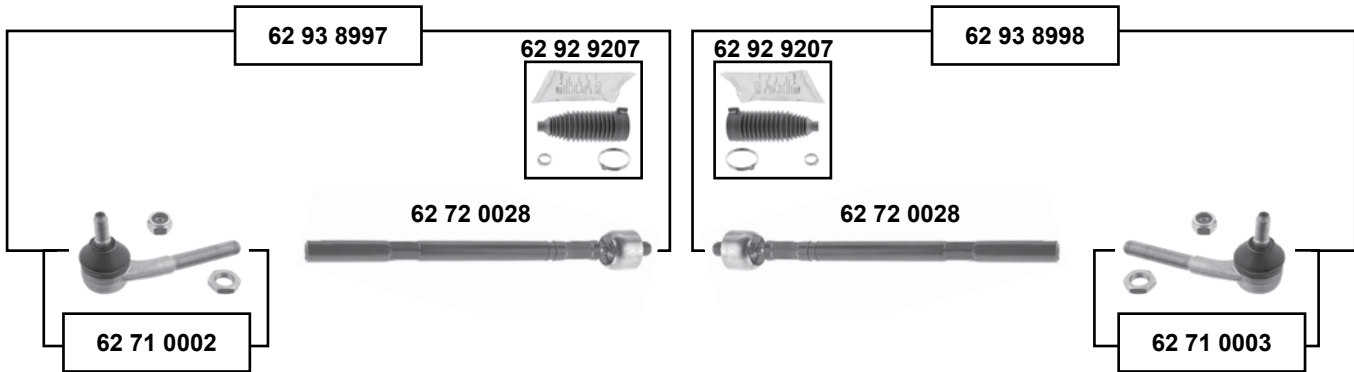



(1)	(mot.) 1,1 // 1,4 8V // 1,6 16V // 1,4 HDI // 1,9 D // 2,0 HDI 90 → O 09440
(2)	(mot.) 1,4 16V // 1,6 HDI außer/except GTI/S16
(3)	(mot.) 1,1 i / 1,4 i / 1,6 i / 1,9 D / 1,4 HDI / 2,0 HDI O 09441 →
(4)	(mot.) 1,6 16V → O 09506 // 2,0 S16 / 2,0 RC / 1,6 HDI
(5)	3-Türer / 3-door (mot.) 1,1 / 1,4 8V / 1,6 i / 1,4 HDI / 1,9 D / 2,0 HDI / 5-Türer / 5-door (mot.) alle /all
(6)	(mot.) 1,1 / 1,4 8V / 1,9 D → O 09275
(7)	(mot.) 1,6 i / 1,6 16V → O 09122 / (mot.) 2,0 HDI → O 09085
(8)	(mot.) 1,9 (DW8/DW8B) ab / from O 09276 → / 1,6 (DV6TED4) / (mot.) 2,0 (DW10TD) ab / from O 09086 → (mot.) 1,1 (TU1JP) ab / from O 09276 / (mot.) 1,4 (TU3JP) ab / from 09276 → (mot.) 1,6 (TU5JP) ab / from O 09123 → / (mot.) 1,6 (TU5JP) ab / from O 09123/10584 → (mot.) 1,4 (ET3J) / (mot.) 2,0 (EW10J4) / 1,4 (TU3A) / 1,4 (DV4TD) ab / from O 09191
(9)	(mot.) 1,4 (TU3AF) // (mot.) 1,6 (TU5JP4) ab / from O 10584 → (mot.) 1,6 (TU5J4G) / 2,0 (EW10J4S) (mot.) 1,4 (TU3A) / 1,4 (DV4TD) / 1,6 (DV6TED4)
(10)	(mot.) DV6TED4 3TR/5TR (GTI/S16) / EW10J4 3TR / EW10JS4 3TR / (mot.) TU5JP4 3TR → O 09506 (mot.) TU5JP4 5TR → O 09530
(11)	(mot.) DV6TED4 / TU5JP4 / TU5JP4G / EW10J4 / EW10 J4S / DV4TD / ET3J4



Ref. - No.



SWAG Ref. - No.	Description	Quantity	Notes	Dimensions
62 71 0002	3817.42	Spurstangenendstück / tie rod end		M10 x 1,25
62 71 0003	3817.41	Spurstangenendstück / tie rod end		M10 x 1,25
62 72 0028	3812.C5	Spurstange / tie rod		L 300
62 73 0024	3521.C8	Querlenker / control arm	(1)	
62 73 0025	3520.G8	Querlenker / control arm	(1)	
62 73 0030	3523.76	Querlenkerlager / control arm mount	(5)	14x55x50,5
62 73 0031	3523.77	Querlenkerlager / control arm mount	(5)	Ø A 55
62 79 0021	5087.74	Verbindungsstange / connecting rod		L 335
62 92 1814	5094.81	Stabilisatorlager / stabilizer mount	(6)	Ø I 18
62 92 1816	5094.80	Stabilisatorlager / stabilizer mount	(7)	Ø I 19
62 92 9207	4066.73	Rep. Satz Lenkmanschette / rep. kit steering boot	servo	
62 92 9422	3520.W0	Querlenker / control arm	(3)	
62 92 9423	3521.S1	Querlenker / control arm	(3)	
62 92 9424	3520.V6	Querlenker / control arm	(4)	
62 92 9425	3521.R7	Querlenker / control arm	(4)	
62 92 9426	3520.V7	Querlenker / control arm	(2)	
62 92 9427	3521.R9	Querlenker / control arm	(2)	
62 93 4801	5094.82	Stabilisatorlager / stabilizer mount	(8)	Ø I 20
62 93 4804	5094.95	Stabilisatorlager / stabilizer mount	(9)	Ø I 21
62 93 8930	4066.56 S1	Rep. Satz Lenkmanschette / rep. kit steering boot	(ex.) servo	L 208
62 93 8997	3812.C5 S1	Rep. Satz Spurstange / rep. kit tie rod	servo	
62 93 8998	3812.C5 S2	Rep. Satz Spurstange / rep. kit tie rod	servo	
62 93 9031	3812.C5 S3	Rep. Satz Spurstange / rep. kit tie rod	(ex.) servo	
62 93 9032	3812.C5 S4	Rep. Satz Spurstange / rep. kit tie rod	(ex.) servo	
62 93 9375	3523.AS	Querlenkerlager / control arm mount	(10)	ØI 14,1 A 55,3
62 93 9686	3523.80	Querlenkerlager / control arm mount	(11)	ØI 14,3 A 55,5
62 94 0750	3521.C8 S1	Rep. Satz Querlenker / rep. kit control arm	(1)	
62 94 0751	3520.G8 S1	Rep. Satz Querlenker / rep. kit control arm	(1)	
62 94 0770	3521.R9 S1	Rep. Satz Querlenker / rep. kit control arm	(2)	
62 94 0771	3520.V7 S1	Rep. Satz Querlenker / rep. kit control arm	(2)	
62 94 0780	3521.R7 S1	Rep. Satz Querlenker / rep. kit control arm	(4)	
62 94 0781	3520.V6 S1	Rep. Satz Querlenker / rep. kit control arm	(4)	
62 94 0790	3521.S1 S1	Rep. Satz Querlenker / rep. kit control arm	(3)	
62 94 0791	3520.W0 S1	Rep. Satz Querlenker / rep. kit control arm	(3)	



PEUGEOT

206 SW
(2002 → 2007)

Vorderachse / Front axle

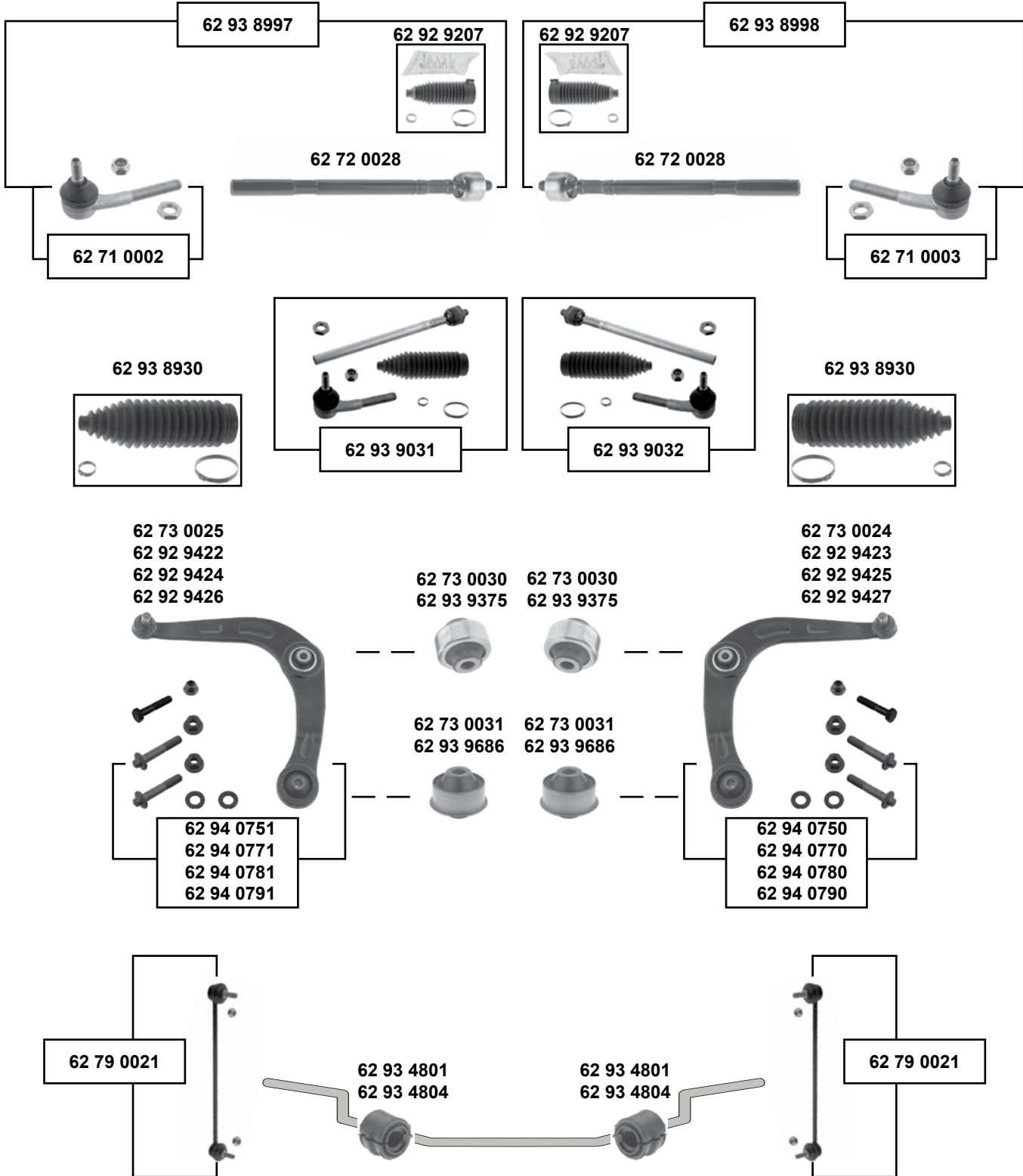



- (1) (mot.) 1,1 / 1,4 / 1,4 HDI / 2,0 HDI → O 09440
- (2) (mot.) 1,6 i O 09452 → / (mot.) DV6TED4 (ex.) GTI/S 16 / (mot.) ET3J4
- (3) (mot.) 1,1 / 1,4 8V / 1,4 16V / 1,4 HDI / 2,0 HDI O 09441 →
- (4) (mot.) 1,6 16V → O 09451 / 1,6 HDI / 2,0 16V
- (5) (mot.) 1,1 / 1,4 8V / 1,4 HDI / 2,0 HDI
- (6) (mot.) 1,4 (ET3J4)
- (7) (mot.) 1,6 (DV6TED) / 2,0 (DW10TD)
- (8) 07.02 → (mot.) DV6TED4 / EW10J4 / TU5JP4 O 09233-09451 → (ex.) ESCAPADE
- (9) (mot.) DV6TED4 / EW10J4 // TU5JP4 O 09233 →



Ref. - No.



Ref. - No.	Description	Quantity	Notes	Dimensions
62 71 0002	3817.42	Spurstangenendstück / tie rod end		M10 x 1,25
62 71 0003	3817.41	Spurstangenendstück / tie rod end		M10 x 1,25
62 72 0028	3812.C5	Axialgelenk / axial joint		L 300
62 73 0024	3521.C8	Querlenker / control arm	(1)	
62 73 0025	3520.G8	Querlenker / control arm	(1)	
62 73 0030	3523.76	Querlenkerlager / control arm mount	(5)	14x55x50,5
62 73 0031	3523.77	Querlenkerlager / control arm mount	(5)	14x55,4x48,8
62 79 0021	5087.74	Verbindungsstange / connecting rod		L 335
62 92 9207	4066.73	Rep. Satz Lenkmanschette / rep. kit steering boot	servo	
62 92 9422	3520.W0	Querlenker / control arm	(3)	
62 92 9423	3521.S1	Querlenker / control arm	(3)	
62 92 9424	3520.V6	Querlenker / control arm	(4)	
62 92 9425	3521.R7	Querlenker / control arm	(4)	
62 92 9426	3520.V7	Querlenker / control arm	(2)	
62 92 9427	3521.R9	Querlenker / control arm	(2)	
62 93 4801	5094.82	Stabilisatorlager / stabilizer mount	(6)	Ø I 20
62 93 4804	5094.95	Stabilisatorlager / stabilizer mount	(7)	Ø I 21
62 93 8930	4066.56 S1	Rep. Satz Lenkmanschette / rep. kit steering boot	(ex.) servo	L 208
62 93 8997	3812.C5 S1	Rep. Satz Spurstange / rep. kit tie rod	servo	
62 93 8998	3812.C5 S2	Rep. Satz Spurstange / rep. kit tie rod	servo	
62 93 9031	3812.C5 S3	Rep. Satz Spurstange / rep. kit tie rod	(ex.) servo	
62 93 9032	3812.C5 S4	Rep. Satz Spurstange / rep. kit tie rod	(ex.) servo	
62 93 9375	3523.AS	Querlenkerlager / control arm mount	(8)	ØI 14,1 A 55,3
62 93 9686	3523.80	Querlenkerlager / control arm mount	(9)	ØI 14,3 A 55,5
62 94 0750	3521.C8 S1	Rep. Satz Querlenker / rep. kit control arm	(1)	
62 94 0751	3520.G8 S1	Rep. Satz Querlenker / rep. kit control arm	(1)	
62 94 0770	3521.R9 S1	Rep. Satz Querlenker / rep. kit control arm	(2)	
62 94 0771	3520.V7 S1	Rep. Satz Querlenker / rep. kit control arm	(2)	
62 94 0780	3521.R7 S1	Rep. Satz Querlenker / rep. kit control arm	(4)	
62 94 0781	3520.V6 S1	Rep. Satz Querlenker / rep. kit control arm	(4)	
62 94 0790	3521.S1 S1	Rep. Satz Querlenker / rep. kit control arm	(3)	
62 94 0791	3520.W0 S1	Rep. Satz Querlenker / rep. kit control arm	(3)	



PEUGEOT

206 CC

(2000 → 2007)

Vorderachse / Front axle

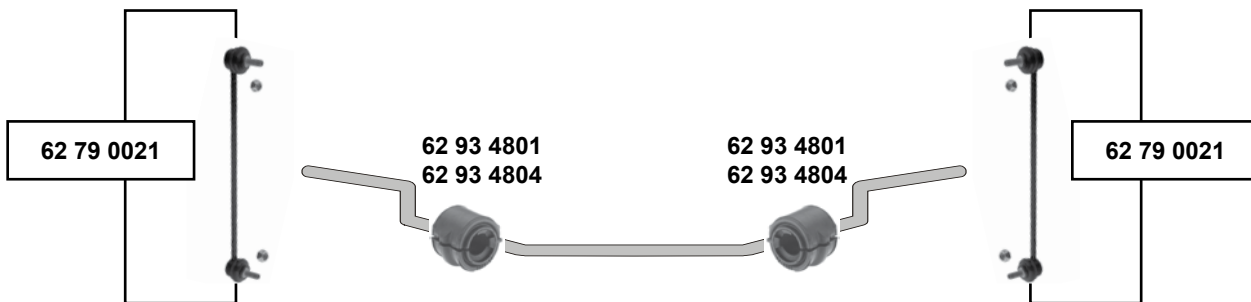
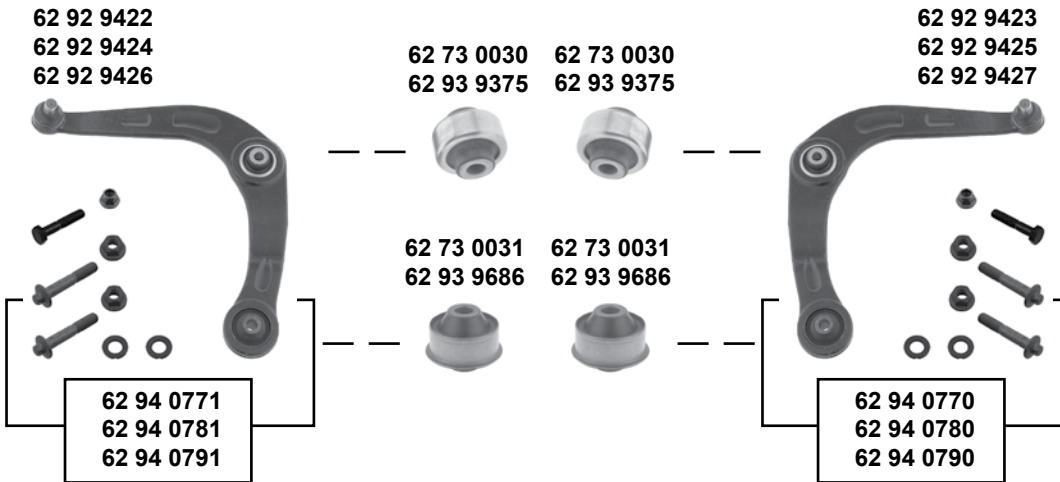
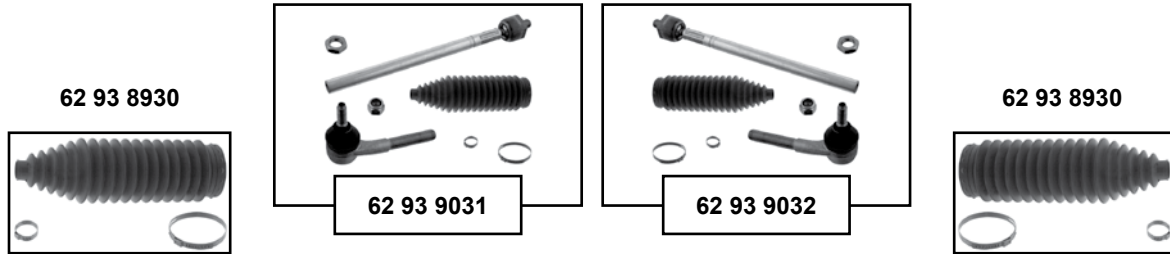
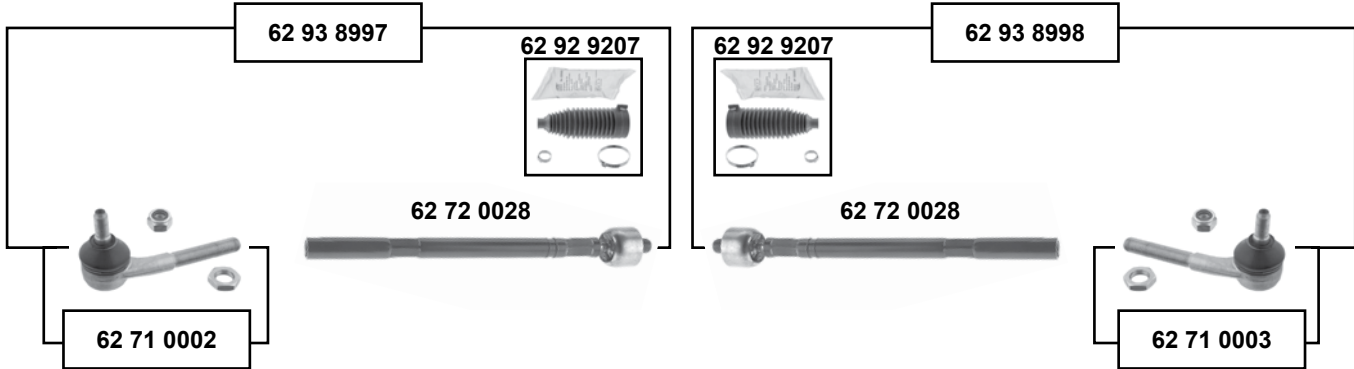



- (1) (mot.) 1,6 16V / O 09440 → // (mot.) 2,0 S16 → O 9440 // (mot.) 1,6 HDI
- (2) (mot.) 1,6 16V / O 09440 →
- (3) (mot.) 1,6 16V / 2,0 S16 → O 09439
- (4) (mot.) 1,6 (TU5JP4) / 2,0 (EW10J4) → O 10555
- (5) (mot.) 1,6 (DV6TED4) / 2,0 (EW10J4) O 10556 →
- (6) (mot.) EW10J4 → O 09440
- (7) (mot.) EW10J4 / DV6TED4 // TU5JP4 BVM O 09440 →



Ref. - No.



SWAG Ref. - No.	Description	Quantity	Notes	Dimensions
62 71 0002	3817.42			M10 x 1,25
62 71 0003	3817.41			M10 x 1,25
62 72 0028	3812.C5			L 300
62 73 0030	3523.76			14x55x50,5
62 73 0031	3523.77			14x55,4x48,8
62 79 0021	5087.74			L 335
62 92 9207	4066.73			
62 92 9422	3520.W0		servo	
62 92 9423	3521.S1	(2)		
62 92 9424	3520.V6	(2)		
62 92 9425	3521.R7	(3)		
62 92 9426	3520.V7	(3)		
62 92 9427	3521.R9	(1)		
62 93 4801	5094.82	(1)		
62 93 4804	5094.95	(4)		Ø 1 20
62 93 8930	4066.56 S1	(5)		Ø 1 21
62 93 8931	3812.C5 S1	(ex.)	servo	L 208
62 93 8932	3812.C5 S2	(ex.)	servo	
62 93 8933	3812.C5 S3	(ex.)	servo	
62 93 8934	3812.C5 S4	(ex.)	servo	
62 93 9375	3523.AS	(6)		ØI 14,1 A 55,3
62 93 9686	3523.80	(7)		ØI 14,3 A 55,5
62 94 0770	3521.C8 S1	(1)		
62 94 0771	3520.V7 S1	(1)		
62 94 0780	3521.R7 S1	(3)		
62 94 0781	3520.V6 S1	(3)		
62 94 0790	3521.S1 S1	(2)		
62 94 0791	3520.W0 S1	(2)		



PEUGEOT



206 +
(2009 →)

Vorderachse / Front axle

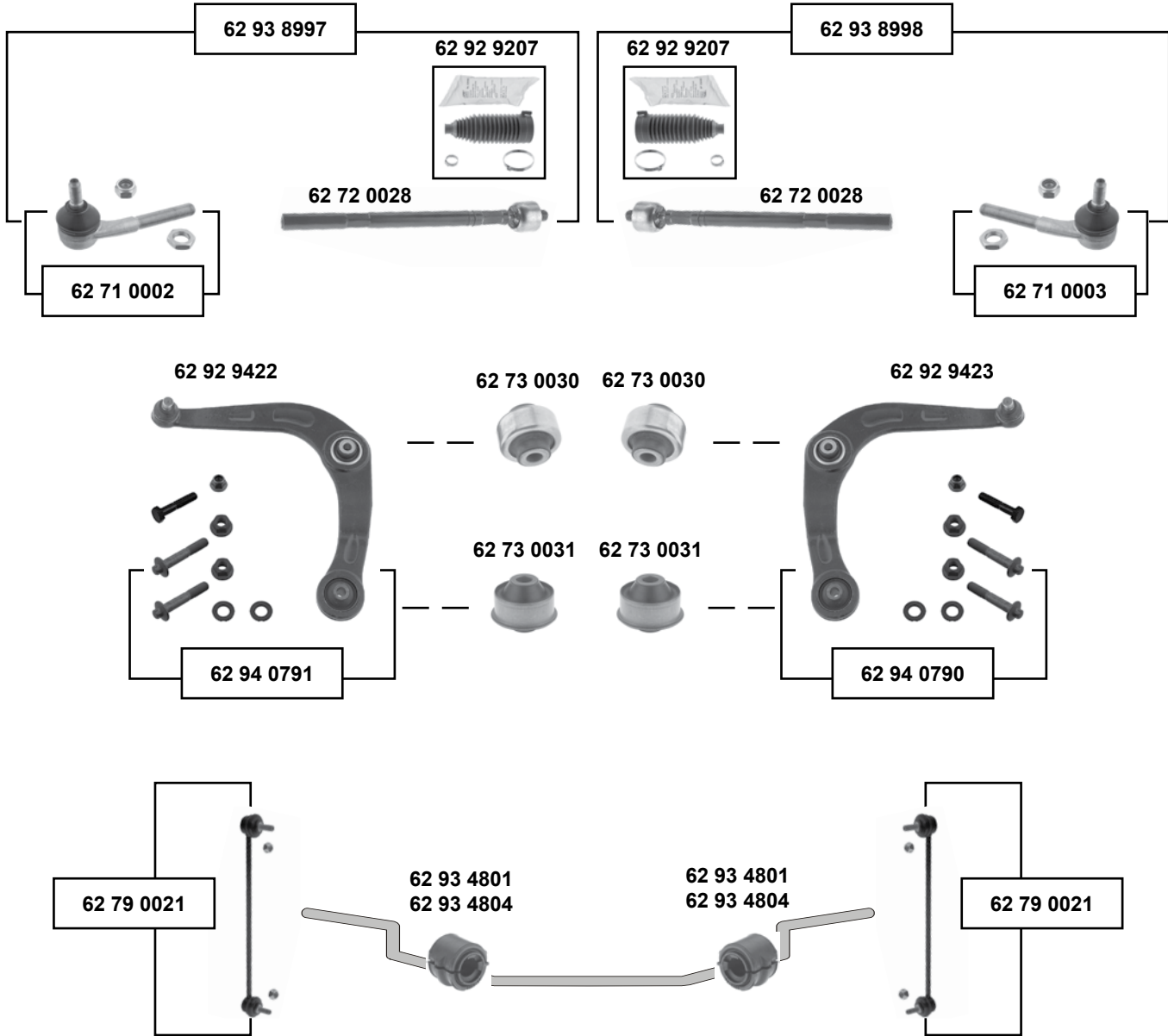

SWAG GERMANY	Ref. - No.			
62 71 0002	3817.42	Spurstangenendstück / tie rod end		M10 x 1,25
62 71 0003	3817.41	Spurstangenendstück / tie rod end		M10 x 1,25
62 72 0028	3812.C5	Axialgelenk / axial joint		L 300
62 73 0030	3523.76	Querlenkerlager / control arm mount		14x55x50,5
62 73 0031	3523.77	Querlenkerlager / control arm mount		14x55,4x48,8
62 79 0021	5087.74	Verbindungsstange / connecting rod		L 335
62 92 9207	4066.73	Rep. Satz Lenkmanschette / rep. kit steering boot	servo	
62 92 9422	3520.W0	Querlenker / control arm		
62 92 9423	3521.S1	Querlenker / control arm		
62 93 4801	5094.82	Stabilisatorlager / stabilizer mount	O 11705 →	Ø 20
62 93 4804	5094.95	Stabilisatorlager / stabilizer mount	O 11705 →	Ø 21
62 93 8997	3812.C5 S1	Rep. Satz Spurstange / rep. kit tie rod		
62 93 8998	3812.C5 S2	Rep. Satz Spurstange / rep. kit tie rod		
62 94 0790	3521.S1 S1	Rep. Satz Querlenker / rep. kit control arm		
62 94 0791	3520.W0 S1	Rep. Satz Querlenker / rep. kit control arm		



207 / CC / SW (2006 →)

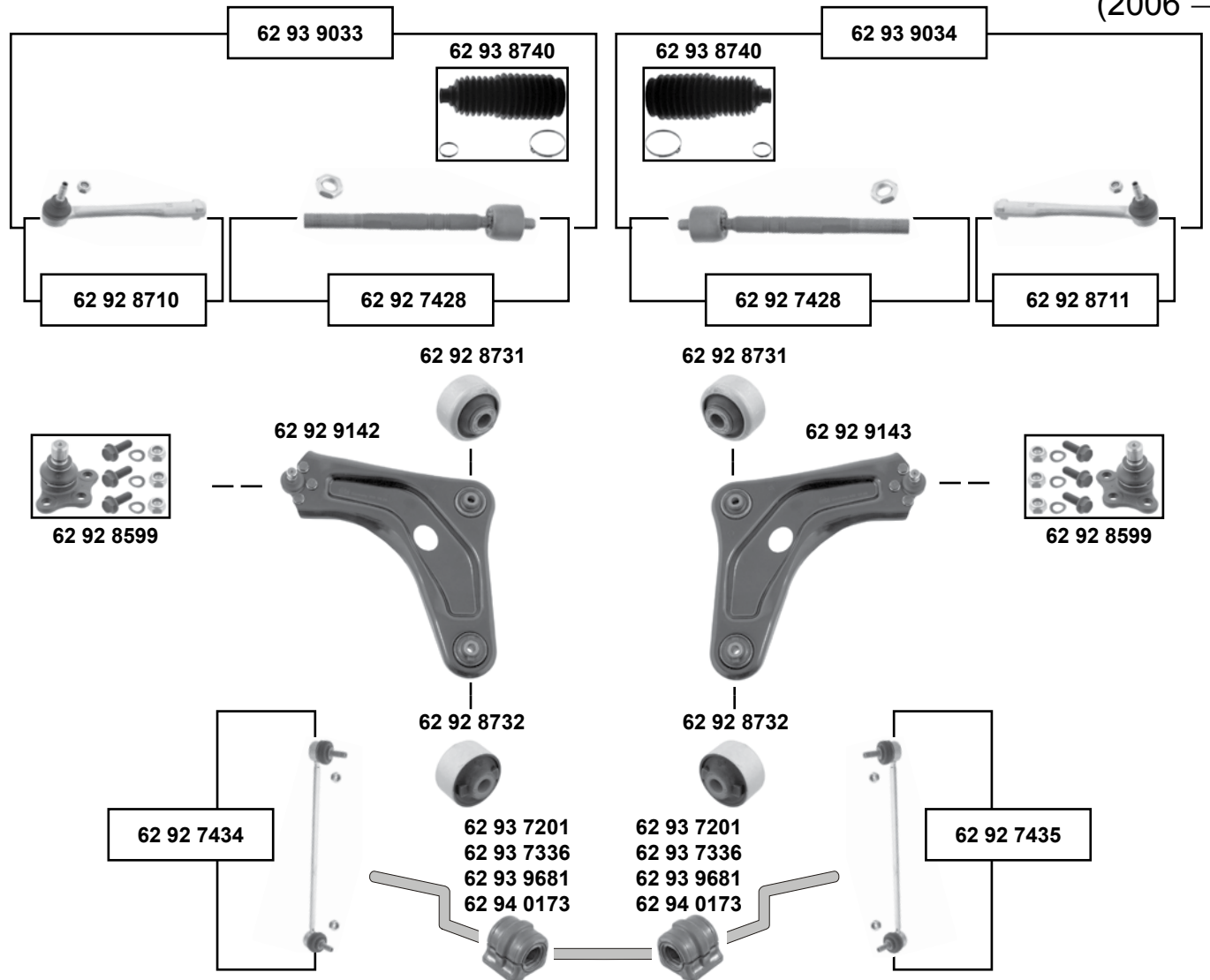

Vorderachse / Front axle



(1) (mot.) (DV6DTE) → O 12529 // (mot.) (EP6DT) O 11326 → // (ex.) EP6DTS



Ref. - No.



Ref. - No.	Description	Notes	Dimensions
62 92 7428	3812.E8 Axialgelenk / axial joint		L 213
62 92 7434	5087.69 Verbindungsstange / connecting rod		L 330 M10x1,5
62 92 7435	5087.68 Verbindungsstange / connecting rod		L 330 M10x1,5
62 92 8599	3640.62 Tragelenk / ball joint		
62 92 8710	3817.67 Spurstangenendstück / tie rod end		M10 x 1,25
62 92 8711	3817.68 Spurstangenendstück / tie rod end		M10 x 1,25
62 92 8731	3520.R7 S1 Querlenkerlager / control arm mount		Ø A 56,1
62 92 8732	3520.R7 S2 Querlenkerlager / control arm mount		Ø A 56,2
62 92 9142	3520.R7 Querlenker / control arm		
62 92 9143	3521.N8 Querlenker / control arm		
62 93 7201	5094.C1 Stabilisatorlager / stabilizer mount		Ø I 20
62 93 7336	5094.C2 Stabilisatorlager / stabilizer mount		Ø I 21
62 93 8740	4066.80 Rep. Satz Lenkmanschette / rep. kit steering boot		L 175
62 93 9033	3812.E8 S1 Rep. Satz Spurstange / rep. kit tie rod		
62 93 9034	3812.E8 S2 Rep. Satz Spurstange / rep. kit tie rod		
62 93 9681	5094.C5 Stabilisatorlager / stabilizer mount		Ø I 23
62 94 0173	5094.C3 Stabilisatorlager / stabilizer mount		Ø I 22





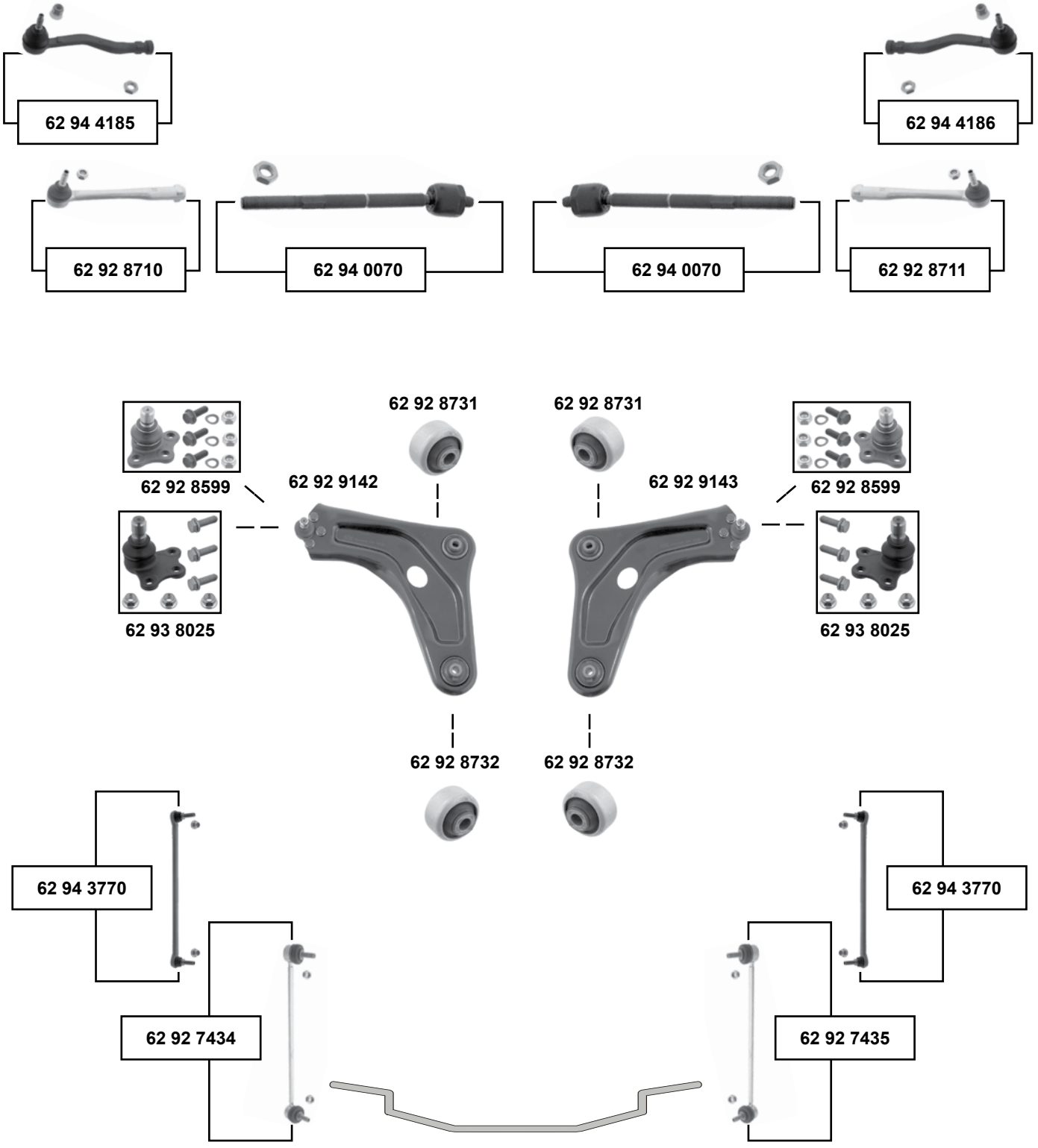

208 (2012 →)

Vorderachse / Front axle





- (1) mit Ø Bremsscheibe 266 mm / with Ø brake disc 266 mm
- (2) mit Ø Bremsscheibe 302 mm / with Ø brake disc 302 mm / Achsschenkel Ø82 / knuckle assembly Ø82
- (3) (ex.) (mot.) EP6CDT / EP6CDTX

	Ref. - No.			
62 92 7434	5087.69	Verbindungsstange / connecting rod	(2)	L 330 M10x1,5
62 92 7435	5087.68	Verbindungsstange / connecting rod	(2)	L 330 M10x1,5
62 92 8599	3640.62	Traggelenk / ball joint	(2)	
62 92 8710	3817.67	Spurstangenendstück / tie rod end	(mot.) EP6CDT	M10 x 1,25
62 92 8711	3817.68	Spurstangenendstück / tie rod end	(mot.) EP6CDT	M10 x 1,25
62 92 8731	3520.R7 S1	Querlenkerlager / control arm mount	(2)	Ø A 56,1
62 92 8732	3520.R7 S2	Querlenkerlager / control arm mount	(2)	Ø A 56,2
62 92 9142	3520.R7	Querlenker / control arm	(2)	
62 92 9143	3521.N8	Querlenker / control arm	(2)	
62 93 8025	3640.77 S1	Traggelenk / ball joint	(1)	M10 x 1,5
62 94 0070	16 080 253 80	Axialgelenk / axial joint	(3)	L 240M14x1,5
62 94 3770	5087.71	Verbindungsstange / connecting rod	(1) → O 13523	L 330 M10x1,5
62 94 4185	16 080 252 80	Spurstangenendstück / tie rod end	(ex.) EP6CDT	M 14 x 1,5
62 94 4186	16 080 251 80	Spurstangenendstück / tie rod end	(ex.) EP6CDT	M 14 x 1,5



301
(2012 →)

Vorderachse / Front axle

62 93 8740



62 93 8740



62 93 8025



62 93 8025



	Ref. - No.			
62 92 7434	5087.69	Verbindungsstange / connecting rod		L 330 M10x1,5
62 92 7435	5087.68	Verbindungsstange / connecting rod		L 330 M10x1,5
62 93 8025	3640.77 S1	Traggelenk / ball joint		M10 x 1,5
62 93 8740	4066.80	Rep. Satz Lenkmanschette / rep. kit steering boot		L 175



→ Modell 96

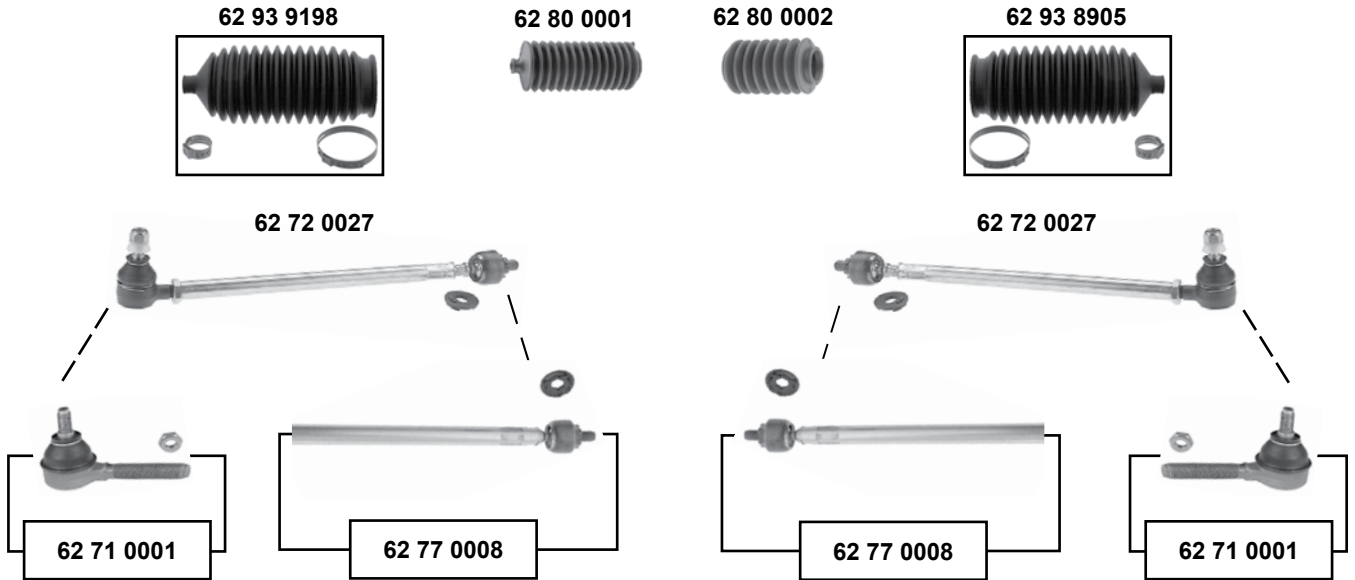

Modell 97 →

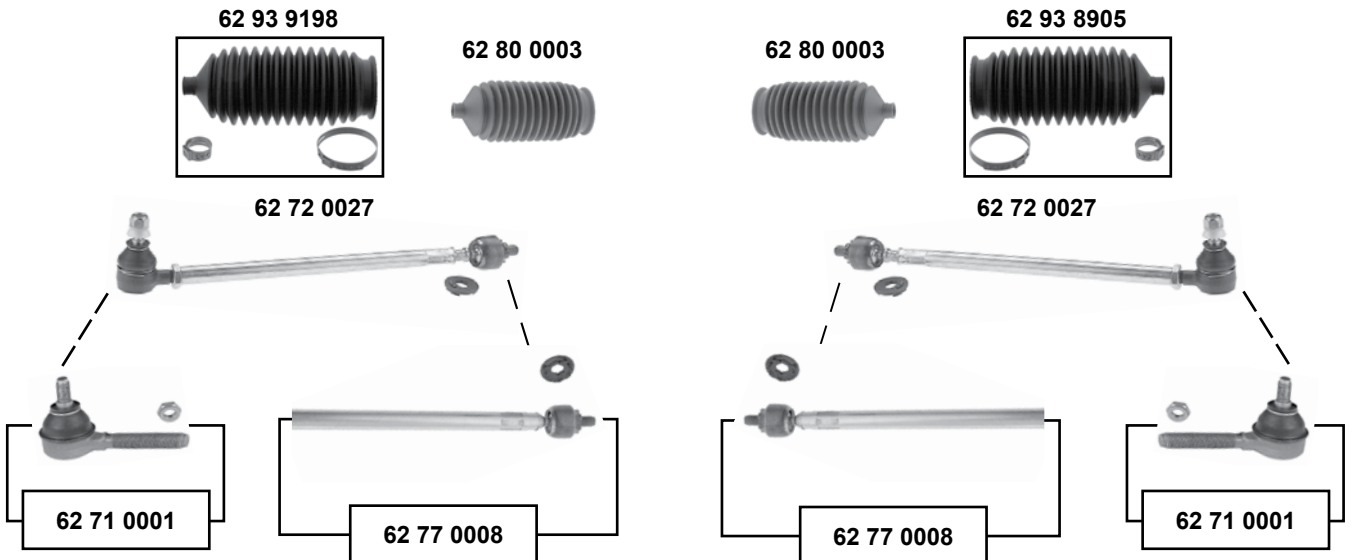

SWAG	Ref. - No.			
62 71 0001	3817.50	Spurstangenendstück / tie rod end		M10 x 1,25
62 72 0027	3812.92 S1	Spurstange / tie rod		
62 77 0008	3812.92	Spurstange / tie rod		L 375
62 80 0001	4066.20	Lenkmanschette / steering boot	(ex.) man. O 06658 →	
62 80 0002	4066.22	Lenkmanschette / steering boot	(ex.) man. O 06658 →	
62 80 0003	4066.43	Lenkmanschette / steering boot		
62 93 8905	4066.44	Rep. Satz Lenkmanschette / rep. kit steering boot	(ex.) servo O 06657 →	L 196,6
62 93 9198	4066.43 S1	Rep. Satz Lenkmanschette / rep. kit steering boot	(ex.) servo O 06657 →	L 154,5



306 (1993 → 2001)

Vorderachse / Front axle

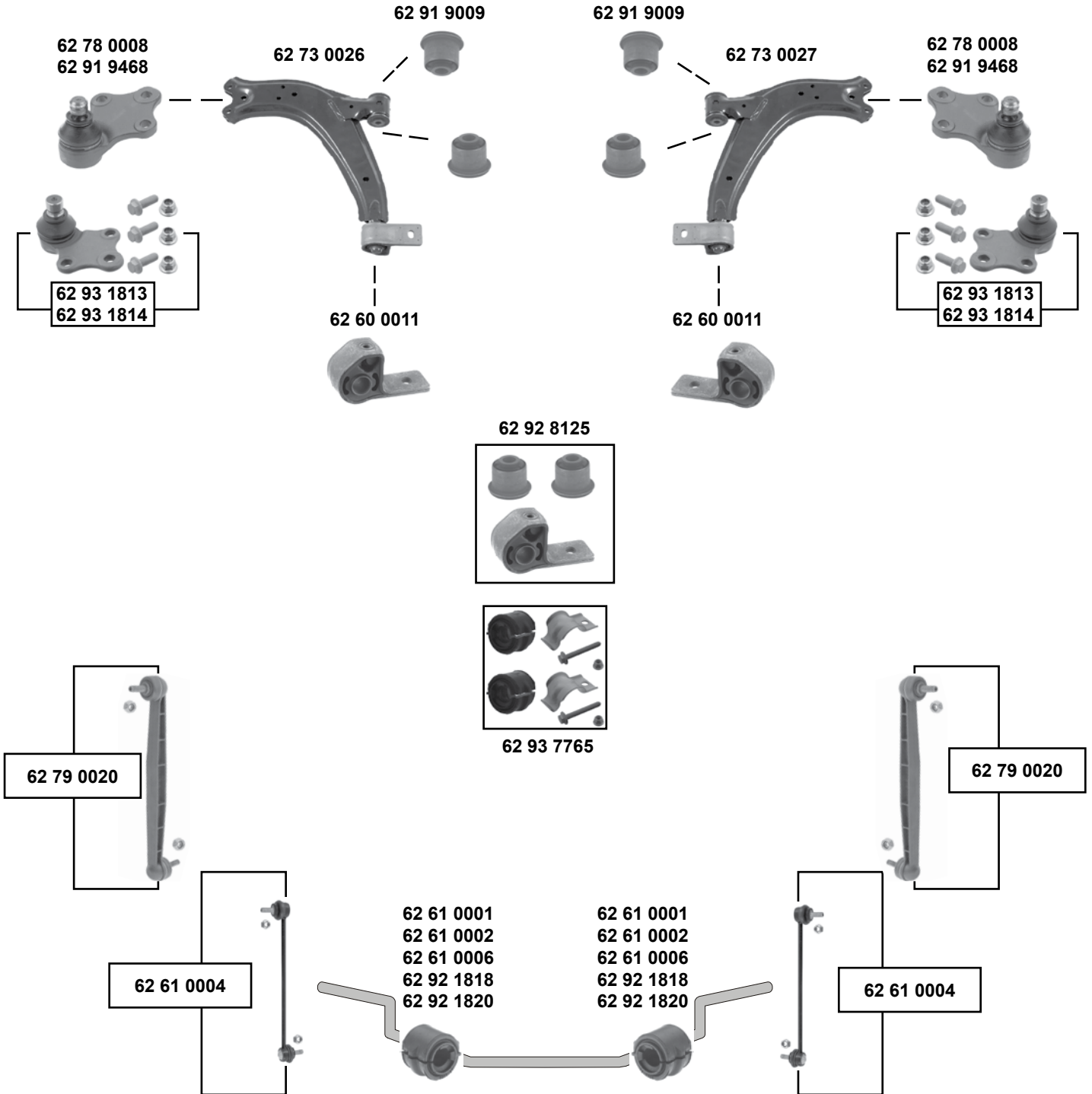



(1) → O 07905 / (ex.) (mot.) 1,9 D ; 2,0 HDI	(2) O 07906 → / (ex.) (mot.) 1,9 D ; 2,0 HDI
(3) 04/93 → 04/97 Sport 05/97 → 05/01 Benzin (mot.) TU, TU5JP, DW8, XU, XUD verstärkte Aufhängung reinforced suspension (mot.) DW10TD, XU, XUD, XU10J4R Sport (mot.) XU7JP, XU7JP4 O 08575 →	

	Ref. - No.			
62 60 0011	3523.75	Querlenkerlager / control arm mount	(ex.) Sport	
62 61 0001	5094.64	Stabilisatorlager / stabilizer mount		Ø I 18
62 61 0002	5094.63	Stabilisatorlager / stabilizer mount		Ø I 17
62 61 0004	5087.61	Verbindungsstange / connecting rod	→ 06/94	L 300
62 61 0006	5094.65	Stabilisatorlager / stabilizer mount		Ø I 21
62 73 0026	3520.H5	Querlenker / control arm		
62 73 0027	3521.E5	Querlenker / control arm		
62 78 0008	3640.37	Traggelenk / ball joint	(1)	Ø A 16
62 79 0020	5087.42	Verbindungsstange / connecting rod	06/94 →	L 300
62 91 9009	3520.H5 S1	Querlenkerlager / control arm mount	Sport	
62 91 9468	3640.48	Traggelenk / ball joint	(2)	Ø A 18
62 92 1818	5094.77	Stabilisatorlager / stabilizer mount		Ø I 22
62 92 1820	5094.66	Stabilisatorlager / stabilizer mount		Ø I 19
62 92 8125	3520.H5 S2	Querlenkerlager / control arm mount	(ex.) Sport	
62 93 1813	3640.37 S1	Rep. Satz Traggelenk / rep. kit ball joint	(2)	Ø A 16
62 93 1814	3640.48 S1	Rep. Satz Traggelenk / rep. kit ball joint	(1)	Ø A 18
62 93 7765	5094.65 S1	Rep. Satz Stabilisatorlagersatz / rep. kit stabilizer mount kit	(3)	



307 / CC / SW
(2001 → 2007)

Vorderachse / Front axle

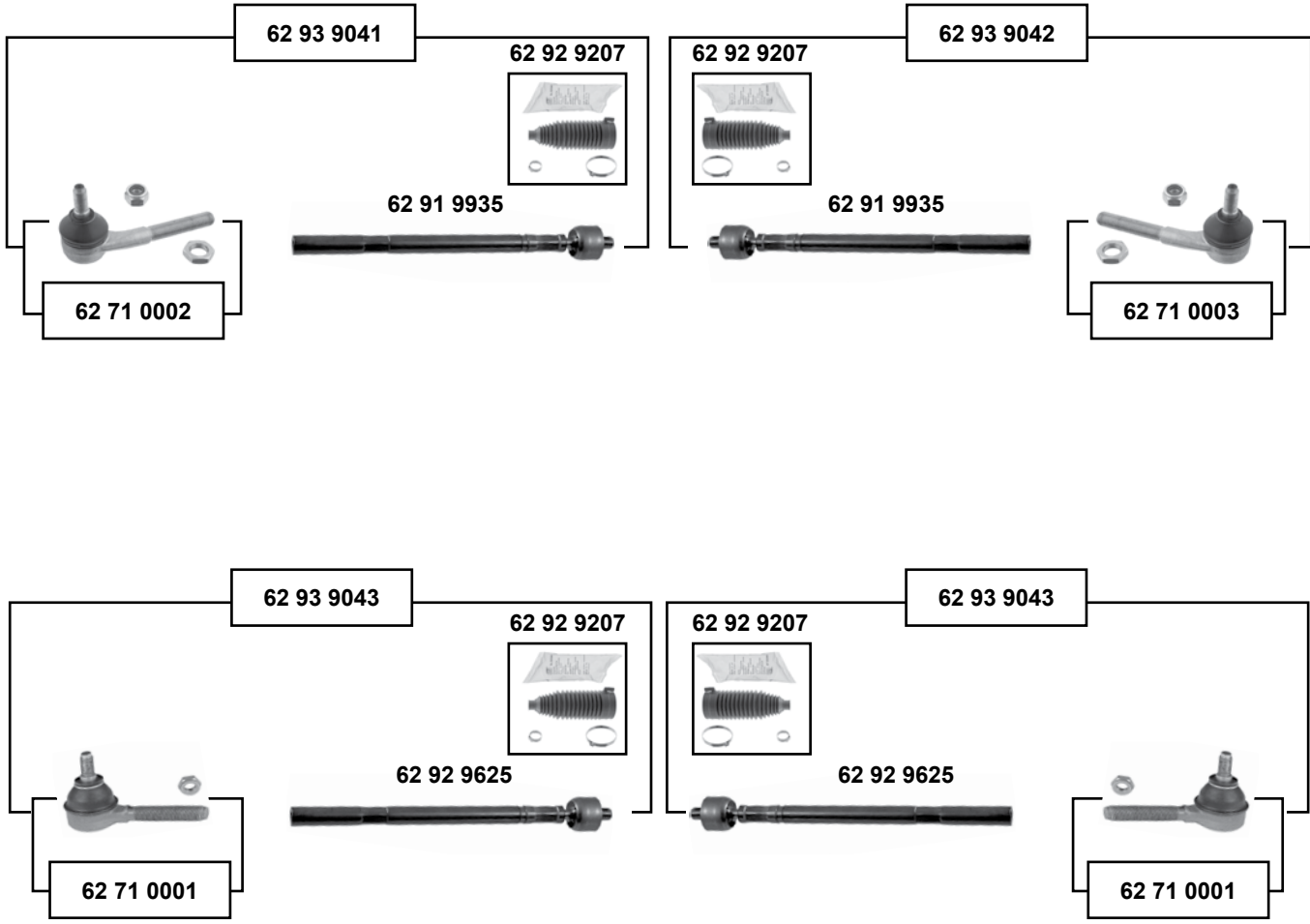

- (1) → 2005 **LHD** = O → 1031087 / O → 1052276 / O → 10492UW / **RHD** = O → 10310
- (2) → **05 LHD** = O1031188 → / O1052377 → / O10493UW → **RHD** = O10311 →
05 → 07 LHD = O → 10919 / O1092088 → / O109277 →
- (3) SW 2002 → / CC 2003 →

	Ref. - No.			
62 71 0001	3817.50	Spurstangenendstück / tie rod end	(3) / O 10311 →	
62 71 0002	3817.42	Spurstangenendstück / tie rod end	(3) / O → 10310	M10 x 1,25
62 71 0003	3817.41	Spurstangenendstück / tie rod end	(3) / O → 10310	M10 x 1,25
62 91 9935	3812.E0	Spurstange / tie rod	(1) / (3)	L 340
62 92 9207	4066.73	Rep. Satz Lenkmanschette / rep. kit steering boot	(3) / servo	
62 92 9625	3812.E5	Spurstange / tie rod	(2) / (3)	L 359
62 93 9041	3812.E0 S4	Rep. Satz Spurstange / rep. kit tie rod	→ O 10310	
62 93 9042	3812.E0 S5	Rep. Satz Spurstange / rep. kit tie rod	→ O 10310	
62 93 9043	3812.E5 S3	Rep. Satz Spurstange / rep. kit tie rod	O 10311 →	



307 / CC / SW (2001 → 2007)

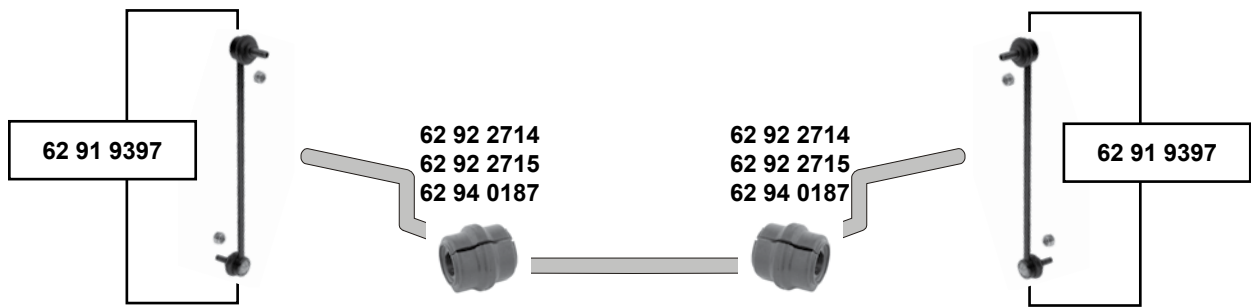

- | | | |
|-----|-----------------|---|
| (1) | Limousine Break | (mot.) EW10J4 / DW10TD / DW10ATED
(mot.) TU3JP / ET3J4 / TU5JP4 |
| (2) | Limousine | (mot.) TU3JP / ET3J4 / TU5JP4 / DV4TD |
| (3) | 307 | → 04/05 (mot.) DV6ATED4 / DV6TED4 |
| | CC | → 04/05 (mot.) EW10J4S O 09731 → |
| | SW | → 04/05 (mot.) EW10J4 / DW10TD O 08827-10103 →
→ 04/05 (mot.) EW10A O 10290 →
→ 04/05 (mot.) DW10BTED4 O 09877 →
→ 04/05 (mot.) DW10ATED O 08974 → |



Ref. - No.	Description	Notes	Dimensions
62 73 0031	3523.92	Querlenkerlager / control arm mount	
62 91 9397	98 049 474 80	Verbindungsstange / connecting rod	
62 92 1490	3640.73	Traggelenk / ball joint	
62 92 1850	3523.91	Querlenkerlager / control arm mount	Ø A 55
62 92 2384	3521.P3	Querlenker / control arm	
62 92 2385	3520.S2	Querlenker / control arm	
62 92 2714	5094.87	Stabilisatorlager / stabilizer mount	(2) Ø I 21
62 92 2715	5094.E0	Stabilisatorlager / stabilizer mount	(1) Ø I 22
62 94 0187	5094.E3	Stabilisatorlager / stabilizer mount	(3) Ø I 23
62 94 0840	3521.P3 S1	Querlenker / control arm	
62 94 0841	3520.S2 S1	Querlenker / control arm	



308 / CC / SW
(2007 → 2013)



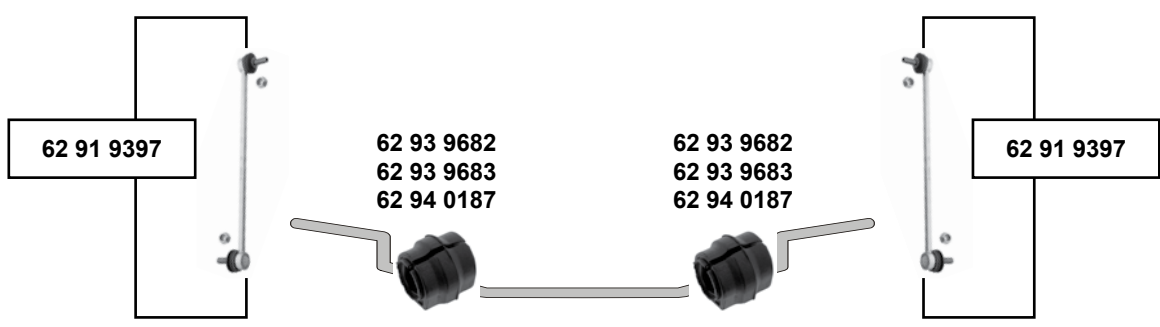
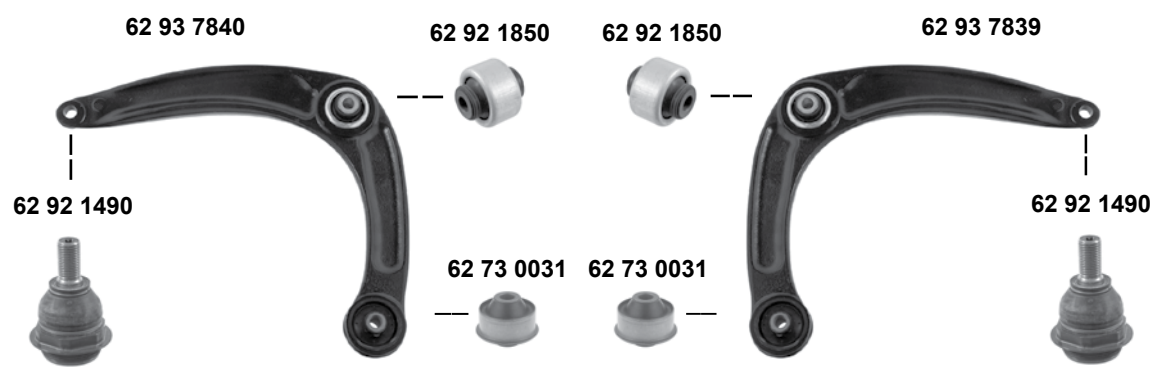
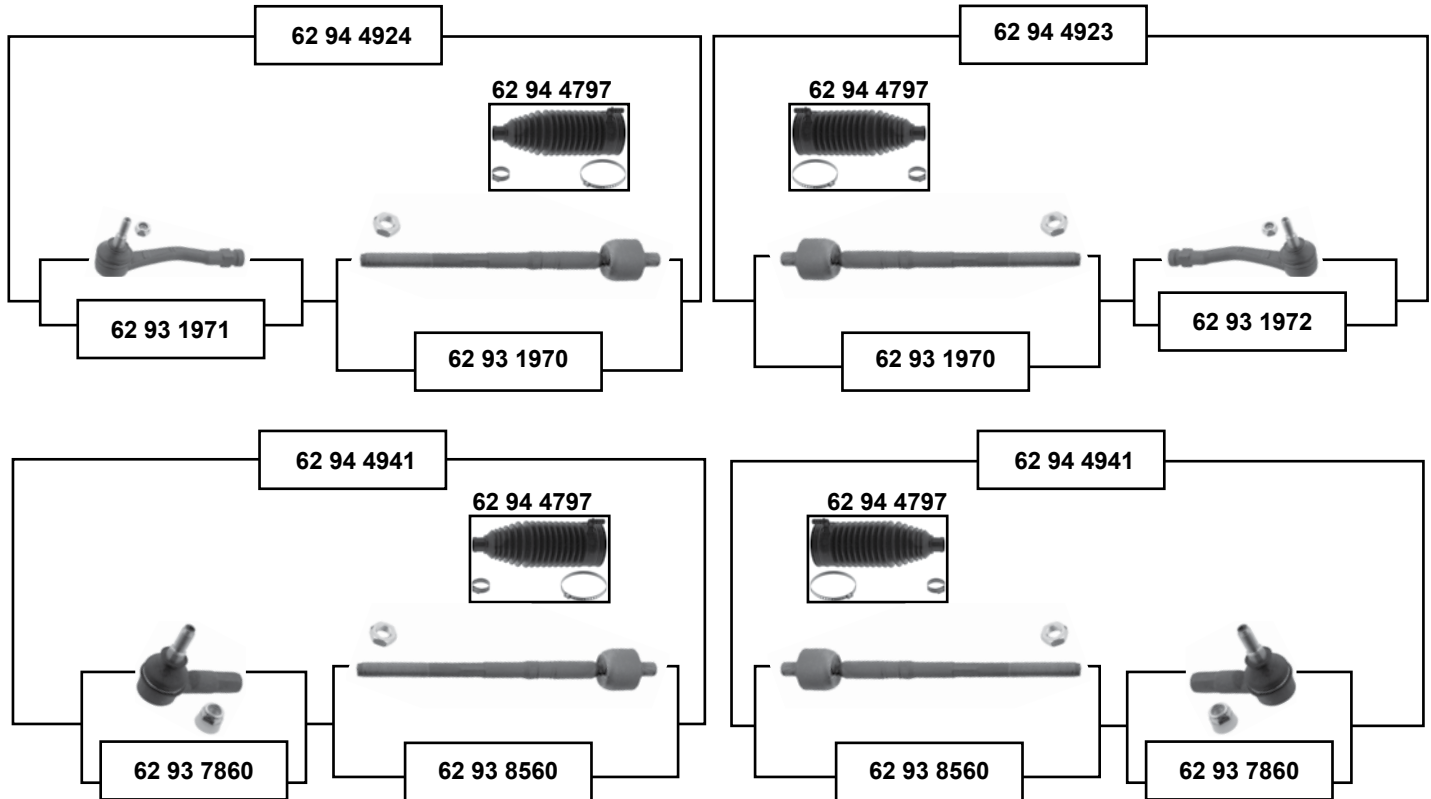

Vorderachse / Front axle





(1) (mot.) EP6CDTX / O 12047 →

(2) (mot.) EP6CDTX O →12047

	Ref. - No.			
62 73 0031	3523.92	Querlenkerlager / control arm mount		A Ø 55
62 91 9397	98 049 474 80	Verbindungsstange / connecting rod		L 335
62 92 1490	3640.73	Traggelenk / ball joint		
62 92 1850	3523.91	Querlenkerlager / control arm mount		Ø A 55
62 93 1970	3812.F2	Axialgelenk / axial joint		L 272
62 93 1971	3817.89	Spurstangenendstück / tie rod end	(ex.) EP6CDTX	M10 x 1,5
62 93 1972	3817.88	Spurstangenendstück / tie rod end	(ex.) EP6CDTX	M10 x 1,5
62 93 7839	3521.R3	Querlenker / control arm		
62 93 7840	3520.V2	Querlenker / control arm		
62 93 7860	3817.73	Spurstangenendstück / tie rod end	(1)	M14 x 1,5
62 93 8560	3812.F8	Axialgelenk / axial joint	(1)	L 380
62 93 9682	5094.E2	Stabilisatorlager / stabilizer mount	→ O 11433	Ø I 22,5
62 93 9683	5094.F2	Stabilisatorlager / stabilizer mount		Ø I 23,5
62 94 0187	5094.E3	Stabilisatorlager / stabilizer mount		Ø I 23
62 94 4797	4066.82	Rep. Satz Lenkmanschette / rep. kit steering boot		L187,4
62 94 4923	3812.F2 S1	Rep. Satz Spurstange / rep. kit tie rod	(ex.) EP6CDTX	
62 94 4924	3812.F2 S2	Rep. Satz Spurstange / rep. kit tie rod	(ex.) EP6CDTX	
62 94 4941	3812.F8 S1	Rep. Satz Spurstange / rep. kit tie rod	(2)	

passend für / to fit

PEUGEOT



308 II (T9)
(2013 →)

Vorderachse / Front axle

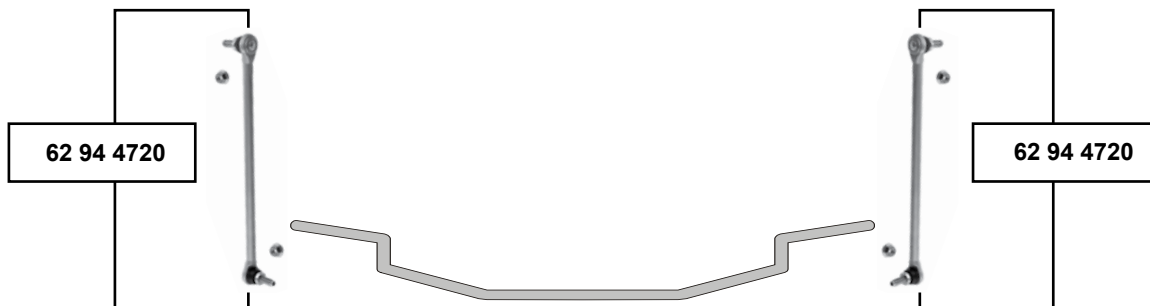

Ref. - No.



62 94 4720 98 069 071 80

Verbindungsstange / connecting rod

M10 x 1,5



man.

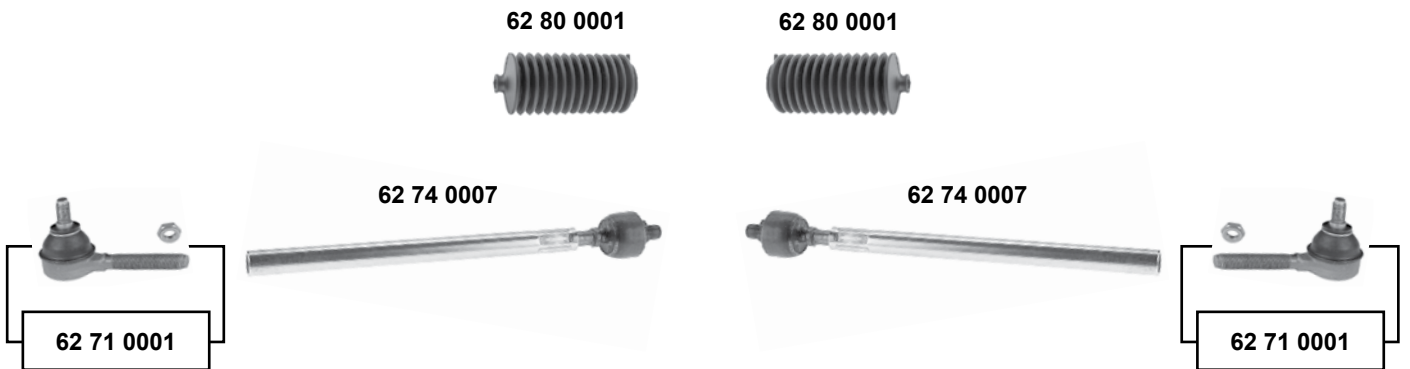

Vorderachse / Front axle

servo

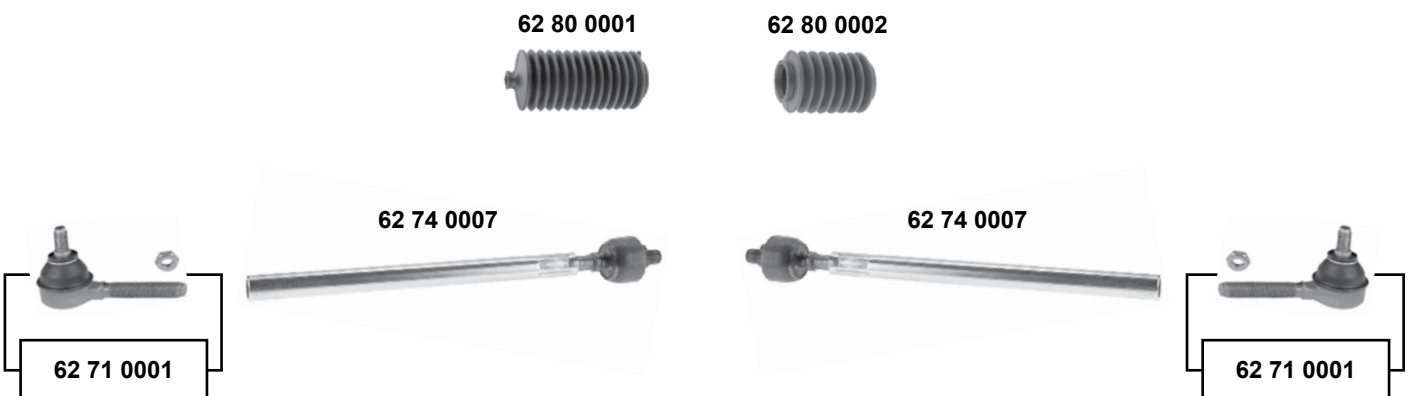

Ref. - No.



62 71 0001	3817.50
62 74 0007	3812.95
62 80 0001	4066.20
62 80 0002	4066.22

Spurstangenendstück / tie rod end
Spurstange / tie rod
Lenkmanschette / steering boot
Lenkmanschette / steering boot

M10 x 1,25



309

(1986 → 1993)

(ex.) GTI / (ex.) Turbo - Diesel

Vorderachse / Front axle

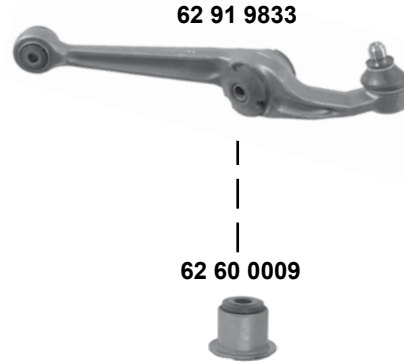
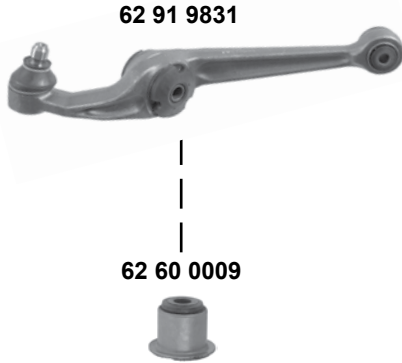

GTI
Turbo - Diesel

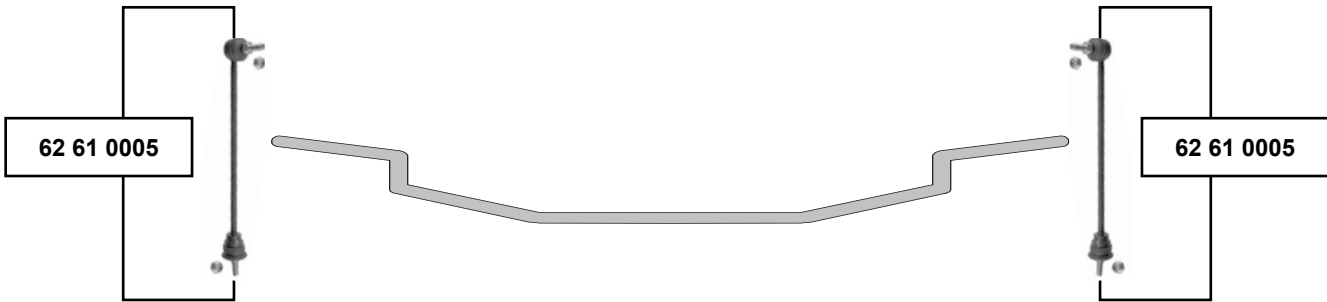
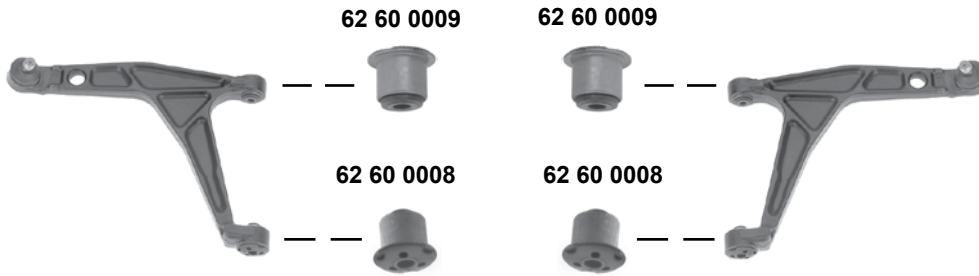

(1) (ch.) S 2108018 → (mot.) E1, G1, J2, XU5M, XU5J, XU5JA, XU9J1, XU92C, XUD7, XUD9
(mot.) TU alle / all



Ref. - No.



62 60 0008	3523.23
62 60 0009	3523.31
62 61 0005	5087.32
62 91 9831	3520.60
62 91 9833	3521.41

Querlenkerlager / control arm mount
Querlenkerlager / control arm mount
Verbindungsstange / connecting rod
Querlenker / control arm
Querlenker / control arm

(1)
(1)

12x31/42x38
12x36x25
L 312



man. 

62 91 9919



62 71 0004



62 74 0002

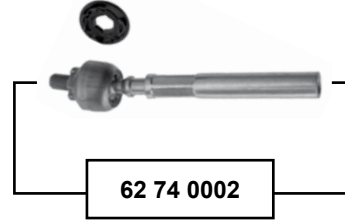

62 74 0002



62 71 0005

Vorderachse / Front axle

62 78 0009

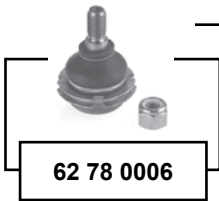

62 78 0006

62 73 0019

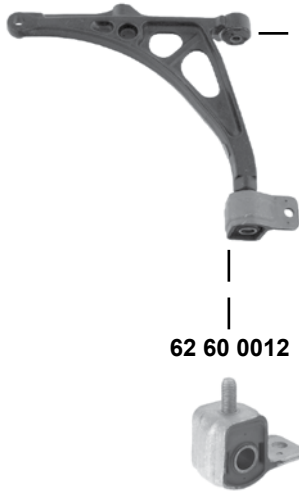

62 60 0012

62 60 0002



62 60 0002



62 73 0022



62 60 0012

62 78 0009

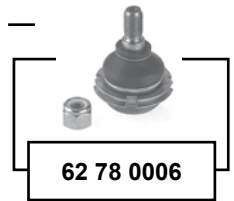

62 78 0006



Ref. - No.



Ref. - No.	Description	Notes	Dimensions
62 60 0002	Querlenkerlager / control arm mount		12x33x38
62 60 0012	Querlenkerlager / control arm mount		
62 71 0004	Spurstangenendstück / tie rod end		M10 x 1,25
62 71 0005	Spurstangenendstück / tie rod end		M10 x 1,25
62 74 0002	Spurstange / tie rod		L 180
62 73 0019	Querlenker / control arm	(ex.) 2.0 Turbo	
62 73 0022	Querlenker / control arm	(ch.) 71358280 →	
62 78 0006	Traggelenk / ball joint	(ch.) 71358280 →	M12 x 1,5
62 78 0009	Traggelenk / ball joint	(ch.) → S 71358275	M14 x 1,5
62 91 9919	Lenkmanschette / steering boot	(ch.) S 71358276 →	



405 (1988 → 1996)

servo

62 80 0004
62 91 9919
62 91 9921

62 80 0004



62 78 0009

62 73 0019

62 60 0002

62 60 0002

62 73 0022

62 78 0009



62 60 0012

62 60 0012



(1) (ex.) 2.0 Turbo 1988 → 1992 / links / left / gauche / izquierdo / sx

(2) (ex.) 2.0 Turbo 1993 → 1996



Ref. - No.



62 60 0002	3523.40	Querlenkerlager / control arm mount		12x33x38
62 60 0012	3523.89	Querlenkerlager / control arm mount		
62 71 0004	3817.48	Spurstangenendstück / tie rod end		M10 x 1,25
62 71 0005	3817.49	Spurstangenendstück / tie rod end		M10 x 1,25
62 73 0019	3520.K4	Querlenker / control arm	(ch.) 71358280 →	
62 73 0022	3521.G4	Querlenker / control arm	(ch.) 71358280 →	
62 74 0002	3812.98	Spurstange / tie rod	(ex.) 2.0 Turbo	L 180
62 78 0006	3640.21	Traggelenk / ball joint	(ch.) → S 71358275	M12 x 1,5
62 78 0009	3640.34	Traggelenk / ball joint	(ch.) S 71358276 →	M14 x 1,5
62 80 0004	4066.30	Lenkmanschette / steering boot	(1)	
62 91 9919	4066.37	Lenkmanschette / steering boot	(2)	
62 91 9921	4066.42	Lenkmanschette / steering boot	2.0 Turbo	Ø I 18

Vorderachse / Front axle

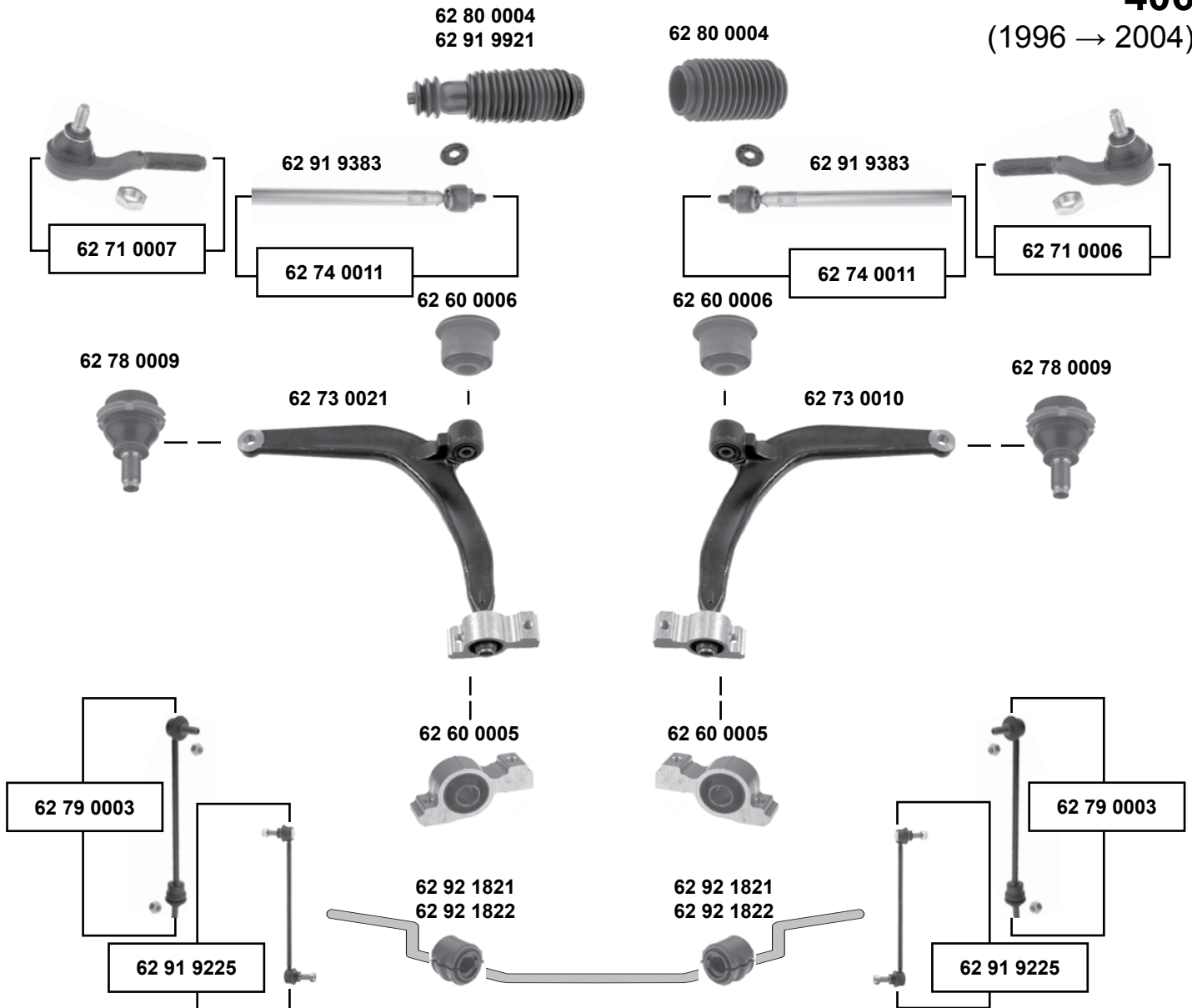
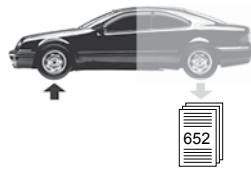

(1) Beachten Sie bitte die Abmessung / please pay attention to the dimension / respecter les dimensions / tenga en cuenta las medidas / fate attenzione alla misura



Ref. - No.



Ref. - No.	Description	Notes	Dimensions
62 60 0005	Querlenkerlager / control arm mount		
62 60 0006	Querlenkerlager / control arm mount		
62 71 0006	Spurstangenendstück / tie rod end		M10 x 1,25
62 71 0007	Spurstangenendstück / tie rod end		M10 x 1,25
62 73 0010	Querlenker / control arm		
62 73 0021	Querlenker / control arm		
62 74 0011	Spurstange / tie rod		
62 78 0009	Traggelenk / ball joint		
62 79 0003	Verbindungsstange / connecting rod		
62 80 0004	Lenkmanschette / steering boot		
62 91 9225	Verbindungsstange / connecting rod		
62 91 9383	Spurstange / tie rod		
62 91 9921	Lenkmanschette / steering boot		
62 92 1821	Stabilisatorlager / stabilizer mount		
62 92 1822	Stabilisatorlager / stabilizer mount		

(1) (ex.) variable servo. L 330
M14 x 1,5
→ O 7664 L 300
(1) (ex.) variable servo. L 120
O 7665→
(1) variable servo.
(1) (ex.) variable servo. Ø | 18
Ø | 23
Ø | 24

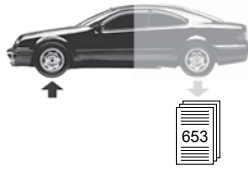

407 / Coupe (2004 →)

Vorderachse / Front axle

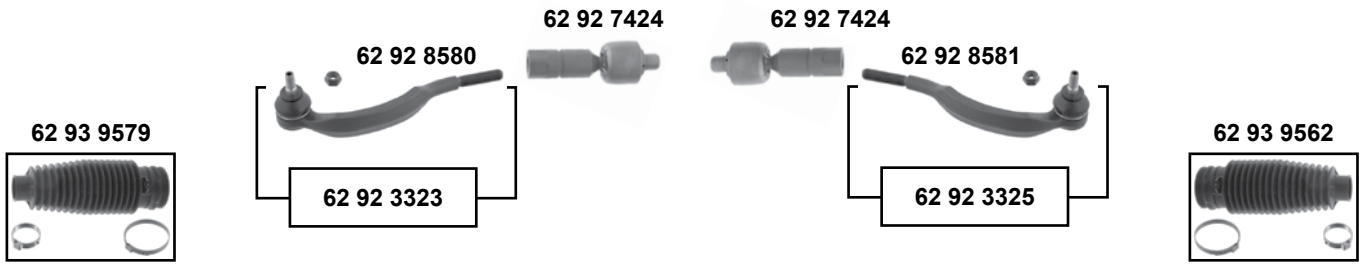



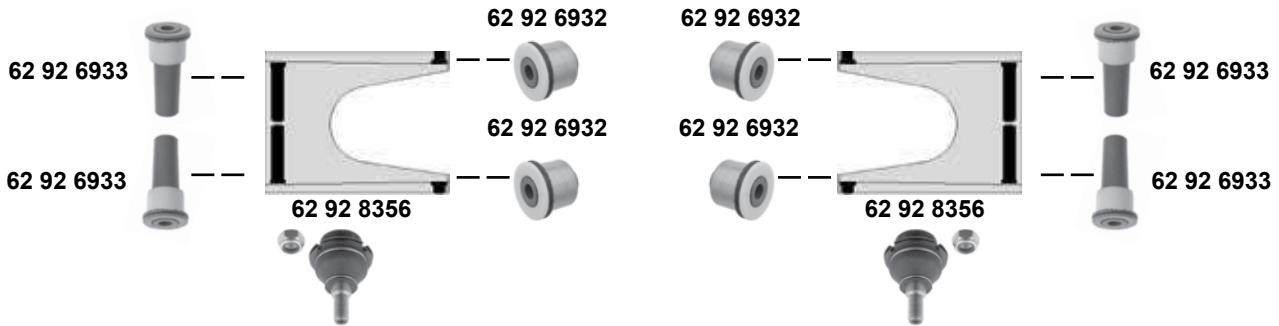

oben / upper

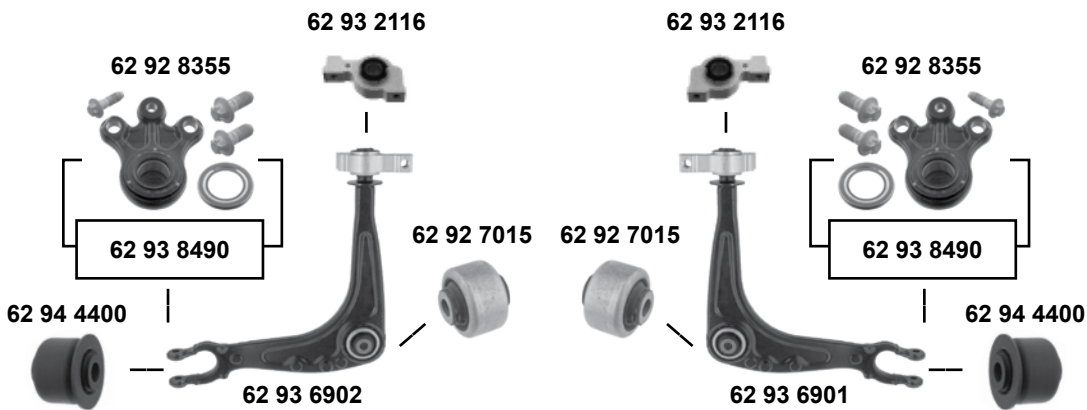
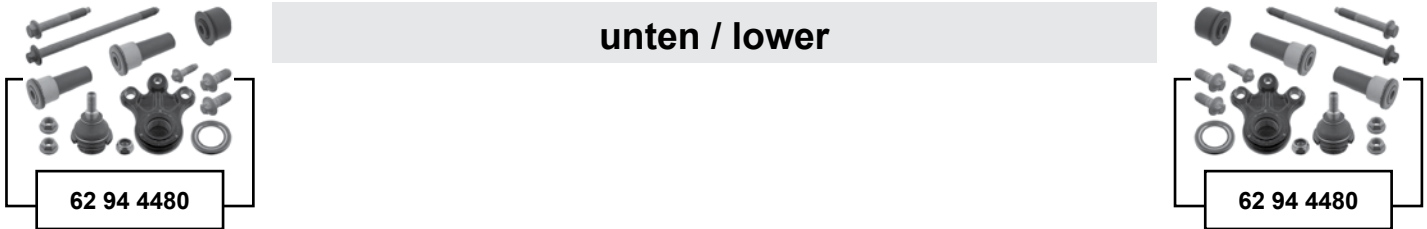

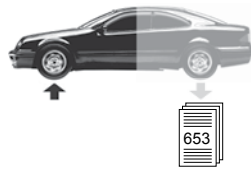
unten / lower



407 / Coupe
 (2004 →)

	Ref. - No.			
62 92 2846	5087.52	Verbindungsstange / connecting rod		
62 92 2847	5087.53	Verbindungsstange / connecting rod		
62 92 3323	3817.58	Spurstangenendstück / tie rod end	→ O 10597	
62 92 3325	3817.57	Spurstangenendstück / tie rod end	→ O 10597	
62 92 6932	3523.CA	Querlenkerlager / control arm mount		
62 92 6933	3523.AZ	Querlenkerlager / control arm mount		
62 92 7015	3523.AQ	Querlenkerlager / control arm mount		A Ø 56
62 92 7424	3812.E7	Spurstange / tie rod		L106 M16x1,5
62 92 8355	3640.72	Traggelenk / ball joint	O 10983 →	
62 92 8356	3640.74	Traggelenk / ball joint		M14 x 1,25
62 92 8580	3817.65	Spurstangenendstück / tie rod end	O 10598 →	
62 92 8581	3817.66	Spurstangenendstück / tie rod end	O 10598 →	
62 93 2116	3520.N6 S1	Querlenkerlager / control arm mount		M14 x 1,25
62 93 3964	5094.A1	Stabilisatorlager / stabilizer mount		Ø I 25
62 93 3965	5094.99	Stabilisatorlager / stabilizer mount		Ø I 24
62 93 6901	3521.J6	Querlenker / control arm	(ex.) variable Federung	M12 x 1,75
62 93 6902	3520.N6	Querlenker / control arm	(ex.) variable Federung	M12 x 1,75
62 93 7202	5094.A0	Stabilisatorlager / stabilizer mount	04 / 05 →	Ø I 24,5
62 93 8490	3640.69 S1	Rep. Satz Traggelenk / rep. kit ball joint	O 10983 →	M14/10x1,5
62 93 9562	4066.71	Rep. Satz Lenkmanschette / rep. kit steering boot		
62 93 9579	4066.72	Rep. Satz Lenkmanschette / rep. kit steering boot		Ø I 24/48
62 94 0082	5094.98	Stabilisatorlager / stabilizer mount		Ø I 23,5
62 94 4400	3656.04 S1	Achsschenkellager / knuckle assembly mount		A Ø 40
62 94 4480	3656.04 S2	Achsschenkellagersatz / knuckle Top Bearing Kit		

passend für / to fit

PEUGEOT



504

(1968 → 1982)

Vorderachse / Front axle

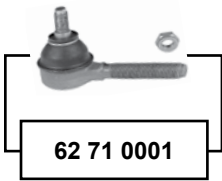

62 80 0001



62 80 0001

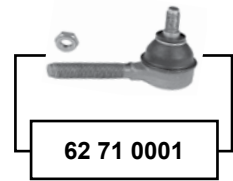

62 78 0010



62 78 0010



Ref. - No.



62 71 0001	3817.50
62 78 0010	3640.27
62 80 0001	4066.20

Spurstangenendstück / tie rod end
Traggelenk / ball joint
Lenkmanschette / steering boot

M10 x 1,25
M12 x 1,25



62 78 0010



62 78 0010



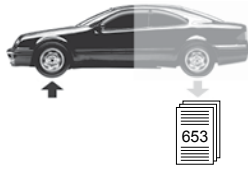

508

(2010 →)

Vorderachse / Front axle

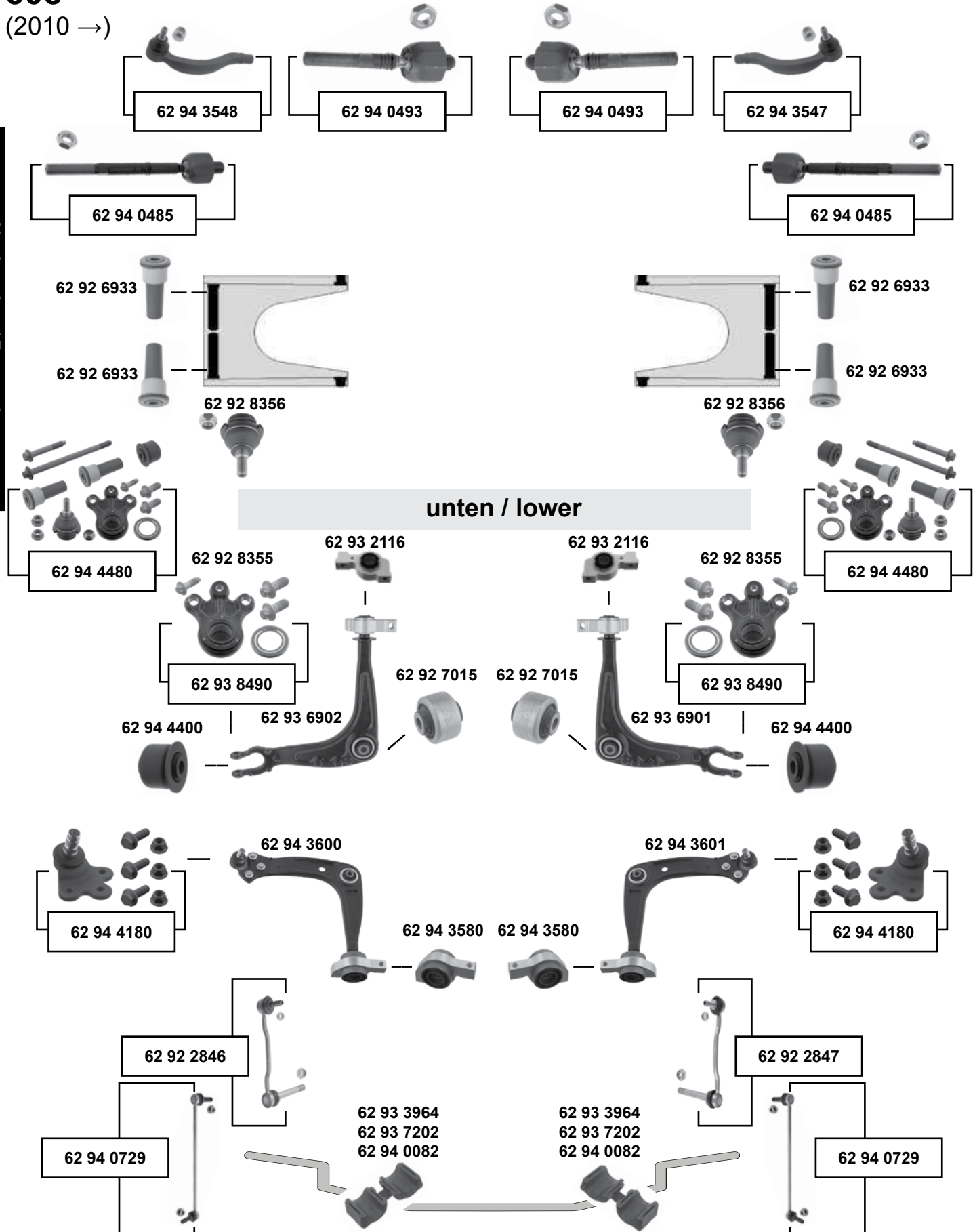

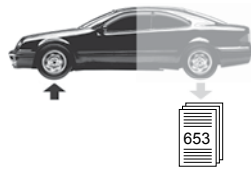

- (1) (ex.) McPherson Vorderachse / front axle
- (2) Vorderachse Typ VH10 / front suspension type VH10
- (3) McPherson Vorderachse / front axle (ex.) Break 4x4



Ref. - No.



SWAG Ref. - No.				
62 92 2846	5087.52	Verbindungsstange / connecting rod	(2)	
62 92 2847	5087.53	Verbindungsstange / connecting rod	(2)	
62 92 6933	3523.AZ	Querlenkerlager/ control arm mount	(2)	
62 92 7015	3523.AQ	Querlenkerlager / control arm mount		A Ø 56
62 92 8355	3640.69	Traggelenk / ball joint	(2)	M14 x 1,5
62 92 8356	3640.74	Traggelenk / ball joint	(2)	M14/42x1,5
62 93 2116	3520.N6 S1	Querlenkerlager / control arm mount	(2)	M14 x 1,25
62 93 3964	5094.A1	Stabilisatorlager / stabilizer mount	(3)	Ø I 25
62 93 6901	3521.J6	Querlenker / control arm	(1)	
62 93 6902	3520.N6	Querlenker / control arm	(1)	
62 93 7202	5094.A0	Stabilisatorlager / stabilizer mount		Ø I 24,5
62 93 8490	3640.69 S1	Rep. Satz Traggelenk / rep. kit ball joint	(2)	M14/10x1,5
62 94 0082	5094.98	Stabilisatorlager / stabilizer mount	(1)	Ø I 23,5
62 94 0493	3812.F3	Axialgelenk / axial joint	(2)	L 145
62 94 0485	3812.G3 SK	Axialgelenk / axial joint	(3)	L 225
62 94 0729	5087.76	Verbindungsstange / connecting rod	(3)	L 345
62 94 3547	16 099 483 80	Spurstangenendstück / tie rod end	(2)	M12 x 1,5
62 94 3548	16 099 482 80	Spurstangenendstück / tie rod end	(2)	M12 x 1,5
62 94 3580	3520.Y0 SK	Querlenkerlager / control arm mount	(3)	M12 x 1,75
62 94 3600	3520.Y0	Querlenker / control arm	(3)	
62 94 3601	3521.V1	Querlenker / control arm	(3)	
62 94 4180	3640.83	Traggelenk / ball joint	(3)	M12 x 1,5
62 94 4400	3656.04 S1	Achsschenkellager / knuckle assembly mount	(2)	Ø A 40
62 94 4480	3656.04 S2	Achsschenkellagersatz / knuckle top bearing kit	(2)	

passend für / to fit

PEUGEOT



604

(1977 → 1986)

Vorderachse / Front axle

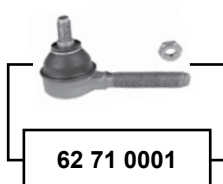

62 78 0010



62 78 0010



Ref. - No.



62 71 0001 3817.50
62 78 0010 3640.27

Spurstangenendstück / tie rod end
Traggelenk / ball joint

M10 x 1,25
M12 x 1,25

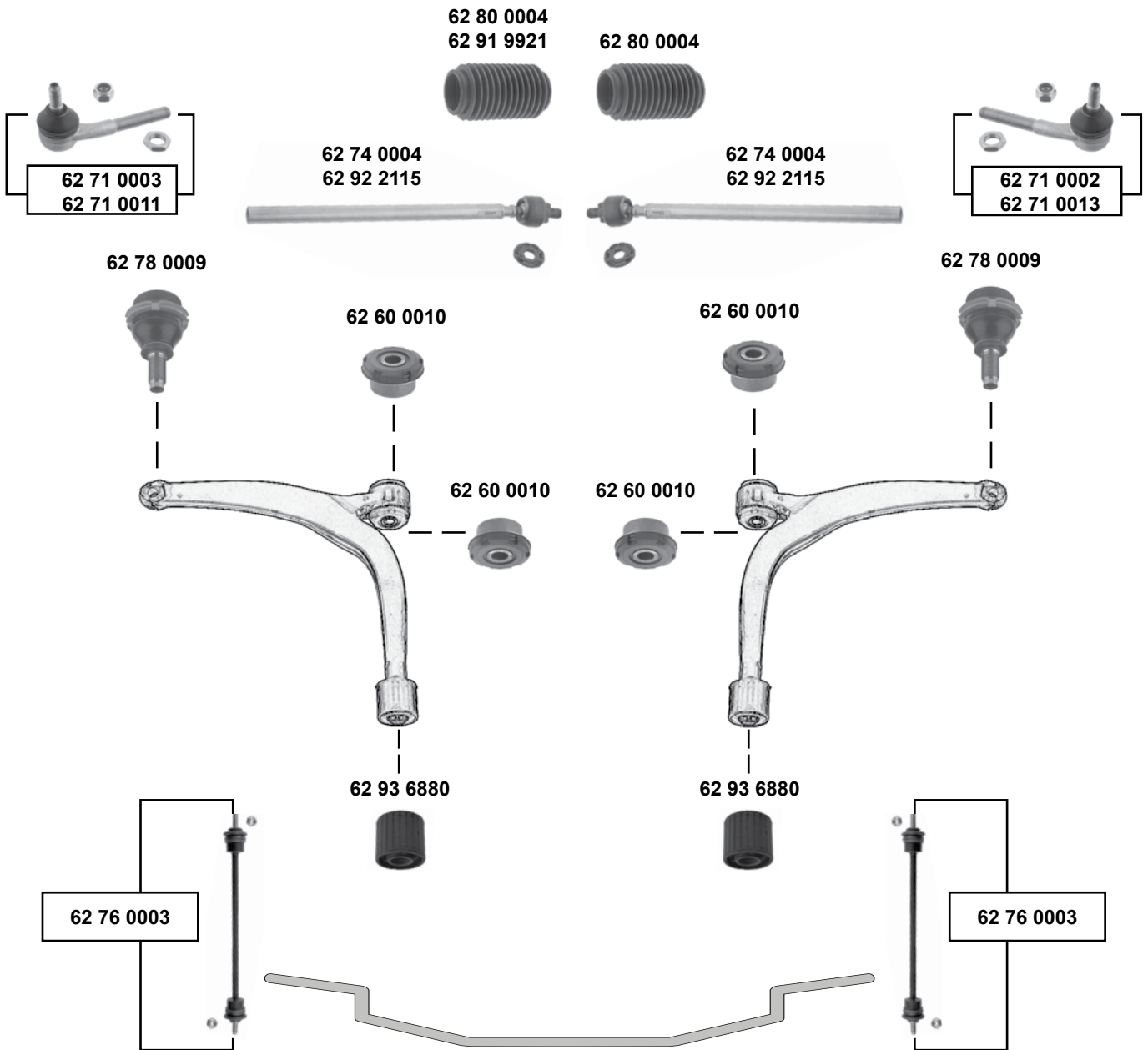
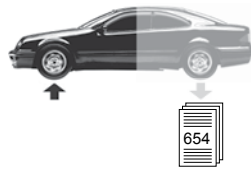

(1) → 09/99 ZPJ / ZPJ4
XU10J2TE, XU (Abmessung beachten / note dimensions)



Ref. - No.



Ref. - No.	Description	Notes	Dimensions
62 60 0010	Querlenkerlager / control arm mount		40x14x25,5
62 71 0002	Spurstangenendstück / tie rod end	→ 94 / servo.	M10 x 1,25
62 71 0003	Spurstangenendstück / tie rod end	→ 94 / servo.	M10 x 1,25
62 71 0011	Spurstangenendstück / tie rod end	94 →	M10 x 1,25
62 71 0013	Spurstangenendstück / tie rod end	94 →	M10 x 1,25
62 74 0004	Spurstange / tie rod	→94 / servo.	Ø A 18
62 76 0003	Verbindungsstange / connecting rod		M14 x 1,5
62 78 0009	Traggelenk / ball joint		
62 80 0004	Lenkmanschette / steering boot	servo.	Ø I 18
62 91 9921	Lenkmanschette / steering boot		Ø I 18
62 92 2115	Spurstange / tie rod	94 →	Ø A 22
62 93 6880	Querlenkerlager / control arm mount	(1)	50x20x45

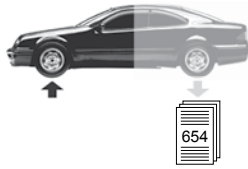

607

(2000 → 2010)

Vorderachse / Front axle

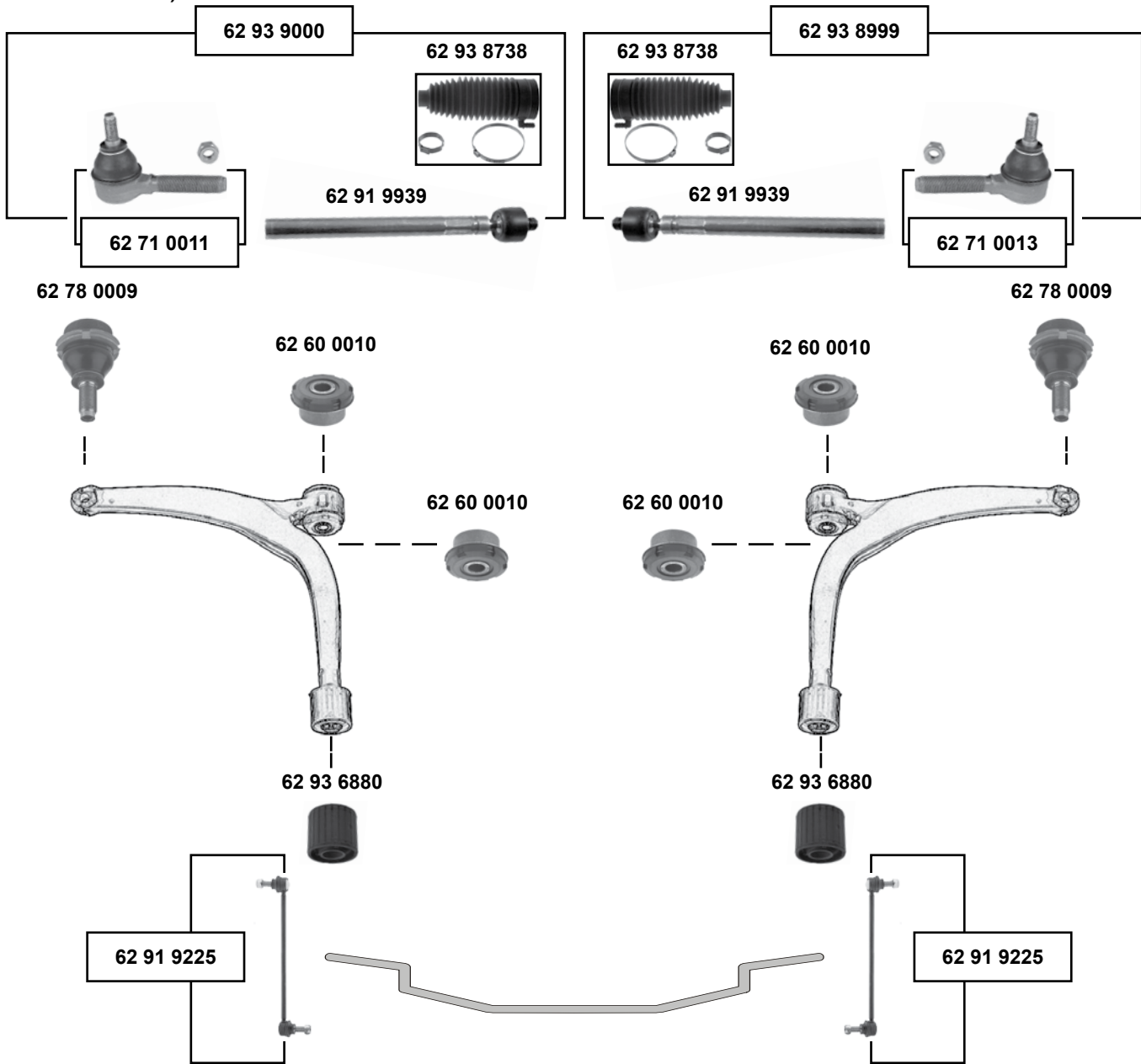

(1) 05/00 → 11/04 ES9J4S → O 09303
 EW10J4, EW12J4, DW10ATED FAP → O 09708
 DW10ATED
 DW12TED4



Ref. - No.



62 60 0010	3523.43	Querlenkerlager / control arm mount	(1)	40x14x25,5
62 78 0009	3640.34	Traggelenk / ball joint		M14 x 1,5
62 71 0011	3817.43	Spurstangenendstück / tie rod end		M10 x 1,25
62 71 0013	3817.44	Spurstangenendstück / tie rod end		
62 91 9225	5087.60	Verbindungsstange / connecting rod		
62 91 9939	3812.C7	Spurstange / tie rod		
62 93 6880	3523.96	Querlenkerlager / control arm mount		50x20x45
62 93 8738	4066.74	Rep. Satz Lenkmanschette / rep. kit steering boot		L 175
62 93 8999	3812.C7 S1	Rep. Satz Spurstange / rep. kit tie rod		
62 93 9000	3812.C7 S2	Rep. Satz Spurstange / rep. kit tie rod		

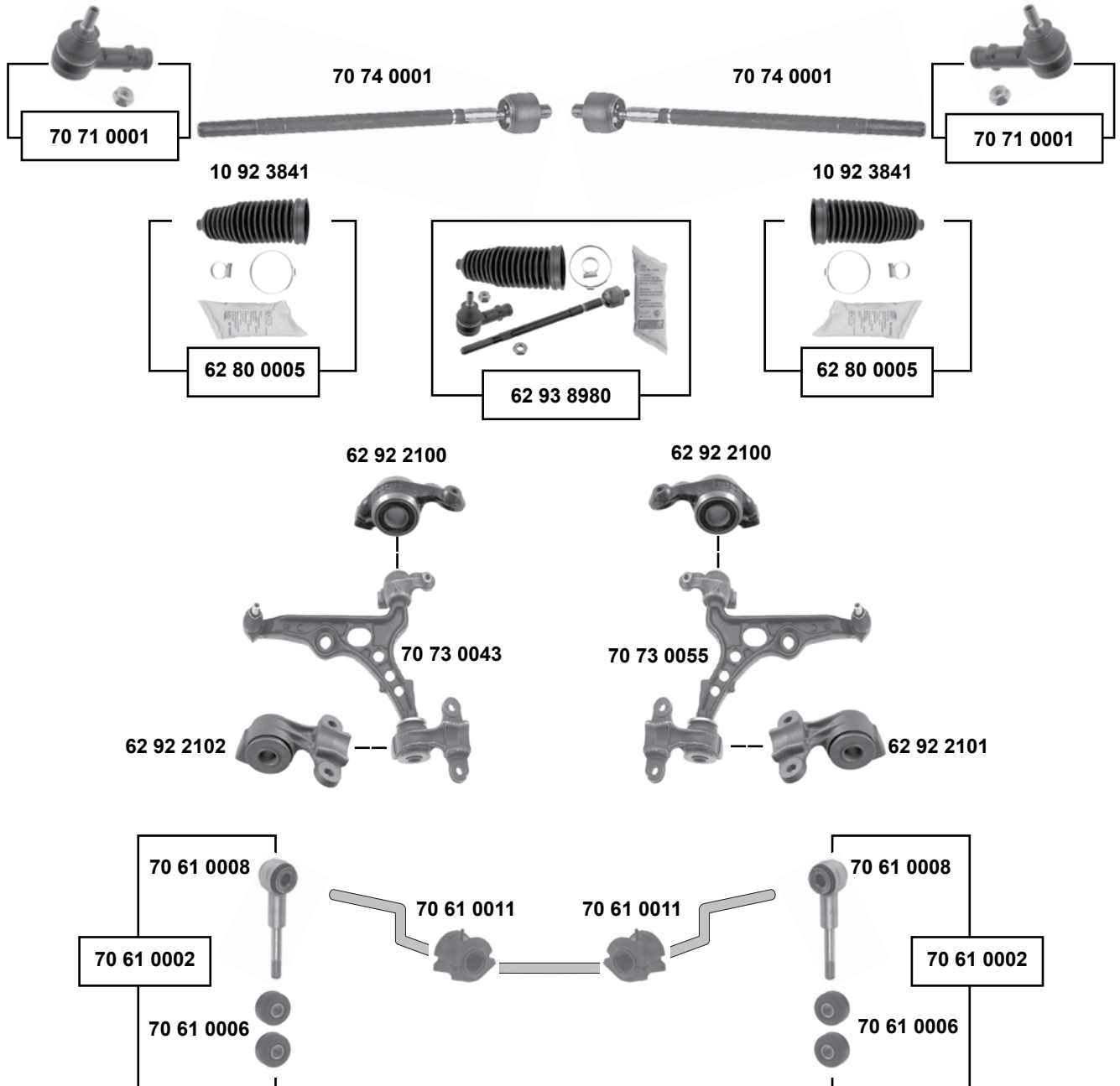

10 92 3841	4066.41 SK	Lenkmanschette / steering boot	
62 80 0005	4066.41	Rep. Satz Lenkmanschette / rep. kit steering boot	
62 92 2100	3520.G9 S1	Querlenkerlager / control arm mount	
62 92 2101	3521.C9 S1	Querlenkerlager / control arm mount	
62 92 2102	3520.G9 S2	Querlenkerlager / control arm mount	
62 93 8980	3812.A4 S1	Rep. Satz Spurstange / rep. kit tie rod	
70 61 0002	5087.35 S1	Rep. Satz Verbindungsstange / rep. kit connecting rod	
70 61 0006	5093.15	Gummilager / rubber mount	
70 61 0008	5087.35	Verbindungsstange / connecting rod	12x38
70 61 0011	5094.69	Stabilisatorlager / stabilizer mount	M12 x 1,25
70 71 0001	4059.09	Spurstangenendstück / tie rod end	Ø 1 24
70 73 0043	3520.P4	Querlenker / control arm	M12 x 1,25
70 73 0055	3521.K4	Querlenker / control arm	
70 74 0001	3812.A4	Axialgelenk / axial joint	L 320



807
(2002 →)

Vorderachse / Front axle

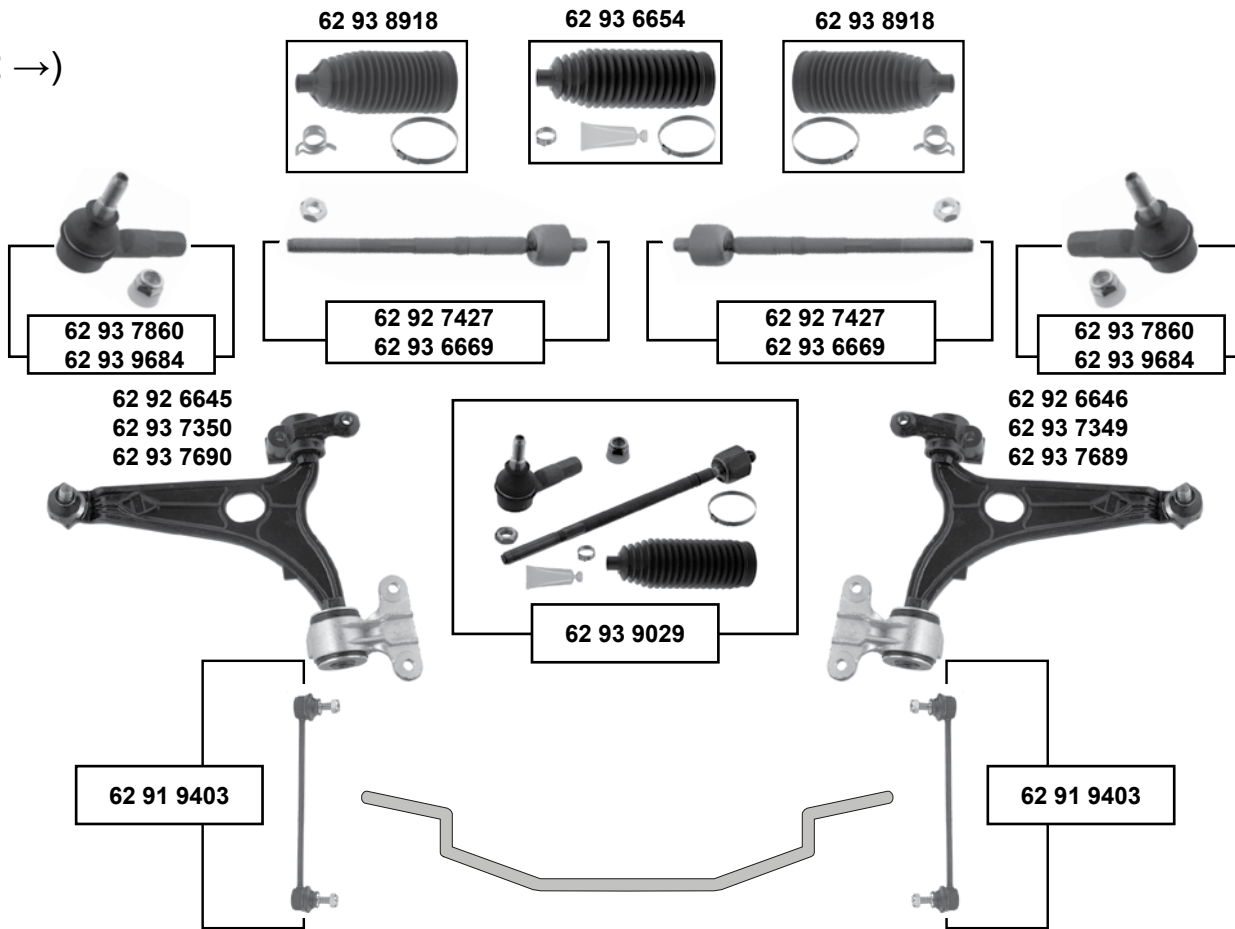

- (1) (ex.) 2,2 HDI / → O 10823
- (2) DW12BTED4 / DW10CTED4 E-hydr. ⚙️ O 12257 →
- (3) (mot.) DW12BTED4 → O 12256 / DW10CTED4 O 12257 →
- (4) (mot.) DW12BTED4, DW10CTED4
- (5) (mot.) DW10CTED4, DW12BTED4 E-hydr. ⚙️ → O 12256
- (6) (mot.) DW10CTED4, DW12BTED4
- (7) (mot.) DW10BTED4, DW10UTED4, EW10A, DW10CB, DW10ATED4, DW12TED4 O 10824 →
- (8) (mot.) DW10CB + E-hydr. ⚙️ O 12257 → / E-hydr. ⚙️ O 10549 → 12256 (ex.) DW12BTED4
- (9) (ex.) (mot.) DW12BTED4 , DW10CTED4



Ref. - No.



Ref. - No.	Description	Notes	Dimensions
62 91 9403	5087.51	Verbindungsstange / connecting rod	
62 92 6645	3520.P6	Querlenker / control arm	(1)
62 92 6646	3521.K6	Querlenker / control arm	(1)
62 92 7427	3812.E2	Spurstange / tie rod	(ex.) 2,0 HDI
62 93 6654	4066.83	Rep. Satz Lenkmanschette / rep. kit steering boot	(2)
62 93 6669	3812.F0	Axialgelenk mit Mutter / axial joint with nut	(3)
62 93 7349	16 075 107 80	Querlenker / control arm	(7) M14 x 1,5
62 93 7350	16 075 106 80	Querlenker / control arm	(7) M14 x 1,5
62 93 7689	3521.S0	Querlenker / control arm	(6) M14 x 1,5
62 93 7690	3520.V8	Querlenker / control arm	(6) M14 x 1,5
62 93 7860	3817.73	Spurstangenendstück / tie rod end	(4) M14 x 1,5
62 93 8918	4066.79	Rep. Satz Lenkmanschette / rep. kit steering boot	(8) L 315
62 93 9029	3812.F0 S1	Rep. Satz Spurstange / rep. kit tie rod	(5) L 185
62 93 9684	4059.12	Spurstangenendstück / tie rod end	(9) L 307

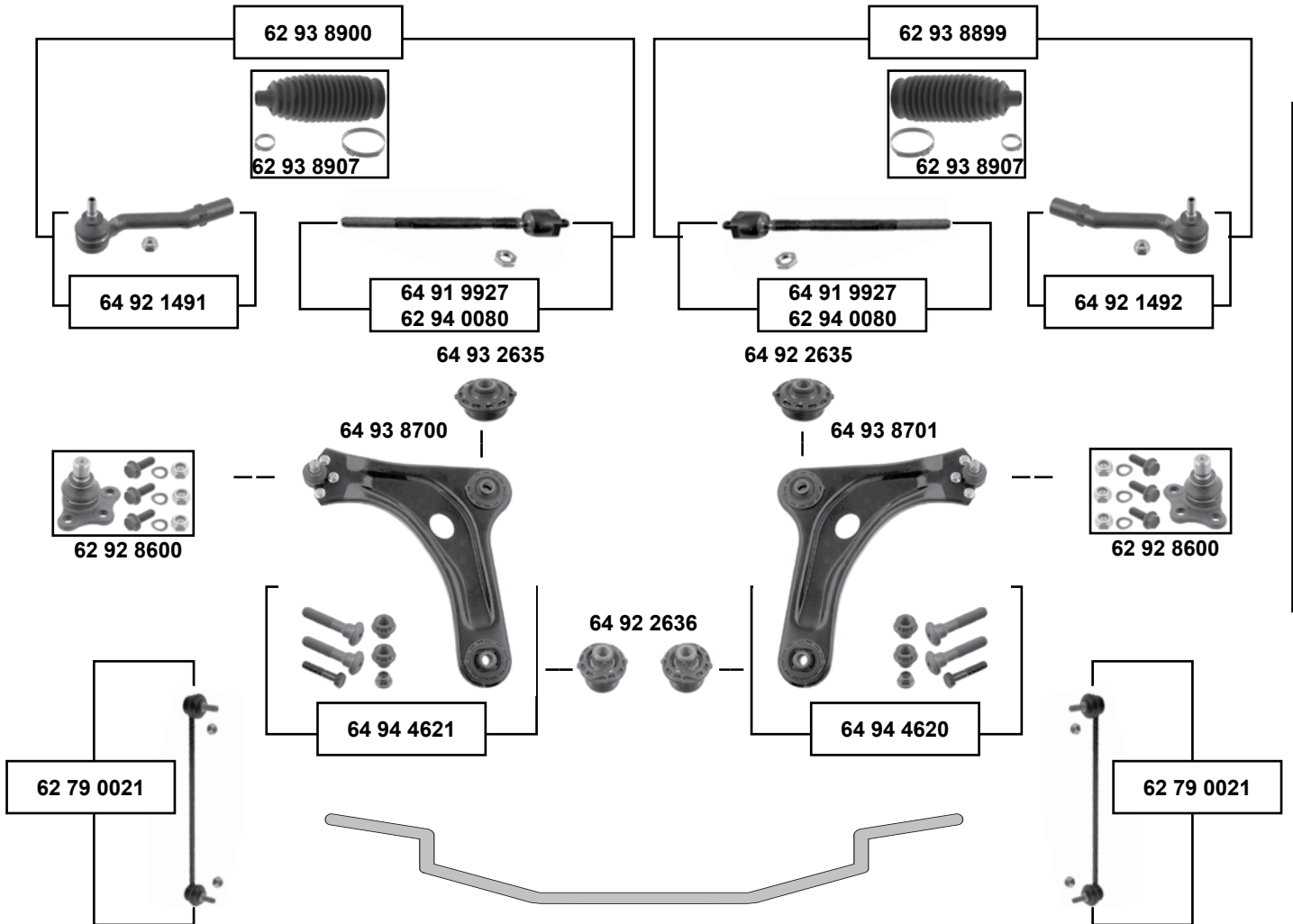

(1) (mot.) DV4TD, ET3J4, TU3A, TU3JP + LHD // TU5JP4 // RHD → O 10618

(2) 04/05 → // → O 11017 (ex.) DV6TED4

(3) (mot.) DV4TD, ET3J4, TU3A, TU3JP / TU5JP4 → O 10618

(4) (mot.) DV6TED4, / TU5JP4 O 10619 →

(5) alle / all → O 11017 (ex.) (mot.) DV6TED4



Ref. - No.



Ref. - No.	Description	Notes	Dimensions
62 79 0021	5087.74 Verbindungsstange / connecting rod		L 335
62 92 8600	3640.66 Traggelenk / ball joint		
62 93 8899	3812.E1 S1 Rep. Satz Spurstange / rep. kit tie rod	(3)	
62 93 8900	3812.E1 S2 Rep. Satz Spurstange / rep. kit tie rod	(3)	
62 93 8907	4066.69 Rep. Satz Lenkmanschette / rep. kit steering boot	(1)	L 167,1
62 94 0080	3812.E6 Axialgelenk / axial joint	(4)	L 255
64 91 9927	3812.E1 Spurstange / tie rod	→ O 10618	L 257
64 92 1491	3817.55 Spurstangenendstück / tie rod end		M14 x 1,5
64 92 1492	3817.56 Spurstangenendstück / tie rod end		M14 x 1,5
64 92 2635	3523.98 Querlenkerlager / control arm mounting		
64 92 2636	3523.AA Querlenkerlager / control arm mounting		
64 93 8700	3520.P1 Querlenker / control arm	(2)	
64 93 8701	3521.K1 Querlenker / control arm	(2)	
64 94 4620	3521.R2 S3 Querlenker / control arm	(5)	
64 94 4621	3520.V1 S3 Querlenker / control arm	(5)	

passend für / to fit

PEUGEOT



2008

(2013 →)

Vorderachse / Front axle

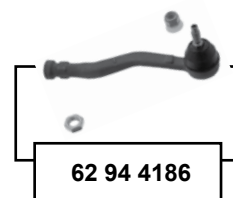
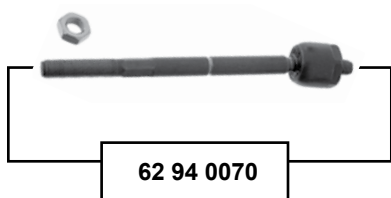

Ref. - No.



62 94 0070	16 080 253 80
62 94 4185	16 080 252 80
62 94 4186	16 080 251 80

Axialgelenk / axial joint
Spurstangenendstück / tie rod end
Spurstangenendstück / tie rod end

L 240M14x1,5
M 14 x 1,5
M 14 x 1,5

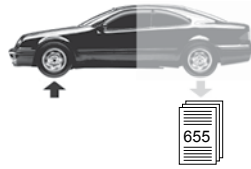

3008
(2009 →)

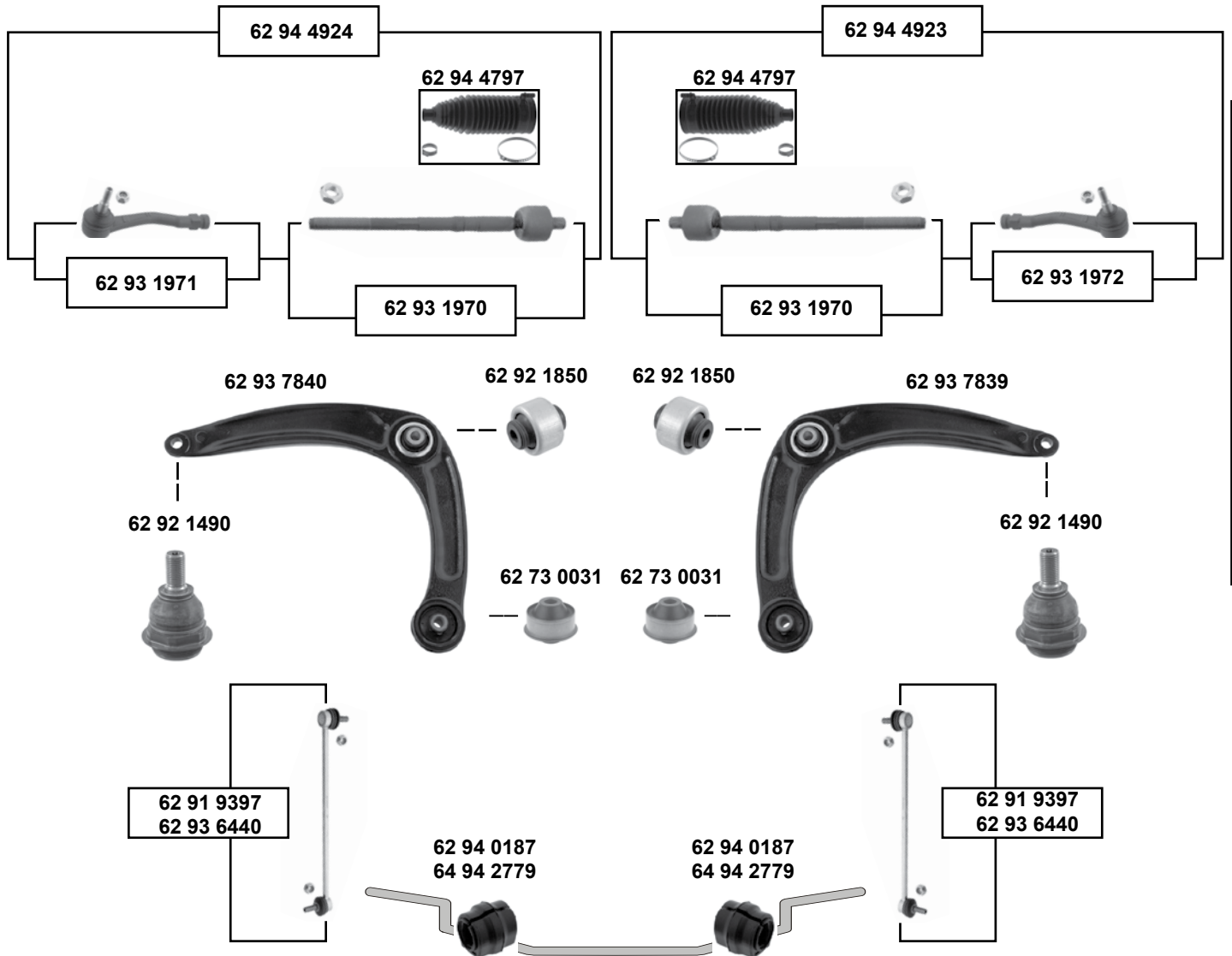

Vorderachse / Front axle



- (1) (ex.) Hybridantrieb / (ex.) hybrid drive
- (2) für Fahrzeuge mit Hybridantrieb / for vehicles with hybrid drive



Ref. - No.



Ref. - No.	Description	Notes	Dimensions
62 73 0031	3523.92 Querlenkerlager / control arm mount		Ø A 55
62 91 9397	98 049 474 80 Verbindungsstange / connecting rod	(1)	L 335
62 92 1490	3640.73 Traggelenk / ball joint		
62 92 1850	3523.91 Querlenkerlager / control arm mount		Ø A 55
62 93 1970	3812.F2 Axialgelenk / axial joint		L 272
62 93 1971	3817.89 Spurstangenendstück / tie rod end		M10 x 1,5
62 93 1972	3817.88 Spurstangenendstück / tie rod end		M10 x 1,5
62 93 6440	98 049 474 80 Verbindungsstange / connecting rod	(2)	L 335
62 93 7839	3521.R3 Querlenker / control arm		
62 93 7840	3520.V2 Querlenker / control arm		
62 94 0187	5094.E3 Stabilisatorlager / stabilizer mount	(1) O 12397 →	Ø I 23
64 94 2779	5094.E7 Stabilisatorlager / stabilizer mount	(2) O 12397 →	Ø I 25
62 94 4797	4066.82 Rep. Satz Lenkmanschette / rep. kit steering boot		L 187,4
62 94 4923	3812.F2 S1 Rep. Satz Spurstange / rep. kit tie rod	DW10CTED4	
62 94 4924	3812.F2 S2 Rep. Satz Spurstange / rep. kit tie rod	DW10CTED4	

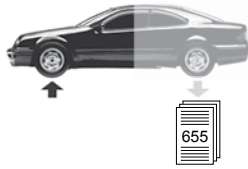

4007 (2007 →)

Vorderachse / Front axle

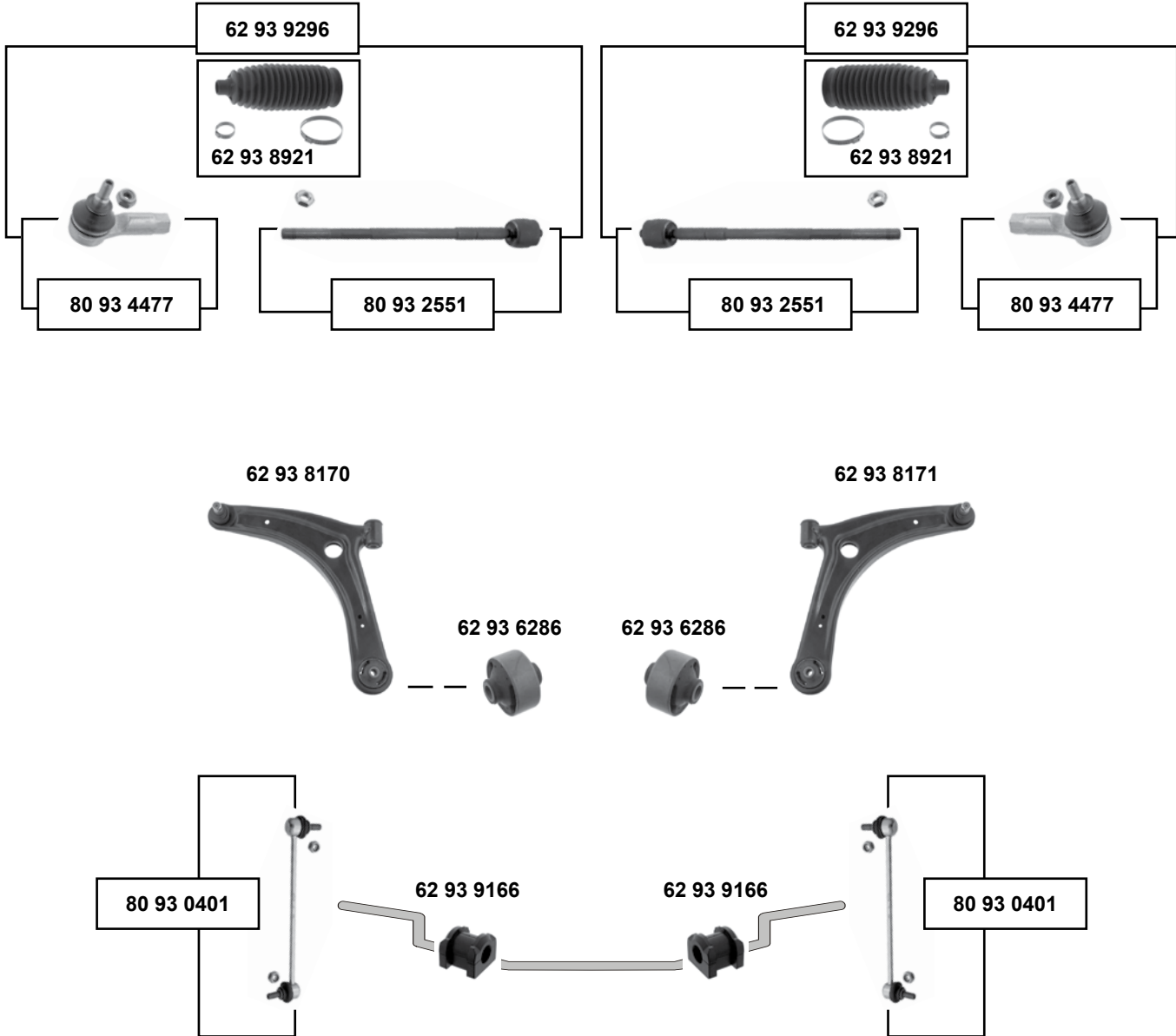

(1) (mot.) 2,4L MMC, DW12METED4 → O 12010



Ref. - No.



62 93 6286	16 099 106 80	Querlenkerlager / control arm mounting		Ø A 60
62 93 8170	3520.X9	Querlenker / control arm		
62 93 8171	3521.V0	Querlenker / control arm		
62 93 8921	4066.84	Rep. Satz Lenkmanschette / rep. kit steering boot	(1)	L 172
62 93 9166	5094.C6	Stabilisatorlager / stabilizer mount		Ø I 21
62 93 9296	4001.69 S1	Rep. Satz Spurstange / rep. kit tie rod	(1)	
80 93 0401	5087.58	Verbindungsstange / connecting rod		L 265
80 93 2551	4001.69 S1	Axialgelenk / axial joint		
80 93 4477	3817.74	Spurstangenendstück / tie rod end		M10 x 1,25

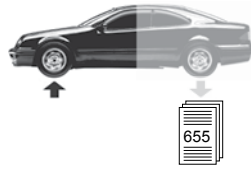

4008
(2012 →)

Vorderachse / Front axle

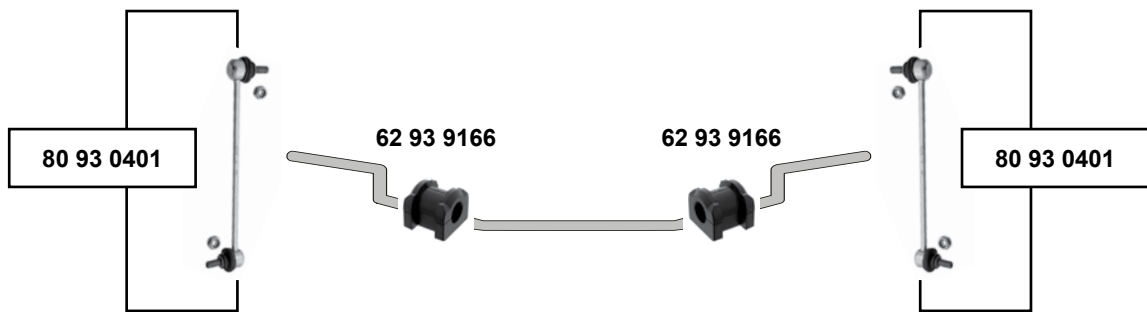
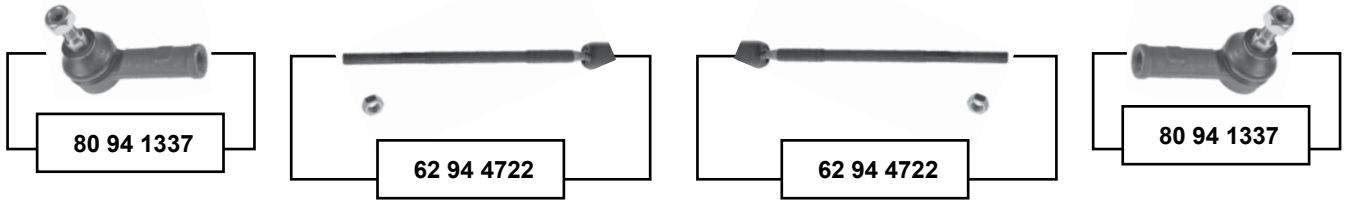

SWAG [®]	Ref. - No.			
62 93 6286	16 099 106 80	Querlenkerlager / control arm mounting	→ O 13510	Ø A 60
62 93 8170	3520.X9	Querlenker / control arm	→ O 13510	
62 93 8171	3521.V0	Querlenker / control arm	→ O 13510	
62 93 9166	5094.C6	Stabilisatorlager / stabilizer mount		Ø I 21
62 94 4722	16 075 025 80	Axialgelenk / axial joint		M14 x 1,5
80 93 0401	5087.58	Verbindungsstange / connecting rod		L 265
80 94 1337	16 075 024 80	Verbindungsstange / connecting rod		M10 x 1,25



5008 (2009 →)

Vorderachse / Front axle

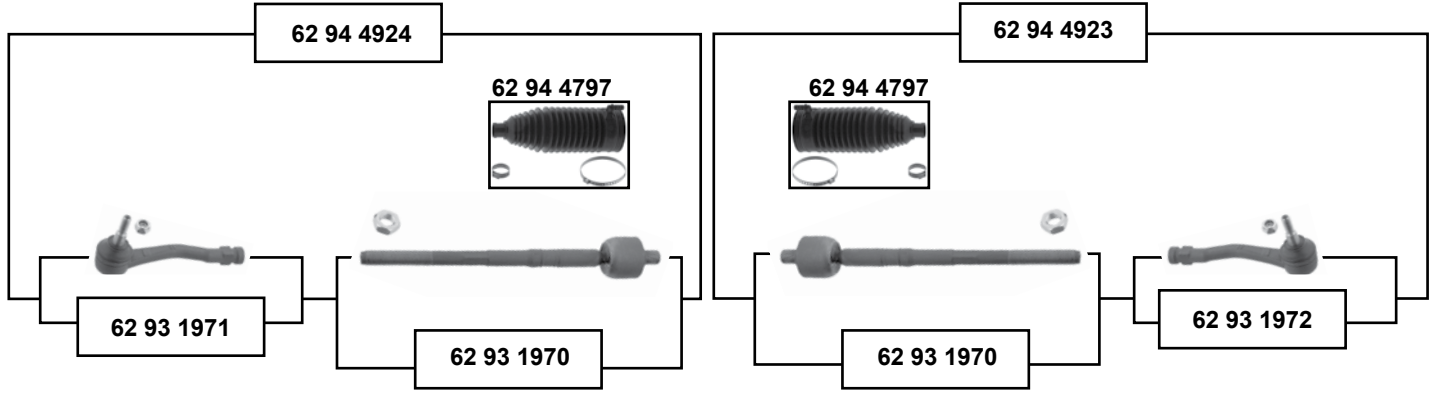



5008
(2009 →)

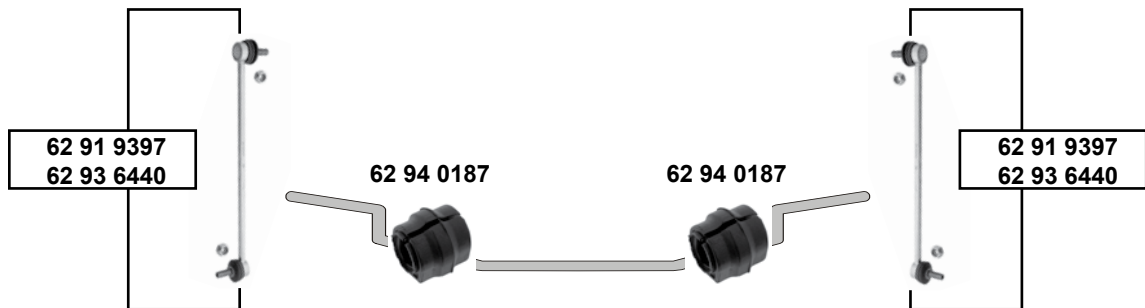

Vorderachse / Front axle

SWAG	Ref. - No.			
62 73 0031	3523.92	Querlenkerlager / control arm mount	→ O 13174	A Ø 55
62 91 9397	98 049 474 80	Verbindungsstange / connecting rod		L 335
62 92 1490	3640.73	Traggelenk / ball joint		
62 92 1850	3523.91	Querlenkerlager / control arm mount		Ø A 55,5
62 93 1970	3812.F2	Axialgelenk / axial joint		L 272
62 93 1971	3817.89	Spurstangenendstück / tie rod end		M10 x 1,5
62 93 1972	3817.88	Spurstangenendstück / tie rod end		M10 x 1,5
62 93 6440	98 049 474 80	Verbindungsstange / connecting rod	→ O 13110	L 335
62 93 7839	3521.R3	Querlenker / control arm	→ O 13173	
62 93 7840	3520.V2	Querlenker / control arm	→ O 13173	
62 93 9686	3523.80	Querlenkerlager / control arm mount	O 13175 →	Ø I14,3 A 55,5
62 94 0187	5094.E3	Stabilisatorlager / stabilizer mount		Ø I 23
62 94 4190	98 056 074 80	Querlenker / control arm	O 13174 →	
62 94 4191	98 056 073 80	Querlenker / control arm	O 13174 →	
62 94 4797	4066.82	Rep. Satz Lenkmanschette / rep. kit steering boot		L187,4
62 94 4923	3812.F2 S1	Rep. Satz Spurstange / rep. kit tie rod		
62 94 4924	3812.F2 S2	Rep. Satz Spurstange / rep. kit tie rod		
62 94 5150	98 056 074 80 S1	Querlenker / control arm	O 13174→13883	
62 94 5151	98 056 073 80 S1	Querlenker / control arm	O 13174→13883	



Bipper / Tepee

(2008 →)

Vorderachse / Front axle

62 93 9237

62 93 9237

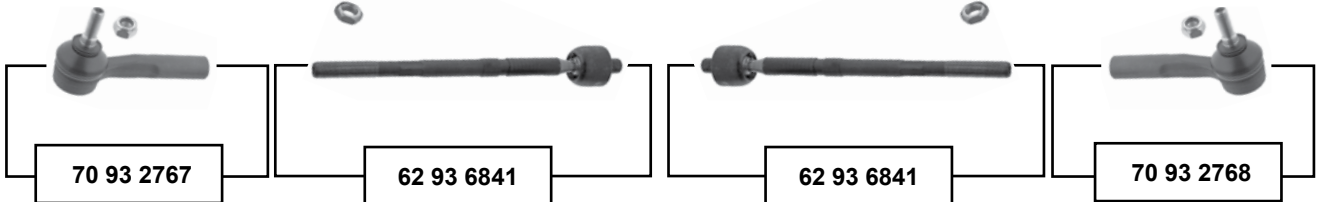
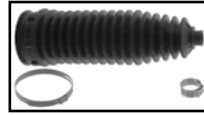
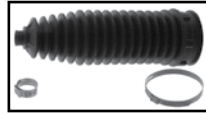

70 93 2767

62 93 6841

62 93 6841

70 93 2768



62 93 9290



62 93 9291

70 92 9144

70 92 9145

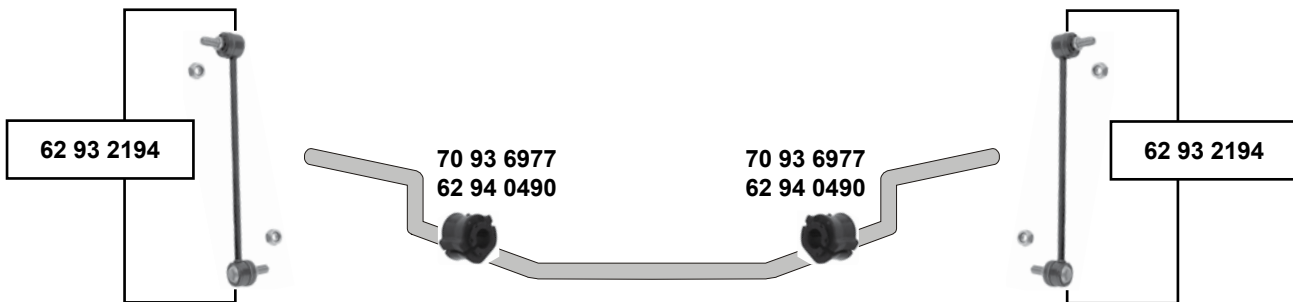

62 93 2194

70 93 6977
62 94 0490

70 93 6977
62 94 0490

62 93 2194



Ref. - No.



62 93 2194	5087.70	Verbindungsstange / connecting rod	L 290
62 93 6841	4001.77 S1	Axialgelenk mit Mutter / axial joint with nut	L 288
62 93 9237	4066.95	Rep. Satz Lenkmanschette / rep. kit steering boot	
62 93 9290	4001.77 S2	Rep. Satz Spurstange / rep. kit tie rod	
62 93 9291	4001.77 S3	Rep. Satz Spurstange / rep. kit tie rod	
62 94 0490	5094.C8	Stabilisatorlager / stabilizer mount	Ø I 20
70 92 9144	3520.Y4	Querlenker / control arm	
70 92 9145	3521.V5	Querlenker / control arm	
70 93 2767	3817.86	Spurstangenendstück / tie rod end	M10 x 1,25
70 93 2768	3817.87	Spurstangenendstück / tie rod end	M10 x 1,25
70 93 6977	5094.E5	Stabilisatorlager / stabilizer mount	Ø I 21



Boxer I + II (1994 → 2006)

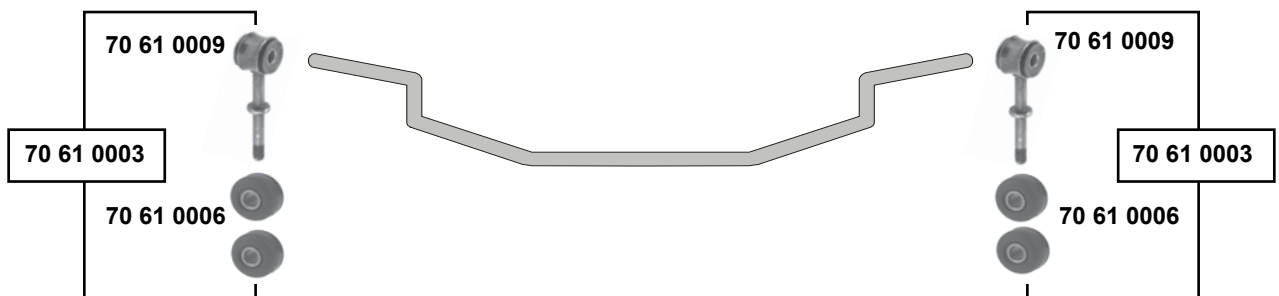
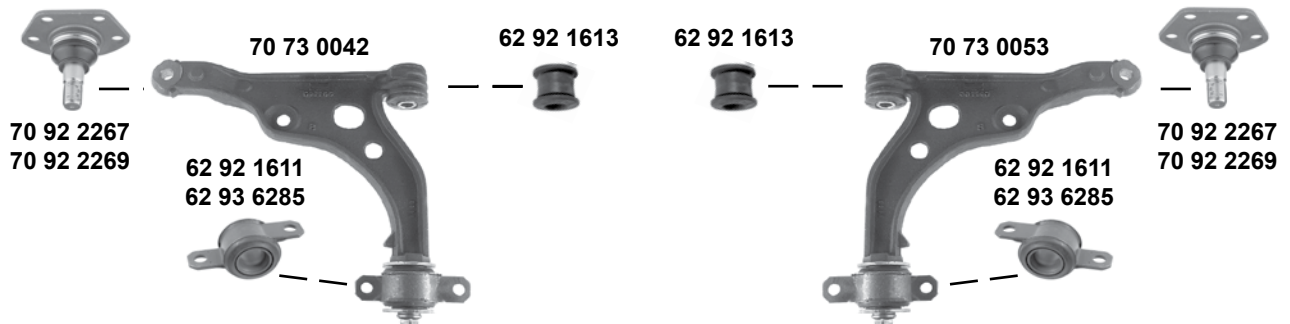
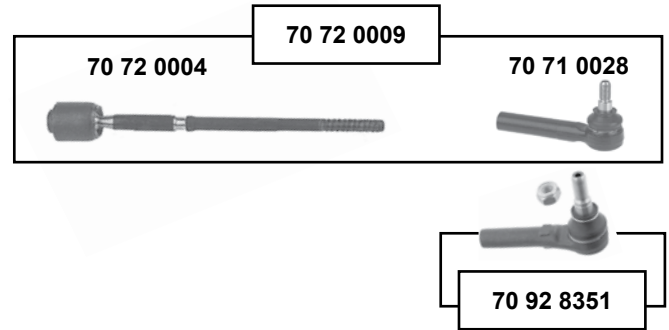
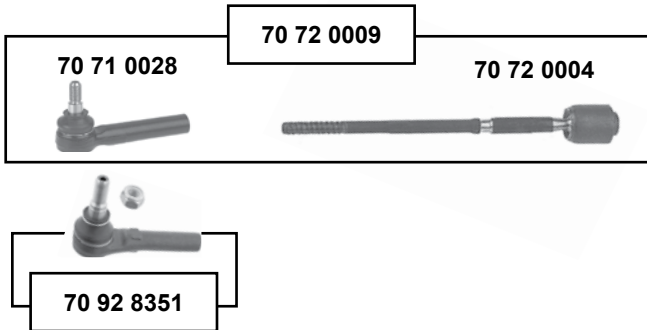

Vorderachse / Front axle

	(1)	(2)	(3) (ch.) 17175291 →
			(4) Boxer I 94 → 02 Boxer II 02 → 06 alle / all → (ch.) 17175290

	Ref. - No.			
62 92 1611	3523.94	Querlenkerlager / control arm mount	02 → (ch.) → 17226522	
62 92 1613	3523.93	Querlenkerlager / control arm mount		
62 93 6285	3523.AP	Querlenkerlager / control arm mount	02 → (ch.) 17226523 →	Ø A 77
70 61 0003	5087.37 S1	Rep. Satz Verbindungsstange / rep. kit connecting rod		
70 61 0006	5093.15	Gummilager / rubber mounting		12x38
70 61 0009	5087.37	Verbindungsstange / connecting rod		M12 x 1,25
70 71 0028	4018.A3	Spurstangenendstück / tie rod end	(4)	M12 x 1,25
70 72 0004	4018.A4	Spurstange / tie rod	servo	L 320
70 72 0009	4006.24 S1	Rep. Satz Spurstange / rep. kit tie rod	servo	
70 73 0042	3520.N3	Querlenker / control arm	(2)	
70 73 0053	3521.J3	Querlenker / control arm	(2)	
70 92 2267	3640.55	Traggelenk / ball joint	02/01 → (2)	
70 92 2269	3640.54	Traggelenk / ball joint	02/01 → (1)	
70 92 8351	4018.E0	Spurstangenendstück / tie rod end	02 → 06 / (3)	M14 x 1,5

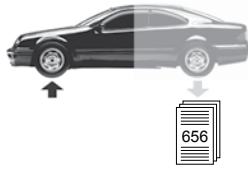

Boxer III

(2006 →)

Vorderachse / Front axle

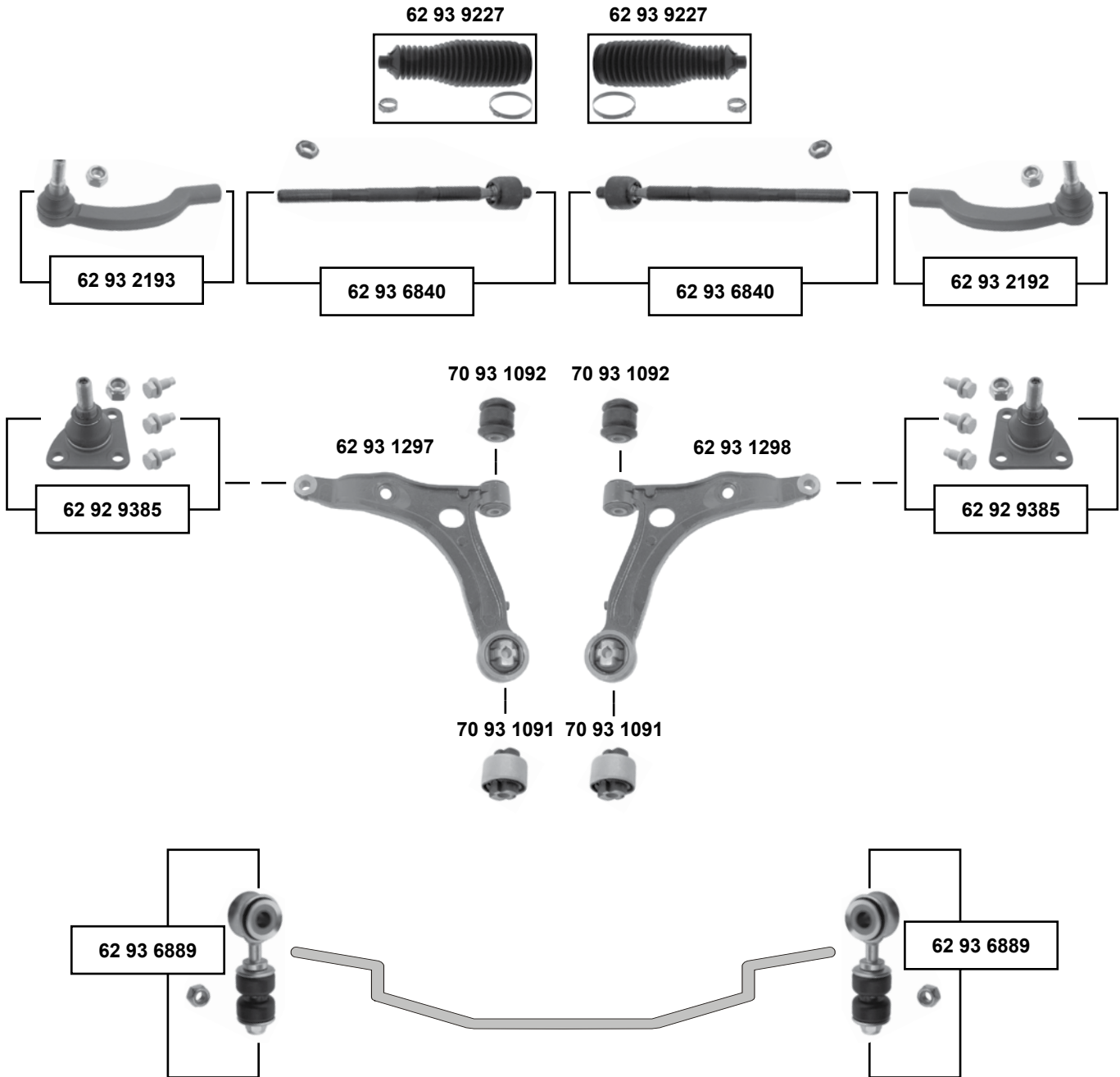

SWAG GERMANY	Ref. - No.			
62 92 9385	3640.67	Traggelenk / ball joint		M18 x 1,5
62 93 1297	3520.S0	Querlenker / control arm		
62 93 1298	3521.P1	Querlenker / control arm		
62 93 2192	3817.70	Spurstangenendstück / tie rod end		M14 x 1,5
62 93 2193	3817.77	Spurstangenendstück / tie rod end		M14 x 1,5
62 93 6840	4001.E4 S1	Axialgelenk mit Mutter / axial joint with nut		L 280
62 93 6889	5081.N9 S1	Verbindungsstange / connecting rod		L 112
62 93 9227	4066.86	Rep. Satz Lenkmanschette / rep. kit steering boot		
70 93 1091	3520.S0 S2	Querlenkerlager / control arm mount		Ø A 73,35 H76
70 93 1092	3520.S0 S1	Querlenkerlager / control arm mount		Ø A 57 H64,7



Expert I + II (1996 → 2007)

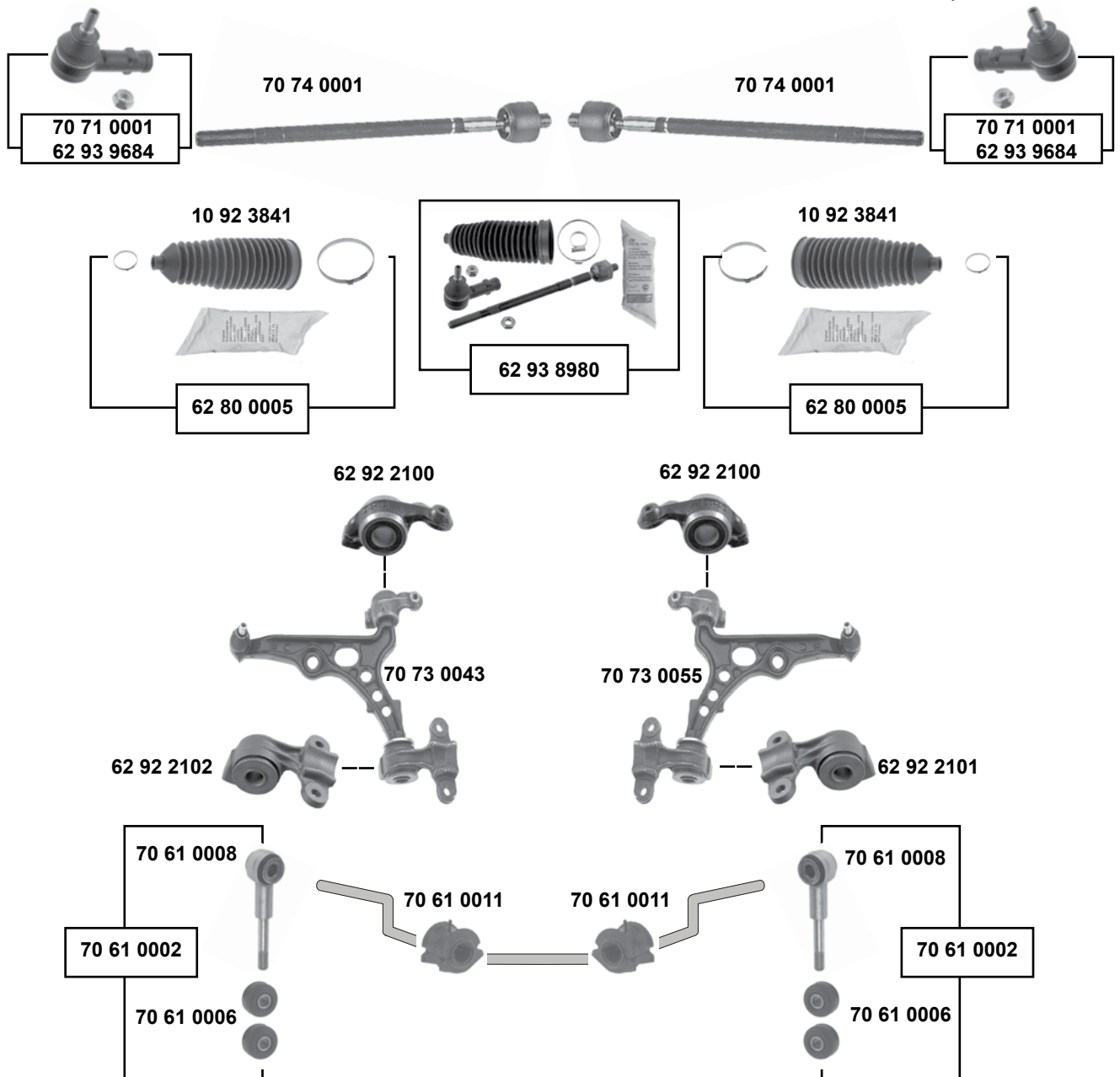

Vorderachse / Front axle



Ref. - No.



10 92 3841	4066.41 SK	Lenkmanschette / steering boot		
62 80 0005	4066.41	Rep. Satz Lenkmanschette / rep. kit steering boot		
62 92 2100	3520.G9 S1	Querlenkerlager / control arm mount		
62 92 2101	3521.C9 S1	Querlenkerlager / control arm mount		
62 92 2102	3520.G9 S2	Querlenkerlager / control arm mount		
62 93 8980	3812.A4 S1	Rep. Satz Spurstange / rep. kit tie rod		
62 93 9684	4059.12	Spurstangenendstück / tie rod end	O 09793 →	
70 61 0002	5087.35 S1	Rep. Satz Verbindungsstange / rep. kit connecting rod		
70 61 0006	5093.15	Gummilager / rubber mounting		12x38
70 61 0008	5087.35	Verbindungsstange / connecting rod		M12 x 1,25
70 61 0011	5094.69	Stabilisatorlager / stabilizer mount		Ø 1 24
70 71 0001	4059.09	Spurstangenendstück / tie rod end	→ O 09792	M12 x 1,25
70 73 0043	3520.P4	Querlenker / control arm		
70 73 0055	3521.K4	Querlenker / control arm		
70 74 0001	3812.A4	Spurstange / tie rod		L 320



Expert III / Tepee

(2007 →)

Vorderachse / Front axle

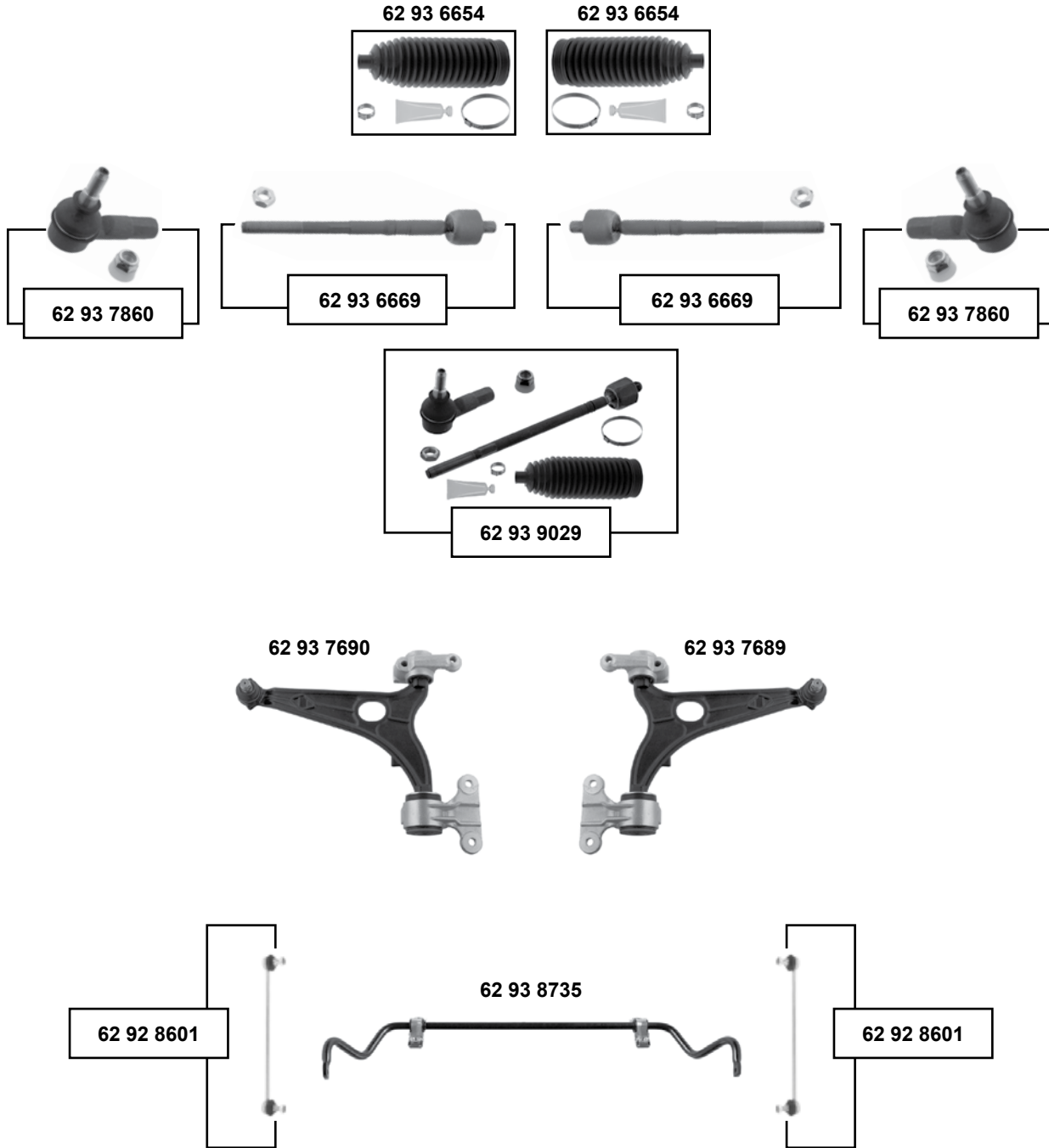

SWAG GERMANY	Ref. - No.			
62 92 8601	5087.56	Verbindungsstange / connecting rod		L 263
62 93 6654	4066.83	Rep. Satz Lenkmanschette / rep. kit steering boot		L 185
62 93 6669	3812.F0	Axialgelenk mit Mutter / axial joint with nut		L 307
62 93 7689	3521.S0	Querlenker / control arm		
62 93 7690	3520.V8	Querlenker / control arm		
62 93 7860	3817.73	Spurstangenendstück / tie rod end		M14 x 1,5
62 93 8735	14 401 772 80	Stabilisator / stabilizer		L 1140
62 93 9029	3812.F0 S1	Rep. Satz Spurstange / rep. kit tie rod		

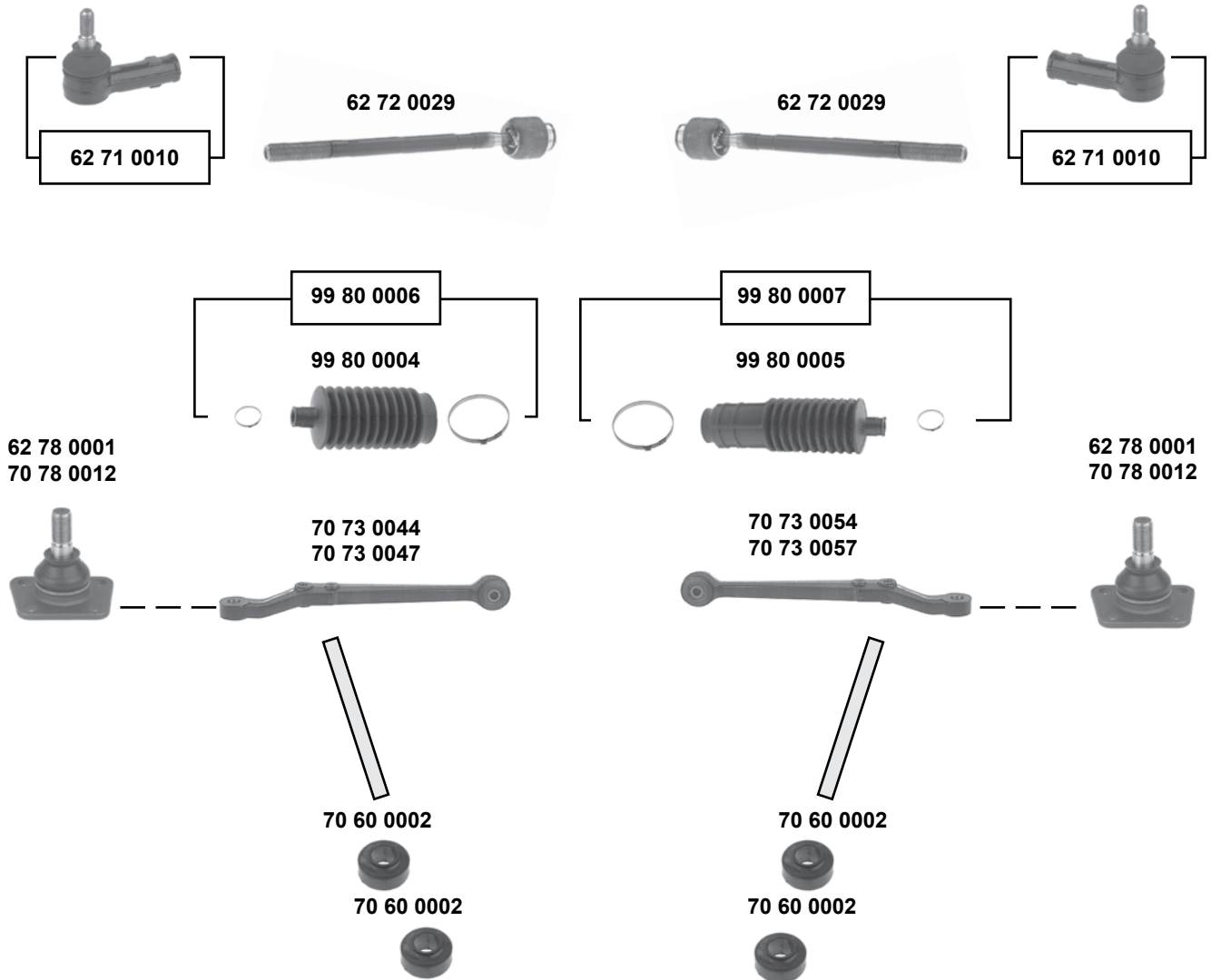
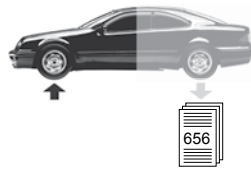

(1) 1,8t
 (ex.)

(2) **J5: 1,8B (mot.) XM7T 1,9D (mot.) XUD9, XUD9A 2,0B (mot.) XN1T, XN1P, XN1TA 2,5D (mot.) CRD93L, CRD93, CRD93LS**
J5 4x4: 2,0B (mot.) XN1T 2,5D (mot.) RD93L, CRD93, CRD93LS

SWAG	Ref. - No.			
62 71 0010	3817.11	Spurstangenendstück / tie rod end		M12 x 1,25
62 72 0029	3812.27	Spurstange / tie rod		L 288
62 78 0001	3640.17	Traggelenk / ball joint	man.	M14 x 1,5
70 60 0002	3561.08	Zugstrebenlager / tension rod mount	(ch.) → S 244300	22x48x24,5
70 73 0044	3520.76	Querlenker / control arm	(1) (2) 01/86 →	
70 73 0047	3520.77	Querlenker / control arm	(2)	
70 73 0054	3521.52	Querlenker / control arm	(1) (2) 01/86 →	
70 73 0057	3521.53	Querlenker / control arm	(2)	
70 78 0012	3640.26	Traggelenk / ball joint	(ch.) S 244300 →	M16 x 1,5
99 80 0004	4066.18	Lenkmanschette / steering boot	man.	
99 80 0005	4066.19	Lenkmanschette / steering boot	man.	
99 80 0006	4066.18 S1	Rep. Satz Lenkmanschette / rep. kit steering boot	man.	
99 80 0007	4066.19 S1	Rep. Satz Lenkmanschette / rep. kit steering boot	man.	



Partner I (1996 → 2002)

man.

Vorderachse / Front axle

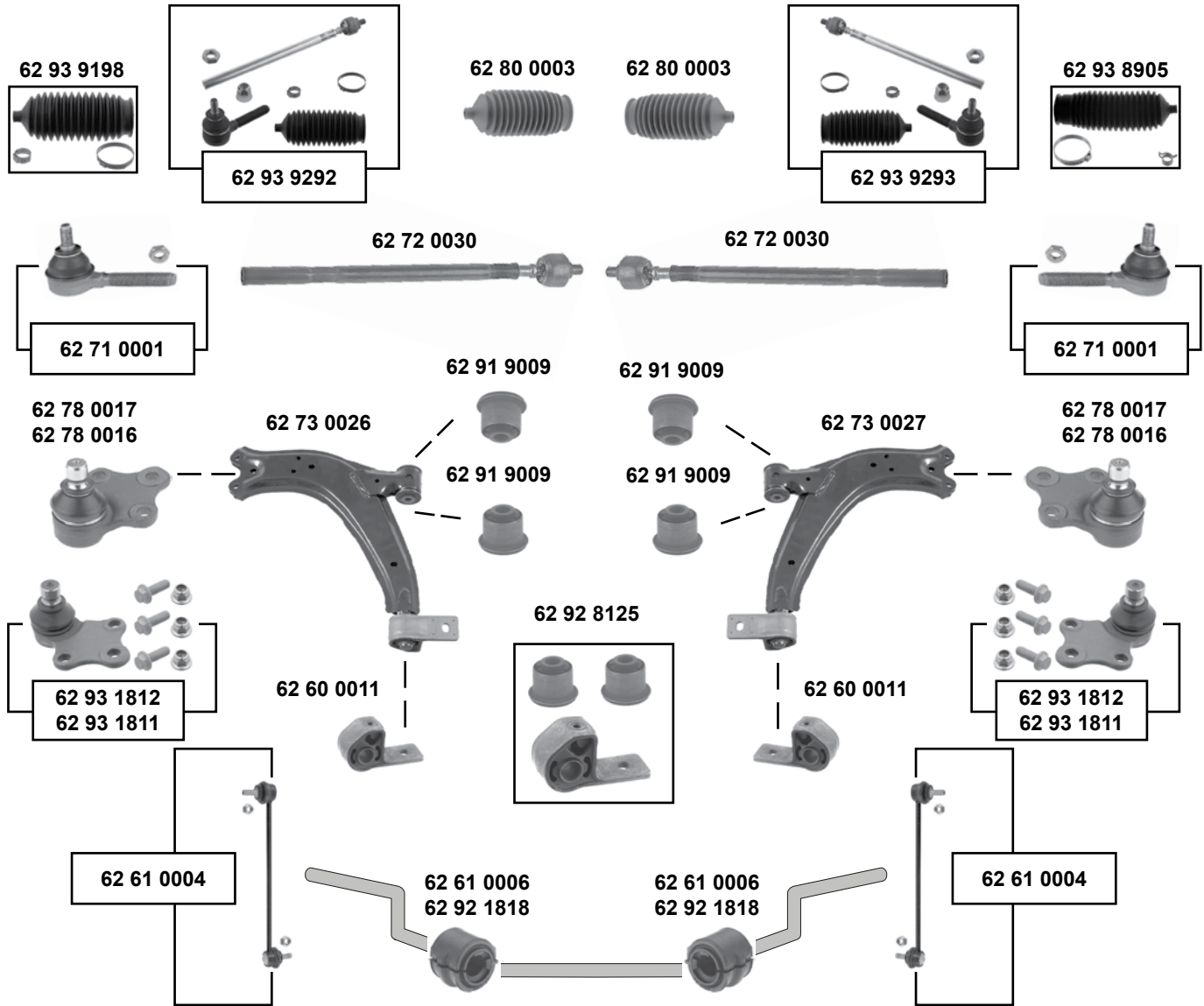

SWAG [®]	Ref. - No.			
62 60 0011	3523.75	Querlenkerlager / control arm mount	(ex.) 2.0 HDI	
62 61 0004	5087.61	Verbindungsstange / connecting rod		L 300
62 61 0006	5094.65	Stabilisatorlager / stabilizer mount		Ø I 21
62 71 0001	3817.50	Spurstangenendstück / tie rod end		M10 x1,25
62 72 0030	3812.C0	Spurstange / tie rod	(ex.) 2.0 HDI	L 345
62 73 0026	3520.H5	Querlenker / control arm	(ex.) 2.0 HDI	
62 73 0027	3521.E5	Querlenker / control arm	(ex.) 2.0 HDI	
62 78 0016	3640.51	Traggelenk / ball joint	(ex.) 2,0 HDI / O 07973 →	Ø A 18
62 78 0017	3640.42	Traggelenk / ball joint	(ex.) 2,0 HDI / → O 07972	Ø A 16
62 80 0003	4066.43	Lenkmanschette / steering boot		
62 91 9009	3520.H5 S1	Querlenkerlager / control arm mount		
62 92 1818	5094.77	Stabilisatorlager / stabilizer mount		Ø I 22
62 92 8125	3520.H5 S2	Querlenkerlager / control arm mount	(ex.) HDI	
62 93 1811	3640.51 S1	Rep. Satz Traggelenk / rep. kit ball joint	(ex.) 2,0 HDI / O 07973 →	Ø A 18
62 93 1812	3640.42 S1	Rep. Satz Traggelenk / rep. kit ball joint	(ex.) 2,0 HDI / → O 07972	Ø A 16
62 93 8905	4066.44	Rep. Satz Lenkmanschette / rep. kit steering boot		L 196,6
62 93 9198	4066.43 S1	Rep. Satz Lenkmanschette / rep. kit steering boot	(mot.) DW10TD	L 154,5
62 93 9292	3812.C0 S1	Rep. Satz Spurstange / rep. kit tie rod		
62 93 9293	3812.C0 S2	Rep. Satz Spurstange / rep. kit tie rod		



Partner I (1996 → 2002)

servo

(ex.) 2.0 HDI

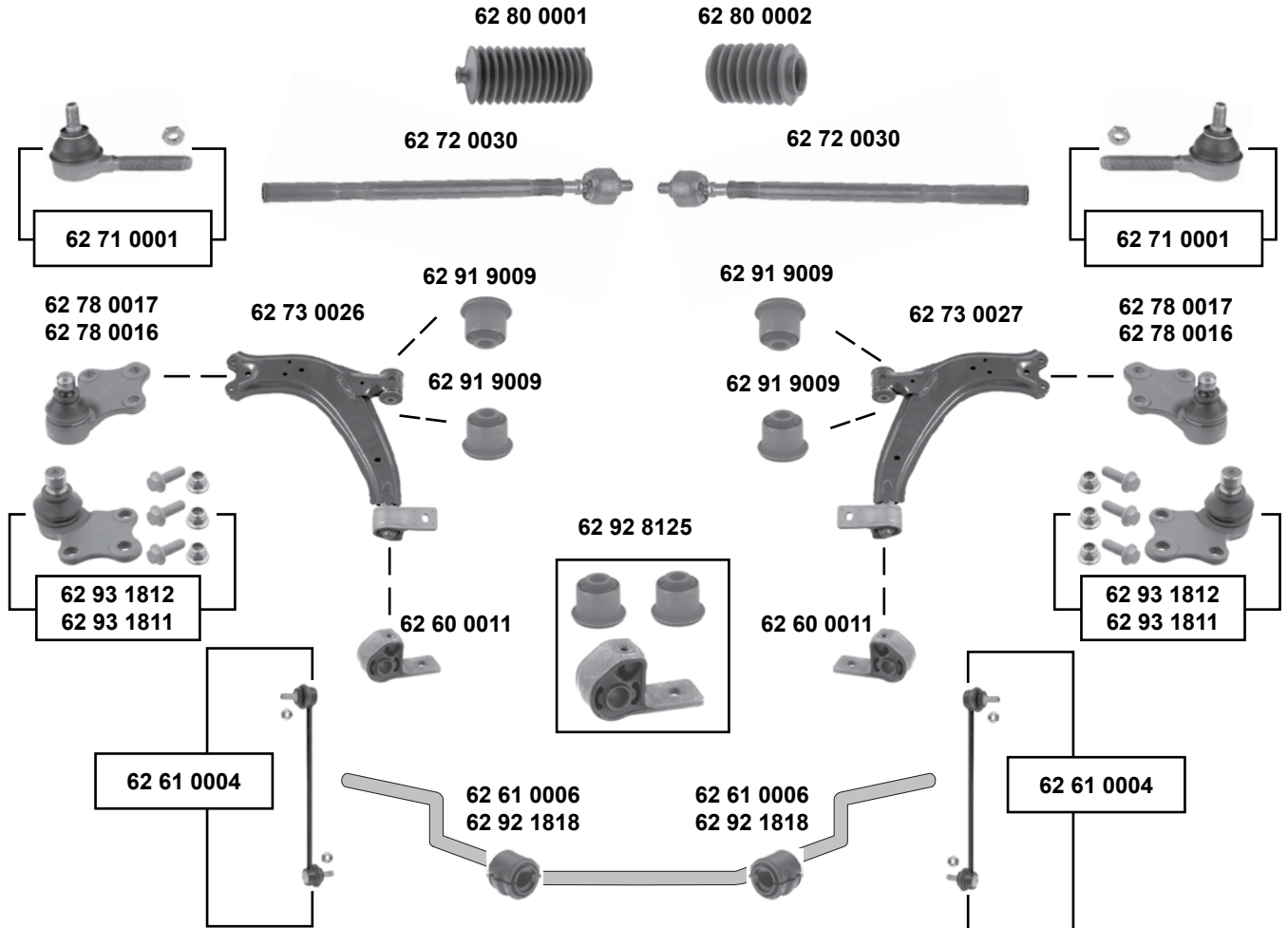

Vorderachse / Front axle



(1) (ex.) Multifunktionsdach / multifunctional roof



Ref. - No.



Part No.	Description	Notes	Dimensions
62 60 0011	Querlenkerlager / control arm mount		L 300
62 61 0004	Verbindungsstange / connecting rod		Ø I 21
62 61 0006	Stabilisatorlager / stabilizer mount		L 345
62 72 0030	Spurstange / tie rod		
62 73 0026	Querlenker / control arm	(1)	
62 73 0027	Querlenker / control arm	(1)	
62 71 0001	Spurstangenendstück / tie rod end		M10 x 1,25
62 78 0016	Traggelenk / ball joint	Ø 7973 →	Ø A 18
62 78 0017	Traggelenk / ball joint	→ Ø 7972	Ø A 16
62 80 0001	Lenkmanschette / steering boot		
62 80 0002	Lenkmanschette / steering boot		
62 91 9009	Querlenkerlager / control arm mount		Ø I 22
62 92 1818	Stabilisatorlager / stabilizer mount		
62 92 8125	Querlenkerlager / control arm mount	(ex.) HDI	
62 93 1811	Rep. Satz Traggelenk / rep. kit ball joint	Ø 07973 →	Ø A 18
62 93 1812	Rep. Satz Traggelenk / rep. kit ball joint	→ Ø 07972	Ø A 16



Partner I (1996 → 2002)

Vorderachse / Front axle

servo 
2.0 HDI

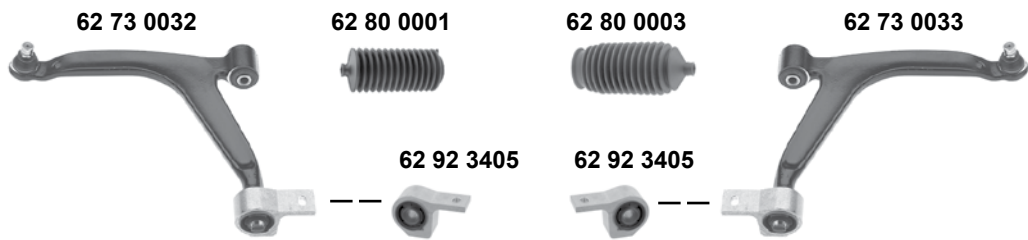
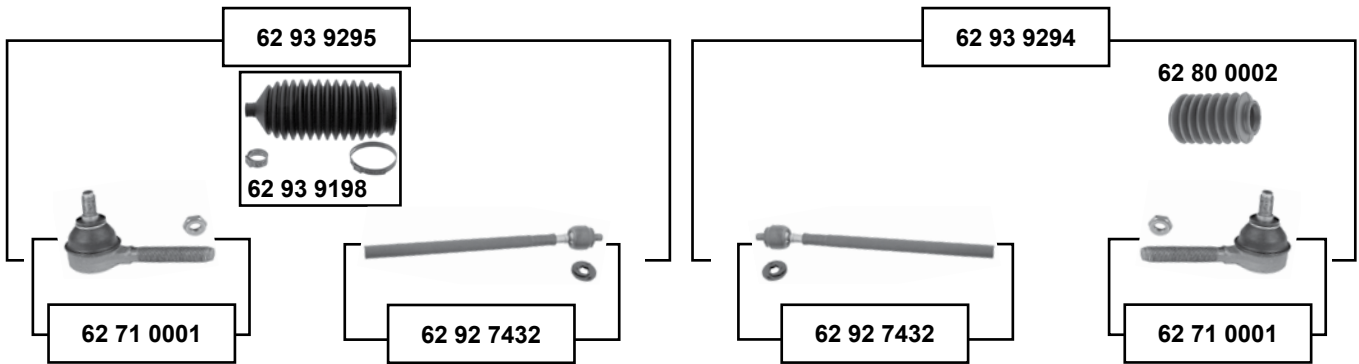



Partner I (1996 → 2002)

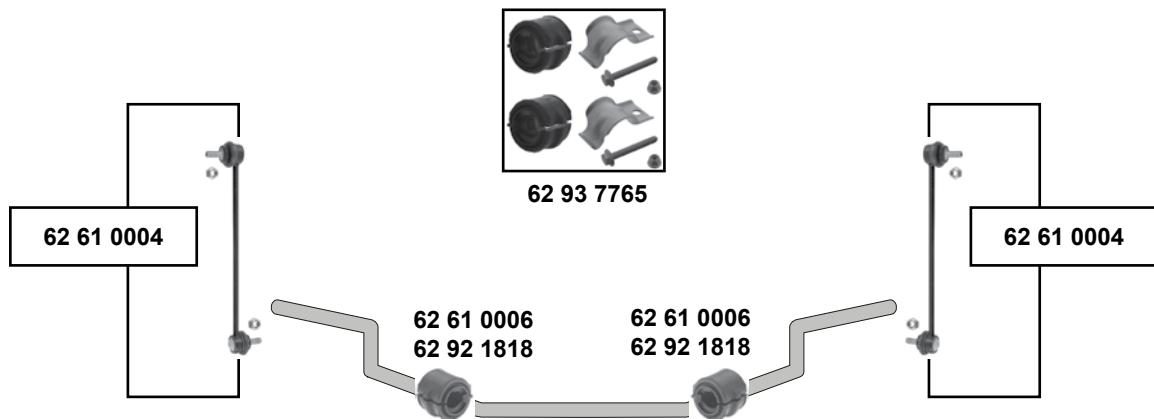

Vorderachse / Front axle



- (1) (mot.) DW10TD /
(mot.) DW8B Multifunktionsdach / multifunctional roof / normale Aufhängung / normal suspension
4X4 verstärkte Aufhängung vorne + hinten / reinforced suspension front + rear / O 08364 →
- (2) alle mit erhöhte Aufhängung / all with increased suspension
Kurzlieferwagen 475, 600 normale Aufhängung / standard suspension / (ex.) DW10TD
alle mit verstärkte Aufhängung → O 08364 / all with reinforced suspension → O 08364



Ref. - No.



Ref. - No.	Description	Notes	Dimensions
62 61 0004	Verbindungsstange / connecting rod		L 300
62 61 0006	Stabilisatorlager / stabilizer mount		Ø I 21
62 71 0001	Spurstangenendstück / tie rod end		M10 x 1,25
62 73 0032	Querlenker / control arm	(1)	
62 73 0033	Querlenker / control arm	(1)	
62 80 0001	Lenkmanschette / steering boot		
62 80 0002	Lenkmanschette / steering boot		
62 80 0003	Lenkmanschette / steering boot		
62 92 1818	Stabilisatorlager / stabilizer mount		Ø I 22
62 92 3405	Querlenkerlager / control arm mount		
62 92 7432	Spurstange / tie rod		
62 93 7765	Stabilisatorlagersatz / rep. kit stabilizer mount kit	(2)	
62 93 9198	Rep. Satz Lenkmanschette / rep. kit steering boot	(ex.) servo	
62 93 9294	Rep. Satz Spurstange / rep. kit tie rod	DW10TD → O 10830	
62 93 9295	Rep. Satz Spurstange / rep. kit tie rod	DW10TD → O 10830	



Partner II (2002 → 2008)

Vorderachse / Front axle

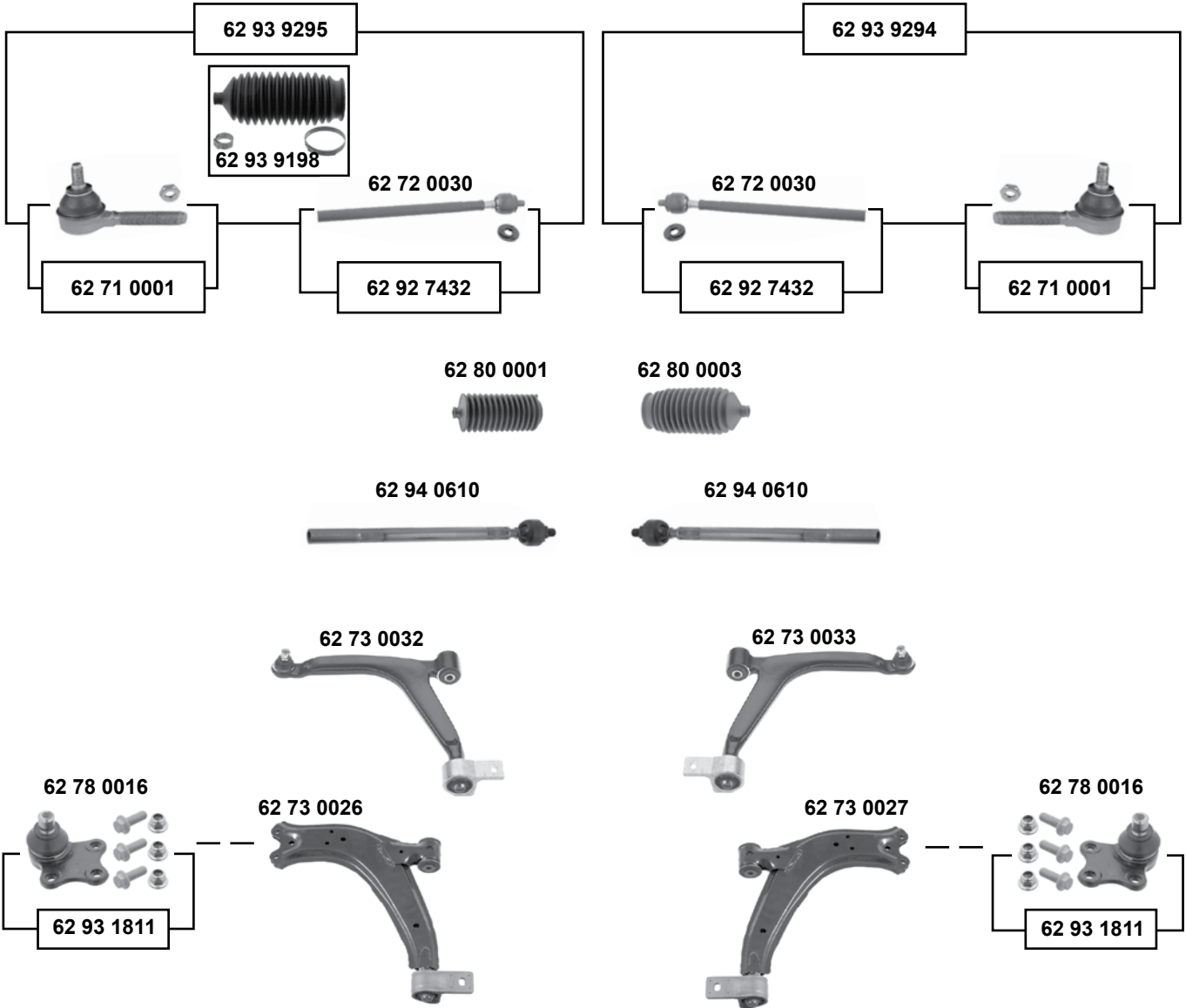



Partner II (2002 → 2008)

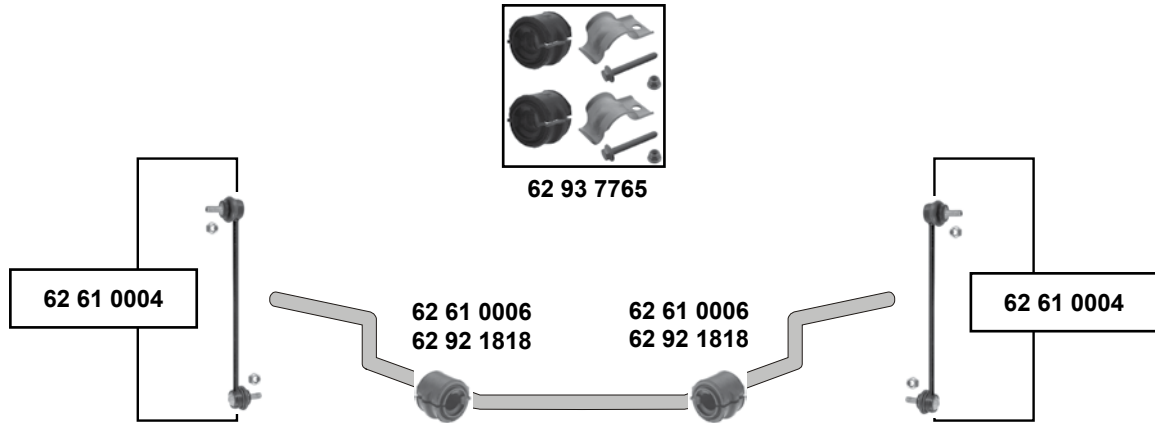

Vorderachse / Front axle

- (1) man. / (ex.) 2,0 HDI / 1,6 HDI / 1,6 16V
- (2) (mot.) 1,6 HDI / 1,6 HDI 90 / 2,0 HDI / 1,4 / 1,6 16V
- (3) (mot.) 1,4
- (4) (5) (ex.) HD
- (6) (mot.) DW8B / TU1JP / TU3JP / TU5JP / TU3A
- (7) (mot.) DW10TD → O 10016 (9) (mot.) DV6B / DV6ATED4 / DW10TD O 10017 →
- (8) alle / all → O 10562 / (ex.) DW8B, DW10TD, DV6DTED M, Kurzlieferwagen 800
- (9) (mot.) DV6ATED4, DV6B, DW10TD



Ref. - No.



Ref. - No.	Description	Notes	Dimensions
62 61 0004	5087.61	Verbindungsstange / connecting rod	L 300
62 61 0006	5094.65	Stabilisatorlager / stabilizer mount	Ø I 21
62 71 0001	3817.50	Spurstangenendstück / tie rod end	M10 x 1,25
62 72 0030	3812.C0	Axialgelenk / axial joint	L 345
62 73 0026	3520.H5	Querlenker / control arm	(6)
62 73 0027	3521.E5	Querlenker / control arm	(3) (5)
62 73 0032	3520.V3	Querlenker / control arm	(3) (5)
62 73 0033	3521.R4	Querlenker / control arm	(2) (4)
62 78 0016	3640.51	Traggelenk / ball joint	(2) (4)
62 80 0001	4066.20	Lenkmanschette / steering boot	(1)
62 80 0003	4066.43	Lenkmanschette / steering boot	Ø 16
62 92 1818	5094.77	Stabilisatorlager / stabilizer mount	Ø I 22
62 92 7432	3812.C6	Spurstange / tie rod	(7)
62 93 1811	3640.51 S1	Rep. Satz Traggelenk / rep. kit ball joint	(1)
62 93 7765	5094.65 S1	Stabilisatorlagersatz / rep. kit stabilizer mount kit	(8)
62 93 9198	4066.43 S1	Rep. Satz Lenkmanschette / rep. kit steering boot	(9)
62 93 9294	3812.C6 S2	Rep. Satz Spurstange / rep. kit tie rod	DW10TD → O 10016
62 93 9295	3812.C6 S1	Rep. Satz Spurstange / rep. kit tie rod	DW10TD → O 10016
62 94 0610	3812.E4	Axialgelenk / axial joint	(9) L 355



PEUGEOT

Partner III / Tepee

(2008 →)

Vorderachse / Front axle

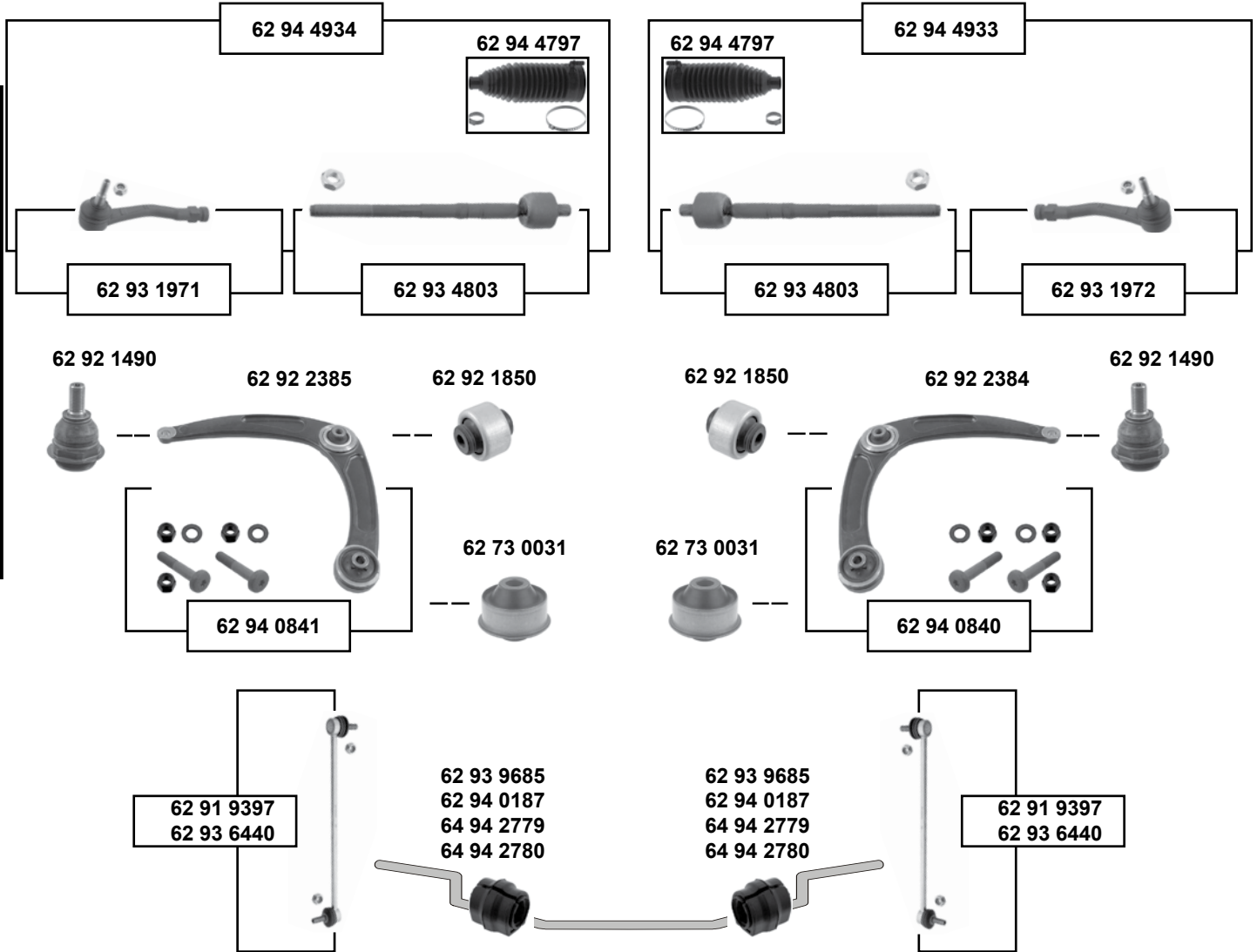

SWAG GERMANY	Ref. - No.			
62 73 0031	3523.92	Querlenkerlager / control arm mount		Ø A 55
62 91 9397	98 049 474 80	Verbindungsstange / connecting rod		L 335
62 92 1490	3640.73	Traggelenk / ball joint		
62 92 1850	3523.91	Querlenkerlager / control arm mount		Ø A 55
62 92 2384	3521.P3	Querlenker / control arm		
62 92 2385	3520.S2	Querlenker / control arm		
62 93 1971	3817.89	Spurstangenendstück / tie rod end		M10 x 1,5
62 93 1972	3817.88	Spurstangenendstück / tie rod end		M10 x 1,5
62 93 4803	3812.F4	Axialgelenk / axial joint		L 280
62 93 6440	98 049 474 80	Verbindungsstange / connecting rod		
62 93 9685	5094.E6	Stabilisatorlager / stabilizer mount		Ø 24,5
62 94 0187	5094.E3	Stabilisatorlager / stabilizer mount		Ø 23
62 94 0840	3521.P3 S1	Querlenker / control arm		
62 94 0841	3520.S2 S1	Querlenker / control arm		
64 94 2779	5094.E7	Stabilisatorlager / stabilizer mount		Ø 25
64 94 2780	5094.E4	Stabilisatorlager / stabilizer mount		Ø 24
62 94 4797	4066.82	Rep. Satz Lenkmanschette / rep. kit steering boot		L187,4
62 94 4933	3812.F4 S1	Rep. Satz Spurstange / rep. kit tie rod		
62 94 4934	3812.F4 S2	Rep. Satz Spurstange / rep. kit tie rod		



RCZ (2010 →)

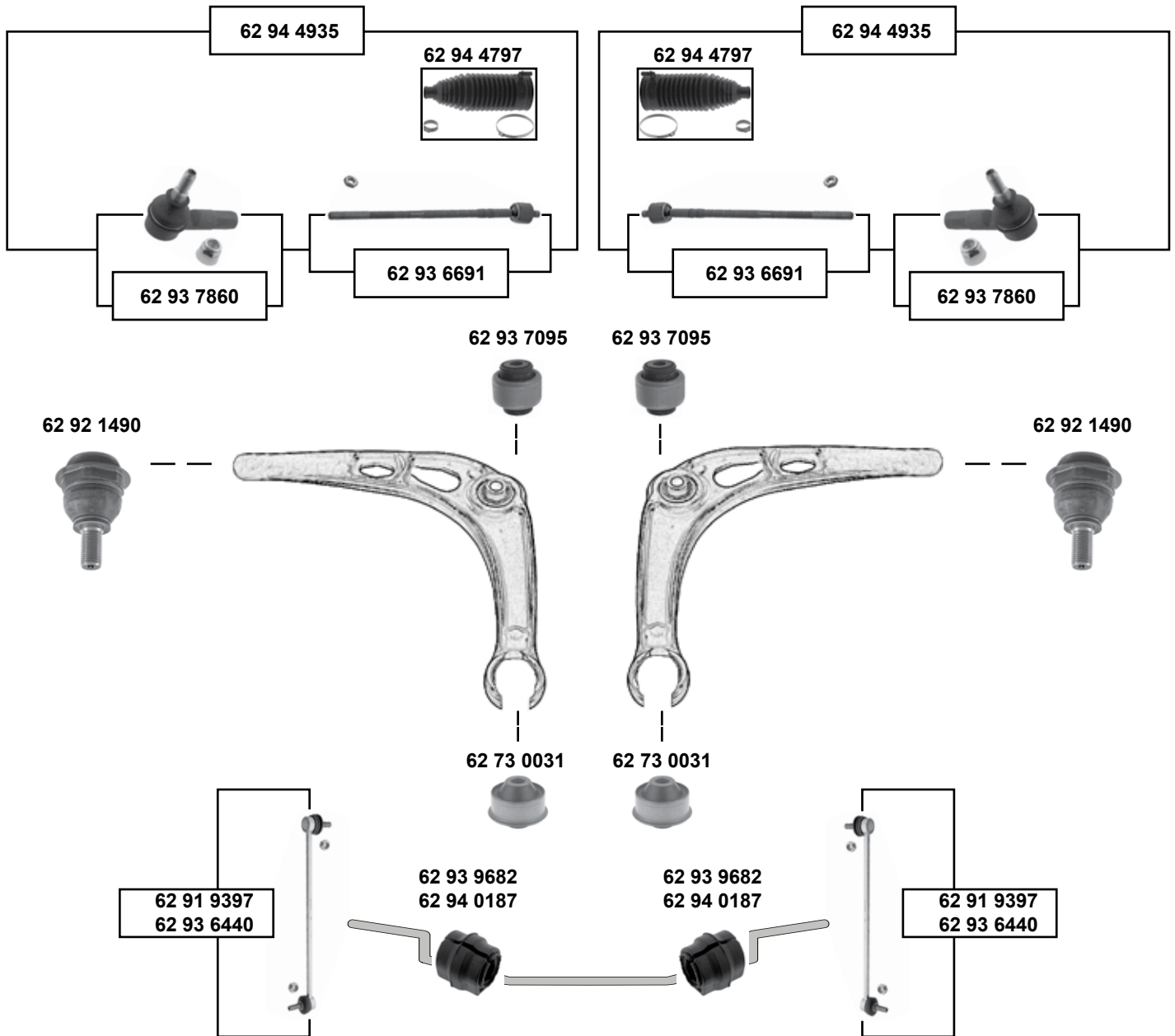

Vorderachse / Front axle



(1) Ø A Radlager 83 mm / Ø A wheel bearing 83 mm



Ref. - No.



62 73 0031	3523.92	Querlenkerlager / control arm mount		Ø A 55
62 91 9397	98 049 474 80	Verbindungsstange / connecting rod		
62 92 1490	3640.73	Traggelenk / ball joint		
62 93 6440	98 049 474 80	Verbindungsstange / connecting rod	→ O 13110	
62 93 6691	3812.F7	Axialgelenk mit Mutter / axial joint with nut		L 385
62 93 7095	3523.CW	Querlenkerlager / control arm mount		Ø A 55,5
62 93 7860	3817.73	Spurstangenendstück / tie rod end	(1)	M14 x 1,5
62 93 9682	5094.E2	Stabilisatorlager / stabilizer mount		Ø I 22,5
62 94 0187	5094.E3	Stabilisatorlager / stabilizer mount		Ø I 23
62 94 4797	4066.82	Rep. Satz Lenkmanschette / rep. kit steering boot		L187,4
62 94 4935	3812.F7 S1	Rep. Satz Spurstange / rep. kit tie rod	(1)	

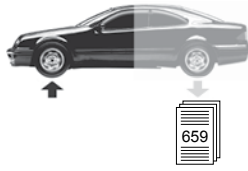

911 Carrera / Turbo (996)

(1998 → 2005)

Vorderachse / Front axle



Ref. - No.



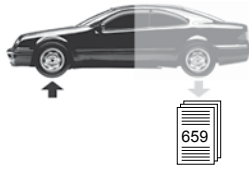

38 92 6531	996 343 069 04	Verbindungsstange / connecting rod	(ex.) Turbo	L 200
38 92 6532	996 343 070 04	Verbindungsstange / connecting rod	(ex.) Turbo	L 200
38 93 8568	996 341 053 16	Querlenker / control arm		
38 93 8883	996 341 043 06	Querlenker / control arm		
38 93 8885	996 347 322 03	Axialgelenk / axial joint		L 214
38 93 8886	996 347 131 04	Spurstangenendstück / tie rod end		
38 94 5445	996 343 073 05 S1	Rep. Satz Verbindungsstange / rep. kit connecting rod		L 284

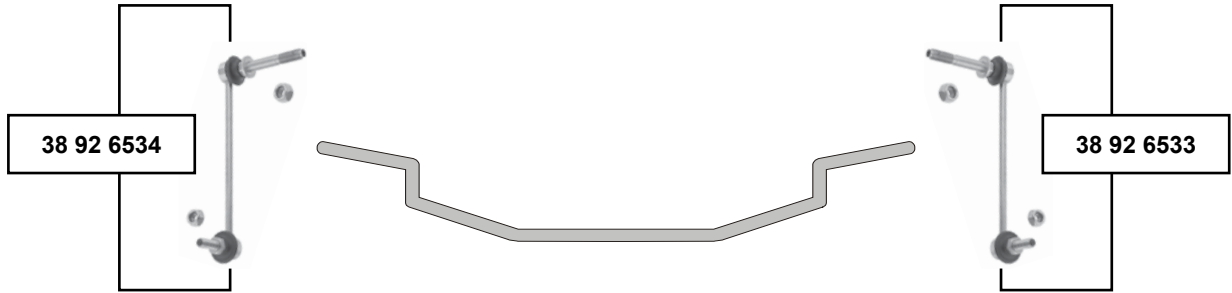

911 Carrera 2 / 2-S (997)
(2005 →)



Vorderachse / Front axle

SWAG [®]	Ref. - No.			
38 92 6533	997 343 070 02	Verbindungsstange / connecting rod		L 200
38 92 6534	997 343 069 02	Verbindungsstange / connecting rod		L 200
38 93 8883	996 341 043 06	Querlenker / control arm	(ex.) 2-S	
38 93 8886	996 347 131 04	Spurstangenendstück / tie rod end	(ex.) 2-S	



924

(1975 → 1989)

Vorderachse / Front axle

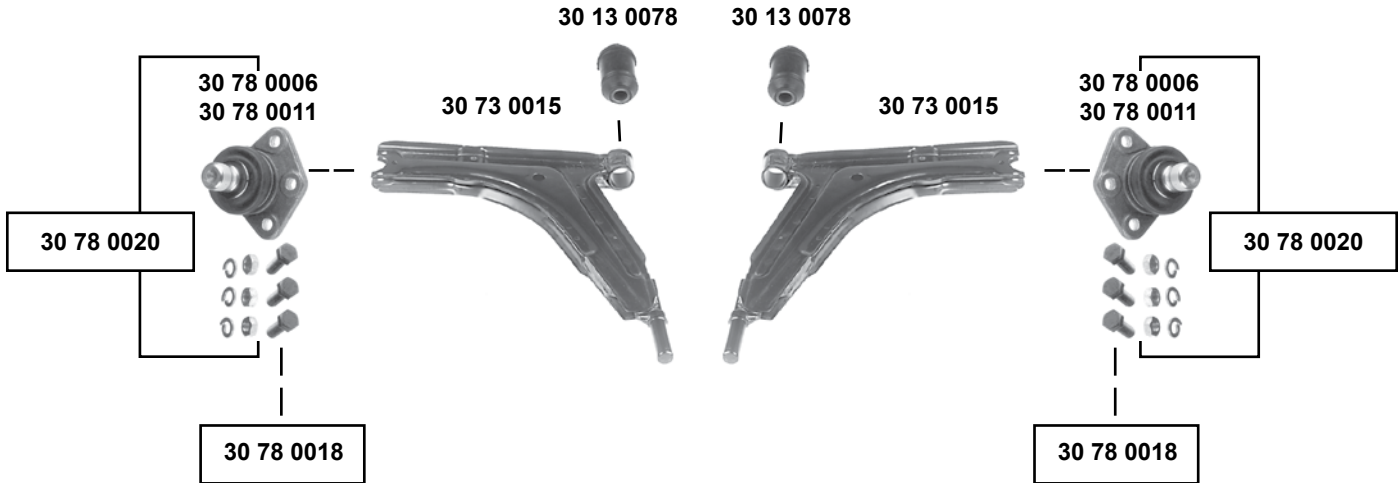
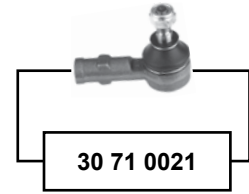

SWAG GERMANY	Ref. - No.			
30 13 0078	171 407 182 D	Querlenkerlager / control arm mount		12x32x61
30 71 0021	171 419 812	Spurstangenendstück / tie rod end		M14x1,5 RHT
30 73 0015	171 407 153 D	Querlenker ohne Gummilager / control arm excl. rubber mounts		
30 78 0006	171 407 365 C	Traggelenk / ball joint		Ø A 15
30 78 0011	171 407 365 F	Traggelenk / ball joint		Ø A 17
30 78 0018	171 407 365 F S1	Rep. Satz Traggelenk / rep. kit ball joint		
30 78 0020	171 407 365 C S1	Rep. Satz Traggelenk / rep. kit ball joint		
30 80 0053	171 419 832 C	Lenkmanschette / steering boot		
30 80 0054	191 419 831	Lenkmanschette / steering boot		
30 80 0062	171 419 832 C S1	Rep. Satz Lenkmanschette / rep. kit steering boot		
30 80 0063	191 419 831 S	Rep. Satz Lenkmanschette / rep. kit steering boot		

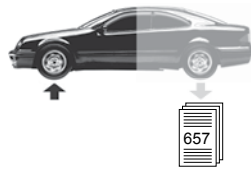

Boxster (986) (1996 → 2004)

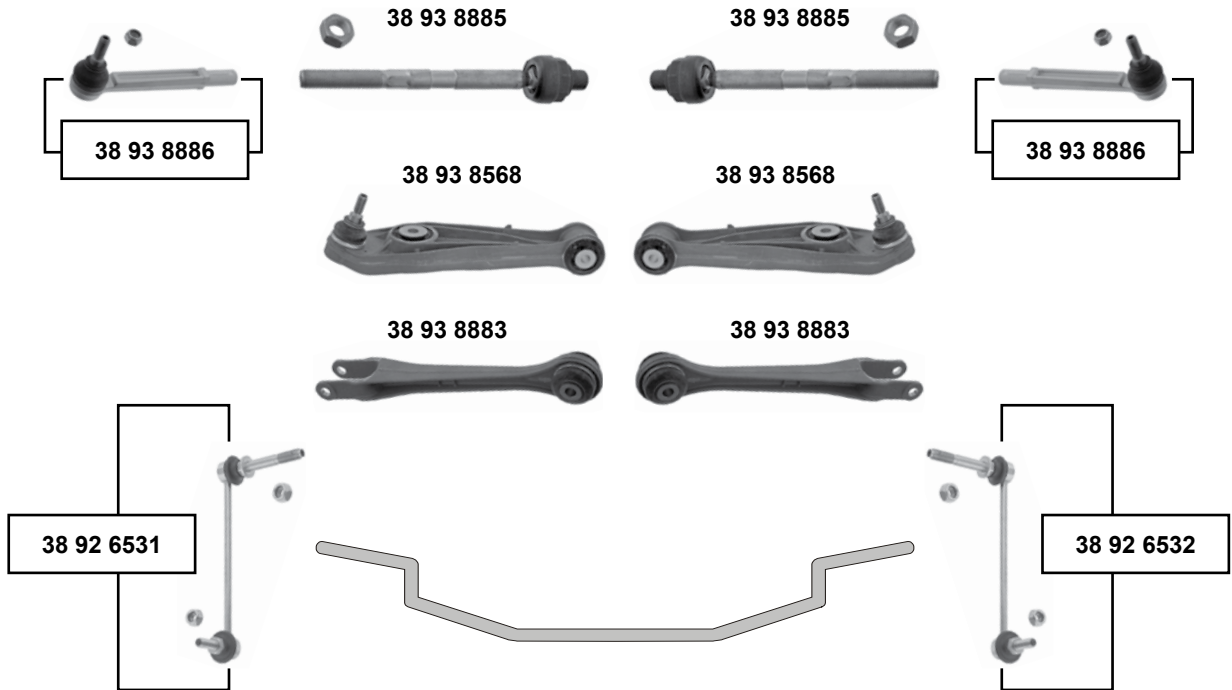

Vorderachse / Front axle

Boxster (987) (2004 → 2012)

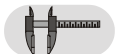
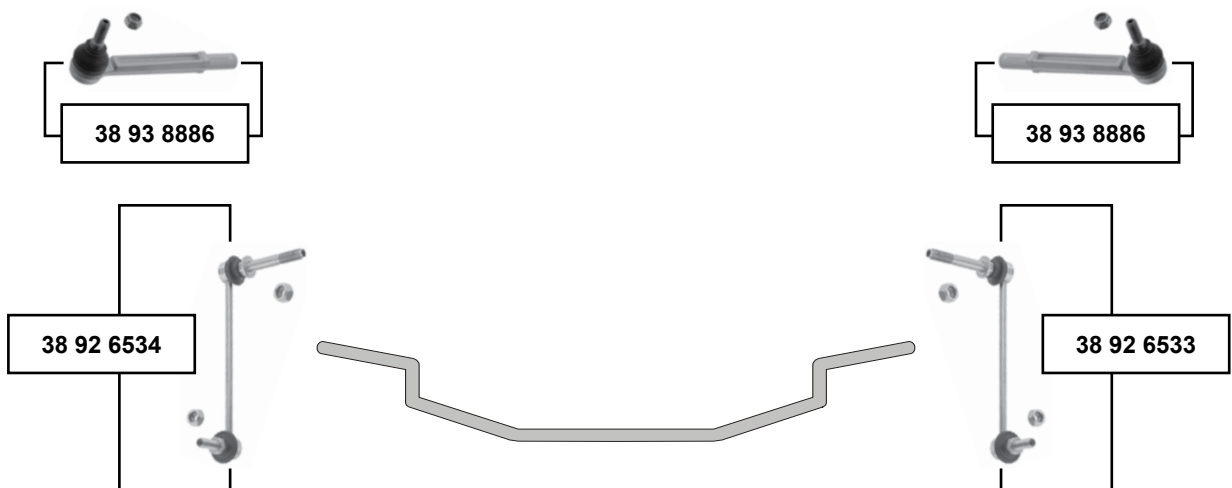

38 92 6531	996 343 069 04	Verbindungsstange / connecting rod	L 200
38 92 6532	996 343 070 04	Verbindungsstange / connecting rod	L 200
38 92 6533	997 343 070 02	Verbindungsstange / connecting rod	L 200
38 92 6534	997 343 069 02	Verbindungsstange / connecting rod	L 200
38 93 8568	996 341 053 16	Querlenker / control arm	
38 93 8883	996 341 043 06	Querlenker / control arm	
38 93 8885	996 347 322 03	Axialgelenk / axial joint	L 214
38 93 8886	996 347 131 04	Spurstangenendstück / tie rod end	



Cayenne (955) S / GTS / Turbo

(2002 → 2010)

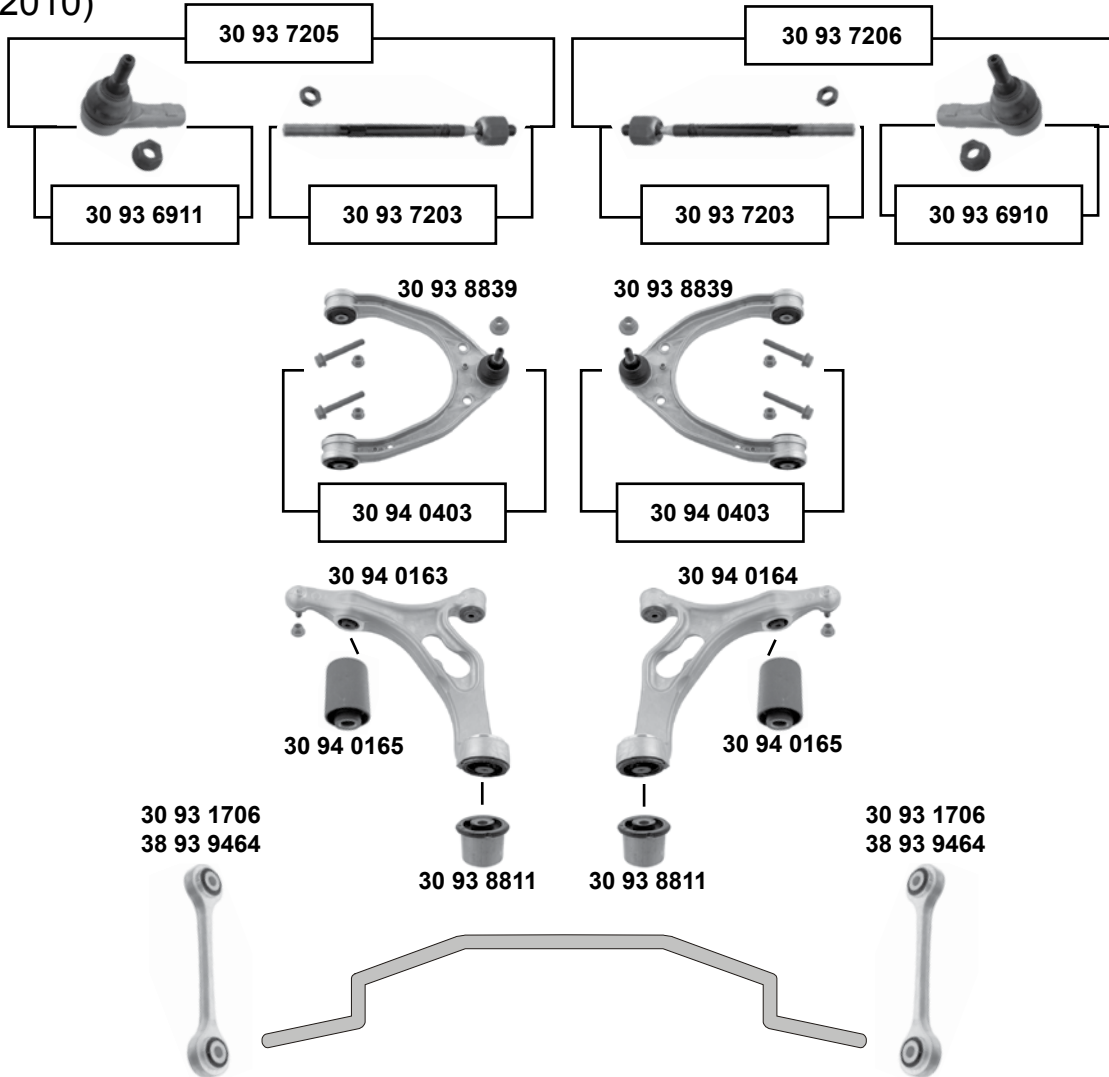

Vorderachse / Front axle

- (1) (ex.) PR-E81 / E8A // 04 → 08 PR-1LK Scheibenbremse / brake disc 330x32 mm (ch.) → 9P8LA34847
- (2) (ex.) PR-E81 / D5Z
- (3) Cayenne Turbo: 3,0D, 4,5B
Cayenne S / Cayenne GTS / Cayenne Turbo S: alle / all
- (4) Cayenne S 3,2B, 4,5B Cayenne Turbo 4,5B → 12/06
Cayenne GTS / Turbo: alle / all 06 → / O 955 341 017 33 / 955 341 018 33
Cayenne S 3,6B, 4,8B 07 → / O 955 341 017 33 / 955 341 018 33



SWAG GERMANY	Ref. - No.			
30 93 1706	955 343 069 00	Verbindungsstange / connecting rod	03 → / PR-0AB	L 244,2
30 93 6910	955 347 132 22	Spurstangenendstück / tie rod end	03 →	M16 x 1,5
30 93 6911	955 347 131 22	Spurstangenendstück / tie rod end	03 →	M16 x 1,5
30 93 7203	955 347 010 22	Axialgelenk / axial joint	(2) 03 →	L 320
30 93 7205	955 347 031 22	Spurstange / tie rod	(2) 03 →	
30 93 7206	955 347 032 22	Spurstange / tie rod	(2) 03 →	
30 93 8811	955 341 242 04	Querlenkerlager / control arm mounting	(4)	H 72 ØA 61
30 93 8839	955 341 027 02 S1	Rep. Satz Querlenker / rep. kit control arm	→ 10	
38 93 9464	955 343 069 10	Verbindungsstange / connecting rod	PR-0AW	L 265
30 94 0163	955 341 017 33 S1	Querlenker / control arm	(1)	Stahlguss
30 94 0164	955 341 018 33 S1	Querlenker / control arm	(1)	Stahlguss
30 94 0165	7L0 412 333 A	Querlenkerlager / control arm mount	(3)	H 74 ØI 14
30 94 0403	955 341 027 02 S2	Rep. Satz Querlenker / rep. kit control arm	→ 10	



Cayenne (958) S / GTS / Turbo S
(2002 →)



Cayenne S / Turbo S (A2)
(2002 →)



Cayenne (9P)
(2002 → 2006)



- (1) Cayenne S / Turbo S (A2): alle / all
Cayenne (958) GTS / Turbo S: alle / all
Cayenne S (958): 3,0B, 3,0D, 3,0H, 3,6B, 4,8B 06/2010 →
Cayenne (9): 4,5B



passend für / to fit

PORSCHE

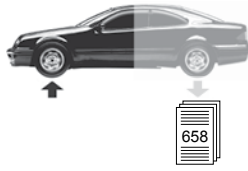

Cayman (987)

(2005 →)

Vorderachse / Front axle

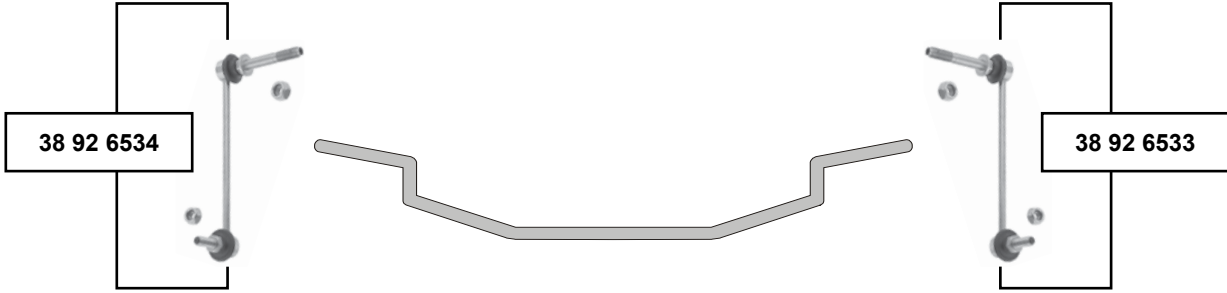

Panamera (970)

(2011 →)



Ref. - No.



38 92 6533	997 343 070 02
38 92 6534	997 343 069 02
30 94 0165	7L0 412 333 A

Verbindungsstange / connecting rod
Verbindungsstange / connecting rod
Querlenkerlager / control arm mount

L 200
L 200
H 74 ØI 14

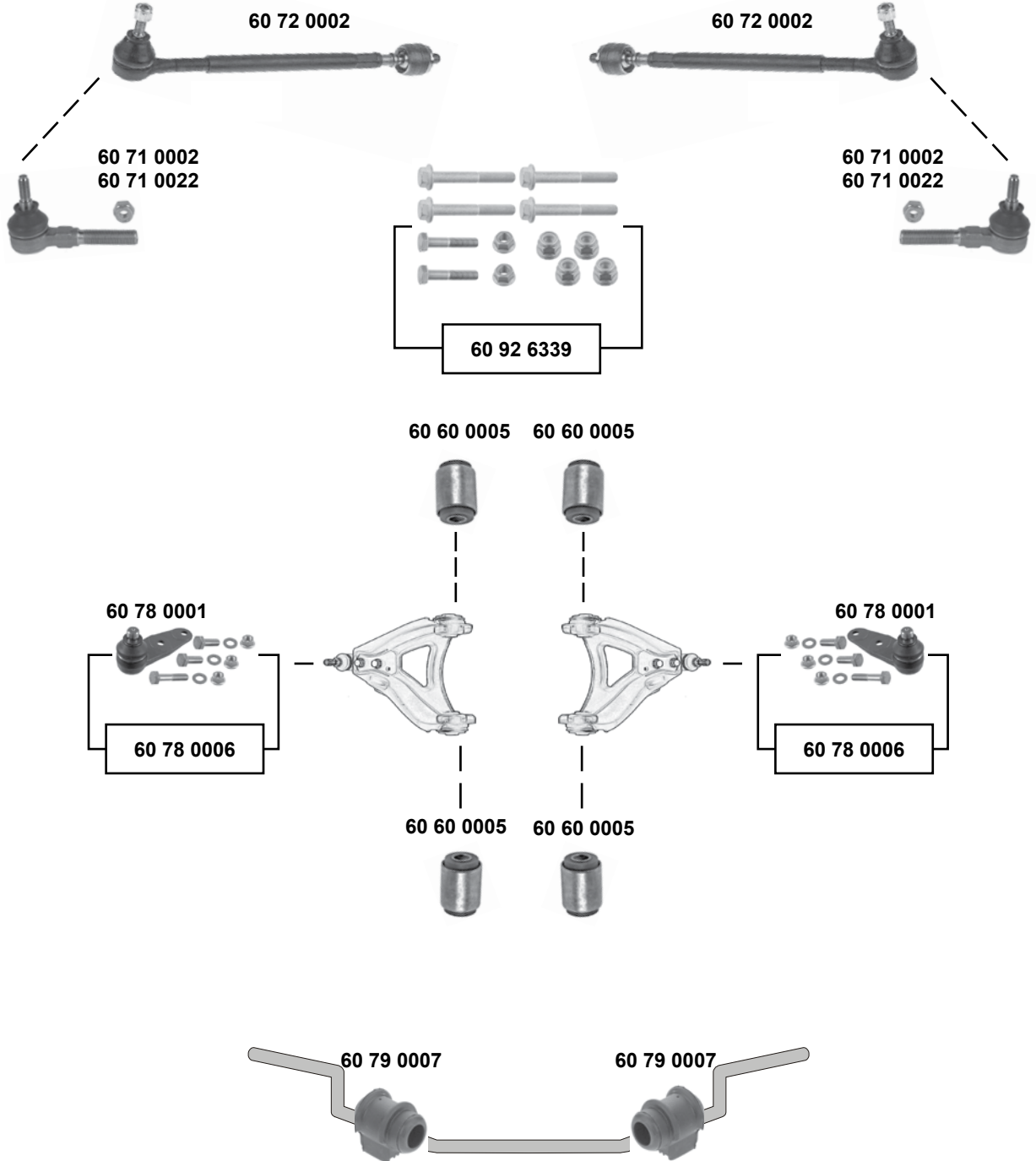

SWAG	Ref. - No.			
60 60 0005	77 04 000 681	Querlenkerlager / control arm mount		12x32x46
60 71 0002	77 01 461 141	Spurstangenendstück / tie rod end	OLD	M14 x 1,5
60 71 0022	77 01 469 231	Spurstangenendstück / tie rod end	NEW	M14 x 1,5
60 72 0002	77 01 463 346	Spurstange / tie rod		
60 78 0001	77 01 468 883 S2	Traggelenk / ball joint		Ø A 16
60 78 0006	77 01 468 883	Rep. Satz Traggelenk / rep. kit ball joint		
60 79 0007	77 00 760 265	Stabilisatorlager / stabilizer mount		Ø I 23
60 92 6339	77 00 763 538 S1	Schraubensatz / screw kit		



R9

(1982 → 1989)

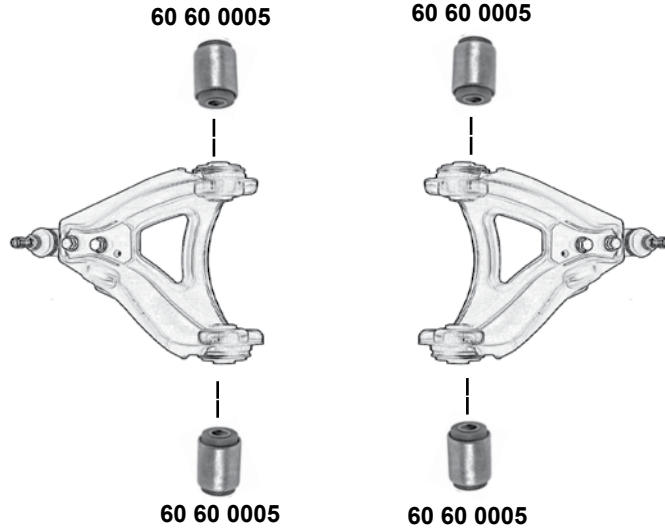

Vorderachse / Front axle

R11

(1982 → 1989)

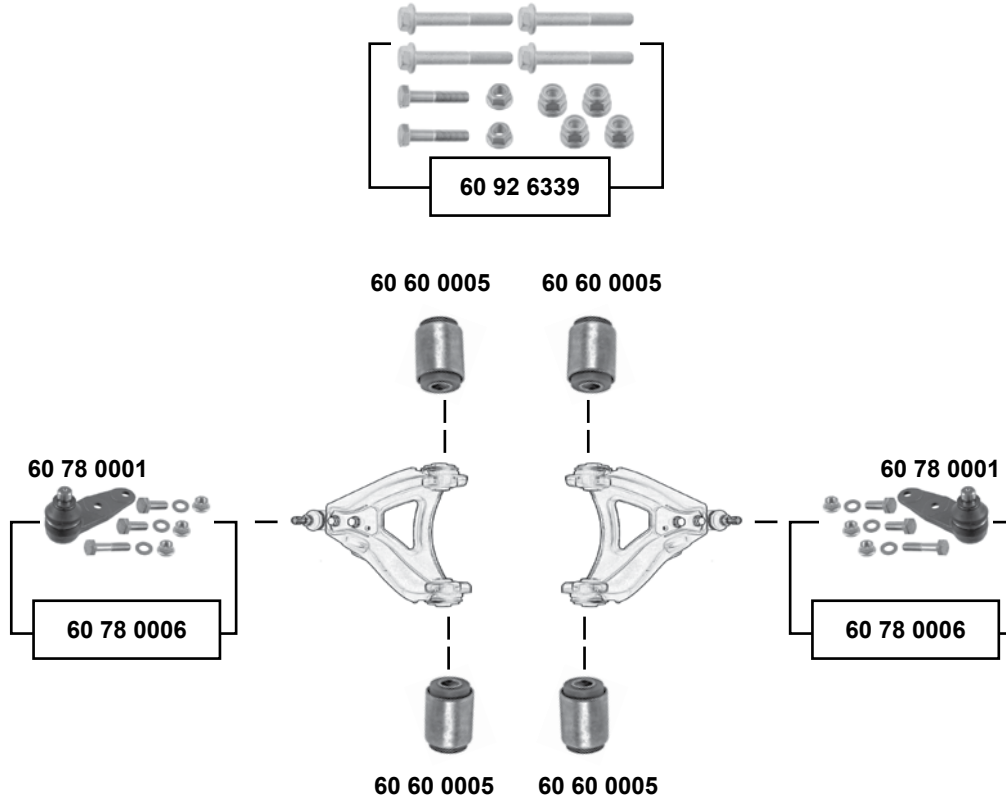

Ref. - No.



60 60 0005	77 04 000 681
60 78 0001	77 01 468 883 S2
60 78 0006	77 01 468 883
60 92 6339	77 00 763 538 S1

Querlenkerlager / control arm mount
Traggelenk / ball joint
Rep. Satz Traggelenk / rep. kit ball joint
Schraubensatz / screw kit

12x32x46
Ø A 16



oben / upper

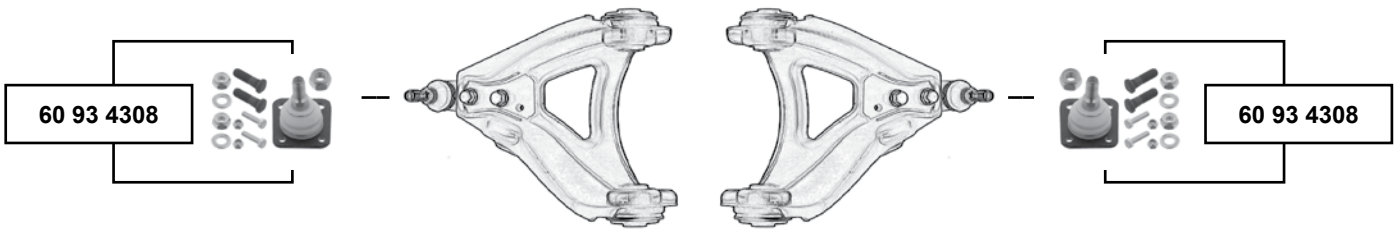

Vorderachse / Front axle

unten / lower

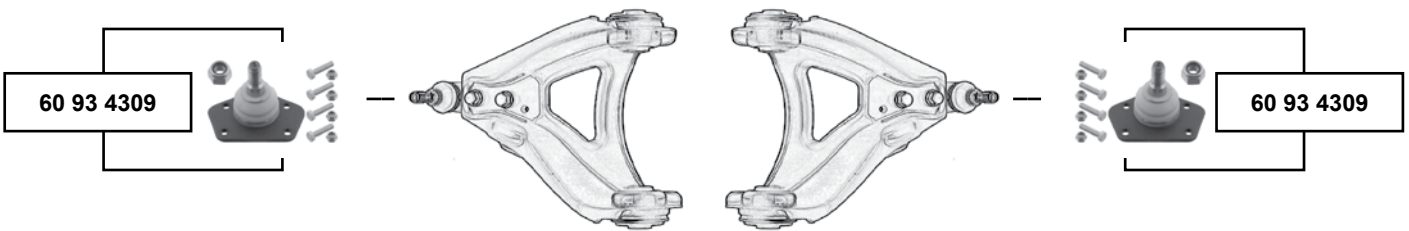



RENAULT

R15 / R17 / R18

(1972 → 1986)

oben / upper

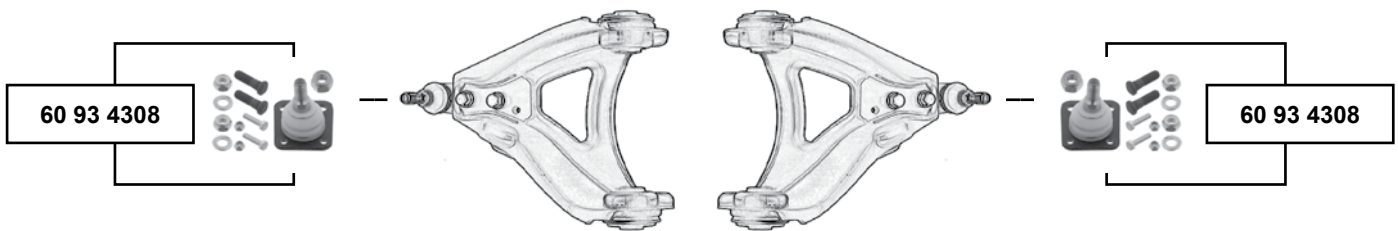

unten / lower

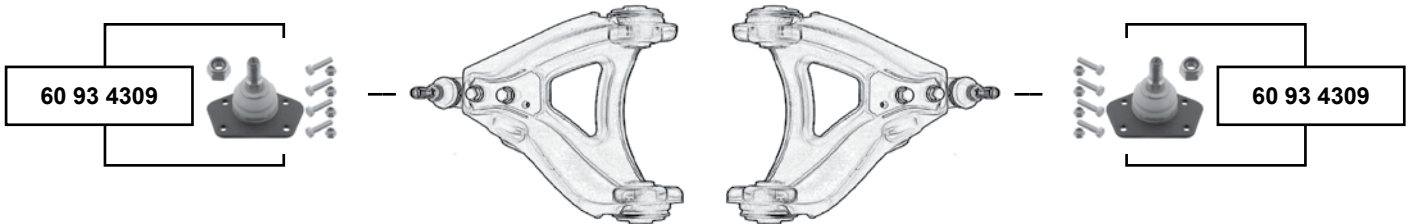

(1) R 15 / R17 72 → 80
R 18 78 → 86



Ref. - No.



60 93 4308	77 01 468 820
60 93 4309	77 01 468 821

Traggelenk / ball joint
Traggelenk / ball joint

(1)
(1)

Vorderachse / Front axle



R19

(1989 → 1995)

(ex.) 1.8 16V

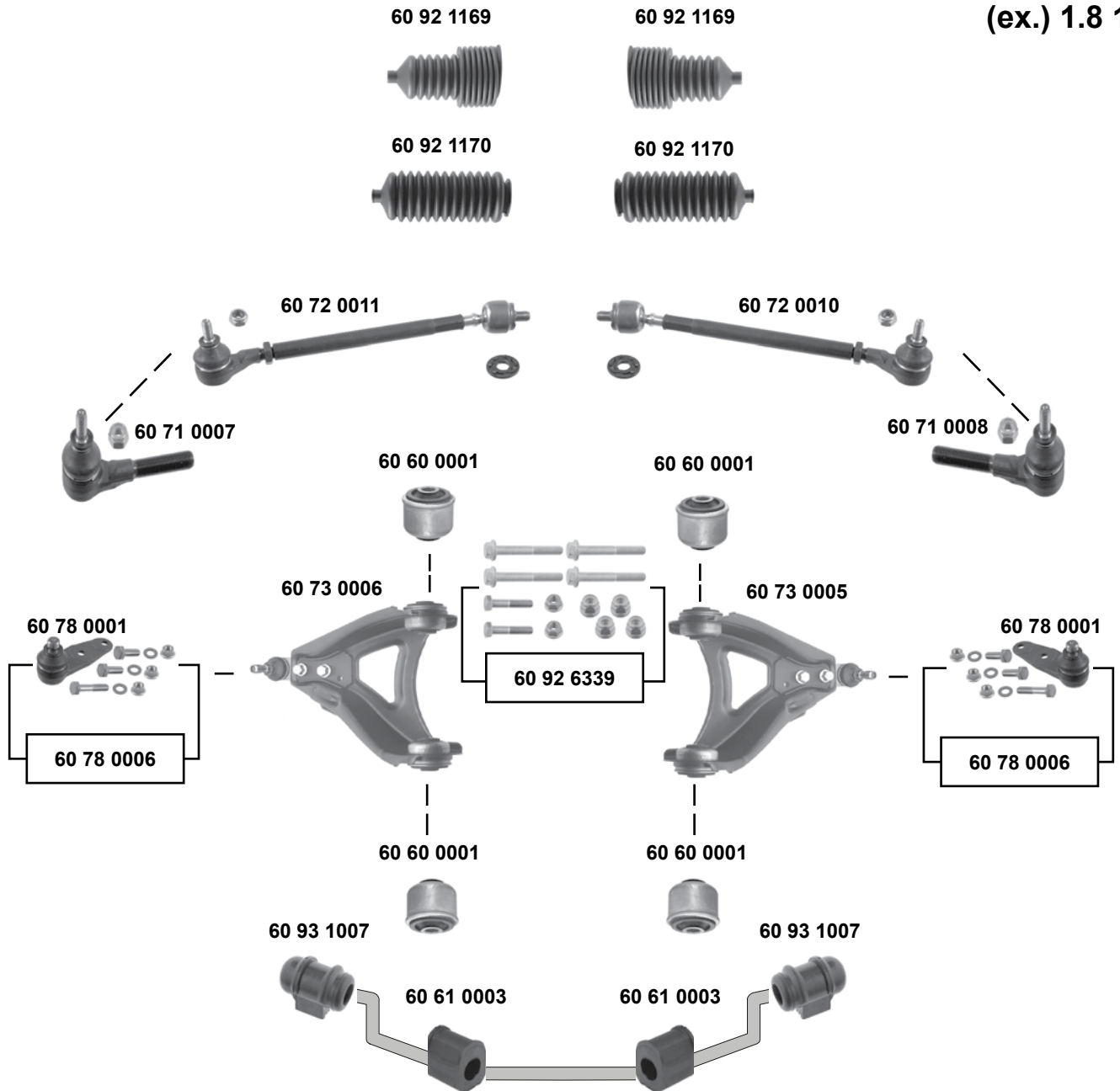

Vorderachse / Front axle



Ref. - No.



60 60 0001	77 00 840 741	Querlenkerlager / control arm mount		12x45x46
60 61 0003	77 00 785 788	Stabilisatorlager / stabilizer mount		Ø I 22
60 71 0007	60 00 030 047	Spurstangenendstück / tie rod end		M14 x 1,5
60 71 0008	60 00 030 048	Spurstangenendstück / tie rod end		M14 x 1,5
60 72 0010	77 01 467 237 S1	Spurstange / tie rod		
60 72 0011	77 01 467 235 S1	Spurstange / tie rod		
60 73 0005	82 00 737 135	Querlenker / control arm		
60 73 0006	82 00 737 134	Querlenker / control arm		
60 78 0001	77 01 468 883 S2	Traggelenk / ball joint		Ø A 16
60 78 0006	77 01 468 883	Rep. Satz Traggelenk / rep. kit ball joint		
60 92 1169	77 01 469 617	Lenkmanschette / steering boot		
60 92 1170	77 01 469 497	Lenkmanschette / steering boot		
60 92 6339	77 00 763 538 S1	Schraubensatz / screw kit		
60 93 1007	77 00 784 170	Stabilisatorlager / stabilizer mount		Ø I 18



R20 / R30

(1977 → 1983)

oben / upper

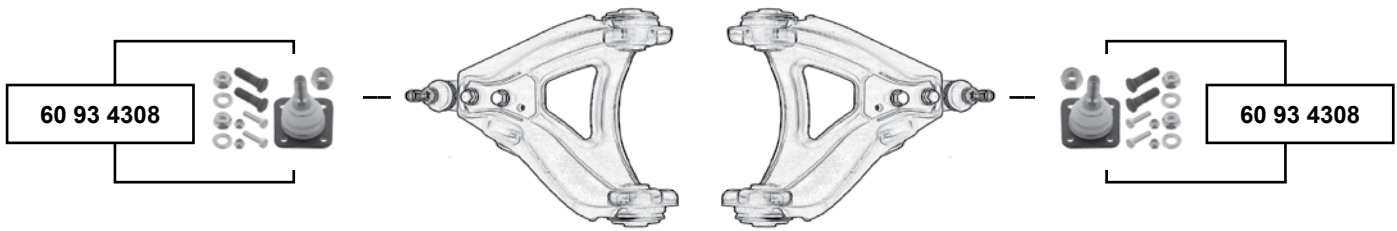

unten / lower

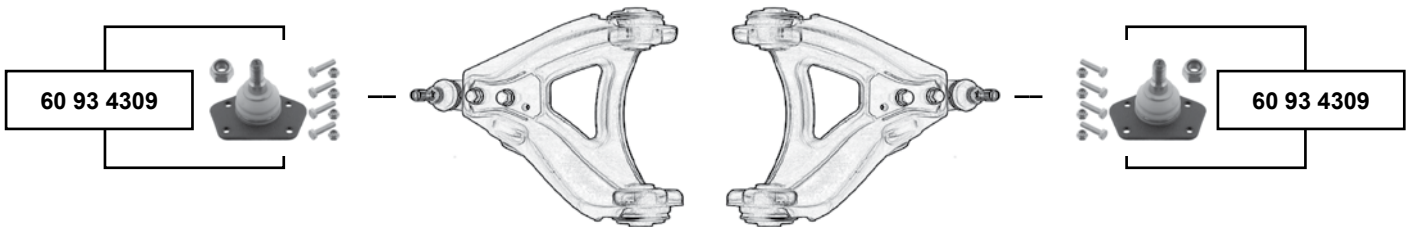

Vorderachse / Front axle



R21

(1986 → 1994)

1.4 → 1.9

Vorderachse / Front axle

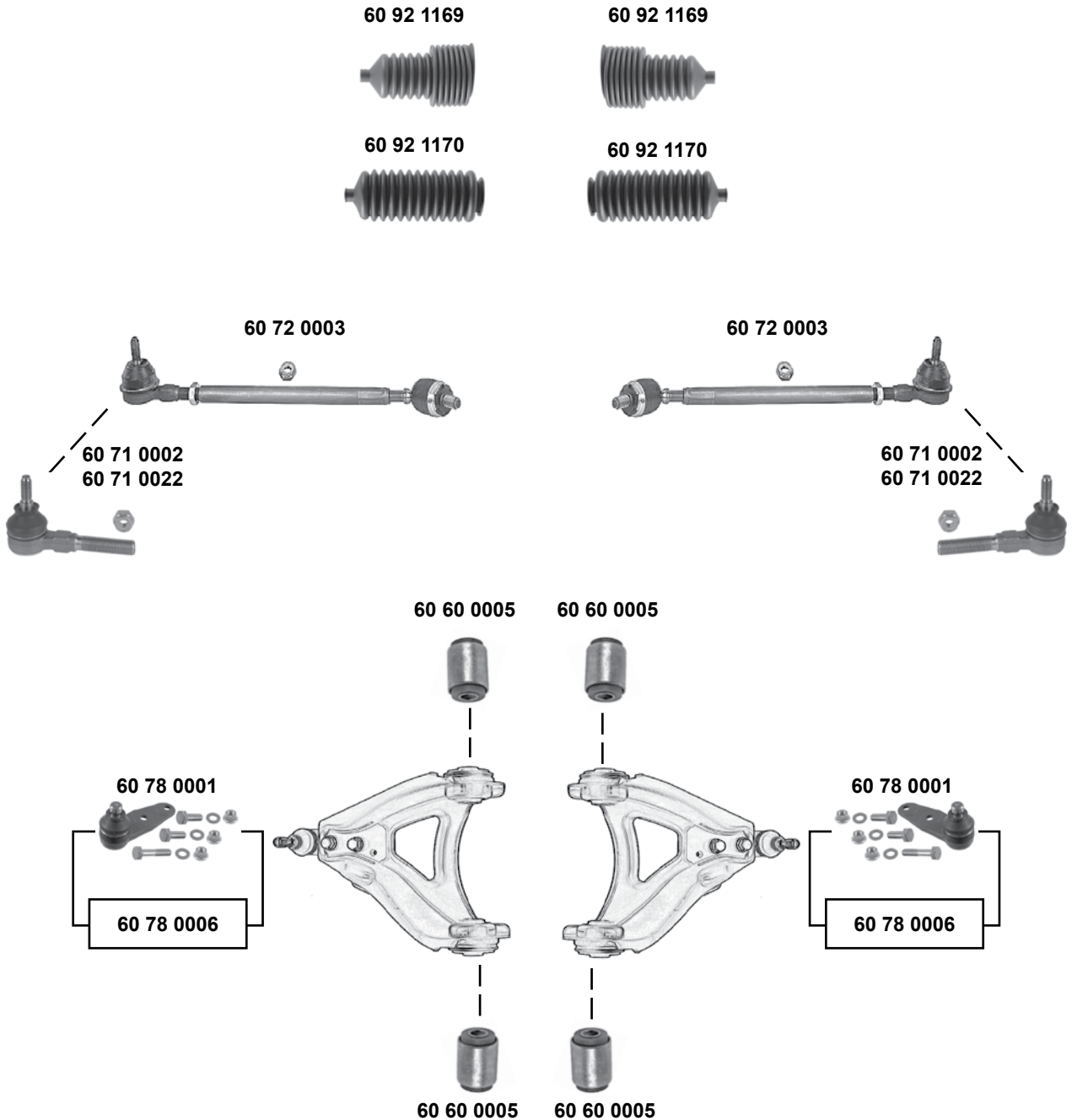

SWAG GERMANY	Ref. - No.			
60 60 0005	77 04 000 681	Querlenkerlager / control arm mount		12x32x46
60 71 0002	77 01 461 141	Spurstangenendstück / tie rod end	OLD	M14 x 1,5
60 71 0022	77 01 469 231	Spurstangenendstück / tie rod end	NEW	M14 x 1,5
60 72 0003	77 01 464 015	Spurstange / tie rod	servo.	
60 78 0001	77 01 468 883 S2	Traggelenk / ball joint		Ø A 16
60 78 0006	77 01 468 883	Rep. Satz Traggelenk / rep. kit ball joint		
60 92 1169	77 01 469 617	Lenkmanschette / steering boot	Nevada / servo	
60 92 1170	77 01 469 497	Lenkmanschette / steering boot	Nevada / man.	



RENAULT

R21

(1986 → 1994)

2.0 → 2.2

2.1 D → 2.1 TD

Vorderachse / Front axle

60 92 1169



60 92 1169



60 92 1170



60 92 1170



60 71 0016



60 71 0016



60 60 0015



60 60 0015



60 78 0021

60 78 0019

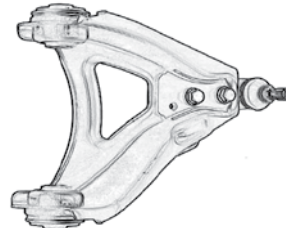
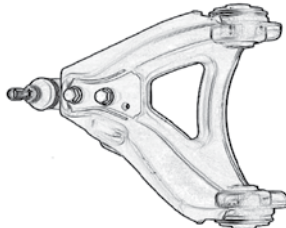

60 78 0021

60 78 0019



60 60 0014



60 60 0014



Ref. - No.



60 60 0014	77 00 772 687
60 60 0015	77 00 754 515
60 71 0016	77 01 469 230
60 78 0019	77 01 464 037
60 78 0021	77 01 464 037 S1
60 92 1169	77 01 469 617
60 92 1170	77 01 469 497

Querlenkerlager / control arm mount
Querlenkerlager / control arm mount
Spurstangenendstück / tie rod end
Rep. Satz Traggelenk / rep. kit ball joint
Traggelenk / ball joint
Lenkmanschette / steering boot
Lenkmanschette / steering boot

Nevada / servo
Nevada / man.

12x36x48,5
12x36x51
M14 x 1,5
Ø A 18



60 71 0022



60 71 0022



oben / upper

60 92 8302

60 92 8302

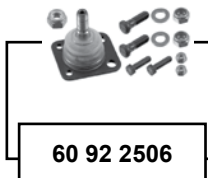

60 92 2506

60 92 2506

unten / lower

60 60 0007
60 60 0006

60 60 0007
60 60 0006

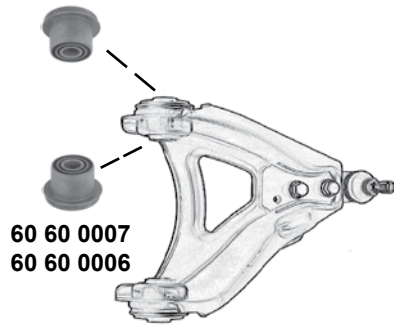
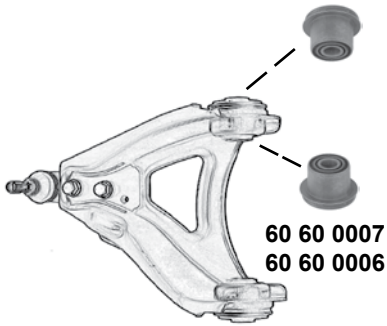

60 92 2507

60 92 2507

60 92 1655 60 60 0011

60 60 0011 60 92 1655



60 60 0007	77 00 781 463
60 60 0006	77 04 002 466
60 60 0011	77 00 777 540
60 71 0022	77 01 469 231
60 92 1655	77 00 781 441
60 92 2506	77 01 469 228
60 92 2507	77 01 465 689
60 92 8302	77 04 001 734

Querlenkerlager / control arm mount
Querlenkerlager / control arm mount
Querlenkerlager / control arm mount
Spurstangenendstück / tie rod end
Querlenkerlager / control arm mount
Traggelenk / ball joint
Traggelenk / ball joint
Querlenkerlager / control arm mount

03/88 →
→ 03/88
→ 03/88
03/88 →



Avantime (2001 → 2003)

Vorderachse / Front axle

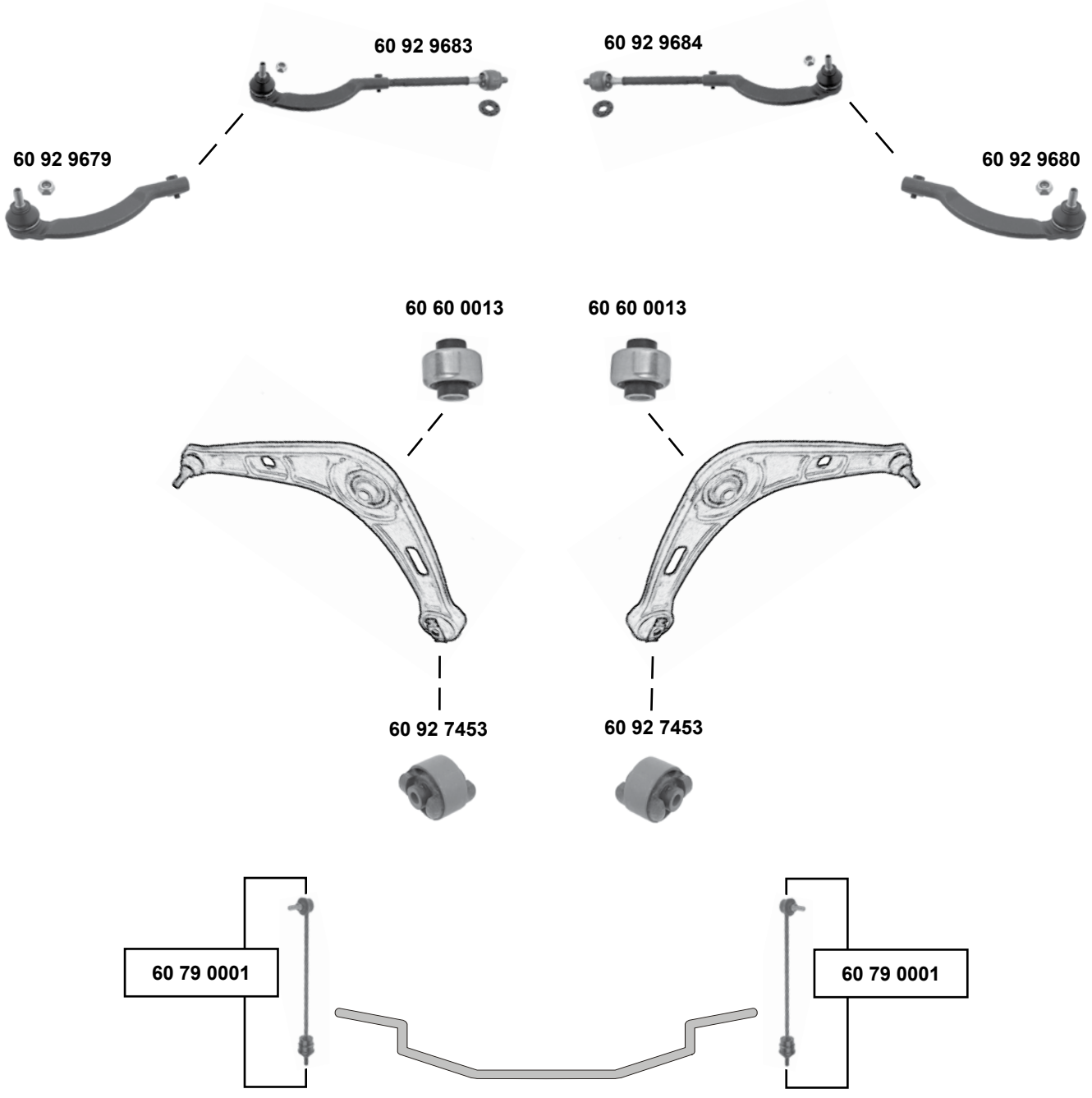

SWAG GERMANY	Ref. - No.			
60 60 0013	77 00 822 503	Querlenkerlager / control arm mount		
60 79 0001	77 00 805 494	Verbindungsstange / connecting rod		L 390
60 92 7453	60 25 311 529	Querlenkerlager / control arm mount		
60 92 9679	60 25 370 229	Spurstangenendstück / tie rod end		M14 x 1,5
60 92 9680	60 25 370 230	Spurstangenendstück / tie rod end		M14 x 1,5
60 92 9683	60 25 370 493	Spurstange / tie rod		M14 x 1,5
60 92 9684	60 25 370 494	Spurstange / tie rod		M14 x 1,5



Clio 1 (1985 → 1998)

60 92 1169



60 92 1169



60 92 1170



60 92 1170



→ 07/94

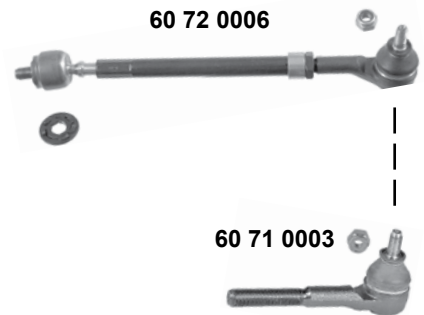
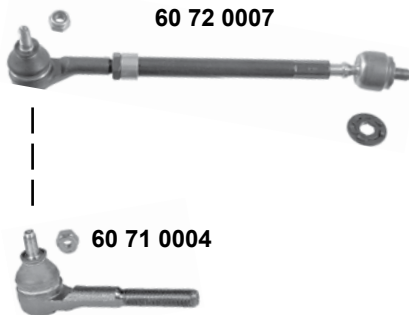

08/94 →

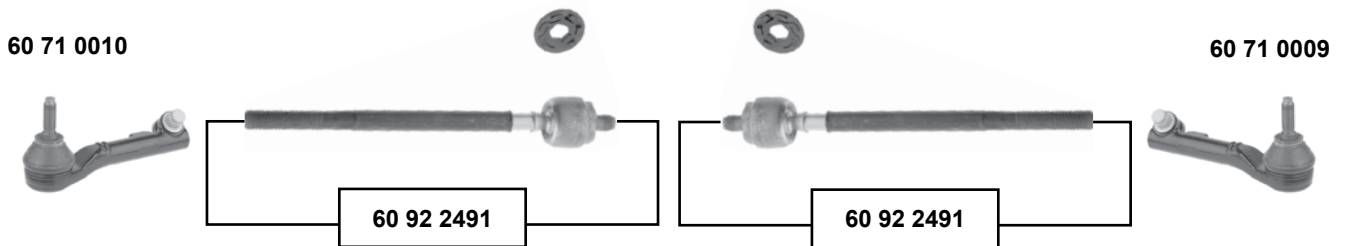

Vorderachse / Front axle

SWAG	Ref. - No.			
60 71 0003	60 00 030 064	Spurstangenendstück / tie rod end	→ 07/94	M14 x 1,5
60 71 0004	60 00 003 065	Spurstangenendstück / tie rod end	→ 07/94	M14 x 1,5
60 71 0009	77 01 041 312	Spurstangenendstück / tie rod end	08/94 →	
60 71 0010	77 01 041 311	Spurstangenendstück / tie rod end	08/94 →	
60 72 0006	77 01 467 272	Spurstange / tie rod	→ 07/94	
60 72 0007	77 01 467 271	Spurstange / tie rod	→ 07/94	
60 92 1169	77 01 469 617	Lenkmanschette / steering boot	servo	
60 92 1170	77 01 469 497	Lenkmanschette / steering boot	man.	
60 92 2491	77 01 469 778 SK	Spurstange / tie rod	08/94 →	



Clio 1 (1985 → 1998)

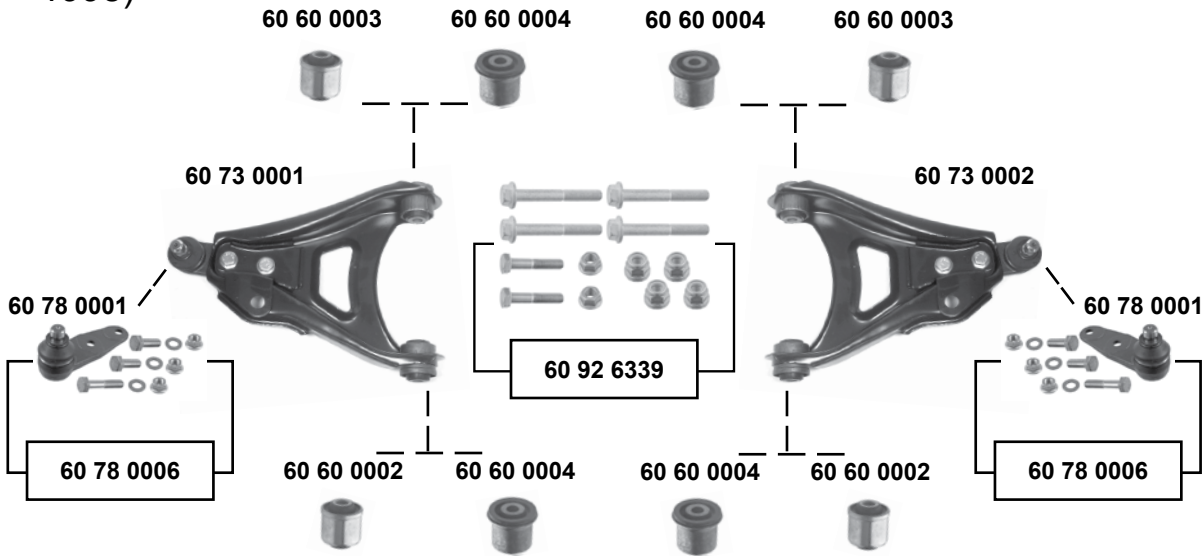

für / to fit Stabi Ø A 22

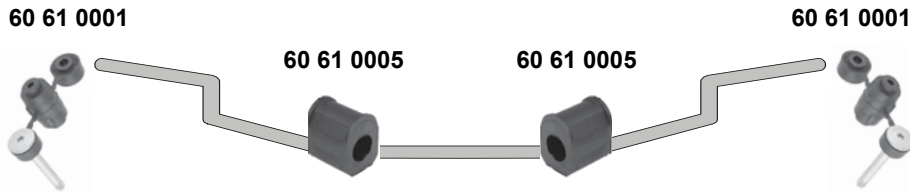

für / to fit Stabi Ø A 23

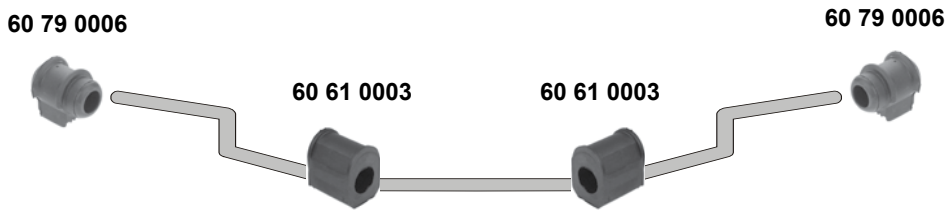

(1) (ex.) S / RSi / RTi / 16V / Williams

(2) S / RSi / RTi / 16V



Ref. - No.



Part No.	Description	Quantity	Dimensions
60 60 0002	Querlenkerlager / control arm mount	(1)	40x12x46
60 60 0003	Querlenkerlager / control arm mount	(1)	40x12x46
60 60 0004	Querlenkerlager / control arm mount	(2)	40x12x46
60 61 0001	Stabilisatorlager / stabilizer mount		
60 61 0003	Stabilisatorlager / stabilizer mount		Ø 23
60 61 0005	Stabilisatorlager / stabilizer mount		Ø 22
60 73 0001	Querlenker / control arm	(1)	
60 73 0002	Querlenker / control arm	(1)	
60 78 0001	Traggelenk / ball joint		Ø A 16
60 78 0006	Rep. Satz Traggelenk / rep. kit ball joint		
60 79 0006	Stabilisatorlager / stabilizer mount		Ø 23
60 92 6339	Schraubensatz / screw kit		

Vorderachse / Front axle

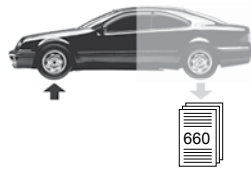

Clio 2 / Symbol
(1998 → 2005)

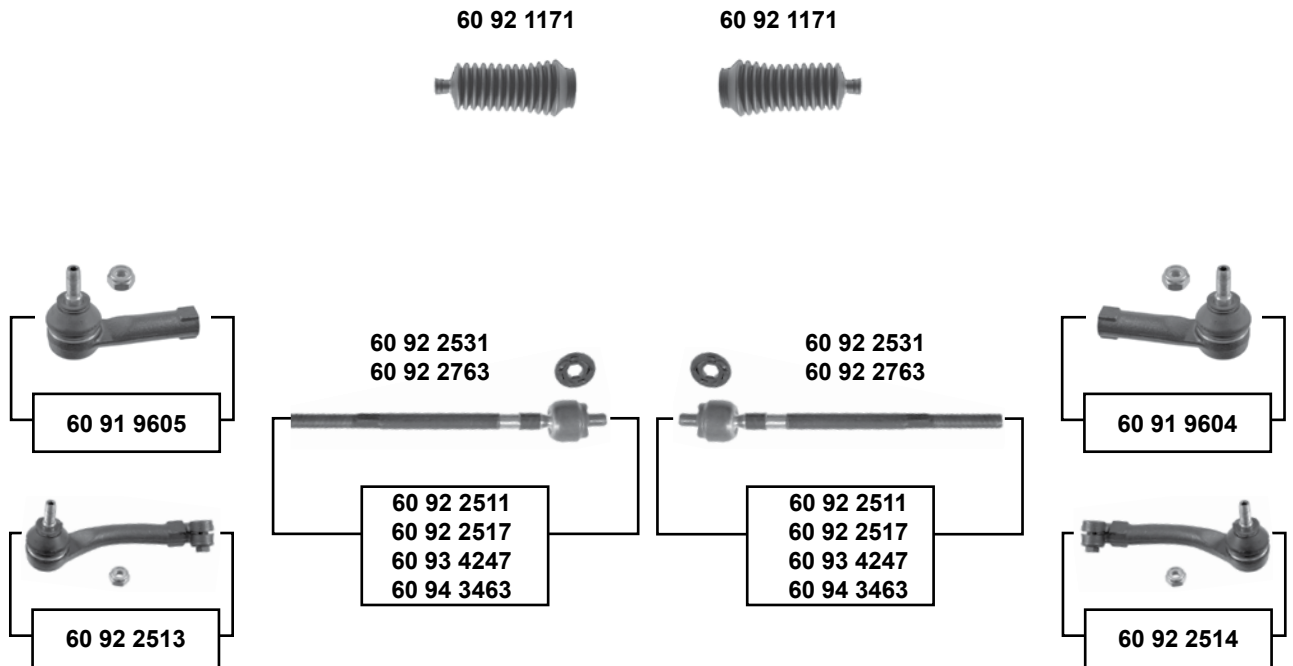

Vorderachse / Front axle

SWAG	Ref. - No.			
60 91 9604	77 01 047 813	Spurstangenendstück / tie rod end	12/99 → 05	M10 x 1,25
60 91 9605	77 01 047 812	Spurstangenendstück / tie rod end	12/99 → 05	M10 x 1,25
60 92 1171	77 01 469 496	Lenkmanschette / steering boot	SMI servo	
60 92 2511	77 01 472 113 SK	Axialgelenk / axial joint	man. 12/99 →	
60 92 2513	77 01 476 762	Spurstangenendstück / tie rod end	→ 12/99	
60 92 2514	77 01 476 763	Spurstangenendstück / tie rod end	→ 12/99	
60 92 2517	77 01 472 120 SK	Axialgelenk / axial joint	SMI servo 12/99 →	
60 92 2531	77 01 471 125 SK	Spurstange / tie rod	servo → 12/99	
60 92 2763	77 01 472 734 SK	Spurstange / tie rod	TRW servo 12/99 →	
60 93 4247	77 01 471 124 SK	Axialgelenk / axial joint	98 → 12/99 / (ex.) servo	L 240
60 94 3463	77 01 471 143 SK	Axialgelenk / axial joint	TRW servo → 12/99	L 240

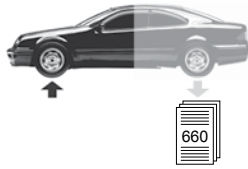

Clio 2 / Symbol

(1998 → 2005)

Vorderachse / Front axle

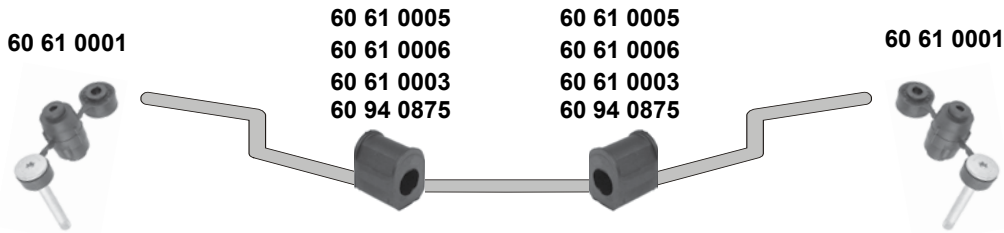
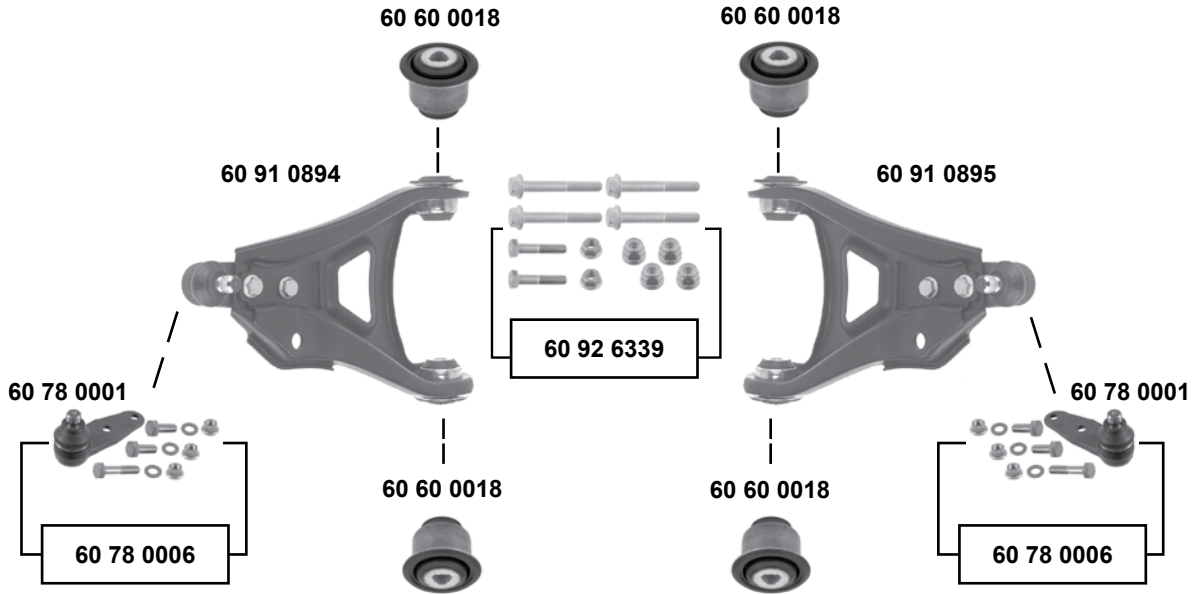

(1) CB15,C,G,N,S,T // CB0M // CB20,1,2



Ref. - No.



60 60 0018	82 00 651 161	Querlenkerlager / control arm mount		45,5x46
60 61 0001	77 00 799 404	Stabilisatorlager / stabilizer mount		
60 61 0003	77 00 785 788	Stabilisatorlager / stabilizer mount		Ø I 23
60 61 0005	77 00 798 053	Stabilisatorlager / stabilizer mount		Ø I 22
60 61 0006	77 00 835 929	Stabilisatorlager / stabilizer mount		Ø I 24
60 78 0001	77 01 468 883 S2	Traggelenk / ball joint		Ø A 16
60 78 0006	77 01 468 883	Rep. Satz Traggelenk / rep. kit ball joint		
60 91 0894	82 00 197 179	Querlenker / control arm		
60 91 0895	82 00 197 187	Querlenker / control arm		
60 92 6339	77 00 763 538 S1	Schraubensatz / screw kit	(ex.) RS V6	
60 94 0875	77 00 847 383	Stabilisatorlager / stabilizer mount	(1)	Ø I 23,5



Clio 3 (2005 → 2012)

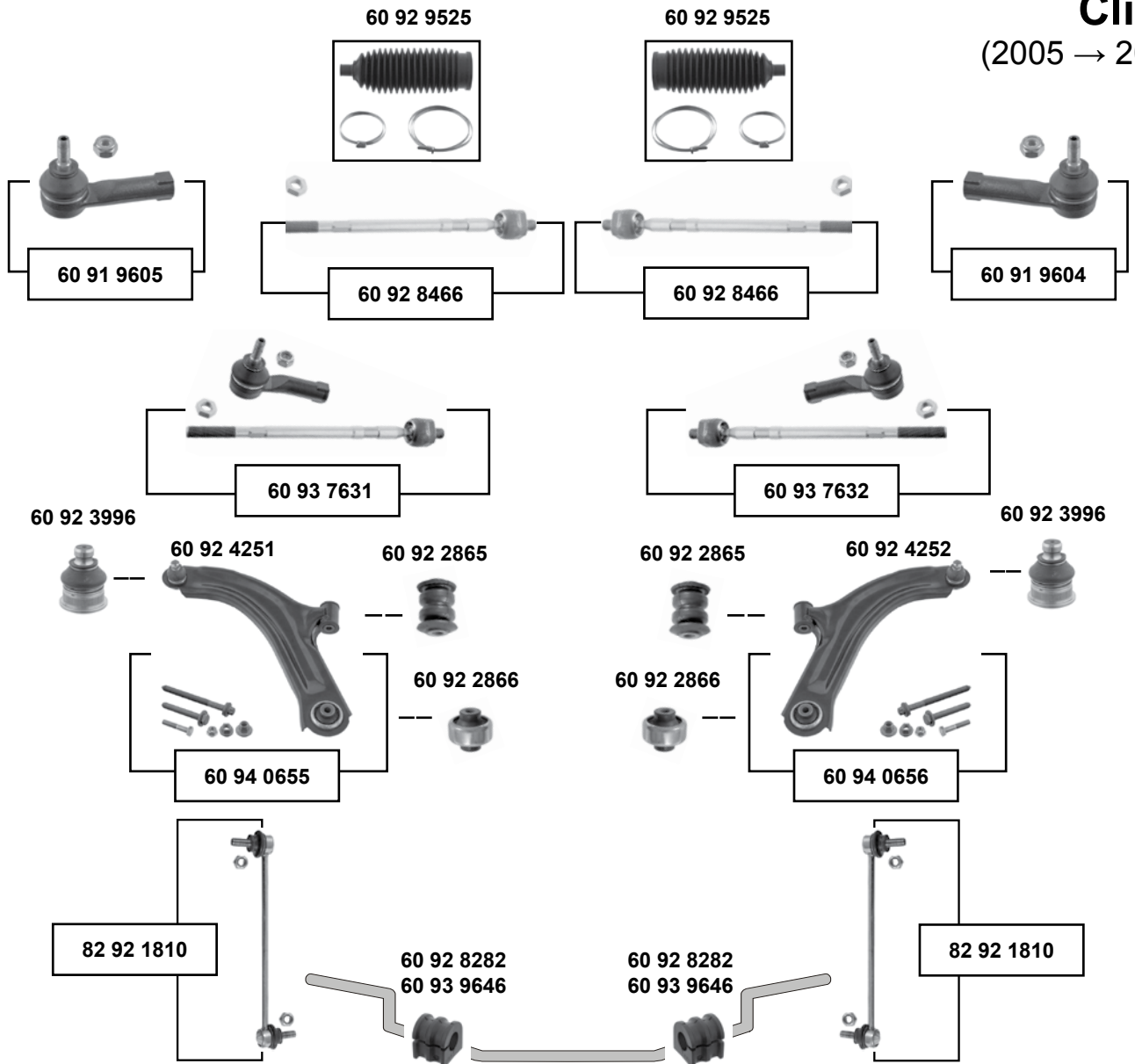

Vorderachse / Front axle



(1) Grandtour: KR00,2,4,9,A,E,G,H,J,P,S / KR10,6,7,A,B,C,H,N,T,U,V / KR21 08 →

(2) nur / only: CRON / CR1D

SWAG [®]	Ref. - No.			
60 91 9604	77 01 047 813	Spurstangenendstück / tie rod end		M10 x 1,25
60 91 9605	77 01 047 812	Spurstangenendstück / tie rod end		M10 x 1,25
60 92 2865	82 00 183 569	Querlenkerlager / rubber mount		Ø A 40 H55
60 92 2866	82 00 183 570	Querlenkerlager / rubber mount		Ø A 68 H53
60 92 3996	40 16 047 93R	Traggelenk / ball joint		Ø A 18
60 92 4251	82 00 744 091	Querlenker / control arm		
60 92 4252	82 00 744 092	Querlenker / control arm		
60 92 8282	77 01 056 678	Stabilisatorlager / stabilizer mount	(2)	Ø I 19,5
60 92 8466	77 01 475 841 SK	Spurstange / tie rod	servo	L 310
60 92 9525	77 01 475 840	Lenkmanschette / steering boot		
60 93 7631	77 01 475 841 S1	Rep. Satz Spurstange / rep. kit tie rod		
60 93 7632	77 01 475 841 S2	Rep. Satz Spurstange / rep. kit tie rod		
60 93 9646	77 01 059 672	Stabilisatorlager / stabilizer mount	(1)	Ø I 20,5
60 94 0655	82 00 744 091 S1	Rep. Satz Querlenker / rep. kit control arm		
60 94 0656	82 00 744 092 S1	Rep. Satz Querlenker / rep. kit control arm		
82 92 1810	82 00 127 308	Verbindungsstange / connecting rod		L 248

passend für / to fit

RENAULT

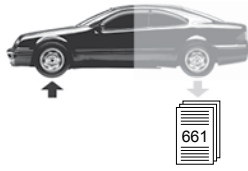

Clio 4
(2013 →)

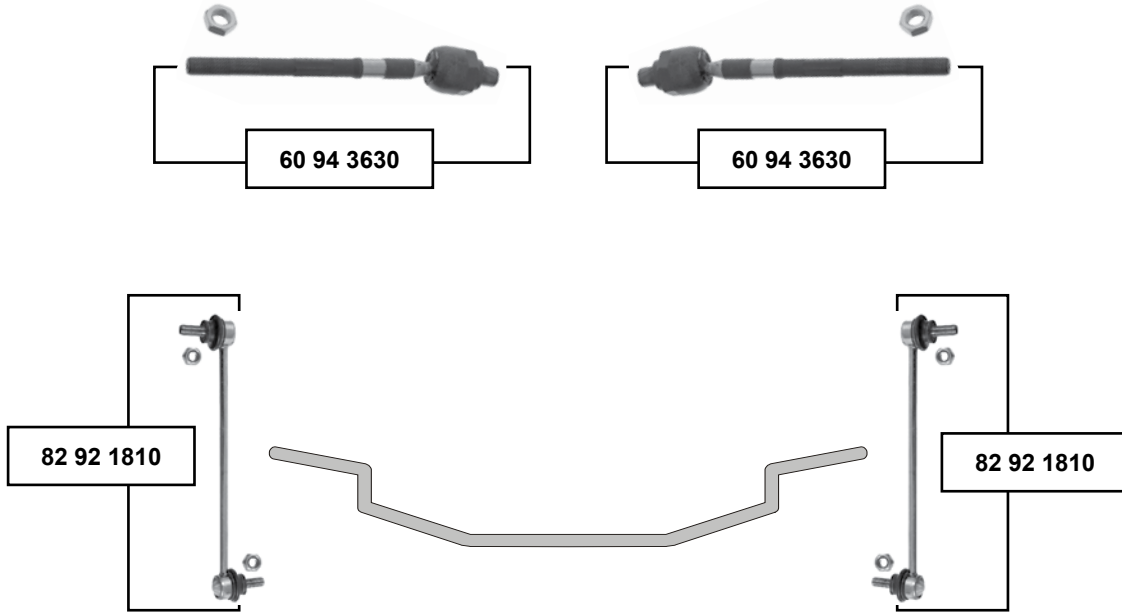

Vorderachse / Front axle

Duster
(2010 →)

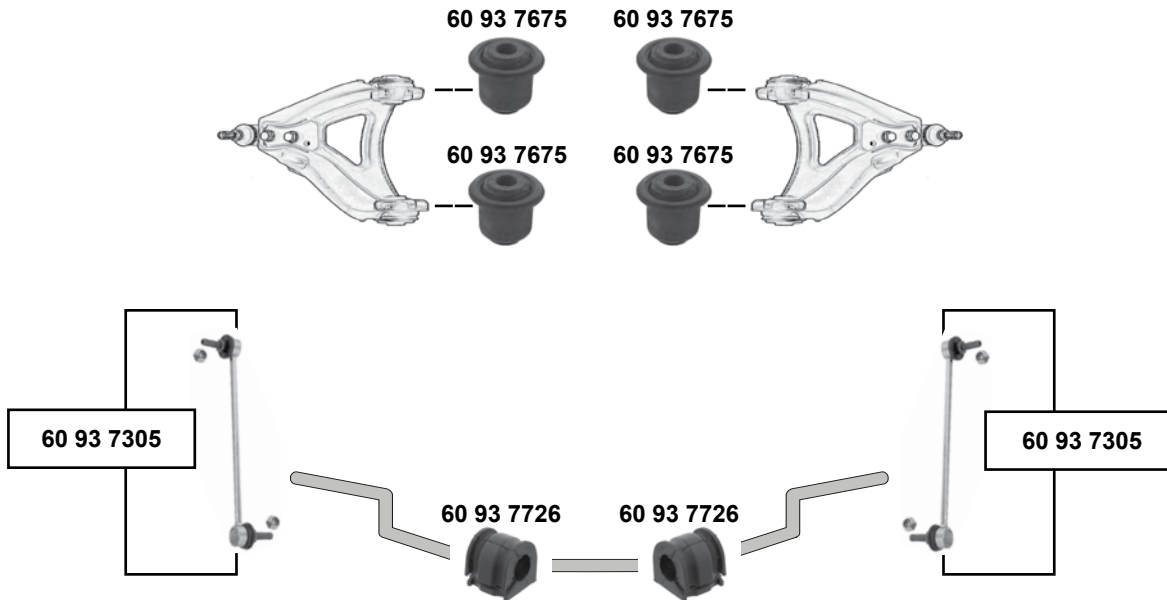

Ref. - No.



60 93 7305	82 00 814 411
60 93 7675	54 56 027 88R
60 93 7726	54 61 142 37R
60 94 3630	48 52 110 71R SK
82 92 1810	82 00 127 308

Verbindungsstange / connecting rod
Querlenkerlager / control arm mount
Stabilisatorlager / stabilizer mount
Axialgelenk / axial joint
Verbindungsstange / connecting rod

alle / all

L 294
Ø A 40,5 / 37
Ø I 18,5
L 232
L 248



Espace 1 (1984 → 1990)

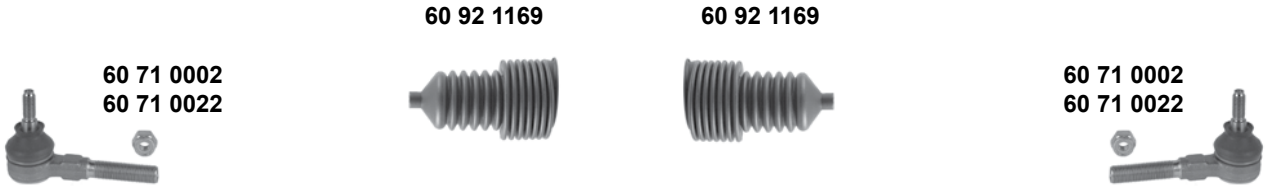

oben / upper



unten / lower

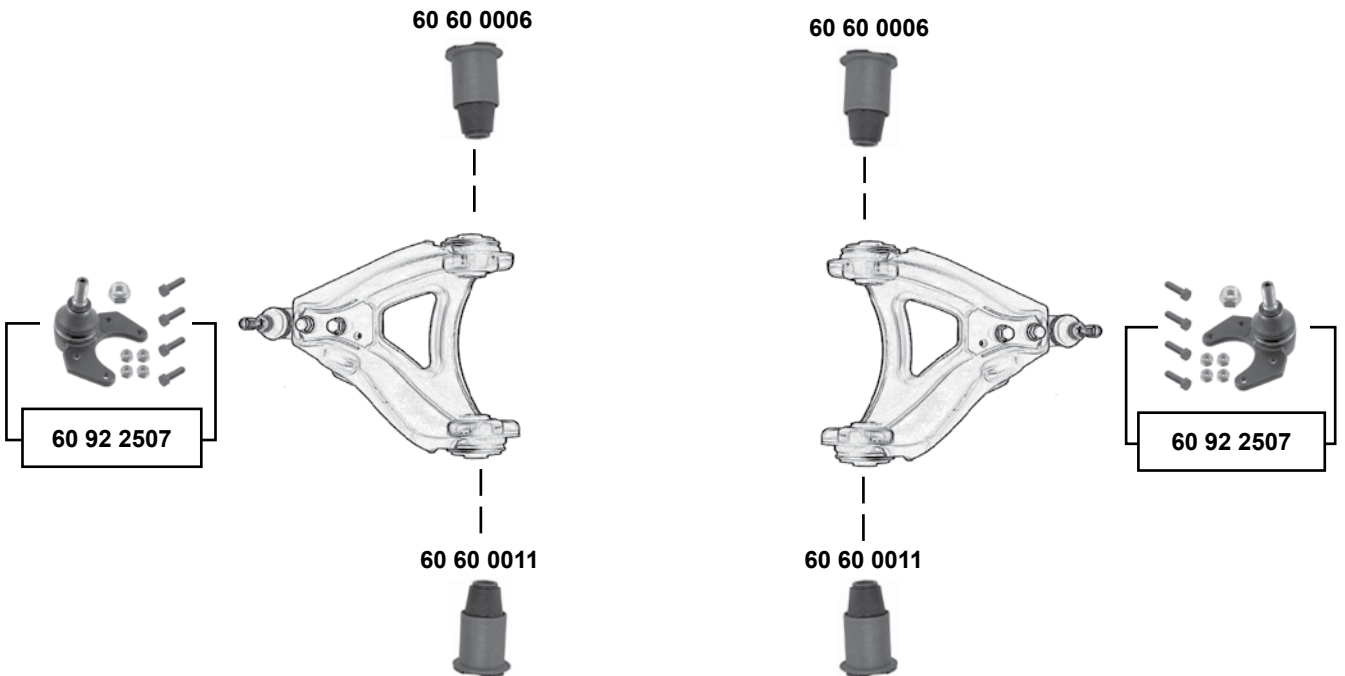

Vorderachse / Front axle

SWAG [®]	Ref. - No.			
60 60 0006	77 04 002 466	Querlenkerlager / control arm mount	OLD NEW servo	40x16x83
60 60 0011	77 00 777 540	Querlenkerlager / control arm mount		40x16x83
60 71 0002	77 01 461 141	Spurstangenendstück / tie rod end		M14 x 1,5
60 71 0022	77 01 469 231	Spurstangenendstück / tie rod end		M14 x 1,5
60 92 1169	77 01 469 617	Lenkmanschette / steering boot		
60 92 2506	77 01 469 228	Traggelenk / ball joint		
60 92 2507	77 01 465 689	Traggelenk / ball joint		



Espace 2 (1991 → 1996)

Vorderachse / Front axle



oben / upper

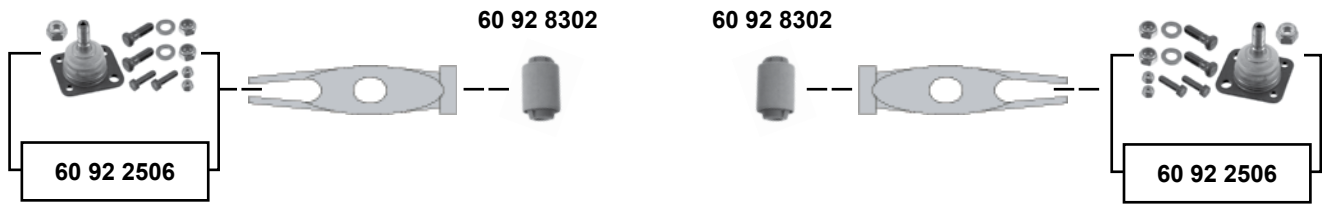

unten / lower

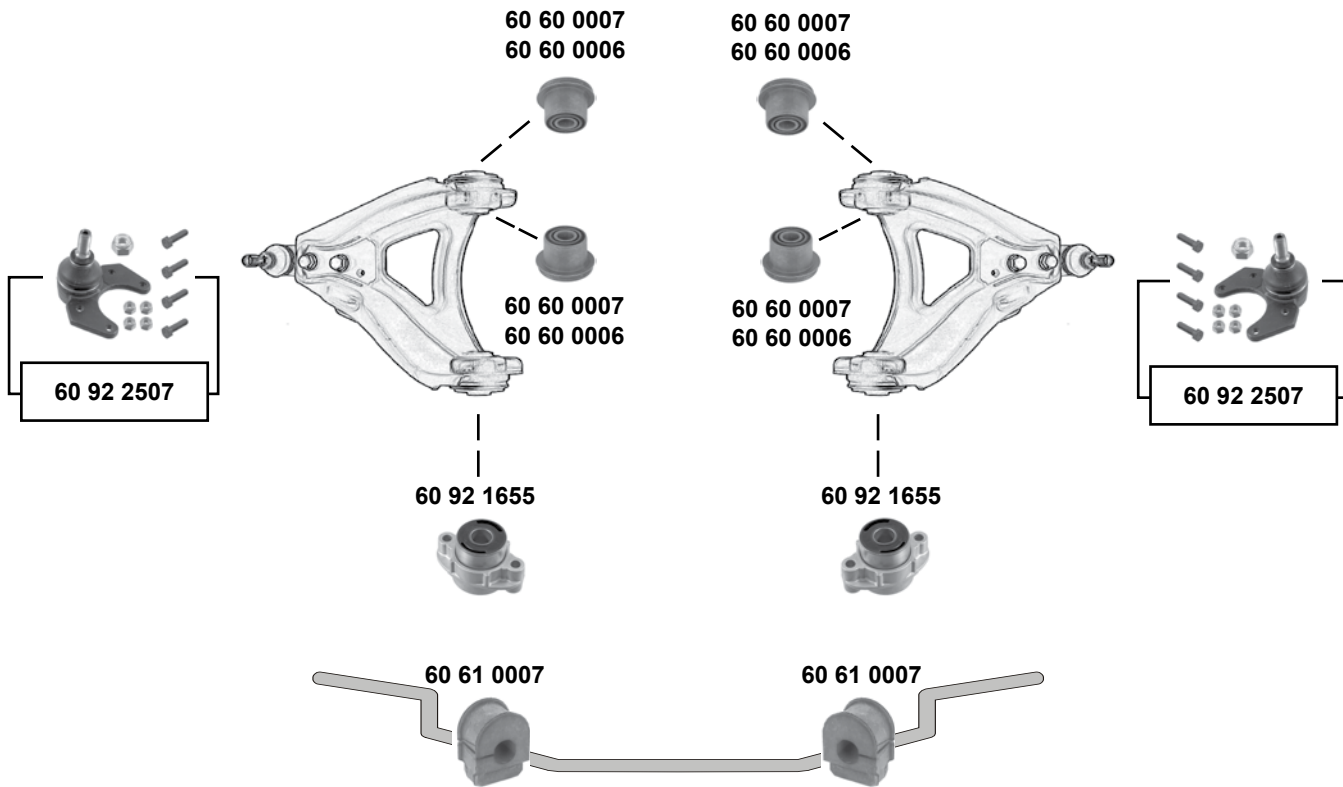

Ref. - No.



60 60 0006	77 04 002 466
60 60 0007	77 00 781 463
60 61 0007	77 00 797 821
60 71 0002	77 01 461 141
60 71 0022	77 01 469 231
60 92 1169	77 01 469 617
60 92 1655	77 00 781 441
60 92 2506	77 01 469 228
60 92 2507	77 01 465 689
60 92 8302	77 04 001 734

Querlenkerlager / control arm mount
Querlenkerlager / control arm mount
Stabilisatorlager / stabilizer mount
Spurstangenendstück / tie rod end
Spurstangenendstück / tie rod end
Lenkmanschette / steering boot
Querlenkerlager / control arm mount
Traggelenk / ball joint
Traggelenk / ball joint
Querlenkerlager / control arm mount

OLD
NEW
servo

Ø | 22
M14 x 1,5
M14 x 1,5



Espace 3
(1997 → 2002)

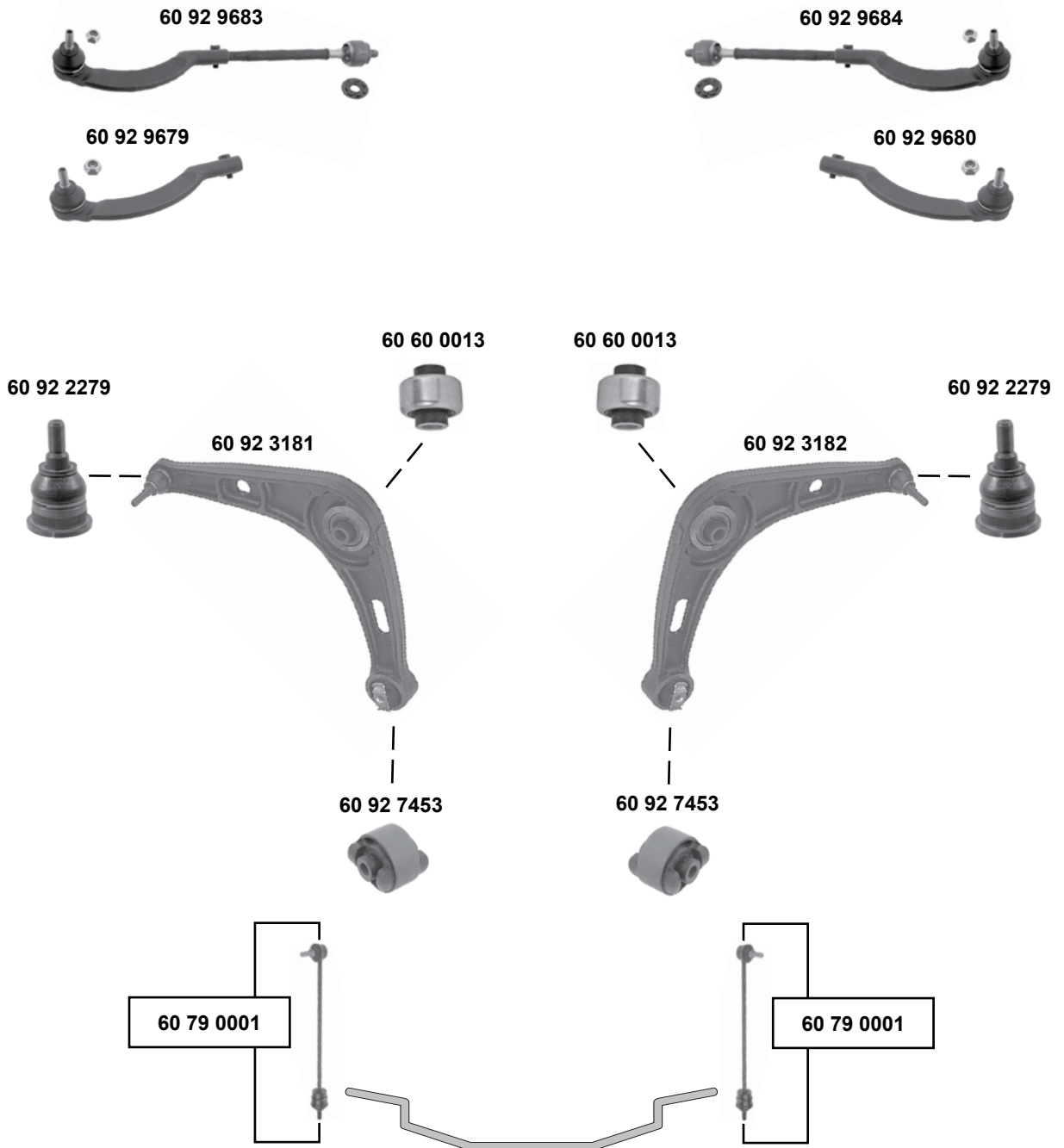

Vorderachse / Front axle

SWAG	Ref. - No.			
60 60 0013	77 00 822 503	Querlenkerlager / control arm mount		
60 79 0001	77 00 805 494	Verbindungsstange / connecting rod		
60 92 2279	60 25 308 155	Traggelenk / ball joint		L 390 M12 x 1,0
60 92 3181	60 25 307 649	Querlenker / control arm		
60 92 3182	60 25 307 650	Querlenker / control arm		
60 92 7453	60 25 311 529	Querlenkerlager / control arm mount		
60 92 9679	60 25 370 229	Spurstangenendstück / tie rod end		M14 x 1,5
60 92 9680	60 25 370 230	Spurstangenendstück / tie rod end		M14 x 1,5
60 92 9683	60 25 370 493	Spurstange / tie rod		M14 x 1,5
60 92 9684	60 25 370 494	Spurstange / tie rod		M14 x 1,5



Espace 4 (2002 → 2015)

Vorderachse / Front axle

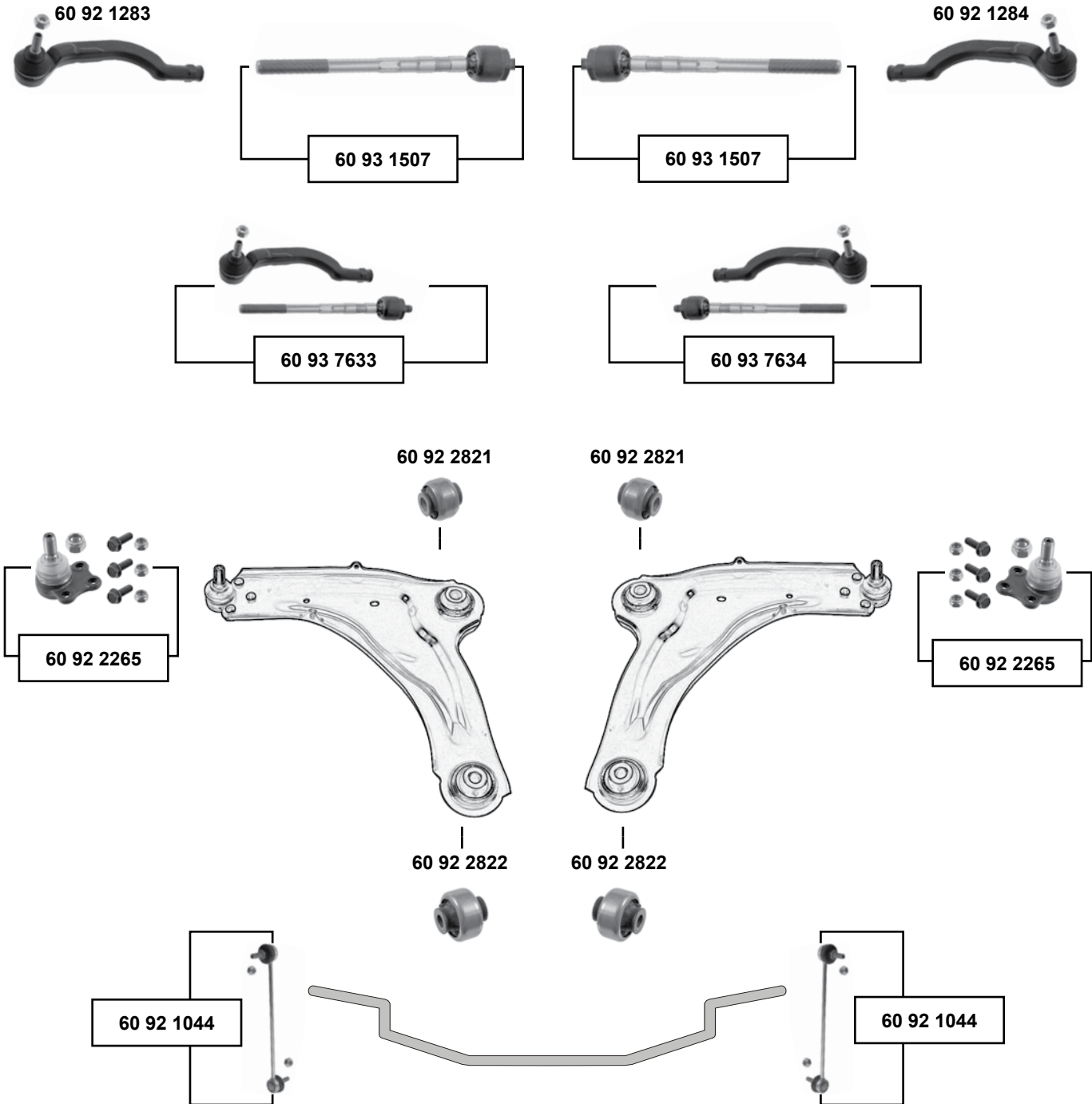

SWAG GERMANY	Ref. - No.			
60 92 1044	82 00 661 217	Verbindungsstange / connecting rod		L 280
60 92 1283	77 01 049 282	Spurstangenendstück / tie rod end		M12 x 1,5
60 92 1284	77 01 049 283	Spurstangenendstück / tie rod end		M12 x 1,5
60 92 2265	77 01 478 029	Traggelenk / ball joint		
60 92 2821	82 00 002 868	Querlenkerlager / control arm mount		
60 92 2822	82 00 002 869	Querlenkerlager / control arm mount		
60 93 1507	77 01 478 522 SK	Spurstange / tie rod		L 247
60 93 7633	77 01 478 552 S1	Rep. Satz Spurstange / rep. kit tie rod		
60 93 7634	77 01 478 552 S2	Rep. Satz Spurstange / rep. kit tie rod		



Fluence (2010 →)

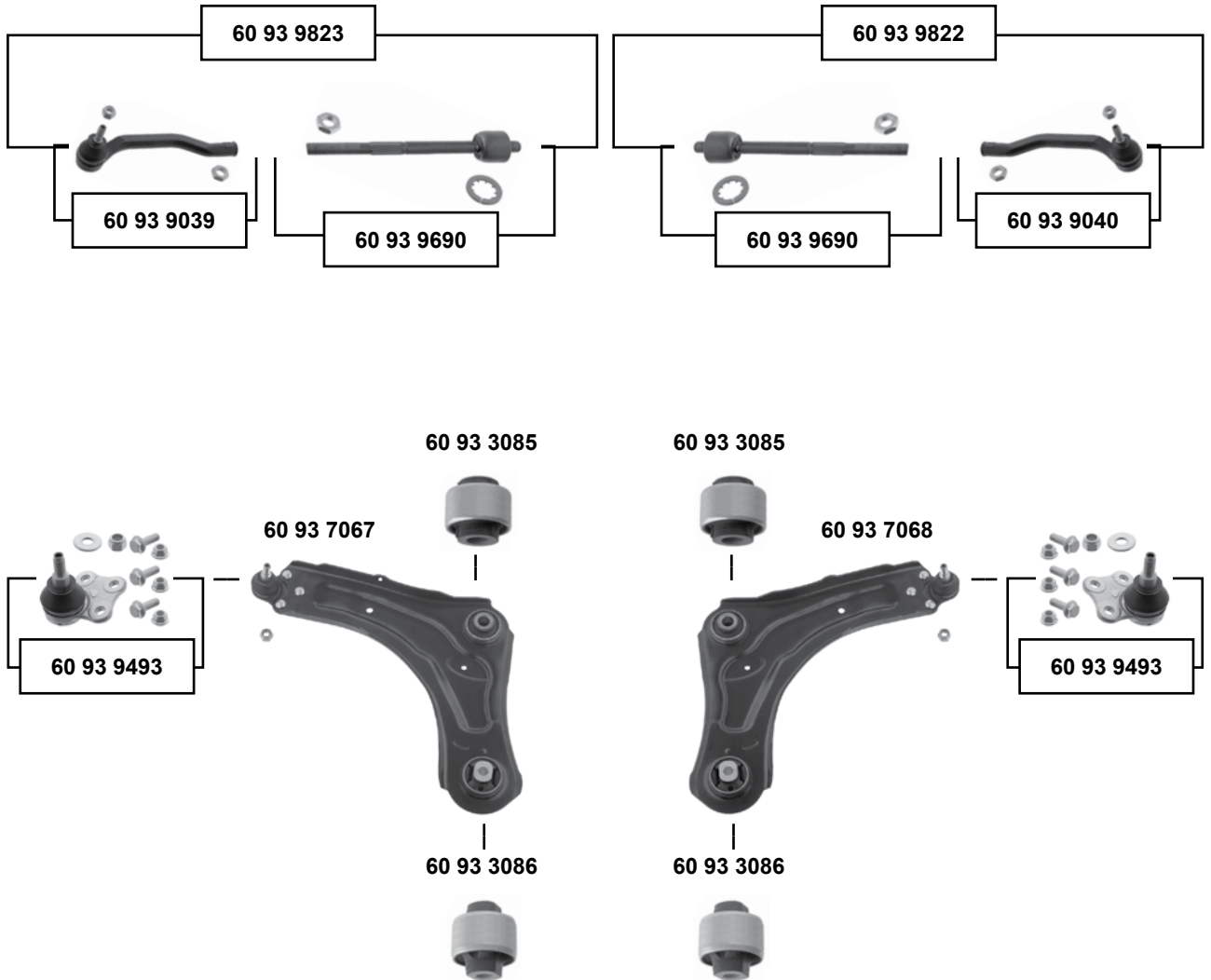

Vorderachse / Front axle



(1) L301,2,4,5,6,7,B,C,D,F,G,H,J,K,L,M,P,R,S,T,V,W,Z

(2) L301,2,4,5,6,7,A,B,C,D,E,F,G,H,J,K,L,M,P,R,S,T,V,W,Z



Ref. - No.



SWAG Ref. - No.	Description	Quantity	Dimension
60 93 3085	Querlenkerlager / control arm mount	(1)	Ø A 55
60 93 3086	Querlenkerlager / control arm mount	(1)	Ø A 58
60 93 7067	Querlenker / control arm	(2)	
60 93 7068	Querlenker / control arm	(2)	
60 93 9039	Spurstangenendstück / tie rod end		L 210
60 93 9040	Spurstangenendstück / tie rod end		L 210
60 93 9493	Traggelenk / ball joint		
60 93 9690	Axialgelenk / axial joint		L 214
60 93 9822	Rep. Satz Spurstange / rep. kit tie rod		
60 93 9823	Rep. Satz Spurstange / rep. kit tie rod		



Kangoo 1 (1998 → 2008)

Vorderachse / Front axle

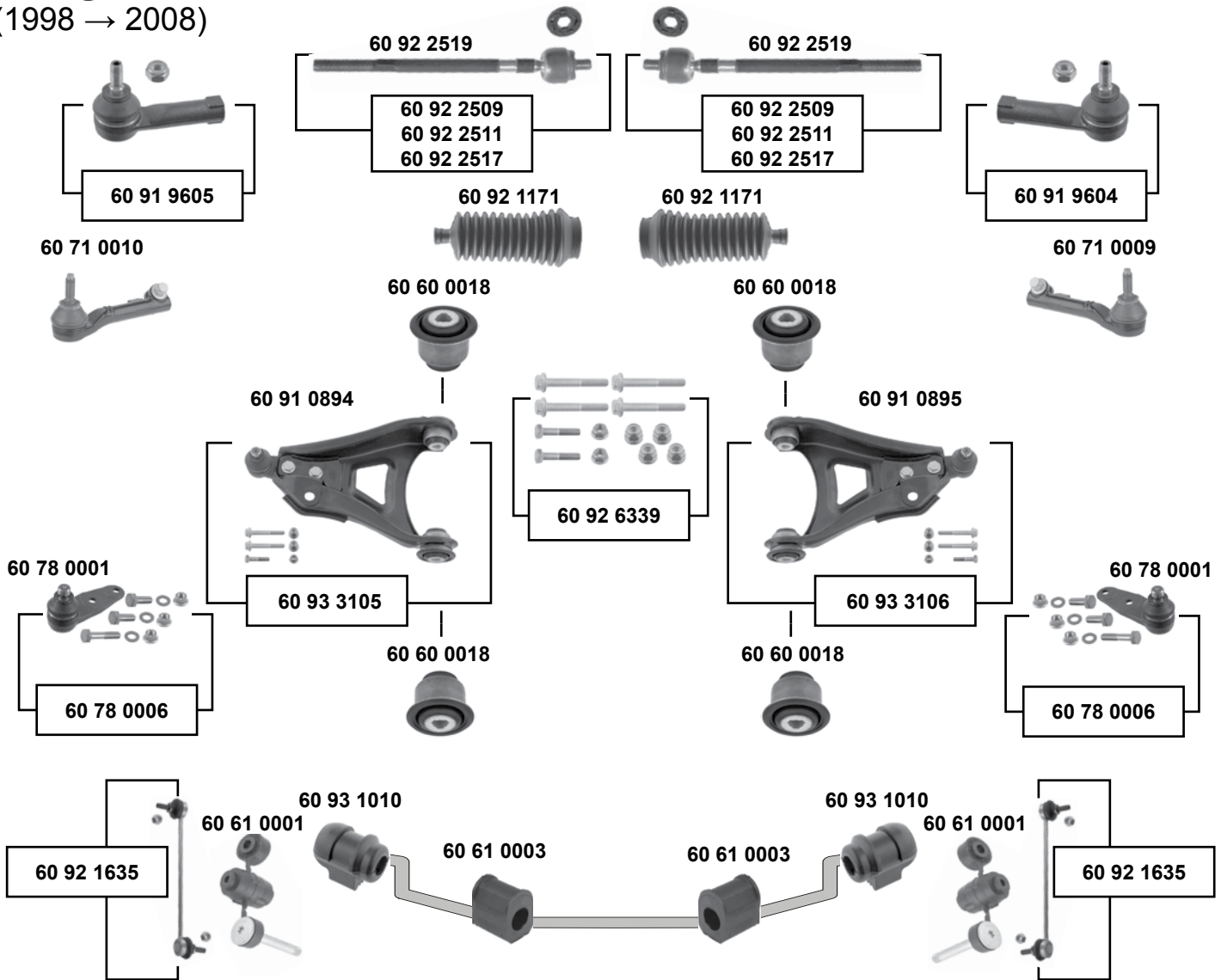

	Ref. - No.			
60 60 0018	82 00 651 161	Querlenkerlager / control arm mount	(ex.) 4x4	45,5x46
60 61 0001	77 00 799 404	Stabilisatorlager / stabilizer mount	(ex.) 4x4	
60 61 0003	77 00 785 788	Stabilisatorlager / stabilizer mount		Ø 23
60 71 0009	77 01 041 312	Spurstangenendstück / tie rod end	→ 02/99	M10 x 1,25
60 71 0010	77 01 041 311	Spurstangenendstück / tie rod end	→ 02/99	M10 x 1,25
60 78 0001	77 01 468 883 S2	Traggelenk / ball joint	(ex.) 4x4	Ø A 16
60 78 0006	77 01 468 883	Rep. Satz Traggelenk / rep. kit ball joint	(ex.) 4x4	
60 91 0894	82 00 197 179	Querlenker / control arm	(ex.) 4x4	
60 91 0895	82 00 197 187	Querlenker / control arm	(ex.) 4x4	
60 91 9604	77 01 047 813	Spurstangenendstück / tie rod end	02/99 → 08	
60 91 9605	77 01 047 812	Spurstangenendstück / tie rod end	02/99 → 08	
60 92 1171	77 01 469 496	Lenkmanschette / steering boot	servo	
60 92 1635	77 00 437 136	Verbindungsstange / connecting rod	4x4	
60 92 2509	77 01 470 763 SK	Axialgelenk / axial joint	→ 02/99 man.	
60 92 2511	77 01 472 113 SK	Axialgelenk / axial joint	02/99 → man.	
60 92 2517	77 01 472 120 SK	Axialgelenk / axial joint	02/99 → servo	
60 92 2519	77 01 470 764 SK	Spurstange / tie rod	→ 02/99 servo	
60 92 6339	77 00 763 538 S1	Schraubensatz / screw kit		
60 93 1010	77 00 314 855	Stabilisatorlager / stabilizer mount		Ø 23
60 93 3105	82 00 197 179 S1	Rep. Satz Querlenker / rep. kit control arm		
60 93 3106	82 00 197 187 S1	Rep. Satz Querlenker / rep. kit control arm		



Kangoo 2 (2008 →)

Vorderachse / Front axle

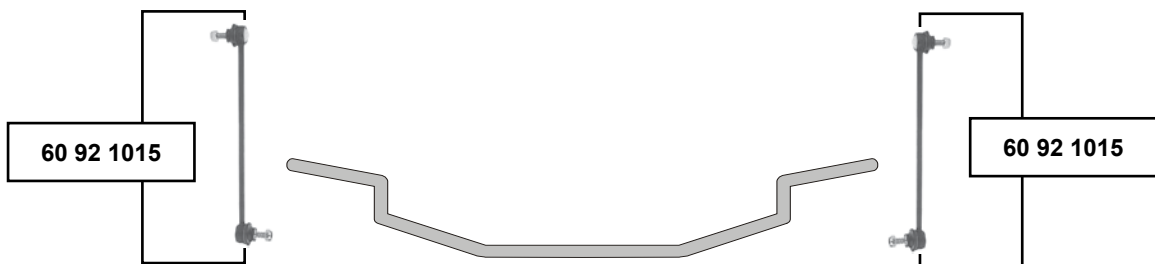
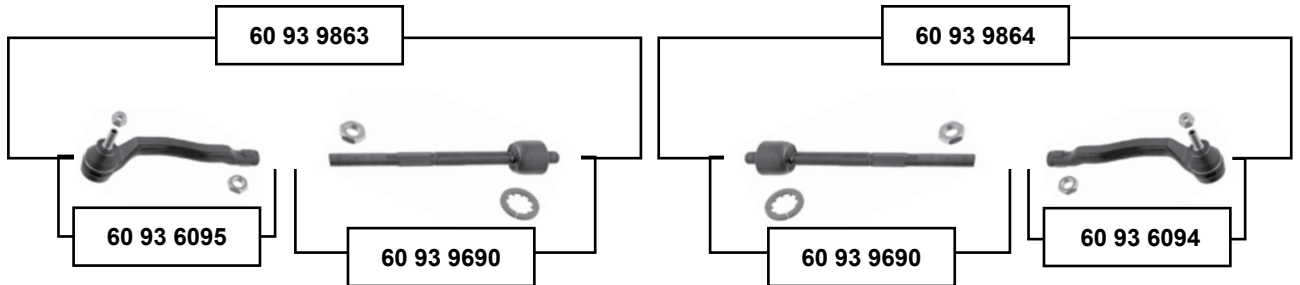

(1) FW00,1,4,5,A,B,C,D,E,F,G,H,K,L,N,P,U,W,Y,Z // KW00,1,4,5,A,B,C,D,E,F,G,H,K,L,N,P,U,V,W,Y



Ref. - No.



Ref. - No.	Description	Quantity	Dimensions
60 92 1015	Verbindungsstange / connecting rod		L 285
60 93 6094	Spurstangenendstück / tie rod end	(1)	L 200
60 93 6095	Spurstangenendstück / tie rod end	(1)	L 200
60 93 6121	Querlenkerlager / control arm mount	(1)	Ø A 40,3/33
60 93 6122	Querlenkerlager / control arm mount	(1)	Ø A 58
60 93 9023	Traggelenk / ball joint	FW0 / KW0	Ø A 20
60 93 9024	Traggelenk / ball joint		Ø A 20
60 93 9690	Axialgelenk / axial joint		L 214
60 93 9863	Rep. Satz Spurstange / rep. kit tie rod		
60 93 9864	Rep. Satz Spurstange / rep. kit tie rod		

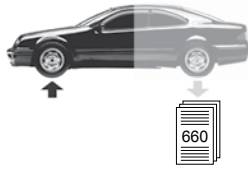

Koleos

(2008 →)

Vorderachse / Front axle

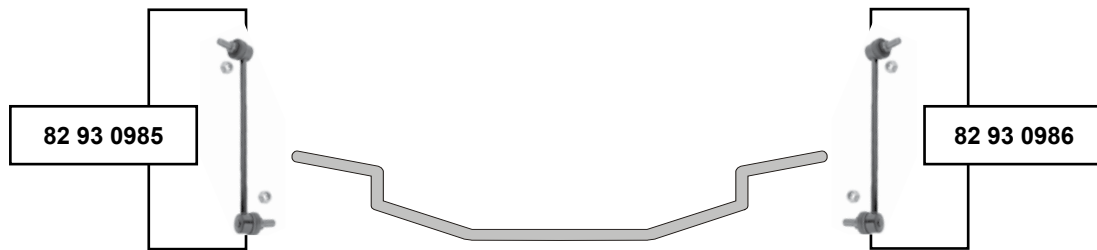
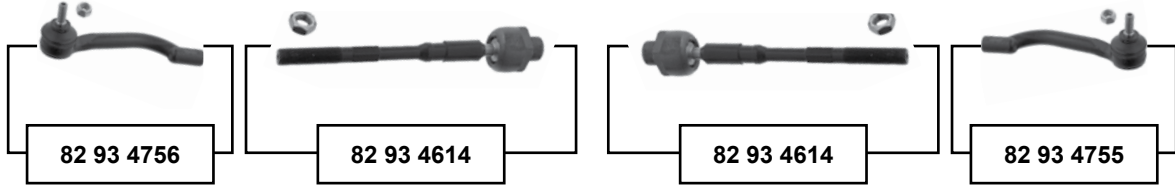

SWAG GERMANY	Ref. - No.			
82 93 0985	54 66 8J0 00A	Verbindungsstange / connecting rod		L 300
82 93 0986	54 61 8J0 00A	Verbindungsstange / connecting rod		L 300
82 93 4614	D8 52 1JG 00A	Axialgelenk / axial joint		L 233
82 93 4666	54 50 0JY 00A S1	Traggelenk / ball joint		Ø 20
82 93 4755	D8 52 0JY 00A	Spurstangenendstück / tie rod end		M10 x 1,25
82 93 4756	D8 64 0JY 00A	Spurstangenendstück / tie rod end		M10 x 1,25
82 94 2630	54 50 551 12R	Querlenker / control arm		
82 94 2631	54 50 404 45R	Querlenker / control arm		



Laguna 1 (1996 → 2001)

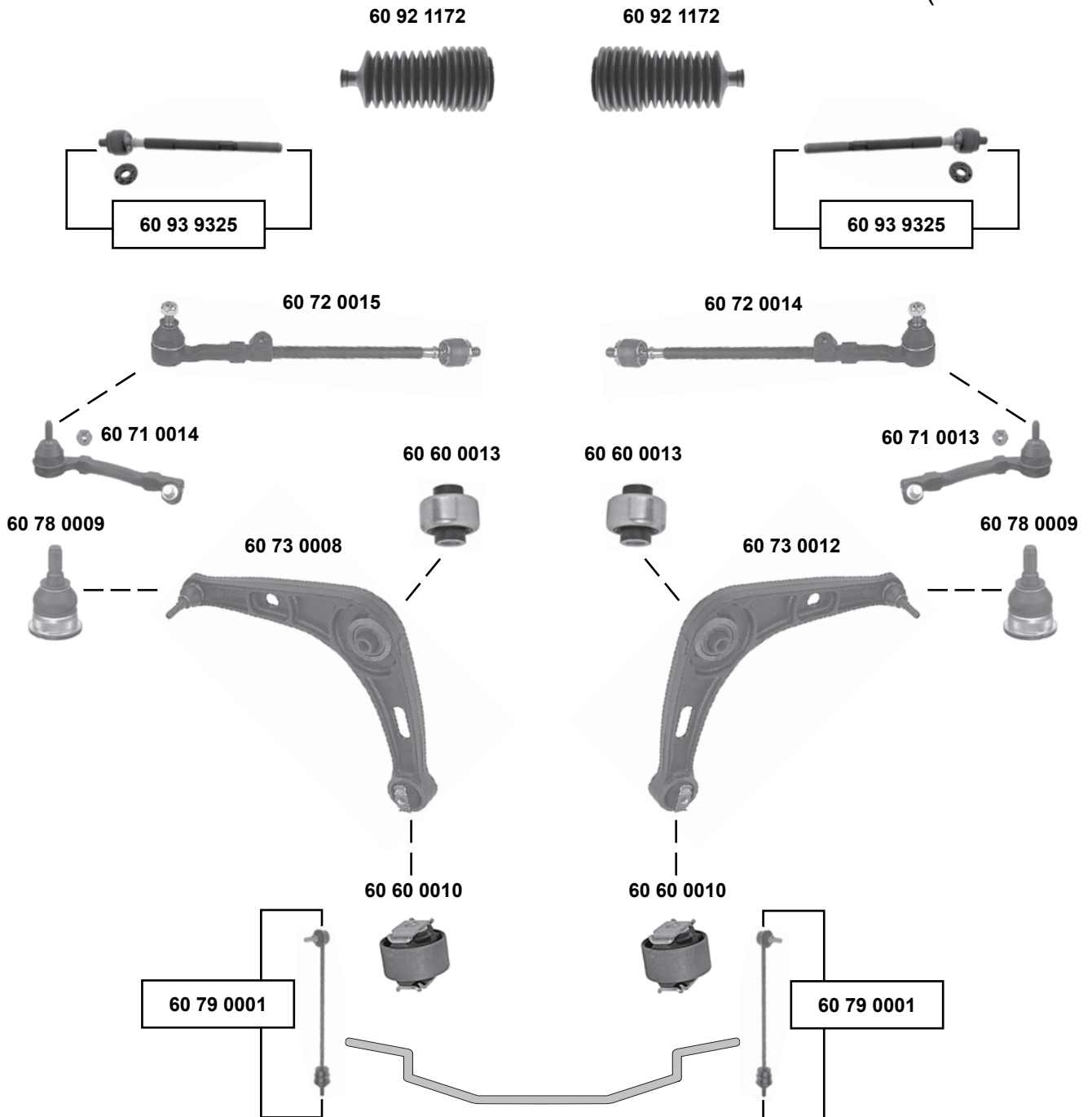

Vorderachse / Front axle

SWAG	Ref. - No.			
60 60 0010	77 00 824 042	Querlenkerlager / control arm mount		12x59x55
60 60 0013	77 00 822 503	Querlenkerlager / control arm mount		
60 71 0013	60 00 022 736	Spurstangenendstück / tie rod end		M14 x 1,5
60 71 0014	60 00 022 737	Spurstangenendstück / tie rod end		M14 x 1,5
60 72 0014	77 01 467 502	Spurstange / tie rod		
60 72 0015	77 01 467 501	Spurstange / tie rod		
60 73 0008	77 00 413 493	Querlenker / control arm		
60 73 0012	77 00 413 494	Querlenker / control arm		
60 78 0009	77 00 421 804	Traggelenk / ball joint		Ø A 16
60 79 0001	77 00 805 494	Verbindungsstange / connecting rod		L 390
60 92 1172	77 01 469 657	Lenkmanschette / steering boot		
60 93 9325	77 01 469 665 SK	Axialgelenk / axial joint		L 265





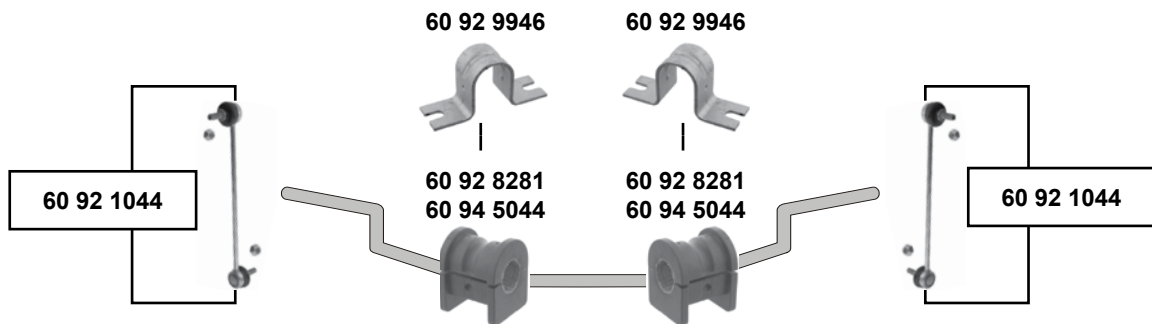
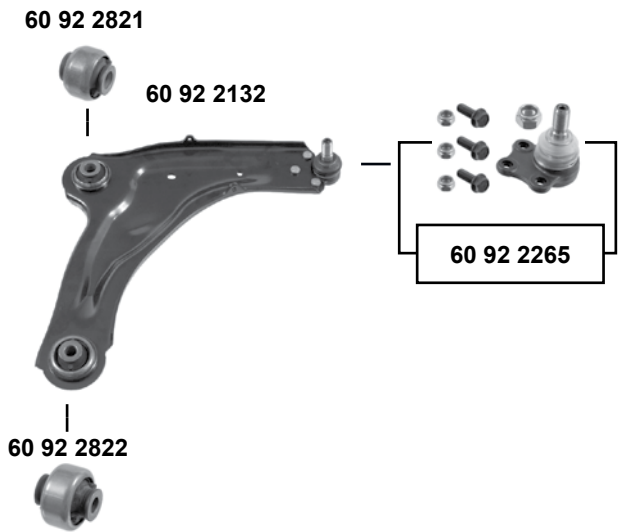
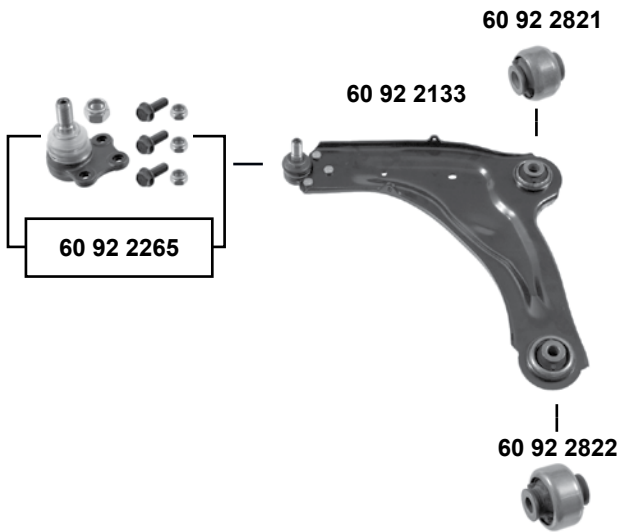
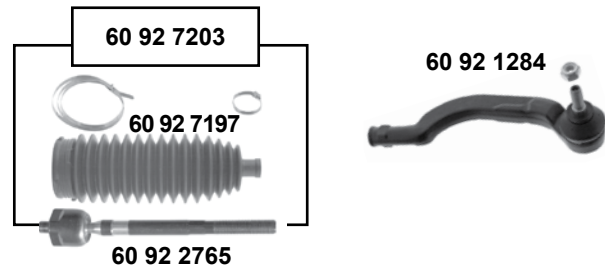
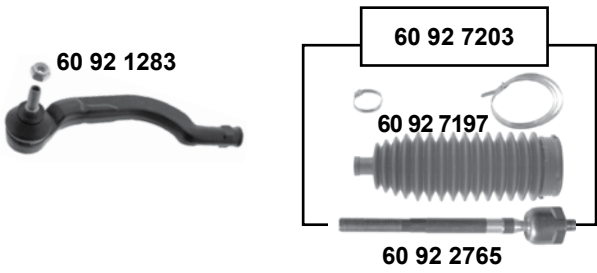

Laguna 2 (2001 → 2007)

Vorderachse / Front axle



Laguna 2
 (2001 → 2007)

- (1) BG0F, G, W, Y, BG00, 1, 2, 9, BG10, KG0F, G, W, Y, 0, 1, 2, 9 (ch.) → MOD0504
- (2) BG0A,B,C,D,E,J,K,L,M,N,R,S,U,V / BG04,6,8 / BG1L,M / KG04,6,8,A,B,C,D,E,J,K,L,M,N,R,S,U,V / KG10
- (3) BG00, 1, 2, 9, F, G, W, Y, BG10, KG00, 1, 2, 9, F, G, W, Y (ch.) MOD0504 →
- (4) BG03,5,P,T,Z / BG12,3,4,A,G,H,K,N,ST,V,W,Y / KG03,5,P,T,V,W,Y / KG12,3,4,A,G,H,N,S,T,V,W,Y

	Ref. - No.			
60 92 1044	82 00 661 217	Verbindungsstange / connecting rod		L 280
60 92 1283	77 01 049 282	Spurstangenendstück / tie rod end		M12 x 1,5
60 92 1284	77 01 049 283	Spurstangenendstück / tie rod end		M12 x 1,5
60 92 2132	82 00 602 613	Querlenker / control arm		
60 92 2133	82 00 602 612	Querlenker / control arm		
60 92 2265	77 01 478 029	Traggelenk / ball joint		
60 92 2765	77 01 472 766 SK	Spurstange / tie rod		L 216
60 92 2821	82 00 002 868	Querlenkerlager / control arm mount	(1) (2)	Ø 19,5
60 92 2822	82 00 002 869	Querlenkerlager / control arm mount		
60 92 7197	77 01 472 765	Rep. Satz Lenkmanschettesatz / rep. kit steering boot set		L 190
60 92 7203	77 01 472 766	Rep. Satz Spurstange / rep. kit tie rod		
60 92 8281	82 00 272 594	Stabilisatorlager / stabilizer mount		Ø 19,5
60 92 9946	82 00 272 596	Schelle / clamp		
60 93 7623	77 01 472 766 S1	Rep. Satz Spurstange / rep. kit tie rod		
60 93 7624	77 01 472 766 S2	Rep. Satz Spurstange / rep. kit tie rod		
60 94 5044	82 00 455 604	Stabilisatorlager / stabilizer mount	(3) (4)	Ø 21



Laguna 3

(2007 →)

Vorderachse / Front axle

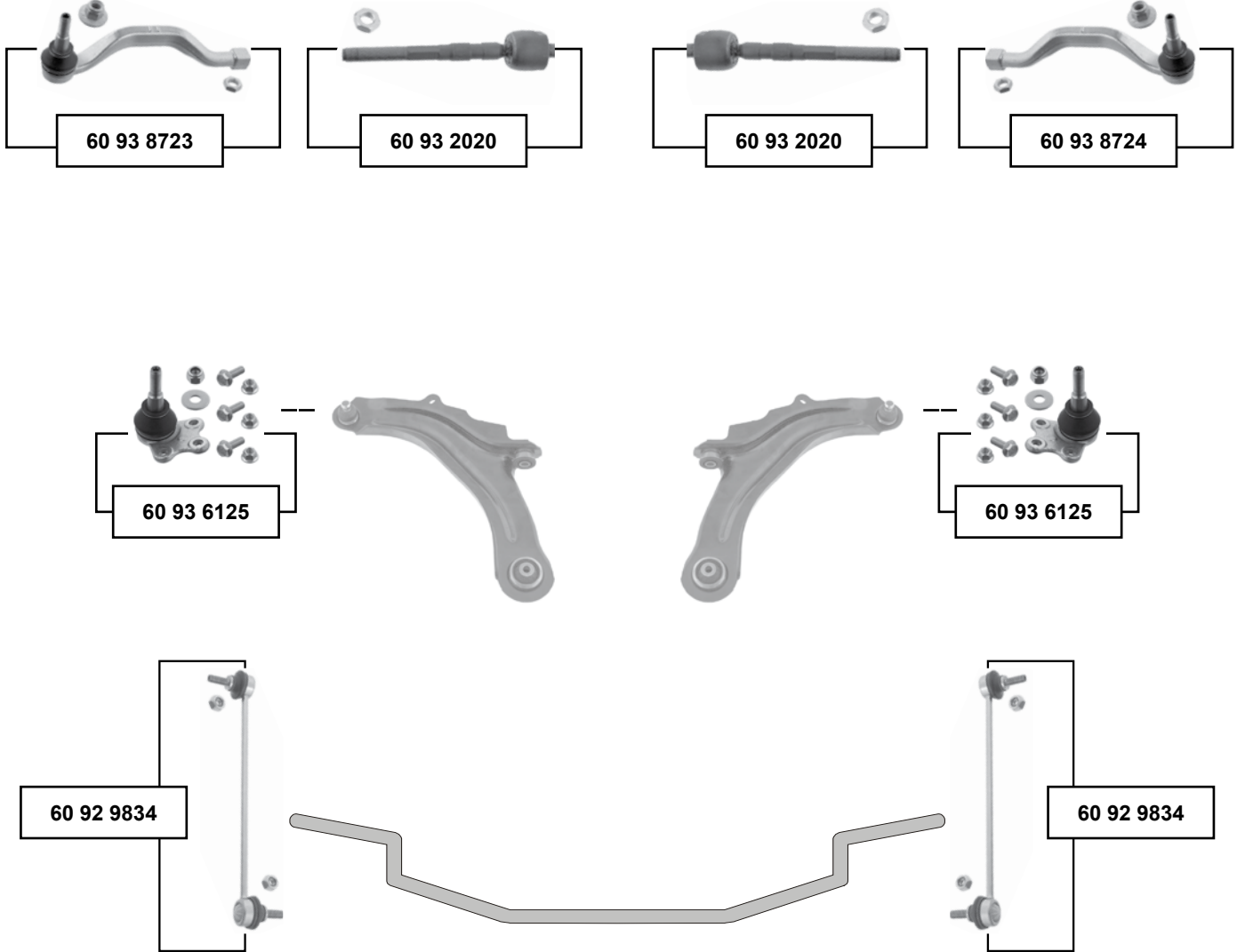

- (1) BT0 / BT1 / DT0 / DT1 / KT0 / KT1
- (2) BT00,1,3,4,5,6,8,9,A,C,D,E,F,G,H,J,K,M,N,P,T,R,U,W,Y
 BT11,2,3,4,5,8,9,A,C,D,E,F,H,J,M,N,S,W
 DT01,3,6,9,B,C,G,H,K,M,N,P,V,Y
 DT11,2,3,5,8,9,C,D,E,F,M,N,U,W
 KT01,3,8,9,A,C,D,F,G,H,J,K,M,N,P,R,W,Y
 KT11,2,3,4,5,8,9,A,C,D,E,F,H,N,S



Ref. - No.



Ref. - No.	Description	Quantity	Length
60 92 9834	Verbindungsstange / connecting rod		L 130
60 93 2020	Spurstange / tie rod		L 190
60 93 6125	Traggelenk / ball joint	(2)	
60 93 8723	Spurstangenendstück / tie rod end	(1)	L 240
60 93 8724	Spurstangenendstück / tie rod end	(1)	L 240



Logan 1 (2004 → 2013)

Vorderachse / Front axle

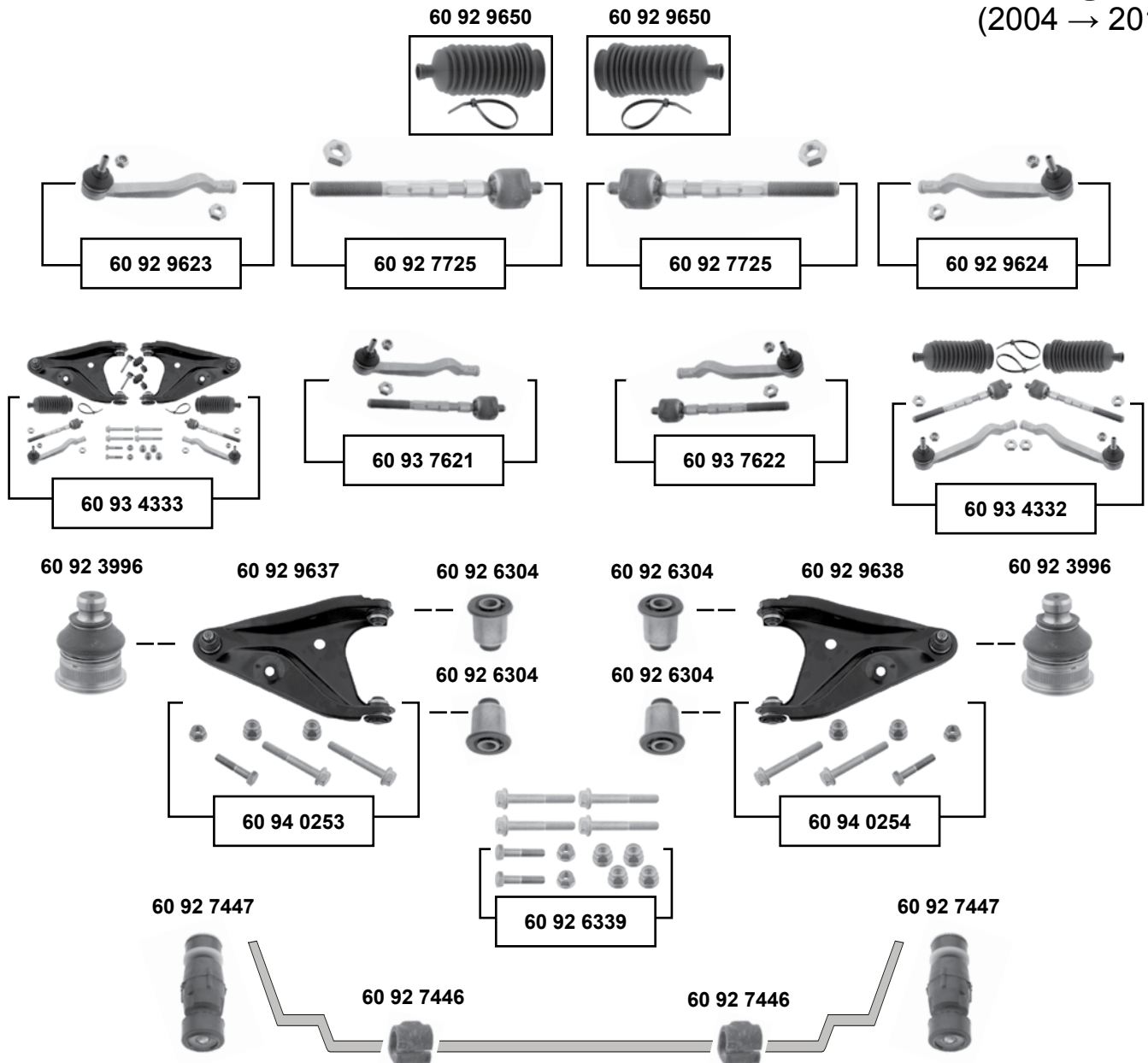

SWAG	Ref. - No.			
60 92 3996	82 00 298 455 S1	Traggelenk / ball joint		Ø A 18
60 92 6304	60 40 002 245	Querlenkerlager / control arm mount		H 42
60 92 6339	77 00 763 538 S1	Schraubensatz / screw kit		
60 92 7446	60 01 547 140	Stabilisatorlager / stabilizer mount		Ø I 23
60 92 7447	60 01 547 138	Stabilisatorlager / stabilizer mount		M8 x 1,25
60 92 7725	60 01 550 441	Spurstange / tie rod		M12 x 1
60 92 9623	60 01 550 442	Spurstangenendstück / tie rod end		L 213
60 92 9624	60 01 550 443	Spurstangenendstück / tie rod end		L 213
60 92 9637	60 01 550 446	Querlenker / control arm		
60 92 9638	60 01 550 447	Querlenker / control arm		
60 92 9650	60 01 547 607	Rep. Satz Lenkmanschette / rep. kit steering boot		L 187
60 93 4332	60 01 550 442 S1	Spurstangensatz / tie rod set		
60 93 4333	60 01 550 446 S1	Rep. Satz Querlenkersatz / rep. kit control arm kit		
60 93 7621	60 01 550 442 S2	Spurstange / tie rod		
60 93 7622	60 01 550 443 S2	Spurstange / tie rod		
60 94 0253	60 01 550 446 S2	Rep. Satz Querlenker / rep. kit control arm		
60 94 0254	60 01 550 447 S2	Rep. Satz Querlenker / rep. kit control arm		



RENAULT

Master 2 (1998 → 2010)

Vorderachse / Front axle

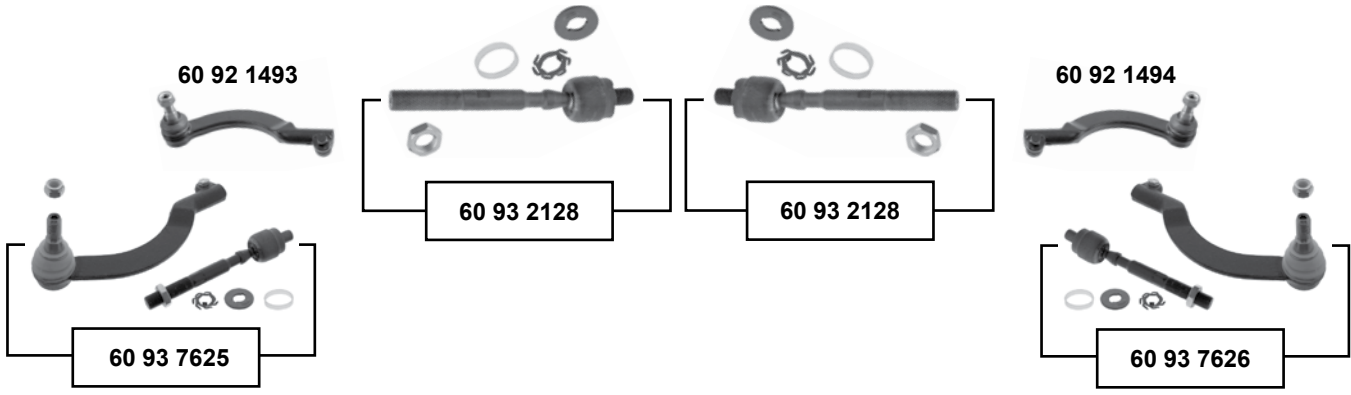



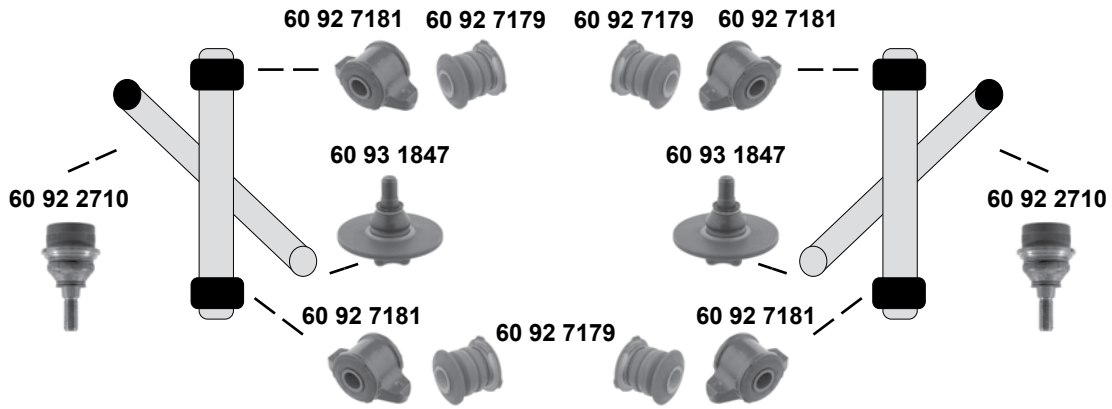

oben / upper

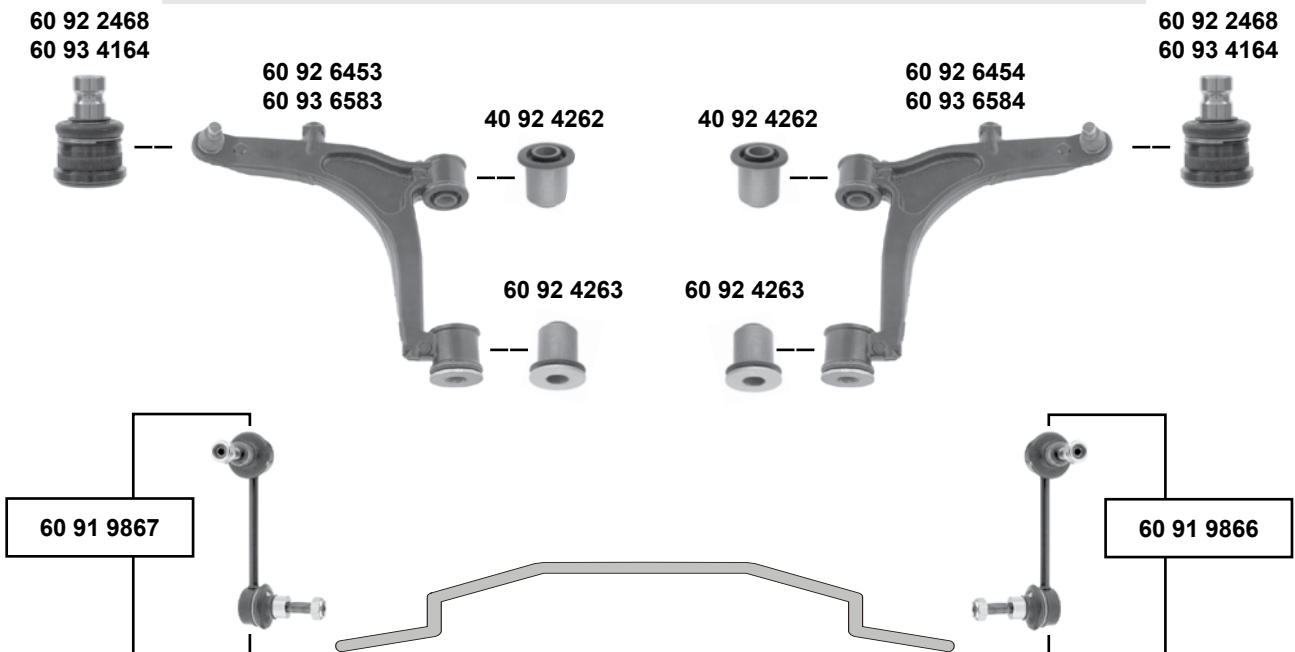

unten / lower



Master 2
 (1998 → 2010)

	Ref. - No.			
40 92 4262	77 00 302 122	Querlenkerlager / control arm mount		Ø A 55,5
60 91 9866	82 00 713 523	Verbindungsstange / connecting rod		L 130
60 91 9867	82 00 713 522	Verbindungsstange / connecting rod		L 130
60 92 1493	77 01 470 363	Spurstangenendstück / tie rod end		M14 x 1,5
60 92 1494	77 01 470 364	Spurstangenendstück / tie rod end		M14 x 1,5
60 92 2468	77 01 056 969	Traggelenk / ball joint	98 → 09/07	Ø A 22
60 92 2710	77 00 312 851	Traggelenk / ball joint	→ 09/02	
60 92 4263	77 00 302 123	Querlenkerlager / control arm mount		Ø A 55,5
60 92 6453	82 00 767 822	Querlenker / control arm	98 → 09/07	
60 92 6454	82 00 767 825	Querlenker / control arm	98 → 09/07	
60 92 7181	77 00 302 115	Querlenkerlager / control arm mount		
60 92 7179	77 00 302 116	Querlenkerlager / control arm mount		
60 93 1847	77 01 056 970	Traggelenk / ball joint		Ø A15/101
60 93 2128	77 01 470 362 SK	Spurstange / tie rod		L 174,5
60 93 4164	77 01 070 154	Traggelenk / ball joint	09/07 → 10	Ø A 24
60 93 6583	82 00 750 273	Querlenker / control arm	09/07 → 10	
60 93 6584	82 00 750 274	Querlenker / control arm	09/07 → 10	
60 93 7625	77 01 470 363 S1	Rep. Satz Spurstange / rep. kit tie rod		
60 93 7626	77 01 470 364 S1	Rep. Satz Spurstange / rep. kit tie rod		



Master 1 (1980 → 1998)



oben / upper



unten / lower

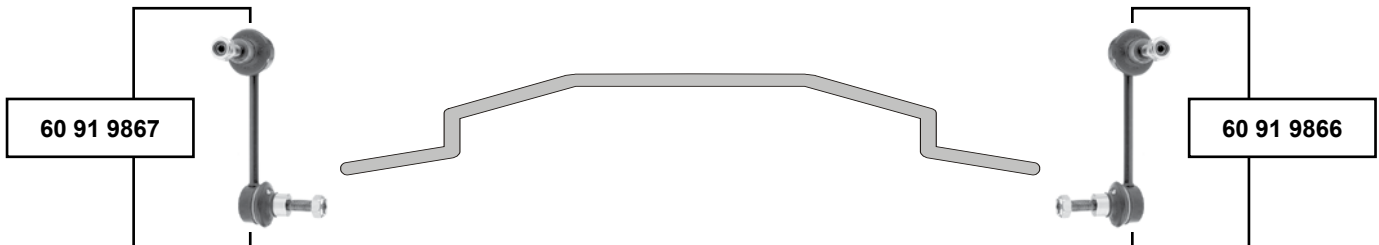
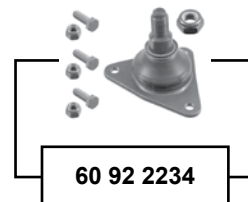

Ref. - No.



60 91 9866	82 00 713 523
60 91 9867	82 00 713 522
60 92 2169	77 01 462 427
60 92 2233	77 01 462 692
60 92 2234	77 01 462 693

Verbindungsstange / connecting rod
Verbindungsstange / connecting rod
Spurstangenendstück / tie rod end
Traggelenk / ball joint
Traggelenk / ball joint

L 130
L 130
L 100
M16 x 1,5
M16 x 1,5

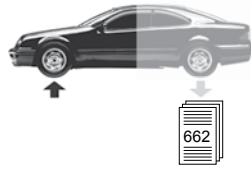

Master 3 (2010 →)

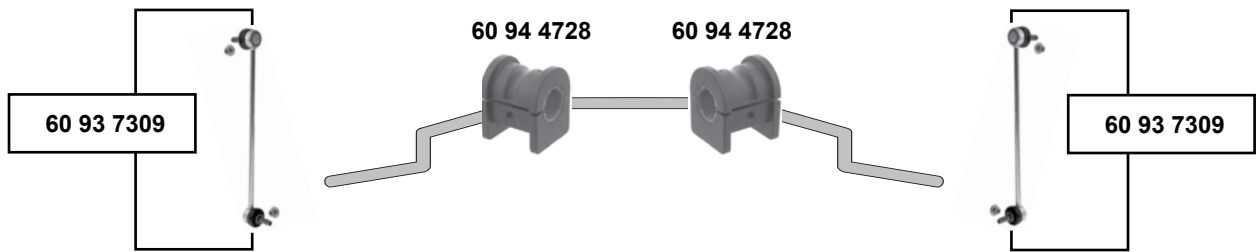
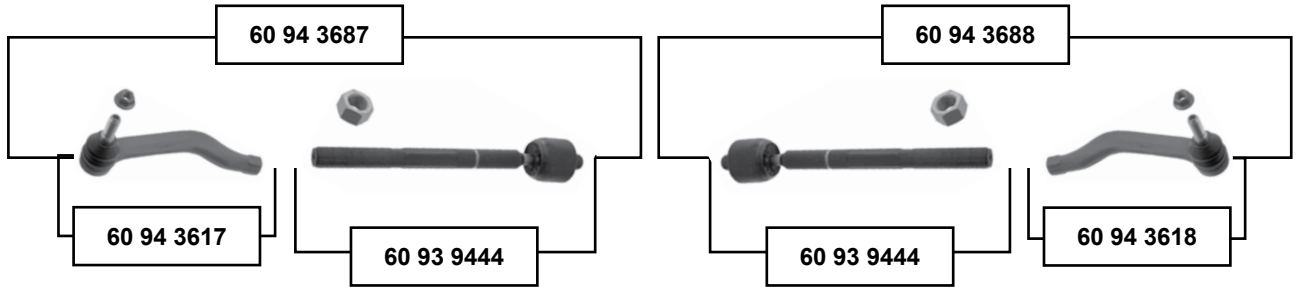

Vorderachse / Front axle



- (1) FV0A, B, C, D, E, F, G, H, J, K / UV0A, B, C, D, E, F, G, H, J, K, M
nur Fahrzeuge mit Frontantrieb / only vehicles with front wheel drive
- (2) EV0A, B, C, D, E, F, G, H, J / JV0A, B, C, D, F, G, H, J



Ref. - No.



Ref. - No.	Description	Length
60 93 7309	Verbindungsstange / connecting rod	L 330
60 93 9444	Axialgelenk / axial joint	
60 94 3617	Spurstangenendstück / tie rod end	L 235
60 94 3618	Spurstangenendstück / tie rod end	L 235
60 94 3687	Rep. Satz Spurstange / rep. kit tie rod	
60 94 3688	Rep. Satz Spurstange / rep. kit tie rod	
60 94 4728	Stabilisatorlager / stabilizer mount	Ø 25,4

(1) (2)



RENAULT

Megane 1 / Coupé

(1996 → 2003)

(ex.) 1.9 DTI/DCI

(ex.) 2.0 16 V

Vorderachse / Front axle

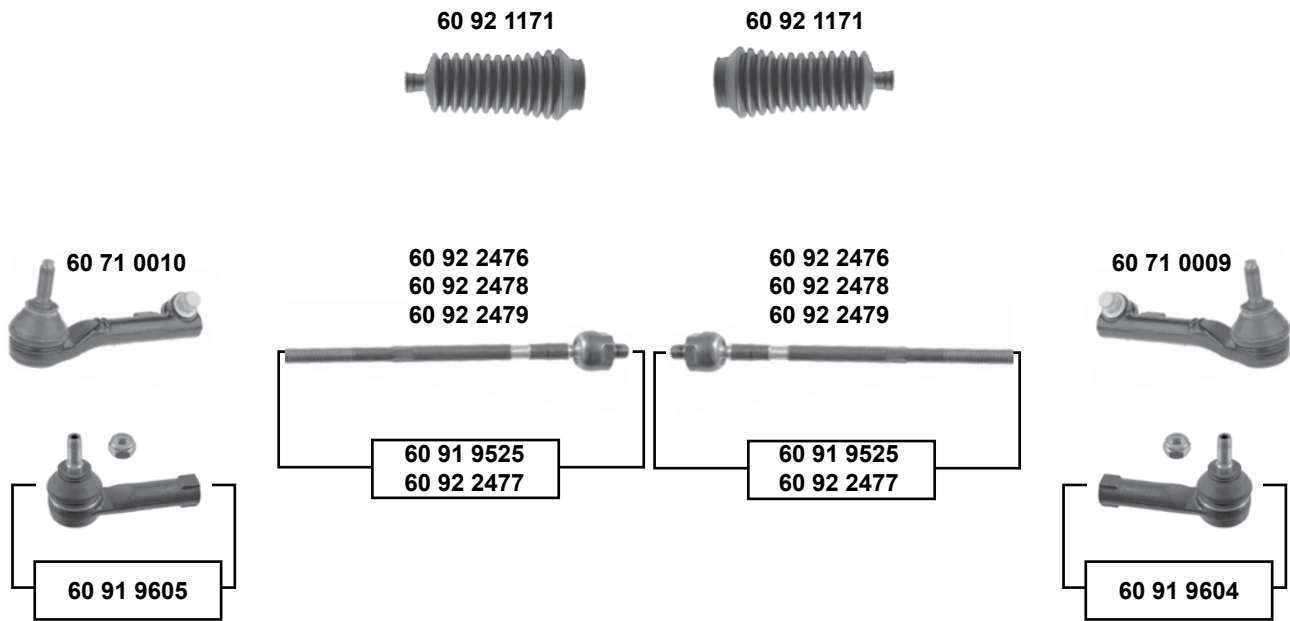

SWAG GERMANY	Ref. - No.			
60 71 0009	77 01 041 312	Spurstangenendstück / tie rod end	→ 02/99	M10 x 1,25
60 71 0010	77 01 041 311	Spurstangenendstück / tie rod end	→ 02/99	M10 x 1,25
60 91 9525	77 01 469 280 SK	Spurstange / tie rod	→ 02/99, TRW	
60 91 9604	77 01 047 813	Spurstangenendstück / tie rod end	SMI 02/99 →, TRW	M10 x 1,25
60 91 9605	77 01 047 812	Spurstangenendstück / tie rod end	SMI 02/99 →, TRW	M10 x 1,25
60 92 1171	77 01 469 496	Lenkmanschette / steering boot	servo	
60 92 2476	77 01 472 087 SK	Spurstange / tie rod	02/99 → TRW	
60 92 2477	77 01 469 502 SK	Spurstange / tie rod	96 → 08/98, SMI	
60 92 2478	77 01 471 885 SK	Spurstange / tie rod	08/98 → 02/99, SMI	
60 92 2479	77 01 471 844 SK	Spurstange / tie rod	03/99 → SMI	

Megane 1 / Coupé

(1996 → 2003)

(ex.) 1.9 DTI/DCI

(ex.) 2.0 16 V

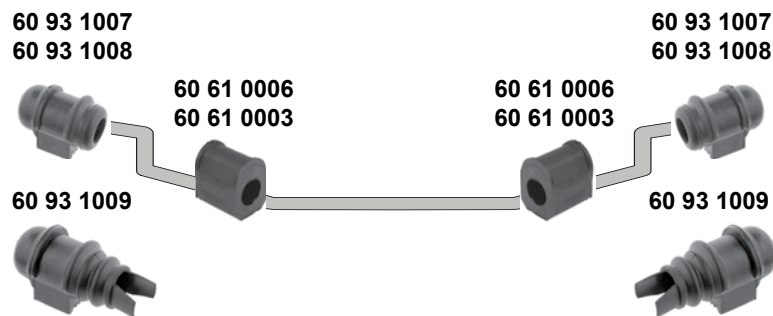
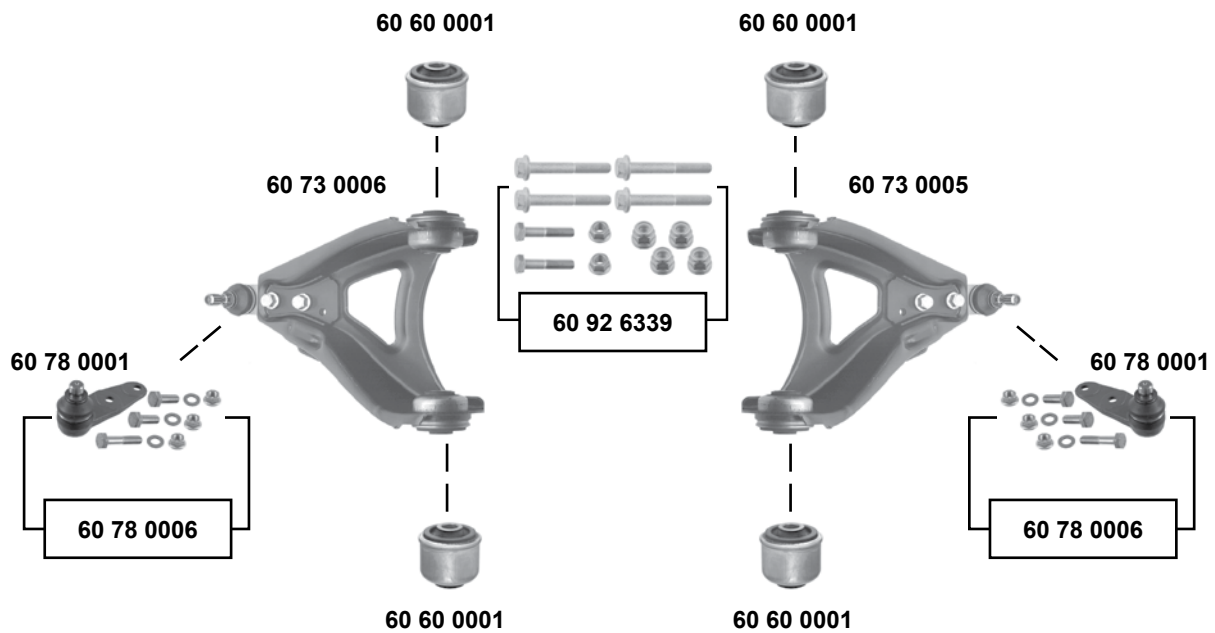

SWAG	Ref. - No.			
60 60 0001	77 00 840 741	Querlenkerlager / control arm mount		12x45x46
60 61 0003	77 00 785 788	Stabilisatorlager / stabilizer mount		Ø 23
60 61 0006	77 00 835 929	Stabilisatorlager / stabilizer mount		Ø 24
60 73 0005	82 00 737 135	Querlenker / control arm		
60 73 0006	82 00 737 134	Querlenker / control arm		
60 78 0001	77 01 468 883 S2	Traggelenk / ball joint		Ø A 16
60 78 0006	77 01 468 883	Rep. Satz Traggelenk / rep. kit ball joint		
60 92 6339	77 00 763 538 S1	Schraubensatz / screw kit		
60 93 1007	77 00 784 170	Stabilisatorlager / stabilizer mount		Ø 18
60 93 1008	77 00 784 171	Stabilisatorlager / stabilizer mount		Ø 24
60 93 1009	82 00 150 759	Stabilisatorlager / stabilizer mount	(ex.) HD	Ø 24,5



RENAULT

Megane 1 / Scenic

(1996 → 2003)

1.9 DCI / DTI / 2,0 16V

Vorderachse / Front axle

60 92 1171

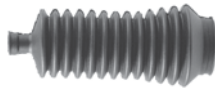

60 92 1171



60 71 0010

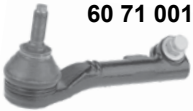

60 92 2477
60 92 2478
60 92 2479

60 92 2477
60 92 2478
60 92 2479

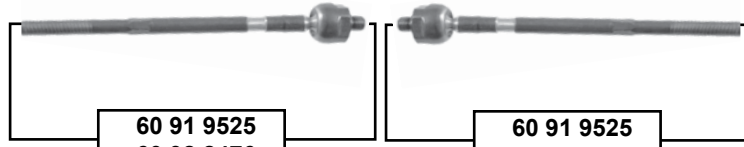

60 91 9525
60 92 2476

60 91 9525
60 92 2476

60 71 0009



60 91 9605



60 91 9604



Ref. - No.



60 71 0009	77 01 041 312	Spurstangenendstück / tie rod end	→ 02/99	M10 x 1,25
60 71 0010	77 01 041 311	Spurstangenendstück / tie rod end	→ 02/99	M10 x 1,25
60 91 9525	77 01 469 280 SK	Spurstange / tie rod	→ 02/99; TRW	
60 91 9604	77 01 047 813	Spurstangenendstück / tie rod end	SMI 02/99 →, TRW	M10 x 1,25
60 91 9605	77 01 047 812	Spurstangenendstück / tie rod end	SMI 02/99 →, TRW	M10 x 1,25
60 92 1171	77 01 469 496	Lenkmanschette / steering boot	servo SMI	
60 92 2476	77 01 472 087 SK	Spurstange / tie rod	02/99 →, TRW	
60 92 2477	77 01 469 502 SK	Spurstange / tie rod	96 → 08/98, SMI	
60 92 2478	77 01 471 885 SK	Spurstange / tie rod	08/98 → 02/99, SMI	
60 92 2479	77 01 471 844 SK	Spurstange / tie rod	03/99 →, SMI	



Megane 1 / Scenic (1996 → 2003)

1.9 DCI / DTI / 2,0 16V

→ 08/97 (ex.) 4x4

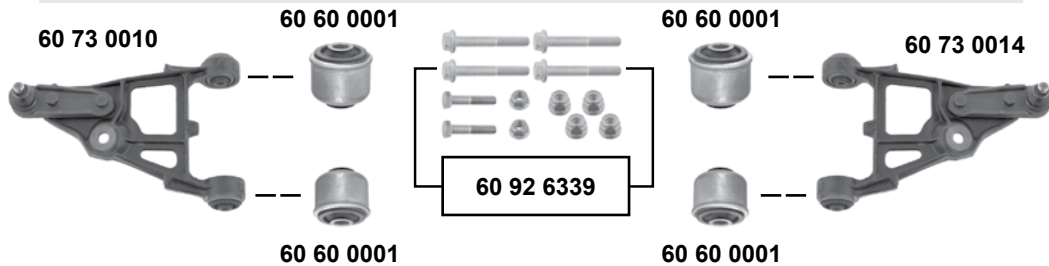

09/97 → (ex.) 4x4

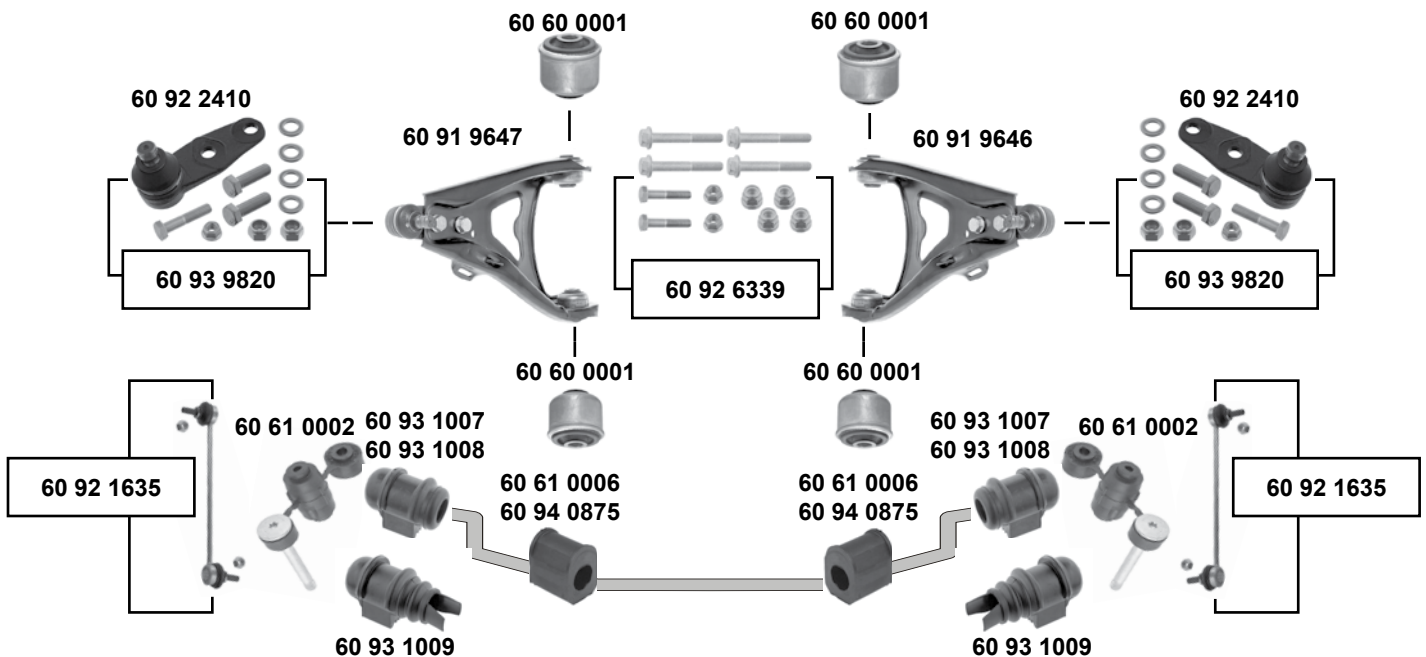

Vorderachse / Front axle



(1) Megane DA0H
Scenic FA0Y,JA0G,J,N 03 → 05/98 // JA0F 03 → 05/98 // JA0K,Y 03 → 10/97



Ref. - No.



Ref. - No.	Description	Notes	Dimensions
60 60 0001	Querlenkerlager / control arm mount		12x45x46
60 61 0002	Stabilisatorlager / stabilizer mount	(ex.) 4x4	
60 61 0006	Stabilisatorlager / stabilizer mount	(ex.) 4x4	Ø 24
60 73 0010	Querlenker / control arm	→ 08/97	
60 73 0014	Querlenker / control arm	→ 08/97	
60 91 9646	Querlenker / control arm	09/97 →	
60 91 9647	Querlenker / control arm	09/97 →	
60 92 1635	Verbindungsstange / connecting rod	4x4	
60 92 2410	Traggelenk / ball joint		
60 92 6339	Schraubensatz / screw kit		
60 93 1007	Stabilisatorlager / stabilizer mount		Ø 18
60 93 1008	Stabilisatorlager / stabilizer mount		Ø 24
60 93 1009	Stabilisatorlager / stabilizer mount	(ex.) HD	Ø 24,5
60 93 9820	Rep. Satz Traggelenk / rep. kit ball joint		
60 94 0875	Stabilisatorlager / stabilizer mount	(1)	Ø 23,5



Megane 2 (2002 → 2008)

Vorderachse / Front axle

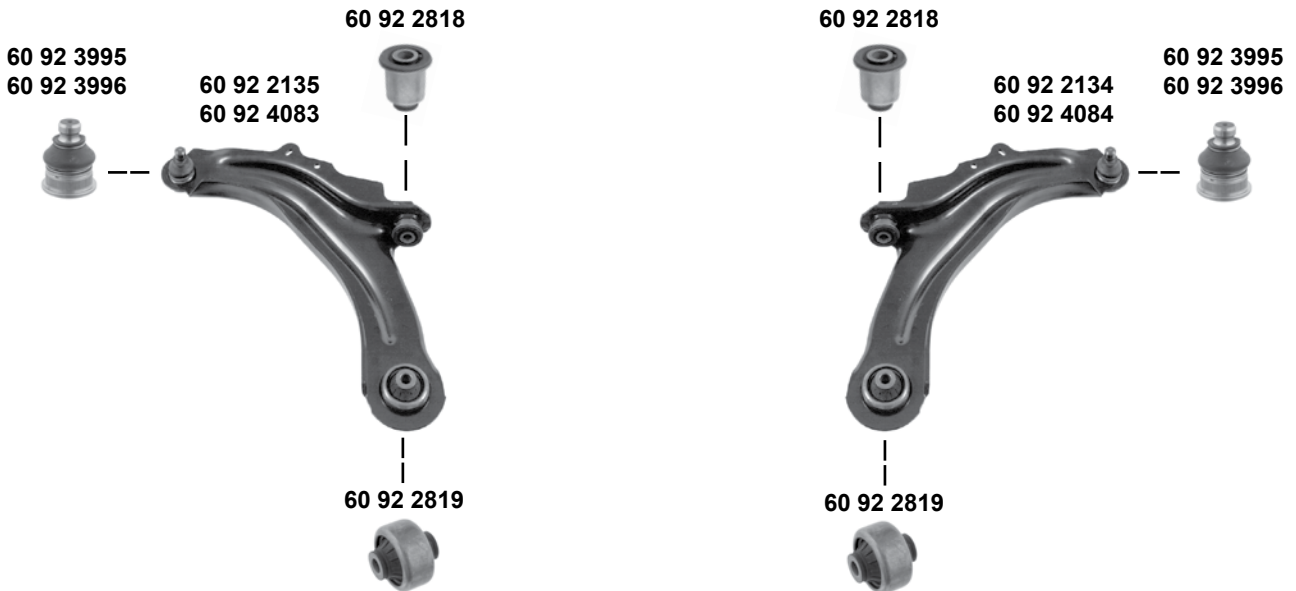
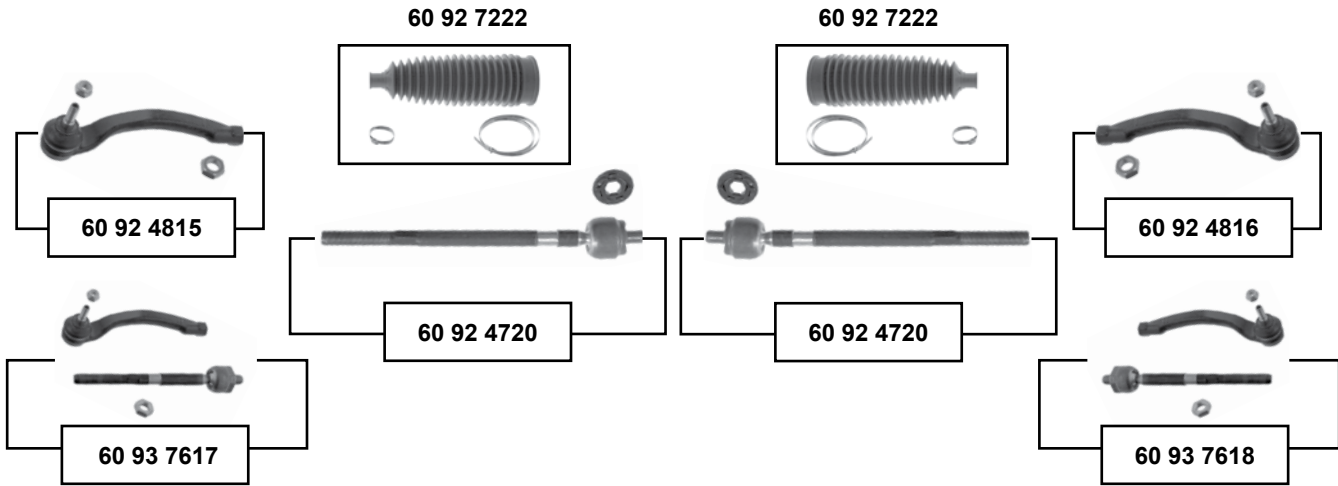



Megane 2 (2002 → 2008)

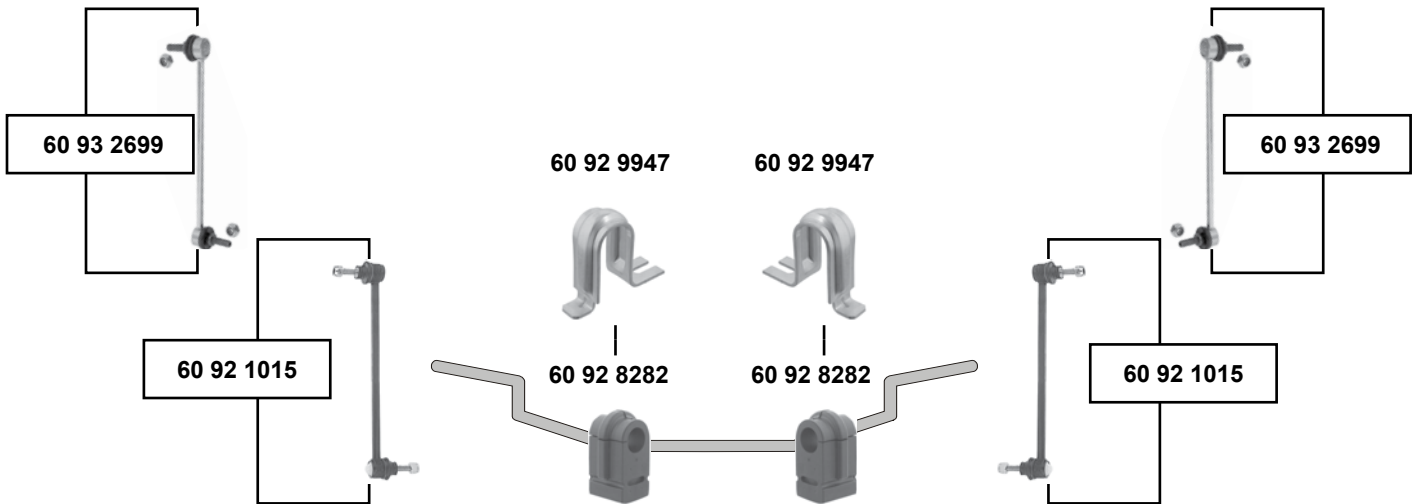

Vorderachse / Front axle

SWAG	Ref. - No.			
60 92 1015	82 00 669 065	Verbindungsstange / connecting rod	(ex.) HD	L 285
60 92 2134	82 00 255 761	Querlenker / control arm	→ 01/03	
60 92 2135	82 00 255 760	Querlenker / control arm	→ 01/03	
60 92 2818	82 00 242 025	Querlenkerlager / control arm mount		
60 92 2819	82 00 041 166	Querlenkerlager / control arm mount		
60 92 3995	82 00 255 761 S1	Traggelenk / ball joint	→ 01/03	Ø A 16
60 92 3996	40 16 047 93R	Traggelenk / ball joint	01/03 →	Ø A 18
60 92 4083	82 00 679 063	Querlenker / control arm	01/03 →	
60 92 4084	82 00 679 067	Querlenker / control arm	01/03 →	
60 92 4720	77 01 474 448 SK	Spurstange / tie rod		L 215
60 92 4815	77 01 474 795	Spurstangenendstück / tie rod end		
60 92 4816	77 01 474 796	Spurstangenendstück / tie rod end		
60 92 7222	77 01 474 447	Rep. Satz Lenkmanschette / rep. kit steering boot		L190
60 92 8282	77 01 056 678	Stabilisatorlager / stabilizer mount		Ø I 19,5
60 92 9947	77 01 056 095	Schelle / clamp		
60 93 2699	82 00 669 066	Verbindungsstange / connecting rod	HD	L 266
60 93 7617	77 01 474 795 S1	Rep. Satz Spurstange / rep. kit tie rod		
60 93 7618	77 07 474 796 S1	Rep. Satz Spurstange / rep. kit tie rod		



Megane 3 (2008 →)

Vorderachse / Front axle

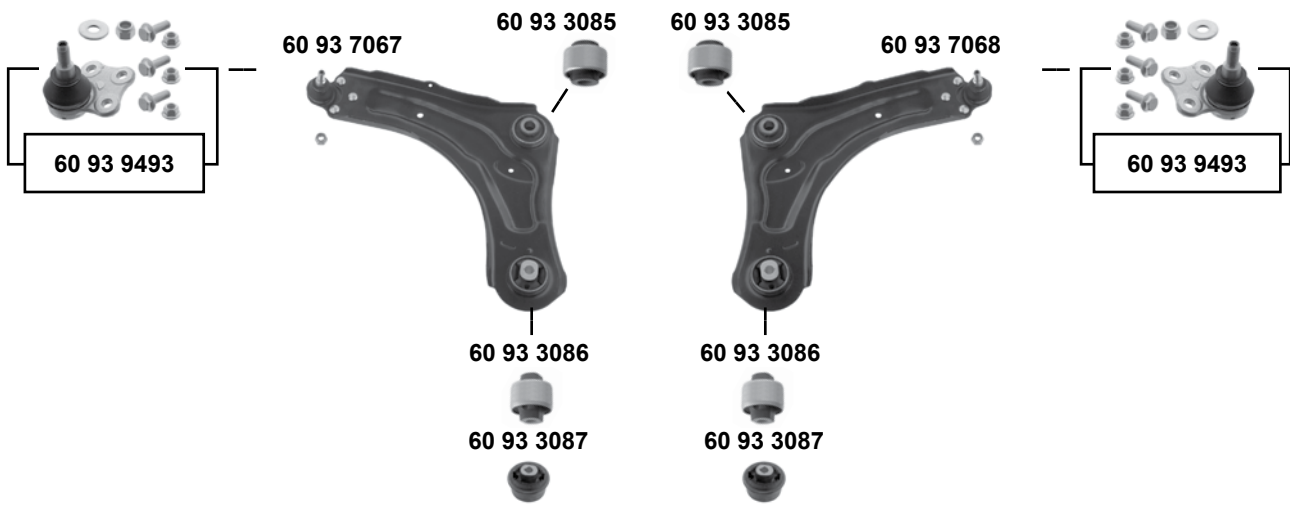
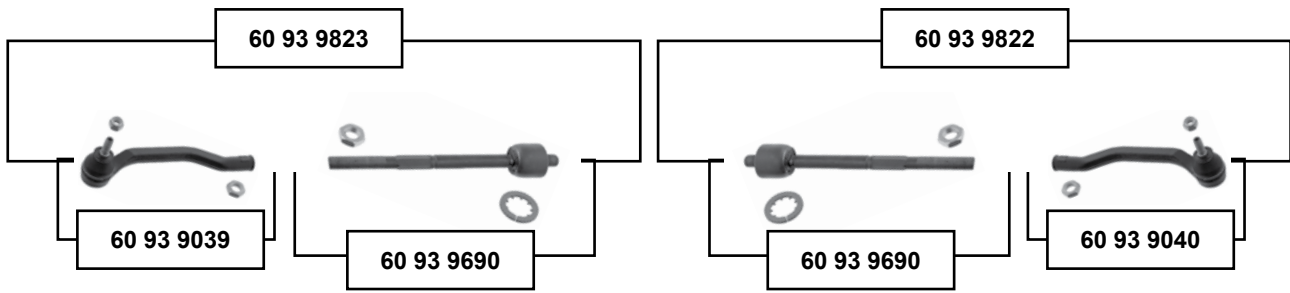



Megane 3 (2008 →)



Vorderachse / Front axle

- (1) BZ03,9,A,B,C,D,F,G,H,J,K,L,N,U,Y / BZ1A,B,F,G,H,J,K,M,P,V,W
DZ03,9,A,B,C,D,F,G,J,K,L,N,U,Y / DZ1A,B,E,F,G,H,K,M,P,S,V,W
EZ03,9,B,D,F,J,K,L,U / EZ1G,P,S,T,U,V
KZ03,9,A,B,C,D,F,G,H,J,K,N,U,Y / KZ1,A,B,F,G,M,P,S,V,W
- (2) BZ09,K,L,Y / DZ09,K,L,Y / EZ09,B,D,J,K,L / EZ1T / Hydraulisch / hydraulic
- (3) BZ03,A,B,C,D,F,G,H,J,N,U / BZ1A,B,F,G,H,J,K,M,P,V,W
DZ03,A,B,C,D,F,G,J,N,U / DZ1A,B,E,F,G,H,K,M,P,S,V,W
EZ03,F,J,U / EZ1G,P,S,U,V
KZ03,9,A,B,C,D,F,G,H,J,K,N,U,Y / KZ1,A,B,F,G,M,P,S,V,W
- (4) BZ03,6,A,B,C,D,F,G,H,J,N,U / BZ1A,B,E,F,G,H,J,K,M;p;R,S,V,W,Y
DZ03,A,B,c,D,F,G,J,N,U / DZ1A,B,E,F,G,H,J,K,M,P,S,U,V,W,Y
EZ03,7,B,F,J,N,U / EZ1E,G,K,P,S,U,V,Q
KZ03,9,A,B,C,D,F,G,H,J,N,U / KZ1A,B,F,G,M,P,R,S,U,V,W,Y
- (5) BZ00,3,6,9,A,B,C,D,F,G,H,J,K,L,N,T,U,Y / BZ11,2,4,6,A,B,E,F,G,H,J,K,M,P,R,S,T,U,V,W,Y / BZ20,7 /
DZ00,3,9,A,B,C,D,F,G,J,K,L,N,U,Y / DZ11,4,6,A,B,E,F,G,H,J,K,M,P,S,T,U,V,W,Y / DZ20,7
- (6) KZ00,3,9,B,D,F,G,H,J,K,L,N,U / KZ11,2,4,A,G,M,P,R,S,T,U,V,W / KZ20,3,7 Sport
- (7) DZ17,N / EZ0K,L / EZ1T / KZ00,3,9,B,D,F,G,H,J,K,L,N,U / KZ11,2,4,6,A,B,F,G,M,P,R,S,T,U,V,W,Y (ex.) Sport
- (8) EZ00,3,7,9,B,D,F,J,N,U / EZ11,4,6,E,G,K,P;S,U,V,Y / KZ0A,C,Y



Ref. - No.



Ref. - No.	Description	Notes	Dimensions
60 93 3085	Querlenkerlager / control arm mount	(1)	Ø A 55
60 93 3086	Querlenkerlager / control arm mount	(3)	Ø A 58
60 93 3087	Querlenkerlager / control arm mount	(2)	Ø A 70/79,5
60 93 7067	Querlenker / control arm	(4)	
60 93 7068	Querlenker / control arm	(4)	
60 93 8822	Verbindungsstange / connecting rod		L 274
60 93 9039	Spurstangenendstück / tie rod end		L 210
60 93 9040	Spurstangenendstück / tie rod end		L 210
60 93 9493	Traggelenk / ball joint		
60 93 9690	Axialgelenk / axial joint		L 214
60 93 9822	Spurstange / tie rod		
60 93 9823	Spurstange / tie rod		
60 94 0144	Stabilisatorlager / stabilizer mount	(5) (6)	Ø I 20
60 94 4483	Stabilisatorlager / stabilizer mount	(7) (8)	Ø I 22



RENAULT

Megane Generation

(2010 →)

Vorderachse / Front axle

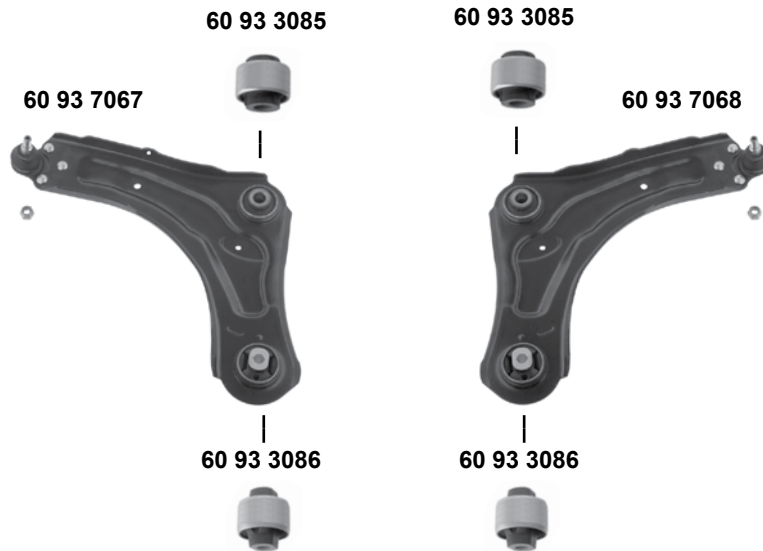
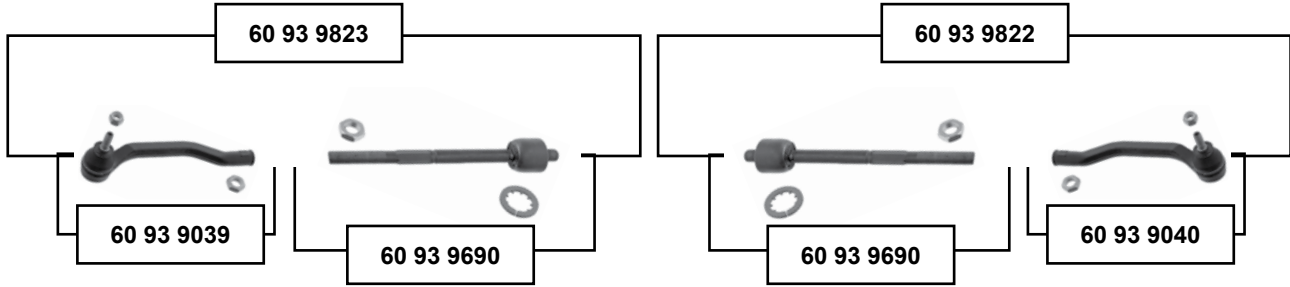

(1) B301,3,A,B,C,D,E,F,G,J,K,L,M,P,R,S,T,V



Ref. - No.



60 93 3085	54 56 000 05R	Querlenkerlager / control arm mount	(1)	Ø A 55
60 93 3086	54 56 000 04R	Querlenkerlager / control arm mount	(1)	Ø A 58
60 93 7067	54 50 140 55R	Querlenker / control arm	(1)	
60 93 7068	54 50 092 07R	Querlenker / control arm	(1)	
60 93 9039	48 52 027 10R	Spurstangenendstück / tie rod end		L 210
60 93 9040	48 52 046 80R	Spurstangenendstück / tie rod end		L 210
60 93 9690	48 52 156 12R SK	Axialgelenk / axial joint		L 214
60 93 9822	48 52 046 80R S1	Spurstange / tie rod		
60 93 9823	48 52 027 10R S1	Spurstange / tie rod		



Modus (2004 →)

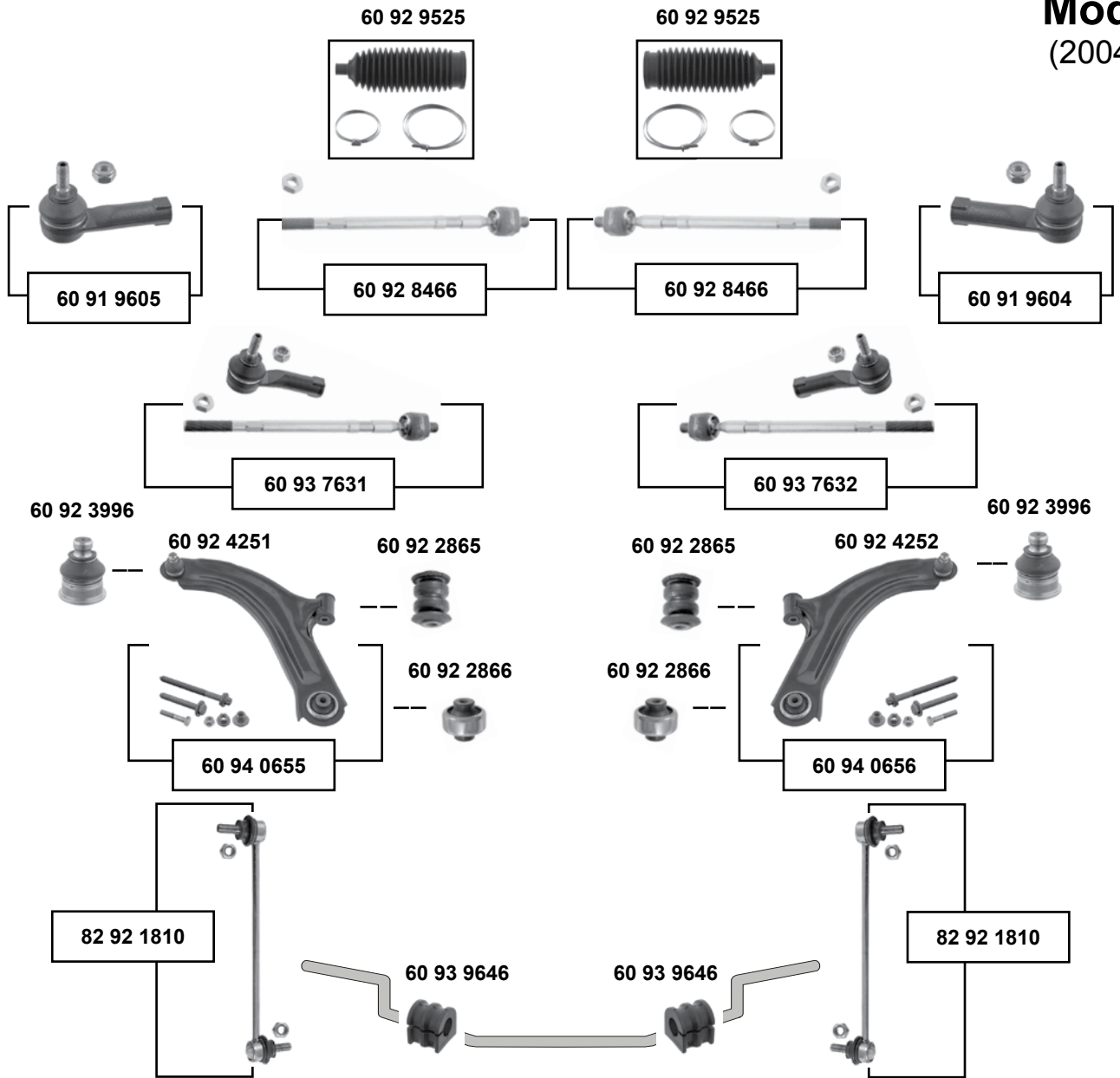

Vorderachse / Front axle



(1) FPOC,D,E,F,G,K,P / FP1B / JP16,7,B,C,D,E,F,G
JP01,2,3,4,5,6,7,9,A,B,C,D,E,F,G,H,J,K,L,M,P,R,S,T,U,V,W,Y



Ref. - No.

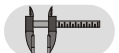

60 91 9604	77 01 047 813	Spurstangenendstück / tie rod end		M10 x 1,25
60 91 9605	77 01 047 812	Spurstangenendstück / tie rod end		M10 x 1,25
60 92 2865	82 00 183 569	Querlenkerlager / rubber mount		Ø A 40 H55
60 92 2866	82 00 183 570	Querlenkerlager / rubber mount		Ø A 68 H53
60 92 3996	82 00 298 455 S1	Traggelenk / ball joint		Ø A 18
60 92 4251	82 00 744 091	Querlenker / control arm		
60 92 4252	82 00 744 092	Querlenker / control arm		
60 92 8466	77 01 475 841 SK	Spurstange / tie rod		L 310
60 92 9525	77 01 475 840	Lenkmanschette / steering boot		
60 93 7631	77 01 475 841 S1	Rep. Satz Spurstange / rep. kit tie rod	servo  SMI	
60 93 7632	77 01 475 841 S2	Rep. Satz Spurstange / rep. kit tie rod		
60 93 9646	77 01 059 672	Stabilisatorlager / stabilizer mount	(1)	Ø I 20,5
60 94 0655	82 00 744 091 S1	Rep. Satz Querlenker / rep. kit control arm		
60 94 0656	82 00 744 092 S1	Rep. Satz Querlenker / rep. kit control arm		
82 92 1810	82 00 127 308	Verbindungsstange / connecting rod		L 248



Rapid (1986 → 1998)

Vorderachse / Front axle

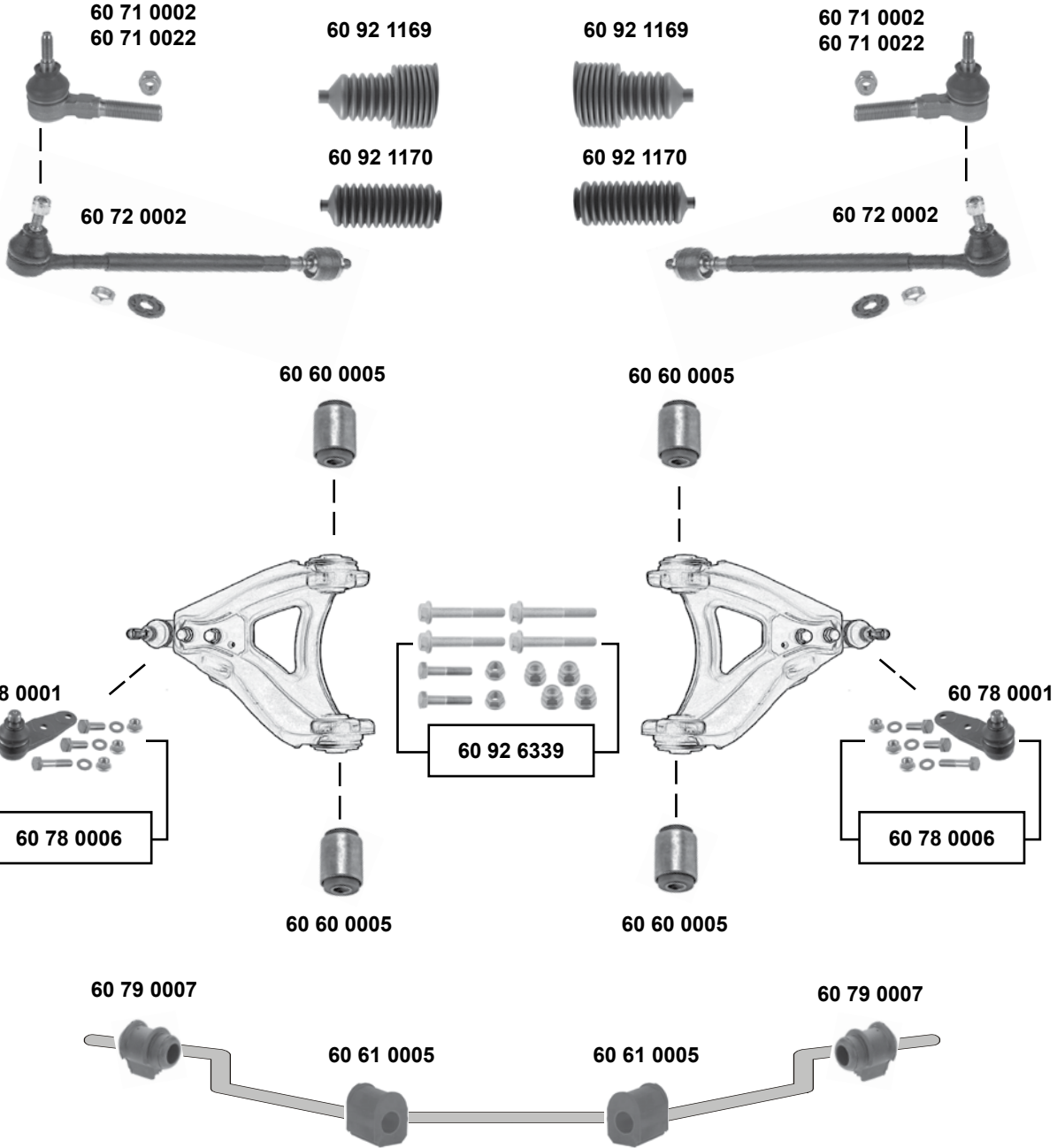

SWAG GERMANY	Ref. - No.			
60 60 0005	77 04 000 681	Querlenkerlager / control arm mount		
60 61 0005	77 00 798 053	Stabilisatorlager / stabilizer mount		Ø I 22
60 71 0002	77 01 461 141	Spurstangenendstück / tie rod end		Ø I 23
60 71 0022	77 01 469 231	Spurstangenendstück / tie rod end	OLD	
60 72 0002	77 01 463 346	Spurstange / tie rod	NEW	
60 79 0007	77 00 760 265	Stabilisatorlager / stabilizer mount		
60 78 0001	77 01 468 883 S2	Traggelenk / ball joint		Ø A 16
60 78 0006	77 01 468 883	Rep. Satz Traggelenk / rep. kit ball joint		
60 92 1169	77 01 469 617	Lenkmanschette / steering boot		
60 92 1170	77 01 469 497	Lenkmanschette / steering boot		
60 92 6339	77 00 763 538 S1	Schraubensatz / screw kit	servo	
			man.	



Safrane
(1992 → 2000)

60 71 0019



60 71 0021

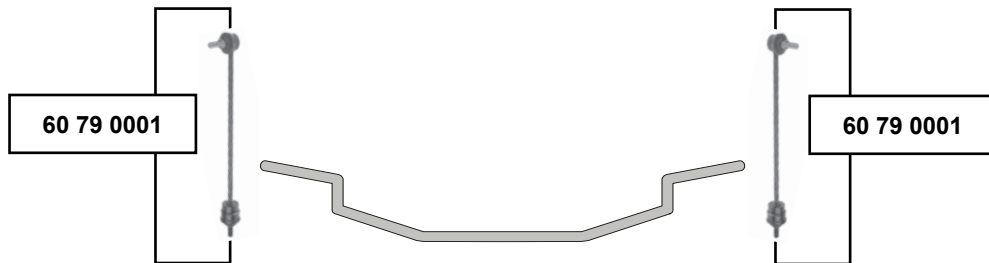
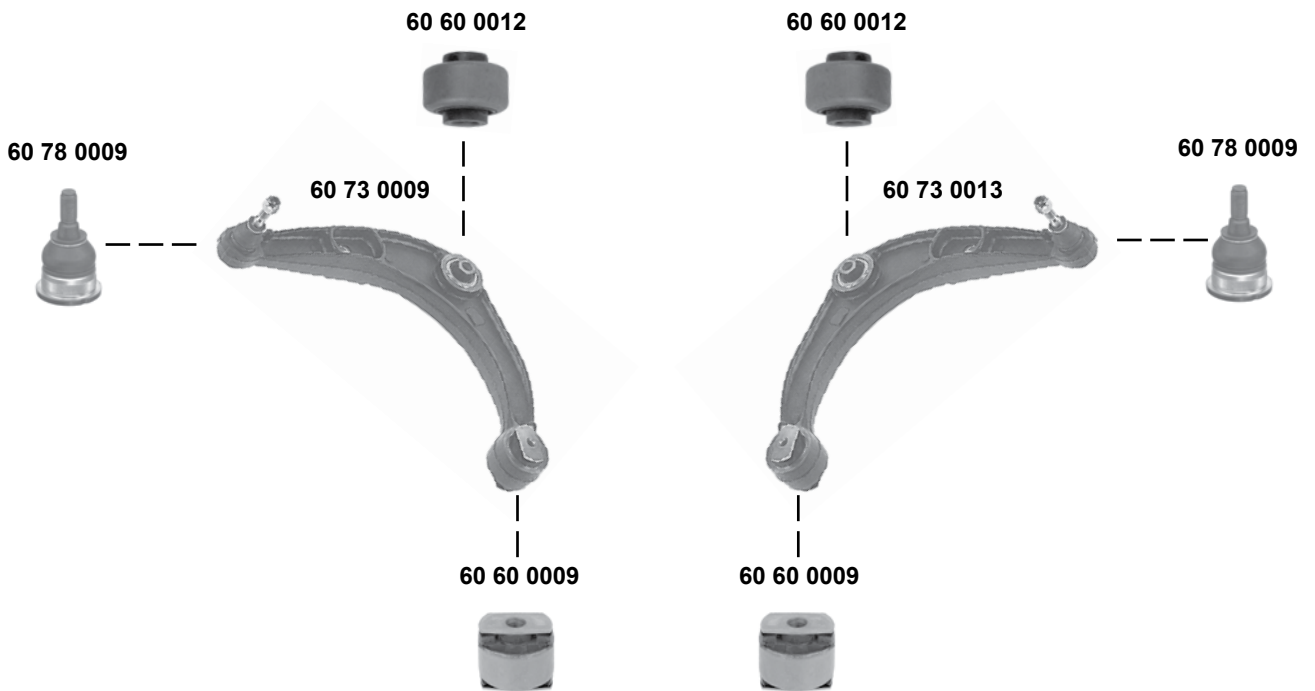

Vorderachse / Front axle

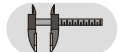

60 60 0012	77 00 806 239	Querlenkerlager / control arm mount	55x18x46
60 60 0009	77 00 806 238	Querlenkerlager / control arm mount	57,5x12,5x50
60 71 0019	60 00 022 714	Spurstangenendstück / tie rod end	M14 x 1,5
60 71 0021	60 00 022 715	Spurstangenendstück / tie rod end	M14 x 1,5
60 73 0009	77 00 807 580	Querlenker / control arm	
60 73 0013	77 00 807 581	Querlenker / control arm	
60 78 0009	77 00 421 804	Traggelenk / ball joint	Ø A 16
60 79 0001	77 00 805 494	Verbindungsstange / connecting rod	L 390



RENAULT

Sandero 1 (2008 → 2013)

Vorderachse / Front axle

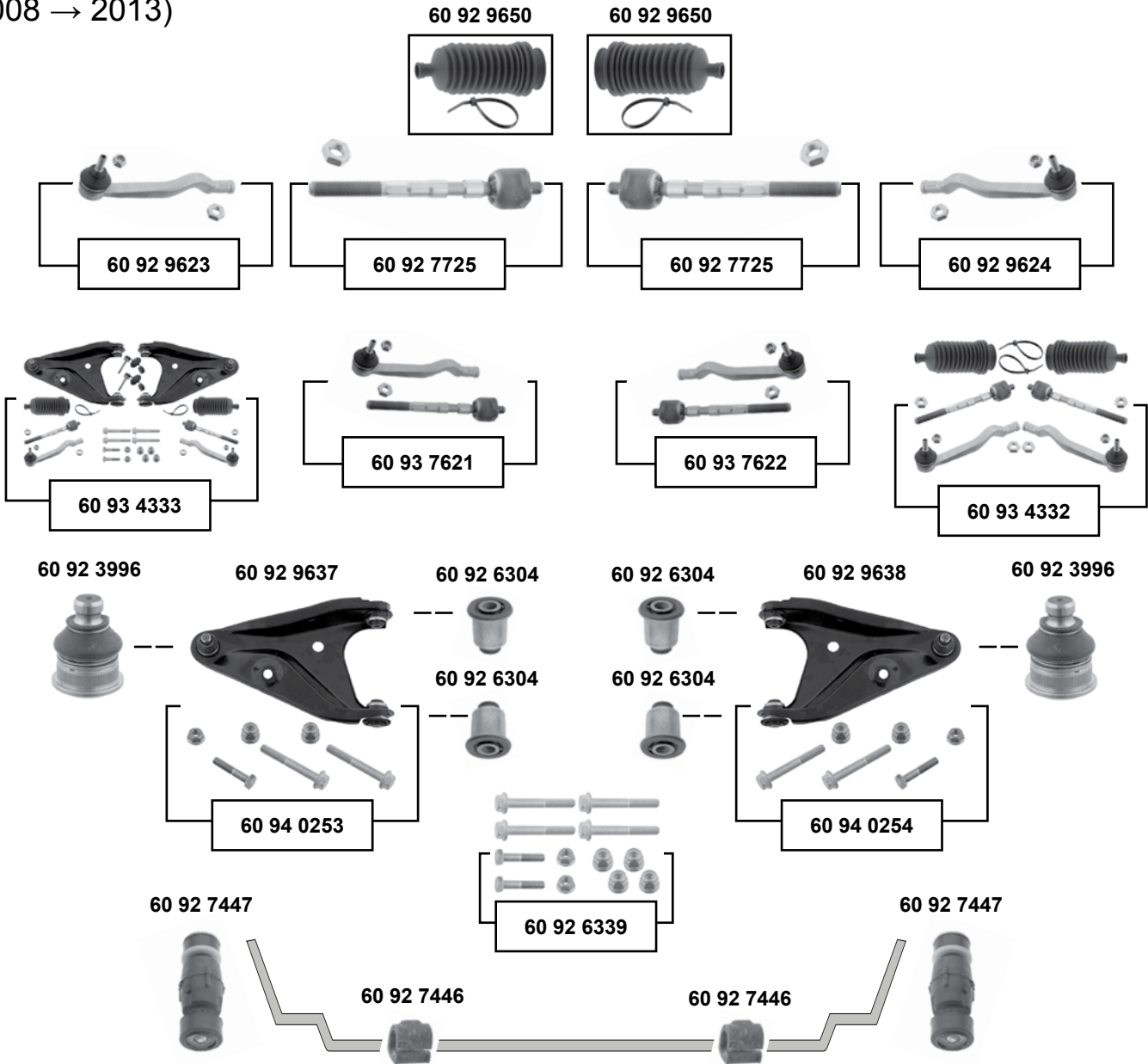

SWAG GERMANY	Ref. - No.			
60 92 3996	82 00 298 455 S1	Traggelenk / ball joint		Ø A 18 H 42
60 92 6304	60 40 002 245	Querlenkerlager / control arm mount		
60 92 6339	77 00 763 538 S1	Schraubensatz / screw kit		
60 92 7446	60 01 547 140	Stabilisatorlager / stabilizer mount		Ø I 23
60 92 7447	60 01 547 138	Stabilisatorlager / stabilizer mount		M8 x 1,25
60 92 7725	60 01 550 441	Spurstange / tie rod		
60 92 9623	60 01 550 442	Spurstangenendstück / tie rod end		L 213
60 92 9624	60 01 550 443	Spurstangenendstück / tie rod end		L 213
60 92 9637	60 01 550 446	Querlenker / control arm		
60 92 9638	60 01 550 447	Querlenker / control arm		
60 92 9650	60 01 547 607	Rep. Satz Lenkmanschette / rep. kit steering boot		L187
60 93 4332	60 01 550 442 S1	Spurstangensatz / tie rod set		
60 93 4333	60 01 550 446 S1	Rep. Satz Querlenkersatz / rep. kit control arm kit		
60 93 7621	60 01 550 442 S2	Spurstange / tie rod		
60 93 7622	60 01 550 443 S2	Spurstange / tie rod		
60 94 0253	60 01 550 446 S2	Rep. Satz Querlenker / rep. kit control arm		
60 94 0254	60 01 550 447 S2	Rep. Satz Querlenker / rep. kit control arm		



Scenic 2 (2003 → 2009)

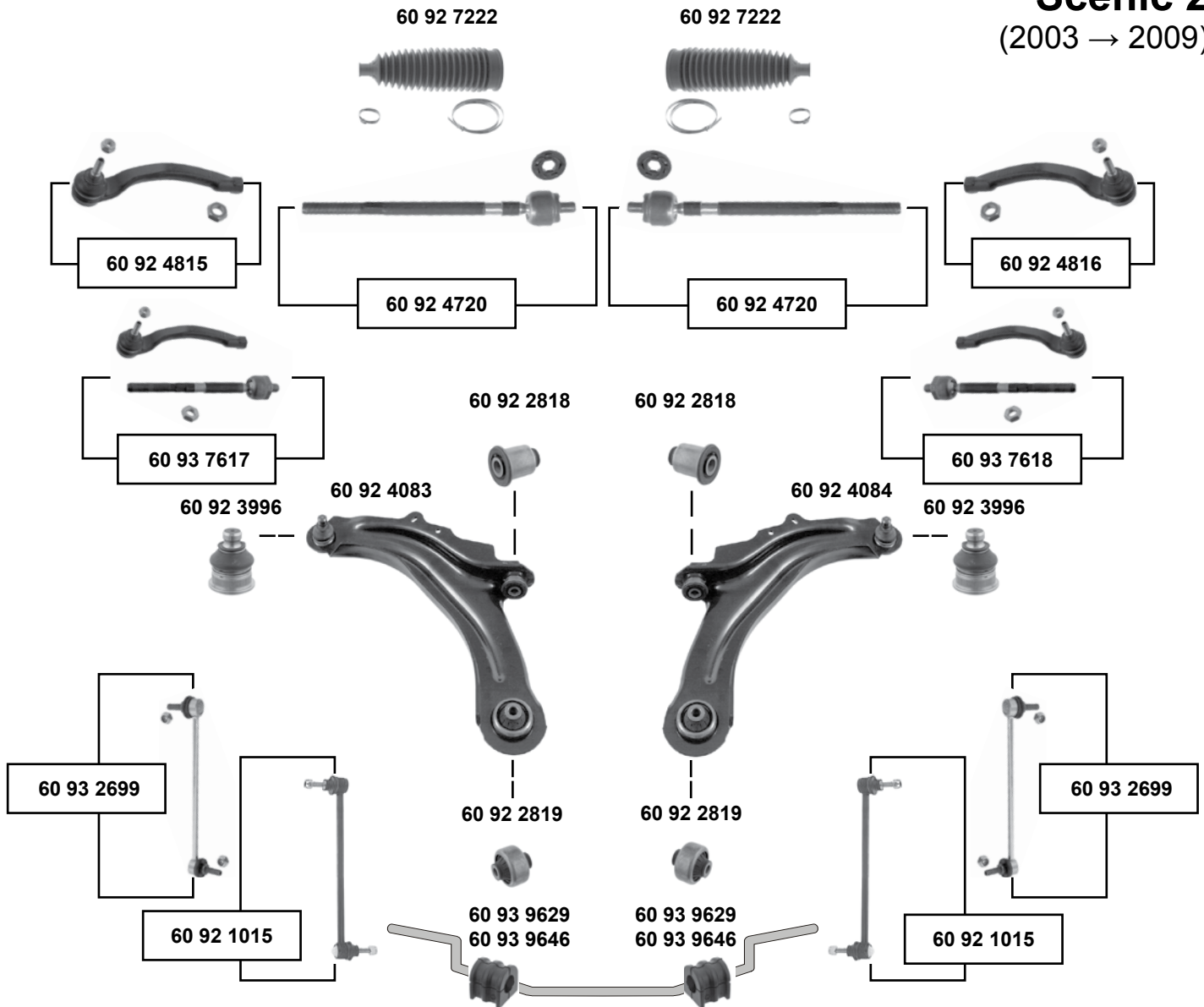

Vorderachse / Front axle

	(1) JM02,5,BC,F,G,H,J,S,U,W,Y 03 → 09 JM12,3,4,5,6,7,A,B,D,E,F,G,K,N,R,S,T,U,Y 03 → 09 JM2C,N 03 → 09 JM0T / JM1M 09/06 → 09	(2) JM2A,B,T,V,Y 03 → 09 JM0T, JM1M 03 → 09/06
--	---	---

	Ref. - No.			
60 92 1015	82 00 669 065	Verbindungsstange / connecting rod	(ex.) HD	L 285
60 92 2818	82 00 242 025	Querlenkerlager / control arm mount		Ø A 32
60 92 2819	82 00 041 166	Querlenkerlager / control arm mount		Ø A 58
60 92 3996	40 16 047 93R	Traggelenk / ball joint		Ø A 18
60 92 4083	82 00 679 063	Querlenker / control arm		
60 92 4084	82 00 679 067	Querlenker / control arm		
60 92 4720	77 01 474 448 SK	Spurstange / tie rod		L 215
60 92 4815	77 01 474 795	Spurstangenendstück / tie rod end		L 200
60 92 4816	77 01 474 796	Spurstangenendstück / tie rod end		L 200
60 92 7222	77 01 474 447	Rep. Satz Lenkmanschette / rep. kit steering boot		L190
60 93 2699	82 00 669 066	Verbindungsstange / connecting rod	HD	L 266
60 93 7617	77 01 474 795 S1	Rep. Satz Spurstange / rep. kit tie rod		
60 93 7618	77 01 474 796 S1	Rep. Satz Spurstange / rep. kit tie rod		
60 93 9629	77 01 059 966	Stabilisatorlager / stabilizer mount	(1)	Ø 20,5
60 93 9646	77 01 059 672	Stabilisatorlager / stabilizer mount	(2)	Ø 21,5



RENAULT

Scenic 3

(2009 →)

Vorderachse / Front axle

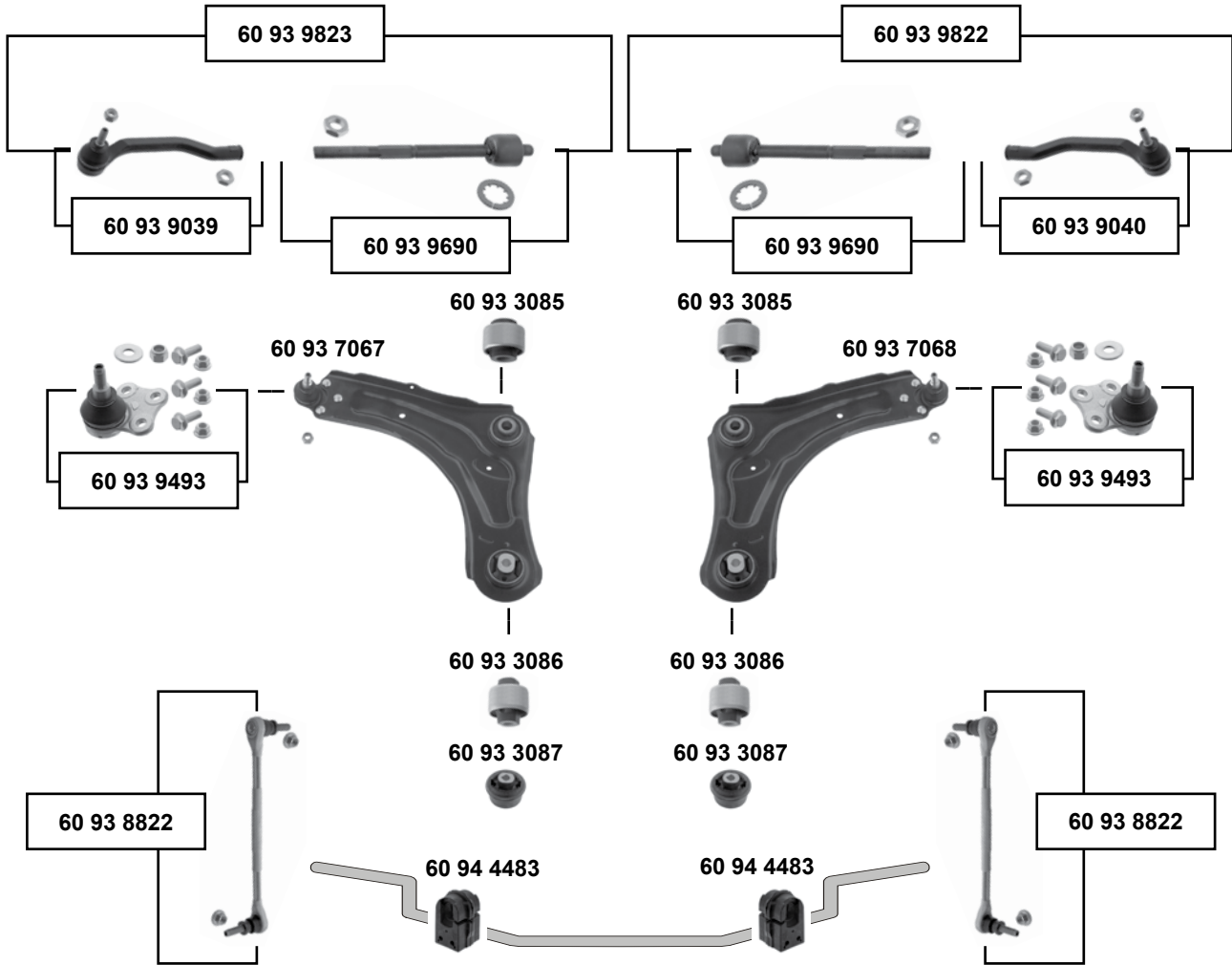

- | | | | |
|-----|---|-----|--|
| (1) | JZ00,2,3,7,9,A,B,D,F,G,J,L,N,U,Y
JZ1B,E,G,H,J,K,M,P,S,U,V,W,Y | (2) | JZ02,3,A,B,D / JZ1B,G,H,M,U,Y
nur / only 15" (ex.) Grand Scenic |
| (3) | JZ00,7,9,F,G,J,L,N,Y / JZ1E,J,K,P,S,V,W
JZ02,3,A,B,D,U / JZ1B,G,H,M,U,Y (ex.) 15" (ex.) Grand Scenic / Grand Scenic alle / all | | |
| (4) | JZ02,3,A,B,D,U,JZ1B,G,H,M,U,Ynur / only 15" (ex.) Grand Scenic | | |
| (5) | JZ00,2,3,7,9,A,B,D,F,G,J,L,N,U,Y / JZ11,2,4,6,B,E,G,H,J,K,M,P,S,U,V,W,Y | | |



Ref. - No.



Ref. - No.	Description	Notes	Dimensions
60 93 3085	Querlenkerlager / control arm mount	(1)	Ø A 55
60 93 3086	Querlenkerlager / control arm mount	(2)	Ø A 58
60 93 3087	Querlenkerlager / control arm mount	(3)	Ø A 70/79,5
60 93 7067	Querlenker / control arm	(4)	
60 93 7068	Querlenker / control arm	(4)	
60 93 8822	Verbindungsstange / connecting rod		L 274
60 93 9039	Spurstangenendstück / tie rod end		L 210
60 93 9040	Spurstangenendstück / tie rod end		L 210
60 93 9493	Traggelenk / ball joint		
60 93 9690	Axialgelenk / axial joint		L 214
60 93 9822	Spurstange / tie rod		
60 93 9823	Spurstange / tie rod		
60 94 4483	Stabilisatorlager / stabilizer mount	(5)	Ø I 22



Thalia (1998 → 2003)

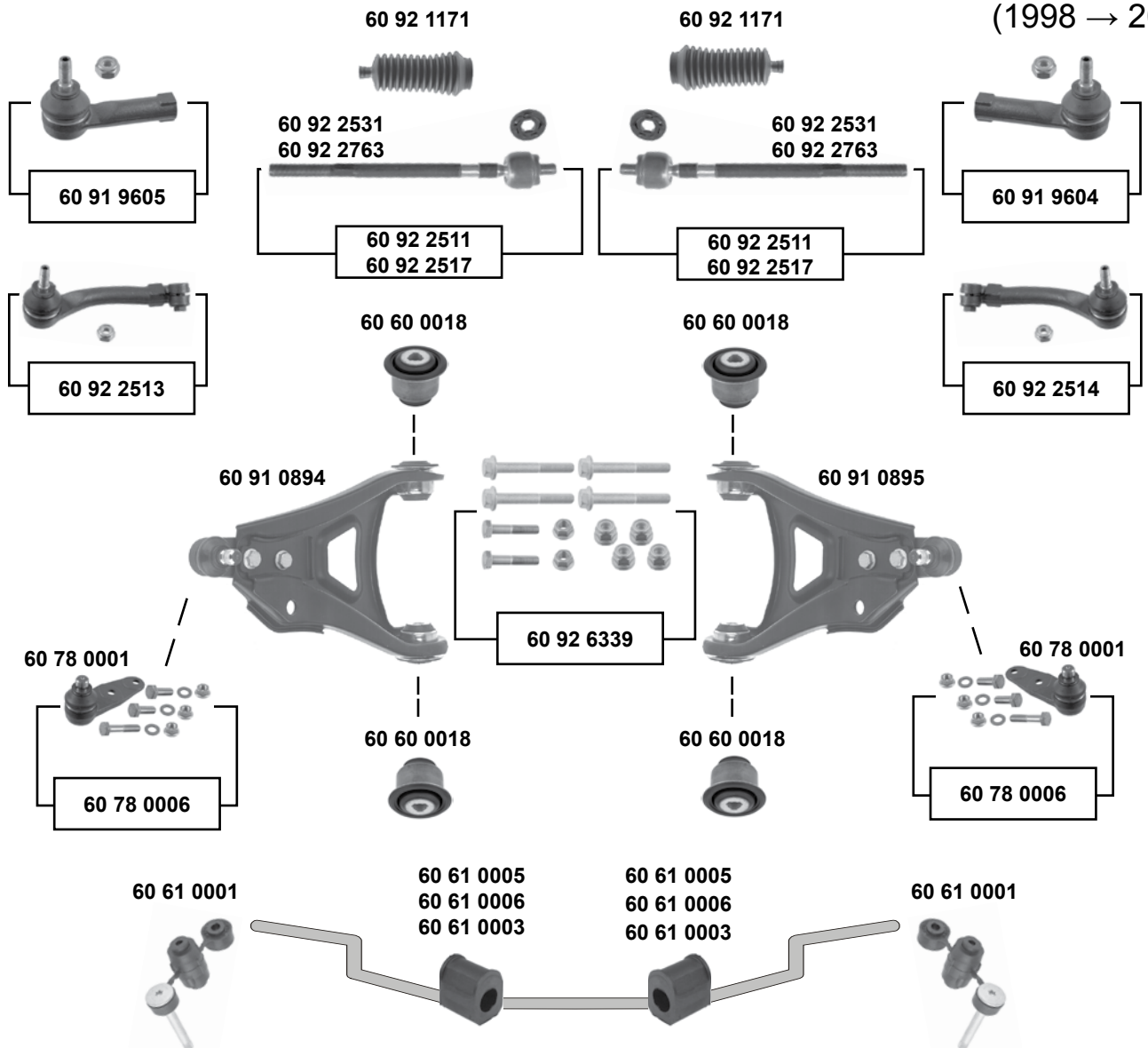

Vorderachse / Front axle

SWAG	Ref. - No.			
60 60 0018	82 00 651 161			45,5x46
60 61 0001	77 00 799 404			
60 61 0003	77 00 785 788			Ø I 23
60 61 0005	77 00 798 053			Ø I 22
60 61 0006	77 00 835 929			Ø I 24
60 78 0001	77 01 468 883 S2			Ø A 16
60 78 0006	77 01 468 883			
60 91 0894	82 00 197 179			
60 91 0895	82 00 197 187			
60 91 9604	77 01 047 813		12/99 →	M10 x 1,25
60 91 9605	77 01 047 812		12/99 →	M10 x 1,25
60 92 1171	77 01 469 496		SMI servo	
60 92 2511	77 01 472 113 SK		man. 12/99 →	
60 92 2513	77 01 476 762		→ 12/99	
60 92 2514	77 01 476 763		→ 12/99	
60 92 2517	77 01 472 120 SK		SMI servo 12/99 →	
60 92 2531	77 01 471 125 SK		servo → 12/99	
60 92 2763	77 01 472 734 SK		TRW servo 12/99 →	
60 92 6339	77 00 763 538 S1			

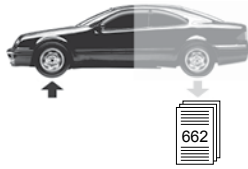

Trafic 1 (1989 → 2001)

Vorderachse / Front axle

60 71 0017



60 71 0017



60 78 0020



60 60 0008



60 60 0008



60 78 0020

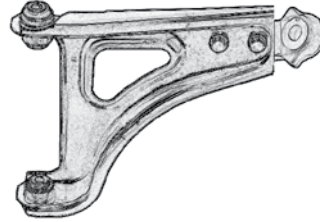
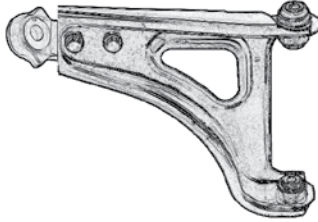

60 60 0008



60 60 0008



60 79 0010

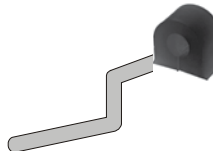

60 79 0010

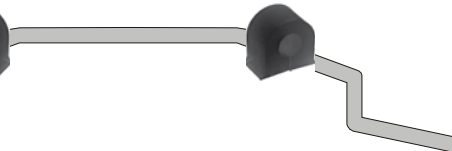

Ref. - No.



60 60 0008	77 01 349 064
60 71 0017	77 01 461 770
60 78 0020	77 01 461 667
60 79 0010	77 00 667 186

Querlenkerlager / control arm mount
Spurstangenendstück / tie rod end
Rep. Satz Traggelenk / rep. kit ball joint
Stabilisatorlager / stabilizer mount

36x18x58,5
M14 x 1,5
Ø A 18
Ø I 25,5



Trafic 2 (2001 →)

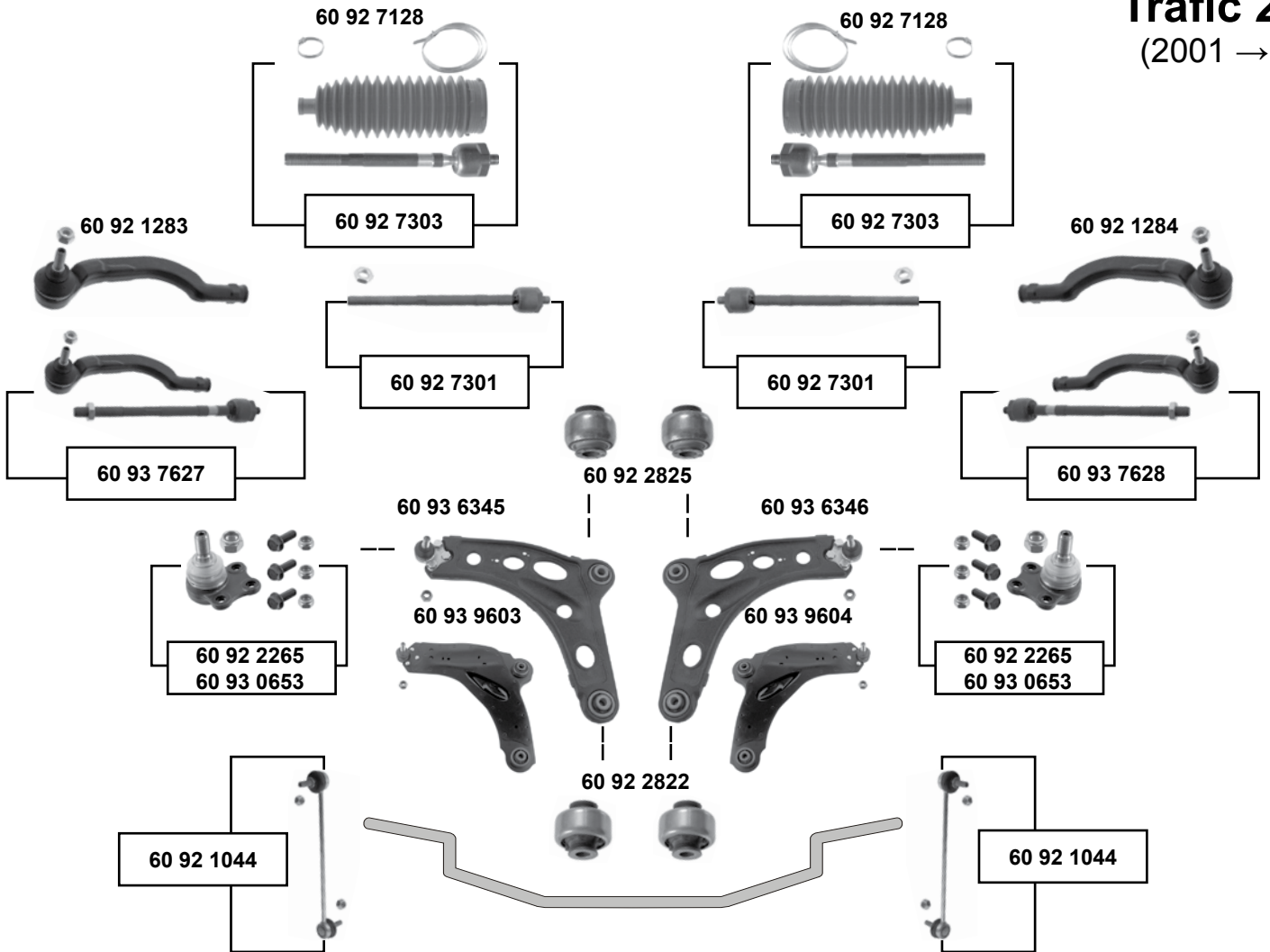

(1) EL00,1,H,J,M,P,R,S,V / FL00,1,2,P,R,S,U,V,W / JL00,1,2,P,R,S,U,V,W : 01 →
EL0L / FLOH,J,K,L,M,N / JLOH,K,L,M,N : 12/06 → (mit Stahlfelge / with steel rim)
EL0L / FLOH,J,K,L,M,N / JLOH,K,L,M,N : 01 → (mit Alufelge / alu steel rim)

(2) EL0A,B,C,D / FL0A,B,C,G / JL0A,B,C,D,G: 01 →
EL0L / FLOH,J,K,L,M,N / JLOH,J,K,L,M,N: 01 → 12/06 (mit Stahlfelge / with steel rim)

(3) EL0H,J,M,R,V / FL0R,U,V,W / JL0R,U,V,W 01 →
EL0L / FLOC,H,J,K,L,M,N / JLOH,J,K,L,M,N 12/06 →



Ref. - No.



Part No.	Ref. - No.	Description	Material	Dimensions
60 92 1044	82 00 661 217	Verbindungsstange / connecting rod		L 280
60 92 1283	77 01 049 282	Spurstangenendstück / tie rod end		M12 x 1,5
60 92 1284	77 01 049 283	Spurstangenendstück / tie rod end		M12 x 1,5
60 92 2265	77 01 478 029	Traggelenk / ball joint		Ø I 10
60 92 2822	82 00 002 869	Querlenkerlager / control arm mount		
60 92 2825	82 00 049 624	Querlenkerlager / control arm mount		
60 92 7128	77 01 473 334	Lenkmanschettensatz / steering boot set		
60 92 7301	77 01 473 333 SK	Axialgelenk / axial joint		
60 92 7303	77 01 473 333	Rep. Satz Axialgelenk / rep. kit axial joint		
60 93 0653	77 01 477 385	Traggelenk / ball joint	(3) Stahlguß	Ø I 12
60 93 6345	82 00 876 659	Querlenker / control arm	(1) Stahlguß	
60 93 6346	82 00 876 657	Querlenker / control arm	(1) Stahlguß	
60 93 7627	77 01 473 333 S1	Rep. Satz Spurstange / rep. kit tie rod		
60 93 7628	77 01 473 333 S2	Rep. Satz Spurstange / rep. kit tie rod		
60 93 9603	82 00 565 072	Querlenker / control arm	(2) Stahlblech	
60 93 9604	82 00 565 079	Querlenker / control arm	(2) Stahlblech	



Twingo 1 (1992 → 2007)

Vorderachse / Front axle

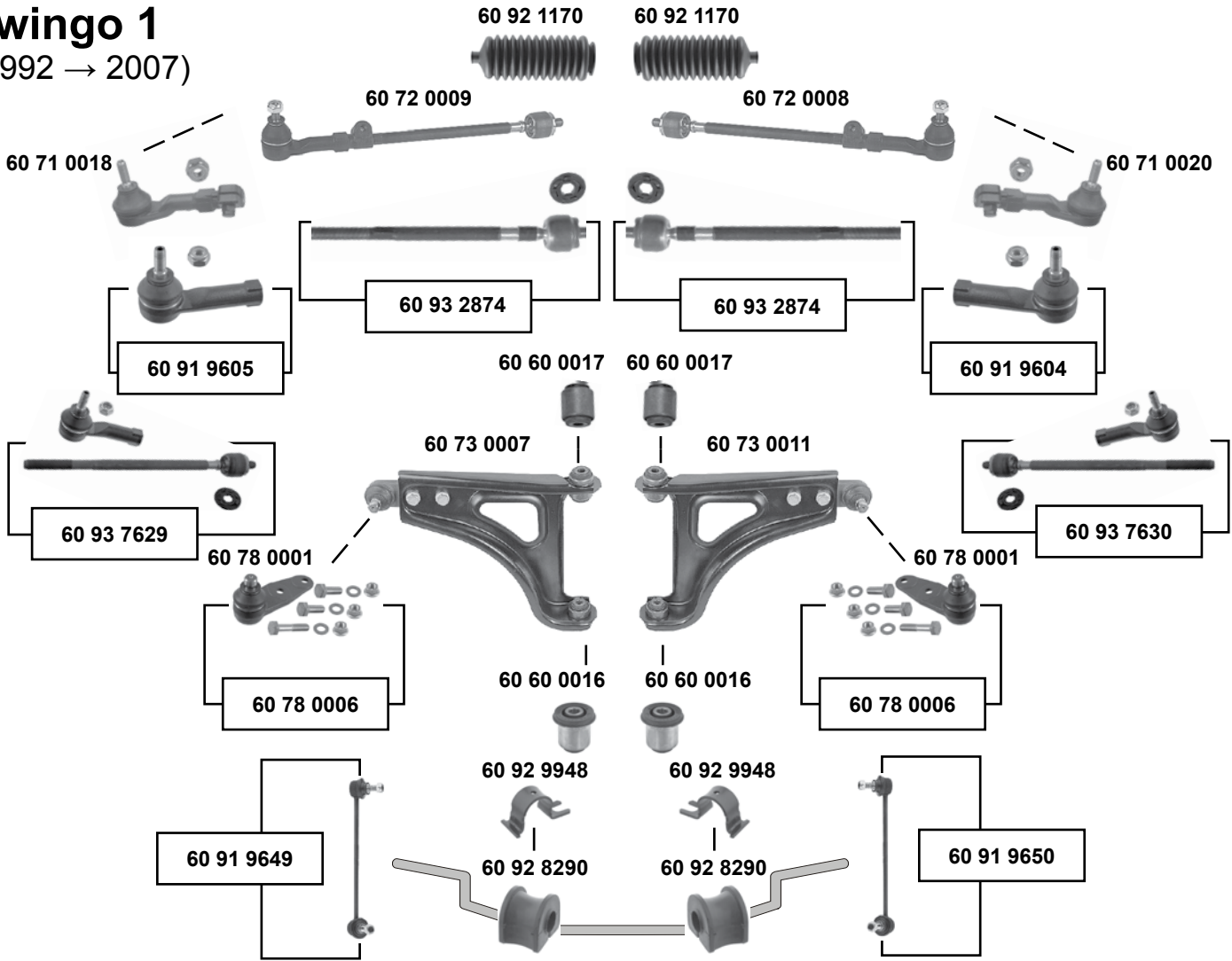

(1) C066,8 / S066,8 : 12/99 → 08 / C06C,D,G,H,K : 92 → 08



Ref. - No.



60 60 0016	77 00 831 364	Querlenkerlager / control arm mount		36x12x46
60 60 0017	77 00 819 929	Querlenkerlager / control arm mount		38x12x46
60 73 0007	82 00 737 125	Querlenker / control arm		
60 73 0011	82 00 737 126	Querlenker / control arm		
60 71 0018	60 00 022 730	Spurstangenendstück / tie rod end	→12/99	M14 x 1,5
60 71 0020	60 00 022 731	Spurstangenendstück / tie rod end	→12/99	M14 x 1,5
60 72 0008	77 01 467 219	Spurstange / tie rod	92 → 12/99	
60 72 0009	77 01 467 218	Spurstange / tie rod	92 → 12/99	
60 78 0001	77 01 468 883 S2	Traggelenk / ball joint	09/92 →	
60 78 0006	77 01 468 883	Rep. Satz Traggelenk / rep. kit ball joint	09/92 →	
60 91 9604	77 01 047 813	Spurstangenendstück / tie rod end	(1)	M10 x 1,25
60 91 9605	77 01 047 812	Spurstangenendstück / tie rod end	(1)	M10 x 1,25
60 91 9649	82 00 040 618	Verbindungsstange / connecting rod		L 255
60 91 9650	82 00 050 191	Verbindungsstange / connecting rod		L 255
60 92 1170	77 01 469 497	Lenkmanschette / steering boot		
60 92 8290	82 00 024 373	Stabilisatorlager / stabilizer mount		Ø I 16
60 92 9948	82 00 040 642	Schelle / clamp		
60 93 2874	77 01 473 498 SK	Axialgelenk / axial joint	12/99 → 07	L 316
60 93 3517	77 01 469 517 SK	Axialgelenk / axial joint	92 → 12/99	L 291
60 93 7629	77 01 473 498 S1	Rep. Satz Spurstange / rep. kit tie rod	12/99 → 07	
60 93 7630	77 01 473 498 S2	Rep. Satz Spurstange / rep. kit tie rod	12/99 → 07	



Twingo 2 (2007 → 2014)

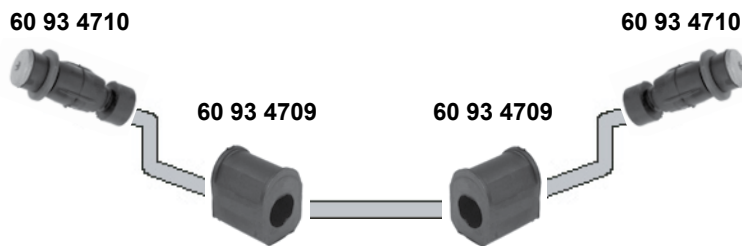
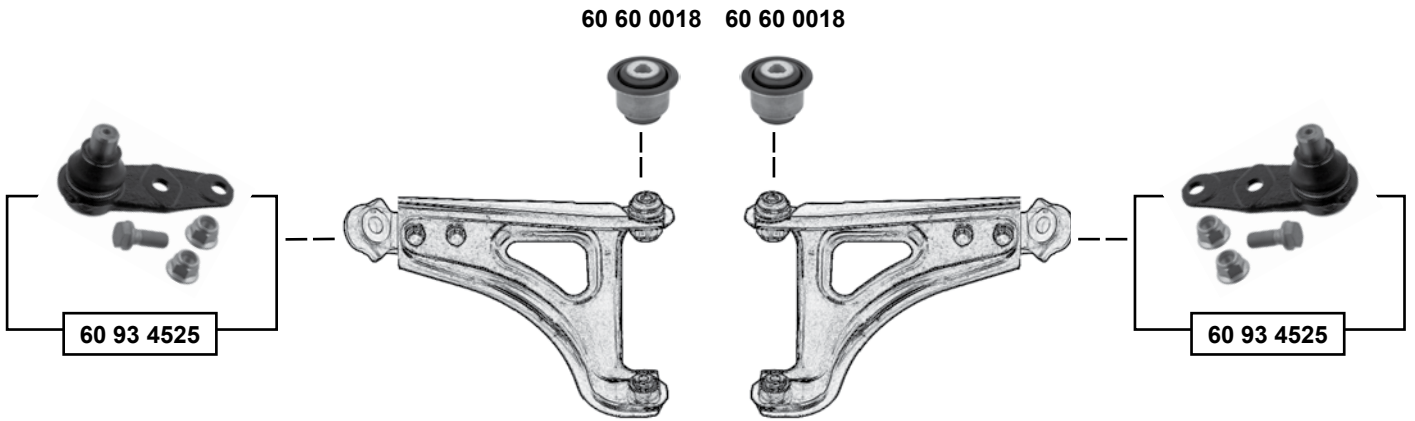
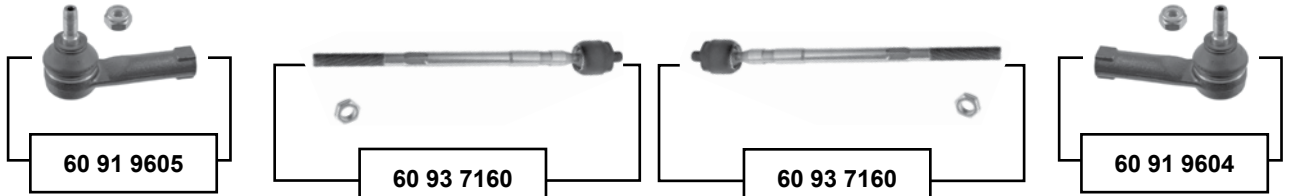

Vorderachse / Front axle

	(1) CN00,3,4,C,E,F,P,U / GN03,C,E CN01,A,B,K,V / GN01 nur / only ESP	(2) CN03,4,A,B,C,D,E,F,K,P,U,V / GN01,3,C,D,E CN00,1 09/08 →
--	---	---

	Ref. - No.			
60 60 0018	82 00 651 161	Querlenkerlager / control arm mount		45,5x46
60 91 9604	77 01 047 813	Spurstangenendstück / tie rod end		M10 x 1,25
60 91 9605	77 01 047 812	Spurstangenendstück / tie rod end		M10 x 1,25
60 93 4525	82 00 942 396 S1	Rep. Satz Traggelenk / rep. kit ball joint	(ex.) CN03	Ø A 18
60 93 4709	82 00 554 863	Stabilisatorlager / stabilizer mount	(1)	Ø I 24
60 93 4710	82 00 891 487	Stabilisatorlager / stabilizer mount	(2)	M12 x 1,25
60 93 7160	77 01 477 878 SK	Axialgelenk / axial joint		L 303,5

passend für / to fit

RENAULT



Twizy
(2012 →)

Vorderachse / Front axle

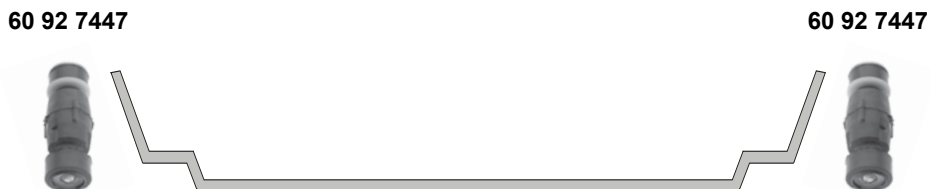
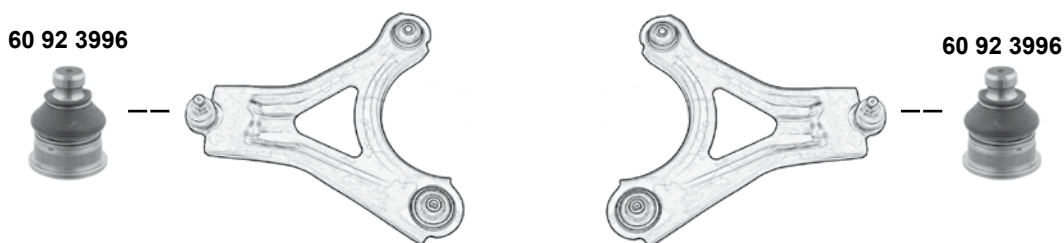

Ref. - No.



60 92 3996 40 16 047 93R
60 92 7447 60 01 547 138

Traggelenk / ball joint
Stabilisatorlager / stabilizer mount

Ø A 18
M8 x 1,25



Vel Satis (2002 →)

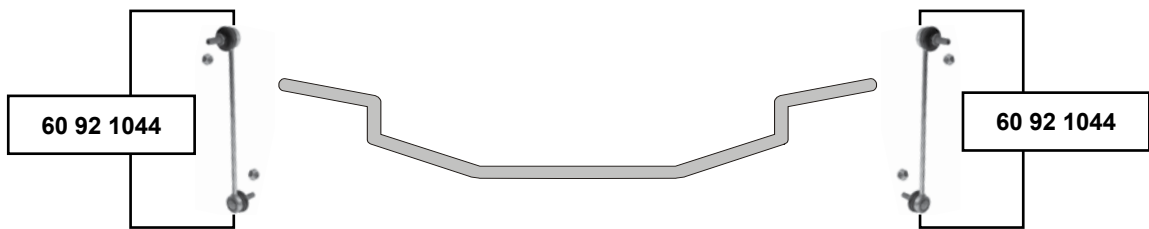
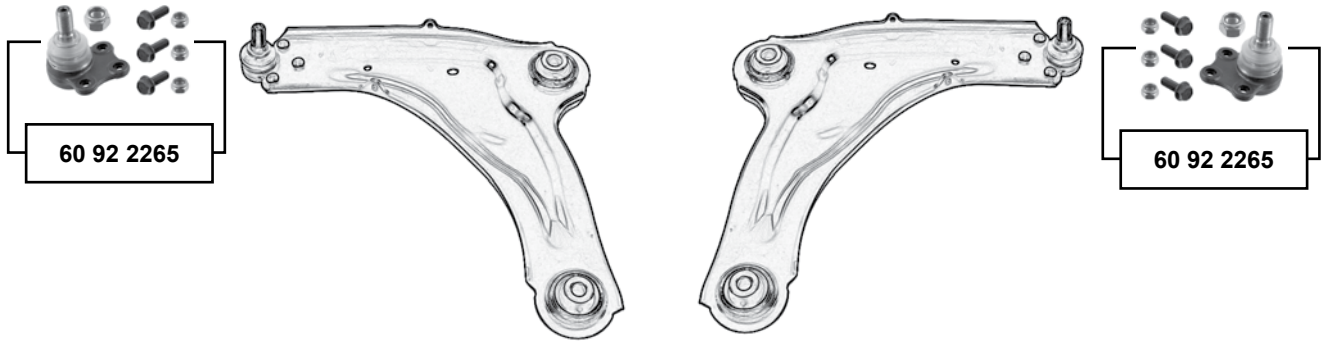
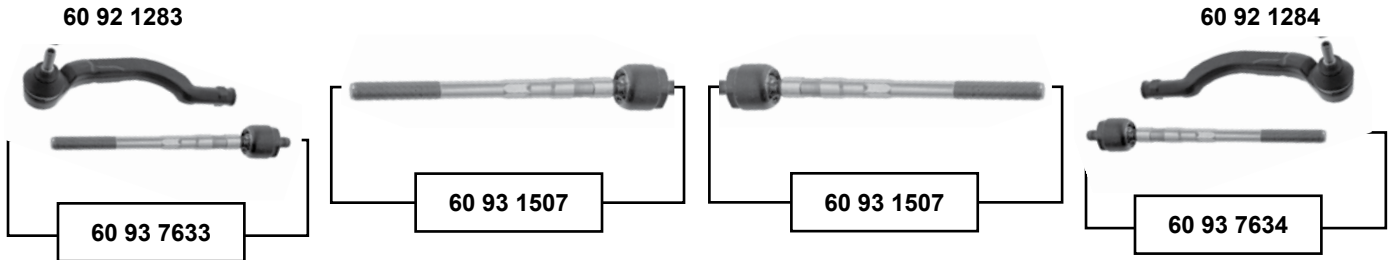

Vorderachse / Front axle



Part No.	Ref. - No.	Description	Dimensions
60 92 1044	82 00 661 217	Verbindungsstange / connecting rod	L 280
60 92 1283	77 01 049 282	Spurstangenendstück / tie rod end	M10 x 1,5
60 92 1284	77 01 049 283	Spurstangenendstück / tie rod end	M10 x 1,5
60 92 2265	77 01 478 029	Traggelenk / ball joint	
60 93 1507	77 01 478 522 SK	Spurstange / tie rod	L 247
60 93 7633	77 01 478 552 S1	Rep. Satz Spurstange / rep. kit tie rod	
60 93 7634	77 01 478 552 S2	Rep. Satz Spurstange / rep. kit tie rod	



Wind

(2010 →)

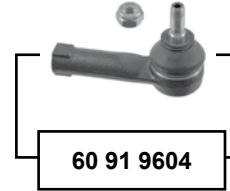
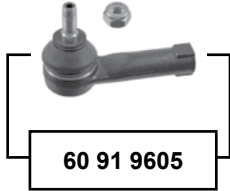

Vorderachse / Front axle

Zoe

(2012 →)

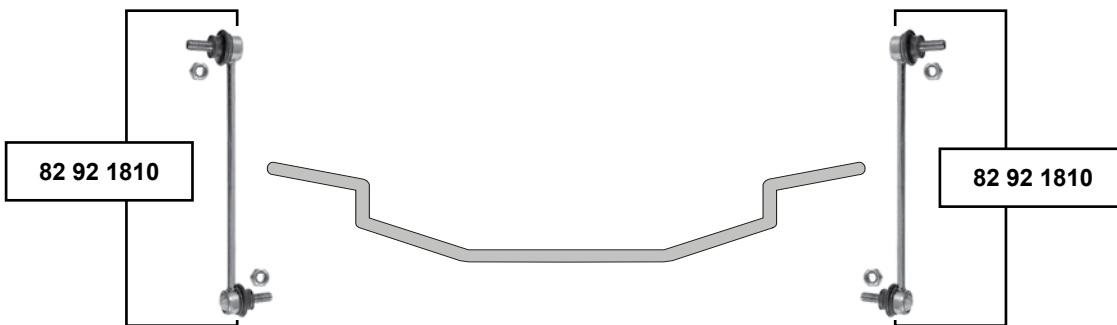

Ref. - No.



60 91 9604	77 01 047 813	Spurstangenendstück / tie rod end	M10 x 1,25
60 91 9605	77 01 047 812	Spurstangenendstück / tie rod end	M10 x 1,25
82 92 1810	82 00 127 308	Verbindungsstange / connecting rod	L 248
60 94 3630	48 52 110 71R SK	Axialgelenk / axial joint	L 232

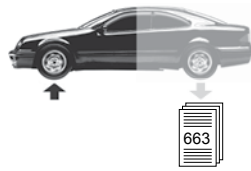

25
(11/99 →)

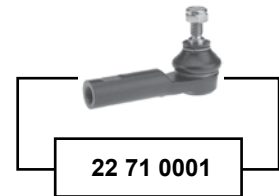

75 (RJ)
(02/99 →)



22 93 0714



22 93 0715

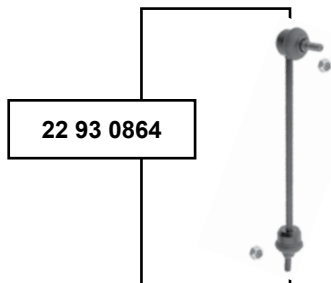

22 93 0864

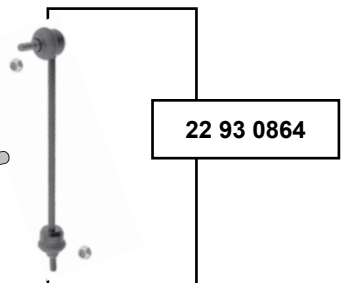

22 93 0864



22 71 0001	GSJ 826
22 93 0714	RBX 101771
22 93 0715	RBX 101761
22 93 0731	QJB100180
22 93 0732	QJB100180
22 93 0864	RBM100240

Spurstangenendstück / tie rod end
Querlenkerlager / control arm mount
Querlenkerlager / control arm mount
Spurstangenendstück / tie rod end
Spurstangenendstück / tie rod end
Verbindungsstange / connecting rod

M14 x 1,5
M14 x 1,5
M14 x 1,5
L 309

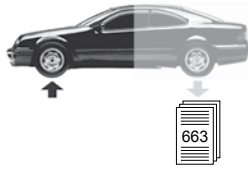

200 (3+5 Tüer/3+5 door saloons)

(10/92 →)

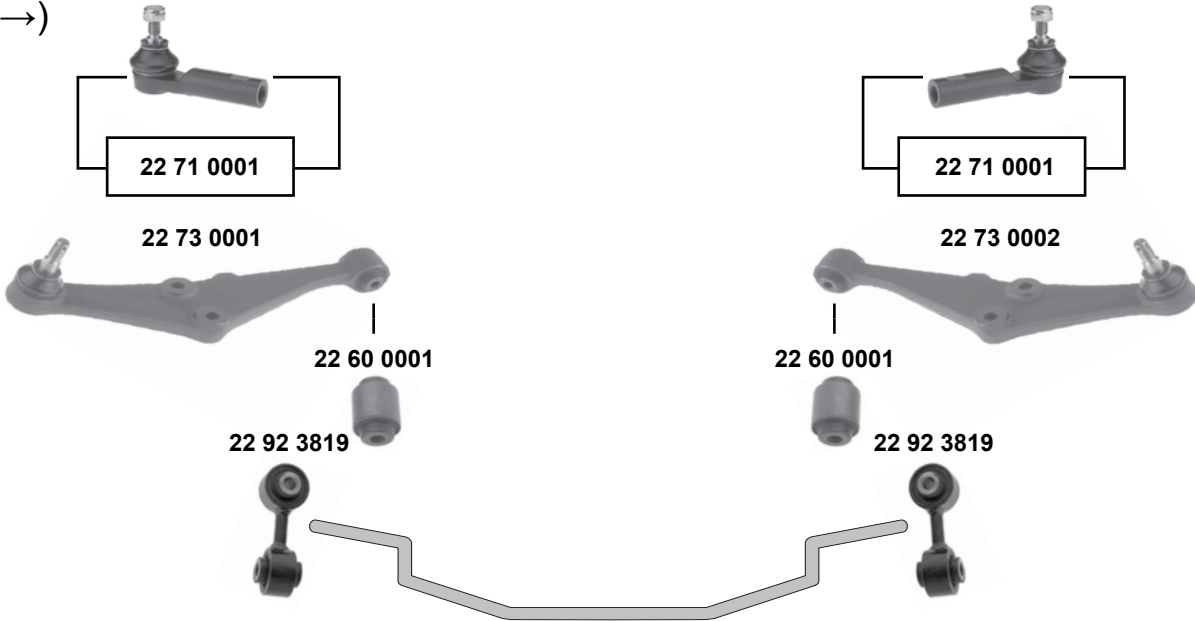

200 (Coupé / Cabrio)

(03/96 →)

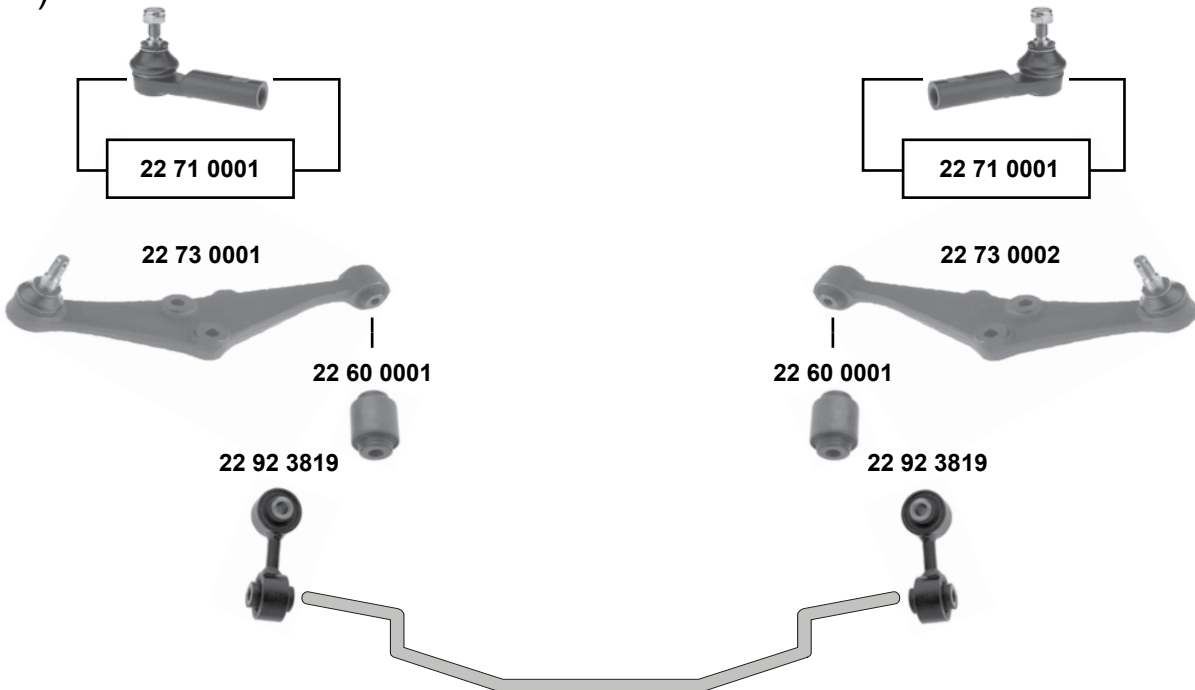

- | | | | | |
|--|-----|---|-----|---|
| | (1) | 3+5 Tüer / 3+5 door saloons alle / all → 02/96
Coupé / Cabrio alle / all 03/96 → 11/99 | (2) | 3+5 Tüer / 3+5 door saloons → 03/00
Coupé / Cabrio → 03/00 |
| | | | | |

	Ref. - No.			
22 60 0001	EGP 1673	Querlenkerlager / control arm mount	(1)	10x32x50 M14 x 1,5
22 71 0001	GSJ 826	Spurstangenendstück / tie rod end		
22 73 0001	GSJ 413	Querlenker / control arm	(2)	L 66
22 73 0002	GSJ 414	Querlenker / control arm		
22 92 3819	EGP 1662	Verbindungsstange / connecting rod		

Vorderachse / Front axle

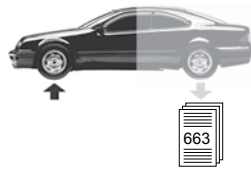

400

(10/92 → 02/96)

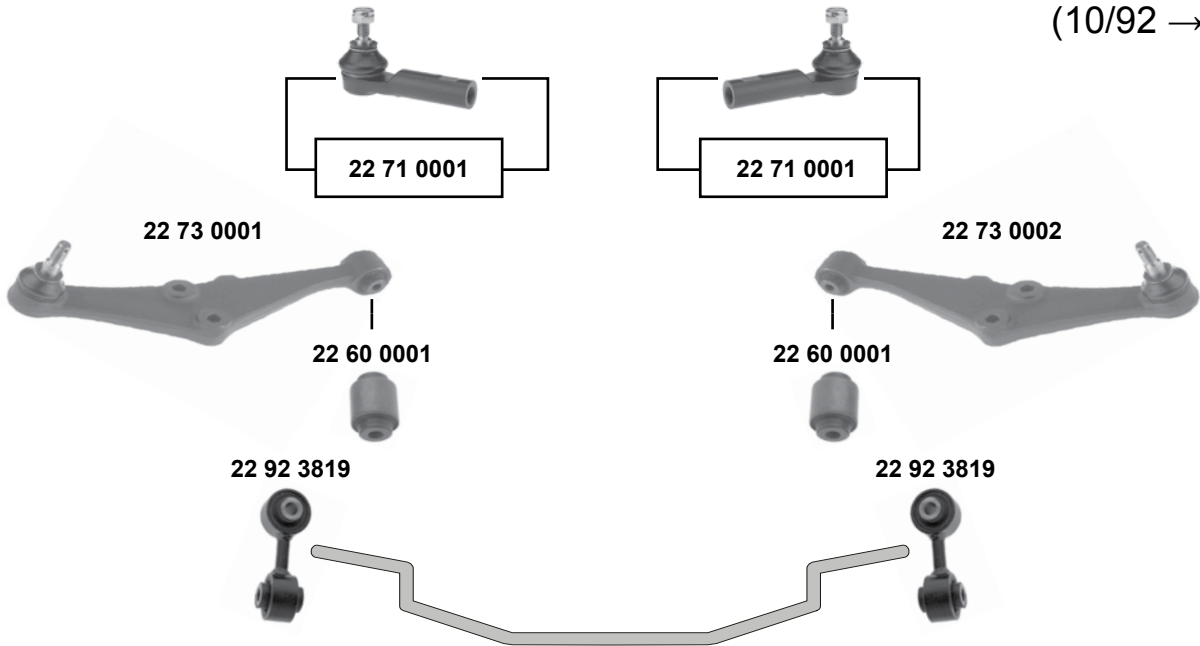

Vorderachse / Front axle

400

(03/96 →)

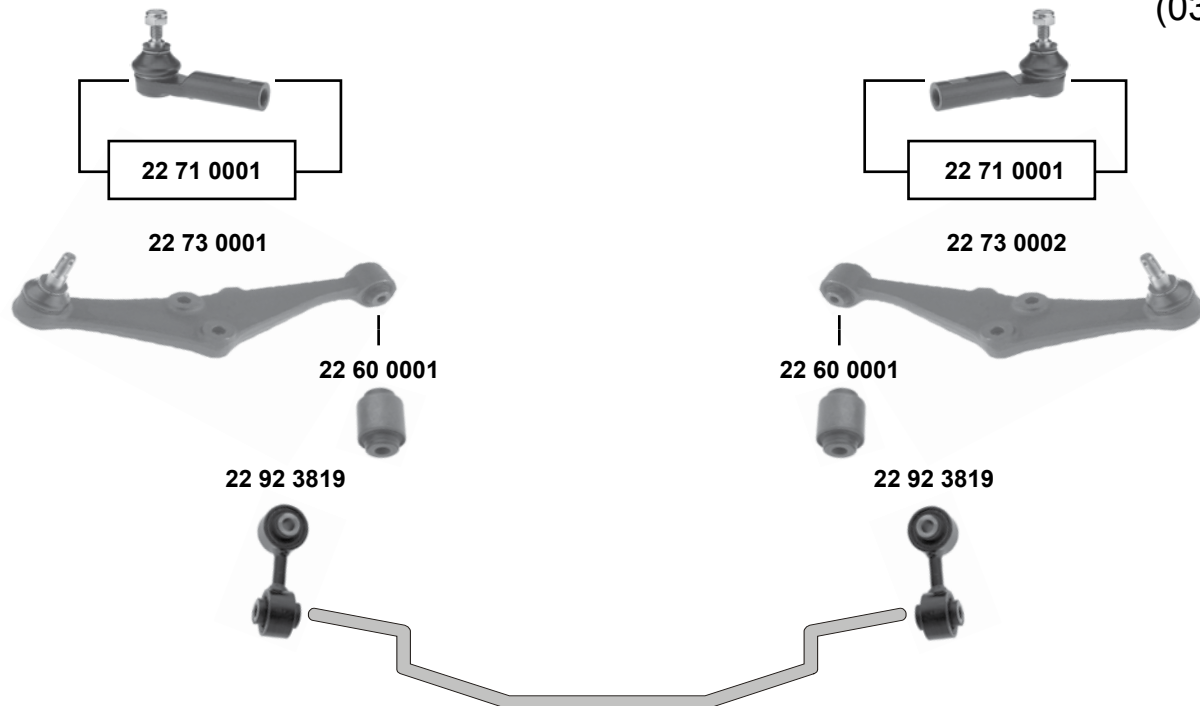

(1) 3+5 Tüer / 3+5 door saloons **alle / all** → 03/00
Coupé / Cabrio **alle / all** → 03/00

(2) 3+5 Tüer / 3+5 door saloons → 03/00
Coupé / Cabrio → 03/00



Ref. - No.



22 60 0001 EGP 1673
22 71 0001 GSJ 826
22 73 0001 GSJ 413
22 73 0002 GSJ 414
22 92 3819 EGP 1662

Querlenkerlager / control arm mount
Spurstangenendstück / tie rod end
Querlenker / control arm
Querlenker / control arm
Verbindungsstange / connecting rod

(1)

(2)

10x32x50
M14 x 1,5

L 66

passend für / to fit

ROVER



600

(10/92 →)



22 71 0003



85 78 0001



85 78 0001

Vorderachse / Front axle

Austin Metro

(11/84 → 1990)



22 71 0002

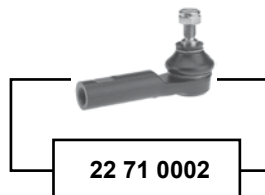

22 71 0002



Ref. - No.



22 71 0002	GSJ 734
22 71 0003	GSJ 407
85 78 0001	GSJ 1002

Spurstangenendstück / tie rod end
Spurstangenendstück / tie rod end
Traggelenk / ball joint

servo

M14 x 1,5

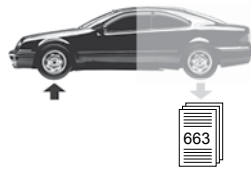

MG ZR/ZT

(11/99 →)

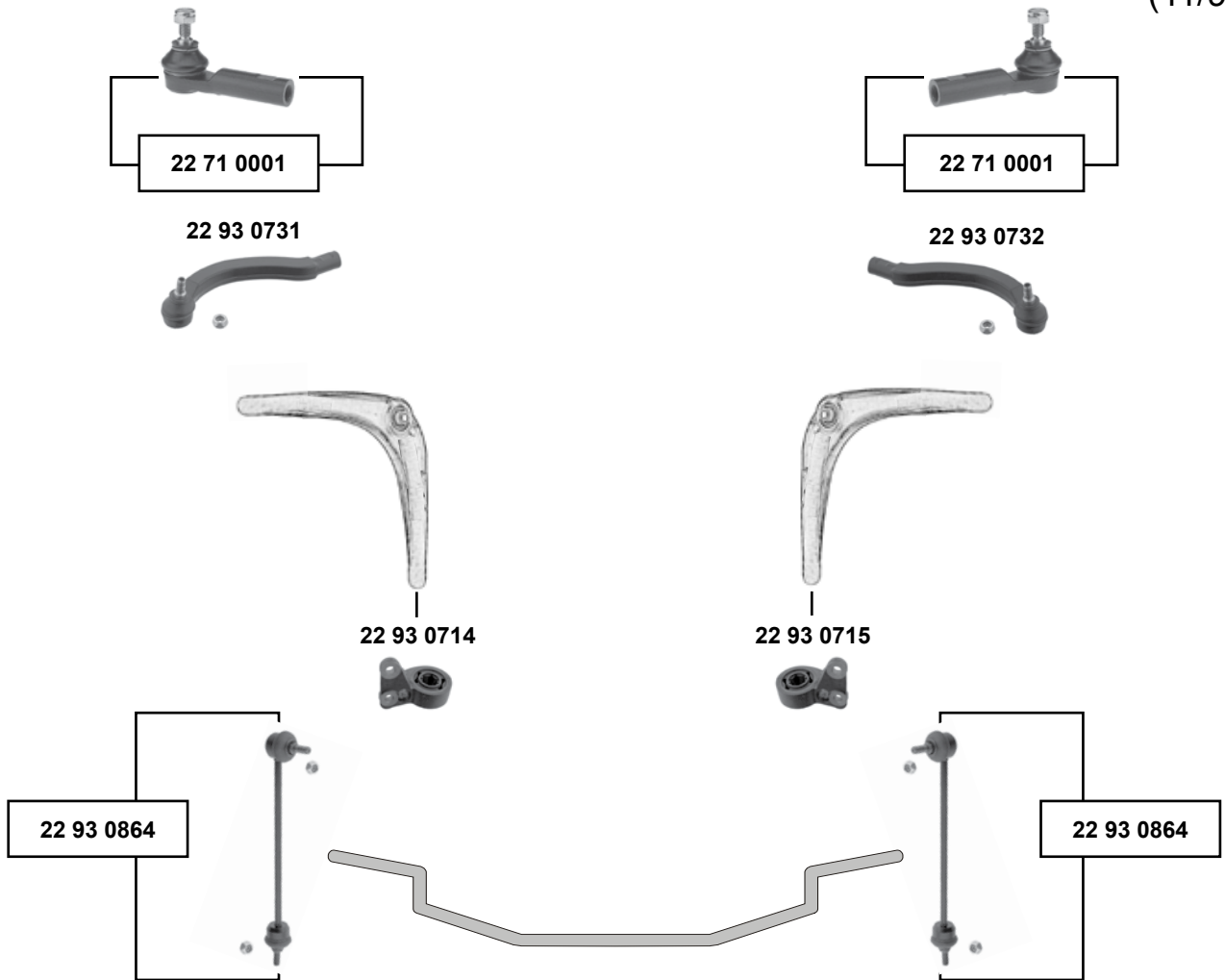



Vorderachse / Front axle

Mini

(1985 →)



SWAG [®]	Ref. - No.			
22 71 0001	QJB 100120	Spurstangenendstück / tie rod end	ZR	
22 71 0002	GSJ 734	Spurstangenendstück / tie rod end	ZT 06/01 →	
22 93 0714	RBX 101771	Querlenkerlager / control arm mount	ZT 06/01 →	
22 93 0715	RBX 101761	Querlenkerlager / control arm mount	ZT 06/01 →	
22 93 0731	QJB100180	Spurstangenendstück / tie rod end	ZT 06/01 →	M14 x 1,5
22 93 0732	QJB100180	Spurstangenendstück / tie rod end	ZT 06/01 →	M14 x 1,5
22 93 0864	RBM100240	Verbindungsstange / connecting rod	ZT 06/01 →	L 309



9-3 I
(1998 → 2002)



oben / upper

40 60 0024



40 60 0024



40 60 0024



40 60 0024



unten / lower

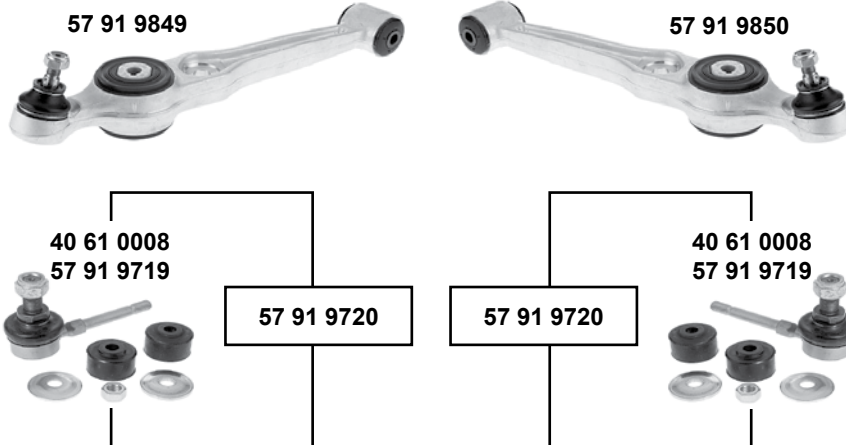

(1) (ch.) → 22029908 , (ch.) → 27008847



Ref. - No.



40 60 0024	42 46 062	Hülse / sleeve			15x16,3x3
40 61 0008	42 46 112	Verbindungsstangenlager / connecting rod bearing			
40 71 0008	42 42 749	Spurstangenendstück / tie rod end			M16 x 2
40 71 0009	42 42 756	Spurstangenendstück / tie rod end			M16 x 2
40 72 0008	42 42 681	Spurstange / tie rod	(1) / servo		M16 x 2
40 72 0009	42 42 673	Spurstange / tie rod	(1) / servo		M16 x 2
40 76 0002	42 42 731	Einstellbolzen / adjusting bolt			M16 x 2
57 72 0005	42 42 681 S1	Rep. Satz Spurstange / rep. kit tie rod	(1) / servo		M16 x 2
57 72 0006	42 42 673 S1	Rep. Satz Spurstange / rep. kit tie rod	(1) / servo		M16 x 2
57 91 9719	45 44 599	Verbindungsstange / connecting rod			L 88
57 91 9720	45 44 599 S1	Rep. Satz Verbindungsstange / rep. kit connecting rod			
57 91 9849	45 43 450	Querlenker / control arm			
57 91 9850	45 43 468	Querlenker / control arm			

Vorderachse / Front axle

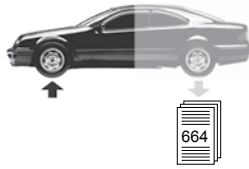

9-3 II

(2002 → 2011)

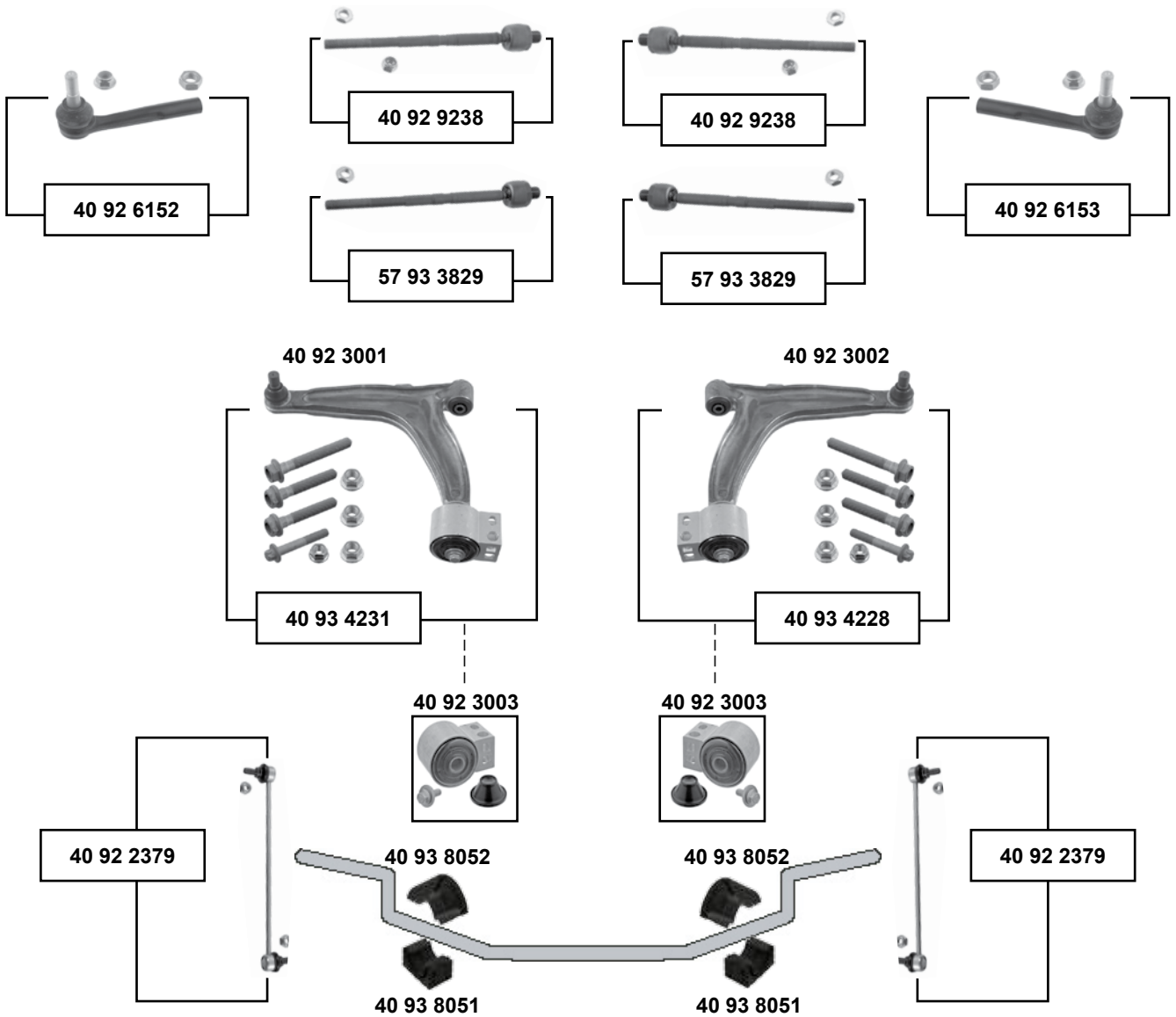

Vorderachse / Front axle

(1) (mot.) Z 1,8 XE / Z 1,9 DT / Z 1,9 DTH → 06

(2) B 284 (ex.) 4x4 / 06 →
Z 1,8 XE, Z 1,9 DT, Z 1,9 DTH / 07 →
Z 1,9 DTR / 08 →



Ref. - No.



Ref. - No.	Description	Material	Dimensions
40 92 2379	Verbindungsstange / connecting rod		L355
40 92 3001	Querlenker / control arm	Alu / alloy	
40 92 3002	Querlenker / control arm	Alu / alloy	
40 92 3003	Rep. Satz Querlenker / rep. kit control arm		
40 92 6152	Spurstangenendstück / tie rod end		M14 x 1,5
40 92 6153	Spurstangenendstück / tie rod end		M14 x 1,5
40 92 9238	Rep. Satz Axialgelenk / rep. kit axial joint	(1)	
40 93 4228	Rep. Satz Querlenker / rep. kit control arm		
40 93 4231	Rep. Satz Querlenker / rep. kit control arm		
40 93 8051	Stabilisatorlager, unten / stabilizer mount, lower		Ø 24
40 93 8052	Stabilisatorlager, oben / stabilizer mount, upper		Ø 24
57 93 3829	Axialgelenk / axial joint	(2)	L 289

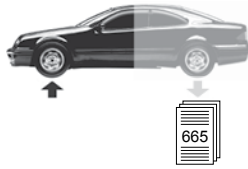

9-5 I
(1998 → 2010)

Vorderachse / Front axle

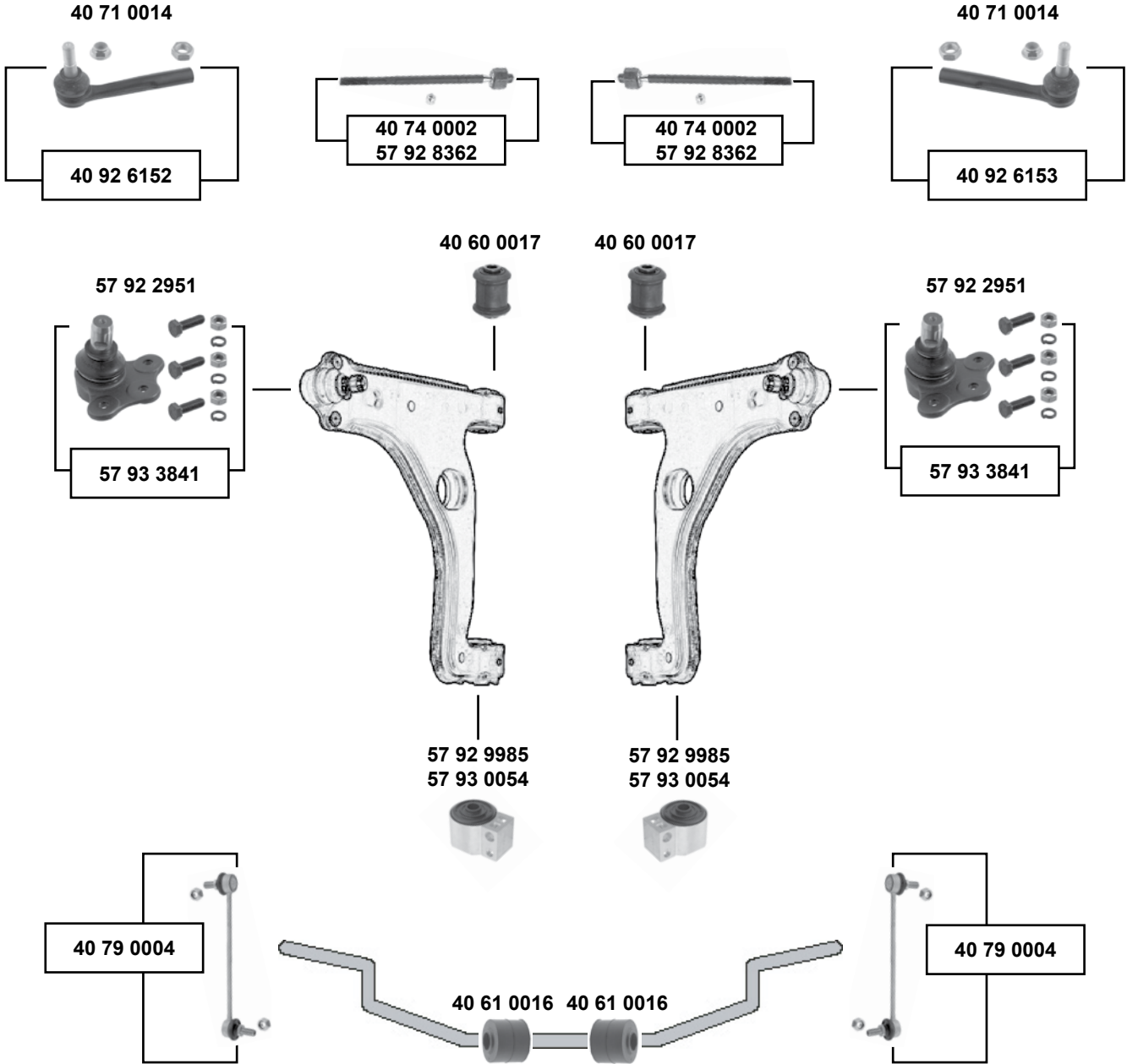

SWAG	Ref. - No.			
40 60 0017	45 66 899	Querlenkerlager / control arm mount		12x36,5x6
40 61 0016	90 468 567	Stabilisatorlager / stabilizer mount		Ø I 10
40 71 0014	48 36 540	Spurstangenendstück / tie rod end	(ch.) → 3034800	M14 x 1,5
40 74 0002	48 36 557	Axialgelenk / axial joint	servo / → 01	L 360
40 79 0004	52 36 823	Verbindungsstange / connecting rod	servo / → 01	L 243,5
40 92 6152	93 172 254	Spurstangenendstück / tie rod end	servo / 02 →	M14 x 1,5
40 92 6153	93 172 255	Spurstangenendstück / tie rod end	servo / 02 →	M14 x 1,5
57 92 2951	52 31 683	Traggelenk / ball joint	→ 01	Ø A 18
57 92 8362	93 194 335	Axialgelenk / axial joint	servo / 02 →	L 301
57 92 9985	50 63 391	Querlenkerlager / control arm mount	→ 01	
57 93 0054	52 33 374	Querlenkerlager / control arm mount	02 →	
57 93 3841	52 37 516	Traggelenk / ball joint	02 →	



40 94 0915

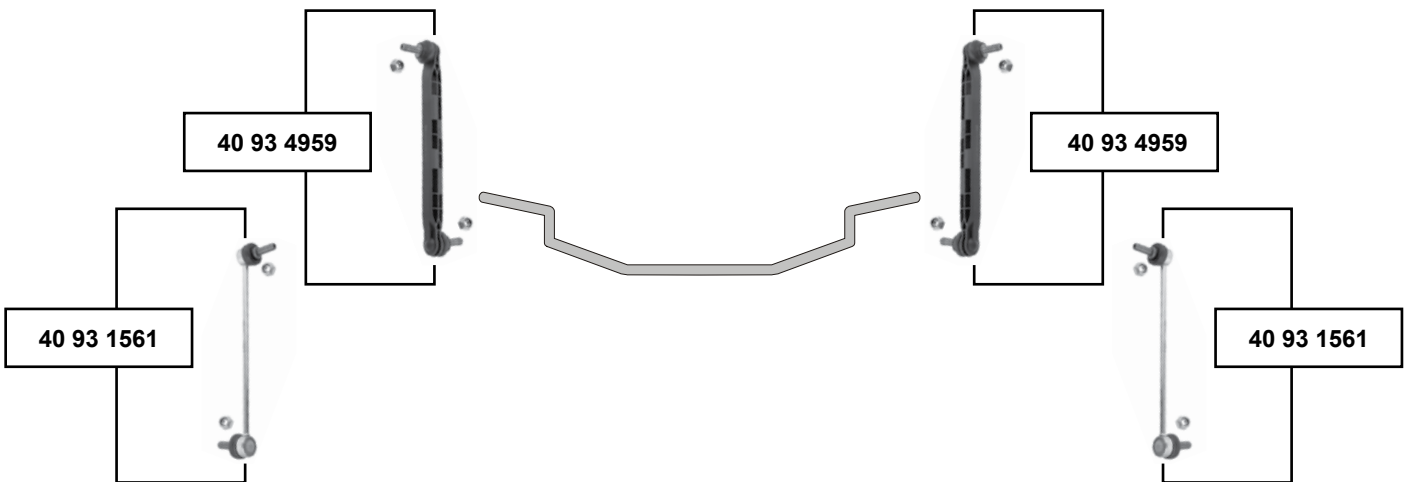
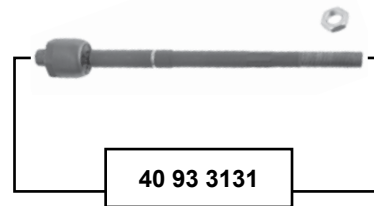
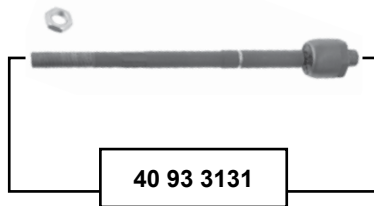

40 93 1561	13 258 058
40 93 3131	13 271 996 SK
40 93 4959	13 219 141
40 93 9351	0352 520
40 93 9352	0352 521
40 94 0915	13271036

Verbindungsstange / connecting rod
Axialgelenk / axial joint
Verbindungsstange / connecting rod
Querlenker / control arm
Querlenker / control arm
Lenkmanschettensatz / steering boot set

(ex.) Sport	L 303,5
(ex.) Sport	L 324
(ex.) Sport / EDC	L 304

passend für / to fit

SAAB



90

(08/74 → 09/87)

57 78 0001



57 78 0001



99

(08/74 → 09/84)

57 78 0001



57 78 0001



900 I

(11/78 → 09/93)

57 71 0002



57 92 2761



57 92 2761



57 71 0002



57 78 0001



57 78 0001



Ref. - No.



57 71 0002	89 93 560
57 78 0001	89 93 321
57 92 2761	89 88 941 SK

Spurstangenendstück / tie rod end
Traggelenk / ball joint
Spurstange / tie rod

11/86 →
900 I 01/85 →
servo

M14x2 RHT
M12 x 1,25
L270

Vorderachse / Front axle



900 II
(09/93 → 02/98)



oben / upper

40 60 0024



40 60 0024



40 60 0024



40 60 0024



unten / lower

57 91 9849



57 91 9850



40 61 0008

57 91 9719



57 91 9720

57 91 9720

40 61 0008

57 91 9719



(1) (ch.) S7014773 →, (ch.) S2012272 →



Ref. - No.



40 60 0024	42 46 062	Hülse / sleeve		15x16,3x30
40 61 0008	42 46 112	Verbindungsstangenlager / connecting rod bearing		
40 71 0008	42 42 749	Spurstangenendstück / tie rod end		M16 x 2
40 71 0009	42 42 756	Spurstangenendstück / tie rod end		M16 x 2
40 72 0008	42 42 681	Spurstange / tie rod	servo	M16 x 2
40 72 0009	42 42 673	Spurstange / tie rod	servo	M16 x 2
40 76 0002	42 42 731	Einstellbolzen / adjusting bolt		M16 x 2
57 72 0005	42 42 681 S1	Rep. Satz Spurstange / rep. kit tie rod	servo	M16 x 2
57 72 0006	42 42 673 S1	Rep. Satz Spurstange / rep. kit tie rod	servo	M16 x 2
57 91 9719	45 44 599	Verbindungsstange / connecting rod	(1)	
57 91 9720	45 44 599 S1	Rep. Satz Verbindungsstange / rep. kit connecting rod	(1)	
57 91 9849	45 43 450	Querlenker / control arm	(1)	
57 91 9850	45 43 468	Querlenker / control arm	(1)	



9000

(03/86 → 12/98)

Vorderachse / Front axle

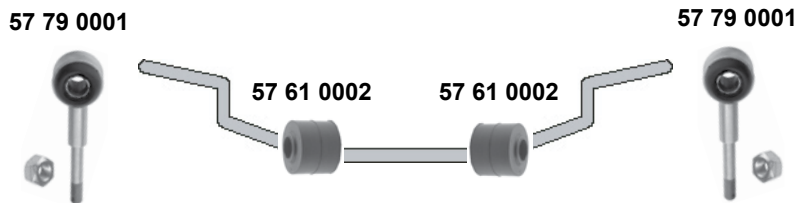
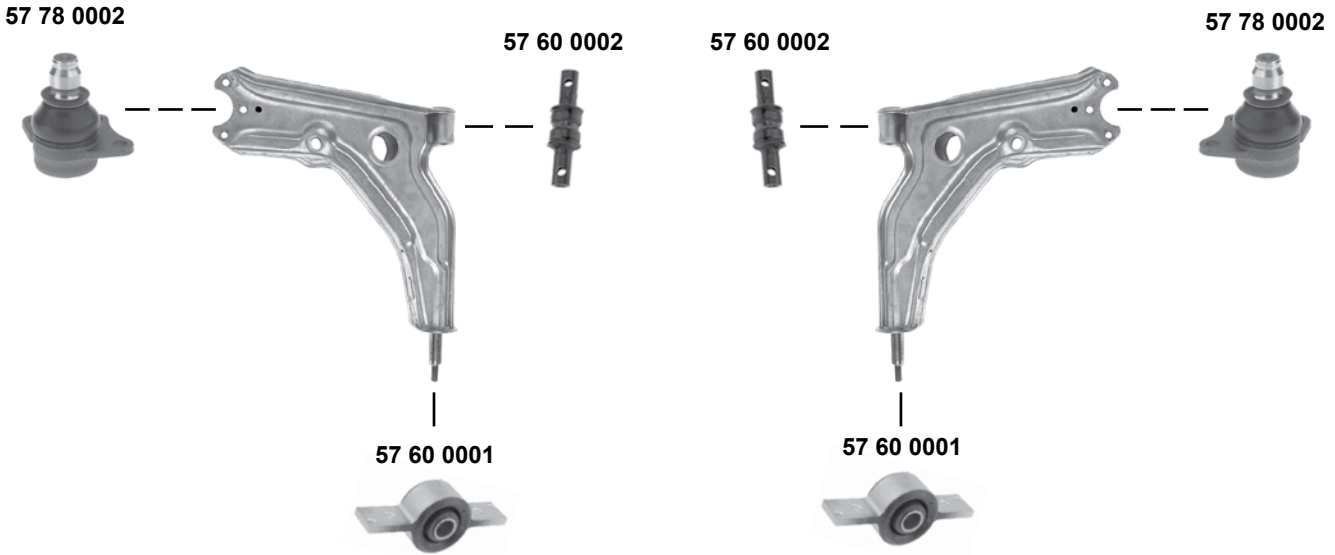

	Ref. - No.			
57 60 0001	89 65 253	Querlenkerlager / control arm mount	→ 91	29/34x136 Ø I 10 M12 x 1,5 M14 x 1,5
57 60 0002	89 61 476	Querlenkerlager / control arm mount		
57 61 0002	89 53 986	Stabilisatorlager / stabilizer mount		
57 71 0003	89 93 453	Spurstangenendstück / tie rod end	servo	
57 72 0001	89 62 250	Spurstange / tie rod	servo	
57 78 0002	89 72 135	Traggelenk / ball joint		
57 79 0001	89 58 944	Verbindungsstange / connecting rod		

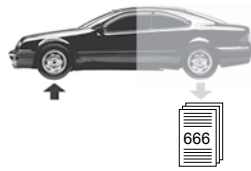

Alhambra (7V8)

(1996 → 2010)

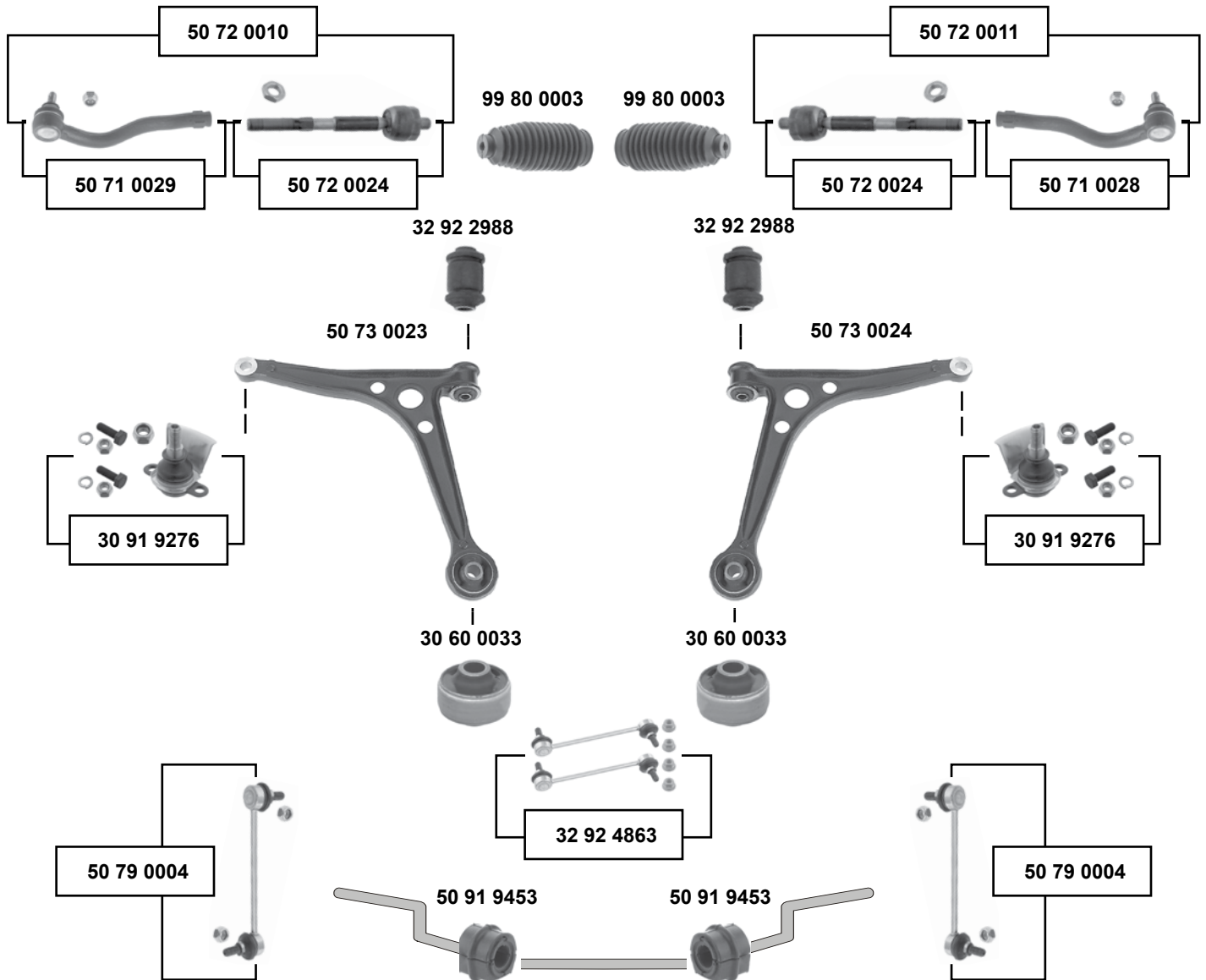

Vorderachse / Front axle



(1) ohne exzentrische Buchse für Spur-Sturz/-einstellung / without eccentric bushing for track-chamber/-gauge



Ref. - No.



Ref. - No.	Description	Notes	Dimensions
30 60 0033	Querlenkerlager / control arm mount		18x60x50
30 91 9276	Traggelenk / ball joint		M14 x 1,5
32 92 2988	Querlenkerlager / control arm mount		Ø A 35
32 92 4863	Verbindungsstangensatz / connecting rod set		L 205
50 71 0028	Spurstangenendstück / tie rod end		M12 x 1,5
50 71 0029	Spurstangenendstück / tie rod end		M12 x 1,5
50 72 0010	Rep. Satz Spurstange mit Endstück / rep. kit tie rod with end		
50 72 0011	Rep. Satz Spurstange mit Endstück / rep. kit tie rod with end		
50 72 0024	Spurstange / tie rod		
50 73 0023	Querlenker / control arm		
50 73 0024	Querlenker / control arm		
50 79 0004	Verbindungsstange / connecting rod		
50 91 9453	Stabilisatorlager / stabilizer mount		L 205
99 80 0003	Lenkmanschette / steering boot		Ø 117

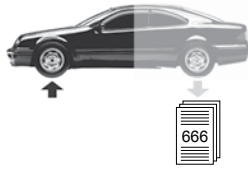

Alhambra (7V9) (2001 → 2010)

Vorderachse / Front axle

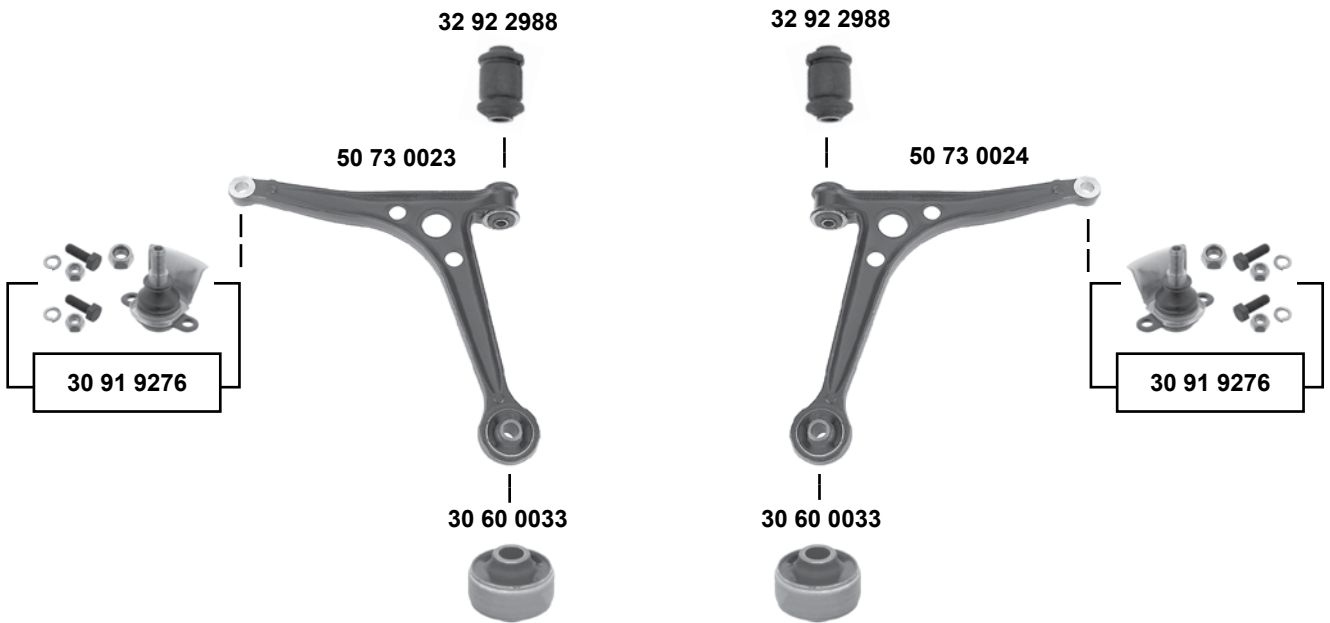
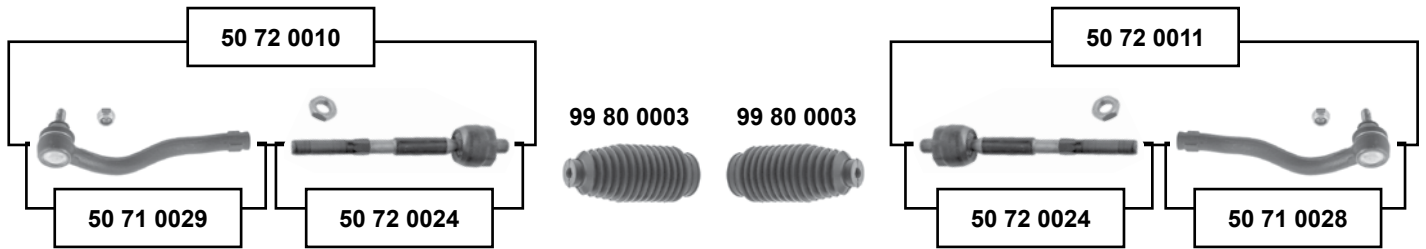

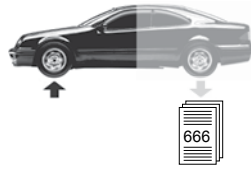

Alhambra (7V9) (2001 → 2010)

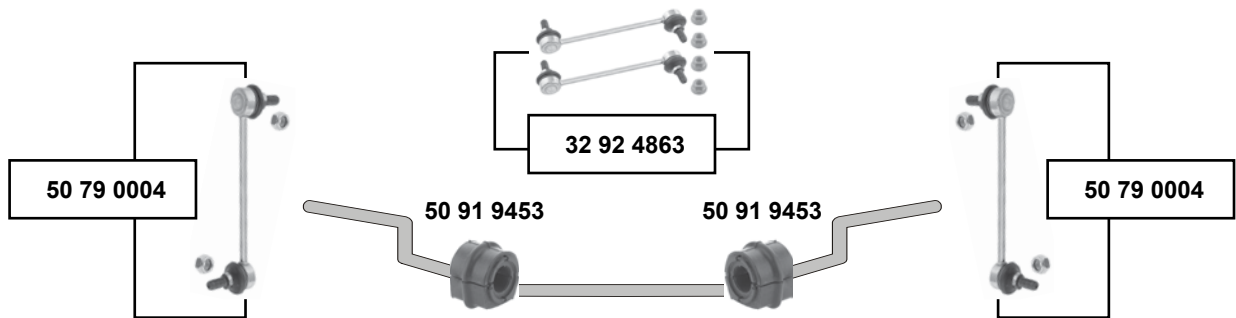

Vorderachse / Front axle



(1) ohne exzentrische Buchse für Spur-Sturz/-einstellung / without eccentric bushing for track-chamber/-gauge



Ref. - No.



Ref. - No.	Description	Notes	Dimensions
30 60 0033	Querlenkerlager / control arm mount		18x60x50
30 91 9276	Traggelenk / ball joint		M14 x 1,5
32 92 2988	Querlenkerlager / control arm mount		Ø A 35
32 92 4863	Verbindungsstangensatz / connecting rod set	(1) → 05	L 205
50 71 0028	Spurstangenendstück / tie rod end		M12 x 1,5
50 71 0029	Spurstangenendstück / tie rod end		M12 x 1,5
50 72 0010	Spurstange mit Endstück / tie rod with end		
50 72 0011	Spurstange mit Endstück / tie rod with end		
50 72 0024	Spurstange / tie rod		
50 73 0023	Querlenker / control arm		
50 73 0024	Querlenker / control arm		
50 79 0004	Verbindungsstange / connecting rod	→ 04 (ch.) → 7M-4-519000	L 205
50 91 9453	Stabilisatorlager / stabilizer mount		Ø I 17
99 80 0003	Lenkmanschette / steering boot		

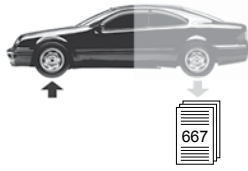

Alhambra (710)

(2011 →)

Vorderachse / Front axle

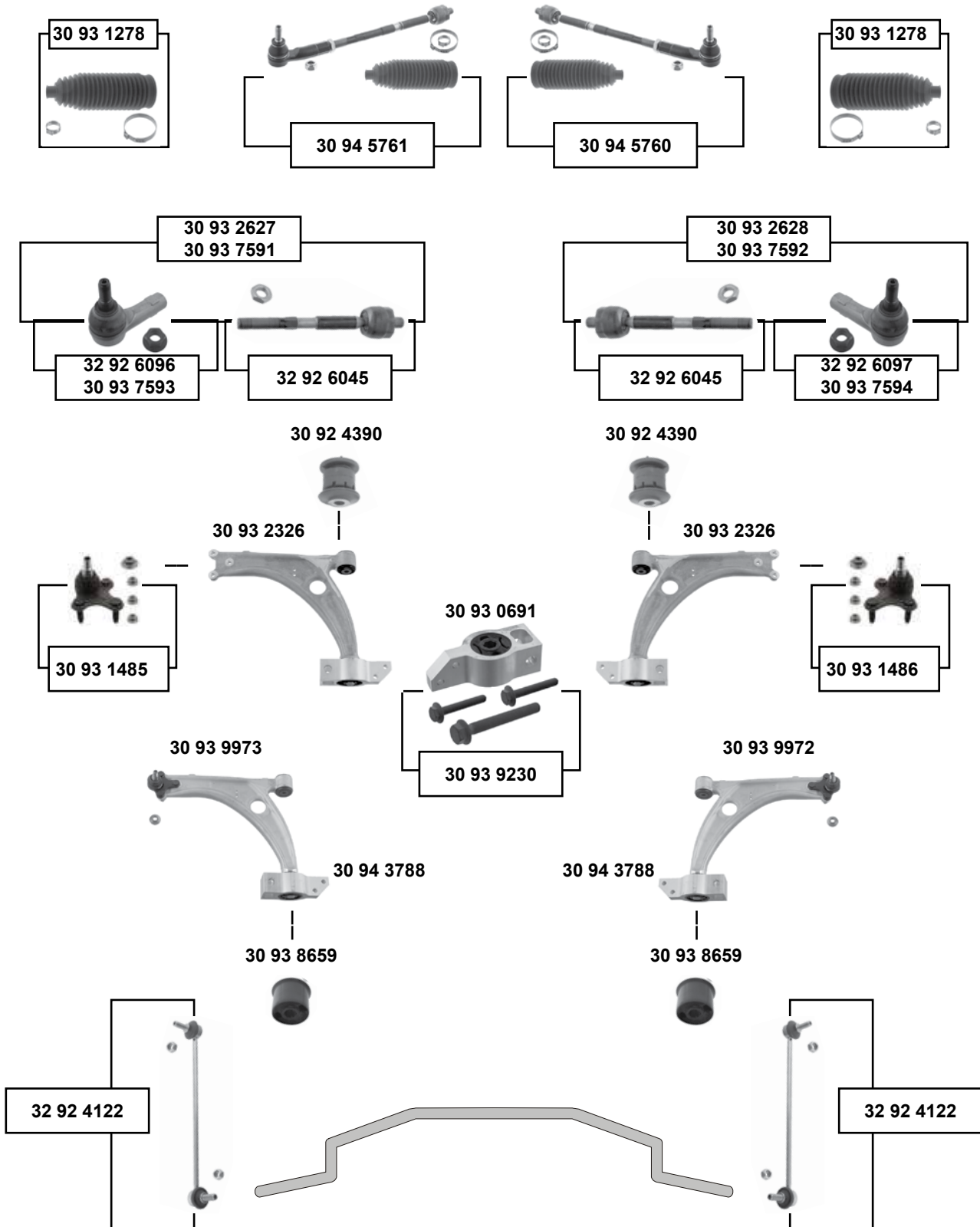

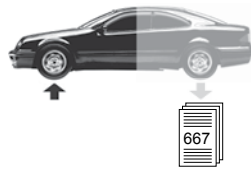

Alhambra (710)

(2011 →)



- (1) PR-F0A ; nicht für Sonderfahrzeuge / not for special purpose vehicles
 (2) (mot.) CDAA / CCZA, für Taxifahrzeuge / for taxis



Ref. - No.



SWAG Ref. - No.				
30 92 4390	1K0 407 182	Querlenkerlager / control arm mount		Ø A 48 H 54
30 93 0691	3C0 199 231 D	Querlenkerlager / control arm mount		
30 93 1278	1K0 423 831 A S1	Rep. Satz Lenkmanschette / rep. kit steering boot		Ø I 15,5 L190
30 93 1485	3C0 407 365 B S1	Traggelenk / ball joint		
30 93 1486	3C0 407 366 B S1	Traggelenk / ball joint		
30 93 2326	3C0 407 151 G	Querlenker / control arm	PR-F0A	
30 93 2627	1K0 423 810 A S1	Rep. Satz Spurstange / rep. kit tie rod	RHT	
30 93 2628	1K0 423 810 A S2	Rep. Satz Spurstange / rep. kit tie rod	RHT	
30 93 7591	1K0 423 811 K S1	Rep. Satz Spurstange / rep. kit tie rod	LHT	L 448
30 93 7592	1K0 423 812 K S1	Rep. Satz Spurstange / rep. kit tie rod	LHT	L 448
30 93 7593	1K0 423 811 K	Spurstangenendstück / tie rod end	LHT	M16 x 1,5
30 93 7594	1K0 423 812 K	Spurstangenendstück / tie rod end	LHT	M16 x 1,5
30 93 8659	1K0 407 183 G	Querlenkerlager / control arm mount	(2)	
30 93 9230	3C0 199 231 E S1	Rep. Satz Querlenkerlagersatz / rep. kit control arm mount kit		
30 93 9972	3C0 407 151 G S1	Querlenker / control arm	(1)	
30 93 9973	3C0 407 151 G S2	Querlenker / control arm	(1)	
30 94 3788	3C0 199 231 F	Querlenkerlager / control arm mount	(2)	
30 94 5761	1K0 423 810 A S3	Rep. Satz Spurstange / rep. kit tie rod	RHT	
30 94 5760	1K0 423 810 A S4	Rep. Satz Spurstange / rep. kit tie rod	RHT	
32 92 4122	1K0 411 315 R	Verbindungsstange / connecting rod		
32 92 6045	1K0 423 810 A	Axialgelenk / axial joint		
32 92 6096	1K0 423 811 E	Spurstangenendstück / tie rod end	RHT	
32 92 6097	1K0 423 812 E	Spurstangenendstück / tie rod end	RHT	

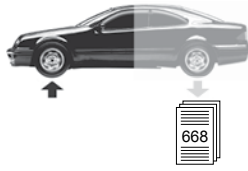

Altea (5P)

(2004 →)

Vorderachse / Front axle

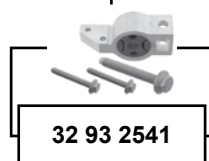
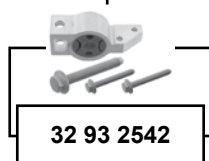
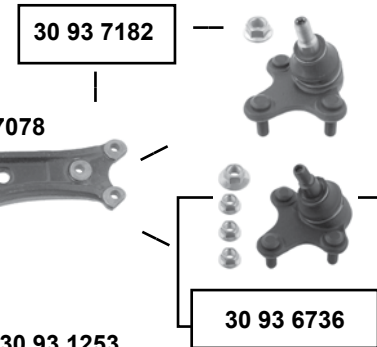
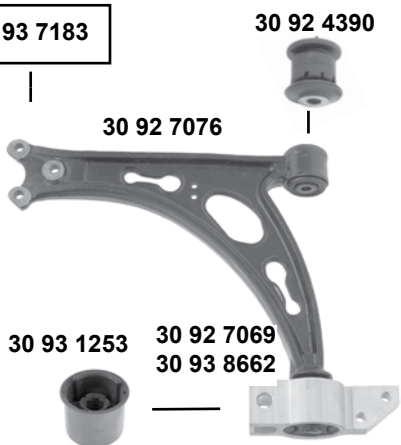
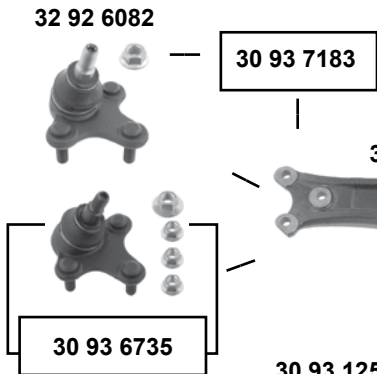
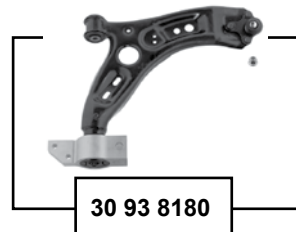
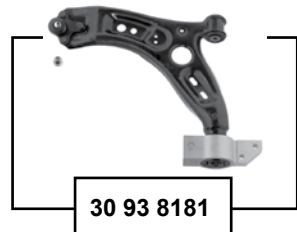
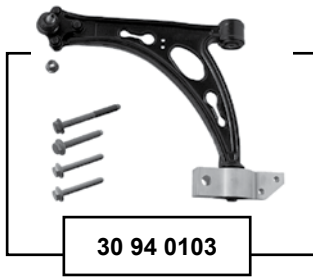
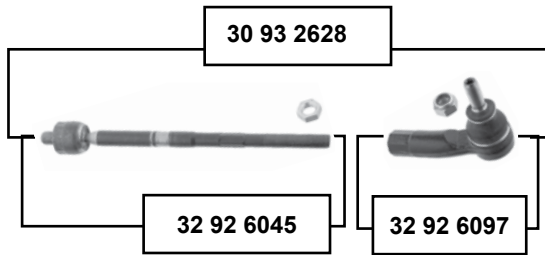
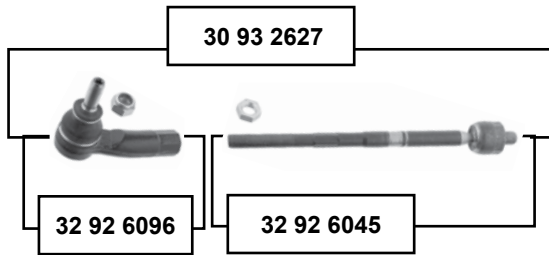
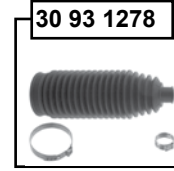
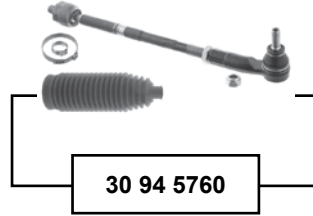
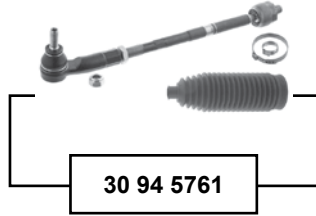

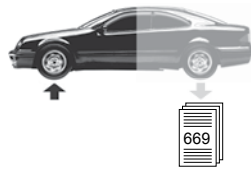

Altea (5P) (2004 →)

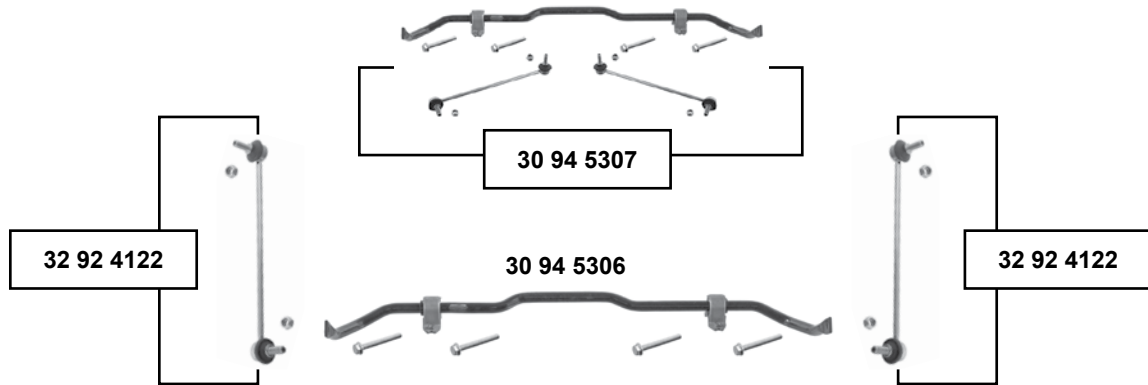

Vorderachse / Front axle



- (1) → (ch.) 5P-4-000 500 / (mot.) BJB / BKC / BKD / AZV / BXE
- (2) Stahl-Gussausführung / keine Mischverbauung mit der Blechausführung zulässig / cast iron execution / not mixable with metall execution
- (3) (ch.) 5P-7-000001 → / (ch.) → 5P-A-045000



Ref. - No.



Ref. - No.	Description	Notes	Material
30 92 4390	1K0 407 182	Querlenkerlager / control arm mount	Ø A 48 H 54
30 92 7069	1K0 199 231 J	Querlenkerlager mit Gehäuse / control arm mount with housing	→ 2006
30 92 7071	1K0 199 232 J	Querlenkerlager mit Gehäuse / control arm mount with housing	→ 2006
30 92 7076	1K0 407 151 AC	Querlenker, kpl. / control arm, cpl.	(1) (2)
30 92 7078	1K0 407 152 AC	Querlenker, kpl. / control arm, cpl.	(1) (2)
30 93 1253	1K0 407 183 E	Querlenkerlager / control arm mount	→ 2006
30 93 1278	1K0 423 831 A S1	Rep. Satz Lenkmanschette / rep. kit steering boot	Ø A 63
30 93 2627	1K0 423 810 A S1	Rep. Satz Spurstange / rep. kit tie rod	Ø I 15,5 L190
30 93 2628	1K0 423 810 A S2	Rep. Satz Spurstange / rep. kit tie rod	
30 93 6735	1K0 407 365 C S1	Rep. Satz Traggelenk / rep. kit ball joint	
30 93 6736	1K0 407 366 C S1	Rep. Satz Traggelenk / rep. kit ball joint	
30 93 7182	1K0 407 152 AC S1	Rep. Satz Querlenker mit Traggelenk / control arm with ball joint	
30 93 7183	1K0 407 151 AC S1	Rep. Satz Querlenker mit Traggelenk / control arm with ball joint	
30 93 8180	1K0 407 152 BC S1	Rep. Satz Querlenker / rep. kit control arm	Stahl / steel
30 93 8181	1K0 407 151 BC S1	Rep. Satz Querlenker / rep. kit control arm	Stahl / steel
30 93 8662	1K0 199 231 K	Querlenkerlager mit Gehäuse / control arm mount with housing	Aluminium
30 93 8663	1K0 199 232 K	Querlenkerlager mit Gehäuse / control arm mount with housing	Aluminium
30 94 0103	1K0 407 151 AC S2	Rep. Satz Querlenker / rep. kit control arm	(3)
30 94 0104	1K0 407 152 AC S2	Rep. Satz Querlenker / rep. kit control arm	(3)
30 94 5306	1K0 411 303 BK S1	Stabilisatorsatz / stabilizer kit	PR-0AE
30 94 5307	1K0 411 303 BK S2	Rep. Satz Stabilisatorsatz / rep. kit stabilizer kit	PR-0AE
30 94 5760	1K0 423 810 A S4	Rep. Satz Spurstange / rep. kit tie rod	
30 94 5761	1K0 423 810 A S3	Rep. Satz Spurstange / rep. kit tie rod	
32 92 4122	1K0 411 315 R	Verbindungsstange / connecting rod	
32 92 6045	1K0 423 810 A	Axialgelenk / axial joint	
32 92 6082	1K0 407 365 C	Traggelenk / ball joint	
32 92 6083	1K0 407 366 C	Traggelenk / ball joint	
32 92 6096	1K0 423 811 E	Spurstangenendstück / tie rod end	
32 92 6097	1K0 423 812 E	Spurstangenendstück / tie rod end	
32 93 2541	1K0 199 232 J S1	Rep. Satz Querlenkerlagersatz / rep. kit control arm mounting kit	→ 2006
32 93 2542	1K0 199 231 J S1	Rep. Satz Querlenkerlagersatz / rep. kit control arm mounting kit	→ 2006



Arosa (6H)
(1997 → 2004)

man.

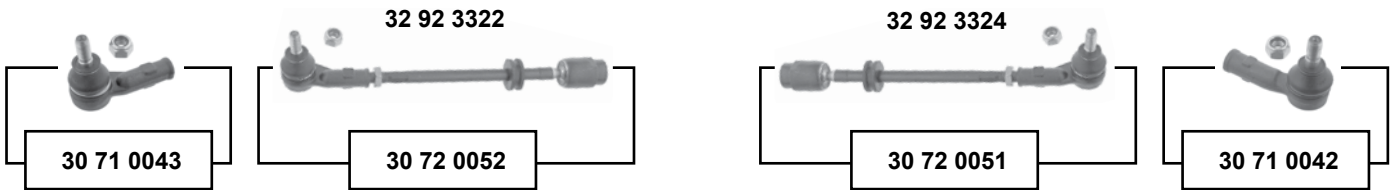
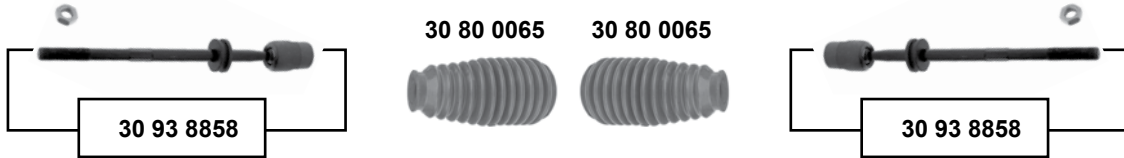

servo

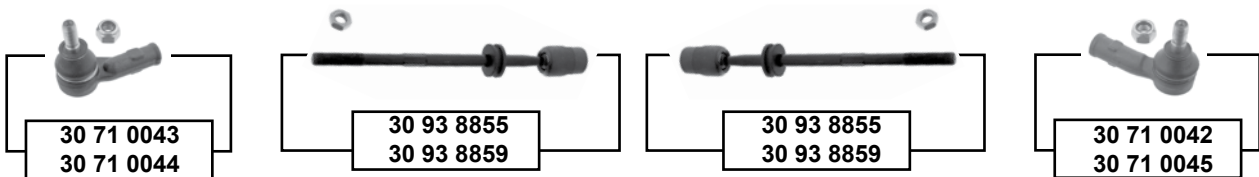
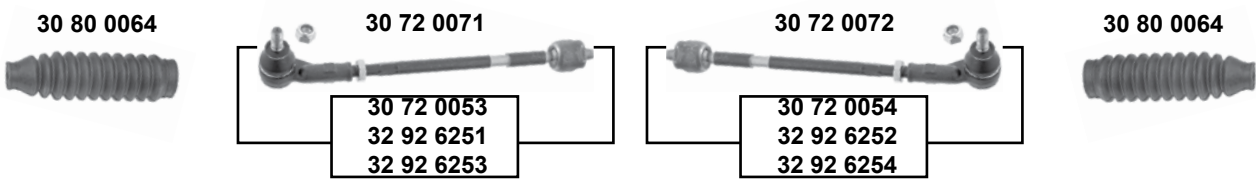

Vorderachse / Front axle







Arosa (6H)

(1997 → 2004)



- (1) 1998 → 2003 = alle / all // 2003 → = 1,0/1,4 8V/1,7 SDi
- (2) (ch.) 6H-W-027 754 → / (ch.) → 6H-W-055 365 (3) (mot.) AFK, AQQ, AMF, AUB
- (4) (ch.) → 6H-W-055 365 / (mot.) AER, ALL, AEX, AKV, APQ, AKU

	Ref. - No.			
30 71 0042	6N0 422 812	Spurstangenendstück / tie rod end	(ch.) → 6H-W-027 753	M12 x 1,5
30 71 0043	6N0 422 811	Spurstangenendstück / tie rod end	(ch.) → 6H-W-027 753	M12 x 1,5
30 71 0044	6E0 419 811	Spurstangenendstück / tie rod end	(ch.) 6H-W-027 754 →	M12 x 1,5
30 71 0045	6E0 419 812	Spurstangenendstück / tie rod end	(ch.) 6H-W-027 754 →	M12 x 1,5
30 72 0051	6N0 419 804	Spurstange / tie rod	(ch.) → 6H-W-055 365	
30 72 0052	6N0 419 803	Spurstange / tie rod	(ch.) → 6H-W-055 365	
30 72 0053	6N0 422 803 A	Spurstange / tie rod	(ch.) → 6H-W-027 753	M12 x 1,5
30 72 0054	6N0 422 804 A	Spurstange / tie rod	(ch.) → 6H-W-027 753	M12 x 1,5
30 72 0071	6X0 422 803	Spurstange / tie rod	(1) (ch.) 6H-W-055 366 →	M12 x 1,5
30 72 0072	6X0 422 804	Spurstange / tie rod	(1) (ch.) 6H-W-055 366 →	M12 x 1,5
30 80 0064	6N0 422 831	Lenkmanschette / steering boot		
30 80 0065	6N0 419 831	Lenkmanschette / steering boot		
30 93 8855	6X0 422 810	Axialgelenk / axial joint	(ch.) 6H-W-055 366 →	
30 93 8858	6N0 419 810	Axialgelenk / axial joint	(4)	
30 93 8859	6N0 422 810 A	Axialgelenk / axial joint	(ch.) → 6H-W-027 753	
32 92 3322	6X0 419 803 A	Spurstange / tie rod	(ch.) 6H-W-055 366 →	
32 92 3324	6X0 419 804 A	Spurstange / tie rod	(ch.) 6H-W-055 366 →	
32 92 6251	6N0 422 803 C	Spurstange / tie rod	(3)	
32 92 6252	6N0 422 804 C	Spurstange / tie rod	(3)	
32 92 6253	6N0 422 803 D	Spurstange / tie rod	(2)	M12 x 1,5
32 92 6254	6N0 422 804 D	Spurstange / tie rod	(2)	M12 x 1,5



Arosa (6H) (1997 → 2004)

Vorderachse / Front axle

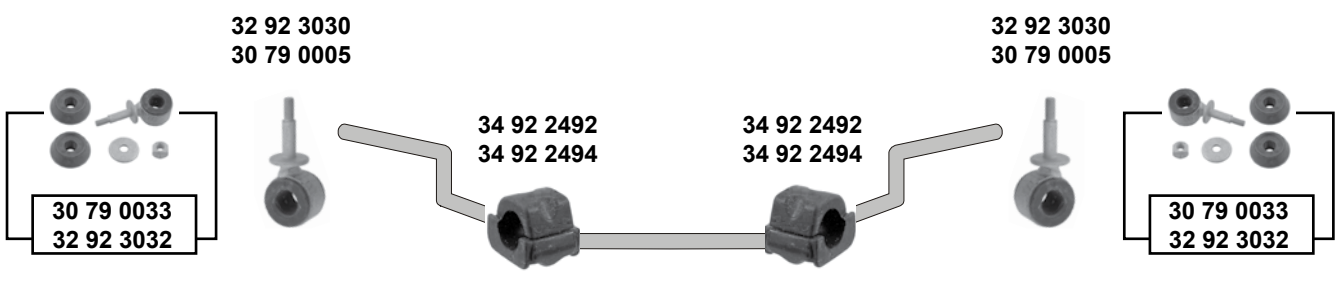
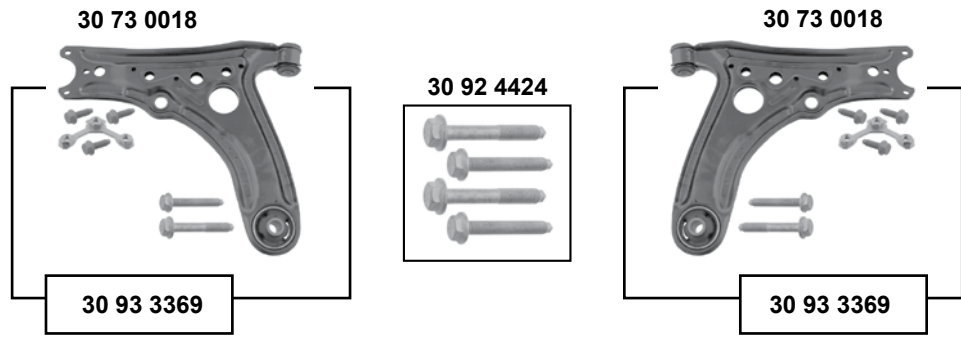
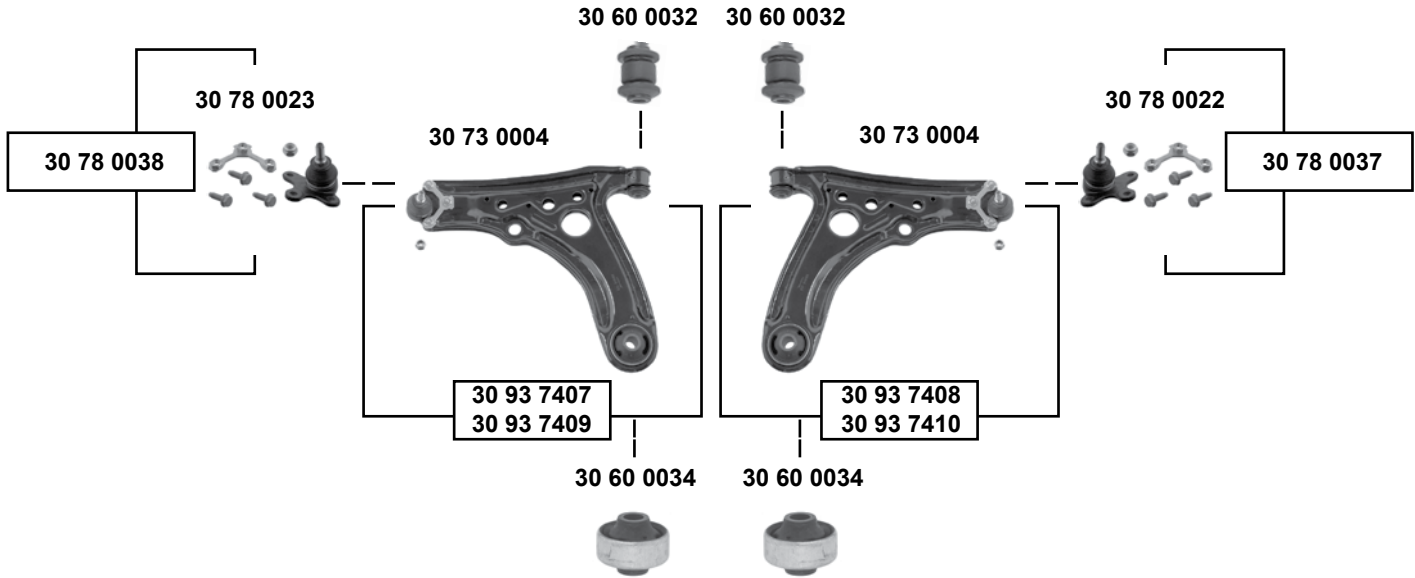



Arosa (6H) (1997 → 2004)



- (1) 98 → 04 / (ch.) 6H-W-055 366 →
- (2) (mot.) AER, AEX, AHT, AKK, AKV, ALD, ALL, ANV, ANW, APQ (ch.) → 6H-Y-028 000
 Einbauseite: Vorderachse links / fitting side: front axle left
 (mot.) AKU, AUC, AUD (ch.) → 6H-Y-028 000 / (ch.) 6H-1-000 001 →
 Einbauseite: Vorderachse links / fitting side: front axle left
 (mot.) AQQ (ch.) → 6H-Y-028000 Einbauseite: Vorderachse rechts / fitting side: front axle right
 (mot.) AFK, AMF (ch.) → 6H-Y-028 000 / (ch.) 6H-1-000 001 →
 Einbauseite: Vorderachse rechts / fitting side: front axle right
 (mot.) AUB Einbauseite: Vorderachse rechts / fitting side: front axle right
- (3) (mot.) AER, AEX, AHT, AKK, AKV, ALD, ALL, ANV, ANW, APQ (ch.) → 6H-Y-028 000
 Einbauseite: Vorderachse recht / fitting side: front axle right
 (mot.) AKU, AUC, AUD (ch.) → 6H-Y-028 000 / (ch.) 6H-1-000 001 →
 Einbauseite: Vorderachse rechts / fitting side: front axle right
 (mot.) AQQ (ch.) → 6H-Y-028000 Einbauseite: Vorderachse links / fitting side: front axle left
 (mot.) AFK, AMF (ch.) → 6H-Y-028 000 / (ch.) 6H-1-000 001 → Einbauseite: Vorderachse links / fitting side:
 front axle left
 (mot.) AUB Einbauseite: Vorderachse links / fitting side: front axle left

SWAG	Ref. - No.			
30 60 0032	6N0 407 182	Querlenkerlager / control arm mount		10x28x47
30 60 0034	6N0 407 181	Querlenkerlager / control arm mount		17x61x46
30 73 0004	6N0 407 151 B	Querlenker / control arm	(ch.) → 6H-W-055 365	
30 73 0018	6X0 407 151 A	Querlenker / control arm	(ch.) 6H-W-055 366 →	
30 78 0022	6N0 407 365 A	Traggelenk / ball joint	(3)	M10 x 1
30 78 0023	6N0 407 365	Traggelenk / ball joint	(2)	M10 x 1
30 78 0037	6N0 407 365 A S1	Rep. Satz Traggelenk / rep. kit ball joint		M10 x 1
30 78 0038	6N0 407 365 S1	Rep. Satz Traggelenk / rep. kit ball joint		M10 x 1
30 79 0005	6N0 411 315	Verbindungsstange / connecting rod		
30 79 0033	6N0 411 315 C S1	Rep. Satz Verbindungsstange / rep. kit connecting rod		
30 92 4424	N 904 840 03 S3	Schraubensatz für Querlenker / screw kit for control arm		
30 93 3369	6X0 407 151 A S1	Rep. Satz Querlenker / rep kit control arm	(1)	
30 93 7407	6X0 407 151 A S2	Rep. Satz Querlenker / rep. kit control arm	(ch.) 6H-W-055 366 →	
30 93 7408	6X0 407 151 A S3	Rep. Satz Querlenker / rep. kit control arm	(ch.) 6H-W-055 366 →	
30 93 7409	6N0 407 151 B S1	Rep. Satz Querlenker / rep. kit control arm	(ch.) → 6H-W-055 365	
30 93 7410	6N0 407 151 B S2	Rep. Satz Querlenker / rep. kit control arm	(ch.) → 6H-W-055 365	
32 92 3030	6N0 411 315 D	Verbindungsstange / connecting rod		
32 92 3032	6N0 411 315 D S1	Rep. Satz Verbindungsstange / rep. kit connecting rod	01 →	
34 92 2492	6X0 411 313	Stabilisatorlager / stabilizer mount		Ø 18
34 92 2494	6X0 411 313 A	Stabilisatorlager / stabilizer mount		Ø 20



Cordoba (6K) (1993 → 1999)

Vorderachse / Front axle

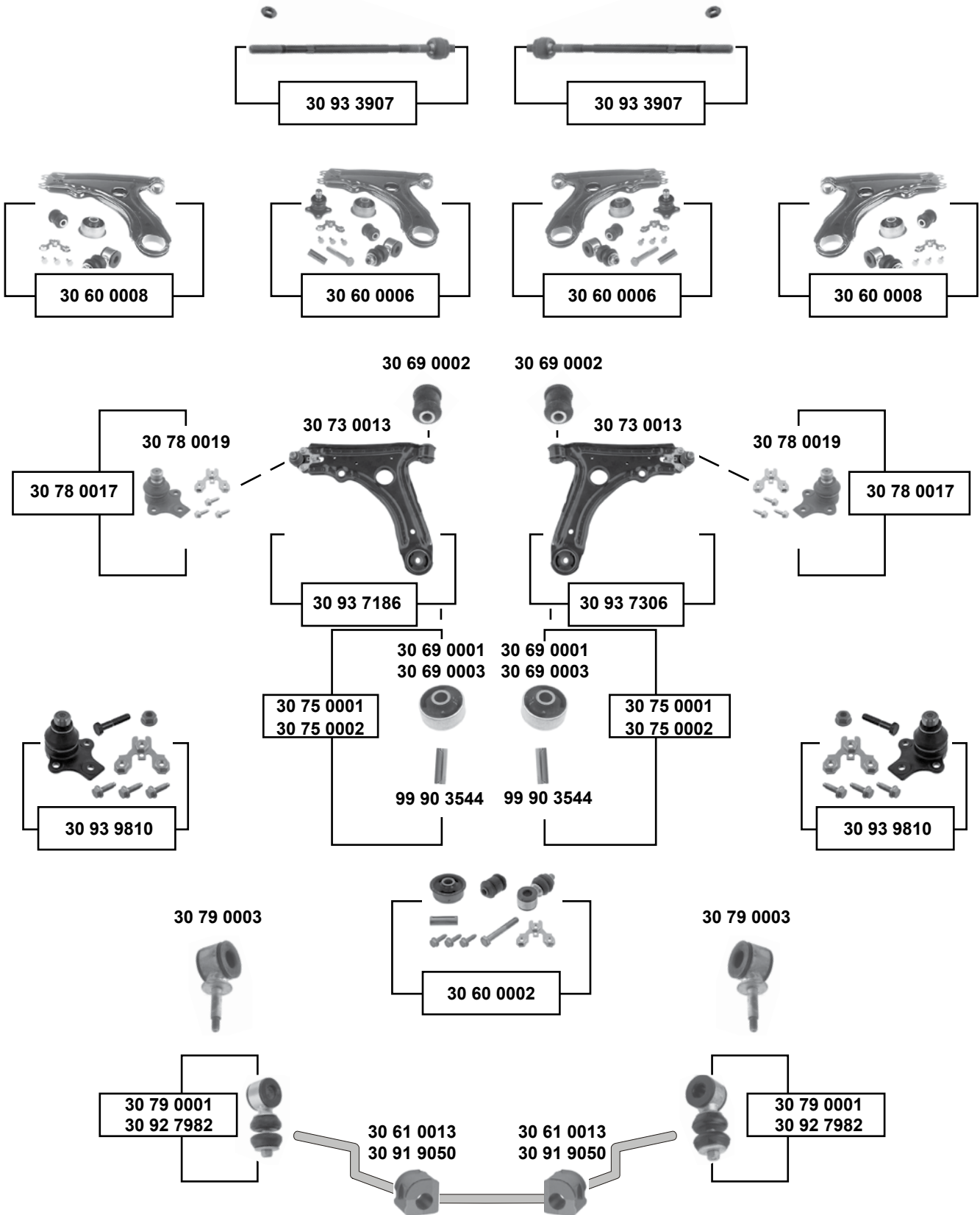



Cordoba (6K) (1993 → 1999)



- (1) (ch.) → 6K-V-143400 alle / all / (ch.) 6K-V-143401 → 1.0 / 1.3 / 1.4 / 1.6 (55kw)
- (2) (ch.) 6K-V-143401 → 1,6 (74kw); Diesel
- (3) 93 → 94 (ch.) → 6K-ZR036 750 / → 6K-ZR546 756
- (4) 93 → 94 (ch.) → 6K-ZR040 000 / → 6K-ZR550 000
- (5) → 12/1994 (ch.) → 6K-ZR-040 000 / 6K-ZR-550 000



Ref. - No.



SWAG Ref. - No.	Description	Notes	Dimensions
30 60 0002	191 407 153 S1	Montagesatz / mounting kit	(5)
30 60 0006	191 407 153 A S3	Rep. Satz Querlenker / rep. kit control arm	→ 12/1994
30 60 0008	191 407 153 A S2	Rep. Satz Querlenker / rep. kit control arm	(1)
30 61 0013	191 411 314	Stabilisatorlager / stabilizer mount	NEW Ø I 17
30 69 0001	191 407 181 D	Querlenkerlager / control arm mount	17x60x41
30 69 0002	357 407 182	Querlenkerlager / control arm mount	12x33x54
30 69 0003	191 407 181 B	Querlenkerlager / control arm mount	OLD 17x60x41
30 73 0013	191 407 151 B	Querlenker mit Gummilager / control arm incl. rubber mounts	OLD
30 75 0001	191 407 181 B S1	Querlenkerlager mit Hülse / control arm mount with sleeve	NEW
30 75 0002	191 407 181 D S1	Querlenkerlager mit Hülse / control arm mount with sleeve	NEW
30 78 0017	357 407 365 S1	Rep. Satz Traggelenk / rep. kit ball joint	
30 78 0019	357 407 365	Traggelenk / ball joint	Ø A 19
30 79 0001	191 411 315 B S1	Rep. Satz Verbindungsstange / rep. kit connecting rod	(4) Metall
30 79 0003	191 411 315 B	Verbindungsstange / connecting rod	(5)
30 91 9050	1H0 411 314	Stabilisatorlager / stabilizer mount	(2) Ø I 19
30 92 7982	6K0 411 315 S1	Verbindungsstange / connecting rod	Ø I 16,5
30 93 3907	191 422 810 A	Axialgelenk / axial joint	(3) servo
30 93 7186	191 407 151 B S1	Rep. Satz Querlenker / rep. kit control arm	
30 93 7306	191 407 151 B S2	Rep. Satz Querlenker / rep. kit control arm	
30 93 9810	357 407 365 S2	Rep. Satz Traggelenk / rep. kit ball joint	
99 90 3544	191 407 190 A	Hülse / sleeve	50x17



Cordoba (6K)

(1993 → 1999)

man.

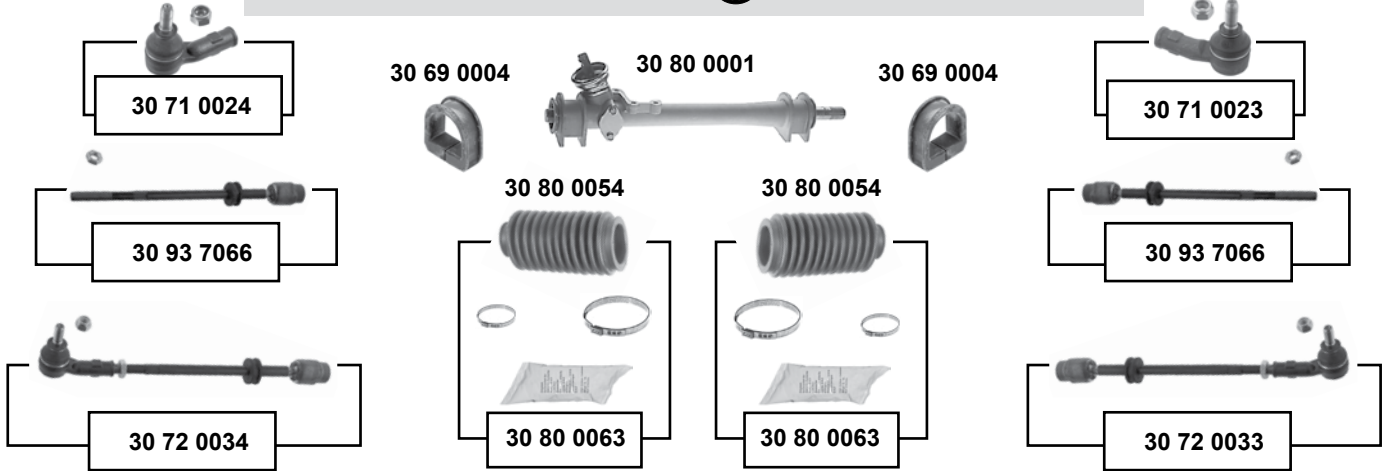

servo

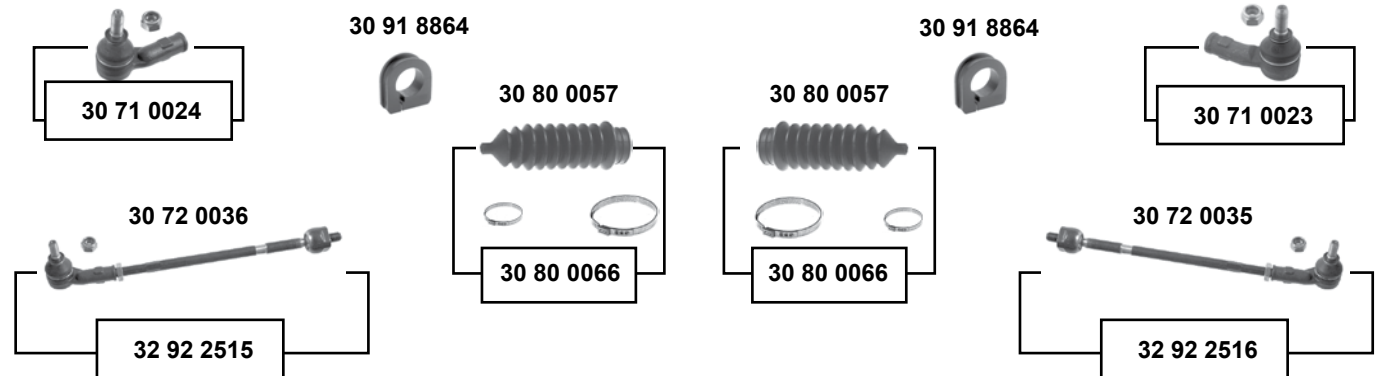

(1) (ch.) 6K-ZR546757 → 6K-TR081919

	Ref. - No.			
30 69 0004	191 419 883	Lenkgetriebelager / steering gear bearing		B 28
30 71 0023	191 419 812	Spurstangenendstück / tie rod end		M12 x 1,5
30 71 0024	191 419 811	Spurstangenendstück / tie rod end		M12 x 1,5
30 72 0033	191 419 804	Spurstange / tie rod		M12 x 1,5
30 72 0034	191 419 803	Spurstange / tie rod		M12 x 1,5
30 72 0036	191 422 803 A	Spurstange / tie rod	(ch.) → 6K-ZR546756	M12 x 1,5
30 72 0035	191 422 804 A	Spurstange / tie rod	(ch.) → 6K-ZR546756	M12 x 1,5
30 80 0001	191 419 063 C	Lenkgetriebe / steering gear	LHD	
30 80 0054	191 419 831	Lenkmanschette / steering boot		
30 80 0057	1H0 422 831 B	Lenkmanschette / steering boot		
30 80 0063	191 419 831 S1	Rep. Satz Lenkmanschette / rep. kit steering boot		
30 80 0066	1H0 422 831 B S1	Rep. Satz Lenkmanschette / rep. kit steering boot		
30 91 8864	1H0 422 884	Lenkgetriebelager / steering gear bearing	(ch.) → 6K-TR018 919	
30 93 7066	191 419 810 A	Spurstange / tie rod		M12 x 1,5
32 92 2515	6K0 422 803	Spurstange / tie rod	(1)	
32 92 2516	6K0 422 804	Spurstange / tie rod	(1)	



Cordoba / Vario (6K) (1999 → 2002)

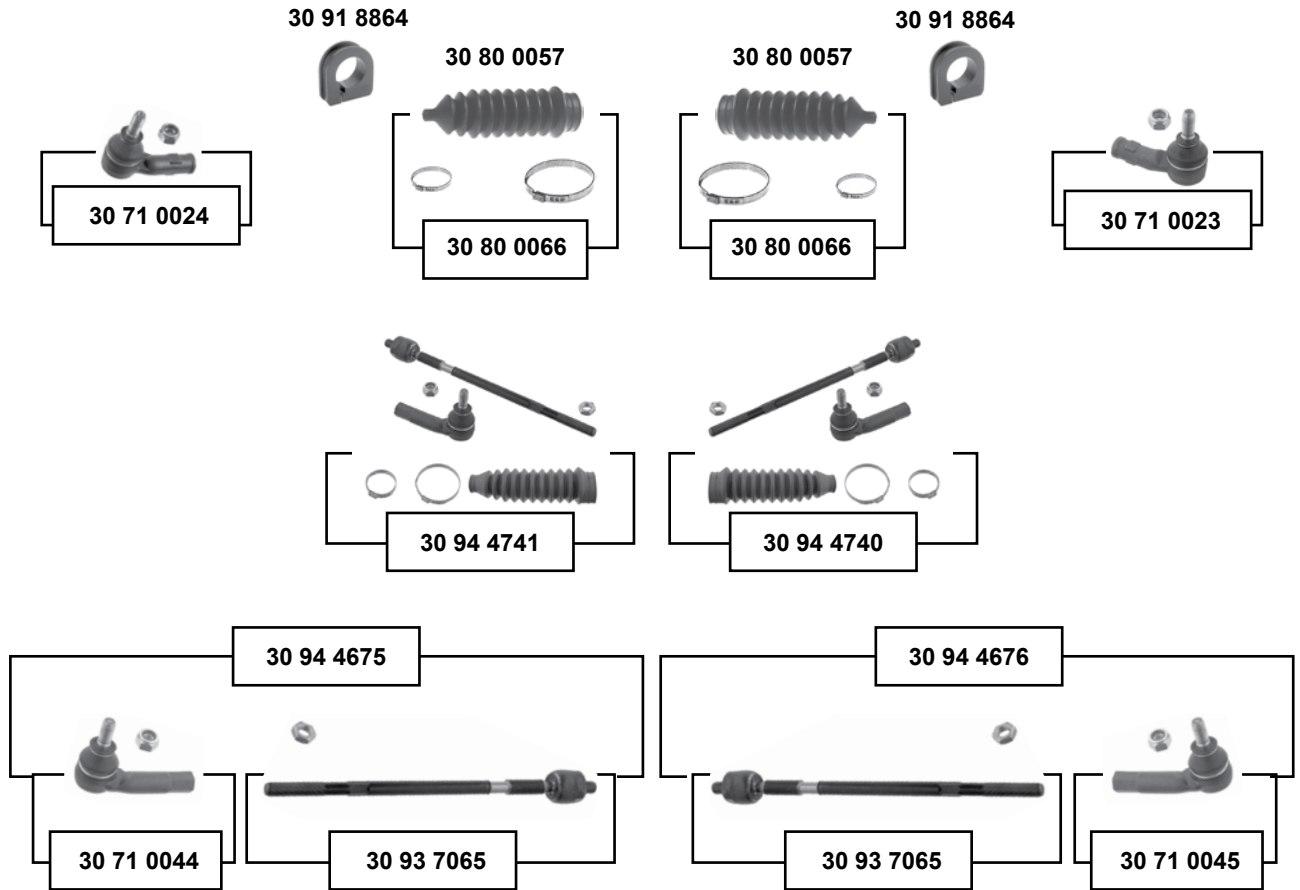

Vorderachse / Front axle

- (1) (ch.) → 6K-1-180000
- (2) (ch.) 6K-1-180001 →
- (3) (ch.) → 6K-X-400 001 / (ch.) 6K-TR130 000 → // Ausstattungsvariante / Equipment Variation : SX
- (4) (ch.) 6K-TR130 000 → / (ex.) Sport

SWAG	Ref. - No.			
30 71 0023	191 419 812	Spurstangenendstück / tie rod end	(1)	M12 x 1,5
30 71 0024	191 419 811	Spurstangenendstück / tie rod end	(1)	M12 x 1,5
30 71 0044	6E0 419 811	Spurstangenendstück / tie rod end	(2)	
30 71 0045	6E0 419 812	Spurstangenendstück / tie rod end	(2)	M12 x 1,5
30 80 0057	1H0 422 831 B	Lenkmanschette / steering boot	(1)	
30 80 0066	1H0 422 831 B S1	Rep. Satz Lenkmanschette / rep. kit steering boot	(1)	
30 91 8864	1H0 422 884	Lenkgetriebelager / steering gear bearing		
30 93 7065	6K0 422 810 E	Axialgelenk / axial joint		
30 94 4675	6K0 422 803 E	Rep. Satz Spurstange / rep. kit tie rod	(3)	M12 x 1,5
30 94 4676	6K0 422 804 E	Rep. Satz Spurstange / rep. kit tie rod	(3)	M12 x 1,5
30 94 4740	6K0 422 804 E S1	Rep. Satz Spurstange / rep. kit tie rod	(4)	
30 94 4741	6K0 422 803 E S1	Rep. Satz Spurstange / rep. kit tie rod	(4)	



Cordoba / Vario (6K)

(1999 → 2002)

Vorderachse / Front axle

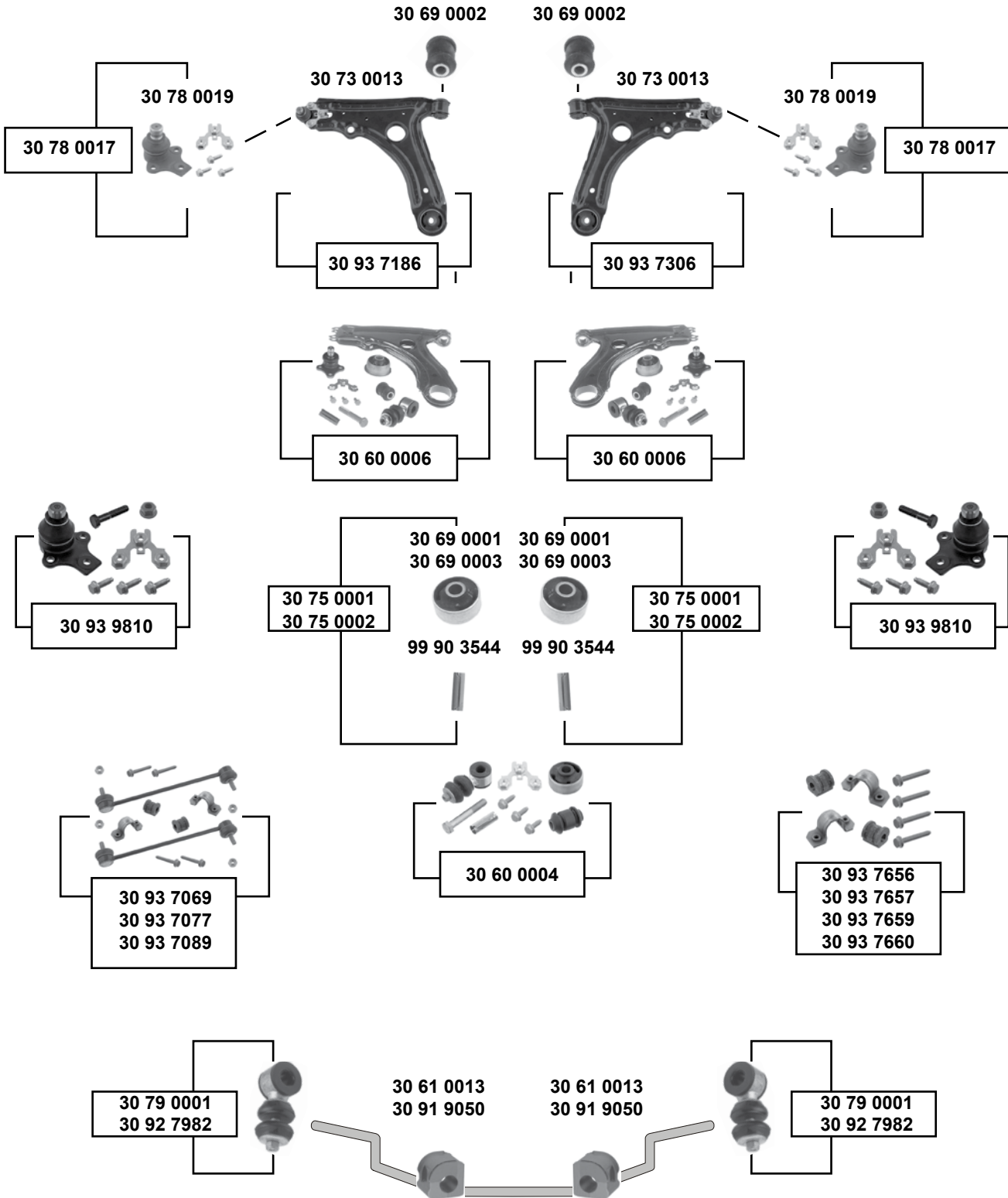



Cordoba / Vario (6K) (1999 → 2002)



- | | | |
|-----|--|-----------------------------|
| (1) | 1.0 / 1.4 (44 kW)
1.6 (55 kW) (ch.) | alle / all
→ 6K-X-430579 |
| (2) | 1,6 (74kw); Diesel (ch.) 6K-V-143401 → | |
| (3) | PR-0AQ / (ch.) 6L-8-157 035 → | |
| (4) | PR-0AR / (ch.) 6L-8-157 035 → | |
| (5) | (ch.) 6L-8-041 365 → / PR-0AR | |



Ref. - No.



SWAG Ref. - No.	Description	Notes	Dimensions
30 60 0004	191 407 153 S2	Montagesatz / mounting kit	
30 60 0006	191 407 153 A S3	Rep. Satz Querlenker / rep. kit control arm	
30 61 0013	191 411 314	Stabilisatorlager / stabilizer mount	
30 69 0001	191 407 181 D	Querlenkerlager / control arm mount	(1) NEW Ø I 17
30 69 0002	357 407 182	Querlenkerlager / control arm mount	17x60x41
30 69 0003	191 407 181 B	Querlenkerlager / control arm mount	OLD 12x33x54
30 73 0013	191 407 151 B	Querlenker mit Gummilager / control arm incl. rubber mounts	17x60x41
30 75 0001	191 407 181 B S1	Querlenkerlager mit Hülse / control arm mount with sleeve	OLD
30 75 0002	191 407 181 D S1	Querlenkerlager mit Hülse / control arm mount with sleeve	NEW
30 78 0017	357 407 365 S1	Rep. Satz Traggelenk / rep. kit ball joint	
30 78 0019	357 407 365	Traggelenk / ball joint	Ø A 19
30 79 0001	191 411 315 B S1	Rep. Satz Verbindungsstange / rep. kit connecting rod	
30 91 9050	1H0 411 314	Stabilisatorlager / stabilizer mount	(2) Ø I 19
30 92 7982	6K0 411 315 S1	Verbindungsstange / connecting rod	Ø I 16,5
30 93 7069	6Q0 411 314 Q S1	Stabilisatorlagersatz / anti roll bar bush kit	(4)
30 93 7077	6Q0 411 314 P S1	Stabilisatorlagersatz / anti roll bar bush kit	(3)
30 93 7089	6Q0 411 314 R S2	Stabilisatorlagersatz / anti roll bar bush kit	PR-0AS
30 93 7186	191 407 151 B S1	Rep. Satz Querlenker / rep. kit control arm	
30 93 7306	191 407 151 B S2	Rep. Satz Querlenker / rep. kit control arm	
30 93 7656	6Q0 411 314 R S3	Stabilisatorlagersatz / anti roll bar bush kit	(2) Ø I 18
30 93 7657	6Q0 411 314 P S2	Stabilisatorlagersatz / anti roll bar bush kit	PR-0AQ Ø I 16
30 93 7659	6Q0 411 314 R S4	Stabilisatorlagersatz / anti roll bar bush kit	PR-0AQ Ø I 18
30 93 7660	6Q0 411 314 Q S2	Stabilisatorlagersatz / anti roll bar bush kit	(5) Ø I 17
30 93 9810	357 407 365 S2	Rep. Satz Traggelenk / rep. kit ball joint	
99 90 3544	191 407 190 A	Hülse / sleeve	50x17



Cordoba / Vario (6L)

(2002 →)

Vorderachse / Front axle

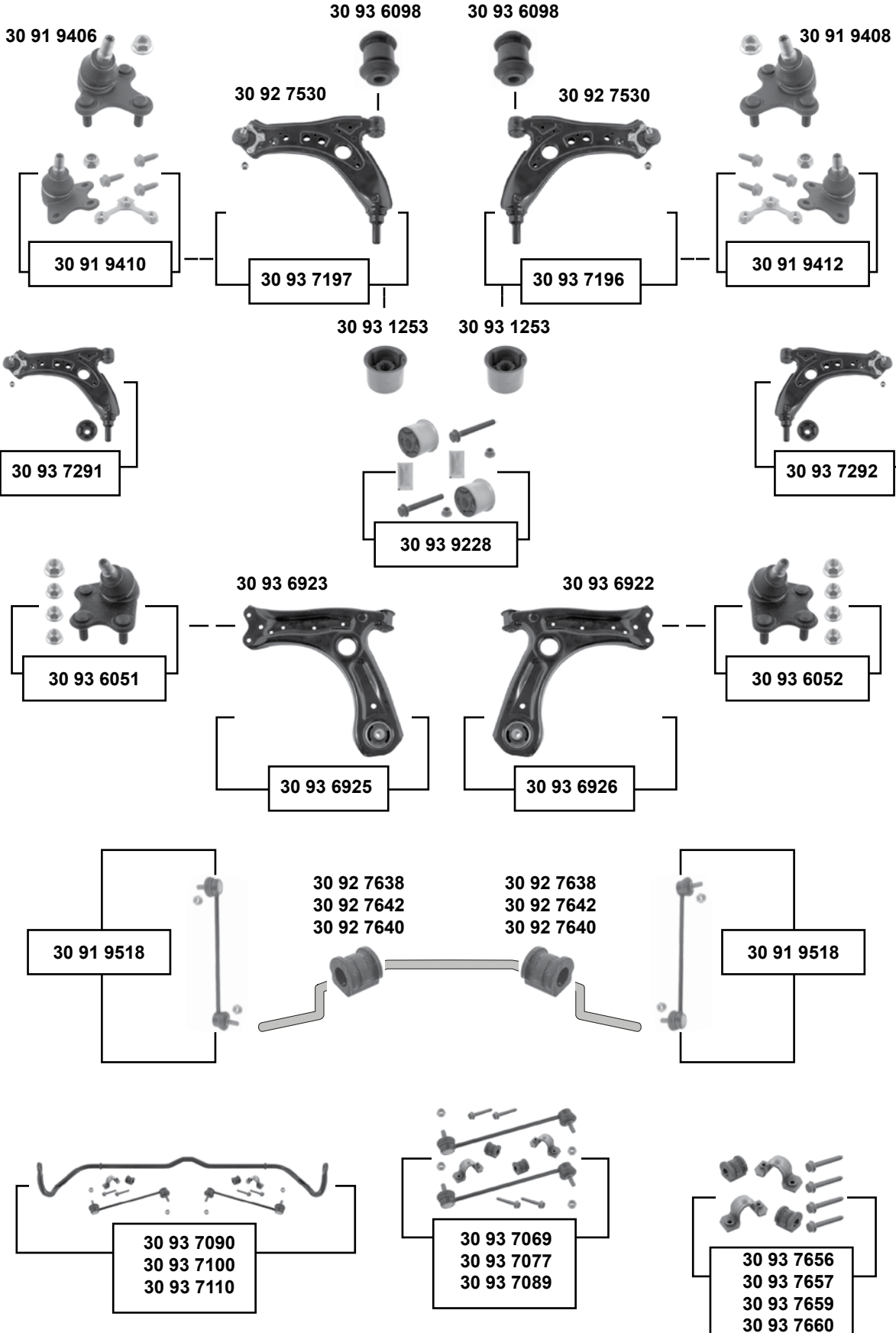



Cordoba / Vario (6L)

(2002 →)



(1) 03 → / (ex.) Cupra R: BPX/BUK/BLZ
 (2) → 09 (ch.) → 6L-3-164 392 / PR-0AS



Ref. - No.



30 91 9406	6Q0 407 365 M	Traggelenk / ball joint		
30 91 9408	6Q0 407 366 M	Traggelenk / ball joint		
30 91 9410	6Q0 407 365 M S1	Rep. Satz Traggelenk / rep. kit ball joint	→ 09 / (ch.) → 6L-8-185 000	
30 91 9412	6Q0 407 366 M S1	Rep. Satz Traggelenk / rep. kit ball joint	→ 09 / (ch.) → 6L-8-185 000	
30 91 9518	6Q0 411 315 Q	Verbindungsstange / connecting rod	03 →	
30 92 7530	6Q0 407 151 L	Querlenker / control arm	→ 08 (ch.) → 6L-8-157 034	
30 92 7638	6Q0 411 314 P	Stabilisatorlager / stabilizer mount	(ch.) 6L-3-164 393 →	Ø I 16
30 92 7640	6Q0 411 314 Q	Stabilisatorlager / stabilizer mount	06 →	Ø I 17
30 92 7642	6Q0 411 314 R	Stabilisatorlager / stabilizer mount	(ch.) → 6L-3-164 392	Ø I 18
30 93 1253	1K0 407 183 E	Querlenkerlager / control arm mount	(1)	Ø A 63
30 93 6051	6R0 407 365 A	Traggelenk / ball joint	(ch.) 6L-8-173 860 →	
30 93 6052	6R0 407 366 A	Traggelenk / ball joint	(ch.) 6L-8-173 860 →	
30 93 6098	6Q0 407 182 A	Querlenkerlager / control arm mount	(ch.) → 6L-8-157 034	Ø A 32
30 93 6922	6R0 407 152 E	Querlenker / control arm	(ch.) 6L-8-173 860 →	
30 93 6923	6R0 407 151 E	Querlenker / control arm	(ch.) 6L-8-173 860 →	
30 93 6925	6R0 407 151 E S1	Rep. Satz Querlenker / rep. kit control arm	(ch.) 6L-8-173 860 →	
30 93 6926	6R0 407 152 E S1	Rep. Satz Querlenker / rep. kit control arm	(ch.) 6L-8-173 860 →	
30 93 7069	6Q0 411 314 Q S1	Stabilisatorlagersatz / anti roll bar bush kit	PR-0AR / (ch.) 6L-8-157 035 →	
30 93 7077	6Q0 411 314 P S1	Stabilisatorlagersatz / anti roll bar bush kit	PR-0AQ / (ch.) 6L-8-157 035 →	
30 93 7089	6Q0 411 314 R S2	Stabilisatorlagersatz / anti roll bar bush kit	PR-0AS	
30 93 7090	6Q0 411 305 AL S2	Rep. Satz Stabilisatorsatz / rep. kit stabilizer kit	PR-0AQ / (ch.) 6L-8-157 035 →	
30 93 7100	6Q0 411 305 AM S2	Rep. Satz Stabilisatorsatz / rep. kit stabilizer kit	PR-0AR / (ch.) 6L-8-157 035 →	
30 93 7110	6Q0 411 305 AN S2	Rep. Satz Stabilisatorsatz / rep. kit stabilizer kit	PR-0AS	
30 93 7196	6Q0 407 151 L S3	Rep. Satz Querlenker / rep. kit control arm		
30 93 7197	6Q0 407 151 L S2	Rep. Satz Querlenker / rep. kit control arm		
30 93 7291	6Q0 407 151 L S5	Rep. Satz Querlenker / rep. kit control arm		
30 93 7292	6Q0 407 151 L S4	Rep. Satz Querlenker / rep. kit control arm		
30 93 7656	6Q0 411 314 R S3	Stabilisatorlagersatz / anti roll bar bush kit	(2)	Ø I 18
30 93 7657	6Q0 411 314 P S2	Stabilisatorlagersatz / anti roll bar bush kit	PR-0AQ	Ø I 16
30 93 7659	6Q0 411 314 R S4	Stabilisatorlagersatz / anti roll bar bush kit	PR-0AS	Ø I 18
30 93 7660	6Q0 411 314 Q S2	Stabilisatorlagersatz / anti roll bar bush kit	(ch.) 6L-8-041 365 → / PR-0AR	Ø I 17
30 93 9228	1K0 407 183 E S1	Querlenkerlagersatz / control arm mounting kit		



Cordoba / Vario (6L)

(2003 →)

für / to fit servo  TRW

30 92 1700

30 92 1700



30 93 8622

30 93 8622

30 93 8621

30 93 8621

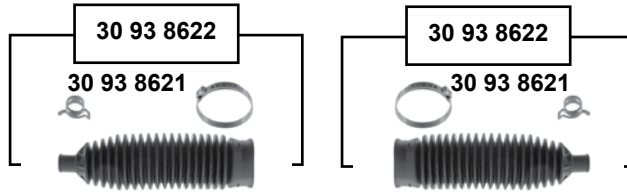

30 91 9816

30 91 9818

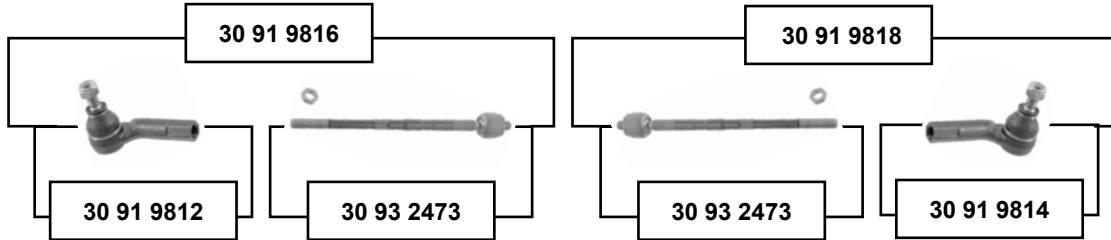

30 91 9812

30 93 2473

30 93 2473

30 91 9814



30 94 4343



30 94 4344

für / to fit servo  KOYO

30 92 6173

30 92 6174

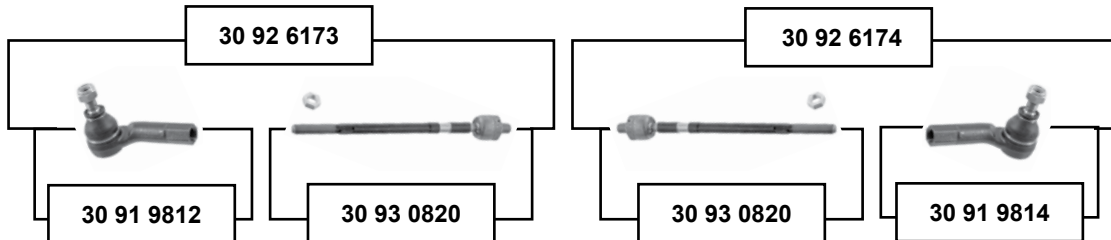

30 91 9812

30 93 0820





30 93 0820

30 91 9814

Vorderachse / Front axle



Cordoba / Vario (6L) (2003 →)

	Ref. - No.			
30 91 9812	6R0 423 811	Spurstangenendstück / tie rod end		
30 91 9814	6R0 423 812	Spurstangenendstück / tie rod end		
30 91 9816	6Q0 423 803 E	Spurstange / tie rod		
30 91 9818	6Q0 423 804 E	Spurstange / tie rod		
30 92 1700	6E0 419 831	Lenkmanschette / steering boot	(ch.) → 6L-3-162 980	
30 92 6173	6Q0 423 803 G	Rep. Satz Spurstange / rep. kit tie rod		
30 92 6174	6Q0 423 804 G	Rep. Satz Spurstange / rep. kit tie rod		
30 93 0820	6Q0 423 810 C	Axialgelenk / axial joint	03 → 05	M14 x 1,5
30 93 2473	6Q0 423 810 P	Axialgelenk / axial joint	03 →	M14 x 1,5
30 93 8621	6Q0 423 831 D	Lenkmanschette / steering boot	(ch.) 6L-3-162 980 →	
30 93 8622	6Q0 423 831 D S1	Rep. Satz Lenkmanschette / rep. kit steering boot	(ch.) 6L-3-162 980 →	
30 94 4343	6Q0 423 803 E S1	Rep. Satz Spurstange / rep. kit tie rod	(ch.) 6L-3-162 981 →	
30 94 4344	6Q0 423 804 E S1	Rep. Satz Spurstange / rep. kit tie rod	(ch.) 6L-3-162 981 →	

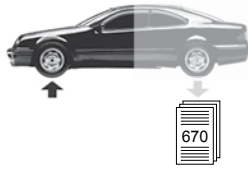

Exeo (3R) (2009 →)

Vorderachse / Front axle

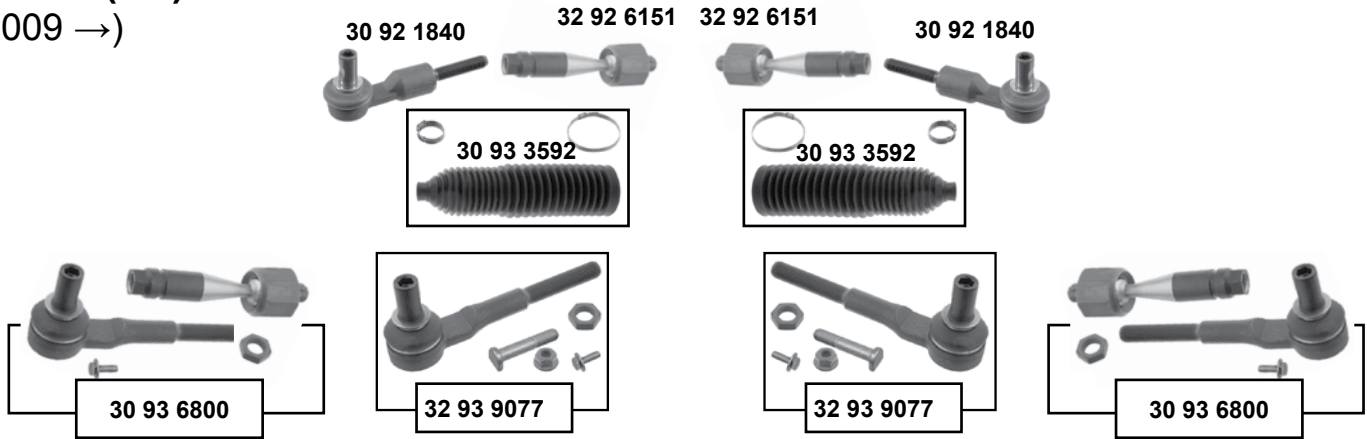

oben / upper

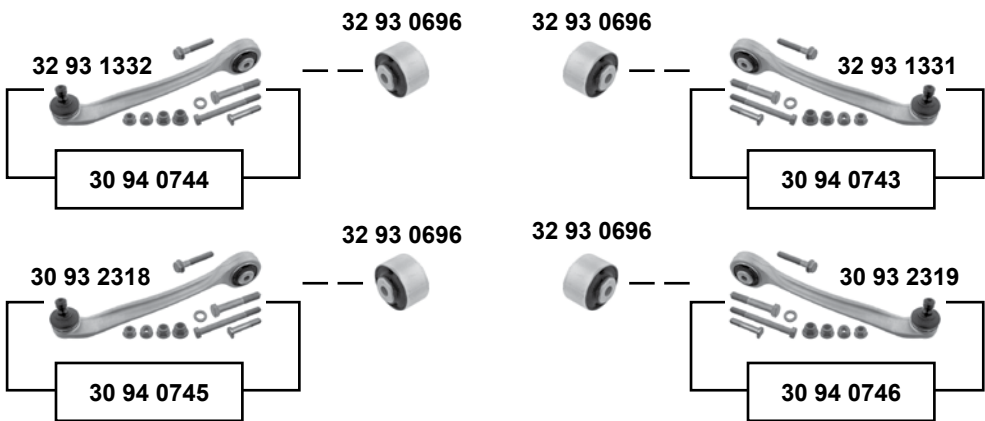

unten / lower

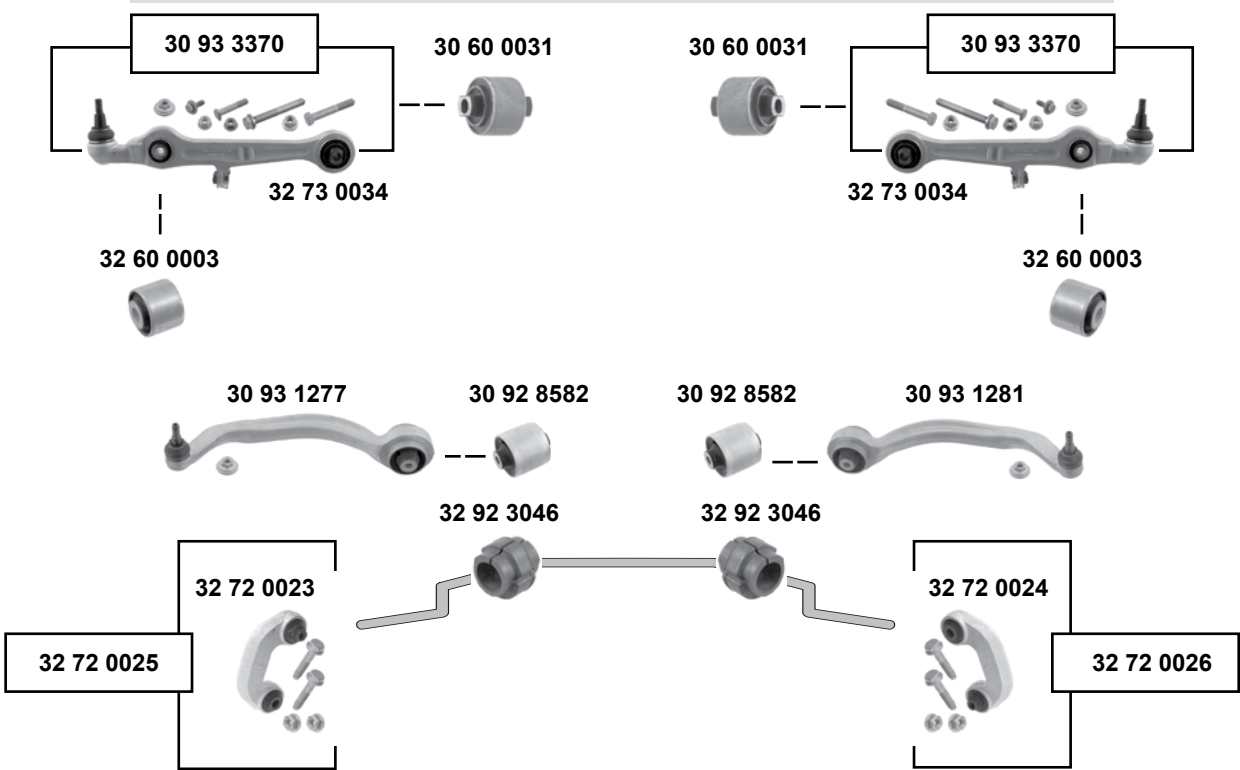

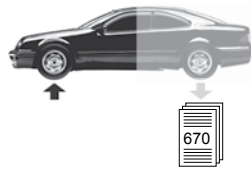

Exeo (3R) (2009 →)

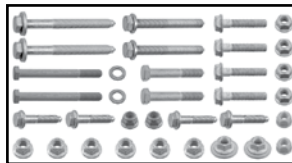

30 93 9754
30 93 9758



(1) Bitte paarweise tauschen / replace in pairs only

SWAG	Ref. - No.			
30 60 0031	4D0 407 182 G	Querlenkerlager / control arm mount		Ø A 50 H 60
30 92 1840	4F0 498 811 A SK	Spurstangenendstück / tie rod end		
30 92 8582	4F0 407 183 E	Querlenkerlager / control arm mount		Ø A 65,20
30 93 1277	8E0 407 693 AL	Querlenker / control arm	(1)	M12 x 1,5
30 93 1281	8E0 407 694 AL	Querlenker / control arm	(1)	M12 x 1,5
30 93 2318	8E0 407 505 P	Querlenker / control arm	Aluminium	
30 93 2319	8E0 407 506 P	Querlenker / control arm	Aluminium	
30 93 3370	8E0 407 151 R S1	Rep. Satz Querlenker / rep. kit control arm		
30 93 3592	8D0 419 831 K S1	Rep. Satz Lenkmanschette / rep. kit steering boot		
30 93 6800	8E0 422 821 C S1	Rep. Satz Spurstange / rep. kit tie rod		
30 93 9754	KIT 11	Montagesatz / mounting kit		
30 93 9758	KIT 12	Montagesatz / mounting kit		
30 94 0743	8E0 407 510 P S1	Rep. Satz Querlenker / rep. kit control arm		
30 94 0744	8E0 407 509 P S1	Rep. Satz Querlenker / rep. kit control arm		
30 94 0745	8E0 407 505 P S1	Rep. Satz Querlenker / rep. kit control arm		
30 94 0746	8E0 407 506 P S1	Rep. Satz Querlenker / rep. kit control arm		
32 60 0003	8E0 407 181 C	Querlenkerlager / control arm mount		
32 72 0023	8E0 411 317	Verbindungsstange / connecting rod		
32 72 0024	8E0 411 318	Verbindungsstange / connecting rod		
32 72 0025	8E0 411 317 S1	Rep. Satz Verbindungsstange / rep. kit connecting rod		
32 72 0026	8E0 411 318 S1	Rep. Satz Verbindungsstange / rep. kit connecting rod		
32 73 0034	8E0 407 151 R	Querlenker, <u> vorne </u> / control arm, <u> front </u>	NEW	
32 92 3046	4D0 411 327 J	Stabilisatorlager / stabilizer mount		Ø I 29
32 92 6151	8E0 422 821 C	Spurstange beidseitig / tie rod both sides		
32 93 0696	8D0 407 515 C	Querlenkerlager / control arm mount		
32 93 1331	8E0 407 510 P	Querlenker / control arm		
32 93 1332	8E0 407 509 P	Querlenker / control arm		
32 93 9077	4F0 498 811 A S1	Spurstangenendstück / tie rod end		



Ibiza (6K) (1993 → 2002)

Vorderachse / Front axle

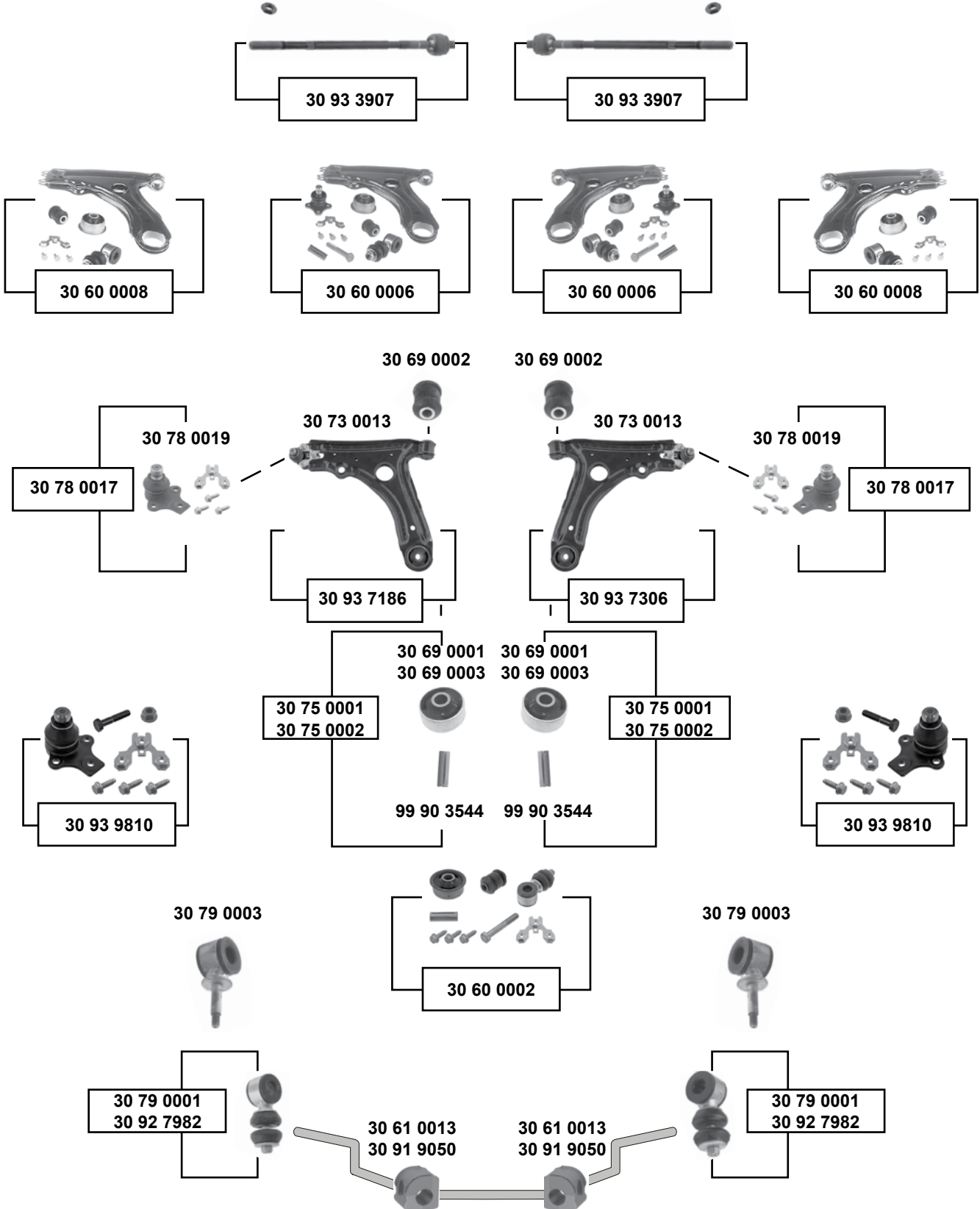



Ibiza (6K) (1993 → 2002)



- (1) (ch.) → 6K-ZR-040 000 / 6K-ZR-550 000
- (2) (ch.) → 6K-V-143400 **alle / all** / (ch.) 6K-V-143401 → 1.0 / 1.3 / 1.4 / 1.6 (55kw)
- (3) (ch.) 6K-V-143401 → 1,6 (74kw); Diesel
- (4) 93 → 94 (ch.) → 6K-ZR036 750 / → 6K-ZR546 756
- (5) → 12/1994 (ch.) → 6K-ZR-040 000 / 6K-ZR-550 000



Ref. - No.



SWAG Ref. - No.				
30 60 0002	191 407 153 S1	Montagesatz / mounting kit	(5)	
30 60 0006	191 407 153 A S3	Rep. Satz Querlenker / rep. kit control arm		
30 60 0008	191 407 153 A S2	Rep. Satz Querlenker / rep. kit control arm	→ 12/1994	
30 61 0013	191 411 314	Stabilisatorlager / stabilizer mount	(2)	Ø I 17
30 69 0001	191 407 181 D	Querlenkerlager / control arm mount	NEW	17x60x41
30 69 0002	357 407 182	Querlenkerlager / control arm mount		12x33x54
30 69 0003	191 407 181 B	Querlenkerlager / control arm mount	OLD	17x60x41
30 73 0013	191 407 151 B	Querlenker mit Gummilager / control arm incl. rubber mounts		
30 75 0001	191 407 181 B S1	Querlenkerlager mit Hülse / control arm mount with sleeve	OLD	
30 75 0002	191 407 181 D S1	Querlenkerlager mit Hülse / control arm mount with sleeve	NEW	
30 78 0017	357 407 365 S1	Rep. Satz Traggelenk / rep. kit ball joint		
30 78 0019	357 407 365	Traggelenk / ball joint		Ø A 19
30 79 0001	191 411 315 B S1	Rep. Satz Verbindungsstange / rep. kit connecting rod	(1)	
30 79 0003	191 411 315 B	Verbindungsstange / connecting rod	(5)	
30 91 9050	1H0 411 314	Stabilisatorlager / stabilizer mount	(3)	
30 92 7982	6K0 411 315 S1	Verbindungsstange / connecting rod	(ch.) 6K-V-143401 →	Ø I 16,5
30 93 3907	191 422 810 A	Axialgelenk / axial joint	(4) servo	
30 93 7186	191 407 151 B S1	Rep. Satz Querlenker / rep. kit control arm		
30 93 7306	191 407 151 B S2	Rep. Satz Querlenker / rep. kit control arm		
30 93 9810	357 407 365 S2	Rep. Satz Traggelenk / rep. kit ball joint		
99 90 3544	191 407 190 A	Hülse / sleeve		50x17



Ibiza (6K)
(1993 → 2002)

man.

30 69 0004

30 69 0004

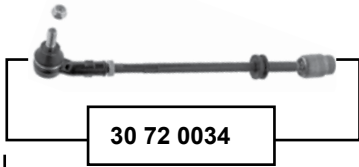
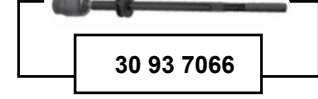

30 80 0054

30 80 0054

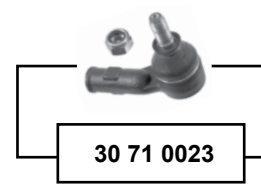
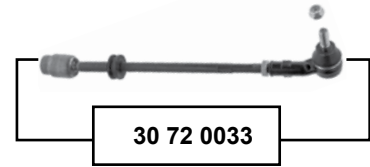

servo

30 91 8864

30 80 0057

30 80 0057

30 91 8864

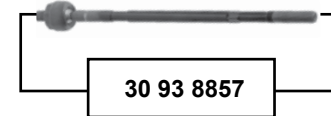
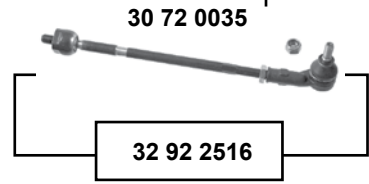
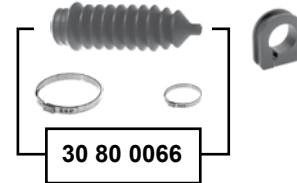
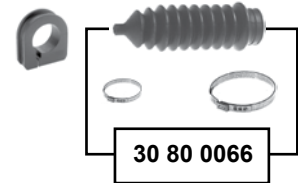
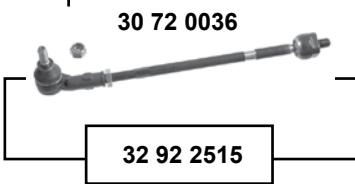

(1) (ch.) 6K-ZR546757 → 6K-TR081919 →

(2) (ch.) → 6K-TR-081919 / → 1996

(3) servo / (ch.) 6K-ZR036751 → / 6K-ZR546757 → / 6K-TR081919 → // → 1996



Ref. - No.



30 69 0004	191 419 883	Lenkgetriebelager / steering gear bearing		
30 71 0023	191 419 812	Spurstangenendstück / tie rod end	(2)	M12 x 1,5
30 71 0024	191 419 811	Spurstangenendstück / tie rod end	(2)	M12 x 1,5
30 72 0033	191 419 804	Spurstange / tie rod		
30 72 0034	191 419 803	Spurstange / tie rod		
30 72 0035	191 422 804 A	Spurstange / tie rod	(ch.) → 6K-ZR546756	
30 72 0036	191 422 803 A	Spurstange / tie rod	(ch.) → 6K-ZR546756	
30 80 0001	191 419 063 C	Lenkgetriebe / steering gear	LHD	
30 80 0054	191 419 831	Lenkmanschette / steering boot		
30 80 0057	1H0 422 831 B	Lenkmanschette / steering boot		
30 80 0063	191 419 831 S1	Rep. Satz Lenkmanschette / rep. kit steering boot		
30 80 0066	1H0 422 831 B S1	Rep. Satz Lenkmanschette / rep. kit steering boot		
30 91 8864	1H0 422 884	Lenkgetriebelager / steering gear bearing	(ch.) → 6K-TR018 919	
30 93 7066	191 419 810 A	Spurstange / tie rod		M12 x 1,5
30 93 8857	6K0 422 810	Axialgelenk / axial joint	(3)	
32 92 2515	6K0 422 803	Spurstange / tie rod	(1)	
32 92 2516	6K0 422 804	Spurstange / tie rod	(1)	



Ibiza (6K) (1999 → 2002)

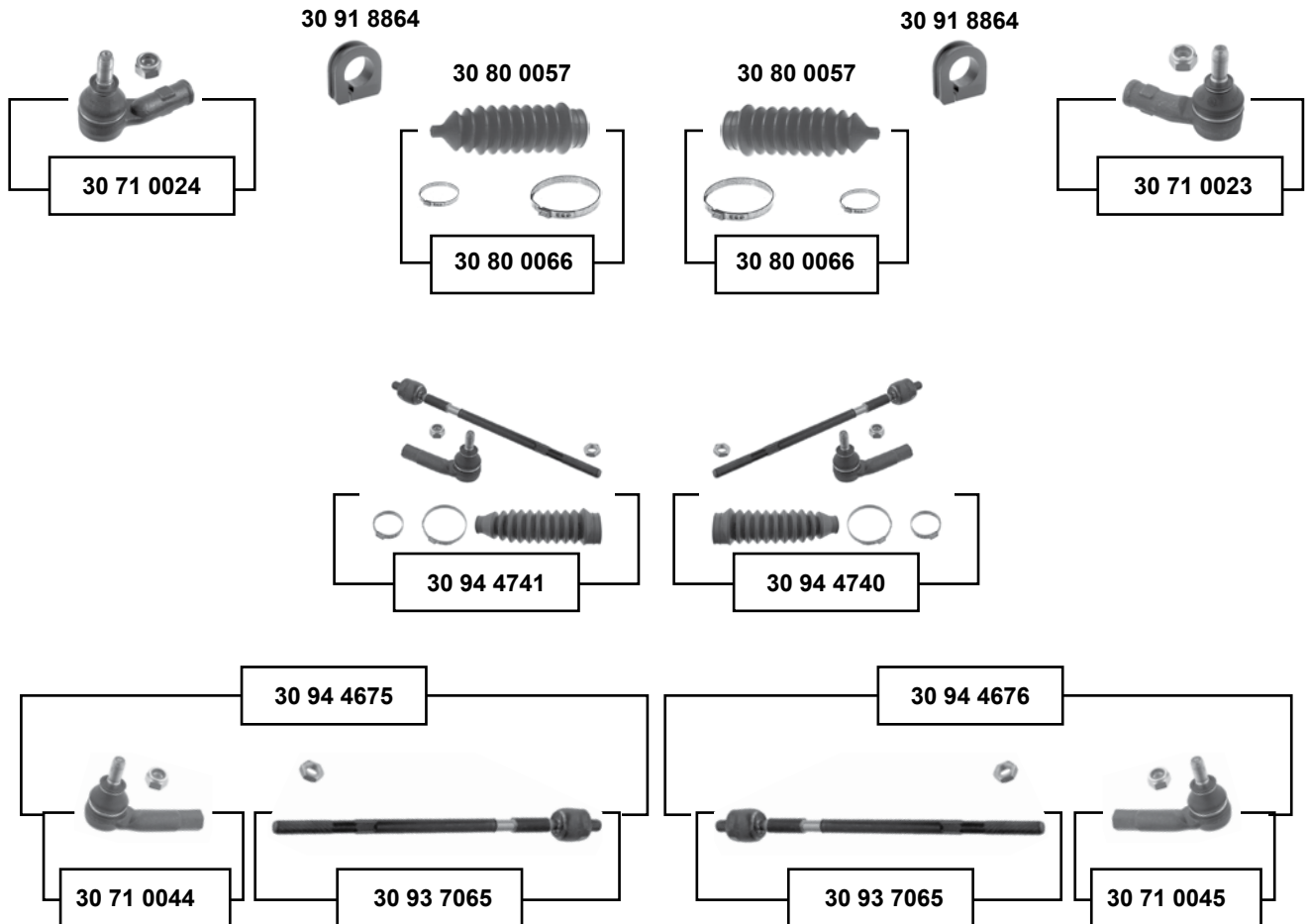

Vorderachse / Front axle



(1) (ch.) → 6K-1-180000

(2) (ch.) 6K-1-180001 → Sport / servo

(3) (ch.) → 6K-X-400 001 / (ch.) 6K-TR130 000 → // Ausstattungsvariante / Equipment Variation : GTI



Ref. - No.



SWAG Ref. - No.	Ref. - No.	Description	Quantity	Notes
30 71 0023	191 419 812	Spurstangenendstück / tie rod end	(1)	M12 x 1,5
30 71 0024	191 419 811	Spurstangenendstück / tie rod end	(1)	M12 x 1,5
30 71 0044	6E0 419 811	Spurstangenendstück / tie rod end	(2)	
30 71 0045	6E0 419 812	Spurstangenendstück / tie rod end	(2)	
30 80 0057	1H0 422 831 B	Lenkmanschette / steering boot	(1)	
30 80 0066	1H0 422 831 B S1	Rep. Satz Lenkmanschette / rep. kit steering boot	(1)	
30 91 8864	1H0 422 884	Lenkgetriebelager / steering gear bearing		
30 93 7065	6K0 422 810 E	Axialgelenk / axial joint		
30 94 4675	6K0 422 803 E	Rep. Satz Spurstange / rep. kit tie rod	(3)	M12 x 1,5
30 94 4676	6K0 422 804 E	Rep. Satz Spurstange / rep. kit tie rod	(3)	M12 x 1,5
30 94 4740	6K0 422 804 E S1	Rep. Satz Spurstange / rep. kit tie rod	(ch.)	6K-TR130 000 →
30 94 4741	6K0 422 803 E S1	Rep. Satz Spurstange / rep. kit tie rod	(ch.)	6K-TR130 000 →



Ibiza (6K) (1999 → 2002)

Vorderachse / Front axle

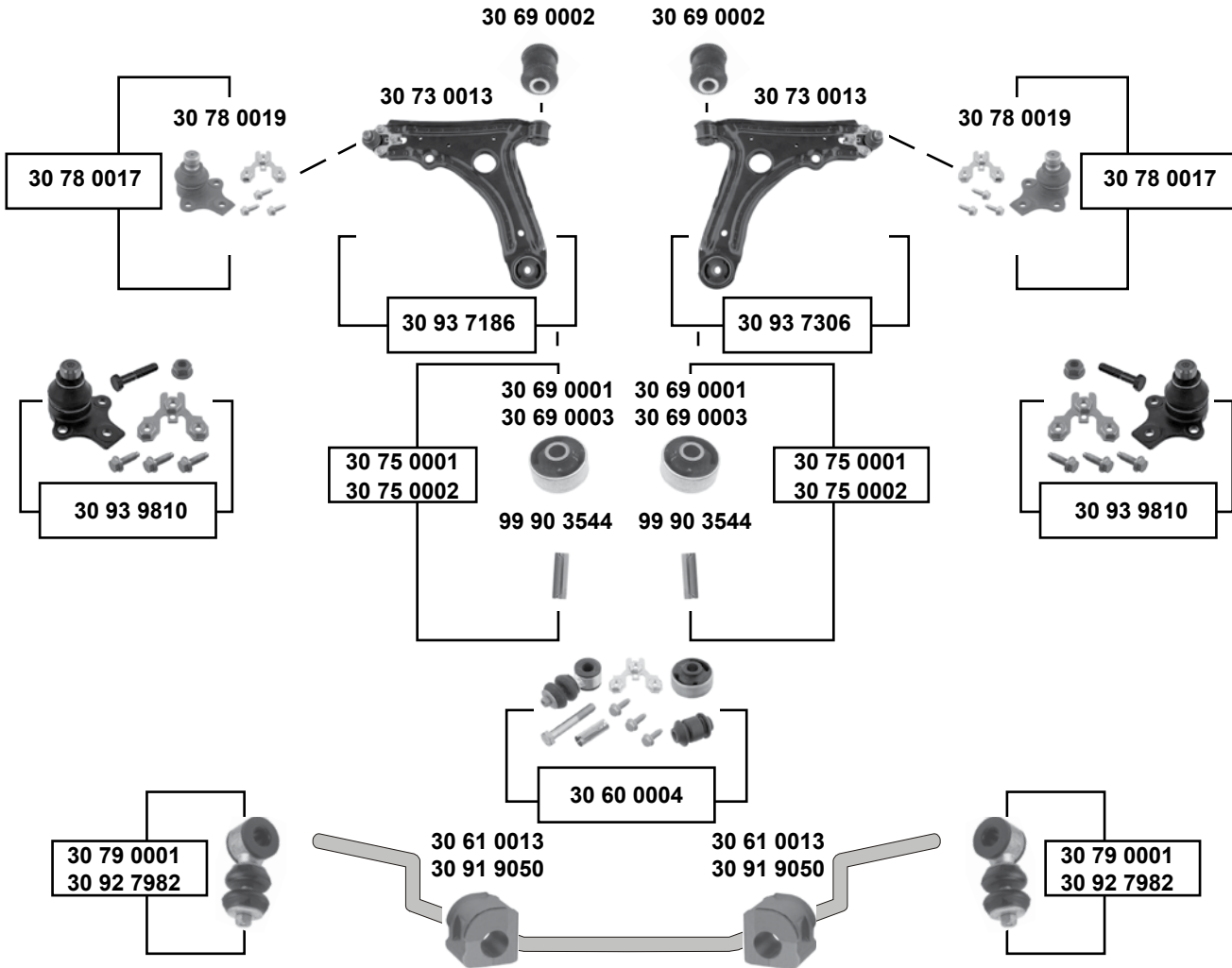

(1) 1.0 / 1.4 (44 kW) **alle / all**
1.6 (55 kW) (ch.) → 6K-X-430579

(2) (ch.) 6K-V-143401 → 1,6 (74kw) / 1,8 Diesel



Ref. - No.



Part No.	Description	Notes	Dimensions
30 60 0004	191 407 153 S2 Montagesatz / mounting kit		
30 61 0013	191 411 314 Stabilisatorlager / stabilizer mount		
30 69 0001	191 407 181 D Querlenkerlager / control arm mount	(1) NEW	Ø I 17 17x60x41
30 69 0002	357 407 182 Querlenkerlager / control arm mount	OLD	12x33x54 17x60x41
30 69 0003	191 407 181 B Querlenkerlager / control arm mount	OLD	
30 73 0013	191 407 151 B Querlenker mit Gummilager / control arm incl. rubber mounts	OLD	
30 75 0001	191 407 181 B S1 Querlenkerlager mit Hülse / control arm mount with sleeve	NEW	
30 75 0002	191 407 181 D S1 Querlenkerlager mit Hülse / control arm mount with sleeve		
30 78 0017	357 407 365 S1 Rep. Satz Traggelenk / rep. kit ball joint		
30 78 0019	357 407 365 Traggelenk / ball joint		Ø A 19
30 79 0001	191 411 315 B S Rep. Satz Verbindungsstange / rep. kit connecting rod	(1)	
30 91 9050	1H0 411 314 Stabilisatorlager / stabilizer mount	(2)	Ø I 19
30 92 7982	6K0 411 315 S1 Rep. Satz Verbindungsstange / rep. kit connecting rod	(2)	
30 93 7186	191 407 151 B S1 Rep. Satz Querlenker / rep. kit control arm		
30 93 7306	191 407 151 B S2 Rep. Satz Querlenker / rep. kit control arm		
30 93 9810	357 407 365 S2 Rep. Satz Traggelenk / rep. kit ball joint		
99 90 3544	191 407 190 A Hülse / sleeve		50x17



Ibiza (6L) (2002 →)

für / to fit **servo**  **TRW**

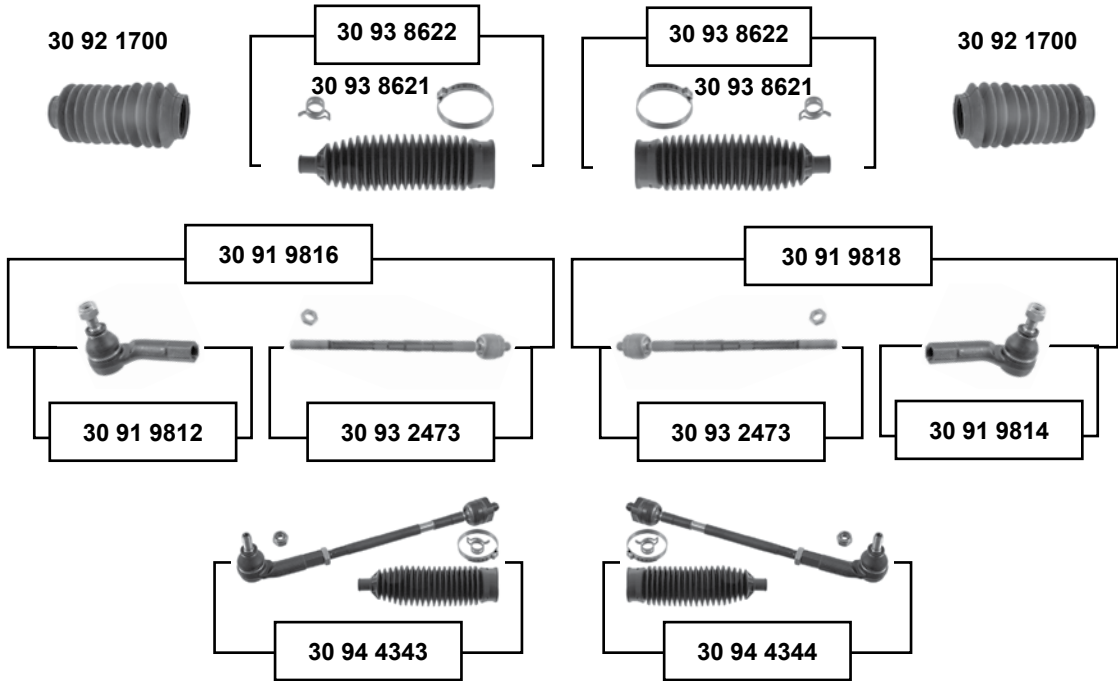

für / to fit **servo**  **KOYO**

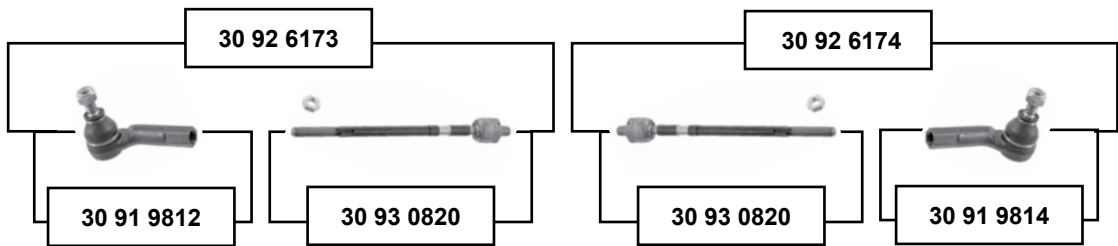

Vorderachse / Front axle



(1) Cupra R (6L) → 10 (mot.) BBU / BLZ / BPX



Ref. - No.



30 91 9812	6R0 423 811	Spurstangenendstück / tie rod end		
30 91 9814	6R0 423 812	Spurstangenendstück / tie rod end		
30 91 9816	6Q0 423 803 E	Spurstange / tie rod		
30 91 9818	6Q0 423 804 E	Spurstange / tie rod		
30 92 1700	6E0 419 831	Lenkmanschette / steering boot	(ch.) → 6L-3-162980	
30 92 6173	6Q0 423 803 G	Rep. Satz Spurstange / rep. kit tie rod		
30 92 6174	6Q0 423 804 G	Rep. Satz Spurstange / rep. kit tie rod		
30 93 0820	6Q0 423 810 C	Axialgelenk / axial joint	06 → 10	M14 x 1,5
30 93 2473	6Q0 423 810 P	Axialgelenk / axial joint	→ 10 (1)	M14 x 1,5
30 93 8621	6Q0 423 831 D	Lenkmanschette / steering boot	(ch.) 6L-3-162 980 →	
30 93 8622	6Q0 423 831 D S1	Rep. Satz Lenkmanschette / rep. kit steering boot	(ch.) 6L-3-162 980 →	
30 94 4343	6Q0 423 803 E S1	Rep. Satz Spurstange / rep. kit tie rod	(ch.) 6L-3-162 981 →	
30 94 4344	6Q0 423 804 E S1	Rep. Satz Spurstange / rep. kit tie rod	(ch.) 6L-3-162 981 →	



Ibiza (6L) (2002 →)

Vorderachse / Front axle

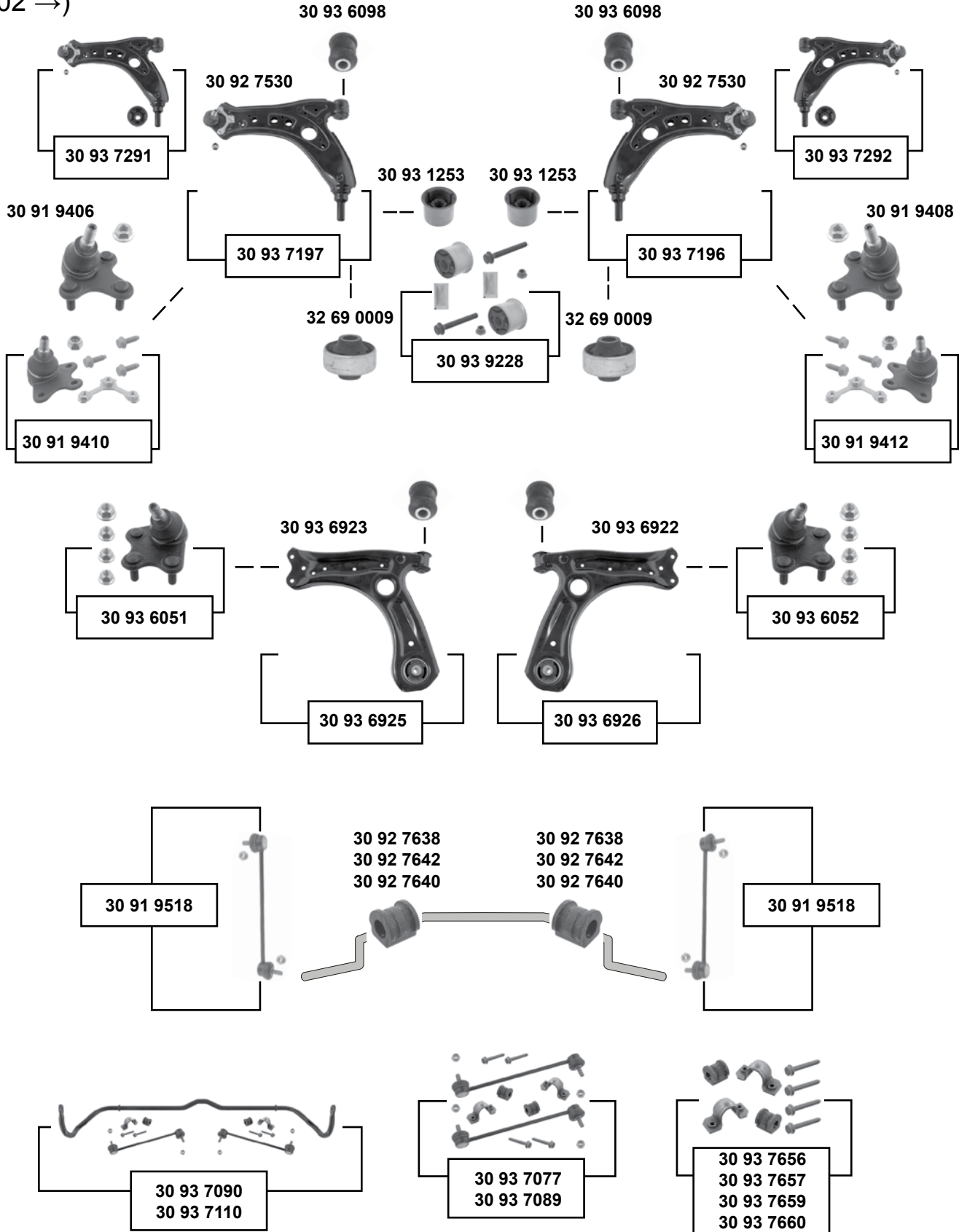



Ibiza (6L) (2002 →)



- (1) (ch.) → 6L-8-157 034 / (ex.) CUPRA
- (2) (ch.) → 6L-3-164392
- (3) (ch.) 6L-3-164393 →
- (4) → 10 / (ex.) Cupra R: BPX/BUK/BLZ
- (5) 08 → 10 / (ex.) Cupra R (ch.) 6L-8-157 035 →
- (6) (ch.) 6L-8-157 035 → / PR-0AQ
- (7) → 09 (ch.) → 6L-3-164 392 / PR-0AQ



Ref. - No.



SWAG Ref. - No.	Description	Notes	Dimensions
30 69 0002	357 407 182	Querlenkerlager / control arm mount	Ø A 33
30 91 9406	6Q0 407 365 M	Traggelenk / ball joint	
30 91 9408	6Q0 407 366 M	Traggelenk / ball joint	
30 91 9410	6Q0 407 365 M S1	Rep. Satz Traggelenk / rep. kit ball joint	
30 91 9412	6Q0 407 366 M S1	Rep. Satz Traggelenk / rep. kit ball joint	
30 91 9518	6Q0 411 315 Q	Verbindungsstange / connecting rod	→ 10
30 92 7530	6Q0 407 151 L	Querlenker / control arm	(1)
30 92 7638	6Q0 411 314 P	Stabilisatorlager / stabilizer mount	(3) Ø I 16
30 92 7640	6Q0 411 314 Q	Stabilisatorlager / stabilizer mount	→ 10 Ø I 17
30 92 7642	6Q0 411 314 R	Stabilisatorlager / stabilizer mount	(2) PR-0AS Ø I 18
30 93 1253	1K0 407 183 E	Querlenkerlager / control arm mount	(4)
30 93 6051	6R0 407 365 A	Traggelenk / ball joint	(ch.) 6L-8-173 860 →
30 93 6052	6R0 407 366 A	Traggelenk / ball joint	(ch.) 6L-8-173 860 →
30 93 6098	6Q0 407 182 A	Querlenkerlager / control arm mount	Ø A 32
30 93 6922	6R0 407 152 E	Querlenker / control arm	(ch.) 6L-8-173 860 →
30 93 6923	6R0 407 151 E	Querlenker / control arm	(ch.) 6L-8-173 860 →
30 93 6925	6R0 407 151 E S1	Rep. Satz Querlenker / rep. kit control arm	(ch.) 6L-8-173 860 →
30 93 6926	6R0 407 152 E S1	Rep. Satz Querlenker / rep. kit control arm	(ch.) 6L-8-173 860 →
30 93 7077	6Q0 411 314 P S1	Stabilisatorlagersatz / anti roll bar bush kit	(6)
30 93 7089	6Q0 411 314 R S2	Stabilisatorlagersatz / anti roll bar bush kit	PR-0AS
30 93 7090	6Q0 411 305 AL S2	Rep. Satz Stabilisatorsatz / rep. kit stabilizer kit	(6)
30 93 7110	6Q0 411 305 AN S2	Rep. Satz Stabilisatorsatz / rep. kit stabilizer kit	PR-0AS
30 93 7196	6Q0 407 151 L S3	Rep. Satz Querlenker / rep. kit control arm	→ 09
30 93 7197	6Q0 407 151 L S2	Rep. Satz Querlenker / rep. kit control arm	→ 09
30 93 7291	6Q0 407 151 L S5	Rep. Satz Querlenker / rep. kit control arm	→ 09
30 93 7292	6Q0 407 151 L S4	Rep. Satz Querlenker / rep. kit control arm	→ 09
30 93 7656	6Q0 411 314 R S3	Stabilisatorlagersatz / anti roll bar bush kit	(7) Ø I 18
30 93 7657	6Q0 411 314 P S2	Stabilisatorlagersatz / anti roll bar bush kit	PR-0AQ Ø I 16
30 93 7659	6Q0 411 314 R S4	Stabilisatorlagersatz / anti roll bar bush kit	PR-0AS Ø I 18
30 93 7660	6Q0 411 314 Q S2	Stabilisatorlagersatz / anti roll bar bush kit	PR-0AR Ø I 17
30 93 9228	1K0 407 183 E S1	Querlenkerlagersatz / control arm mounting kit	
32 69 0009	1J0 407 181	Querlenkerlager / control arm mount	(5) Ø A 60 Ø I 13



Ibiza (6J)

(2009 →)

Vorderachse / Front axle

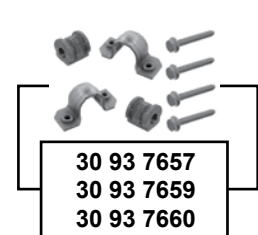
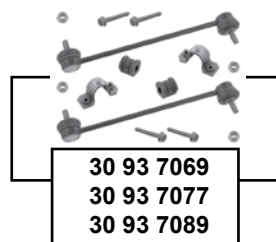
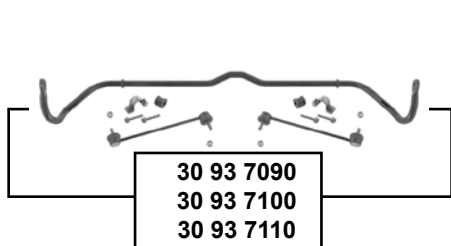
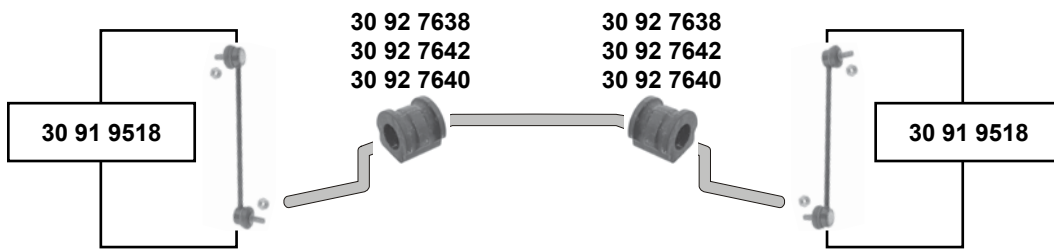
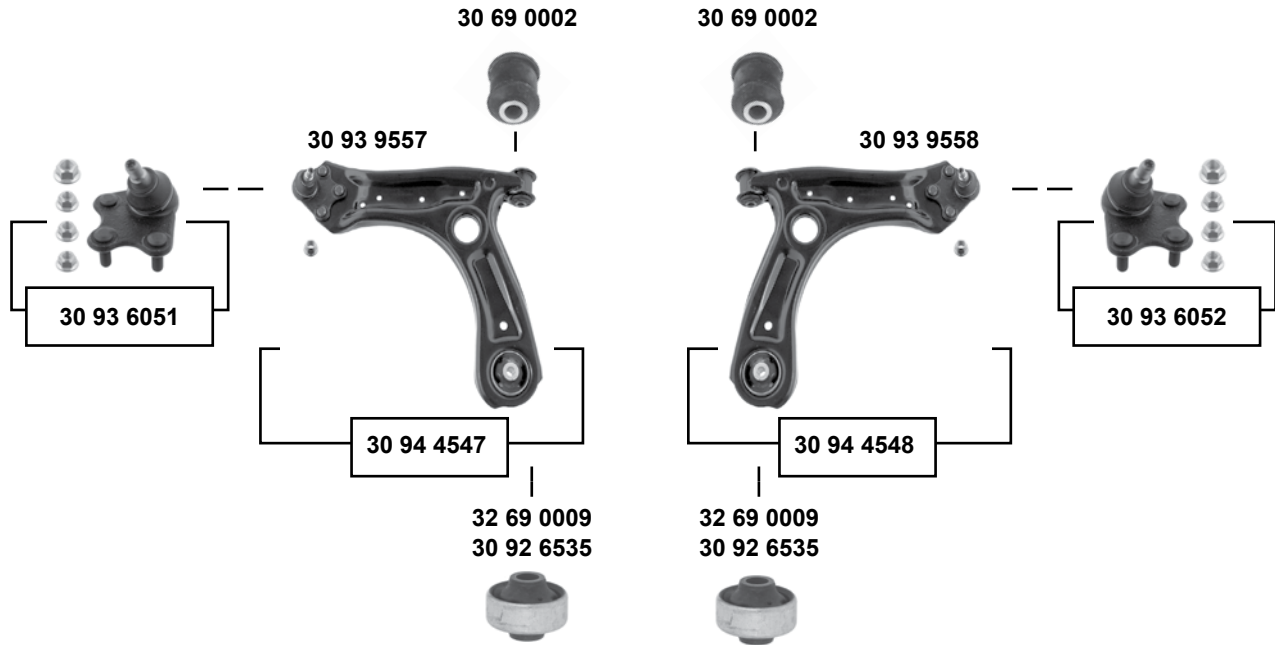
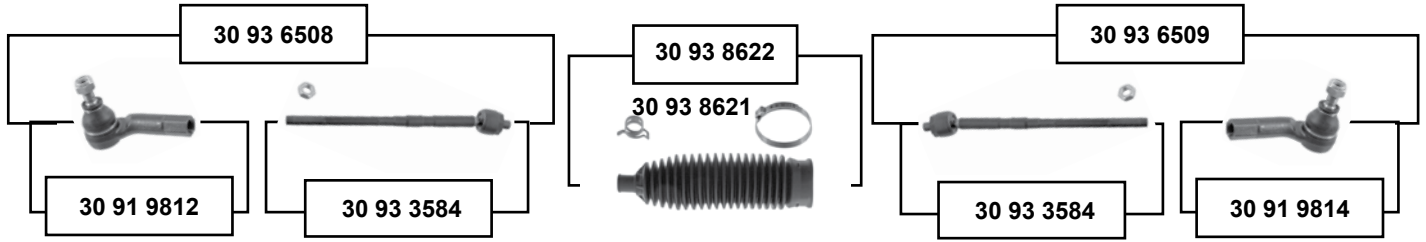



Ibiza (6J) (2009 →)



(1) PR-G17,G18,G19,G20



Ref. - No.



30 69 0002	357 407 182	Querlenkerlager / control arm mount		
30 91 9518	6Q0 411 315 Q	Verbindungsstange / connecting rod	09 →	
30 91 9812	6RD 423 811 B	Spurstangenendstück / tie rod end		
30 91 9814	6RD 423 812 B	Spurstangenendstück / tie rod end		
30 92 6535	8N0 407 181 B	Querlenkerlager / control arm mount		13x60x41
30 92 7638	6Q0 411 314 P	Stabilisatorlager / stabilizer mount		Ø I 16
30 92 7640	6Q0 411 314 Q	Stabilisatorlager / stabilizer mount	→ 09	Ø I 17
30 92 7642	6Q0 411 314 R	Stabilisatorlager / stabilizer mount	→ 08 / PR-0AS	Ø I 18
30 93 3584	6R0 423 810 A	Axialgelenk / axial joint	09 →	M14 x 1,5
30 93 6051	6R0 407 365 A	Traggelenk / ball joint	(ch.) 6L-8-173 860 →	
30 93 6052	6R0 407 366 A	Traggelenk / ball joint	(ch.) 6L-8-173 860 →	
30 93 6508	6R0 423 803 A	Spurstange, komplett / tie rod, complete		M12/14x1,5
30 93 6509	6R0 423 804 A	Spurstange, komplett / tie rod, complete		M12/14x1,5
30 93 7069	6Q0 411 314 Q S1	Stabilisatorlagersatz / anti roll bar bush kit	08 → / PR-0AR	
30 93 7077	6Q0 411 314 P S1	Stabilisatorlagersatz / anti roll bar bush kit	08 → / PR-0AQ	
30 93 7089	6Q0 411 314 R S2	Stabilisatorlagersatz / anti roll bar bush kit	08 → / PR-0AS	
30 93 7090	6Q0 411 305 AL S2	Rep. Satz Stabilisatorsatz / rep. kit stabilizer kit	08 → / PR-0AQ	
30 93 7100	6Q0 411 305 AM S2	Rep. Satz Stabilisatorsatz / rep. kit stabilizer kit	08 → / PR-0AR	
30 93 7110	6Q0 411 305 AN S2	Rep. Satz Stabilisatorsatz / rep. kit stabilizer kit	08 → / PR-0AS	
30 93 7657	6Q0 411 314 P S2	Stabilisatorlagersatz / anti roll bar bush kit	08 → / PR-0AQ	Ø I 16
30 93 7659	6Q0 411 314 R S4	Stabilisatorlagersatz / anti roll bar bush kit	08 → / PR-0AS	Ø I 18
30 93 7660	6Q0 411 314 Q S2	Stabilisatorlagersatz / anti roll bar bush kit	08 → / PR-0AR	Ø I 17
30 93 8621	6Q0 423 831 D	Rep. Satz Lenkmanschette / rep. kit steering boot	PR-1N2 / 1AC / 1AT	
30 93 8622	6Q0 423 831 D S1	Rep. Satz Lenkmanschette / rep. kit steering boot	PR-1N2 / 1AC / 1AT	
30 93 9557	6R0 407 151 F	Querlenker / control arm	(1)	
30 93 9558	6R0 407 152 F	Querlenker / control arm	(1)	
30 94 4547	6R0 407 151 F S1	Querlenker, kpl. / control arm, cpl.	(1)	
30 94 4548	6R0 407 152 F S1	Querlenker, kpl. / control arm, cpl.	(1)	
32 69 0009	1J0 407 181	Querlenkerlager / control arm mount	09 → / (ex.) Sport	Ø A 60 Ø I 13



Inca (6K9) (1996 → 2003)

Vorderachse / Front axle

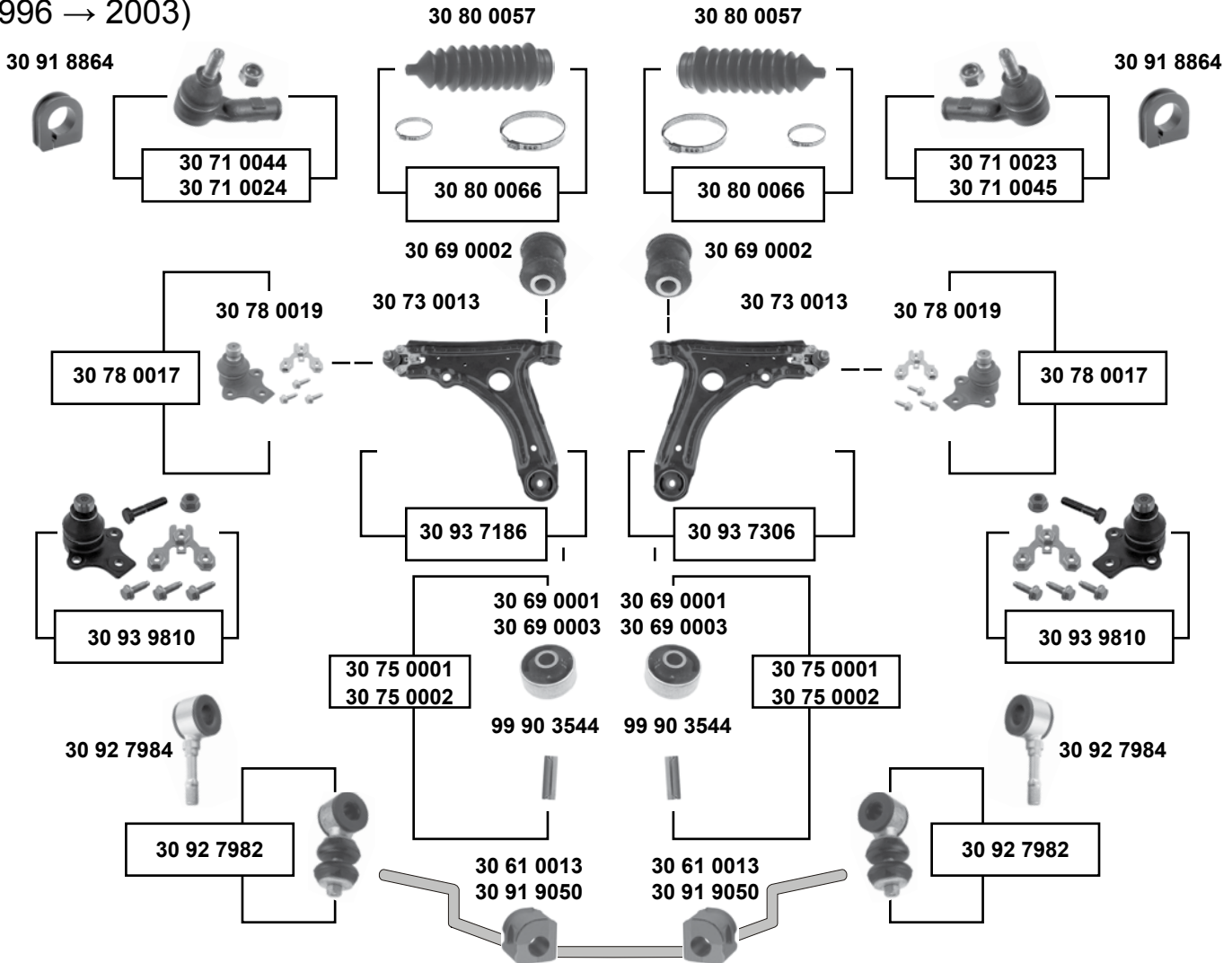

SWAG GERMANY	Ref. - No.			
30 61 0013	191 411 314	Stabilisatorlager / stabilizer mount	(ch.) → 9K-V-012 500	Ø I 17
30 69 0001	191 407 181 D	Querlenkerlager / control arm mount	NEW	17x60x41
30 69 0002	357 407 182	Querlenkerlager / control arm mount	OLD	12x33x54
30 69 0003	191 407 181 B	Querlenkerlager / control arm mount		17x60x41
30 71 0023	191 419 812	Spurstangenendstück / tie rod end	(ch.) → 9K-1-013 000	M12 x 1,5
30 71 0024	191 419 811	Rep. Satz Spurstangenendstück / rep. kit tie rod end	(ch.) → 9K-1-013 000	M12 x 1,5
30 71 0044	6E0 419 811	Spurstangenendstück / tie rod end	(ch.) 9K-1-013 000 →	
30 71 0045	6E0 419 812	Spurstangenendstück / tie rod end	(ch.) 9K-1-013 000 →	
30 73 0013	191 407 151 B	Querlenker / control arm		
30 75 0001	191 407 181 B S1	Querlenkerlager mit Hülse / control arm mount with sleeve	OLD	
30 75 0002	191 407 181 D S1	Querlenkerlager mit Hülse / control arm mount with sleeve	NEW	
30 78 0017	357 407 365 S1	Rep. Satz Traggelenk / rep. kit ball joint		
30 78 0019	357 407 365	Rep. Satz Traggelenk / rep. kit ball joint		Ø A 19
30 80 0057	1H0 422 831 B	Lenkmanschette / steering boot		
30 80 0066	1H0 422 831 B S1	Rep. Satz Lenkmanschette / rep. kit steering boot		
30 91 8864	1H0 422 884	Lenkgetriebelager / steering gear bearing		
30 91 9050	1H0 411 314	Stabilisatorlager / stabilizer mount	servo	
30 92 7982	6K0 411 315 S1	Verbindungsstange / connecting rod	(ch.) 9K-V-012 501 →	Ø I 19
30 92 7984	6K0 411 315	Verbindungsstange / connecting rod	(ch.) 9K-V-012 501 →	Ø I 16,5
30 93 7186	191 407 151 B S1	Rep. Satz Querlenker / rep kit control arm	(ch.) 9K-V-012 501 →	
30 93 7306	191 407 151 B S2	Rep. Satz Querlenker / rep kit control arm		
30 93 9810	357 407 365 S2	Rep. Satz Traggelenk / rep. kit ball joint		
99 90 3544	191 407 190 A	Hülse / sleeve		50x17

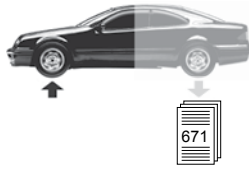

Leon (1M) (1999 → 2005)

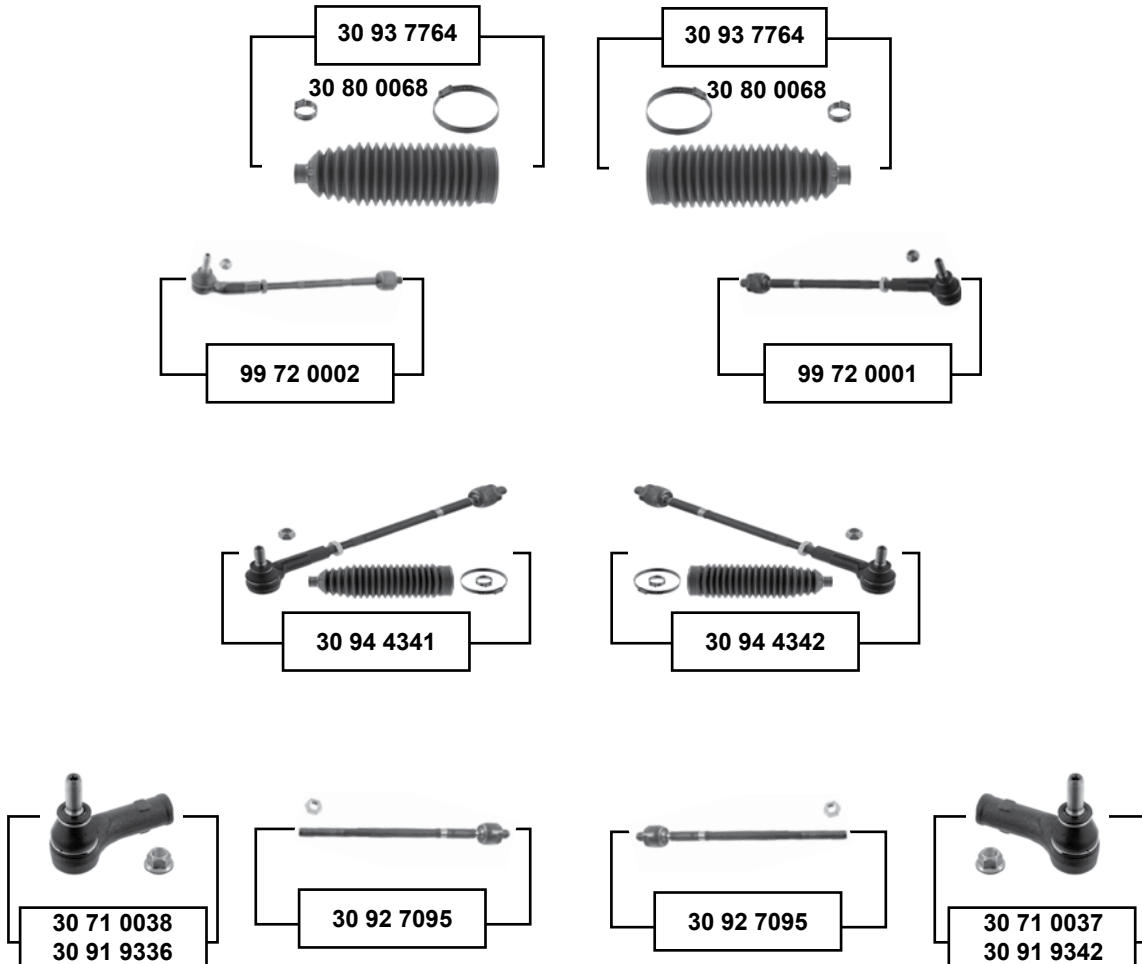

Vorderachse / Front axle



(1) ZF servo / (ex.) Cupra



Ref. - No.



SWAG Ref. - No.			
30 71 0037	1J0 422 812 B	Spurstangenendstück / tie rod end	(1)
30 71 0038	1J0 422 811 B	Spurstangenendstück / tie rod end	(1)
30 80 0068	1J0 422 831 B	Lenkmanschette / steering boot	(ex.) Cupra
30 91 9336	8N0 422 811 A	Spurstangenendstück / tie rod end	Cupra
30 91 9342	8N0 422 812 A	Spurstangenendstück / tie rod end	Cupra
30 92 7095	1J0 422 810 B	Axialgelenk / axial joint	
30 93 7764	1J0 422 831 B S1	Rep. Satz Lenkmanschette / rep. kit steering boot	
30 94 4341	1J0 422 803 H S1	Rep. Satz Spurstange / rep. kit tie rod	
30 94 4342	1J0 422 804 H S1	Rep. Satz Spurstange / rep. kit tie rod	
99 72 0001	1J0 422 804 H	Spurstange / tie rod	(ex.) Cupra
99 72 0002	1J0 422 803 H	Spurstange / tie rod	(ex.) Cupra

M14 x 1,5
M14 x 1,5

L 321

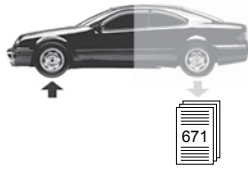

Leon (1M) (1999 → 2006)

Vorderachse / Front axle

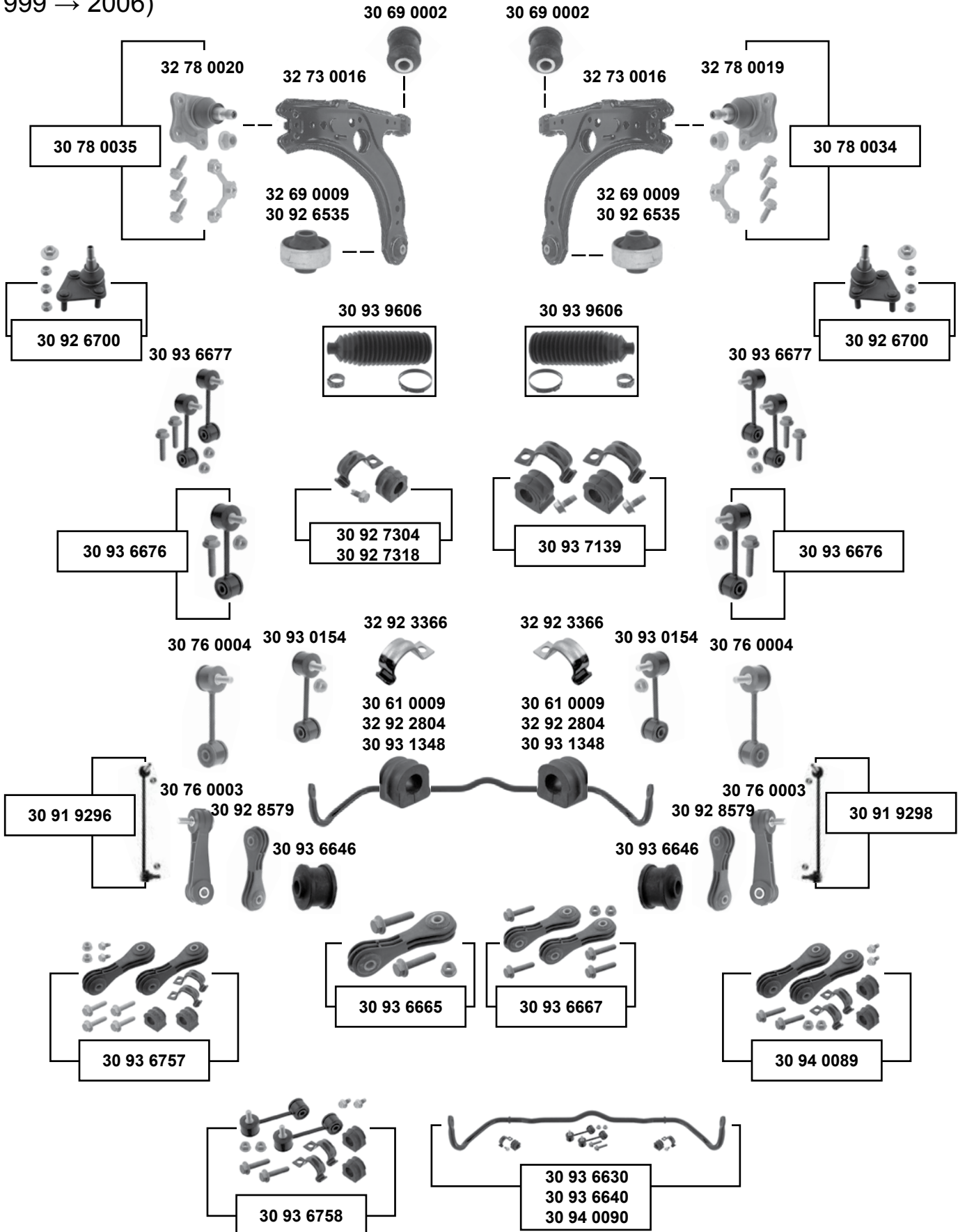

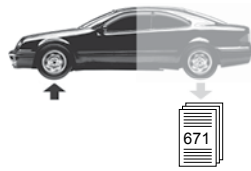

Leon (1M) (1999 → 2006)



Rep. Sätze / rep. kits

30 91 9820 30 91 9822



(1)	für/to fit Stabi Ø A 21 (ch.) → 1M-X-010 000 PR-0AE	(3)	für/to fit Stabi Ø A 23 01 → 06 (ch.) 1M-1-035 001 → (ex.) AJQ/ARY/AUE/ARL/BDE
(2)	00 → 01 (ch.) → 1M-1-035 000 02 → 04 (ch.) → 1M-4-136 650	(4)	Leon 4 00 → 06 alle /all Leon (ex. Leon 4) 02 → 06 (ex.) Ø A 23
(5)	00 → 05 / (ch.) 1M-4-136 650 →		
(6)	(ch.) 1M-1-035 001 → / PR-0AE / Ø A 23		
(7)	Ø Stabilisator / stabilizer 23 / PR- 0AE // (ch.) → 1M-4-136 650 / PR-0AS Ø Stabilisator / stabilizer 20		



Ref. - No.



Ref. - No.	Description	Notes	Dimensions
30 61 0009	1J0 411 314 T	Stabilisatorlager / stabilizer mount	Ø I 23
30 69 0002	357 407 182	Querlenkerlager / control arm mount	12x33x54
30 76 0003	1J0 411 315 J	Verbindungsstange / connecting rod	L 105
30 76 0004	1J0 411 315 G	Verbindungsstange / connecting rod	L 105
30 78 0034	1J0 407 366 H S1	Rep. Satz Traggelenk / rep. kit ball joint	(ex.) Cupra R
30 78 0035	1J0 407 365 H S1	Rep. Satz Traggelenk / rep. kit ball joint	(ex.) Cupra R
30 91 9296	1J0 411 315 D	Verbindungsstange / connecting rod	(4)
30 91 9298	1J0 411 316 D	Verbindungsstange / connecting rod	(4)
30 91 9820	1J0 407 365 H S2	Querlenker / control arm	(ex.) Cupra R
30 91 9822	1J0 407 366 H S2	Querlenker / control arm	(ex.) Cupra R
30 92 6535	8N0 407 181 B	Querlenkerlager / control arm mount	02 → 06
30 92 6700	8N0 407 365 C	Traggelenk / ball joint	Cupra R
30 92 7304	1J0 411 314 R S1	Rep. Satz Stabilisatorlagersatz / rep. kit stabilizer mount kit	(2)
30 92 7318	1J0 411 314 T S1	Rep. Satz Stabilisatorlagersatz / rep. kit stabilizer mount kit	Ø I 18
30 92 8579	1J0 411 315 K	Verbindungsstange / connecting rod	Ø I 21
30 93 0154	1J0 411 315 G S1	Verbindungsstange / connecting rod	L 105,5
30 93 1348	1J0 411 314 AC	Stabilisatorlager / stabilizer mount	L 105
30 93 6630	1J0 411 305 B S1	Rep. Satz Stabilisatorsatz / rep. kit stabilizer kit	Ø I 18
30 93 6640	1J0 411 305 E S1	Rep. Satz Stabilisatorsatz / rep. kit stabilizer kit	→ 05 (ch.) → 1M-1-035 000
30 93 6646	1J0 411 327 A	Verbindungsstangenlager / connecting rod mount	→ 05 (ch.) 1M-X-010 001 → Ø A 29
30 93 6665	1J0 411 315 K S1	Rep. Satz Verbindungsstange / rep. kit connection rod	(ch.) 1M-1-035 001 → L 105,5
30 93 6667	1J0 411 315 K S2	Verbindungsstangensatz / connecting rod set	(ch.) 1M-1-035 001 → L 105,5
30 93 6676	1J0 411 315 G S1	Rep. Satz Verbindungsstange / rep. kit connection rod	→ 05 (ch.) → 1M-1-035 000
30 93 6677	1J0 411 315 G S2	Verbindungsstange / connecting rod	→ 05 (ch.) → 1M-1-035 000
30 93 6757	1J0 411 315 G S3	Stabilisatorlagersatz / anti roll bar bush kit	→ 05 (ch.) → 1M-1-035 000
30 93 6758	1J0 411 315 G S4	Stabilisatorlagersatz / anti roll bar bush kit	Ø I 21
30 93 7139	1J0 411 314 AC S1	Stabilisatorlagersatz / anti roll bar bush kit	Ø I 21
30 93 9606	8N0 422 831 S1	Rep. Satz Lenkmanschette / rep. kit steering boot	00 → 05
30 94 0089	1J0 411 314 T S2	Stabilisatorlagersatz / anti roll bar bush kit	(6)
30 94 0090	1J0 411 305 E S2	Rep. Satz Stabilisatorsatz / rep. kit stabilizer kit	(6)
32 69 0009	1J0 407 181	Querlenkerlager / control arm mount	(ex.) Cupra R
32 73 0016	1J0 407 151 C	Querlenker / control arm	(ex.) Cupra R / 00 → 06
32 78 0019	1J0 407 366 H	Traggelenk / ball joint	13x60x41
32 78 0020	1J0 407 365 H	Traggelenk / ball joint	M12 x 1,5
32 92 2804	1J0 411 314 R	Stabilisatorlager / stabilizer mount	M12 x 1,5
32 92 3366	1J0 411 336 D	Schelle / clamp	

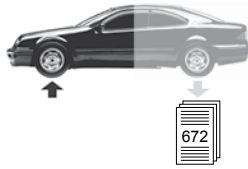

Leon (1P) (2005 →)

Vorderachse / Front axle

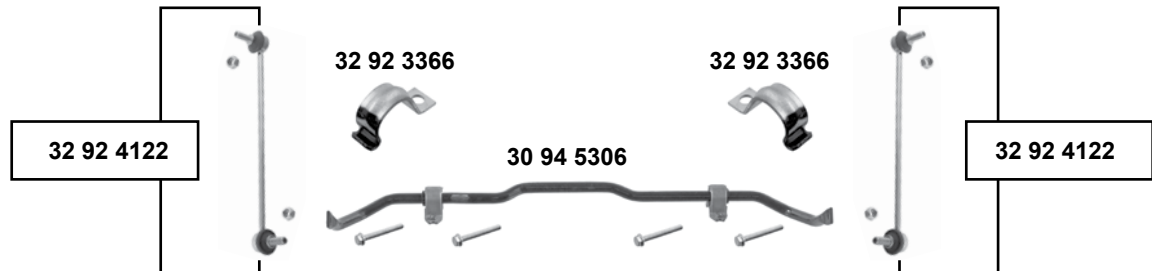
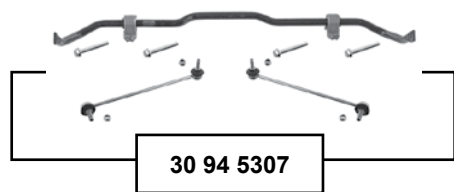
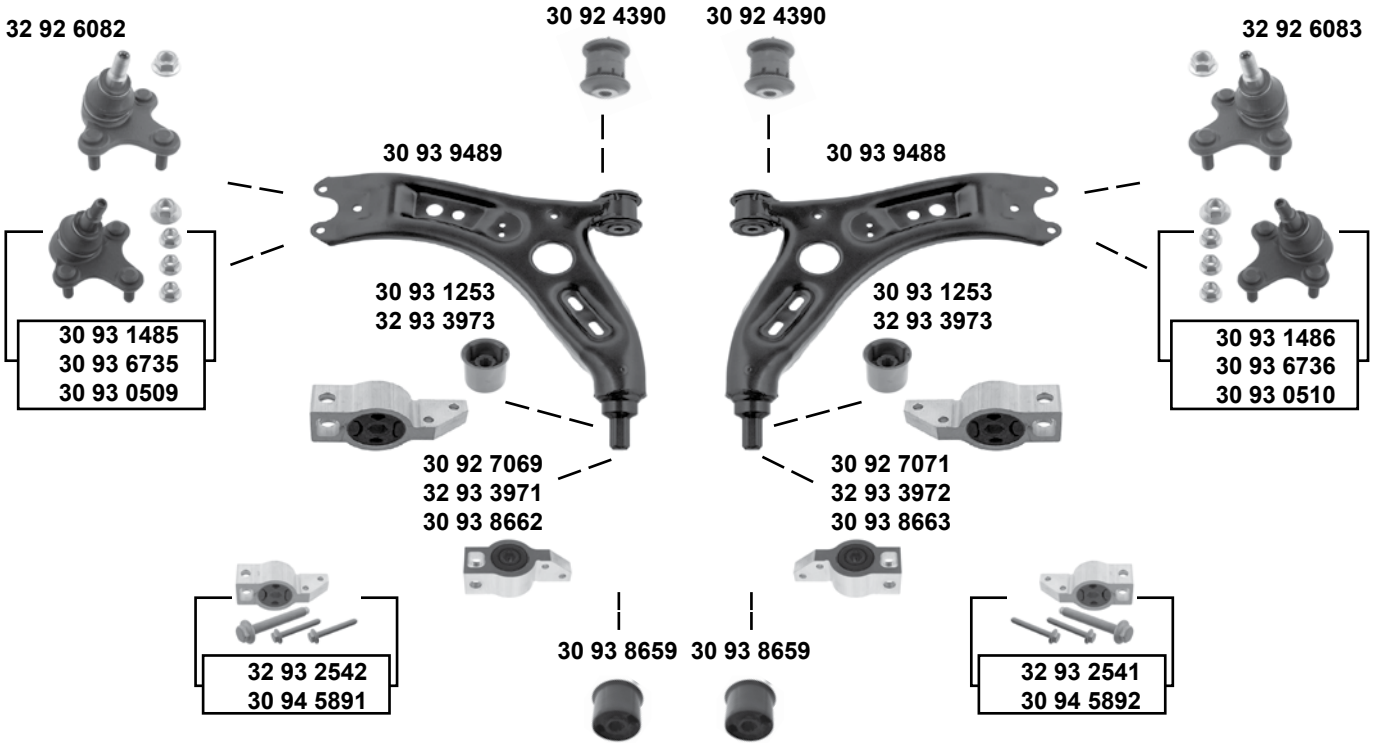

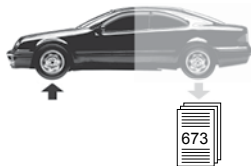

Leon (1P) (2005 →)



- (1) 06 → / PR-1LU/1LB/1LT / Scheibenbremse vorne / brake disc front
- (2) Leon / 4 (1P) 06 → (mot.) BWJ / CDLD / CDLA
- (3) 06 → / (ch.) → 3C-7-020 000
- (4) 06 → / (ch.) → 1P-6-102 599 alle / all // (ch.) 1P-6-102 599 → PR-1LU Scheibenbremse vorne / brake disc front
- (5) (ch.) → 1P-A-085 000 (mot.) BXF / BXE / BKD / BMM



Ref. - No.



SWAG Ref. - No.				
30 92 4390	1K0 407 182	Querlenkerlager / control arm mount	06 →	Ø A 48 H 54
30 92 7069	1K0 199 231 J	Querlenkerlager mit Gehäuse/ control arm mount with housing	→ 2006	
30 92 7071	1K0 199 232 J	Querlenkerlager mit Gehäuse/ control arm mount with housing	→ 2006	Ø A 63
30 93 0509	3C0 407 365 B	Rep. Satz Traggelenk / rep. kit ball joint	(4)	
30 93 0510	3C0 407 366 B	Rep. Satz Traggelenk / rep. kit ball joint	(4)	Ø A 63
30 93 1253	1K0 407 183 E	Querlenkerlager / control arm mount	06 →	
30 93 1485	3C0 407 365 A S1	Rep. Satz Traggelenk / rep. kit ball joint	(1)	Ø A 63
30 93 1486	3C0 407 366 A S1	Rep. Satz Traggelenk / rep. kit ball joint	(1)	
30 93 6735	1K0 407 365 C S1	Rep. Satz Traggelenk / rep. kit ball joint		Ø A 63
30 93 6736	1K0 407 366 C S1	Rep. Satz Traggelenk / rep. kit ball joint		
30 93 8659	1K0 407 183 G	Querlenkerlager / control arm mount	(5)	Ø A 63
30 93 8662	1K0 199 231 K	Querlenkerlager mit Gehäuse / control arm mount with housing	(5) Aluminium	
30 93 8663	1K0 199 232 K	Querlenkerlager mit Gehäuse / control arm mount with housing	(5) Aluminium	Ø A 63
30 93 9488	1K0 407 152 BC	Querlenker mit Lagern / control arm with bushes	Stahl / steel	
30 93 9489	1K0 407 151 BC	Querlenker mit Lagern / control arm with bushes	Stahl / steel	Ø A 63
30 94 5306	1K0 411 303 BK S1	Stabilisatorsatz / stabilizer kit	PR-0AD / OAE	
30 94 5307	1K0 411 303 BK S2	Rep. Satz Stabilisatorsatz / rep. kit stabilizer kit	PR-0AD / OAE	Ø A 63
30 94 5891	1K0 199 231 K S1	Rep. Satz Querlenkerlagersatz / rep. kit control arm mounting kit	(5)	
30 94 5892	1K0 199 232 K S1	Rep. Satz Querlenkerlagersatz / rep. kit control arm mounting kit	(5)	Ø A 63
32 92 3366	1J0 411 336 D	Schelle / clamp		
32 92 4122	1K0 411 315 R	Verbindungsstange / connecting rod	(3)	Ø A 63
32 92 6082	1K0 407 365 C	Traggelenk / ball joint	06 →	
32 92 6083	1K0 407 366 C	Traggelenk / ball joint	06 →	Ø A 63
32 93 2541	1K0 199 232 J S1	Rep. Satz Querlenkerlagersatz / rep. kit control arm mounting kit		
32 93 2542	1K0 199 231 J S1	Rep. Satz Querlenkerlagersatz / rep. kit control arm mounting kit		Ø A 63
32 93 3971	1K0 199 231 N	Querlenkerlager / control arm mount	(2) Aluminium	
32 93 3972	1K0 199 232 N	Querlenkerlager / control arm mount	(2) Aluminium	Ø A 63
32 93 3973	8J0 407 183	Querlenkerlager / control arm mount	(2)	

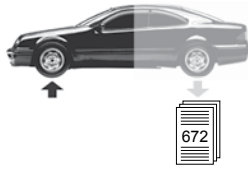

Leon (1P) (2005 →)

Vorderachse / Front axle

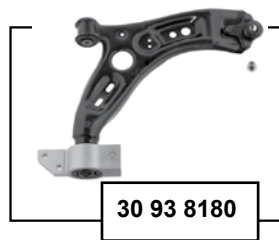
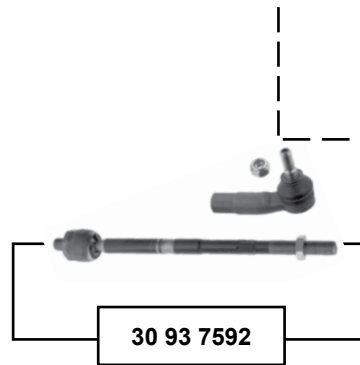
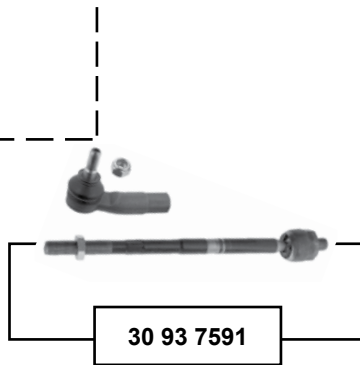
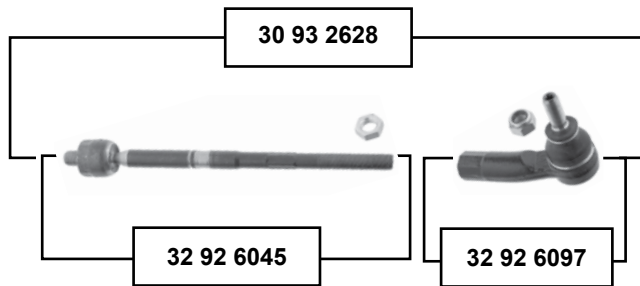
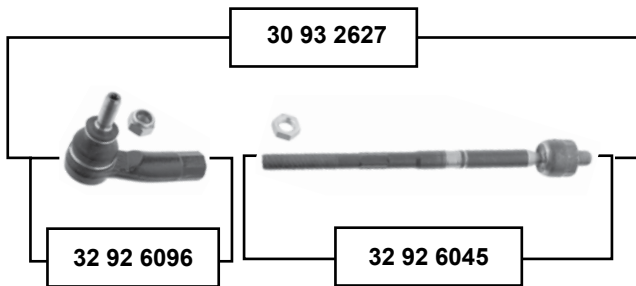
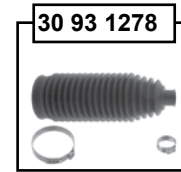
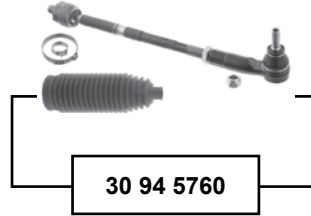
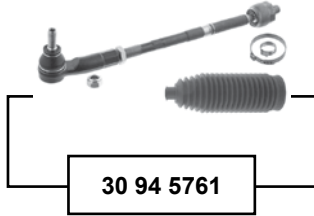

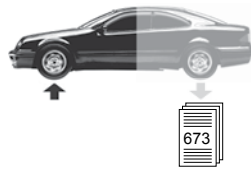
Leon (1P)
 (2005 →)



- (1) Leon / 4 (1P) 06 → 10 / → 1P-A-063 000
 Leon / 4 (1P) 11 → / PR-1N3 / PR-1N5 = E servo
- (2) PR-1N9 / (ch.) 1P-B-000 001 → / servo
- (3) → 11 PR-1N9 / servo



Ref. - No.

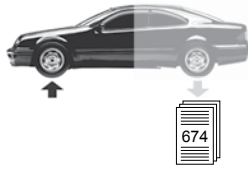

SWAG Ref. - No.				
30 93 1278	1K0 423 831 A S1	Rep. Satz Lenkmanschette / rep. kit steering boot		Ø 15,5 L190
30 93 2627	1K0 423 810 A S1	Rep. Satz Spurstange links / rep. kit tie rod left	(1)	
30 93 2628	1K0 423 810 A S2	Rep. Satz Spurstange rechts / rep. kit tie rod right	(1)	
30 93 7591	1K0 423 811 K S1	Rep. Satz Spurstange / rep. kit tie rod	(2)	L 448
30 93 7592	1K0 423 812 K S1	Rep. Satz Spurstange / rep. kit tie rod	(2)	L 448
30 93 7593	1K0 423 811 K	Spurstangenendstück / tie rod end	(3)	M16 x 1,5
30 93 7594	1K0 423 812 K	Spurstangenendstück / tie rod end	(3)	M16 x 1,5
30 93 8180	1K0 407 152 BC S1	Rep. Satz Querlenker / rep. kit control arm		Stahl / steel
30 93 8181	1K0 407 151 BC S1	Rep. Satz Querlenker / rep. kit control arm		Stahl / steel
30 94 5760	1K0 423 810 A S4	Rep. Satz Spurstange / rep. kit tie rod		PR-1N3 / PR-1N5
30 94 5761	1K0 423 810 A S3	Rep. Satz Spurstange / rep. kit tie rod		PR-1N3 / PR-1N5
32 92 6045	1K0 423 810 A	Axialgelenk / axial joint	06 →	
32 92 6096	1K0 423 811 E	Spurstangenendstück / tie rod end	06 →	
32 92 6097	1K0 423 812 E	Spurstangenendstück / tie rod end	06 →	



Leon (5F) (2012 →)

Vorderachse / Front axle

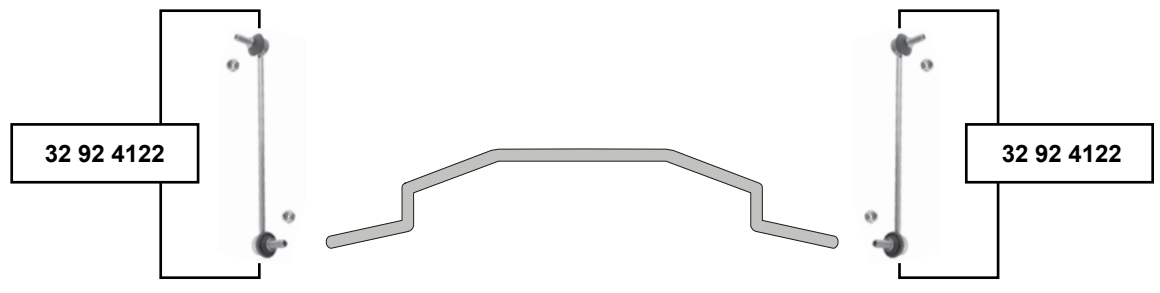
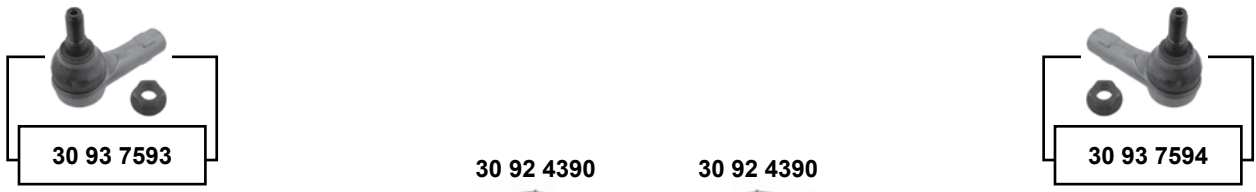
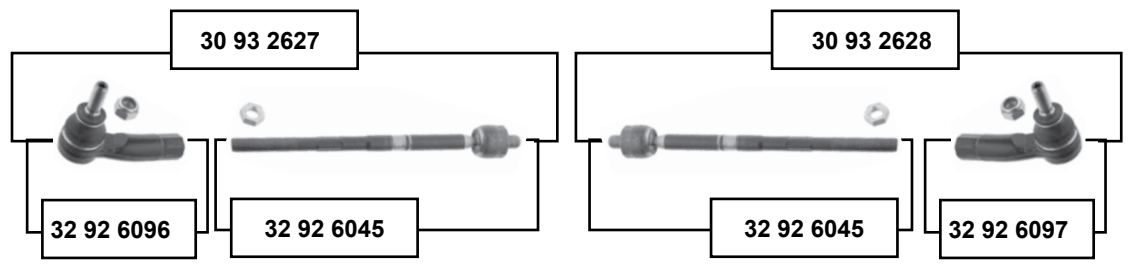
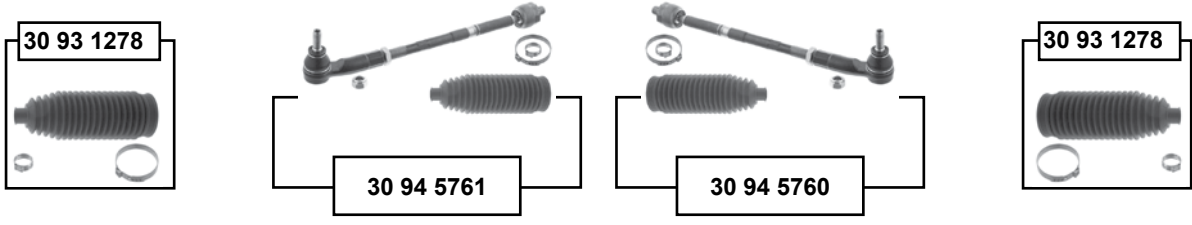

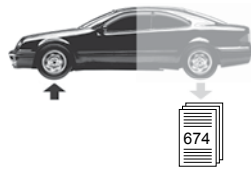
Leon (5F)
 (2012 →)



(1) für Bremsscheibendicke / for brake disk thickness 25 mm /
 für Bremsscheibendurchmesser / for brake disk diameter 288 mm

	Ref. - No.			
30 92 4390	1K0 407 182	Querlenkerlager / control arm mount		Ø A 48 H 54
30 93 1278	1K0 423 831 A S1	Rep. Satz Lenkmanschette / rep. kit steering boot		Ø I 15,5 L190
30 93 1485	3C0 407 365 A S1	Rep. Satz Traggelenk / rep. kit ball joint		
30 93 1486	3C0 407 366 A S1	Rep. Satz Traggelenk / rep. kit ball joint		
30 93 2627	1K0 423 810 A S1	Rep. Satz Spurstange / rep. kit tie rod		
30 93 2628	1K0 423 810 A S2	Rep. Satz Spurstange / rep. kit tie rod		
30 93 7593	1K0 423 811 K	Spurstangenendstück / tie rod end		M16 x 1,5
30 93 7594	1K0 423 812 K	Spurstangenendstück / tie rod end		M16 x 1,5
30 93 8403	5Q0 407 183 E	Querlenkerlager / control arm mount	PR-1ZE,1ZF,1ZA,1LG	Ø A 65
30 94 0668	5Q0 407 365 A S1	Rep. Satz Traggelenk / rep. kit ball joint	(1) PR-1ZE / 1ZP	
30 94 0669	5Q0 407 366 A S1	Rep. Satz Traggelenk / rep. kit ball joint	(1) PR-1ZE / 1ZP	
30 94 5760	1K0 423 810 A S4	Rep. Satz Spurstange / rep. kit tie rod		
30 94 5761	1K0 423 810 A S3	Rep. Satz Spurstange / rep. kit tie rod		
32 92 4122	1K0 411 315 R	Verbindungsstange / connecting rod		
32 92 6045	1K0 423 810 A	Axialgelenk / axial joint		
32 92 6096	1K0 423 811 E	Spurstangenendstück / tie rod end		
32 92 6097	1K0 423 812 E	Spurstangenendstück / tie rod end		

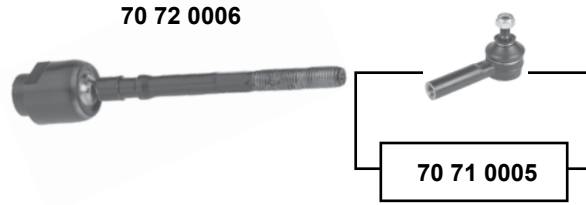
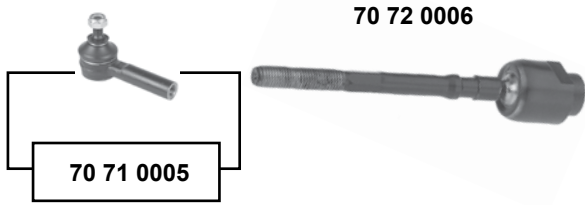

Marbella
(1990 → 1997)

Vorderachse / Front axle







99 78 0001

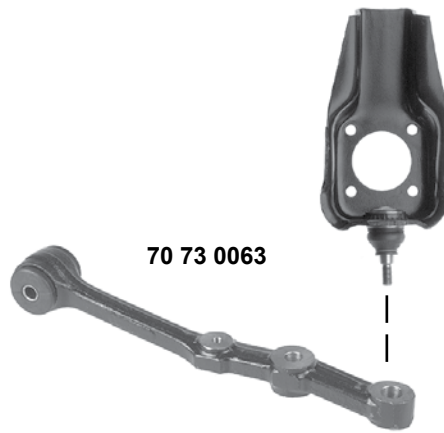

99 78 0001



	Ref. - No.			
70 71 0005	SE141162410A	Spurstangenendstück / tie rod end		M10 x 1,25
70 72 0006	SE141162449A	Spurstange / tie rod		L 280
70 73 0063	SE028156110A	Querlenker / control arm		
99 78 0001	SE028140104A	Traggelenk / ball joint		M10 x 1,25



Mii (KF) (2012 →)

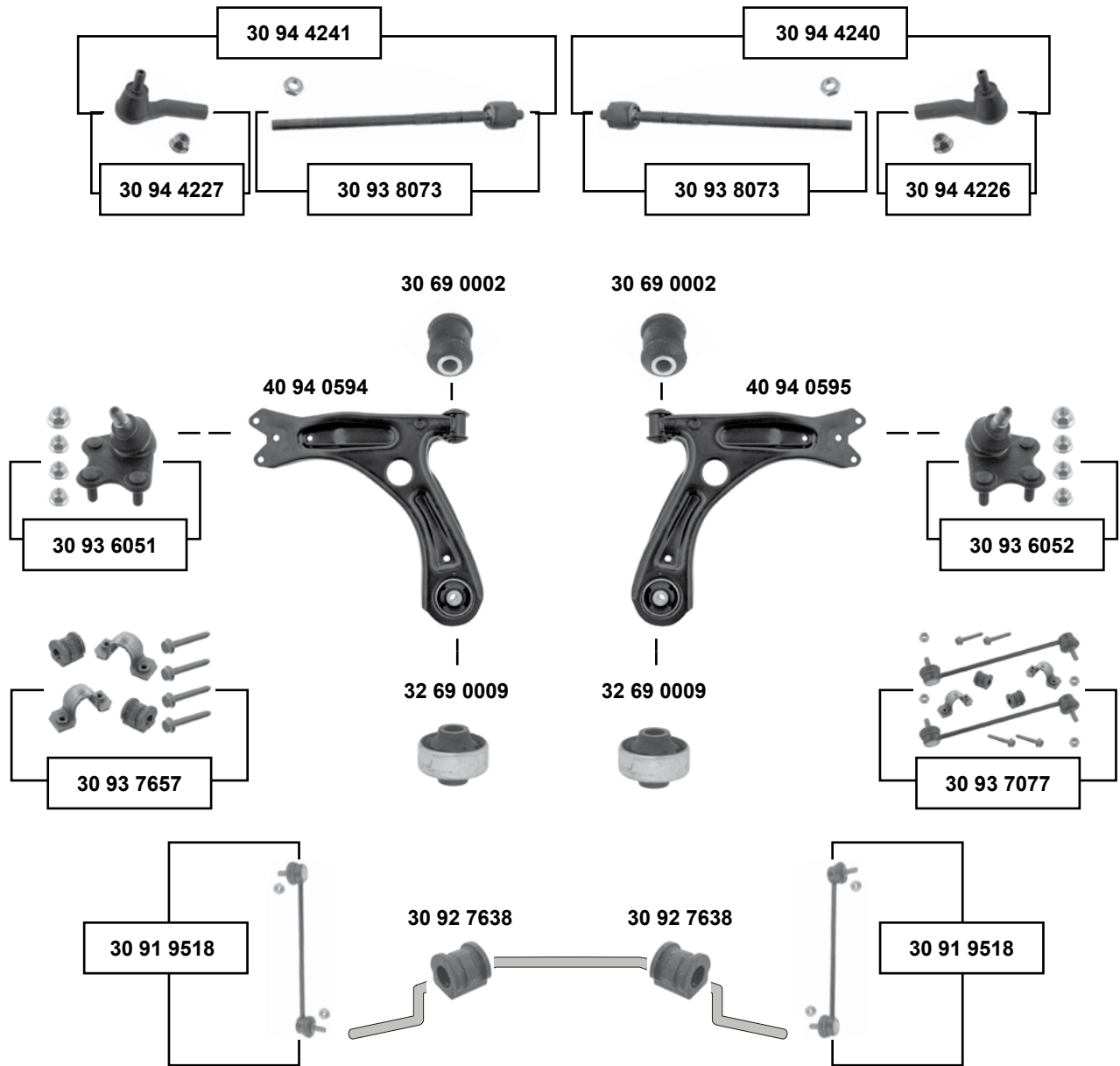

SWAG [®]	Ref. - No.			
30 69 0002	1J0 407 181	Querlenkerlager / control arm mount		Ø A 33
30 91 9518	6Q0 411 315 Q	Verbindungsstange / connecting rod		
30 92 7638	6Q0 411 314 P	Stabilisatorlager / stabilizer mount		Ø I 16
30 93 6051	6R0 407 365 A	Traggelenk / ball joint		
30 93 6052	6R0 407 366 A	Traggelenk / ball joint		
30 93 7077	6Q0 411 314 P S1	Stabilisatorlagersatz / anti roll bar bush kit	PR-0AQ	
30 93 7657	6Q0 411 314 P S2	Stabilisatorlagersatz / anti roll bar bush kit	08 → / PR-0AQ	Ø I 16
30 93 8073	1S0 423 810 A	Axialgelenk / axial joint		M14 x 1,5
30 94 4240	1S0 423 810 A S1	Spurstange / tie rod		
30 94 4241	1S0 423 810 A S2	Spurstange / tie rod		
30 94 4226	1S0 423 812 A	Spurstangenendstück / tie rod end		
30 94 4227	1S0 423 811 A	Spurstangenendstück / tie rod end		
32 69 0009	1J0 407 181	Querlenkerlager hinten / control arm mount rear		Ø A 60 Ø I 13
40 94 0594	1S0 407 151	Querlenker / control arm		Stahl / steel
40 94 0595	1S0 407 152	Querlenker / control arm		Stahl / steel



Toledo (1L)
(1993 → 1999)
(ex.) 2.0 16V

man. 

Vorderachse / Front axle

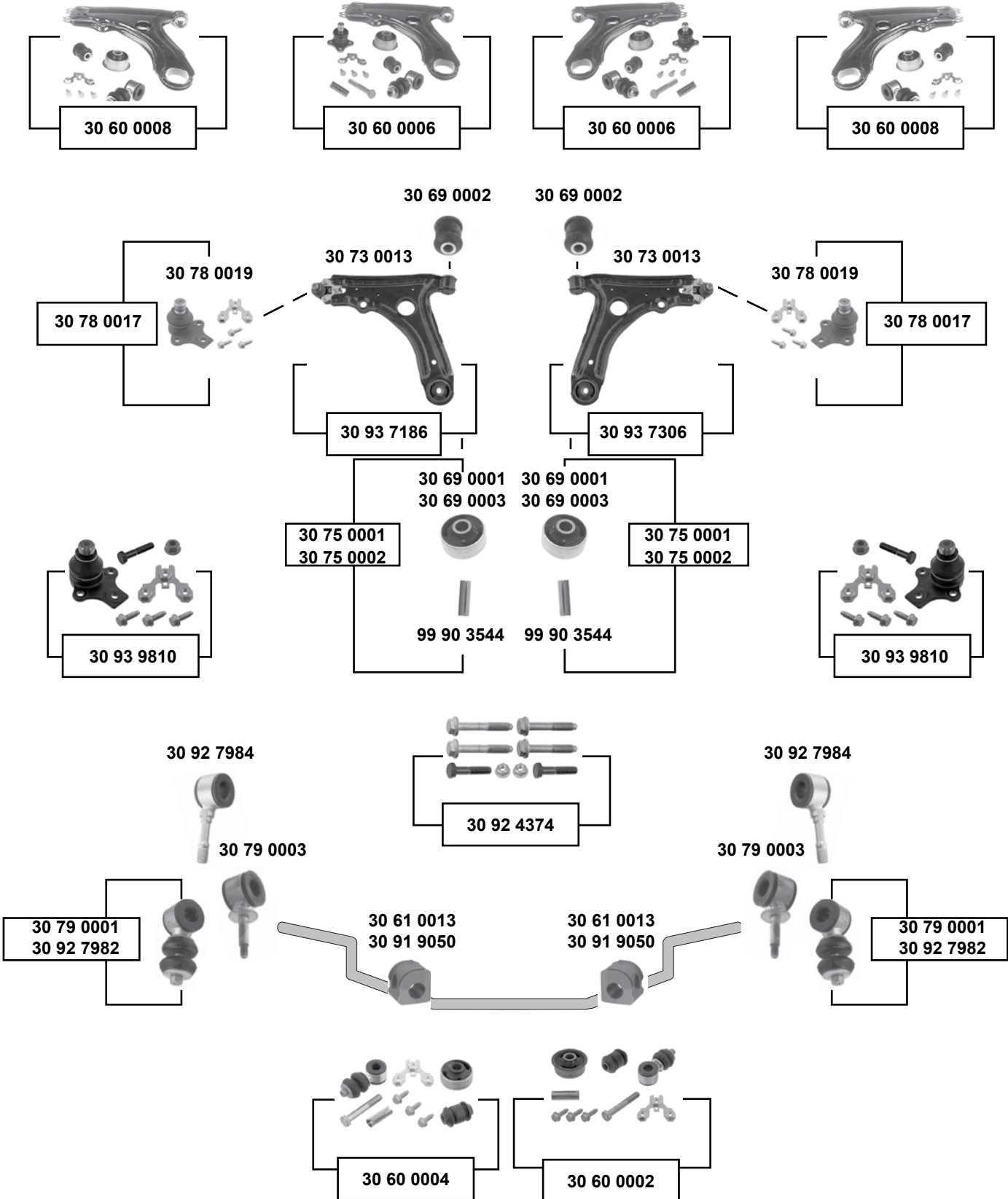

Toledo (1L)

(1993 → 1999)

(ex.) 2.0 16V



- | | | |
|-----|--------------------------------|-----------------------------------|
| (1) | (ch.) → 1L-ZD-320 000 | |
| (2) | (ch.) → 1L-VR-025 500 | alle / all |
| | (ch.) 1L-VR-025 501 → | 1.6 (55KW) / 1.8 / 1.9 D / 1.9 TD |
| (3) | (ch.) 1L-VR-025 501 → | 1.6 (74KW) / 1,9 TDi |
| (4) | 97 → 99 (ch.) 1L-VR025 501 → | |
| (5) | → 12/1994 (ch.) → 1L-ZD320 000 | |



Ref. - No.



30 60 0002	191 407 153 S1	Montagesatz / mounting kit	(5)	
30 60 0004	191 407 153 S2	Montagesatz / mounting kit	→ 12/1994	
30 60 0006	191 407 153 A S3	Rep. Satz Querlenker / rep. kit control arm		
30 60 0008	191 407 153 A S2	Rep. Satz Querlenker / rep. kit control arm	→ 12/1994	
30 61 0013	191 411 314	Stabilisatorlager / stabilizer mount	(2)	Ø I 17
30 69 0001	191 407 181 D	Querlenkerlager / control arm mount	NEW	17x60x41
30 69 0002	357 407 182	Querlenkerlager / control arm mount	(ex.) Cupra R	12x33x54
30 69 0003	191 407 181 B	Querlenkerlager / control arm mount	OLD	17x60x41
30 73 0013	191 407 151 B	Querlenker mit Gummilager / control arm incl. rubber mounts		
30 75 0001	191 407 181 B S1	Querlenkerlager mit Hülse / control arm mount with sleeve	OLD	
30 75 0002	191 407 181 D S1	Querlenkerlager mit Hülse / control arm mount with sleeve	NEW	
30 78 0017	357 407 365 S1	Rep. Satz Traggelenk / rep. kit ball joint		
30 78 0019	357 407 365	Traggelenk / ball joint		Ø A 19
30 79 0001	191 411 315 B S1	Rep. Satz Verbindungsstange / rep. kit connecting rod	(1) 92 → 96	
30 79 0003	191 411 315 B	Verbindungsstange / connecting rod	(1)	
30 91 9050	1H0 411 314	Stabilisatorlager / stabilizer mount	(3)	Ø I 19
30 92 4374	N 904 840 03 S2	Rep. Satz Schraube / rep. kit screw		
30 92 7982	6K0 411 315 S1	Verbindungsstange / connecting rod	(4)	Ø I 19
30 92 7984	6K0 411 315	Verbindungsstange / connecting rod	(4)	Ø I 19
30 93 7186	191 407 151 B S1	Rep. Satz Querlenker / rep. kit control arm		
30 93 7306	191 407 151 B S2	Rep. Satz Querlenker / rep. kit control arm		
30 93 9810	357 407 365 S2	Rep. Satz Traggelenk / rep. kit ball joint		
99 90 3544	191 407 190 A	Hülse / sleeve		50x17



Toledo (1L)
(1993 → 1999)

man.

Vorderachse / Front axle

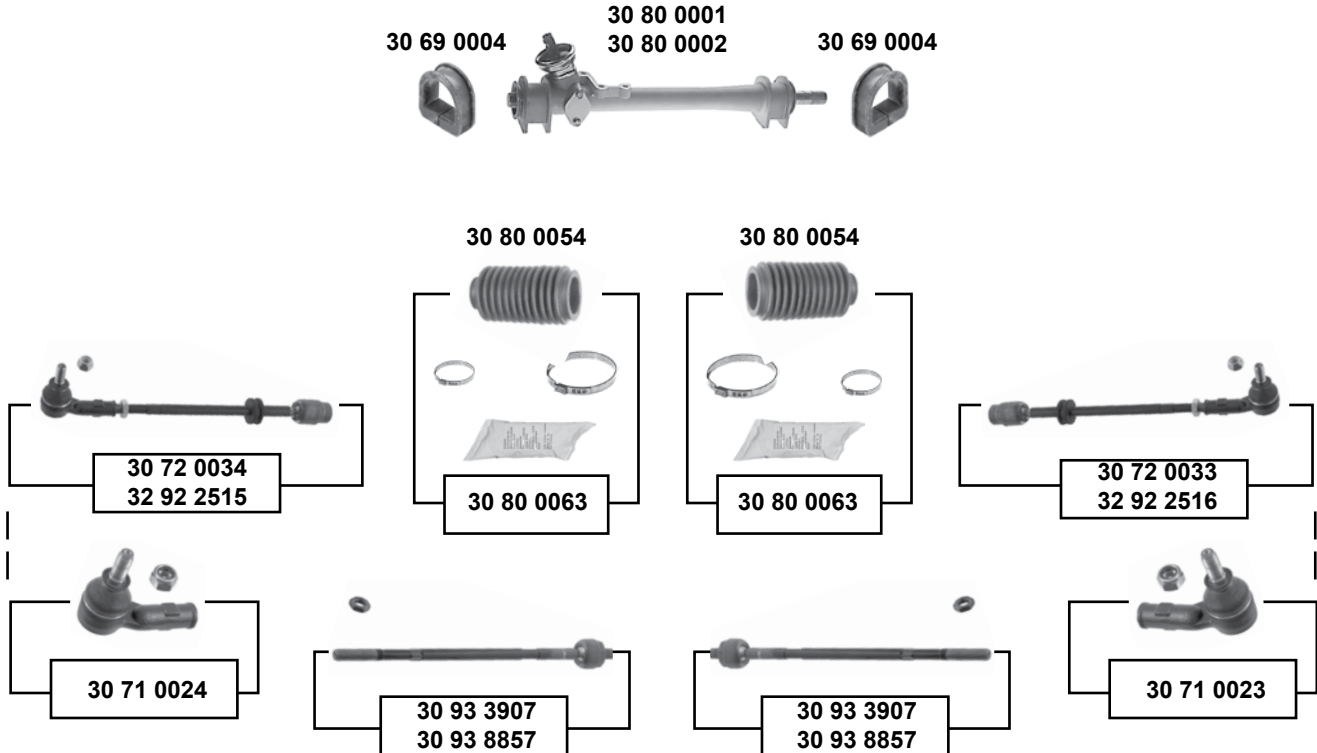

- (1) servo (mot.) 1Z (ch.) → 1L-ZD073752
servo (mot.) 1F/1Y/2E/AAZ/ABN/ABS/ADZ/EZ/PL/RP (ch.) 1L-ZD307000 → 1L-ZD073752
- (2) 92 → 96 = → 1L-TR016 347 (mot.) alle/all
97 → = → 1L-VR003 794 (mot.) ABF
- (3) 92 (ch.) → 1L-ZD307 000
- (4) servo (ch.) → 1-LTR-016347 / → 1-LZD-307000



Ref. - No.



Ref. - No.	Description	Notes	Dimensions
30 69 0004	191 419 883 Lenkgetriebelager / steering gear bearing		
30 71 0023	191 419 812 Spurstangenendstück / tie rod end	(2)	M12 x 1,5
30 71 0024	191 419 811 Spurstangenendstück / tie rod end	(2)	M12 x 1,5
30 72 0033	191 419 804 Spurstange / tie rod		
30 72 0034	191 419 803 Spurstange / tie rod		
30 80 0001	191 419 063 C Lenkgetriebe / steering gear	LHD (ch.) 1L-ZD073 753 →	
30 80 0002	191 419 063 B Lenkgetriebe / steering gear	LHD (ch.) → 1L-ZD073 752	
30 80 0054	191 419 831 Lenkmanschette / steering boot		
30 80 0063	191 419 831 S1 Rep. Satz Lenkmanschette / rep. kit steering boot		
30 93 3907	191 407 151 B S1 Axialgelenk / axial joint	(3)	
30 93 8857	6K0 422 810 Axialgelenk / axial joint	(4)	
32 92 2515	6K0 422 803 Spurstange / tie rod	(1)	
32 92 2516	6K0 422 804 Spurstange / tie rod	(1)	



Toledo (1L)

(1993 → 1999)
(ex.) 2.0 16V

servo

(ch.) → 1L-ZD307 000

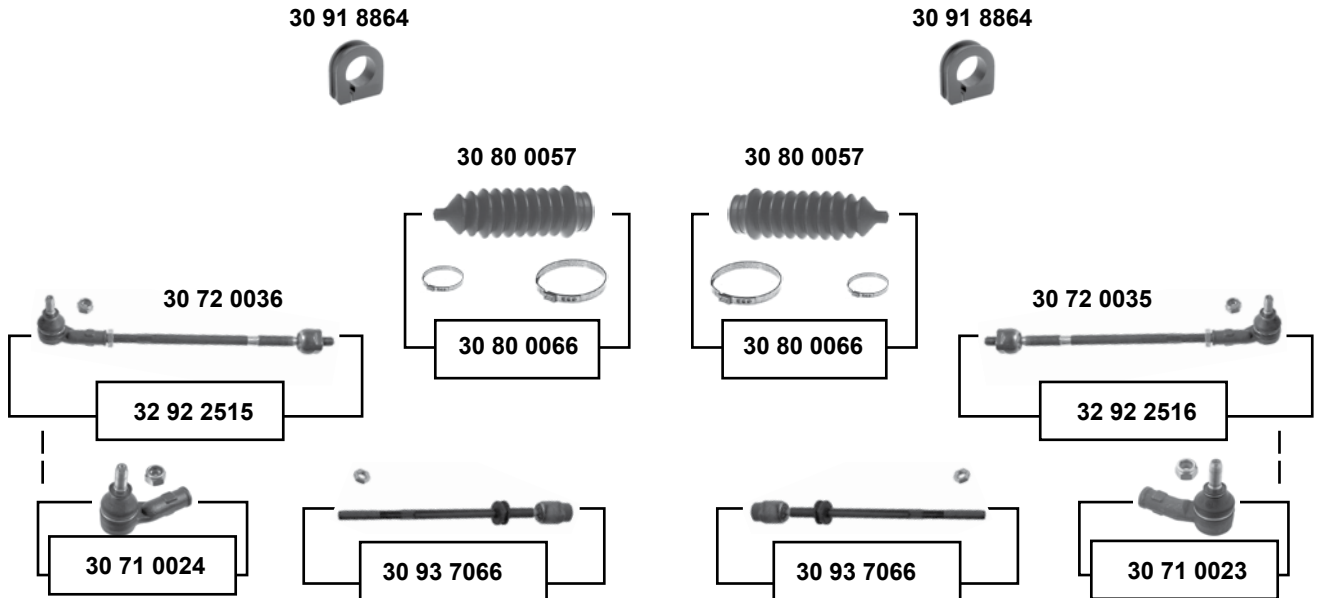

(ch.) 1L-ZD307 001 →

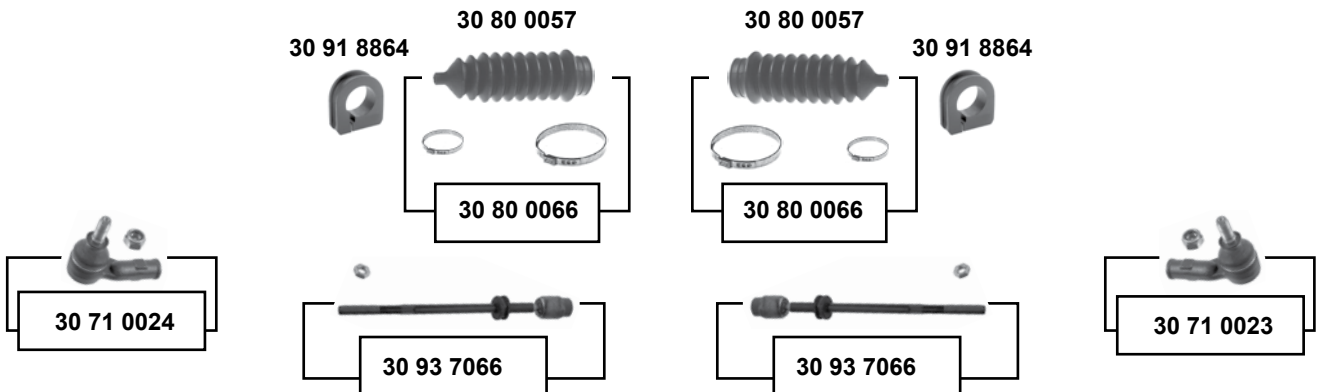

Vorderachse / Front axle

SWAG	Ref. - No.			
30 71 0023	191 419 812	Spurstangenendstück / tie rod end		M12 x 1,5
30 71 0024	191 419 811	Spurstangenendstück / tie rod end		M12 x 1,5
30 72 0035	191 422 804 A	Spurstange / tie rod		
30 72 0036	191 422 803 A	Spurstange / tie rod		
30 80 0057	1H0 422 831 B	Lenkmanschette / steering boot		
30 80 0066	1H0 422 831 B S1	Rep. Satz Lenkmanschette / rep. kit steering boot		
30 91 8864	1H0 422 884	Lenkgetriebebelager / steering gear bearing		
30 93 7066	191 419 810	Axialgelenk / axial joint		M12x1,5
32 92 2515	6K0 422 803	Spurstange / tie rod		
32 92 2516	6K0 422 804	Spurstange / tie rod		



SEAT

Toledo (1L)

(1993 → 1999)

(ex.) 2.0 16V

servo

Vorderachse / Front axle

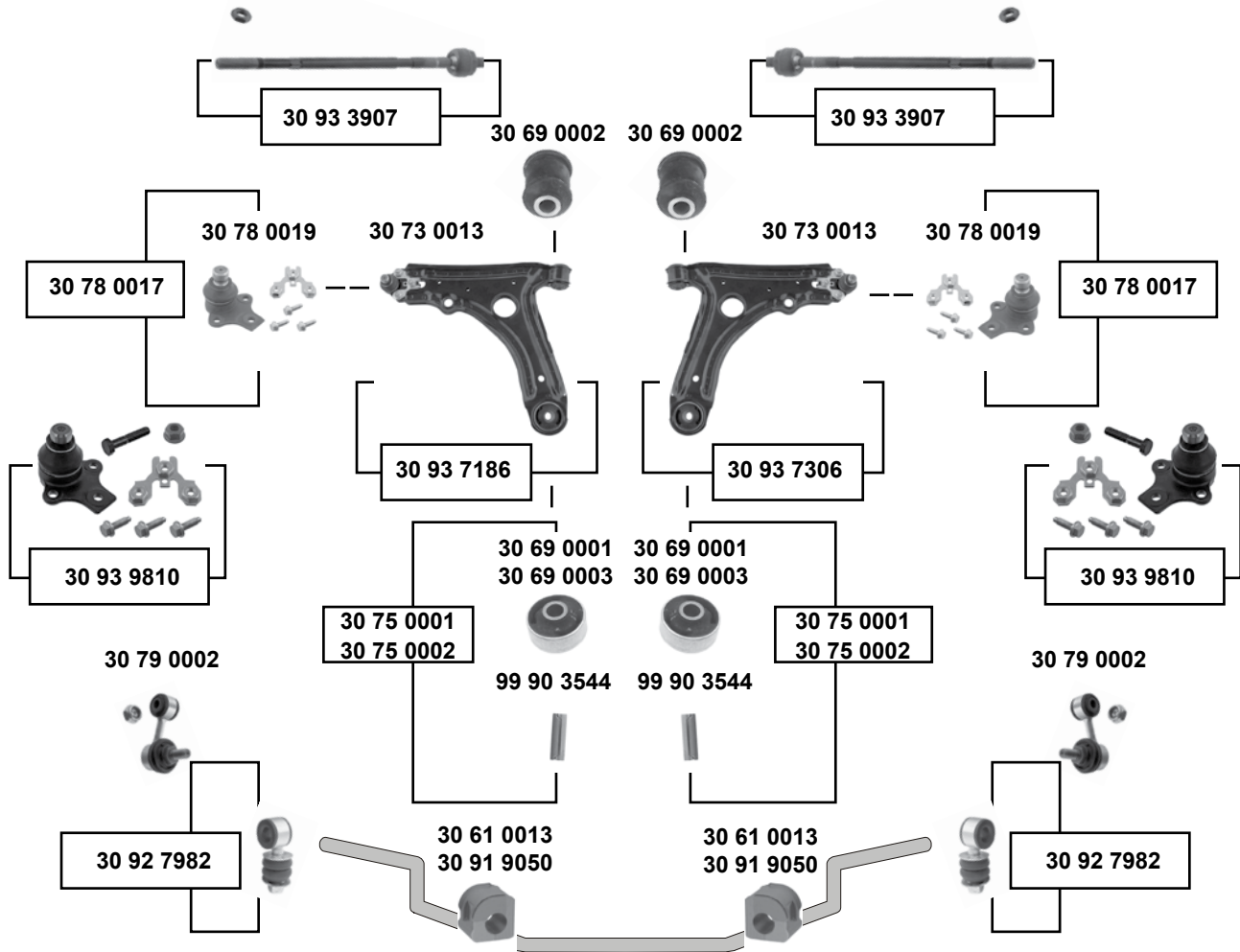

- (1) (ch.) → 1L-VR-025500 **alle / all / (ch.)** 1L-VR-025501 → 1.6 (55KW) / 1.8 / 1.9 D / 1.9 TD
- (2) (ch.) 1L-VR-025501 → 1.6 (74KW) / 1,9 TDi

	Ref. - No.			
30 61 0013	191 411 314	Stabilisatorlager / stabilizer mount	(1)	Ø I 17
30 69 0001	191 407 181 D	Querlenkerlager / control arm mount	NEW	17x60x41
30 69 0002	357 407 182	Querlenkerlager / control arm mount	OLD	12x33x54
30 69 0003	191 407 181 B	Querlenkerlager / control arm mount	OLD	17x60x41
30 73 0013	191 407 151 B	Querlenker mit Gummilager / control arm incl. rubber mounts	OLD	
30 75 0001	191 407 181 B S1	Querlenkerlager mit Hülse / control arm mount with sleeve	NEW	
30 75 0002	191 407 181 D S1	Querlenkerlager mit Hülse / control arm mount with sleeve		
30 78 0017	357 407 365 S1	Rep. Satz Traggelenk / rep. kit ball joint		
30 78 0019	357 407 365	Traggelenk / ball joint		Ø A 19
30 79 0002	535 411 315	Verbindungsstange / connecting rod	2,0 16V	L 55
30 91 9050	1H0 411 314	Stabilisatorlager / stabilizer mount	(2)	Ø I 19
30 92 7982	6K0 411 315 S1	Verbindungsstange / connecting rod	(1)	Ø I 16,5
30 93 3907	191 422 810 A	Axialgelenk / axial joint	92 → 1L-ZD307 000	
30 93 7186	191 407 151 B S1	Rep. Satz Querlenker / rep. kit control arm		
30 93 7306	191 407 151 B S2	Rep. Satz Querlenker / rep. kit control arm		
30 93 9810	357 407 365 S2	Rep. Satz Traggelenk / rep. kit ball joint		
99 90 3544	191 407 190 A	Hülse / sleeve		50x17



Toledo (1L) (1993 → 1999) 2.0 16V

(ch.) → 1L-VR003 794

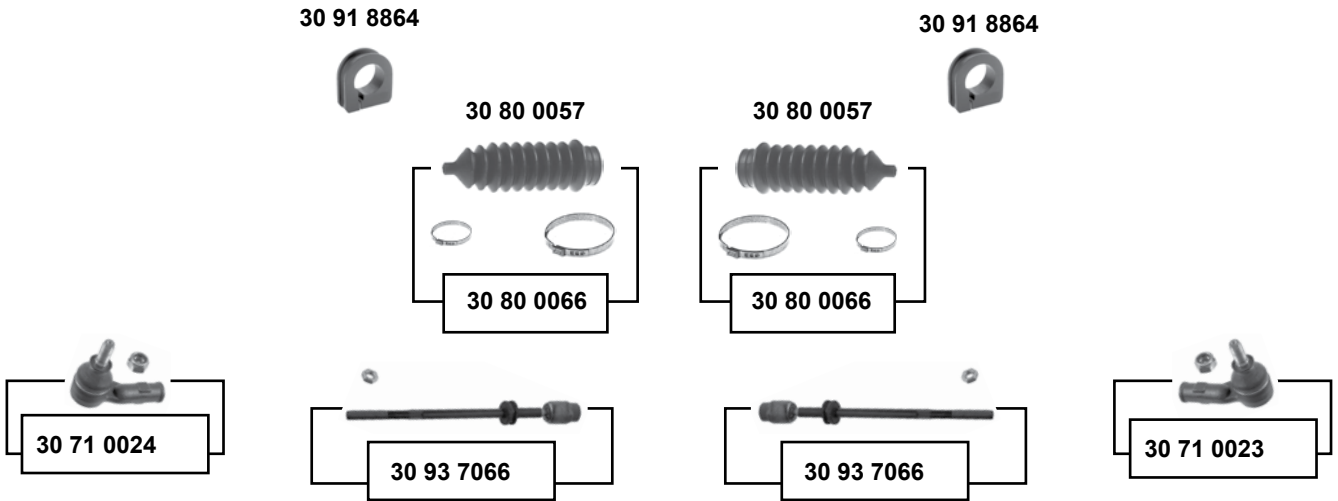

Vorderachse / Front axle

(ch.) 1L-VR003 795 →

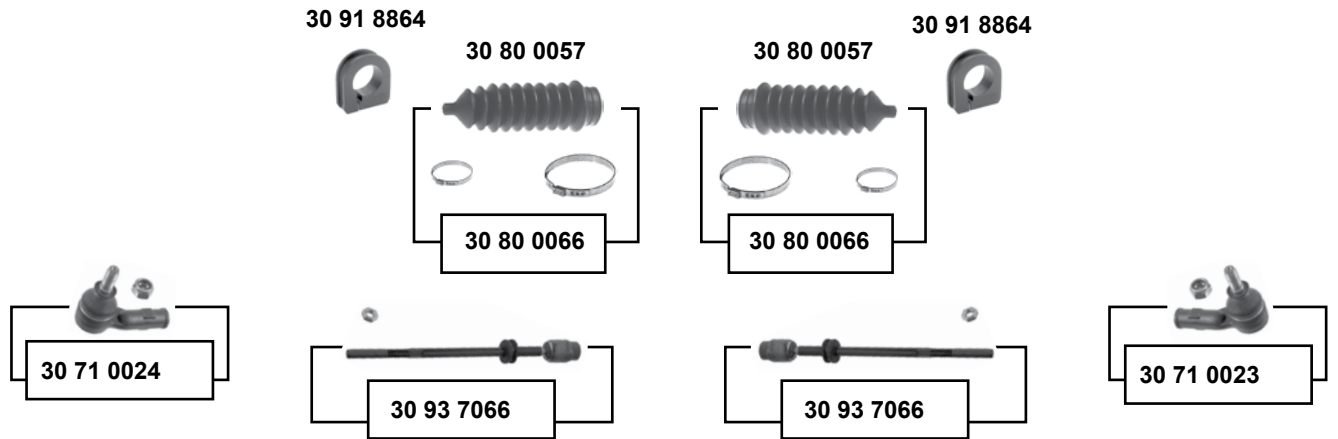

SWAG [®]	Ref. - No.			
30 71 0023	191 419 812	Spurstangenendstück / tie rod end		M12 x 1,5
30 71 0024	191 419 811	Spurstangenendstück / tie rod end		M12 x 1,5
30 80 0057	1H0 422 831 B	Lenkmanschette / steering boot		
30 80 0066	1H0 422 831 B S1	Rep. Satz Lenkmanschette / rep. kit steering boot		
30 91 8864	1H0 422 884	Lenkgetriebelager / steering gear bearing		
30 93 7066	191 419 810	Axialgelenk / axial joint		M12 x 1,5



SEAT

Toledo (1L) (1991 → 1999) 2.0 16V

Vorderachse / Front axle

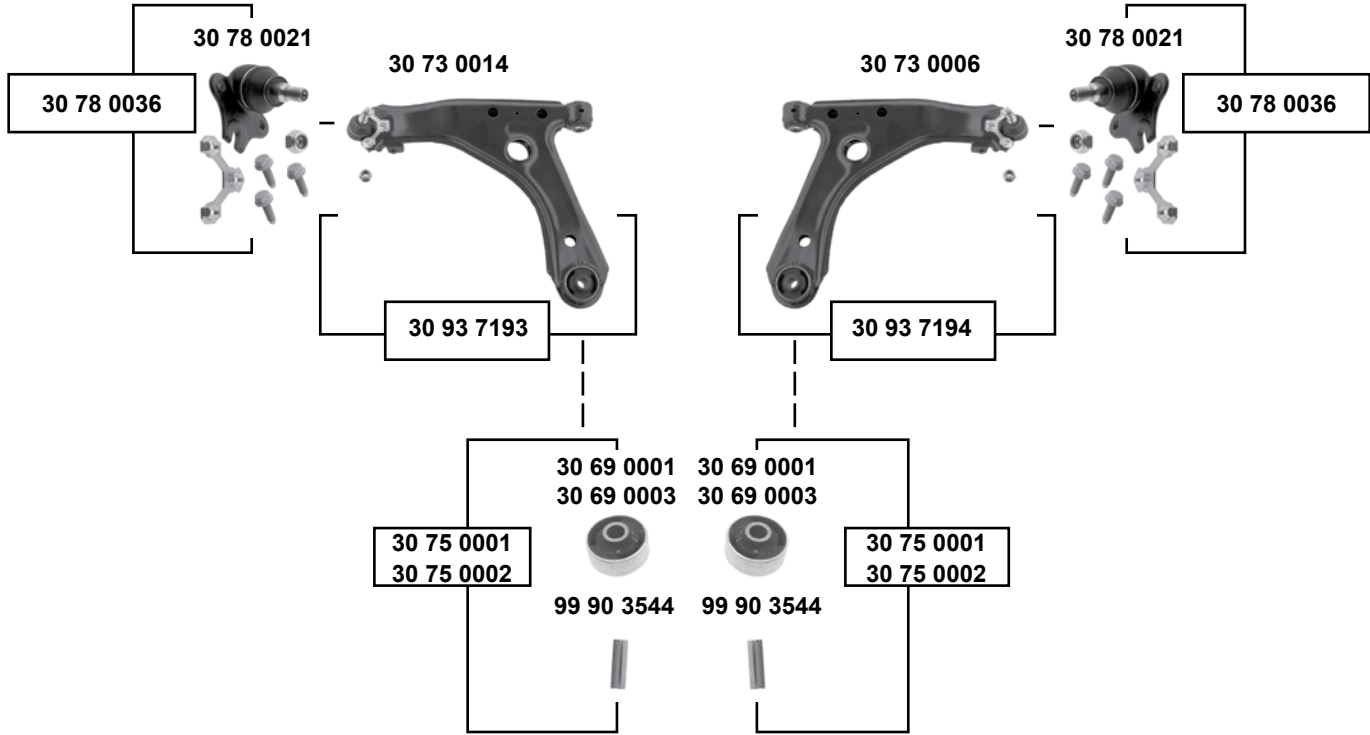

SWAG GERMANY	Ref. - No.			
30 69 0001	191 407 181 D	Querlenkerlager / control arm mount	NEW	12x33x54
30 69 0003	191 407 181 B	Querlenkerlager / control arm mount	OLD	17x60x41
30 73 0006	1H0 407 152	Querlenker / control arm		
30 73 0014	1H0 407 151 A	Querlenker / control arm		
30 75 0001	191 407 181 B S1	Querlenkerlager mit Hülse / control arm mount with sleeve	OLD	
30 75 0002	191 407 181 D S1	Querlenkerlager mit Hülse / control arm mount with sleeve	NEW	
30 78 0021	1H0 407 365	Traggelenk / ball joint		M12 x 1,5
30 78 0036	1H0 407 365 S1	Rep. Satz Traggelenk / rep. kit ball joint		
30 79 0002	535 411 315	Verbindungsstange / connecting rod		
30 91 9050	1H0 411 314	Stabilisatorlager / stabilizer mount	(ch.) 1L-VR 025 501 → Ø 1 19	
30 93 7193	1H0 407 151 A S1	Querlenker mit Traggelenk / control arm with ball joint	94 → 98	
30 93 7194	1H0 407 152 S1	Querlenker mit Traggelenk / control arm with ball joint	94 → 98	
99 90 3544	191 407 190 A	Hülse / sleeve		50x17



Toledo (1M) (2000 → 2006)

Vorderachse / Front axle

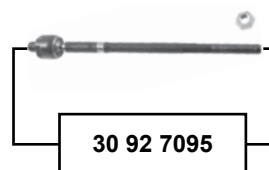
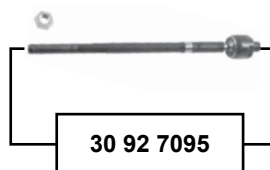
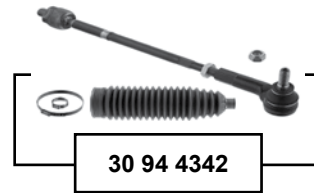
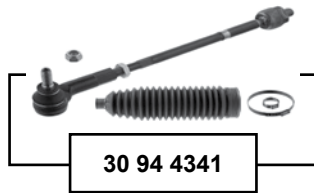
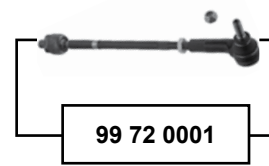
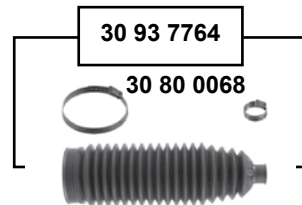
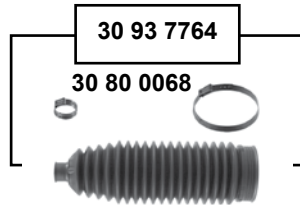

SWAG	Ref. - No.			
30 71 0037	1J0 422 812 B	Spurstangenendstück / tie rod end	ZF	M14 x 1,5
30 71 0038	1J0 422 811 B	Spurstangenendstück / tie rod end	ZF	M14 x 1,5
30 80 0068	1J0 422 831 B	Lenkmanschette / steering boot		
30 92 7095	1J0 422 810 B	Axialgelenk / axial joint		L 321
30 93 7764	1J0 422 831 B S1	Rep. Satz Lenkmanschette / rep. kit steering boot		
30 94 4341	1J0 422 803 H S1	Rep. Satz Spurstange / rep. kit tie rod		
30 94 4342	1J0 422 804 H S1	Rep. Satz Spurstange / rep. kit tie rod		
99 72 0001	1J0 422 804 H	Spurstange / tie rod	ZF servo	
99 72 0002	1J0 422 803 H	Spurstange / tie rod	ZF servo	



Toledo (1M) (2000 → 2006)

Vorderachse / Front axle

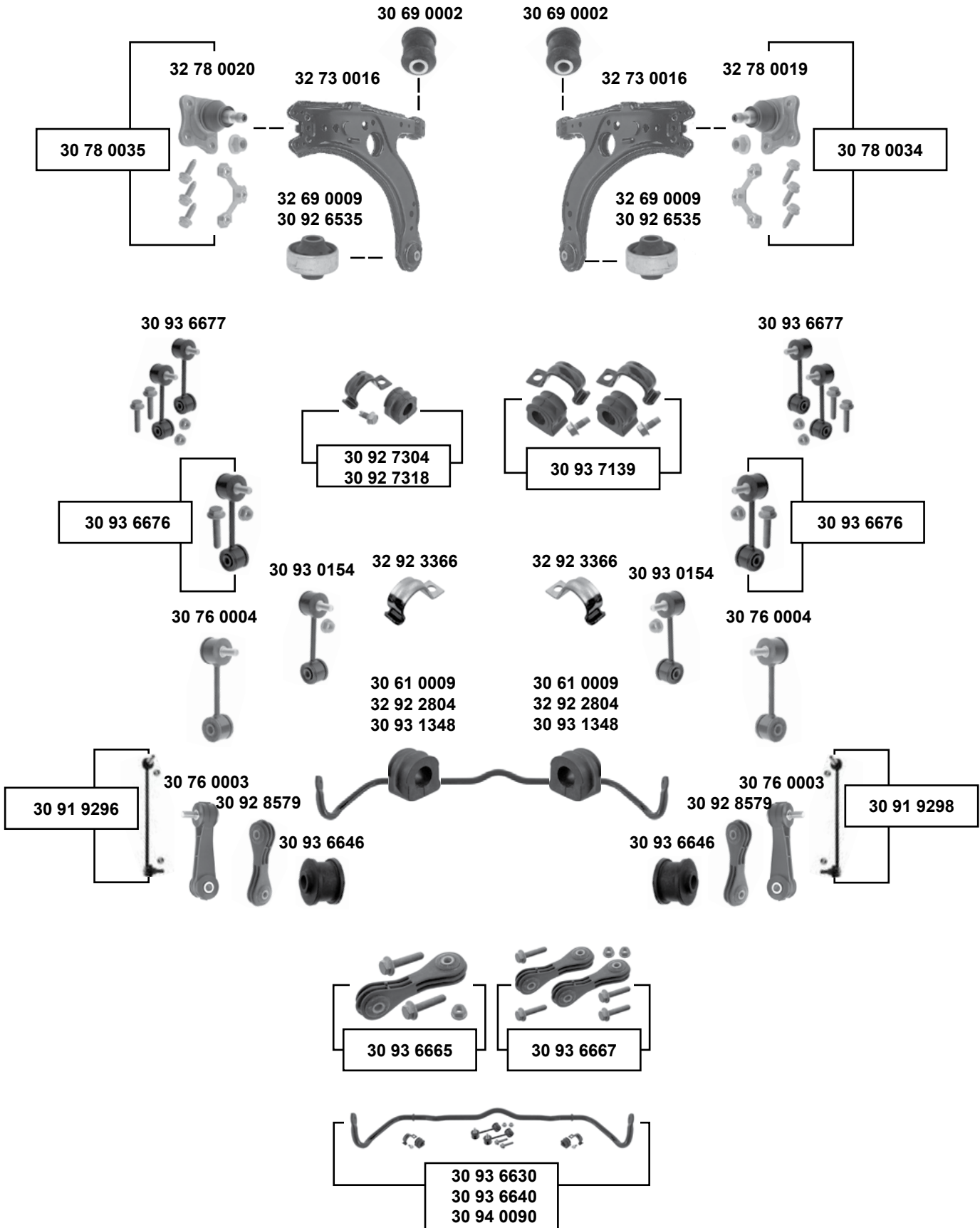



Toledo (1M) (2000 → 2006)

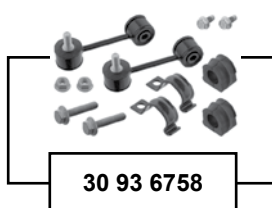
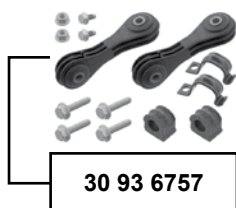

Rep. Sätze / rep. kits

30 91 9820 30 91 9822



(1) (ch.) → 1M-4-136650 / Stabi Ø A 21 alle / all	(2) → 05 (ch.) → 1M-1-035000
(3) für/to fit Stabi Ø A 23 01 → 06 (ch.) 1M-1-035001 → (ex.) AJQ/ARY/AUE/ARL/BDE	
(4) 2002 → 2004 (ex.) Stabi Ø A 23	
(5) 99 → 01 (ch.) → 1M-1-035 000 / 02 → 04 (ch.) → 1M-4-136 650	
(6) (ch.) 1M-1-035 001 → / PR-OAE / Ø A 23	(7) (ch.) → 1M-X-010 000 PR-OAE



Ref. - No.



Ref. - No.	Description	Notes	Dimensions
30 61 0009	1J0 411 314 T Stabilisatorlager / stabilizer mount		Ø I 23
30 69 0002	357 407 182 Querlenkerlager / control arm mount	(ex.) Cupra R	12x33x54
30 76 0003	1J0 411 315 J Verbindungsstange / connecting rod	(2)	L 105
30 76 0004	1J0 411 315 G Verbindungsstange / connecting rod	(7) Stabi Ø A 23	L 105
30 78 0034	1J0 407 366 M S1 Rep. Satz Traggelenk / rep. kit ball joint		
30 78 0035	1J0 407 365 M S1 Rep. Satz Traggelenk / rep. kit ball joint		
30 91 9296	1J0 411 315 D Verbindungsstange / connecting rod	(4)	
30 91 9298	1J0 411 316 D Verbindungsstange / connecting rod	(4)	
30 91 9820	1J0 407 365 H S2 Querlenker, kpl. / control arm, cpl.	99 → 01	
30 91 9822	1J0 407 366 H S2 Querlenker, kpl. / control arm, cpl.	99 → 01	
30 92 6535	8N0 407 181 B Querlenkerlager / control arm mount	02 → 06	13x60x41
30 92 7304	1J0 411 314 R S1 Rep. Satz Stabilisatorlagersatz / rep. kit stabilizer mount kit	(5)	Ø I 18
30 92 7318	1J0 411 314 T S1 Rep. Satz Stabilisatorlagersatz / rep. kit stabilizer mount kit		Ø I 21
30 92 8579	1J0 411 315 K Verbindungsstange / connecting rod	(3)	L 105,5
30 93 0154	1J0 411 315 G S1 Verbindungsstange / connecting rod	(2)	L 105 / M10
30 93 1348	1J0 411 314 AC Stabilisatorlager / stabilizer mount	00 → 04	Ø I 18
30 93 6630	1J0 411 305 B S1 Rep. Satz Stabilisatorsatz / rep. kit stabilizer kit	→ 05 (ch.) → 1M-1-035000	
30 93 6640	1J0 411 305 E S1 Rep. Satz Stabilisatorsatz / rep. kit stabilizer kit		
30 93 6646	1J0 411 327 A Verbindungsstangenlager / connecting rod mount	→ 05 (ch.) 1M-X-010001→	Ø A 29
30 93 6665	1J0 411 315 K S1 Rep. Satz Verbindungsstange / rep. kit connection rod	(ch.) 1M-1-035 001→	L 105,5
30 93 6667	1J0 411 315 K S2 Verbindungsstangensatz / connecting rod set	(ch.) 1M-1-035 001→	L 105,5
30 93 6676	1J0 411 315 G S1 Rep. Satz Verbindungsstange / rep. kit connecting rod	(2)	
30 93 6677	1J0 411 315 G S2 Verbindungsstange / connecting rod	(2)	
30 93 6757	1J0 411 315 G S3 Stabilisatorlagersatz / anti roll bar bush kit	→ 05 (ch.) → 1M-1-035000	Ø I 21
30 93 6758	1J0 411 315 G S4 Stabilisatorlagersatz / anti roll bar bush kit		Ø I 21
30 93 7139	1J0 411 314 AC S1 Stabilisatorlagersatz / anti roll bar bush kit	00 → 05	
30 94 0089	1J0 411 314 T S2 Stabilisatorlagersatz / anti roll bar bush kit	(6)	
30 94 0090	1J0 411 305 E S2 Rep. Satz Stabilisatorsatz / rep. kit stabilizer kit	(6)	
32 69 0009	1J0 407 181 Querlenkerlager / control arm mount	(ex.) Cupra R / 99 → 04	13x60
32 73 0016	1J0 407 151 C Querlenker / control arm	(ex.) Cupra R / 99 → 04	
32 78 0019	1J0 407 366 H Traggelenk / ball joint		M12 x 1,5
32 78 0020	1J0 407 365 H Traggelenk / ball joint		M12 x 1,5
32 92 2804	1J0 411 314 R Stabilisatorlager / stabilizer mount	NEW / (1)	Ø I 18
32 92 3366	1J0 411 336 D Schelle / clamp		

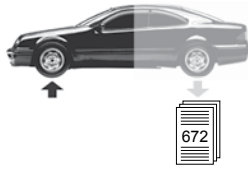

Toledo (5P)
(2005 →)

Vorderachse / Front axle

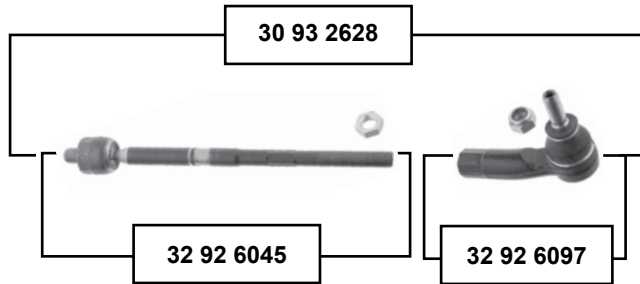
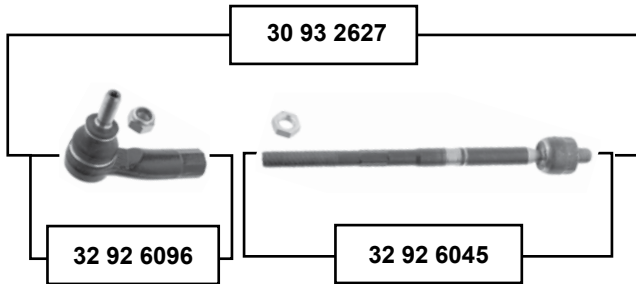
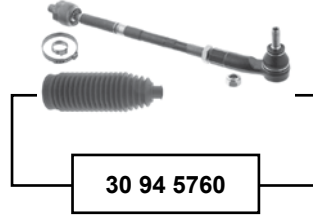
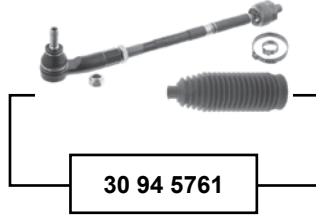

30 93 1278	1K0 423 831 A S1
30 93 2627	1K0 423 810 A S1
30 93 2628	1K0 423 810 A S2
30 94 5760	1K0 423 810 A S4
30 94 5761	1K0 423 810 A S3
32 92 6045	1K0 423 810 A
32 92 6096	1K0 423 811 E
32 92 6097	1K0 423 812 E

Rep. Satz Lenkmanschette / rep. kit steering boot
Rep. Satz Spurstange links / rep. kit tie rod left
Rep. Satz Spurstange rechts / rep. kit tie rod right
Rep. Satz Spurstange / rep. kit tie rod
Rep. Satz Spurstange / rep. kit tie rod
Axialgelenk / axial joint
Spurstangenendstück / tie rod end
Spurstangenendstück / tie rod end

Ø | 15,5 L190

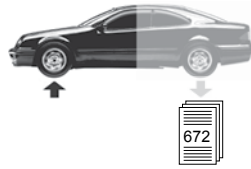

Toledo (5P)

(2005 →)

Vorderachse / Front axle

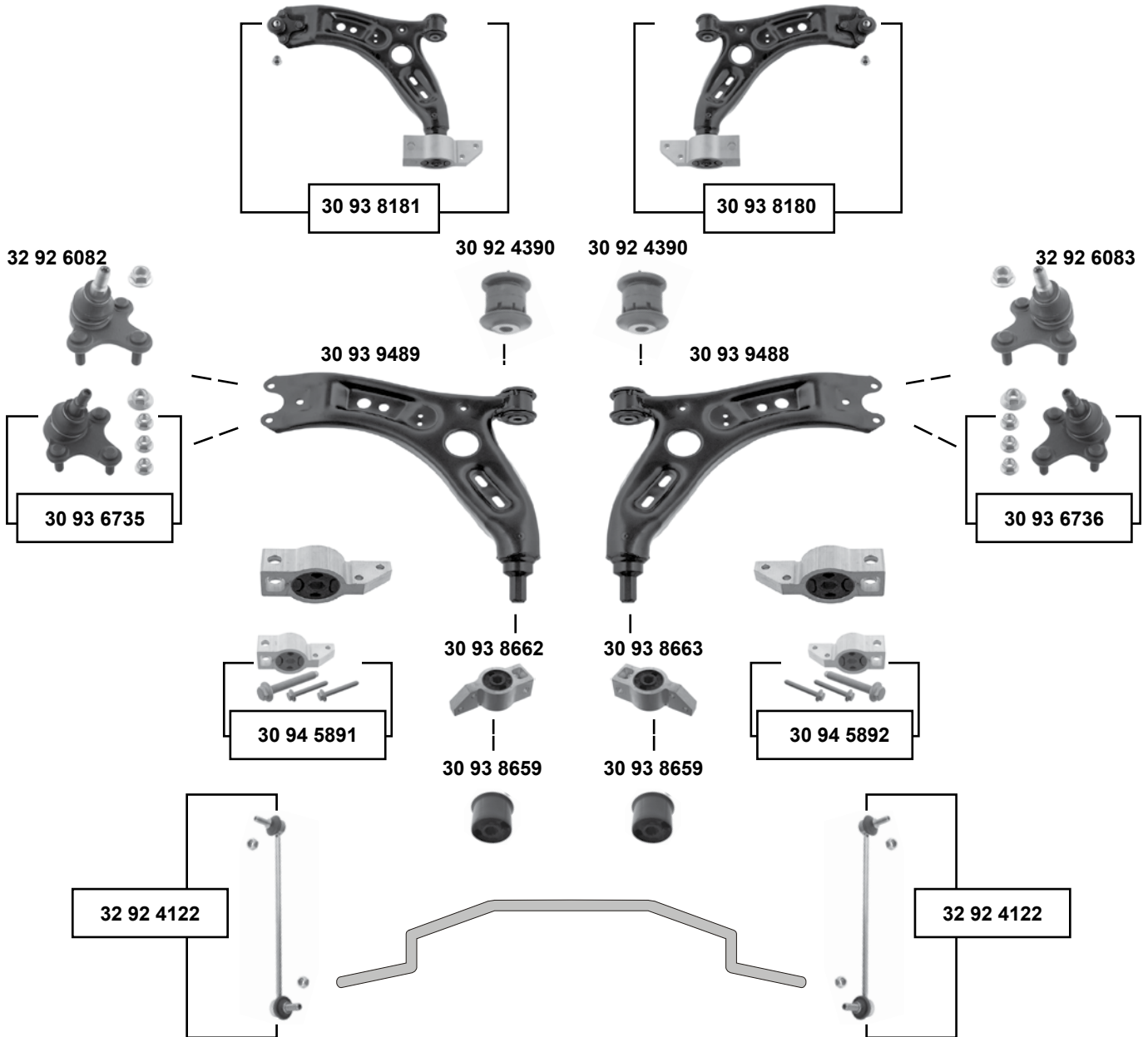

SWAG [®]	Ref. - No.			
30 92 4390	1K0 407 182	Querlenkerlager / control arm mount		Ø A 48 H 54
30 93 6735	1K0 407 365 C S1	Rep. Satz Traggelenk / rep. kit ball joint		
30 93 6736	1K0 407 366 C S1	Rep. Satz Traggelenk / rep. kit ball joint		
30 93 8180	1K0 407 152 BC S1	Rep. Satz Querlenker / rep. kit control arm	Stahl / steel	
30 93 8181	1K0 407 151 BC S1	Rep. Satz Querlenker / rep. kit control arm	Stahl / steel	
30 93 8659	1K0 407 183 G	Querlenkerlager / control arm mount		
30 93 8662	1K0 199 231 K	Querlenkerlager mit Gehäuse / control arm mount with housing	Aluminium	
30 93 8663	1K0 199 232 K	Querlenkerlager mit Gehäuse / control arm mount with housing	Aluminium	
30 93 9488	1K0 407 152 BC	Querlenker mit Lagern / control arm with bushes	Stahl / steel	
30 93 9489	1K0 407 151 BC	Querlenker mit Lagern / control arm with bushes	Stahl / steel	
30 94 5891	1K0 199 231 K S1	Rep. Satz Querlenkerlagersatz / rep. kit control arm mounting kit		
30 94 5892	1K0 199 232 K S1	Rep. Satz Querlenkerlagersatz / rep. kit control arm mounting kit		
32 92 4122	1K0 411 315 R	Verbindungsstange / connecting rod		
32 92 6082	1K0 407 365 C	Traggelenk / ball joint		
32 92 6083	1K0 407 366 C	Traggelenk / ball joint		



Toledo (KG3)

(2012 →)

Vorderachse / Front axle

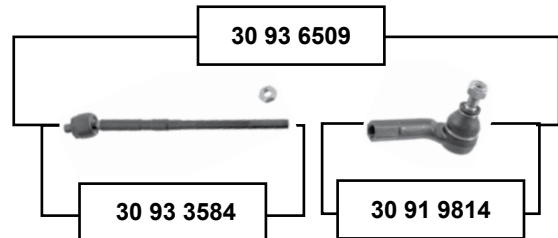
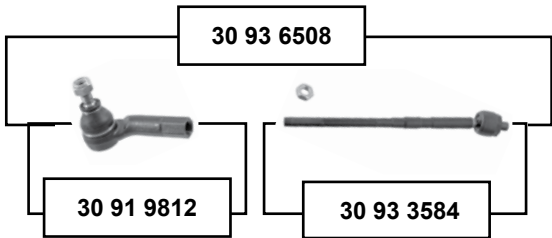
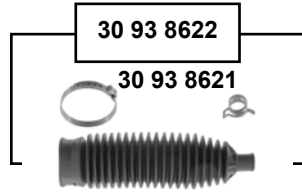

30 69 0002

30 69 0002

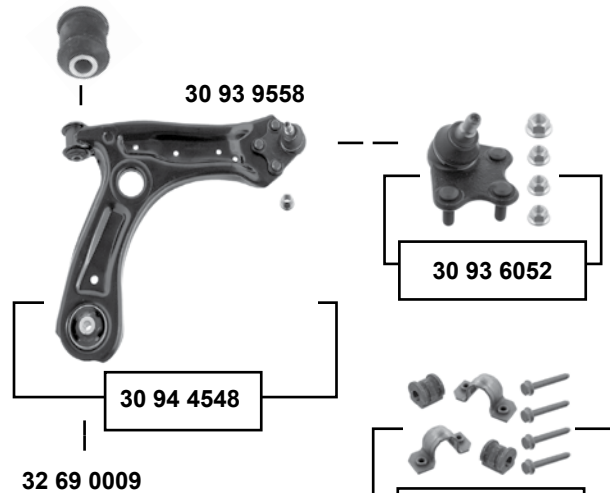
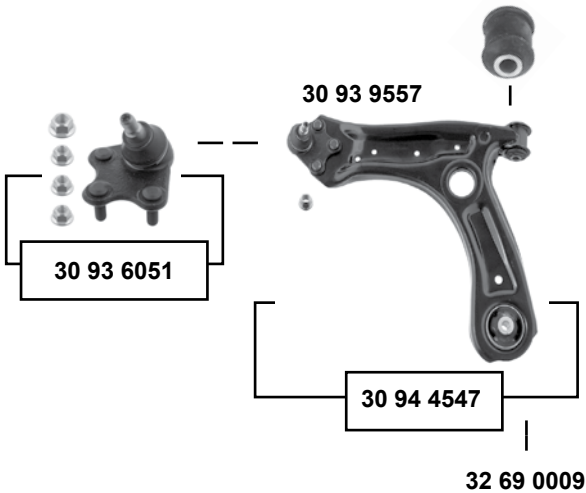

32 69 0009

32 69 0009

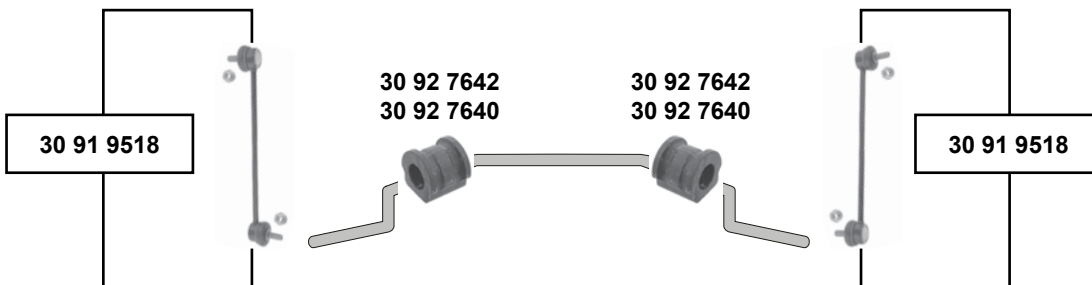

Toledo (KG3)
 (2012 →)

(1) PR-1N2 / PR-1AC / PR-1AT / PR-G0C / PR-G0K / PR-G1C // E-hydr.

	Ref. - No.			
30 69 0002	357 407 182	Querlenkerlager / control arm mount		Ø A 33
30 91 9518	6Q0 411 315 Q	Verbindungsstange / connecting rod		
30 91 9812	6R0 423 811	Spurstangenendstück / tie rod end	(1)	
30 91 9814	6R0 423 812	Spurstangenendstück / tie rod end	(1)	
30 92 7640	6Q0 411 314 Q	Stabilisatorlager / stabilizer mount	PR-0AR	Ø I 19
30 92 7642	6Q0 411 314 R	Stabilisatorlager / stabilizer mount	PR-0AS	Ø I 20
30 93 3584	6R0 423 810 A	Axialgelenk / axial joint	PR-1N2 E-hydr.	
30 93 6051	6R0 407 365 A	Traggelenk / ball joint		
30 93 6052	6R0 407 366 A	Traggelenk / ball joint		
30 93 6508	6R0 423 803 A	Spurstange, komplett / tie rod, complete	PR-1N2 E-hydr.	M12/14x1,5
30 93 6509	6R0 423 804 A	Spurstange, komplett / tie rod, complete	PR-1N2 E-hydr.	M12/14x1,5
30 93 7659	6Q0 411 314 R S4	Stabilisatorlagersatz / anti roll bar bush kit	PR-0AS	Ø I 20
30 93 7660	6Q0 411 314 Q S2	Stabilisatorlagersatz / anti roll bar bush kit	PR-0AR	Ø I 19
30 93 8621	6Q0 423 831 D	Lenkmanschette / steering boot	PR-1N2	
30 93 8622	6Q0 423 831 D S1	Rep. Satz Lenkmanschette / rep. kit steering boot	PR-1N2	
30 93 9557	6R0 407 151 F	Querlenker / control arm		
30 93 9558	6R0 407 152 F	Querlenker / control arm		
30 94 4547	6R0 407 151 F S1	Querlenker, kpl. / control arm, cpl.		
30 94 4548	6R0 407 152 F S1	Querlenker, kpl. / control arm, cpl.		
30 94 6299	6C0 423 810 C	Axialgelenk / axial joint	PR-1N2, 1N3	
32 69 0009	1J0 407 181	Querlenkerlager / control arm mount		Ø A 60 Ø I 13

passend für / to fit

ŠKODA





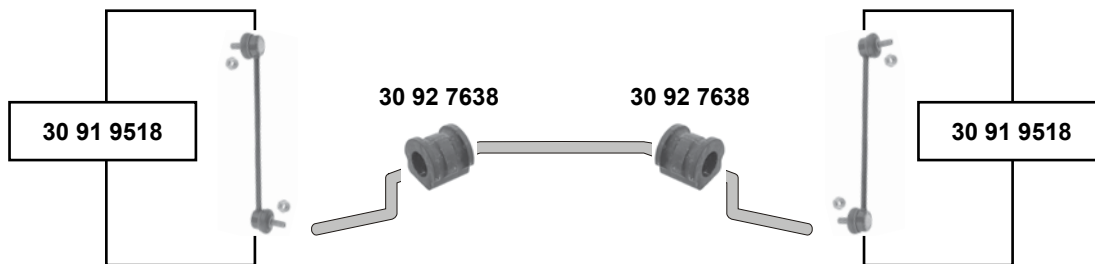
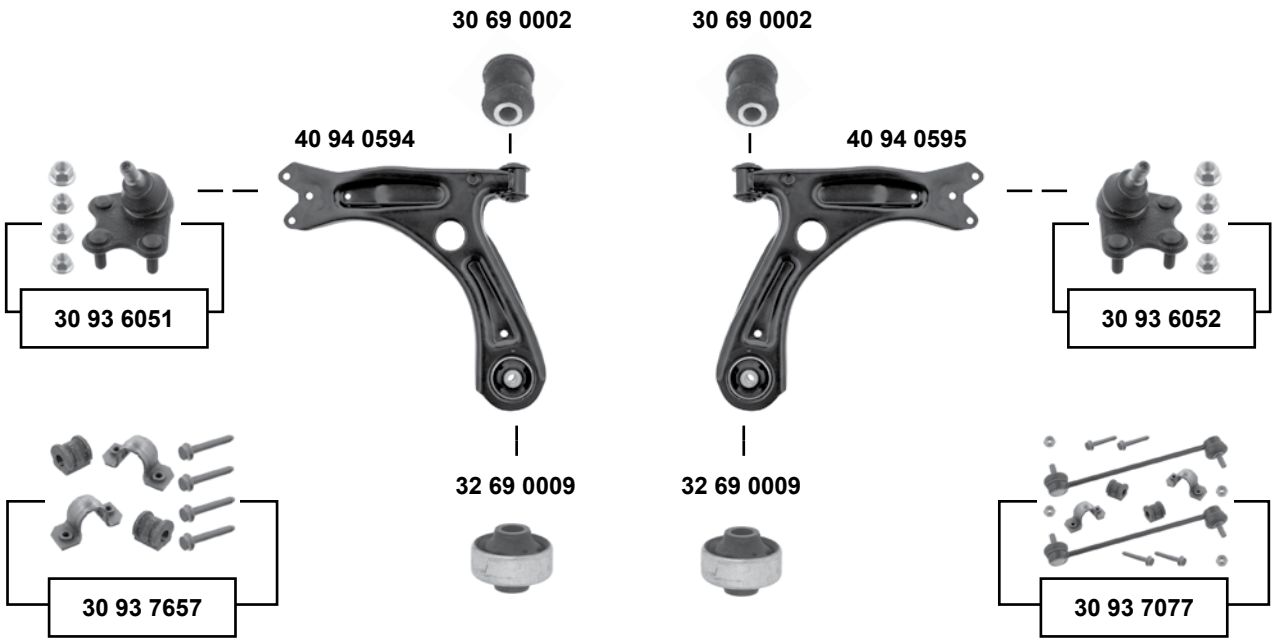
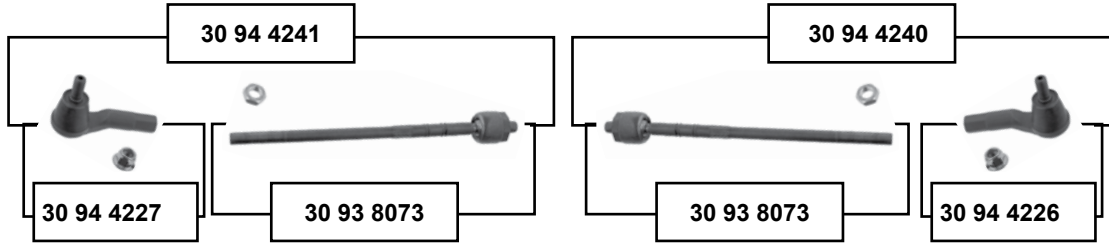

Citigo (NF) (2012 →)

Vorderachse / Front axle





Citigo (NF)
 (2012 →)

	Ref. - No.			
30 69 0002	357 407 182	Querlenkerlager / control arm mount		Ø A 33
30 91 9518	6Q0 411 315 Q	Verbindungsstange / connecting rod		
30 92 7638	6Q0 411 314 P	Stabilisatorlager / stabilizer mount		Ø I 16
30 93 6051	6R0 407 365 A	Traggelenk / ball joint		
30 93 6052	6R0 407 366 A	Traggelenk / ball joint		
30 93 7077	6Q0 411 314 P S1	Stabilisatorlagersatz / anti roll bar bush kit	PR-0AQ	
30 93 7657	6Q0 411 314 P S2	Stabilisatorlagersatz / anti roll bar bush kit	08 → / PR-0AQ	Ø I 16
30 93 8073	1S0 423 810 A	Axialgelenk / axial joint		M14 x 1,5
30 94 4226	1S0 423 812 A	Spurstangenendstück / tie rod end		
30 94 4227	1S0 423 811 A	Spurstangenendstück / tie rod end		
30 94 4240	1S0 423 810 A S1	Spurstange / tie rod		
30 94 4241	1S0 423 810 A S2	Spurstange / tie rod		
32 69 0009	1J0 407 181	Querlenkerlager hinten / control arm mount rear		Ø A 60 Ø I 13
40 94 0594	1S0 407 151	Querlenker / control arm		Stahl / steel
40 94 0595	1S0 407 152	Querlenker / control arm		Stahl / steel



Fabia (6Y) (2000 → 2008)

man.

Vorderachse / Front axle

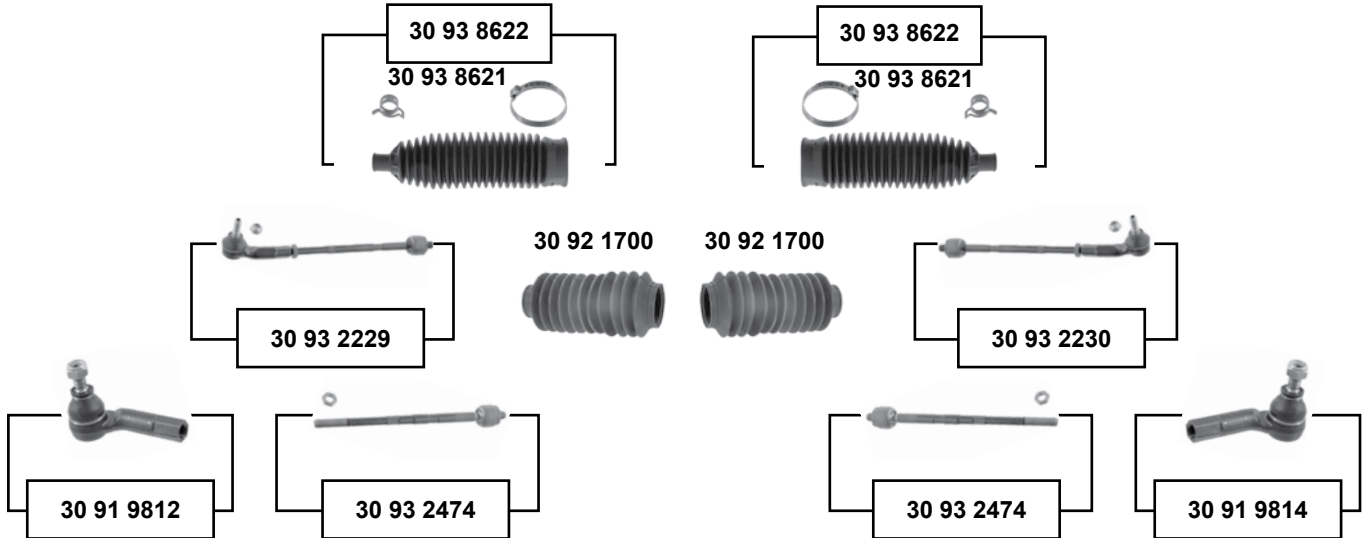

für / to fit servo TRW

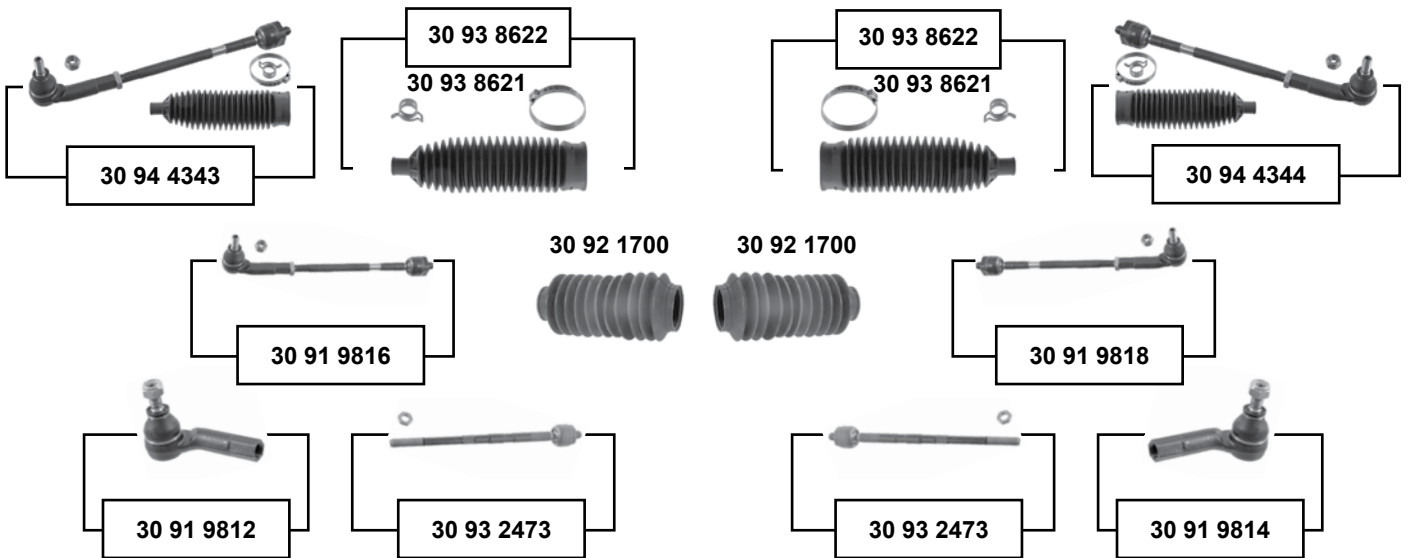

für / to fit servo KOYO

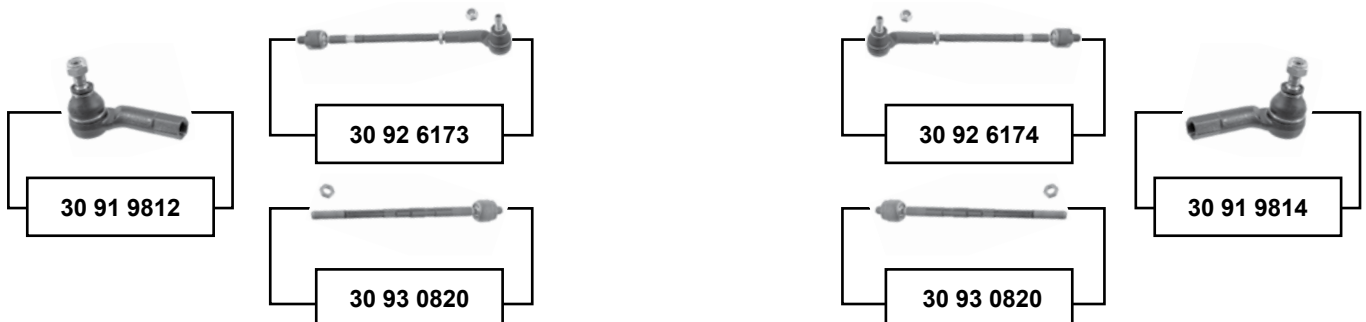



Fabia (6Y)
(2000 → 2008)



- (1) (ch.) → 6Y-3-736552
- (2) (ch.) 6Y-3-736553 → / PR-1N2, 1N5



Ref. - No.



SWAG Ref. - No.				
30 91 9812	6R0 423 811	Spurstangenendstück / tie rod end		
30 91 9814	6R0 423 812	Spurstangenendstück / tie rod end		
30 91 9816	6Q0 423 803 P	Spurstange / tie rod		
30 91 9818	6Q0 423 804 P	Spurstange / tie rod		
30 92 1700	6E0 419 831	Lenkmanschette / steering boot	(1)	
30 92 6173	6Q0 423 803 G	Rep. Satz Spurstange / rep. kit tie rod		
30 92 6174	6Q0 423 804 G	Rep. Satz Spurstange / rep. kit tie rod		
30 93 0820	6Q0 423 810 C	Axialgelenk / axial joint		M14 x 1,5
30 93 2229	6Q0 423 803 F	Rep. Satz Spurstange / rep. kit tie rod	2002 →	
30 93 2230	6Q0 419 804 F	Rep. Satz Spurstange / rep. kit tie rod		M12 x 1,5
30 93 2473	6Q0 423 810 P	Axialgelenk / axial joint		M14 x 1,5
30 93 2474	6Q0 419 810 B	Axialgelenk / axial joint		M14 x 1,5
30 93 8621	6Q0 423 831 D	Lenkmanschette / steering boot	(2)	
30 93 8622	6Q0 423 831 D S1	Rep. Satz Lenkmanschette / rep. kit steering boot	(2)	
30 94 4343	6Q0 423 803 P S1	Rep. Satz Spurstange / rep. kit tie rod	PR-1N2/1N5	
30 94 4344	6Q0 423 804 P S1	Rep. Satz Spurstange / rep. kit tie rod	PR-1N2/1N5	



Fabia (6Y)
(2000 → 2008)

Vorderachse / Front axle

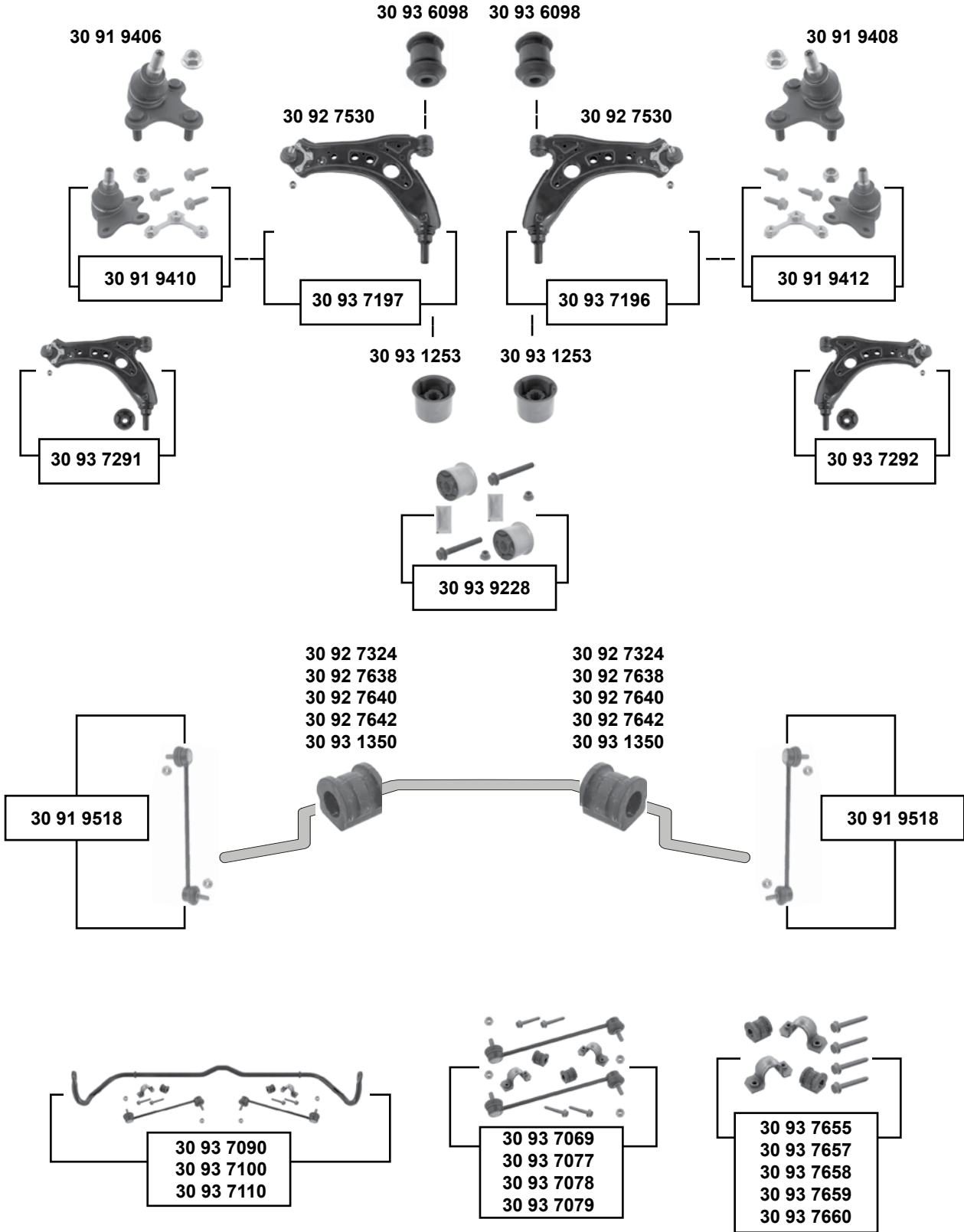



Fabia (6Y) (2000 → 2008)

(1)	(ch.)	→ 6Y-3-651 670		
(2)	(6Y) 03 → 08 (ch.)	6Y-3-651 671 → / (5J) 07 →		
(3)	(ch.)	6Y-3-651 671 →	(4)	(6Y) 00 → 08 / (5J) combi 07 →
(5)	Modell (6Y)	→ 2008		
	Modell (5J)	2007 → 2008 (ch.) → 5J-8A502 656		
		2007 → 2008 (ch.) → 5J-8B503 031		
		2007 → 2008 (ch.) → 5J-8K450 960		
		2007 → 2008 (ch.) → 5J-83172 973		
(6)	Fabia / combi (6Y) / 00 → 03 (ch.)	→ 6Y-3-651 670 (ex.) (mot.) BMD/BME/BKY		
(7)	Modell (5J)	(ch.) → 5J-8A502 656 / (ch.) → 5J-8B503 031 / (ch.) → 5J-8K450 960 / (ch.) → 5J-83172 973		
	Modell (6Y)	PR-1N0 / 1N2 / 1N4 / 1N5		
(8)	Fabia / combi	(ch.) 5J-BB500 000 → / (ch.) 5J-BK500 000 → / (ch.) 5J-B3008 700 → PR-G02 / G03 / 0AQ für Fahrzeuge mit Standard Fahrwerk / for vehicles with standard chassis		
(9)	Modell (5J)	PR-0AQ / für Fahrzeuge ohne tiefergelegtem Fahrwerk / for vehicles without lowered chassis		
(10)	Modell (5J)	PR-0AR / für Fahrzeuge mit tiefergelegtem Fahrwerk / for vehicles with lowered chassis		
	Modell (6Y)	PR-0AR / (ch.) 6Y-3 651 671 → / → 07		
(11)	Modell (5J)	06 → PR-0AR / für Fahrzeuge mit tiefergelegtem Fahrwerk / for vehicles with lowered chassis		
	Modell (6Y)	PR-0AR / (ch.) 6Y-3-651 671 →		
(12)	Modell (5J)	PR-0AS	(13)	Modell (6Y) PR-0AR (ch.) → 6Y-3-651 670
	Modell (6Y)	PR-0AS / (ch.) 6Y-3-651 671 →	(14)	Modell (6Y) PR-0AS (ch.) → 6Y-3-651 670



Ref. - No.



30 91 9406	6Q0 407 365 M	Traggelenk / ball joint		
30 91 9408	6Q0 407 366 A	Traggelenk / ball joint		
30 91 9410	6Q0 407 365 M S1	Rep. Satz Traggelenk / rep. kit ball joint	(7)	
30 91 9412	6Q0 407 366 A S1	Rep. Satz Traggelenk / rep. kit ball joint	(7)	
30 91 9518	6Q0 411 315 Q	Verbindungsstange / connecting rod		
30 92 7324	6Q0 411 314 F	Stabilisatorlager / stabilizer mount	(1)	Ø I 19,8
30 92 7530	6Q0 407 151 L	Querlenker / control arm	(5)	
30 92 7638	6Q0 411 314 P	Stabilisatorlager / stabilizer mount		Ø I 16
30 92 7640	6Q0 411 314 Q	Stabilisatorlager / stabilizer mount	(2)	Ø I 17
30 92 7642	6Q0 411 314 R	Stabilisatorlager / stabilizer mount	(3) PR-0AS	Ø I 18
30 93 1253	1K0 407 183 E	Querlenkerlager / control arm mount	(4)	Ø A 63
30 93 1350	8Z0 411 314 B	Stabilisatorlager / stabilizer mount	(6)	Ø I 20,8
30 93 6098	6Q0 407 182 A	Querlenkerlager / control arm mount		Ø A 32
30 93 7069	6Q0 411 314 Q S1	Stabilisatorlagersatz / anti roll bar bush kit	(10)	
30 93 7077	6Q0 411 314 P S1	Stabilisatorlagersatz / anti roll bar bush kit	→ 06 (9)	
30 93 7078	6Q0 411 314 F S1	Stabilisatorlagersatz / anti roll bar bush kit	PR-0AR	
30 93 7079	8Z0 411 314 B S1	Stabilisatorlagersatz / anti roll bar bush kit	PR-0AS (ch.) → 6Y-3-651 670	
30 93 7090	6Q0 411 305 AL S2	Rep. Satz Stabilisatorsatz / rep. kit stabilizer kit	→ 06 (9)	
30 93 7100	6Q0 411 305 AM S2	Rep. Satz Stabilisatorsatz / rep. kit stabilizer kit	(10)	
30 93 7110	6Q0 411 305 AN S2	Rep. Satz Stabilisatorsatz / rep. kit stabilizer kit	PR-0AS	
30 93 7196	6Q0 407 151 L S3	Rep. Satz Querlenker / rep. kit control arm		
30 93 7197	6Q0 407 151 L S2	Rep. Satz Querlenker / rep. kit control arm		
30 93 7291	6Q0 407 151 L S5	Rep. Satz Querlenker / rep. kit control arm		
30 93 7292	6Q0 407 151 L S4	Rep. Satz Querlenker / rep. kit control arm		
30 93 7655	8Z0 411 314 B S2	Stabilisatorlagersatz / anti roll bar bush kit	(14)	Ø I 20,8
30 93 7675	6Q0 411 314 P S2	Stabilisatorlagersatz / anti roll bar bush kit	(8) HD	Ø I 16
30 93 7658	6Q0 411 314 F S2	Stabilisatorlagersatz / anti roll bar bush kit	(13)	Ø I 19,8
30 93 7659	6Q0 411 314 R S4	Stabilisatorlagersatz / anti roll bar bush kit	(12)	Ø I 18
30 93 7660	6Q0 411 314 Q S2	Stabilisatorlagersatz / anti roll bar bush kit	(11)	Ø I 17
30 93 9228	1K0 407 183 E S1	Querlenkerlagersatz / control arm mounting kit		

passend für / to fit

ŠKODA



Fabia II (5J)

(2007 →)

Vorderachse / Front axle

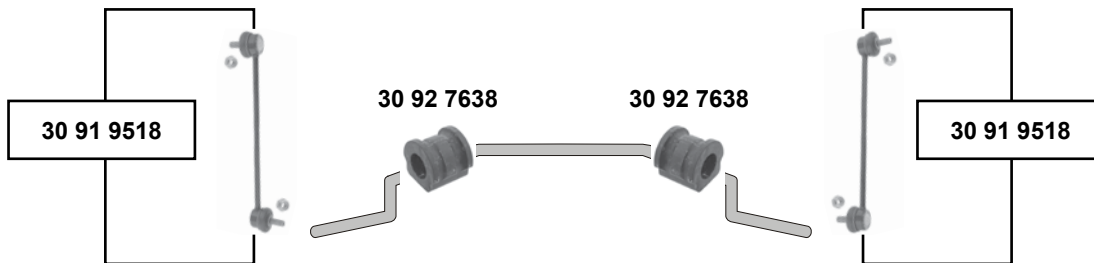
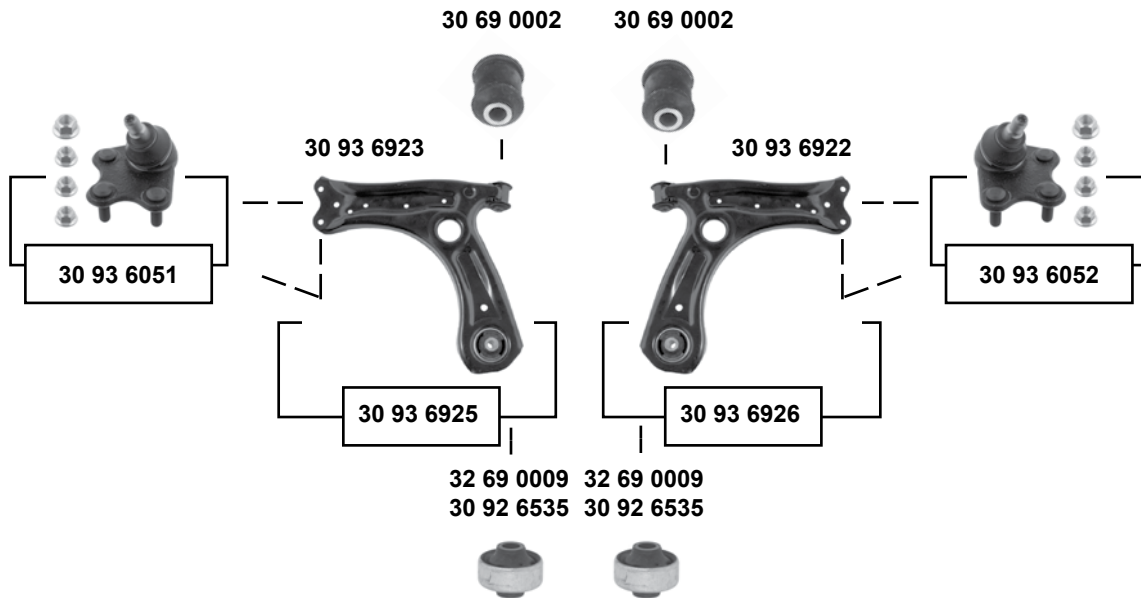
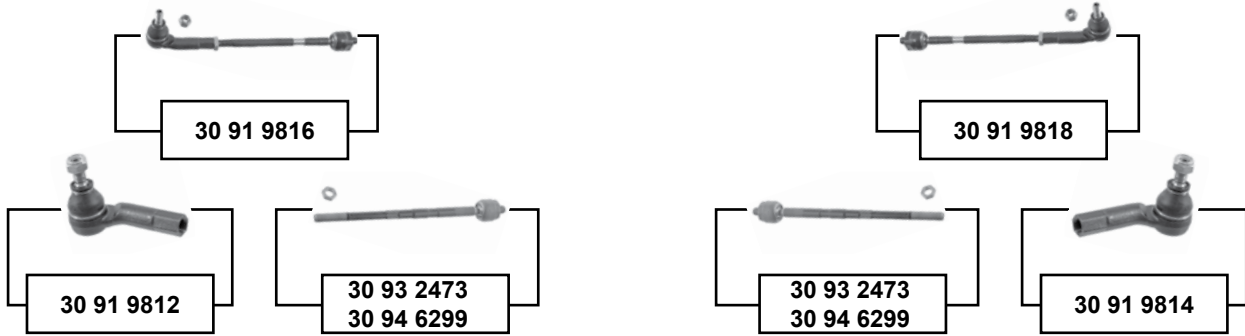



Fabia II (5J) (2007 →)

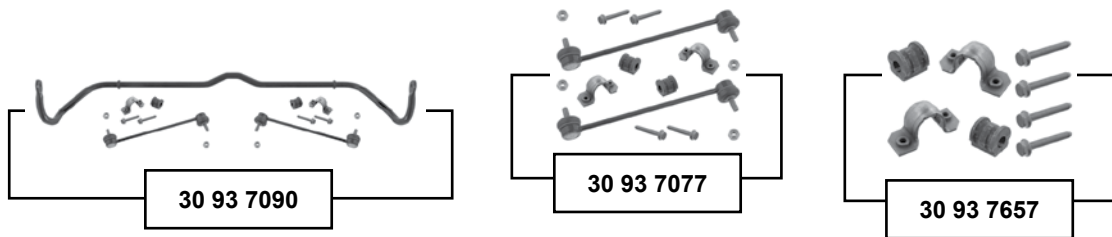

Vorderachse / Front axle

- (1)** → 10 (ch.) 5J-8A502 657 → / 5J-8B503 032 → / 5J-8K450 961 → / 5J-83172 974 →
11 → alle / all
- (2)** (ch.) 5J-BB500 000 → / (ch.) 5J-BK500 000 → / (ch.) 5J-B3008 700 →
PR-G02 / G03 / 0AQ / für Fahrzeuge mit Standard Fahrwerk / for vehicles with standard chassis
- (3)** → 09 (ch.) 5J-8A502 657 → / 5J-8B503 032 → / 5J-8K450 961 → / 5J-83172 974 →
09 → 10 (ch.) → 5J-AG013 530
- (4)** (ch.) 5J-8A502 657 → / (ch.) 5J-8B503 032 →
(ch.) 5J-8K450 961 → / (ch.) 5J-83172 974 →
- (5)** (ch.) 5J-AG-013 530 → / (ch.) 5J-BB-500 580 →
(ch.) 5J-BK-502 478 → / (ch.) 5J-B3-056 973 →



Ref. - No.



SWAG Ref. - No.				
30 69 0002	357 407 182	Querlenkerlager / control arm mount	08 →	Ø A 33
30 91 9518	6Q0 411 315 Q	Verbindungsstange / connecting rod	08 →	
30 91 9812	6R0 423 811	Spurstangenendstück / tie rod end		
30 91 9814	6R0 423 812	Spurstangenendstück / tie rod end		
30 91 9816	6Q0 423 803 P	Spurstange / tie rod		
30 91 9818	6Q0 423 804 P	Spurstange / tie rod		
30 92 6535	8N0 407 181 B	Querlenkerlager / control arm mount	PR-G01/G07	H 41 Ø I 14
30 92 7638	6Q0 411 314 P	Stabilisatorlager / stabilizer mount		Ø I 16
30 93 2473	6Q0 423 810 P	Axialgelenk / axial joint		M14 x 1,5
30 93 6051	6R0 407 365 A	Traggelenk / ball joint	(4)	
30 93 6052	6R0 407 366 A	Traggelenk / ball joint	(4)	
30 93 6922	6R0 407 152 E	Querlenker / control arm	(3)	
30 93 6923	6R0 407 151 E	Querlenker / control arm	(3)	
30 93 6925	6R0 407 151 E S1	Rep. Satz Querlenker / rep. kit control arm	(5) 09 →	
30 93 6926	6R0 407 152 E S1	Rep. Satz Querlenker / rep. kit control arm	(5) 09 →	
30 93 7077	6Q0 411 314 P S1	Stabilisatorlagersatz / anti roll bar bush kit	PR-0AQ	
30 93 7090	6Q0 411 305 AL S2	Rep. Satz Stabilisatorsatz / rep. kit stabilizer kit	PR-0AQ	
30 93 7657	6Q0 411 314 P S2	Stabilisatorlagersatz / anti roll bar bush kit	(2) / HD	Ø I 16
30 94 6299	6C0 423 810 C	Axialgelenk / axial joint		
32 69 0009	1J0 407 181	Querlenkerlager hinten / control arm mount rear	(1)	Ø A 60 Ø I 13



Fabia III (NJ)
(2014 →)

Vorderachse / Front axle

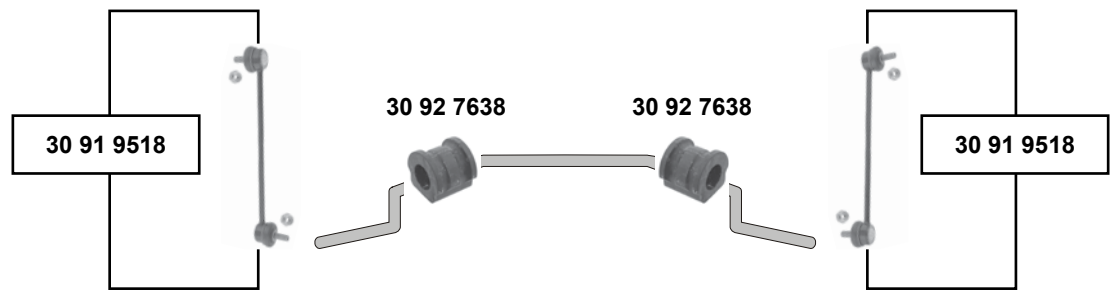
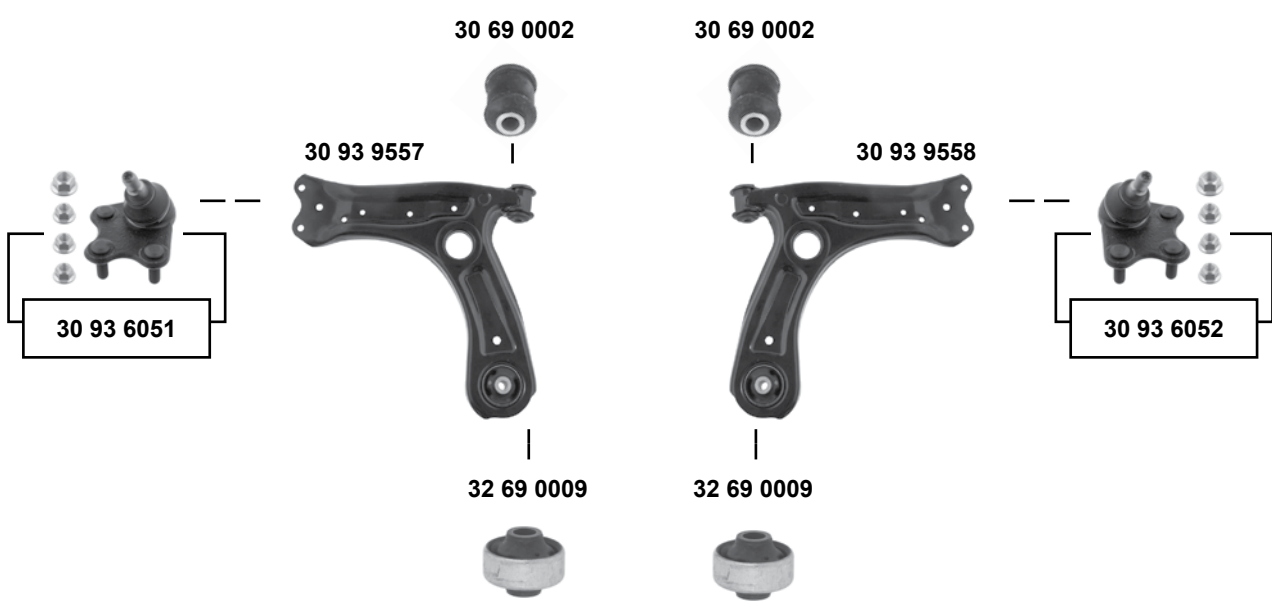
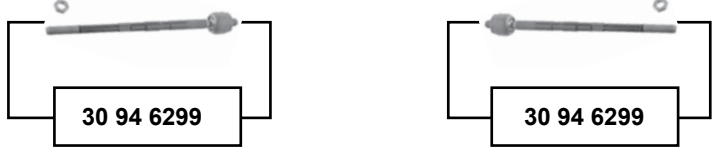

SWAG GERMANY	Ref. - No.			
30 69 0002	357 407 182	Querlenkerlager / control arm mount		Ø A 33
30 91 9518	6Q0 411 315 Q	Verbindungsstange / connecting rod		Ø I 18
30 92 7638	6Q0 411 314 P	Stabilisatorlager / stabilizer mount		
30 93 6051	6R0 407 365 A	Traggelenk / ball joint		
30 93 6052	6R0 407 366 A	Traggelenk / ball joint		
30 93 9557	6R0 407 151 F	Querlenker / control arm		
30 93 9558	6R0 407 152 F	Querlenker / control arm		
30 94 6299	6C0 423 810 C	Axialgelenk / axial joint		
32 69 0009	1J0 407 181	Querlenkerlager / control arm mount		Ø A 60 Ø I 13



Favorit 785 Forman
(1991 → 1995)

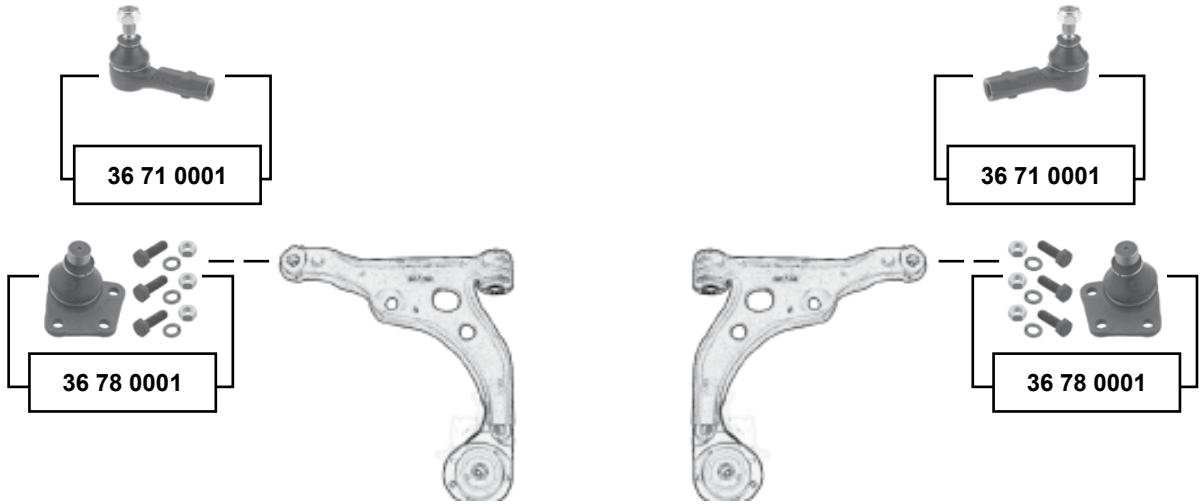

Vorderachse / Front axle

Felicia (4X) (6X)
(2005) (1995 → 2001)

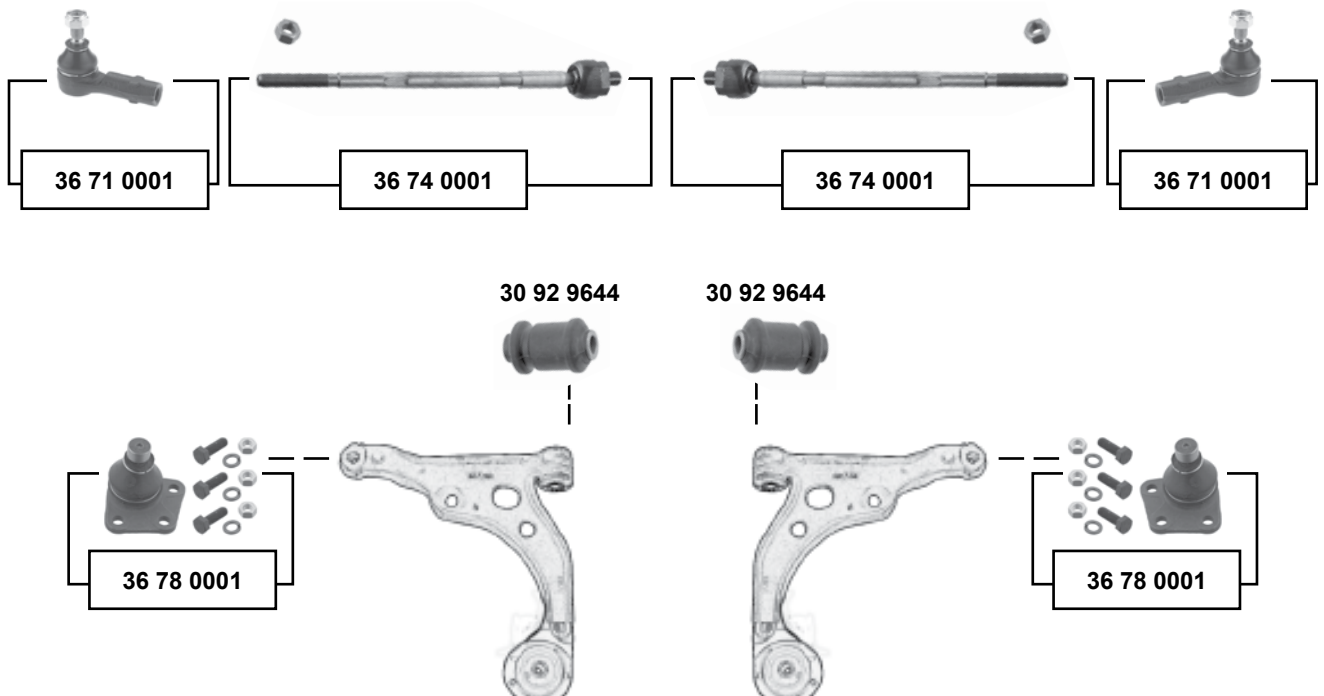

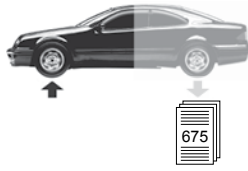

Octavia (1U) (1997 → 2010)

(ch.) → 1U-W-061 000

Vorderachse / Front axle

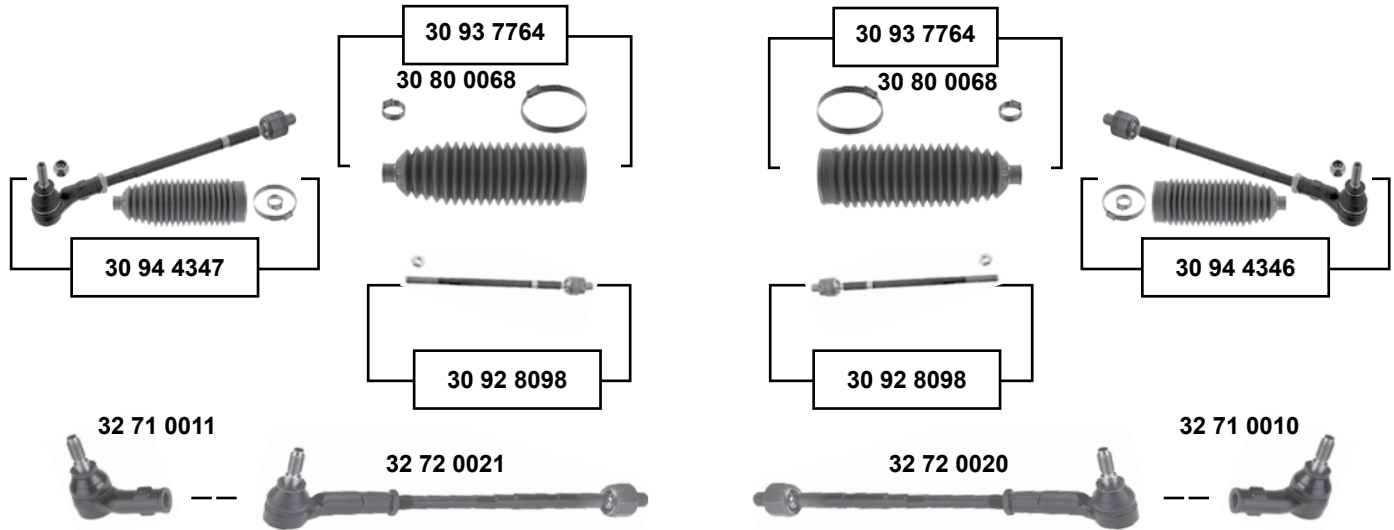



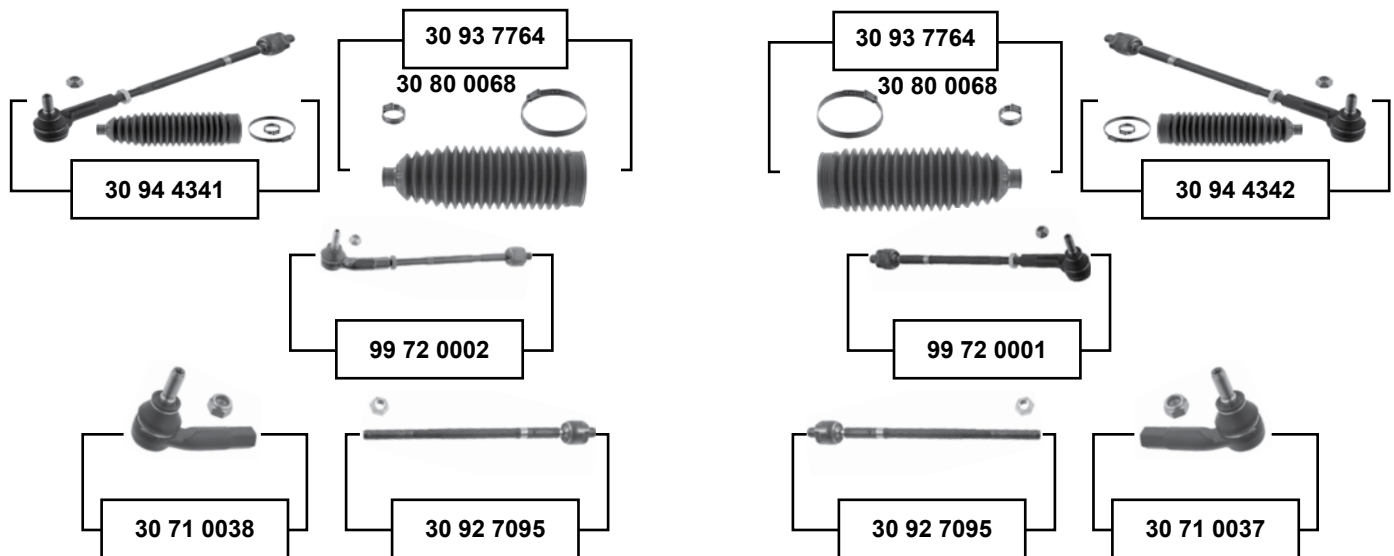

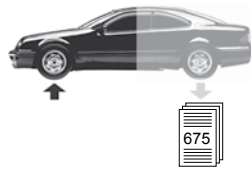
(ch.) 1U-W-061 001 →





Octavia (1U)
 (1997 → 2010)

	Ref. - No.			
30 71 0037	1J0 422 812 B	Spurstangenendstück / tie rod end	(ch.) 1U-W-061001 →	M14 x 1,5
30 71 0038	1J0 422 811 B	Spurstangenendstück / tie rod end	(ch.) 1U-W-061001 →	M14 x 1,5
30 80 0068	1J0 422 831 B	Lenkmanschette / steering boot		
30 92 7095	1J0 422 810 B	Axialgelenk / axial joint		
30 92 8098	1J0 422 810 A	Axialgelenk / axial joint		
30 93 7764	1J0 422 831 B S1	Rep. Satz Lenkmanschette / rep. kit steering boot		
30 94 4341	1J0 422 803 H S1	Rep. Satz Spurstange / rep. kit tie rod		
30 94 4342	1J0 422 804 H S1	Rep. Satz Spurstange / rep. kit tie rod		
30 94 4346	1J0 422 804 A S1	Rep. Satz Spurstange / rep. kit tie rod		
30 94 4347	1J0 422 803 A S1	Rep. Satz Spurstange / rep. kit tie rod		
32 71 0010	1J0 422 812 A	Spurstangenendstück / tie rod end		M14 x 1,5
32 71 0011	1J0 422 811 A	Spurstangenendstück / tie rod end		M14 x 1,5
32 72 0020	1J0 422 804 A	Spurstange / tie rod		
32 72 0021	1J0 422 803 A	Spurstange / tie rod		
99 72 0001	1J0 422 804 H	Spurstange / tie rod		
99 72 0002	1J0 422 803 H	Spurstange / tie rod		

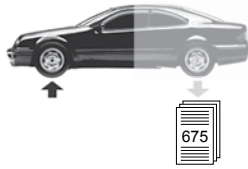

Octavia (1U) (1997 → 2010)

Vorderachse / Front axle

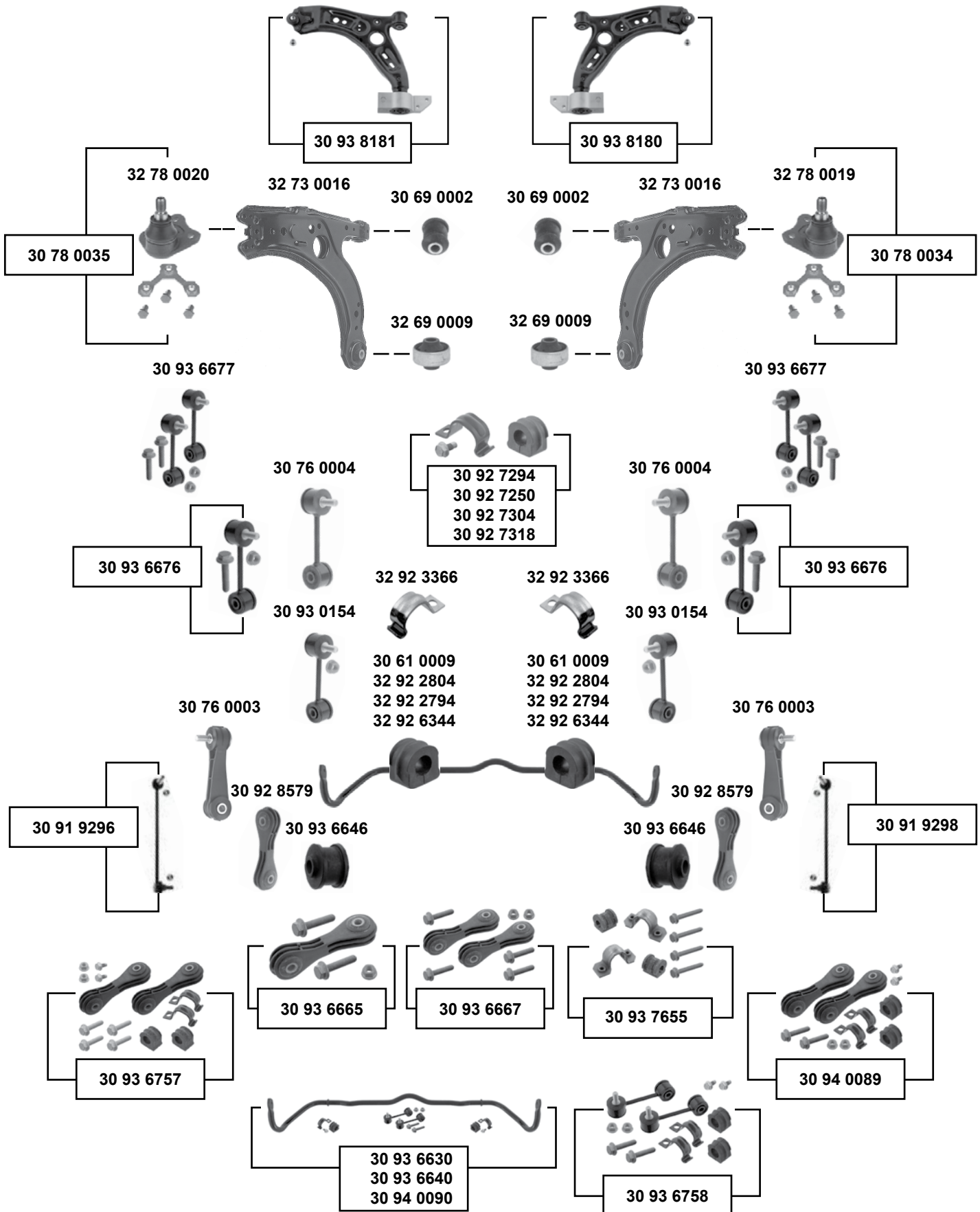

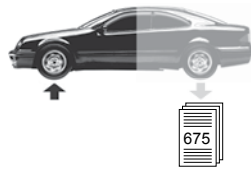

Octavia (1U) (1997 → 2010)

Rep Sätze / rep. kits



- (1) (ch.) → 1U-18438 500 / (ch.) → 1U-1-471 000
- (2) (ch.) 1U-4A022801 → / (ch.) 1U-42948655 → / (ch.) 1U-48756166 →
- (3) 01 → (ch.) 1U-18438 501 → / (ch.) 1U-1-471 001 → / (ch.) 1U-3A006 219 →
- (4) (ch.) → 1U-4A022800 / (ch.) → 1U-42948654 / (ch.) → 1U-48756165
- (5) (ch.) 1U-X-210 001 → / (ch.) → 1U-18-438 500
- (6) (ch.) 1U-12430 013 → / (ch.) 1U-18430 003 → / PR-0AE / Ø A 23



Ref. - No.



SWAG Ref. - No.	Description	Notes	Dimensions
30 61 0009	1J0 407 365 H S1	Stabilisatorlager / stabilizer mount	Ø 21
30 69 0002	357 407 182	Querlenkerlager / control arm mount	12 x 33 x 54
30 76 0003	1J0 411 315 J	Verbindungsstange / connecting rod	L 105
30 76 0004	1J0 411 315 G	Verbindungsstange / connecting rod	L 105
30 78 0034	1J0 407 366 H S	Rep. Satz Traggelenk / rep. kit ball joint	
30 78 0035	1J0 407 365 H S1	Rep. Satz Traggelenk / rep. kit ball joint	
30 91 9296	1J0 411 315 D	Verbindungsstange / connecting rod	
30 91 9298	1J0 411 316 D	Verbindungsstange / connecting rod	
30 91 9820	1J0 407 365 H S2	Querlenker, kpl. / control arm, cpl.	
30 91 9822	1J0 407 366 H S2	Querlenker, kpl. / control arm, cpl.	
30 92 7250	1J0 411 314 S S1	Rep. Satz Stabilisatorlagersatz / rep. kit stabilizer mount kit	Ø 17
30 92 7294	1J0 411 314 P S1	Rep. Satz Stabilisatorlagersatz / rep. kit stabilizer mount kit	Ø 20
30 92 7304	1J0 411 314 R S1	Stabilisatorlagersatz / stabilizer mount	Ø 18
30 92 7318	1J0 411 314 T S1	Rep. Satz Stabilisatorlagersatz / rep. kit stabilizer mount kit	Ø 21
30 92 8579	1J0 411 315 K	Verbindungsstange / connecting rod	L 105,5
30 93 0154	1J0 411 315 G S1	Verbindungsstange / connecting rod	L 105
30 93 6630	1J0 411 305 B S1	Rep. Satz Stabilisatorsatz / rep. kit stabilizer kit	
30 93 6640	1J0 411 305 E S1	Rep. Satz Stabilisatorsatz / rep. kit stabilizer kit	
30 93 6646	1J0 411 327 A	Verbindungsstangenlager / connecting rod mount	Ø A 29
30 93 6665	1J0 411 315 K S1	Rep. Satz Verbindungsstange / rep. kit connecting rod	L 105,5
30 93 6667	1J0 411 315 K S2	Verbindungsstangensatz / connecting rod set	L 105,5
30 93 6676	1J0 411 315 G S1	Verbindungsstange / connecting rod	(ch.) → 1U-1-8438 500
30 93 6677	1J0 411 315 G S2	Rep. Satz Verbindungsstange / rep. kit connecting rod	(ch.) → 1U-1-8438 500
30 93 6757	1J0 411 315 G S3	Stabilisatorlagersatz / anti roll bar bush kit	Ø 21
30 93 6758	1J0 411 315 G S4	Stabilisatorlagersatz / anti roll bar bush kit	Ø 21
30 93 7655	8Z0 411 314 B S2	Stabilisatorlagersatz / anti roll bar bush kit	Ø 20,8
30 93 8180	1K0 407 152 BC S1	Rep. Satz Querlenker / rep. kit control arm	Stahl / steel
30 93 8181	1K0 407 151 BC S1	Rep. Satz Querlenker / rep. kit control arm	Stahl / steel
30 94 0089	1J0 411 314 T S2	Stabilisatorlagersatz / anti roll bar bush kit	(6)
30 94 0090	1J0 411 305 E S2	Rep. Satz Stabilisatorsatz / rep. kit stabilizer kit	(6)
32 69 0009	1J0 407 181	Querlenkerlager / control arm mount	13 x 60 x 41
32 73 0016	1J0 407 151 C	Querlenker / control arm	
32 78 0019	1J0 407 366 H	Traggelenk / ball joint	M12 x 1,5
32 78 0020	1J0 407 365 H	Traggelenk / ball joint	M12 x 1,5
32 92 2794	1J0 411 314 P	Stabilisatorlager / stabilizer mount	(4) Ø 20
32 92 2804	1J0 411 314 R	Stabilisatorlager / stabilizer mount	Ø 18
32 92 3366	1J0 411 336 D	Schelle / clamp	
32 92 6344	1J0 411 314 S	Stabilisatorlager / stabilizer mount	(2) Ø 17

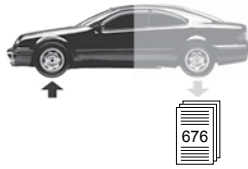

Octavia (1Z) (2004 →)

Vorderachse / Front axle

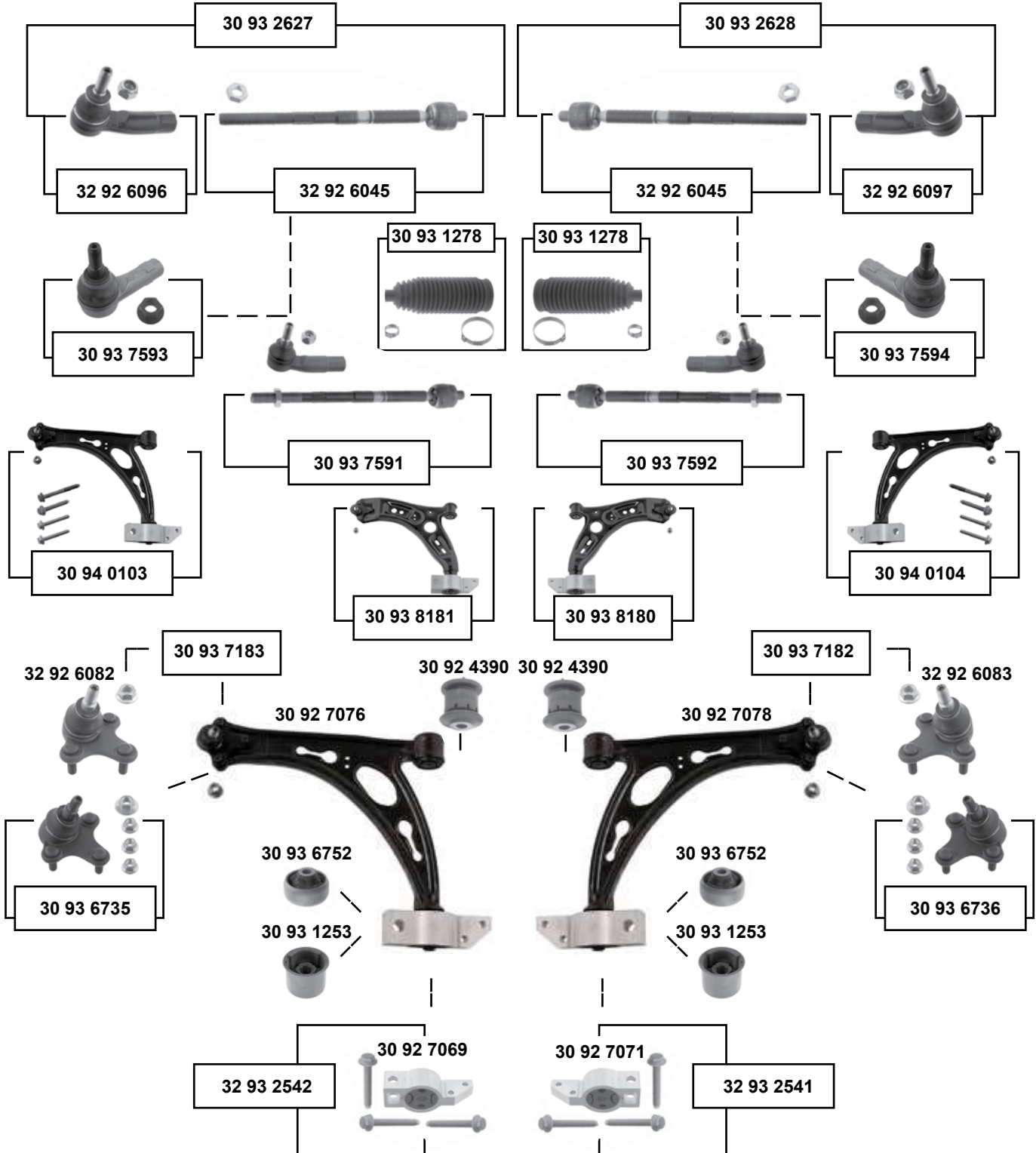

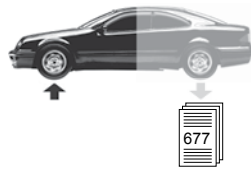

Octavia (1Z) (2004 →)

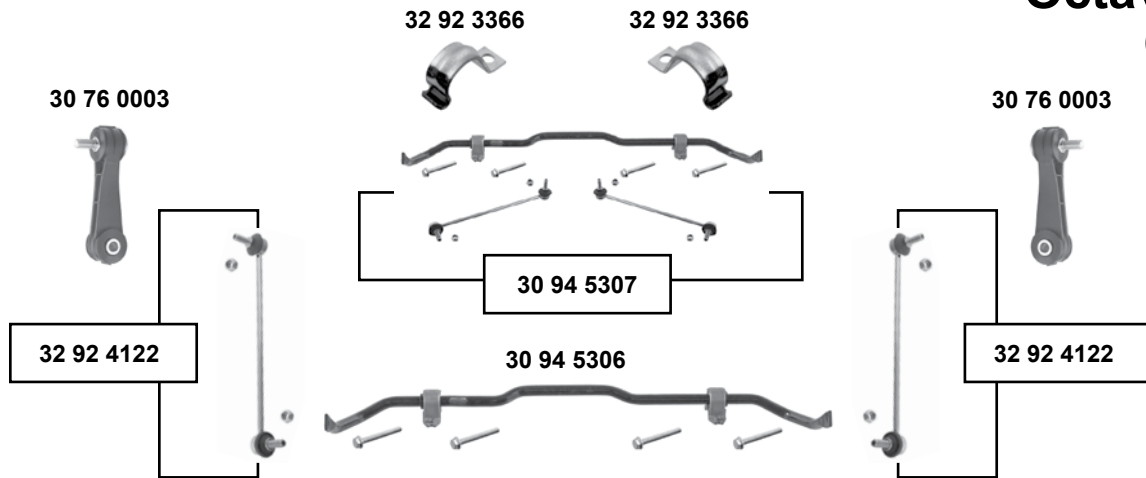

- (1) Stahl-Gussausführung / keine Mischverbauung mit der Blechausführung zulässig / cast iron execution / not mixable with metall execution
- (2) (ch.) → 1Z-BA150648 / (ch.) → 1Z-BB153225 / (ch.) → 1Z-BD150229 / (ch.) → 1Z-B2091806 / (ch.) → 1Z-B8029834 // Gummimetalllager / rubber metal mount
- (3) (ch.) → 1Z-8A156300 / (ch.) → 1Z-8B160560 / (ch.) → 1Z-8C014469 / (ch.) → 1Z-8D150073 / (ch.) → 1Z-8K156426 / (ch.) → 1Z-82245091 / (ch.) → 1Z-88038538



Ref. - No.



Ref. - No.	Description	Material	Dimensions
30 76 0003	1J0 411 315 J Verbindungsstange / connecting rod	Stabi Ø A 21	L 105
30 92 4390	1K0 407 182 Querlenkerlager / control arm mount		Ø A 48 H 54
30 92 7069	1K0 199 231 J Querlenkerlager mit Gehäuse / control arm mount with housing		
30 92 7071	1K0 199 232 J Querlenkerlager mit Gehäuse / control arm mount with housing		
30 92 7076	1K0 407 151 AC Querlenker, kpl. / control arm, cpl.	(1) → 08	
30 92 7078	1K0 407 152 AC Querlenker, kpl. / control arm, cpl.	(1) → 08	
30 93 1253	1K0 407 183 E Querlenkerlager / control arm mount		Ø A 63
30 93 1278	1K0 423 831 A S1 Rep. Satz Lenkmanschette / rep. kit steering boot		Ø I 15,5 L190
30 93 2627	1K0 423 810 A S1 Rep. Satz Spurstange links / rep. kit tie rod left		
30 93 2628	1K0 423 810 A S2 Rep. Satz Spurstange rechts / rep. kit tie rod right		
30 93 6735	1K0 407 365 C S1 Rep. Satz Traggelenk / rep. kit ball joint		
30 93 6736	1K0 407 366 C S1 Rep. Satz Traggelenk / rep. kit ball joint		
30 93 6752	1K0 407 183 P Querlenkerlager / control arm mount	(2)	Ø I 13
30 93 7182	1K0 407 152 AC S1 Rep. Satz Querlenker mit Traggelenk / control arm with ball joint	PR-8Q3	
30 93 7183	1K0 407 151 AC S1 Rep. Satz Querlenker mit Traggelenk / control arm with ball joint	PR-8Q3	
30 93 7591	1K0 423 811 K S1 Rep. Satz Spurstange / rep. kit tie rod		L 448
30 93 7592	1K0 423 812 K S1 Rep. Satz Spurstange / rep. kit tie rod		L 448
30 93 7593	1K0 423 811 K Spurstangenendstück / tie rod end		M16 x 1,5
30 93 7594	1K0 423 812 K Spurstangenendstück / tie rod end		M16 x 1,5
30 93 8180	1K0 407 152 BC S1 Rep. Satz Querlenker / rep. kit control arm	Stahl / steel	
30 93 8181	1K0 407 151 BC S1 Rep. Satz Querlenker / rep. kit control arm	Stahl / steel	
30 94 0103	1K0 407 151 AC S2 Rep. Satz Querlenker / rep. kit control arm	(3)	
30 94 0104	1K0 407 152 AC S2 Rep. Satz Querlenker / rep. kit control arm	(3)	
30 94 5306	1K0 411 303 BK S1 Stabilisatorsatz / stabilizer kit	PR-0AD / OAE	
30 94 5307	1K0 411 303 BK S2 Rep. Satz Stabilisatorsatz / rep. kit stabilizer kit	PR-0AD / OAE	
32 92 3366	1J0 411 336 D Schelle / clamp		
32 92 4122	1K0 411 315 R Verbindungsstange / connecting rod		
32 92 6045	1K0 423 810 A Spurstange / tie rod		
32 92 6082	1K0 407 365 C Traggelenk / ball joint		
32 92 6083	1K0 407 366 C Traggelenk / ball joint		
32 92 6096	1K0 423 811 E Spurstangenendstück / tie rod end		
32 92 6097	1K0 423 812 E Spurstangenendstück / tie rod end		
32 93 2541	1K0 199 232 J S1 Querlenkerlager rechts / control arm mount left		
32 93 2542	1K0 199 231 J S1 Querlenkerlager links / control arm mount left		

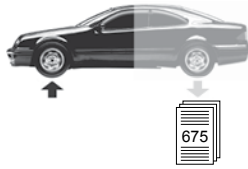

Octavia (5E/NL3/NR3)

(2012 →)

Vorderachse / Front axle

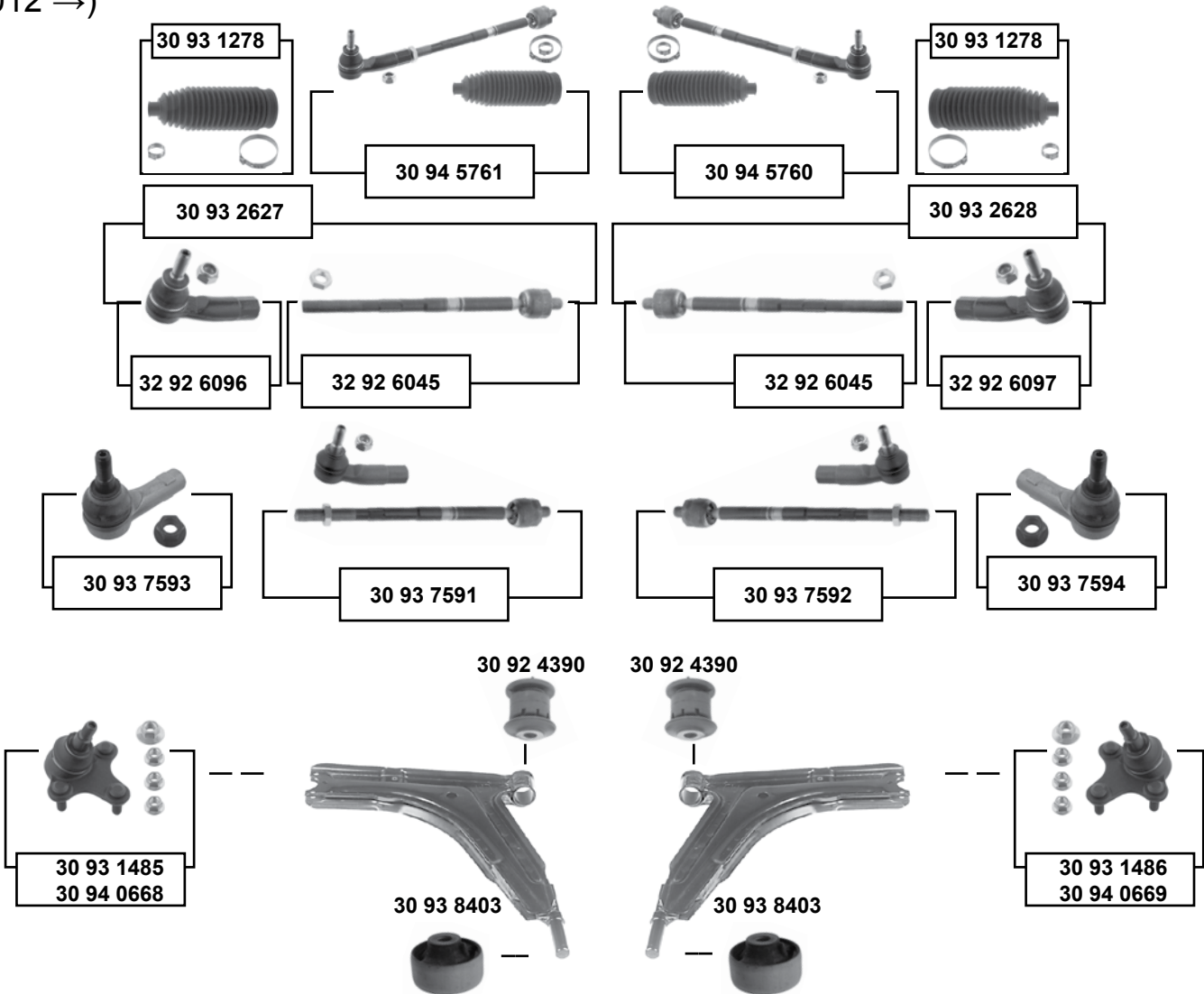

i (1) für Bremsscheibendicke / for brake disk thickness 25 mm /
für Bremsscheibendurchmesser / for brake disk diameter 288 mm

SWAG	Ref. - No.		i	
30 92 4390	1K0 407 182	Querlenkerlager / control arm mount		Ø A 48 H 54 Ø I 15,5 L190
30 93 1278	1K0 423 831 A S1	Rep. Satz Lenkmanschette / rep. kit steering boot		
30 93 1485	3C0 407 365 A S1	Rep. Satz Traggelenk / rep. kit ball joint	PR-1LG / 1ZA	
30 93 1486	3C0 407 366 A S1	Rep. Satz Traggelenk / rep. kit ball joint	PR-1LG / 1ZA	
30 93 2627	1K0 423 810 A S1	Rep. Satz Spurstange / rep. kit tie rod	PR-1N3/1N7 / RHT	
30 93 2628	1K0 423 810 A S2	Rep. Satz Spurstange / rep. kit tie rod	PR-1N3/1N7 / RHT	
30 93 7591	1K0 423 811 K S1	Rep. Satz Spurstange / rep. kit tie rod		L 448
30 93 7592	1K0 423 812 K S1	Rep. Satz Spurstange / rep. kit tie rod		L 448
30 93 7593	1K0 423 811 K	Spurstangenendstück / tie rod end		M16 x 1,5
30 93 7594	1K0 423 812 K	Spurstangenendstück / tie rod end		M16 x 1,5
30 93 8403	5Q0 407 183 E	Querlenkerlager / control arm mount	5E / NL3	Ø A 65
30 94 0668	5Q0 407 365 A S1	Rep. Satz Traggelenk / rep. kit ball joint	(1) PR-1ZE / 1ZP	
30 94 0669	5Q0 407 366 A S1	Rep. Satz Traggelenk / rep. kit ball joint	(1) PR-1ZE / 1ZP	
30 94 5760	1K0 423 810 A S4	Rep. Satz Spurstange / rep. kit tie rod	PR-1N3/1N7 / RHT	
30 94 5761	1K0 423 810 A S3	Rep. Satz Spurstange / rep. kit tie rod	PR-1N3/1N7 / RHT	
32 92 6045	1K0 423 810 A	Axialgelenk / axial joint		
32 92 6096	1K0 423 811 E	Spurstangenendstück / tie rod end	PR-1N3/1N7 / RHT	
32 92 6097	1K0 423 812 E	Spurstangenendstück / tie rod end	PR-1N3/1N7 / RHT	



Pick-Up (6U)
(1996 → 2001)



30 92 9644



30 92 9644



Vorderachse / Front axle



passend für / to fit

ŠKODA



Rapid (NH/NK)

(2012 →)

Vorderachse / Front axle

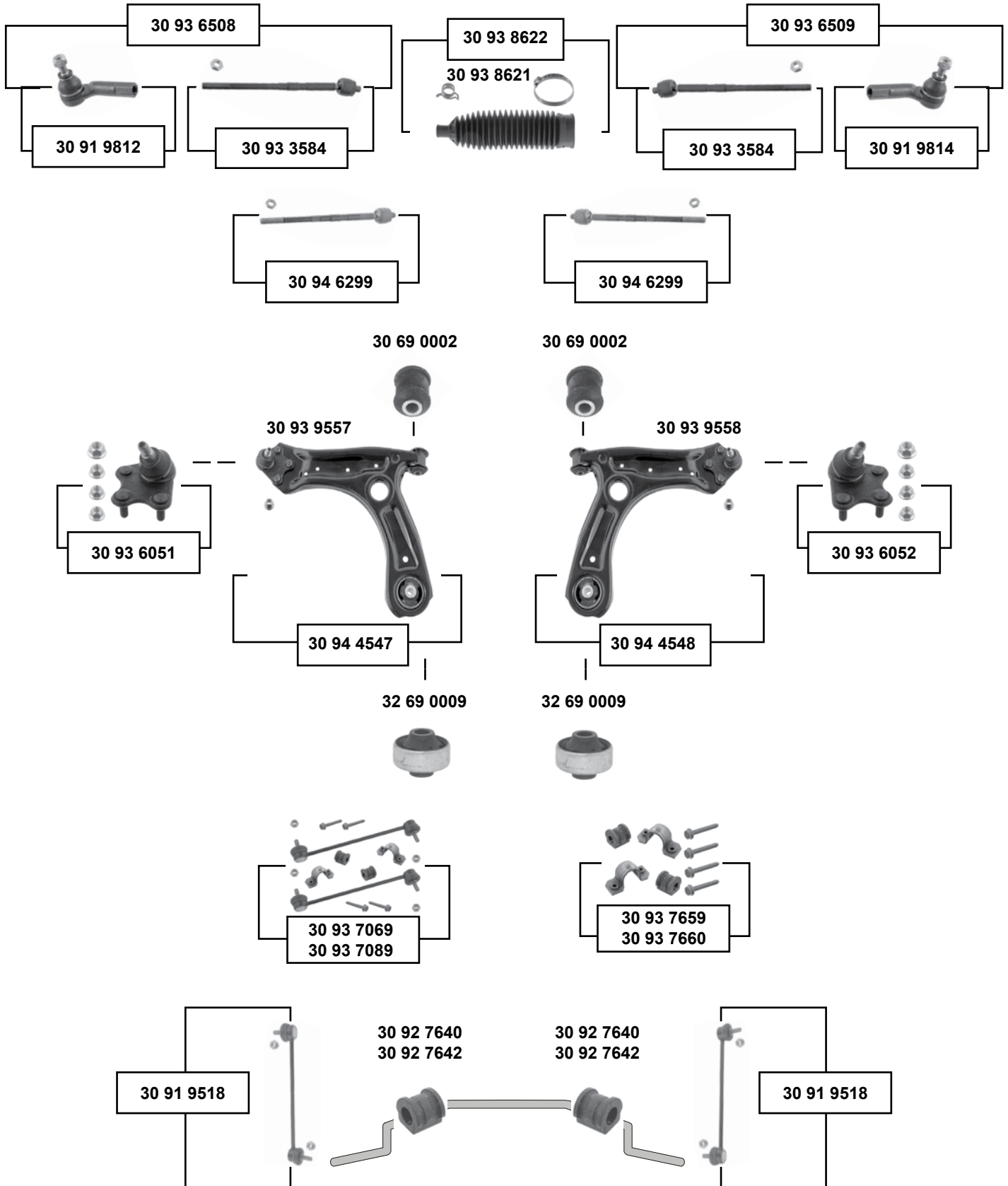



Rapid (NH/NK) (2012 →)



(1) PR-1N2 / PR-1AC / PR-1AT / PR-G0C / PR-G0K / PR-G1C // E-hydr.



Ref. - No.



SWAG Ref. - No.	Description	Notes	Dimensions
30 69 0002	357 407 182	Querlenkerlager / control arm mount	Ø A 33
30 91 9518	6Q0 411 315 Q	Verbindungsstange / connecting rod	
30 91 9812	6R0 423 811	Spurstangenendstück / tie rod end	(1)
30 91 9814	6R0 423 812	Spurstangenendstück / tie rod end	(1)
30 92 7640	6Q0 411 314 Q	Stabilisatorlager / stabilizer mount	PR-0AR Ø I 19
30 92 7642	6Q0 411 314 R	Stabilisatorlager / stabilizer mount	PR-0AS Ø I 20
30 93 3584	6R0 423 810 A	Axialgelenk / axial joint	PR-1N2 E-hydr.
30 93 6051	6R0 407 365 A	Traggelenk / ball joint	
30 93 6052	6R0 407 366 A	Traggelenk / ball joint	
30 93 6508	6R0 423 803 A	Spurstange, komplett / tie rod, complete	PR-1N2 E-hydr.
30 93 6509	6R0 423 804 A	Spurstange, komplett / tie rod, complete	PR-1N2 E-hydr.
30 93 7069	6Q0 411 314 Q S1	Stabilisatorlagersatz / anti roll bar bush kit	PR-0AR
30 93 7089	6Q0 411 314 R S2	Stabilisatorlagersatz / anti roll bar bush kit	PR-0AS
30 93 7659	6Q0 411 314 R S4	Stabilisatorlagersatz / anti roll bar bush kit	PR-0AS Ø I 20
30 93 7660	6Q0 411 314 Q S2	Stabilisatorlagersatz / anti roll bar bush kit	PR-0AR Ø I 19
30 93 8621	6Q0 423 831 D	Lenkmanschette / steering boot	PR-1N2
30 93 8622	6Q0 423 831 D S1	Rep. Satz Lenkmanschette / rep. kit steering boot	PR-1N2
30 93 9557	6R0 407 151 F	Querlenker / control arm	
30 93 9558	6R0 407 152 F	Querlenker / control arm	
30 94 4547	6R0 407 151 F S1	Querlenker, kpl. / control arm, cpl.	
30 94 4548	6R0 407 152 F S1	Querlenker, kpl. / control arm, cpl.	
30 94 6299	6C0 423 810 C	Axialgelenk / axial joint	PR-1N2, 1N3
32 69 0009	1J0 407 181	Querlenkerlager / control arm mount	Ø A 60 Ø I 13



Roomster (5J)

(2006 →)

Vorderachse / Front axle

man. 

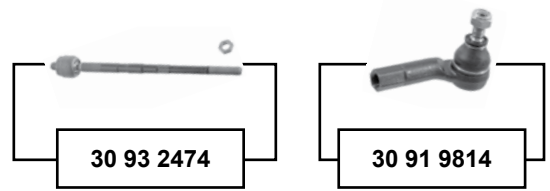
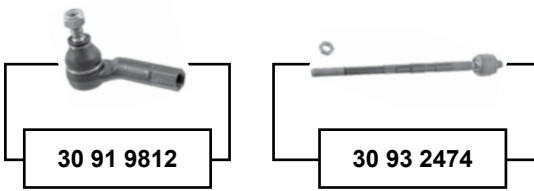

für / to fit servo  TRW

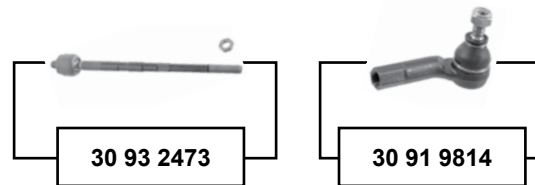
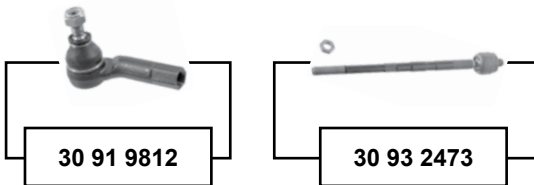





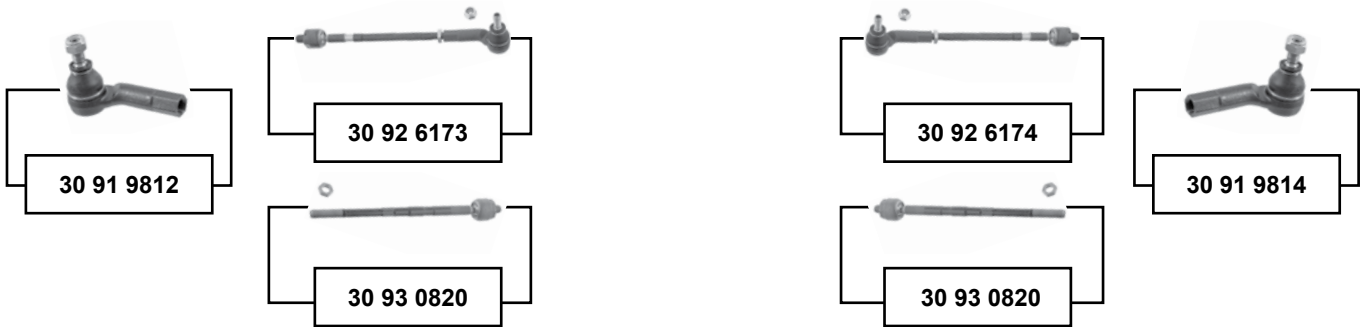

Roomster (5J)
(2006 →)

für / to fit servo  **KOYO**



Vorderachse / Front axle

	Ref. - No.			
30 91 9812	6R0 423 811	Spurstangenendstück / tie rod end		
30 91 9814	6R0 423 812	Spurstangenendstück / tie rod end		
30 91 9816	6Q0 423 803 P	Spurstange / tie rod		
30 91 9818	6Q0 423 804 P	Spurstange / tie rod		
30 92 6173	6Q0 423 803 G	Rep. Satz Spurstange / rep. kit tie rod		
30 92 6174	6Q0 423 804 G	Rep. Satz Spurstange / rep. kit tie rod		
30 93 0820	6Q0 423 810 C	Spurstange / tie rod		
30 93 2473	6Q0 423 810 P	Rep. Satz Axialgelenk / rep. kit axial joint		M14 x 1,5
30 93 2474	6Q0 419 810 B	Rep. Satz Axialgelenk / rep. kit axial joint		M14 x 1,5
30 94 4343	6Q0 423 803 P S1	Rep. Satz Spurstange / rep. kit tie rod		
30 94 4344	6Q0 423 804PE S1	Rep. Satz Spurstange / rep. kit tie rod		



Roomster (5J)

(2006 →)

Vorderachse / Front axle

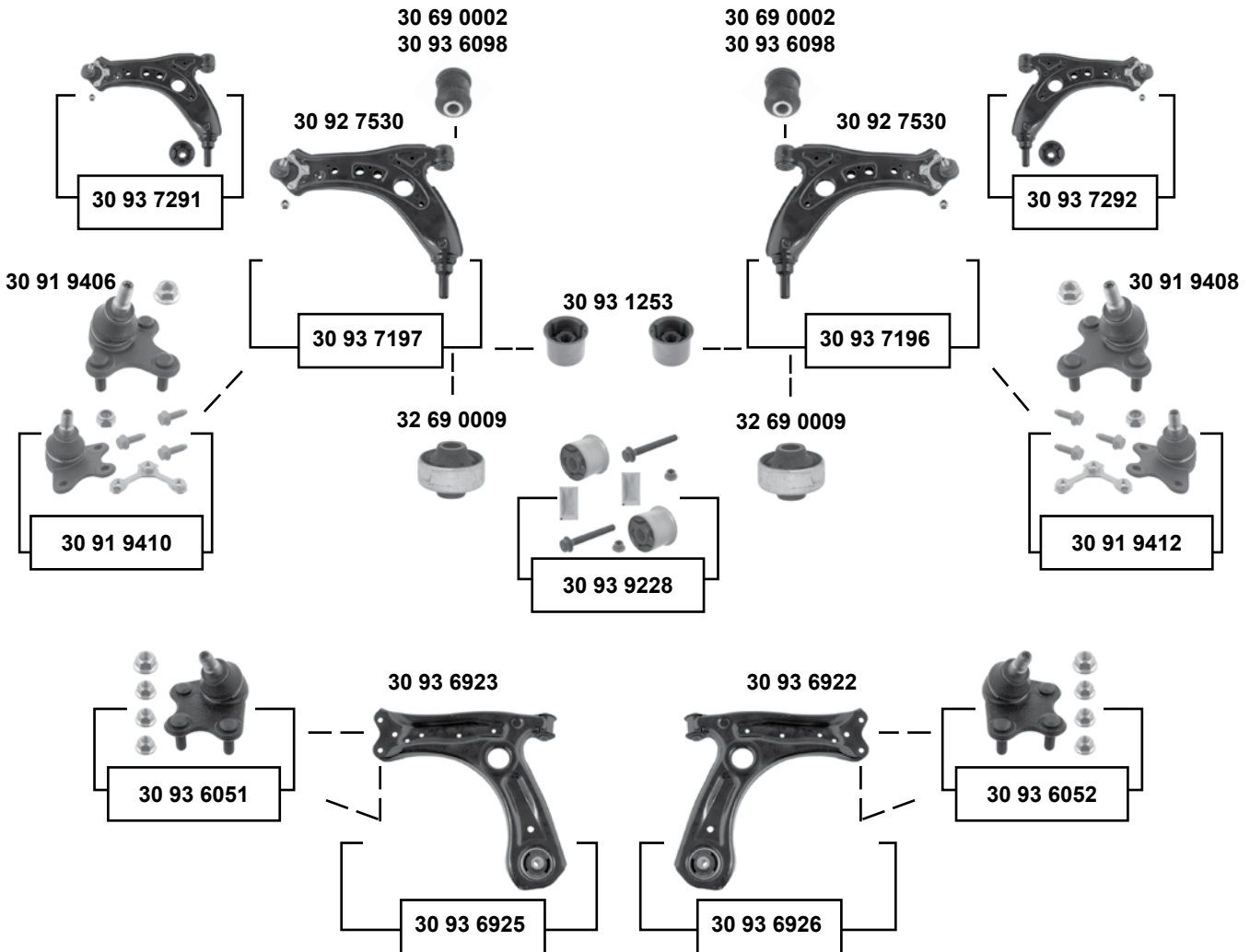



Roomster (5J) (2006 →)

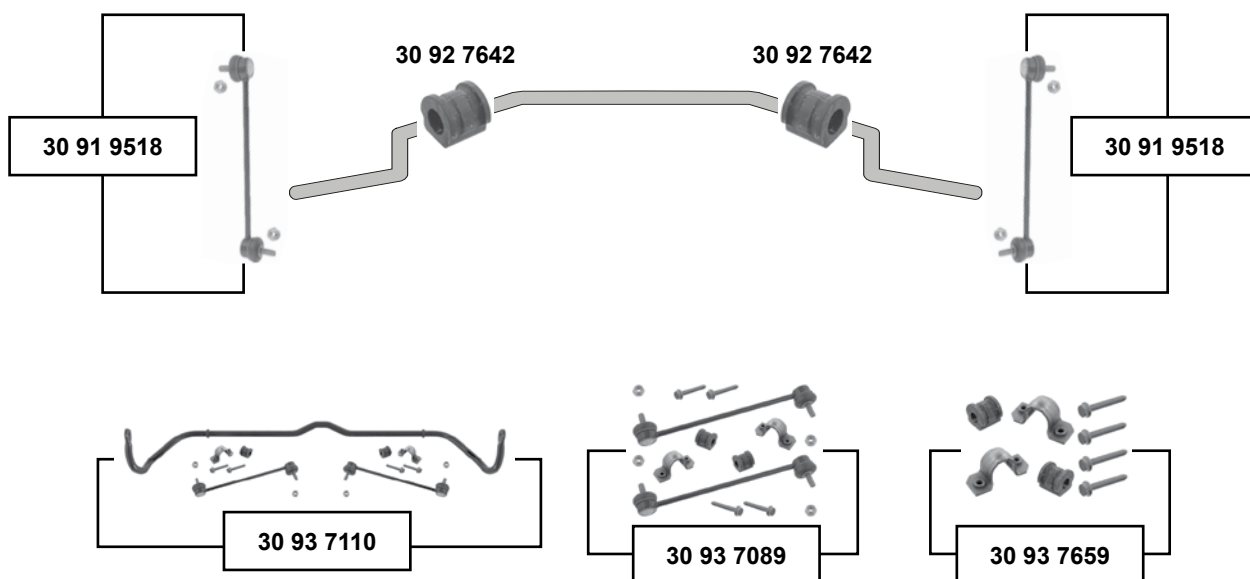

- (1) 08 → 10 (ch.) 5J-8B600 705 → / (ch.) 5J-85069 021 → / 11 → alle / all
- (2) → 08 (ch.) → 5J-8B600 704 / (ch.) → 5J-85069 020
- (3) (ch.) → 5J-8B600 704 / (ch.) → 5J-85069 020
- (4) → 10 (ch.) → 5J-9B600 824 / (ch.) → 5J-95032 968
- (5) (ch.) 5J-8B600 787 → / (ch.) 5J-850 666 688 →
- (6) → 09 (ch.) 5J-CB-600 095 → / (ch.) 5J-C7-009 705 →
- (7) (ch.) → 5J-8B600 704 / (ch.) → 5J-85069 020

Vorderachse / Front axle



SWAG	Ref. - No.			
30 69 0002	357 407 182	Querlenkerlager / control arm mount	(1)	Ø A 33
30 91 9406	6Q0 407 365 M	Traggelenk / ball joint		
30 91 9408	6Q0 407 366 A	Traggelenk / ball joint		
30 91 9410	6Q0 407 365 M S1	Rep. Satz Traggelenk / rep. kit ball joint	(3)	
30 91 9412	6Q0 407 366 A S1	Rep. Satz Traggelenk / rep. kit ball joint	(3)	
30 91 9518	6Q0 411 315 Q	Verbindungsstange / connecting rod	(4)	
30 92 7530	6Q0 407 151 L	Querlenker / control arm		
30 92 7642	6Q0 411 314 R	Stabilisatorlager / stabilizer mount	PR-0AS	Ø I 18
30 93 1253	1K0 407 183 E	Querlenkerlager / control arm mount	(2)	Ø A 63
30 93 6051	6R0 407 365 A	Traggelenk / ball joint	(5)	
30 93 6052	6R0 407 366 A	Traggelenk / ball joint	(5)	
30 93 6098	6Q0 407 182 A	Querlenkerlager / control arm mount	(2)	Ø A 32
30 93 6922	6R0 407 152 E	Querlenker / control arm	(5)	
30 93 6923	6R0 407 151 E	Querlenker / control arm	(5)	
30 93 6925	6R0 407 151 E S1	Rep. Satz Querlenker / rep. kit control arm	(6)	
30 93 6926	6R0 407 152 E S1	Rep. Satz Querlenker / rep. kit control arm	(6)	
30 93 7089	6Q0 411 314 R S2	Stabilisatorlagersatz / anti roll bar bush kit	PR-0AS	
30 93 7110	6Q0 411 305 AN S2	Rep. Satz Stabilisatorsatz / rep. kit stabilizer kit	PR-0AS	
30 93 7196	6Q0 407 151 L S3	Rep. Satz Querlenker / rep. kit control arm		
30 93 7197	6Q0 407 151 L S2	Rep. Satz Querlenker / rep. kit control arm		
30 93 7291	6Q0 407 151 L S5	Rep. Satz Querlenker / rep. kit control arm		
30 93 7292	6Q0 407 151 L S4	Rep. Satz Querlenker / rep. kit control arm		
30 93 7659	6Q0 411 314 R S4	Stabilisatorlagersatz / anti roll bar bush kit	PR-0AS	Ø I 18
30 93 9228	1K0 407 183 E S1	Querlenkerlagersatz / control arm mounting kit	(7)	
32 69 0009	1J0 407 181	Querlenkerlager / control arm mount	(1)	



Superb (3U) (2002 → 2008)

Vorderachse / Front axle

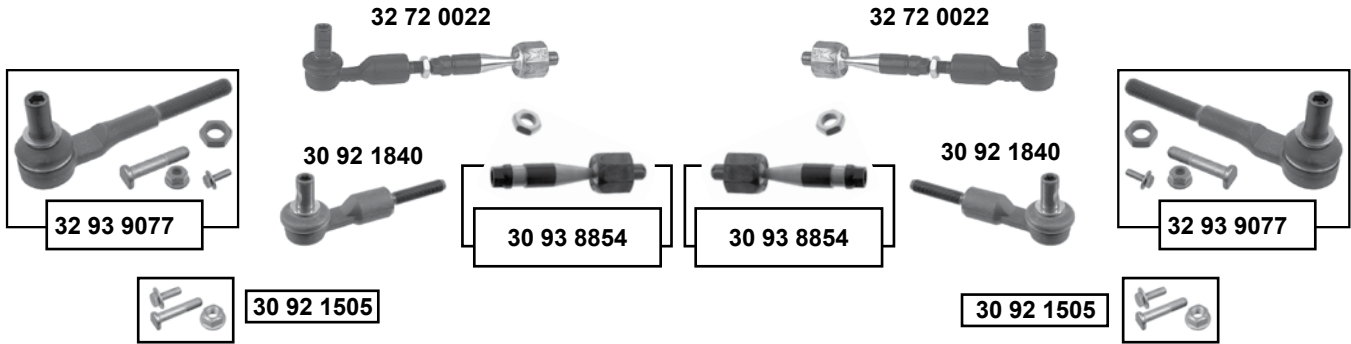

oben / upper

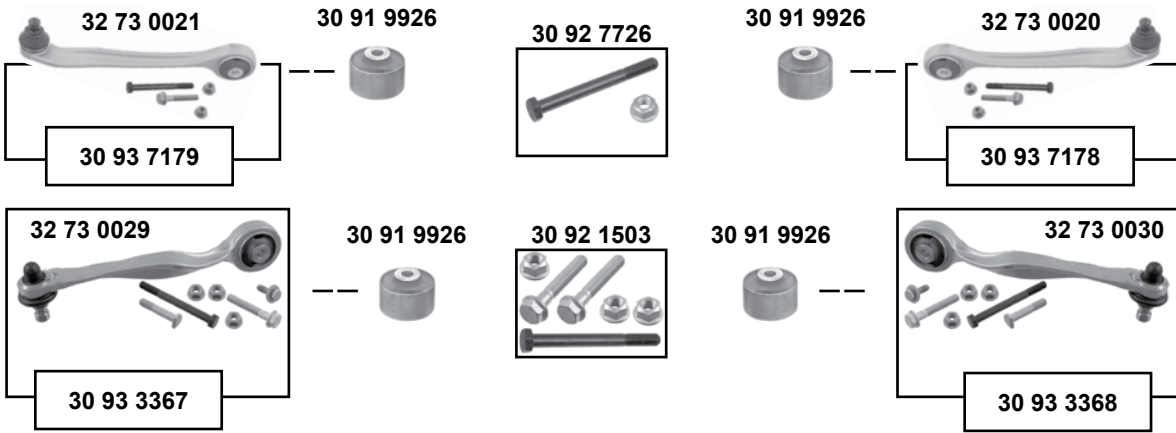

unten / lower

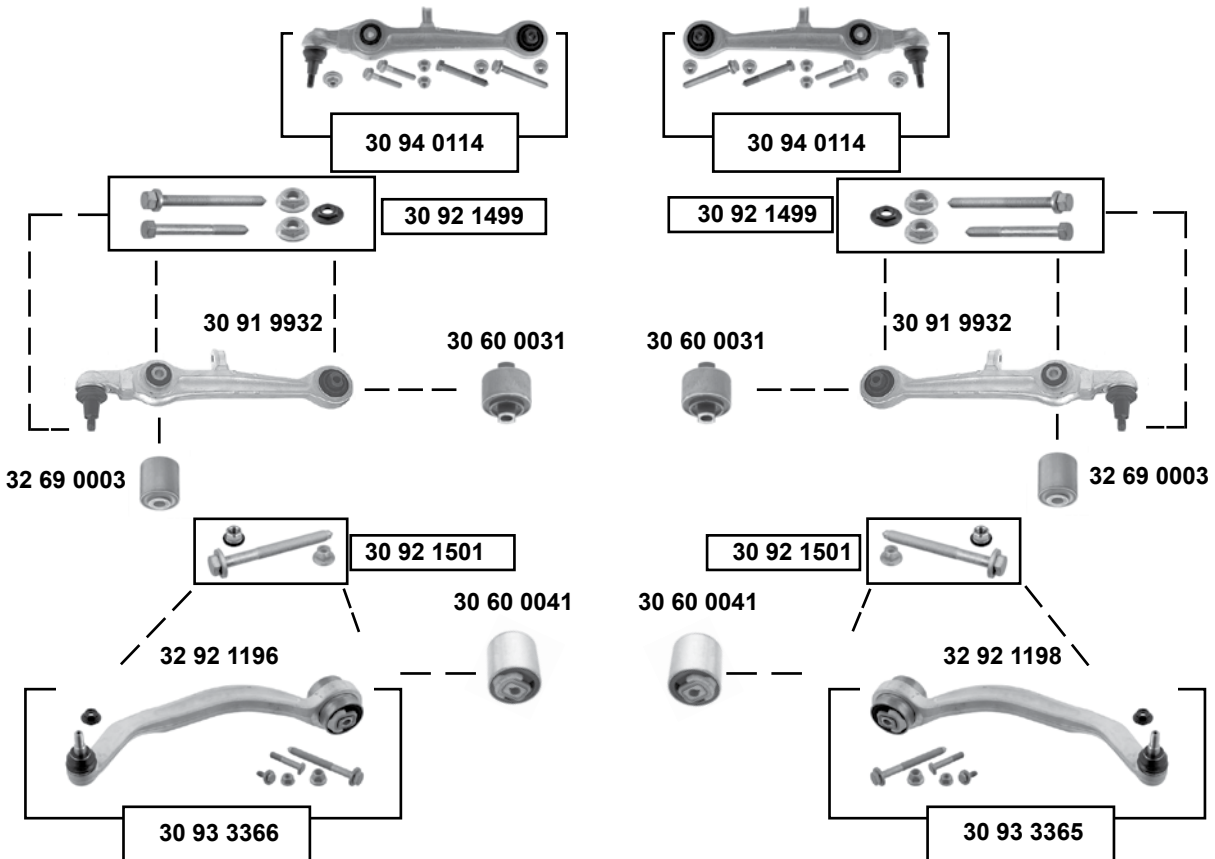



Superb (3U) (2002 → 2008)

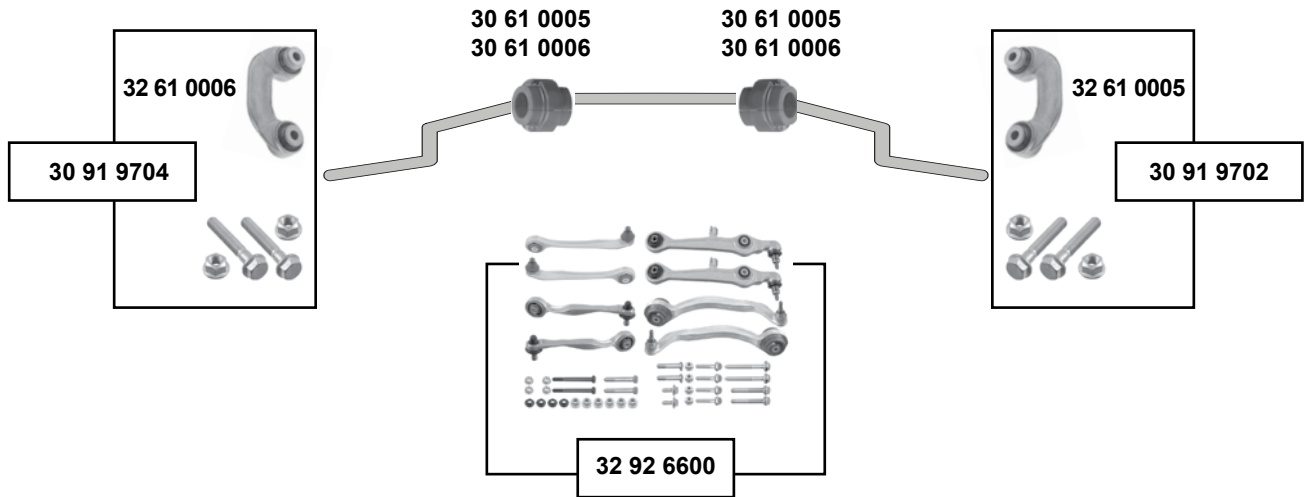

Vorderachse / Front axle



(1) (ch.) → 3U-6A300 290 // (ch.) → 32U-69116 637



Ref. - No.



30 60 0031	4D0 407 182 G	Querlenkerlager / control arm mount		Ø 12 H 60
30 60 0041	4D0 407 183 AC	Querlenkerlager / control arm mount		
30 61 0005	4D0 411 327 G	Stabilisatorlager / stabilizer mount		Ø 25
30 61 0006	4D0 411 327 H	Stabilisatorlager / stabilizer mount		Ø 27
30 91 9702	8D0 411 318 D S1	Rep. Satz Verbindungsstange / rep. kit connecting rod		
30 91 9704	8D0 411 317 D S1	Rep. Satz Verbindungsstange / rep. kit connecting rod		
30 91 9926	4B0 407 515	Querlenkerlager / control arm mount	(ch.) 3U-3-021 398 →	
30 91 9932	4B3 407 151 K	Querlenker / control arm	(ch.) 3U-3-021 398 →	
30 92 1501	-	Schraubensatz / screw kit		
30 92 1503	-	Schraubensatz / screw kit		
30 92 1505	-	Schraubensatz / screw kit		
30 92 1840	4F0 498 811 A SK	Spurstangenendstück / tie rod end		
30 92 7726	N 034 790 8 S1	Montagesatz / mounting kit		
30 93 3366	8E0 407 693 AG S1	Querlenker / control arm		
30 93 3365	8E0 407 694 AG S1	Querlenker / control arm		
30 93 3367	8E0 407 509 A S1	Querlenker / control arm		
30 93 3368	8E0 407 510 A S1	Querlenker / control arm		
30 93 7178	8E0 407 506 A S1	Querlenker / control arm		
30 93 7179	8E0 407 505 A S2	Querlenker / control arm		
30 93 8854	4B0 419 810 M	Axialgelenk / axial joint	(1)	
30 94 0114	4B3 407 151 K S1	Rep. Satz Querlenker / rep. kit control arm	(ch.) 3U-3-021 398 →	
32 61 0005	8D0 411 318 D	Verbindungsstange / connecting rod	(ex.) 4WD	
32 61 0006	8D0 411 317 D	Verbindungsstange / connecting rod	(ex.) 4WD	
32 69 0003	4D0 407 181 H	Querlenkerlager / control arm mount		12x40x50
32 72 0022	4B0 419 801 M	Spurstange / tie rod		
32 73 0017	4D0 407 151 P	Querlenker / control arm	(ch.) → 3U-3-021 397	
32 73 0020	8E0 407 506 A	Querlenker mit Gummilager / control arm with rubber mount		Alu
32 73 0021	8E0 407 505 A	Querlenker mit Gummilager / control arm with rubber mount		Alu
32 73 0029	8E0 407 509 A	Querlenker / control arm		
32 73 0030	8E0 407 510 A	Querlenker / control arm		
32 92 1196	8E0 407 693 AG	Querlenker, <u>hinten</u> / control arm, <u>rear</u>		Alu
32 92 1198	8E0 407 694 AG	Querlenker, <u>hinten</u> / control arm, <u>rear</u>		Alu
32 92 1499	-	Schraubensatz / screw kit		
32 92 6600	8D0 498 998 B	Querlenkersatz / control arm kit	(ch.) → 3U-3-021 397	
32 93 9077	4F0 498 811 A S1	Spurstangenendstück / tie rod end		

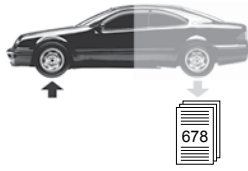

Superb (3T) (2008 →)

Vorderachse / Front axle

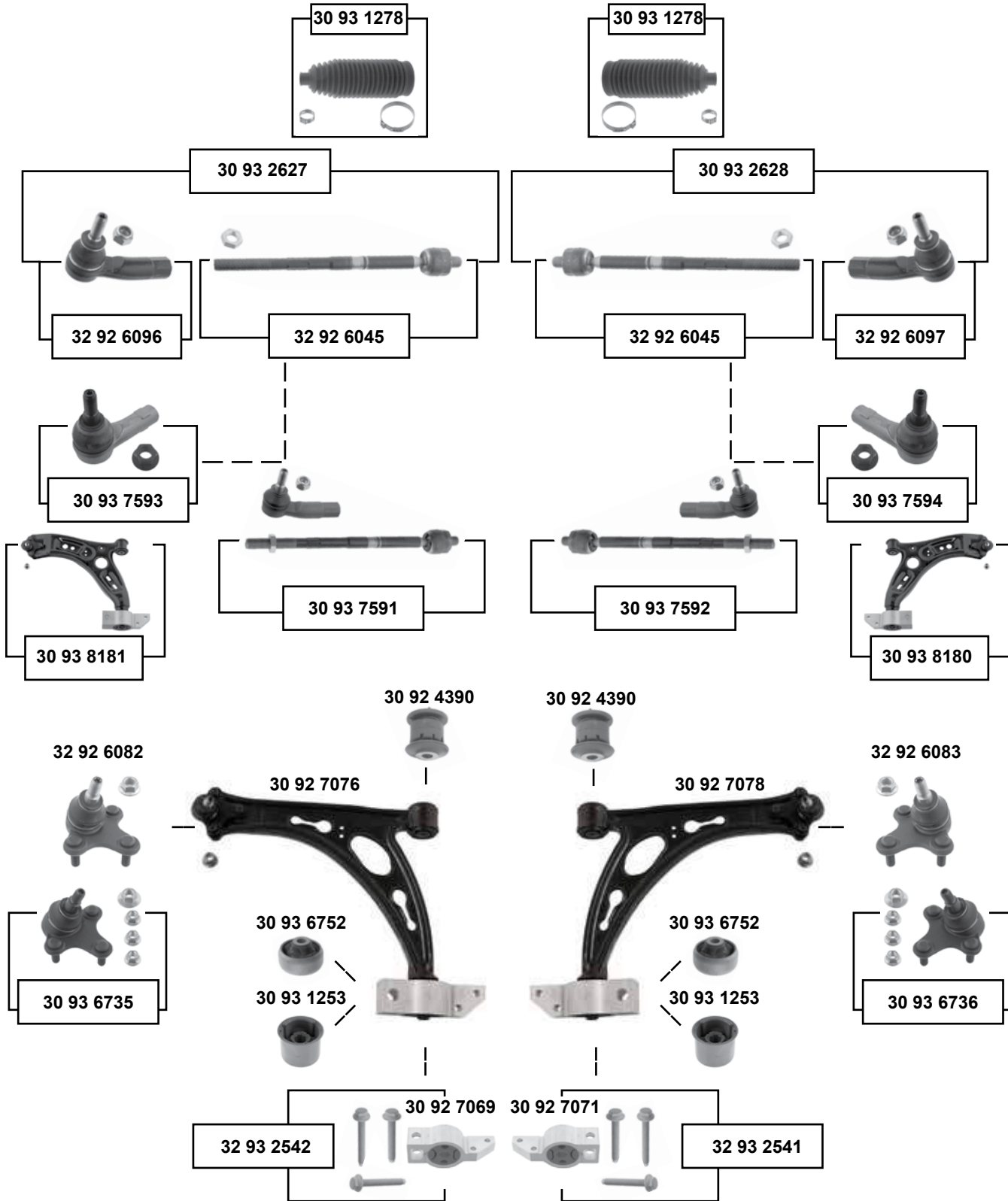

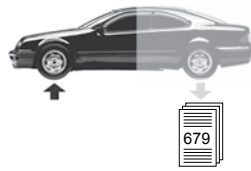

Superb (3T) (2008 →)

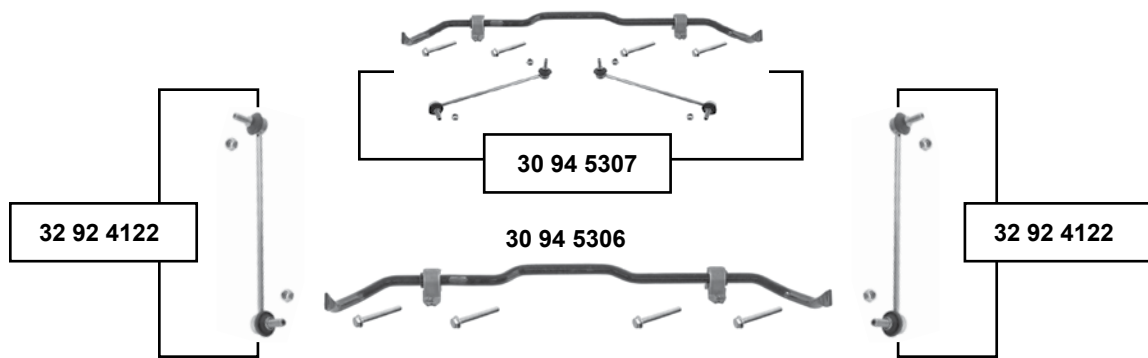

Vorderachse / Front axle



(1) Gummimetalllager / rubber metal mount

SWAG	Ref. - No.			
30 92 4390	1K0 407 182	Querlenkerlager / control arm mount		Ø A 48 H 54
30 92 7069	1K0 199 231 J	Querlenkerlager mit Gehäuse / control arm mount with housing		
30 92 7071	1K0 199 232 J	Querlenkerlager mit Gehäuse / control arm mount with housing		
30 92 7076	1K0 407 151 AC	Querlenker, kpl. / control arm, cpl.		
30 92 7078	1K0 407 152 AC	Querlenker, kpl. / control arm, cpl.		
30 93 1253	1K0 407 183 E	Querlenkerlager / control arm mount		Ø A 63
30 93 1278	1K0 423 831 A S1	Rep. Satz Lenkmanschette / rep. kit steering boot		Ø I 15,5 L190
30 93 2627	1K0 423 810 A S1	Rep. Satz Spurstange / rep. kit tie rod		
30 93 2628	1K0 423 810 A S2	Rep. Satz Spurstange / rep. kit tie rod		
30 93 6735	1K0 407 365 C S1	Rep. Satz Traggelenk / rep. kit ball joint		
30 93 6736	1K0 407 366 C S1	Rep. Satz Traggelenk / rep. kit ball joint		
30 93 6752	1K0 407 183 P	Querlenkerlager / control arm mount	(1)	Ø I 13
30 93 7591	1K0 423 811 K S1	Rep. Satz Spurstange / rep. kit tie rod		L 448
30 93 7592	1K0 423 812 K S1	Rep. Satz Spurstange / rep. kit tie rod		L 448
30 93 7593	1K0 423 811 K	Spurstangenendstück / tie rod end	→ 10	M16 x 1,5
30 93 7594	1K0 423 812 K	Spurstangenendstück / tie rod end	→ 10	M16 x 1,5
30 93 8180	1K0 407 152 BC S1	Rep. Satz Querlenker / rep. kit control arm	Stahl / steel	
30 93 8181	1K0 407 151 BC S1	Rep. Satz Querlenker / rep. kit control arm	Stahl / steel	
30 94 5306	1K0 411 303 BK S1	Stabilisatorsatz / stabilizer kit	PR-0AE	
30 94 5307	1K0 411 303 BK S2	Rep. Satz Stabilisatorsatz / rep. kit stabilizer kit	PR-0AE	
32 92 4122	1K0 411 315 R	Verbindungsstange / connecting rod		
32 92 6045	1K0 423 810 A	Axialgelenk / axial joint		
32 92 6082	1K0 407 365 C	Traggelenk / ball joint		
32 92 6083	1K0 407 366 C	Traggelenk / ball joint		
32 92 6096	1K0 423 811 E	Spurstangenendstück / tie rod end		
32 92 6097	1K0 423 812 E	Spurstangenendstück / tie rod end		
32 93 2541	1K0 199 232 J S1	Rep. Satz Querlenkerlagersatz / rep. kit control arm mounting kit		
32 93 2542	1K0 199 231 J S1	Rep. Satz Querlenkerlagersatz / rep. kit control arm mounting kit		

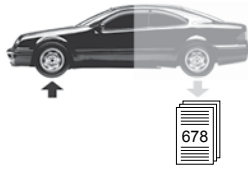

Yeti 4x4 (5L)

(2010 →)

Vorderachse / Front axle

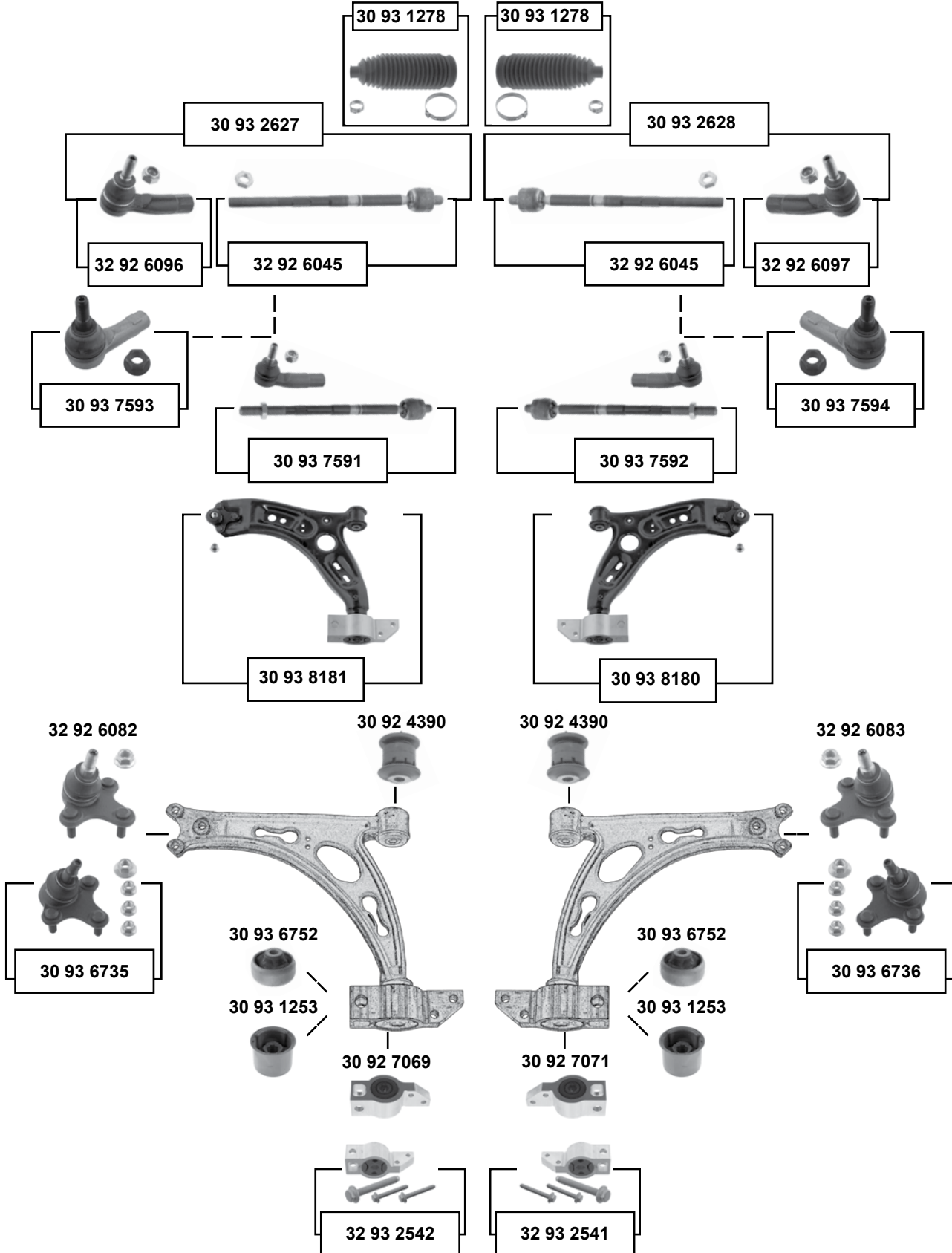

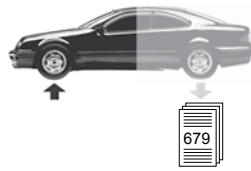

Yeti 4x4 (5L) (2010 →)

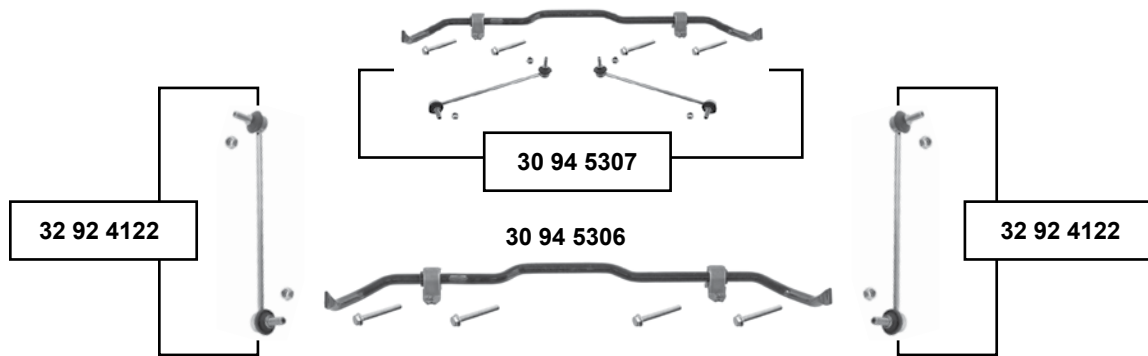

Vorderachse / Front axle



(1) Gummimetalllager / rubber metal mount



Ref. - No.



Ref. - No.	Description	Material	Dimensions
30 92 4390	Querlenkerlager / control arm mount		Ø A 48 H 54
30 92 7069	Querlenkerlager mit Gehäuse / control arm mount with housing		
30 92 7071	Querlenkerlager mit Gehäuse / control arm mount with housing		
30 93 1253	Querlenkerlager / control arm mount		Ø A 63
30 93 1278	Rep. Satz Lenkmanschette / rep. kit steering boot		Ø I 15,5 L190
30 93 2627	Rep. Satz Spurstange / rep. kit tie rod		
30 93 2628	Rep. Satz Spurstange / rep. kit tie rod		
30 93 6735	Rep. Satz Traggelenk / rep. kit ball joint		
30 93 6736	Rep. Satz Traggelenk / rep. kit ball joint		
30 93 6752	Querlenkerlager / control arm mount	(1)	Ø I 13
30 93 7591	Rep. Satz Spurstange / rep. kit tie rod		L 448
30 93 7592	Rep. Satz Spurstange / rep. kit tie rod		L 448
30 93 7593	Spurstangenendstück / tie rod end		M16 x 1,5
30 93 7594	Spurstangenendstück / tie rod end		M16 x 1,5
30 93 8180	Rep. Satz Querlenker / rep. kit control arm	Stahl / steel	
30 93 8181	Rep. Satz Querlenker / rep. kit control arm	Stahl / steel	
30 94 5306	Stabilisatorsatz / stabilizer kit	PR-0AE	
30 94 5307	Rep. Satz Stabilisatorsatz / rep. kit stabilizer kit	PR-0AE	
32 92 4122	Verbindungsstange / connecting rod		
32 92 6045	Axialgelenk / axial joint		
32 92 6082	Traggelenk / ball joint		
32 92 6083	Traggelenk / ball joint		
32 92 6096	Spurstangenendstück / tie rod end		
32 92 6097	Spurstangenendstück / tie rod end		
32 93 2541	Rep. Satz Querlenkerlagersatz / rep. kit control arm mounting kit		
32 93 2542	Rep. Satz Querlenkerlagersatz / rep. kit control arm mounting kit		



City Coupé / Cabrio
(1998 → 2004)

Vorderachse / Front axle

12 92 7569

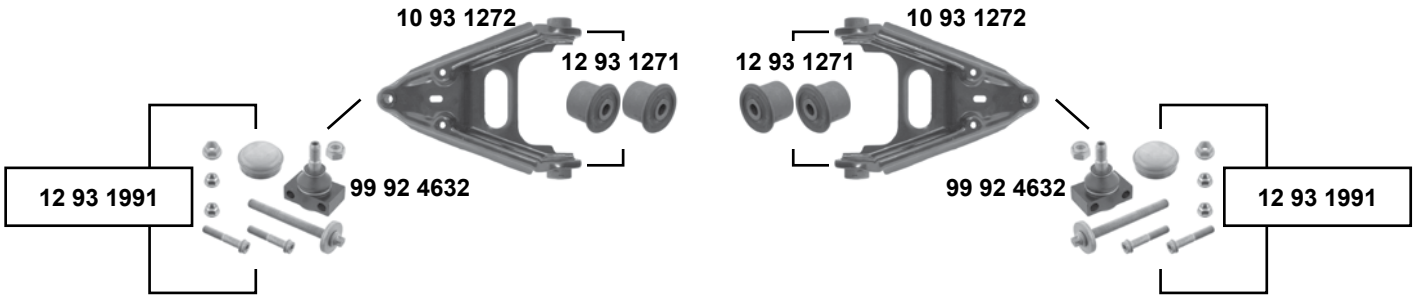

Ref. - No.



10 93 1272	0014141V002000000	Querlenker / control arm
12 92 7569	0004873V002	Lenkungsdämpfer / steering-damper
12 93 1271	451 333 00 10	Querlenkerlagersatz / rubber mount
12 93 1991	0015642V002000S2	Traggelenk / ball joint
99 92 4632	0002271V009000	Traggelenk / ball joint



Crossblade (2002 →)

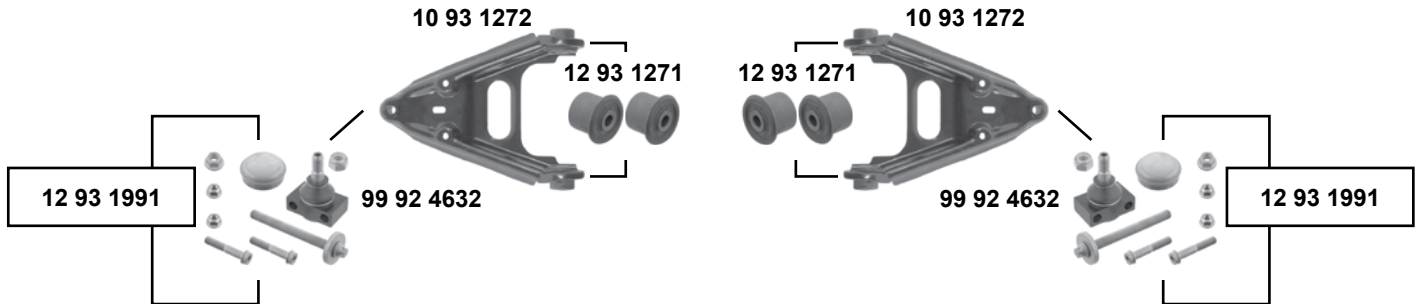

Forfour (BM 454) (2004 →)

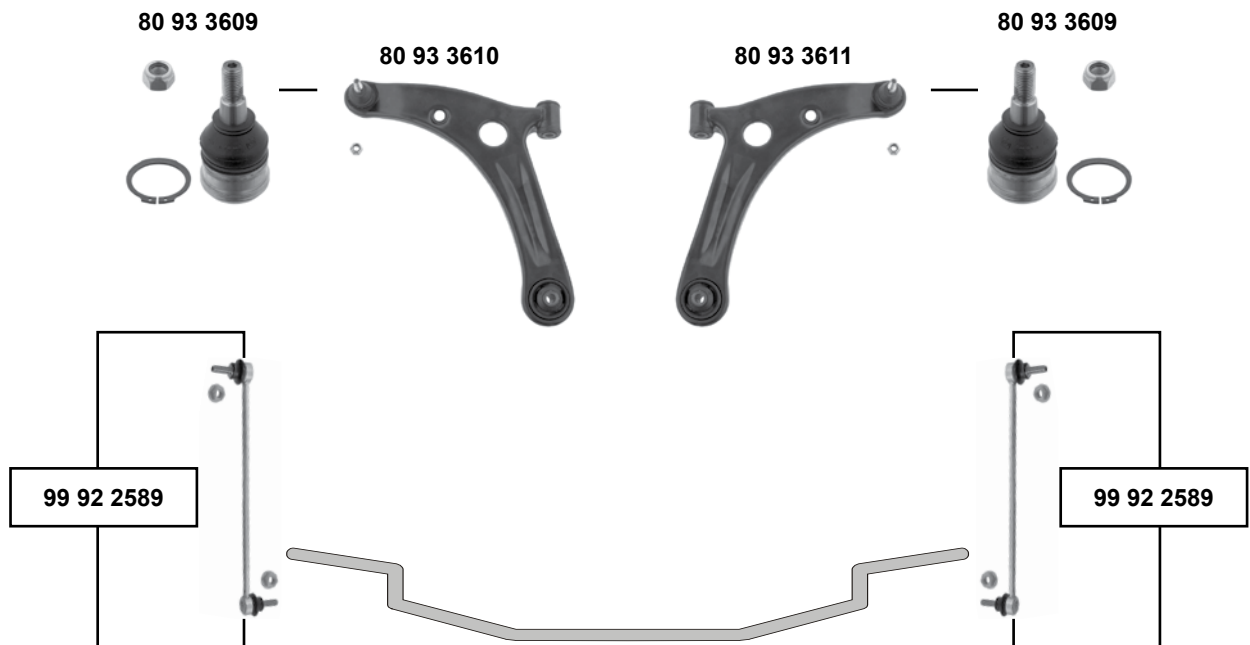

Vorderachse / Front axle



(1) (ex) : 1,1 / 1,5 Brabus



Ref. - No.



10 93 1272	0014141V002000000	Querlenker / control arm		
12 93 1271	451 333 00 10	Querlenkerlagersatz / rubber mount		
12 93 1991	0015642V002000S2	Rep. Satz Traggelenk / rep. kit ball joint		
80 93 3609	454 333 01 27	Traggelenk / ball joint	(1)	M12 x 1,5
80 93 3610	454 330 07 07	Querlenker / control arm	(1)	M12 x 1,5
80 93 3611	454 330 08 07	Querlenker / control arm	(1)	M12 x 1,5
99 92 2589	454 320 00 10 S1	Verbindungsstange / connecting rod		L175
99 92 4632	2271V00900000	Traggelenk / ball joint		

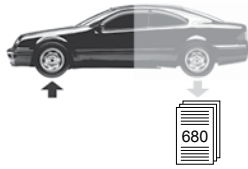

Fortwo / Cabrio (BM 450)

(2004 →)

Vorderachse / Front axle

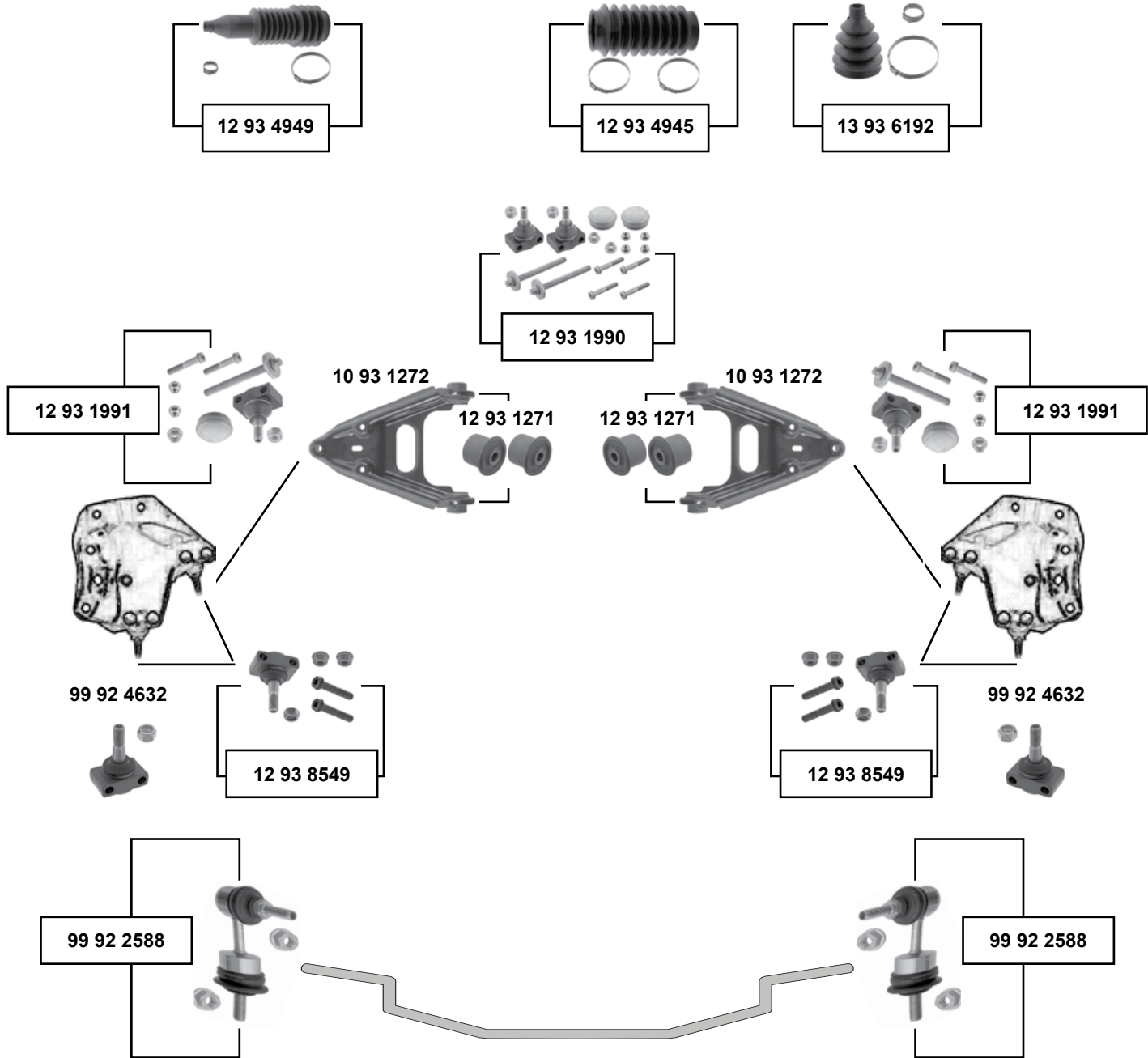

Ref. - No.



10 93 1272	0014141V002000000	Querlenker / control arm		
12 93 1271	451 333 00 10	Querlenkerlagersatz / rubber mount		
12 93 1990	0015642V002000000	Traggelenksatz / ball joint kit		
12 93 1991	0015642V002000S2	Traggelenk / ball joint		
12 93 4945	Q0004914V002000000S1	Rep. Satz Lenkmanschette / rep. kit steering boot	links / left	Ø 49 / L 136
12 93 4949	451 460 00 96	Rep. Satz Lenkmanschette / rep. kit steering boot		Ø 49,9 / 14,6 L 206
13 93 6192	Q0005374V001000000S1	Rep. Satz Lenkmanschette / rep. kit steering boot		Ø 49,9 / 14,6 L 136
12 93 8549	2271V007000005 S2	Traggelenk / ball joint		
99 92 2588	5102V005	Verbindungsstange / connecting rod		L 135
99 92 4632	0002271V009000	Traggelenk / ball joint		



Fortwo / Cabrio / Coupé (BM 451)
(2007 →)

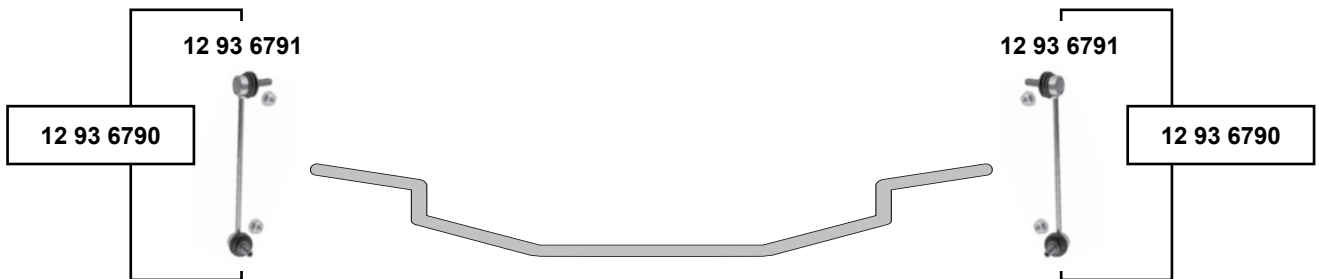
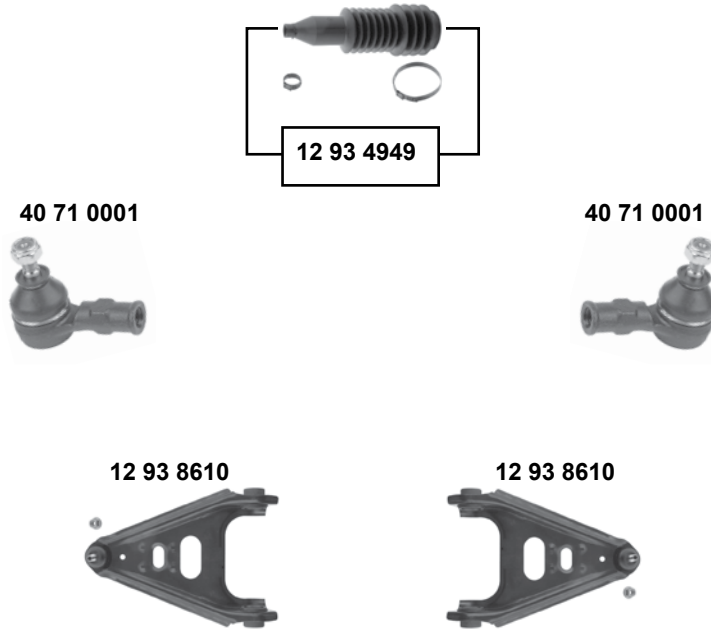

Vorderachse / Front axle



(1) nur für mechanische Lenkung beidseitig / only for mechanical steering both side



Ref. - No.



12 93 4949	451 460 00 96	Rep. Satz Lenkmanschette / rep. kit steering boot	(1)	Ø I 49,9 / 14,6 L206
12 93 6790	451 320 01 89 S1	Verbindungsstange / connecting rod		
12 93 6791	451 320 01 89	Verbindungsstange / connecting rod		
12 93 8610	451 330 00 10 S1	Querlenker / control arm		M12 x 1,5
40 71 0001	451 338 01 37 S1	Spurstangenendstück / tie rod end		M12 x 1,5



Roadster (BM 452)
(2003 → 2007)

Vorderachse / Front axle

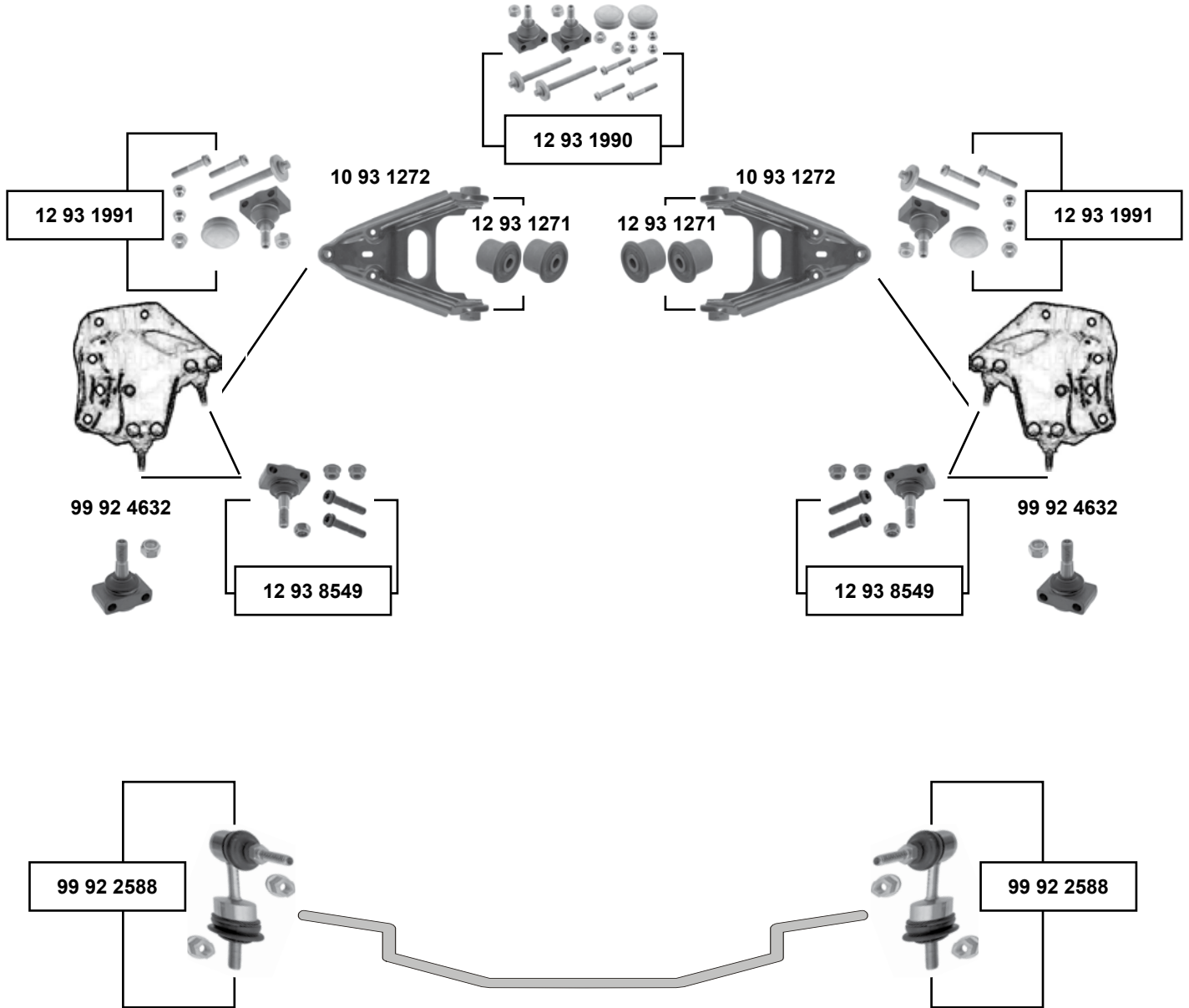

	Ref. - No.			
10 93 1272	0014141V002000000	Querlenker / control arm		
12 93 1271	451 333 00 10	Querlenkerlagersatz / rubber mount		
12 93 1990	0015642V002000000	Traggelenksatz / ball joint kit		
12 93 1991	0015642V002000S2	Traggelenk / ball joint		
12 93 8549	2271V007000005 S2	Traggelenk / ball joint		
99 92 2588	5102V005	Verbindungsstange / connecting rod		L 135
99 92 4632	0002271V009000	Traggelenk / ball joint		

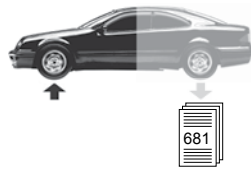

E 12 (D11)

(1992 → 1998)

87 92 7820

87 92 7820

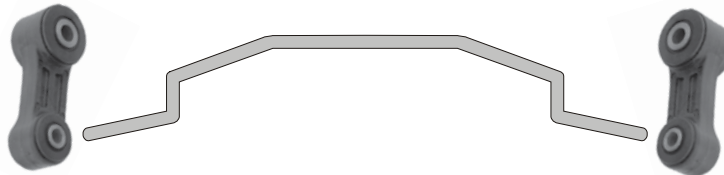

Forester (S10)

(1997 → 2002)

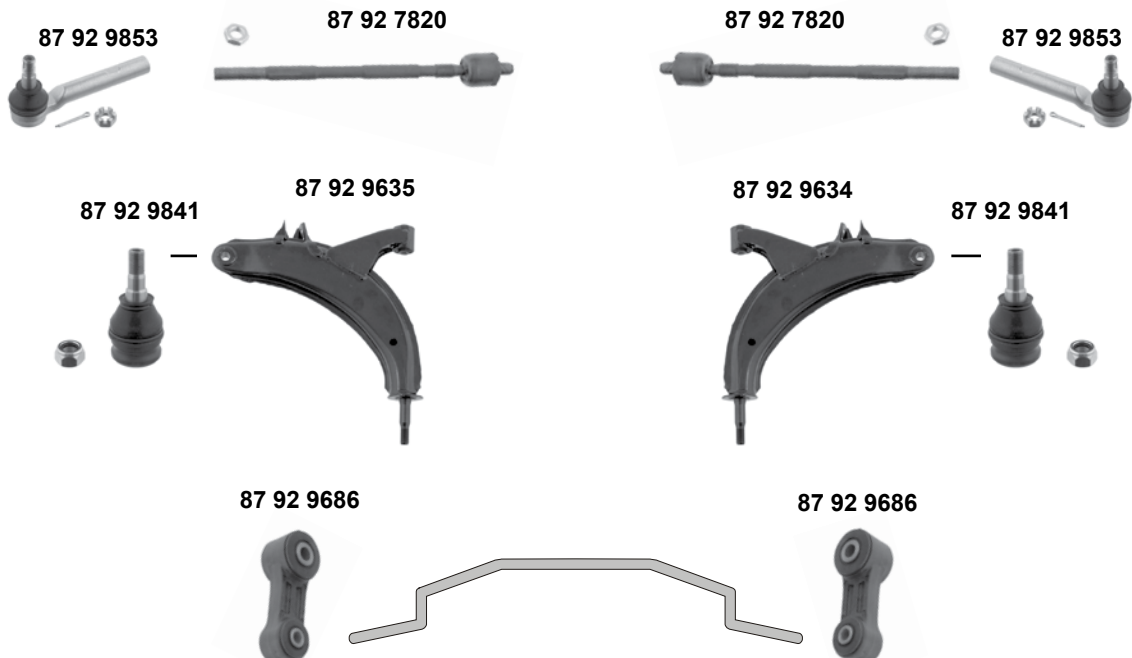

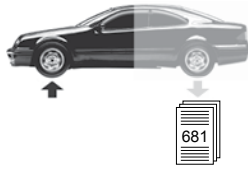

Forester (S11)
(2002 → 2008)

Vorderachse / Front axle

87 92 9853



87 92 9853



87 92 9841



87 92 9635



87 92 9634



87 92 9841



Ref. - No.



87 92 9634	20200AA200
87 92 9635	20200AA210
87 92 8199	20470SA000
87 92 9841	21067GA050
87 92 9853	34141AA042

Querlenker / control arm
Querlenker / control arm
Verbindungsstange / connecting rod
Traggelenk / ball joint
Spurstangenendstück / tie rod end



M16 x 1,25
M16 x 1,25
L 60
M12 x 1,25
M12 x 1,25

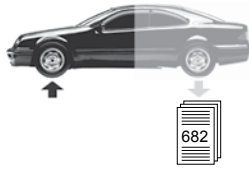

Forester (S12) (2008 →)

87 92 9853



87 92 9853



Impreza (G10) (1992 → 2002)

87 93 0740



87 93 0739



87 92 7820



87 92 7820



87 92 9853



87 92 9853



87 92 9841



87 92 9635



87 92 9634



87 92 9841



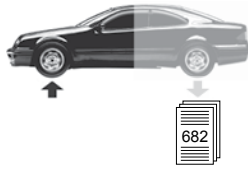

Impreza (G11)
(2000 → 2007)

Vorderachse / Front axle

87 92 9853



87 92 9853



87 92 9841

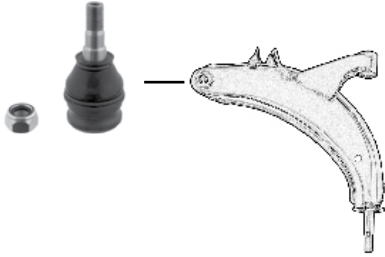

87 92 9841

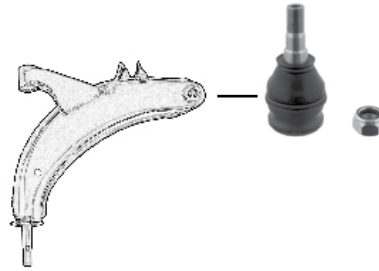

87 92 9686

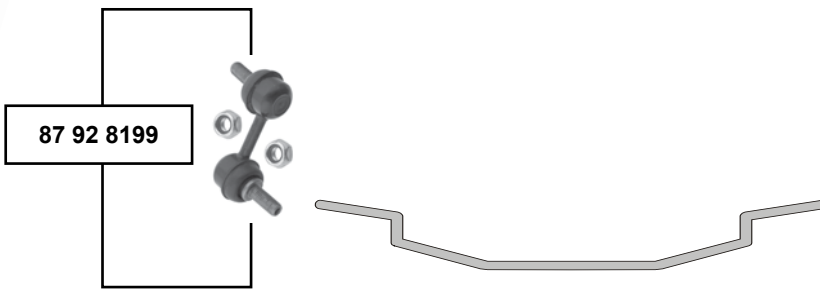

87 92 8199

87 92 9686

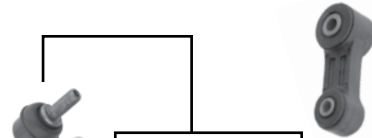

87 92 8199

Impreza (G12)
(2008 →)

87 92 9853



87 92 9853



87 92 9841

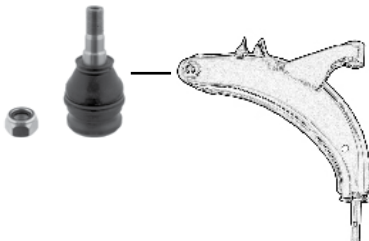

87 92 9841

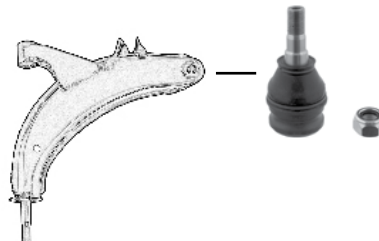

Ref. - No.



87 92 8199	20470SA000
87 92 9686	20420AA004
87 92 9841	21067GA050
87 92 9853	34141AA042

Verbindungsstange / connecting rod
Verbindungsstange / connecting rod
Traggelenk / ball joint
Spurstangenendstück / tie rod end

Limousine / sedan



L 60
L 67
M12x1,25
M12x1,25

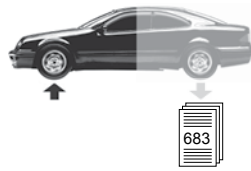

Justy IV (M300) (2007 →)

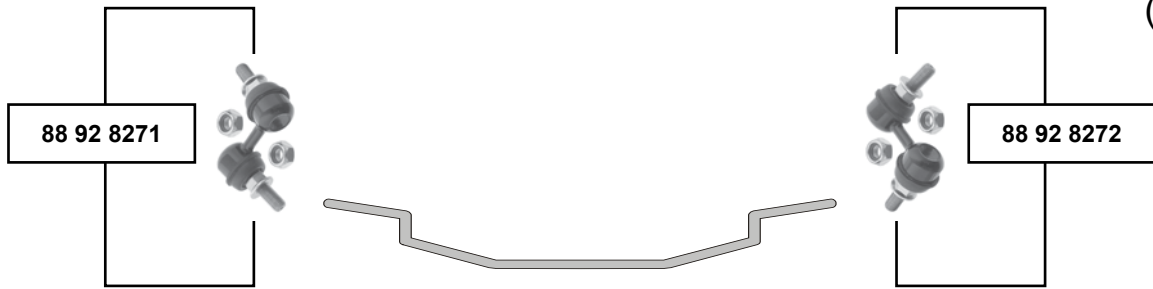

Legacy I (B10) (1989 → 1994)

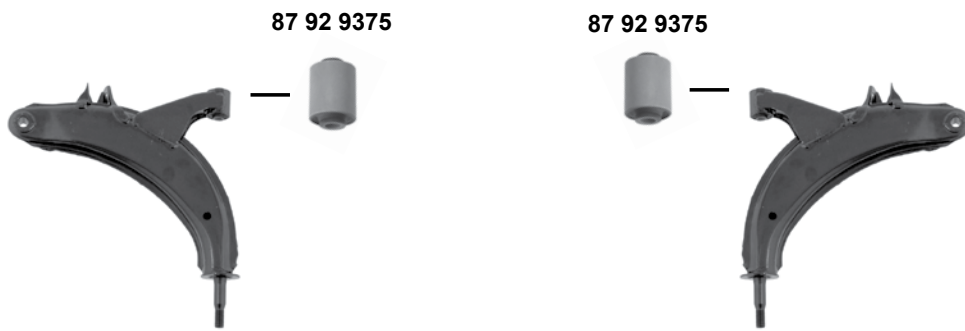

Legacy II (B11) (1993 → 1998)

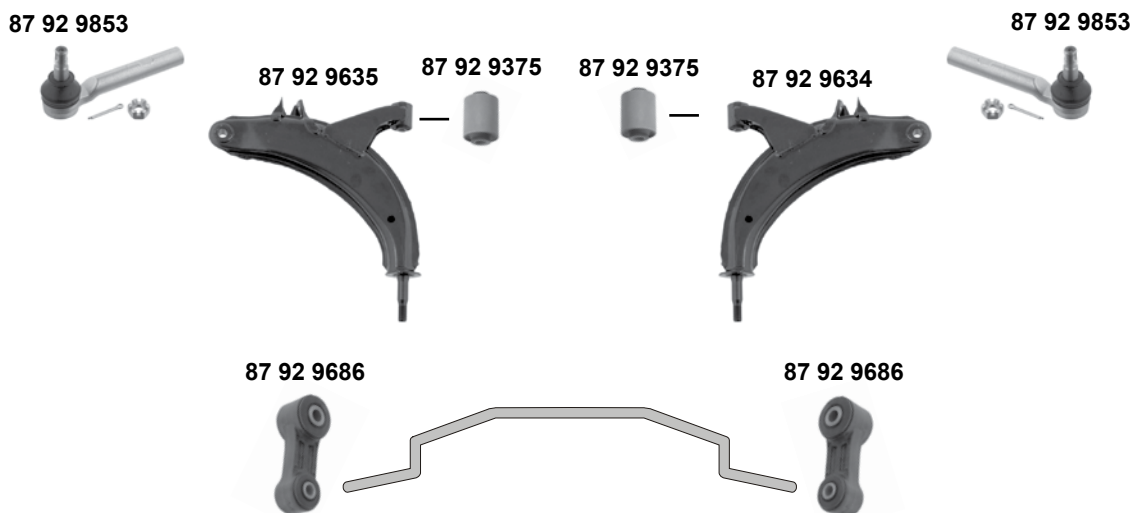

87 92 9375	20201AA000
87 92 9634	20200AA200
87 92 9635	20200AA210
87 92 9686	20420AA004
87 92 9853	34141AA042
88 92 8271	48831B1010
88 92 8272	48821B1010

Querlenkerlager / control arm mount
Querlenker / control arm
Querlenker / control arm
Verbindungsstange / connecting rod
Spurstangenendstück / tie rod end
Verbindungsstange / connecting rod
Verbindungsstange / connecting rod

Ø A 38
M16 x 1,25
M16 x 1,25
L 67
M12 x 1,25
L 49
L 49

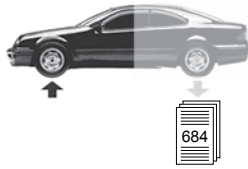

Legacy III (B12)
(1998 → 2003)

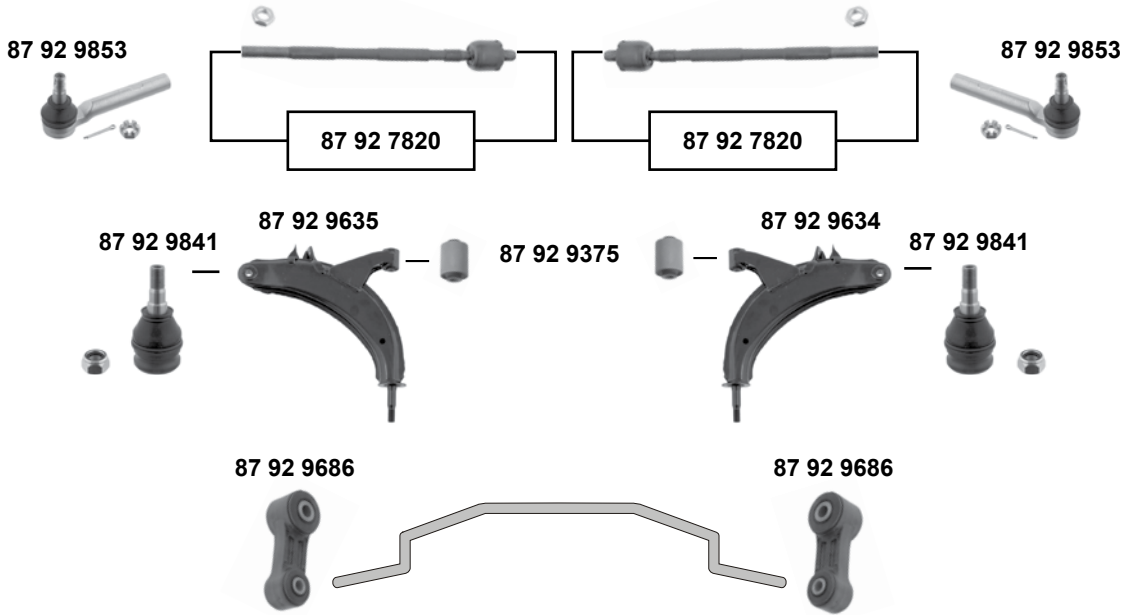

Legacy IV (B13)
(2003 → 2009)

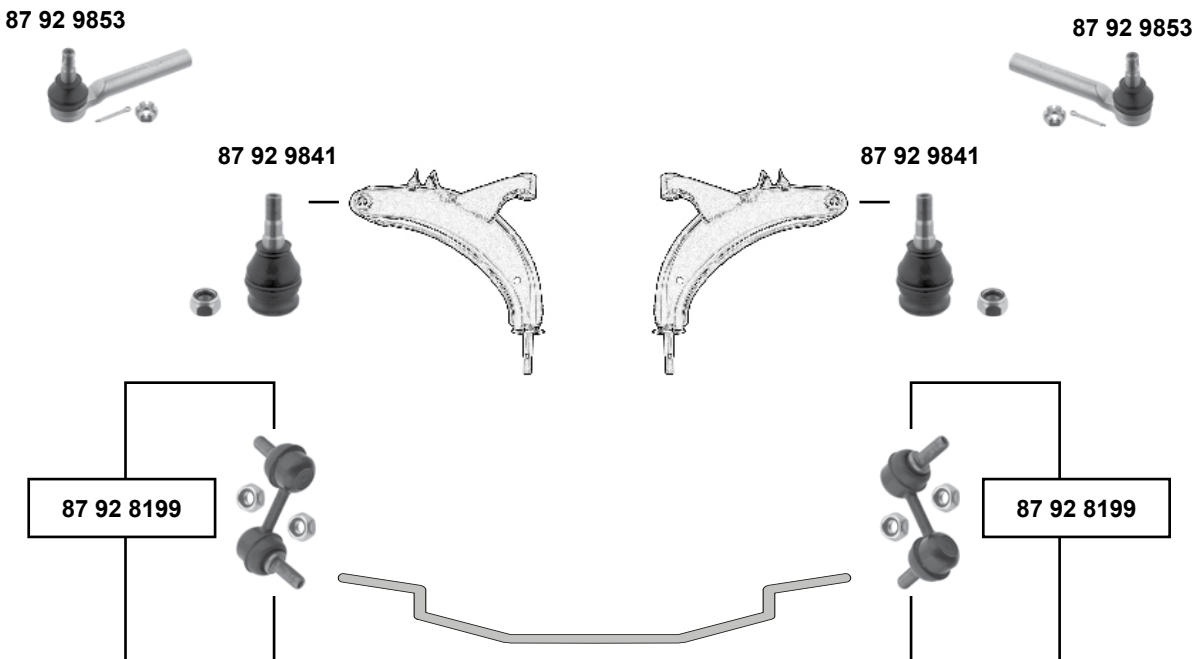

Ref. - No.



87 92 7820	34140FC000	Spurstange / tie rod	L 292
87 92 8199	20470SA000	Verbindungsstange / connecting rod	L 60
87 92 9375	20201AA000	Querlenkerlager / control arm mount	Ø A 38
87 92 9634	20200AA200	Querlenker / control arm	M16 x 1,25
87 92 9635	20200AA210	Querlenker / control arm	M16 x 1,25
87 92 9686	20420AA004	Verbindungsstange / connecting rod	L 67
87 92 9841	21067GA050	Traggelenk / ball joint	M12 x 1,25
87 92 9853	34141AA042	Spurstangenendstück / tie rod end	M12 x 1,25



Vorderachse / Front axle



Alto
(1980 →)

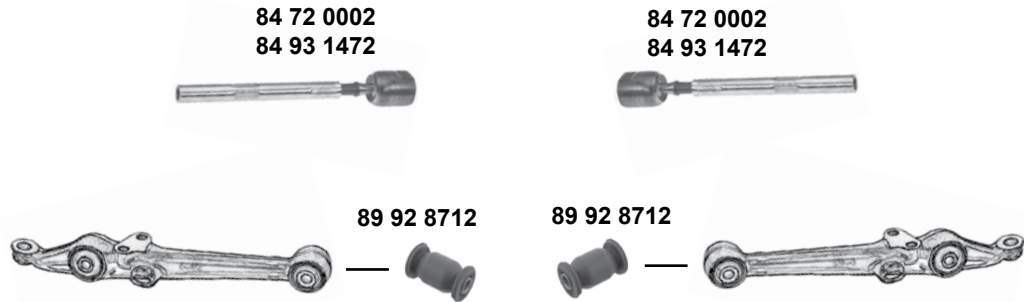

Vorderachse / Front axle

Alto V
(2009 →)

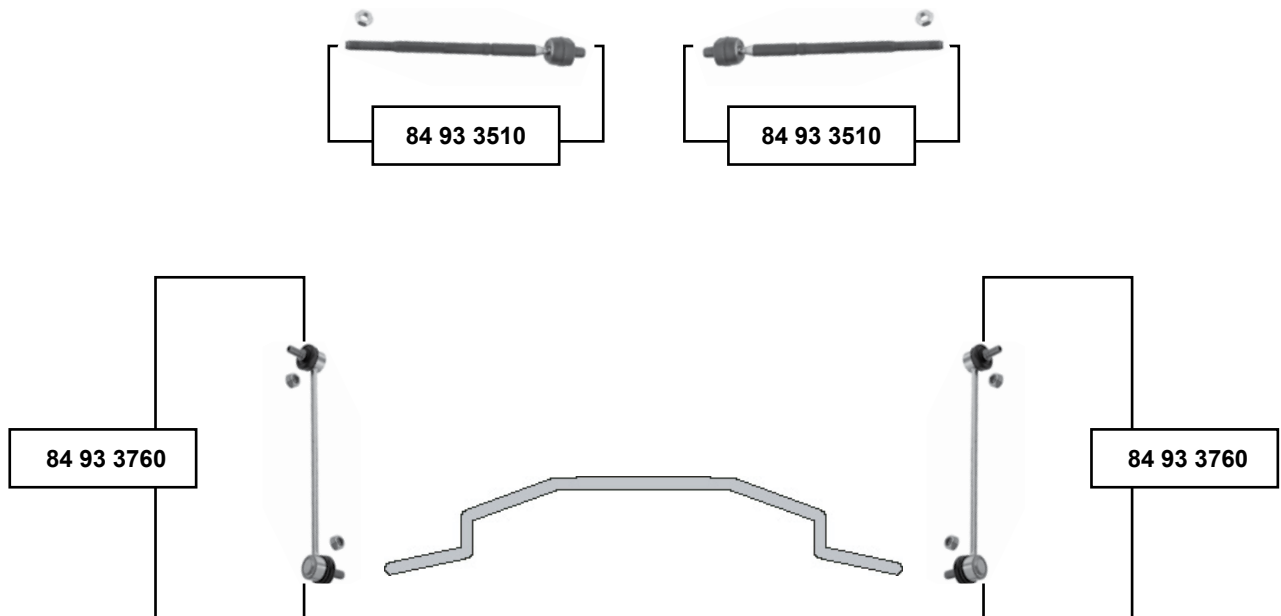

84 72 0002	48830-84000-000	Spurstange / tie rod	01/84 → 12/93	L 222
84 93 1472	48830-M70F00	Spurstange / tie rod	09/1994 → 01/2009	L 222
84 93 3510	48830M68K00	Axialgelenk / axial joint		L 290 / M12x1,25
84 93 3760	42420M68K00	Verbindungsstange / connecting rod		L 282
89 92 8712	09319-10030-000	Querlenkerlager / control arm mount		Ø A 49

passend für / to fit

SUZUKI



Baleno

(1995 → 2003)

Vorderachse / Front axle

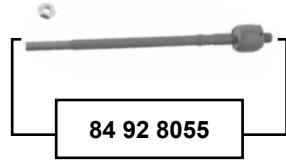

Carry

(1999 →)

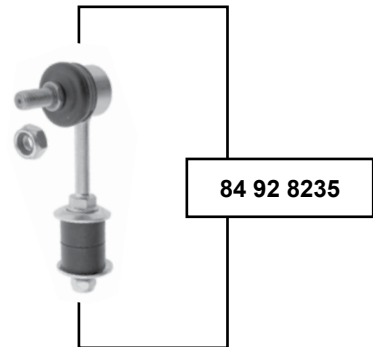
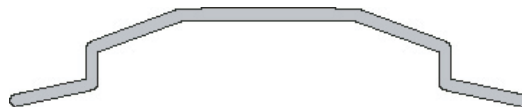
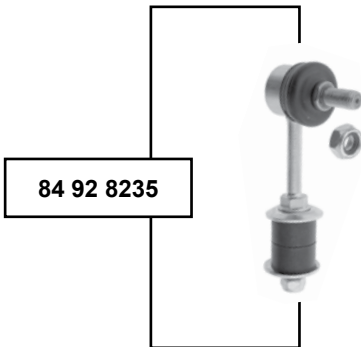

(1) Carry 11/80 → 10/85
Carry S 10/85 → 03/99



Ref. - No.



84 92 8055 48830-60G00-000
84 92 8235 42420-77A00-000
89 92 8712 09319-10030-000

Axialgelenk / axial joint
Verbindungsstange / connecting rod
Querlenkerlager / control arm mount

(1)

L 306
L 112
Ø A 49



Grand Vitara / XL
(1998 → 2005)

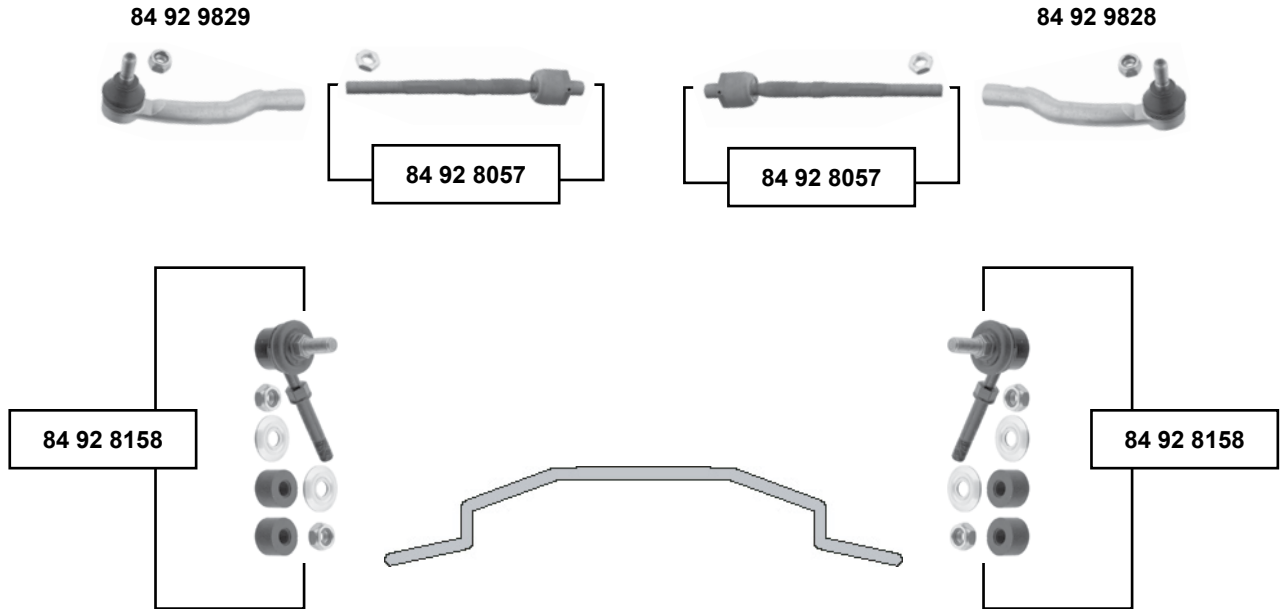

Vorderachse / Front axle

Grand Vitara
(2005 →)

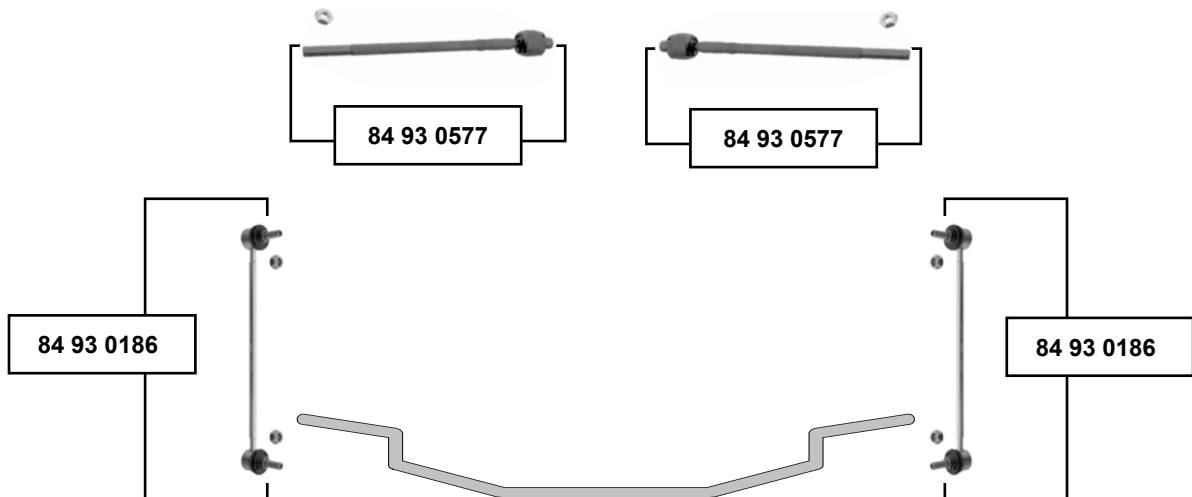

84 92 8057	48830-65D00-000	Axialgelenk / axial joint	L 227
84 92 8158	42420-65D00-000 S1	Verbindungsstange / connecting rod	L 90
84 92 9828	48810-65D01-000	Spurstangenstück / tie rod end	
84 92 9829	448820-65D01-000	Spurstangenstück / tie rod end	
84 93 0186	42420-65J00-000	Verbindungsstange / connecting rod	L 300
84 93 0577	48830-65J00-000	Axialgelenk / axial joint	L 343



Ignis
(2003 →)

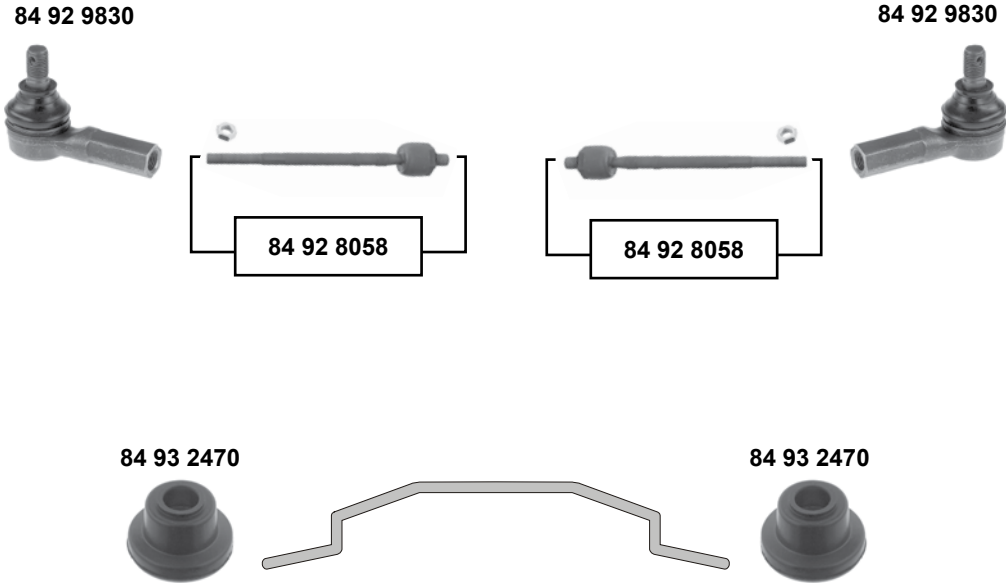

Vorderachse / Front axle

Jimny
(1998 →)

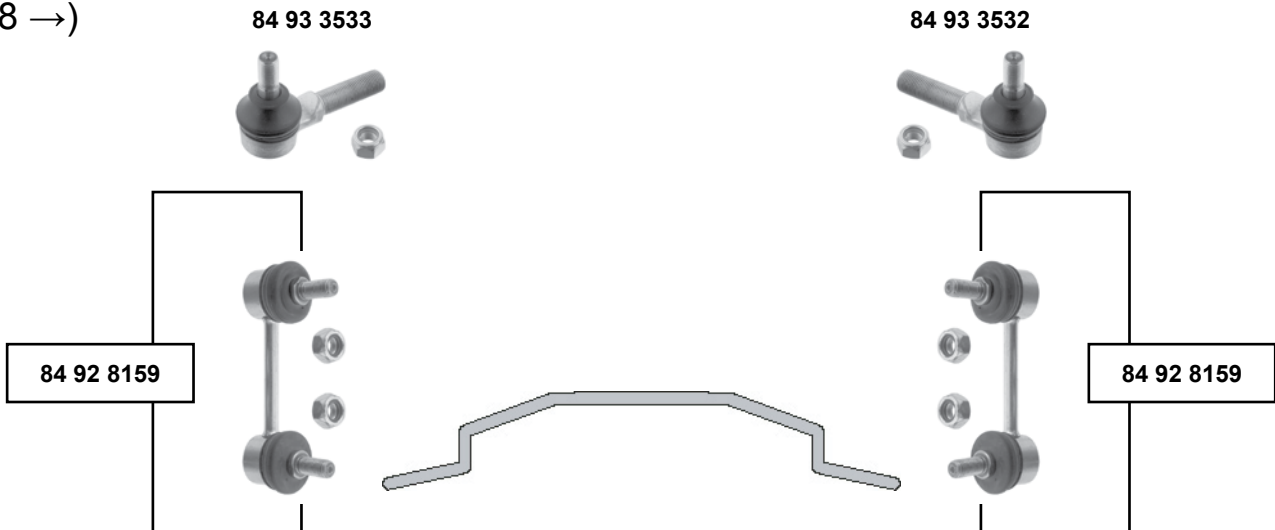

	Ref. - No.			
84 92 8058	48830-86G00-000	Axialgelenk / axial joint		L 263
84 92 8159	42420-81A10-000	Verbindungsstange / connecting rod		L 93
84 92 9830	48810-60810-000	Spurstangenstück / tie rod end	1,3 / 1,5	M12 x 1,25
84 93 2470	42451-76G00-000	Stabilisatorlager / stabilizer mounting		I Ø 20
84 93 3532	48810-81A00-000	Spurstangenendstück / tie rod end	09/98 → 08/05	M12 x 1,25
84 93 3533	48820-81A00-000	Spurstangenendstück / tie rod end	09/98 → 08/05	M12 x 1,25



Splash (2008 →)

84 92 9830

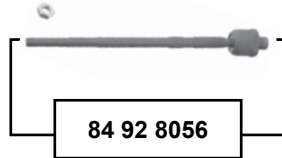

84 92 8056

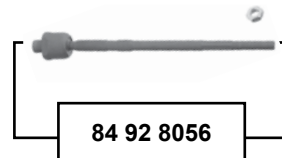

84 92 8056

84 92 9830



84 92 9826



84 93 2140



84 93 2141



84 92 9826



84 92 9827



84 92 9827

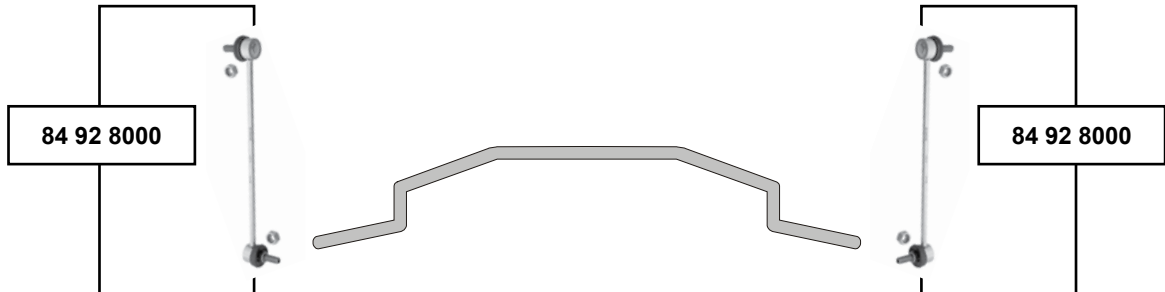

84 92 8000	42420-62J00-000	Verbindungsstange / connecting rod
84 92 8056	48830-63J00-000	Axialgelenk / axial joint
84 92 9826	45201-62J00-000 S1	Traggelenk / ball joint
84 92 9827	45540-62J00-000 S1	Querlenkerlager / control arm mount
84 92 9830	48810-60810-000	Spurstangenendstück / tie rod end
84 93 2140	45202-57KA0-000	Querlenkerlager / control arm mount
84 93 2141	45201-57KA0-000	Querlenkerlager / control arm mount

L 306

Ø A 60,11
M12x1,25

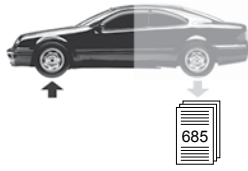

Swift I + II
(1983 → 2005)

Vorderachse / Front axle



	Ref. - No.			
84 71 0001	48810-76G00-000	Spurstangenstück / tie rod end	01/84 →	M12 x 1,25
84 73 0001	45200-82000-000	Querlenker / control arm	Swift I → 12/89	
84 92 9632	45200-60812-000	Querlenker / control arm	Swift II → 05/01	
84 92 9633	45200-60822-000	Querlenker / control arm	Swift II → 05/01	
84 92 9840	48830-60B00-000	Axialgelenk / axial joint	Swift II 89 → 01	L 290



Swift III (2005 →)

84 92 9830

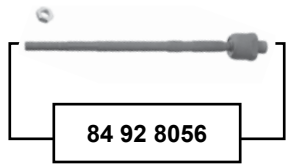

84 92 8056

84 92 9830

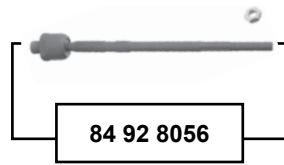

84 92 8056

84 92 9826



84 92 9932



84 92 9827



84 92 9931



84 92 9827



84 92 9826

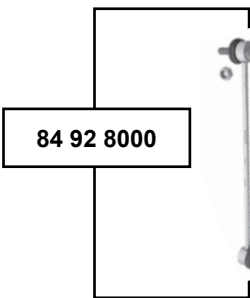

84 92 8000

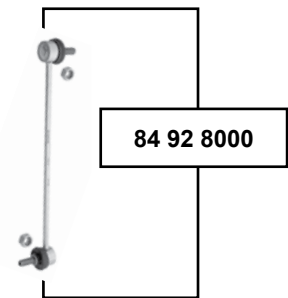
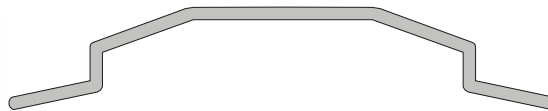

84 92 8000



84 92 8000	42420-62J00-000	Verbindungsstange / connecting rod
84 92 8056	48830-63J00-000	Axialgelenk / axial joint
84 92 9826	45201-62J00-000 S1	Traggelenk / ball joint
84 92 9827	45540-62J00-000 S1	Querlenkerlager / control arm mount
84 92 9830	48810-60810-000	Spurstangenstück / tie rod end
84 92 9931	45202-62J00-000	Querlenker / control arm
84 92 9932	45201-62J00-000	Querlenker / control arm

passend für / to fit

SUZUKI



SX-4
(2006 →)

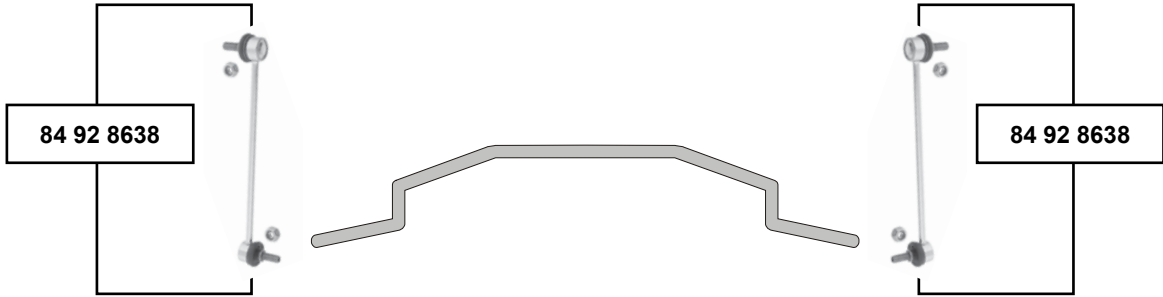

Vorderachse / Front axle

Vitara
(1988 → 1998)

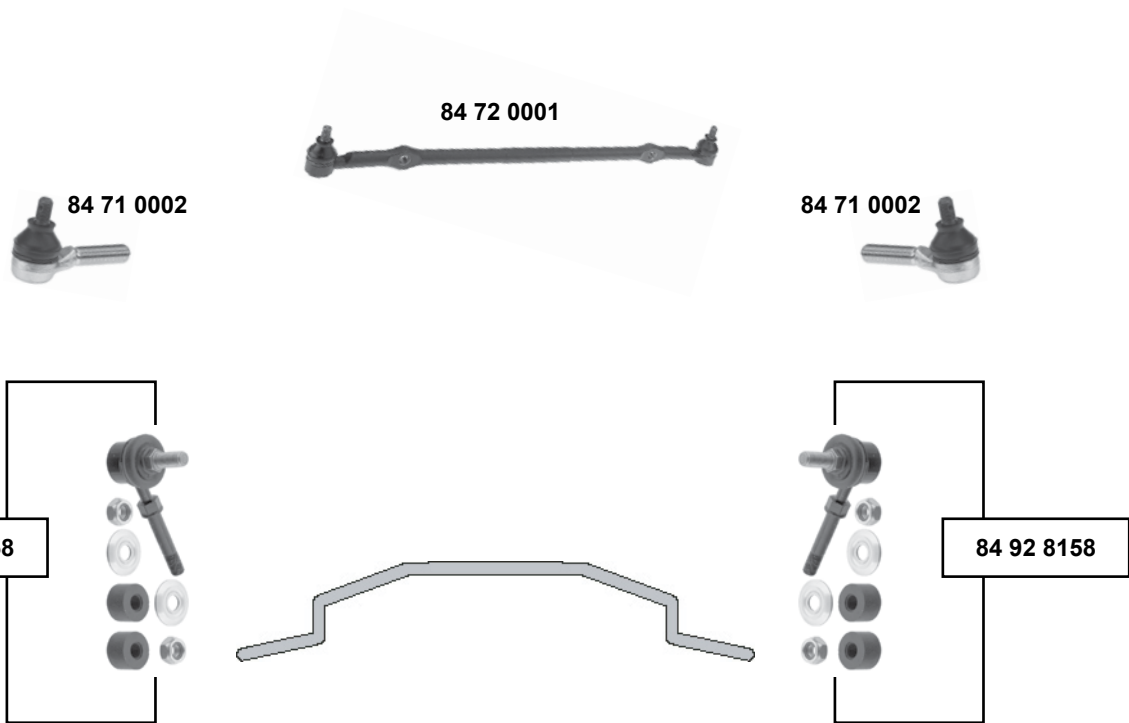

SWAG GERMANY	Ref. - No.			
84 71 0002	48810-60A00	Spurstangenendstück / tie rod end		M12 x 1,25
84 72 0001	48850-60A00-000	Spurstange / tie rod		
84 92 8158	42420-65D00-000 S1	Verbindungsstange / connecting rod		L 90
84 92 8638	42420-80J00-000	Verbindungsstange / connecting rod		L 270

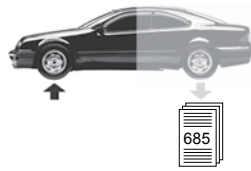

Wagon R+
(1997 → 2003)



Wagon R+II
(2000 → 2008)

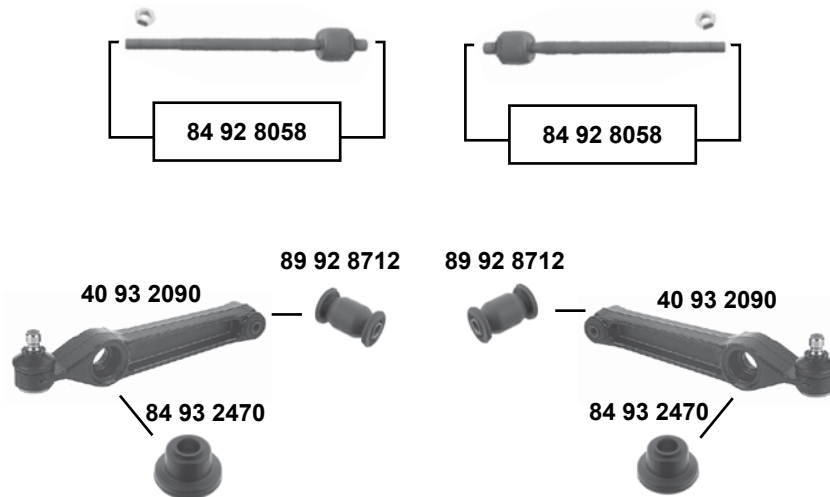

X-90
(1995 →)

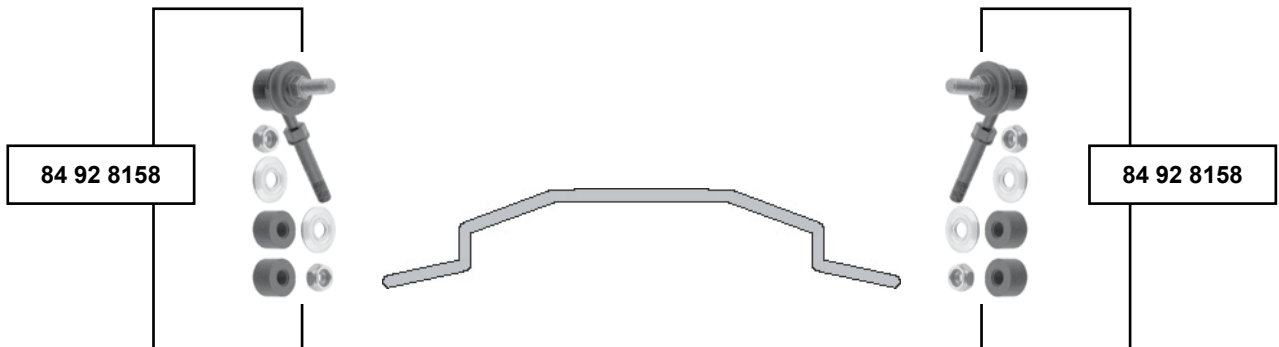

40 91 9501	45200-75F21-000	Querlenker / control arm
40 93 2090	4500-84E00-000	Querlenker / control arm
84 92 8058	48830-86G00-000	Axialgelenk / axial joint
84 92 8158	42420-65D00-000 S1	Verbindungsstange / connecting rod
84 93 2470	42451-76G00-000	Stabilisatorlager / stabilizer mounting
89 92 8712	09319-10030-000	Querlenkerlager / control arm mount

(ch.) → 140196
(ch.) 140197 →

L263
L 90
Ø I 20
Ø A 49

passend für / to fit

TOYOTA



Alphard (GGH20)

(2008 →)

Vorderachse / Front axle



Ref. - No.



81 92 8513 48820-42030

Verbindungsstange / connecting rod

L 360,5



Auris (_E15_) (2006 →)

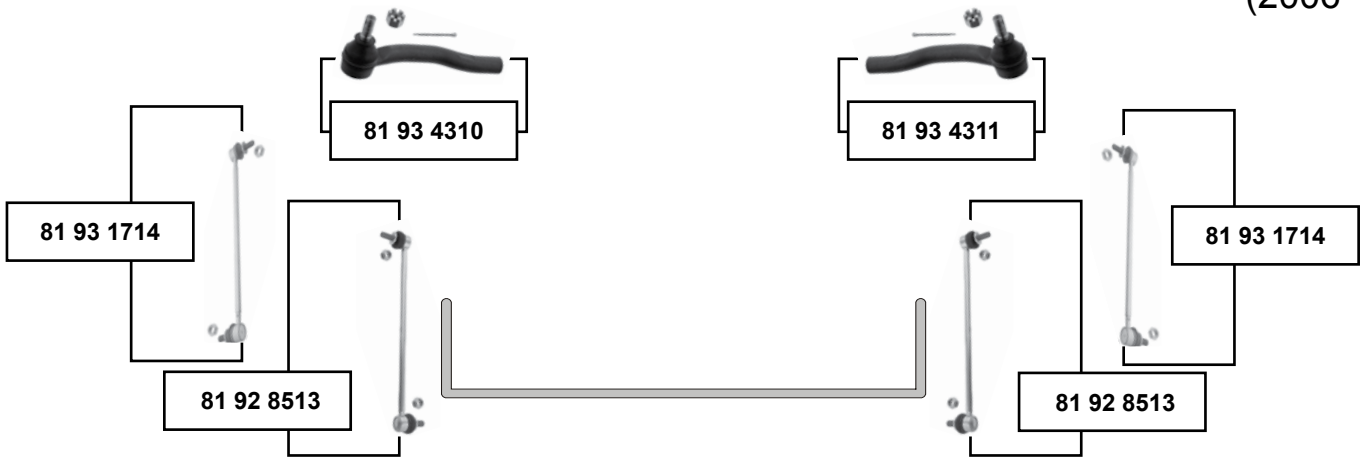

Avalon (_X10_) (1994 → 1999)

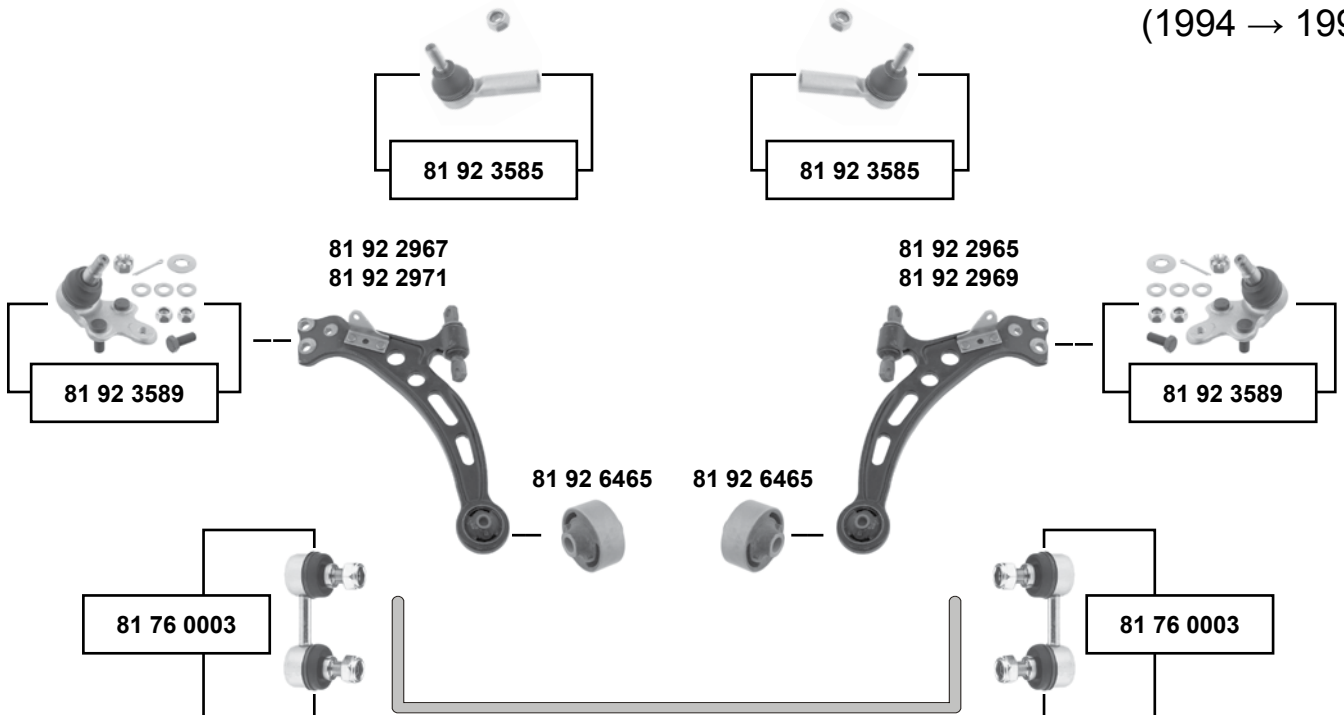

(1) **BM NRE150 / 02/07 →**

(2) **BM ADE150 / NDE150 / ZRE151 / ZZE150 / 10/06 →**



Ref. - No.



SWAG Ref. - No.	Description	Notes	Dimensions
81 76 0003	48820-33010 Verbindungsstange / connecting rod	→ 08/96	L 60
81 92 2965	48068-33020 Querlenker / control arm	→ 08/96	
81 92 2967	48069-33020 Querlenker / control arm	→ 08/96	
81 92 2969	48068-33030 Querlenker / control arm	08/96 →	
81 92 2971	48069-33031 Querlenker / control arm	08/96 →	
81 92 3585	45046-29255 Spurstangenendstück / tie rod end		M12 x 1,25
81 92 3589	43330-39435 Traggelenk / ball joint		
81 92 6465	48655-07010 Querlenkerlager / control arm mount		
81 92 8513	48820-42030 Verbindungsstange / connecting rod	(2)	L 360,5
81 93 1714	48820-02070 Verbindungsstange / connecting rod	(1)	L 360
81 93 4310	45047-19215 Spurstangenendstück / tie rod end		M15 x 1,5
81 93 4311	45046-19415 Spurstangenendstück / tie rod end		M15 x 1,5

passend für / to fit

TOYOTA



SWAG[®]
GERMANY

Avalon (_X20_)

(1999 →)

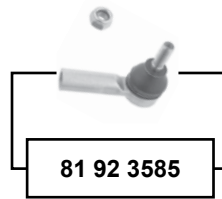

Vorderachse / Front axle

Avalon (_X30_)

(2005 →)

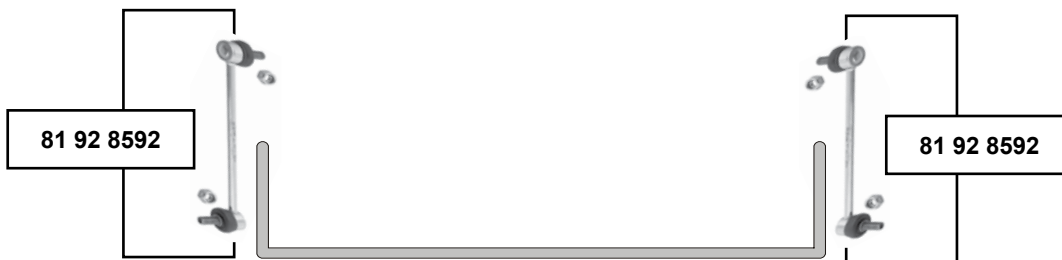

SWAG[®]
GERMANY

Ref. - No.



81 92 3585 45046-29255
81 92 8592 48820-06040

Spurstangenendstück / tie rod end
Verbindungsstange / connecting rod

M12 x 1,25
L 260,1

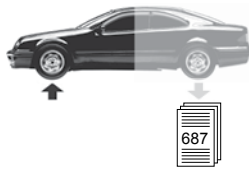

Avensis (_T22_) (1997 → 2003)

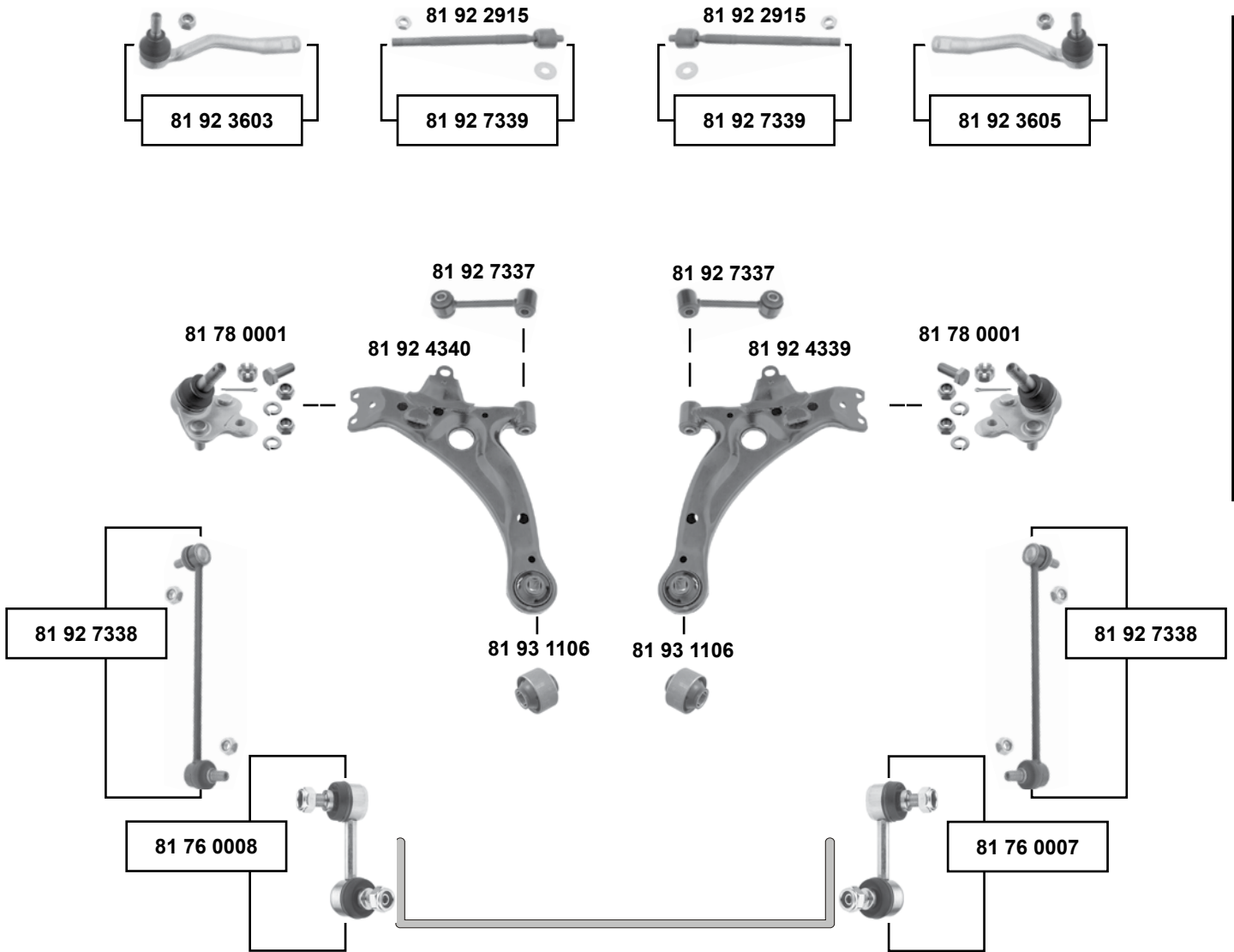

Vorderachse / Front axle



(1) AT22, AZT220, CDT220, CT220, ST220, ZZT22)

SWAG	Ref. - No.			
81 76 0007	48820-05012	Verbindungsstange / connecting rod		
81 76 0008	48810-05012	Verbindungsstange / connecting rod		
81 78 0001	43330-29315	Traggelenk / ball joint		
81 92 2915	45503-05050	Axialgelenk / axial joint	(1)	M16 x 1,5
81 92 3603	45047-09030	Spurstangenendstück / tie rod end		
81 92 3605	45046-29365	Spurstangenendstück / tie rod end		
81 92 4339	48068-05050	Querlenker / control arm		
81 92 4340	48069-05050	Querlenker / control arm		
81 92 7337	48650-20021	Verbindungsstange / connecting rod		
81 92 7338	48820-44020	Verbindungsstange / connecting rod		
81 92 7339	45503-49105	Spurstange / tie rod		
81 93 1106	48061-05010	Querlenkerlager / control arm		

MAN 07/00 → 02/03
MAN 07/00 → 02/03
MAN
Verso

L152
L 280

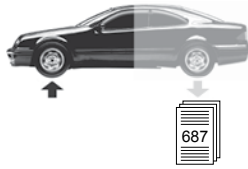

Avensis (_T25_)

(2003 →)

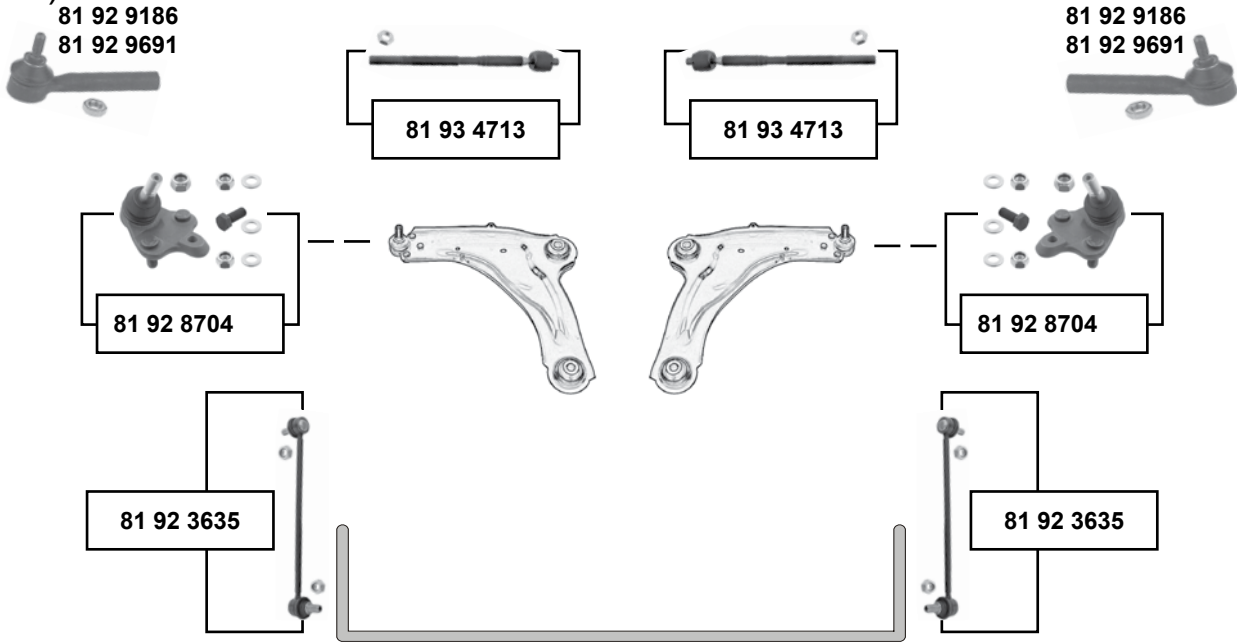

Vorderachse / Front axle

Avensis (_T27_)

(2008 →)



Avensis Verso (ACM/20)

(2001 → 2005)

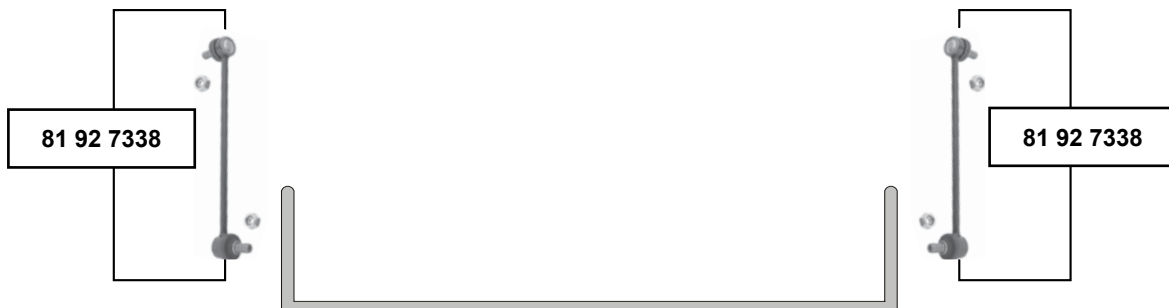

	Ref. - No.			
81 92 3635	48820-47010	Verbindungsstange / connecting rod		L 285
81 92 7338	48820-44020	Verbindungsstange / connecting rod		L 152
81 92 8704	43330-09210 S1	Traggelenk / ball joint		M14 x 1,5
81 92 9186	45046-29425	Spurstangenendstück / tie rod end	(ex.) (mot.) 1,6 / 1,8	M12 x 1,25
81 92 9691	45046-09230	Spurstangenendstück / tie rod end	(mot.) 1,6 / 1,8	M12 x 1,25
81 93 1714	48820-02070	Verbindungsstange / connecting rod		L 360
81 93 4713	45503-0F010	Spurstange / tie rod		L 305



Aygo (WNB10) (2005 →)

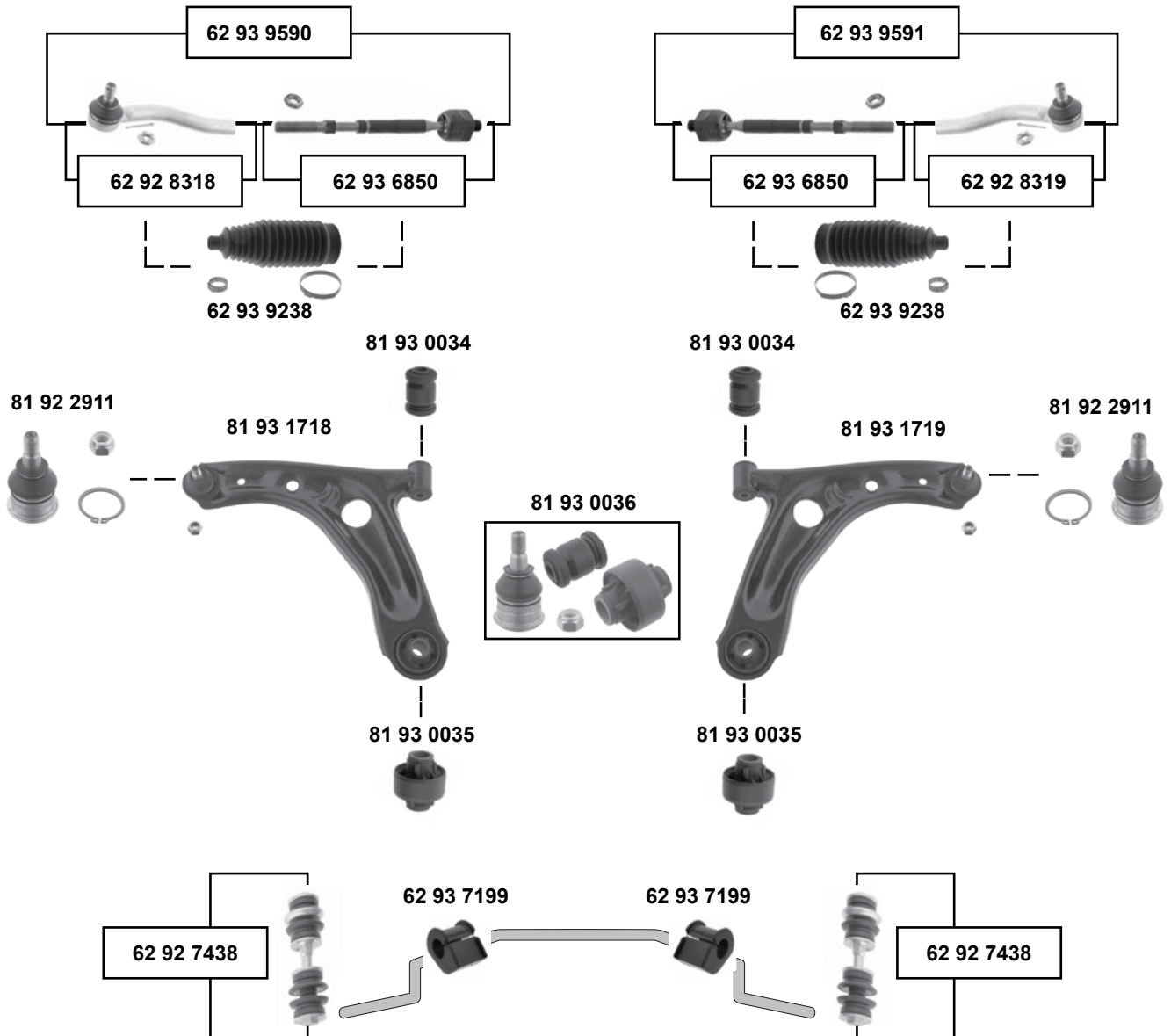

Vorderachse / Front axle



Ref. - No.



Ref. - No.	Description	Notes	Dimensions
62 92 7438	48819-70010 S1	Verbindungsstange / connecting rod	L 92
62 92 8318	45047-09125	Spurstangenendstück / tie rod end	M12 x 1,25
62 92 8319	45046-09295	Spurstangenendstück / tie rod end	M12 x 1,25
62 93 6850	45500-0H010 S1	Axialgelenk / axial joint	L 223
62 93 7199	48815-0H010	Stabilisatorlager / stabilizer mount	Ø 122
62 93 9238	45535-09180	Lenkmanschetzensatz / steering boot set	L 170
62 93 9590	45500-0H010 S2	Axialgelenk / axial joint	
62 93 9591	45500-0H010 S3	Axialgelenk / axial joint	
81 92 2911	48069-0H010 S1	Traggelenk / ball joint	M12 x 1,25
81 93 0034	48069-0H010 S2	Querlenkerlager / control arm mount	Ø A 33
81 93 0035	48069-0H010 S3	Querlenkerlager / control arm mount	Ø A 57,3
81 93 0036	48069-0H010 S4	Rep. Satz Querlenker / rep. kit control arm	M12 x 1,25
81 93 1718	48069-0H010	Querlenker / control arm	M12 x 1,25
81 93 1719	48068-0H010	Querlenker / control arm	M12 x 1,25

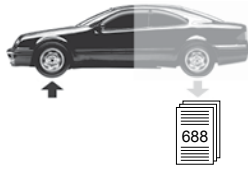

Camry (_V2_)
(1986 → 1991)



Vorderachse / Front axle

Camry (_V10_)
(1991 → 1996)

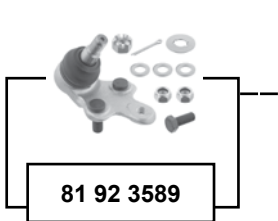
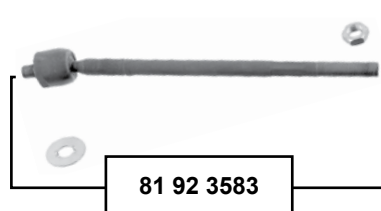

81 92 2967



81 92 6465



81 92 6465



81 92 2965

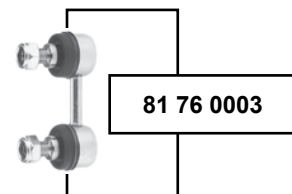
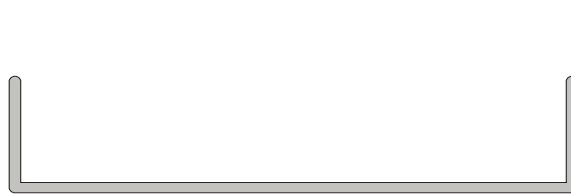
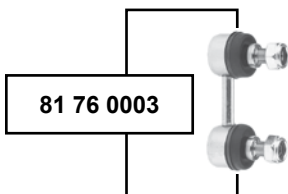
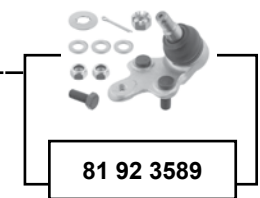

SWAG GERMANY	Ref. - No.			
81 71 0002	45046-29305	Spurstangenendstück / tie rod end		M12 x 1,25
81 76 0003	48820-33010	Verbindungsstange / connecting rod		L 60
81 92 2965	48068-33020	Querlenker / control arm	→ 08/96	
81 92 2967	48069-33020	Querlenker / control arm	→ 08/96	
81 92 3583	45503-39135	Spurstange / tie rod		L 351
81 92 3585	45046-29255	Spurstangenendstück / tie rod end		M12 x 1,25
81 92 3589	43330-39435	Traggelenk / ball joint		
81 92 6465	48655-07010	Querlenkerlager / control arm mount		



Camry (_V20_) (1996 → 2001)

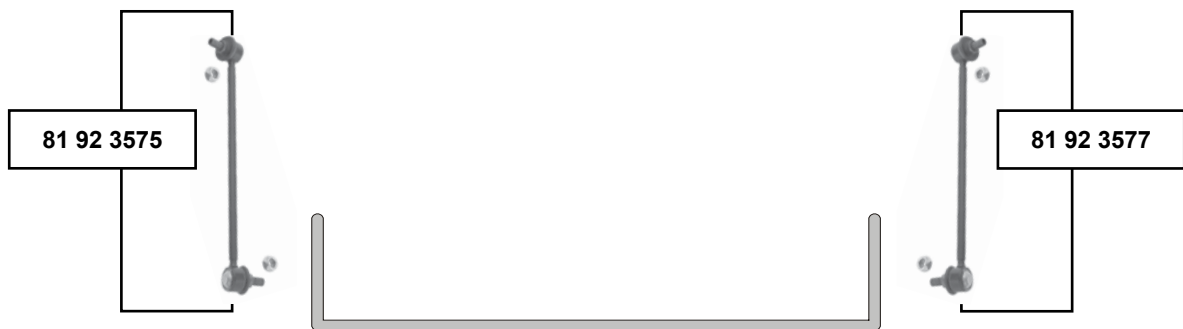
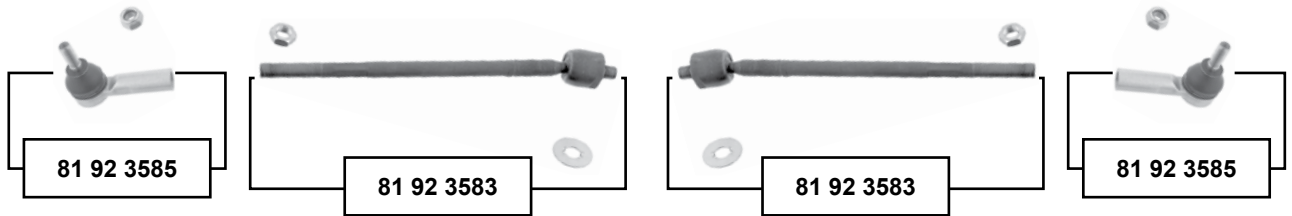

Vorderachse / Front axle



Ref. - No.



81 92 2969	48068-33030
81 92 2971	48069-33031
81 92 3575	48810-33010
81 92 3577	48820-33020
81 92 3583	45503-39135
81 92 3585	45046-29255
81 92 3589	43330-39435

Querlenker / control arm
Querlenker / control arm
Verbindungsstange / connecting rod
Verbindungsstange / connecting rod
Spurstange / tie rod
Spurstangenendstück / tie rod end
Traggelenk / ball joint

L 285
L 285
L 351
M12 x 1,25

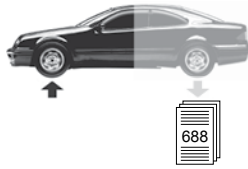

Camry (_V30/31_)
(2001 → 2006)

Vorderachse / Front axle

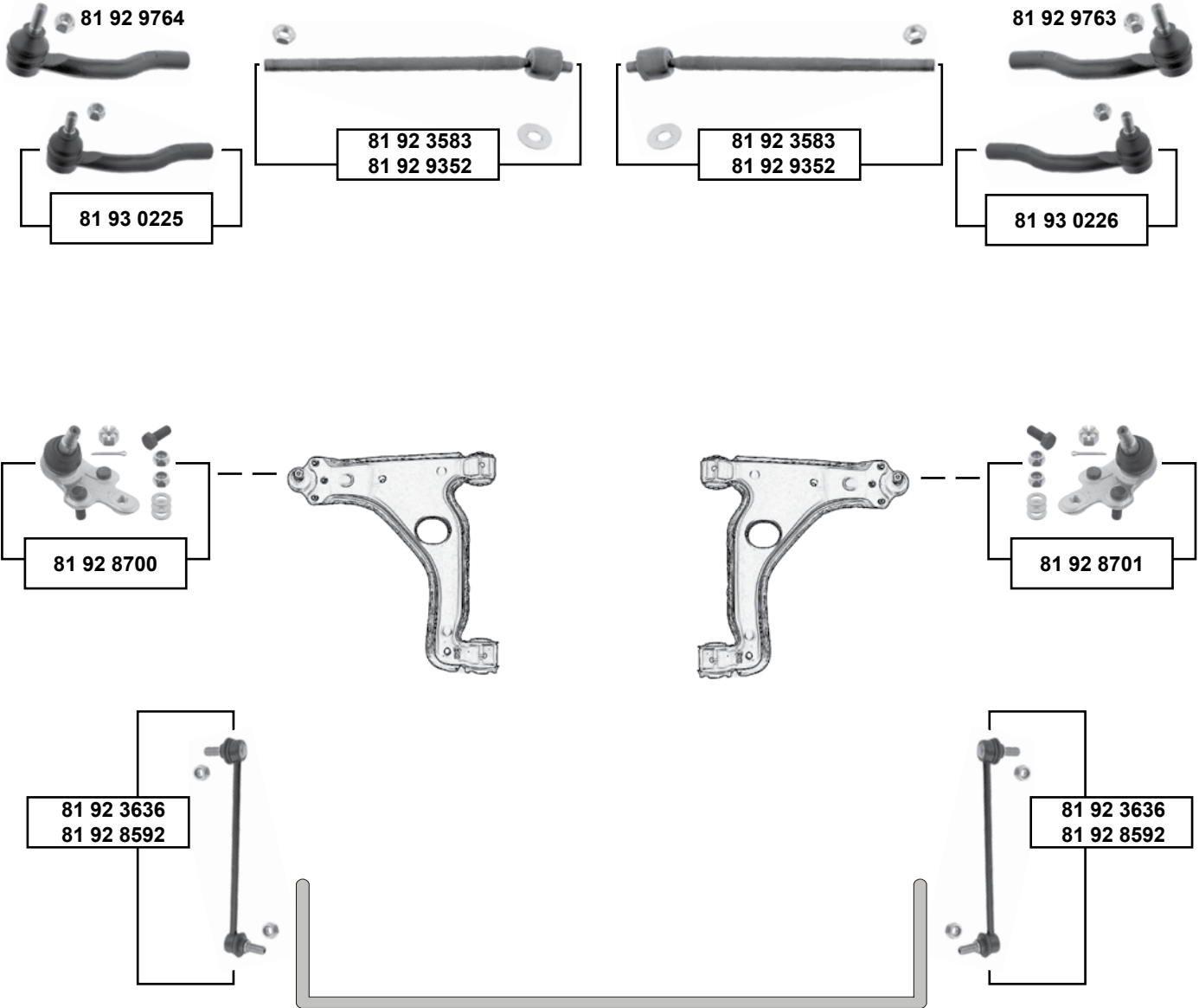

- (1) nur Produktion Japan / only production japan /
 producion unique au Japon / sólo producción japón / produzione unica giappone
- (2) nur Produktion NA / only production NA /
 producion unique au NA / sólo producción NA /
 produzione unica NA



Ref. - No.



81 92 3583	45503-39135	Spurstange / tie rod		L 351
81 92 3636	48820-28050	Verbindungsstange / connecting rod	(1)	L 260
81 92 8592	48820-06040	Verbindungsstange / connecting rod	(2)	L 260
81 92 8700	43340-09010 S1	Traggelenk / ball joint		M14 x 1,5
81 92 8701	43330-09560 S1	Traggelenk / ball joint		M14 x 1,5
81 92 9352	45503-39225	Spurstange / tie rod		L 238
81 92 9763	45460-39615	Spurstangenendstück rechts / tie rod end right	08/01 → 07/04	M15 x 1,5
81 92 9764	45470-39215	Spurstangenendstück links / tie rod end left	08/01 → 07/04	M15 x 1,5
81 93 0225	45470-39225	Spurstangenendstück / tie rod end	07/04 → 01/06	M15 x 1,5
81 93 0226	45460-39635	Spurstangenendstück / tie rod end	07/04 → 01/06	M15 x 1,5

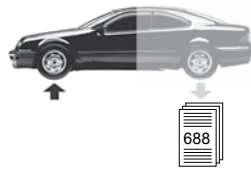

Camry (_V36_)
(2002 → 2006)

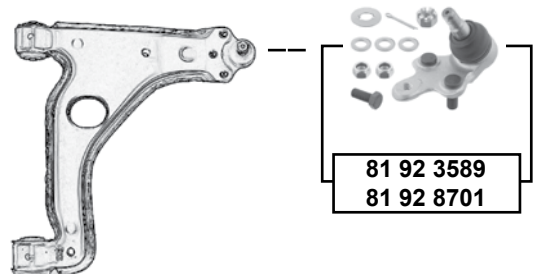
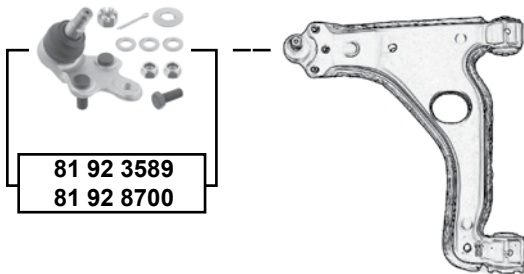
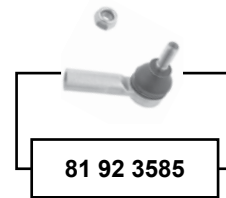

Vorderachse / Front axle

Camry (_V40_)
(2006 →)

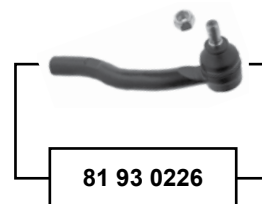

81 92 3585	45046-29255	Spurstangenendstück / tie rod end	M12 x 1,25
81 92 3589	43330-39435	Traggelenk / ball joint	
81 92 8700	43340-09010 S1	Traggelenk / ball joint	M14 x 1,5
81 92 8701	43330-09560 S1	Traggelenk / ball joint	M14 x 1,5
81 93 0225	45470-39225	Spurstangenendstück / tie rod end	M15 x 1,5
81 93 0226	45460-39635	Spurstangenendstück / tie rod end	M15 x 1,5

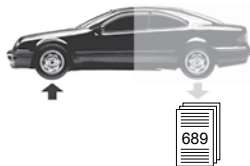

Carina (_T15_)
(1983 → 1987)



Vorderachse / Front axle

Carina (_T17_)
(1987 → 1992)

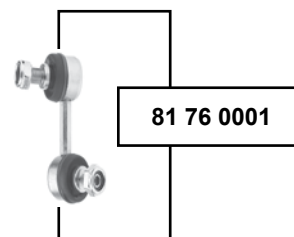
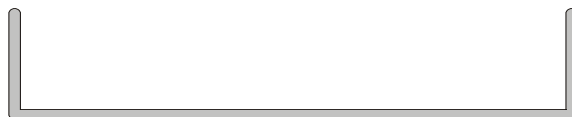
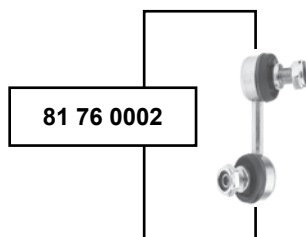

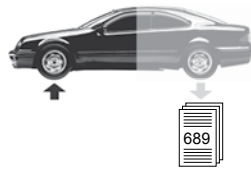

Carina (_T19_) (1992 → 1997)

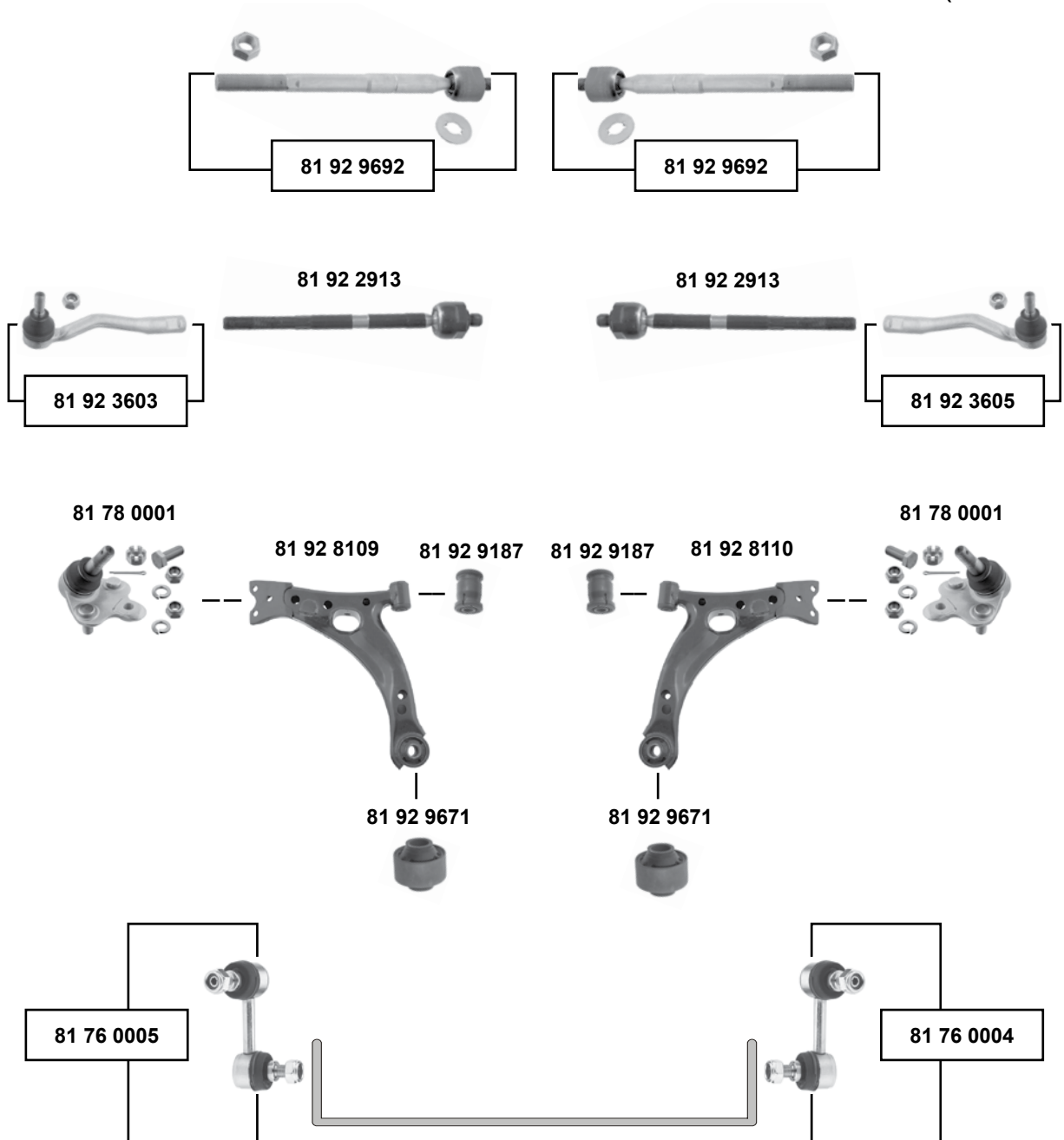

Vorderachse / Front axle

SWAG	Ref. - No.			
81 76 0004	48820-20040	Verbindungsstange / connecting rod		M10 x 1,25
81 76 0005	48810-20020	Verbindungsstange / connecting rod		M10 x 1,25
81 78 0001	43330-29315	Traggelenk / ball joint		M14 x 1,5
81 92 2913	45503-05010	Spurstange / tie rod	servo.	L 238
81 92 3603	45047-09030	Spurstangenendstück / tie rod end	→ 01/96	
81 92 3605	45046-29365	Spurstangenendstück / tie rod end	→ 01/96	
81 92 8109	48069-20260	Querlenker / control arm	→ 01/96	
81 92 8110	48068-20260	Querlenker / control arm	→ 01/96	
81 92 9187	48069-20260 S1	Querlenkerlager / control arm mount	→ 01/96	Ø A 36,7
81 92 9671	48068-20260 S2	Querlenkerlager / control arm mount	→ 01/96	Ø A 60,5
81 92 9692	45503-05010	Spurstange / tie rod		

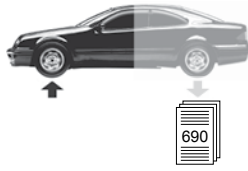

Celica (_T16_)

(1985 → 1989)

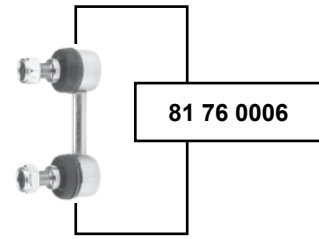
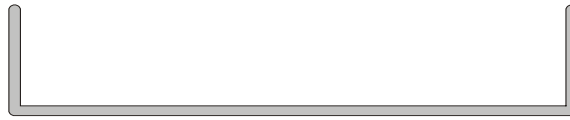
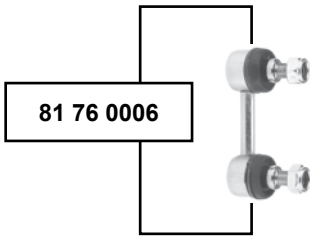

Celica (_T18_)

(1989 → 1993)

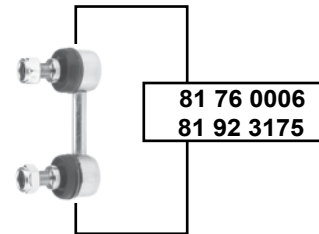
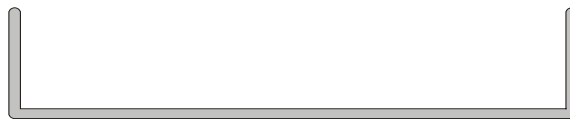
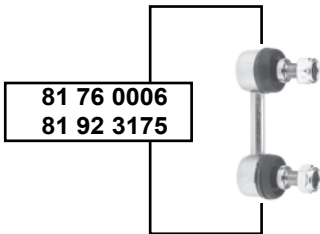
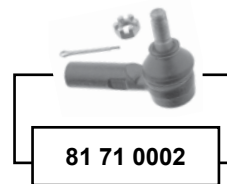

Vorderachse / Front axle

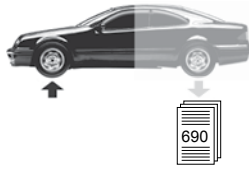

Celica (_ T20_)

(1993 → 1999)



81 78 0001



81 78 0001

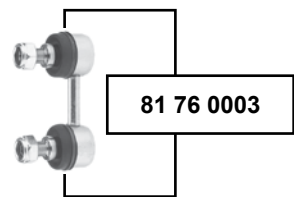
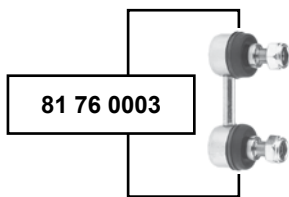

Vorderachse / Front axle

Celica (ZZT23)

(1999 → 2005)

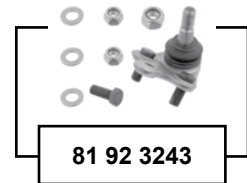
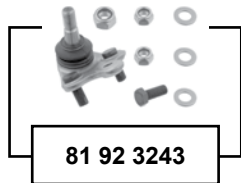

81 92 2993

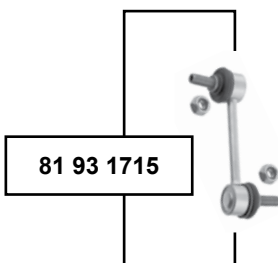

81 92 2993

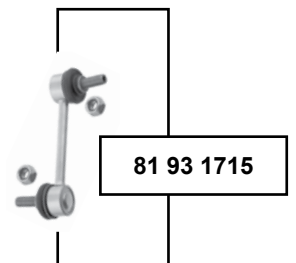



Corolla (_E8_)
(1983 → 1988)



Vorderachse / Front axle

Corolla (_E9_)
(1987 → 1995)

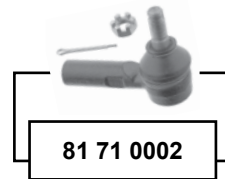

81 92 3244



81 92 8237







81 92 8238

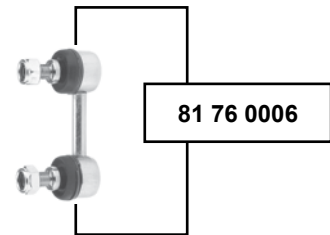
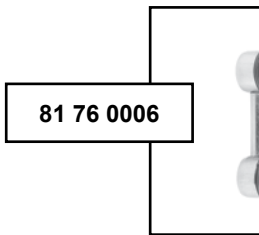

81 92 3245



	Ref. - No.			
81 71 0002	45046-29305	Spurstangenendstück / tie rod end		M12 x 1,25
81 76 0006	48820-20010	Verbindungsstange / connecting rod		
81 92 3244	43340-19016	Traggelenk / ball joint		
81 92 3245	43330-19066	Traggelenk / ball joint		
81 92 8237	48069-12110	Querlenker / control arm		M14 x 1,5
81 92 8238	48068-12110	Querlenker / control arm		M14 x 1,5



Corolla (_E10_) (1992 → 1997)

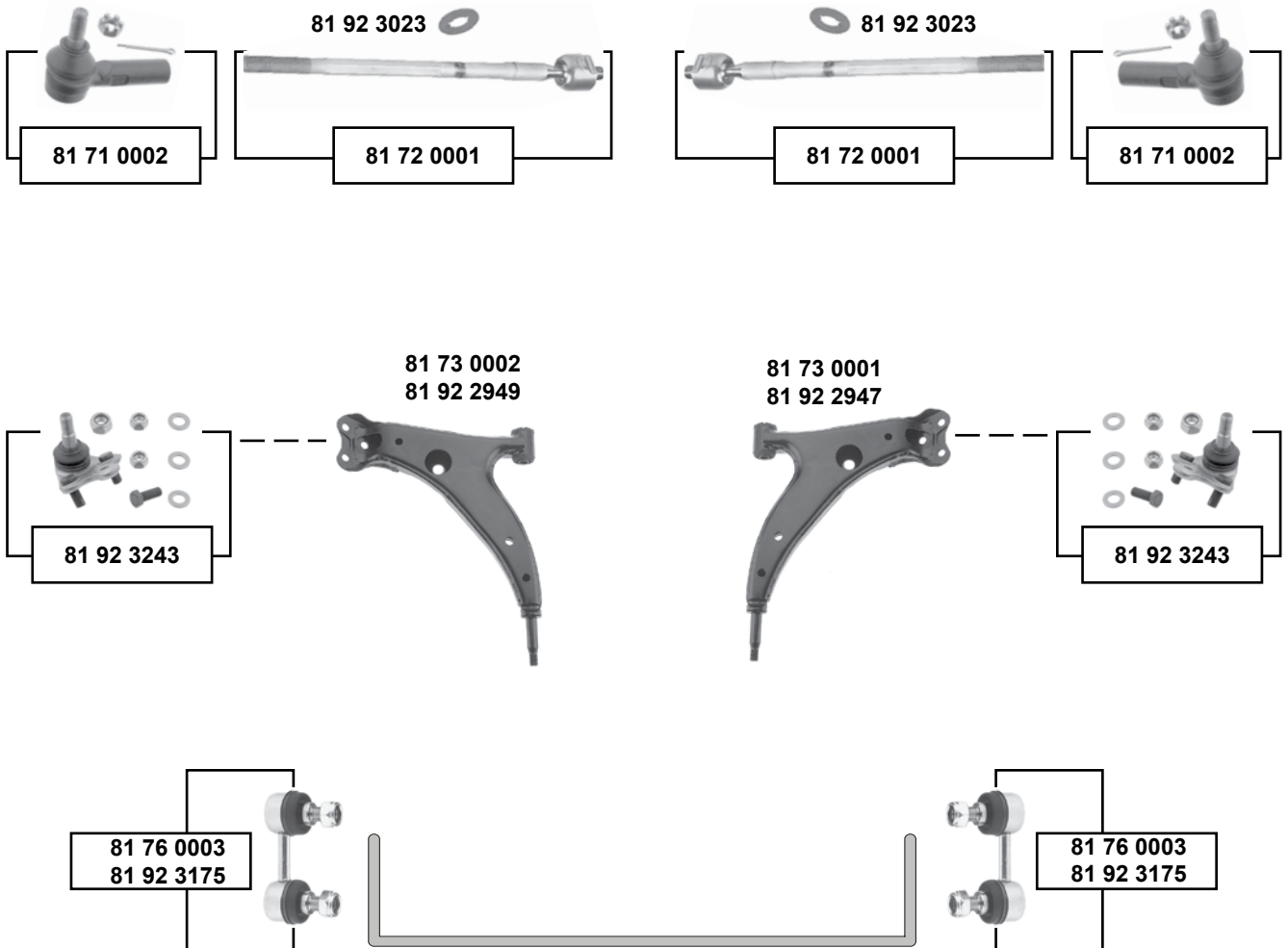

Vorderachse / Front axle



Rep. Sätze / rep. kits

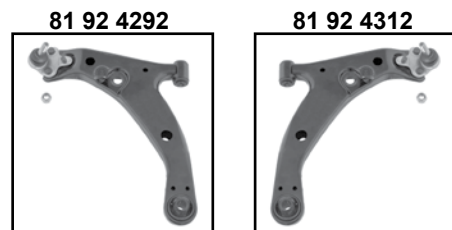

SWAG	Ref. - No.			
81 71 0002	45046-29305	Spurstangenendstück / tie rod end		M12 x 1,25
81 72 0001	45503-19205	Spurstange / tie rod		L 350
81 73 0001	48068-12140	Querlenker / control arm		
81 73 0002	48069-12140	Querlenker / control arm		
81 76 0003	48820-33010	Verbindungsstange / connecting rod		L 60
81 92 2947	48068-12191	Querlenker / control arm	06/95 →	
81 92 2949	48069-12191	Querlenker / control arm	06/95 →	
81 92 3023	45503-19215	Spurstange / tie rod	servo	L 350
81 92 3175	48820-20021	Verbindungsstange / connecting rod		L 55
81 92 3243	43330-19115	Traggelenk / ball joint	08/91 → 11/01	
81 92 4292	48069-12191 S1	Rep. Satz Querlenker / rep. kit control arm	06/95 →	
81 92 4312	48068-12191 S1	Rep. Satz Querlenker / rep. kit control arm	06/95 →	

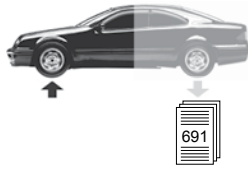

Corolla (_E11_)
(1997 → 2002)

Vorderachse / Front axle

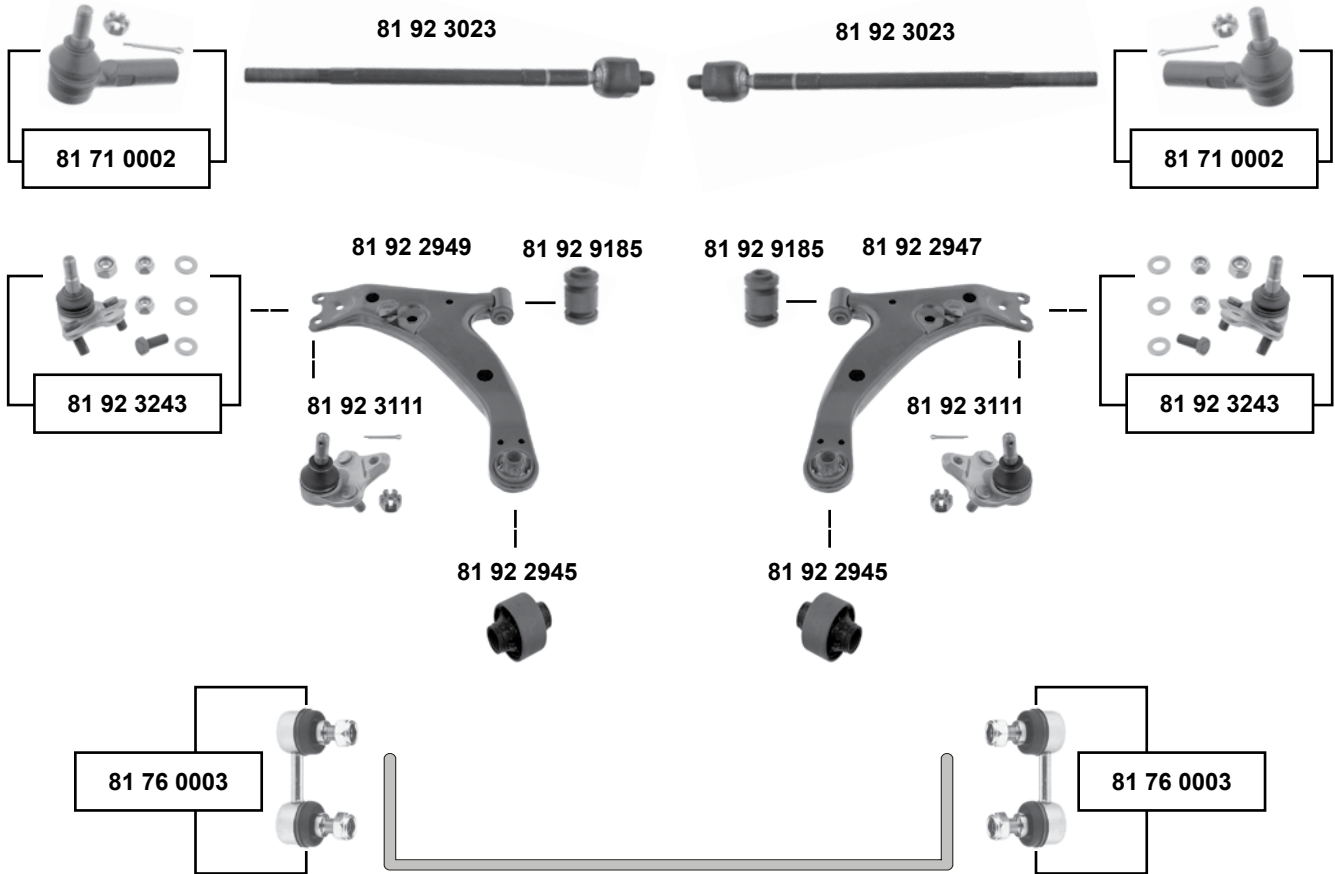

Rep. Sätze / rep. kits

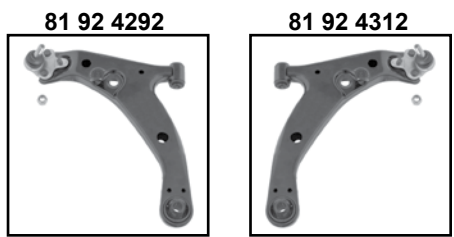

- (1) Sedan / Wagon (Hatchback/Liftback nur Produktion Japan / only production japan / producion unique au Japon / sólo producción japon / produzione unica giappone)
- (2) Hatchback / Liftback nur Produktion GB / only production GB / producion unique au GB / sólo producción GB / produzione unica GB) / 09.98 → 11.01

SWAG	Ref. - No.			
81 71 0002	45046-29305	Spurstangenendstück / tie rod end		M12 x 1,25 L 60
81 76 0003	48820-33010	Verbindungsstange / connecting rod		
81 92 2945	48068-12191 S2	Querlenkerlager / control arm mount		(2) (1) 04/97 → 09/01 (1) (1)
81 92 2947	48068-12191	Querlenker / control arm		
81 92 2949	48069-12191	Querlenker / control arm		
81 92 3023	45503-19215	Spurstange / tie rod		
81 92 3111	43330-09090	Traggelenk / ball joint		
81 92 3243	43330-19115	Traggelenk / ball joint		
81 92 4292	48069-12191 S1	Querlenker / control arm		
81 92 4312	48068-12191 S1	Querlenker / control arm		
81 92 9185	48068-12191 S3	Querlenkerlager / control arm mount		

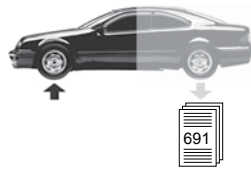

Corolla (_E12_) (2002 →)

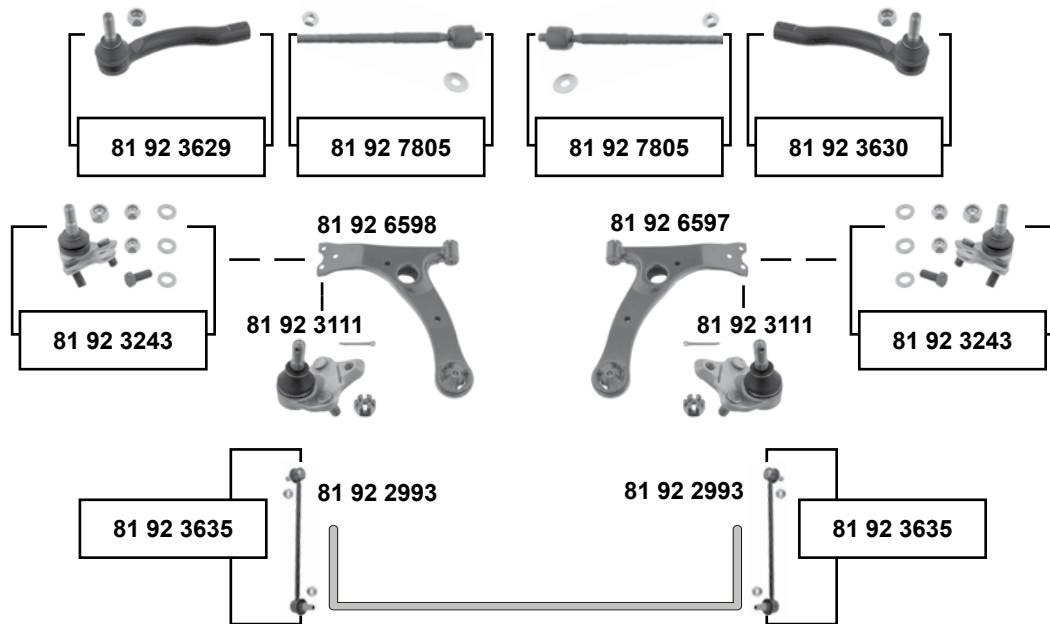

Corolla (_E15_) (2007 →)

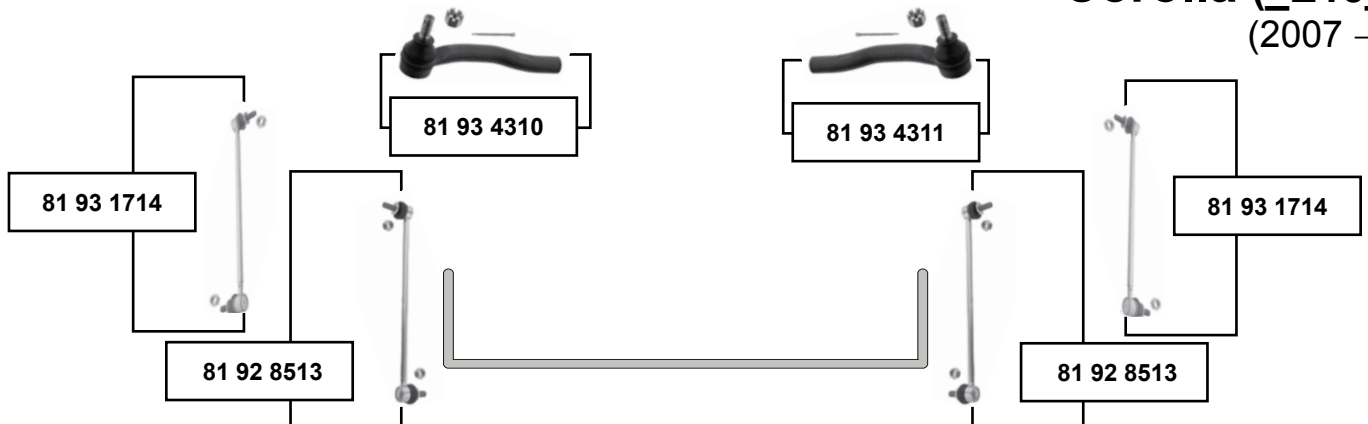

- (1) **BM** ZRE152 / 03/07 →
- (2) **BM** ZRE150/151;ADE150;ZZE150;NDE150 // 07/07 →
- (3) NZE121 08/00 → 08/07 / ZRE120 05/07 → / NZE141 04/07 →
- (4) NDE150/ZRE151/ZZE150 / 10/06 → / ZRE152 03/07 →
- (5) CDE120/10/01 → 10/06 / NDE120/05/04 →10/06 / CE120 / NZE120/121/
ZZE12/08/00 → 08/07 / ZZE130/ 04/02 → NZE141 / 04/07 →



Ref. - No.	Description	Notes	Length
81 92 2993	Verbindungsstange / connecting rod	(Modell) UK	L 285
81 92 3111	Traggelenk / ball joint	11/01 → 02/07	
81 92 3243	Traggelenk / ball joint	(5)	
81 92 3629	Spurstangenendstück / tie rod end	(3)	
81 92 3630	Spurstangenendstück / tie rod end	(3)	
81 92 3635	Verbindungsstange / connecting rod	(Modell) Japan	L 285
81 92 6597	Querlenker / control arm		
81 92 6598	Querlenker / control arm		
81 92 7805	Spurstange / tie rod	(Modell) 08/00→09/06	L 273
81 92 8513	Verbindungsstange / connecting rod	(1)	L 360,5
81 93 1714	Verbindungsstange / connecting rod	(2)	L 360
81 93 4310	Spurstangenendstück / tie rod end	(4)	M15 x 1,5
81 93 4311	Spurstangenendstück / tie rod end	(4)	M15 x 1,5



Corolla Verso (_E12_)

(2001 → 2003)

Vorderachse / Front axle

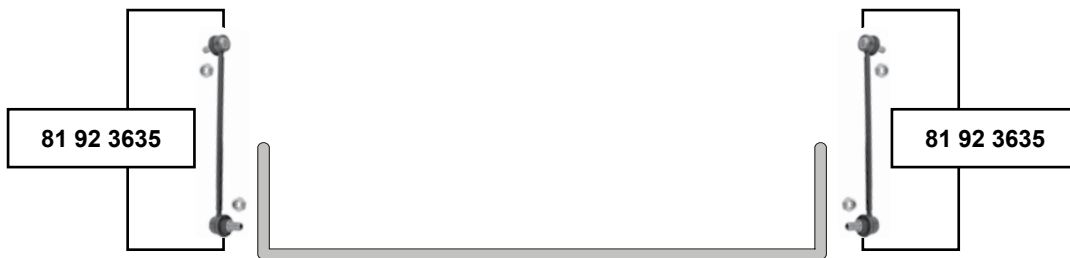
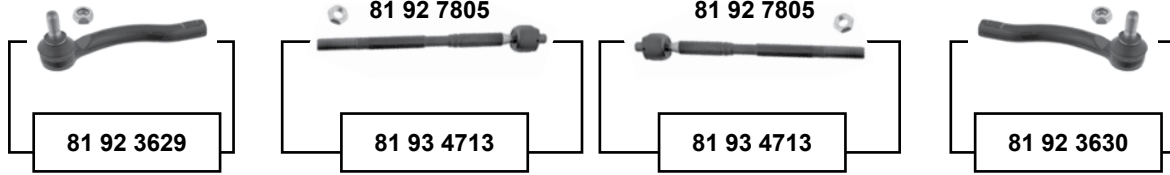

	Ref. - No.			
81 92 3243	43330-19115	Traggelenk / ball joint	09/01 → 01/04	L 285
81 92 3629	45047-19115	Spurstangenendstück / tie rod end	(Modell) 08/00→12/05	
81 92 3630	45046-19265	Spurstangenendstück / tie rod end	(Modell) 08/00→12/05	
81 92 3635	48820-47010	Verbindungsstange / connecting rod	(Modell) Japan	
81 92 6597	48068-12260	Querlenker / control arm		
81 92 6598	48069-12260	Querlenker / control arm		
81 92 7805	45503-19255	Spurstange / tie rod	(modell) 08/00→09/06	L 273
81 93 4713	45503-0F010	Spurstange / tie rod	02/04 →	L 305

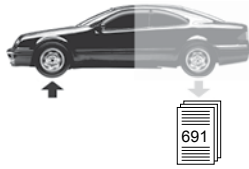

Corona (AT190/210ST191/210) (1996 → 2001)

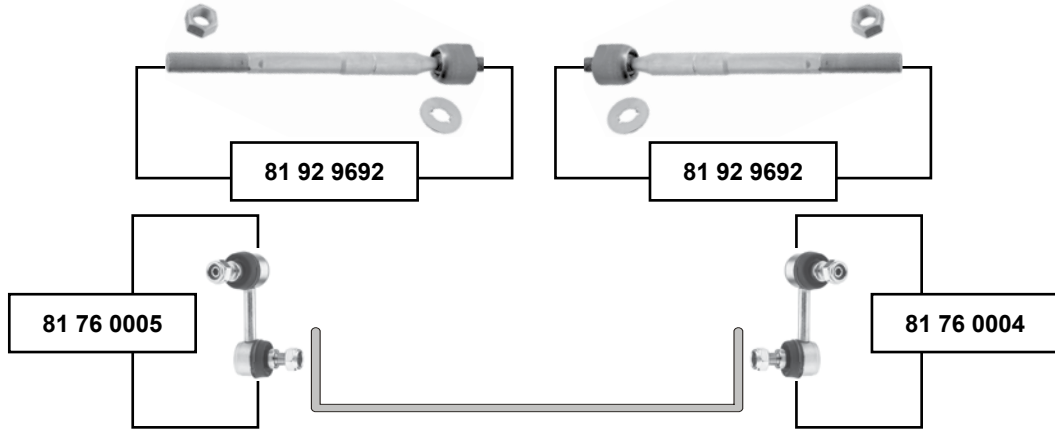

Corona (AT220/CT220/ST210) (1997 → 2003)

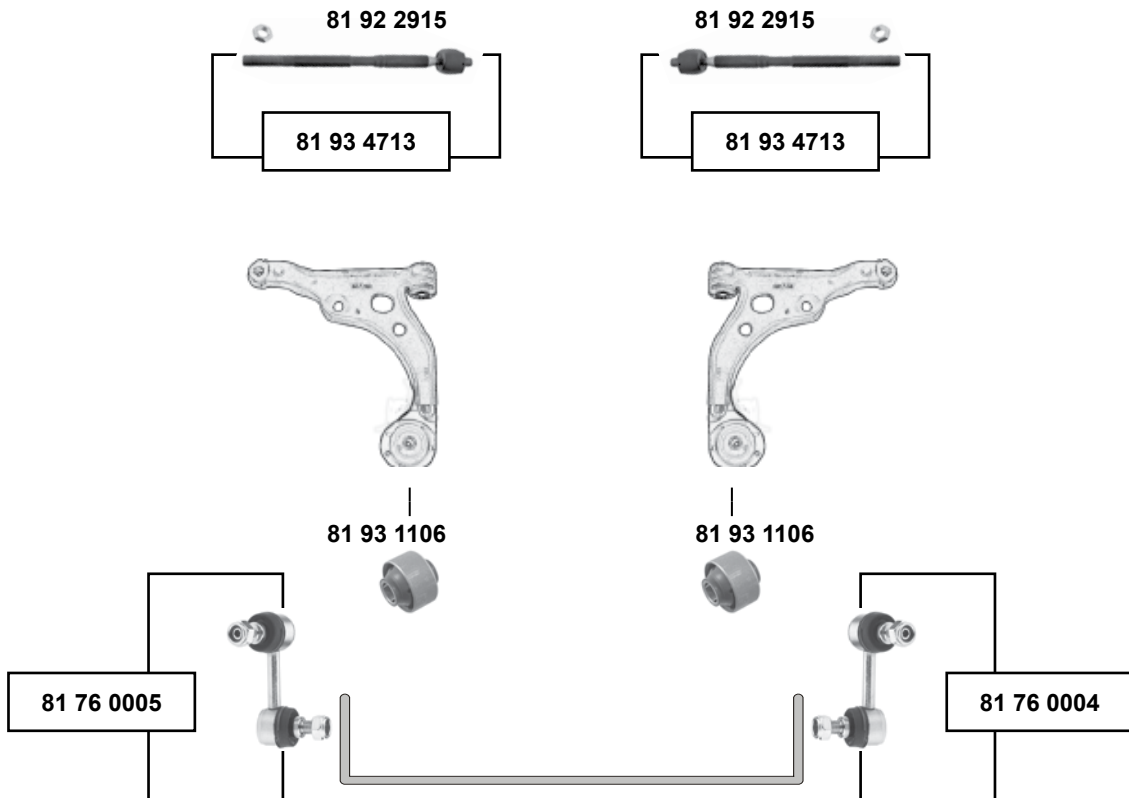

- (1) AT190 / CT190 / ST191 // 03/92 → 05/98
(2) AT210 / ST210 // 01/96 → 12/01



Ref. - No.



Ref. - No.	Description	Quantity	Dimensions
81 76 0004	Verbindungsstange / connecting rod	(1) (2)	M10 x 1,25
81 76 0005	Verbindungsstange / connecting rod	(1) (2)	M10 x 1,25
81 92 2915	Axialgelenk / axial joint	AT220/CT220/ST220	M16 x 1,5
81 92 9692	Spurstange / tie rod		L240,5
81 93 1106	Querlenker / control arm		
81 93 4713	Spurstange / tie rod	01/03 →	L 305

passend für / to fit



TOYOTA

Corona (AT151/CT150/ST15)

(1984 → 1987)

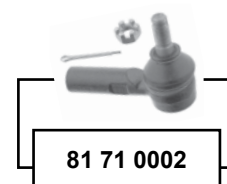

Vorderachse / Front axle

Crown (GS151/JZS155)

(1995 → 2001)



(1) JZS175 // 09/99 → 12/03



Ref. - No.



81 71 0002 45046-29305
81 93 4664 48820-22041

Spurstangenendstück / tie rod end
Verbindungsstange / connecting rod

(1)

M12 x 1,25
L 107



Dyna (LY100/YY100)
(1995 → 2001)

81 92 3246



81 92 3246





Echo / Verso (NCP 12/13/20)

(1999 → 2005)

Vorderachse / Front axle



Hiace III (_H10_)

(1989 → 1995)

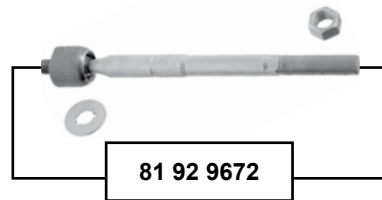

81 92 3246



81 92 3246



(1) RZH102 / 103 / 104 / 105 / 112 / 113 / 114 / 115 / 125 / 135 / 153 / 154 / 172 / 174 / 184 / LH172 / 174 / 184 / LH10 / 11 / 125 / 135 / 15 // 08/93 → 02/06



Ref. - No.



81 71 0002	45046-29305	Spurstangenendstück / tie rod end	(1)	M12 x 1,25
81 92 3246	43330-29515	Traggelenk / ball joint		M12 x 1,25
81 92 3641	45047-59026	Spurstangenendstück / tie rod end		M12 x 1,25
81 92 3643	45046-59026	Spurstangenendstück / tie rod end		M12 x 1,25
81 92 7262	48819-52010 S1	Rep. Satz Verbindungsstange / rep. kit connecting rod		L 97,5
81 92 9672	45503-29255	Spurstange / tie rod		L 274,6



Hiace IV (_H1_H2_)
(1995 →)

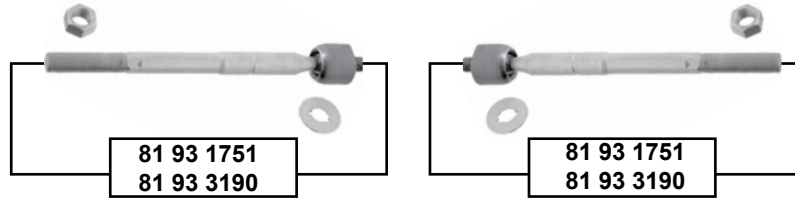

81 92 3246



81 92 3246



Vorderachse / Front axle

Hilux 2WD (N5)
(1983 →)

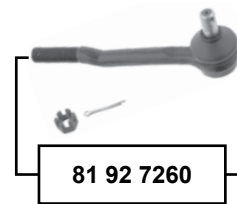
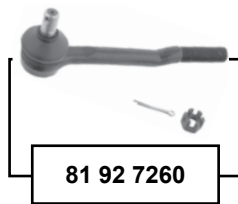

81 92 3247

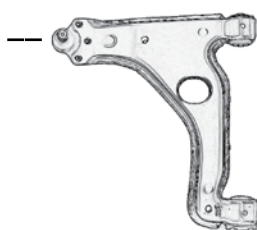

81 92 3247



(1) LXH12/22 / RCH13/23 / KLH12/22 / 07/99 → 05/04

(2) LH166/176/08/98 → 08/04/LXH18/28/08/96 → 08/01/RCH18/19/28/29/08/96 → 05/06/KLH18/28/07/99 →



Ref. - No.



81 92 3246	43330-29515	Traggelenk / ball joint	(1)	
81 92 3247	43350-39075	Traggelenk / ball joint	08/83 → 06/01	
81 92 7260	45406-39185	Spurstangenendstück / tie rod end		L 204
81 93 1751	45503-29565	Spurstange / tie rod		
81 93 3190	45503-29575	Spurstange / tie rod	(2)	L 245

passend für / to fit

TOYOTA

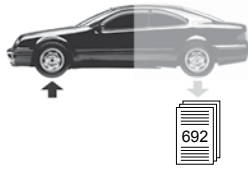

Highlander (U20)

(2001 →)

Vorderachse / Front axle

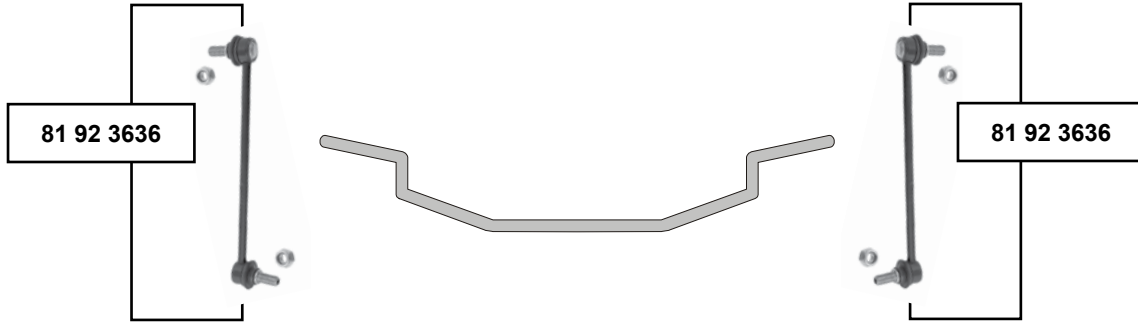

Hilux (RN 125)

(1991 → 1993)



(1) KZN130 / LN130 / VZN130 / LN13 / RN12/13 / VZN120/130 / YN130 08/89 → 11/95



Ref. - No.



81 92 3636 48820-28050
81 93 4665 48820-35010

Verbindungsstange / connecting rod
Verbindungsstange / connecting rod

(1)

L 260
L 92

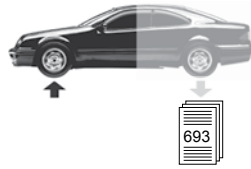

Land Cruiser (J7_J8)
(1990 → 1996)

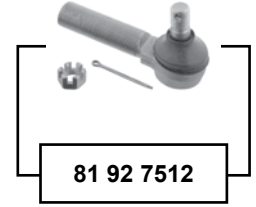

81 92 6736



81 92 6737



Land Cruiser (J9)
(1996 → 2004)

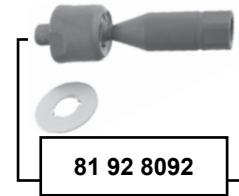
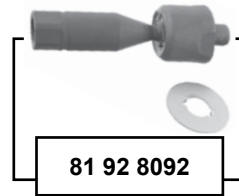

81 92 6736	48810-60010	Verbindungsstange / connecting rod	M12 x 1,25
81 92 6737	48820-60010	Verbindungsstange / connecting rod	M12 x 1,25
81 92 7511	45047-69085	Spurstangenkopf links / tie rod end left	L 70
81 92 7512	45046-69135	Spurstangenkopf rechts / tie rod end right	L 70
81 92 8092	45503-39075	Spurstange / tie rod	L 131
81 92 8591	48820-AD010	Verbindungsstange / connecting rod	L 192,6

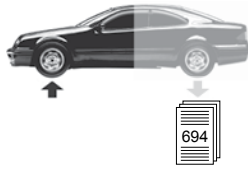

Land Cruiser (J10)

(1998 → 2002)

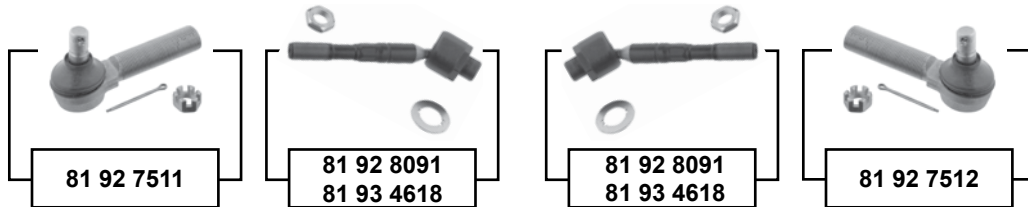

81 92 7511

81 92 8091
81 93 4618

81 92 8091
81 93 4618

81 92 7512

Vorderachse / Front axle

Land Cruiser (J12)

(2002 →)

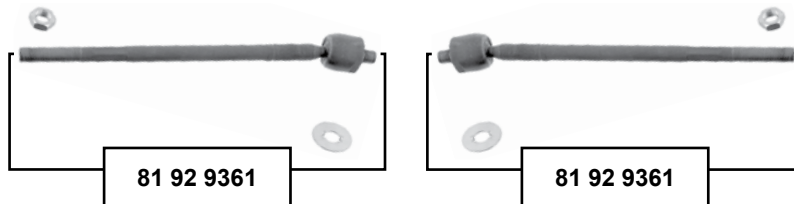

81 92 9361

81 92 9361

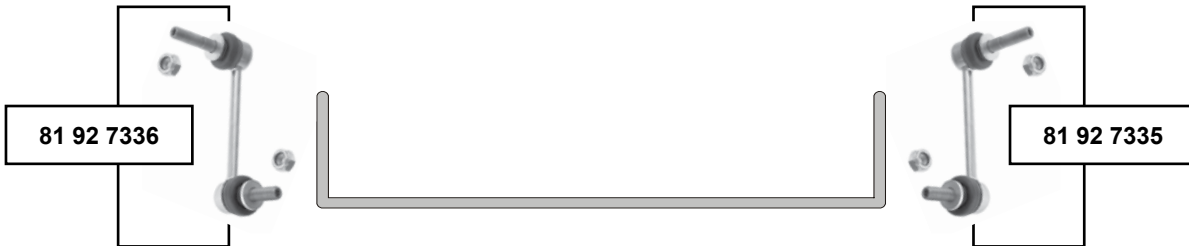

81 92 7336

81 92 7335



Ref. - No.



81 92 7335	48820-60050
81 92 7336	48810-60040
81 92 7511	45047-69085
81 92 7512	45046-69135
81 92 8091	45503-69015
81 92 9361	45503-39265
81 93 4618	45503-69025

Verbindungsstange / connecting rod
Verbindungsstange / connecting rod
Spurstangenendstück / tie rod end
Spurstangenendstück / tie rod end
Spurstange / tie rod
Spurstange / tie rod
Spurstange / tie rod

08/02 → 08/07

L 140
L 140
L 214
L 261
L 208



MR 2 (ZZW20) (1990 → 1999)

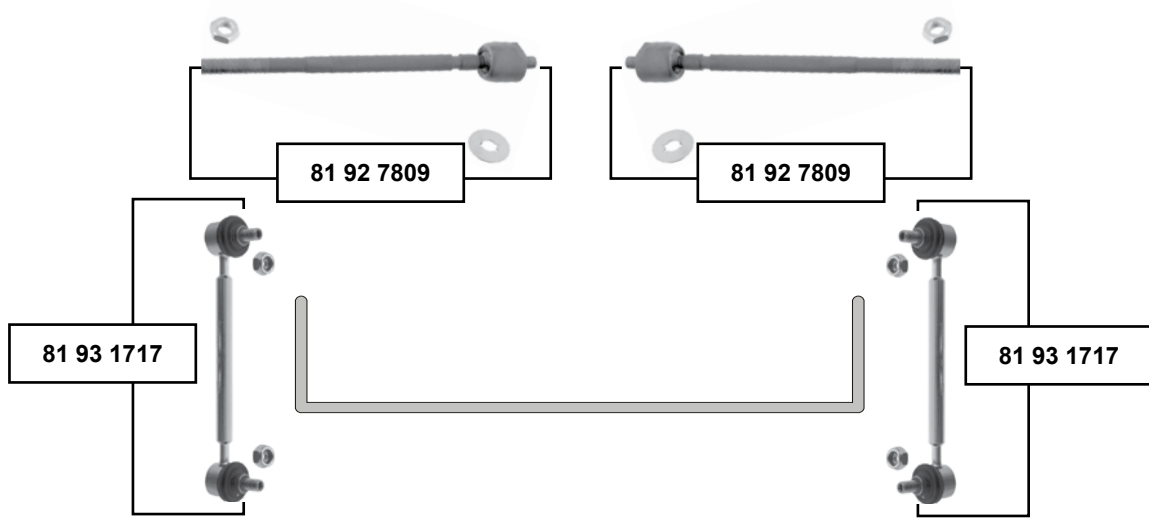

Vorderachse / Front axle

MR 2 (ZZW30) (1999 →)

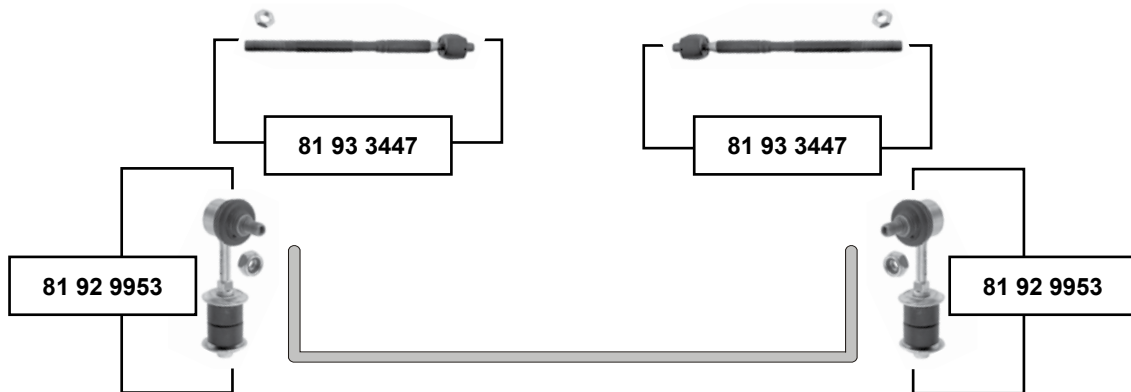

Noah (ZRR70) (2008 →)

81 93 0231



81 93 0232



SWAG [®]	Ref. - No.			
81 92 7809	45503-19145	Spurstange / tie rod	servo	L 288
81 92 9953	48820-17050 S1	Verbindungsstange / connecting rod	→ 01/05	L 106
81 93 0231	45047-49025	Spurstangenendstück links / tie rod end left	→ 05	M15 x 1,5
81 93 0232	45046-49095	Spurstangenendstück rechts / tie rod end right	→ 05	M15 x 1,5
81 93 1717	48820-17040	Verbindungsstange / connecting rod		L 204
81 93 3447	45503-17040	Axialgelenk / axial joint	12/99 → 09/05	



TOYOTA

Paseo (EL44)
(1991 → 1994)

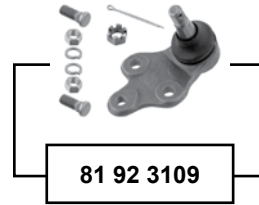
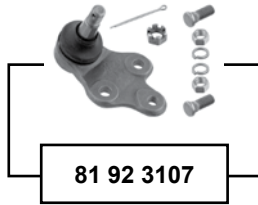

Vorderachse / Front axle

Picnic (_XM10_)
(1996 → 2001)

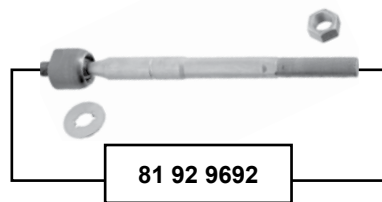

81 78 0001



81 78 0001

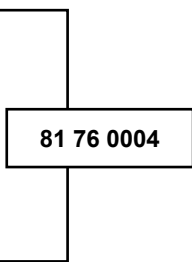
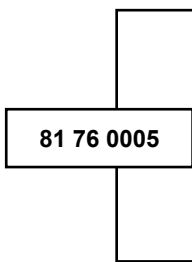

Ref. - No.



81 76 0004	48820-20040
81 76 0005	48810-20020
81 78 0001	43330-29315
81 92 3107	43340-19025
81 92 3109	48810-28020
81 92 9692	45503-29615

Verbindungsstange / connecting rod
Verbindungsstange / connecting rod
Traggelenk / ball joint
Traggelenk / ball joint
Traggelenk / ball joint
Traggelenk / ball joint
Spurstange / tie rod

09/96 → 04/00
09/96 → 04/00

L 240,5



Previa (R1) (1990 → 2000)

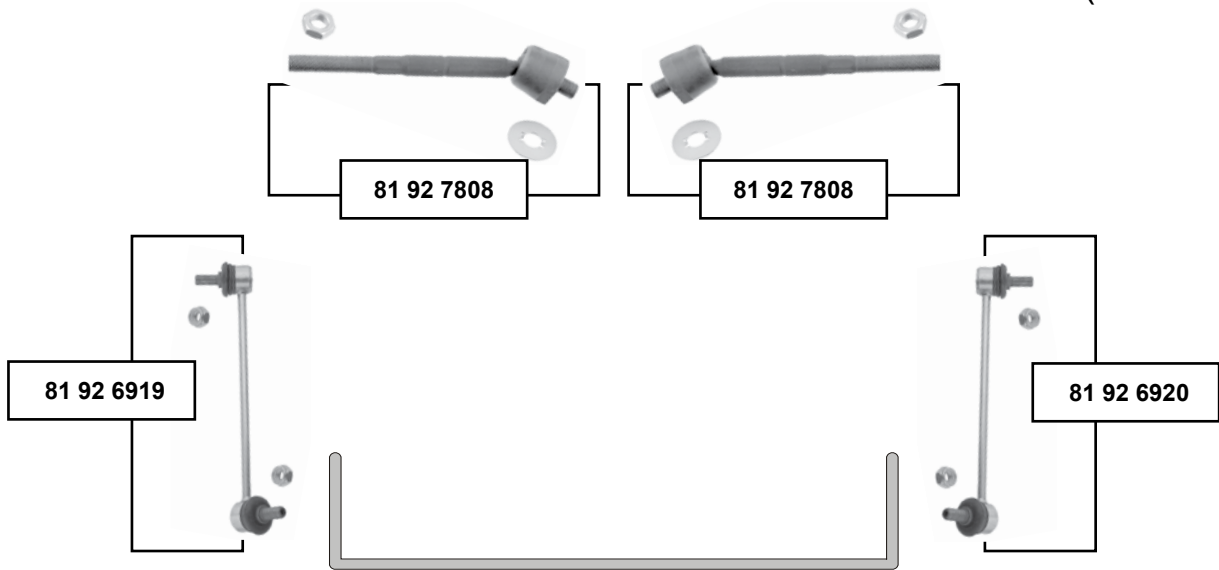

Vorderachse / Front axle

Previa (R3) (2000 →)

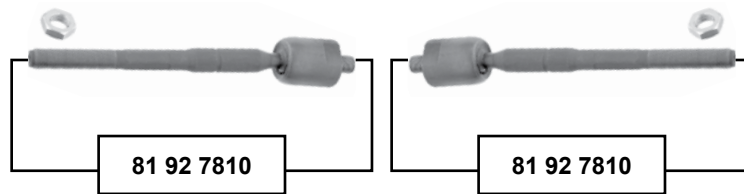

Previa (_R5_) (2006 →)

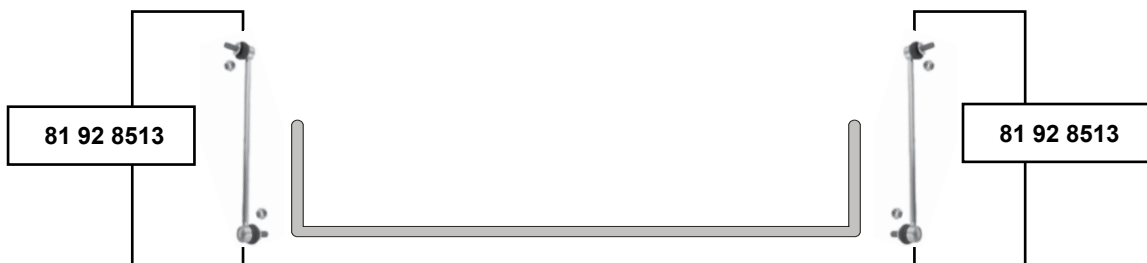

81 92 6919	48810-28020	Verbindungsstange / connecting rod		L 255
81 92 6920	48810-28030	Verbindungsstange / connecting rod		L 255
81 92 7808	45503-29295	Spurstange / tie rod		L 215
81 92 7810	45503-29765	Spurstange / tie rod		L 252
81 92 8513	48820-42030	Verbindungsstange / connecting rod	ACR50, GSR50	L 360,5

passend für / to fit

TOYOTA



Prius (NHW11)

(2000 → 2003)

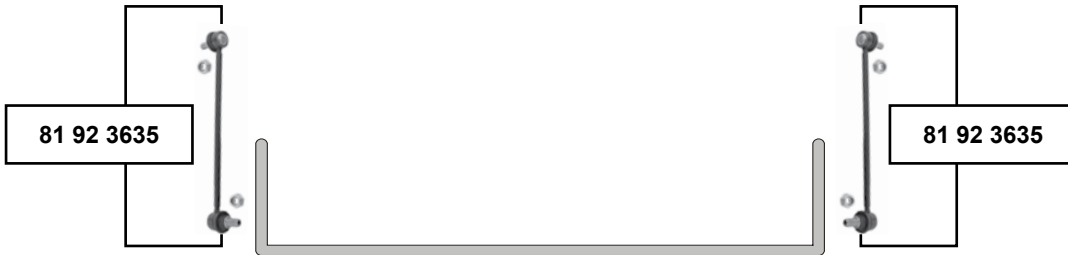
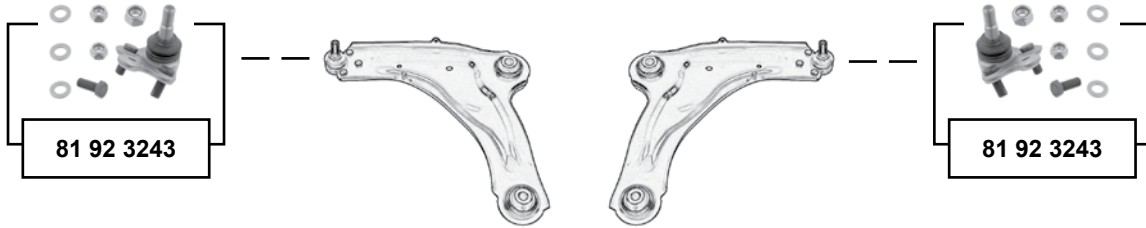

Prius (NHW20)

(2004 →)

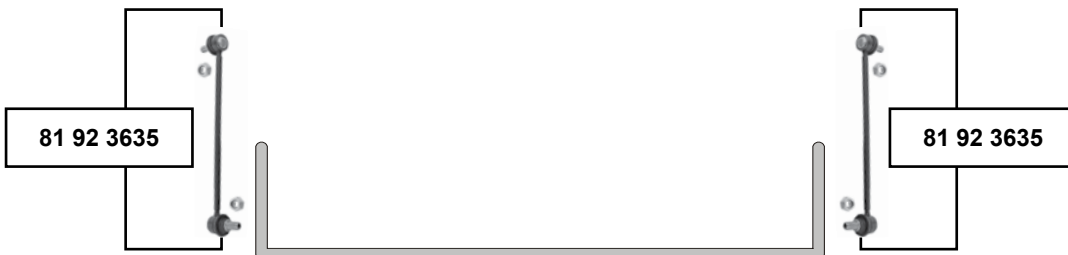
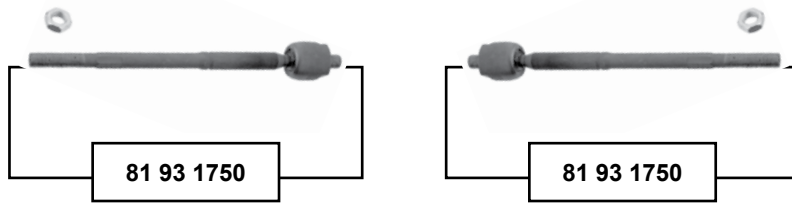

Ref. - No.



81 92 3243	43330-19115
81 92 3635	48820-47010
81 93 1750	45503-47030

Traggelenk / ball joint
Verbindungsstange / connecting rod
Spurstange / tie rod

L 285
L 297

Vorderachse / Front axle



RAV 4 I (_SXA1/10/11/16_)

(1994 → 2000)

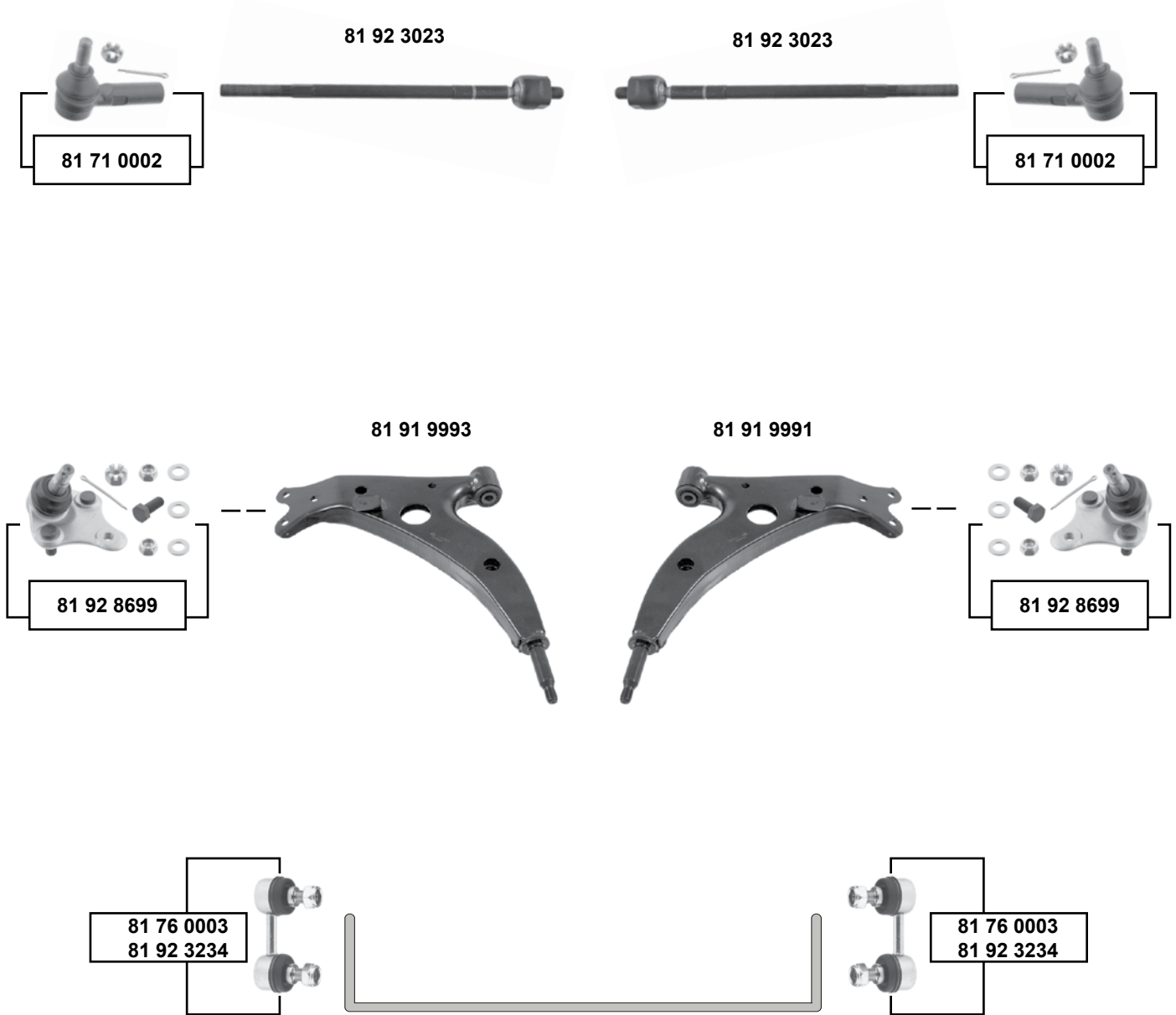

Vorderachse / Front axle

(1) (SXA10) : 08/96 → 08/00
(SXA11,16) : 04/95 → 08/00

SWAG [®]	Ref. - No.		(1)	
81 71 0002	45046-29305	Spurstangenendstück / tie rod end		M12 x 1,25
81 76 0003	48820-33010	Verbindungsstange / connecting rod		L 60
81 91 9991	48068-42022	Querlenker / control arm		
81 91 9993	48069-42022	Querlenker / control arm		
81 92 3023	45503-19215	Spurstange / tie rod		
81 92 3234	48820-42010	Verbindungsstange / connecting rod	(1)	M12 x 1,25
81 92 8699	43330-49025 S1	Traggelenk / ball joint		M14 x 1,5

passend für / to fit

TOYOTA

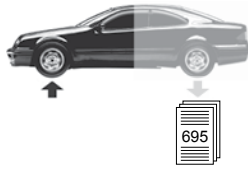

SWAG[®]
GERMANY

RAV 4 I (_BEA11_)

(1997 → 2003)

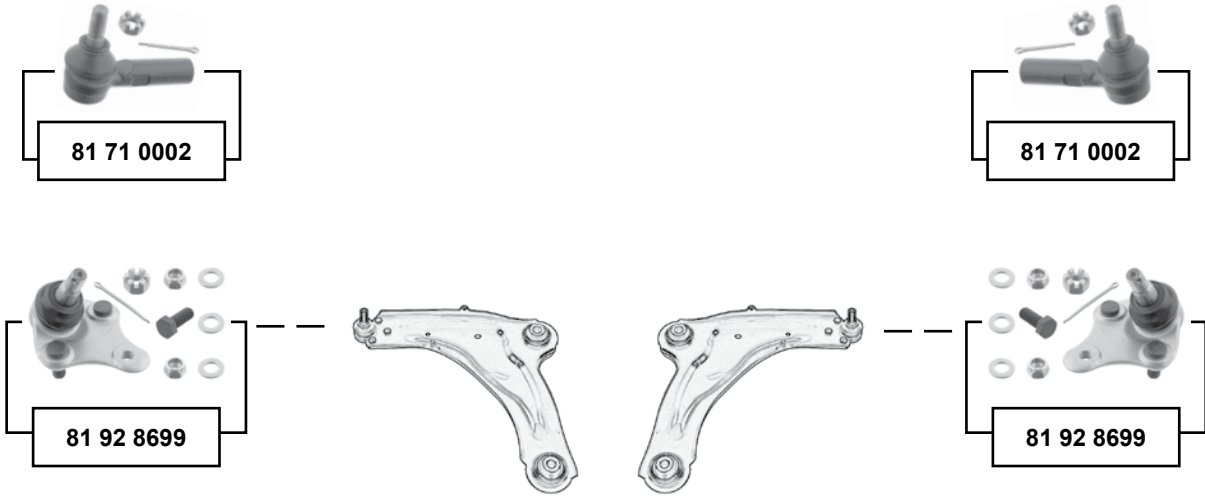

RAV 4 II (_XA2_)

(2000 → 2005)

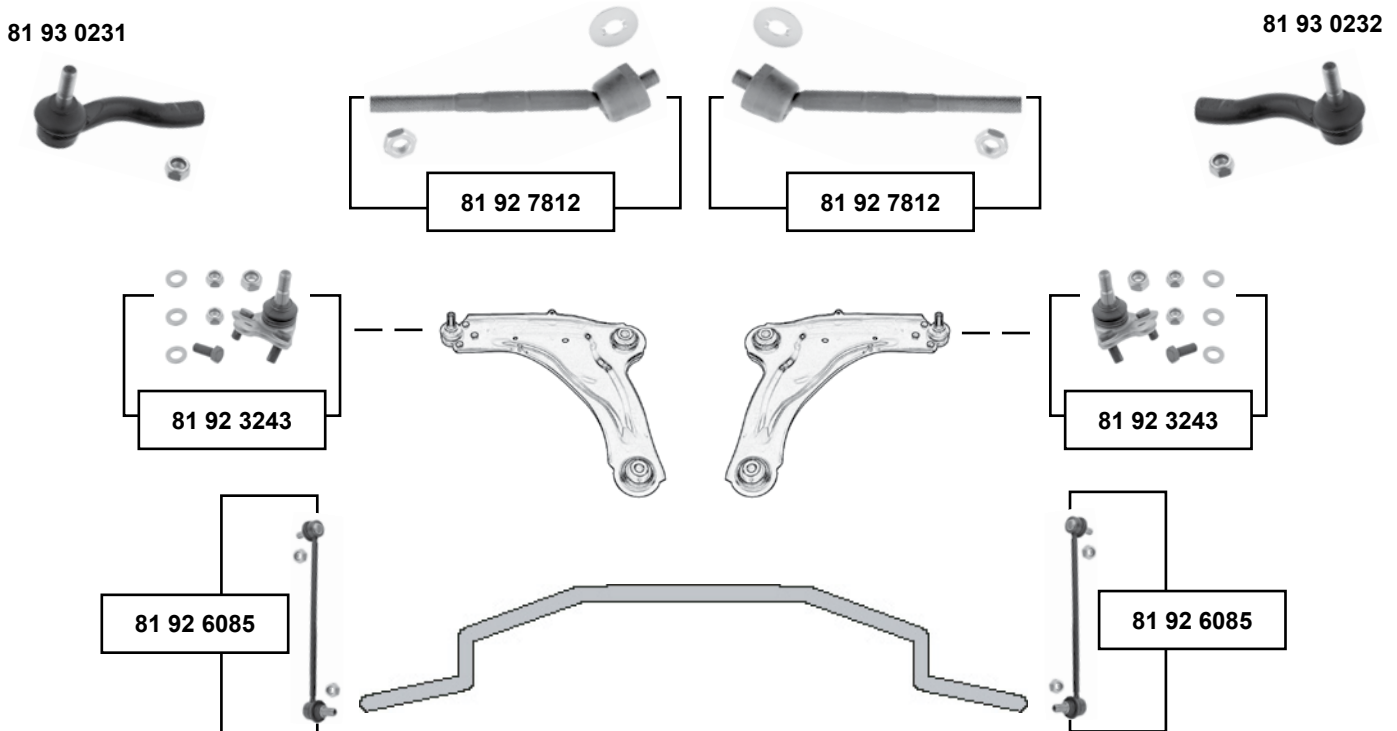

SWAG[®]
GERMANY

Ref. - No.



81 71 0002 45046-29305
81 92 3243 43330-19115
81 92 6085 48820-42020
81 92 7812 45503-49055
81 92 8699 43330-49025 S1
81 93 0231 45047-49025
81 93 0232 45046-49095

Spurstangenendstück / tie rod end
Traggelenk / ball joint
Verbindungsstange / connecting rod
Spurstange / tie rod
Traggelenk / ball joint
Spurstangenendstück links / tie rod end left
Spurstangenendstück rechts / tie rod end right

08/00 → 11/05
→ 03

L 260
L 298
M14 x 1,5
M15 x 1,5
M15 x 1,5

Vorderachse / Front axle

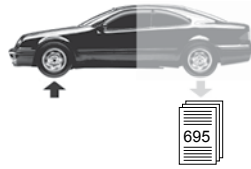

RAV 4 III (_A3_)
(2005 →)

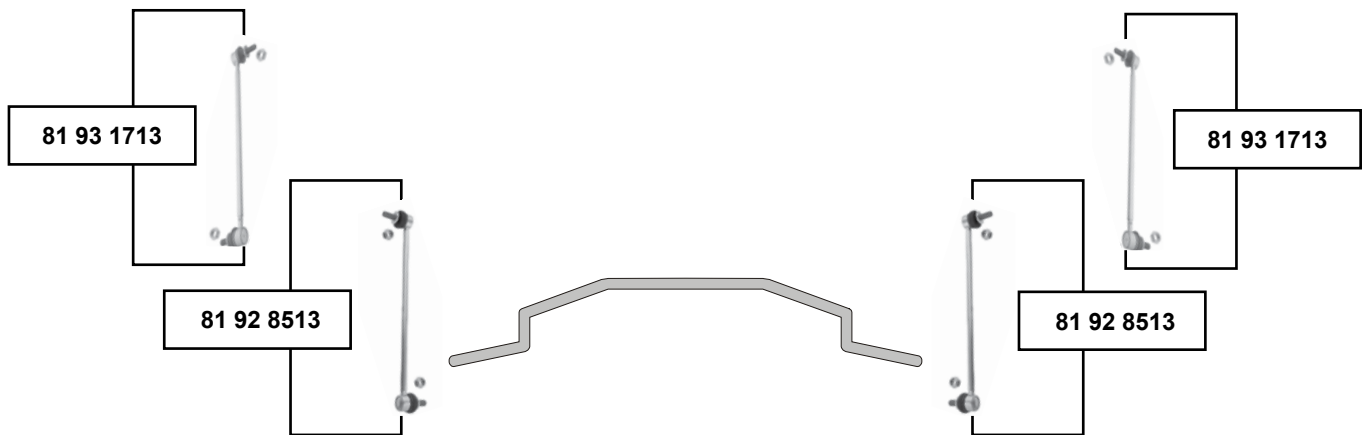

Vorderachse / Front axle



(1) BM ACA30, ALA30, GSA33 11/05 →



Ref. - No.



81 92 8513 48820-42030
81 93 1713 48820-0R010

Verbindungsstange / connecting rod
Verbindungsstange / connecting rod

(1)
BM ASA3*

L 360,5
L 360

passend für / to fit

TOYOTA



Rukus

(2010 →)

Vorderachse / Front axle

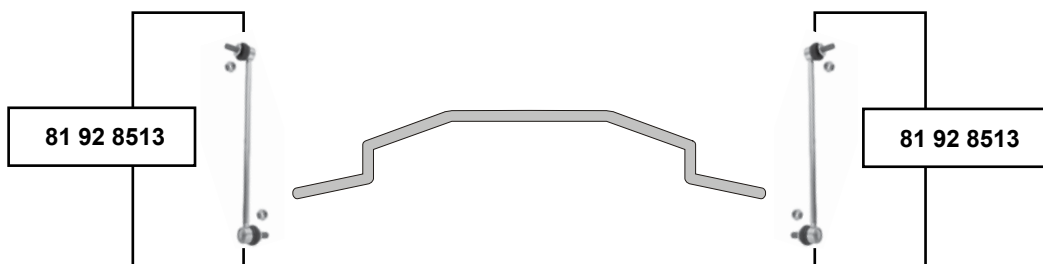

Ref. - No.



81 92 8513	48820-42030
81 93 4310	45047-19215
81 93 4311	45046-19415

Verbindungsstange / connecting rod
Spurstangenendstück / tie rod end
Spurstangenendstück / tie rod end

AZE151 03/10 →

L 360,5
M15 x 1,5
M15 x 1,5



Scion (_10_) (1996 →)

81 93 0231

81 93 0232



Scion XA/XB (_NCP_) (2003 → 2006)

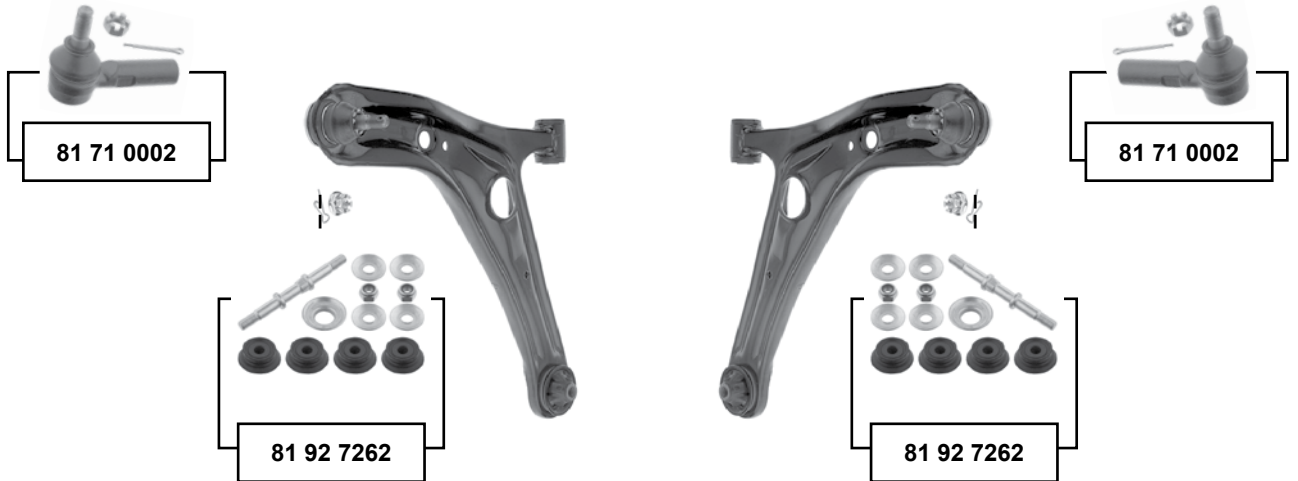

Scion XB (_AZE_) (2007 →)



81 71 0002	45046-29305	Spurstangenendstück / tie rod end		
81 92 3635	48820-47010	Verbindungsstange / connecting rod		L 285
81 92 7262	48819-52010 S1	Rep. Satz Verbindungsstange / rep. kit connecting rod	04/03 → 12/06	L 97,5
81 92 8513	48820-42030	Verbindungsstange / connecting rod	Scion xB 03/07 →	L 360,5
81 93 0231	45047-49025	Spurstangenendstück / tie rod end	Scion TC 05/04 →	M15 x 1,5
81 93 0232	45046-49095	Spurstangenendstück / tie rod end	Scion TC 05/04 →	M15 x 1,5

passend für / to fit

TOYOTA



Sienna (_L_)
(1997 → 2000)

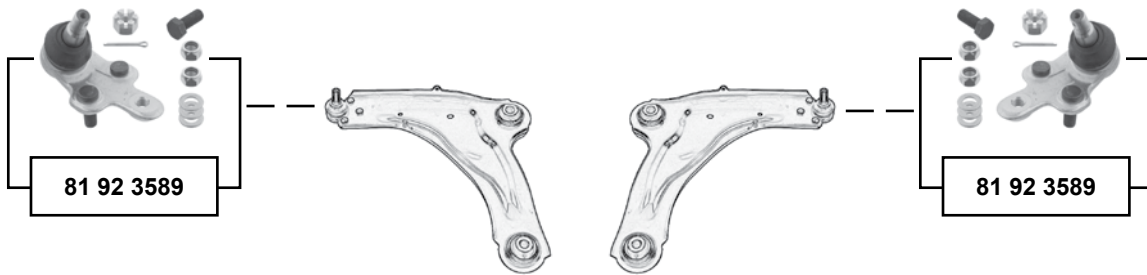

Vorderachse / Front axle

Sienna (_L_)
(2003 →)

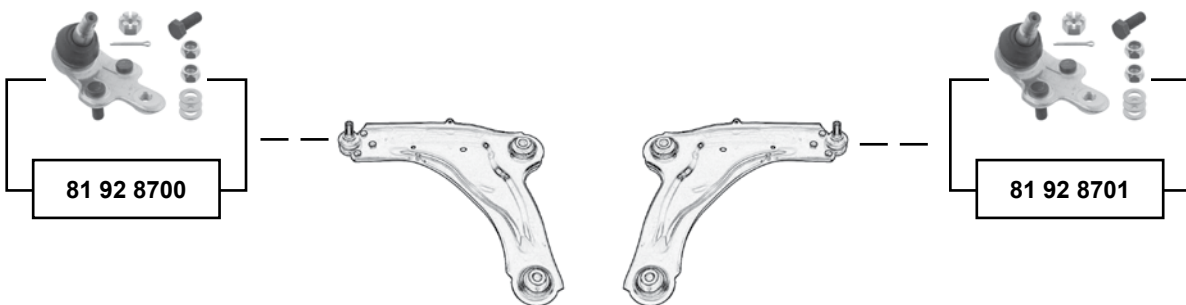

Ref. - No.



81 92 3589	43330-39435
81 92 8700	43330-09010 S1
81 92 8701	43330-09560 S1

Traggelenk / ball joint
Traggelenk / ball joint
Traggelenk / ball joint

M14 x 1,5
M14 x 1,5



Solara
(1998 → 2001)

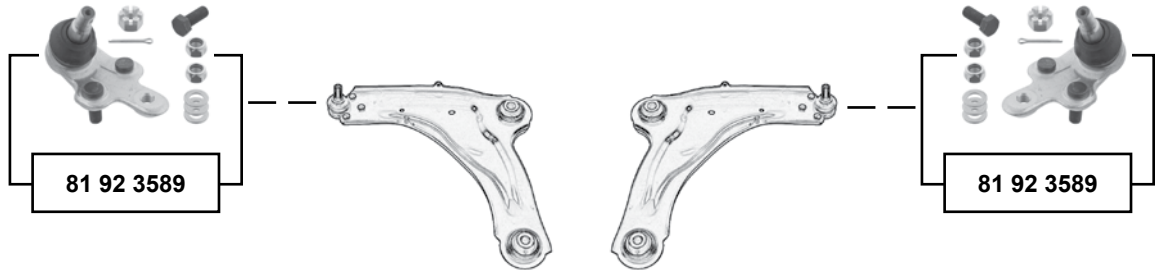

Solara
(2003 →)

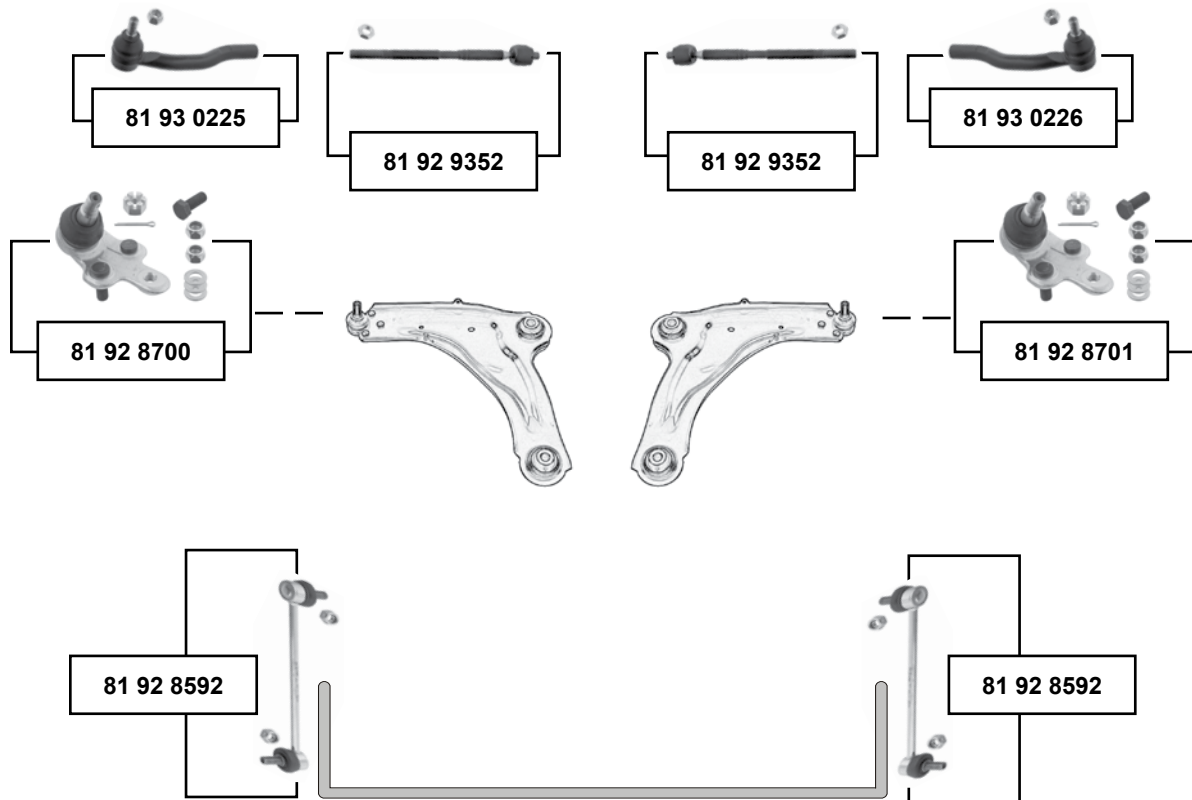

Vorderachse / Front axle



81 92 3589	43330-39435	Traggelenk / ball joint		
81 92 8592	48820-06040	Verbindungsstange / connecting rod		L 260,1
81 92 8700	43330-09010 S1	Traggelenk / ball joint		M14 x 1,5
81 92 8701	43330-09560 S1	Traggelenk / ball joint		M14 x 1,5
81 92 9352	45503-39225	Spurstange / tie rod		L 238
81 93 0225	45470-39225	Spurstangenendstück / tie rod end	07/03 → 03/05	M15 x 1,5
81 93 0226	45460-39635	Spurstangenendstück / tie rod end	07/03 → 03/05	M15 x 1,5



Spacio (AE111) (1998 → 2001)



Vorderachse / Front axle

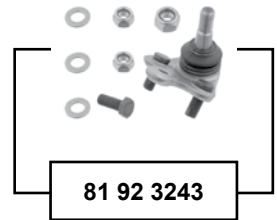



Starlet (_P7_)
(1984 → 1989)

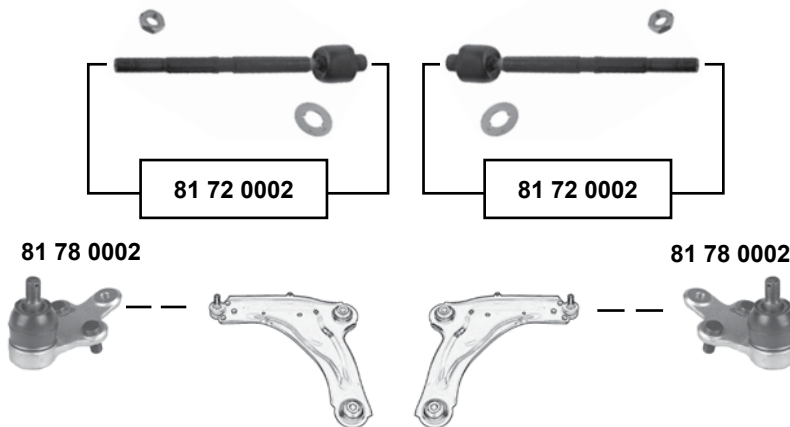

Starlet (_P8_)
(1989 → 1996)



Starlet (_P9_)
(1996 → 1999)



Vorderachse / Front axle



passend für / to fit

TOYOTA



Supra (MA70) / (JZA80)
(1991 → 1998)

Vorderachse / Front axle

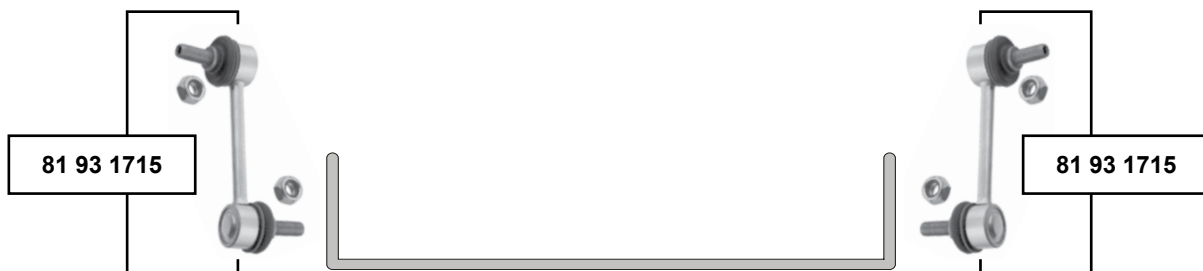

Ref. - No.



81 93 1715 48820-24010

Verbindungsstange / connecting rod

L 111



Tacoma (_RZ/VZ_)
(1995 → 2004)

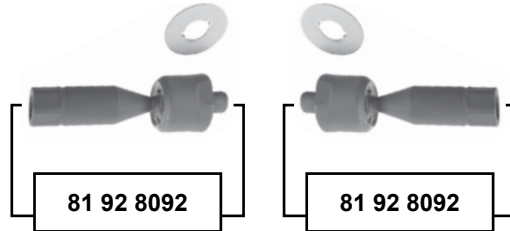

Tacoma (_RN22_)
(2004 →)

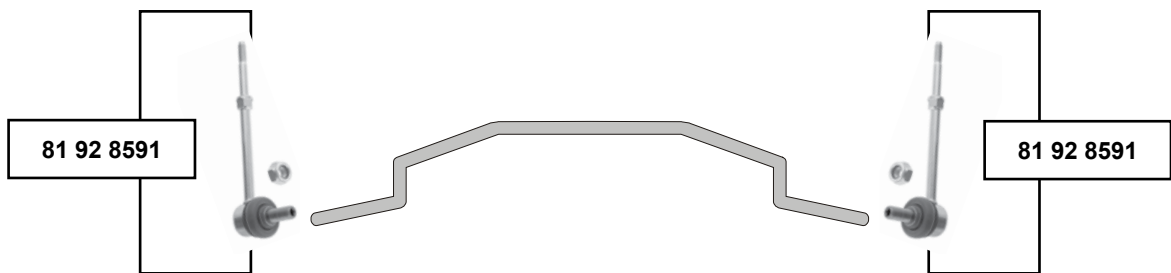



Tarago (_R1_)
(1990 → 2000)

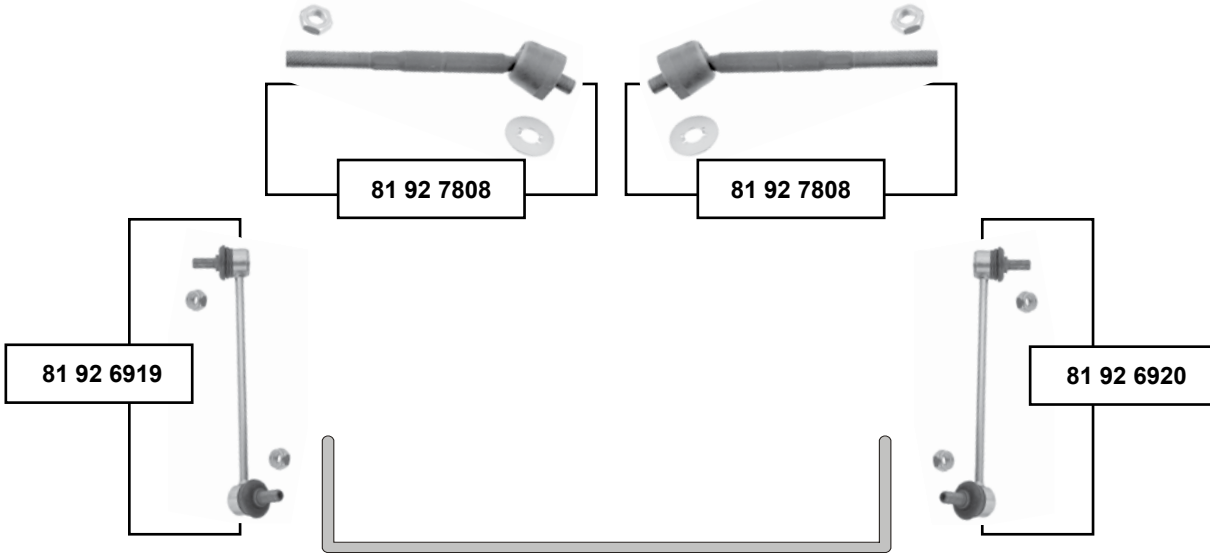



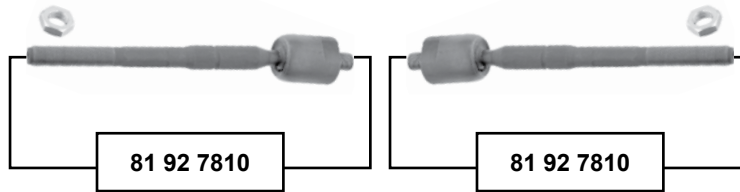

Vorderachse / Front axle

Tarago (_R3_)
(2001 →)



Tarago (_R5_)
(2006 →)



	Ref. - No.			
81 92 6919	48810-28020	Verbindungsstange / connecting rod		L 255
81 92 6920	48810-28030	Verbindungsstange / connecting rod		L 255
81 92 7808	45503-29295	Spurstange / tie rod		L 215
81 92 7810	45503-29765	Spurstange / tie rod		L 252
81 92 8513	48820-42030	Verbindungsstange / connecting rod	ACR50, GSR50	L 360,5



Tercel (_EL31_)
(1986 → 1990)



Tercel (_EL40/42/53_)
(1990 → 1999)

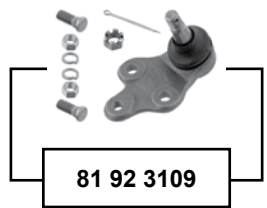
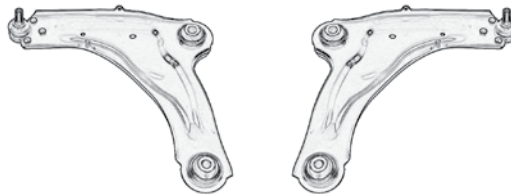
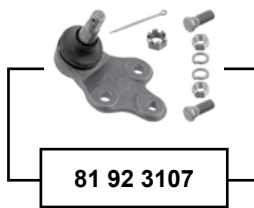

Tundra (_CK30/40_)
(1999 → 2000)

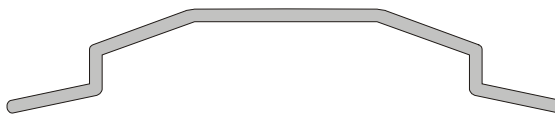
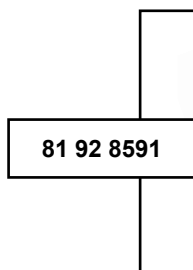

Vorderachse / Front axle



Ref. - No.



81 71 0002	45046-29305
81 92 3107	43340-19025
81 92 3109	48810-28020
81 92 8591	48820-AD010

Spurstangenendstück / tie rod end
Traggelenk / ball joint
Traggelenk / ball joint
Verbindungsstange / connecting rod

M12 x 1,25
L 192,6

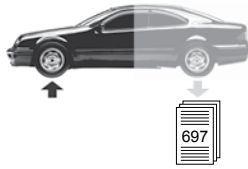

4 Runner (_N 130_)

(1985 → 1995)

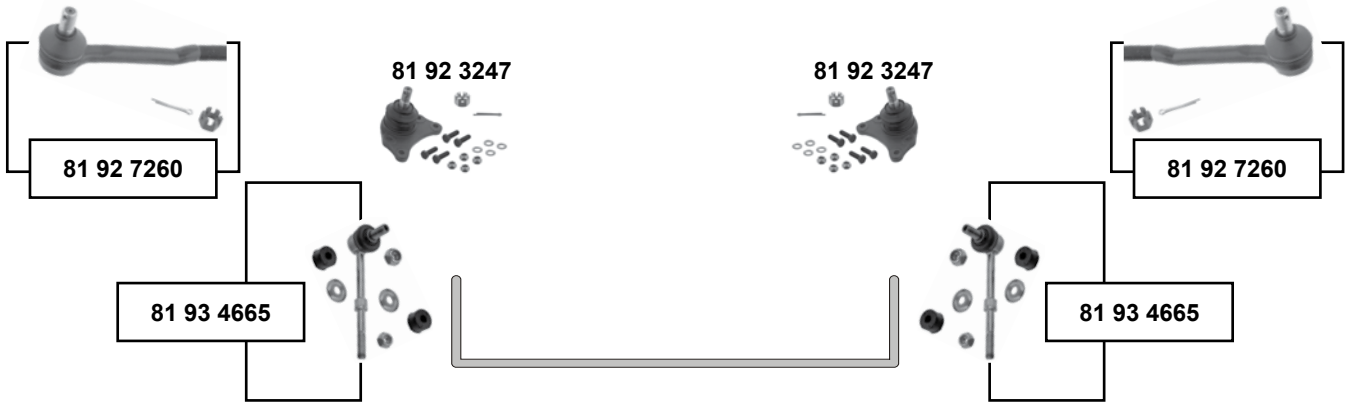

Vorderachse / Front axle

4 Runner

(1996 → 2004)

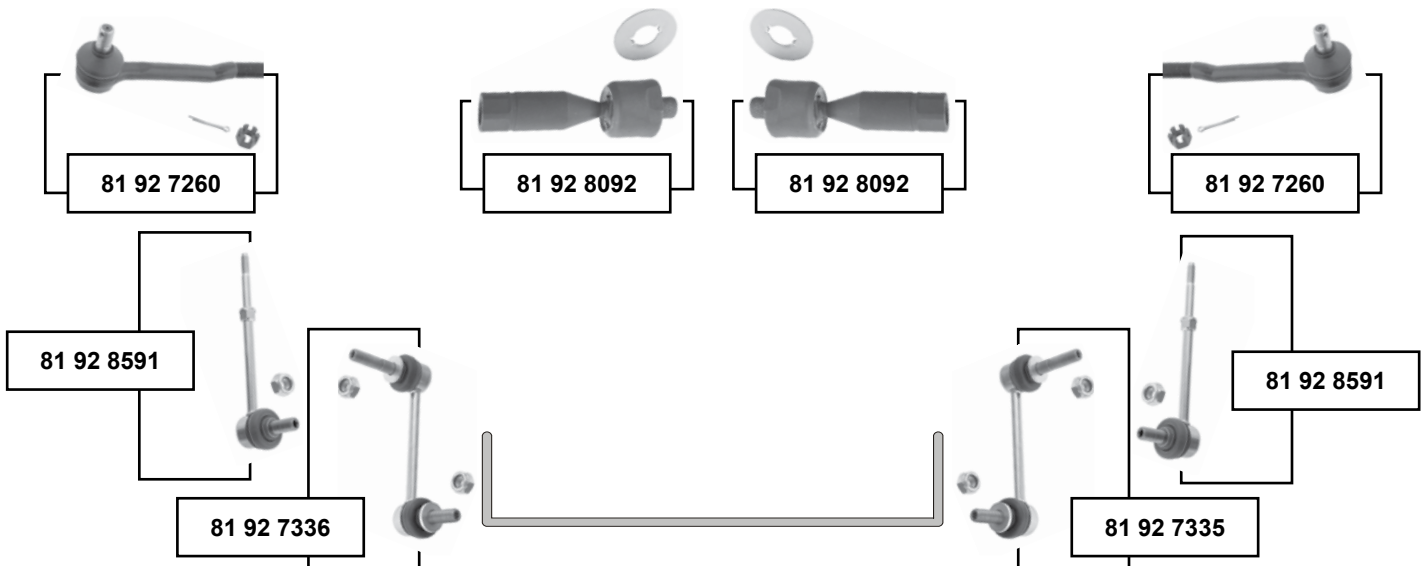

4 Runner (_N21_)

(2002 →)

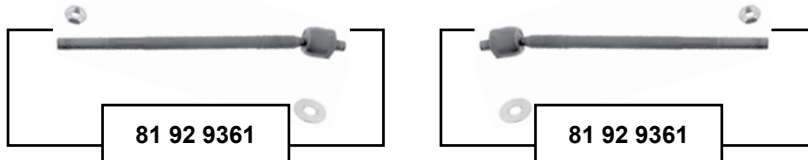

(1) LN5/RN5/7/8/90/VZN85/9// 08/83 → 01/95

(2) LN13/RN12/13/VZN 120/130/YN130 08/89 → 11/95



Ref. - No.



81 92 3247	43350-39075	Traggelenk / ball joint	(1)	
81 92 7260	45406-39185	Spurstangenendstück/ tie rod end		L 204
81 92 7335	48820-60050	Verbindungsstange / connecting rod	02 →	L140
81 92 7336	48810-60040	Verbindungsstange / connecting rod	02 →	L140
81 92 8092	45503-39075	Spurstange / tie rod	95 → 02	L 131
81 92 8591	48820-AD010	Verbindungsstange / connecting rod	95 → 02	L 192,6
81 92 9361	45503-39265	Spurstange / tie rod		L 261
81 93 4665	48820-35010	Verbindungsstange / connecting rod	(2)	L 92



Vios / Soluna Vios (2002 →)

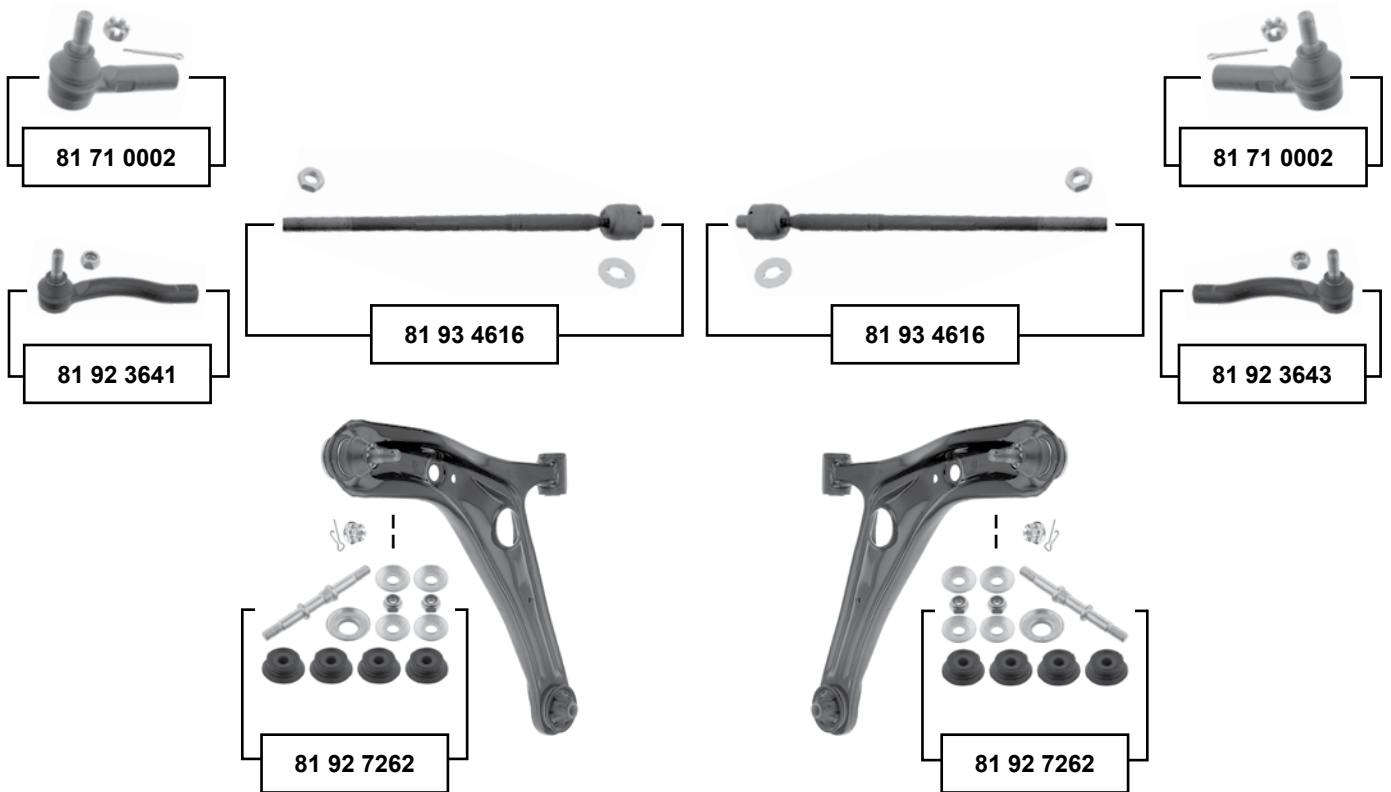

Vorderachse / Front axle



(1) Vios / Soluna Vios (AXP4) 10/02 → 11/05
Vios / Soluna Vios (NCP4) 12/02 → 09/07
Vios / Soluna Vios (SCP4) 08/06 →

(2) Vios / Soluna Vios (AXP4) 04/04 → 08/06
Vios / Soluna Vios (SCP4) 08/06 →



Ref. - No.



81 71 0002 45046-29305
81 92 3641 45047-59026
81 92 3643 45046-59026
81 92 7262 48819-52010 S1
81 93 4616 45503-59055

Spurstangenendstück / tie rod end
Spurstangenendstück / tie rod end
Spurstangenendstück / tie rod end
Rep. Satz Verbindungsstange / rep. kit connecting rod
Axialgelenk / tie rod

(2)
AXP4 11/05 → 08/06 M12 x 1,25
AXP4 11/05 → 08/06 M12 x 1,25
(1)
AXP4 11/05 → 08/06 L 341



Wish (ANE11)

(2003 →)

81 93 0231



81 93 0232



Wish (_ZNE10_)

(2008 → 2009)

Vorderachse / Front axle

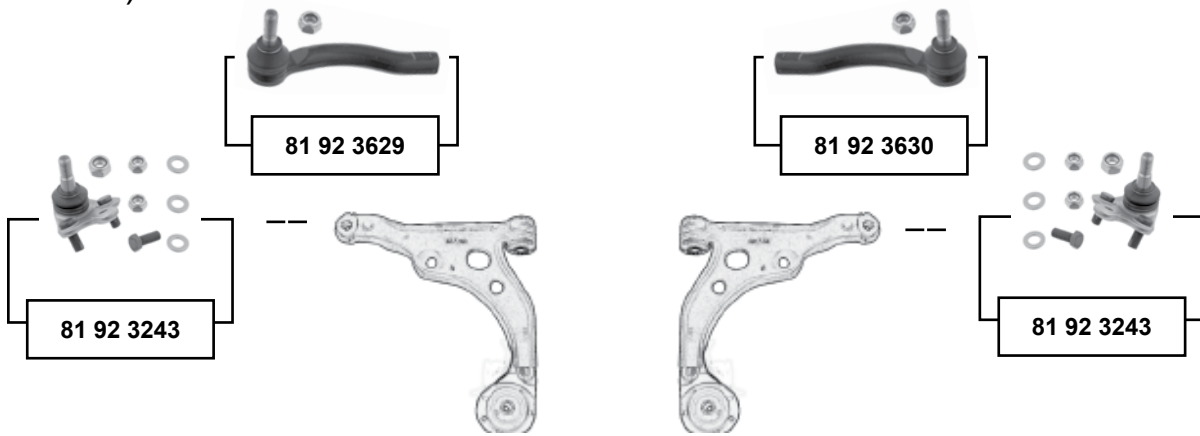

Wish (_ZGE10_)

(2009 →)

81 93 0231



81 93 0232

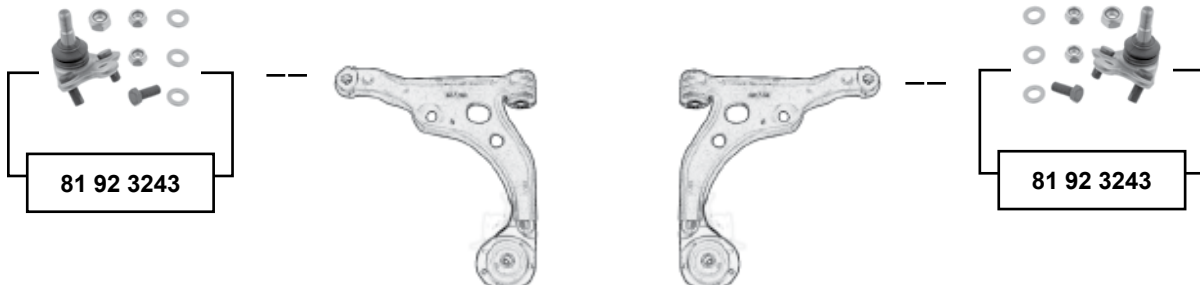

(1) ZNE10 04/08 → 03/09
ZGE20/21 / 09/09 →

(2) ANE11 12/03 →
ZGE20/21/22 11/09 →



Ref. - No.



81 92 3243	43330-19115
81 92 3629	45047-19115
81 92 3630	45046-19265
81 93 0231	45047-49025
81 93 0232	45046-49095

Traggelenk / ball joint	(1)
Spurstangenendstück / tie rod end	(2)
Spurstangenendstück / tie rod end	(2)
Spurstangenendstück / tie rod end	(2)
Spurstangenendstück / tie rod end	(2)

M12 x 1,25
M12 x 1,25
M15 x 1,5
M15 x 1,5



Yaris / Yaris Verso (1999 → 2005)

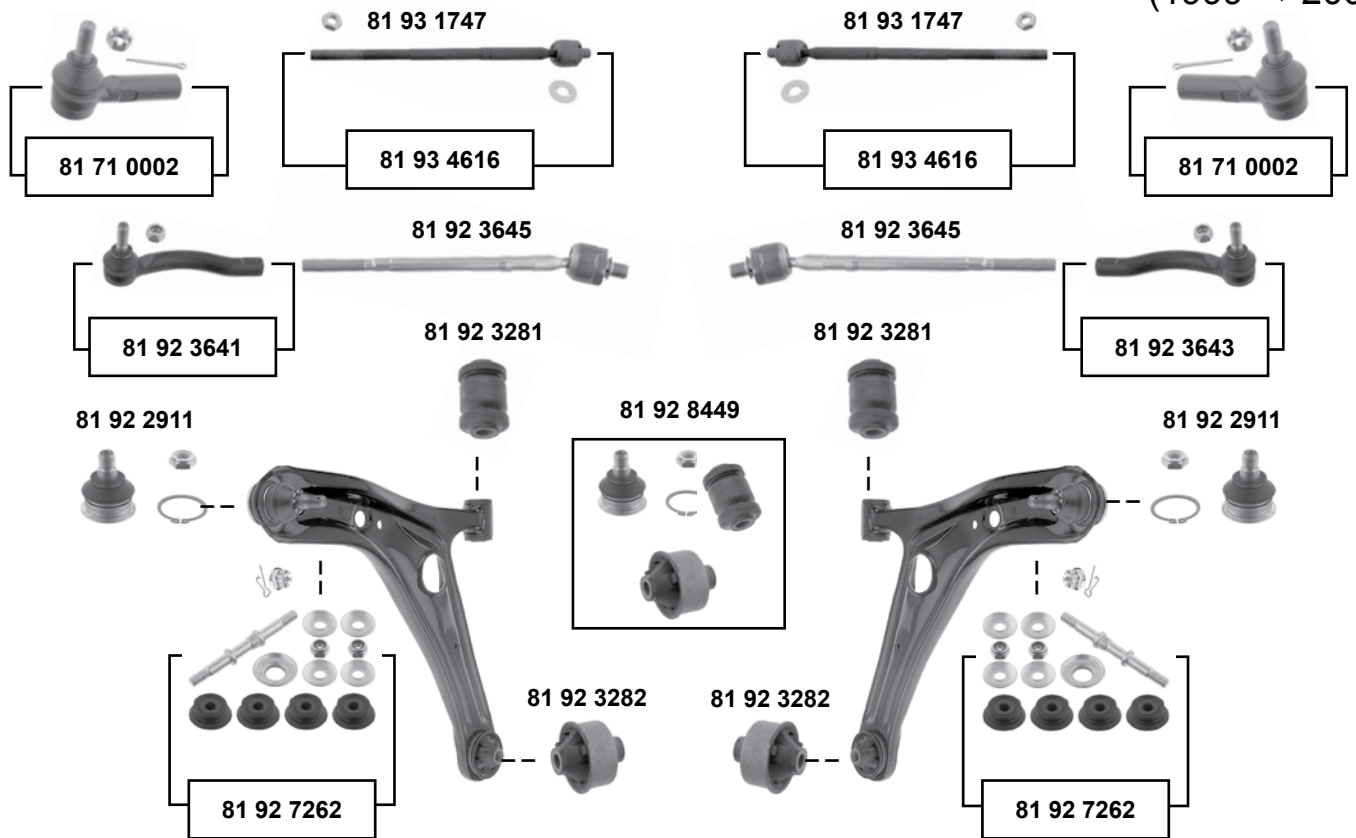

Vorderachse / Front axle

Yaris (2005 →)

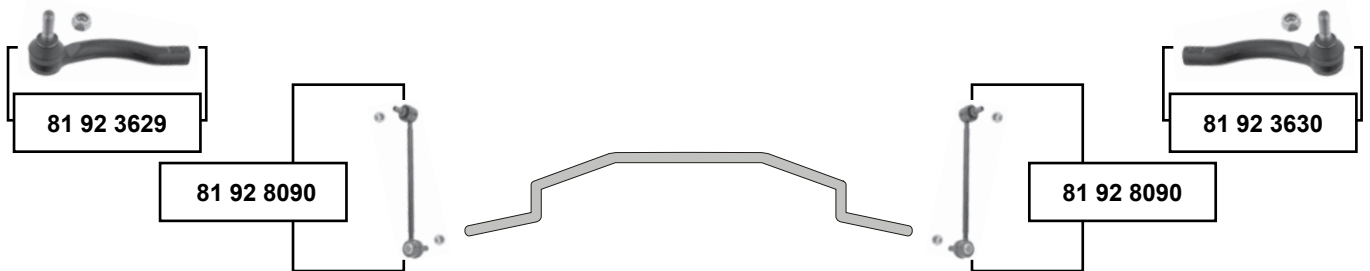

Ref. - No.



81 71 0002	45046-29305	Spurstangenendstück / tie rod end	NCP13 01/01 → 08/05	M12 x 1,25
81 92 2911	48068-59035 S1	Tragelenk / ball joint		
81 92 3281	48068-59035 S3	Querlenkerlager / control arm mount		
81 92 3282	48068-59035 S2	Querlenkerlager / control arm mount		
81 92 3629	45047-19115	Spurstangenendstück / tie rod end		M12 x 1,25
81 92 3630	45046-19265	Spurstangenendstück / tie rod end		M12 x 1,25
81 92 3641	45047-59026	Spurstangenendstück / tie rod end		M12 x 1,25
81 92 3643	45046-59026	Spurstangenendstück / tie rod end		M12 x 1,25
81 92 3645	45503-59045	Spurstange / tie rod	01/99 → 02/03	L 240
81 92 7262	48819-52010 S1	Rep. Satz Verbindungsstange / rep. kit connecting rod		L 97,5
81 92 8090	48820-0D010	Verbindungsstange / connecting rod		L 360
81 92 8449	48068-59035 S4	Rep. Satz Querlenker / rep. kit control arm		
81 93 1747	45503-0D030	Spurstange / tie rod	02/03 → 11/05	
81 93 4616	45503-59055	Axialgelenk / tie rod	01/01 → 08/05	L 341



Adam
(2013 →)

Vorderachse / Front axle

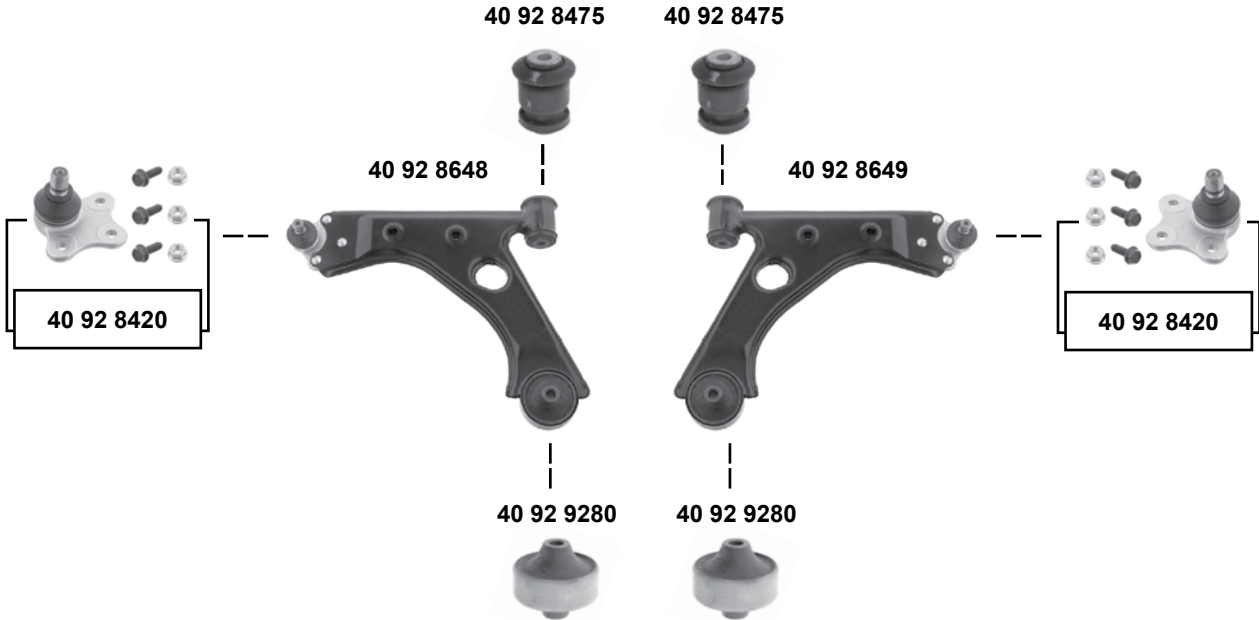

(1) (ex.) B1,4NEH / LPG Sport



Ref. - No.



40 92 8420	93190907	Traggelenk / ball joint	
40 92 8475	13260666	Querlenkerlager / control arm mount	Ø 16/12x52x68
40 92 8648	55703230	Querlenker / control arm	
40 92 8649	55703231	Querlenker / control arm	
40 92 9280	13167940	Querlenkerlager / control arm mount	12x72x66
40 94 5219	13391512	Verbindungsstange / connecting rod	L 310
70 93 8586	13343139	Stabilisatorsatz / stabilizer set	L 1045

(1)



Agila Mk I (2000 → 2007)

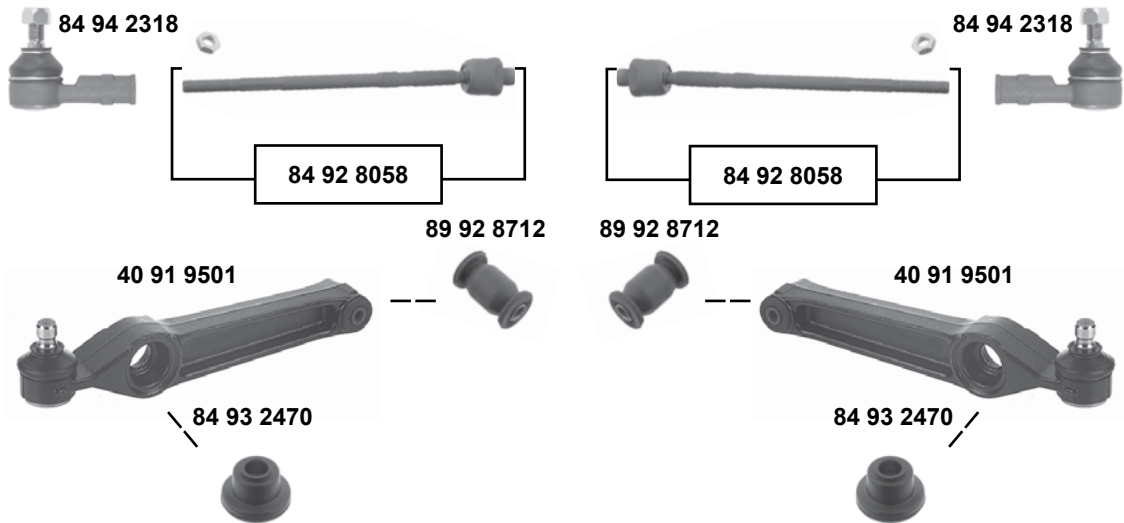

Agila Mk II (2008 →)

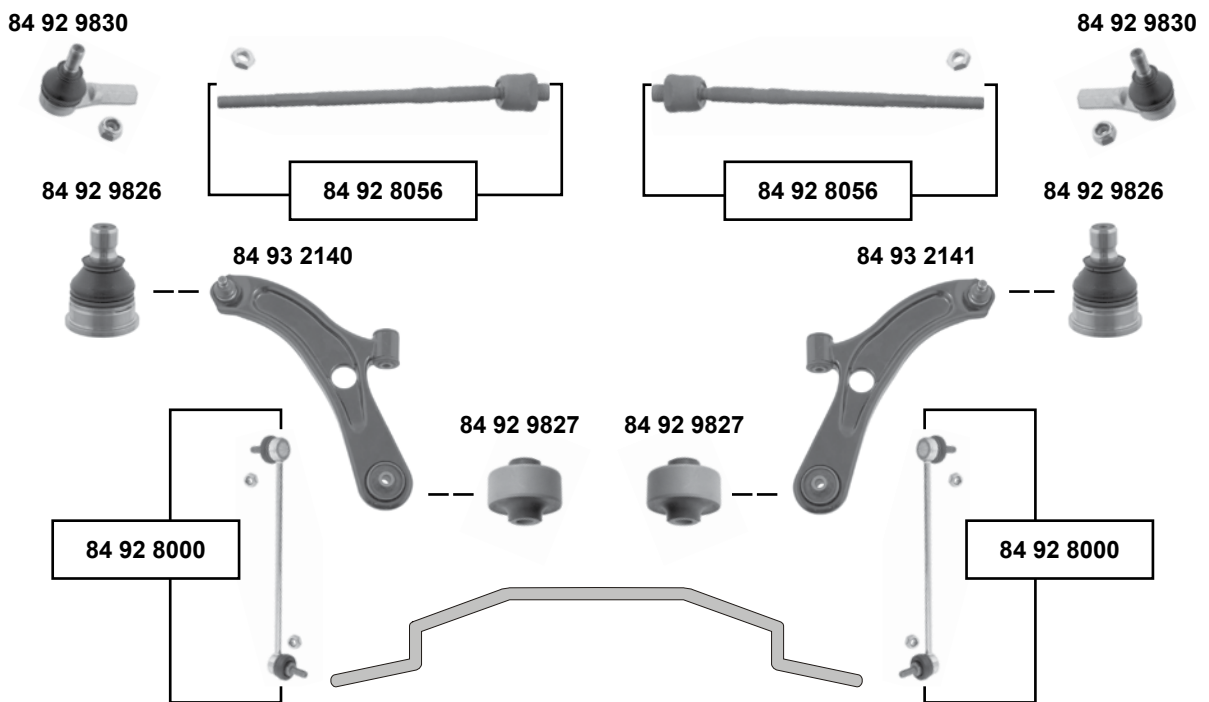

Vorderachse / Front axle

SWAG	Ref. - No.			
40 91 9501	09208987	Querlenker / control arm	(ch.) → 16075421	
84 92 8000	93195093	Verbindungsstange / connecting rod		L 300
84 92 8056	93194002	Spurstange / tie rod		L 306
84 92 8058	09204752	Spurstange / tie rod	00 → 07	L 263
84 92 9826	93193130 S1	Traggelenk / ball joint		60x50
84 92 9827	93193130 S2	Querlenkerlager / control arm mount		M12 x 1,25
84 92 9830	93194035	Spurstangenendstück / tie rod end		
84 93 2140	93193131	Querlenker / control arm		
84 93 2141	93193130	Querlenker / control arm		
84 93 2470	09209466	Stabilisatorlager / stabilizer mount		Ø A 48 / I 20
84 94 2318	09210351	Spurstangenendstück / tie rod end		M14 x 1,5
89 92 8712	09208989	Querlenkerlager / control arm mount		52x28

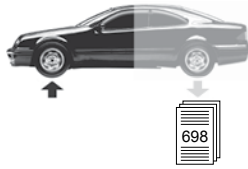

Antara
(2006 →)

Vorderachse / Front axle

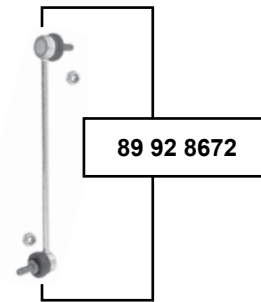
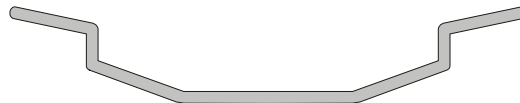
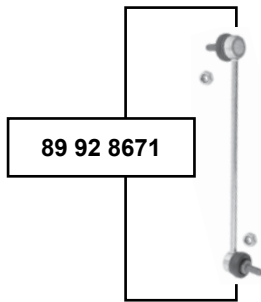
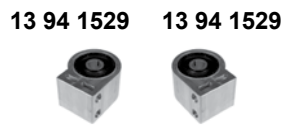

(1) (ch.) → AB999999, → A3999999

(2) (ch.) → 80999999, → AB999999, → A3999999



Ref. - No.



13 94 1529	96809676	Querlenkerlager / control arm mount	(2)	
13 94 1740	96819161	Querlenker / control arm		
13 94 1741	96819162	Querlenker / control arm		
13 94 1929	96626667	Spurstangenendstück / tie rod end		
89 92 8347	96819161 SK	Traggelenk / ball joint	(2)	
89 92 8671	96996450	Verbindungsstange / connecting rod	(1)	L 286
89 92 8672	96996451	Verbindungsstange / connecting rod	(1)	L 286



Ampera (2011 →)

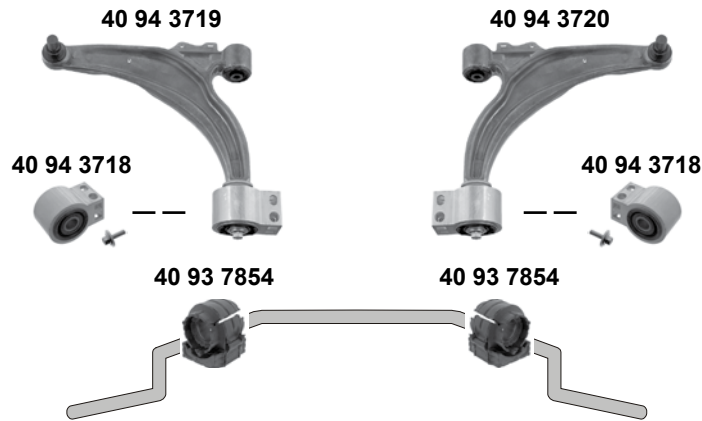

Arena (1997 → 2001)

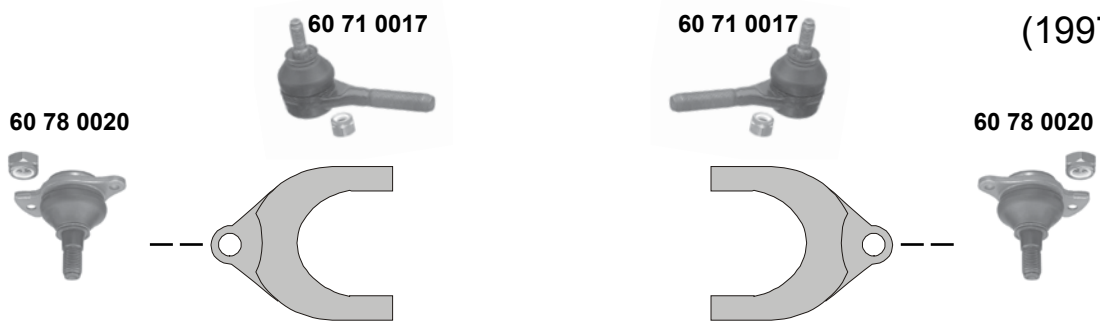

Astra Mk I (1979 → 1984)

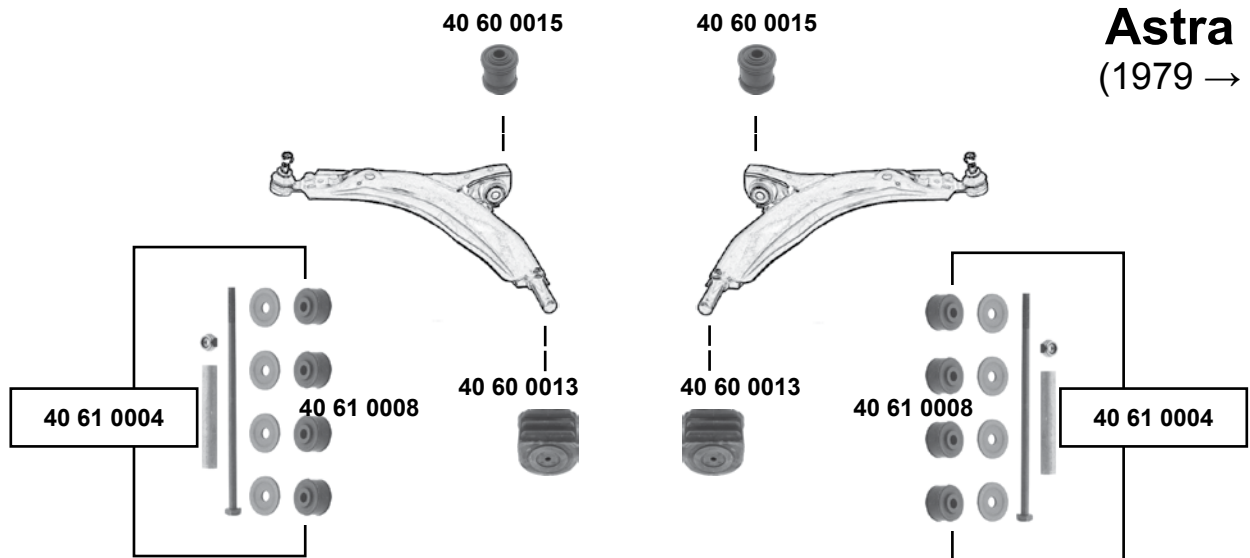

Vorderachse / Front axle



(1) (ch.) FD 2630572 / D 5109110 / CE 173724 →



Ref. - No.



40 60 0013	90235040	Querlenkerlager / control arm mount	für / to fit Caravan	21x56x54,5
40 60 0015	90335966	Querlenkerlager / control arm mount	für / to fit Caravan	14,5x46x59
40 61 0004	90009367	Stabilisatorlager / stabilizer mount	(1)	
40 61 0008	2875013	Verbindungsstangenlager / connecting rod bearing		8,5x30x19
40 93 7854	13281782	Stabilisatorlager / stabilizer mount		Ø I 25
40 94 3718	13334021	Querlenkerlager / control arm mount		106 x80 x65
40 94 3719	13334022	Querlenker / control arm		
40 94 3720	13334023	Querlenker / control arm		
60 71 0017	4403 661	Spurstangenendstück / tie rod end	servo	M14 x 1,5
60 78 0020	09111641	Traggelenk / ball joint		



Astra Mk II
(1984 → 1994)

man.

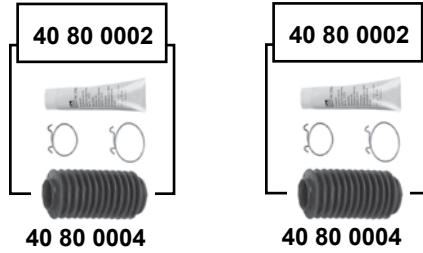

servo

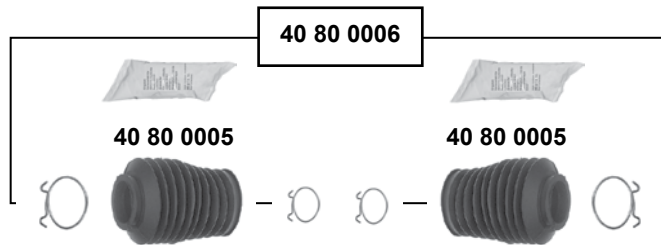

	Ref. - No.			
40 71 0006	90140006	Spurstangenendstück / tie rod end		M16x1,5 LHT
40 71 0007	90140007	Spurstangenendstück / tie rod end		M16x1,5 RHT
40 72 0006	90125568	Spurstange / tie rod		L 429
40 72 0007	90125567	Spurstange / tie rod		L 429
40 76 0001	90105358	Einstellbolzen / adjusting bolt	M16x1,5x98,5	
40 80 0002	90345195 S1	Rep. Satz Lenkmanschette / rep. kit steering boot		
40 80 0004	90345195	Lenkmanschette / steering boot		
40 80 0005	90398968 S1	Lenkmanschette / steering boot	LHD / für/to fit servo	ZF
40 80 0006	90398968 SK	Lenkmanschette / steering boot	LHD / für/to fit servo	ZF

Vorderachse / Front axle



Astra Mk II (1984 → 1994)

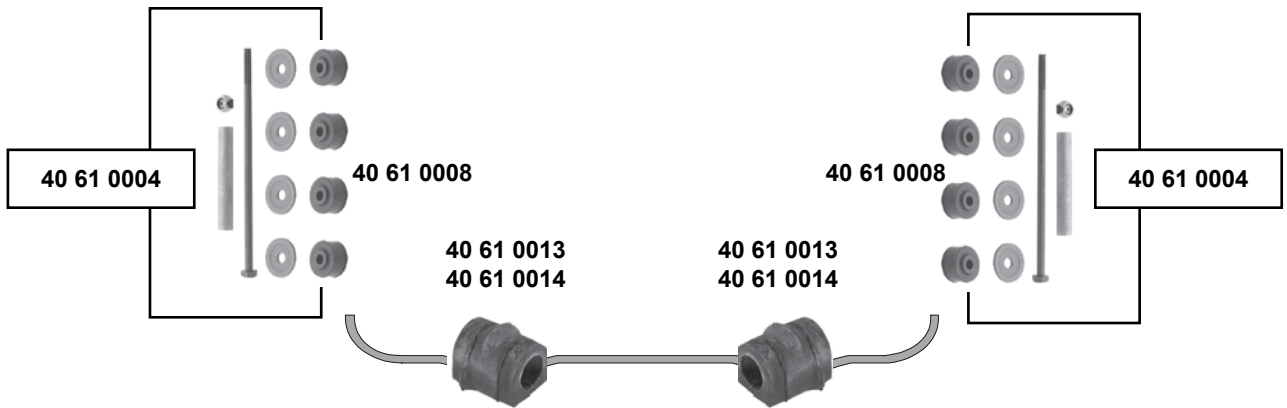
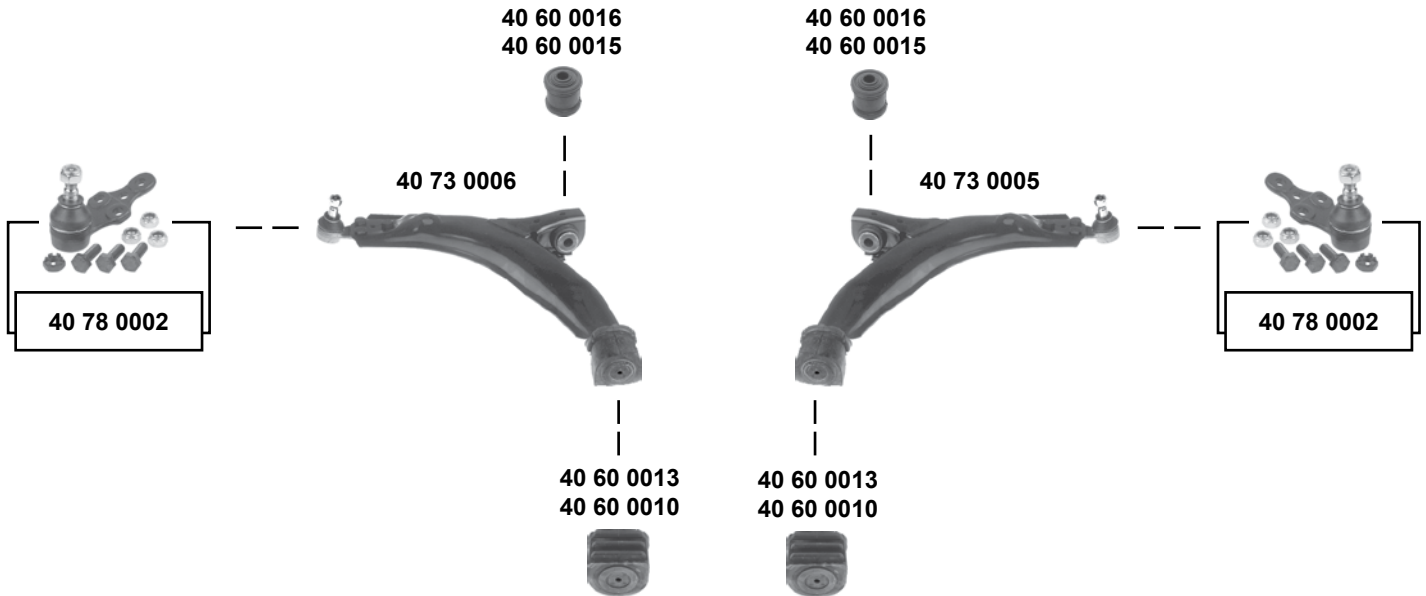

Vorderachse / Front axle



(1) 1.8 E / SE Caravan, 2.0 Cabrio / Stufenheck
GSi / GTE

(2) (ex.) 1.8 E / SE Caravan, 2.0 Cabrio / Stufenheck
GSi / GTE



Ref. - No.



Part No.	Description	Quantity	Dimensions
40 60 0010	Querlenkerlager / control arm mount	(1)	21x56x54,5
40 60 0013	Querlenkerlager / control arm mount	(2)	21x56x54,5
40 60 0015	Querlenkerlager / control arm mount	(2)	59x46x14,5
40 60 0016	Querlenkerlager / control arm mount	(1)	59x43,5x14,5
40 61 0004	Stabilisatorlager / stabilizer mount		
40 61 0008	Verbindungsstangenlager / connecting rod bearing		8,5x30x19
40 61 0013	Stabilisatorlager / stabilizer mount		Ø 20
40 61 0014	Stabilisatorlager / stabilizer mount		Ø 17,5
40 73 0005	Querlenker / control arm	(2)	
40 73 0006	Querlenker / control arm	(2)	
40 78 0002	Traggelenk / ball joint		M12 x 1,5



Astra Mk III

(1991 → 1998)

(ch.) → R 2595225, R 5111734, R 8145949

Vorderachse / Front axle

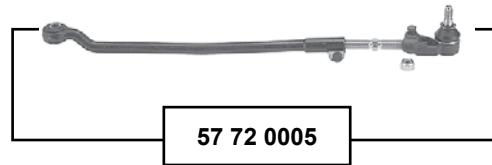
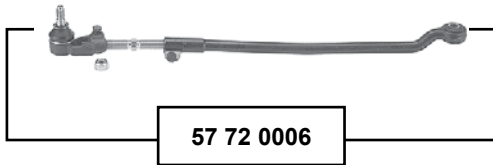

40 71 0008



40 76 0002



40 72 0009



40 72 0008



40 76 0002



40 71 0009



Ref. - No.



40 76 0002	90373523
40 71 0008	90369704
40 71 0009	90369705
40 72 0008	90373522
40 72 0009	90373521
57 72 0005	90373522 S1
57 72 0006	90373521 S1

Einstellbolzen / adjusting bol
Spurstangenendstück / tie rod end
Spurstangenendstück / tie rod end
Spurstange / tie rod
Spurstange / tie rod
Spurstange / tie rod
Spurstange / tie rod

M16x2x105,5
M16x1,5 RHT
M16x1,5 LHT
L 434
L 434



Astra Mk III (1991 → 1998)

(ch.) → R 2595225, R 5111734, R 8145949

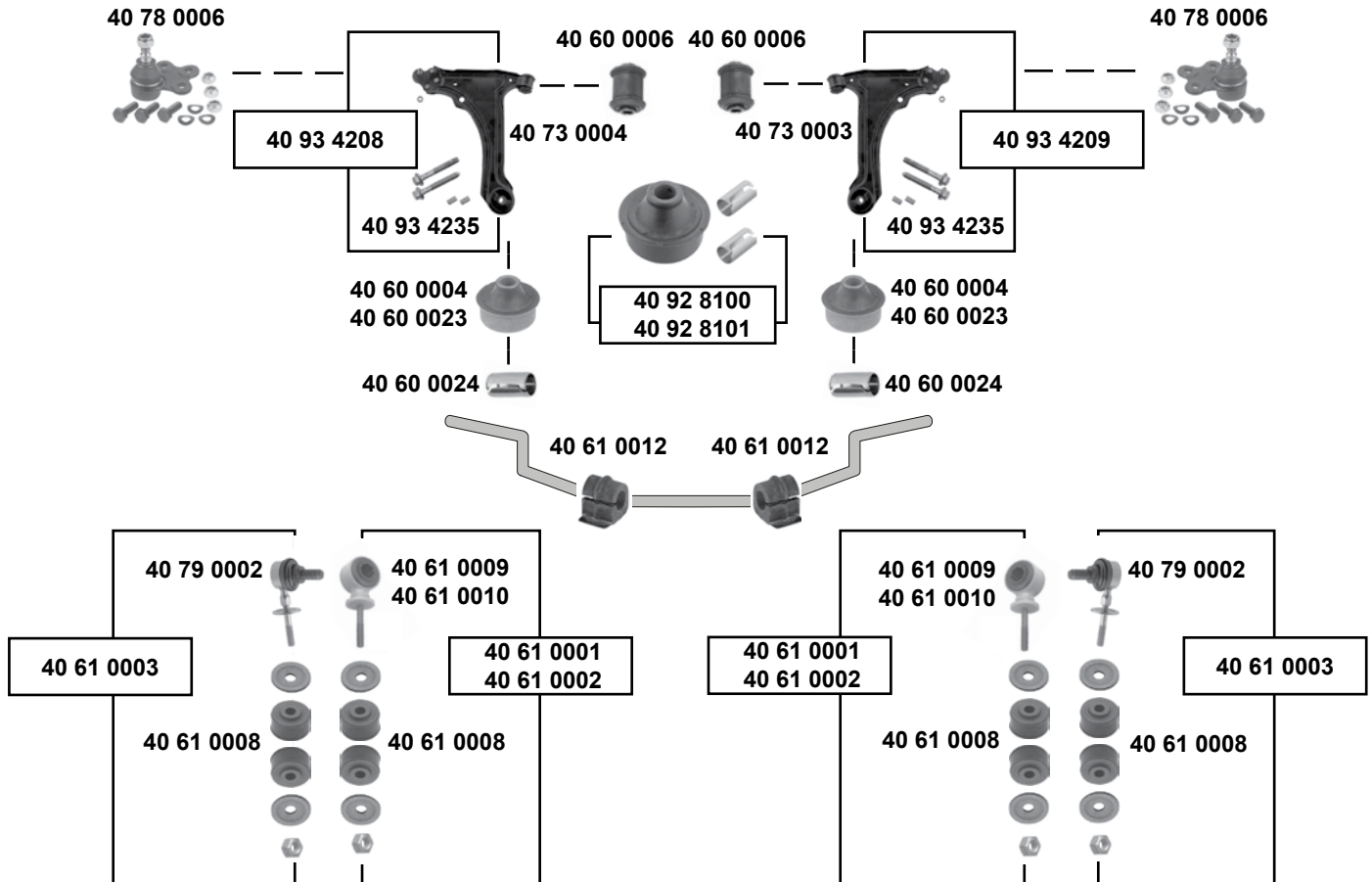

Vorderachse / Front axle



(1) (ch.) → P 2603822
(ch.) → P 8146889

(2) (ch.) P 2603823 → R 2595225
(ch.) P 5000000 → R 5111734
(ch.) P 8146890 → R 8145949



Ref. - No.



Part No.	Ref. - No.	Description	Notes	Dimensions
40 60 0004	90268463	Querlenkerlager / control arm mount	(1)	16x60x58
40 60 0006	90373778	Querlenkerlager / control arm mount	(1)	12x39x60
40 60 0023	90373264	Querlenkerlager / control arm mount	(2)	
40 60 0024	90250709	Hülse / sleeve		16,3x30
40 61 0001	90278579 S1	Rep. Satz Verbindungsstange / rep. kit connecting rod		
40 61 0002	90278577 S1	Rep. Satz Verbindungsstange / rep. kit connecting rod		
40 61 0003	90495045 S1	Rep. Satz Verbindungsstange / rep. kit connecting rod		L 86
40 61 0008	02875013	Verbindungsstangenlager / connecting rod bearing		8,5x30x19
40 61 0009	90278579	Verbindungsstange / connecting rod		Ø 22
40 61 0010	90278577	Verbindungsstange / connecting rod		Ø 18
40 61 0012	90447867	Stabilisatorlager / stabilizer mount		Ø 20
40 73 0003	90495160	Querlenker / control arm	(ex.) GSI	
40 73 0004	90495159	Querlenker / control arm	(ex.) GSI	
40 78 0006	90297863	Traggelenk / ball joint		M12 x 1,5
40 79 0002	90495045	Verbindungsstange / connecting rod		L 86
40 92 8100	90268463 S1	Querlenkerlager / control arm mount	(1)	16x60x58
40 92 8101	90373264 S1	Querlenkerlager / control arm mount	(2)	16x60x58
40 93 4208	90495195 S1	Rep. Satz Querlenker / rep. kit control arm	(ex.) GSI	
40 93 4209	90495160 S1	Rep. Satz Querlenker / rep. kit control arm	(ex.) GSI	
40 93 4235	11092273 S1	Schraubensatz für Querlenker / screw kit for control arm		



Astra Mk III

(1991 → 1998)

(ch.) R 2595226, R 5111735, R 8145950 →

Vorderachse / Front axle

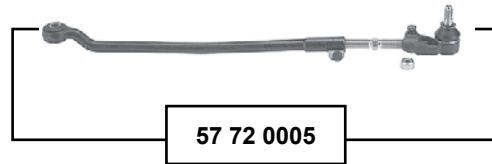
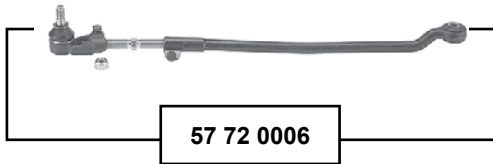

40 71 0008

40 71 0009



40 76 0002

40 72 0009



40 72 0008



40 76 0002



Ref. - No.



40 71 0008	90369704	Spurstangenendstück / tie rod end	M16x1,5 RHT
40 71 0009	90369705	Spurstangenendstück / tie rod end	M16x1,5 LHT
40 72 0008	90373522	Spurstange / tie rod	L 434
40 72 0009	90373521	Spurstange / tie rod	L 434
40 76 0002	90373523	Einstellbolzen / adjusting bolt	M16x2x105,5
57 72 0005	90373522 S1	Spurstange / tie rod	
57 72 0006	90373521 S1	Spurstange / tie rod	



Astra Mk III (1991 → 1998)

(ch.) R 2587416, R 5111735, R 8145950 →

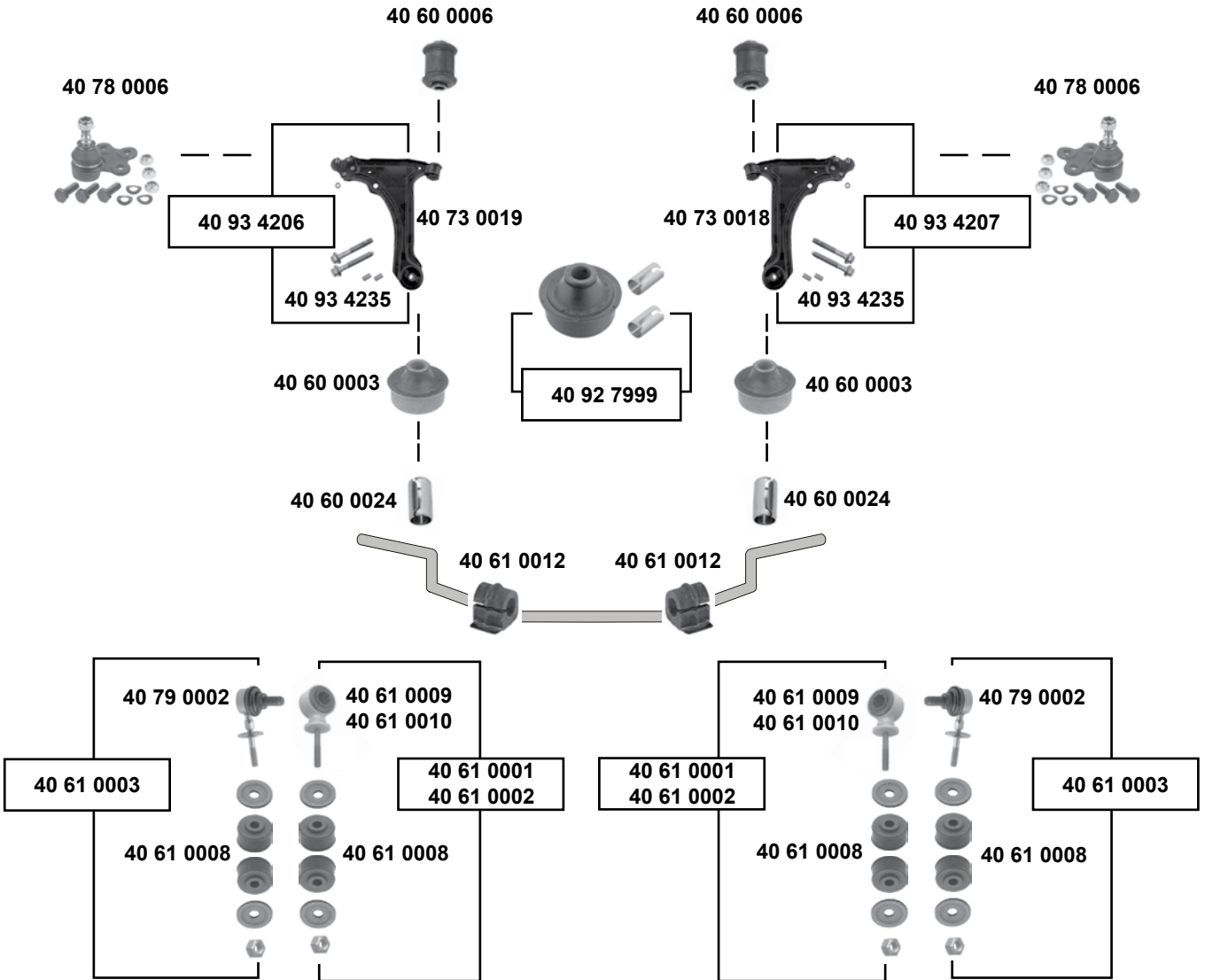

Vorderachse / Front axle



Ref. - No.

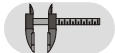

40 60 0003	90495046	Querlenkerlager / control arm mount		16x60x58
40 60 0006	90373778	Querlenkerlager / control arm mount		12x39x60
40 60 0024	90250709	Hülse / sleeve		16,3x30
40 61 0001	90278579 S1	Rep. Satz Verbindungsstange / rep. kit connecting rod		
40 61 0002	90278577 S1	Rep. Satz Verbindungsstange / rep. kit connecting rod		
40 61 0003	90495045 S1	Rep. Satz Verbindungsstange / rep. kit connecting rod		L 86
40 61 0008	02875013	Verbindungsstangenlager / connecting rod bearing		8,5x30x19
40 61 0009	90278579	Verbindungsstange / connecting rod		Ø 22
40 61 0010	90278577	Verbindungsstange / connecting rod		Ø 18
40 61 0012	90447867	Stabilisatorlager / stabilizer mount		Ø 22
40 73 0018	90495104	Querlenker / control arm	(ex.) GSI	
40 73 0019	90495103	Querlenker / control arm	(ex.) GSI	
40 78 0006	90297863	Traggelenk / ball joint		M12 x 1,5
40 79 0002	90495045	Verbindungsstange / connecting rod		L 86
40 92 7999	90495046 S1	Querlenkerlager / control arm mount		16x60x58
40 93 4206	90495103 S1	Rep. Satz Querlenker / rep. kit control arm	(ex.) GSI	
40 93 4207	90495104 S1	Rep. Satz Querlenker / rep. kit control arm	(ex.) GSI	
40 93 4235	11092273 S1	Schraubensatz für Querlenker / screw kit for control arm		







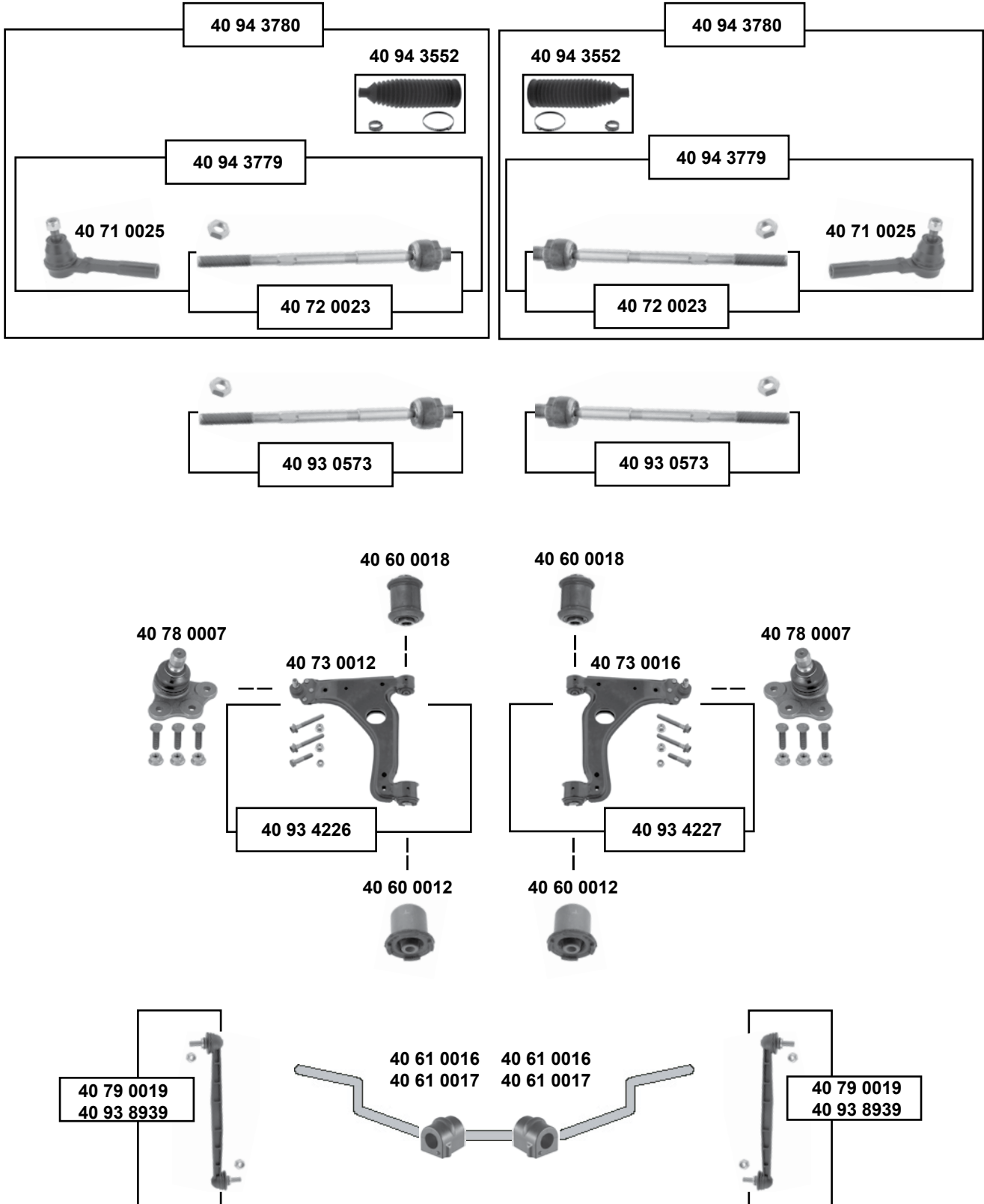

Astra Mk IV (1998 → 2004)

Vorderachse / Front axle



Astra Mk IV
 (1998 → 2004)

- | | |
|---|--|
|  | (1) 1.2 (ch.) → X 2999999 / X 5999999 / X 6999999 / X 8999999 |
| | (2) 1.2 (ch.) Y 2000001 / Y 5000001 / Y 6000001 / Y 8000001 → / 1.4 / 1.6 / 1.8 / 2.0 / 1.7 TD / DTI / 2.0 DI / DTI |
| | (3) Z1,4 XEP + servo  elektronisch / electronic
Coupe/Cabrio + servo  TRW |
| | (4) Nur für TRW-Lenkung / TRW-steering only |

	Ref. - No.			
40 60 0012	90498740	Querlenkerlager / control arm mount		12x45/48x60
40 60 0018	90498738	Querlenkerlager / control arm mount		12x36,5x60
40 61 0016	90468567	Stabilisatorlager / stabilizer mount	(1)	Ø I 16
40 61 0017	90538865	Stabilisatorlager / stabilizer mount	(2)	Ø I 18
40 71 0025	93186537	Spurstangenendstück / tie rod end	(ex.) OPC	M14x1,5 RHT
40 72 0023	26059293	Spurstange / tie rod	(ex.) OPC	L 300
40 73 0012	90498735	Querlenker / control arm		
40 73 0016	90498736	Querlenker / control arm		
40 78 0007	90512982	Traggelenk / ball joint		Ø A 18
40 79 0019	13169439	Verbindungsstange / connecting rod	OLD	L 300
40 93 0573	93191529 SK	Spurstange / tie rod	(3)	L 304
40 93 4226	90498735 S1	Rep. Satz Querlenker / rep. kit control arm		
40 93 4227	90498736 S1	Rep. Satz Querlenker / rep. kit control arm		
40 93 8939	13327928	Verbindungsstange / connecting rod	NEW	L 350
40 94 3552	93191260	Lenkmanschettensatz / steering boot set	(4)	L 211
40 94 3779	1603 643 S5	Spurstange / tie rod	(4)	M18 x 1,5
40 94 3780	1603 643 S6	Spurstange / tie rod	(4)	M18 x 1,5



Astra Mk V (2004 → 2009)

Vorderachse / Front axle

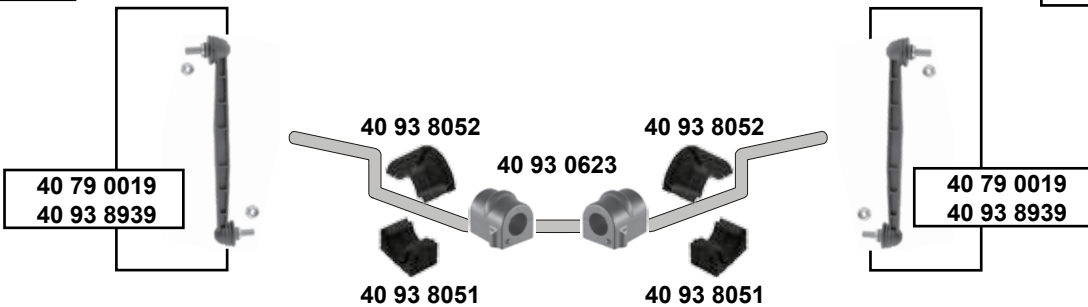
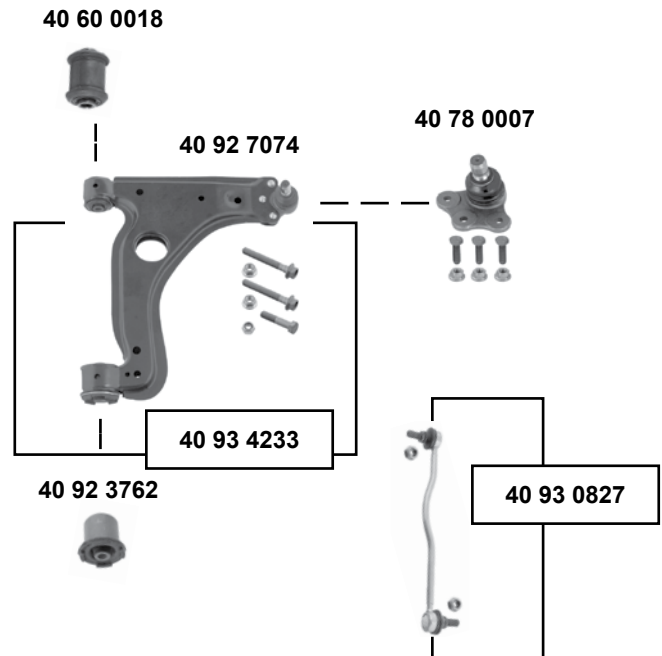
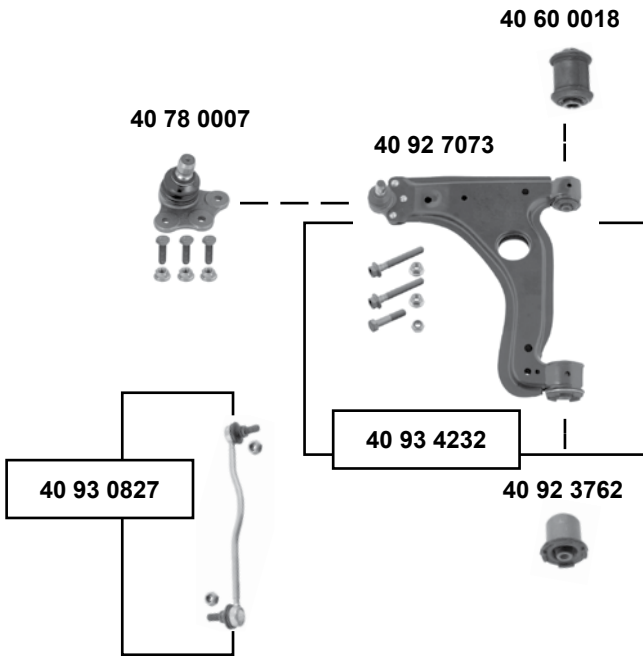
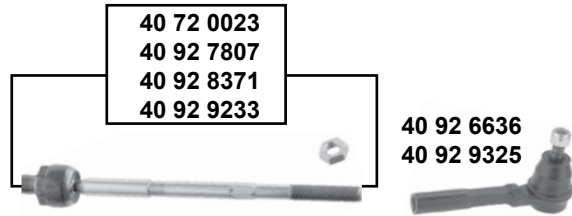
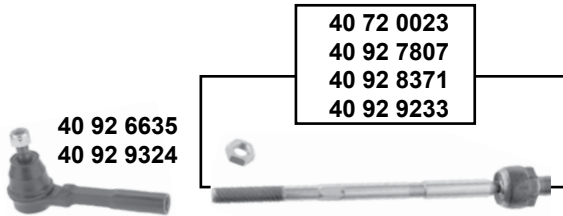
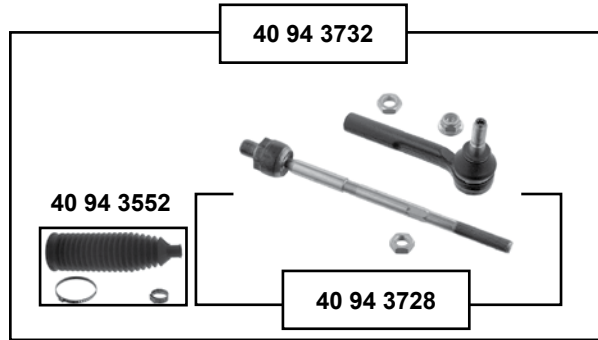
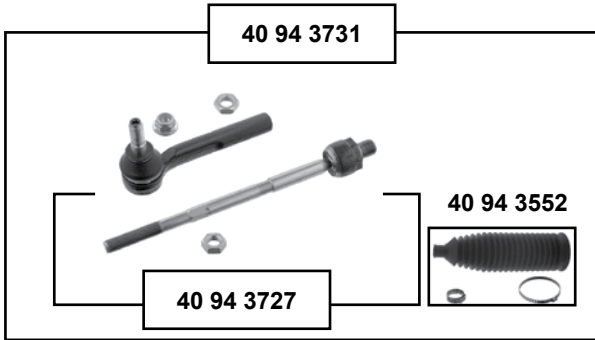



Astra Mk V (2004 → 2009)

(1) servo ZF (ex.) Sport	(2) servo ZF Sport (ex.) 18/19"
(3) servo ZF Sport + 18/19"	(4) TRW Generation II
(5) Schrägheck/Hatchback (ch.) → 52999999, 55999999, 58999999	
(6) (ch.) 72094720 - , (ch.) 75080481 - , (ch.) 78048189 - , (ch.) 8B000001 - , (ch.) 7G -	
(7) Nur für TRW-Lenkung / TRW-steering only (ch.) 72094720 , (ch.) 75080481 , (ch.) 78048189 , (ch.) 8B000001, (ch.) 7G-	



Ref. - No.



Ref. - No.	Description	Notes	Dimensions
40 60 0018	90498738 Querlenkerlager / control arm mount		12x36,5x60
40 72 0023	26059293 Spurstange / tie rod	(4) servo	L 279
40 78 0007	90512982 Traggelenk / ball joint		
40 79 0019	13169439 Verbindungsstange / connecting rod	(ex.) IDS+ / OLD	L 300
40 92 3762	24439582 Querlenkerlager / control arm mount		12x46x60
40 92 6635	93181232 Spurstangenendstück / tie rod end	servo ZF	M14 x 1,5
40 92 6636	93181233 Spurstangenendstück / tie rod end	servo ZF	M14 x 1,5
40 92 7073	24454477 Querlenker / control arm		
40 92 7074	22454478 Querlenker / control arm		
40 92 7807	93189668 SK Spurstange / tie rod end	(1)	L 295
40 92 8371	93189669 SK Spurstange / tie rod	(2)	L 279
40 92 9233	93189670 SK Spurstange / tie rod	(3)	L 279
40 92 9324	93186333 Spurstangenendstück / tie rod end	servo TRW	M14 x 1,5
40 92 9325	93186332 Spurstangenendstück / tie rod end	servo TRW	M14 x 1,5
40 93 0623	13125492 Stabilisatorlager / stabilizer mounting	(5)	
40 93 0827	24461353 Verbindungsstange / connecting rod	IDS+	
40 93 4232	24454477 S1 Rep. Satz Querlenker links / rep. kit control arm left		
40 93 4233	24454478 S1 Rep. Satz Querlenker rechts / rep. kit control arm right		
40 93 8051	13204071 Stabilisatorlager, unten / stabilizer mount, lower	nur/only Cabrio	Ø I 24
40 93 8052	13204070 Stabilisatorlager, oben / stabilizer mount, upper	nur/only Cabrio	Ø I 24
40 93 8939	13327928 Verbindungsstange / connecting rod	(ex.) IDS+ / NEW	L 350
40 94 3552	93191260 Lenkmanschettensatz / steering boot set	(7)	L 211
40 94 3727	1603 643 S1 Spurstange / tie rod	(4)	M18 x 1,5
40 94 3728	1603 643 S2 Spurstange / tie rod	(4)	M18 x 1,5
40 94 3731	93191526 S3 Spurstange / tie rod	(4) (6)	M18 x 1,5
40 94 3732	93191526 S4 Spurstange / tie rod	(4) (6)	M18 x 1,5



Astra Mk VI (2009 → 2015)

Vorderachse / Front axle

40 94 5095



40 94 5095



40 94 5096



40 94 5096



40 94 4424



40 94 4424



40 94 4446



40 94 4338



40 94 4446



40 94 4156



40 94 4434



40 94 4156



40 94 4249



40 94 4447



40 94 4250



Astra Mk VI (2009 → 2015)

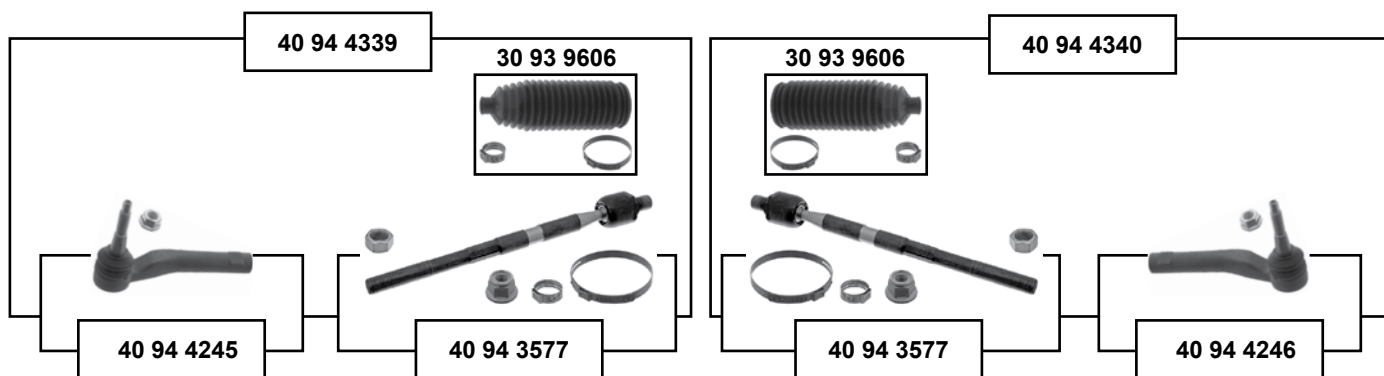

Vorderachse / Front axle

- (1) (ch.) → A3999999 / A8999999 / AG999999
- (2) 3-türer / doors mit / with servo
- (3) Coupe : Nur mit hydraulischer servo / combined with hydraulic servo
- (4) 5-türer / doors / servo / (ch.) C1000001 → , (ch.) B3000001 → , (ch.) B8000001 → , (ch.) BG000001 →
- (5) → (ch.) A3999999 / → (ch.) A8999999 / → (ch.) AG999999
- (6) 3-türer / doors E - servo
- (7) 5-türer / doors E - servo



Ref. - No.



SWAG	Ref. - No.			
30 93 9606	13278357	Rep. Satz Lenkmanschette / rep. kit steering boot	servo	
40 94 3577	13314168	Rep. Satz Axialgelenk / rep. kit axial joint	(1) servo	L 294
40 94 4156	13354542	Rep. Satz Axialgelenk / axial joint	Coupe E - servo	L 223
40 94 4245	13354538	Spurstangenendstück / tie rod end	(2)	M12 x 1,75
40 94 4246	13354540	Spurstangenendstück / tie rod end	(2)	M12 x 1,75
40 94 4249	13354542 S1	Spurstange / tie rod	(6)	
40 94 4250	13354542 S2	Spurstange / tie rod	(6)	
40 94 4338	13314168 S1	Spurstange / tie rod	(5) (7)	
40 94 4339	13314168 S2	Spurstange / tie rod	(2) (5)	L 396
40 94 4340	13314168 S3	Spurstange / tie rod	(2) (5)	L 396
40 94 4424	13337891	Rep. Satz Axialgelenk / axial joint	(3)	L 228
40 94 4434	13337891 S1	Spurstange / tie rod	(3)	
40 94 4446	13278358	Rep. Satz Axialgelenk / axial joint	(4)	L 284
40 94 4447	13278358 S1	Spurstange / tie rod	servo	
40 94 5095	13354440 SK1	Lenkmanschette / steering rack boot	E - servo	
40 94 5096	13354440	Lenkmanschettensatz / steering boot set	E - servo	



Astra Mk VI
(2009 → 2015)

Vorderachse / Front axle

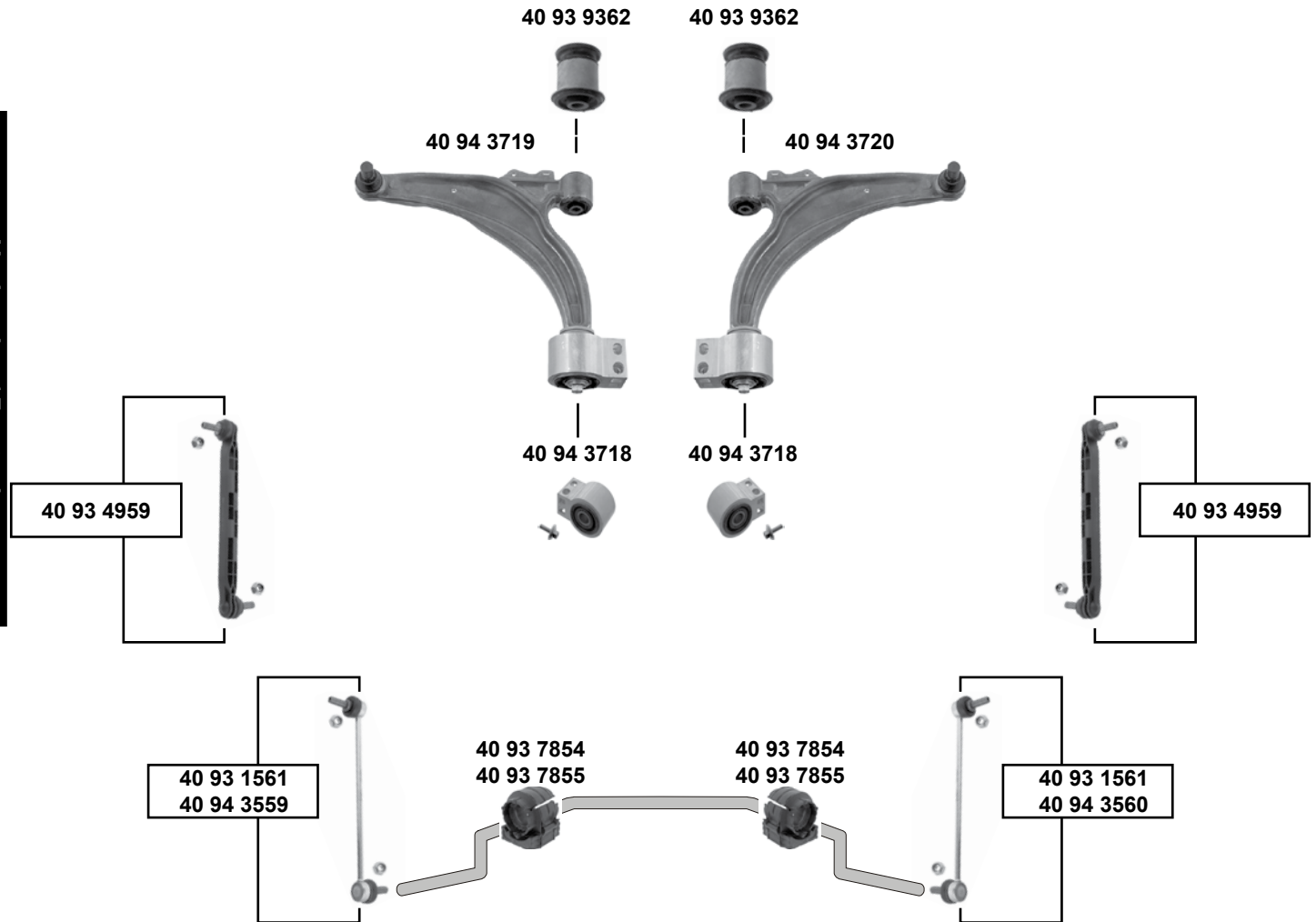

(1) Für Fahrzeuge mit Flexride Fahrwerk (aktives Fahrwerk) / for vehicles with flexride chassis only

(2) alle (ex.) Flexride Fahrwerk / all (ex.) flexride chassis

(3) (ch.) B8106940 - B8999999 / (ch.) BG140001 - BG999999
(ch.) C0000001 → / (ch.) C1000001 → / (ch.) C3000001 → / (ch.) C8000001 / → (ch.) CG000001 →
(ex.) Biturbo

(4) (mot.) A 2,0 NFT 3-türer // alle / all 5-türer

(5) A2,0DTR , A2,0DTH , Y2,0DTJ , Z2,0DTC nur 3-türer / 3-doors only

(6) (5-türer / doors Schrägheck / Sufenheck / Caravan) außer / except Biturbo



SWAG GERMANY	Ref. - No.			
40 93 1561	13258052	Verbindungsstange / connecting rod	(1)	L 303,5
40 93 4959	13219141	Verbindungsstange / connecting rod	(2)	L 304
40 93 7854	13281782	Stabilisatorlager / stabilizer mount	(4)	Ø I 25
40 93 7855	13281784	Stabilisatorlager / stabilizer mount	(5)	Ø I 23
40 93 9362	13219090	Querlenkerlager / control arm mount	(6)	12x52x60
40 94 3559	13282834	Verbindungsstange / connecting rod	3-türer / doors	L 290
40 94 3560	13285628	Verbindungsstange / connecting rod	3-türer / doors	L 290
40 94 3718	13334021	Querlenkerlager / control arm mount	(6)	106x80x65
40 94 3719	13334022	Querlenker / control arm	(3)	
40 94 3720	13334023	Querlenker / control arm	(3)	

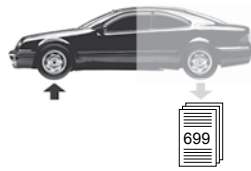

Calibra (1990 → 1997)

man.

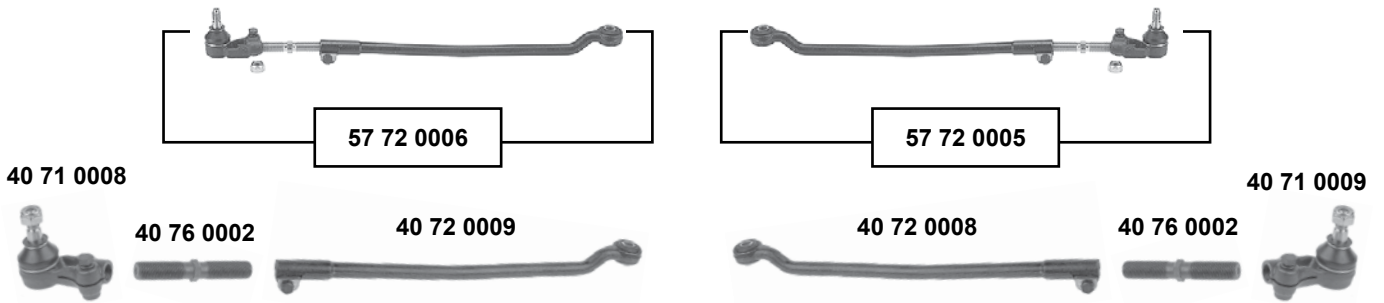

servo

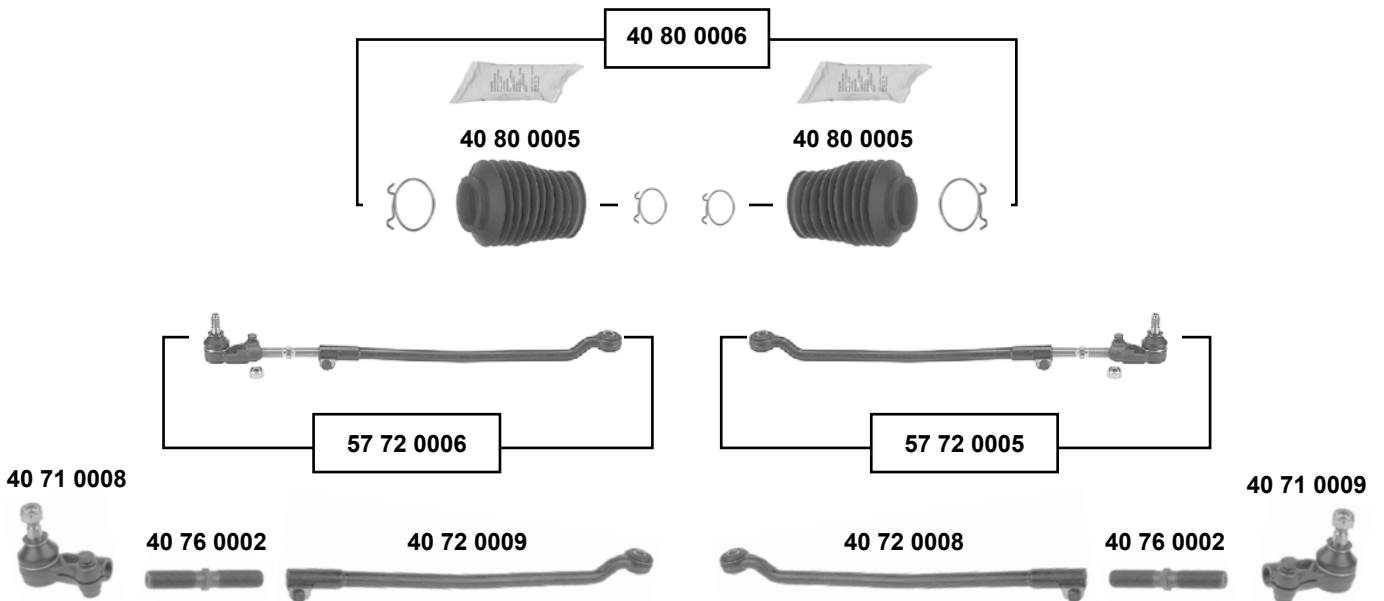

Vorderachse / Front axle



Ref. - No.



40 76 0002	90373523
40 71 0008	90369704
40 71 0009	90369705
40 72 0008	90373522
40 72 0009	90373521
40 80 0005	90398968 S1
40 80 0006	90398968 SK
57 72 0005	90373522 S1
57 72 0006	90373521 S1

Einstellbolzen / adjusting bolt
Spurstangenendstück / tie rod end
Spurstangenendstück / tie rod end
Spurstange / tie rod
Spurstange / tie rod
Lenkmanschette / steering boot
Lenkmanschette / steering boot
Spurstange / tie rod
Spurstange / tie rod

LHD / für/to fit servo ZF
LHD / für/to fit servo ZF

M16x2x105,5
M16x1,5 RHT
M16x1,5 LHT
L 434
L 434

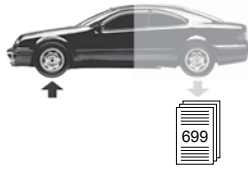

Calibra
(1990 → 1997)

Vorderachse / Front axle

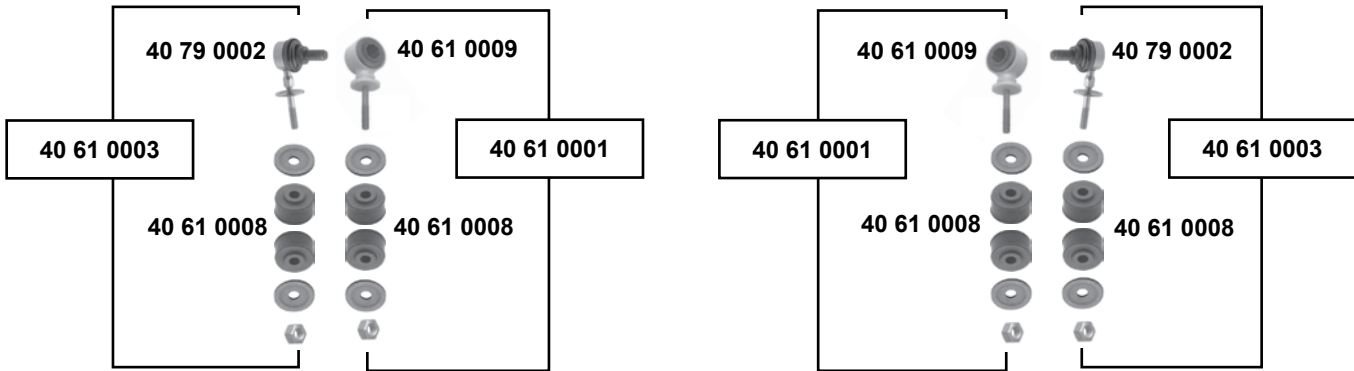
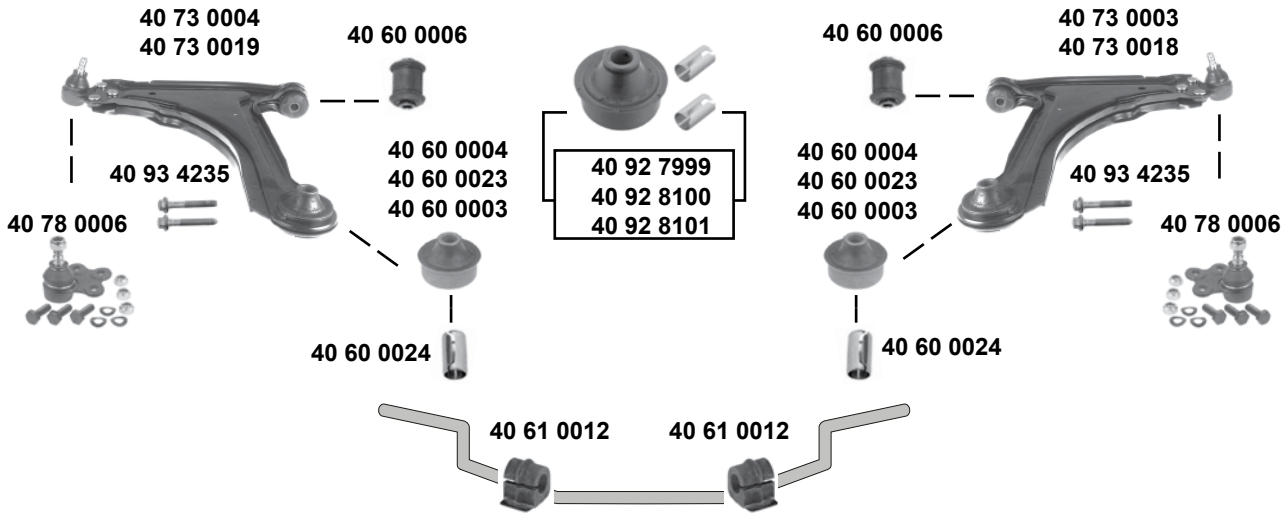

	(1) 2.0 i (85kW) (ch.) → R 9003127	(3) 2.0 i (85kW) (ch.) R 9003128
	(2) 2.0 i 16V → 2.5 V6 (ch.) → R 9003174	→ 2.0 i 16V → 2.5 V6 (ch.) R 9003175
	(4) 2.0 i (85kW) / 2.0 i 16V (ch.) R 9003128 →	

	Ref. - No.			
40 60 0003	90495046	Querlenkerlager / control arm mount	(3)	16x60x58
40 60 0004	90268463	Querlenkerlager / control arm mount	(1)	16x60x58
40 60 0006	90373778	Querlenkerlager / control arm mount	2.0 i (85 kW)	12x39x60
40 60 0023	90373264	Querlenkerlager / control arm mount	(2)	
40 60 0024	90250709	Hülse / sleeve		16,3x30
40 61 0001	90278579 S1	Rep. Satz Verbindungsstange / rep. kit connecting rod		
40 61 0003	90495045 S1	Rep. Satz Verbindungsstange / rep. kit connecting rod		L 86
40 61 0008	02875013	Verbindungsstangenlager / connecting rod bearing		8,5x30x19
40 61 0009	90278579	Verbindungsstange / connecting rod		Ø I 22
40 61 0012	90447867	Stabilisatorlager / stabilizer mount		Ø I 22
40 73 0003	90495160	Querlenker / control arm	(1)	
40 73 0004	90495159	Querlenker / control arm	(1)	
40 73 0018	90495104	Querlenker / control arm	(4)	
40 73 0019	90495103	Querlenker / control arm	(4)	
40 78 0006	90297863	Traggelenk / ball joint	(ex.) 2.5 V6	M12 x 1,5
40 79 0002	90495045	Verbindungsstange / connecting rod		L 86
40 92 7999	90495046 S1	Querlenkerlager / control arm mount	(3)	16x60x58
40 92 8100	90268463 S1	Querlenkerlager / control arm mount	(1)	16x60x58
40 92 8101	90373264 S1	Querlenkerlager / control arm mount	(2)	
40 93 4235	11092273 S1	Schraubensatz für Querlenker / screw kit for control arm		

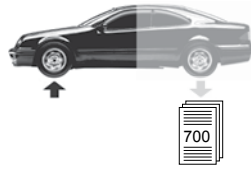

Carlton (1986 → 1994)

99 90 9158
40 92 2099



40 72 0003

40 72 0004

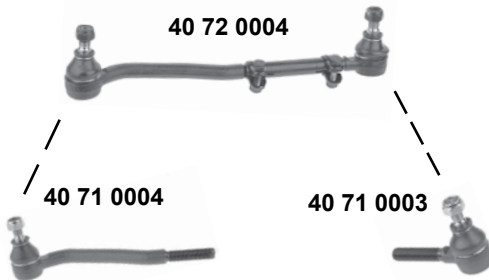

40 71 0004

40 71 0003

40 72 0005

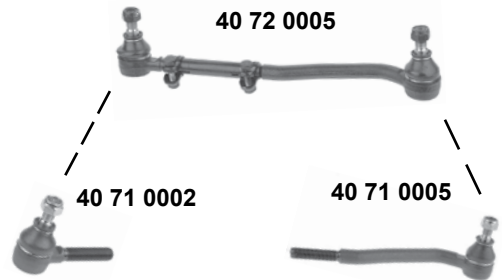

40 71 0002

40 71 0005



(1) (mot.) 1.8 / 2.0 / 2.4



Ref. - No.



40 71 0002	90510640	Spurstangenendstück / tie rod end	(ch.) H1169261 →	M14x1,5 RHT
40 71 0003	90510639	Spurstangenendstück / tie rod end	(ch.) H1169261 →	M14x1,5 LHT
40 71 0004	90510643	Spurstangenendstück / tie rod end	(ch.) H1169261 →	M14x1,5 RHT
40 71 0005	90510644	Spurstangenendstück / tie rod end	(ch.) H1169261 →	M14x1,5 LHT
40 72 0003	90392553	Spurstange / tie rod		L 572
40 72 0004	90510641	Spurstange / tie rod		L 347
40 72 0005	90510642	Spurstange / tie rod		L 347
40 92 2099	09195731	Lenkhebel / steering arm	(1)	L 110 Ø 18
99 90 9158	90092492	Lenkhebel / steering arm		L 121 Ø 18

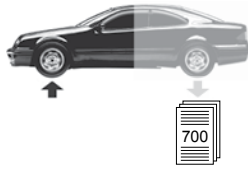

Carlton
(1986 → 1994)

Vorderachse / Front axle

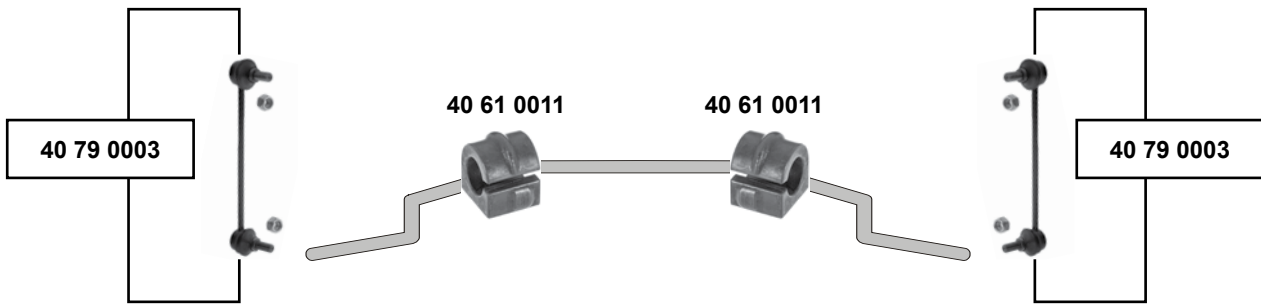
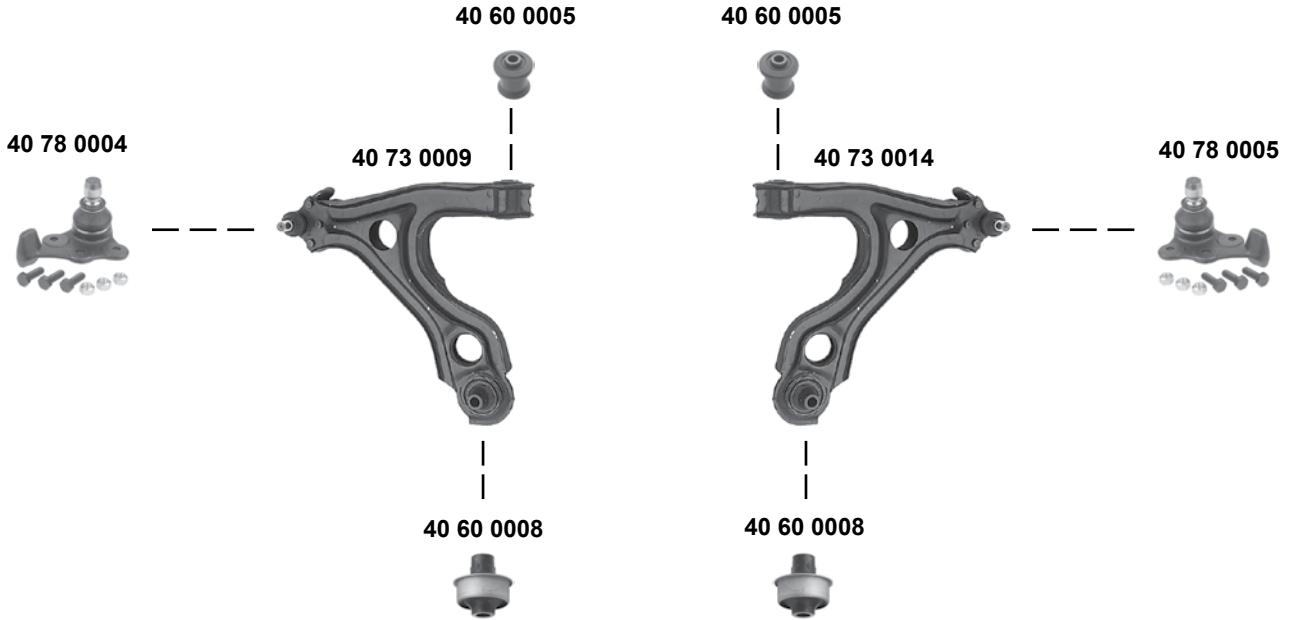

SWAG GERMANY	Ref. - No.			
40 60 0005	90279193	Querlenkerlager / control arm mount		12x41/47x60
40 60 0008	90373854	Querlenkerlager / control arm mount		16x60x69,5
40 61 0011	90278624	Stabilisatorlager / stabilizer mount		Ø I 22
40 73 0009	90288387	Querlenker / control arm		
40 73 0014	90288388	Querlenker / control arm		
40 78 0004	90272194	Traggelenk / ball joint		Ø A 18
40 78 0005	90272195	Traggelenk / ball joint		Ø A 18
40 79 0003	90445137	Verbindungsstange / connecting rod		L 225



Cascade (2013 →)

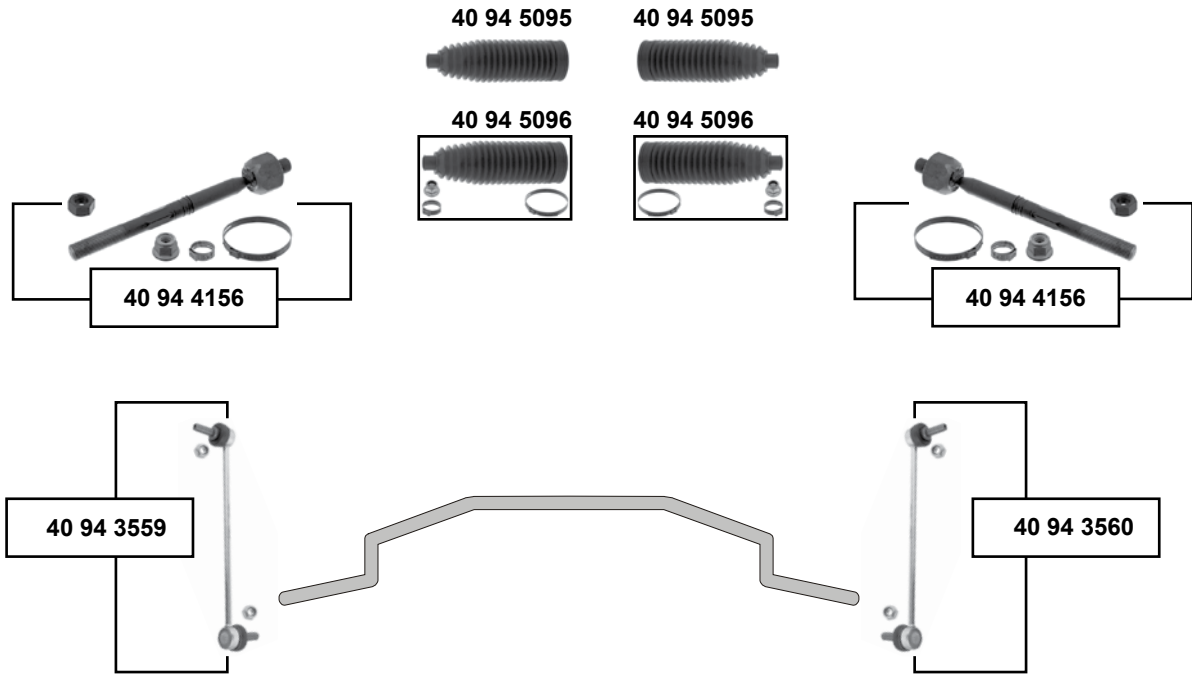

Vorderachse / Front axle

Cavalier Mk II (1981 → 1988)

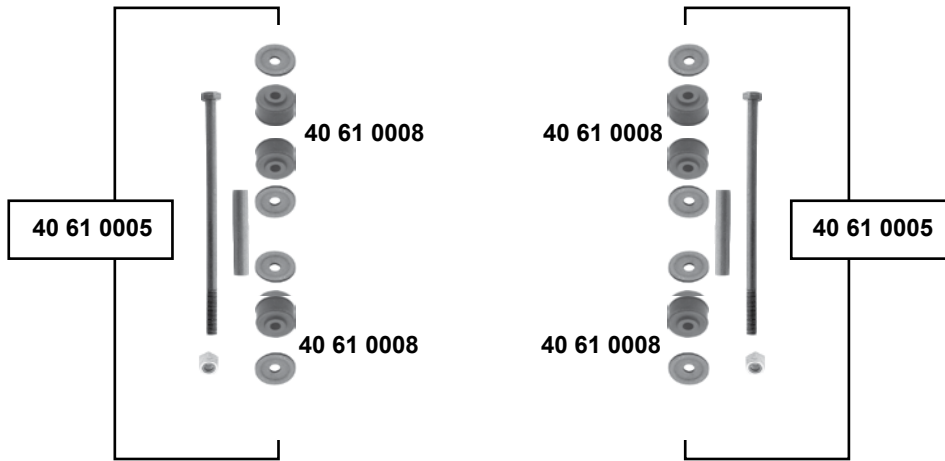

SWAG	Ref. - No.			
40 61 0005	90009368	Rep. Satz Stabilisator / rep. kit stabilizer		
40 61 0008	2875013	Verbindungsstangenlager / connecting rod bearing		
40 94 3559	13282834	Verbindungsstange / connecting rod		L 290
40 94 3560	13285628	Verbindungsstange / connecting rod		L 290
40 94 4156	13354542	Rep. Satz Axialgelenk / rep. kit axial joint	E - servo	L 223
40 94 5095	13354440 SK1	Lenkmanschette / steering rack boot	E - servo	
40 94 5096	13354440	Lenkmanschettensatz / steering boot set	E - servo	

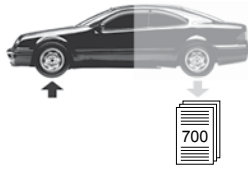

Cavalier Mk III

(1988 → 1995)

1.4 → 2.0 i (ex.)16 V

1.7 D / TD

Vorderachse / Front axle

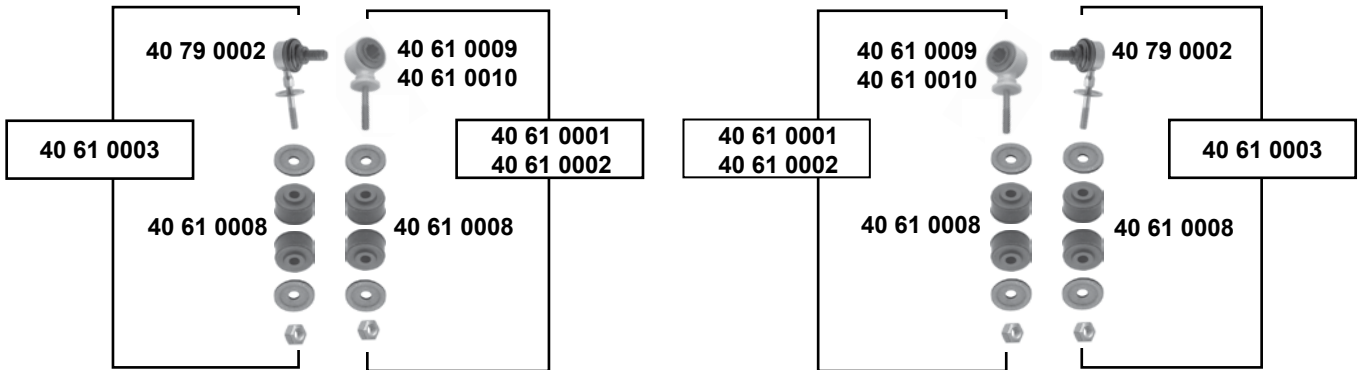
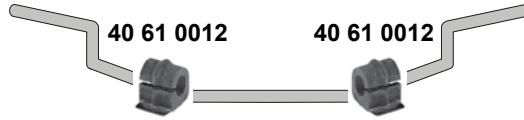
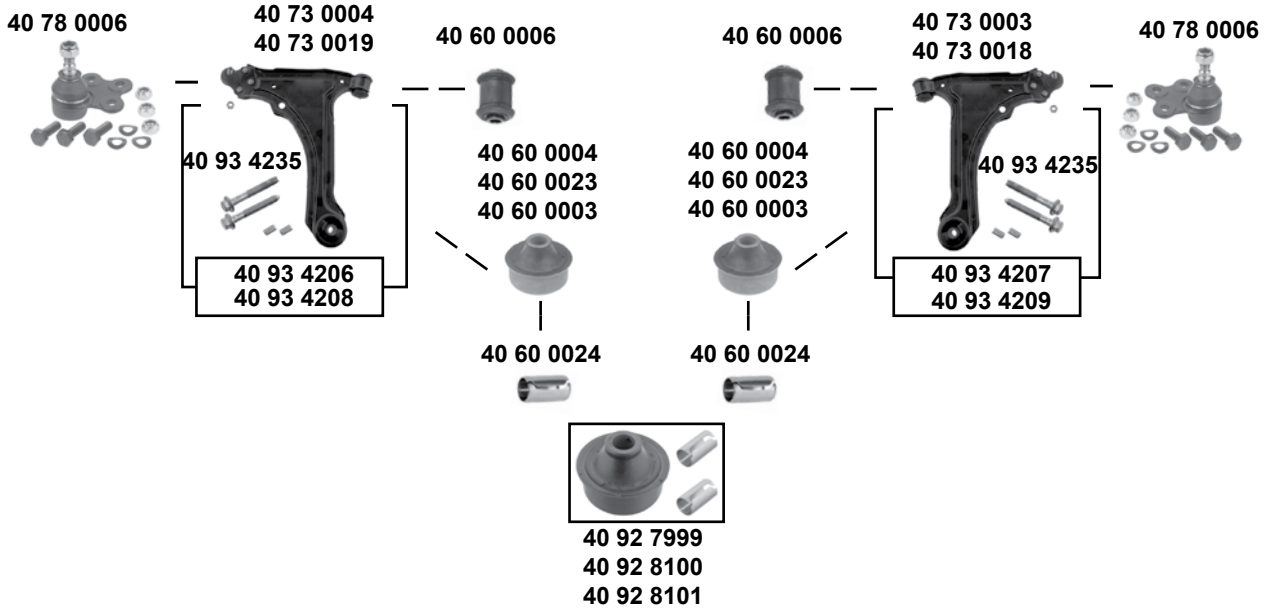

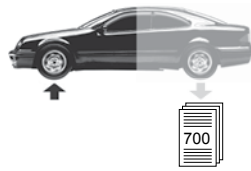

Cavalier Mk III

(1988 → 1995)
1.4 → 2.0 i (ex.)16 V
1.7 D / TD



(1) (ch.) → NV 535971 / P 1001687 / P 5004910

(3) (ch.) NV 535972 / P 1001688 / P 5004911 →

(2) (ch.) R 75440516 / R 1049315 / R 5112257 →

(4) (ch.) → R 75440515 / R 1049314 / R 5112256

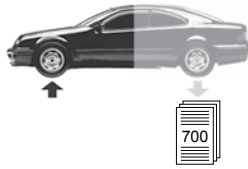
	Ref. - No.			
40 60 0003	90495046	Querlenkerlager / control arm mount	(2) (ex.) 2.5 V6	16x60x58
40 60 0004	90268463	Querlenkerlager / control arm mount	(1) (ex.) 2.5 V6	16x60x58
40 60 0006	90373778	Querlenkerlager / control arm mount	(1) (ex.) 2.5 V6	12x39x60
40 60 0023	90373264	Querlenkerlager / control arm mount	(3) (4) (ex.) 2.5 V6	Ø I 12
40 60 0024	90250709	Hülse / sleeve		16,3x30
40 61 0001	90278579 S1	Rep. Satz Verbindungsstange / rep. kit connecting rod		
40 61 0002	90278577 S1	Rep. Satz Verbindungsstange / rep. kit connecting rod		
40 61 0003	90495045 S1	Rep. Satz Verbindungsstange / rep. kit connecting rod		L 86
40 61 0008	02875013	Verbindungsstangenlager / connecting rod bearing		8,5x30x19
40 61 0009	90278579	Verbindungsstange / connecting rod		Ø I 22
40 61 0010	90278577	Verbindungsstange / connecting rod		Ø I 18
40 61 0012	90447867	Stabilisatorlager / stabilizer mount		Ø I 20
40 73 0018	90495104	Querlenker / control arm	(2) (ex.) 2.5 V6	
40 73 0019	90495103	Querlenker / control arm	(2) (ex.) 2.5 V6	
40 73 0003	90495160	Querlenker / control arm	(4) (ex.) 2.5 V6	
40 73 0004	90495159	Querlenker / control arm	(4) (ex.) 2.5 V6	
40 78 0006	90297863	Traggelenk / ball joint	(ex.) 2.5 V6	M12 x 1,5
40 79 0002	90495045	Verbindungsstange / connecting rod		L 86
40 92 7999	90495046 S1	Querlenkerlager / control arm mount	(2) (ex.) 2.5 V6	16x60x58
40 92 8100	90268463 S1	Querlenkerlager / control arm mount	(1) (ex.) 2.5 V6	16x60x58
40 92 8101	90373264 S1	Querlenkerlager / control arm mount	(3) (4) (ex.) 2.5 V6	
40 93 4206	90495103 S1	Rep. Satz Querlenker links / rep. kit control arm left	(2)	
40 93 4207	90495104 S1	Rep. Satz Querlenker rechts / rep. kit control arm right	(2)	
40 93 4208	90495195 S1	Rep. Satz Querlenker links / rep. kit control arm left	(4)	
40 93 4209	90495160 S1	Rep. Satz Querlenker rechts / rep. kit control arm right	(4)	
40 93 4235	11092273 S1	Schraubensatz für Querlenker / screw kit for control arm		



Cavalier Mk III

(1988 → 1995)

1.4 → 2.0 i (ex.)16 V

1.7 D / TD

man.

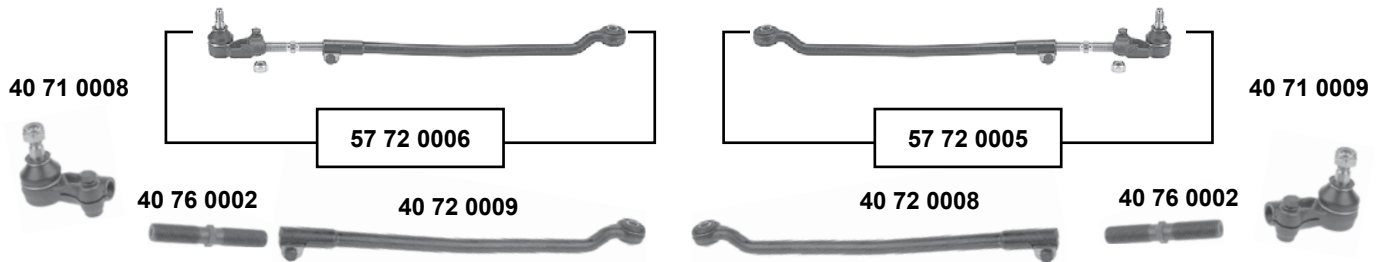
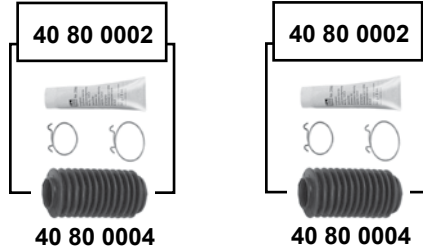

servo

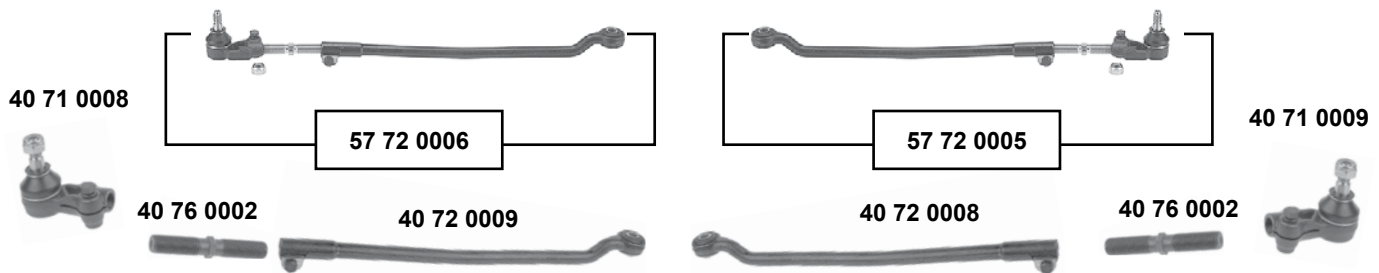
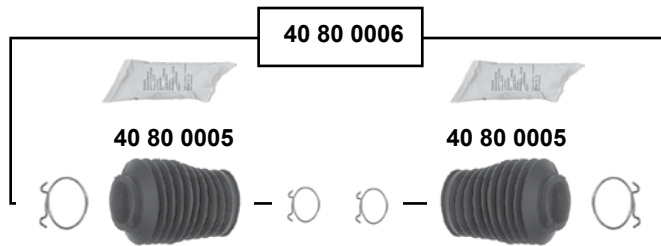

(1) (ch.) → M 1300367 / M 5396085 / NV 102027

SWAG	Ref. - No.			
40 71 0008	90369704	Spurstangenendstück / tie rod end		M16x2 RHT
40 71 0009	90369705	Spurstangenendstück / tie rod end		M16x2 LHT
40 72 0008	90373522	Spurstange / tie rod		L 434
40 72 0009	90373521	Spurstange / tie rod		L 434
40 76 0002	90373523	Einstellbolzen / adjusting bolt		M16x2x105,5
40 80 0002	90345195 S1	Rep. Satz Lenkmanschette / rep. kit steering boot	(1)	
40 80 0004	90345195	Lenkmanschette / steering boot	(1)	
40 80 0005	90398968 S1	Lenkmanschette / steering boot	LHD / für/to fit servo	ZF
40 80 0006	90398968 SK	Lenkmanschette / steering boot	LHD / für/to fit servo	ZF
57 72 0005	90373522 S1	Spurstange / tie rod		M16 x 2
57 72 0006	90373521 S1	Spurstange / tie rod		M16 x 2

Vorderachse / Front axle

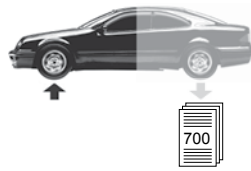

Cavalier Mk III

(1988 → 1995)

2.0 i 16V → 2.5 V6

man.

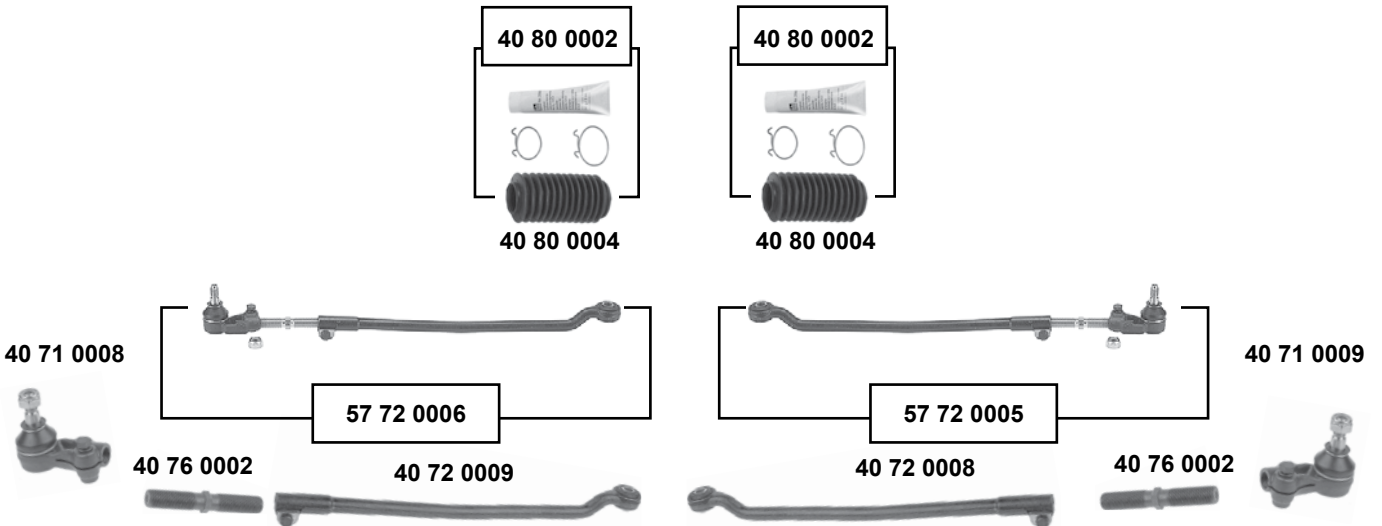

servo

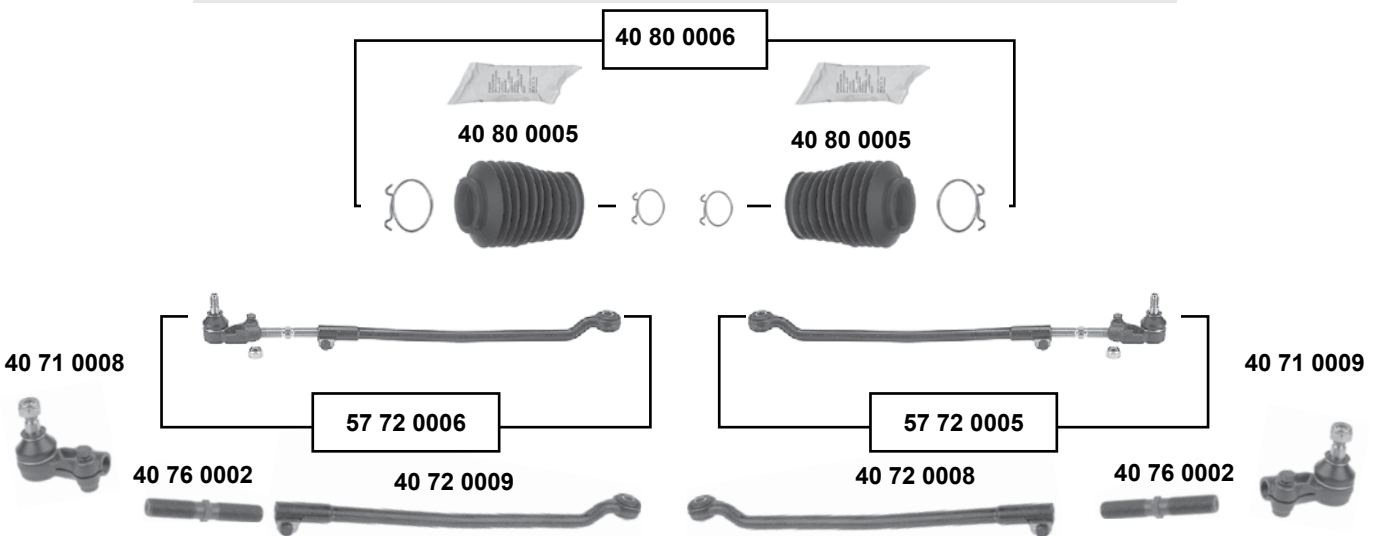

(1) (ch.) → M 1300367 / M 5396085 / NV 102027



Ref. - No.



40 71 0008	90369704	Spurstangenendstück / tie rod end		M16x1,5 RHT
40 71 0009	90369705	Spurstangenendstück / tie rod end		M16x1,5 LHT
40 72 0008	90373522	Spurstange / tie rod		L 434
40 72 0009	90373521	Spurstange / tie rod		L 434
40 76 0002	90373523	Einstellbolzen / adjusting bolt		M16x2x105,5
40 80 0002	90345195 S1	Rep. Satz Lenkmanschette / rep. kit steering boot	(1)	
40 80 0004	90345195	Lenkmanschette / steering boot	(1)	
40 80 0005	90398968 S1	Lenkmanschette / steering boot	LHD / für/to fit servo	ZF
40 80 0006	90398968 SK	Lenkmanschette / steering boot	LHD / für/to fit servo	ZF
57 72 0005	90373522 S1	Spurstange / tie rod		M16 x 2
57 72 0006	90373521 S1	Spurstange / tie rod		M16 x 2

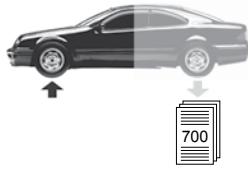

Cavalier Mk III

(1988 → 1995)

2.0 i 16V → 2.5 V6

Vorderachse / Front axle

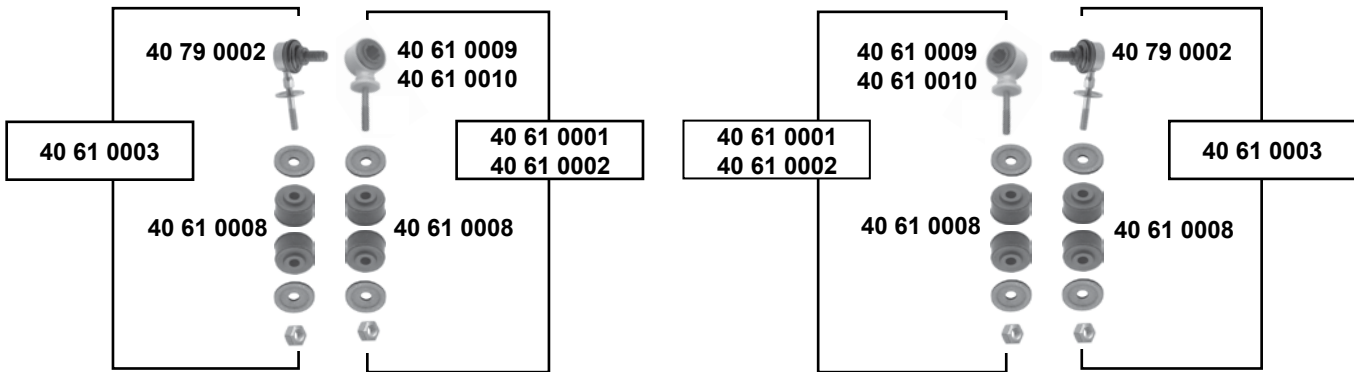
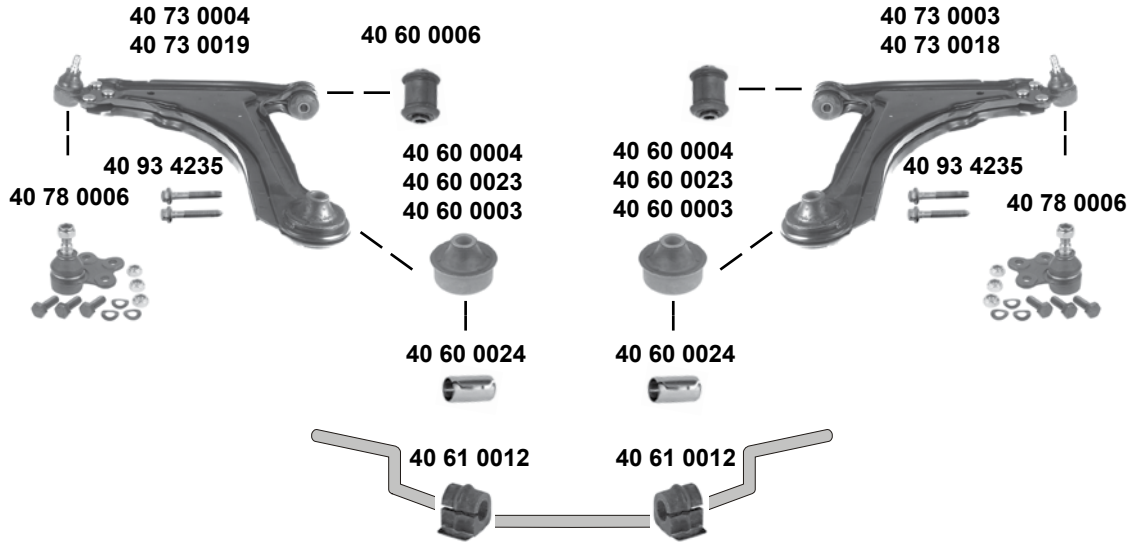

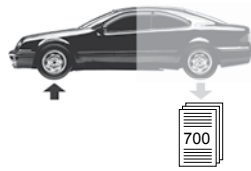

Cavalier Mk III

(1988 → 1995)
2.0 i 16V → 2.5 V6







(1) (ch.) → NV 535971 / P 1001687 / P 5004910

(3) (ch.) NV 535972 / P 1001688 / P 5004911 →

(2) (ch.) R 75440516 / R 1049315 / R 5112257 →

(4) (ch.) → R 75440515 / R 1049314 / R 5112256

	Ref. - No.			
40 60 0003	90495046	Querlenkerlager / control arm mount	(2) (ex.) 2.5 V6	16x60x58
40 60 0004	90268463	Querlenkerlager / control arm mount	(1) (ex.) 2.5 V6	16x60x58
40 60 0006	90373778	Querlenkerlager / control arm mount	(1) (ex.) 2.5 V6	12x39x60
40 60 0023	90373264	Querlenkerlager / control arm mount	(3) (4) (ex.) 2.5 V6	Ø 12
40 60 0024	90250709	Hülse / sleeve		16,3x30
40 61 0001	90278579 S1	Rep. Satz Verbindungsstange / rep. kit connecting rod		
40 61 0002	90278577 S1	Rep. Satz Verbindungsstange / rep. kit connecting rod		
40 61 0003	90495045 S1	Rep. Satz Verbindungsstange / rep. kit connecting rod		
40 61 0008	02875013	Verbindungsstangenlager / connecting rod bearing		8,5x30x19
40 61 0009	90278579	Verbindungsstange / connecting rod		Ø 22
40 61 0010	90278577	Verbindungsstange / connecting rod		Ø 18
40 61 0012	90447867	Stabilisatorlager / stabilizer mount		Ø 20
40 73 0003	90495160	Querlenker / control arm	(4) (ex.) 2.5 V6	
40 73 0004	90495159	Querlenker / control arm	(4) (ex.) 2.5 V6	
40 73 0018	90495104	Querlenker / control arm	(2) (ex.) 2.5 V6	
40 73 0019	90495103	Querlenker / control arm	(2) (ex.) 2.5 V6	
40 78 0006	90297863	Traggelenk / ball joint	(ex.) 2.5 V6	M12 x 1,5
40 79 0002	90495045	Verbindungsstange / connecting rod		
40 93 4235	11092273 S1	Schraubensatz für Querlenker / screw kit for control arm		



Corsa Mk I
(1993 → 2001)

(ch.) → V 3023597, V 4166925, V 6066279

Vorderachse / Front axle

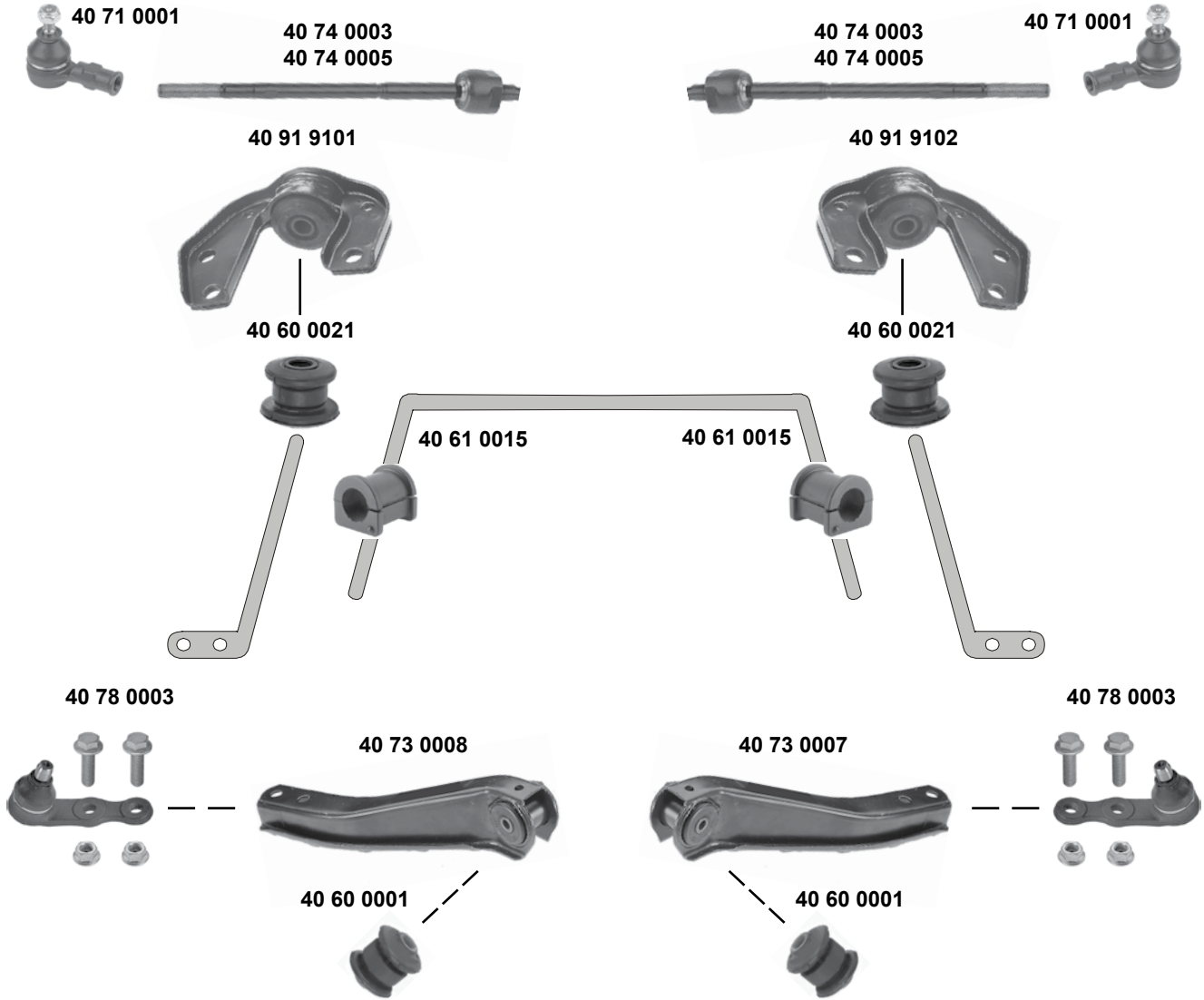

(1) Combo (ch.) V 3037204 →



Ref. - No.



40 60 0001	90445097	Querlenkerlager / control arm mount		10x35x52
40 60 0021	90445098	Zugstrebenlager / tension rod mount		14x36/50x40
40 61 0015	90447946	Stabilisatorlager / stabilizer mount		Ø 21,5
40 71 0001	93192419	Spurstangenendstück / tie rod end		M12x1,5 RHT
40 73 0007	90511261	Querlenker / control arm		
40 73 0008	90511260	Querlenker / control arm		
40 74 0003	93192445 SK	Spurstange / tie rod		
40 74 0005	26032284	Spurstange / tie rod		
40 78 0003	90444294	Traggelenk / ball joint		
40 91 9101	90445100	Halter / retainer	(1)	
40 91 9102	90445101	Halter / retainer	(1)	
			man. / E - servo	L 325
			servo	L 290
				Ø A 15



Corsa Mk I (1993 → 2001)

(ch.) V 3023598, V 4166926, V 6066280 →

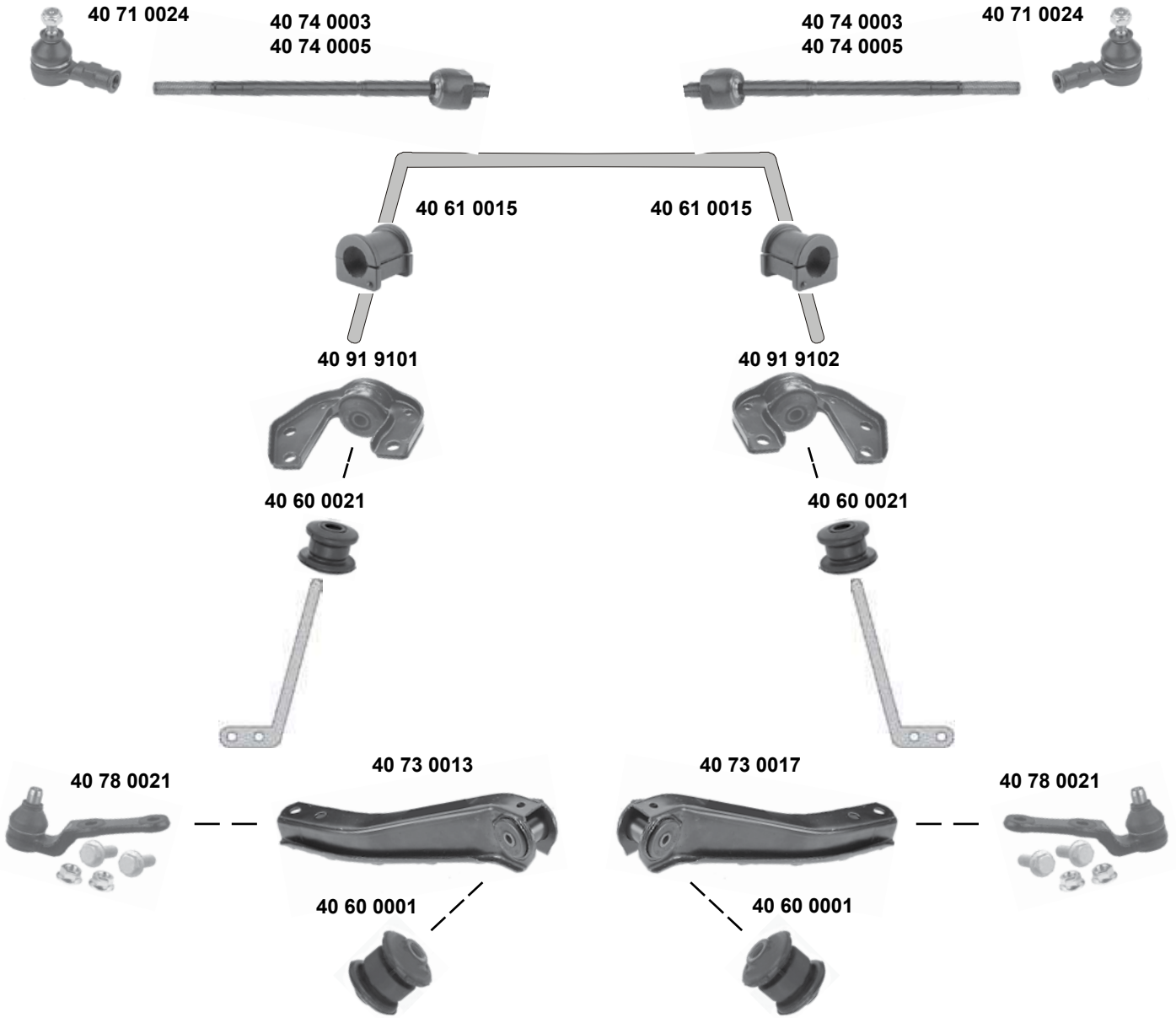

Vorderachse / Front axle

SWAG	Ref. - No.			
40 60 0001	90445097	Querlenkerlager / control arm mount		10x35x52
40 60 0021	90445098	Zugstrebenlager / tie arm bush		14x36/50x40
40 61 0015	90447946	Stabilisatorlager / stabilizer mount		Ø I 21,5
40 71 0024	93192446	Spurstangenendstück / tie rod end		M12x1,5 RHT
40 73 0013	90542572	Querlenker / control arm		
40 73 0017	90542573	Querlenker / control arm		
40 74 0003	93192445 SK	Spurstange / tie rod	man. / E - servo	L 325
40 74 0005	26032284	Spurstange / tie rod	servo	L 290
40 78 0021	90542574	Traggelenk / ball joint		Ø A 15
40 91 9101	90445100	Halter / retainer		
40 91 9102	90445101	Halter / retainer		



Corsa Mk II

(2001 → 2006)

Vorderachse / Front axle

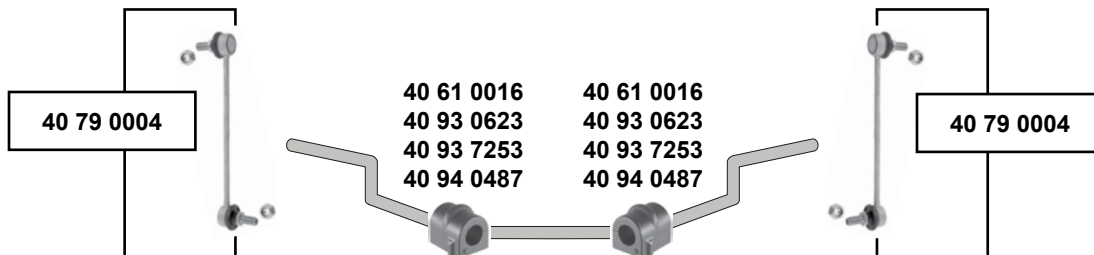
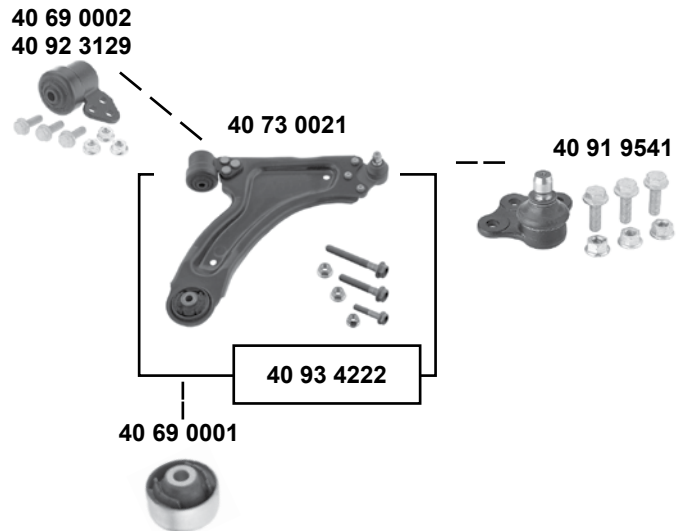
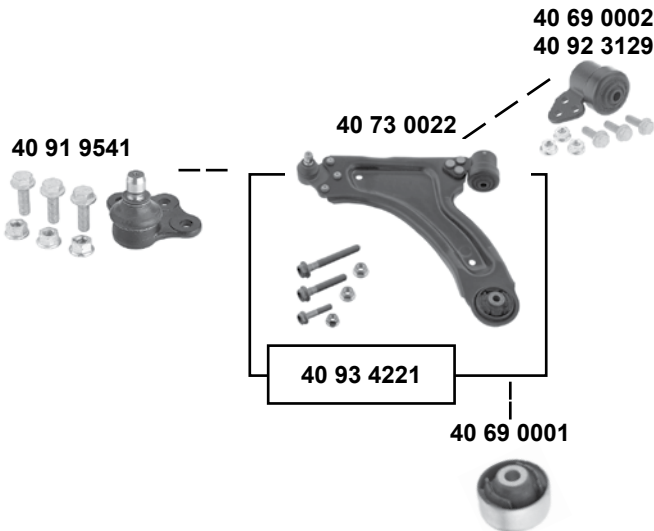
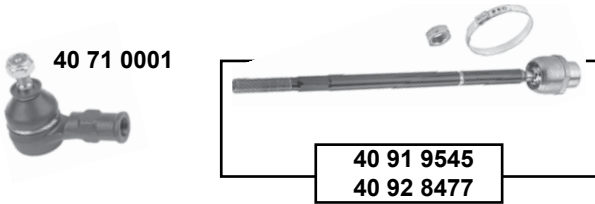
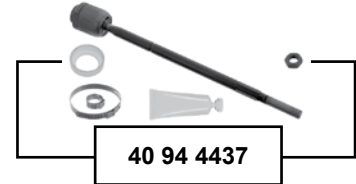

Corsa Mk II
 (2001 → 2006)

(1) (ch.) 33999999 →, (ch.) 34999999 → (ch.) 36999999 →	(2) (ch.) 43000001 →, (ch.) 44000001 → (ch.) 46000001 →
(3) (ex.) Combo (mot.) 1,0 / 1,2 / Y 1,3 DT / Z 1,3 DT / 1,4 / Z 1,7 DTH alle / all (ex.) Sport / (ex.) HD	
(4) (ex.) Combo (mot.) Z 1,0 XE / Z 1,2 XE / für Fahrzeuge mit / for cars with HD (ex.) Sport (ch.) → 14999999, 16999999	
(5) (ex.) Combo (mot.) Z 1,4 XE für Fahrzeuge mit / for cars with Sport oder /or HD (ch.) → 14999999, 16999999	
(6) Combo für alle Fahrzeuge (ex.) / Combo for all cars (ex.) HD	
(7) nur/only Combo (ch.) 43000001 →, 74000001 →	
(8) nur Combos mit Stabilisator Ø 22 mm / only Combos with stabilizer Ø 22 mm	
(9) (ex.) Z13DTJ / servo	



	Ref. - No.			
40 61 0016	90468567	Stabilisatorlager / stabilizer mounting		Ø I 16
40 69 0001	13138151	Querlenkerlager / control arm mount		Ø A 59,5
40 69 0002	93188303	Querlenkerlager / control arm mount	(ex.) HD	Ø A 60/49
40 71 0001	93192419	Spurstangenendstück / tie rod end	(1)	M12x1,5 RHT
40 73 0021	13140038	Querlenker / control arm	(ex.) Sport / HD	
40 73 0022	13140037	Querlenker / control arm	(ex.) Sport / HD	
40 79 0004	90496116	Verbindungsstange / connecting rod		L 243,5
40 91 9541	09196394	Traggelenk / ball joint		
40 91 9545	93192421	Spurstange / tie rod	(1)	L 315
40 92 3129	93188302	Querlenkerlager / control arm mount	HD	Ø A 60/49
40 92 8477	93192420	Spurstange / tie rod	(2)	L 318
40 93 0623	13125492	Stabilisatorlager / stabilizer mounting	(7)	
40 93 4221	13140037 S1	Rep. Satz Querlenker / rep. kit control arm	(3) (4) (5) (6)	
40 93 4222	13140038 S1	Rep. Satz Querlenker / rep. kit control arm	(3) (4) (5) (6)	
40 93 7253	24403523	Stabilisatorlager / stabilizer mount	(ex.) HD	Ø I 15 L 43,5
40 94 0487	24406498	Stabilisatorlager / stabilizer mount	(8)	Ø 22
40 94 4437	93192418	Rep. Satz Axialgelenk / rep. kit axial joint	(9)	L 317



Corso Mk III

(2006 → 2014)

Vorderachse / Front axle

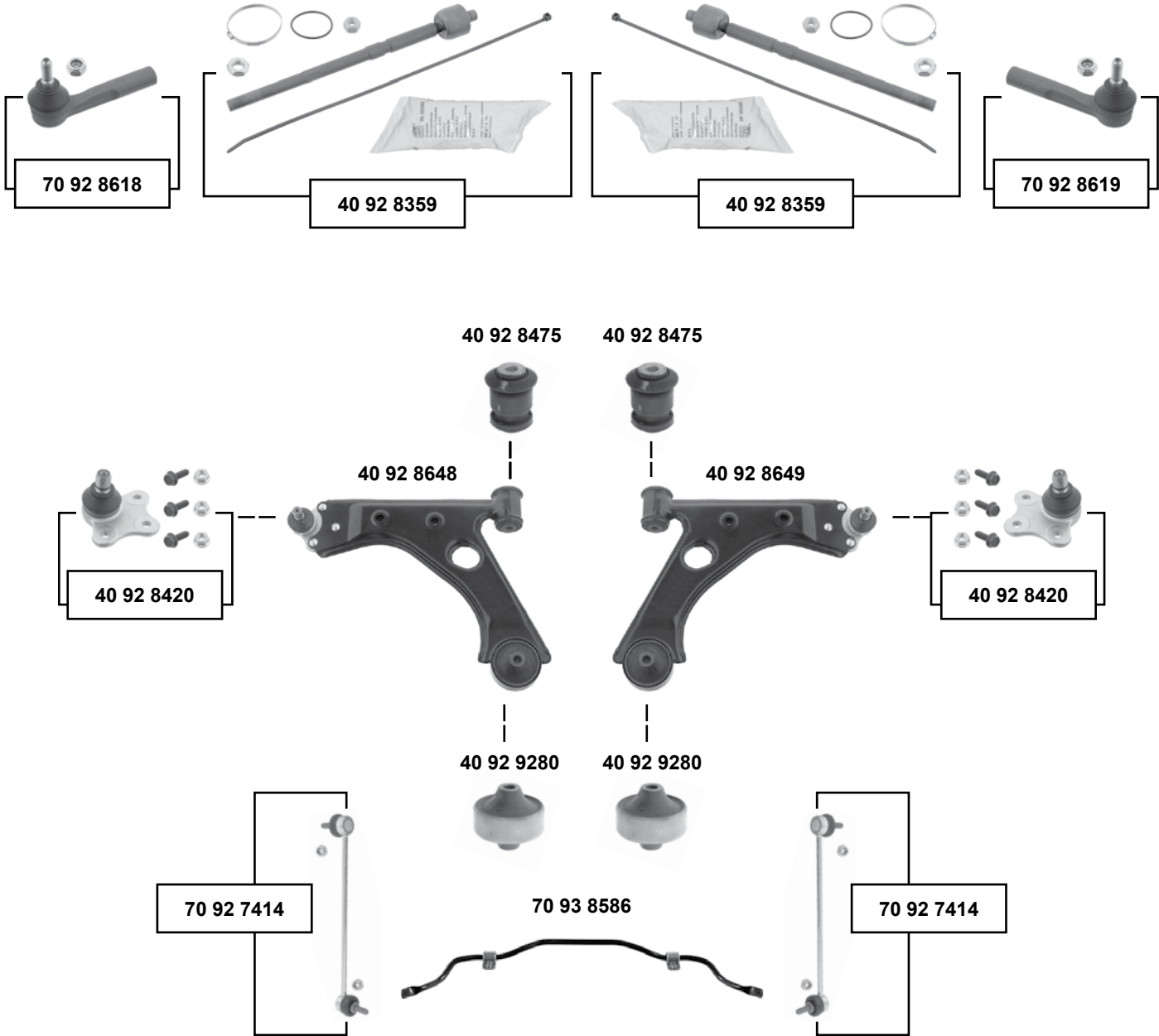

i (1) (ch.) → 94170397, 96065974

SWAG	Ref. - No.		i	
40 92 8359	93189022	Spurstange / tie rod		L 305
40 92 8420	93190907	Traggelenk / ball joint		Ø A 16
40 92 8475	13260666	Querlenkerlager / control arm mount		12x52x68
40 92 8648	55703230	Querlenker / control arm		
40 92 8649	55703231	Querlenker / control arm		
40 92 9280	13167940	Querlenkerlager / control arm mount		12x72x66
70 92 7414	13321280	Verbindungsstange / connecting rod		L 301
70 92 8618	93189023	Spurstangenendstück / tie rod end	(1)	M14 x 1,5
70 92 8619	93189024	Spurstangenendstück / tie rod end	(1)	M14 x 1,5
70 93 8586	13343139	Stabilisatorsatz / stabilizer set		L 1045



Corsa Mk IV
(2014 →)

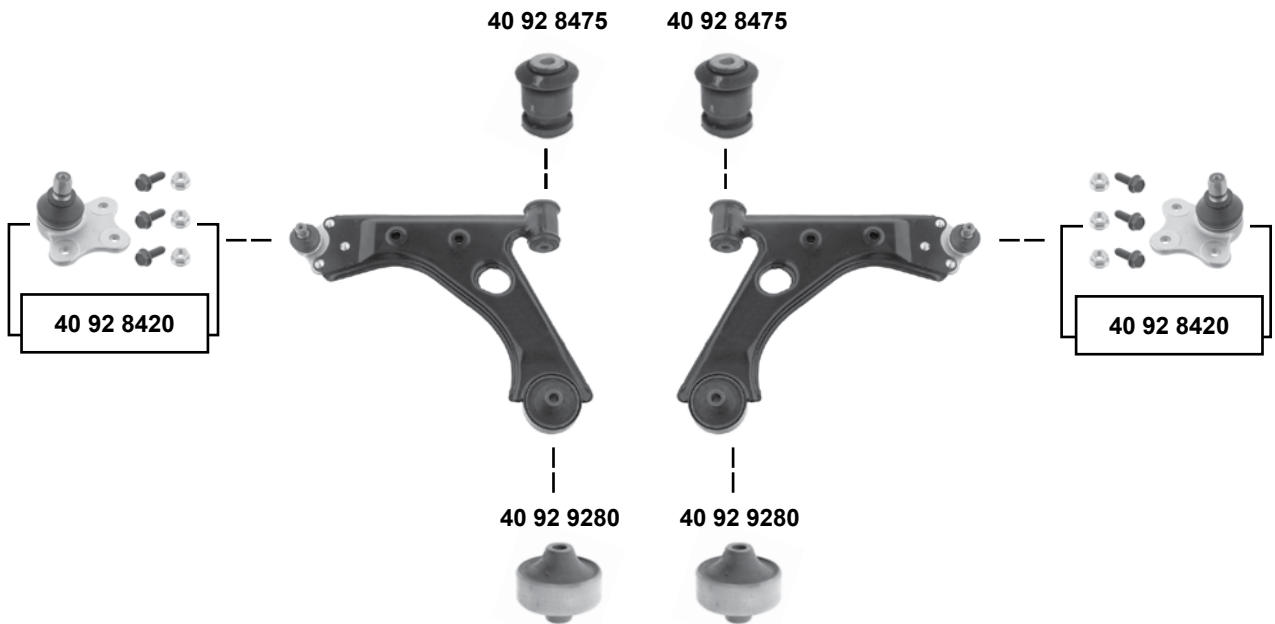

40 94 5219

40 94 5219

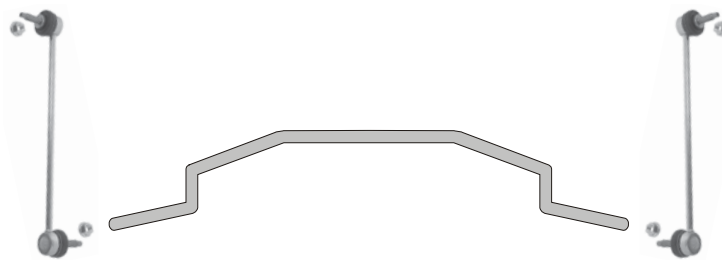



Combo Mk II
(2001 → 2010)

Vorderachse / Front axle

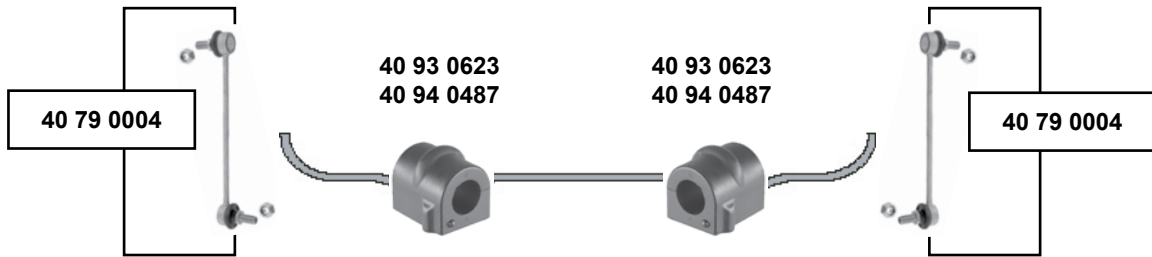
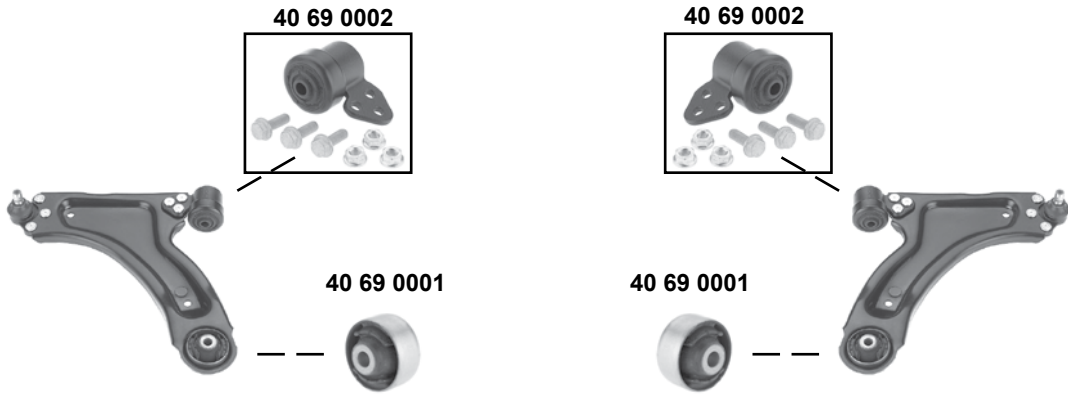

- (1) F06 (ch.) 43000001, 74000001→
- (2) F06 (ch.) → 33999999 / F25 alle / all

	Ref. - No.			
40 69 0001	13138151	Querlenkerlager / control arm mount		13x61x46
40 69 0002	93188303	Rep. Satz Querlenkerlager / rep. kit control arm mount		12x59x70
40 79 0004	90496116	Verbindungsstange / connecting rod		L 243,5
40 93 0623	13125492	Stabilisatorlager / stabilizer mount	(1)	Ø 1 21
40 94 0487	24406498	Stabilisatorlager / stabilizer mount	(2)	Ø 22



Combo Mk III (2011 →)

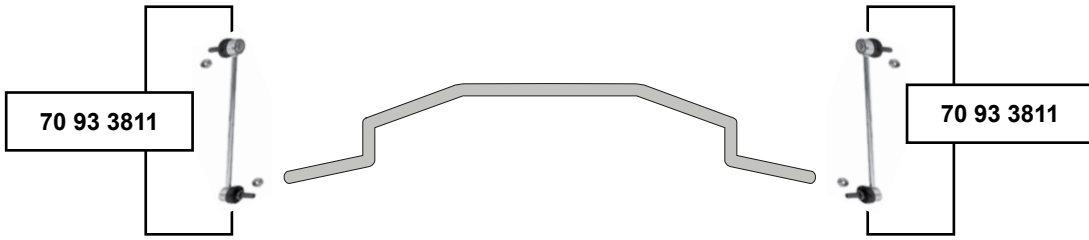

Frontera Mk I (1992 → 1998)

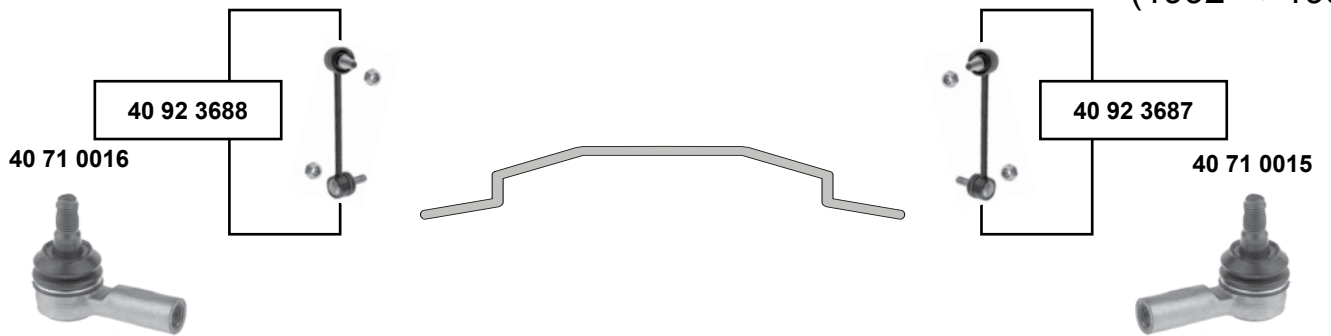

oben / upper

40 78 0009
40 92 6125

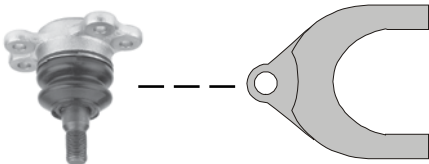

40 78 0009
40 92 6125

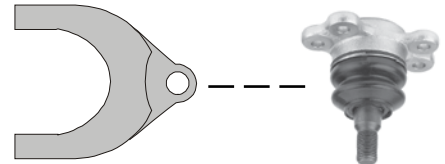

unten / lower

40 78 0008

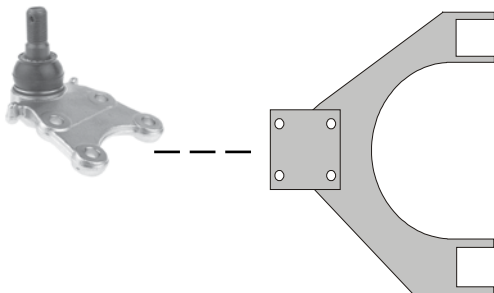

40 78 0008

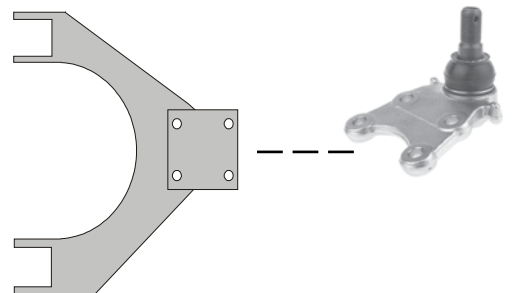

Vorderachse / Front axle



40 71 0015	97020954	Spurstangenendstück / tie rod end			M14 x 1,5
40 71 0016	97020953	Spurstangenendstück / tie rod end			M14 x 1,5
40 78 0008	94459465	Traggelenk / ball joint			M18 x 1,5
40 78 0009	94459453	Traggelenk / ball joint		(ch.) → SV 720102	M18 x 1,5
40 92 3687	97018227	Verbindungsstange / connecting rod		(ch.) SV 720103 →	L 150
40 92 3688	97018228	Verbindungsstange / connecting rod		(ch.) SV 720103 →	L 150
40 92 6125	94374424	Traggelenk / ball joint		(ch.) SV 720103 →	M14 x 1,5
70 93 3811	95511247	Verbindungsstange / connecting rod			L 297



Frontera Mk II

(1998 → 2004)

Vorderachse / Front axle

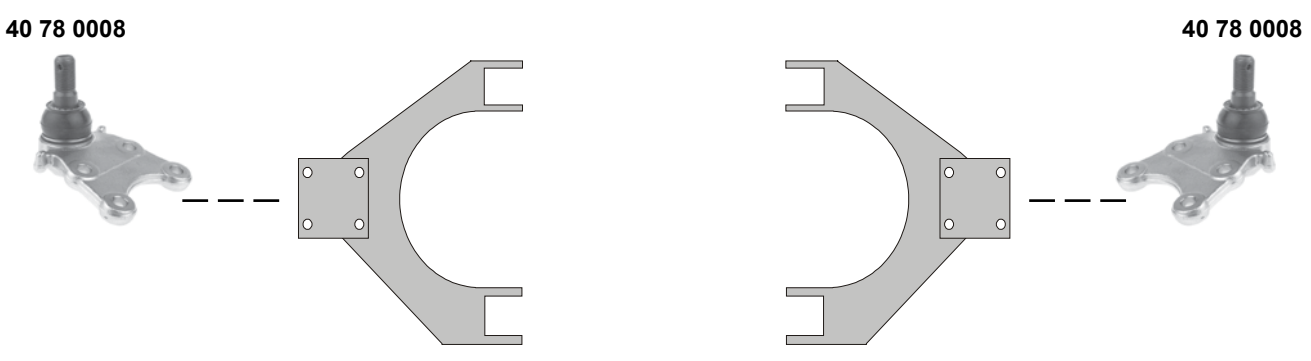
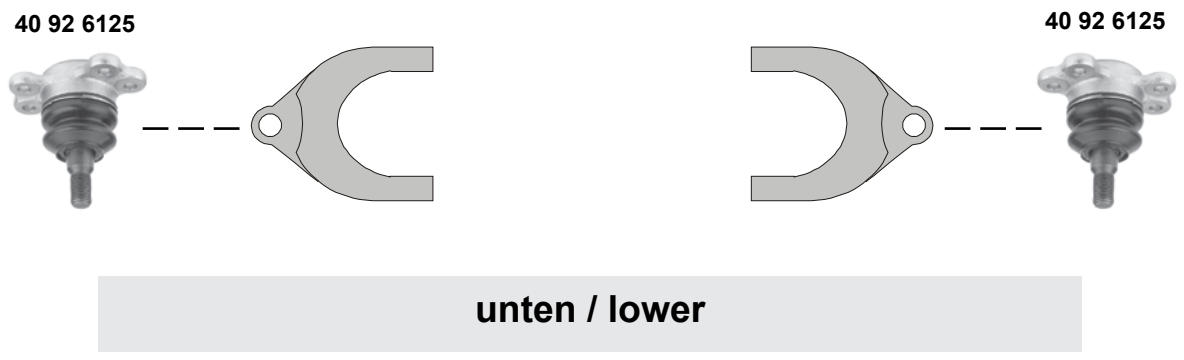
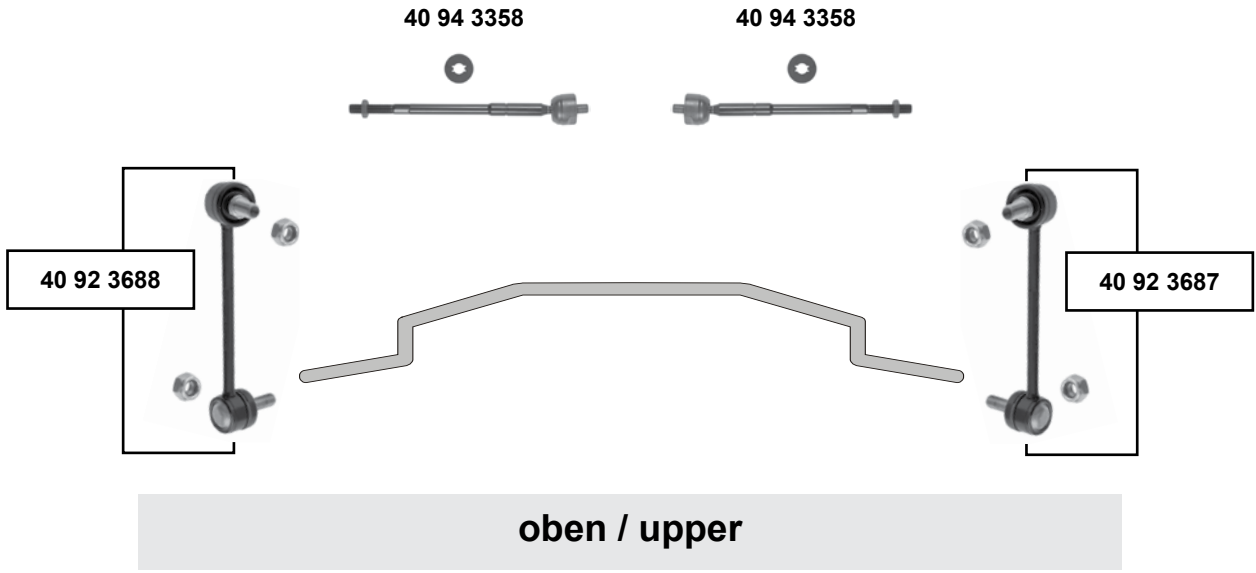

	Ref. - No.			
40 78 0008	94459465	Traggelenk / ball joint		M18 x 1,5
40 92 3687	97018227	Verbindungsstange / connecting rod		L 150
40 92 3688	97018228	Verbindungsstange / connecting rod		L 150
40 92 6125	94374424	Traggelenk / ball joint		M14 x 1,5
40 94 3358	97184819	Axialgelenk / axial joint		L 312

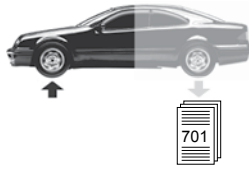

Insignia (2008 →)

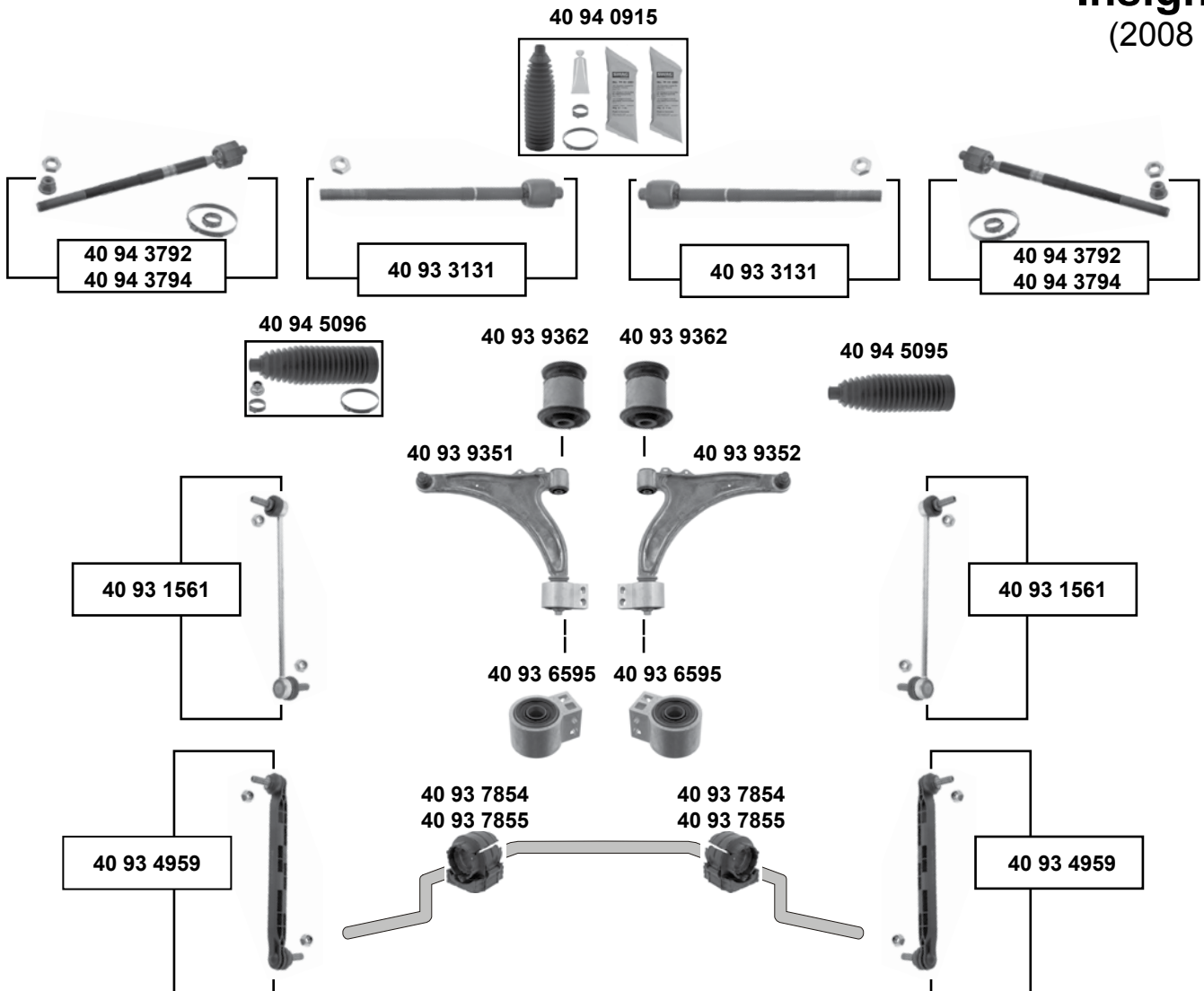

Vorderachse / Front axle

- (1) Für Fahrzeuge mit Flexride Fahrwerk (aktives Fahrwerk) / for vehicles with flexride chassis only
- (2) **alle (ex.)** Flexride Fahrwerk / **all (ex.)** flexride chassis
- (3) für reduzierten Stellweg der Zahnstange / for reduced range of the steering rack POC / NJ0
- (4) für normalen Stellweg der Zahnstange / for normal range of the steering rack POC / NJ1
- (5) **(ex.)** 4x4 / **(ch.)** POC XJ6 / **(ch.)** POC XJ2 / **(ch.)** POC XJ4



Ref. - No.



Ref. - No.				
40 93 1561	13258052	Verbindungsstange / connecting rod	(1)	L 303,5
40 93 3131	13271996 SK	Axialgelenk ohne Endstück / axial joint without end		L 209
40 93 4959	13219141	Verbindungsstange / connecting rod	(2)	L 304
40 93 6595	13257785	Querlenkerlager / control arm mount		Ø 22
40 93 7854	13281782	Stabilisatorlager / stabilizer mount		Ø 25
40 93 7855	13281784	Stabilisatorlager / stabilizer mount		Ø 23
40 93 9351	22792990	Querlenker / control arm	(5)	
40 93 9352	22792991	Querlenker / control arm	(5)	
40 93 9362	13219090	Querlenkerlager / control arm mount		12x52x60
40 94 0915	13271036	Lenkmanschettensatz / steering boot set	servo	
40 94 3792	13332653	Axialgelenk ohne Endstück / axial joint without end	(3) E - servo	L 314
40 94 3794	13332651	Axialgelenk ohne Endstück / axial joint without end	(4) E - servo	L 311
40 94 5095	13354440 SK1	Lenkmanschette / steering rack boot	E - servo	
40 94 5096	13354440	Lenkmanschettensatz / steering boot set	E - servo	



Meriva Mk I
(2003 → 2010)

Vorderachse / Front axle

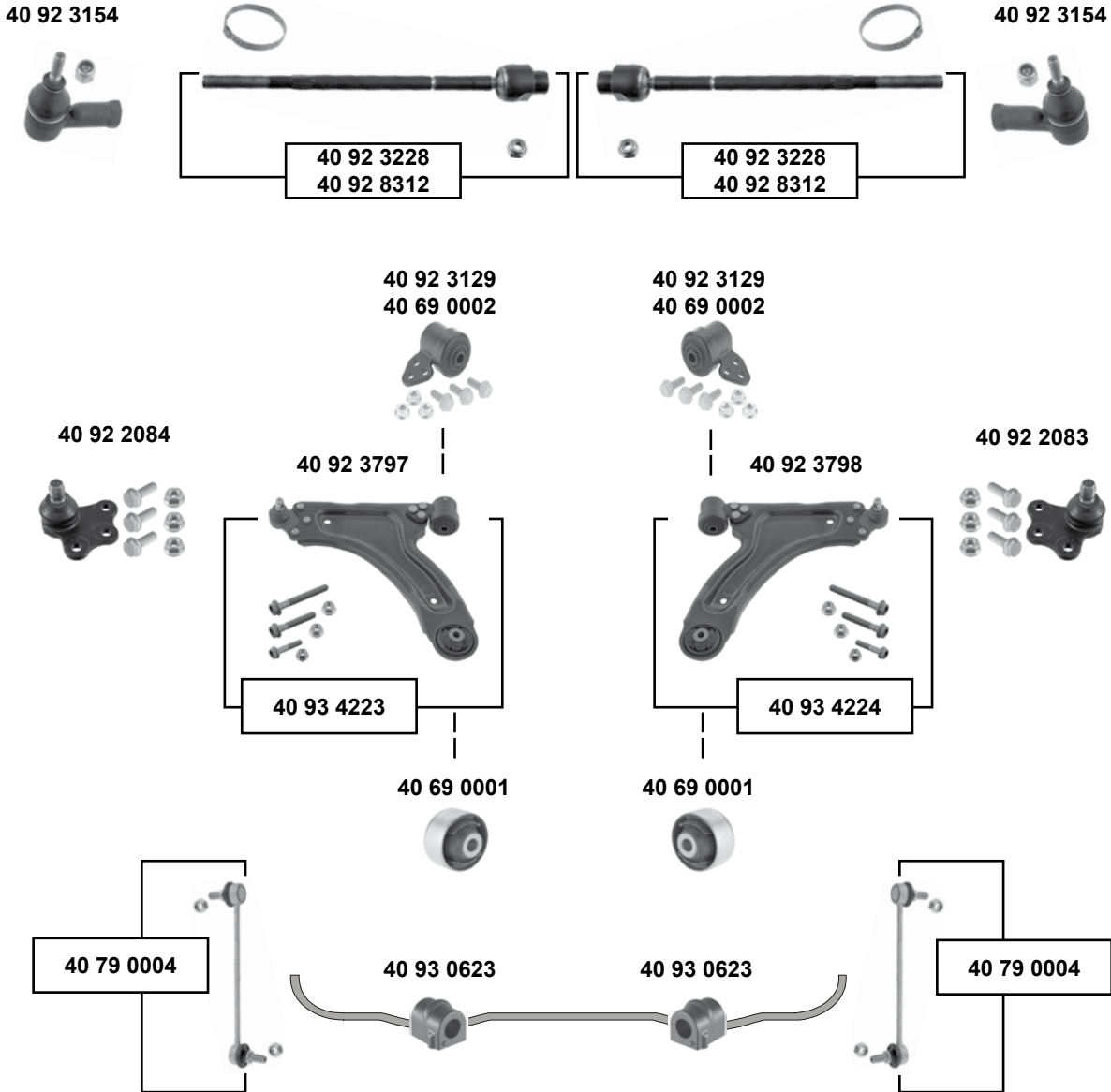

SWAG GERMANY	Ref. - No.			
40 69 0001	13138151	Gummilager / rubber mount		12x60x27/46
40 69 0002	93188303	Querlenkerlagersatz / control arm mount kit		12x59x70
40 79 0004	90496116	Verbindungsstange / connecting rod	(ex.) Z 1,6 LET	L 243,5
40 92 2083	93190906	Traggelenk / ball joint		Ø A 16
40 92 2084	93174598	Traggelenk / ball joint		Ø A 16
40 92 3129	93188302	Gummilager / rubber mount	Z 1,6 LET	12x49/50x70
40 92 3154	26102923 SK	Spurstangenendstück / tie rod end	E- servo	M14 x 1,5
40 92 3228	26102923	Spurstange / tie rod	E- servo	L 333
40 92 3797	93388568	Querlenker / control arm	(ex.) OPC	
40 92 3798	93388569	Querlenker / control arm	(ex.) OPC	
40 92 8312	93192415	Spurstange / tie rod	(ex.) servo	L 332
40 93 0623	13125492	Stabilisatorlager / stabilizer mounting		
40 93 4223	93388568 S1	Rep. Satz Querlenker links / rep. kit control arm left	(ex.) OPC + VXR	
40 93 4224	93388569 S1	Rep. Satz Querlenker rechts / rep. kit control arm right	(ex.) OPC + VXR	



Meriva Mk II (2010 →)

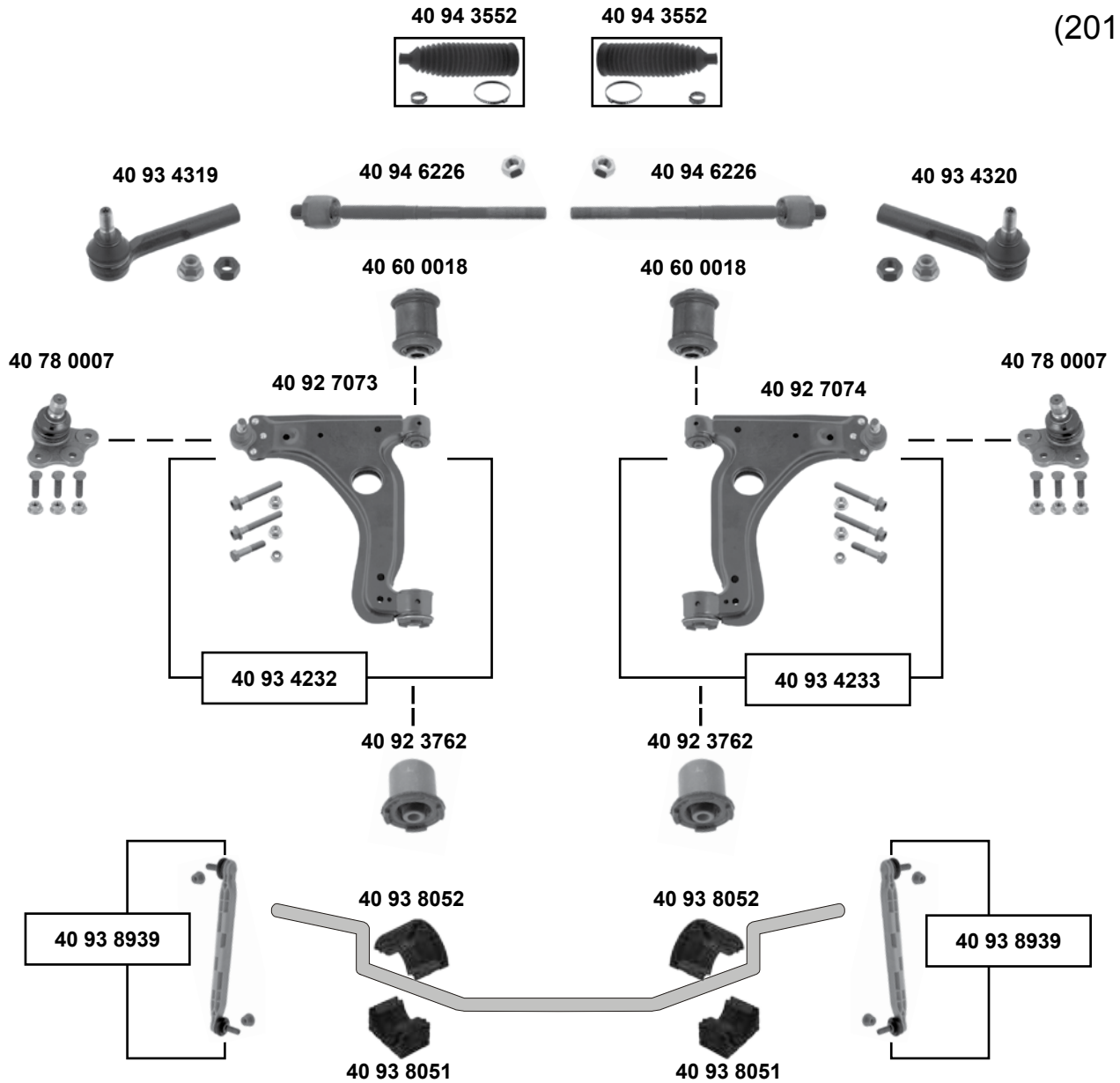

Vorderachse / Front axle



(1) Nur für TRW-Lenkung / TRW-steering only



Ref. - No.



40 60 0018	90498738	Querlenkerlager / control arm mount		12x36,5x60
40 78 0007	90512982	Traggelenk / ball joint		
40 92 3762	24439582	Querlenkerlager / control arm mount		12x46x60
40 92 7073	24454477	Querlenker / control arm		
40 92 7074	22454478	Querlenker / control arm		
40 93 4232	24454477 S1	Rep. Satz Querlenker links / rep. kit control arm left		
40 93 4233	24454478 S1	Rep. Satz Querlenker rechts / rep. kit control arm right		
40 93 4319	93196780	Spurstangenendstück / tie rod end		
40 93 4320	93196779	Spurstangenendstück / tie rod end		
40 93 8051	13204071	Stabilisatorlager, unten / stabilizer mount, lower		Ø 24-25,5
40 93 8052	13204070	Stabilisatorlager, oben / stabilizer mount, upper		Ø 24-25,5
40 93 8939	13327928	Rep. Satz Verbindungsstange / rep. kit connecting rod		L 350
40 94 3552	93191260	Lenkmanschettensatz / steering boot set	(1)	L 211
40 94 6226	93196778 SK1	Axialgelenk / axial joint	POC 1	L276



Movano Mk I

(1998 → 2010)

Vorderachse / Front axle

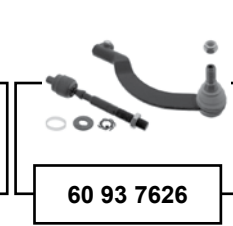
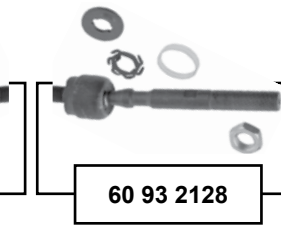
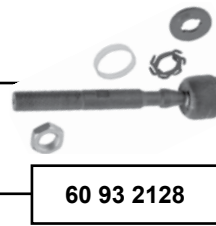
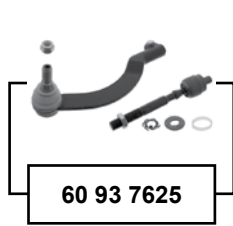
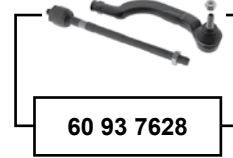

oben / upper

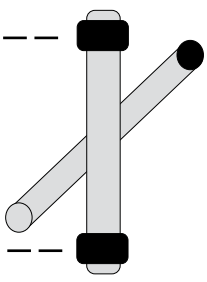
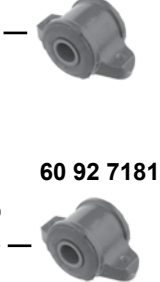
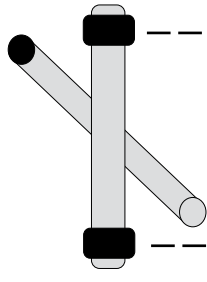

unten / lower

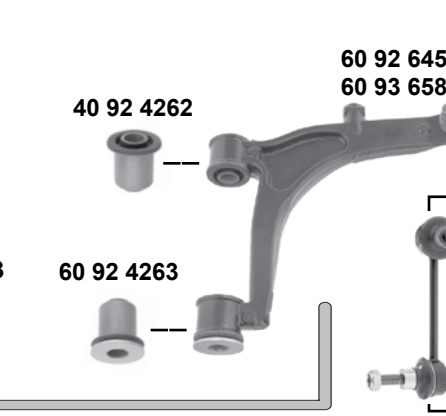
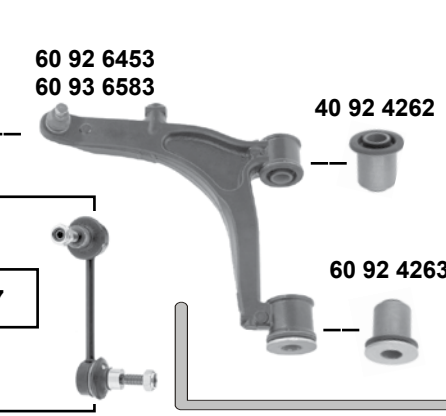

60 91 9867

60 91 9866

Movano Mk I
 (1998 → 2010)



- (1) ED (ch.) B809446 → / FD (ch.) BB35303 → / FD (ch.) J023003 → / HD (ch.) B784591 → / JD (ch.) B794054 → / UD (ch.) B822153 → / außer Fahrzeuge mit erhöhtem Bodenabstand / except vehicles with increased ground distance
- (2) ED (ch.) → B810866 / FD (ch.) → BB57431 / HD (ch.) → B785825 / JD (ch.) → B794913 / UD (ch.) → B825494
- (3) (ch.) → B810866 (ED) / (ch.) → BB54731 (ED) / (ch.) → B785825 (ED) / (ch.) → B794913(ED) / (ch.) → B825494 (ED)



Ref. - No.

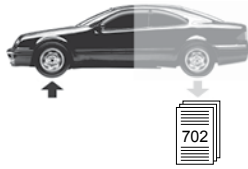

40 92 4262	09160394	Querlenkerlager / control arm mount		
60 91 9866	09160499	Verbindungsstange / connecting rod		L 130
60 91 9867	09160498	Verbindungsstange / connecting rod		L 130
60 92 1493	09161562	Spurstangenendstück / tie rod end		L 225
60 92 1494	09161563	Spurstangenendstück / tie rod end		L 225
60 92 2468	09109909	Traggelenk / ball joint		Ø A 22
60 92 2710	09160554	Traggelenk / ball joint	→ 09/02	
60 92 4263	09160395	Querlenkerlager / control arm mount		
60 92 6453	93192689	Querlenker / control arm		
60 92 6454	93192690	Querlenker / control arm		
60 92 7181	09160391	Querlenkerlager oben / upper control arm mount		M10 x 1,5
60 93 1847	09109910	Traggelenk / ball joint		Ø A15/101
60 93 2128	09161561 SK	Spurstange / tie rod		L 174,5
60 93 4164	93194857	Traggelenk / ball joint lower right+left	(1)	Ø A 24
60 93 6583	93194853	Querlenker / control arm	(1) 07 → 10	
60 93 6584	93194855	Querlenker / control arm	(1) 07 → 10	
60 93 7625	09161561 S1	Spurstange / tie rod	(3)	
60 93 7626	09161561 S2	Spurstange / tie rod	(3)	
60 93 7627	91160037 S1	Spurstange / tie rod	(2)	
60 93 7628	91160037 S2	Spurstange / tie rod	(2)	



Movano Mk II

(2010 →)

Vorderachse / Front axle

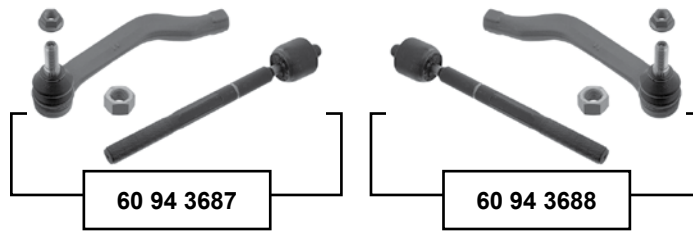
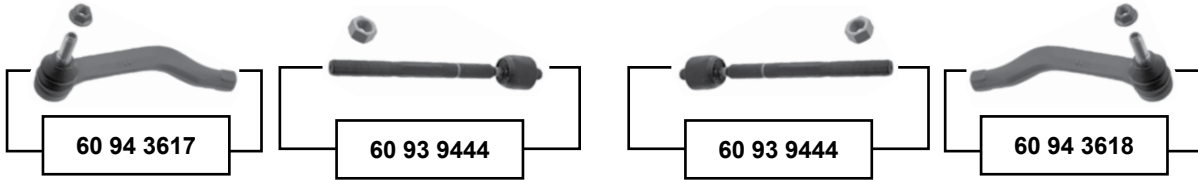

60 94 2634

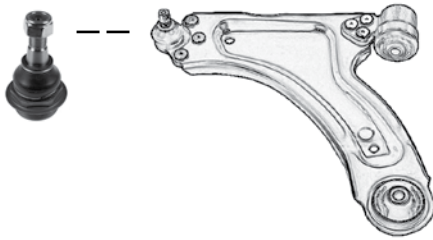

60 94 2634

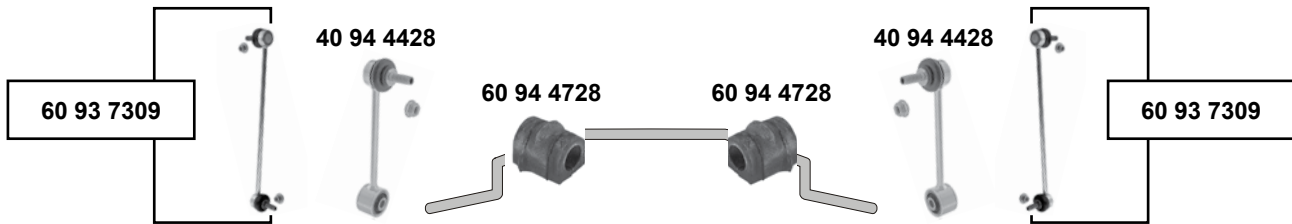
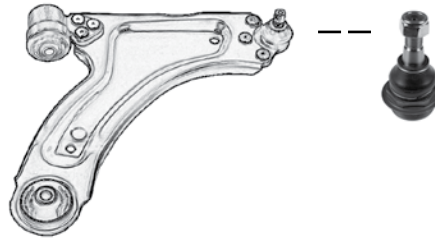

(1) alle mit Heckantrieb in Verbindung mit Doppelbereifung / all with Rear Drive combined with Double Tires

(2) EV0 , FV0 , HV0 , UV0 , JV0

Nur Fahrzeuge mit Frontantrieb mit einem Gesamtgewicht von 3300 u. 3500 kg / only vehicles with front wheel drive combined with a total weight of 3300 a. 3500 kg

(3) Vorderradantrieb oder Heckantrieb ohne Doppelbereifung / front-wheel drive or rear-wheel drive without double tires



Ref. - No.



40 94 4428	93168675	Verbindungsstange / connecting rod	(1)	L 166
60 93 7309	93197325	Verbindungsstange / connecting rod	(3)	L 330
60 93 9444	93167687 SK	Axialgelenk / axial joint		L 253
60 94 2634	93197233	Traggelenk / ball joint	→ 22.07.10	
60 94 3617	93167688	Spurstangenendstück / tie rod end		M18 x 1,5
60 94 3618	93167689	Spurstangenendstück / tie rod end		M18 x 1,5
60 94 3687	93167688 S1	Rep. Satz Spurstange / rep. kit tie rod		
60 94 3688	93167689 S1	Rep. Satz Spurstange / rep. kit tie rod		
60 94 4728	93197327	Stabilisatorlager / stabilizer mount	(2)	Ø 25,4



Mokka
(2013 →)

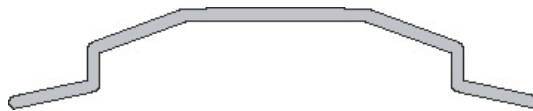
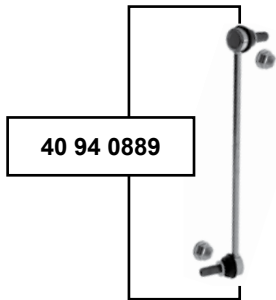
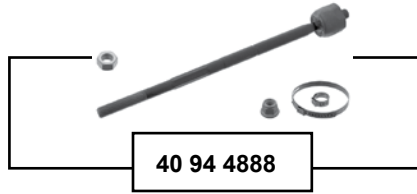

Vorderachse / Front axle





Nova

(1982 → 1993)

Vorderachse / Front axle

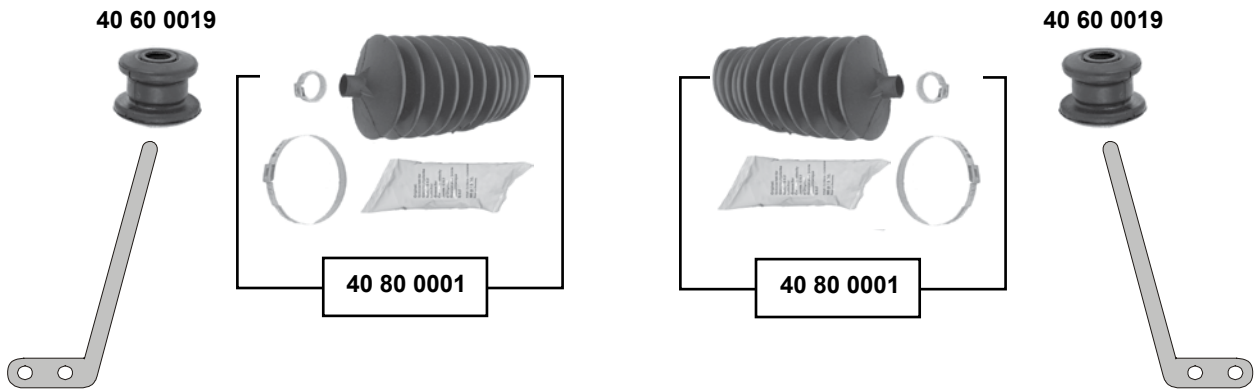
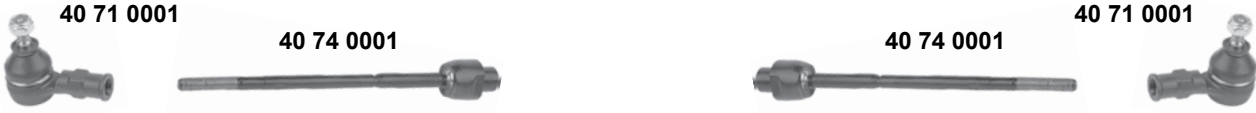

	Ref. - No.			
40 60 0002	90170152	Querlenkerlager / control arm mount		10x35x52
40 60 0019	90135359	Zugstrebenlager / tension rod mount		14x32/45x36
40 71 0001	93192419	Spurstangenendstück / tie rod end		M12x1,5 RHT
40 73 0001	90166390	Querlenker / control arm		
40 73 0002	90166391	Querlenker / control arm		
40 78 0003	90444294	Traggelenk / ball joint		Ø A 15
40 74 0001	26010028	Spurstange / tie rod		L 300
40 80 0001	07840451	Rep. Satz Lenkmanschette / rep. kit steering boot		

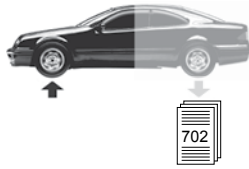

Omega (1994 → 2003)

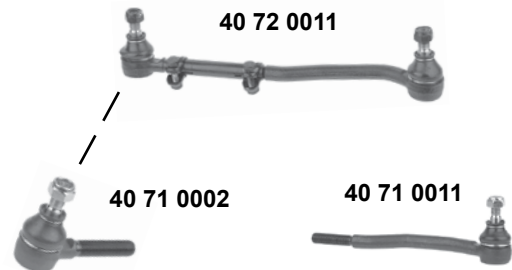
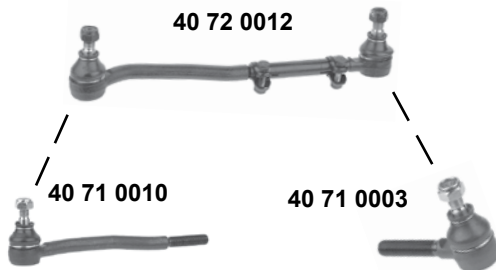

Vorderachse / Front axle



(1) (ch.) → X 1999999
(ch.) Y 2000000 →

alle / all
(ex.) Sport



Ref. - No.



40 71 0002	90510640	Spurstangenendstück / tie rod end			M14x1,5 RHT
40 71 0003	90510639	Spurstangenendstück / tie rod end			M14x1,5 LHT
40 71 0010	90510653	Spurstangenendstück / tie rod end		(ch.) → X 1999999	M14x1,5 RHT
40 71 0011	93169283	Spurstangenendstück / tie rod end		(ch.) → X 1999999	M14x1,5 LHT
40 72 0010	90510647	Spurstange / tie rod		(1) LHD	L 605
40 72 0011	90510650	Spurstange / tie rod		(ch.) → X 1999999	L 354
40 72 0012	93169261	Spurstange / tie rod		(ch.) → X 1999999	L 354
40 92 2099	09195731	Lenkhebel / steering arm			L 110 / Ø 18

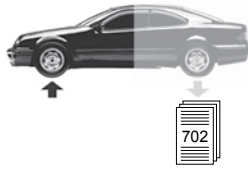

Omega
(1994 → 2003)

Vorderachse / Front axle

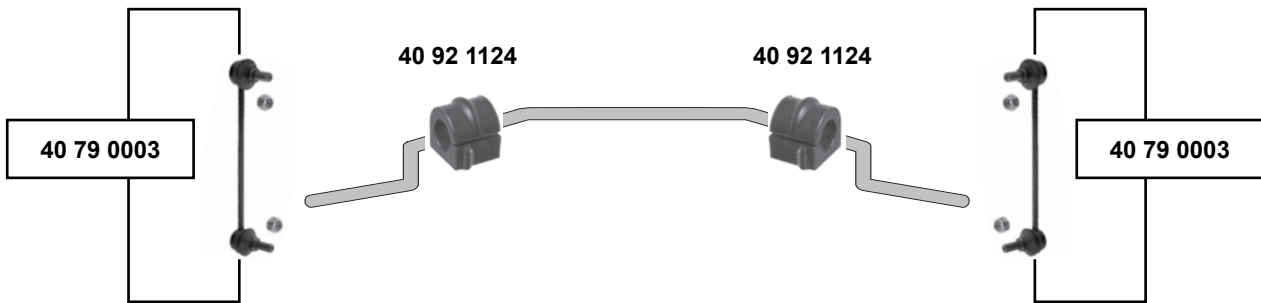
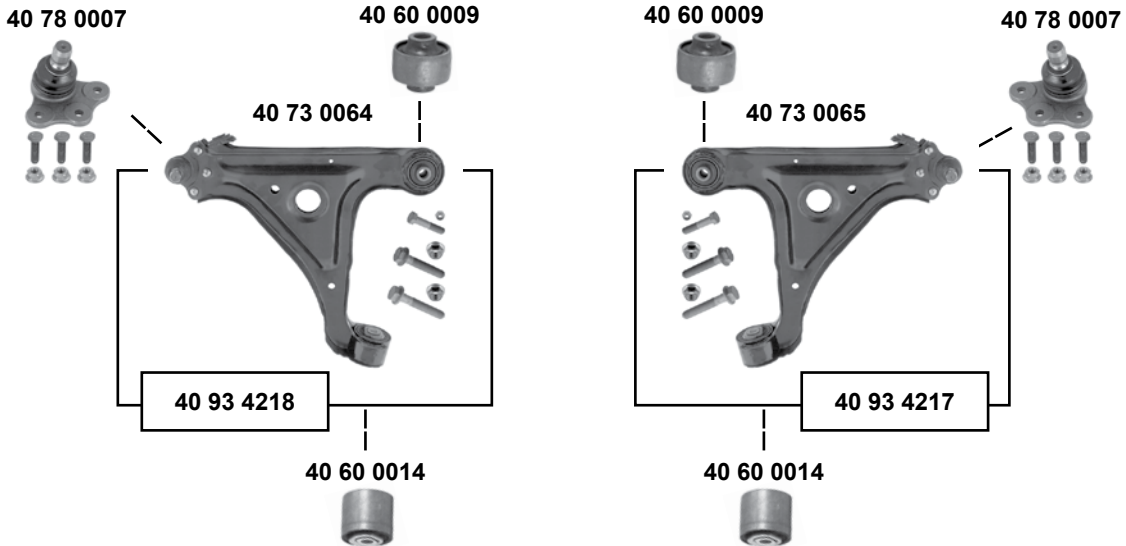

SWAG GERMANY	Ref. - No.			
40 60 0009	09156605	Querlenkerlager / control arm mount		14x49x45,5
40 60 0014	90576775	Querlenkerlager / control arm mount		14x58,5x56
40 73 0064	90576788	Querlenker / control arm		
40 73 0065	90576789	Querlenker / control arm		
40 78 0007	90512982	Traggelenk / ball joint	(ch.) → W 1172238	Ø A 18
40 79 0003	90445137	Verbindungsstange / connecting rod		L 225
40 92 1124	90445625	Stabilisatorlager / stabilizer mounting		Ø I 23
40 93 4217	90576789 S1	Rep. Satz Querlenker / rep. kit control arm		
40 93 4218	90576788 S1	Rep. Satz Querlenker / rep. kit control arm		



Royale

(1978 → 1987)

Vorderachse / Front axle

99 90 9158

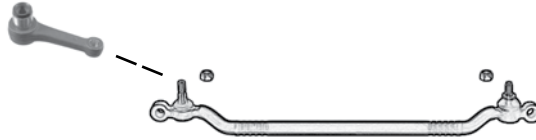

40 71 0018



40 71 0017



40 71 0017



40 71 0018

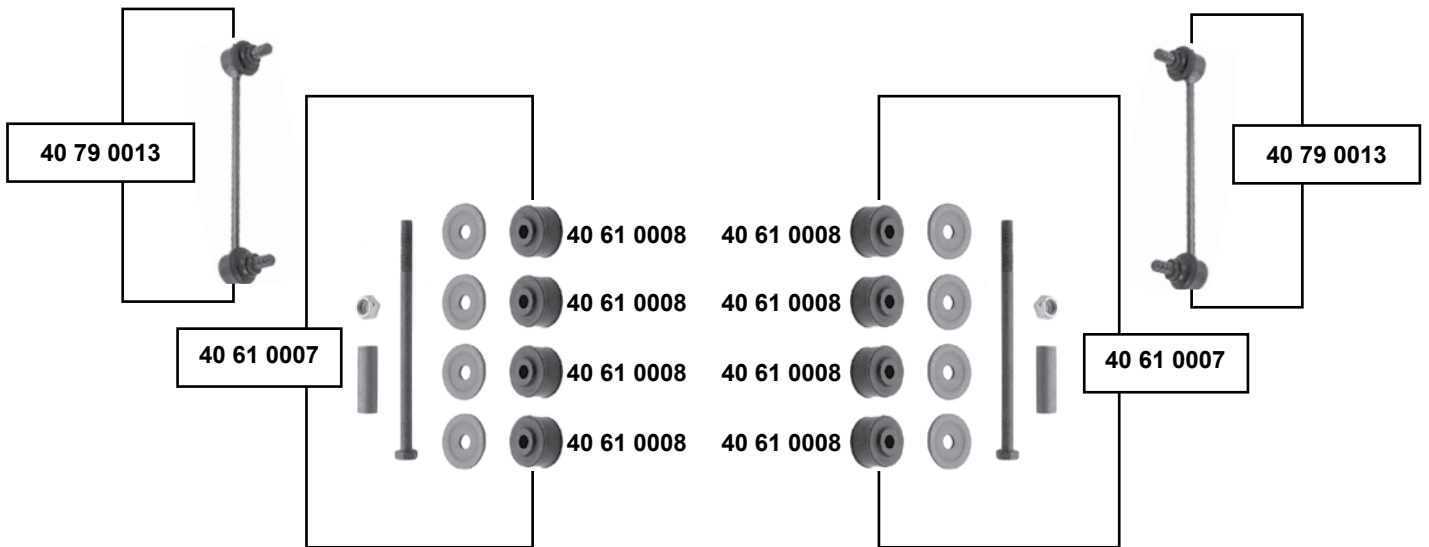

40 61 0007	90009369
40 61 0008	02875013
40 71 0017	90188428
40 71 0018	90188427
40 79 0013	90236577
99 90 9158	90092492

Rep. Satz Stabilisatorlager / rep. kit stabilizer mount
Verbindungsstangenlager / connecting rod bearing
Spurstangenendstück / tie rod end
Spurstangenendstück / tie rod end
Verbindungsstange / connecting rod
Lenkhebel / steering arm

8,5x30x19
M14x1,5 RHT
M14x1,5 LHT
L 195
L 121 Ø 18

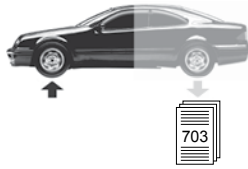

Senator Mk II

(1986 → 1994)

Vorderachse / Front axle

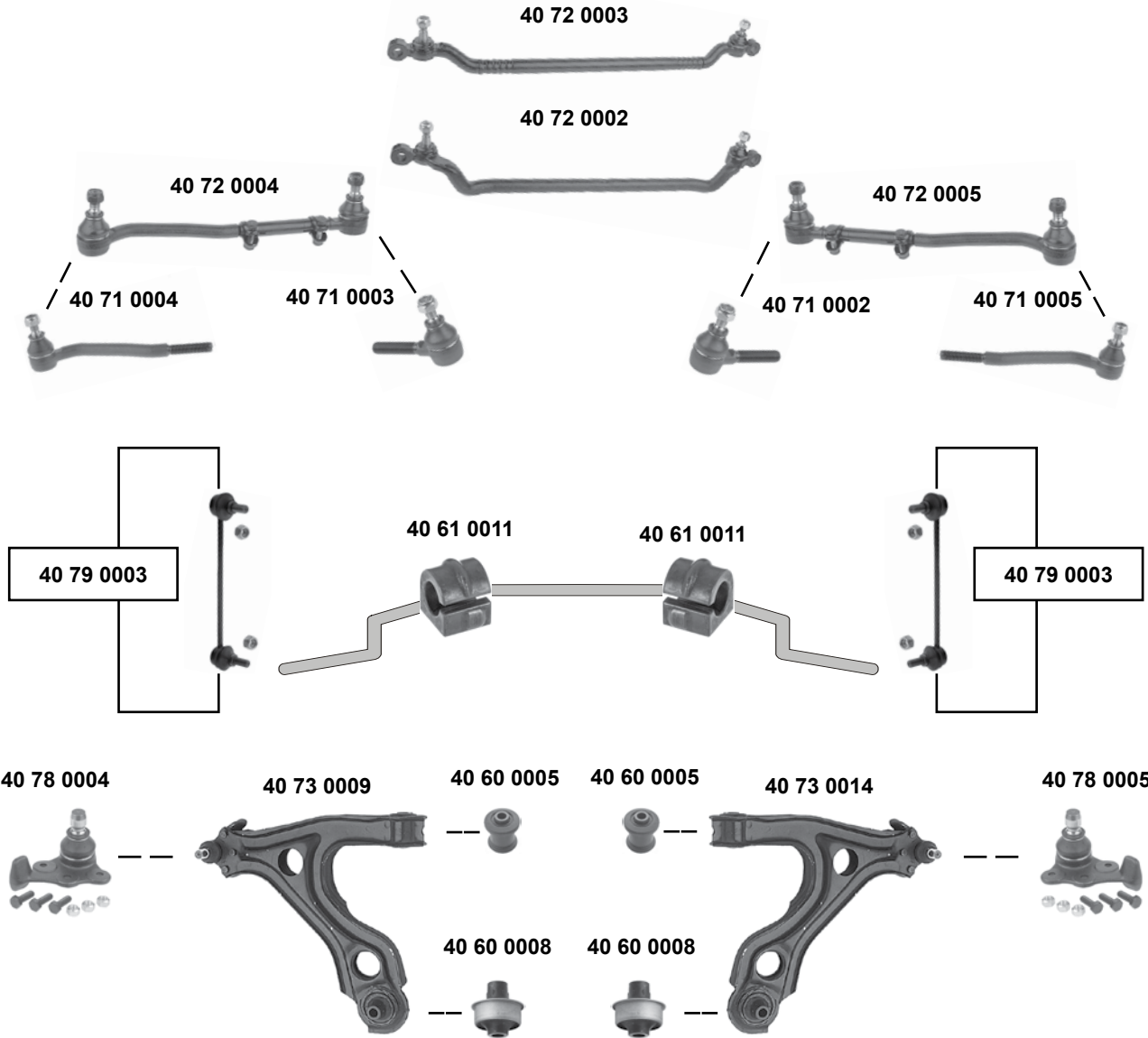

SWAG GERMANY	Ref. - No.			
40 60 0005	90279193	Querlenkerlager / control arm mount		12x41/47x60
40 60 0008	90373854	Querlenkerlager / control arm mount		16x60x69,5
40 61 0011	90278624	Stabilisatorlager / stabilizer mount		Ø I 22
40 71 0002	90510640	Spurstangenendstück / tie rod end	(ch.) H 1169261 →	M14x1,5 RHT
40 71 0003	90510639	Spurstangenendstück / tie rod end	(ch.) H 1169261 →	M14x1,5 LHT
40 71 0004	90510643	Spurstangenendstück / tie rod end	(ch.) H 1169261 →	M14x1,5 RHT
40 71 0005	90510644	Spurstangenendstück / tie rod end	(ch.) H 1169261 →	M14x1,5 LHT
40 72 0002	90369125	Spurstange / tie rod	LHD	L 572
40 72 0003	90392553	Spurstange / tie rod	LHD	L 572
40 72 0004	90510641	Spurstange / tie rod		L 347
40 72 0005	90510642	Spurstange / tie rod		L 347
40 73 0009	90288387	Querlenker / control arm		
40 73 0014	90288388	Querlenker / control arm		
40 78 0004	90272194	Traggelenk / ball joint		Ø A 18
40 78 0005	90272195	Traggelenk / ball joint		Ø A 18
40 79 0003	90445137	Verbindungsstange / connecting rod		L 225

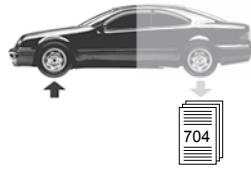

Signum (2002 → 2008)

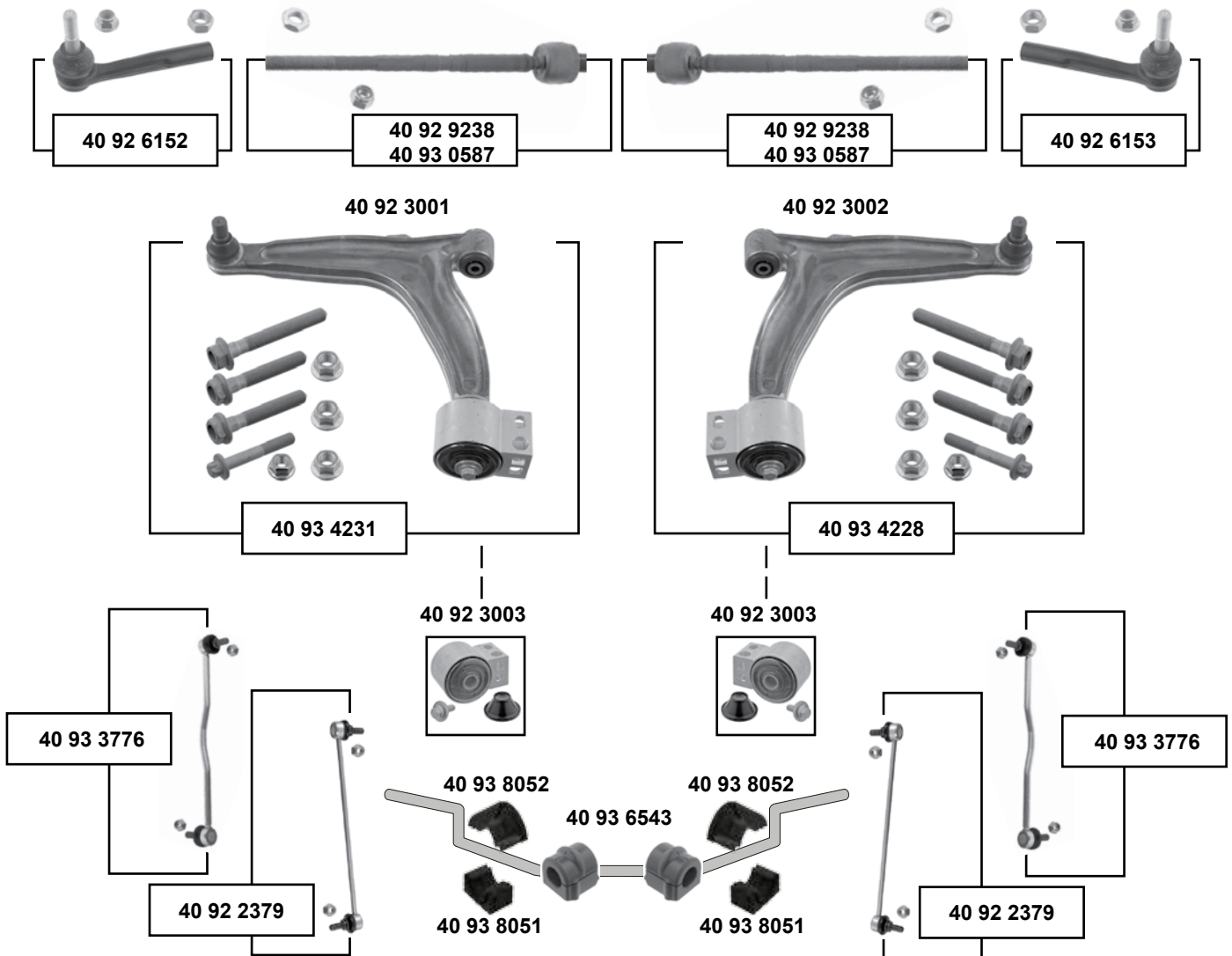

Vorderachse / Front axle

(1) 18" → (ch.) 41000001 → 61039489

(2) (ex.) IDS + alle/ all / IDS+ (ch.) → 31999999

(3) nur Fahrzeuge mit IDS + Fahrwerk / vehicles with IDS + chassis / (ch.) 41000001 →

(4) → 05 / (ch.) → 51999999 / für / to fit Stabi Ø A 25,2



Ref. - No.



Ref. - No.	Description	Notes	Dimensions
40 92 2379	Verbindungsstange / connecting rod	(2)	L 355
40 92 3001	Querlenker / control arm	Alu / alloy	
40 92 3002	Querlenker / control arm	Alu / alloy	
40 92 3003	Rep. Satz Querlenker / rep. kit control arm		
40 92 6152	Spurstangenendstück / tie rod end		M14 x 1,5
40 92 6153	Spurstangenendstück / tie rod end		M14 x 1,5
40 92 9238	Spurstange / tie rod	→ 17"	L 284
40 93 0587	Spurstange / tie rod	(1)	L 305
40 93 3776	Verbindungsstange / connecting rod	(3)	L.395
40 93 4228	Rep. Satz Querlenker rechts / rep. kit control arm right	(ex.) OPC / VXR	
40 93 4231	Rep. Satz Querlenker links / rep. kit control arm left	(ex.) OPC / VXR	
40 93 6543	Stabilisatorlager / stabilizer mount	(4)	
40 93 8051	Stabilisatorlager, unten / stabilizer mount, lower	(ch.) 61000001 →	Ø I 24
40 93 8052	Stabilisatorlager, oben / stabilizer mount, upper	(ch.) 61000001 →	Ø I 24



Tigra

(1994 → 2000)

(ch.) → V 3023597, V 4166925, V 6066279

Vorderachse / Front axle

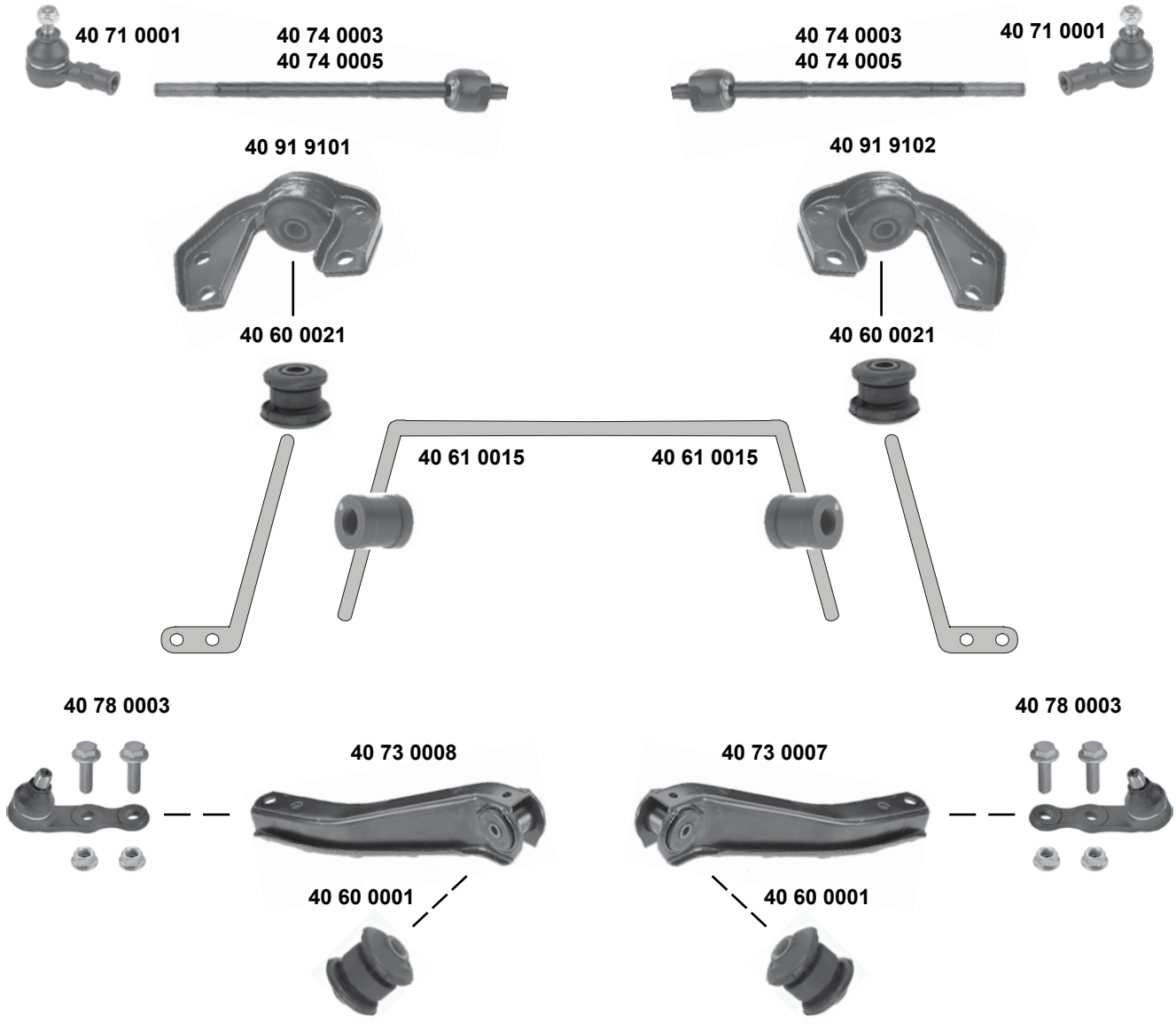

SWAG	Ref. - No.		i	
40 60 0001	90445097	Querlenkerlager / control arm mount		10x35x52
40 60 0021	90445098	Zugstrebenlager / tension rod mount		14x36/50x40
40 61 0015	90447946	Stabilisatorlager / stabilizer mount		Ø 21,5
40 71 0001	93192419	Spurstangenendstück / tie rod end		M12x1,5 RHT
40 73 0007	90511261	Querlenker / control arm		
40 73 0008	90511260	Querlenker / control arm		
40 74 0003	93192445 SK	Spurstange / tie rod		
40 74 0005	26032284	Spurstange / tie rod		
40 78 0003	90444294	Traggelenk / ball joint		
40 91 9101	90445100	Halter / retainer		
40 91 9102	90445101	Halter / retainer		

man. / E - servo
servo

L 325
L 290
Ø A 15



Tigra

(1994 → 2000)

(ch.) V 3023598, V 4166926, V 6066280 →

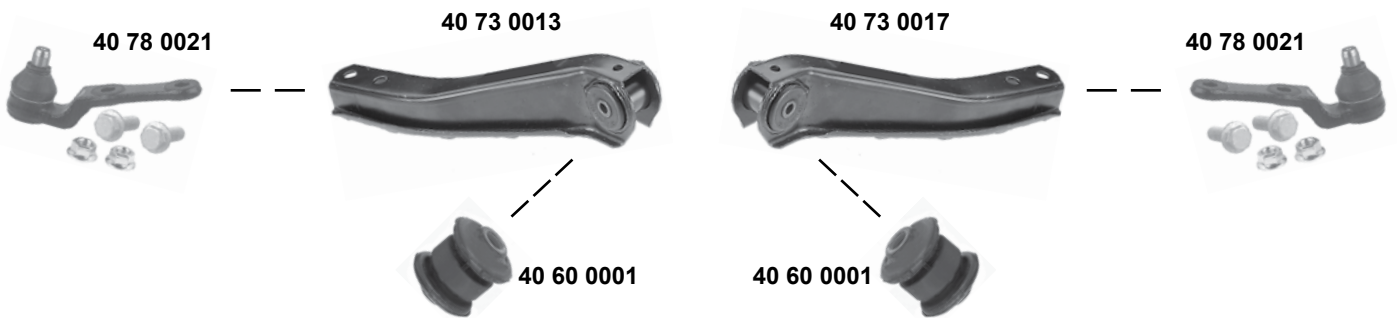
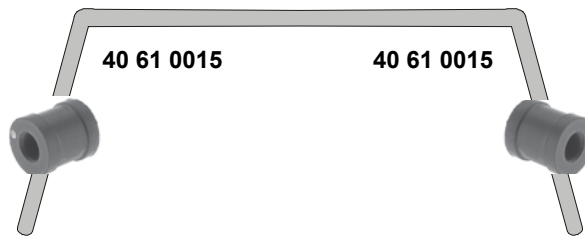

Vorderachse / Front axle

SWAG GERMANY	Ref. - No.			
40 60 0001	90445097	Querlenkerlager / control arm mount		10x35x52
40 61 0015	90447946	Stabilisatorlager / stabilizer mount		Ø 21,5
40 71 0024	93192446	Spurstangenendstück / tie rod end		M12x1,5 RHT
40 73 0013	90542572	Querlenker / control arm		
40 73 0017	90542573	Querlenker / control arm		
40 74 0003	93192445 SK	Spurstange / tie rod	man. / E - servo	L 325
40 74 0005	26032284	Spurstange / tie rod	servo	L 300
40 78 0021	90542574	Traggelenk / ball joint		Ø A 15



Tigra TwinTop
(2004 → 2009)

Vorderachse / Front axle

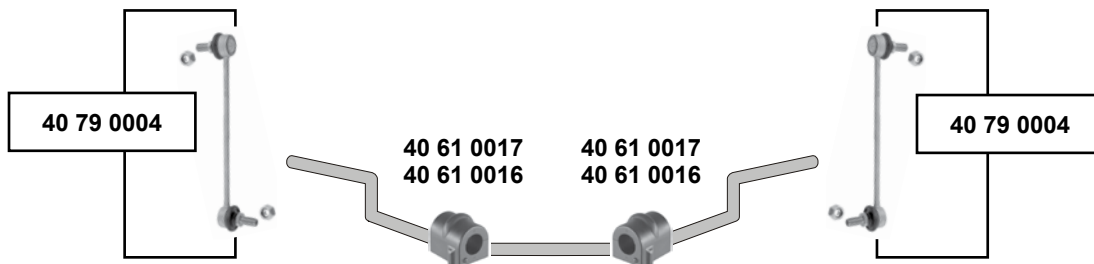
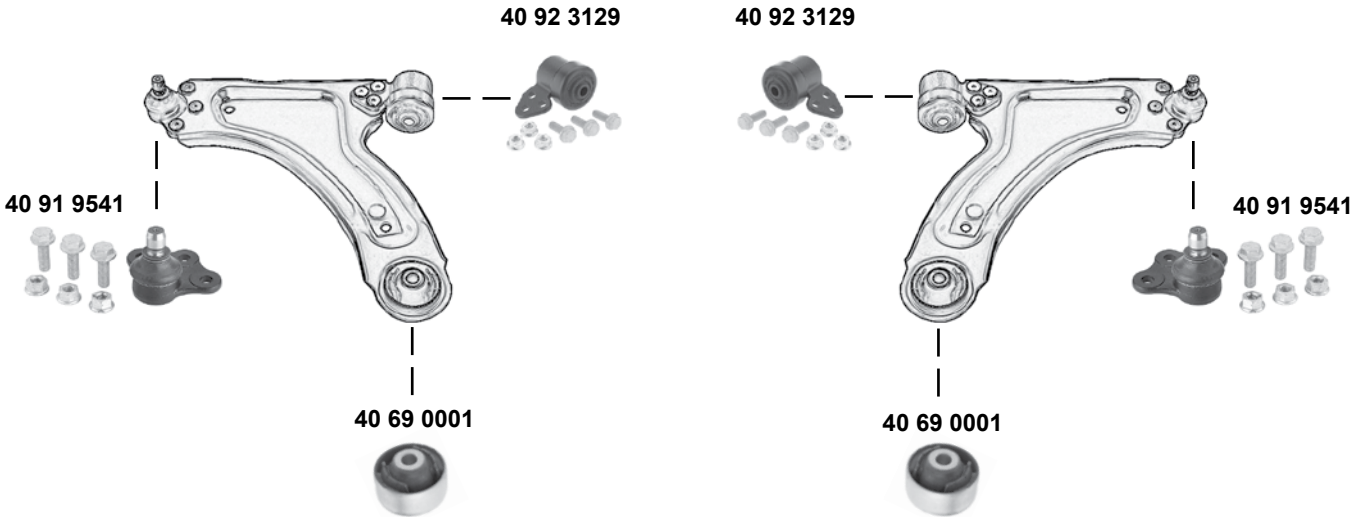

Ref. - No.



40 61 0016	90468567	Stabilisatorlager / stabilizer mounting		Ø I 16 Ø I 18 Ø A 59,5 M12 x 1,5 L 243,5
40 61 0017	90538865	Stabilisatorlager / stabilizer mounting		
40 69 0001	13138151	Querlenkerlager / control arm mount		
40 71 0001	93192419	Spurstangenendstück / tie rod end		
40 79 0004	90496116	Verbindungsstange / connecting rod		
40 91 9541	09196394	Traggelenk / ball joint		
40 92 3129	93188302	Querlenkerlager / control arm mount	(ch.) → 5E999999	

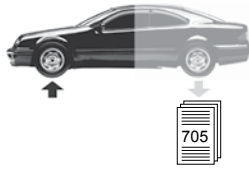

Vectra Mk I (1995 → 2002)

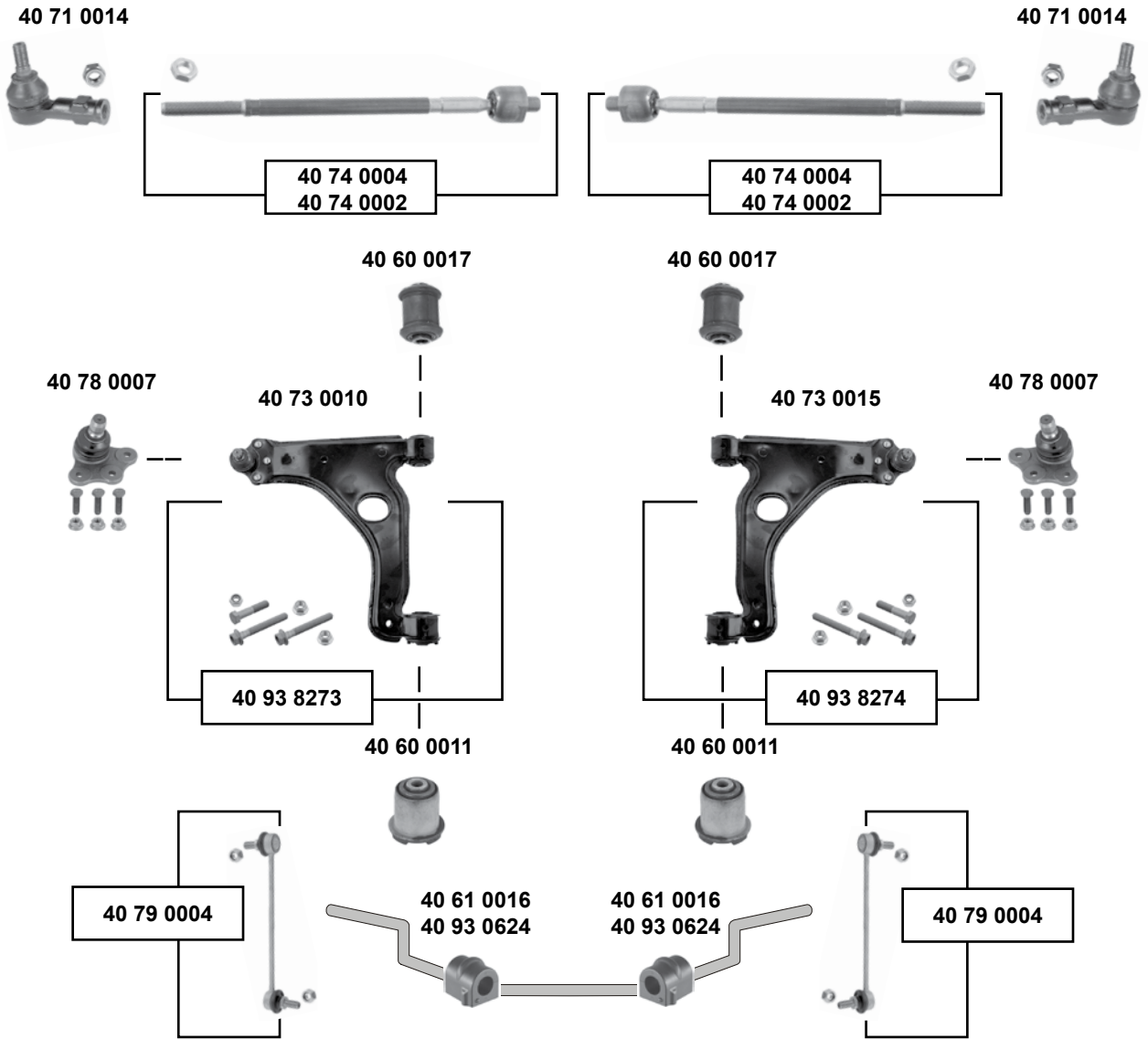

Vorderachse / Front axle



(1) (ch.) → W 1999999 / W 5999999 / W 7999999
(ch.) XL 000001 → XL 999999

(2) (ex.) Sport (ch.) X 1000001, X 7000001 YL 000001 → // Sport (ch.) Y 1000001, Y 7000001 →



Ref. - No.



Ref. - No.	Description	Notes	Dimensions
40 60 0011	Querlenkerlager / control arm mount		12x47,5x60
40 60 0017	Querlenkerlager / control arm mount		12x36,5x60
40 61 0016	Stabilisatorlager / stabilizer mount		Ø I 16
40 71 0014	Spurstangenendstück / tie rod end		M14 x 1,5
40 73 0010	Querlenker / control arm		
40 73 0015	Querlenker / control arm		
40 74 0002	Spurstange / tie rod		L 360
40 74 0004	Spurstange / tie rod	servo ZF servo Saginaw	L 360
40 78 0007	Traggelenk / ball joint		Ø A 18
40 79 0004	Verbindungsstange / connecting rod		L 243,5
40 93 0624	Stabilisatorlager / stabilizer mount		Ø I 17
40 93 8273	Rep. Satz Querlenker / rep. kit control arm	(1) (ex.) Sport	
40 93 8274	Rep. Satz Querlenker / rep. kit control arm	(2)	

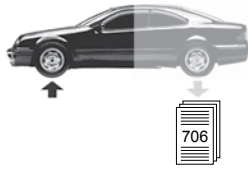

Vectra Mk II

(2002 → 2008)

Vorderachse / Front axle

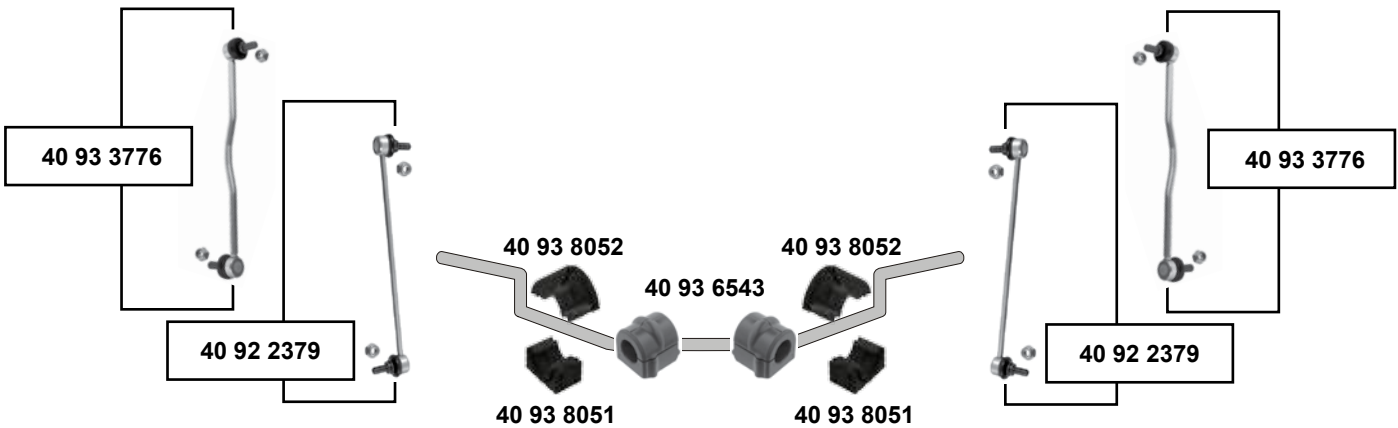
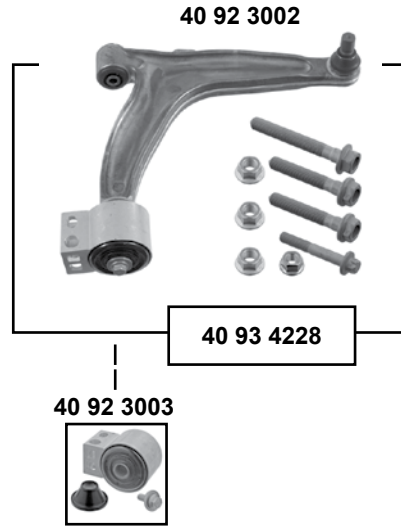
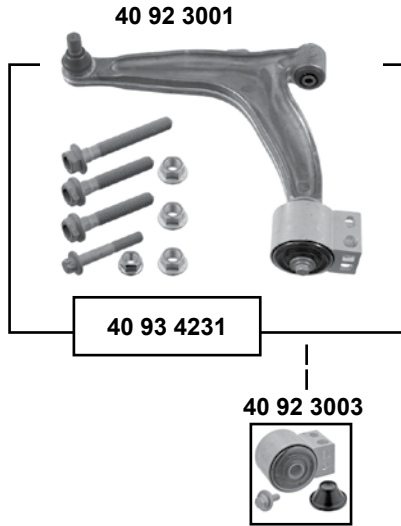
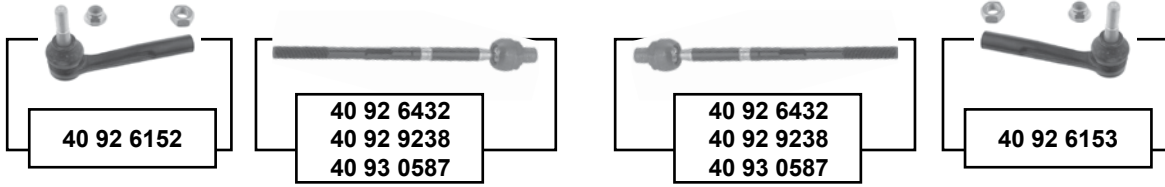

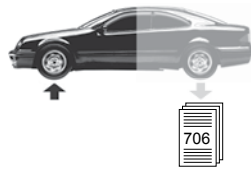
Vectra Mk II
 (2002 → 2008)

	(1) Limousine: → 17" / (ch.) 31032141, 3804656 → Caravan : → 17" alle / all	(3) Limousine: 18" → / (ch.) → 61039489 Caravan : 18" → alle / all
	(2) → (ch.) 31032140, 38040655 / (ex.) Caravan	(4) (ex.) IDS+ alle/ all // IDS+ (ch.) → 31999999, 38999999 / Caravan: → 17"
	(5) nur Fahrzeuge mit IDS + Fahrwerk / vehicles with IDS +chassis only / (ch.) 41000001,48000001 →	
	(6) → 05 / (ch.) → 410105077, 48008980 → 05 / (ch.) 41010578 → 51999999, 48008981 → 58999999 / (ex.) HD	

	Ref. - No.			
40 92 2379	13237130	Verbindungsstange / connecting rod	(4)	L 355
40 92 3001	24413015	Querlenker / control arm	Alu / alloy	
40 92 3002	24413016	Querlenker / control arm	Alu / alloy	
40 92 3003	93171448	Rep. Satz Querlenker / rep. kit control arm		
40 92 6152	93172254	Spurstangenendstück / tie rod end		M14 x 1,5
40 92 6153	93172255	Spurstangenendstück / tie rod end		M14 x 1,5
40 92 6432	93191671 SK	Spurstange / tie rod	(2)	L 300
40 92 9238	93191672 SK	Spurstange / tie rod	(1)	L 300
40 93 0587	93191673 SK	Spurstange / tie rod	(3)	L 305
40 93 3776	13116332	Verbindungsstange / connecting rod	(5)	L 395
40 93 4228	24413016 S1	Rep. Satz Querlenker rechts / rep. kit control arm right	(ex.) OPC / VXR	
40 93 4231	24413015 S1	Rep. Satz Querlenker links / rep. kit control arm left	(ex.) OPC / VXR	
40 93 6543	09191188	Stabilisatorlager / stabilizer mount	(6)	Ø 23,3
40 93 8051	13204071	Stabilisatorlager, unten / stabilizer mount, lower	(ch.) 61000001 →	Ø 24
40 93 8052	13204070	Stabilisatorlager, oben / stabilizer mount, upper	(ch.) 61000001 →	Ø 24



Viceroy

(1980 → 1982)

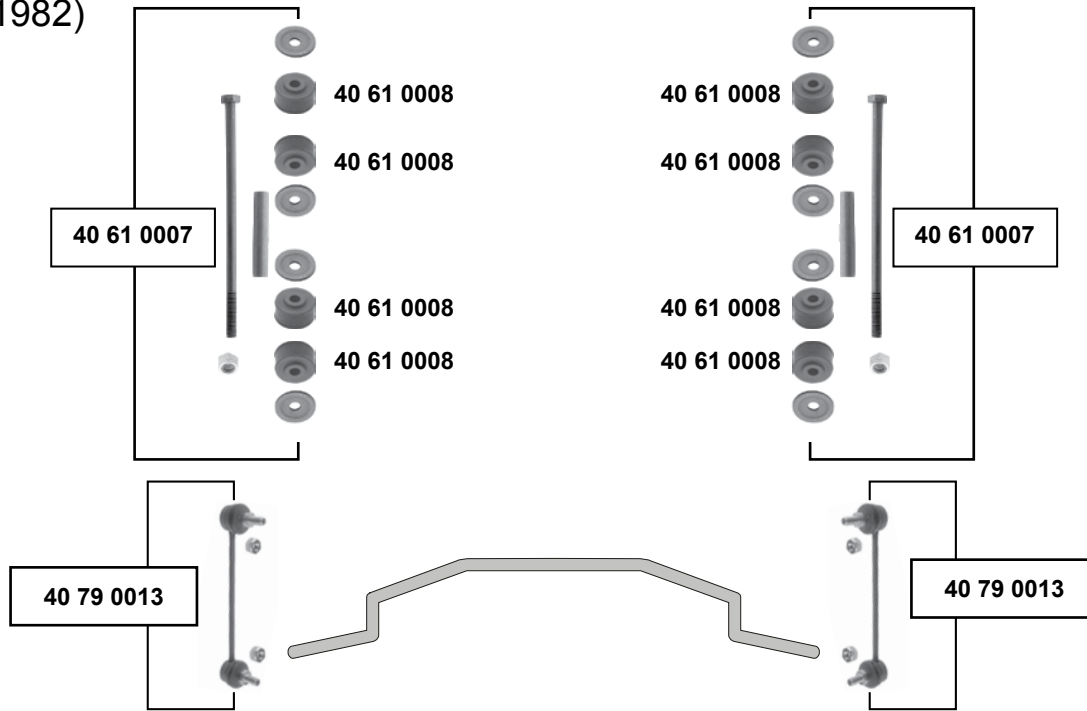

Vorderachse / Front axle

Vivaro A

(2001 → 2014)

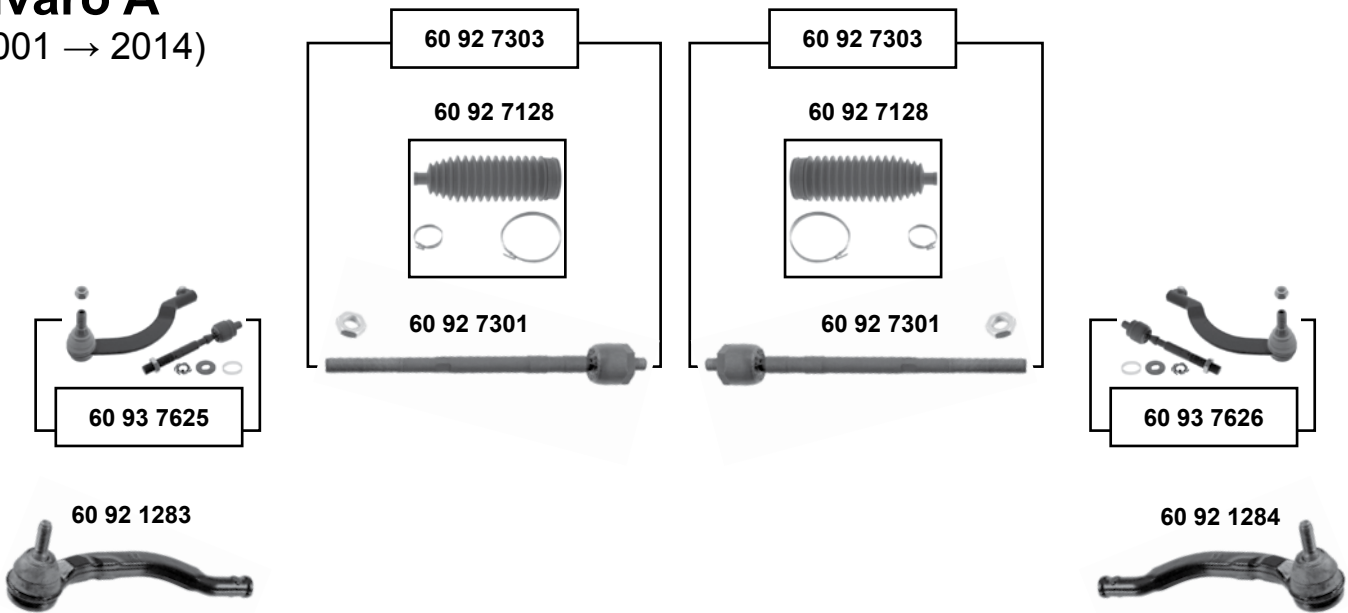

SWAG GERMANY	Ref. - No.			
40 61 0007	90009369	Rep. Satz Stabilisatorlager / rep. kit stabilizer		
40 61 0008	02875013	Verbindungsstangenlager / connecting rod bearing		8,5x30x19
40 79 0013	90236577	Verbindungsstange / connecting rod		L 195
60 92 1283	91160043	Spurstangenendstück / tie rod end		L 230
60 92 1284	91160044	Spurstangenendstück / tie rod end		L 230
60 92 7128	91160038	Lenkmanschettensatz / steering boot set		L 205
60 92 7301	91160037 SK	Spurstange / tie rod		L 245
60 92 7303	91160037	Rep. Satz Spurstange / rep. kit tie rod		L 245
60 93 7625	09161561 S1	Spurstange / tie rod		
60 93 7626	09161561 S2	Spurstange / tie rod		



Vivaro A (2001 → 2014)

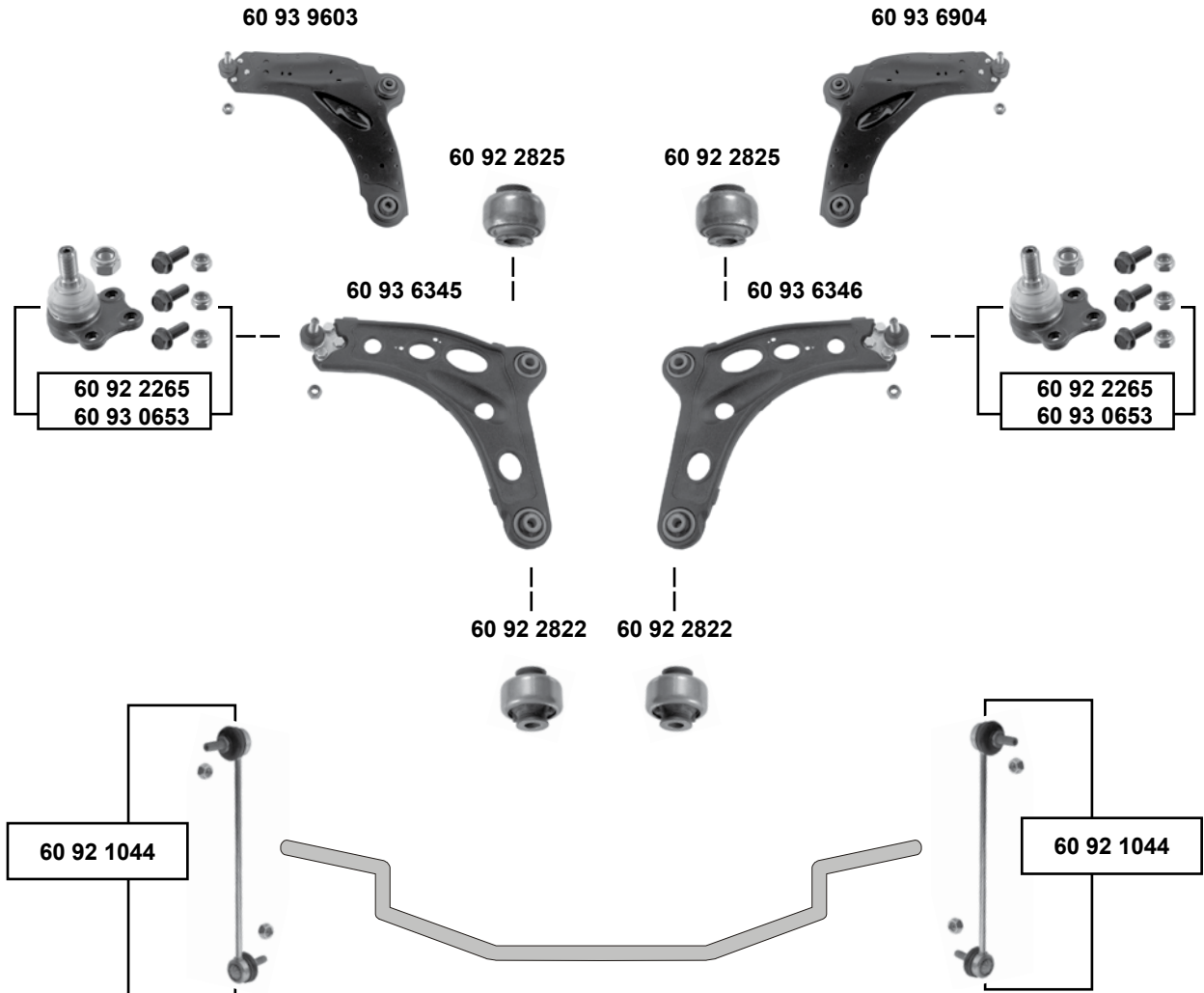

(1) (ch.) C 7V621198, C 7V721613 →

(3) 07 → / (ch.) 7V600001 → / 7Y000001 →

(2) (ch.) → C 7V621197, C 7V721612

(4) Blech / metal sheet ; → (ch.) 6V999999, 6Y699999



Ref. - No.



60 92 1044	93858917	Verbindungsstange / connecting rod		L 280
60 92 2265	93196923	Traggelenk / ball joint	(2)	Ø I 10
60 92 2822	93858141 SK3	Querlenkerlager / control arm mount		Ø A 58
60 92 2825	93858141 SK2	Querlenkerlager / control arm mount		Ø A 55
60 93 0653	93161884	Traggelenk / ball joint	(1)	Ø I 12
60 93 6345	93862136	Querlenker / control arm	(3)	
60 93 6346	93862135	Querlenker / control arm	(3)	
60 93 9603	93858141	Querlenker / control arm	(4)	
60 93 6904	93858142	Querlenker / control arm	(4)	





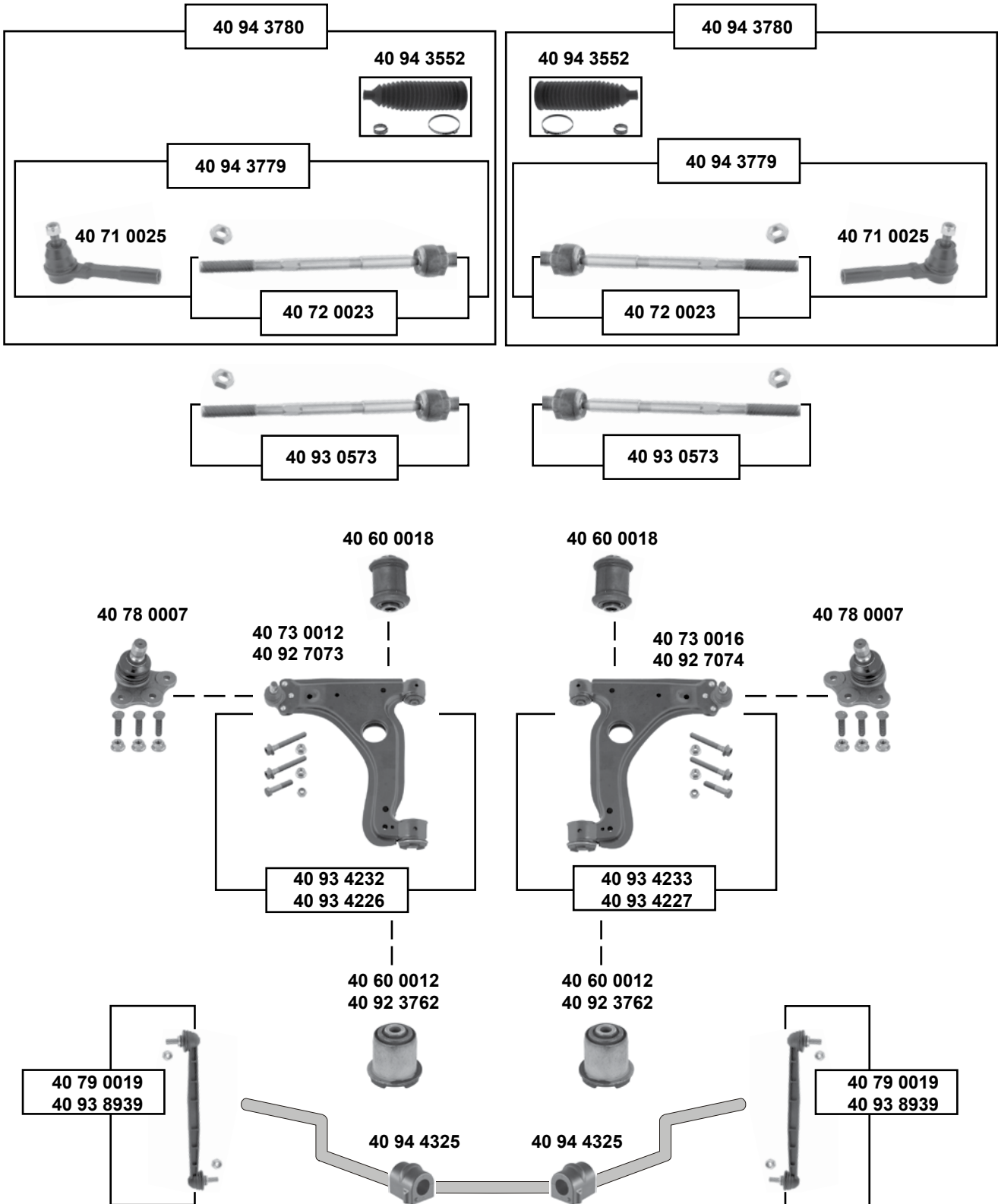

Zafira Mk I (1998 → 2005)

Vorderachse / Front axle



Zafira Mk I
 (1998 → 2005)



(1) Nur für TRW-Lenkung / TRW-steering only

	Ref. - No.			
40 60 0012	90498740	Querlenkerlager / control arm mount	(ch.) → 42125089	12x45/48x60
40 60 0018	90498738	Querlenkerlager / control arm mount	(ch.) 42125090, 4G000001 →	12x36,5x60
40 71 0025	93186537	Spurstangenendstück / tie rod end		M14x1,5 RHT
40 72 0023	26059293	Spurstange / tie rod		L 300
40 73 0012	90498735	Querlenker / control arm	(ch.) → 42125089	
40 73 0016	90498736	Querlenker / control arm	(ch.) → 42125089	
40 78 0007	90512982	Traggelenk / ball joint	(ch.) 42125090, 4G000001 →	Ø A 18
40 79 0019	13169439	Verbindungsstange / connecting rod	OLD	L 300
40 92 3762	24439582	Querlenkerlager / control arm mount	(ch.) 42125090 →	12x46x603
40 92 7073	24454477	Querlenker / control arm	(ch.) 42125090, 4G000001 →	
40 92 7074	22454478	Querlenker / control arm	(mot.) Z 2,0 LET	L 304
40 93 0573	93191529 SK	Spurstange / tie rod	(ch.) → 42125089	
40 93 4226	90498735 S1	Rep. Satz Querlenker / rep. kit control arm	(ch.) → 42125089	
40 93 4227	90498736 S1	Rep. Satz Querlenker / rep. kit control arm	(ch.) 42125090, 4G000001 →	
40 93 4232	24454477 S1	Rep. Satz Querlenker / rep. kit control arm	(ch.) 42125090, 4G000001 →	
40 93 4233	24454478 S1	Rep. Satz Querlenker / rep. kit control arm	NEW	L 350
40 93 8939	13327928	Verbindungsstange / connecting rod	(1)	L 211
40 94 3552	1609 356	Lenkmanschettensatz / steering boot set	(1)	M18 x 1,5
40 94 3779	93191526 S5	Spurstange / tie rod	(1)	M18 x 1,5
40 94 3780	93191526 S6	Spurstange / tie rod	(1)	Ø1 24
40 94 4325	0350 093	Stabilisatorlager / stabilizer mount	(1)	

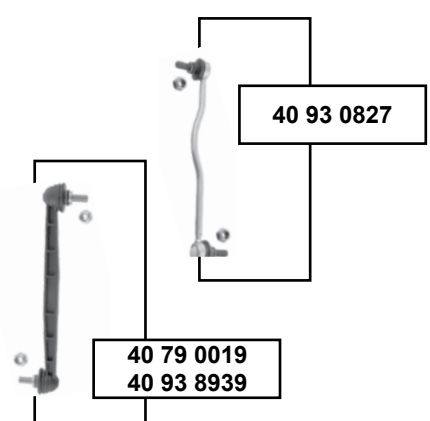
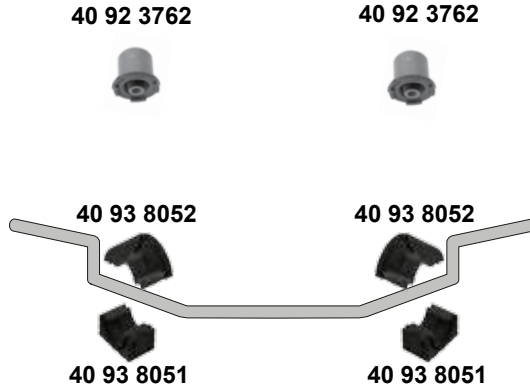
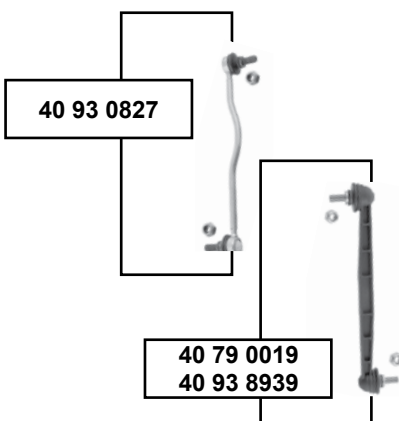
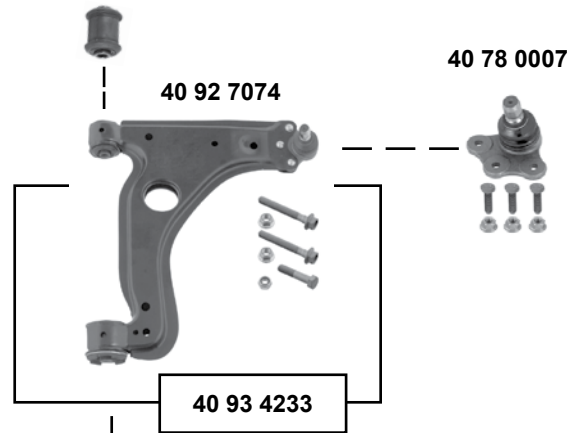
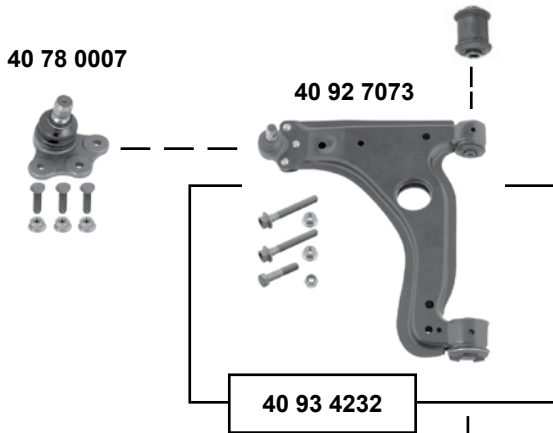
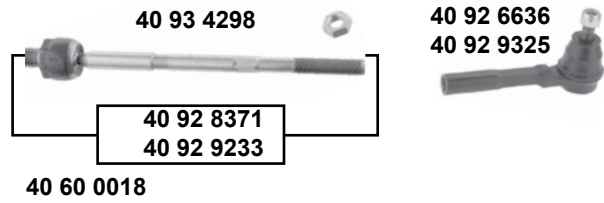
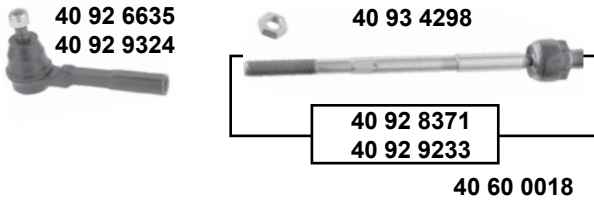
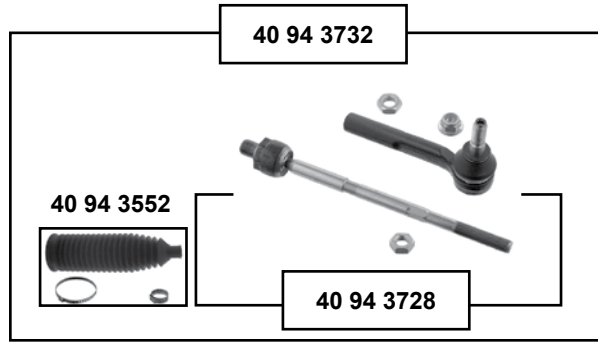
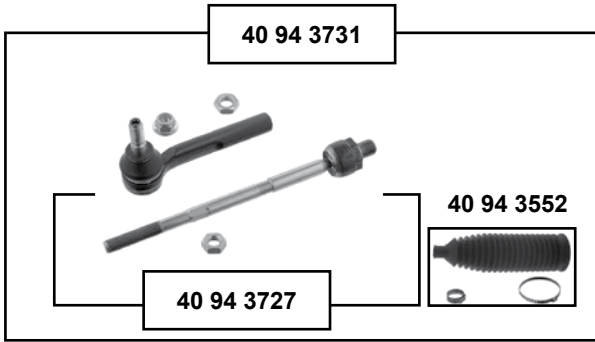

Zafira Mk II (2005 → 2011)

Vorderachse / Front axle



Zafira Mk II
 (2005 → 2011)

- | | | |
|--|---|---|
| | (1) servo TRW // Z1,6 XEP, XER, XE1 alle/ all
Z1,8 XER (ex.) ESP | (2) Fahrzeuge mit TRW 2. Generation Lenkung /
vehicles with TRW 2. generation steering |
| | (3) servo ZF, (ex.) 18" / (mot.) Y 1,6YNG / Z16YNG / Z16XNT / A16XNT / Z 1,7 DTR / Z17DTJ / A17DTJ / A17DTR / Z 1,8 XER / A18XER / Z 1,9 DT / Z 1,9 DTL / Z 1,9 DTH / Z 2,0 LER / Z 2,0 LEH | |
| | (4) Nur für TRW-Lenkung / TRW-steering only // (ch.) 72095157- (ch.) 7G066982- | |
| | (5) Z1,6 XEP, XER, XE1, A16XER alle/ all // Z1,8XER, A18XER (ex.) ESP | |
| | (6) (ch.) 72095157 - , (ch.) 7G066982 - Z1,6 XEP, XER, XE1, A16XER alle/ all // Z1,8XER, A18XER (ex.) ESP | |



Ref. - No.



SWAG Ref. - No.	Description	Notes	Dimensions
40 60 0018	90498738	Querlenkerlager / control arm mount	12x36,5x60
40 78 0007	90512982	Traggelenk / ball joint	Ø A 18
40 79 0019	13169439	Verbindungsstange / connecting rod	L 300
40 92 3762	24439582	Querlenker / control arm	12x46x60
40 92 6635	93181232	Spurstangenendstück / tie rod end	M14 x 1,5
40 92 6636	93181233	Spurstangenendstück / tie rod end	M14 x 1,5
40 92 7073	24454477	Querlenker / control arm	
40 92 7074	22454478	Querlenker / control arm	
40 92 8371	93189669 SK	Spurstange / tie rod	L 279
40 92 9233	93189670 SK	Spurstange / tie rod	L 279
40 92 9324	93186333	Spurstangenendstück / tie rod end	M14 x 1,5
40 92 9325	93186332	Spurstangenendstück / tie rod end	M14 x 1,5
40 93 0827	24461353	Verbindungsstange / connecting rod	
40 93 4232	24454477 S1	Rep. Satz Querlenker links / rep. kit control arm left	
40 93 4233	24454478 S1	Rep. Satz Querlenker rechts / rep. kit control arm right	
40 93 4298	93191521 SK	Spurstange / tie rod	
40 93 8051	13204071	Stabilisatorlager, unten / stabilizer mount, lower	Ø I 24
40 93 8052	13204070	Stabilisatorlager, oben / stabilizer mount, upper	Ø I 24
40 93 8939	13327928	Verbindungsstange / connecting rod	L 350
40 94 3552	93191260	Lenkmanschettensatz / steering boot set	L 211
40 94 3727	93191526 S1	Spurstange / tie rod	M18 x 1,5
40 94 3728	93191526 S2	Spurstange / tie rod	M18 x 1,5
40 94 3731	93191526 S3	Spurstange / tie rod	M18 x 1,5
40 94 3732	93191526 S4	Spurstange / tie rod	M18 x 1,5



Zafira Mk III
(2012 →)

Vorderachse / Front axle

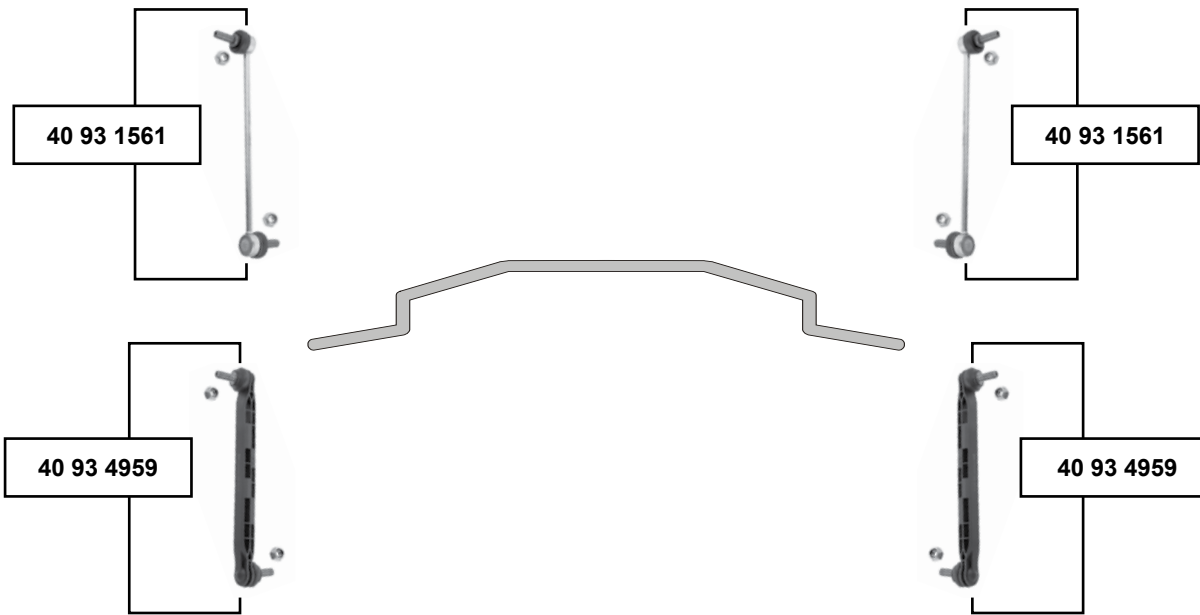
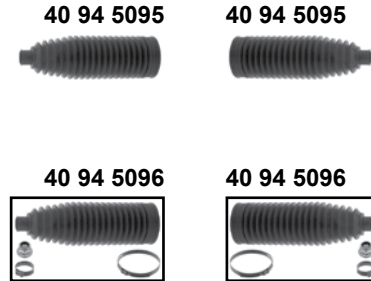

(1) Für Fahrzeuge mit Flexride Fahrwerk (aktives Fahrwerk) / for vehicles with flexride chassis only

(2) alle (ex.) Flexride Fahrwerk / all (ex.) flexride chassis



Ref. - No.



40 93 1561	13258052
40 93 4959	13219141
40 94 5095	13354440 SK1
40 94 5096	13354440

Verbindungsstange / connecting rod
Verbindungsstange / connecting rod
Lenkmanschette / steering rack boot
Lenkmanschettensatz / steering boot set

(1)
(2)
E - servo
E - servo

L 303,5
L 304



Amarok (2H) (2010 →)

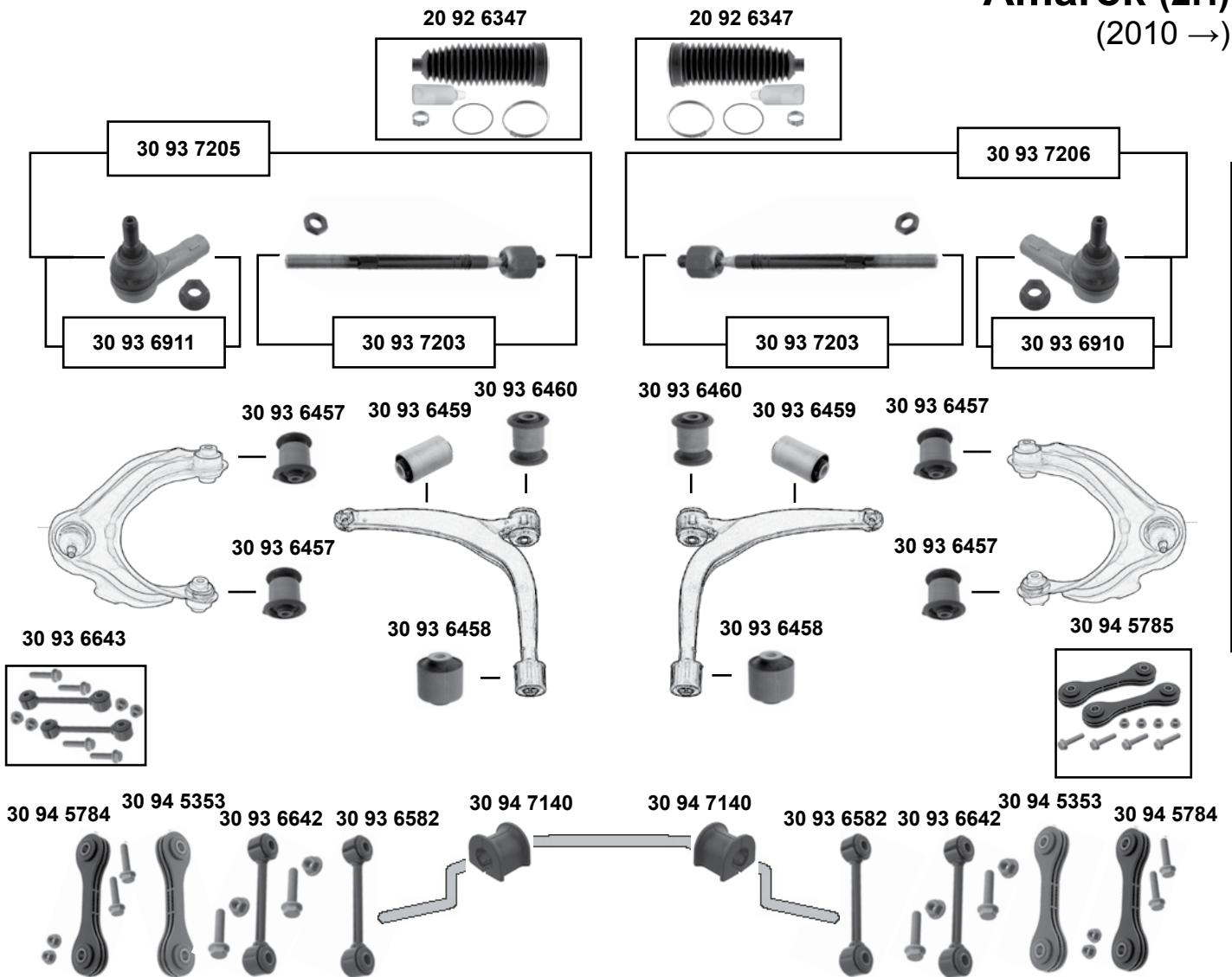

Vorderachse / Front axle

- (1)** Amarok / 4 motion 2H (mot.) CDBA, CDCA, CFPA, CNEA, CNFA, CSHA 03/12 →
Amarok / 4 motion (S1B) alle / all // Amarok / 4 motion 2H (mot.) CNFB
- (2)** (mot.) CNFB, CFPA, CNEA, CSHA, CDBA, CNFA, CUBA → 06/2015 // (mot.) CDCA

SWAG GERMANY	Ref. - No.			
20 92 6347	7L0 422 831 A S1	Rep. Satz Lenkmanschette / rep. kit steering boot		
30 93 6457	2H0 407 077 A	Querlenkerlager / control arm mount		Ø A 60
30 93 6458	2H0 407 182 A	Querlenkerlager / control arm mount		Ø A 60 H 64,5
30 93 6459	2H0 412 333 A	Querlenkerlager / control arm mount		Ø I 14,3 H84,2
30 93 6460	2H0 407 183 A	Querlenkerlager / control arm mount		Ø A 60 H 60
30 93 6582	2H0 411 317	Verbindungsstange / connecting rod	→ 03/12	Ø I 12,02
30 93 6642	2H0 411 317 S1	Rep. Satz Verbindungsstange / rep. kit connecting rod	→ 03/12	L 180
30 93 6643	2H0 411 317 S2	Verbindungsstangensatz / connecting rod set	→ 03/12	L 180
30 93 6910	7L0 422 818 D	Spurstangenendstück / tie rod end		M16 x 1,5
30 93 6911	7L0 422 817 D	Spurstangenendstück / tie rod end		M16 x 1,5
30 93 7203	7L0 422 810 D	Rep. Satz Axialgelenk / rep. kit axial joint		L 320
30 93 7205	7L0 422 803 D	Rep. Satz Spurstange / rep. kit tie rod		L 434
30 93 7206	7L0 422 804 D	Rep. Satz Spurstange / rep. kit tie rod		L 434
30 94 5353	2H0 411 317 B	Verbindungsstange / rep. kit connecting rod	(1)	
30 94 5784	2H0 411 317 B S1	Verbindungsstange / rep. kit connecting rod	(1)	
30 94 5785	2H0 411 317 B S2	Verbindungsstangensatz / connecting rod set	(1)	
30 94 7140	2H0 411 313 C	Stabilisatorlager / stabilizer mount	(2)	

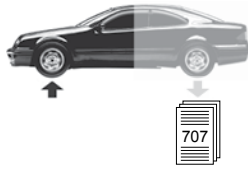

Bora (1J) (1999 → 2005)

Vorderachse / Front axle

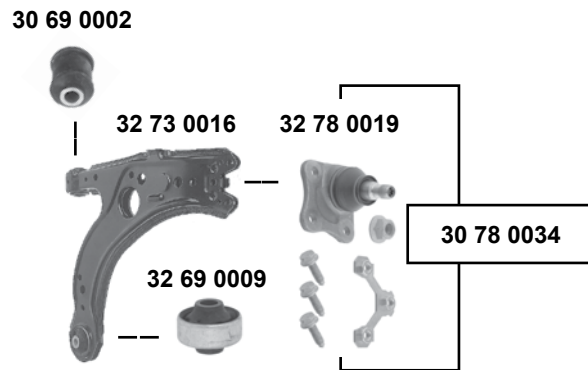
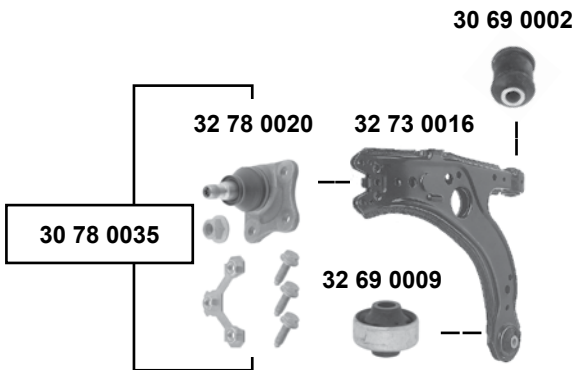
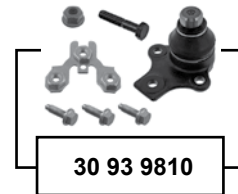
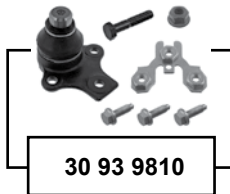
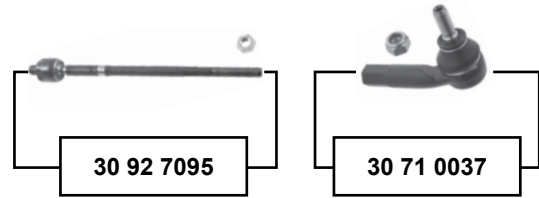
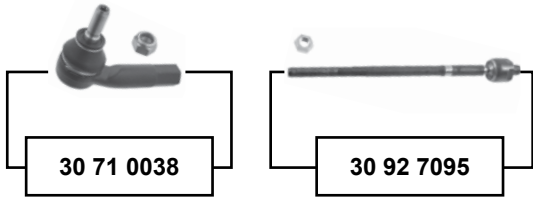
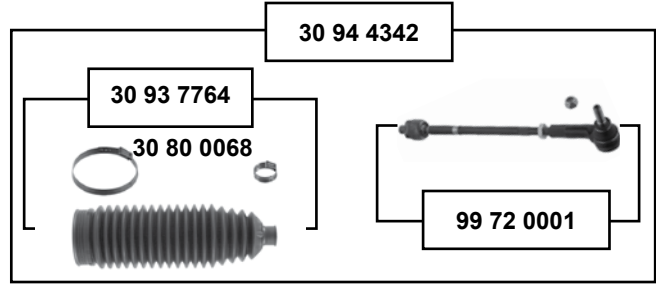
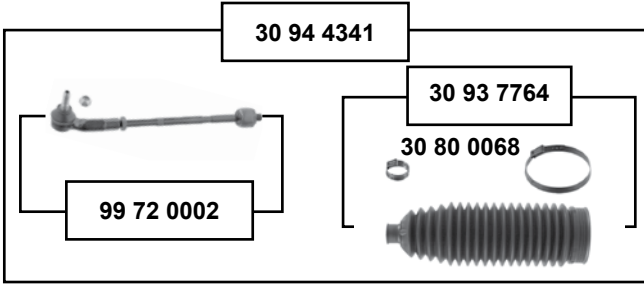

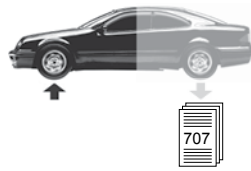
Bora (1J)
 (1999 → 2005)

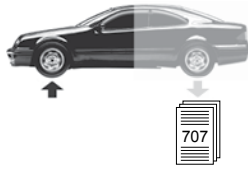

- (1) Bora (**mot.**) AEH, AGN, AGP, AGR, AGU, AGZ, AHF, AHW, AJM, AKL, AKQ, ALH, APE, APF, APK, AQM, AQN, AQP, AQY, ARL, ARX, ASV, ASZ, ATD, ATN, AUE, AUM, AUQ, AUS, AUJ, AVH, AVU, AXP, AXR, AZD, AZG, AZH, AZJ, BAD, BCA, BCB, BFQ
 Bora Variant, Bora 4 motion, Bora Variant 4 motion **alle / all**
- (2) Bora Variant 4 motion (**mot.**) ARX 00 → 01

	Ref. - No.			
30 69 0002	357 407 182	Querlenkerlager / control arm mount		12x33x54
30 71 0037	1J0 422 812 B	Spurstangenendstück / tie rod end		M14 x 1,5
30 71 0038	1J0 422 811 B	Spurstangenendstück / tie rod end		M14 x 1,5
30 78 0034	1J0 407 366 H S1	Rep. Satz Traggelenk / rep. kit ball joint		
30 78 0035	1J0 407 365 H S1	Rep. Satz Traggelenk / rep. kit ball joint		
30 80 0068	1J0 422 831 B	Lenkmanschette / steering boot	(ex.) R32	
30 92 7095	1J0 422 810 B	Axialgelenk / axial joint		L 321
30 93 7764	1J0 422 831 B S1	Rep. Satz Lenkmanschette / rep. kit steering boot	ZF	
30 93 9810	357 407 365 S2	Rep. Satz Traggelenk / rep. kit ball joint	(2)	
30 94 4341	1J0 422 803 H S1	Spurstange / tie rod	(1)	12 x 1,5
30 94 4342	1J0 422 804 H S1	Spurstange / tie rod	(1)	12 x 1,5
32 69 0009	1J0 407 181	Querlenkerlager / control arm mount		13x60x41
32 71 0010	1J0 422 812 A	Spurstangenendstück / tie rod end		M14 x 1,5
32 71 0011	1J0 422 811 A	Spurstangenendstück / tie rod end		M14 x 1,5
32 73 0016	1J0 407 151 C	Querlenker / control arm		
32 78 0019	1J0 407 366 H	Traggelenk / ball joint		M12 x 1,5
32 78 0020	1J0 407 365 H	Traggelenk / ball joint		M12 x 1,5
99 72 0001	1J0 422 804 H	Spurstange / tie rod	ZF	
99 72 0002	1J0 422 803 H	Spurstange / tie rod	ZF	

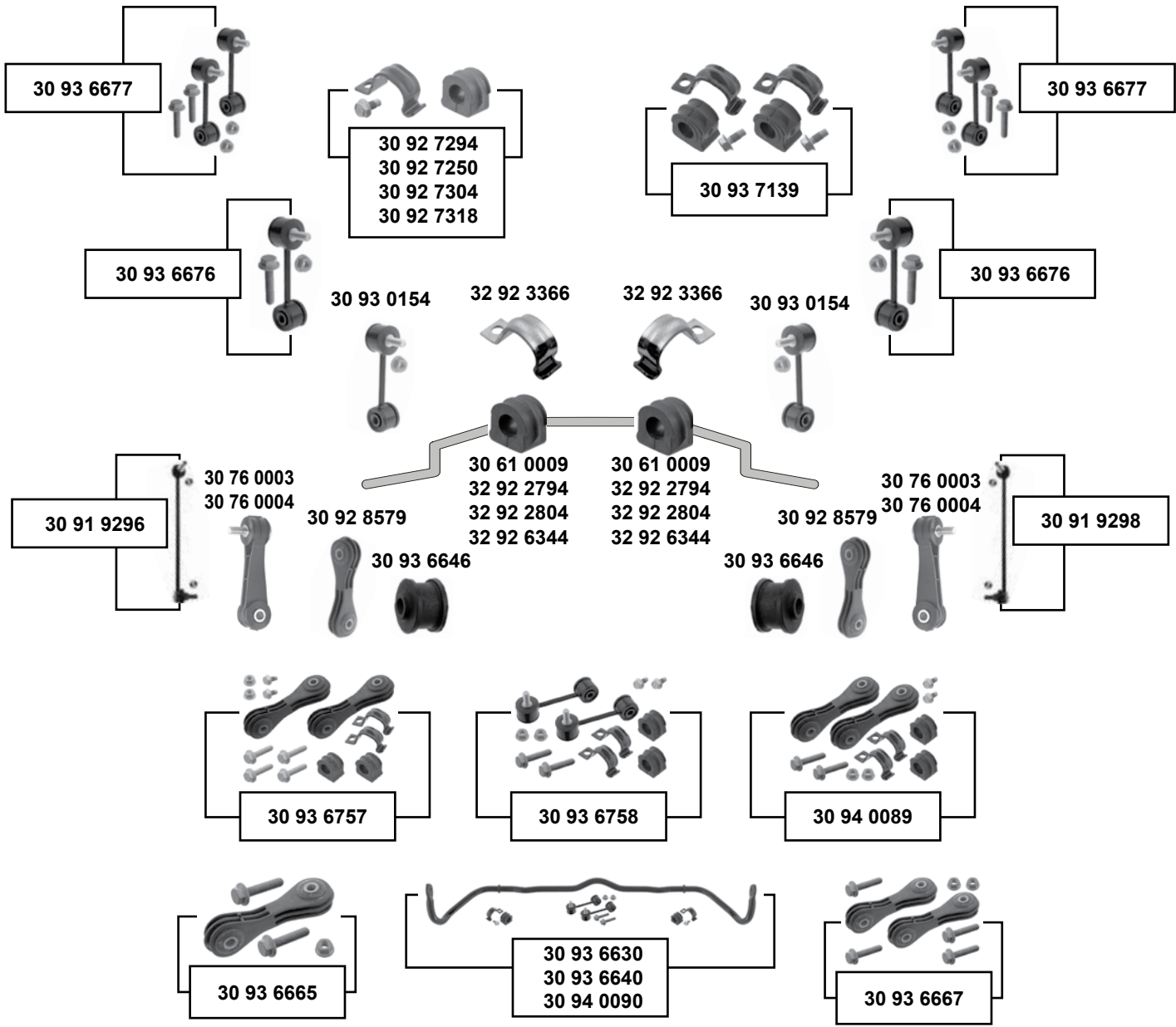

Bora (1J) (1999 → 2005)

Vorderachse / Front axle



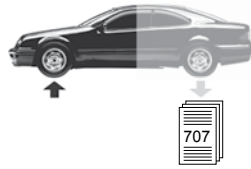

Bora (1J)
(1999 → 2005)

Rep. Sätze / rep. kits

30 91 9820



30 91 9822



- | | |
|---|---|
| (1) variant (ex.) 4motiton 01 → 05 (ch.) 1J-1-480 001 → | (2) 99 (ch.) → 1J-X-999 000 / 01 → (ch.) 1J-Y-000 001 → |
| (3) → 00 (ch.) → 1J-Y-800 000 / 01 → (ch.) 1J-1-000 001 → | |
| (4) 99 → 01 alle / all / 04 → 05 (ch.) 01J-4-220 01 → | (5) (ch.) → 1J-X-999 000 / (ch.) 1J-Y-000 001 → |
| (6) (ch.) 1J-Y-000 001 → / (ch.) → 1J-1-480 000 / (ch.) → 1J-Y-800 000 / (ch.) → 1J-X-999 000 | |
| (7) (ch.) → 1J-Y-800 000 / (ch.) → 1J-1-480 000 / (ch.) 1J-1-480 001 → | |
| (8) (ch.) 1J-1-480 001 → / PR-0AE / Ø A 23 | |
| (9) 00 → 01 (ch.) 1J-Y-000 001 → (ch.) 1J-1-480 000 alle/all | |



Ref. - No.



Ref. - No.	Description	Notes	Dimensions
30 61 0009	1J0 411 314 T Stabilisatorlager / stabilizer mount	(ch.) → 1J-4-220 000	Ø 21
30 76 0003	1J0 411 315 J Verbindungsstange / connecting rod		L 105
30 76 0004	1J0 411 315 G Verbindungsstange / stabilizer link	(9)	L 105
30 91 9296	1J0 411 315 D Verbindungsstange / connecting rod	4motion	
30 91 9298	1J0 411 316 D Verbindungsstange / connecting rod	4motion	
30 91 9820	1J0 407 365 H S2 Querlenker, kpl. / control arm, cpl.		
30 91 9822	1J0 407 366 H S2 Querlenker, kpl. / control arm, cpl.		
30 92 7250	1J0 411 314 S S1 Rep. Satz Stabilisatorlagersatz / rep. kit stabilizer mount kit	(4)	Ø 17
30 92 7294	1J0 411 314 P S1 Rep. Satz Stabilisatorlagersatz / rep. kit stabilizer mount kit	(3)	Ø 20
30 92 7304	1J0 411 314 R S1 Rep. Satz Stabilisatorlagersatz / rep. kit stabilizer mount kit	(2)	Ø 18
30 92 7318	1J0 411 314 T S1 Rep. Satz Stabilisatorlagersatz / rep. kit stabilizer mount kit	(ch.) 1J-Y-000 001 →	Ø 21
30 92 8579	1J0 411 315 K Verbindungsstange / connecting rod	(1)	L 105
30 93 0154	1J0 411 315 G S1 Verbindungsstange / rep. kit connecting rod		L 105
30 93 6630	1J0 411 305 B S1 Rep. Satz Stabilisatorsatz / rep. kit stabilizer kit	(ch.) → 1J-X-999 000	
30 93 6640	1J0 411 305 E S1 Rep. Satz Stabilisatorsatz / rep. kit stabilizer kit	(5)	
30 93 6646	1J0 411 327 A Verbindungsstangenlager / connecting rod mount	(6)	Ø A 29
30 93 6665	1J0 411 315 K S1 Rep. Satz Verbindungsstange / rep. kit connecting rod	(ch.) 1J-1-000 001 →	L 105,5
30 93 6667	1J0 411 315 K S2 Verbindungsstangensatz / connecting rod set	(ch.) 1J-1-000 001 →	L 105,5
30 93 6676	1J0 411 315 G S1 Rep. Satz Verbindungsstange / rep. kit connecting rod	(7)	
30 93 6677	1J0 411 315 G S2 Verbindungsstange / stabiliser link	(7)	
30 93 6757	1J0 411 315 G S3 Stabilisatorlagersatz / anti roll bar bush kit	(ch.) → 1J-X-999 000	Ø 21
30 93 6758	1J0 411 315 G S4 Stabilisatorlagersatz / anti roll bar bush kit	(5)	Ø 21
30 93 7139	1J0 411 314 AC S1 Stabilisatorlagersatz / anti roll bar bush kit		
30 94 0089	1J0 411 314 T S2 Stabilisatorlagersatz / anti roll bar bush kit	(8)	
30 94 0090	1J0 411 305 E S2 Rep. Satz Stabilisatorsatz / rep. kit stabilizer kit	(8)	
32 92 2794	1J0 411 314 P Stabilisatorlager / stabilizer mount	(ch.) → 1J-4-220 000	Ø 20
32 92 2804	1J0 411 314 R Stabilisatorlager / stabilizer mount	R32	Ø 18
32 92 3366	1J0 411 336 D Schelle / clamp		
32 92 6344	1J0 411 314 S Stabilisatorlager / stabilizer mount	(ch.) 1J-4-220 001 →	Ø 17



VOLKSWAGEN

Caddy (14) (1983 → 1992)

Vorderachse / Front axle

30 80 0054



30 80 0053



30 72 0027

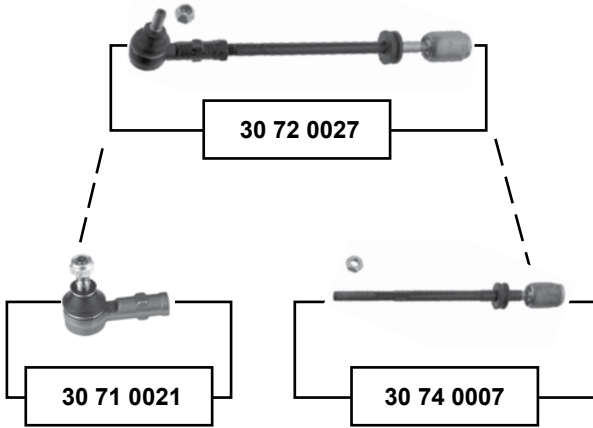

30 72 0027

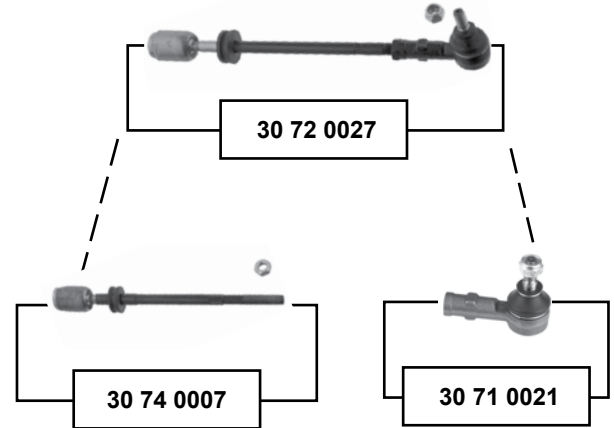

SWAG GERMANY	Ref. - No.			
30 71 0021	171 419 812	Spurstangenendstück / tie rod end		M14x1,5 RHT
30 72 0027	171 419 804	Rep. Satz Spurstange / rep. kit tie rod		
30 74 0007	171 419 821	Axialgelenk / axial joint		M14x1,5 RHT
30 80 0053	171 419 832 C	Lenkmanschette / steering boot		
30 80 0054	191 419 831	Lenkmanschette / steering boot		
30 80 0062	171 419 832 C S1	Rep. Satz Lenkmanschette / rep. kit steering boot		
30 80 0063	191 419 831 S	Rep. Satz Lenkmanschette / rep. kit steering boot		



Caddy (14) (1983 → 1992)

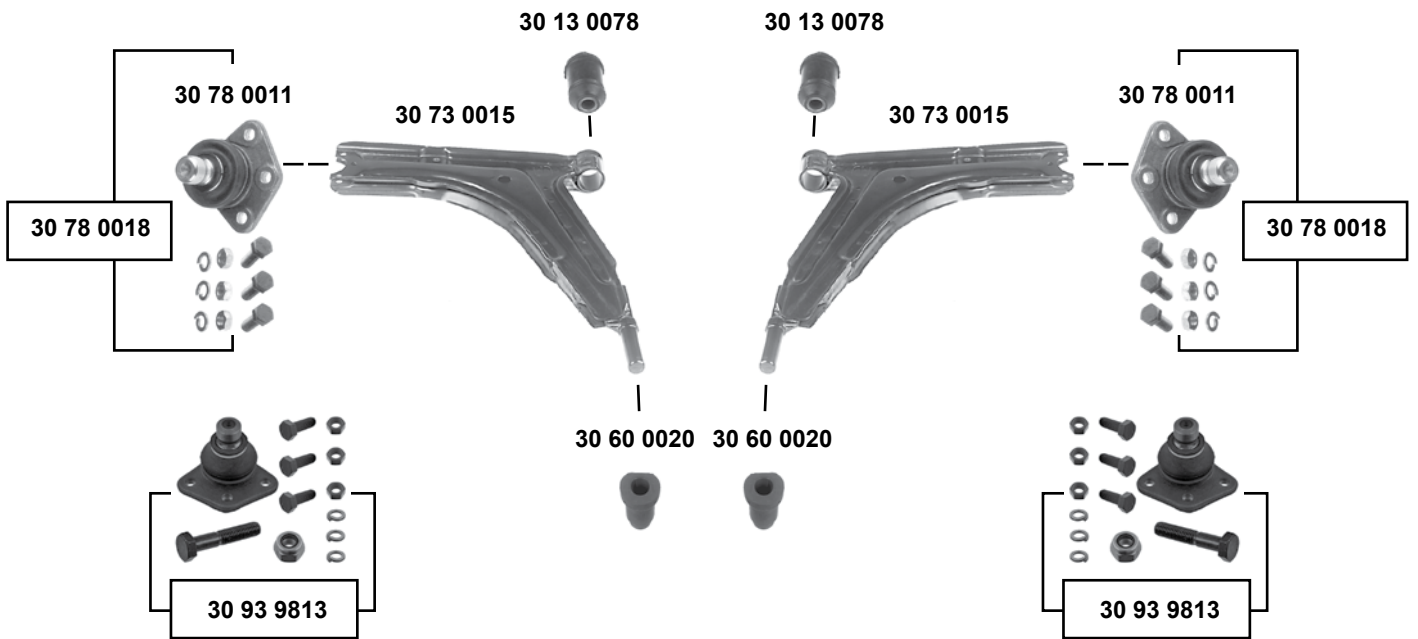

Vorderachse / Front axle

SWAG GERMANY	Ref. - No.			
30 13 0078	171 407 182 D	Querlenkerlager / control arm mount		12x32x61
30 60 0020	171 407 181 A	Querlenkerlager / control arm mount		16x38x55
30 73 0015	171 407 153 D	Querlenker ohne Gummilager / control arm excl. rubber mounts		
30 78 0011	171 407 365 F	Traggelenk / ball joint		Ø A 17
30 78 0018	171 407 365 F S1	Rep. Satz Traggelenk / rep. kit ball joint		
30 93 9813	171 407 365 F S2	Rep. Satz Traggelenk / rep. kit ball joint		



VOLKSWAGEN

Caddy (9K) (1996 → 2003)

30 91 8864



30 91 8864



(ch.) → 9K-1-523000

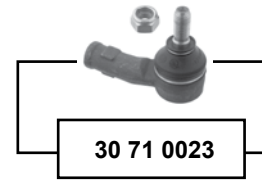
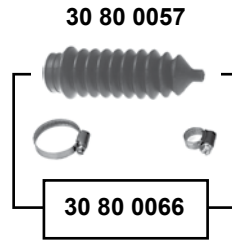
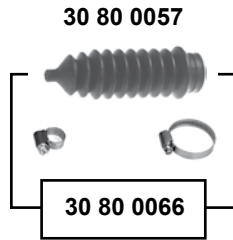

(ch.) 9K-1-523001 →

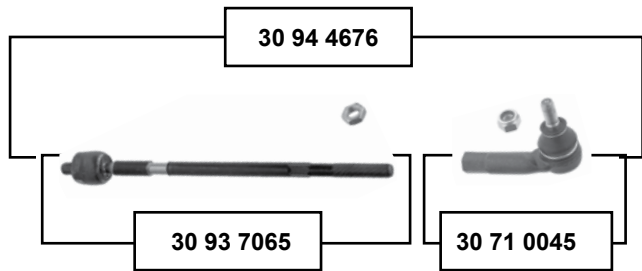
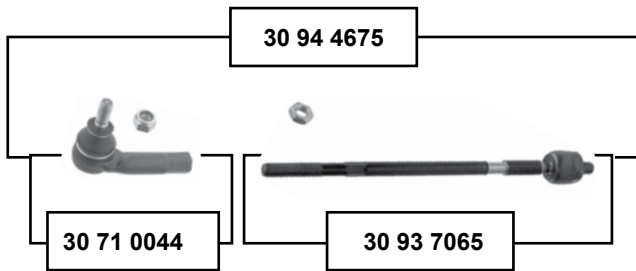
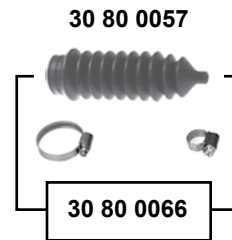
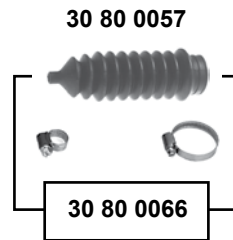
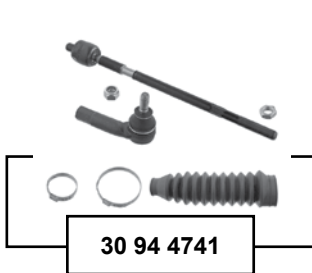

(1) Reifenabmessung / Tyre Size 185/60 R14H



Ref. - No.



30 71 0023	191 419 812	Spurstangenendstück / tie rod end		
30 71 0024	191 419 811	Spurstangenendstück / tie rod end		M12 x 1,5
30 71 0044	6E0 419 811	Spurstangenendstück / tie rod end		M12 x 1,5
30 71 0045	6E0 419 812	Spurstangenendstück / tie rod end		
30 80 0057	1H0 422 831 B	Lenkmanschette / steering boot		
30 80 0066	1H0 422 831 B S1	Rep. Satz Lenkmanschette / rep. kit steering boot		
30 91 8864	1H0 422 884	Lenkgetriebelager / steering gear bearing		
30 93 7065	6K0 422 810 E	Axialgelenk / axial joint		
30 94 4675	6K0 422 803 E	Rep. Satz Spurstange / rep. kit tie rod	(1)	M12 x 1,5
30 94 4676	6K0 422 804 E	Rep. Satz Spurstange / rep. kit tie rod	(1)	M12 x 1,5
30 94 4740	6K0 422 804 E S1	Rep. Satz Spurstange / rep. kit tie rod	(1)	
30 94 4741	6K0 422 803 E S1	Rep. Satz Spurstange / rep. kit tie rod	(1)	

Vorderachse / Front axle



Caddy (9K) (1996 → 2003)

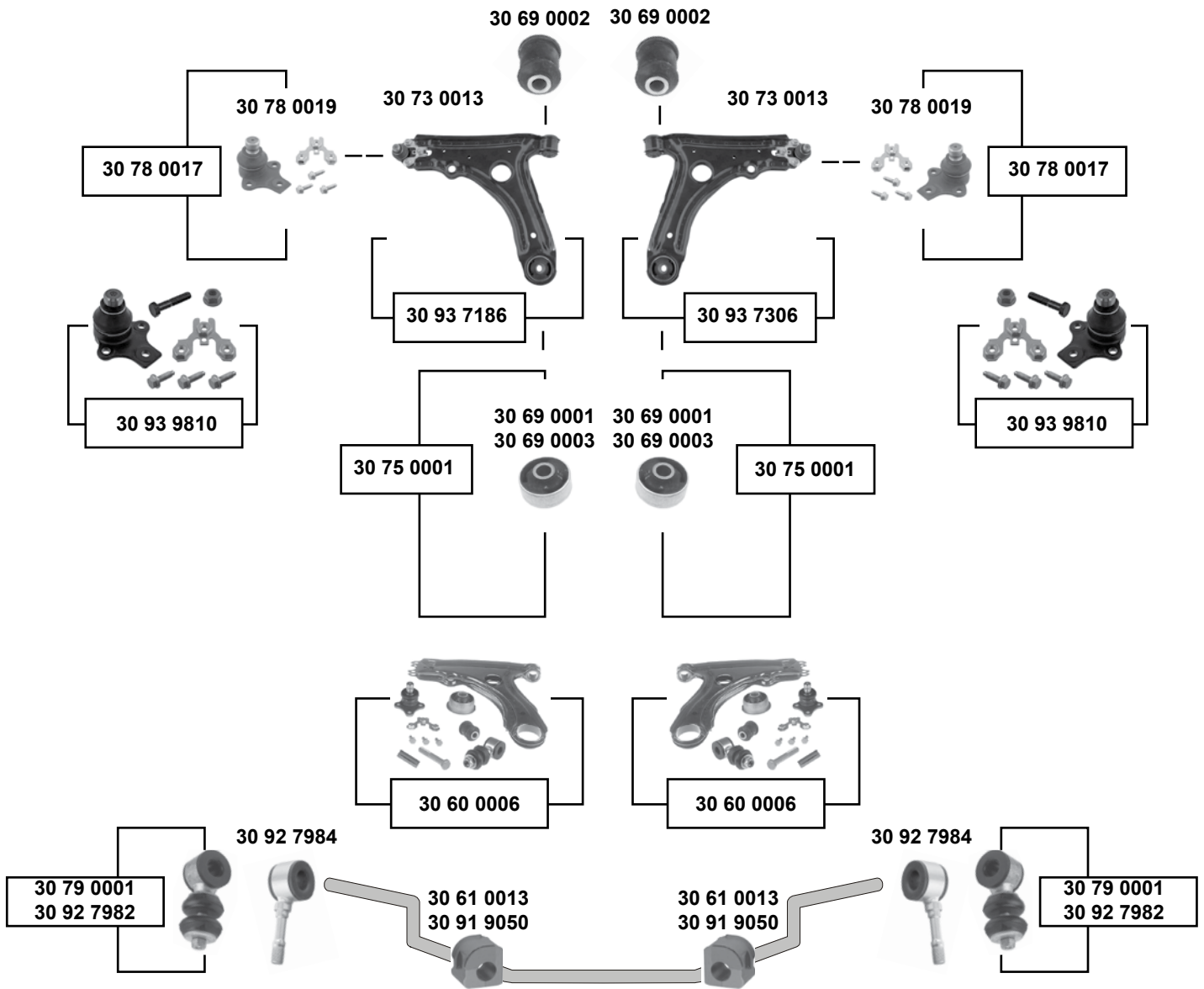

Vorderachse / Front axle

SWAG	Ref. - No.			
30 60 0006	191 407 153 A S3	Rep. Satz Querlenker / rep. kit control arm		
30 61 0013	191 411 314	Stabilisatorlager / stabilizer mount	(ch.) → 9K-V-525700	Ø I 17
30 69 0001	191 407 181 D	Querlenkerlager / control arm mount	NEW	17x60x41
30 69 0002	357 407 182	Querlenkerlager / control arm mount		12x33x54
30 69 0003	191 407 181 B	Querlenkerlager / control arm mount	OLD	17x60x41
30 73 0013	191 407 151 B	Querlenker mit Gummilager / control arm incl. rubber mounts		
30 75 0001	191 407 181 B S1	Querlenkerlager mit Hülse / control arm mount with sleeve	OLD	
30 78 0017	357 407 365 S1	Rep. Satz Traggelenk / rep. kit ball joint		
30 78 0019	357 407 365	Traggelenk / ball joint		Ø A 19
30 79 0001	191 411 315 B S1	Verbindungsstange / connecting rod	(ch.) → 9K-V-525700	
30 91 9050	1H0 411 314	Stabilisatorlager / stabilizer mount		Ø I 19
30 92 7982	6K0 411 315 S1	Verbindungsstange / connecting rod	(ch.) 9K-V-525701 →	Ø I 16,5
30 92 7984	6K0 411 315	Verbindungsstange / connecting rod	(ch.) 9K-V-525701 →	Ø I 16,5
30 93 7186	191 407 151 B S1	Rep. Satz Querlenker / rep. kit control arm		
30 93 7306	191 407 151 B S2	Rep. Satz Querlenker / rep. kit control arm		
30 93 9810	357 407 365 S2	Rep. Satz Traggelenk / rep. kit ball joint		

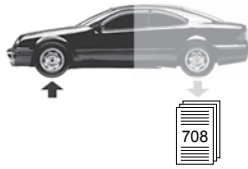

Caddy (2K) (2004 → 2011)

Vorderachse / Front axle

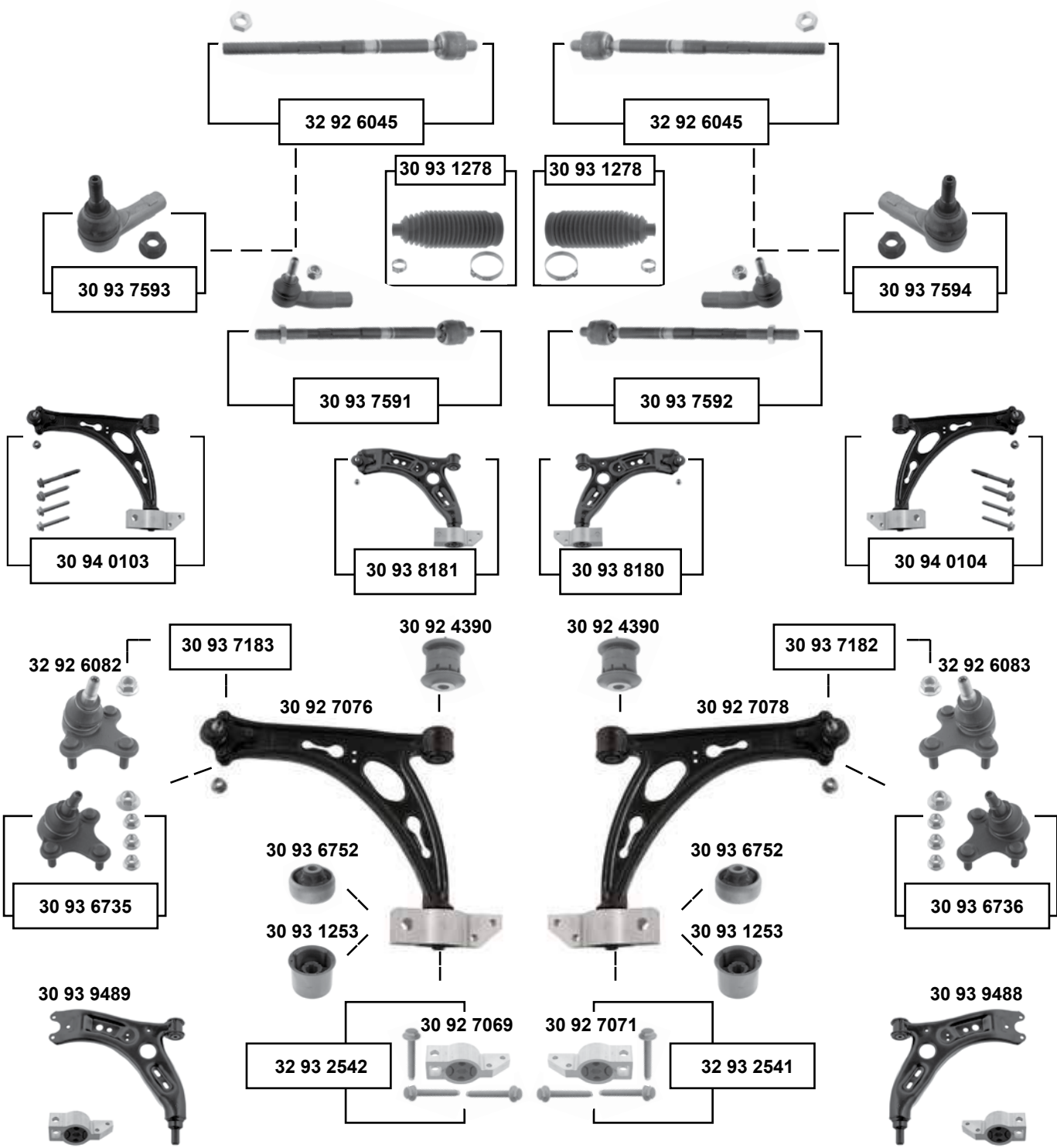

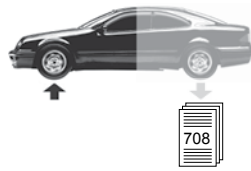

Caddy (2K) (2004 → 2011)

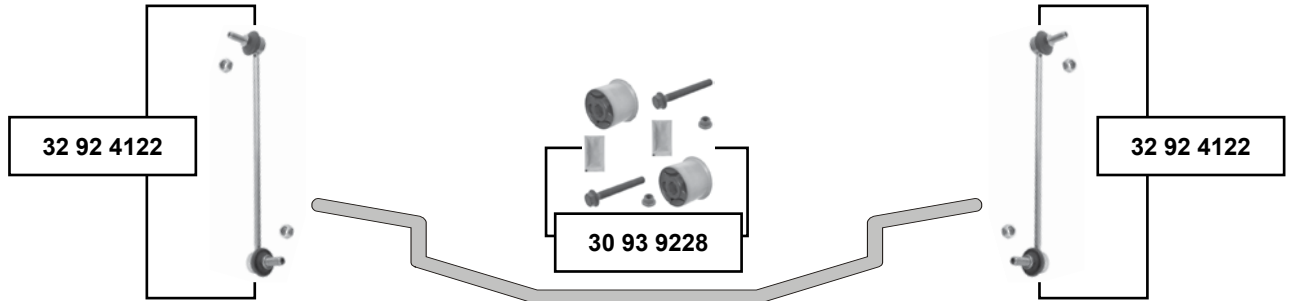

- (1)** Stahl-Gussausführung / keine Mischverbauung mit der Blechausführung zulässig / cast iron execution / not mixable with metall execution
- (2)** → 10 / PR- K4A / **(ch.)** → 2K-A 004 784 / **(ch.)** → 2K-4-016 000
Caddy Maxi 06 → 10 / PR- A9K, A9M, G0C, G1A / **(ch.)** → 2K-A-004 784
- (3)** 2K → 10 / 2C 10 →
- (4)** Gummimetalllager / rubber metal mount
- (5)** **(ch.)** → 2K-4 016 000 / **(ch.)** → 2K-A-004 784 / **(ch.)** 2K-9 000 001 → PR-0E2, A9K, A9M, E02, G0C
- (6)** Caddy 3 **(mot.)** **(ch.)** 2K-4-016 001 → Caddy 3 **(mot.)** BDJ, BJB, BLS, BMM, BSE, BSF, BST, BSU, BSX, BUD Caddy Maxi **(mot.)** BLS, BMM, BSE, BSF, BSX → Caddy 3 **(mot.)** BGU
Caddy 3 4 motion alle / all **(ch.)** → 2K-9-150 000 **(ch.)** → 2K-A-004 784



Ref. - No.



Ref. - No.	Description	Notes	Dimensions
30 92 4390	1K0 407 182	Querlenkerlager / control arm mount	Ø A 48 H 54
30 92 7069	1K0 199 231 J	Querlenkerlager mit Gehäuse / control arm mount with housing	
30 92 7071	1K0 199 232 J	Querlenkerlager mit Gehäuse / control arm mount with housing	
30 92 7076	1K0 407 151 AC	Querlenker, kpl. / control arm, cpl.	(1)
30 92 7078	1K0 407 152 AC	Querlenker, kpl. / control arm, cpl.	(1)
30 93 1253	1K0 407 183 E	Querlenkerlager / control arm mount	Ø A 63
30 93 1278	1K0 423 831 A S1	Rep. Satz Lenkmanschette / rep. kit steering boot	Ø I 15,5 L190
30 93 6735	1K0 407 365 C S1	Rep. Satz Traggelenk / rep. kit ball joint	(3)
30 93 6736	1K0 407 366 C S1	Rep. Satz Traggelenk / rep. kit ball joint	(3)
30 93 6752	1K0 407 183 P	Querlenkerlager / control arm mount	(4) PR-0E1/0E2 Ø I 13
30 93 7182	1K0 407 152 AC S1	Rep. Satz Querlenker mit Traggelenk / control arm with ball joint	(2)
30 93 7183	1K0 407 151 AC S1	Rep. Satz Querlenker mit Traggelenk / control arm with ball joint	(2)
30 93 7591	1K0 423 811 K S1	Rep. Satz Spurstange / rep. kit tie rod	L 448
30 93 7592	1K0 423 812 K S1	Rep. Satz Spurstange / rep. kit tie rod	L 448
30 93 7593	1K0 423 811 K	Spurstangenendstück / tie rod end	M16 x 1,5
30 93 7594	1K0 423 812 K	Spurstangenendstück / tie rod end	M16 x 1,5
30 93 8180	1K0 407 152 BC S1	Rep. Satz Querlenker / rep. kit control arm	Stahl / steel
30 93 8181	1K0 407 151 BC S1	Rep. Satz Querlenker / rep. kit control arm	Stahl / steel
30 93 9228	1K0 407 183 E S1	Querlenkerlagersatz / control arm mounting kit	
30 93 9488	1K0 407 152 BC	Querlenker / control arm	(6)
30 93 9489	1K0 407 151 BC	Querlenker / control arm	(6)
30 94 0103	1K0 407 151 AC S2	Rep. Satz Querlenker / rep. kit control arm	(1) (4) (5)
30 94 0104	1K0 407 152 AC S2	Rep. Satz Querlenker / rep. kit control arm	(1) (4) (5)
32 92 4122	1K0 411 315 R	Verbindungsstange / connecting rod	
32 92 6045	1K0 423 810 A	Spurstange / tie rod	
32 92 6082	1K0 407 365 C	Traggelenk / ball joint	
32 92 6083	1K0 407 366 C	Traggelenk / ball joint	
32 93 2541	1K0 199 232 J S1	Querlenkerlager rechts / control arm mount right	
32 93 2542	1K0 199 231 J S1	Querlenkerlager links / control arm mount left	

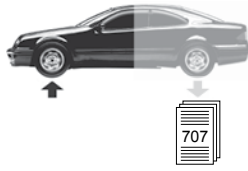

Caddy (2C) (2010 →)

Vorderachse / Front axle

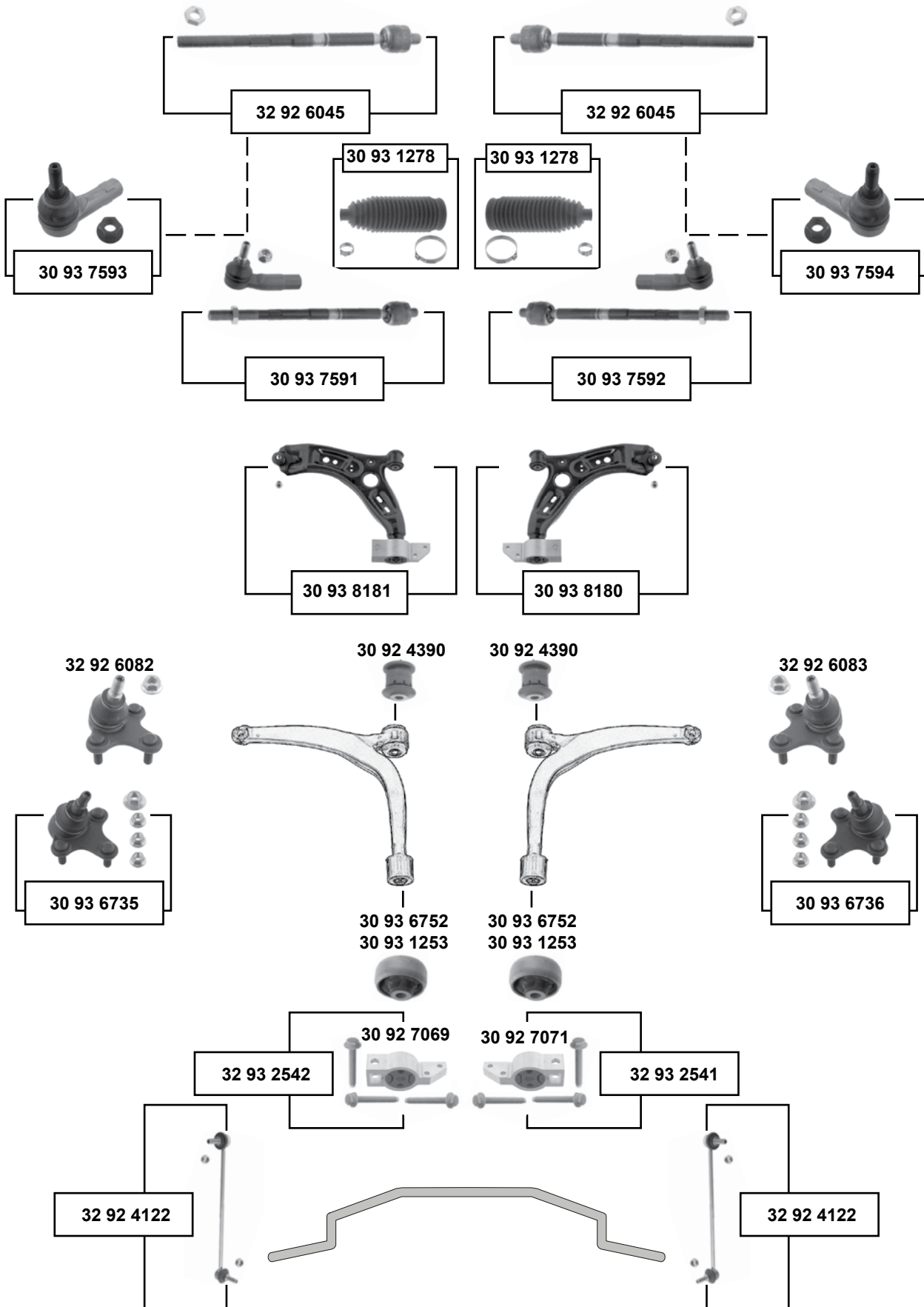

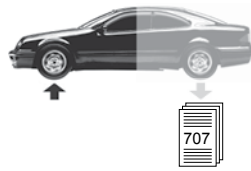
Caddy (2C)
 (2010 →)

- (1) PR-0E2 (mot.) CFHC, CFHE, CFHF
- (2) (mot.) BSF, BSX, CAYD, CAYE, CBZA, CBZB, CFHC, CFHE, CFHF, CHGA, CLCA
- (3) (mot.) BSF, BSX, CAYD, CAYE, CBZA, CBZB, CFHC, CFHE, CFHF, CFJA, CHGA, CLCA
- (4) Caddy 4 (mot.) BSF, BSX, CAYD, CAYE, CBZA, CBZB, CFHC, CFHE, CLCA
 Caddy Maxi (mot.) BSX, CAYD, CBZB, CFHC, CFHE, CLCA
 Caddy 4 4 motion, Caddy 4 4 motion, Caddy Maxi 4 motion, Caddy Maxi 4 motion alle / all

	Ref. - No.			
30 92 4390	1K0 407 182	Querlenkerlager / control arm mount		Ø A40 H54
30 92 7069	1K0 199 231 J	Querlenkerlager mit Gehäuse / control arm mount with housing	PR-0E2	
30 92 7071	1K0 199 232 J	Querlenkerlager mit Gehäuse / control arm mount with housing	PR-0E2	
30 93 1253	1K0 407 183 E	Querlenkerlager / control arm mount	(1)	
30 93 1278	1K0 423 831 A S1	Rep. Satz Lenkmanschette / rep. kit steering boot		Ø I 15,5 L190
30 93 6735	1K0 407 365 C S1	Rep. Satz Traggelenk / rep. kit ball joint	(2)	
30 93 6736	1K0 407 366 C S1	Rep. Satz Traggelenk / rep. kit ball joint	(2)	
30 93 6752	1K0 407 183 P	Querlenkerlager / control arm mount	PR-0E2	Ø I13 B50
30 93 7591	1K0 423 811 K S1	Rep. Satz Spurstange / rep. kit tie rod		L 448
30 93 7592	1K0 423 812 K S1	Rep. Satz Spurstange / rep. kit tie rod		L 448
30 93 7593	1K0 423 811 K	Spurstangenendstück / tie rod end	(3)	M16 x 1,5
30 93 7594	1K0 423 812 K	Spurstangenendstück / tie rod end	(3)	M16 x 1,5
30 93 8180	1K0 407 152 BC S1	Rep. Satz Querlenker / rep. kit control arm	(4) Stahl / steel	
30 93 8181	1K0 407 151 BC S1	Rep. Satz Querlenker / rep. kit control arm	(4) Stahl / steel	
32 92 4122	1K0 411 315 P	Rep. Satz Verbindungsstange / rep. kit connecting rod		
32 92 6045	1K0 423 810 A	Spurstange / tie rod		
32 92 6082	1K0 407 365 C	Traggelenk / ball joint		
32 92 6083	1K0 407 366 C	Traggelenk / ball joint		
32 93 2541	1K0 199 232 J S1	Querlenkerlager rechts / control arm mount right		
32 93 2542	1K0 199 231 J S1	Querlenkerlager rechts / control arm mount right		

passend für / to fit

VOLKSWAGEN



Caddy Pickup (9U) (1997 → 2003)

Vorderachse / Front axle

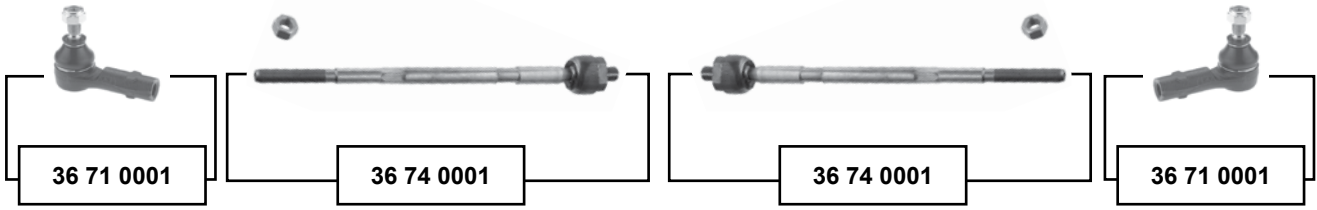

	Ref. - No.			
30 92 9644	6U0 407 182	Querlenkerlager / control arm mount	 	Ø A 31,5 M12 x 1,5 L 335 Ø A 17
36 71 0001	6U0 422 811	Spurstangenendstück / tie rod end		
36 74 0001	6U0 422 807	Spurstange / tie rod		
36 78 0001	6U0 407 365	Traggelenk / ball joint		

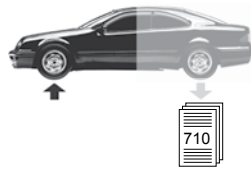

CC (3C)
(2012 →)

Vorderachse / Front axle

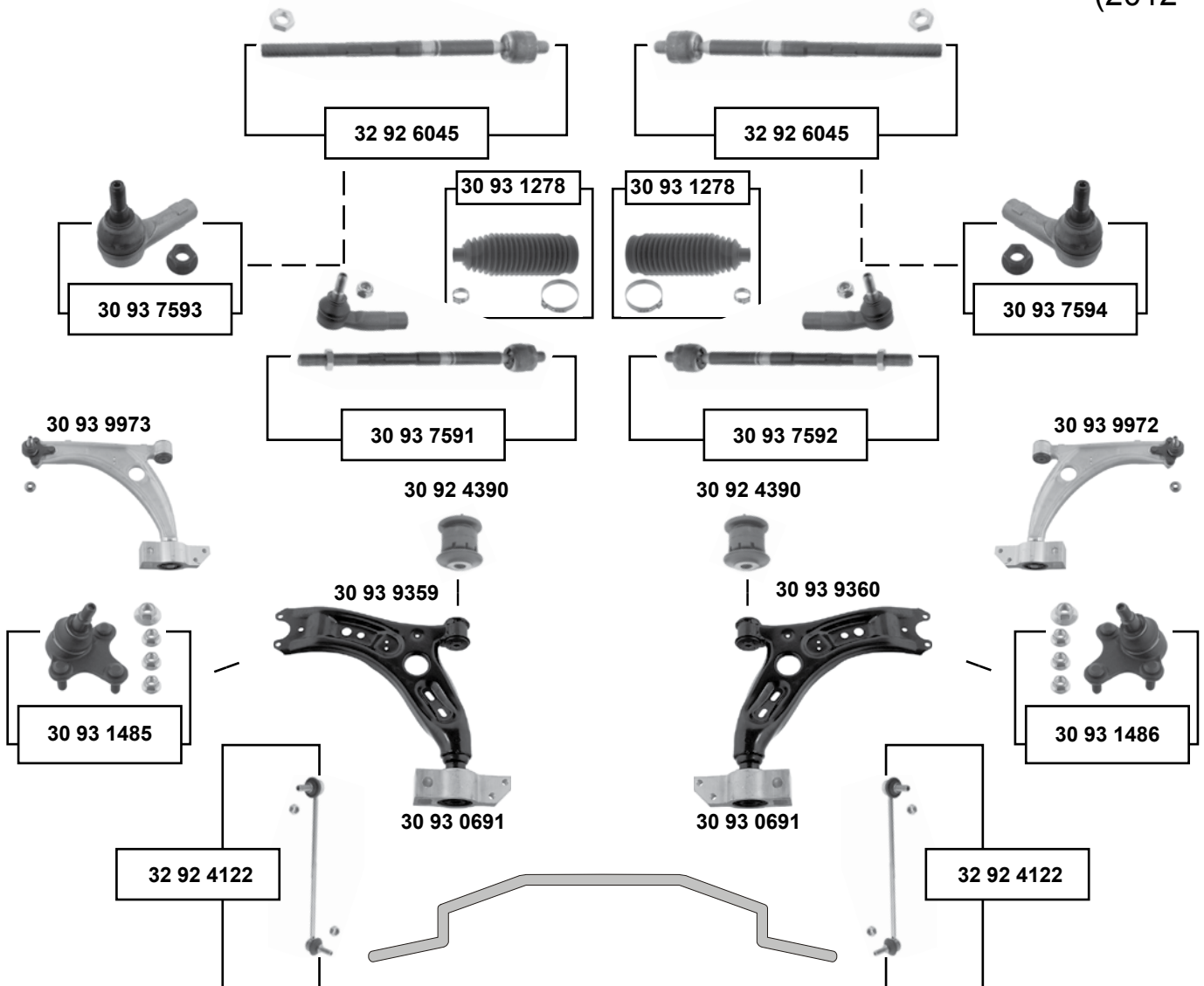

(1) (mot.) BWS, CBFA, CCZB, CDAА, CDAB, CFFA, CFFB, CFGB, CKMA, CLLA

(2) (mot.) CFFA, CFFB, CFGB, CFGC, CLLA / PR 1LA/1LB
(mot.) CBFA, CCTA, CCZB, CDAА, CDAB, CKMA, CNNA, CTHD /PR 1LA/1LB/1LK
CC 4 motion alle / all PR-1LA/1LB



Ref. - No.



Ref. - No.			
30 92 4390	1K0 407 182	Querlenkerlager / control arm mount	Ø A40 H54
30 93 0691	3C0 199 231 D	Querlenkerlager / control arm mount	
30 93 1278	1K0 423 831 A S1	Rep. Satz Lenkmanschette / rep. kit steering boot	Ø I 15,5
30 93 1485	3C0 407 365 A S1	Rep. Satz Traggelenk / rep. kit ball joint	M12 x 1,5
30 93 1486	3C0 407 366 A S1	Rep. Satz Traggelenk / rep. kit ball joint	M12 x 1,5
30 93 7591	1K0 423 811 K S1	Rep. Satz Spurstange / rep. kit tie rod	L 448
30 93 7592	1K0 423 812 K S1	Rep. Satz Spurstange / rep. kit tie rod	L 448
30 93 7593	1K0 423 811 K	Spurstangenendstück / tie rod end	M16 x 1,5
30 93 7594	1K0 423 812 K	Spurstangenendstück / tie rod end	M16 x 1,5
30 93 9359	5N0 407 151	Querlenker / control arm	(1)
30 93 9360	5N0 407 152	Querlenker / control arm	PR-1ZG/1ZM
30 93 9972	3C0 407 151 G S1	Querlenker / control arm	PR-1ZG/1ZM
30 93 9973	3C0 407 151 G S2	Querlenker / control arm	(2)
32 92 4122	1K0 411 315 R	Rep. Satz Verbindungsstange / rep. kit connecting rod	(2)
32 92 6045	1K0 423 810 A	Spurstange / tie rod	



Corrado (50)

(1989 → 1995)

(ex.) 2.9 VR6

Vorderachse / Front axle

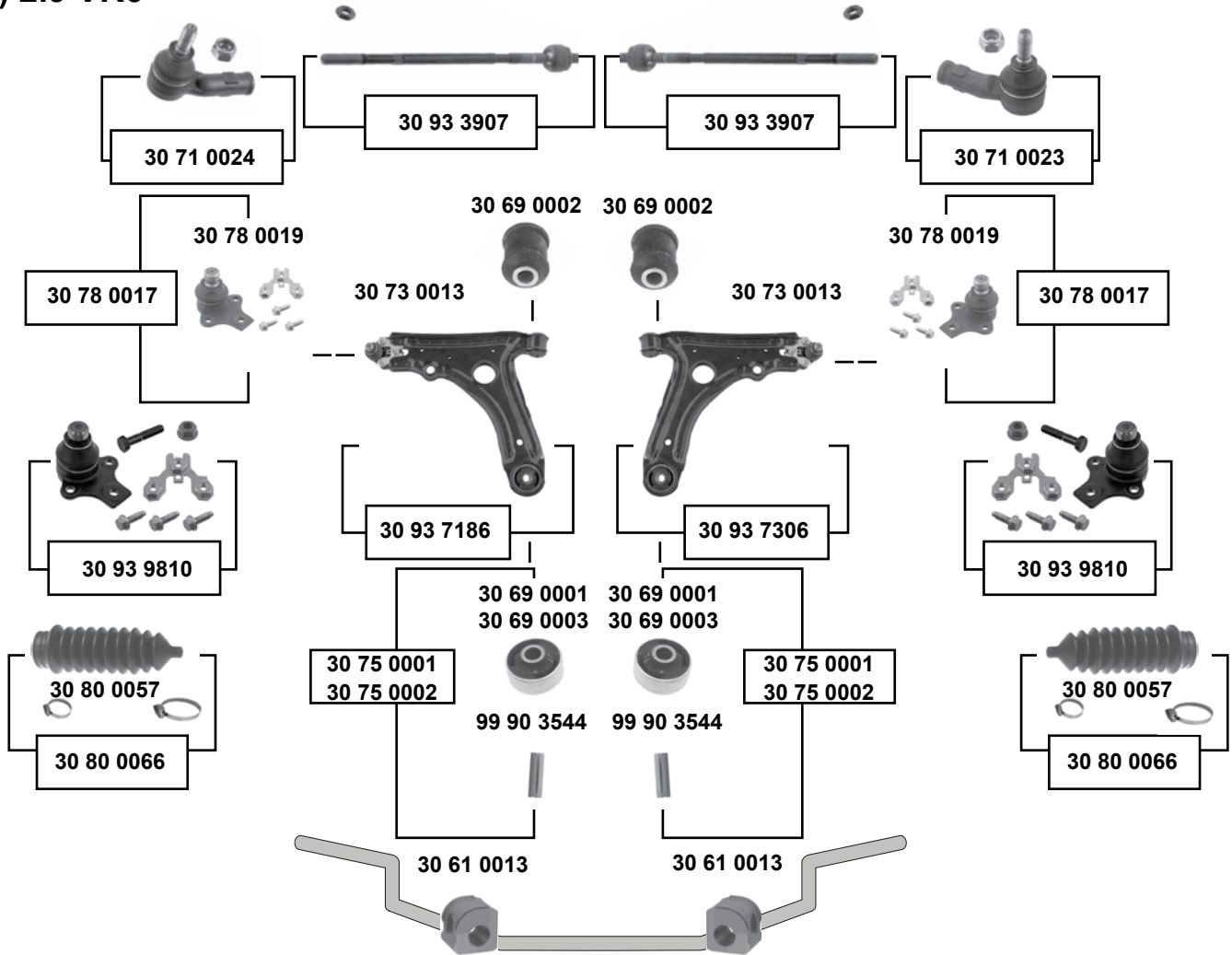

(1) (ex.) Fahrzeuge mit 205 / 50 Bereifung / (ex.) cars with 205 / 50 tyres

SWAG GERMANY	Ref. - No.			
30 61 0013	191 411 314	Stabilisatorlager / stabilizer mount		Ø I 17
30 69 0001	191 407 181 D	Querlenkerlager / control arm mount	NEW	17x60x41
30 69 0002	357 407 182	Querlenkerlager / control arm mount		12x33x54
30 69 0003	191 407 181 B	Querlenkerlager / control arm mount	OLD	17x60x41
30 71 0023	191 419 812	Spurstangenendstück / tie rod end		M12 x 1,5
30 71 0024	191 419 811	Spurstangenendstück / tie rod end		M12 x 1,5
30 73 0013	191 407 151 B	Querlenker / control arm		
30 75 0001	191 407 181 B S1	Querlenkerlager mit Hülse / control arm mount with sleeve	OLD	
30 75 0002	191 407 181 D S1	Querlenkerlager mit Hülse / control arm mount with sleeve	NEW	
30 78 0017	357 407 365 S1	Rep. Satz Traggelenk / rep. kit ball joint		
30 78 0019	357 407 365	Traggelenk / ball joint		Ø A 19
30 80 0057	1H0 422 831 B	Lenkmanschette / steering boot		
30 80 0066	1H0 422 831 B S1	Rep. Satz Lenkmanschette / rep. kit steering boot		
30 93 3907	191 422 810 A	Spurstange / tie rod	(1) servo.	
30 93 7186	191 407 151 B S1	Rep. Satz Querlenker / rep. kit control arm		
30 93 7306	191 407 151 B S2	Rep. Satz Querlenker / rep. kit control arm		
30 93 9810	357 407 365 S2	Rep. Satz Traggelenk / rep. kit ball joint		
99 90 3544	191 407 190 A	Hülse / sleeve		50x17



Corrado (50)

(1989 → 1995)

2.9 VR6

für / to fit servo  ZF

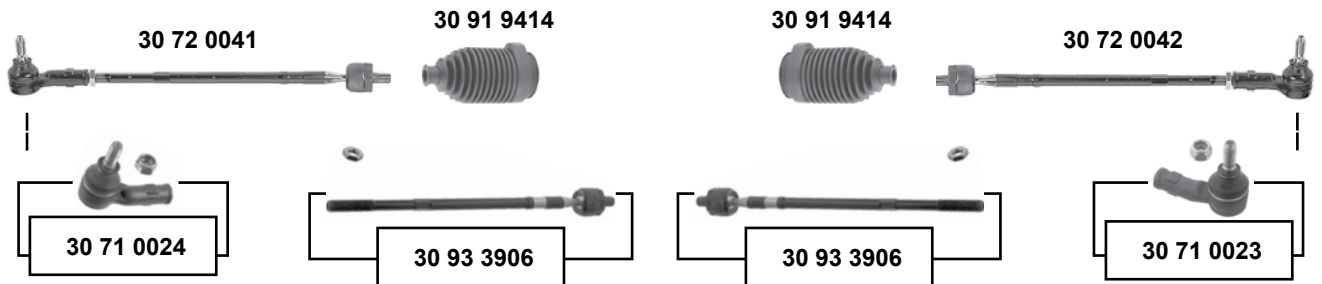

Vorderachse / Front axle

für / to fit servo  TRW

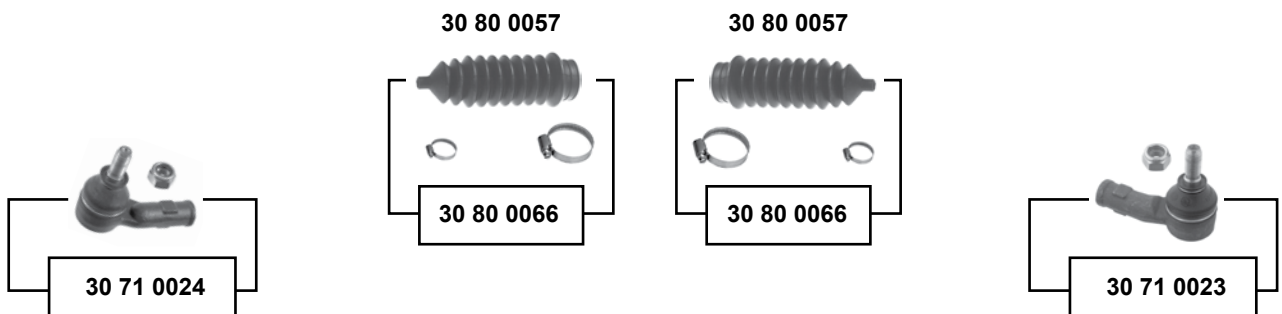

30 71 0023	191 419 812	Spurstangenendstück / tie rod end		M12 x 1,5
30 71 0024	191 419 811	Spurstangenendstück / tie rod end		
30 72 0041	1H0 422 803 B	Spurstange / tie rod		M12 x 1,5
30 72 0042	1H0 422 804 B	Spurstange / tie rod		
30 80 0057	1H0 422 831 B	Lenkmanschette / steering boot		
30 80 0066	1H0 422 831 B S1	Rep. Satz Lenkmanschette / rep. kit steering boot		
30 91 9414	357 422 831 B	Lenkmanschette / steering boot	LHD / RHD	
30 93 3906	1H0 422 810 B	Spurstange / tie rod		



VOLKSWAGEN

Corrado (50)

(1989 → 1995)

2.9 VR6

Vorderachse / Front axle

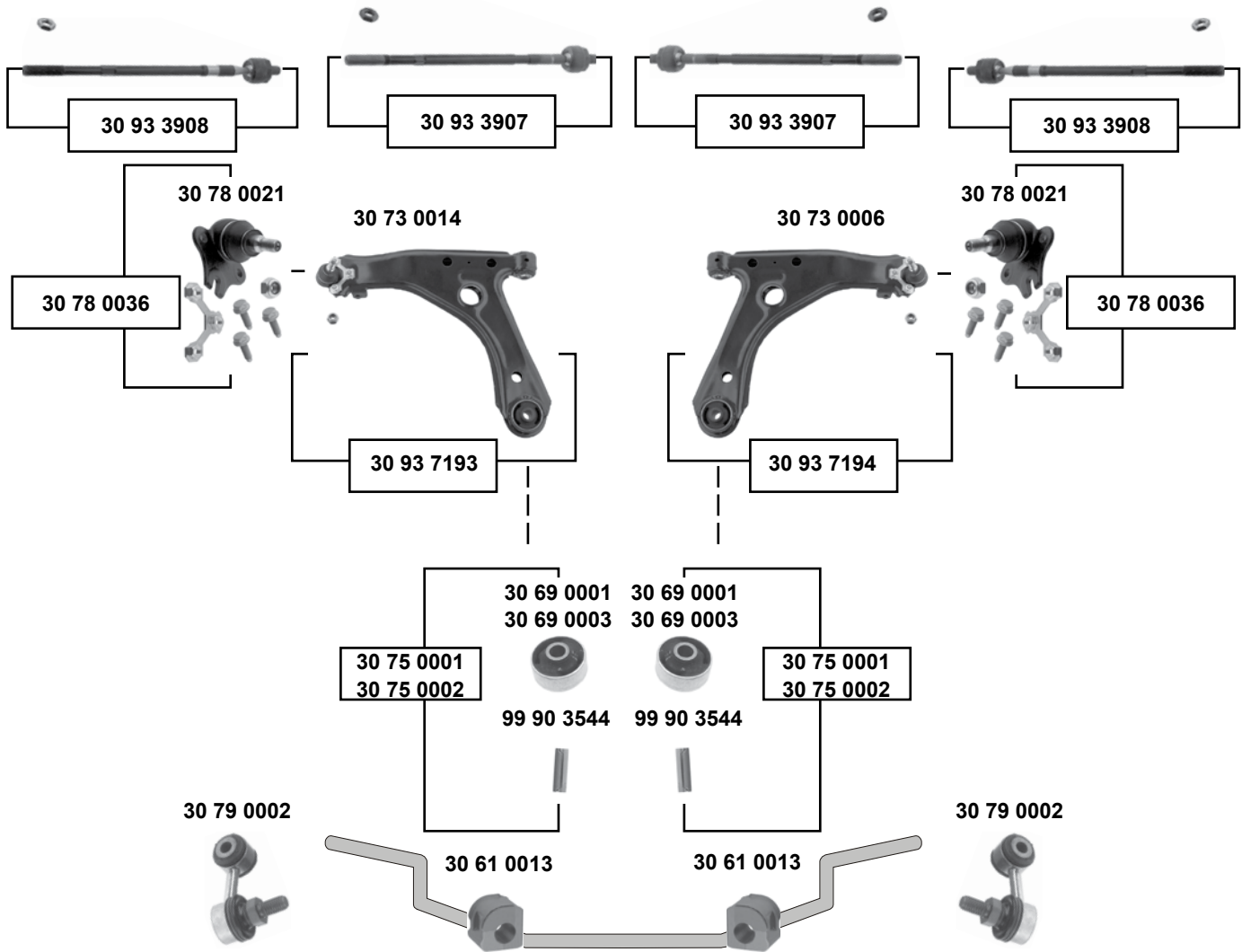

(1) (ex.) Fahrzeuge mit 205 / 50 Bereifung / (ex.) cars with 205 / 50 tyres

SWAG GERMANY	Ref. - No.			
30 61 0013	191 411 314	Stabilisatorlager / stabilizer mount		Ø 17
30 69 0001	191 407 181 D	Querlenkerlager / control arm mount	NEW	17x60x41
30 69 0003	191 407 181 B	Querlenkerlager / control arm mount	OLD	17x60x41
30 73 0006	1H0 407 152	Querlenker / control arm		
30 73 0014	1H0 407 151 A	Querlenker / control arm		
30 75 0001	191 407 181 B S1	Querlenkerlager mit Hülse / control arm mount with sleeve	OLD	
30 75 0002	191 407 181 D S1	Querlenkerlager mit Hülse / control arm mount with sleeve	NEW	
30 78 0021	1H0 407 365	Traggelenk / ball joint		M12 x 1,5
30 78 0036	1H0 407 365 S1	Rep. Satz Traggelenk / rep. kit ball joint		
30 79 0002	535 411 315	Verbindungsstange / connecting rod		
30 93 3907	191 422 810 A	Spurstange / tie rod	(1) servo. TRW	M14 x 1,5
30 93 3908	1H0 422 810	Axialgelenk / axial joint		
30 93 7193	1H0 407 151 A S1	Querlenker mit Traggelenk / control arm with ball joint	91 → 95	
30 93 7194	1H0 407 152 S1	Querlenker mit Traggelenk / control arm with ball joint	91 → 95	
99 90 3544	191 407 190 A	Hülse / sleeve		50x17

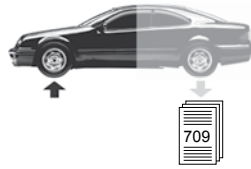

Crafter (2E) (2006 →)

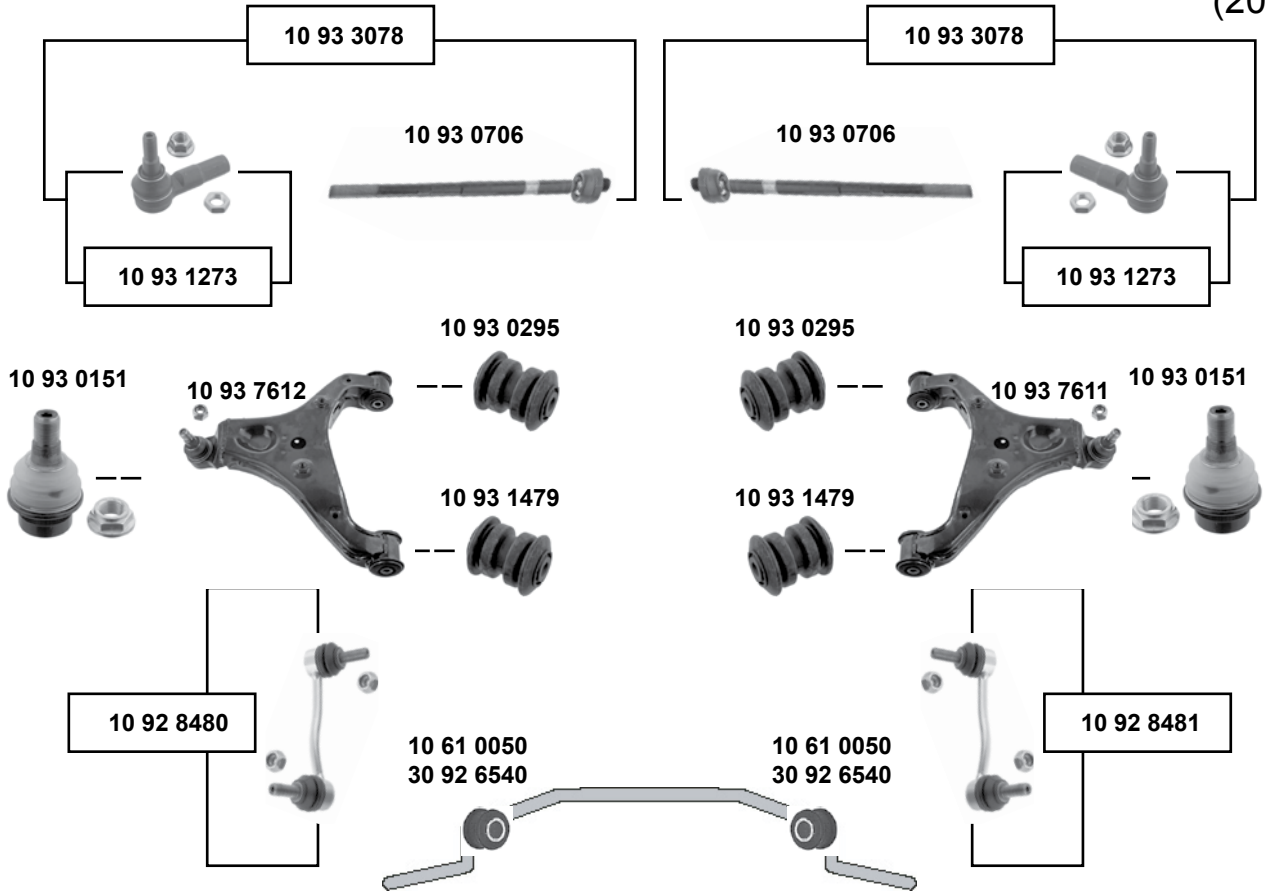

Vorderachse / Front axle

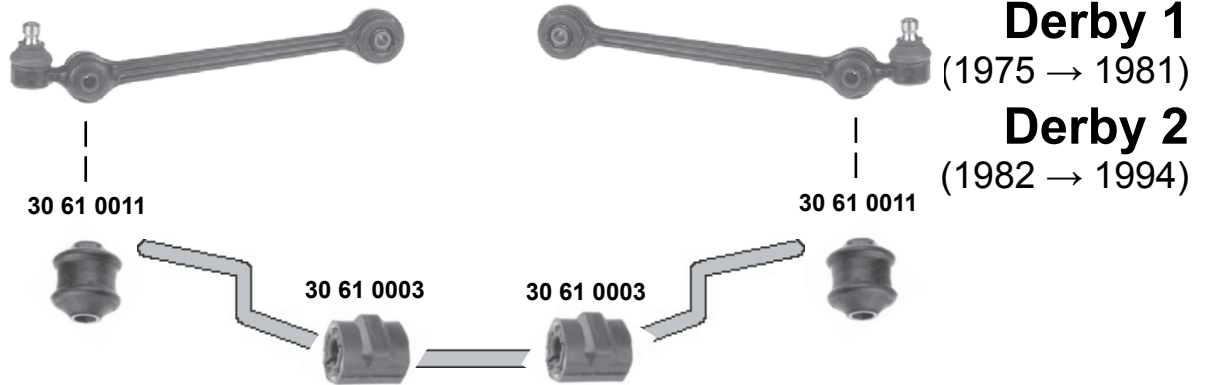

10 61 0050	2D0 511 413	Stabilisatorlager / stabilizer mount	12x26x26
10 92 8480	2E0 411 317 C	Verbindungsstange / connecting rod	L 138,1
10 92 8481	2E0 411 318 C	Verbindungsstange / connecting rod	L 138,1
10 93 0151	2E0 407 151 M S1	Traggelenk / ball joint	
10 93 0295	2E0 407 523	Querlenkerlager / control arm mount	Ø A 59
10 93 0706	2E0 713 491 SK	Spurstange / tie rod	L 400
10 93 1273	2E0 498 104	Spurstangenendstück / tie rod end	M16 x 1,5
10 93 1479	2E0 407 523 A	Querlenkerlager / control arm mount	
10 93 3078	2E0 713 491 S1	Rep. Satz Spurstange / rep. kit tie rod	L 400
10 93 7611	2E0 407 152 L	Querlenker / control arm	
10 93 7612	2E0 407 151 L	Querlenker / control arm	
30 61 0003	867 411 313	Stabilisatorlager / stabilizer mount	Ø I 16,5
30 61 0011	861 407 183	Stabilisatorlager / stabilizer mount	
30 92 6540	7H0 411 313	Stabilisatorlager / stabilizer mount	

passend für / to fit

VOLKSWAGEN

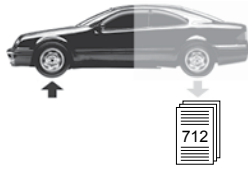

Eos (1F) (2006 →)

Vorderachse / Front axle

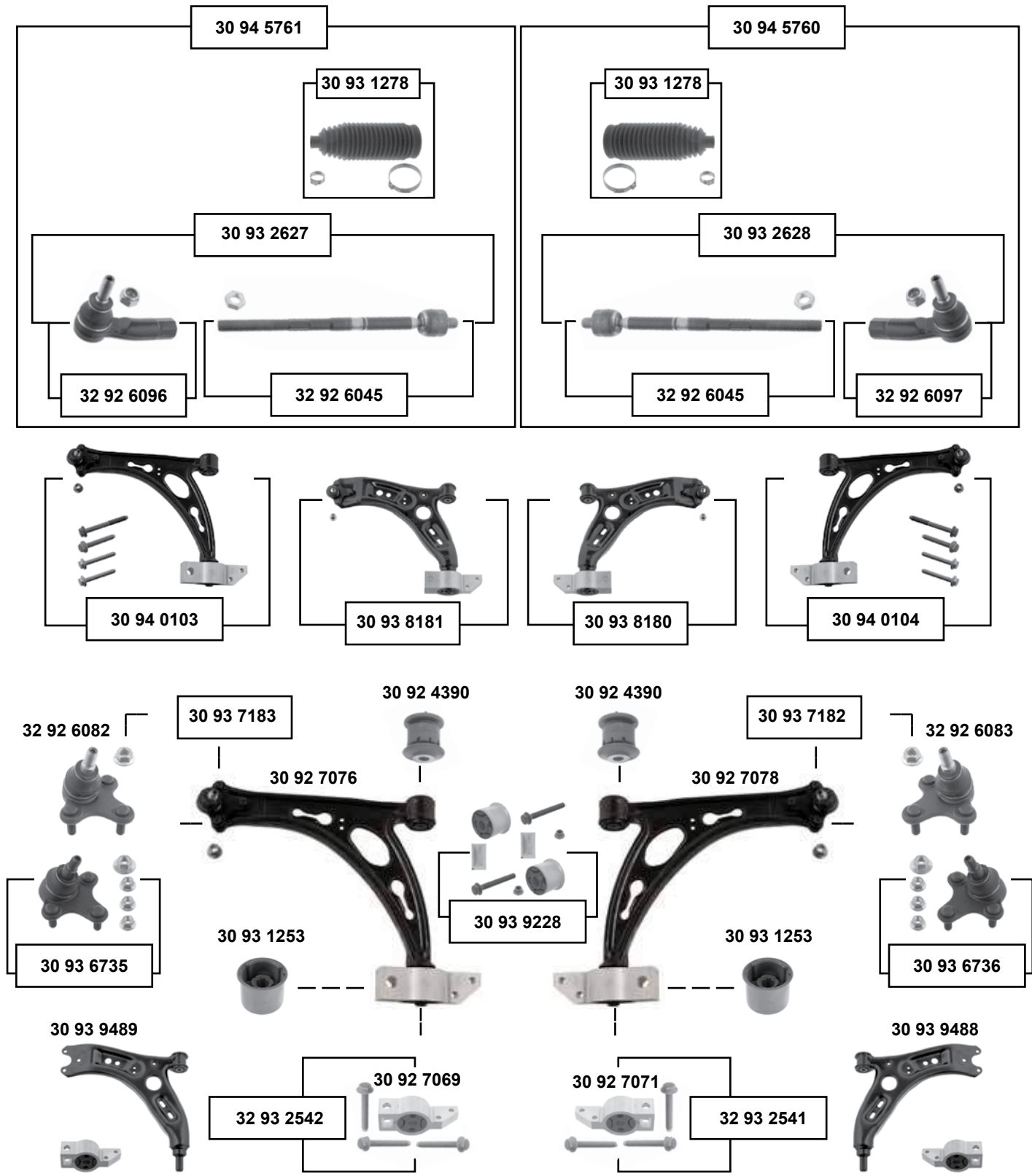

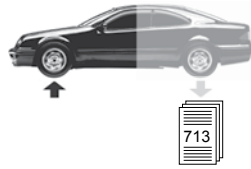

Eos (1F) (2006 →)

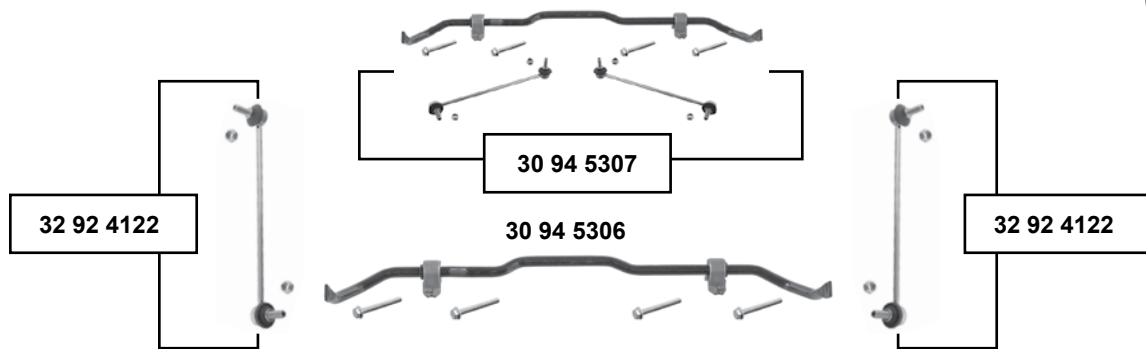

- (1) Stahl-Gussausführung / keine Mischverbauung mit der Blechausführung zulässig / cast iron execution / not mixable with metall execution
- (2) Eos Cabrio : nicht für / not for PR-1ZD, 1ZE, 1LJ, 1ZA / (ch.) → 1F-9-040 000 10 → / PR-1LA
- (3) PR-0AD / 0AE / (ch.) 1F-9-002 396 →
- (4) Eos Cabriolet (mot.) BPY, BUB, BWA, CAVD, CAWB, CAXA, CBAB, CCTA, CCZA, CCZB, CDVA 06/2009 → Eos Cabriolet (mot.) CAVD, CAXA, CBFA, CCZA, CCZB, CTHD
- (5) Eos Cabriolet (mot.) BPY, BUB, BWA, CAVD, CAWB, CAXA, CBAB, CCTA, CCZA, CCZB, CDVA 06/2009 → Eos Cabriolet (mot.) BLF, BMM, BVY, BVZ



Ref. - No.



SWAG Ref. - No.	Part Description	Notes	Dimensions
30 92 4390	1K0 407 182	Querlenkerlager / control arm mount	Ø A48 H54
30 92 7069	1K0 199 231 J	Querlenkerlager mit Gehäuse / control arm mount with housing	
30 92 7071	1K0 199 232 J	Querlenkerlager mit Gehäuse / control arm mount with housing	
30 92 7076	1K0 407 151 AC	Querlenker / control arm	(1)
30 92 7078	1K0 407 152 AC	Querlenker / control arm	(1)
30 93 1253	1K0 407 183 E	Querlenkerlager / control arm mount	Ø A 63
30 93 1278	1K0 423 831 A S1	Rep. Satz Lenkmanschette / rep. kit steering boot	Ø I 15,5 L190
30 93 2627	1K0 423 810 A S1	Rep. Satz Spurstange links / rep. kit tie rod left	
30 93 2628	1K0 423 810 A S2	Rep. Satz Spurstange rechts / rep. kit tie rod right	
30 93 6735	1K0 407 365 C S1	Rep. Satz Traggelenk / rep. kit ball joint	
30 93 6736	1K0 407 366 C S1	Rep. Satz Traggelenk / rep. kit ball joint	
30 93 7182	1K0 407 152 AC S1	Rep. Satz Querlenker mit Traggelenk / control arm with ball joint	(2)
30 93 7183	1K0 407 151 AC S1	Rep. Satz Querlenker mit Traggelenk / control arm with ball joint	(2)
30 93 8180	1K0 407 152 BC S1	Rep. Satz Querlenker / rep. kit control arm	Stahl / steel
30 93 8181	1K0 407 151 BC S1	Rep. Satz Querlenker / rep. kit control arm	Stahl / steel
30 93 9228	1K0 407 183 E S1	Querlenkerlagersatz / control arm mounting kit	
30 93 9488	1K0 407 152 BC	Querlenker / control arm	(4)
30 93 9489	1K0 407 151 BC	Querlenker / control arm	(4)
30 94 0103	1K0 407 151 AC S2	Rep. Satz Querlenker / rep. kit control arm	(5)
30 94 0104	1K0 407 152 AC S2	Rep. Satz Querlenker / rep. kit control arm	(5)
30 94 5306	1K0 411 303 BK S1	Stabilisatorsatz / stabilizer kit	(3)
30 94 5307	1K0 411 303 BK S2	Rep. Satz Stabilisatorsatz / rep. kit stabilizer kit	(3)
30 94 5760	1K0 423 810 A S4	Rep. Satz Spurstange / rep. kit tie rod	
30 94 5761	1K0 423 810 A S3	Rep. Satz Spurstange / rep. kit tie rod	
32 92 4122	1K0 411 315 R	Verbindungsstange / connecting rod	
32 92 6045	1K0 423 810 A	Spurstange / tie rod	
32 92 6082	1K0 407 365 C	Traggelenk / ball joint	
32 92 6083	1K0 407 366 C	Traggelenk / ball joint	
32 92 6096	1K0 423 811 E	Spurstangenendstück / tie rod end	
32 92 6097	1K0 423 812 E	Spurstangenendstück / tie rod end	
32 93 2541	1K0 199 232 J S1	Querlenkerlager / control arm mount	
32 93 2542	1K0 199 231 J S1	Querlenkerlager / control arm mount	



Fox (5Z)

(2004 →)

Vorderachse / Front axle

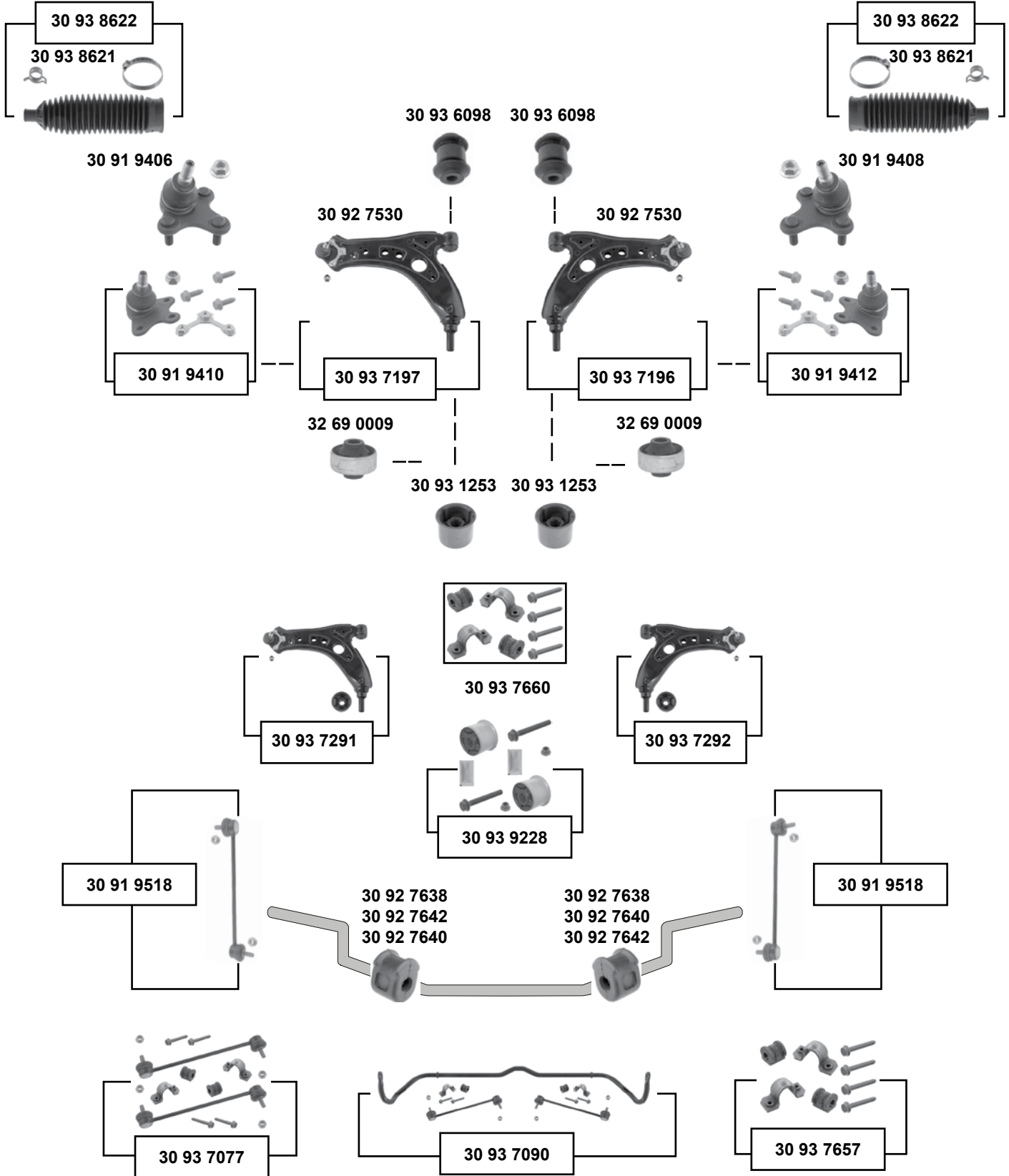

Fox (5Z)
 (2004 →)

	(1) (ch.) 5Z-70040 000 → (ch.) 5Z-74068 000 →	(2) Fox 05 → / PR-1ZF / 1ZN / 0AQ Crossfox 07 → / PR-1ZF / 0AQ
	(3) (mot.) AQZ, CCNA, BAH, BLH, CCRA (ch.) 5Z-94092 001 → / PR 1BA	
	(4) (mot.) AQZ, BAH, BJE (ch.) 5Z-54072 197 → / PR-0AS+1BD / Ø Stabilisator / stabilizer 20 (mot.) ASY, BNX, BPA, CCNA, CCRA / PR-0AS+1BD / Ø Stabilisator / stabilizer 20	
	(5) (mot.) CHFB PR-1ZN/1ZF/0AR	



Ref. - No.



SWAG Ref. - No.				
30 91 9406	6Q0 407 365 A	Traggelenk / ball joint	(1)	
30 91 9408	6Q0 407 366 A	Traggelenk / ball joint	(1)	
30 91 9410	6Q0 407 365 A S1	Rep. Satz Traggelenk / rep. kit ball joint	PR-1ZN / 1ZF	
30 91 9412	6Q0 407 366 A S1	Rep. Satz Traggelenk / rep. kit ball joint	PR-1ZN / 1ZF	
30 91 9518	6Q0 411 315 Q	Verbindungsstange / connecting rod	05 →	
30 92 7530	6Q0 407 151 L	Querlenker / control arm		
30 92 7638	6Q0 411 314 P	Stabilisatorlager / stabilizer mount		Ø I 16
30 92 7640	6Q0 411 314 Q	Stabilisatorlager / stabilizer mount	05 →	Ø I 17
30 92 7642	6Q0 411 314 Q	Stabilisatorlager / stabilizer mount	(4)	
30 93 1253	1K0 407 183 E	Querlenkerlager / control arm mount	05 →	Ø A 63
30 93 6098	6Q0 407 182 A	Querlenkerlager / control arm mount		Ø A 32
30 93 7077	6Q0 411 314 P S1	Stabilisatorlagersatz / anti roll bar bush kit	05 → / PR-0AQ	
30 93 7090	6Q0 411 305 AL S2	Rep. Satz Stabilisatorsatz / rep. kit stabilizer kit	05 → / PR-0AQ	
30 93 7196	6Q0 407 151 L S3	Rep. Satz Querlenker / rep. kit control arm	05 →	
30 93 7197	6Q0 407 151 L S2	Rep. Satz Querlenker / rep. kit control arm	05 →	
30 93 7291	6Q0 407 151 L S5	Rep. Satz Querlenker / rep. kit control arm	05 →	
30 93 7292	6Q0 407 151 L S4	Rep. Satz Querlenker / rep. kit control arm	05 →	
30 93 7657	6Q0 411 314 P S2	Stabilisatorlagersatz / anti roll bar bush kit	(2)	Ø I 16
30 93 7660	6Q0 411 314 Q S2	Stabilisatorlagersatz / stabilizer mount kit	(5)	Ø I 17
30 93 8621	6Q0 423 831 D	Lenkmanschette / steering boot	PR-1N2	
30 93 8622	6Q0 423 831 D S1	Rep. Satz Lenkmanschette / rep. kit steering boot	PR-1N2	
30 93 9228	1K0 407 183 E S1	Querlenkerlagersatz / control arm mounting kit		
32 69 0009	1J0 407 181	Querlenkerlager / control arm mount	(3)	3x60x41



Fox (5Z) (2004 →)

Vorderachse / Front axle

man.

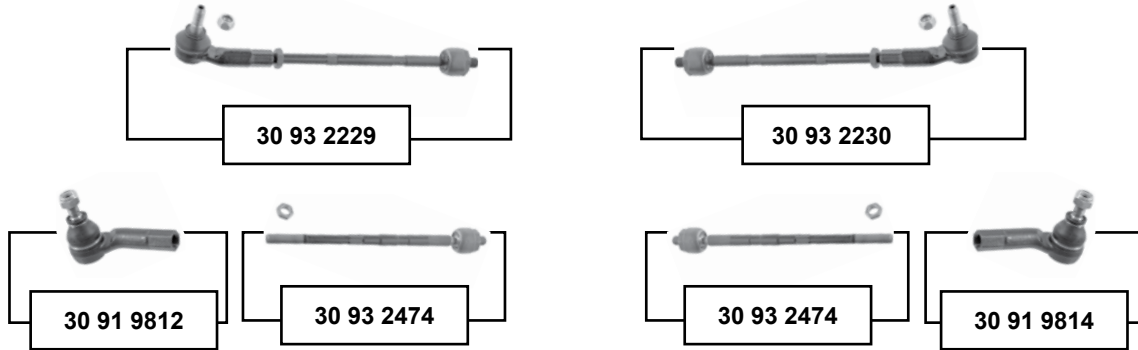

für / to fit servo TRW

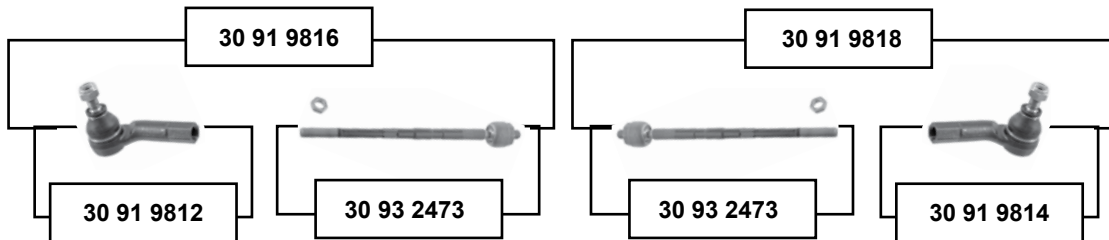

für / to fit servo KOYO

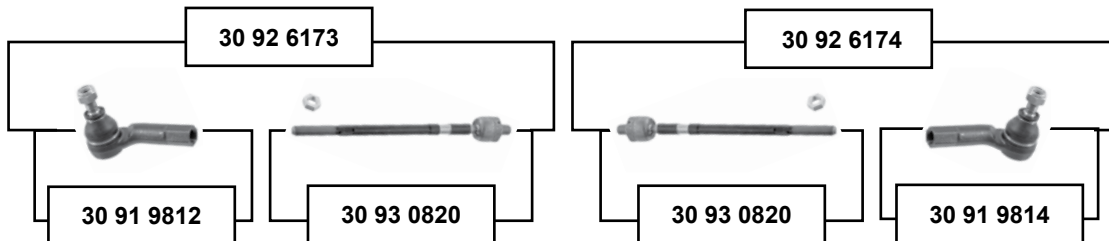

(1) 05 → 07 (ch.) → 5Z-7000 800 / ch.) → 5Z-74047 547



Ref. - No.



30 91 9812	6R0 423 811	Spurstangenendstück / tie rod end		
30 91 9814	6R0 423 812	Spurstangenendstück / tie rod end		
30 91 9816	6Q0 423 803 P	Spurstange / tie rod		
30 91 9818	6Q0 423 804 P	Spurstange / tie rod		
30 92 6173	6Q0 423 803 G	Rep. Satz Spurstange / rep. kit tie rod		
30 92 6174	6Q0 423 804 G	Rep. Satz Spurstange / rep. kit tie rod		
30 93 0820	6Q0 423 810 C	Spurstange / tie rod	(1) LHD	M14 x 1,5
30 93 2229	6Q0 419 803 F	Spurstange / tie rod		M12 x 1,5
30 93 2230	6Q0 419 804 F	Spurstange / tie rod		M12 x 1,5
30 93 2473	6Q0 423 810 P	Spurstange / tie rod	05 →	M14 x 1,5
30 93 2474	6Q0 419 810 B	Spurstange / tie rod		M14 x 1,5



Golf 1 (17) / Cabrio (15) (1975 → 1984) / (1979 → 1993)

man.

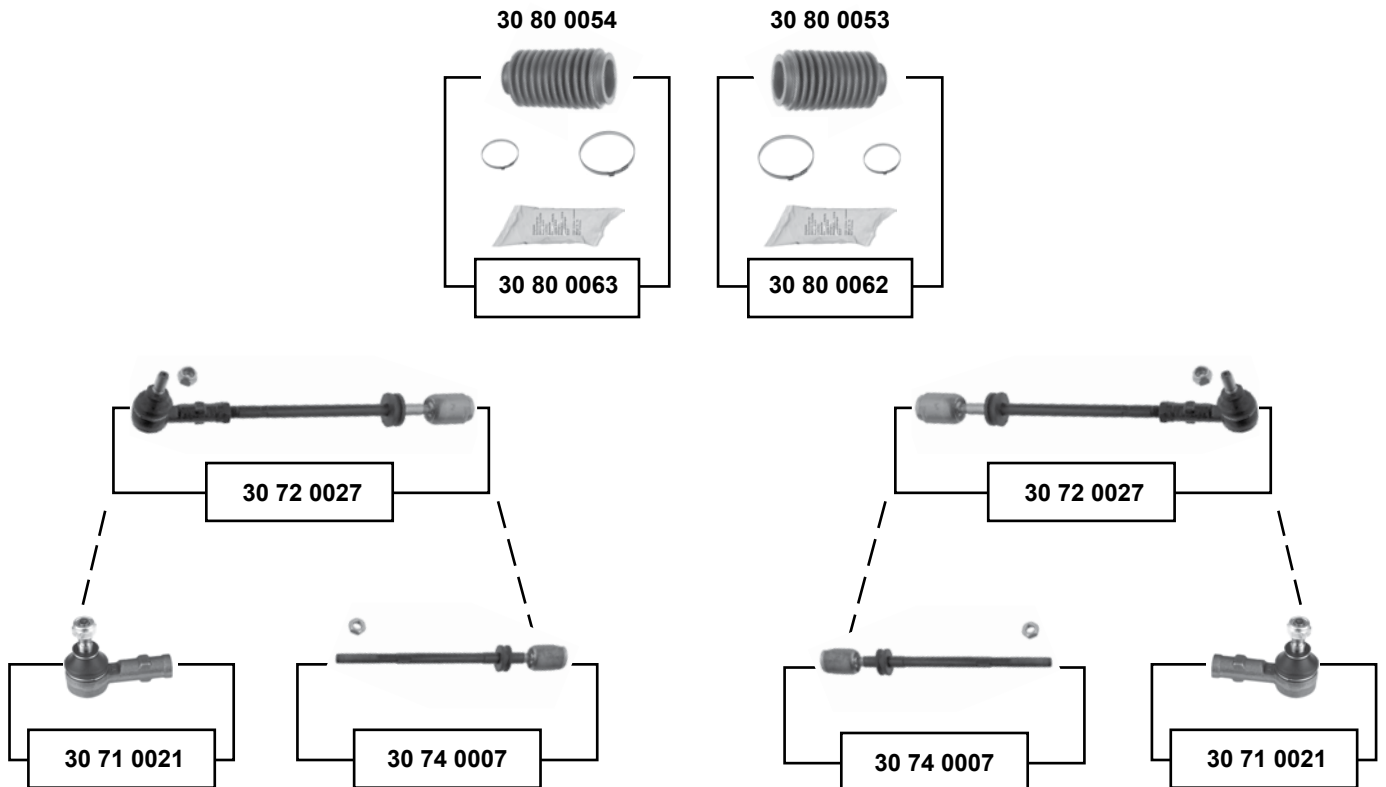

servo

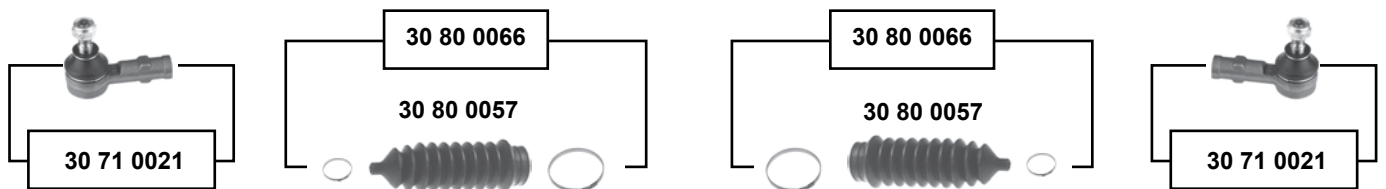

30 71 0021	171 419 812	Rep. Satz Spurstangenendstück / rep. kit tie rod end	M14x1,5 RHT
30 72 0027	171 419 804	Rep. Satz Spurstange / rep. kit tie rod	
30 74 0007	171 419 821	Axialgelenk / axial joint	M14x1,5 RHT
30 80 0053	171 419 832 C	Lenkmanschette / steering boot	
30 80 0054	191 419 831	Lenkmanschette / steering boot	
30 80 0057	1H0 422 831 B	Lenkmanschette / steering boot	
30 80 0062	171 419 832 C S1	Rep. Satz Lenkmanschette / rep. kit steering boot	
30 80 0063	191 419 831 S	Rep. Satz Lenkmanschette / rep. kit steering boot	
30 80 0066	1H0 422 831 B S1	Rep. Satz Lenkmanschette / rep. kit steering boot	



VOLKSWAGEN

Golf 1 (17) / Cabrio (15) (1975 → 1984) / (1979 → 1993)

Vorderachse / Front axle

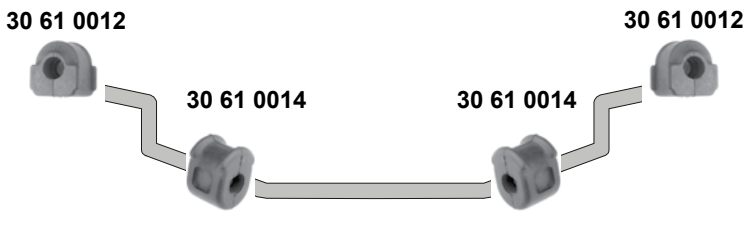
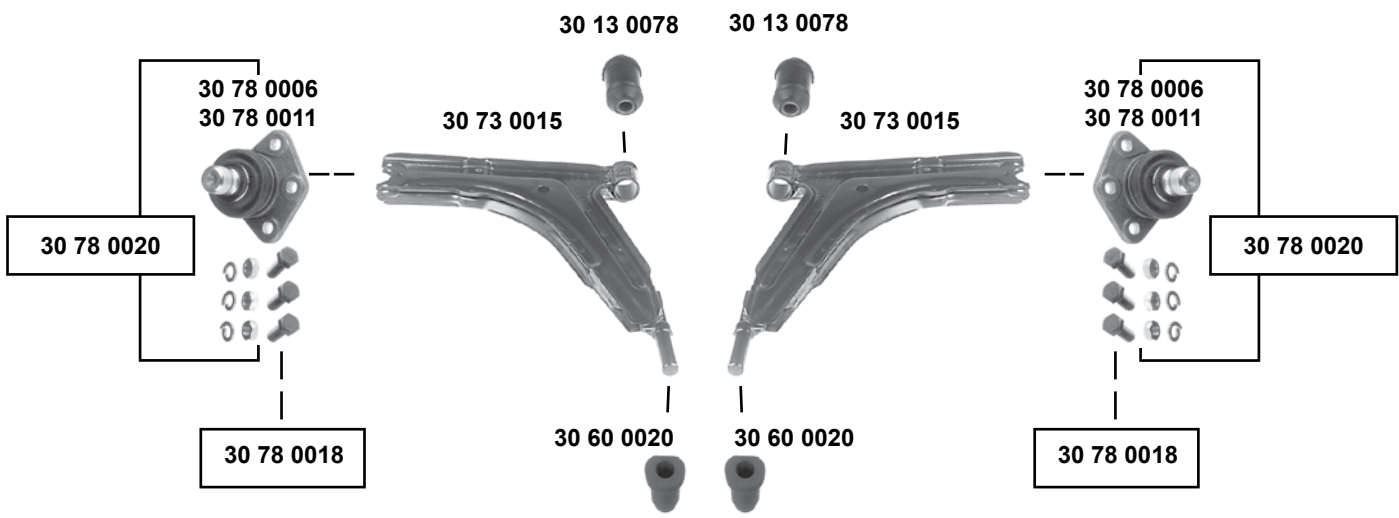

Ref. - No.



30 13 0078	171 407 182 D	Querlenkerlager / control arm mount		
30 60 0020	171 407 181 A	Querlenkerlager / control arm mount		12x32x61 16x38x55
30 61 0012	171 411 314 A	Stabilisatorlager / stabilizer mount		Ø I 15
30 61 0014	171 411 313	Stabilisatorlager / stabilizer mount		Ø I 15
30 73 0015	171 407 153 D	Querlenker ohne Gummilager / control arm excl. rubber mounts		
30 78 0006	171 407 365 C	Traggelenk / ball joint	(ch.) → 178 3173 583	Ø A 15
30 78 0011	171 407 365 F	Traggelenk / ball joint	(ch.) 178 3173 584 →	Ø A 17
30 78 0018	171 407 365 F S1	Rep. Satz Traggelenk / rep. kit ball joint	(ch.) 178 3173 584 →	
30 78 0020	171 407 365 C S1	Rep. Satz Traggelenk / rep. kit ball joint	(ch.) → 178 3173 583	
30 93 9813	171 407 365 F S2	Rep. Satz Traggelenk / rep. kit ball joint		



Golf 2 (19/1G) (1984 → 1992)

man.

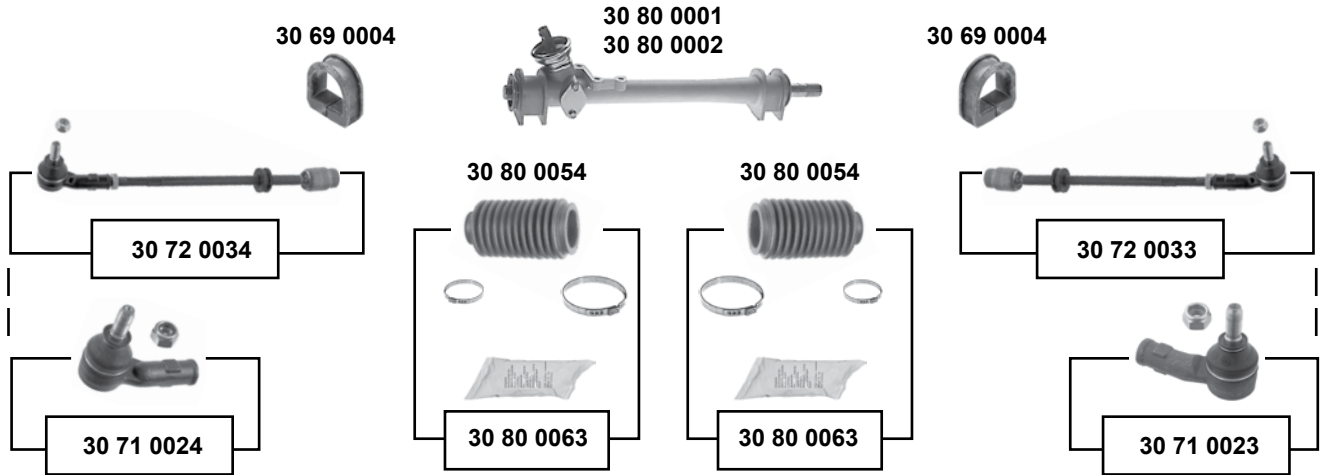

servo

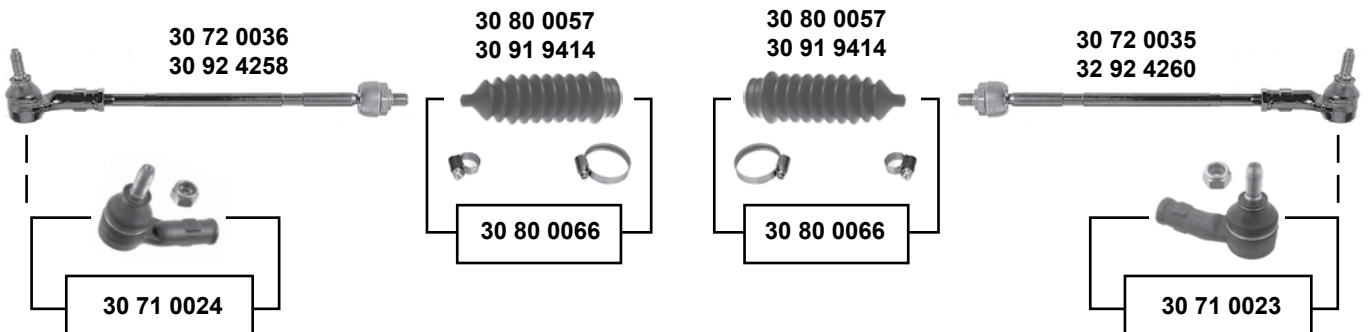

(1) (ch.) 1G-MW-339 716 / 1G-MB-125 000 →

(2) (ch.) → 1G-MW-339 715 / 1G-MB 124 999



Ref. - No.



30 69 0004	191 419 883	Lenkgetriebelager / steering gear bearing		
30 71 0023	191 419 812	Spurstangenendstück / tie rod end	(ch.) 19-E-300 000 →	M12 x 1,5
30 71 0024	191 419 811	Spurstangenendstück / tie rod end	(ch.) 19-E-300 000 →	M12 x 1,5
30 72 0033	191 419 804	Spurstange / tie rod	TRW servo	
30 72 0034	191 419 803	Spurstange / tie rod	TRW servo	
30 72 0035	191 422 804 A	Spurstange / tie rod		
30 72 0036	191 422 803 A	Spurstange / tie rod		
30 80 0001	191 419 063 C	Lenkgetriebe / steering gear	(1) LHD	
30 80 0002	191 419 063 B	Lenkgetriebe / steering gear	(2) LHD	
30 80 0054	191 419 831	Lenkmanschette / steering boot		
30 80 0057	1H0 422 831 B	Lenkmanschette / steering boot	TRW servo	
30 80 0063	191 419 831 S	Rep. Satz Lenkmanschette / rep. kit steering boot		
30 80 0066	1H0 422 831 B S1	Rep. Satz Lenkmanschette / rep. kit steering boot		
30 91 9414	357 422 831 B	Lenkmanschette / steering boot	ZF servo	
30 92 4258	191 422 803 C	Spurstange / tie rod	ZF servo	
32 92 4260	191 422 804 C	Spurstange / tie rod	ZF servo	



Golf 2 (19/1G) (1984 → 1992)

Vorderachse / Front axle

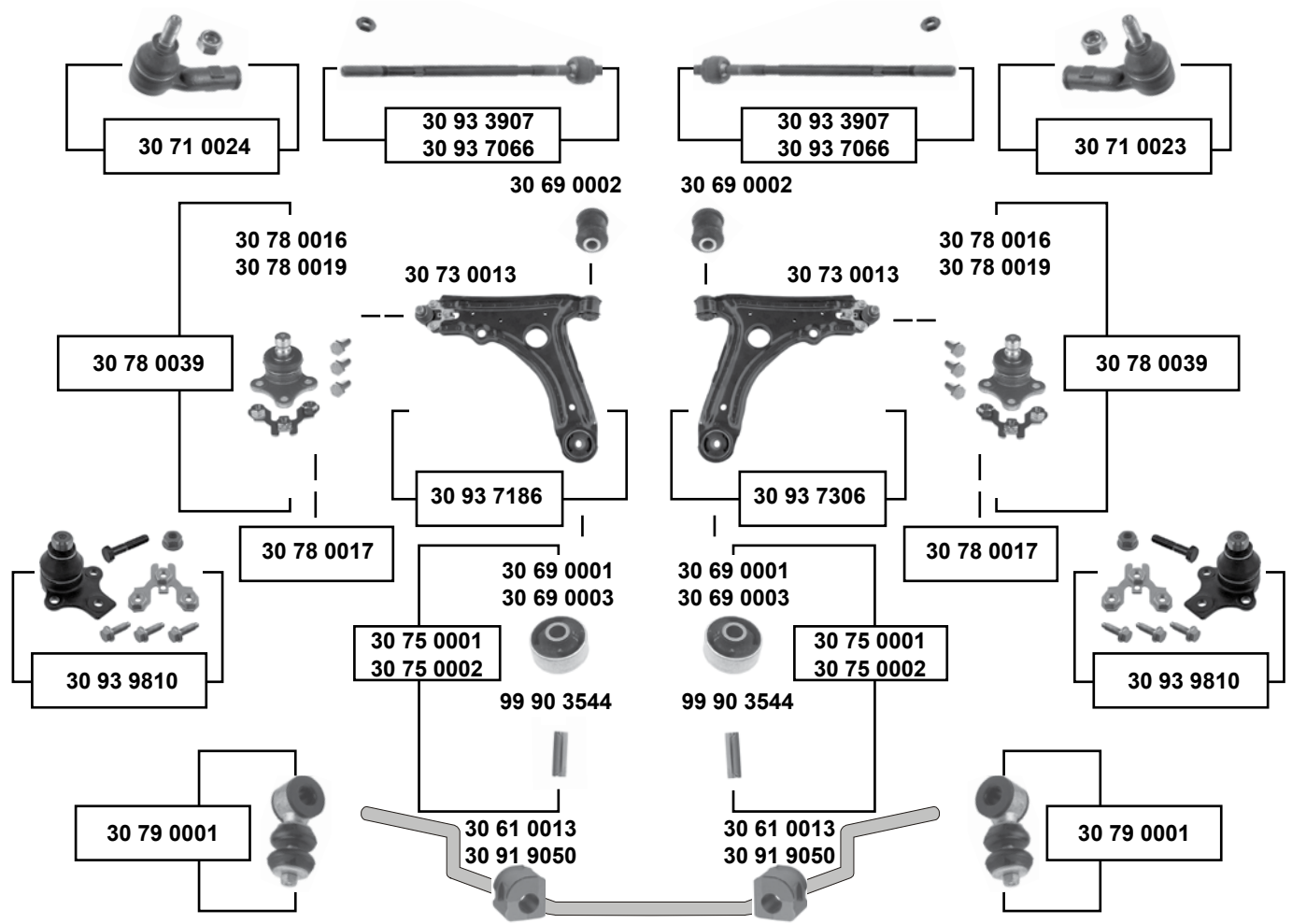

- (1) 84 → 89 alle / all // 90 → 92 (ex.) (mot.) ABF / 2,0 16V
- (2) (ch.) 19-JB000 001 → / (ch.) 1-JW000 001 →

SWAG GERMANY	Ref. - No.			
30 61 0013	191 411 314	Stabilisatorlager / stabilizer mount	(ex.) G60	Ø 17
30 69 0001	191 407 181 D	Querlenkerlager / control arm mount	NEW	17x60x41
30 69 0002	357 407 182	Querlenkerlager / control arm mount		12x33x54
30 69 0003	191 407 181 B	Querlenkerlager / control arm mount	OLD	17x60x41
30 71 0023	191 419 812	Spurstangenendstück / tie rod end		M12 x 1,5
30 71 0024	191 419 811	Spurstangenendstück / tie rod end		M12 x 1,5
30 73 0013	191 407 151 B	Querlenker mit Gummilagern / control arm incl. rubber mounts		
30 75 0001	191 407 181 B S1	Querlenkerlager mit Hülse / control arm mount with sleeve		
30 75 0002	191 407 181 D S1	Querlenkerlager mit Hülse / control arm mount with sleeve		
30 78 0016	191 407 365	Traggelenk / ball joint	(ch.) → H-999 999	Ø A 17
30 78 0017	357 407 365 S1	Rep. Satz Traggelenk / rep. kit ball joint	(ch.) J-000 001 →	
30 78 0019	357 407 365	Traggelenk / ball joint	(ch.) J-000 001 →	Ø A 19
30 78 0039	191 407 365 S1	Rep. Satz Traggelenk / rep. kit ball joint	(ch.) → H-999 999	
30 79 0001	191 411 315 B S1	Rep. Satz Verbindungsstange / rep. kit connecting rod	(1)	Metall
30 91 9050	1H0 411 314	Stabilisatorlager / stabilizer mount		Ø 19
30 93 3907	191 422 810 A	Axialgelenk / axial joint	servo.	
30 93 7066	191 419 810	Axialgelenk / axial joint	(ex.) servo.	M12 x 1,5
30 93 7186	191 407 151 B S1	Rep. Satz Querlenker / rep. kit control arm		
30 93 7306	191 407 151 B S2	Rep. Satz Querlenker / rep. kit control arm		
30 93 9810	357 407 365 S2	Rep. Satz Traggelenk / rep. kit ball joint	(2)	
99 90 3544	191 407 190 A	Hülse / sleeve		50x17



Golf 3 (1H)

(1992 → 1999)

Golf 3 Limousine (ex.) 16V / VR6 / GTI

man.

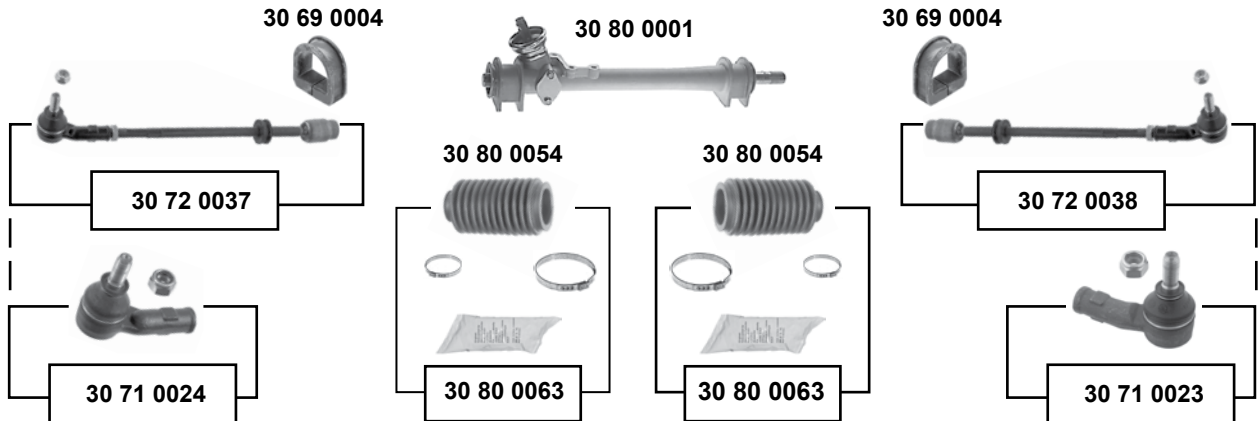

für / to fit servo ZF

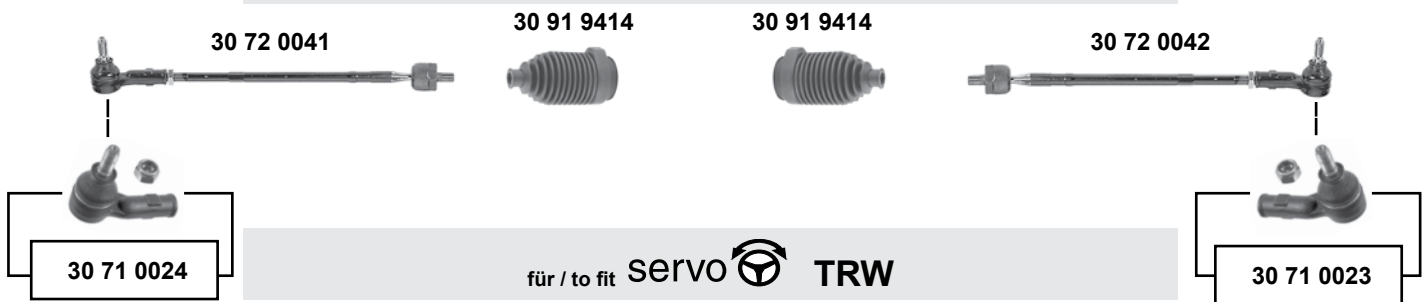

für / to fit servo TRW

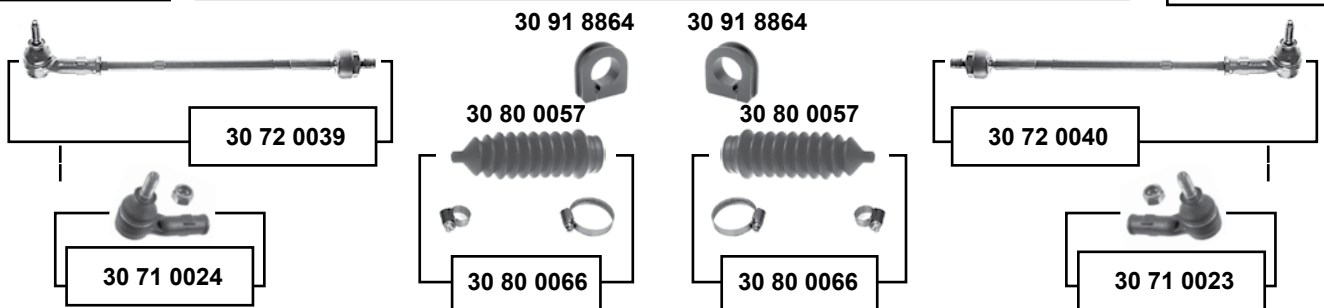

Ref. - No.



SWAG Ref. - No.	Ref. - No.	Description	Notes	Dimensions
30 69 0004	191 419 883	Lenkgetriebelager / steering gear bearing		
30 71 0023	191 419 812	Spurstangenendstück / tie rod end		M12 x 1,5
30 71 0024	191 419 811	Spurstangenendstück / tie rod end		M12 x 1,5
30 72 0037	1H0 419 803	Spurstange / tie rod		
30 72 0038	1H0 419 804	Spurstange / tie rod		
30 72 0039	1H0 422 803	Spurstange / tie rod		
30 72 0040	1H0 422 804	Spurstange / tie rod		
30 72 0041	1H0 422 803 B	Spurstange / tie rod		
30 72 0042	1H0 422 804 B	Spurstange / tie rod		
30 80 0001	191 419 063 C	Lenkgetriebe / steering gear	LHD	
30 80 0054	191 419 831	Lenkmanschette / steering boot		
30 80 0057	1H0 422 831 B	Lenkmanschette / steering boot		
30 80 0063	191 419 831 S	Rep. Satz Lenkmanschette / rep. kit steering boot		
30 80 0066	1H0 422 831 B S1	Rep. Satz Lenkmanschette / rep. kit steering boot		
30 91 8864	1H0 422 884	Lenkgetriebelager / steering gear bearing		
30 91 9414	357 422 831 B	Lenkmanschette / steering boot		



VOLKSWAGEN

Golf 3 (1H) (1992 → 1999)

Golf 3 Limousine (ex.) 16V / VR6 / GTI

Vorderachse / Front axle

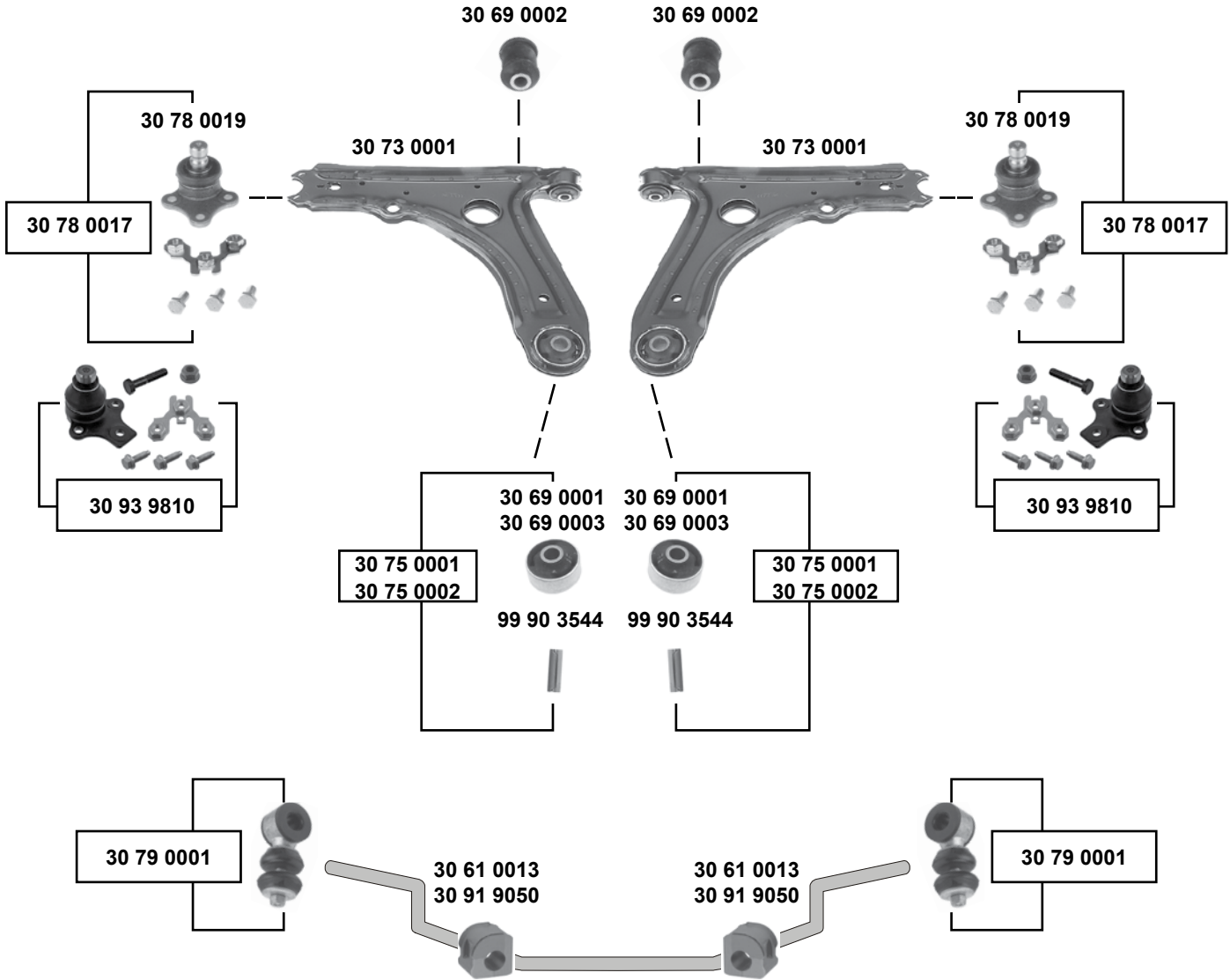

SWAG GERMANY	Ref. - No.			
30 60 0001	191 407 181 D	Querlenkerlager / control arm mount	NEW	17x60x41
30 61 0013	191 411 314	Stabilisatorlager / stabilizer mount	(ex.) 2.0	Ø I 17
30 69 0002	357 407 182	Querlenkerlager / control arm mount	OLD	12x33x54
30 69 0003	191 407 181 B	Querlenkerlager / control arm mount	OLD	17x60x41
30 73 0001	1H0 407 151	Querlenker / control arm	OLD	
30 75 0001	191 407 181 B S1	Querlenkerlager mit Hülse / control arm mount with sleeve	OLD	
30 75 0002	191 407 181 D S1	Querlenkerlager mit Hülse / control arm mount with sleeve	NEW	
30 78 0017	357 407 365 S1	Rep. Satz Traggelenk / rep. kit ball joint		
30 78 0019	357 407 365	Traggelenk / ball joint		Ø A 19
30 79 0001	191 411 315 B S1	Rep. Satz Verbindungsstange / rep. kit connecting rod	→ 98	Metall
30 91 9050	1H0 411 314	Stabilisatorlager / stabilizer mount		Ø I 19
30 93 9810	357 407 365 S2	Rep. Satz Traggelenk / rep. kit ball joint		
99 90 3544	191 407 190 A	Hülse / sleeve		50x17



Golf 3 (1H) (1992 → 1999)

Golf 3 Limousine 16V / VR6 / GTI

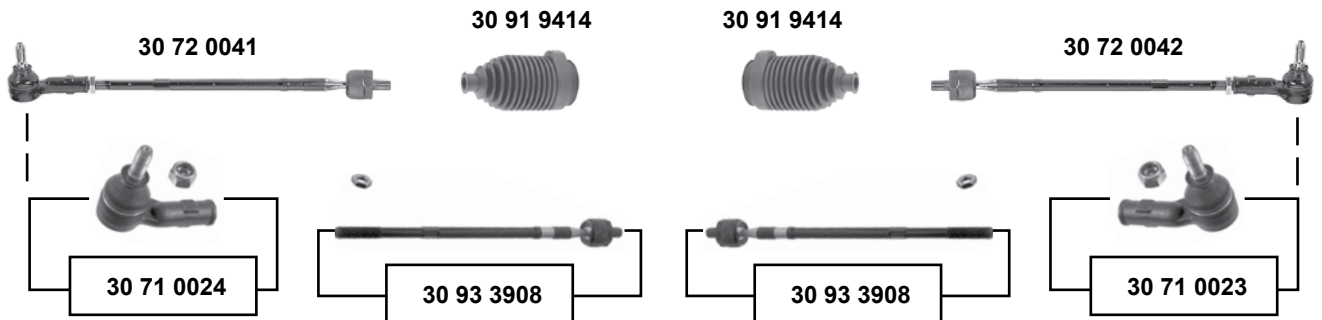

für / to fit servo  ZF

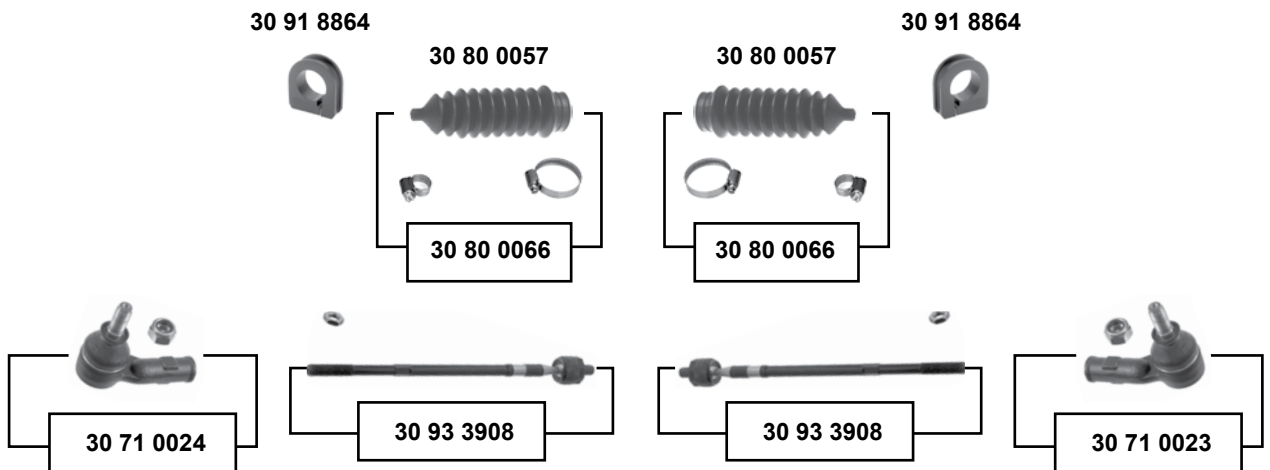

für / to fit servo  TRW



Vorderachse / Front axle

SWAG	Ref. - No.			
30 71 0023	191 419 812	Spurstangenendstück / tie rod end		M12 x 1,5
30 71 0024	191 419 811	Spurstangenendstück / tie rod end		M12 x 1,5
30 72 0041	1H0 422 803 B	Spurstange / tie rod		
30 72 0042	1H0 422 804 B	Spurstange / tie rod		
30 80 0057	1H0 422 831 B	Lenkmanschette / steering boot		
30 80 0066	1H0 422 831 B S1	Rep. Satz Lenkmanschette / rep. kit steering boot		
30 91 8864	1H0 422 884	Lenkgetriebebelager / steering gear bearing		
30 91 9414	357 422 831 B	Lenkmanschette / steering boot		
30 93 3908	1H0 422 810	Axialgelenk / axial joint		M14 x 1,5



VOLKSWAGEN

Golf 3 (1H) (1992 → 1999)

Golf 3 Limousine 16V / VR6 / GTI

Vorderachse / Front axle

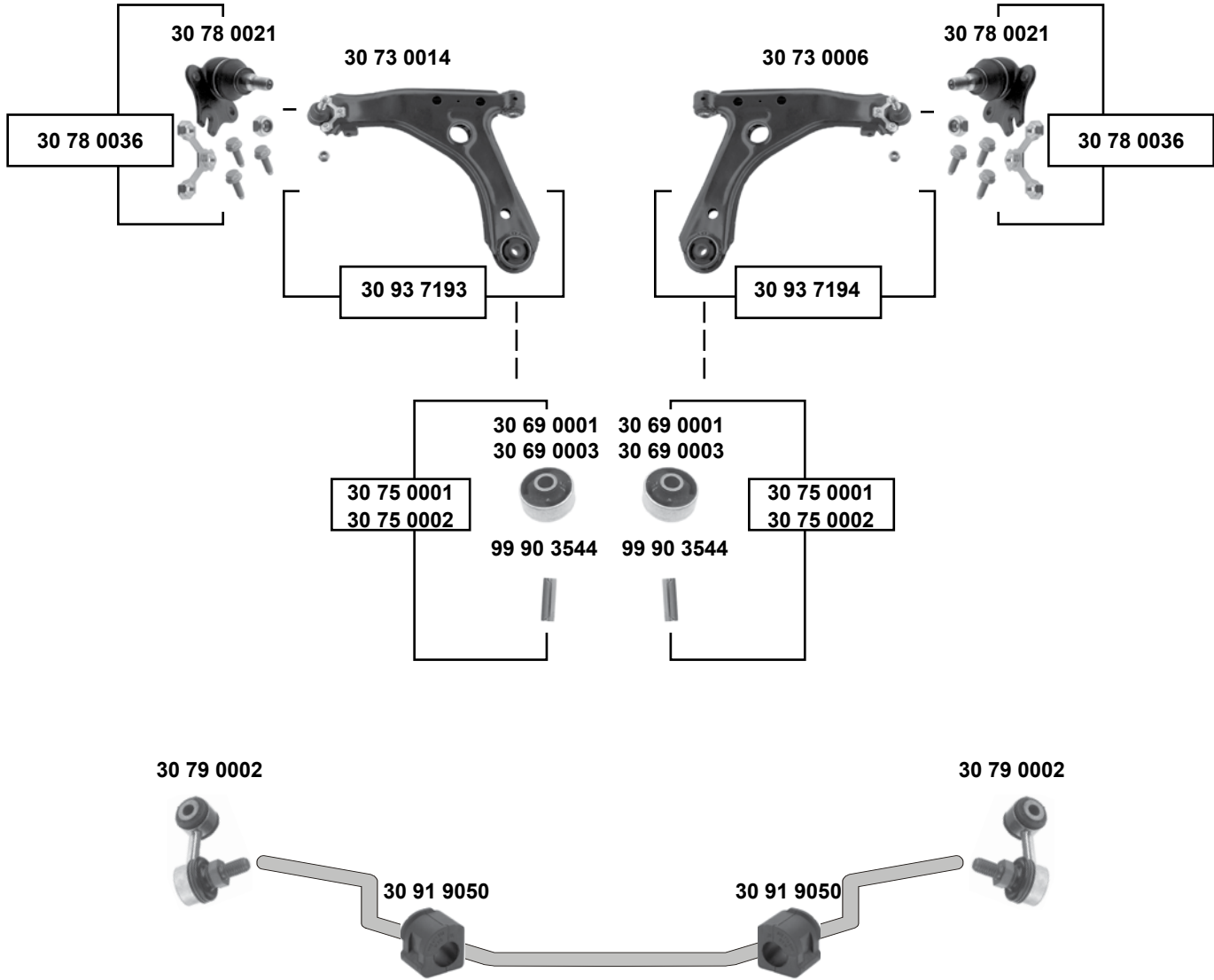

SWAG GERMANY	Ref. - No.			
30 60 0001	191 407 181 D	Querlenkerlager / control arm mount	NEW	17x60x41
30 69 0003	191 407 181 B	Querlenkerlager / control arm mount	OLD	17x60x41
30 73 0006	1H0 407 152	Querlenker / control arm		
30 73 0014	1H0 407 151 A	Querlenker / control arm		
30 75 0001	191 407 181 B S1	Querlenkerlager mit Hülse / control arm mount with sleeve	OLD	
30 75 0002	191 407 181 D S1	Querlenkerlager mit Hülse / control arm mount with sleeve	NEW	
30 78 0021	1H0 407 365	Traggelenk / ball joint		M12 x 1,5
30 78 0036	1H0 407 365 S1	Rep. Satz Traggelenk / rep. kit ball joint		
30 79 0002	535 411 315	Verbindungsstange / connecting rod		L 55
30 91 9050	1H0 411 314	Stabilisatorlager / stabilizer mount		Ø 1 19
30 93 7193	1H0 407 151 A S1	Querlenker mit Traggelenk / control arm with ball joint	→ 97	
30 93 7194	1H0 407 152 S1	Querlenker mit Traggelenk / control arm with ball joint	→ 97	
99 90 3544	191 407 190 A	Hülse / sleeve		50x17



Golf 3 Variant (1H) (1992 → 1999)

man.

Vorderachse / Front axle

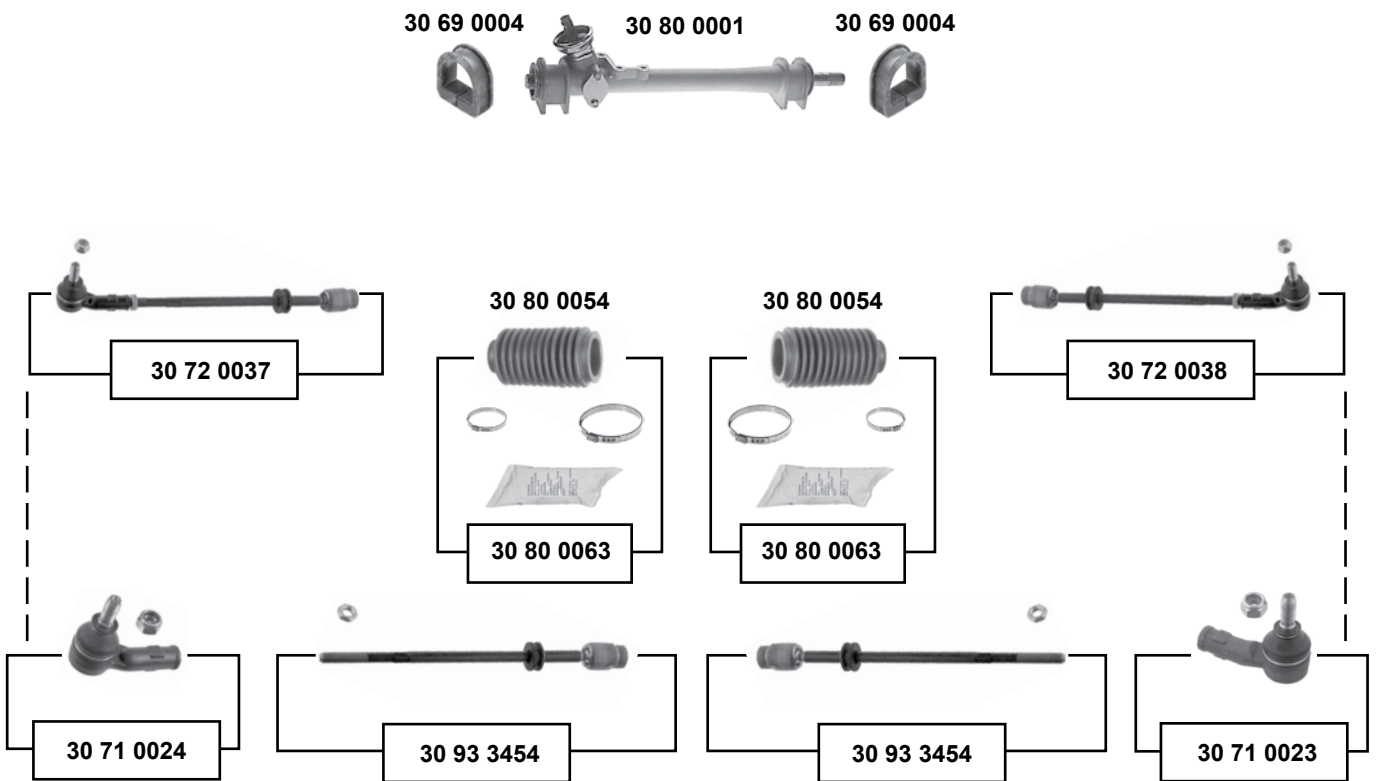

SWAG	Ref. - No.			
30 69 0004	191 419 883			
30 71 0023	191 419 812			M12 x 1,5
30 71 0024	191 419 811			M12 x 1,5
30 72 0037	1H0 419 803			
30 72 0038	1H0 419 804			
30 80 0001	191 419 063 C		LHD	
30 80 0054	191 419 831			
30 80 0063	191 419 831 S			
30 93 3454	1H0 419 810			
		Lenkgetriebelager / steering gear bearing		
		Spurstangenendstück / tie rod end		
		Spurstangenendstück / tie rod end		
		Spurstange / tie rod		
		Spurstange / tie rod		
		Lenkgetriebe / steering gear	LHD	
		Lenkmanschette / steering boot		
		Rep. Satz Lenkmanschette / rep. kit steering boot		
		Spurstange / tie rod		



Golf 3 Variant (1H)

(1992 → 1999)

man.

Vorderachse / Front axle

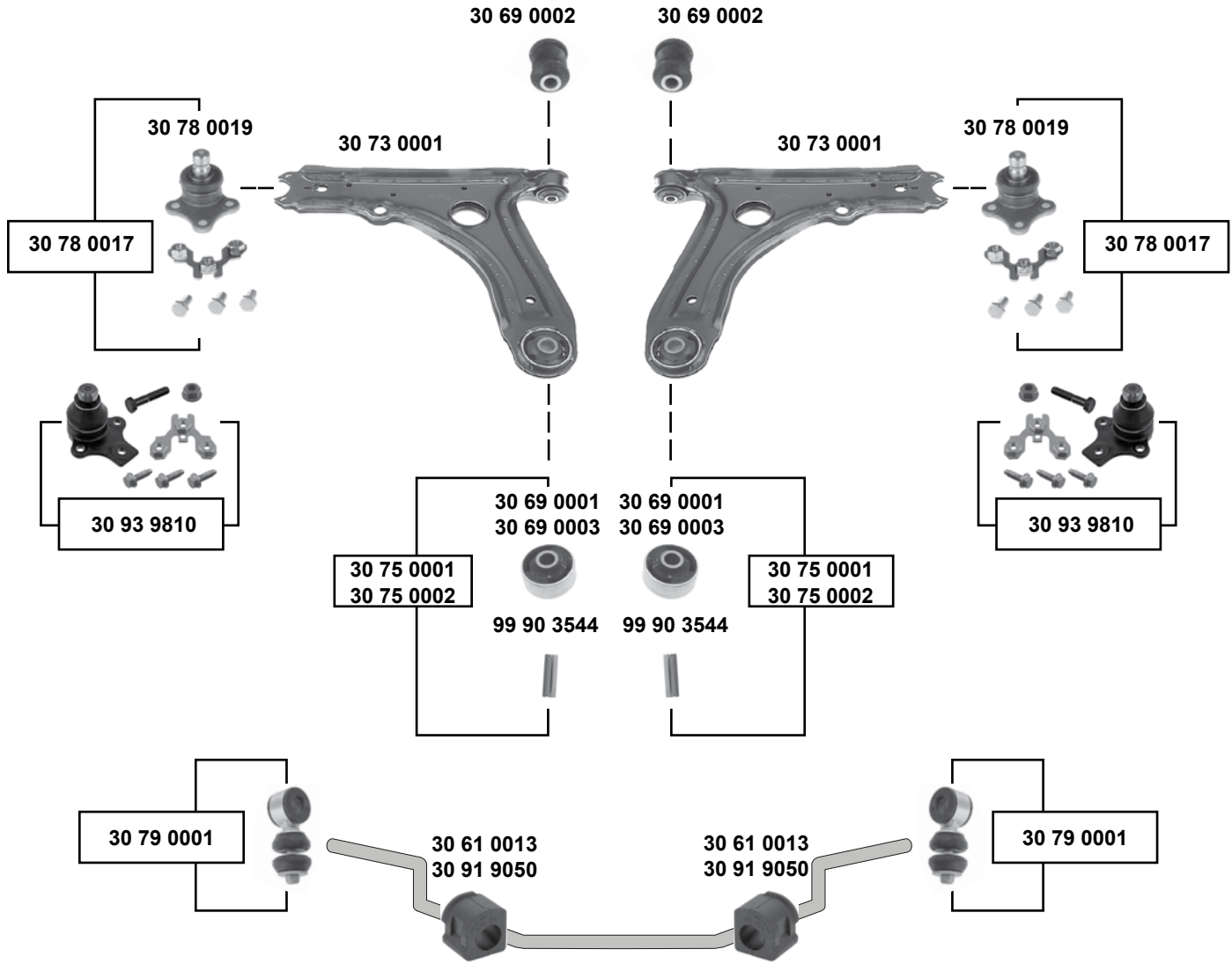

SWAG GERMANY	Ref. - No.			
30 61 0013	191 411 314	Stabilisatorlager / stabilizer mount	(ex.) 2.0	Ø I 17
30 69 0001	191 407 181 D	Querlenkerlager / control arm mount	NEW	17x60x41
30 69 0002	357 407 182	Querlenkerlager / control arm mount	OLD	12x33x54
30 69 0003	191 407 181 B	Querlenkerlager / control arm mount	OLD	17x60x41
30 73 0001	1H0 407 151	Querlenker / control arm	OLD	
30 75 0001	191 407 181 B S1	Querlenkerlager mit Hülse / control arm mount with sleeve	NEW	
30 75 0002	191 407 181 D S1	Querlenkerlager mit Hülse / control arm mount with sleeve		
30 78 0017	357 407 365 S1	Rep. Satz Traggelenk / rep. kit ball joint		
30 78 0019	357 407 365	Traggelenk / ball joint		Ø A 19
30 79 0001	191 411 315 B S1	Rep. Satz Verbindungsstange / rep. kit connecting rod		
30 91 9050	1H0 411 314	Stabilisatorlager / stabilizer mount		Ø I 19
30 93 9810	357 407 365 S2	Rep. Satz Traggelenk / rep. kit ball joint		
99 90 3544	191 407 190 A	Hülse / sleeve		50x17



Golf 3 Variant (1H) (1992 → 1999)

für / to fit servo  ZF

(ex.) 1.9 TDI (81kW)

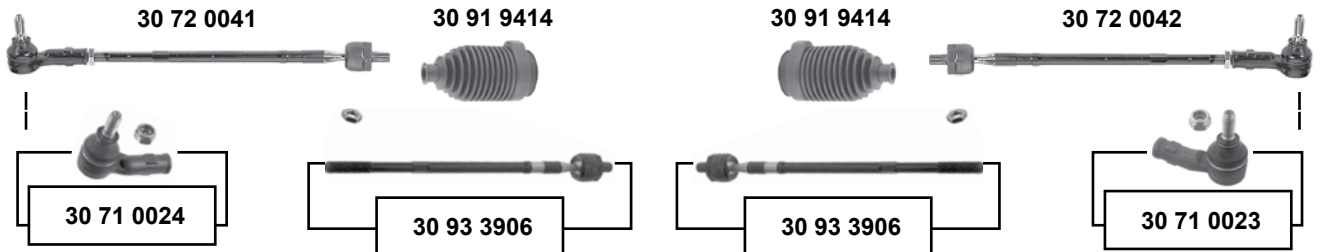

1.9 TDI (81kW)



30 91 8864

für / to fit servo  TRW

30 91 8864

(ch.) → 1H-R-458 663

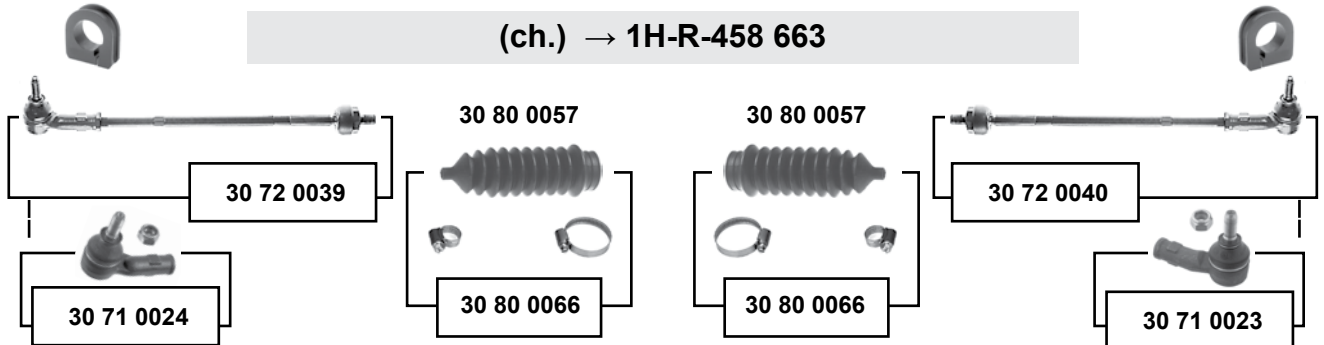

(ch.) 1H-R-458 664 →

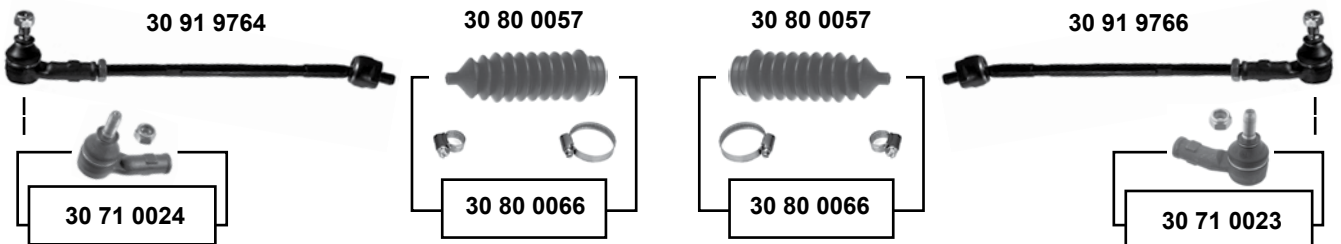

30 71 0023	191 419 812
30 71 0024	191 419 811
30 72 0039	1H0 422 803
30 72 0040	1H0 422 804
30 72 0041	1H0 422 803 B
30 72 0042	1H0 422 804 B
30 80 0057	1H0 422 831 B
30 80 0066	1H0 422 831 B S1
30 91 8864	1H0 422 884
30 91 9414	357 422 831 B
30 91 9764	1H0 422 803 D
30 91 9766	1H0 422 804 D
30 93 3906	1H0 422 810 B

Spurstangenendstück / tie rod end
Spurstangenendstück / tie rod end
Spurstange / tie rod
Spurstange / tie rod
Spurstange / tie rod
Spurstange / tie rod
Lenkmanschette / steering boot
Rep. Satz Lenkmanschette / rep. kit steering boot
Lenkgetriebelager / steering gear bearing
Lenkmanschette / steering boot
Spurstange / tie rod
Spurstange / tie rod
Spurstange / tie rod

M12 x 1,5
M12 x 1,5



Golf 3 Variant (1H)

(1992 → 1999)

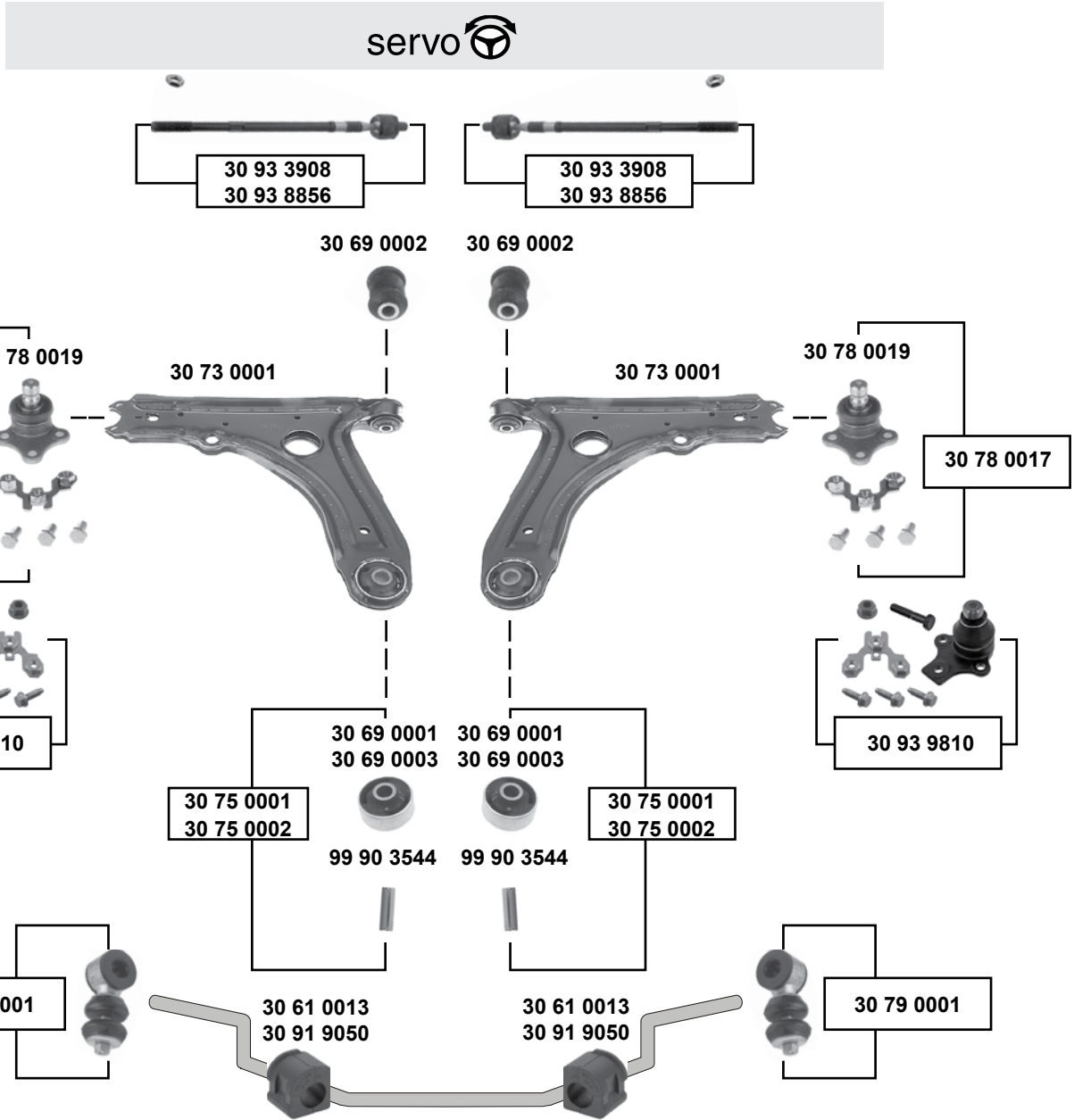

SWAG GERMANY	Ref. - No.			
30 61 0013	191 411 314	Stabilisatorlager / stabilizer mount		Ø I 17
30 69 0001	191 407 181 D	Querlenkerlager / control arm mount	NEW	17x60x41
30 69 0002	357 407 182	Querlenkerlager / control arm mount	OLD	12x33x54
30 69 0003	191 407 181 B	Querlenkerlager / control arm mount		17x60x41
30 73 0001	1H0 407 151	Querlenker / control arm		
30 75 0001	191 407 181 B S1	Querlenkerlager mit Hülse / control arm mount with sleeve	OLD	
30 75 0002	191 407 181 D S1	Querlenkerlager mit Hülse / control arm mount with sleeve	NEW	
30 78 0017	357 407 365 S1	Rep. Satz Traggelenk / rep. kit ball joint		
30 78 0019	357 407 365	Traggelenk / ball joint		Ø A 19
30 79 0001	191 411 315 B S1	Rep. Satz Verbindungsstange / rep. kit connecting rod		
30 91 9050	1H0 411 314	Stabilisatorlager / stabilizer mount		Ø I 19
30 93 3908	1H0 422 810	Axialgelenk / axial joint		
30 93 8856	1H0 422 810 D	Axialgelenk / axial joint	(ch.) 1G-R-458 664 →	
30 93 9810	357 407 365 S2	Rep. Satz Traggelenk / rep. kit ball joint		
99 90 3544	191 407 190 A	Hülse / sleeve		50x17

Vorderachse / Front axle



Golf 3 Cabrio (1E) (1994 → 2002)

für / to fit servo  ZF

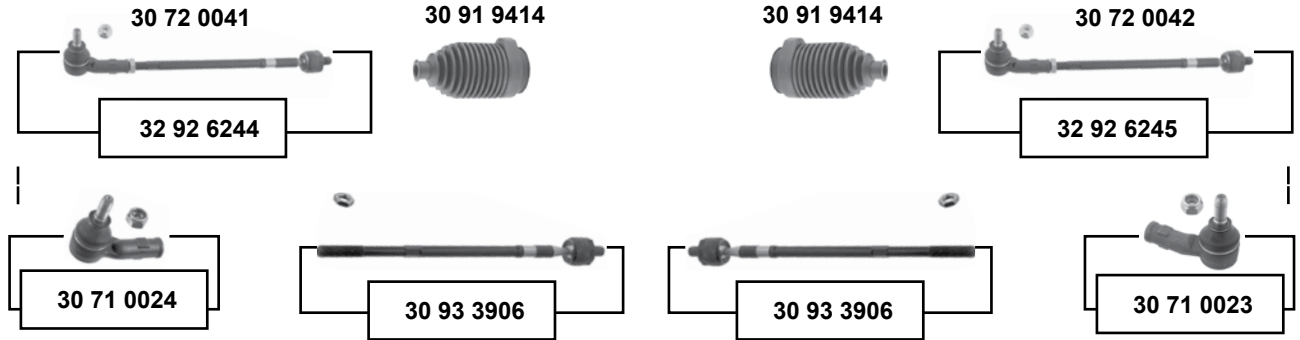

für / to fit servo  TRW

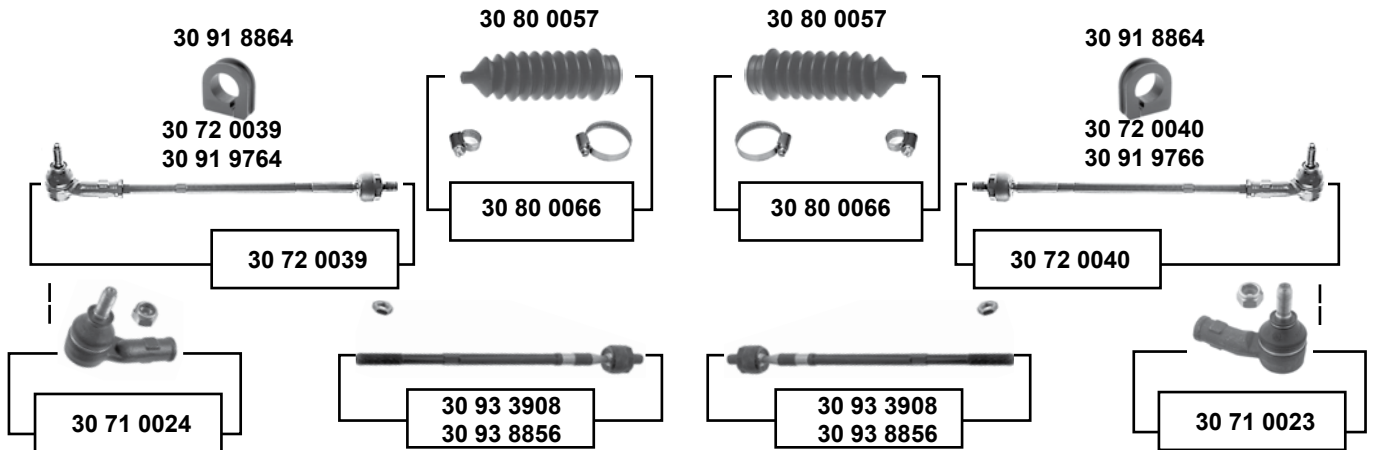

(1) ZF servo  / LHD / RHD / (ch.) → 1E-R-030 000



Ref. - No.



30 72 0041	1H0 422 803 B	Spurstange / tie rod	(ch.) → 1E-R-030 000	
30 72 0042	1H0 422 804 B	Spurstange / tie rod	(ch.) → 1E-R-030 000	
30 71 0023	191 419 812	Rep. Satz Spurstangenendstück / rep. kit tie rod end		M12 x 1,5
30 71 0024	191 419 811	Rep. Satz Spurstangenendstück / rep. kit tie rod end		M12 x 1,5
30 80 0057	1H0 422 831 B	Lenkmanschette / steering boot		
30 72 0040	1H0 422 804	Spurstange / tie rod		M12 x 1,5
30 72 0039	1H0 422 803	Spurstange / tie rod		M12 x 1,5
30 80 0066	1H0 422 831 B S1	Rep. Satz Lenkmanschette / rep. kit steering boot		
30 91 8864	1H0 422 884	Lenkgetriebelager / steering gear bearing		
30 91 9414	357 422 831 B	Lenkmanschette / steering boot	(ex.) Diesel	
30 91 9764	1H0 422 803 D	Spurstange / tie rod	(ch.) 1E-S-000 001 →	
30 91 9766	1H0 422 804 D	Spurstange / tie rod	(ch.) 1E-S-000 001 →	
32 92 6244	1H0 422 803 E	Spurstange / tie rod	(ch.) 1E-S-000 001 →	
32 92 6245	1H0 422 804 E	Spurstange / tie rod	(ch.) 1E-S-000 001 →	
30 93 3906	1H0 422 810 B	Spurstange / tie rod	(1)	
30 93 3908	1H0 422 810	Axialgelenk / axial joint	(ch.) → 1E-R-030 000	M14 x 1,5
30 93 8856	1H0 422 810 D	Axialgelenk / axial joint	(ch.) 1E-S-000 001 →	



Golf 3 Cabrio (1E)

(1994 → 2002)

Vorderachse / Front axle

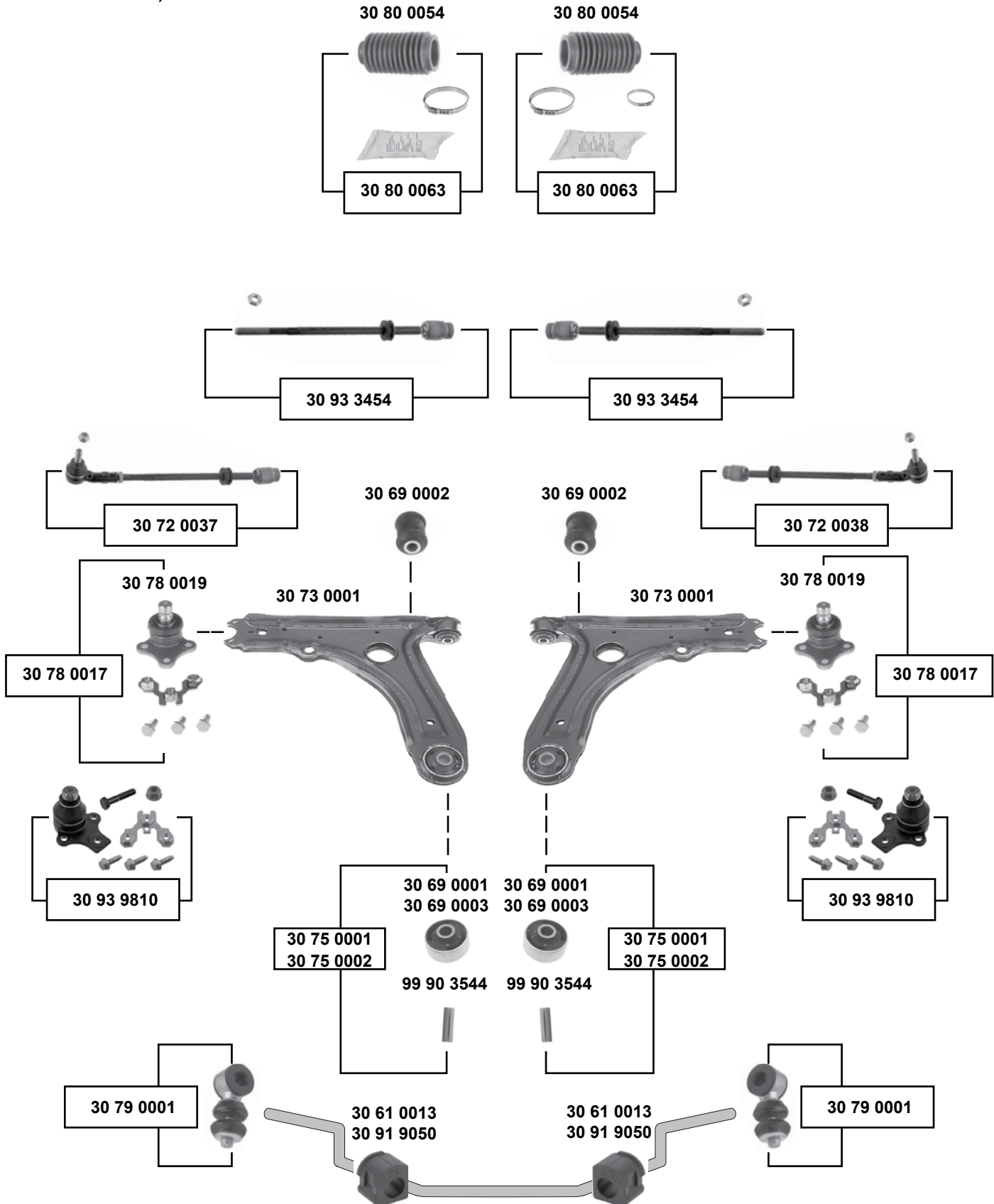











Golf 3 Cabrio (1E)
 (1994 → 2002)

(1) 1.9 TDI (ch.) 1E-V-006001 →

(2) (mot.) ADZ, 2E

(3) (mot.) 2E / PR-1N0

	Ref. - No.			
30 61 0013	191 411 314	Stabilisatorlager / stabilizer mount	(1)	Ø I 17
30 69 0001	191 407 181 D	Querlenkerlager / control arm mount	NEW	17x60x41
30 69 0002	357 407 182	Querlenkerlager / control arm mount		12x33x54
30 69 0003	191 407 181 B	Querlenkerlager / control arm mount	OLD	17x60x41
30 72 0037	1H0 419 803	Spurstange / tie rod	(2) (ex.) servo 	
30 72 0038	1H0 419 804	Spurstange / tie rod	(2) (ex.) servo 	
30 73 0001	1H0 407 151	Querlenker / control arm		
30 75 0001	191 407 181 B S1	Querlenkerlager mit Hülse / control arm mount with sleeve	OLD	
30 75 0002	191 407 181 D S1	Querlenkerlager mit Hülse / control arm mount with sleeve	NEW	
30 78 0017	357 407 365 S1	Rep. Satz Traggelenk / rep. kit ball joint		
30 78 0019	357 407 365	Traggelenk / ball joint		Ø A 19
30 79 0001	191 411 315 B S1	Rep. Satz Verbindungsstange / rep. kit connecting rod		Metall
30 80 0054	191 419 831	Lenkmanschette / steering boot	(2) servo 	
30 80 0063	191 419 831 S	Rep. Satz Lenkmanschette / rep. kit steering boot	(2) servo 	
30 91 9050	1H0 411 314	Stabilisatorlager / stabilizer mount		Ø I 19
30 93 3454	1H0 419 810	Spurstange / tie rod	(3) (ex.) servo 	
30 93 9810	357 407 365 S2	Rep. Satz Traggelenk / rep. kit ball joint		
99 90 3544	191 407 190 A	Hülse / sleeve		50x17



VOLKSWAGEN

Golf 4 (ex.) 4 Motion (1J)

(1998 → 2004)

(ch.) → 1J-WP-050 831 / 1J-WD-039 149 / 1J-WB-027 483 / 1J-WW-062 358

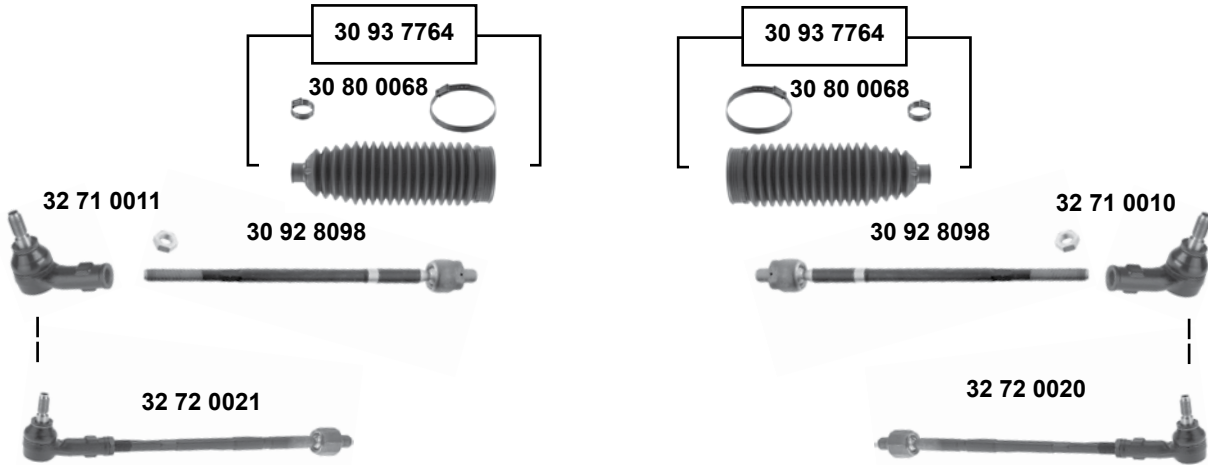

(ch.) 1J-WP-050 832 / 1J-WD-039 150 / 1J-WB-027 484 / 1J-WW-062 359 →

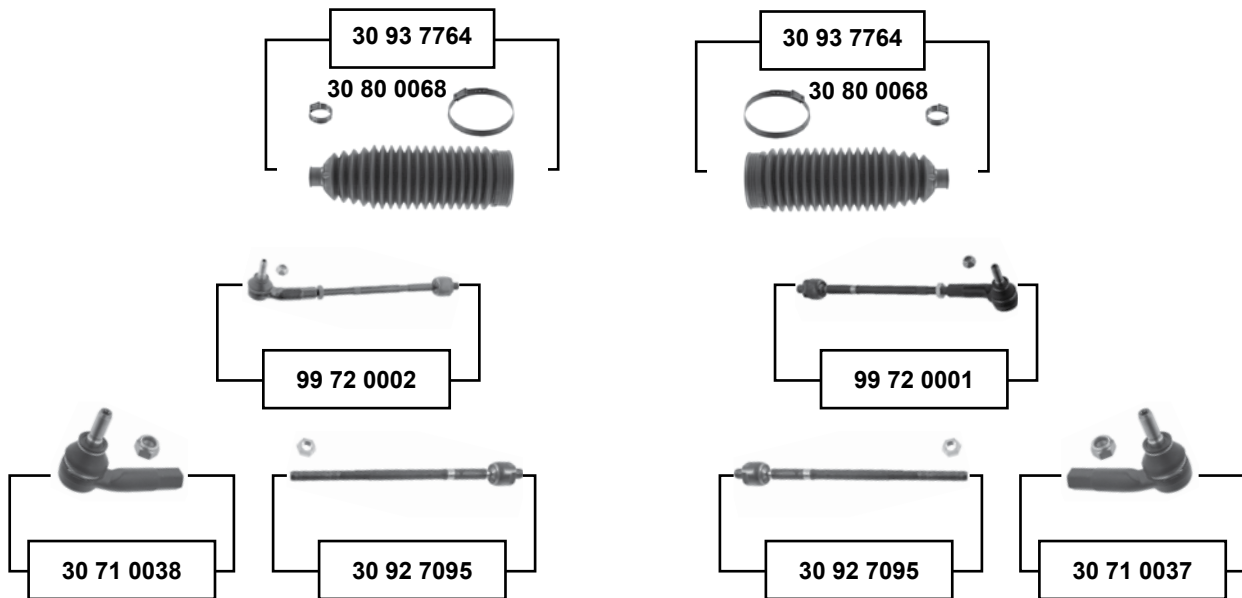

SWAG GERMANY	Ref. - No.			
30 71 0037	1J0 422 812 B	Spurstangenendstück / tie rod end		M14 x 1,5
30 71 0038	1J0 422 811 B	Spurstangenendstück / tie rod end		M14 x 1,5
30 80 0068	1J0 422 831 B	Lenkmanschette / steering boot		
30 92 7095	1J0 422 810 B	Axialgelenk / axial joint		L 321
30 92 8098	1J0 422 810 A	Spurstange / tie rod		
30 93 7764	1J0 422 831 B S1	Rep. Satz Lenkmanschette / rep. kit steering boot		
32 71 0010	1J0 422 812 A	Spurstangenendstück / tie rod end		M14 x 1,5
32 71 0011	1J0 422 811 A	Spurstangenendstück / tie rod end		M14 x 1,5
32 72 0020	1J0 422 804 A	Spurstange / tie rod		
32 72 0021	1J0 422 803 A	Spurstange / tie rod		
99 72 0001	1J0 422 804 H	Spurstange / tie rod	ZF	
99 72 0002	1J0 422 803 H	Spurstange / tie rod	ZF	

Vorderachse / Front axle



Golf 4 (ex.) 4 Motion (1J) (1998 → 2004)

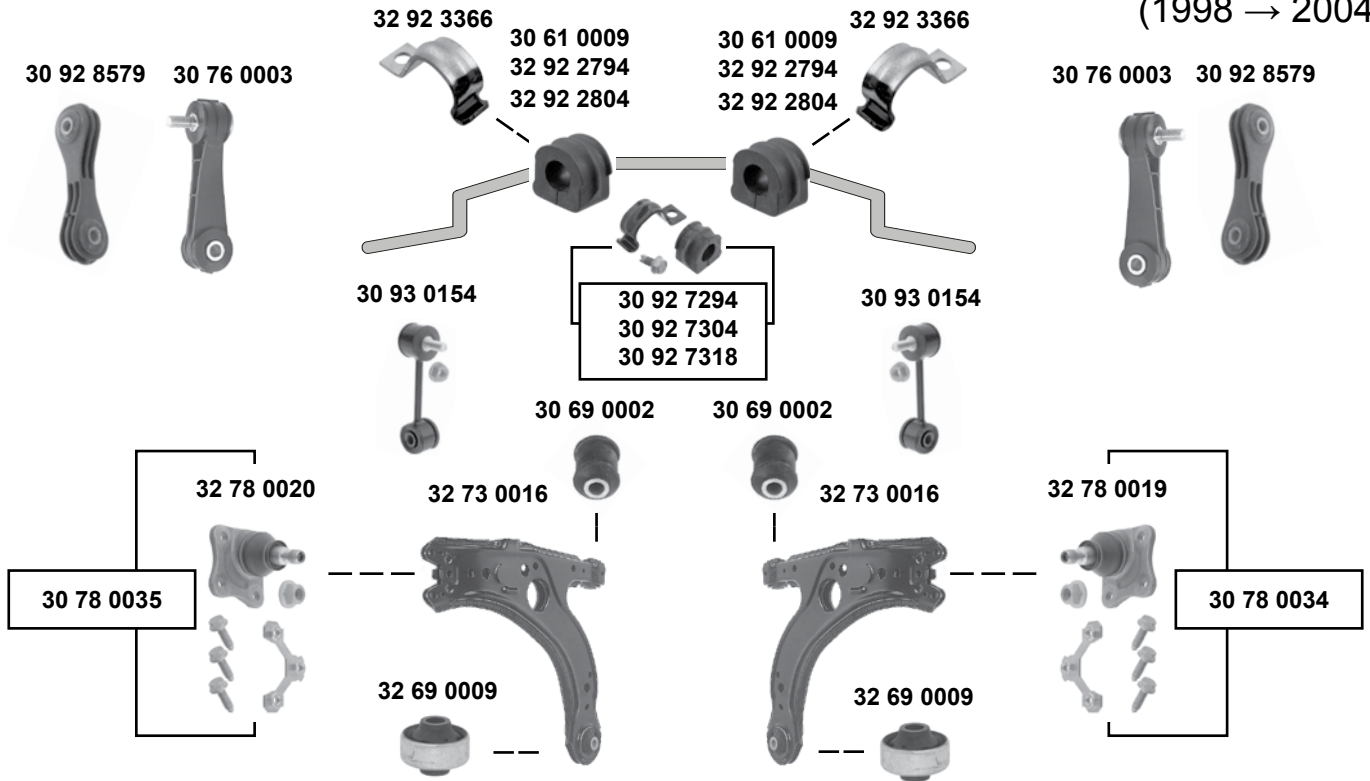

Vorderachse / Front axle



Rep. Sätze / rep. kits



30 91 9820



30 91 9822

(1) 99 → 01 (ch.) → 1J-1-480 000

(2) 01 → 04 (ch.) 1J-1-480 001 → / GTI 25 J 02 → 04

(3) 98 → 00 (ch.) → 1J-Y-900 000 für/to fit Stabi Ø A 20,7+21+18 / 01 → 04 alle / all



Ref. - No.



Ref. - No.	Description	Quantity	Dimensions / Notes
30 61 0009	Stabilisatorlager / stabilizer mount		Ø 21
30 69 0002	Querlenkerlager / control arm mount		12x33x54
30 76 0003	Verbindungsstange / connecting rod		L 105
30 78 0034	Rep. Satz Traggelenk / rep. kit ball joint		
30 78 0035	Rep. Satz Traggelenk / rep. kit ball joint		
30 91 9820	Querlenker, kpl. / control arm, cpl.		
30 91 9822	Querlenker, kpl. / control arm, cpl.		
30 92 7294	Rep. Satz Stabilisatorlagersatz / rep. kit stabilizer mount	(3)	Ø 20
30 92 7304	Rep. Satz Stabilisatorlagersatz / rep. kit stabilizer mount		
30 92 7318	Rep. Satz Stabilisatorlagersatz / rep. kit stabilizer mount		Ø 21
30 92 8579	Verbindungsstange / connecting rod	(2)	L 105
30 93 0154	Verbindungsstange / rep. kit connecting rod	(1)	L 105 / M10
32 69 0009	Querlenkerlager / control arm mount		13x60x41
32 73 0016	Querlenker / control arm		
32 78 0019	Traggelenk / ball joint		M12 x 1,5
32 78 0020	Traggelenk / ball joint		M12 x 1,5
32 92 2794	Stabilisatorlager / stabilizer mount		Ø 20
32 92 2804	Stabilisatorlager / stabilizer mount		Ø 18
32 92 3366	Schelle / clamp		

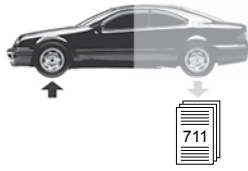

Golf 4 4 Motion (1J)

(1998 → 2004)

(ch.) → 1J-WP-050 831 / 1J-WD-039 149 / 1J-WB-027 483 / 1J-WW-062 358

Vorderachse / Front axle

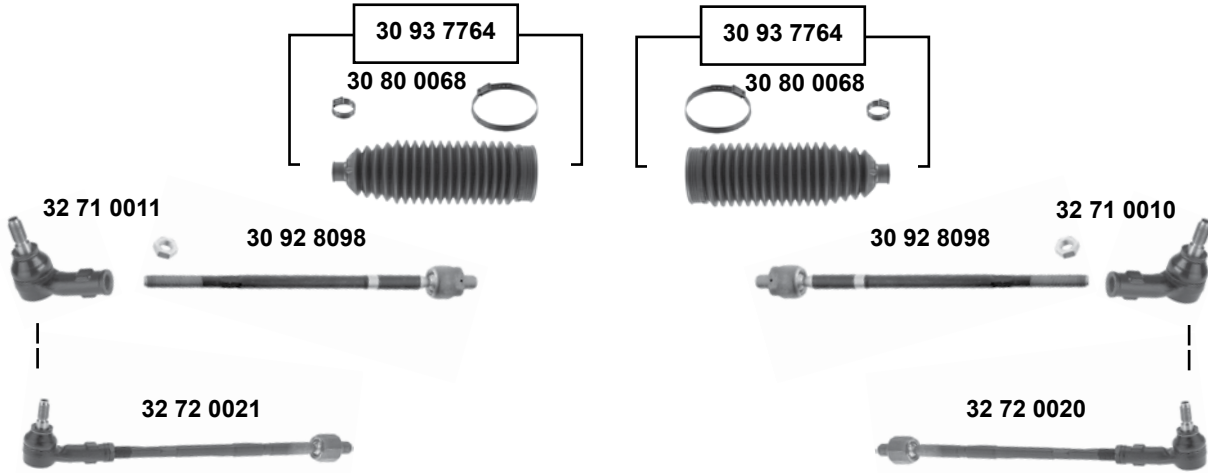



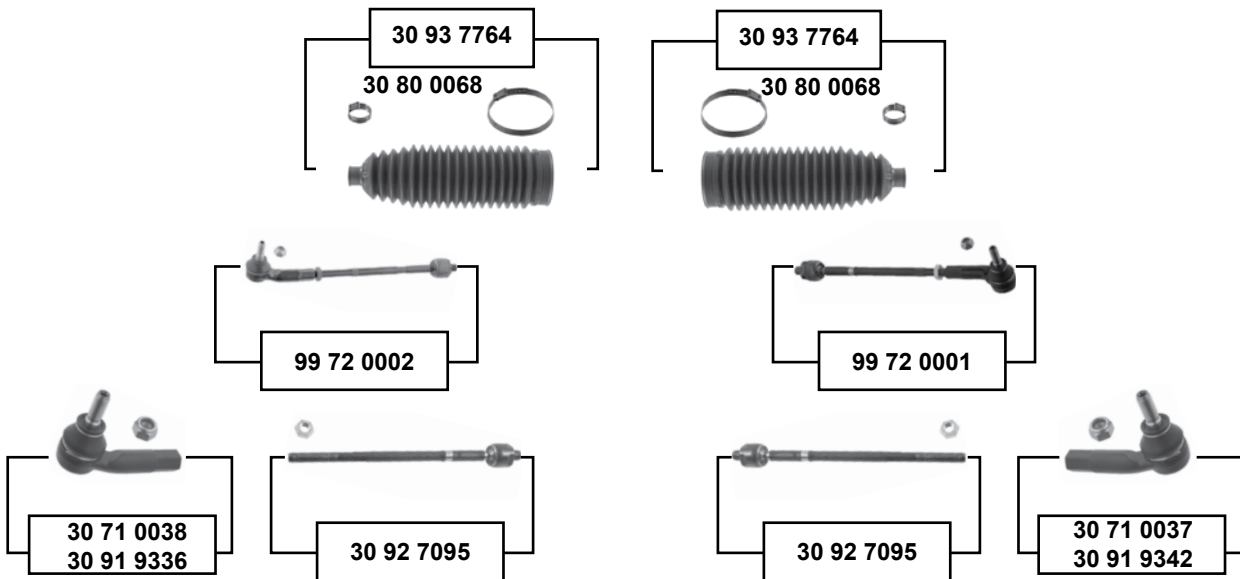

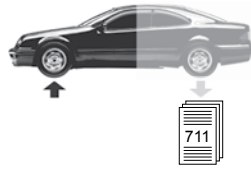
(ch.) 1J-WP-050 832 / 1J-WD-039 150 / 1J-WB-027 484 / 1J-WW-062 359 →





Golf 4 4 Motion (1J) (1998 → 2004)

	Ref. - No.			
30 71 0037	1J0 422 812 B	Spurstangenendstück / tie rod end	(ex.) R32	M14 x 1,5
30 71 0038	1J0 422 811 B	Spurstangenendstück / tie rod end	(ex.) R32	M14 x 1,5
30 91 9336	8N0 422 811 A	Spurstangenendstück / tie rod end	R32	
30 91 9342	8N0 422 812 A	Spurstangenendstück / tie rod end	R32	
30 80 0068	1J0 422 831 B	Lenkmanschette / steering boot	(ex.) R32	
30 92 7095	1J0 422 810 B	Spurstange / tie rod		L 321
30 92 8098	1J0 422 810 A	Spurstange / tie rod		
30 93 7764	1J0 422 831 B S1	Rep. Satz Lenkmanschette / rep. kit steering boot		
32 71 0010	1J0 422 812 A	Spurstangenendstück / tie rod end		M14 x 1,5
32 71 0011	1J0 422 811 A	Spurstangenendstück / tie rod end		M14 x 1,5
32 72 0020	1J0 422 804 A	Spurstange / tie rod		
32 72 0021	1J0 422 803 A	Spurstange / tie rod		
99 72 0001	1J0 422 804 H	Spurstange / tie rod	(ex.) R32	
99 72 0002	1J0 422 803 H	Spurstange / tie rod	(ex.) R32	

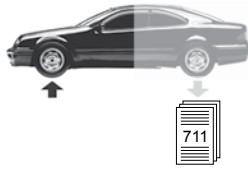

Golf 4 4 Motion (1J)

(1998 → 2006)

Vorderachse / Front axle

30 69 0002
30 92 8621

30 69 0002
30 92 8621

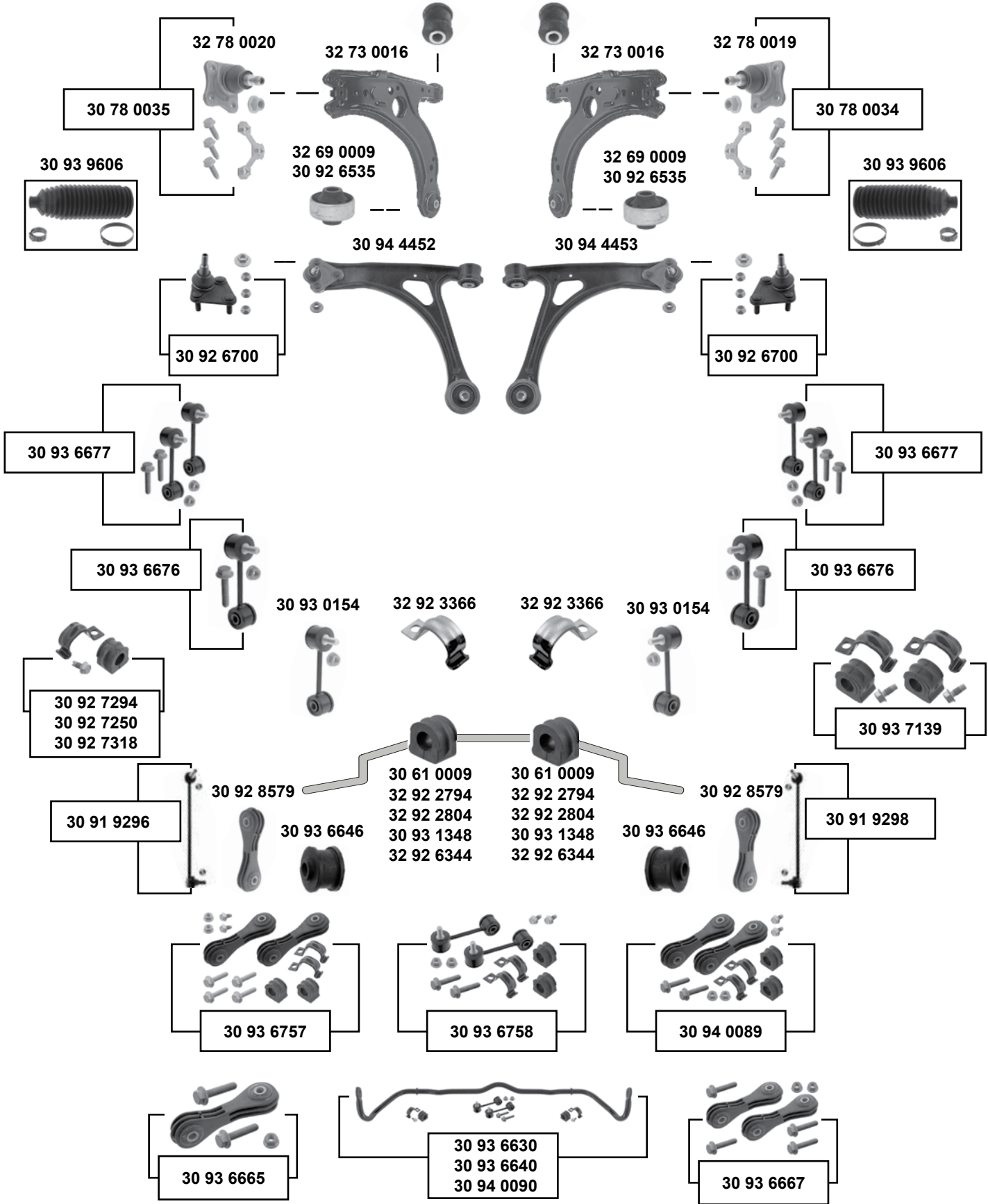

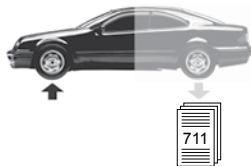

Golf 4 4 Motion (1J) (1998 → 2006)

Rep. Sätze / rep. kits



30 91 9820



30 91 9822



- (1) (ch.) → 1J-1-480 000 / (ch.) → 1J-Y-900 000
- (2) (ch.) 1J-1-000 001 → / (ch.) 1J-1-480 001 →
- (3) (ch.) 1J-1-480 001 → / PR-0AE / Ø A 23
- (4) (ch.) → 1J-4-060 000 / PR-0AE / Ø Stabilisator / stabilizer 20
Ø Stabilisator / stabilizer 23 / PR-0AE



Ref. - No.



Ref. - No.	Description	Notes	Dimensions
30 61 0009	1J0 411 314 T	Stabilisatorlager / stabilizer mount	Ø 21
30 69 0002	357 407 182	Querlenkerlager / control arm mount	12x33x54
30 78 0034	1J0 407 366 H S1	Rep. Satz Traggelenk / rep. kit ball joint	
30 78 0035	1J0 407 365 H S1	Rep. Satz Traggelenk / rep. kit ball joint	
30 91 9296	1J0 411 315 D	Verbindungsstange / connecting rod	
30 91 9298	1J0 411 316 D	Verbindungsstange / connecting rod	
30 91 9820	1J0 407 365 H S2	Querlenker, kpl. / control arm, cpl.	(ex.) R32
30 91 9822	1J0 407 366 H S2	Querlenker, kpl. / control arm, cpl.	(ex.) R32
30 92 6535	8N0 407 181 B	Querlenkerlager / control arm mount	02 → 06
30 92 6700	8N0 407 365 C	Traggelenk / ball joint	R32
30 92 7250	1J0 411 314 S S1	Stabilisatorlagersatz / rep. kit stabilizer mount	→ 04
30 92 7294	1J0 411 314 P S1	Stabilisatorlagersatz / rep. kit stabilizer mount	→ 04 (ch.) → 1J-4-220 000
30 92 7318	1J0 411 314 T S1	Stabilisatorlagersatz / rep. kit stabilizer mount	→ 04
30 92 8579	1J0 411 315 K	Verbindungsstange / connecting rod	
30 92 8621	8N0 407 182 A	Querlenkerlager / control arm mount	R32 / 03 → 06
30 93 0154	1J0 411 315 G S1	Verbindungsstange / rep. kit connection rod	
30 93 1348	1J0 411 314 AC	Stabilisatorlager / stabilizer mount	PR-0AS
30 93 6630	1J0 411 305 B S1	Rep. Satz Stabilisatorsatz / rep. kit stabilizer kit	
30 93 6640	1J0 411 305 E S1	Rep. Satz Stabilisatorsatz / rep. kit stabilizer kit	(ch.) → 1J-X-800 000
30 93 6646	1J0 411 327 A	Verbindungsstangenlager / connecting rod mount	(1)
30 93 6665	1J0 411 315 K S1	Rep. Satz Verbindungsstange / rep. kit connection rod	(2)
30 93 6667	1J0 411 315 K S2	Verbindungsstangensatz / connecting rod set	(2)
30 93 6676	1J0 411 315 G S1	Rep. Satz Verbindungsstange / rep. kit connection rod	(1)
30 93 6677	1J0 411 315 G S2	Verbindungsstange / stabiliser link	(1)
30 93 6757	1J0 411 315 G S3	Stabilisatorlagersatz / anti roll bar bush kit	
30 93 6758	1J0 411 315 G S4	Stabilisatorlagersatz / anti roll bar bush kit	(ch.) → 1J-X-800 000
30 93 7139	1J0 411 314 AC S1	Stabilisatorlagersatz / anti roll bar bush kit	
30 93 9606	8N0 422 831 S1	Rep. Satz Lenkmanschette / rep. kit steering boot	02 → 06
30 94 0089	1J0 411 314 T S2	Stabilisatorlagersatz / anti roll bar bush kit	(3)
30 94 0090	1J0 411 305 E S2	Rep. Satz Stabilisatorsatz / rep. kit stabilizer kit	(3)
30 94 4452	8N0 407 151 D S1	Querlenker / control arm	Gummi / rubber
30 94 4453	8N0 407 152 D S1	Querlenker / control arm	Gummi / rubber
32 69 0009	1J0 407 181	Querlenkerlager / control arm mount	(ex.) R32
32 73 0016	1J0 407 151 C	Querlenker / control arm	(ex.) R32
32 78 0019	1J0 407 366 H	Traggelenk / ball joint	(ex.) R32
32 78 0020	1J0 407 365 H	Traggelenk / ball joint	(ex.) R32
32 92 2794	1J0 411 314 P	Stabilisatorlager / stabilizer mount	(ch.) → 1J-4-220 000
32 92 2804	1J0 411 314 R	Stabilisatorlager / stabilizer mount	R32
32 92 3366	1J0 411 336 D	Schelle / clamp	
32 92 6344	1J0 411 314 S	Stabilisatorlager / stabilizer mount	(ch.) 1J-4-220 001 →

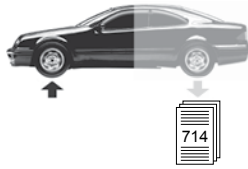

Golf 5 / Plus (1K)

(2004 → 2009)

Vorderachse / Front axle

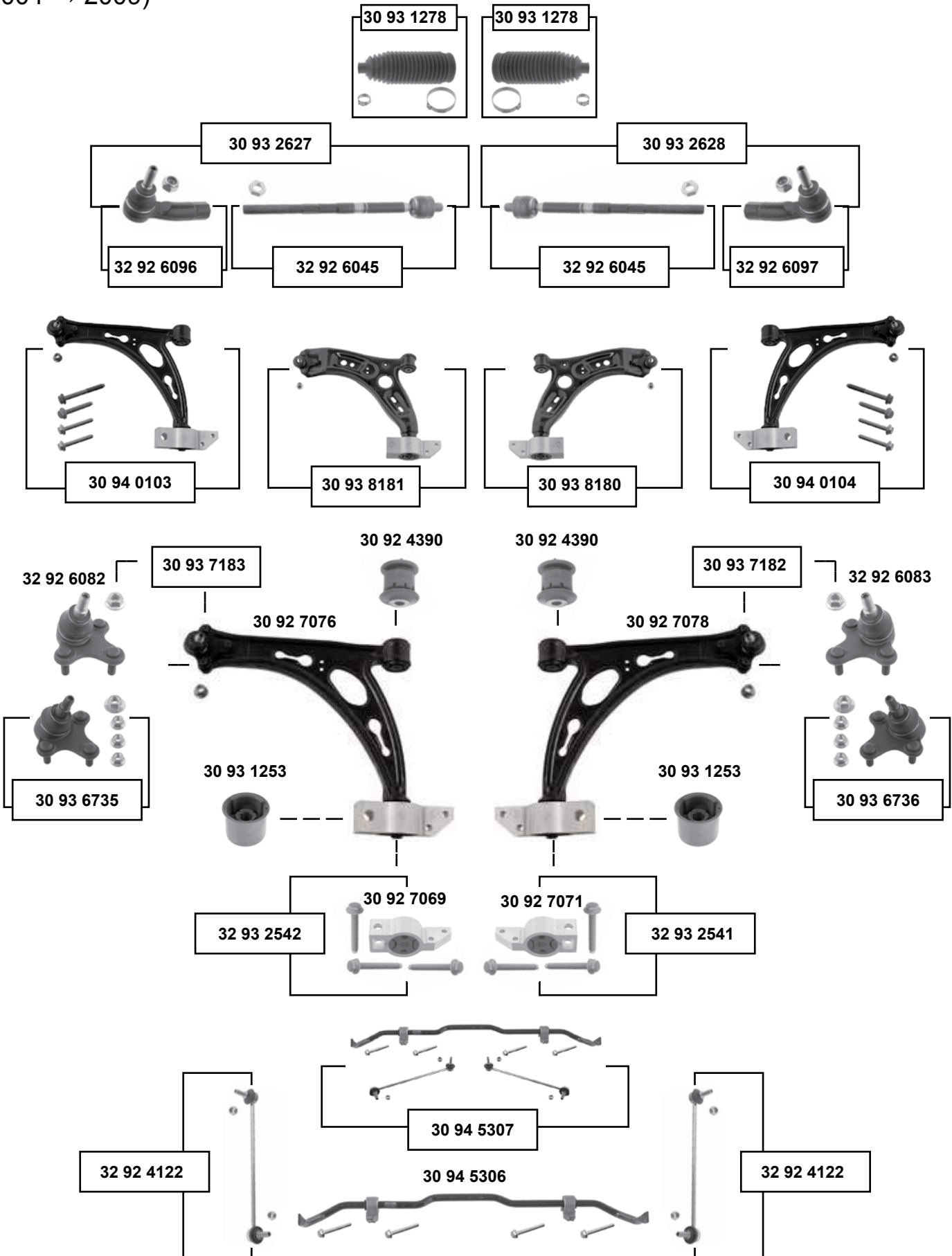

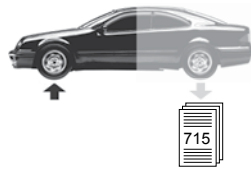
Golf 5 / Plus (1K)
 (2004 → 2009)

	(1) Stahl-Gussausführung / keine Mischverbauung mit der Blechausführung zulässig / cast iron execution / not mixable with metall execution
	(2) Golf 5 plus (1K) 05 → 09
	(3) Golf 5 Plus 05 → 08 PR-8Q6 / (ch.) → 1K-6-590 000 / (ch.) → 1K-9-855 000 Golf 5 / 4 motion → 09 nicht für / not for PR-8Q0, 8Q1, 8Q3, 8Q6 / (ch.) → 1K-6-061 500 Golf 5 Variant / 4 motion 07 → 09 PR-8Q3, 8Q6
	(4) PR-8Q1, 8Q3, 8Q6 (ch.) → 1K-5-600 000 (ch.) 1K-6-000 001 → (ch.) → 1K-6-061 500 (ch.) 1K-6-020 501 → (ch.) → 1K-6-020 500 (ch.) 1K-6-190 001 → (ch.) → 1K-6-250 000 (ch.) 1K-6-020 500 → (ch.) → 1K-6-590 000 (ch.) 1K-7-000 001 → (ch.) → 1K-9-855 000 (ch.) 1K-8-000 001 → (ch.) → 1K-9-955 000 (ch.) 1K-8-500 001 →

	Ref. - No.			
30 92 4390	1K0 407 182	Querlenkerlager / control arm mount	(2)	Ø A 40 H 54
30 92 7069	1K0 199 231 J	Querlenkerlager mit Gehäuse / control arm mount with housing		
30 92 7071	1K0 199 232 J	Querlenkerlager mit Gehäuse / control arm mount with housing		
30 92 7076	1K0 407 151 AC	Querlenker, kpl. / control arm, cpl.	(1) (2)	
30 92 7078	1K0 407 152 AC	Querlenker, kpl. / control arm, cpl.	(1) (2)	
30 93 1253	1K0 407 183 E	Querlenkerlager / control arm mount	(2)	Ø A 63 Ø I 15,5 L190
30 93 1278	1K0 423 831 A	Rep. Satz Lenkmanschette / rep. kit steering boot		
30 93 2627	1K0 423 810 A S1	Rep. Satz Spurstange links / rep. kit tie rod left	(2)	
30 93 2628	1K0 423 810 A S2	Rep. Satz Spurstange rechts / rep. kit tie rod right	(2)	
30 93 6735	1K0 407 365 C S1	Rep. Satz Traggelenk / rep. kit ball joint		
30 93 6736	1K0 407 366 C S1	Rep. Satz Traggelenk / rep. kit ball joint		
30 93 7182	1K0 407 152 AC S1	Rep. Satz Querlenker mit Traggelenk / control arm with ball joint	(3)	
30 93 7183	1K0 407 151 AC S1	Rep. Satz Querlenker mit Traggelenk / control arm with ball joint	(3)	
30 93 8180	1K0 407 152 BC S1	Rep. Satz Querlenker / rep. kit control arm	Stahl / steel	
30 93 8181	1K0 407 151 BC S1	Rep. Satz Querlenker / rep. kit control arm	Stahl / steel	
30 94 0103	1K0 407 151 AC S2	Rep. Satz Querlenker / rep. kit control arm	(1) (4)	
30 94 0104	1K0 407 152 AC S2	Rep. Satz Querlenker / rep. kit control arm	(1) (4)	
30 94 5306	1K0 411 303 BK S1	Stabilisatorsatz / stabilizer kit	PR-0AD / OAE	
30 94 5307	1K0 411 303 BK S2	Rep. Satz Stabilisatorsatz / rep. kit stabilizer kit	PR-0AD / OAE	
32 92 4122	1K0 411 315 R	Verbindungsstange / connecting rod	(2)	
32 92 6045	1K0 423 810 A	Spurstange / tie rod	(2)	
32 92 6082	1K0 407 365 C	Traggelenk / ball joint	(2)	
32 92 6083	1K0 407 366 C	Traggelenk / ball joint	(2)	
32 92 6096	1K0 423 811 E	Spurstangenendstück / tie rod end	(2)	
32 92 6097	1K0 423 812 E	Spurstangenendstück / tie rod end	(2)	
32 93 2541	1K0 199 232 J S1	Rep. Satz Querlenkerlagersatz / rep. kit control arm mounting kit		
32 93 2542	1K0 199 231 J S1	Rep. Satz Querlenkerlagersatz / rep. kit control arm mounting kit		

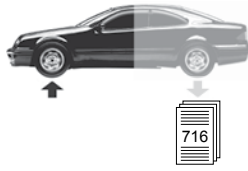

Golf 6 / Plus (1K)

(2009 →)

Vorderachse / Front axle

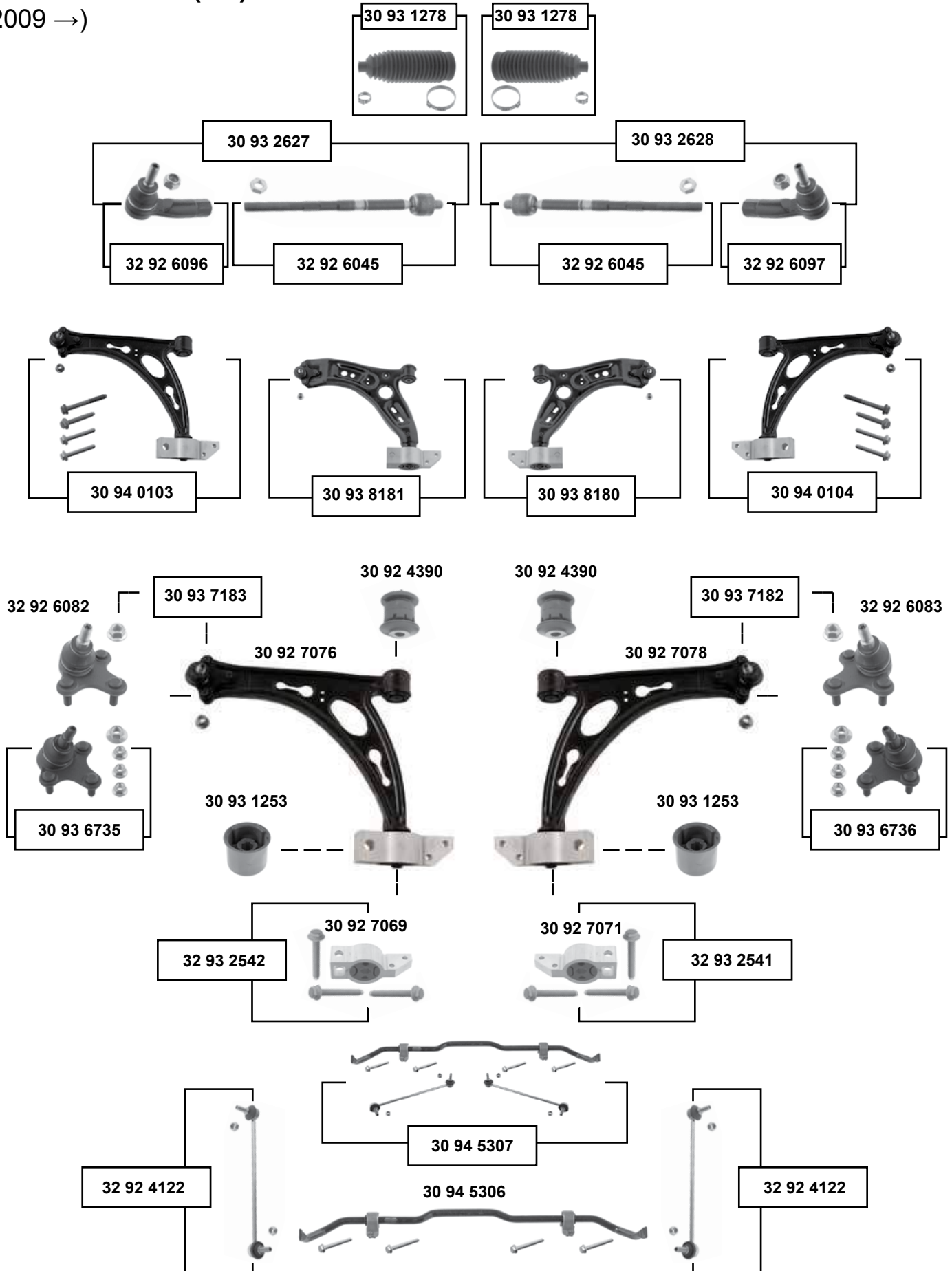

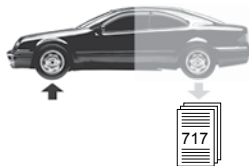

Golf 6 / Plus (1K)
 (2009 →)

- (1) Stahl-Gussausführung / keine Mischverbauung mit der Blechausführung zulässig / cast iron execution / not mixable with metall execution
- (2) Golf 6 plus (1K) 09 → 11
- (3) **(ex.)** Fahrschulwagen / **(ex.)** cars for driving school
- (4) Golf 6 Variant / Variant 4 motion / PR-8Q3, 8Q4
Golf 6 / 4 motion / PR-F0A, F4J, F6M, C6Q / **(ch.)** → 1K-9P422 726 / **(ch.)** → 1K-9U016 920 / **(ch.)** → 1K-9W415 461 / PR-2H1
- (5) PR-2H1, C6Q, F0A, F4J, F6M / **(ch.)** → 1K9-P434 947 / **(ch.)** → 1K9-W441 280

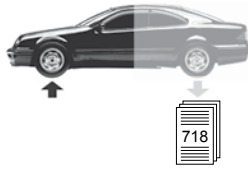

Ref. - No.

SWAG Ref. - No.	Hand Icon	Description	Info Icon (i)	Caliper Icon
30 92 4390		Querlenkerlager / control arm mount	(2)	Ø A 48 H 54
30 92 7069		Querlenkerlager mit Gehäuse / control arm mount with housing	(3)	
30 92 7071		Querlenkerlager mit Gehäuse / control arm mount with housing	(3)	
30 92 7076		Querlenker, kpl. / control arm, cpl.	(1)	Ø A 63 Ø I 15,5 L190
30 92 7078		Querlenker, kpl. / control arm, cpl.	(1)	
30 93 1253		Querlenkerlager / control arm mount		
30 93 1278		Rep. Satz Lenkmanschette / rep. kit steering boot		
30 93 2627		Rep. Satz Spurstange links / rep. kit tie rod left	(2)	
30 93 2628		Rep. Satz Spurstange rechts / rep. kit tie rod right	(2)	
30 93 6735		Rep. Satz Traggelenk / rep. kit ball joint	Cabrio 11 →	
30 93 6736		Rep. Satz Traggelenk / rep. kit ball joint	Cabrio 11 →	
30 93 7182		Rep. Satz Querlenker mit Traggelenk / control arm with ball joint	(4)	
30 93 7183		Rep. Satz Querlenker mit Traggelenk / control arm with ball joint	(4)	
30 93 8180		Rep. Satz Querlenker / rep. kit control arm	Stahl / steel	
30 93 8181		Rep. Satz Querlenker / rep. kit control arm	Stahl / steel	
30 94 0103		Rep. Satz Querlenker / rep. kit control arm	(1) (5)	
30 94 0104		Rep. Satz Querlenker / rep. kit control arm	(1) (5)	
30 94 5306		Stabilisatorsatz / stabilizer kit	PR-0AD / OAE	
30 94 5307		Rep. Satz Stabilisatorsatz / rep. kit stabilizer kit	PR-0AD / OAE	
32 92 4122		Verbindungsstange / connecting rod	(2)	
32 92 6045		Spurstange / tie rod	(2)	
32 92 6082		Traggelenk / ball joint	(2)	
32 92 6083		Traggelenk / ball joint	(2)	
32 92 6096		Spurstangenendstück / tie rod end	(2)	
32 92 6097		Spurstangenendstück / tie rod end	(2)	
32 93 2541		Rep. Satz Querlenkerlagersatz / rep. kit control arm mounting kit	(3)	
32 93 2542		Rep. Satz Querlenkerlagersatz / rep. kit control arm mounting kit	(3)	

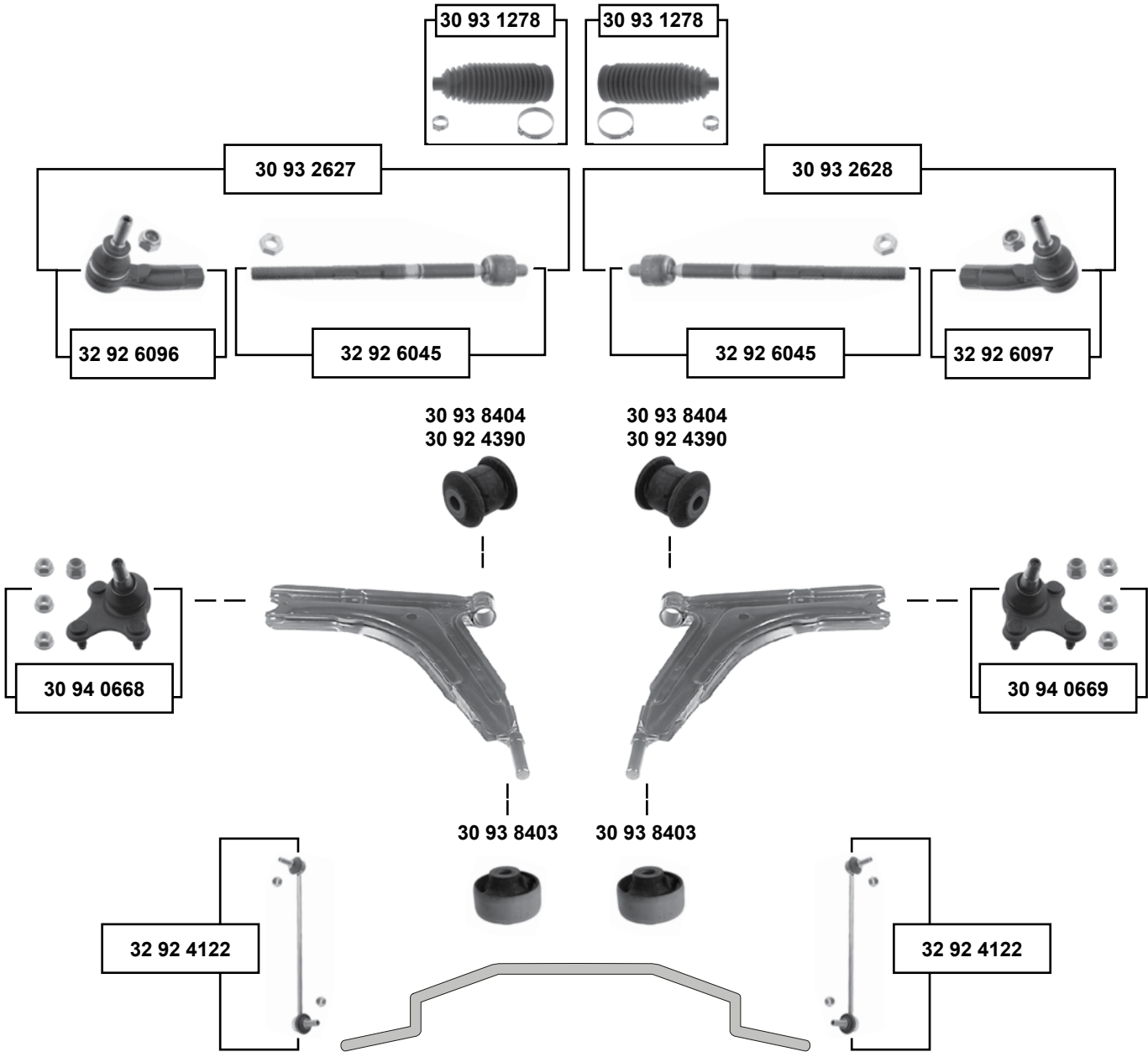

Golf 7 (5G) (2012 →)

Vorderachse / Front axle



(1) für Bremsscheibendicke / for brake disk thickness 25 mm /
für Bremsscheibendurchmesser / for brake disk diameter 288 mm

SWAG GERMANY	Ref. - No.			
30 92 4390	1K0 407 182	Querlenkerlager / control arm mount		Ø A48 H54
30 93 1278	1K0 423 831 A	Rep. Satz Lenkmanschette / rep. kit steering boot		Ø I 15,5 L190
30 93 2627	1K0 423 810 A S1	Rep. Satz Spurstange links / rep. kit tie rod left		
30 93 2628	1K0 423 810 A S2	Rep. Satz Spurstange rechts / rep. kit tie rod right		
30 93 8403	5Q0 407 183 E	Querlenkerlager / control arm mount		Ø A 65
30 93 8404	5Q0 407 182	Querlenkerlager / control arm mount		L53,8 Ø A 40
30 94 0668	5Q0 407 365 A S1	Rep. Satz Traggelenk / rep. kit ball joint	(1) PR-1ZE / 1ZP	
30 94 0669	5Q0 407 366 A S1	Rep. Satz Traggelenk / rep. kit ball joint	(1) PR-1ZE / 1ZP	
32 92 4122	1K0 411 315 R	Verbindungsstange / connecting rod		
32 92 6045	1K0 423 810 A	Spurstange / tie rod		
32 92 6096	1K0 423 811 E	Spurstangenendstück / tie rod end		
32 92 6097	1K0 423 812 E	Spurstangenendstück / tie rod end		



Golf 7 Sportsvan
(2014 →)

30 93 8404

30 93 8404



32 92 4122

32 92 4122

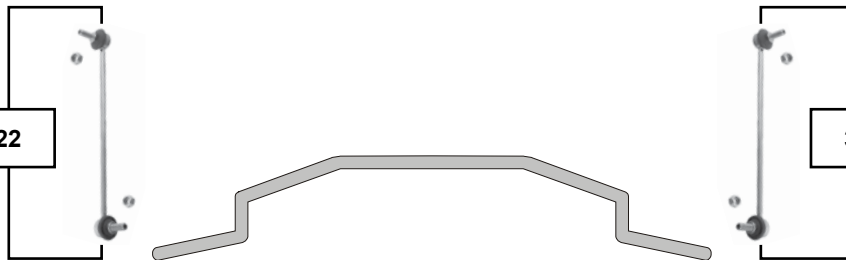



Jetta 1 (16) (1975 → 1984)

man.

30 80 0054



30 80 0063

30 80 0053



30 80 0062

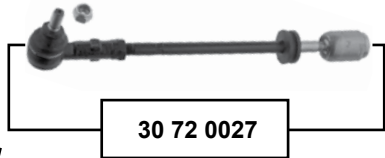

30 72 0027



30 71 0021

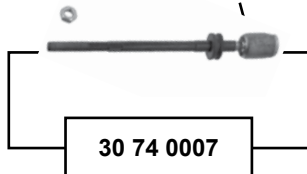

30 74 0007

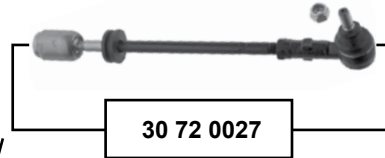

30 72 0027

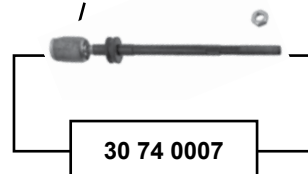

30 74 0007



30 71 0021

servo

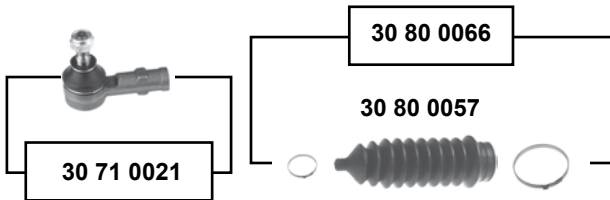

30 80 0066

30 80 0057

30 71 0021

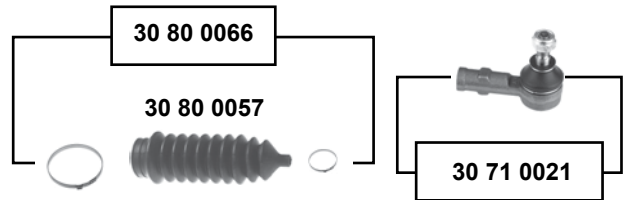

30 80 0066

30 80 0057

30 71 0021



Ref. - No.



30 74 0007	171 419 821
30 80 0053	171 419 832 C
30 80 0054	191 419 831
30 71 0021	171 419 812
30 72 0027	171 419 804
30 80 0057	1H0 422 831 B
30 80 0062	171 419 832 C S1
30 80 0063	191 419 831 S
30 80 0066	1H0 422 831 B S1

Axialgelenk / axial joint
Lenkmanschette / steering boot
Lenkmanschette / steering boot
Spurstangenendstück / tie rod end
Rep. Satz Spurstange / rep. kit tie rod
Lenkmanschette / steering boot
Rep. Satz Lenkmanschette / rep. kit steering boot
Rep. Satz Lenkmanschette / rep. kit steering boot
Rep. Satz Lenkmanschette / rep. kit steering boot

M14x1,5 RHT

M14x1,5 RHT

Vorderachse / Front axle



Jetta 1 (16) (1975 → 1984)

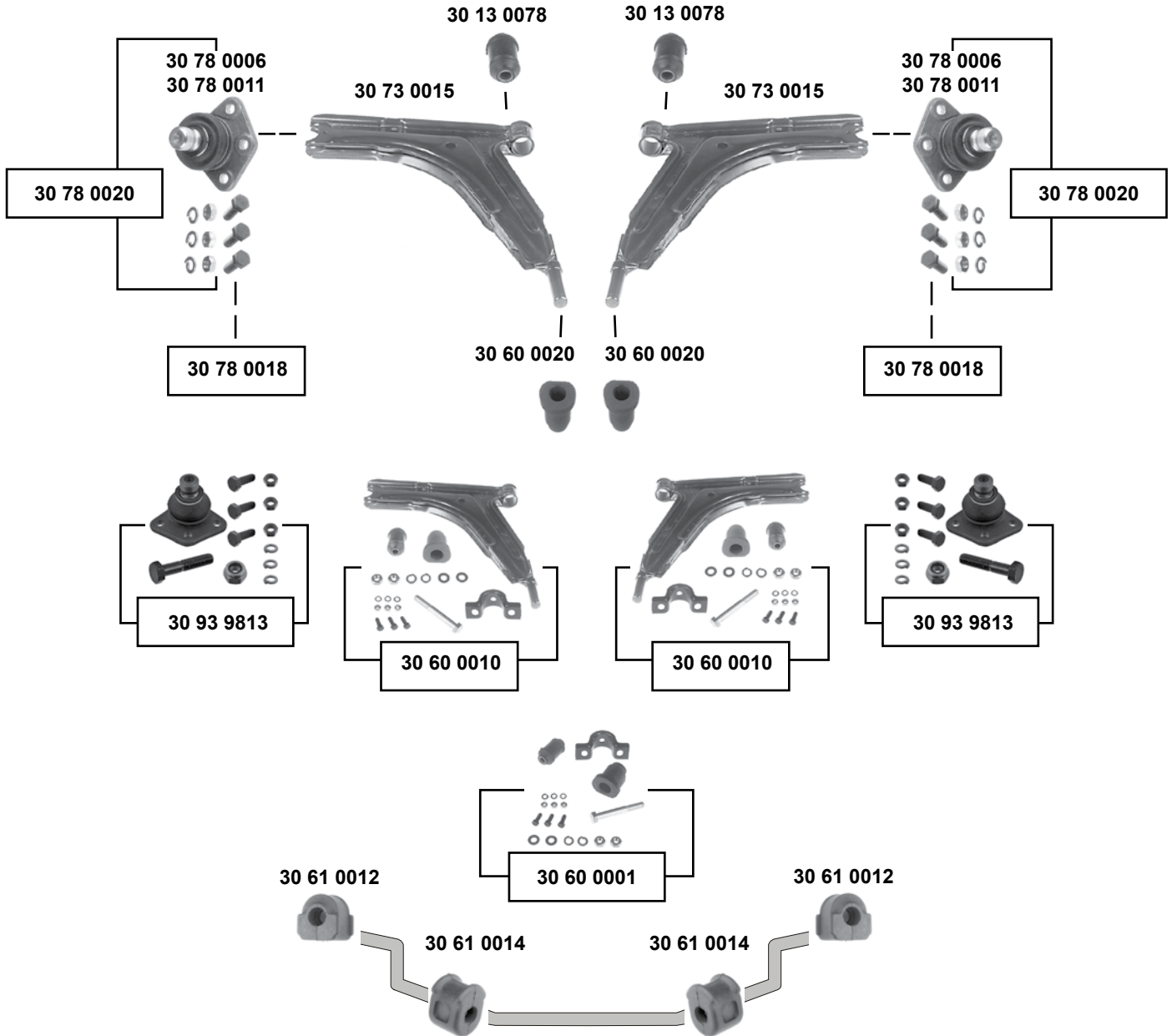

Vorderachse / Front axle

SWAG	Ref. - No.			
30 13 0078	171 407 182 D	Querlenkerlager / control arm mount		12x32x61
30 60 0001	171 407 153 D S4	Montagesatz / mounting kit		
30 60 0010	171 407 153 D S3	Rep. Satz Querlenker / rep. kit control arm		
30 60 0020	171 407 181 A	Querlenkerlager / control arm mount		16x38x55
30 61 0012	171 411 314 A	Stabilisatorlager / stabilizer mount		Ø 15
30 61 0014	171 411 313	Stabilisatorlager / stabilizer mount		Ø 15
30 73 0015	171 407 153 D	Querlenker ohne Gummilager / control arm excl. rubber mounts		
30 78 0006	171 407 365 C	Traggelenk / ball joint	(ch.) → 178 3173 583	Ø A 15
30 78 0011	171 407 365 F	Traggelenk / ball joint	(ch.) 178 3173 584 →	Ø A 17
30 78 0018	171 407 365 F S1	Rep. Satz Traggelenk / rep. kit ball joint	(ch.) 178 3173 584 →	
30 78 0020	171 407 365 C S1	Rep. Satz Traggelenk / rep. kit ball joint	(ch.) → 178 3173 583	
30 93 9813	171 407 365 F S2	Rep. Satz Traggelenk / rep. kit ball joint		



Jetta 2 (16/1G) (1984 → 1992)

Vorderachse / Front axle

man.

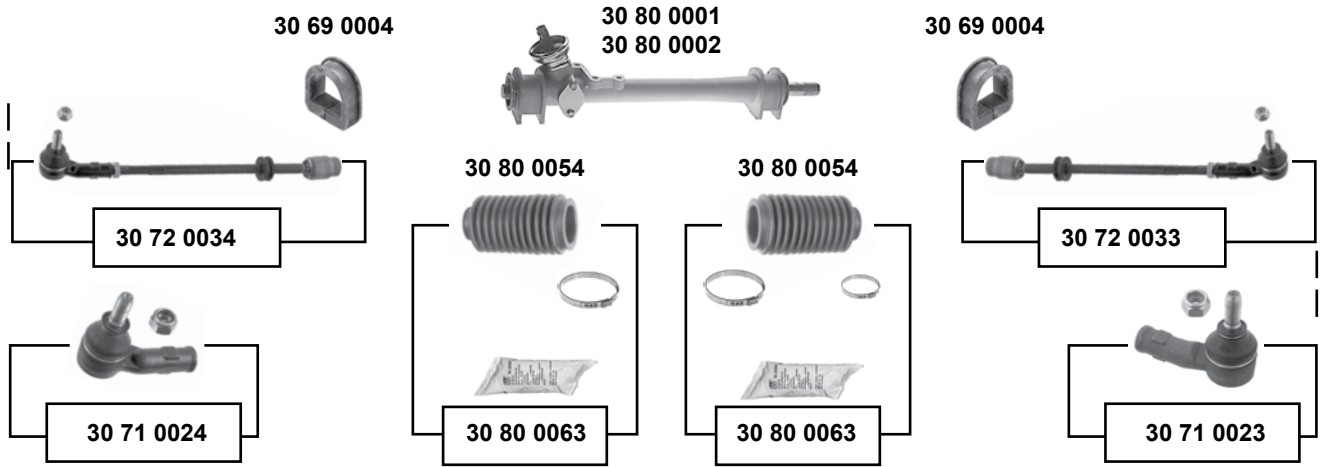

servo

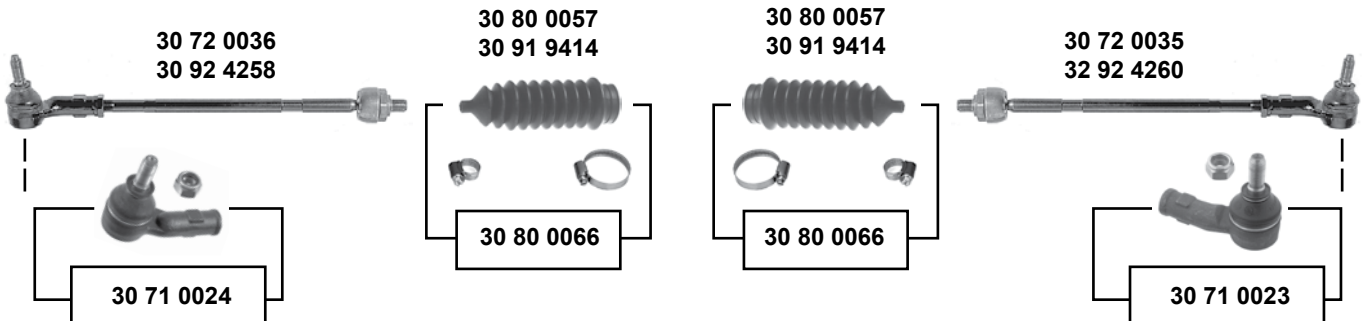







Jetta 2 (16/1G)
 (1984 → 1992)

(1) (ch.) 1G-MW-339 716 / 1G-MB-125 000 →

(2) (ch.) → 1G-MW-339 715 / 1G-MB 124 999



Ref. - No.

30 69 0004	191 419 883	Lenkgetriebelager / steering gear bearing		
30 71 0023	191 419 812	Spurstangenendstück / tie rod end	(ch.) 16-E-300 001 →	M12 x 1,5
30 71 0024	191 419 811	Spurstangenendstück / tie rod end	(ch.) 16-E-300 001 →	M12 x 1,5
30 72 0033	191 419 804	Spurstange / tie rod	TRW servo 	
30 72 0034	191 419 803	Spurstange / tie rod	TRW servo 	
30 72 0035	191 422 804 A	Spurstange / tie rod		
30 72 0036	191 422 803 A	Spurstange / tie rod		
30 80 0001	191 419 063 C	Lenkgetriebe / steering gear	(1) LHD	
30 80 0002	191 419 063 B	Lenkgetriebe / steering gear	(2) LHD	
30 80 0054	191 419 831	Lenkmanschette / steering boot		
30 80 0057	1H0 422 831 B	Lenkmanschette / steering boot	TRW servo 	
30 80 0063	191 419 831 S	Rep. Satz Lenkmanschette / rep. kit steering boot		
30 80 0066	1H0 422 831 B S1	Rep. Satz Lenkmanschette / rep. kit steering boot		
30 91 9414	357 422 831 B	Lenkmanschette / steering boot	servo  ZF	
30 92 4258	191 422 803 C	Spurstange / tie rod	ZF servo 	
32 92 4260	191 422 804 C	Spurstange / tie rod	ZF servo 	

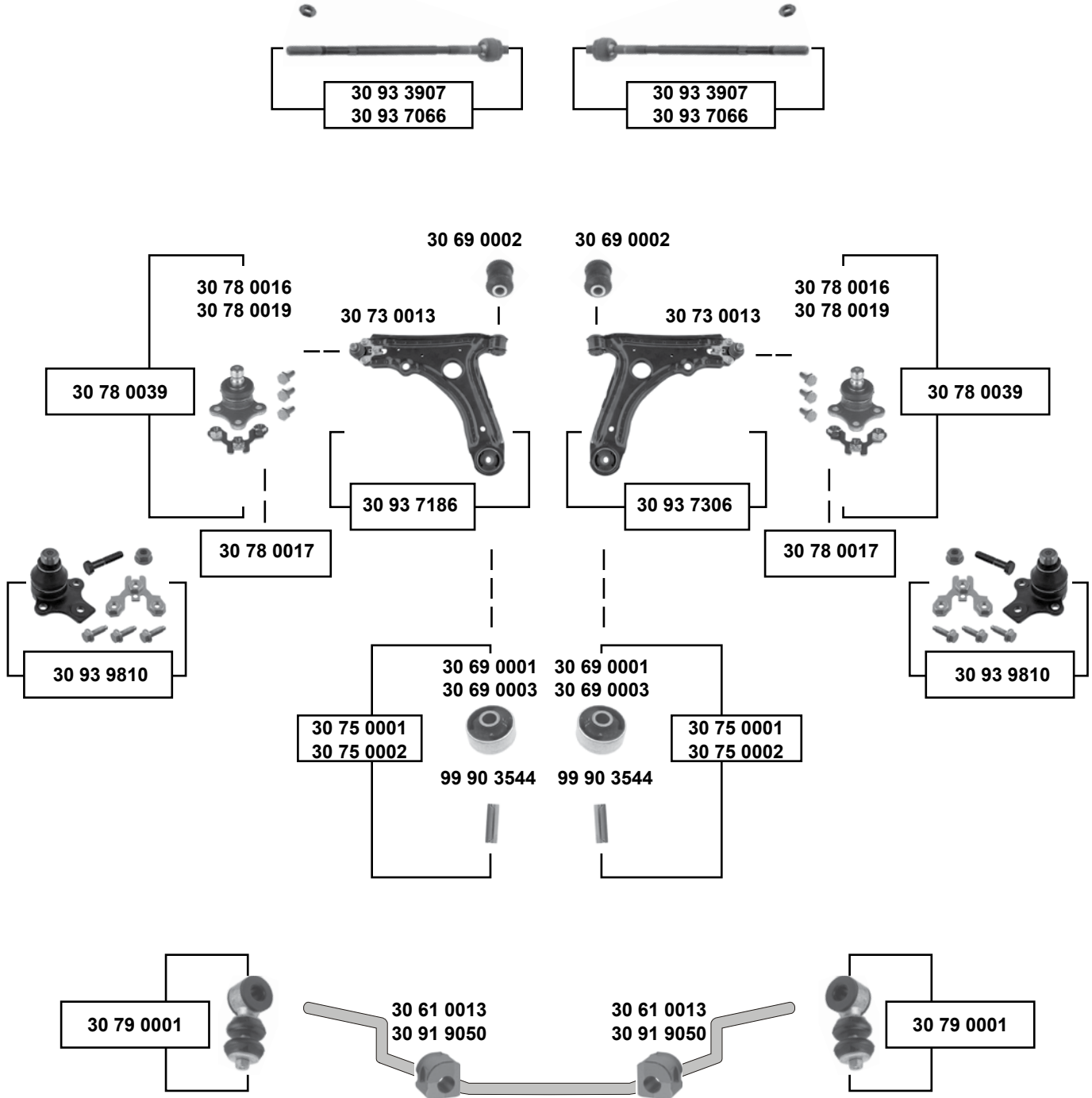

Jetta 2 (16/1G) (1984 → 1992)

Vorderachse / Front axle



Jetta 2 (16/1G)
 (1984 → 1992)

(1) (ch.) 19-JB000 001 → / (ch.) 1-JW000 001 →

	Ref. - No.			
30 61 0013	191 411 314	Stabilisatorlager / stabilizer mount	(ex.) G60	Ø I 17
30 69 0001	191 407 181 D	Querlenkerlager / control arm mount	NEW	17x60x41
30 69 0002	357 407 182	Querlenkerlager / control arm mount		12x33x54
30 69 0003	191 407 181 B	Querlenkerlager / control arm mount	OLD	17x60x41
30 73 0013	191 407 151 B	Querlenker mit Gummilager / control arm incl. rubber mounts		
30 75 0001	191 407 181 B S1	Querlenkerlager mit Hülse / control arm mount with sleeve		
30 75 0002	191 407 181 D S1	Querlenkerlager mit Hülse / control arm mount with sleeve		
30 78 0016	191 407 365	Traggelenk / ball joint	(ch.) → H-999 999	Ø A 17
30 78 0017	357 407 365 S1	Rep. Satz Traggelenk / rep. kit ball joint	(ch.) J-000 001 →	
30 78 0019	357 407 365	Traggelenk / ball joint	(ch.) J-000 001 →	Ø A 19
30 78 0039	191 407 365 S1	Rep. Satz Traggelenk / rep. kit ball joint	(ch.) → H-999 999	
30 79 0001	191 411 315 B S1	Rep. Satz Verbindungsstange / rep. kit connecting rod	(ex.) G60	
30 91 9050	1H0 411 314	Stabilisatorlager / stabilizer mount		Ø I 19
30 93 3907	191 422 810 A	Axialgelenk / axial joint	servo.	
30 93 7066	191 419 810	Axialgelenk / axial joint	(ex.) servo.	M12x1,5
30 93 7186	191 407 151 B S1	Rep. Satz Querlenker / rep. kit control arm		
30 93 7306	191 407 151 B S2	Rep. Satz Querlenker / rep. kit control arm		
30 93 9810	357 407 365 S2	Rep. Satz Traggelenk / rep. kit ball joint	(1)	
99 90 3544	191 407 190 A	Hülse / sleeve		50x17



Jetta 2 Syncro

(1984 → 1992)

Vorderachse / Front axle

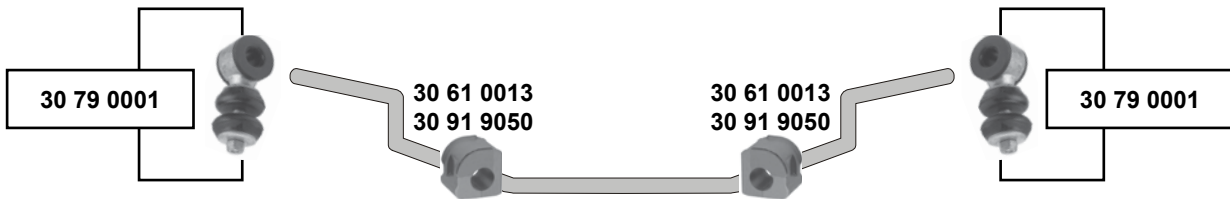
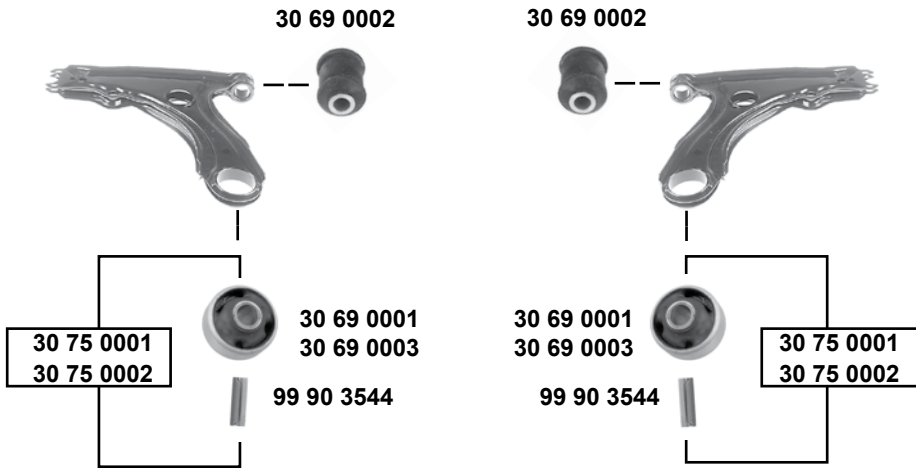

SWAG GERMANY	Ref. - No.			
30 61 0013	191 411 314	Stabilisatorlager / stabilizer mount		Ø 17
30 69 0001	191 407 181 E	Querlenkerlager / control arm mount	NEW	17x60x41
30 69 0002	357 407 182	Querlenkerlager / control arm mount		12x33x54
30 69 0003	191 407 181 B	Querlenkerlager / control arm mount	OLD	17x60x41
30 75 0001	191 407 181 B S1	Querlenkerlager / control arm mount	OLD	
30 75 0002	191 407 181 E S1	Querlenkerlager / control arm mount	NEW	
30 79 0001	191 411 315 B S1	Rep. Satz Verbindungsstange / rep. kit connecting rod		
30 91 9050	1H0 411 314	Stabilisatorlager / stabilizer mount		Ø 19
99 90 3544	191 407 190 A	Hülse / sleeve		50x17

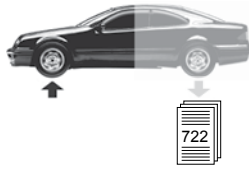

Jetta (16) (2011 →)

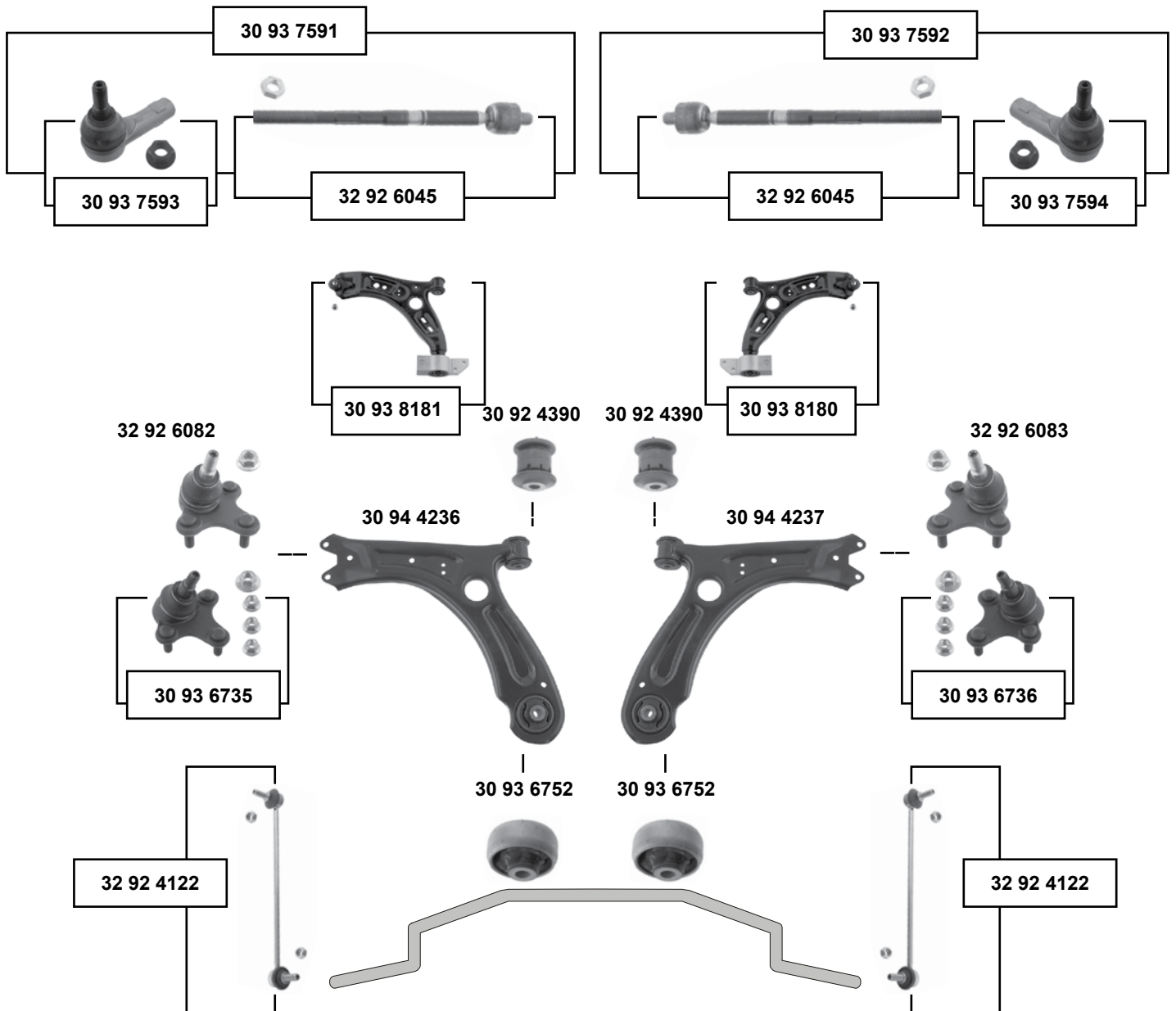

Vorderachse / Front axle



Ref. - No.



30 92 4390	1K0 407 182	Querlenkerlager / control arm mount		Ø A 40 H 54
30 93 6735	1K0 407 365 C S1	Rep. Satz Traggelenk / rep. kit ball joint		
30 93 6736	1K0 407 366 C S1	Rep. Satz Traggelenk / rep. kit ball joint		
30 93 6752	1K0 407 183 P	Querlenkerlager / control arm mount		Ø I 13 B 50
30 93 7591	1K0 423 811 K S1	Rep. Satz Spurstange / rep. kit tie rod		L 448
30 93 7592	1K0 423 812 K S1	Rep. Satz Spurstange / rep. kit tie rod		L 448
30 93 7593	1K0 423 811 K	Spurstangenendstück / tie rod end		M16 x 1,5
30 93 7594	1K0 423 812 K	Spurstangenendstück / tie rod end		M16 x 1,5
30 93 8180	1K0 407 152 BC S1	Rep. Satz Querlenker / rep. kit control arm	Stahl / steel	
30 93 8181	1K0 407 151 BC S1	Rep. Satz Querlenker / rep. kit control arm	Stahl / steel	
30 94 4236	5C0 407 151 B	Querlenker / control arm	Stahl / steel	
30 94 4237	5C0 407 152 B	Querlenker / control arm	Stahl / steel	
32 92 4122	1K0 411 315 R	Verbindungsstange / connecting rod		
32 92 6045	1K0 423 810 A	Rep. Satz Spurstange / rep. kit tie rod		
32 92 6082	1K0 407 365 C	Traggelenk / ball joint		
32 92 6083	1K0 407 366 C	Traggelenk / ball joint		

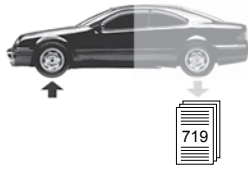

Jetta (1K) (2006 → 2010)

Vorderachse / Front axle

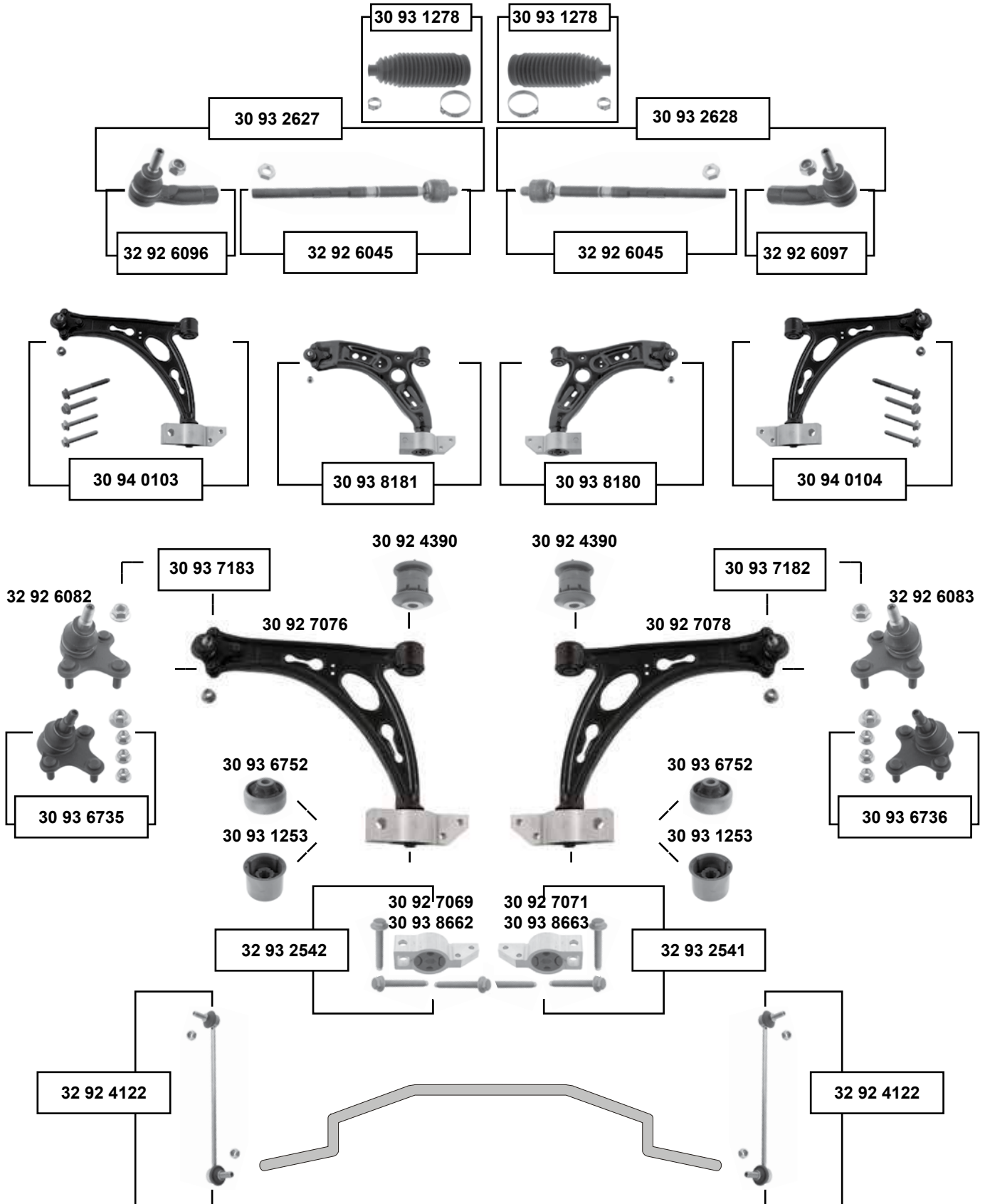

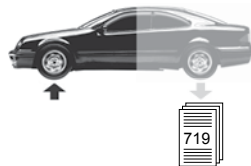
Jetta (1K)
 (2006 → 2010)

(1) Stahl-Gussausführung / keine Mischverbauung mit der Blechausführung zulässig /
 cast iron execution / not mixable with metall execution



Ref. - No.



SWAG Ref. - No.			
30 92 4390	1K0 407 182	Querlenkerlager / control arm mount	Ø A48 H54
30 92 7069	1K0 199 231 J	Querlenkerlager mit Gehäuse / control arm mount with housing	
30 92 7071	1K0 199 232 J	Querlenkerlager mit Gehäuse / control arm mount with housing	
30 92 7076	1K0 407 151 AC	Querlenker, kpl. / control arm, cpl.	(1)
30 92 7078	1K0 407 152 AC	Querlenker, kpl. / control arm, cpl.	(1)
30 93 1253	1K0 407 183 E	Querlenkerlager / control arm mount	Ø A 63
30 93 1278	1K0 423 831 A	Rep. Satz Lenkmanschette / rep. kit steering boot	Ø I 15,5 L190
30 93 2627	1K0 423 810 A S1	Rep. Satz Spurstange links / rep. kit tie rod left	
30 93 2628	1K0 423 810 A S2	Rep. Satz Spurstange rechts / rep. kit tie rod right	
30 93 6735	1K0 407 365 C S1	Rep. Satz Traggelenk / rep. kit ball joint	
30 93 6736	1K0 407 366 C S1	Rep. Satz Traggelenk / rep. kit ball joint	
30 93 6752	1K0 407 183 P	Querlenkerlager / control arm mount	(1)
30 93 7182	1K0 407 152 AC S1	Rep. Satz Querlenker mit Traggelenk / control arm with ball joint	PR-8Q3
30 93 7183	1K0 407 151 AC S1	Rep. Satz Querlenker mit Traggelenk / control arm with ball joint	PR-8Q3
30 93 8180	1K0 407 152 BC S1	Rep. Satz Querlenker / rep. kit control arm	Stahl / steel
30 93 8181	1K0 407 151 BC S1	Rep. Satz Querlenker / rep. kit control arm	Stahl / steel
30 93 8662	1K0 199 231 K	Querlenkerlager mit Gehäuse / control arm mount with housing	Aluminium
30 93 8663	1K0 199 232 K	Querlenkerlager mit Gehäuse / control arm mount with housing	Aluminium
30 94 0103	1K0 407 151 AC S2	Rep. Satz Querlenker / rep. kit control arm	
30 94 0104	1K0 407 152 AC S2	Rep. Satz Querlenker / rep. kit control arm	
32 92 4122	1K0 411 315 R	Verbindungsstange / connecting rod	
32 92 6045	1K0 423 810 A	Spurstange / tie rod	
32 92 6082	1K0 407 365 C	Traggelenk / ball joint	
32 92 6083	1K0 407 366 C	Traggelenk / ball joint	
32 92 6096	1K0 423 811 E	Spurstangenendstück / tie rod end	
32 92 6097	1K0 423 812 E	Spurstangenendstück / tie rod end	
32 93 2541	1K0 199 232 J S1	Rep. Satz Querlenkerlagersatz / rep. kit control arm mounting kit	
32 93 2542	1K0 199 231 J S1	Rep. Satz Querlenkerlagersatz / rep. kit control arm mounting kit	



VOLKSWAGEN

Käfer

(1200, 1300, 1302, 1303, 1500)

(1947 → 1986)

(ex.)

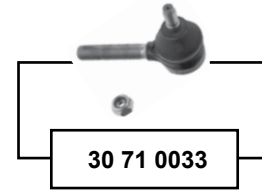

30 90 1153



(ch.) → 2 921 552

32 90 1156



32 90 1156



(ch.) 2 921 553 → 115 999 000

32 90 1157



32 90 1155



32 90 1157

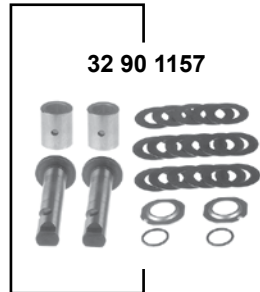

Ref. - No.



30 90 1153	111 498 021/2
30 90 1154	111 498 021
30 71 0033	131 415 812
30 71 0034	131 415 811
32 90 1155	111 498 051 A/2
32 90 1156	111 498 051
32 90 1157	111 498 051 A

Rep. Satz Achsbolzen / rep. kit king pin
Rep. Satz Achsbolzen / rep. kit king pin
Spurstangenendstück / tie rod end
Spurstangenendstück / tie rod end
Rep. Satz Bundbolzen / rep. kit collar bolt
Rep. Satz Bundbolzen / rep. kit collar bolt
Rep. Satz Bundbolzen / rep. kit collar bolt

(ex.) 1500
(ex.) 1500
= 2x 32 90 1157

M 14x1,5 RHT
M 14x1,5 LHT

Vorderachse / Front axle



Käfer

(1200,1300,1302,1303,1500)

(1947→1986)

Typ 1 1200 → 1500 (ch.) 116 000 001 →

oben / upper

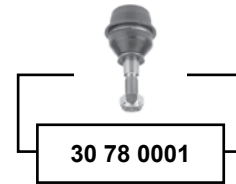
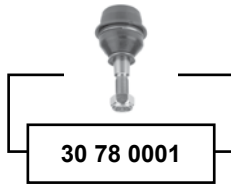

unten / lower

30 78 0027

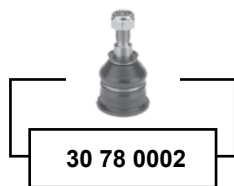

30 78 0002

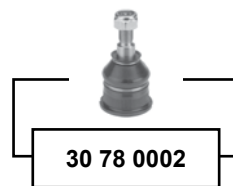

30 78 0002

30 78 0027



(1961 → 1975)

Typ 3 1500 / 1600

oben / upper

30 78 0033



30 78 0033



unten / lower

30 78 0026



30 78 0026



(1) (ch.) → 112 3200 000
(ch.) → 133 3200 000

Mod. 1302
Mod. 1303



Ref. - No.



30 78 0001	131 405 361 F
30 78 0002	131 405 371 G
30 78 0026	311 405 371 C
30 78 0027	113 407 361 E
30 78 0033	311 405 361 B

Führungsgelenk / guide joint
Traggelenk / ball point
Führungsgelenk / ball joint
Traggelenk / ball joint
Führungsgelenk / ball joint

(1)

Ø A 38,3
Ø A 38,3
M20 x 1,5
M20 x 1,5



VOLKSWAGEN

LT (28/29) (21)

(1976 → 1996)

Einzelradaufhängung Independent Wheel Suspension

Vorderachse / Front axle

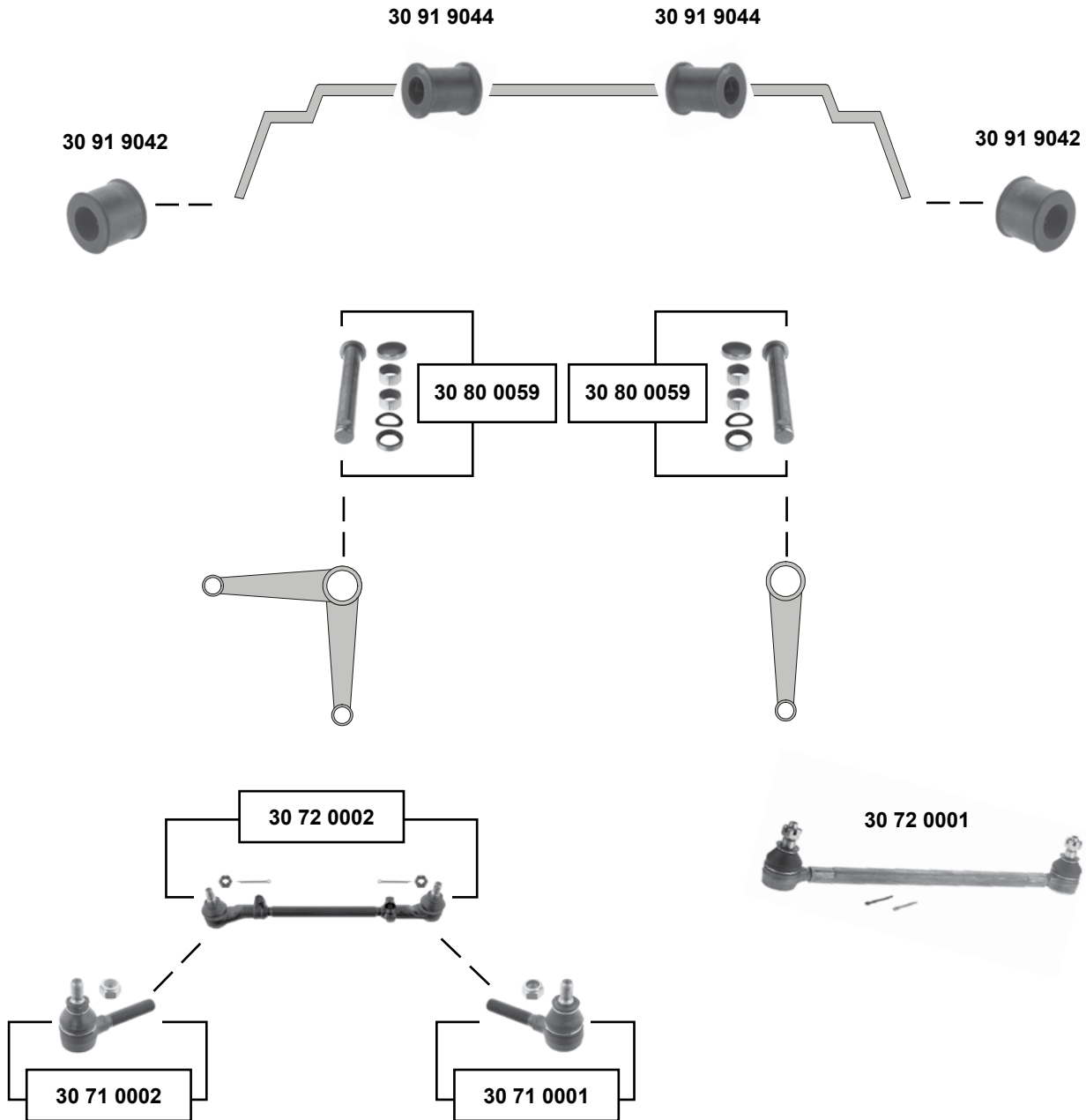

SWAG GERMANY	Ref. - No.			
30 71 0001	281 415 812	Spurstangenendstück / tie rod end		M14 x 1,5
30 71 0002	281 415 811	Spurstangenendstück / tie rod end		M14 x 1,5
30 72 0001	281 415 802 A	Spurstange / tie rod		L 360
30 72 0002	281 415 801 D	Spurstange / tie rod		
30 80 0059	281 498 171 A	Rep. Satz Lenkhebelwelle / rep. kit steering arm shaft	(ch.) 288 2519 374 →	24x192
30 91 9042	281 411 045	Gummilager / rubber mount		
30 91 9044	281 411 041	Stabilisatorlager / stabilizer mounting		Ø 21



LT (28/29) (21)
(1976 → 1996)

Einzelradaufhängung
Independent Wheel Suspension

oben / upper

30 78 0009



30 60 0013



30 60 0013

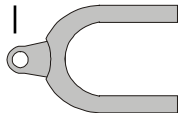

30 78 0009



30 60 0013



30 60 0013

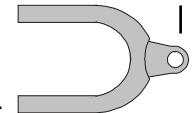

Vorderachse / Front axle

unten / lower

30 60 0028



30 60 0028



30 60 0027



30 60 0027



30 60 0035



30 60 0035



30 78 0008



30 78 0008



Ref. - No.



30 60 0013	281 407 077	Querlenkerlager / control arm mount	20x38x58
30 60 0027	281 407 180	Zugstrebenlager / tension rod mount	30x66x40
30 60 0028	281 407 179	Zugstrebenlager / tension rod mount	30x66x40
30 60 0035	281 407 091 B	Anschlagpuffer / buffer	120x68x20
30 78 0008	281 407 187 B	Traggelenk / ball joint	M20 x 1,5
30 78 0009	281 407 361	Traggelenk / ball joint	M18 x 1,5



VOLKSWAGEN

LT (28/29) (21)

(1976 → 1996)

Starrachse Rigid Axle

Vorderachse / Front axle

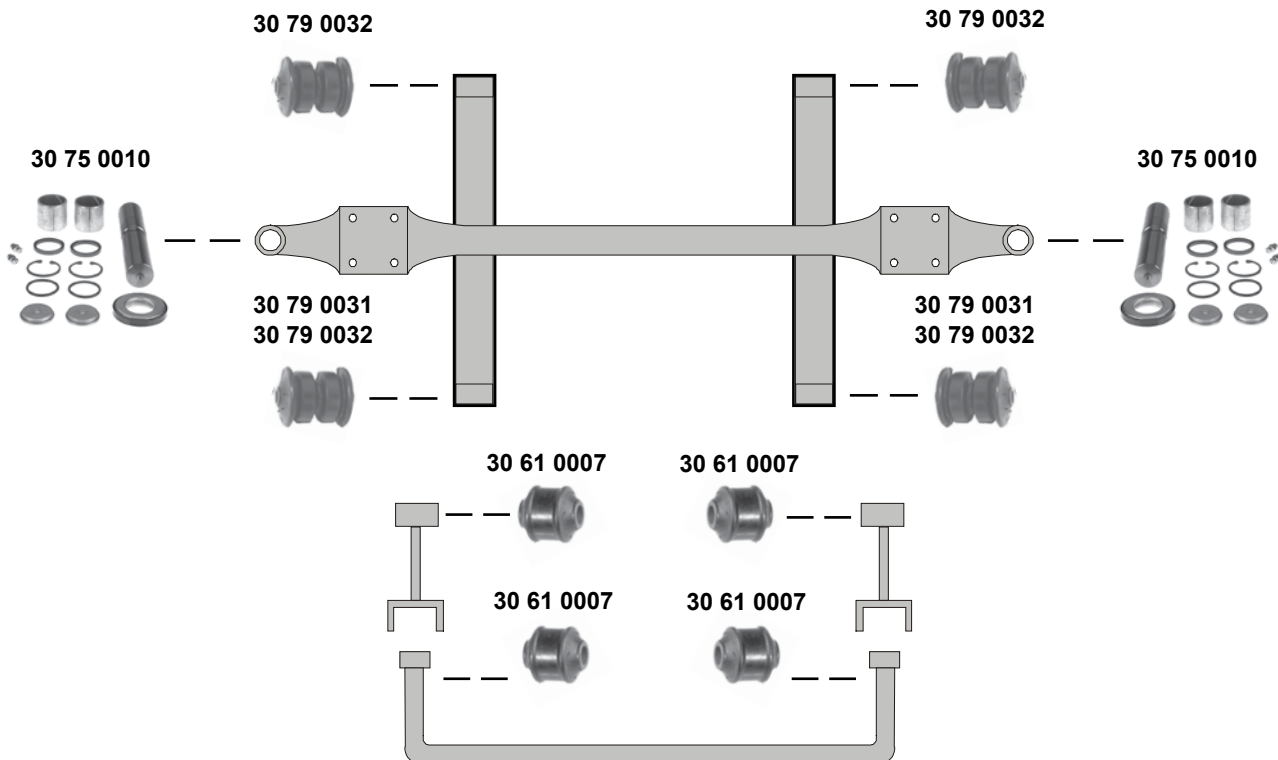
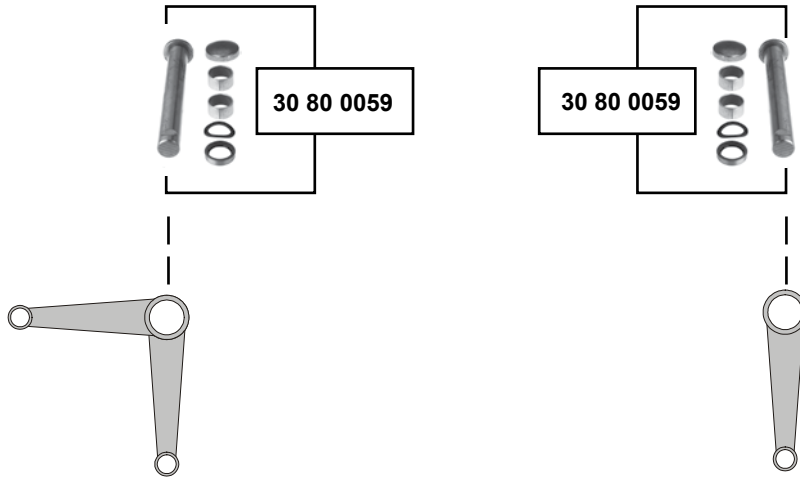

SWAG GERMANY	Ref. - No.			
30 61 0007	291 411 045	Stabilisatorlager / stabilizer mount		12x37,5x40
30 75 0010	291 498 173 A	Rep. Satz Achsbolzen / rep. satz king pin		25x131,5
30 79 0031	291 511 181	Blattfederlager / leaf-spring bearing		12x49x75
30 79 0032	291 511 171 C	Blattfederlager / leaf-spring bearing		14x52x75
30 80 0059	281 498 171 A	Rep. Satz Lenkhebelwelle / rep. kit steering arm shaft	(ch.) 288 2519 374 →	24x192

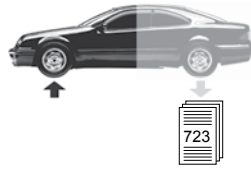

LT 28 / LT 35
(1997 → 2003)

Vorderachse / Front axle

10 92 6325



10 92 6325

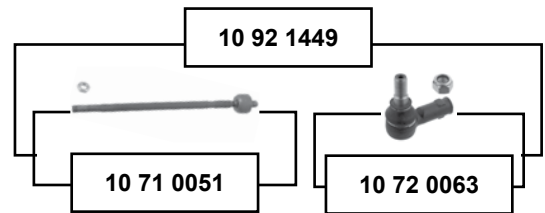
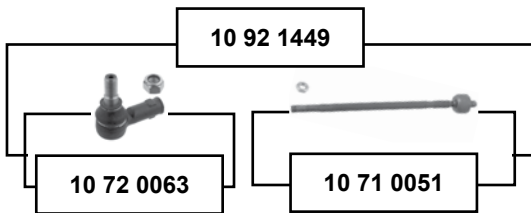

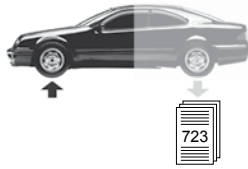

LT 28 / LT 35

(1997 → 2003)

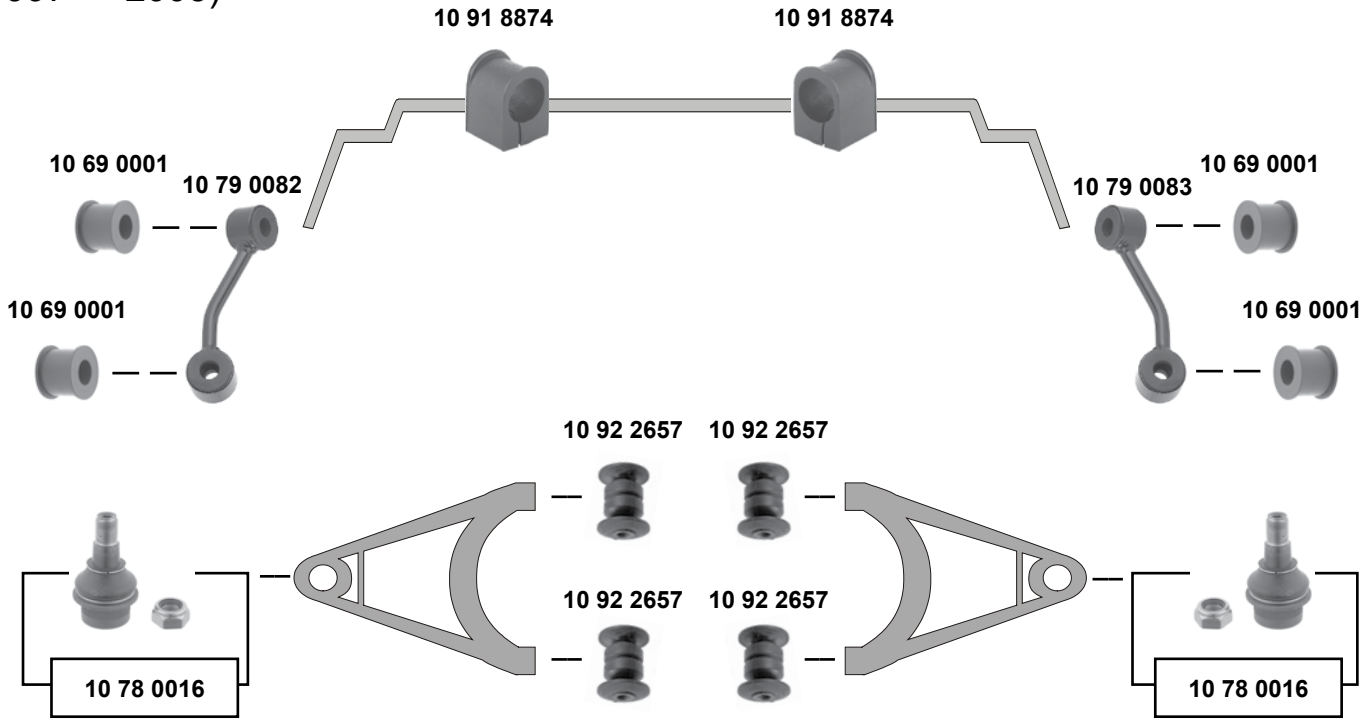

Vorderachse / Front axle

LT 46

(1997 → 2007)

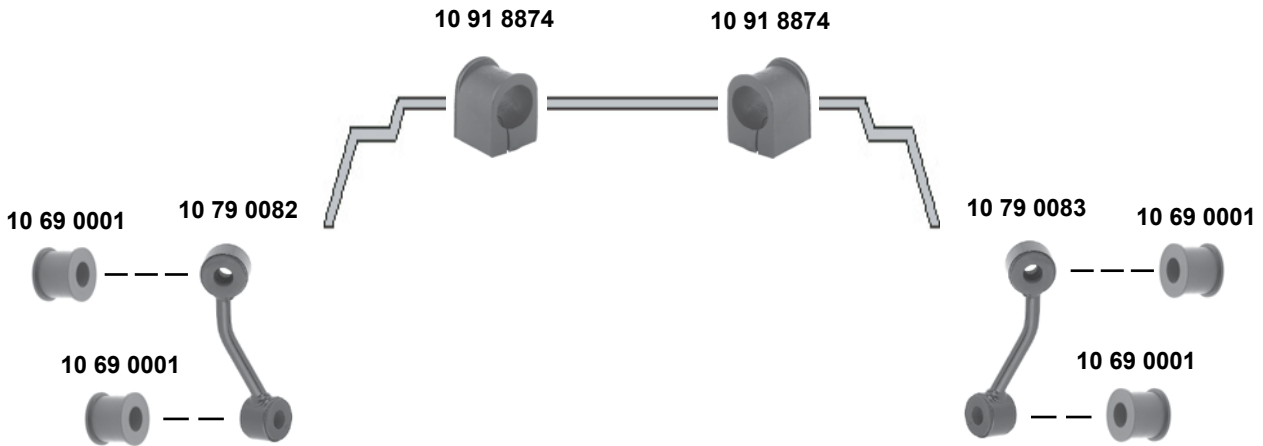

SWAG GERMANY	Ref. - No.			
10 69 0001	2D0 411 041 A	Gummilager / rubber mount		M20 x 1,5
10 78 0016	2D0 407 361 B	Traggelenk / ball joint		
10 79 0082	2D0 411 051 S1	Verbindungsstange / connecting rod		Ø 25
10 79 0083	2D0 411 052 S1	Verbindungsstange / connecting rod		
10 91 8874	2D0 411 041 B	Stabilisatorlager / stabilizer mount		
10 92 2657	2D0 407 140	Querlenkerlager / rubber mount	→ 07 / 4x4	



Lupo (6X) (1999 → 2006)

man.

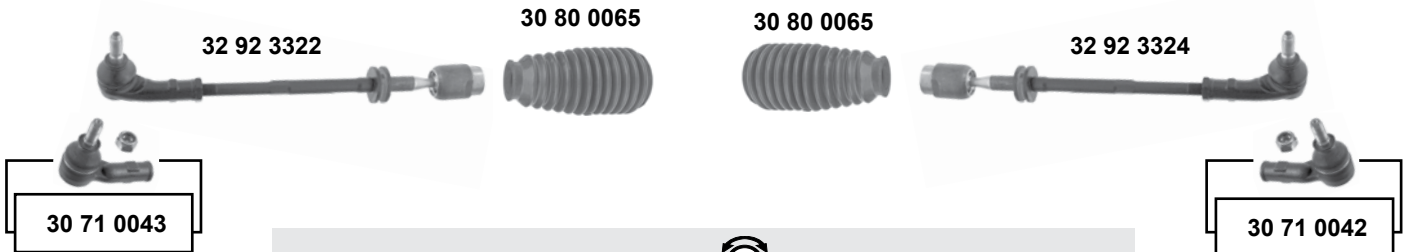

servo

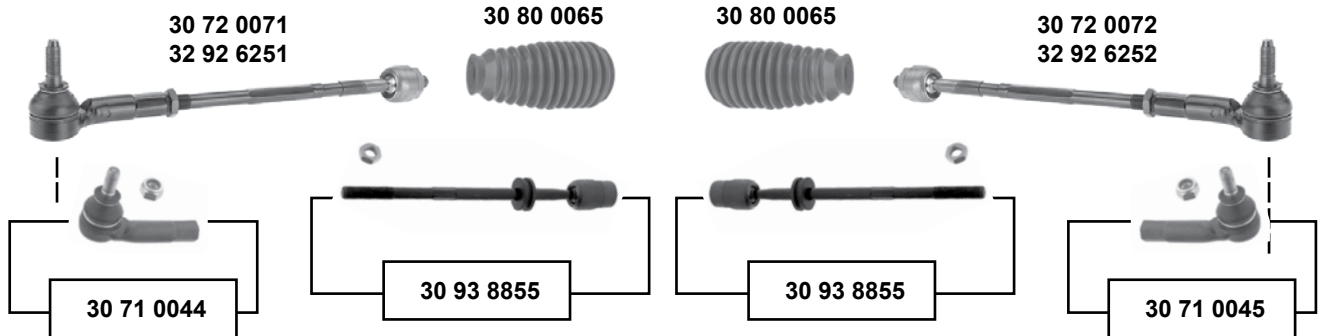

Lupo 3L (6E)

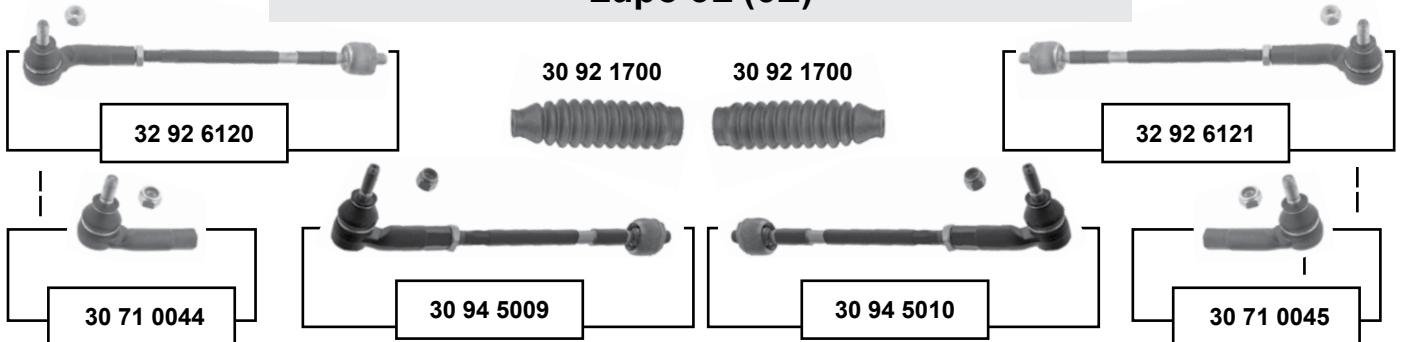

(1) Lupo 6X / 6E → 06 / (ex.) servo

(2) (ex.) (mot.) AFK, AQQ, AMF, AUB

(3) (mot.) AFK, AQQ, AMF, AUB

(4) servo / PR-1N1 / PR-1N5

SWAG GERMANY	Ref. - No.			
30 71 0042	6N0 422 812	Spurstangenendstück / tie rod end	(2) servo	M12 x 1,5
30 71 0043	6N0 422 811	Spurstangenendstück / tie rod end	(2) servo	M12 x 1,5
30 71 0044	6E0 419 811	Spurstangenendstück / tie rod end		M12 x 1,5
30 71 0045	6X0 422 812	Spurstangenendstück / tie rod end		M12 x 1,5
30 72 0071	6X0 422 803	Spurstange / tie rod	(2)	
30 72 0072	6X0 422 804	Spurstange / tie rod	(2)	
30 80 0065	6N0 419 831	Lenkmanschette / steering boot	(2)	
30 92 1700	6E0 419 831	Lenkmanschette / steering boot		
30 93 8855	6X0 422 810	Axialgelenk / axial joint	(4)	
30 94 5009	6E0 422 803	Spurstange / tie rod	PR-1N1 / 1N5	
30 94 5010	6E0 422 804	Spurstange / tie rod	PR-1N1 / 1N5	
32 92 3322	6X0 419 803 A	Spurstange / tie rod	(1)	
32 92 3324	6X0 419 804 A	Spurstange / tie rod	(1)	
32 92 6120	6E0 419 803 A	Spurstange / tie rod	PR-1N0 / 1N6	
32 92 6121	6E0 419 804 A	Spurstange / tie rod	PR-1N0 / 1N6	
32 92 6251	6N0 422 803 C	Spurstange / tie rod	(3)	
32 92 6252	6N0 422 804 C	Spurstange / tie rod	(3)	



Lupo (6X) (1999 → 2006)

Vorderachse / Front axle

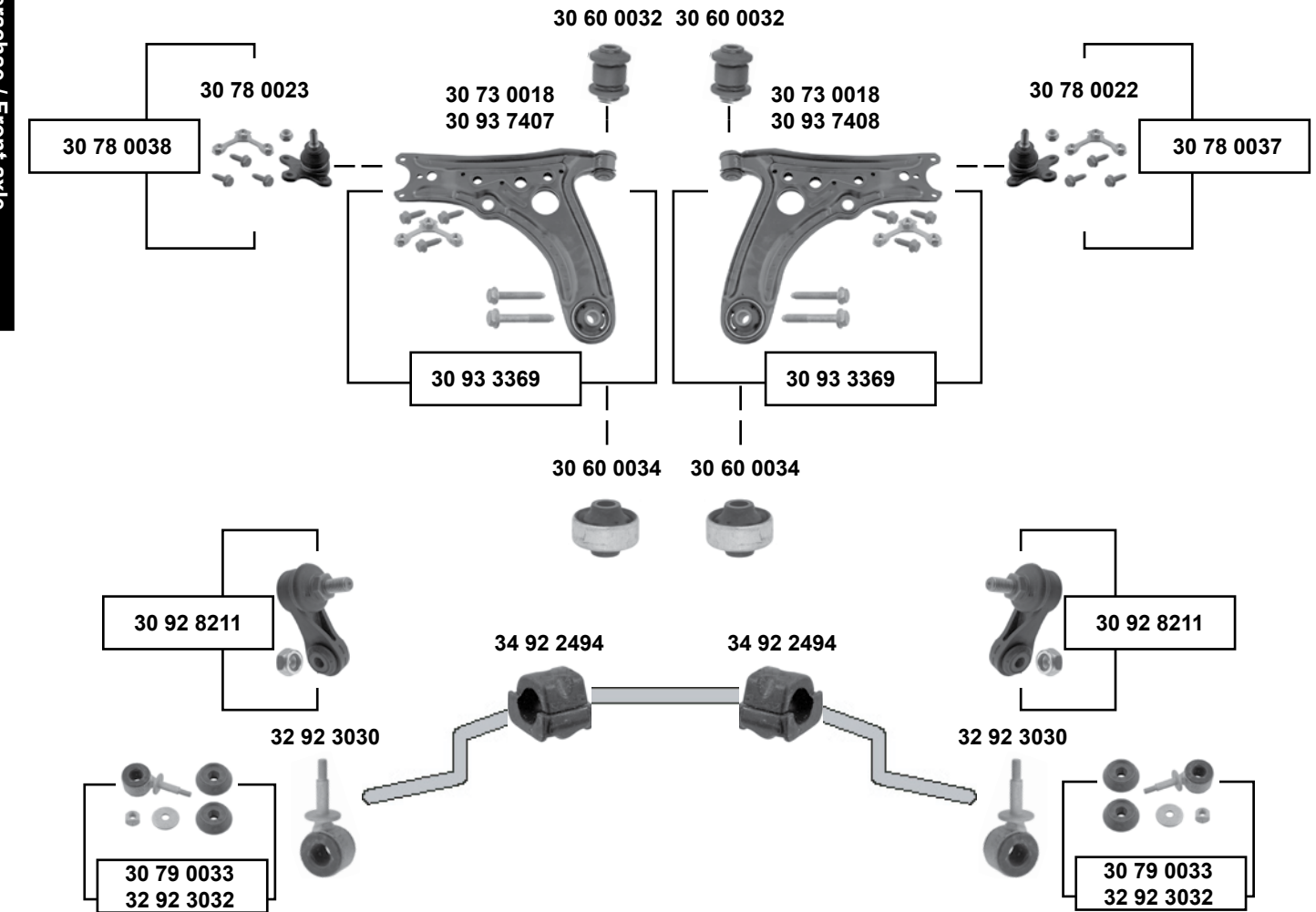



Lupo (6X)
 (1999 → 2006)

- (1)** → 03 Stabilisator / stabilizer Ø 18 mm / 04 → **(mot.)** ALD / AUC / AUB / AUD / VBBY / AHW / AMF / AJKU
- (2)** Stabilisator / stabilizer Ø 20/22 mm
- (3)** Stabilisator / stabilizer Ø 18 mm
- (4)** **(mot.)** ANY, AYZ (3L TDI) ARR, (1,4 FSI) Stabilisator / stabilizer Ø 18 mm
- (5)** **(ex.)** FSI = **(mot.)** ARR / **(ex.)** 3L TDI
- (6)** **(mot.)** AER, AHT, AKQ, ALL, ANV, APE Einbauseite: Vorderachse links / fitting side: front axle left
(mot.) AHW, AKU, ALD, AUC, AUD / PR-1LB/1LM/1ZC/1ZN / für Bremsscheibendurchmesser (mm) / for brakedisk diameter (mm): 239 / für Bremsscheibendicke (mm) / for brake disk thickness (mm) 18 / Einbauseite: Vorderachse links / fitting side: front axle left
(mot.) AHW, AKU, ALD, AUC, AUD, BBY / PR-1ZE/1ZJ/1ZK / für Bremsscheibendurchmesser (mm) / for brakedisk diameter (mm): 256 / für Bremsscheibendicke (mm) / for brake disk thickness (mm) 20 / Einbauseite: Vorderachse rechts / fitting side: front axle right
(mot.) AFK, AQQ / PR-1ZE/1ZK / für Bremsscheibendurchmesser (mm) / for brakedisk diameter (mm): 256 / für Bremsscheibendicke (mm) / for brake disk thickness (mm) 20 / Einbauseite: Vorderachse rechts / fitting side: front axle right
(mot.) AMF, AUB / PR-1ZE/1ZJ/1ZK / für Bremsscheibendurchmesser (mm) / for brakedisk diameter (mm): 256 / für Bremsscheibendicke (mm) / for brake disk thickness (mm) 20 / Einbauseite: Vorderachse rechts / fitting side: front axle right
(mot.) AMF, AUB, AVY PR-1LM/1ZN / für Bremsscheibendurchmesser (mm) / for brakedisk diameter (mm): 239 / für Bremsscheibendicke (mm) / for brake disk thickness (mm) 18 / Einbauseite: Vorderachse links / fitting side: front axle left
(mot.) AUA, BBY **(ex.)** PR-1LB/1LM/1ZC/1ZN / für Bremsscheibendurchmesser (mm) / for brakedisk diameter (mm): 239 / für Bremsscheibendicke (mm) / for brake disk thickness (mm) 18 / Einbauseite: Vorderachse links / fitting side: front axle left

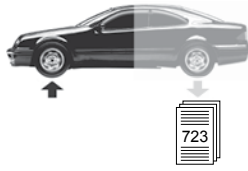

	Ref. - No.			
30 60 0032	6N0 407 182	Querlenkerlager / control arm mount	(ex.) 3L TDI	Ø A 28
30 60 0034	6N0 407 181	Querlenkerlager / control arm mount	(ex.) 3L TDI	17x61x46
30 73 0018	6X0 407 151 A	Querlenker / control arm	(ex.) 3L TDI	
30 78 0022	6N0 407 365 A	Traggelenk / ball joint	(6)	M10 x 1
30 78 0023	6N0 407 365	Traggelenk / ball joint	(6)	M10 x 1
30 78 0037	6N0 407 365 A S1	Rep. Satz Traggelenk / rep. kit ball joint	(ex.) 3L TDI	
30 78 0038	6N0 407 365 S1	Rep. Satz Traggelenk / rep. kit ball joint	(ex.) 3L TDI	
30 79 0033	6N0 411 315 C S1	Rep. Satz Verbindungsstange / rep. kit connecting rod	(1)	
30 92 8211	6E0 411 315	Verbindungsstange / connecting rod	(4)	
30 93 3369	6X0 407 151 A S1	Rep. Satz Querlenker / rep. kit control arm	(5)	
30 93 7407	6X0 407 151 A S2	Rep. Satz Querlenker / rep. kit control arm	PR-1LB,1LM,1ZC,1ZN	
30 93 7408	6X0 407 151 A S3	Rep. Satz Querlenker / rep. kit control arm	PR-1LB,1LM,1ZC,1ZN	
32 92 3030	6N0 411 315 D	Verbindungsstange / connecting rod		
32 92 3032	6N0 411 315 D S1	Rep. Satz Verbindungsstange / rep. kit connecting rod	(2)	
34 92 2494	6X0 411 313 A	Stabilager / stabilizer mounting	(3)	



New Beetle (1C/9C)

(1999 → 2010)

(ch.) → 1C-W-0047 125

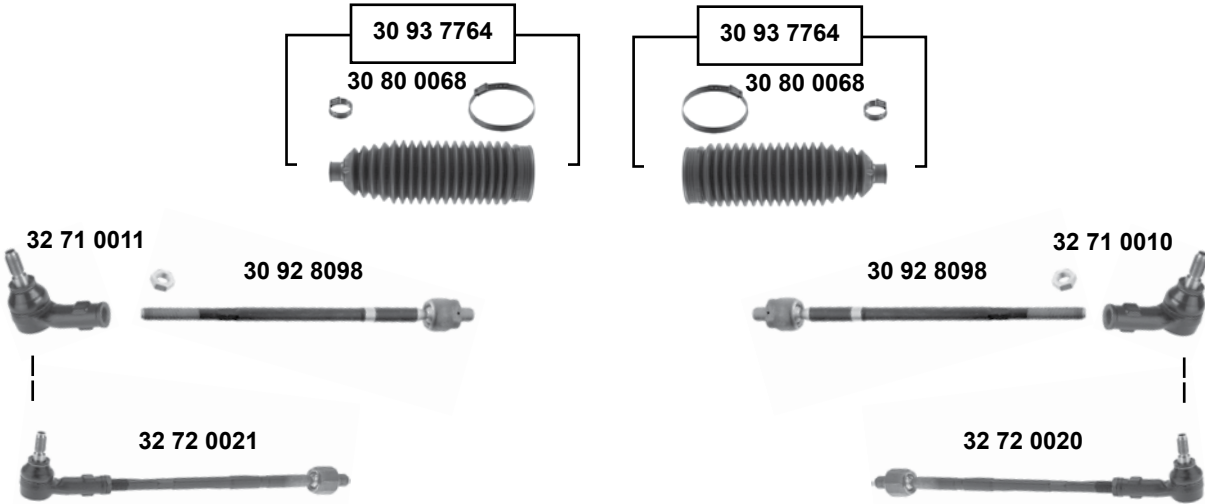



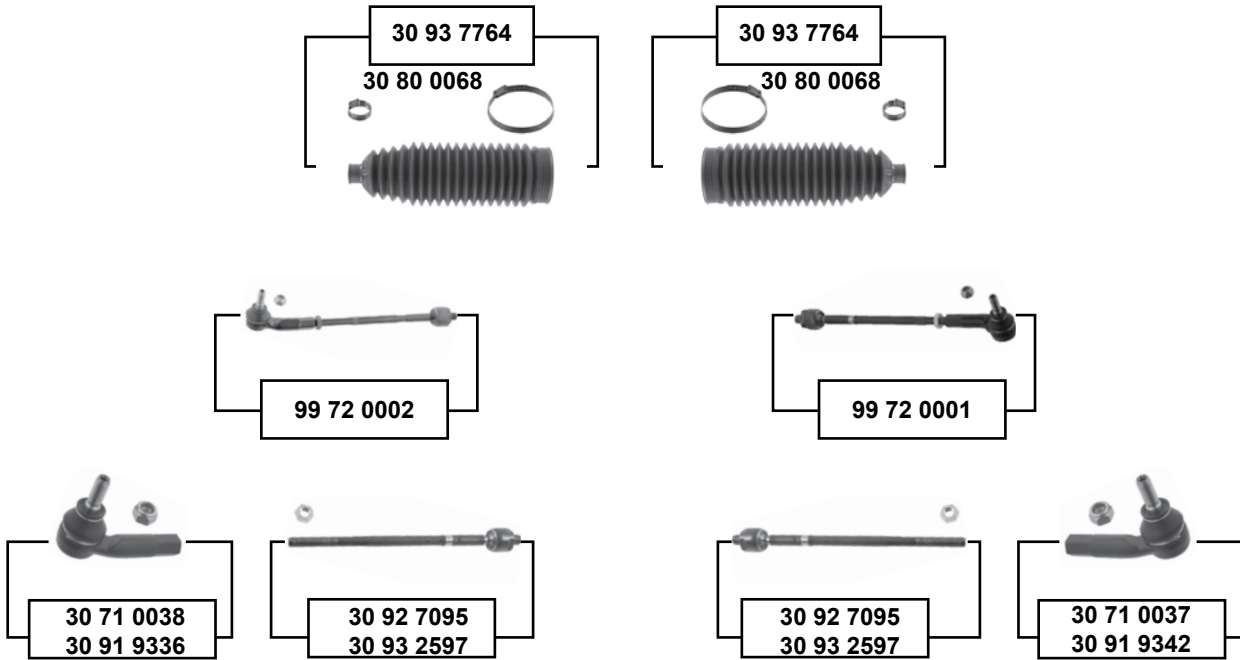

(ch.) 1C-W-0047 126 →

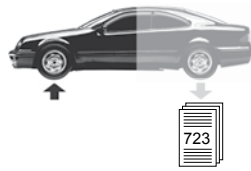

Vorderachse / Front axle



New Beetle (1C/9C) (1999 → 2010)

	Ref. - No.			
30 71 0037	1J0 422 812 B	Spurstangenendstück / tie rod end	ZF	M14 x 1,5
30 71 0038	1J0 422 811 B	Spurstangenendstück / tie rod end	ZF	M14 x 1,5
30 80 0068	1J0 422 831 B	Lenkmanschette / steering boot	(ex.) RSi	
30 91 9336	8N0 422 811 A	Spurstangenendstück / tie rod end	RSi	M14 x 1,5
30 91 9342	8N0 422 812 A	Spurstangenendstück / tie rod end	RSi	
30 92 7095	1J0 422 810 B	Spurstange / tie rod	(ex.) RSi	L 321
30 92 8098	1J0 422 810 A	Spurstange / tie rod		
30 93 2597	8N0 422 810 C	Spurstange / tie rod	RSi	M16 x 1,5
30 93 7764	1J0 422 831 B S1	Rep. Satz Lenkmanschette / rep. kit steering boot		
32 71 0010	1J0 422 811 A	Spurstangenendstück / tie rod end		M14 x 1,5
32 71 0011	1J0 422 811 A	Spurstangenendstück / tie rod end		M14 x 1,5
32 72 0020	1J0 422 804 A	Spurstange / tie rod		
32 72 0021	1J0 422 804 A	Spurstange / tie rod		
99 72 0001	1J0 422 804 H	Spurstange / tie rod	(ex.) RSi	
99 72 0002	1J0 422 803 H	Spurstange / tie rod	(ex.) RSi	

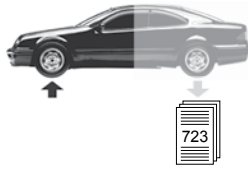

New Beetle (1C/9C) (1999 → 2010)

Vorderachse / Front axle

30 69 0002
30 92 8621

30 69 0002
30 92 8621

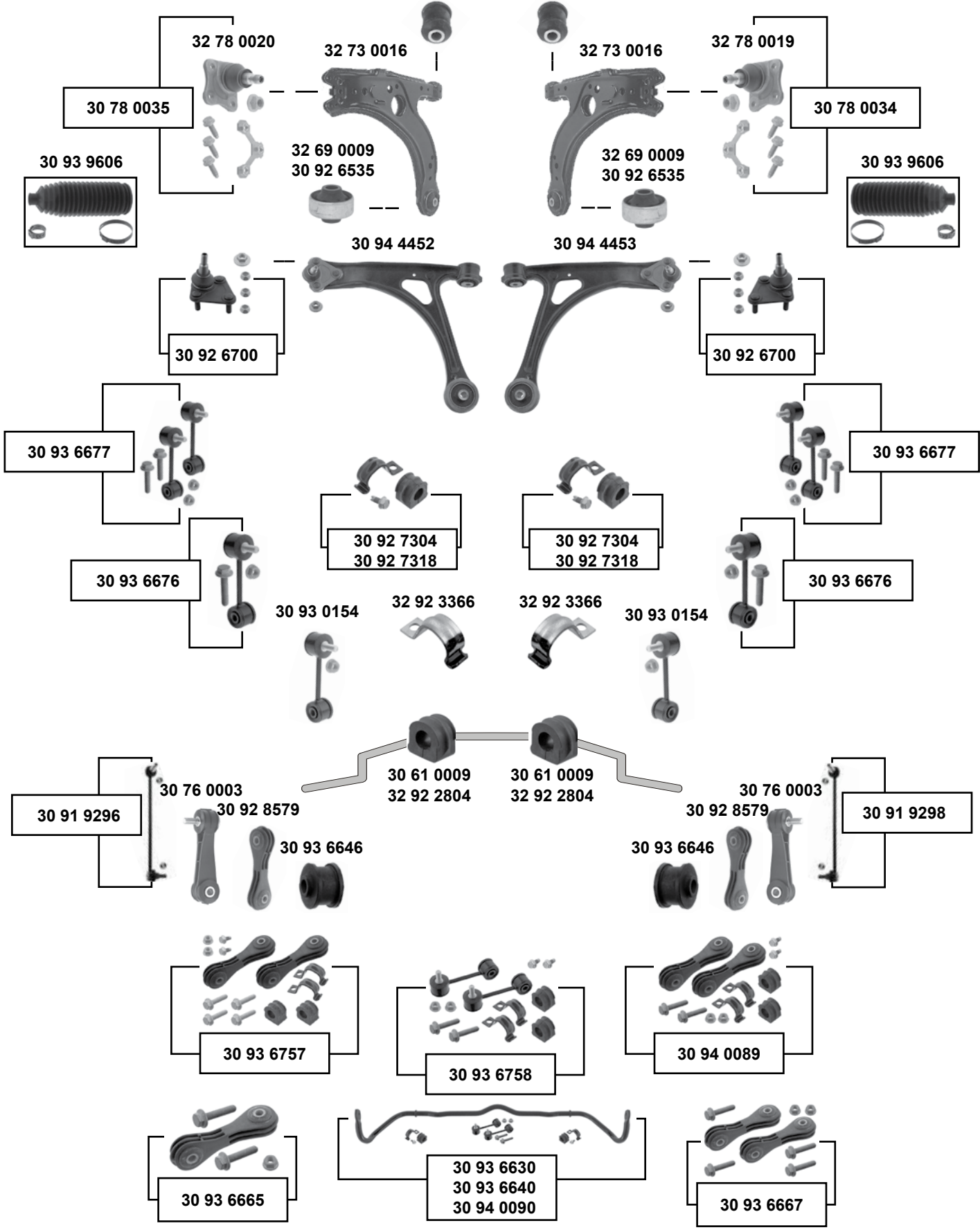

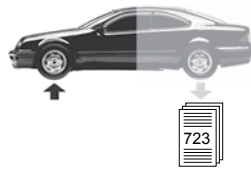

New Beetle (1C/9C) (1999 → 2010)



Rep. Sätze / rep. kits

30 91 9820

30 91 9822



(1)	(ch.) → 1C-X-499 000 / 9C-X-999 000	(2)	(ch.) 1C-Y-400 000 → / (ch.) → 1C-1-451 000
(3)	(1C / 9C) → 10 / cabrio 03 → 10		
(4)	01 → 10 (ch.) 1C-1-451-001 → / (ch.) 9C-1-636 001 → / cabrio (1Y) 03 → 10		
(5)	03 → alle / all / 04 (ch.) 1C-4-400 001 → / 9C-4-400 001 →		
(6)	→ 05 / (ch.) → 1C-X-499 000 / (ch.) → 9C-X-999 000		
(7)	(ch.) → 1C-9-512 683 / (ch.) 1C-Y-400 001 → / (ch.) → 9C-9-557 246 / (ch.) 9C-Y-600 001 →		
(8)	Cabrio → 03 / (ch.) → 1Y-9-408 477		
(9)	→ 05 (ch.) 1C-Y-400 001 → / (ch.) → 1C-1-451 000		
(10)	1C (ch.) 1C-1-451 001 → / 9C → 05 (ch.) 9C-1-636 001 → / Cabrio 03 →		
(11)	1C: (ch.) 1C-1-451 001 → / (ch.) → 1C-7-512 081 / (ch.) → 1C-9-512 683 9C: (ch.) 9C-1-636 001 → / (ch.) → 9C-9-557 246 / (ch.) → 9C-9-555 760 // Cabrio (ch.) → 1Y-7-413 420		



Ref. - No.



Ref. - No.	Description	Notes	Dimensions
30 61 0009	1J0 411 314 T Stabilisatorlager / stabilizer mount		Ø I 21
30 69 0002	357 407 182 Querlenkerlager / control arm mount	(ex.) RSI	12x33x54
30 76 0003	1J0 411 315 J Verbindungsstange / connecting rod	(1)	L 105
30 78 0034	1J0 407 366 H S1 Rep. Satz Traggelenk / rep. kit ball joint		
30 78 0035	1J0 407 365 H S1 Rep. Satz Traggelenk / rep. kit ball joint		
30 91 9296	1J0 411 315 D Verbindungsstange / connecting rod	4motion	
30 91 9298	1J0 411 316 D Verbindungsstange / connecting rod	4motion	
30 91 9820	1J0 407 365 H S2 Querlenker, kpl. / control arm, cpl.	(ex.) R32	
30 91 9822	1J0 407 366 H S2 Querlenker, kpl. / control arm, cpl.	(ex.) R32	
30 92 6535	8N0 407 181 B Querlenkerlager / control arm mount	00 → 01	14x60x41
30 92 6700	8N0 407 365 C Traggelenk beidseitig / ball joint both sides	RSI	
30 92 7304	1J0 411 314 R S1 Stabilisatorlagersatz / stabilizer mount	→ 01	Ø I 18
30 92 7318	1J0 411 314 T S1 Stabilisatorlagersatz / stabilizer mount	(5)	Ø I 21
30 92 8579	1J0 411 315 K Verbindungsstange / connecting rod	(4)	L 105,5
30 92 8621	8N0 407 182 A Querlenkerlager / control arm mount	RSI / → 01	Ø A 54
30 93 0154	1J0 411 315 G S1 Verbindungsstange / rep. kit connecting rod	(2)	L 105 / M10
30 93 6630	1J0 411 305 B S1 Rep. Satz Stabilisatorsatz / rep. kit stabilizer kit	(6)	
30 93 6640	1J0 411 305 E S1 Rep. Satz Stabilisatorsatz / rep. kit stabilizer kit	(7) (8)	
30 93 6646	1J0 411 327 A Verbindungsstangenlager / connecting rod mount	(9)	Ø A 29
30 93 6665	1J0 411 315 K S1 Rep. Satz Verbindungsstange / rep. kit connecting rod	(10)	L 105,5
30 93 6667	1J0 411 315 K S2 Verbindungsstangensatz / connecting rod set	(10)	L 105,5
30 93 6676	1J0 411 315 G S1 Verbindungsstange / stabiliser link	(2)	
30 93 6677	1J0 411 315 G S2 Rep. Satz Verbindungsstange / rep. kit connecting rod	(2)	
30 93 6757	1J0 411 315 G S3 Stabilisatorlagersatz / anti roll bar bush kit	(6)	Ø I 21
30 93 6758	1J0 411 315 G S4 Stabilisatorlagersatz / anti roll bar bush kit	(7) (8)	Ø I 21
30 93 9606	8N0 422 831 S1 Rep. Satz Lenkmanschette / rep. kit steering boot	00 → 01	
30 94 0089	1J0 411 314 T S2 Stabilisatorlagersatz / anti roll bar bush kit	(11) PR-OAE	Ø A 23
30 94 0090	1J0 411 305 E S2 Rep. Satz Stabilisatorsatz / rep. kit stabilizer kit	(11)	Ø A 23
30 94 4452	8N0 407 151 D S1 Querlenker / control arm	Gummi / rubber	
30 94 4453	8N0 407 152 D S1 Querlenker / control arm	Gummi / rubber	
32 69 0009	1J0 407 181 Querlenkerlager / control arm mount	(3) (ex.) RSI	13x60x41
32 73 0016	1J0 407 151 C Querlenker / control arm	(3) (ex.) RSI	
32 78 0019	1J0 407 366 H Traggelenk / ball joint		M12 x 1,5
32 78 0020	1J0 407 365 H Traggelenk / ball joint		M12 x 1,5
32 92 2804	1J0 411 314 R Stabilisatorlager / stabilizer mount		Ø I 18
32 92 3366	1J0 411 336 D Schelle / clamp		

passend für / to fit

VOLKSWAGEN





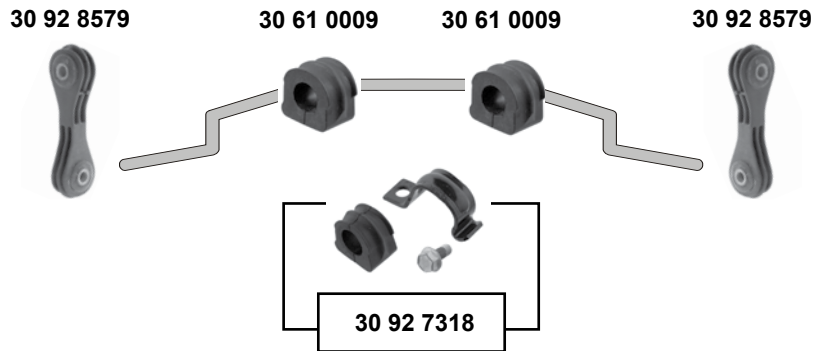
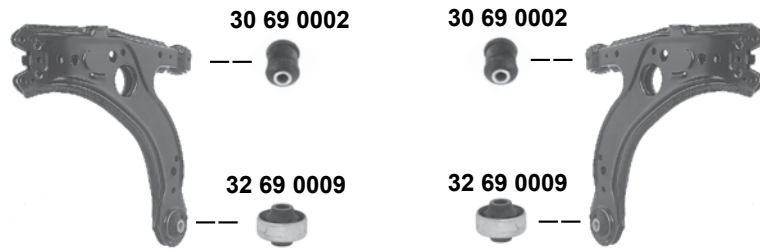

New Beetle Cabrio (1Y)

(2003 → 2010)

Vorderachse / Front axle



	Ref. - No.			
30 61 0009	1J0 411 314 T	Stabilisatorlager / stabilizer mount	für / to fit Stabi 23	Ø I 21
30 69 0002	357 407 182	Querlenkerlager / control arm mount		12x33x54
30 92 7318	1J0 411 314 T S1	Rep. Satz Stabilisatorlagersatz / rep. kit stabilizer mount kit		
30 92 8579	1J0 411 315 K	Verbindungsstange / connecting rod		L 105
32 69 0009	1J0 407 181	Querlenkerlager / control arm mount		13x60x41

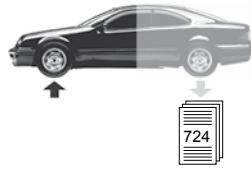

New Beetle (5C1) (2012 →)

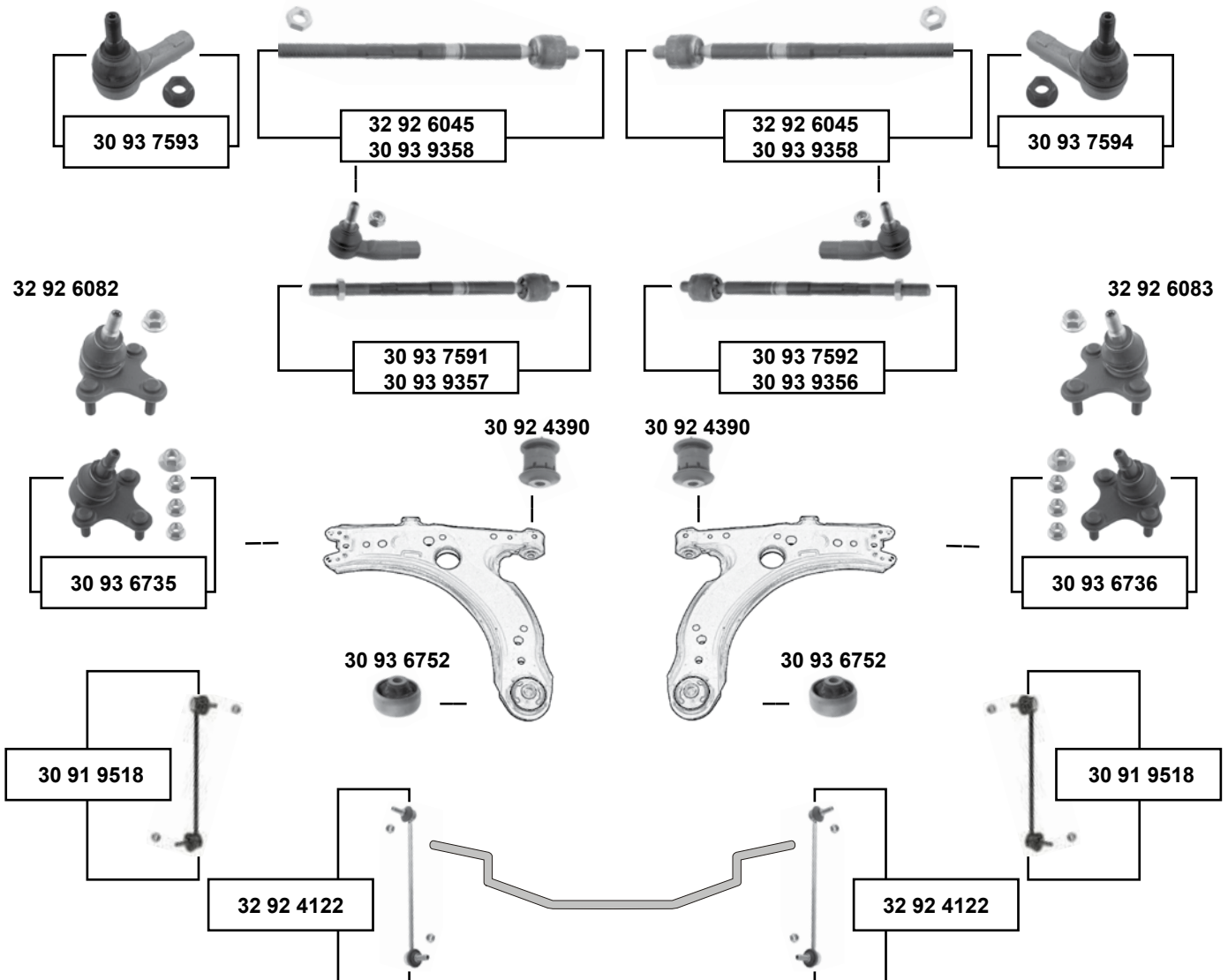

Vorderachse / Front axle



(1) Gummimetalllager / rubber metal mount

SWAG	Ref. - No.			
30 91 9518	6Q0 411 315 Q	Rep. Satz Verbindungsstange / rep. kit connecting rod		
30 92 4390	1K0 407 182	Querlenkerlager / control arm mount		Ø A48 H54
30 93 6735	1K0 407 365 C S1	Rep. Satz Traggelenk / rep. kit ball joint		
30 93 6736	1K0 407 366 C S1	Rep. Satz Traggelenk / rep. kit ball joint		
30 93 6752	1K0 407 183 P	Querlenkerlager / control arm mount		
30 93 7591	1K0 423 811 K S1	Rep. Satz Spurstange / rep. kit tie rod		
30 93 7592	1K0 423 812 K S1	Rep. Satz Spurstange / rep. kit tie rod		
30 93 7593	1K0 423 811 K	Spurstangenendstück / tie rod end		
30 93 7594	1K0 423 812 K	Spurstangenendstück / tie rod end		
30 93 9356	561 423 810 S1	Rep. Satz Spurstange / rep. kit tie rod		
30 93 9357	561 423 810 S2	Rep. Satz Spurstange / rep. kit tie rod		
30 93 9358	561 423 810	Axialgelenk / axial joint		
32 92 4122	1K0 411 315 R	Verbindungsstange / connecting rod		
32 92 6045	1K0 423 810 A	Spurstange / tie rod		
32 92 6082	1K0 407 365 C	Traggelenk / ball joint		
32 92 6083	1K0 407 366 C	Traggelenk / ball joint		
			(1) (ch.) 16-C-500 001 →	Ø I 13
			PR-1N3 / servo	L 448
			PR-1N3 / servo	L 448
			PR-1N3 / servo	M16 x 1,5
			PR-1N3 / servo	M16 x 1,5
			PR-1N1/1N3 / servo	
			PR-1N1/1N3 / servo	
			Servotronic / PR-1N3	M16 x 1,5



New Beetle Cabrio (5C7)

(2013 →)

Vorderachse / Front axle

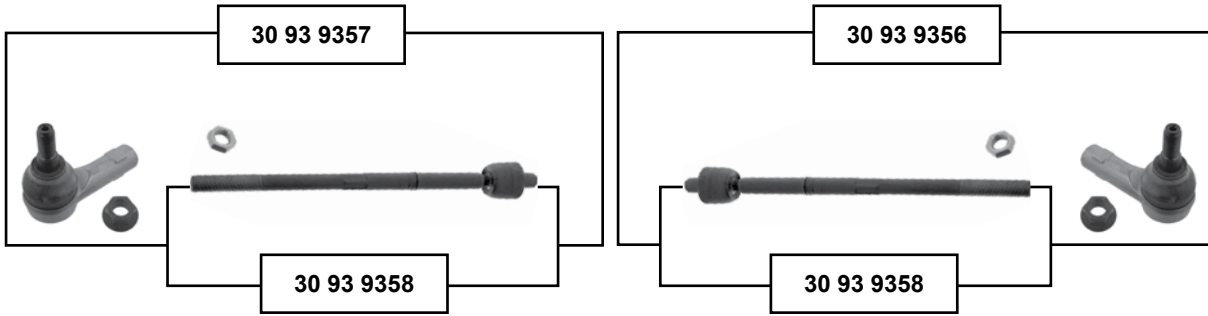

32 92 6082

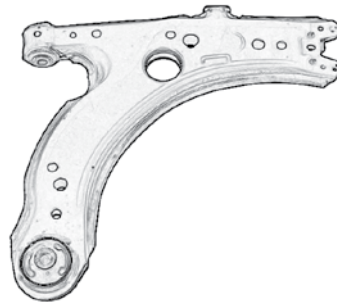
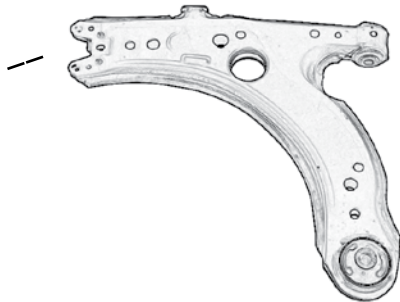

32 92 6083

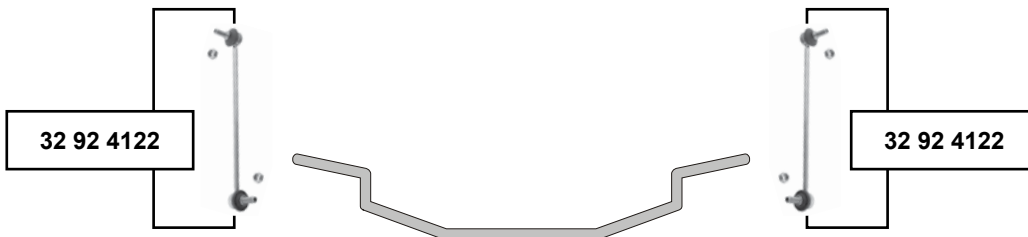

Ref. - No.



30 93 9356	561 423 810 S1
30 93 9357	561 423 810 S2
30 93 9358	561 423 810
32 92 4122	1K0 411 315 R
32 92 6082	1K0 407 365 C
32 92 6083	1K0 407 366 C

Rep. Satz Spurstange / rep. kit tie rod
Rep. Satz Spurstange / rep. kit tie rod
Axialgelenk / axial joint
Verbindungsstange / connecting rod
Traggelenk / ball joint
Traggelenk / ball joint

PR-1N1/1N3 / servo
PR-1N1/1N3 / servo
Servotronic / PR-1N3

M16 x 1,5



Passat 1(32) (1974 → 1980)

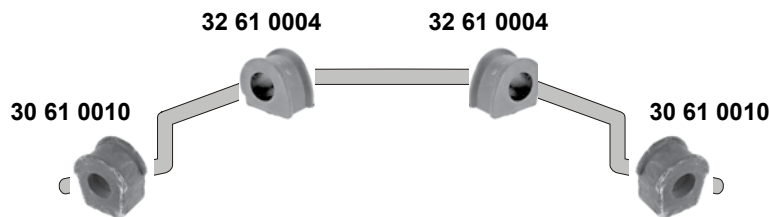
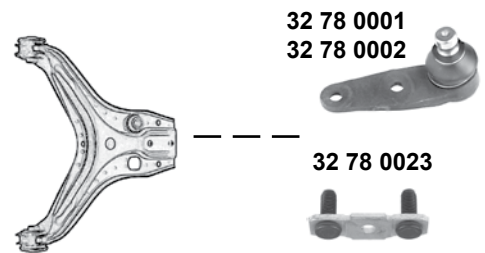
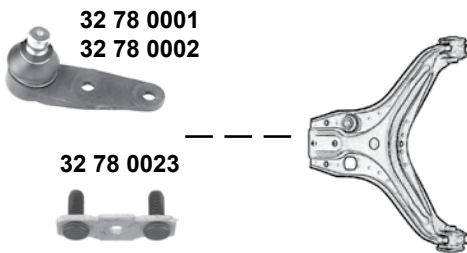

	Ref. - No.			
30 61 0010	823 411 313 A	Stabilisatorlager / stabilizer mount		Ø 12,5
32 61 0004	823 411 327 B	Stabilisatorlager / stabilizer mount		
32 71 0002	811 419 812	Spurstangenendstück / tie rod end		M10 x 1
32 78 0001	823 407 365 C	Traggelenk / ball joint	(ch.) → 328 2002 000	Ø A 15
32 78 0002	823 407 365 E	Traggelenk / ball joint	(ch.) 328 2002 001 →	Ø A 17
32 78 0023	811 407 175 A	Sicherungsblech / lock washer		



VOLKSWAGEN

Passat 2 (32)

(1981 → 1988)

(ex.) Syncro

man.

(ch.) → 32-B-040 821

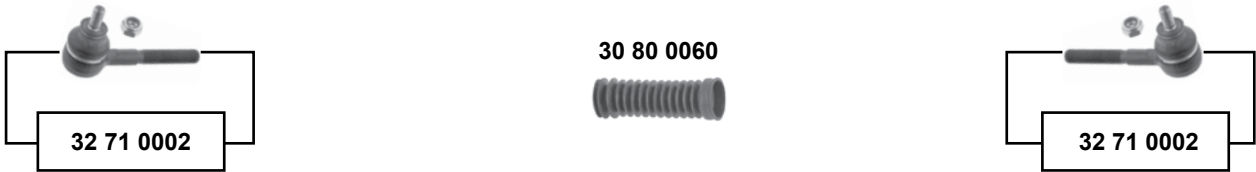

(ch.) 32-B-040 822 →

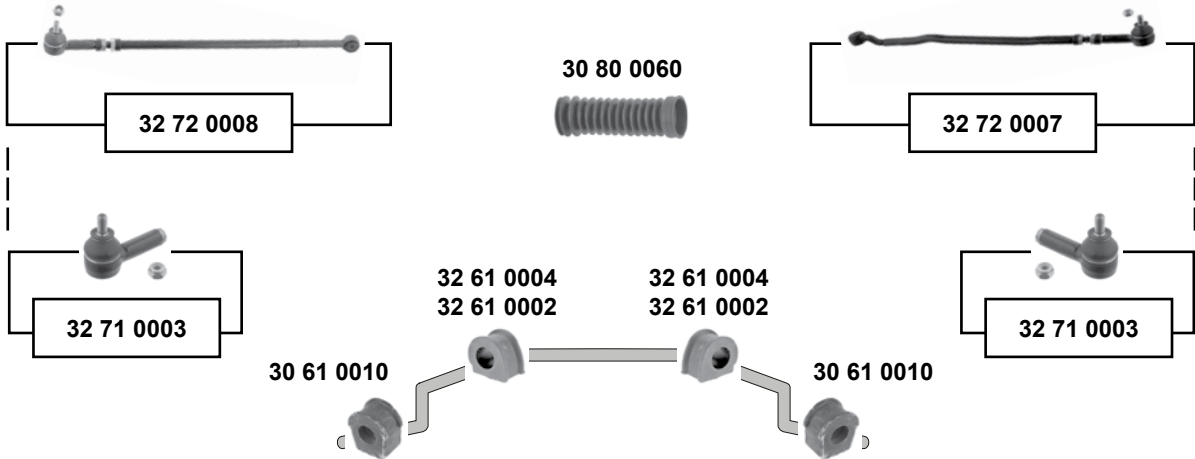

SWAG GERMANY	Ref. - No.			
30 61 0010	823 411 313 A	Stabilisatorlager / stabilizer mount		Ø I 12,5
30 80 0060	811 419 831 B	Lenkmanschette / steering boot		L 150
32 61 0002	811 411 327 A	Stabilisatorlager / stabilizer mount	(ch.) 32-F-390001 →	Ø I 20
32 61 0004	823 411 327 B	Stabilisatorlager / stabilizer mount	(ch.) → 32-F-390000	Ø I 19
32 69 0007	811 407 181 A	Querlenkerlager / control arm mount		10x38x44
32 71 0002	811 419 812	Spurstangenendstück / tie rod end	(ch.) → 32-B-040821	M10 x 1
32 71 0003	811 419 812 A	Spurstangenendstück / tie rod end	(ch.) 32-B-040822 →	M10 x 1
32 72 0007	811 419 802 J	Spurstange / tie rod	(ch.) → 32-G-275000	LHD
32 72 0008	811 419 801 E	Spurstange / tie rod		LHD
32 73 0005	893 407 147 G	Querlenker / control arm		
32 78 0002	823 407 365 E	Traggelenk / ball joint		Ø A 17
32 78 0023	811 407 175 A	Sicherungsblech / lock washer		

Vorderachse / Front axle



Passat 2 (32)
(1981 → 1988)
(ex.) Syncro

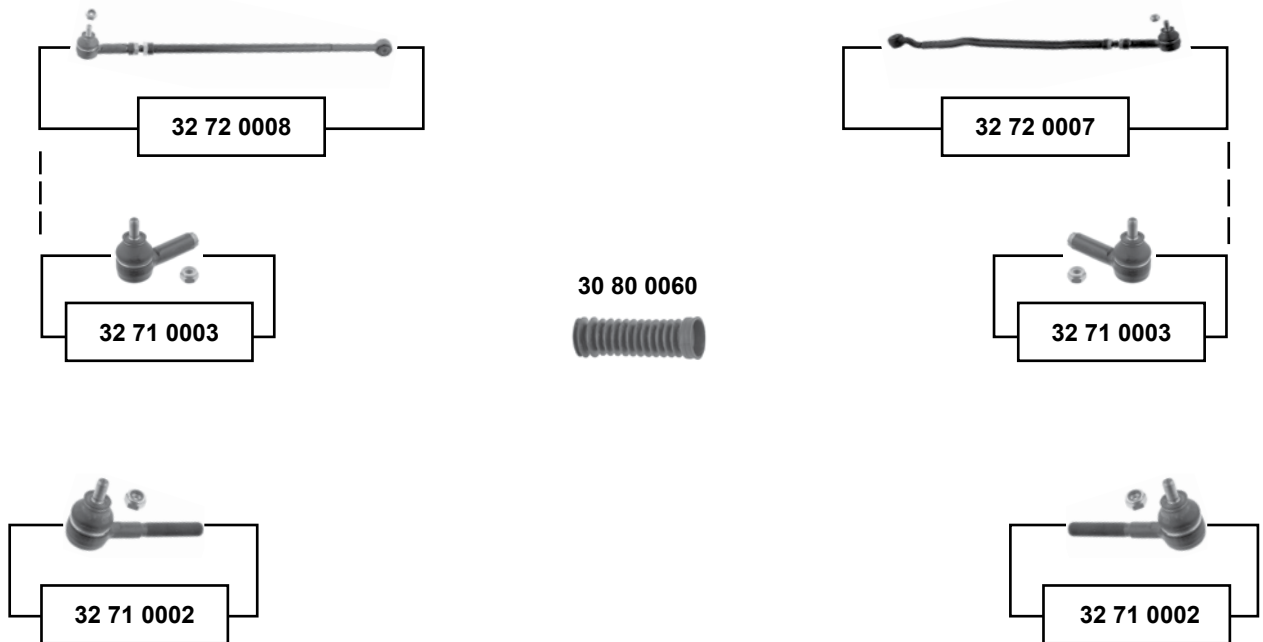

Ref. - No.



30 80 0060	811 419 831 B
32 71 0002	811 419 812
32 71 0003	811 419 812 A
32 72 0007	811 419 802 J
32 72 0008	811 419 801 E

Lenkmanschette / steering boot
Spurstangenendstück / tie rod end
Spurstangenendstück / tie rod end
Spurstange / tie rod
Spurstange / tie rod

(ch.) → 32-B-040 821
(ch.) 32-B-040 822 →
(ch.) → 32-G-275 000

L 150
M10 x 1
M10 x 1



VOLKSWAGEN

Passat 2 (32) (1981 → 1988) (ex.) Syncro

servo

4 cyl. (ch.) → 32-E-150 000
5 cyl. (ch.) → 32-D-099 298

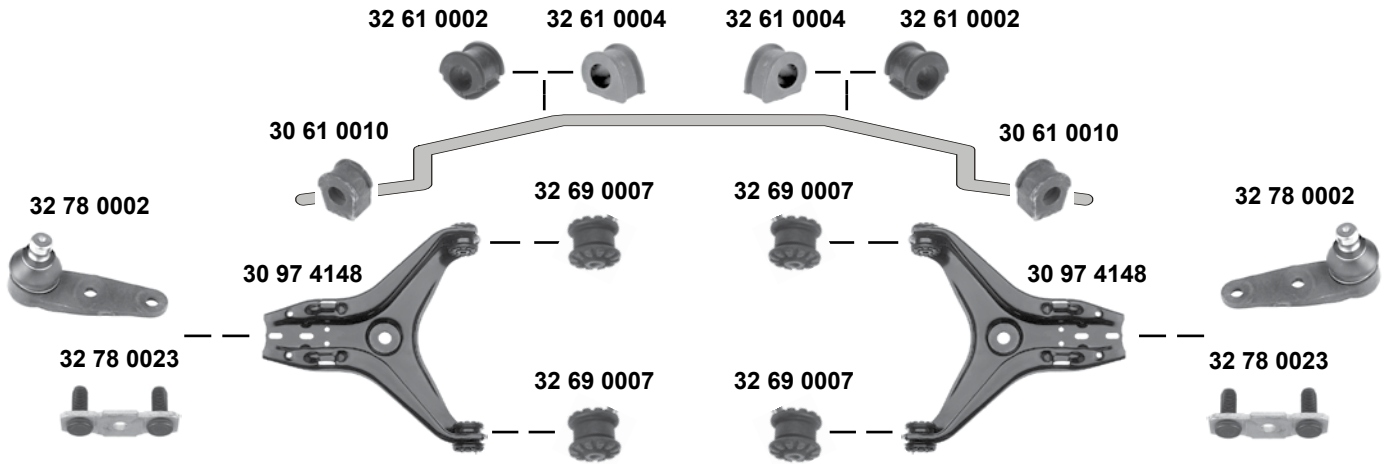

4 cyl. (ch.) 32-E-150 001 →
5 cyl. (ch.) 32-D-099 299 →

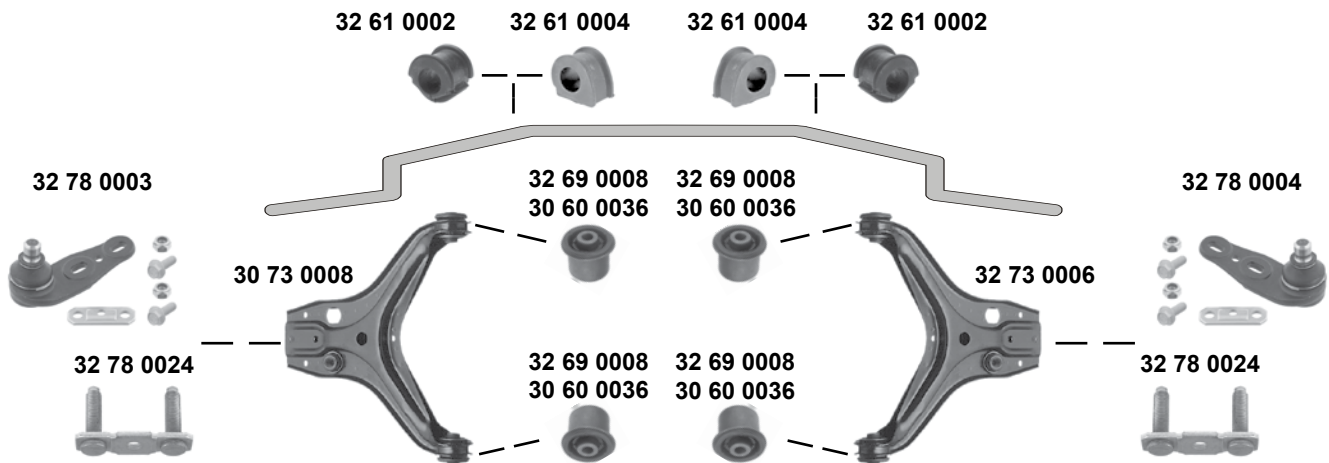

Ref. - No.



30 60 0036	8A0 407 181	Querlenkerlager / control arm mount	NEW	10x37x44
30 61 0010	823 411 313 A	Stabilisatorlager / stabilizer mount		Ø 12,5
30 73 0008	893 407 147 C	Querlenker / control arm		
30 97 4148	893 407 147 G	Querlenker / control arm		
32 61 0002	811 411 327 A	Stabilisatorlager / stabilizer mount	(ch.) 32-F-390 001 →	Ø 20
32 61 0004	823 411 327 B	Stabilisatorlager / stabilizer mount	(ch.) → 32-F-390 000	
32 69 0007	811 407 181 A	Querlenkerlager / control arm mount		10x38x44
32 69 0008	857 407 181	Querlenkerlager / control arm mount	OLD	10x37,5x44
32 73 0006	893 407 148 C	Querlenker / control arm		
32 78 0002	823 407 365 E	Traggelenk / ball joint		Ø A 17
32 78 0003	855 407 365 A	Traggelenk / ball joint		Ø A 17
32 78 0004	855 407 366 A	Traggelenk / ball joint		Ø A 17
32 78 0023	811 407 175 A	Sicherungsblech / lock washer		
32 78 0024	857 407 175	Sicherungsblech / lock washer		

Vorderachse / Front axle



Passat 2 (32)
(1981 → 1988)

Syncro



30 80 0060



Vorderachse / Front axle





VOLKSWAGEN

Passat 2 (32)

(1981 → 1988)

Syncro

Vorderachse / Front axle

4 cyl. man. (ex.) ABS

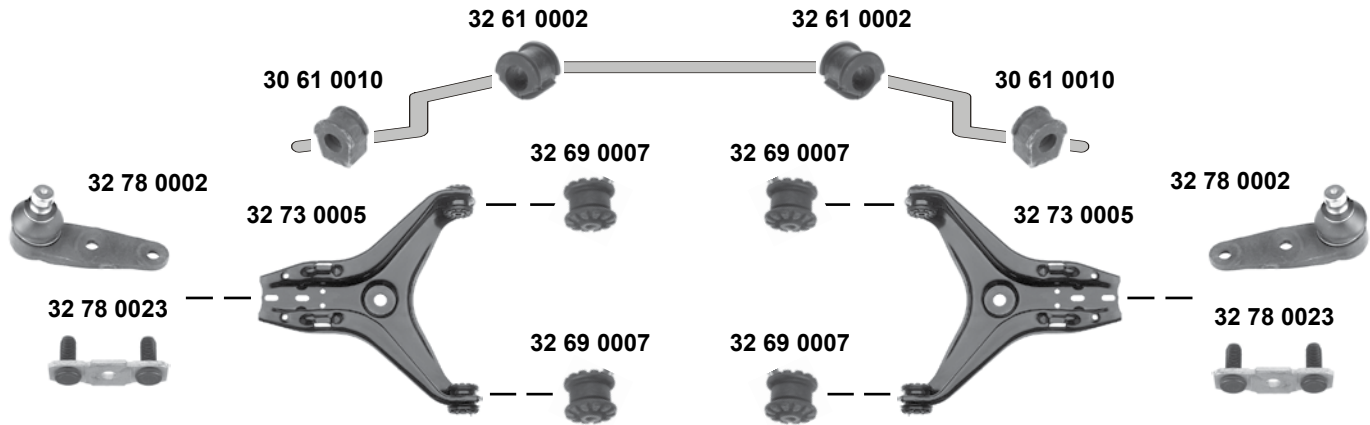

**4 cyl. man. + ABS
4 cyl. servo
5 cyl. alle / all**

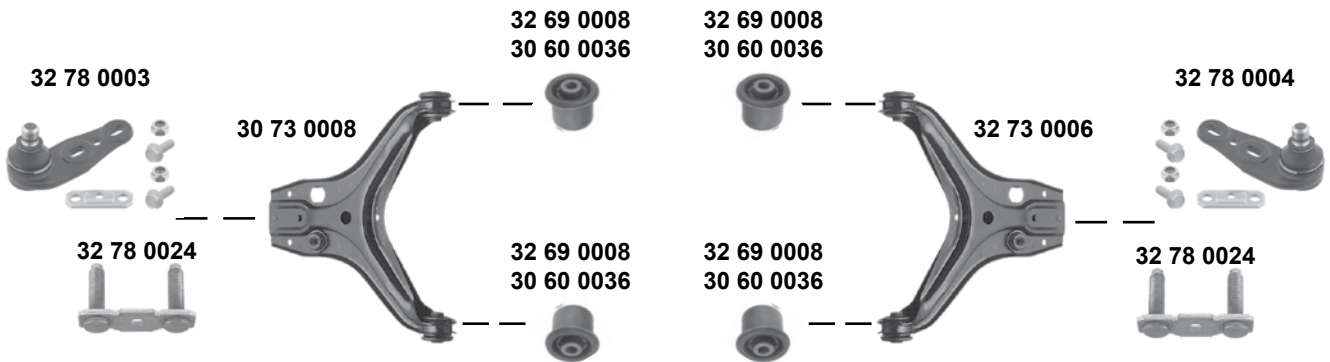

SWAG GERMANY	Ref. - No.			
30 60 0036	8A0 407 181	Querlenkerlager / control arm mount	NEW	10x37x44
30 61 0010	823 411 313 A	Stabilisatorlager / stabilizer mount		Ø I 12,5
30 73 0008	893 407 147 C	Querlenker / control arm		
32 61 0002	811 411 327 A	Stabilisatorlager / stabilizer mount	(ch.) 32-F-390 001 →	Ø I 20
32 69 0007	811 407 181 A	Querlenkerlager / control arm mount		10x38x44
32 69 0008	857 407 181	Querlenkerlager / control arm mount	OLD	10x37,5x44
32 73 0005	893 407 147 G	Querlenker / control arm		
32 73 0006	893 407 148 C	Querlenker / control arm		
32 78 0002	823 407 365 E	Traggelenk / ball joint		Ø A 17
32 78 0003	855 407 365 A	Traggelenk / ball joint	(ex.) 4 cyl. + ABS	Ø A 17
32 78 0004	855 407 366 A	Traggelenk / ball joint	(ex.) 4 cyl. + ABS	Ø A 17
32 78 0023	811 407 175 A	Sicherungsblech / lock washer		
32 78 0024	857 407 175	Sicherungsblech / lock washer		



Passat 3 (31/3A)
(1988 → 1997)

(ex.) 2.0 16V / VR6 / 1.9 TDI (81 kW)

man. 

Vorderachse / Front axle

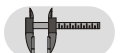
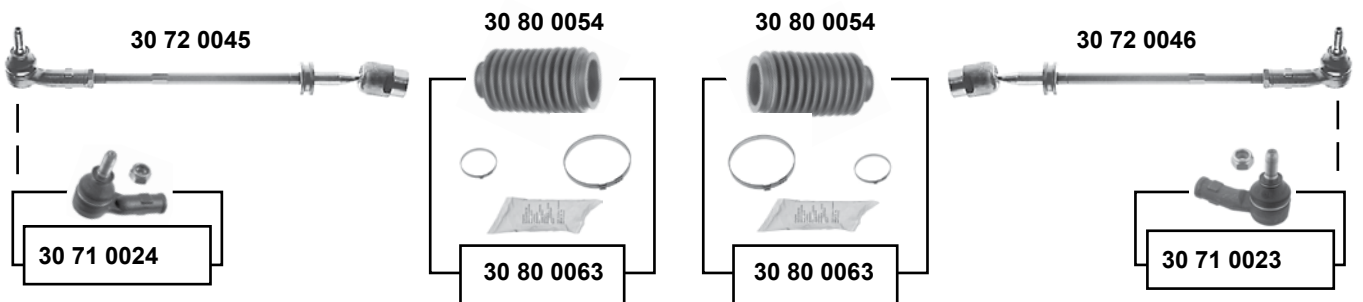

30 71 0023	191 419 812
30 71 0024	191 419 811
30 72 0045	357 419 803
30 72 0046	357 419 804
30 80 0054	191 419 831
30 80 0063	191 419 831 S

Spurstangenendstück / tie rod end
Spurstangenendstück / tie rod end
Spurstange / tie rod
Spurstange / tie rod
Lenkmanschette / steering boot
Rep. Satz Lenkmanschette / rep. kit steering boot

M12 x 1,5
M12 x 1,5



VOLKSWAGEN

Passat 3 (31/3A)

(1988 → 1997)

(ex.) 2.0 16V / VR6 / 1.9 TDI (81 kW)

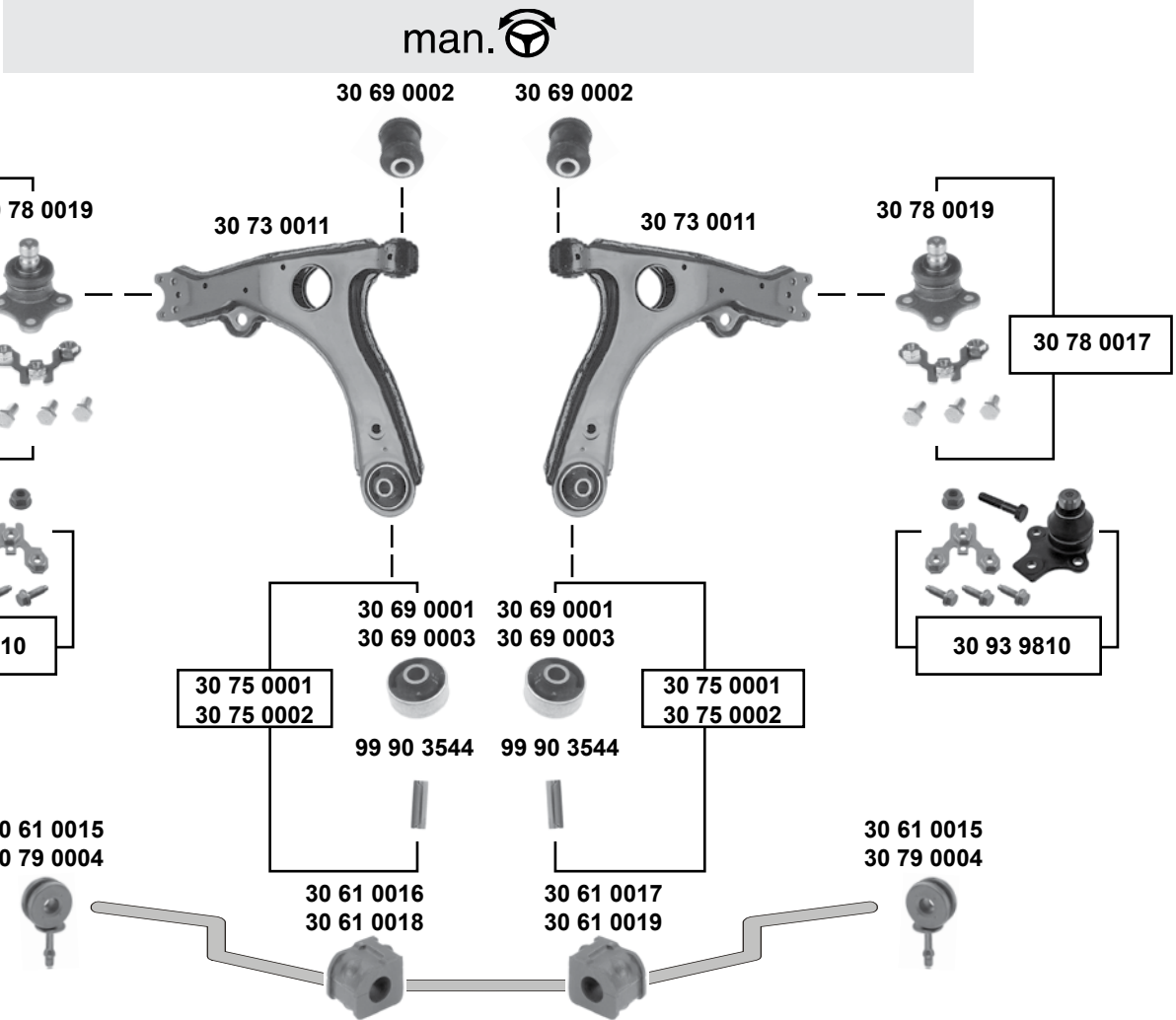

Vorderachse / Front axle

- (1) Modell 88 → 93 Limousine → 66 kW
- (2) Modell 88 → 93 Limousine 74 kW →
 Modell 94 → 97 **alle/ all**
 Modell 88 → 93 Variant

SWAG GERMANY	Ref. - No.			
30 61 0015	357 411 315 C	Verbindungsstange / connecting rod	(1)	Ø I 18
30 61 0016	357 411 313	Stabilisatorlager / stabilizer mount	(1)	Ø I 21
30 61 0017	357 411 314	Stabilisatorlager / stabilizer mount	(1)	Ø I 21
30 61 0018	357 411 313 A	Stabilisatorlager / stabilizer mount	(2)	Ø I 22,7
30 61 0019	357 411 314 A	Stabilisatorlager / stabilizer mount	(2)	Ø I 22,7
30 69 0001	191 407 181 D	Querlenkerlager / control arm mount	NEW	17x60x41
30 69 0002	357 407 182	Querlenkerlager / control arm mount	OLD	12x33x54
30 69 0003	191 407 181 B	Querlenkerlager / control arm mount	OLD	17x60x41
30 73 0011	357 407 151	Querlenker / control arm		
30 75 0001	191 407 181 B S1	Querlenkerlager mit Hülse / control arm mount with sleeve	OLD	
30 75 0002	191 407 181 D S1	Querlenkerlager mit Hülse / control arm mount with sleeve	NEW	
30 78 0017	357 407 365 S1	Rep. Satz Traggelenk / rep. kit ball joint		
30 78 0019	357 407 365	Traggelenk / ball joint		Ø A 19
30 79 0004	357 411 315 D	Verbindungsstange / connecting rod	(2)	Ø I 19
30 93 9810	357 407 365 S2	Rep. Satz Traggelenk / rep. kit ball joint		
99 90 3544	91 407 190 A	Hülse / sleeve		50x17



Passat 3 (31/3A)

(1988 → 1997)

(ex.) 2.0 16V / VR6 / 1.9 TDI (81 kW)

für / to fit servo  TRW

(ch.) → 3A-R-099264

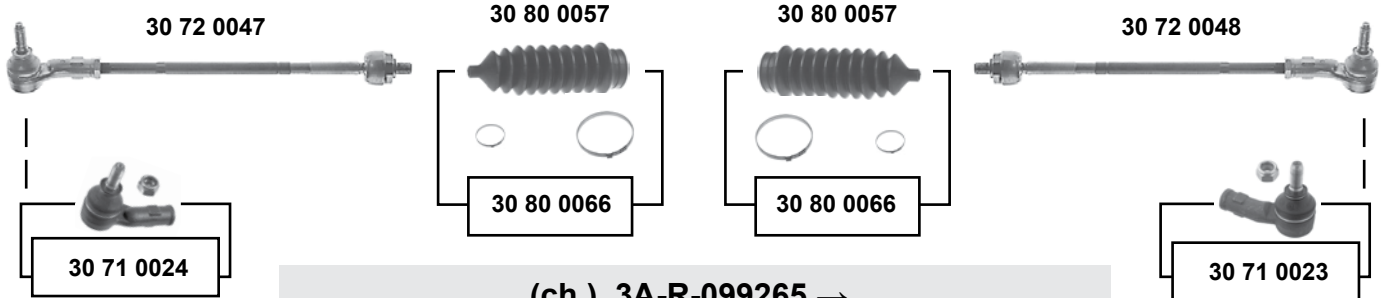

(ch.) 3A-R-099265 →

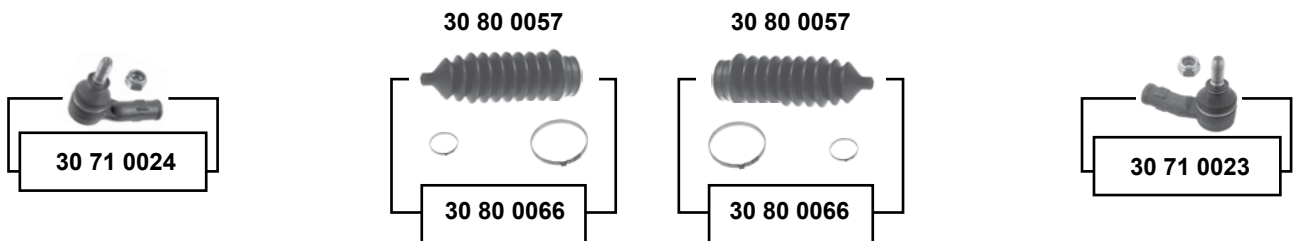

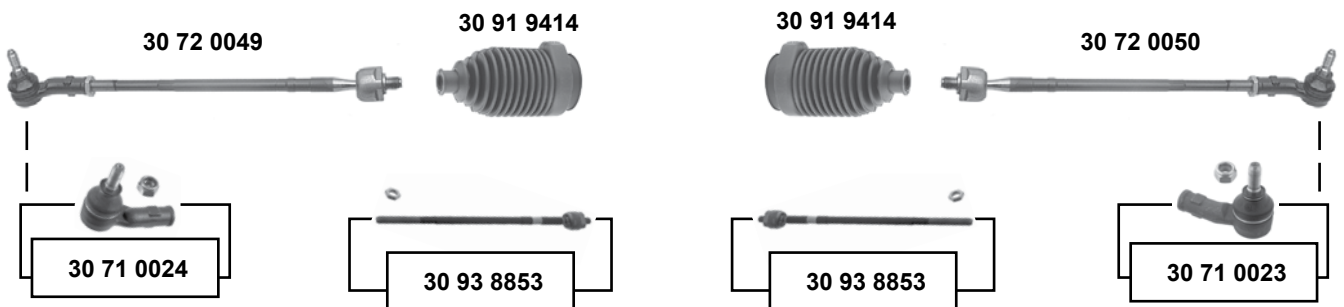

für / to fit servo  ZF



(1) 1988 → 1992 (ch.) → 31-N-080 000
1993 → 1994 (ch.) → 3A-R-099 264



(2) 1988 → 1996 servo 
1993 → 1997 (ch.) → 3A-R-099 264 servo 



Ref. - No.



30 71 0023	191 419 812	Spurstangenendstück / tie rod end	(1)	M12 x 1,5
30 71 0024	191 419 811	Spurstangenendstück / tie rod end	(1)	M12 x 1,5
30 72 0047	357 422 803	Spurstange / tie rod		
30 72 0048	357 422 804	Spurstange / tie rod		
30 72 0049	357 422 803 A	Spurstange / tie rod		
30 72 0050	357 422 804 A	Spurstange / tie rod		
30 80 0057	1H0 422 831 B	Lenkmanschette / steering boot		
30 80 0066	1H0 422 831 B S1	Rep. Satz Lenkmanschette / rep. kit steering boot		
30 91 9414	357 422 831 B	Lenkmanschette / steering boot		
30 93 8853	357 422 810 A	Axialgelenk / axial joint	(2)	



Passat 3 (31/3A)

(1988 → 1997)

(ex.) 2.0 16V / VR6 / 1.9 TDI (81 kW)



Vorderachse / Front axle

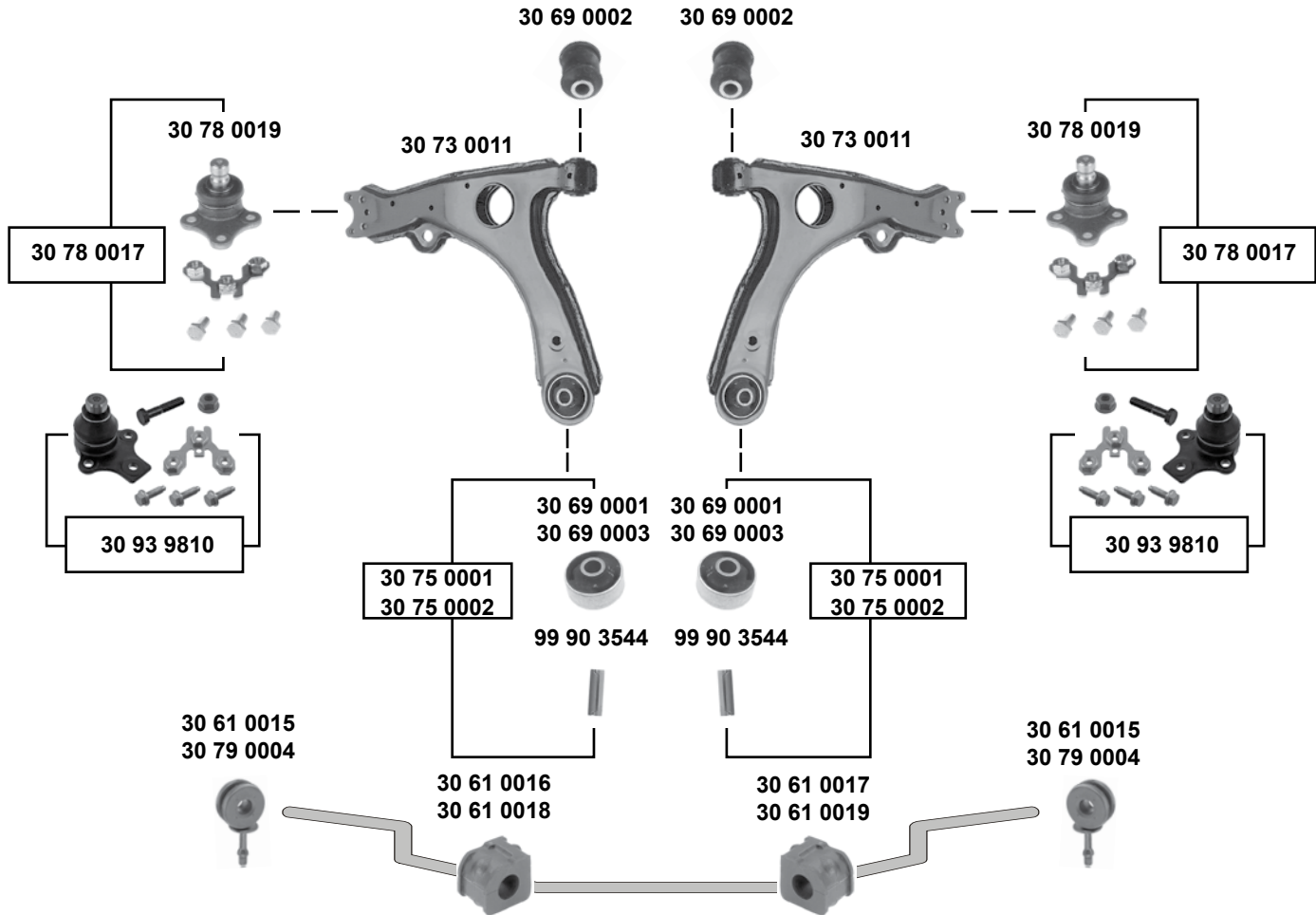

- (1) Modell 88 → 93 Limousine → 66 kW
- (2) Modell 88 → 93 Limousine 74 kW →
 Modell 94 → 97 **alle/ all**
 Modell 88 → 93 Variant

SWAG GERMANY	Ref. - No.			
30 61 0015	357 411 315 C	Verbindungsstange / connecting rod	(1)	Ø 18
30 61 0016	357 411 313	Stabilisatorlager / stabilizer mount	(1)	Ø 21
30 61 0017	357 411 314	Stabilisatorlager / stabilizer mount	(1)	Ø 21
30 61 0018	357 411 313 A	Stabilisatorlager / stabilizer mount	(2)	Ø 22,7
30 61 0019	357 411 314 A	Stabilisatorlager / stabilizer mount	(2)	Ø 22,7
30 69 0001	191 407 181 D	Querlenkerlager / control arm mount	NEW	17x60x41
30 69 0002	357 407 182	Querlenkerlager / control arm mount	OLD	12x33x54
30 69 0003	191 407 181 B	Querlenkerlager / control arm mount	OLD	17x60x41
30 73 0011	357 407 151	Querlenker / control arm		
30 75 0001	191 407 181 B S1	Querlenkerlager mit Hülse / control arm mount with sleeve	OLD	
30 75 0002	191 407 181 D S1	Querlenkerlager mit Hülse / control arm mount with sleeve	NEW	
30 78 0017	357 407 365 S1	Rep. Satz Traggelenk / rep. kit ball joint		
30 78 0019	357 407 365	Traggelenk / ball joint		Ø A 19
30 79 0004	357 411 315 D	Verbindungsstange / connecting rod	(2)	Ø 19
30 93 9810	357 407 365 S2	Rep. Satz Traggelenk / rep. kit ball joint		
99 90 3544	191 407 181 D	Hülse / sleeve		50x17





Passat 3 (31/3A)
(1988 → 1997)

2.0 16V / VR6 / 1.9 TDI (81 kW)

für / to fit servo  TRW

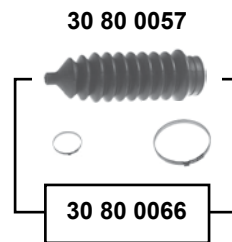
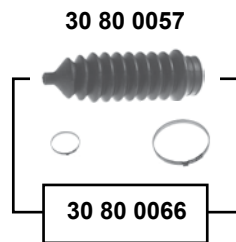
(ch.) → 3A-R-099264



für / to fit servo  ZF

(ch.) → 31-N-255989



30 71 0023	191 419 812	Spurstangenendstück / tie rod end	M12 x 1,5
30 71 0024	191 419 811	Spurstangenendstück / tie rod end	M12 x 1,5
30 80 0057	1H0 422 831 B	Lenkmanschette / steering boot	
30 80 0066	1H0 422 831 B S1	Rep. Satz Lenkmanschette / rep. kit steering boot	
30 91 9414	357 422 831 B	Lenkmanschette / steering boot	



VOLKSWAGEN

Passat 3 (31/3A)

(1988 → 1997)

2.0 16V / VR6 / 1.9 TDI (81 kW)

Vorderachse / Front axle

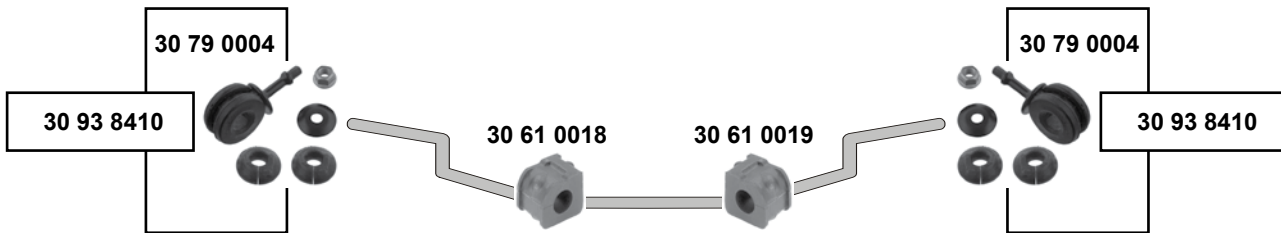
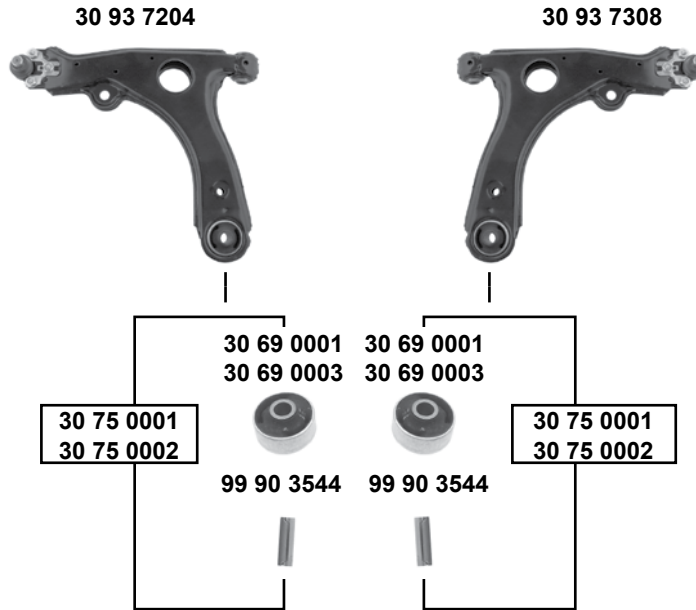

SWAG GERMANY	Ref. - No.			
30 61 0018	357 411 313 A	Stabilisatorlager / stabilizer mount		Ø 22,7
30 61 0019	357 411 314 A	Stabilisatorlager / stabilizer mount		Ø 22,7
30 69 0001	191 407 181 D	Querlenkerlager / control arm mount	NEW	17x60x41
30 69 0003	191 407 181 B	Querlenkerlager / control arm mount	OLD	17x60x41
30 75 0001	191 407 181 B S1	Querlenkerlager mit Hülse / control arm mount with sleeve	OLD	
30 75 0002	191 407 181 D S1	Querlenkerlager mit Hülse / control arm mount with sleeve	NEW	
30 79 0004	357 411 315 D	Verbindungsstange / connecting rod		Ø 20
30 93 7204	357 407 151 S1	Querlenker / control arm	→ 93 (ch.) → 31-N-255 989	
30 93 7308	357 407 151 S2	Querlenker / control arm	→ 93 (ch.) → 31-N-255 989	
30 93 8410	357 411 315 D S1	Rep. Satz Verbindungsstange / rep. kit connecting rod		Ø 20
99 90 3544	191 407 190 A	Hülse / sleeve		50x17

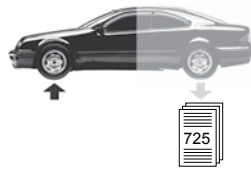

Passat 4 4motion (3B2 / 3B5 / 3B6) (1997 → 2005)

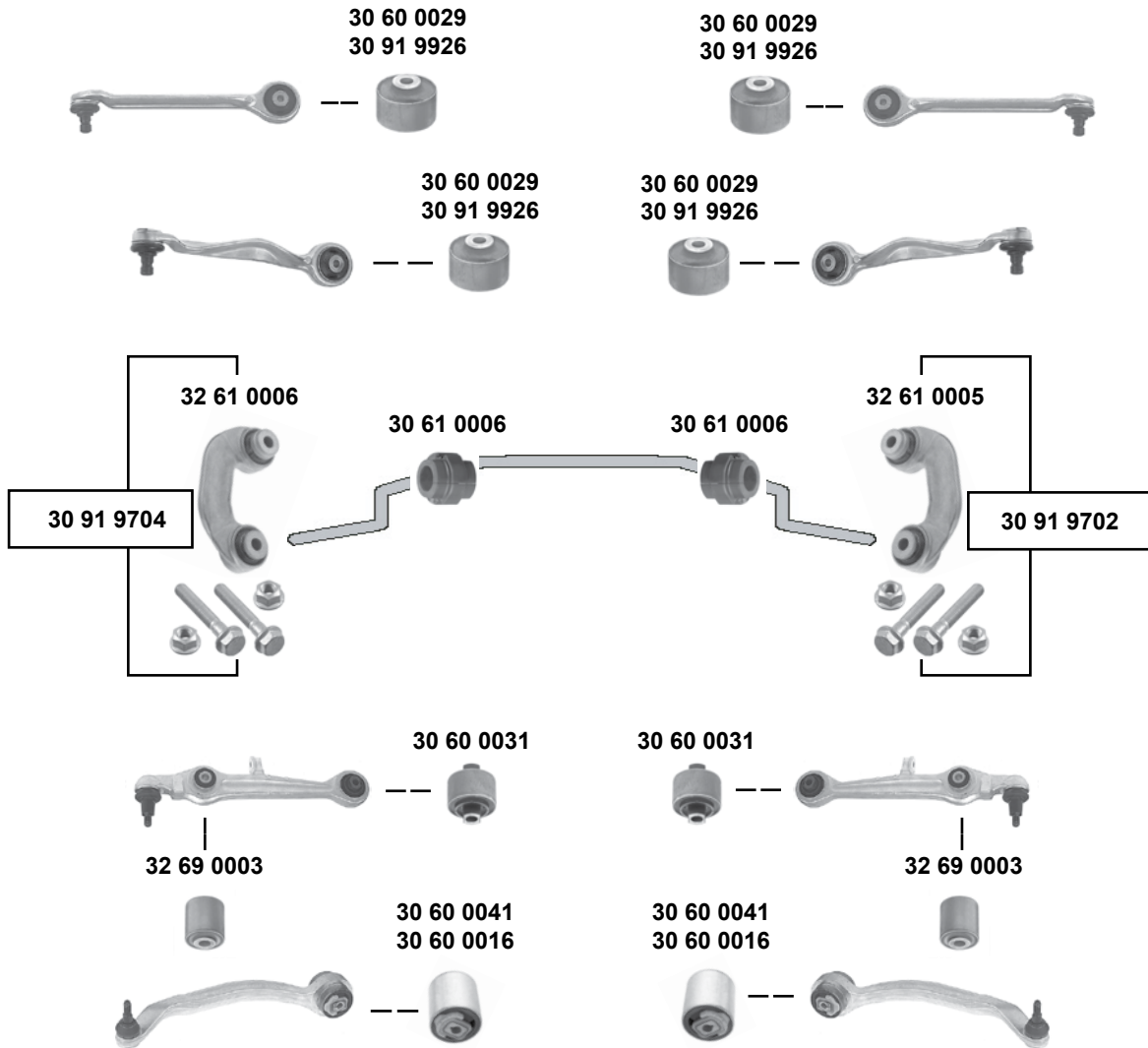

Vorderachse / Front axle

SWAG	Ref. - No.			
30 60 0016	4D0 407 183 AC	Querlenkerlager / control arm mount	OLD	12x65x80
30 60 0029	4D0 407 515 C	Querlenkerlager / control arm mount	(ch.) → 3B-XE-113 734	10x46x40
30 60 0031	4D0 407 182 E	Querlenkerlager / control arm mount		12x50x60
30 60 0041	4D0 407 183 AC	Querlenkerlager / control arm mount	NEW	
30 61 0006	4D0 411 327 H	Stabilisatorlager / stabilizer mount		Ø 27
30 91 9702	8D0 411 318 D S1	Rep. Satz Verbindungsstange / rep. kit connecting rod		
30 91 9704	8D0 411 317 D S1	Rep. Satz Verbindungsstange / rep. kit connecting rod		
30 91 9926	4B0 407 515	Querlenkerlager / control arm mount	(ch.) 3B-XE-113 734 →	10x46x40
32 61 0005	8D0 411 318 D	Verbindungsstange rechts / connecting rod right		
32 61 0006	8D0 411 317 D	Verbindungsstange links / connecting rod left		
32 69 0003	4D0 407 181 H	Querlenkerlager / control arm mount		12x40x50

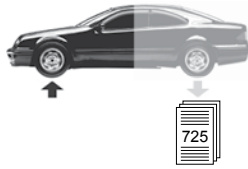

Passat 4 (3B)

(1997 → 2005)

Vorderachse / Front axle

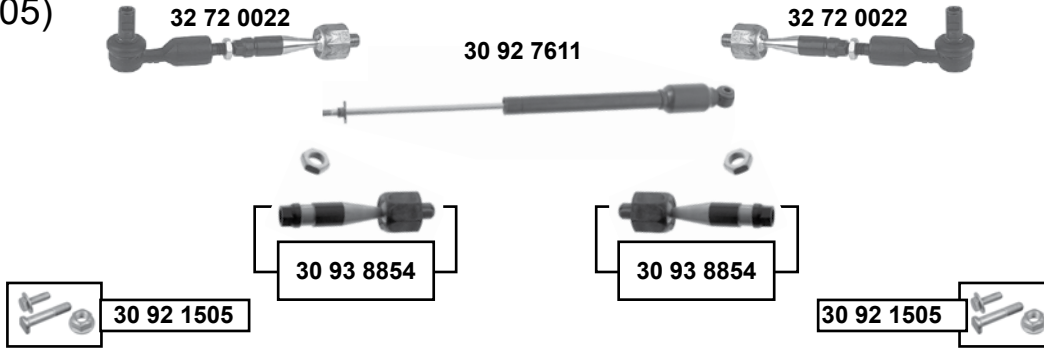

oben / upper

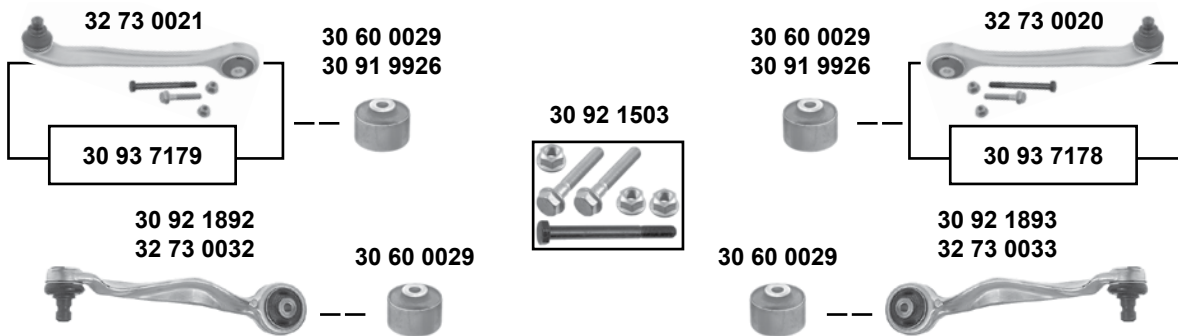

unten / lower

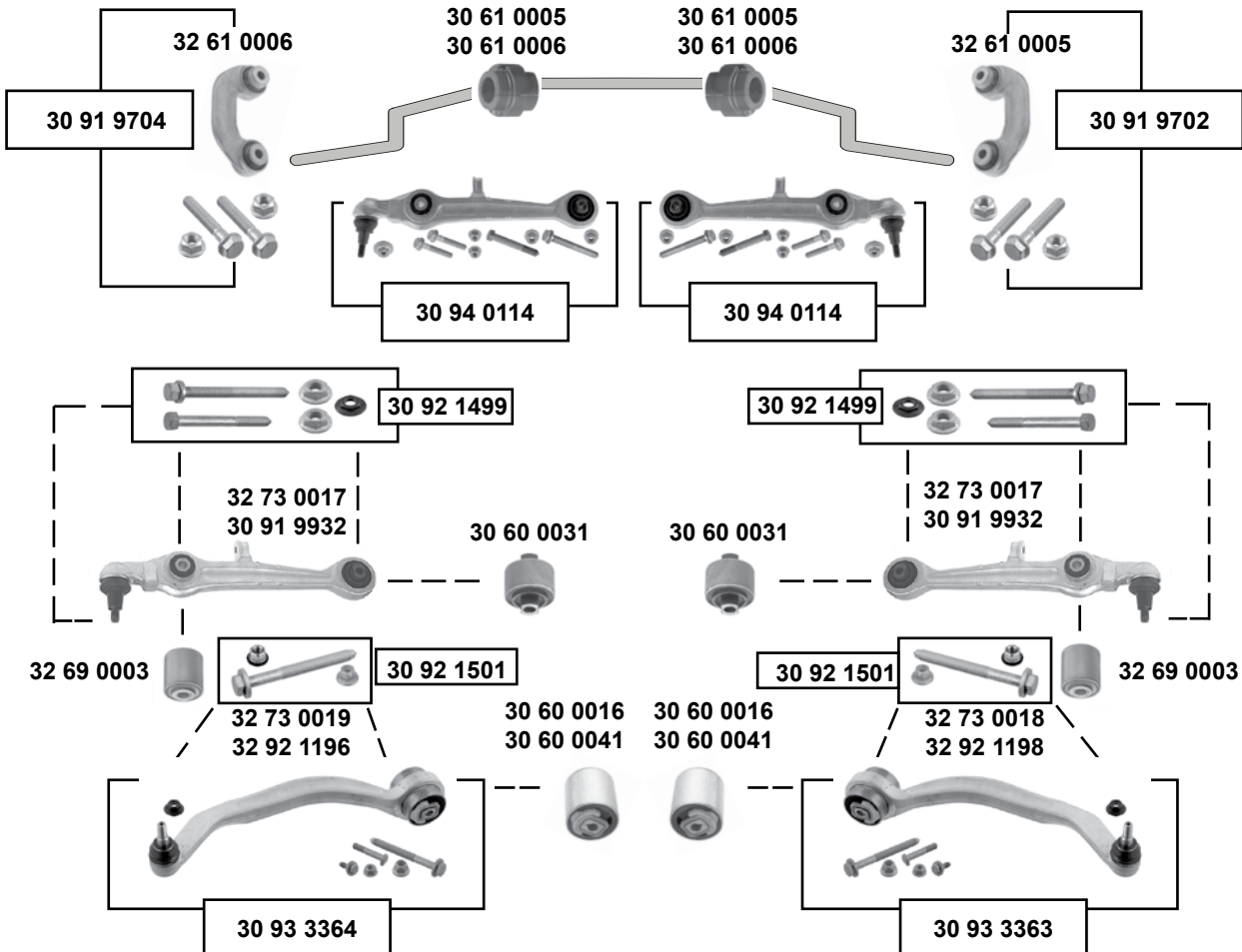

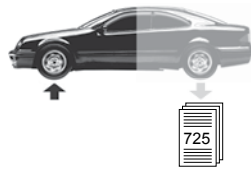

30 92 1497
32 75 0001
32 92 4900
32 92 4832
32 92 6600

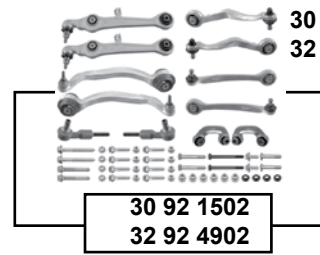
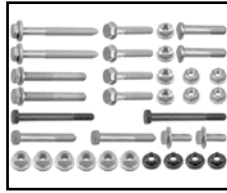

30 92 1498
32 92 4834
Passat 4 (3B)
(1997 → 2005)



- (1) (ch.) → 3B-VE-083 008 (4) (ex.) 1,9 TDi (96 kw) /
(ch.) → 3B-VP-102 593 01 → 02: auch für Sonderschutzfahrzeuge / to fit for armoured vehicles
- (2) (ch.) 3B-VE-083 009 → / (ch.) 3B-VP-102 594 → (5) (ch.) 3B-3-072 000 →
- (3) (ex.) (mot.) AVF/AWX/ATJ / 97 → 03 (ch.) 3B-VE-083 009 → 3B-3-072 000 / (ch.) 3B-VP-102 594 → 3B-3-072 000



Ref. - No.

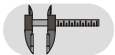

Ref. - No.				
30 60 0016	4D0 407 183 P	Querlenkerlager / control arm mount	97 → 00	12x65x80
30 60 0029	4D0 407 515 C	Querlenkerlager / control arm mount	(ch.) → 3B-XE-113 734	10x46x40
30 60 0031	4D0 407 182 G	Querlenkerlager / control arm mount		12x50x60
30 60 0041	4D0 407 183 AC	Querlenkerlager / control arm mounting	01 →	
30 61 0005	4D0 411 327 G	Stabilisatorlager / stabilizer mount	Limousine	Ø 25
30 61 0006	4D0 411 327 H	Stabilisatorlager / stabilizer mount	Variant / 4motion	Ø 27
30 91 9702	8D0 411 318 D S1	Rep. Satz Verbindungsstange / rep. kit connecting rod		
30 91 9704	8D0 411 317 D S1	Rep. Satz Verbindungsstange / rep. kit connecting rod		
30 91 9926	4B0 407 515	Querlenkerlager / control arm mount	(ch.) 3B-XE-113 735 →	
30 91 9932	4B3 407 151 K	Querlenker / control arm	(4) (ch.) 3B-3-072000 →	
30 92 1497	-	Schraubensatz / screw kit	(3)	
30 92 1499	-	Schraubensatz / screw kit		
30 92 1498	-	Schraubensatz / screw kit	(3)	
30 92 1501	-	Schraubensatz / screw kit		
30 92 1502	8D0 498 998 S1	Rep. Satz Querlenker / rep. kit control arm	(3)	
30 92 1503	-	Schraubensatz / screw kit		
30 92 1505	-	Schraubensatz / screw kit		
30 92 1892	8D0 407 509 G	Querlenker, <u>hinten</u> / control arm, <u>rear</u>	(1)	
30 92 1893	8D0 407 510 G	Querlenker, <u>hinten</u> / control arm, <u>rear</u>	(1)	
30 92 7611	4D0 425 021 D	Lenkungsdämpfer / steering-damper		
30 93 3363	8E0 407 694 E S1	Rep. Satz Querlenker / rep. kit control arm	97 → 00	
30 93 3364	8E0 407 693 E S1	Rep. Satz Querlenker / rep. kit control arm	97 → 00	
30 93 7178	8E0 407 506 A S1	Querlenker / control arm		
30 93 7179	8E0 407 505 A S2	Querlenker / control arm		
30 93 8854	4B0 419 810 M	Axialgelenk / axial joint		
30 94 0114	4B3 407 151 K S1	Rep. Satz Querlenker / rep. kit control arm	(ch.) 3U-3-021398 / 3B-3-072001 →	
32 61 0005	8D0 411 318 D	Verbindungsstange / connecting rod		L 90
32 61 0006	8D0 411 317 D	Verbindungsstange / connecting rod		L 90
32 69 0003	4D0 407 181 H	Querlenkerlager / control arm mount		12x40x50
32 72 0022	4B0 419 801 M	Spurstange / tie rod	(ch.) → 3B-X-400000	
32 73 0017	4D0 407 151 P	Querlenker, vorne / control arm, front	(ch.) → 3B-3-071999	
32 73 0018	8E0 407 694 E	Querlenker, hinten / control arm, rear	97 → 00	
32 73 0019	8E0 407 693 E	Querlenker, hinten / control arm, rear	97 → 00	
32 73 0020	8E0 407 506 A	Querlenker, <u>vorne</u> / control arm, <u>front</u>		Alu
32 73 0021	8E0 407 505 A	Querlenker, <u>vorne</u> / control arm, <u>front</u>		Alu
32 73 0032	8E0 407 509 A	Querlenker / control arm	(2)	
32 73 0033	8E0 407 510 A	Querlenker / control arm	(2)	
32 75 0001	8D0 498 998	Rep. Satz Querlenker / rep. kit control arm	(3)	
32 92 1196	8E0 407 693 AG	Querlenker, <u>hinten</u> / control arm, <u>rear</u>	Variant / 4motion 03 → 05	Alu
32 92 1198	8E0 407 694 AG	Querlenker, <u>hinten</u> / control arm, <u>rear</u>	Variant / 4motion 03 → 05	Alu
32 92 4832	-	Schraubensatz / screw kit	(5)	
32 92 4834	-	Schraubensatz / screw kit	(5)	
32 92 4900	4B3 498 998	Rep. Satz Querlenker / rep. kit control arm	(5)	
32 92 4902	4B3 498 998 S1	Rep. Satz Querlenker / rep. kit control arm	(5)	
32 92 6600	8D0 498 998 B	Rep. Satz Querlenker / rep. kit control arm	(3)	

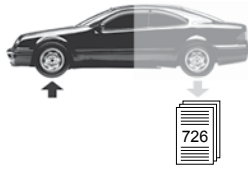

Passat 5 / CC (3C)

(2005 →)(2009 →) (2011 →)

Vorderachse / Front axle

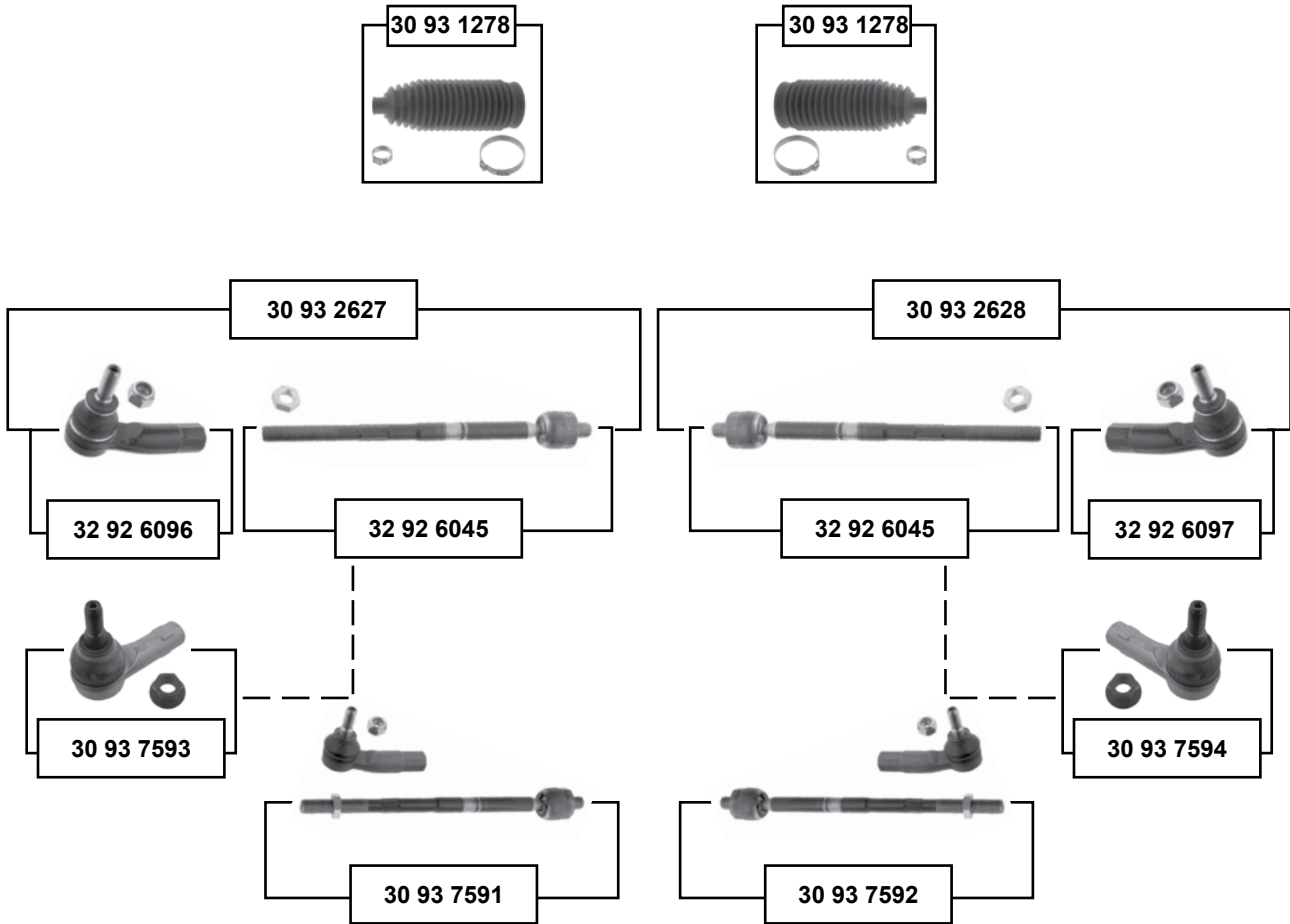

(1) Passat 5 / variant / 4motion (3C) 06 → 11
 Passat (Typ 36) / variant / 4motion 11 →
 Passat CC (3C) 09 →



Ref. - No.



30 93 1278	1K0 423 831 A S1	Rep. Satz Lenkmanschette / rep. kit steering boot	
30 93 2627	1K0 423 810 A S1	Rep. Satz Spurstange links / rep. kit tie rod left	
30 93 2628	1K0 423 810 A S2	Rep. Satz Spurstange rechts / rep. kit tie rod right	
30 93 7591	1K0 423 811 K S1	Rep. Satz Spurstange / rep. kit tie rod	L 448
30 93 7592	1K0 423 812 K S1	Rep. Satz Spurstange / rep. kit tie rod	L 448
30 93 7593	1K0 423 811 K	Spurstangenendstück / tie rod end	M16 x 1,5
30 93 7594	1K0 423 812 K	Spurstangenendstück / tie rod end	M16 x 1,5
32 92 6045	1K0 423 810 A	Spurstange / tie rod	(1)
32 92 6096	1K0 423 811 E	Spurstangenendstück / tie rod end	M16 x 1,5
32 92 6097	1K0 423 812 E	Spurstangenendstück / tie rod end	M16 x 1,5

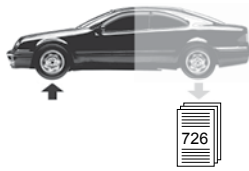

Passat 5 / CC (3C) (2005 →) (2009 →) (2011 →)

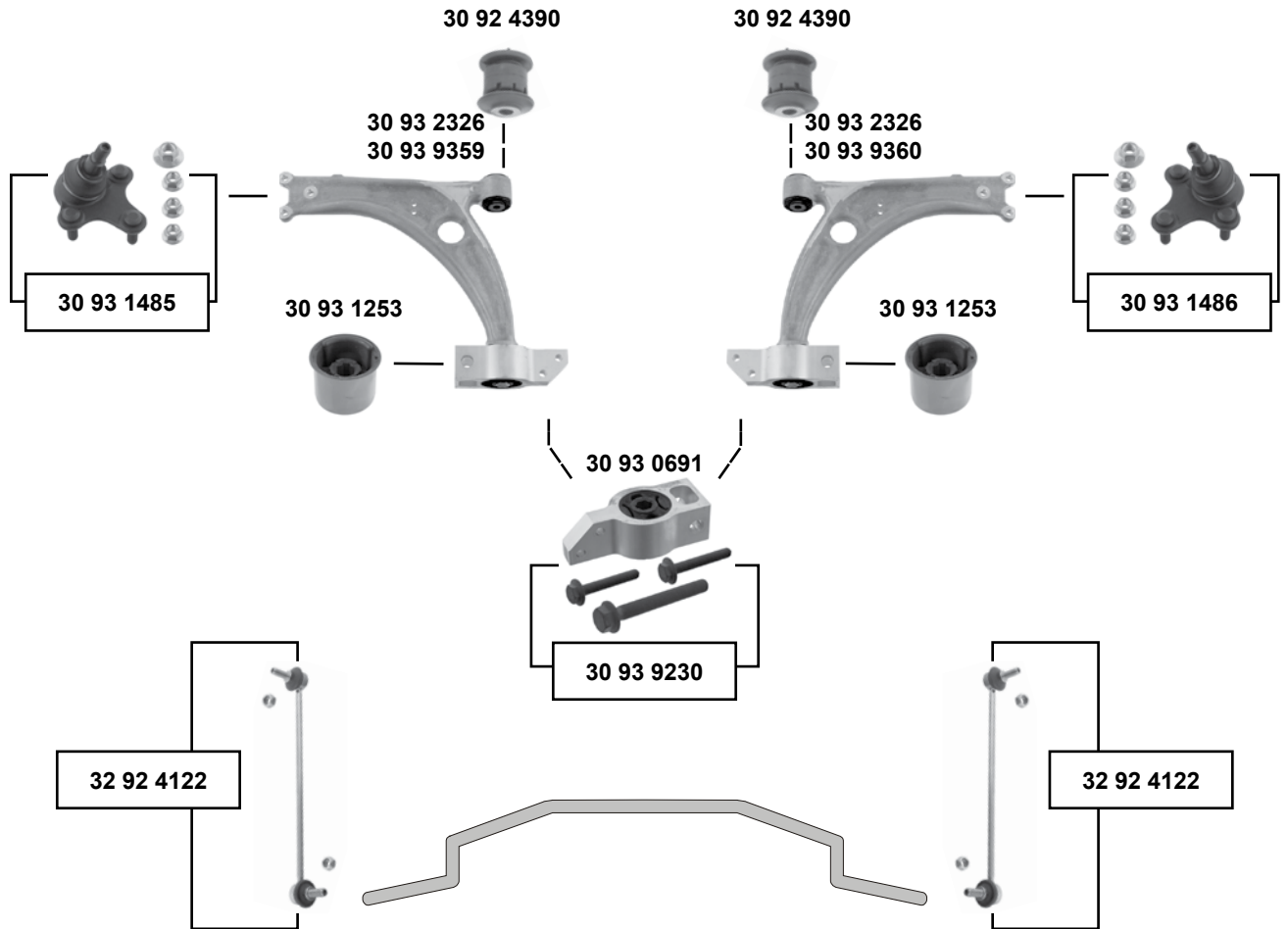

Vorderachse / Front axle

(1) Passat 5 / variant / 4motion : 06 → 11
Passat CC : 09 → (ex.) PR-1ZG/1ZM

(2) Passat 5 / variant / 4motion (3C) 06 → 11
Passat (Typ 36) / variant / 4motion 11 →
Passat CC (3C) 09 →

(3) Passat CC PR-1ZG/1ZM



Ref. - No.



Ref. - No.	Description	Quantity	Material
30 92 4390	Querlenkerlager / control arm mount	(2)	Ø A 48 H 54
30 93 0691	Querlenkerlager / control arm mount	(1)	
30 93 1253	Querlenkerlager / control arm mount	(2)	Ø A 63
30 93 1485	Rep. Satz Traggelenk / rep. kit ball joint	(1)	M12 x 1,5
30 93 1486	Rep. Satz Traggelenk / rep. kit ball joint	(1)	M12 x 1,5
30 93 2326	Querlenker / control arm	(1) Alu	
30 93 9230	Rep. Satz Querlenkerlagersatz / rep. kit control arm mount kit		
30 93 9359	Querlenker / control arm	(3) Stahl / steel	
30 93 9360	Querlenker / control arm	(3) Stahl / steel	
32 92 4122	Verbindungsstange / connecting rod	(2)	

passend für / to fit

VOLKSWAGEN



Passat (Typ 36)
(2011 →)

Vorderachse / Front axle

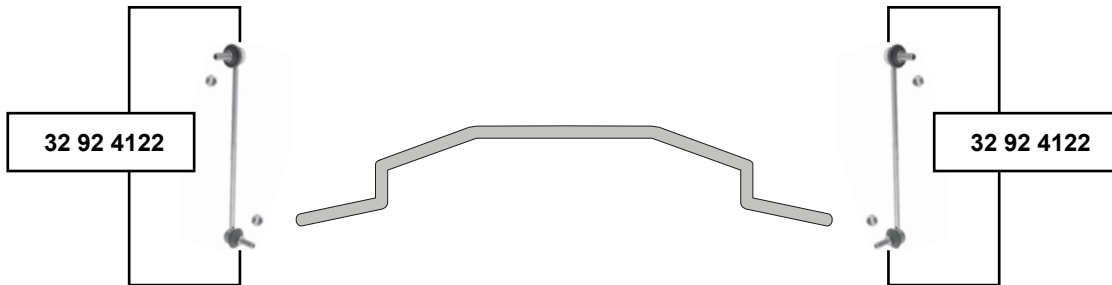
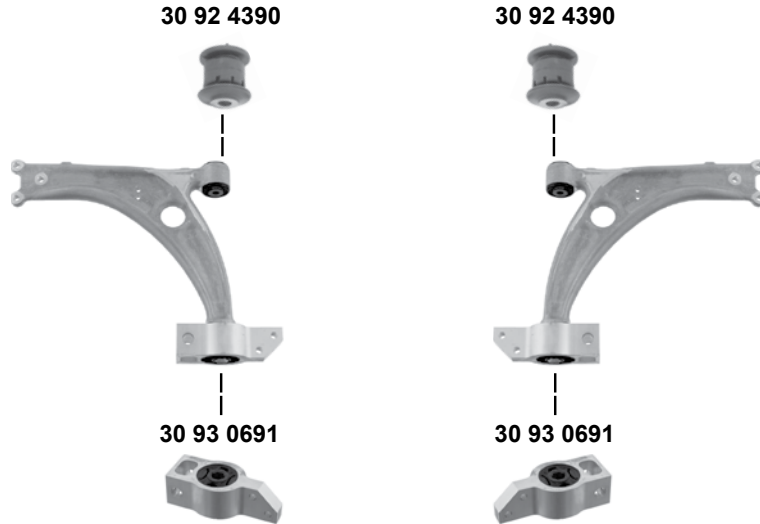

Ref. - No.



30 92 4390	1K0 407 182
30 93 0691	3C0 199 231 D
32 92 4122	1K0 411 315 R

Querlenkerlager / control arm mount
 Querlenkerlager / control arm mount
 Rep. Satz Verbindungsstange / rep. kit connecting rod

Ø A40 H54

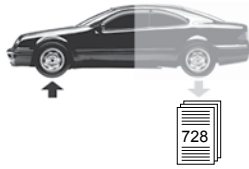

Passat 6 (A32)
(2011 →)

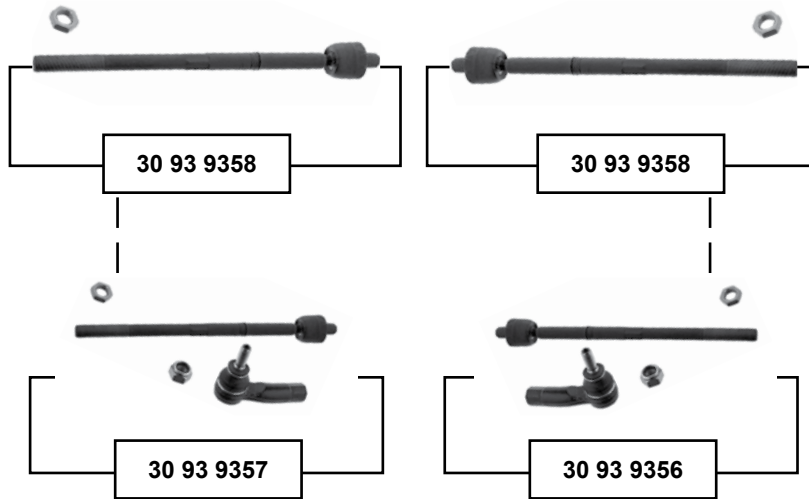

Vorderachse / Front axle



(1) Gummimetalllager / rubber metal mount

(2) PR-1ZG/1ZM



Ref. - No.



30 93 6752	1K0 407 183 P
30 93 9356	561 423 810 S1
30 93 9357	561 423 810 S2
30 93 9358	561 423 810
30 93 9359	5N0 407 151
30 93 9360	5N0 407 152

Querlenkerlager / control arm mount
Rep. Satz Spurstange / rep. kit tie rod
Rep. Satz Spurstange / rep. kit tie rod
Axialgelenk / axial joint
Querlenker / control arm
Querlenker / control arm

(1)
PR-1N1/1N3 / servo
PR-1N1/1N3 / servo
Servotronic / PR-1N3
(2) Stahl / steel
(2) Stahl / steel

Ø 13
M16 x 1,5

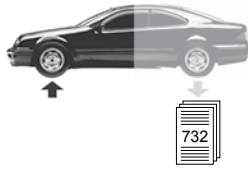

Phaeton (3D)

(2002 →)

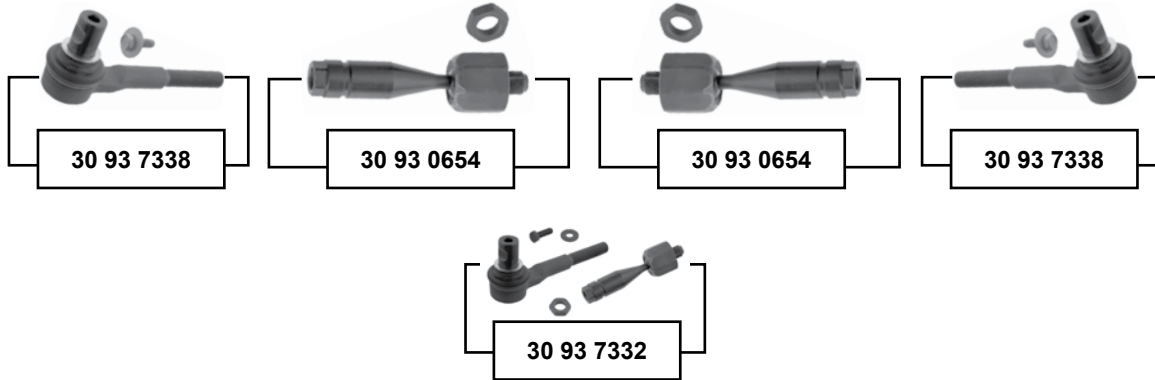

oben / upper

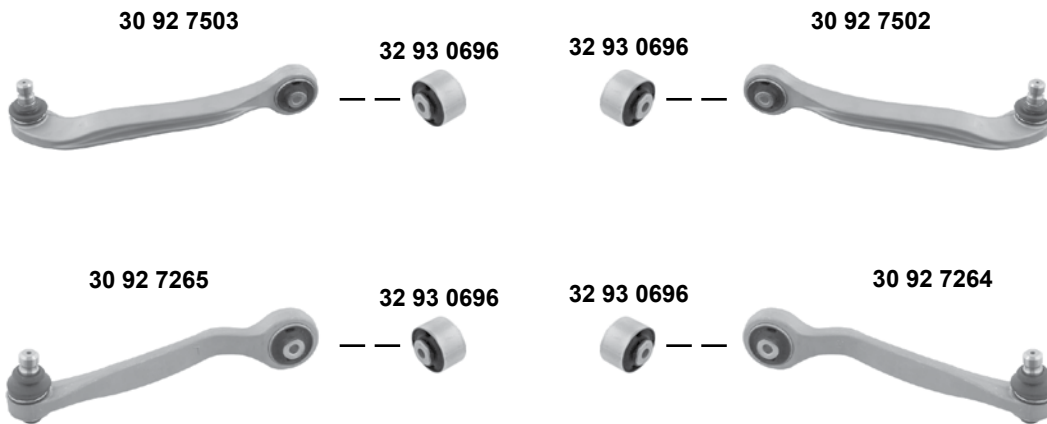

unten / lower

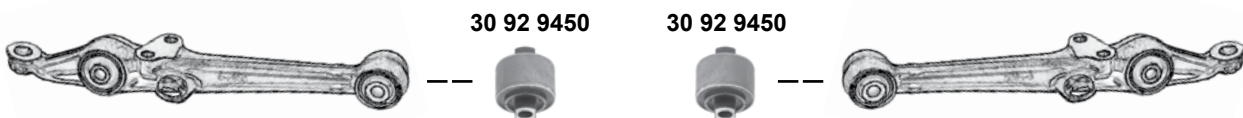

Ref. - No.



30 92 7502	4E0 407 506 B
30 92 7503	4E0 407 505 B
30 92 7264	4E0 407 510 B
30 92 7265	4E0 407 509 B
30 92 9450	4E0 407 182 C
30 93 0654	4E0 419 810 C
32 93 0696	8D0 407 515 C
30 93 7332	4E0 419 801 E S2
30 93 7338	4E0 419 811 E S1

Querlenker / control arm
Querlenker / control arm
Querlenker / control arm
Querlenker / control arm
Querlenkerlager / control arm mounting
Axialgelenk / axial joint
Querlenkerlager / control arm mounting
Rep. Satz Spurstange mit Schraube / rep. kit tie rod with screw
Spurstangenendstück / tie rod end

Ø A 55
M16 x 1,5

Vorderachse / Front axle



Polo 1 / 2 (80/86/87) (1975 → 1994) (ex.) G40

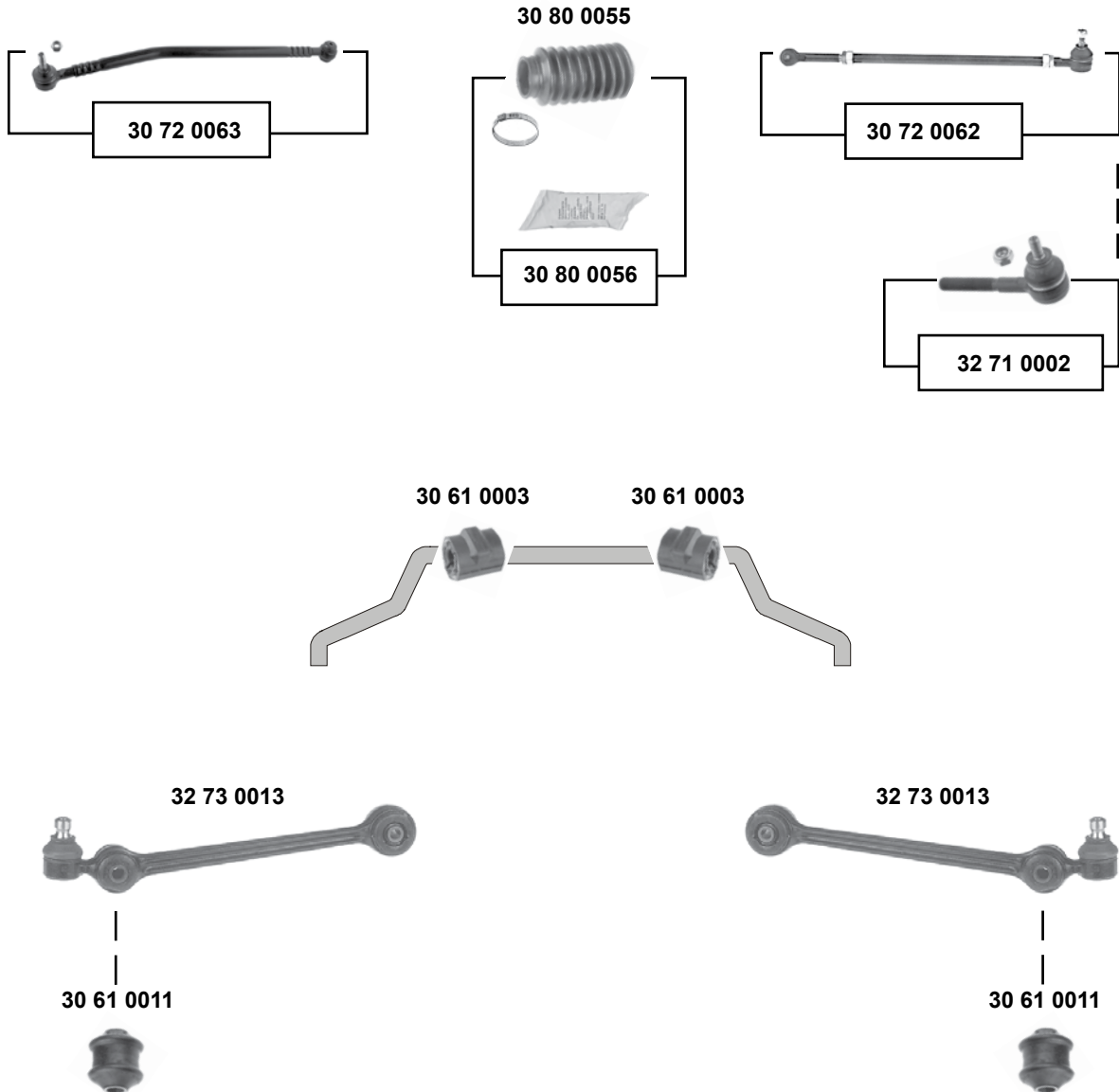

Vorderachse / Front axle

	Ref. - No.			
30 61 0003	867 411 313	Stabilisatorlager / stabilizer mount		Ø 16,5
30 61 0011	861 407 183	Stabilisatorlager / stabilizer mount		12x34x44,5
30 72 0062	871 419 802	Spurstange / tie rod	LHD / (ch.) -D-000 001 →	
30 72 0063	871 419 801 A	Spurstange / tie rod	LHD / (ch.) -D-000 001 →	
30 80 0055	861 419 831 B S1	Rep. Satz Lenkmanschette / rep. kit steering boot	(ch.) F 86A 0000 001 →	
30 80 0056	861 419 831 B	Lenkmanschette / steering boot	(ch.) F 86A 0000 001 →	
32 71 0002	811 419 812	Spurstangenendstück / tie rod end		M10 x 1
32 73 0013	861 407 151 B	Querlenker / control arm	(ch.) 869 2523 523 →	



VOLKSWAGEN

Polo 3 (6N1) (1995 → 2000)

Vorderachse / Front axle

man.

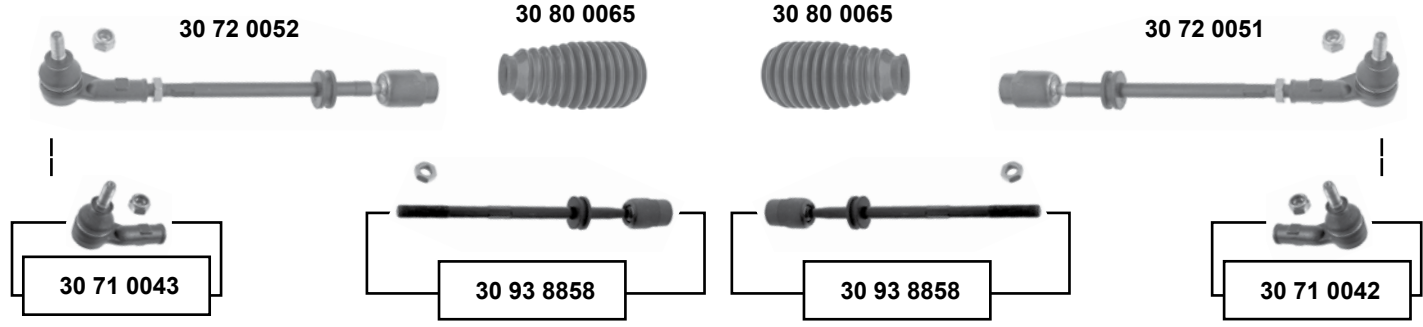

servo

(ch.) → 6N-WW-078 256 / 6N-WX-078 256 / 6N-XY-156 681 (LHD) / 6N-WY-172 198 (RHD)

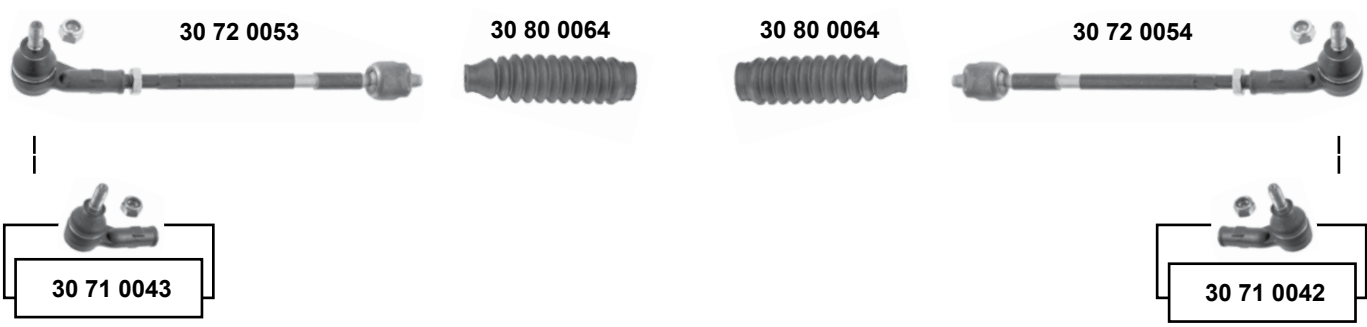

(ch.) 6N-WW-078 257 / 6N-WX-078 257 / 6N-XY-156 682 (LHD) / 6N-WY-172 199 (RHD) →

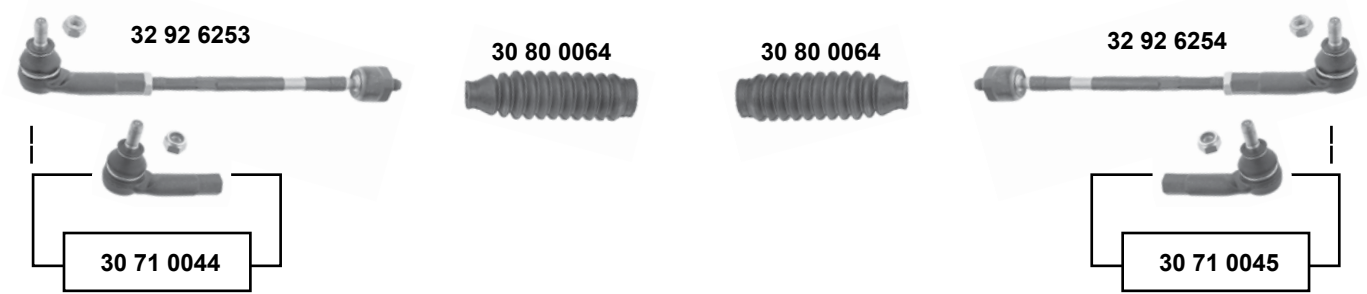

SWAG GERMANY	Ref. - No.			
30 71 0042	6N0 422 812	Spurstangenendstück / tie rod end	servo	M12 x 1,5
30 71 0043	6N0 422 811	Spurstangenendstück / tie rod end	servo	M12 x 1,5
30 71 0044	6E0 419 811	Spurstangenendstück / tie rod end		M12 x 1,5
30 71 0045	6X0 422 812	Spurstangenendstück / tie rod end		M12 x 1,5
30 72 0051	6N0 419 804	Spurstange / tie rod		
30 72 0052	6N0 419 803	Spurstange / tie rod		
30 72 0053	6N0 422 803 A	Spurstange / tie rod		
30 72 0054	6N0 422 804 A	Spurstange / tie rod		
30 80 0064	6N0 422 831	Lenkmanschette / steering boot		
30 80 0065	6N0 419 831	Lenkmanschette / steering boot		
30 93 8858	6N0 419 810	Axialgelenk / axial joint	(ch.) → 6N-Y-050 000	
32 92 6253	6N0 422 803 D	Spurstange / tie rod		M12 x 1,5
32 92 6254	6N0 422 804 D	Spurstange / tie rod		M12 x 1,5



Polo 3 (6N1) (1995 → 2000)

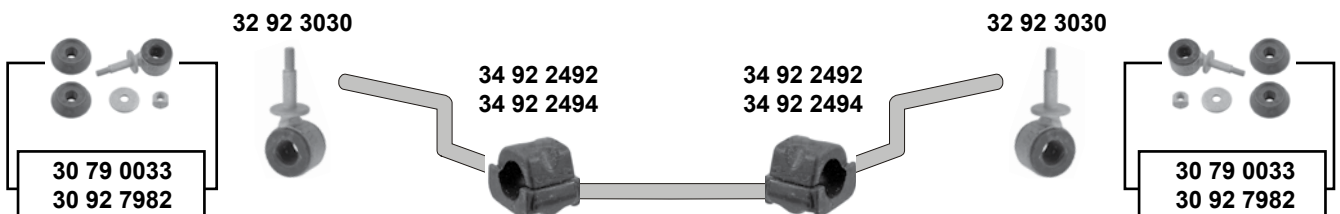
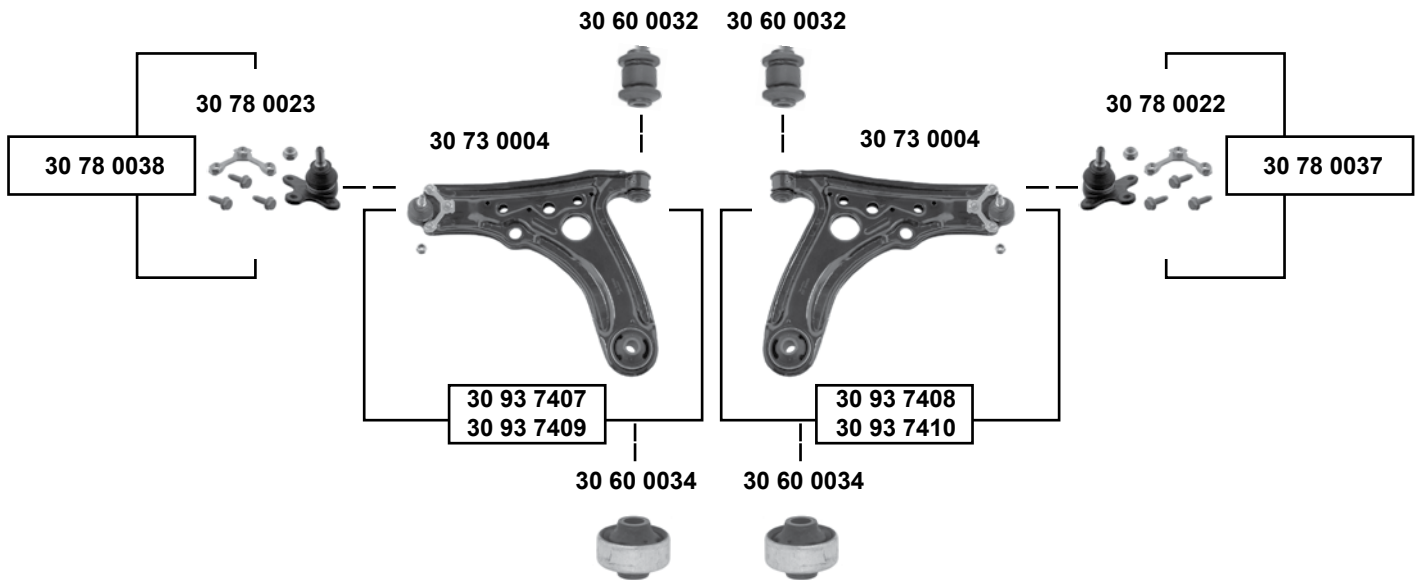

(1) für Bremsscheibendurchmesser (mm) / for brake disk diameter (mm): 239

(2) Stabilisator / stabilizer Ø 20/22 mm



Ref. - No.



30 60 0032	6N0 407 182	Querlenkerlager / control arm mount		10x28x47
30 60 0034	6N0 407 181	Querlenkerlager / control arm mount		17x61x46
30 73 0004	6N0 407 151 B	Querlenker / control arm		
30 78 0022	6N0 407 365	Traggelenk / ball joint		M10 x 1
30 78 0023	6N0 407 365	Traggelenk / ball joint		M10 x 1
30 78 0037	6N0 407 365 A S1	Traggelenk / rep. kit ball joint		M10 x 1
30 78 0038	6N0 407 365 S1	Rep. Satz Traggelenk / rep. kit ball joint		M10 x 1
30 79 0033	6N0 411 315 C S1	Verbindungsstange / connecting rod	(ch.) → 6K-V-047 501	
30 92 7982	6K0 411 315 S1	Verbindungsstange / connecting rod	(ch.) 6K-V-047 501→	Ø 1 16,5
30 93 7407	6X0 407 151 A S2	Rep. Satz Querlenker / rep. kit control arm	PR-1LB,1LM,1ZC,1ZN	
30 93 7408	6X0 407 151 A S3	Rep. Satz Querlenker / rep. kit control arm	PR-1LB,1LM,1ZC,1ZN	
30 93 7409	6N0 407 151 B S1	Rep. Satz Querlenker / rep. kit control arm	(1)	
30 93 7410	6N0 407 151 B S2	Rep. Satz Querlenker / rep. kit control arm	(1)	
32 92 3030	6N0 411 315 D	Verbindungsstange / connecting rod	(2)	
34 92 2492	6X0 411 313	Stabilager / stabilizer mounting		Ø 18
34 92 2494	6X0 411 313 A	Stabilager / stabilizer mounting		Ø 20



Polo 3 (6N2) (2000 → 2002)

man.

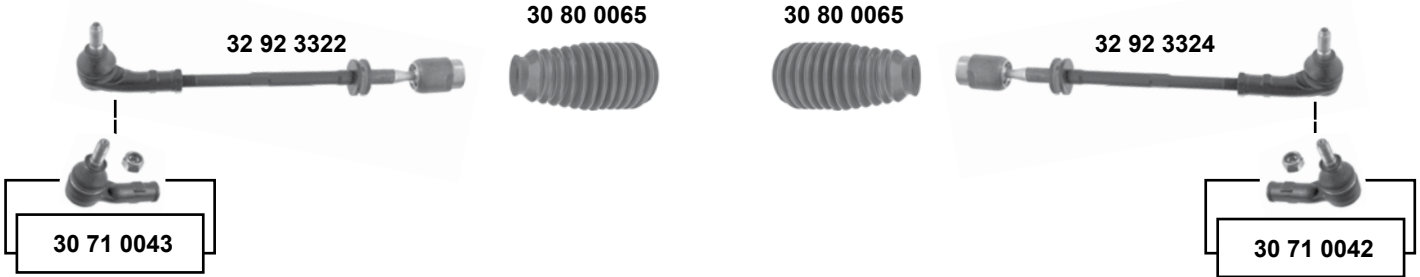

servo

→ 47 Kw (64 PS)

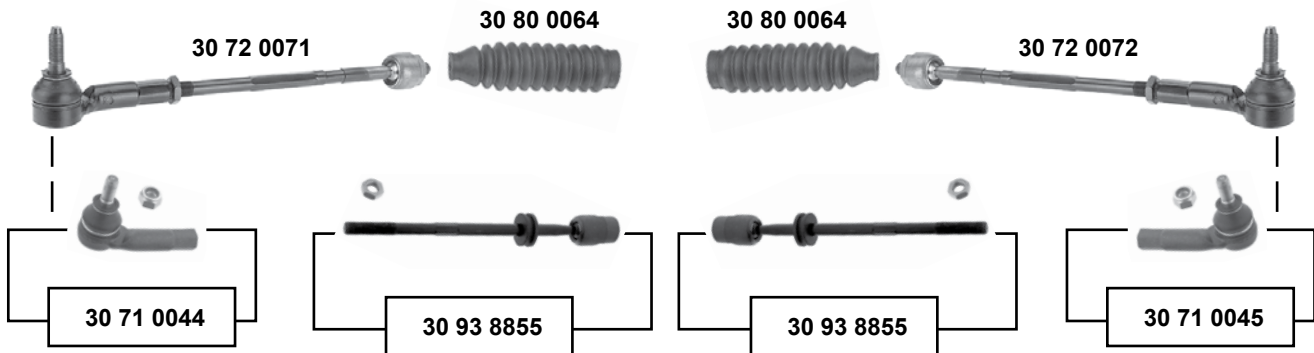

55 Kw (75PS) →

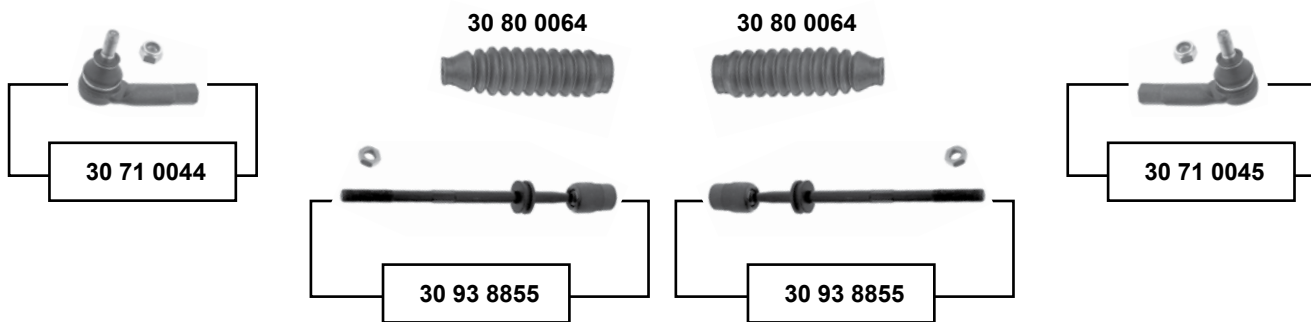

SWAG GERMANY	Ref. - No.			
30 71 0042	6N0 422 812	Spurstangenendstück / tie rod end	servo	M12 x 1,5
30 71 0043	6N0 422 811	Spurstangenendstück / tie rod end	servo	M12 x 1,5
30 71 0044	6E0 419 811	Spurstangenendstück / tie rod end		M12 x 1,5
30 71 0045	6X0 422 812	Spurstangenendstück / tie rod end		M12 x 1,5
30 72 0071	6X0 422 803	Spurstange / tie rod		
30 72 0072	6X0 422 804	Spurstange / tie rod		
30 80 0064	6N0 422 831	Lenkmanschette / steering boot		
30 80 0065	6N0 419 831	Lenkmanschette / steering boot		
30 93 8855	6X0 422 810	Axialgelenk / axial joint	servo / PR-1N1/1N5	
32 92 3322	6X0 419 803 A	Spurstange / tie rod	(mot.) ALD/AUC	
32 92 3324	6X0 419 804 A	Spurstange / tie rod		

Vorderachse / Front axle



Polo 3 (6N2) (2000 → 2002)

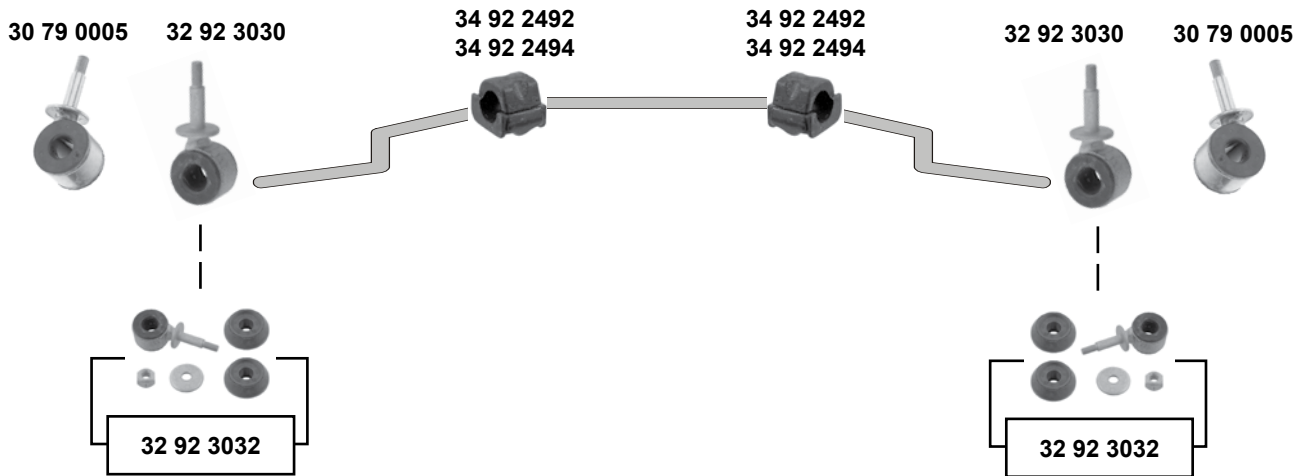
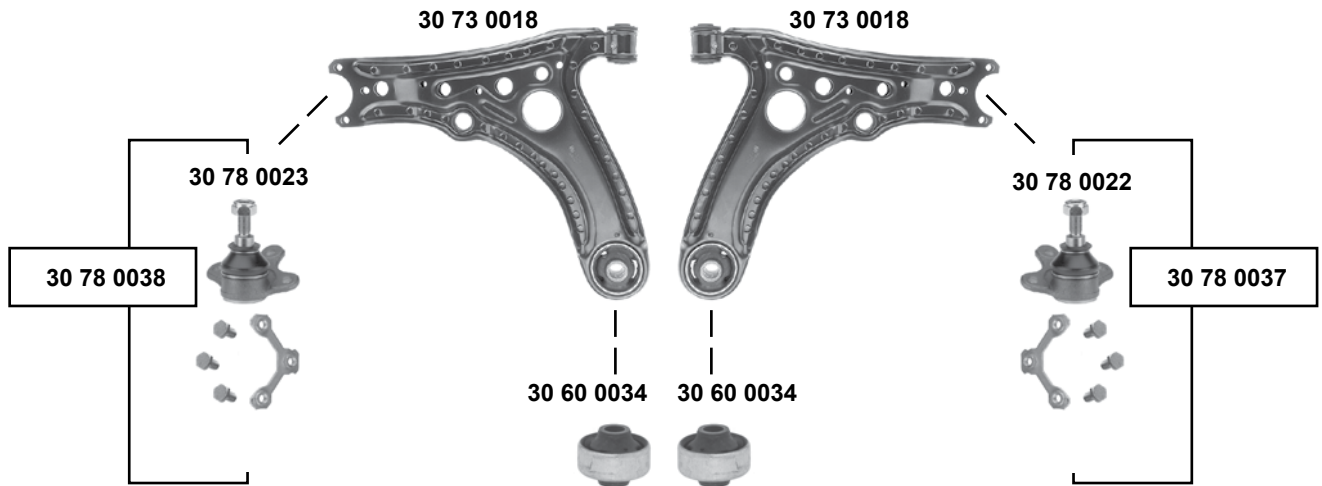

- (1) Stabilisator / stabilizer Ø 18 mm / (ch.) 6N-Y-500 001→
- (2) Stabilisator / stabilizer Ø 20/22 mm



Ref. - No.



SWAG Ref. - No.	Part Description	Quantity	Dimensions
30 60 0034	Querlenkerlager / control arm mount		17x61x46
30 73 0018	Querlenker / control arm		
30 78 0022	Traggelenk / ball joint		M10 x 1
30 78 0023	Traggelenk / ball joint		M10 x 1
30 78 0037	Rep. Satz Traggelenk / rep. kit ball joint		M10 x 1
30 78 0038	Rep. Satz Traggelenk / rep. kit ball joint		M10 x 1
30 79 0005	Verbindungsstange / connecting rod	(1)	
32 92 3030	Verbindungsstange / connecting rod	(2)	
32 92 3032	Rep. Satz Verbindungsstange / rep. kit connecting rod	(2)	
34 92 2492	Stabilager / stabilizer mounting		Ø 18
34 92 2494	Stabilager / stabilizer mounting		Ø 20



Polo 4 (9N) (2002 → 2010)

Vorderachse / Front axle

man.

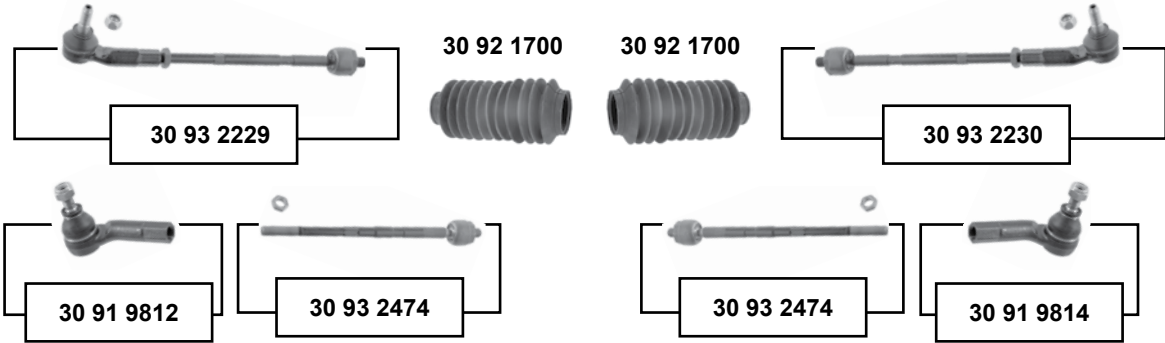

für / to fit servo TRW

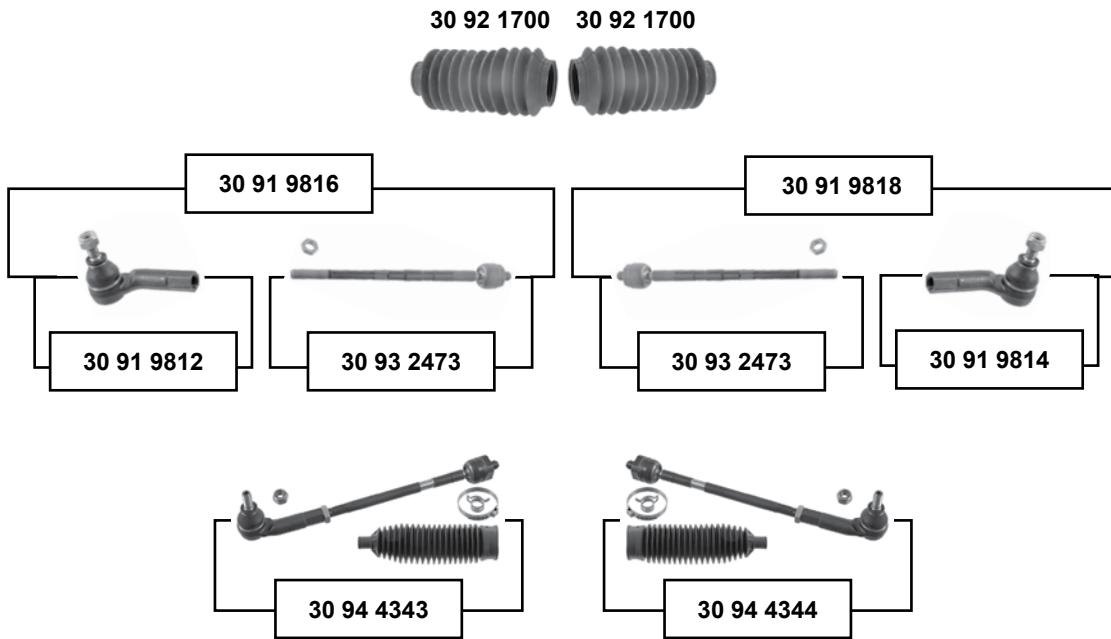

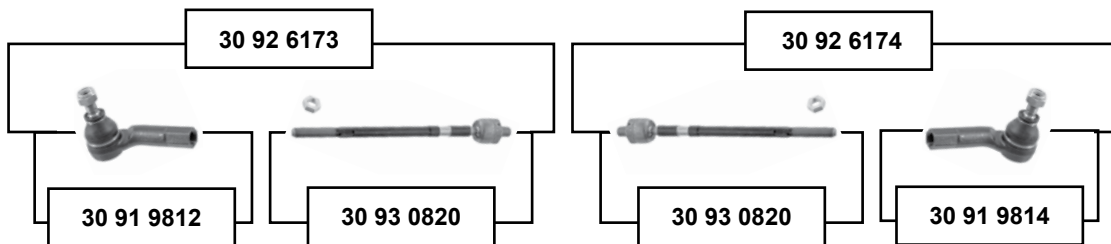

für / to fit servo KOYO





Polo 4 (9N)
 (2002 → 2010)

(1) (ch.) 9N-2000001 → 9N-3-190000



(2) man.  (ch.) → 9N-3Y201497 servo  TRW: (ch.) → 9N-3D150674

(3) servo  TRW: (ch.) → 9N-3Y201497 man.  (ch.) → 9N-3D150674

(4) 02 → 07 (ch.) → 9N-7B006 318 / (ch.) → 9N-7D045 484 / (ch.) → 9N-7Y123 244



Ref. - No.



30 91 9812	6R0 423 811	Spurstangenendstück / tie rod end	(2)	
30 91 9814	6R0 423 812	Spurstangenendstück / tie rod end	(2)	
30 91 9816	6Q0 423 803 P	Spurstange / tie rod	(1)	
30 91 9818	6Q0 423 804 P	Spurstange / tie rod	(1)	
30 92 1700	6E0 419 831	Lenkmanschette / steering boot	(3)	
30 92 6173	6Q0 423 803 G	Rep. Satz Spurstange / rep. kit tie rod		
30 92 6174	6Q0 423 804 G	Rep. Satz Spurstange / rep. kit tie rod		
30 93 0820	6Q0 423 810 C	Spurstange / tie rod	(4)	M14 x 1,5
30 93 2229	6Q0 419 803 F	Spurstange / tie rod		M12 x 1,5
30 93 2230	6Q0 419 804 F	Spurstange / tie rod		M12 x 1,5
30 93 2473	6Q0 423 810 P	Spurstange / tie rod	→ 10	M14 x 1,5
30 93 2474	6Q0 419 810 B	Spurstange / tie rod		M14 x 1,5
30 94 4343	6Q0 423 803 P S1	Rep. Satz Spurstange / rep. kit tie rod	PR-1N2/1N5	
30 94 4344	6Q0 423 804 P S1	Rep. Satz Spurstange / rep. kit tie rod	PR-1N2/1N5	



Polo 4 (9N)
(2002 → 2010)

Vorderachse / Front axle



30 69 0002

30 69 0002

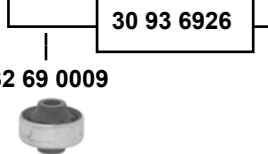
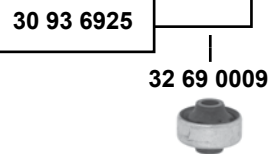
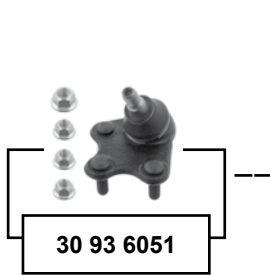

32 69 0009

32 69 0009

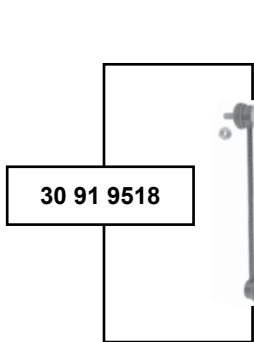

30 92 7324
30 92 7638
30 92 7640
30 92 7642
30 93 1350

30 92 7324
30 92 7638
30 92 7640
30 92 7642
30 93 1350

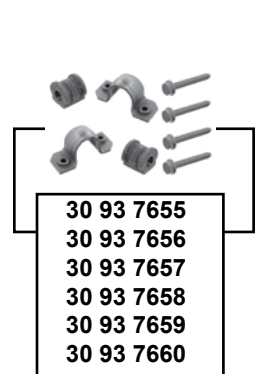
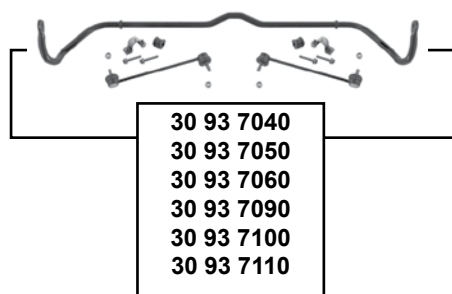
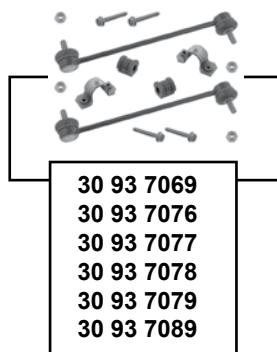
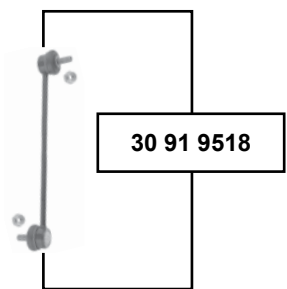



Polo 4 (9N) (2002 → 2010)

(1)	09 → 10 / (ch.) 9N-9-050001 → / (mot.) BBM / BZG / BUD / BTS / BJX / BBU / BNM / BNV / BWB / BMS / ASY / ATD / AXR / BMT / ASZ / BLT	
(2)	(ch.) 9N-9-175001 → (mot.) BLM / BAH / BBX	(3) → 03 / (ch.) → 9N-3-150 000
(4)	02 → 03 / (ch.) → 9N-3D-170 762 / (ch.) → 9N-3Y-245 376	
(5)	(ch.) 9N-9Y035 001 → / (ch.) 9N-9B031 001 → / (ch.) 9N-9U022 151 → / PR-1LQ/1LR/1ZF/1ZG/1ZJ/1LN/1ZH	
(6)	→ 05 / (ch.) → 9N-3-150 000 / PR-0AQ	(9) → 05 / (ch.) 9N-3-150 001 → / PR-0AQ
(7)	→ 05 / (ch.) → 9N-3-150 000 / PR-0AR	(10) → 05 / (ch.) 9N-3-150 001 → / PR-0AR
(8)	→ 05 / (ch.) → 9N-3D-170 762 / 9N-3Y-245 376	(11) → 05 / (ch.) 9N-3-150 001 → / PR-0AS
(12)	05 → 09 (ch.) 9N-9Y035 001 → / (ch.) 9N-9B031 001 → / (ch.) 9N-9U022 151 →	
(13)	PR-0AS / (ch.) 9N-3D170 763 → / (ch.) 9N-3Y245 377 →	
(14)	→ 05 PR-0AR / (ch.) → 9N-3-150 000	(15) → 05 PR-0AQ / (ch.) → 9N-3-150 000
(16)	PR-0AS / (ch.) → 9N-3D170 762 / (ch.) → 9N-3Y245 376	
(17)	(ch.) 9N-9Y035 001 → / (ch.) 9N-9B031 001 → / (ch.) 9N-9U022 151 →	



SWAG	Ref. - No.			
30 69 0002	357 407 182	Querlenkerlager / control arm mount	(1)	Ø A 33
30 91 9518	6Q0 411 315 Q	Verbindungsstange / connecting rod	Limousine (Sedan) 04 → 07	
30 91 9812	6R0 423 811	Spurstangenendstück / tie rod end	(2)	
30 91 9814	6R0 423 812	Spurstangenendstück / tie rod end	(2)	
30 92 7324	6Q0 411 314 F	Stabilisatorlager / stabilizer mount	(3)	Ø I 19,8
30 92 7638	6Q0 411 314 P	Stabilisatorlager / stabilizer mount		Ø I 16
30 92 7640	6Q0 411 314 Q	Stabilisatorlager / stabilizer mount		Ø I 17
30 92 7642	6Q0 411 314 R	Stabilisatorlager / stabilizer mount	PR-0AS	Ø I 18
30 93 1350	8Z0 411 314 B	Stabilisatorlager / stabilizer mount	(4)	Ø I 20,8
30 93 2229	6Q0 419 803 F	Spurstange / tie rod		M12 x 1,5
30 93 2230	6Q0 419 804 F	Spurstange / tie rod		M12 x 1,5
30 93 2474	6Q0 419 810 B	Spurstange / tie rod		M14 x 1,5
30 93 6051	6R0 407 365 A	Traggelenk / ball joint	(5)	
30 93 6052	6R0 407 366 A	Traggelenk / ball joint	(5)	
30 93 6922	6R0 407 152 E	Querlenker / control arm	(12)	
30 93 6923	6R0 407 151 E	Querlenker / control arm	(12)	
30 93 6925	6R0 407 151 E S1	Rep. Satz Querlenker / rep. kit control arm	(17)	
30 93 6926	6R0 407 152 E S1	Rep. Satz Querlenker / rep. kit control arm	(17)	
30 93 7040	6Q0 411 305 AL S1	Rep. Satz Stabilisatorsatz / rep. kit stabilizer kit	(6)	
30 93 7050	6Q0 411 305 AM S1	Rep. Satz Stabilisatorsatz / rep. kit stabilizer kit	(7)	
30 93 7060	6Q0 411 305 AN S1	Rep. Satz Stabilisatorsatz / rep. kit stabilizer kit	(8) PR-0AS	
30 93 7069	6Q0 411 314 Q S1	Stabilisatorlagersatz / anti roll bar bush kit	(10)	
30 93 7076	6Q0 411 314 R S1	Stabilisatorlagersatz / anti roll bar bush kit	(6)	
30 93 7077	6Q0 411 314 P S1	Stabilisatorlagersatz / anti roll bar bush kit	(9)	
30 93 7078	6Q0 411 314 F S1	Stabilisatorlagersatz / anti roll bar bush kit	(7)	
30 93 7079	8Z0 411 314 B S1	Stabilisatorlagersatz / anti roll bar bush kit	(8) PR-0AS	
30 93 7089	6Q0 411 314 R S2	Stabilisatorlagersatz / anti roll bar bush kit	(11)	
30 93 7090	6Q0 411 305 AL S2	Rep. Satz Stabilisatorsatz / rep. kit stabilizer kit	(9)	
30 93 7100	6Q0 411 305 AM S2	Rep. Satz Stabilisatorsatz / rep. kit stabilizer kit	(10)	
30 93 7110	6Q0 411 305 AN S2	Rep. Satz Stabilisatorsatz / rep. kit stabilizer kit	(11)	
30 93 7655	8Z0 411 314 B S2	Stabilisatorlagersatz / anti roll bar bush kit	(16)	Ø I 20,8
30 93 7656	6Q0 411 314 R S3	Stabilisatorlagersatz / anti roll bar bush kit	(15)	Ø I 18
30 93 7657	6Q0 411 314 P S2	Stabilisatorlagersatz / anti roll bar bush kit	→ 09 PR-0AQ	Ø I 16
30 93 7658	6Q0 411 314 F S2	Stabilisatorlagersatz / anti roll bar bush kit	(14)	Ø I 19,8
30 93 7659	6Q0 411 314 R S4	Stabilisatorlagersatz / anti roll bar bush kit	(13)	Ø I 18
30 93 7660	6Q0 411 314 Q S2	Stabilisatorlagersatz / anti roll bar bush kit	PR-0AR	Ø I 17
32 69 0009	1J0 407 181	Querlenkerlager hinten / control arm mount rear	(1) (2)	Ø A 60 Ø I 13



VOLKSWAGEN

Polo 4 (9N) (2002 → 2010)

Vorderachse / Front axle

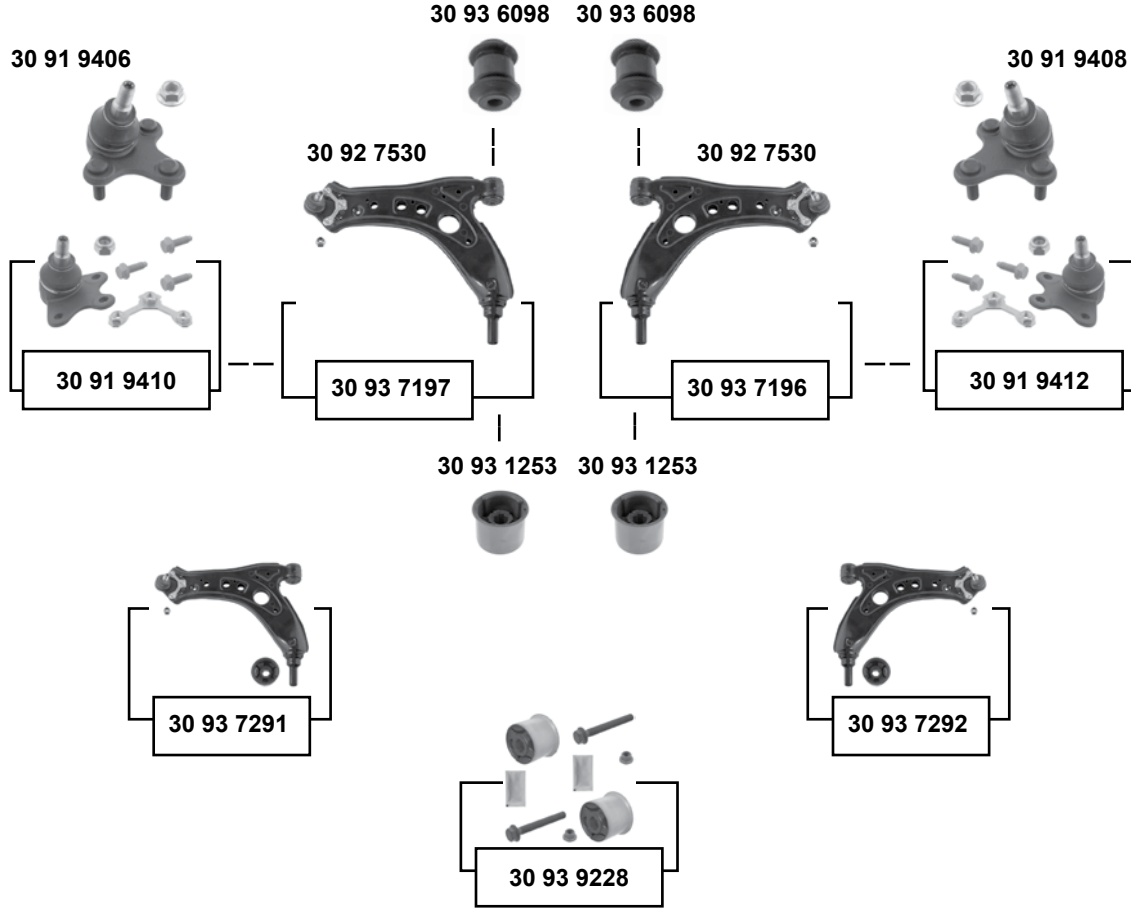

- (1) → 2009 / → 9N-9-050 000 (mot.) BBM / BZG / BUD / BTS / BJX / BBU / BNM / BNV / BWB / BMS / ASY / ATD / AXR / BMT / ASZ / BLT
→ 2009 / → 9N-9-175 000 (mot.) BLU/BAH/BBX
- (2) (ch.) → 9N-9Y035 000 / (ch.) → 9N-9B031 000 / (ch.) → 9N-9U022 150 / PR-1LM/1ZN
- (3) Polo → 09 / Crosspolo 05 → 09
- (4) Polo 4 nicht für / not for PR-1N0
Crosspolo 05 → 09 (ch.) → 9N-9Y035 000 (ch.) → 9N-9B031 000 (ch.) → 9N-9U022 150
nicht für / not for PR-1LM/1ZN



Ref. - No.



Ref. - No.	Description	Notes	Dimensions
30 91 9406	6Q0 407 365 A	Traggelenk / ball joint	(ch.) 9N-2-000001 →
30 91 9408	6Q0 407 366 A	Traggelenk / ball joint	(ch.) 9N-2-000001 →
30 91 9410	6Q0 407 365 A S1	Rep. Satz Traggelenk / rep. kit ball joint	(2)
30 91 9412	6Q0 407 366 A S1	Rep. Satz Traggelenk / rep. kit ball joint	(2)
30 92 7530	6Q0 407 151 L	Querlenker / control arm	(1)
30 93 1253	1K0 407 183 E	Querlenkerlager / control arm mount	05 → 09
30 93 6098	6Q0 407 182 A	Querlenkerlager / control arm mount	
30 93 7196	6Q0 407 151 L S3	Rep. Satz Querlenker / rep. kit control arm	(3)
30 93 7197	6Q0 407 151 L S2	Rep. Satz Querlenker / rep. kit control arm	(3)
30 93 7291	6Q0 407 151 L S5	Rep. Satz Querlenker / rep. kit control arm	(4)
30 93 7292	6Q0 407 151 L S4	Rep. Satz Querlenker / rep. kit control arm	(4)
30 93 9228	1K0 407 183 E S1	Querlenkerlagersatz / control arm mounting kit	

Ø A 63
Ø A 32



Polo (6C)
(2009 →)





VOLKSWAGEN

Polo Classic / Variant (6K)

(1996 → 2002)

Vorderachse / Front axle

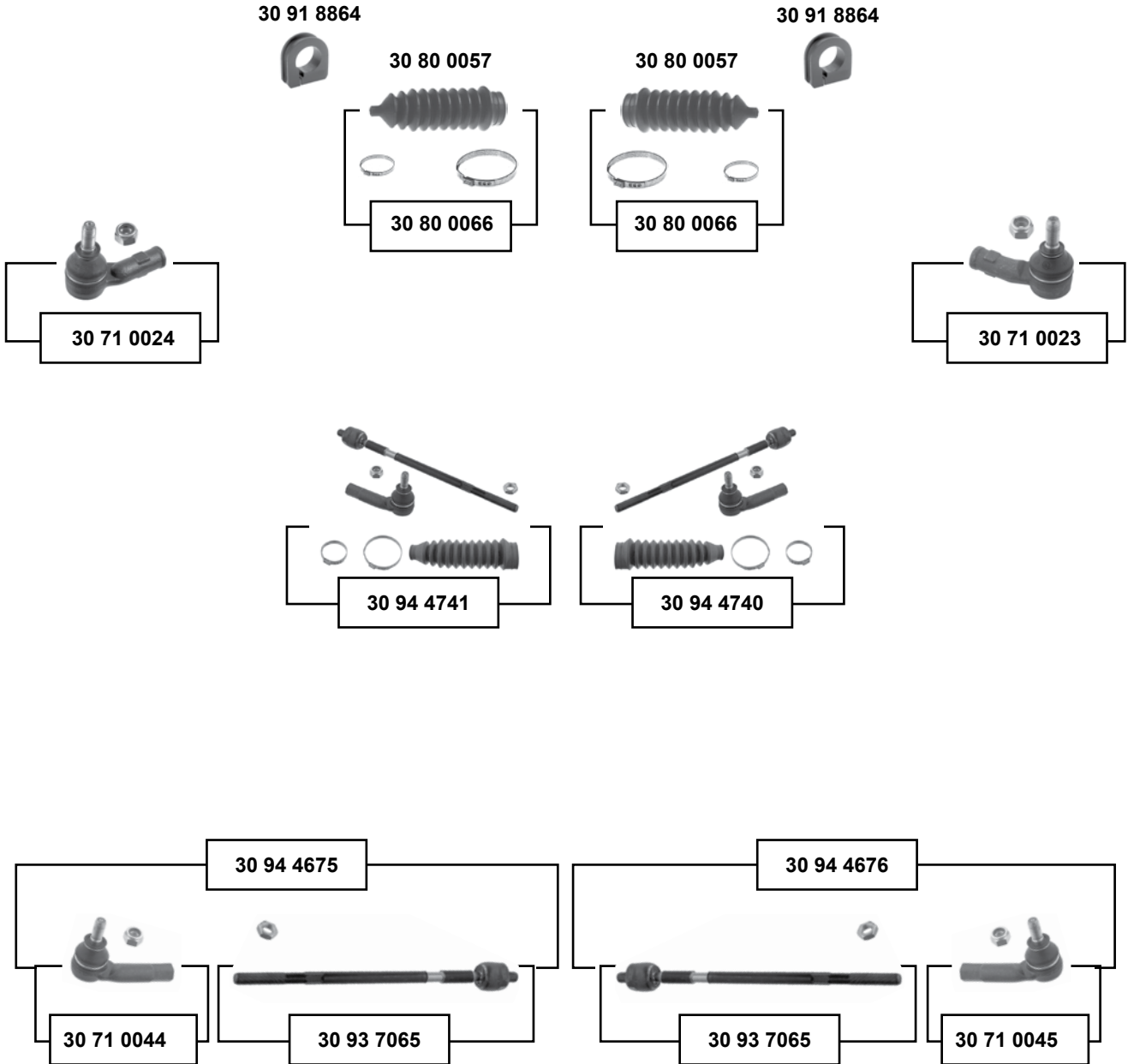



Polo Classic / Variant (6K) (1996 → 2002)



- (1) (ch.) → 6K-1-536000 Sport
- (2) (ch.) → 6K-1-536000 (ex.) Sport
- (3) (ch.) 6K-1-536000 → Sport
- (4) (ch.) 6K-1-536000 → (ex.) Sport



Ref. - No.



SWAG Ref. - No.				
30 71 0023	191 419 812	Spurstangenendstück / tie rod end	(1) (2)	
30 71 0024	191 419 811	Spurstangenendstück / tie rod end	(1) (2)	
30 71 0044	6E0 419 811	Spurstangenendstück / tie rod end	(3) (4)	
30 71 0045	6E0 419 812	Spurstangenendstück / tie rod end	(3) (4)	
30 80 0057	1H0 422 831 B	Lenkmanschette / steering boot	(2)	
30 80 0066	1H0 422 831 B S1	Rep. Satz Lenkmanschette / rep. kit steering boot	(2)	
30 91 8864	1H0 422 884	Lenkgetriebebelager / steering gear bearing		
30 93 7065	6K0 422 810 E	Axialgelenk / axial joint		
30 94 4675	6K0 422 803 E	Rep. Satz Spurstange / rep. kit tie rod		M12 x 1,5
30 94 4676	6K0 422 804 E	Rep. Satz Spurstange / rep. kit tie rod		M12 x 1,5
30 94 4740	6K0 422 804 E S1	Rep. Satz Spurstange / rep. kit tie rod	(ex.) Sport	
30 94 4741	6K0 422 803 E S1	Rep. Satz Spurstange / rep. kit tie rod	(ex.) Sport	



Polo Classic / Variant (6K)



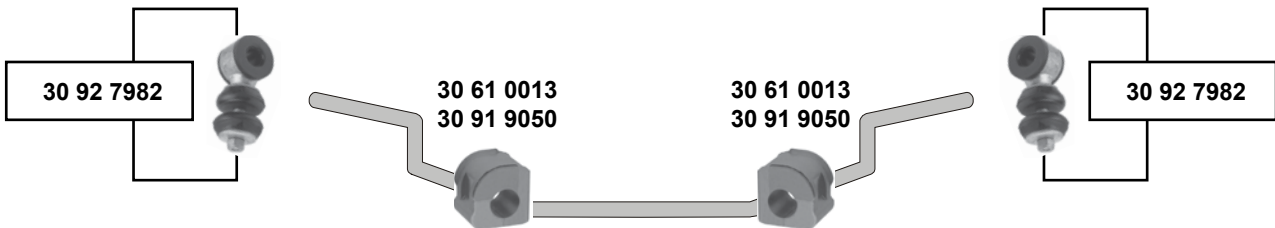
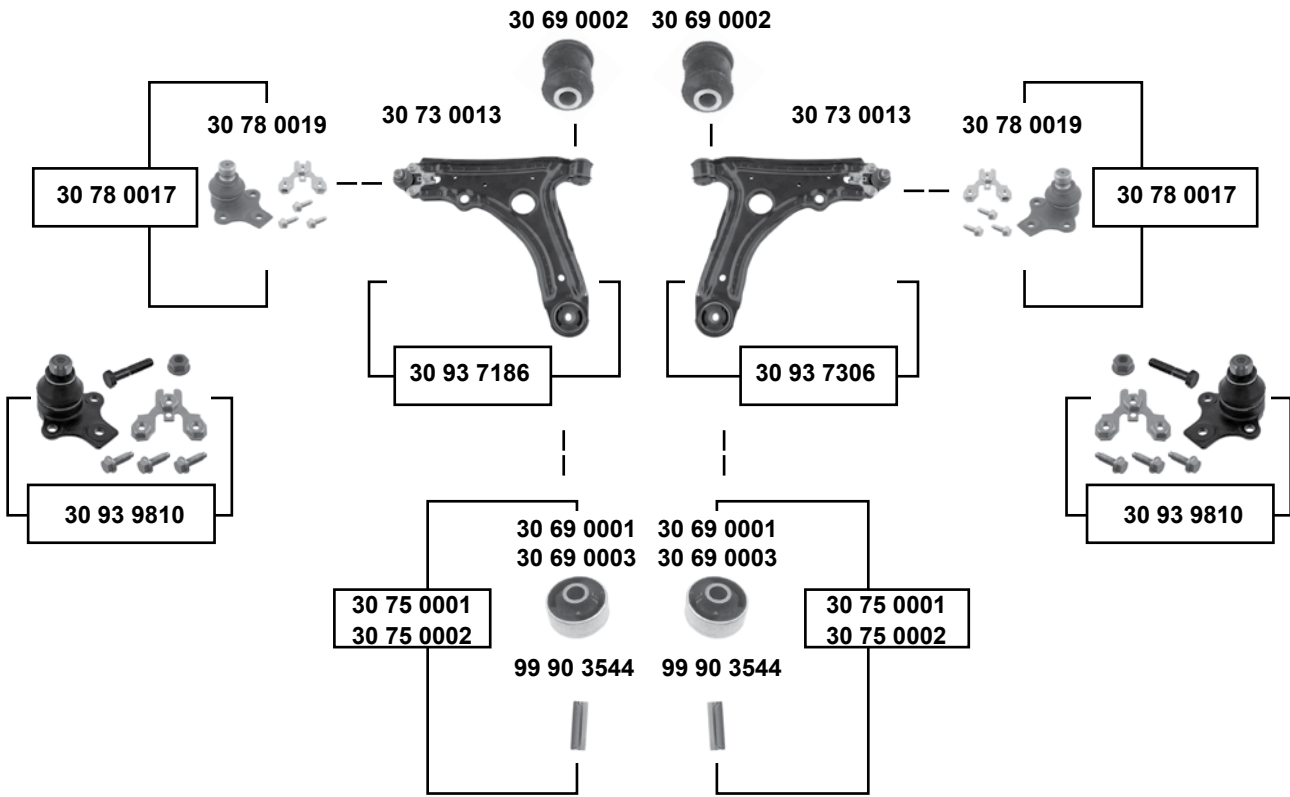
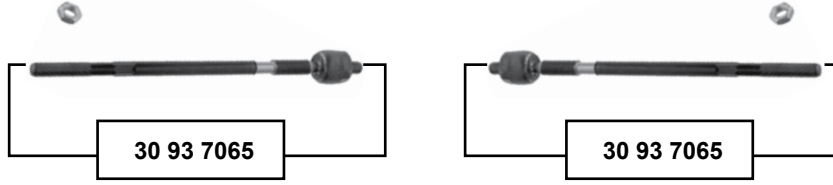

(1996 → 2002)

Vorderachse / Front axle





Polo Classic / Variant (6K) (1996 → 2002)

	Ref. - No.			
30 61 0013	191 411 314	Stabilisatorlager / stabilizer mount		Ø 17
30 69 0001	191 407 181 D	Querlenkerlager / control arm mount	NEW	17x60x41
30 69 0002	357 407 182	Querlenkerlager / control arm mount		12x33x54
30 69 0003	191 407 181 B	Querlenkerlager / control arm mount	OLD	17x60x41
30 73 0013	191 407 151 B	Querlenker mit Gummilager / control arm incl. rubber mounts		
30 75 0001	191 407 181 B S1	Querlenkerlager mit Hülse / control arm mount with sleeve	OLD	
30 75 0002	191 407 181 D S1	Querlenkerlager mit Hülse / control arm mount with sleeve	NEW	
30 78 0017	357 407 365 S1	Rep. Satz Traggelenk / rep. kit ball joint		
30 78 0019	357 407 365	Traggelenk / ball joint		Ø A 19
30 91 9050	1H0 411 314	Stabilisatorlager / stabilizer mount		Ø 19
30 92 7982	6K0 411 315 S1	Rep. Satz Verbindungsstange / rep. kit connecting rod		Ø 16,5
30 93 7065	6K0 422 810 E	Axialgelenk / axial joint		M12 x 1,5
30 93 7186	191 407 151 B S1	Rep. Satz Querlenker / rep. kit control arm		
30 93 7306	191 407 151 B S2	Rep. Satz Querlenker / rep. kit control arm		
30 93 9810	357 407 365 S2	Rep. Satz Traggelenk / rep. kit ball joint		
99 90 3544	191 407 190 A	Hülse / sleeve		50x17

passend für / to fit

VOLKSWAGEN



Polo (6R)

(2009 →)

Vorderachse / Front axle

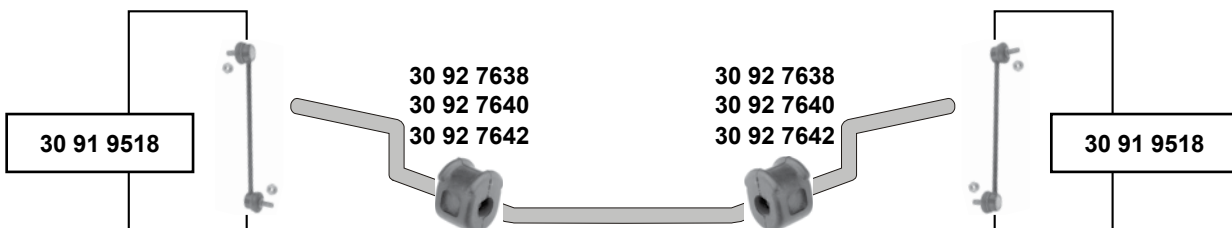
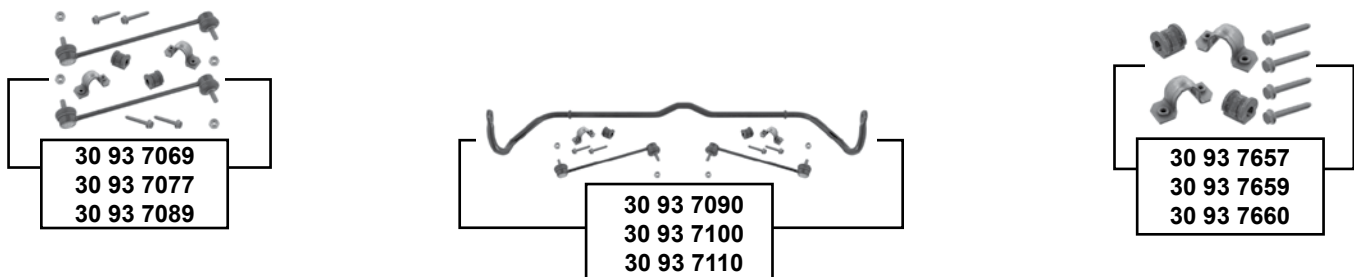
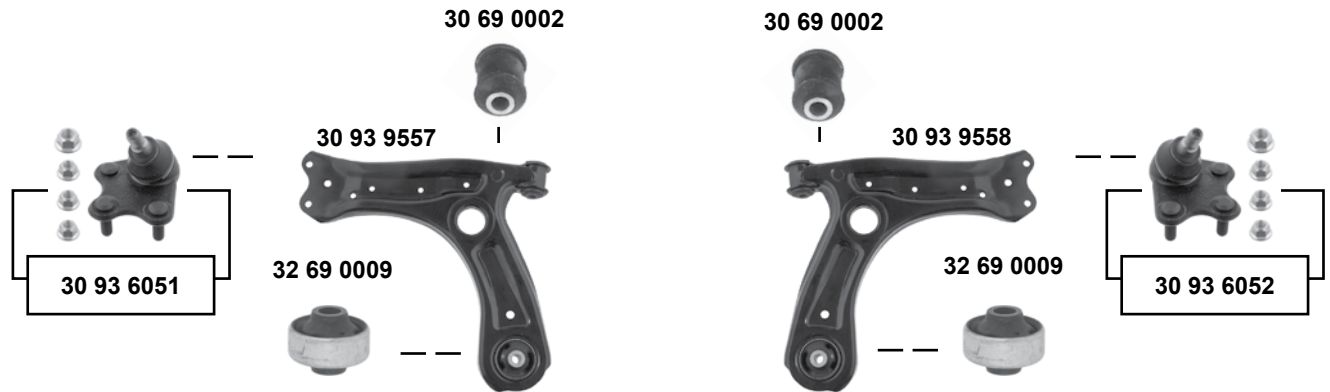
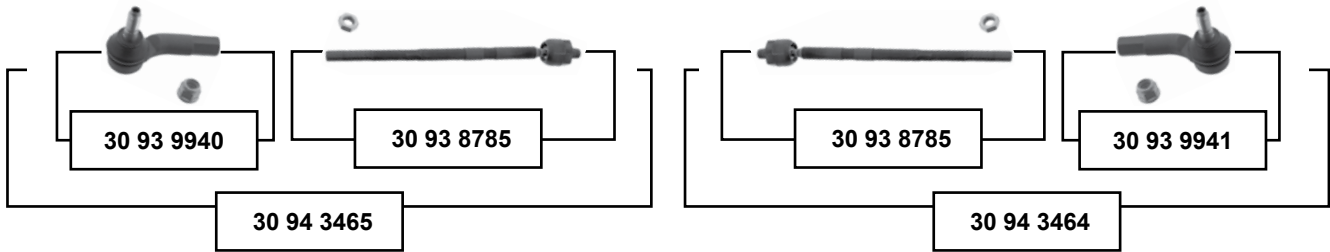
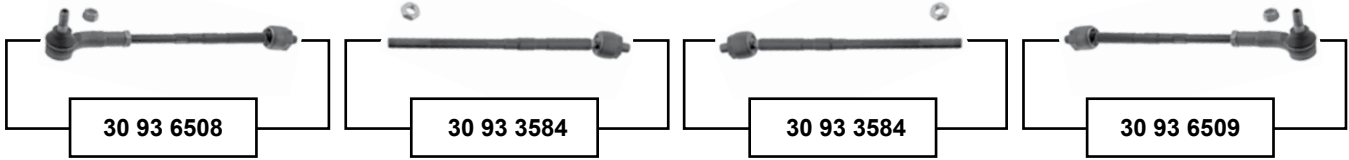



Polo (6R) (2009 →)



(1) PR-LN / 1LR / 1ZC / 1ZD / 1ZG / ZJ



Ref. - No.



30 69 0002	357 407 182	Querlenkerlager / control arm mount			Ø A 33
30 91 9518	6Q0 411 315 Q	Verbindungsstange / connecting rod			
30 92 7638	6Q0 411 314 P	Stabilisatorlager / stabilizer mount		(ex.) GTI	Ø I 16
30 92 7640	6Q0 411 314 Q	Stabilisatorlager / stabilizer mount			Ø I 17
30 92 7642	6Q0 411 314 R	Stabilisatorlager / stabilizer mount		PR-0AS	Ø I 18
30 93 3584	6R0 423 810 A	Spurstange / tie rod		PR-1N2	M14 x 1,5
30 93 6051	6R0 407 365 A	Traggelenk / ball joint		(1)	
30 93 6052	6R0 407 366 A	Traggelenk / ball joint			
30 93 6508	6R0 423 803 A	Spurstange, komplett / tie rod, complete		PR-1N2 E-hydr.	M12/14x1,5
30 93 6509	6R0 423 804 A	Spurstange, komplett / tie rod, complete		PR-1N2 E-hydr.	M12/14x1,5
30 93 7069	6Q0 411 314 Q S1	Stabilisatorlagersatz / anti roll bar bush kit		PR-0AR	
30 93 7077	6Q0 411 314 P S1	Stabilisatorlagersatz / anti roll bar bush kit		PR-0AQ	
30 93 7089	6Q0 411 314 R S2	Stabilisatorlagersatz / anti roll bar bush kit		PR-0AS	
30 93 7090	6Q0 411 305 AL S2	Rep. Satz Stabilisatorsatz / rep. kit stabilizer kit		PR-0AQ	
30 93 7100	6Q0 411 305 AM S2	Rep. Satz Stabilisatorsatz / rep. kit stabilizer kit		PR-0AR	
30 93 7110	6Q0 411 305 AN S2	Rep. Satz Stabilisatorsatz / rep. kit stabilizer kit		PR-0AS	
30 93 7657	6Q0 411 314 P S2	Stabilisatorlagersatz / anti roll bar bush kit		PR-0AQ	Ø I 16
30 93 7659	6Q0 411 314 R S4	Stabilisatorlagersatz / anti roll bar bush kit		PR-0AS	Ø I 18
30 93 7660	6Q0 411 314 Q S2	Stabilisatorlagersatz / anti roll bar bush kit		PR-0AR	Ø I 17
30 93 8785	8Z0 423 810 F	Axialgelenk / axial joint		PR-1N4 servo	
30 93 9557	6R0 407 151 F	Querlenker / control arm			
30 93 9558	6R0 407 152 F	Querlenker / control arm			
30 93 9940	6R0 423 811 A S1	Rep. Satz Spurstangenendstück / rep. kit tie rod end		PR-1N4 servo	M14 x 1,5
30 93 9941	6R0 423 812 A S1	Rep. Satz Spurstangenendstück / rep. kit tie rod end		PR-1N4 servo	M14 x 1,5
30 94 3464	6R0 423 804 D	Rep. Satz Spurstange / rep. kit tie rod		PR-1N4 servo	
30 94 3465	6R0 423 803 D	Rep. Satz Spurstange / rep. kit tie rod		PR-1N4 servo	
32 69 0009	1J0 407 181	Querlenkerlager hinten / control arm mount rear			Ø A 60 Ø I 13



Santana (32)

(1981 → 1988)

man.

(ch.) → 32-B-040 821



30 80 0060

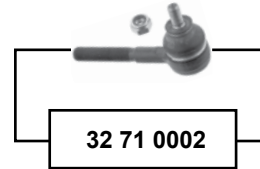

(ch.) 32-B-040 822 →

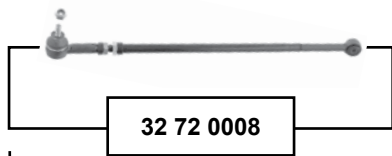

30 80 0060

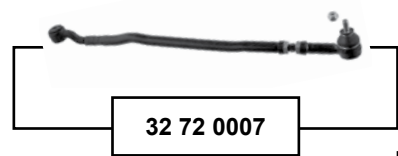

servo

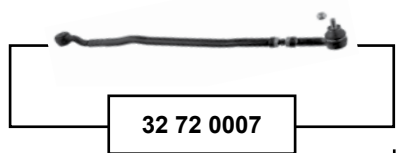
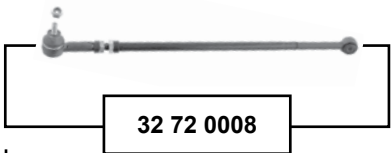

30 80 0060



Vorderachse / Front axle



Santana (32)
(1981 → 1988)

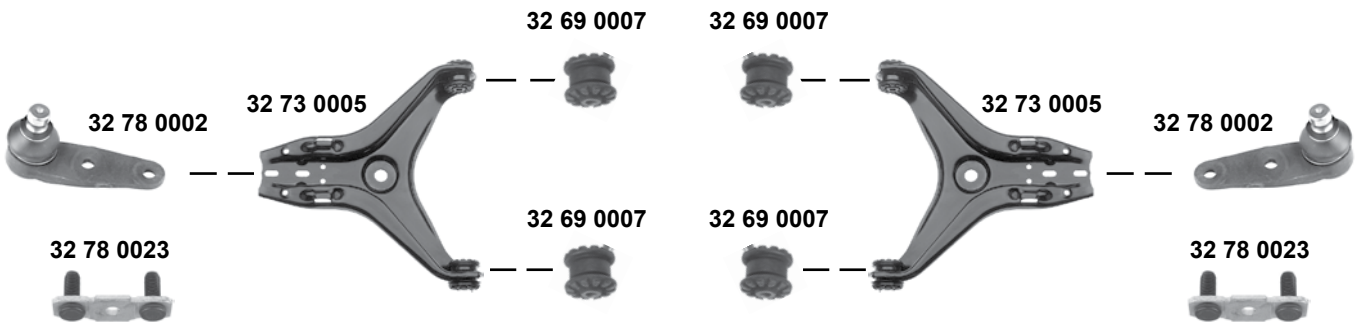
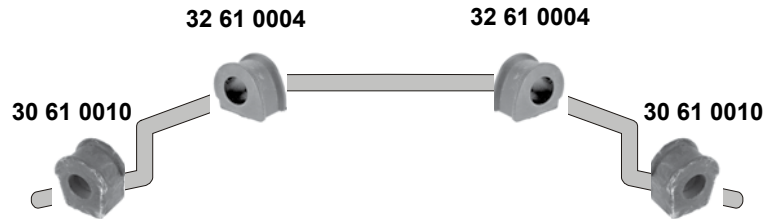

Vorderachse / Front axle

	Ref. - No.			
30 61 0010	823 411 313 A	Stabilisatorlager / stabilizer mount	(ch.) → 32-F-390000	Ø 12,5
32 69 0007	811 407 181 A	Querlenkerlager / control arm mount		10x38x44
32 61 0004	823 411 327 B	Stabilisatorlager / stabilizer mount		Ø 19
32 73 0005	893 407 147 G	Querlenker / control arm		
32 78 0002	823 407 365 E	Traggelenk / ball joint		Ø A 17
32 78 0023	811 407 175 A	Sicherungsblech / lock washer		



Santana (32) (1981 → 1988)

servo

4 cyl. (ch.) → 32-E-150 000
5 cyl. (ch.) → 32-D-099 298

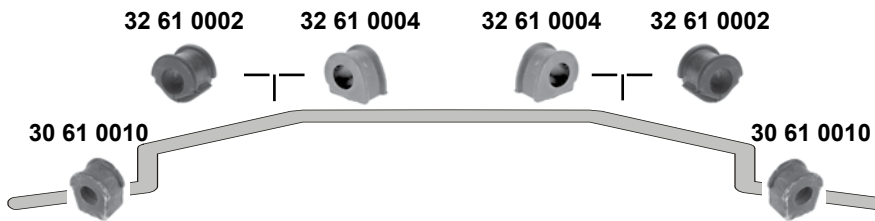

Ref. - No.



30 61 0010	823 411 313 A
32 61 0002	811 411 327 A
32 61 0004	823 411 327 B
32 69 0007	811 407 181 A
32 73 0005	893 407 147 G
32 78 0002	823 407 365 E
32 78 0023	811 407 175 A

Stabilisatorlager / stabilizer mount
Stabilisatorlager / stabilizer mount
Stabilisatorlager / stabilizer mount
Querlenkerlager / control arm mount
Querlenker / control arm
Traggelenk / ball joint
Sicherungsblech / lock washer

(ch.) 32-F-390 001 →
(ch.) → 32-F-390 000

Ø 12,5
Ø 20
10x38x44
Ø A 17

Vorderachse / Front axle

Santana (32)
 (1981 → 1988)

servo

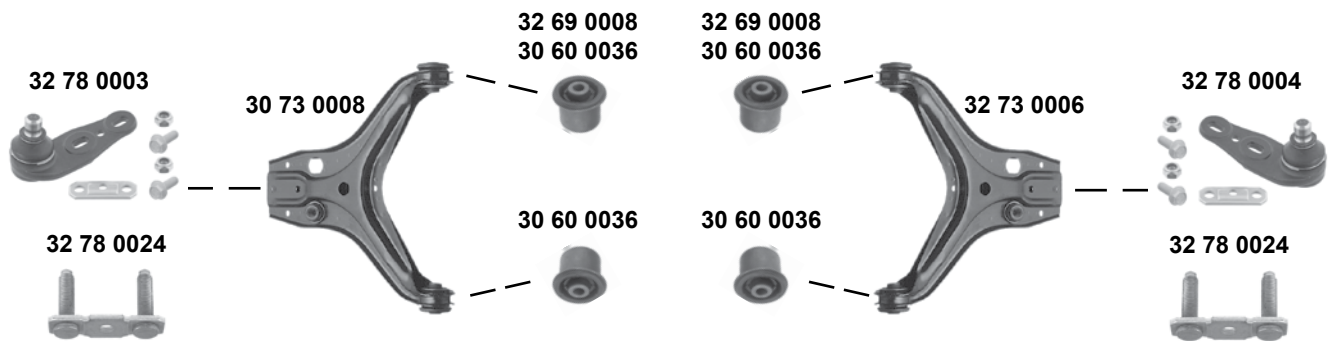
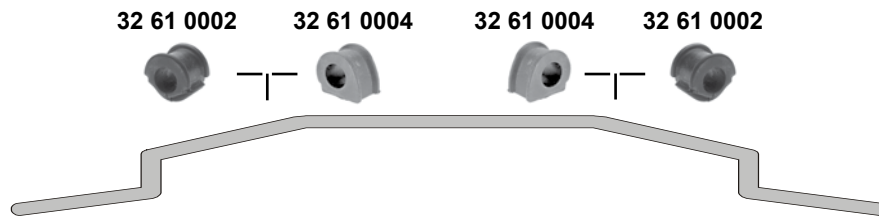
 4 cyl. (ch.) 32-E-150 001 →
 5 cyl. (ch.) 32-D-099 299 →

Vorderachse / Front axle

	Ref. - No.			
30 60 0036	8A0 407 181	Querlenkerlager / control arm mount	NEW	10x37x44
30 73 0008	893 407 147 C	Querlenker / control arm		
32 61 0002	811 411 327 A	Stabilisatorlager / stabilizer mount	(ch.) 32-F-390 001 →	Ø I 20
32 61 0004	823 411 327 B	Stabilisatorlager / stabilizer mount	(ch.) → 32-F-390 000	
32 69 0008	857 407 181	Querlenkerlager / control arm mount	OLD	10x37,5x44
32 73 0006	893 407 148 C	Querlenker / control arm		
32 78 0003	855 407 365 A	Traggelenk / ball joint		Ø A 17
32 78 0004	855 407 366 A	Traggelenk / ball joint		Ø A 17
32 78 0024	857 407 175	Sicherungsblech / lock washer		



VOLKSWAGEN

Scirocco 1+2 (53)

(1975 → 1992)

man.

30 80 0054

30 80 0053

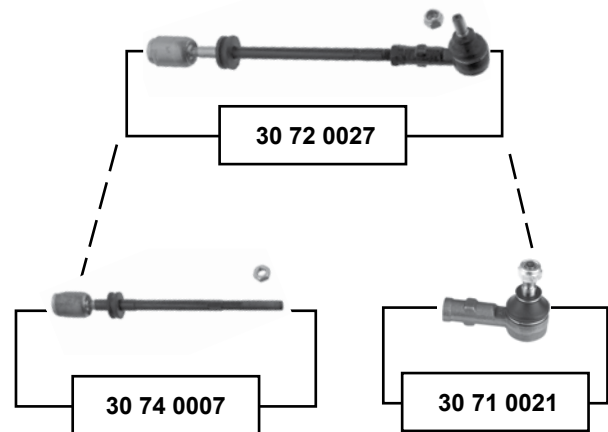
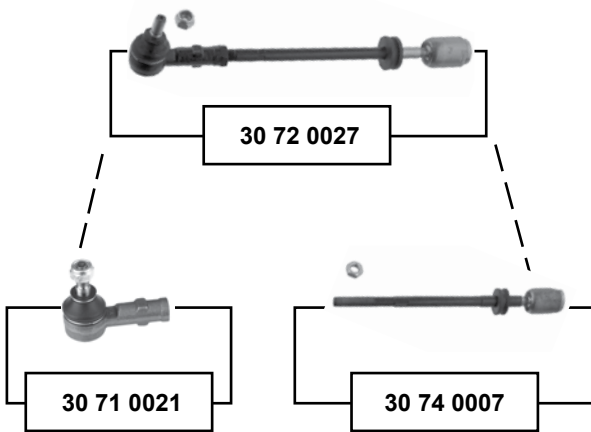

servo

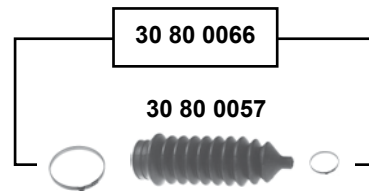
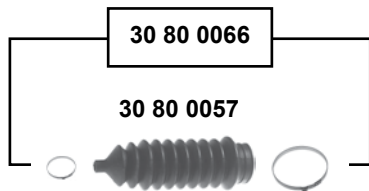

Ref. - No.



30 71 0021	171 419 812	Spurstangenendstück / tie rod end	M14x1,5 RHT
30 72 0027	171 419 804	Spurstange / tie rod	
30 74 0007	171 419 821	Axialgelenk / axial joint	M14x1,5 RHT
30 80 0053	171 419 832 C	Lenkmanschette / steering boot	
30 80 0054	191 419 831	Lenkmanschette / steering boot	
30 80 0057	1H0 422 831 B	Lenkmanschette / steering boot	
30 80 0062	171 419 832 C S1	Rep. Satz Lenkmanschette / rep. kit steering boot	
30 80 0063	191 419 831 S1	Rep. Satz Lenkmanschette / rep. kit steering boot	
30 80 0066	1H0 422 831 B S1	Rep. Satz Lenkmanschette / rep. kit steering boot	



Scirocco 1+2 (53) (1975 → 1992)

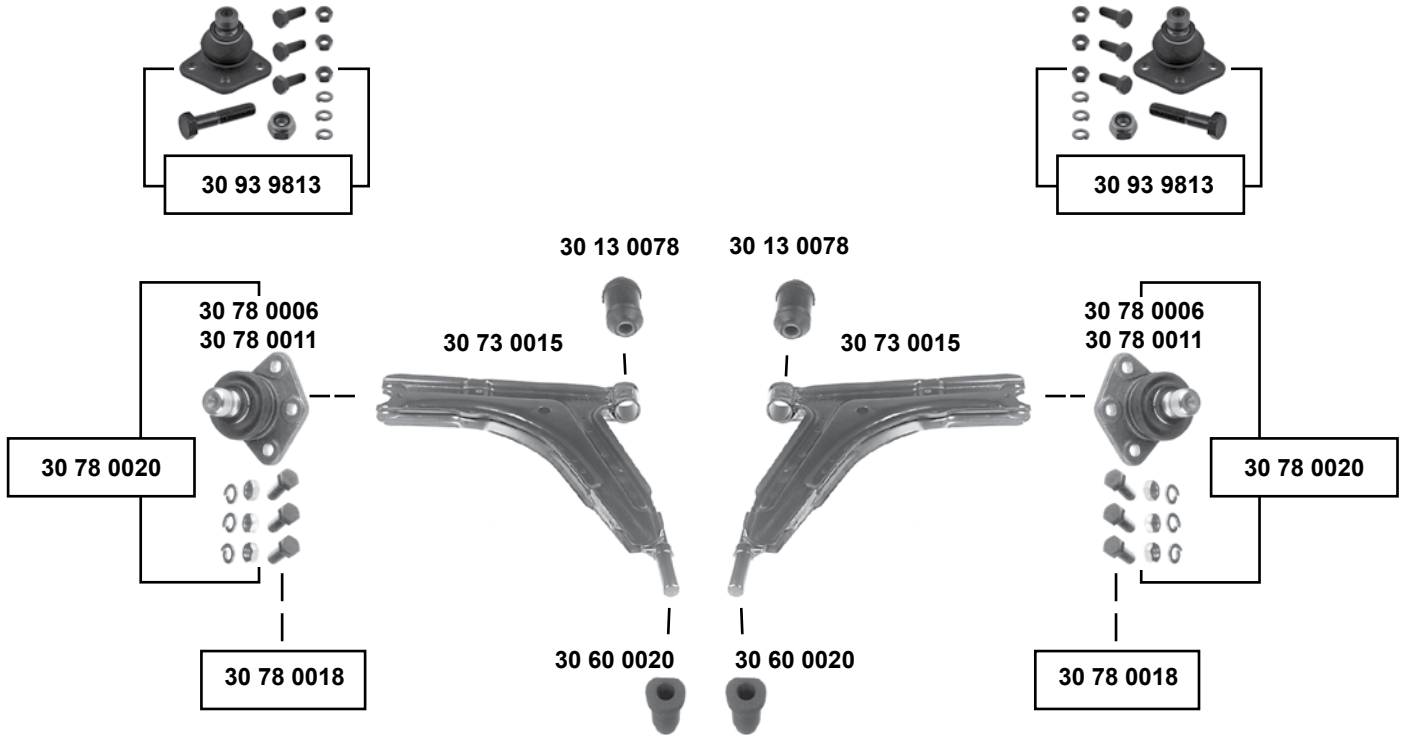

Vorderachse / Front axle

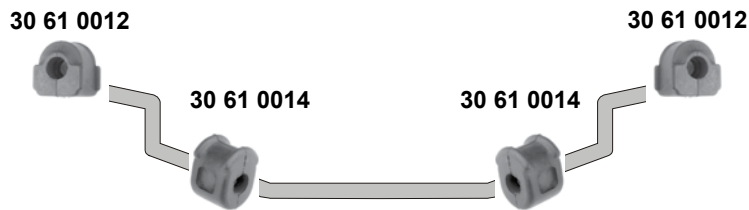

SWAG	Ref. - No.			
30 13 0078	171 407 182 D	Querlenkerlager / control arm mount		12x32x61
30 60 0020	171 407 181 A	Querlenkerlager / control arm mount		16x38x55
30 61 0012	171 411 314 A	Stabilisatorlager / stabilizer mount		Ø I 15
30 61 0014	171 411 313	Stabilisatorlager / stabilizer mount		Ø I 15
30 73 0015	171 407 153 D	Querlenker ohne Gummilager / control arm excl. rubber mounts		
30 78 0006	171 407 365 C	Traggelenk / ball joint	(ch.) → 538 2028 902	Ø A 15
30 78 0011	171 407 365 F	Traggelenk / ball joint	(ch.) 538 2028 903 →	Ø A 17
30 78 0018	171 407 365 F S1	Rep. Satz Traggelenk / rep. kit ball joint	(ch.) 538 2028 903 →	
30 78 0020	171 407 365 C S1	Rep. Satz Traggelenk / rep. kit ball joint	(ch.) → 538 2028 902	
30 93 9813	171 407 365 F S2	Rep. Satz Traggelenk / rep. kit ball joint		

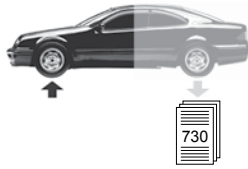

Scirocco 3 (13)

(2009 →)

Vorderachse / Front axle

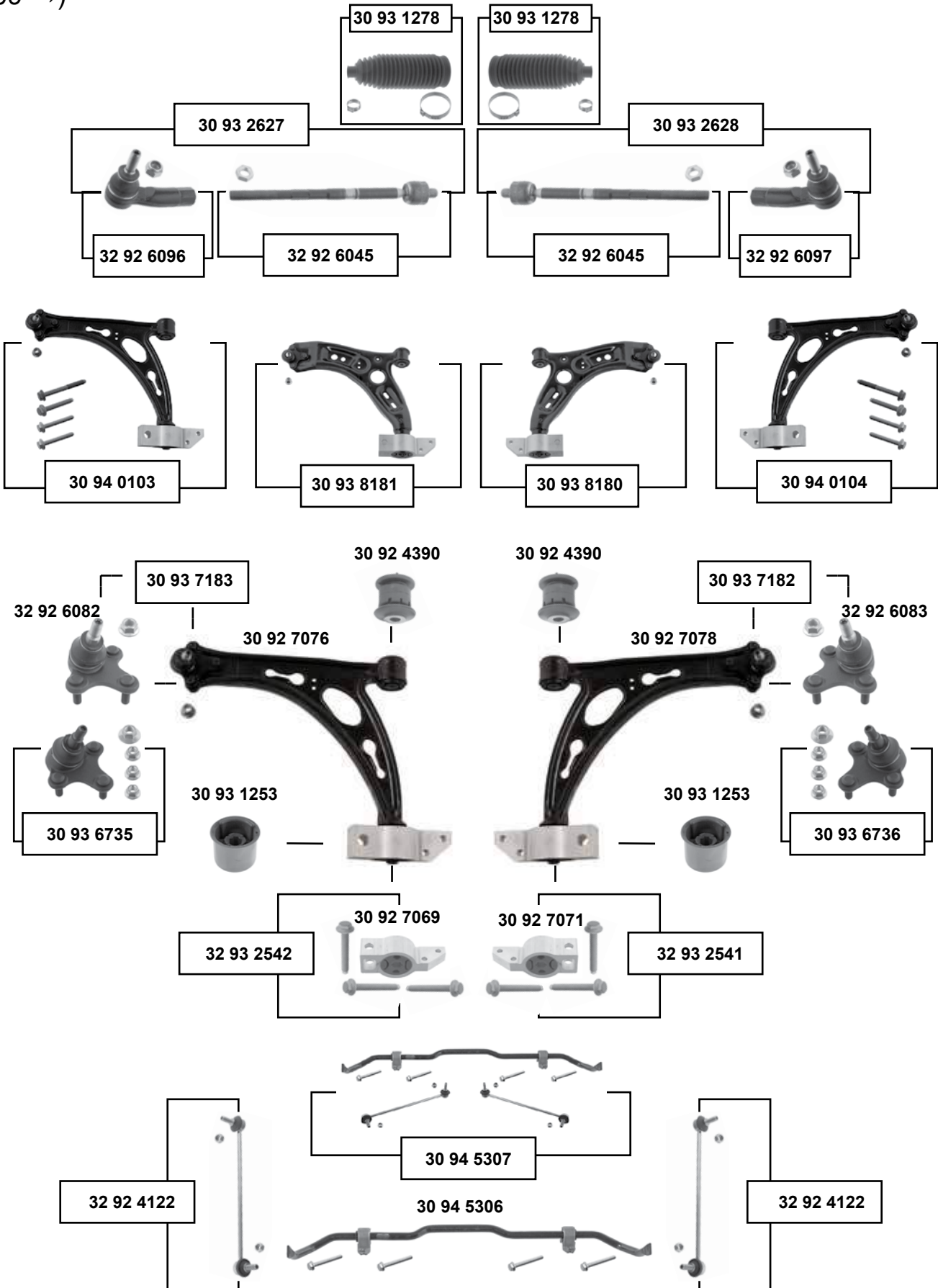

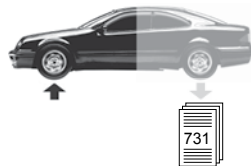
Scirocco 3 (13)
 (2009 →)



(1) Stahl-Gussausführung / keine Mischverbauung mit der Blechausführung zulässig /
 cast iron execution / not mixable with metall execution



Ref. - No.

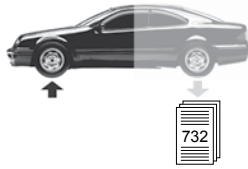

30 92 4390	1K0 407 182	Querlenkerlager / control arm mount		Ø A 48 H 54
30 92 7069	1K0 199 231 J	Querlenkerlager mit Gehäuse / control arm mount with housing		
30 92 7071	1K0 199 232 J	Querlenkerlager mit Gehäuse / control arm mount with housing		
30 92 7076	1K0 407 151 AC	Querlenker, kpl. / control arm, cpl.	(1)	
30 92 7078	1K0 407 152 AC	Querlenker, kpl. / control arm, cpl.	(1)	
30 93 1253	1K0 407 183 E	Querlenkerlager / control arm mount		Ø A 63
30 93 1278	1K0 423 831 A S1	Rep. Satz Lenkmanschette / rep. kit steering boot		Ø I 15,5 L190
30 93 2627	1K0 423 810 A S1	Rep. Satz Spurstange links / rep. kit tie rod left		
30 93 2628	1K0 423 810 A S2	Rep. Satz Spurstange rechts / rep. kit tie rod right		
30 93 6735	1K0 407 365 C S1	Rep. Satz Traggelenk / rep. kit ball joint		
30 93 6736	1K0 407 366 C S1	Rep. Satz Traggelenk / rep. kit ball joint		
30 93 7182	1K0 407 152 AC S1	Rep. Satz Querlenker mit Traggelenk / control arm with ball joint	(ch.) → 13A-402 632	
30 93 7183	1K0 407 151 AC S1	Rep. Satz Querlenker mit Traggelenk / control arm with ball joint	PR-8Q3	
30 93 8180	1K0 407 152 BC S1	Rep. Satz Querlenker / rep. kit control arm	Stahl / steel	
30 93 8181	1K0 407 151 BC S1	Rep. Satz Querlenker / rep. kit control arm	Stahl / steel	
30 94 0103	1K0 407 151 AC S2	Rep. Satz Querlenker / rep. kit control arm	(1)	
30 94 0104	1K0 407 152 AC S2	Rep. Satz Querlenker / rep. kit control arm	(1)	
30 94 5306	1K0 411 303 BK S1	Stabilisatorsatz / stabilizer kit	PR-0AD / OAE	
30 94 5307	1K0 411 303 BK S2	Rep. Satz Stabilisatorsatz / rep. kit stabilizer kit	PR-0AD / OAE	
32 92 4122	1K0 411 315 R	Verbindungsstange / connecting rod		
32 92 6045	1K0 423 810 A	Spurstange / tie rod		
32 92 6082	1K0 407 365 C	Traggelenk / ball joint		
32 92 6083	1K0 407 366 C	Traggelenk / ball joint		
32 92 6096	1K0 423 811 E	Spurstangenendstück / tie rod end		
32 92 6097	1K0 423 812 E	Spurstangenendstück / tie rod end		
32 93 2541	1K0 199 232 J S1	Rep. Satz Querlenkerlagersatz / rep. kit control arm mounting kit		Alu
32 93 2542	1K0 199 231 J S1	Rep. Satz Querlenkerlagersatz / rep. kit control arm mounting kit		Alu



Sharan (7M8/7M9/7M6)

(1995 →)

Vorderachse / Front axle

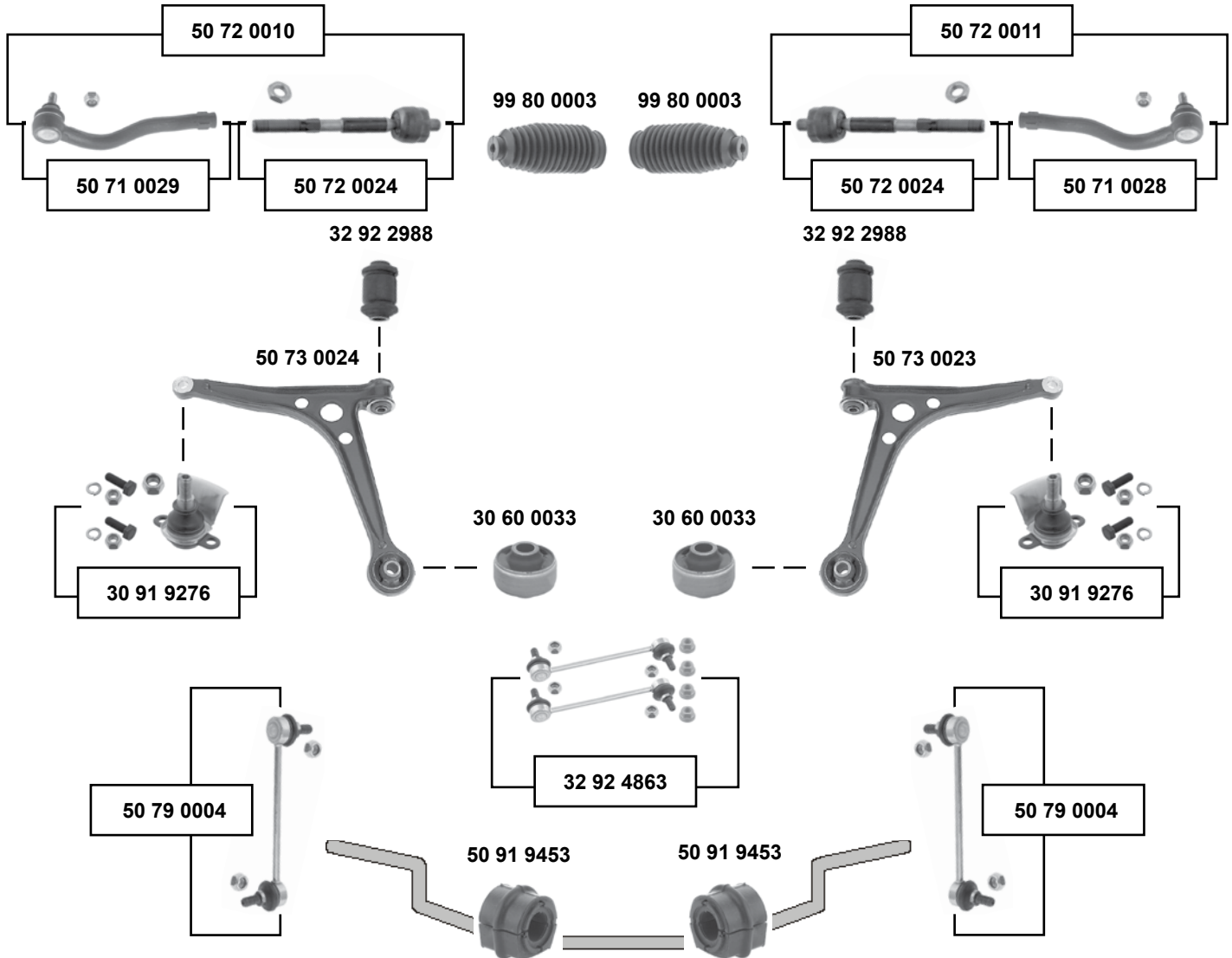

(1) syncro (7M) 96 → 00 / 4motion (7M) 01 → 10
ohne exzentrische Buchse für Spur-Sturz/-einstellung / without eccentric bushing for track-chamber/-gauge

SWAG GERMANY	Ref. - No.		(1)	
30 60 0033	7M0 407 181 A	Querlenkerlager / control arm mount		18x60x50
30 91 9276	7M3 407 365 C	Traggelenk / ball joint	(1)	
32 92 2988	7M0 501 541	Querlenkerlager / control arm mount	(1)	
32 92 4863	7M3 498 317	Verbindungsstangensatz / connecting rod set		L 205
50 71 0028	7M3 422 818	Spurstangenendstück / tie rod end	(1)	M12 x 1,5
50 71 0029	7M3 422 817	Spurstangenendstück / tie rod end	(1)	M12 x 1,5
50 72 0010	7M3 422 803 A	Spurstange / tie rod	(1)	
50 72 0011	7M3 422 804 A	Spurstange / tie rod	(1)	
50 72 0024	7M3 422 810	Spurstange / tie rod	(1)	
50 73 0023	7M0 407 152 B	Querlenker / control arm	(1)	
50 73 0024	7M0 407 151 B	Querlenker / control arm	(1)	
50 79 0004	7M3 411 317 C	Verbindungsstange / connecting rod		L 205
50 91 9453	7M0 411 031	Stabilisatorlager / stabilizer mount	→ 10	Ø I 17
99 80 0003	7M3 422 831	Lenkmanschette / steering boot	(1)	

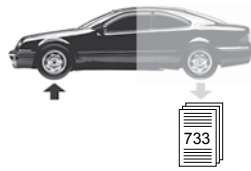

Sharan (7N) (2011 →)

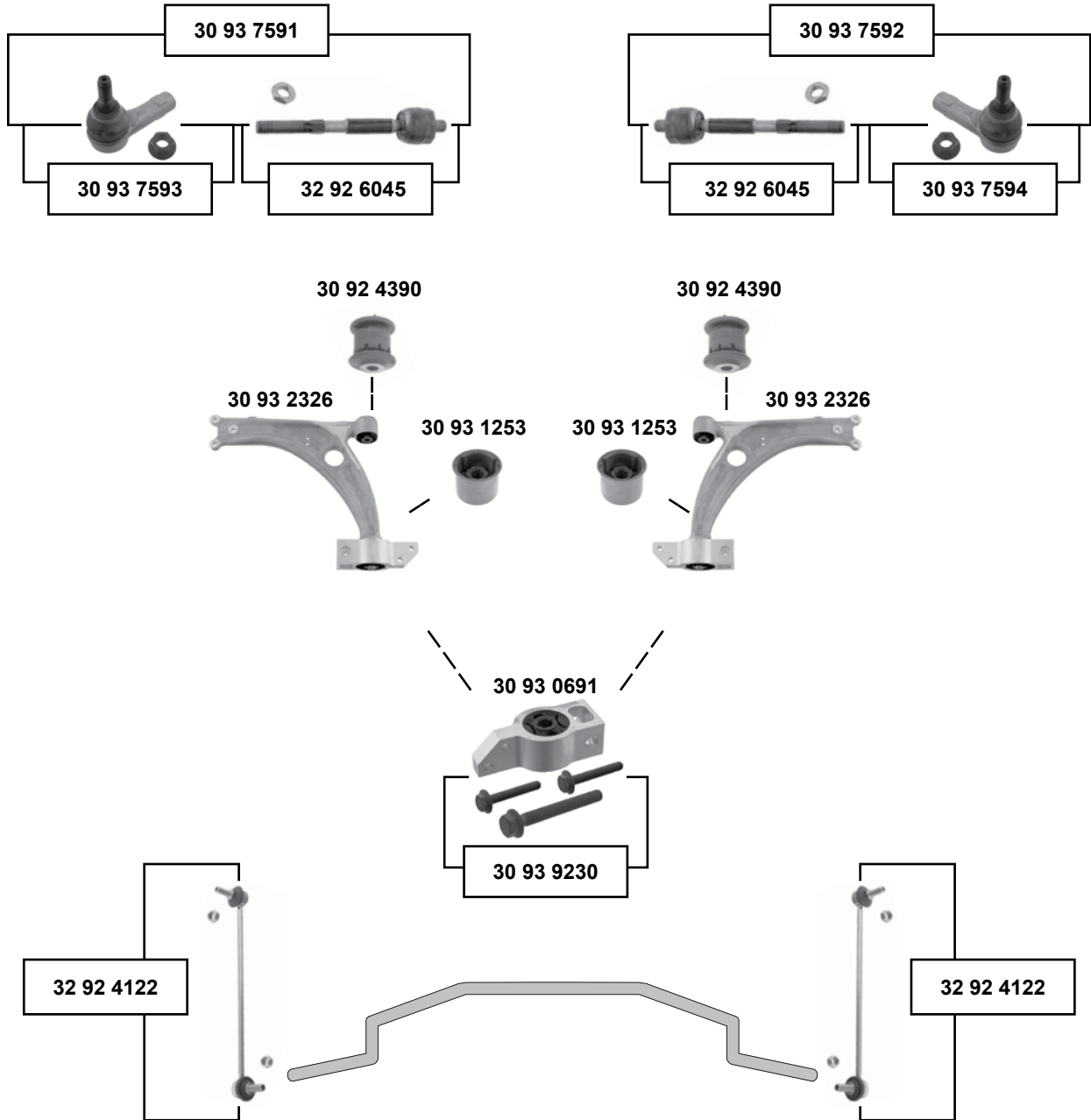

Vorderachse / Front axle

SWAG	Ref. - No.			
30 92 4390	1K0 407 182	Querlenkerlager / control arm mount	(ex.) Taxiausführung	Ø A 48 H 54
30 93 0691	3C0 199 231 D	Querlenkerlager / control arm mount		Ø A 63
30 93 1253	1K0 407 183 E	Querlenkerlager / control arm mount		
30 93 2326	3C0 407 151 G	Querlenker / control arm		
30 93 7591	1K0 423 811 K S1	Rep. Satz Spurstange / rep. kit tie rod		L 448
30 93 7592	1K0 423 812 K S1	Rep. Satz Spurstange / rep. kit tie rod		L 448
30 93 7593	1K0 423 811 K	Spurstangenendstück / tie rod end		M16 x 1,5
30 93 7594	1K0 423 812 K	Spurstangenendstück / tie rod end		M16 x 1,5
30 93 9230	3C0 199 231 E S1	Rep. Satz Querlenkerlagersatz / rep. kit control arm mount kit		
32 92 4122	1K0 411 315 R	Verbindungsstange / connecting rod		
32 92 6045	1K0 423 810 A	Spurstange / tie rod		

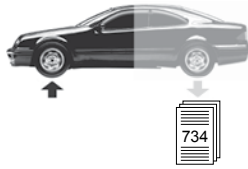

Tiguan (5N) (2008 →)

Vorderachse / Front axle

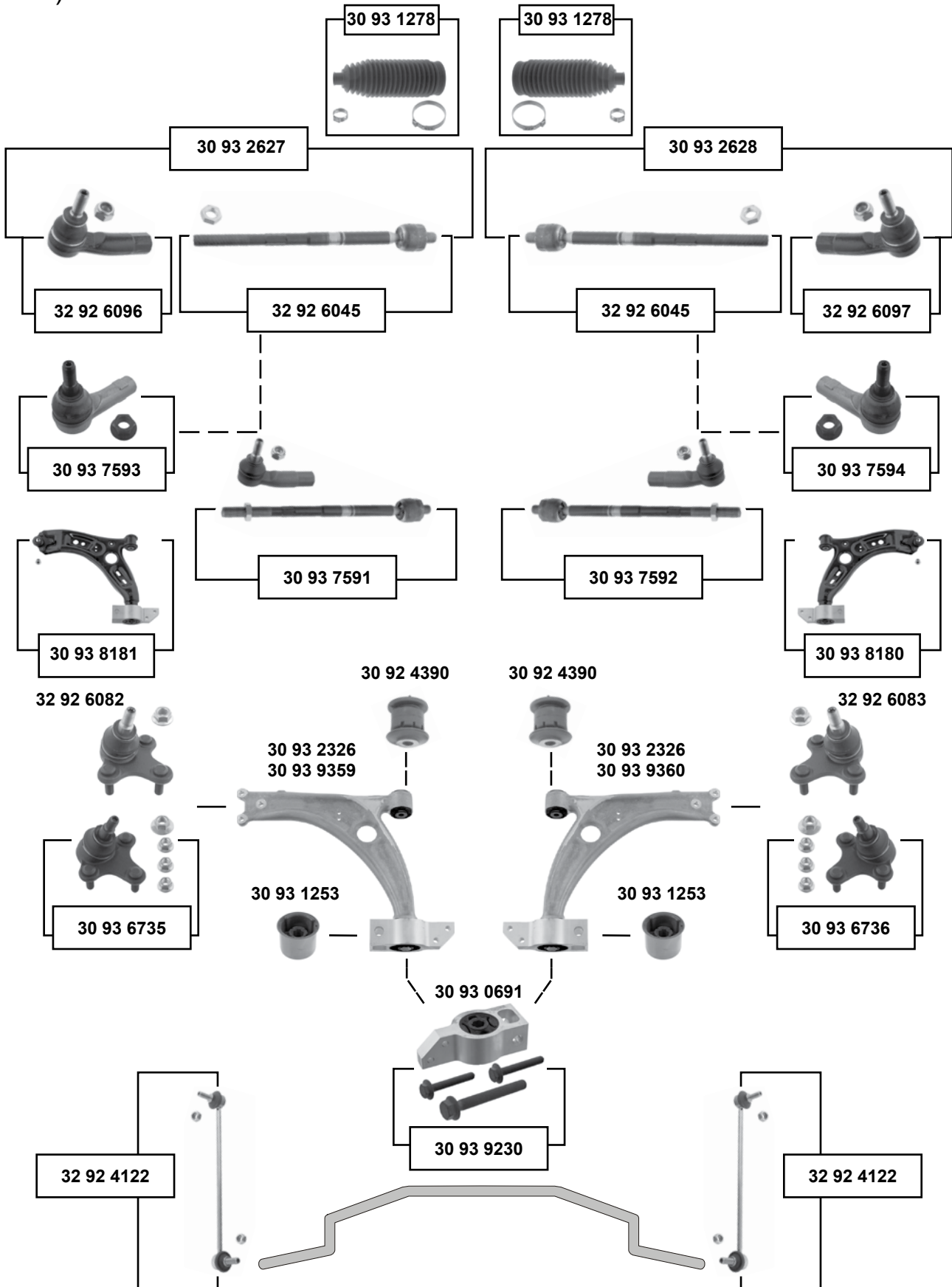

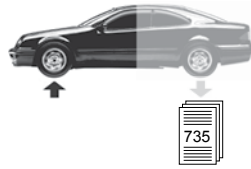

Tiguan (5N)
 (2008 →)

(1) → 10 / (ch.) → 5N-A-000 001

(2) 10 → / (ch.) 5N-A-000 001 →

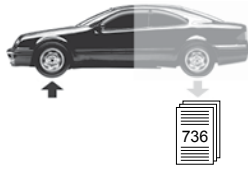
	Ref. - No.			
30 92 4390	1K0 407 182	Querlenkerlager / control arm mount	(1) Alu	Ø A 48 H 54
30 93 0691	3C0 199 231 D	Querlenkerlager / control arm mount		Ø A 63 Ø I 15,5 L190
30 93 1253	1K0 407 183 E	Querlenkerlager / control arm mount		
30 93 1278	1K0 423 831 A S1	Rep. Satz Lenkmanschette / rep. kit steering boot		
30 93 2326	3C0 407 151 G	Querlenker / control arm		
30 93 2627	1K0 423 810 A S1	Rep. Satz Spurstange links / rep. kit tie rod left		
30 93 2628	1K0 423 810 A S2	Rep. Satz Spurstange rechts / rep. kit tie rod right		
30 93 6735	1K0 407 365 C S1	Rep. Satz Traggelenk / rep. kit ball joint		
30 93 6736	1K0 407 366 C S1	Rep. Satz Traggelenk / rep. kit ball joint		
30 93 7591	1K0 423 811 K S1	Rep. Satz Spurstange / rep. kit tie rod		
30 93 7592	1K0 423 812 K S1	Rep. Satz Spurstange / rep. kit tie rod	L 448	
30 93 7593	1K0 423 811 K	Spurstangenendstück / tie rod end	M16 x 1,5	
30 93 7594	1K0 423 812 K	Spurstangenendstück / tie rod end	M16 x 1,5	
30 93 8180	1K0 407 152 BC S1	Rep. Satz Querlenker / rep. kit control arm	Stahl / steel	M12 x 1,5 M12 x 1,5
30 93 8181	1K0 407 151 BC S1	Rep. Satz Querlenker / rep. kit control arm	Stahl / steel	
30 93 9230	3C0 199 231 E S1	Rep. Satz Querlenkerlagersatz / rep. kit control arm mount kit		
30 93 9359	5N0 407 151	Querlenker / control arm	(2) Stahl / steel	
30 93 9360	5N0 407 152	Querlenker / control arm	(2) Stahl / steel	
32 92 4122	1K0 411 315 R	Verbindungsstange / connecting rod		
32 92 6045	1K0 423 810 A	Spurstange / tie rod		
32 92 6082	1K0 407 365 C	Traggelenk / ball joint		
32 92 6083	1K0 407 366 C	Traggelenk / ball joint		
32 92 6096	1K0 423 811 E	Spurstangenendstück / tie rod end		
32 92 6097	1K0 423 812 E	Spurstangenendstück / tie rod end		



Touareg (7L) (2003 → 2010)

oben / upper

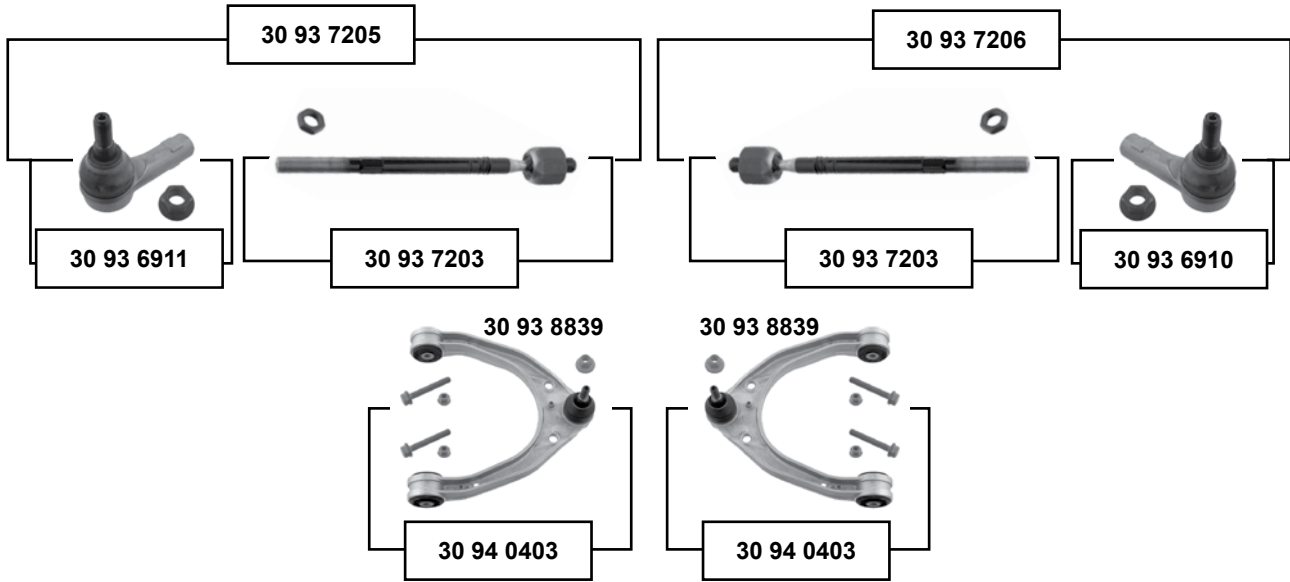

unten / lower

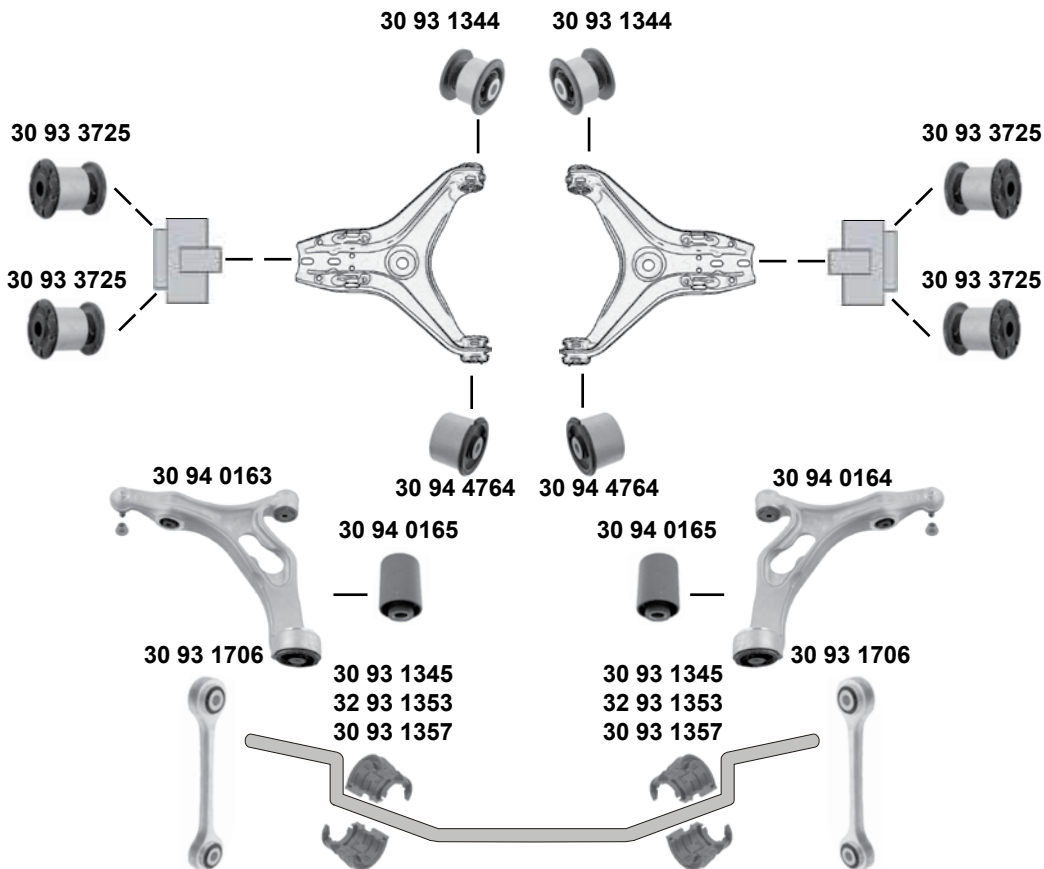

Vorderachse / Front axle

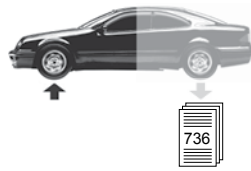
Touareg (7L)
 (2003 → 2010)

- (1) (ch.) → 7L-9D003 602 PR-1LB, 1LC, 1LE, 1LF
- (2) 01/10 → PR-0K0, 0K1 / servo → 05/10
- (3) 11/2002 → 05/2008 PR-0AB, PR-0AG / 12/2006 → 05/2010 PR-1BK
- (4) 11/2002 → 05/2008 PR-1BK, PR-1BE, PR-0AB /
12/2006 → 05/2010 PR-1BE, PR-1BK /
01/2010 → PR-1BK, PR-1BY
- (5) PR-1BK/2MA für Fahrzeuge mit elektrischer Dämpferregulierung / for vehicles with electronic suspension control
Gummi / rubber

	Ref. - No.			
30 93 1344	7L0 407 077	Querlenkerlager / control arm mount		Ø A 40
30 93 1345	7L8 411 313 B	Stabilisatorlager, unten + oben / stabilizer mount, lower + upper	(5)	Ø A 38
30 93 1357	7L0 411 313 J	Stabilisatorlager, unten + oben / stabilizer mount, lower + upper	(4)	
30 93 1706	7L0 411 317	Verbindungsstange / connecting rod		L 244,2 / 197
30 93 3725	7L0 407 183 A	Querlenkerlager / control arm mount		Ø A 40
30 93 6910	7L0 422 818 D	Spurstangenendstück / tie rod end		M16 x 1,5
30 93 6911	7L0 422 817 D	Spurstangenendstück / tie rod end		M16 x 1,5
30 93 7203	7L0 422 810 D	Rep. Satz Axialgelenk / rep. kit axial joint		L 320
30 93 7205	7L0 422 803 D	Rep. Satz Spurstange / rep. kit tie rod	(2)	L 434
30 93 7206	7L0 422 804 D	Rep. Satz Spurstange / rep. kit tie rod	(2)	L 434
30 93 8839	7L0 407 021 B S1	Rep. Satz Querlenker / rep. kit control arm		
30 94 0403	7L0 407 021 B S2	Rep. Satz Querlenker / rep. kit control arm		
30 94 0163	7L0 407 151 H S1	Querlenker / control arm	(1)	Stahlguss
30 94 0164	7L0 407 152 H S1	Querlenker / control arm	(1)	Stahlguss
30 94 0165	7L0 412 333 A	Querlenkerlager / control arm mount		Ø A 46,5
30 94 4764	7L0 407 182 G	Querlenkerlager / control arm mount		Ø A 72,05
32 93 1353	7L0 411 313 G	Stabilisatorlager, unten + oben / stabilizer mount, lower + upper	(3)	

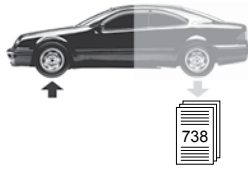

Touran (1T)

(2003 →)

Vorderachse / Front axle

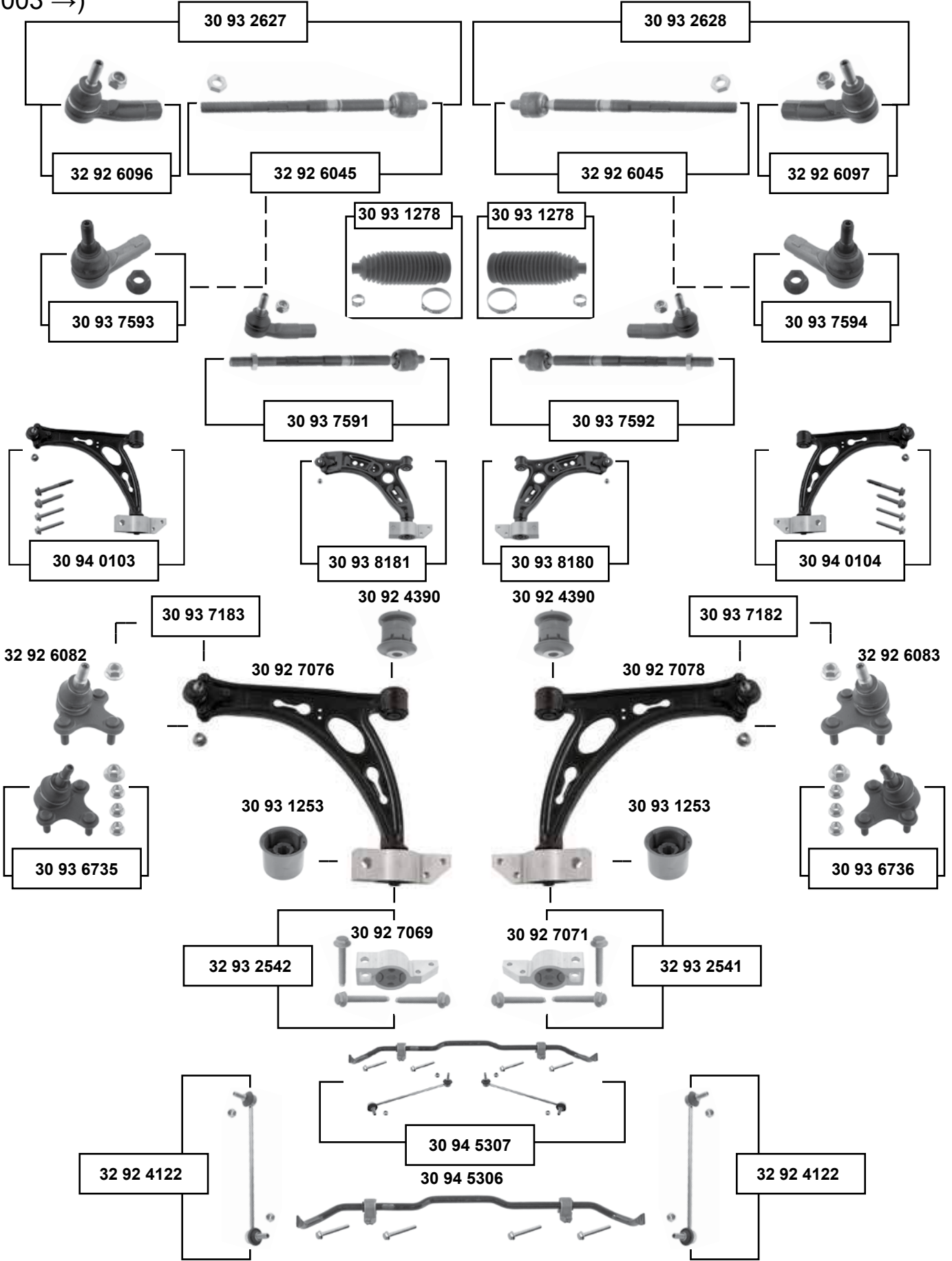

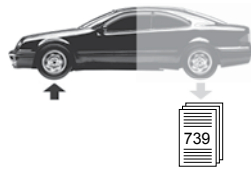
Touran (1T)
 (2003 →)



- (1) Stahl-Gussausführung / keine Mischverbauung mit der Blechausführung zulässig / cast iron execution / not mixable with metall execution
- (2) Touran / Crosstouran (ch.) → 1T-A-000 001
- (3) (ch.) → 1T-A-150 000
- (4) Touran / Crosstouran PR-0AF+2H1 / 0AE+2H1 für Fahrzeuge mit Drive-Select / for vehicles with drive select



Ref. - No.

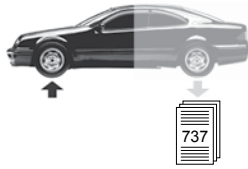

Ref. - No.	Description	Quantity	Material	Dimensions
30 92 4390	1K0 407 182	Querlenkerlager / control arm mount		Ø A 48 H 54
30 92 7069	1K0 199 231 J	Querlenkerlager mit Gehäuse / control arm mount with housing		
30 92 7071	1K0 199 232 J	Querlenkerlager mit Gehäuse / control arm mount with housing		
30 92 7076	1K0 407 151 AC	Querlenker, kpl. / control arm, cpl.	→ 10 / (1)	
30 92 7078	1K0 407 152 AC	Querlenker, kpl. / control arm, cpl.	→ 10 / (1)	
30 93 1253	1K0 407 183 E	Querlenkerlager / control arm mount		Ø A 63
30 93 1278	1K0 423 831 A S1	Rep. Satz Lenkmanschette / rep. kit steering boot		Ø I 15,5 L190
30 93 2627	1K0 423 810 A S1	Rep. Satz Spurstange links / rep. kit tie rod left		
30 93 2628	1K0 423 810 A S2	Rep. Satz Spurstange rechts / rep. kit tie rod right		
30 93 6735	1K0 407 365 C S1	Rep. Satz Traggelenk / rep. kit ball joint		
30 93 6736	1K0 407 366 C S1	Rep. Satz Traggelenk / rep. kit ball joint		
30 93 7182	1K0 407 152 AC S1	Rep. Satz Querlenker mit Traggelenk / control arm with ball joint	(2)	
30 93 7183	1K0 407 151 AC S1	Rep. Satz Querlenker mit Traggelenk / control arm with ball joint	(2)	
30 93 7591	1K0 423 811 K S1	Rep. Satz Spurstange / rep. kit tie rod		L 448
30 93 7592	1K0 423 812 K S1	Rep. Satz Spurstange / rep. kit tie rod		L 448
30 93 7593	1K0 423 811 K	Spurstangenendstück / tie rod end		M16 x 1,5
30 93 7594	1K0 423 812 K	Spurstangenendstück / tie rod end		M16 x 1,5
30 93 8180	1K0 407 152 BC S1	Rep. Satz Querlenker / rep. kit control arm	Stahl / steel	
30 93 8181	1K0 407 151 BC S1	Rep. Satz Querlenker / rep. kit control arm	Stahl / steel	
30 94 0103	1K0 407 151 AC S2	Rep. Satz Querlenker / rep. kit control arm	(1) (3)	
30 94 0104	1K0 407 152 AC S2	Rep. Satz Querlenker / rep. kit control arm	(1) (3)	
30 94 5306	1K0 411 303 BK S1	Stabilisatorsatz / stabilizer kit	(4)	
30 94 5307	1K0 411 303 BK S2	Rep. Satz Stabilisatorsatz / rep. kit stabilizer kit	(4)	
32 92 4122	1K0 411 315 R	Verbindungsstange / connecting rod		
32 92 6045	1K0 423 810 A	Spurstange / tie rod		
32 92 6082	1K0 407 365 C	Traggelenk / ball joint		
32 92 6083	1K0 407 366 C	Traggelenk / ball joint		
32 92 6096	1K0 423 811 G	Spurstangenendstück / tie rod end		M12 x 1,5
32 92 6097	1K0 423 812 E	Spurstangenendstück / tie rod end		M12 x 1,5
32 93 2541	1K0 199 232 J S1	Rep. Satz Querlenkerlagersatz / rep. kit control arm mounting kit		
32 93 2542	1K0 199 231 J S1	Rep. Satz Querlenkerlagersatz / rep. kit control arm mounting kit		



Touareg (7P) (2010 →)

Vorderachse / Front axle

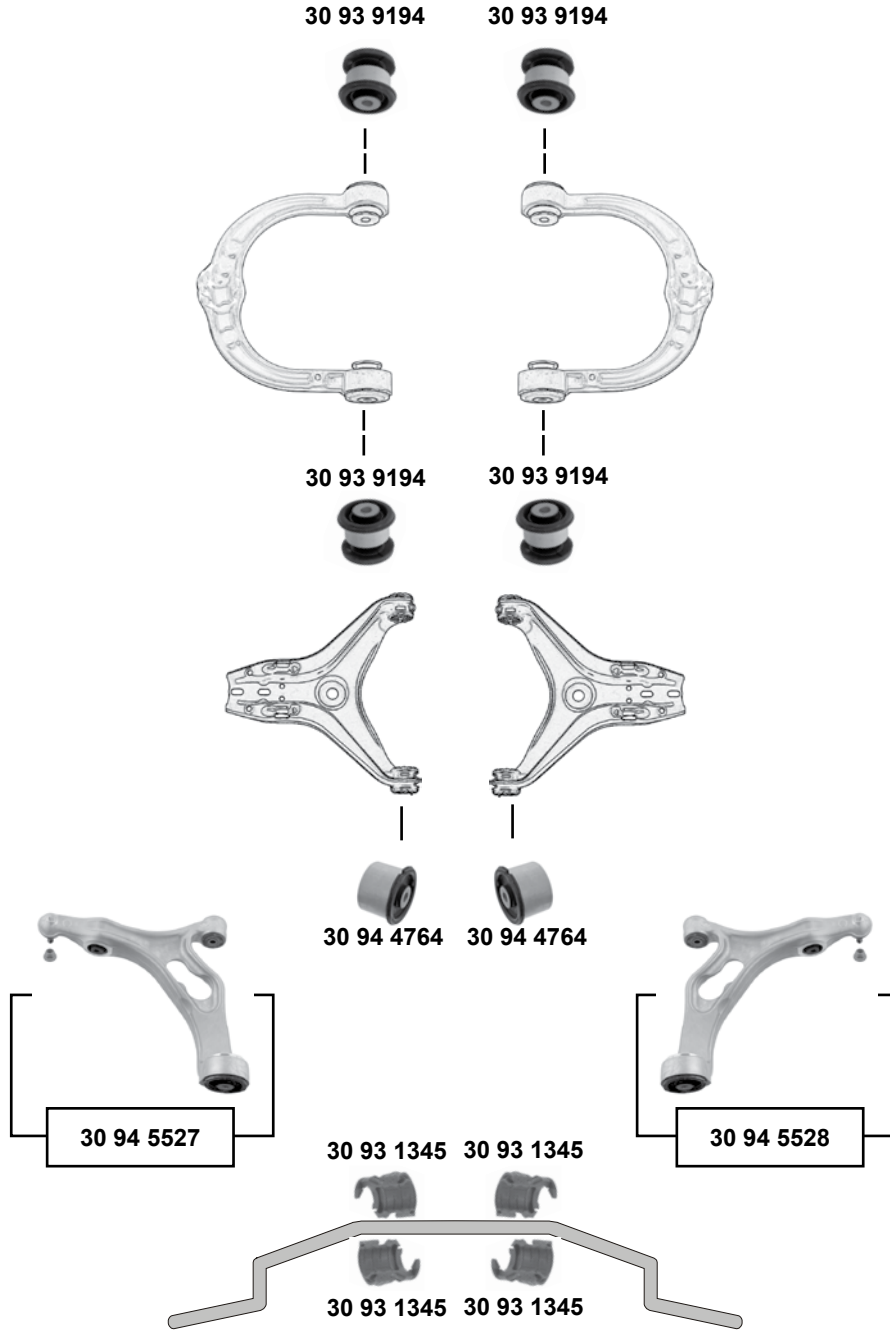

- (1) PR-1BK/1BY für Fahrzeuge mit elektrischer Dämpferregulierung / for vehicles with electronic suspension control / **HD**
 PR-1BA/1BB/1BE
 PR-2MA für Fahrzeuge mit elektrischer Dämpferregulierung / for vehicles with electronic suspension control
 Gummi / rubber



Ref. - No.



30 93 1345	7L8 411 313 B
30 93 9194	7P0 407 077
30 94 4764	7L0 407 182 G
30 94 5527	7L8 407 151 K S1
30 94 5528	7L8 407 152 K S1

Stabilisatorlager / stabilizer mount
Querlenkerlager / control arm mount
Querlenkerlager / control arm mount
Rep. Satz Querlenker / rep. kit control arm
Rep. Satz Querlenker / rep. kit control arm

(1)

Ø I 10 / A 52
 Ø A 72,05
 Alu
 Alu

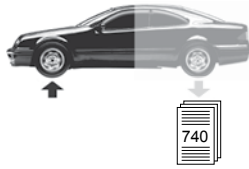

Transporter Typ 3 (24)
(1980 → 1992)

30 86 0002



99 90 1118



99 90 1118



30 80 0050



30 80 0050



99 90 1118



99 90 1118

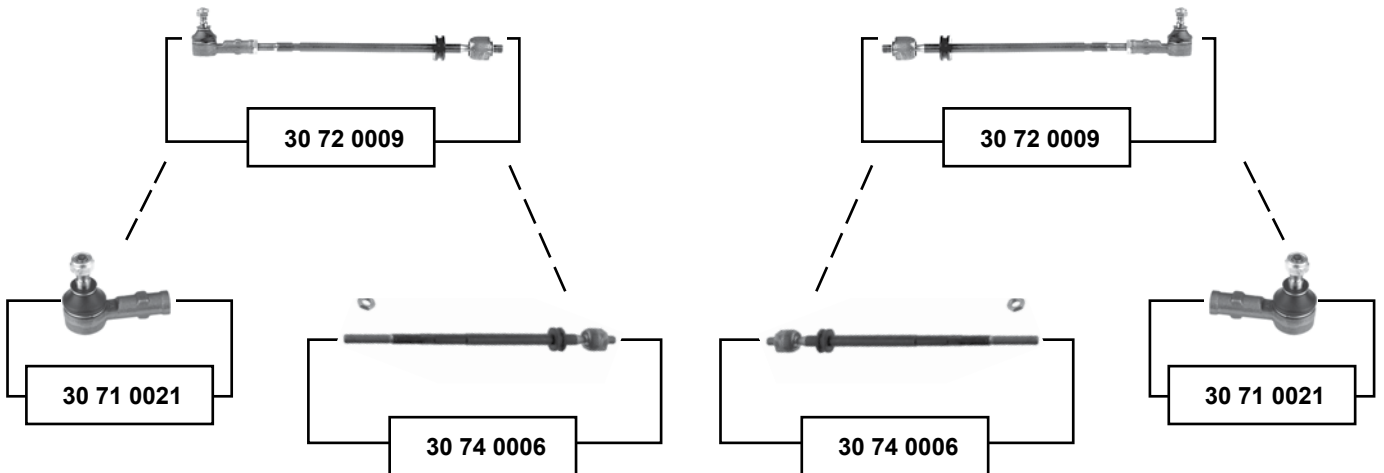

Vorderachse / Front axle



30 71 0021	171 419 812	Spurstangenendstück / tie rod end	M14x1,5 RHT
30 72 0009	251 419 803	Spurstange / tie rod	
30 74 0006	251 419 803 S1	Axialgelenk / axial joint	M14x1,5 RHT
30 80 0050	251 419 831 A	Lenkmanschette / steering boot	
30 86 0002	251 419 417 B	Gelenkscheibe / flexible disc	
99 90 1118	251 419 081	Lenkgetriebebelager / steering gear bearing	Ø A 27,5

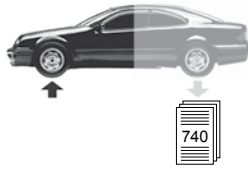

Transporter Typ 3 (24)

(1980 → 1992)

oben / upper

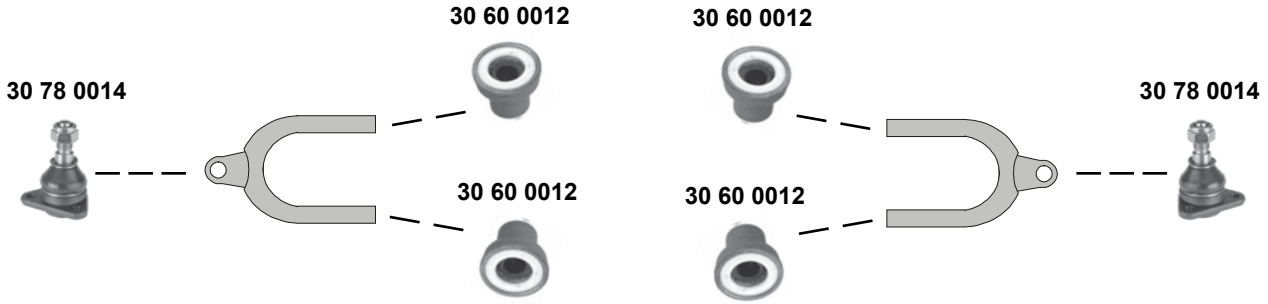

unten / lower

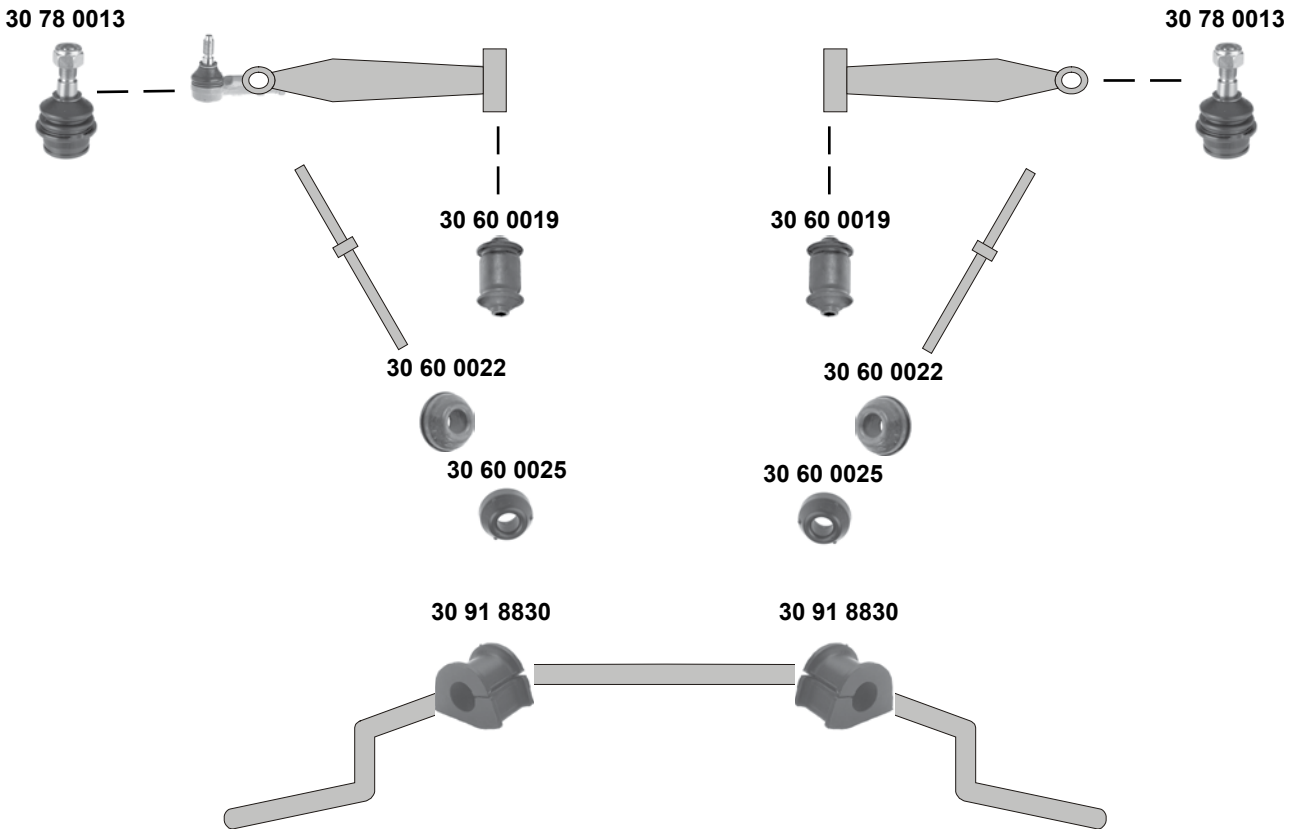

30 60 0012	251 407 077
30 60 0019	251 407 183
30 60 0022	251 407 179
30 60 0025	251 407 175
30 78 0014	251 407 361
30 78 0013	251 407 187
30 91 8830	251 411 041 C

Querlenkerlager / control arm mount
Querlenkerlager / control arm mount
Zugstrebenlager / tension rod mount
Zugstrebenlager / tension rod mount
Traggelenk / ball joint
Traggelenk / ball joint
Stabilisatorlager / stabilizer mount

18,7x35,5x54
12x43,5x85
26x66x39,5

M16 x 1,5

Vorderachse / Front axle



Transporter T4 (70) (1991 → 1995)

alle/all

30 92 7612



(ch.) → 70-M-096 448

man.

30 71 0010



30 72 0011
30 72 0015



30 80 0051
30 80 0067



30 80 0051
30 80 0067



30 72 0010



30 71 0009



servo

30 71 0010



30 72 0015



30 80 0051
30 80 0067



30 80 0051
30 80 0067



30 72 0010

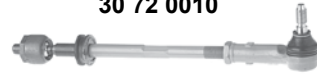

30 71 0009



(ch.) 70-M-096 449 → 70-S-002 791

man.

30 71 0012



30 72 0013



30 80 0051
30 80 0067



30 80 0051
30 80 0067



30 72 0012



30 71 0011



servo

30 71 0012



30 72 0017

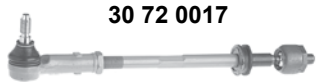

30 80 0051
30 80 0067



30 80 0051
30 80 0067



30 72 0012

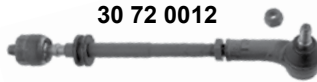

30 71 0011



30 71 0009	701 419 812	Spurstangenendstück / tie rod end		M12 x 1,5
30 71 0010	701 419 811 A	Spurstangenendstück / tie rod end		M12 x 1,5
30 71 0011	701 419 812 A	Spurstangenendstück / tie rod end		M12 x 1,5
30 71 0012	701 419 811 B	Spurstangenendstück / tie rod end		M12 x 1,5
30 72 0015	702 419 803 A	Spurstange / tie rod		M12 x 1,5
30 72 0017	702 419 803 B	Spurstange / tie rod		
30 72 0010	701 419 804 C	Spurstange / tie rod		
30 72 0011	701 419 803 C	Spurstange / tie rod		
30 72 0012	701 419 804 D	Spurstange / tie rod		
30 72 0013	701 419 803 D	Spurstange / tie rod		
30 80 0051	701 419 831	Lenkmanschette / steering boot	OLD	
30 80 0067	7D0 419 831	Lenkmanschette / steering boot	NEW	
30 92 7612	701 425 021	Lenkungs­dämpfer / steering-damper		



Transporter T4 (70)

(1991 → 1995)

(ch.) → 70-S-002 791

oben / upper

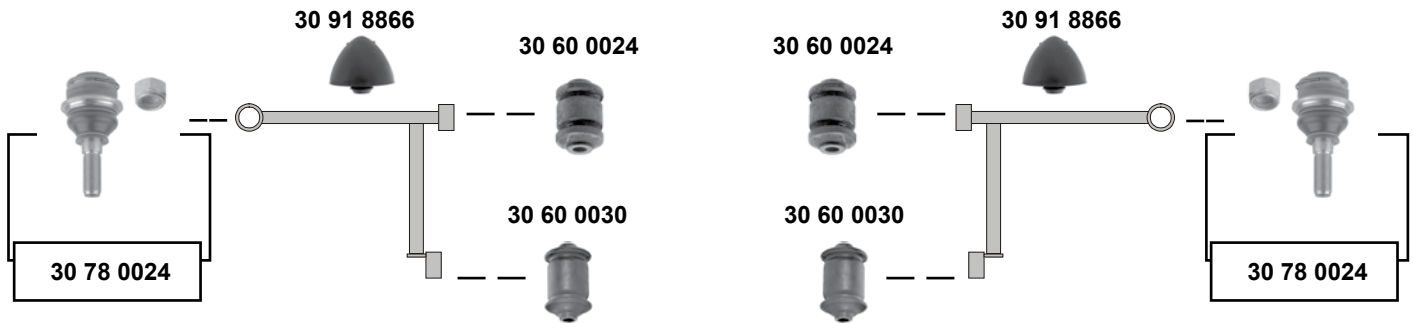

unten / lower

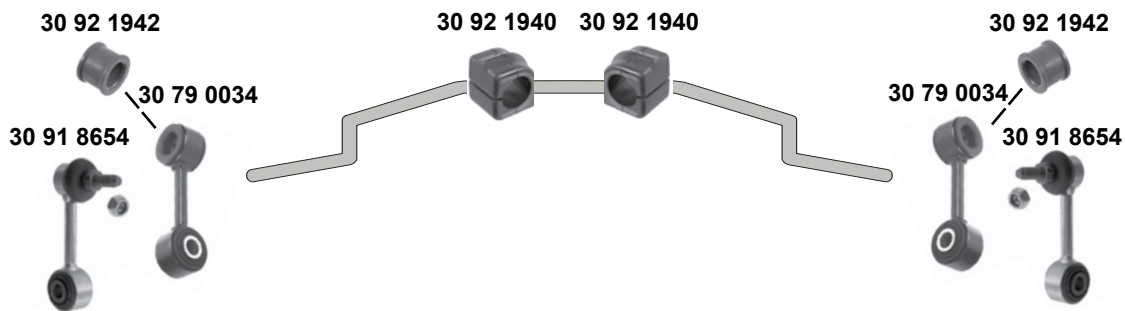

Ref. - No.



30 60 0014	7D0 407 140	Querlenkerlager / control arm mount	OLD	14x50x60
30 60 0023	701 407 183	Querlenkerlager / control arm mount		14x35x60
30 60 0024	701 407 077 A	Querlenkerlager / control arm mount		12x39x60
30 60 0030	701 407 087	Querlenkerlager / control arm mount		12x35x60
30 78 0024	701 407 187 B	Traggelenk / ball joint		M16 x 1,5
30 78 0025	701 407 361 B	Traggelenk / ball joint		M16 x 1,5
30 91 8654	701 411 049 B	Verbindungsstange / connecting rod		Ø I 27
30 91 8866	701 407 303	Anschlagpuffer für Querlenker / buffer for control arm		
30 79 0034	7D0 411 049	Verbindungsstange / connecting rod	(ex.) Ø Stabi 27	
30 92 1940	701 411 041	Stabilisatorlager / stabilizer mounting		Ø I 23
30 92 1942	7D0 411 045	Gummilager / rubber mount		
32 92 3364	7D0 407 140 A	Querlenkerlager / control arm mount	NEW	14x50x60

Vorderachse / Front axle



Transporter T4 (7D) (1995 → 2003)

(ch.) 70-S-002 792 → 70-T-199 999

man.



servo

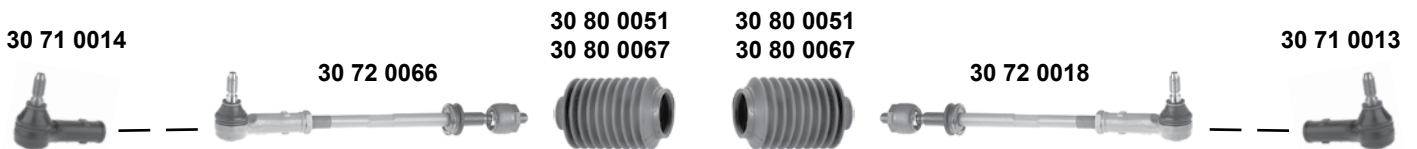

(ch.) 70-T-200 000 →

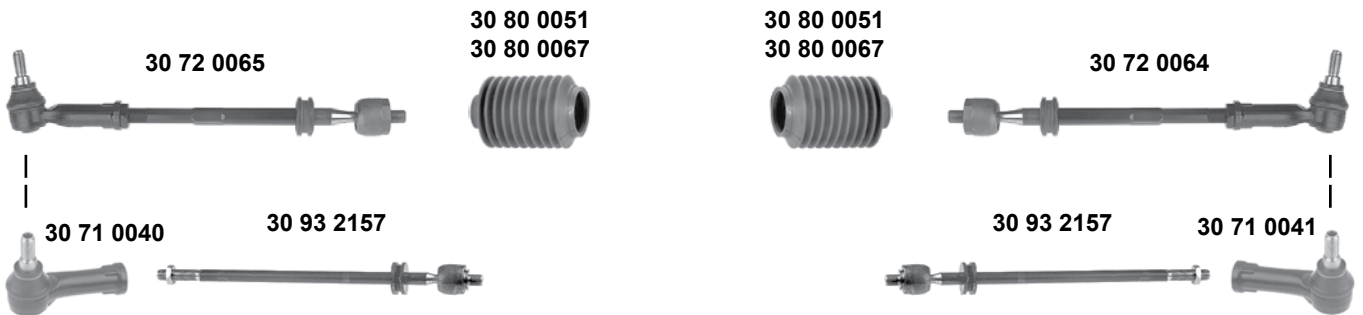

Vorderachse / Front axle

SWAG®	Ref. - No.			
30 71 0013	701 419 812 B	Spurstangenendstück / tie rod end		M12 x 1,5
30 71 0014	701 419 811 C	Spurstangenendstück / tie rod end		M12 x 1,5
30 71 0041	701 419 812 D	Spurstangenendstück / tie rod end		M12 x 1,5
30 71 0040	701 419 811 E	Spurstangenendstück / tie rod end		M12 x 1,5
30 72 0018	701 419 804 E	Spurstange / tie rod		
30 72 0019	701 419 803 E	Spurstange / tie rod		
30 72 0064	701 419 804 F	Spurstange / tie rod		
30 72 0065	702 419 803 D	Spurstange / tie rod		
30 72 0066	702 419 803 C	Spurstange / tie rod		
30 72 0067	702 419 804 C	Spurstange / tie rod		
30 80 0051	701 419 831	Lenkmanschette / steering boot	OLD	
30 80 0067	7D0 419 831	Lenkmanschette / steering boot	NEW	
30 93 2157	701 419 810 B	Spurstange / tie rod		



VOLKSWAGEN

Transporter T4 (7D)

(1995 → 2003)

Vorderachse / Front axle

oben / upper

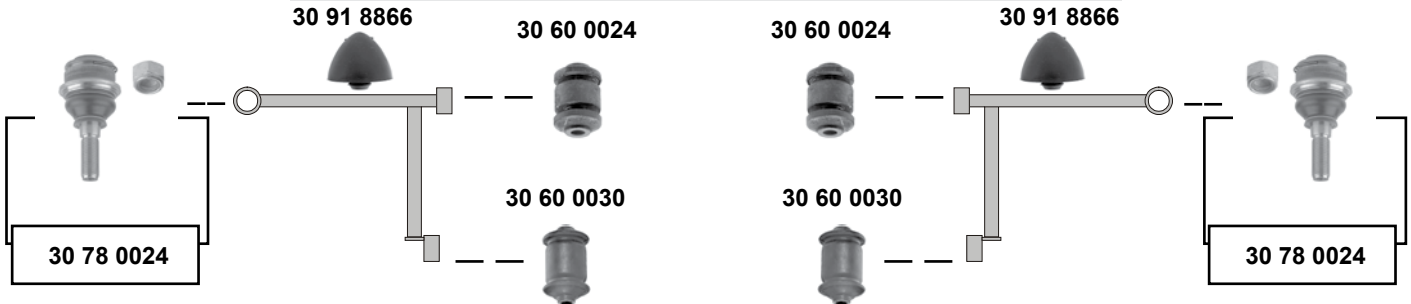

unten / lower

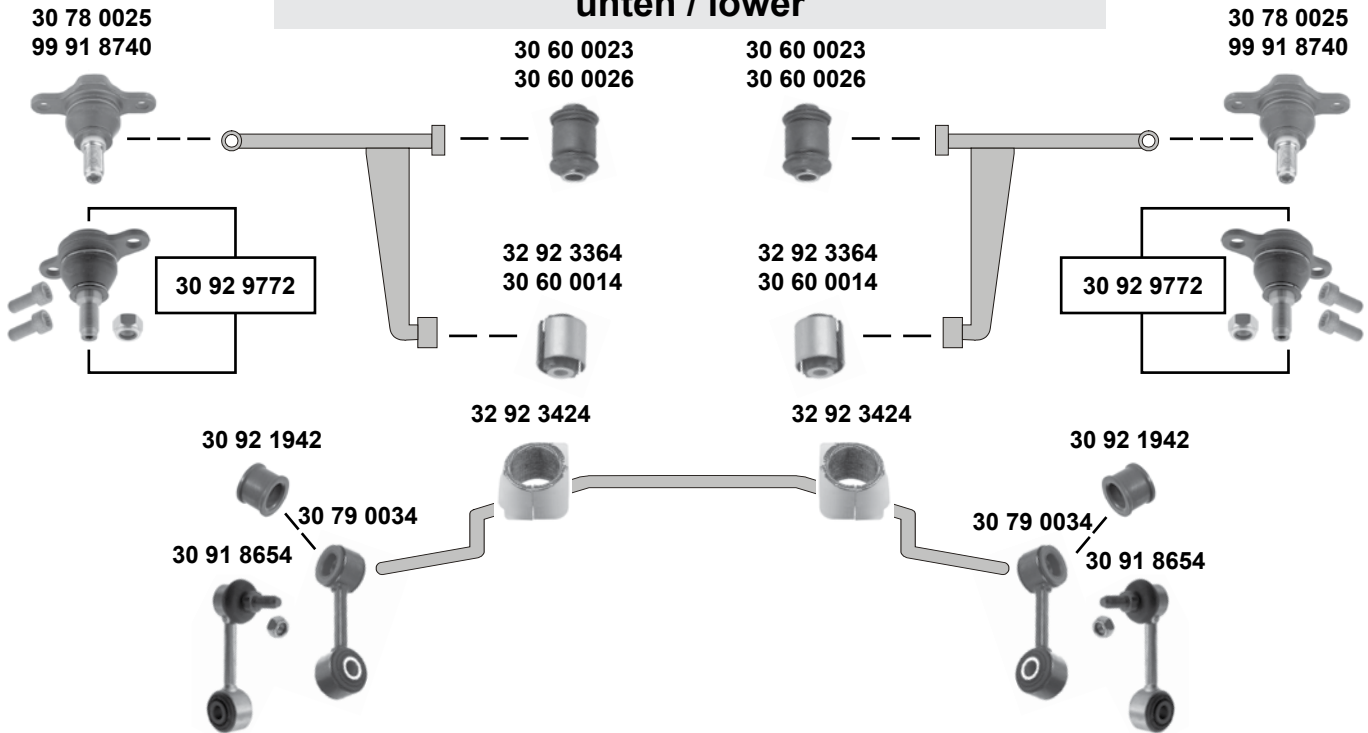

i (1) 95 → 98
99 → 03 (mot.) AAC / ABL / ACV / AET / AES / AEU / AHY / AJA / AJT / AMV / APL / AUF / AXG / AYY

SWAG GERMANY	Ref. - No.		i	
30 60 0014	7D0 407 140	Querlenkerlager / control arm mount	OLD	14x50x60
30 60 0023	701 407 183	Querlenkerlager / control arm mount	(ch.) → 70-T-199 999	14x35x60
30 60 0024	701 407 077 A	Querlenkerlager / control arm mount		12x39x60
30 60 0026	7D0 407 183	Querlenkerlager / control arm mount	(ch.) 70-T-200 000 →	14x41x60
30 60 0030	701 407 087	Querlenkerlager / control arm mount		12x35x60
30 78 0024	701 407 187 B	Traggelenk / ball joint		M16 x 1,5
30 78 0025	701 407 361 B	Traggelenk / ball joint	(ch.) → 70-T-199 999	M16 x 1,5
30 79 0034	7D0 411 049	Verbindungsstange / connecting rod		Ø 23
30 91 8654	701 411 049 B	Verbindungsstange / connecting rod		Ø 27
30 91 8866	701 407 303	Anschlagpuffer für Querlenker / buffer for control arm		
30 92 1942	7D0 411 045	Gummilager / rubber mount		
32 92 3364	7D0 407 140 A	Querlenkerlager / control arm mount		Ø 27
32 92 3424	701 411 041 D	Stabilisatorlager / stabilizer mount	NEW (1)	14x50x60
30 92 9772	7D0 407 361 S1	Rep. Satz Traggelenk / rep. kit ball joint	(ch.) 70-T-200 000 →	
99 91 8740	7D0 407 361	Traggelenk / ball joint	(ch.) 70-T-200 000 →	

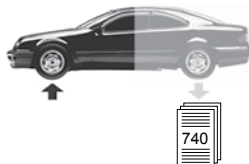

Transporter T5 (7H/7J) (2003 →)

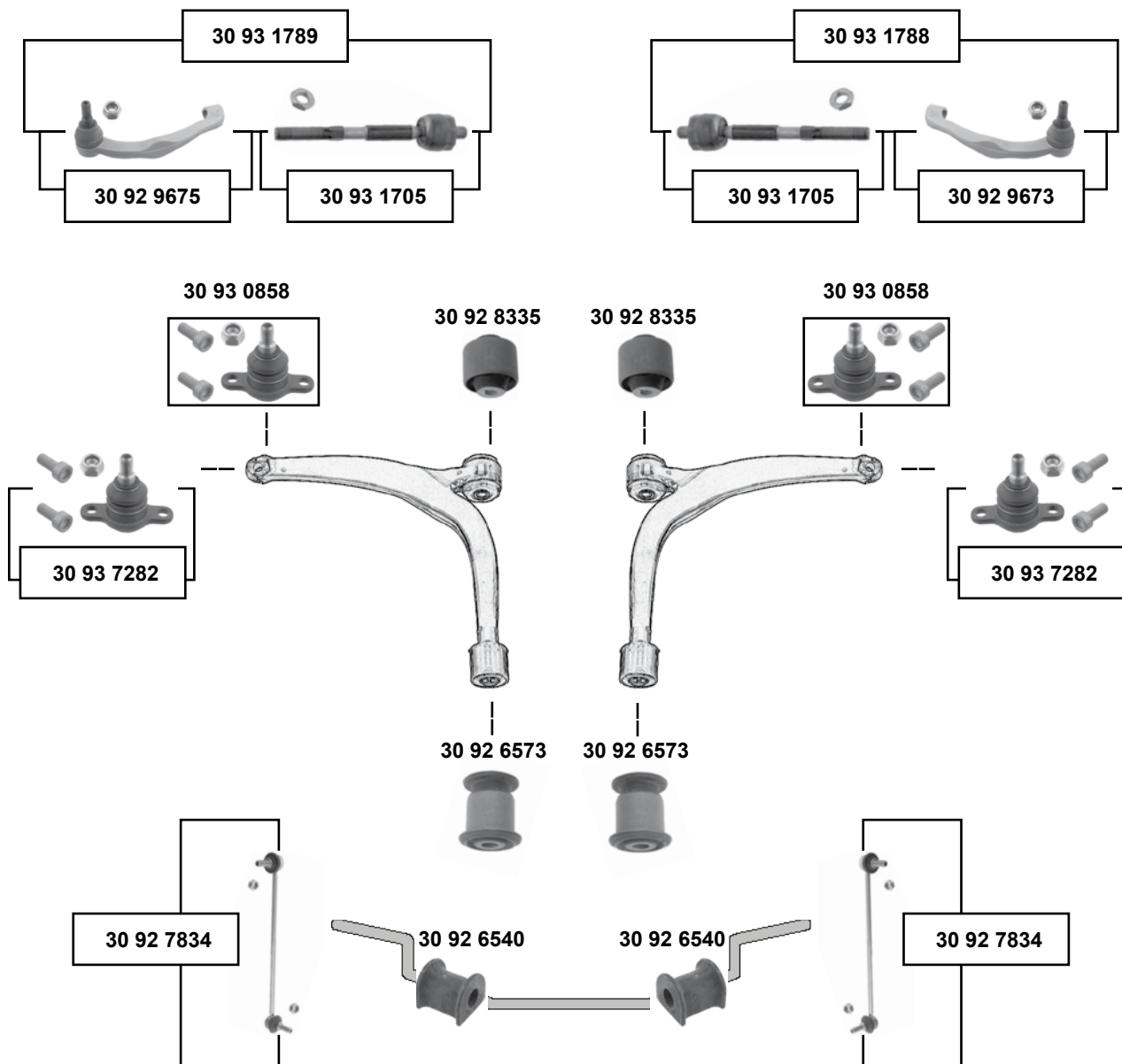

Vorderachse / Front axle



(1) (ex.) zulässiges Gesamtgewicht 3,2 Tonnen / (ex.) maximum total weight 3,2 tons

(2) 7H / 7J → 09 // 7E / 7F 09 →



Ref. - No.



Ref. - No.	Description	Notes	Dimensions
30 92 6540	7H0 411 313 Stabilisatorlager / stabilizer mounting		
30 92 6573	7H0 407 183 Querlenkerlager / control arm mount		Ø A 52
30 92 7834	7H5 411 317 A Verbindungsstange / connecting rod		L 260
30 92 8335	7H0 407 182 A Querlenkerlager / control arm mount		Ø A 60
30 92 9673	7H0 422 818 D Spurstangenendstück / tie rod end		M14 x 1,5
30 92 9675	7H0 422 817 D Spurstangenendstück / tie rod end		M14 x 1,5
30 93 0858	7H0 407 361 A S1 Rep. Satz Traggelenk / rep. kit ball joint	(1)	M14 x 1,5
30 93 1705	7H0 419 810 F Spurstange / tie rod		M16 x 1,5
30 93 1788	7H0 419 804 F Spurstange komplett rechts / tie rod complete right		
30 93 1789	7H0 419 803 F Spurstange komplett links / tie rod complete left		
30 93 7282	7H8 407 361 A S1 Rep. Satz Traggelenk / rep. kit ball joint	(2)	

passend für / to fit

VOLKSWAGEN



Typ 3 (1500 / 1600) (1961 → 1968)

Vorderachse / Front axle

(ex.) 

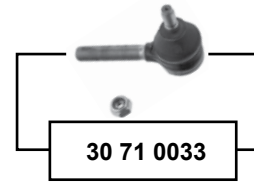

oben / upper

30 78 0033



30 78 0033







unten / lower

30 78 0026



30 78 0026



	Ref. - No.			
30 71 0033	131 415 812	Spurstangenendstück / tie rod end	(ex.) 1500	M14x1,5 RHT
30 71 0034	131 415 811	Spurstangenendstück / tie rod end	(ex.) 1500	M14x1,5 LHT
30 78 0026	311 405 371 C	Traggelenk / ball joint	Modell 63 →	Ø A 18
30 78 0033	311 405 361 B	Führungsgelenk / ball joint	Modell 63 →	M20 x 1,5



up! (121) / e-up! (BL1) (2011 →) / (2013 →)

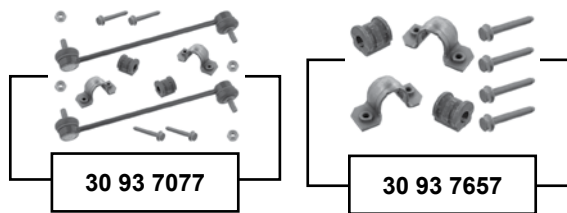
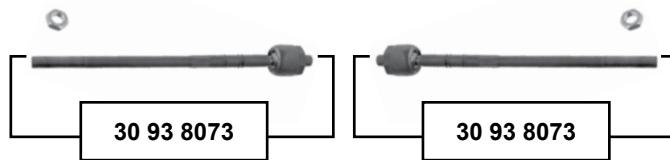

Vorderachse / Front axle

SWAG GERMANY	Ref. - No.			
30 93 6051	6R0 407 365 A	Traggelenk / ball joint		
30 93 6052	6R0 407 366 A	Traggelenk / ball joint		
30 93 7657	6Q0 411 314 P S2	Stabilisatorlagersatz / anti roll bar bush kit	PR-0AQ	Ø 16
30 93 7077	6Q0 411 314 P S1	Stabilisatorlagersatz / anti roll bar bush kit	PR-0AQ	
30 93 8073	1S0 423 810 A	Axialgelenk / axial joint		M14 x 1,5
40 94 0594	1S0 407 151	Querlenker / control arm		Stahl / steel
40 94 0595	1S0 407 152	Querlenker / control arm		Stahl / steel



Vento (1H)
(1992 → 1999)
(ex.) VR6 / GT

Vorderachse / Front axle

man. 

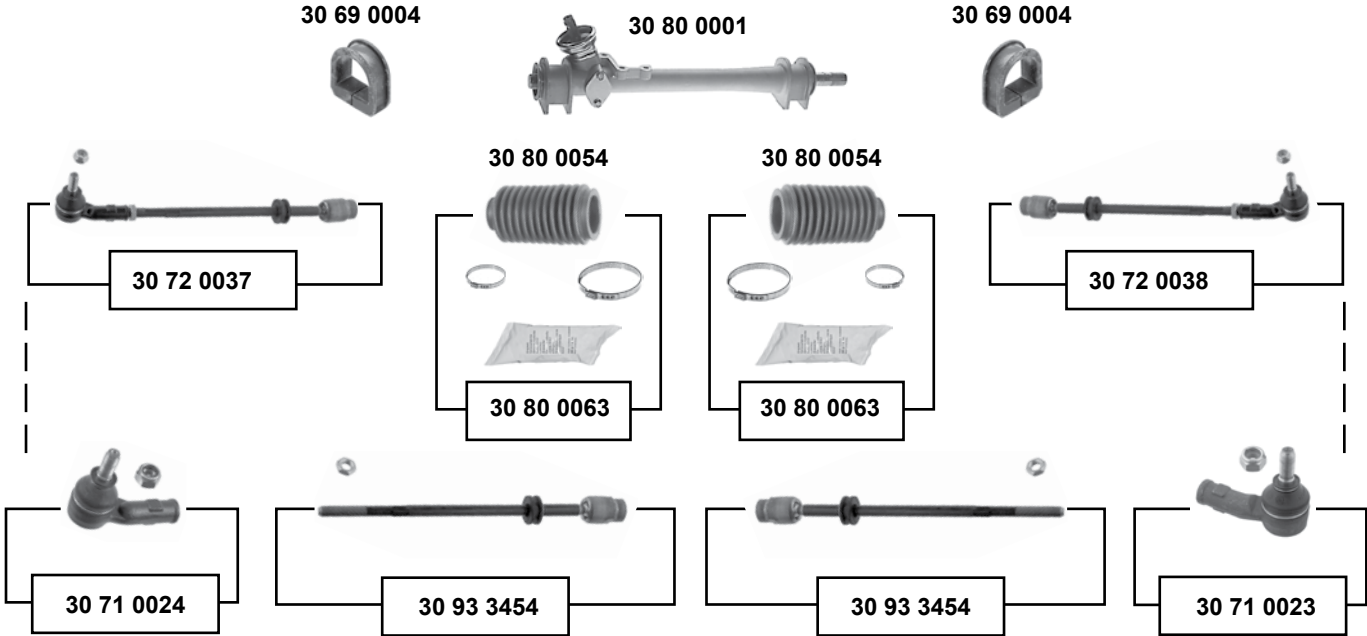

servo  ZF

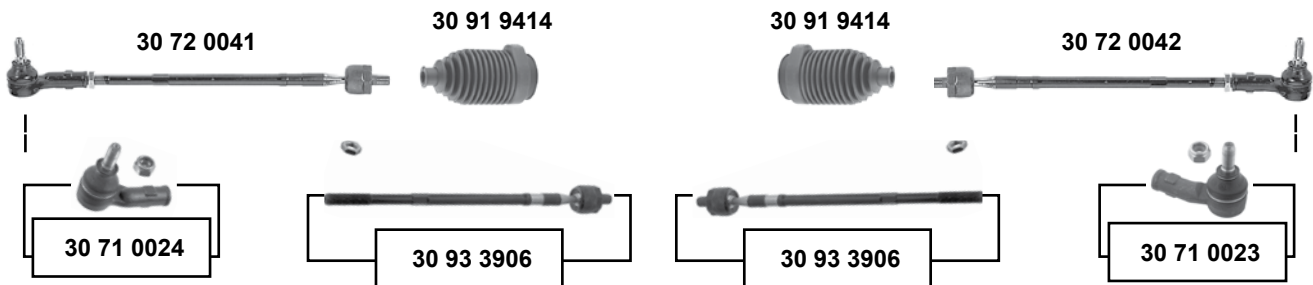

servo  TRW

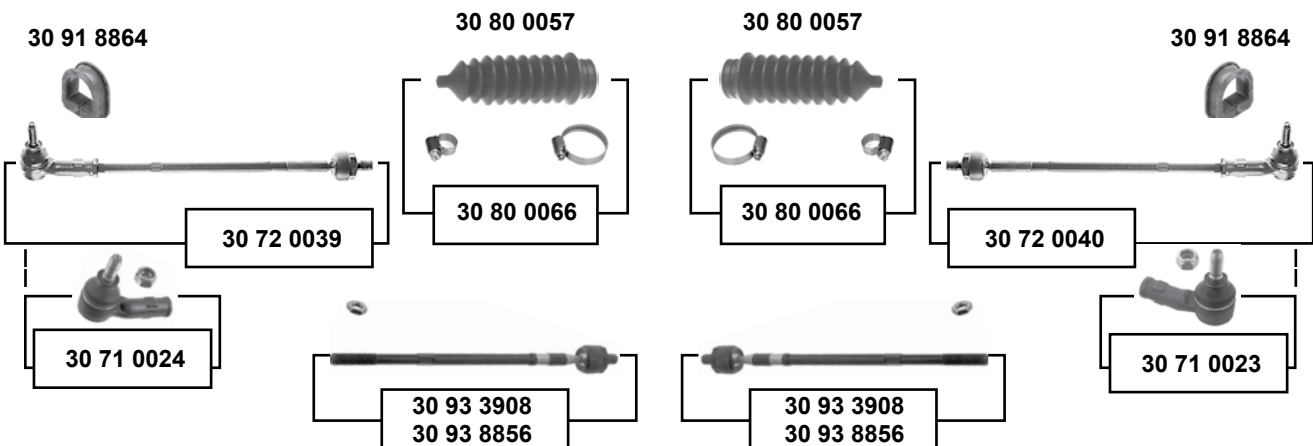



Vento (1H)
 (1992 → 1999)
 (ex.) VR6 / GT



(1) ZF servo / LHD / RHD

(2) TRW servo (ch.) 1G-R-458 664

	Ref. - No.			
30 69 0004	191 419 883	Lenkgetriebelager / steering gear bearing		
30 71 0023	191 419 812	Spurstangenendstück / tie rod end		M12 x 1,5
30 71 0024	191 419 811	Spurstangenendstück / tie rod end		M12 x 1,5
30 72 0037	1H0 419 803	Spurstange / tie rod		
30 72 0038	1H0 419 804	Spurstange / tie rod		
30 72 0039	1H0 422 803	Spurstange / tie rod		
30 72 0040	1H0 422 804	Spurstange / tie rod		
30 72 0041	1H0 422 803 B	Spurstange / tie rod		
30 72 0042	1H0 422 804 B	Spurstange / tie rod		
30 80 0001	191 419 063 C	Lenkgetriebe / steering gear	LHD	
30 80 0054	191 419 831	Lenkmanschette / steering boot		
30 80 0057	1H0 422 831 B	Lenkmanschette / steering boot		
30 80 0063	191 419 831 S1	Rep. Satz Lenkmanschette / rep. kit steering boot		
30 80 0066	1H0 422 831 B S1	Rep. Satz Lenkmanschette / rep. kit steering boot		
30 91 8864	1H0 422 884	Lenkgetriebelager / steering gear bearing		
30 91 9414	357 422 831 B	Lenkmanschette / steering boot		
30 93 3454	1H0 419 810	Axialgelenk / axial joint		
30 93 3906	1H0 422 810 B	Axialgelenk / axial joint	(1)	
30 93 3908	1H0 422 810	Axialgelenk / axial joint		
30 93 8856	1H0 422 810 D	Axialgelenk / axial joint	(2)	



Vento (1H) (1992 → 1999) (ex.) VR6 / GT

Vorderachse / Front axle

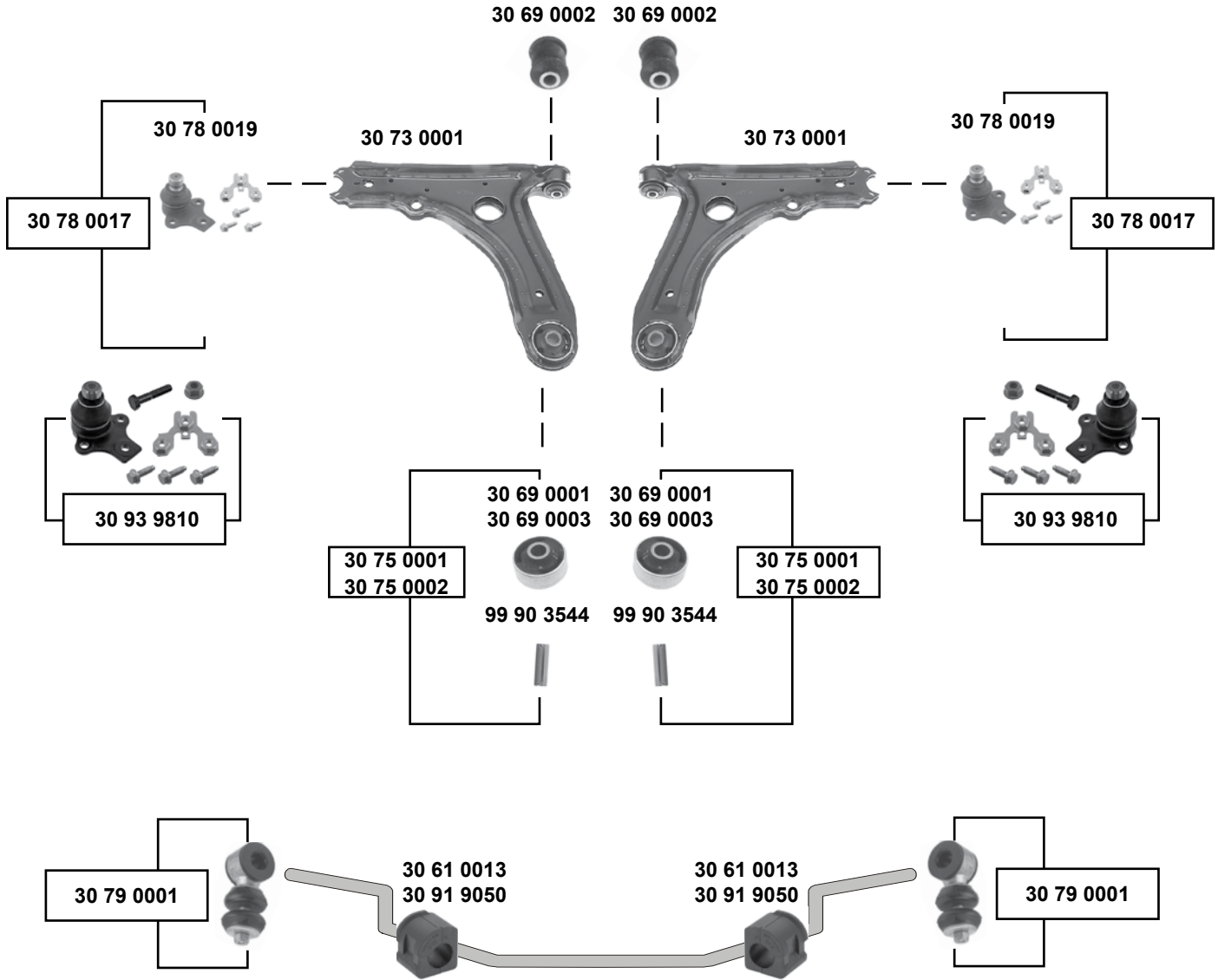

SWAG GERMANY	Ref. - No.			
30 79 0001	191 411 315 B S1	Rep. Satz Verbindungsstange / rep. kit connecting rod		
30 61 0013	191 411 314	Stabilisatorlager / stabilizer mount	(ex.) 2.0	Ø I 17
30 69 0001	191 407 181 D	Querlenkerlager / control arm mount	NEW	17x60x41
30 69 0002	357 407 182	Querlenkerlager / control arm mount	OLD	12x33x54
30 69 0003	191 407 181 B	Querlenkerlager / control arm mount		17x60x41
30 73 0001	1H0 407 151	Querlenker / control arm		
30 75 0001	191 407 181 B S1	Querlenkerlager mit Hülse / control arm mount with sleeve	OLD	
30 75 0002	191 407 181 D S1	Querlenkerlager mit Hülse / control arm mount with sleeve	NEW	
30 78 0017	357 407 365 S1	Rep. Satz Traggelenk / rep. kit ball joint		
30 78 0019	357 407 365	Traggelenk / ball joint		Ø A 19
30 91 9050	1H0 411 314	Stabilisatorlager / stabilizer mount		Ø I 19
30 93 9810	357 407 365 S2	Rep. Satz Traggelenk / rep. kit ball joint		
99 90 3544	191 407 190 A	Hülse / sleeve		50x17



Vento (1H)
(1992 → 1999)

VR6 / GT

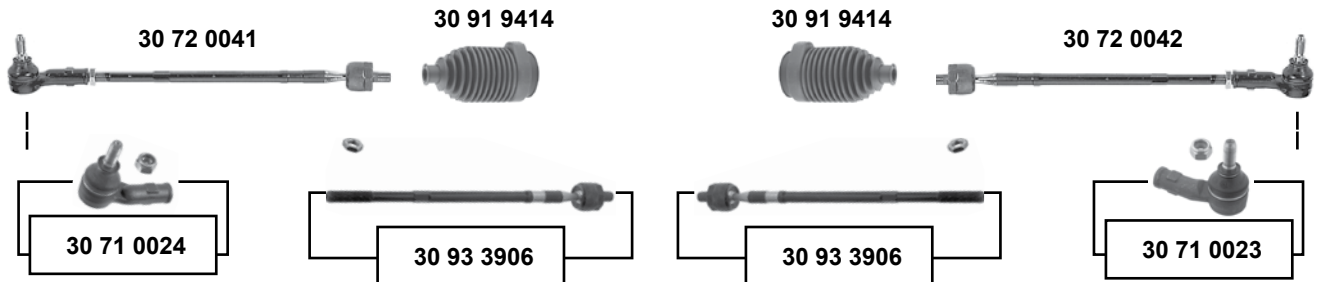

servo  ZF

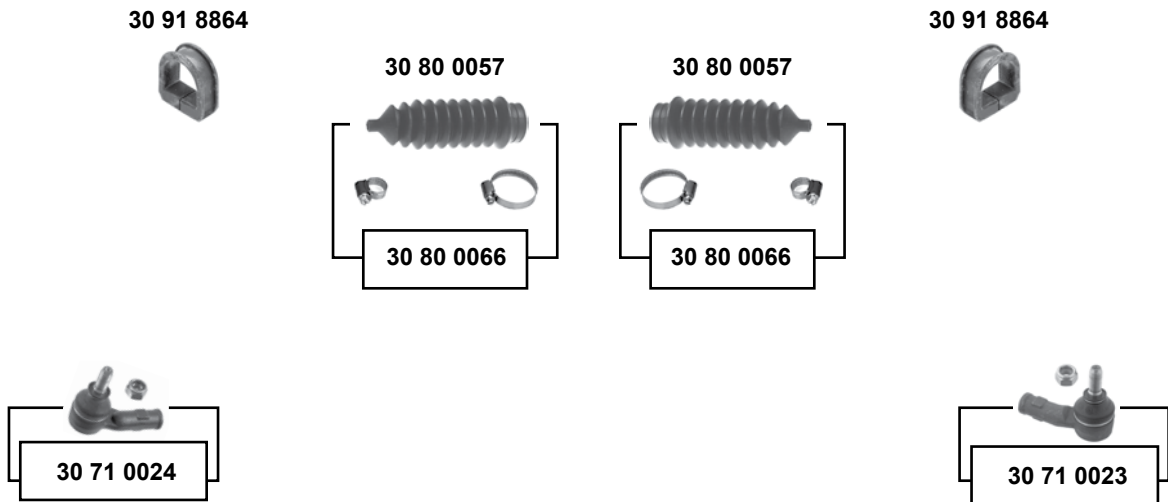

servo  TRW



Vorderachse / Front axle

SWAG GERMANY	Ref. - No.			
30 71 0023	191 419 812	Spurstangenendstück / tie rod end	LHD / RHD	M12 x 1,5
30 71 0024	191 419 811	Spurstangenendstück / tie rod end		M12 x 1,5
30 72 0041	1H0 422 803 B	Spurstange / tie rod		
30 72 0042	1H0 422 804 B	Spurstange / tie rod		
30 80 0057	1H0 422 831 B	Lenkmanschette / steering boot		
30 80 0066	1H0 422 831 B S1	Rep. Satz Lenkmanschette / rep. kit steering boot		
30 91 8864	1H0 422 884	Lenkgetriebebelager / steering gear bearing		
30 91 9414	357 422 831 B	Lenkmanschette / steering boot		
30 93 3906	1H0 422 810 B	Spurstange / tie rod		



VOLKSWAGEN

Vento (1H) (1992 → 1999)

VR6 / GT

Vorderachse / Front axle

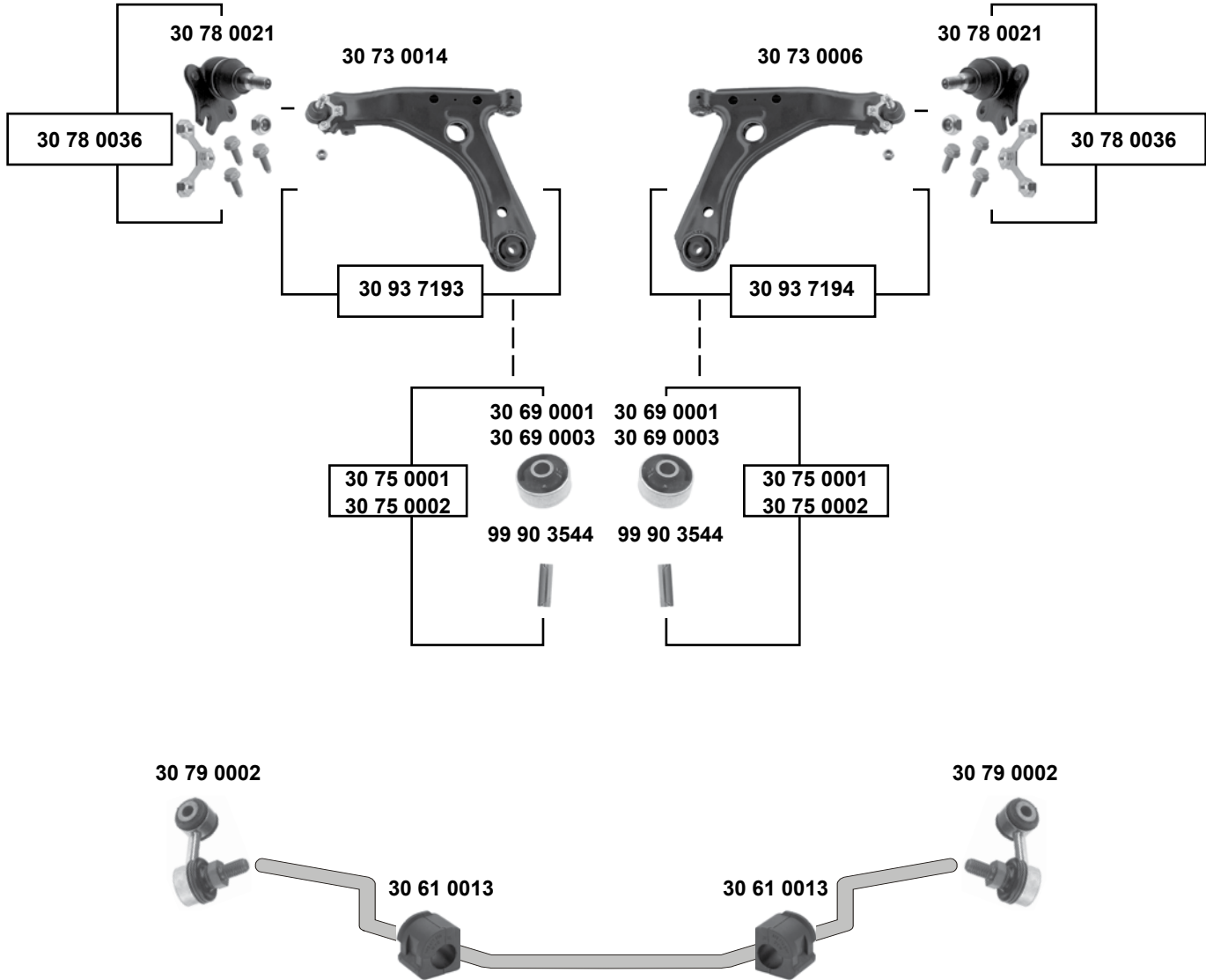

SWAG GERMANY	Ref. - No.			
30 61 0013	191 411 314	Stabilisatorlager / stabilizer mount	(ex.) GTI/16V/VR6	Ø 17
30 69 0001	191 407 181 D	Querlenkerlager / control arm mount	NEW	17x60x41
30 69 0003	191 407 181 B	Querlenkerlager / control arm mount	OLD	17x60x41
30 73 0006	1H0 407 152	Querlenker / control arm		
30 73 0014	1H0 407 151 A	Querlenker / control arm		
30 75 0001	191 407 181 B S1	Querlenkerlager mit Hülse / control arm mount with sleeve	OLD	
30 75 0002	191 407 181 D S1	Querlenkerlager mit Hülse / control arm mount with sleeve	NEW	
30 78 0021	1H0 407 365	Traggelenk / ball joint		M12 x 1,5
30 78 0036	1H0 407 365 S	Rep. Satz Traggelenk / rep. kit ball joint		
30 79 0002	535 411 315	Verbindungsstange / connecting rod		L 55
30 93 7193	1H0 407 151 A S1	Querlenker mit Traggelenk / control arm with ball joint	→ 98	
30 93 7194	1H0 407 152 S1	Querlenker mit Traggelenk / control arm with ball joint	→ 98	
99 90 3544	191 407 190 A	Hülse / sleeve		50x17

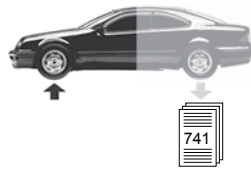

240 → 260
(1979 → 1993)

man.

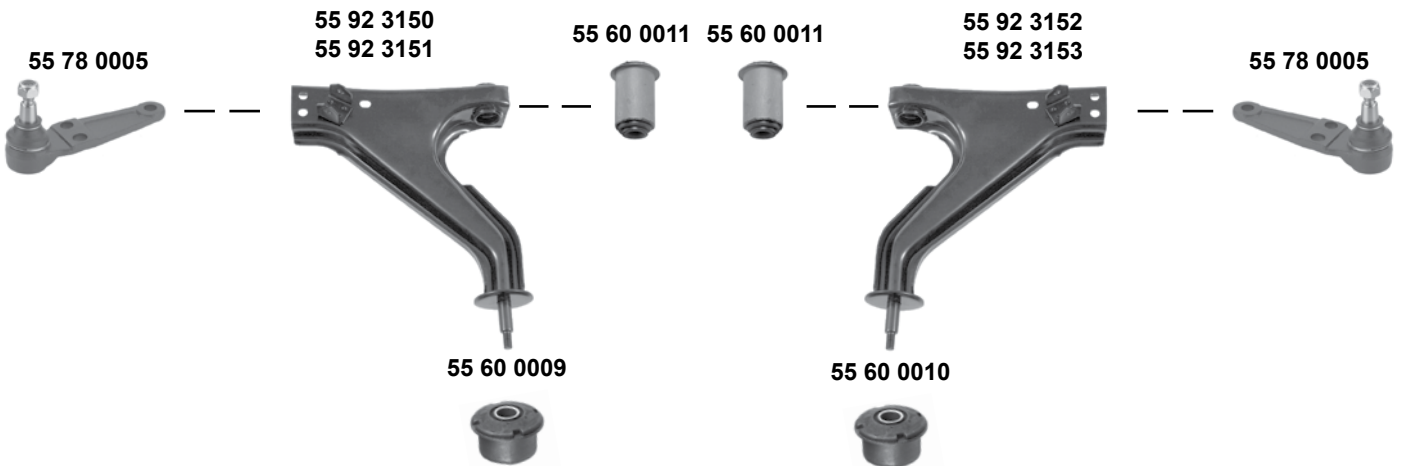
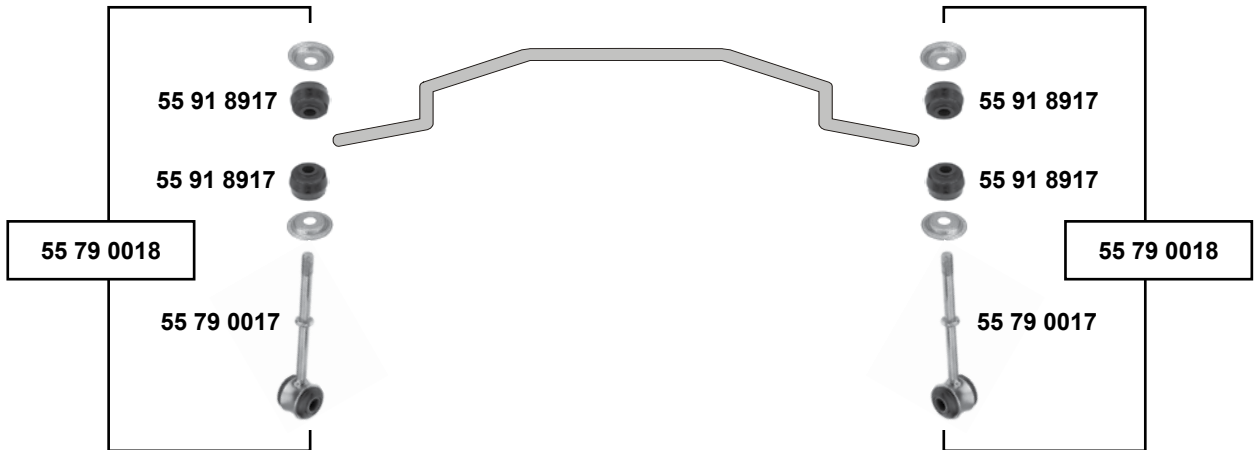

Vorderachse / Front axle

SWAG	Ref. - No.			
55 60 0009	1359812	Querlenkerlager / control arm mount		18x54,5x45
55 60 0010	1273778	Querlenkerlager / control arm mount		18x54,5x45
55 60 0011	1205825	Querlenkerlager / control arm mount		12x34,5x65
55 78 0005	274117	Traggelenk / ball joint		M12 x 1,75 L 140
55 79 0017	1206667	Koppelstange / connecting rod		
55 79 0018	1206667 S1	Verbindungsstange / connecting rod		
55 91 8917	1205991	Gummilager / rubber mount		10x32,5x22,5
55 92 3150	1205680	Querlenker / control arm		
55 92 3151	1205680 S1	Querlenker / control arm	mit Lager / with bearing	
55 92 3152	1205686	Querlenker / control arm		
55 92 3153	1205686 S1	Querlenker / control arm	mit Lager / with bearing	

passend für / to fit

VOLVO

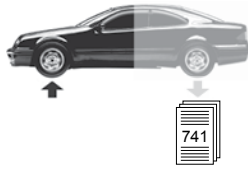

240 → 260
(1979 → 1993)



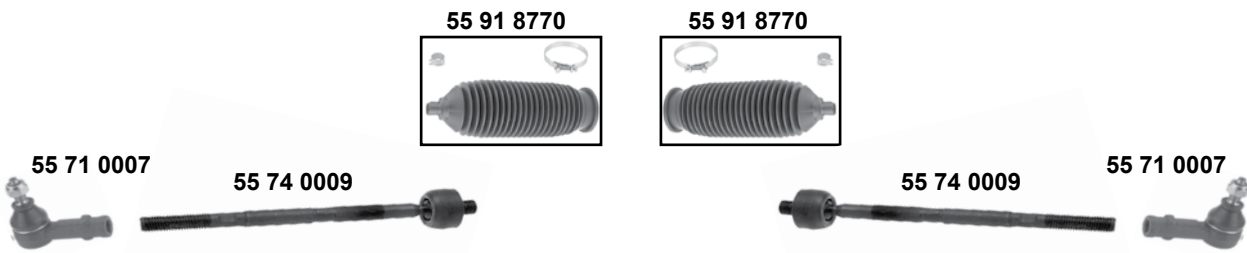

 **CAM**

Vorderachse / Front axle

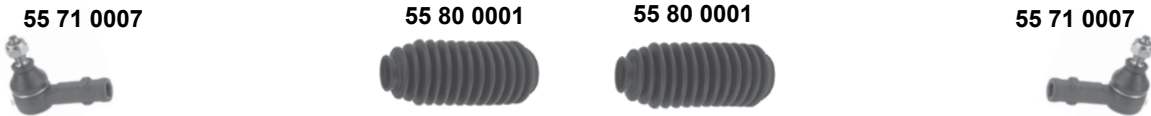

 **ZF**



	Ref. - No.			
55 71 0007	3516944	Spurstangenendstück / tie rod end	88 →	M12 x 1,5 L 285
55 74 0009	9140505	Spurstange / tie rod		
55 80 0001	1228425	Lenkmanschette / steering boot		
55 91 8770	270597 S1	Rep. Satz Lenkmanschette / rep. kit steering boot		

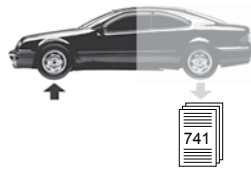

240 → 260
(1979 → 1993)

servo

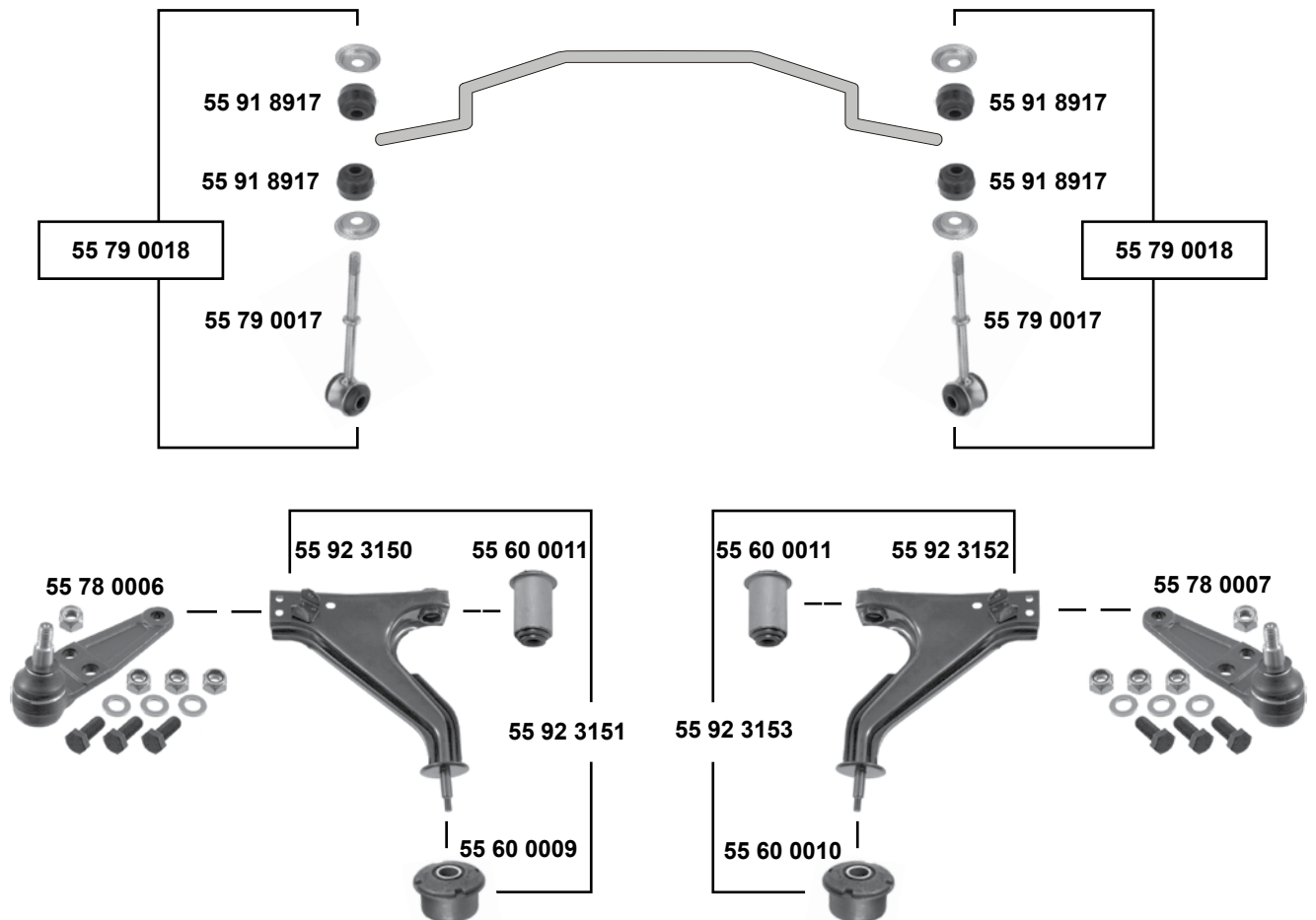

Vorderachse / Front axle



(1) fertig montiert / already pressed / prémonté / completamente montado / premontato

	Ref. - No.			
55 60 0009	1359812	Querlenkerlager / control arm mount		18x54,5x45
55 60 0010	1273778	Querlenkerlager / control arm mount		18x54,5x45
55 60 0011	1205825	Querlenkerlager / control arm mount		12x34,5x65
55 78 0006	274118	Traggelenk / ball joint		M12 x 1,25
55 78 0007	274119	Traggelenk / ball joint		M12 x 1,25
55 79 0017	1206667	Verbindungsstange / connecting rod		L 140
55 79 0018	1206667 S1	Verbindungsstange / connecting rod		
55 91 8917	1205991	Gummilager / rubber mount		10x32,5x2,5
55 92 3150	1205680	Querlenker / control arm		
55 92 3151	1205680 S1	Rep. Satz Querlenker / rep. kit control arm	(1)	
55 92 3152	1205686	Querlenker / control arm		
55 92 3153	1205686 S1	Rep. Satz Querlenker / rep. kit control arm	(1)	

passend für / to fit

VOLVO



340 → 360
(1975 → 1990)

Vorderachse / Front axle

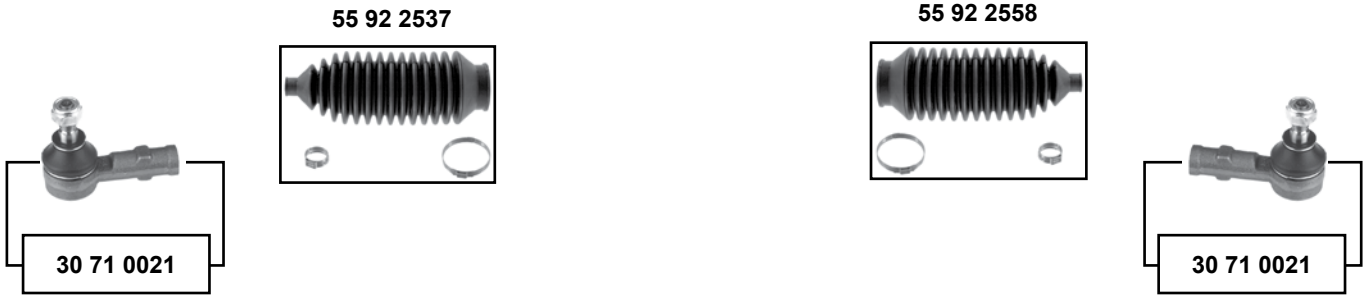

alle / all

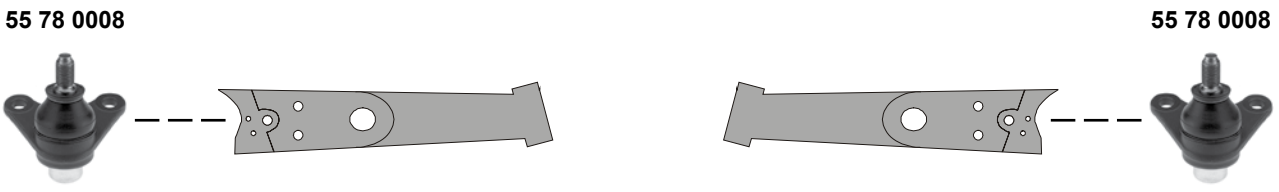

	Ref. - No.			
30 71 0021	3211955	Spurstangenendstück / tie rod end	man.	M12 x 1,5
55 78 0008	3211956	Traggelenk / ball joint		
55 92 2537	3343641	Rep. Satz Lenkmanschette / rep. kit steering boot		
55 92 2558	3343642	Rep. Satz Lenkmanschette / rep. kit steering boot		

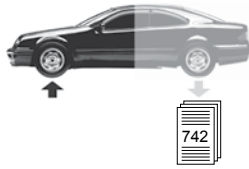

440 → 460
(1988 → 1995)

man.

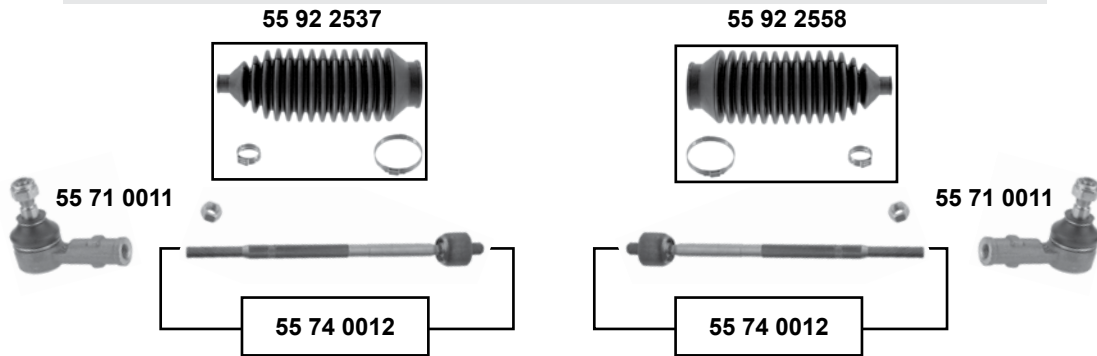

servo

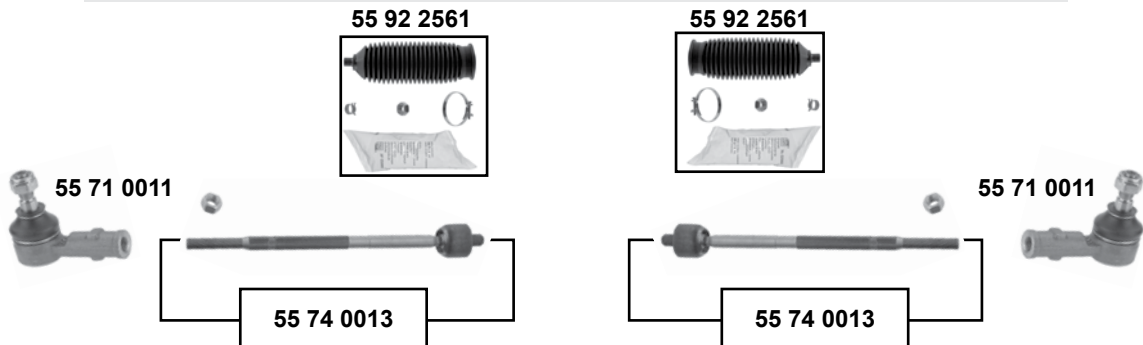

alle / all

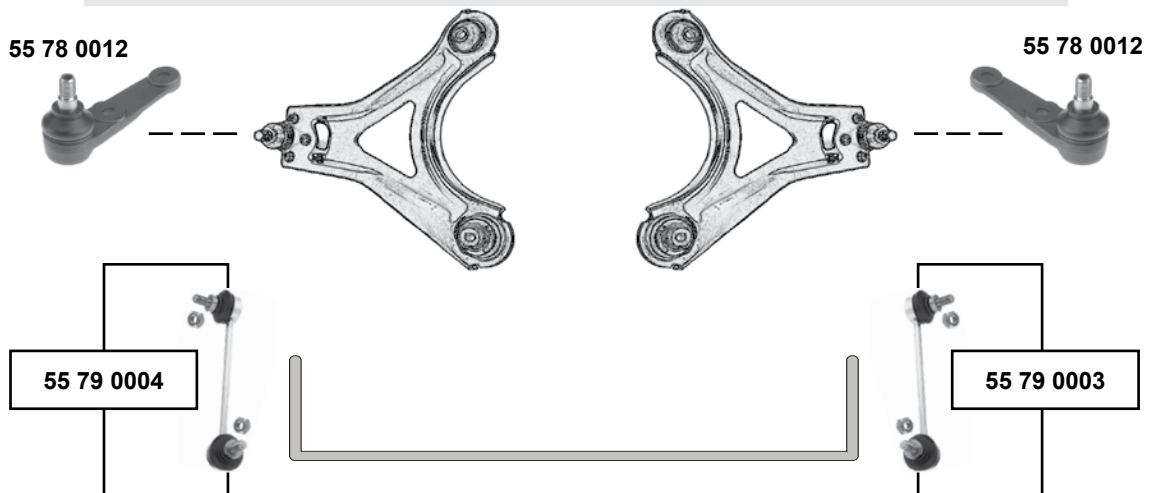

55 71 0011	3480012	Spurstangenendstück / tie rod end	M12 x 1,25
55 74 0012	3410369	Spurstange / tie rod	L 286
55 74 0013	3342824	Spurstange / tie rod	L 289
55 78 0012	3270523	Traggelenk / ball joint	M12 x 1,25
55 79 0003	3467714	Verbindungsstange / connecting rod	L 160
55 79 0004	3467713	Verbindungsstange / connecting rod	L 160
55 92 2537	3343641	Rep. Satz Lenkmanschette / rep. kit steering boot	
55 92 2558	3343642	Rep. Satz Lenkmanschette / rep. kit steering boot	
55 92 2561	3342893 S1	Rep. Satz Lenkmanschette / rep. kit steering boot	

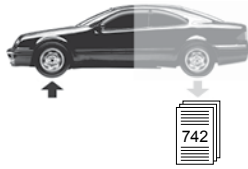

480

(1986 → 1994)

Vorderachse / Front axle

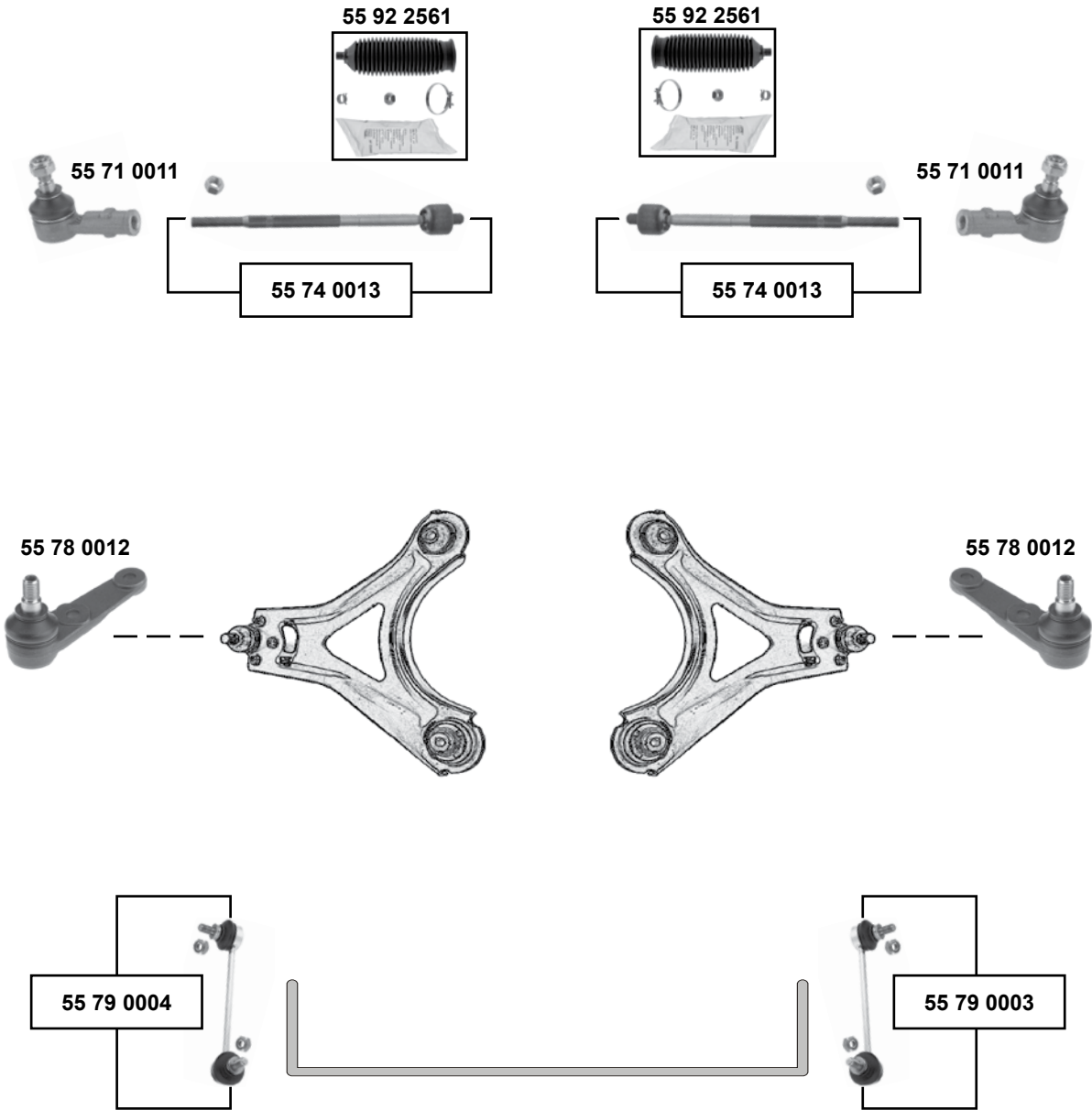

(1) Kunststoff / plastic / plastique / plástico / plastica

SWAG GERMANY	Ref. - No.			
55 71 0011	3480012	Spurstangenendstück / tie rod end		M12 x 1,25
55 74 0013	3342824	Spurstange / tie rod		L 289
55 78 0012	3270523	Traggelenk / ball joint		
55 79 0003	3467714	Verbindungsstange / connecting rod		L 160
55 79 0004	3467713	Verbindungsstange / connecting rod		L 160
55 92 2561	3342893 S1	Rep. Satz Lenkmanschette / rep. kit steering boot	(1) servo	

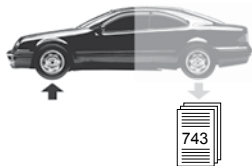

740 → 760
(1985 → 1992)

für / to fit **CAM**

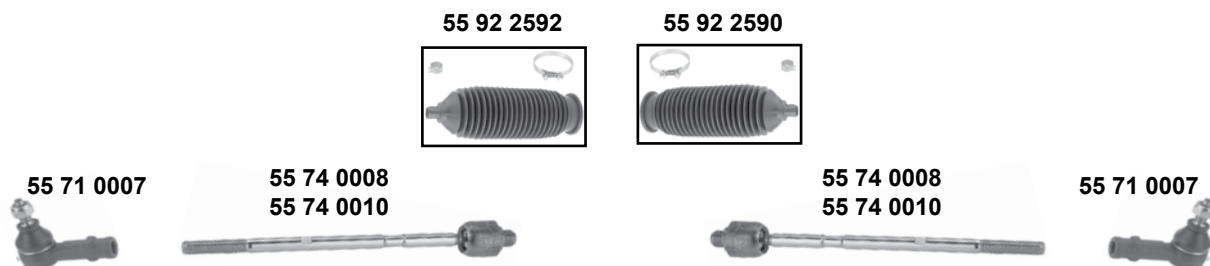

für / to fit **ZF**

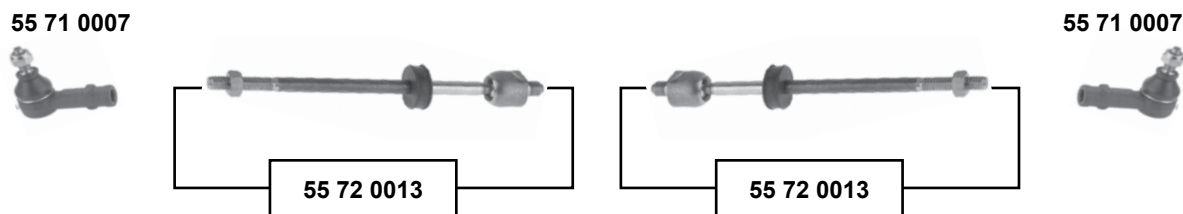

für / to fit **TRW**

740 Mod. 85 →
760 Mod. → 87



(1) 744 (ch.) → 294 099 / 764 (ch.) → 58 499
745 (ch.) → 176 799 / 765 (ch.) → 23 499

(2) 744 (ch.) 294 100 → / 764 (ch.) 58 500 →
745 (ch.) 176 800 → / 764 (ch.) 23 500 →



Ref. - No.



55 71 0007	3516944	Spurstangenendstück / tie rod end			M12 x 1,5
55 72 0013	271389	Spurstange / tie rod			L 310 M16x1,5
55 74 0008	1359347	Spurstange / tie rod		(1)	L 310 M18x1,5
55 74 0010	9140504	Spurstange / tie rod		(2)	L 310 M14x1,5
55 92 2528	270475 S1	Rep. Satz Lenkmanschette / rep. kit steering boot		Gummi / rubber	
55 92 2590	271470	Rep. Satz Lenkmanschette / rep. kit steering boot		(1)	
55 92 2592	271469	Rep. Satz Lenkmanschette / rep. kit steering boot		(1)	

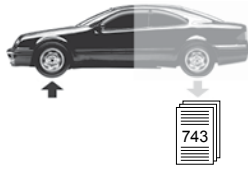

740 → 760
(1985 → 1992)

Vorderachse / Front axle

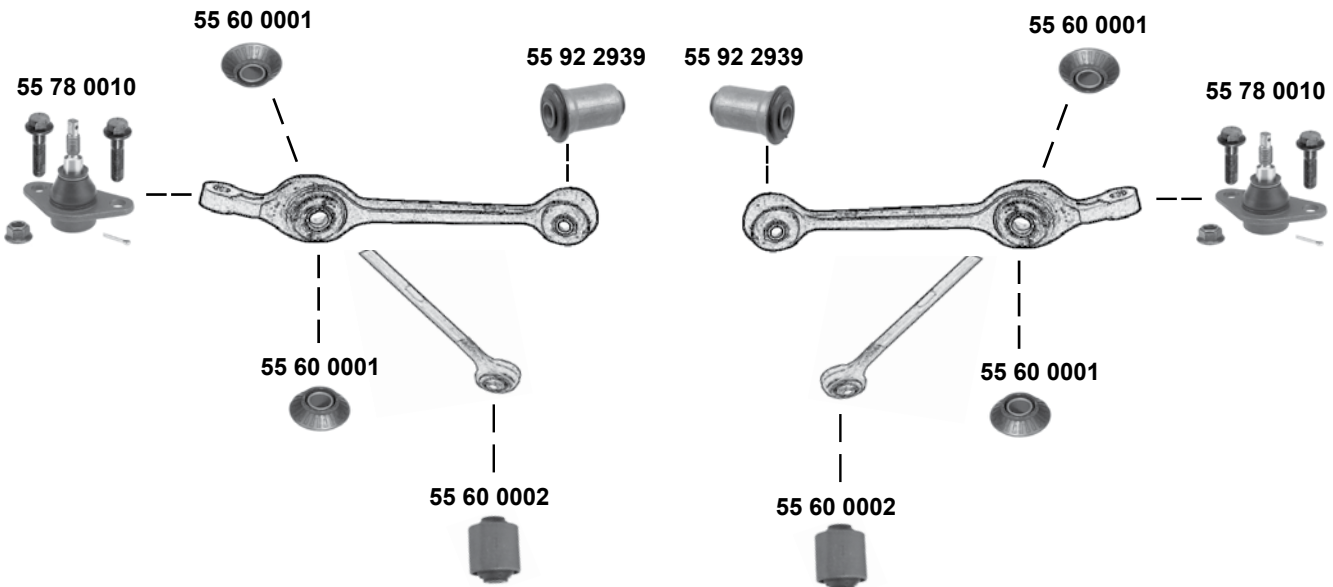
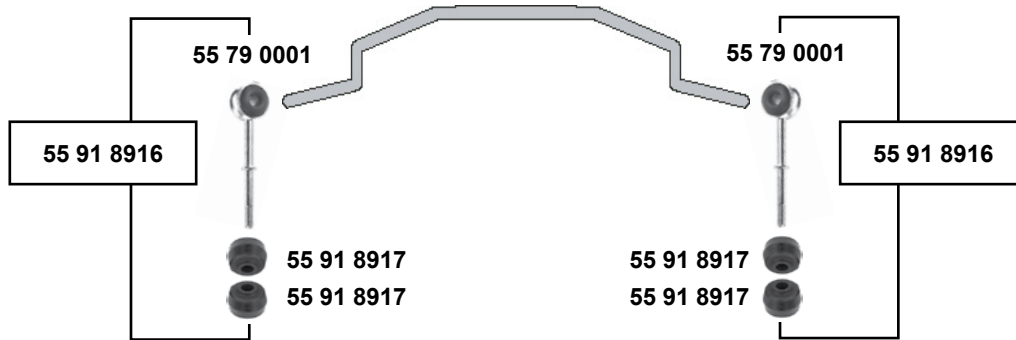

(1) Stahl-Querlenker / steel control arm / pour bras de suspension en acier / para el brazo oscilante transversal de acero / per braccio in acciaio

SWAG GERMANY	Ref. - No.			
55 60 0001	1359599	Zugstrebenlager / tension rod bearing	(1)	17x51x27
55 60 0002	1329655	Zugstrebenlager / tension rod bearing		14x47x67,5
55 78 0010	270477	Traggelenk / ball joint		
55 79 0001	9157725	Verbindungsstange / connecting rod		L 140
55 91 8916	9157725	Verbindungsstange / connecting rod		
55 91 8917	1205991	Verbindungsstangenlager / connecting rod bearing		10x32,5x22,5
55 92 2939	1273235	Querlenkerlager / control arm mount	13x34/37x65	

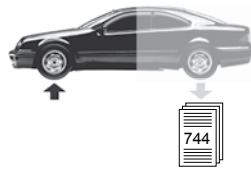

780
(1987 → 1990)

für / to fit **CAM**

55 91 8770
55 92 2592



55 91 8770
55 92 2590



55 92 2939

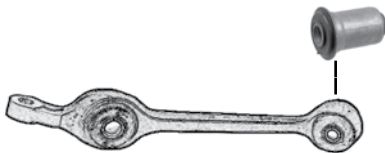

55 92 2939

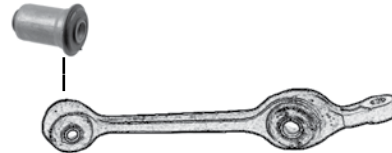

Vorderachse / Front axle

850
(1991 → 1996)

für / to fit **TRW**



55 94 0567

55 92 2557



55 92 2557

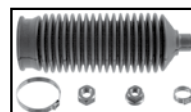

55 94 0568

55 71 0010



55 74 0011



55 74 0011



55 71 0009



55 71 0009	271599	Spurstangenendstück / tie rod end		
55 71 0010	271598	Spurstangenendstück / tie rod end		
55 74 0011	3546266	Spurstange / tie rod		M14 x 2 M14 x 2 L 195
55 91 8770	270597 S1	Rep. Satz Lenkmanschette / rep. kit steering boot		
55 92 2557	271601 SK	Rep. Satz Lenkmanschette / rep. kit steering boot	(ch.) → 2018	13x34/37x65
55 92 2590	271470	Rep. Satz Lenkmanschette / rep. kit steering boot	(ch.) 2018 →	
55 92 2592	271469	Rep. Satz Lenkmanschette / rep. kit steering boot	(ch.) 2018 →	
55 92 2939	1273235	Querlenkerlager / control arm mount		
55 94 0567	3546266 S1	Rep. Satz Spurstange / rep. kit tie rod		
55 94 0568	3546266 S2	Rep. Satz Spurstange / rep. kit tie rod		

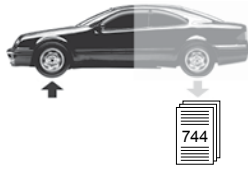

850

(1991 → 1996)

Vorderachse / Front axle

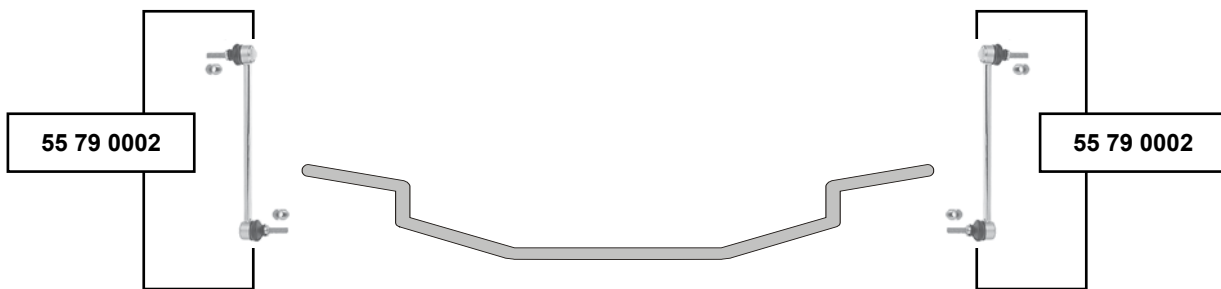
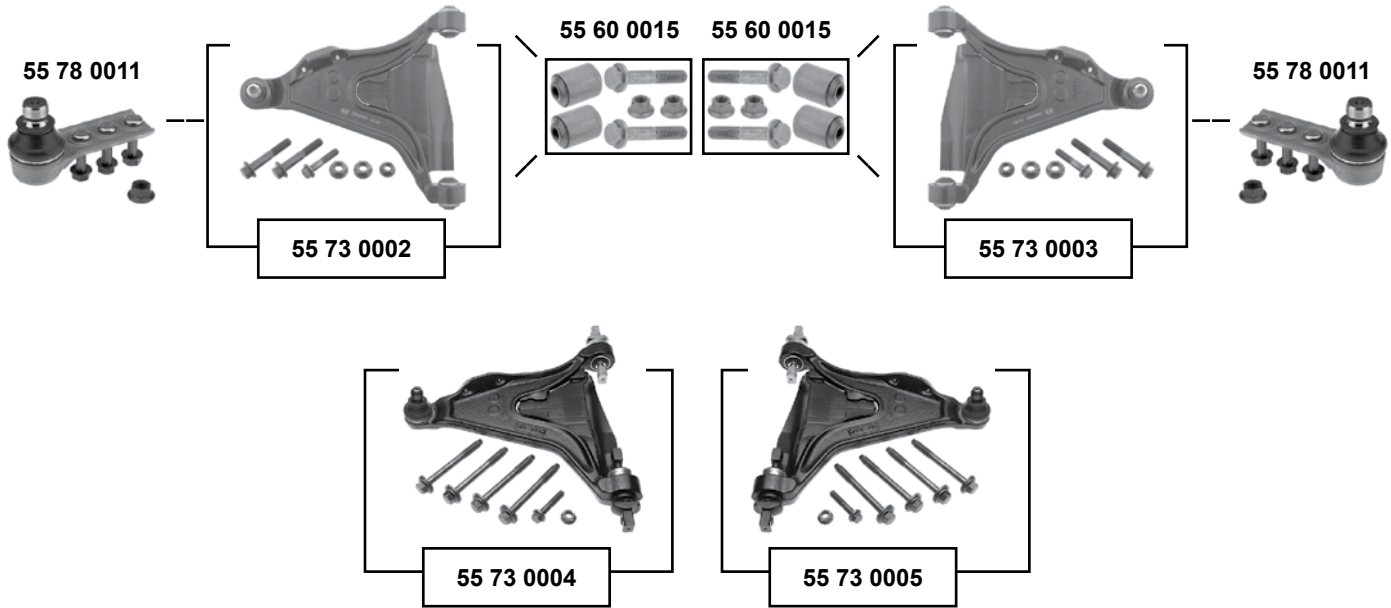

(1) (ch.) → 131536 / AWD / 4-türer / 4-doors
(ch.) → 37527 5-türer / 5-doors



Ref. - No.



55 73 0002	8628495	Rep. Satz Querlenker / rep. kit control arm	(ex.) Diesel / AWD
55 73 0003	8628496	Rep. Satz Querlenker / rep. kit control arm	(ex.) Diesel / AWD
55 73 0004	8628497	Rep. Satz Querlenker / rep. kit control arm	Diesel / AWD
55 73 0005	8628498	Rep. Satz Querlenker / rep. kit control arm	Diesel / AWD
55 60 0015	271631	Rep. Satz Querlenkerlager / rep. kit control arm mount	(ex.) Diesel / AWD
55 78 0011	271591	Traggelenk / ball joint	(ex.) Diesel / (1)
55 79 0002	30714686	Verbindungsstange / connecting rod	

L 300

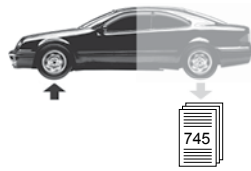

940 → 960
(1991 → 1998)

KOYO

→ Modell 93

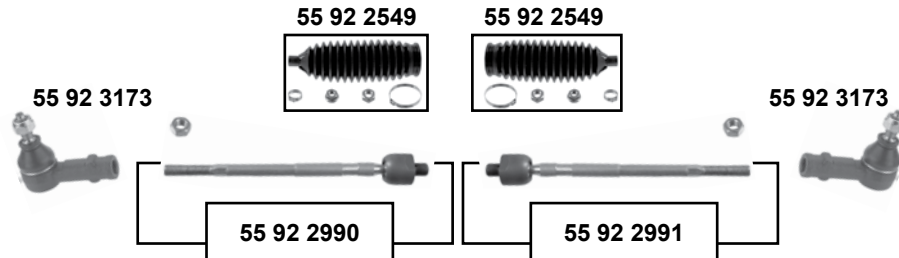

CAM

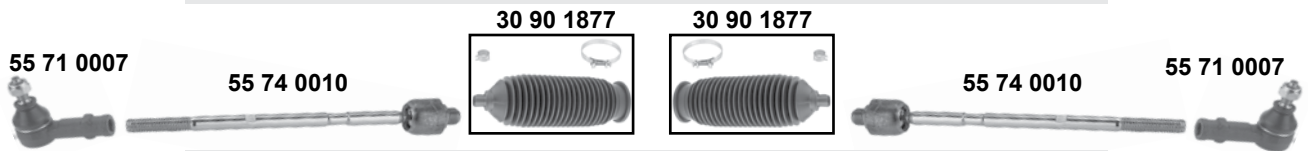

ZF

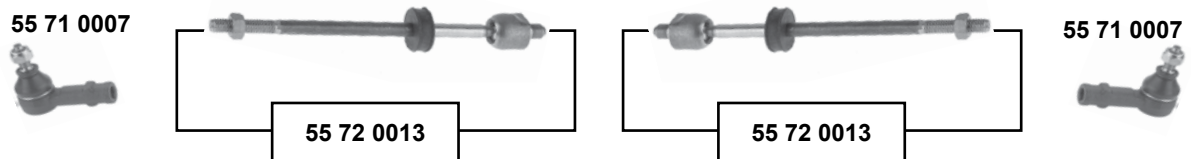

TRW

→ Modell 94

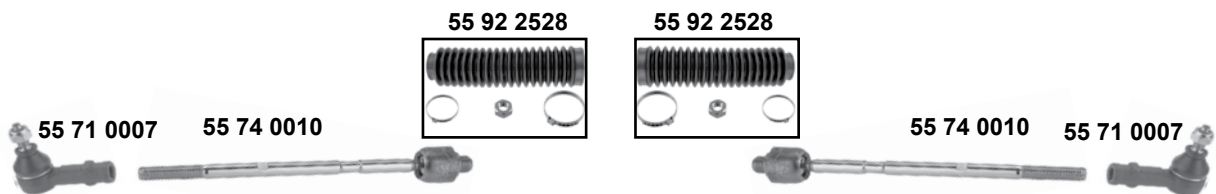

Modell 95 →



Ref. - No.			
55 71 0007	3516944	Spurstangenendstück / tie rod end	M12 x 1,5
55 71 0009	271599	Spurstangenendstück / tie rod end	M14 x 2
55 71 0010	271598	Spurstangenendstück / tie rod end	M14 x 2
55 72 0013	271389	Spurstange / tie rod	L 310
55 72 0015	9140788	Spurstange / tie rod	L 240
55 74 0010	9140504	Spurstange / tie rod	L 310
55 91 8770	270597 S1	Rep. Satz Lenkmanschette / rep. kit steering boot	Gummi / rubber
55 92 2528	270475 S1	Rep. Satz Lenkmanschette / rep. kit steering boot	
55 92 2549	271699	Rep. Satz Lenkmanschette / rep. kit steering boot	
55 92 2990	6819455	Spurstange / tie rod	L 310
55 92 2991	6819454	Spurstange / tie rod	L 310
55 92 3173	271701	Spurstangenendstück / tie rod end	M12 x 1,75

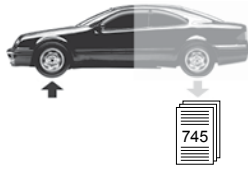

940 → 960

(1991 → 1998)

940 alle / all 960 → Modell 94

Vorderachse / Front axle

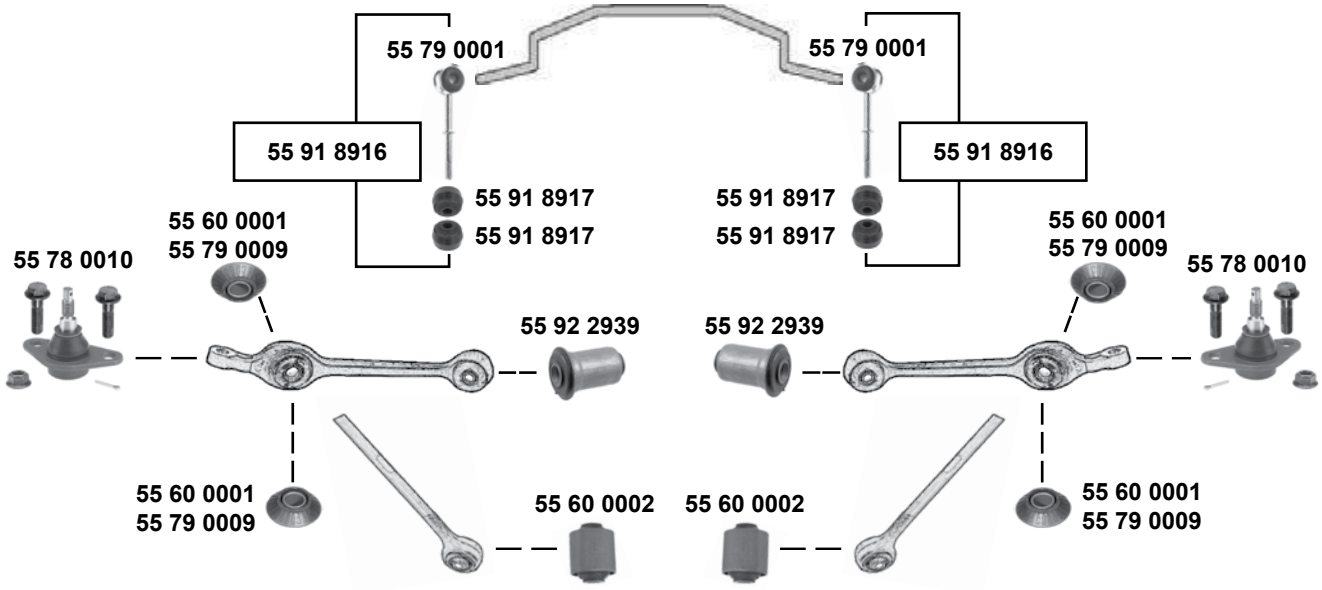



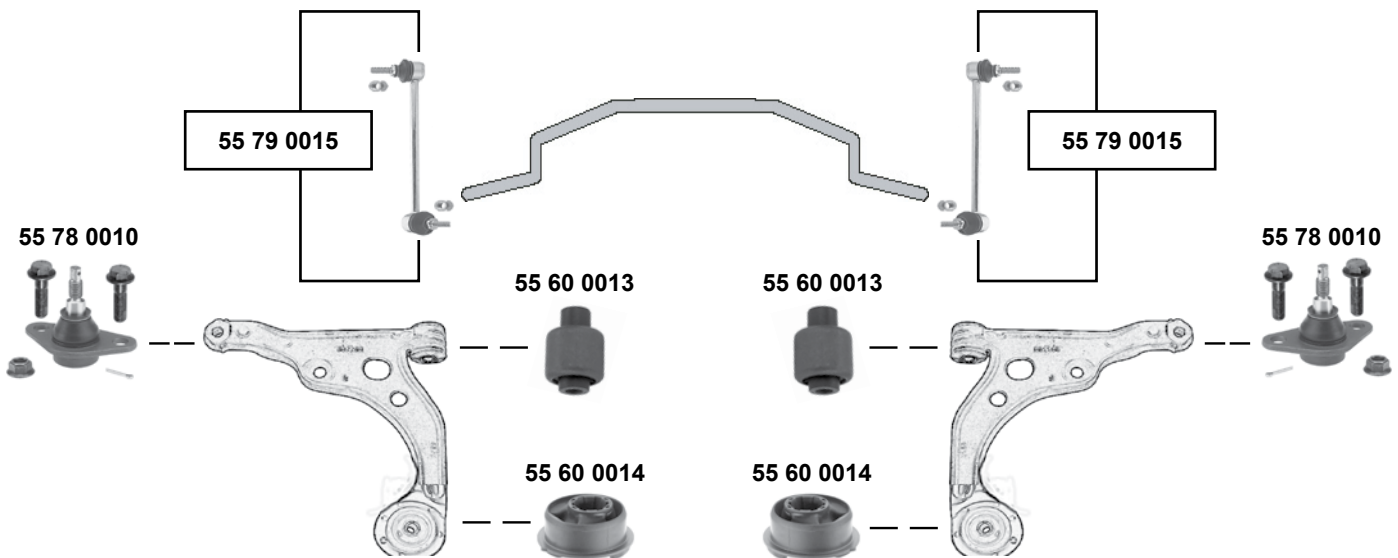

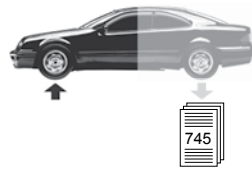
960 Modell 95 →



940 → 960
 (1991 → 1998)

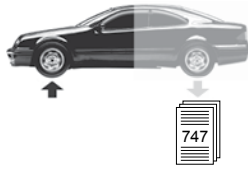

(1) Stahl-Querlenker / steel control arm / pour bras de suspension en acier / para el brazo oscilante transversal de acero / per braccio in acciaio

	Ref. - No.			
55 60 0001	1359599	Zugstrebenlager / tension rod bearing	(ex.) Zugstrebe / tie arm L 388,5	17x51x27
55 60 0002	1329655	Zugstrebenlager / tension rod bearing		14x47x67,5
55 60 0013	6819537	Querlenkerlager / control arm mount		12x40x39/65
55 60 0014	9191537	Querlenkerlager / control arm mount		
55 78 0010	270477	Traggelenk / ball joint		
55 79 0001	9157725	Verbindungsstange / connecting rod	(1) Zugstrebe / tie arm L 388,5	L 140
55 79 0009	6819057	Zugstrebenlager / tension rod bearing		17x52x27
55 79 0015	272991	Verbindungsstange / connecting rod		L 245
55 91 8916	9157725 S1	Verbindungsstange / connecting rod	(1)	L 140
55 91 8917	1205991	Gummilager / rubber mount		
55 92 2939	1273235	Gummilager / rubber mount		13x34/37x65





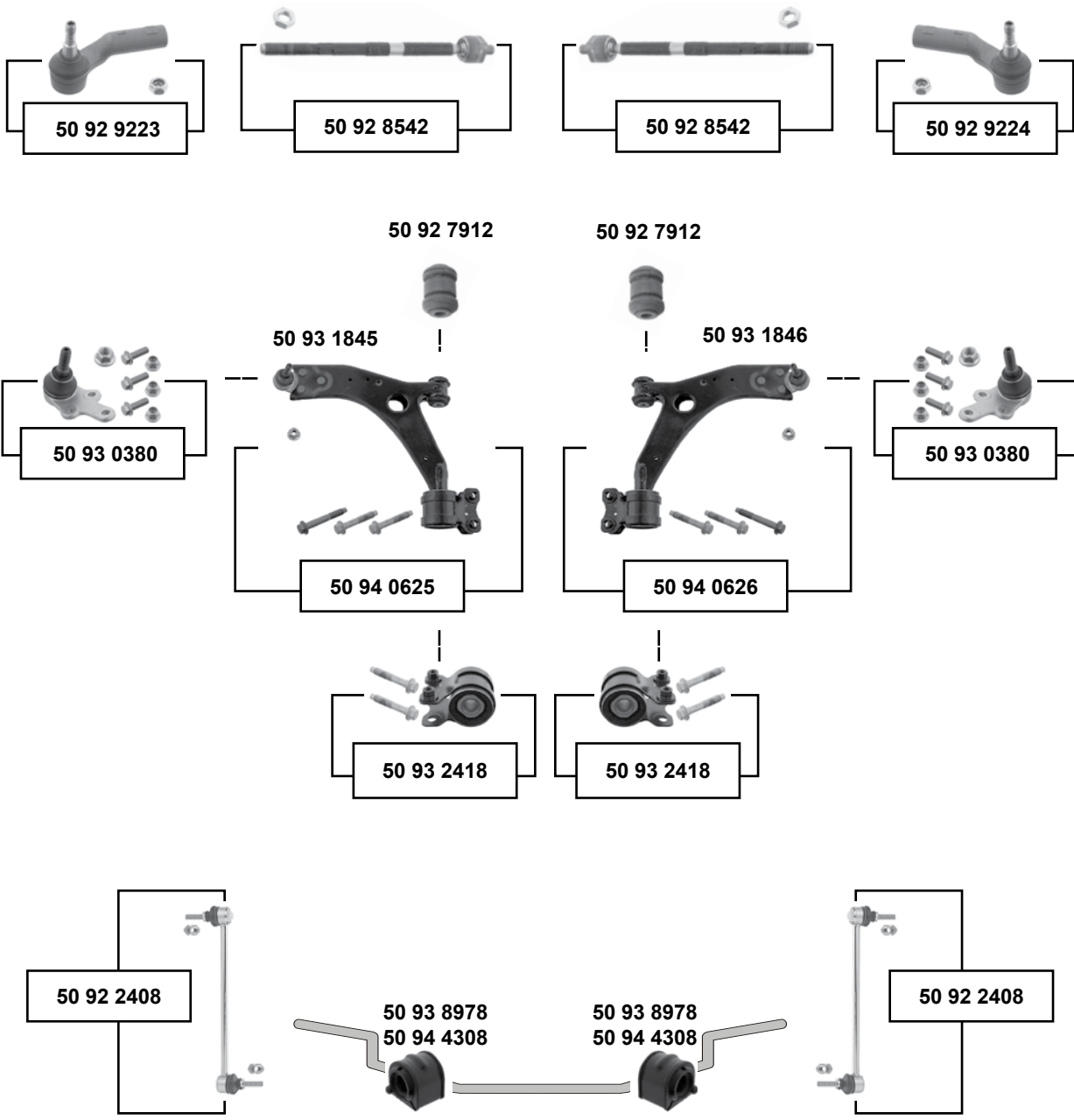

C 30 (2005 →)

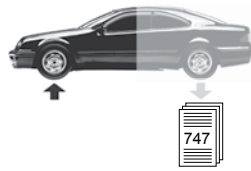
Vorderachse / Front axle





- (1) B 5..., D 5..., D 4204 T (ch.) 190000 → **Sport**
(ex.) B 4164 S3 → (ch.) 189999 **Sport**
D 5204 T, B5244 S4, B5254 T3, D 5244 T8/T9 In Verbindung mit Fahrgestell Dynamic /
combined with chassis Dynamic
- (2) B 4204 S3, B4184 S8/S11, B4164 S3, D 4164 T in Verbindung mit Fahrgestell Dynamic /
combined with chassis Dynamic
alle / all in Verbindung mit Fahrgestell Efficiency / combined with chassis efficiency
B 4164 S3 **Sport**
B 4204 S3/S4, D 4164 T/T2 (ch.) 190000 → i **Sport**

	Ref. - No.			
50 92 2408	8623576	Verbindungsstange / connecting rod		L 298
50 92 7912	31277464 S2	Querlenkerlager / control arm mount		
50 92 8542	31201817	Spurstange / tie rod		L 294,5
50 92 9223	31201413	Spurstangenendstück / tie rod end		M16 x 1,5
50 92 9224	31201412	Spurstangenendstück / tie rod end		M16 x 1,5
50 93 0380	31277463 SK	Rep. Satz Traggelenk / rep. kit ball joint		Ø A 21
50 93 1845	31277463	Querlenker / control arm		
50 93 1846	31277462	Querlenker / control arm		
50 93 2418	31277464 S3	Rep. Satz Querlenkerlager / rep. kit control arm mount		
50 93 8978	30666266	Stabilisatorlager / stabilizer mount	(1)	Ø I 18
50 94 0625	1 570 285 S1	Rep. Satz Querlenker / rep. kit control arm		
50 94 0626	1 570 284 S1	Rep. Satz Querlenker / rep. kit control arm		
50 94 4308	30748803	Stabilisatorlager / stabilizer mount	(2)	Ø I 18

passend für / to fit

VOLVO

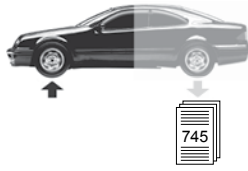

C 70 I

(1997 → 2000)

TRW

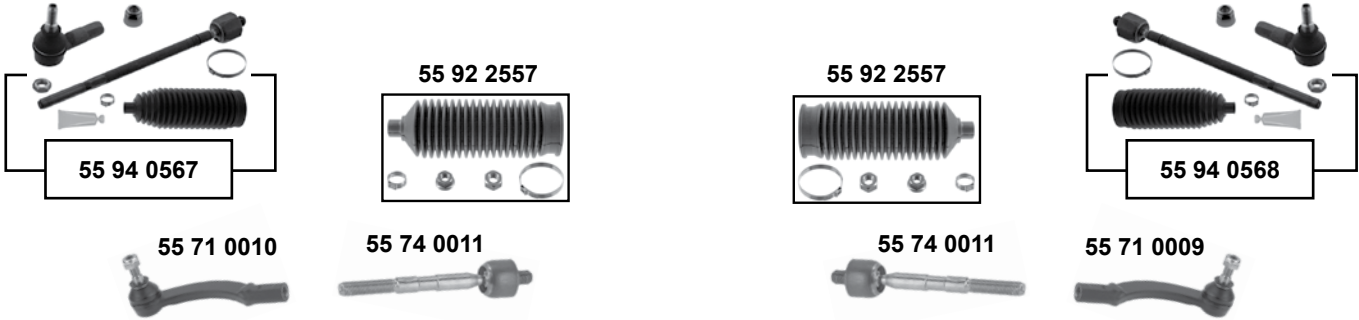

SMI

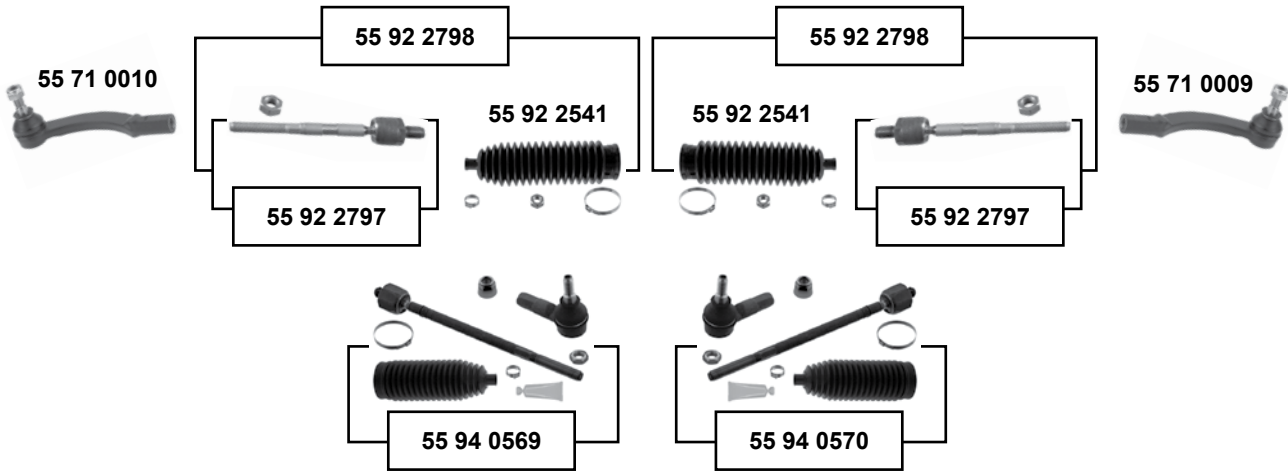

alle / all

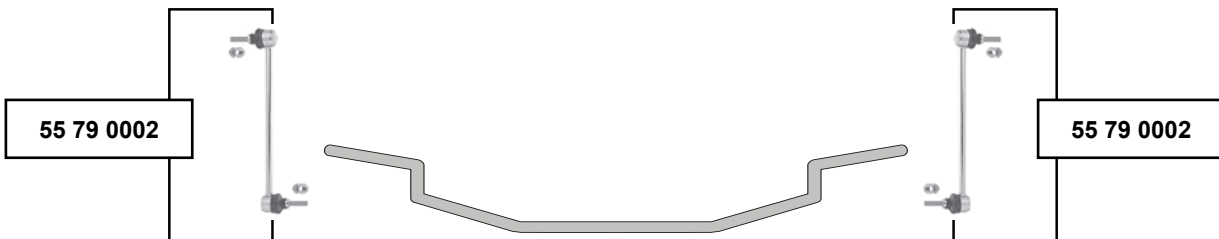

Vorderachse / Front axle

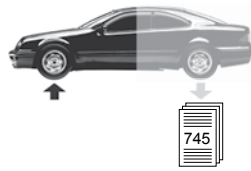

- (1) Kunststoff / plastic / plastique / plástico / plastica
- (2) LHD → (ch.) 572014, 549830 / RHD → (ch.) 585074, 563168
- (3) LHD (ch.) 572015, 549831 → / RHD (ch.) 585075, 563169 →

Ref. - No.

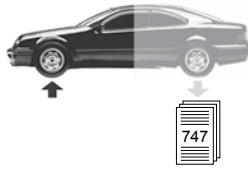

SWAG Ref. - No.			
55 71 0009	271599	Spurstangenendstück / tie rod end	
55 71 0010	271598	Spurstangenendstück / tie rod end	
55 74 0011	3546266	Spurstange / tie rod	
55 79 0002	30714686	Verbindungsstange / connecting rod	
55 92 2541	9191409	Rep. Satz Lenkmanschette / rep. kit steering boot	(1)
55 92 2557	271601 SK	Rep. Satz Lenkmanschette / rep. kit steering boot	
55 92 2797	9191410 SK	Rep. Satz Spurstange / rep. kit tie rod	(ex.) 4x4
55 92 2798	9191410	Rep. Satz Spurstange / rep. kit tie rod	(ex.) 4x4
55 94 0567	3546266 S1	Rep. Satz Spurstange / rep. kit tie rod	(2)
55 94 0568	3546266 S2	Rep. Satz Spurstange / rep. kit tie rod	(2)
55 94 0569	9191410 S2	Rep. Satz Spurstange / rep. kit tie rod	(3)
55 94 0570	9191410 S3	Rep. Satz Spurstange / rep. kit tie rod	(3)
			M12 x 1,75 M12 x 1,75 L 190 M14x1,5 L 300 L 200 M16x1,5 L 200 M16x1,5



C 70 II

(2006 →)

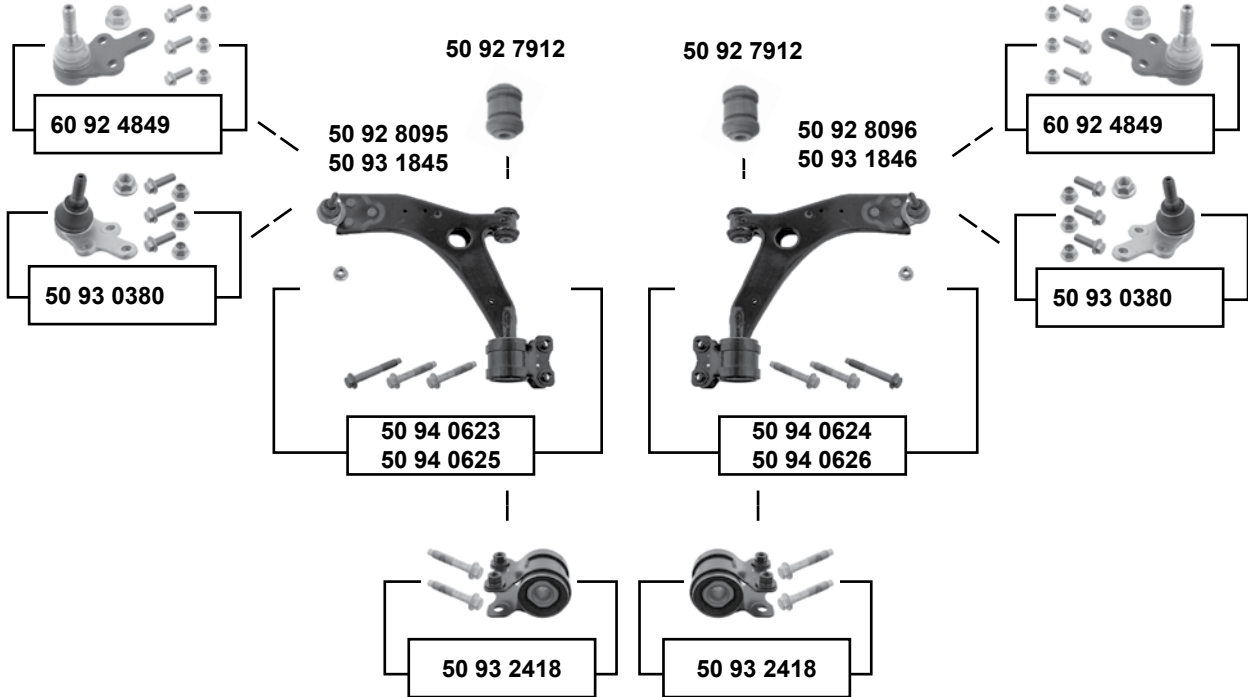
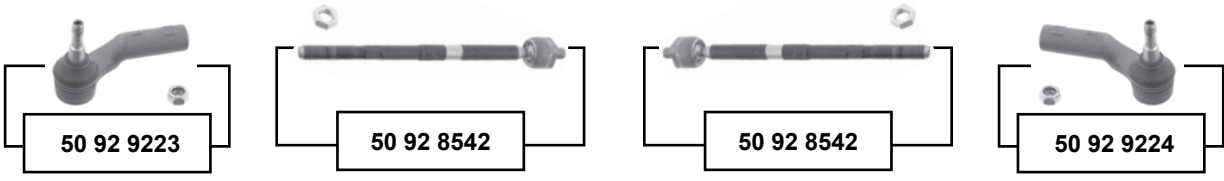
Vorderachse / Front axle



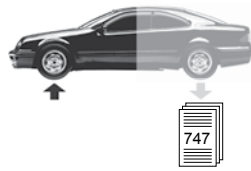

- (1) mit Traggelenk 18mm / with ball joint 18mm
- (2) mit Traggelenk 21mm/ with ball joint 21mm
- (3) In Verbindung mit Fahrgestell Comfort / combined with chassis comfort

	Ref. - No.			
50 92 2408	8623576	Verbindungsstange / connecting rod		L 298
60 92 4849	31212979 SK	Rep. Satz Traggelenk / rep. kit ball joint	(ch.) → 2742	Ø A 18
50 92 7912	31277464 S2	Querlenkerlager / control arm mount		
50 92 8095	31212979	Querlenker / control arm	(ch.) → 2742	
50 92 8096	31212980	Querlenker / control arm	(ch.) → 2742	
50 92 8542	31201817	Spurstange / tie rod		L 107
50 92 9223	31201413	Spurstangenendstück / tie rod end		M16 x 1,5
50 92 9224	31201412	Spurstangenendstück / tie rod end		M16 x 1,5
50 93 0380	31277463 SK	Rep. Satz Traggelenk / rep. kit ball joint	(ch.) 2743 →	Ø A 21
50 93 1845	31277463	Querlenker / control arm	(ch.) 2743 →	
50 93 1846	31277462	Querlenker / control arm	(ch.) 2743 →	
50 93 2418	31277464 S3	Rep. Satz Querlenkerlager / rep. kit control arm mount		
50 93 8978	30666266	Stabilisatorlager / stabilizer mount		Ø i 18
50 94 0623	31277464 S4	Rep. Satz Querlenker / rep. kit control arm	(1) (ch.) → 2742	
50 94 0624	31277465 S4	Rep. Satz Querlenker / rep. kit control arm	(1) (ch.) → 2742	
50 94 0625	31277463 S1	Rep. Satz Querlenker / rep. kit control arm	(2) (ch.) 2743 →	
50 94 0626	31277462 S1	Rep. Satz Querlenker / rep. kit control arm	(2) (ch.) 2743 →	

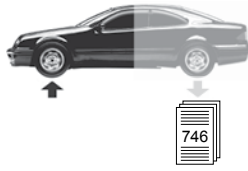

S 40 I / V 40 I



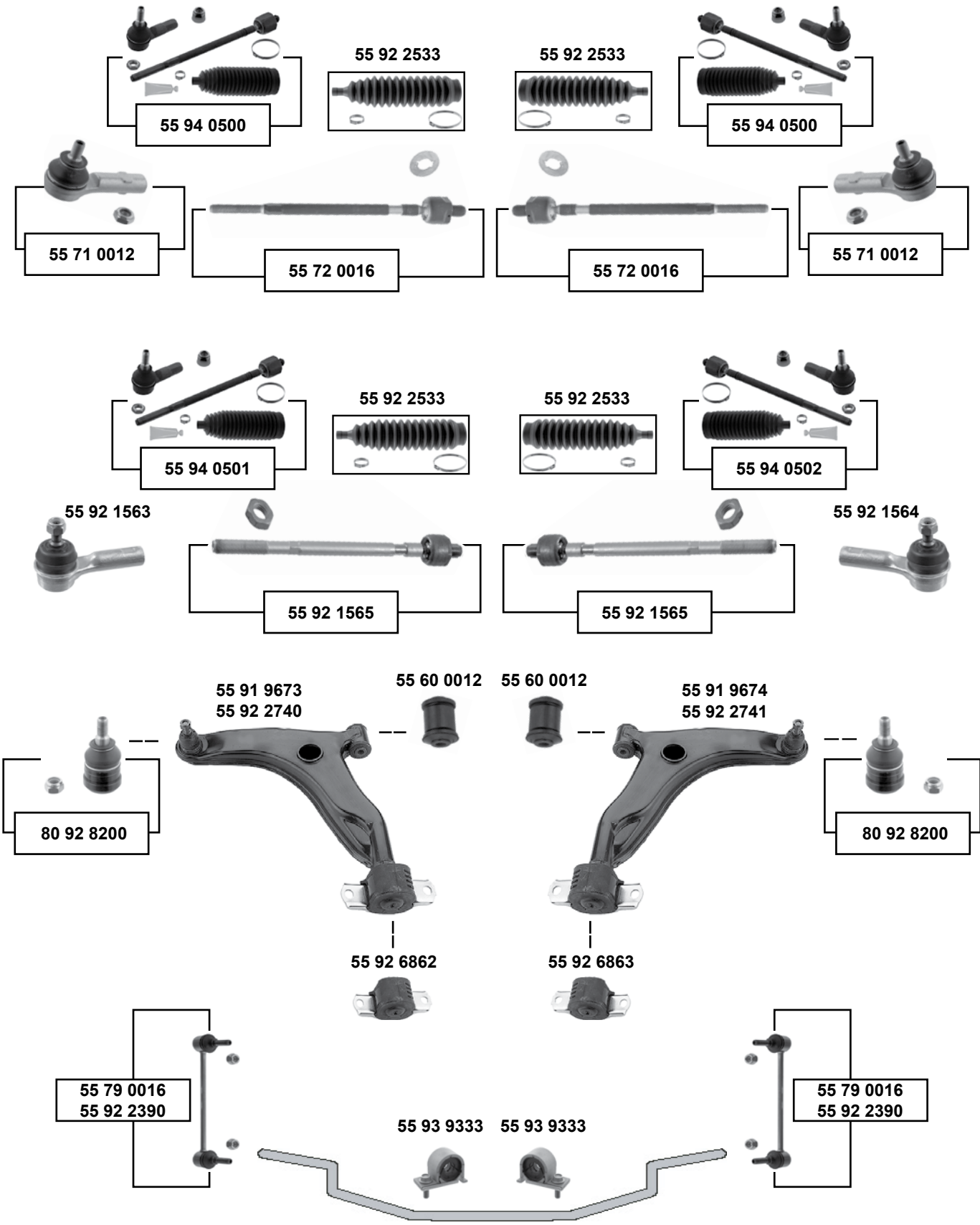

(1995 → 2003)

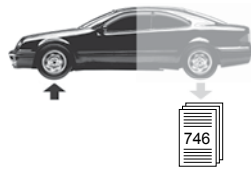
Vorderachse / Front axle





S 40 I / V 40 I
(1995 → 2003)

	Ref. - No.			
55 60 0012	30818467	Querlenkerlager / control arm mount		12x36x60
55 71 0012	30875012	Spurstangenendstück / tie rod end	→ 00	M12 x 1,25
55 72 0016	3345797	Spurstange / tie rod	→ 00	L 300
55 79 0016	30884358	Verbindungsstange / connecting rod	→ 00	L 200
55 91 9673	30887025	Querlenker / control arm	→ 00	
55 91 9674	30887033	Querlenker / control arm	→ 00	
55 92 1563	274225	Spurstangenendstück / tie rod end	01 →	L 90
55 92 1564	274226	Spurstangenendstück / tie rod end	01 →	L 90
55 92 1565	274224	Spurstange / tie rod	01 →	L 340
55 92 2390	30884179	Verbindungsstange / connecting rod	01 →	L 267
55 92 2533	3345796	Rep. Satz Lenkmanschette / rep. kit steering boot		
55 92 2740	30887653	Querlenker / control arm	01 →	
55 92 2741	30887654	Querlenker / control arm	01 →	
55 92 6862	30872510	Querlenkerlager / control arm bearing		
55 92 6863	30872511	Querlenkerlager / control arm bearing		
55 93 9333	30620989 S1	Stabilisatorlagersatz / stabilizer mount kit		Ø 1 15
55 94 0500	3345797 S1	Rep. Satz Spurstange / rep. kit tie rod	→ 00	
55 94 0501	274224 S1	Rep. Satz Spurstange / rep. kit tie rod	01 →	
55 94 0502	274224 S2	Rep. Satz Spurstange / rep. kit tie rod	01 →	
80 92 8200	30863990	Traggelenk / ball joint	→ 00	

passend für / to fit

VOLVO

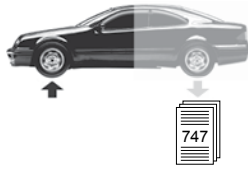

S 40 II / V 50

(2004 → 2012)

Vorderachse / Front axle

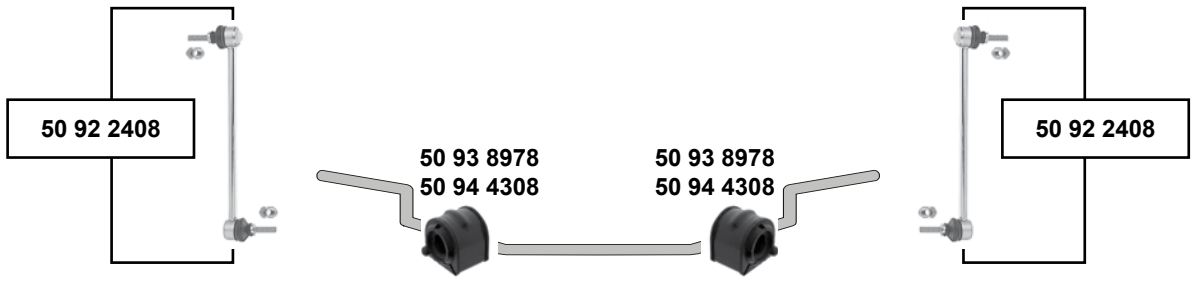
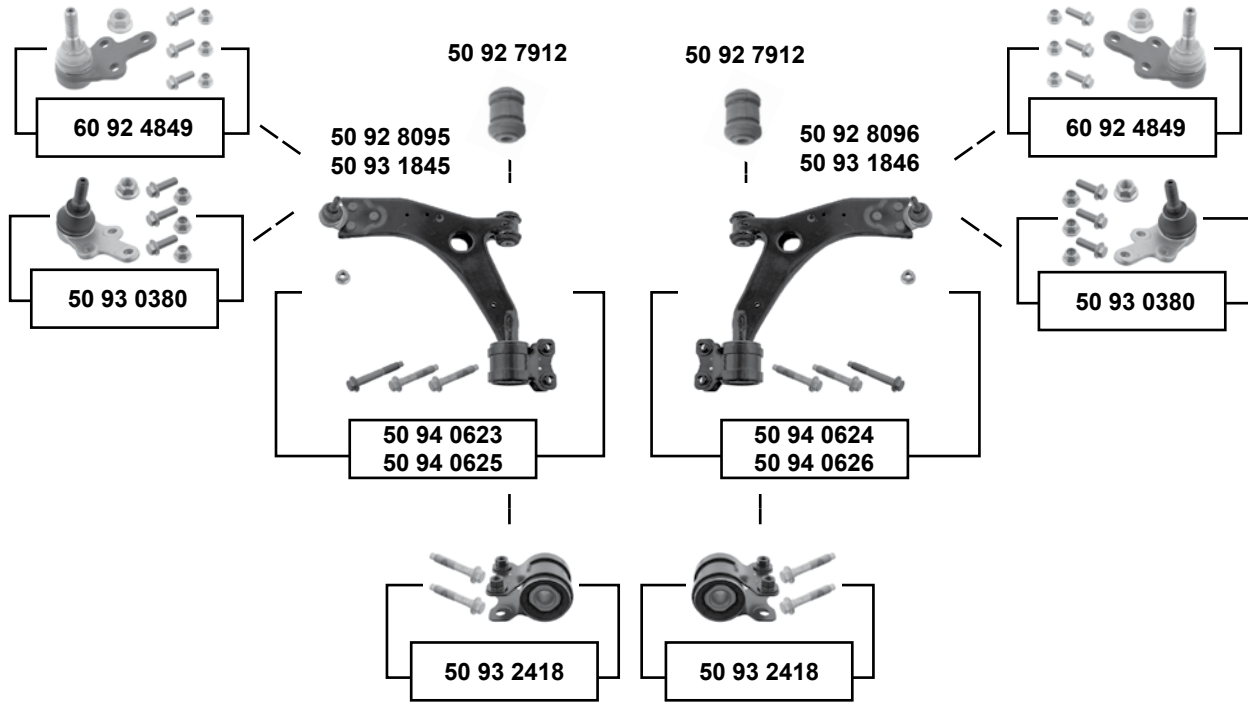
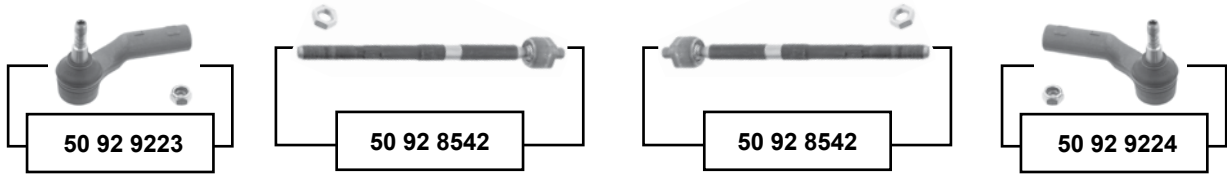

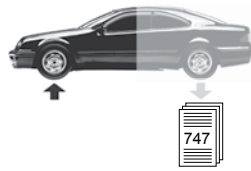





S 40 II / V 50
(2004 → 2012)



- (1) S 40 (ch.) → 209290 / V 50 (ch.) → 214682
- (2) S 40 (ch.) 209291 → / V 50 (ch.) 214683 →
- (3) mit Traggelenk 18mm / with ball joint 18mm
- (4) mit Traggelenk 21mm/ with ball joint 21mm
- (5) In Verbindung mit Fahrgestell Comfort / combined with chassis comfort
Schaltgetriebe MTX75 in Verbindung mit Fahrgestell Effizienz / Manual Transmission MTX75 combined with chassis Efficiency
D 5244 T8 In Verbindung mit Fahrgestell Dynamic / combined with chassis Dynamic
- (6) In Verbindung mit Fahrgestell Comfort / combined with chassis comfort

	Ref. - No.			
50 92 2408	8623576	Verbindungsstange / connecting rod		L 298
50 92 7912	31277464 S2	Querlenkerlager / control arm mount		
50 92 8095	31212979	Querlenker / control arm	(1)	
50 92 8096	31212980	Querlenker / control arm	(1)	
50 92 8542	31201817	Spurstange / tie rod		L 294,5
50 92 9223	31201413	Spurstangenendstück / tie rod end		M16 x 1,5
50 92 9224	31201412	Spurstangenendstück / tie rod end		M10 x 1,5
50 93 0380	31277463 SK	Rep. Satz Traggelenk / rep. kit ball joint	(2)	Ø A 21
50 93 1845	31277463	Querlenker / control arm	(2)	
50 93 1846	31277462	Querlenker / control arm	(2)	
50 93 2418	31277464 S3	Rep. Satz Querlenkerlager / rep. kit control arm mount		
50 93 8978	30666266	Stabilisatorlager / stabilizer mount	(5)	Ø I 18
50 94 0623	31277464 S4	Rep. Satz Querlenker / rep. kit control arm	(1) (3)	
50 94 0624	31277465 S4	Rep. Satz Querlenker / rep. kit control arm	(1) (3)	
50 94 0625	31277463 S1	Rep. Satz Querlenker / rep. kit control arm	(2) (4)	
50 94 0626	31277462 S1	Rep. Satz Querlenker / rep. kit control arm	(2) (4)	
50 94 4308	30748803	Stabilisatorlager / stabilizer mount	(6)	Ø I 18
60 92 4849	31212979 SK	Rep. Satz Traggelenk / rep. kit ball joint	(1)	Ø A 18

passend für / to fit

VOLVO

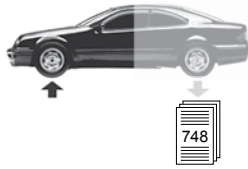

S 60 I

(2000 → 2010)

Vorderachse / Front axle

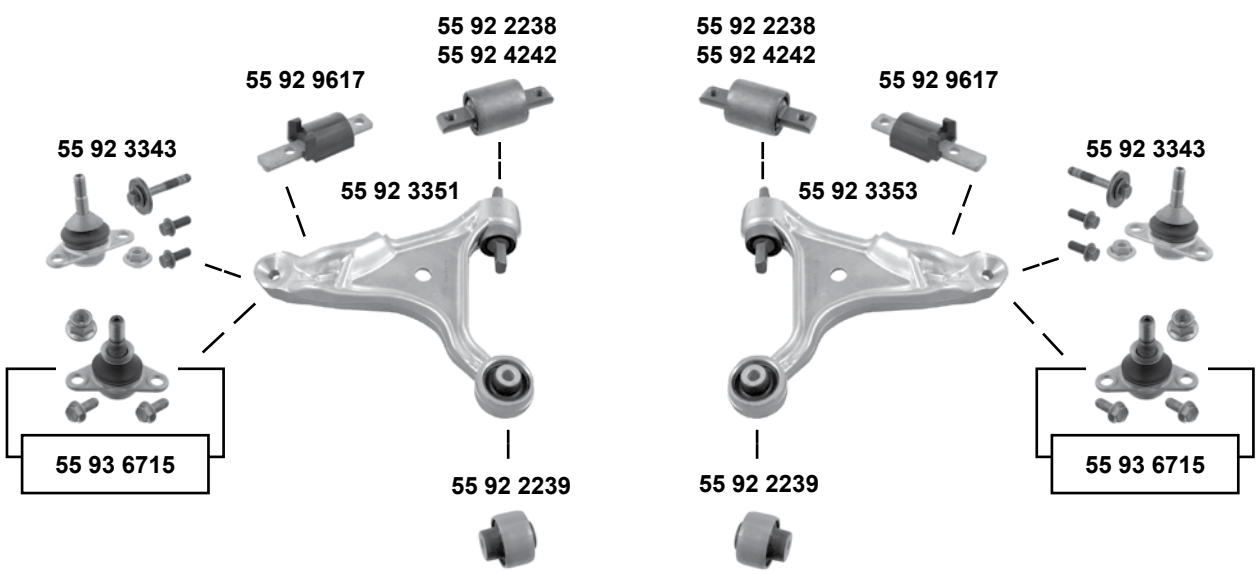
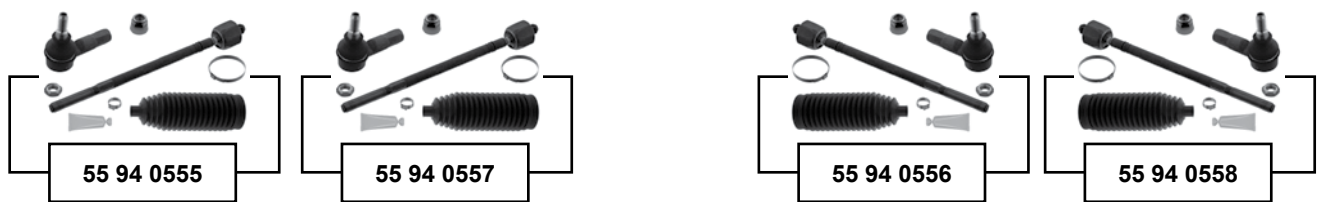
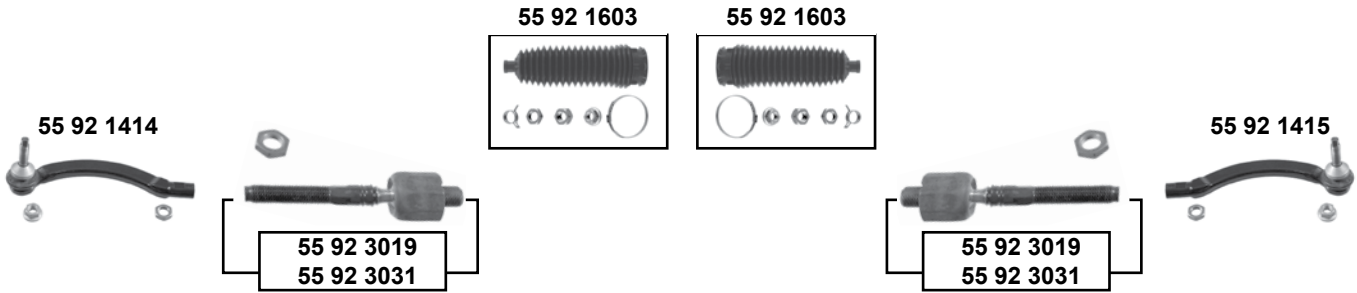

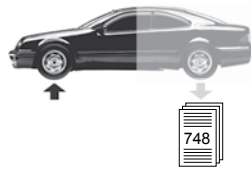

(1) ZF / Mod.04 → / (ex.) B5254T4 / LHD

(2) SMI / Mod.→ 03 / (ex.) B5254T4 / LHD

	Ref. - No.			
55 91 9379	31212692	Verbindungsstange / connecting rod		L 335
55 92 1414	30761719	Spurstangenendstück / tie rod end	(ex.) B5254T4	M14 x 1,5
55 92 1415	30761718	Spurstangenendstück / tie rod end	(ex.) B5254T4	M14 x 1,5
55 92 1603	272418	Rep. Satz Lenkmanschette / rep. kit steering boot	LHD	
55 92 2238	9443882	Gummilager / rubber mount	wahlweise / alternatively	Ø I 48x123
55 92 2239	8630604	Gummilager / rubber mount	(ch.) → 626501 / Alu/alloy	14x53x29/50
55 92 3019	274179	Spurstange / tie rod	SMI / Mod.→ 03	L 148
55 92 3031	274353	Spurstange / tie rod	ZF / Mod.04 →	L 141
55 92 3343	274548	Traggelenk / ball joint	(ch.) → 626501	
55 92 3351	30635229	Querlenker / control arm	(ch.) → 626501	
55 92 3353	30635230	Querlenker / control arm	(ch.) → 626501	
55 92 4242	9465971	Gummilager / rubber mount	wahlweise / alternatively	Ø I 48x123
55 92 9617	31212191	Anschlagpuffer / buffer	schwarz / black	100x31x27
55 93 6715	31201485	Traggelenk / ball joint	(ch.) 626502 →	M14 x 1,5
55 94 0555	274353 S1	Rep. Satz Spurstange / rep. kit tie rod	(1)	
55 94 0556	274353 S2	Rep. Satz Spurstange / rep. kit tie rod	(1)	
55 94 0557	274179 S1	Rep. Satz Spurstange / rep. kit tie rod	(2)	
55 94 0558	274179 S2	Rep. Satz Spurstange / rep. kit tie rod	(2)	

passend für / to fit

VOLVO

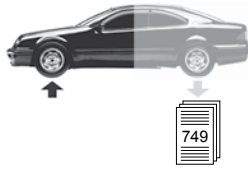

S 60 II / V 60

(2010 →)

Vorderachse / Front axle



55 93 4294
55 93 4371

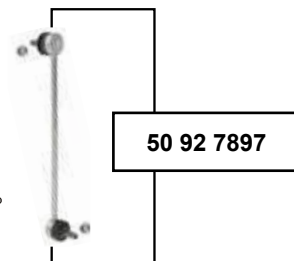
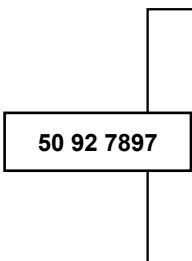
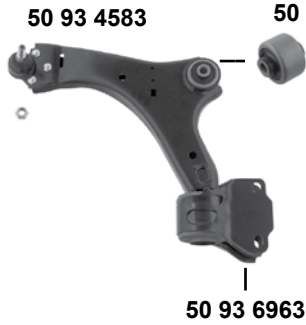
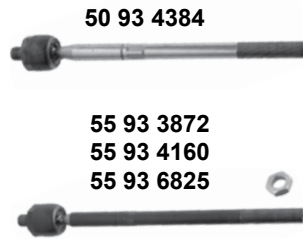
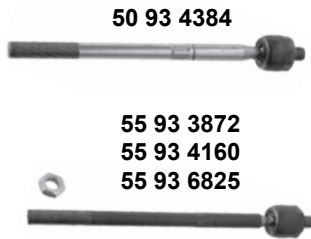

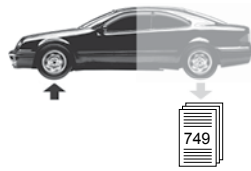

S 60 II / V 60 (2010 →)



- (1) S 60 II (ch.) 7321 → / V 60 (ch.) 1274 →
- (2) S 60 II → (ch.) 7320 / V 60 → (ch.) 1273
- (3) S 60 II (ex.) 4x4 alle/all → (ch.) 75999 / V 60 (ex.) 4x4 alle/all → (ch.) 35000
- (4) S 60 II E-servo (ch.) 7321 → / V 60 E-servo (ch.) 1274 →

Ref. - No.			
50 92 7897 30648461	Rep. Satz Verbindungsstange / rep. kit connecting rod		L300
50 93 2163 31317661 SK	Traggelenk / ball joint	(ex.) 4x4	M14 x 1,5
55 93 3872 31280409 SK	Axialgelenk / axial joint	(2) (ex.) E-servo	M16x1,5/18x1,5
55 93 4160 31280408 SK	Axialgelenk / axial joint	(2) E-servo	M16x1,5/18x1,5
55 93 4293 30776251	Rep. Satz Lenkmanschette / rep. kit steering boot	(ex.) E-servo	
55 93 4294 31280409	Rep. Satz Axialgelenk / rep. kit axial joint	(2) (ex.) E-servo	
55 93 4371 31280658 SK2	Rep. Satz Axialgelenk / rep. kit axial joint	(1) (ex.) E-servo	
50 93 4384 31280658 SK1	Axialgelenk / axial joint	(1) (ex.) E-servo	
50 93 4583 31317661	Querlenker / control arm	(3)	
50 93 4584 31317662	Querlenker / control arm	(3)	
55 93 6825 30776255 SK	Axialgelenk / axial joint	(4)	M18x1,5/16x1,5
50 93 6962 31317661 SK 1	Querlenkerlager / control arm mount	(ex.) 4x4	Ø A 60
50 93 6963 31387571	Querlenkerlager / control arm mount	(ex.) 4x4	
50 93 6964 31387572	Querlenkerlager / control arm mount	(ex.) 4x4	
55 93 8865 31302344	Spurstangenendstück / tie rod end		M14x2/18x1,5
55 93 8866 31302345	Spurstangenendstück / tie rod end		M14x2/18x1,5
55 93 9833 30776252	Rep. Satz Lenkmanschette / rep. kit steering boot	E-servo	

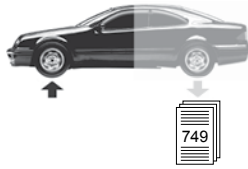

S 70 I / V 70 I

(1997 → 2000)

TRW

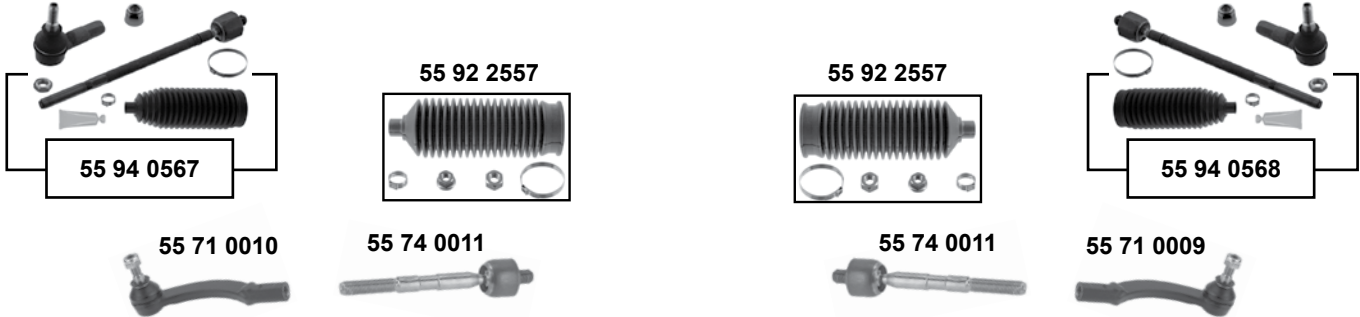

SMI

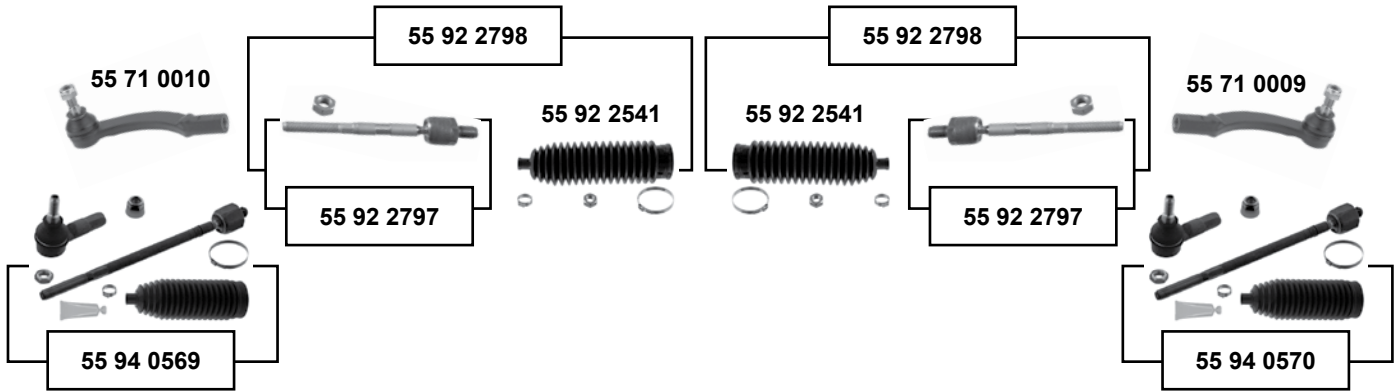

alle / all

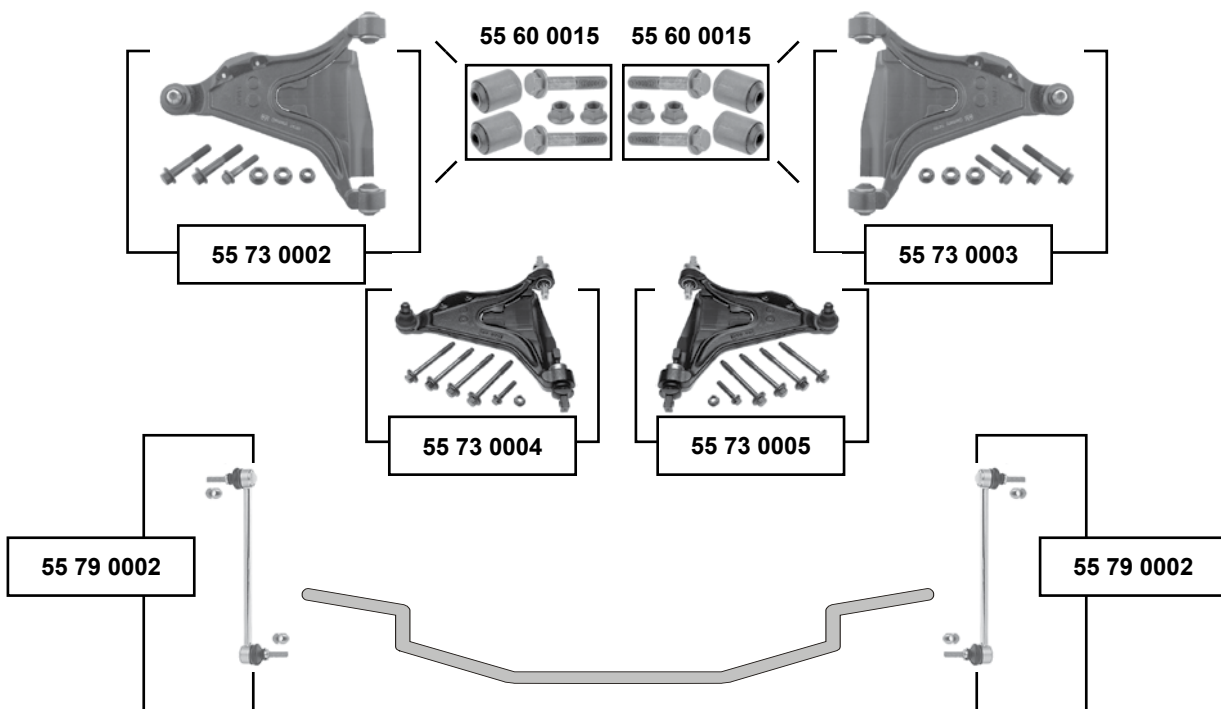

Vorderachse / Front axle

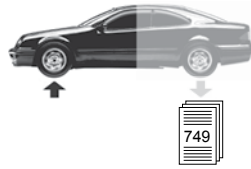

S 70 I / V 70 I
 (1997 → 2000)

	(1) S 70 (ch.) → 572014 V 70 (ch.) → 549830
	(2) Kunststoff / plastic / plastique / plástico / plastica
	(3) LHD → (ch.) 572014, 549830 / RHD → (ch.) 585074, 563168
	(4) LHD (ch.) 572015, 549831 → / RHD (ch.) 585075, 563169 →

	Ref. - No.			
55 60 0015	271631	Rep. Satz Querlenkerlager / rep. kit control arm mount	(ex.) Turbo / (ex.) Diesel	
55 71 0009	271599	Spurstangenendstück / tie rod end	(ex.) B5254T4	M14 x 2
55 71 0010	271598	Spurstangenendstück / tie rod end	(ex.) B5254T4	M14 x 2
55 73 0002	8628495	Rep. Satz Querlenker / rep. kit control arm	(ex.) Turbo / (ex.) Diesel	
55 73 0003	8628496	Rep. Satz Querlenker / rep. kit control arm	(ex.) Turbo / (ex.) Diesel	
55 73 0004	8628497	Rep. Satz Querlenker / rep. kit control arm	Turbo / Diesel	
55 73 0005	8628498	Rep. Satz Querlenker / rep. kit control arm	Turbo / Diesel	
55 74 0011	3546266	Spurstange / tie rod		L 195 M14x2
55 79 0002	30714686	Verbindungsstange / connecting rod		L 300
55 92 2541	9191409	Rep. Satz Lenkmanschette / rep. kit steering boot	→ 02/00 (2)	
55 92 2557	271601 SK	Rep. Satz Lenkmanschette / rep. kit steering boot	(1)	
55 92 2797	9191410 SK	Rep. Satz Spurstange / rep. kit tie rod		L 200 M14x2
55 92 2798	9191410	Rep. Satz Spurstange / rep. kit tie rod		L 200 M14x2
55 94 0567	3546266 S1	Rep. Satz Spurstange / rep. kit tie rod	(3)	
55 94 0568	3546266 S2	Rep. Satz Spurstange / rep. kit tie rod	(3)	
55 94 0569	9191410 S2	Rep. Satz Spurstange / rep. kit tie rod	(4)	
55 94 0570	9191410 S3	Rep. Satz Spurstange / rep. kit tie rod	(4)	

passend für / to fit

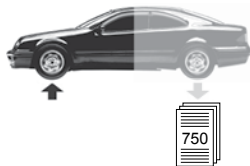
VOLVO



V 40 II
(2012 →)

Vorderachse / Front axle

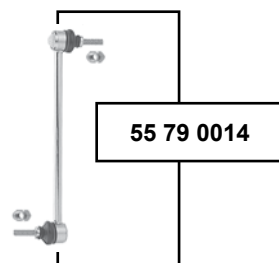
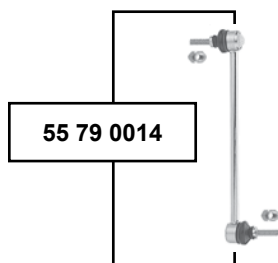

Ref. - No.



50 92 2408 8623576
50 93 8814 31317779

Verbindungsstange / connecting rod
Axialgelenk / axial joint

L 298
L 294

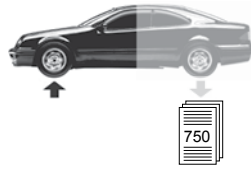

V 40 Cross Country
(2012 →)

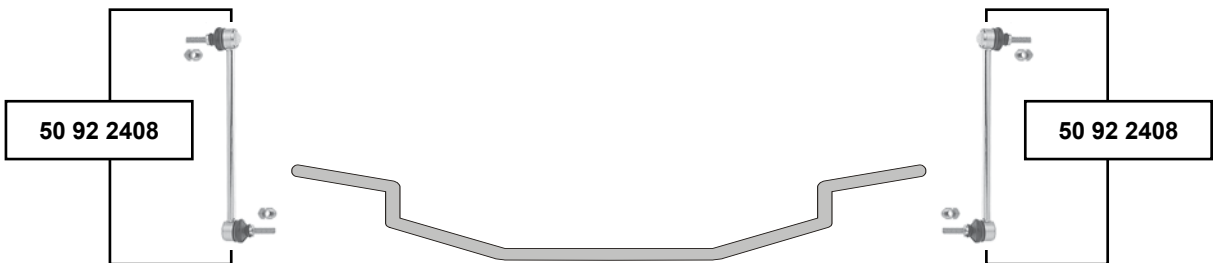
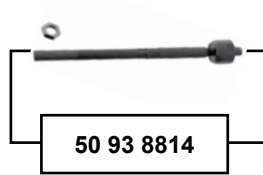

Vorderachse / Front axle



passend für / to fit

VOLVO

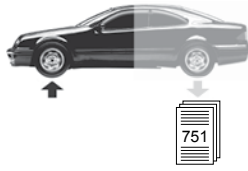



V 70 II



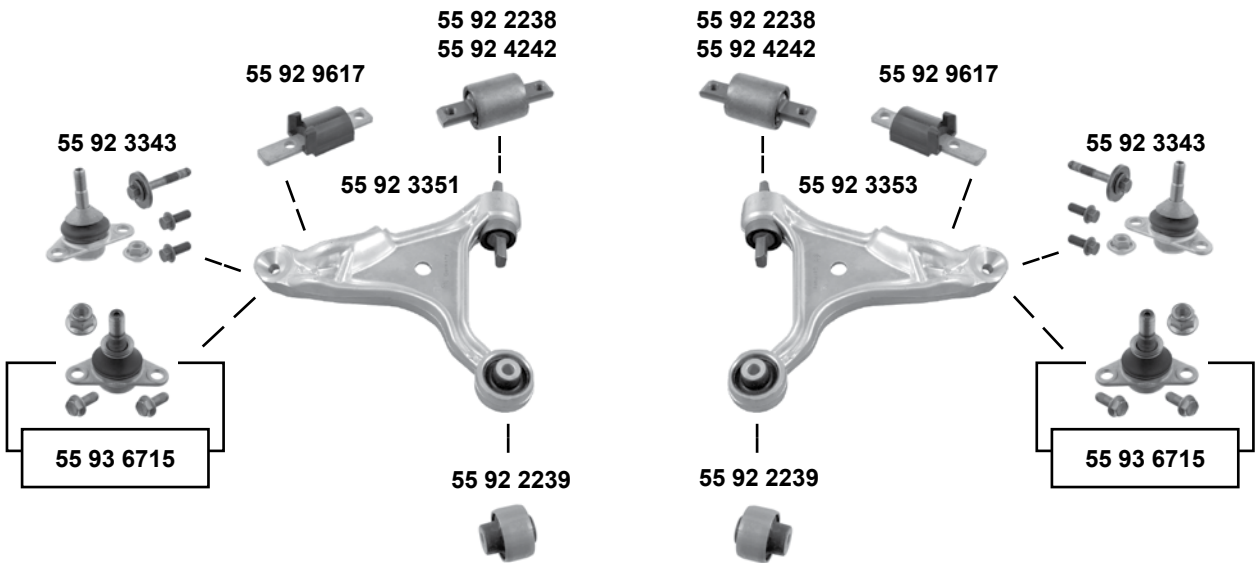
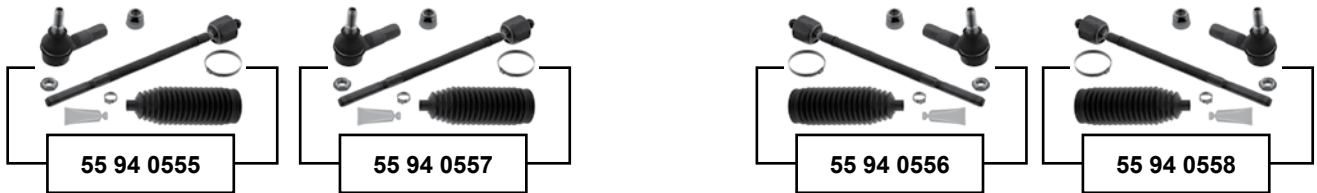
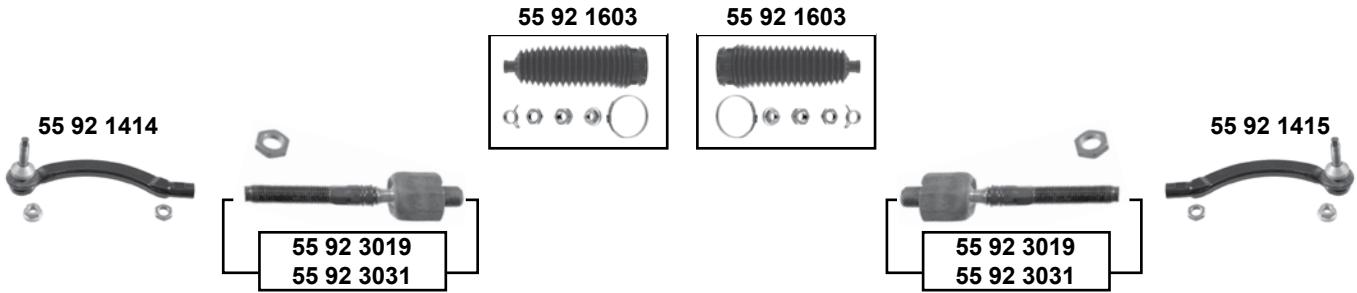

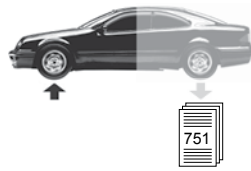

(2000 → 2007)

Vorderachse / Front axle





- (1) (ch.) → FC1 647148 / (ch.) → FC2 645617
- (2) (ex.) AWD (4x4) / → FC1 (ch.) 647148, 645617
- (3) (ch.) → FC1 647149 / (ch.) FC2 645618 →
- (4) ZF  / Mod.04 → / (ex.) B5254T4 / LHD
- (5) SMI  / Mod.→ 03 / (ex.) B5254T4 / LHD

	Ref. - No.			
55 91 9379	31212692	Verbindungsstange / connecting rod		L 335
55 92 1414	30761719	Spurstangenendstück / tie rod end	(ex.) B5254T4	M14 x 1,5
55 92 1415	30761718	Spurstangenendstück / tie rod end	(ex.) B5254T4	M14 x 1,5
55 92 1603	272418	Rep. Satz Lenkmanschette / rep. kit steering boot	LHD	
55 92 2238	9443882	Gummilager / rubber mount	wahlweise/alternatively	Ø I 48x123
55 92 2239	8630604	Gummilager / rubber mount	Alu/alloy / (2)	14x53x29/50
55 92 3019	274179	Spurstange / tie rod	SMI  / → Mod.03	L148
55 92 3031	274353	Spurstange / tie rod	ZF  / Mod.04 →	L141
55 92 3343	274548	Traggelenk / ball joint	(1)	
55 92 3351	30635229	Querlenker / control arm	(1)	
55 92 3353	30635230	Querlenker / control arm	(1)	
55 92 4242	9465971	Gummilager / rubber mount	wahlweise/alternatively	Ø I 48x123
55 92 9617	31212191	Anschlagpuffer / buffer	schwarz / black	100x31x27
55 93 6715	31201485	Traggelenk / ball joint	(3)	M14 x 1,5
55 94 0555	274353 S1	Rep. Satz Spurstange / rep. kit tie rod	(4)	
55 94 0556	274353 S2	Rep. Satz Spurstange / rep. kit tie rod	(4)	
55 94 0557	274179 S1	Rep. Satz Spurstange / rep. kit tie rod	(5)	
55 94 0558	274179 S2	Rep. Satz Spurstange / rep. kit tie rod	(5)	

passend für / to fit

VOLVO

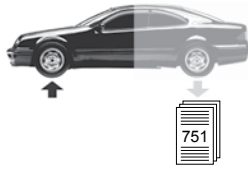

V 70 XC II / XC 70 II

(2000 → 2007)

Vorderachse / Front axle

55 93 9833



55 92 1603

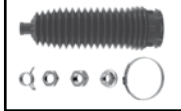

55 92 1603



55 93 9833



55 92 1414

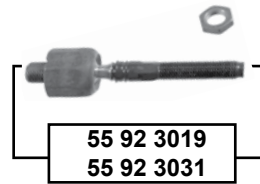
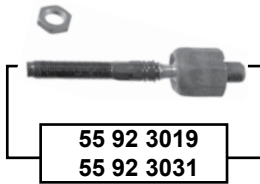

55 92 1415



55 94 0555



55 94 0557



55 94 0556



55 94 0558



55 92 9617

55 92 2238

55 92 2238

55 92 9617

55 92 3343

55 93 2511

55 93 2512

55 92 3343

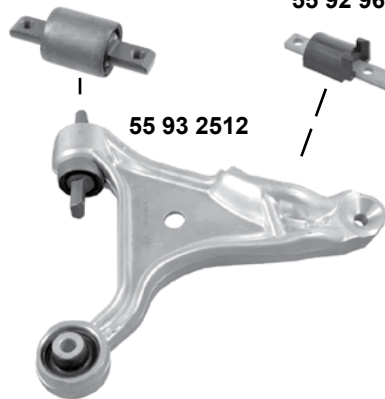
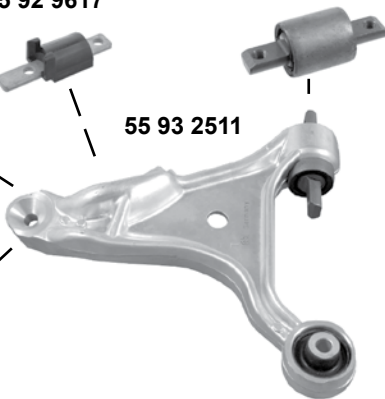

55 93 6715



55 93 6715



55 91 9379

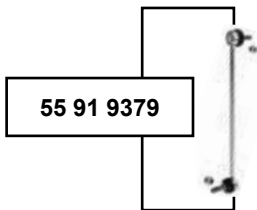

55 91 9379

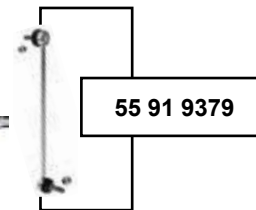

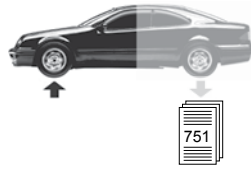

V 70 XC II / XC 70 II

(2000 → 2007)



- (1) XC 70 II (ch.) → 269745
- (2) nur für geschwindigkeitsabhängige Servolenkung / only for speed depending power steering
- (3) XC 70 II ZF / Mod.04 → / (ex.) B5254T4 / LHD
- (4) V 70 XC II ZF / Mod.04 → / LHD
- (5) XC 70 II SMI / Mod.→ 03 / (ex.) B5254T4 / LHD
- (6) V 70 XC II SMI / Mod.→ 03 / LHD

	Ref. - No.			
55 91 9379	31212692	Verbindungsstange / connecting rod		L 335
55 92 1414	30761718	Spurstangenendstück / tie rod end	XC 70 II (ex.) B5254T4	
55 92 1415	30761718	Spurstangenendstück / tie rod end	XC 70 II (ex.) B5254T4	
55 92 1603	272418	Rep. Satz Lenkmanschette / rep. kit steering boot	LHD	
55 92 2238	9443882	Gummilager / rubber mount		Ø 48x123
55 92 3019	274179	Spurstange / tie rod	SMI / → Mod.03	L 148
55 92 3031	274353	Spurstange / tie rod	ZF / Mod.04 →	L 141
55 92 3343	274548	Traggelenk / ball joint	(1)	
55 92 9617	31212191	Anschlagpuffer / buffer	schwarz / black	100x31x27
55 93 2511	30635231	Querlenker / control arm		
55 93 2512	30635232	Querlenker / control arm		
55 93 6715	31201485	Traggelenk / ball joint	XC 70 II (ch.) 269746 →	M14 x 1,5
55 93 9833	30776252	Rep. Satz Lenkmanschette / rep. kit steering boot	(2) XC 70 II	
55 94 0555	274353 S1	Rep. Satz Spurstange / rep. kit tie rod	(3) (4)	
55 94 0556	274353 S2	Rep. Satz Spurstange / rep. kit tie rod	(3) (4)	
55 94 0557	274179 S1	Rep. Satz Spurstange / rep. kit tie rod	(5) (6)	
55 94 0558	274179 S2	Rep. Satz Spurstange / rep. kit tie rod	(5) (6)	

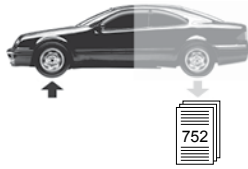

V 70 III / XC 70 III

(2008 →)

Vorderachse / Front axle

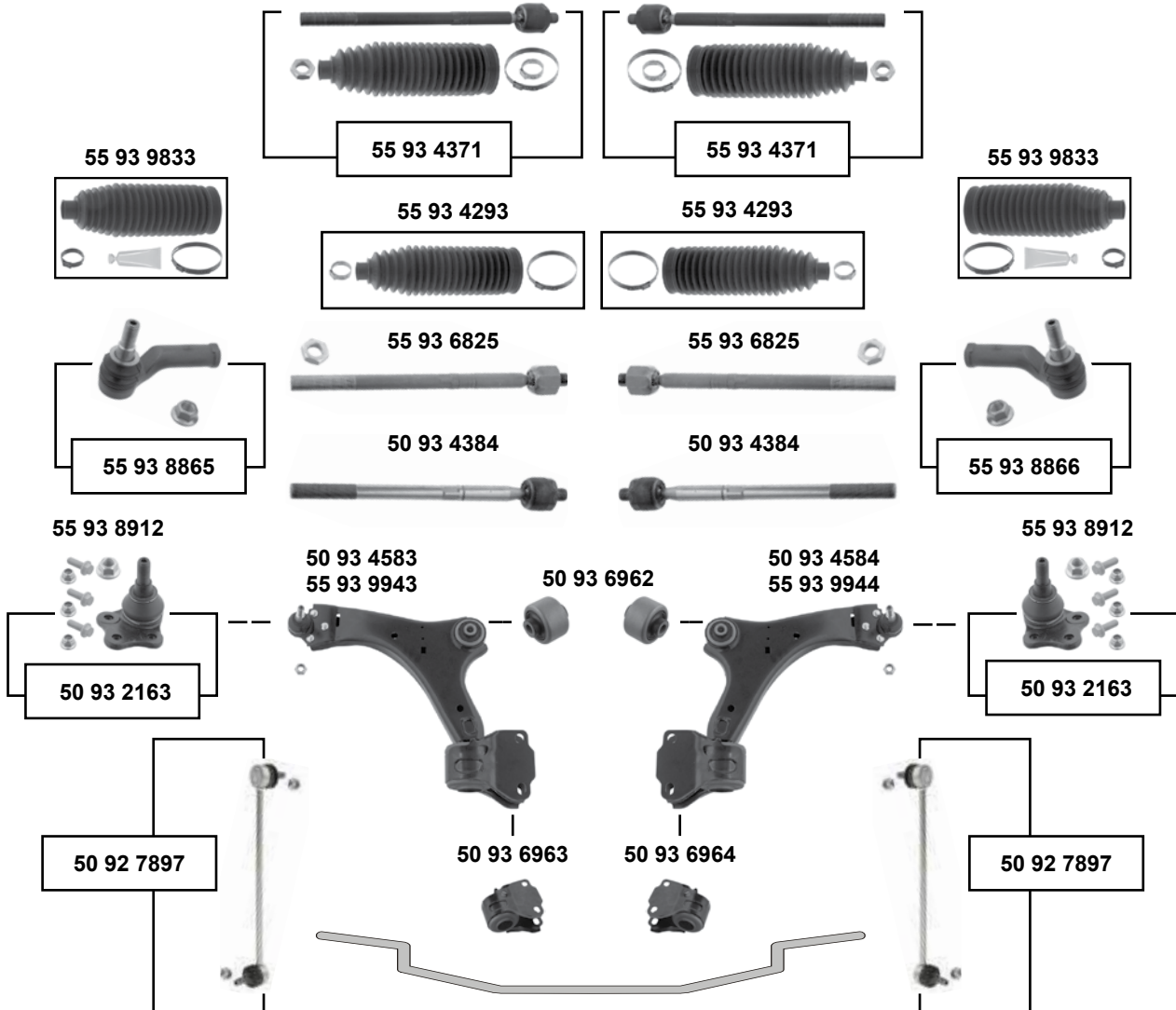

- (1) (ex.) XC 70 / V 70 III 4x4
- (2) V 70 III (ex.) 4x4 → (ch.) 213026
- (3) nur für geschwindigkeitsabhängige Servolenkung / only for speed depending power steering



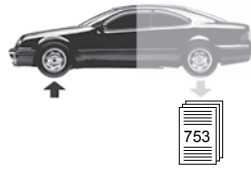

Ref. - No.			
50 92 7897	30648461	Verbindungsstange / connecting rod	L300
50 93 2163	31317661 SK	Traggelenk / ball joint	M14 x 1,5
50 93 4384	31280658 SK 1	Axialgelenk / axial joint	(1) (ex.) E-servo
50 93 4583	31317661	Querlenker / control arm	(2)
50 93 4584	31317662	Querlenker / control arm	(2)
50 93 6962	31317661 SK 1	Querlenkerlager / control arm mount	V 70 III
50 93 6963	31387571	Querlenkerlager / control arm mount	V 70 III
50 93 6964	31387572	Querlenkerlager / control arm mount	V 70 III
55 93 4293	30776251	Rep. Satz Lenkmanschette / rep. kit steering boot	(ex.) E-servo
55 93 4371	31280658 SK 2	Rep. Satz Axialgelenk / rep. kit axial joint	(ex.) E-servo
55 93 6825	30776255 SK	Axialgelenk / axial joint	E-servo
55 93 8865	31302344	Spurstangenendstück / tie rod end	(ex.) 4x4
55 93 8866	31302345	Spurstangenendstück / tie rod end	(ex.) 4x4
55 93 8912	31317665 SK	Traggelenk / ball joint	XC 70 III
55 93 9833	30776252	Rep. Satz Lenkmanschette / rep. kit steering boot	(3) V 70 III
55 93 9943	31317663	Querlenker / control arm	XC 70 III
55 93 9944	31317664	Querlenker / control arm	XC 70 III

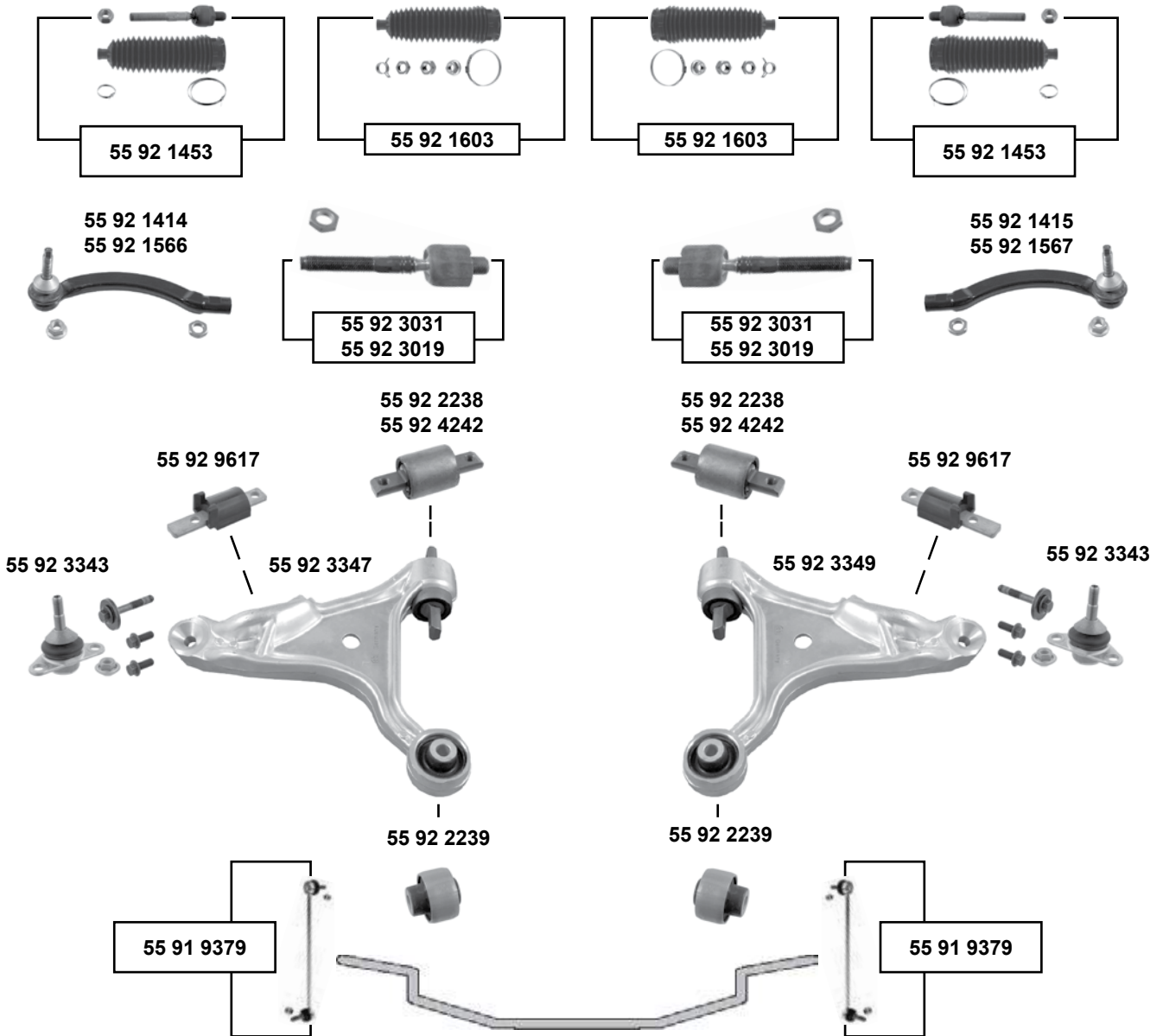

S 80 I (1999 → 2007)



Vorderachse / Front axle

SWAG [®]	Ref. - No.			
55 91 9379	31212692	Verbindungsstange / connecting rod		L 335
55 92 1414	30761719	Spurstangenendstück / tie rod end	00 → (ex.) B5254T4	M14 x 1,5
55 92 1415	30761718	Spurstangenendstück / tie rod end	00 → (ex.) B5254T4	M14 x 1,5
55 92 1453	272428	Spurstange / tie rod	Mod. 99	M14 x 2
55 92 1566	272416	Spurstangenendstück / tie rod end	Mod. 99	M14 x 2
55 92 1567	272417	Spurstangenendstück / tie rod end	Mod. 99	M14 x 2
55 92 1603	272418	Rep. Satz Lenkmanschette / rep. kit steering boot		
55 92 2238	9443882	Gummilager / rubber mount	LHD	∅ 48x123
55 92 2239	8630604	Gummilager / rubber mount	wahlweise/alternatively	14x53x29/50
55 92 3019	274179	Spurstange / tie rod	Alu/alloy	L 148
55 92 3031	274353	Spurstange / tie rod	SMI  / Mod.00 → 03	L 141
55 92 3343	274548	Traggelenk / ball joint	ZF  / Mod.04 →	
55 92 3347	30635227	Querlenker / control arm		
55 92 3349	30635228	Querlenker / control arm		
55 92 4242	9465971	Gummilager / rubber mount	wahlweise/alternatively	∅ 48x123
55 92 9617	31212191	Anschlagpuffer / buffer	schwarz / black	100x31x27

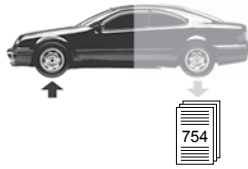

S 80 II
(2007→)

Vorderachse / Front axle

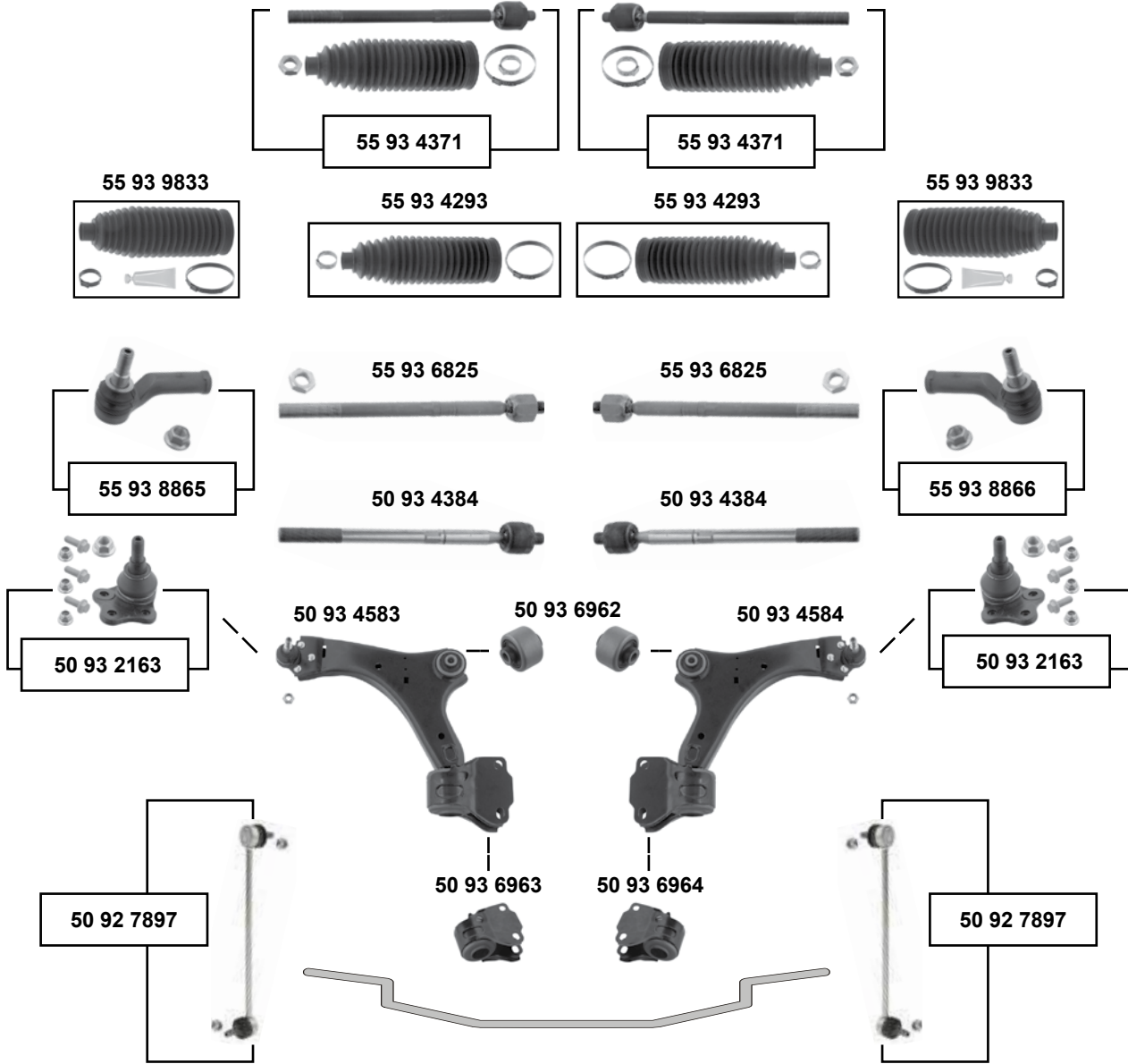

(1) S 80 II (ex.) 4x4 (ch.) → 151013



Ref. - No.



SWAG Ref. - No.	Description	Notes	Dimensions
50 92 7897	30648461 Verbindungsstange / connecting rod		L300
50 93 2163	31317661 SK Traggelenk / ball joint	(ex.) 4x4	M14 x 1,5
50 93 4384	31280658 SK 1 Axialgelenk / axial joint	(ex.) E-servo	
50 93 4583	31317661 Querlenker / control arm	(1)	
50 93 4584	31317662 Querlenker / control arm	(1)	
50 93 6962	31317661 SK 1 Querlenkerlager / control arm mount	(ex.) 4x4	Ø A 60
50 93 6963	31387571 Querlenkerlager / control arm mount	(ex.) 4x4	
50 93 6964	31387572 Querlenkerlager / control arm mount	(ex.) 4x4	
55 93 4293	30776251 Rep. Satz Lenkmanschette / rep. kit steering boot	(ex.) 4x4	
55 93 4371	31280658 SK 2 Rep. Satz Axialgelenk / rep. kit axial joint	(ex.) E-servo	
55 93 6825	30776255 SK Axialgelenk / axial joint	(ex.) E-servo	
55 93 8865	31302344 Spurstangenendstück / tie rod end	E-servo	M18 x 1,5
55 93 8866	31302345 Spurstangenendstück / tie rod end		L 112
55 93 9833	30776252 Rep. Satz Lenkmanschette / rep. kit steering boot	E-servo	L 112

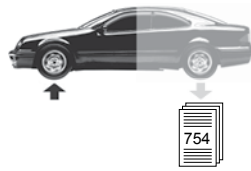

S 90 / V 90

(1997 → 1998)

CAM

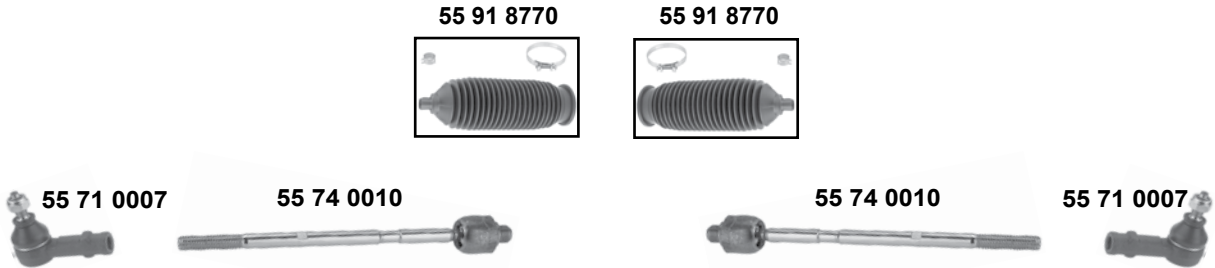

TRW

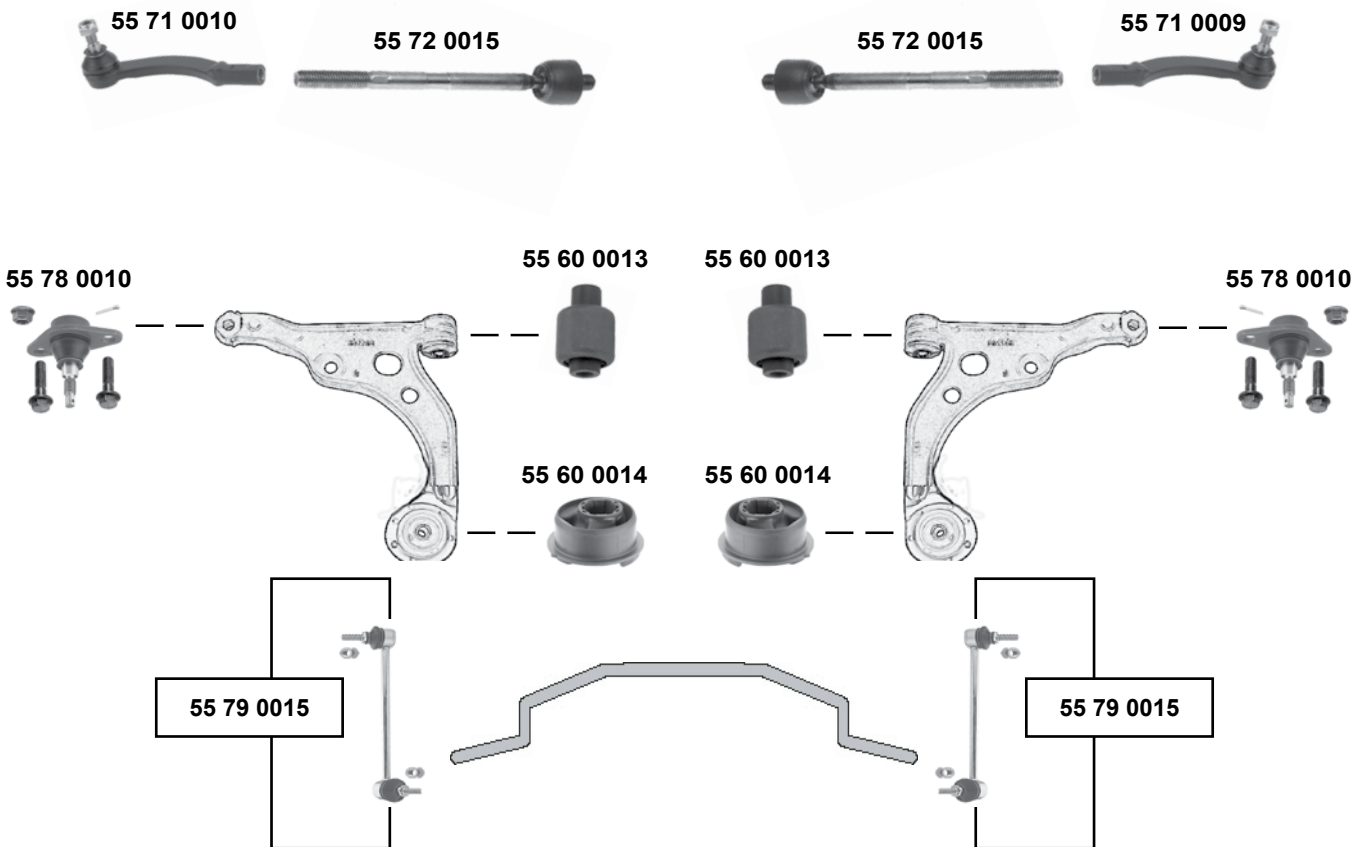

Vorderachse / Front axle

SWAG	Ref. - No.			
55 60 0013	6819537	Querlenkerlager / control arm mount		12x40x39/65
55 60 0014	9191537	Querlenkerlager / control arm mount		
55 71 0007	3516944	Spurstangenendstück / tie rod end		M12 x 1,5
55 71 0009	271599	Spurstangenendstück / tie rod end		M14 x 2
55 71 0010	271598	Spurstangenendstück / tie rod end		M14 x 2
55 72 0015	9140788	Spurstange / tie rod		L 240
55 74 0010	9140504	Spurstange / tie rod		L 310
55 78 0010	270477	Traggelenk / ball joint		
55 79 0015	272991	Verbindungsstange / connecting rod		L 245
55 91 8770	270597 S1	Rep. Satz Lenkmanschette / rep. kit steering boot		

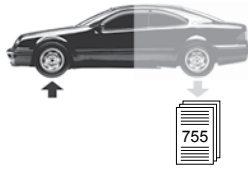

755

XC 60
(2010 →)

Vorderachse / Front axle

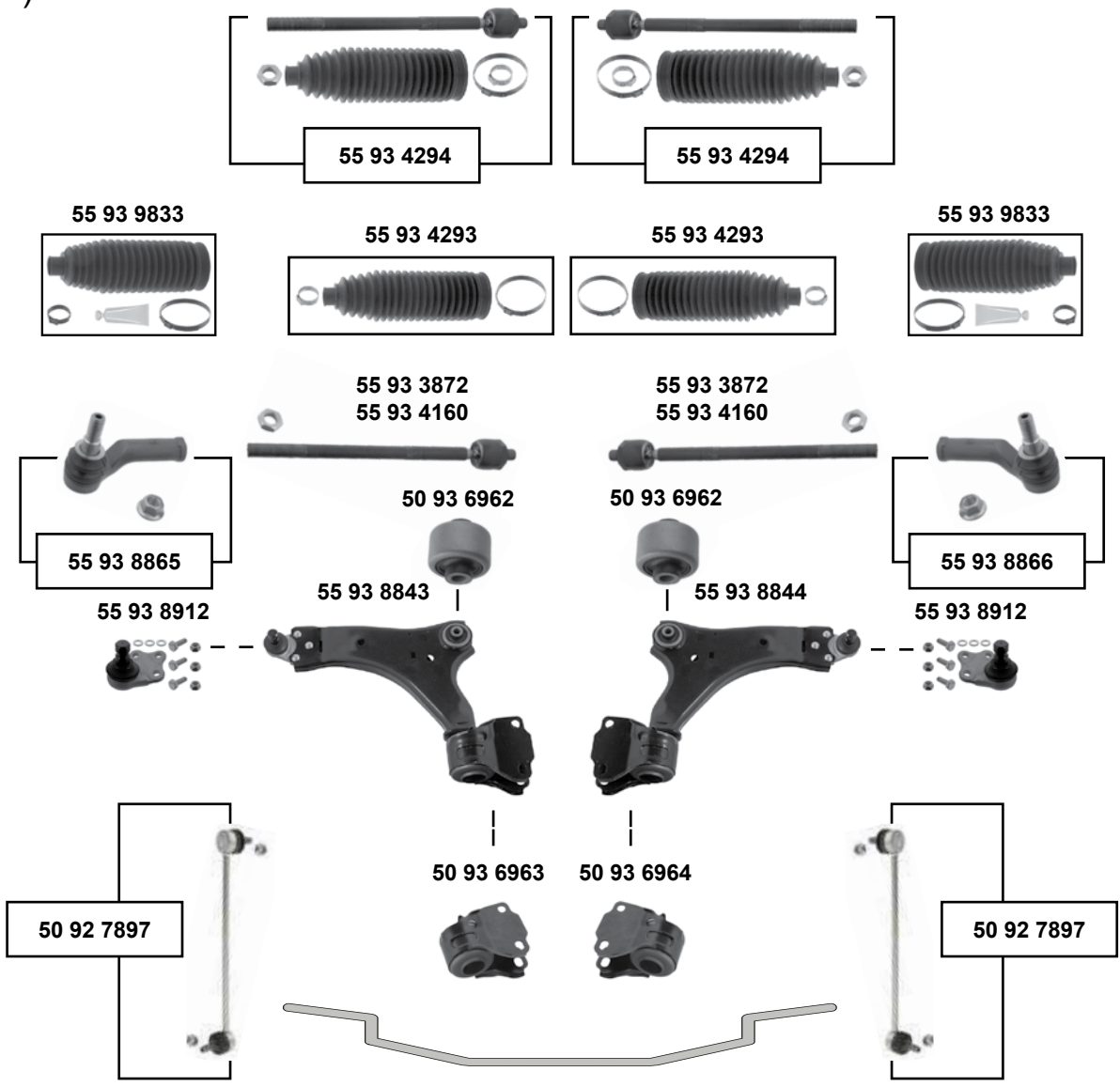

- (1) Modelle ohne elektronische Servolenkung / models without electronical power steering
- (2) Modelle mit elektronischer Servolenkung / models with electronical power steering



Ref. - No.			
50 92 7897	30648461	Verbindungsstange / connecting rod	L300
50 93 6962	31317661 SK1	Querlenkerlager / control arm mount	(ex.) 4x4 60x38x60
50 93 6963	31387571	Querlenkerlager / control arm mount	
50 93 6964	31387572	Querlenkerlager / control arm mount	
55 93 3872	31280409 SK	Axialgelenk / axial joint	(1) L350
55 93 4160	31280408 SK	Axialgelenk / axial joint	(2) L318
55 93 4293	30776251	Rep. Satz Lenkmanschette / rep. kit steering boot	(1)
55 93 4294	31280409	Rep. Satz Axialgelenk / rep. kit axial joint	(1)
55 93 8843	31317665	Querlenker / control arm	
55 93 8844	31317666	Querlenker / control arm	
55 93 8865	31302344	Spurstangenendstück / tie rod end	L 112
55 93 8866	31302345	Spurstangenendstück / tie rod end	L 112
55 93 8912	31317665 SK	Traggelenk / ball joint	Ø 22
55 93 9833	30776252	Rep. Satz Lenkmanschette / rep. kit steering boot	(2)

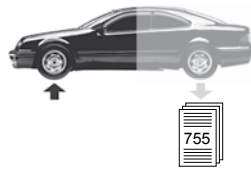

XC 90 I

(2002 → 2014)

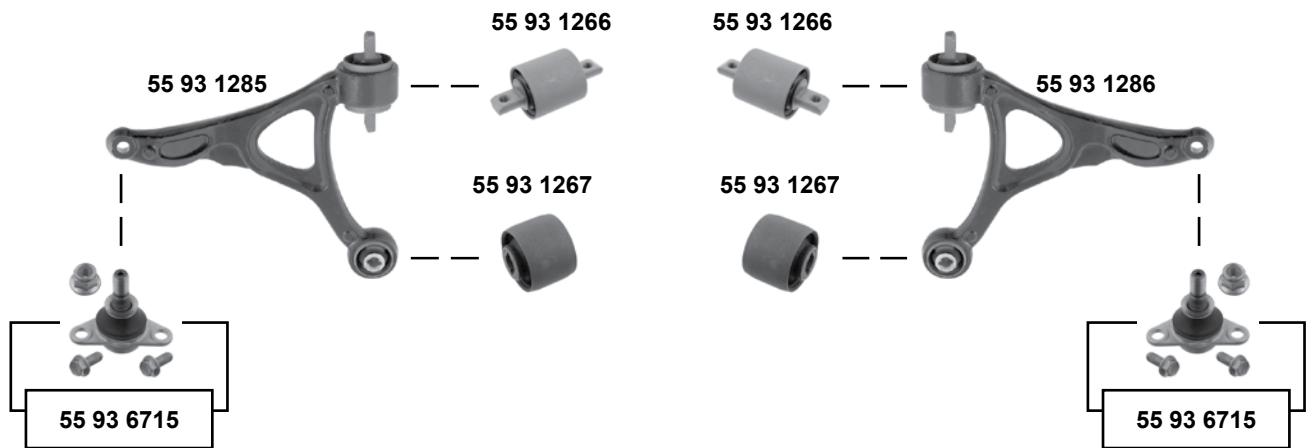
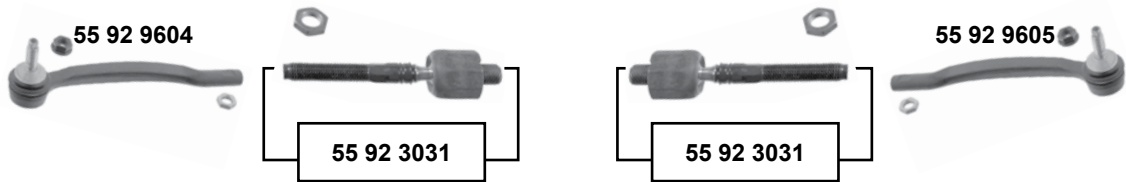

SWAG	Ref. - No.			
55 91 9379	31212692	Verbindungsstange / connecting rod	ZF	L335
55 92 3031	274353	Spurstange / tie rod	ZF	L141
55 92 9604	31201228	Spurstangenendstück / tie rod end		
55 92 9605	31201229	Spurstangenendstück / tie rod end		
55 93 1266	30639368	Querlenkerlager / control arm mount		10x58x123
55 93 1267	31304040	Querlenkerlager / control arm mount		20x98x280
55 93 1285	31201004	Querlenker / control arm		
55 93 1286	31201005	Querlenker / control arm		
55 93 6715	31201485	Traggelenk / ball joint		M14 x 1,5

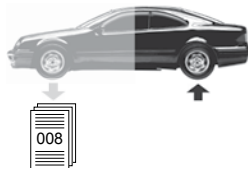

Micra (K11)
(1992 → 2003)



Murano (Z50)
(2004 → 2008)

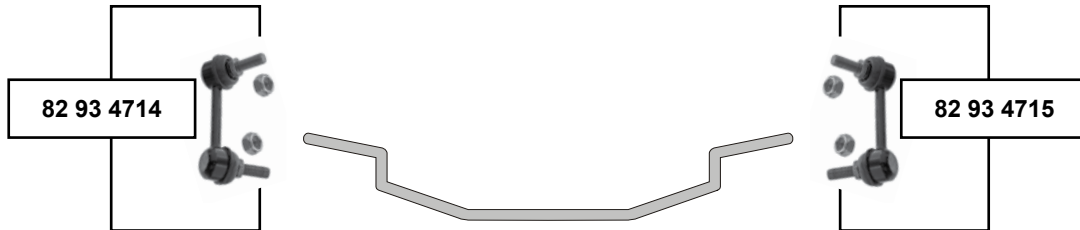

Murano (Z51)
(2008 →)

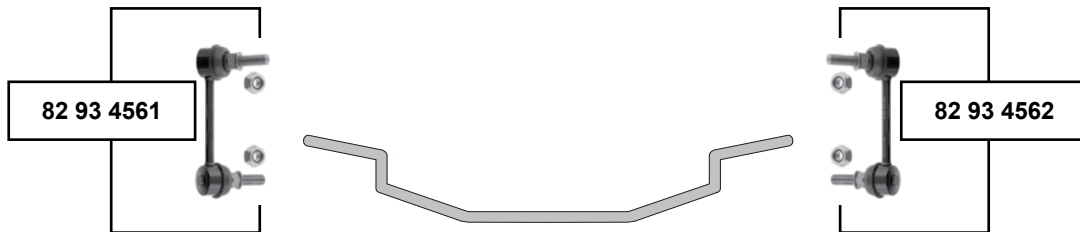

Hinterachse / Rear axle



- (1) 06/08 → (mot.) 3,5 Benzin (VQ35DE), (mot.) 2,5 Diesel (YD25)
- (2) 11/04 → 06/08 (mot.) VQ35DE



Ref. - No.



82 91 5425	56261-4F725	Verbindungsstange / connecting rod		L 90
82 93 4561	56261-1AA0B	Verbindungsstange / connecting rod	(1)	L 105
82 93 4562	56261-1AA0A	Verbindungsstange / connecting rod	(1)	L 105
82 93 4714	54668-CA010	Verbindungsstange / connecting rod	(2)	L 85
82 93 4715	54618-CA010	Verbindungsstange / connecting rod	(2)	L 85

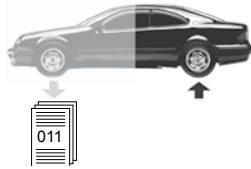

NV400 (X62)
(1997 → 2004)



Pathfinder (R50)
(1997 → 2004)



Hinterachse / Rear axle



(1) Alle mit Heckantrieb und Doppelbereifung / all with rear drive and double tires



Ref. - No.



40 94 4428 56261-00Q0B
82 93 1139 56260-0W001

Verbindungsstange / connecting rod
Verbindungsstange / connecting rod

(1)

L 166
L 210

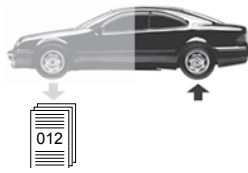

Pathfinder (R51)

(2005 →)

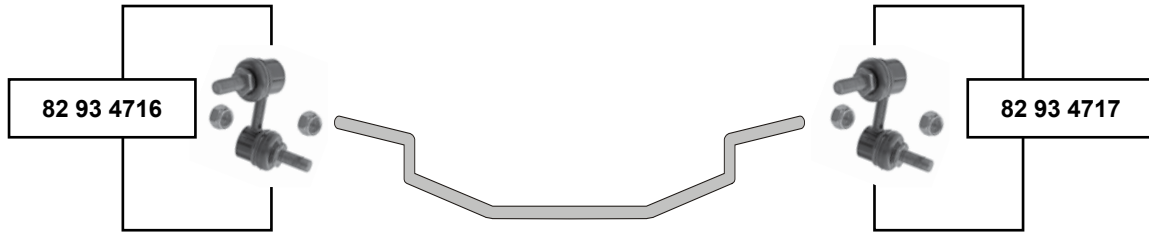

Patrol (Y60 + Y61)

(1987 →)

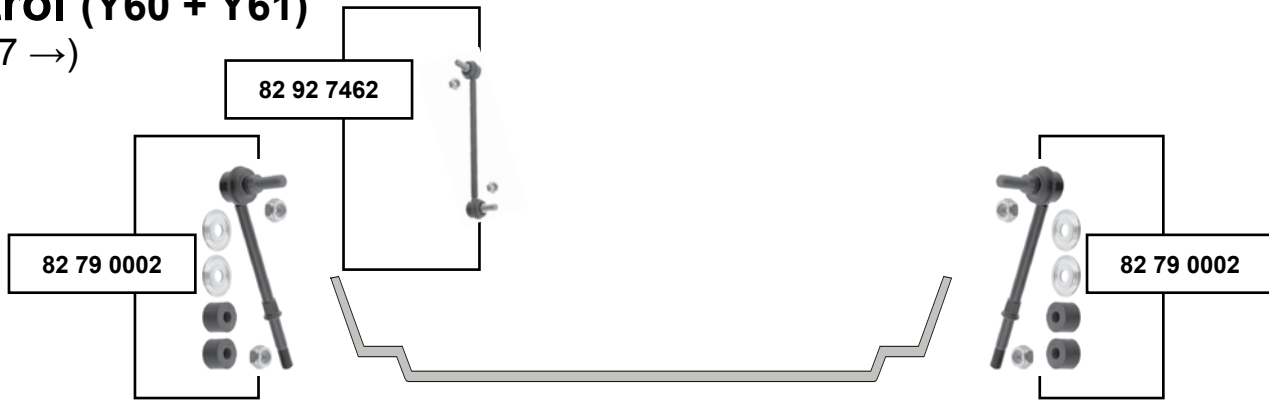

Primera (P10 / W10)

(1990 → 1998)



Primera (P12 / WP12)

(2002 →)



Hinterachse / Rear axle



(1) 01/05 → (mot.) YD25DDTi, (mot.) VQ40DE, (mot.) V9X



Ref. - No.



82 79 0002	56260-01J10	Verbindungsstange / connecting rod	→ 10/02	L 161
82 79 0004	56261-86J25	Verbindungsstange / connecting rod		L 115
82 92 7462	56260-VB010	Verbindungsstange links / connecting rod left	Y 61 → 11/06	L 235
82 93 2567	56261-AV611	Verbindungsstange / connecting rod		L 90,5
82 93 4716	56261-EA510	Verbindungsstange / connecting rod	(1)	L 65
82 93 4717	56261-EA500	Verbindungsstange / connecting rod	(1)	L 65

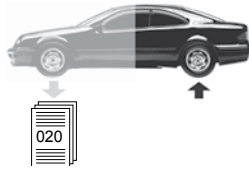

Qashqai (J10E/JJ10E) (2006 →)

82 93 2574

82 93 2573

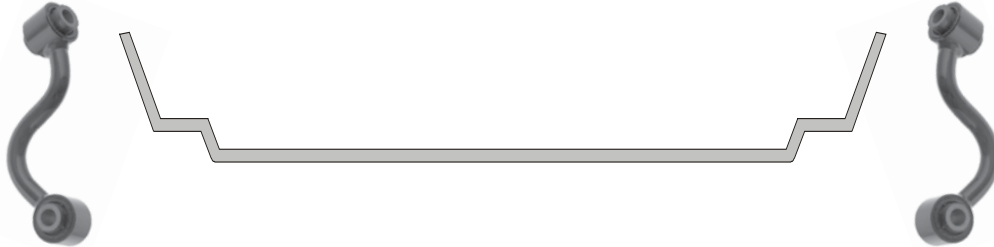

Teana (J31) (2007 →)

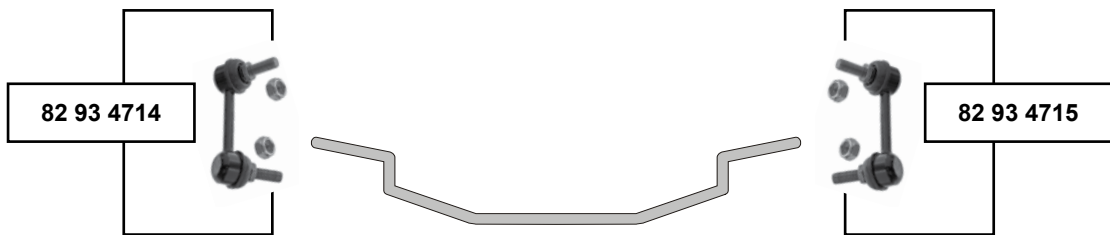

82 93 4714

82 93 4715

Teana (J32R) (2009 →)

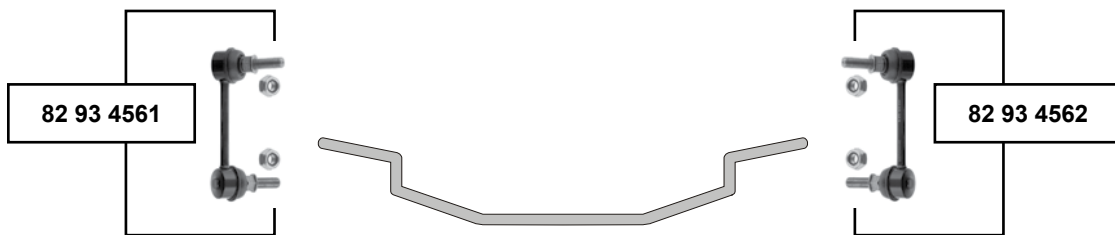

82 93 4561

82 93 4562

- (1) Qashqai (JJ10E) 08/08 →
- (2) Teana (J32R) 03/10 → (mot.) 2,5 Benzin (QR25DE)
- (3) Teana (J31) 05/07 → (mot.) QR20DE, VQ23DE



Ref. - No.	Description	Quantity	Length
82 93 2573	55618-JD00A Verbindungsstange / connecting rod	(1)	L 142,5
82 93 2574	55619-JD00A Verbindungsstange / connecting rod	(1)	L 142,5
82 93 4561	56261-1AA0B Verbindungsstange / connecting rod	(2)	L 105
82 93 4562	56261-1AA0A Verbindungsstange / connecting rod	(2)	L 105
82 93 4714	54668-CA010 Verbindungsstange / connecting rod	(3)	L 85
82 93 4715	54618-CA010 Verbindungsstange / connecting rod	(3)	L 85

passend für / to fit

NISSAN

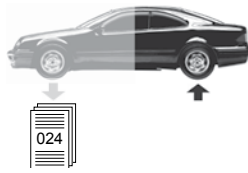

Terrano II (R20)

(1993 →)



X-Trail (T30)

(2001 → 2007)



X-Trail (T31 / T31R)

(2007 →)

82 93 2574



82 93 2573



Hinterachse / Rear axle



Ref. - No.



82 92 4016	56260-0F001
82 92 7305	56261-EQ000
82 93 2573	55 61 8JY 00B
82 93 2574	55 61 9JY 00B

Verbindungsstange / connecting rod
Verbindungsstange / connecting rod
Verbindungsstange / connecting rod
Verbindungsstange / connecting rod

L 208
L 115 / 10 x 1,25
L 142,5
L 142,5

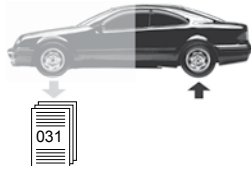

Antara
(2006 →)

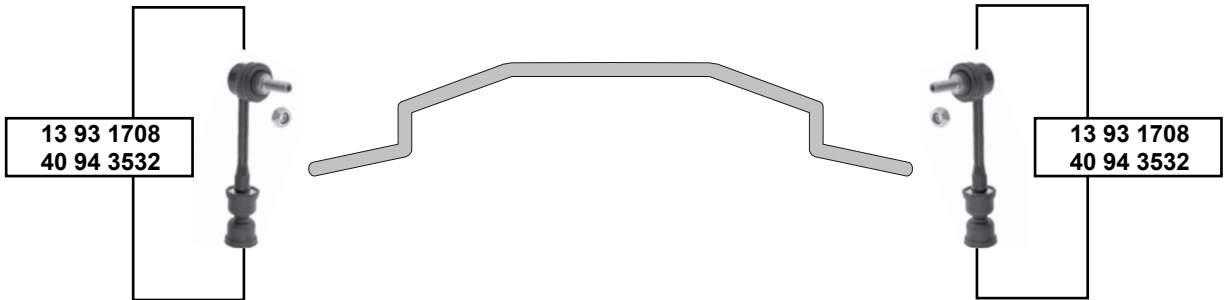

Hinterachse / Rear axle



(1) (ch.) → AB999999, → A3999999

(2) (ch.) BB000001 →, B3000001 →



Ref. - No.



13 93 1708 4817 539
40 94 3532 4808 136

Verbindungsstange / connecting rod
Verbindungsstange / connecting rod

(1)
(2)

L 167
L 106,5

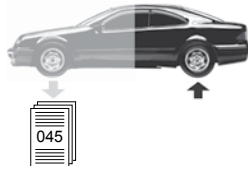

Calibra

(1990 → 1997)

40 79 0012

40 79 0012

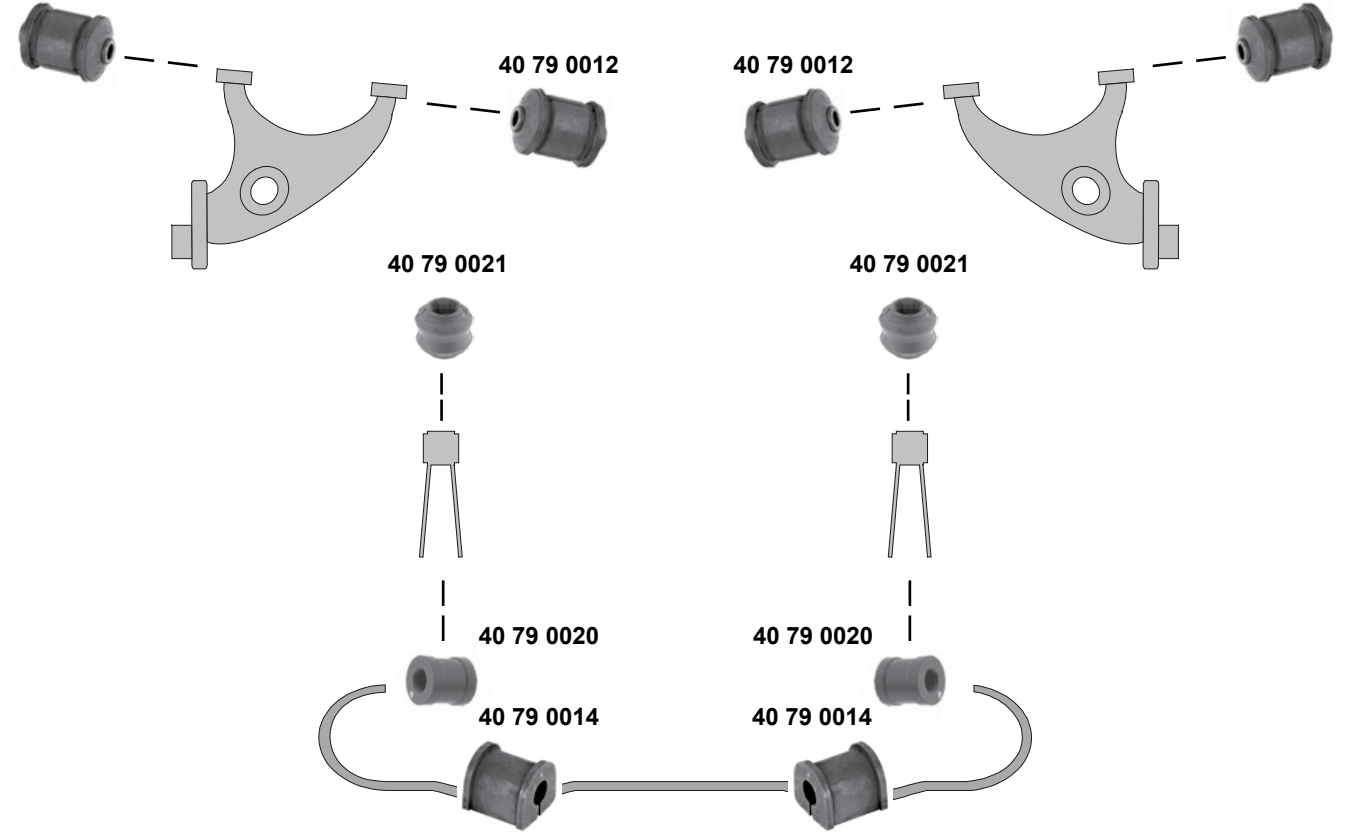

Insignia

(2008 →)

40 93 9089

40 93 9089

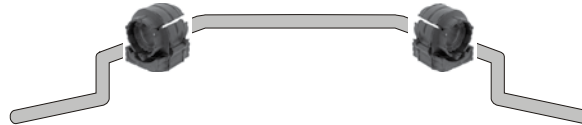

Hinterachse / Rear axle

- (1) Schrägheck/Stufenheck:
Standardchassis / standard chassis alle/all
tiefergelegtes chassis / lowered chassis nur/only Diesel D-1000001 →
HD (ex.) A14NET, A16LET, A20XER, Diesel D1000001 →
Sportstourer: **HD** nur/only Diesel D-1000001 →



Ref. - No.



40 79 0012	0423 313
40 79 0014	0444 153
40 79 0020	0444 336
40 79 0021	0444 347
40 93 9089	0444 091

Schräglenkerlager / semi-trailing arm bush
Stabilisatorlager / stabilizer mount
Stabilisatorlager / stabilizer mount
Verbindungsstangenlager / connecting rod bearing
Stabilisatorlager / stabilizer mount

(1) (ex.) 4x4

12x45x71
Ø 14
13x26x28
Ø 20

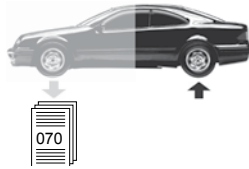

Movano B (2010 →)

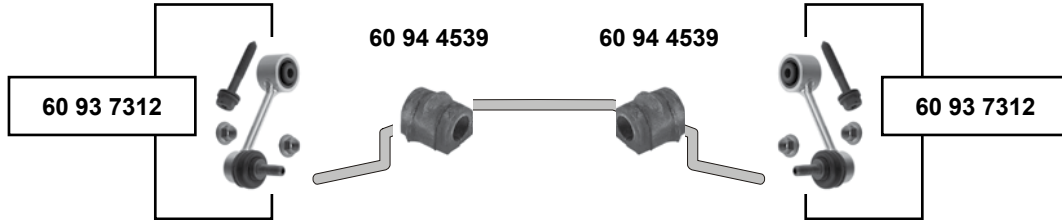

Omega A (1986 → 1994)

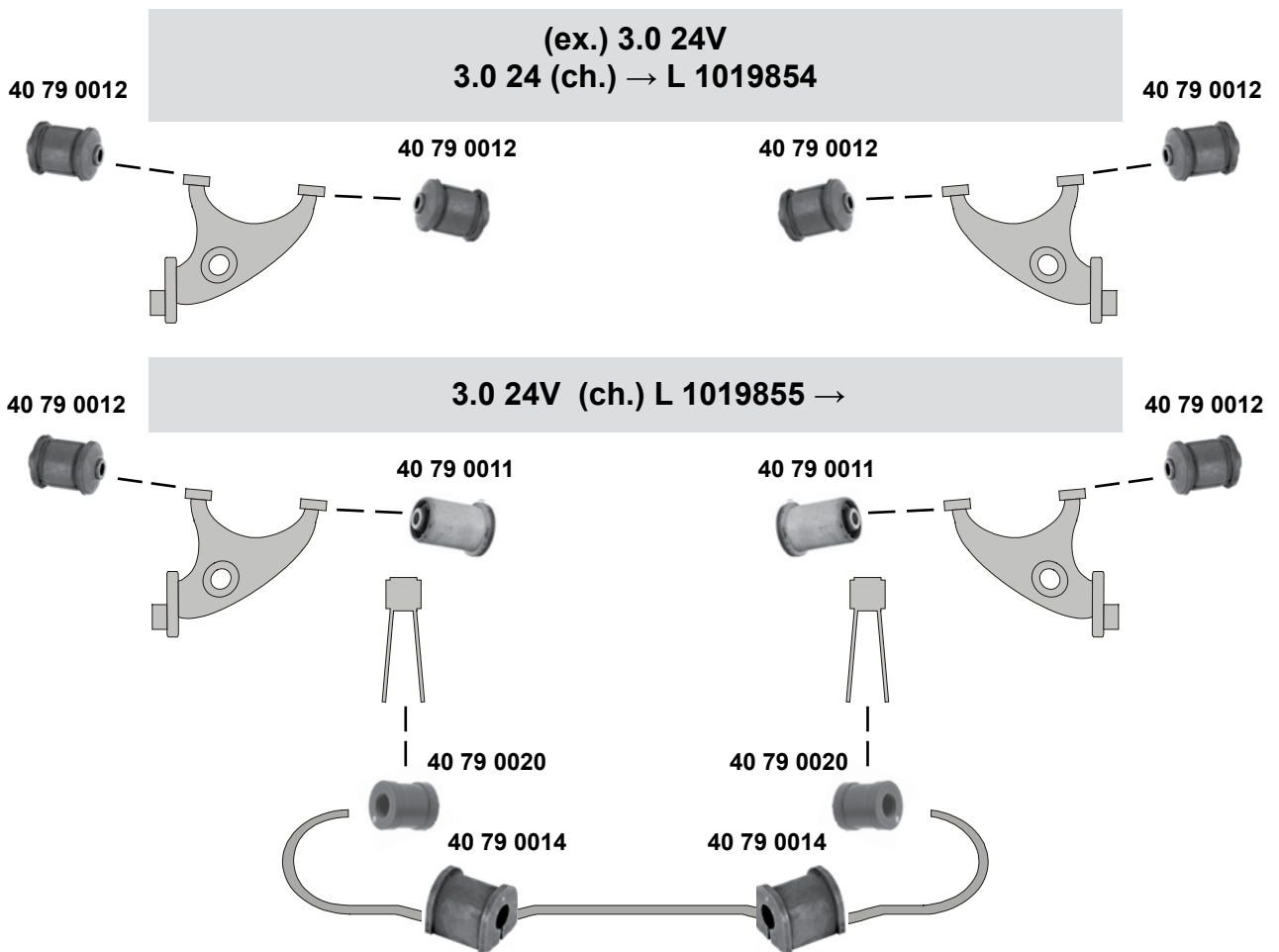

Hinterachse / Rear axle



(1) nur Fahrzeuge mit Frontantrieb / only vehicles with front wheel drive

(2) Vorderradantrieb + Hinterradantrieb mit Einzelbereifung / front wheel drive + rear-wheel drive with single tires



Ref. - No.





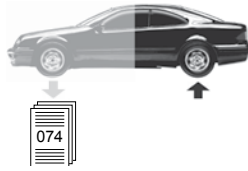

40 79 0011	0423 315	Schräglager / semi-trailing arm bush		12x43x71
40 79 0012	0423 313	Schräglager / semi-trailing arm bush		12x45x71
40 79 0014	0444 153	Stabilisatorlager / stabilizer mount		Ø 14
40 79 0020	0444 336	Stabilisatorlager / stabilizer mount		13x26x28
60 93 7312	4419 304 S1	Rep. Satz Verbindungsstange / rep. kit connecting rod	(2)	L 105,5
60 94 4539	4419 308	Stabilisatorlager / stabilizer mount	(1)	Ø 28

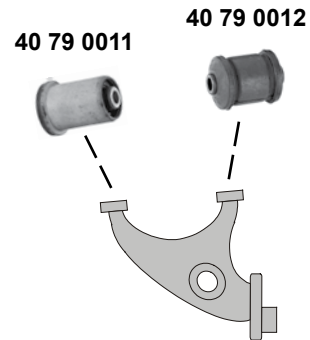
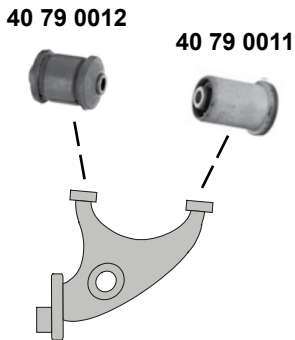
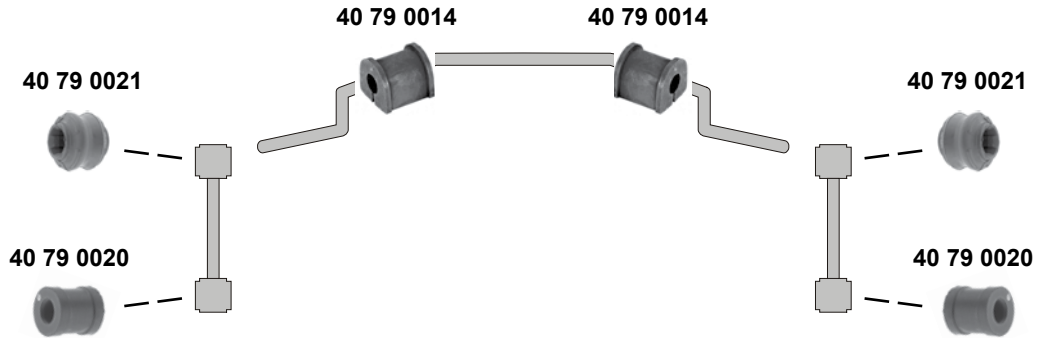

Omega B
(1994 → 2003)



Hinterachse / Rear axle

	Ref. - No.			
40 79 0011	0423 315	Schräglenkerlager / semi-trailing arm bush		12x43x71
40 79 0012	0423 313	Schräglenkerlager / semi-trailing arm bush		12x45x71
40 79 0014	0444 153	Stabilisatorlager / stabilizer mount		Ø 1 14
40 79 0020	0444 336	Stabilisatorlager / stabilizer mount		13x26x28
40 79 0021	0444 347	Verbindungsstangenlager / connecting rod bearing		29/32x29

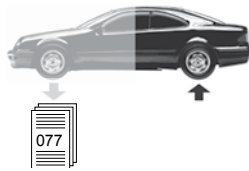

Senator B
(1986 → 1994)

(ch.) → L 1019854 / 5155054

40 79 0012

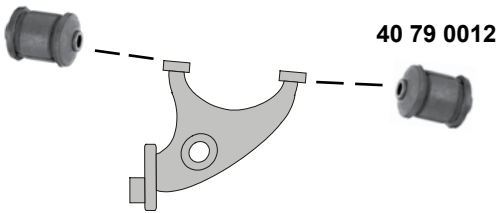

40 79 0012

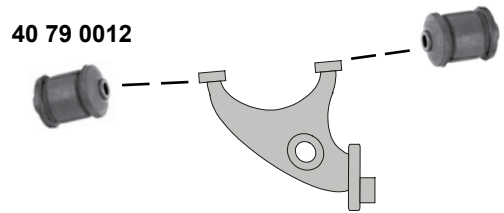

(ch.) L 1019855 / 5155055 →

40 79 0012

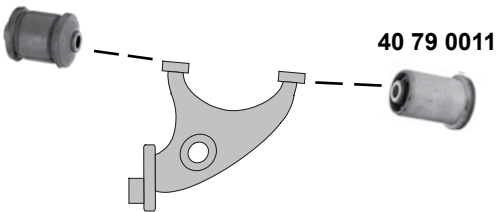

40 79 0012

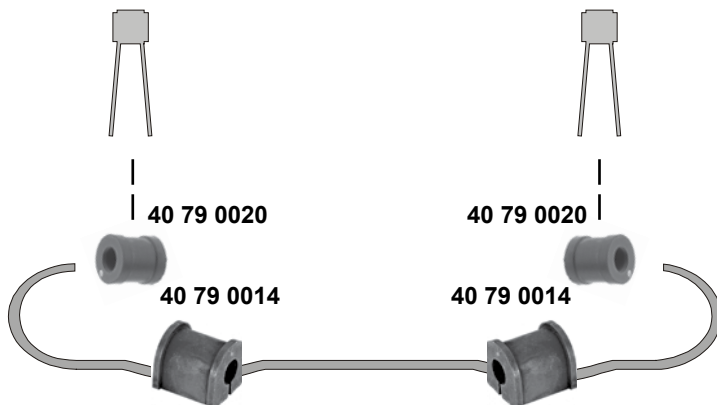
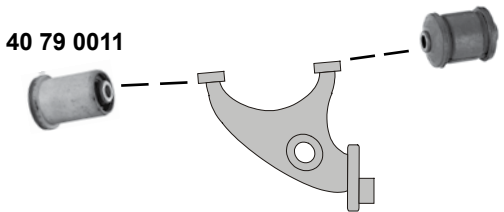

Hinterachse / Rear axle

SWAG	Ref. - No.			
40 79 0011	0423 315	Schräglenkerlager / semi-trailing arm bush		12x43x71
40 79 0012	0423 313	Schräglenkerlager / semi-trailing arm bush		12x45x71
40 79 0014	0444 153	Stabilisatorlager / stabilizer mount		Ø 1 14
40 79 0020	0444 336	Stabilisatorlager / stabilizer mount		13x26x28

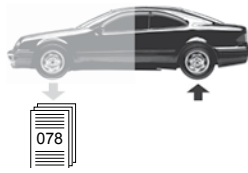

Signum
(2002 → 2008)

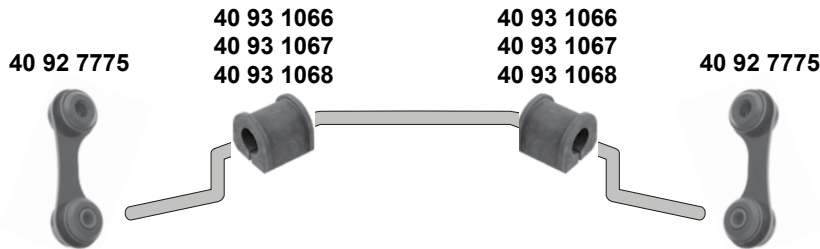
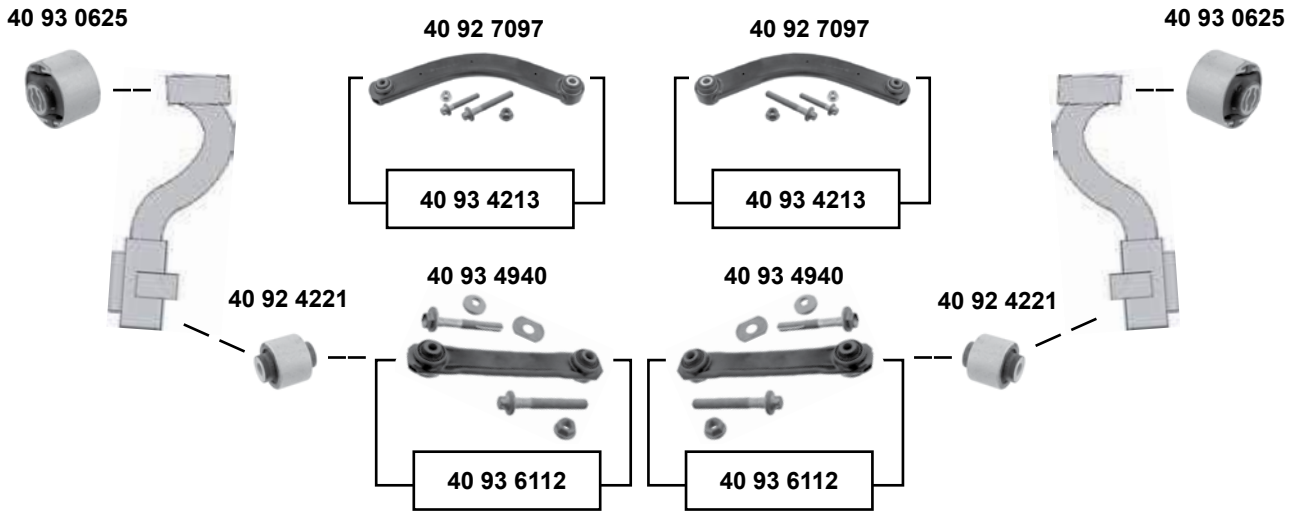

Hinterachse / Rear axle

SWAG	Ref. - No.			
40 92 4221	0423 320	Querlenkerlager / control arm mount		12x45,5x52
40 92 7097	0423 035	Querlenker / control arm		L 380
40 92 7775	0444 275	Verbindungsstange / connecting rod		L 86
40 93 0625	0423 319	Querlenkerlager / control arm mount		
40 93 1066	0444 160	Stabilisatorlager / stabilizer mount		Ø 17
40 93 1067	0444 161	Stabilisatorlager / stabilizer mount		Ø 18
40 93 1068	0444 162	Stabilisatorlager / stabilizer mount		Ø 19
40 93 4213	0423 035 S1	Rep. Satz Querlenker / rep. kit control arm		
40 93 4940	0423 032	Querlenker / control arm		
40 93 6112	0423 032 S1	Rep. Satz Querlenker / rep. kit control arm		

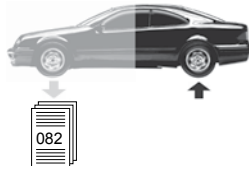

Vectra A

(1988 → 1995)

2.0 i 16V (110 / 115 kw)

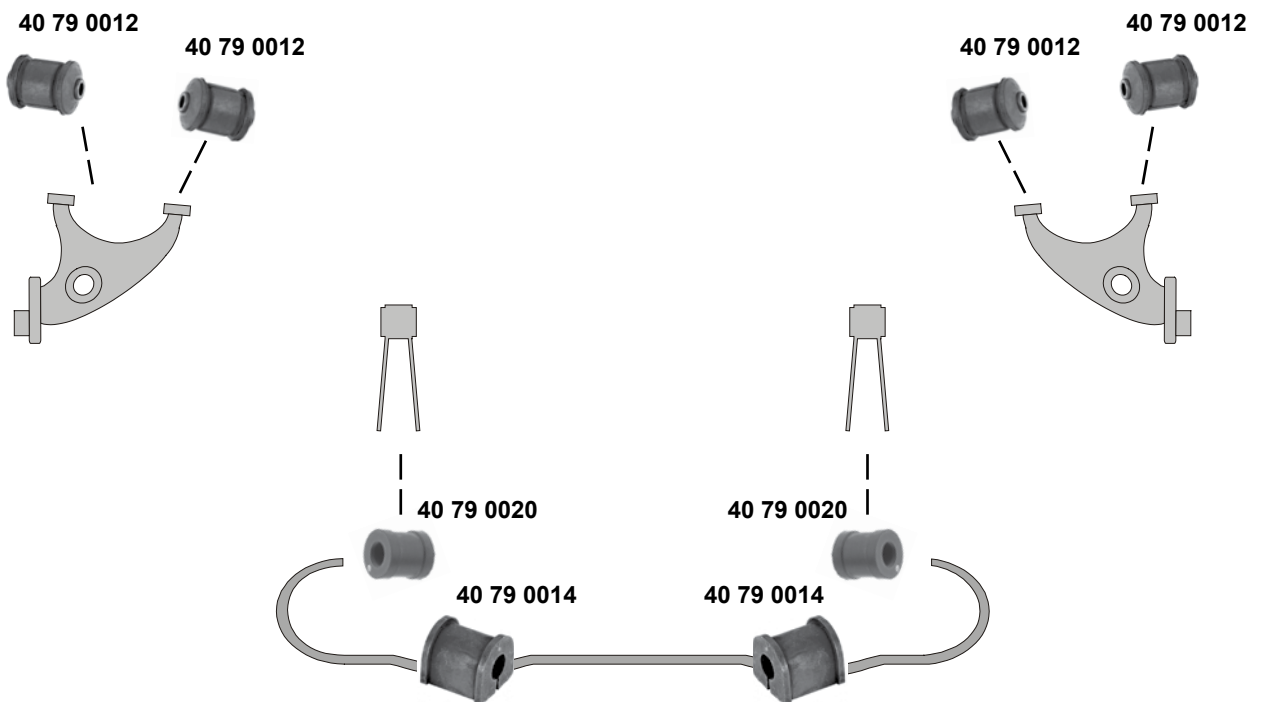

Hinterachse / Rear axle



(1) (ch.) → N 1999999 / N 5999999 / NV 999999

(2) (ch.) P 1000001 / P 5000001 / P 7100001 →



Ref. - No.



Part No.	Ref. - No.	Description	Quantity	Dimensions
40 79 0012	0423 313	Schräglenkerlager / semi-trailing arm bush	(1)	12x45x71
40 79 0014	0444 153	Stabilisatorlager / stabilizer mount	(2)	Ø 1 14
40 79 0020	0444 336	Stabilisatorlager / stabilizer mount	(2)	13x26x28

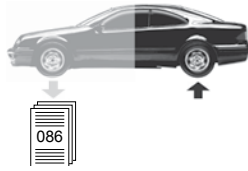

Vectra B
(1995 → 2002)

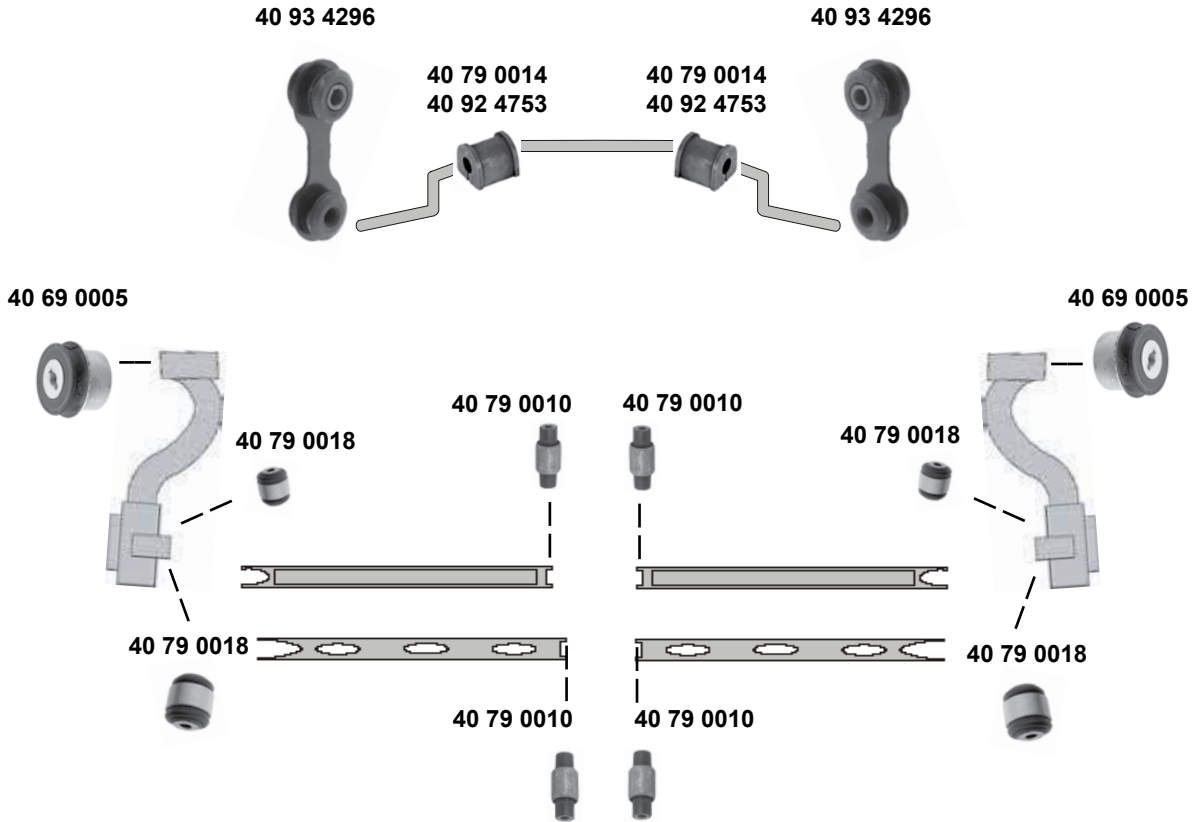

- (1) 1.6 (ch.) → W 1999999 / W 5999999 / W 7999999
- (2) 1.6 (ch.) X 1000001 / X 7000001 →
 1.7 (mot.) X17TD
 1.8 (mot.) X18XE
 (mot.) X18XE1 (ch.) → W 1999999 / W 5999999 / W 7999999
 (mot.) Z18XE (ch.) X 1000001 / X 7000001 →
 (mot.) Z18XEL (ex.) Sportfahrwerk / sports chassis
- 2.0 (mot.) X20XEV
 (mot.) X20DTH / DTL / 20NEJ / C20SEL
 (ch.) → W 1999999 / W 5999999 / W 7999999
- 2.2 (mot.) C22SEL
 (mot.) Z22SE (ex.) Sportfahrwerk / sports chassis
- 2.5 (mot.) X25XE
- (3) 1.6 (ex.) Z 1.6 XE (ch.) X 1000001 / X7000001 / XL0000001 →
 Fahrzeuge **ohne** Tieferlegung / vehicles **without** lowered chassis
- (4) X 1.6 XEL, Y 1.6 XE, Z 1.6 XE (ch.) Y 1000001 / Y7000001 / XL 0000001 →
 Fahrzeuge **mit** Tieferlegung / vehicles **with** lowered chassis
- (5) 1.8 / 2.0 Benzin (ex.) 2.0 NEJ
 2.0 TD / 2.2 Benzin+Diesel / 2.5 / 2.6
- (6) 2.0 NEJ (ex.) Ägypten / (ex.) egypt

Hinterachse / Rear axle



SWAG GERMANY	Ref. - No.			
40 69 0005	0423 302	Querlenkerlager / control arm mount		
40 79 0010	0423 316	Querlenkerlager / control arm mount		12x35x89
40 79 0014	0444 153	Stabilisatorlager / stabilizer mount	(1)	Ø 1 14
40 79 0018	0423 121	Querlenkerlager / control arm mount		12x45x52
40 92 4753	0444 200	Stabilisatorlager / stabilizer mount	(2)	
40 93 4296	0444 291	Verbindungsstange / connecting rod	(3) (4) (5) (6)	

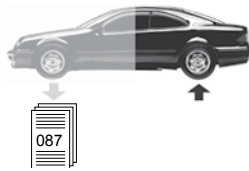

Vectra C (2002 → 2008)

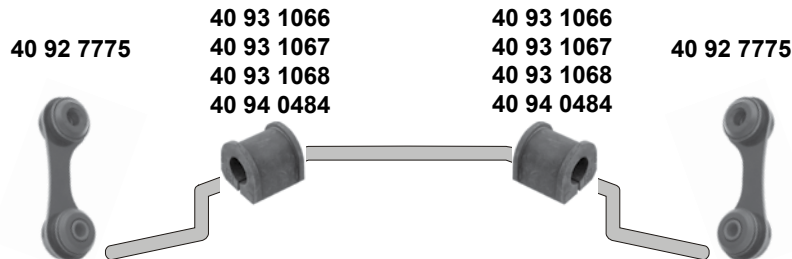
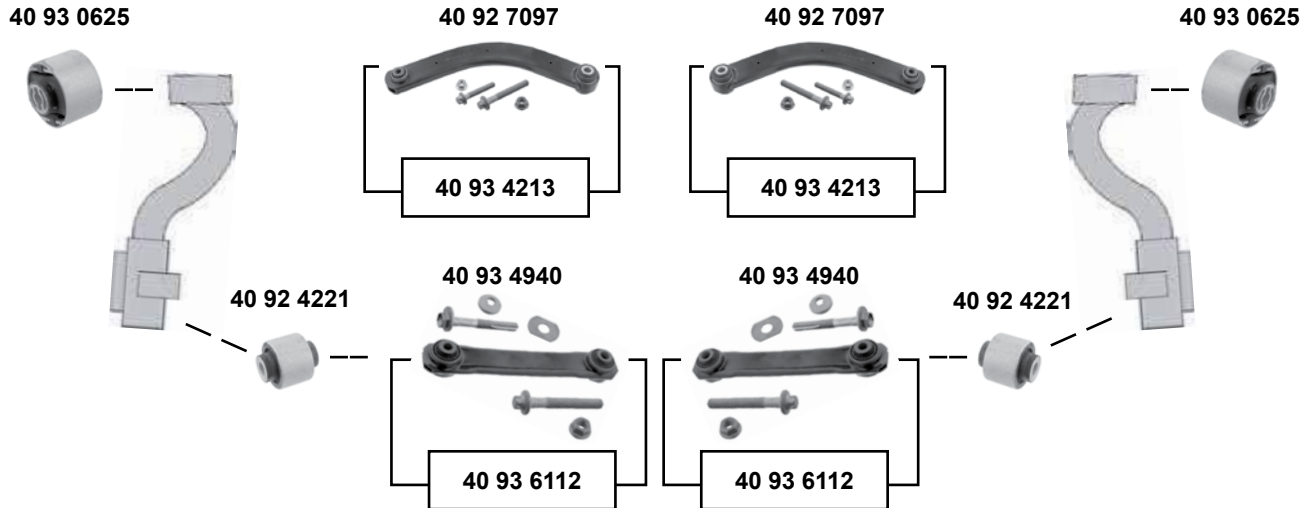

40 92 4221	0423 320	Querlenkerlager / control arm mount	12x45,5x52
40 92 7097	0423 035	Querlenker / control arm	L 380
40 92 7775	0444 275	Verbindungsstange / connecting rod	L 86
40 93 0625	0423 319	Querlenkerlager / control arm mount	
40 93 1066	0444 160	Stabilisatorlager / stabilizer mount	Ø 17
40 93 1067	0444 161	Stabilisatorlager / stabilizer mount	Ø 18
40 93 1068	0444 162	Stabilisatorlager / stabilizer mount	Ø 19
40 93 4213	0423 035 S1	Rep. Satz Querlenker / rep. kit control arm	
40 93 4940	0423 032	Querlenker / control arm	
40 93 6112	0423 032 S1	Rep. Satz Querlenker / rep. kit control arm	
40 94 0484	0444 163	Stabilisatorlager / stabilizer mount	Ø 16

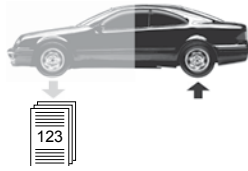

406

(1996 → 2004)

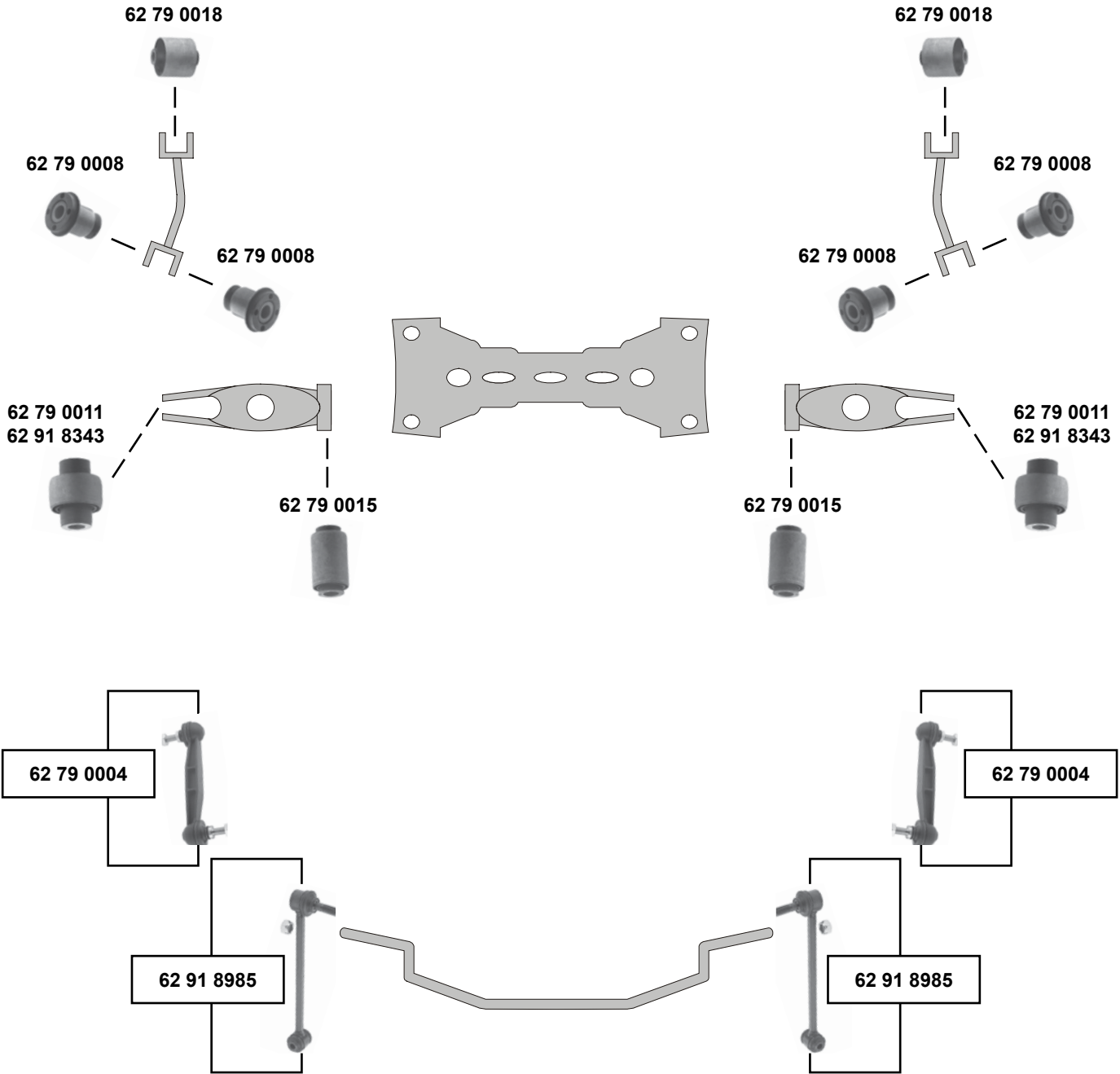

Hinterachse / Rear axle



(1) → O 7665 (ex.) Coupé



Ref. - No.



62 79 0004	5178.38	Verbindungsstange / connecting rod
62 79 0008	5131.78	Längslenkerlager / trailing arm bush
62 79 0011	3640.41	Querlenkerlager / control arm mount
62 79 0015	5131.80	Querlenkerlager / control arm mount
62 79 0018	5131.99	Längslenkerlager / trailing arm bush
62 91 8343	3640.35	Querlenkerlager / control arm mount
62 91 8985	5178.39	Verbindungsstange / connecting rod

O 7665 →

(1)

12x27/41x41
14x45x57
12x32x48/60
14x56x46/65

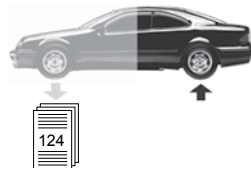

407
(2004 →)

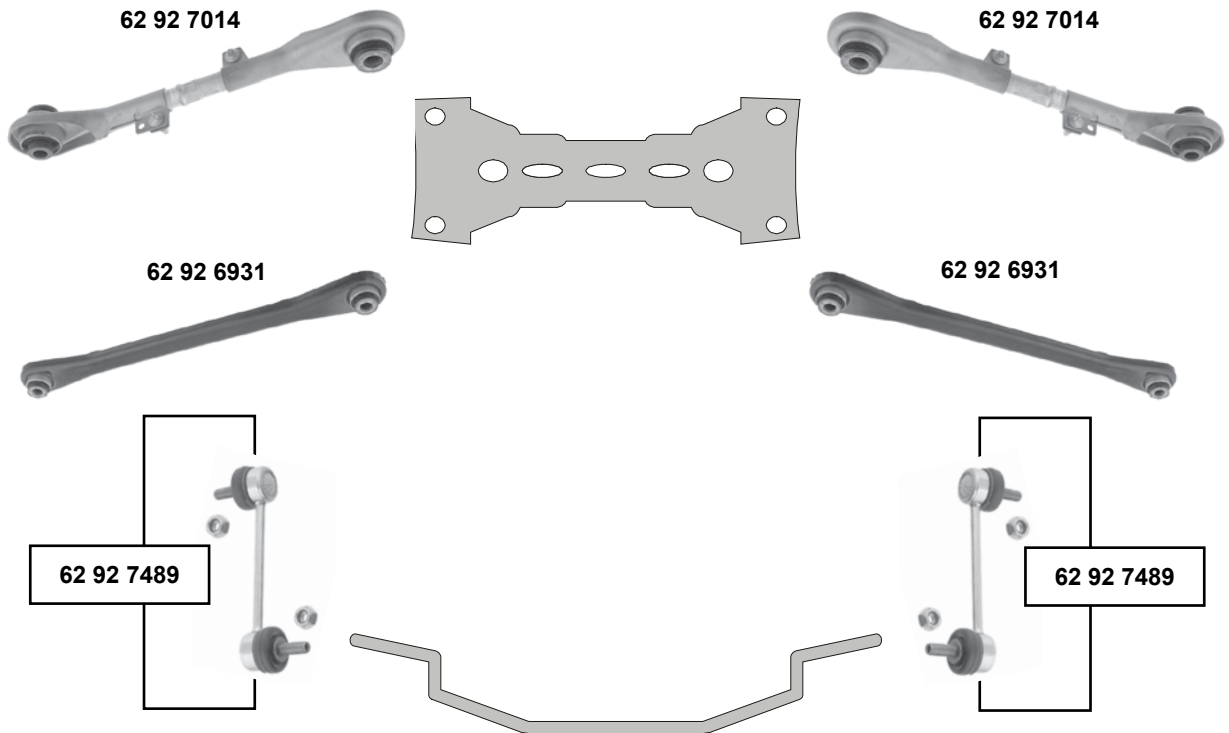

508
(2010 →)

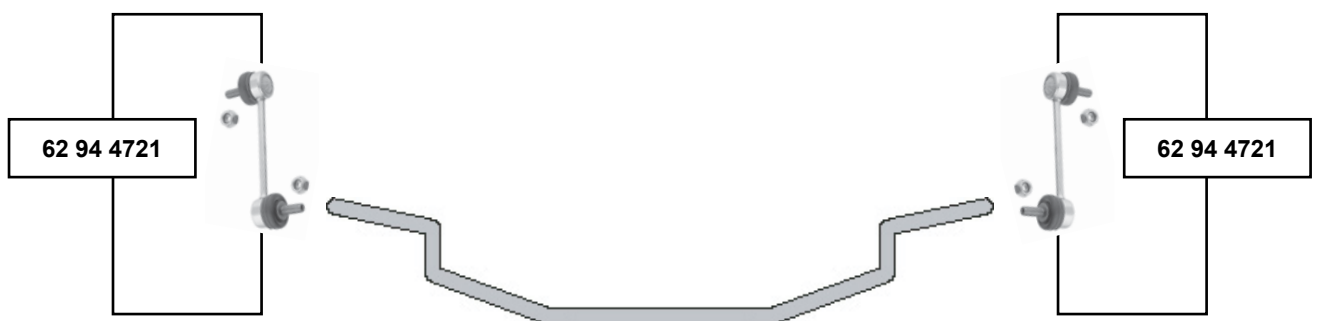

Hinterachse / Rear axle



(1) DW10CTED4 // nur / only Hybrid



Ref. - No.



62 92 6931 5175.CF
62 92 7014 5178.47
62 92 7489 5178.52
62 94 4721 5178.57

Querstrebe / cross rod
Querstrebe / cross rod
Verbindungsstange / connecting rod
Verbindungsstange / connecting rod

(1)

L 495
L 141
M10 x 1,5

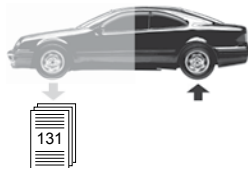

605 / 607

(1990 →)

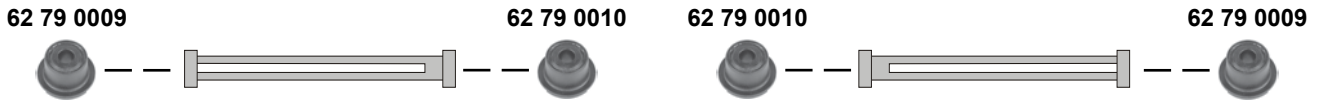
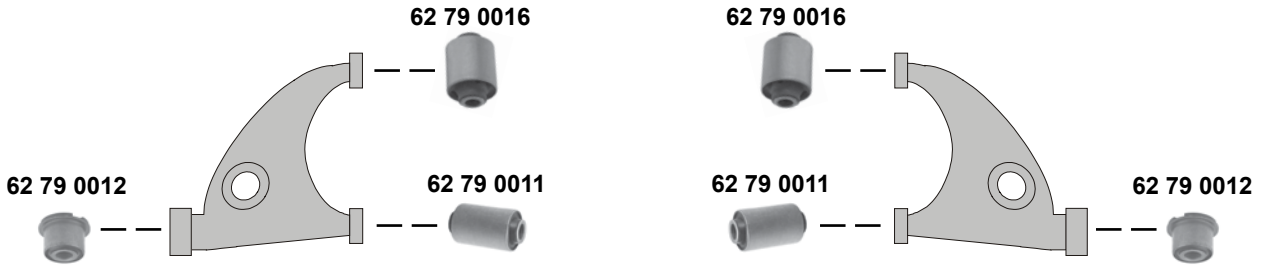
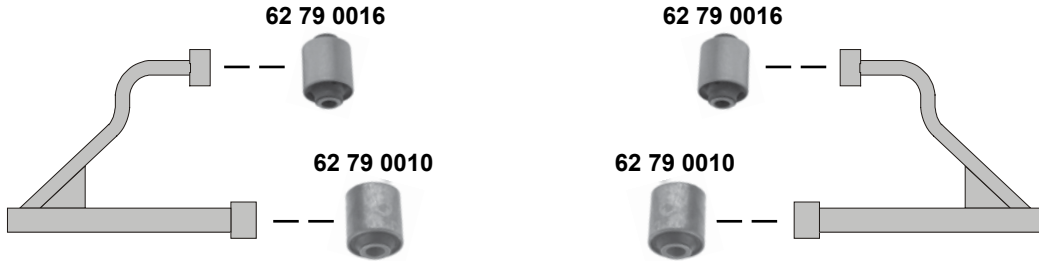

Hinterachse / Rear axle



(1) 607 mit variabler Federung / with variable suspension



Ref. - No.



62 79 0009	3332.07	Zugstrebenlager / tie-arm bush		12x32x25
62 79 0010	5131.54	Querlenkerlager / control arm mount		12x36x45
62 79 0011	5131.56	Querlenkerlager / control arm mount		12x32x60
62 79 0012	5131.55	Querlenkerlager / control arm mount		14x34x30
62 79 0016	5131.53	Querlenkerlager / control arm mount		12x40x40/60
62 91 9067	5178.43	Verbindungsstange / connecting rod		
62 91 9071	5178.44	Verbindungsstange / connecting rod		
62 92 1823	5172.47	Stabilisatorlager / stabilizer mount	(1)	Ø 25

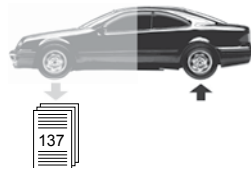

3008
(06/09 →)

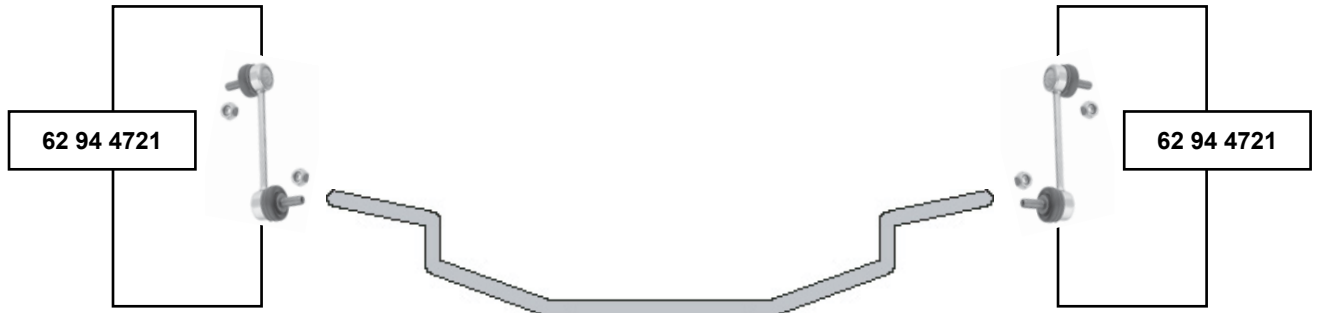

4007
(2007 →)

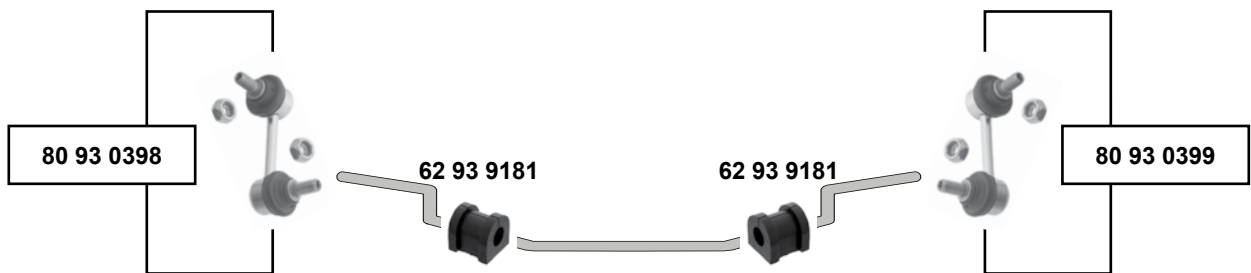

4008
(2012 →)

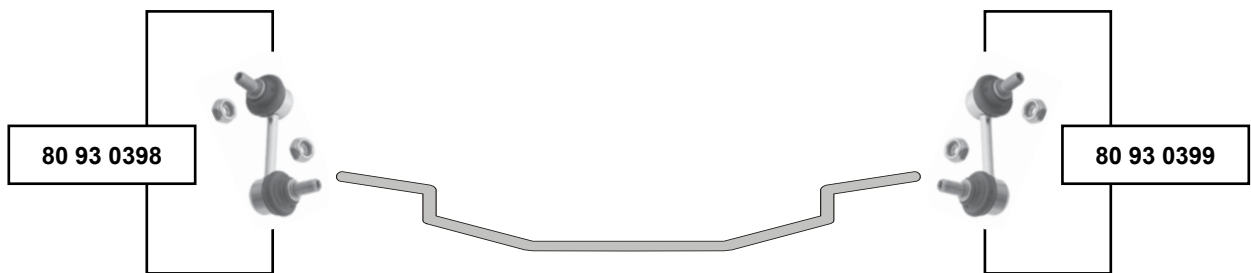

Hinterachse / Rear axle



(1) DW10CTED4 // nur / only Hybrid O 12397 →



Ref. - No.



62 93 9181 5172.58
62 94 4721 5178.57
80 93 0398 5178.48
80 93 0399 5178.49

Stabilisatorlager / stabilizer mount
Verbindungsstange / connecting rod
Verbindungsstange / connecting rod
Verbindungsstange / connecting rod

(ex.) 2,0L MMC
(1)

Ø | 19,5
M10 x 1,5
L 80
L 80

passend für / to fit

PEUGEOT

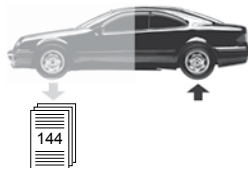

Boxer III

(2006 →)

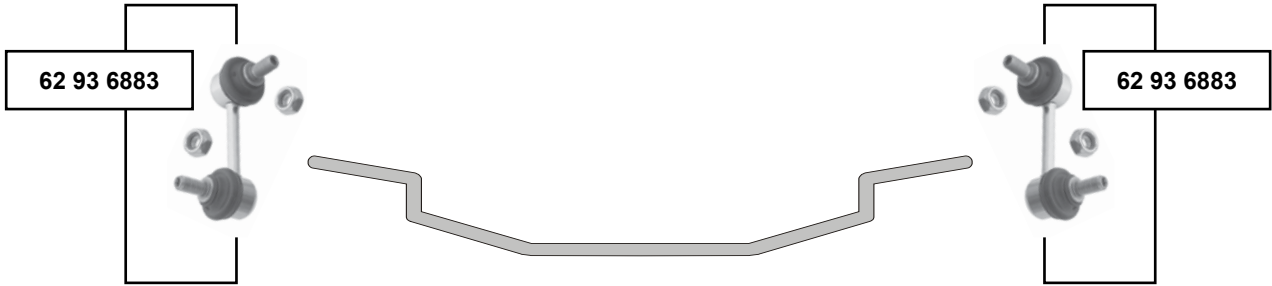

J5

(1982 → 1994)

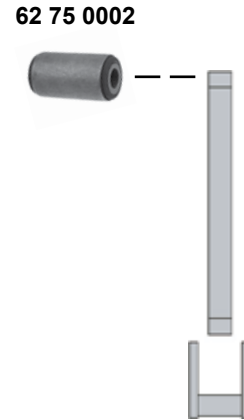
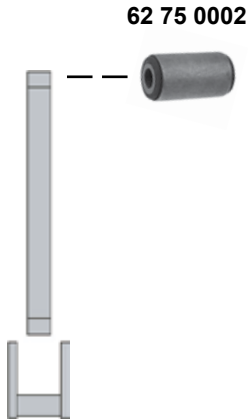

Hinterachse / Rear axle



Ref. - No.



62 75 0002
62 93 6883

5131.46
5170.F5 S1

Blattfederlager / leaf-spring bearing
Verbindungsstange / connecting rod

16x38x72
L 100

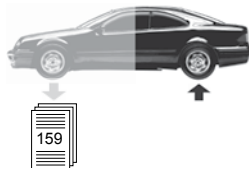

Boxster (986)
(1996 → 2004)

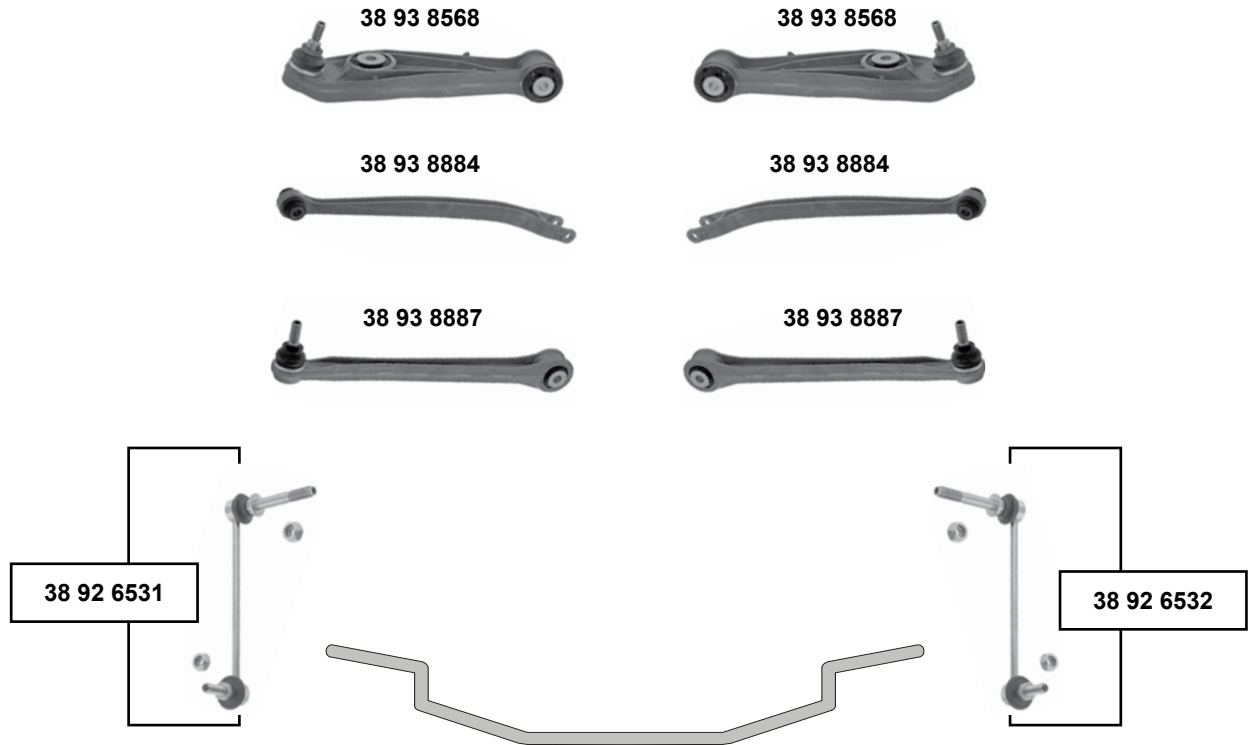

Boxster (987)
(2004 → 2012)



Hinterachse / Rear axle



(1) 987 (ch.) → 986U7 03033 / (ch.) → 986U7 22298



Ref. - No.



38 92 6531	996 343 069 04
38 92 6532	996 343 070 04
38 93 8568	996 341 053 16
38 93 8884	986 331 043 07
38 93 8887	997 331 045 04

Verbindungsstange / connecting rod
Verbindungsstange / connecting rod
Querlenker / control arm
Querlenker / control arm
Querlenker / control arm

(1)

L 200
L 200

passend für / to fit

PORSCHE

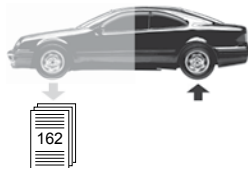

Cayman (987)
(2005 →)

38 93 8568



38 93 8568



38 93 8887



38 93 8887



Hinterachse / Rear axle



Ref. - No.



38 93 8568 996 341 053 16
38 93 8887 997 331 045 04

Querlenker / control arm
Querlenker / control arm

(ch.) → 986U7 74551

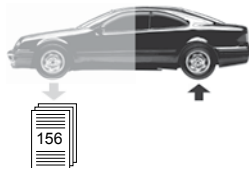

911 Carrera / Turbo (996)
(1998 → 2005)

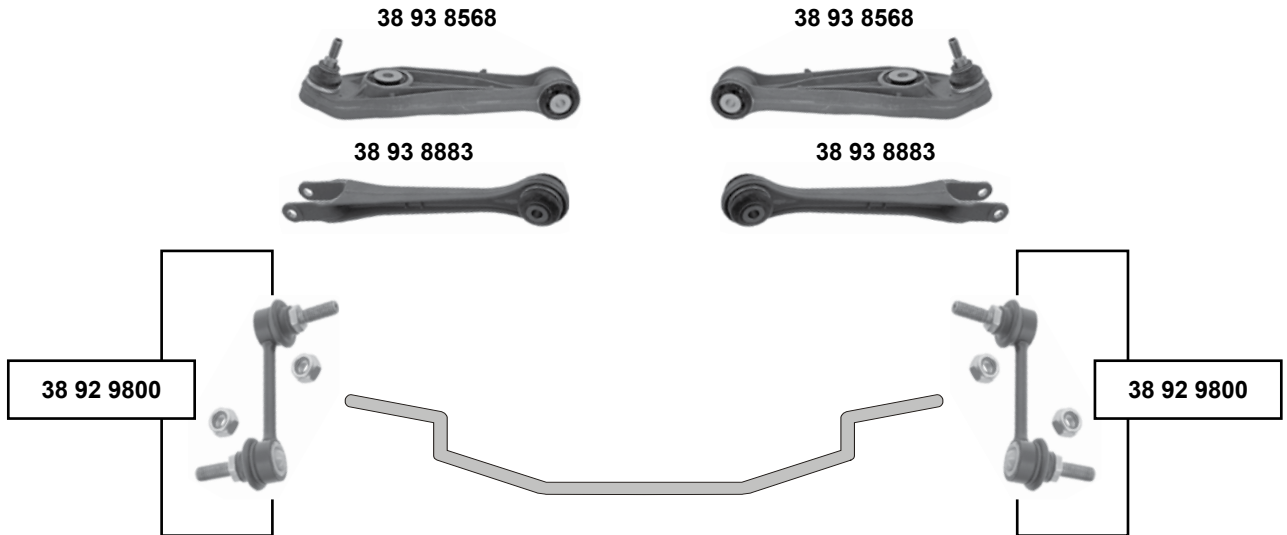

911 Carrera 2 (997)
(2005 →)



(1) 996 alle / all

(2) 997 (ch.) → 996S7 02239 / (ch.) → 996S7 51332 / (ch.) → 996S7 35222 / (ch.) → 996S7 62833
(ch.) → 996S7 02240 / (ch.) → 996S7 51333 / (ch.) → 996S7 35223 / (ch.) → 996S7 62837



Ref. - No.



38 92 9800	996 333 069 04
38 93 8568	996 341 053 16
38 93 8883	996 341 043 06
38 93 8887	997 331 045 04

Verbindungsstange / connecting rod
Querlenker / control arm
Querlenker / control arm
Querlenker / control arm

(ex.) GT2 / GT3
(1) (2)

L 99,5

passend für / to fit

RENAULT

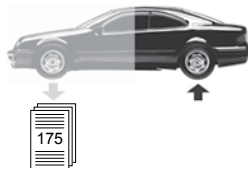

Clio 2 / RS V6

(1998 → 2005)

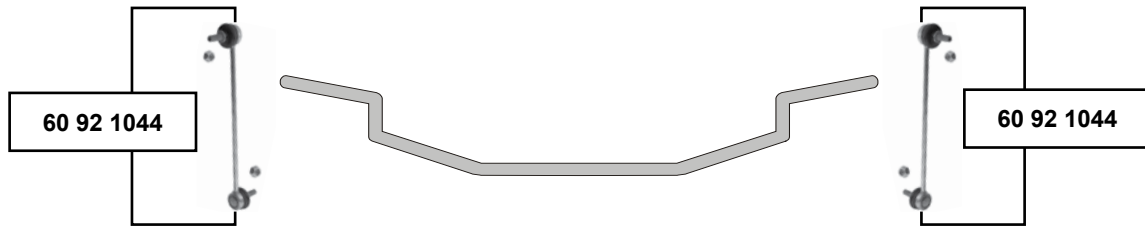

Koleos

(2008 →)

Hinterachse / Rear axle

82 93 2574

82 93 2573



Ref. - No.



60 92 1044	82 00 661 217
82 93 2573	55 61 8JY 00B
82 93 2574	55 61 9JY 00B

Verbindungsstange / connecting rod
Verbindungsstange / connecting rod
Verbindungsstange / connecting rod

nur / only RS V6

L 280
L 142,5
L 142,5

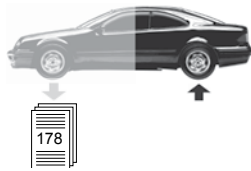

Duster
(2010 →)

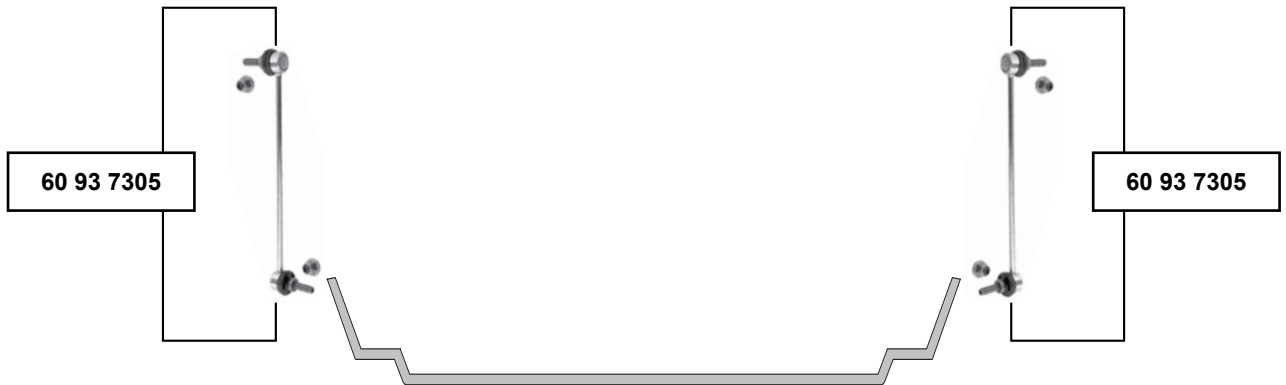

60 93 6435



60 93 6436



60 93 6396



60 93 6396



60 93 6395



60 93 6395



Hinterachse / Rear axle



60 93 6395	82 00 839 119
60 93 6396	82 00 839 124
60 93 6435	82 00 841 004
60 93 6436	82 00 839 107
60 93 7305	82 00 814 411

Querstrebe / cross rod
Querstrebe / cross rod
Querstrebe / cross rod
Querstrebe / cross rod
Verbindungsstange / connecting rod

nur / only 4x4
nur / only 4x4
nur / only 4x4
nur / only 4x4
nur / only 4x4

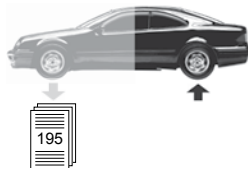

Master 3 (2010 →)

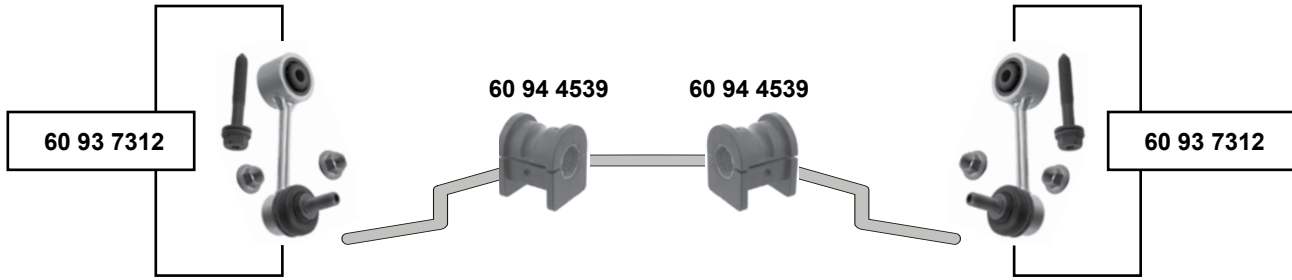

Traffic 1 (1989 → 2001)

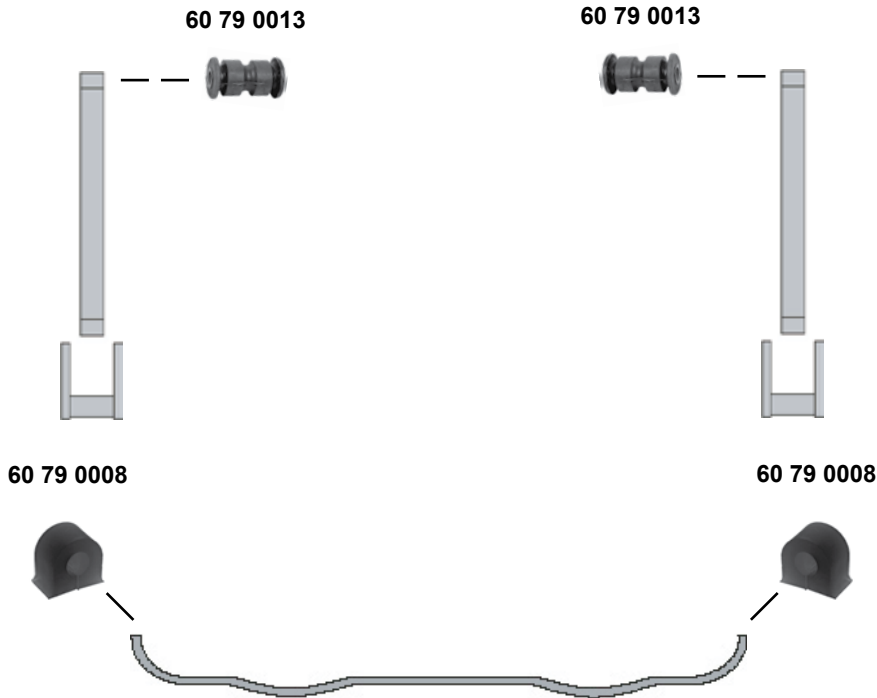

Hinterachse / Rear axle



(1) EV0,FV0,HV0,JV0,UV0 Nur Fahrzeuge mit Frontantrieb / only vehicles with front wheel drive



Ref. - No.



60 79 0008	77 04 001 091	Stabilisatorlager / stabilizer mount	T5	
60 79 0013	77 00 730 733	Blattfederlager / leaf spring bearing	(ex.) TC	
60 93 7312	55 11 000 19R S1	Rep. Satz Verbindungsstange / rep. kit connecting rod	(1)	L 105,5
60 94 4539	54 61 354 90R	Stabilisatorlager / stabilizer mount	(1)	Ø 28

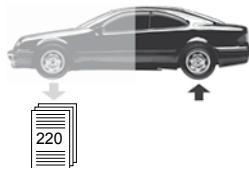

200 + 400
(1992 →)

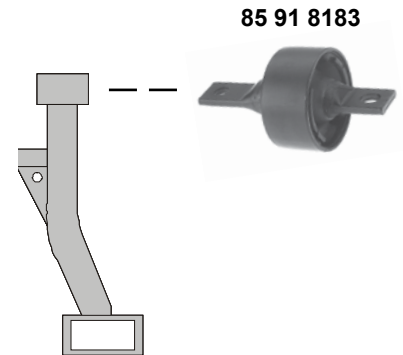
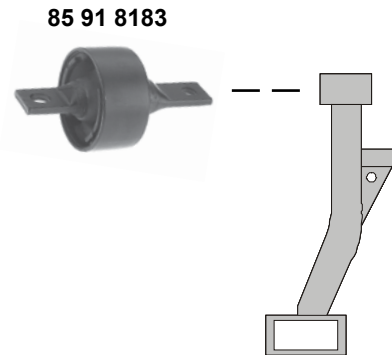

75 (RJ)
(1999 →)

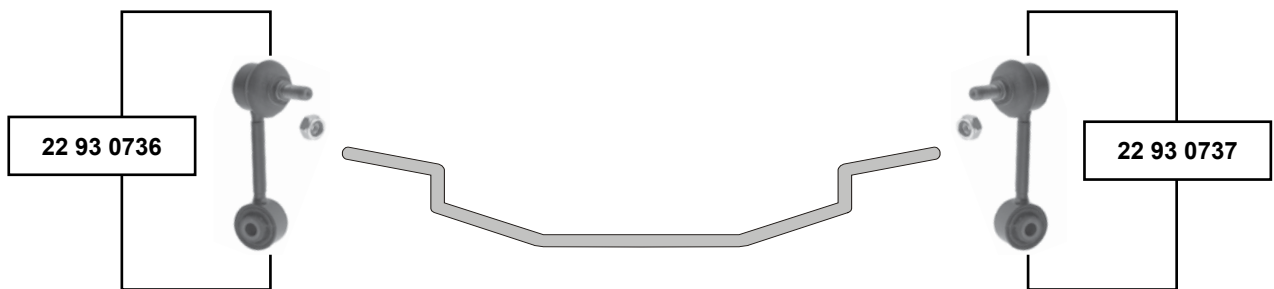

MG ZT
(2001 →)

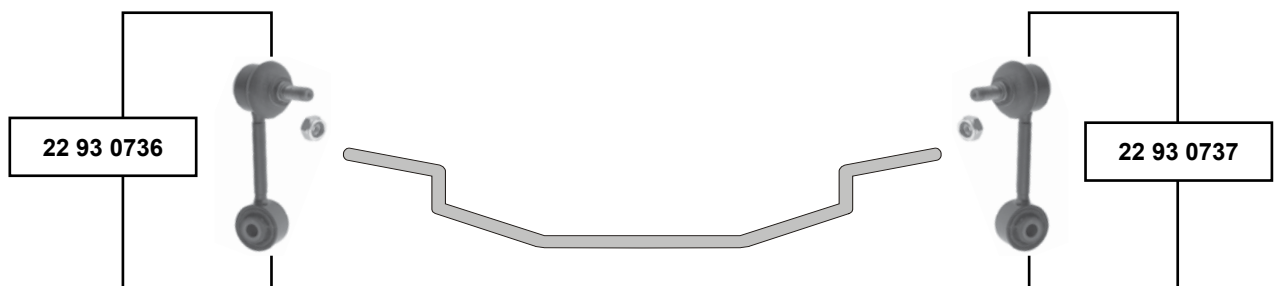

Hinterachse / Rear axle

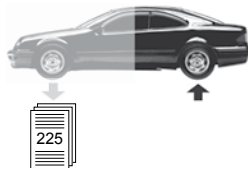

9-3 II
(2002 →)

oben / upper

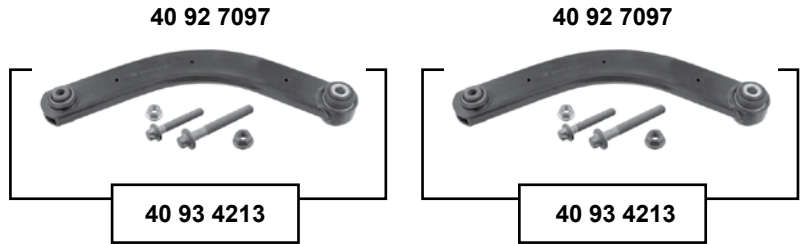

unten / lower

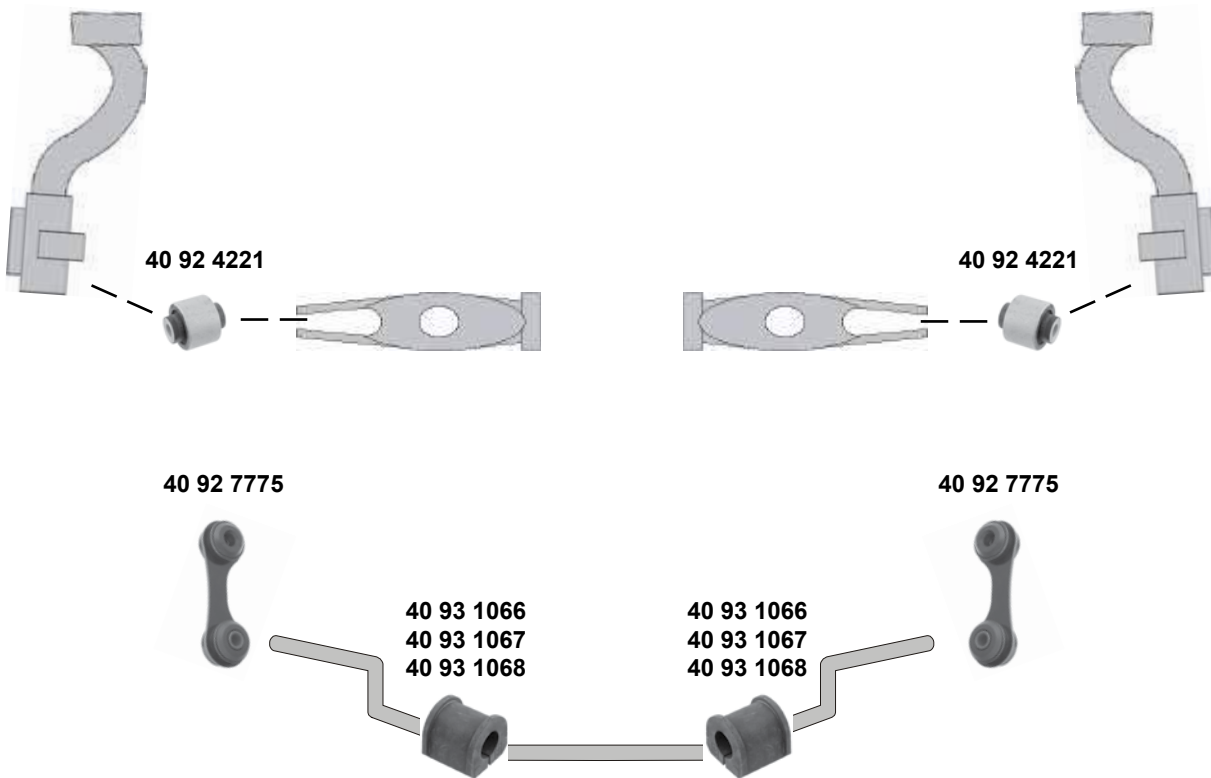

Hinterachse / Rear axle

SWAG [®]	Ref. - No.			
40 92 4221	24 469 643	Querlenkerlager / control arm mount		12x45,5x52
40 92 7097	13 230 274	Querlenker / control arm		L 380
40 92 7775	13 104 120	Verbindungsstange / connecting rod		L 86
40 93 1066	24 457 385	Stabilisatorlager / stabilizer mount		Ø 17
40 93 1067	24 457 386	Stabilisatorlager / stabilizer mount		Ø 18
40 93 1068	24 457 343	Stabilisatorlager / stabilizer mount		Ø 19
40 93 4213	13 230 274 S1	Rep. Satz Führungslenker / rep. kit guide link		L 380

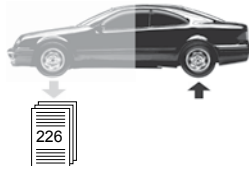

9-5 I
(1997 → 2010)

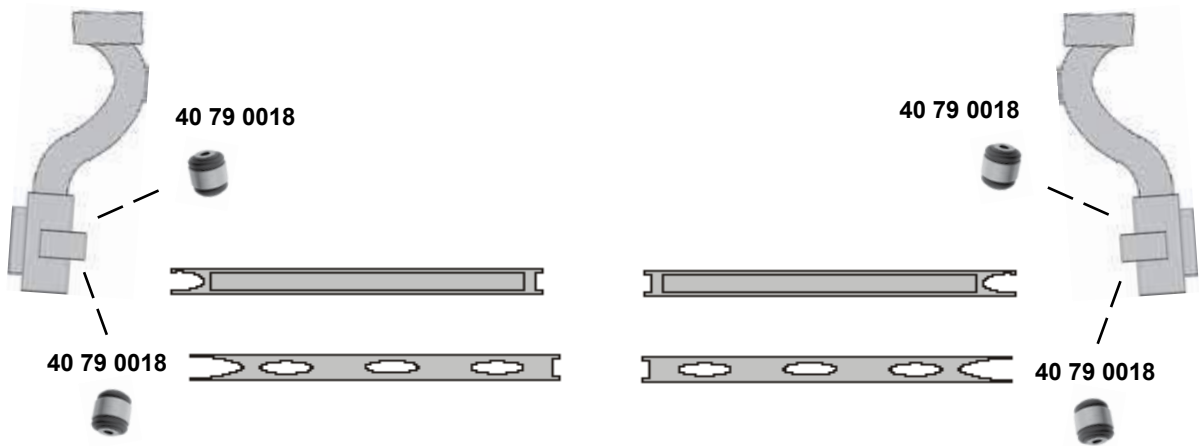

Hinterachse / Rear axle

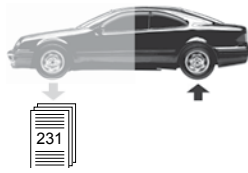

Alhambra (7V8)

(1996 → 2010)

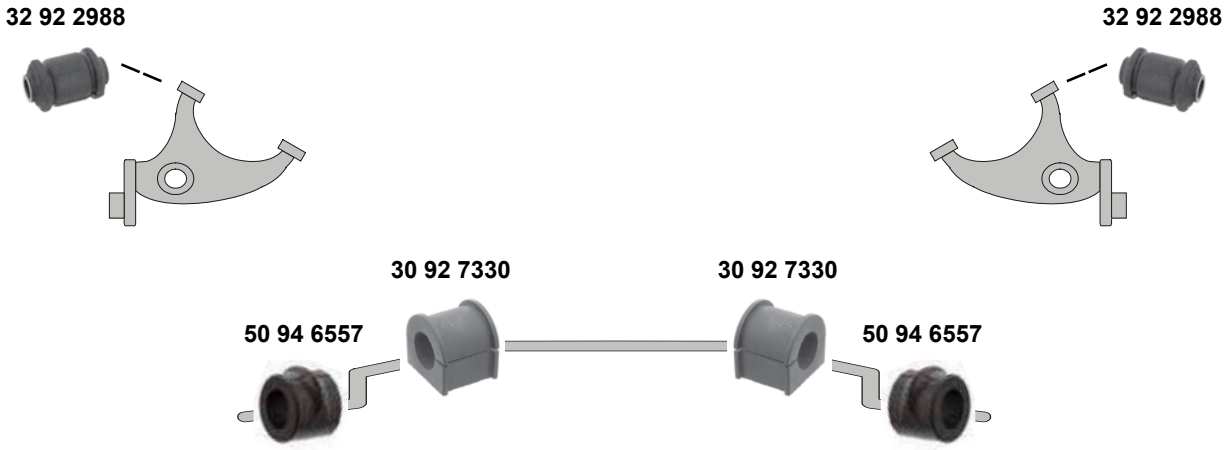

Alhambra (7V9)

(2001 → 2010)

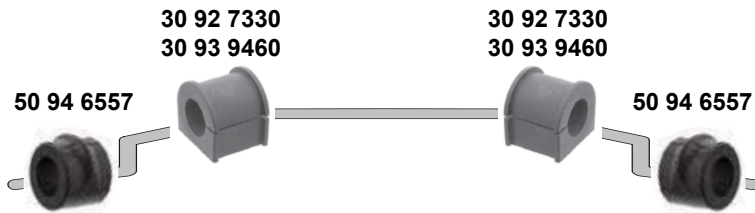

Hinterachse / Rear axle

(1) 06/2000 → 11/2008 für Fahrzeuge mit Komfortfahrwerk / for vehicles with comfort suspension
06/2000 → **Sport** für Fahrzeuge mit Komfortfahrwerk / for vehicles with comfort suspension

(2) 7V8 (ex.) **Sport**
7V9 (ex.) **Sport (ex.) HD**

(3) 7V9 (ex.) **Sport / PR-1BA / 1BB / 1BJ / 1BR**



Ref. - No.



32 92 2988	7M0 501 541	Querlenkerlager außen / control arm mount outer		Ø A 35 L 35
30 92 7330	7M0 511 413 A	Stabilisatorlager / stabilizer mount	(3)	Ø I 21
30 93 9460	7M0 511 413 B	Stabilisatorlager / stabilizer mount	(1) PR-1BH	Ø I 22
50 94 6557	7M0 511 414 B	Stabilisatorlager / stabilizer mount	(2)	Ø I 21

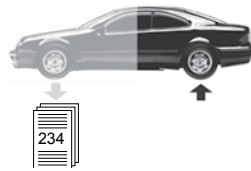

Alhambra (710)

(2011 →)

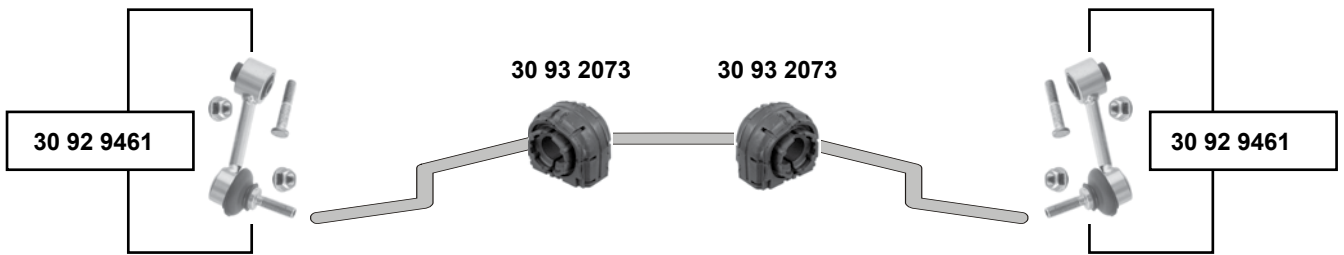
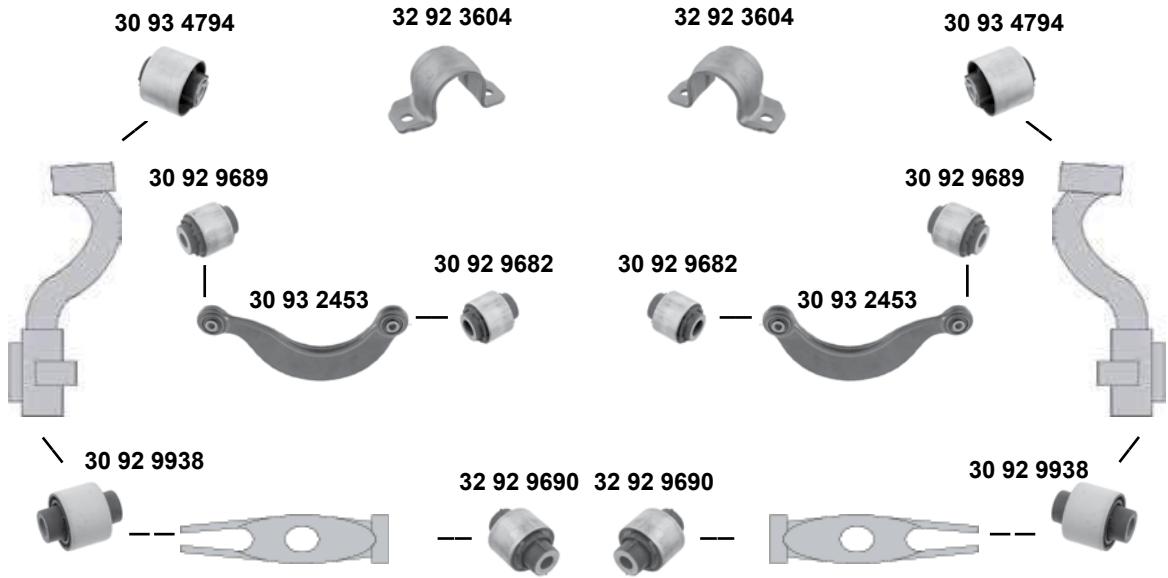

(1) PR-1X0+0BB / 1X1+0BC



Ref. - No.



Ref. - No.	Description	Dimensions
30 92 9461	1K0 505 465 K S1 Rep. Satz Verbindungsstange / rep. kit connecting rod	L 95,5
30 92 9682	1K0 505 203 A Querlenkerlager oben / control arm mount upper	Ø A 38 H 45
30 92 9689	1K0 505 279 A Querlenkerlager oben / control arm mount upper	Ø A 38,5 H 45
30 92 9938	1K0 505 553 A Querlenkerlager außen / control arm mount outer	Ø A 37 H 50
30 93 2073	1K0 511 327 AQ Stabilisatorlager hinten / stabilizer mount rear	Ø A 19,6
30 93 2453	1K0 505 323 N Querlenker oben / control arm upper	
30 93 4794	3C0 505 541 Querlenkerlager / control arm mount	Ø I 12 H 64
32 92 3604	1K0 511 439 E Klemmschelle / clamping clip	
32 92 9690	1K0 505 171 C Querlenkerlager unten / control arm mount lower	Ø A 42 H 60

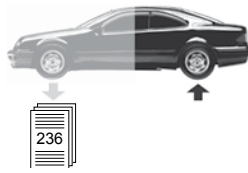

Altea (5P) (2004 →)

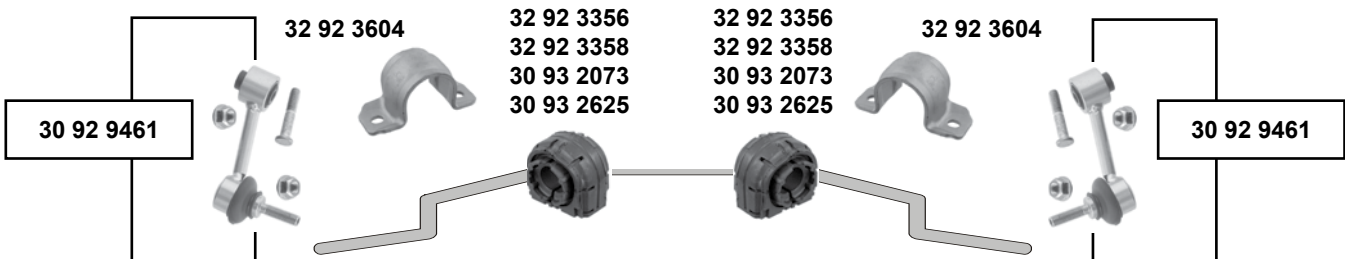
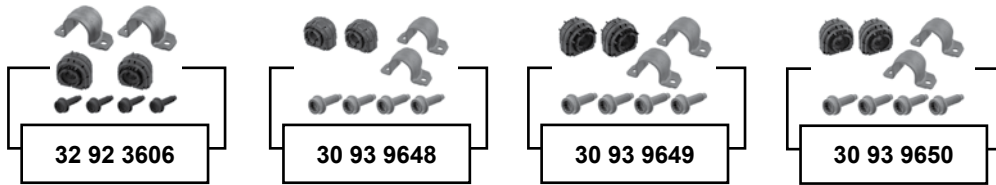
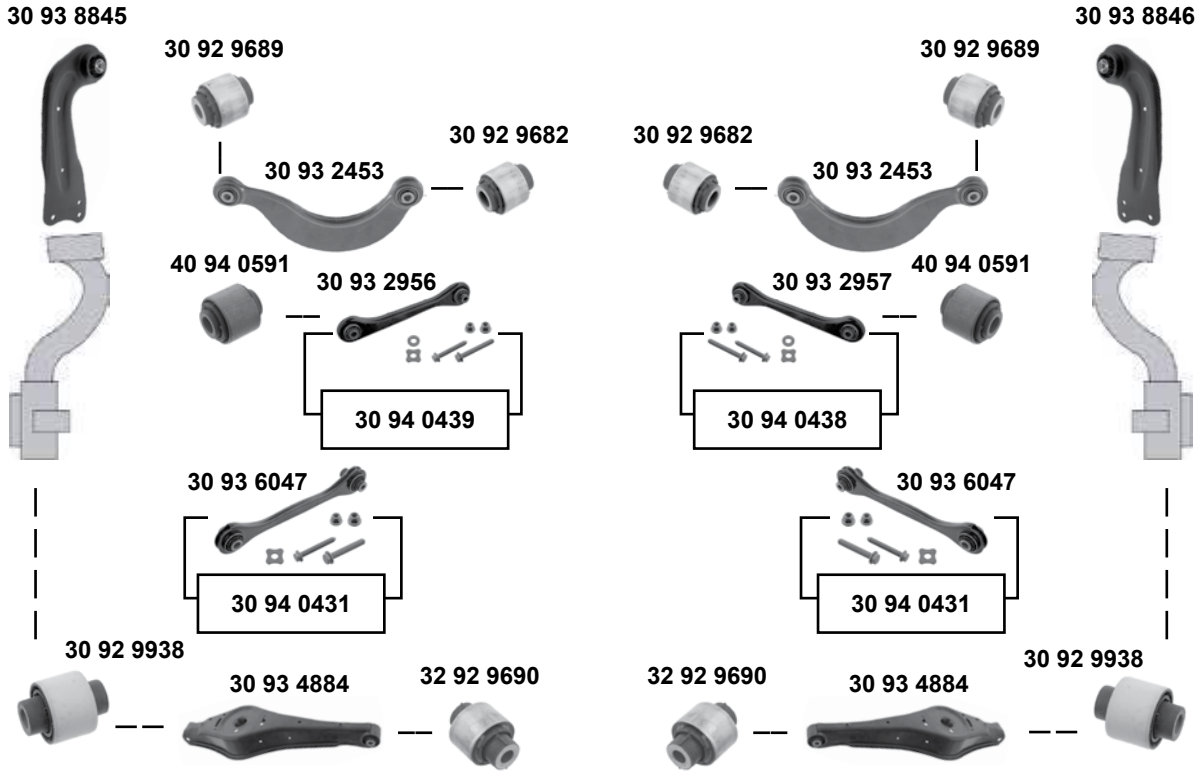

Hinterachse / Rear axle

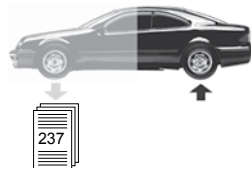
Altea (5P)
 (2004 →)



- (1) nur paarweise tauschen / replace in pairs only
 (2) PR-0BF / (ch.) 5P-7-000 001 →



Ref. - No.

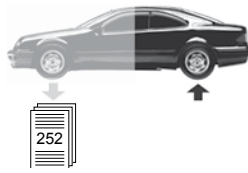

SWAG Ref. - No.				
30 92 9461	1K0 505 465 K S1	Rep. Satz Verbindungsstange / rep. kit connecting rod		L 95,5
30 92 9682	1K0 505 203 A	Querlenkerlager oben / control arm mount upper		Ø A38 H45
30 92 9689	1K0 505 279 A	Querlenkerlager oben / control arm mount upper		Ø A 38,5H45
30 92 9938	1K0 505 553 A	Querlenkerlager außen / control arm mount outer		Ø A 37 H50
30 93 2073	1K0 511 327 AQ	Stabilisatorlager / stabilizer mount	(1)	Ø A 19,6
30 93 2453	1K0 505 323 N	Querlenker oben / control arm upper		
30 93 2625	1K0 511 327 AS	Stabilisatorlager / stabilizer mount	(1)	Ø A 21,7
30 93 2956	1K0 501 529 F	Querlenker mit Gummilagern / control arm with rubber mounts	→ 10	
30 93 2957	1K0 501 530 C	Querlenker mit Gummilagern / control arm with rubber mounts	→ 10	
30 93 4884	1K0 505 311 AB	Querlenker / control arm		
30 93 6047	1K0 501 529 J	Querlenker mit Gummilagern / control arm with rubber mounts	(ch.) 5P-9-506 750→	Stahl
30 93 8845	1K0 505 223 K	Querlenker / control arm		Blech
30 93 8846	1K0 505 224 K	Querlenker / control arm		Blech
30 93 9648	1K0 511 327 AR S1	Stabilisatorlagersatz / anti roll bar bush kit	(1) PR-0BE	
30 93 9649	1K0 511 327 AS S1	Stabilisatorlagersatz / anti roll bar bush kit	(1) (2)	
30 93 9650	1K0 511 327 AQ S1	Stabilisatorlagersatz / anti roll bar bush kit	(1) PR-0BD	
30 94 0431	1K0 501 529 J S1	Rep. Satz Querlenker / rep. kit control arm	05/09 →	
30 94 0438	1K0 501 530 C S1	Rep. Satz Querlenker / rep. kit control arm	(ch.) → 5P-9-508 000	
30 94 0439	1K0 501 529 F S1	Rep. Satz Querlenker / rep. kit control arm	(ch.) → 5P-9-508 000	
32 92 3356	1K0 511 327 AP	Stabilisatorlager / stabilizer mount	(1)	Ø I 18,5
32 92 3358	1K0 511 327 AR	Stabilisatorlager / stabilizer mount	(1) 07 →	Ø A 20,7
32 92 3604	1K0 511 439 E	Klemmschelle / clamping clip		
32 92 3606	1K0 511 327 AP S1	Stabilisatorlagersatz / anti roll bar bush kit	(1)	Ø I 18,5
32 92 9690	1K0 505 171 C	Querlenkerlager unten / control arm mount lower		Ø A 42 H60
40 94 0591	1K0 505 543 A	Querlenkerlager / control arm mount		



Exeo (3R)
(2009 →)

30 93 0494



30 93 8774



30 93 0494

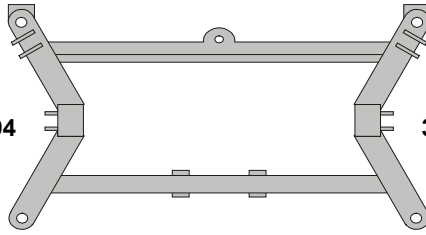

30 93 0494



30 93 8774



30 93 0494

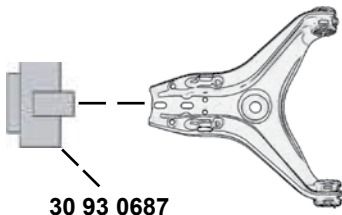

30 93 0687

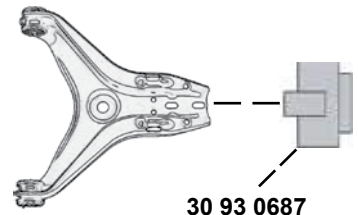

30 93 0687



30 93 2491



30 93 9817



30 93 9817



30 93 2491



Hinterachse / Rear axle



Ref. - No.



30 93 0494	8E0 501 541 S
30 93 0687	8E0 505 203 D
30 93 2491	8E0 505 465 AF S1
30 93 8774	8E0 501 529 P
30 93 9817	8E0 511 327 A

Querlenkerlager / control arm mount
Gummilager / rubber mount
Rep. Satz Verbindungsstange / rep. kit connecting rod
Querlenker / control arm
Stabilisatorlager / stabilizer mount

Ø A 36,5 B46
Ø A 36,5 B46
Ø I 17

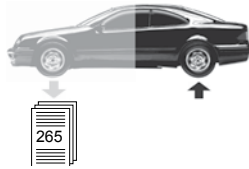

Leon (1M)
(1999 → 2006)

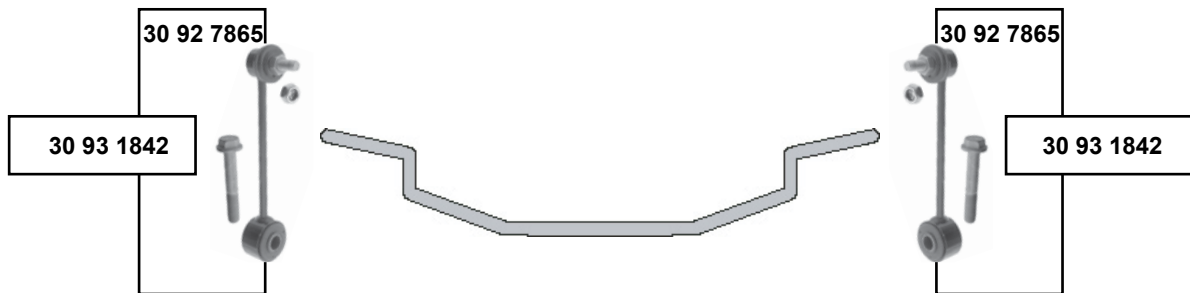

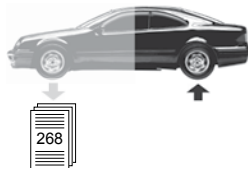

Leon (1P) / Toledo (5P) (2006 →) / (2004 →)

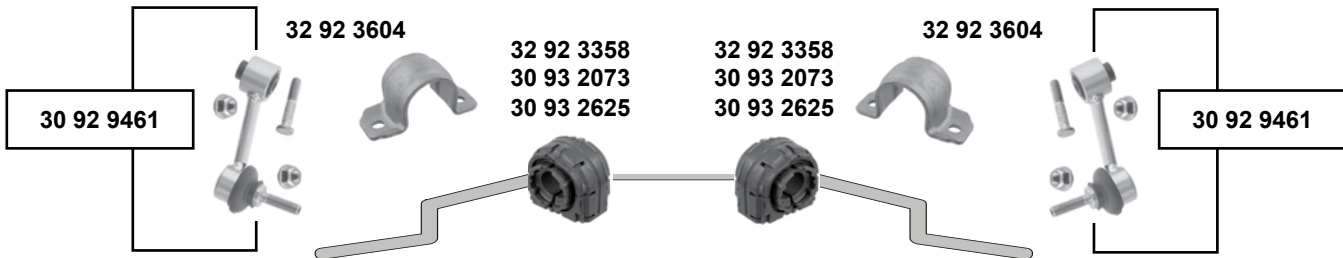
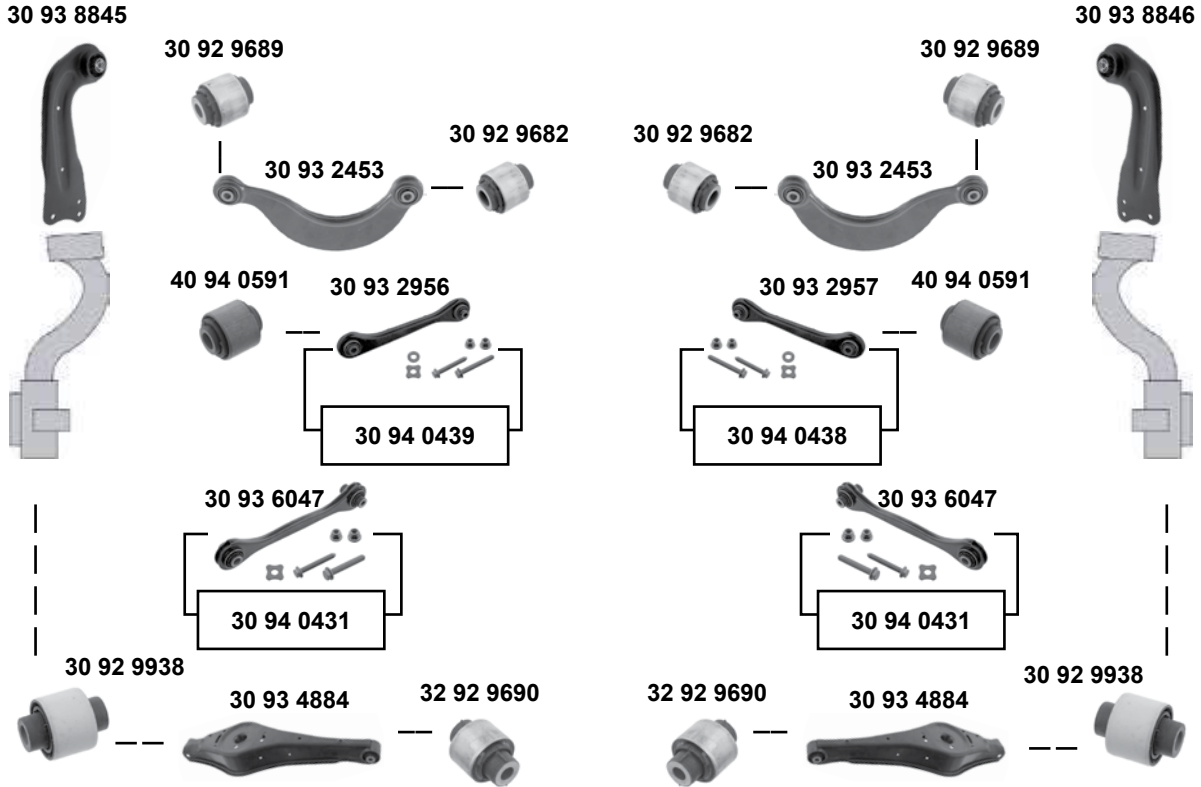

Hinterachse / Rear axle

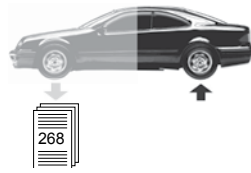

Leon (1P) / Toledo (5P)

(2006 →) / (2004 →)

- (1) Leon / 4 (1P) 06 → / Toledo 3 / 4 (5P) 05 → 09
- (2) Leon / 4 (1P) 06 → 10 / Toledo 3 (5P) 05 → 09
- (3) Leon / 4 06 →
- (4) Leon 05 → (ch.) 1P-9-510 700 → / Toledo alle / all
- (5) nur paarweise tauschen / replace in pairs only
- (6) Leon 05 → / Toledo → 09
- (7) Leon (ch.) 1P-9-520 000 →
- (8) Leon (ch.) → 1P-9-520 000 / Toledo → 09

Ref. - No.

Ref. - No.	Description	Quantity	Dimensions / Notes
30 92 9461	1K0 505 465 K S1 Rep. Satz Verbindungsstange / rep. kit connecting rod	(1)	L 95,5
30 92 9682	1K0 505 203 A Querlenkerlager oben / control arm mount upper	(1)	Ø A 38 H 45
30 92 9689	1K0 505 279 A Querlenkerlager oben / control arm mount upper	(1)	Ø A 38,5H45
30 92 9938	1K0 505 553 A Querlenkerlager außen / control arm mount outer	(1)	Ø A 37 H 50
30 93 2073	1K0 511 327 AQ Stabilisatorlager / stabilizer mount	(5)	Ø A 19,6
30 93 2453	1K0 505 323 N Querlenker oben / control arm upper	(1)	
30 93 2625	1K0 511 327 AS Stabilisatorlager / stabilizer mount	(5)	Ø A 21,7
30 93 2956	1K0 501 529 F Querlenker mit Gummilagern / control arm with rubber mounts	(2)	
30 93 2957	1K0 501 530 C Querlenker mit Gummilagern / control arm with rubber mounts	(2)	
30 93 4884	1K0 505 311 AB Querlenker / control arm	(6)	
30 93 6047	1K0 501 529 J Querlenker mit Gummilagern / control arm with rubber mounts	(4)	Stahl
30 93 8845	1K0 505 223 K Querlenker / control arm	(6)	Blech
30 93 8846	1K0 505 224 K Querlenker / control arm	(6)	Blech
30 93 9648	1K0 511 327 AR S1 Stabilisatorlagersatz / anti roll bar bush kit	(5)	Leon / PR-0BE
30 93 9649	1K0 511 327 AS S1 Stabilisatorlagersatz / anti roll bar bush kit	(5)	Leon / PR-0BF
30 93 9650	1K0 511 327 AQ S1 Stabilisatorlagersatz / anti roll bar bush kit	(5)	Toledo / PR-0BD
30 94 0431	1K0 501 529 J S1 Rep. Satz Querlenker / rep. kit control arm	(7)	
30 94 0438	1K0 501 530 C S1 Rep. Satz Querlenker / rep. kit control arm	(8)	
30 94 0439	1K0 501 529 F S1 Rep. Satz Querlenker / rep. kit control arm	(8)	
32 92 3358	1K0 511 327 AR Stabilisatorlager / stabilizer mount	(3) (5)	Ø A 20,7
32 92 3604	1K0 511 439 E Klemmschelle / clamping clip	(1)	
32 92 9690	1K0 505 171 C Querlenkerlager unten / control arm mount lower		Ø A 42 H 60
40 94 0591	1K0 505 543 A Querlenkerlager / control arm mount		

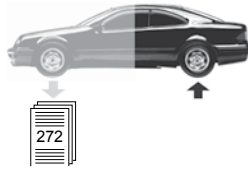

Leon (5F)
(2012 →)

30 92 9938



30 93 2453



30 92 9938



30 93 2453



30 94 3733
30 94 5860

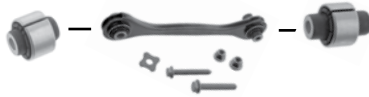

30 94 3733
30 94 5859

30 94 3733
30 94 5859



30 94 3733
30 94 5860

Hinterachse / Rear axle



- (1) Einzelradaufhängung / independent wheel suspension
- (2) Multi-link Achse / multilink axle



Ref. - No.



30 92 9938	1K0 505 553 A	Querlenkerlager / control arm mount		Ø A 37 H 50
30 93 2453	1K0 505 323 N	Querlenker oben / control arm upper		
30 94 3733	5Q0 505 171	Querlenkerlager / control arm mount	(2) PR-0N4	
30 94 5859	5Q0 501 129 B	Spurstangenlager / tie rod bush	(1) PR-0N4	
30 94 5860	5Q0 505 543 B	Spurstangenlager / tie rod bush	(2) PR-0N4	

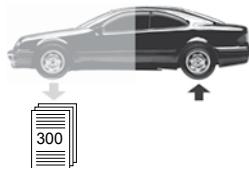

Octavia 4x4 (1U)
(1997 → 2004)

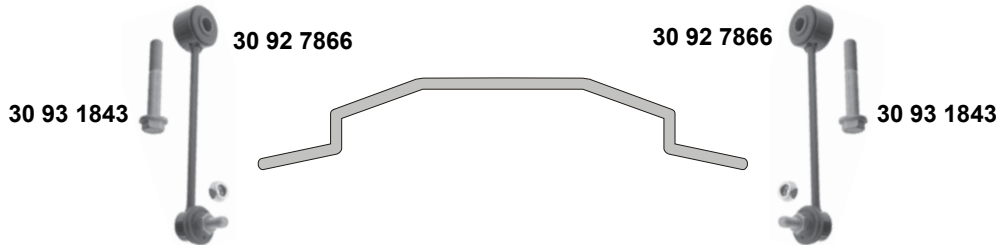

Octavia (5E/NL3/NR3)
(2012 →)



- (1) Einzelradaufhängung / independent wheel suspension
- (2) Multi-link Achse / multilink axle



Ref. - No.



Ref. - No.	Description	Quantity	Dimensions
30 92 7866	Verbindungsstange / connecting rod		L 194,5
30 92 9938	Querlenkerlager / control arm mount		Ø A 37 H 50
30 93 1843	Verbindungsstange / connecting rod		
30 93 2453	Querlenker oben / control arm upper		
30 94 3733	Querlenkerlager / control arm mount	(2) PR-0N4	
30 94 5859	Spurstangenlager / tie rod bush	(1) PR-0N4	
30 94 5860	Spurstangenlager / tie rod bush	(2) PR-0N4	

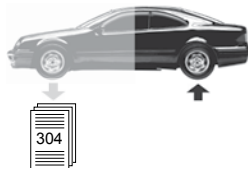

Octavia (1Z) (2004 →)

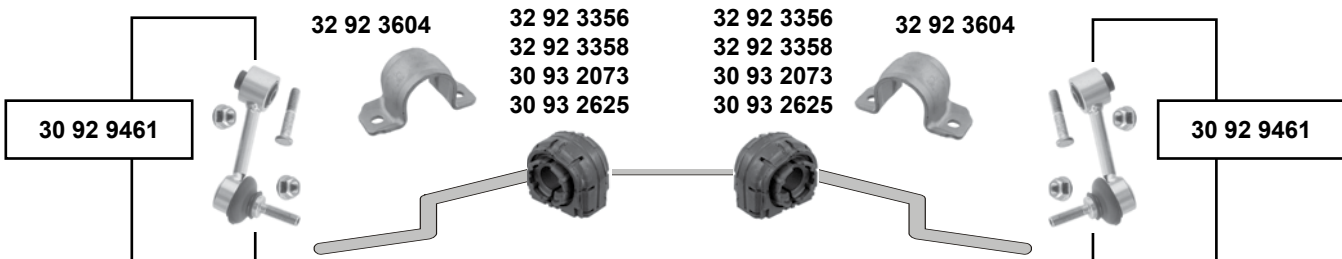
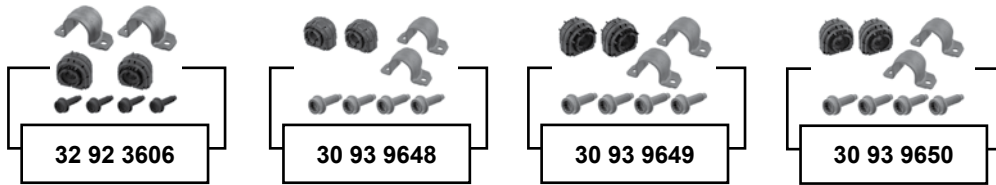
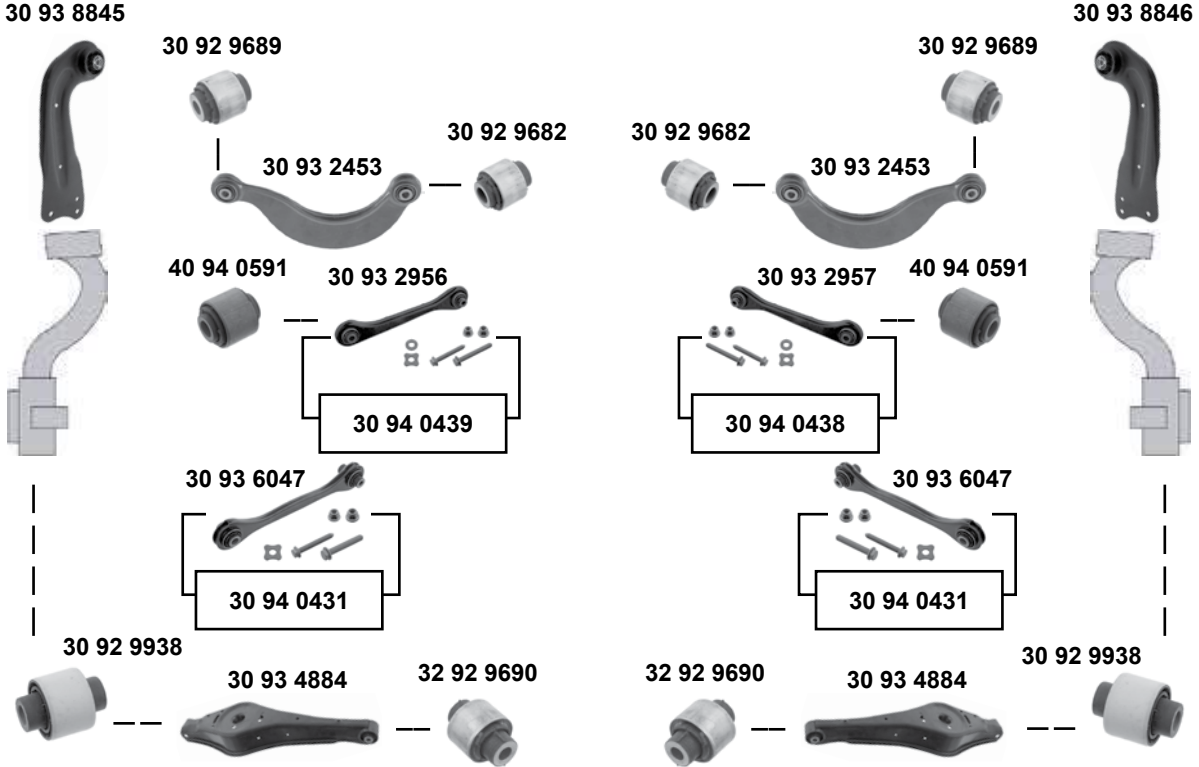

Hinterachse / Rear axle

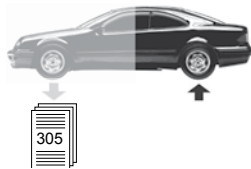

Octavia (1Z) (2004 →)



- (1) → 09 (ch.) → 1Z-9A151 059 / (ch.) → 1Z-9C010 104 / (ch.) → 1Z-9D015 004 / (ch.) → 1Z-9K153 480 / (ch.) → 1Z-92066 810 / (ch.) → 1Z-98019 774
- (2) nur paarweise tauschen / replace in pairs only
- (3) (ch.) 1Z-8A156 300 → / (ch.) 1Z-8B160 560 → / (ch.) 1Z-8C014 469 → / (ch.) 1Z-8D150 073 → / (ch.) 1Z-8K156 426 → / (ch.) 1Z-82245 091 → / (ch.) 1Z-88038 538 →



Ref. - No.



SWAG Ref. - No.	Description	Quantity	Material / Specification
30 92 9461	1K0 505 465 K S1 Rep. Satz Verbindungsstange / rep. kit connecting rod		L 95,5
30 92 9682	1K0 505 203 A Querlenkerlager oben / control arm mount upper		Ø A 38 H 45
30 92 9689	1K0 505 279 A Querlenkerlager oben / control arm mount upper		Ø A 38,5 H 45
30 92 9938	1K0 505 553 A Querlenkerlager außen / control arm mount outer		Ø A 37 H 50
30 93 2073	1K0 511 327 AQ Stabilisatorlager hinten / stabilizer mount rear	(2)	Ø A 19,6
30 93 2453	1K0 505 323 N Querlenker oben / control arm upper		
30 93 2625	1K0 511 327 AS Stabilisatorlager hinten / stabilizer mount rear	(2)	Ø A 21,7
30 93 2956	1K0 501 529 F Querlenker mit Gummilagern / control arm with rubber mounts	(1)	
30 93 2957	1K0 501 530 C Querlenker mit Gummilagern / control arm with rubber mounts	(1)	
30 93 4884	1K0 505 311 AB Querlenker / control arm		
30 93 6047	1K0 501 529 J Querlenker mit Gummilagern / control arm with rubber mounts	(3)	Stahl
30 93 8845	1K0 505 223 K Querlenker / control arm		Blech
30 93 8846	1K0 505 224 K Querlenker / control arm		Blech
30 93 9648	1K0 511 327 AR S1 Stabilisatorlagersatz / anti roll bar bush kit	(2)	PR-0BE
30 93 9649	1K0 511 327 AS S1 Stabilisatorlagersatz / anti roll bar bush kit	(2)	PR-0BF, 0BL
30 93 9650	1K0 511 327 AQ S1 Stabilisatorlagersatz / anti roll bar bush kit	(2)	PR-0BD
30 94 0431	1K0 501 529 J S1 Rep. Satz Querlenker / rep. kit control arm		05/09 →
30 94 0438	1K0 501 530 C S1 Rep. Satz Querlenker / rep. kit control arm		→ 05/09
30 94 0439	1K0 501 529 F S1 Rep. Satz Querlenker / rep. kit control arm		→ 05/09
32 92 3356	1K0 511 327 AP Stabilisatorlager / stabilizer mount	(2)	→ 07 Ø I 18,5
32 92 3358	1K0 511 327 AR Stabilisatorlager / stabilizer mount	(2)	Ø A 20,7
32 92 3604	1K0 511 439 E Klemmschelle / Clamp		
32 92 3606	1K0 511 327 AP S1 Stabilisatorlagersatz / anti roll bar bush kit	(2)	Ø I 18,5
32 92 9690	1K0 505 171 C Querlenkerlager unten / control arm mount lower		Ø A 42 H 60
40 94 0591	1K0 505 543 A Querlenkerlager / control arm mount		

Hinterachse / Rear axle

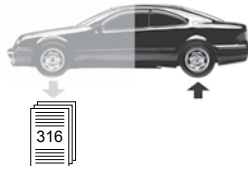

Superb (3T) / Yeti (5L)

(2008 →) / (2010 →)

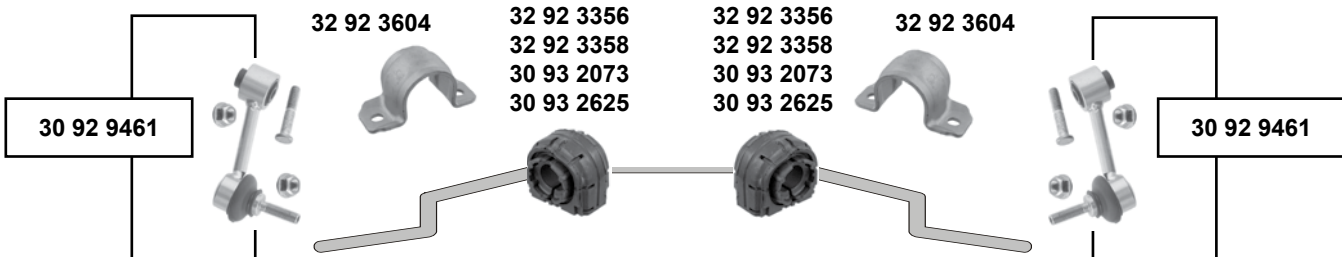
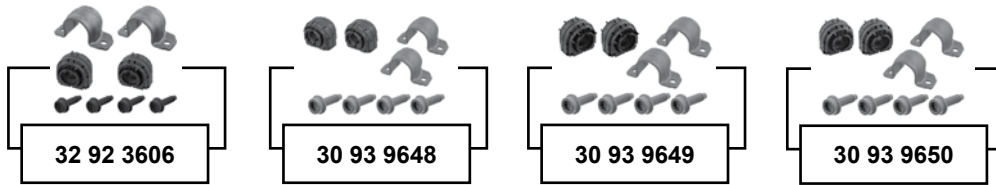
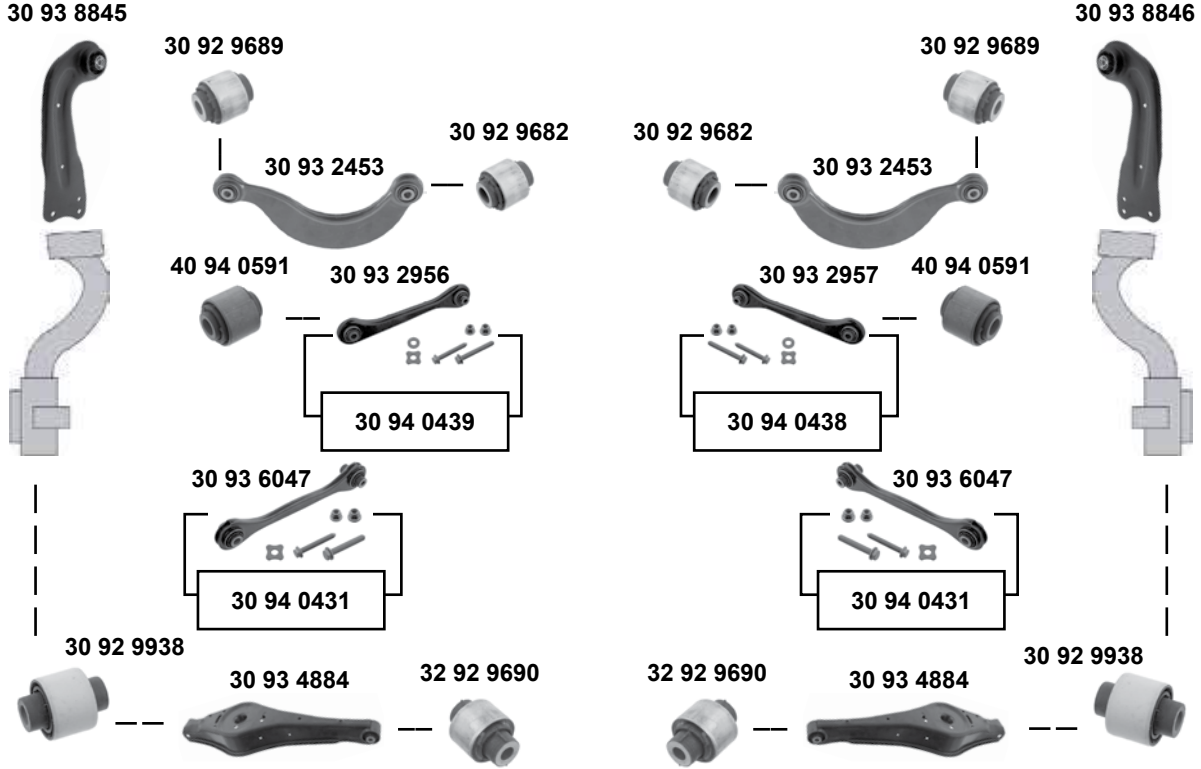

Hinterachse / Rear axle

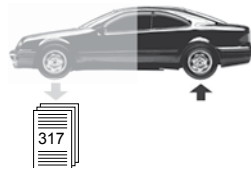

Superb (3T) / Yeti (5L) (2008 →) / (2010 →)



- (1) Superb / combi (3T) → 09 (ch.) → 3T-9K300 275 / → 09 (ch.) → 3T-99039 240
Yeti / 4x4 (5L) 10 → (ch.) → 5L-A-6006 169
- (2) Yeti / 4x4 10 →
- (3) Suberb 2 / combi (3T) 08 →
- (4) Superb 08 → (ch.) 3T-AK300 014 → / (ch.) 3T-A9006 854 →
- (5) nur paarweise tauschen / replace in pairs only
- (6) Superb PR-0BF, 0BG, 0BL

	Ref. - No.			
30 92 9461	1K0 505 465 K S1	Rep. Satz Verbindungsstange / rep. kit connecting rod	(2)	L 95,5
30 92 9682	1K0 505 203 A	Querlenkerlager oben / control arm mount upper		Ø A 38 H45
30 92 9689	1K0 505 279 A	Querlenkerlager oben / control arm mount upper	(2)	Ø A 38,5H45
30 92 9938	1K0 505 553 A	Querlenkerlager außen / control arm mount outer		Ø A 37 H50
30 93 2073	1K0 511 327 AQ	Stabilisatorlager hinten / stabilizer mount rear	(5)	Ø A 19,6
30 93 2453	1K0 505 323 N	Querlenker oben / control arm upper	(2) (3)	
30 93 2625	1K0 511 327 AS	Stabilisatorlager hinten / stabilizer mount rear	(5)	Ø A 21,7
30 93 2956	1K0 501 529 F	Querlenker mit Gummilagern / control arm with rubber mounts	(1)	
30 93 2957	1K0 501 530 C	Querlenker mit Gummilagern / control arm with rubber mounts	(1)	
30 93 4884	1K0 505 311 AB	Querlenker / control arm		
30 93 6047	1K0 501 529 J	Querlenker mit Gummilagern / control arm with rubber mounts	(4)	Stahl
30 93 8845	1K0 505 223 K	Querlenker / control arm		Blech
30 93 8846	1K0 505 224 K	Querlenker / control arm		Blech
30 93 9648	1K0 511 327 AR S1	Stabilisatorlagersatz / anti roll bar bush kit	(5) 3T / PR-0BE	
30 93 9649	1K0 511 327 AS S1	Stabilisatorlagersatz / anti roll bar bush kit	(5) (6)	
30 93 9650	1K0 511 327 AQ S1	Stabilisatorlagersatz / anti roll bar bush kit	(5) Yeti PR-0BD	
30 94 0431	1K0 501 529 J S1	Rep. Satz Querlenker / rep. kit control arm	05/09 →	
30 94 0438	1K0 501 530 C S1	Rep. Satz Querlenker / rep. kit control arm	Superb → 05/09	
30 94 0439	1K0 501 529 F S1	Rep. Satz Querlenker / rep. kit control arm	Superb → 05/09	
32 92 3356	1K0 511 327 AP	Stabilisatorlager / stabilizer mount	(5)	Ø I 18,5
32 92 3358	1K0 511 327 AR	Stabilisatorlager / stabilizer mount	(3) (5)	Ø A 20,7
32 92 3604	1K0 511 439 E	Klemmschelle / clamping clip	(2)	
32 92 3606	1K0 511 327 AP S1	Stabilisatorlagersatz / anti roll bar bush kit	(5)	Ø I 18,5
32 92 9690	1K0 505 171 C	Querlenkerlager unten / control arm mount lower		Ø A 42 H60
40 94 0591	1K0 505 543 A	Querlenkerlager / control arm mount		

passend für / to fit

SMART

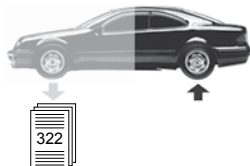

Fortwo (BM 450)

(1998 →)

99 92 2587



99 92 2587

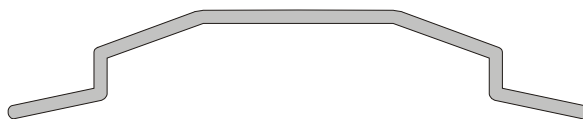

Hinterachse / Rear axle



Ref. - No.



99 92 2587 0001802V004

Verbindungsstange / connecting rod

L174

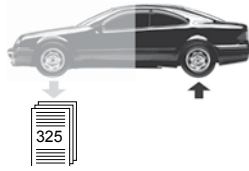

Forester (S10)
(1997 → 2002)

87 92 9685



87 92 9685



Forester (S11)
(2002 → 2008)

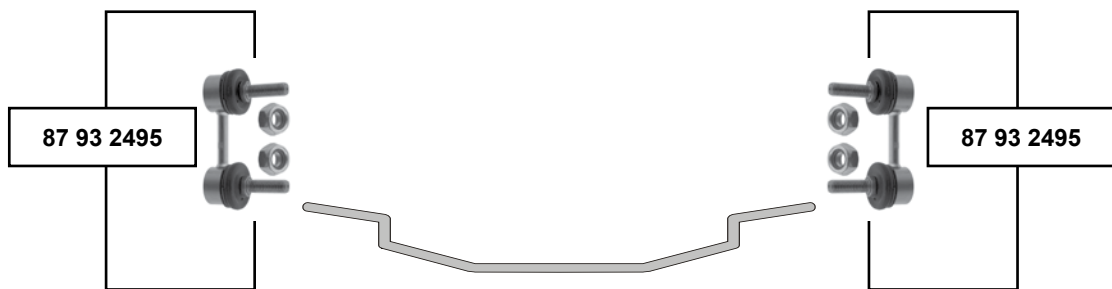

Hinterachse / Rear axle



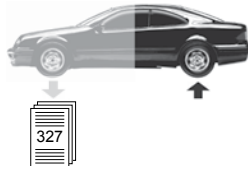

Impreza (G10)
(1992 → 2000)

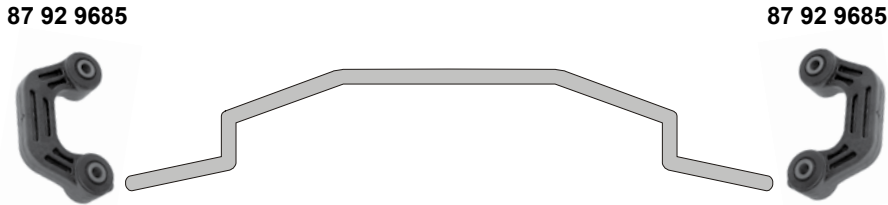

Impreza (G11)
(2000 → 2007)

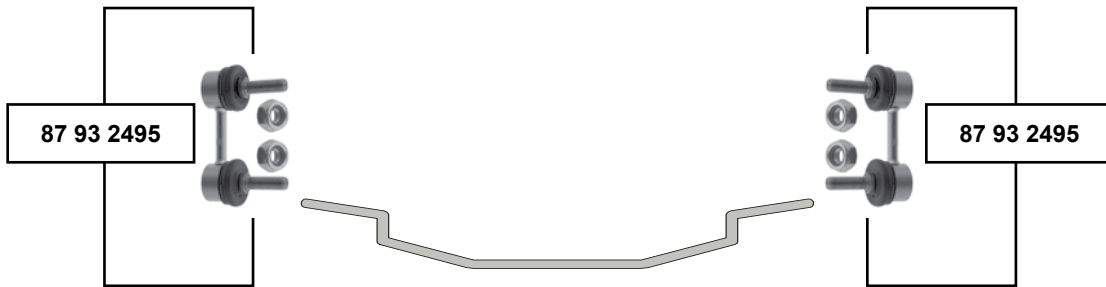
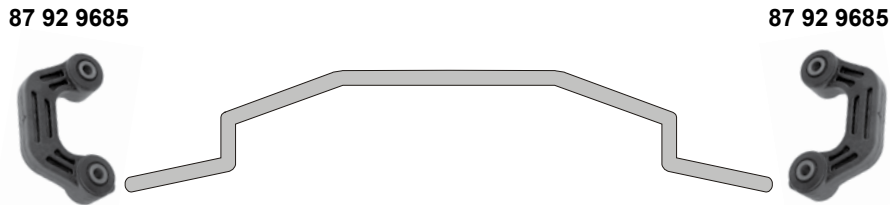

Hinterachse / Rear axle



- (1) (ex.) 2,0 WRX STi (EJ207) / (ex.) 2,5 WRX STi (EJ257)
- (2) 2,0 WRX STi (EJ207) / 2,5 WRX STi (EJ257)



Ref. - No.



87 92 9685	20481AA001
87 93 2495	20470SA011

Verbindungsstange / connecting rod
Verbindungsstange / connecting rod

(1)
(2)

L 100
L 70

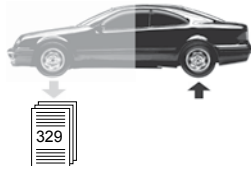

Legacy II (B11)
(1993 → 1998)

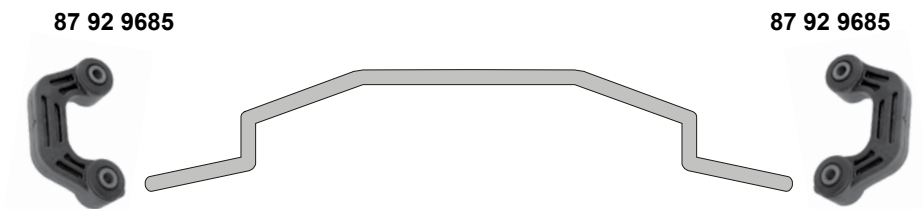

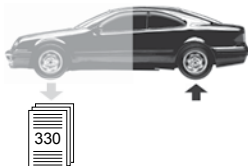

Legacy III (B12)

(1998 → 2003)



Legacy IV (B13)

(2003 → 2009)



Hinterachse / Rear axle

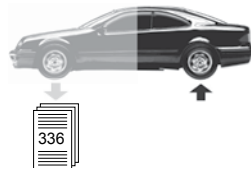

Swift II
(1989 → 2001)

84 92 9376



84 92 9376



84 92 9761



84 92 9760



Wagon R+
(2000 →)

84 93 2475

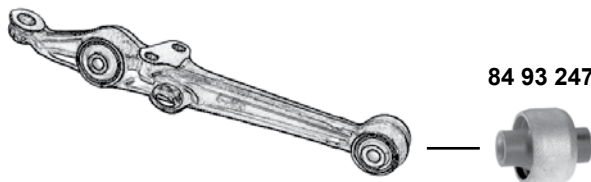

84 93 2475

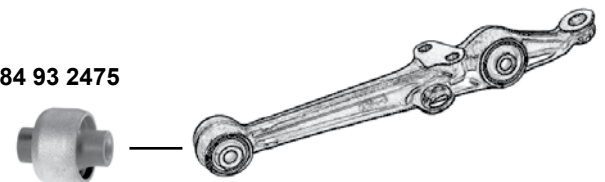

Hinterachse / Rear axle





TOYOTA

Auris (ADE157)

(2008 →)

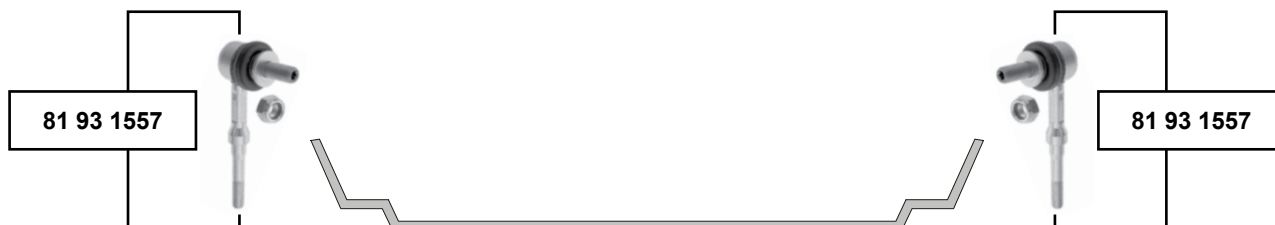

Avalon (MCX10)

(1994 →)

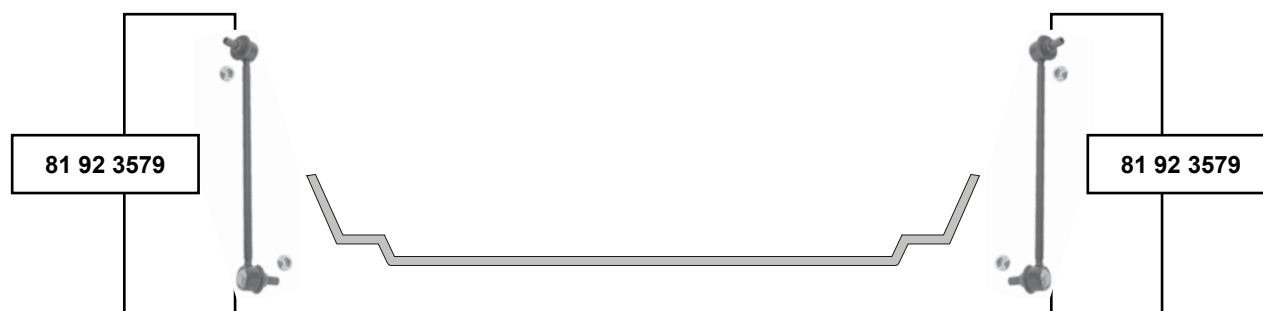

Hinterachse / Rear axle

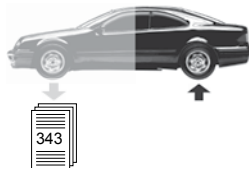

Avensis (_T22_)
(1997 → 2003)

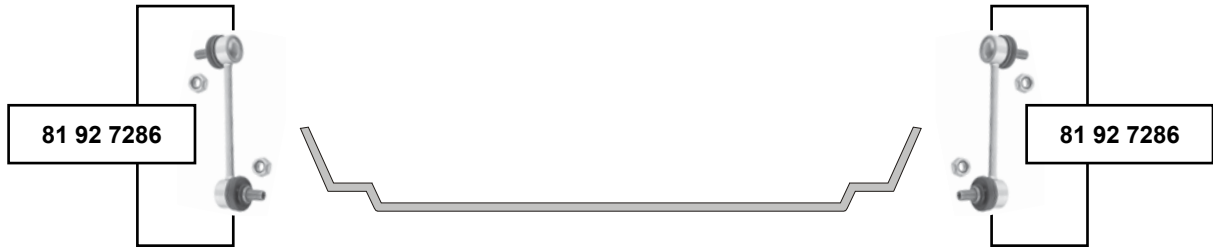

Avensis (_T25_)
(2003 →)



Avensis (_T27_)
(2008 →)

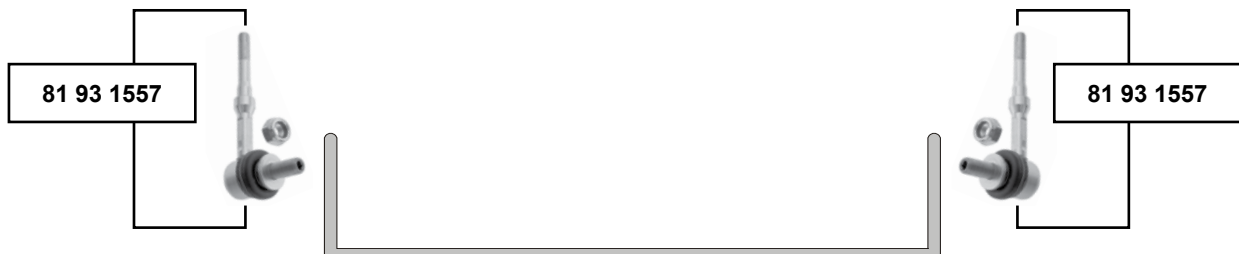

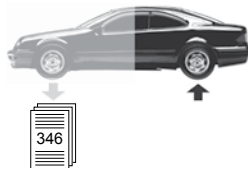

Camry (_V2_)
(1986 → 2001)



Camry (_V30_)
(2001 → 2006)



Camry (_V36_)
(2002 → 2006)



Hinterachse / Rear axle

SWAG	Ref. - No.			
66 91 8105	48830-20010	Verbindungsstange / connecting rod		L 103
81 92 3579	48830-33010	Verbindungsstange / connecting rod		M10 x 1,25
81 92 6520	48830-48010	Verbindungsstange / connecting rod		L 235

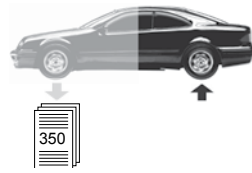

Carina 2 (_T17_)
(1987 → 1992)

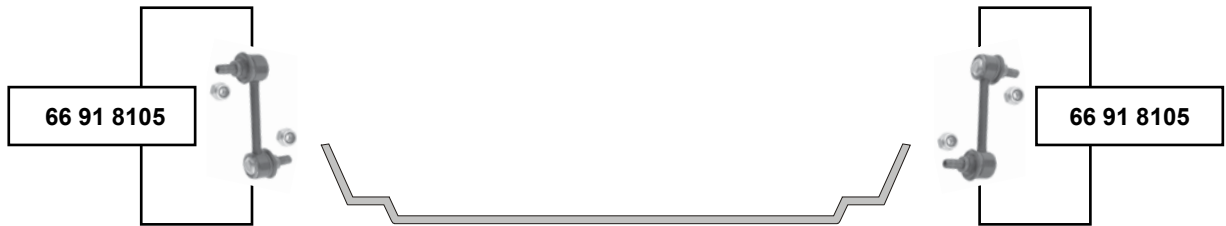

Carina E (_T19_)
(1992 → 1997)

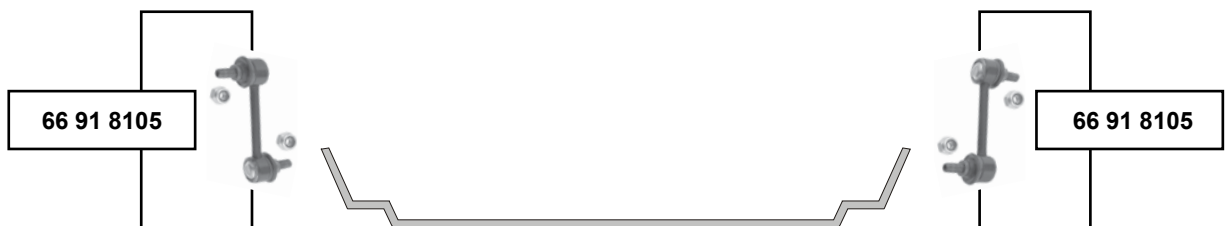

Hinterachse / Rear axle



passend für / to fit

TOYOTA

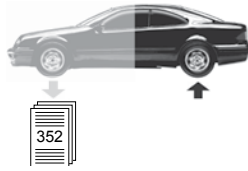

Celica (T16 / T18 / T20)

(1985 → 1999)



Corolla

(1987 →)

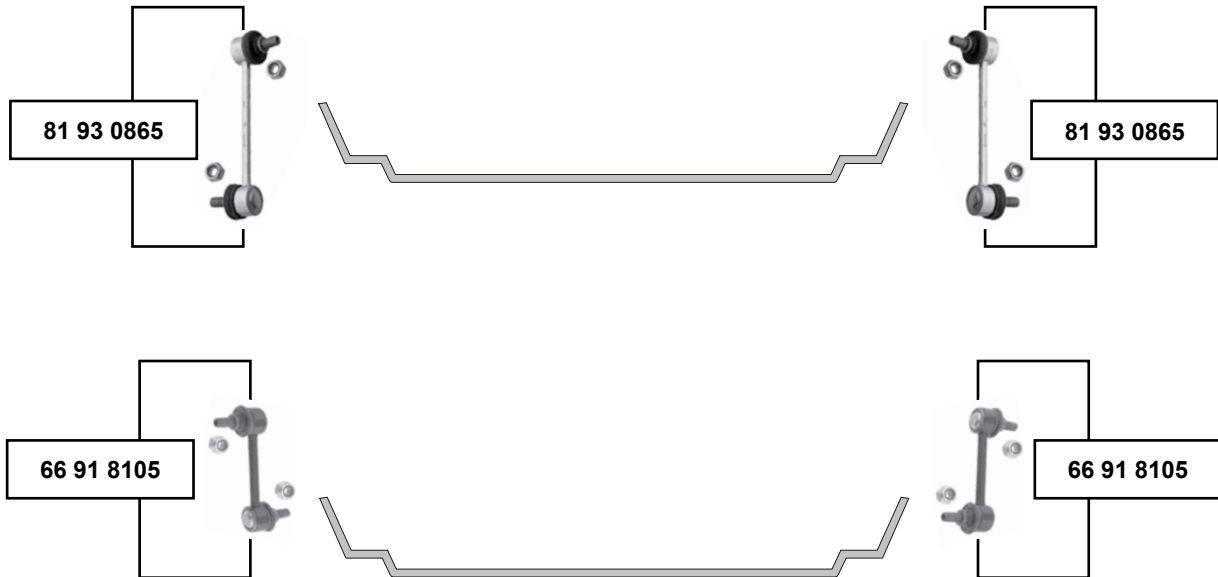

Hinterachse / Rear axle



(1) 1,8 mod. E10 / 95 → 01 / 4WD



Ref. - No.



66 91 8105 48830-20010
81 93 0865 48830-12050

Verbindungsstange / connecting rod
Verbindungsstange / connecting rod

(1)
(ex.) 1,8 4WD / → 97

L 103
L 150

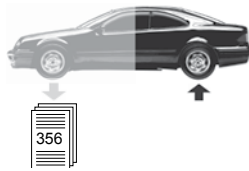

Corolla (E11)
(1997 → 2002)

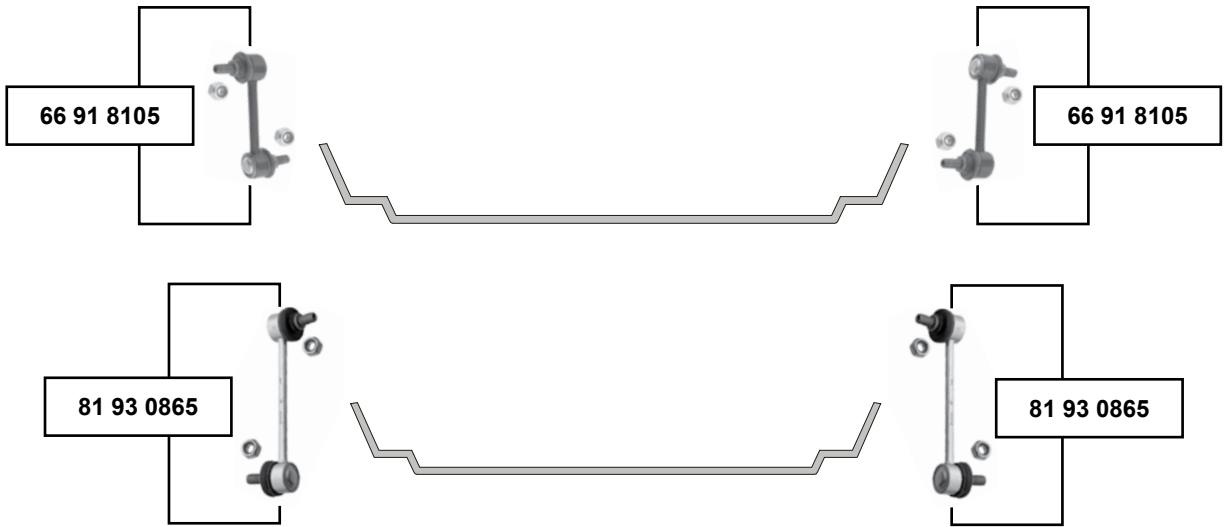

Corolla Verso (_E12_)
(2001 → 2003)

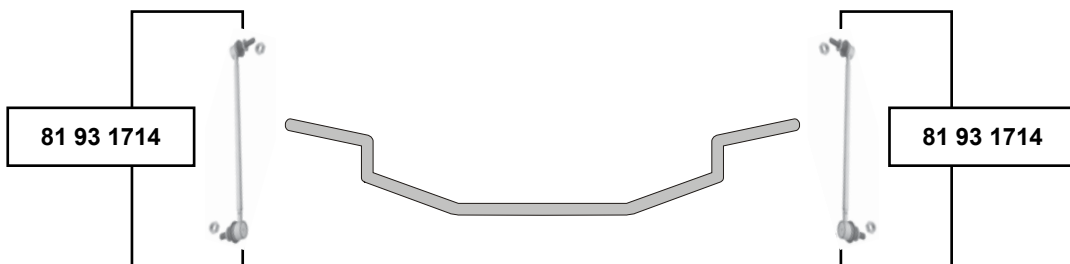

Corona (AT220/CT220/ST210)
(1997 → 2003)



Hinterachse / Rear axle

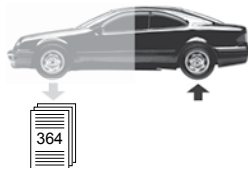

FJ Cruiser (US)

(2006 →)



Highlander (U20)

(2001 →)



Highlander (U25)

(2001 → 2003)

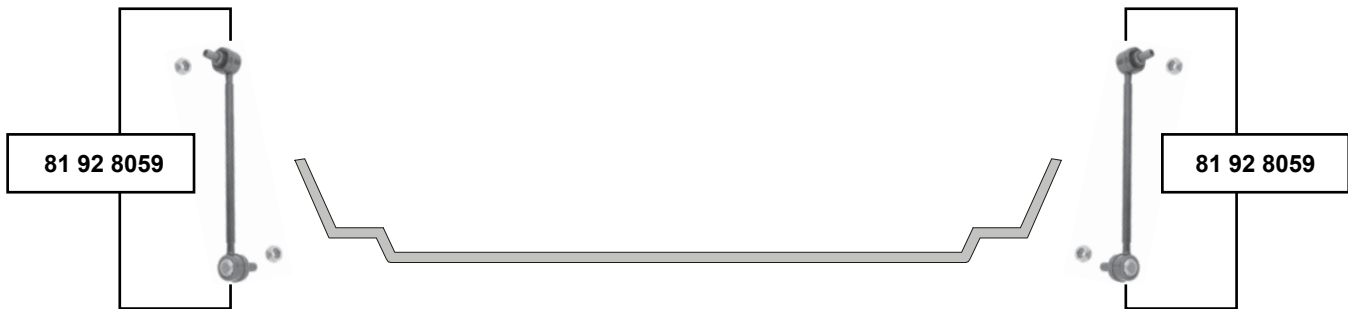

Hinterachse / Rear axle

	Ref. - No.			
81 92 6520	48830-48010	Verbindungsstange / connecting rod		
81 92 7287	48830-60030	Verbindungsstange / connecting rod		L 175
81 92 8059	48830-32040	Verbindungsstange / connecting rod		L 250

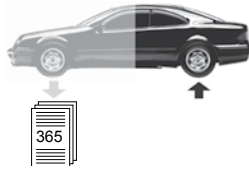

Kluger (_U28_)
(2003 →)



Land Cruiser (_J7_)
(1999 → 2009)



Land Cruiser (_J8_)
(1990 → 1998)



Hinterachse / Rear axle

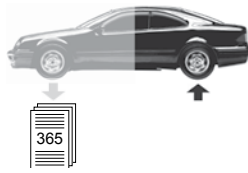

Land Cruiser (_J9_)

(1996 →)

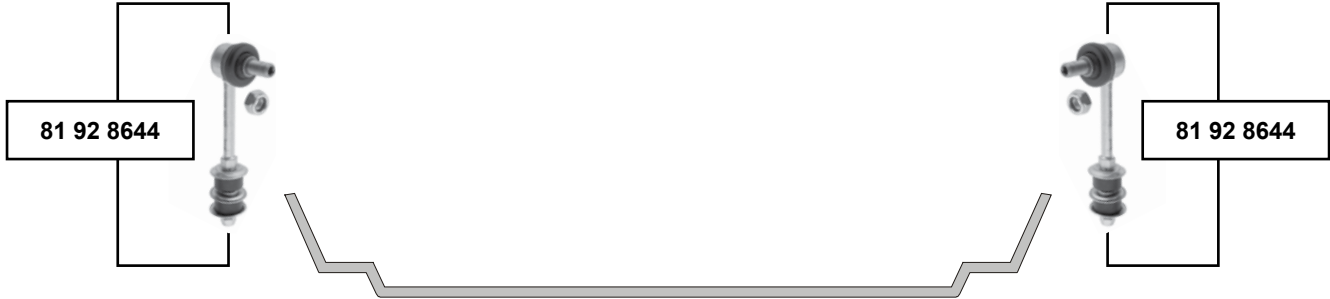

Land Cruiser (_J10_)

(1998 → 2007)





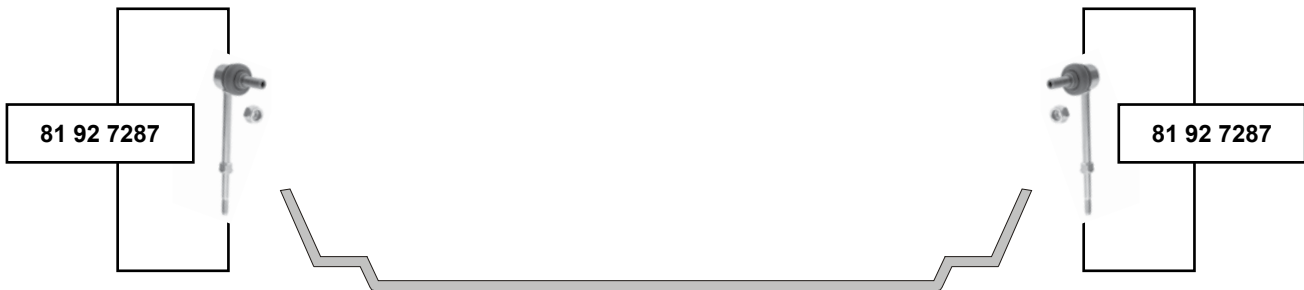

Land Cruiser (_J12_)

(2002 →)



Hinterachse / Rear axle

	Ref. - No.			
81 92 7287	48830-60030	Verbindungsstange / connecting rod	→ 04	L 175
81 92 8644	48830-35020 S1	Verbindungsstange / connecting rod		L 153
81 93 4662	48802-60090 S1	Verbindungsstange / connecting rod		L 110

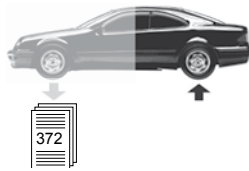

MR 2 (_W2_)
(1989 → 1999)



MR 2 (_W3_)
(1999 → 2005)

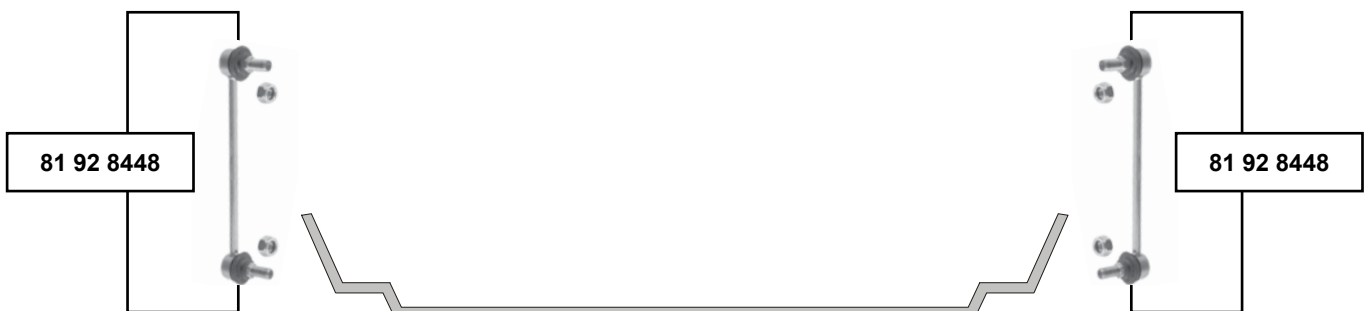

Rav 4 II / Rav 4 III
(2000 → 2005) (2005 →)



Hinterachse / Rear axle



Ref. - No.



81 92 8448	48830-17070	Verbindungsstange / connecting rod		L 198,8
81 92 8628	48840-42010	Verbindungsstange / connecting rod	Rav 4 II	L 100
81 92 8629	48830-42010	Verbindungsstange / connecting rod	Rav 4 II	L 100
81 93 1558	48830-0R010	Verbindungsstange / connecting rod	Rav 4 III	L 47
81 93 1716	48830-17050	Rep. Satz Verbindungsstange / rep. kit connecting rod		L 204



TOYOTA

Scion TC (2004 →)



Solara (_V20_) (1998 → 2001)

Hinterachse / Rear axle



Ref. - No.



81 92 3579	48830-33010
81 92 7331	48840-21010
81 92 7332	48830-21020

Verbindungsstange / connecting rod
Verbindungsstange / connecting rod
Verbindungsstange / connecting rod

L 165
L 105
L 105

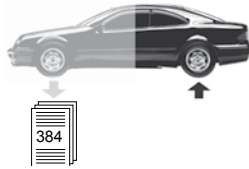

4 Runner (_ZN18_)
(1995 → 2002)



4 Runner (_RN21_)
(2002 → 2004)

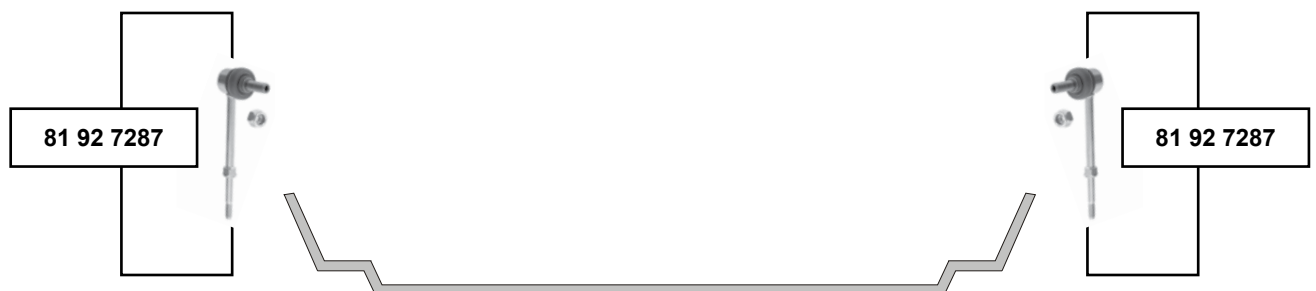

Hinterachse / Rear axle

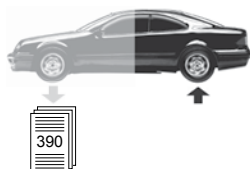

Antara
(2006 →)

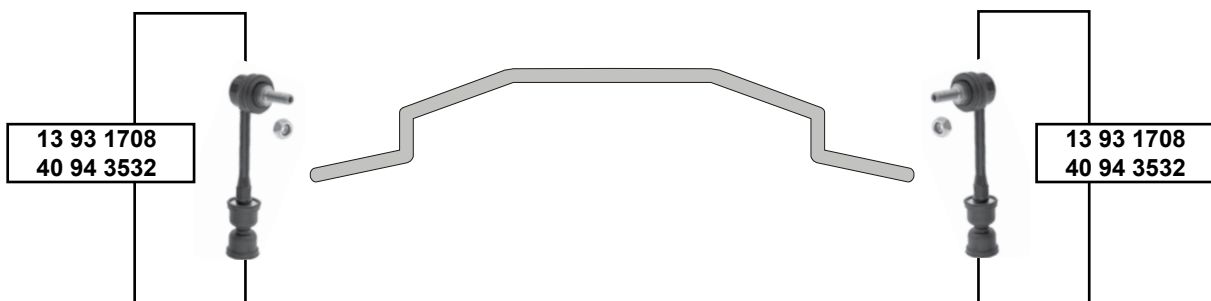

Hinterachse / Rear axle



(1) (ch.) → AB999999, → A3999999

(2) (ch.) BB000001 →, B3000001 →



Ref. - No.



13 93 1708 96996460
40 94 3532 22737680

Verbindungsstange / connecting rod
Verbindungsstange / connecting rod

(1)
(2)

L 167
L 106,5

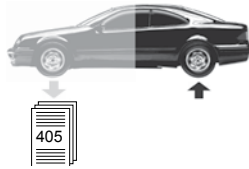

Calibra
(1990 → 1997)

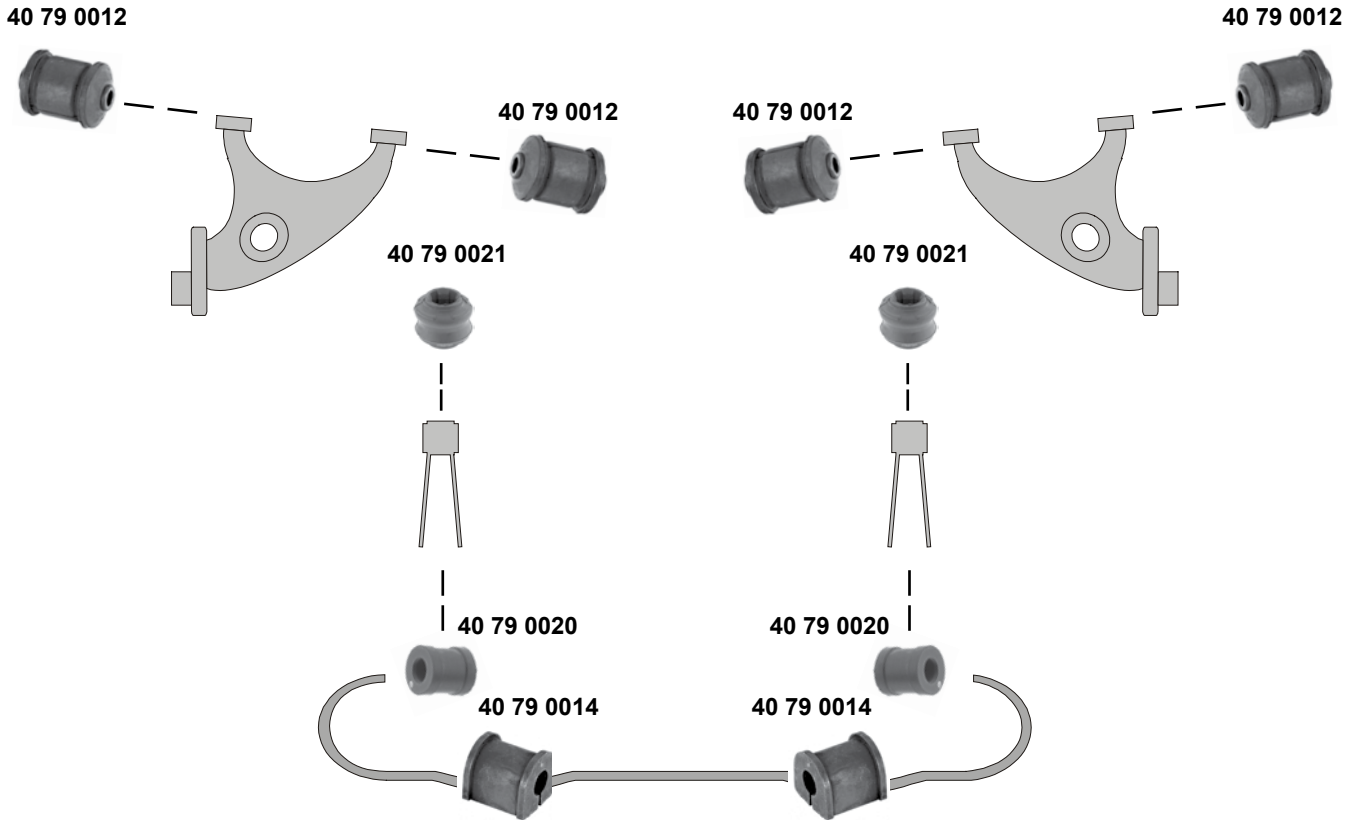

Hinterachse / Rear axle

SWAG	Ref. - No.			
40 79 0012	90223456	Schrägenkerlager / semi-trailing arm bush		12x45x71
40 79 0014	90373771	Stabilisatorlager / stabilizer mount		Ø 14
40 79 0020	90343305	Stabilisatorlager / stabilizer mount		13x26x28
40 79 0021	90343847	Verbindungsstangenlager / connecting rod bearing		

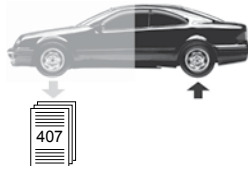

Carlton Mk III
(1986 → 1994)

(ex.) 3.0 24V
3.0 24 (ch.) → L 1019854

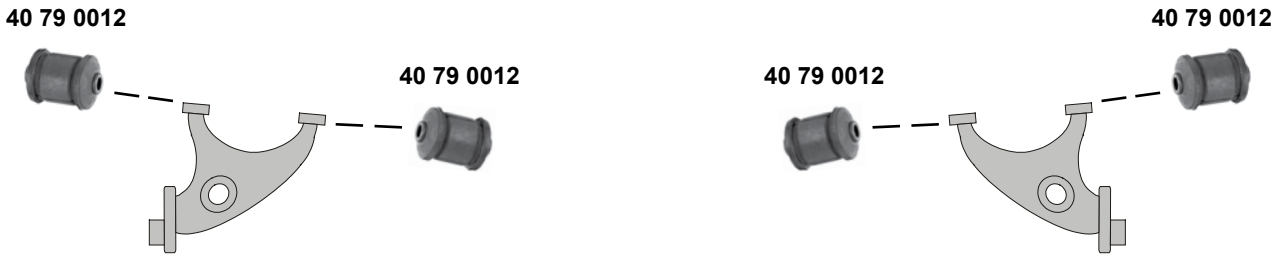

3.0 24V (ch.) L 1019855 →

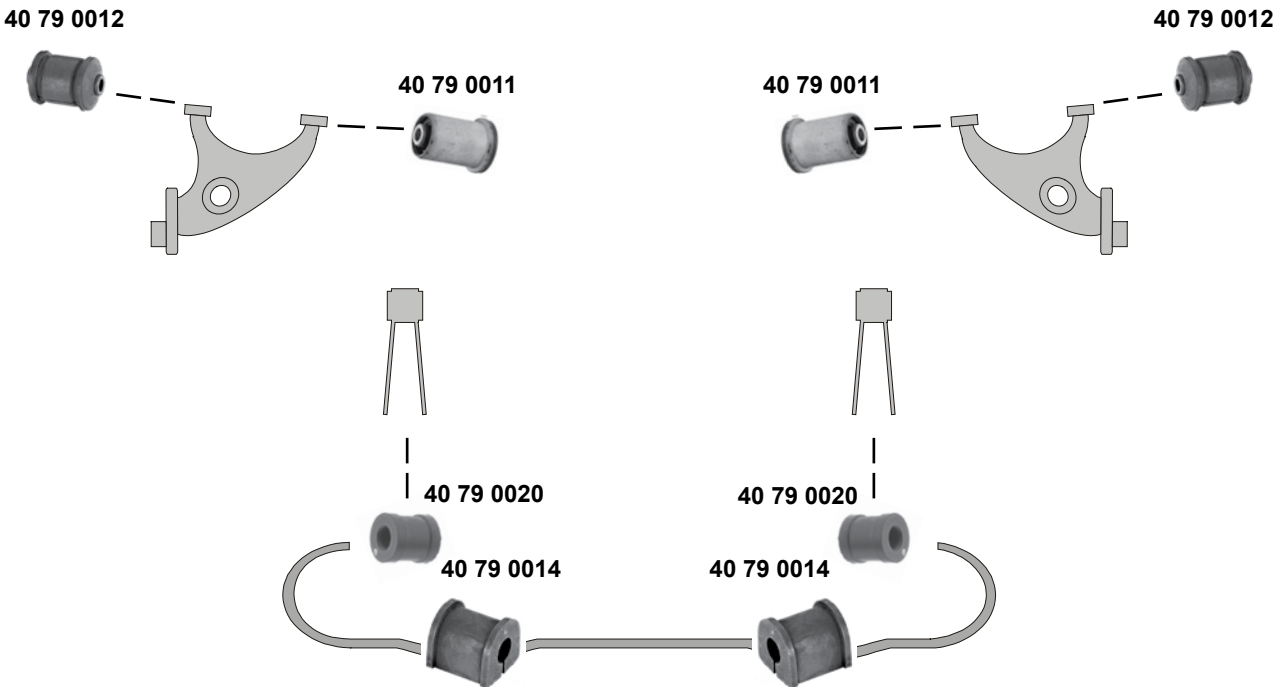

Hinterachse / Rear axle

	Ref. - No.			
40 79 0011	90334925	Schräglenkerlager / semi-trailing arm bush		12x43x71
40 79 0012	90223456	Schräglenkerlager / semi-trailing arm bush		12x45x71
40 79 0014	90373771	Stabilisatorlager / stabilizer mount		Ø 14
40 79 0020	90343305	Stabilisatorlager / stabilizer mount		13x26x28

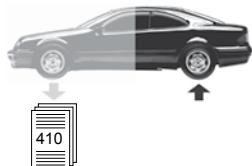

Cavalier Mk III (1988 → 1995)

2.0 i 16V (110 / 115 kw)

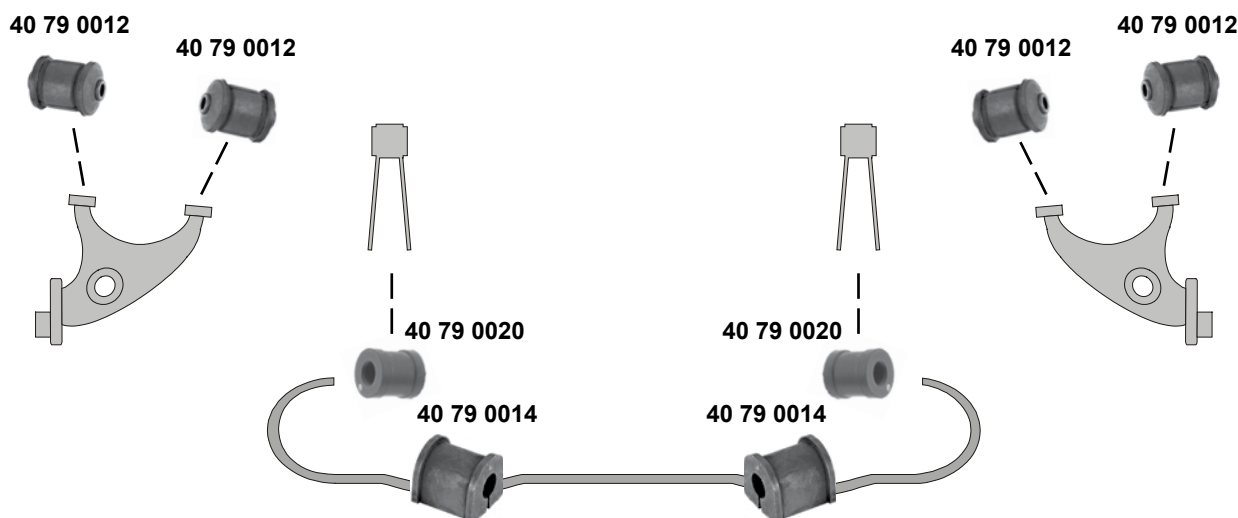

Insignia (2008 →)

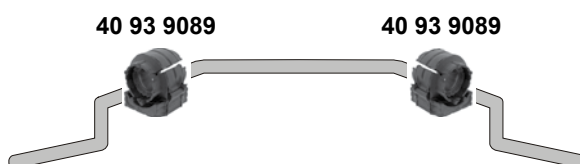

- (1) (ch.) → N 1999999 / N 5999999 / NV 999999
- (2) (ch.) P 1000001 / P 5000001 / P 7100001 →
- (3) Schrägheck/Stufenheck:
Standardchassis / standard chassis alle/all
tiefergelegtes chassis / lowered chassis nur/only Diesel D-1000001 →
HD (ex.) A14NET, A16LET, A20XER, Diesel D1000001 →
Sportstourer: **HD** nur/only Diesel D-1000001 →

Hinterachse / Rear axle



Ref. - No.



Ref. - No.	Description	Quantity	Dimensions
40 79 0012	Schräglager / semi-trailing arm bush	(1)	12x45x71
40 79 0014	Stabilisatorlager / stabilizer mount	(2)	Ø 14
40 79 0020	Stabilisatorlager / stabilizer mount	(2)	13x26x28
40 93 9089	Stabilisatorlager / stabilizer mount	(3) (ex.) 4x4	Ø 20

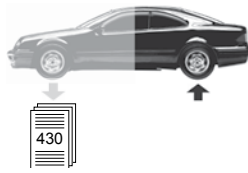

Movano Mk II

(2010 →)

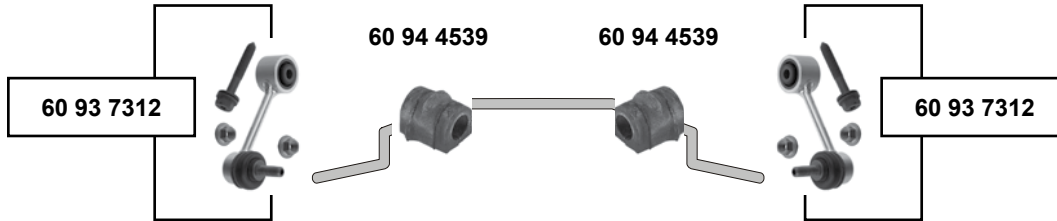

Omega

(1994 → 2003)

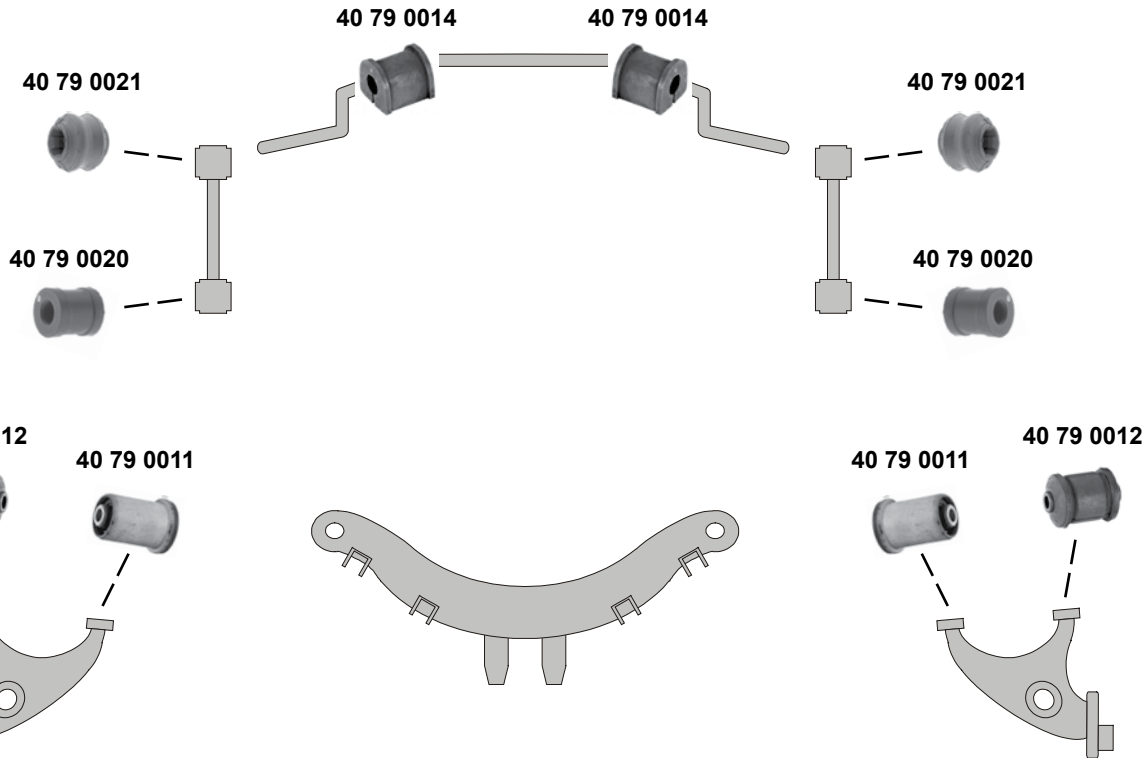

Hinterachse / Rear axle

- (1) Vorderradantrieb + Hinterradantrieb mit Einzelbereifung / front wheel drive + rear-wheel drive with single tires
- (2) nur Fahrzeuge mit Frontantrieb / only vehicles with front wheel drive

SWAG GERMANY	Ref. - No.			
40 79 0011	90334925	Schräglenkerlager / semi-trailing arm bush Arm		12x43x71
40 79 0012	90223456	Schräglenkerlager / semi-trailing arm bush Arm		12x45x71
40 79 0014	90373771	Stabilisatorlager / stabilizer mount		Ø I 14
40 79 0020	90343305	Stabilisatorlager / stabilizer mount		13x26x28
40 79 0021	90343847	Verbindungsstangenlager / connecting rod bearing		29/32x29
60 93 7312	93197332 S1	Rep. Satz Verbindungsstange / rep. kit connecting rod	(1)	L 105,5
60 94 4539	93197335	Stabilisatorlager / stabilizer mount	(2)	Ø 28

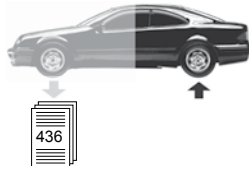

Senator Mk II
(1986 → 1994)

(ch.) → L 1019854 / 5155054

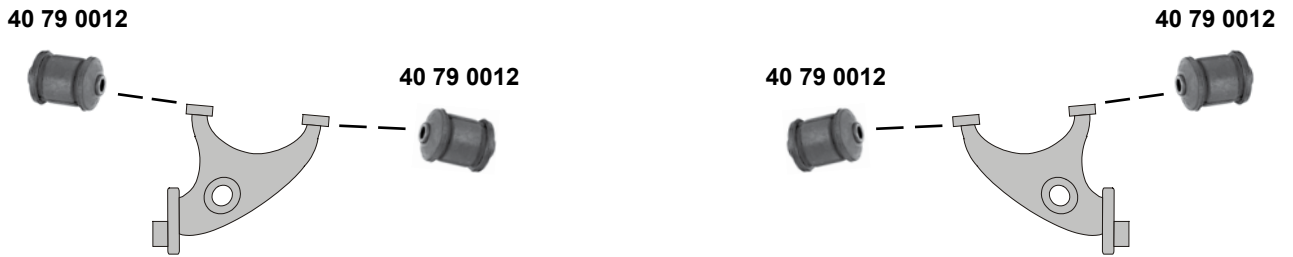

(ch.) L 1019855 / 5155055 →

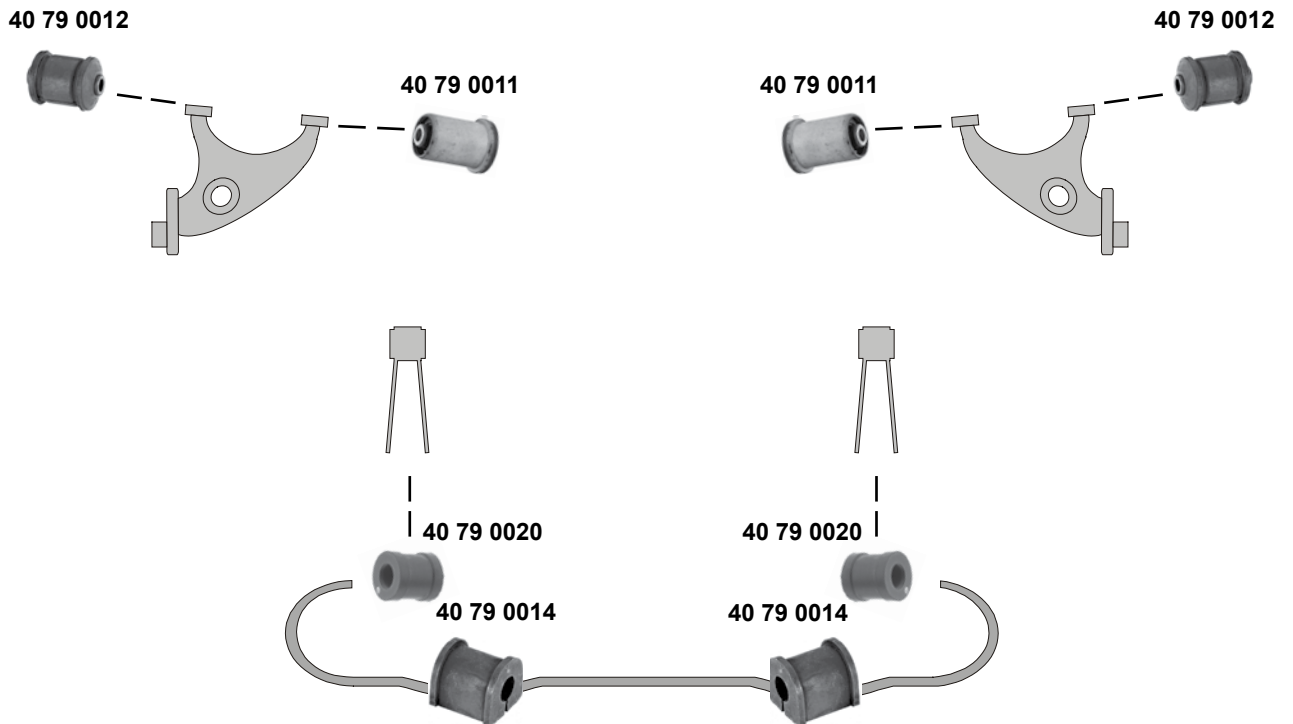

Hinterachse / Rear axle

SWAG	Ref. - No.			
40 79 0011	90334925	Schräglenkerlager / semi-trailing arm bush		12x43x71
40 79 0012	90223456	Schräglenkerlager / semi-trailing arm bush		12x45x71
40 79 0014	90373771	Stabilisatorlager / stabilizer mount		Ø 14
40 79 0020	90343305	Stabilisatorlager / stabilizer mount		13x26x28

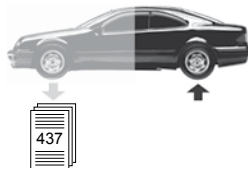

Signum
(2002 → 2008)

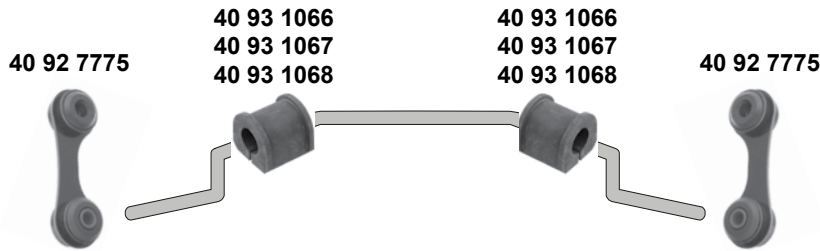
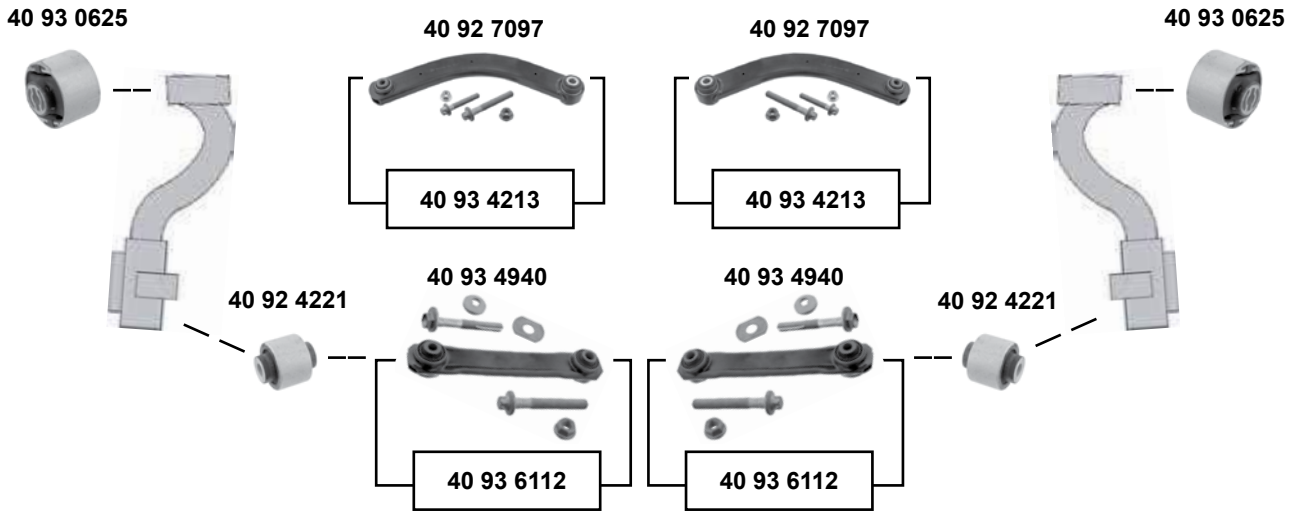

Hinterachse / Rear axle

SWAG	Ref. - No.			
40 92 4221	24469643	Querlenkerlager / control arm mount		12x45,5x52
40 92 7097	0423 035	Querlenker / control arm		L 380
40 92 7775	13104120	Verbindungsstange / connecting rod		L 86
40 93 0625	24452034	Querlenkerlager / control arm mount		
40 93 1066	24457385	Stabilisatorlager / stabilizer mount		Ø 17
40 93 1067	24457386	Stabilisatorlager / stabilizer mount		Ø 18
40 93 1068	24457843	Stabilisatorlager / stabilizer mount		Ø 19
40 93 4213	13230274 S1	Rep. Satz Querlenker / rep. kit control arm		
40 93 4940	13204112	Querlenker / control arm		
40 93 6112	13204112 S1	Rep. Satz Querlenker / rep. kit control arm		

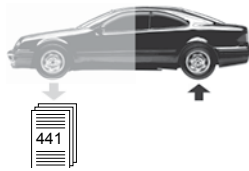

Vectra Mk I (1995 → 2002)

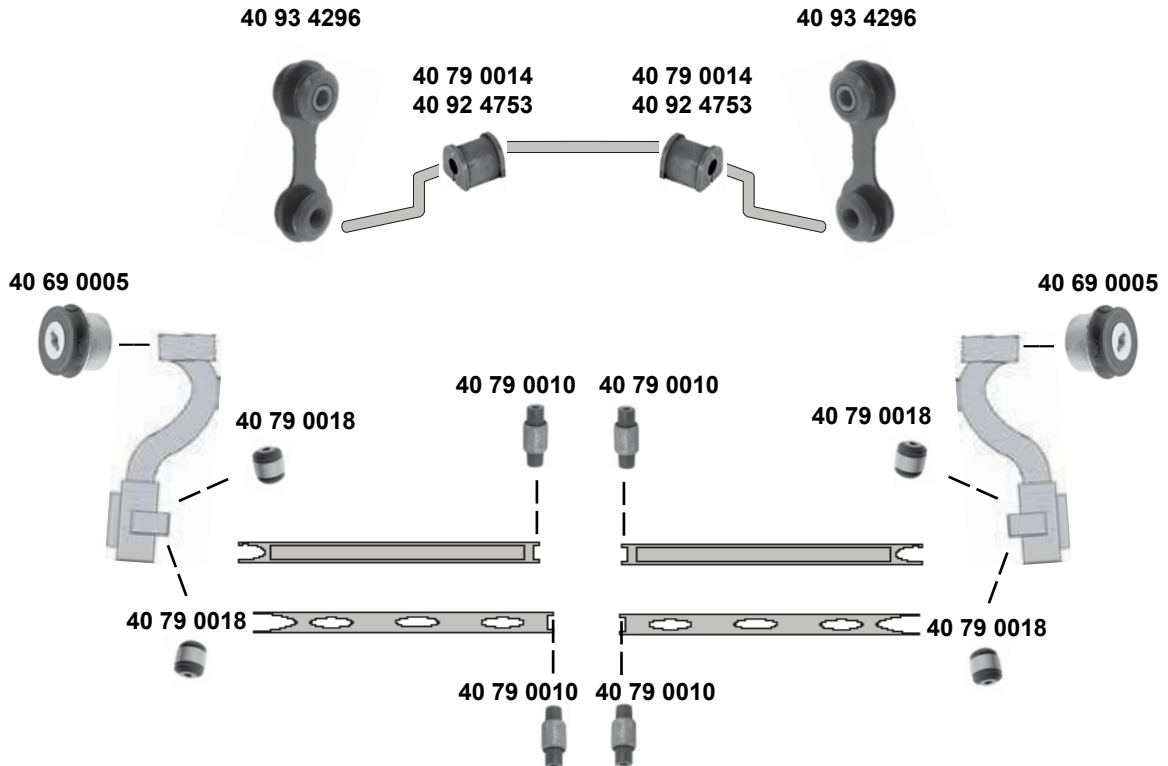

- (1)** 1.6 (ch.) → W 1999999 / W 5999999 / W 7999999
- (2)** 1.6 (ch.) X 1000001 / X 7000001 →
 1.7 (mot.) X17TD
 1.8 (mot.) X18XE
 (mot.) X18XE1 (ch.) → W 1999999 / W 5999999 / W 7999999
 (mot.) Z18XE (ch.) X 1000001 / X 7000001 →
 (mot.) Z18XEL (ex.) Sportfahrwerk / sports chassis
 2.0 (mot.) X20XEV
 (mot.) X20DTH / DTL / 20NEJ / C20SEL
 (ch.) → W 1999999 / W 5999999 / W 7999999
 2.2 (mot.) C22SEL
 (mot.) Z22SE (ex.) Sportfahrwerk / sports chassis
 2.5 (mot.) X25XE
- (3)** 1.6 (ex.) Z1.6 XE (ch.) X 1000001 / X7000001 / XL0000001 →
 Fahrzeuge **ohne** Tieferlegung / vehicles **without** lowered chassis
- (4)** X 1.6 XEL / Y 1.6 XE / Z 1.6 XE (ch.) Y1000001 / Y7000001 / XL0000001 →
 Fahrzeuge **mit** Tieferlegung / vehicles **with** lowered chassis
- (5)** 1.8, 2.0 Benzin (ex.) 2.0 NEJ / 2.0 TD / 2.2 Benzin+Diesel / 2.5 / 2.6
- (6)** 2.0 NEJ (ex.) Ägypten / (ex.) egypt



Ref. - No.	Description	Quantity	Dimensions
40 69 0005	Querlenkerlager / control arm mount		
40 79 0010	Querlenkerlager / control arm mount		12x35x89
40 79 0014	Stabilisatorlager / stabilizer mount	(1)	Ø 1 14
40 79 0018	Querlenkerlager / control arm mount		12x45x52
40 92 4753	Stabilisatorlager / stabilizer mount	(2)	
40 93 4296	Verbindungsstange / connecting rod	(3) (4) (5) (6)	

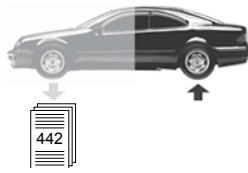

Vectra Mk II
(2002 → 2008)

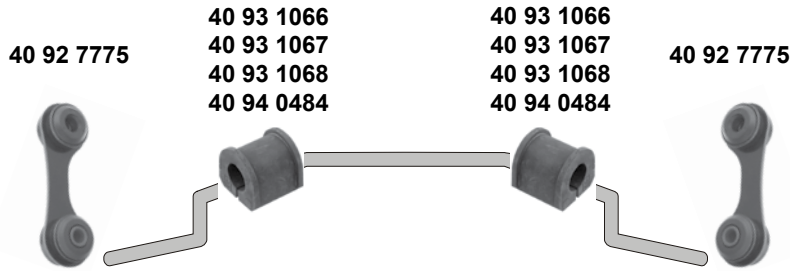
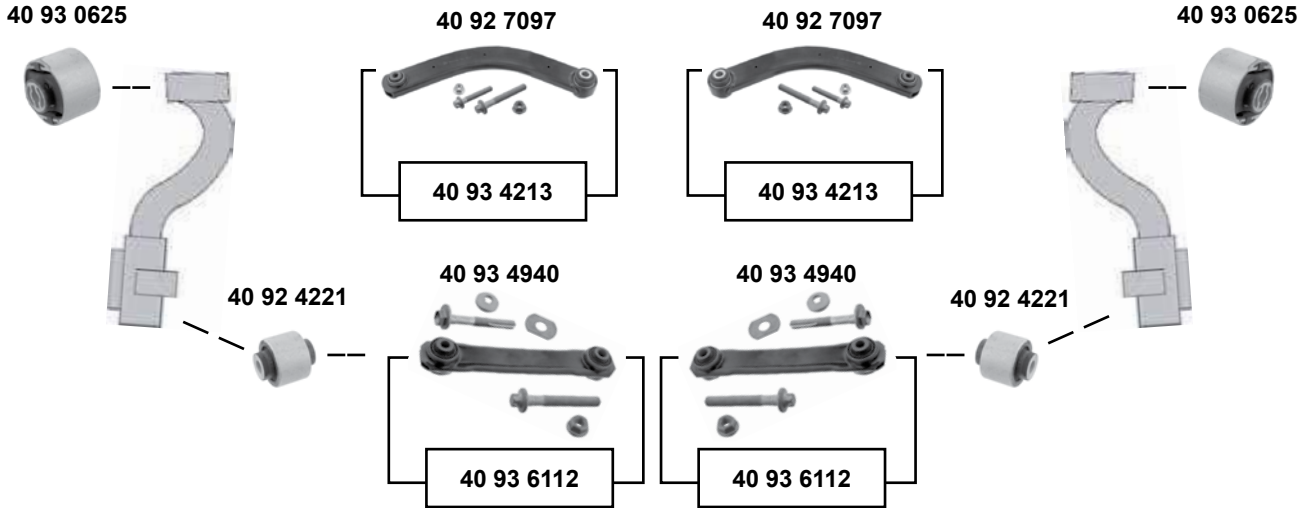

Hinterachse / Rear axle

SWAG	Ref. - No.			
40 92 4221	24469643	Querlenkerlager / control arm mount		12x45,5x52
40 92 7097	0423 035	Querlenker / control arm		L 380
40 92 7775	13104120	Verbindungsstange / connecting rod		L 86
40 93 0625	24452034	Querlenkerlager / control arm mount		
40 93 1066	24457385	Stabilisatorlager / stabilizer mount		Ø 17
40 93 1067	24457386	Stabilisatorlager / stabilizer mount		Ø 18
40 93 1068	24457843	Stabilisatorlager / stabilizer mount		Ø 19
40 93 4213	13230274 S1	Rep. Satz Querlenker / rep. kit control arm		
40 93 4940	13204112	Querlenker / control arm		
40 93 6112	13204112 S1	Rep. Satz Querlenker / rep. kit control arm		
40 94 0484	13131963	Stabilisatorlager / stabilizer mount	(ex.) Sport	Ø 16

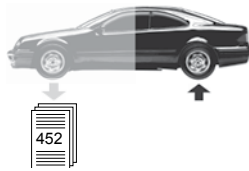
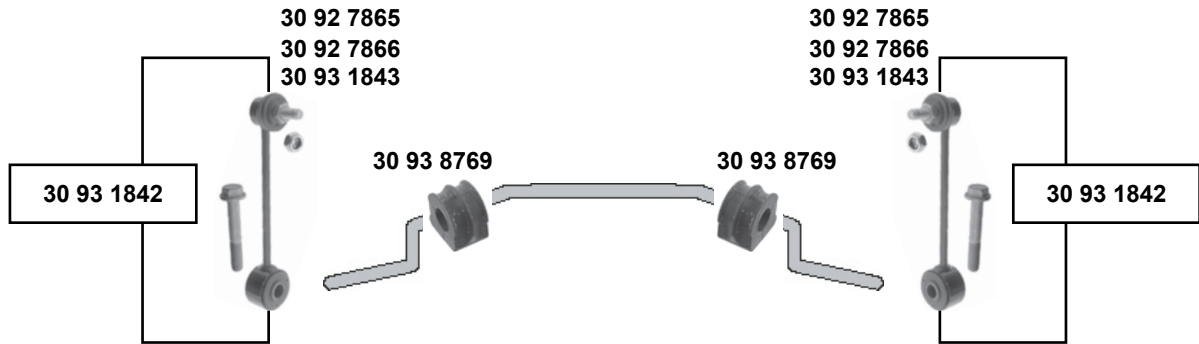
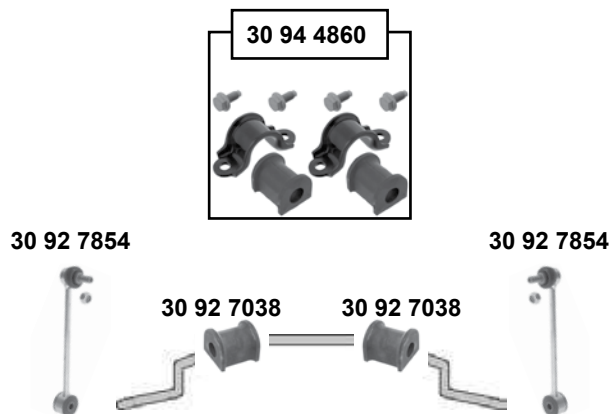
Bora (1J)
 (1999 → 2005)

Caddy (2C)
 (2010 →)

- (1) (ex.)** Schlechtwegeausführung / rough road equipment
- (2)** Schlechtwegeausführung / rough road equipment
- (3)** Bora 4 motion / Bora Variant 4 motion **(mot.)** AGN, AGZ, AJM, AQP, ARX, AUE, AUJ, AZH → 01
 Ø Stabilisator / stabilizer 13, 14, 15
 Bora 4 motion **(mot.)** AGR, AQN, ARL, ASZ, ATD, AZJ, BDE /
 Bora Variant 4 motion **(mot.)** AQN, ARL, ASZ, ATD
 AZJ, BDE 00 → **(ch.)** 1J-3-000 001 → / PR 0BL/0BS Ø Stabilisator / stabilizer 13, 14
- (4)** Durchmesser Stabilisator / Stabilisator Diameter : 20



Ref. - No.				
30 92 7038	2K0 511 413 D	Stabilisatorlager / stabilizer mount	(4)	Ø1 19
30 92 7854	2K0 505 465 E	Verbindungsstange / connecting rod		L 240
30 92 7865	1J0 505 466 B	Verbindungsstange / connecting rod	(1)	L 175
30 92 7866	1J0 505 466 C	Verbindungsstange / connecting rod	(2)	L 194,5
30 93 1842	1J0 505 466 B S1	Rep. Satz Verbindungsstange / rep. kit connecting rod	(1)	
30 93 1843	1J0 505 466 C S1	Verbindungsstange / connecting rod	(2)	
30 93 8769	8D0 511 327 C	Stabilisatorlager / stabilizer mount	(3)	
30 94 4860	2K0 511 413 D S1	Stabilisatorlagersatz / anti roll bar bush kit	(4)	Ø1 19

passend für / to fit

VOLKSWAGEN

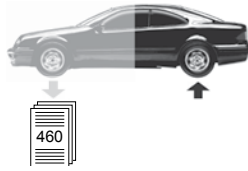

Caddy (2K)
(2004 →)

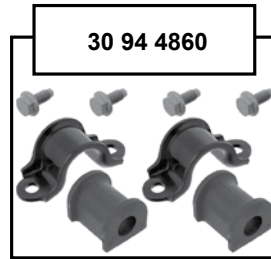

30 92 7854



30 92 7038

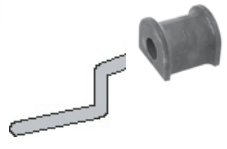

30 92 7038

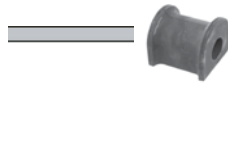

30 92 7854



Hinterachse / Rear axle



(1) Durchmesser Stabilisator / Stabilisator Diameter : 20
Caddy 3 (2KA) alle / all // Caddy 3 (2KB) 1,4b (mot.) BCA, BUD) 1,6B (mot.) BGU, BSE, BSF) 1,9D (mot.)
BJB, BLS, BSU 2,0D (mot.) BMM, BST 2,06 (mot.) BSX



Ref. - No.



30 92 7038 2K0 511 413 D
30 92 7854 2K0 505 465 E
30 94 4860 2K0 511 413 D S1

Stabilisatorlager / stabilizer mount
Verbindungsstange / connecting rod
Stabilisatorlagersatz / anti roll bar bush kit

(1)

L 240
ØI 19

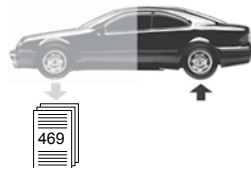

Crafter (2E)
(2006 →)

10 93 1429



10 91 8875
10 93 6130
10 93 8536
10 94 5856



10 91 8875
10 93 6130
10 93 8536
10 94 5856



10 93 1429



- (1) 04/2006 → 07/2011 PR-0BC
04/2006 → (ch.) 2F-C-015 000 / (ch.) 2E-C-040 000 // PR-0BC
- (2) (mot.) BJL, BJM, BJK
- (3) (ch.) 2E-C-000 001 → / PR-0BC



Ref. - No.



Ref. - No.	Description	Quantity	Dimensions
10 91 8875	Stabilisatorlager / stabilizer mount	(2)	L 300 ØI 12
10 93 1429	Verbindungsstange / stabiliser link	PR-0BC	Ø I 30
10 93 6130	Stabilisatorlager / stabilizer mount	(1)	Ø I 15,5
10 93 8536	Stabilisatorlager / stabilizer mount	(3)	Ø I 19
10 94 5856	Stabilisatorlager / stabilizer mount		

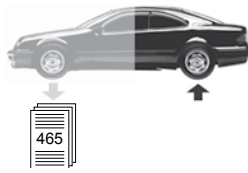

CC (3C) (2012 →)

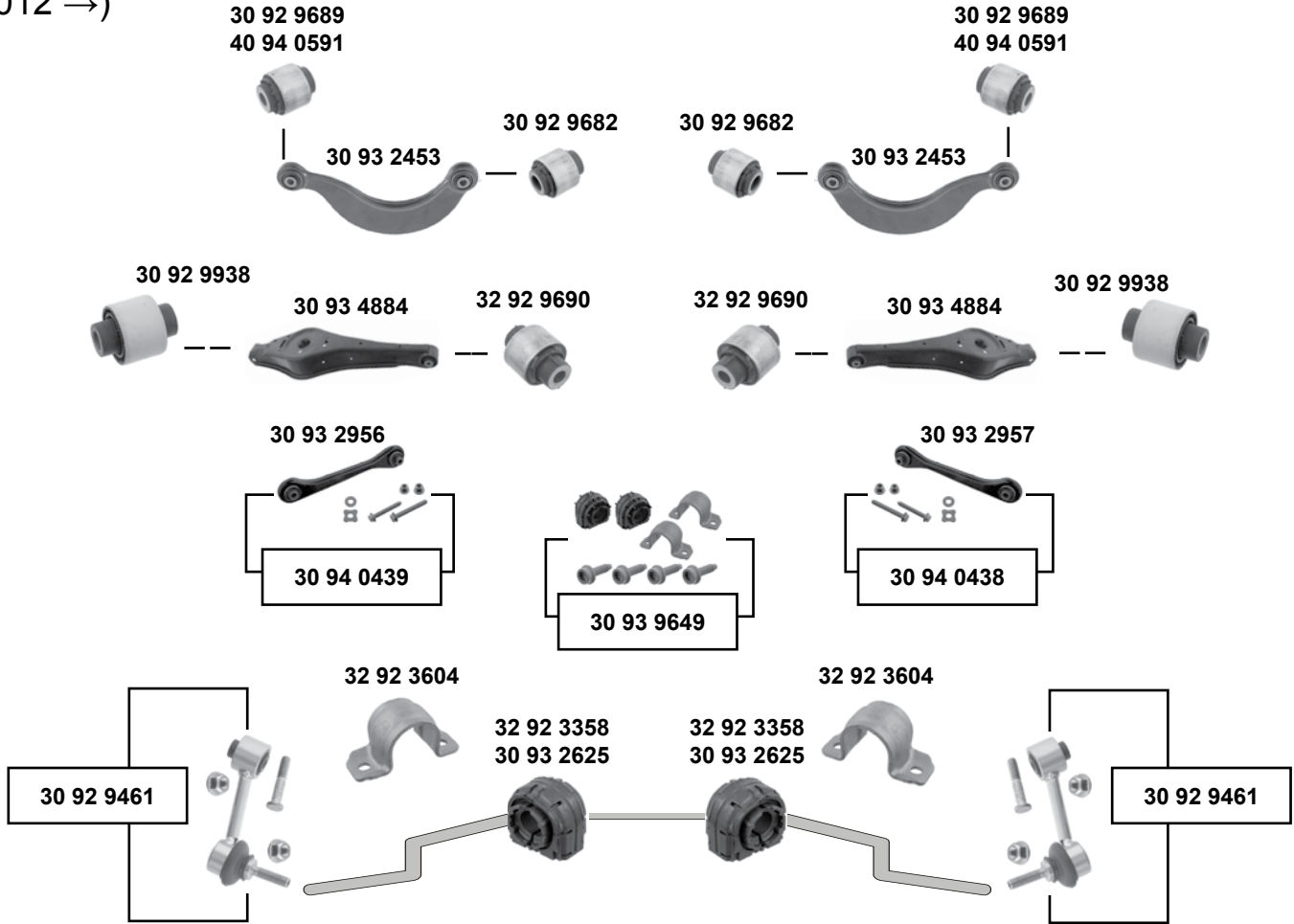

- (1) CC 4 motion (mot.) BWS, CNNA / PR-1JP/UA4/UC1 / Ø Stabilisator / stabilizer 21,7
CC (mot.) CNNA, CCZB, CCTA, CBFA, CDAA, CDAB, CTHD, CKMA, CZDA / PR-1VH / Ø Stabilisator / stabilizer 21,7
- (2) CC, CC 4 motion (mot.) BWS, CNNA Ø Stabilisator / stabilizer 21,7 / nur paarweise tauschen / replace in pairs only

Hinterachse / Rear axle

SWAG GERMANY	Ref. - No.			
30 92 9461	1K0 505 465 K S1	Rep. Satz Verbindungsstange / rep. kit stabilizer link		L 95,5
30 92 9682	1K0 505 203 A	Querlenkerlager oben / control arm mount upper		Ø A 38 H 45
30 92 9689	1K0 505 279 A	Querlenkerlager oben / control arm mount upper	→ 05/12	Ø A 38,5 H 45
30 92 9938	1K0 505 553 A	Querlenkerlager außen / control arm mount outer		Ø A 37 H 50
30 93 2453	1K0 505 323 N	Querlenker oben / control arm upper		
30 93 2625	1K0 511 327 AS	Stabilisatorlager / stabilizer mount	(1)	Ø A 21,7
30 93 2956	1K0 501 529 F	Querlenker mit Gummilagern / control arm with rubber mounts		
30 93 2957	1K0 501 530 C	Querlenker mit Gummilagern / control arm with rubber mounts		
30 93 4884	1K0 505 311 AB	Querlenker / control arm		
30 93 9649	1K0 511 327 AS S1	Stabilisatorlagersatz / anti roll bar bush kit	(2)	
30 94 0438	1K0 501 530 C S1	Rep. Satz Querlenker / rep. kit control arm		
30 94 0439	1K0 501 529 F S1	Rep. Satz Querlenker / rep. kit control arm		
32 92 3358	1K0 511 327 AR	Stabilisatorlager / stabilizer mount		Ø I 20,7
32 92 3604	1K0 511 439 E	Befestigungsbügel / attachment bracket		
32 92 9690	1K0 505 171 C	Querlenkerlager unten / control arm mount lower		Ø A 42 H 60
40 94 0591	1K0 505 543 A	Querlenkerlager / control arm bush		Ø I 14 Ø A 45

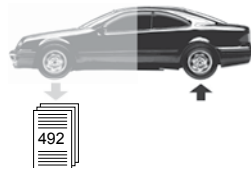

Golf 4 4motion / Bora 4 4motion (1J)
(1998 → 2006)

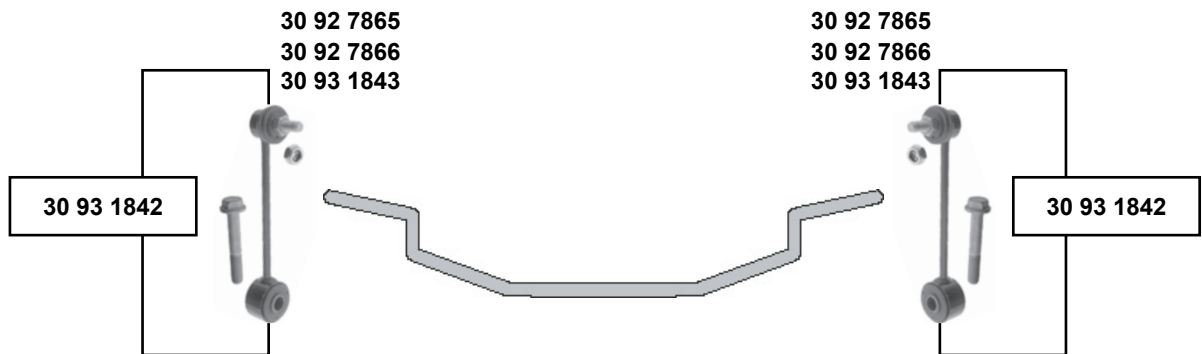

- (1) (ex.) Schlechtwegeausführung / rough road equipment
- (2) Schlechtwegeausführung / rough road equipment



Ref. - No.



Ref. - No.	Description	Quantity	Length
30 92 7865	1J0 505 466 B Verbindungsstange / connecting rod	(1)	L 175
30 92 7866	1J0 505 466 C Verbindungsstange / connecting rod	(2)	L 194,5
30 93 1842	1J0 505 466 B S1 Rep. Satz Verbindungsstange / rep. kit connecting rod	(1)	
30 93 1843	1J0 505 466 C S1 Verbindungsstange / connecting rod	(2)	

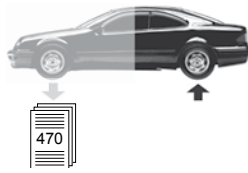

Eos (1F) (2006 →)

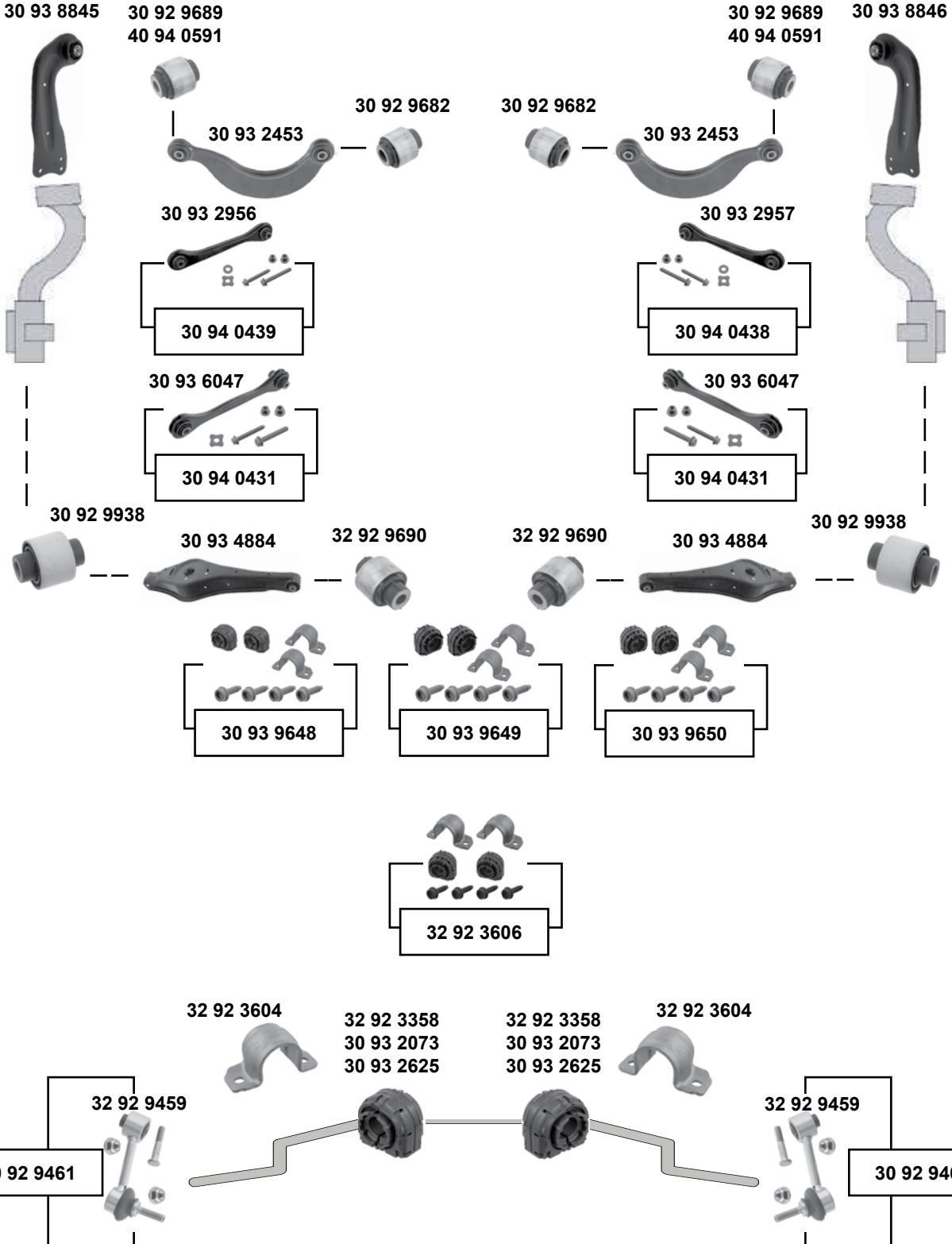

Hinterachse / Rear axle

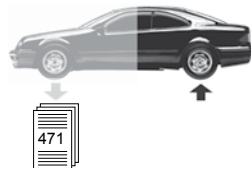
Eos (1F)
 (2006 →)

- (1)** → 09 → 1F-9-016 326 / Blech / metal sheet
- (2)** (ch.) 1F-9-016 325 →
- (3)** nur paarweise tauschen / replace in pairs only
- (4)** (ch.) → 1F-9-016 325
- (5)** Eos Cabrio (mot.) CCZB / PR 0BC / 0BH Ø Stabilisator / stabilizer 18,5 / 19



Ref. - No.



Ref. - No.	Description	Quantity	Dimensions / Notes
30 92 9459	1K0 505 465 AA Verbindungsstange / connecting rod		
30 92 9461	1K0 505 465 K S1 Rep. Satz Verbindungsstange / rep. kit connecting rod		L 95,5
30 92 9682	1K0 505 203 A Querlenkerlager oben / control arm mount upper		Ø A 38 H 45
30 92 9689	1K0 505 279 A Querlenkerlager oben / control arm mount upper		Ø A 38,5 H 45
30 92 9938	1K0 505 553 A Querlenkerlager außen / control arm mount outer		Ø A 37 H 50
30 93 2073	1K0 511 327 AQ Stabilisatorlager hinten / stabilizer mount rear	(3)	Ø A 19,6
30 93 2453	1K0 505 323 N Querlenker oben / control arm upper		
30 93 2625	1K0 511 327 AS Stabilisatorlager / stabilizer mount	(3)	Ø A 21,7
30 93 2956	1K0 501 529 F Querlenker mit Gummilagern / control arm with rubber mounts	(1)	
30 93 2957	1K0 501 530 C Querlenker mit Gummilagern / control arm with rubber mounts	(1)	
30 93 4884	1K0 505 311 AB Querlenker / control arm		
30 93 6047	1K0 501 529 J Querlenker mit Gummilagern / control arm with rubber mounts	(2)	Stahl
30 93 8845	1K0 505 223 K Querlenker / control arm		Blech
30 93 8846	1K0 505 224 K Querlenker / control arm		Blech
30 93 9648	1K0 511 327 AR S1 Stabilisatorlagersatz / anti roll bar bush kit	(3) → 10 PR-0BE	
30 93 9649	1K0 511 327 AS S1 Stabilisatorlagersatz / anti roll bar bush kit	(3) PR-0BF	
30 93 9650	1K0 511 327 AQ S1 Stabilisatorlagersatz / anti roll bar bush kit	(3) PR-0BD	
30 94 0431	1K0 501 529 J S1 Rep. Satz Querlenker / rep. kit control arm	(2)	
30 94 0438	1K0 501 530 C S1 Rep. Satz Querlenker / rep. kit control arm	(4)	
30 94 0439	1K0 501 529 F S1 Rep. Satz Querlenker / rep. kit control arm	(4)	
32 92 3358	1K0 511 327 AR Stabilisatorlager / stabilizer mount	(3)	Ø A 20,7
32 92 3604	1K0 511 439 E Klemmschelle / clamping clip		
32 92 3606	1K0 511 327 AP S1 Stabilisatorlagersatz / anti roll bar bush kit	(3) (5)	Ø I 18,5
32 92 9690	1K0 505 171 C Querlenkerlager unten / control arm mount lower		Ø A 42 H 60
40 94 0591	1K0 505 543 A Querlenkerlager / control arm bush		Ø I 14 Ø A 45

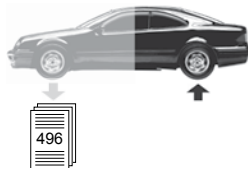

Golf 5 / Plus / 4motion (1K)

(2004 → 2009)

30 93 8845

30 93 8846

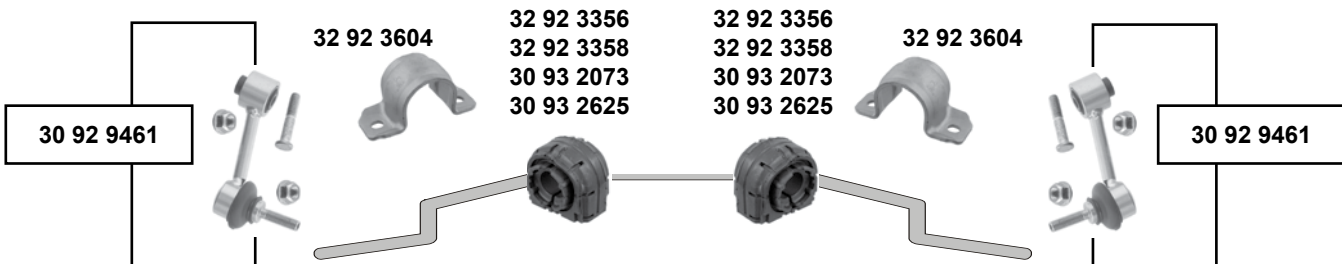
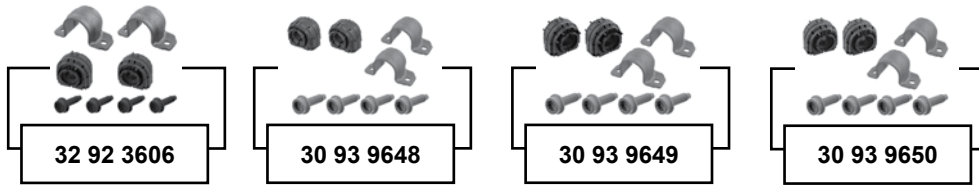
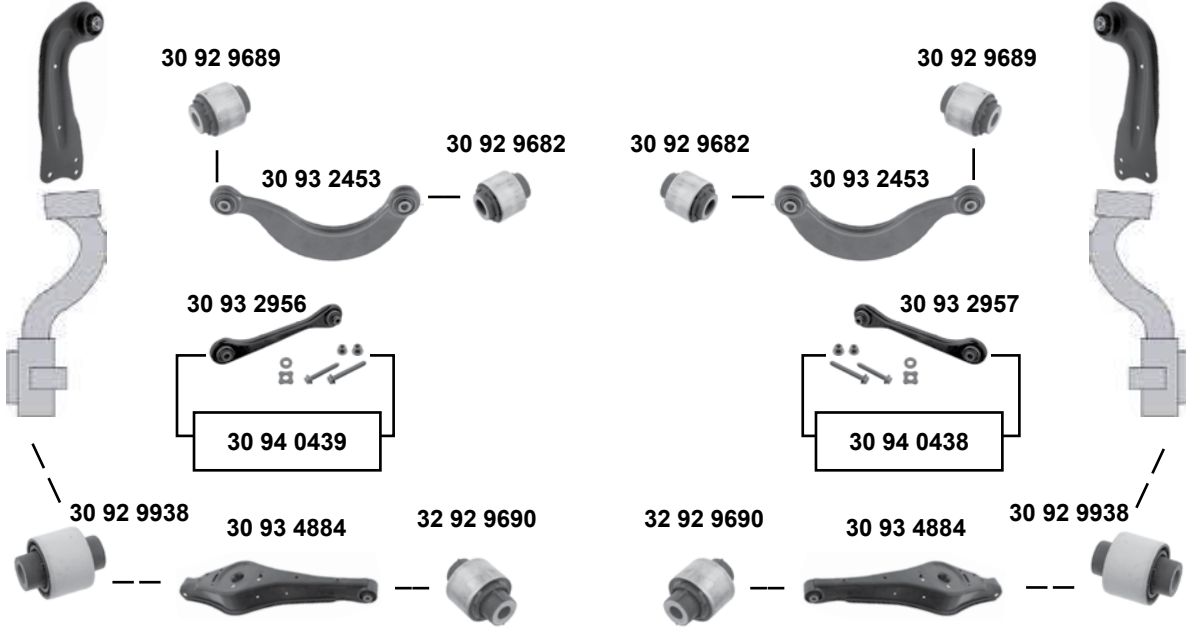

Hinterachse / Rear axle

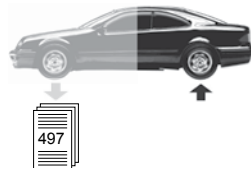

Golf 5 / Plus / 4motion (1K)

(2004 → 2009)



- (1) Golf 5 plus (1K) 05 → 09
- (2) 07 → 09 (ch.) → 1K-9-295 790 / 07 → 09 (ch.) → 1K-9U016 920 / 05 → 09 (ch.) → 1K-9-855 000
- (3) Golf 5 / variant / 4motion 04 → 09
- (4) nur paarweise tauschen / replace in pairs only
- (5) (ch.) → 1K--9-400000

Ref. - No.

SWAG	Ref. - No.			
30 92 9461	1K0 505 465 K S1	Rep. Satz Verbindungsstange / rep. kit connecting rod	(1) (3)	L 95,5
30 92 9682	1K0 505 203 A	Querlenkerlager oben / control arm mount upper		Ø A 38 H 45
30 92 9689	1K0 505 279 A	Querlenkerlager oben / control arm mount upper	(1) (3)	Ø A 38,5H 45
30 92 9938	1K0 505 553 A	Querlenkerlager außen / control arm mount outer	(1) (3)	Ø A 37 H 50
30 93 2073	1K0 511 327 AQ	Stabilisatorlager / stabilizer mount	(4)	Ø A 19,6
30 93 2453	1K0 505 323 N	Querlenker oben / control arm upper	(1)	
30 93 2625	1K0 511 327 AS	Stabilisatorlager / stabilizer mount	(4)	Ø A 21,7
30 93 2956	1K0 501 529 F	Querlenker / control arm	(2) (3)	Blech
30 93 2957	1K0 501 530 C	Querlenker / control arm	(2) (3)	Blech
30 93 4884	1K0 505 311 AB	Querlenker / control arm		
30 93 8845	1K0 505 223 K	Querlenker / control arm		Blech
30 93 8846	1K0 505 224 K	Querlenker / control arm		Blech
30 93 9648	1K0 511 327 AR S1	Stabilisatorlagersatz / anti roll bar bush kit	(4) PR-0BE	
30 93 9649	1K0 511 327 AS S1	Stabilisatorlagersatz / anti roll bar bush kit	(4) PR-0BF	
30 93 9650	1K0 511 327 AQ S1	Stabilisatorlagersatz / anti roll bar bush kit	(4) (5) PR-0BD	
30 94 0438	1K0 501 530 C S1	Rep. Satz Querlenker / rep. kit control arm		
30 94 0439	1K0 501 529 F S1	Rep. Satz Querlenker / rep. kit control arm		
32 92 3356	1K0 511 327 AP	Stabilisatorlager / stabilizer mount	(4)	Ø I 18,5
32 92 3358	1K0 511 327 AR	Stabilisatorlager / stabilizer mount	(1) (3) (4)	Ø A 20,7
32 92 3604	1K0 511 439 E	Klemmschelle / clamping clip	(1) (3)	
32 92 3606	1K0 511 327 AP S1	Stabilisatorlagersatz / anti roll bar bush kit	(4)	Ø I 18,5
32 92 9690	1K0 505 171 C	Querlenkerlager unten / control arm mount lower		Ø A 42

passend für / to fit

VOLKSWAGEN

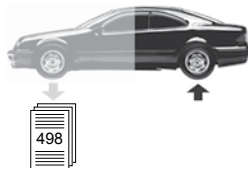

Golf 6 / Golf 6 plus (1K)

(2009 →)

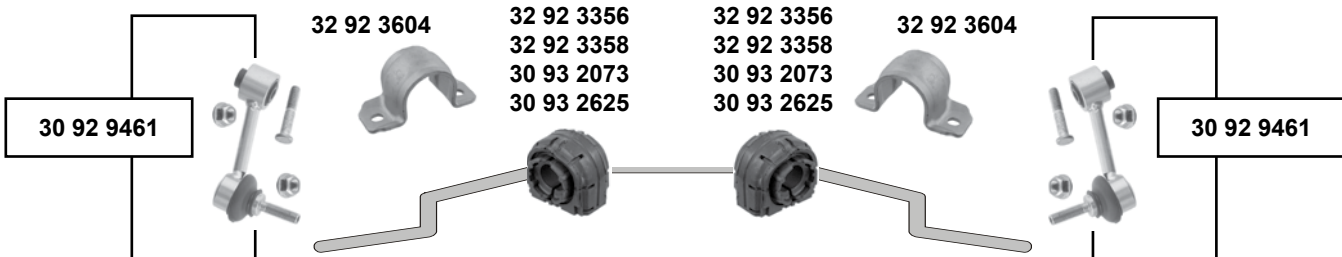
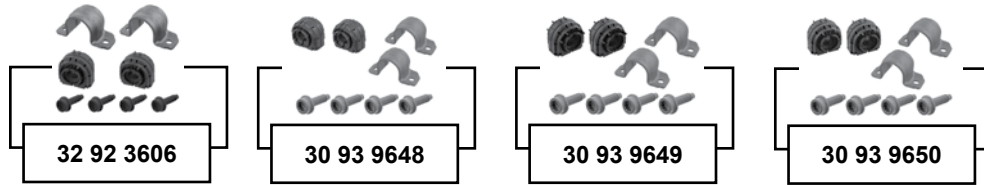
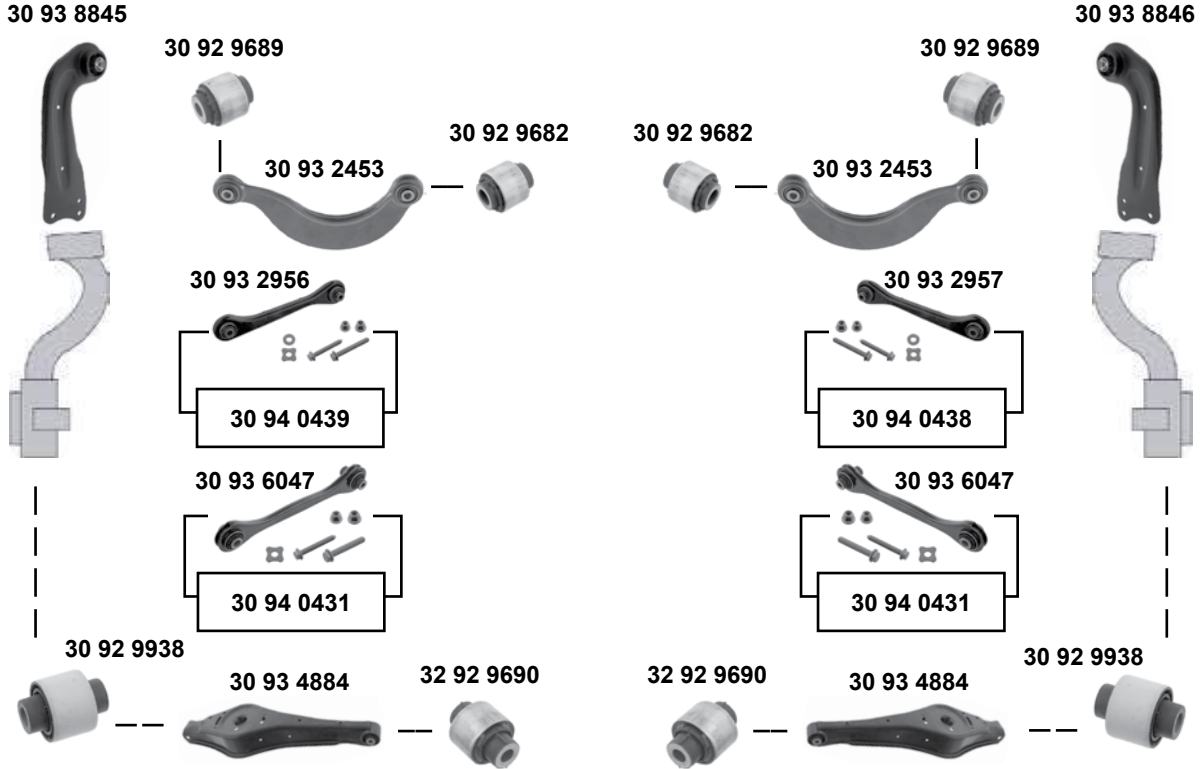

Hinterachse / Rear axle

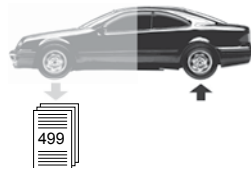

Golf 6 / Golf 6 plus (1K) (2009 →)

- (1) (ex.) variant 09 → (ch.) → 1K-9-400 000
- (2) Golf 6 / variant / 4motion 09 → / Golf 6 plus 09 → 11
- (3) Golf 6 09 → (ch.) → 1K-9P422 726 / 1K-9W415 461
- (4) nur paarweise tauschen / replace in pairs only
- (5) PR-0BF, 0BL, 0BM, 0BN
- (6) (ch.) 1K-9W415 461 →
- (7) (ch.) → 1K-9W415 461

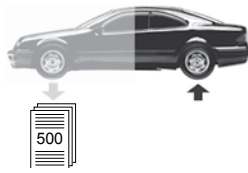

Ref. - No.

SWAG Ref. - No.				
30 92 9461	1K0 505 465 K S1	Rep. Satz Verbindungsstange / rep. kit connecting rod	(2)	L 95,5
30 92 9682	1K0 505 203 A	Querlenkerlager oben / control arm mount upper		Ø A 38 H45
30 92 9689	1K0 505 279 A	Querlenkerlager oben / control arm mount upper		Ø A 38,5 H45
30 92 9938	1K0 505 553 A	Querlenkerlager außen / control arm mount outer	→ 11	Ø A 37 H50
30 93 2073	1K0 511 327 AQ	Stabilisatorlager hinten / stabilizer mount rear	(1) (4)	Ø A 19,6
30 93 2453	1K0 505 323 N	Querlenker oben / control arm upper		
30 93 2625	1K0 511 327 AS	Stabilisatorlager / stabilizer mount	(4)	Ø A 21,7
30 93 2956	1K0 501 529 F	Querlenker mit Gummilagern / control arm with rubber mounts	(3)	Blech
30 93 2957	1K0 501 530 C	Querlenker mit Gummilagern / control arm with rubber mounts	(3)	Blech
30 93 4884	1K0 505 311 AB	Querlenker / control arm		
30 93 6047	1K0 501 529 J	Querlenker mit Gummilagern / control arm with rubber mounts		Stahl
30 93 8845	1K0 505 223 K	Querlenker / control arm		Blech
30 93 8846	1K0 505 224 K	Querlenker / control arm		Blech
30 93 9648	1K0 511 327 AR S1	Stabilisatorlagersatz / anti roll bar bush kit	(4) PR-0BE	
30 93 9649	1K0 511 327 AS S1	Stabilisatorlagersatz / anti roll bar bush kit	(4) (5)	
30 93 9650	1K0 511 327 AQ S1	Stabilisatorlagersatz / anti roll bar bush kit	(4) PR-0BD	
30 94 0431	1K0 501 529 J S1	Rep. Satz Querlenker / rep. kit control arm	(6)	
30 94 0438	1K0 501 530 C S1	Rep. Satz Querlenker / rep. kit control arm	(7)	
30 94 0439	1K0 501 529 F S1	Rep. Satz Querlenker / rep. kit control arm	(7)	
32 92 3356	1K0 511 327 AP	Stabilisatorlager / stabilizer mount	(4)	Ø I 18,5
32 92 3358	1K0 511 327 AR	Stabilisatorlager / stabilizer mount	(4)	Ø A 20,7
32 92 3604	1K0 511 439 E	Klemmschelle / clamp	(2)	
32 92 3606	1K0 511 327 AP S1	Stabilisatorlagersatz / anti roll bar bush kit	(4)	Ø I 18,5
32 92 9690	1K0 505 171 C	Querlenkerlager unten / control arm mount lower		Ø A 42 H60

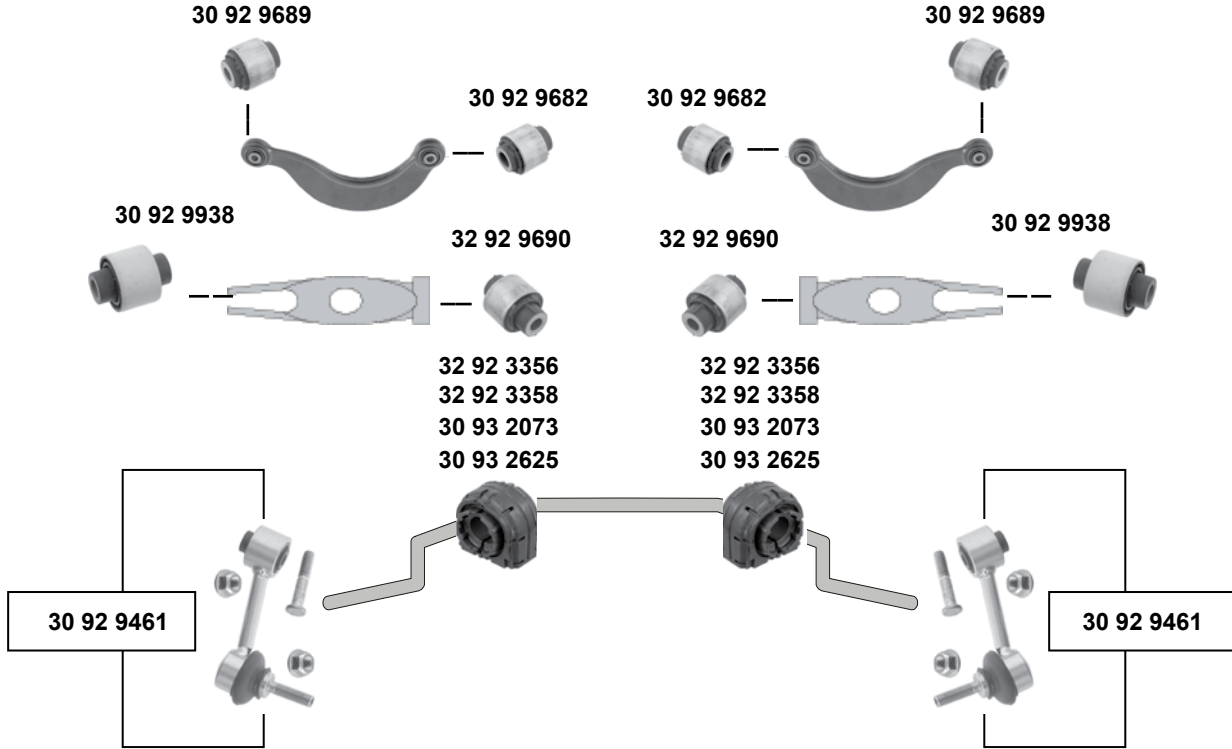

Golf 6 Cabrio (51)

(2011 →)



Golf 7 (5G)

(2012 →)



(1) nur paarweise tauschen / replace in pairs only



Ref. - No.



Ref. - No.	Description	Quantity	Dimension
30 92 9461	1K0 505 465 K S1 Rep. Satz Verbindungsstange / rep. kit connecting rod		L 95,5
30 92 9682	1K0 505 203 A Querlenkerlager oben / control arm mount upper		Ø A 38 H45
30 92 9689	1K0 505 279 A Querlenkerlager oben / control arm mount upper		Ø A 38,5
30 92 9938	1K0 505 553 A Querlenkerlager außen / control arm mount outer		Ø A 37 H50
30 93 2073	1K0 511 327 AQ Stabilisatorlager hinten / stabilizer mount rear	(1)	Ø A 19,6
30 93 2453	1K0 505 323 N Querlenker oben / control arm upper		
30 93 2625	1K0 511 327 AS Stabilisatorlager / stabilizer mount	(1)	Ø A 21,7
32 92 3356	1K0 511 327 AP Stabilisatorlager / stabilizer mount		Ø I 18,5
32 92 3358	1K0 511 327 AR Stabilisatorlager / stabilizer mount	(1)	Ø A 20,7
32 92 9690	1K0 505 171 C Querlenkerlager unten / control arm mount lower		Ø A 42

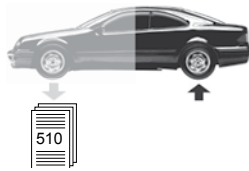

Jetta 3 / syncro (1K) (2006 → 2010)

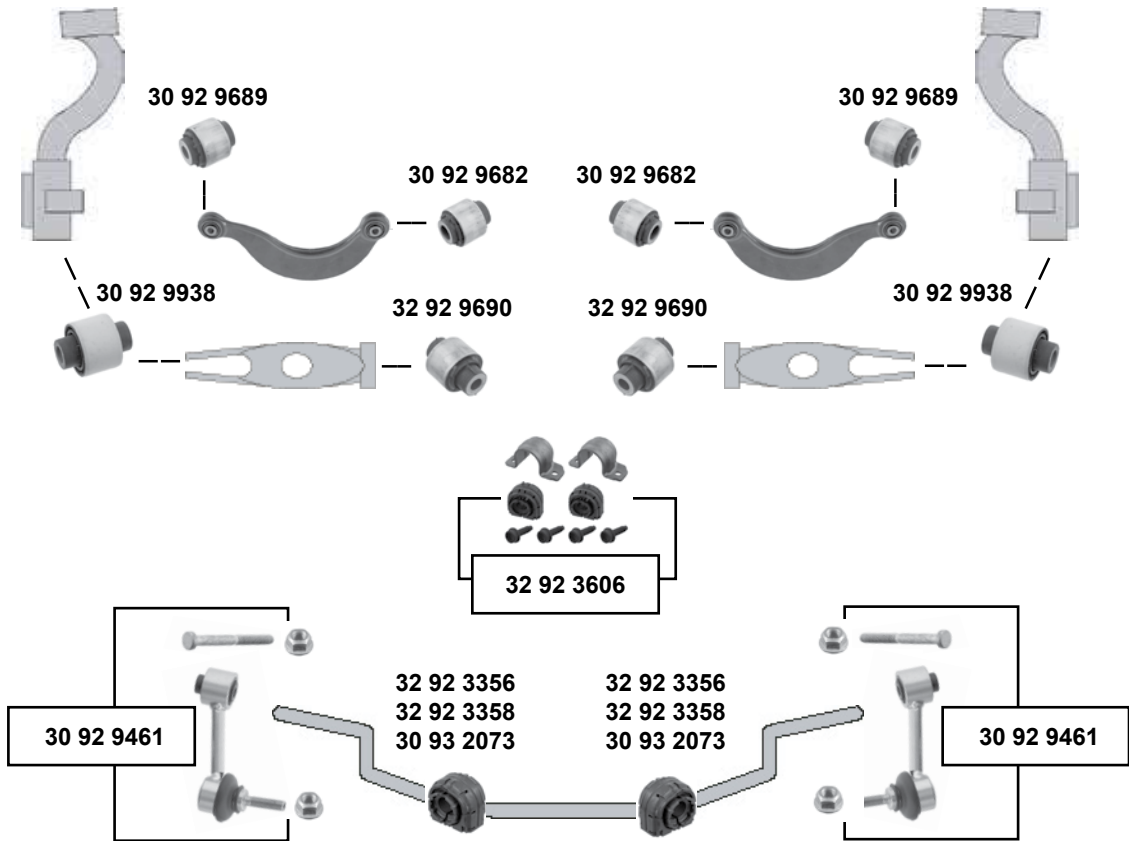

(1) nur paarweise tauschen / replace in pairs only

Beachten Sie bitte die Abmessung / please pay attention to the dimension



Ref. - No.



30 92 9461	1K0 505 465 K S1	Rep. Satz Verbindungsstange / rep. kit connecting rod		
30 92 9682	1K0 505 203 A	Querlenkerlager oben / control arm mount upper	→ 2008	Ø A 38 H45
30 92 9689	1K0 505 279 A	Querlenkerlager oben / control arm mount upper	→ 2008	Ø A 38,5
30 92 9938	1K0 505 553 A	Querlenkerlager außen / control arm mount outer		Ø A 37 H50
30 93 2073	1K0 511 327 AQ	Stabilisatorlager / stabilizer mount	(1)	Ø I 15/17
32 92 3356	1K0 511 327 AP	Stabilisatorlager / stabilizer mount	(1)	Ø I 18,5
32 92 3358	1K0 511 327 AR	Stabilisatorlager / stabilizer mount	(1)	Ø I 20,7
32 92 3606	1K0 511 327 AP S1	Stabilisatorlagersatz / anti roll bar bush kit	paarweise tauschen	Ø I 18,5
32 92 9690	1K0 505 171 C	Querlenkerlager unten / control arm mount lower		Ø A 42

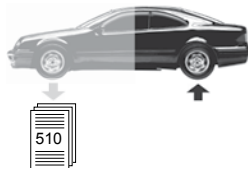

Jetta (1K) (2006 →)

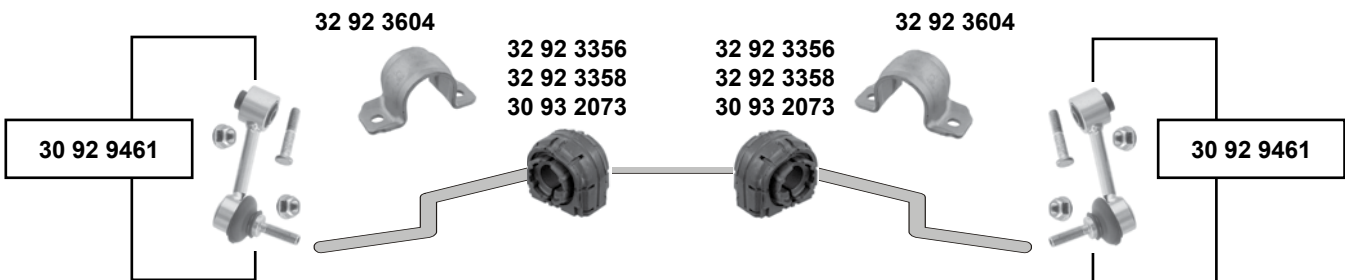
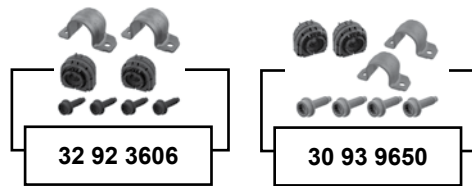
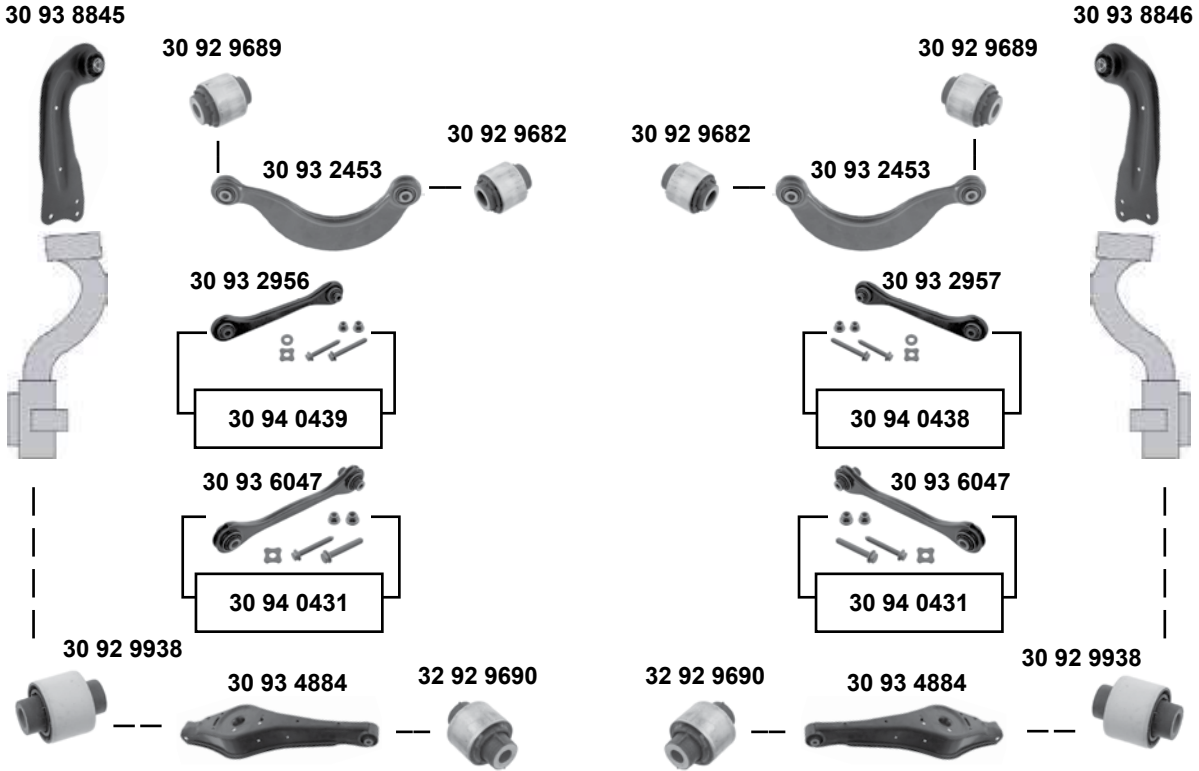

Hinterachse / Rear axle

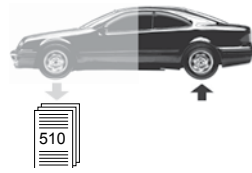
Jetta (1K)
 (2006 →)



- (1) nur paarweise tauschen / replace in pairs only
- (2) → 09 / (ch.) → 1K-9-091 375
- (3) → 10/2010 / (ch.) 1K-9-091 376 → / 04/2010 →
- (4) (ch.) 1K-9-091 376 →
- (5) (ch.) → 1K-9-091 375



Ref. - No.

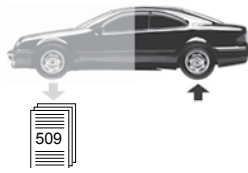

SWAG Ref. - No.				
30 92 9461	1K0 505 465 K S1	Rep. Satz Verbindungsstange / rep. kit connecting rod		L 95,5
30 92 9682	1K0 505 203 A	Querlenkerlager oben / control arm mount upper	→ 2008	Ø A 38 H 45
30 92 9689	1K0 505 279 A	Querlenkerlager oben / control arm mount upper	→ 2008	Ø A 38,5 H 45
30 92 9938	1K0 505 553 A	Querlenkerlager außen / control arm mount outer		Ø A 37 H 50
30 93 2073	1K0 511 327 AQ	Stabilisatorlager hinten / stabilizer mount rear	(1)	Ø I 15
30 93 2453	1K0 505 323 N	Querlenker oben / control arm upper		Metall
30 93 2956	1K0 501 529 F	Querlenker mit Gummilagern / control arm with rubber mounts	(2)	
30 93 2957	1K0 501 530 C	Querlenker mit Gummilagern / control arm with rubber mounts	(2)	
30 93 4884	1K0 505 311 AB	Querlenker / control arm		
30 93 6047	1K0 501 529 J	Querlenker mit Gummilagern / control arm with rubber mounts	(3)	Stahl
30 93 8845	1K0 505 223 K	Querlenker / control arm		Blech
30 93 8846	1K0 505 224 K	Querlenker / control arm		Blech
30 93 9650	1K0 511 327 AQ S1	Stabilisatorlagersatz / anti roll bar bush kit	(1) PR-0BJ	
30 94 0431	1K0 501 529 J S1	Rep. Satz Querlenker / rep. kit control arm	(4)	
30 94 0438	1K0 501 530 C S1	Rep. Satz Querlenker / rep. kit control arm	(5)	
30 94 0439	1K0 501 529 F S1	Rep. Satz Querlenker / rep. kit control arm	(5)	
32 92 3356	1K0 511 327 AP	Stabilisatorlager / stabilizer mount	(1)	18,5x2,5
32 92 3358	1K0 511 327 AR	Stabilisatorlager / stabilizer mount	(1)	20,7x2,8
32 92 3604	1K0 511 439 E	Klemmschelle / clamping clip		
32 92 3606	1K0 511 327 AP S1	Stabilisatorlagersatz / anti roll bar bush kit	(1)	Ø I 18,5
32 92 9690	1K0 505 171 C	Querlenkerlager unten / control arm mount lower		Ø A 42 H



Jetta (16)

(2011 →)

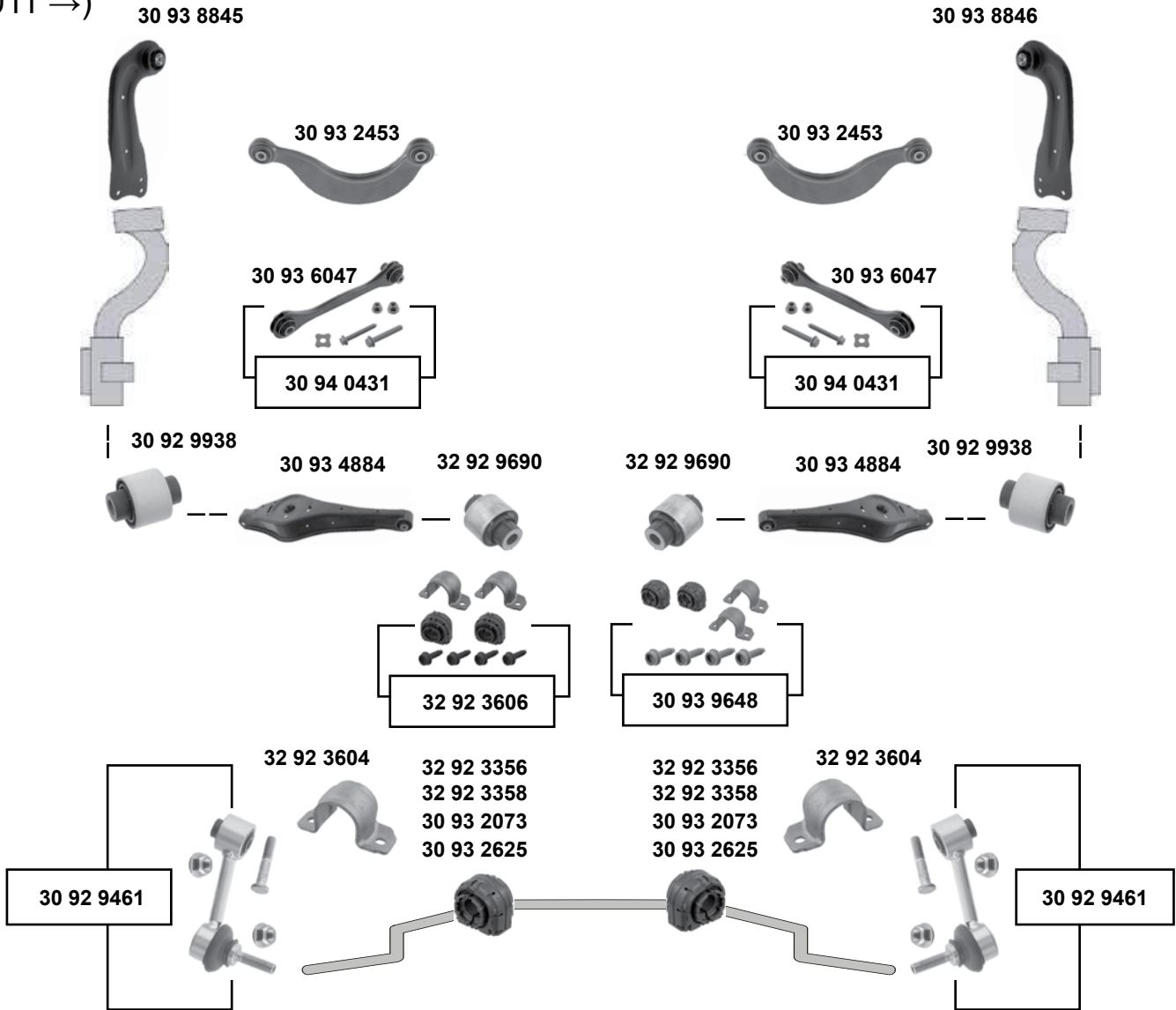

(1) nur paarweise tauschen / replace in pairs only



Ref. - No.



Ref. - No.	Description	Quantity	Material
30 92 9461	Rep. Satz Verbindungsstange / rep. kit connecting rod		L 95,5
30 92 9938	Querlenkerlager außen / control arm mount outer		Ø A 37 H 50
30 93 2073	Stabilisatorlager / stabilizer mount	(1)	Ø I 15/17
30 93 2453	Querlenker oben / control arm upper		
30 93 2625	Stabilisatorlager / stabilizer mount	(1)	Ø A 21,7
30 93 4884	Querlenker / control arm		
30 93 6047	Querlenker mit Gummilagern / control arm with rubber mounts		Stahl
30 93 8845	Querlenker / control arm		Blech
30 93 8846	Querlenker / control arm		Blech
30 93 9648	Stabilisatorlagersatz / anti roll bar bush kit	(1)	
30 94 0431	Rep. Satz Querlenker / rep. kit control arm	PR-0N4	
32 92 3356	Stabilisatorlager / stabilizer mount	(1)	18,5x2,5
32 92 3358	Stabilisatorlager / stabilizer mount	(1)	20,7x2,8
32 92 3604	Klemmschelle / clamping clip		
32 92 3606	Stabilisatorlagersatz / anti roll bar bush kit	(1)	Ø I 18,5
32 92 9690	Querlenkerlager unten / control arm mount lower		Ø A 42 H

Hinterachse / Rear axle

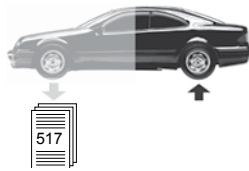

LT 28 / LT 35 (2D)
(1997 → 2007)

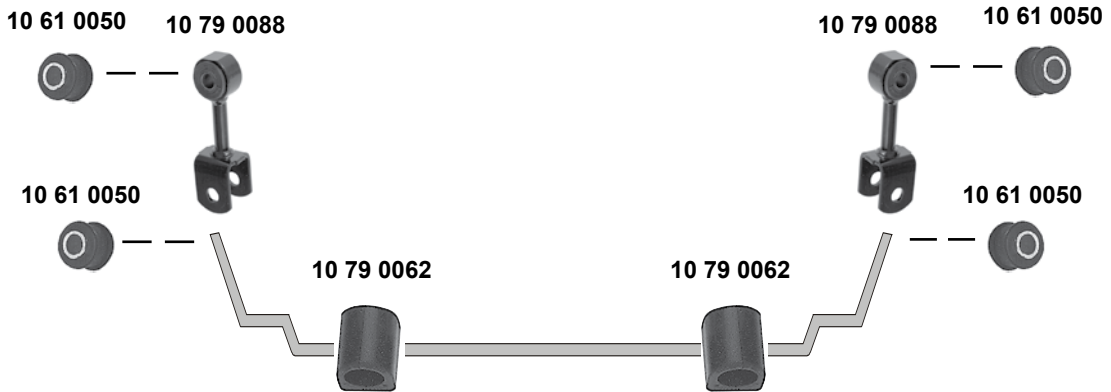

LT 46
(1997 → 2007)



New Beetle (1C/9C)
(1999 → 2010)

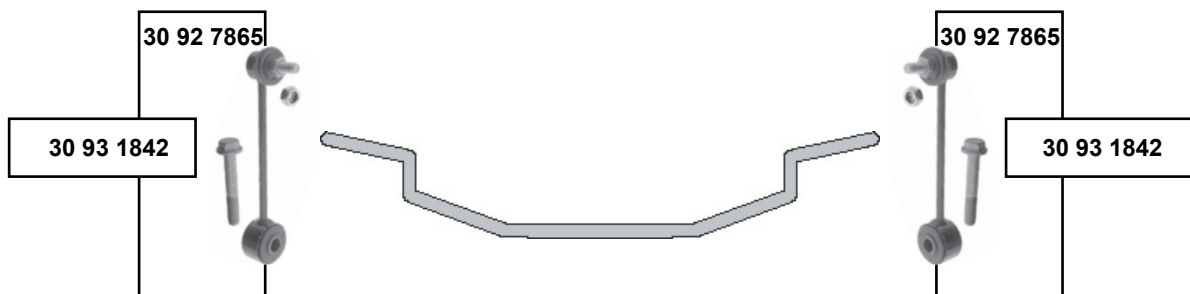

Hinterachse / Rear axle



Ref. - No.



10 61 0050	2D0 511 413	Stabilisatorlager / stabilizer mount		12x26x26
10 79 0062	2D0 511 413 A	Stabilisatorlager / stabilizer mount		Ø 23
10 79 0088	2D0 511 329	Verbindungsstange / connecting rod		
30 92 7865	1 J0 505 466 B	Verbindungsstange / connecting rod	RSI	L 208,4
30 93 1842	1 J0 505 466 B S1	Rep. Satz Verbindungsstange / rep. kit connecting rod	RSI	L 208,4

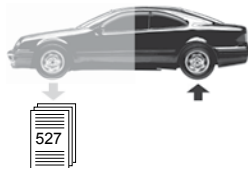

New Beetle (5C)

(2010 →)

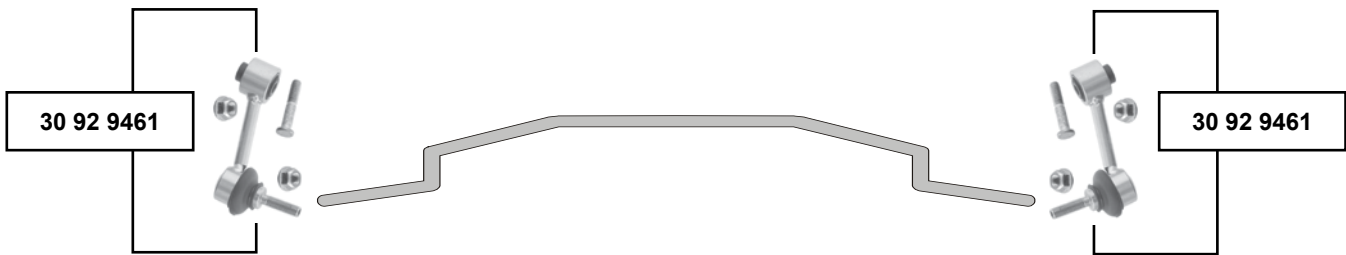
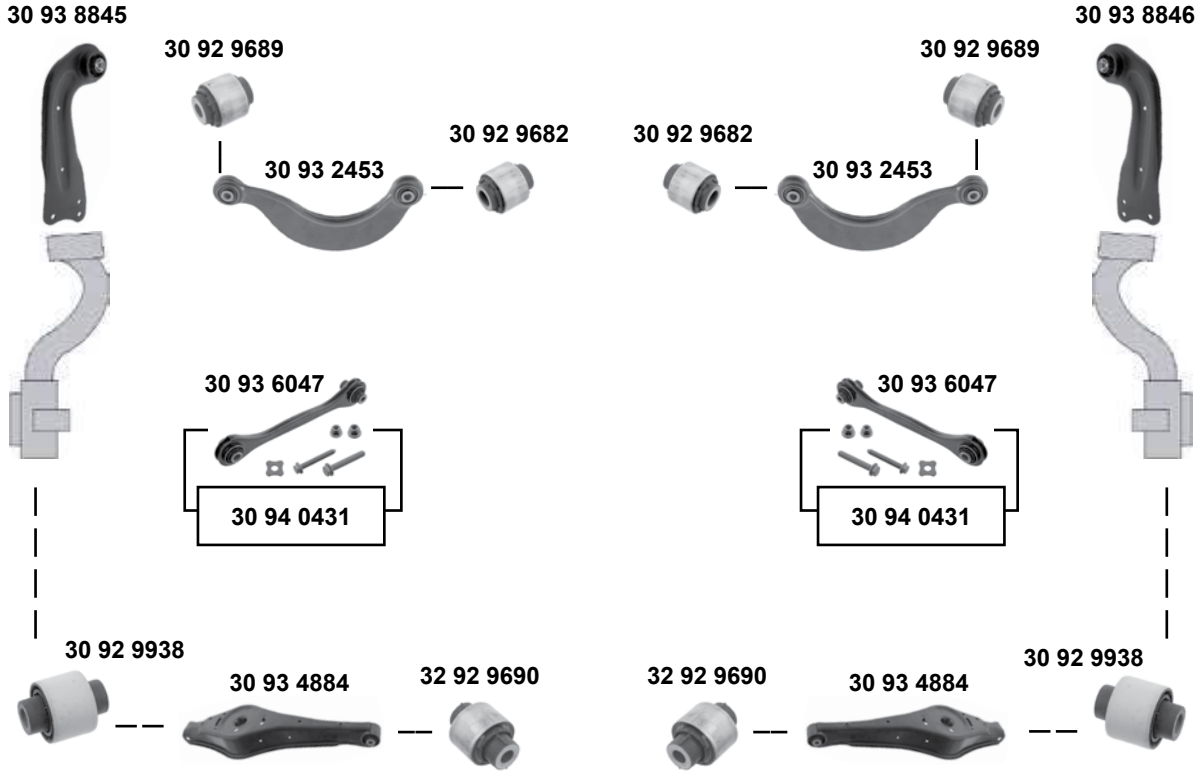

Hinterachse / Rear axle

SWAG GERMANY	Ref. - No.			
30 92 9461	1K0 505 465 K S1	Rep. Satz Verbindungsstange / rep. kit connecting rod		L 95,5
30 92 9682	1K0 505 203 A	Querlenkerlager oben / control arm mount upper		Ø A 38 H 45
30 92 9689	1K0 505 279 A	Querlenkerlager oben / control arm mount upper		Ø A 38,5H45
30 92 9938	1K0 505 553 A	Querlenkerlager außen / control arm mount outer		Ø A 37 H 50
30 93 2453	1K0 505 323 N	Querlenker oben / control arm upper		
30 93 4884	1K0 505 311 AB	Querlenker / control arm		
30 93 6047	1K0 501 529 J	Querlenker mit Gummilagern / control arm with rubber mounts	PR-0N4	Stahl
30 93 8845	1K0 505 223 K	Querlenker / control arm		Blech
30 93 8846	1K0 505 224 K	Querlenker / control arm		Blech
30 94 0431	1K0 501 529 J S1	Rep. Satz Querlenker / rep. kit control arm	PR-0N4	
32 92 9690	1K0 505 171 C	Querlenkerlager unten / control arm mount lower		Ø A 42 H 60

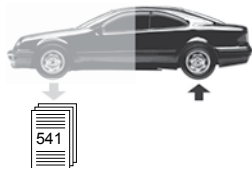

Passat 4 / 4motion / variant (3B) (1998 → 2005)

oben / upper

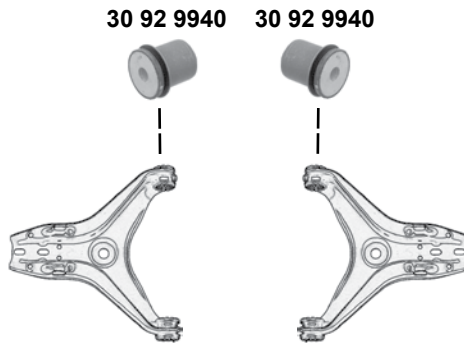

unten / lower

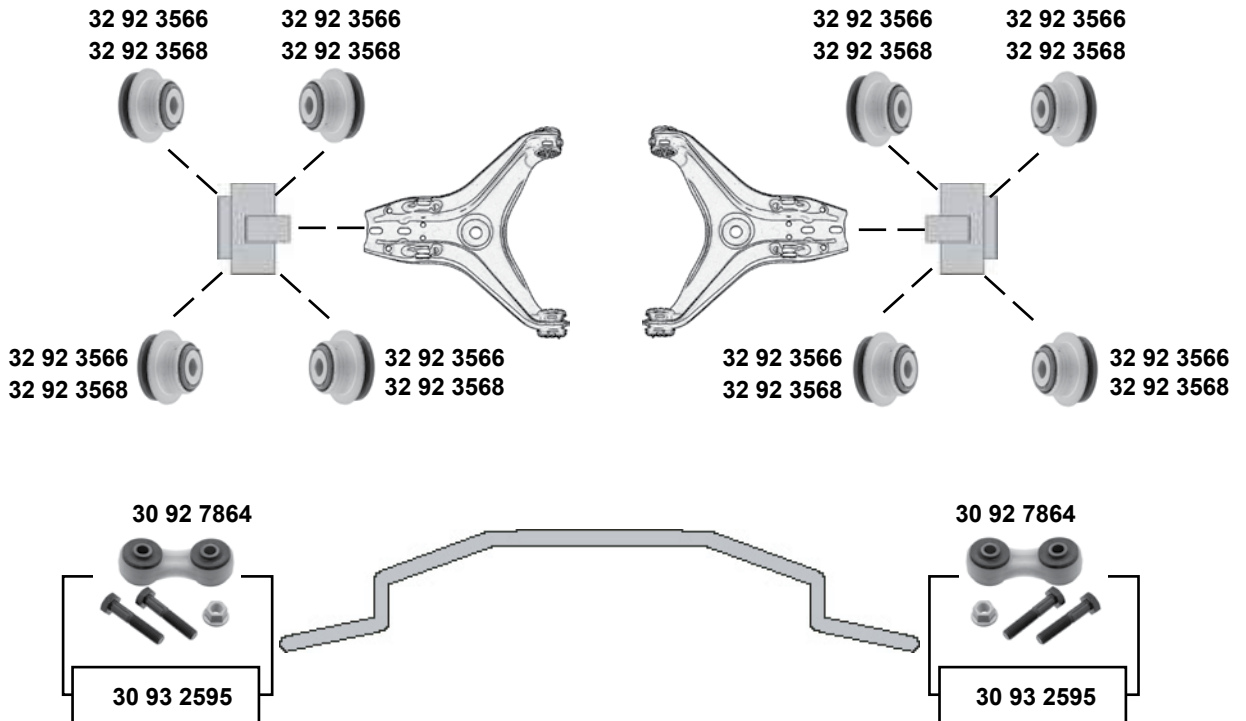

Hinterachse / Rear axle



Ref. - No.



30 92 7864	8E0 505 465 D	Verbindungsstange / connecting rod		L 98
30 92 9940	8E0 505 185 C	Querlenkerlager / control arm mount	2000 →	
30 93 2595	8E0 505 465 D S1	Rep. Satz Verbindungsstange / rep. kit connecting rod		L 98
32 92 3566	8E0 505 172 B	Querlenkerlager / control arm mount	W8	
32 92 3568	8E0 505 172 A	Querlenkerlager / control arm mount	(ex.) W8	

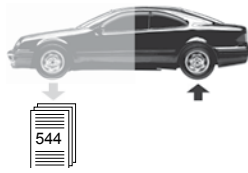

Passat 5 / 4motion (3C)

(2006 →)

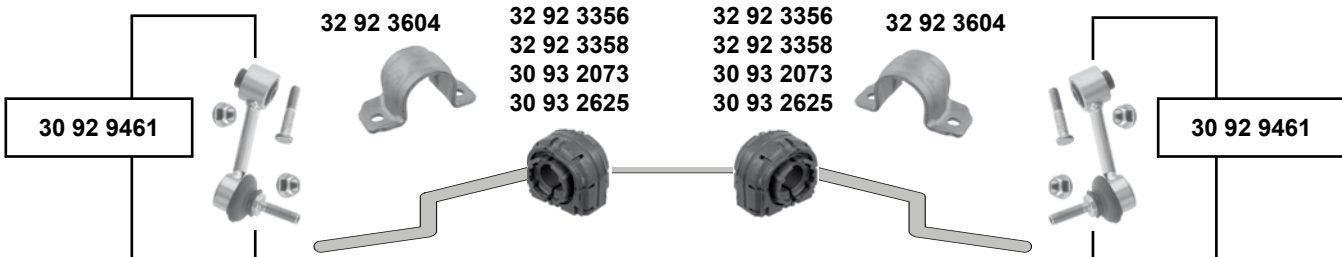
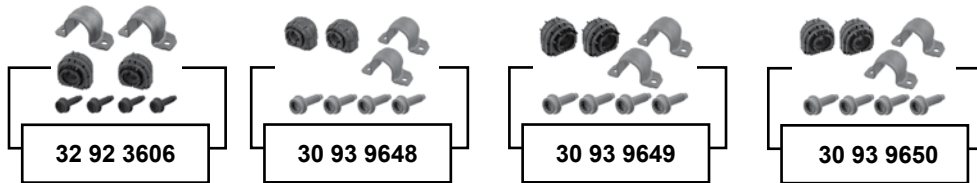
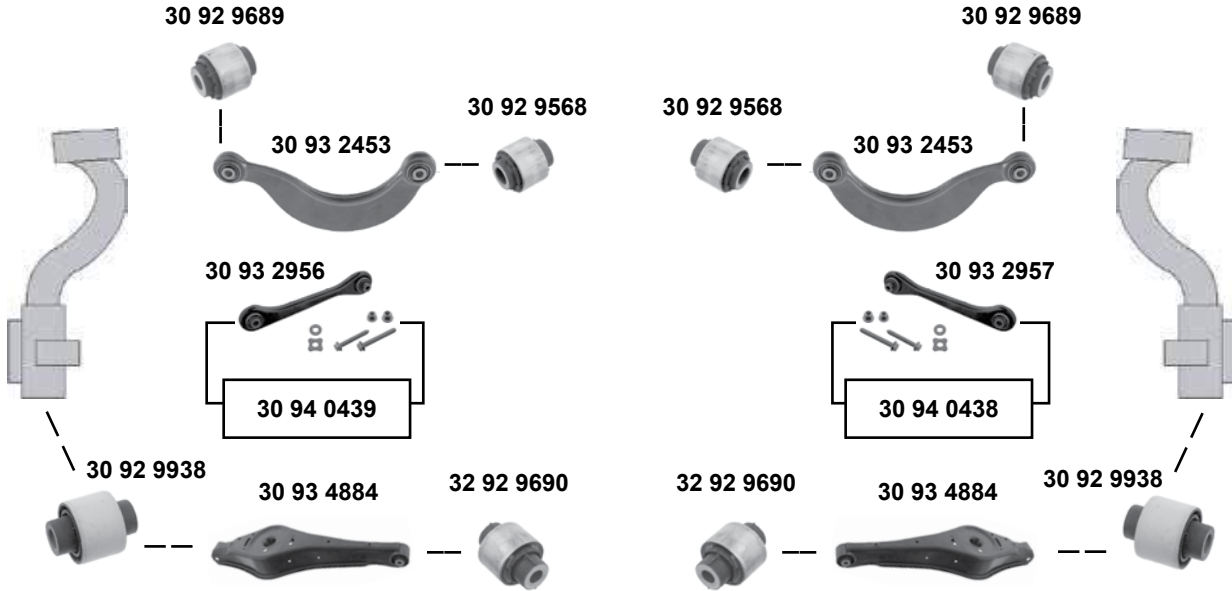

Hinterachse / Rear axle

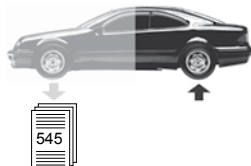

Passat 5 / 4motion (3C) (2006 →)



- (1) Passat 5 / variant / 4motion (3C) → 11 / Passat (Typ 36) / variant / 4motion 11 →
- (2) nur paarweise tauschen / replace in pairs only
- (3) (ch.) → 3C-6-050 000 / (ex.) Sport
- (4) PR-0BF, 0BE, 0BM
(ch.) 3C-6-050 001 → / PR-1JB, 1JC, 1JK / Sport / HD

	Ref. - No.			
30 92 9461	1K0 505 465 K S1	Rep. Satz Verbindungsstange / rep. kit connecting rod	(1)	L 95,5
30 92 9568	1K0 505 203 A	Querlenkerlager oben / control arm mount upper		Ø A 38 H 45
30 92 9689	1K0 505 279 A	Querlenkerlager oben / control arm mount upper		Ø A 38,5 H 45
30 92 9938	1K0 505 553 A	Querlenkerlager außen / control arm mount outer	→ 11	Ø A 37 H 50
30 93 2073	1K0 511 327 AQ	Stabilisatorlager hinten / stabilizer mount rear	(2)	Ø A 19,6
30 93 2453	1K0 505 323 N	Querlenker oben / control arm upper	→ 11	
30 93 2625	1K0 511 327 AS	Stabilisatorlager / stabilizer mount	(2)	Ø A 21,7
30 93 2956	1K0 501 529 F	Querlenker mit Gummilagern / control arm with rubber mounts	(1)	Blech
30 93 2957	1K0 501 530 C	Querlenker mit Gummilagern / control arm with rubber mounts	(1)	Blech
30 93 4884	1K0 505 311 AB	Querlenker / control arm		
30 93 9648	1K0 511 327 AR S1	Stabilisatorlagersatz / anti roll bar bush kit	(2) PR-0BE	
30 93 9649	1K0 511 327 AS S1	Stabilisatorlagersatz / anti roll bar bush kit	(2) (4)	
30 93 9650	1K0 511 327 AQ S1	Stabilisatorlagersatz / anti roll bar bush kit	(2) (3)	
30 94 0438	1K0 501 530 C S1	Rep. Satz Querlenker / rep. kit control arm		
30 94 0439	1K0 501 529 F S1	Rep. Satz Querlenker / rep. kit control arm		
32 92 3356	1K0 511 327 AP	Stabilisatorlager / stabilizer mount	(2)	Ø I 18,5
32 92 3358	1K0 511 327 AR	Stabilisatorlager / stabilizer mount	(2)	Ø A 20,7
32 92 3604	1K0 511 439 E	Klemmschelle / Clamp	(1)	
32 92 3606	1K0 511 327 AP S1	Stabilisatorlagersatz / anti roll bar bush kit	(2)	
32 92 9690	1K0 505 171 C	Querlenkerlager unten / control arm mount lower		Ø A 42 H 60

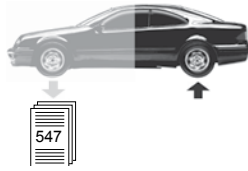

Passat 6 / 4motion

(2012 →)

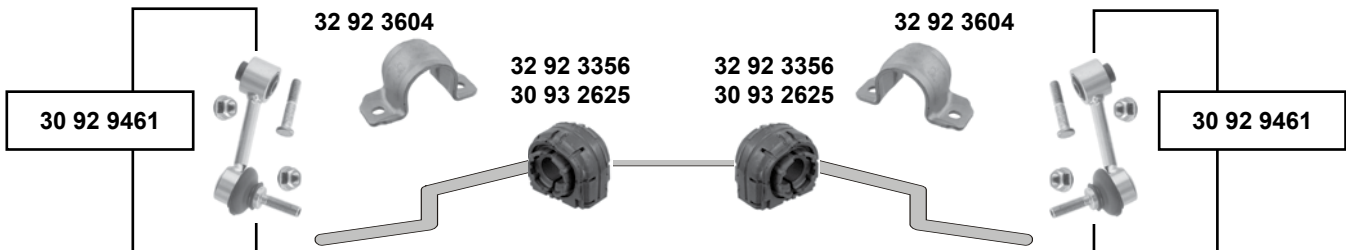
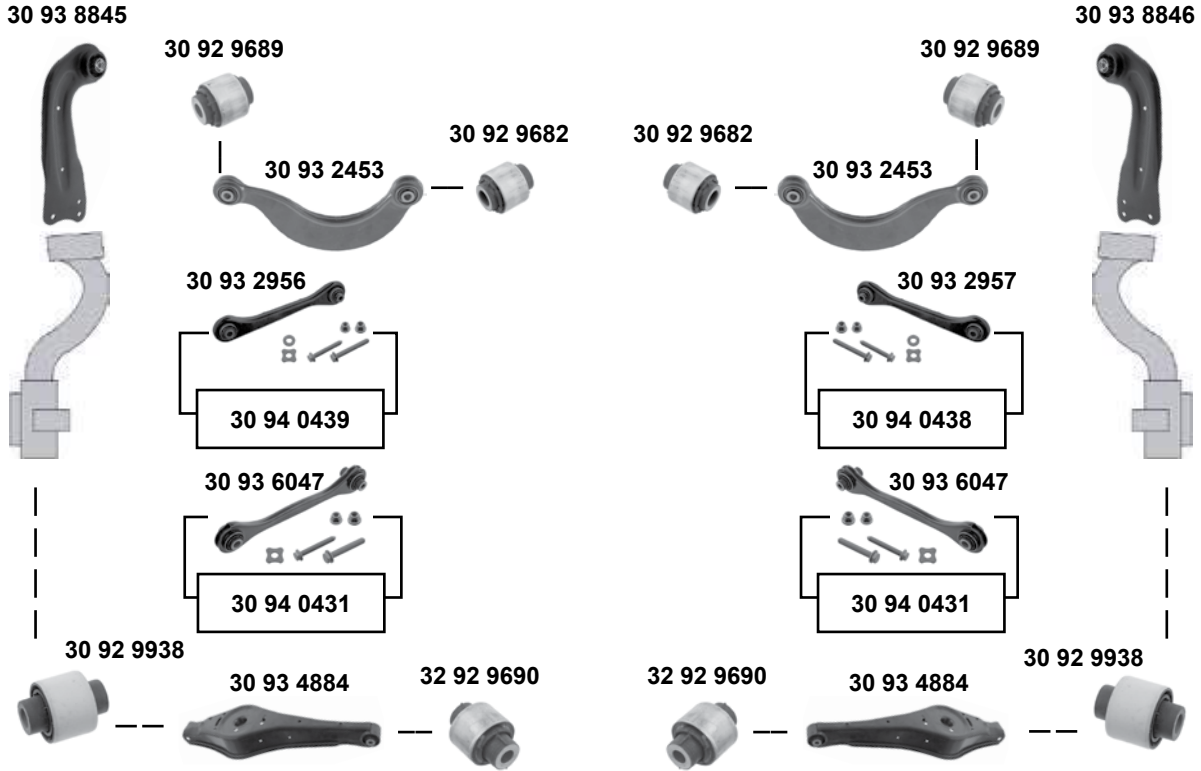

Hinterachse / Rear axle

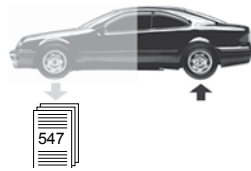

Passat 6 / 4motion

(2012 →)



(1) nur paarweise tauschen / replace in pairs only

(2) PR-1JB, 1JC, 1JK, UA5, UC7, UC8 **Sport / HD**

	Ref. - No.			
30 92 9461	1K0 505 465 K S1	Rep. Satz Verbindungsstange / rep. kit connecting rod		L 95,5
30 92 9682	1K0 505 203 A	Querlenkerlager oben / control arm mount upper		Ø A 38 H 45
30 92 9689	1K0 505 279 A	Querlenkerlager oben / control arm mount upper		Ø A 38,5H 45
30 92 9938	1K0 505 553 A	Querlenkerlager außen / control arm mount outer		Ø A 37 H 50
30 93 2453	1K0 505 323 N	Querlenker oben / control arm upper	(1)	
30 93 2625	1K0 511 327 AS	Stabilisatorlager / stabilizer mount	(1)	Ø A 21,7
30 93 2956	1K0 501 529 F	Querlenker / control arm		Blech
30 93 2957	1K0 501 530 C	Querlenker / control arm		Blech
30 93 4884	1K0 505 311 AB	Querlenker / control arm		
30 93 6047	1K0 501 529 J	Querlenker mit Gummilagern / control arm with rubber mounts		Stahl
30 93 8845	1K0 505 223 K	Querlenker / control arm		Blech
30 93 8846	1K0 505 224 K	Querlenker / control arm		Blech
30 93 9649	1K0 511 327 AS S1	Stabilisatorlagersatz / anti roll bar bush kit	(1) (2)	
30 94 0431	1K0 501 529 J S1	Rep. Satz Querlenker / rep. kit control arm		
30 94 0438	1K0 501 530 C S1	Rep. Satz Querlenker / rep. kit control arm		
30 94 0439	1K0 501 529 F S1	Rep. Satz Querlenker / rep. kit control arm		
32 92 3356	1K0 511 327 AP	Stabilisatorlager / stabilizer mount	(1)	Ø I 18,5
32 92 3604	1K0 511 439 E	Klemmschelle / clamping clip		
32 92 3606	1K0 511 327 AP S1	Stabilisatorlagersatz / anti roll bar bush kit	(1)	Ø I 18,5
32 92 9690	1K0 505 171 C	Querlenkerlager unten / control arm mount lower		Ø A 42

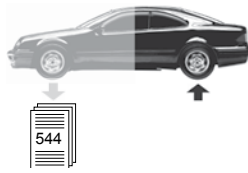

Passat CC (3C) Scirocco (13) (2009 →)

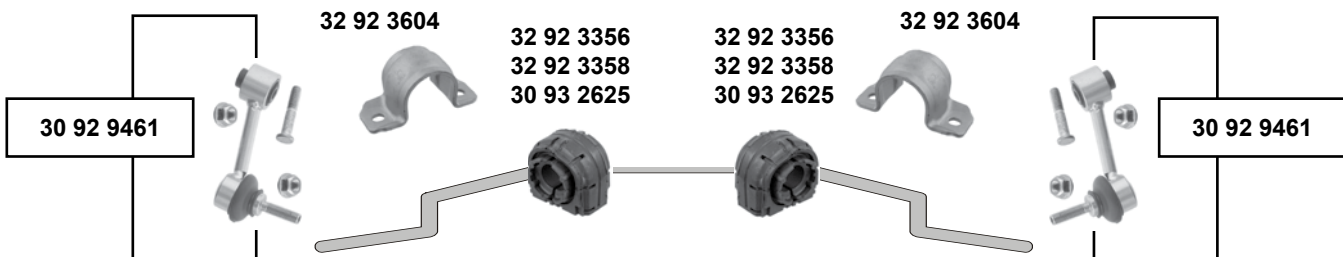
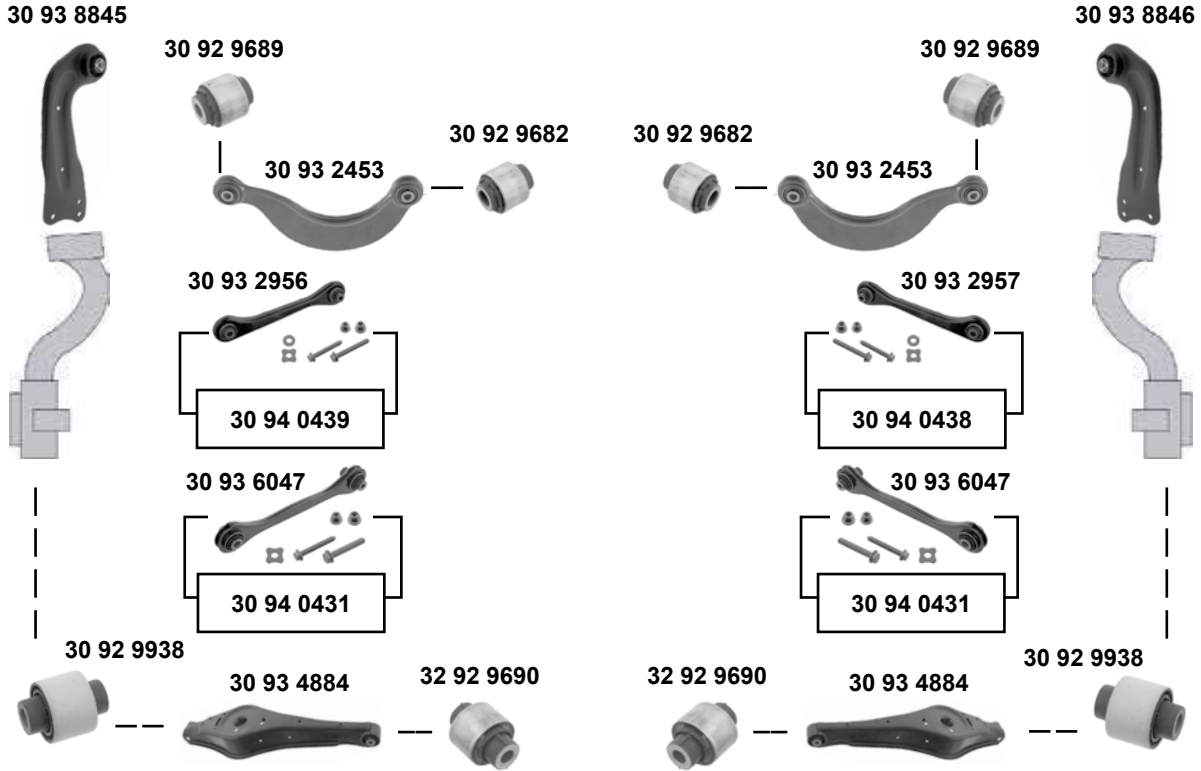

Hinterachse / Rear axle

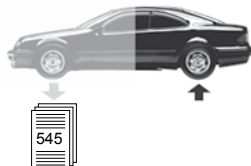

Passat CC (3C) Scirocco (13) (2009 →)



- (1) Passat CC / 4motion (3C) 09 → / Scirocco (13) / 09 (ch.) → 13-9-014-734
- (2) Passat (Typ 36) / variant / 4motion 11 → / Passat CC (3C) / Scirocco (13) 09 →
- (3) nur paarweise tauschen / replace in pairs only
- (4) Passat CC (ch.) → 3C-AE501 676 / (ch.) → 3C-AG500 003 // Scirocco PR-0BF, 0BM
- (5) Scirocco (ch.) 13-9-014 734 →
- (6) Scirocco (ch.) → 13-9-014 734

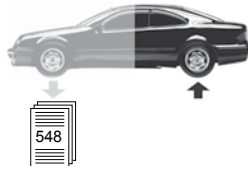

Ref. - No.

SWAG Ref. - No.	Description	Quantity	Material
30 92 9461	1K0 505 465 K S1 Rep. Satz Verbindungsstange / rep. kit connecting rod	(2)	L 95,5
30 92 9682	1K0 505 203 A Querlenkerlager oben / control arm mount upper		Ø A 38 H 45
30 92 9689	1K0 505 279 A Querlenkerlager oben / control arm mount upper		Ø A 38,5 H 45
30 92 9938	1K0 505 553 A Querlenkerlager außen / control arm mount outer		Ø A 37 H 50
30 93 2453	1K0 505 323 N Querlenker oben / control arm upper	(2)	
30 93 2625	1K0 511 327 AS Stabilisatorlager / stabilizer mount	(3)	Ø A 21,7
30 93 2956	1K0 501 529 F Querlenker mit Gummilagern / control arm with rubber mounts	(1)	Blech
30 93 2957	1K0 501 530 C Querlenker mit Gummilagern / control arm with rubber mounts	(1)	Blech
30 93 4884	1K0 505 311 AB Querlenker / control arm		
30 93 6047	1K0 501 529 J Querlenker mit Gummilagern / control arm with rubber mounts		Stahl
30 93 8845	1K0 505 223 K Querlenker / control arm		Blech
30 93 8846	1K0 505 224 K Querlenker / control arm		Blech
30 93 9648	1K0 511 327 AR S1 Stabilisatorlagersatz / anti roll bar bush kit	(3) PR-0BE	
30 93 9649	1K0 511 327 AS S1 Stabilisatorlagersatz / anti roll bar bush kit	(3) (4)	
30 94 0431	1K0 501 529 J S1 Rep. Satz Querlenker / rep. kit control arm	(5)	
30 94 0438	1K0 501 530 C S1 Rep. Satz Querlenker / rep. kit control arm	(6)	
30 94 0439	1K0 501 529 F S1 Rep. Satz Querlenker / rep. kit control arm	(6)	
32 92 3356	1K0 511 327 AP Stabilisatorlager / stabilizer mount	(3)	Ø I 18,5mm
32 92 3358	1K0 511 327 AR Stabilisatorlager / stabilizer mount	(3)	Ø A 20,7
32 92 3604	1K0 511 439 E Klemmschelle / clamp		
32 92 3606	1K0 511 327 AP S1 Stabilisatorlagersatz / anti roll bar bush kit	(3)	Ø I 18,5
32 92 9690	1K0 505 171 C Querlenkerlager unten / control arm mount lower		Ø A 42 H 60

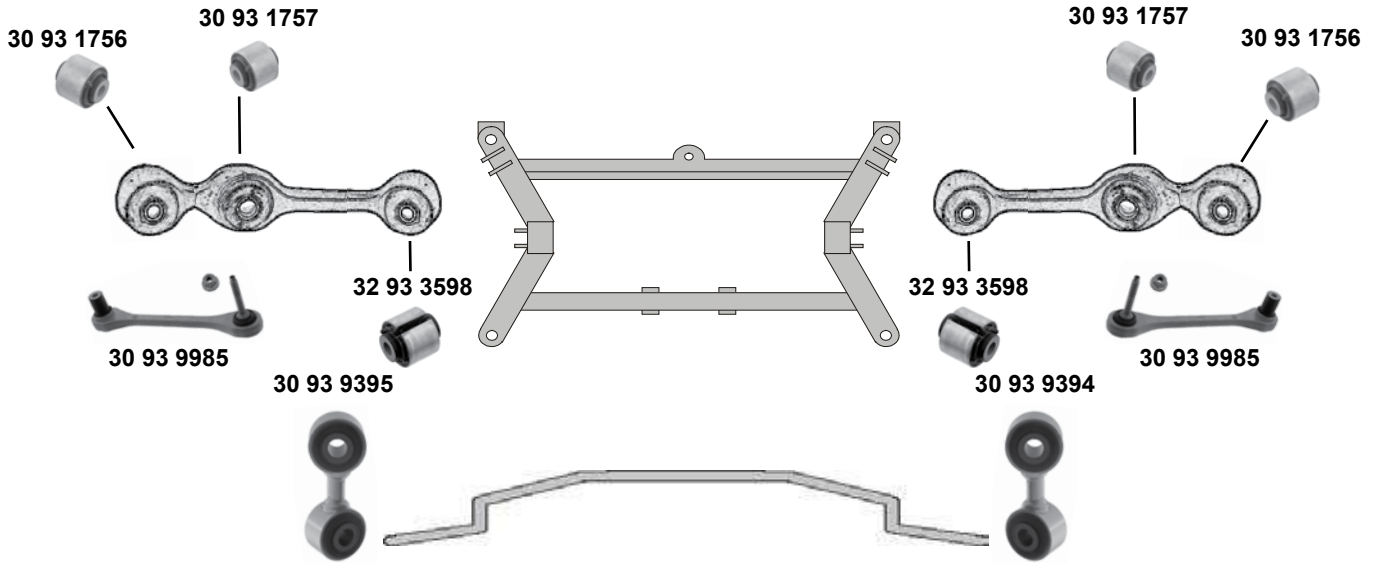

Phaeton (3D)

(2002 →)



Sharan (7M)

(1995 →)

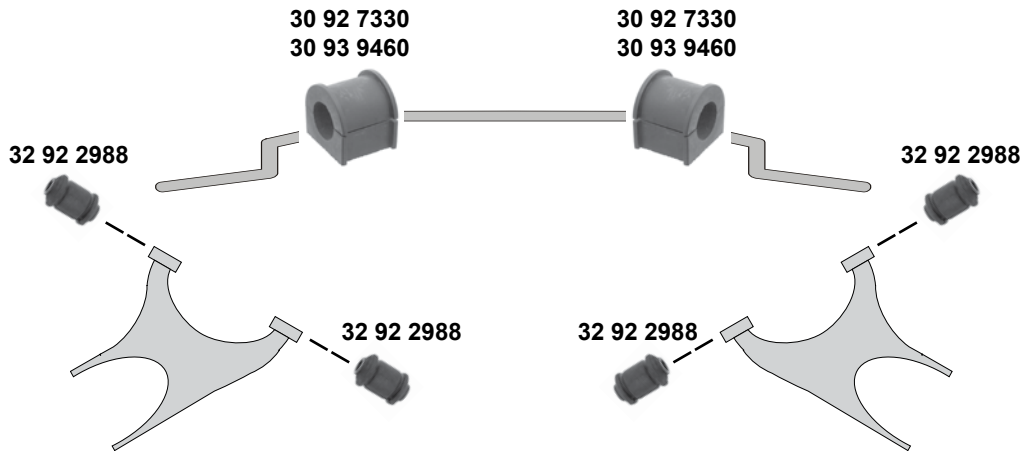

Hinterachse / Rear axle



- (1) 09/1995 → 05/2000 Sport
 03/2000 → 03/2010 Sport für Fahrzeuge mit Standard Fahrwerk / for vehicles with standard chassis
 04/2000 → 03/2010 für Fahrzeuge mit Standard Fahrwerk / for vehicles with standard chassis



Ref. - No.



30 92 7330	7M0 511 413 A	Stabilisatorlager / stabilizer mount	(ex.) Sport (ex.) PR-1BH	Ø 21
30 93 1756	4E0 505 203 D	Querlenkerlager / control arm mount		Ø 12 H 46
30 93 1757	4E0 505 203 B	Querlenkerlager / control arm mount		Ø 13 H 50
30 93 9394	4E0 505 548 M	Verbindungsstange / connecting rod		Ø 12 H 28
30 93 9395	4E0 505 547 M	Verbindungsstange / connecting rod		Ø 12 H 28
30 93 9460	7M0 511 413 B	Stabilisatorlager / stabilizer mount	(1) PR-1BE/1BH	Ø 22
30 93 9985	4E0 501 529 G S1	Querlenker / control arm	(ch.) 3D-4-008 501 →	M12 x 1,5
32 92 2988	7M0 501 541	Querlenkerlager / control arm mount		Ø 14 H 60
32 93 3598	4E0 505 203 A	Querlenkerlager / control arm mount		Ø 12 H 46

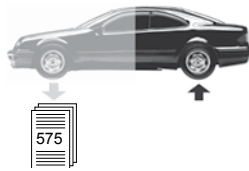

Sharan (7N)
(2011 →)

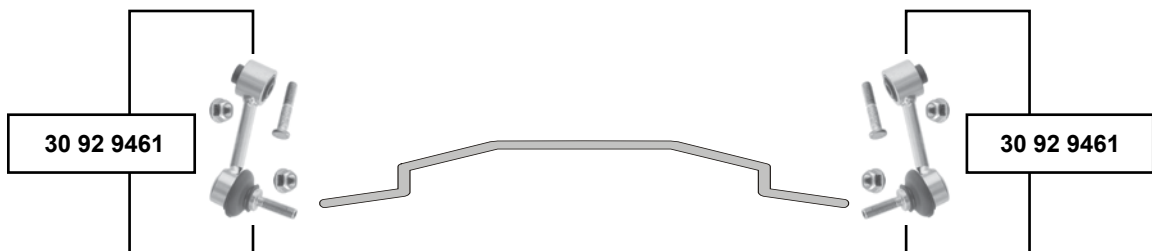

Hinterachse / Rear axle



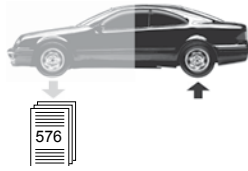

Tiguan (5N) (2008 →)

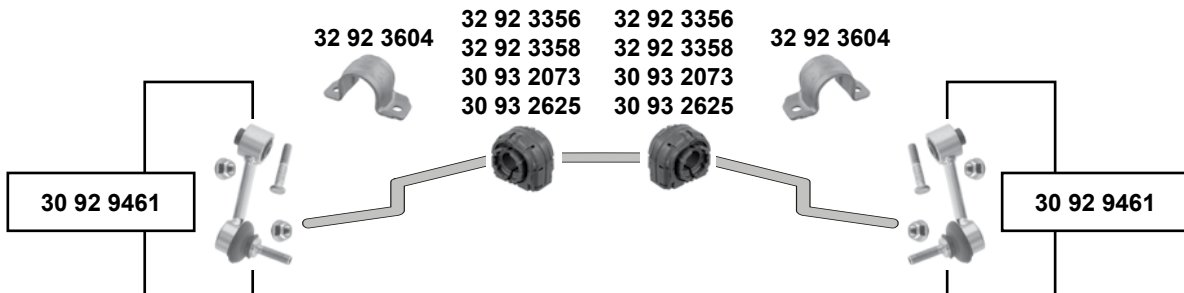
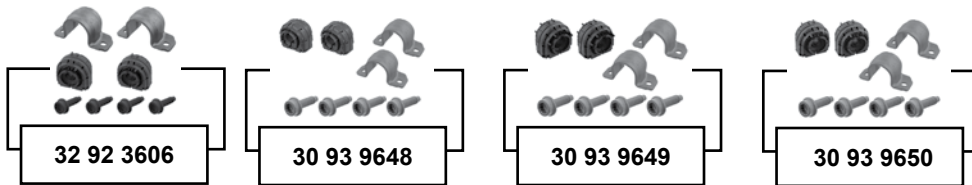
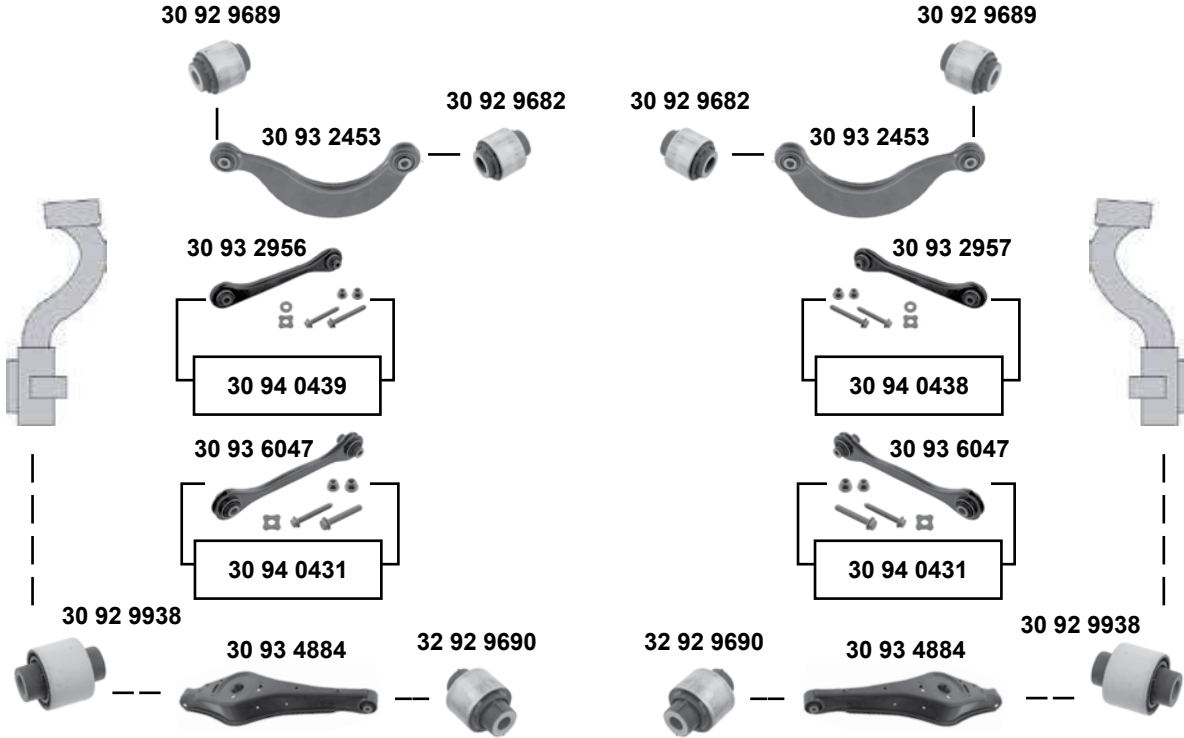

Hinterachse / Rear axle

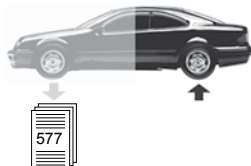
Tiguan (5N)
 (2008 →)

- (1) Tiguan / 4motion (5N) (ch.) → 5N-9G003 567 / (ch.) → 5N-9W058 242 / (ch.) → 5N-9W522 914
- (2) 08 → 09 (ch.) → 5N-9G003 567 / (ch.) → 5N-9W058 242 / (ch.) → 5N-9G003 878
 09 → (ch.) 5N-9G010 000 → / (ch.) 5N-9W120 000 → / (ch.) 5N-9W550 000 →
- (3) nur paarweise tauschen / replace in pairs only
- (4) (ch.) → 5N-9G003 567 / (ch.) → 5N-9W058 242 / (ch.) → 5N-9G003 878
 (ch.) 5N-9G010 000 → / (ch.) 5N-9W120 000 → / (ch.) 5N-9W550 000 →
- (5) (ch.) 5N-9G003 567 → (ch.) 5N-9W058 242 → (ch.) 5N-9W522 914 → / (ch.) → 5N-B-600 000
- (6) (ch.) → 5N-9W522 914



Ref. - No.



SWAG Ref. - No.			
30 92 9461	1K0 505 465 K S1	Rep. Satz Verbindungsstange / rep. kit connecting rod	L 95,5
30 92 9682	1K0 505 203 A	Querlenkerlager oben / control arm mount upper	Ø A 38 H45
30 92 9689	1K0 505 279 A	Querlenkerlager oben / control arm mount upper	Ø A 38,5 H45
30 92 9938	1K0 505 553 A	Querlenkerlager außen / control arm mount outer	Ø A 37 H50
30 93 2073	1K0 511 327 AQ	Stabilisatorlager hinten / stabilizer mount rear	Ø A 19,6
30 93 2453	1K0 505 323 N	Querlenker oben / control arm upper	
30 93 2625	1K0 511 327 AS	Stabilisatorlager / stabilizer mount	Ø A 21,7
30 93 2956	1K0 501 529 F	Querlenker mit Gummilagern / control arm with rubber mounts	Blech
30 93 2957	1K0 501 530 C	Querlenker mit Gummilagern / control arm with rubber mounts	Blech
30 93 4884	1K0 505 311 AB	Querlenker / control arm	
30 93 6047	1K0 501 529 J	Querlenker mit Gummilagern / control arm with rubber mounts	Stahl
30 93 9648	1K0 511 327 AR S1	Stabilisatorlagersatz / anti roll bar bush kit	(3) (4) PR-0BE
30 93 9649	1K0 511 327 AS S1	Stabilisatorlagersatz / anti roll bar bush kit	(3) PR-0BE
30 93 9650	1K0 511 327 AQ S1	Stabilisatorlagersatz / anti roll bar bush kit	(3) → 09/PR-0BE
30 94 0431	1K0 501 529 J S1	Rep. Satz Querlenker / rep. kit control arm	→ 09
30 94 0438	1K0 501 530 C S1	Rep. Satz Querlenker / rep. kit control arm	(6)
30 94 0439	1K0 501 529 F S1	Rep. Satz Querlenker / rep. kit control arm	(6)
32 92 3356	1K0 511 327 AP	Stabilisatorlager / stabilizer mount	Ø I 18,5
32 92 3358	1K0 511 327 AR	Stabilisatorlager / stabilizer mount	Ø A 20,7
32 92 3604	1K0 511 439 E	Klemmschelle / clamping clip	
32 92 3606	1K0 511 327 AP S1	Stabilisatorlagersatz / anti roll bar bush kit	Ø I 18,5
32 92 9690	1K0 505 171 C	Querlenkerlager unten / control arm mount lower	Ø A 42 H60

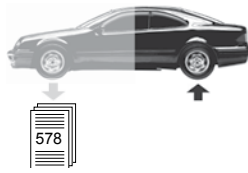

Touareg (7L) (2003 →)

oben / upper

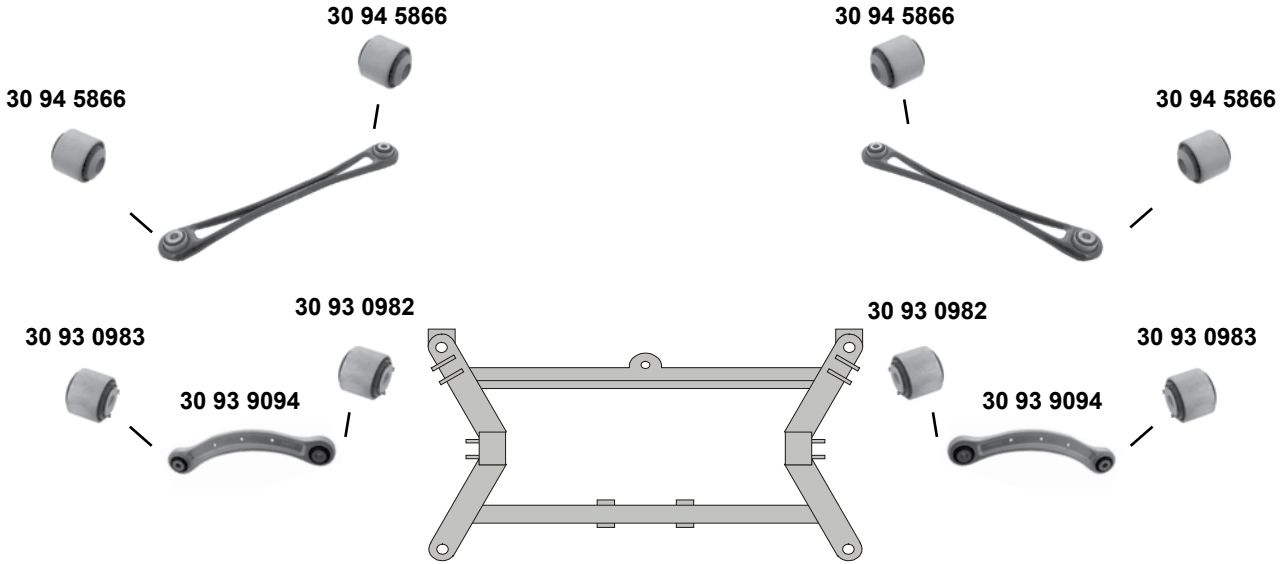

unten / lower

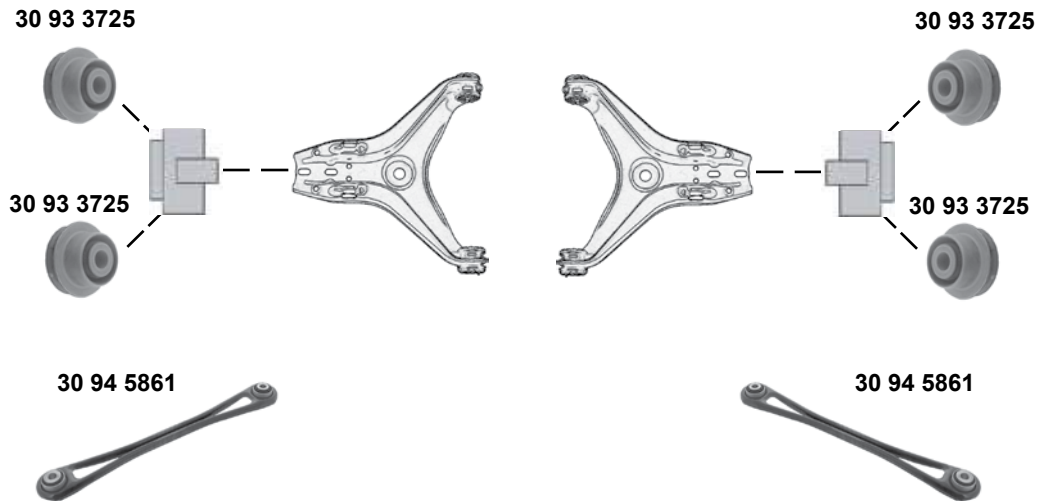

Hinterachse / Rear axle



Ref. - No.



30 93 0982	7L0 505 554
30 93 0983	7L0 505 553
30 93 3725	7L0 407 183 A
30 93 9094	7L0 505 323 A
30 94 5861	7L8 501 529 A
30 94 5866	7L0 501 537 B

Querlenkerlager innen / control arm mount inner
Querlenkerlager außen / control arm mount outer
Querlenkerlager / control arm mount
Querlenker / control arm
Querlenker / control arm
Querlenkerlager / control arm mount

Aluminium
Blech / sheet

Ø A 44 H40
Ø A 44,5 H4
Ø A 40 H60

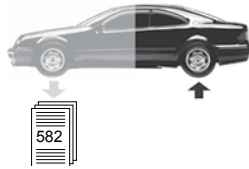

Touareg (7P)
(2010 →)

oben / upper

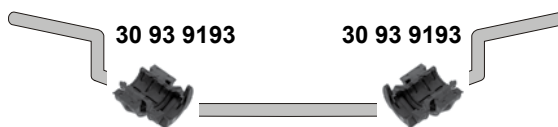

Hinterachse / Rear axle



(1) Für Fahrzeuge mit Komfortfahrwerk / for vehicles with comfort suspension // PR-1BW



Ref. - No.



30 93 9193 7P0 511 413 A
30 94 5866 7L0 501 537 B

Stabilisatorlager / stabilizer mount
Querlenkerlager / control arm mount

(1)

Ø 23,6

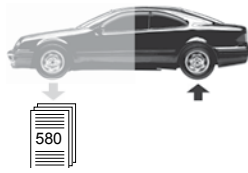

Touran (1T) (2003 →)

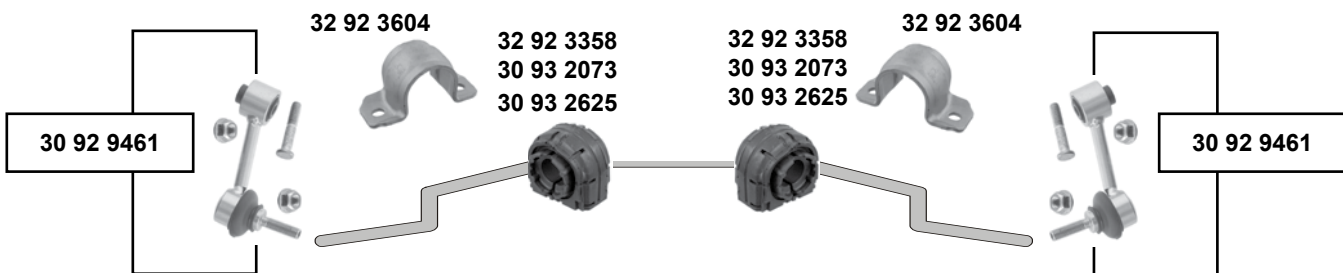
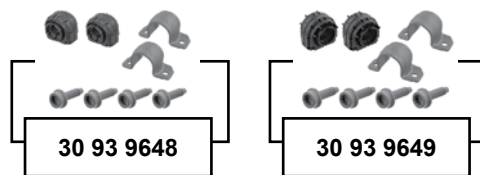
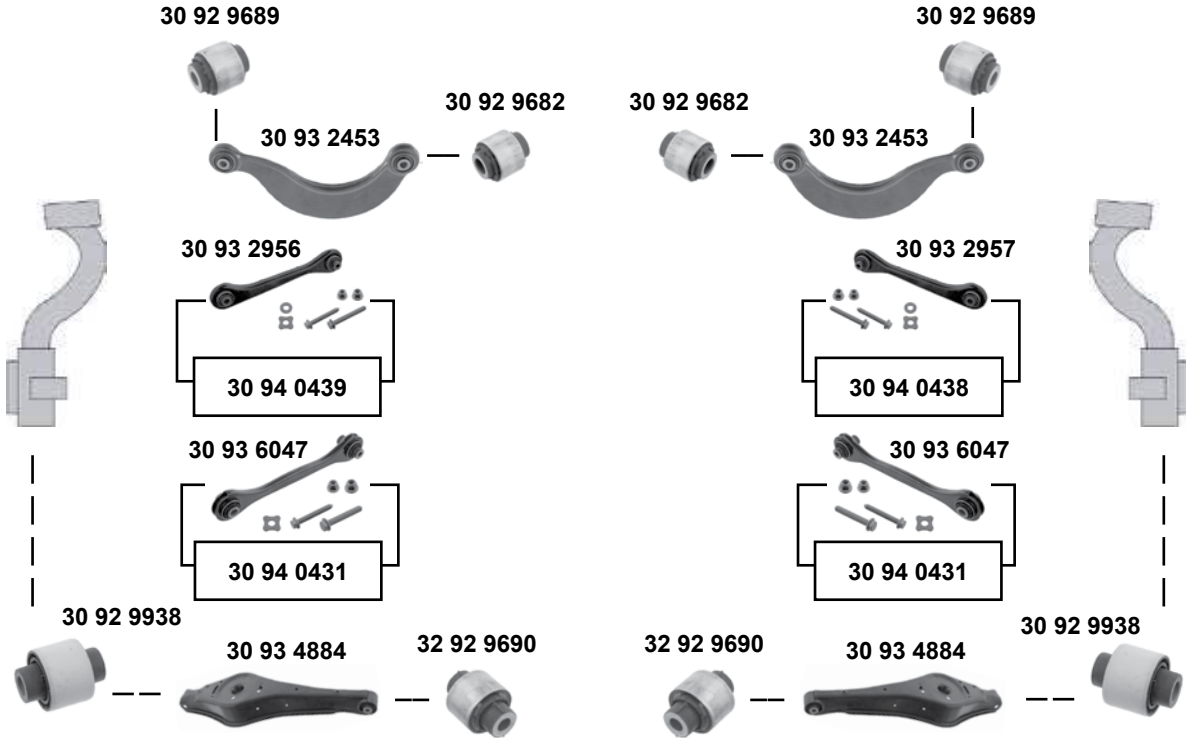

Hinterachse / Rear axle

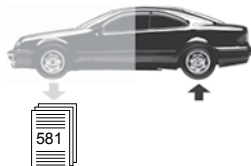
Touran (1T)
 (2003 →)

- (1)** (ch.) → 1T-9-068 180 / (ch.) → 1T-9-090 000
- (2)** 03 → (ex.) mot. BSX/CDGA = Erdgas / gas // 08 → 10 (ch.) 1T-8 085 001 → 1T-A-060 000 / BSX/CDGA
- (3)** nur paarweise tauschen / replace in pairs only
- (4)** 06 → (ch.) → 1T-8-085 001 / → (ch.) 1T-A-060 000
- (5)** (ch.) 1T-7-000 001 → / PR-2H0
- (6)** (ch.) 1T-9-068 180 → / (ch.) 1T-9-090 000 →



Ref. - No.



SWAG	Ref. - No.			
30 92 9461	1K0 505 465 K S1	Rep. Satz Verbindungsstange / rep. kit connecting rod		
30 92 9682	1K0 505 203 A	Querlenkerlager oben / control arm mount upper		Ø A 38 H 45
30 92 9689	1K0 505 279 A	Querlenkerlager oben / control arm mount upper		Ø A 38,5 H 45
30 92 9938	1K0 505 553 A	Querlenkerlager außen / control arm mount outer		Ø A 37 H 50
30 93 2073	1K0 511 327 AQ	Stabilisatorlager hinten / stabilizer mount rear		Ø I 15/17
30 93 2453	1K0 505 323 N	Querlenker oben / control arm upper		
30 93 2625	1K0 511 327 AS	Stabilisatorlager / stabilizer mount	(3)	Ø A 21,7
30 93 2956	1K0 501 529 F	Querlenker mit Gummilagern / control arm with rubber mounts	(1)	
30 93 2957	1K0 501 530 C	Querlenker mit Gummilagern / control arm with rubber mounts	(1)	
30 93 4884	1K0 505 311 AB	Querlenker / control arm		
30 93 6047	1K0 501 529 J	Querlenker mit Gummilagern / control arm with rubber mounts	(ch.) 1T-9-090 001 →	Stahl
30 93 9648	1K0 511 327 AR S1	Stabilisatorlagersatz / anti roll bar bush kit	(3) (4) PR-0BE	
30 93 9649	1K0 511 327 AS S1	Stabilisatorlagersatz / anti roll bar bush kit	(3) (5)	
30 94 0431	1K0 501 529 J S1	Rep. Satz Querlenker / rep. kit control arm	(6)	
30 94 0438	1K0 501 530 C S1	Rep. Satz Querlenker / rep. kit control arm	(1)	
30 94 0439	1K0 501 529 F S1	Rep. Satz Querlenker / rep. kit control arm	(1)	
32 92 3358	1K0 511 327 AR	Stabilisatorlager / stabilizer mount	(2) (3)	Ø A 20,7
32 92 3604	1K0 511 439 E	Klemmschelle / Clamp		
32 92 9690	1K0 505 171 C	Querlenkerlager unten / control arm mount lower		Ø A 42 H 60

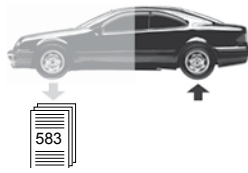

Transporter Typ 3 (24)

(1980 → 1992)

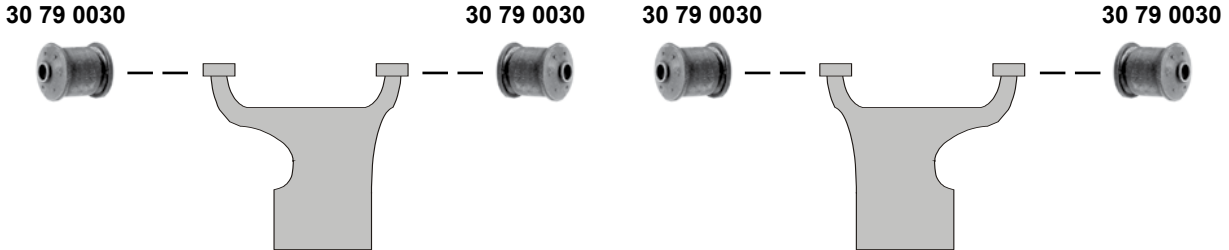

Transporter T4 / Multivan

(1990 → 2003)



Transporter T5 / Multivan

(2003 →)

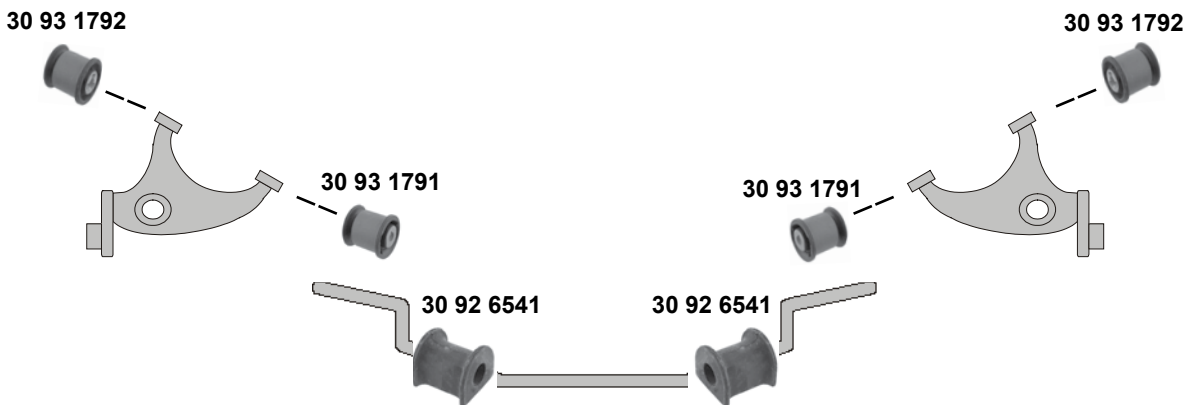

Hinterachse / Rear axle



(1) (ex.) zulässiges Gesamtgewicht 3.2 t / (ex.) maximum load 3.2 t (PR-0WR)



Ref. - No.



30 79 0030	251 501 131 A
30 92 6541	7H0 511 414
30 93 1791	7H0 501 132 A
30 93 1792	7H0 501 131 A
30 93 6005	701 501 131

Querlenkerlager / control arm mount	
Stabilisatorlager / stabilizer mount	
Achslenklerlager / axle link mount	(1)
Achslenklerlager / axle link mount	(1)
Querlenkerlager / control arm mount	

12x47x75
Ø 24
Ø 14 H 75
Ø 14 H 75
Ø 14 H 75

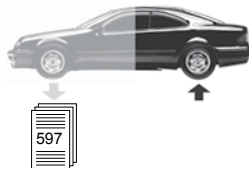

240 → 260
(1981 → 1992)

Starrachse / rigid axle: oben / upper

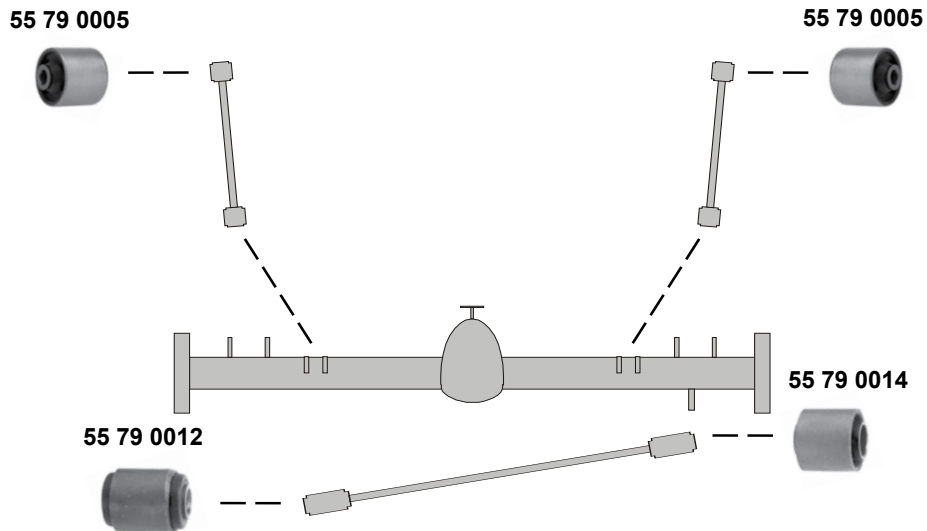

Starrachse / rigid axle: unten / lower

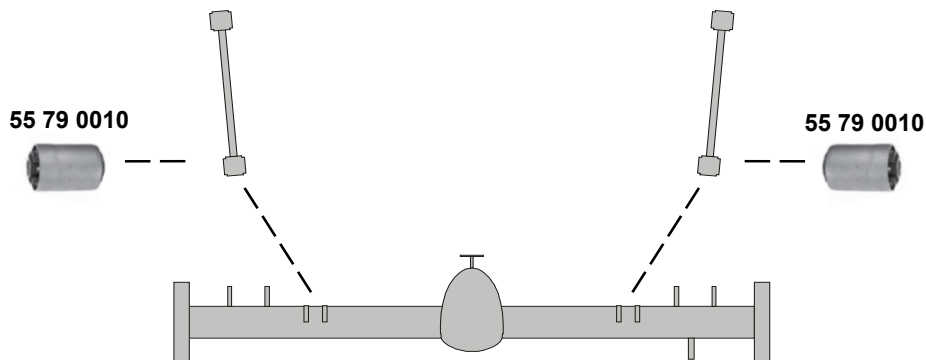

(1) 242 (ch.) 205101 → / 244 (ch.) 675001 →
245 (ex.) Turbo (ch.) 362901 →
262 / 264 (ch.) 122298 →
265 (ch.) 30465 →



Ref. - No.



55 79 0005	1273622
55 79 0010	1229165
55 79 0012	1330973
55 79 0014	1330427

Gummilager / rubber mount	(1)
Gummilager / rubber mount	
Gummilager / rubber mount	
Gummilager / rubber mount	

12x48x37/50
Ø A 57
Ø A 40
Ø A 40,5

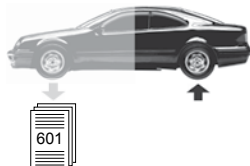

440 → 460

(1988 → 1995)

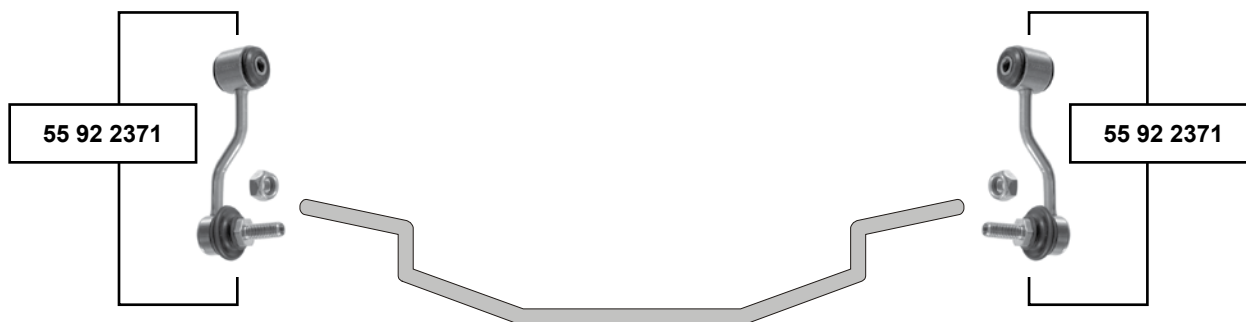

480

(1986 → 1994)

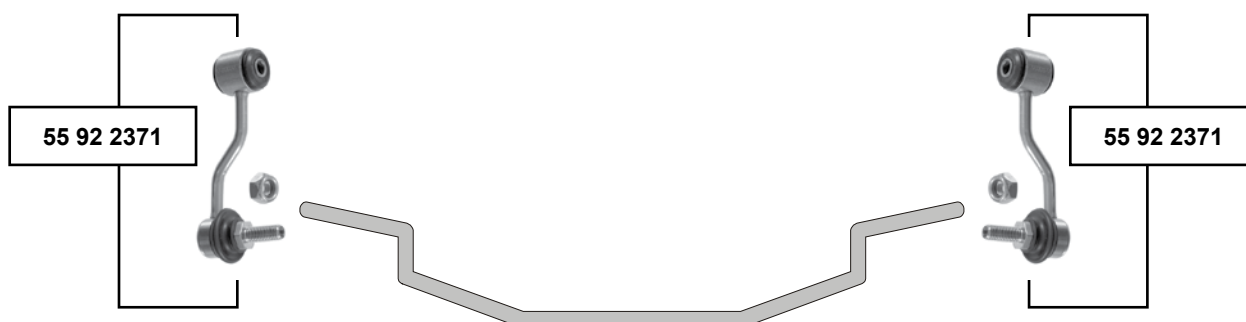

Hinterachse / Rear axle

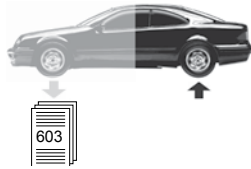

740 → 760
(1985 → 1992)

Starrachse / Rigid axle

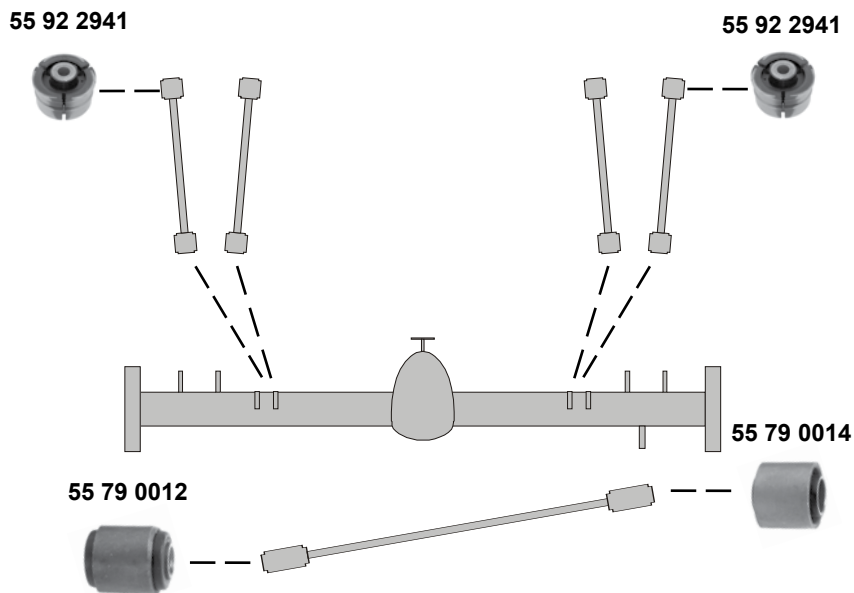

Hinterachse / Rear axle



passend für / to fit

VOLVO

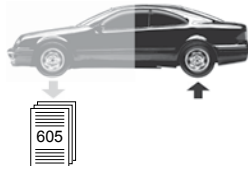

850

(1991 → 1997)

Vorderradantrieb / Front Wheel Drive

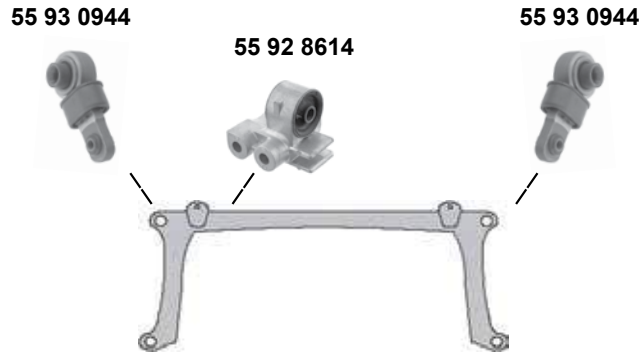

Allrad / 4 Wheel Drive (AWD)

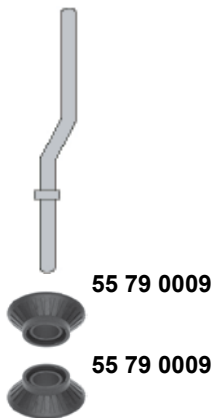

Hinterachse / Rear axle



Ref. - No.



55 79 0009	6819057
55 92 8614	9181013
55 93 0944	3516122

Zugstrebenlager / tie arm bush
Halterung / Support
Gelenk für Hinterachskörper / joint for rear subframe

(ex.) 4WD

17x52x26,5

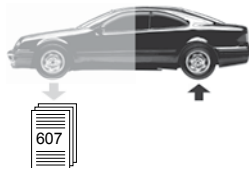

940 → 960
(1991 → 1998)

Starrachse / Rigid axle

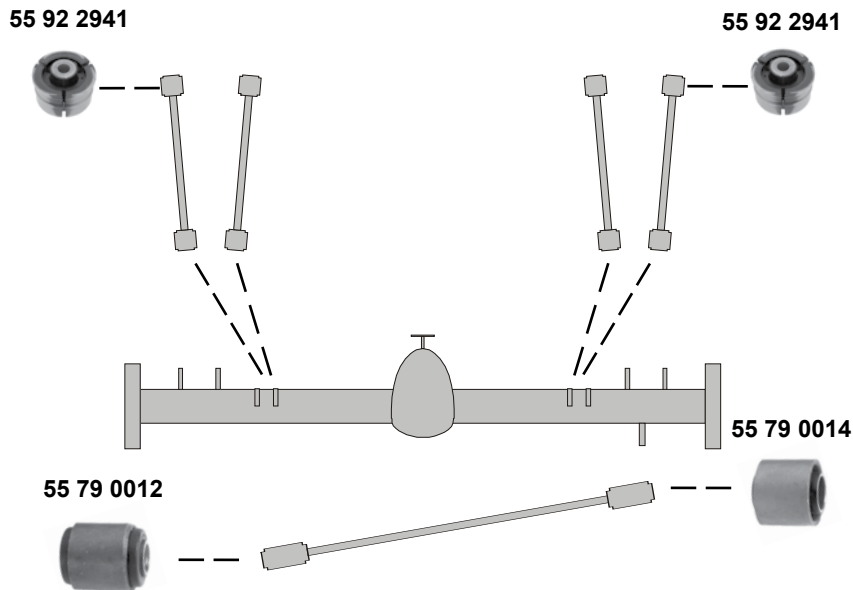

C 70 I
(1997 → 2005)

55 92 8614



Hinterachse / Rear axle



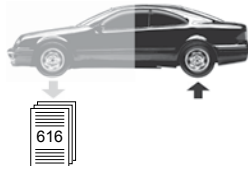



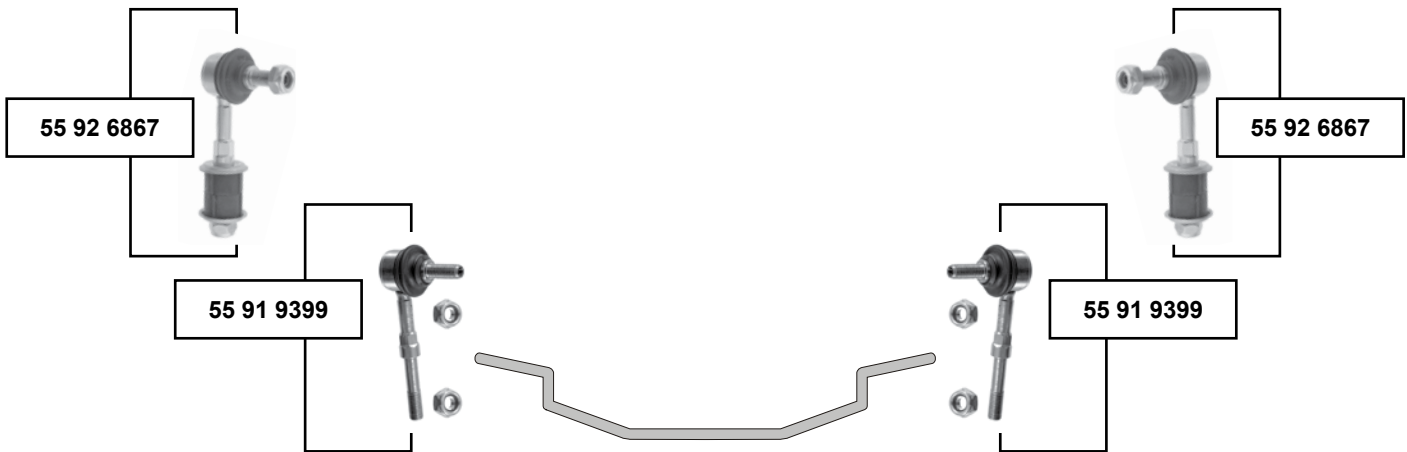
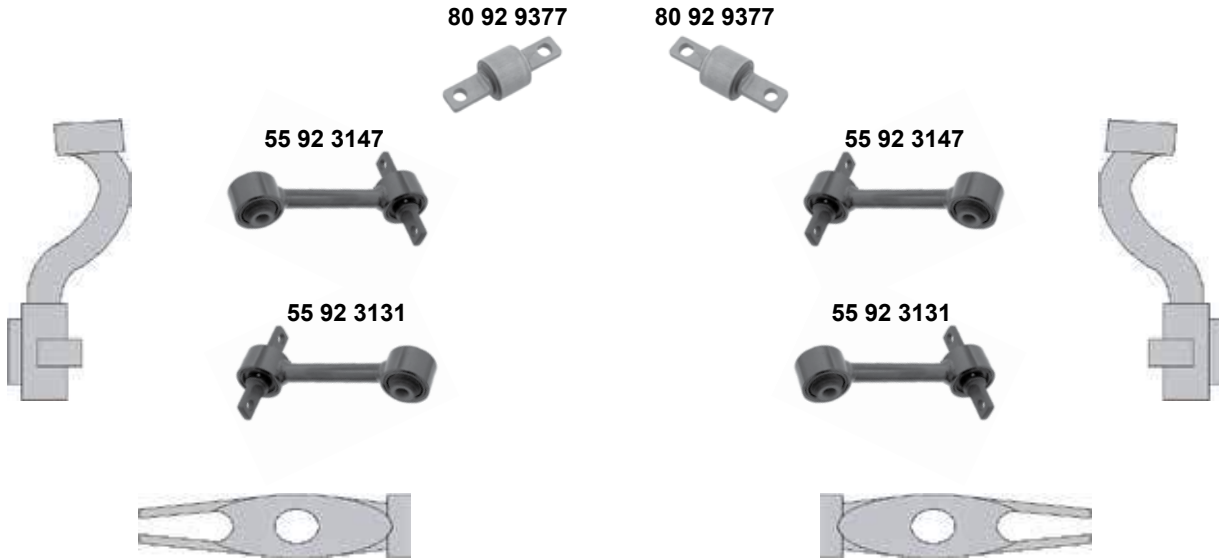

S 40 I / V 40 I

(1995 → 2003)



Hinterachse / Rear axle

	Ref. - No.			
55 91 9399	30884359	Verbindungsstange / connecting rod		L 102,5
55 92 3131	30620785	Achsstrebe unten / axle rod lower		
55 92 3147	30620786	Achsstrebe oben / axle rod upper	modell 1998 →	
55 92 6867	30884359 S1	Verbindungsstange kompl. / connecting rod compl.		
80 92 9377	30818096 S1	Querlenkerlager oben / control arm mount upper	modell → 1998	

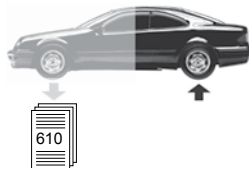

C 30 / C 70 II / S 40 II / V 50
(2004 →)

50 92 3047

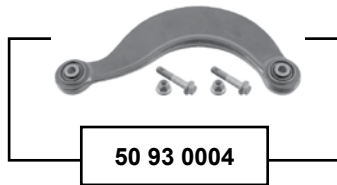

50 92 3047

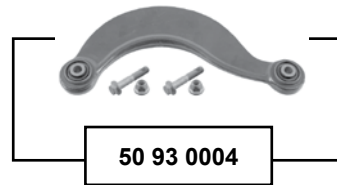

50 92 4211



50 92 4211

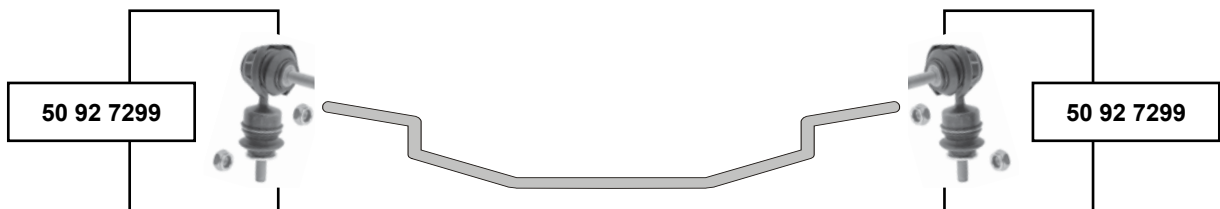

Hinterachse / Rear axle



50 92 3047	31277305
50 92 4211	30683067
50 92 7299	31212548
50 93 0000	30683067 S1
50 93 0004	31277305 S1

Querstrebe / cross rod
Querstrebe / cross rod
Verbindungsstange / connecting rod
Rep. Satz Querstrebe / rep. kit cross rod
Rep. Satz Querstrebe / rep. kit cross rod

(ex.) 4x4 / AWD
(ex.) 4x4 / AWD
(ex.) C30
(ex.) 4x4 / AWD
(ex.) 4x4 / AWD

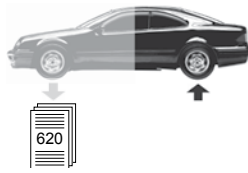

S 60 I
(2000 → 2010)

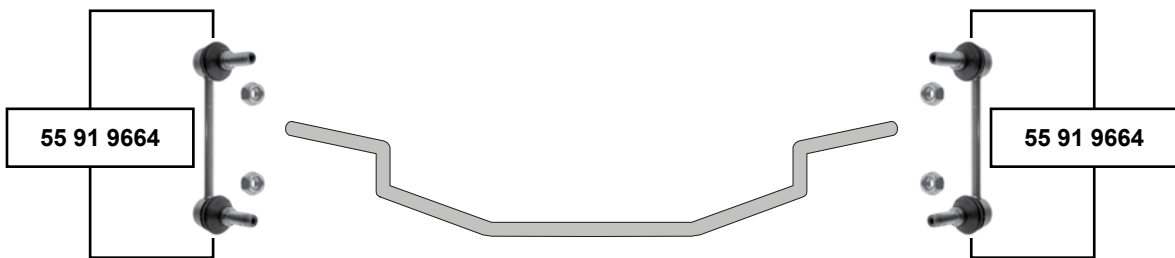
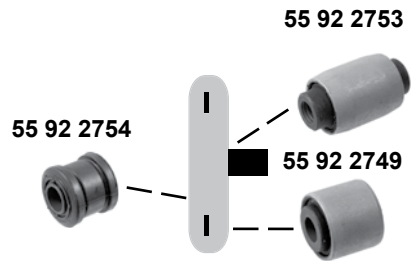
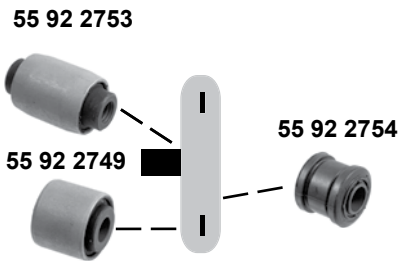
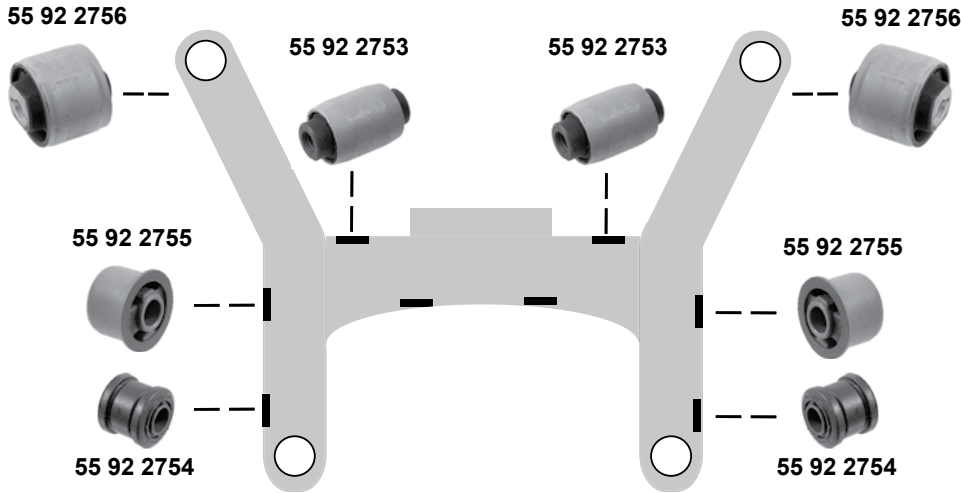

Hinterachse / Rear axle

	Ref. - No.			
55 91 9664	31201603	Verbindungsstange / connecting rod		L 140
55 92 2749	9127363	Gummilager / rubber mount		12x34x28/34
55 92 2753	9492181	Gummilager / rubber mount		12x40x50/70
55 92 2754	9173761	Gummilager / rubber mount		20x43/47x48
55 92 2755	31277899	Gummilager / rubber mount		20x53/62x50
55 92 2756	31277893	Gummilager / rubber mount		12x60x45/60

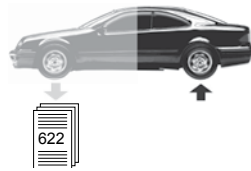

S 60 II / V 60
(2010 →)

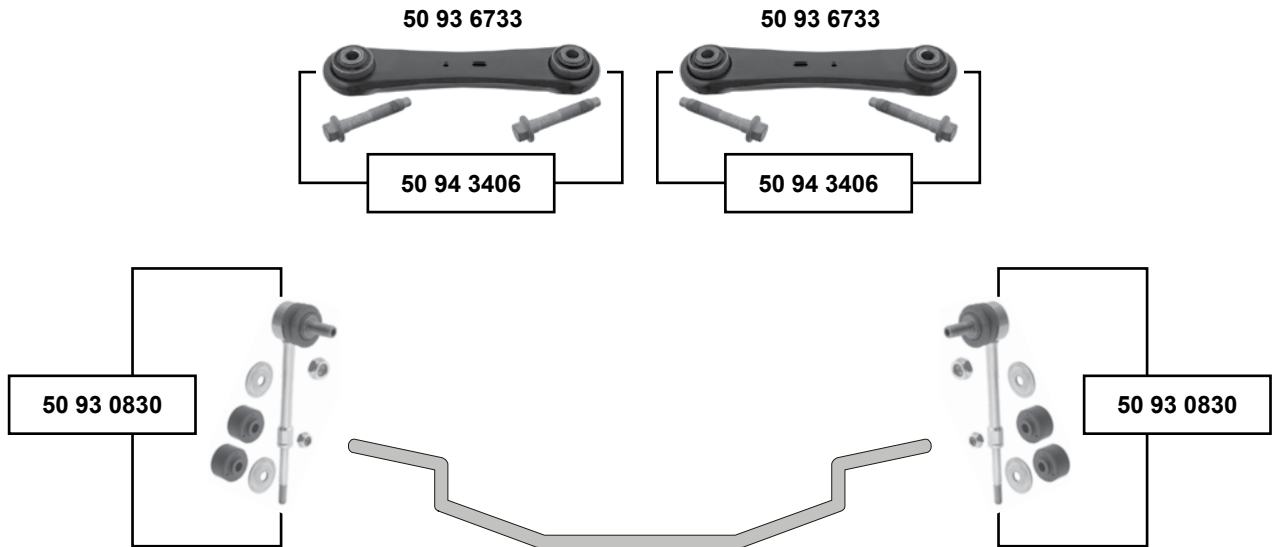

S 70 I
(1997 → 2000)

55 92 8614



SWAG	Ref. - No.			
55 92 8614	9181013	Halterung / Support	(ex.) 4WD	
50 93 0830	30760678	Verbindungsstange / connecting rod		
50 93 6733	31262930	Hinterachsstrebe / rear axle rod		L 196
50 94 3406	31262930 S1	Querstrebe / cross rod		

passend für / to fit

VOLVO

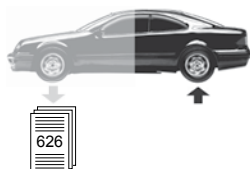

V 40 II
(2012 →)



V 40 Cross Country
(2012 →)

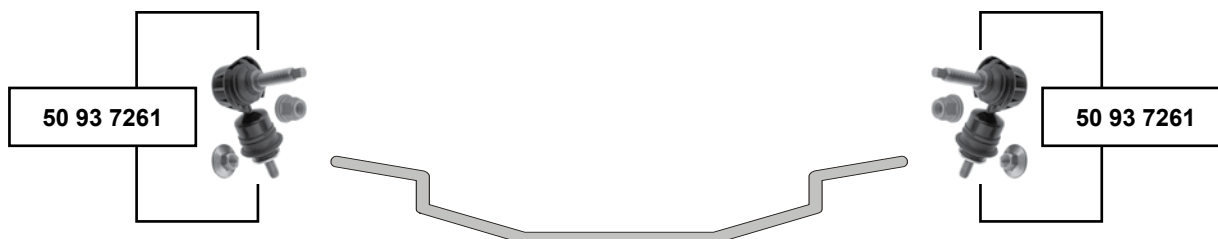

Hinterachse / Rear axle



Ref. - No.



50 93 7261 31317271 S1

Rep. Satz Verbindungsstange / rep. kit connecting rod

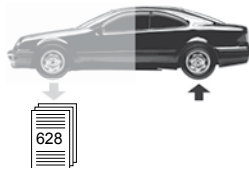

V 70 II / V 70 XC / XC 70 II
(2001 → 2007)

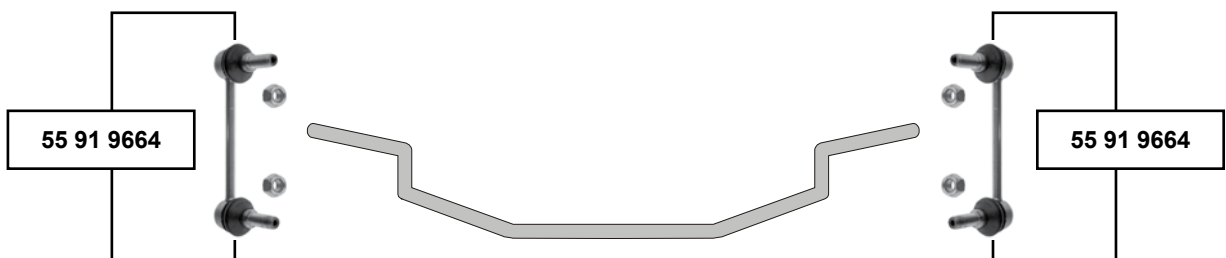
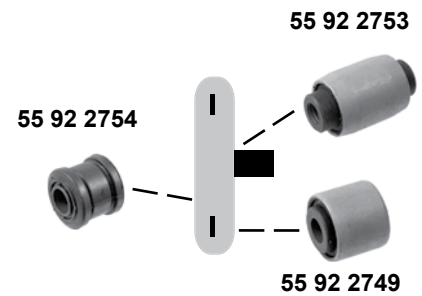
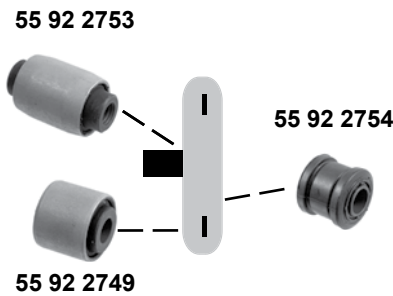
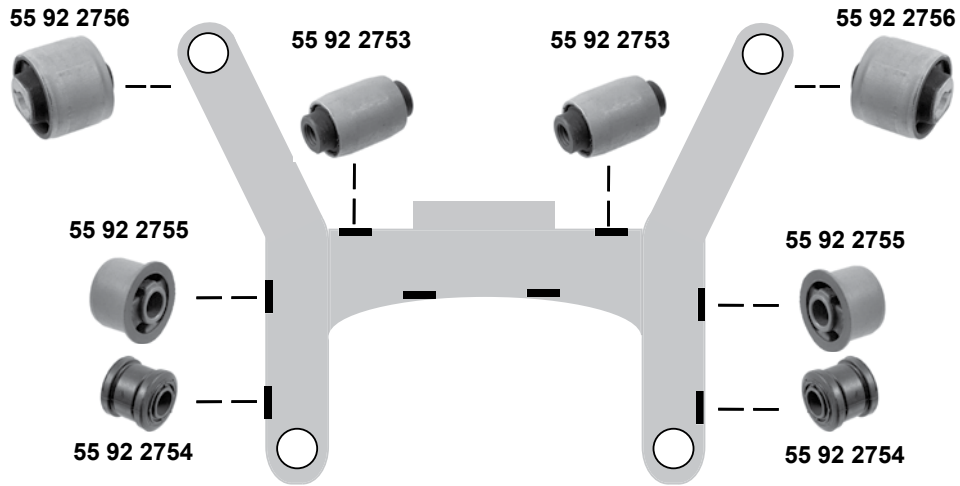

Hinterachse / Rear axle



55 91 9664	31201603
55 92 2749	9127363
55 92 2753	9492181
55 92 2754	9173761
55 92 2755	31277899
55 92 2756	31277893

Verbindungsstange / connecting rod
Gummilager / rubber mount
Gummilager / rubber mount
Gummilager / rubber mount
Gummilager / rubber mount
Gummilager / rubber mount

L140
12x34x28/34
12x40x50/70
20x43/47x48
20x53/62x50
12x60x45/60

passend für / to fit

VOLVO

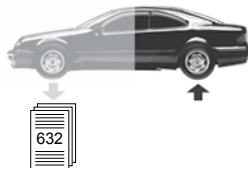

V 70 III / XC 70 III

(2007 →)

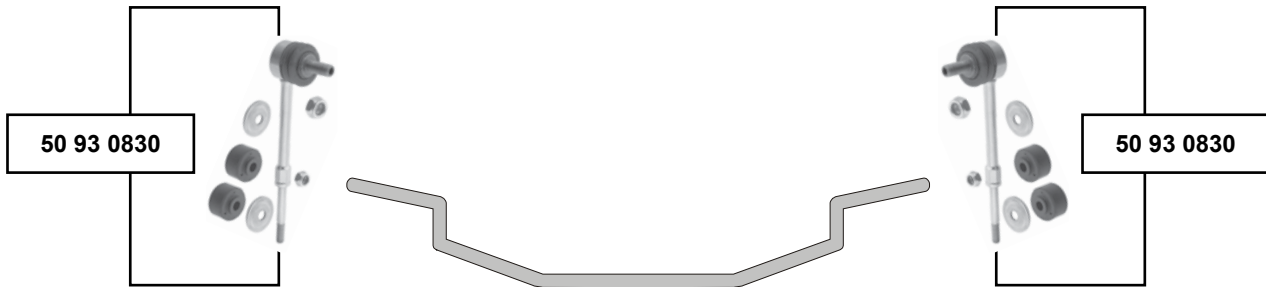
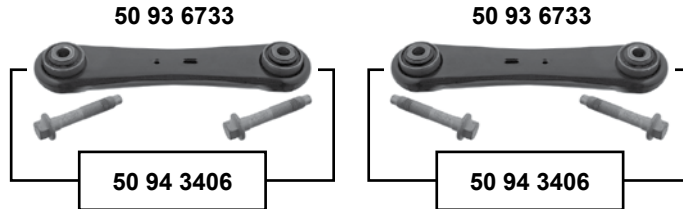

Hinterachse / Rear axle



(1) V 70 III: (mot.) B 5254 T8 (ch.) 67701 → (ex.) Sport



Ref. - No.

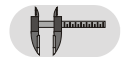

50 93 0830	30760678
50 93 6733	31262930
50 94 3406	31262930 S1

Verbindungsstange / connecting rod	
Hinterachsstrebe / rear axle rod	(1)
Querstrebe / cross rod	(1)

L 196

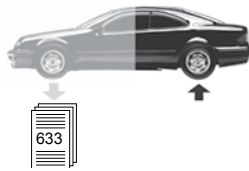

S 80 I
(1998 → 2007)

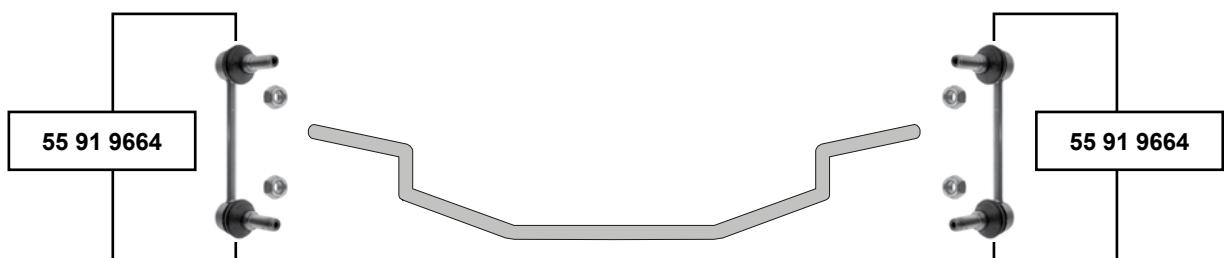
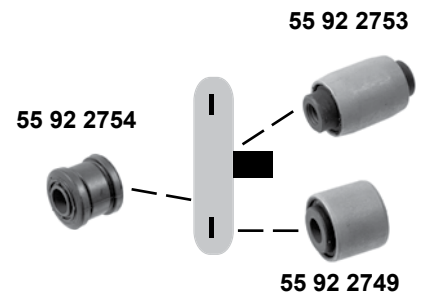
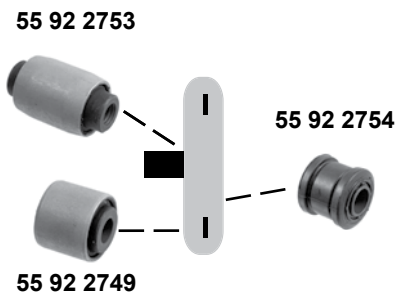
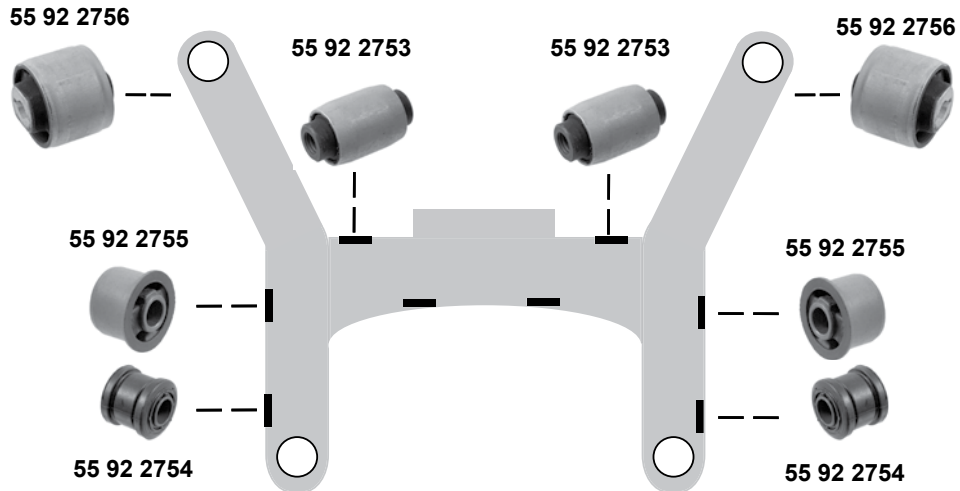

Hinterachse / Rear axle



55 91 9664	31201603
55 92 2749	9127363
55 92 2753	9492181
55 92 2754	9173761
55 92 2755	31277899
55 92 2756	31277893

Verbindungsstange / connecting rod
Gummilager / rubber mount
Gummilager / rubber mount
Gummilager / rubber mount
Gummilager / rubber mount
Gummilager / rubber mount

L 140
12x34x28/34
12x40x50/70
20x43/47x48
20x53/62x50
12x60x45/60

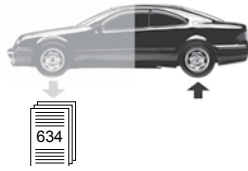

S 80 II
(2006 →)

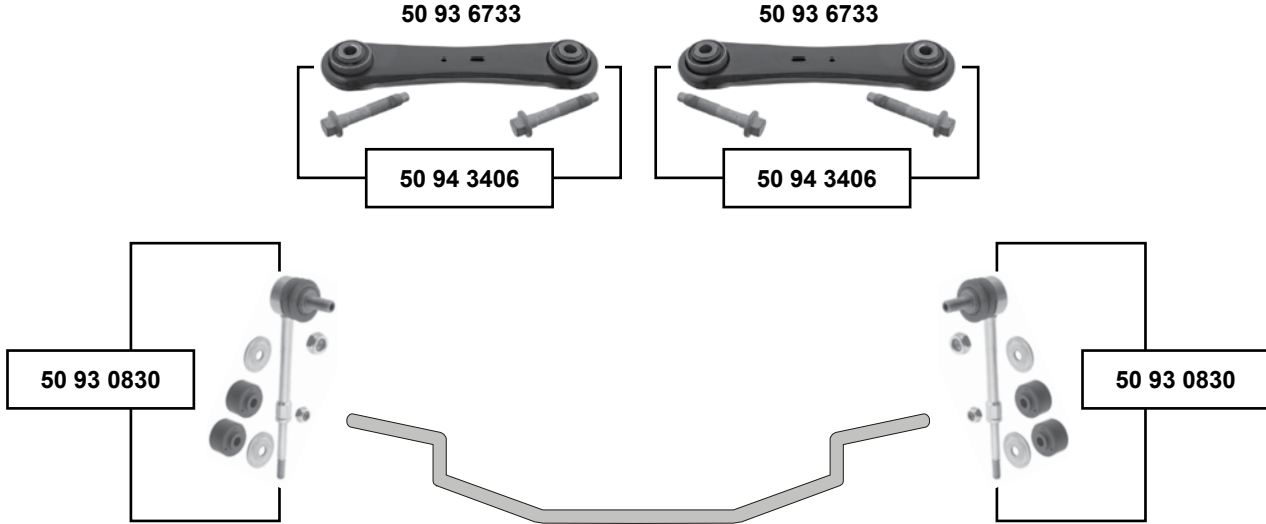

S 90 / V 90
(1997 → 1998)

Starrachse / Rigid axle

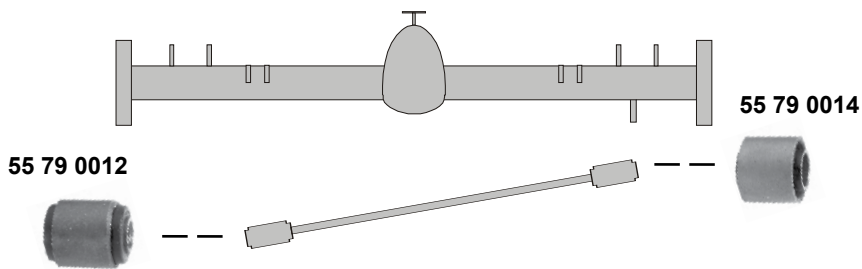

Hinterachse / Rear axle

	Ref. - No.			
50 93 0830	30760678	Verbindungsstange / connecting rod		
50 93 6733	31262930	Hinterachsstrebe / rear axle rod		L 196
50 94 3406	31262930 S1	Querstrebe / cross rod		
55 79 0012	1330973	Gummilager / rubber mount		Ø A 40
55 79 0014	1330427	Gummilager / rubber mount		Ø A 40,5

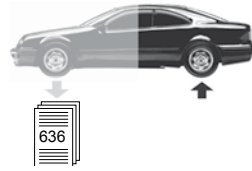

XC 60
(2008 →)

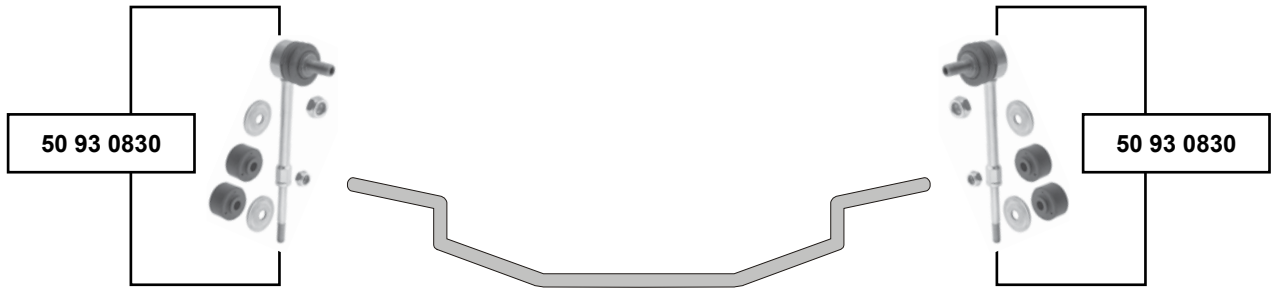

XC 90 I
(2002 → 2014)

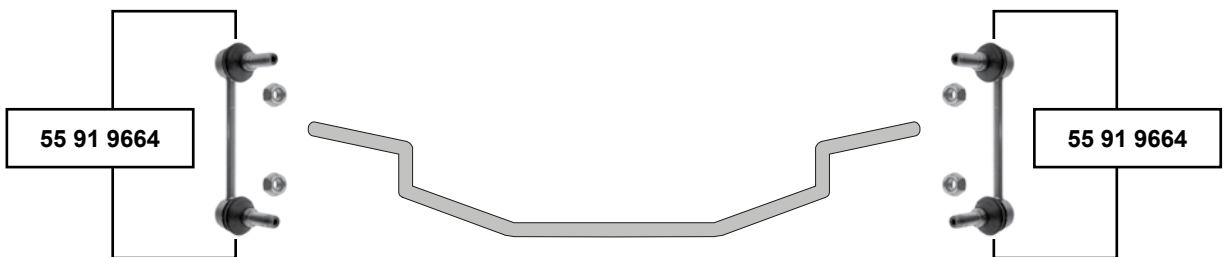

Hinterachse / Rear axle



Ref. - No.

**SWAG**
GERMANY**SWAG**
GERMANY

Ref. - No.

SWAG
GERMANY

Ref. - No.

SWAG
GERMANY

passend für / to fit:

NISSAN

D8521-JD00B	82 93 4614	20, 27
D8521-JG00A	82 93 4614	20, 27
40110-B9500	99 78 0002	5, 23, 25
40110-T3060	99 78 0002	5, 23, 25
40110-T6000	99 78 0002	5, 23, 25
40110-T6025	99 78 0002	5, 23, 25
40110-00QAA	60 93 1847	4
40110-00QAB	60 93 1847	4
40110-01G25	99 78 0002	5, 23, 25
40160-00QAB	60 92 2710	4
40160-00QAC	60 92 2468	4
40160-00QAD	60 92 2468	4
40160-00Q0A	60 93 0653	15
40160-00Q0B	60 93 4164	4
40160-00Q0C	60 92 2265	15
40160-50W00	82 78 0011	5, 23
40160-50W01	82 78 0011	5, 23
40160-50W25	82 78 0011	5, 23
40160-93G25	82 78 0011	5, 23
48203-00QAE	60 92 7128	15
48510-4A00C	84 93 3510	13
48520-AX600	82 93 0528	9
48520-BM400	82 93 2023	2
48520-BM425	82 93 2023	2
48520-0P725	82 92 6536	26
48520-00AQL	60 92 1284	15
48520-00QAH	60 92 1493	4
48520-00QAH S1	60 93 7625	4
48520-00QAJ	60 92 1494	4
48520-00QAJ S1	60 93 7626	4
48520-00QAK	60 92 1283	15
48520-00QAL	60 92 1284	15
48520-00QAM	60 92 7303	15
48520-00QAM SK	60 92 7301	15
48520-00QAM S1	60 93 7627	15
48520-00QAM S2	60 93 7628	15
48520-00QAN	60 91 9605	6, 14
48520-00QAP	60 91 9604	6, 14
48520-00Q0E	60 94 3618	11
48520-00Q0E S1	60 94 3688	11
48520-00Q0F	60 94 3617	11

48520-00Q0F S1	60 94 3687	11
48520-01B25	82 71 0025	8
48520-17B25	82 71 0025	8
48520-31G25	82 71 0012	5, 23, 24
48520-4F125	82 71 0026	8
48520-6F625	82 71 0026	8
48520-7F000	82 71 0012	5, 23, 24
48520-73J25	82 71 0008	2, 16, 17, 18, 19, 20, 21, 26
48520-9C025	82 71 0008	2, 16, 17, 18, 19, 20, 21, 26
48521-D0100	82 72 0001	8
48521-EA000	82 93 3453	10, 12
48521-0W025	82 93 4720	12
48521-00QAA	60 92 2511	6, 14
48521-00QAA SK	60 92 2511	6, 14
48521-00QAF	60 93 2128	4
48521-00QAG	60 92 2517	6, 14
48521-00QAG SK	60 92 2517	6, 14
48521-00Q0B	60 93 2128	4
48521-00Q0B SK	60 93 2128	4
48521-00Q0E SK	60 93 9444	11
48521-35F00	82 72 0001	8
48521-50Y00	82 72 0002	17, 21
48521-70A00	82 72 0001	8
48521-70A06	82 72 0001	8
48521-8H325	82 93 3452	26
48521-8H328	82 93 3452	26
48521-8H385	82 93 3452	26
48521-8H386	82 93 3452	26
48527-JD01A	82 93 4755	20
48527-1U61A	82 93 0530	9
48640-AX600	82 93 0527	9
48647-JD01A	82 93 4756	20
48647-1U61A	82 93 0529	9, 11
54423-00QAA	60 92 4263	4
54450-00QAA	60 92 7181	4
54476-01B00	82 73 0014	8
54500-AX600	82 92 2750	9
54500-BM400	82 92 6278	2
54500-BM410	82 92 6278	2
54500-BN300	82 92 6278	2
54500-F4600	82 92 6278	2



Ref. - No.	SWAG GERMANY	
54500-JD000 S1	82 93 4666	20
54500-0M010	82 73 0013	2
54500-0M020	82 73 0013	2
54500-0M060	82 73 0013	2
54500-00QAC	60 92 6454	4
54500-00QAD	60 92 6454	4
54500-00QAE	60 92 6454	4
54500-00QAH	60 91 0895	6, 14
54500-00QAH S1	60 92 6339	6, 14
54500-00Q0E	60 93 6584	4
54500-2F500	82 73 0007	18
54500-21B00	82 73 0001	8
54500-4F102	82 73 0009	8
54500-4F105	82 73 0009	8
54500-4M400	82 92 6278	2
54500-4M410	82 92 6278	2
54500-4M500	82 92 6278	2
54500-5M000	82 92 6278	2
54500-52Y10	82 73 0011	1, 21
54500-52Y15	82 73 0011	1, 21
54500-52Y60	82 73 0011	1, 21
54500-52Y70	82 73 0011	1, 21
54500-69Y10	82 73 0011	1, 21
54500-86J00	82 73 0003	16
54501-AX600	82 92 2747	9
54501-BC41A	82 92 2747	9
54501-BC42A	82 92 2747	9
54501-BM400	82 92 6277	2
54501-BM410	82 92 6277	2
54501-BN300	82 92 6277	2
54501-F4600	82 92 6277	2
54501-0M010	82 91 7203	2
54501-0M020	82 91 7203	2
54501-0M060	82 91 7203	2
54501-00QAC	60 92 6453	4
54501-00QAD	60 92 6453	4
54501-00QAE	60 92 6453	4
54501-00QAH	60 91 0894	6, 14
54501-00QAH S1	60 78 0006	6, 14
54501-00QAH S2	60 78 0001	6, 14
54501-00Q0E	60 93 6583	4
54501-2F500	82 73 0008	18
54501-21B00	82 73 0002	8

Ref. - No.	SWAG GERMANY	
54501-4F102	82 73 0010	8
54501-4F105	82 73 0010	8
54501-4M400	82 92 6277	2
54501-4M410	82 92 6277	2
54501-4M500	82 92 6277	2
54501-52Y10	82 73 0012	1, 21
54501-52Y15	82 73 0012	1, 21
54501-52Y60	82 73 0012	1, 21
54501-52Y70	82 73 0012	1, 21
54501-69Y10	82 73 0012	1, 21
54501-86J00	82 73 0004	16
54502-00QAA	60 93 9604	15
54502-00QAA SK2	60 92 2825	15
54502-00QAA SK3	60 92 2822	15
54502-00QAB	60 93 9604	15
54502-00QAB SK2	60 92 2825	15
54502-00QAB SK3	60 92 2822	15
54502-00Q0A	60 93 6346	15
54502-00Q0B	60 93 9604	15
54502-00Q0B SK2	60 92 2825	15
54502-00Q0B SK3	60 92 2822	15
54502-00Q0C	60 93 6346	15
54502-00Q0D	60 93 6346	15
54502-00Q0E	60 93 6346	15
54503-00QAA	60 93 9603	15
54503-00QAA SK2	60 92 2825	15
54503-00QAA SK3	60 92 2822	15
54503-00QAB	60 93 9603	15
54503-00QAB SK2	60 92 2825	15
54503-00QAB SK3	60 92 2822	15
54503-00Q0A	60 93 6345	15
54503-00Q0B	60 93 9603	15
54503-00Q0B SK2	60 92 2825	15
54503-00Q0B SK3	60 92 2822	15
54503-00Q0C	60 93 6345	15
54503-00Q0D	60 93 6345	15
54503-00Q0E	60 93 6345	15
54524-AV600	82 92 4418	19
54524-AV601	82 92 4418	19
54524-2F010	82 73 0005	16, 18
54525-AV600	82 92 4417	19
54525-AV601	82 92 4417	19
54525-2F010	82 73 0006	16, 18

Ref. - No.

**SWAG**
GERMANY**SWAG**
GERMANY

Ref. - No.

SWAG
GERMANY

Ref. - No.

SWAG
GERMANY

54535-01B00	82 73 0015	8
54560-AX600	60 92 2865	9
54560-00QAB	60 60 0018	6, 14
54570-AX600	82 92 2867	9
54570-00QAA	40 92 4262	4
54613-JD04A	82 93 4067	20
54613-JD17A	82 93 4068	20
54616-00QAA	60 61 0001	6, 14
54616-00QAC	60 92 1044	15
54616-4A00B	84 93 3760	13
54618-AU000	82 92 1815	19
54618-AX600	82 92 1810	9
54618-CA010	82 93 4715	638, 641
54618-D5000	82 79 0001	2, 16, 17, 21
54618-D5010	82 79 0001	2, 16, 17, 21
54618-EA010	82 93 4121	10, 12
54618-JD00A	82 93 0986	10, 20, 22, 27
54618-0E000	82 93 1166	7
54618-0F000	82 92 3171	24
54618-0W000	82 93 2888	12
54618-0W001	82 93 2888	12
54618-00QAA	60 91 9866	4
54618-00QAB	60 91 9867	4
54618-1AA0A	82 93 0986	10, 20, 22, 27
54618-2F010	82 92 3724	16, 18
54618-2Y000	82 92 1812	7
54618-3W400	82 93 2888	12
54618-4M400	82 92 1808	2
54618-4U000	82 92 7464	3
54618-50Y00	82 79 0001	2, 16, 17, 21
54618-8H300	82 92 7360	26
54618-86J00	82 92 3724	16, 18
54618-86J25	82 92 3724	16, 18
54618-9C000	82 92 3516	20, 26
54618-9C002	82 92 3515	20, 26
54618-90J11	82 92 3724	16, 18
54619-00Q0A	60 92 1044	15
54668-AU000	82 92 1813	19
54668-CA010	82 93 4714	638, 641
54668-EA010	82 93 4120	10, 12
54668-JD00A	82 93 0985	10, 20, 22, 27
54668-1AA0A	82 93 0985	10, 20, 22, 27
54668-2Y000	82 92 1811	7

54668-4U000	82 92 7463	3
54668-8H300	82 92 7359	26
54668-9C000	82 92 3516	20, 26
55618-JD00A	82 93 2573	641, 642
55619-JD00A	82 93 2574	641, 642
56260-VB010	82 92 7462	640
56260-0F001	82 92 4016	642
56260-0W001	82 93 1139	639
56260-01J10	82 79 0002	13, 640
56261-AV610	82 93 2567	640
56261-AV611	82 93 2567	640
56261-AW000	82 93 2567	640
56261-EA500	82 93 4717	640
56261-EA510	82 93 4716	640
56261-EQ000	82 92 7305	642
56261-00Q0C	40 94 4428	639
56261-1AA0A	82 93 4562	638, 641
56261-1AA0B	82 93 4561	638, 641
56261-4F702	82 91 5425	638
56261-4F725	82 91 5425	638
56261-50J00	82 79 0004	640
56261-86J00	82 79 0004	640
56261-86J25	82 79 0004	640
56261-90J01	82 79 0004	640
-	60 61 0003	14
-	60 92 1171	14
-	60 61 0005	14
-	60 92 2514	14
-	60 92 2513	14
-	60 92 2531	14
-	60 61 0006	14
-	60 92 2763	14

passend für / to fit:

OPEL

0310 821	40 78 0009	56
0310 823	40 92 6125	56, 57
0322 002	40 72 0012	74
0322 003	40 72 0011	74
0322 078	40 74 0001	49
0322 079	40 72 0009	35, 45, 82, 84
0322 079 S1	57 72 0006	35, 45, 82, 84
0322 080	40 72 0008	35, 45, 82, 84
0322 125	40 72 0007	33, 61



Ref. - No.	SWAG GERMANY	
0322 126	40 72 0006	33, 61
0322 136	40 72 0002	72, 77
0322 140	40 72 0003	72, 77
0322 142	40 72 0004	72, 77
0322 143	40 72 0005	72, 77
0322 145	40 72 0002	72, 77
0322 146	40 72 0008	35, 45, 82, 84
0322 146 S1	57 72 0005	35, 45, 82, 84
0322 147	40 72 0009	35, 45, 82, 84
0322 147 S1	57 72 0006	35, 45, 82, 84
0322 148	40 72 0003	72, 77
0322 149	40 74 0001	49
0322 150	40 71 0004	72, 77
0322 151	40 71 0003	72, 74, 77
0322 152	40 71 0005	72, 77
0322 154	40 71 0002	72, 74, 77
0322 155	40 74 0003	50, 51, 79, 80
0322 158	40 74 0005	50, 51, 79, 80
0322 159	40 72 0012	74
0322 160	40 72 0011	74
0322 166	40 72 0010	74
0322 168	40 72 0011	74
0322 169	40 72 0012	74
0322 171	40 71 0003	72, 74, 77
0322 172	40 71 0002	72, 74, 77
0322 173	40 72 0004	72, 77
0322 174	40 72 0005	72, 77
0322 175	40 71 0004	72, 77
0322 176	40 71 0005	72, 77
0322 177	40 71 0003	72, 74, 77
0322 178	40 71 0002	72, 74, 77
0322 179	40 71 0010	74
0322 180	40 71 0011	74
0322 194	40 72 0012	74
0322 575	40 76 0001	33, 59, 60, 61
0322 576	40 76 0002	35, 45, 82, 84
0322 577	40 76 0002	35, 45, 82, 84
0324 038	40 71 0006	33, 61
0324 039	40 71 0007	33, 61
0324 042	40 71 0001	49, 50, 53, 79, 81
0324 044	40 71 0018	48, 71, 75, 76
0324 045	40 71 0017	48, 71, 75, 76
0324 050	40 71 0001	49, 50, 53, 79, 81

Ref. - No.	SWAG GERMANY	
0324 053	40 71 0008	35, 45, 82, 84
0324 054	40 71 0009	35, 45, 82, 84
0324 055	40 71 0008	35, 45, 82, 84
0324 056	40 71 0009	35, 45, 82, 84
0324 057	40 71 0016	56, 67
0324 058	40 71 0015	56, 67
0324 059	40 71 0010	74
0324 060	40 71 0011	74
0324 061	40 71 0003	72, 74, 77
0324 062	40 71 0002	72, 74, 77
0324 063	40 71 0014	86
0324 066	40 71 0024	51, 80
0324 117	40 71 0018	48, 71, 75, 76
0324 118	40 71 0017	48, 71, 75, 76
0324 155	40 71 0011	74
0324 186 SK	40 74 0002	86
0350 078	40 61 0012	36, 37, 46, 83, 85
0350 086	40 93 0624	86
0350 087	40 94 4325	91
0350 093	40 94 4325	91
0350 104	40 93 7253	53
0350 112	40 61 0014	62
0350 113	40 61 0013	62
0350 116	40 61 0011	73, 77
0350 123	40 61 0012	36, 37, 46, 83, 85
0350 127	40 61 0015	50, 51, 79, 80
0350 130	40 61 0016	39, 53, 81, 86
0350 138	40 61 0017	39, 81
0350 143	40 94 0487	47, 53
0350 145	40 93 6543	78, 87
0350 147	40 92 1124	74
0350 153	40 61 0008	34, 36, 37, 46, 48, 59, 60, 62, 63, 71, 75, 76, 83, 85
0350 160	40 93 6543	78, 87
0350 161	40 93 0623	41, 47, 53, 64
0350 175	70 92 7414	54
0350 176	40 93 8939	39, 41, 65, 91, 93
0350 181	70 93 8586	28, 54
0350 198	70 93 3811	48
0350 207	70 93 8586	28, 54
0350 231	40 94 0889	66
0350 232	40 94 0890	66

Ref. - No.

**SWAG**
GERMANY**SWAG**
GERMANY

Ref. - No.

SWAG
GERMANY

Ref. - No.

SWAG
GERMANY

0350 233	40 94 5219	28, 55
0350 260	40 61 0009	36, 37, 46, 83, 85
0350 260 S1	40 61 0001	36, 37, 46, 83, 85
0350 261	40 61 0010	36, 37, 83, 85
0350 261 S1	40 61 0002	36, 37, 46, 83, 85
0350 263	40 79 0002	36, 37, 46, 83, 85
0350 263 S1	40 61 0003	36, 37, 46, 83, 85
0350 390	40 93 8052	41, 65, 78, 87, 93
0350 391	40 93 8051	41, 65, 78, 87, 93
0350 600	40 79 0003	73, 74, 77
0350 602	40 79 0013	48, 71, 75, 76
0350 603	40 92 2379	78, 87
0350 607	40 92 3688	56, 57
0350 608	40 92 3687	56, 57
0350 609	40 79 0003	73, 74, 77
0350 610	40 79 0004	47, 53, 64, 81, 86
0350 611	40 79 0019	39, 41, 91, 93
0350 611	40 93 8939	39, 41, 65, 91, 93
0350 612	40 93 3776	78, 87
0350 613	40 93 0827	41, 93
0350 614	40 79 0019	39, 41, 91, 93
0350 614	40 93 8939	39, 41, 65, 91, 93
0350 615	40 92 2379	78, 87
0350 616	70 92 7414	54
0350 617	40 93 4959	44, 58, 94
0350 618	40 93 1561	44, 58, 94
0350 621	40 93 7854	32, 44, 58
0350 622	40 93 7855	44, 58
0352 002	40 73 0007	50, 79
0352 003	40 73 0008	50, 79
0352 028	40 73 0065	74
0352 028 S1	40 93 4217	74
0352 029	40 73 0064	74
0352 029 S1	40 93 4218	74
0352 030	40 73 0015	86
0352 030 S1	40 93 8274	86
0352 041	40 73 0022	53
0352 041 S1	40 93 4221	53
0352 042	40 73 0021	53
0352 042 S1	40 93 4222	53
0352 043	40 73 0001	49
0352 044	40 73 0002	49
0352 050	40 93 9351	58

0352 051	40 92 3001	78, 87
0352 051 S1	40 93 4231	78, 87
0352 052	40 92 3002	78, 87
0352 052 S1	40 93 4228	78, 87
0352 061	40 73 0022	53
0352 061 S1	40 93 4221	53
0352 063	40 73 0021	53
0352 063 S1	40 93 4222	53
0352 067	40 92 8420	28, 54, 55
0352 071	40 93 9352	58
0352 076	40 73 0003	36, 46, 83, 85
0352 076 S1	40 93 4209	36, 85
0352 077	40 73 0004	36, 46, 83, 85
0352 077 S1	40 93 4208	36, 85
0352 080	40 93 9352	58
0352 085	40 92 2084	64
0352 086	40 92 2083	64
0352 087	40 92 8420	28, 54, 55
0352 110	40 94 3719	32, 44
0352 115	40 94 3720	32, 44
0352 123	40 73 0006	62
0352 124	40 73 0005	62
0352 132	40 73 0009	73, 77
0352 134	40 73 0014	73, 77
0352 135	40 73 0009	73, 77
0352 136	40 73 0014	73, 77
0352 144	40 73 0018	37, 46, 83, 85
0352 144 S1	40 93 4207	37, 85
0352 147	40 73 0006	62
0352 148	40 73 0005	62
0352 169	40 73 0006	62
0352 172	40 73 0005	62
0352 181	40 73 0008	50, 79
0352 182	40 73 0007	50, 79
0352 192	40 73 0003	36, 46, 83, 85
0352 192 S1	40 93 4209	36, 85
0352 193	40 73 0004	36, 46, 83, 85
0352 193 S1	40 93 4208	36, 85
0352 196	40 73 0065	74
0352 196 S1	40 93 4217	74
0352 197	40 73 0064	74
0352 197 S1	40 93 4218	74
0352 300	40 60 0006	36, 37, 46, 83, 85

Ref. - No.	SWAG GERMANY	
0352 301	40 60 0001	50, 51, 79, 80
0352 302	40 60 0014	74
0352 303	40 60 0009	74
0352 309	40 69 0002	47, 53, 64
0352 310	40 69 0001	47, 53, 64, 81
0352 319	40 92 3003	78, 87
0352 320	40 69 0001	47, 53, 64, 81
0352 324	40 92 3762	41, 65, 91, 93
0352 327	40 60 0002	49
0352 330	40 60 0016	62
0352 334	40 60 0015	60, 62
0352 335	40 60 0013	60, 62
0352 338	40 60 0010	62
0352 341	40 60 0005	73, 77
0352 342	40 60 0008	73, 77
0352 343	40 60 0008	73, 77
0352 346	40 60 0006	36, 37, 46, 83, 85
0352 347	40 60 0004	36, 46, 83, 85
0352 348	40 60 0004	36, 46, 83, 85
0352 348 S1	40 92 8100	36, 46, 83, 85
0352 349	40 60 0015	60, 62
0352 351	40 60 0006	36, 37, 46, 83, 85
0352 352	40 60 0023	36, 46, 85
0352 352 S1	40 92 8101	36, 46, 85
0352 355	40 60 0008	73, 77
0352 356	40 60 0003	37, 46, 83, 85
0352 356 S1	40 92 7999	37, 46, 83, 85
0352 357	40 60 0017	86
0352 358	40 60 0011	86
0352 364	40 60 0018	39, 41, 65, 91, 93
0352 365	40 60 0012	39, 91
0352 366	40 69 0002	47, 53, 64
0352 366	40 92 3129	53, 64, 81
0352 377	40 69 0002	47, 53, 64
0352 377	40 92 3129	53, 64, 81
0352 378	40 69 0002	47, 53, 64
0352 380	40 92 8475	28, 54, 55
0352 457	40 60 0009	74
0352 458	40 60 0014	74
0352 491	40 94 3718	32, 44
0352 492	40 94 3719	32, 44
0352 493	40 94 3720	32, 44
0352 494	40 94 3718	32, 44

Ref. - No.	SWAG GERMANY	
0352 519	40 93 6595	58
0352 520	40 93 9351	58
0352 521	40 93 9352	58
0352 800	40 78 0007	39, 41, 65, 74, 86, 91, 93
0352 803	40 91 9541	53, 81
0352 826	40 78 0004	73, 77
0352 827	40 78 0005	73, 77
0352 828	40 78 0008	56, 57, 67
0352 829	40 78 0007	39, 41, 65, 74, 86, 91, 93
0352 864	40 92 9280	28, 54, 55
0352 866	40 93 9362	44, 58
0352 868	40 93 6595	58
0352 869	40 93 9351	58
0352 870	40 93 9352	58
0352 872	40 93 9352	58
0352 947	40 92 8475	28, 54, 55
0353 280	40 91 9102	50, 79
0353 281	40 91 9101	50, 79
0353 460	40 60 0024	36, 37, 46, 83, 85
0353 560	40 60 0019	49
0353 561	40 60 0021	50, 79
0423 002	40 93 4940	648, 651
0423 002 S1	40 93 6112	648, 651
0423 008	40 92 7097	648, 651
0423 008 S1	40 93 4213	648, 651
0423 032	40 93 4940	648, 651
0423 032 S1	40 93 6112	648, 651
0423 033	40 92 7097	648, 651
0423 033 S1	40 93 4213	648, 651
0423 035	40 92 7097	648, 651
0423 035 S1	40 93 4213	648, 651
0423 121	40 79 0018	650
0423 302	40 69 0005	650
0423 313	40 79 0012	644, 645, 646, 647, 649
0423 315	40 79 0011	645, 646, 647
0423 316	40 79 0010	650
0423 318	40 69 0005	650
0423 319	40 93 0625	648, 651
0423 320	40 92 4221	648, 651
0444 091	40 93 9089	644

Ref. - No.

SWAG
GERMANY

SWAG[®]
GERMANY

Ref. - No.

SWAG
GERMANY

0444 153	40 79 0014	644, 645, 646, 647, 649, 650
0444 160	40 93 1066	648, 651
0444 161	40 93 1067	648, 651
0444 162	40 93 1068	648, 651
0444 163	40 94 0484	651
0444 199	40 79 0014	644, 645, 646, 647, 649, 650
0444 200	40 92 4753	650
0444 275	40 92 7775	648, 651
0444 291	40 93 4296	650
0444 325	40 79 0020	644, 645, 646, 647, 649
0444 336	40 79 0020	644, 645, 646, 647, 649
0444 347	40 79 0021	644, 646
0900 905	40 94 3358	57
0902 010	30 93 9606	43
0902 825	40 80 0004	33, 59, 60, 61, 82, 84
0902 825 S1	40 80 0002	33, 59, 60, 61, 82, 84
0902 826	40 80 0001	49
0902 828	40 80 0004	33, 59, 60, 61, 82, 84
0902 828 S1	40 80 0002	33, 59, 60, 61, 82, 84
0920 005	40 94 3577	43
0920 005 S1	40 94 4338	43
0920 005 S2	40 94 4339	43
0920 005 S3	40 94 4340	43
0920 007	40 94 4446	43
0920 007 S1	40 94 4447	43
0920 352	40 92 2099	72, 74
0920 355	40 92 2099	72, 74
0920 367	99 90 9158	71, 72, 75, 76
0920 368	40 92 2099	72, 74
0920 373	40 71 0016	56, 67
0920 374	40 71 0015	56, 67
1603 003	40 93 0573	39, 91
1603 008	40 91 9545	53
1603 009	40 71 0001	49, 50, 53, 79, 81
1603 016 SK	40 92 3228	64

Ref. - No.

SWAG
GERMANY

1603 017	40 92 8477	53
1603 120	40 78 0002	60, 62
1603 121	40 78 0006	34, 36, 37, 46, 83, 85
1603 128	40 78 0003	49, 50, 79
1603 147	40 61 0007	48, 71, 75, 76
1603 148	40 61 0004	60, 62
1603 149	40 61 0005	34
1603 161	40 78 0003	49, 50, 79
1603 163	40 78 0006	34, 36, 37, 46, 83, 85
1603 164	40 78 0002	60, 62
1603 167	40 78 0006	34, 36, 37, 46, 83, 85
1603 187	40 78 0003	49, 50, 79
1603 198 S1	40 74 0002	86
1603 199 SK	40 74 0004	86
1603 202	40 78 0021	51, 80
1603 206 SK	40 74 0002	86
1603 213	40 72 0023	39, 41, 91
1603 213 S1	40 94 3727	41, 93
1603 213 S6	40 94 3780	39, 91
1603 214	40 71 0025	39, 91
1603 215	40 71 0025	39, 91
1603 216	40 72 0023	39, 41, 91
1603 216 S1	40 94 3727	41, 93
1603 216 S6	40 94 3780	39, 91
1603 227	40 92 6152	78, 87
1603 228	40 92 6153	78, 87
1603 229	40 92 6432	87
1603 239	40 92 8312	64
1603 240	40 92 3154	64
1603 244	40 92 9238	78, 87
1603 252 SK	40 93 0587	78, 87
1603 256	40 72 0023	39, 41, 91
1603 256 S1	40 94 3727	41, 93
1603 256 S6	40 94 3780	39, 91
1603 257	40 92 9325	41, 93
1603 258	40 92 9324	41, 93
1603 264 SK	40 92 7807	41
1603 265 SK	40 92 8371	41, 93
1603 266	40 92 6635	41, 93
1603 267	40 92 6636	41, 93



Ref. - No.



1603 268	40 92 9233	41, 93
1603 286 SK	40 71 0014	86
1603 287	40 93 4298	93
1603 288	40 92 9325	41, 93
1603 289	40 92 9324	41, 93
1603 290 SK	40 93 0587	78, 87
1603 302 SK	40 72 0023	39, 41, 91
1603 302 SK2	40 94 3727	41, 93
1603 302 SK7	40 94 3780	39, 91
1603 303	40 93 4298	93
1603 357 SK	40 92 7807	41
1603 358 SK	40 92 8371	41, 93
1603 359 SK	40 92 9233	41, 93
1603 384	40 92 9238	78, 87
1603 415 SK	40 92 6432	87
1603 416 SK	40 92 9238	78, 87
1603 417 SK	40 93 0587	78, 87
1603 428	40 92 8312	64
1603 429 SK	40 92 3228	64
1603 430	40 92 3154	64
1603 453 SK	40 74 0003	50, 51, 79, 80
1603 455	40 71 0024	51, 80
1603 542	40 71 0025	39, 91
1603 543	40 92 8359	54
1603 544	70 92 8618	54
1603 545	70 92 8619	54
1603 642 SK	40 93 4298	93
1603 643	40 72 0023	39, 41, 91
1603 643 SK	40 72 0023	39, 41, 91
1603 643 SK2	40 94 3727	41, 93
1603 643 SK7	40 94 3780	39, 91
1603 643 S1	40 94 3727	41, 93
1603 643 S6	40 94 3780	39, 91
1603 644 SK	40 93 0573	39, 91
1603 645	40 71 0001	49, 50, 53, 79, 81
1603 844	40 92 8477	53
1603 845	40 91 9545	53
1609 011	40 94 6226	65
1609 011 SK1	40 94 6226	65
1609 012	40 93 4320	65
1609 013	40 93 4319	65
1609 028	40 94 5096	43, 47, 58, 94
1609 028 SK1	40 94 5095	43, 47, 58, 94

Ref. - No.



1609 045 SK	40 80 0006	33, 45, 61, 82, 84
1609 053	40 93 0587	78, 87
1609 073 SK	40 80 0006	33, 45, 61, 82, 84
1609 073 S1	40 80 0005	33, 45, 61, 82, 84
1609 137	40 94 4245	43
1609 164	40 94 4246	43
1609 169	40 94 4424	43
1609 169 S1	40 94 4434	43
1609 181	40 94 3794	58
1609 182	40 94 5096	43, 47, 58, 94
1609 182 SK1	40 94 5095	43, 47, 58, 94
1609 183	40 94 3792	58
1609 185	40 94 4245	43
1609 186	40 94 4246	43
1609 187	40 94 4156	43, 47
1609 187 S1	40 94 4249	43
1609 187 S2	40 94 4250	43
1609 213	40 94 4888	66
1609 356	40 94 3552	39, 41, 65, 91, 93
1609 357	40 94 0915	58
350 176	40 79 0019	39, 41, 91, 93
4401 852	60 92 6453	69
4401 853	60 92 6454	69
4401 909	60 92 2468	69
4401 940	60 92 6453	69
4401 941	60 92 6454	69
4403 641	60 78 0020	32
4403 661	60 71 0017	32
4404 047	60 92 6453	69
4404 048	60 92 6454	69
4408 474	60 92 7303	89
4408 474 SK	60 92 7301	89
4408 474 S1	60 93 7627	69
4408 474 S2	60 93 7628	69
4408 476	60 92 7128	89
4408 510	60 92 1283	89
4408 511	60 92 1284	89
4408 904	60 92 1044	89
4408 958	60 93 9603	89
4408 958 SK	60 92 2265	89
4408 958 SK2	60 92 2825	89
4408 958 SK3	60 92 2822	89
4408 959	60 93 9604	89

Ref. - No.

**SWAG**
GERMANY**SWAG**
GERMANY

Ref. - No.

SWAG
GERMANY

Ref. - No.

SWAG
GERMANY

4408 959 SK	60 92 2265	89
4408 959 SK2	60 92 2825	89
4408 959 SK3	60 92 2822	89
4412 934	60 93 9603	89
4412 934 SK2	60 92 2825	89
4412 934 S3	60 92 2822	89
4412 936	60 93 9604	89
4412 936 SK2	60 92 2825	89
4412 936 S3	60 92 2822	89
4417 177	60 93 6345	89
4417 178	60 93 6346	89
4417 973	60 92 1044	89
4418 192	60 91 9867	69
4418 193	60 91 9866	69
4418 212	60 92 6453	69
4418 213	60 92 6454	69
4418 223	60 93 9603	89
4418 223 SK2	60 92 2825	89
4418 223 SK3	60 92 2822	89
4418 224	60 93 9604	89
4418 224 SK2	60 92 2825	89
4418 224 SK3	60 92 2822	89
4418 225	60 93 6345	89
4418 226	60 93 6346	89
4418 629	60 92 6453	69
4418 629	60 93 6583	69
4418 630	60 93 6584	69
4418 630	60 92 6454	69
4418 780 SK	60 93 2128	69
4419 075	60 92 2265	89
4419 219	60 94 2634	70
4419 291	60 93 7309	70
4419 304 S1	60 93 7312	645
4419 308	60 94 4539	645
4419 323	60 94 4728	70
4420 096 SK	60 93 9444	70
4420 096 SK1	60 94 3687	70
4420 096 SK2	60 94 3688	70
4420 097	60 94 3617	70
4420 097 S1	60 94 3687	70
4420 098	60 94 3618	70
4420 098 S1	60 94 3688	70
4420 954	40 94 4428	70

4421 646	60 93 6346	89
4421 647	60 93 6345	89
4431 869	60 93 0653	89
4500 091	60 92 7181	69
4500 092	60 92 6453	69
4500 093	60 92 6454	69
4500 094	40 92 4262	69
4500 095	60 92 4263	69
4500 198	60 91 9867	69
4500 199	60 91 9866	69
4500 254	60 92 2710	69
4500 255	60 92 2468	69
4501 261 SK	60 93 2128	69
4501 261 S1	60 93 7625	69
4501 261 S2	60 93 7626	69
4501 262	60 92 1493	69
4501 263	60 92 1494	69
4701 744	84 94 2318	29
4701 745	84 92 8058	29
4703 866	89 92 8712	29
4705 172	40 91 9501	29
4705 409	84 93 2470	29
4705 655	84 94 2318	29
4705 716	84 94 2318	29
4705 742	40 93 2090	29
4706 664	89 92 8712	29
4706 665	40 93 2090	29
4707 280	40 93 2090	29
4708 299	84 93 2141	30
4708 299 S1	84 92 9826	30
4708 299 S2	84 92 9827	30
4708 300	84 93 2140	30
4708 300 S1	84 92 9826	30
4708 300 S2	84 92 9827	30
4709 161	84 92 8056	30
4709 195	84 92 9830	30
4709 702	84 92 8000	30
4801 837	40 94 3532	643
4803 429	13 94 1929	31
4804 642	13 93 1708	643
4806 300 SK	89 92 8347	31
4806 301	13 94 1741	31
4806 301 SK	89 92 8347	31



Ref. - No.



4806 304	89 92 8671	31
4806 305	89 92 8672	31
4808 136	40 94 3532	643
4810 831	13 94 1740	31
4810 831 SK	89 92 8347	31
4812 870	13 94 1741	31
4812 870 SK	89 92 8347	31
4817 539	13 93 1708	643
4817 776	13 94 1529	31
4817 777	13 94 1740	31
4817 777 SK	89 92 8347	31
4817 778	13 94 1741	31
4817 778 SK	89 92 8347	31
4817 869	13 94 1529	31
5352 000	40 73 0018	37, 46, 83, 85
5352 000 S1	40 93 4207	37, 85
5352 001	40 73 0019	37, 46, 83, 85
5352 001 S1	40 93 4206	37, 85
5352 004	40 73 0015	86
5352 004 S1	40 93 8274	86
5352 005	40 73 0010	86
5352 005 S1	40 93 8273	86
5352 007	40 73 0064	74
5352 007 S1	40 93 4218	74
5352 008	40 73 0065	74
5352 008 S1	40 93 4217	74
5352 011	40 73 0013	51, 80
5352 012	40 73 0017	51, 80
5352 014	40 73 0006	62
5352 016	40 73 0012	39, 91
5352 016 S1	40 93 4226	39, 90, 91
5352 017	40 73 0016	38, 39, 91
5352 017 S1	40 93 4227	39, 90, 91
5352 019	40 92 3688	56, 57
5352 020	40 92 3687	56, 57
5352 025	40 92 2084	64
5352 026	40 92 2083	64
5352 027	40 92 3797	64
5352 027 S1	40 93 4223	64
5352 028	40 92 3798	64
5352 028 S1	40 93 4224	64
5352 029	40 92 7073	41, 65, 91, 93
5352 029 S1	40 93 4232	41, 65, 90, 91, 93

Ref. - No.



5352 030	40 92 7074	41, 65, 91, 93
5352 030 S1	40 93 4233	41, 65, 90, 91, 93
5352 038	40 92 8649	28, 54
5352 039	40 92 8648	28, 54
6606 030 SK	40 93 3131	58

passend für / to fit:

PEUGEOT

0591.10	62 92 7438	97
13057 82080	70 61 0011	133, 145
1414.80	81 93 0034	97
1415.80	81 93 0035	97
14 401 772 80	62 93 8735	146
16 070 184 80	62 93 3964	125, 129
16 071 423 80	62 94 0485	129
16 071 423 80 SK	62 94 0485	129
16 075 024 80	80 94 1337	139
16 075 106 80	62 93 7350	134
16 075 107 80	62 93 7349	134
16 080 251 80	62 94 4186	109, 136
16 080 252 80	62 94 4185	109, 136
16 080 253 80	62 94 0070	109, 136
16 086 520 80	62 93 8740	107, 110
16 099 106 80	62 93 6286	138, 139
16 099 482 80	62 94 3548	129
16 099 483 80	62 94 3547	129
16 109 762 80	62 93 9227	144
3332.07	62 79 0009	654
3520.A6	62 73 0019	121, 122
3520.A7	62 73 0019	121, 122
3520.A8	62 73 0026	113, 148, 149, 153
3520.A9	62 73 0026	113, 148, 149, 153
3520.C0	62 73 0021	123
3520.C5	70 73 0043	133, 145
3520.C6	62 73 0026	113, 148, 149, 153
3520.C7	62 73 0026	113, 148, 149, 153
3520.E0	62 73 0026	113, 148, 149, 153
3520.E1	62 73 0026	113, 148, 149, 153
3520.E4	62 73 0026	113, 148, 149, 153
3520.E6	62 73 0026	113, 148, 149, 153
3520.E7	62 73 0026	113, 148, 149, 153
3520.E8	62 73 0026	113, 148, 149, 153
3520.E9	62 73 0026	113, 148, 149, 153
3520.F1	62 73 0026	113, 148, 149, 153

Ref. - No.



Ref. - No.



Ref. - No.



3520.F2	62 73 0026	113, 148, 149, 153
3520.F3	62 73 0026	113, 148, 149, 153
3520.F5	62 73 0026	113, 148, 149, 153
3520.F6	62 73 0026	113, 148, 149, 153
3520.F7	62 73 0026	113, 148, 149, 153
3520.F8	62 73 0026	113, 148, 149, 153
3520.G8	62 73 0025	101, 103
3520.G8	62 94 0751	101, 103
3520.G8 S1	62 94 0751	101, 103
3520.G9	70 73 0043	133, 145
3520.G9 S	62 92 2102	133, 145
3520.G9 S1	62 92 2100	133, 145
3520.G9 S2	62 92 2102	133, 145
3520.H1	62 73 0021	123
3520.H3	62 73 0026	113, 148, 149, 153
3520.H3 S2	62 92 8125	113, 148, 149
3520.H4 S2	62 92 8125	113, 148, 149
3520.H5	62 73 0026	113, 148, 149, 153
3520.H5 S1	62 91 9009	113, 148, 149
3520.H5 S2	62 92 8125	113, 148, 149
3520.H7	62 94 0781	101, 103, 105
3520.H7	62 92 9424	101, 103, 105
3520.H9	62 73 0032	151, 153
3520.J3	62 73 0032	151, 153
3520.J4	62 73 0032	151, 153
3520.K4	62 73 0019	121, 122
3520.K8	62 92 2385	115, 154
3520.K8	62 94 0841	115, 154
3520.K8 S1	62 94 0841	115, 154
3520.L0	70 73 0042	143
3520.L3	64 94 4621	135
3520.L3	64 93 8700	135
3520.L3 S3	64 94 4621	135
3520.L4	64 94 4621	135
3520.L4	64 93 8700	135
3520.L4 S3	64 94 4621	135
3520.L7	62 92 9422	101, 103, 105, 106
3520.L7	62 94 0791	101, 103, 105, 106
3520.L8	62 92 9426	101, 103, 105
3520.L8	62 94 0771	101, 103, 105
3520.L9	64 94 4621	135
3520.L9	64 93 8700	135
3520.L9 S3	64 94 4621	135

3520.N1	64 93 8700	135
3520.N1	64 94 4621	135
3520.N1 S3	64 94 4621	135
3520.N3	70 73 0042	143
3520.N5	62 94 0841	115, 154
3520.N5 S1	62 94 0841	115, 154
3520.N6	62 93 6902	124, 125, 129
3520.N6 SK	62 93 2116	125, 129
3520.N9	70 73 0043	133, 145
3520.P1	64 94 4621	135
3520.P1	64 93 8700	135
3520.P2	62 94 0781	101, 103, 105
3520.P2	62 92 9424	101, 103, 105
3520.P4	70 73 0043	133, 145
3520.P6	62 92 6645	134
3520.P8	70 73 0043	133, 145
3520.P9	64 93 8700	135
3520.P9	64 94 4621	135
3520.P9 S3	64 94 4621	135
3520.Q0	64 93 8700	135
3520.Q2	81 93 1718	97
3520.Q2 S1	81 92 2911	97
3520.Q2 S2	81 93 0034	97
3520.Q2 S3	81 93 0035	97
3520.Q2 S4	81 93 0036	97
3520.Q3	62 73 0032	151, 153
3520.Q5	62 73 0032	151, 153
3520.Q9	62 92 9142	107, 109
3520.Q9	64 94 4621	135
3520.Q9 S3	64 94 4621	135
3520.R0	64 94 4621	135
3520.R0	64 93 8700	135
3520.R0 S3	64 94 4621	135
3520.R1	64 93 8700	135
3520.R1	64 94 4621	135
3520.R1 S3	64 94 4621	135
3520.R2	64 93 8700	135
3520.R2	64 94 4621	135
3520.R2 S3	64 94 4621	135
3520.R3	64 93 8700	135
3520.R3	64 94 4621	135
3520.R3 S3	64 94 4621	135
3520.R4	64 93 8700	135



Ref. - No.	SWAG GERMANY	
3520.R4	64 94 4621	135
3520.R4 S3	64 94 4621	135
3520.R5	64 93 8700	135
3520.R5	64 94 4621	135
3520.R5 S3	64 94 4621	135
3520.R6	64 93 8700	135
3520.R6	64 94 4621	135
3520.R7	62 92 9142	107, 109
3520.R7 S1	62 92 8731	107, 109
3520.R7 S2	62 92 8732	107, 109
3520.R8	62 93 7690	134, 146
3520.S0	62 93 1297	144
3520.S0 S1	70 93 1092	144
3520.S0 S2	70 93 1091	144
3520.S1	62 93 1297	144
3520.S1 S1	70 93 1092	144
3520.S1 S2	70 93 1091	144
3520.S2	62 94 0841	115, 154
3520.S2	62 92 2385	115, 154
3520.S2 S1	62 94 0841	115, 154
3520.S3	62 92 9426	101, 103, 105
3520.S3 S1	62 94 0771	101, 103, 105
3520.S4	62 94 0751	101, 103
3520.S4	62 73 0025	101, 103
3520.S4 S1	62 94 0751	101, 103
3520.S5	62 93 7350	134
3520.T0	62 94 0841	115, 154
3520.T0	62 92 2385	115, 154
3520.T0 S1	62 94 0841	115, 154
3520.V0	62 93 8170	138, 139
3520.V1	64 93 8700	135
3520.V1	64 94 4621	135
3520.V1 S2	64 93 8700	135
3520.V1 S3	64 94 4621	135
3520.V2	62 93 7840	117, 137, 141
3520.V3	62 73 0032	151, 153
3520.V6	62 92 9424	101, 103, 105
3520.V6 S1	62 94 0781	101, 103, 105
3520.V7	62 92 9426	101, 103, 105
3520.V7 S1	62 94 0771	101, 103, 105
3520.V8	62 93 7690	134, 146
3520.W0	62 92 9422	101, 103, 105, 106
3520.W0 S1	62 94 0791	101, 103, 105, 106

Ref. - No.	SWAG GERMANY	
3520.W3	70 92 9144	142
3520.W4	62 93 7350	134
3520.X0	62 93 7350	134
3520.X9	62 93 8170	138, 139
3520.Y0	62 94 3600	129
3520.Y0	62 94 3580	129
3520.Y0 SK	62 94 3580	129
3520.Y4	70 92 9144	142
3520.48	62 73 0001	99
3520.50	62 73 0001	99
3520.51	62 73 0001	99
3520.54	62 73 0028	99
3520.60	62 91 9831	120
3520.76	70 73 0044	147
3520.77	70 73 0047	147
3520.78	62 73 0004	96
3520.79	62 73 0003	96
3520.80	62 91 9731	96
3520.81	62 91 9733	96
3520.92	62 91 9731	96
3520.93	62 91 9733	96
3520.95	70 73 0042	143
3520.98	62 73 0026	113, 148, 149, 153
3520.99	62 73 0026	113, 148, 149, 153
3521.A1	62 73 0027	113, 148, 149, 153
3521.A2	62 73 0027	113, 148, 149, 153
3521.A3	62 73 0027	113, 148, 149, 153
3521.A5	62 73 0027	113, 148, 149, 153
3521.A6	62 73 0027	113, 148, 149, 153
3521.A7	62 73 0027	113, 148, 149, 153
3521.A8	62 73 0027	113, 148, 149, 153
3521.C8	62 94 0750	101, 103
3521.C8	62 73 0024	101, 103
3521.C8 S1	62 94 0750	101, 103
3521.C9	70 73 0055	133, 145
3521.C9 S	62 92 2101	133, 145
3521.C9 S1	62 92 2101	133, 145
3521.E1	62 73 0010	123
3521.E3	62 73 0027	113, 148, 149, 153
3521.E4	62 73 0027	113, 148, 149, 153
3521.E5	62 73 0027	113, 148, 149, 153
3521.E7	62 92 9425	101, 103, 105
3521.E7	62 94 0780	101, 103, 105

Ref. - No.

**SWAG**
GERMANY**SWAG**
GERMANY

Ref. - No.

SWAG
GERMANY

Ref. - No.

SWAG
GERMANY

3521.E9	62 73 0033	151, 153
3521.F3	62 73 0033	151, 153
3521.F4	62 73 0033	151, 153
3521.G4	62 73 0022	121, 122
3521.G8	62 94 0840	115, 154
3521.G8	62 92 2384	115, 154
3521.G8 S1	62 94 0840	115, 154
3521.H0	62 93 7349	134
3521.H1	62 92 6646	134
3521.H2	70 73 0053	143
3521.H5	64 93 8701	135
3521.H5	64 94 4620	135
3521.H5 S3	64 94 4620	135
3521.H6	64 94 4620	135
3521.H6	64 93 8701	135
3521.H6 S3	64 94 4620	135
3521.H9	62 94 0790	101, 103, 105, 106
3521.H9	62 92 9423	101, 103, 105, 106
3521.J0	62 92 9427	101, 103, 105
3521.J0	62 94 0770	101, 103, 105
3521.J1	64 93 8701	135
3521.J1	64 94 4620	135
3521.J1 S3	64 94 4620	135
3521.J2	64 93 8701	135
3521.J2	64 94 4620	135
3521.J2 S3	64 94 4620	135
3521.J3	70 73 0053	143
3521.J5	62 94 0840	115, 154
3521.J5 S1	62 94 0840	115, 154
3521.J6	62 93 6901	124, 125, 129
3521.J6 SK	62 93 2116	125, 129
3521.J9	70 73 0055	133, 145
3521.K1	64 93 8701	135
3521.K1	64 94 4620	135
3521.K1 S3	64 94 4620	135
3521.K2	62 94 0780	101, 103, 105
3521.K2	62 92 9425	101, 103, 105
3521.K3	62 92 2384	115, 154
3521.K3	62 94 0840	115, 154
3521.K3 S1	62 94 0840	115, 154
3521.K4	70 73 0055	133, 145
3521.K6	62 92 6646	134
3521.K8	64 93 8701	135

3521.K8	64 94 4620	135
3521.K8 S3	64 94 4620	135
3521.L0	70 73 0055	133, 145
3521.L1	64 93 8701	135
3521.L1	64 94 4620	135
3521.L1 S3	64 94 4620	135
3521.L3	81 93 1719	97
3521.L3 S1	81 92 2911	97
3521.L3 S2	81 93 0034	97
3521.L3 S3	81 93 0035	97
3521.L3 S4	81 93 0036	97
3521.L4	62 73 0033	151, 153
3521.L6	62 73 0033	151, 153
3521.N0	62 92 9143	107, 109
3521.N1	64 94 4620	135
3521.N1	64 93 8701	135
3521.N1 S3	64 94 4620	135
3521.N2	64 94 4620	135
3521.N2	64 93 8701	135
3521.N2 S3	64 94 4620	135
3521.N3	64 93 8701	135
3521.N3	64 94 4620	135
3521.N3 S3	64 94 4620	135
3521.N4	64 93 8701	135
3521.N4	64 94 4620	135
3521.N4 S3	64 94 4620	135
3521.N5	64 94 4620	135
3521.N5	64 93 8701	135
3521.N5 S3	64 94 4620	135
3521.N6	64 93 8701	135
3521.N6	64 94 4620	135
3521.N6 S3	64 94 4620	135
3521.N7	64 93 8701	135
3521.N7	64 94 4620	135
3521.N7 S3	64 94 4620	135
3521.N8	62 92 9143	107, 109
3521.N9	62 93 7689	134, 146
3521.P1	62 93 1298	144
3521.P1 S1	70 93 1092	144
3521.P1 S2	70 93 1091	144
3521.P2	62 93 1298	144
3521.P2 S1	70 93 1092	144
3521.P2 S2	70 93 1091	144



Ref. - No.	SWAG GERMANY	
3521.P3	62 94 0840	115, 154
3521.P3	62 92 2384	115, 154
3521.P3 S1	62 94 0840	115, 154
3521.P4	62 92 9427	101, 103, 105
3521.P4 S1	62 94 0770	101, 103, 105
3521.P5	62 73 0024	101, 103
3521.P5	62 94 0750	101, 103
3521.P5 S1	62 94 0750	101, 103
3521.P6	62 93 7349	134
3521.Q1	62 94 0840	115, 154
3521.Q1	62 92 2384	115, 154
3521.Q1 S1	62 94 0840	115, 154
3521.R1	62 93 8171	138, 139
3521.R2	64 94 4620	135
3521.R2	64 93 8701	135
3521.R2 S2	64 93 8701	135
3521.R2 S3	64 94 4620	135
3521.R3	62 93 7839	117, 137, 141
3521.R4	62 73 0033	151, 153
3521.R7	62 92 9425	101, 103, 105
3521.R7 S1	62 94 0780	101, 103, 105
3521.R9	62 92 9427	101, 103, 105
3521.R9 S1	62 94 0770	101, 103, 105
3521.S0	62 93 7689	134, 146
3521.S1	62 92 9423	101, 103, 105, 106
3521.S1 S1	62 94 0790	101, 103, 105, 106
3521.S6	70 92 9145	142
3521.S7	62 93 7349	134
3521.T2	62 93 7349	134
3521.V0	62 93 8171	138, 139
3521.V1	62 94 3601	129
3521.V1	62 94 3580	129
3521.V1 SK	62 94 3580	129
3521.V5	70 92 9145	142
3521.31	62 73 0002	99
3521.33	62 73 0002	99
3521.34	62 73 0002	99
3521.37	62 73 0029	99
3521.41	62 91 9833	120
3521.52	70 73 0054	147
3521.53	70 73 0054	147
3521.53	70 73 0057	147
3521.65	70 73 0042	143

Ref. - No.	SWAG GERMANY	
3521.68	62 73 0027	113, 148, 149, 153
3521.69	62 73 0027	113, 148, 149, 153
3521.76	62 73 0022	121, 122
3521.77	62 73 0022	121, 122
3521.78	62 73 0027	113, 148, 149, 153
3521.79	62 73 0027	113, 148, 149, 153
3521.80	62 73 0010	123
3521.85	70 73 0055	133, 145
3521.86	62 73 0027	113, 148, 149, 153
3521.87	62 73 0027	113, 148, 149, 153
3521.90	62 73 0027	113, 148, 149, 153
3521.91	62 73 0027	113, 148, 149, 153
3521.94	62 73 0027	113, 148, 149, 153
3521.95	62 73 0027	113, 148, 149, 153
3521.96	62 73 0027	113, 148, 149, 153
3521.97	62 73 0027	113, 148, 149, 153
3521.98	62 73 0027	113, 148, 149, 153
3521.99	62 73 0027	113, 148, 149, 153
3523.AA	64 92 2636	135
3523.AG	62 73 0030	101, 103, 105, 106
3523.AJ	62 92 1850	115, 117, 137, 141, 154
3523.AL	62 92 6933	125, 129
3523.AP	62 93 6285	143
3523.AQ	62 92 7015	125, 129
3523.AS	62 93 9375	101, 103, 105
3523.AT	64 92 2636	135
3523.AV	62 92 6932	125
3523.AW	62 92 6933	125, 129
3523.AZ	62 92 6933	125, 129
3523.CA	62 92 6932	125
3523.CC	62 92 8732	107, 109
3523.CE	62 92 8731	107, 109
3523.CJ	62 93 9686	101, 103, 105, 141
3523.CS	62 93 6286	138, 139
3523.CW	62 93 7095	155
3523.20	62 60 0004	99
3523.23	62 60 0008	99
3523.27	62 61 0003	99
3523.31	62 60 0009	99, 120
3523.40	62 60 0002	121, 122
3523.42	62 60 0012	121, 122
3523.43	62 60 0010	131, 132

Ref. - No.

**SWAG**
GERMANY**SWAG**
GERMANY

Ref. - No.

SWAG
GERMANY

Ref. - No.

SWAG
GERMANY

3523.45	62 93 6880	131
3523.49	62 61 0003	99
3523.50	62 60 0007	96
3523.51	62 60 0003	96
3523.52	62 69 0001	96
3523.53	62 92 1934	96
3523.60	62 60 0006	123
3523.61	62 60 0005	123
3523.62	62 60 0011	113, 148, 149
3523.64	62 69 0001	96
3523.75	62 60 0011	113, 148, 149
3523.76	62 73 0030	101, 103, 105, 106
3523.77	62 73 0031	101, 103, 105, 106, 115, 117, 137, 141, 154, 155
3523.79	62 93 9375	101, 103, 105
3523.80	62 93 9686	101, 103, 105, 141
3523.83	62 92 3405	151
3523.89	62 60 0012	121, 122
3523.90	62 93 6880	131
3523.91	62 92 1850	115, 117, 137, 141, 154
3523.92	62 73 0031	101, 103, 105, 106, 115, 117, 137, 141, 154, 155
3523.93	62 92 1613	143
3523.94	62 92 1611	143
3523.96	62 93 6880	131
3523.98	64 92 2635	135
3561.08	70 60 0002	147
3640.15	62 78 0010	126, 127, 130
3640.17	62 78 0001	147
3640.20	62 78 0006	121, 122
3640.21	62 78 0006	121, 122
3640.25	62 78 0010	126, 127, 130
3640.26	70 78 0012	147
3640.27	62 78 0010	126, 127, 130
3640.28	62 78 0009	121, 122, 123, 131, 132
3640.30	62 78 0008	113
3640.30 S1	62 93 1813	113
3640.31 S1	62 93 1813	113
3640.33	70 92 2269	143

3640.34	62 78 0009	121, 122, 123, 131, 132
3640.35	62 91 8343	652
3640.36	62 78 0005	96
3640.37	62 78 0008	113
3640.37 S1	62 93 1813	113
3640.38	62 78 0017	148, 149
3640.38 S1	62 93 1812	148, 149
3640.41	62 79 0008	652
3640.42	62 78 0017	148, 149
3640.42 S1	62 93 1812	148, 149
3640.43	62 78 0017	148, 149
3640.43 S1	62 93 1812	148, 149
3640.44 S1	62 93 1813	113
3640.48	62 91 9468	113
3640.48 S1	62 93 1814	113
3640.49	62 91 9468	113
3640.49 S1	62 93 1814	113
3640.50	62 78 0016	148, 149, 153
3640.50 S1	62 93 1811	148, 149, 153
3640.51	62 78 0016	148, 149, 153
3640.51 S1	62 93 1811	148, 149, 153
3640.53	62 92 1490	115, 117, 137, 141, 154, 155
3640.54	70 92 2269	143
3640.55	70 92 2267	143
3640.57	62 92 8356	125, 129
3640.58	62 92 8355	125, 129
3640.58	62 93 8490	125, 129
3640.59	62 92 8600	135
3640.60	62 92 1490	115, 117, 137, 141, 154, 155
3640.61	62 92 8599	107, 109
3640.62	62 92 8599	107, 109
3640.66	62 92 8600	135
3640.67	62 92 9385	144
3640.68	62 92 1490	115, 117, 137, 141, 154, 155
3640.69	62 92 8355	125, 129
3640.69	62 93 8490	125, 129
3640.69 S1	62 93 8490	125, 129
3640.70	62 92 1490	115, 117, 137, 141, 154, 155



Ref. - No.	SWAG GERMANY	
3640.71	62 78 0009	121, 122, 123, 131, 132
3640.72	62 93 8490	125, 129
3640.72	62 92 8355	125, 129
3640.73	62 92 1490	115, 117, 137, 141, 154, 155
3640.74	62 92 8356	125, 129
3640.76	62 92 9385	144
3640.77	62 93 8025	109, 110
3640.77 S1	62 93 8025	109, 110
3640.83	62 94 4180	129
3656.04	62 94 4480	125, 129
3656.04	62 94 4400	124, 125, 128, 129
3656.04 S1	62 94 4400	124, 125, 128, 129
3656.04 S2	62 94 4480	125, 129
3657.04	62 94 4480	125, 129
3657.04	62 94 4400	124, 125, 128, 129
3657.04 S1	62 94 4400	124, 125, 128, 129
3657.04 S2	62 94 4480	125, 129
3717.42	62 93 9041	114
3812.A4	62 93 8980	133, 145
3812.A4	70 74 0001	133, 145
3812.A4 S1	62 93 8980	133, 145
3812.A6	62 92 2115	131
3812.A9	62 74 0011	123
3812.C0	62 93 9292	148
3812.C0	62 93 9293	148
3812.C0	62 72 0030	148, 149, 153
3812.C0 S1	62 93 9292	148
3812.C0 S2	62 93 9293	148
3812.C1	62 91 9383	123
3812.C3	62 91 9383	123
3812.C4	62 91 9383	123
3812.C5	62 72 0028	101, 103, 105, 106
3812.C5	62 93 8998	101, 103, 105, 106
3812.C5	62 93 8997	101, 103, 105, 106
3812.C5	62 93 9031	101, 103, 105
3812.C5	62 93 9032	101, 103, 105
3812.C5 S1	62 93 8997	101, 103, 105, 106
3812.C5 S2	62 93 8998	101, 103, 105, 106
3812.C5 S3	62 93 9031	101, 103, 105
3812.C5 S4	62 93 9032	101, 103, 105
3812.C6	62 93 9294	151, 153

Ref. - No.	SWAG GERMANY	
3812.C6	62 93 9295	151, 153
3812.C6	62 92 7432	151, 153
3812.C6 S1	62 93 9295	151, 153
3812.C6 S2	62 93 9294	151, 153
3812.C7	62 93 9000	132
3812.C7	62 93 8999	132
3812.C7	62 91 9939	132
3812.C7 S1	62 93 8999	132
3812.C7 S2	62 93 9000	132
3812.E0	62 93 9041	114
3812.E0	62 91 9935	114
3812.E0	62 93 9042	114
3812.E0 S4	62 93 9041	114
3812.E0 S5	62 93 9042	114
3812.E1	62 93 8899	135
3812.E1	62 93 8900	135
3812.E1	64 91 9927	135
3812.E1 S1	62 93 8899	135
3812.E1 S2	62 93 8900	135
3812.E2	62 92 7427	134
3812.E3	62 92 7424	125
3812.E4	62 94 0610	152, 153
3812.E5	62 93 9043	114
3812.E5	62 92 9625	114
3812.E5 S3	62 93 9043	114
3812.E6	62 94 0080	135
3812.E7	62 92 7424	125
3812.E8	62 93 9033	107
3812.E8	62 93 9034	107
3812.E8	62 92 7428	107
3812.E8 S1	62 93 9033	107
3812.E8 S2	62 93 9034	107
3812.F0	62 93 6669	134, 146
3812.F0	62 93 9029	134, 146
3812.F0 S1	62 93 9029	134, 146
3812.F2	62 93 1970	117, 137, 141
3812.F2	62 94 4923	117, 137, 141
3812.F2 S1	62 94 4923	117, 137, 141
3812.F3	62 94 0493	129
3812.F4	62 94 4934	154
3812.F4 S2	62 94 4934	154
3812.F7	62 93 6691	155
3812.F8	62 93 8560	117

Ref. - No.

**SWAG**
GERMANY**SWAG**
GERMANY

Ref. - No.

SWAG
GERMANY

Ref. - No.

SWAG
GERMANY

3812.G3	62 94 0485	129
3812.G3 SK	62 94 0485	129
3812.27	62 72 0029	147
3812.32	62 74 0007	98, 119
3812.38	62 74 0007	98, 119
3812.92	62 77 0008	111
3812.92 S	62 72 0027	111
3812.92 S1	62 72 0027	111
3812.95	62 74 0007	98, 119
3812.97	62 74 0007	98, 119
3812.98	62 74 0002	121, 122
3812.99	62 74 0004	131
3817.A5	62 93 7860	117, 134, 146, 155
3817.11	62 71 0010	147
3817.14	62 71 0003	95, 101, 103, 105, 106, 114, 131
3817.16	62 71 0002	95, 101, 103, 105, 106, 114, 131
3817.18	62 71 0001	98, 111, 114, 119, 126, 127, 130, 148, 149, 151, 153
3817.21	62 71 0004	121, 122
3817.22	62 71 0005	121, 122
3817.26	62 71 0004	121, 122
3817.27	62 71 0005	121, 122
3817.27 S1	62 71 0005	121, 122
3817.30	62 71 0003	95, 101, 103, 105, 106, 114, 131
3817.31	62 71 0002	95, 101, 103, 105, 106, 114, 131
3817.32	62 94 0005	95
3817.33	62 94 0005	95
3817.35	62 94 0004	95
3817.36 S1	62 94 0004	95
3817.37	62 71 0011	131, 132
3817.38	62 71 0013	131, 132
3817.39	62 71 0006	123
3817.40	62 71 0007	123
3817.41	62 93 9042	114
3817.41	62 93 9032	101, 103, 105
3817.41	62 93 8998	101, 103, 105, 106
3817.41	62 71 0003	95, 101, 103, 105, 106, 114, 131

3817.41 S2	62 93 8998	101, 103, 105, 106
3817.41 S4	62 93 9032	101, 103, 105
3817.41 S5	62 93 9042	114
3817.42	62 93 8997	101, 103, 105, 106
3817.42	62 93 9031	101, 103, 105
3817.42	62 71 0002	95, 101, 103, 105, 106, 114, 131
3817.42 S1	62 93 8997	101, 103, 105, 106
3817.42 S3	62 93 9031	101, 103, 105
3817.42 S4	62 93 9041	114
3817.43	62 93 9000	132
3817.43	62 71 0011	131, 132
3817.43 S2	62 93 9000	132
3817.44	62 93 8999	132
3817.44	62 71 0013	131, 132
3817.44 S1	62 93 8999	132
3817.47	62 93 0876	95
3817.48	62 71 0004	121, 122
3817.49	62 71 0005	121, 122
3817.50	62 93 9295	151, 153
3817.50	62 93 9043	114
3817.50	62 71 0001	98, 111, 114, 119, 126, 127, 130, 148, 149, 151, 153
3817.50	62 93 9293	148
3817.50	62 93 9292	148
3817.50	62 93 9294	151, 153
3817.50 S1	62 93 9295	151, 153
3817.50 S1	62 93 9292	148
3817.50 S2	62 93 9294	151, 153
3817.50 S2	62 93 9293	148
3817.50 S3	62 93 9043	114
3817.55	64 92 1491	135
3817.55	62 93 8900	135
3817.55 S2	62 93 8900	135
3817.56	62 93 8899	135
3817.56	64 92 1492	135
3817.56 S1	62 93 8899	135
3817.57	62 92 3325	125
3817.58	62 92 3323	125
3817.63	62 92 8318	97
3817.63	62 93 9590	97
3817.63 S2	62 93 9590	97



Ref. - No.	SWAG GERMANY	
3817.64	62 92 8319	97
3817.64	62 93 9591	97
3817.64 S3	62 93 9591	97
3817.65	62 92 8580	125
3817.66	62 92 8581	125
3817.67	62 93 9033	107
3817.67	62 92 8710	107, 109
3817.67 S1	62 93 9033	107
3817.67 S2	62 93 9034	107
3817.68	62 92 8711	107, 109
3817.68	62 93 9034	107
3817.70	62 93 2192	144
3817.73	62 93 9029	134, 146
3817.73	62 93 7860	117, 134, 146, 155
3817.73 S1	62 93 9029	134, 146
3817.74	62 93 9296	138
3817.74	80 93 4477	138
3817.74 S1	62 93 9296	138
3817.75	62 93 1972	117, 137, 141, 154
3817.75	62 94 4923	117, 137, 141
3817.76	62 94 4934	154
3817.76	62 93 1971	117, 137, 141, 154
3817.77	62 93 2193	144
3817.80	62 94 3548	129
3817.81	62 94 3547	129
3817.86	62 93 9290	142
3817.86	70 93 2767	142
3817.86 S2	62 93 9290	142
3817.87	70 93 2768	142
3817.87	62 93 9291	142
3817.87 S3	62 93 9291	142
3817.88	62 94 4923	117, 137, 141
3817.88	62 93 1972	117, 137, 141, 154
3817.89	62 94 4934	154
3817.89	62 93 1971	117, 137, 141, 154
4001.E4	62 93 6840	144
4001.E4 S1	62 93 6840	144
4001.33	62 93 6850	97
4001.33	62 93 9591	97
4001.33	62 93 9590	97
4001.33 S1	62 93 6850	97
4001.33 S1	62 93 9590	97
4001.33 S2	62 93 9590	97

Ref. - No.	SWAG GERMANY	
4001.33 S3	62 93 9591	97
4001.69	62 93 9296	138
4001.69 S1	80 93 2551	138
4001.69 S1	62 93 9296	138
4001.77	62 93 9290	142
4001.77	62 93 9291	142
4001.77	62 93 6841	142
4001.77 S1	62 93 6841	142
4001.77 S2	62 93 9290	142
4001.77 S3	62 93 9291	142
4006.24	70 72 0004	143
4006.24 S	70 72 0009	143
4006.24 S1	70 72 0009	143
4018.A3	70 71 0028	143
4018.A4	70 72 0004	143
4018.E0	70 92 8351	143
4018.H4	70 71 0028	143
4059.09	70 71 0001	133, 145
4059.09	62 93 8980	133, 145
4059.09 S1	62 93 8980	133, 145
4059.12	62 93 9684	134, 145
4060.22	62 93 9294	151, 153
4060.43	62 93 9295	151, 153
4066.A3	62 93 9238	97
4066.A3	62 93 9591	97
4066.A3	62 93 9590	97
4066.A3 S2	62 93 9590	97
4066.A3 S3	62 93 9591	97
4066.18	99 80 0004	147
4066.18 S	99 80 0006	147
4066.18 S1	99 80 0006	147
4066.19	99 80 0005	147
4066.19 S	99 80 0007	147
4066.19 S1	99 80 0007	147
4066.20	62 80 0001	98, 111, 119, 126, 149, 151, 153
4066.22	62 80 0002	98, 111, 119, 149, 151
4066.22 S2	62 93 9294	151, 153
4066.30	62 80 0004	122, 123, 131
4066.32	62 91 9917	95
4066.37	62 91 9919	121, 122
4066.41	62 80 0005	133, 145

Ref. - No.

**SWAG**
GERMANY**SWAG**
GERMANY

Ref. - No.

SWAG
GERMANY

Ref. - No.

SWAG
GERMANY

4066.41	62 93 8980	133, 145
4066.41 SK	10 92 3841	133, 145
4066.41 S1	62 93 8980	133, 145
4066.42	62 91 9921	122, 123, 131
4066.43	62 80 0003	111, 148, 151, 153
4066.43	62 93 9292	148
4066.43	62 93 9198	111, 148, 151, 153
4066.43 S1	62 93 9292	148
4066.43 S1	62 93 9198	111, 148, 151, 153
4066.43 S1	62 93 9295	151, 153
4066.44	62 93 9293	148
4066.44	62 93 8905	111, 148
4066.44 S1	62 93 9293	148
4066.52	62 80 0002	98, 111, 119, 149, 151
4066.56	62 93 8930	101, 103, 105
4066.56	62 93 9032	101, 103, 105
4066.56	62 93 9031	101, 103, 105
4066.56 S1	62 93 8930	101, 103, 105
4066.56 S3	62 93 9031	101, 103, 105
4066.56 S4	62 93 9032	101, 103, 105
4066.57	62 92 9207	101, 103, 105, 106, 114
4066.64	62 92 9207	101, 103, 105, 106, 114
4066.64	62 93 8738	132
4066.69	62 93 8899	135
4066.69	62 93 8907	135
4066.69	62 93 8900	135
4066.69 S1	62 93 8899	135
4066.69 S2	62 93 8900	135
4066.71	62 93 9562	125
4066.72	62 93 9579	125
4066.73	62 93 9042	114
4066.73	62 93 8998	101, 103, 105, 106
4066.73	62 92 9207	101, 103, 105, 106, 114
4066.73	62 93 9043	114
4066.73	62 93 9041	114
4066.73	62 93 8997	101, 103, 105, 106
4066.73 S1	62 93 8997	101, 103, 105, 106
4066.73 S2	62 93 8998	101, 103, 105, 106
4066.73 S3	62 93 9043	114

4066.73 S4	62 93 9041	114
4066.73 S5	62 93 9042	114
4066.74	62 93 8999	132
4066.74	62 93 8738	132
4066.74	62 93 9000	132
4066.74 S1	62 93 8999	132
4066.74 S2	62 93 9000	132
4066.79	62 93 8918	134
4066.80	62 93 8740	107, 110
4066.80	62 93 9034	107
4066.80	62 93 9033	107
4066.80 S1	62 93 9033	107
4066.80 S2	62 93 9034	107
4066.82	62 94 4923	117, 137, 141
4066.82	62 94 4797	117, 137, 141, 154, 155
4066.82	62 94 4934	154
4066.83	62 93 6654	134, 146
4066.83	62 93 9029	134, 146
4066.83 S1	62 93 9029	134, 146
4066.84	62 93 8921	138
4066.84	62 93 9296	138
4066.84 S1	62 93 9296	138
4066.85	62 94 4797	117, 137, 141, 154, 155
4066.85	62 94 4923	117, 137, 141
4066.85	62 94 4934	154
4066.86	62 93 9227	144
4066.92	62 94 4934	154
4066.92	62 94 4923	117, 137, 141
4066.92	62 94 4797	117, 137, 141, 154, 155
4066.93	62 94 4797	117, 137, 141, 154, 155
4066.93	62 94 4934	154
4066.93	62 94 4923	117, 137, 141
4066.95	62 93 9290	142
4066.95	62 93 9237	142
4066.95	62 93 9291	142
4066.95 S2	62 93 9290	142
4066.95 S3	62 93 9291	142
5081.L0	62 93 8735	146
5081.N9	62 93 6889	144



Ref. - No.	SWAG GERMANY	
5081.N9 S1	62 93 6889	144
5081.Q3	62 93 8735	146
5087.23	62 61 0005	99, 120
5087.30	62 76 0003	131
5087.32	62 61 0005	99, 120
5087.33	62 79 0001	96
5087.34	62 61 0004	113, 148, 149, 151, 153
5087.35	70 61 0008	133, 145
5087.35 S	70 61 0002	133, 145
5087.35 S1	70 61 0002	133, 145
5087.37	70 61 0009	143
5087.37 S	70 61 0003	143
5087.37 S1	70 61 0003	143
5087.39	62 61 0004	113, 148, 149, 151, 153
5087.40	62 79 0003	96, 123
5087.41	62 76 0003	131
5087.42	62 79 0020	113
5087.45	62 79 0021	101, 103, 105, 106, 135
5087.46	62 61 0004	113, 148, 149, 151, 153
5087.48	62 91 9225	123, 132
5087.49	62 76 0003	131
5087.50	62 91 9397	115, 117, 137, 141, 154, 155
5087.51	62 91 9403	134
5087.52	62 92 2846	125, 129
5087.53	62 92 2847	125, 129
5087.54	62 92 7434	107, 109, 110
5087.55	62 92 7435	107, 109, 110
5087.56	62 92 8601	146
5087.57	62 93 6440	137, 141, 154, 155
5087.58	80 93 0401	138, 139
5087.59	62 79 0021	101, 103, 105, 106, 135
5087.60	62 91 9225	123, 132
5087.61	62 61 0004	113, 148, 149, 151, 153
5087.62	62 91 9397	115, 117, 137, 141, 154, 155

Ref. - No.	SWAG GERMANY	
5087.64	62 91 9397	115, 117, 137, 141, 154, 155
5087.65	62 93 2194	142
5087.66	62 79 0021	101, 103, 105, 106, 135
5087.68	62 92 7435	107, 109, 110
5087.69	62 92 7434	107, 109, 110
5087.70	62 93 2194	142
5087.71	62 94 3770	109
5087.74	62 79 0021	101, 103, 105, 106, 135
5087.76	62 94 0729	129
5087.77	62 91 9397	115, 117, 137, 141, 154, 155
5087.78	62 91 9397	115, 117, 137, 141, 154, 155
5087.79	62 93 2194	142
5091.10 S1	62 92 7438	97
5093.15	70 61 0006	133, 143, 145
5094.A0	62 93 7202	125, 129
5094.A1	62 93 3964	125, 129
5094.A7	62 92 7438	97
5094.A7 S1	62 92 7438	97
5094.A8	62 93 7199	97
5094.C1	62 93 7201	107
5094.C2	62 93 7336	107
5094.C3	62 94 0173	107
5094.C4	62 93 9682	117, 155
5094.C5	62 93 9681	107
5094.C6	62 93 9166	138, 139
5094.C8	62 94 0490	142
5094.E0	62 92 2715	115
5094.E2	62 93 9682	117, 155
5094.E3	62 94 0187	115, 117, 137, 141, 154, 155
5094.E4	64 94 2780	154
5094.E5	70 93 6977	142
5094.E6	62 93 9685	154
5094.E7	64 94 2779	137, 154
5094.F2	62 93 9683	117
5094.F3	62 94 0082	125, 129
5094.56	62 92 1914	96
5094.57	62 92 1915	96

Ref. - No.

**SWAG**
GERMANY**SWAG**
GERMANY

Ref. - No.

SWAG
GERMANY

Ref. - No.

SWAG
GERMANY

5094.59	62 92 1250	96
5094.63	62 61 0002	113
5094.64	62 61 0001	113
5094.65	62 61 0006	113, 148, 149, 151, 153
5094.65 S1	62 93 7765	113, 151, 153
5094.66	62 92 1820	113
5094.69	70 61 0011	133, 145
5094.74	62 92 1821	123
5094.75	62 92 1822	123
5094.77	62 92 1818	113, 148, 149, 151, 153
5094.80	62 92 1816	101
5094.81	62 92 1814	101
5094.82	62 93 4801	101, 103, 105, 106
5094.87	62 92 2714	115
5094.88	62 92 2715	115
5094.89	62 94 0187	115, 117, 137, 141, 154, 155
5094.95	62 93 4804	101, 103, 105, 106
5094.98	62 94 0082	125, 129
5094.99	62 93 3965	125
5097.39 S1	62 93 7765	113, 151, 153
5131.53	62 79 0016	654
5131.54	62 79 0010	654
5131.55	62 79 0012	654
5131.56	62 79 0011	654
5131.78	62 79 0019	652
5131.79	62 79 0018	652
5131.80	62 79 0015	652
5131.99	62 79 0018	652
5170.F5	62 93 6883	656
5170.F5 S1	62 93 6883	656
5170.F6	62 93 6883	656
5170.F6 S1	62 93 6883	656
5172.29	62 92 1823	654
5172.47	62 92 1823	654
5172.58	62 93 9181	655
5175.CF	62 92 6931	653
5178.17	62 91 9067	654
5178.18	62 91 9071	654
5178.21	62 91 9067	654
5178.22	62 91 9071	654

5178.30	62 91 9067	654
5178.31	62 91 9071	654
5178.38	62 79 0004	652
5178.39	62 91 8985	652
5178.43	62 91 9067	654
5178.44	62 91 9071	654
5178.46	62 92 7489	653
5178.47	62 92 7014	653
5178.48	80 93 0398	655
5178.49	80 93 0399	655
5178.52	62 92 7489	653
5178.57	62 94 4721	653, 655
6822.R9	62 92 7438	97
6822.S0	62 92 7438	97
6822.TV	62 92 7438	97
6925.B2	62 94 0004	95
6933.14	62 94 0004	95
6947.78	62 94 0004	95
96 147 514	62 79 0001	96
96 032 460 86	62 74 0004	131
96 719 188 80	62 93 7095	155
96 829 541 80	62 94 3770	109
96 857 197 80	62 93 9682	117, 155
96 857 198 80	64 94 2779	137, 154
96 857 199 80	62 93 9683	117
96 857 200 80	64 94 2780	154
96 872 667 80	62 93 9685	154
96 872 668 80	64 94 2779	137, 154
97 507 980	62 71 0010	147
98 049 474 80	62 93 6440	137, 141, 154, 155
98 056 073 80	62 94 4191	141
98 056 074 80	62 94 4190	141
98 069 071 80	62 94 4720	118
98 071 300 80	62 92 7489	653
98 090 457 80	62 94 4720	118

passend für / to fit:

PORSCHE

986 331 043 04	38 93 8884	657
986 331 043 05	38 93 8884	657
986 331 043 06	38 93 8884	657
986 331 043 07	38 93 8884	657
996 331 045 05	38 93 8887	657, 658, 659
996 331 045 06	38 93 8887	657, 658, 659



Ref. - No.	SWAG GERMANY	
996 331 045 07	38 93 8887	657, 658, 659
996 331 045 08	38 93 8887	657, 658, 659
996 331 045 10	38 93 8887	657, 658, 659
996 331 045 12	38 93 8887	657, 658, 659
997 331 045 04	38 93 8887	657, 658, 659
996 333 069 02	38 92 9800	659
996 333 069 03	38 92 9800	659
996 333 069 04	38 92 9800	659
955 341 013 31 S1	30 94 0163	160
955 341 017 30 S1	30 94 0163	160
955 341 017 32 S1	30 94 0163	160
955 341 017 33 S1	30 94 0163	160
955 341 018 30 S1	30 94 0164	160
955 341 018 31 S1	30 94 0164	160
955 341 018 32 S1	30 94 0164	160
955 341 018 33 S1	30 94 0164	160
955 341 027 00 S1	30 93 8839	160
955 341 027 00 S2	30 94 0403	160
955 341 027 01 S1	30 93 8839	160
955 341 027 01 S2	30 94 0403	160
955 341 027 02 S1	30 93 8839	160
955 341 027 02 S2	30 94 0403	160
996 341 043 03	38 93 8883	156, 157, 159, 659
996 341 043 06	38 93 8883	156, 157, 159, 659
996 341 053 05	38 93 8568	156, 159, 657, 658, 659
996 341 053 06	38 93 8568	156, 159, 657, 658, 659
996 341 053 07	38 93 8568	156, 159, 657, 658, 659
996 341 053 14	38 93 8568	156, 159, 657, 658, 659
996 341 053 16	38 93 8568	156, 159, 657, 658, 659
996 341 053 17	38 93 8568	156, 159, 657, 658, 659
955 341 242 03	30 93 8811	160, 161
955 341 242 04	30 93 8811	160, 161
996 341 941 00	38 93 8568	156, 159, 657, 658, 659
955 343 069 00	30 93 1706	160
955 343 069 10	38 93 9464	160
996 343 069 02	38 92 6531	156, 159, 657

Ref. - No.	SWAG GERMANY	
996 343 069 03	38 92 6531	156, 159, 657
996 343 069 04	38 92 6531	156, 159, 657
997 343 069 00	38 92 6534	157, 159, 162
997 343 069 01	38 92 6534	157, 159, 162
997 343 069 02	38 92 6534	157, 159, 162
996 343 070 02	38 92 6532	156, 159, 657
996 343 070 03	38 92 6532	156, 159, 657
996 343 070 04	38 92 6532	156, 159, 657
997 343 070 00	38 92 6533	157, 159, 162
997 343 070 01	38 92 6533	157, 159, 162
997 343 070 02	38 92 6533	157, 159, 162
996 343 073 03 S1	38 94 5445	156
996 343 073 04 S1	38 94 5445	156
996 343 073 05 S1	38 94 5445	156
955 343 243 01	30 94 0165	160, 161, 162
955 347 010 22	30 93 7203	160
955 347 031 20	30 93 7205	160
955 347 031 20 SK	30 93 7203	160
955 347 031 21 SK	30 93 7203	160
955 347 031 21	30 93 7205	160
955 347 031 22	30 93 7205	160
955 347 031 22 SK	30 93 7203	160
955 347 032 20	30 93 7206	160
955 347 032 21	30 93 7206	160
955 347 032 22	30 93 7206	160
955 347 131 20	30 93 6911	160
955 347 131 21	30 93 6911	160
955 347 131 22	30 93 6911	160
996 347 131 03	38 93 8886	156, 157, 159
996 347 131 04	38 93 8886	156, 157, 159
947 347 132 20	30 93 6910	160
955 347 132 21	30 93 6910	160
955 347 132 22	30 93 6910	160
996 347 322 03	38 93 8885	156, 159
944 347 333 00	30 71 0021	158
171 407 153 D	30 73 0015	158
171 407 182 D	30 13 0078	158
171 407 365 C	30 78 0006	158
171 407 365 C S1	30 78 0020	158
171 407 365 D	30 78 0006	158
171 407 365 F	30 78 0011	158
171 407 365 G	30 78 0011	158
171 407 365 G S1	30 78 0018	158

Ref. - No.

**SWAG**
GERMANY**SWAG**
GERMANY

Ref. - No.

SWAG
GERMANY

Ref. - No.

SWAG
GERMANY

171 419 831 C	30 80 0054	158
171 419 832 C	30 80 0053	158
passend für / to fit:		
RENAULT		
-	82 94 2630	186
-	82 94 2631	186
-	82 94 2631	186
-	82 94 2630	186
D8 52 0JY 00A	82 93 4755	186
D8 52 1JG 00A	82 93 4614	186
D8 64 0JY 00A	82 93 4756	186
40 16 000 04R	60 93 6125	190
40 16 047 93R	60 92 3996	177, 191, 201, 205, 208, 209, 216
40 16 090 60R	60 93 9493	183, 203, 210
48 52 000 01R	60 93 8723	190
48 52 000 02R	60 93 8724	190
48 52 004 10R	60 92 9624	191, 208
48 52 007 80R	60 94 3618	195
48 52 007 80R S1	60 94 3688	195
48 52 027 10R	60 93 9039	183, 203, 204, 210
48 52 027 10R S1	60 93 9823	183, 203, 204, 210
48 52 028 67R	60 92 9623	191, 208
48 52 046 80R	60 93 9040	183, 203, 204, 210
48 52 046 80R S1	60 93 9822	183, 203, 204, 210
48 52 067 30R	60 94 3617	195
48 52 067 30R S1	60 94 3687	195
48 52 100 01R	60 93 2020	190
48 52 100 01R SK	60 93 2020	190
48 52 110 71R	60 94 3630	178, 218
48 52 110 71R SK	60 94 3630	178, 218
48 52 123 73R	60 93 9444	195
48 52 123 73R SK	60 93 9444	195
48 52 156 12R	60 93 9690	183, 185, 203, 204, 210
48 52 156 12R SK	60 93 9690	183, 185, 203, 204, 210
48 52 159 61R	60 93 9690	183, 185, 203, 204, 210
50 00 387 023	60 92 2234	194
50 00 387 653	60 92 2234	194
50 00 387 654	60 92 2233	194
50 55 384 809	60 92 2233	194

54 50 0JY 00A S1	82 93 4666	186
54 50 042 69R	60 92 9638	191, 208
54 50 092 07R	60 93 7068	183, 203, 204, 210
54 50 113 62R	60 92 9637	191, 208
54 50 140 55R	60 93 7067	183, 203, 204, 210
54 56 000 04R	60 93 3086	183, 203, 204, 210
54 56 000 05R	60 93 3085	183, 203, 204, 210
54 56 016 84R	60 93 3087	203, 210
54 56 027 88R	60 93 7675	178
54 61 142 37R	60 93 7726	178
54 61 200 05R	60 94 0144	203
54 61 200 07R	60 94 4483	203, 210
54 61 354 90R	60 94 4539	662
54 61 8JD 00A	82 93 0986	186
54 61 800 01R	60 92 9834	190
54 61 800 02R	60 93 8822	203, 210
54 61 800 04R	60 93 7309	195
54 66 8JD 00A	82 93 0985	186
55 11 000 19R S1	60 93 7312	662
55 11 078 94R	60 93 6436	661
55 11 079 16R	82 92 1810	177, 178, 205, 218
55 61 8JY 00B	82 93 2573	660
55 61 9JY 00B	82 93 2574	660
60 00 022 714	60 71 0019	207
60 00 022 715	60 71 0021	207
60 00 022 720	60 71 0010	173, 184, 196, 198
60 00 022 721	60 71 0009	173, 184, 196, 198
60 00 022 730	60 71 0018	214
60 00 022 731	60 71 0020	214
60 00 022 736	60 71 0013	187
60 00 022 737	60 71 0014	187
60 00 022 752	60 71 0010	173, 184, 196, 198
60 00 022 753	60 71 0009	173, 184, 196, 198
60 00 025 363	60 92 1172	187
60 00 025 546	60 92 1171	175, 184, 196, 198, 211
60 00 025 597	60 92 1172	187
60 00 030 047	60 71 0007	167
60 00 030 048	60 71 0008	167
60 00 030 064	60 71 0003	173
60 00 030 065	60 71 0004	173
60 01 547 138	60 92 7447	191, 208, 216
60 01 547 140	60 92 7446	191, 208

Ref. - No.	SWAG GERMANY	
60 01 547 519	60 92 9638	191, 208
60 01 547 520	60 92 9637	191, 208
60 01 547 606	60 92 7725	191, 208
60 01 547 607	60 92 9650	191, 208
60 01 547 610	60 92 9623	191, 208
60 01 547 611	60 92 9624	191, 208
60 01 550 441	60 92 7725	191, 208
60 01 550 442	60 92 9623	191, 208
60 01 550 442 S1	60 93 4332	191, 208
60 01 550 442 S2	60 93 7621	191, 208
60 01 550 443	60 92 9624	191, 208
60 01 550 443 S2	60 93 7622	191, 208
60 01 550 446	60 92 9637	191, 208
60 01 550 446 S1	60 93 4333	191, 208
60 01 550 446 S2	60 94 0253	191, 208
60 01 550 447	60 92 9638	191, 208
60 01 550 447 S2	60 94 0254	191, 208
60 01 550 909	60 92 9637	191, 208
60 01 550 910	60 92 9638	191, 208
60 20 022 736	60 71 0013	187
60 20 022 737	60 71 0014	187
60 25 305 572	60 92 3181	181
60 25 305 573	60 92 3182	181
60 25 306 471	60 92 7453	172, 181
60 25 307 649	60 92 3181	181
60 25 307 650	60 92 3182	181
60 25 308 155	60 92 2279	181
60 25 311 529	60 92 7453	172, 181
60 25 370 229	60 92 9679	172, 181
60 25 370 230	60 92 9680	172, 181
60 25 370 493	60 92 9683	172, 181
60 25 370 494	60 92 9684	172, 181
60 40 002 105	60 92 2265	182, 189, 213, 217
60 40 002 245	60 92 6304	191, 208
60 40 096 299	60 92 6304	191, 208
60 40 205 623	60 93 3087	203, 210
77 00 302 115	60 92 7181	193
77 00 302 116	60 92 7179	193
77 00 302 118	60 92 6453	193
77 00 302 119	60 92 6454	193
77 00 302 122	40 92 4262	193
77 00 302 123	60 92 4263	193
77 00 302 165	60 91 9867	193, 194

Ref. - No.	SWAG GERMANY	
77 00 302 439	40 92 4262	193
77 00 302 440	60 92 4263	193
77 00 307 343	60 91 9866	193, 194
77 00 309 070	60 91 9867	193, 194
77 00 309 071	60 91 9866	193, 194
77 00 309 189	60 92 6453	193
77 00 309 190	60 92 6454	193
77 00 312 851	60 92 2710	193
77 00 312 852	60 92 2468	193
77 00 313 944	60 91 0894	176, 184, 211
77 00 313 945	60 91 0895	176, 184, 211
77 00 314 855	60 93 1010	184
77 00 413 493	60 73 0008	187
77 00 413 494	60 73 0012	187
77 00 418 693	60 78 0009	187, 207
77 00 419 236	60 60 0018	176, 184, 211, 215
77 00 419 249	60 60 0018	176, 184, 211, 215
77 00 421 804	60 78 0009	187, 207
77 00 424 399	60 60 0018	176, 184, 211, 215
77 00 424 459	60 60 0018	176, 184, 211, 215
77 00 425 227	60 91 0894	176, 184, 211
77 00 425 228	60 91 0895	176, 184, 211
77 00 428 666	60 93 1009	197, 199
77 00 430 765	60 91 9647	199
77 00 430 766	60 91 9646	199
77 00 430 766 S1	60 92 2410	199
77 00 430 766 S2	60 93 9820	199
77 00 434 177	60 78 0006	163, 164, 167, 169, 174, 176, 184, 197, 206, 211, 214
77 00 436 302	60 73 0006	167, 197
77 00 436 303	60 73 0005	167, 197
77 00 437 136	60 92 1635	184, 199
77 00 667 186	60 79 0010	212
77 00 678 649	60 92 1170	167, 169, 170, 173, 206, 214
77 00 678 697	60 92 1170	167, 169, 170, 173, 206, 214
77 00 706 007	60 92 1169	167, 169, 170, 173, 179, 180, 206
77 00 754 515	60 60 0015	170
77 00 760 264	60 79 0006	174
77 00 760 265	60 79 0007	163, 206

Ref. - No.

**SWAG**
GERMANY**SWAG**
GERMANY

Ref. - No.

SWAG
GERMANY

Ref. - No.

SWAG
GERMANY

77 00 763 538 S1	60 92 6339	163, 164, 167, 174, 176, 184, 191, 197, 199, 206, 208, 211
77 00 765 840	60 60 0011	171, 179
77 00 772 687	60 60 0014	170
77 00 777 540	60 60 0011	171, 179
77 00 781 034	60 73 0006	167, 197
77 00 781 035	60 73 0005	167, 197
77 00 781 095	60 92 1169	167, 169, 170, 173, 179, 180, 206
77 00 781 097	60 92 1170	167, 169, 170, 173, 206, 214
77 00 781 441	60 92 1655	171, 180
77 00 781 463	60 60 0007	171, 180
77 00 781 464	60 92 1655	171, 180
77 00 783 447	60 78 0006	163, 164, 167, 169, 174, 176, 184, 197, 206, 211, 214
77 00 784 170	60 93 1007	167, 197, 199
77 00 784 171	60 93 1008	197, 199
77 00 785 788	60 61 0003	167, 174, 176, 184, 197, 211
77 00 789 478	60 60 0001	167, 197, 199
77 00 794 386	60 73 0001	174
77 00 794 387	60 73 0002	174
77 00 797 821	60 61 0007	180
77 00 798 053	60 61 0005	174, 176, 206, 211
77 00 799 064	60 60 0002	174
77 00 799 065	60 60 0003	174
77 00 799 066	60 60 0004	174
77 00 799 404	60 61 0001	174, 176, 184, 211
77 00 800 976	60 61 0005	174, 176, 206, 211
77 00 805 494	60 79 0001	172, 181, 187, 207
77 00 806 238	60 60 0009	207
77 00 806 239	60 60 0012	207
77 00 807 194	60 78 0009	187, 207
77 00 807 580	60 73 0009	207
77 00 807 581	60 73 0013	207
77 00 818 051	60 73 0006	167, 197
77 00 818 052	60 73 0005	167, 197
77 00 819 415	60 92 1170	167, 169, 170, 173, 206, 214
77 00 819 928	60 60 0016	214

77 00 819 929	60 60 0017	214
77 00 820 028	60 73 0007	214
77 00 820 029	60 73 0011	214
77 00 822 503	60 60 0013	172, 181, 187
77 00 823 097	60 73 0008	187
77 00 823 098	60 73 0012	187
77 00 824 042	60 60 0010	187
77 00 829 322	60 78 0009	187, 207
77 00 831 364	60 60 0016	214
77 00 831 368	60 73 0006	167, 197
77 00 831 369	60 73 0005	167, 197
77 00 834 916	60 73 0010	199
77 00 834 917	60 73 0014	199
77 00 835 929	60 61 0006	176, 197, 199, 211
77 00 840 741	60 60 0001	167, 197, 199
77 00 847 382	60 61 0002	199
77 00 847 383	60 94 0875	176, 199
77 01 041 311	60 71 0010	173, 184, 196, 198
77 01 041 312	60 71 0009	173, 184, 196, 198
77 01 047 415	60 91 9605	175, 177, 184, 196, 198, 205, 211, 214, 215, 218
77 01 047 416	60 91 9604	175, 177, 184, 196, 198, 205, 211, 214, 215, 218
77 01 047 812	60 91 9605	175, 177, 184, 196, 198, 205, 211, 214, 215, 218
77 01 047 813	60 91 9604	175, 177, 184, 196, 198, 205, 211, 214, 215, 218
77 01 049 282	60 92 1283	182, 189, 213, 217
77 01 049 283	60 92 1284	182, 189, 213, 217
77 01 056 095	60 92 9947	201
77 01 056 678	60 92 8282	177, 201
77 01 056 969	60 92 2468	193
77 01 059 672	60 93 9646	177, 205, 209
77 01 059 966	60 93 9629	209
77 01 070 154	60 93 4164	193
77 01 349 064	60 60 0008	212
77 01 455 905	60 93 4309	165, 166, 168
77 01 455 906	60 93 4308	165, 166, 168
77 01 460 886	60 93 4309	165, 166, 168



Ref. - No.	SWAG GERMANY	
77 01 461 141	60 71 0002	163, 169, 179, 180, 206
77 01 461 667	60 78 0020	212
77 01 461 770	60 71 0017	212
77 01 462 182	60 78 0006	163, 164, 167, 169, 174, 176, 184, 197, 206, 211, 214
77 01 462 182 S	60 78 0001	163, 164, 167, 169, 174, 176, 184, 197, 206, 211, 214
77 01 462 427	60 92 2169	194
77 01 462 692	60 92 2233	194
77 01 462 693	60 92 2234	194
77 01 463 229	60 92 2506	171, 179, 180
77 01 463 230	60 92 2507	171, 179, 180
77 01 463 346	60 72 0002	163, 206
77 01 464 015	60 72 0003	169
77 01 464 019	60 71 0016	170
77 01 464 037	60 78 0019	170
77 01 464 037 S	60 78 0021	170
77 01 464 037 S1	60 78 0021	170
77 01 464 441	60 71 0016	170
77 01 465 689	60 92 2507	171, 179, 180
77 01 467 218	60 72 0009	214
77 01 467 219	60 72 0008	214
77 01 467 235	60 72 0011	167
77 01 467 235 S	60 72 0011	167
77 01 467 235 S1	60 72 0011	167
77 01 467 237	60 72 0010	167
77 01 467 237 S	60 72 0010	167
77 01 467 237 S1	60 72 0010	167
77 01 467 271	60 72 0007	173
77 01 467 272	60 72 0006	173
77 01 467 273	60 71 0004	173
77 01 467 274	60 71 0003	173
77 01 467 501	60 72 0015	187
77 01 467 502	60 72 0014	187
77 01 468 411	60 78 0006	163, 164, 167, 169, 174, 176, 184, 197, 206, 211, 214
77 01 468 411 S	60 78 0001	163, 164, 167, 169, 174, 176, 184, 197, 206, 211, 214

Ref. - No.	SWAG GERMANY	
77 01 468 820	60 93 4308	165, 166, 168
77 01 468 821	60 93 4309	165, 166, 168
77 01 468 883	60 78 0006	163, 164, 167, 169, 174, 176, 184, 197, 206, 211, 214
77 01 468 883 S	60 78 0001	163, 164, 167, 169, 174, 176, 184, 197, 206, 211, 214
77 01 468 883 S2	60 78 0001	163, 164, 167, 169, 174, 176, 184, 197, 206, 211, 214
77 01 469 228	60 92 2506	171, 179, 180
77 01 469 230	60 71 0016	170
77 01 469 231	60 71 0022	163, 169, 171, 179, 180, 206
77 01 469 251	60 93 9325	187
77 01 469 280	60 91 9525	196, 198
77 01 469 280 SK	60 91 9525	196, 198
77 01 469 496	60 92 1171	175, 184, 196, 198, 211
77 01 469 497	60 92 1170	167, 169, 170, 173, 206, 214
77 01 469 502	60 92 2477	196, 198
77 01 469 502 SK	60 92 2477	196, 198
77 01 469 517	60 93 3517	214
77 01 469 517 SK	60 93 3517	214
77 01 469 617	60 92 1169	167, 169, 170, 173, 179, 180, 206
77 01 469 657	60 92 1172	187
77 01 469 665	60 93 9325	187
77 01 469 665 SK	60 93 9325	187
77 01 469 777	60 92 2491	173
77 01 469 777 SK	60 92 2491	173
77 01 469 778	60 92 2491	173
77 01 469 778 SK	60 92 2491	173
77 01 470 362	60 93 2128	193
77 01 470 362 SK	60 93 2128	193
77 01 470 363	60 92 1493	193
77 01 470 363 S1	60 93 7625	193
77 01 470 364	60 92 1494	193
77 01 470 364 S1	60 93 7626	193
77 01 470 763	60 92 2509	184
77 01 470 763 SK	60 92 2509	184

Ref. - No.

**SWAG**
GERMANY**SWAG**
GERMANY

Ref. - No.

SWAG
GERMANY

Ref. - No.

SWAG
GERMANY

77 01 470 764	60 92 2519	184
77 01 470 764 SK	60 92 2519	184
77 01 470 765	60 71 0010	173, 184, 196, 198
77 01 470 766	60 71 0009	173, 184, 196, 198
77 01 471 124	60 93 4247	175
77 01 471 124 SK	60 93 4247	175
77 01 471 125	60 92 2531	175, 211
77 01 471 125 SK	60 92 2531	175, 211
77 01 471 126	60 92 2513	175, 211
77 01 471 127	60 92 2514	175, 211
77 01 471 143	60 94 3463	175
77 01 471 143 SK	60 94 3463	175
77 01 471 144	60 94 3463	175
77 01 471 145	60 92 2513	175, 211
77 01 471 146	60 92 2514	175, 211
77 01 471 844	60 92 2479	196, 198
77 01 471 844 SK	60 92 2479	196, 198
77 01 471 885	60 92 2478	196, 198
77 01 471 885 SK	60 92 2478	196, 198
77 01 472 038	60 78 0006	163, 164, 167, 169, 174, 176, 184, 197, 206, 211, 214
77 01 472 038 S	60 78 0001	163, 164, 167, 169, 174, 176, 184, 197, 206, 211, 214
77 01 472 087	60 92 2476	196, 198
77 01 472 087 SK	60 92 2476	196, 198
77 01 472 113	60 92 2511	175, 184, 211
77 01 472 113 SK	60 92 2511	175, 184, 211
77 01 472 120	60 92 2517	175, 184, 211
77 01 472 120 SK	60 92 2517	175, 184, 211
77 01 472 734	60 92 2763	175, 211
77 01 472 734 SK	60 92 2763	175, 211
77 01 472 735	60 92 2763	175, 211
77 01 472 765	60 92 7197	189
77 01 472 766	60 92 7203	189
77 01 472 766 SK	60 92 2765	189
77 01 472 766 S1	60 93 7623	189
77 01 472 766 S2	60 93 7624	189
77 01 472 843	60 91 9605	175, 177, 184, 196, 198, 205, 211, 214, 215, 218
77 01 473 333	60 92 7303	213

77 01 473 333 SK	60 92 7301	213
77 01 473 333 S1	60 93 7627	213
77 01 473 333 S2	60 93 7628	213
77 01 473 334	60 92 7128	213
77 01 473 498	60 93 2874	214
77 01 473 498 SK	60 93 2874	214
77 01 473 498 S1	60 93 7629	214
77 01 473 498 S2	60 93 7630	214
77 01 474 076	60 93 1507	182, 217
77 01 474 447	60 92 7222	201, 209
77 01 474 448	60 92 4720	201, 209
77 01 474 448 SK	60 92 4720	201, 209
77 01 474 492	60 91 9605	175, 177, 184, 196, 198, 205, 211, 214, 215, 218
77 01 474 493	60 91 9604	175, 177, 184, 196, 198, 205, 211, 214, 215, 218
77 01 474 641	60 91 9605	175, 177, 184, 196, 198, 205, 211, 214, 215, 218
77 01 474 642	60 91 9604	175, 177, 184, 196, 198, 205, 211, 214, 215, 218
77 01 474 795	60 92 4815	201, 209
77 01 474 795 S1	60 93 7617	201, 209
77 01 474 796	60 92 4816	201, 209
77 01 474 796 S1	60 93 7618	201, 209
77 01 475 840	60 92 9525	177, 205
77 01 475 841	60 92 8466	177, 205
77 01 475 841 SK	60 92 8466	177, 205
77 01 475 841 S1	60 93 7631	177, 205
77 01 475 841 S2	60 93 7632	177, 205
77 01 475 842	60 91 9605	175, 177, 184, 196, 198, 205, 211, 214, 215, 218
77 01 475 843	60 91 9604	175, 177, 184, 196, 198, 205, 211, 214, 215, 218
77 01 476 576	60 92 2265	182, 189, 213, 217
77 01 476 760	60 71 0010	173, 184, 196, 198
77 01 476 761	60 71 0009	173, 184, 196, 198
77 01 476 762	60 92 2513	175, 211



Ref. - No.	SWAG GERMANY	
77 01 476 763	60 92 2514	175, 211
77 01 477 385	60 93 0653	213
77 01 477 878	60 93 7160	215
77 01 477 878 SK	60 93 7160	215
77 01 478 029	60 92 2265	182, 189, 213, 217
77 01 478 406	60 93 9690	183, 185, 203, 204, 210
77 01 478 407	60 93 6095	185
77 01 478 407 S1	60 93 9863	185
77 01 478 408	60 93 6094	185
77 01 478 408 S1	60 93 9864	185
77 01 478 551	60 92 7203	189
77 01 478 552	60 93 1507	182, 217
77 01 478 552 SK	60 93 1507	182, 217
77 01 478 552 S1	60 93 7633	182, 217
77 01 478 552 S2	60 93 7634	182, 217
77 01 478 762	60 93 2128	193
77 01 834 570	60 71 0010	173, 184, 196, 198
77 01 834 571	60 71 0009	173, 184, 196, 198
77 04 000 681	60 60 0005	163, 164, 169, 206
77 04 001 734	60 92 8302	171, 180
77 04 002 466	60 60 0006	171, 179, 180
77 04 002 468	60 60 0011	171, 179
82 00 002 868	60 92 2821	182, 189
82 00 002 869	60 92 2822	182, 189, 213
82 00 002 870	60 92 1044	182, 189, 213, 217, 660
82 00 024 373	60 92 8290	214
82 00 026 654	60 92 2133	189
82 00 026 655	60 92 2132	189
82 00 040 618	60 91 9649	214
82 00 040 642	60 92 9948	214
82 00 041 166	60 92 2819	201, 209
82 00 049 624	60 92 2825	213
82 00 050 191	60 91 9650	214
82 00 054 003	60 93 9603	213
82 00 127 308	82 92 1810	177, 178, 205, 218
82 00 150 759	60 93 1009	197, 199
82 00 166 159	60 92 1015	185, 201, 209
82 00 166 160	60 93 2699	201, 209
82 00 183 569	60 92 2865	177, 205
82 00 183 570	60 92 2866	177, 205
82 00 197 179	60 91 0894	176, 184, 211

Ref. - No.	SWAG GERMANY	
82 00 197 179 S1	60 93 3105	184
82 00 197 187	60 91 0895	176, 184, 211
82 00 197 187 S1	60 93 3106	184
82 00 242 025	60 92 2818	201, 209
82 00 247 898	60 93 9603	213
82 00 247 898 S	60 92 2265	182, 189, 213, 217
82 00 247 900	60 93 9604	213
82 00 255 760	60 92 2135	201
82 00 255 761	60 92 2134	201
82 00 255 761 S	60 92 3995	201
82 00 255 761 S1	60 92 3995	201
82 00 270 055	60 92 6453	193
82 00 270 058	60 92 6454	193
82 00 272 594	60 92 8281	189
82 00 272 596	60 92 9946	189
82 00 273 728	60 92 2133	189
82 00 273 729	60 92 2132	189
82 00 277 960	60 92 7447	191, 208, 216
82 00 298 454	60 92 4083	201, 209
82 00 298 455	60 92 4084	201, 209
82 00 298 455 S	60 92 3996	177, 191, 201, 205, 208, 209, 216
82 00 298 455 S1	60 92 3996	177, 191, 201, 205, 208, 209, 216
82 00 346 941	60 92 4251	177, 205
82 00 346 942	60 92 4252	177, 205
82 00 389 134	60 92 2133	189
82 00 389 134 S	60 92 2265	182, 189, 213, 217
82 00 389 135	60 92 2132	189
82 00 395 007	60 93 6345	213
82 00 395 034	60 93 6346	213
82 00 452 715	60 92 2133	189
82 00 452 716	60 92 2132	189
82 00 457 208	60 92 4083	201, 209
82 00 457 209	60 92 4084	201, 209
82 00 554 863	60 93 4709	215
82 00 565 072	60 93 9603	213
82 00 565 079	60 93 9604	213
82 00 586 561 S1	60 93 9023	185
82 00 586 564	60 93 6121	185
82 00 586 567 S1	60 93 9024	185
82 00 586 570	60 93 6122	185
82 00 602 612	60 92 2133	189

Ref. - No.

**SWAG**
GERMANY**SWAG**
GERMANY

Ref. - No.

SWAG
GERMANY

Ref. - No.

SWAG
GERMANY

82 00 602 613	60 92 2132	189
82 00 603 492	60 93 4710	215
82 00 605 381	82 92 1810	177, 178, 205, 218
82 00 615 057	60 92 4251	177, 205
82 00 615 058	60 92 4252	177, 205
82 00 626 959	60 93 6345	213
82 00 626 961	60 93 6346	213
82 00 651 161	60 60 0018	176, 184, 211, 215
82 00 651 163	60 60 0001	167, 197, 199
82 00 651 164	60 60 0017	214
82 00 651 168	60 60 0016	214
82 00 661 217	60 92 1044	182, 189, 213, 217, 660
82 00 669 065	60 92 1015	185, 201, 209
82 00 669 066	60 93 2699	201, 209
82 00 679 063	60 92 4083	201, 209
82 00 679 067	60 92 4084	201, 209
82 00 696 347	60 92 2866	177, 205
82 00 711 554	60 60 0018	176, 184, 211, 215
82 00 713 522	60 91 9867	193, 194
82 00 713 523	60 91 9866	193, 194
82 00 714 446	60 91 9649	214
82 00 714 448	60 91 9650	214
82 00 737 123	60 91 0894	176, 184, 211
82 00 737 125	60 73 0007	214
82 00 737 126	60 73 0011	214
82 00 737 129	60 91 0895	176, 184, 211
82 00 737 132	60 91 9647	199
82 00 737 133	60 91 9646	199
82 00 737 134	60 73 0006	167, 197
82 00 737 135	60 73 0005	167, 197
82 00 744 091	60 92 4251	177, 205
82 00 744 091 S1	60 94 0655	177, 205
82 00 744 092	60 92 4252	177, 205
82 00 744 092 S1	60 94 0656	177, 205
82 00 750 273	60 93 6583	193
82 00 750 274	60 93 6584	193
82 00 767 822	60 92 6453	193
82 00 767 825	60 92 6454	193
82 00 814 411	60 93 7305	178, 661
82 00 820 918	60 92 9638	191, 208
82 00 820 930	60 92 9637	191, 208
82 00 839 107	60 93 6436	661

82 00 839 119	60 93 6395	661
82 00 839 124	60 93 6396	661
82 00 841 004	60 93 6435	661
82 00 852 550	60 93 7726	178
82 00 876 657	60 93 6346	213
82 00 876 659	60 93 6345	213
82 00 891 487	60 93 4710	215
82 00 942 396 S1	60 93 4525	215
82 01 079 463	82 92 1810	177, 178, 205, 218

passend für / to fit:

ROVER

EGP 1662	22 92 3819	220, 221
EGP 1673	22 60 0001	220, 221
FAM 8157	22 71 0002	222, 223
GSJ 100	22 71 0002	222, 223
GSJ 1002	85 78 0001	222
GSJ 286	22 73 0001	220, 221
GSJ 287	22 73 0002	220, 221
GSJ 288	22 71 0001	219, 220, 221, 223
GSJ 291	22 71 0002	222, 223
GSJ 404	85 78 0001	222
GSJ 407	22 71 0003	222
GSJ 413	22 73 0001	220, 221
GSJ 414	22 73 0002	220, 221
GSJ 734	22 71 0002	222, 223
GSJ 826	22 71 0001	219, 220, 221, 223
QJB 100120	22 71 0001	219, 220, 221, 223
QJB 100180	22 93 0732	219, 223
QJB100190	22 93 0731	219, 223
RBM 100240	22 93 0864	219, 223
RBX 101761	22 93 0715	219, 223
RBX 101771	22 93 0714	219, 223
RGD 100561	22 93 0737	663
RGD 100562	22 93 0737	663
RGD 100571	22 93 0736	663
RGD 100572	22 93 0736	663
RGX 10007	85 91 8183	663
RGX 100980	85 91 8183	663

passend für / to fit:

SAAB

12 786 412	40 92 3003	225
12 787 821	40 92 6152	225, 226
12 787 822	40 92 6153	225, 226



Ref. - No.	SWAG GERMANY	
12 796 013	40 92 3001	225
12 796 013 S1	40 93 4231	225
12 796 014	40 92 3002	225
12796014 S1	40 93 4228	225
12 799 199	40 92 3001	225
12 799 199 S1	40 93 4231	225
12 799 200	40 92 3002	225
12799200 S1	40 93 4228	225
12 801 423	40 92 6152	225, 226
12 801 424	40 92 6153	225, 226
13 104 120	40 92 7775	664
13 105 744	40 92 7097	664
13 105 744 S1	40 93 4213	664
13 204 070	40 93 8052	225
13 204 071	40 93 8051	225
13 204 115	40 92 7097	664
13 204 115 S1	40 93 4213	664
13 219 141	40 93 4959	227
13 230 274	40 92 7097	664
13 230 274 S1	40 93 4213	664
13 237 130	40 92 2379	225
13 258 058	40 93 1561	227
13 271 036	40 94 0915	227
13 271 996 SK	40 93 3131	227
13 318 886	40 93 9351	227
13 318 887	40 93 9352	227
24 413 015 S1	40 93 4231	225
24 417 251	40 92 2379	225
24 457 385	40 93 1066	664
24 457 386	40 93 1067	664
24 457 843	40 93 1068	664
24 469 643	40 92 4221	664
42 42 673	40 72 0009	224, 229
42 42 673 S1	57 72 0006	224, 229
42 42 681	40 72 0008	224, 229
42 42 681 S1	57 72 0005	224, 229
42 42 731	40 76 0002	224, 229
42 42 749	40 71 0008	224, 229
42 42 756	40 71 0009	224, 229
42 46 062	40 60 0024	224, 229
42 46 112	40 61 0008	224, 229
45 43 450	57 91 9849	224, 229
45 43 468	57 91 9850	224, 229

Ref. - No.	SWAG GERMANY	
45 44 599	57 91 9719	224, 229
45 44 599 S1	57 91 9720	224, 229
45 66 899	40 60 0017	226
45 67 244	40 79 0018	665
46 86 606	40 79 0004	226
46 86 820	40 61 0016	226
48 35 740	57 92 2951	226
48 36 540	40 71 0014	226
48 36 557	40 74 0002	226
49 08 109	57 92 9985	226
50 63 391	57 92 9985	226
52 31 683	57 92 2951	226
52 33 374	57 93 0054	226
52 35 585	57 92 8362	226
52 35 650	40 92 6152	225, 226
52 35 668	40 92 6153	225, 226
52 36 823	40 79 0004	226
52 37 516	57 93 3841	226
52 39 314	40 92 6152	225, 226
52 39 322	40 92 6153	225, 226
52 39 330	57 92 8362	226
89 05 416	57 78 0001	228
89 24 177	57 71 0002	228
89 53 986	57 61 0002	230
89 57 045	57 78 0002	230
89 57 839	57 71 0003	230
89 58 944	57 79 0001	230
89 61 476	57 60 0002	230
89 62 250	57 72 0001	230
89 65 253	57 60 0001	230
89 72 135	57 78 0002	230
89 85 160	57 71 0002	228
89 85 384	57 78 0001	228
89 85 388	57 78 0001	228
89 88 941 SK	57 92 2761	228
89 93 321	57 78 0001	228
89 93 354	57 71 0002	228
89 93 388	57 78 0001	228
89 93 396	57 71 0002	228
89 93 453	57 71 0003	230
89 93 560	57 71 0002	228
89 94 212 S1	57 78 0002	230
90 468 567	40 61 0016	226

Ref. - No.

**SWAG**
GERMANY**SWAG**
GERMANY

Ref. - No.

SWAG
GERMANY

Ref. - No.

SWAG
GERMANY

93 172 254	40 92 6152	225, 226
93 172 255	40 92 6153	225, 226
93 175 520	40 92 9238	225
93 185 278	57 92 2951	226
93 187 434	40 92 9238	225
93 187 485 SK	57 93 3829	225
93 191 672 SK	40 92 9238	225
93 191 674 SK	57 93 3829	225
93 194 335	57 92 8362	226

passend für / to fit:

SEAT

KIT 11	30 93 9754	253
KIT 12	30 93 9758	253
N 904 840 03 S2	30 92 4374	276, 277
SE028140104A	99 78 0001	274
SE028156110A	70 73 0063	274
SE141162410A	70 71 0005	274
SE141162449A	70 72 0006	274
1K0 199 231 G	30 92 7069	237, 269
1K0 199 231 G S1	32 93 2542	237, 268, 269
1K0 199 231 H	30 93 8662	237, 269, 287
1K0 199 231 H S1	30 94 5891	268, 269, 287
1K0 199 231 J	30 92 7069	237, 269
1K0 199 231 J SK	30 93 1253	237, 249, 261, 269
1K0 199 231 J S1	32 93 2542	237, 268, 269
1K0 199 231 K	30 93 8662	237, 269, 287
1K0 199 231 K S1	30 94 5891	268, 269, 287
1K0 199 231 K SK	30 93 8659	234, 235, 268, 269, 287
1K0 199 231 N	32 93 3971	269
1K0 199 231 N S1	32 93 3973	269
1K0 199 231 P	30 92 7069	237, 269
3C0 199 231 A S1	30 93 9230	235
3C0 199 231 B S1	30 93 9230	235
3C0 199 231 D S1	30 93 9230	235
3C0 199 231 E S1	30 93 9230	235
3C0 199 231 F	30 94 3788	234, 235
3C0 199 231 F SK	30 93 8659	234, 235, 268, 269, 287
8J0 199 231 SK	32 93 3973	269
1K0 199 232 G	30 92 7071	237, 269
1K0 199 232 G S1	32 93 2541	237, 268, 269
1K0 199 232 H	30 93 8663	237, 269, 287

1K0 199 232 H S1	30 94 5892	268, 269, 287
1K0 199 232 J	30 92 7071	237, 269
1K0 199 232 J SK	30 93 1253	237, 249, 261, 269
1K0 199 232 J S1	32 93 2541	237, 268, 269
1K0 199 232 K	30 93 8663	237, 269, 287
1K0 199 232 K SK	30 93 8659	234, 235, 268, 269, 287
1K0 199 232 K S1	30 94 5892	268, 269, 287
1K0 199 232 N	32 93 3972	269
1K0 199 232 N S1	32 93 3973	269
1K0 199 232 P	30 92 7071	237, 269
1H0 407 151 A	30 73 0014	282
1H0 407 151 A S1	30 93 7193	282
1J0 407 151 A	32 73 0016	267, 285
1J0 407 151 A S1	30 91 9820	267, 285
1J0 407 151 A S2	30 91 9822	267, 285
1J0 407 151 B	32 73 0016	267, 285
1J0 407 151 B S2	30 91 9822	267, 285
1J0 407 151 B S1	30 91 9820	267, 285
1J0 407 151 C	32 73 0016	267, 285
1J0 407 151 C S1	30 91 9820	267, 285
1J0 407 151 C S2	30 91 9822	267, 285
1K0 407 151 AA	30 93 9489	268, 269, 287
1K0 407 151 AA S1	30 93 8181	237, 271, 287
1K0 407 151 AB	30 93 9489	268, 269, 287
1K0 407 151 AC S2	30 94 0103	237
1K0 407 151 AC S1	30 93 7183	236, 237
1K0 407 151 AC	30 92 7076	237
1K0 407 151 AE	30 93 9489	268, 269, 287
1K0 407 151 AE S1	30 93 8181	237, 271, 287
1K0 407 151 AH S1	30 93 8181	237, 271, 287
1K0 407 151 AH	30 93 9489	268, 269, 287
1K0 407 151 AL	30 94 0103	237
1K0 407 151 BC	30 93 9489	268, 269, 287
1K0 407 151 BC S1	30 93 8181	237, 271, 287
1K0 407 151 BD	30 93 9489	268, 269, 287
1K0 407 151 M	30 92 7076	237
1K0 407 151 M S2	30 94 0103	237
1K0 407 151 M S1	30 93 7183	236, 237
1K0 407 151 N	30 93 9489	268, 269, 287
1K0 407 151 N S1	30 93 8181	237, 271, 287
1K0 407 151 P	30 93 9489	268, 269, 287
1K0 407 151 P S1	30 93 8181	237, 271, 287



Ref. - No.	SWAG GERMANY	
1K0 407 151 Q	30 93 9489	268, 269, 287
1K0 407 151 Q S1	30 93 8181	237, 271, 287
1K0 407 151 T	30 92 7076	237
1S0 407 151	40 94 0594	275
191 407 151 B	30 73 0013	243, 247, 255, 258, 264, 277, 280
191 407 151 B S2	30 93 7306	243, 247, 255, 258, 264, 277, 280
191 407 151 B S1	30 93 7186	243, 247, 255, 258, 264, 277, 280
3C0 407 151 A S2	30 93 9973	234, 235
3C0 407 151 A S1	30 93 9972	234, 235
3C0 407 151 B S2	30 93 9973	234, 235
3C0 407 151 B S1	30 93 9972	234, 235
3C0 407 151 E S1	30 93 9972	234, 235
3C0 407 151 E S2	30 93 9973	234, 235
3C0 407 151 G S2	30 93 9973	234, 235
3C0 407 151 G S1	30 93 9972	234, 235
6N0 407 151	30 73 0004	241
6N0 407 151 A	30 73 0018	241
6N0 407 151 A S1	30 93 3369	241
6N0 407 151 A S3	30 93 7408	241
6N0 407 151 A S2	30 93 7407	241
6N0 407 151 B	30 73 0004	241
6N0 407 151 B S1	30 93 7409	241
6N0 407 151 B S2	30 93 7410	241
6N0 407 151 S1	30 93 7409	241
6N0 407 151 S2	30 93 7410	241
6Q0 407 151 D	30 92 7530	249, 261
6Q0 407 151 D S3	30 93 7196	249, 261
6Q0 407 151 D S5	30 93 7291	249, 261
6Q0 407 151 D S4	30 93 7292	249, 261
6Q0 407 151 D S2	30 93 7197	249, 261
6Q0 407 151 E	30 92 7530	249, 261
6Q0 407 151 E S5	30 93 7291	249, 261
6Q0 407 151 E S3	30 93 7196	249, 261
6Q0 407 151 E S2	30 93 7197	249, 261
6Q0 407 151 E S4	30 93 7292	249, 261
6Q0 407 151 L	30 92 7530	249, 261
6Q0 407 151 L S2	30 93 7197	249, 261
6Q0 407 151 L S3	30 93 7196	249, 261
6Q0 407 151 L S5	30 93 7291	249, 261
6Q0 407 151 L S4	30 93 7292	249, 261

Ref. - No.	SWAG GERMANY	
6Q0 407 151 L S1	30 93 6098	249, 261
6R0 407 151	30 93 6923	249, 261
6R0 407 151 A	30 93 9557	263, 289
6R0 407 151 A S1	30 94 4547	262, 263, 288, 289
6R0 407 151 E	30 93 6923	249, 261
6R0 407 151 E S1	30 93 6925	249, 261
6R0 407 151 F	30 93 9557	263, 289
6R0 407 151 F S1	30 94 4547	262, 263, 288, 289
6R0 407 151 S1	30 93 6925	249, 261
6X0 407 151	30 73 0018	241
6X0 407 151 A	30 73 0018	241
6X0 407 151 A S3	30 93 7408	241
6X0 407 151 A S1	30 93 3369	241
6X0 407 151 A S2	30 93 7407	241
6X0 407 151 S1	30 93 3369	241
6X0 407 151 S2	30 93 7407	241
6X0 407 151 S3	30 93 7408	241
7M0 407 151 B	50 73 0024	231, 233
8E0 407 151 E	32 73 0034	253
8E0 407 151 E S1	30 93 3370	253
8E0 407 151 K	32 73 0034	253
8E0 407 151 K S1	30 93 3370	253
8E0 407 151 L	32 73 0034	253
8E0 407 151 L S1	30 93 3370	253
8E0 407 151 M	32 73 0034	253
8E0 407 151 M S1	30 93 3370	253
8E0 407 151 N	32 73 0034	253
8E0 407 151 N S1	30 93 3370	253
8E0 407 151 R	32 73 0034	253
8E0 407 151 R S1	30 93 3370	253
1H0 407 152	30 73 0006	282
1H0 407 152 S1	30 93 7194	282
1K0 407 152 AA	30 93 9448	268, 269, 287
1K0 407 152 AA S1	30 93 8180	236, 237, 271, 287
1K0 407 152 AB	30 93 9448	268, 269, 287
1K0 407 152 AB S1	30 93 8180	236, 237, 271, 287
1K0 407 152 AC	30 92 7078	237
1K0 407 152 AC S2	30 94 0104	237
1K0 407 152 AC S1	30 93 7182	236, 237
1K0 407 152 AE S1	30 93 8180	236, 237, 271, 287
1K0 407 152 AE	30 93 9448	268, 269, 287
1K0 407 152 AF S1	30 93 8180	236, 237, 271, 287
1K0 407 152 AH	30 93 9448	268, 269, 287

Ref. - No.

**SWAG**
GERMANY**SWAG**
GERMANY

Ref. - No.

SWAG
GERMANY

Ref. - No.

SWAG
GERMANY

1K0 407 152 AH S1	30 93 8180	236, 237, 271, 287
1K0 407 152 AL	30 94 0104	237
1K0 407 152 BC	30 93 9448	268, 269, 287
1K0 407 152 BC S1	30 93 8180	236, 237, 271, 287
1K0 407 152 BD	30 93 9448	268, 269, 287
1K0 407 152 M	30 92 7078	237
1K0 407 152 M S2	30 94 0104	237
1K0 407 152 M S1	30 93 7182	236, 237
1K0 407 152 N	30 93 9448	268, 269, 287
1K0 407 152 N S1	30 93 8180	236, 237, 271, 287
1K0 407 152 P	30 93 9448	268, 269, 287
1K0 407 152 P S1	30 93 8180	236, 237, 271, 287
1K0 407 152 Q	30 93 9448	268, 269, 287
1K0 407 152 Q S1	30 93 8180	236, 237, 271, 287
1K0 407 152 T	30 92 7078	237
1S0 407 152	40 94 0595	275
6R0 407 152	30 93 6922	249, 261
6R0 407 152 A	30 93 9558	263, 289
6R0 407 152 A S1	30 94 4548	263, 289
6R0 407 152 E	30 93 6922	249, 261
6R0 407 152 E S1	30 93 6926	249, 261
6R0 407 152 F	30 93 9558	263, 289
6R0 407 152 F S1	30 94 4548	263, 289
6R0 407 152 S1	30 93 6926	249, 261
7M0 407 152 B	50 73 0023	231, 233
191 407 153 A	30 73 0013	243, 247, 255, 258, 264, 277, 280
191 407 153 A S2	30 60 0008	242, 243, 254, 255, 276, 277
191 407 153 A S3	30 60 0006	242, 243, 246, 247, 254, 255, 276, 277
191 407 153 SO	30 60 0002	242, 243, 254, 255, 276, 277
191 407 153 S XN	30 60 0006	242, 243, 246, 247, 254, 255, 276, 277
191 407 153 S XO	30 60 0008	242, 243, 254, 255, 276, 277
191 407 153 S1	30 60 0002	242, 243, 254, 255, 276, 277
191 407 153 S2	30 60 0004	247, 258, 277
1J0 407 181	32 69 0009	261, 263, 267, 275, 285, 289

1J0 407 181 A	32 69 0009	261, 263, 267, 275, 285, 289
191 407 181 A	30 69 0003	243, 247, 255, 258, 264, 277, 280, 282
191 407 181 AS	30 75 0001	242, 243, 246, 247, 254, 255, 258, 264, 276, 277, 280, 282
191 407 181 B	30 69 0003	243, 247, 255, 258, 264, 277, 280, 282
191 407 181 BS	30 75 0001	242, 243, 246, 247, 254, 255, 258, 264, 276, 277, 280, 282
191 407 181 B S1	30 75 0001	242, 243, 246, 247, 254, 255, 258, 264, 276, 277, 280, 282
191 407 181 D	30 69 0001	243, 247, 255, 258, 264, 277, 280, 282
191 407 181 E	30 69 0001	243, 247, 255, 258, 264, 277, 280, 282
357 407 181	30 69 0001	243, 247, 255, 258, 264, 277, 280, 282
6N0 407 181	30 60 0034	241
6R0 407 181 B	30 92 6535	263, 267, 285
7M0 407 181 A	30 60 0033	231, 233
8E0 407 181 C	32 60 0003	253
8N0 407 181 B	30 92 6535	263, 267, 285
1K0 407 182	30 92 4390	237, 269, 273, 287
1K0 407 182 A	30 92 4390	237, 269, 273, 287
191 407 182	30 69 0002	243, 247, 255, 258, 261, 263, 264, 267, 275, 277, 280, 285, 289
357 407 182	30 69 0002	243, 247, 255, 258, 261, 263, 264, 267, 275, 277, 280, 285, 289
4D0 407 182 E	30 60 0031	253
4D0 407 182 G	30 60 0031	253
5Q0 407 182 A	30 92 4390	237, 269, 273, 287
6N0 407 182	30 60 0032	241
6Q0 407 182 A	30 93 6098	249, 261
1K0 407 183 E	30 93 1253	237, 249, 261, 269
1K0 407 183 E S1	30 93 9228	249, 261



Ref. - No.	SWAG GERMANY	
1K0 407 183 G	30 93 8659	234, 235, 268, 269, 287
4D0 407 183 L	30 92 8582	253
4F0 407 183 A	30 92 8582	253
4F0 407 183 B	30 92 8582	253
4F0 407 183 E	30 92 8582	253
5Q0 407 183 E	30 93 8403	273
5Q0 407 183 G	30 93 8403	273
6Q0 407 183	30 93 1253	237, 249, 261, 269
6Q0 407 183 A	30 93 1253	237, 249, 261, 269
6Q0 407 183 A S1	30 93 9228	249, 261
6Q0 407 183 B	30 93 1253	237, 249, 261, 269
6Q0 407 183 B S1	30 93 9228	249, 261
6Q0 407 183 S1	30 93 9228	249, 261
8J0 407 183	32 93 3973	269
1H0 407 365	30 78 0021	282
1H0 407 365 S	30 78 0036	282
1H0 407 365 S1	30 78 0036	282
1J0 407 365	30 78 0035	267, 285
1J0 407 365 A	30 78 0035	267, 285
1J0 407 365 A	32 78 0020	267, 285
1J0 407 365 C	32 78 0020	267, 285
1J0 407 365 C	30 78 0035	267, 285
1J0 407 365 CS	30 78 0035	267, 285
1J0 407 365 C S1	30 78 0035	267, 285
1J0 407 365 D	32 78 0020	267, 285
1J0 407 365 H	32 78 0020	267, 285
1J0 407 365 H S1	30 78 0035	267, 285
1J0 407 365 J	32 78 0020	267, 285
1J0 407 365 J S1	30 78 0035	267, 285
1K0 407 365 B	32 92 6082	237, 269, 287
1K0 407 365 B S1	30 93 6735	237, 269, 287
1K0 407 365 C	32 92 6082	237, 269, 287
1K0 407 365 C S1	30 93 6735	237, 269, 287
1K0 407 365 E	32 92 6082	237, 269, 287
1K0 407 365 E S1	30 93 6735	237, 269, 287
3C0 407 365 A	30 93 0509	269
3C0 407 365 A S1	30 93 1485	235, 269, 273
3C0 407 365 B	30 93 0509	269
3C0 407 365 B S1	30 93 1485	235, 269, 273
357 407 365	30 78 0019	243, 247, 255, 258, 264, 277, 280

Ref. - No.	SWAG GERMANY	
357 407 365 A	30 78 0019	243, 247, 255, 258, 264, 277, 280
357 407 365 A S2	30 93 9810	243, 247, 255, 258, 264, 277, 280
357 407 365 K PL	30 78 0017	243, 247, 255, 258, 264, 277, 280
357 407 365 S	30 78 0017	243, 247, 255, 258, 264, 277, 280
357 407 365 S1	30 78 0017	243, 247, 255, 258, 264, 277, 280
357 407 365 S2	30 93 9810	243, 247, 255, 258, 264, 277, 280
5Q0 407 365 A S1	30 94 0668	273
6N0 407 365	30 78 0023	241
6N0 407 365 A	30 78 0022	241
6N0 407 365 A S	30 78 0037	241
6N0 407 365 A S1	30 78 0037	241
6N0 407 365 S	30 78 0038	241
6N0 407 365 S1	30 78 0038	241
6Q0 407 365 A	30 91 9406	249, 261
6Q0 407 365 A S1	30 91 9410	249, 261
6Q0 407 365 D	30 91 9406	249, 261
6Q0 407 365 E	30 91 9406	249, 261
6Q0 407 365 M	30 91 9406	249, 261
6Q0 407 365 M S1	30 91 9410	249, 261
6R0 407 365	30 93 6051	249, 261, 263, 275, 289
6R0 407 365 A	30 93 6051	249, 261, 263, 275, 289
6R0 407 365 B	30 93 6051	249, 261, 263, 275, 289
7M0 407 365 A	30 91 9276	231, 233
7M3 407 365 A	30 91 9276	231, 233
7M3 407 365 C	30 91 9276	231, 233
8N0 407 365 A	30 92 6700	267
8N0 407 365 B	30 92 6700	267
8N0 407 365 C	30 92 6700	267
8Z0 407 365 A S1	30 78 0035	267, 285
1J0 407 366 A	32 78 0019	267, 285
1J0 407 366 AS	30 78 0034	267, 285
1J0 407 366 C	32 78 0019	267, 285
1J0 407 366 C S1	30 78 0034	267, 285
1J0 407 366 CS	30 78 0034	267, 285

Ref. - No.

**SWAG**
GERMANY**SWAG**
GERMANY

Ref. - No.

SWAG
GERMANY

Ref. - No.

SWAG
GERMANY

1J0 407 366 D	32 78 0019	267, 285
1J0 407 366 H	32 78 0019	267, 285
1J0 407 366 H S1	30 78 0034	267, 285
1J0 407 366 J	32 78 0019	267, 285
1J0 407 366 J S1	30 78 0034	267, 285
1K0 407 366 B	32 92 6083	237, 269, 287
1K0 407 366 B S1	30 93 6736	237, 269, 287
1K0 407 366 C	32 92 6083	237, 269, 287
1K0 407 366 C S1	30 93 6736	237, 269, 287
1K0 407 366 E	32 92 6083	237, 269, 287
1K0 407 366 E S1	30 93 6736	237, 269, 287
3C0 407 366 A	30 93 0510	269
3C0 407 366 A S1	30 93 1486	235, 269, 273
3C0 407 366 B	30 93 0510	269
3C0 407 366 B S1	30 93 1486	235, 269, 273
5Q0 407 366 A S1	30 94 0669	273
6Q0 407 366 A	30 91 9408	249, 261
6Q0 407 366 A S1	30 91 9412	249, 261
6Q0 407 366 D	30 91 9408	249, 261
6Q0 407 366 E	30 91 9408	249, 261
6Q0 407 366 M	30 91 9408	249, 261
6Q0 407 366 M S1	30 91 9412	249, 261
6R0 407 366	30 93 6052	249, 261, 263, 275, 289
6R0 407 366 A	30 93 6052	249, 261, 263, 275, 289
6R0 407 366 B	30 93 6052	249, 261, 263, 275, 289
8N0 407 366 A	30 92 6700	267
8Z0 407 366 A S1	30 78 0034	267, 285
8D0 407 505 D	30 93 2318	253
8D0 407 505 D S1	30 94 0745	253
8D0 407 505 E	30 93 2318	253
8D0 407 505 E S1	30 94 0745	253
8D0 407 505 L	30 93 2318	253
8D0 407 505 L S1	30 94 0745	253
8E0 407 505 C	30 93 2318	253
8E0 407 505 C S1	30 94 0745	253
8E0 407 505 P	30 93 2318	253
8E0 407 505 P S1	30 94 0745	253
8D0 407 506 D	30 93 2319	253
8D0 407 506 D S1	30 94 0746	253
8D0 407 506 E	30 93 2319	253

8D0 407 506 E S1	30 94 0746	253
8D0 407 506 L	30 93 2319	253
8D0 407 506 L S1	30 94 0746	253
8E0 407 506 C	30 93 2319	253
8E0 407 506 C S1	30 94 0746	253
8E0 407 506 P	30 93 2319	253
8E0 407 506 P S1	30 94 0746	253
8D0 407 509	32 93 1332	253
8D0 407 509 A	32 93 1332	253
8D0 407 509 A S1	30 94 0744	253
8D0 407 509 F	32 93 1332	253
8D0 407 509 F S1	30 94 0744	253
8D0 407 509 S1	30 94 0744	253
8E0 407 509 C	32 93 1332	253
8E0 407 509 C S1	30 94 0744	253
8E0 407 509 P	32 93 1332	253
8E0 407 509 P S1	30 94 0744	253
8D0 407 510	32 93 1331	253
8D0 407 510 A	32 93 1331	253
8D0 407 510 A S1	30 94 0743	253
8D0 407 510 F	32 93 1331	253
8D0 407 510 F S1	30 94 0743	253
8D0 407 510 S1	30 94 0743	253
8E0 407 510 C	32 93 1331	253
8E0 407 510 C S1	30 94 0743	253
8E0 407 510 P	32 93 1331	253
8E0 407 510 P S1	30 94 0743	253
8D0 407 515 A	32 93 0696	253
8D0 407 515 B	32 93 0696	253
8D0 407 515 C	32 93 0696	253
8E0 407 693 AA	30 93 1277	253
8E0 407 693 AC	30 93 1277	253
8E0 407 693 AF	30 93 1277	253
8E0 407 693 AJ	30 93 1277	253
8E0 407 693 AK	30 93 1277	253
8E0 407 693 AL	30 93 1277	253
8E0 407 693 AM	30 93 1277	253
8E0 407 693 N	30 93 1277	253
8E0 407 693 T	30 93 1277	253
8E0 407 694 AA	30 93 1281	253
8E0 407 694 AC	30 93 1281	253
8E0 407 694 AF	30 93 1281	253
8E0 407 694 AJ	30 93 1281	253



Ref. - No.	SWAG GERMANY	
8E0 407 694 AK	30 93 1281	253
8E0 407 694 AL	30 93 1281	253
8E0 407 694 AM	30 93 1281	253
8E0 407 694 N	30 93 1281	253
8E0 407 694 T	30 93 1281	253
7M0 411 031	50 91 9453	231, 233
1K0 411 303 AL S1	30 94 5306	237, 268, 269
1K0 411 303 AL S2	30 94 5307	237, 269
1K0 411 303 BJ S2	30 94 5307	237, 269
1K0 411 303 BJ S1	30 94 5306	237, 268, 269
1K0 411 303 BK S1	30 94 5306	237, 268, 269
1K0 411 303 BK S2	30 94 5307	237, 269
1J0 411 305 B S1	30 93 6630	267, 285
1J0 411 305 E S1	30 93 6640	267, 285
1J0 411 305 E S2	30 94 0090	267, 285
6Q0 411 305 AC S2	30 93 7110	249, 261, 263
6Q0 411 305 AL S2	30 93 7090	249, 261, 263
6Q0 411 305 AM S2	30 93 7100	249, 263
6Q0 411 305 AN S2	30 93 7110	249, 261, 263
6N0 411 313	34 92 2492	241
6N0 411 313 A	34 92 2494	241
6X0 411 313	34 92 2492	241
6X0 411 313 A	34 92 2494	241
1H0 411 314	30 91 9050	243, 247, 255, 258, 264, 277, 280, 282
1J0 411 314 AC S1	30 93 7139	267, 284, 285
1J0 411 314 AC	30 93 1348	267, 285
1J0 411 314 G	30 61 0009	267, 285
1J0 411 314 M	32 92 2804	267, 285
1J0 411 314 N	32 92 2804	267, 285
1J0 411 314 R	32 92 2804	267, 285
1J0 411 314 R S1	30 92 7304	267, 285
1J0 411 314 T	30 61 0009	267, 285
1J0 411 314 T S2	30 94 0089	267, 285
1J0 411 314 T S1	30 92 7318	267, 285
191 411 314	30 61 0013	243, 247, 255, 258, 264, 277, 280
6Q0 411 314 E	30 92 7642	249, 261, 263, 289
6Q0 411 314 E S2	30 93 7089	247, 249, 261, 263
6Q0 411 314 E S4	30 93 7659	246, 247, 248, 249, 260, 261, 262, 263, 288, 289

Ref. - No.	SWAG GERMANY	
6Q0 411 314 E S3	30 93 7656	246, 247, 248, 249, 260, 261
6Q0 411 314 J	30 92 7638	249, 261, 263, 275
6Q0 411 314 J S1	30 93 7077	247, 249, 261, 263, 275
6Q0 411 314 J S2	30 93 7657	246, 247, 248, 249, 260, 261, 262, 263, 275
6Q0 411 314 L	30 92 7638	249, 261, 263, 275
6Q0 411 314 L S1	30 93 7077	247, 249, 261, 263, 275
6Q0 411 314 L S2	30 93 7657	246, 247, 248, 249, 260, 261, 262, 263, 275
6Q0 411 314 M	30 92 7640	249, 261, 263, 289
6Q0 411 314 M S2	30 93 7660	246, 247, 248, 249, 260, 261, 262, 263, 288, 289
6Q0 411 314 M S1	30 93 7069	247, 249, 263
6Q0 411 314 N	30 92 7642	249, 261, 263, 289
6Q0 411 314 N S4	30 93 7659	246, 247, 248, 249, 260, 261, 262, 263, 288, 289
6Q0 411 314 N S3	30 93 7656	246, 247, 248, 249, 260, 261
6Q0 411 314 N S2	30 93 7089	247, 249, 261, 263
6Q0 411 314 P	30 92 7638	249, 261, 263, 275
6Q0 411 314 P S1	30 93 7077	247, 249, 261, 263, 275
6Q0 411 314 P S2	30 93 7657	246, 247, 248, 249, 260, 261, 262, 263, 275
6Q0 411 314 Q	30 92 7640	249, 261, 263, 289
6Q0 411 314 Q S2	30 93 7660	246, 247, 248, 249, 260, 261, 262, 263, 288, 289
6Q0 411 314 Q S1	30 93 7069	247, 249, 263
6Q0 411 314 R	30 92 7642	249, 261, 263, 289
6Q0 411 314 R S3	30 93 7656	246, 247, 248, 249, 260, 261
6Q0 411 314 R S4	30 93 7659	246, 247, 248, 249, 260, 261, 262, 263, 288, 289

Ref. - No.

**SWAG**
GERMANY**SWAG**
GERMANY

Ref. - No.

SWAG
GERMANY

Ref. - No.

SWAG
GERMANY

6Q0 411 314 R S2	30 93 7089	247, 249, 261, 263
8N0 411 314 B	32 92 2804	267, 285
1J0 411 315 C	30 76 0003	267, 285
1J0 411 315 D	30 91 9296	267, 285
1J0 411 315 E	30 76 0004	266, 267, 284, 285
1J0 411 315 E S1	30 93 6676	267, 285
1J0 411 315 E S3	30 93 6757	267, 285
1J0 411 315 E S4	30 93 6758	267, 285
1J0 411 315 E S2	30 93 6677	266, 267, 284, 285
1J0 411 315 G	30 76 0004	266, 267, 284, 285
1J0 411 315 G S4	30 93 6758	267, 285
1J0 411 315 G S3	30 93 6757	267, 285
1J0 411 315 G S1	30 93 0154	266, 267, 284, 285
1J0 411 315 G S2	30 93 6677	266, 267, 284, 285
1J0 411 315 G S1	30 93 6676	267, 285
1J0 411 315 H	30 92 8579	267, 285
1J0 411 315 H S1	30 93 6665	267, 285
1J0 411 315 H S2	30 93 6667	267, 285
1J0 411 315 J	30 76 0003	267, 285
1J0 411 315 K	30 92 8579	267, 285
1J0 411 315 K S2	30 93 6667	267, 285
1J0 411 315 K S1	30 93 6665	267, 285
1K0 411 315 B	32 92 4122	235, 237, 269, 273, 287
1K0 411 315 D	32 92 4122	235, 237, 269, 273, 287
1K0 411 315 G	32 92 4122	235, 237, 269, 273, 287
1K0 411 315 J	32 92 4122	235, 237, 269, 273, 287
1K0 411 315 K	32 92 4122	235, 237, 269, 273, 287
1K0 411 315 N	32 92 4122	235, 237, 269, 273, 287
1K0 411 315 P	32 92 4122	235, 237, 269, 273, 287
1K0 411 315 R	32 92 4122	235, 237, 269, 273, 287
191 411 315	30 79 0001	243, 247, 255, 276, 277
191 411 315 B	30 79 0003	242, 243, 254, 255, 276, 277

191 411 315 BS	30 79 0001	243, 247, 255, 276, 277
191 411 315 B S1	30 79 0001	243, 247, 255, 276, 277
5Q0 411 315 A	32 92 4122	235, 237, 269, 273, 287
535 411 315	30 79 0002	280, 282
6K0 411 315	30 92 7984	264, 277
6K0 411 315 S1	30 92 7982	243, 247, 255, 264, 276, 277, 280
6N0 411 315 A	32 92 3030	241
6N0 411 315 A S1	32 92 3032	241
6N0 411 315 B	32 92 3030	241
6N0 411 315 D	32 92 3030	241
6N0 411 315 D S1	32 92 3032	241
6Q0 411 315 A	30 91 9518	249, 261, 263, 275, 289
6Q0 411 315 B	30 91 9518	249, 261, 263, 275, 289
6Q0 411 315 C	30 91 9518	249, 261, 263, 275, 289
6Q0 411 315 D	30 91 9518	249, 261, 263, 275, 289
6Q0 411 315 E	30 91 9518	249, 261, 263, 275, 289
6Q0 411 315 F	30 91 9518	249, 261, 263, 275, 289
6Q0 411 315 G	30 91 9518	249, 261, 263, 275, 289
6Q0 411 315 H	30 91 9518	249, 261, 263, 275, 289
6Q0 411 315 J	30 91 9518	249, 261, 263, 275, 289
6Q0 411 315 L	30 91 9518	249, 261, 263, 275, 289
6Q0 411 315 M	30 91 9518	249, 261, 263, 275, 289
6Q0 411 315 N	30 91 9518	249, 261, 263, 275, 289
6Q0 411 315 P	30 91 9518	249, 261, 263, 275, 289
6Q0 411 315 Q	30 91 9518	249, 261, 263, 275, 289



Ref. - No.	SWAG GERMANY	
6R0 411 315	30 91 9518	249, 261, 263, 275, 289
6R0 411 315 A	30 91 9518	249, 261, 263, 275, 289
1J0 411 316 D	30 91 9298	267, 285
7M0 411 317 C	50 79 0004	231, 233
7M0 411 317 D	50 79 0004	231, 233
7M3 411 317	50 79 0004	231, 233
7M3 411 317 A	50 79 0004	231, 233
7M3 411 317 B	50 79 0004	231, 233
7M3 411 317 C	50 79 0004	231, 233
7M3 411 317 E	50 79 0004	231, 233
8E0 411 317	32 72 0023	253
8E0 411 317 S1	32 72 0025	253
8E0 411 318	32 72 0024	253
8E0 411 318 S1	32 72 0026	253
1J0 411 327 A	30 93 6646	267, 285
4D0 411 327 J	32 92 3046	253
1J0 411 336 B	32 92 3366	267, 269, 285
1J0 411 336 C	32 92 3366	267, 269, 285
1J0 411 336 D	32 92 3366	267, 269, 285
191 419 063	30 80 0002	278
191 419 063 B	30 80 0002	278
191 419 063 C	30 80 0001	244, 256, 278
191 419 063 CX	30 80 0001	244, 256, 278
191 419 803	30 72 0034	244, 256, 278
191 419 803 A	30 72 0034	244, 256, 278
191 419 803 A SK	30 93 7066	244, 256, 279, 281
191 419 803 SK	30 93 7066	244, 256, 279, 281
6N0 419 803	30 72 0052	239
6N0 419 803 SK	30 93 8858	239
6X0 419 803 A	32 92 3322	239
191 419 804	30 72 0033	244, 256, 278
191 419 804 A	30 72 0033	244, 256, 278
191 419 804 A SK	30 93 7066	244, 256, 279, 281
191 419 804 SK	30 93 7066	244, 256, 279, 281
6N0 419 804	30 72 0051	239
6N0 419 804 SK	30 93 8858	239
6X0 419 804 A	32 92 3324	239
191 419 810	30 93 7066	244, 256, 279, 281
191 419 810 A	30 93 7066	244, 256, 279, 281
6N0 419 810	30 93 8858	239

Ref. - No.	SWAG GERMANY	
191 419 811	30 71 0024	244, 245, 256, 257, 264, 278, 279, 281
4F0 419 811 C	30 92 1840	253
4F0 419 811 C	32 93 9077	253
6E0 419 811	30 71 0044	239, 245, 257, 264
191 419 812	30 71 0023	244, 245, 256, 257, 264, 278, 279, 281
6E0 419 812	30 71 0045	239, 245, 257, 264
171 419 831 B	30 80 0063	244, 256, 278
171 419 831 B	30 80 0054	244, 256, 278
171 419 831 C	30 80 0063	244, 256, 278
171 419 831 C	30 80 0054	244, 256, 278
191 419 831	30 80 0054	244, 256, 278
191 419 831 S1	30 80 0063	244, 256, 278
6E0 419 831	30 92 1700	251, 259
6N0 419 831	30 80 0065	239
8D0 419 831 K S1	30 93 3592	253
8E0 419 831 S1	30 93 3592	253
191 419 883	30 69 0004	244, 256, 278
1J0 422 803 B	99 72 0002	265, 283
1J0 422 803 B S1	30 94 4341	265, 283
1J0 422 803 B SK	30 92 7095	265, 283
1J0 422 803 E	99 72 0002	265, 283
1J0 422 803 E S1	30 94 4341	265, 283
1J0 422 803 H	99 72 0002	265, 283
1J0 422 803 H SK	30 92 7095	265, 283
1J0 422 803 H S1	30 94 4341	265, 283
191 422 803	30 72 0036	244, 256, 279
191 422 803 A	30 72 0036	244, 256, 279
191 422 803 A SK	30 93 3907	243, 255, 278, 280
191 422 803 SK	30 93 3907	243, 255, 278, 280
6K0 422 803	32 92 2515	244, 256, 278, 279
6K0 422 803 B	30 94 4675	245, 257
6K0 422 803 B S1	30 94 4741	245, 257
6K0 422 803 E	30 94 4675	245, 257
6K0 422 803 E S1	30 94 4741	245, 257
6K0 422 803 E SK	30 93 7065	245, 257
6K0 422 803 SK	30 93 8857	256, 278
6N0 422 803	30 72 0053	239
6N0 422 803 A	30 72 0053	239
6N0 422 803 A SK	30 93 8859	238, 239
6N0 422 803 C	32 92 6251	239
6N0 422 803 D	32 92 6253	239

Ref. - No.

**SWAG**
GERMANY**SWAG**
GERMANY

Ref. - No.

SWAG
GERMANY

Ref. - No.

SWAG
GERMANY

6N0 422 803 SK	30 93 8859	238, 239
6X0 422 803	30 72 0071	239
6X0 422 803 SK	30 93 8855	238, 239
7M0 422 803 F	50 72 0010	231, 233
7M0 422 803 G	50 72 0010	231, 233
7M3 422 803	50 72 0010	231, 233
7M3 422 803 A	50 72 0010	231, 233
1J0 422 804 B	99 72 0001	265, 283
1J0 422 804 B S1	30 94 4342	265, 283
1J0 422 804 B SK	30 92 7095	265, 283
1J0 422 804 E	99 72 0001	265, 283
1J0 422 804 E S1	30 94 4342	265, 283
1J0 422 804 H	99 72 0001	265, 283
1J0 422 804 H S1	30 94 4342	265, 283
1J0 422 804 H SK	30 92 7095	265, 283
191 422 804	30 72 0035	244, 256, 279
191 422 804 A	30 72 0035	244, 256, 279
191 422 804 A SK	30 93 3907	243, 255, 278, 280
191 422 804 SK	30 93 3907	243, 255, 278, 280
6K0 422 804	32 92 2516	244, 256, 278, 279
6K0 422 804 B	30 94 4676	245, 257
6K0 422 804 B S1	30 94 4740	245, 257
6K0 422 804 E	30 94 4676	245, 257
6K0 422 804 E SK	30 93 7065	245, 257
6K0 422 804 E S1	30 94 4740	245, 257
6K0 422 804 SK	30 93 8857	256, 278
6N0 422 804	30 72 0054	239
6N0 422 804 A	30 72 0054	239
6N0 422 804 A SK	30 93 8859	238, 239
6N0 422 804 C	32 92 6252	239
6N0 422 804 D	32 92 6254	239
6N0 422 804 SK	30 93 8859	238, 239
6X0 422 804	30 72 0072	238, 239
6X0 422 804 SK	30 93 8855	238, 239
7M0 422 804 F	50 72 0011	231, 233
7M0 422 804 G	50 72 0011	231, 233
7M3 422 804	50 72 0011	231, 233
7M3 422 804 A	50 72 0011	231, 233
1J0 422 810 B	30 92 7095	265, 283
191 422 810 A	30 93 3907	243, 255, 278, 280
6K0 422 810	30 93 8857	256, 278
6K0 422 810 E	30 93 7065	245, 257
6N0 422 810 A	30 93 8859	238, 239

6X0 422 810	30 93 8855	238, 239
1J0 422 811 B	30 71 0038	265, 283
1J0 422 811 E	30 71 0038	265, 283
3A0 422 811	30 71 0024	244, 245, 256, 257, 264, 278, 279, 281
6K0 422 811	30 71 0044	239, 245, 257, 264
6N0 422 811	30 71 0043	239
6X0 422 811	30 71 0044	239, 245, 257, 264
8N0 422 811	30 91 9336	265
8N0 422 811 A	30 91 9336	265
1J0 422 812 B	30 71 0037	265, 283
1J0 422 812 E	30 71 0037	265, 283
3A0 422 812	30 71 0023	244, 245, 256, 257, 264, 278, 279, 281
6K0 422 812	30 71 0045	239, 245, 257, 264
6N0 422 812	30 71 0042	239
6X0 422 812	30 71 0045	239, 245, 257, 264
8N0 422 812	30 91 9342	265
8N0 422 812 A	30 91 9342	265
7M0 422 817	50 71 0029	231, 233
7M0 422 817 A	50 71 0029	231, 233
7M0 422 817 B	50 71 0029	231, 233
7M3 422 817	50 71 0029	231, 233
7M0 422 818	50 71 0028	231, 233
7M0 422 818 A	50 71 0028	231, 233
7M0 422 818 B	50 71 0028	231, 233
7M3 422 818	50 71 0028	231, 233
8E0 422 821	32 92 6151	253
8E0 422 821 C	32 92 6151	253
8E0 422 821 C S1	30 93 6800	253
1H0 422 831	30 80 0057	244, 245, 256, 257, 264, 279, 281
1H0 422 831	30 80 0066	244, 245, 256, 257, 264, 279, 281
1H0 422 831 B	30 80 0057	244, 245, 256, 257, 264, 279, 281
1H0 422 831 B S1	30 80 0066	244, 245, 256, 257, 264, 279, 281
1J0 422 831	30 93 7764	265, 283
1J0 422 831	30 80 0068	265, 283
1J0 422 831 B	30 80 0068	265, 283
1J0 422 831 B	30 93 7764	265, 283
1J0 422 831 B S1	30 93 7764	265, 283



Ref. - No.	SWAG GERMANY	
175 422 831	30 80 0057	244, 245, 256, 257, 264, 279, 281
175 422 831	30 80 0066	244, 245, 256, 257, 264, 279, 281
191 422 831	30 80 0057	244, 245, 256, 257, 264, 279, 281
191 422 831	30 80 0066	244, 245, 256, 257, 264, 279, 281
357 422 831	30 80 0057	244, 245, 256, 257, 264, 279, 281
357 422 831	30 80 0066	244, 245, 256, 257, 264, 279, 281
357 422 831 A	30 80 0066	244, 245, 256, 257, 264, 279, 281
357 422 831 A	30 80 0057	244, 245, 256, 257, 264, 279, 281
6N0 422 831	30 80 0064	239
7M0 422 831 B	99 80 0003	231, 233
7M3 422 831	99 80 0003	231, 233
8N0 422 831 S1	30 93 9606	267
1H0 422 884	30 91 8864	244, 245, 256, 257, 264, 279, 281
6Q0 423 803 B	30 91 9816	251, 259
6Q0 423 803 B SK	30 93 2473	251, 259
6Q0 423 803 B S1	30 94 4343	251, 259
6Q0 423 803 C	30 92 6173	251, 259
6Q0 423 803 E	30 91 9816	251, 259
6Q0 423 803 E SK	30 93 2473	251, 259
6Q0 423 803 E S1	30 94 4343	251, 259
6Q0 423 803 G	30 92 6173	251, 259
6Q0 423 803 P	30 91 9816	251, 259
6Q0 423 803 P SK	30 93 2473	251, 259
6Q0 423 803 P S1	30 94 4343	251, 259
6R0 423 803	30 93 6508	263, 289
6R0 423 803 A	30 93 6508	263, 289
6R0 423 803 A SK	30 93 3584	263, 289
6R0 423 803 B SK	30 93 3584	263, 289
6R0 423 803 C SK	30 93 3584	263, 289
6R0 423 803 D SK	30 93 3584	263, 289
6R0 423 803 SK	30 93 3584	263, 289
6Q0 423 804 B	30 91 9818	251, 259
6Q0 423 804 B S1	30 94 4344	251, 259
6Q0 423 804 B SK	30 93 2473	251, 259

Ref. - No.	SWAG GERMANY	
6Q0 423 804 C	30 92 6174	251, 259
6Q0 423 804 E	30 91 9818	251, 259
6Q0 423 804 E S1	30 94 4344	251, 259
6Q0 423 804 E SK	30 93 2473	251, 259
6Q0 423 804 G	30 92 6174	251, 259
6Q0 423 804 P	30 91 9818	251, 259
6Q0 423 804 P SK	30 93 2473	251, 259
6Q0 423 804 P S1	30 94 4344	251, 259
6R0 423 804	30 93 6509	263, 289
6R0 423 804 A	30 93 6509	263, 289
6R0 423 804 A SK	30 93 3584	263, 289
6R0 423 804 B SK	30 93 3584	263, 289
6R0 423 804 C SK	30 93 3584	263, 289
6R0 423 804 D SK	30 93 3584	263, 289
6R0 423 804 SK	30 93 3584	263, 289
1K0 423 810 A	32 92 6045	235, 237, 271, 273, 286
1K0 423 810 A S1	30 93 2627	235, 237, 271, 273, 286
1K0 423 810 A S4	30 94 5760	235, 237, 271, 273, 286
1K0 423 810 A S3	30 94 5761	235, 237, 271, 273, 286
1K0 423 810 A S2	30 93 2628	235, 237, 271, 273, 286
1S0 423 810 A	30 93 8073	275
1S0 423 810 A S1	30 94 4240	275
1S0 423 810 A S2	30 94 4241	275
3C0 423 810 A	32 92 6045	235, 237, 271, 273, 286
6C0 423 810 A	30 94 6299	289
6C0 423 810 B	30 94 6299	289
6C0 423 810 C	30 94 6299	289
6Q0 423 810 B	30 93 2473	251, 259
6Q0 423 810 C	30 93 0820	251, 259
6Q0 423 810 E	30 93 2473	251, 259
6Q0 423 810 P	30 93 2473	251, 259
6R0 423 810	30 93 3584	263, 289
6R0 423 810 A	30 93 3584	263, 289
6R0 423 810 B	30 93 3584	263, 289
1K0 423 811 A	32 92 6096	235, 237, 271, 273, 286
1K0 423 811 C	30 93 7593	235, 271, 273

Ref. - No.

**SWAG**
GERMANY**SWAG**
GERMANY

Ref. - No.

SWAG
GERMANY

Ref. - No.

SWAG
GERMANY

1K0 423 811 C S2	30 93 7591	235, 271
1K0 423 811 E	32 92 6096	235, 237, 271, 273, 286
1K0 423 811 G	30 93 7593	235, 271, 273
1K0 423 811 G S2	30 93 7591	235, 271
1K0 423 811 J	32 92 6096	235, 237, 271, 273, 286
1K0 423 811 K	30 93 7593	235, 271, 273
1K0 423 811 K S1	30 93 7591	235, 271
1S0 423 811 A	30 94 4227	275
3C0 423 811 B	32 92 6096	235, 237, 271, 273, 286
6Q0 423 811	30 91 9812	251, 259, 263, 289
6Q0 423 811 C	30 91 9812	251, 259, 263, 289
6Q0 423 811 C SK	30 93 0820	251, 259
6RD 423 811 A	30 91 9812	251, 259, 263, 289
6RD 423 811 B	30 91 9812	251, 259, 263, 289
6R0 423 811	30 91 9812	251, 259, 263, 289
1K0 423 812 A	32 92 6097	234, 235, 237, 271, 273, 286
1K0 423 812 C	30 93 7594	234, 235, 271, 273
1K0 423 812 C S2	30 93 7592	235, 271
1K0 423 812 E	32 92 6097	234, 235, 237, 271, 273, 286
1K0 423 812 G	30 93 7594	234, 235, 271, 273
1K0 423 812 G S2	30 93 7592	235, 271
1K0 423 812 J	32 92 6097	234, 235, 237, 271, 273, 286
1K0 423 812 K	30 93 7594	234, 235, 271, 273
1K0 423 812 K S1	30 93 7592	235, 271
1S0 423 812 A	30 94 4226	275
3C0 423 812 B	32 92 6097	234, 235, 237, 271, 273, 286
6Q0 423 812	30 91 9814	251, 259, 263, 289
6Q0 423 812 C SK	30 93 0820	251, 259
6RD 423 812 A	30 91 9814	251, 259, 263, 289
6RD 423 812 B	30 91 9814	251, 259, 263, 289
6R0 423 812	30 91 9814	251, 259, 263, 289
1K0 423 831 A S1	30 93 1278	235, 237, 271, 273, 286
6Q0 423 831	30 92 1700	251, 259
6Q0 423 831 D	30 93 8622	251, 259, 263, 289
6Q0 423 831 D	30 93 8621	251, 259, 263, 289

6Q0 423 831 D S1	30 93 8622	251, 259, 263, 289
7M3 498 317	32 92 4863	231, 233
4F0 498 811 A	32 93 9077	253
4F0 498 811 A S1	32 93 9077	253
4F0 498 811 A SK	30 92 1840	253
5Q0 501 129 B	30 94 5859	674
1K0 501 529 E	30 93 2956	669, 673
1K0 501 529 E S1	30 94 0439	669, 673
1K0 501 529 F	30 93 2956	669, 673
1K0 501 529 F S1	30 94 0439	669, 673
1K0 501 529 F SK	40 94 0591	668, 669, 672, 673
1K0 501 529 H	30 93 6047	669, 673
1K0 501 529 H	30 93 2956	669, 673
1K0 501 529 H S1	30 94 0439	669, 673
1K0 501 529 H S1	30 94 0438	669, 673
1K0 501 529 H SK	40 94 0591	668, 669, 672, 673
1K0 501 529 J	30 93 6047	669, 673
1K0 501 529 J SK	40 94 0591	668, 669, 672, 673
1K0 501 529 J S1	30 94 0431	669, 673
5Q0 501 529 C SK	30 94 5859	674
5Q0 501 529 C SK	30 94 5860	674
8E0 501 529 F	30 93 8774	670
8E0 501 529 G	30 93 8774	670
8E0 501 529 K	30 93 8774	670
8E0 501 529 P	30 93 8774	670
1K0 501 530 B	30 93 2957	669, 673
1K0 501 530 B S1	30 94 0438	669, 673
1K0 501 530 C	30 93 2957	669, 673
1K0 501 530 C S1	30 94 0438	669, 673
1K0 501 530 C SK	40 94 0591	668, 669, 672, 673
7M0 501 541	32 92 2988	231, 233, 666
8E0 501 541 J	30 93 0494	670
8E0 501 541 Q	30 93 0494	670
8E0 501 541 S	30 93 0494	670
1K0 505 171 B	32 92 9690	667, 669, 673
1K0 505 171 C	32 92 9690	667, 669, 673
5Q0 505 171	30 94 3733	674
1K0 505 173 C	32 92 9690	667, 669, 673
1K0 505 203 A	30 92 9682	667, 669, 673
1K0 505 223 E	30 93 8846	669, 673
1K0 505 223 E	30 93 8845	669, 673
1K0 505 223 H	30 93 8845	669, 673
1K0 505 223 K	30 93 8845	669, 673



Ref. - No.	SWAG GERMANY	
1K0 505 224 E	30 93 8846	669, 673
1K0 505 224 E	30 93 8845	669, 673
1K0 505 224 H	30 93 8846	669, 673
1K0 505 224 K	30 93 8846	669, 673
1K0 505 279 A	30 92 9689	667, 669, 673
1K0 505 311 AA SK	32 92 9690	667, 669, 673
1K0 505 311 AA	30 93 4884	669, 673
1K0 505 311 AB	30 93 4884	669, 673
1K0 505 311 AB SK	32 92 9690	667, 669, 673
1K0 505 311 AH SK	32 92 9690	667, 669, 673
1K0 505 311 H	30 93 4884	669, 673
1K0 505 311 J	30 93 4884	669, 673
1K0 505 311 S	30 93 4884	669, 673
1K0 505 311 S SK	32 92 9690	667, 669, 673
1K0 505 311 T	30 93 4884	669, 673
5Q0 505 311 C SK	30 94 3733	674
5Q0 505 311 D SK	30 94 3733	674
7N0 505 311 SK	32 92 9690	667, 669, 673
1K0 505 323 D	30 93 2453	667, 669, 673
1K0 505 323 D SK	30 92 9689	667, 669, 673
1K0 505 323 D SK	30 92 9682	667, 669, 673
1K0 505 323 G	30 93 2453	667, 669, 673
1K0 505 323 G SK	30 92 9682	667, 669, 673
1K0 505 323 G SK	30 92 9689	667, 669, 673
1K0 505 323 H	30 93 2453	667, 669, 673
1K0 505 323 H SK	30 92 9682	667, 669, 673
1K0 505 323 H SK	30 92 9689	667, 669, 673
1K0 505 323 M	30 93 2453	667, 669, 673
1K0 505 323 N	30 93 2453	667, 669, 673
1K0 505 323 N SK	30 92 9689	667, 669, 673
1K0 505 323 N SK	30 92 9682	667, 669, 673
1K0 505 323 P	30 93 2453	667, 669, 673
5Q0 505 323 C	30 93 2453	667, 669, 673
5Q0 505 323 C SK	30 92 9682	667, 669, 673
5Q0 505 323 C SK	30 92 9689	667, 669, 673
5Q0 505 323 D	30 93 2453	667, 669, 673
1K0 505 465 AA S1	30 92 9461	667, 669, 673
1K0 505 465 C S1	30 92 9461	667, 669, 673
1K0 505 465 D S1	30 92 9461	667, 669, 673
1K0 505 465 H S1	30 92 9461	667, 669, 673
1K0 505 465 J S1	30 92 9461	667, 669, 673
1K0 505 465 K S1	30 92 9461	667, 669, 673
1K0 505 465 L S1	30 92 9461	667, 669, 673

Ref. - No.	SWAG GERMANY	
8E0 505 465 AC S1	30 93 2491	670
8E0 505 465 AF S1	30 93 2491	670
8E0 505 465 K S1	30 93 2491	670
8E0 505 465 T S1	30 93 2491	670
1J0 505 466 B S1	30 93 1842	671
3C0 505 541	30 93 4794	667
1K0 505 543 A	40 94 0591	668, 669, 672, 673
5Q0 505 543 B	30 94 5860	674
1K0 505 553	30 92 9938	667, 669, 673, 674
1K0 505 553 A	30 92 9938	667, 669, 673, 674
3C0 505 553	30 92 9938	667, 669, 673, 674
1K0 511 327 AP S1	32 92 3606	669
1K0 511 327 AQ S1	30 93 9650	669, 673
1K0 511 327 AQ	30 93 2073	667, 669, 673
1K0 511 327 AR S1	30 93 9648	669, 673
1K0 511 327 AR	32 92 3358	669, 673
1K0 511 327 AS	30 93 2625	669, 673
1K0 511 327 AS S1	30 93 9649	669, 673
8E0 511 327 A	30 93 9817	670
7M0 511 413 B	30 93 9460	666
7M0 511 414 B	50 94 6557	666
1K0 511 439 E	32 92 3604	667, 669, 673

passend für / to fit:

ŠKODA

KIT 03	30 92 1499	315
KIT 04	30 92 1501	315
KIT 05	30 92 1503	315
KIT 06	30 92 1505	315
N 034 790 7 S1	30 92 7726	315
N 034 790 8 S1	30 92 7726	315
1K0 199 231 G	30 92 7069	305, 317, 319
1K0 199 231 G S1	32 93 2542	305, 317, 319
1K0 199 231 J	30 92 7069	305, 317, 319
1K0 199 231 J S1	32 93 2542	305, 317, 319
1K0 199 231 J SK	30 93 1253	295, 305, 313, 317, 319
1K0 199 231 P	30 92 7069	305, 317, 319
1K0 199 232 G	30 92 7071	305, 317, 319
1K0 199 232 G S1	32 93 2541	305, 317, 319
1K0 199 232 J	30 92 7071	305, 317, 319
1K0 199 232 J S1	32 93 2541	305, 317, 319
1K0 199 232 J SK	30 93 1253	295, 305, 313, 317, 319

Ref. - No.

**SWAG**
GERMANY**SWAG**
GERMANY

Ref. - No.

SWAG
GERMANY

Ref. - No.

SWAG
GERMANY

1K0 199 232 P	30 92 7071	305, 317, 319
007 350 278 N	36 74 0001	299
1J0 407 151 A	32 73 0016	303
1J0 407 151 A S2	30 91 9822	303
1J0 407 151 A S1	30 91 9820	303
1J0 407 151 B	32 73 0016	303
1J0 407 151 B S2	30 91 9822	303
1J0 407 151 B S1	30 91 9820	303
1J0 407 151 C	32 73 0016	303
1J0 407 151 C S1	30 91 9820	303
1J0 407 151 C S2	30 91 9822	303
1K0 407 151 AA S1	30 93 8181	303, 305, 317, 319
1K0 407 151 AC S2	30 94 0103	305
1K0 407 151 AC S1	30 93 7183	304, 305
1K0 407 151 AC	30 92 7076	305, 317
1K0 407 151 AE S1	30 93 8181	303, 305, 317, 319
1K0 407 151 AH S1	30 93 8181	303, 305, 317, 319
1K0 407 151 AL	30 94 0103	305
1K0 407 151 BC S1	30 93 8181	303, 305, 317, 319
1K0 407 151 M	30 92 7076	305, 317
1K0 407 151 M S1	30 93 7183	304, 305
1K0 407 151 M S2	30 94 0103	305
1K0 407 151 N S1	30 93 8181	303, 305, 317, 319
1K0 407 151 P S1	30 93 8181	303, 305, 317, 319
1K0 407 151 Q S1	30 93 8181	303, 305, 317, 319
1K0 407 151 T	30 92 7076	305, 317
1S0 407 151	40 94 0594	290, 291
4B0 407 151	30 91 9932	315
4B3 407 151 A	30 91 9932	315
4B3 407 151 A S1	30 94 0114	315
4B3 407 151 C	30 91 9932	315
4B3 407 151 C S1	30 94 0114	315
4B3 407 151 K	30 91 9932	315
4B3 407 151 K S1	30 94 0114	315
4D0 407 151 P	32 73 0017	315
6Q0 407 151 D	30 92 7530	295, 313
6Q0 407 151 D S4	30 93 7292	295, 313
6Q0 407 151 D S3	30 93 7196	295, 313
6Q0 407 151 D S5	30 93 7291	295, 313
6Q0 407 151 D S2	30 93 7197	295, 313
6Q0 407 151 E	30 92 7530	295, 313
6Q0 407 151 E S3	30 93 7196	295, 313
6Q0 407 151 E S2	30 93 7197	295, 313

6Q0 407 151 E S5	30 93 7291	295, 313
6Q0 407 151 E S4	30 93 7292	295, 313
6Q0 407 151 L	30 92 7530	295, 313
6Q0 407 151 L S1	30 93 6098	295, 313
6Q0 407 151 L S2	30 93 7197	295, 313
6Q0 407 151 L S4	30 93 7292	295, 313
6Q0 407 151 L S3	30 93 7196	295, 313
6Q0 407 151 L S5	30 93 7291	295, 313
6R0 407 151	30 93 6923	297, 313
6R0 407 151 A	30 93 9557	298, 309
6R0 407 151 A S1	30 94 4547	308, 309
6R0 407 151 E	30 93 6923	297, 313
6R0 407 151 E S1	30 93 6925	297, 313
6R0 407 151 F	30 93 9557	298, 309
6R0 407 151 F S1	30 94 4547	308, 309
6R0 407 151 S1	30 93 6925	297, 313
8D0 407 151 E	32 73 0017	315
8D0 407 151 F	32 73 0017	315
1K0 407 152 AA S1	30 93 8180	303, 305, 317, 319
1K0 407 152 AB S1	30 93 8180	303, 305, 317, 319
1K0 407 152 AC S1	30 93 7182	304, 305
1K0 407 152 AC	30 92 7078	305, 317
1K0 407 152 AC S2	30 94 0104	305
1K0 407 152 AE S1	30 93 8180	303, 305, 317, 319
1K0 407 152 AF S1	30 93 8180	303, 305, 317, 319
1K0 407 152 AH S1	30 93 8180	303, 305, 317, 319
1K0 407 152 AL	30 94 0104	305
1K0 407 152 BC S1	30 93 8180	303, 305, 317, 319
1K0 407 152 M	30 92 7078	305, 317
1K0 407 152 M S2	30 94 0104	305
1K0 407 152 M S1	30 93 7182	304, 305
1K0 407 152 N S1	30 93 8180	303, 305, 317, 319
1K0 407 152 P S1	30 93 8180	303, 305, 317, 319
1K0 407 152 Q S1	30 93 8180	303, 305, 317, 319
1K0 407 152 T	30 92 7078	305, 317
1S0 407 152	40 94 0595	290, 291
6R0 407 152	30 93 6922	297, 313
6R0 407 152 A	30 93 9558	298, 309
6R0 407 152 A S1	30 94 4548	309
6R0 407 152 E	30 93 6922	297, 313
6R0 407 152 E S1	30 93 6926	297, 313
6R0 407 152 F	30 93 9558	298, 309
6R0 407 152 F S1	30 94 4548	309



Ref. - No.	SWAG GERMANY	
6R0 407 152 S1	30 93 6926	297, 313
1J0 407 181	32 69 0009	291, 297, 298, 303, 309, 313
1J0 407 181 A	32 69 0009	291, 297, 298, 303, 309, 313
180 407 181	32 69 0009	291, 297, 298, 303, 309, 313
4D0 407 181 F	32 69 0003	315
4D0 407 181 H	32 69 0003	315
6R0 407 181 B	30 92 6535	297
1KD 407 182	30 92 4390	305, 306, 317, 319
1K0 407 182	30 92 4390	305, 306, 317, 319
1K0 407 182 A	30 92 4390	305, 306, 317, 319
180 407 182	30 69 0002	291, 297, 298, 303, 309, 313
191 407 182	30 69 0002	291, 297, 298, 303, 309, 313
357 407 182	30 69 0002	291, 297, 298, 303, 309, 313
4D0 407 182 E	30 60 0031	315
4D0 407 182 G	30 60 0031	315
5Q0 407 182	30 92 4390	305, 306, 317, 319
5Q0 407 182 A	30 92 4390	305, 306, 317, 319
6Q0 407 182 A	30 93 6098	295, 313
6U0 407 182	30 92 9644	299, 307
1K0 407 183 E	30 93 1253	295, 305, 313, 317, 319
1K0 407 183 E S1	30 93 9228	295, 313
1K0 407 183 M	30 93 6752	305, 317, 319
1K0 407 183 P	30 93 6752	305, 317, 319
4D0 407 183 AB	30 60 0041	315
4D0 407 183 AC	30 60 0041	315
4D0 407 183 P	30 60 0041	315
4D0 407 183 Q	30 60 0041	315
4D0 407 183 S	30 60 0041	315
5C0 407 183 A	30 93 6752	305, 317, 319
5Q0 407 183 E	30 93 8403	306
5Q0 407 183 G	30 93 8403	306
6Q0 407 183	30 93 1253	295, 305, 313, 317, 319
6Q0 407 183 A	30 93 1253	295, 305, 313, 317, 319
6Q0 407 183 A S1	30 93 9228	295, 313

Ref. - No.	SWAG GERMANY	
6Q0 407 183 B	30 93 1253	295, 305, 313, 317, 319
6Q0 407 183 B S1	30 93 9228	295, 313
6Q0 407 183 S1	30 93 9228	295, 313
1J0 407 365 A	30 78 0035	303
1J0 407 365 A	32 78 0020	303
1J0 407 365 AS	30 78 0035	303
1J0 407 365 C	32 78 0020	303
1J0 407 365 C	30 78 0035	303
1J0 407 365 C S1	30 78 0035	303
1J0 407 365 CS	30 78 0035	303
1J0 407 365 D	32 78 0020	303
1J0 407 365 H	32 78 0020	303
1J0 407 365 H S1	30 78 0035	303
1J0 407 365 J	32 78 0020	303
1J0 407 365 J S1	30 78 0035	303
1KD 407 365	32 92 6082	305, 317, 319
1KD 407 365 S1	30 93 6735	305, 317, 319
1K0 407 365 B	32 92 6082	305, 317, 319
1K0 407 365 B S1	30 93 6735	305, 317, 319
1K0 407 365 C	32 92 6082	305, 317, 319
1K0 407 365 C S1	30 93 6735	305, 317, 319
1K0 407 365 E	32 92 6082	305, 317, 319
1K0 407 365 E S1	30 93 6735	305, 317, 319
3C0 407 365 B S1	30 93 1485	306
5Q0 407 365 A S1	30 94 0668	306
6Q0 407 365 A	30 91 9406	295, 313
6Q0 407 365 A S1	30 91 9410	295, 313
6Q0 407 365 D	30 91 9406	295, 313
6Q0 407 365 E	30 91 9406	295, 313
6Q0 407 365 M	30 91 9406	295, 313
6Q0 407 365 M S1	30 91 9410	295, 313
6R0 407 365	30 93 6051	291, 297, 298, 309, 313
6R0 407 365 A	30 93 6051	291, 297, 298, 309, 313
6U0 407 365	36 78 0001	299, 307
8Z0 407 365 A S1	30 78 0035	303
1J0 407 366 A	32 78 0019	303
1J0 407 366 AS	30 78 0034	303
1J0 407 366 C	32 78 0019	303
1J0 407 366 CS	30 78 0034	303
1J0 407 366 C S1	30 78 0034	303

Ref. - No.

**SWAG**
GERMANY**SWAG**
GERMANY

Ref. - No.

SWAG
GERMANY

Ref. - No.

SWAG
GERMANY

1J0 407 366 D	32 78 0019	303
1J0 407 366 H	32 78 0019	303
1J0 407 366 H S1	30 78 0034	303
1J0 407 366 J	32 78 0019	303
1J0 407 366 J S1	30 78 0034	303
1KD 407 366	32 92 6083	305, 317, 319
1KD 407 366 S1	30 93 6736	305, 317, 319
1K0 407 366 B	32 92 6083	305, 317, 319
1K0 407 366 B S1	30 93 6736	305, 317, 319
1K0 407 366 C	32 92 6083	305, 317, 319
1K0 407 366 C S1	30 93 6736	305, 317, 319
1K0 407 366 E	32 92 6083	305, 317, 319
1K0 407 366 E S1	30 93 6736	305, 317, 319
3C0 407 366 B S1	30 93 1486	306
5Q0 407 366 A S1	30 94 0669	306
6Q0 407 366 A	30 91 9408	295, 313
6Q0 407 366 A S1	30 91 9412	295, 313
6Q0 407 366 D	30 91 9408	295, 313
6Q0 407 366 E	30 91 9408	295, 313
6Q0 407 366 M	30 91 9408	295, 313
6Q0 407 366 M S1	30 91 9412	295, 313
6R0 407 366	30 93 6052	291, 297, 298, 309, 313
6R0 407 366 A	30 93 6052	291, 297, 298, 309, 313
8Z0 407 366 A S1	30 78 0034	303
4Z7 407 505	32 73 0021	315
4Z7 407 505 A	32 73 0021	315
4Z7 407 505 A S2	30 93 7179	315
4Z7 407 505 S2	30 93 7179	315
8D0 407 505 B	32 73 0021	315
8D0 407 505 B S2	30 93 7179	315
8D0 407 505 F	32 73 0021	315
8D0 407 505 F S2	30 93 7179	315
8D0 407 505 H	32 73 0021	315
8D0 407 505 H S2	30 93 7179	315
8D0 407 505 K	32 73 0021	315
8D0 407 505 K S2	30 93 7179	315
8E0 407 505 A	32 73 0021	315
8E0 407 505 A S2	30 93 7179	315
4Z7 407 506	32 73 0020	315
4Z7 407 506 A	32 73 0020	315
4Z7 407 506 A S1	30 93 7178	315

4Z7 407 506 S1	30 93 7178	315
8D0 407 506 B	32 73 0020	315
8D0 407 506 B S1	30 93 7178	315
8D0 407 506 F	32 73 0020	315
8D0 407 506 F S1	30 93 7178	315
8D0 407 506 H	32 73 0020	315
8D0 407 506 H S1	30 93 7178	315
8D0 407 506 K	32 73 0020	315
8D0 407 506 K S1	30 93 7178	315
8E0 407 506 A	32 73 0020	315
8E0 407 506 A S1	30 93 7178	315
4D0 407 509 F	32 73 0032	315
4D0 407 509 F S1	30 93 3367	315
4D0 407 509 G	32 73 0032	315
4D0 407 509 G S1	30 93 3367	315
4D0 407 509 H	32 73 0032	315
4D0 407 509 H S1	30 93 3367	315
4D0 407 509 J	32 73 0032	315
4D0 407 509 J S1	30 93 3367	315
8D0 407 509 C	32 73 0032	315
8D0 407 509 C S1	30 93 3367	315
8D0 407 509 E	32 73 0032	315
8D0 407 509 E S1	30 93 3367	315
8E0 407 509 A	32 73 0032	315
8E0 407 509 A S1	30 93 3367	315
4D0 407 510 F	32 73 0033	315
4D0 407 510 F S1	30 93 3368	315
4D0 407 510 G	32 73 0033	315
4D0 407 510 G S1	30 93 3368	315
4D0 407 510 H	32 73 0033	315
4D0 407 510 H S1	30 93 3368	315
4D0 407 510 J	32 73 0033	315
4D0 407 510 J S1	30 93 3368	315
8D0 407 510 C	32 73 0033	315
8D0 407 510 C S1	30 93 3368	315
8D0 407 510 E	32 73 0033	315
8D0 407 510 E S1	30 93 3368	315
8E0 407 510 A	32 73 0033	315
8E0 407 510 A S1	30 93 3368	315
4B0 407 515	30 91 9926	315
8E0 407 693	32 92 1196	315
8E0 407 693 AG S1	30 93 3366	315
8E0 407 693 AG	32 92 1196	315



Ref. - No.	SWAG GERMANY	
8E0 407 693 E	32 92 1196	315
8E0 407 693 E S1	30 93 3366	315
8E0 407 693 K	32 92 1196	315
8E0 407 693 K S1	30 93 3366	315
8E0 407 693 P	32 92 1196	315
8E0 407 693 Q	32 92 1196	315
8E0 407 693 Q S1	30 93 3366	315
8E0 407 693 S1	30 93 3366	315
8E0 407 694	32 92 1198	315
8E0 407 694 AG S1	30 93 3365	315
8E0 407 694 AG	32 92 1198	315
8E0 407 694 E	32 92 1198	315
8E0 407 694 E S1	30 93 3365	315
8E0 407 694 K	32 92 1198	315
8E0 407 694 K S1	30 93 3365	315
8E0 407 694 P	32 92 1198	315
8E0 407 694 P S1	30 93 3365	315
8E0 407 694 Q	32 92 1198	315
8E0 407 694 Q S1	30 93 3365	315
8E0 407 694 S1	30 93 3365	315
6U0 407 807	36 78 0001	299, 307
1K0 411 303 AL S2	30 94 5307	305, 317, 319
1K0 411 303 AL S1	30 94 5306	305, 317, 319
1K0 411 303 BJ S2	30 94 5307	305, 317, 319
1K0 411 303 BJ S1	30 94 5306	305, 317, 319
1K0 411 303 BK S1	30 94 5306	305, 317, 319
1K0 411 303 BK S2	30 94 5307	305, 317, 319
1J0 411 305 B S1	30 93 6630	303
1J0 411 305 E S1	30 93 6640	303
1J0 411 305 E S2	30 94 0090	303
6Q0 411 305 AC S2	30 93 7110	295, 313
6Q0 411 305 AL S2	30 93 7090	295, 297
6Q0 411 305 AM S2	30 93 7100	295
6Q0 411 305 AN S2	30 93 7110	295, 313
1J0 411 314 G	30 61 0009	303
1J0 411 314 M	32 92 2804	303
1J0 411 314 N	32 92 2804	303
1J0 411 314 P	32 92 2794	303
1J0 411 314 P S1	30 92 7294	303
1J0 411 314 R	32 92 2804	303
1J0 411 314 R S1	30 92 7304	303
1J0 411 314 S	32 92 6344	303
1J0 411 314 S S1	30 92 7250	303

Ref. - No.	SWAG GERMANY	
1J0 411 314 T	30 61 0009	303
1J0 411 314 T S1	30 92 7318	303
1J0 411 314 T S2	30 94 0089	303
6Q0 411 314 E	30 92 7642	295, 309, 313
6Q0 411 314 E S2	30 93 7089	309, 313
6Q0 411 314 E S4	30 93 7659	294, 295, 308, 309, 313
6Q0 411 314 F	30 92 7324	295
6Q0 411 314 F S1	30 93 7078	295
6Q0 411 314 F S2	30 93 7658	294, 295
6Q0 411 314 J	30 92 7638	291, 295, 297, 298
6Q0 411 314 J S2	30 93 7657	291, 294, 295, 297
6Q0 411 314 J S1	30 93 7077	291, 295, 297
6Q0 411 314 L	30 92 7638	291, 295, 297, 298
6Q0 411 314 L S2	30 93 7657	291, 294, 295, 297
6Q0 411 314 L S1	30 93 7077	291, 295, 297
6Q0 411 314 M	30 92 7640	295, 309
6Q0 411 314 M S2	30 93 7660	294, 295, 308, 309
6Q0 411 314 M S1	30 93 7069	295, 309
6Q0 411 314 N	30 92 7642	295, 309, 313
6Q0 411 314 N S4	30 93 7659	294, 295, 308, 309, 313
6Q0 411 314 N S2	30 93 7089	309, 313
6Q0 411 314 P	30 92 7638	291, 295, 297, 298
6Q0 411 314 P S2	30 93 7657	291, 294, 295, 297
6Q0 411 314 P S1	30 93 7077	291, 295, 297
6Q0 411 314 Q	30 92 7640	295, 309
6Q0 411 314 Q S2	30 93 7660	294, 295, 308, 309
6Q0 411 314 Q S1	30 93 7069	295, 309
6Q0 411 314 R	30 92 7642	295, 309, 313
6Q0 411 314 R S2	30 93 7089	309, 313
6Q0 411 314 R S4	30 93 7659	294, 295, 308, 309, 313
8N0 411 314 B	32 92 2804	303
8Z0 411 314 B	30 93 1350	295
8Z0 411 314 B S2	30 93 7655	294, 295, 302, 303
8Z0 411 314 B S1	30 93 7079	295
1J0 411 315 C	30 76 0003	303, 305
1J0 411 315 D	30 91 9296	303
1J0 411 315 E	30 76 0004	302, 303
1J0 411 315 E S3	30 93 6757	303
1J0 411 315 E S2	30 93 6677	302, 303
1J0 411 315 E S4	30 93 6758	303

Ref. - No.

**SWAG**
GERMANY**SWAG**
GERMANY

Ref. - No.

SWAG
GERMANY

1J0 411 315 E S1	30 93 6676	303
1J0 411 315 G	30 76 0004	302, 303
1J0 411 315 G S2	30 93 6677	302, 303
1J0 411 315 G S1	30 93 0154	302, 303
1J0 411 315 G S3	30 93 6757	303
1J0 411 315 G S4	30 93 6758	303
1J0 411 315 G S1	30 93 6676	303
1J0 411 315 H	30 92 8579	303
1J0 411 315 H S2	30 93 6667	303
1J0 411 315 H S1	30 93 6665	303
1J0 411 315 J	30 76 0003	303, 305
1J0 411 315 K	30 92 8579	303
1J0 411 315 K S1	30 93 6665	303
1J0 411 315 K S2	30 93 6667	303
1K0 411 315 B	32 92 4122	305, 317, 319
1K0 411 315 D	32 92 4122	305, 317, 319
1K0 411 315 G	32 92 4122	305, 317, 319
1K0 411 315 J	32 92 4122	305, 317, 319
1K0 411 315 K	32 92 4122	305, 317, 319
1K0 411 315 N	32 92 4122	305, 317, 319
1K0 411 315 P	32 92 4122	305, 317, 319
1K0 411 315 R	32 92 4122	305, 317, 319
6Q0 411 315 A	30 91 9518	291, 295, 297, 298, 309, 313
6Q0 411 315 B	30 91 9518	291, 295, 297, 298, 309, 313
6Q0 411 315 C	30 91 9518	291, 295, 297, 298, 309, 313
6Q0 411 315 D	30 91 9518	291, 295, 297, 298, 309, 313
6Q0 411 315 E	30 91 9518	291, 295, 297, 298, 309, 313
6Q0 411 315 F	30 91 9518	291, 295, 297, 298, 309, 313
6Q0 411 315 G	30 91 9518	291, 295, 297, 298, 309, 313
6Q0 411 315 H	30 91 9518	291, 295, 297, 298, 309, 313
6Q0 411 315 J	30 91 9518	291, 295, 297, 298, 309, 313
6Q0 411 315 L	30 91 9518	291, 295, 297, 298, 309, 313

Ref. - No.

SWAG
GERMANY

6Q0 411 315 M	30 91 9518	291, 295, 297, 298, 309, 313
6Q0 411 315 N	30 91 9518	291, 295, 297, 298, 309, 313
6Q0 411 315 P	30 91 9518	291, 295, 297, 298, 309, 313
6Q0 411 315 Q	30 91 9518	291, 295, 297, 298, 309, 313
6R0 411 315	30 91 9518	291, 295, 297, 298, 309, 313
6R0 411 315 A	30 91 9518	291, 295, 297, 298, 309, 313
1J0 411 316 D	30 91 9298	303
8D0 411 317 D	32 61 0006	315
8D0 411 317 D S1	30 91 9704	315
8D0 411 318 D	32 61 0005	315
8D0 411 318 D S1	30 91 9702	315
1J0 411 327 A	30 93 6646	303
4D0 411 327 F	30 61 0006	315
4D0 411 327 G	30 61 0005	315
4D0 411 327 H	30 61 0006	315
1J0 411 336 B	32 92 3366	303, 305
1J0 411 336 C	32 92 3366	303, 305
1J0 411 336 D	32 92 3366	303, 305
8D0 411 506 K	32 61 0006	315
4B0 419 801 B SK	30 93 8854	315
4B0 419 801 E SK	30 93 8854	315
4B0 419 801 M	32 72 0022	315
4B0 419 801 M SK	30 93 8854	315
4D0 419 801 B SK	30 93 8854	315
4D0 419 801 D SK	30 93 8854	315
4D0 419 801 E SK	30 93 8854	315
4D0 419 801 G SK	30 93 8854	315
4D0 419 801 L SK	30 93 8854	315
6Q0 419 803 B SK	30 93 2474	293, 311
6Q0 419 803 D	30 93 2229	293
6Q0 419 803 F	30 93 2229	293
6Q0 419 803 F SK	30 93 2474	293, 311
6Q0 419 803 SK	30 93 2474	293, 311
6Q0 419 804 B	30 93 2230	293
6Q0 419 804 B SK	30 93 2474	293, 311
6Q0 419 804 D	30 93 2230	293
6Q0 419 804 F	30 93 2230	293



Ref. - No.	SWAG GERMANY	
6Q0 419 804 F SK	30 93 2474	293, 311
6Q0 419 804 SK	30 93 2474	293, 311
4B0 419 810 M	30 93 8854	315
6Q0 419 810	30 93 2474	293, 311
6Q0 419 810 B	30 93 2474	293, 311
6Q0 419 810 F	30 93 2474	293, 311
4F0 419 811 C	30 92 1840	315
4F0 419 811 C	32 93 9077	315
4F0 419 811 D	30 92 1840	315
4F0 419 811 D	32 93 9077	315
6Q0 419 811 C	30 91 9812	293, 297, 309, 311
6Q0 419 812 C	30 91 9814	293, 297, 309, 311
6E0 419 831	30 92 1700	293
115 420 240	36 78 0001	299, 307
115 420 241	36 78 0001	299, 307
1J0 422 803	32 72 0021	301
1J0 422 803 A	32 72 0021	301
1J0 422 803 A SK	30 92 8098	301
1J0 422 803 A S1	30 94 4347	301
1J0 422 803 B	99 72 0002	301
1J0 422 803 B S1	30 94 4341	301
1J0 422 803 B SK	30 92 7095	301
1J0 422 803 C	32 72 0021	301
1J0 422 803 C S1	30 94 4347	301
1J0 422 803 E	99 72 0002	301
1J0 422 803 E S1	30 94 4341	301
1J0 422 803 H	99 72 0002	301
1J0 422 803 H S1	30 94 4341	301
1J0 422 803 H SK	30 92 7095	301
1J0 422 803 SK	30 92 8098	301
1J0 422 803 S1	30 94 4347	301
1J0 422 804	32 72 0020	301
1J0 422 804 A	32 72 0020	301
1J0 422 804 A SK	30 92 8098	301
1J0 422 804 A S1	30 94 4346	301
1J0 422 804 B	99 72 0001	301
1J0 422 804 B SK	30 92 7095	301
1J0 422 804 B S1	30 94 4342	301
1J0 422 804 C	32 72 0020	301
1J0 422 804 C S1	30 94 4346	301
1J0 422 804 E	99 72 0001	301
1J0 422 804 E S1	30 94 4342	301
1J0 422 804 H	99 72 0001	301

Ref. - No.	SWAG GERMANY	
1J0 422 804 H SK	30 92 7095	301
1J0 422 804 H S1	30 94 4342	301
1J0 422 804 SK	30 92 8098	301
1J0 422 804 S1	30 94 4346	301
6U0 422 807	36 74 0001	299
1J0 422 810	30 92 8098	301
1J0 422 810 A	30 92 8098	301
1J0 422 810 B	30 92 7095	301
1J0 422 811	32 71 0011	301
1J0 422 811 A	32 71 0011	301
1J0 422 811 B	30 71 0038	301
1J0 422 811 C	32 71 0011	301
6RD 422 811	30 91 9812	293, 297, 309, 311
6U0 422 811	36 71 0001	299
1J0 422 812	32 71 0010	301
1J0 422 812 A	32 71 0010	301
1J0 422 812 B	30 71 0037	301
1J0 422 812 C	32 71 0010	301
6RD 422 812	30 91 9814	293, 297, 309, 311
4D0 422 821 A	30 93 8854	315
1J0 422 831	30 93 7764	301
1J0 422 831	30 80 0068	301
1J0 422 831 B	30 80 0068	301
1J0 422 831 B	30 93 7764	301
1J0 422 831 B S1	30 93 7764	301
6Q0 423 803 B	30 91 9816	293, 297, 311
6Q0 423 803 B S1	30 94 4343	293, 311
6Q0 423 803 B SK	30 93 2473	293, 297, 311
6Q0 423 803 C	30 92 6173	293, 311
6Q0 423 803 E	30 91 9816	293, 297, 311
6Q0 423 803 E SK	30 93 2473	293, 297, 311
6Q0 423 803 E S1	30 94 4343	293, 311
6Q0 423 803 G	30 92 6173	293, 311
6Q0 423 803 P	30 91 9816	293, 297, 311
6Q0 423 803 P SK	30 93 2473	293, 297, 311
6Q0 423 803 P S1	30 94 4343	293, 311
6R0 423 803 A	30 93 6508	309
6R0 423 803 A SK	30 93 3584	309
6R0 423 803 B SK	30 93 3584	309
6R0 423 803 C SK	30 93 3584	309
6R0 423 803 D SK	30 93 3584	309
6R0 423 803 SK	30 93 3584	309
6Q0 423 804 B	30 91 9818	293, 297, 311

Ref. - No.

**SWAG**
GERMANY**SWAG**
GERMANY

Ref. - No.

SWAG
GERMANY

Ref. - No.

SWAG
GERMANY

6Q0 423 804 B SK	30 93 2473	293, 297, 311
6Q0 423 804 B S1	30 94 4344	293, 311
6Q0 423 804 C	30 92 6174	293, 311
6Q0 423 804 E	30 91 9818	293, 297, 311
6Q0 423 804 E SK	30 93 2473	293, 297, 311
6Q0 423 804 E S1	30 94 4344	293, 311
6Q0 423 804 G	30 92 6174	293, 311
6Q0 423 804 P	30 91 9818	293, 297, 311
6Q0 423 804 P S1	30 94 4344	293, 311
6Q0 423 804 P SK	30 93 2473	293, 297, 311
6R0 423 804 A	30 93 6509	309
6R0 423 804 A SK	30 93 3584	309
6R0 423 804 B SK	30 93 3584	309
6R0 423 804 C SK	30 93 3584	309
6R0 423 804 D SK	30 93 3584	309
6R0 423 804 SK	30 93 3584	309
1K0 423 810 A	32 92 6045	305, 306, 317, 319
1K0 423 810 A S1	30 93 2627	305, 306, 317, 319
1K0 423 810 A S2	30 93 2628	305, 306, 317, 319
1K0 423 810 A S4	30 94 5760	306
1K0 423 810 A S3	30 94 5761	306
1S0 423 810 A	30 93 8073	291
1S0 423 810 A S1	30 94 4240	291
1S0 423 810 A S2	30 94 4241	291
3C0 423 810 A	32 92 6045	305, 306, 317, 319
6C0 423 810 A	30 94 6299	297, 298, 309
6C0 423 810 B	30 94 6299	297, 298, 309
6C0 423 810 C	30 94 6299	297, 298, 309
6Q0 423 810 B	30 93 2473	293, 297, 311
6Q0 423 810 C	30 93 0820	293, 311
6Q0 423 810 E	30 93 2473	293, 297, 311
6Q0 423 810 P	30 93 2473	293, 297, 311
6R0 423 810	30 93 3584	309
6R0 423 810 A	30 93 3584	309
6R0 423 810 B	30 93 3584	309
1K0 423 811 A	32 92 6096	305, 306, 317, 319
1K0 423 811 C	30 93 7593	305, 306, 317, 319
1K0 423 811 C S2	30 93 7591	305, 306, 317, 319
1K0 423 811 E	32 92 6096	305, 306, 317, 319
1K0 423 811 G	30 93 7593	305, 306, 317, 319
1K0 423 811 G S2	30 93 7591	305, 306, 317, 319
1K0 423 811 K	30 93 7593	305, 306, 317, 319
1K0 423 811 K S1	30 93 7591	305, 306, 317, 319

1S0 423 811 A	30 94 4227	291
6Q0 423 811 C SK	30 93 0820	293, 311
6RD 423 811 A	30 91 9812	293, 297, 309, 311
6RD 423 811 B	30 91 9812	293, 297, 309, 311
6R0 423 811	30 91 9812	293, 297, 309, 311
1K0 423 812 A	32 92 6097	305, 306, 317, 319
1K0 423 812 C	30 93 7594	305, 306, 317, 319
1K0 423 812 C S2	30 93 7592	305, 306, 317, 319
1K0 423 812 E	32 92 6097	305, 306, 317, 319
1K0 423 812 G	30 93 7594	305, 306, 317, 319
1K0 423 812 G S2	30 93 7592	305, 306, 317, 319
1K0 423 812 K	30 93 7594	305, 306, 317, 319
1K0 423 812 K S1	30 93 7592	305, 306, 317, 319
1S0 423 812 A	30 94 4226	291
6Q0 423 812	30 91 9814	293, 297, 309, 311
6Q0 423 812 C SK	30 93 0820	293, 311
6RD 423 812 A	30 91 9814	293, 297, 309, 311
6RD 423 812 B	30 91 9814	293, 297, 309, 311
6R0 423 812	30 91 9814	293, 297, 309, 311
1K0 423 831 A S1	30 93 1278	305, 306, 317, 319
6Q0 423 831	30 92 1700	293
6Q0 423 831 D	30 93 8622	293, 309
6Q0 423 831 D	30 93 8621	293, 309
6Q0 423 831 D S1	30 93 8622	293, 309
4F0 498 811 A	32 93 9077	315
4F0 498 811 A S1	32 93 9077	315
4F0 498 811 A SK	30 92 1840	315
8D0 498 998 B	32 92 6600	315
5Q0 501 129 B	30 94 5859	675
1K0 501 529 E	30 93 2956	677, 679
1K0 501 529 E S1	30 94 0439	677, 679
1K0 501 529 F	30 93 2956	677, 679
1K0 501 529 F SK	40 94 0591	676, 677, 678, 679
1K0 501 529 F S1	30 94 0439	677, 679
1K0 501 529 H	30 93 2956	677, 679
1K0 501 529 H	30 93 2957	677, 679
1K0 501 529 H S1	30 94 0439	677, 679
1K0 501 529 H S1	30 94 0438	677, 679
1K0 501 529 H SK	40 94 0591	676, 677, 678, 679
1K0 501 529 J	30 93 6047	677, 679
1K0 501 529 J S1	30 94 0431	677, 679
1K0 501 529 J SK	40 94 0591	676, 677, 678, 679
5Q0 501 529 C SK	30 94 5859	675

Ref. - No.	SWAG GERMANY	
5Q0 501 529 C SK	30 94 5860	675
1K0 501 530 B	30 93 2957	677, 679
1K0 501 530 B S1	30 94 0438	677, 679
1K0 501 530 C	30 93 2957	677, 679
1K0 501 530 C S1	30 94 0438	677, 679
1K0 501 530 C SK	40 94 0591	676, 677, 678, 679
1K0 505 171 B	32 92 9690	677, 679
1K0 505 171 C	32 92 9690	677, 679
5Q0 505 171	30 94 3733	675
1K0 505 173 C	32 92 9690	677, 679
1K0 505 203 A	30 92 9682	677, 679
1K0 505 223 E	30 93 8846	677, 679
1K0 505 223 E	30 93 8845	677, 679
1K0 505 223 H	30 93 8845	677, 679
1K0 505 223 K	30 93 8845	677, 679
1K0 505 224 E	30 93 8846	677, 679
1K0 505 224 E	30 93 8845	677, 679
1K0 505 224 H	30 93 8846	677, 679
1K0 505 224 K	30 93 8846	677, 679
1K0 505 279 A	30 92 9689	677, 679
1K0 505 311 AA SK	32 92 9690	677, 679
1K0 505 311 AA	30 93 4884	677, 679
1K0 505 311 AB	30 93 4884	677, 679
1K0 505 311 AB SK	32 92 9690	677, 679
1K0 505 311 AH SK	32 92 9690	677, 679
1K0 505 311 H	30 93 4884	677, 679
1K0 505 311 S	30 93 4884	677, 679
1K0 505 311 S SK	32 92 9690	677, 679
5Q0 505 311 C SK	30 94 3733	675
5Q0 505 311 D SK	30 94 3733	675
1K0 505 323 D	30 93 2453	677, 679
1K0 505 323 D SK	30 92 9682	677, 679
1K0 505 323 D SK	30 92 9689	677, 679
1K0 505 323 G	30 93 2453	677, 679
1K0 505 323 G SK	30 92 9689	677, 679
1K0 505 323 G SK	30 92 9682	677, 679
1K0 505 323 H	30 93 2453	677, 679
1K0 505 323 H SK	30 92 9689	677, 679
1K0 505 323 H SK	30 92 9682	677, 679
1K0 505 323 M	30 93 2453	677, 679
1K0 505 323 N	30 93 2453	677, 679
1K0 505 323 N SK	30 92 9682	677, 679
1K0 505 323 N SK	30 92 9689	677, 679

Ref. - No.	SWAG GERMANY	
1K0 505 323 P	30 93 2453	677, 679
5Q0 505 323 C	30 93 2453	677, 679
5Q0 505 323 C SK	30 92 9689	677, 679
5Q0 505 323 C SK	30 92 9682	677, 679
5Q0 505 323 D	30 93 2453	677, 679
1K0 505 465 AA S1	30 92 9461	677, 679
1K0 505 465 C S1	30 92 9461	677, 679
1K0 505 465 D S1	30 92 9461	677, 679
1K0 505 465 H S1	30 92 9461	677, 679
1K0 505 465 J S1	30 92 9461	677, 679
1K0 505 465 K S1	30 92 9461	677, 679
1K0 505 465 L S1	30 92 9461	677, 679
1J0 505 466 C	30 92 7866	675
1J0 505 466 C	30 93 1843	675
1J0 505 466 C S1	30 93 1843	675
1K0 505 543 A	40 94 0591	676, 677, 678, 679
5Q0 505 543 B	30 94 5860	675
1K0 505 553	30 92 9938	675, 677, 679
1K0 505 553 A	30 92 9938	675, 677, 679
3C0 505 553	30 92 9938	675, 677, 679
1K0 511 327 AE	32 92 3356	677, 679
1K0 511 327 AP S1	32 92 3606	677, 679
1K0 511 327 AP	32 92 3356	677, 679
1K0 511 327 AQ S1	30 93 9650	677, 679
1K0 511 327 AQ	30 93 2073	677, 679
1K0 511 327 AR S1	30 93 9648	677, 679
1K0 511 327 AR	32 92 3358	677, 679
1K0 511 327 AS	30 93 2625	677, 679
1K0 511 327 AS S1	30 93 9649	677, 679
1K0 511 439 E	32 92 3604	677, 679
passend für / to fit:		
SMART		
0001802V004	99 92 2587	680
0001802V004000000	99 92 2587	680
0002271V003000005	99 92 4632	320, 321, 322, 324
0002271V003000005 S1	12 93 8549	322, 324
0002271V007000000 S1	99 92 4632	320, 321, 322, 324
0002271V007000005 S1	99 92 4632	320, 321, 322, 324
0002271V007000005 S1	12 93 8549	322, 324
0004873V002	12 92 7569	320
0004873V002000000	12 92 7569	320
0004879V001000000 S1	99 92 4632	320, 321, 322, 324
0004879V001000000 S2	12 93 8549	322, 324

Ref. - No.

**SWAG**
GERMANY**SWAG**
GERMANY

Ref. - No.

SWAG
GERMANY

Ref. - No.

SWAG
GERMANY

0004879V003000000 S1	99 92 4632	320, 321, 322, 324
0004879V003000000 S2	12 93 8549	322, 324
0004880V001000000 S1	99 92 4632	320, 321, 322, 324
0004880V001000000 S1	12 93 8549	322, 324
0004914V002000000 S1	12 93 4945	322
0005102V004	99 92 2588	322, 324
0005102V004000000	99 92 2588	322, 324
0005102V005	99 92 2588	322, 324
0005102V005000000	99 92 2588	322, 324
0005374V001 S1	13 93 6192	322
0005376V001000000 S1	12 93 4949	322, 323
0007001V006	10 93 1272	320, 321, 322, 324
0007001V006000000	10 93 1272	320, 321, 322, 324
0007001V006000000 S1	12 93 1271	320, 321, 322, 324
0007001V007	10 93 1272	320, 321, 322, 324
0007001V007000000	10 93 1272	320, 321, 322, 324
0007001V007000000 S1	12 93 1271	320, 321, 322, 324
0014141V001	10 93 1272	320, 321, 322, 324
0014141V001 S1	12 93 1271	320, 321, 322, 324
0014141V001000000	10 93 1272	320, 321, 322, 324
0014141V001000000 S1	12 93 1271	320, 321, 322, 324
0014141V002	10 93 1272	320, 321, 322, 324
0014141V002 S1	12 93 1271	320, 321, 322, 324
0014141V002000000	10 93 1272	320, 321, 322, 324
0014141V002000000 S1	12 93 1271	320, 321, 322, 324
0015642V001	99 92 4632	320, 321, 322, 324
0015642V001 S1	12 93 8549	322, 324
0015642V00100000 S1	12 93 8549	322, 324
0015642V001000000	99 92 4632	320, 321, 322, 324
0015642V002000000	12 93 1991	320, 321, 322, 324
0015642V002000000	12 93 1990	322, 324
0015642V002000000 S1	99 92 4632	320, 321, 322, 324
0015642V002000000 S2	12 93 1991	320, 321, 322, 324
0015642V002000000 S3	12 93 8549	322, 324
14141V001	10 93 1272	320, 321, 322, 324
14141V001 S1	12 93 1271	320, 321, 322, 324
14141V001000000	10 93 1272	320, 321, 322, 324
14141V001000000 S1	12 93 1271	320, 321, 322, 324
14141V002	10 93 1272	320, 321, 322, 324
14141V002 S1	12 93 1271	320, 321, 322, 324
14141V002000000	10 93 1272	320, 321, 322, 324
14141V002000000 S1	12 93 1271	320, 321, 322, 324
15642V001	99 92 4632	320, 321, 322, 324

15642V001 S1	12 93 8549	322, 324
15642V001000000	99 92 4632	320, 321, 322, 324
1802V004000000	99 92 2587	680
2271V007	99 92 4632	320, 321, 322, 324
2271V007 S1	12 93 8549	322, 324
2271V007000005	99 92 4632	320, 321, 322, 324
2271V007000005 S1	99 92 4632	320, 321, 322, 324
2271V007000005 S2	12 93 8549	322, 324
450 333 00 14	12 93 1271	320, 321, 322, 324
451 320 01 89	12 93 6791	323
451 320 01 89 S1	12 93 6790	323
451 330 00 10 S1	12 93 8610	323
451 338 00 37 SK1	40 71 0001	323
451 338 01 37 SK1	40 71 0001	323
451 460 00 96	12 93 4949	322, 323
454 320 00 10 S1	99 92 2589	321
454 330 07 07	80 93 3610	321
454 330 07 07 S1	80 93 3609	321
454 330 08 07	80 93 3611	321
454 330 08 07 S1	80 93 3609	321
454 333 01 27	80 93 3609	321
5102V005	99 92 2588	322, 324
5102V005000000	99 92 2588	322, 324
7001V006	10 93 1272	320, 321, 322, 324
7001V006000000	10 93 1272	320, 321, 322, 324
7001V007	10 93 1272	320, 321, 322, 324
7001V007000000	10 93 1272	320, 321, 322, 324

passend für / to fit:

SUBARU

20200AA200	87 92 9634	325, 326, 327, 329, 330
20200AA210	87 92 9635	325, 326, 327, 329, 330
20201AA000	87 92 9375	329, 330
20201AA070	87 92 9375	329, 330
20420AA002	87 92 9686	325, 328, 329, 330
20420AA003	87 92 9686	325, 328, 329, 330
20420AA004	87 92 9686	325, 328, 329, 330
20470AE000	87 92 8439	684
20470AE001	87 92 8439	684
20470AE010	87 92 8439	684
20470FE000	87 92 8199	326, 328, 330
20470SA000	87 92 8199	326, 328, 330



Ref. - No.	SWAG GERMANY	
20470SA001	87 92 8199	326, 328, 330
20470SA010	87 93 2495	681, 682
20470SA011	87 93 2495	681, 682
20481AA000	87 92 9685	681, 682, 683
20481AA001	87 92 9685	681, 682, 683
21067GA050	87 92 9841	325, 326, 327, 328, 330
31320GA190	87 93 0739	327
31320GA200	87 93 0740	327
34140FC000	87 92 7820	325, 327, 330
34141AA041	87 92 9853	325, 326, 327, 328, 329, 330
34141AA042	87 92 9853	325, 326, 327, 328, 329, 330
48821B1010	88 92 8272	329
48831B1010	88 92 8271	329
passend für / to fit:		
SUZUKI		
09319-10030	89 92 8712	331, 339
09319-10030-000	89 92 8712	331, 339
42420-M68K0	84 93 3760	331
42420-M68K0-000	84 93 3760	331
42420-60A00	84 92 8158	333, 338, 339
42420-62J00	84 92 8000	335, 337
42420-62J00-000	84 92 8000	335, 337
42420-65D00	84 92 8158	333, 338, 339
42420-65D00-000 S1	84 92 8158	333, 338, 339
42420-65J00	84 93 0186	333
42420-65J00-000	84 93 0186	333
42420-77A00	84 92 8235	332
42420-77A00-000	84 92 8235	332
42420-80J00	84 92 8638	338
42420-80J00-000	84 92 8638	338
42420-81A10	84 92 8159	334
42420-81A10-000	84 92 8159	334
42420-85C00	84 92 8158	333, 338, 339
42451-76G00	84 93 2470	334, 339
42451-76G00-000	84 93 2470	334, 339
45200-60810-000	84 92 9632	336
45200-60812	84 92 9632	336
45200-60812-000	84 92 9632	336
45200-60820	84 92 9633	336
45200-60820-000	84 92 9633	336

Ref. - No.	SWAG GERMANY	
45200-60822	84 92 9633	336
45200-60822-000	84 92 9633	336
45200-75F00	40 91 9501	339
45200-75F20	40 91 9501	339
45200-75F21-000	40 91 9501	339
45200-82000	84 73 0001	336
45200-82000-000	84 73 0001	336
45200-83E00	40 93 2090	339
45200-83E00-000	40 93 2090	339
45200-84E00	40 93 2090	339
45200-84E00-000	40 93 2090	339
45201-57KA0-000	84 93 2141	335
45201-57K00-000	84 93 2141	335
45201-62J00	84 92 9932	337
45201-62J00 S1	84 92 9826	335, 337
45201-62J00-000	84 92 9932	337
45201-62J00-000 S1	84 92 9826	335, 337
45201-63J00	84 92 9932	337
45201-63J00 S1	84 92 9826	335, 337
45201-63J00-000	84 92 9932	337
45201-63J00-000 S1	84 92 9826	335, 337
45201-72K00	84 92 9932	337
45201-72K00-000	84 92 9932	337
45201-72K00-000	84 93 2141	335
45201-72K01	84 92 9932	337
45201-72K01-000	84 92 9932	337
45202-57KA0	84 93 2140	335
45202-57KA0-000	84 93 2140	335
45202-57K00	84 93 2140	335
45202-57K00-000	84 93 2140	335
45202-62J00	84 92 9931	337
45202-62J00-000	84 92 9931	337
45202-63J00	84 92 9931	337
45202-63J00 S1	84 92 9826	335, 337
45202-63J00-000	84 92 9931	337
45202-63J00-000 S1	84 92 9826	335, 337
45202-72K00	84 92 9931	337
45202-72K00	84 93 2140	335
45202-72K00-000	84 92 9931	337
45202-72K00-000	84 93 2140	335
45202-72K01	84 93 2140	335
45202-72K01	84 92 9931	337
45202-72K01-000	84 93 2140	335

Ref. - No.

**SWAG**
GERMANY**SWAG**
GERMANY

Ref. - No.

SWAG
GERMANY

Ref. - No.

SWAG
GERMANY

45202-72K01-000	84 92 9931	337
45261-77A10	89 92 8712	331, 339
45261-77A10-000	89 92 8712	331, 339
45262-54L00	84 92 9827	335, 337
45262-54L00-000	84 92 9827	335, 337
45262-79J00	84 92 9827	335, 337
45262-79J00-000	84 92 9827	335, 337
45540-57K00	84 92 9827	335, 337
45540-57K00-000	84 92 9827	335, 337
45540-62J00 S1	84 92 9827	335, 337
45540-62J00-000	84 92 9827	335, 337
45540-62J00-000 S1	84 92 9827	335, 337
46201-60B11	84 92 9760	685
46201-60B11-000	84 92 9760	685
46201-83E00 S2	84 93 2475	685
46201-83E00-000 S2	84 93 2475	685
46201-83E20 S2	84 93 2475	685
46201-83E20-000 S2	84 93 2475	685
46201-86G00 S2	84 93 2475	685
46201-86G00-000 S2	84 93 2475	685
46202-60B11	84 92 9761	685
46202-60B11-000	84 92 9761	685
46202-83E00 S2	84 93 2475	685
46202-83E00-000 S2	84 93 2475	685
46202-83E20 S2	84 93 2475	685
46202-83E20-000 S2	84 93 2475	685
46202-86G00 S2	84 93 2475	685
46202-86G00-000 S2	84 93 2475	685
46300-60B00	84 92 9376	685
46300-60B00-000	84 92 9376	685
46300-60B01	84 92 9376	685
46300-60B01-000	84 92 9376	685
46300-60B10	84 92 9376	685
46300-60B10-000	84 92 9376	685
46300-70C02	84 92 9376	685
46300-70C02-000	84 92 9376	685
48810-60A00	84 71 0002	338
48810-60B00	84 71 0001	336
48810-60J00-000	84 92 9830	334, 335, 337
48810-60810-000	84 92 9830	334, 335, 337
48810-63J00	84 92 9830	334, 335, 337
48810-63J00-000	84 92 9830	334, 335, 337
48810-65D00	84 92 9828	333

48810-65D00-000	84 92 9828	333
48810-65D01-000	84 92 9828	333
48810-76G00	84 71 0001	336
48810-76G00-000	84 71 0001	336
48810-81A00	84 93 3532	334
48810-81A00-000	84 93 3532	334
48810-82000	84 71 0001	336
48820-65D00	84 92 9829	333
48820-65D00-000	84 92 9829	333
48820-65D01-000	84 92 9829	333
48820-81A00	84 93 3533	334
48820-81A00-000	84 93 3533	334
48830M68K00	84 93 3510	331
48830-M70F00	84 93 1472	331
48830-60B00	84 92 9840	336
48830-60B00-000	84 92 9840	336
48830-60G00	84 92 8055	332
48830-60G00-000	84 92 8055	332
48830-63J00	84 92 8056	335, 337
48830-63J00-000	84 92 8056	335, 337
48830-65D00	84 92 8057	333
48830-65D00-000	84 92 8057	333
48830-65J00	84 93 0577	333
48830-65J00-000	84 93 0577	333
48830-83E00	84 92 8058	334, 339
48830-83E00-000	84 92 8058	334, 339
48830-84000	84 72 0002	331
48830-84000-000	84 72 0002	331
48830-86G00	84 92 8058	334, 339
48830-86G00-000	84 92 8058	334, 339
48850-60A00	84 72 0001	338
48850-60A00-000	84 72 0001	338
48850-85C00	84 72 0001	338

passend für / to fit:

TOYOTA

43330-09050	81 92 3589	341, 346, 347, 349, 376, 377
43330-09090	81 92 3111	356, 357
43330-09160	81 92 8701	348, 349, 376, 377
43330-09210 S1	81 92 8704	344
43330-09560 S1	81 92 8701	348, 349, 376, 377
43330-19045	81 78 0002	379
43330-19065	81 92 3245	354



Ref. - No.	SWAG GERMANY	
43330-19066	81 92 3245	354
43330-19075	81 78 0002	379
43330-19085	81 92 3109	368, 379, 383
43330-19095	81 92 3243	353, 355, 356, 357, 358, 370, 372, 378, 386
43330-19115	81 92 3243	353, 355, 356, 357, 358, 370, 372, 378, 386
43330-29265	81 78 0001	343, 351, 353, 368
43330-29295	81 92 3246	361, 362, 363
43330-29315	81 78 0001	343, 351, 353, 368
43330-29375	81 78 0001	343, 351, 353, 368
43330-29515	81 92 3246	361, 362, 363
43330-39285	81 92 3589	341, 346, 347, 349, 376, 377
43330-39435	81 92 3589	341, 346, 347, 349, 376, 377
43330-49025 S1	81 92 8699	371, 372
43340-09010 S1	81 92 8700	348, 349, 376, 377
43340-19015	81 92 3244	354
43340-19016	81 92 3244	354
43340-19025	81 92 3107	368, 379, 383
43350-39035	81 92 3247	363, 384
43350-39075	81 92 3247	363, 384
45046-09020	81 92 3585	341, 342, 346, 347, 349
45046-09050	81 92 3605	343, 351
45046-09100	81 92 3605	343, 351
45046-09230	81 92 9691	344
45046-09295	62 93 9591	345
45046-09295	62 92 8319	345
45046-09295 S3	62 93 9591	345
45046-19175	81 71 0002	346, 350, 352, 353, 354, 355, 356, 360, 362, 371, 372, 375, 378, 383, 385, 387
45046-19265	81 92 3630	357, 358, 386, 387
45046-19415	81 93 4311	341, 357, 374
45046-29255	81 92 3585	341, 342, 346, 347, 349

Ref. - No.	SWAG GERMANY	
45046-29305	81 71 0002	346, 350, 352, 353, 354, 355, 356, 360, 362, 371, 372, 375, 378, 383, 385, 387
45046-29365	81 92 3605	343, 351
45046-29425	81 92 9186	344
45046-49095	81 93 0232	367, 372, 375, 386
45046-59025	81 92 3643	362, 385, 387
45046-59026	81 92 3643	362, 385, 387
45046-69135	81 92 7512	365, 366
45047-09010	81 92 3603	343, 351
45047-09030	81 92 3603	343, 351
45047-09125	62 92 8318	345
45047-09125	62 93 9590	345
45047-09125 S2	62 93 9590	345
45047-19115	81 92 3629	357, 358, 386, 387
45047-19215	81 93 4310	341, 357, 374
45047-29125	81 92 3603	343, 351
45047-49025	81 93 0231	367, 372, 375, 386
45047-59025	81 92 3641	362, 385, 387
45047-59026	81 92 3641	362, 385, 387
45047-69085	81 92 7511	365, 366
45406-39135	81 92 7260	363, 384
45406-39185	81 92 7260	363, 384
45460-39615	81 92 9763	348
45460-39635	81 93 0226	348, 349, 377
45470-39215	81 92 9764	348
45470-39225	81 93 0225	348, 349, 377
45500-0H010	62 93 6850	345
45500-0H010	62 93 9590	345
45500-0H010	62 93 9591	345
45500-0H010 S1	62 93 6850	345
45500-0H010 S1	62 93 9590	345
45500-0H010 S2	62 93 9590	345
45500-0H010 S3	62 93 9591	345
45503-0D030	81 93 1747	387
45503-0F010	81 93 4713	344, 358, 359
45503-05010	81 92 2913	351
45503-05020	81 92 2915	343, 359
45503-05050	81 92 2915	343, 359
45503-09230	81 92 9352	348, 377
45503-12130	81 92 7805	357, 358
45503-17040	81 93 3447	367

Ref. - No.

**SWAG**
GERMANY**SWAG**
GERMANY

Ref. - No.

SWAG
GERMANY

Ref. - No.

SWAG
GERMANY

45503-19075	81 72 0002	379
45503-19145	81 92 7809	367
45503-19205	81 72 0001	355
45503-19215	81 92 3023	355, 356, 371
45503-19255	81 92 7805	357, 358
45503-29255	81 92 9672	362
45503-29295	81 92 7808	369, 382
45503-29355	81 92 3583	346, 347, 348
45503-29365	81 92 3023	355, 356, 371
45503-29385	81 72 0001	355
45503-29435	81 92 9692	351, 359, 368
45503-29565	81 93 1751	363
45503-29575	81 93 3190	363
45503-29615	81 92 9692	351, 359, 368
45503-29765	81 92 7810	369, 382
45503-39055	81 92 3583	346, 347, 348
45503-39075	81 92 8092	365, 381, 384
45503-39135	81 92 3583	346, 347, 348
45503-39225	81 92 9352	348, 377
45503-39235	81 92 9361	366, 384
45503-39265	81 92 9361	366, 384
45503-47030	81 93 1750	370
45503-49055	81 92 7812	372
45503-49105	81 92 7339	343
45503-59045	81 92 3645	387
45503-59055	81 93 4616	385, 387
45503-69015	81 92 8091	366
45503-69025	81 93 4618	366
45535-09180	62 93 9238	345
45535-09180	62 93 9590	345
45535-09180	62 93 9591	345
45535-09180 S2	62 93 9590	345
45535-09180 S3	62 93 9591	345
48061-05010	81 93 1106	343, 359
48068-0H010	81 93 1719	345
48068-0H010 S1	81 92 2911	345, 387
48068-0H010 S2	81 93 0034	345
48068-0H010 S3	81 93 0035	345
48068-0H010 S4	81 93 0036	345
48068-02010	81 92 2947	355, 356
48068-02010 S1	81 92 4312	355, 356
48068-05050	81 92 4339	343
48068-12110	81 92 8238	354

48068-12130	81 73 0001	355
48068-12140	81 73 0001	355
48068-12170	81 92 2947	355, 356
48068-12170 S1	81 92 4312	355, 356
48068-12171	81 92 2947	355, 356
48068-12171 S1	81 92 4312	355, 356
48068-12180	81 92 2947	355, 356
48068-12180 S1	81 92 4312	355, 356
48068-12181	81 92 2947	355, 356
48068-12181 S1	81 92 4312	355, 356
48068-12190	81 92 2947	355, 356
48068-12190 S2	81 92 2945	356
48068-12190 S3	81 92 9185	356
48068-12191	81 92 2947	355, 356
48068-12191 S1	81 92 4312	355, 356
48068-12191 S2	81 92 2945	356
48068-12191 S3	81 92 9185	356
48068-12260	81 92 6597	357, 358
48068-20260	81 92 8110	351
48068-20260 S1	81 92 9187	351
48068-20260 S2	81 92 9671	351
48068-33010	81 92 2965	341, 346
48068-33020	81 92 2965	341, 346
48068-33030	81 92 2969	341, 347
48068-42022	81 91 9991	371
48068-59035	81 92 8449	387
48068-59035 S1	81 92 2911	345, 387
48068-59035 S2	81 92 3282	387
48068-59035 S3	81 92 3281	387
48068-59035 S4	81 92 8449	387
48069-0H010	81 93 1718	345
48069-0H010 S1	81 92 2911	345, 387
48069-0H010 S2	81 93 0034	345
48069-0H010 S3	81 93 0035	345
48069-0H010 S4	81 93 0036	345
48069-02010	81 92 2949	355, 356
48069-02010 S1	81 92 4292	355, 356
48069-05050	81 92 4340	343
48069-12110	81 92 8237	354
48069-12130	81 73 0002	355
48069-12140	81 73 0002	355
48069-12160	81 92 2949	355, 356
48069-12160 S1	81 92 4292	355, 356



Ref. - No.	SWAG GERMANY	
48069-12170	81 92 2949	355, 356
48069-12170 S1	81 92 4292	355, 356
48069-12171	81 92 2949	355, 356
48069-12171 S1	81 92 4292	355, 356
48069-12180	81 92 2949	355, 356
48069-12180 S1	81 92 4292	355, 356
48069-12181	81 92 2949	355, 356
48069-12181 S1	81 92 4292	355, 356
48069-12190	81 92 2949	355, 356
48069-12190 S1	81 92 4292	355, 356
48069-12191	81 92 2949	355, 356
48069-12191 S1	81 92 4292	355, 356
48069-12260	81 92 6598	357, 358
48069-20260	81 92 8109	351
48069-20260 S1	81 92 9187	351
48069-20260 S2	81 92 9671	351
48069-33010	81 92 2967	341, 346
48069-33020	81 92 2967	341, 346
48069-33030	81 92 2971	341, 347
48069-33031	81 92 2971	341, 347
48069-42022	81 91 9993	371
48069-59035	81 92 8449	387
48069-59035 S1	81 92 2911	345, 387
48069-59035 S4	81 92 8449	387
48650-20020	81 92 7337	343
48650-20021	81 92 7337	343
48654-0H010	81 93 0034	345
48654-12070	81 92 9185	356
48654-12120	81 92 2945	356
48654-20150	81 92 9187	351
48655-0H010	81 93 0035	345
48655-07010	81 92 6465	341, 346
48655-20140	81 93 1106	343, 359
48802-60060	81 93 4661	693
48802-60090 S1	81 93 4662	693, 694
48810-0K010	81 92 7336	366, 384
48810-0K020	81 92 7336	366, 384
48810-05012	81 76 0008	343
48810-20010	81 76 0002	350
48810-20020	81 76 0005	351, 359, 368
48810-28010	81 92 6919	369, 382
48810-28020	81 92 6919	369, 382
48810-33010	81 92 3575	347

Ref. - No.	SWAG GERMANY	
48810-44010	81 76 0005	351, 359, 368
48810-60010	81 92 6736	365
48810-60040	81 92 7336	366, 384
48815-0H010	62 93 7199	345
48817-0D010	62 92 7438	345
48817-0D010 S1	62 92 7438	345
48817-30010	81 93 4662	693, 694
48817-52010	81 92 7262	362, 375, 385, 387
48819-52010	81 92 7262	362, 375, 385, 387
48819-52010 S1	81 92 7262	362, 375, 385, 387
48819-70010	62 92 7438	345
48819-70010 S1	62 92 7438	345
48820-AD010	81 92 8591	365, 381, 383, 384
48820-0D010	81 92 8090	387
48820-0K030	81 92 7335	366, 384
48820-0K040	81 92 7335	366, 384
48820-0R010	81 93 1713	373
48820-02020	81 92 2993	353, 357
48820-02070	81 93 1714	341, 344, 357
48820-05012	81 76 0007	343
48820-06040	81 92 8592	342, 348, 377
48820-17020	81 93 1717	367
48820-17030	81 93 1717	367
48820-17040	81 93 1717	367
48820-17050 S1	81 92 9953	367
48820-20010	81 76 0006	352, 354
48820-20021	81 92 3175	352, 355
48820-20030	81 76 0001	350
48820-20040	81 76 0004	351, 359, 368
48820-22041	81 93 4664	360
48820-24010	81 93 1715	353, 380
48820-28010	81 92 6920	369, 382
48820-28030	81 92 6920	369, 382
48820-28050	81 92 3636	348, 364
48820-32010	81 92 2993	353, 357
48820-33010	81 76 0003	341, 346, 353, 355, 356, 371
48820-33020	81 92 3577	347
48820-35010	81 93 4665	364, 384
48820-35030	81 92 8591	365, 381, 383, 384
48820-42010	81 92 3234	371
48820-42020	81 92 6085	372

Ref. - No.

**SWAG**
GERMANY**SWAG**
GERMANY

Ref. - No.

SWAG
GERMANY

Ref. - No.

SWAG
GERMANY

48820-42030	81 92 8513	340, 341, 357, 369, 373, 374, 375, 382
48820-44010	81 76 0004	351, 359, 368
48820-44020	81 92 7338	343, 344
48820-47010	81 92 3635	344, 357, 358, 370, 375
48820-60010	81 92 6737	365
48820-60050	81 92 7335	366, 384
48830-0R010	81 93 1558	695
48830-05020	81 92 7286	687
48830-05030	81 93 1557	686, 687
48830-06020	81 92 3579	686, 688, 696
48830-06030	81 92 6520	688, 692, 693
48830-12050	81 93 0865	691
48830-12060	66 91 8105	688, 689, 690, 691
48830-12070	81 93 1557	686, 687
48830-17070	81 92 8448	695
48830-20010	66 91 8105	688, 689, 690, 691
48830-21020	81 92 7332	687, 696
48830-32010	66 91 8105	688, 689, 690, 691
48830-32020	66 91 8105	688, 689, 690, 691
48830-32040	81 92 8059	692
48830-33010	81 92 3579	686, 688, 696
48830-35020 S1	81 92 8644	694, 697
48830-42010	81 92 8629	695
48830-48010	81 92 6520	688, 692, 693
48830-60030	81 92 7287	692, 694, 697
48840-21010	81 92 7331	687, 696
48840-42010	81 92 8628	695
90177-W0002	62 92 7438	345
90179-08062	81 93 4662	693, 694
90948-02126	81 93 4662	693, 694
90948-02127	81 93 4662	693, 694
90948-02178	81 92 7262	362, 375, 385, 387
90948-02179	81 92 7262	362, 375, 385, 387
94182-10800	81 92 7262	362, 375, 385, 387

passend für / to fit:

VAUXHALL

02875013	40 61 0008	393, 395, 397, 406, 409, 411, 415, 435, 444
0423 008	40 92 7097	704, 706
0423 033	40 92 7097	704, 706

0423 035	40 92 7097	704, 706
06655341	40 79 0020	699, 700, 701, 702, 703
07840451	40 80 0001	432
07840452	40 71 0001	416, 419, 432, 438, 440
07840453	40 74 0001	432
09109852	60 92 6453	429
09109853	60 92 6454	429
09109909	60 92 2468	429
09109940	60 92 6453	429
09109941	60 92 6454	429
09111641	60 78 0020	391
09111661	60 71 0017	391
09112047	60 92 6453	429
09112048	60 92 6454	429
09118127	40 71 0025	399, 447
09118128	40 72 0023	399, 401, 447
09118128 S1	40 94 3727	401, 449
09118128 S6	40 94 3780	399, 447
09156605	40 60 0009	434
09160391	60 92 7181	429
09160392	60 92 6453	429
09160393	60 92 6454	429
09160394	40 92 4262	429
09160395	60 92 4263	429
09160498	60 91 9867	429
09160499	60 91 9866	429
09160554	60 92 2710	429
09160555	60 92 2468	429
09161561 SK	60 93 2128	429
09161561 S1	60 93 7625	429, 444
09161561 S2	60 93 7626	429, 444
09161562	60 92 1493	429
09161563	60 92 1494	429
09191188	40 93 6543	437, 442, 443
09191309	40 69 0005	705
09191649	40 93 0624	441
09193088	40 72 0012	433
09193094	40 72 0011	433
09195731	40 92 2099	407, 433
09196394	40 91 9541	419, 440
09196409	40 93 0573	399, 447



Ref. - No.	SWAG GERMANY	
09199576	40 69 0002	419, 422, 426
09199961	40 92 3129	419, 426, 440
09199961	40 69 0002	419, 422, 426
09204751	84 94 2318	389
09204752	84 92 8058	389
09208987	40 91 9501	389
09208989	89 92 8712	389
09209466	84 93 2470	389
09210168	84 94 2318	389
09210351	84 94 2318	389
09212533	89 92 8712	389
09223176	40 94 4325	447
09228477	40 73 0015	441
09228477 S1	40 93 8274	441
13104120	40 92 7775	704, 706
13105744	40 92 7097	704, 706
13105744 S1	40 93 4213	704, 706
13116332	40 93 3776	437, 443
13125492	40 93 0623	401, 419, 422, 426
13131232	40 93 6543	437, 442, 443
13131963	40 94 0484	706
13138151	40 69 0001	419, 422, 426, 440
13140037	40 73 0022	419
13140037 S1	40 93 4221	419
13140038	40 73 0021	419
13140038 S1	40 93 4222	419
13167940	40 92 9280	388, 420, 421
13169439	40 79 0019	399, 401, 447, 449
13169439	40 93 8939	399, 401, 427, 447, 449
13204070	40 93 8052	401, 427, 437, 443, 449
13204071	40 93 8051	401, 427, 437, 443, 449
13204112	40 93 4940	704, 706
13204112 S1	40 93 6112	704, 706
13204115	40 92 7097	704, 706
13204115 S1	40 93 4213	704, 706
13219090	40 93 9362	404, 425
13219141	40 93 4959	404, 425, 450
13230274	40 92 7097	704, 706
13230274 S1	40 93 4213	704, 706
13237130	40 92 2379	437, 443

Ref. - No.	SWAG GERMANY	
13257785	40 93 6595	425
13258052	40 93 1561	404, 425, 450
13260666	40 92 8475	388, 420, 421
13271036	40 94 0915	425
13271996 SK	40 93 3131	425
13273604	40 93 9351	425
13273605	40 93 9352	425
13278357	30 93 9606	403
13278358	40 94 4446	403
13278358 S1	40 94 4447	403
13280211	40 93 9352	425
13281782	40 93 7854	391, 404, 425
13281784	40 93 7855	404, 425
13281790	40 93 9089	701
13286689	40 94 5096	403, 409, 425, 450
13286689 SK1	40 94 5095	403, 409, 425, 450
13314168	40 94 3577	403
13314168 S1	40 94 4338	403
13314168 S2	40 94 4339	403
13314168 S3	40 94 4340	403
13318884	40 93 9351	425
13318885	40 93 9352	425
13318886	40 93 9351	425
13318887	40 93 9352	425
13321280	70 92 7414	420
13321338	40 94 3719	391, 404
13321339	40 94 3720	391, 404
13327928	40 79 0019	399, 401, 447, 449
13327928	40 93 8939	399, 401, 427, 447, 449
13332651	40 94 3794	425
13332653	40 94 3792	425
13334021	40 94 3718	391, 404
13334022	40 94 3719	391, 404
13334023	40 94 3720	391, 404
13337880	40 94 4245	403
13337882	40 94 4246	403
13337891	40 94 4424	403
13337891 S1	40 94 4434	403
13343139	70 93 8586	388, 420
13354440	40 94 5096	403, 409, 425, 450
13354440 SK1	40 94 5095	403, 409, 425, 450
13354538	40 94 4245	403

Ref. - No.

**SWAG**
GERMANY**SWAG**
GERMANY

Ref. - No.

SWAG
GERMANY

Ref. - No.

SWAG
GERMANY

13354540	40 94 4246	403
13354542	40 94 4156	403, 409
13354542 S1	40 94 4249	403
13354542 S2	40 94 4250	403
13360017	40 93 9351	425
13360018	40 93 9352	425
13360020	40 93 9352	425
13391512	40 94 5219	388, 421
20835938	40 94 3718	391, 404
20911128	40 94 3532	698
22454478	40 92 7074	401, 427, 447, 449
22737680	40 94 3532	698
22792989	40 93 6595	425
22792990	40 93 9351	425
22792991	40 93 9352	425
24403523	40 93 7253	419
24406498	40 94 0487	419, 422
24413015	40 92 3001	437, 443
24 413 015 S1	40 93 4231	437, 443
24413016	40 92 3002	437, 443
24413016 S1	40 93 4228	437, 443
24417251	40 92 2379	437, 443
24428548	40 93 4940	704, 706
24428548 S1	40 93 6112	704, 706
24428977	40 73 0022	419
24428977 S1	40 93 4221	419
24428978	40 73 0021	419
24428978 S1	40 93 4222	419
24428982	40 69 0002	419, 422, 426
24430103	40 69 0001	419, 422, 426, 440
24439582	40 92 3762	401, 427, 447, 449
24452034	40 93 0625	704, 706
24454477	40 92 7073	401, 427, 447, 449
24454477 S1	40 93 4232	401, 427, 446, 447, 449
24454478 S1	40 93 4233	401, 427, 446, 447, 449
24457385	40 93 1066	704, 706
24457386	40 93 1067	704, 706
24457843	40 93 1068	704, 706
24461353	40 93 0827	401, 449
24469643	40 92 4221	704, 706
25995127	13 94 1529	390

25995128	13 94 1740	390
25995128 SK	89 92 8347	390
25995129	13 94 1741	390
25995129 SK	89 92 8347	390
26010028	40 74 0001	432
26011925	40 71 0001	416, 419, 432, 438, 440
26030411	40 74 0003	416, 417, 438, 439
26032284	40 74 0005	416, 417, 438, 439
26055219 SK	40 74 0004	441
26059293	40 72 0023	399, 401, 447
26059293 S1	40 94 3727	401, 449
26059293 S6	40 94 3780	399, 447
26059294	40 71 0025	399, 447
26065265	40 71 0024	417, 439
26087867	40 91 9545	419
26087868	40 71 0001	416, 419, 432, 438, 440
26102922	40 92 8312	426
26102923	40 92 3154	426
26110429 SK	40 92 3228	426
26110430	40 92 8477	419
55700753	70 92 7414	420
55700770	70 93 8586	388, 420
55703230	40 92 8648	388, 420
55703231	40 92 8649	388, 420
55703232	40 92 8475	388, 420, 421
90009367	40 61 0004	393
90009368	40 61 0005	409
90009369	40 61 0007	435, 444
90090811	40 80 0004	392, 412, 413
90090811 S1	40 80 0002	392, 412, 413
90092492	99 90 9158	407, 435
90092805	40 92 2099	407, 433
90105358	40 76 0001	392
90125567	40 72 0007	392
90125568	40 72 0006	392
90135359	40 60 0019	432
90140006	40 71 0006	392
90140007	40 71 0007	392
90166390	40 73 0001	432
90166391	40 73 0002	432
90166394	40 78 0003	416, 432, 438



Ref. - No.	SWAG GERMANY	
90170152	40 60 0002	432
90188427	40 71 0018	435
90188428	40 71 0017	435
90188878 SK	40 80 0006	392, 405, 412, 413
90193117	40 60 0016	393
90216574	40 61 0014	393
90223456	40 79 0012	699, 700, 701, 702, 703
90235040	40 60 0013	393
90235041	40 60 0010	393
90235058	40 61 0013	393
90235332	40 73 0009	408, 436
90235333	40 73 0014	408, 436
90236577	40 79 0013	435, 444
90250709	40 60 0024	395, 397, 406, 411, 415
90268463	40 60 0004	395, 406, 411, 415
90268463 S1	40 92 8100	395, 406, 411
90272194	40 78 0004	408, 436
90272195	40 78 0005	408, 436
90272683	40 78 0002	393
90278577	40 61 0010	395, 397, 411, 415
90278577 S1	40 61 0002	395, 397, 411, 415
90278579	40 61 0009	395, 397, 406, 411, 415
90278579 S1	40 61 0001	395, 397, 406, 411, 415
90278624	40 61 0011	408, 436
90279193	40 60 0005	408, 436
90279437	40 60 0008	408, 436
90288207	40 60 0008	408, 436
90288232	40 60 0006	395, 397, 406, 411, 415
90288387	40 73 0009	408, 436
90288388	40 73 0014	408, 436
90289915	40 76 0002	394, 396, 405, 412, 413
90295324	40 78 0003	416, 432, 438
90295625	40 72 0003	407, 436
90297863	40 78 0006	395, 397, 406, 411, 415
90304225	40 61 0012	395, 397, 406, 411, 415

Ref. - No.	SWAG GERMANY	
90304625	40 72 0009	394, 396, 405, 412, 413
90304625 S1	57 72 0006	394, 396, 405, 412, 413
90304626	40 72 0008	394, 396, 405, 412, 413
90334027	40 72 0004	407, 436
90334028	40 72 0005	407, 436
90334031	40 71 0004	407, 436
90334032	40 71 0005	407, 436
90334035	40 71 0003	407, 433, 436
90334036	40 71 0002	407, 433, 436
90334925	40 79 0011	700, 702, 703
90335966	40 60 0015	393
90343305	40 79 0020	699, 700, 701, 702, 703
90343847	40 79 0021	699, 702
90345195	40 80 0004	392, 412, 413
90345195 S1	40 80 0002	392, 412, 413
90350447	40 71 0008	394, 396, 405, 412, 413
90350448	40 71 0009	394, 396, 405, 412, 413
90369125	40 72 0002	436
90369704	40 71 0008	394, 396, 405, 412, 413
90369705	40 71 0009	394, 396, 405, 412, 413
90373263	40 60 0006	395, 397, 406, 411, 415
90373264	40 60 0023	395, 406, 411, 415
90373264 S1	40 92 8101	395, 406, 411
90373521	40 72 0009	394, 396, 405, 412, 413
90373521 S1	57 72 0006	394, 396, 405, 412, 413
90373522	40 72 0008	394, 396, 405, 412, 413
90373522 S1	57 72 0005	394, 396, 405, 412, 413
90373523	40 76 0002	394, 396, 405, 412, 413

Ref. - No.

**SWAG**
GERMANY**SWAG**
GERMANY

Ref. - No.

SWAG
GERMANY

Ref. - No.

SWAG
GERMANY

90373771	40 79 0014	699, 700, 701, 702, 703, 705
90373778	40 60 0006	395, 397, 406, 411, 415
90373854	40 60 0008	408, 436
90375505	40 73 0006	393
90375506	40 73 0005	393
90392553	40 72 0003	407, 436
90398968 SK	40 80 0006	392, 405, 412, 413
90398968 S1	40 80 0005	392, 405, 412, 413
90444294	40 78 0003	416, 432, 438
90445097	40 60 0001	416, 417, 438, 439
90445098	40 60 0021	416, 438
90445100	40 91 9101	416, 438
90445101	40 91 9102	416, 438
90445118	40 73 0008	416, 438
90445119	40 73 0007	416, 438
90445137	40 79 0003	408, 434, 436
90445565	40 60 0014	434
90445571	40 60 0009	434
90445625	40 92 1124	434
90445644	40 72 0012	433
90445646	40 72 0011	433
90445669	40 73 0064	434
90445669 S1	40 93 4218	434
90445670	40 73 0065	434
90445670 S1	40 93 4217	434
90447867	40 61 0012	395, 397, 406, 411, 415
90447946	40 61 0015	416, 417, 438, 439
90468012	40 92 2099	407, 433
90468567	40 61 0016	399, 419, 440, 441
90468636	40 60 0017	441
90468638	40 60 0011	441
90468930	40 79 0003	408, 434, 436
90473226	40 73 0004	395, 406, 411, 415
90473226 S1	40 93 4208	395, 411
90473227	40 73 0003	395, 406, 411, 415
90473227 S1	40 93 4209	395, 411
90473811	40 71 0010	433
90473812	40 71 0011	433
90487561	40 78 0007	399, 401, 427, 434, 441, 447, 449

90495045	40 79 0002	395, 397, 406, 411, 415
90495045 S1	40 61 0003	395, 397, 406, 411, 415
90495046	40 60 0003	397, 406, 411, 415
90495046 S1	40 92 7999	397, 406, 411
90495103	40 73 0019	397, 406, 411, 415
90495103 S1	40 93 4206	397, 411
90495104	40 73 0018	397, 406, 411, 415
90495104 S1	40 93 4207	397, 411
90495159	40 73 0004	395, 406, 411, 415
90495160	40 73 0003	395, 406, 411, 415
90495160 S1	40 93 4209	395, 411
90495195 S1	40 93 4208	395, 411
90495585	40 69 0005	705
90496014	40 71 0003	407, 433, 436
90496015	40 71 0002	407, 433, 436
90496039	40 73 0010	441
90496039 S1	40 93 8273	441
90496040	40 73 0015	441
90496040 S1	40 93 8274	441
90496116	40 79 0004	419, 422, 426, 440, 441
90496686	40 79 0010	705
90496700	40 79 0018	705
90496706	40 92 4753	705
90496711	40 93 4296	705
90497307	40 73 0064	434
90497307 S1	40 93 4218	434
90497308	40 73 0065	434
90497308 S1	40 93 4217	434
90498181 SK	40 74 0002	441
90498735	40 73 0012	399, 447
90498735 S1	40 93 4226	399, 446, 447
90498736	40 73 0016	399, 447
90498736 S1	40 93 4227	399, 446, 447
90498738	40 60 0018	399, 401, 427, 447, 449
90498740	40 60 0012	399, 447
90498745	40 79 0019	399, 401, 447, 449
90498745	40 93 8939	399, 401, 427, 447, 449
90510639	40 71 0003	407, 433, 436



Ref. - No.	SWAG GERMANY	
90510640	40 71 0002	407, 433, 436
90510641	40 72 0004	407, 436
90510642	40 72 0005	407, 436
90510643	40 71 0004	407, 436
90510644	40 71 0005	407, 436
90510647	40 72 0010	433
90510649	40 72 0012	433
90510650	40 72 0011	433
90510651	40 71 0003	407, 433, 436
90510652	40 71 0002	407, 433, 436
90510653	40 71 0010	433
90510654	40 71 0011	433
90511260	40 73 0008	416, 438
90511261	40 73 0007	416, 438
90512775	40 71 0014	441
90512982	40 78 0007	399, 401, 427, 434, 441, 447, 449
90538865	40 61 0017	399, 440
90540319 S1	40 74 0002	441
90542572	40 73 0013	417, 439
90542573	40 73 0017	417, 439
90542574	40 78 0021	417, 439
90576775	40 60 0014	434
90576788	40 73 0064	434
90576788 S1	40 93 4218	434
90576789	40 73 0065	434
90576789 S1	40 93 4217	434
90581043	40 94 4325	447
91160037	60 92 7303	444
91160037 SK	60 92 7301	444
91160037 S1	60 93 7627	429
91160037 S2	60 93 7628	429
91160038	60 92 7128	444
91160043	60 92 1283	444
91160044	60 92 1284	444
91166461	60 93 9604	445
91166461 SK	60 92 2265	445
91166461 SK2	60 92 2825	445
91166461 SK3	60 92 2822	445
91166462	60 93 9603	445
91166462 SK	60 92 2265	445
91166462 SK2	60 92 2825	445
91166462 SK3	60 92 2822	445

Ref. - No.	SWAG GERMANY	
91167000	60 92 1044	445
93161884	60 93 0653	445
93167687 SK	60 93 9444	430
93167687 SK1	60 94 3687	430
93167687 SK2	60 94 3688	430
93167688	60 94 3617	430
93167688 S1	60 94 3687	430
93167689	60 94 3618	430
93167689 S1	60 94 3688	430
93168675	40 94 4428	430
93169261	40 72 0012	433
93169283	40 71 0011	433
93171448	40 92 3003	437, 443
93172254	40 92 6152	437, 443
93172255	40 92 6153	437, 443
93172256	40 92 6432	443
93174598	40 92 2084	426
93174599	40 92 2083	426
93175520	40 92 9238	437
93178160 SK	40 93 0587	437, 443
93179557	40 72 0023	399, 401, 447
93179557 S1	40 94 3727	401, 449
93179557 S6	40 94 3780	399, 447
93179559	40 92 9324	401, 449
93181229 SK	40 92 7807	401
93181230 SK	40 92 8371	401, 448, 449
93181232	40 92 6635	401, 449
93181233	40 92 6636	401, 449
93181662	40 92 9233	401, 448, 449
93186321 SK	40 71 0014	441
93186330	40 93 4298	449
93186332	40 92 9325	401, 449
93186333	40 92 9324	401, 449
93186537	40 71 0025	399, 447
93187434	40 92 9238	437
93187435 SK	40 93 0587	437, 443
93188302	40 69 0002	419, 422, 426
93188302	40 92 3129	419, 426, 440
93188303	40 69 0002	419, 422, 426
93188808	40 92 8420	388, 420, 421
93189022	40 92 8359	420
93189023	70 92 8618	420
93189024	70 92 8619	420

Ref. - No.

**SWAG**
GERMANY**SWAG**
GERMANY

Ref. - No.

SWAG
GERMANY

Ref. - No.

SWAG
GERMANY

93189451	40 93 4298	449
93189668 SK	40 92 7807	401
93189669 SK	40 92 8371	401, 448, 449
93189670 SK	40 92 9233	401, 448, 449
93190905	40 92 2084	426
93190906	40 92 2083	426
93190907	40 92 8420	388, 420, 421
93191260	40 94 3552	399, 401, 427, 447, 449
93191521 SK	40 93 4298	449
93191526	40 72 0023	399, 401, 447
93191526 SK	40 72 0023	399, 401, 447
93191526 SK2	40 94 3727	401, 449
93191526 SK7	40 94 3780	399, 447
93191526 S1	40 94 3727	401, 449
93191526 S6	40 94 3780	399, 447
93191529 SK	40 93 0573	399, 447
93191671 SK	40 92 6432	443
93191672 SK	40 92 9238	437
93191673 SK	40 93 0587	437, 443
93192415	40 92 8312	426
93192416 SK	40 92 3228	426
93192417	40 92 3154	426
93192419	40 71 0001	416, 419, 432, 438, 440
93192420	40 92 8477	419
93192421	40 91 9545	419
93192445 SK	40 74 0003	416, 417, 438, 439
93192446	40 71 0024	417, 439
93192673	60 91 9867	429
93192674	60 91 9866	429
93193130	84 93 2141	389
93193130 S1	84 92 9826	389
93193130 S2	84 92 9827	389
93193131	84 93 2140	389
93193131 S1	84 92 9826	389
93193131 S2	84 92 9827	389
93194002	84 92 8056	389
93194035	84 92 9830	389
93194853	60 93 6583	429
93194855	60 93 6584	429
93195093	84 92 8000	389
93196241 SK	60 93 2128	429

93196778 SK1	40 94 6226	427
93196779	40 93 4320	427
93196780	40 93 4319	427
93196923	60 92 2265	445
93197233	60 94 2634	430
93197325	60 93 7309	430
93197327	60 94 4728	430
93197332 S1	60 93 7312	702
93197335	60 94 4539	702
93388568	40 92 3797	426
93388568 S1	40 93 4223	426
93388569	40 92 3798	426
93388569 S1	40 93 4224	426
93851117	60 93 9603	445
93851117 SK2	60 92 2825	445
93851117 S3	60 92 2822	445
93851118	60 93 9604	445
93851118 SK2	60 92 2825	445
93851118 S3	60 92 2822	445
93853465	60 93 6346	445
93858141	60 93 9603	445
93858141 SK2	60 92 2825	445
93858141 SK3	60 92 2822	445
93858142	60 93 9604	445
93858142 SK2	60 92 2825	445
93858917	60 92 1044	445
93862135	60 93 6346	445
93862136	60 93 6345	445
94374424	40 92 6125	423, 424
94459453	40 78 0009	423
94459465	40 78 0008	423, 424
94459480	40 71 0016	423
94459481	40 71 0015	423
95507451	40 93 0587	437, 443
95511247	70 93 3811	423
95942519	40 94 0889	431
95942520	40 94 0890	431
95952929	40 94 4888	431
96626150	13 93 1708	698
96626235	13 94 1740	390
96626236	13 94 1741	390
96626236 SK	89 92 8347	390
96626247	89 92 8671	390



Ref. - No.	SWAG GERMANY	
96626248	89 92 8672	390
96626667	13 94 1929	390
96809676	13 94 1529	390
96819161	13 94 1740	390
96819161 SK	89 92 8347	390
96819162	13 94 1741	390
96819162 SK	89 92 8347	390
96996460	13 93 1708	698
97018227	40 92 3687	423, 424
97018228	40 92 3688	423, 424
97020953	40 71 0016	423
97020954	40 71 0015	423
97125013	40 92 3687	423, 424
97125014	40 92 3688	423, 424
97184819	40 94 3358	424
99262535 SK	89 92 8347	390
passend für / to fit:		
VOLKSWAGEN		
KIT 01	30 92 1497	543
KIT 02	30 92 1498	543
KIT 03	30 92 1499	543
KIT 04	30 92 1501	543
KIT 05	30 92 1503	543
KIT 06	30 92 1505	543
KIT 09	32 92 4832	543
KIT 10	32 92 4834	543
1K0 199 231 G	30 92 7069	461, 463, 471, 497, 499, 511, 573, 581
1K0 199 231 G S1	32 93 2542	461, 463, 471, 573, 581
1K0 199 231 H	30 93 8662	511
1K0 199 231 J	30 92 7069	461, 463, 471, 497, 499, 511, 573, 581
1K0 199 231 J SK	30 93 1253	461, 462, 463, 471, 473, 497, 499, 511, 545, 558, 573, 575, 577, 581
1K0 199 231 J S1	32 93 2542	461, 463, 471, 573, 581
1K0 199 231 K	30 93 8662	511
1K0 199 231 P	30 92 7069	461, 463, 471, 497, 499, 511, 573, 581

Ref. - No.	SWAG GERMANY	
2K0 199 231	30 92 7069	461, 463, 471, 497, 499, 511, 573, 581
3C0 199 231 A	30 93 0691	465, 545, 546, 575, 577
3C0 199 231 A S1	30 93 9230	545, 575, 577
3C0 199 231 B	30 93 0691	465, 545, 546, 575, 577
3C0 199 231 B S1	30 93 9230	545, 575, 577
3C0 199 231 D	30 93 0691	465, 545, 546, 575, 577
3C0 199 231 D S1	30 93 9230	545, 575, 577
3C0 199 231 E	30 93 0691	465, 545, 546, 575, 577
3C0 199 231 E S1	30 93 9230	545, 575, 577
1K0 199 232 G	30 92 7071	461, 463, 471, 497, 499, 511, 573, 581
1K0 199 232 G S1	32 93 2541	461, 463, 471, 573, 581
1K0 199 232 H	30 93 8663	511
1K0 199 232 J	30 92 7071	461, 463, 471, 497, 499, 511, 573, 581
1K0 199 232 J S1	32 93 2541	461, 463, 471, 573, 581
1K0 199 232 J SK	30 93 1253	461, 462, 463, 471, 473, 497, 499, 511, 545, 558, 573, 575, 577, 581
1K0 199 232 K	30 93 8663	511
1K0 199 232 P	30 92 7071	461, 463, 471, 497, 499, 511, 573, 581
2K0 199 232	30 92 7071	461, 463, 471, 497, 499, 511, 573, 581
311 405 361 B	30 78 0033	590
311 405 361 C	30 78 0033	590
311 405 371 C	30 78 0026	590
7L0 407 021 A S1	30 93 8839	578, 579
7L0 407 021 A S2	30 94 0403	579
7L0 407 021 B S1	30 93 8839	578, 579
7L0 407 021 B S2	30 94 0403	579
7L0 407 021 S1	30 93 8839	578, 579
7L0 407 021 S2	30 94 0403	579
2H0 407 077 A	30 93 6457	451
251 407 077	30 60 0012	584

Ref. - No.

**SWAG**
GERMANY**SWAG**
GERMANY

Ref. - No.

SWAG
GERMANY

Ref. - No.

SWAG
GERMANY

251 407 077 B	30 60 0012	584
7L0 407 077	30 93 1344	578, 579
7P0 407 077	30 93 9194	582
701 407 077	30 60 0024	586, 588
701 407 077 A	30 60 0024	586, 588
701 407 087	30 60 0030	586, 588
7D0 407 140	32 92 3364	586, 588
7D0 407 140	30 60 0014	586, 588
7D0 407 140 A	32 92 3364	586, 588
701 407 140 B	32 92 3364	586, 588
701 407 140 B	30 60 0014	586, 588
701 407 140 C	30 60 0014	586, 588
701 407 140 C	32 92 3364	586, 588
811 407 147 B	32 73 0005	530, 532, 534, 567, 568
857 407 147 A	30 73 0008	532, 534, 569
893 407 147 C	30 73 0008	532, 534, 569
893 407 147 E	30 73 0008	532, 534, 569
893 407 147 G	32 73 0005	530, 532, 534, 567, 568
857 407 148 A	32 73 0006	532, 534, 569
857 407 148 C	32 73 0006	532, 534, 569
893 407 148 C	32 73 0006	532, 534, 569
893 407 148 E	32 73 0006	532, 534, 569
1H0 407 151	30 73 0001	480, 594
1H0 407 151 A	30 73 0014	468, 482, 536, 538, 596
1H0 407 151 A S1	30 93 7193	468, 482, 596
1J0 407 151 A	32 73 0016	453, 525
1J0 407 151 A S1	30 91 9820	455, 491, 495, 525
1J0 407 151 A S2	30 91 9822	455, 525
1J0 407 151 B	32 73 0016	453, 525
1J0 407 151 B S2	30 91 9822	455, 525
1J0 407 151 B S1	30 91 9820	455, 491, 495, 525
1J0 407 151 C	32 73 0016	453, 525
1J0 407 151 C S2	30 91 9822	455, 525
1J0 407 151 C S1	30 91 9820	455, 491, 495, 525
1K0 407 151 AA	30 93 9489	461, 471
1K0 407 151 AA S1	30 93 8181	461, 463, 471, 497, 499, 509, 511, 573, 577, 581
1K0 407 151 AB	30 93 9489	461, 471

1K0 407 151 AC S2	30 94 0103	461, 471, 497, 499, 511, 573, 581
1K0 407 151 AC	30 92 7076	461, 471, 573, 581
1K0 407 151 AC S1	30 93 7183	460, 461, 470, 471, 496, 497, 498, 499, 510, 511, 572, 573, 580, 581
1K0 407 151 AE	30 93 9489	461, 471
1K0 407 151 AE S1	30 93 8181	461, 463, 471, 497, 499, 509, 511, 573, 577, 581
1K0 407 151 AH	30 93 9489	461, 471
1K0 407 151 AH S1	30 93 8181	461, 463, 471, 497, 499, 509, 511, 573, 577, 581
1K0 407 151 AL	30 94 0103	461, 471, 497, 499, 511, 573, 581
1K0 407 151 BC	30 93 9489	461, 471
1K0 407 151 BC S1	30 93 8181	461, 463, 471, 497, 499, 509, 511, 573, 577, 581
1K0 407 151 BD	30 93 9489	461, 471
1K0 407 151 M	30 92 7076	461, 471, 573, 581
1K0 407 151 M S2	30 94 0103	461, 471, 497, 499, 511, 573, 581
1K0 407 151 M S1	30 93 7183	460, 461, 470, 471, 496, 497, 498, 499, 510, 511, 572, 573, 580, 581
1K0 407 151 N	30 93 9489	461, 471
1K0 407 151 N S1	30 93 8181	461, 463, 471, 497, 499, 509, 511, 573, 577, 581
1K0 407 151 P	30 93 9489	461, 471
1K0 407 151 P S1	30 93 8181	461, 463, 471, 497, 499, 509, 511, 573, 577, 581
1K0 407 151 Q	30 93 9489	461, 471
1K0 407 151 Q S1	30 93 8181	461, 463, 471, 497, 499, 509, 511, 573, 577, 581
1K0 407 151 T	30 92 7076	461, 471, 573, 581
1S0 407 151	40 94 0594	591



Ref. - No.	SWAG GERMANY	
191 407 151 B	30 73 0013	459, 466, 478, 563
191 407 151 B S2	30 93 7306	459, 466, 478, 507, 563
191 407 151 B S1	30 93 7186	459, 466, 478, 507, 563
2E0 407 151 L	10 93 7612	469
2E0 407 151 L S1	10 93 0151	469
2E0 407 151 M	10 93 7612	469
2E0 407 151 M S1	10 93 0151	469
3C0 407 151 A	30 93 2326	545, 575, 577
3C0 407 151 A S2	30 93 9973	465
3C0 407 151 A S1	30 93 9972	465
3C0 407 151 B	30 93 2326	545, 575, 577
3C0 407 151 B S1	30 93 9972	465
3C0 407 151 B S2	30 93 9973	465
3C0 407 151 E	30 93 2326	545, 575, 577
3C0 407 151 E S2	30 93 9973	465
3C0 407 151 E S1	30 93 9972	465
3C0 407 151 G	30 93 2326	545, 575, 577
3C0 407 151 G S1	30 93 9972	465
3C0 407 151 G S2	30 93 9973	465
357 407 151	30 73 0011	536, 538
357 407 151 S1	30 93 7204	540
357 407 151 S2	30 93 7308	540
4B0 407 151	30 91 9932	543
4B3 407 151 A	30 91 9932	543
4B3 407 151 A S1	30 94 0114	543
4B3 407 151 C	30 91 9932	543
4B3 407 151 C S1	30 94 0114	543
4B3 407 151 K	30 91 9932	543
4B3 407 151 K S1	30 94 0114	543
4D0 407 151 A	32 73 0017	543
4D0 407 151 B	32 73 0017	543
4D0 407 151 C	32 73 0017	543
4D0 407 151 E	32 73 0017	543
4D0 407 151 G	32 73 0017	543
4D0 407 151 H	32 73 0017	543
4D0 407 151 J	32 73 0017	543
4D0 407 151 P	32 73 0017	543
5C0 407 151 A	30 94 4236	509
5C0 407 151 B	30 94 4236	509
5N0 407 151	30 93 9359	465, 545, 547, 577
6N0 407 151	30 73 0004	551

Ref. - No.	SWAG GERMANY	
6N0 407 151 A	30 73 0018	521, 553
6N0 407 151 A S1	30 93 3369	521
6N0 407 151 A S2	30 93 7407	521, 551
6N0 407 151 A S3	30 93 7408	521, 551
6N0 407 151 B	30 73 0004	551
6N0 407 151 B S2	30 93 7410	551
6N0 407 151 B S1	30 93 7409	551
6N0 407 151 S1	30 93 7409	551
6N0 407 151 S2	30 93 7410	551
6Q0 407 151 D	30 92 7530	473, 558
6Q0 407 151 D S3	30 93 7196	473, 558
6Q0 407 151 D S5	30 93 7291	473, 558
6Q0 407 151 D S2	30 93 7197	473, 558
6Q0 407 151 D S4	30 93 7292	473, 558
6Q0 407 151 E	30 92 7530	473, 558
6Q0 407 151 E S2	30 93 7197	473, 558
6Q0 407 151 E S3	30 93 7196	473, 558
6Q0 407 151 E S5	30 93 7291	473, 558
6Q0 407 151 E S4	30 93 7292	473, 558
6Q0 407 151 L	30 92 7530	473, 558
6Q0 407 151 L S4	30 93 7292	473, 558
6Q0 407 151 L S5	30 93 7291	473, 558
6Q0 407 151 L S3	30 93 7196	473, 558
6Q0 407 151 L S1	30 93 6098	473, 558
6Q0 407 151 L S2	30 93 7197	473, 558
6R0 407 151	30 93 6923	557
6R0 407 151 A	30 93 9557	565
6R0 407 151 E	30 93 6923	557
6R0 407 151 E S1	30 93 6925	557
6R0 407 151 F	30 93 9557	565
6R0 407 151 S1	30 93 6925	557
6X0 407 151	30 73 0018	521, 553
6X0 407 151 A	30 73 0018	521, 553
6X0 407 151 A S2	30 93 7407	521, 551
6X0 407 151 A S1	30 93 3369	521
6X0 407 151 A S3	30 93 7408	521, 551
6X0 407 151 S1	30 93 3369	521
6X0 407 151 S2	30 93 7407	521, 551
6X0 407 151 S3	30 93 7408	521, 551
7L0 407 151 C S1	30 94 0163	578, 579
7L0 407 151 D S1	30 94 0163	578, 579
7L0 407 151 E S1	30 94 0163	578, 579
7L0 407 151 H S1	30 94 0163	578, 579

Ref. - No.

**SWAG**
GERMANY**SWAG**
GERMANY

Ref. - No.

SWAG
GERMANY

Ref. - No.

SWAG
GERMANY

7L8 407 151 K S1	30 94 5527	582
7M0 407 151 B	50 73 0024	574
7P0 407 151 C S1	30 94 5527	582
7P0 407 151 D S1	30 94 5527	582
7P0 407 151 E S1	30 94 5527	582
8D0 407 151 E	32 73 0017	543
8D0 407 151 F	32 73 0017	543
8N0 407 151 A S1	30 94 4452	494, 495, 524, 525
8N0 407 151 D S1	30 94 4452	494, 495, 524, 525
861 407 151 B	32 73 0013	549
1H0 407 152	30 73 0006	468, 482, 596
1H0 407 152 S1	30 93 7194	468, 482, 596
1K0 407 152 AA	30 93 9448	461, 471
1K0 407 152 AA S1	30 93 8180	461, 462, 463, 470, 471, 496, 497, 498, 499, 509, 510, 511, 572, 573, 577, 581
1K0 407 152 AB S1	30 93 8180	461, 462, 463, 470, 471, 496, 497, 498, 499, 509, 510, 511, 572, 573, 577, 581
1K0 407 152 AB	30 93 9448	461, 471
1K0 407 152 AC	30 92 7078	461, 471, 573, 581
1K0 407 152 AC S2	30 94 0104	461, 471, 497, 499, 511, 573, 581
1K0 407 152 AC S1	30 93 7182	460, 461, 470, 471, 496, 497, 498, 499, 510, 511, 572, 573, 580, 581
1K0 407 152 AE S1	30 93 8180	461, 462, 463, 470, 471, 496, 497, 498, 499, 509, 510, 511, 572, 573, 577, 581
1K0 407 152 AE	30 93 9448	461, 471
1K0 407 152 AF S1	30 93 8180	461, 462, 463, 470, 471, 496, 497, 498, 499, 509, 510, 511, 572, 573, 577, 581
1K0 407 152 AH	30 93 9448	461, 471
1K0 407 152 AH S1	30 93 8180	461, 462, 463, 470, 471, 496, 497, 498, 499, 509, 510, 511, 572, 573, 577, 581

1K0 407 152 AL	30 94 0104	461, 471, 497, 499, 511, 573, 581
1K0 407 152 BC	30 93 9448	461, 471
1K0 407 152 BC S1	30 93 8180	461, 462, 463, 470, 471, 496, 497, 498, 499, 509, 510, 511, 572, 573, 577, 581
1K0 407 152 BD	30 93 9448	461, 471
1K0 407 152 M	30 92 7078	461, 471, 573, 581
1K0 407 152 M S1	30 93 7182	460, 461, 470, 471, 496, 497, 498, 499, 510, 511, 572, 573, 580, 581
1K0 407 152 M S2	30 94 0104	461, 471, 497, 499, 511, 573, 581
1K0 407 152 N	30 93 9448	461, 471
1K0 407 152 N S1	30 93 8180	461, 462, 463, 470, 471, 496, 497, 498, 499, 509, 510, 511, 572, 573, 577, 581
1K0 407 152 P	30 93 9448	461, 471
1K0 407 152 P S1	30 93 8180	461, 462, 463, 470, 471, 496, 497, 498, 499, 509, 510, 511, 572, 573, 577, 581
1K0 407 152 Q	30 93 9448	461, 471
1K0 407 152 Q S1	30 93 8180	461, 462, 463, 470, 471, 496, 497, 498, 499, 509, 510, 511, 572, 573, 577, 581
1K0 407 152 T	30 92 7078	461, 471, 573, 581
1S0 407 152	40 94 0595	591
2E0 407 152 L	10 93 7611	469
2E0 407 152 L S1	10 93 0151	469
2E0 407 152 M	10 93 7611	469
2E0 407 152 M S1	10 93 0151	469
5C0 407 152 A	30 94 4237	509
5C0 407 152 B	30 94 4237	509
5N0 407 152	30 93 9360	465, 545, 547, 577
6R0 407 152	30 93 6922	557
6R0 407 152 A	30 93 9558	565
6R0 407 152 E	30 93 6922	557
6R0 407 152 E S1	30 93 6926	557

Ref. - No.	SWAG GERMANY	
6R0 407 152 F	30 93 9558	565
6R0 407 152 S1	30 93 6926	557
7L0 407 152 C S1	30 94 0164	578, 579
7L0 407 152 D S1	30 94 0164	578, 579
7L0 407 152 E S1	30 94 0164	578, 579
7L0 407 152 H S1	30 94 0164	578, 579
7L8 407 152 K S1	30 94 5528	582
7M0 407 152 B	50 73 0023	574
7P0 407 152 C S1	30 94 5528	582
7P0 407 152 D S1	30 94 5528	582
7P0 407 152 E S1	30 94 5528	582
8N0 407 152 A S1	30 94 4453	494, 495, 524, 525
8N0 407 152 D S1	30 94 4453	494, 495, 524, 525
171 407 153 D	30 73 0015	457, 476, 571
191 407 153 A	30 73 0013	459, 466, 478, 563
191 407 153 A S3	30 60 0006	459
191 407 153 S XN	30 60 0006	459
357 407 153	30 73 0011	536, 538
357 407 153 S1	30 93 7204	540
357 407 153 S2	30 93 7308	540
251 407 175	30 60 0025	584
251 407 175 A	30 60 0025	584
811 407 175 A	32 78 0023	529, 530, 532, 534, 567, 568
857 407 175	32 78 0024	532, 534, 569
251 407 179	30 60 0022	584
1J0 407 181	32 69 0009	453, 473, 525, 557, 565
1J0 407 181 A	32 69 0009	453, 473, 525, 557, 565
171 407 181	30 60 0020	457, 476, 571
171 407 181 A	30 60 0020	457, 476, 571
180 407 181	32 69 0009	453, 473, 525, 557, 565
191 407 181 A	30 69 0003	459, 466, 468, 478, 480, 482, 536, 538, 540, 563, 594, 596
191 407 181 AS	30 75 0001	455, 459, 466, 468, 478, 480, 482, 484, 486, 488, 506, 508, 536, 538, 540, 562, 563, 594, 596

Ref. - No.	SWAG GERMANY	
191 407 181 B	30 69 0003	459, 466, 468, 478, 480, 482, 536, 538, 540, 563, 594, 596
191 407 181 B S1	30 75 0001	455, 459, 466, 468, 478, 480, 482, 484, 486, 488, 506, 508, 536, 538, 540, 562, 563, 594, 596
191 407 181 BS	30 75 0001	455, 459, 466, 468, 478, 480, 482, 484, 486, 488, 506, 508, 536, 538, 540, 562, 563, 594, 596
191 407 181 D	30 69 0001	459, 466, 468, 478, 480, 482, 536, 538, 540, 563, 594, 596
191 407 181 D S1	30 75 0002	466, 468, 478, 480, 482, 484, 486, 488, 506, 508, 536, 538, 540, 562, 563, 594, 596
191 407 181 DS	30 75 0002	466, 468, 478, 480, 482, 484, 486, 488, 506, 508, 536, 538, 540, 562, 563, 594, 596
191 407 181 E	30 69 0001	459, 466, 468, 478, 480, 482, 536, 538, 540, 563, 594, 596
191 407 181 E S1	30 75 0002	466, 468, 478, 480, 482, 484, 486, 488, 506, 508, 536, 538, 540, 562, 563, 594, 596
191 407 181 ES	30 75 0002	466, 468, 478, 480, 482, 484, 486, 488, 506, 508, 536, 538, 540, 562, 563, 594, 596
357 407 181	30 69 0001	459, 466, 468, 478, 480, 482, 536, 538, 540, 563, 594, 596
357 407 181 S	30 75 0002	466, 468, 478, 480, 482, 484, 486, 488, 506, 508, 536, 538, 540, 562, 563, 594, 596
4D0 407 181 F	32 69 0003	541, 543
4D0 407 181 H	32 69 0003	541, 543
6N0 407 181	30 60 0034	521, 551, 553

Ref. - No.

**SWAG**
GERMANY**SWAG**
GERMANY

Ref. - No.

SWAG
GERMANY

Ref. - No.

SWAG
GERMANY

7M0 407 181 A	30 60 0033	574
8A0 407 181	30 60 0036	532, 534, 569
8N0 407 181 B	30 92 6535	525
811 407 181	32 69 0007	530, 532, 534, 567, 568
811 407 181 A	32 69 0007	530, 532, 534, 567, 568
857 407 181	32 69 0008	532, 534, 569
857 407 181	30 60 0036	532, 534, 569
1KD 407 182	30 92 4390	461, 463, 465, 471, 527, 545, 546, 573, 575, 577, 581
1K0 407 182	30 92 4390	461, 463, 465, 471, 527, 545, 546, 573, 575, 577, 581
1K0 407 182 A	30 92 4390	461, 463, 465, 471, 527, 545, 546, 573, 575, 577, 581
171 407 182 D	30 13 0078	457, 476, 571
180 407 182	30 69 0002	453, 459, 466, 478, 480, 525, 536, 538, 557, 563, 565, 594
191 407 182	30 69 0002	453, 459, 466, 478, 480, 525, 536, 538, 557, 563, 565, 594
2H0 407 182 A	30 93 6458	451
357 407 182	30 69 0002	453, 459, 466, 478, 480, 525, 536, 538, 557, 563, 565, 594
4D0 407 182 E	30 60 0031	541, 543
4D0 407 182 G	30 60 0031	541, 543
4E0 407 182 B	30 92 9450	548
4E0 407 182 C	30 92 9450	548
5Q0 407 182	30 92 4390	461, 463, 465, 471, 527, 545, 546, 573, 575, 577, 581
5Q0 407 182	30 93 8404	500, 501
5Q0 407 182 A	30 92 4390	461, 463, 465, 471, 527, 545, 546, 573, 575, 577, 581
6N0 407 182	30 60 0032	521, 551
6Q0 407 182 A	30 93 6098	473, 558
6U0 407 182	30 92 9644	464

7H0 407 182 A	30 92 8335	589
7L0 407 182 D	30 94 4764	578, 579, 582
7L0 407 182 F	30 94 4764	578, 579, 582
7L0 407 182 G	30 94 4764	578, 579, 582
8N0 407 182 A	30 92 8621	525
1K0 407 183 E	30 93 1253	461, 462, 463, 471, 473, 497, 499, 511, 545, 558, 573, 575, 577, 581
1K0 407 183 E S1	30 93 9228	461, 470, 471, 472, 473, 558
1K0 407 183 M	30 93 6752	461, 462, 463, 509, 511, 527, 547
1K0 407 183 P	30 93 6752	461, 462, 463, 509, 511, 527, 547
2H0 407 183 A	30 93 6460	451
251 407 183	30 60 0019	584
251 407 183 B	30 60 0019	584
4D0 407 183 AB	30 60 0041	541, 543
4D0 407 183 AC	30 60 0041	541, 543
4D0 407 183 M	30 60 0016	541, 543
4D0 407 183 N	30 60 0016	541, 543
4D0 407 183 P	30 60 0016	541, 543
4D0 407 183 P	30 60 0041	541, 543
4D0 407 183 Q	30 60 0041	541, 543
4D0 407 183 S	30 60 0041	541, 543
5C0 407 183 A	30 93 6752	461, 462, 463, 509, 511, 527, 547
5Q0 407 183 D	30 93 8403	500
5Q0 407 183 E	30 93 8403	500
5Q0 407 183 G	30 93 8403	500
6Q0 407 183	30 93 1253	461, 462, 463, 471, 473, 497, 499, 511, 545, 558, 573, 575, 577, 581
6Q0 407 183 A	30 93 1253	461, 462, 463, 471, 473, 497, 499, 511, 545, 558, 573, 575, 577, 581
6Q0 407 183 A S1	30 93 9228	461, 470, 471, 472, 473, 558

Ref. - No.	SWAG GERMANY	
6Q0 407 183 B	30 93 1253	461, 462, 463, 471, 473, 497, 499, 511, 545, 558, 573, 575, 577, 581
6Q0 407 183 B S1	30 93 9228	461, 470, 471, 472, 473, 558
6Q0 407 183 S1	30 93 9228	461, 470, 471, 472, 473, 558
7D0 407 183	30 60 0026	588
7H0 407 183	30 92 6573	589
7L0 407 183 A	30 93 3725	579, 736
701 407 183	30 60 0023	586, 588
701 407 183 C	30 60 0026	588
861 407 183	30 61 0011	549
251 407 187	30 78 0013	584
251 407 187 B	30 78 0013	584
701 407 187 A	30 78 0024	586, 588
701 407 187 B	30 78 0024	586, 588
191 407 190 A	99 90 3544	466, 468, 478, 480, 482, 507, 508, 536, 538, 540, 563, 594, 596
251 407 361	30 78 0014	584
7D0 407 361	99 91 8740	588
7D0 407 361 S1	30 92 9772	588
7H0 407 361 A S1	30 93 0858	589
7H0 407 361 S1	30 93 0858	589
7H8 407 361 A S1	30 93 7282	589
7H8 407 361 S1	30 93 7282	589
701 407 361	30 78 0025	586, 588
701 407 361 B	30 78 0025	586, 588
1H0 407 365	30 78 0021	468, 482, 596
1H0 407 365 S	30 78 0036	468, 482, 596
1H0 407 365 S1	30 78 0036	468, 482, 596
1J0 407 365 A	32 78 0020	453, 525
1J0 407 365 AS	30 78 0035	453, 525
1J0 407 365 C	30 78 0035	453, 525
1J0 407 365 C	32 78 0020	453, 525
1J0 407 365 CS	30 78 0035	453, 525
1J0 407 365 C S1	30 78 0035	453, 525
1J0 407 365 D	32 78 0020	453, 525
1J0 407 365 H	32 78 0020	453, 525
1J0 407 365 H S1	30 78 0035	453, 525

Ref. - No.	SWAG GERMANY	
1J0 407 365 J	32 78 0020	453, 525
1J0 407 365 J S1	30 78 0035	453, 525
1KD 407 365	32 92 6082	461, 463, 471, 527, 528, 573, 577, 581
1KD 407 365 S1	30 93 6735	461, 463, 471, 497, 499, 509, 511, 527, 573, 577, 581
1K0 407 365 B	32 92 6082	461, 463, 471, 527, 528, 573, 577, 581
1K0 407 365 B S1	30 93 6735	461, 463, 471, 497, 499, 509, 511, 527, 573, 577, 581
1K0 407 365 C	32 92 6082	461, 463, 471, 527, 528, 573, 577, 581
1K0 407 365 C S1	30 93 6735	461, 463, 471, 497, 499, 509, 511, 527, 573, 577, 581
1K0 407 365 E	32 92 6082	461, 463, 471, 527, 528, 573, 577, 581
1K0 407 365 E S1	30 93 6735	461, 463, 471, 497, 499, 509, 511, 527, 573, 577, 581
171 407 365 C	30 78 0006	476, 571
171 407 365 CK PL	30 78 0020	476, 571
171 407 365 C S1	30 78 0020	476, 571
171 407 365 CS	30 78 0020	476, 571
171 407 365 D	30 78 0006	476, 571
171 407 365 DK PL	30 78 0020	476, 571
171 407 365 F	30 78 0011	457, 476, 571
171 407 365 FK PL	30 78 0018	457, 476, 571
171 407 365 F S1	30 78 0018	457, 476, 571
171 407 365 FS	30 78 0018	457, 476, 571
171 407 365 F S2	30 93 9813	457, 476, 503, 571
171 407 365 G	30 78 0011	457, 476, 571
171 407 365 GK PL	30 78 0018	457, 476, 571
171 407 365 G S2	30 93 9813	457, 476, 503, 571
191 407 365	30 78 0016	478
191 407 365 A	30 78 0016	478
191 407 365 B	30 78 0016	478
191 407 365 KP L	30 78 0039	478
191 407 365 S	30 78 0039	478
191 407 365 S1	30 78 0039	478
3C0 407 365 A S1	30 93 1485	465, 545

Ref. - No.

**SWAG**
GERMANY**SWAG**
GERMANY

Ref. - No.

SWAG
GERMANY

Ref. - No.

SWAG
GERMANY

3C0 407 365 B S1	30 93 1485	465, 545
357 407 365	30 78 0019	459, 466, 478, 480, 536, 538, 563, 594
357 407 365 A	30 78 0019	459, 466, 478, 480, 536, 538, 563, 594
357 407 365 A S2	30 93 9810	453, 459, 466, 478, 480, 484, 486, 489, 507, 536, 538, 563, 594
357 407 365 KP L	30 78 0017	459, 466, 478, 480, 536, 538, 563, 594
357 407 365 S	30 78 0017	459, 466, 478, 480, 536, 538, 563, 594
357 407 365 S1	30 78 0017	459, 466, 478, 480, 536, 538, 563, 594
357 407 365 S2	30 93 9810	453, 459, 466, 478, 480, 484, 486, 489, 507, 536, 538, 563, 594
5Q0 407 365 A S1	30 94 0668	500
5U0 407 365 A	30 93 6051	557, 565, 591
5Z0 407 365 B	30 91 9406	473, 558
6N0 407 365	30 78 0023	521, 551, 553
6N0 407 365 A	30 78 0022	521, 551, 553
6N0 407 365 A S1	30 78 0037	521, 551, 553
6N0 407 365 A S	30 78 0037	521, 551, 553
6N0 407 365 S	30 78 0038	521, 551, 553
6N0 407 365 S1	30 78 0038	521, 551, 553
6Q0 407 365 A	30 91 9406	473, 558
6Q0 407 365 A S1	30 91 9410	473, 558
6Q0 407 365 D	30 91 9406	473, 558
6Q0 407 365 E	30 91 9406	473, 558
6Q0 407 365 M	30 91 9406	473, 558
6Q0 407 365 M S1	30 91 9410	473, 558
6R0 407 365	30 93 6051	557, 565, 591
6R0 407 365 A	30 93 6051	557, 565, 591
6R0 407 365 B	30 93 6051	557, 565, 591
6U0 407 365	36 78 0001	464
7M0 407 365 A	30 91 9276	574
7M3 407 365 A	30 91 9276	574
7M3 407 365 C	30 91 9276	574
8N0 407 365 A	30 92 6700	525
8N0 407 365 B	30 92 6700	525

8N0 407 365 C	30 92 6700	525
8Z0 407 365 A S1	30 78 0035	453, 525
823 407 365 A	32 78 0001	529
823 407 365 C	32 78 0001	529
823 407 365 E	32 78 0002	529, 530, 532, 534, 567, 568
855 407 365 A	32 78 0003	532, 534, 569
855 407 365 B	32 78 0003	532, 534, 569
1J0 407 366 A	32 78 0019	453, 525
1J0 407 366 AS	30 78 0034	453, 525
1J0 407 366 C	32 78 0019	453, 525
1J0 407 366 CS	30 78 0034	453, 525
1J0 407 366 C S1	30 78 0034	453, 525
1J0 407 366 D	32 78 0019	453, 525
1J0 407 366 H	32 78 0019	453, 525
1J0 407 366 H S1	30 78 0034	453, 525
1J0 407 366 J	32 78 0019	453, 525
1J0 407 366 J S1	30 78 0034	453, 525
1KD 407 366	32 92 6083	461, 463, 471, 527, 528, 573, 577, 581
1KD 407 366 S1	30 93 6736	461, 463, 471, 497, 499, 509, 511, 527, 573, 577, 581
1K0 407 366 B	32 92 6083	461, 463, 471, 527, 528, 573, 577, 581
1K0 407 366 B S1	30 93 6736	461, 463, 471, 497, 499, 509, 511, 527, 573, 577, 581
1K0 407 366 C	32 92 6083	461, 463, 471, 527, 528, 573, 577, 581
1K0 407 366 C S1	30 93 6736	461, 463, 471, 497, 499, 509, 511, 527, 573, 577, 581
1K0 407 366 E	32 92 6083	461, 463, 471, 527, 528, 573, 577, 581
1K0 407 366 E S1	30 93 6736	461, 463, 471, 497, 499, 509, 511, 527, 573, 577, 581
3C0 407 366 A S1	30 93 1486	465, 545
3C0 407 366 B S1	30 93 1486	465, 545
5Q0 407 366 A S1	30 94 0669	500
5U0 407 366 A	30 93 6052	557, 565, 591
5Z0 407 366 B	30 91 9408	473, 558



Ref. - No.	SWAG GERMANY	
6Q0 407 366 A	30 91 9408	473, 558
6Q0 407 366 A S1	30 91 9412	473, 558
6Q0 407 366 D	30 91 9408	473, 558
6Q0 407 366 E	30 91 9408	473, 558
6Q0 407 366 M	30 91 9408	473, 558
6Q0 407 366 M S1	30 91 9412	473, 558
6R0 407 366	30 93 6052	557, 565, 591
6R0 407 366 A	30 93 6052	557, 565, 591
6R0 407 366 B	30 93 6052	557, 565, 591
8N0 407 366 A	30 92 6700	525
8Z0 407 366 A S1	30 78 0034	453, 525
855 407 366 A	32 78 0004	532, 534, 569
855 407 366 B	32 78 0004	532, 534, 569
4E0 407 505 B	30 92 7503	548
4E0 407 505 E	30 92 7503	548
4Z7 407 505	32 73 0021	543
4Z7 407 505 A	32 73 0021	543
4Z7 407 505 A S2	30 93 7179	543
4Z7 407 505 S2	30 93 7179	543
8D0 407 505 B	32 73 0021	543
8D0 407 505 B S2	30 93 7179	543
8D0 407 505 F	32 73 0021	543
8D0 407 505 F S2	30 93 7179	543
8D0 407 505 H	32 73 0021	543
8D0 407 505 H S2	30 93 7179	543
8D0 407 505 K	32 73 0021	543
8D0 407 505 K S2	30 93 7179	543
8E0 407 505 A	32 73 0021	543
8E0 407 505 A S2	30 93 7179	543
4E0 407 506 B	30 92 7502	548
4E0 407 506 E	30 92 7502	548
4Z7 407 506	32 73 0020	543
4Z7 407 506 A	32 73 0020	543
4Z7 407 506 A S1	30 93 7178	543
4Z7 407 506 S1	30 93 7178	543
8D0 407 506 B	32 73 0020	543
8D0 407 506 B S1	30 93 7178	543
8D0 407 506 F	32 73 0020	543
8D0 407 506 F S1	30 93 7178	543
8D0 407 506 H	32 73 0020	543
8D0 407 506 H S1	30 93 7178	543
8D0 407 506 K	32 73 0020	543
8D0 407 506 K S1	30 93 7178	543

Ref. - No.	SWAG GERMANY	
8E0 407 506 A	32 73 0020	543
8E0 407 506 A S1	30 93 7178	543
4D0 407 509 F	32 73 0032	543
4D0 407 509 G	32 73 0032	543
4D0 407 509 H	32 73 0032	543
4D0 407 509 J	32 73 0032	543
4E0 407 509 B	30 92 7265	548
4E0 407 509 E	30 92 7265	548
4E0 407 509 G	30 92 7265	548
4E0 407 509 K	30 92 7265	548
8D0 407 509 C	32 73 0032	543
8D0 407 509 E	32 73 0032	543
8D0 407 509 G	30 92 1892	543
8E0 407 509 A	32 73 0032	543
4D0 407 510 F	32 73 0033	543
4D0 407 510 G	32 73 0033	543
4D0 407 510 H	32 73 0033	543
4D0 407 510 J	32 73 0033	543
4E0 407 510 B	30 92 7264	548
4E0 407 510 E	30 92 7264	548
4E0 407 510 G	30 92 7264	548
4E0 407 510 K	30 92 7264	548
8D0 407 510 C	32 73 0033	543
8D0 407 510 E	32 73 0033	543
8D0 407 510 G	30 92 1893	543
8E0 407 510 A	32 73 0033	543
4B0 407 515	30 91 9926	541, 543
4D0 407 515 C	30 60 0029	541, 543
8D0 407 515 A	32 93 0696	548
8D0 407 515 B	32 93 0696	548
8D0 407 515 C	32 93 0696	548
2E0 407 523	10 93 0295	469
2E0 407 523 A	10 93 1479	469
4D0 407 693 AC	32 73 0019	543
4D0 407 693 AC S1	30 93 3364	543
4D0 407 693 AD	32 73 0019	543
4D0 407 693 AD S1	30 93 3364	543
4D0 407 693 E	32 73 0019	543
4D0 407 693 E S1	30 93 3364	543
4D0 407 693 H	32 73 0019	543
4D0 407 693 H S1	30 93 3364	543
4D0 407 693 K	32 73 0019	543
4D0 407 693 K S1	30 93 3364	543

Ref. - No.

**SWAG**
GERMANY**SWAG**
GERMANY

Ref. - No.

SWAG
GERMANY

Ref. - No.

SWAG
GERMANY

4D0 407 693 M	32 73 0019	543
4D0 407 693 M S1	30 93 3364	543
4D0 407 693 N	32 73 0019	543
4D0 407 693 N S1	30 93 3364	543
8E0 407 693	32 92 1196	543
8E0 407 693 AG	32 92 1196	543
8E0 407 693 E	32 73 0019	543
8E0 407 693 E	32 92 1196	543
8E0 407 693 E S1	30 93 3364	543
8E0 407 693 K	32 92 1196	543
8E0 407 693 P	32 92 1196	543
8E0 407 693 Q	32 92 1196	543
4D0 407 694 AC S1	30 93 3363	543
4D0 407 694 AC	32 73 0018	543
4D0 407 694 AD	32 73 0018	543
4D0 407 694 AD S1	30 93 3363	543
4D0 407 694 E	32 73 0018	543
4D0 407 694 E S1	30 93 3363	543
4D0 407 694 H	32 73 0018	543
4D0 407 694 H S1	30 93 3363	543
4D0 407 694 K	32 73 0018	543
4D0 407 694 K S1	30 93 3363	543
4D0 407 694 M	32 73 0018	543
4D0 407 694 M S1	30 93 3363	543
4D0 407 694 N	32 73 0018	543
4D0 407 694 N S1	30 93 3363	543
8E0 407 694	32 92 1198	543
8E0 407 694 AG	32 92 1198	543
8E0 407 694 E	32 73 0018	543
8E0 407 694 E	32 92 1198	543
8E0 407 694 E S1	30 93 3363	543
8E0 407 694 K	32 92 1198	543
8E0 407 694 P	32 92 1198	543
8E0 407 694 Q	32 92 1198	543
6U0 407 807	36 78 0001	464
701 411 019 B	30 91 8654	586, 588
7M0 411 031	50 91 9453	574
251 411 041 C	30 91 8830	584
701 411 041	30 92 1940	586
701 411 041 D	32 92 3424	588
7D0 411 045	30 92 1942	586, 588
701 411 045	30 92 1942	586, 588
7D0 411 049	30 79 0034	586, 588

701 411 049	30 79 0034	586, 588
701 411 049 B	30 91 8654	586, 588
1K0 411 303 AL S1	30 94 5306	471, 496, 497, 498, 499, 572, 573, 580, 581
1K0 411 303 AL S2	30 94 5307	471, 497, 499, 573, 581
1K0 411 303 BJ S1	30 94 5306	471, 496, 497, 498, 499, 572, 573, 580, 581
1K0 411 303 BJ S2	30 94 5307	471, 497, 499, 573, 581
1K0 411 303 BK S2	30 94 5307	471, 497, 499, 573, 581
1K0 411 303 BK S1	30 94 5306	471, 496, 497, 498, 499, 572, 573, 580, 581
1J0 411 305 B S1	30 93 6630	455, 495, 525
1J0 411 305 E S2	30 94 0090	455, 495, 525
1J0 411 305 E S1	30 93 6640	455, 495, 525
6Q0 411 305 AC S2	30 93 7110	557, 565
6Q0 411 305 AC S1	30 93 7060	557
6Q0 411 305 AL S2	30 93 7090	473, 557, 565
6Q0 411 305 AL S1	30 93 7040	557
6Q0 411 305 AM S2	30 93 7100	557, 565
6Q0 411 305 AM S1	30 93 7050	557
6Q0 411 305 AN S2	30 93 7110	557, 565
6Q0 411 305 AN S1	30 93 7060	557
171 411 313	30 61 0014	476, 571
2H0 411 313 B	30 94 7140	451
2H0 411 313 C	30 94 7140	451
357 411 313	30 61 0016	536, 538
357 411 313 A	30 61 0018	536, 538, 540
6N0 411 313	34 92 2492	551, 553
6N0 411 313 A	34 92 2494	521, 551, 553
6X0 411 313	34 92 2492	551, 553
6X0 411 313 A	34 92 2494	521, 551, 553
7H0 411 313	30 92 6540	589
7L0 411 313 G	32 93 1353	579
7L0 411 313 J	30 93 1357	579
7L0 411 313 K	30 93 1345	579, 582
7L8 411 313 B	30 93 1345	579, 582



Ref. - No.	SWAG GERMANY	
823 411 313 A	30 61 0010	529, 530, 532, 534, 567, 568
861 411 313 E	30 61 0003	549
867 411 313	30 61 0003	549
1H0 411 314	30 91 9050	459, 478, 480, 482, 563, 594
1J0 411 314 AC S1	30 93 7139	454, 455, 494, 495
1J0 411 314 AC	30 93 1348	495
1J0 411 314 G	30 61 0009	455, 495, 525
1J0 411 314 M	32 92 2804	455, 495, 525
1J0 411 314 N	32 92 2804	455, 495, 525
1J0 411 314 P	32 92 2794	455, 495
1J0 411 314 P S1	30 92 7294	455, 491, 495
1J0 411 314 R	32 92 2804	455, 495, 525
1J0 411 314 R S1	30 92 7304	455, 491, 525
1J0 411 314 S	32 92 6344	455, 495
1J0 411 314 S S1	30 92 7250	455, 495
1J0 411 314 T	30 61 0009	455, 495, 525
1J0 411 314 T S1	30 92 7318	455, 491, 495, 525, 526
1J0 411 314 T S2	30 94 0089	455, 495, 525
171 411 314	30 61 0012	476, 571
171 411 314 A	30 61 0012	476, 571
191 411 314	30 61 0013	459, 466, 468, 478, 480, 563, 594, 596
357 411 314	30 61 0017	536, 538
357 411 314 A	30 61 0019	536, 538, 540
6Q0 411 314 E	30 92 7642	473, 557, 565
6Q0 411 314 E S3	30 93 7656	556, 557
6Q0 411 314 E S4	30 93 7659	556, 557, 564, 565
6Q0 411 314 E S1	30 93 7076	557
6Q0 411 314 E S2	30 93 7089	557, 565
6Q0 411 314 F	30 92 7324	557
6Q0 411 314 F S2	30 93 7658	556, 557
6Q0 411 314 F S1	30 93 7078	557
6Q0 411 314 J	30 92 7638	473, 557, 565
6Q0 411 314 J S2	30 93 7657	473, 556, 557, 564, 565, 591
6Q0 411 314 J S1	30 93 7077	472, 473, 557, 565, 591
6Q0 411 314 L	30 92 7638	473, 557, 565

Ref. - No.	SWAG GERMANY	
6Q0 411 314 L S1	30 93 7077	472, 473, 557, 565, 591
6Q0 411 314 L S2	30 93 7657	473, 556, 557, 564, 565, 591
6Q0 411 314 M	30 92 7640	473, 557, 565
6Q0 411 314 M S1	30 93 7069	557, 565
6Q0 411 314 M S2	30 93 7660	473, 556, 557, 564, 565
6Q0 411 314 N	30 92 7642	473, 557, 565
6Q0 411 314 N S1	30 93 7076	557
6Q0 411 314 N S2	30 93 7089	557, 565
6Q0 411 314 N S4	30 93 7659	556, 557, 564, 565
6Q0 411 314 N S3	30 93 7656	556, 557
6Q0 411 314 P	30 92 7638	473, 557, 565
6Q0 411 314 P S1	30 93 7077	472, 473, 557, 565, 591
6Q0 411 314 P S2	30 93 7657	473, 556, 557, 564, 565, 591
6Q0 411 314 Q	30 92 7640	473, 557, 565
6Q0 411 314 Q S2	30 93 7660	473, 556, 557, 564, 565
6Q0 411 314 Q S1	30 93 7069	557, 565
6Q0 411 314 R	30 92 7642	473, 557, 565
6Q0 411 314 R S2	30 93 7089	557, 565
6Q0 411 314 R S4	30 93 7659	556, 557, 564, 565
6Q0 411 314 R S3	30 93 7656	556, 557
6Q0 411 314 R S1	30 93 7076	557
8N0 411 314 B	32 92 2804	455, 495, 525
8Z0 411 314 B	30 93 1350	557
8Z0 411 314 B S2	30 93 7655	556, 557
8Z0 411 314 B S1	30 93 7079	557
1J0 411 315	30 76 0003	455, 525
1J0 411 315 C	30 76 0003	455, 525
1J0 411 315 D	30 91 9296	455, 525
1J0 411 315 E	30 76 0004	455
1J0 411 315 E S1	30 93 6676	455, 495, 525
1J0 411 315 E S4	30 93 6758	455, 495, 525
1J0 411 315 E S3	30 93 6757	455, 495, 525
1J0 411 315 E S2	30 93 6677	454, 455, 494, 495, 524, 525
1J0 411 315 G	30 76 0004	455
1J0 411 315 G S1	30 93 0154	454, 455, 491, 494, 495, 524, 525

Ref. - No.

**SWAG**
GERMANY**SWAG**
GERMANY

Ref. - No.

SWAG
GERMANY

Ref. - No.

SWAG
GERMANY

1J0 411 315 G S1	30 93 6676	455, 495, 525
1J0 411 315 G S2	30 93 6677	454, 455, 494, 495, 524, 525
1J0 411 315 G S3	30 93 6757	455, 495, 525
1J0 411 315 G S4	30 93 6758	455, 495, 525
1J0 411 315 H	30 92 8579	455, 525
1J0 411 315 H S1	30 93 6665	455, 495, 525
1J0 411 315 H S2	30 93 6667	454, 455, 494, 495, 524, 525
1J0 411 315 J	30 76 0003	455, 525
1J0 411 315 K	30 92 8579	455, 525
1J0 411 315 K S1	30 93 6665	455, 495, 525
1J0 411 315 K S2	30 93 6667	454, 455, 494, 495, 524, 525
1K0 411 315 B	32 92 4122	461, 463, 465, 471, 527, 528, 545, 546, 573, 575, 577, 581
1K0 411 315 D	32 92 4122	461, 463, 465, 471, 527, 528, 545, 546, 573, 575, 577, 581
1K0 411 315 G	32 92 4122	461, 463, 465, 471, 527, 528, 545, 546, 573, 575, 577, 581
1K0 411 315 J	32 92 4122	461, 463, 465, 471, 527, 528, 545, 546, 573, 575, 577, 581
1K0 411 315 K	32 92 4122	461, 463, 465, 471, 527, 528, 545, 546, 573, 575, 577, 581
1K0 411 315 N	32 92 4122	461, 463, 465, 471, 527, 528, 545, 546, 573, 575, 577, 581
1K0 411 315 P	32 92 4122	461, 463, 465, 471, 527, 528, 545, 546, 573, 575, 577, 581
1K0 411 315 R	32 92 4122	461, 463, 465, 471, 527, 528, 545, 546, 573, 575, 577, 581
191 411 315	30 79 0001	459, 478, 480, 594
191 411 315 BS	30 79 0001	459, 478, 480, 594
191 411 315 B S1	30 79 0001	459, 478, 480, 594
357 411 315	30 61 0015	536, 538
357 411 315 A	30 79 0004	536, 538, 540

357 411 315 A S1	30 93 8410	540
357 411 315 C	30 61 0015	536, 538
357 411 315 D	30 79 0004	536, 538, 540
357 411 315 D S1	30 93 8410	540
5Q0 411 315 A	32 92 4122	461, 463, 465, 471, 527, 528, 545, 546, 573, 575, 577, 581
535 411 315	30 79 0002	468, 482, 596
6E0 411 315	30 92 8211	521
6K0 411 315	30 92 7984	459
6K0 411 315 S1	30 92 7982	459, 551, 563
6N0 411 315	30 79 0005	553
6N0 411 315 A	32 92 3030	521, 551, 553
6N0 411 315 A S1	32 92 3032	521, 553
6N0 411 315 B	32 92 3030	521, 551, 553
6N0 411 315 C	30 79 0005	553
6N0 411 315 C S1	30 79 0033	521, 551
6N0 411 315 D	32 92 3030	521, 551, 553
6N0 411 315 D S1	32 92 3032	521, 553
6N0 411 315 S1	30 79 0033	521, 551
6Q0 411 315 A	30 91 9518	473, 527, 557, 565
6Q0 411 315 B	30 91 9518	473, 527, 557, 565
6Q0 411 315 C	30 91 9518	473, 527, 557, 565
6Q0 411 315 D	30 91 9518	473, 527, 557, 565
6Q0 411 315 E	30 91 9518	473, 527, 557, 565
6Q0 411 315 F	30 91 9518	473, 527, 557, 565
6Q0 411 315 G	30 91 9518	473, 527, 557, 565
6Q0 411 315 H	30 91 9518	473, 527, 557, 565
6Q0 411 315 J	30 91 9518	473, 527, 557, 565
6Q0 411 315 L	30 91 9518	473, 527, 557, 565
6Q0 411 315 M	30 91 9518	473, 527, 557, 565
6Q0 411 315 N	30 91 9518	473, 527, 557, 565
6Q0 411 315 P	30 91 9518	473, 527, 557, 565
6Q0 411 315 Q	30 91 9518	473, 527, 557, 565
6R0 411 315	30 91 9518	473, 527, 557, 565
6R0 411 315 A	30 91 9518	473, 527, 557, 565
1J0 411 316 D	30 91 9298	455, 525
2E0 411 317 C	10 92 8480	469
2H0 411 317	30 93 6582	451
2H0 411 317 B	30 94 5353	451
2H0 411 317 B S2	30 94 5785	451
2H0 411 317 B S1	30 94 5784	451
2H0 411 317 S1	30 93 6642	451



Ref. - No.	SWAG GERMANY	
2H0 411 317 S2	30 93 6643	451
7H0 411 317	30 92 7834	589
7H0 411 317 A	30 92 7834	589
7H5 411 317	30 92 7834	589
7H5 411 317 A	30 92 7834	589
7H5 411 317 B	30 92 7834	589
7H5 411 317 D	30 92 7834	589
7L0 411 317	30 93 1706	579
7M0 411 317 C	50 79 0004	574
7M0 411 317 D	50 79 0004	574
7M3 411 317	50 79 0004	574
7M3 411 317 A	50 79 0004	574
7M3 411 317 B	50 79 0004	574
7M3 411 317 C	50 79 0004	574
7M3 411 317 E	50 79 0004	574
8D0 411 317 D	32 61 0006	541, 543
8D0 411 317 D S1	30 91 9704	541, 543
2E0 411 318 C	10 92 8481	469
8D0 411 318 D	32 61 0005	541, 543
8D0 411 318 D S1	30 91 9702	541, 543
1J0 411 327 A	30 93 6646	455, 495, 525
4D0 411 327 E	30 61 0005	543
4D0 411 327 F	30 61 0006	541, 543
4D0 411 327 G	30 61 0005	543
4D0 411 327 H	30 61 0006	541, 543
811 411 327 A	32 61 0002	530, 532, 534, 568, 569
823 411 327 B	32 61 0004	529, 530, 532, 567, 568, 569
1J0 411 336 B	32 92 3366	455, 525
1J0 411 336 C	32 92 3366	455, 525
1J0 411 336 D	32 92 3366	455, 525
8D0 411 506 K	32 61 0006	541, 543
2H0 412 333 A	30 93 6459	451
7L0 412 333	30 94 0165	578, 579
7L0 412 333 A	30 94 0165	578, 579
111 415 417	30 86 0002	583
131 415 811	30 71 0034	590
131 415 812	30 71 0033	590
191 419 063	30 80 0002	477
191 419 063 B	30 80 0002	477
191 419 063 C	30 80 0001	477, 479, 593
191 419 063 CX	30 80 0001	477, 479, 593

Ref. - No.	SWAG GERMANY	
251 419 081	99 90 1118	583
251 419 417 B	30 86 0002	583
4B0 419 801 B	32 72 0022	543
4B0 419 801 B SK	30 93 8854	543
4B0 419 801 E	32 72 0022	543
4B0 419 801 E SK	30 93 8854	543
4B0 419 801 M	32 72 0022	543
4B0 419 801 M SK	30 93 8854	543
4D0 419 801 B	32 72 0022	543
4D0 419 801 B SK	30 93 8854	543
4D0 419 801 D	32 72 0022	543
4D0 419 801 D SK	30 93 8854	543
4D0 419 801 E	32 72 0022	543
4D0 419 801 E SK	30 93 8854	543
4D0 419 801 G	32 72 0022	543
4D0 419 801 G SK	30 93 8854	543
4D0 419 801 L	32 72 0022	543
4D0 419 801 L SK	30 93 8854	543
4E0 419 801 C	30 93 7332	548
4E0 419 801 C S2	30 93 7332	548
4E0 419 801 D	30 93 7332	548
4E0 419 801 D S2	30 93 7332	548
4E0 419 801 E	30 93 7332	548
4E0 419 801 E S2	30 93 7332	548
4E0 419 801 E SK	30 93 0654	548
811 419 801 C	32 72 0008	530, 531, 566
811 419 801 E	32 72 0008	530, 531, 566
871 419 801 A	30 72 0063	549
811 419 802 J	32 72 0007	530, 531, 566
871 419 802	30 72 0062	549
1H0 419 803	30 72 0037	479, 593
1H0 419 803 SK	30 93 3454	483, 489, 593
191 419 803	30 72 0034	477
191 419 803 A	30 72 0034	477
191 419 803 A SK	30 93 7066	478, 507
191 419 803 SK	30 93 7066	478, 507
2H0 419 803	30 93 7205	451, 579
2H0 419 803 SK	30 93 7203	451, 579
251 419 803	30 72 0009	583
251 419 803 A	30 72 0009	583
251 419 803 SK	30 74 0006	583
357 419 803	30 72 0045	535
357 419 803 A	30 72 0045	535

Ref. - No.

**SWAG**
GERMANY**SWAG**
GERMANY

Ref. - No.

SWAG
GERMANY

Ref. - No.

SWAG
GERMANY

6E0 419 803 A	32 92 6120	519
6N0 419 803	30 72 0052	550
6N0 419 803 SK	30 93 8858	550
6Q0 419 803 B SK	30 93 2474	474, 555, 557
6Q0 419 803 D	30 93 2229	474, 555, 557
6Q0 419 803 F	30 93 2229	474, 555, 557
6Q0 419 803 F SK	30 93 2474	474, 555, 557
6Q0 419 803 SK	30 93 2474	474, 555, 557
6X0 419 803 A	32 92 3322	519, 552
7H0 419 803 B	30 93 1789	589
7H0 419 803 B SK	30 93 1705	589
7H0 419 803 C	30 93 1789	589
7H0 419 803 C SK	30 93 1705	589
7H0 419 803 D	30 93 1789	589
7H0 419 803 E	30 93 1789	589
7H0 419 803 F	30 93 1789	589
7H0 419 803 F SK	30 93 1705	589
701 419 803 A	30 72 0011	585
701 419 803 C	30 72 0011	585
701 419 803 D	30 72 0013	585
701 419 803 E	30 72 0019	587
702 419 803	30 72 0015	585
702 419 803 A	30 72 0015	585
702 419 803 B	30 72 0017	585
702 419 803 C	30 72 0066	587
702 419 803 D	30 72 0065	587
1H0 419 804	30 72 0038	479, 593
1H0 419 804 SK	30 93 3454	483, 489, 593
171 419 804	30 72 0027	456, 475, 570
171 419 804 A	30 72 0027	456, 475, 570
171 419 804 SK	30 74 0007	456, 475, 570
175 419 804	30 72 0027	456, 475, 570
191 419 804	30 72 0033	477
191 419 804 A	30 72 0033	477
191 419 804 A SK	30 93 7066	478, 507
191 419 804 SK	30 93 7066	478, 507
2H0 419 804	30 93 7206	451, 579
2H0 419 804 SK	30 93 7203	451, 579
357 419 804	30 72 0046	535
6E0 419 804 A	32 92 6121	519
6N0 419 804	30 72 0051	550
6N0 419 804 SK	30 93 8858	550
6Q0 419 804 B	30 93 2230	474, 555, 557

6Q0 419 804 B SK	30 93 2474	474, 555, 557
6Q0 419 804 D	30 93 2230	474, 555, 557
6Q0 419 804 F	30 93 2230	474, 555, 557
6Q0 419 804 F SK	30 93 2474	474, 555, 557
6Q0 419 804 SK	30 93 2474	474, 555, 557
6X0 419 804 A	32 92 3324	519, 552
7H0 419 804 B	30 93 1788	589
7H0 419 804 B SK	30 93 1705	589
7H0 419 804 C	30 93 1788	589
7H0 419 804 C SK	30 93 1705	589
7H0 419 804 D	30 93 1788	589
7H0 419 804 D SK	30 93 1705	589
7H0 419 804 E	30 93 1788	589
7H0 419 804 E SK	30 93 1705	589
7H0 419 804 F	30 93 1788	589
7H0 419 804 F SK	30 93 1705	589
701 419 804 A	30 72 0010	585
701 419 804 C	30 72 0010	585
701 419 804 D	30 72 0012	585
701 419 804 E	30 72 0018	587
701 419 804 F	30 72 0064	587
702 419 804 C	30 72 0067	587
1H0 419 810	30 93 3454	483, 489, 593
171 419 810	30 74 0007	456, 475, 570
191 419 810	30 93 7066	478, 507
191 419 810 A	30 93 7066	478, 507
2H0 419 810 SK	30 93 7203	451, 579
251 419 810	30 74 0006	583
4B0 419 810 M	30 93 8854	543
4E0 419 810 A	30 93 0654	548
4E0 419 810 C	30 93 0654	548
6N0 419 810	30 93 8858	550
6Q0 419 810	30 93 2474	474, 555, 557
6Q0 419 810 B	30 93 2474	474, 555, 557
6Q0 419 810 F	30 93 2474	474, 555, 557
7H0 419 810 B	30 93 1705	589
7H0 419 810 C	30 93 1705	589
7H0 419 810 D	30 93 1705	589
7H0 419 810 D SK	30 93 1705	589
7H0 419 810 E	30 93 1705	589
7H0 419 810 E SK	30 93 1705	589
7H0 419 810 F	30 93 1705	589
701 419 810 B	30 93 2157	587



Ref. - No.	SWAG GERMANY	
171 419 811	30 71 0021	456, 475, 570, 583
171 419 811 A	30 71 0021	456, 475, 570, 583
191 419 811	30 71 0024	458, 466, 467, 477, 478, 479, 481, 535, 537, 539, 561, 593, 595
251 419 811	30 71 0021	456, 475, 570, 583
321 419 811 A	32 71 0002	529, 530, 531, 549, 566
4E0 419 811 C S1	30 93 7338	548
4E0 419 811 D S1	30 93 7338	548
4E0 419 811 E S1	30 93 7338	548
5Z1 419 811	30 91 9812	474, 555, 557
6E0 419 811	30 71 0044	458, 519, 550, 552, 561
6Q0 419 811 C	30 91 9812	474, 555, 557
701 419 811	30 71 0012	585
701 419 811 A	30 71 0010	585
701 419 811 B	30 71 0012	585
701 419 811 C	30 71 0014	587
701 419 811 E	30 71 0040	587
823 419 811	32 71 0002	529, 530, 531, 549, 566
171 419 812	30 71 0021	456, 475, 570, 583
191 419 812	30 71 0023	458, 466, 467, 477, 478, 479, 481, 535, 537, 539, 561, 593, 595
5Z1 419 812	30 91 9814	474, 555, 557
6E0 419 812	30 71 0045	458, 519, 550, 552, 561
6Q0 419 812 C	30 91 9814	474, 555, 557
701 419 812	30 71 0009	585
701 419 812 A	30 71 0011	585
701 419 812 B	30 71 0013	587
701 419 812 D	30 71 0041	587
811 419 812	32 71 0002	529, 530, 531, 549, 566
811 419 812 A	32 71 0003	530, 531, 533, 566
811 419 812 B	32 71 0003	530, 531, 533, 566
861 419 812	32 71 0002	529, 530, 531, 549, 566
1H0 419 821 A	30 93 3454	483, 489, 593

Ref. - No.	SWAG GERMANY	
4E0 419 821 A	30 93 0654	548
4E0 419 821 A SK	30 93 0654	548
4E0 419 821 SK	30 93 0654	548
171 419 831 B	30 80 0054	456, 475, 477, 479, 535, 570, 593
171 419 831 B	30 80 0063	456, 475, 477, 479, 535, 570, 593
171 419 831 C	30 80 0063	456, 475, 477, 479, 535, 570, 593
171 419 831 C	30 80 0054	456, 475, 477, 479, 535, 570, 593
191 419 831	30 80 0054	456, 475, 477, 479, 535, 570, 593
191 419 831 S1	30 80 0063	456, 475, 477, 479, 535, 570, 593
251 419 831 A	30 80 0050	583
6E0 419 831	30 92 1700	519, 555
6N0 419 831	30 80 0065	519, 550, 552
7D0 419 831	30 80 0067	585, 587
701 419 831	30 80 0051	585, 587
811 419 831 B	30 80 0060	530, 531, 533, 566
861 419 831 B	30 80 0056	549
861 419 831 B S1	30 80 0055	549
861 419 831 BS	30 80 0055	549
171 419 832 A	30 80 0053	456, 475, 570
171 419 832 C	30 80 0053	456, 475, 570
171 419 832 C S1	30 80 0062	456, 475, 570
171 419 832 CS	30 80 0062	456, 475, 570
191 419 883	30 69 0004	477, 479, 593
115 420 240	36 78 0001	464
115 420 241	36 78 0001	464
1GD 422 803	30 92 4258	477
1H0 422 803	30 72 0039	479, 593
1H0 422 803 A SK	30 93 3908	468, 481, 486, 487, 593
1H0 422 803 B	30 72 0041	467, 479, 481, 593, 595
1H0 422 803 B SK	30 93 3906	467, 485, 487, 593, 595
1H0 422 803 C	30 72 0041	467, 479, 481, 593, 595
1H0 422 803 C SK	30 93 3906	467, 485, 487, 593, 595

Ref. - No.

**SWAG**
GERMANY**SWAG**
GERMANY

Ref. - No.

SWAG
GERMANY

Ref. - No.

SWAG
GERMANY

1H0 422 803 D SK	30 93 8856	486, 487, 593
1H0 422 803 SK	30 93 3908	468, 481, 486, 487, 593
1J0 422 803	32 72 0021	523
1J0 422 803 A	32 72 0021	523
1J0 422 803 A SK	30 92 8098	523
1J0 422 803 B	99 72 0002	453, 523
1J0 422 803 B S1	30 94 4341	453
1J0 422 803 B SK	30 92 7095	453, 523
1J0 422 803 C	32 72 0021	523
1J0 422 803 E	99 72 0002	453, 523
1J0 422 803 E S1	30 94 4341	453
1J0 422 803 H	99 72 0002	453, 523
1J0 422 803 H S1	30 94 4341	453
1J0 422 803 H SK	30 92 7095	453, 523
1J0 422 803 SK	30 92 8098	523
191 422 803	30 72 0036	477
191 422 803 A	30 72 0036	477
191 422 803 A SK	30 93 3907	466, 468, 478, 507
191 422 803 C	30 92 4258	477
191 422 803 SK	30 93 3907	466, 468, 478, 507
357 422 803	30 72 0047	537
357 422 803 A	30 72 0049	537
357 422 803 A SK	30 93 8853	537
6E0 422 803	30 94 5009	519
6K0 422 803 B	30 94 4675	458, 561
6K0 422 803 B S1	30 94 4741	458, 561
6K0 422 803 E	30 94 4675	458, 561
6K0 422 803 E S1	30 94 4741	458, 561
6K0 422 803 E SK	30 93 7065	458, 561, 563
6N0 422 803	30 72 0053	550
6N0 422 803 A	30 72 0053	550
6N0 422 803 C	32 92 6251	519
6N0 422 803 D	32 92 6253	550
6X0 422 803	30 72 0071	519, 552
6X0 422 803 SK	30 93 8855	519, 552
7L0 422 803 B	30 93 7205	451, 579
7L0 422 803 B SK	30 93 7203	451, 579
7L0 422 803 C	30 93 7205	451, 579
7L0 422 803 C SK	30 93 7203	451, 579
7L0 422 803 D	30 93 7205	451, 579
7L0 422 803 D SK	30 93 7203	451, 579
7M0 422 803 F	50 72 0010	574

7M0 422 803 G	50 72 0010	574
7M3 422 803	50 72 0010	574
7M3 422 803 A	50 72 0010	574
8N0 422 803 C SK	30 93 2597	523
1GD 422 804	32 92 4260	477
1H0 422 804	30 72 0040	479, 593
1H0 422 804 A SK	30 93 3908	468, 481, 486, 487, 593
1H0 422 804 B	30 72 0042	467, 479, 481, 593, 595
1H0 422 804 B SK	30 93 3906	467, 485, 487, 593, 595
1H0 422 804 C	30 72 0042	467, 479, 481, 593, 595
1H0 422 804 C SK	30 93 3906	467, 485, 487, 593, 595
1H0 422 804 D SK	30 93 8856	486, 487, 593
1H0 422 804 SK	30 93 3908	468, 481, 486, 487, 593
1J0 422 804	32 72 0020	523
1J0 422 804 A	32 72 0020	523
1J0 422 804 A SK	30 92 8098	523
1J0 422 804 B	99 72 0001	453, 523
1J0 422 804 B SK	30 92 7095	453, 523
1J0 422 804 B S1	30 94 4342	453
1J0 422 804 C	32 72 0020	523
1J0 422 804 E	99 72 0001	453, 523
1J0 422 804 E S1	30 94 4342	453
1J0 422 804 H	99 72 0001	453, 523
1J0 422 804 H S1	30 94 4342	453
1J0 422 804 H SK	30 92 7095	453, 523
1J0 422 804 SK	30 92 8098	523
191 422 804	30 72 0035	477
191 422 804 A	30 72 0035	477
191 422 804 A SK	30 93 3907	466, 468, 478, 507
191 422 804 C	32 92 4260	477
191 422 804 SK	30 93 3907	466, 468, 478, 507
357 422 804	30 72 0048	537
357 422 804 A	30 72 0050	537
357 422 804 A SK	30 93 8853	537
6E0 422 804	30 94 5010	519
6K0 422 804 B	30 94 4676	458, 561
6K0 422 804 B S1	30 94 4740	458, 561



Ref. - No.	SWAG GERMANY	
6K0 422 804 E	30 94 4676	458, 561
6K0 422 804 E SK	30 93 7065	458, 561, 563
6K0 422 804 E S1	30 94 4740	458, 561
6N0 422 804	30 72 0054	550
6N0 422 804 A	30 72 0054	550
6N0 422 804 C	32 92 6252	519
6N0 422 804 D	32 92 6254	550
6X0 422 804	30 72 0072	519, 552
6X0 422 804 SK	30 93 8855	519, 552
7L0 422 804 B	30 93 7206	451, 579
7L0 422 804 B SK	30 93 7203	451, 579
7L0 422 804 C	30 93 7206	451, 579
7L0 422 804 C SK	30 93 7203	451, 579
7L0 422 804 D	30 93 7206	451, 579
7L0 422 804 D SK	30 93 7203	451, 579
7M0 422 804 F	50 72 0011	574
7M0 422 804 G	50 72 0011	574
7M3 422 804	50 72 0011	574
7M3 422 804 A	50 72 0011	574
7M3 422 804 SK	50 72 0024	574
8N0 422 804 C SK	30 93 2597	523
6U0 422 807	36 74 0001	464
1H0 422 810	30 93 3908	468, 481, 486, 487, 593
1H0 422 810 A	30 93 3908	468, 481, 486, 487, 593
1H0 422 810 B	30 93 3906	467, 485, 487, 593, 595
1H0 422 810 D	30 93 8856	486, 487, 593
1J0 422 810	30 92 8098	523
1J0 422 810 A	30 92 8098	523
1J0 422 810 B	30 92 7095	453, 523
191 422 810 A	30 93 3907	466, 468, 478, 507
357 422 810 A	30 93 8853	537
6K0 422 810 E	30 93 7065	458, 561, 563
6X0 422 810	30 93 8855	519, 552
7L0 422 810 D	30 93 7203	451, 579
7M3 422 810	50 72 0024	574
8N0 422 810 C	30 93 2597	523
1J0 422 811	32 71 0011	453, 523
1J0 422 811 A	32 71 0011	453, 523
1J0 422 811 B	30 71 0038	453, 523
1J0 422 811 C	32 71 0011	453, 523

Ref. - No.	SWAG GERMANY	
1J0 422 811 E	30 71 0038	453, 523
3A0 422 811	30 71 0024	458, 466, 467, 477, 478, 479, 481, 535, 537, 539, 561, 593, 595
6K0 422 811	30 71 0044	458, 519, 550, 552, 561
6N0 422 811	30 71 0043	519, 550, 552
6RD 422 811	30 91 9812	474, 555, 557
6U0 422 811	36 71 0001	464
6X0 422 811	30 71 0044	458, 519, 550, 552, 561
8N0 422 811	30 91 9336	523
8N0 422 811 A	30 91 9336	523
1J0 422 812	32 71 0010	453, 523
1J0 422 812 A	32 71 0010	453, 523
1J0 422 812 B	30 71 0037	453, 523
1J0 422 812 C	32 71 0010	453, 523
1J0 422 812 E	30 71 0037	453, 523
3A0 422 812	30 71 0023	458, 466, 467, 477, 478, 479, 481, 535, 537, 539, 561, 593, 595
6K0 422 812	30 71 0045	458, 519, 550, 552, 561
6N0 422 812	30 71 0042	519, 550, 552
6RD 422 812	30 91 9814	474, 555, 557
6X0 422 812	30 71 0045	458, 519, 550, 552, 561
8N0 422 812	30 91 9342	523
8N0 422 812 A	30 91 9342	523
2H0 422 817	30 93 6911	451, 579
7H0 422 817 A	30 92 9675	589
7H0 422 817 B	30 92 9675	589
7H0 422 817 C	30 92 9675	589
7H0 422 817 D	30 92 9675	589
7L0 422 817 B	30 93 6911	451, 579
7L0 422 817 C	30 93 6911	451, 579
7L0 422 817 D	30 93 6911	451, 579
7M0 422 817	50 71 0029	574
7M0 422 817 A	50 71 0029	574
7M0 422 817 B	50 71 0029	574
7M3 422 817	50 71 0029	574

Ref. - No.

**SWAG**
GERMANY**SWAG**
GERMANY

Ref. - No.

SWAG
GERMANY

Ref. - No.

SWAG
GERMANY

2H0 422 818	30 93 6910	451, 579
7H0 422 818 A	30 92 9673	589
7H0 422 818 B	30 92 9673	589
7H0 422 818 C	30 92 9673	589
7H0 422 818 D	30 92 9673	589
7L0 422 818 B	30 93 6910	451, 579
7L0 422 818 C	30 93 6910	451, 579
7L0 422 818 D	30 93 6910	451, 579
7M0 422 818	50 71 0028	574
7M0 422 818 A	50 71 0028	574
7M0 422 818 B	50 71 0028	574
7M3 422 818	50 71 0028	574
4D0 422 821 A	30 93 8854	543
1H0 422 831	30 80 0066	458, 466, 467, 475, 477, 479, 481, 537, 539, 561, 570, 593, 595
1H0 422 831	30 80 0057	458, 466, 467, 475, 477, 479, 481, 537, 539, 561, 570, 593, 595
1H0 422 831 A	30 91 9414	467, 477, 479, 481, 537, 539, 593, 595
1H0 422 831 B	30 80 0057	458, 466, 467, 475, 477, 479, 481, 537, 539, 561, 570, 593, 595
1H0 422 831 B S1	30 80 0066	458, 466, 467, 475, 477, 479, 481, 537, 539, 561, 570, 593, 595
1J0 422 831	30 80 0068	453, 523
1J0 422 831	30 93 7764	453, 490, 493, 523
1J0 422 831 B	30 93 7764	453, 490, 493, 523
1J0 422 831 B	30 80 0068	453, 523
1J0 422 831 B S1	30 93 7764	453, 490, 493, 523
175 422 831	30 80 0057	458, 466, 467, 475, 477, 479, 481, 537, 539, 561, 570, 593, 595

175 422 831	30 80 0066	458, 466, 467, 475, 477, 479, 481, 537, 539, 561, 570, 593, 595
191 422 831	30 80 0066	458, 466, 467, 475, 477, 479, 481, 537, 539, 561, 570, 593, 595
191 422 831	30 80 0057	458, 466, 467, 475, 477, 479, 481, 537, 539, 561, 570, 593, 595
357 422 831	30 80 0057	458, 466, 467, 475, 477, 479, 481, 537, 539, 561, 570, 593, 595
357 422 831	30 80 0066	458, 466, 467, 475, 477, 479, 481, 537, 539, 561, 570, 593, 595
357 422 831 A	30 80 0066	458, 466, 467, 475, 477, 479, 481, 537, 539, 561, 570, 593, 595
357 422 831 A	30 80 0057	458, 466, 467, 475, 477, 479, 481, 537, 539, 561, 570, 593, 595
357 422 831 B	30 91 9414	467, 477, 479, 481, 537, 539, 593, 595
6N0 422 831	30 80 0064	550, 552
7L0 422 831 A S1	20 92 6347	451
7M0 422 831 B	99 80 0003	574
7M3 422 831	99 80 0003	574
8N0 422 831 S1	30 93 9606	495, 525
2D0 422 833	10 92 1449	517
1H0 422 884	30 91 8864	458, 479, 481, 485, 561, 593, 595
6Q0 423 803 B	30 91 9816	474, 555
6Q0 423 803 B SK	30 93 2473	474, 555
6Q0 423 803 B S1	30 94 4343	555
6Q0 423 803 C	30 92 6173	474, 555
6Q0 423 803 E	30 91 9816	474, 555



Ref. - No.	SWAG GERMANY	
6Q0 423 803 E S1	30 94 4343	555
6Q0 423 803 E SK	30 93 2473	474, 555
6Q0 423 803 G	30 92 6173	474, 555
6Q0 423 803 P	30 91 9816	474, 555
6Q0 423 803 P SK	30 93 2473	474, 555
6Q0 423 803 P S1	30 94 4343	555
6R0 423 803	30 93 6508	565
6R0 423 803 A	30 93 6508	565
6R0 423 803 A SK	30 93 3584	565
6R0 423 803 B	30 94 3465	565
6R0 423 803 B SK	30 93 3584	565
6R0 423 803 C	30 94 3465	565
6R0 423 803 C SK	30 93 3584	565
6R0 423 803 C SK	30 93 8785	565
6R0 423 803 D	30 94 3465	565
6R0 423 803 D SK	30 93 8785	565
6R0 423 803 D SK	30 93 3584	565
6R0 423 803 SK	30 93 3584	565
6Q0 423 804 B	30 91 9818	474, 555
6Q0 423 804 B S1	30 94 4344	555
6Q0 423 804 B SK	30 93 2473	474, 555
6Q0 423 804 C	30 92 6174	474, 555
6Q0 423 804 E	30 91 9818	474, 555
6Q0 423 804 E SK	30 93 2473	474, 555
6Q0 423 804 E S1	30 94 4344	555
6Q0 423 804 G	30 92 6174	474, 555
6Q0 423 804 P	30 91 9818	474, 555
6Q0 423 804 P S1	30 94 4344	555
6Q0 423 804 P SK	30 93 2473	474, 555
6R0 423 804	30 93 6509	565
6R0 423 804 A	30 93 6509	565
6R0 423 804 A SK	30 93 3584	565
6R0 423 804 B	30 94 3464	565
6R0 423 804 B SK	30 93 3584	565
6R0 423 804 C	30 94 3464	565
6R0 423 804 C SK	30 93 3584	565
6R0 423 804 C SK	30 93 8785	565
6R0 423 804 D	30 94 3464	565
6R0 423 804 D SK	30 93 3584	565
6R0 423 804 D SK	30 93 8785	565
6R0 423 804 SK	30 93 3584	565

Ref. - No.	SWAG GERMANY	
1K0 423 810 A	32 92 6045	461, 463, 465, 471, 527, 544, 573, 575, 577, 581
1K0 423 810 A S3	30 94 5761	471
1K0 423 810 A S4	30 94 5760	471
1K0 423 810 A S2	30 93 2628	471, 544, 573, 577, 581
1K0 423 810 A S1	30 93 2627	471, 544, 573, 577, 581
1S0 423 810 A	30 93 8073	591
3C0 423 810 A	32 92 6045	461, 463, 465, 471, 527, 544, 573, 575, 577, 581
561 423 810	30 93 9358	527, 528, 547
561 423 810 S1	30 93 9356	527, 528, 547
561 423 810 S2	30 93 9357	527, 528, 547
6C0 423 810 A	30 94 6299	559
6C0 423 810 B	30 94 6299	559
6C0 423 810 C	30 94 6299	559
6Q0 423 810 B	30 93 2473	474, 555
6Q0 423 810 C	30 93 0820	474, 555
6Q0 423 810 E	30 93 2473	474, 555
6Q0 423 810 P	30 93 2473	474, 555
6R0 423 810	30 93 3584	565
6R0 423 810 A	30 93 3584	565
6R0 423 810 B	30 93 3584	565
6R0 423 810 C	30 93 8785	565
6R0 423 810 D	30 93 8785	565
1K0 423 811 A	32 92 6096	471, 544, 573, 577, 581
1K0 423 811 C	30 93 7593	461, 463, 465, 509, 527, 544, 575, 577, 581
1K0 423 811 C S2	30 93 7591	461, 463, 465, 509, 527, 544, 575, 577, 581
1K0 423 811 E	32 92 6096	471, 544, 573, 577, 581
1K0 423 811 G	30 93 7593	461, 463, 465, 509, 527, 544, 575, 577, 581

Ref. - No.

**SWAG**
GERMANY**SWAG**
GERMANY

Ref. - No.

SWAG
GERMANY

Ref. - No.

SWAG
GERMANY

1K0 423 811 G S2	30 93 7591	461, 463, 465, 509, 527, 544, 575, 577, 581
1K0 423 811 J	32 92 6096	471, 544, 573, 577, 581
1K0 423 811 K	30 93 7593	461, 463, 465, 509, 527, 544, 575, 577, 581
1K0 423 811 K S1	30 93 7591	461, 463, 465, 509, 527, 544, 575, 577, 581
3C0 423 811 B	32 92 6096	471, 544, 573, 577, 581
6Q0 423 811	30 91 9812	474, 555, 557
6Q0 423 811 C SK	30 93 0820	474, 555
6RD 423 811 A	30 91 9812	474, 555, 557
6RD 423 811 B	30 91 9812	474, 555, 557
6R0 423 811	30 91 9812	474, 555, 557
6R0 423 811 A S1	30 93 9940	565
1K0 423 812 A	32 92 6097	471, 544, 573, 577, 581
1K0 423 812 C	30 93 7594	461, 463, 465, 509, 527, 544, 575, 577, 581
1K0 423 812 C S2	30 93 7592	461, 463, 465, 509, 527, 544, 575, 577, 581
1K0 423 812 E	32 92 6097	471, 544, 573, 577, 581
1K0 423 812 G	30 93 7594	461, 463, 465, 509, 527, 544, 575, 577, 581
1K0 423 812 G S2	30 93 7592	461, 463, 465, 509, 527, 544, 575, 577, 581
1K0 423 812 J	32 92 6097	471, 544, 573, 577, 581
1K0 423 812 K	30 93 7594	461, 463, 465, 509, 527, 544, 575, 577, 581
1K0 423 812 K S1	30 93 7592	461, 463, 465, 509, 527, 544, 575, 577, 581

3C0 423 812 B	32 92 6097	471, 544, 573, 577, 581
6Q0 423 812	30 91 9814	474, 555, 557
6Q0 423 812 C SK	30 93 0820	474, 555
6RD 423 812 A	30 91 9814	474, 555, 557
6RD 423 812 B	30 91 9814	474, 555, 557
6R0 423 812	30 91 9814	474, 555, 557
6R0 423 812 A S1	30 93 9941	565
1K0 423 831 A S1	30 93 1278	461, 463, 465, 471, 544, 573, 577, 581
5C0 423 831 S1	30 93 1278	461, 463, 465, 471, 544, 573, 577, 581
6Q0 423 831	30 92 1700	519, 555
6Q0 423 831 D	30 93 8622	473
6Q0 423 831 D	30 93 8621	473
6Q0 423 831 D S1	30 93 8622	473
4D0 425 021	30 92 7611	543
4D0 425 021 A	30 92 7611	543
4D0 425 021 B	30 92 7611	543
4D0 425 021 C	30 92 7611	543
4D0 425 021 D	30 92 7611	543
701 425 021	30 92 7612	585
2E0 498 104	10 93 1273	469
2E0 498 104 A	10 93 1273	469
2E0 498 104 S1	10 93 3078	469
7M3 498 317	32 92 4863	574
4B3 498 998	32 92 4900	543
4B3 498 998 S1	32 92 4902	543
8D0 498 998	32 75 0001	543
8D0 498 998 B	32 92 6600	543
8D0 498 998 S1	30 92 1502	543
701 501 131	30 93 6005	740
1K0 501 529 E	30 93 2956	710, 713, 715, 717, 721, 727, 729, 731, 735, 739
1K0 501 529 E S1	30 94 0439	710, 713, 715, 717, 721, 727, 729, 731, 735, 739
1K0 501 529 F	30 93 2956	710, 713, 715, 717, 721, 727, 729, 731, 735, 739
1K0 501 529 F SK	40 94 0591	710, 713



Ref. - No.	SWAG GERMANY	
1K0 501 529 F S1	30 94 0439	710, 713, 715, 717, 721, 727, 729, 731, 735, 739
1K0 501 529 H	30 93 2957	710, 713, 715, 717, 721, 727, 729, 731, 735, 739
1K0 501 529 H	30 93 2956	710, 713, 715, 717, 721, 727, 729, 731, 735, 739
1K0 501 529 H SK	40 94 0591	710, 713
1K0 501 529 H S1	30 94 0438	710, 713, 715, 717, 721, 727, 729, 731, 735, 739
1K0 501 529 H S1	30 94 0439	710, 713, 715, 717, 721, 727, 729, 731, 735, 739
1K0 501 529 J	30 93 6047	713, 717, 721, 722, 724, 729, 731, 735, 739
1K0 501 529 J S1	30 94 0431	713, 717, 721, 722, 724, 729, 731, 735, 739
1K0 501 529 J SK	40 94 0591	710, 713
4E0 501 529 C S1	30 93 9985	732
4E0 501 529 D S1	30 93 9985	732
4E0 501 529 G S1	30 93 9985	732
7L0 501 529 C	30 94 5861	736
7L0 501 529 D	30 94 5861	736
7L8 501 529	30 94 5861	736
7L8 501 529 A	30 94 5861	736
7L8 501 529 A SK	30 93 0983	736
7L8 501 529 A SK	30 94 5866	736, 737
1K0 501 530 B	30 93 2957	710, 713, 715, 717, 721, 727, 729, 731, 735, 739
1K0 501 530 B S1	30 94 0438	710, 713, 715, 717, 721, 727, 729, 731, 735, 739
1K0 501 530 C	30 93 2957	710, 713, 715, 717, 721, 727, 729, 731, 735, 739
1K0 501 530 C SK	40 94 0591	710, 713

Ref. - No.	SWAG GERMANY	
1K0 501 530 C S1	30 94 0438	710, 713, 715, 717, 721, 727, 729, 731, 735, 739
7L0 501 537 B	30 94 5866	736, 737
7M0 501 541	32 92 2988	574, 732
1K0 505 171 B	32 92 9690	724, 735
1K0 505 171 C	32 92 9690	724, 735
1K0 505 173 C	32 92 9690	724, 735
1K0 505 203 A	30 92 9682	710, 713, 724, 733
4E0 505 203 A	32 93 3598	732
1K0 505 223 E	30 93 8846	713, 715, 717, 721, 722, 724, 729, 731
1K0 505 223 E	30 93 8845	713, 715, 717, 721, 722, 724, 729, 731
1K0 505 223 H	30 93 8845	713, 715, 717, 721, 722, 724, 729, 731
1K0 505 223 K	30 93 8845	713, 715, 717, 721, 722, 724, 729, 731
1K0 505 224 E	30 93 8846	713, 715, 717, 721, 722, 724, 729, 731
1K0 505 224 E	30 93 8845	713, 715, 717, 721, 722, 724, 729, 731
1K0 505 224 H	30 93 8846	713, 715, 717, 721, 722, 724, 729, 731
1K0 505 224 K	30 93 8846	713, 715, 717, 721, 722, 724, 729, 731
1K0 505 279 A	30 92 9689	710, 713, 724, 733
1K0 505 311 AA	30 93 4884	710, 713, 715, 717, 721, 722, 724, 727, 729, 731, 735, 739
1K0 505 311 AA SK	32 92 9690	724, 735
1K0 505 311 AB	30 93 4884	710, 713, 715, 717, 721, 722, 724, 727, 729, 731, 735, 739
1K0 505 311 AB SK	32 92 9690	724, 735
1K0 505 311 AH SK	32 92 9690	724, 735
1K0 505 311 H	30 93 4884	710, 713, 715, 717, 721, 722, 724, 727, 729, 731, 735, 739
1K0 505 311 S	30 93 4884	710, 713, 715, 717, 721, 722, 724, 727, 729, 731, 735, 739
1K0 505 311 S SK	32 92 9690	724, 735

Ref. - No.

**SWAG**
GERMANY**SWAG**
GERMANY

Ref. - No.

SWAG
GERMANY

Ref. - No.

SWAG
GERMANY

7N0 505 311 SK	32 92 9690	724, 735
1K0 505 323 D	30 93 2453	717, 718, 724, 735
1K0 505 323 D SK	30 92 9682	710, 713, 724, 733
1K0 505 323 D SK	30 92 9689	710, 713, 724, 733
1K0 505 323 G	30 93 2453	717, 718, 724, 735
1K0 505 323 G SK	30 92 9682	710, 713, 724, 733
1K0 505 323 G SK	30 92 9689	710, 713, 724, 733
1K0 505 323 H	30 93 2453	717, 718, 724, 735
1K0 505 323 H SK	30 92 9682	710, 713, 724, 733
1K0 505 323 H SK	30 92 9689	710, 713, 724, 733
1K0 505 323 M	30 93 2453	717, 718, 724, 735
1K0 505 323 N	30 93 2453	717, 718, 724, 735
1K0 505 323 N SK	30 92 9689	710, 713, 724, 733
1K0 505 323 N SK	30 92 9682	710, 713, 724, 733
1K0 505 323 P	30 93 2453	717, 718, 724, 735
4E0 505 323 Q SK	32 93 3598	732
5Q0 505 323 C	30 93 2453	717, 718, 724, 735
5Q0 505 323 C SK	30 92 9689	710, 713, 724, 733
5Q0 505 323 C SK	30 92 9682	710, 713, 724, 733
5Q0 505 323 D	30 93 2453	717, 718, 724, 735
7L0 505 323 A	30 93 9094	736
7L0 505 323 A SK	30 93 0982	736
7L0 505 323 A SK	30 93 0983	736
7L0 505 375 A	30 93 9094	736
7L0 505 397 SK	30 94 5866	736, 737
7L0 505 398 SK	30 94 5866	736, 737
1K0 505 465 AA S1	30 92 9461	710, 713, 718, 724
1K0 505 465 AA	30 92 9459	713
1K0 505 465 C	30 92 9459	713
1K0 505 465 C S1	30 92 9461	710, 713, 718, 724
1K0 505 465 D	30 92 9459	713
1K0 505 465 D S1	30 92 9461	710, 713, 718, 724
1K0 505 465 H	30 92 9459	713
1K0 505 465 H S1	30 92 9461	710, 713, 718, 724
1K0 505 465 J	30 92 9459	713
1K0 505 465 J S1	30 92 9461	710, 713, 718, 724
1K0 505 465 K	30 92 9459	713
1K0 505 465 K S1	30 92 9461	710, 713, 718, 724
1K0 505 465 L	30 92 9459	713
1K0 505 465 L S1	30 92 9461	710, 713, 718, 724
1K0 505 465 R	30 92 9459	713
1K0 505 465 R S1	30 92 9461	710, 713, 718, 724
2K0 505 465 B	30 92 7854	707, 708

2K0 505 465 C	30 92 7854	707, 708
2K0 505 465 E	30 92 7854	707, 708
2K5 505 465 A	30 92 7854	707, 708
8E0 505 465 C	30 92 7864	725
8E0 505 465 D	30 92 7864	725
1J0 505 466 B S1	30 93 1842	707, 711
1J0 505 466 C	30 92 7866	707, 711
1J0 505 466 C	30 93 1843	707, 711
1J0 505 466 C S1	30 93 1843	707, 711
1K0 505 543 A	40 94 0591	710, 713
4E0 505 547 B	30 93 9395	732
4E0 505 547 M	30 93 9395	732
4E0 505 548 B	30 93 9394	732
4E0 505 548 M	30 93 9394	732
1K0 505 553	30 92 9938	724, 735
1K0 505 553 A	30 92 9938	724, 735
3C0 505 553	30 92 9938	724, 735
7L0 505 553	30 93 0983	736
7L0 505 554	30 93 0982	736
2E0 511 051 F	10 93 1429	709
1K0 511 327 AE	32 92 3356	717
1K0 511 327 AP	32 92 3356	717
1K0 511 327 AP S1	32 92 3606	719
1K0 511 327 AQ	30 93 2073	717, 727, 739
1K0 511 327 AQ S1	30 93 9650	713, 715, 717, 721, 727, 735
1K0 511 327 AR	32 92 3358	710, 713, 717, 718, 727, 735
1K0 511 327 AR S1	30 93 9648	713, 715, 717, 722, 727, 731, 735, 739
1K0 511 327 AS S1	30 93 9649	710, 713, 715, 717, 727, 729, 731, 735, 739
1K0 511 327 AS	30 93 2625	717, 722, 727, 735
8D0 511 327 C	30 93 8769	707
2D0 511 413	10 61 0050	469
2D0 511 413 C	10 93 6130	709
2E0 511 413 G	10 93 8536	709
2E0 511 413 M	10 94 5856	709
2K0 511 413 A S1	30 94 4860	707, 708
2K0 511 413 C S1	30 94 4860	707, 708
2K0 511 413 D S1	30 94 4860	707, 708
7M0 511 413 B	30 93 9460	732



Ref. - No.	SWAG GERMANY	
7P0 511 413 A	30 93 9193	737
7H5 511 414	30 92 6541	740
1K0 511 439 E	32 92 3604	710
2E0 713 410	10 93 0706	469
2E0 713 491	10 93 0706	469
2E0 713 491 SK	10 93 0706	469
2E0 713 491 S1	10 93 3078	469
2E0 713 501	10 93 1273	469
passend für / to fit:		
VOLVO		
1205658	55 71 0007	598, 603, 607, 635
1205680	55 92 3150	597, 599
1205680 S1	55 92 3151	597, 599
1205686	55 92 3152	597, 599
1205686 S1	55 92 3153	597, 599
1205811	55 78 0005	597
1205825	55 60 0011	597, 599
1205991	55 91 8917	597, 599, 604, 609
1206667	55 79 0017	597, 599
1206667 S1	55 79 0018	597, 599
1228425	55 80 0001	598
1228800	55 78 0007	599
1229165	55 79 0010	741
1229297	55 60 0001	604, 609
1229391	55 79 0001	604, 609
1229573	55 78 0010	604, 609, 635
1229628	55 79 0010	741
1229636	55 92 2941	743, 745
1229715	55 79 0012	741, 743, 745, 754
1273126	55 74 0008	603
1273136	55 78 0005	597
1273139	55 78 0006	599
1273140	55 78 0007	599
1273143	55 78 0006	599
1273235	55 92 2939	604, 605, 609
1273622	55 79 0005	741
1273628	55 92 2941	743, 745
1273778	55 60 0010	597, 599
1273819	55 78 0010	604, 609, 635
1329655	55 60 0002	604, 609
1330427	55 79 0014	741, 743, 745, 754
1330819	55 78 0005	597
1330820	55 78 0007	599

Ref. - No.	SWAG GERMANY	
1330821	55 78 0006	599
1330973	55 79 0012	741, 743, 745, 754
1359347	55 74 0008	603
1359590	55 78 0010	604, 609, 635
1359599	55 60 0001	604, 609
1359812	55 60 0009	597, 599
1387356	55 72 0013	603, 607
1387451	55 74 0009	598
1387463	55 74 0010	603, 607, 635
1387860	55 79 0002	606, 613, 625
270475 S1	55 92 2528	603, 607
270477	55 78 0010	604, 609, 635
270597 SK	55 91 8770	598, 605, 607, 635
271389	55 72 0013	603, 607
271469	55 92 2592	603, 605
271470	55 92 2590	603, 605
271554	55 92 2592	603, 605
271555	55 92 2590	603, 605
271591	55 78 0011	606
271598	55 71 0010	605, 607, 613, 625, 635
271598 S1	55 94 0567	605, 613, 625
271598 S2	55 94 0569	613, 625
271599	55 71 0009	605, 607, 613, 625, 635
271599 S1	55 94 0568	605, 613, 625
271599 S2	55 94 0570	613, 625
271601 SK	55 92 2557	605, 613, 625
271628	55 73 0002	606, 625
271629	55 73 0003	606, 625
271631	55 60 0015	606, 625
271699	55 92 2549	607
271700	55 92 2549	607
271701	55 92 3173	607
271901	55 73 0002	606, 625
271902	55 73 0003	606, 625
272273	55 73 0004	606, 625
272336	55 73 0004	606, 625
272337	55 73 0005	606, 625
272416	55 92 1566	633
272417	55 92 1567	633
272418	55 92 1603	621, 629, 631, 633
272428	55 92 1453	633

Ref. - No.

**SWAG**
GERMANY**SWAG**
GERMANY

Ref. - No.

SWAG
GERMANY

Ref. - No.

SWAG
GERMANY

272991	55 79 0015	609, 635
274117	55 78 0005	597
274118	55 78 0006	599
274119	55 78 0007	599
274175	55 92 1414	621, 629, 631, 633
274175 S1	55 94 0555	621, 629, 631
274175 S2	55 94 0557	621, 629, 631
274176	55 92 1415	621, 629, 631, 633
274176 S1	55 94 0556	621, 629, 631
274176 S2	55 94 0558	621, 629, 631
274179	55 92 3019	621, 629, 631, 633
274179 S1	55 94 0557	621, 629, 631
274179 S2	55 94 0558	621, 629, 631
274186	55 92 3343	621, 629, 631, 633
274193	55 92 3343	621, 629, 631, 633
274224	55 92 1565	617
274224 S1	55 94 0501	617
274224 S2	55 94 0502	617
274225	55 92 1563	617
274226	55 92 1564	617
274303	55 91 9379	621, 629, 631, 633, 637
274351	55 92 9604	637
274352	55 92 9605	637
274353	55 92 3031	621, 629, 631, 633, 637
274353 S1	55 94 0555	621, 629, 631
274353 S2	55 94 0556	621, 629, 631
274377	55 93 6715	621, 629, 631, 637
274456	55 91 9379	621, 629, 631, 633, 637
274496	55 92 1414	621, 629, 631, 633
274496 S1	55 94 0555	621, 629, 631
274496 S2	55 94 0557	621, 629, 631
274497	55 92 1415	621, 629, 631, 633
274497 S1	55 94 0556	621, 629, 631
274497 S2	55 94 0558	621, 629, 631
274498	55 92 9604	637
274499	55 92 9605	637
274500	50 92 9224	611, 615, 619
274500	50 92 9223	611, 615, 619
274501	50 92 9223	611, 615, 619
274501	50 92 9224	611, 615, 619

274502	50 92 8542	611, 615, 619
274523	55 93 6715	621, 629, 631, 637
274524	55 92 3343	621, 629, 631, 633
274544	55 92 3343	621, 629, 631, 633
274548	55 92 3343	621, 629, 631, 633
274573	55 93 6715	621, 629, 631, 637
2772274	55 73 0005	606, 625
30620785	55 92 3131	746
30620786	55 92 3147	746
30620989 S1	55 93 9333	617
30620990 S1	55 93 9333	617
30635227	55 92 3347	633
30635228	55 92 3349	633
30635229	55 92 3351	621, 629
30635230	55 92 3353	621, 629
30635231	55 93 2511	631
30635232	55 93 2512	631
30639368	55 93 1266	637
30639780	55 93 1285	637
30639781	55 93 1286	637
30645845	55 93 1285	637
30645846	55 93 1286	637
30645847	55 93 1267	637
30647920	55 91 9664	748, 751, 753, 755
30648461	50 92 7897	623, 632, 634, 636
30666266	50 93 8978	611, 615, 619
30666300	50 92 4211	747
30666300 S1	50 93 0000	747
30678440 SK3	50 93 2418	611, 615, 619
30681487	55 93 8843	636
30681487 SK	55 93 8912	632, 636
30681488	55 93 8844	636
30681488 SK	55 93 8912	632, 636
30681614	55 93 1285	637
30681615	55 93 1286	637
30683067	50 92 4211	747
30683067 S1	50 93 0000	747
30683232	50 92 7299	747
30683248	55 93 9943	632
30683249	55 93 9944	632
30714422	50 92 8095	615, 619
30714466	50 92 7299	747
30714678	55 91 9664	748, 751, 753, 755

Ref. - No.	SWAG GERMANY	
30714685	55 91 9379	621, 629, 631, 633, 637
30714686	55 79 0002	606, 613, 625
30714977	55 92 9617	621, 629, 631, 633
30730829	50 92 8095	615, 619
30730830	50 92 8096	615, 619
30736864	50 93 6733	749, 752, 754
30736864 S1	50 94 3406	749, 752, 754
30748230	50 92 8096	615, 619
30748231	50 92 8095	615, 619
30748803	50 94 4308	611, 619
30760069	50 93 6733	749, 752, 754
30760069 S1	50 94 3406	749, 752, 754
30760279	50 93 1846	611, 615, 619
30760279 SK	50 93 0380	611, 615, 619
30760280	50 93 1845	611, 615, 619
30760280 SK	50 93 0380	611, 615, 619
30760678	50 93 0830	749, 752, 754, 755
30760720	50 93 4583	623, 632, 634
30760806	55 92 9604	637
30760807	55 92 9605	637
30761718	55 92 1415	621, 629, 631, 633
30761718 S1	55 94 0556	621, 629, 631
30761718 S2	55 94 0558	621, 629, 631
30761719	55 92 1414	621, 629, 631, 633
30761719 S1	55 94 0555	621, 629, 631
30761719 S2	55 94 0557	621, 629, 631
30776248	55 93 8866	623, 632, 634, 636
30776249	55 93 8865	623, 632, 634, 636
30776250 SK1	50 93 4384	623, 632, 634
30776250 SK2	55 93 4371	622, 623, 632, 634
30776251	55 93 4293	623, 632, 634, 636
30776252	55 93 9833	622, 623, 630, 631, 632, 634, 636
30776255 SK	55 93 6825	623, 632, 634
30776283	50 92 8542	611, 615, 619
30776323	55 92 9604	637
30776324	55 92 9605	637
30776425 SK	55 93 6825	623, 632, 634
30818091	55 92 3131	746
30818092	55 92 3131	746
30818096 S1	80 92 9377	746
30818097 S1	80 92 9377	746

Ref. - No.	SWAG GERMANY	
30818467	55 60 0012	617
30821650	55 91 9673	617
30821650 S1	80 92 8200	617
30821651	55 91 9674	617
30821651 S1	80 92 8200	617
30852103	55 91 9399	746
30852103 S1	55 92 6867	746
30863990	80 92 8200	617
30864208	55 91 9673	617
30864208 S1	80 92 8200	617
30864209	55 91 9674	617
30864209 S1	80 92 8200	617
30870695	55 71 0012	617
30871770	55 79 0016	617
30872510	55 92 6862	617
30872511	55 92 6863	617
30873100	55 79 0016	617
30875012	55 71 0012	617
30875012 S1	55 94 0500	617
30883988	55 91 9673	617
30883988 S1	80 92 8200	617
30883989	55 91 9674	617
30883989 S1	80 92 8200	617
30884179	55 92 2390	617
30884358	55 79 0016	617
30884359	55 91 9399	746
30884359 S1	55 92 6867	746
30884360	55 92 3147	746
30887025	55 91 9673	617
30887025 S1	80 92 8200	617
30887033	55 91 9674	617
30887033 S1	80 92 8200	617
30887469	55 91 9673	617
30887469 S1	80 92 8200	617
30887470	55 91 9674	617
30887470 S1	80 92 8200	617
30887653	55 92 2740	617
30887654	55 92 2741	617
30889962	55 91 9673	617
30889962 S1	80 92 8200	617
30889963	55 91 9674	617
30889963 S1	80 92 8200	617
31200448	50 93 4583	623, 632, 634

Ref. - No.

**SWAG**
GERMANY**SWAG**
GERMANY

Ref. - No.

SWAG
GERMANY

Ref. - No.

SWAG
GERMANY

31200563	50 93 4583	623, 632, 634
31200775	50 93 4584	623, 632, 634
31200775 SK	50 93 2163	623, 632, 634
31200776	50 93 4583	623, 632, 634
31200776 SK	50 93 2163	623, 632, 634
31201003	55 93 1267	637
31201004	55 93 1285	637
31201005	55 93 1286	637
31201180	50 93 1846	611, 615, 619
31201180 SK	50 93 0380	611, 615, 619
31201181	50 93 1845	611, 615, 619
31201181 SK	50 93 0380	611, 615, 619
31201228	55 92 9604	637
31201229	55 92 9605	637
31201412	50 92 9224	611, 615, 619
31201413	50 92 9223	611, 615, 619
31201485	55 93 6715	621, 629, 631, 637
31201602	55 91 9379	621, 629, 631, 633, 637
31201603	55 91 9664	748, 751, 753, 755
31201817	50 92 8542	611, 615, 619
31202228	55 93 9943	632
31202229	55 93 9944	632
31212191	55 92 9617	621, 629, 631, 633
31212503	50 92 3047	747
31212503 S1	50 93 0004	747
31212548	50 92 7299	747
31212692	55 91 9379	621, 629, 631, 633, 637
31212730	55 79 0002	606, 613, 625
31212781	50 93 4584	623, 632, 634
31212781 SK	50 93 2163	623, 632, 634
31212782	50 93 4583	623, 632, 634
31212782 SK	50 93 2163	623, 632, 634
31212979	50 92 8095	615, 619
31212979 SK1	60 92 4849	615, 619
31212980	50 92 8096	615, 619
31212980 SK1	60 92 4849	615, 619
31262037	50 93 1846	611, 615, 619
31262037 SK	50 93 0380	611, 615, 619
31262039	50 93 1845	611, 615, 619
31262039 SK	50 93 0380	611, 615, 619
31262127	50 93 6733	749, 752, 754

31262127 S1	50 94 3406	749, 752, 754
31262930	50 93 6733	749, 752, 754
31262930 S1	50 94 3406	749, 752, 754
31277305	50 92 3047	747
31277305 S1	50 93 0004	747
31277343	50 93 4583	623, 632, 634
31277343 SK	50 93 2163	623, 632, 634
31277344	50 93 4584	623, 632, 634
31277344 SK	50 93 2163	623, 632, 634
31277345	55 93 9943	632
31277345 SK	55 93 8912	632, 636
31277346	55 93 9944	632
31277346 SK	55 93 8912	632, 636
31277462	50 93 1846	611, 615, 619
31277462 SK	50 93 0380	611, 615, 619
31277462 SK2	50 92 7912	611, 615, 619
31277462 SK3	50 93 2418	611, 615, 619
31277462 S1	50 94 0626	611, 615, 619
31277463	50 93 1845	611, 615, 619
31277463 SK	50 93 0380	611, 615, 619
31277463 SK2	50 92 7912	611, 615, 619
31277463 SK3	50 93 2418	611, 615, 619
31277463 S1	50 94 0625	611, 615, 619
31277464	50 92 8095	615, 619
31277464 SK1	60 92 4849	615, 619
31277464 SK2	50 92 7912	611, 615, 619
31277464 SK3	50 93 2418	611, 615, 619
31277464 S1	50 94 0623	615, 619
31277465	50 92 8096	615, 619
31277465 SK1	60 92 4849	615, 619
31277465 SK2	50 92 7912	611, 615, 619
31277465 SK3	50 93 2418	611, 615, 619
31277465 S4	50 94 0624	615, 619
31277525	55 93 8843	636
31277525 SK	55 93 8912	632, 636
31277526	55 93 8844	636
31277526 SK	55 93 8912	632, 636
31277652	50 92 2408	611, 615, 619, 626, 627
31277893	55 92 2756	748, 751, 753
31277899	55 92 2755	748, 751, 753
31280000	55 93 8865	623, 632, 634, 636
31280001	55 93 8866	623, 632, 634, 636



Ref. - No.	SWAG GERMANY	
31280002 SK1	50 93 4384	623, 632, 634
31280002 SK2	55 93 4371	622, 623, 632, 634
31280408 SK	55 93 4160	623, 636
31280409	55 93 4294	622, 623, 636
31280409 SK	55 93 3872	623, 636
31280658 SK1	50 93 4384	623, 632, 634
31280658 SK2	55 93 4371	622, 623, 632, 634
31302344	55 93 8865	623, 632, 634, 636
31302345	55 93 8866	623, 632, 634, 636
31304040	55 93 1267	637
31317271 S1	50 93 7261	750
31317661	50 93 4583	623, 632, 634
31317661 SK	50 93 2163	623, 632, 634
31317661 SK1	50 93 6962	623, 632, 634, 636
31317662	50 93 4584	623, 632, 634
31317662 SK	50 93 2163	623, 632, 634
31317662 SK1	50 93 6962	623, 632, 634, 636
31317663	55 93 9943	632
31317663 SK	55 93 8912	632, 636
31317664	55 93 9944	632
31317664 SK	55 93 8912	632, 636
31317665	55 93 8843	636
31317665 SK	55 93 8912	632, 636
31317666	55 93 8844	636
31317666 SK	55 93 8912	632, 636
31317779	50 93 8814	626, 627
31340273	50 92 2408	611, 615, 619, 626, 627
31387571	50 93 6963	623, 632, 634, 636
31387572	50 93 6964	623, 632, 634, 636
3211955	30 71 0021	600
3211956	55 78 0008	600
3265974	30 71 0021	600
3268631	55 78 0008	600
3268834	55 92 2537	600, 601
3268835	55 92 2558	600, 601
3270523	55 78 0012	601, 602
3342824	55 74 0013	601, 602
3342893 S1	55 92 2561	601, 602
3343234	55 71 0011	601, 602
3343641	55 92 2537	600, 601
3343642	55 92 2558	600, 601
3345796	55 92 2533	617

Ref. - No.	SWAG GERMANY	
3345797	55 72 0016	617
3345797 S1	55 94 0500	617
3410364	55 71 0011	601, 602
3410369	55 74 0012	601
3410412	55 74 0013	601, 602
3410519	55 78 0012	601, 602
3411022	55 92 2558	600, 601
3416129	55 79 0004	601, 602
3416130	55 79 0003	601, 602
3434868	55 92 2371	742
3448334	55 71 0011	601, 602
3465482	55 78 0012	601, 602
3467713	55 79 0004	601, 602
3467714	55 79 0003	601, 602
3480012	55 71 0011	601, 602
3516122	55 93 0944	744
3516944	55 71 0007	598, 603, 607, 635
3524221	55 92 9617	621, 629, 631, 633
3530202	55 92 8614	744, 745, 746, 749
3530230	55 79 0001	604, 609
3530388	55 92 2939	604, 605, 609
3546266	55 74 0011	605, 613, 625
3546266 S1	55 94 0567	605, 613, 625
3546266 S2	55 94 0568	605, 613, 625
3546267	55 71 0010	605, 607, 613, 625, 635
3546267 S1	55 94 0567	605, 613, 625
3546267 S2	55 94 0569	613, 625
3546268	55 71 0009	605, 607, 613, 625, 635
3546268 S1	55 94 0568	605, 613, 625
3546268 S2	55 94 0570	613, 625
3546524	55 78 0011	606
410369	55 74 0012	601
410519	55 78 0012	601, 602
675807	55 79 0014	741, 743, 745, 754
6819057	55 79 0009	609, 744
6819253	55 79 0015	609, 635
6819287	55 60 0014	609, 635
6819454	55 92 2991	607
6819455	55 92 2990	607
6819537	55 60 0013	609, 635

Ref. - No.

**SWAG**
GERMANY**SWAG**
GERMANY

Ref. - No.

SWAG
GERMANY

Ref. - No.

SWAG
GERMANY

8623576	50 92 2408	611, 615, 619, 626, 627
8623955	55 92 3347	633
8623956	55 92 3349	633
8626031	55 79 0002	606, 613, 625
8628495	55 73 0002	606, 625
8628496	55 73 0003	606, 625
8628497	55 73 0004	606, 625
8628498	55 73 0005	606, 625
8628726	55 79 0002	606, 613, 625
8630604	55 92 2239	621, 629, 633
8634736	55 91 9379	621, 629, 631, 633, 637
8634869	55 91 9664	748, 751, 753, 755
8646064	50 92 4211	747
8646064 S1	50 93 0000	747
8649541	55 92 3347	633
8649542	55 92 3349	633
8649543	55 92 3351	621, 629
8649544	55 92 3353	621, 629
8649545	55 93 2511	631
8649546	55 93 2512	631
8671921	50 92 3047	747
8671921 S1	50 93 0004	747
8672220	55 92 2754	748, 751, 753
8672224	55 93 1267	637
8672446	55 91 9664	748, 751, 753, 755
9127363	55 92 2749	748, 751, 753
9140504	55 74 0010	603, 607, 635
9140505	55 74 0009	598
9140767	55 79 0002	606, 613, 625
9140788	55 72 0015	607, 635
9140995	55 79 0001	604, 609
9157572	55 92 2755	748, 751, 753
9157725	55 79 0001	604, 609
9157725 S1	55 91 8916	604, 609
9169080	55 91 9664	748, 751, 753, 755
9169204	55 92 2756	748, 751, 753
9173618	55 92 4242	621, 629, 633
9173761	55 92 2754	748, 751, 753
9173954	55 60 0014	609, 635
9181013	55 92 8614	744, 745, 746, 749
9191409	55 92 2541	613, 625

9191410	55 92 2798	613, 625
9191410 SK1	55 92 2797	613, 625
9191410 S2	55 94 0569	613, 625
9191410 S3	55 94 0570	613, 625
9191537	55 60 0014	609, 635
9443882	55 92 4242	621, 629, 633
9443882	55 92 2238	621, 629, 631, 633
9461626	55 92 2239	621, 629, 633
9465971	55 92 4242	621, 629, 633
9465971	55 92 2238	621, 629, 631, 633
9473207	55 92 9617	621, 629, 631, 633
9492105	55 92 3347	633
9492106	55 92 3349	633
9492181	55 92 2753	748, 751, 753
9492531	55 73 0003	606, 625
9492532	55 73 0004	606, 625
9492558	55 92 9617	621, 629, 631, 633
9492804	55 79 0002	606, 613, 625
9492837	55 79 0015	609, 635
9492914	55 73 0002	606, 625
9492915	55 73 0003	606, 625
9492916	55 73 0004	606, 625
9492917	55 73 0005	606, 625



10 61 0050	2D0 511 413	469
10 92 1449	2D0 422 833	517
10 92 3841	4066.41 SK	133, 145
10 92 8480	2E0 411 317 C	469
10 92 8481	2E0 411 318 C	469
10 93 0151	2E0 407 151 M S1	469
10 93 0295	2E0 407 523	469
10 93 0706	2E0 713 410	469
10 93 1272	0014141V002000000	320, 321, 322, 324
10 93 1273	2E0 498 104 A	469
10 93 1429	2E0 511 051 F	709
10 93 1479	2E0 407 523 A	469
10 93 3078	2E0 713 491 S1	469
10 93 6130	2D0 511 413 C	709
10 93 7611	2E0 407 152 L	469
10 93 7612	2E0 407 151 L	469
10 93 8536	2E0 511 413 G	709
10 94 5856	2E0 511 413 M	709
12 92 7569	0004873V002000000	320
12 93 1271	450 333 00 14	320, 321, 322, 324
12 93 1990	0015642V002000000	322, 324
12 93 1991	0015642V002000000 S2	320, 321, 322, 324
12 93 4945	0004914V002000000 S1	322
12 93 4949	451 460 00 96	322, 323
12 93 6790	451 320 01 89 S1	323
12 93 6791	451 320 01 89	323
12 93 8549	2271V007000005 S2	322, 324
12 93 8610	451 330 00 10 S1	323
13 93 1708	4817 539	643
13 93 1708	96996460	698
13 93 6192	0005374V001 S1	322
13 94 1529	4817 869	31
13 94 1529	96809676	390
13 94 1740	4810 831	31
13 94 1740	96819161	390
13 94 1741	4812 870	31
13 94 1741	96819162	390
13 94 1929	4803 429	31
13 94 1929	96626667	390
20 92 6347	7L0 422 831 A S1	451
22 60 0001	EGP 1673	220, 221
22 71 0001	QJB 100120	219, 220, 221, 223
22 71 0002	GSJ 734	222, 223



22 71 0003	GSJ 407	222
22 73 0001	GSJ 413	220, 221
22 73 0002	GSJ 414	220, 221
22 92 3819	EGP 1662	220, 221
22 93 0714	RBX 101771	219, 223
22 93 0715	RBX 101761	219, 223
22 93 0731	QJB100190	219, 223
22 93 0732	QJB 100180	219, 223
22 93 0736	RGD 100572	663
22 93 0737	RGD 100562	663
22 93 0864	RBM 100240	219, 223
30 13 0078	171 407 182 D	158
30 13 0078	171 407 182 D	457, 476, 571
30 60 0002	191 407 153 S1	242, 243, 254, 255, 276, 277
30 60 0004	191 407 153 S2	247, 258, 277
30 60 0006	191 407 153 A S3	242, 243, 246, 247, 254, 255, 276, 277
30 60 0006	191 407 153 A S3	459
30 60 0008	191 407 153 A S2	242, 243, 254, 255, 276, 277
30 60 0012	251 407 077	584
30 60 0014	7D0 407 140	586, 588
30 60 0016	4D0 407 183 P	541, 543
30 60 0019	251 407 183	584
30 60 0020	171 407 181 A	457, 476, 571
30 60 0022	251 407 179	584
30 60 0023	701 407 183	586, 588
30 60 0024	701 407 077 A	586, 588
30 60 0025	251 407 175	584
30 60 0026	7D0 407 183	588
30 60 0029	4D0 407 515 C	541, 543
30 60 0030	701 407 087	586, 588
30 60 0031	4D0 407 182 G	253
30 60 0031	4D0 407 182 G	315
30 60 0031	4D0 407 182 G	541, 543
30 60 0032	6N0 407 182	241
30 60 0032	6N0 407 182	521, 551
30 60 0033	7M0 407 181 A	231, 233
30 60 0033	7M0 407 181 A	574
30 60 0034	6N0 407 181	241
30 60 0034	6N0 407 181	521, 551, 553
30 60 0036	8A0 407 181	532, 534, 569



30 60 0041	4D0 407 183 AC	315
30 60 0041	4D0 407 183 AC	541, 543
30 61 0003	867 411 313	549
30 61 0005	4D0 411 327 G	315
30 61 0005	4D0 411 327 G	543
30 61 0006	4D0 411 327 H	315
30 61 0006	4D0 411 327 H	541, 543
30 61 0009	1J0 411 314 T	267, 285
30 61 0009	1J0 411 314 T	303
30 61 0009	1J0 411 314 T	455, 495, 525
30 61 0010	823 411 313 A	529, 530, 532, 534, 567, 568
30 61 0011	861 407 183	549
30 61 0012	171 411 314 A	476, 571
30 61 0013	191 411 314	243, 247, 255, 258, 264, 277, 280
30 61 0013	191 411 314	459, 466, 468, 478, 480, 563, 594, 596
30 61 0014	171 411 313	476, 571
30 61 0015	357 411 315 C	536, 538
30 61 0016	357 411 313	536, 538
30 61 0017	357 411 314	536, 538
30 61 0018	357 411 313 A	536, 538, 540
30 61 0019	357 411 314 A	536, 538, 540
30 69 0001	191 407 181 D	243, 247, 255, 258, 264, 277, 280, 282
30 69 0001	191 407 181 D	459, 466, 468, 478, 480, 482, 536, 538, 540, 563, 594, 596
30 69 0002	357 407 182	243, 247, 255, 258, 261, 263, 264, 267, 275, 277, 280, 285, 289
30 69 0002	357 407 182	291, 297, 298, 303, 309, 313
30 69 0002	357 407 182	453, 459, 466, 478, 480, 525, 536, 538, 557, 563, 565, 594
30 69 0003	191 407 181 B	243, 247, 255, 258, 264, 277, 280, 282
30 69 0003	191 407 181 B	459, 466, 468, 478, 480, 482, 536, 538, 540, 563, 594, 596

30 69 0004	191 419 883	244, 256, 278
30 69 0004	191 419 883	477, 479, 593
30 71 0009	701 419 812	585
30 71 0010	701 419 811 A	585
30 71 0011	701 419 812 A	585
30 71 0012	701 419 811 B	585
30 71 0013	701 419 812 B	587
30 71 0014	701 419 811 C	587
30 71 0021	944 347 333 00	158
30 71 0021	3211955	600
30 71 0021	171 419 812	456, 475, 570, 583
30 71 0023	191 419 812	244, 245, 256, 257, 264, 278, 279, 281
30 71 0023	191 419 812	458, 466, 467, 477, 478, 479, 481, 535, 537, 539, 561, 593, 595
30 71 0024	191 419 811	244, 245, 256, 257, 264, 278, 279, 281
30 71 0024	191 419 811	458, 466, 467, 477, 478, 479, 481, 535, 537, 539, 561, 593, 595
30 71 0033	131 415 812	590
30 71 0034	131 415 811	590
30 71 0037	1J0 422 812 B	265, 283
30 71 0037	1J0 422 812 B	301
30 71 0037	1J0 422 812 B	453, 523
30 71 0038	1J0 422 811 B	265, 283
30 71 0038	1J0 422 811 B	301
30 71 0038	1J0 422 811 B	453, 523
30 71 0040	701 419 811 E	587
30 71 0041	701 419 812 D	587
30 71 0042	6N0 422 812	239
30 71 0042	6N0 422 812	519, 550, 552
30 71 0043	6N0 422 811	239
30 71 0043	6N0 422 811	519, 550, 552
30 71 0044	6E0 419 811	239, 245, 257, 264
30 71 0044	6E0 419 811	458, 519, 550, 552, 561
30 71 0045	6E0 419 812	239, 245, 257, 264
30 71 0045	6E0 419 812	458, 519, 550, 552, 561



30 72 0009	251 419 803	583
30 72 0010	701 419 804 C	585
30 72 0011	701 419 803 C	585
30 72 0012	701 419 804 D	585
30 72 0013	701 419 803 D	585
30 72 0015	702 419 803 A	585
30 72 0017	702 419 803 B	585
30 72 0018	701 419 804 E	587
30 72 0019	701 419 803 E	587
30 72 0027	171 419 804	456, 475, 570
30 72 0033	191 419 804	244, 256, 278
30 72 0033	191 419 804	477
30 72 0034	191 419 803	244, 256, 278
30 72 0034	191 419 803	477
30 72 0035	191 422 804 A	244, 256, 279
30 72 0035	191 422 804 A	477
30 72 0036	191 422 803 A	244, 256, 279
30 72 0036	191 422 803 A	477
30 72 0037	1H0 419 803	479, 593
30 72 0038	1H0 419 804	479, 593
30 72 0039	1H0 422 803	479, 593
30 72 0040	1H0 422 804	479, 593
30 72 0041	1H0 422 803 B	467, 479, 481, 593, 595
30 72 0042	1H0 422 804 B	467, 479, 481, 593, 595
30 72 0045	357 419 803	535
30 72 0046	357 419 804	535
30 72 0047	357 422 803	537
30 72 0048	357 422 804	537
30 72 0049	357 422 803 A	537
30 72 0050	357 422 804 A	537
30 72 0051	6N0 419 804	239
30 72 0051	6N0 419 804	550
30 72 0052	6N0 419 803	239
30 72 0052	6N0 419 803	550
30 72 0053	6N0 422 803 A	239
30 72 0053	6N0 422 803 A	550
30 72 0054	6N0 422 804 A	239
30 72 0054	6N0 422 804 A	550
30 72 0062	871 419 802	549
30 72 0063	871 419 801 A	549
30 72 0064	701 419 804 F	587



30 72 0065	702 419 803 D	587
30 72 0066	702 419 803 C	587
30 72 0067	702 419 804 C	587
30 72 0071	6X0 422 803	239
30 72 0071	6X0 422 803	519, 552
30 72 0072	6X0 422 804	238, 239
30 72 0072	6X0 422 804	519, 552
30 73 0001	1H0 407 151	480, 594
30 73 0004	6N0 407 151 B	241
30 73 0004	6N0 407 151 B	551
30 73 0006	1H0 407 152	282
30 73 0006	1H0 407 152	468, 482, 596
30 73 0008	893 407 147 C	532, 534, 569
30 73 0011	357 407 151	536, 538
30 73 0013	191 407 151 B	243, 247, 255, 258, 264, 277, 280
30 73 0013	191 407 151 B	459, 466, 478, 563
30 73 0014	1H0 407 151 A	282
30 73 0014	1H0 407 151 A	468, 482, 536, 538, 596
30 73 0015	171 407 153 D	158
30 73 0015	171 407 153 D	457, 476, 571
30 73 0018	6X0 407 151 A	241
30 73 0018	6X0 407 151 A	521, 553
30 74 0006	251 419 810	583
30 74 0007	171 419 810	456, 475, 570
30 75 0001	191 407 181 B S1	242, 243, 246, 247, 254, 255, 258, 264, 276, 277, 280, 282
30 75 0001	191 407 181 B S1	455, 459, 466, 468, 478, 480, 482, 484, 486, 488, 506, 508, 536, 538, 540, 562, 563, 594, 596
30 75 0002	191 407 181 D S1	466, 468, 478, 480, 482, 484, 486, 488, 506, 508, 536, 538, 540, 562, 563, 594, 596
30 76 0003	1J0 411 315 J	267, 285
30 76 0003	1J0 411 315 J	303, 305
30 76 0003	1J0 411 315 J	455, 525
30 76 0004	1J0 411 315 G	266, 267, 284, 285
30 76 0004	1J0 411 315 G	302, 303
30 76 0004	1J0 411 315 G	455



30 78 0006	171 407 365 C	158
30 78 0006	171 407 365 C	476, 571
30 78 0011	171 407 365 F	158
30 78 0011	171 407 365 F	457, 476, 571
30 78 0013	251 407 187	584
30 78 0014	251 407 361	584
30 78 0016	191 407 365	478
30 78 0017	357 407 365 S1	243, 247, 255, 258, 264, 277, 280
30 78 0017	357 407 365 S1	459, 466, 478, 480, 536, 538, 563, 594
30 78 0018	171 407 365 G S1	158
30 78 0018	171 407 365 F S1	457, 476, 571
30 78 0019	357 407 365	243, 247, 255, 258, 264, 277, 280
30 78 0019	357 407 365	459, 466, 478, 480, 536, 538, 563, 594
30 78 0020	171 407 365 C S1	158
30 78 0020	171 407 365 C S1	476, 571
30 78 0021	1H0 407 365	282
30 78 0021	1H0 407 365	468, 482, 596
30 78 0022	6N0 407 365 A	241
30 78 0022	6N0 407 365 A	521, 551, 553
30 78 0023	6N0 407 365	241
30 78 0023	6N0 407 365	521, 551, 553
30 78 0024	701 407 187 B	586, 588
30 78 0025	701 407 361 B	586, 588
30 78 0026	311 405 371 C	590
30 78 0033	311 405 361 B	590
30 78 0034	1J0 407 366 H S1	267, 285
30 78 0034	1J0 407 366 H S1	303
30 78 0034	1J0 407 366 H S1	453, 525
30 78 0035	1J0 407 365 H S1	267, 285
30 78 0035	1J0 407 365 H S1	303
30 78 0035	1J0 407 365 H S1	453, 525
30 78 0036	1H0 407 365 S1	282
30 78 0036	1H0 407 365 S1	468, 482, 596
30 78 0037	6N0 407 365 A S1	241
30 78 0037	6N0 407 365 A S1	521, 551, 553
30 78 0038	6N0 407 365 S1	241
30 78 0038	6N0 407 365 S1	521, 551, 553
30 78 0039	191 407 365 S1	478



30 79 0001	191 411 315 B S1	243, 247, 255, 276, 277
30 79 0001	191 411 315 B S1	459, 478, 480, 594
30 79 0002	535 411 315	280, 282
30 79 0002	535 411 315	468, 482, 596
30 79 0003	191 411 315 B	242, 243, 254, 255, 276, 277
30 79 0004	357 411 315 D	536, 538, 540
30 79 0005	6N0 411 315 C	553
30 79 0033	6N0 411 315 C S1	521, 551
30 79 0034	7D0 411 049	586, 588
30 80 0001	191 419 063 C	244, 256, 278
30 80 0001	191 419 063 C	477, 479, 593
30 80 0002	191 419 063 B	278
30 80 0002	191 419 063 B	477
30 80 0050	251 419 831 A	583
30 80 0051	701 419 831	585, 587
30 80 0053	171 419 832 C	158
30 80 0053	171 419 832 C	456, 475, 570
30 80 0054	171 419 831 C	158
30 80 0054	191 419 831	244, 256, 278
30 80 0054	191 419 831	456, 475, 477, 479, 535, 570, 593
30 80 0055	861 419 831 B S1	549
30 80 0056	861 419 831 B	549
30 80 0057	1H0 422 831 B	244, 245, 256, 257, 264, 279, 281
30 80 0057	1H0 422 831 B	458, 466, 467, 475, 477, 479, 481, 537, 539, 561, 570, 593, 595
30 80 0060	811 419 831 B	530, 531, 533, 566
30 80 0062	171 419 832 C S1	456, 475, 570
30 80 0063	191 419 831 S1	244, 256, 278
30 80 0063	191 419 831 S1	456, 475, 477, 479, 535, 570, 593
30 80 0064	6N0 422 831	239
30 80 0064	6N0 422 831	550, 552
30 80 0065	6N0 419 831	239
30 80 0065	6N0 419 831	519, 550, 552
30 80 0066	1H0 422 831 B S1	244, 245, 256, 257, 264, 279, 281



30 80 0066	1H0 422 831 B S1	458, 466, 467, 475, 477, 479, 481, 537, 539, 561, 570, 593, 595
30 80 0067	7D0 419 831	585, 587
30 80 0068	1J0 422 831 B	265, 283
30 80 0068	1J0 422 831 B	301
30 80 0068	1J0 422 831 B	453, 523
30 86 0002	251 419 417 B	583
30 91 8654	701 411 049 B	586, 588
30 91 8830	251 411 041 C	584
30 91 8864	1H0 422 884	244, 245, 256, 257, 264, 279, 281
30 91 8864	1H0 422 884	458, 479, 481, 485, 561, 593, 595
30 91 9050	1H0 411 314	243, 247, 255, 258, 264, 277, 280, 282
30 91 9050	1H0 411 314	459, 478, 480, 482, 563, 594
30 91 9276	7M3 407 365 C	231, 233
30 91 9276	7M3 407 365 C	574
30 91 9296	1J0 411 315 D	267, 285
30 91 9296	1J0 411 315 D	303
30 91 9296	1J0 411 315 D	455, 525
30 91 9298	1J0 411 316 D	267, 285
30 91 9298	1J0 411 316 D	303
30 91 9298	1J0 411 316 D	455, 525
30 91 9336	8N0 422 811 A	265
30 91 9336	8N0 422 811 A	523
30 91 9342	8N0 422 812 A	265
30 91 9342	8N0 422 812 A	523
30 91 9406	6Q0 407 365 M	249, 261
30 91 9406	6Q0 407 365 M	295, 313
30 91 9406	6Q0 407 365 M	473, 558
30 91 9408	6Q0 407 366 M	249, 261
30 91 9408	6Q0 407 366 M	295, 313
30 91 9408	6Q0 407 366 M	473, 558
30 91 9410	6Q0 407 365 M S1	249, 261
30 91 9410	6Q0 407 365 M S1	295, 313
30 91 9410	6Q0 407 365 M S1	473, 558
30 91 9412	6Q0 407 366 M S1	249, 261
30 91 9412	6Q0 407 366 M S1	295, 313
30 91 9412	6Q0 407 366 M S1	473, 558



30 91 9414	357 422 831 B	467, 477, 479, 481, 537, 539, 593, 595
30 91 9518	6R0 411 315 A	249, 261, 263, 275, 289
30 91 9518	6R0 411 315 A	291, 295, 297, 298, 309, 313
30 91 9518	6R0 411 315 A	473, 527, 557, 565
30 91 9702	8D0 411 318 D S1	315
30 91 9702	8D0 411 318 D S1	541, 543
30 91 9704	8D0 411 317 D S1	315
30 91 9704	8D0 411 317 D S1	541, 543
30 91 9812	6RD 423 811 B	251, 259, 263, 289
30 91 9812	6RD 423 811 B	293, 297, 309, 311
30 91 9812	6RD 423 811 B	474, 555, 557
30 91 9814	6RD 423 812 B	251, 259, 263, 289
30 91 9814	6RD 423 812 B	293, 297, 309, 311
30 91 9814	6RD 423 812 B	474, 555, 557
30 91 9816	6Q0 423 803 P	251, 259
30 91 9816	6Q0 423 803 P	293, 297, 311
30 91 9816	6Q0 423 803 P	474, 555
30 91 9818	6Q0 423 804 P	251, 259
30 91 9818	6Q0 423 804 P	293, 297, 311
30 91 9818	6Q0 423 804 P	474, 555
30 91 9820	1J0 407 151 C S1	267, 285
30 91 9820	1J0 407 151 C S1	303
30 91 9820	1J0 407 151 C S1	455, 491, 495, 525
30 91 9822	1J0 407 151 C S2	267, 285
30 91 9822	1J0 407 151 C S2	303
30 91 9822	1J0 407 151 C S2	455, 525
30 91 9926	4B0 407 515	315
30 91 9926	4B0 407 515	541, 543
30 91 9932	4B3 407 151 K	315
30 91 9932	4B3 407 151 K	543
30 92 1497	KIT 01	543
30 92 1498	KIT 02	543
30 92 1499	KIT 03	315
30 92 1499	KIT 03	543
30 92 1501	KIT 04	315
30 92 1501	KIT 04	543
30 92 1502	8D0 498 998 S1	543
30 92 1503	KIT 05	315
30 92 1503	KIT 05	543
30 92 1505	KIT 06	315



30 92 1505	KIT 06	543
30 92 1700	6E0 419 831	251, 259
30 92 1700	6E0 419 831	293
30 92 1700	6E0 419 831	519, 555
30 92 1840	4F0 498 811 A SK	253
30 92 1840	4F0 498 811 A SK	315
30 92 1892	8D0 407 509 G	543
30 92 1893	8D0 407 510 G	543
30 92 1940	701 411 041	586
30 92 1942	7D0 411 045	586, 588
30 92 4258	191 422 803 C	477
30 92 4374	N 904 840 03 S2	276, 277
30 92 4390	1K0 407 182	237, 269, 273, 287
30 92 4390	1K0 407 182	305, 306, 317, 319
30 92 4390	1K0 407 182	461, 463, 465, 471, 527, 545, 546, 573, 575, 577, 581
30 92 6173	6Q0 423 803 G	251, 259
30 92 6173	6Q0 423 803 G	293, 311
30 92 6173	6Q0 423 803 G	474, 555
30 92 6174	6Q0 423 804 G	251, 259
30 92 6174	6Q0 423 804 G	293, 311
30 92 6174	6Q0 423 804 G	474, 555
30 92 6535	8N0 407 181 B	263, 267, 285
30 92 6535	8N0 407 181 B	525
30 92 6540	7H0 411 313	589
30 92 6541	7H5 511 414	740
30 92 6573	7H0 407 183	589
30 92 6700	8N0 407 365 C	267
30 92 6700	8N0 407 365 C	525
30 92 7069	1K0 199 231 J	237, 269
30 92 7069	1K0 199 231 J	305, 317, 319
30 92 7069	1K0 199 231 J	461, 463, 471, 497, 499, 511, 573, 581
30 92 7071	1K0 199 232 J	237, 269
30 92 7071	1K0 199 232 J	305, 317, 319
30 92 7071	1K0 199 232 J	461, 463, 471, 497, 499, 511, 573, 581
30 92 7076	1K0 407 151 AC	237
30 92 7076	1K0 407 151 AC	305, 317
30 92 7076	1K0 407 151 AC	461, 471, 573, 581
30 92 7078	1K0 407 152 AC	237
30 92 7078	1K0 407 152 AC	305, 317

30 92 7078	1K0 407 152 AC	461, 471, 573, 581
30 92 7095	1J0 422 803 H SK	265, 283
30 92 7095	1J0 422 804 H SK	265, 283
30 92 7095	1J0 422 810 B	265, 283
30 92 7095	1J0 422 803 H SK	301
30 92 7095	1J0 422 804 H SK	301
30 92 7095	1J0 422 810 B	301
30 92 7095	1J0 422 803 H SK	453, 523
30 92 7095	1J0 422 804 H SK	453, 523
30 92 7095	1J0 422 810 B	453, 523
30 92 7250	1J0 411 314 S S1	303
30 92 7250	1J0 411 314 S S1	455, 495
30 92 7264	4E0 407 510 E	548
30 92 7265	4E0 407 509 E	548
30 92 7294	1J0 411 314 P S1	303
30 92 7294	1J0 411 314 P S1	455, 491, 495
30 92 7304	1J0 411 314 R S1	267, 285
30 92 7304	1J0 411 314 R S1	303
30 92 7304	1J0 411 314 R S1	455, 491, 525
30 92 7318	1J0 411 314 T S1	267, 285
30 92 7318	1J0 411 314 T S1	303
30 92 7318	1J0 411 314 T S1	455, 491, 495, 525, 526
30 92 7324	6Q0 411 314 F	295
30 92 7324	6Q0 411 314 F	557
30 92 7502	4E0 407 506 E	548
30 92 7503	4E0 407 505 E	548
30 92 7530	6Q0 407 151 L	249, 261
30 92 7530	6Q0 407 151 L	295, 313
30 92 7530	6Q0 407 151 L	473, 558
30 92 7611	4D0 425 021 D	543
30 92 7612	701 425 021	585
30 92 7638	6Q0 411 314 P	249, 261, 263, 275
30 92 7638	6Q0 411 314 P	291, 295, 297, 298
30 92 7638	6Q0 411 314 P	473, 557, 565
30 92 7640	6Q0 411 314 Q	249, 261, 263, 289
30 92 7640	6Q0 411 314 Q	295, 309
30 92 7640	6Q0 411 314 Q	473, 557, 565
30 92 7642	6Q0 411 314 R	249, 261, 263, 289
30 92 7642	6Q0 411 314 R	295, 309, 313
30 92 7642	6Q0 411 314 R	473, 557, 565
30 92 7726	N 034 790 8 S1	315
30 92 7834	7H5 411 317 A	589



30 92 7854	2K5 505 465 A	707, 708
30 92 7864	8E0 505 465 D	725
30 92 7866	1J0 505 466 C	675
30 92 7866	1J0 505 466 C	707, 711
30 92 7982	6K0 411 315 S1	243, 247, 255, 264, 276, 277, 280
30 92 7982	6K0 411 315 S1	459, 551, 563
30 92 7984	6K0 411 315	264, 277
30 92 7984	6K0 411 315	459
30 92 8098	1J0 422 810 A	301
30 92 8098	1J0 422 810 A	523
30 92 8211	6E0 411 315	521
30 92 8335	7H0 407 182 A	589
30 92 8579	1J0 411 315 K	267, 285
30 92 8579	1J0 411 315 K	303
30 92 8579	1J0 411 315 K	455, 525
30 92 8582	4F0 407 183 E	253
30 92 8621	8N0 407 182 A	525
30 92 9450	4E0 407 182 C	548
30 92 9459	1K0 505 465 AA	713
30 92 9461	1K0 505 465 AA S1	667, 669, 673
30 92 9461	1K0 505 465 AA S1	677, 679
30 92 9461	1K0 505 465 AA S1	710, 713, 718, 724
30 92 9644	6U0 407 182	299, 307
30 92 9644	6U0 407 182	464
30 92 9673	7H0 422 818 D	589
30 92 9675	7H0 422 817 D	589
30 92 9682	1K0 505 203 A	667, 669, 673
30 92 9682	1K0 505 203 A	677, 679
30 92 9682	1K0 505 203 A	710, 713, 724, 733
30 92 9689	1K0 505 279 A	667, 669, 673
30 92 9689	1K0 505 279 A	677, 679
30 92 9689	1K0 505 279 A	710, 713, 724, 733
30 92 9772	7D0 407 361 S1	588
30 92 9938	1K0 505 553 A	667, 669, 673, 674
30 92 9938	1K0 505 553 A	675, 677, 679
30 92 9938	1K0 505 553 A	724, 735
30 93 0154	1J0 411 315 G S1	266, 267, 284, 285
30 93 0154	1J0 411 315 G S1	302, 303
30 93 0154	1J0 411 315 G S1	454, 455, 491, 494, 495, 524, 525
30 93 0494	8E0 501 541 S	670
30 93 0509	3C0 407 365 B	269



30 93 0510	3C0 407 366 B	269
30 93 0654	4E0 419 821 A	548
30 93 0691	3C0 199 231 E	465, 545, 546, 575, 577
30 93 0820	6Q0 423 810 C	251, 259
30 93 0820	6Q0 423 810 C	293, 311
30 93 0820	6Q0 423 810 C	474, 555
30 93 0858	7H0 407 361 A S1	589
30 93 0982	7L0 505 554	736
30 93 0983	7L0 505 553	736
30 93 1253	1K0 407 183 E	237, 249, 261, 269
30 93 1253	1K0 407 183 E	295, 305, 313, 317, 319
30 93 1253	1K0 407 183 E	461, 462, 463, 471, 473, 497, 499, 511, 545, 558, 573, 575, 577, 581
30 93 1277	8E0 407 693 AL	253
30 93 1278	1K0 423 831 A S1	235, 237, 271, 273, 286
30 93 1278	1K0 423 831 A S1	305, 306, 317, 319
30 93 1278	1K0 423 831 A S1	461, 463, 465, 471, 544, 573, 577, 581
30 93 1281	8E0 407 694 AL	253
30 93 1344	7L0 407 077	578, 579
30 93 1345	7L8 411 313 B	579, 582
30 93 1348	1J0 411 314 AC	267, 285
30 93 1348	1J0 411 314 AC	495
30 93 1350	8Z0 411 314 B	295
30 93 1350	8Z0 411 314 B	557
30 93 1357	7L0 411 313 J	579
30 93 1485	3C0 407 365 B S1	235, 269, 273
30 93 1485	3C0 407 365 B S1	306
30 93 1485	3C0 407 365 B S1	465, 545
30 93 1486	3C0 407 366 B S1	235, 269, 273
30 93 1486	3C0 407 366 B S1	306
30 93 1486	3C0 407 366 B S1	465, 545
30 93 1705	7H0 419 810 F	589
30 93 1706	955 343 069 00	160
30 93 1706	7L0 411 317	579
30 93 1788	7H0 419 804 F	589
30 93 1789	7H0 419 803 F	589
30 93 1842	1J0 505 466 B S1	671



30 93 1842	1J0 505 466 B S1	707, 711
30 93 1843	1J0 505 466 C S1	675
30 93 1843	1J0 505 466 C S1	707, 711
30 93 2073	1K0 511 327 AQ	667, 669, 673
30 93 2073	1K0 511 327 AQ	677, 679
30 93 2073	1K0 511 327 AQ	717, 727, 739
30 93 2157	701 419 810 B	587
30 93 2229	6Q0 419 803 F	293
30 93 2229	6Q0 419 803 F	474, 555, 557
30 93 2230	6Q0 419 804 F	293
30 93 2230	6Q0 419 804 F	474, 555, 557
30 93 2318	8E0 407 505 P	253
30 93 2319	8E0 407 506 P	253
30 93 2326	3C0 407 151 G	545, 575, 577
30 93 2453	5Q0 505 323 C	667, 669, 673
30 93 2453	5Q0 505 323 C	677, 679
30 93 2453	5Q0 505 323 C	717, 718, 724, 735
30 93 2473	6Q0 423 810 P	251, 259
30 93 2473	6Q0 423 810 P	293, 297, 311
30 93 2473	6Q0 423 810 P	474, 555
30 93 2474	6Q0 419 810 B	293, 311
30 93 2474	6Q0 419 810 B	474, 555, 557
30 93 2491	8E0 505 465 AF S1	670
30 93 2597	8N0 422 810 C	523
30 93 2625	1K0 511 327 AS	669, 673
30 93 2625	1K0 511 327 AS	677, 679
30 93 2625	1K0 511 327 AS	717, 722, 727, 735
30 93 2627	1K0 423 810 A S1	235, 237, 271, 273, 286
30 93 2627	1K0 423 810 A S1	305, 306, 317, 319
30 93 2627	1K0 423 810 A S1	471, 544, 573, 577, 581
30 93 2628	1K0 423 810 A S2	235, 237, 271, 273, 286
30 93 2628	1K0 423 810 A S2	305, 306, 317, 319
30 93 2628	1K0 423 810 A S2	471, 544, 573, 577, 581
30 93 2956	1K0 501 529 F	669, 673
30 93 2956	1K0 501 529 F	677, 679
30 93 2956	1K0 501 529 F	710, 713, 715, 717, 721, 727, 729, 731, 735, 739
30 93 2957	1K0 501 530 C	669, 673

30 93 2957	1K0 501 530 C	677, 679
30 93 2957	1K0 501 530 C	710, 713, 715, 717, 721, 727, 729, 731, 735, 739
30 93 3363	8E0 407 694 E S1	543
30 93 3364	8E0 407 693 E S1	543
30 93 3365	8E0 407 694 AG S1	315
30 93 3366	8E0 407 693 AG S1	315
30 93 3367	8E0 407 509 A S1	315
30 93 3368	8E0 407 510 A S1	315
30 93 3369	6X0 407 151 A S1	241
30 93 3369	6X0 407 151 A S1	521
30 93 3370	8E0 407 151 R S1	253
30 93 3454	1H0 419 810	483, 489, 593
30 93 3584	6R0 423 810 A	263, 289
30 93 3584	6R0 423 810 A	309
30 93 3584	6R0 423 810 A	565
30 93 3592	8D0 419 831 K S1	253
30 93 3725	7L0 407 183 A	579, 736
30 93 3906	1H0 422 810 B	467, 485, 487, 593, 595
30 93 3907	191 422 810 A	243, 255, 278, 280
30 93 3907	191 422 810 A	466, 468, 478, 507
30 93 3908	1H0 422 810	468, 481, 486, 487, 593
30 93 4794	3C0 505 541	667
30 93 4884	1K0 505 311 AB	669, 673
30 93 4884	1K0 505 311 AB	677, 679
30 93 4884	1K0 505 311 AB	710, 713, 715, 717, 721, 722, 724, 727, 729, 731, 735, 739
30 93 6005	701 501 131	740
30 93 6047	1K0 501 529 J	669, 673
30 93 6047	1K0 501 529 J	677, 679
30 93 6047	1K0 501 529 J	713, 717, 721, 722, 724, 729, 731, 735, 739
30 93 6051	6R0 407 365 A	249, 261, 263, 275, 289
30 93 6051	6R0 407 365 A	291, 297, 298, 309, 313
30 93 6051	6R0 407 365 A	557, 565, 591

Ref. - No.

30 93 6052	6R0 407 366 A	249, 261, 263, 275, 289
30 93 6052	6R0 407 366 A	291, 297, 298, 309, 313
30 93 6052	6R0 407 366 A	557, 565, 591
30 93 6098	6Q0 407 182 A	249, 261
30 93 6098	6Q0 407 182 A	295, 313
30 93 6098	6Q0 407 182 A	473, 558
30 93 6457	2H0 407 077 A	451
30 93 6458	2H0 407 182 A	451
30 93 6459	2H0 412 333 A	451
30 93 6460	2H0 407 183 A	451
30 93 6508	6R0 423 803 A	263, 289
30 93 6508	6R0 423 803 A	309
30 93 6508	6R0 423 803 A	565
30 93 6509	6R0 423 804 A	263, 289
30 93 6509	6R0 423 804 A	309
30 93 6509	6R0 423 804 A	565
30 93 6582	2H0 411 317	451
30 93 6630	1J0 411 305 B S1	267, 285
30 93 6630	1J0 411 305 B S1	303
30 93 6630	1J0 411 305 B S1	455, 495, 525
30 93 6640	1J0 411 305 E S1	267, 285
30 93 6640	1J0 411 305 E S1	303
30 93 6640	1J0 411 305 E S1	455, 495, 525
30 93 6642	2H0 411 317 S1	451
30 93 6643	2H0 411 317 S2	451
30 93 6646	1J0 411 327 A	267, 285
30 93 6646	1J0 411 327 A	303
30 93 6646	1J0 411 327 A	455, 495, 525
30 93 6665	1J0 411 315 K S1	267, 285
30 93 6665	1J0 411 315 K S1	303
30 93 6665	1J0 411 315 K S1	455, 495, 525
30 93 6667	1J0 411 315 K S2	267, 285
30 93 6667	1J0 411 315 K S2	303
30 93 6667	1J0 411 315 K S2	454, 455, 494, 495, 524, 525
30 93 6676	1J0 411 315 G S1	267, 285
30 93 6676	1J0 411 315 G S1	303
30 93 6676	1J0 411 315 G S1	455, 495, 525
30 93 6677	1J0 411 315 G S2	266, 267, 284, 285
30 93 6677	1J0 411 315 G S2	302, 303

Ref. - No.

30 93 6677	1J0 411 315 G S2	454, 455, 494, 495, 524, 525
30 93 6735	1K0 407 365 C S1	237, 269, 287
30 93 6735	1K0 407 365 C S1	305, 317, 319
30 93 6735	1K0 407 365 C S1	461, 463, 471, 497, 499, 509, 511, 527, 573, 577, 581
30 93 6736	1K0 407 366 C S1	237, 269, 287
30 93 6736	1K0 407 366 C S1	305, 317, 319
30 93 6736	1K0 407 366 C S1	461, 463, 471, 497, 499, 509, 511, 527, 573, 577, 581
30 93 6752	1K0 407 183 P	305, 317, 319
30 93 6752	1K0 407 183 P	461, 462, 463, 509, 511, 527, 547
30 93 6757	1J0 411 315 G S3	267, 285
30 93 6757	1J0 411 315 G S3	303
30 93 6757	1J0 411 315 G S3	455, 495, 525
30 93 6758	1J0 411 315 G S4	267, 285
30 93 6758	1J0 411 315 G S4	303
30 93 6758	1J0 411 315 G S4	455, 495, 525
30 93 6800	8E0 422 821 C S1	253
30 93 6910	955 347 132 22	160
30 93 6910	7L0 422 818 D	451, 579
30 93 6911	955 347 131 22	160
30 93 6911	7L0 422 817 D	451, 579
30 93 6922	6R0 407 152 E	249, 261
30 93 6922	6R0 407 152 E	297, 313
30 93 6922	6R0 407 152 E	557
30 93 6923	6R0 407 151 E	249, 261
30 93 6923	6R0 407 151 E	297, 313
30 93 6923	6R0 407 151 E	557
30 93 6925	6R0 407 151 E S1	249, 261
30 93 6925	6R0 407 151 E S1	297, 313
30 93 6925	6R0 407 151 E S1	557
30 93 6926	6R0 407 152 E S1	249, 261
30 93 6926	6R0 407 152 E S1	297, 313
30 93 6926	6R0 407 152 E S1	557
30 93 7040	6Q0 411 305 AL S1	557
30 93 7050	6Q0 411 305 AM S1	557
30 93 7060	6Q0 411 305 AN S1	557
30 93 7065	6K0 422 810 E	245, 257
30 93 7065	6K0 422 810 E	458, 561, 563



30 93 7066	191 419 810 A	244, 256, 279, 281
30 93 7066	191 419 810 A	478, 507
30 93 7069	6Q0 411 314 Q S1	247, 249, 263
30 93 7069	6Q0 411 314 Q S1	295, 309
30 93 7069	6Q0 411 314 Q S1	557, 565
30 93 7076	6Q0 411 314 R S1	557
30 93 7077	6Q0 411 314 P S1	247, 249, 261, 263, 275
30 93 7077	6Q0 411 314 P S1	291, 295, 297
30 93 7077	6Q0 411 314 P S1	472, 473, 557, 565, 591
30 93 7078	6Q0 411 314 F S1	295
30 93 7078	6Q0 411 314 F S1	557
30 93 7079	8Z0 411 314 B S1	295
30 93 7079	8Z0 411 314 B S1	557
30 93 7089	6Q0 411 314 R S2	247, 249, 261, 263
30 93 7089	6Q0 411 314 R S2	309, 313
30 93 7089	6Q0 411 314 R S2	557, 565
30 93 7090	6Q0 411 305 AL S2	249, 261, 263
30 93 7090	6Q0 411 305 AL S2	295, 297
30 93 7090	6Q0 411 305 AL S2	473, 557, 565
30 93 7100	6Q0 411 305 AM S2	249, 263
30 93 7100	6Q0 411 305 AM S2	295
30 93 7100	6Q0 411 305 AM S2	557, 565
30 93 7110	6Q0 411 305 AN S2	249, 261, 263
30 93 7110	6Q0 411 305 AN S2	295, 313
30 93 7110	6Q0 411 305 AN S2	557, 565
30 93 7139	1J0 411 314 AC S1	267, 284, 285
30 93 7139	1J0 411 314 AC S1	454, 455, 494, 495
30 93 7178	8E0 407 506 A S1	315
30 93 7178	8E0 407 506 A S1	543
30 93 7179	8E0 407 505 A S2	315
30 93 7179	8E0 407 505 A S2	543
30 93 7182	1K0 407 152 AC S1	236, 237
30 93 7182	1K0 407 152 AC S1	304, 305
30 93 7182	1K0 407 152 AC S1	460, 461, 470, 471, 496, 497, 498, 499, 510, 511, 572, 573, 580, 581
30 93 7183	1K0 407 151 AC S1	236, 237
30 93 7183	1K0 407 151 AC S1	304, 305

30 93 7183	1K0 407 151 AC S1	460, 461, 470, 471, 496, 497, 498, 499, 510, 511, 572, 573, 580, 581
30 93 7186	191 407 151 B S1	243, 247, 255, 258, 264, 277, 280
30 93 7186	191 407 151 B S1	459, 466, 478, 507, 563
30 93 7193	1H0 407 151 A S1	282
30 93 7193	1H0 407 151 A S1	468, 482, 596
30 93 7194	1H0 407 152 S1	282
30 93 7194	1H0 407 152 S1	468, 482, 596
30 93 7196	6Q0 407 151 L S3	249, 261
30 93 7196	6Q0 407 151 L S3	295, 313
30 93 7196	6Q0 407 151 L S3	473, 558
30 93 7197	6Q0 407 151 L S2	249, 261
30 93 7197	6Q0 407 151 L S2	295, 313
30 93 7197	6Q0 407 151 L S2	473, 558
30 93 7203	955 347 010 22	160
30 93 7203	7L0 422 810 D	451, 579
30 93 7204	357 407 151 S1	540
30 93 7205	955 347 031 22	160
30 93 7205	7L0 422 803 D	451, 579
30 93 7206	955 347 032 22	160
30 93 7206	7L0 422 804 D	451, 579
30 93 7282	7H8 407 361 A S1	589
30 93 7291	6Q0 407 151 L S5	249, 261
30 93 7291	6Q0 407 151 L S5	295, 313
30 93 7291	6Q0 407 151 L S5	473, 558
30 93 7292	6Q0 407 151 L S4	249, 261
30 93 7292	6Q0 407 151 L S4	295, 313
30 93 7292	6Q0 407 151 L S4	473, 558
30 93 7306	191 407 151 B S2	243, 247, 255, 258, 264, 277, 280
30 93 7306	191 407 151 B S2	459, 466, 478, 507, 563
30 93 7308	357 407 151 S2	540
30 93 7332	4E0 419 801 E S2	548
30 93 7338	4E0 419 811 E S1	548
30 93 7407	6X0 407 151 A S2	241
30 93 7407	6X0 407 151 A S2	521, 551
30 93 7408	6X0 407 151 A S3	241
30 93 7408	6X0 407 151 A S3	521, 551



30 93 7409	6N0 407 151 B S1	241
30 93 7409	6N0 407 151 B S1	551
30 93 7410	6N0 407 151 B S2	241
30 93 7410	6N0 407 151 B S2	551
30 93 7591	1K0 423 811 K S1	235, 271
30 93 7591	1K0 423 811 K S1	305, 306, 317, 319
30 93 7591	1K0 423 811 K S1	461, 463, 465, 509, 527, 544, 575, 577, 581
30 93 7592	1K0 423 812 K S1	235, 271
30 93 7592	1K0 423 812 K S1	305, 306, 317, 319
30 93 7592	1K0 423 812 K S1	461, 463, 465, 509, 527, 544, 575, 577, 581
30 93 7593	1K0 423 811 K	235, 271, 273
30 93 7593	1K0 423 811 K	305, 306, 317, 319
30 93 7593	1K0 423 811 K	461, 463, 465, 509, 527, 544, 575, 577, 581
30 93 7594	1K0 423 812 K	234, 235, 271, 273
30 93 7594	1K0 423 812 K	305, 306, 317, 319
30 93 7594	1K0 423 812 K	461, 463, 465, 509, 527, 544, 575, 577, 581
30 93 7655	8Z0 411 314 B S2	294, 295, 302, 303
30 93 7655	8Z0 411 314 B S2	556, 557
30 93 7656	6Q0 411 314 R S3	246, 247, 248, 249, 260, 261
30 93 7656	6Q0 411 314 R S3	556, 557
30 93 7657	6Q0 411 314 P S2	246, 247, 248, 249, 260, 261, 262, 263, 275
30 93 7657	6Q0 411 314 P S2	291, 294, 295, 297
30 93 7657	6Q0 411 314 P S2	473, 556, 557, 564, 565, 591
30 93 7658	6Q0 411 314 F S2	294, 295
30 93 7658	6Q0 411 314 F S2	556, 557
30 93 7659	6Q0 411 314 R S4	246, 247, 248, 249, 260, 261, 262, 263, 288, 289
30 93 7659	6Q0 411 314 R S4	294, 295, 308, 309, 313
30 93 7659	6Q0 411 314 R S4	556, 557, 564, 565



30 93 7660	6Q0 411 314 Q S2	246, 247, 248, 249, 260, 261, 262, 263, 288, 289
30 93 7660	6Q0 411 314 Q S2	294, 295, 308, 309
30 93 7660	6Q0 411 314 Q S2	473, 556, 557, 564, 565
30 93 7764	1J0 422 831 B S1	265, 283
30 93 7764	1J0 422 831 B S1	301
30 93 7764	1J0 422 831 B S1	453, 490, 493, 523
30 93 8073	1S0 423 810 A	275
30 93 8073	1S0 423 810 A	291
30 93 8073	1S0 423 810 A	591
30 93 8180	1K0 407 152 BC S1	236, 237, 271, 287
30 93 8180	1K0 407 152 BC S1	303, 305, 317, 319
30 93 8180	1K0 407 152 BC S1	461, 462, 463, 470, 471, 496, 497, 498, 499, 509, 510, 511, 572, 573, 577, 581
30 93 8181	1K0 407 151 BC S1	237, 271, 287
30 93 8181	1K0 407 151 BC S1	303, 305, 317, 319
30 93 8181	1K0 407 151 BC S1	461, 463, 471, 497, 499, 509, 511, 573, 577, 581
30 93 8403	5Q0 407 183 E	273
30 93 8403	5Q0 407 183 E	306
30 93 8403	5Q0 407 183 E	500
30 93 8404	5Q0 407 182	500, 501
30 93 8410	357 411 315 D S1	540
30 93 8621	6Q0 423 831 D	251, 259, 263, 289
30 93 8621	6Q0 423 831 D	293, 309
30 93 8621	6Q0 423 831 D	473
30 93 8622	6Q0 423 831 D S1	251, 259, 263, 289
30 93 8622	6Q0 423 831 D S1	293, 309
30 93 8622	6Q0 423 831 D S1	473
30 93 8659	1K0 407 183 G	234, 235, 268, 269, 287
30 93 8662	1K0 199 231 K	237, 269, 287
30 93 8662	1K0 199 231 K	511
30 93 8663	1K0 199 232 K	237, 269, 287
30 93 8663	1K0 199 232 K	511
30 93 8769	8D0 511 327 C	707
30 93 8774	8E0 501 529 P	670
30 93 8785	6R0 423 810 D	565



30 93 8811	955 341 242 04	160, 161
30 93 8839	955 341 027 02 S1	160
30 93 8839	7L0 407 021 B S1	578, 579
30 93 8845	1K0 505 223 K	669, 673
30 93 8845	1K0 505 223 K	677, 679
30 93 8845	1K0 505 223 K	713, 715, 717, 721, 722, 724, 729, 731
30 93 8846	1K0 505 224 K	669, 673
30 93 8846	1K0 505 224 K	677, 679
30 93 8846	1K0 505 224 K	713, 715, 717, 721, 722, 724, 729, 731
30 93 8853	357 422 810 A	537
30 93 8854	4B0 419 810 M	315
30 93 8854	4B0 419 810 M	543
30 93 8855	6X0 422 810	238, 239
30 93 8855	6X0 422 810	519, 552
30 93 8856	1H0 422 810 D	486, 487, 593
30 93 8857	6K0 422 810	256, 278
30 93 8858	6N0 419 810	239
30 93 8858	6N0 419 810	550
30 93 8859	6N0 422 810 A	238, 239
30 93 9094	7L0 505 323 A	736
30 93 9193	7P0 511 413 A	737
30 93 9194	7P0 407 077	582
30 93 9228	1K0 407 183 E S1	249, 261
30 93 9228	1K0 407 183 E S1	295, 313
30 93 9228	1K0 407 183 E S1	461, 470, 471, 472, 473, 558
30 93 9230	3C0 199 231 E S1	235
30 93 9230	3C0 199 231 E S1	545, 575, 577
30 93 9356	561 423 810 S1	527, 528, 547
30 93 9357	561 423 810 S2	527, 528, 547
30 93 9358	561 423 810	527, 528, 547
30 93 9359	5N0 407 151	465, 545, 547, 577
30 93 9360	5N0 407 152	465, 545, 547, 577
30 93 9394	4E0 505 548 M	732
30 93 9395	4E0 505 547 M	732
30 93 9448	1K0 407 152 BC	268, 269, 287
30 93 9448	1K0 407 152 BC	461, 471
30 93 9460	7M0 511 413 B	666
30 93 9460	7M0 511 413 B	732
30 93 9489	1K0 407 151 BC	268, 269, 287
30 93 9489	1K0 407 151 BC	461, 471



30 93 9557	6R0 407 151 F	263, 289
30 93 9557	6R0 407 151 F	298, 309
30 93 9557	6R0 407 151 F	565
30 93 9558	6R0 407 152 F	263, 289
30 93 9558	6R0 407 152 F	298, 309
30 93 9558	6R0 407 152 F	565
30 93 9606	0902 010	43
30 93 9606	8N0 422 831 S1	267
30 93 9606	13278357	403
30 93 9606	8N0 422 831 S1	495, 525
30 93 9648	1K0 511 327 AR S1	669, 673
30 93 9648	1K0 511 327 AR S1	677, 679
30 93 9648	1K0 511 327 AR S1	713, 715, 717, 722, 727, 731, 735, 739
30 93 9649	1K0 511 327 AS S1	669, 673
30 93 9649	1K0 511 327 AS S1	677, 679
30 93 9649	1K0 511 327 AS S1	710, 713, 715, 717, 727, 729, 731, 735, 739
30 93 9650	1K0 511 327 AQ S1	669, 673
30 93 9650	1K0 511 327 AQ S1	677, 679
30 93 9650	1K0 511 327 AQ S1	713, 715, 717, 721, 727, 735
30 93 9754	KIT 11	253
30 93 9758	KIT 12	253
30 93 9810	357 407 365 S2	243, 247, 255, 258, 264, 277, 280
30 93 9810	357 407 365 S2	453, 459, 466, 478, 480, 484, 486, 489, 507, 536, 538, 563, 594
30 93 9813	171 407 365 F S2	457, 476, 503, 571
30 93 9817	8E0 511 327 A	670
30 93 9940	6R0 423 811 A S1	565
30 93 9941	6R0 423 812 A S1	565
30 93 9972	3C0 407 151 G S1	234, 235
30 93 9972	3C0 407 151 G S1	465
30 93 9973	3C0 407 151 G S2	234, 235
30 93 9973	3C0 407 151 G S2	465
30 93 9985	4E0 501 529 G S1	732
30 94 0089	1J0 411 314 T S2	267, 285
30 94 0089	1J0 411 314 T S2	303
30 94 0089	1J0 411 314 T S2	455, 495, 525

Ref. - No.

30 94 0090	1J0 411 305 E S2	267, 285
30 94 0090	1J0 411 305 E S2	303
30 94 0090	1J0 411 305 E S2	455, 495, 525
30 94 0103	1K0 407 151 AC S2	237
30 94 0103	1K0 407 151 AC S2	305
30 94 0103	1K0 407 151 AC S2	461, 471, 497, 499, 511, 573, 581
30 94 0104	1K0 407 152 AC S2	237
30 94 0104	1K0 407 152 AC S2	305
30 94 0104	1K0 407 152 AC S2	461, 471, 497, 499, 511, 573, 581
30 94 0114	4B3 407 151 K S1	315
30 94 0114	4B3 407 151 K S1	543
30 94 0163	955 341 017 33 S1	160
30 94 0163	7L0 407 151 H S1	578, 579
30 94 0164	955 341 018 33 S1	160
30 94 0164	7L0 407 152 H S1	578, 579
30 94 0165	955 343 243 01	160, 161, 162
30 94 0165	7L0 412 333 A	578, 579
30 94 0403	955 341 027 02 S2	160
30 94 0403	7L0 407 021 B S2	579
30 94 0431	1K0 501 529 J S1	669, 673
30 94 0431	1K0 501 529 J S1	677, 679
30 94 0431	1K0 501 529 J S1	713, 717, 721, 722, 724, 729, 731, 735, 739
30 94 0438	1K0 501 529 H S1	669, 673
30 94 0438	1K0 501 530 C S1	669, 673
30 94 0438	1K0 501 529 H S1	677, 679
30 94 0438	1K0 501 530 C S1	677, 679
30 94 0438	1K0 501 529 H S1	710, 713, 715, 717, 721, 727, 729, 731, 735, 739
30 94 0438	1K0 501 530 C S1	710, 713, 715, 717, 721, 727, 729, 731, 735, 739
30 94 0439	1K0 501 529 F S1	669, 673
30 94 0439	1K0 501 529 F S1	677, 679
30 94 0439	1K0 501 529 F S1	710, 713, 715, 717, 721, 727, 729, 731, 735, 739
30 94 0668	5Q0 407 365 A S1	273
30 94 0668	5Q0 407 365 A S1	306

Ref. - No.

30 94 0668	5Q0 407 365 A S1	500
30 94 0669	5Q0 407 366 A S1	273
30 94 0669	5Q0 407 366 A S1	306
30 94 0669	5Q0 407 366 A S1	500
30 94 0743	8E0 407 510 P S1	253
30 94 0744	8E0 407 509 P S1	253
30 94 0745	8E0 407 505 P S1	253
30 94 0746	8E0 407 506 P S1	253
30 94 3464	6R0 423 804 D	565
30 94 3465	6R0 423 803 D	565
30 94 3733	5Q0 505 171	674
30 94 3733	5Q0 505 171	675
30 94 3788	3C0 199 231 F	234, 235
30 94 4226	1S0 423 812 A	275
30 94 4226	1S0 423 812 A	291
30 94 4227	1S0 423 811 A	275
30 94 4227	1S0 423 811 A	291
30 94 4236	5C0 407 151 B	509
30 94 4237	5C0 407 152 B	509
30 94 4240	1S0 423 810 A S1	275
30 94 4240	1S0 423 810 A S1	291
30 94 4241	1S0 423 810 A S2	275
30 94 4241	1S0 423 810 A S2	291
30 94 4341	1J0 422 803 H S1	265, 283
30 94 4341	1J0 422 803 H S1	301
30 94 4341	1J0 422 803 H S1	453
30 94 4342	1J0 422 804 H S1	265, 283
30 94 4342	1J0 422 804 H S1	301
30 94 4342	1J0 422 804 H S1	453
30 94 4343	6Q0 423 803 P S1	251, 259
30 94 4343	6Q0 423 803 P S1	293, 311
30 94 4343	6Q0 423 803 P S1	555
30 94 4344	6Q0 423 804 P S1	251, 259
30 94 4344	6Q0 423 804 P S1	293, 311
30 94 4344	6Q0 423 804 P S1	555
30 94 4346	1J0 422 804 A S1	301
30 94 4347	1J0 422 803 A S1	301
30 94 4452	8N0 407 151 D S1	494, 495, 524, 525
30 94 4453	8N0 407 152 D S1	494, 495, 524, 525
30 94 4547	6R0 407 151 F S1	262, 263, 288, 289
30 94 4547	6R0 407 151 F S1	308, 309
30 94 4548	6R0 407 152 F S1	263, 289
30 94 4548	6R0 407 152 F S1	309



30 94 4675	6K0 422 803 E	245, 257
30 94 4675	6K0 422 803 E	458, 561
30 94 4676	6K0 422 804 E	245, 257
30 94 4676	6K0 422 804 E	458, 561
30 94 4740	6K0 422 804 E S1	245, 257
30 94 4740	6K0 422 804 E S1	458, 561
30 94 4741	6K0 422 803 E S1	245, 257
30 94 4741	6K0 422 803 E S1	458, 561
30 94 4764	7L0 407 182 G	578, 579, 582
30 94 4860	2K0 511 413 D S1	707, 708
30 94 5009	6E0 422 803	519
30 94 5010	6E0 422 804	519
30 94 5306	1K0 411 303 BK S1	237, 268, 269
30 94 5306	1K0 411 303 BK S1	305, 317, 319
30 94 5306	1K0 411 303 BK S1	471, 496, 497, 498, 499, 572, 573, 580, 581
30 94 5307	1K0 411 303 BK S2	237, 269
30 94 5307	1K0 411 303 BK S2	305, 317, 319
30 94 5307	1K0 411 303 BK S2	471, 497, 499, 573, 581
30 94 5353	2H0 411 317 B	451
30 94 5527	7L8 407 151 K S1	582
30 94 5528	7L8 407 152 K S1	582
30 94 5760	1K0 423 810 A S4	235, 237, 271, 273, 286
30 94 5760	1K0 423 810 A S4	306
30 94 5760	1K0 423 810 A S4	471
30 94 5761	1K0 423 810 A S3	235, 237, 271, 273, 286
30 94 5761	1K0 423 810 A S3	306
30 94 5761	1K0 423 810 A S3	471
30 94 5784	2H0 411 317 B S1	451
30 94 5785	2H0 411 317 B S2	451
30 94 5859	5Q0 501 129 B	674
30 94 5859	5Q0 501 129 B	675
30 94 5860	5Q0 505 543 B	674
30 94 5860	5Q0 505 543 B	675
30 94 5861	7L8 501 529 A	736
30 94 5866	7L0 501 537 B	736, 737
30 94 5891	1K0 199 231 K S1	268, 269, 287
30 94 5892	1K0 199 232 K S1	268, 269, 287
30 94 6299	6C0 423 810 C	289



30 94 6299	6C0 423 810 C	297, 298, 309
30 94 6299	6C0 423 810 C	559
30 94 7140	2H0 411 313 C	451
32 60 0003	8E0 407 181 C	253
32 61 0002	811 411 327 A	530, 532, 534, 568, 569
32 61 0004	823 411 327 B	529, 530, 532, 567, 568, 569
32 61 0005	8D0 411 318 D	315
32 61 0005	8D0 411 318 D	541, 543
32 61 0006	8D0 411 317 D	315
32 61 0006	8D0 411 317 D	541, 543
32 69 0003	4D0 407 181 H	315
32 69 0003	4D0 407 181 H	541, 543
32 69 0007	811 407 181 A	530, 532, 534, 567, 568
32 69 0008	857 407 181	532, 534, 569
32 69 0009	1J0 407 181	261, 263, 267, 275, 285, 289
32 69 0009	1J0 407 181	291, 297, 298, 303, 309, 313
32 69 0009	1J0 407 181	453, 473, 525, 557, 565
32 71 0002	811 419 812	529, 530, 531, 549, 566
32 71 0003	811 419 812 A	530, 531, 533, 566
32 71 0010	1J0 422 812 A	301
32 71 0010	1J0 422 812 A	453, 523
32 71 0011	1J0 422 811 A	301
32 71 0011	1J0 422 811 A	453, 523
32 72 0007	811 419 802 J	530, 531, 566
32 72 0008	811 419 801 E	530, 531, 566
32 72 0020	1J0 422 804 A	301
32 72 0020	1J0 422 804 A	523
32 72 0021	1J0 422 803 A	301
32 72 0021	1J0 422 803 A	523
32 72 0022	4B0 419 801 M	315
32 72 0022	4B0 419 801 M	543
32 72 0023	8E0 411 317	253
32 72 0024	8E0 411 318	253
32 72 0025	8E0 411 317 S1	253
32 72 0026	8E0 411 318 S1	253

Ref. - No.

32 73 0005	893 407 147 G	530, 532, 534, 567, 568
32 73 0006	893 407 148 C	532, 534, 569
32 73 0013	861 407 151 B	549
32 73 0016	1J0 407 151 C	267, 285
32 73 0016	1J0 407 151 C	303
32 73 0016	1J0 407 151 C	453, 525
32 73 0017	4D0 407 151 P	315
32 73 0017	4D0 407 151 P	543
32 73 0018	8E0 407 694 E	543
32 73 0019	8E0 407 693 E	543
32 73 0020	8E0 407 506 A	315
32 73 0020	8E0 407 506 A	543
32 73 0021	8E0 407 505 A	315
32 73 0021	8E0 407 505 A	543
32 73 0032	8E0 407 509 A	315
32 73 0032	8E0 407 509 A	543
32 73 0033	8E0 407 510 A	315
32 73 0033	8E0 407 510 A	543
32 73 0034	8E0 407 151 R	253
32 75 0001	8D0 498 998	543
32 78 0001	823 407 365 C	529
32 78 0002	823 407 365 E	529, 530, 532, 534, 567, 568
32 78 0003	855 407 365 A	532, 534, 569
32 78 0004	855 407 366 A	532, 534, 569
32 78 0019	1J0 407 366 H	267, 285
32 78 0019	1J0 407 366 H	303
32 78 0019	1J0 407 366 H	453, 525
32 78 0020	1J0 407 365 H	267, 285
32 78 0020	1J0 407 365 H	303
32 78 0020	1J0 407 365 H	453, 525
32 78 0023	811 407 175 A	529, 530, 532, 534, 567, 568
32 78 0024	857 407 175	532, 534, 569
32 92 1196	8E0 407 693 AG	315
32 92 1196	8E0 407 693 AG	543
32 92 1198	8E0 407 694 AG	315
32 92 1198	8E0 407 694 AG	543
32 92 2515	6K0 422 803	244, 256, 278, 279
32 92 2516	6K0 422 804	244, 256, 278, 279
32 92 2794	1J0 411 314 P	303
32 92 2794	1J0 411 314 P	455, 495

Ref. - No.

32 92 2804	1J0 411 314 R	267, 285
32 92 2804	1J0 411 314 R	303
32 92 2804	1J0 411 314 R	455, 495, 525
32 92 2988	7M0 501 541	231, 233, 666
32 92 2988	7M0 501 541	574, 732
32 92 3030	6N0 411 315 D	241
32 92 3030	6N0 411 315 D	521, 551, 553
32 92 3032	6N0 411 315 D S1	241
32 92 3032	6N0 411 315 D S1	521, 553
32 92 3046	4D0 411 327 J	253
32 92 3322	6X0 419 803 A	239
32 92 3322	6X0 419 803 A	519, 552
32 92 3324	6X0 419 804 A	239
32 92 3324	6X0 419 804 A	519, 552
32 92 3356	1K0 511 327 AP	677, 679
32 92 3356	1K0 511 327 AP	717
32 92 3358	1K0 511 327 AR	669, 673
32 92 3358	1K0 511 327 AR	677, 679
32 92 3358	1K0 511 327 AR	710, 713, 717, 718, 727, 735
32 92 3364	7D0 407 140 A	586, 588
32 92 3366	1J0 411 336 D	267, 269, 285
32 92 3366	1J0 411 336 D	303, 305
32 92 3366	1J0 411 336 D	455, 525
32 92 3424	701 411 041 D	588
32 92 3604	1K0 511 439 E	667, 669, 673
32 92 3604	1K0 511 439 E	677, 679
32 92 3604	1K0 511 439 E	710
32 92 3606	1K0 511 327 AP S1	669
32 92 3606	1K0 511 327 AP S1	677, 679
32 92 3606	1K0 511 327 AP S1	719
32 92 4122	1K0 411 315 R	235, 237, 269, 273, 287
32 92 4122	1K0 411 315 R	305, 317, 319
32 92 4122	1K0 411 315 R	461, 463, 465, 471, 527, 528, 545, 546, 573, 575, 577, 581
32 92 4260	191 422 804 C	477
32 92 4832	KIT 09	543
32 92 4834	KIT 10	543
32 92 4863	7M3 498 317	231, 233
32 92 4863	7M3 498 317	574
32 92 4900	4B3 498 998	543



32 92 4902	4B3 498 998 S1	543
32 92 6045	1K0 423 810 A	235, 237, 271, 273, 286
32 92 6045	1K0 423 810 A	305, 306, 317, 319
32 92 6045	1K0 423 810 A	461, 463, 465, 471, 527, 544, 573, 575, 577, 581
32 92 6082	1K0 407 365 C	237, 269, 287
32 92 6082	1K0 407 365 C	305, 317, 319
32 92 6082	1K0 407 365 C	461, 463, 471, 527, 528, 573, 577, 581
32 92 6083	1K0 407 366 C	237, 269, 287
32 92 6083	1K0 407 366 C	305, 317, 319
32 92 6083	1K0 407 366 C	461, 463, 471, 527, 528, 573, 577, 581
32 92 6096	1K0 423 811 J	235, 237, 271, 273, 286
32 92 6096	1K0 423 811 E	305, 306, 317, 319
32 92 6096	1K0 423 811 J	471, 544, 573, 577, 581
32 92 6097	1K0 423 812 J	234, 235, 237, 271, 273, 286
32 92 6097	1K0 423 812 E	305, 306, 317, 319
32 92 6097	1K0 423 812 J	471, 544, 573, 577, 581
32 92 6120	6E0 419 803 A	519
32 92 6121	6E0 419 804 A	519
32 92 6151	8E0 422 821 C	253
32 92 6251	6N0 422 803 C	239
32 92 6251	6N0 422 803 C	519
32 92 6252	6N0 422 804 C	239
32 92 6252	6N0 422 804 C	519
32 92 6253	6N0 422 803 D	239
32 92 6253	6N0 422 803 D	550
32 92 6254	6N0 422 804 D	239
32 92 6254	6N0 422 804 D	550
32 92 6344	1J0 411 314 S	303
32 92 6344	1J0 411 314 S	455, 495
32 92 6600	8D0 498 998 B	315
32 92 6600	8D0 498 998 B	543
32 92 9690	1K0 505 171 C	667, 669, 673
32 92 9690	1K0 505 171 C	677, 679
32 92 9690	1K0 505 171 C	724, 735

32 93 0696	8D0 407 515 C	253
32 93 0696	8D0 407 515 C	548
32 93 1331	8E0 407 510 P	253
32 93 1332	8E0 407 509 P	253
32 93 1353	7L0 411 313 G	579
32 93 2541	1K0 199 232 J S1	237, 268, 269
32 93 2541	1K0 199 232 J S1	305, 317, 319
32 93 2541	1K0 199 232 J S1	461, 463, 471, 573, 581
32 93 2542	1K0 199 231 J S1	237, 268, 269
32 93 2542	1K0 199 231 J S1	305, 317, 319
32 93 2542	1K0 199 231 J S1	461, 463, 471, 573, 581
32 93 3598	4E0 505 203 A	732
32 93 3971	1K0 199 231 N	269
32 93 3972	1K0 199 232 N	269
32 93 3973	8J0 407 183	269
32 93 9077	4F0 498 811 A S1	253
32 93 9077	4F0 498 811 A S1	315
34 92 2492	6X0 411 313	241
34 92 2492	6X0 411 313	551, 553
34 92 2494	6X0 411 313 A	241
34 92 2494	6X0 411 313 A	521, 551, 553
36 71 0001	6U0 422 811	299
36 71 0001	6U0 422 811	464
36 74 0001	6U0 422 807	299
36 74 0001	6U0 422 807	464
36 78 0001	6U0 407 365	299, 307
36 78 0001	6U0 407 365	464
38 92 6531	996 343 069 04	156, 159, 657
38 92 6532	996 343 070 04	156, 159, 657
38 92 6533	997 343 070 02	157, 159, 162
38 92 6534	997 343 069 02	157, 159, 162
38 92 9800	996 333 069 04	659
38 93 8568	996 341 053 16	156, 159, 657, 658, 659
38 93 8883	996 341 043 06	156, 157, 159, 659
38 93 8884	986 331 043 07	657
38 93 8885	996 347 322 03	156, 159
38 93 8886	996 347 131 04	156, 157, 159
38 93 8887	997 331 045 04	657, 658, 659
38 93 9464	955 343 069 10	160
38 94 5445	996 343 073 05 S1	156

Ref. - No.

40 60 0001	0352 301	50, 51, 79, 80
40 60 0001	90445097	416, 417, 438, 439
40 60 0002	0352 327	49
40 60 0002	90170152	432
40 60 0003	0352 356	37, 46, 83, 85
40 60 0003	90495046	397, 406, 411, 415
40 60 0004	0352 348	36, 46, 83, 85
40 60 0004	90268463	395, 406, 411, 415
40 60 0005	0352 341	73, 77
40 60 0005	90279193	408, 436
40 60 0006	0352 300	36, 37, 46, 83, 85
40 60 0006	90373778	395, 397, 406, 411, 415
40 60 0008	0352 355	73, 77
40 60 0008	90373854	408, 436
40 60 0009	0352 303	74
40 60 0009	09156605	434
40 60 0010	0352 338	62
40 60 0010	90235041	393
40 60 0011	0352 358	86
40 60 0011	90468638	441
40 60 0012	0352 365	39, 91
40 60 0012	90498740	399, 447
40 60 0013	0352 335	60, 62
40 60 0013	90235040	393
40 60 0014	0352 302	74
40 60 0014	90576775	434
40 60 0015	0352 349	60, 62
40 60 0015	90335966	393
40 60 0016	0352 330	62
40 60 0016	90193117	393
40 60 0017	0352 357	86
40 60 0017	45 66 899	226
40 60 0017	90468636	441
40 60 0018	0352 364	39, 41, 65, 91, 93
40 60 0018	90498738	399, 401, 427, 447, 449
40 60 0019	0353 560	49
40 60 0019	90135359	432
40 60 0021	0353 561	50, 79
40 60 0021	90445098	416, 438
40 60 0023	0352 352	36, 46, 85
40 60 0023	90373264	395, 406, 411, 415

Ref. - No.

40 60 0024	0353 460	36, 37, 46, 83, 85
40 60 0024	42 46 062	224, 229
40 60 0024	90250709	395, 397, 406, 411, 415
40 61 0001	0350 260 S1	36, 37, 46, 83, 85
40 61 0001	90278579 S1	395, 397, 406, 411, 415
40 61 0002	0350 261 S1	36, 37, 46, 83, 85
40 61 0002	90278577 S1	395, 397, 411, 415
40 61 0003	0350 263 S1	36, 37, 46, 83, 85
40 61 0003	90495045 S1	395, 397, 406, 411, 415
40 61 0004	1603 148	60, 62
40 61 0004	90009367	393
40 61 0005	1603 149	34
40 61 0005	90009368	409
40 61 0007	1603 147	48, 71, 75, 76
40 61 0007	90009369	435, 444
40 61 0008	0350 153	34, 36, 37, 46, 48, 59, 60, 62, 63, 71, 75, 76, 83, 85
40 61 0008	42 46 112	224, 229
40 61 0008	02875013	393, 395, 397, 406, 409, 411, 415, 435, 444
40 61 0009	0350 260	36, 37, 46, 83, 85
40 61 0009	90278579	395, 397, 406, 411, 415
40 61 0010	0350 261	36, 37, 83, 85
40 61 0010	90278577	395, 397, 411, 415
40 61 0011	0350 116	73, 77
40 61 0011	90278624	408, 436
40 61 0012	0350 078	36, 37, 46, 83, 85
40 61 0012	90447867	395, 397, 406, 411, 415
40 61 0013	0350 113	62
40 61 0013	90235058	393
40 61 0014	0350 112	62
40 61 0014	90216574	393
40 61 0015	0350 127	50, 51, 79, 80
40 61 0015	90447946	416, 417, 438, 439
40 61 0016	0350 130	39, 53, 81, 86
40 61 0016	90 468 567	226



40 61 0016	90468567	399, 419, 440, 441
40 61 0017	0350 138	39, 81
40 61 0017	90538865	399, 440
40 69 0001	0352 320	47, 53, 64, 81
40 69 0001	13138151	419, 422, 426, 440
40 69 0002	0352 378	47, 53, 64
40 69 0002	93188303	419, 422, 426
40 69 0005	0423 302	650
40 69 0005	09191309	705
40 71 0001	1603 645	49, 50, 53, 79, 81
40 71 0001	451 338 01 37 SK1	323
40 71 0001	93192419	416, 419, 432, 438, 440
40 71 0002	0322 172	72, 74, 77
40 71 0002	90510640	407, 433, 436
40 71 0003	0322 171	72, 74, 77
40 71 0003	90510639	407, 433, 436
40 71 0004	0322 175	72, 77
40 71 0004	90510643	407, 436
40 71 0005	0322 176	72, 77
40 71 0005	90510644	407, 436
40 71 0006	0324 038	33, 61
40 71 0006	90140006	392
40 71 0007	0324 039	33, 61
40 71 0007	90140007	392
40 71 0008	0324 055	35, 45, 82, 84
40 71 0008	42 42 749	224, 229
40 71 0008	90369704	394, 396, 405, 412, 413
40 71 0009	0324 056	35, 45, 82, 84
40 71 0009	42 42 756	224, 229
40 71 0009	90369705	394, 396, 405, 412, 413
40 71 0010	0322 179	74
40 71 0010	90510653	433
40 71 0011	0324 155	74
40 71 0011	93169283	433
40 71 0014	1603 286 SK	86
40 71 0014	48 36 540	226
40 71 0014	93186321 SK	441
40 71 0015	0324 058	56, 67
40 71 0015	97020954	423
40 71 0016	0324 057	56, 67

40 71 0016	97020953	423
40 71 0017	0324 045	48, 71, 75, 76
40 71 0017	90188428	435
40 71 0018	0324 044	48, 71, 75, 76
40 71 0018	90188427	435
40 71 0024	1603 455	51, 80
40 71 0024	93192446	417, 439
40 71 0025	1603 542	39, 91
40 71 0025	93186537	399, 447
40 72 0002	0322 145	72, 77
40 72 0002	90369125	436
40 72 0003	0322 148	72, 77
40 72 0003	90392553	407, 436
40 72 0004	0322 173	72, 77
40 72 0004	90510641	407, 436
40 72 0005	0322 174	72, 77
40 72 0005	90510642	407, 436
40 72 0006	0322 126	33, 61
40 72 0006	90125568	392
40 72 0007	0322 125	33, 61
40 72 0007	90125567	392
40 72 0008	0322 146	35, 45, 82, 84
40 72 0008	42 42 681	224, 229
40 72 0008	90373522	394, 396, 405, 412, 413
40 72 0009	0322 147	35, 45, 82, 84
40 72 0009	42 42 673	224, 229
40 72 0009	90373521	394, 396, 405, 412, 413
40 72 0010	0322 166	74
40 72 0010	90510647	433
40 72 0011	0322 168	74
40 72 0011	90510650	433
40 72 0012	0322 194	74
40 72 0012	93169261	433
40 72 0023	1603 643	39, 41, 91
40 72 0023	93191526	399, 401, 447
40 73 0001	0352 043	49
40 73 0001	90166390	432
40 73 0002	0352 044	49
40 73 0002	90166391	432
40 73 0003	0352 192	36, 46, 83, 85
40 73 0003	90495160	395, 406, 411, 415

Ref. - No.

40 73 0004	0352 193	36, 46, 83, 85
40 73 0004	90495159	395, 406, 411, 415
40 73 0005	0352 172	62
40 73 0005	90375506	393
40 73 0006	5352 014	62
40 73 0006	90375505	393
40 73 0007	0352 002	50, 79
40 73 0007	90511261	416, 438
40 73 0008	0352 003	50, 79
40 73 0008	90511260	416, 438
40 73 0009	0352 135	73, 77
40 73 0009	90288387	408, 436
40 73 0010	5352 005	86
40 73 0010	90496039	441
40 73 0012	5352 016	39, 91
40 73 0012	90498735	399, 447
40 73 0013	5352 011	51, 80
40 73 0013	90542572	417, 439
40 73 0014	0352 136	73, 77
40 73 0014	90288388	408, 436
40 73 0015	0352 030	86
40 73 0015	09228477	441
40 73 0016	5352 017	38, 39, 91
40 73 0016	90498736	399, 447
40 73 0017	5352 012	51, 80
40 73 0017	90542573	417, 439
40 73 0018	5352 000	37, 46, 83, 85
40 73 0018	90495104	397, 406, 411, 415
40 73 0019	5352 001	37, 46, 83, 85
40 73 0019	90495103	397, 406, 411, 415
40 73 0021	0352 063	53
40 73 0021	13140038	419
40 73 0022	0352 061	53
40 73 0022	13140037	419
40 73 0064	0352 029	74
40 73 0064	90576788	434
40 73 0065	0352 028	74
40 73 0065	90576789	434
40 74 0001	0322 149	49
40 74 0001	26010028	432
40 74 0002	1603 206 SK	86
40 74 0002	48 36 557	226
40 74 0002	90540319 S1	441

Ref. - No.

40 74 0003	1603 453 SK	50, 51, 79, 80
40 74 0003	93192445 SK	416, 417, 438, 439
40 74 0004	1603 199 SK	86
40 74 0004	26055219 SK	441
40 74 0005	0322 158	50, 51, 79, 80
40 74 0005	26032284	416, 417, 438, 439
40 76 0001	0322 575	33, 59, 60, 61
40 76 0001	90105358	392
40 76 0002	0322 577	35, 45, 82, 84
40 76 0002	42 42 731	224, 229
40 76 0002	90373523	394, 396, 405, 412, 413
40 78 0002	1603 164	60, 62
40 78 0002	90272683	393
40 78 0003	1603 187	49, 50, 79
40 78 0003	90444294	416, 432, 438
40 78 0004	0352 826	73, 77
40 78 0004	90272194	408, 436
40 78 0005	0352 827	73, 77
40 78 0005	90272195	408, 436
40 78 0006	1603 167	34, 36, 37, 46, 83, 85
40 78 0006	90297863	395, 397, 406, 411, 415
40 78 0007	0352 800	39, 41, 65, 74, 86, 91, 93
40 78 0007	90512982	399, 401, 427, 434, 441, 447, 449
40 78 0008	0352 828	56, 57, 67
40 78 0008	94459465	423, 424
40 78 0009	0310 821	56
40 78 0009	94459453	423
40 78 0021	1603 202	51, 80
40 78 0021	90542574	417, 439
40 79 0002	0350 263	36, 37, 46, 83, 85
40 79 0002	90495045	395, 397, 406, 411, 415
40 79 0003	0350 609	73, 74, 77
40 79 0003	90445137	408, 434, 436
40 79 0004	0350 610	47, 53, 64, 81, 86
40 79 0004	52 36 823	226
40 79 0004	90496116	419, 422, 426, 440, 441



40 79 0010	0423 316	650
40 79 0010	90496686	705
40 79 0011	0423 315	645, 646, 647
40 79 0011	90334925	700, 702, 703
40 79 0012	0423 313	644, 645, 646, 647, 649
40 79 0012	90223456	699, 700, 701, 702, 703
40 79 0013	0350 602	48, 71, 75, 76
40 79 0013	90236577	435, 444
40 79 0014	0444 153	644, 645, 646, 647, 649, 650
40 79 0014	90373771	699, 700, 701, 702, 703, 705
40 79 0018	0423 121	650
40 79 0018	45 67 244	665
40 79 0018	90496700	705
40 79 0019	0350 614	39, 41, 91, 93
40 79 0019	350 176	39, 41, 91, 93
40 79 0019	13169439	399, 401, 447, 449
40 79 0019	13327928	399, 401, 447, 449
40 79 0020	0444 336	644, 645, 646, 647, 649
40 79 0020	90343305	699, 700, 701, 702, 703
40 79 0021	0444 347	644, 646
40 79 0021	90343847	699, 702
40 80 0001	0902 826	49
40 80 0001	07840451	432
40 80 0002	0902 828 S1	33, 59, 60, 61, 82, 84
40 80 0002	90345195 S1	392, 412, 413
40 80 0004	0902 828	33, 59, 60, 61, 82, 84
40 80 0004	90345195	392, 412, 413
40 80 0005	1609 073 S1	33, 45, 61, 82, 84
40 80 0005	90398968 S1	392, 405, 412, 413
40 80 0006	1609 073 SK	33, 45, 61, 82, 84
40 80 0006	90398968 SK	392, 405, 412, 413
40 91 9101	0353 281	50, 79
40 91 9101	90445100	416, 438
40 91 9102	0353 280	50, 79
40 91 9102	90445101	416, 438

40 91 9501	4705 172	29
40 91 9501	45200-75F21-000	339
40 91 9501	09208987	389
40 91 9541	0352 803	53, 81
40 91 9541	09196394	419, 440
40 91 9545	1603 845	53
40 91 9545	93192421	419
40 92 1124	0350 147	74
40 92 1124	90445625	434
40 92 2083	0352 086	64
40 92 2083	93190906	426
40 92 2084	0352 085	64
40 92 2084	93190905	426
40 92 2099	0920 355	72, 74
40 92 2099	09195731	407, 433
40 92 2379	0350 615	78, 87
40 92 2379	13 237 130	225
40 92 2379	13237130	437, 443
40 92 3001	0352 051	78, 87
40 92 3001	12 796 013	225
40 92 3001	24413015	437, 443
40 92 3002	0352 052	78, 87
40 92 3002	12 796 014	225
40 92 3002	24413016	437, 443
40 92 3003	0352 319	78, 87
40 92 3003	12 786 412	225
40 92 3003	93171448	437, 443
40 92 3129	0352 377	53, 64, 81
40 92 3129	93188302	419, 426, 440
40 92 3154	1603 430	64
40 92 3154	93192417	426
40 92 3228	1603 429 SK	64
40 92 3228	93192416 SK	426
40 92 3687	0350 608	56, 57
40 92 3687	97018227	423, 424
40 92 3688	0350 607	56, 57
40 92 3688	97018228	423, 424
40 92 3762	0352 324	41, 65, 91, 93
40 92 3762	24439582	401, 427, 447, 449
40 92 3797	5352 027	64
40 92 3797	93388568	426
40 92 3798	5352 028	64
40 92 3798	93388569	426

Ref. - No.

40 92 4221	0423 320	648, 651
40 92 4221	24 469 643	664
40 92 4221	24469643	704, 706
40 92 4262	54570-00QAA	4
40 92 4262	4500 094	69
40 92 4262	77 00 302 122	193
40 92 4262	09160394	429
40 92 4753	0444 200	650
40 92 4753	90496706	705
40 92 6125	0310 823	56, 57
40 92 6125	94374424	423, 424
40 92 6152	1603 227	78, 87
40 92 6152	93 172 254	225, 226
40 92 6152	93172254	437, 443
40 92 6153	1603 228	78, 87
40 92 6153	93 172 255	225, 226
40 92 6153	93172255	437, 443
40 92 6432	1603 415 SK	87
40 92 6432	93191671 SK	443
40 92 6635	1603 266	41, 93
40 92 6635	93181232	401, 449
40 92 6636	1603 267	41, 93
40 92 6636	93181233	401, 449
40 92 7073	5352 029	41, 65, 91, 93
40 92 7073	24454477	401, 427, 447, 449
40 92 7074	5352 030	41, 65, 91, 93
40 92 7074	22454478	401, 427, 447, 449
40 92 7097	0423 035	648, 651
40 92 7097	13 230 274	664
40 92 7097	0423 035	704, 706
40 92 7775	0444 275	648, 651
40 92 7775	13 104 120	664
40 92 7775	13104120	704, 706
40 92 7807	1603 357 SK	41
40 92 7807	93189668 SK	401
40 92 7999	0352 356 S1	37, 46, 83, 85
40 92 7999	90495046 S1	397, 406, 411
40 92 8100	0352 348 S1	36, 46, 83, 85
40 92 8100	90268463 S1	395, 406, 411
40 92 8101	0352 352 S1	36, 46, 85
40 92 8101	90373264 S1	395, 406, 411
40 92 8312	1603 428	64
40 92 8312	93192415	426

Ref. - No.

40 92 8359	1603 543	54
40 92 8359	93189022	420
40 92 8371	1603 358 SK	41, 93
40 92 8371	93189669 SK	401, 448, 449
40 92 8420	0352 087	28, 54, 55
40 92 8420	93190907	388, 420, 421
40 92 8475	0352 947	28, 54, 55
40 92 8475	13260666	388, 420, 421
40 92 8477	1603 844	53
40 92 8477	93192420	419
40 92 8648	5352 039	28, 54
40 92 8648	55703230	388, 420
40 92 8649	5352 038	28, 54
40 92 8649	55703231	388, 420
40 92 9233	1603 359 SK	41, 93
40 92 9233	93189670 SK	401, 448, 449
40 92 9238	1603 416 SK	78, 87
40 92 9238	93 191 672 SK	225
40 92 9238	93191672 SK	437
40 92 9280	0352 864	28, 54, 55
40 92 9280	13167940	388, 420, 421
40 92 9324	1603 289	41, 93
40 92 9324	93186333	401, 449
40 92 9325	1603 288	41, 93
40 92 9325	93186332	401, 449
40 93 0573	1603 644 SK	39, 91
40 93 0573	93191529 SK	399, 447
40 93 0587	1603 417 SK	78, 87
40 93 0587	93191673 SK	437, 443
40 93 0623	0350 161	41, 47, 53, 64
40 93 0623	13125492	401, 419, 422, 426
40 93 0624	0350 086	86
40 93 0624	09191649	441
40 93 0625	0423 319	648, 651
40 93 0625	24452034	704, 706
40 93 0827	0350 613	41, 93
40 93 0827	24461353	401, 449
40 93 1066	0444 160	648, 651
40 93 1066	24 457 385	664
40 93 1066	24457385	704, 706
40 93 1067	0444 161	648, 651
40 93 1067	24 457 386	664
40 93 1067	24457386	704, 706



40 93 1068	0444 162	648, 651
40 93 1068	24 457 843	664
40 93 1068	24457843	704, 706
40 93 1561	0350 618	44, 58, 94
40 93 1561	13 258 058	227
40 93 1561	13258052	404, 425, 450
40 93 2090	4707 280	29
40 93 2090	45200-84E00-000	339
40 93 3131	6606 030 SK	58
40 93 3131	13 271 996 SK	227
40 93 3131	13271996 SK	425
40 93 3776	0350 612	78, 87
40 93 3776	13116332	437, 443
40 93 4206	5352 001 S1	37, 85
40 93 4206	90495103 S1	397, 411
40 93 4207	5352 000 S1	37, 85
40 93 4207	90495104 S1	397, 411
40 93 4208	0352 193 S1	36, 85
40 93 4208	90495195 S1	395, 411
40 93 4209	0352 192 S1	36, 85
40 93 4209	90495160 S1	395, 411
40 93 4213	0423 035 S1	648, 651
40 93 4213	13 230 274 S1	664
40 93 4213	13230274 S1	704, 706
40 93 4217	0352 028 S1	74
40 93 4217	90576789 S1	434
40 93 4218	0352 029 S1	74
40 93 4218	90576788 S1	434
40 93 4221	0352 061 S1	53
40 93 4221	13140037 S1	419
40 93 4222	0352 063 S1	53
40 93 4222	13140038 S1	419
40 93 4223	5352 027 S1	64
40 93 4223	93388568 S1	426
40 93 4224	5352 028 S1	64
40 93 4224	93388569 S1	426
40 93 4226	5352 016 S1	39, 90, 91
40 93 4226	90498735 S1	399, 446, 447
40 93 4227	5352 017 S1	39, 90, 91
40 93 4227	90498736 S1	399, 446, 447
40 93 4228	0352 052 S1	78, 87
40 93 4228	12796014 S1	225
40 93 4228	24413016 S1	437, 443



40 93 4231	0352 051 S1	78, 87
40 93 4231	24 413 015 S1	225
40 93 4231	24 413 015 S1	437, 443
40 93 4232	5352 029 S1	41, 65, 90, 91, 93
40 93 4232	24454477 S1	401, 427, 446, 447, 449
40 93 4233	5352 030 S1	41, 65, 90, 91, 93
40 93 4233	24454478 S1	401, 427, 446, 447, 449
40 93 4296	0444 291	650
40 93 4296	90496711	705
40 93 4298	1603 642 SK	93
40 93 4298	93191521 SK	449
40 93 4319	1609 013	65
40 93 4319	93196780	427
40 93 4320	1609 012	65
40 93 4320	93196779	427
40 93 4940	0423 032	648, 651
40 93 4940	13204112	704, 706
40 93 4959	0350 617	44, 58, 94
40 93 4959	13 219 141	227
40 93 4959	13219141	404, 425, 450
40 93 6112	0423 032 S1	648, 651
40 93 6112	13204112 S1	704, 706
40 93 6543	0350 145	78, 87
40 93 6543	09191188	437, 442, 443
40 93 6595	0352 868	58
40 93 6595	13257785	425
40 93 7253	0350 104	53
40 93 7253	24403523	419
40 93 7854	0350 621	32, 44, 58
40 93 7854	13281782	391, 404, 425
40 93 7855	0350 622	44, 58
40 93 7855	13281784	404, 425
40 93 8051	0350 391	41, 65, 78, 87, 93
40 93 8051	13 204 071	225
40 93 8051	13204071	401, 427, 437, 443, 449
40 93 8052	0350 390	41, 65, 78, 87, 93
40 93 8052	13 204 070	225
40 93 8052	13204070	401, 427, 437, 443, 449
40 93 8273	5352 005 S1	86

Ref. - No.

40 93 8273	90496039 S1	441
40 93 8274	0352 030 S1	86
40 93 8274	09228477 S1	441
40 93 8939	0350 176	39, 41, 65, 91, 93
40 93 8939	13327928	399, 401, 427, 447, 449
40 93 9089	0444 091	644
40 93 9089	13281790	701
40 93 9351	0352 520	58
40 93 9351	13 318 886	227
40 93 9351	22792990	425
40 93 9352	0352 521	58
40 93 9352	13 318 887	227
40 93 9352	22792991	425
40 93 9362	0352 866	44, 58
40 93 9362	13219090	404, 425
40 94 0484	0444 163	651
40 94 0484	13131963	706
40 94 0487	0350 143	47, 53
40 94 0487	24406498	419, 422
40 94 0591	1K0 505 543 A	668, 669, 672, 673
40 94 0591	1K0 505 543 A	676, 677, 678, 679
40 94 0591	1K0 505 543 A	710, 713
40 94 0594	1S0 407 151	275
40 94 0594	1S0 407 151	290, 291
40 94 0594	1S0 407 151	591
40 94 0595	1S0 407 152	275
40 94 0595	1S0 407 152	290, 291
40 94 0595	1S0 407 152	591
40 94 0889	0350 231	66
40 94 0889	95942519	431
40 94 0890	0350 232	66
40 94 0890	95942520	431
40 94 0915	1609 357	58
40 94 0915	13 271 036	227
40 94 0915	13271036	425
40 94 3358	0900 905	57
40 94 3358	97184819	424
40 94 3532	4808 136	643
40 94 3532	22737680	698
40 94 3552	1609 356	39, 41, 65, 91, 93
40 94 3552	93191260	399, 401, 427, 447, 449

Ref. - No.

40 94 3577	0920 005	43
40 94 3577	13314168	403
40 94 3718	0352 491	32, 44
40 94 3718	13334021	391, 404
40 94 3719	0352 492	32, 44
40 94 3719	13334022	391, 404
40 94 3720	0352 493	32, 44
40 94 3720	13334023	391, 404
40 94 3727	1603 643 S1	41, 93
40 94 3727	93191526 S1	401, 449
40 94 3780	1603 643 S6	39, 91
40 94 3780	93191526 S6	399, 447
40 94 3792	1609 183	58
40 94 3792	13332653	425
40 94 3794	1609 181	58
40 94 3794	13332651	425
40 94 4156	1609 187	43, 47
40 94 4156	13354542	403, 409
40 94 4245	1609 185	43
40 94 4245	13354538	403
40 94 4246	1609 186	43
40 94 4246	13354540	403
40 94 4249	1609 187 S1	43
40 94 4249	13354542 S1	403
40 94 4250	1609 187 S2	43
40 94 4250	13354542 S2	403
40 94 4325	0350 093	91
40 94 4325	09223176	447
40 94 4338	0920 005 S1	43
40 94 4338	13314168 S1	403
40 94 4339	0920 005 S2	43
40 94 4339	13314168 S2	403
40 94 4340	0920 005 S3	43
40 94 4340	13314168 S3	403
40 94 4424	1609 169	43
40 94 4424	13337891	403
40 94 4428	56261-00Q0C	639
40 94 4428	4420 954	70
40 94 4428	93168675	430
40 94 4434	1609 169 S1	43
40 94 4434	13337891 S1	403
40 94 4446	0920 007	43
40 94 4446	13278358	403



40 94 4447	0920 007 S1	43
40 94 4447	13278358 S1	403
40 94 4888	1609 213	66
40 94 4888	95952929	431
40 94 5095	1609 182 SK1	43, 47, 58, 94
40 94 5095	13354440 SK1	403, 409, 425, 450
40 94 5096	1609 182	43, 47, 58, 94
40 94 5096	13354440	403, 409, 425, 450
40 94 5219	0350 233	28, 55
40 94 5219	13391512	388, 421
40 94 6226	1609 011 SK1	65
40 94 6226	93196778 SK1	427
50 71 0028	7M3 422 818	231, 233
50 71 0028	7M3 422 818	574
50 71 0029	7M3 422 817	231, 233
50 71 0029	7M3 422 817	574
50 72 0010	7M3 422 803 A	231, 233
50 72 0010	7M3 422 803 A	574
50 72 0011	7M3 422 804 A	231, 233
50 72 0011	7M3 422 804 A	574
50 72 0024	7M3 422 810	574
50 73 0023	7M0 407 152 B	231, 233
50 73 0023	7M0 407 152 B	574
50 73 0024	7M0 407 151 B	231, 233
50 73 0024	7M0 407 151 B	574
50 79 0004	7M3 411 317 E	231, 233
50 79 0004	7M3 411 317 E	574
50 91 9453	7M0 411 031	231, 233
50 91 9453	7M0 411 031	574
50 92 2408	31340273	611, 615, 619, 626, 627
50 92 3047	31277305	747
50 92 4211	30683067	747
50 92 7299	31212548	747
50 92 7897	30648461	623, 632, 634, 636
50 92 7912	31277464 SK2	611, 615, 619
50 92 8095	31277464	615, 619
50 92 8096	31277465	615, 619
50 92 8542	31201817	611, 615, 619
50 92 9223	31201413	611, 615, 619
50 92 9224	31201412	611, 615, 619
50 93 0000	30683067 S1	747
50 93 0004	31277305 S1	747

50 93 0380	31277463 SK	611, 615, 619
50 93 0830	30760678	749, 752, 754, 755
50 93 1845	31277463	611, 615, 619
50 93 1846	31277462	611, 615, 619
50 93 2163	31317661 SK	623, 632, 634
50 93 2418	31277464 SK3	611, 615, 619
50 93 4384	31280658 SK1	623, 632, 634
50 93 4583	31317661	623, 632, 634
50 93 4584	31317662	623, 632, 634
50 93 6733	31262930	749, 752, 754
50 93 6962	31317661 SK1	623, 632, 634, 636
50 93 6963	31387571	623, 632, 634, 636
50 93 6964	31387572	623, 632, 634, 636
50 93 7261	31317271 S1	750
50 93 8814	31317779	626, 627
50 93 8978	30666266	611, 615, 619
50 94 0623	31277464 S1	615, 619
50 94 0624	31277465 S4	615, 619
50 94 0625	31277463 S1	611, 615, 619
50 94 0626	31277462 S1	611, 615, 619
50 94 3406	31262930 S1	749, 752, 754
50 94 4308	30748803	611, 619
50 94 6557	7M0 511 414 B	666
55 60 0001	1359599	604, 609
55 60 0002	1329655	604, 609
55 60 0009	1359812	597, 599
55 60 0010	1273778	597, 599
55 60 0011	1205825	597, 599
55 60 0012	30818467	617
55 60 0013	6819537	609, 635
55 60 0014	9191537	609, 635
55 60 0015	271631	606, 625
55 71 0007	3516944	598, 603, 607, 635
55 71 0009	271599	605, 607, 613, 625, 635
55 71 0010	271598	605, 607, 613, 625, 635
55 71 0011	3480012	601, 602
55 71 0012	30875012	617
55 72 0013	271389	603, 607
55 72 0015	9140788	607, 635
55 72 0016	3345797	617
55 73 0002	8628495	606, 625

Ref. - No.

55 73 0003	8628496	606, 625
55 73 0004	8628497	606, 625
55 73 0005	8628498	606, 625
55 74 0008	1359347	603
55 74 0009	9140505	598
55 74 0010	9140504	603, 607, 635
55 74 0011	3546266	605, 613, 625
55 74 0012	3410369	601
55 74 0013	3342824	601, 602
55 78 0005	274117	597
55 78 0006	274118	599
55 78 0007	274119	599
55 78 0008	3211956	600
55 78 0010	270477	604, 609, 635
55 78 0011	271591	606
55 78 0012	3270523	601, 602
55 79 0001	9157725	604, 609
55 79 0002	31212730	606, 613, 625
55 79 0003	3467714	601, 602
55 79 0004	3467713	601, 602
55 79 0005	1273622	741
55 79 0009	6819057	609, 744
55 79 0010	1229165	741
55 79 0012	1330973	741, 743, 745, 754
55 79 0014	1330427	741, 743, 745, 754
55 79 0015	272991	609, 635
55 79 0016	30884358	617
55 79 0017	1206667	597, 599
55 79 0018	1206667 S1	597, 599
55 80 0001	1228425	598
55 91 8770	270597 SK	598, 605, 607, 635
55 91 8916	9157725 S1	604, 609
55 91 8917	1205991	597, 599, 604, 609
55 91 9379	31201602	621, 629, 631, 633, 637
55 91 9399	30884359	746
55 91 9664	31201603	748, 751, 753, 755
55 91 9673	30887025	617
55 91 9674	30887033	617
55 92 1414	30761719	621, 629, 631, 633
55 92 1415	30761718	621, 629, 631, 633
55 92 1453	272428	633
55 92 1563	274225	617

Ref. - No.

55 92 1564	274226	617
55 92 1565	274224	617
55 92 1566	272416	633
55 92 1567	272417	633
55 92 1603	272418	621, 629, 631, 633
55 92 2238	9443882	621, 629, 631, 633
55 92 2239	8630604	621, 629, 633
55 92 2371	3434868	742
55 92 2390	30884179	617
55 92 2528	270475 S1	603, 607
55 92 2533	3345796	617
55 92 2537	3343641	600, 601
55 92 2541	9191409	613, 625
55 92 2549	271699	607
55 92 2557	271601 SK	605, 613, 625
55 92 2558	3343642	600, 601
55 92 2561	3342893 S1	601, 602
55 92 2590	271470	603, 605
55 92 2592	271469	603, 605
55 92 2740	30887653	617
55 92 2741	30887654	617
55 92 2749	9127363	748, 751, 753
55 92 2753	9492181	748, 751, 753
55 92 2754	9173761	748, 751, 753
55 92 2755	31277899	748, 751, 753
55 92 2756	31277893	748, 751, 753
55 92 2797	9191410 SK1	613, 625
55 92 2798	9191410	613, 625
55 92 2939	1273235	604, 605, 609
55 92 2941	1273628	743, 745
55 92 2990	6819455	607
55 92 2991	6819454	607
55 92 3019	274179	621, 629, 631, 633
55 92 3031	274353	621, 629, 631, 633, 637
55 92 3131	30620785	746
55 92 3147	30620786	746
55 92 3150	1205680	597, 599
55 92 3151	1205680 S1	597, 599
55 92 3152	1205686	597, 599
55 92 3153	1205686 S1	597, 599
55 92 3173	271701	607
55 92 3343	274548	621, 629, 631, 633



55 92 3347	30635227	633
55 92 3349	30635228	633
55 92 3351	30635229	621, 629
55 92 3353	30635230	621, 629
55 92 4242	9465971	621, 629, 633
55 92 6862	30872510	617
55 92 6863	30872511	617
55 92 6867	30884359 S1	746
55 92 8614	9181013	744, 745, 746, 749
55 92 9604	31201228	637
55 92 9605	31201229	637
55 92 9617	31212191	621, 629, 631, 633
55 93 0944	3516122	744
55 93 1266	30639368	637
55 93 1267	31304040	637
55 93 1285	31201004	637
55 93 1286	31201005	637
55 93 2511	30635231	631
55 93 2512	30635232	631
55 93 3872	31280409 SK	623, 636
55 93 4160	31280408 SK	623, 636
55 93 4293	30776251	623, 632, 634, 636
55 93 4294	31280409	622, 623, 636
55 93 4371	31280658 SK2	622, 623, 632, 634
55 93 6715	31201485	621, 629, 631, 637
55 93 6825	30776255 SK	623, 632, 634
55 93 8843	31317665	636
55 93 8844	31317666	636
55 93 8865	31302344	623, 632, 634, 636
55 93 8866	31302345	623, 632, 634, 636
55 93 8912	31317665 SK	632, 636
55 93 9333	30620989 S1	617
55 93 9833	30776252	622, 623, 630, 631, 632, 634, 636
55 93 9943	31317663	632
55 93 9944	31317664	632
55 94 0500	3345797 S1	617
55 94 0501	274224 S1	617
55 94 0502	274224 S2	617
55 94 0555	274353 S1	621, 629, 631
55 94 0556	274353 S2	621, 629, 631
55 94 0557	274179 S1	621, 629, 631
55 94 0558	274179 S2	621, 629, 631

55 94 0567	3546266 S1	605, 613, 625
55 94 0568	3546266 S2	605, 613, 625
55 94 0569	9191410 S2	613, 625
55 94 0570	9191410 S3	613, 625
57 60 0001	89 65 253	230
57 60 0002	89 61 476	230
57 61 0002	89 53 986	230
57 71 0002	89 93 560	228
57 71 0003	89 93 453	230
57 72 0001	89 62 250	230
57 72 0005	0322 146 S1	35, 45, 82, 84
57 72 0005	42 42 681 S1	224, 229
57 72 0005	90373522 S1	394, 396, 405, 412, 413
57 72 0006	0322 147 S1	35, 45, 82, 84
57 72 0006	42 42 673 S1	224, 229
57 72 0006	90373521 S1	394, 396, 405, 412, 413
57 78 0001	89 93 321	228
57 78 0002	89 72 135	230
57 79 0001	89 58 944	230
57 91 9719	45 44 599	224, 229
57 91 9720	45 44 599 S1	224, 229
57 91 9849	45 43 450	224, 229
57 91 9850	45 43 468	224, 229
57 92 2761	89 88 941 SK	228
57 92 2951	52 31 683	226
57 92 8362	93 194 335	226
57 92 9985	50 63 391	226
57 93 0054	52 33 374	226
57 93 3829	93 191 674 SK	225
57 93 3841	52 37 516	226
60 60 0001	82 00 651 163	167, 197, 199
60 60 0002	77 00 799 064	174
60 60 0003	77 00 799 065	174
60 60 0004	77 00 799 066	174
60 60 0005	77 04 000 681	163, 164, 169, 206
60 60 0006	77 04 002 466	171, 179, 180
60 60 0007	77 00 781 463	171, 180
60 60 0008	77 01 349 064	212
60 60 0009	77 00 806 238	207
60 60 0010	77 00 824 042	187
60 60 0011	77 00 777 540	171, 179

Ref. - No.

60 60 0012	77 00 806 239	207
60 60 0013	77 00 822 503	172, 181, 187
60 60 0014	77 00 772 687	170
60 60 0015	77 00 754 515	170
60 60 0016	82 00 651 168	214
60 60 0017	82 00 651 164	214
60 60 0018	54560-00QAB	6, 14
60 60 0018	82 00 651 161	176, 184, 211, 215
60 61 0001	54616-00QAA	6, 14
60 61 0001	77 00 799 404	174, 176, 184, 211
60 61 0002	77 00 847 382	199
60 61 0003	-	14
60 61 0003	77 00 785 788	167, 174, 176, 184, 197, 211
60 61 0005	-	14
60 61 0005	77 00 798 053	174, 176, 206, 211
60 61 0006	-	14
60 61 0006	77 00 835 929	176, 197, 199, 211
60 61 0007	77 00 797 821	180
60 71 0002	77 01 461 141	163, 169, 179, 180, 206
60 71 0003	60 00 030 064	173
60 71 0004	60 00 030 065	173
60 71 0007	60 00 030 047	167
60 71 0008	60 00 030 048	167
60 71 0009	77 01 476 761	173, 184, 196, 198
60 71 0010	77 01 476 760	173, 184, 196, 198
60 71 0013	60 00 022 736	187
60 71 0014	60 00 022 737	187
60 71 0016	77 01 469 230	170
60 71 0017	4403 661	32
60 71 0017	77 01 461 770	212
60 71 0017	09111661	391
60 71 0018	60 00 022 730	214
60 71 0019	60 00 022 714	207
60 71 0020	60 00 022 731	214
60 71 0021	60 00 022 715	207
60 71 0022	77 01 469 231	163, 169, 171, 179, 180, 206
60 72 0002	77 01 463 346	163, 206
60 72 0003	77 01 464 015	169
60 72 0006	77 01 467 272	173
60 72 0007	77 01 467 271	173

Ref. - No.

60 72 0008	77 01 467 219	214
60 72 0009	77 01 467 218	214
60 72 0010	77 01 467 237 S1	167
60 72 0011	77 01 467 235 S1	167
60 72 0014	77 01 467 502	187
60 72 0015	77 01 467 501	187
60 73 0001	77 00 794 386	174
60 73 0002	77 00 794 387	174
60 73 0005	82 00 737 135	167, 197
60 73 0006	82 00 737 134	167, 197
60 73 0007	82 00 737 125	214
60 73 0008	77 00 413 493	187
60 73 0009	77 00 807 580	207
60 73 0010	77 00 834 916	199
60 73 0011	82 00 737 126	214
60 73 0012	77 00 413 494	187
60 73 0013	77 00 807 581	207
60 73 0014	77 00 834 917	199
60 78 0001	54501-00QAH S2	6, 14
60 78 0001	77 01 468 883 S2	163, 164, 167, 169, 174, 176, 184, 197, 206, 211, 214
60 78 0006	54501-00QAH S1	6, 14
60 78 0006	77 01 468 883	163, 164, 167, 169, 174, 176, 184, 197, 206, 211, 214
60 78 0009	77 00 421 804	187, 207
60 78 0019	77 01 464 037	170
60 78 0020	4403 641	32
60 78 0020	77 01 461 667	212
60 78 0020	09111641	391
60 78 0021	77 01 464 037 S1	170
60 79 0001	77 00 805 494	172, 181, 187, 207
60 79 0006	77 00 760 264	174
60 79 0007	77 00 760 265	163, 206
60 79 0010	77 00 667 186	212
60 91 0894	54501-00QAH	6, 14
60 91 0894	82 00 197 179	176, 184, 211
60 91 0895	54500-00QAH	6, 14
60 91 0895	82 00 197 187	176, 184, 211
60 91 9525	77 01 469 280 SK	196, 198
60 91 9604	48520-00QAP	6, 14



60 91 9604	77 01 047 813	175, 177, 184, 196, 198, 205, 211, 214, 215, 218
60 91 9605	48520-00QAN	6, 14
60 91 9605	77 01 047 812	175, 177, 184, 196, 198, 205, 211, 214, 215, 218
60 91 9646	82 00 737 133	199
60 91 9647	82 00 737 132	199
60 91 9649	82 00 714 446	214
60 91 9650	82 00 714 448	214
60 91 9866	54618-00QAA	4
60 91 9866	4418 193	69
60 91 9866	82 00 713 523	193, 194
60 91 9866	93192674	429
60 91 9867	54618-00QAB	4
60 91 9867	4418 192	69
60 91 9867	82 00 713 522	193, 194
60 91 9867	93192673	429
60 92 1015	82 00 669 065	185, 201, 209
60 92 1044	54616-00QAC	15
60 92 1044	4417 973	89
60 92 1044	82 00 661 217	182, 189, 213, 217, 660
60 92 1044	93858917	445
60 92 1169	77 01 469 617	167, 169, 170, 173, 179, 180, 206
60 92 1170	77 01 469 497	167, 169, 170, 173, 206, 214
60 92 1171	-	14
60 92 1171	77 01 469 496	175, 184, 196, 198, 211
60 92 1172	77 01 469 657	187
60 92 1283	48520-00QAK	15
60 92 1283	4408 510	89
60 92 1283	77 01 049 282	182, 189, 213, 217
60 92 1283	91160043	444
60 92 1284	48520-00QAL	15
60 92 1284	4408 511	89
60 92 1284	77 01 049 283	182, 189, 213, 217
60 92 1284	91160044	444
60 92 1493	48520-00QAH	4
60 92 1493	4501 262	69

60 92 1493	77 01 470 363	193
60 92 1493	09161562	429
60 92 1494	48520-00QAJ	4
60 92 1494	4501 263	69
60 92 1494	77 01 470 364	193
60 92 1494	09161563	429
60 92 1635	77 00 437 136	184, 199
60 92 1655	77 00 781 441	171, 180
60 92 2132	82 00 602 613	189
60 92 2133	82 00 602 612	189
60 92 2134	82 00 255 761	201
60 92 2135	82 00 255 760	201
60 92 2169	77 01 462 427	194
60 92 2233	77 01 462 692	194
60 92 2234	77 01 462 693	194
60 92 2265	40160-00Q0C	15
60 92 2265	4419 075	89
60 92 2265	77 01 478 029	182, 189, 213, 217
60 92 2265	93196923	445
60 92 2279	60 25 308 155	181
60 92 2410	77 00 430 766 S1	199
60 92 2468	40160-00QAD	4
60 92 2468	4401 909	69
60 92 2468	77 01 056 969	193
60 92 2468	09109909	429
60 92 2476	77 01 472 087 SK	196, 198
60 92 2477	77 01 469 502 SK	196, 198
60 92 2478	77 01 471 885 SK	196, 198
60 92 2479	77 01 471 844 SK	196, 198
60 92 2491	77 01 469 778 SK	173
60 92 2506	77 01 469 228	171, 179, 180
60 92 2507	77 01 465 689	171, 179, 180
60 92 2509	77 01 470 763 SK	184
60 92 2511	48521-00QAA SK	6, 14
60 92 2511	77 01 472 113 SK	175, 184, 211
60 92 2513	-	14
60 92 2513	77 01 476 762	175, 211
60 92 2514	-	14
60 92 2514	77 01 476 763	175, 211
60 92 2517	48521-00QAG SK	6, 14
60 92 2517	77 01 472 120 SK	175, 184, 211
60 92 2519	77 01 470 764 SK	184
60 92 2531	-	14



60 92 2531	77 01 471 125 SK	175, 211
60 92 2710	40160-00QAB	4
60 92 2710	4500 254	69
60 92 2710	77 00 312 851	193
60 92 2710	09160554	429
60 92 2763	-	14
60 92 2763	77 01 472 734 SK	175, 211
60 92 2765	77 01 472 766 SK	189
60 92 2818	82 00 242 025	201, 209
60 92 2819	82 00 041 166	201, 209
60 92 2821	82 00 002 868	182, 189
60 92 2822	54503-00Q0B SK3	15
60 92 2822	4418 223 SK3	89
60 92 2822	82 00 002 869	182, 189, 213
60 92 2822	93858141 SK3	445
60 92 2825	54503-00Q0B SK2	15
60 92 2825	4418 223 SK2	89
60 92 2825	82 00 049 624	213
60 92 2825	93858141 SK2	445
60 92 2865	54560-AX600	9
60 92 2865	82 00 183 569	177, 205
60 92 2866	82 00 183 570	177, 205
60 92 3181	60 25 307 649	181
60 92 3182	60 25 307 650	181
60 92 3995	82 00 255 761 S1	201
60 92 3996	40 16 047 93R	177, 191, 201, 205, 208, 209, 216
60 92 4083	82 00 679 063	201, 209
60 92 4084	82 00 679 067	201, 209
60 92 4251	82 00 744 091	177, 205
60 92 4252	82 00 744 092	177, 205
60 92 4263	54423-00QAA	4
60 92 4263	4500 095	69
60 92 4263	77 00 302 123	193
60 92 4263	09160395	429
60 92 4720	77 01 474 448 SK	201, 209
60 92 4815	77 01 474 795	201, 209
60 92 4816	77 01 474 796	201, 209
60 92 4849	31277464 SK1	615, 619
60 92 6304	60 40 002 245	191, 208
60 92 6339	54500-00QAH S1	6, 14



60 92 6339	77 00 763 538 S1	163, 164, 167, 174, 176, 184, 191, 197, 199, 206, 208, 211
60 92 6453	54501-00QAE	4
60 92 6453	4418 212	69
60 92 6453	82 00 767 822	193
60 92 6453	09109852	429
60 92 6454	54500-00QAE	4
60 92 6454	4418 213	69
60 92 6454	82 00 767 825	193
60 92 6454	09109853	429
60 92 7128	48203-00QAE	15
60 92 7128	4408 476	89
60 92 7128	77 01 473 334	213
60 92 7128	91160038	444
60 92 7179	77 00 302 116	193
60 92 7181	54450-00QAA	4
60 92 7181	4500 091	69
60 92 7181	77 00 302 115	193
60 92 7181	09160391	429
60 92 7197	77 01 472 765	189
60 92 7203	77 01 478 551	189
60 92 7222	77 01 474 447	201, 209
60 92 7301	48520-00QAM SK	15
60 92 7301	4408 474 SK	89
60 92 7301	77 01 473 333 SK	213
60 92 7301	91160037 SK	444
60 92 7303	48520-00QAM	15
60 92 7303	4408 474	89
60 92 7303	77 01 473 333	213
60 92 7303	91160037	444
60 92 7446	60 01 547 140	191, 208
60 92 7447	82 00 277 960	191, 208, 216
60 92 7453	60 25 311 529	172, 181
60 92 7725	60 01 550 441	191, 208
60 92 8281	82 00 272 594	189
60 92 8282	77 01 056 678	177, 201
60 92 8290	82 00 024 373	214
60 92 8302	77 04 001 734	171, 180
60 92 8466	77 01 475 841 SK	177, 205
60 92 9525	77 01 475 840	177, 205
60 92 9623	60 01 550 442	191, 208
60 92 9624	60 01 550 443	191, 208



60 92 9637	54 50 113 62R	191, 208
60 92 9638	54 50 042 69R	191, 208
60 92 9650	60 01 547 607	191, 208
60 92 9679	60 25 370 229	172, 181
60 92 9680	60 25 370 230	172, 181
60 92 9683	60 25 370 493	172, 181
60 92 9684	60 25 370 494	172, 181
60 92 9834	54 61 800 01R	190
60 92 9946	82 00 272 596	189
60 92 9947	77 01 056 095	201
60 92 9948	82 00 040 642	214
60 93 0653	40160-00Q0A	15
60 93 0653	4431 869	89
60 93 0653	77 01 477 385	213
60 93 0653	93161884	445
60 93 1007	77 00 784 170	167, 197, 199
60 93 1008	77 00 784 171	197, 199
60 93 1009	82 00 150 759	197, 199
60 93 1010	77 00 314 855	184
60 93 1507	77 01 478 552 SK	182, 217
60 93 1847	40110-00QAB	4
60 93 2020	48 52 100 01R SK	190
60 93 2128	48521-00Q0B SK	4
60 93 2128	4501 261 SK	69
60 93 2128	77 01 470 362 SK	193
60 93 2128	09161561 SK	429
60 93 2699	82 00 669 066	201, 209
60 93 2874	77 01 473 498 SK	214
60 93 3085	54 56 000 05R	183, 203, 204, 210
60 93 3086	54 56 000 04R	183, 203, 204, 210
60 93 3087	54 56 016 84R	203, 210
60 93 3105	82 00 197 179 S1	184
60 93 3106	82 00 197 187 S1	184
60 93 3517	77 01 469 517 SK	214
60 93 4164	40160-00Q0B	4
60 93 4164	77 01 070 154	193
60 93 4247	77 01 471 124 SK	175
60 93 4308	77 01 468 820	165, 166, 168
60 93 4309	77 01 468 821	165, 166, 168
60 93 4332	60 01 550 442 S1	191, 208
60 93 4333	60 01 550 446 S1	191, 208
60 93 4525	82 00 942 396 S1	215
60 93 4709	82 00 554 863	215

60 93 4710	82 00 891 487	215
60 93 6094	77 01 478 408	185
60 93 6095	77 01 478 407	185
60 93 6121	82 00 586 564	185
60 93 6122	82 00 586 570	185
60 93 6125	40 16 000 04R	190
60 93 6345	54503-00Q0E	15
60 93 6345	4421 647	89
60 93 6345	82 00 876 659	213
60 93 6345	93862136	445
60 93 6346	54502-00Q0E	15
60 93 6346	4421 646	89
60 93 6346	82 00 876 657	213
60 93 6346	93862135	445
60 93 6395	82 00 839 119	661
60 93 6396	82 00 839 124	661
60 93 6435	82 00 841 004	661
60 93 6436	55 11 078 94R	661
60 93 6583	54501-00Q0E	4
60 93 6583	4418 629	69
60 93 6583	82 00 750 273	193
60 93 6583	93194853	429
60 93 6584	54500-00Q0E	4
60 93 6584	4418 630	69
60 93 6584	82 00 750 274	193
60 93 6584	93194855	429
60 93 7067	54 50 140 55R	183, 203, 204, 210
60 93 7068	54 50 092 07R	183, 203, 204, 210
60 93 7160	77 01 477 878 SK	215
60 93 7305	82 00 814 411	178, 661
60 93 7309	4419 291	70
60 93 7309	54 61 800 04R	195
60 93 7309	93197325	430
60 93 7312	4419 304 S1	645
60 93 7312	55 11 000 19R S1	662
60 93 7312	93197332 S1	702
60 93 7617	77 01 474 795 S1	201, 209
60 93 7618	77 01 474 796 S1	201, 209
60 93 7621	60 01 550 442 S2	191, 208
60 93 7622	60 01 550 443 S2	191, 208
60 93 7623	77 01 472 766 S1	189
60 93 7624	77 01 472 766 S2	189
60 93 7625	48520-00QAH S1	4



60 93 7625	4501 261 S1	69
60 93 7625	77 01 470 363 S1	193
60 93 7625	09161561 S1	429, 444
60 93 7626	48520-00QAJ S1	4
60 93 7626	4501 261 S2	69
60 93 7626	77 01 470 364 S1	193
60 93 7626	09161561 S2	429, 444
60 93 7627	48520-00QAM S1	15
60 93 7627	4408 474 S1	69
60 93 7627	77 01 473 333 S1	213
60 93 7627	91160037 S1	429
60 93 7628	48520-00QAM S2	15
60 93 7628	4408 474 S2	69
60 93 7628	77 01 473 333 S2	213
60 93 7628	91160037 S2	429
60 93 7629	77 01 473 498 S1	214
60 93 7630	77 01 473 498 S2	214
60 93 7631	77 01 475 841 S1	177, 205
60 93 7632	77 01 475 841 S2	177, 205
60 93 7633	77 01 478 552 S1	182, 217
60 93 7634	77 01 478 552 S2	182, 217
60 93 7675	54 56 027 88R	178
60 93 7726	54 61 142 37R	178
60 93 8723	48 52 000 01R	190
60 93 8724	48 52 000 02R	190
60 93 8822	54 61 800 02R	203, 210
60 93 9023	82 00 586 561 S1	185
60 93 9024	82 00 586 567 S1	185
60 93 9039	48 52 027 10R	183, 203, 204, 210
60 93 9040	48 52 046 80R	183, 203, 204, 210
60 93 9325	77 01 469 665 SK	187
60 93 9444	48521-00Q0E SK	11
60 93 9444	4420 096 SK	70
60 93 9444	48 52 123 73R SK	195
60 93 9444	93167687 SK	430
60 93 9493	40 16 090 60R	183, 203, 210
60 93 9603	54503-00Q0B	15
60 93 9603	4418 223	89
60 93 9603	82 00 565 072	213
60 93 9603	93858141	445
60 93 9604	54502-00Q0B	15
60 93 9604	4418 224	89
60 93 9604	82 00 565 079	213



60 93 9604	93858142	445
60 93 9629	77 01 059 966	209
60 93 9646	77 01 059 672	177, 205, 209
60 93 9690	48 52 156 12R SK	183, 185, 203, 204, 210
60 93 9820	77 00 430 766 S2	199
60 93 9822	48 52 046 80R S1	183, 203, 204, 210
60 93 9823	48 52 027 10R S1	183, 203, 204, 210
60 93 9863	77 01 478 407 S1	185
60 93 9864	77 01 478 408 S1	185
60 94 0144	54 61 200 05R	203
60 94 0253	60 01 550 446 S2	191, 208
60 94 0254	60 01 550 447 S2	191, 208
60 94 0655	82 00 744 091 S1	177, 205
60 94 0656	82 00 744 092 S1	177, 205
60 94 0875	77 00 847 383	176, 199
60 94 2634	4419 219	70
60 94 2634	93197233	430
60 94 3463	77 01 471 143 SK	175
60 94 3617	48520-00Q0F	11
60 94 3617	4420 097	70
60 94 3617	48 52 067 30R	195
60 94 3617	93167688	430
60 94 3618	48520-00Q0E	11
60 94 3618	4420 098	70
60 94 3618	48 52 007 80R	195
60 94 3618	93167689	430
60 94 3630	48 52 110 71R SK	178, 218
60 94 3687	48520-00Q0F S1	11
60 94 3687	4420 097 S1	70
60 94 3687	48 52 067 30R S1	195
60 94 3687	93167688 S1	430
60 94 3688	48520-00Q0E S1	11
60 94 3688	4420 098 S1	70
60 94 3688	48 52 007 80R S1	195
60 94 3688	93167689 S1	430
60 94 4483	54 61 200 07R	203, 210
60 94 4539	4419 308	645
60 94 4539	54 61 354 90R	662
60 94 4539	93197335	702
60 94 4728	4419 323	70
60 94 4728	93197327	430
62 60 0002	3523.40	121, 122



62 60 0003	3523.51	96
62 60 0004	3523.20	99
62 60 0005	3523.61	123
62 60 0006	3523.60	123
62 60 0007	3523.50	96
62 60 0008	3523.23	99
62 60 0009	3523.31	99, 120
62 60 0010	3523.43	131, 132
62 60 0011	3523.75	113, 148, 149
62 60 0012	3523.89	121, 122
62 61 0001	5094.64	113
62 61 0002	5094.63	113
62 61 0003	3523.49	99
62 61 0004	5087.61	113, 148, 149, 151, 153
62 61 0005	5087.32	99, 120
62 61 0006	5094.65	113, 148, 149, 151, 153
62 69 0001	3523.52	96
62 71 0001	3817.50	98, 111, 114, 119, 126, 127, 130, 148, 149, 151, 153
62 71 0002	3817.42	95, 101, 103, 105, 106, 114, 131
62 71 0003	3817.41	95, 101, 103, 105, 106, 114, 131
62 71 0004	3817.48	121, 122
62 71 0005	3817.49	121, 122
62 71 0006	3817.39	123
62 71 0007	3817.40	123
62 71 0010	3817.11	147
62 71 0011	3817.43	131, 132
62 71 0013	3817.44	131, 132
62 72 0027	3812.92 S1	111
62 72 0028	3812.C5	101, 103, 105, 106
62 72 0029	3812.27	147
62 72 0030	3812.C0	148, 149, 153
62 73 0001	3520.51	99
62 73 0002	3521.34	99
62 73 0003	3520.79	96
62 73 0004	3520.78	96
62 73 0010	3521.E1	123
62 73 0019	3520.K4	121, 122

62 73 0021	3520.H1	123
62 73 0022	3521.G4	121, 122
62 73 0024	3521.C8	101, 103
62 73 0025	3520.G8	101, 103
62 73 0026	3520.H5	113, 148, 149, 153
62 73 0027	3521.E5	113, 148, 149, 153
62 73 0028	3520.54	99
62 73 0029	3521.37	99
62 73 0030	3523.76	101, 103, 105, 106
62 73 0031	3523.92	101, 103, 105, 106, 115, 117, 137, 141, 154, 155
62 73 0032	3520.V3	151, 153
62 73 0033	3521.R4	151, 153
62 74 0002	3812.98	121, 122
62 74 0004	3812.99	131
62 74 0007	3812.95	98, 119
62 74 0011	3812.A9	123
62 76 0003	5087.49	131
62 77 0008	3812.92	111
62 78 0001	3640.17	147
62 78 0005	3640.36	96
62 78 0006	3640.21	121, 122
62 78 0008	3640.37	113
62 78 0009	3640.71	121, 122, 123, 131, 132
62 78 0010	3640.27	126, 127, 130
62 78 0016	3640.51	148, 149, 153
62 78 0017	3640.42	148, 149
62 79 0001	5087.33	96
62 79 0003	5087.40	96, 123
62 79 0004	5178.38	652
62 79 0008	3640.41	652
62 79 0009	3332.07	654
62 79 0010	5131.54	654
62 79 0011	5131.56	654
62 79 0012	5131.55	654
62 79 0015	5131.80	652
62 79 0016	5131.53	654
62 79 0018	5131.99	652
62 79 0019	5131.78	652
62 79 0020	5087.42	113



62 79 0021	5087.74	101, 103, 105, 106, 135
62 80 0001	4066.20	98, 111, 119, 126, 149, 151, 153
62 80 0002	4066.22	98, 111, 119, 149, 151
62 80 0003	4066.43	111, 148, 151, 153
62 80 0004	4066.30	122, 123, 131
62 80 0005	4066.41	133, 145
62 91 8343	3640.35	652
62 91 8985	5178.39	652
62 91 9009	3520.H5 S1	113, 148, 149
62 91 9067	5178.43	654
62 91 9071	5178.44	654
62 91 9225	5087.60	123, 132
62 91 9383	3812.C4	123
62 91 9397	5087.78	115, 117, 137, 141, 154, 155
62 91 9403	5087.51	134
62 91 9468	3640.48	113
62 91 9731	3520.92	96
62 91 9733	3520.93	96
62 91 9831	3520.60	120
62 91 9833	3521.41	120
62 91 9917	4066.32	95
62 91 9919	4066.37	121, 122
62 91 9921	4066.42	122, 123, 131
62 91 9935	3812.E0	114
62 91 9939	3812.C7	132
62 92 1250	5094.59	96
62 92 1490	3640.73	115, 117, 137, 141, 154, 155
62 92 1611	3523.94	143
62 92 1613	3523.93	143
62 92 1814	5094.81	101
62 92 1816	5094.80	101
62 92 1818	5094.77	113, 148, 149, 151, 153
62 92 1820	5094.66	113
62 92 1821	5094.74	123
62 92 1822	5094.75	123
62 92 1823	5172.47	654



62 92 1850	3523.91	115, 117, 137, 141, 154
62 92 1914	5094.56	96
62 92 1915	5094.57	96
62 92 1934	3523.53	96
62 92 2100	3520.G9 S1	133, 145
62 92 2101	3521.C9 S1	133, 145
62 92 2102	3520.G9 S2	133, 145
62 92 2115	3812.A6	131
62 92 2384	3521.P3	115, 154
62 92 2385	3520.S2	115, 154
62 92 2714	5094.87	115
62 92 2715	5094.E0	115
62 92 2846	5087.52	125, 129
62 92 2847	5087.53	125, 129
62 92 3323	3817.58	125
62 92 3325	3817.57	125
62 92 3405	3523.83	151
62 92 6645	3520.P6	134
62 92 6646	3521.K6	134
62 92 6931	5175.CF	653
62 92 6932	3523.CA	125
62 92 6933	3523.AZ	125, 129
62 92 7014	5178.47	653
62 92 7015	3523.AQ	125, 129
62 92 7424	3812.E7	125
62 92 7427	3812.E2	134
62 92 7428	3812.E8	107
62 92 7432	3812.C6	151, 153
62 92 7434	5087.69	107, 109, 110
62 92 7435	5087.68	107, 109, 110
62 92 7438	5091.10 S1	97
62 92 7438	48819-70010 S1	345
62 92 7489	98 071 300 80	653
62 92 8125	3520.H5 S2	113, 148, 149
62 92 8318	3817.63	97
62 92 8318	45047-09125	345
62 92 8319	3817.64	97
62 92 8319	45046-09295	345
62 92 8355	3640.69	125, 129
62 92 8356	3640.74	125, 129
62 92 8580	3817.65	125
62 92 8581	3817.66	125



62 92 8599	3640.62	107, 109
62 92 8600	3640.66	135
62 92 8601	5087.56	146
62 92 8710	3817.67	107, 109
62 92 8711	3817.68	107, 109
62 92 8731	3520.R7 S1	107, 109
62 92 8732	3520.R7 S2	107, 109
62 92 9142	3520.R7	107, 109
62 92 9143	3521.N8	107, 109
62 92 9207	4066.73	101, 103, 105, 106, 114
62 92 9385	3640.76	144
62 92 9422	3520.W0	101, 103, 105, 106
62 92 9423	3521.S1	101, 103, 105, 106
62 92 9424	3520.V6	101, 103, 105
62 92 9425	3521.R7	101, 103, 105
62 92 9426	3520.V7	101, 103, 105
62 92 9427	3521.R9	101, 103, 105
62 92 9625	3812.E5	114
62 93 0876	3817.47	95
62 93 1297	3520.S0	144
62 93 1298	3521.P1	144
62 93 1811	3640.51 S1	148, 149, 153
62 93 1812	3640.42 S1	148, 149
62 93 1813	3640.37 S1	113
62 93 1814	3640.48 S1	113
62 93 1970	3812.F2	117, 137, 141
62 93 1971	3817.89	117, 137, 141, 154
62 93 1972	3817.88	117, 137, 141, 154
62 93 2116	3520.N6 SK	125, 129
62 93 2192	3817.70	144
62 93 2193	3817.77	144
62 93 2194	5087.79	142
62 93 3964	5094.A1	125, 129
62 93 3965	5094.99	125
62 93 4801	5094.82	101, 103, 105, 106
62 93 4804	5094.95	101, 103, 105, 106
62 93 6285	3523.AP	143
62 93 6286	16 099 106 80	138, 139
62 93 6440	98 049 474 80	137, 141, 154, 155
62 93 6654	4066.83	134, 146
62 93 6669	3812.F0	134, 146
62 93 6691	3812.F7	155

62 93 6840	4001.E4 S1	144
62 93 6841	4001.77 S1	142
62 93 6850	4001.33 S1	97
62 93 6850	45500-0H010 S1	345
62 93 6880	3523.96	131
62 93 6883	5170.F5 S1	656
62 93 6889	5081.N9 S1	144
62 93 6901	3521.J6	124, 125, 129
62 93 6902	3520.N6	124, 125, 129
62 93 7095	3523.CW	155
62 93 7199	5094.A8	97
62 93 7199	48815-0H010	345
62 93 7201	5094.C1	107
62 93 7202	5094.A0	125, 129
62 93 7336	5094.C2	107
62 93 7349	16 075 107 80	134
62 93 7350	16 075 106 80	134
62 93 7689	3521.S0	134, 146
62 93 7690	3520.V8	134, 146
62 93 7765	5094.65 S1	113, 151, 153
62 93 7839	3521.R3	117, 137, 141
62 93 7840	3520.V2	117, 137, 141
62 93 7860	3817.73	117, 134, 146, 155
62 93 8025	3640.77 S1	109, 110
62 93 8170	3520.X9	138, 139
62 93 8171	3521.V0	138, 139
62 93 8490	3640.69 S1	125, 129
62 93 8560	3812.F8	117
62 93 8735	14 401 772 80	146
62 93 8738	4066.74	132
62 93 8740	4066.80	107, 110
62 93 8899	3812.E1 S1	135
62 93 8900	3812.E1 S2	135
62 93 8905	4066.44	111, 148
62 93 8907	4066.69	135
62 93 8918	4066.79	134
62 93 8921	4066.84	138
62 93 8930	4066.56 S1	101, 103, 105
62 93 8980	3812.A4 S1	133, 145
62 93 8997	3812.C5 S1	101, 103, 105, 106
62 93 8998	3812.C5 S2	101, 103, 105, 106
62 93 8999	3812.C7 S1	132
62 93 9000	3812.C7 S2	132

Ref. - No.

62 93 9029	3812.F0 S1	134, 146
62 93 9031	3812.C5 S3	101, 103, 105
62 93 9032	3812.C5 S4	101, 103, 105
62 93 9033	3812.E8 S1	107
62 93 9034	3812.E8 S2	107
62 93 9041	3812.E0 S4	114
62 93 9042	3812.E0 S5	114
62 93 9043	3812.E5 S3	114
62 93 9166	5094.C6	138, 139
62 93 9181	5172.58	655
62 93 9198	4066.43 S1	111, 148, 151, 153
62 93 9227	16 109 762 80	144
62 93 9237	4066.95	142
62 93 9238	4066.A3	97
62 93 9238	45535-09180	345
62 93 9290	4001.77 S2	142
62 93 9291	4001.77 S3	142
62 93 9292	3812.C0 S1	148
62 93 9293	3812.C0 S2	148
62 93 9294	3812.C6 S2	151, 153
62 93 9295	3812.C6 S1	151, 153
62 93 9296	4001.69 S1	138
62 93 9375	3523.AS	101, 103, 105
62 93 9562	4066.71	125
62 93 9579	4066.72	125
62 93 9590	4001.33 S2	97
62 93 9590	45500-0H010 S2	345
62 93 9591	4001.33 S3	97
62 93 9591	45500-0H010 S3	345
62 93 9681	5094.C5	107
62 93 9682	5094.E2	117, 155
62 93 9683	5094.F2	117
62 93 9684	4059.12	134, 145
62 93 9685	5094.E6	154
62 93 9686	3523.80	101, 103, 105, 141
62 94 0004	3817.36 S1	95
62 94 0005	3817.33	95
62 94 0070	16 080 253 80	109, 136
62 94 0080	3812.E6	135
62 94 0082	5094.98	125, 129
62 94 0173	5094.C3	107
62 94 0187	5094.E3	115, 117, 137, 141, 154, 155

Ref. - No.

62 94 0485	3812.G3 SK	129
62 94 0490	5094.C8	142
62 94 0493	3812.F3	129
62 94 0610	3812.E4	152, 153
62 94 0729	5087.76	129
62 94 0750	3521.C8 S1	101, 103
62 94 0751	3520.G8 S1	101, 103
62 94 0770	3521.R9 S1	101, 103, 105
62 94 0771	3520.V7 S1	101, 103, 105
62 94 0780	3521.R7 S1	101, 103, 105
62 94 0781	3520.V6 S1	101, 103, 105
62 94 0790	3521.S1 S1	101, 103, 105, 106
62 94 0791	3520.W0 S1	101, 103, 105, 106
62 94 0840	3521.P3 S1	115, 154
62 94 0841	3520.S2 S1	115, 154
62 94 3547	16 099 483 80	129
62 94 3548	16 099 482 80	129
62 94 3580	3520.Y0 SK	129
62 94 3600	3520.Y0	129
62 94 3601	3521.V1	129
62 94 3770	5087.71	109
62 94 4180	3640.83	129
62 94 4185	16 080 252 80	109, 136
62 94 4186	16 080 251 80	109, 136
62 94 4190	98 056 074 80	141
62 94 4191	98 056 073 80	141
62 94 4400	3656.04 S1	124, 125, 128, 129
62 94 4480	3656.04 S2	125, 129
62 94 4720	98 069 071 80	118
62 94 4721	5178.57	653, 655
62 94 4797	4066.82	117, 137, 141, 154, 155
62 94 4923	3812.F2 S1	117, 137, 141
62 94 4934	3812.F4 S2	154
64 91 9927	3812.E1	135
64 92 1491	3817.55	135
64 92 1492	3817.56	135
64 92 2635	3523.98	135
64 92 2636	3523.AA	135
64 93 8700	3520.V1 S2	135
64 93 8701	3521.R2 S2	135
64 94 2779	5094.E7	137, 154
64 94 2780	5094.E4	154



64 94 4620	3521.R2 S3	135
64 94 4621	3520.V1 S3	135
66 91 8105	48830-20010	688, 689, 690, 691
70 60 0002	3561.08	147
70 61 0002	5087.35 S1	133, 145
70 61 0003	5087.37 S1	143
70 61 0006	5093.15	133, 143, 145
70 61 0008	5087.35	133, 145
70 61 0009	5087.37	143
70 61 0011	5094.69	133, 145
70 71 0001	4059.09	133, 145
70 71 0005	SE141162410A	274
70 71 0028	4018.A3	143
70 72 0004	4018.A4	143
70 72 0006	SE141162449A	274
70 72 0009	4006.24 S1	143
70 73 0042	3520.N3	143
70 73 0043	3520.P4	133, 145
70 73 0044	3520.76	147
70 73 0053	3521.J3	143
70 73 0054	3521.52	147
70 73 0055	3521.K4	133, 145
70 73 0057	3521.53	147
70 73 0057	3520.77	147
70 73 0063	SE028156110A	274
70 74 0001	3812.A4	133, 145
70 78 0012	3640.26	147
70 92 2267	3640.55	143
70 92 2269	3640.54	143
70 92 7414	0350 175	54
70 92 7414	13321280	420
70 92 8351	4018.E0	143
70 92 8618	1603 544	54
70 92 8618	93189023	420
70 92 8619	1603 545	54
70 92 8619	93189024	420
70 92 9144	3520.Y4	142
70 92 9145	3521.V5	142
70 93 1091	3520.S0 S2	144
70 93 1092	3520.S0 S1	144
70 93 2767	3817.86	142
70 93 2768	3817.87	142
70 93 3811	0350 198	48

70 93 3811	95511247	423
70 93 6977	5094.E5	142
70 93 8586	0350 181	28, 54
70 93 8586	13343139	388, 420
80 92 8200	30863990	617
80 92 9377	30818096 S1	746
80 93 0398	5178.48	655
80 93 0399	5178.49	655
80 93 0401	5087.58	138, 139
80 93 2551	4001.69 S1	138
80 93 3609	454 333 01 27	321
80 93 3610	454 330 07 07	321
80 93 3611	454 330 08 07	321
80 93 4477	3817.74	138
80 94 1337	16 075 024 80	139
81 71 0002	45046-29305	346, 350, 352, 353, 354, 355, 356, 360, 362, 371, 372, 375, 378, 383, 385, 387
81 72 0001	45503-19205	355
81 72 0002	45503-19075	379
81 73 0001	48068-12140	355
81 73 0002	48069-12140	355
81 76 0001	48820-20030	350
81 76 0002	48810-20010	350
81 76 0003	48820-33010	341, 346, 353, 355, 356, 371
81 76 0004	48820-20040	351, 359, 368
81 76 0005	48810-20020	351, 359, 368
81 76 0006	48820-20010	352, 354
81 76 0007	48820-05012	343
81 76 0008	48810-05012	343
81 78 0001	43330-29315	343, 351, 353, 368
81 78 0002	43330-19075	379
81 91 9991	48068-42022	371
81 91 9993	48069-42022	371
81 92 2911	3520.Q2 S1	97
81 92 2911	48068-59035 S1	345, 387
81 92 2913	45503-05010	351
81 92 2915	45503-05050	343, 359
81 92 2945	48068-12191 S2	356
81 92 2947	48068-12191	355, 356
81 92 2949	48069-12191	355, 356



81 92 2965	48068-33020	341, 346
81 92 2967	48069-33020	341, 346
81 92 2969	48068-33030	341, 347
81 92 2971	48069-33031	341, 347
81 92 2993	48820-32010	353, 357
81 92 3023	45503-19215	355, 356, 371
81 92 3107	43340-19025	368, 379, 383
81 92 3109	43330-19085	368, 379, 383
81 92 3111	43330-09090	356, 357
81 92 3175	48820-20021	352, 355
81 92 3234	48820-42010	371
81 92 3243	43330-19115	353, 355, 356, 357, 358, 370, 372, 378, 386
81 92 3244	43340-19016	354
81 92 3245	43330-19066	354
81 92 3246	43330-29515	361, 362, 363
81 92 3247	43350-39075	363, 384
81 92 3281	48068-59035 S3	387
81 92 3282	48068-59035 S2	387
81 92 3575	48810-33010	347
81 92 3577	48820-33020	347
81 92 3579	48830-33010	686, 688, 696
81 92 3583	45503-39135	346, 347, 348
81 92 3585	45046-29255	341, 342, 346, 347, 349
81 92 3589	43330-39435	341, 346, 347, 349, 376, 377
81 92 3603	45047-09030	343, 351
81 92 3605	45046-29365	343, 351
81 92 3629	45047-19115	357, 358, 386, 387
81 92 3630	45046-19265	357, 358, 386, 387
81 92 3635	48820-47010	344, 357, 358, 370, 375
81 92 3636	48820-28050	348, 364
81 92 3641	45047-59026	362, 385, 387
81 92 3643	45046-59026	362, 385, 387
81 92 3645	45503-59045	387
81 92 4292	48069-12191 S1	355, 356
81 92 4312	48068-12191 S1	355, 356
81 92 4339	48068-05050	343
81 92 4340	48069-05050	343
81 92 6085	48820-42020	372



81 92 6465	48655-07010	341, 346
81 92 6520	48830-48010	688, 692, 693
81 92 6597	48068-12260	357, 358
81 92 6598	48069-12260	357, 358
81 92 6736	48810-60010	365
81 92 6737	48820-60010	365
81 92 6919	48810-28020	369, 382
81 92 6920	48820-28030	369, 382
81 92 7260	45406-39185	363, 384
81 92 7262	48819-52010 S1	362, 375, 385, 387
81 92 7286	48830-05020	687
81 92 7287	48830-60030	692, 694, 697
81 92 7331	48840-21010	687, 696
81 92 7332	48830-21020	687, 696
81 92 7335	48820-60050	366, 384
81 92 7336	48810-60040	366, 384
81 92 7337	48650-20021	343
81 92 7338	48820-44020	343, 344
81 92 7339	45503-49105	343
81 92 7511	45047-69085	365, 366
81 92 7512	45046-69135	365, 366
81 92 7805	45503-19255	357, 358
81 92 7808	45503-29295	369, 382
81 92 7809	45503-19145	367
81 92 7810	45503-29765	369, 382
81 92 7812	45503-49055	372
81 92 8059	48830-32040	692
81 92 8090	48820-0D010	387
81 92 8091	45503-69015	366
81 92 8092	45503-39075	365, 381, 384
81 92 8109	48069-20260	351
81 92 8110	48068-20260	351
81 92 8237	48069-12110	354
81 92 8238	48068-12110	354
81 92 8448	48830-17070	695
81 92 8449	48068-59035 S4	387
81 92 8513	48820-42030	340, 341, 357, 369, 373, 374, 375, 382
81 92 8591	48820-AD010	365, 381, 383, 384
81 92 8592	48820-06040	342, 348, 377
81 92 8628	48840-42010	695
81 92 8629	48830-42010	695
81 92 8644	48830-35020 S1	694, 697



81 92 8699	43330-49025 S1	371, 372
81 92 8700	43340-09010 S1	348, 349, 376, 377
81 92 8701	43330-09560 S1	348, 349, 376, 377
81 92 8704	43330-09210 S1	344
81 92 9185	48068-12191 S3	356
81 92 9186	45046-29425	344
81 92 9187	48069-20260 S1	351
81 92 9352	45503-39225	348, 377
81 92 9361	45503-39265	366, 384
81 92 9671	48068-20260 S2	351
81 92 9672	45503-29255	362
81 92 9691	45046-09230	344
81 92 9692	45503-29615	351, 359, 368
81 92 9763	45460-39615	348
81 92 9764	45470-39215	348
81 92 9953	48820-17050 S1	367
81 93 0034	3520.Q2 S2	97
81 93 0034	48069-0H010 S2	345
81 93 0035	3520.Q2 S3	97
81 93 0035	48069-0H010 S3	345
81 93 0036	3520.Q2 S4	97
81 93 0036	48069-0H010 S4	345
81 93 0225	45470-39225	348, 349, 377
81 93 0226	45460-39635	348, 349, 377
81 93 0231	45047-49025	367, 372, 375, 386
81 93 0232	45046-49095	367, 372, 375, 386
81 93 0865	48830-12050	691
81 93 1106	48061-05010	343, 359
81 93 1557	48830-05030	686, 687
81 93 1558	48830-0R010	695
81 93 1713	48820-0R010	373
81 93 1714	48820-02070	341, 344, 357
81 93 1715	48820-24010	353, 380
81 93 1717	48820-17040	367
81 93 1718	3520.Q2	97
81 93 1718	48069-0H010	345
81 93 1719	3521.L3	97
81 93 1719	48068-0H010	345
81 93 1747	45503-0D030	387
81 93 1750	45503-47030	370
81 93 1751	45503-29565	363
81 93 3190	45503-29575	363
81 93 3447	45503-17040	367

81 93 4310	45047-19215	341, 357, 374
81 93 4311	45046-19415	341, 357, 374
81 93 4616	45503-59055	385, 387
81 93 4618	45503-69025	366
81 93 4661	48802-60060	693
81 93 4662	48802-60090 S1	693, 694
81 93 4664	48820-22041	360
81 93 4665	48820-35010	364, 384
81 93 4713	45503-0F010	344, 358, 359
82 71 0008	48520-73J25	2, 16, 17, 18, 19, 20, 21, 26
82 71 0012	48520-7F000	5, 23, 24
82 71 0025	48520-17B25	8
82 71 0026	48520-6F625	8
82 72 0001	48521-70A06	8
82 72 0002	48521-50Y00	17, 21
82 73 0001	54500-21B00	8
82 73 0002	54501-21B00	8
82 73 0003	54500-86J00	16
82 73 0004	54501-86J00	16
82 73 0005	54524-2F010	16, 18
82 73 0006	54525-2F010	16, 18
82 73 0007	54500-2F500	18
82 73 0008	54501-2F500	18
82 73 0009	54500-4F105	8
82 73 0010	54501-4F105	8
82 73 0011	54500-52Y70	1, 21
82 73 0012	54501-52Y70	1, 21
82 73 0013	54500-0M060	2
82 73 0014	54476-01B00	8
82 73 0015	54535-01B00	8
82 78 0011	40160-93G25	5, 23
82 79 0001	54618-50Y00	2, 16, 17, 21
82 79 0002	56260-01J10	13, 640
82 79 0004	56261-86J25	640
82 91 5425	56261-4F725	638
82 91 7203	54501-0M060	2
82 92 1808	54618-4M400	2
82 92 1810	54618-AX600	9
82 92 1810	82 01 079 463	177, 178, 205, 218
82 92 1811	54668-2Y000	7
82 92 1812	54618-2Y000	7
82 92 1813	54668-AU000	19

Ref. - No.

82 92 1815	54618-AU000	19
82 92 2747	54501-BC42A	9
82 92 2750	54500-AX600	9
82 92 2867	54570-AX600	9
82 92 3171	54618-0F000	24
82 92 3515	54618-9C002	20, 26
82 92 3516	54668-9C000	20, 26
82 92 3724	54618-86J25	16, 18
82 92 4016	56260-0F001	642
82 92 4417	54525-AV601	19
82 92 4418	54524-AV601	19
82 92 6277	54501-4M410	2
82 92 6278	54500-4M410	2
82 92 6536	48520-0P725	26
82 92 7305	56261-EQ000	642
82 92 7359	54668-8H300	26
82 92 7360	54618-8H300	26
82 92 7462	56260-VB010	640
82 92 7463	54668-4U000	3
82 92 7464	54618-4U000	3
82 93 0527	48640-AX600	9
82 93 0528	48520-AX600	9
82 93 0529	48647-1U61A	9, 11
82 93 0530	48527-1U61A	9
82 93 0985	54668-JD00A	10, 20, 22, 27
82 93 0985	54 66 8JD 00A	186
82 93 0986	54618-JD00A	10, 20, 22, 27
82 93 0986	54 61 8JD 00A	186
82 93 1139	56260-0W001	639
82 93 1166	54618-0E000	7
82 93 2023	48520-BM425	2
82 93 2567	56261-AV611	640
82 93 2573	55618-JD00A	641, 642
82 93 2573	55 61 8JY 00B	660
82 93 2574	55619-JD00A	641, 642
82 93 2574	55 61 9JY 00B	660
82 93 2888	54618-0W001	12
82 93 3452	48521-8H386	26
82 93 3453	48521-EA000	10, 12
82 93 4067	54613-JD04A	20
82 93 4068	54613-JD17A	20
82 93 4120	54668-EA010	10, 12
82 93 4121	54618-EA010	10, 12

Ref. - No.

82 93 4561	56261-1AA0B	638, 641
82 93 4562	56261-1AA0A	638, 641
82 93 4614	D8521-JD00B	20, 27
82 93 4614	D8 52 1JG 00A	186
82 93 4666	54500-JD000 S1	20
82 93 4666	54 50 0JY 00A S1	186
82 93 4714	54668-CA010	638, 641
82 93 4715	54618-CA010	638, 641
82 93 4716	56261-EA510	640
82 93 4717	56261-EA500	640
82 93 4720	48521-0W025	12
82 93 4755	48527-JD01A	20
82 93 4755	D8 52 0JY 00A	186
82 93 4756	48647-JD01A	20
82 93 4756	D8 64 0JY 00A	186
84 71 0001	48810-76G00-000	336
84 71 0002	48810-60A00	338
84 72 0001	48850-60A00-000	338
84 72 0002	48830-84000-000	331
84 73 0001	45200-82000-000	336
84 92 8000	4709 702	30
84 92 8000	42420-62J00-000	335, 337
84 92 8000	93195093	389
84 92 8055	48830-60G00-000	332
84 92 8056	4709 161	30
84 92 8056	48830-63J00-000	335, 337
84 92 8056	93194002	389
84 92 8057	48830-65D00-000	333
84 92 8058	4701 745	29
84 92 8058	48830-86G00-000	334, 339
84 92 8058	09204752	389
84 92 8158	42420-65D00-000 S1	333, 338, 339
84 92 8159	42420-81A10-000	334
84 92 8235	42420-77A00-000	332
84 92 8638	42420-80J00-000	338
84 92 9376	46300-60B10-000	685
84 92 9632	45200-60812-000	336
84 92 9633	45200-60822-000	336
84 92 9760	46201-60B11-000	685
84 92 9761	46202-60B11-000	685
84 92 9826	4708 299 S1	30
84 92 9826	45201-62J00-000 S1	335, 337
84 92 9826	93193130 S1	389

























84 92 9827	4708 299 S2	30
84 92 9827	45540-62J00-000 S1	335, 337
84 92 9827	93193130 S2	389
84 92 9828	48810-65D01-000	333
84 92 9829	48820-65D01-000	333
84 92 9830	4709 195	30
84 92 9830	48810-60810-000	334, 335, 337
84 92 9830	93194035	389
84 92 9840	48830-60B00-000	336
84 92 9931	45202-72K01-000	337
84 92 9932	45201-72K01-000	337
84 93 0186	42420-65J00-000	333
84 93 0577	48830-65J00-000	333
84 93 1472	48830-M70F00	331
84 93 2140	4708 300	30
84 93 2140	45202-57KA0-000	335
84 93 2140	93193131	389
84 93 2141	4708 299	30
84 93 2141	45201-57KA0-000	335
84 93 2141	93193130	389
84 93 2470	4705 409	29
84 93 2470	42451-76G00-000	334, 339
84 93 2470	09209466	389
84 93 2475	46201-83E20-000 S2	685
84 93 3510	48510-4A00C	13
84 93 3510	48830M68K00	331
84 93 3532	48810-81A00-000	334
84 93 3533	48820-81A00-000	334
84 93 3760	54616-4A00B	13
84 93 3760	42420-M68K0-000	331
84 94 2318	4705 716	29
84 94 2318	09210351	389
85 78 0001	GSJ 1002	222
85 91 8183	RGX 100980	663
87 92 7820	34140FC000	325, 327, 330
87 92 8199	20470SA001	326, 328, 330
87 92 8439	20470AE001	684
87 92 9375	20201AA000	329, 330
87 92 9634	20200AA200	325, 326, 327, 329, 330
87 92 9635	20200AA210	325, 326, 327, 329, 330
87 92 9685	20481AA001	681, 682, 683
87 92 9686	20420AA004	325, 328, 329, 330

87 92 9841	21067GA050	325, 326, 327, 328, 330
87 92 9853	34141AA042	325, 326, 327, 328, 329, 330
87 93 0739	31320GA190	327
87 93 0740	31320GA200	327
87 93 2495	20470SA011	681, 682
88 92 8271	48831B1010	329
88 92 8272	48821B1010	329
89 92 8347	4810 831 SK	31
89 92 8347	96819161 SK	390
89 92 8671	4806 304	31
89 92 8671	96626247	390
89 92 8672	4806 305	31
89 92 8672	96626248	390
89 92 8712	4703 866	29
89 92 8712	09319-10030-000	331, 339
89 92 8712	09208989	389
99 72 0001	1J0 422 804 H	265, 283
99 72 0001	1J0 422 804 H	301
99 72 0001	1J0 422 804 H	453, 523
99 72 0002	1J0 422 803 H	265, 283
99 72 0002	1J0 422 803 H	301
99 72 0002	1J0 422 803 H	453, 523
99 78 0001	SE028140104A	274
99 78 0002	40110-01G25	5, 23, 25
99 80 0003	7M3 422 831	231, 233
99 80 0003	7M3 422 831	574
99 80 0004	4066.18	147
99 80 0005	4066.19	147
99 80 0006	4066.18 S1	147
99 80 0007	4066.19 S1	147
99 90 1118	251 419 081	583
99 90 3544	191 407 190 A	466, 468, 478, 480, 482, 507, 508, 536, 538, 540, 563, 594, 596
99 90 9158	0920 367	71, 72, 75, 76
99 90 9158	90092492	407, 435
99 91 8740	7D0 407 361	588
99 92 2587	0001802V004	680
99 92 2588	5102V005	322, 324
99 92 2589	454 320 00 10 S1	321
99 92 4632	2271V007000005 S1	320, 321, 322, 324

Translation	Übersetzungen	Traduction	Traducciones	переводы
				
all	alle	tous	todos	все
aluminum	Aluminium	aluminium	aluminio	алюминий
mounting kit	Anbausatz	kit de construction rapportée	juego de montaje	хомут глушителя
leaf-spring bearing	Blattfederlager	palier de ressort à lames	soporte de ballesta	сайлентблок рессоры
sealing kit power steering	Dichtsatz Servolenkung	kit d'étanchéité direction assistée	juego estanq. para servodirección	уплотнительный комплект рул.упр. с сервопривод.
adjusting bolt	Einstellbolzen	axe de réglage	perno de ajuste	болт рулевой тяги
independent wheel suspension	Einzelradaufhängung	suspension á roue indépendante	independiente suspensión de rueda	независимая подвеска колес
guide joint	Führungsgelenk	joint de coulisse	articulación guía	шаровая опора
guide rod	Führungsstange	barre conductrice	vástago de guía	направляющая штанга
rubber mount	Gummilager	support en caoutchouc	soporte de goma	втулка резиновая
sleeve	Hülse	manchon	casquillo	втулка
connecting rod	Koppelstange	barre de couplage	barra de acoplamiento	тяга стабилизаторов
connecting rod bearing	Koppelstangenlager	palier de barre de couplage	cojinete de barra de acoplamiento	втулка стойки стабилизатора
steering gear	Lenkgetriebe	mécánisme de direction	engranaje de dirección	рулевая рейка
steering gear bearing	Lenkgetriebelager	roulement de mécanisme de direction	soporte de engranaje de dirección	крепление рулевого механизма
steering arm	Lenkhebel	levier de direction	palanca de dirección	рулевая сошка
steering arm bearing	Lenkhebellager	roulement de levier de direction	soporte de palanca de dirección	рулевая сошка подшипника
steering boot	Lenkmanschette	manchette de direction	manguito de dirección	пыльник рулевой рейки
drag link	Lenkstange	barre de direction	arbol de dirección	продольная рулевая тяга
drag link end	Lenkstangenendstück	rotule de barre de direction	terminal de arbol de dirección	наконечник рулевой тяги
steering damper	Lenkungsdämpfer	amortisseur de direction	amortiguador de dirección	амортизатор рулевого управления
upper / above	oben	haut	arriba	вверху
suitable for	passend für	adaptè á	apropiado para	подходящий для
control arm	Querlenker	bras de suspension	brazo oscilante transversal	поперечный рычаг подвески
control arm complete	Querlenker komplett	bras de suspension complet	brazo oscilante transversal completo	поперечный рычаг подвески комплект
control arm with rubber mount	Querlenker mit Gummilager	bras de suspension avec support en caoutchouc	brazo oscilante transversal con soporte de goma	поперечный рычаг подвески с резиновой опорой
control arm without rubber mount	Querlenker ohne Gummilager	bras de suspension sans support en caoutchouc	brazo oscilante transversal sin soporte de goma	поперечный рычаг подвески без резиновой опорой
control arm, rear	Querlenker, hinten	bras de suspension, arrière	brazo oscilante transversal, trasero	поперечный рычаг подвески, сзади
control arm, front	Querlenker, vorne	bras de suspension, avant	brazo oscilante transversal, delantero	поперечный рычаг подвески, спереди
control arm mount	Querlenkerlager	support de bras de suspension	soporte de brazo oscilante transversal	сайлентблок
rep. kit king pin	Rep. Satz Achsschenkelbolzen	kit de rép. pivot	jgo. rep. pivote de mangueta	р/к шкворень поворотного кулака
rep. kit eccentric bolt	Rep. Satz Exzenterbolzen	kit de rép. axe excentrique	jgo. rep. bulón excéntrico	болт эксцентриковый в комплекте
rep. kit guide rod	Rep. Satz Führungsstange	kit de rép. barre conductrice	jgo. rep. vastago de guía	ремкомплект рычага подвески
rep. kit connecting rod	Rep. Satz Koppelstange	kit de réparation barre d'accouplement	jgo. rep. barra de acoplamiento	ремкомплект тяги стабилизатора

Translation	Übersetzungen	Traduction	Traducciones	переводы
 rep. kit steering arm	 Rep. Satz Lenkhebel	 kit de rép. levier de direction	 jgo. rep. palanca de dirección	 ремкомплект рулевой сошки
rep. kit steering arm shaft	Rep. Satz Lenkhebelwelle	kit de rép. arbre de levier de direction	jgo. rep. arbol de palanca de dirección	ремкомплект вал рулевой сошки
rep. kit steering boot	Rep. Satz Lenkmanschette	kit de rép. Soufflet de direction	jgo. rep. guarnición de dirección	р/к манжета рулевой передачи
rep. kit control arm	Rep. Satz Querlenker	kit de rép. bras de suspension	jgo. rep. brazo oscilante transversa	р/к поперечного рычага подвески
rep. kit control arm mount	Rep. Satz Querlenkerlager	kit de rép. support de bras de suspension	jgo. rep. soporte de brazo oscilante transversal	р/к подш-к попереч.рыч. подвески
rep. kit power steering	Rep. Satz Servolenkung	kit de rép. direction assistée	jgo. rep. servodirección	р/к рулевого механизма с усилителем
rep. kit tie rod	Rep. Satz Spurstange	kit de rép. barre d'accouplement	jgo. rep. Barra de acoplamiento	р/к поперечная рулевая тяга
rep. kit stabilizer mount	Rep. Satz Stabilisatorlager	kit de rép. support de stabilisateur	jgo. rep. Soporte de estabilizador	р/к втулка стабилизатора
rep. kit support link	Rep. Satz Stützgelenk	kit de rép. support articulé	jgo. rep. articulación de apoyo	ремкомплект шаровой опоры
rep. kit ball joint	Rep. Satz Traggelenk	kit de rép. support articulé	jgo. rep. articulación soportando	ремкомплект шаровой опоры
rep. kit tension rod	Rep. Satz Zugstrebe	kit de rép. tirant	jgo. rep. tirante de tracción	ремкомплект тяговая распорка
lock washer	Sicherungsblech	tôle de sécurité	chapa de fijación	стопорная шайба
tie rod	Spurstange	barre d'accouplement	barra de acoplamiento	рулевая тяга
tie rod end	Spurstangenendstück	about de barre d'accouplement	terminal de barra de acoplamiento	наконечник рулевых тяг
stabilizer mount	Stabilisatorlager	support de stabilisateur	soporte de estabilizador	втулка стабилизатора
steel	Stahl	acier	acero	сталь
Rigid Axle	Starrachse	essieu rigide	eje rígido	жесткий мост
support link	Stützgelenk	support articulé	articulación de apoyo	опора шаровая
support link bearing	Stützgelenklager	palier de support articulé	cojinete de articulación de apoyo	сайлентблок рычага подвески
ball joint down, below, lower	Traggelenk unten	support articulé bas	articulación soportando abajo	шаровая опора снизу
connecting rod	Verbindungsstange	barre d'accouplement	tirante de unión	тяга заднего стабилизатора
optional	wahlweise	optionellement	optativo	на выбор
tension rod	Zugstrebe	tirant	puntal de tracción	рычаг подвески
tension rod mount	Zugstrebenlager	palier de barre de traction	cojinete de tirante de tracción	сайлент-блок тяги

	Symbols & Abbreviations 	Symbole & Abkürzungen 	Symboles & Abréviations 	Símbolos & Abreviaciones 	Символ & о́кращение 
	SWAG no.	SWAG-Nr.	n° SWAG	n° de SWAG	SWAG-номер
Ref. - No.	reference number	Referenznummer	référéncé	número de referencia	оригинальный номер
	part designation	Bezeichnung	désignation de la pièce	denominación de las piezas	Обозначение
	restrictions and exceptions	Abgrenzungen und Ausnahmen	limitations et exceptions	limitaciones y excepciones	Ограничения и исключения
	dimensions	Abmessungen	dimensions	dimensiones	размеры
OLD	old implementation	alte Ausführung	vieille construction	ejecución antiguo	старое исполнение
NEW	new implementation	neue Ausführung	nouvelles construction	nueva ejecución	новая конструкция
Sport	sports suspension	Sportfahrwerk	châssis sport	chasis deportivo	спортивная ходовая часть
AC	air conditioning	Klimaanlage	climatisation	aire acondicionado	Кондиционер
	Niveauregulierung	levelling system	Régulateur de Niveau	Regulación de Nivel	Regolatore di livello
HD	Rough road equipment	Schlechtwege-ausrüstung	Equipement piste accidentée	Equipo para caminos inadecuados	Оборудование для плохих дорог
	manual transmission	Schaltgetriebe	boîte de vitesse	cambio manual	механическая коробка передач
	automatic transmission	Automatikgetriebe	boîte automatique	cambio automático	Автоматическая коробка передач
	steering - damper	Lenkungsdämpfer	amortisseur de	amortiguador de	амортизатор рулевого управления
	axle load	Achslast	charge de l'essieu	carga sobre el eje	осевая нагрузка
	left	links	gauche	izquierda	слева
	right	rechts	droite	derecha	справа
	15" - wheels	15" Räder	jantes 15"	ruedas 15"	15" Колеса
	16" - wheels	16" Räder	jantes 16"	ruedas 16"	16" Колеса
man. 	manual steering	Manuelle Lenkung	direction non assistée	dirección no asistida	ручной рулевое управления
servo. 	power steering	Servolenkung	direction assistée	dirección asistida	рулевое управление с гидроусилителем
E-servo. 	electronical power steering	Elektrische Servolenkung	direction assistée électronique	dirección asistida electrónica	универсальные рулевое управление с гидроусилителем
E-hydr. 	elektrohydraulic power steering	Elektrohydraulische Lenkung	direction électronique hydraulique	dirección electrohidráulica	Система рулевого управления с электрогидравлическим усилителем
(ch.) xxx →	from chassis number	ab Fahrgestellnummer	à partir du numéro de châssis	desde núm. de chasis	Начиная с номера шасси
(ch.) → xxx	up to chassis number	bis Fahrgestellnummer	jusqu'au numéro de châssis	hasta núm.de chasis	До номера шасси
Ø A	external diameter	Durchmesser außen	diamètre extérieur	diámetro exterior	diametro estero
Ø I	internal diameter	Durchmesser innen	diamètre intérieur	diámetro interior	diametro interno

Symbols & Abbreviations

Symbole & Abkürzungen

Symboles & Abréviations

Símbolos & Abreviaciones

Символ & о́бращение

(axle)	axle	Achse	pivot de direction	eje	ось
(incl.)	with	mit	avec	con	с
(ex.)	except	außer	sauf	excepto	кроме
(excl.)	without	ohne	sans	sin	senza
ABS	ABS	Antiblockiersystem	système antiblocage	sistema antibloqueo	антиблокирующая система
AWD	4-wheel drive	Allrad	4x4	accionamiento por	Привод на все колеса
4WD	4-wheel drive	Allrad	4x4	accionamiento por	Привод на все колеса
EDC	electronic shock absorber control	Elektronische Dämpfer Kontrolle	contrôle électronique des amortisseurs	control electrónico de amortiguadores	электронный демфер контроль
ESP	ESP	Elektronisches Stabilitätsprogramm	ESP	ESP	ESP
H	height	Höhe	hauteur (la)	altura	высота
L	length	Länge	longueur	largo / longitud	длина
LHT	left hand thread	Linksgewinde	filetage à gauche	rosca a la izquierda	левая резьба
RHT	right hand thread	Rechtsgewinde	filetage à droite	rosca a la derecha	правая резьба
LHD	left hand drive	Linkslenkung	conduite à gauche	conducción a lado izquierdo	левое рулевое управление
RHD	right hand drive	Rechtsslenkung	conduite à droite	conducción a lado derecho	правое рулевое управление
4 - cyl.	4 - cylinder	4 - Zylinder	4 cylindres	4 - cilindro	4 - Цилиндр
5 - cyl.	5 - cylinder	5 - Zylinder	5 cylindres	5 - cilindro	5 - Цилиндр
4 - türig	4 - door	4 - türig	4 portes	4 - puertas	4 - Дверь
5 - türig	5 - door	5 - türig	5 portes	5 - puertas	5 - Дверь



SWAG Autoteile GmbH · Am Kiesberg 4-6 · 42117 Wuppertal · Germany
www.swag.de · Tel. +49 202 26454-0 · Fax +49 202 26454-5000 · E-Mail info@swag.de

SWAG is a bilstein group brand



SWAG No. 8 00 1013