

BRAKE COMPONENTS CLASSIFIED BY FIGURES
 PIÈCES DE FREINAGE CLASSIFIÉES PAR FIGURE
 INTERTEILE VON BREMSSEN KLASSIFIZIERT DURCH ZEICHNUNGEN

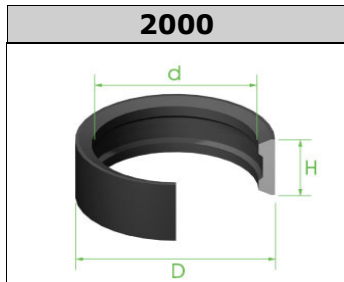

REFER.	D	d	H
22233	34,8	29	11,5
21809	38,5	32,7	12,3

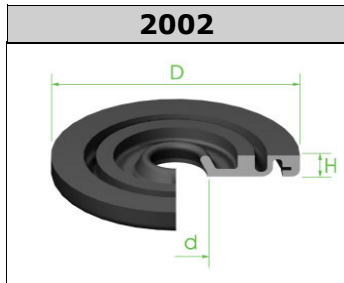

REFER.	D	d	H
21446	41	9,2	5
22339	41	16	4,4
22484	44	17	4,4

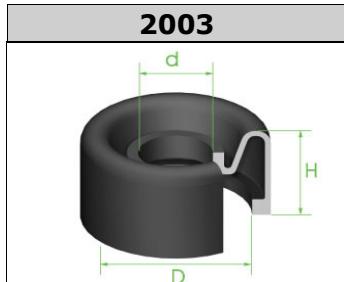

REFER.	D	d	H
22272	14,8	9,3	14
28067	14,8	9,7	15,5
21508	18,6	10,2	12
21510	21	10,5	11,9
20734A	26,5	8,7	24,6
20734	27,5	6,3	21
20805A	28	6,5	18
22400	28	10,5	20
21899	28	13,8	16,6
20848	32	6,3	25,6
20752	32	17,7	15
20735	38	15,7	22,5

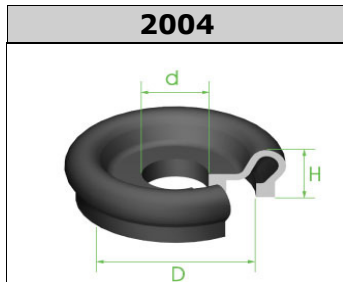

REFER.	D	d	H
28218	19	11	9
20707	25,4	10	9,6
28032	40	26,3	14,5
20865	44	30,3	15,5

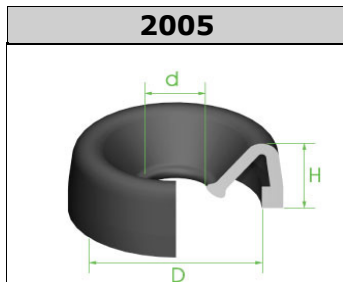

REFER.	D	d	H
20709	20	8,5	10,9
20728	21,1	7,5	9,5
21846	23,6	4,8	10
20711	27	6,3	12,5
20799	29,5	8,8	10
20797	30,6	11,2	13,5
20751	35,5	13	12
20815	44	12,5	13

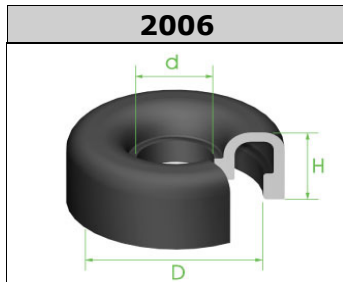

REFER.	D	d	H
21593	18,3	5,5	12,5
22024	20,6	8,5	9,8
20702	22	7	9
20704	26	9,2	10,5
20805	26,5	6	14

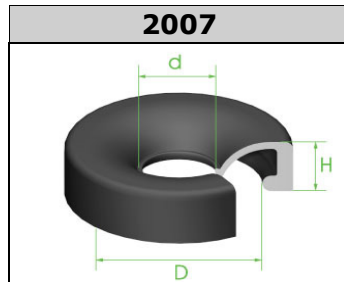

REFER.	D	d	H
20712A	30,7	7	12,5
20894	35,8	14,5	15,6
21532	36,3	11,9	13
22413	48	12	16

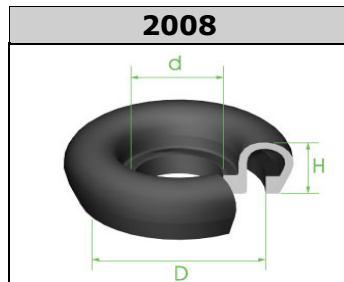

REFER.	D	d	H
21525	17,8	7,9	7,6
20727	23	10	11,5
28303	24,5	7,5	11,5
20803	25	7	9
21550	38,8	15	18,8

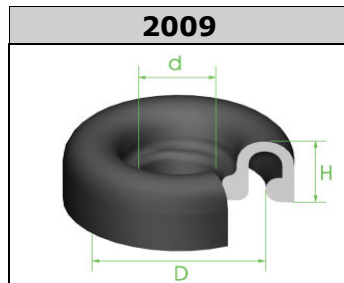

REFER.	D	d	H
20747A	18,1	9,8	7,4
20748A	23,5	10	8
20723	27	10,8	12,5
22093	41	12,7	18

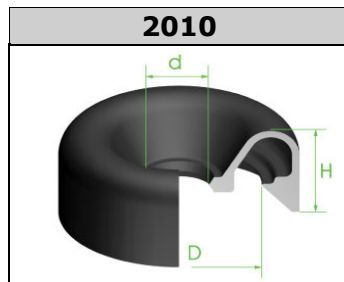

REFER.	D	d	H
21863	13,2	6,9	12
21862	17,2	6	11,8

22487	17,5	6	11,6
21864	19,5	7,3	12,3

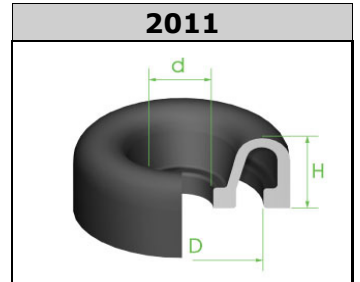

REFER.	D	d	H
20706	22	8,5	10
20713	23	7,3	9,6
20708	24	8,3	9,6
20710	28	6,1	9,5
20712	31,5	7,5	10
20779	32	14	12
20714	33	8,8	11
20716	39,2	10	11,5
20718	43	8,8	14

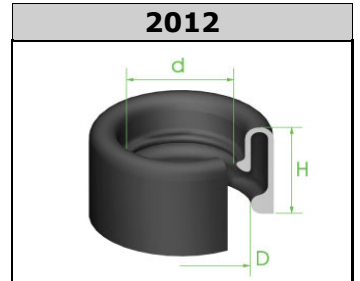

REFER.	D	d	H
21830	24	19,5	18
20731A	24,7	19,7	16,3

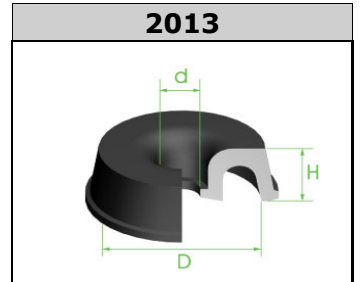

REFER.	D	d	H
22046	18	7	9
20804	20,5	5,5	8

BRAKE COMPONENTS CLASSIFIED BY FIGURES
 PIÈCES DE FREINAGE CLASSIFIÉES PAR FIGURE
 INTERTEILE VON BREMSSEN KLASSIFIZIERT DURCH ZEICHNUNGEN

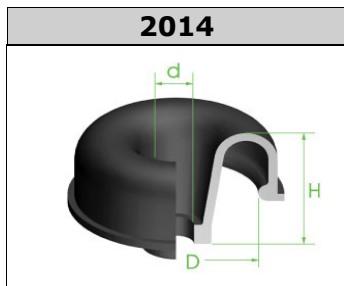

REFER.	D	d	H
21581	19,3	6	15,5
20796	24,2	6,9	16,1
20760	27	12	14,5
21878	28,5	6,2	22,4
20798	31	10,5	24,5
21574	31,1	7	24,5
20768	44,1	14	30

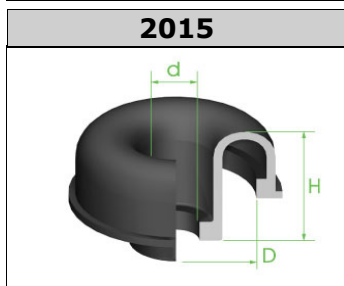

REFER.	D	d	H
20788	25	5,5	22,5
20766	38	13,5	20

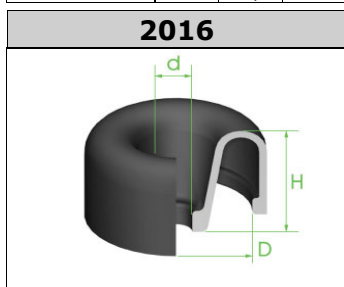

REFER.	D	d	H
20747	18,3	6,7	10,3
20706S	19,5	6	8,5
22308	22	6,5	17,6
20748	22,4	7,8	10,6
20802	22,5	5	19
20705	27	7,2	14
20750	29	14	12
22092	38,3	13,8	19

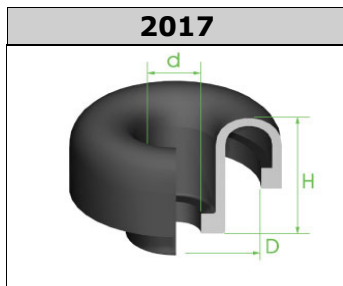

REFER.	D	d	H
20761	33	13	20

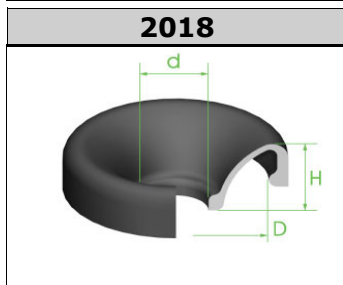

REFER.	D	d	H
21533	52	18	22

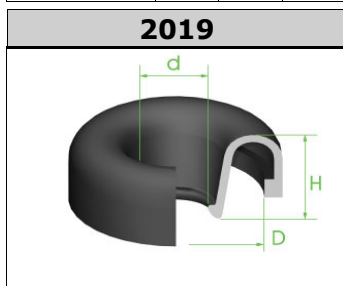

REFER.	D	d	H
20703	24	7	12
21536	41	18	21

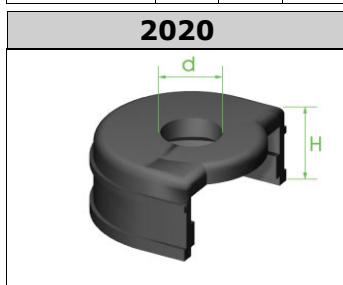

REFER.	D	d	H
22040	0	9,4	12,5
22023	0	9,5	14
20778	0	11	18,5

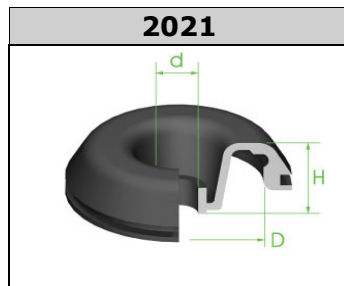

REFER.	D	d	H
21503	19,5	5	9,5
21504	22,2	6,9	9,7

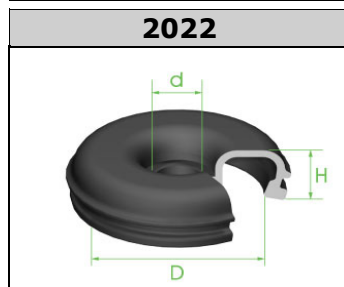

REFER.	D	d	H
22026	20,5	6,5	8,5

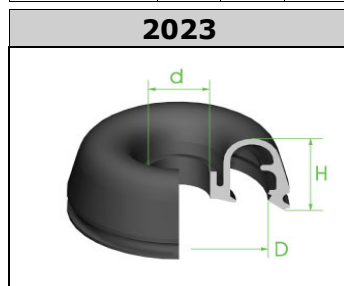

REFER.	D	d	H
20745	19,8	8,5	9,2
20746	24,3	8,6	11,6

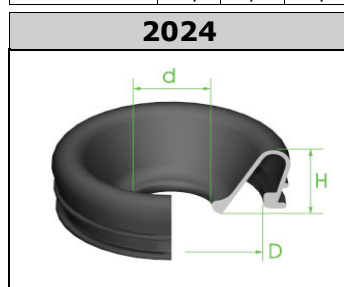

REFER.	D	d	H
20789	44	18,2	18

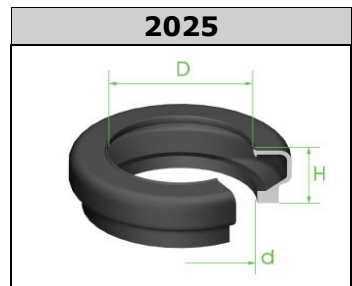

REFER.	D	d	H
22282	29,5	24	14
22283	29,5	26,9	14,8
22242	31,3	27,3	15,3
21850	31,5	31	13,6
22489	37	37,5	15
22393	42	41,5	17

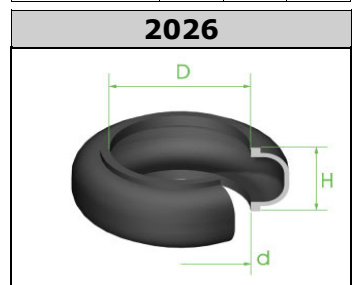

REFER.	D	d	H
21563	21	21	11,2
21848	32	33,3	15,2

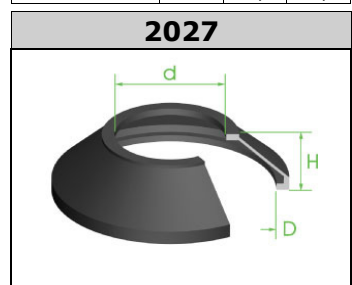

REFER.	D	d	H
22302	57	30	18
22390	57,3	18,5	11

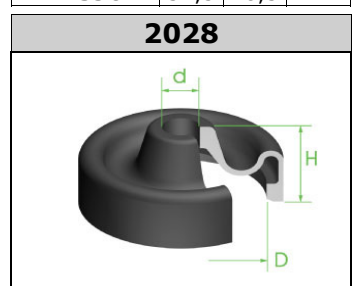

REFER.	D	d	H
20754	30,8	8,7	20
21599	40	8,8	21
22055	40	10	31,2
22415	41	9	18,5

BRAKE COMPONENTS CLASSIFIED BY FIGURES
 PIÈCES DE FREINAGE CLASSIFIÉES PAR FIGURE
 INTERTEILE VON BREMSSEN KLASSIFIZIERT DURCH ZEICHNUNGEN

2029

REFER.	D	d	H
21584	19,7	8	13,7
21562	30,1	12,6	10,5

2033

REFER.	D	d	H
21803	22,2	8	14,2
28245	26	8,2	11

2037

REFER.	D	d	H
20822	28	7,6	24

2041

REFER.	D	d	H
22034	37,8	26,3	12,4

2030

REFER.	D	d	H
21854	23,2	16	8,8
20786	23,5	10,5	15
20895	25,5	12,2	16,5

2034

REFER.	D	d	H
21520	21,7	8,2	11
20729	27,3	13,5	12

2038

REFER.	D	d	H
21639M	22,5	5,5	29,5

2042

REFER.	D	d	H
22285	21,7	8	12,4
22414	23	13	17

2031

REFER.	D	d	H
21591	23,4	8,4	9,7

2035

REFER.	D	d	H
20731	31	12	11,6

2039

REFER.	D	d	H
21847	32,1	26,9	16,5
21564	37,9	32,2	15,7

2043

REFER.	D	d	H
22031	28	14,2	16,2
21800	32,3	13,3	16,1
21580	37,6	19	15,8

2032

REFER.	D	d	H
22236	20,4	13,2	15,7
21843	24,3	13,8	9,3
22422	29	12	10,5
22284	29,5	26,7	14

2036

REFER.	D	d	H
20873	44	18,5	32

2040

REFER.	D	d	H
22466	27,5	24	10,8
22286	28	26,7	12
21596	28	28	13,3
22030	29,5	29,5	18,4
21598	30,8	32,4	11,6

2044

REFER.	D	d	H
20780	26,5	13	10,5

BRAKE COMPONENTS CLASSIFIED BY FIGURES
 PIÈCES DE FREINAGE CLASSIFIÉES PAR FIGURE
 INTERTEILE VON BREMSEN KLASSIFIZIERT DURCH ZEICHNUNGEN

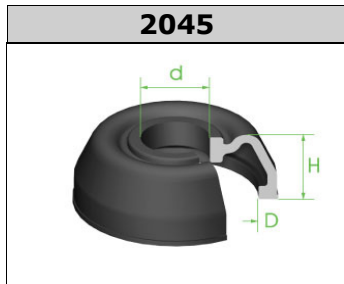

REFER.	D	d	H
22394	19,5	6	12
21546	22	5	10
22032	29,9	10,4	19,3

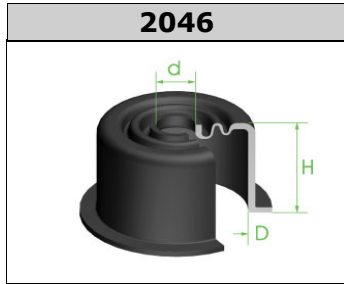

REFER.	D	d	H
21891	29,5	8,2	40,5
22088	30	8,1	22

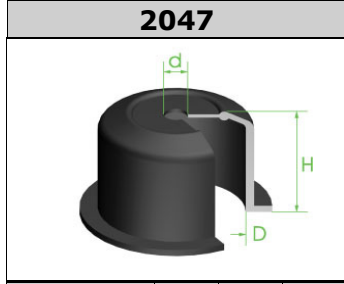

REFER.	D	d	H
28114	25,5	12,5	23,5
20897	28	5	23
28113	30	6,6	32
22297	33	5,5	29

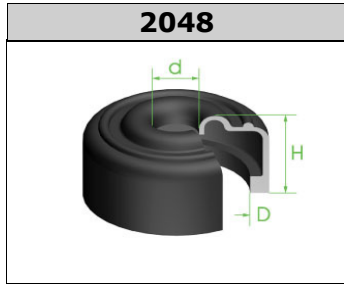

REFER.	D	d	H
20821	27	6,6	20
20823	27,5	7	13,2
20846	39	8,1	26,5
20888	51,5	14,5	13,5

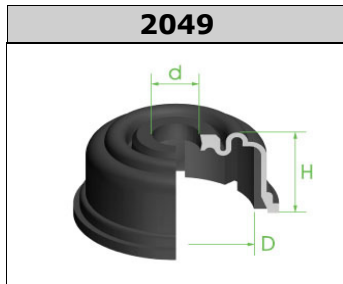

REFER.	D	d	H
22291	34	8,5	17,5

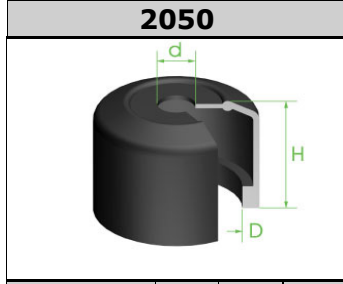

REFER.	D	d	H
20824	26,7	5,8	24,6
20824B	28,5	4,5	23,5
20744	33	7,5	21

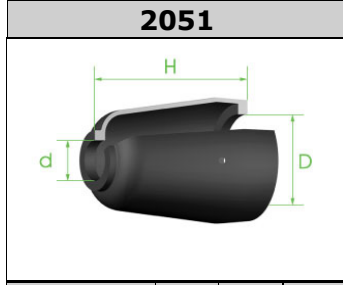

REFER.	D	d	H
21866	17,7	9,8	15,5
21836	17,8	8	18
20826	19	6	39
21835	20,5	8	17,8
21877	22	7,8	18,5
20825	23	8,2	42,6
20833	24	8	47,8
20830	25,5	12,5	48
22340	33,3	12,5	52,5
20828	34,2	6	43

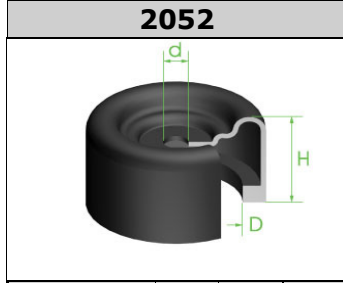

REFER.	D	d	H
28041	20	5	18

22243	20,2	6,5	15,5
-------	------	-----	------

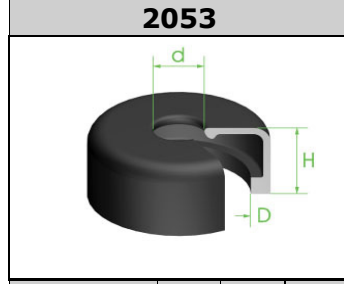

REFER.	D	d	H
21888	20	4	12
21582	20	7	16,4
20800	20,8	7,3	14
20801	22	7	9
20831	30	9,4	15

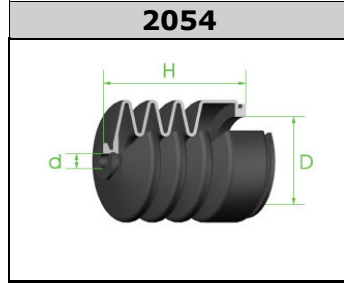

REFER.	D	d	H
22240	22,5	16	51

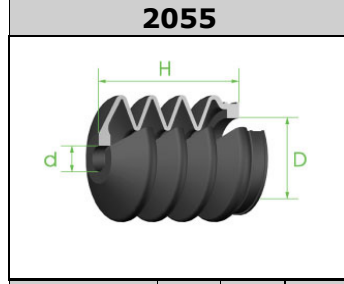

REFER.	D	d	H
21871	19	5	43
21538	20	3,8	30
22332	25	6,7	50
22470	32	10,5	82

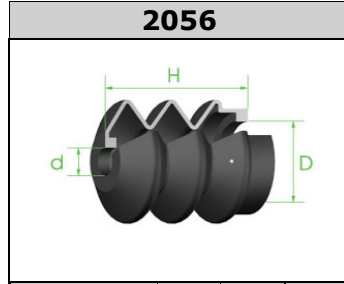

REFER.	D	d	H
28156	21	9,5	58
21568	28,5	13,2	40
20840	30	15,6	52,5

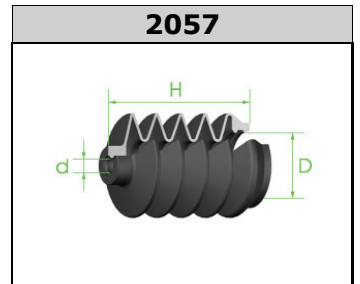

REFER.	D	d	H
20836	18,5	8,2	46,6

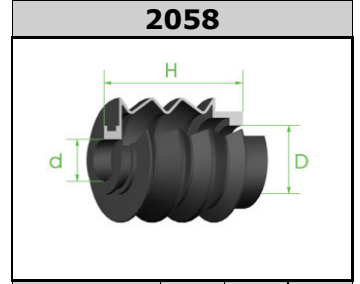

REFER.	D	d	H
20842	27,5	7	52

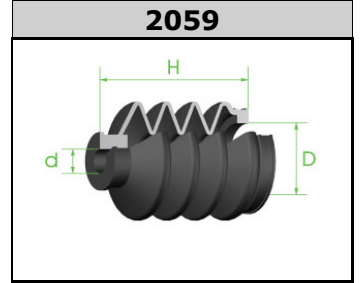

REFER.	D	d	H
22329	28	12	49

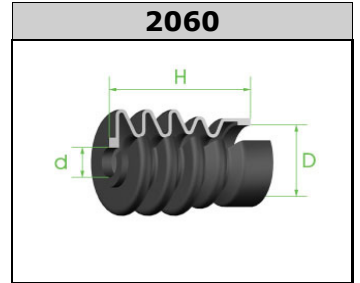

REFER.	D	d	H
22084	18	4	58
22281	24	8	40
22473	27,5	17	74

BRAKE COMPONENTS CLASSIFIED BY FIGURES
 PIÈCES DE FREINAGE CLASSIFIÉES PAR FIGURE
 INTERTEILE VON BREMSEN KLASSIFIZIERT DURCH ZEICHNUNGEN

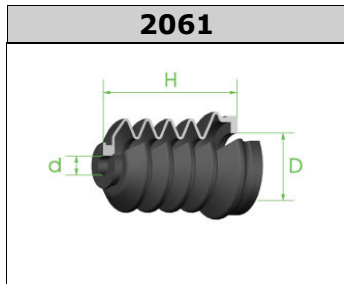

REFER.	D	d	H
21833	15,5	6	44
22469	17,5	8	74
22294	27,5	8,5	84

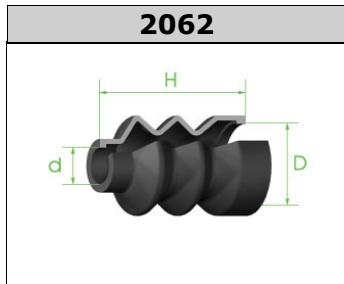

REFER.	D	d	H
22079	22	5,5	55
22483	24,5	6,3	44,5
20806	25	11	47
20844	25,5	7,2	65,5
22328	26,7	10	46
20807	28,3	10	51,5
20808	28,5	11,3	42
22316	30	9	40
20809	32,6	7,8	56
20810	32,8	11,8	58
20812	35,5	13,5	51
20810A	37,8	11,8	54,4
20814	39	19	59
20818	43	19	69

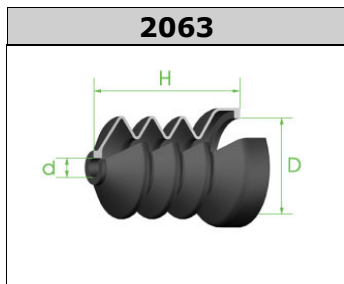

REFER.	D	d	H
21565	16,7	8	57
22417	23,5	5	64
22279	28,2	17,2	48,3
22326	29	5,5	56
22386	30,5	19,2	55
22287	41,6	8,5	60

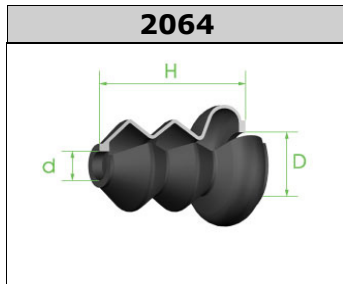

REFER.	D	d	H
20811	28,6	12,2	70

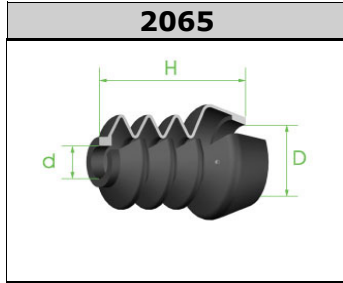

REFER.	D	d	H
21834	16,7	5,6	41,6

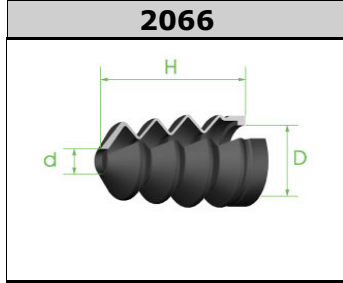

REFER.	D	d	H
21867	21	5	30
22490	26,5	6	57

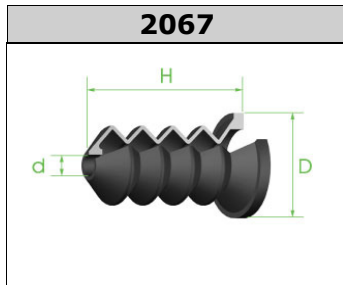

REFER.	D	d	H
21516	29,5	5,8	46

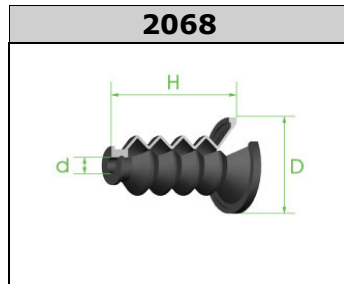

REFER.	D	d	H
21857	38,6	6,4	48
22038	38,6	8,4	46,7

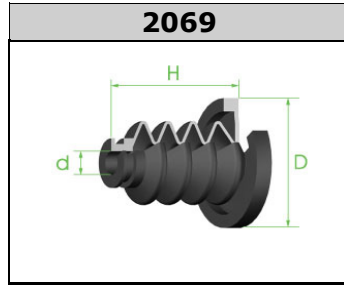

REFER.	D	d	H
20898	9,6	6	42

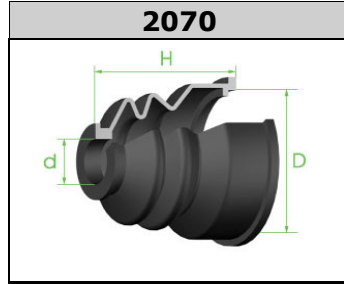

REFER.	D	d	H
22280	43,5	16,8	35

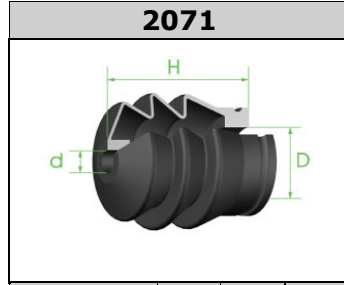

REFER.	D	d	H
21537	23,3	4,5	36

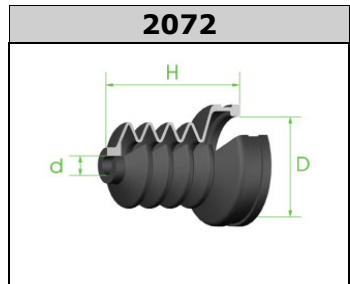

REFER.	D	d	H
28246	20,5	9,5	60
22289	30	6	43
22330	37,6	7	56

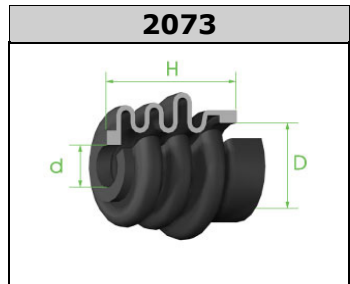

REFER.	D	d	H
22087	17,2	8,4	26

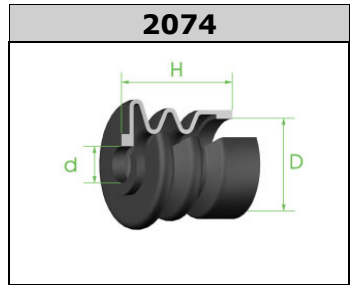

REFER.	D	d	H
21583	21	5	25,7

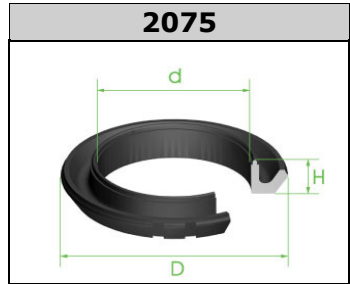

REFER.	D	d	H
22028	42,3	28,3	7,5
22082	43,5	32	5,2
22078	43,5	32,1	4,1

BRAKE COMPONENTS CLASSIFIED BY FIGURES
 PIÈCES DE FREINAGE CLASSIFIÉES PAR FIGURE
 INTERTEILE VON BREMSEN KLASSIFIZIERT DURCH ZEICHNUNGEN

2076

REFER.	D	d	H
22090	40	27	12,3

2083

REFER.	D	d	H
20843	46,7	15,5	68

2089

REFER.	D	d	H
22412	29	12	4

3100

REFER.	D	d	H
31231	28,1	22,8	2,8
31281	34,1	28,2	3,2
31302M	35	29,9	2,5
31301	36,2	30,3	3,2
31321	36,5	31,5	2,5
31310	37,1	31,1	3,2
31331M	38	33	2,55
31320	38,3	32,3	3,2
31343	39,6	33,6	3,2
31342	40,5	34,5	3,2
31363M	40,5	35,8	2,5
31341	41	35	3,2
31400	41,8	29,7	3,2
31351	42	36	3,2
31361	42,4	36,4	3,2
31362	43,2	37,3	3,2
31382	44	37	3,5
31381	44,2	38,2	3,2
31241	44,5	24,5	2,5
31383	44,8	38,8	3,2
31402M	44,8	39,8	2,5
31401	46,3	40,3	3,2
31403	46,3	40,3	4,5
31421	46,5	41,5	2,5
31423M	46,7	41,7	2,5
31410	47,5	41,5	3,2
31411	47,5	41,5	4,3
31422	48,5	42,5	3,2
31432M	49,2	43,2	2,5
31431	49,2	43,2	3,2
31452	50	44,8	2,65
31452M	50	44,8	2,65
31430	50	44,8	3,2
31441	50,5	44,5	3,2
31451	51,5	45,5	3,2
31462	52	46	3,2
31463	52	46,1	3,8
31464	53,3	47	4,8
31461	53,5	47,5	3,2
31482	54,1	48,1	3,2
31483	54,1	48,1	3,7
31481	54,5	48,5	3,2
31501M	56,4	50,7	3,05
31511	56,9	51	3,6
31513	57	51	3,6
31512	57,5	51,5	3,2
31521	58,3	52,3	3,2

2077

REFER.	D	d	H
22385	34,2	8,3	77

2085

REFER.	D	d	H
21501	20	20	31

2090

REFER.	D	d	H
22472	23,5	6	23

2079

REFER.	D	d	H
28054	21,2	14	53

2086

REFER.	D	d	H
21517	35,7	6,5	4,5

2091

REFER.	D	d	H
22474	33	17	84

2081

REFER.	D	d	H
20738	18	9,5	12

2087

REFER.	D	d	H
22391	34	32,5	13,6

2092

REFER.	D	d	H
22029	36,7	30	4,2

BRAKE COMPONENTS CLASSIFIED BY FIGURES
 PIÈCES DE FREINAGE CLASSIFIÉES PAR FIGURE
 INTERTEILE VON BREMSEN KLASSIFIZIERT DURCH ZEICHNUNGEN

31531	59	53	3,2
31544M	60	54	3,2
31541	60,3	54,3	3,2
31542	61,3	55,3	3,2
31545	62,2	55,6	3,5
31540	62,4	56	3,2
31572	63	57	3,2
31570M	63,2	57,2	3,2
31571	63,6	57,6	3,2
31581	64,5	58,5	3,2
31602	65	59	3,2
31605M	66	60	3,2
31604	66,5	60,5	4
31611	66,8	61	3,2
31601	67,6	61,4	3,1
31603	68,3	62	3,2
31632	69,6	63,6	3,2
31680	69,8	63,7	4
31630	70,5	64,3	3,2
31662	72,6	66,6	3,2
31661	72,6	66,6	3,7
31681	74,5	68,5	3,2

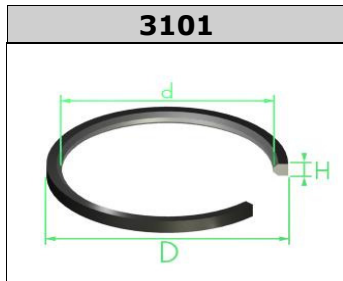

REFER.	D	d	H
31491	56	49	3,5
31631	72,5	64,5	4

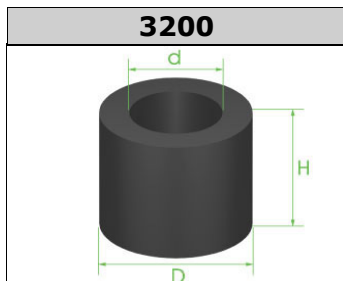

REFER.	D	d	H
32900M	6	3,5	11
32903	6	3,5	11
32901	6,9	4,3	10,9
32902M	7	4,5	11
32904	10,3	6,5	7,5
32129	12,7	7,8	13,3

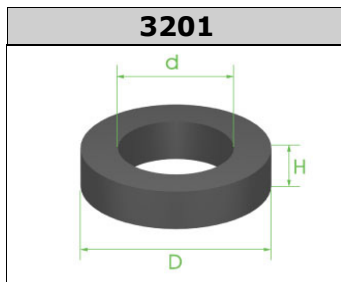

REFER.	D	d	H
32103	10,1	6	2,2
32110	11	7	2
32111M	11	7	2
32130	12,3	8,3	2
32127	12,7	7,8	2,9
32152	15,2	10	3,2
32151	15,3	8,6	2,6
32158	15,8	12,4	1,7
32170	17,5	12,5	2
32171	17,5	13,2	2,3
32190	19	15,6	1,7
32193	19,3	14,9	2,3
32210	21	12	4,8
32230	23	17	3
32235	23,5	19,2	3,3
32245	24,3	18	3,6
32256	25,6	21,8	2,5
32258	25,8	13,5	6,2
32260	26	19	5,7
32201	26,7	20,3	2,6
32905	30,8	27,2	5
32415	41,5	28,1	2,4
32430	42,8	24,3	2
32550	54,4	47	2,6
32630	63	43,3	2,3

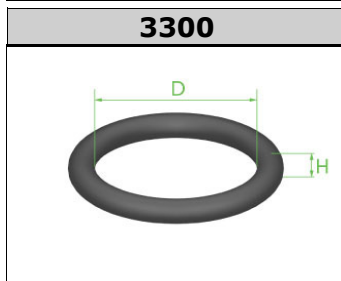

REFER.	D	d	H
33030	3,7	0	1,8
33042	4,5	0	1,8
33040	4,9	0	1,9
33051	5,2	0	1,8
33050	5,5	0	1,7
33052	5,9	0	1
33070M	7	0	2
33072	7	0	2
33081	8	0	2
33092	9,6	0	2,4
33102	10	0	2

33101	10	0	2,5
33103	10,7	0	2,6
33103M	10,7	0	2,6
33104	10,8	0	1,8
33114	11	0	2
33111	11,5	0	2,4
33112	11,9	0	2,6
33120M	12	0	2
33123	12,4	0	2,62
33180M	12,7	0	2,7
33131	13	0	2
33132	13,6	0	2,5
33130	14	0	2
33190	14	0	2,5
33152	15,5	0	2,62
33151	15,6	0	1,8
33161	15,8	0	2,7
33200M	16,7	0	2
33172	17	0	1,8
33171	17,1	0	2,62
33182	18,6	0	3,5
33191M	19	0	1,8
33192	19	0	2,5
33201	20	0	2
33202	20	0	3
33203	20,3	0	2,62
33211	21	0	3
33212	21,3	0	3,6
33280	22	0	3
33230M	23,3	0	3,7
33242	24	0	2
33240M	24,5	0	3,6
33250	25	0	2
33251	25,8	0	3,5
33261	26,5	0	2,4
33263	26,8	0	1,8
33281	28	0	2
33290	29,8	0	3,5
33300	30	0	2
33301	30	0	2,5
33320	32	0	2,5
33340	34	0	2
33350	35	0	3
33351	35,6	0	3,6
33361M	36,5	0	2,7
33360	36,8	0	3,5
33372	37,4	0	1,8
33370M	37,5	0	2,4
33401M	40	0	3,5
33410M	41,5	0	2,5
33421M	42	0	1,5
33431M	43	0	2,6
33450M	45	0	2
33451M	45	0	3
33460	45,7	0	2,6
33490M	49	0	2,5

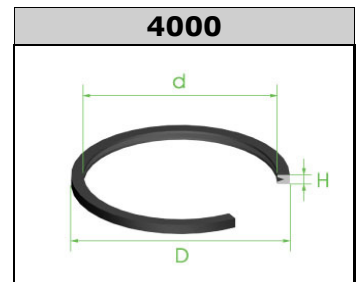

REFER.	D	d	H
40699M	36	30	3
41579M	40,4	34	2,5
42396M	41,6	35,5	3
41543	42	36,2	2,5
41881	46,5	40,6	3
41514	47	42	2,5
40695M	47,9	41,5	3
48150	50,5	44,5	2,5
41263	51	45	3
40697M	51	45	3
41880	52,5	47,3	2,5
40690	58,8	50,8	3,8
41573	62	55	3,8
41534	65,4	58,4	3,8



REFER.	D	d	H
48051	34,8	22	11,3
41531	38,3	21,5	11,9
41872	41,4	23,5	9,2
45944	42	25	11,5
41529	42,2	26,3	11,5
42448	44	28	13,8
42254	44,4	29,7	11
41509	45	29,9	11,1
41801	46,4	29	12
41897	46,8	32,3	11,2
42312	47,7	31,2	12
48358	48	30	11,5
41890	49,5	34,8	11
42264	50	31	11,3
42064	50,7	32	12
41894	51,5	36,4	11
48359	52,5	31,7	11,2
42245	52,6	34,5	13,7
42449	54	36	11,2
41553	54,4	37	11,5
48130	55	34	12
40879	55	36,6	11

BRAKE COMPONENTS CLASSIFIED BY FIGURES

PIÈCES DE FREINAGE CLASSIFIÉES PAR FIGURE
INTERTEILE VON BREMSEN KLASSIFIZIERT DURCH ZEICHNUNGEN

42481	56	38,3	10
41524	58,7	39,5	9,1
42025	59,2	38,1	10,3
41518	60	44,5	11,1
41898	61	45,2	15
41868	61,5	43	11
41560	61,7	40,5	10
48360	62	40,7	11,2
48253	62	41,5	11
41875	64	46	11,6
41873	64,2	45,2	11,4
41545	64,8	43,9	10,7
42388	65	48,7	14
42259	66,5	50	13,5
48301	66,5	50,5	13
42244	67,5	46	11
41512	68,5	46,3	11,5
48238	71	50	11,5
42089	74	53	11,4
41505	75	55	11,7
42343	75,4	57,5	13

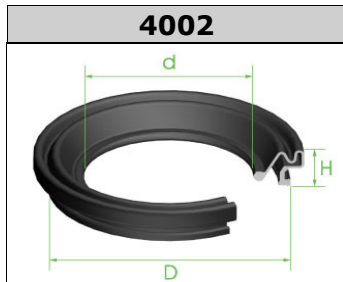

REFER.	D	d	H
41870	37,5	21,5	9
42325	40,2	22,9	11
42361	41	22,8	12,4
48267	50	34,5	13,7
41528	52,8	34	13
48268	54	37	10,2
41838	55	36,5	12
40896	55,6	37	12,5
42052	58,3	41	14,3
42402	58,7	45	8,7
41544	59	40,3	11,5
42053	60	43,6	13,5
41829	61	43	10,5
42331	62	42	10,5
40891	62,3	44	10,7
42069	62,5	46,5	13,8
41861	63	44	12
41819	64,5	46	10,5
41822	66	50	14
42365	66,5	47,6	14



REFER.	D	d	H
42278	61	41	7,5

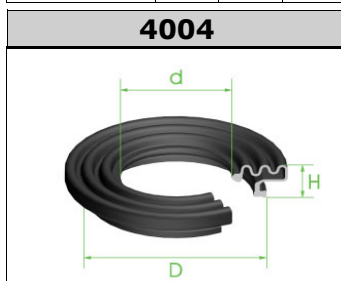

REFER.	D	d	H
41842	44	24,5	8,5
42368	45,6	26,3	9,8
42363	47	32	10
48299	74	53	11,5



REFER.	D	d	H
42275	40,5	22,5	12
41808	45,7	29	11,7
40878	60,8	41,3	10
42313	62	44,2	11,5
41855	64,2	51,5	10,8
48355	65,5	50,7	11,5



REFER.	D	d	H
41832	51,4	33,5	9
40899	57,2	38,5	8,3
42060	66	47,5	10

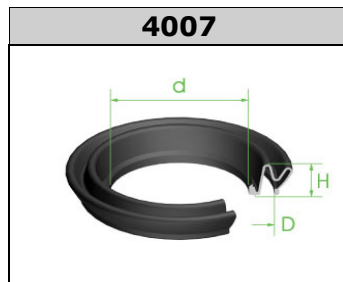

REFER.	D	d	H
42226	37,2	20,3	10
41597	40,2	23,1	10,8
42447	42	26	10
41896	44	27	10,5
41511	48,5	35	10
41551	50,6	35,6	8,6
40890	52,3	37	10,9
41811	58	43,5	10,5

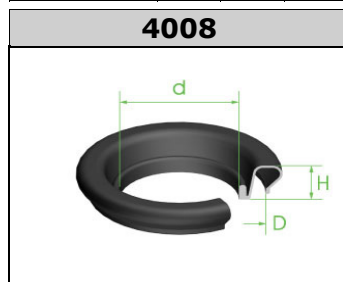

REFER.	D	d	H
41818	33	17,2	10,4

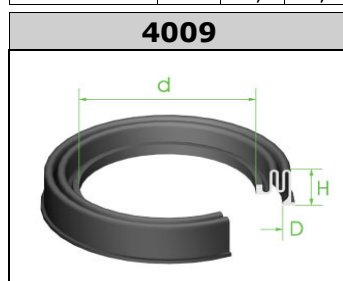

REFER.	D	d	H
41541	33,5	23,8	10
41886	40	24,5	10
40875	52	40,8	10,3
40889	53	37,5	11,5
40876	55	43,5	9,8
41845	58,5	48	10,5

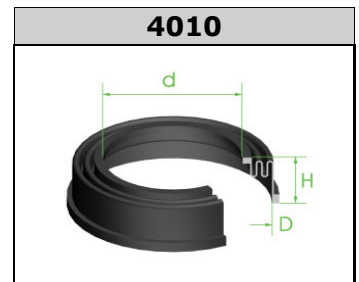

REFER.	D	d	H
40877	46	31,6	14,5
41554	54	37,7	11,2
41519	58,5	44,7	11,5

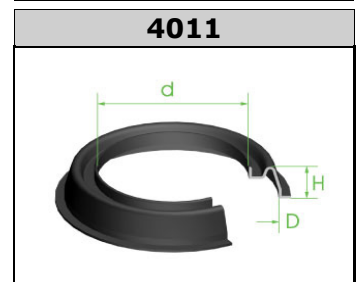

REFER.	D	d	H
42397	37	24	10,5
41549	50,2	37	7,5
40784	51	37	9

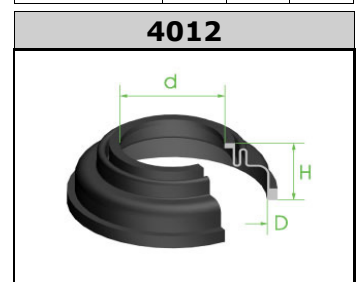

REFER.	D	d	H
40864	41,5	22	15
40863	49,3	33	17



REFER.	D	d	H
40867	57,5	39	9

BRAKE COMPONENTS CLASSIFIED BY FIGURES
 PIÈCES DE FREINAGE CLASSIFIÉES PAR FIGURE
 INTERTEILE VON BREMSEN KLASSIFIZIERT DURCH ZEICHNUNGEN

4014			
REFER.	D	d	H
40869	62,2	39	8,7
42370	63,7	38	10

4015			
REFER.	D	d	H
48196	43,5	22	7
42445	45	23	8
41595	47,7	23,2	6,3
42239	51,4	29	8,5
41876	52,4	25,5	8
42399	57	33	5,5
42306	60	39	7
42374	61,5	36	9
41802	66	37	6,3
42027	66,2	41,6	7,5
41889	72,3	42,5	7,5
42274	74	48	5
42268	81	55,5	6

4016			
REFER.	D	d	H
41893	58	33,6	8
41823	66,2	37	8,8

4017			
REFER.	D	d	H
41812	46	22,1	10,2
42234	47,5	27	7
42276	63	36,5	8
41805	68,8	39,3	7,7
42066	70	43	7

4018			
REFER.	D	d	H
41820	36	18,2	12,5
42323	40	19	8
40782	43	20	8
40861	46	24,5	8,5
40861A	49,2	29	8,1
42266	55	29,5	10,5
40862	57	38,6	8,5
42324	58	34,5	10,5
40866	58,5	39	8,5
40868	64,2	36,5	9

4019			
REFER.	D	d	H
41831	50,2	37,4	5,8
42311	52	37	5,5
42296	53,5	32	7,5
41556	57,8	43	5,8

4020			
REFER.	D	d	H
42424	42	27,5	5,7
41555	43,4	27,2	6,1

4021			
REFER.	D	d	H
40686	36,3	26	3
41817	38	24,5	5
41527	43,5	25	7
42309	45,5	28	7,5
42319	45,5	28	8
41559	47	31,5	5,5
48221	47	33	7
42277	49	32,8	5
42301	53,5	35	7
41557	56,5	42,7	6,2
41592	59,5	47	7

4022			
REFER.	D	d	H
42022	47,5	30	5
40872	53,3	38,5	5

4023			
REFER.	D	d	H
42401	44,5	30	6,6
42320	48,4	32,7	6
40874	58,4	42	5,5
42321	59	43,5	6

4024			
REFER.	D	d	H
42021	47,5	21	10

4025			
REFER.	D	d	H
41826	45	30	8

4026			
REFER.	D	d	H
41515	46,5	32	8

BRAKE COMPONENTS CLASSIFIED BY FIGURES
 PIÈCES DE FREINAGE CLASSIFIÉES PAR FIGURE
 INTERTEILE VON BREMSEN KLASSIFIZIERT DURCH ZEICHNUNGEN

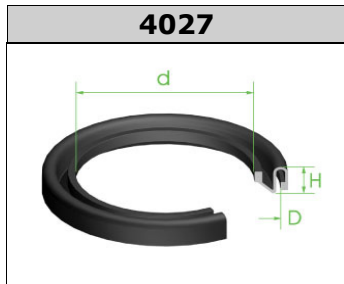

REFER.	D	d	H
41828	41,5	28	8,5
41825	59,5	45,6	8,4
41827	62	48,7	8,5

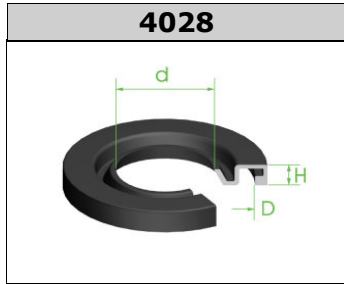

REFER.	D	d	H
41824	50,5	37	5,4

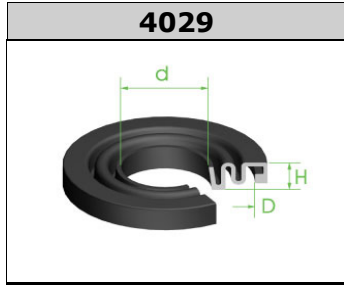

REFER.	D	d	H
40867A	51	36,6	7,3

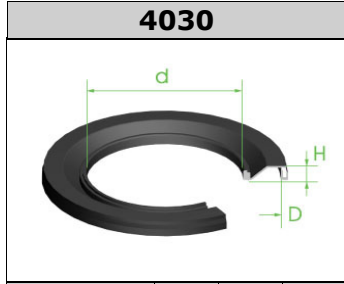

REFER.	D	d	H
48178	34	18,5	6
48120	35,5	20	5,6
48187	37,5	21,2	6
41814	40	23,5	6
48122	41,5	25,5	6,5
48029	41,6	26	7
42378	42,7	25,4	7,5
48154	43,7	27	6
42387	44,5	26,3	6,4
48100	45,5	28	5,5

42499	45,5	29,2	5,8
42065	46,5	26,5	6,5
48153	47,6	30	6
48020	49,7	33	5,6
48215	51,5	35	6,5
48377	62,5	45,5	5,7
41571	63,8	44,3	6,5
42488	64,8	34	7
42450	66	43	5
41552	68,4	45,5	5

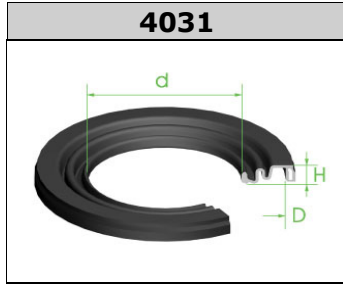

REFER.	D	d	H
42333	41,1	23,2	5,3
48028	42,7	25,5	6
48093	44,5	27	6
48094	48,5	31,5	6
48127	50,5	32,6	5,5
42438	51,5	32,5	6
42305	52,7	33,7	4,8
42369	54,2	34	7,5
41570	61,5	39	6
42020	67,6	44,5	5
42206	69,4	36,5	8,6
42262	71,5	45,5	6
42375	78,7	40,2	7,5

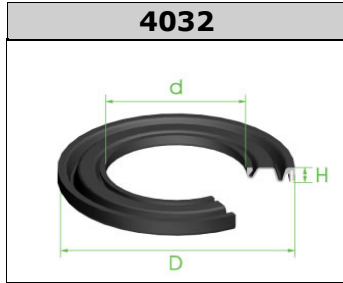

REFER.	D	d	H
42486	52,8	24,3	5,5
40870	61	36,7	4,7

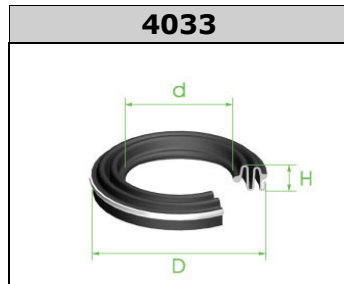

REFER.	D	d	H
48149	55	33	14
48344	56,3	32	12
48385	58	34	8,5
41806	58,8	36,5	10,6
42463	63,5	41,5	12,5
48233	64,5	43	10,5
42460	71,5	45	12
42096	76,8	53	10

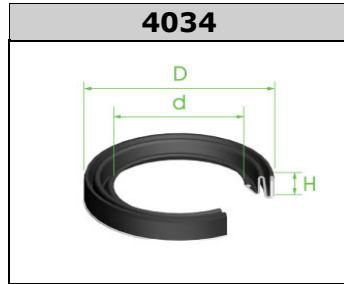

REFER.	D	d	H
42446	43,7	25	9,5
41869	46,5	21,5	9
42200	48,7	30,3	9
42492	49,3	30	10,5
42210	50,5	32,5	9,5
42095	52,4	34,3	8,9
42098	52,5	30,4	9,5
42430	55,5	36,5	10
42437	57	35,7	13
48177	57,5	32	8,5
48376	58	34	8,7
42099	58,5	37,5	9,2
48176	60,8	38	8,5
42482	61,5	41	11
42376	63,2	43	9,3
41577	64,7	44,2	9,1
42204	64,8	41,7	9,5
41575	67,8	46,7	9
42097	69,6	48,3	9,5

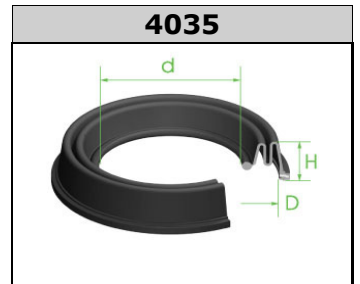

REFER.	D	d	H
42480	46	25,3	13
42431	47,5	27,4	12,2
48306	49,5	29	12,5
42377	51	30,8	13
48372	54	35,5	14
48023	55	35	13,4
42462	57	38	13,5
42464	59,7	37,5	9,8
42076	63,5	41,5	13,7
42461	66	45	14
42395	69	50	14
42261	70,5	48	12
48298	75,5	53	13,5
42258	78,5	53	11,5

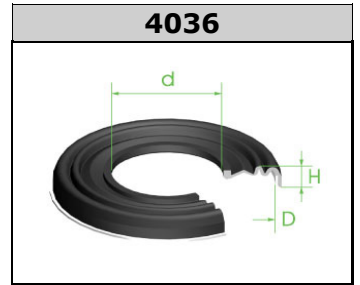

REFER.	D	d	H
40871	62,8	32,5	7,5
42063	64,8	37,1	7,4

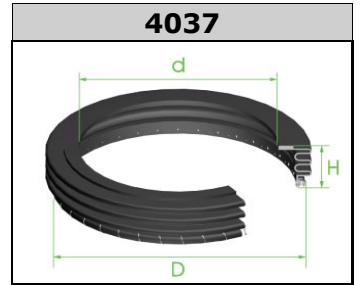

REFER.	D	d	H
41535	77	60	16

BRAKE COMPONENTS CLASSIFIED BY FIGURES
 PIÈCES DE FREINAGE CLASSIFIÉES PAR FIGURE
 INTERTEILE VON BREMSSEN KLASSIFIZIERT DURCH ZEICHNUNGEN

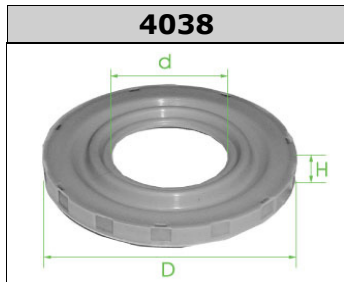

REFER.	D	d	H
42298	74,5	34	8,5

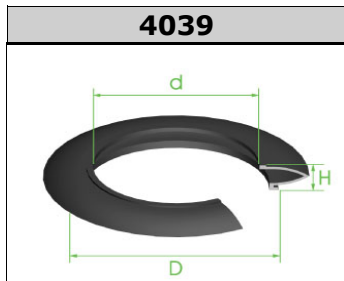

REFER.	D	d	H
41856	46,5	34,3	10
48236	49	36	12
42219	59,2	45	7
48200	63,4	49,5	9,2

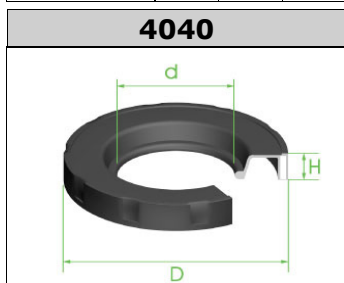

REFER.	D	d	H
42209	59	32	7,8

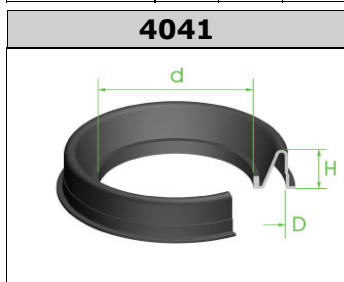

REFER.	D	d	H
42441	34,5	24,4	11,5
48052	39,5	26	11
48058	48,5	34	11,3
42039	52	38	12
42267	55,5	41	11,5
42041	57	42	11

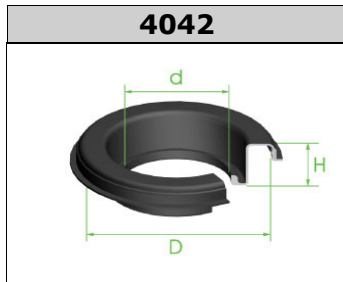

REFER.	D	d	H
42411	52	30	12
42419	55,5	38	12

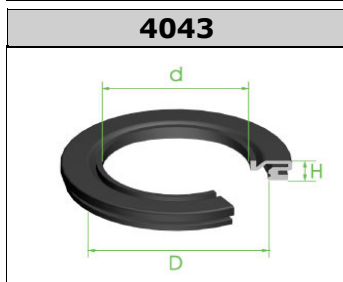

REFER.	D	d	H
42416	47,6	38	6
48083	49,5	34	5,5



REFER.	D	d	H
42379	49,5	21	7,8
42436	59,7	31,7	8



REFER.	D	d	H
41594	49,2	33,3	6,6



REFER.	D	d	H
48074	58,9	37	13,3
48381	62	41	10,2
48169	63,6	42,5	12,5
48134	70,5	50	10,5
48195	70,5	50	11
48325	72,5	50,5	8,6



REFER.	D	d	H
48191	49	23	9
48209	49,3	25,6	9,8
48265	52	25	9
48126	55	29	10,5
48266	56,5	30	9
48384	64,5	37,5	9
48192	66	40	8,5
48219	71,5	45	8,5
48107	73,5	44	9
48193	75,5	46	9



REFER.	D	d	H
48095	40	34	10

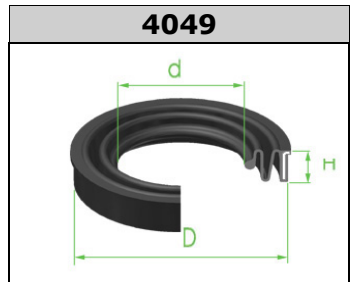

REFER.	D	d	H
48230	43,5	25,5	10,5
48188	45,5	26	10,8
48128	54,6	32,7	9
48207	58,6	37,3	9,5
48132	64	43,5	10,8
48222	73,7	50	9,7

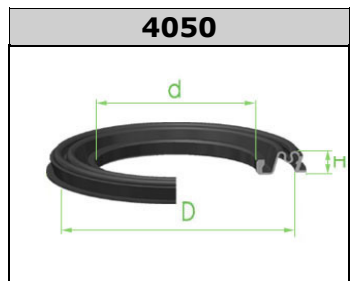

REFER.	D	d	H
48109	47	31,5	6,4
48112	49,5	33,5	5
48250	51	35,5	6
48206	56	40	5,5



REFER.	D	d	H
48131	54,8	39	10,5



REFER.	D	d	H
48354	46,7	32	10,6
48356	62,2	48	10,5

BRAKE COMPONENTS CLASSIFIED BY FIGURES
 PIÈCES DE FREINAGE CLASSIFIÉES PAR FIGURE
 INTERTEILE VON BREMSEN KLASSIFIZIERT DURCH ZEICHNUNGEN

4054

REFER.	D	d	H
48357	73	51	7

4055

REFER.	D	d	H
18350	27	20,3	5

4056

REFER.	D	d	H
58362	24,8	12,2	21,2

5000

REFER.	D	d	H
62315	11	7	6,5

5001

REFER.	D	d	H
52271	8	8	28,5
52420	8	11,2	29
52442	8	11,5	28,5
58389	8	75	8
52458	9,5	10,5	27
58242	9,5	11	21,5
58137	9,9	12	28,5
58243	10	12	19,5
52348	10,3	10,5	27
58260	10,5	13	28,5
58140	10,5	13	35
52428	10,8	11,8	37
58251	11,5	13,5	28,5
58190	11,5	13,5	37

5002

REFER.	D	d	H
52383	13,6	9,3	18,3
51851	14,5	9,6	22,4
52269	16,5	10	22,5

5003

REFER.	D	d	H
52357	15,3	6,7	20,2
52355	15,7	10,7	27,8
52056	19,7	9	20
52405	21	11,2	20
52346	21	11,2	24,8
52263	21	12,5	20
52434	23,8	11,5	22
58055	27,5	15	23,2

5004

REFER.	D	d	H
51885	10,8	11,4	26,7
51547	11	11	29
52457	12	12	28
52372	13,2	9,8	19,3
52352	13,5	13,5	25
58308	14	14	29
52403	15	13,5	24,8
52062	16,8	11,9	21,5
51506	18,5	15	24,5

5005

REFER.	D	d	H
52057	14	10,2	18,5
50834	15,9	10,9	22,5
52497	27,2	27,2	17,5

5006

REFER.	D	d	H
58225	12	12	26
51586	20	20	21,5

5009

REFER.	D	d	H
52322	9,5	10	22

52453	10	10	21,5
52049	11,5	9,5	21,5
52314	16	12,5	23

5010

REFER.	D	d	H
52404	14,8	16,7	22,5
51548	15	10	25
51860	16,5	11,5	24
58256	20	11,5	27

5011

REFER.	D	d	H
52409	7	5,7	7
52223	16	11,5	18
52058	19	9,5	18

5012

REFER.	D	d	H
52222	13,5	7	16,5

5013

REFER.	D	d	H
51813	13,3	7,5	13
52220	16,3	11,5	25

BRAKE COMPONENTS CLASSIFIED BY FIGURES
 PIÈCES DE FREINAGE CLASSIFIÉES PAR FIGURE
 INTERTEILE VON BREMSEN KLASSIFIZIERT DURCH ZEICHNUNGEN

5014

REFER.	D	d	H
51572	17	10	22

5015

REFER.	D	d	H
52059	17,5	11,5	9
51542	24	15	8
52380	25,5	16	8

5016

REFER.	D	d	H
52213	20	14	19

5017

REFER.	D	d	H
52249	11	5	15
52247	11	6,5	40
52371	13	8	17,5
52248	13	8	20
52080	13,8	11	25
52214	14	7,7	16
52246	14	8	21,5
52216	15	7,5	12

5018

REFER.	D	d	H
52452	9,2	7	47
52217	11	7,5	50
52086	11,5	7,5	47
52358	11,5	8	40
52050	13,5	10	63
52250	13,5	10,5	52,5

5019

REFER.	D	d	H
52070	17,5	12	18,5
52071	18	13	32,5
58053	20	12	19
52075	21	13,5	18,5

5020

REFER.	D	d	H
51569	20	11,5	18
52459	20	11,5	29,5
58370	21	14	28
58168	24	16	18

5021

REFER.	D	d	H
58252	14,7	10,3	24

52043	17,2	11,8	25
52270	21,3	12,3	23
52496	23,3	11,5	27
58159	25	11,5	24

5022

REFER.	D	d	H
51807	15	9,7	24,2

5023

REFER.	D	d	H
50892	25,6	16,1	18,8
52381	26,5	18	18

5024

REFER.	D	d	H
51567	30,5	15,2	8,7

5025

REFER.	D	d	H
52423	35	14,5	22,5
51882	38	18	22

5026

REFER.	D	d	H
58064	23,3	10,1	24
52335	23,6	10,3	22,6
52212	25,2	15	29
52439	25,4	14,4	25
52336	25,5	13,5	26
52334	25,6	17	19,4
52337	27,6	14,5	22,5

5027

REFER.	D	d	H
52265	20,5	9	13

5028

REFER.	D	d	H
52256	17	10	18,5
52048	18,5	10	17
52061	18,5	10	17,5
52257	20	12,5	16
52252	20	12,5	37,5
52255	20,5	10	14
52215	20,5	12	17,5
52440	20,5	13	27,5

BRAKE COMPONENTS CLASSIFIED BY FIGURES
 PIÈCES DE FREINAGE CLASSIFIÉES PAR FIGURE
 INTERTEILE VON BREMSEN KLASSIFIZIERT DURCH ZEICHNUNGEN

5029

REFER.	D	d	H
52384	16,4	14	70

5034

REFER.	D	d	H
52345	16,7	12,3	11

5039

REFER.	D	d	H
51837	27,5	14,5	16

5043

REFER.	D	d	H
58025	10,5	8	18

5030

REFER.	D	d	H
52382	16	16,8	20

5035

REFER.	D	d	H
52047	14,5	10	13,5
51844	15	10	14,2

5040

REFER.	D	d	H
52260	27	17	31

5045

REFER.	D	d	H
51804	15	10	11,8
58361	15,2	20,3	12,2
51590	16	11,5	12
58386	16,5	13	15
51513	18	10,2	14,3
58157	20	15,5	16

5031

REFER.	D	d	H
51887	9,7	7	15
52273	12	8	16,5
52373	13,6	10,9	18
52407	16	12	14

5036

REFER.	D	d	H
52398	9	10	22
52465	10	7,7	21,3
58165	10,7	12	22

5041

REFER.	D	d	H
52362	38	17	70,3
58220	43,5	11	63
58027	44,5	18	72

5046

REFER.	D	d	H
58068	25	14,5	14,5

5032

REFER.	D	d	H
52354	12,9	7,4	15,7

5037

REFER.	D	d	H
58066	13	9	25
52433	13,5	8,6	21,7

5042

REFER.	D	d	H
52435	11,8	12,8	40,8

5047

REFER.	D	d	H
52054	10,5	10,5	34,5

BRAKE COMPONENTS CLASSIFIED BY FIGURES
 PIÈCES DE FREINAGE CLASSIFIÉES PAR FIGURE
 INTERTEILE VON BREMSEN KLASSIFIZIERT DURCH ZEICHNUNGEN

5048			
			
REFER.	D	d	H
51874	11,7	11,7	32,4

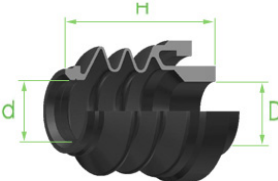
5052			
			
REFER.	D	d	H
58254	9,7	11,5	30

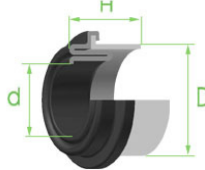
5056			
			
REFER.	D	d	H
58319	19,5	10,5	13

5060			
			
REFER.	D	d	H
58373	27	22	23

5049			
			
REFER.	D	d	H
52304	23,8	10,2	28,2

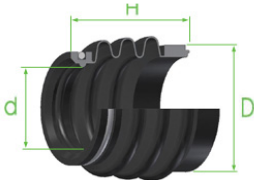
5053			
			
REFER.	D	d	H
58309	24,5	16	25

5057			
			
REFER.	D	d	H
58371	18,5	15	23

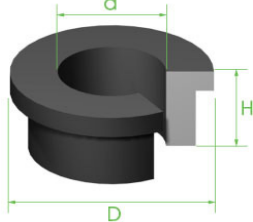
6000			
			
REFER.	D	d	H
62292	17,5	10	8

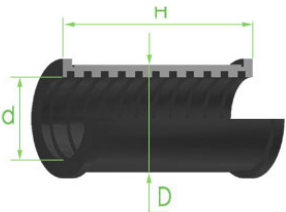
5050			
			
REFER.	D	d	H
58198	30	20,8	54

5054			
			
REFER.	D	d	H
52350	16,5	11	30

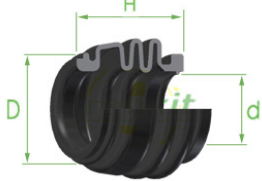
5058			
			
REFER.	D	d	H
52353	16,5	10	17

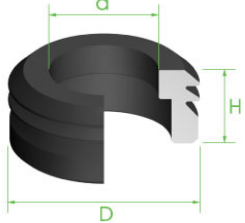
6001			
			
REFER.	D	d	H
62230	25,4	14,8	12

5051			
			
REFER.	D	d	H
58240	10,5	14	42

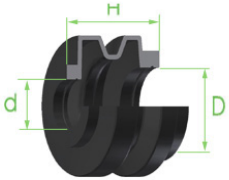
5055			
			
REFER.	D	d	H
51853	13	9,5	20

5059			
			
REFER.	D	d	H
58374	14	9	30

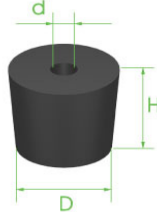
6002			
			
REFER.	D	d	H
61701	8,7	2,7	8,3

BRAKE COMPONENTS CLASSIFIED BY FIGURES
 PIÈCES DE FREINAGE CLASSIFIÉES PAR FIGURE
 INTERTEILE VON BREMSEN KLASSIFIZIERT DURCH ZEICHNUNGEN

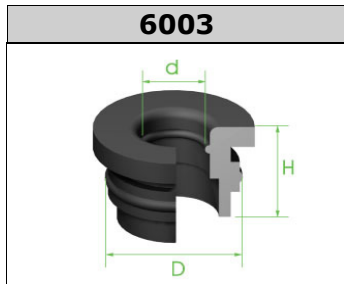

REFER.	D	d	H
68310	22,8	12,5	15,7
60791	22,8	12,5	17,8
62293	23,3	12,5	16

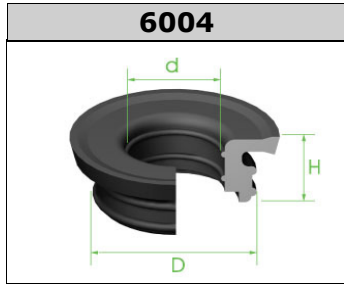

REFER.	D	d	H
68065	17,4	9,3	13
62085	17,5	7	11,8
61892	18,3	8	11
62299	19,3	8	12,2
62081	22,5	12	10
62475	23,3	12,2	12,4
62077	23,4	13	11,5
68249	24	11,5	12
62300	24,5	10,8	12
62290	24,5	13,5	11
62288	30	17,6	11,5

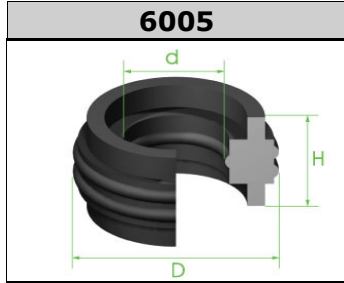

REFER.	D	d	H
61816	23	11,3	12

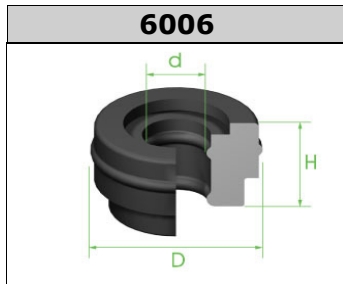

REFER.	D	d	H
61521	17,5	6,5	10,3
68368	20	9	10

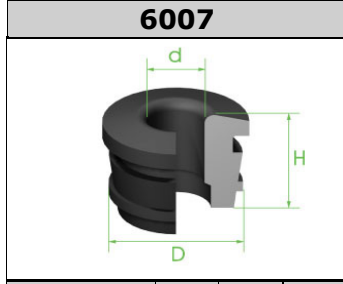

REFER.	D	d	H
60791C	19,2	8,7	17

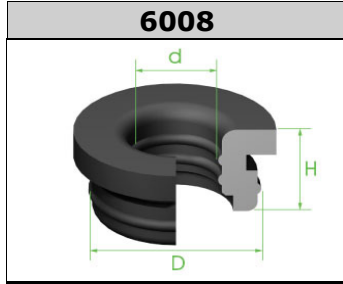

REFER.	D	d	H
61507	17,5	6,5	13,7
62307	20	8,5	13,5
68057	22	11	13
60791B	23	8	13
60791A	23	11	13
60791AM	23	11	13

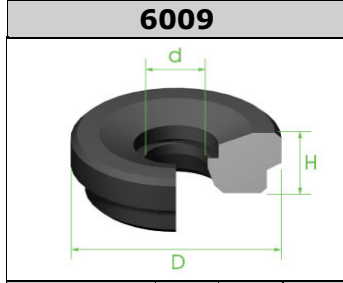

REFER.	D	d	H
61523	24	6,9	8

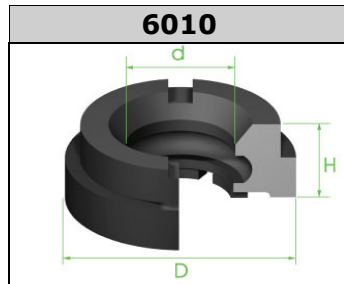

REFER.	D	d	H
61522	23,5	10,6	9

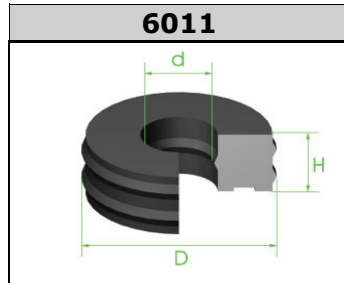

REFER.	D	d	H
60791E	21,3	7,6	7,4

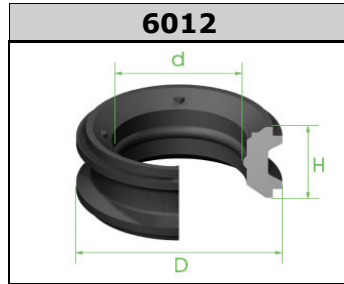

REFER.	D	d	H
61526	21,6	13,3	9,1

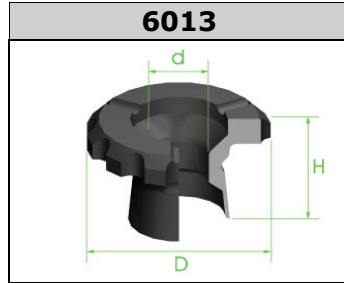

REFER.	D	d	H
62231	13,8	6,5	11,5
62235	21	6,5	13,3

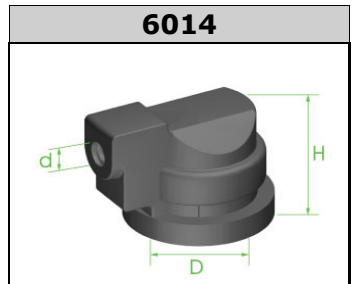

REFER.	D	d	H
68119	10,5	4,5	18,2
61879	12,3	3,55	20

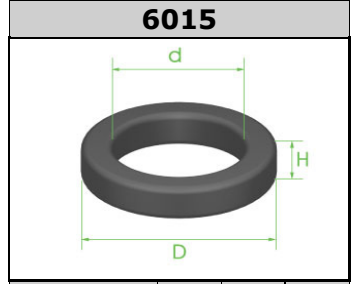

REFER.	D	d	H
61919	15	11,5	2
61920	20	17	2,5

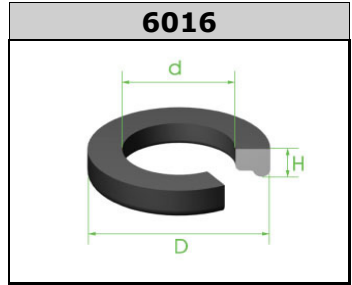

REFER.	D	d	H
62033	12,6	7,8	2,3



REFER.	D	d	H
62429	10	7	18
62456	10	7,1	15,9
68189	12	8,5	18,2
68264	17,8	14,5	12,5

BRAKE COMPONENTS CLASSIFIED BY FIGURES
 PIÈCES DE FREINAGE CLASSIFIÉES PAR FIGURE
 INTERTEILE VON BREMSEN KLASSIFIZIERT DURCH ZEICHNUNGEN

6018

REFER.	D	d	H
62426	26	20,8	16

6019

REFER.	D	d	H
61839	17	0	1

6020

REFER.	D	d	H
62091	8	4,8	2,2
68146	9,9	7	2,2

6021

REFER.	D	d	H
61566	25,5	17	6

6022

REFER.	D	d	H
62068	20,2	14	4,8

6023

REFER.	D	d	H
62067	11,5	8,2	26
68330	11,5	9	28
62421	13,5	9,5	26,5

6024

REFER.	D	d	H
68382	7,8	5,4	26
68204	8,5	5,8	22,7
68151	9,5	7	19
62227	10	7	18
68201	10	7	20
68226	10,7	8	21,5
68062	11	6	18,6
68387	11,7	8,5	20
68261	12	6,5	18
68375	13,5	10	26

6025

REFER.	D	d	H
68304	8,8	6,1	4,8

62232	9	4,7	8
68241	10	6	9
68202	10	6,5	9,3
62349	10,2	6	7,8
62455	10,7	6,7	9,9
62229	11	7	8
62351	12	9	5

6026

REFER.	D	d	H
60795	4,5	0	9,5

6027

REFER.	D	d	H
61841	40	5,5	8,5

6028

REFER.	D	d	H
62224	28,5	16,5	5
62367	29	13,8	5

6029

REFER.	D	d	H
62051	20,2	8	10
68321	25,5	13,5	9,7
62471	27	16	9,3

6030

REFER.	D	d	H
61884	25	12,2	7
62094	28	12,8	7,4

6031

REFER.	D	d	H
62073	21	16,2	8
68199	30,8	28,6	6,7

6032

REFER.	D	d	H
61895	19,5	16,7	13,7
68173	21,5	18,8	13
68214	23,5	20,8	13,5

6033

REFER.	D	d	H
62074	37	26	10

BRAKE COMPONENTS CLASSIFIED BY FIGURES
 PIÈCES DE FREINAGE CLASSIFIÉES PAR FIGURE
 INTERTEILE VON BREMSEN KLASSIFIZIERT DURCH ZEICHNUNGEN

6034

REFER.	D	d	H
62211	25,7	12,5	12,2

6038

REFER.	D	d	H
62356	25,5	13	8,8

6042

REFER.	D	d	H
62443	22,5	0	14,5

6048

REFER.	D	d	H
61714	18	6,5	18,5

6035

REFER.	D	d	H
62342	24,4	15	6
68021	47	33,5	7

6039

REFER.	D	d	H
62359	9,2	0	5

6043

REFER.	D	d	H
62148	7,9	4	1,9

6049

REFER.	D	d	H
62360	12,9	0	5,2

6036

REFER.	D	d	H
61772	27	14,5	4
68363	38,2	18	4

6040

REFER.	D	d	H
62364	9,3	9,3	7,5

6044

REFER.	D	d	H
62491	13,7	9,5	4
68152	20	13,2	4

6050

REFER.	D	d	H
62425	14,5	4,4	10

6037

REFER.	D	d	H
62225	23,5	12,6	5,9

6041

REFER.	D	d	H
62366	23	12,3	8,5

6045

REFER.	D	d	H
60792	13,4	5,7	5,8

6052

REFER.	D	d	H
62454	11,5	9	4

BRAKE COMPONENTS CLASSIFIED BY FIGURES
 PIÈCES DE FREINAGE CLASSIFIÉES PAR FIGURE
 INTERTEILE VON BREMSEN KLASSIFIZIERT DURCH ZEICHNUNGEN

6053

REFER.	D	d	H
62478	44,6	34	4,7

6057

REFER.	D	d	H
68010	17,1	10,4	12,7

6061

REFER.	D	d	H
68258	17	8	11,7

6070

REFER.	D	d	H
68323	13,5	7,5	7,2

6054

REFER.	D	d	H
62582	31,2	13,8	7,5

6058

REFER.	D	d	H
68147	58,6	44	9

6066

REFER.	D	d	H
68255	20,8	9	4,5

6071

REFER.	D	d	H
86109	17,5	8,5	10

6055

REFER.	D	d	H
62596	37	27	7,5

6059

REFER.	D	d	H
68170	17,5	14,5	24,5
68171	19,5	17	25

6067

REFER.	D	d	H
68305	25	13	10,5

6072

REFER.	D	d	H
68365	4,5	9,3	4,5

6056

REFER.	D	d	H
68009	43	29	4
68056	50	34	3,8

6060

REFER.	D	d	H
68138	10	5	8,5

6068

REFER.	D	d	H
68307	26,8	7,5	14,5

6073

REFER.	D	d	H
68369	15	9,5	4

BRAKE COMPONENTS CLASSIFIED BY FIGURES
 PIÈCES DE FREINAGE CLASSIFIÉES PAR FIGURE
 INTERTEILE VON BREMSEN KLASSIFIZIERT DURCH ZEICHNUNGEN

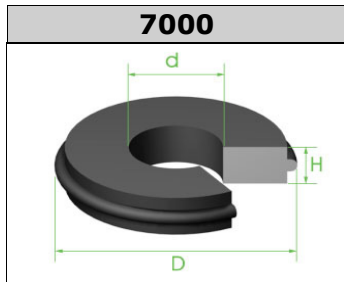

REFER.	D	d	H
70012	24,8	9,7	4,5
72106	25,4	19,3	1,6

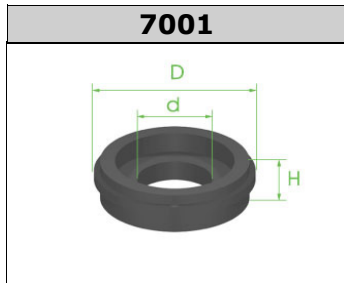

REFER.	D	d	H
72105	6,4	1,8	3,7
70877	10	5	4
70019	11	5	4
72143	11,4	3	5,1
70019A	15	7	4

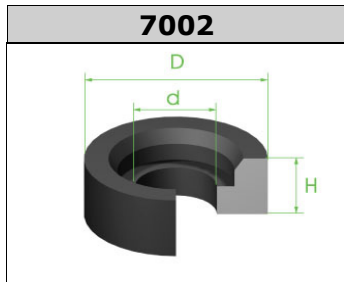

REFER.	D	d	H
71651	8,8	2,6	5,5
71396	9	4,1	4

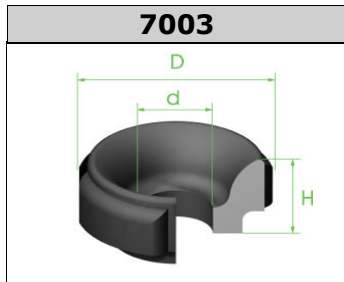

REFER.	D	d	H
70411	18,3	6,7	8
70458	22,3	6,4	10,4

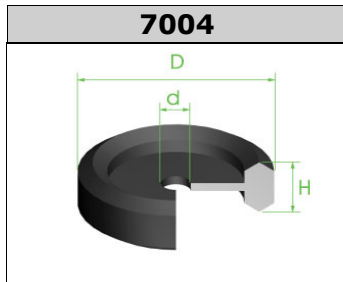

REFER.	D	d	H
70020	16,5	2,5	5

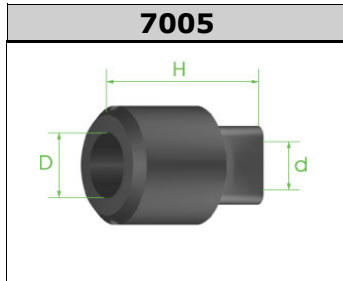

REFER.	D	d	H
72044	5	2	12
71762	5	3	14,6

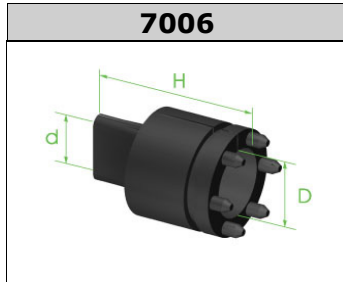

REFER.	D	d	H
71688	5,8	5,5	13



REFER.	D	d	H
70789	15,9	0	0
71147	19,1	0	0
71148	20,5	0	0

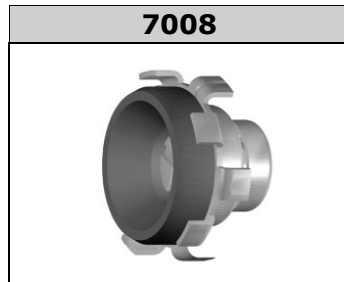

REFER.	D	d	H
71150	25,4	0	0
71104	31,8	0	0
71108	38,1	0	0



REFER.	D	d	H
70159	19,1	0	0

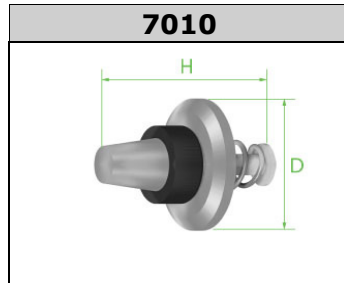

REFER.	D	d	H
71161	18,6	0	25,4

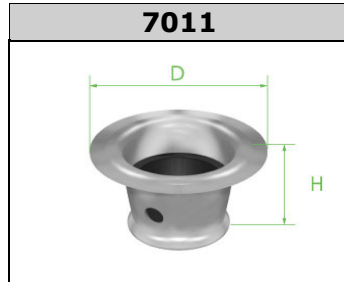

REFER.	D	d	H
71125	17,5	0	9,5
70916	19,1	0	12
71130	25,4	0	13,5

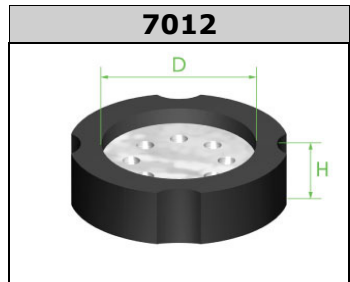

REFER.	D	d	H
71307	9	0	4
71383A	13	0	6

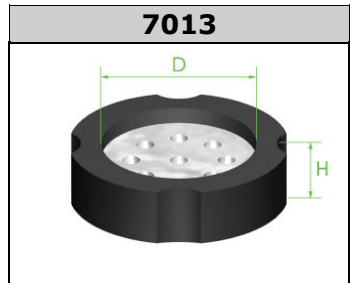

REFER.	D	d	H
72042	10,4	0	5,2
71383	13	0	6



REFER.	D	d	H
71133	19,1	0	0
71132	22,2	0	0
71131	25,4	0	0
71134	31,8	0	0



REFER.	D	d	H
71136	19,1	0	0

BRAKE COMPONENTS CLASSIFIED BY FIGURES
 PIÈCES DE FREINAGE CLASSIFIÉES PAR FIGURE
 INTERTEILE VON BREMSEN KLASSIFIZIERT DURCH ZEICHNUNGEN

7016			
REFER.	D	d	H
71137	15,9	0	0

7017			
REFER.	D	d	H
70414	14	5,9	4,2

7018			
REFER.	D	d	H
71140	17	0	18,5

7019			
REFER.	D	d	H
70009	16,5	13	8,5

7020			
REFER.	D	d	H
72138	15,3	7	10,3
70018	17,2	10,2	10,5

7021			
REFER.	D	d	H
70413	11	4,7	3,8

7022			
REFER.	D	d	H
71141	10,2	0,5	9,2

7025			
REFER.	D	d	H
72477	9	0	7,9

7026			
REFER.	D	d	H
78257	12,5	4,5	7,5
72479	14,5	6	9,4

7027			
REFER.	D	d	H
71135	38,1	0	0

8100			
REFER.	D	d	H
81171	17,6	0	2,5
81421	42,5	37,8	2,8
81477	47,3	0	2,7
81510	51	0	2,25
81525	52,5	0	2,6
81588	58,8	0	4
81620	62	0	3,9
81654	65,4	0	3,9
81655	67,7	63,5	4
81660	70	66,3	4

REFER.	D	d	H
81171	17,6	0	2,5
81421	42,5	37,8	2,8
81477	47,3	0	2,7
81510	51	0	2,25
81525	52,5	0	2,6
81588	58,8	0	4
81620	62	0	3,9
81654	65,4	0	3,9
81655	67,7	63,5	4
81660	70	66,3	4

8101			
REFER.	D	d	H
81105	50	0	1,5
81104	54	0	1,5

81103	58	0	1,5
81101	67	0	1,5
81100	71	0	1,5
81102	78	0	1,5
81106	94	0	1,5

8102			
REFER.	D	d	H
81205	41	0	1,4
81200	47,5	0	1,5
81206	50,5	0	1,8
81201	54,5	0	1,8
81202	60	0	1,8
81203	65,5	0	1,8

81205	41	0	1,4
81200	47,5	0	1,5
81206	50,5	0	1,8
81201	54,5	0	1,8
81202	60	0	1,8
81203	65,5	0	1,8

8103			
REFER.	D	d	H
81301	43,5	0	2,5
81300	52,2	0	2,5
81303	60	0	2,5
81304	69,5	0	2,5

81301	43,5	0	2,5
81300	52,2	0	2,5
81303	60	0	2,5
81304	69,5	0	2,5

8200			
REFER.	D	d	H
82118	19,5	0	1
82119	20,5	0	1
82120	21,5	0	1
82121	22,5	0	1
82122	23,5	0	1
82123	24,6	0	1,2
82124	25,9	0	1,2
82125	26,9	0	1,2
82126	27,9	0	1,2
82127	29,1	0	1,2

82118	19,5	0	1
82119	20,5	0	1
82120	21,5	0	1
82121	22,5	0	1
82122	23,5	0	1
82123	24,6	0	1,2
82124	25,9	0	1,2
82125	26,9	0	1,2
82126	27,9	0	1,2
82127	29,1	0	1,2

BRAKE COMPONENTS CLASSIFIED BY FIGURES
 PIÈCES DE FREINAGE CLASSIFIÉES PAR FIGURE
 INTERTEILE VON BREMSEN KLASSIFIZIERT DURCH ZEICHNUNGEN

82128	30,1	0	1,2
82130	32,1	0	1,2
82131	33,4	0	1,2
82132	34,4	0	1,2
82134	36,5	0	1,5
82135	37,8	0	1,5
82136	39	0	1,5
82137	40	0	1,5
82140	43,5	0	1,75
82142	45,5	0	1,75

8201

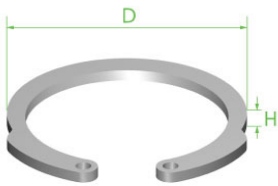

REFER.	D	d	H
82220	18	0	1
82224	24	0	1,2
82230	28	0	1,2
82232	30	0	1,2

8202

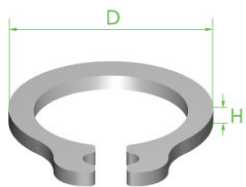

REFER.	D	d	H
82695	9,5	0	0,8

8203

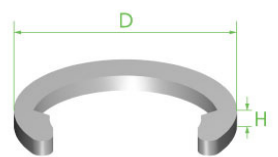

REFER.	D	d	H
82510	10	0	0,8

8204

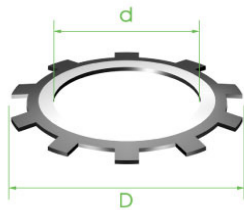

REFER.	D	d	H
82325	25,5	16,1	0
82335	35,5	24,9	0

8205

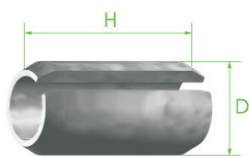

REFER.	D	d	H
82001	4	0	30
82002	4,5	0	45

8206



REFER.	D	d	H
82745	45	0	2,4

8207

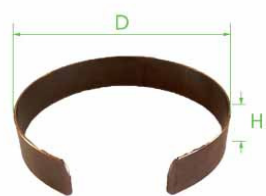

REFER.	D	d	H
86020	60	0	12,2

8208

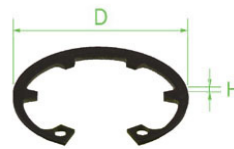

REFER.	D	d	H
82430	32,6	0	1,2

8210



REFER.	D	d	H
86009	35	0	1,5

8211



REFER.	D	d	H
82701	35	0	1

8300

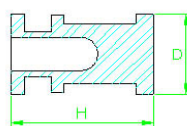

REFER.	D	d	H
83191	19	0	32

8301

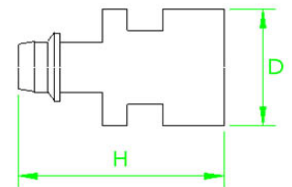

REFER.	D	d	H
83199	19	0	31,5
83202	20,6	0	35

8302



REFER.	D	d	H
83195	19,1	0	50,5

8303

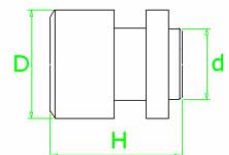

REFER.	D	d	H
83194	19	0	0
83251	25,4	16,5	29
83252	25,4	16,5	29

8304

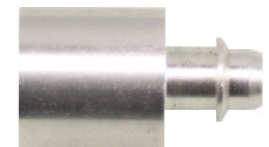

REFER.	D	d	H
83198	19	0	31,9
87191	19	0	31,9

BRAKE COMPONENTS CLASSIFIED BY FIGURES
 PIÉCES DE FREINAGE CLASSIFIÉES PAR FIGURE
 INTERTEILE VON BREMSEN KLASSIFIZIERT DURCH ZEICHNUNGEN

8305



REFER.	D	d	H
83199.3	19	0	68

8309

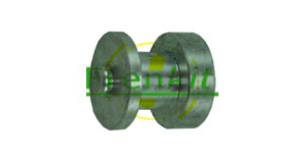

REFER.	D	d	H
83280	28,6	0	30,2
83300	30	0	0

8313



REFER.	D	d	H
83203	20,6	0	0

8318



REFER.	D	d	H
83199.2	19	19	49

8306



REFER.	D	d	H
87193	23,8	0	0

8310



REFER.	D	d	H
83283	28,6	0	0

8314



REFER.	D	d	H
83197	19	0	40

8400

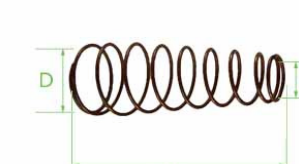

REFER.	D	d	H
84300	0	0	0

8307



REFER.	D	d	H
83230	16	0	50

8311

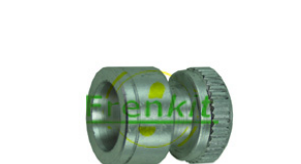

REFER.	D	d	H
83270	27	0	0

8316



REFER.	D	d	H
83150	15,9	0	0

REFER.	D	d	H
84150	11,5	8	65
84192	14	7	22
84194	17	10	43
84193	17	14	73
84191	17	14	74
84180	18	12	71
84196	18	13	40
84208	18,8	10	37
84190	19	10	48
84205	20,6	9,5	45
84223	22,2	0	0
84270	25,8	22,5	46
84282	28,6	0	0

8308



REFER.	D	d	H
87192	19	0	0

8312



REFER.	D	d	H
83222	22,2	0	0
83250	25,4	0	0

8317



REFER.	D	d	H
83192	19	0	34

8401

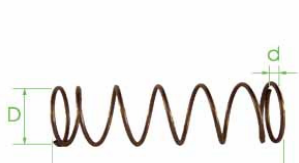

REFER.	D	d	H
84301	17	1,2	75
84251	18,7	1,4	63
84280	22,5	0	44

BRAKE COMPONENTS CLASSIFIED BY FIGURES
 PIÈCES DE FREINAGE CLASSIFIÉES PAR FIGURE
 INTERTEILE VON BREMSEN KLASSIFIZIERT DURCH ZEICHNUNGEN

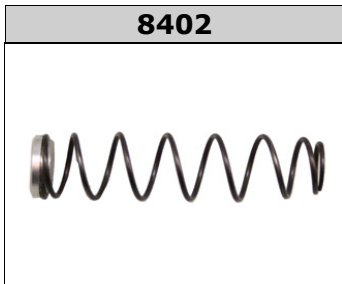

REFER.	D	d	H
84250	0	0	0
84110	10,9	10,7	73,4
84197	15	14	78
84209	17,8	1,5	82

8403

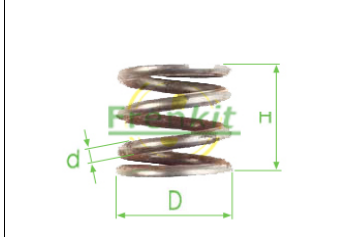

REFER.	D	d	H
84224	22	3	20,5
84230	23,5	2,5	17

8404

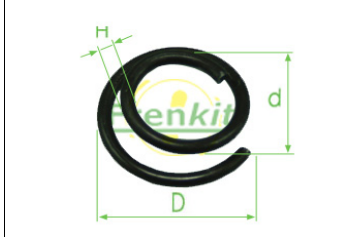

REFER.	D	d	H
84302	30	20	3

8405

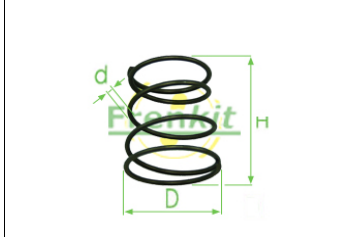

REFER.	D	d	H
84310	31	18	39

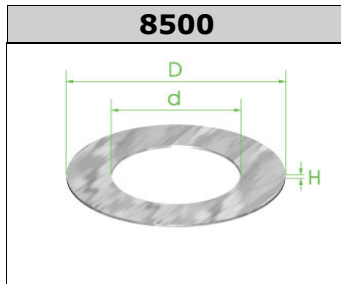

REFER.	D	d	H
85100	10	7	1
85101	10,2	7,4	0,1
85132	13,8	8,2	0,15
85130	13,9	10,3	0,15
85140	14,8	7,5	0,15
85151	15	8,2	0,15
85141	15	10	1,5
85150	15,5	9,8	0,15
85160	16	10	1,5
85170	17	9,2	0,15
85171	17	10,5	0,15
85183	18,2	8,2	0,15
85182	18,3	10,2	0,15
85181	18,5	10,7	0,15
85180	18,5	11,3	0,15
85191	19,2	12,7	0,15
85190	19,7	10,4	0,15
85204	20	10,4	2,6
85211	20	10,8	0,15
85202	20	13,3	0,15
85201	20,1	11,1	0,15
85203	20,4	8,3	0,15
85215	21	10,5	2
85217	21	13	1
85210	21,3	13,5	0,15
85214	21,5	14,4	0,15
85223	22	12	0,5
85222	22	15,5	0,4
85233	22,5	15,5	0,15
85221	22,7	14,4	0,15
85230	23	10,7	0,15
85232	23	13,3	0,15
85184	24	18	1
85243	24,3	17	0,15
85247	24,5	18,2	0,15
85242	24,7	16,2	0,15
85250	25,5	16	0,8
85263	26	13,1	0,15
85261	26,3	18,7	0,15
85270	27	18	0,6
85271	27	20	0,15
85290	29	19	1
85310	31	21,5	0,15
85312	31,3	25,2	1,5
85331	33,8	24	2
85380	38	16	0,2

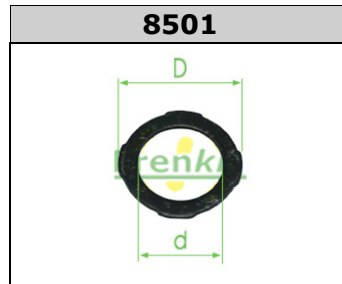

REFER.	D	d	H
85235	23	15,5	1

8502



REFER.	D	d	H
85152	29	15,2	0,4

8503



REFER.	D	d	H
85218	21	14	0,25
85234	23	16	0,4
85251	25	19	0,3
85264	26	18	0,3

8600

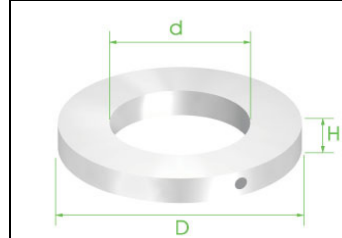

REFER.	D	d	H
86070	24,7	14	6
86001	24,8	14,1	3

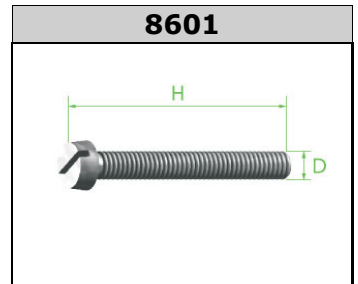

REFER.	D	d	H
86002	4	0	32

8602



REFER.	D	d	H
86058	8	0	45
86057	8	0	55
86072	8	0	70
86097	8	1,25	60

8604

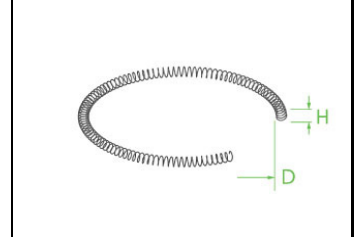

REFER.	D	d	H
86008	24,5	0	1,6

8605

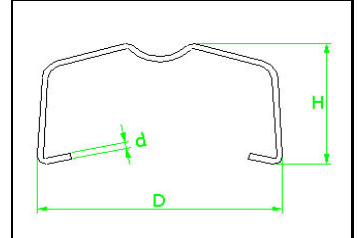

REFER.	D	d	H
86012	66	1,5	38

BRAKE COMPONENTS CLASSIFIED BY FIGURES
 PIÈCES DE FREINAGE CLASSIFIÉES PAR FIGURE
 INTERTEILE VON BREMSEN KLASSIFIZIERT DURCH ZEICHNUNGEN

8606

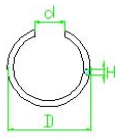

REFER.	D	d	H
86114	26,5	6	2,5
86034	27,3	10	2

8611

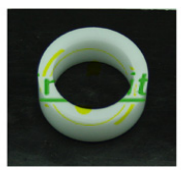

REFER.	D	d	H
86067	22	16	12

8615

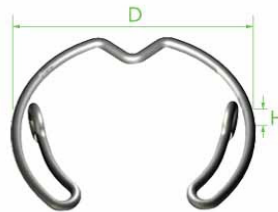

REFER.	D	d	H
86241	30	0	1,6
86035	32	0	1,4
86242	32	0	1,8

8619



REFER.	D	d	H
86037	51,6	25	14

8608



REFER.	D	d	H
86004	0	0	0

8612



REFER.	D	d	H
86100	8	6	61

8616



REFER.	D	d	H
86013	76	42,5	8

8620



REFER.	D	d	H
86039	54,5	31,3	10

8609



REFER.	D	d	H
86007	175	10	25

8613



REFER.	D	d	H
86033	0	0	0

8617



REFER.	D	d	H
86014	76	42,5	8

8621



REFER.	D	d	H
86055	49	34,5	0,8
86041	50	36	0,8
86054	53	38,5	0,9
86042	53	39,5	0,9

8610



REFER.	D	d	H
86065	52,5	0	3,5

8614



REFER.	D	d	H
86016	34	16,9	8,5
86068	36	17	8,5

8618



REFER.	D	d	H
86038	51,6	25	14

8622



REFER.	D	d	H
86043	73,5	50,5	4

BRAKE COMPONENTS CLASSIFIED BY FIGURES
 PIÈCES DE FREINAGE CLASSIFIÉES PAR FIGURE
 INTERTEILE VON BREMSEN KLASSIFIZIERT DURCH ZEICHNUNGEN

8623			
			
REFER.	D	d	H
86044	76,5	53,3	4

8627			
			
REFER.	D	d	H
86052	55	23	13,5

8631			
			
REFER.	D	d	H
86063	52,5	3,5	3,5

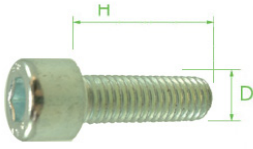
8636			
			
REFER.	D	d	H
86006	10	0	30

8624			
			
REFER.	D	d	H
86046	60	30	7,5
86047	73	39	7,5

8628			
			
REFER.	D	d	H
86051	55	23	13,5

8632			
			
REFER.	D	d	H
86062	0	0	0

8637			
			
REFER.	D	d	H
86056	8	1,25	21

8625			
			
REFER.	D	d	H
86045	60	30	7,5
86048	76	39	7,5

8629			
			
REFER.	D	d	H
86050	71,3	42	8

8634			
			
REFER.	D	d	H
86017	60	40	8

8638			
			
REFER.	D	d	H
86074	25	8,5	19

8626			
			
REFER.	D	d	H
86053	57	41,8	4,4

8630			
			
REFER.	D	d	H
86049	72,3	42	8

8635			
			
REFER.	D	d	H
86010	0	0	0

8639			
			
REFER.	D	d	H
86075	20	16	7,7

BRAKE COMPONENTS CLASSIFIED BY FIGURES
 PIÈCES DE FREINAGE CLASSIFIÉES PAR FIGURE
 INTERTEILE VON BREMSEN KLASSIFIZIERT DURCH ZEICHNUNGEN

8640



REFER.	D	d	H
86064	53	37	10

8641



REFER.	D	d	H
86099	19,6	18	6,5

8642



REFER.	D	d	H
86111	18	16	10
86022	23,2	20,2	15

8643



REFER.	D	d	H
86090	20,5	12,5	3

8644

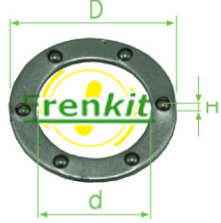

REFER.	D	d	H
86091	20	13,5	2
86224	26,5	18	3

8645



REFER.	D	d	H
86024	10	1,25	70
86083	10	1,25	80
86245	10	1,25	97
86023	12	1,25	85

8646



REFER.	D	d	H
86025	8	1	67

8647



REFER.	D	d	H
86027	8	4,8	58,5

8648



REFER.	D	d	H
86028	1,4	0	0

8649



REFER.	D	d	H
86029	0	0	0

8650



REFER.	D	d	H
86076	31,5	25,5	0,5

8651



REFER.	D	d	H
86077	30	24	0,5

8652



REFER.	D	d	H
86106	20	16,5	3,5
86078	34	21,9	5
86107	37	25	5

8654

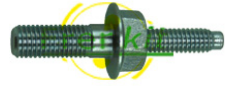

REFER.	D	d	H
86080	8	6	47

8655

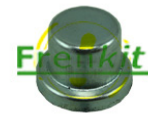

REFER.	D	d	H
86081	19	15,5	21

8656



REFER.	D	d	H
86082	16,8	10	8

BRAKE COMPONENTS CLASSIFIED BY FIGURES
 PIÈCES DE FREINAGE CLASSIFIÉES PAR FIGURE
 INTERTEILE VON BREMSEN KLASSIFIZIERT DURCH ZEICHNUNGEN

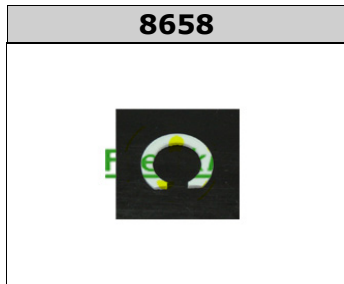

REFER.	D	d	H
86084	11,8	8	1,3



REFER.	D	d	H
86086	8	1,25	72



REFER.	D	d	H
86087	20	12	19,5
86089	20	12	24,5
86088	20	13	24,5



REFER.	D	d	H
86092	24	12,6	2
86095	27	12,8	1,5
86096	32,3	12,8	1,6

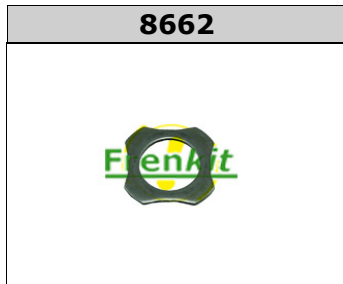

REFER.	D	d	H
86093	24	12,8	1,5
86094	24	13,8	1,5



REFER.	D	d	H
86101	15,5	6	7



REFER.	D	d	H
86011	0	0	0



REFER.	D	d	H
86103	20,6	16,4	6
86102	20,6	16,4	36



REFER.	D	d	H
86079	26	22,5	3



REFER.	D	d	H
86073	30	21,2	15,7



REFER.	D	d	H
86244	14	10	7
86104	14	12	5,7

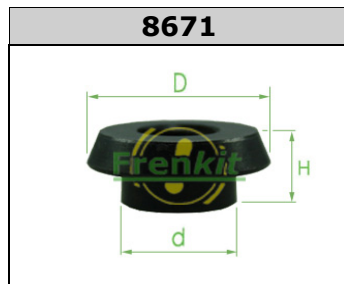

REFER.	D	d	H
86221	23	14,5	10

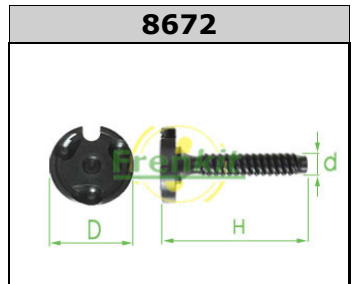

REFER.	D	d	H
86222	30,5	10	54

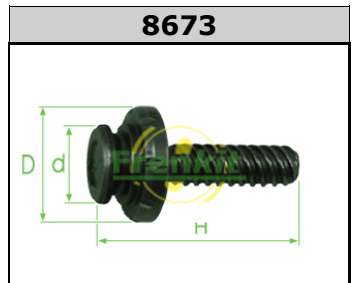

REFER.	D	d	H
86226	26	18	44,5

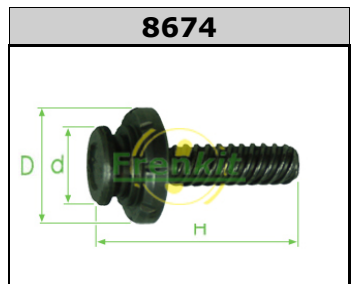

REFER.	D	d	H
86227	26	18	44,5

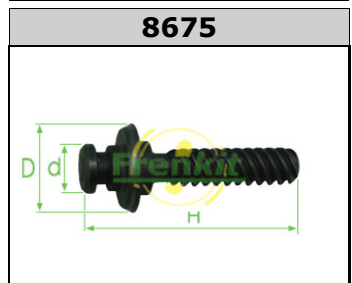

REFER.	D	d	H
86228	21	12	50
86246	25	10	69

BRAKE COMPONENTS CLASSIFIED BY FIGURES
 PIÈCES DE FREINAGE CLASSIFIÉES PAR FIGURE
 INTERTEILE VON BREMSEN KLASSIFIZIERT DURCH ZEICHNUNGEN

8676

REFER.	D	d	H
86230	26	10	50,5
86236	26	12	55

8680

REFER.	D	d	H
86115	33	24	3

8685

REFER.	D	d	H
86229	26	16	3,5

8689

REFER.	D	d	H
86220	11	5	15

8677

REFER.	D	d	H
86231	26	10	50,5
86237	26	12	55

8681

REFER.	D	d	H
86116	17,5	15	29

8686

REFER.	D	d	H
86232	30,5	10	73

8690

REFER.	D	d	H
86243	25,7	10	25

8678

REFER.	D	d	H
86112	20,5	15	2

8682

REFER.	D	d	H
86119	20	13	20

8687

REFER.	D	d	H
86233	30,5	10	73

8691

REFER.	D	d	H
86225	30,5	10	54

8679

REFER.	D	d	H
86235	23	18	34
86118	23	18	37
86117	23	18	37
86234	28	18	45
86113	28,5	18	43
86238	29	18	36

8684

REFER.	D	d	H
86223	25,5	15	4

8688

REFER.	D	d	H
86040	54	0	0
86110	57	0	0

8701

REFER.	D	d	H
87141	6,35	3	28,5
87702	7	3	26
87704	7	3	34,5
87701	7	3,5	22
87703	7	3,5	30,5
87561	7,8	3,3	30,5
87801	8	2,5	26
87808	8	2,5	26,5
87809	8	3	33,5
87803	8	3,5	32,5
87802	8	3,5	35,5
87804	8	3,5	38

BRAKE COMPONENTS CLASSIFIED BY FIGURES
 PIÈCES DE FREINAGE CLASSIFIÉES PAR FIGURE
 INTERTEILE VON BREMSEN KLASSIFIZIERT DURCH ZEICHNUNGEN

87381	9,53	3,5	30,5
87001	10	3	30
87003	10	3,5	28
87007	10	3,5	31
87002	10	3,5	36
87004	10	3,5	37,5
87005	10	4	29,5

8702



REFER.	D	d	H
G123501	12,5	8	35
G124501	12,5	8	45
G125101	13	8,5	51
G164901	16	10	49,5
G167301	16	10	73
G166501	16	10,5	65,5

8703



REFER.	D	d	H
G125301	12	9	53,5

8704



REFER.	D	d	H
G125401	12	9	54
G126601	12	9	66,5
G125601	12,7	10	56
G126301	12,7	10	63
G136501	14	9	65
G146801	14	10	68
G165501	16	10	55
G158601	16	10	86
G168801	16	10	88

8705



REFER.	D	d	H
G136101	13	8,4	61
G134901	13,3	8,4	49
G135201	13,5	8,5	52
G145401	14,1	8,3	54
G145202	14,3	8,5	52
G155701	15	9	57
G157701	15	9	77
G155201	15	11	52
G155901	15,6	10,2	59
G154601	15,6	10,7	46
G165001	16	10	50
G166801	16	10	68
G165901	16	10,2	59
G168201	16	10,2	82,5
G164601	16	10,5	46
G166101	16	10,5	61,5
G166802	16	10,5	68,5
G167701	16	10,5	77,5
G165701	16	11	57,5
G168001	16	11	80,5
G206701	20	11	67
G206901	20	12	69
G204601	20	12,5	46,5
G205001	20	12,5	50
G226901	22	10,5	69
G227701	22	10,5	77
G226902	22	12,5	69

8706



REFER.	D	d	H
G107005	10	8	70
G107204	10	8	72

8707



REFER.	D	d	H
G206201	20	12,5	62,5
G207301	20	12,5	73,5

8708



REFER.	D	d	H
G134502	13,9	8,5	45

8710



REFER.	D	d	H
G097202	10	8	72,5

8711



REFER.	D	d	H
G086102	8	8	61,5
G086604	8	8	66,5
G086601	8,5	8	66
G105901	10	8	59
G105903	10	8	59,5
G096701	10	8	67
G107003	10	8	70
G107203	10	8	72
G107601	10	8	76,5
G118502	11	10	85
G118501	11	10	85

G125801	12	8	58
G127502	12	10	75
G128201	12,2	10	82

8712



REFER.	D	d	H
G086605	7,8	8	66,6
G105902	10	8	59,5
G096702	10	8	67
G106902	10	8	69
G107602	10	8	76,5
G118201	11,6	10	82

8713

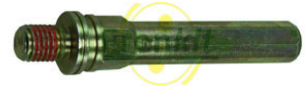

REFER.	D	d	H
G127001	12	10	70
G127801	12	10	78

8714



REFER.	D	d	H
G086603	8,4	8	66,5
G086004	8,5	8	60
G086001	8,5	8	60
G086003	8,5	8	60
G086101	8,5	8	61,5
G087101	8,5	8	71
G087501	8,5	8	75
G096502	9	8	65
G097204	9,9	8	71
G105905	10	8	59
G106101	10	8	61
G106501	10	8	65,4
G107205	10	8	72
G107202	10	8	72,5

BRAKE COMPONENTS CLASSIFIED BY FIGURES
 PIÈCES DE FREINAGE CLASSIFIÉES PAR FIGURE
 INTERTEILE VON BREMSEN KLASSIFIZIERT DURCH ZEICHNUNGEN

G107901	10	8	79,5
G107001	11	8	70

8715



REFER.	D	d	H
G086201	8	8	62,5

8717



REFER.	D	d	H
G145201	14	10	52,5
G188001	18	10	80

8718



REFER.	D	d	H
G097201	9,5	8	72

8719



REFER.	D	d	H
86060	8	1	22
86026	10	1	25
86085	10	1,25	31

8723



REFER.	D	d	H
G077201	7,5	10	72,5
G088701	8	12	87
G088001	8,5	12	81
G097901	9,2	14	79,5
G108101	10	12	81
G098701	10	12	87
G109001	10	14	90
G119201	10,9	14	92
G119003	11		90
G119001	11	15	90

8724



REFER.	D	d	H
G088301	8	12	83,5
G088702	8	12	87
G098901	9,5	12	90
G108301	10	12	83
G109202	10	14	92
G119002	10,7	15	90,5
G119202	10,8	14	92

8727



REFER.	D	d	H
G097101	9,8	8	71
G107301	10	8	73,5
G107002	11	8	70

8728



REFER.	D	d	H
G135501	13	8,5	55
G134501	14	8,5	45,5
G185801	18	8,5	58

8729



REFER.	D	d	H
G186602	18	8,5	66

8730



REFER.	D	d	H
G106901	10	8	70

8731



REFER.	D	d	H
G076301	8	8	63

8732



REFER.	D	d	H
G086202	8	8	62,5

8733



REFER.	D	d	H
G086602	8,5	8	66

8734



REFER.	D	d	H
G096501	10	8,5	65

8736



REFER.	D	d	H
G105904	10	8	59
G106502	10	8	65
G107201	10	8	72,5
G107801	10	8	78,5
G116201	11	8	62
G116601	11	8	66
G127501	12	10	75
G147701	14	10	77

BRAKE COMPONENTS CLASSIFIED BY FIGURES
 PIÈCES DE FREINAGE CLASSIFIÉES PAR FIGURE
 INTERTEILE VON BREMSEN KLASSIFIZIERT DURCH ZEICHNUNGEN

8737



REFER.	D	d	H
G106601	10	10	66

8741



REFER.	D	d	H
G107703	10	8	77

8745



REFER.	D	d	H
G126001	12	8	60

8749



REFER.	D	d	H
G096801	9,9	9,9	68,5

8738



REFER.	D	d	H
G107501	10	8	75

8742



REFER.	D	d	H
G108401	10	10	84,5

8746



REFER.	D	d	H
G145901	14	10	59

8750



REFER.	D	d	H
G086701	8,5	10	67,5

8739



REFER.	D	d	H
G107701	10	8	77

8743



REFER.	D	d	H
G096601	9,8	8	66,5
G106002	10	8	60
G106001	10	8	60
G107101	10	8	71,5
G108501	10,8	10	85

8747



REFER.	D	d	H
G168301	16	10	83

8751

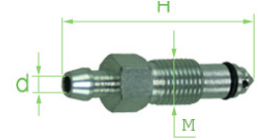

REFER.	D	d	H
87006	10	3	41,5

8740



REFER.	D	d	H
G107702	10	8	77

8744



REFER.	D	d	H
G109201	10	10	92,5

8748



REFER.	D	d	H
G227702	22	10,5	77
G258701	25	12,5	87

8752

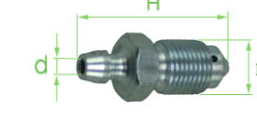

REFER.	D	d	H
87201	12	3	32

BRAKE COMPONENTS CLASSIFIED BY FIGURES
 PIÈCES DE FREINAGE CLASSIFIÉES PAR FIGURE
 INTERTEILE VON BREMSSEN KLASSIFIZIERT DURCH ZEICHNUNGEN

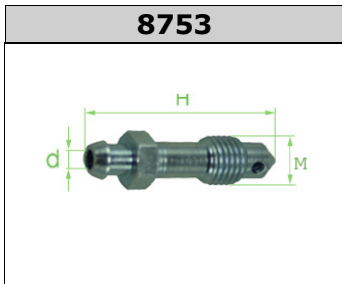

REFER.	D	d	H
87382	9,5	3,5	36

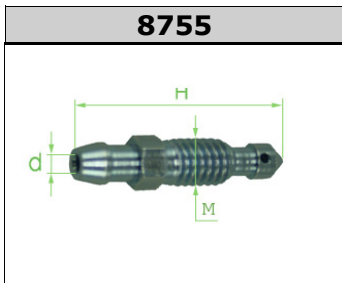

REFER.	D	d	H
87805	8	3	34,5

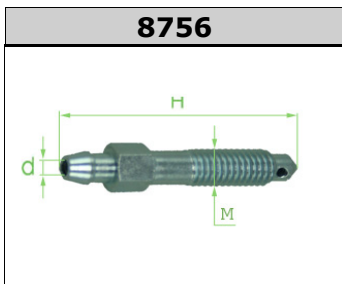

REFER.	D	d	H
87601	6	3,5	38
87807	8	3	49



REFER.	D	d	H
G186301	18	8,5	63
G186601	18	8,5	66



REFER.	D	d	H
G107102	9,7	8	71,3
G106401	10	8	64
G106904	10	8	69



REFER.	D	d	H
G106402	10	8	64
G106903	10	8	69



REFER.	D	d	H
G087502	8,5	8	75
G107004	9,9	8	70,5



REFER.	D	d	H
G105701	10	8	57



REFER.	D	d	H
G146402	14	10	64



REFER.	D	d	H
G146401	14	10	64



REFER.	D	d	H
G096001	9	8	60



REFER.	D	d	H
P234101	23,4	19,5	41,3

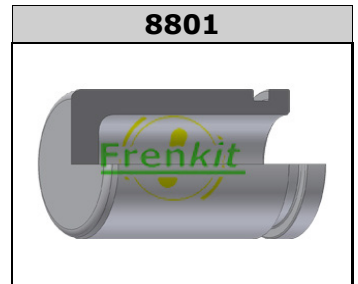

REFER.	D	d	H
P284701	28	18,5	47,5
P304602	30	21	46,5
P304702	30	21	47,5
P364501	36	26	45,8
P365301	36	27	53,5
P404101	40	31,5	41,7
P405002	40	33,4	50



REFER.	D	d	H
P302801	30	19,5	28,8
P402901	40	21,5	29
P403004	40	21,5	30
P443701	44	25	37

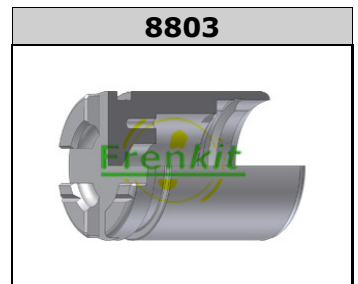

REFER.	D	d	H
P303801	30	24	38,5
P323801	32	24	38,5



REFER.	D	d	H
P304102	30	24,5	41
P304101	30	26,3	41,6

BRAKE COMPONENTS CLASSIFIED BY FIGURES
 PIÈCES DE FREINAGE CLASSIFIÉES PAR FIGURE
 INTERTEILE VON BREMSEN KLASSIFIZIERT DURCH ZEICHNUNGEN

P364401	36	30	44
----------------	----	----	----

8805

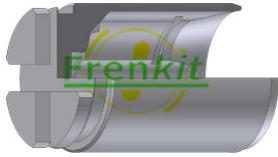

REFER.	D	d	H
P304002	30	27	40,5
P304301	30	27	43,8
P344401	34	28	44
P344702	34	28	47,2
P384701	38	33	47,2
P404701	40,4	24,5	47

8806

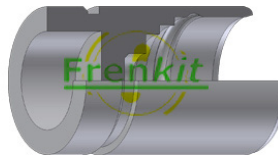

REFER.	D	d	H
P304501	30	25,8	45,5
P324501	32	25,7	45,5
P354505	35	25,8	45,5

8807

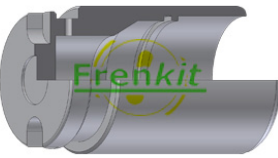

REFER.	D	d	H
P334601	34	29	46,8
P344801	34	29	48
P344101	34	29,4	41
P344201	34	30	42,8
P344706	34	30	47,2
P364805	36	31	48
P384102	38	29,5	41
P384601	38	33	46,8
P385101	38	33	51
P415101	41	35	51
P424601	43	34,4	46,8
P425102	43	34,4	51,3

8808

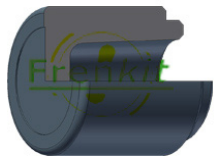

REFER.	D	d	H
P323201	32	17,5	32,6
P452601	45	32	26,5

8810



REFER.	D	d	H
P283201	28	21	32
P303201	30	22	32
P332901	33	23	29,5
P362903	36	26,6	29,2
P422601	42	32	26

8811

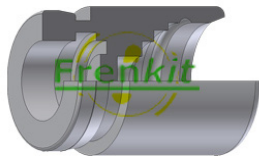

REFER.	D	d	H
P334401	33	25,8	44,1
P414301	41	26	44

8812



REFER.	D	d	H
P334901	33	22	49
P516001	51	42,4	60,5

8813



REFER.	D	d	H
P304701	30	22	47,5
P314701	31	22	47,5
P324701	32	26	47,5
P335001	33	23	50,2
P354601	35	25	46
P364702	36	29	47,5
P384802	38	29	48,5
P385201	38	29	52,5
P424401	42	32	44,6
P434503	43	32	45

8814



REFER.	D	d	H
P342801	34	23	28,6
P362801	36	25	28,8
P432801	43	31	28,6
P483301	48	32	33
P514506	51	31	45

8815



REFER.	D	d	H
P342802	34	22	28,5

8816



REFER.	D	d	H
P342901	34	22	29
P362901	36	22	29,2
P464701	46	31	47

8817



REFER.	D	d	H
P343001	34	19	30
P352601	35	23	26,6
P352801	35	23	28,5
P403003	40	21,5	30
P422901	42	21,5	29,5
P442901	44	21,5	29,5
P443001	44	25	30,6
P483001	48	32	30

8818



REFER.	D	d	H
P344602	34	25	46
P344705	34	25	47,5
P344703	34	25	47,5
P354502	35	23	45,8
P354901	35	26	49
P515301	51	43	53

BRAKE COMPONENTS CLASSIFIED BY FIGURES
 PIÈCES DE FREINAGE CLASSIFIÉES PAR FIGURE
 INTERTEILE VON BREMSEN KLASSIFIZIERT DURCH ZEICHNUNGEN



REFER.	D	d	H
P344701	34	31	47
P364701	36	32	47
P384702	38	34	47



REFER.	D	d	H
P304001	30	26	40
P354001	35	29,5	40
P354501	35	30	45



REFER.	D	d	H
P334501	33	18,5	45
P344802	34	20	48
P364803	36	22	48
P384801	38	20	48
P385001	38	22	50
P405203	40	22	52
P404802	40	25	48
P424802	42	25	48
P425201	42	25	52
P464801	46	30	48



REFER.	D	d	H
P382802	38	25	28,5
P382905	38	25	29
P382903	38	25	29,3
P403204	40	28	32
P422903	42	23	29,5
P423003	42	30	30
P423101	42	30	31,8
P462901	46	30	29,1
P463002	46	30	30



REFER.	D	d	H
P345001	34	29	49,7
P365001	36	29	50
P384902	38	29	49,7
P404905	40	29	49,7
P454901	45	29	49,7



REFER.	D	d	H
P344501	34	26	45,5
P344001	34	26,3	40
P364502	36	26	45,5
P364503	36	26	45,5

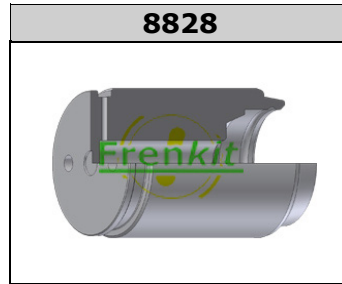

REFER.	D	d	H
P365101	36	26	50,9
P466601	46	26	66

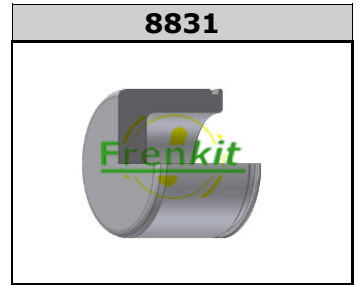

REFER.	D	d	H
P382803	38	26	29
P432901	43	32	29

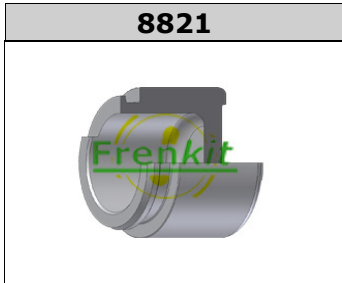

REFER.	D	d	H
P362902	36	21,5	29,6

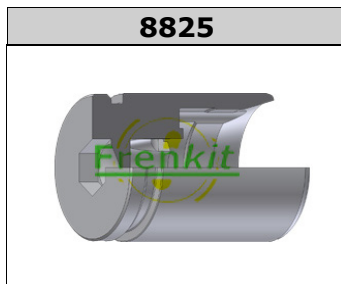

REFER.	D	d	H
P364801	36	29	48



REFER.	D	d	H
P382801	38	26	28,5
P422801	43	31	28,5
P484201	48	39,5	42

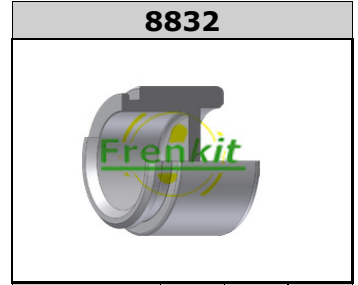

REFER.	D	d	H
P382901	38	25	29,9



REFER.	D	d	H
P353001	35	19	30,1
P363001	36	19	30,6

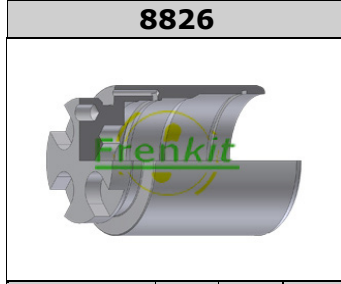

REFER.	D	d	H
P364802	36	32	48,5

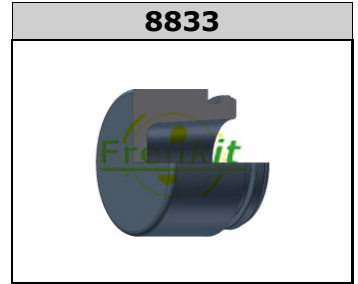

REFER.	D	d	H
P282901	28	13,5	29
P283001	28	13,5	30
P283101	28	13,5	31,5

BRAKE COMPONENTS CLASSIFIED BY FIGURES
 PIÈCES DE FREINAGE CLASSIFIÉES PAR FIGURE
 INTERTEILE VON BREMSEN KLASSIFIZIERT DURCH ZEICHNUNGEN

P283202	28	13,5	32
P303001	30	13,5	30
P303101	30	13,5	31,5
P302901	30	15,5	29
P303202	30	15,5	32
P323001	32	13,5	30
P323101	32	13,5	31,5
P343101	34	13,5	31,5
P363004	36	13,5	30
P363101	36	13,5	31,5
P363005	36	20,5	30
P383103	38	13,5	31,5
P382902	38	22,5	29
P383203	38	22,5	32
P383005	38	23	30
P403202	40	23	32
P402904	40	23,5	29
P403005	40	25	30
P422902	42	25,5	29
P423005	42	25,5	30
P423202	42	25,5	32
P422904	42	30	29,5
P442902	44	25	29
P443201	44	27	32
P443002	44	27,5	30
P573102	57	39,7	31

8834



REFER.	D	d	H
P383001	38	26	30,5

8835



REFER.	D	d	H
P332801	33	21,5	28,2
P363002	36	25	30
P383004	38	23	30
P383003	38	25	30,2
P383101	38	25	31,4
P383202	38	25	32,5
P403002	40	25	30,2
P423002	42	30	30,2

8837



REFER.	D	d	H
P324401	32	20	44
P324502	32	22	45
P324504	32	22	45
P354504	35	26	45
P364001	36	27	40
P385203	38	27	52,5
P384401	38	29	44,5
P384501	38	29	45
P385104	38	29	51
P385105	38	29	51,5
P385301	38	29	53,6
P384101	38	30	41,5
P384603	38	30	46
P404903	40	31,5	49,6
P405301	40	31,5	53
P404901	40	32	49
P425101	42	30	51
P425301	42	30	53,2
P434502	43	32,5	45
P434804	43	34	48
P424801	43	34	48,9
P434901	43	34	48,9
P435101	43	34	51,5
P434802	43	35	48
P435301	43	35	53,6
P445701	44	35	57,5
P446101	44	35	61
P446301	44	35	63
P444801	44	36	48
P454902	45	34	49
P454802	45	35	48
P455601	45	35	56,3
P454801	45	36	48
P455301	45	37	53
P465601	46	33	56,6
P465901	46	37	59,5
P514401	51	40	44,5
P514802	51	40	48
P514201	51	42,5	42
P525602	52	39	56,6
P524802	52	42,4	48,8
P544402	54	45	44
P544601	54	45	46
P544903	54	45	49
P545103	54	45	51
P575302	57	48	53,6
P574601	57	48,2	46,5

P575001	57	48,2	49,8
P575102	57	48,2	51,5
P575101	57	48,2	51,7
P575304	57	48,2	53,6
P575202	57	48,5	52,5
P586301	58	46	63,7
P606502	60	43,5	65
P605301	60	50	53
P606301	60	50	63,3
P605003	60	51	50
P605204	60	51	52,5
P674801	67	55,5	48
P684901	68	57	49,5

8838

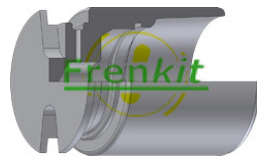

REFER.	D	d	H
P364901	36	31,5	49
P384901	38	32,2	49
P485205	48	38	52

8839



REFER.	D	d	H
P324503	32	23,3	45,8
P384602	38	25,5	46
P384803	38	27	48,8
P384704	38	29	47
P384903	38	29	49,4
P444501	44	29	45,8
P445201	44	34	52,4
P454601	45	34	46
P454903	45	34	49
P455304	45	34	53
P514504	51	42	45
P574801	57	42	48,3
P604601	60	42	46,6
P604804	60	47	48
P605101	60	48	51,5
P604807	60,5	47	48,7
P634801	63,4	48	48
P635301	63,4	48	53

8840



REFER.	D	d	H
P385102	38	33	51
P385103	38	33	51

8841



REFER.	D	d	H
P363003	36	25	30
P402902	40	30	29,3
P403101	40	30	31,5
P433101	43	27	31
P433102	43	31	31,5
P452901	45	34	29
P483101	48	37	31,5

8842



REFER.	D	d	H
P403001	40	25	30

8843



REFER.	D	d	H
P403201	40	22	32

BRAKE COMPONENTS CLASSIFIED BY FIGURES
 PIÈCES DE FREINAGE CLASSIFIÉES PAR FIGURE
 INTERTEILE VON BREMSEN KLASSIFIZIERT DURCH ZEICHNUNGEN



REFER.	D	d	H
P354403	35	26	44
P384502	38	27	45
P404902	40	26	49,8
P404501	40,4	26	45



REFER.	D	d	H
P362802	36	28	28,3
P412801	41	31	28,4
P413401	41	31	34,2
P463001	46	36	30,7
P513901	51	41,8	39
P542902	54	42	29
P572801	57	48	28,5



REFER.	D	d	H
P414501	41	29	45,8



REFER.	D	d	H
P423501	42	27	35,7



REFER.	D	d	H
P403203	40	25	32,9

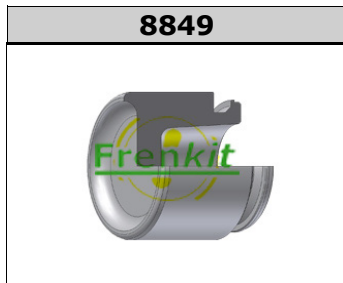

REFER.	D	d	H
P403501	40	23,5	35,2
P443501	44	27	35,2



REFER.	D	d	H
P404801	40	20	48



REFER.	D	d	H
P424602	42	30	46,9
P454501	45	37	45
P514501	51	42,5	45
P544401	54	45	44,5
P545102	54	45	51,5
P545201	54	45	52,5



REFER.	D	d	H
P424803	42	25	48
P484806	48	36,5	48
P604802	60	42	48,9

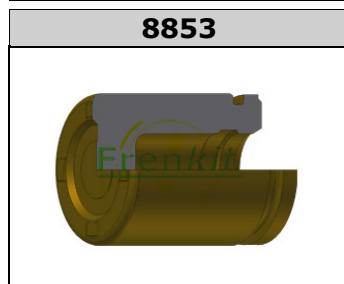

REFER.	D	d	H
P485004	48	24	50,5
P485204	48	24	52
P485505	48	25,5	55,5



REFER.	D	d	H
P434501	43	25	44,8
P434505	43	29	45
P434504	43	32	45
P444502	44	25	45,5
P484402	48	34,5	44
P485003	48	34,5	50



REFER.	D	d	H
P434801	43	29	48
P435001	43	29	50

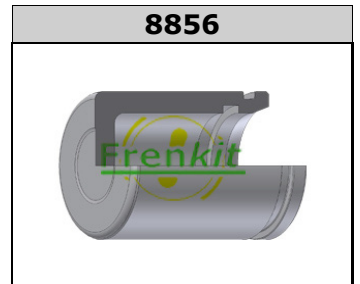

REFER.	D	d	H
P435501	43	30,5	55



REFER.	D	d	H
P443401	44	29,5	34,6



REFER.	D	d	H
P445001	44	23	50,8



REFER.	D	d	H
P433103	43	29,5	31,5
P453102	45	32	31,5
P483102	48	34,5	31,5
P513101	51	37,5	31,5

BRAKE COMPONENTS CLASSIFIED BY FIGURES
 PIÈCES DE FREINAGE CLASSIFIÉES PAR FIGURE
 INTERTEILE VON BREMSEN KLASSIFIZIERT DURCH ZEICHNUNGEN

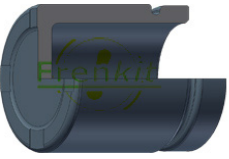
8861			
			
REFER.	D	d	H
P455001	45	33,5	50,3
P484805	48	32,5	48,3

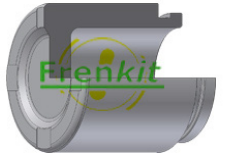
8865			
			
REFER.	D	d	H
P434701	43	32	47
P464601	46	31	46,5

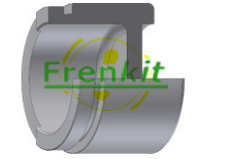
8868			
			
REFER.	D	d	H
P484401	48	35	44,4

8871			
			
REFER.	D	d	H
P484602	48	38	46,6

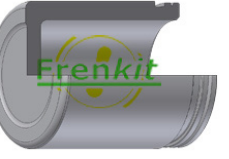
8862			
			
REFER.	D	d	H
P445502	44	35	55
P455101	45	36	51
P465801	46	37	58
P485506	48	38	55,5
P485901	48	38	59,5
P486401	48	38,5	64
P525801	52	42,5	58
P526001	52	42,5	60,5
P544901	54	45	49,8
P545301	54	45	53,7
P575401	57	48,2	54,8

8866			
			
REFER.	D	d	H
P402903	40	26	29
P442903	44	32	29
P443301	44	32	32,5
P482902	48	31	29
P482903	48	31	29
P482901	48	37	29
P542903	54	42	29
P543201	54	42	32,5
P544201	54	42	42,5
P542901	54	42,2	29
P544504	54	44	45

8869			
			
REFER.	D	d	H
P484905	48	38	49
P484403	48	38,3	44,5
P484503	48	38,3	45,5
P484701	48	38,3	47
P484802	48	38,3	48
P484901	48	38,3	49,7
P484804	48	38,5	48,5
P485102	48	38,5	51
P485203	48	38,5	52,5
P485202	48	38,5	52,8
P485302	48	38,5	53,6
P485501	48	38,5	55,2
P485701	48	38,5	57,5
P486001	48	38,5	60,5
P484502	48	39,5	45
P484501	48	39,5	45
P484803	48	39,5	48,5
P484902	48	39,5	49
P485001	48	39,5	50
P485002	48	39,5	50,5

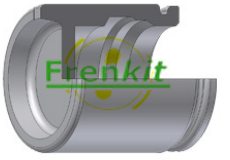
8872			
			
REFER.	D	d	H
P484801	48	34	48,8

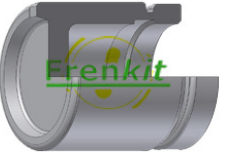
8873			
			
REFER.	D	d	H
P485101	48	34	51
P525302	52	38	54,2
P545101	54	40	51
P605102	60	46	51

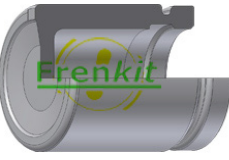
8863			
			
REFER.	D	d	H
P455302	45	30	53,1
P545403	54	40	54
P575505	57	35,3	55,7
P575301	57	43	53
P575501	57	43	55,2
P575701	57	43	57,5
P575801	57	43	58,5
P574902	57	43,1	49,5
P604901	60	46	49
P605602	60	46	56
P605801	60	46	58
P665202	66	55,8	52

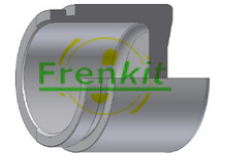
8867			
			
REFER.	D	d	H
P484301	48	36	43,5
P524301	52	38	43,5
P544301	54	40	43,5

8870			
			
REFER.	D	d	H
P384604	38	30	46
P484601	48	36,5	46,6
P485401	48	36,5	54,6
P545105	54	40	51,7

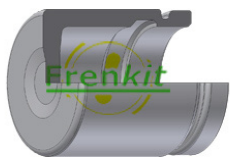
8874			
			
REFER.	D	d	H
P485201	48	37	52,7
P545501	54	43	55,5
P575502	57	46	55,5

BRAKE COMPONENTS CLASSIFIED BY FIGURES
 PIÈCES DE FREINAGE CLASSIFIÉES PAR FIGURE
 INTERTEILE VON BREMSEN KLASSIFIZIERT DURCH ZEICHNUNGEN

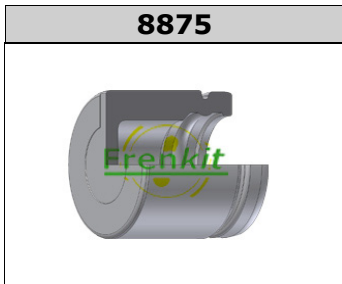

REFER.	D	d	H
P385003	38	28,5	50,5
P405001	40	30	50,5
P405501	40	30,1	55
P485502	48	36,2	55,5

8876

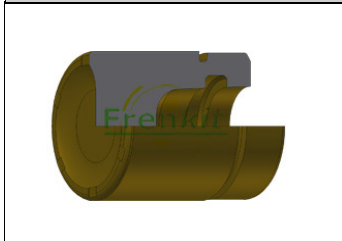

REFER.	D	d	H
P525601	52	25,3	56,8

8877



REFER.	D	d	H
P512801	51	41,8	28,3
P542801	54	45	28
P605306	60	51	53

8878



REFER.	D	d	H
P514505	51	38	45
P514601	51	40	46
P605105	60,5	50	51



REFER.	D	d	H
P404601	40,4	29	46
P514301	51	37	43,8
P514403	51	37	44,2
P514502	51	38	45
P514202	51	39	42,5
P544704	54	30	47,5
P544602	54	35	46,8
P544501	54	40	45
P544701	54	40	47,5
P544902	54	40	49
P544603	54	42	46
P544804	54	43	48,5
P574603	57	43	46,1
P574901	57	43	49
P574502	57	44	45
P574503	57	44	45,5
P574803	57	46	48
P604902	60	48	49
P634901	63,4	51	49
P635901	63,4	54	59,5

8880



REFER.	D	d	H
P514503	51	43,3	45

8881



REFER.	D	d	H
P454502	45	36	45,5
P455102	45	37	51
P465103	46	37	51
P465101	46	37	51

P514801	51	40,5	48
P544905	54	44	49
P544302	54	45	43
P544703	54	45	47,7
P544904	54	45	49
P545104	54	45	51
P574604	57	48	46
P575103	57	48,2	51,2
P575203	57	48,2	52,2
P605202	60,5	48	52,5

8882

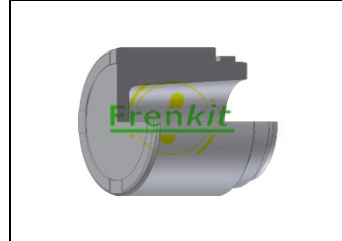

REFER.	D	d	H
P525001	52	30	50,2

8883

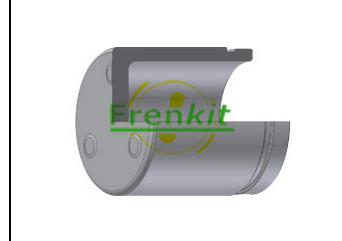

REFER.	D	d	H
P344704	34	28	47,5
P514402	51	43	44,8
P525301	52	42,4	53,7
P545001	54	45,5	50,5
P575204	57	46	52,5
P574903	57	48	49
P574802	57	48,2	48
P575506	57	48,2	55

8884

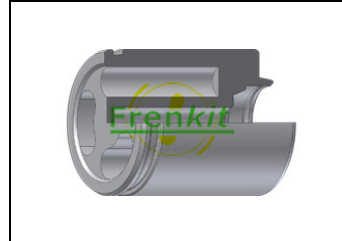

REFER.	D	d	H
P526501	52	26	65
P606501	60	26	65

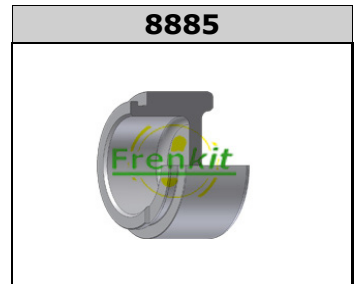

REFER.	D	d	H
P542905	54	35	29,3
P543301	54	35	33
P572901	57	38	29,5
P573401	57	38	34
P573002	57	39	30,5
P573001	57	42	30
P602901	60	42	29,5
P603101	60	42	31

8886

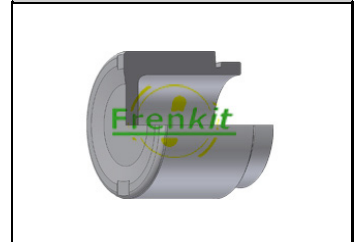

REFER.	D	d	H
P544702	54	36,5	47
P574602	57	46	46

8887



REFER.	D	d	H
P544801	54	40	48,1
P605201	60	46	52

8888

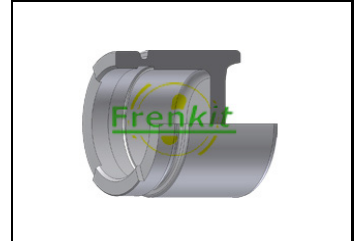

REFER.	D	d	H
P524801	52	38	48
P544803	54	38	48
P545302	54	40	53,1

BRAKE COMPONENTS CLASSIFIED BY FIGURES
 PIÈCES DE FREINAGE CLASSIFIÉES PAR FIGURE
 INTERTEILE VON BREMSEN KLASSIFIZIERT DURCH ZEICHNUNGEN

8889



REFER.	D	d	H
P545202	54	45	52,4

8893

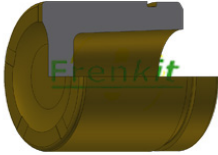

REFER.	D	d	H
P434805	43	23	48
P545503	54	34	55,3
P605504	60,5	0	55

8896



REFER.	D	d	H
P405201	40	25	52
P425502	42	25	55,5
P425202	42	25,1	52,3
P445002	44	30	50,5
P545601	54	36	56
P545305	54	41	53,5
P575503	57	43	55,5
P575306	57	44	53
P605501	60	46	55,5
P605304	60	47	53,5

8900



REFER.	D	d	H
P604801	60	46	47,8

8890



REFER.	D	d	H
P545203	54	46	52,7
P575201	57	49	52,7

8894

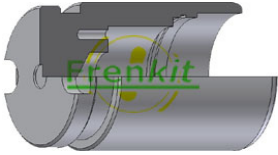

REFER.	D	d	H
P304502	30	26	45
P304503	30	26	45
P353901	35	28	39,5
P354503	35	29	45
P384103	38	32,5	40,8
P414101	41	32	41
P414601	41	35	46,5
P434602	43	35	46
P444602	44,3	35	46
P544503	54	46	45

8897



REFER.	D	d	H
P575504	57	43	55,4

8901



REFER.	D	d	H
P604803	60	48	48,2

8891

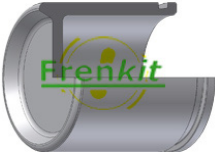

REFER.	D	d	H
P545401	54	45	54,3

8895



REFER.	D	d	H
P545303	54	40	53
P575303	57	40	53

8898



REFER.	D	d	H
P383102	38	25	31,7
P573101	57	43	31
P603002	60	45,6	30,8

8902



REFER.	D	d	H
P604805	60	48	48,3

8892



REFER.	D	d	H
P425002	42	30	50,5
P425501	42	30	55,5
P445501	44	32	55,5
P545003	54	0	50,5
P545502	54	40	55,5
P545801	54	40	58,5
P605502	60	46	55,5
P665501	66	51	55,5

8899



REFER.	D	d	H
P604602	60	50	46

8903



REFER.	D	d	H
P605001	60,5	51	50

BRAKE COMPONENTS CLASSIFIED BY FIGURES
 PIÈCES DE FREINAGE CLASSIFIÉES PAR FIGURE
 INTERTEILE VON BREMSEN KLASSIFIZIERT DURCH ZEICHNUNGEN



REFER.	D	d	H
P575403	57	43	54
P605303	60	46	53
P605302	60	46	53



REFER.	D	d	H
P586302	58	45	63,8
P606302	60	45	63,5
P686301	68	45	63,7

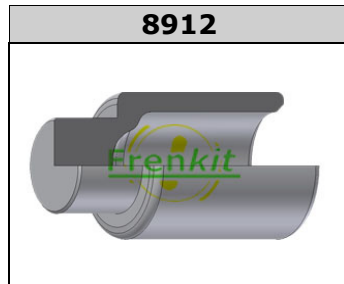

REFER.	D	d	H
P305101	30	22	51



REFER.	D	d	H
P434601	43	25	46
P634802	63	46	48



REFER.	D	d	H
P604701	60	48	47
P605601	60	50	56,7



REFER.	D	d	H
P383002	38	25	30,8
P383201	38	25	32,7
P423001	42	30	30,8
P423201	42	30	32,7

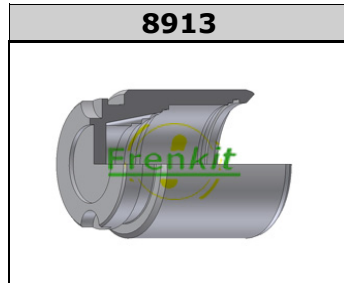

REFER.	D	d	H
P344102	34	27	41

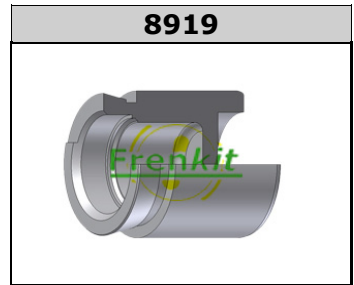

REFER.	D	d	H
P444601	44	30	46,5



REFER.	D	d	H
P606701	60	46	67,3

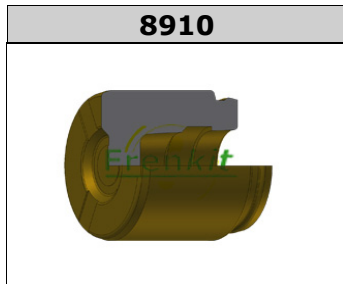

REFER.	D	d	H
P484703	48	23	47,3

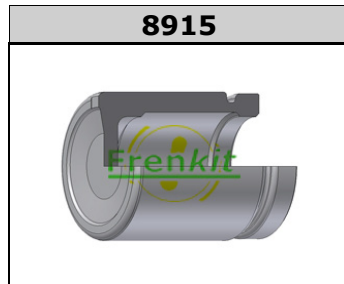

REFER.	D	d	H
P404904	40	25	49
P424901	42	25,6	49



REFER.	D	d	H
P445301	44	29	53

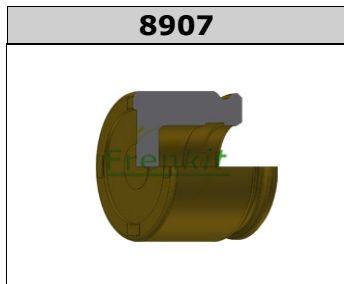

REFER.	D	d	H
P545204	54	32,5	52
P605002	60	36	50,5
P605203	60	38,5	52
P665201	66	35,8	52

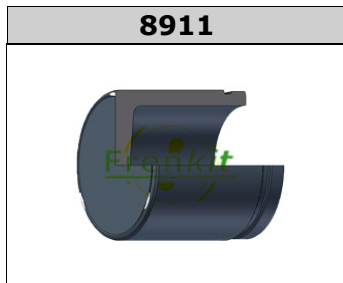

REFER.	D	d	H
P605701	60	47,5	57,4



REFER.	D	d	H
P405202	40	25	52
P425601	42	25	56
P445601	44	25	56

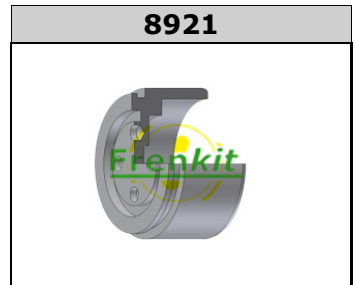

REFER.	D	d	H
P542904	54	46	29,7

BRAKE COMPONENTS CLASSIFIED BY FIGURES
 PIÈCES DE FREINAGE CLASSIFIÉES PAR FIGURE
 INTERTEILE VON BREMSEN KLASSIFIZIERT DURCH ZEICHNUNGEN



REFER.	D	d	H
P543302	54	46,2	33,3

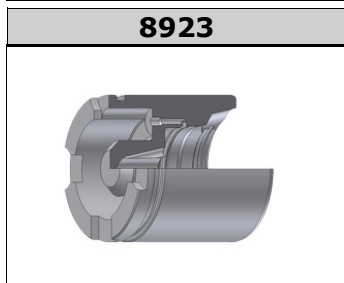

REFER.	D	d	H
P545402	54	32	54
P575104	57	32	51,6
P605104	60	34	51,2

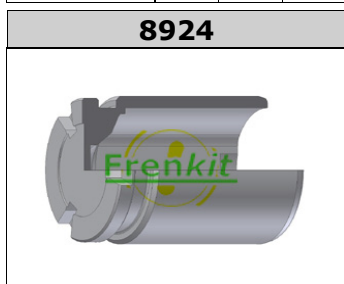

REFER.	D	d	H
P345201	34	29,5	52
P385202	38	29	52
P415201	41	29	52
P435201	43	33	52



REFER.	D	d	H
P404401	40,4	27,5	44,2
P605503	60	47	55

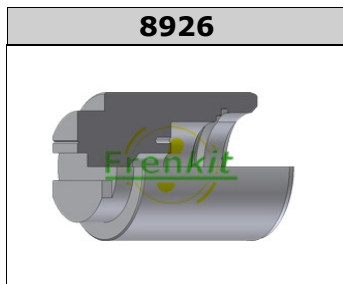

REFER.	D	d	H
P454503	45	33	45,5
P486301	48	33	63,5

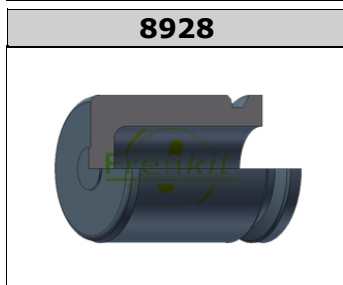

REFER.	D	d	H
P354402	35	20	44,5



REFER.	D	d	H
P544805	54	45	48
P574501	57	46	45,5
P686302	68	58,5	63,5



REFER.	D	d	H
P686501	68	36,5	65

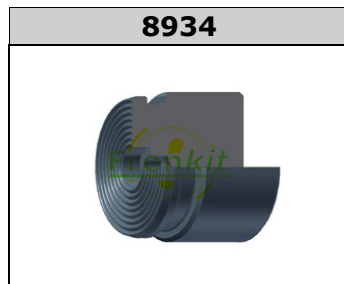

REFER.	D	d	H
P443202	44	6	32
P463201	46	4	32

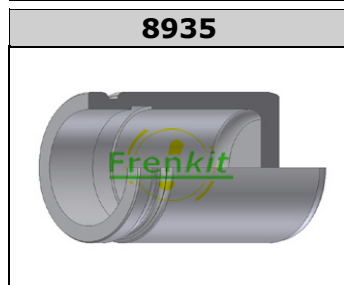

REFER.	D	d	H
P444701	44	34	47,5



REFER.	D	d	H
P503801	50	22	38

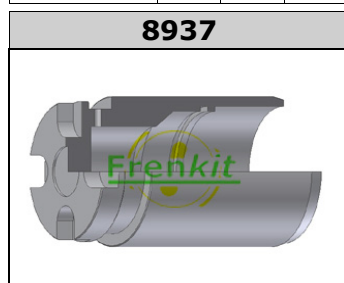

REFER.	D	d	H
P304401	30	25,5	44,7
P304504	30	25,5	45
P304601	30	26	46,7



REFER.	D	d	H
P485503	48	37	55



REFER.	D	d	H
P606503	60	48,5	65

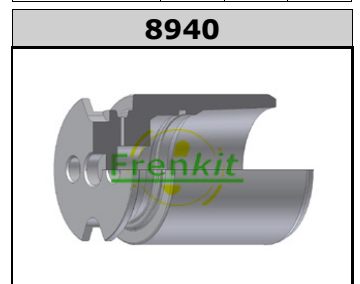

REFER.	D	d	H
P385002	38	33,4	50,4

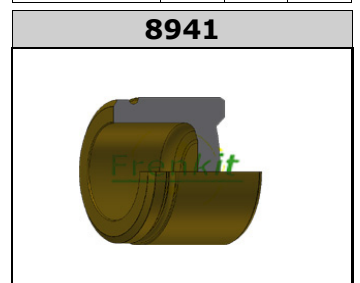

REFER.	D	d	H
P465102	46	28	51
P484904	48	29,5	49,5
P575305	57	40,5	53,8
P665301	66	43,5	54
P665302	66	44	53,4

BRAKE COMPONENTS CLASSIFIED BY FIGURES
 PIÈCES DE FREINAGE CLASSIFIÉES PAR FIGURE
 INTERTEILE VON BREMSEN KLASSIFIZIERT DURCH ZEICHNUNGEN

8942



REFER.	D	d	H
P686502	68	48,5	65

8946

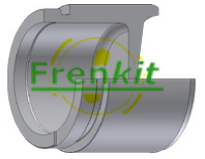

REFER.	D	d	H
P524401	52	39,5	44,2

8950

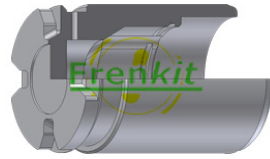

REFER.	D	d	H
P344707	34	28,5	47

8954

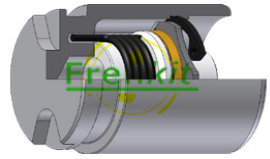

REFER.	D	d	H
K304101	30	26,3	41,6

8943

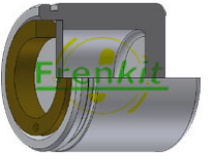

REFER.	D	d	H
P686305	68	52	63

8947



REFER.	D	d	H
P604905	60,5	44,5	49

8951



REFER.	D	d	H
P384805	38	29	48
P404803	40	29	48

8955



REFER.	D	d	H
K304503	30	26	45
K304502	30	26	45
K353901	35	28	39,5
K354503	35	29	45
K414601	41,2	35	46,5
K434602	43	35	46
K444602	44,3	35	46

8944



REFER.	D	d	H
P334801	33	18,5	48
P354801	35	18,5	48

8948

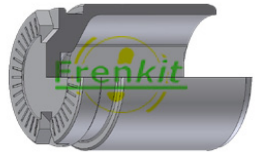

REFER.	D	d	H
P384804	38	28	48,5

8952



REFER.	D	d	H
P485303	48	43	53,5
P605401	60	54	54

8956

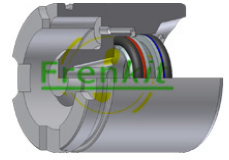

REFER.	D	d	H
K545402	54	32	54
K575104	57	32	51,6
K605104	60	34	51,2

8945

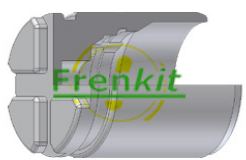

REFER.	D	d	H
P384703	38	33	47

8949



REFER.	D	d	H
P324101	32	24	41,5
P384104	38	24	41,5

8953



REFER.	D	d	H
P686303	68	45	63

8957

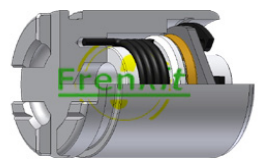

REFER.	D	d	H
K303801	30	24	38,5
K304102	30	24,5	41
K323801	32	24	38,5

BRAKE COMPONENTS CLASSIFIED BY FIGURES
 PIÈCES DE FREINAGE CLASSIFIÉES PAR FIGURE
 INTERTEILE VON BREMSEN KLASSIFIZIERT DURCH ZEICHNUNGEN

8958

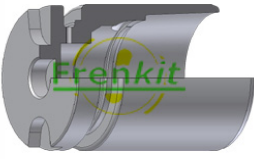

REFER.	D	d	H
P425103	42	36,5	51

8962

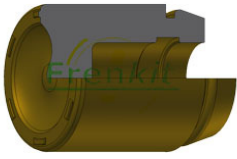

OEM: PHENOLIC FRENKIT: STEEL

REFER.	D	d	H
P425104	42	20	51

8966



REFER.	D	d	H
P485005	48	40,5	50

8969



REFER.	D	d	H
K345001	34	29	49,7
K365001	36	29	50
K384805	38	29	48
K384902	38	29	49,7
K404803	40	29	48
K404905	40	29	49,7
K454901	45	29	49,7

8959



OEM: PHENOLIC FRENKIT: STEEL

REFER.	D	d	H
P344901	34	16	49
P364804	36	16	48,5
P425001	42	20	51

8963

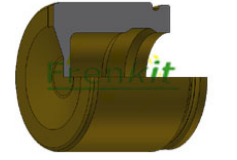

OEM: PHENOLIC FRENKIT: STEEL

REFER.	D	d	H
P605603	60	34,8	56
P605103	60	36	51

8967

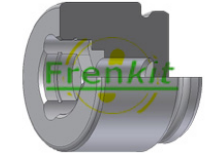

REFER.	D	d	H
P443502	44	22	35

8970



REFER.	D	d	H
K304001	30	26	40
K354001	35	29,5	40

8960



OEM: PHENOLIC FRENKIT: STEEL

REFER.	D	d	H
P485601	48	25,5	56,7
P485206	48	30	52,4
P515201	51	32,5	52,5

8964

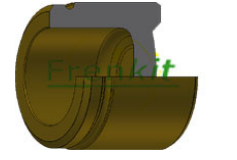

OEM: PHENOLIC FRENKIT: STEEL

REFER.	D	d	H
P385004	38	22	50
P455002	45	28,5	50
P544502	54	29,5	45,5

8968



REFER.	D	d	H
K304504	30	25,5	45
K304601	30	26	46,7
K334601	34	29	46,8
K344801	34	29	48
K344101	34	29,4	41
K344201	34	30	42,8
K364805	36	31	48
K384102	38	29,5	41
K384601	38	33	46,8
K385101	38	33	51
K415101	41	35	51
K424601	43	34,4	46,8
K425102	43	34,4	51,3

8971



REFER.	D	d	H
K304301	30	27	43,8
K304002	30,2	27	40,5
K344401	34	28	44
K344702	34	28	47,2
K384701	38	33	47,2
K404701	40,4	24,5	47

8961

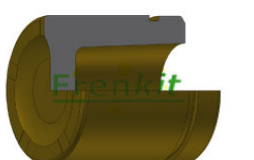

OEM: PHENOLIC FRENKIT: STEEL

REFER.	D	d	H
P455303	45	25,5	53,6
P475901	47,5	26	59
P485504	48	30	55
P515501	51	28	55
P574401	57	29	44

8965

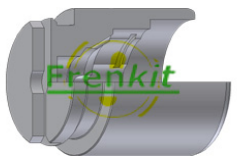

REFER.	D	d	H
P344603	34	30	46

BRAKE COMPONENTS CLASSIFIED BY FIGURES
 PIÈCES DE FREINAGE CLASSIFIÉES PAR FIGURE
 INTERTEILE VON BREMSEN KLASSIFIZIERT DURCH ZEICHNUNGEN



REFER.	D	d	H
K304501	30	25,8	45,5
K324501	32	25,7	45,5
K334401	33	25,8	44,1
K354505	35	25,8	45,5
K383001	38	26	30,5
K414301	41	26	44

8973



REFER.	D	d	H
K344603	34	30	46
K354501	35	30	45

8974



REFER.	D	d	H
K344701	34	31	47
K364701	36	32	47
K384702	38	34	47

8975

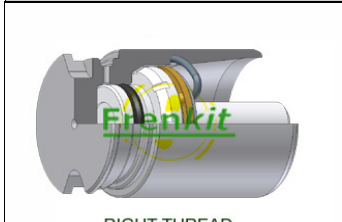

REFER.	D	d	H
K364901R	36	31,5	49
K384901R	38	32,2	49
K385103R	38	33	51
K385002R	38	33,4	50,4

K425103R	42	36,5	51
K485205R	48	38	52

8976

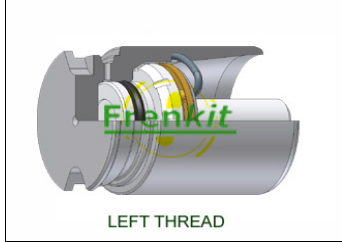

REFER.	D	d	H
K364901L	36	31,5	49
K384901L	38	32,2	49
K385103L	38	33	51
K385002L	38	33,4	50,4
K425103L	42	36,5	51
K485205L	48	38	52

8977

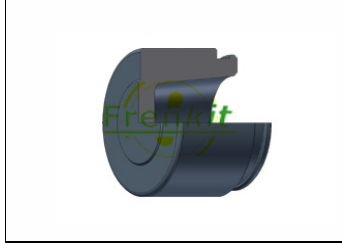

REFER.	D	d	H
P433104	43	27	31

8978

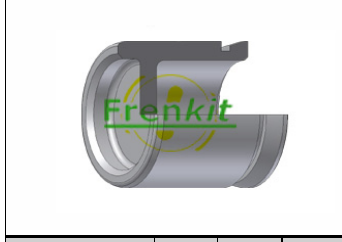

REFER.	D	d	H
P545304	54	40	53

8979



REFER.	D	d	H
K365101R	36	26	50,9
K466601R	46	26	66
K526501R	52	26	65
K606501L	60	26	65

8980



REFER.	D	d	H
K365101L	36	26	50,9
K466601L	46	26	66
K526501L	52	26	65
K606501R	60	26	65

8981

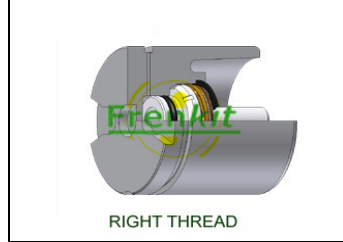

REFER.	D	d	H
K545203R	54	46	52,7
K575201R	57	49	52,7

8982

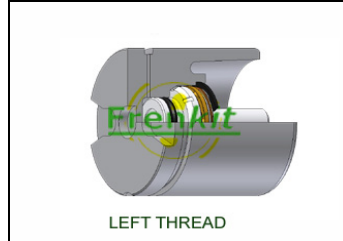

REFER.	D	d	H
K545203L	54	46	52,7
K575201L	57	49	52,7

8983

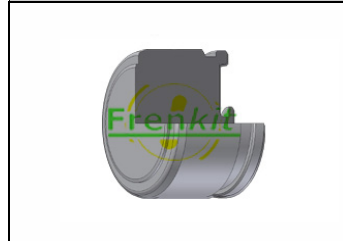

REFER.	D	d	H
P443003	44	0	30

8984

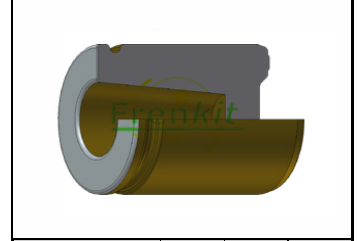

REFER.	D	d	H
P425302	42	21	53

8985



REFER.	D	d	H
K385102L	38	33	51

8986



REFER.	D	d	H
K385102R	38	33	51