

2012-2013



Electrical accessories
Security systems
Column switches
Window regulators

Accessoires électriques
Sécurité habitacle
Commutation sous volant
Lève-vitres

Accesorios eléctricos
Seguridad habitaculo
Comutador de volante
Elevallunas

Acessórios eléctricos
Seguridade habitaculo
Comutador de volante
Elevadores janelas

Accessori elettrici
Sicurezza abitacolo
Devioguida
Alzacristalli Electrici

Electrisches accessoires
Beveiligingsystemen
Stuurkolomschakelaars
Raammechanismes

Elektrisches Zubehör
Sicherheitssysteme
Lenkstockscharter
Fensterheber

Aksesoria elektryczne
Systemy zabezpieczeń
Przełączniki kolumnowe
Podnośniki szyb

Elektrikli aksesuarlar
Güvenlik Sistemleri
Far-koma-silecek kimanda kollari
cam mekanizmasi



www.valeoservice.com

valeo added

Automotive technology, naturally

Valeo

Truck by Valeo

Your solution provider

Top Column Modules
66 PNs



Window lifts
102 PNs

Steering Column
Locks & Collections
23 PNs



Locks, Latches
& Actuators
24 PNs



Fuel caps
& AdBlue® caps
44 PNs



- › Valeo, main player in OE
- › One stop shop supplier, multi-product expertise
- › International paper and digital catalogues

valeo added™

Automotive technology, naturally



Valeo, votre fournisseur de solutions Poids Lourds

Antivol de direction
et collections
23 références



Commodo
66 références



Lève-vitres
102 références



Verrous, Serrures
et actionneurs
24 références



Bouchons à carburant
et de réservoir AdBlue®
44 références



- Valeo, un acteur majeur en première monte
- Expertise multi-produit
- Catalogue digital et papier international

valeo added

La technologie automobile, naturellement

Valeo

Valeo, su proveedor de soluciones vehículo pesado

Commutador de volante
66 Referencias



Elevallunas
102 Referencias

Antirrobo &
Conjuntos antirrobo
23 Referencias



Cerraduras,
mecanismos &
motores de cerradura
24 Referencias



Tapón carburante &
Tapón AdBlue®
44 Referencias



- Valeo, un principal actor en OE
- Mutiproducto experiencia
- Catálogo de Papel y Digital internacional

valeo added

Automotive technology, naturally

Valeo

Valeo Veicoli Industriali, il vostro partner ideale

Moduli per Montanti
66 Riferimenti



Alzacristalli
102 Riferimenti

Serrature Montante Sterzo
23 Riferimenti



Serrature,
Meccanismo
serratura & Atturatori
24 Riferimenti



Tappi carburante
& AdBlue®
44 Riferimenti



- Valeo, uno dei principali attori del Mercato OE
- Un unico fornitore, con esperienza da multispecialista
- Documenti internazionali e cataloghi digitali

valeo added

Automotive technology, naturally

Valeo

Valeo, uw truck leverancier

Contactsloten & sets
23 artikelnummers



Stuurkolomschakelaars
66 artikelnummers



Raammechanismen
102 artikelnummers



Sloten,
Deurvergrendeling
en Actuatoren
24 artikelnummers



Tankdoppen
& AdBlue®
44 artikelnummers



- › Valeo, een belangrijke speler in OE
- › One stop shop leverancier, multispecialist
- › Internationale catalogi, zowel gedrukt als digitaal beschikbaar

valeo added 

Automotive technology, naturally

Valeo

Valeo, Ihr NKW Systemlieferant

Lenkschlösser & Sets
23 Artikel



Lenkstockschalter
66 Artikel



Fensterheber
102 Artikel



Schließzylinder,
Schlösser &
Betätigungselemente
24 Artikel



Tankdeckel
& AdBlue®
44 Artikel



- › Valeo, einer der bedeutendsten Erstausrüster
- › Vollsortimenter und Multispezialist
- › Internationaler Katalog, sowohl Druckversion als auch digital verfügbar

valeo added 

Automotive technology, naturally

Valeo

Valeo Truck, dostawca profesjonalnych rozwiązań

23 referencji
stacyjek



66 referencji
przełączników
kolumnowych



102 referencji
podnośników szyb

24 referencji
siłowników,
zamek



44 referencji
Korki wlewu paliwa &
AdBlue®



- Valeo, główny dostawca OE
- Profesjonalny dostawca, ekspert od multiliniowości
- Katalogi drukowane i elektroniczne

valeo added 

Automotive technology, naturally

Valeo

Tehergépjármű alkatrész a Valeo-tól megoldás beszállítójától

Kormányoszlop
kapcsolók és gyűjtők:
23 cikkszám



felső oszlop modulok:
66 cikkszám



Ablakemelők:
102 cikkszám



Zárak, Reteszek
és kapcsolók:
24 cikkszám



Benzinsapkák &
AdBlue®:
44 cikkszám



- › Valeo, az OE szegmens fő beszállítója
- › Mindent egy helyen, többvonalas kínálat, szakértelem
- › Nemzetközi papír és digitális katalógus adatbázis

valeo added

Automotive technology, naturally

Valeo

Tehergépjármű alkatrész a Valeo-tól megoldás beszállítójától

Kormányoszlop
kapcsolók és gyűjtők:
23 cikkszám



felső oszlop modulok:
66 cikkszám



Ablakemelők:
102 cikkszám



Zárak, Reteszek
és kapcsolók:
24 cikkszám



Benzinsapkák &
AdBlue®:
44 cikkszám



- › Valeo, az OE szegmens fő beszállítója
- › Mindent egy helyen, többvonalas kínálat, szakértelem
- › Nemzetközi papír és digitális katalógus adatbázis

valeo added

Automotive technology, naturally

Valeo

Valeo Camioane, partenerul ideal!

Blocaj coloană
de direcție
23 coduri



Blocuri de lumini
66 coduri



Macarale geamuri
102 coduri



Închizători,
Închizători și actuatori
24 coduri



Dopuri carburant
& AdBlue®
44 coduri



- › Valeo, actor principal pe piața OE
- › Furnizor unic, având expertiză multi-specializată
- › Cataloage internaționale tipărite și digitale

valeo added™ 

Automotive technology, naturally

Valeo

Предложение Valeo

для грузовиков - лучшее решение
Ваших проблем!

Замки рулевых
колонок и комплекты
23 артикулов



Подрулевые
переключатели
66 артикулов



Стеклоподъёмники
102 артикулов



Личинки замков,
Замки дверей
и приводы
24 артикулов



Крышки топливного
бака и AdBlue®
44 артикулов



- Valeo - один из основных поставщиков на конвейер
- Вся гамма продукции от одного поставщика
- Бумажный и электронный каталог на разных языках

valeo added 

Automotive technology, naturally

Valeo

Valeo, ağır vasıta çözüm ortağınız

Direksiyon çevresi
kumanda kollarında
66 parça numarası



Cam mekanizmalarında
102 parça numarası



Kilitli kontak ve
kilit takımlarında
23 parça numarası



Kilitlerde,
kapı kilidi ve
hareketlendiricilerde
24 parça numarası



Yakıt depo kapakları
ve AdBlue®
44 parça numarası



- › Valeo öncü OE sağlayıcısı
- › Tüm ihtiyaçlar için tek durak, tüm ürünlerde uzmanlık
- › Uluslararası basılı ve e-kataloglar

valeo added 

Automotive technology, naturally

Valeo

Σειρά προϊόντων για Φορτηγά από τη Valeo, ο ιδανικός συνεργάτης που σας παρέχει λύσεις

Κλειδαριές κολώνας
τιμονιού & Συλλογές
23 Κωδικοί



Μονάδες κολώνας τιμονιού:
66 Κωδικοί



Γρύλλοι Παραθύρων:
102 Κωδικοί



Κλειδαριές,
Μεντεσέδες
& Ενεργοποιητές
24 Κωδικοί



Τάπες Βενζίνης
& AdBlue®
44 Κωδικοί



- › Η Valeo, βασικός συντελεστής στην Πρώτη Τοποθέτηση
- › Ένας-για-όλα προμηθευτής, ειδικός σε πολλαπλά προϊόντα
- › Διεθνή έγγραφα και ψηφιακοί κατάλογοι

valeo added 

Automotive technology, naturally

Valeo

1

Security Systems
 Sécurité Habitacle
 Seguridad Habitaculo
 Seguridad habitaculo
 Sicurezza abitacolo
 Beveiligingssystemen
 Sicherheitssysteme
 Systemy zabezpieczeń
 Системы безопасности
 Güvenlik Sistemleri
 Συστήματα ασφαλείας

1		Valeo		7
2		Valeo		13
3		Valeo		21
4		Valeo		23
5		Valeo		31
6	Valeo			33
7				37
8				47
9		Valeo		57
10		Valeo		59

2

Steering column switches
 Commutation sous volant
 Conmutador de volante
 Comutador de volante
 DevioGUIDA a sgancio
 Stuurkolomschakelaars
 Lenkstockschafter
 Przełączniki kolumny kierownicy
 Переключатель рулевой колонки
 Far-korna-silecek kumanda kolları
 Διακόπτης Τιμονιού

1				65
2				73
3		Valeo		85
4				93
5				95

3

Electrical accessories
 Accessoires électriques
 Accesorios eléctricos
 Acessórios elétricos
 Accessori elettrici
 Elektrisches accessoires
 Elektrisches Zubehör
 Akcesoria elektryczne
 Электроприборы
 Elektrikli aksesuarlar

1		Valeo		97
2		Valeo		115
3		Valeo		121
4		Valeo		129
5		Valeo		157
6		Valeo		175
7		Valeo		179

4

Window regulators
 Lève-vitres
 Elevavinas
 Elevadores janela
 Alzacristalli Elettrici
 Raammechanismes
 Fensterheber
 Podnośników szyb
 cam mekanizması
 Γρύλοι Ηρααλύρων

1				183
2		Valeo		211
3				221
4				223

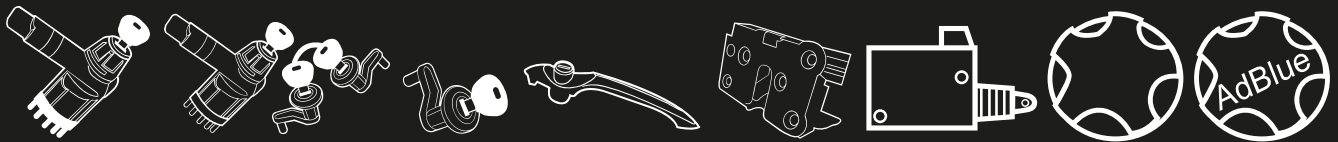

Security Systems

Sécurité Habitacle

Seguridad Habitaculo

Seguridad Habitaculo

Sicurezza abitacolo

Beveiligingssystemen

Sicherheitssysteme

Systemy zabezpieczeń

Системы безопасности

Güvenlik Sistemleri

Συστήματα ασφαλείας



Vehicle
Vehículo
Vehículo
Viatura
Veicolo
Voertuig
Fahrzeug
Pojazd
Автомобиль
Агаç
Οχημα



Photo
Photo
Foto
Foto
Foto
Foto
Foto
Zdjęcie
Фото
Fotograf
Φωτογραφία



OE reference
Référence Constructeur
Referencia constructor
Referència constructor
Riferimento Costruttore
OE referentie
OE-Nummer
Referenca konstruktora
OE номер
OE referansi
Κωδικός κατασκευαστή οχήματος



Steering column locks
Antirrobo
Antirrobo
Anti-roubo de coluna de direcção
Bloccasterzo
Stuurkolomslot
Lenkschlösser
Stacyjki
Замки рулевой колонки
Kilitli kontak
Κλειδαριές κολώνας τιμονιού



Locks
Verrous
Cerraduras
Fechaduras
Serrature
Sloten
Schließzylindereinheiten
Zamki
Замки
Kilidler
Κλειδαριές



Handles
Poignées
Manecillas
Muletas
Maniglie
Hendels
Türgriffe
Klamki
Ручки дверей
Tutamas
Χειρολαβές



Collection (SCL + locks set)
Collections
Conjuntos antirrobo
Conjuntos
Kit (bloccasterzo + serrature)
Collectie (stuur kolom slot + slotenset)
Set
Zestawy (stacyjka + zestaw zamków)
комплект (замок рулевой колонки + набор замков)
Takım (Kilitli kontak + kilidler)
Συλλογή κλειδαριών



Latches
Serrures
Mecanismos de cerraduras
Fechaduras
Meccanismo serratura
Deurvergrendeling
Schlösser
Zamki
Защелки
Kilit
Κλειδαριές π όρτας



Actuators
Actionneurs
Motores de cerradura
Actuadores
Attuatore
Regeleenheid
Betätigungselemente
Silowniki
привода
Hareketlendirici
Επ ενεργητές



Application date
Date d'application
Fecha de aplicación
Data de aplicação
Data d'applicazione
Applicatie datum
Baujahr
Data produkcji samochodu
Дата производства
Uygulama tarihi
Ημερομηνία κατασκευής

ch ▶

▶ ch



From chassis number
Depuis N° de chassis
Desde número de chasis
Desde o nº de chassi
Dal numero di telaio
Van Chassisnummer
Ab Fahrgestellnummer Nr.
Od numeru nadwozia
от номера шасси
Şasi numarasından itibaren
Απ ό Σασί

To chassis number
Jusqu'au N° de chassis
Hasta número de chasis
Atê o nº de chassi
Al numero di telaio
Tot chassisnummer
Bis Fahrgestellnummer Nr.
Do numeru nadwozia
до номера шасси
Şasi numarasına kadar
Μέχρι Σασί

Product information
Information produit
Información producto
Informação de produto
Informazione prodotto
Produktinformatie
Artikelinformation
Informacja o produkcie
Информация о продукте
Ürün bilgileri
Πληροφορίες π ροϊόντος



Number of doors
Nombre de portes
Número de puertas
Número de portas
Numero di porte
Aantal deuren
Anzahl der Türen
Ilość drzwi
ΚΑΛΙΧΕΣΤΒΟ ΔΒΕΡΕΪ
Καρι sayısı
Αριθμός θυρών

M / A

E / D

EI

Manual / Automatic gear box
Boîte Manuelle / Automatique
Cambio Manual / Automático
Caixa Manual / Automatica
Cambio Manuale / Automatico
Handgeschakeld/ automaat
Schaltgetriebe / Automatik
Manualna / Automatyczna skrzynia biegów
механическая/автоматическая КПП
Otomatik / Düz şanzıman
Χειροκίνητο / Αυτόματο κιβώτιο ταχυτήτων

Petrol / Diesel
Essence / Diesel
Gasolina / Diesel
Gasolina / Diesel
Benzina / Diesel
Benzine/ Diesel
Benzin / Diesel
Benzyna / Diesel
БЕНЗИН / ДИЗЕЛЬ
Benzin / Diesel
Βενζίνη / Π ετρέλαιο

Engine Immobilizer
Anti-démarrage
Inmovilizador
Inmovilizador
Imobilizer
Starttonderbreker
Wegfahrsperre
Imobilizer
Имобилайзер
Imobilizer
Immobilizer μηχανής

Complete steering column lock
Antivol complet
Antirrobo completo
Anti-roubo de coluna de direcção completo
Bloccasterzo completo (con blocchetto avviamento)
Complet stuurslot
Lenkschloß, komplett
Kompletna stacyjka
Замок рулевой колонки в сборе
Kilitli kontak (Tamamı)
Πλήρη κλειδαριά κολώνας τιμονιού



Barrel only
Barillet seul
Bombillo solo
Somente o cilindro
Cilindretto solo
Enkel cylinderslot
Schließzylinder
Wkładka zamka
Только цилиндр
Sadese kilitli kontak kovani
Μόνο σώμα (βαρελάκι)



SCL housing only
Corps seul
Cuerpo de antirrobo solo
Corpo da trava de direcção
Bloccasterzo senza blocchetto d'avviamento
Stuur kolom slot behuizing
Lenkschloß ohne Schließzylinder
Obudowa stacyjki
только корпус замка рулевой колонки
Sadese kilitli kontak yuvasi
Π ερίβλημα κλειδαριάς τιμονιού



SCL housing+ switch
Corps + interrupteur
Cuerpo de antirrobo + interruptor
Anti-roubo de coluna de direcção + interruptor
Bloccasterzo senza blocchetto d'avviamento + commutatore elettrico
Stuur kolom slot behuizing + switch
Lenkschloßgehäuse + Schalter
Obudowa stacyjki + włącznik
корпус замка рулевой колонки + выключатель
Kilitli kontak yuvasi + şalter
Π ερίβλημα κλειδαριάς τιμονιού + διακόπτης



Ignition switch only
Interrupteur seul
Interruptor solo
Somente o interruptor
Commutatore elettrico solo
Ontstekings switch
Schalter
Włącznik stacyjki
только замок зажигания
Sadese kilitli kontak şalteri
Διακόπτης ανάφλεξης μόνο



1 lock
Verrou seul
Cerradura sola
Só fechadura
Serratura
1 slot
1 Schließzylindereinheit
1 zamek
Один замок
Tek kilit
1 κλειδαριά



Lock set
Ensemble verrous
Conjunto de cerraduras
Conjunto de fechaduras
Kit serrature
Slotenset
Schließset
Zestaw zamków
Комплект замков
Kilit takımı
Σετ κλειδαριών











Products location
Emplacement des produits
Localización de los productos
Posicionamiento do produto
Posizione dei prodotti
Produktlocaties
Anordnung der Produkte
Miejsce produkcji
Расположение продуктов
Parça konumu
Θέση π ροϊόντων



Unique application
Application unique
Aplicación única
Aplicação unica
Applicazione unica
Unieke applicatie
Spezifische Teile
Jedno zastosowanie
специальное применение
Tekli uygulama
Μοναδική εφαρμογή



2 products for front doors (1 left + 1 right)
2 produits pour portes avant (1 gauche + 1 droite)
2 productos para puertas delantera (1 izquierda + 1 derecha)
2 produtos para portas dianteiras (1 esquerda + 1 direita)
2 prodotti per porte anteriori (1 sinistra + 1 destra)
2 producten voor de voordeuren (een rechts een links)
2 Artikel für Vordertür (1 rechts + 1 links)
2 produkty do przednich drzwi (prawa i lewa strona)
два элемента для передних дверей (левая + правая)
On kari için 2 parça (1 sağ + 1 sol)
2 π ροϊόντα για εμπ ρόσθιες π όρτες (1 αριστερά + 1 δεξιά)

	<p>Multiple application (interchangeable) Application multiple (interchangeable) Aplicación múltiple Aplicação multipla Applicazione multipla (intercambiabile) Universele applicatie Universalteil Viele zastosowań Разнообразное применение (взаимозаменяемый) Çoklu uygulama (birbiri yerine geçebilir) Π ολλαπλών εφαρμογών (εναλλάξιμο)</p> <p>1 product for front door, can be fitted left OR right 1 produit pour porte avant, pouvant se monter à gauche OU à droite 1 producto para puerta delantera (puede ser montado en la derecha o en la izquierda) 1 produto para porta dianteira (pode ser montado na direita e na esquerda) 1 prodotto per porta anteriore, può essere montato a sinistra o a destra 1 produkt, past zowel rechts als links 1 Artikel für Vordertüren, kann rechts ODER links eingebaut werden 1 produkt może być zamontowany w prawych lub lewych drzwiach один элемент для передней двери, может быть установлен как слева, так и справа Ön kapı için 1 parça. Sağ ya da sol kapıya uyumlu 1 π ροίόν για εμπ ροσθια π όρτα, μη ορεί να τοπ οθετηθεί αριστερά ή δεξιά</p>		<p>Right hand drive Conduite à droite Circulación a derechas Condução a direita Guida a destra Stuur rechts Linksverkehr Kierownica z prawej strony правостороннее расположение руля Sağdan direksiyon Δεξιότιμο</p> <hr/> <p>With / Without Airbag Avec / Sans Airbag Con / Sin Airbag Com / Sem Airbag Con / Senza Airbag Met/ Zonder airbag Mit / Ohne Airbag Z / Bez Airbag с/без подушки безопасности Havayastıklı / Havayastıksız Με / Χωρίς Αερόσακο</p> <hr/> <p>Without barrel or keys Fourni sans barillet ni clé Sin bombillo ni llaves Sem cilindro e sem chaves Senza cilindretto e chiavi Zonder cylinder en sleutels Ohne Schlüsselzylinder und Schlüssel geliefert Bez wkładek i kluczy без цилиндра или ключей Kovan ve anahtar olmadan Χωρίς σώμα (βαρελάκι) ή κλειδιά</p> <hr/> <p>With / Without Avec / Sans Con / Sin Com / Sem Con / Senza Met / Zonder Mit / Ohne Z / Bez C / БЕЗ birlikte / ayrı Με / Χωρίς</p>
	<p>Single actuator Actionneur simple Motor para cerradura simple Actuadores simples Attuatore semplice Enkele regelenheid Betätigungselement Pojedynczy silownik один привод Sadece hareketlendirici Μονός επ ενεργητής</p>	 	
 <p>MECA</p>	<p>Actuator with contactor Actionneur à contacteur Motor para cerradura con contactor Actuadores con contato Attuatore a contatto Regeleenheid met contact Betätigungselement mit Schalter Silownik z kontaktem привод с замыкателем Kontaklı hareketlendirici Επ ενεργητής με επ αφέα – διακόπ τη</p>	<p>+/-</p>	
<p>CL</p>	<p>Mechanical locking Fermeture mécanique Cierre mecánico Fechadura mecânica Chiusura meccanica Mechanische sluiting Mechanische Verriegelung Mechaniczne zamknięcie механический замок Mekanik kilitleme Μηχανική κλειδαριά</p>		
<p>EDW</p>	<p>Central locking Fermeture centralisée Cierre centralizado Fechadura centralizada Chiusura centralizzata Centrale deurvergrendeling Zentralverriegelung Centralny zamek центральный замок Merkezi kilit Κεντρικό κλείδωμα</p>		
	<p>Central locking with electronical protection Fermeture centralisée avec protection électronique Cierre centralizado con protección electrónica Fecho central com protecção eletrónica Chiusura centralizzata con protezione elettronica Centrale deurvergrendeling met elektronische bescherming Zentralverriegelung mit Wegfahrsperr Centralny zamek z elektronicznym zabezpieczeniem центральный замок с электронной защитой Elektronik korumalı merkezi kilit Κεντρικό κλείδωμα με ηλεκτρονική π ρο-σταςία</p>		
	<p>Left hand drive Conduite à gauche Circulación a izquierdas Condução a esquerda Guida a sinistra Stuur links Rechtsverkehr Kierownica z lewej strony левостороннее расположение руля Soldan direksiyon Αριστεροτίμο</p>		

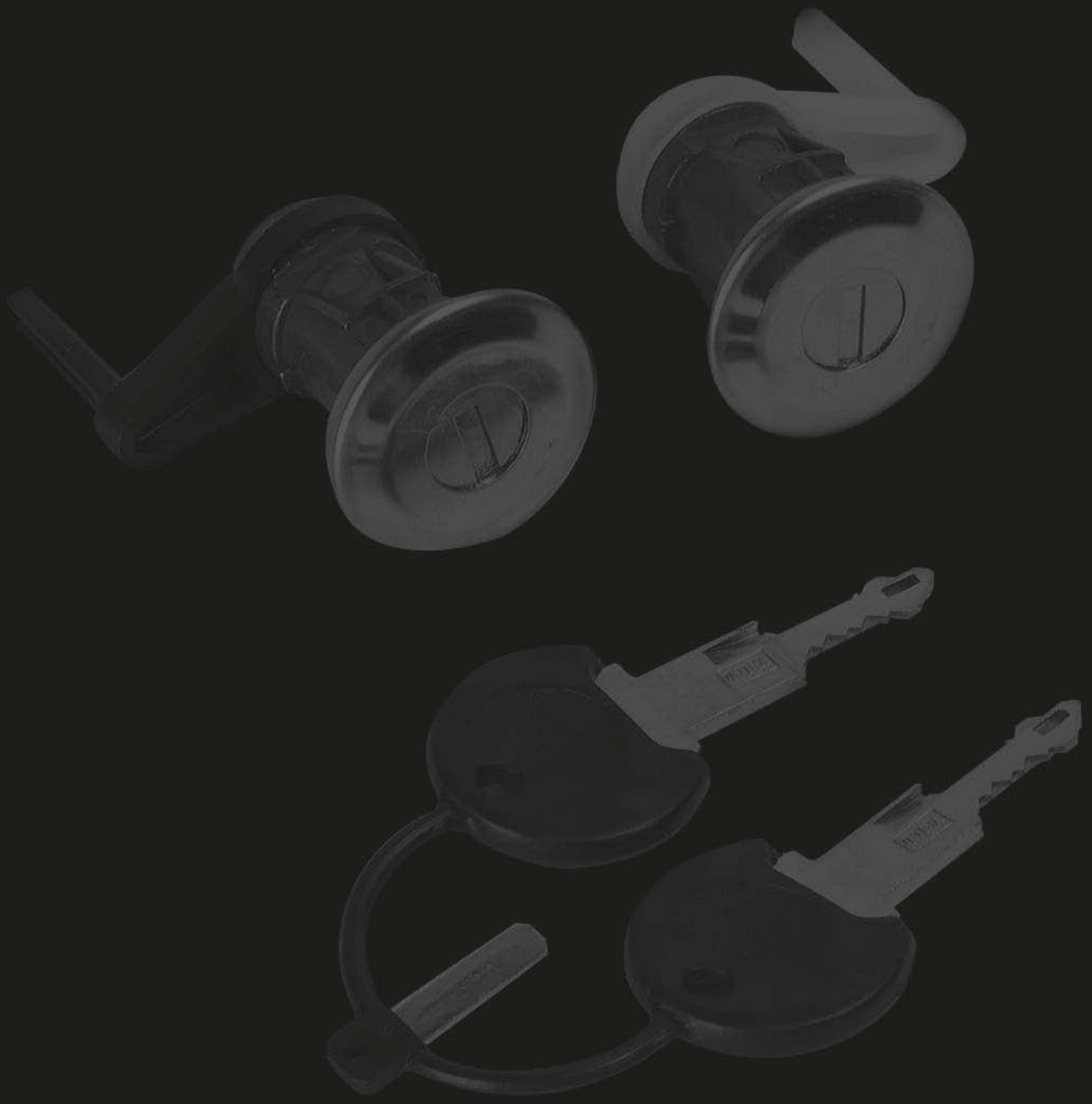



Valeo



Valeo



CITROEN BERLINGO

	07/96 ▶ 09/98	252526		
	07/96 ▶ 09/98	252521		

C15

	10/84 ▶ 02/01	252168		SIMPLEX
	06/84 ▶ 02/01	252007		SIMPLEX

DISPATCH

	09/95 ▶ 09/98	252614		
	09/95 ▶ 09/98	252402		

JUMPY

	09/95 ▶ 09/98	252614		
	09/95 ▶ 09/98	252402		

DAF 65 F

	09/87 ▶ 02/98	256499		
--	---------------	--------	--	--

95 F

	09/87 ▶ 02/98	256499		
--	---------------	--------	--	--

Artikel lieferbar solange Vorrat reicht
Dostepna do wyczerpania stocku
Stoklar bitene kadar

Referencia disponible até fin do stock
Riferimento ad esaurimento stock
Leverbaar zolang de voorraad strekt

Available until exhaustion of stocks
Disponible jusqu'à épuisement des stocks
Producto disponible hasta agotar existencias

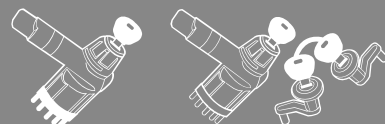



DAF  (.../...)

XF 95

	03/97 ▶	256941	 	
--	---------	---------------	--	--

FIAT 

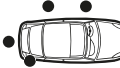
SCUDO



	07/95 ▶ 09/98	252614	 	
	07/95 ▶ 09/98	252402		

NISSAN 

TRADE

	04/93 ▶	252427		
--	---------	---------------	---	--

VANETTE

E	04/87 ▶ 05/90	252401		
E	06/90 ▶ 06/94	252428		

OPEL 

COMBO

	03/93 ▶ ch R4999999	252644		
--	---------------------	---------------	--	--

PEUGEOT 

EXPERT

	09/95 ▶ 09/98	252402		
	09/95 ▶ 09/98	252614	 	



Valeo



Valeo



PEUGEOT  (.../...)

J7

07/75 ▶ 01/80

252019



J9

01/80 ▶ 06/86

252019



07/86 ▶ 1991

252129



PARTNER

3

06/96 ▶ 09/98

252521



3

06/96 ▶ 09/98

252526

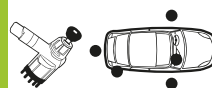

RANCH

3

06/96 ▶ 09/98

252526

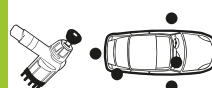

RENAULT EXPRESS 

09/85 ▶ 08/97

252039



EXTRA

09/91 ▶ 08/97

252132



09/91 ▶ 08/97

252415



MASTER

04/87 ▶ 09/97

252045



NEIMAN

Доступен до окончания на складе

Artikel lieferbar solange Vorrat reicht

Dostępna do wyczerpania stocku

Stoklar bitene kadar

Referencia disponível até fim do stock

Riferimento ad esaurimento stock

Leverbaar zolang de voorraad strekt

Available until exhaustion of stocks

Disponibile jusqu'à épuisement des stocks

Producto disponible hasta agotar existencias





RENAULT  (.../...)

TRAFIC

4	07/80 ▶ 06/86	252042		NEIMAN
	07/86 ▶ 06/91	252039		NEIMAN
	07/91 ▶ 08/97	252454		

SEAT 

INCA

	11/95 ▶ 10/97	252011		
--	---------------	---------------	--	--

TERRA

	02/87 ▶ 07/91	252013		
--	---------------	---------------	--	--

VOLKSWAGEN 

TRANSPORTER

3 ,M	11/92 ▶ 05/96	252608		
------	---------------	---------------	--	--

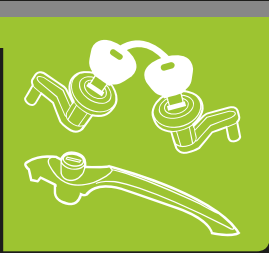



Valeo



Valeo



CITROEN BERLINGO

	07/96 ▶ 12/02	252522				
	05/08 ▶	•256967				
	05/08 ▶	•256968				
	05/08 ▶	•256969				
	05/08 ▶	•256970				

C15

	10/84 ▶ 02/01	252373				SIMPLEX
	10/84 ▶ 02/01	252186				SIMPLEX
	10/84 ▶	252388				SIMPLEX

MERCEDES SPRINTER

	02/95 ▶	256750				
	02/95 ▶	256749				

TRANSPORTER

	07/81 ▶ 02/96	256750				
410, 407D, 408D, 409D, 410D	07/81 ▶ 02/96	256749				

MB

	12/80 ▶ 01/96	256749				
--	---------------	---------------	--	--	--	--

VITO

	01/96 ▶ 09/03	256750				
--	---------------	---------------	--	--	--	--

Доступен до окончания на складе

Artikel lieferbar solange Vorrat reicht

Dostępna do wyczerpania stocku

Stoklar bitene kadar

Referencia disponivel até fim do stock

Rifornimento ad esaurimento stock

Leverbaar zolang de voorraad strekt

Available until exhaustion of stocks

Disponibile jusqu'à épuisement des stocks

Producto disponible hasta agotar existencias



• New Nouveau Nuevo Novo Nuovo Nieuw Neu Nowość Yeni Новый Νέο Novy



MERCEDES  (.../...)

1113-1124

1114/L/K/AK/, 1114/L

03/84 ▶

256750



1114/L/K/AK/, 1114/L

03/84 ▶

256749



1213-1245

1214C/K, 1215/C

01/83 ▶

256750



1213/K/S/K0/AK/AS/AK0, 1217/K/L/S/AK/LS
1219/F/K/S/K0/AK

05/82 ▶

256749



1313-1332

1314/L/AK, 1317K, 1318

07/84 ▶

256750



1413-1428

1418R, 1420

07/85 ▶

256750



1413/K/K0, 1417, 1419/F/S, 1424/K, LAP1424

04/84 ▶

256749



1514-1525

1514/K, 1517

01/89 ▶

256750



1614-1650

1619L, 1624L/LS, 1626/AK/AS, 1632/K/L/S/AS/LS
OH1636L

05/82 ▶ 03/91

256749



1718-1733

1718A/M, 1720/A/K, 1723/S

02/90 ▶

256750



1719/S/K/AK, LU1720

02/90 ▶

256749



1814-1843

1823/K, 1835LS, 1843LS

07/91 ▶

256750



1919-1948

1938S, 1944S

11/80 ▶

256750





Valeo



Valeo



MERCEDES  (.../...)

1919-1948 (.../...)

1919/K/S, 1924, 1926/K/S/AS, 1928, 1932/K/AK/AS/LS LU1920, LU1921, LU1924	11/80 ▶	256749				
--	---------	---------------	--	--	---	--

2020-2036

2029	08/83 ▶	256749				
------	---------	---------------	--	--	---	--

2219-2244

2219/B/K/L, 2224/B/K/S	06/76 ▶ 03/91	256749				
------------------------	---------------	---------------	--	--	---	--

2420-2448

2423/B/K, 2428, 2429L, 2434L, 2435L/LS, 2438/L/LS	02/83 ▶	256750				
---	---------	---------------	---	--	--	--

2517-2550

2523/K, 2528, 2535L, 2538L, 2543L, 2544L, 2550L	01/86 ▶	256750				
---	---------	---------------	---	--	--	--

2622-2650

2623, 2628B/K, 2631B, 2633B, 2643B	02/80 ▶	256750				
------------------------------------	---------	---------------	---	--	--	--

2624, 2628, 2629, 2632, 2635, 2637, 2644	02/80 ▶	256749				
--	---------	---------------	--	--	---	--

3225-3250

3228, 3235B/L, 3243B, 3248B, 3253L	07/87 ▶	256750				
------------------------------------	---------	---------------	---	--	--	--

3321-3346

3321B, 3331B, 3340B, 3346B	07/82 ▶	256750				
----------------------------	---------	---------------	---	--	--	--

4140-4150

4140B, 4146B	07/87 ▶	256750				
--------------	---------	---------------	---	--	--	--

709-714

709/D/K, 711/D	01/86 ▶	256750				
----------------	---------	---------------	---	--	--	--

Dostupen do okonczania na sklade

Artikel lieferbar solange Vorrat reicht

Dostepna do wyczerpania stocku

Stoklar bitene kadar

Referencia disponivel até fim do stock

Rifornimento ad esaurimento stock

Leverbaar zolang de voorraad strekt

Available until exhaustion of stocks

Disponible jusqu'à épuisement des stocks

Producto disponible hasta agotar existencias



MERCEDES  (.../...)

709-714 (.../...)

709/K, 711

01/86 ▶

256749



808-817

809, 811/K, 814/F/K/LS, 809D/DT, 810DT, 811D/DK
812D, 814D/DA, 815D/DA, O810, O814, O815

01/86 ▶

256750



809, 811/K

01/86 ▶

256749



911-917

914/K

01/87 ▶

256750



917

01/87 ▶

256749



ACTROS I

09/96 ▶

256750



ACTROS II

2535L, 2543L

04/03 ▶

256750



ATEGO

03/98 ▶

256750



AXOR

1215, 1517, 1823/K, 1835LS, 1843LS, 2523/K, 2528
2623L, 2628B/K/L, 3228

10/01 ▶

256750



MEDIO

10/00 ▶

256749



VARIO

10/96 ▶

256750



10/96 ▶

256749





Valeo



Valeo



MERCEDES  (.../...)

O 404

09/91 ▶

256750



NISSAN 
VANETTE

4 **5**

11/82 ▶ 11/94

252550

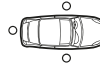

PEUGEOT 
PARTNER

3

06/96 ▶

252522

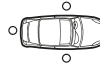

05/08 ▶

•256967



05/08 ▶

•256968

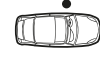

05/08 ▶

•256969

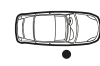

05/08 ▶

•256970



RENAULT 
EXPRESS

09/85 ▶ 08/97

256603

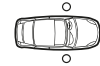

09/85 ▶ 08/97

252085



KANGOO

09/97 ▶ 06/98

256890

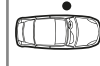

09/97 ▶ 06/98

256891

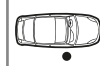

09/97 ▶

256892

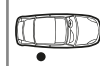

KANGOO II

01/08 ▶

•256977

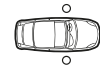

Artikel lieferbar solange Vorrat reicht
Dostepna do wyczerpania stocku
Stoklar bitene kadar

Referencia disponible até fim do stock
Rifornimento ad esaurimento stock
Leverbaar zolang de voorraad strekt

Available until exhaustion of stocks
Disponibile jusqu'à épuisement des stocks
Producto disponible hasta agotar existencias



RENAULT  (.../...)

KANGOO II (.../...)

01/08 ▶

•256978



MASTER

D

09/97 ▶

256523

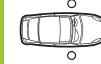

MASTER III

04/10 ▶

•256978

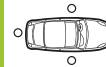

RENAULT TRUCKS 

KERAX

09/97 ▶

256466



MASCOTT

01/99 ▶

256523



PREMIUM

02/96 ▶ 12/02

256466



SISU

256466



SEAT 

INCA

11/95 ▶ ch V015000

252251



09/00 ▶ 06/03

252600



VOLKSWAGEN 

CADDY

09/00 ▶ 06/03

252600





Valeo



Valeo



Доступен до окончания на складе

Artikel lieferbar solange Vorrat reicht

Dostępna do wyczerpania stocku

Stoklar bitene kadar

Referencia disponible até fim do stock

Riferimento ad esaurimento stock

Leverbaar zolang de voorraad strekt

Available until exhaustion of stocks

Disponible jusqu'à épuisement des stocks

Producto disponible hasta agotar existencias



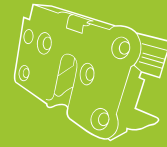

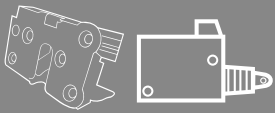

Valeo



Valeo



CITROEN BERLINGO

07/96 ▶ 12/02

256364

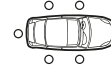

PEUGEOT PARTNER

06/96 ▶ 11/02

256364

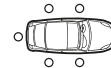

RANCH

06/96 ▶ 11/02

256364

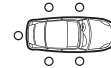

RENAULT EXPRESS

09/85 ▶ 08/97

256411



EXTRA

09/85 ▶ 08/97

256411



RAPID

09/85 ▶ 03/98

256411



Доступен до окончания на окладe

Artikel lieferbar solange Vorrat reicht

Dostępna do wyczerpania stanu

Stoklar bitene kadar

Referencia disponivel até fim do stock

Riferimento ad esaurimento stock

Leverbaar zolang de voorraad strekt

Available until exhaustion of stocks

Disponible jusqu'à épuisement des stocks

Producto disponible hasta agotar existencias



• New Nouveau Nuevo Novo Nuovo Nieuw Neu Nowość Yeni Новый Νέο Novy

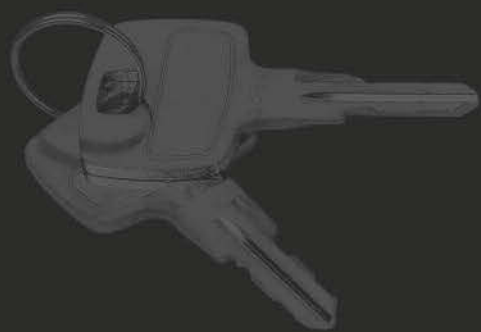



Valeo

Pour / for



Valeo

S



ALFA ROMEO

30, 32, 35, 40 AR8

▶ 1983

247700

B221



96

M80x2

+

1984 ▶

247704

B225



88

∅ 60

+

CITROEN

350 - 370 - 450

▶ 1980

247607

B128



77,5

M60x2

-

Acadiane

▶ 1985

247504

B54



72

∅57

+

AZU - AK

▶ 1985

247504

B54



72

∅57

+

C Crosser

07/07 ▶

247605

B126



72

∅ 40

-

07/07 ▶

247606

B127



72

∅ 40

-

C25

▶ 12/87

247607

B128



77,5

M60x2

-

C32

1985 ▶ 1988

247504

B54



72

∅57

+

C35

1985 ▶ 1988

247504

B54



72

∅57

+

HY - HZ - HYP - HYV

▶ 1981

247504

B54



72

∅57

+

Jumper, Relay

02/94 ▶ 1998

247558

B108



77,5

M62,5x6,3

-

1999 ▶

247601

B122



72,5

∅ 40

+

Jumpy II

01/07 ▶

247605

B126



72

∅ 40

-

01/07 ▶

247606

B127



72

∅ 40

-

Jumpy

▶ 04/07

247610

B132



111

∅ 41

-

DAF

ALL TRUCKS

247703

B224



122

∅ 80

+

FIAT

Citivan

1988 ▶

247518

B68



48,5

∅ 35

-

Doblo

10/00 ▶

247601

B122



72,5

∅ 40

+

Ducato

03/90 ▶ 1993

247511

B61



48,5

∅35

-

1994 ▶ 1998

247558

B108



77,5

M62,5x6,3

-

1999 ▶

247601

B122



72,5

∅ 40

+

Locking petrol caps - Bouchons à carburant - Tapones depósito de combustible - Tappi carburante - Tankdoppen - Tankdeckel - Крышки бензобака - Υακτινί δεπο καυσίου



Pour / for		Valeo	S				
FIAT							
Ducato	11/81 ▶ 12/87	247607	B128		77,5	M60x2	-
Duna	1987 ▶ 1991	247518	B68		48,5	Ø 35	-
Fiorino	1983 ▶ 1989	247518	B68		48,5	Ø 35	-
	1989 ▶ 1991	247518	B68		48,5	Ø 35	-
	12/07 ▶	247601	B122		72,5	Ø 40	+
Fiorino 127	1977 ▶ 1988	247518	B68		48,5	Ø 35	-
Scudo II	01/07 ▶	247605	B126		72	Ø 40	-
	01/07 ▶	247606	B127		72	Ø 40	-
Talento	03/90 ▶ 1995	247511	B61		48,5	Ø35	-
	09/88 ▶ 02/90	247607	B128		77,5	M60x2	-
Scudo	▶ 01/07	247610	B132		111	Ø 41	-
FORD							
ALL TRUCKS	1984 ▶ 1992	247704	B225		88	Ø 60	+
		247703	B224		122	Ø 80	+
FORD							
Courrier	1996 ▶	247561	B111		72,5	Ø 40	+
Tourneo	10/94 ▶	745370	B116		73X82	Ø 40	-
Transit	1972 ▶ 1986	247547	B97		87	Ø 48	+
	1986 ▶ 1988	247548	B98		82	Ø 35	+
	2000 ▶	247602	B123		72,5	Ø 40	+
	1989 ▶ 12/91	745368	B114		82	Ø 40	-
	10/94 ▶ 2000	745370	B116		73X82	Ø 40	-
HANOMAG							
ALL TRUCKS		247703	B224		122	Ø 80	+



Pour / for



Valeo

S



INTERNATIONAL

ALL TRUCKS

247700

B221



96

M80x2

+

IVECO

ALL TRUCKS

247700

B221



96

M80x2

+

1988 ▶

247703

B224



122

Ø 80

+

ALL TRUCKS (plastic tank)

2003 ▶

247710

B231



103

M65x6,5

+

▶ 2002

247709

B230



103

M80x6

+

EuroCargo

2003 ▶

247710

B231



103

M65x6,5

+

▶ 2002

247709

B230



103

M80x6

+

EuroCargo 130 -> 180E - 4x4

247703

B224



122

Ø 80

+

EuroCargo Tector 60 -> 180 E

2003 ▶

247710

B231



103

M65x6,5

+

▶ 2002

247709

B230



103

M80x6

+

EuroStar, EuroTech, EuroTrakker

247703

B224



122

Ø 80

+

Stralis

247707

B228



129

Ø 80

+

IVECO

Daily - Grinta : 30, 35, 40, 45, 49

1984 ▶

247704

B225



88

Ø 60

+

Daily 30

▶ 1983

247700

B221



96

M80x2

+

Daily City

2003 ▶

247710

B231



103

M65x6,5

+

▶ 2002

247709

B230



103

M80x6

+

Daily, Turbodayly

06/91 ▶ 1998

247709

B230



103

M80x6

+

Daily

1999 ▶

247601

B122



72,5

Ø 40

+

Daily Fourgon 30.8, 32.8, 35.8, 40.8

▶ 1987

247518

B68



48,5

Ø 35

-

KÄSSBOHRER

ALL TRUCKS

247703

B224



122

Ø 80

+

Locking petrol caps - Bouchons à carburant - Tapones depósito de combustible - Tappi carburante - Tankdoppen - Tankdeckel - Κοκκι κλεισι παλινα - Крышки бензобака - Yakit depo kapagi - Τάπες δοχείου καυσίμου



Pour / for		Valeo	S				
MACK							
ALL TRUCKS		247700	B221		96	M80x2	+
MAGIRUS-DEUTZ							
ALL TRUCKS		247703	B224		122	Ø 80	+
MAN							
ALL TRUCKS		247703	B224		122	Ø 80	+
MAZDA							
E 1600	▶ 1984	247538	B88		65	Ø 35	+
E 2000 - 2200 Bus	1984 ▶	247538	B88		65	Ø 35	+
MERCEDES							
Corriere (bus)		247703	B224		122	Ø 80	+
MERCEDES							
814, S-817-914, AK-1117-1314K, AK-1317-1320, S-1517, K-1520-1826, L, S-1833L, LL, LS-1922K, AK-1935, S-1948, S-2433L, LL, 6x2-2629K, AK M.O.- 2635K, SMO		247703	B224		122	Ø 80	+
Actros	1999 ▶	247703	B224		122	Ø 80	+
Atego	01/98 ▶	247703	B224		122	Ø 80	+
Axor	01/02 ▶	247703	B224		122	Ø 80	+
MERCEDES							
Sprinter	2002 ▶	247613	B135		65	Ø 40	+
MITSUBISHI							
Canter	1999 ▶	247703	B224		122	Ø 80	+
NISSAN							
Trade	1987 ▶	247518	B68		48,5	Ø 35	-
Vanette	1979 ▶ 1991	247538	B88		65	Ø 35	+

**Valeo**

Pour / for

**Valeo****S****OPEL**

Astra	1991 ▶ 1997	745371	B117		72	Ø 40	-
Combo	12/94 ▶ 02/02	745371	B117		72	Ø 40	-

PEGASO

Troner		247703	B224		122	Ø 80	+
---------------	--	---------------	------	--	-----	------	---

PEUGEOT

Boxer	02/94 ▶	247558	B108		77,5	M62,5x6,3	-
Expert II	01/07 ▶	247605	B126		72	Ø 40	-
	01/07 ▶	247606	B127		72	Ø 40	-
J5	1981 ▶ 1987	247607	B128		77,5	M60x2	-
J7	1974 ▶ 1989	247503	B53		72	Ø 63	+
J9	1974 ▶ 1989	247503	B53		72	Ø 63	+

RENAULT

Estafette	▶ 1981	247500	B50		72	Ø36	+
Express - Rapid - Extra	09/91 ▶ 04/93	247528	B78		111	Ø 39	-
	05/93 ▶	247529	B79		41	Ø 41	-
Kangoo	09/97 ▶	745373	B119		155X117	Ø 38	-
	01/00 ▶	247611	B133		155X117	Ø 41	-
Master	▶ 1998	247702	B223		72,5	Ø 36	+
	▶ 1997	247500	B50		72	Ø36	+
Messenger - B	1986 ▶	247500	B50		72	Ø36	+
Trafic		247702	B223		72,5	Ø 36	+
	1980 ▶	247500	B50		72	Ø36	+

RENAULT

Messenger - B	1986 ▶	247702	B223		72,5	Ø 36	+
----------------------	--------	---------------	------	--	------	------	---

Locking petrol caps - Bouchons à carburant - Tapones depósito de combustible - Tampões de depósito de combustível - Tappi carburante - Tankdoppen
 Tankdeckel - Korki wiewu paliwa - Крышки бензобака - Υακτι δεπο καπαγι - Τάπες δεξαυτου καυσιμου



Pour / for		Valeo	S				
RENAULT							
Master	1998 ▶	247525	B75		72	Ø 47	-
RENAULT TRUCKS							
ALL TRUCKS (metal tank)		247703	B224		122	Ø 80	+
		247706	B227		122	Ø 90	+
ALL TRUCKS (plastic tank)		247711	B232		124	M80x6,3	-
Magnum	11/00 ▶	247703	B224		122	Ø 80	+
Midlum (metal tank)	11/00 ▶	247703	B224		122	Ø 80	+
Midlum (plastic tank)	11/00 ▶	247711	B232		124	M80x6,3	-
Premium	11/00 ▶	247703	B224		122	Ø 80	+
RENAULT TRUCKS							
Mascott		247711	B232		124	M80x6,3	-
SAVIEM							
SG2, SG3, SG5		247702	B223		72,5	Ø 36	+
SCANIA							
Serie 2, Serie 3	1989 ▶ 1997	247705	B226		88	Ø 60	+
Serie 4	1998 ▶	247708	B229		103	M65x6,5	-
Series P,G,R,T	2004 ▶	247708	B229		103	M65x6,5	-
SEAT							
Fura	10/77 ▶ 1984	247518	B68		48,5	Ø 35	-
Terra	1988 ▶ 1995	247607	B128		77,5	M60x2	-
STEYR							
ALL TRUCKS		247703	B224		122	Ø 80	+



Pour / for



Valeo

S



TOYOTA

Dyna	► 1980	247538	B88		65	Ø 35	+
Hiace	1980 ► 1990	247538	B88		65	Ø 35	+
Hilux	1980 ► 1995	247538	B88		65	Ø 35	+
Liteace	1980 ► 1990	247538	B88		65	Ø 35	+

VAN HOOL

ALL TRUCKS		247700	B221		96	M80x2	+
-------------------	--	---------------	------	--	----	-------	---

VOLKSWAGEN

MT 8136 - 9136		247703	B224		122	Ø 80	+
-----------------------	--	---------------	------	--	-----	------	---

VOLKSWAGEN

LT-Series	1975 ► 1988	247507	B57		72	Ø35	+
Multivan	12/95 ►	247603	B124		72	Ø 40	-
Transporter - Caravelle	1990 ► 2002	247603	B124		72	Ø 40	-
Transporter	► 1973	247507	B57		72	Ø35	+

VOLVO

FH	1999 ►	247703	B224		122	Ø 80	+
FL, FM		247704	B225		88	Ø 60	+

Locking petrol caps - Bouchons à carburant - Tapones depósito de combustible - Tappi carburante - Tankdoppen
 Tankdeckel - Korkki wiewu paliwa - Крышки бензобака - Yakıt depo kapakları - Τάπες δοχείου καυσίμου





Pour / for		Valeo	S				
DAF							
CF75/85, XF105		247713	B234		66	Ø 40	-
LF45-55, CF65		247714	B235		95	Ø 40	+
DAF LF 45 - 55		247718	B237		66	Ø 60	+
IVECO							
Modelli Models : Eurocargo, Stralis		247712	B233		96	Ø 60	-
MAN							
All trucks - vented tank		247713	B234		66	Ø 40	-
MERCEDES							
All trucks - vented tank		247713	B234		66	Ø 40	-
NISSAN							
Cabstar		247617	B238		94	Ø 46,5	-
RENAULT TRUCKS							
Maxity		247617	B238		94	Ø 46,5	-
All trucks - non vented tank		247714	B235		95	Ø 40	+
SCANIA							
All trucks - non vented tank		247714	B235		95	Ø 40	+
Adaptater Scania		247715					
VOLVO							
All trucks - non vented tank		247714	B235		95	Ø 40	+



247500	36" 2	RENAULT	Estafette, Master ,Messenger - B, Trafic
247503	63" 3	PEUGEOT	J7, J9
247504	57" 2	CITROEN	Acadiane, AZU - AK, C32, C35, HY - HZ - HYP - HYV
247507	35" 2	VOLKSWAGEN	LT-Series, Transporter
247511	35" 2	FIAT	Ducato, Talento
247518	35" 2	IVECO	Daily Fourgon 30.8, 32.8, 35.8, 40.8
247525	47" 2	RENAULT	Master
247528	39" 2	RENAULT	Express, Rapid, Extra
247529	41" 2	RENAULT	Express, Rapid, Extra
247538	35" 2	MAZDA	E1600, E 2000 - 2200 Bus
		NISSAN	Vanette
		TOYOTA	Dyna, Hiace, Hilux, Liteace
247547	48" 2	FORD	Transit
247548	35" 2	FORD	Transit
247558	M62,5x6,3	CITROEN	Jumper, Relay
		FIAT	Ducato
		PEUGEOT	Boxer
247561	40" 3	FORD	Courier
247601	40" 2	IVECO	Daily
		IVECO	Daily
		CITROEN	Jumper, Relay
		FIAT	Doblo, Ducato, Fiorino
247602	40" 3	FORD	Transit
247603	40" 3	VOLKSWAGEN	Multivan, Transporter, Caravelle
247605	40" 2	CITROEN	C Crosser, Jumpy II
		FIAT	Scudo II
		PEUGEOT	Expert II
247606	40" 2	CITROEN	C Crosser, Jumpy II
		FIAT	Scudo II
		PEUGEOT	Expert II



247607	M60x2	CITROEN FIAT PEUGEOT SEAT	C25, 350 - 370 - 450 Ducato, Talento J5 Terra
247610	41	CITROEN FIAT	Jumpy Scudo
247611	41	RENAULT	Kangoo
247613	40	MERCEDES	Sprinter
247617	46,5	RENAULT TRUCKS NISSAN	Maxity Cabstar
247700	M80x2	ALFA ROMEO INTERNATIONAL IVECO MACK VAN HOOL	30, 32, 35, 40 AR8 ALL TRUCKS Daily 30, ALL TRUCKS ALL TRUCKS ALL TRUCKS
247701	41	VOLVO	Amaz 121, 122S, F82, F82B, F83B (mod 465), PV444, PV544
247702	36	RENAULT SAVIEM	Master, Messenger - B, Trafic SG2, SG3, SG5
247703	80	DAF FORD HANOMAG IVECO KÄSSBOHRER MAGIRUS-DEUTZ MAN MERCEDES MITSUBISHI	ALL TRUCKS ALL TRUCKS ALL TRUCKS EuroCargo, EuroStar, EuroTech, EuroTrakker, ALL TRUCKS ALL TRUCKS ALL TRUCKS ALL TRUCKS ALL TRUCKS 814, S-817-914, AK-1117-1314K, AK-1317-1320, S-1517 K-1520-1826, L, S-1833L, LL, LS-1922K, AK-1935, S-1948 S-2433L, LL, 6x2-2629K, AK M.O.- 2635K, SMO, Actros, Atego Axor, Corriere (bus) Canter

247703		PEGASO RENAULT TRUCKS STEYR VOLKSWAGEN VOLVO	Troner Magnum, Midlum, Premium, ALL TRUCKS (metal tank) ALL TRUCKS MT 8136 - 9136 FH
247704		ALFA ROMEO FORD IVECO VOLVO	30, 32, 35, 40 AR8 ALL TRUCKS Daily - Grinta : 30, 35, 40, 45, 49 FL, FM
247705		SCANIA	Serie 2, Serie 3
247706		RENAULT TRUCKS	ALL TRUCKS (metal tank)
247707		IVECO	Stralis
247708		SCANIA	Serie 4 Series P,G,R,T
247709		IVECO	Daily, Daily City, Turbodaily, EuroCargo, ALL TRUCKS
247710		IVECO	Daily City, EuroCargo, ALL TRUCKS
247711		RENAULT TRUCKS	Mascott, Midlum, ALL TRUCKS (plastic tank)
247712		IVECO	Modelli Models : Eurocargo, Stralis
247713		DAF RENAULT TRUCKS SCANIA	CF75/85, XF105 All Trucks - non vented tank All Trucks - non vented tank
247714		VOLVO	All Trucks - non vented tank
247715		SCANIA	Adaptater Scania
247718		DAF	DAF LF 45 - 55
745368		FORD	Transit
745370		FORD	Tourneo, Transit
745371		OPEL	Astra, Combo
745373		RENAULT	Kangoo





Valeo

252007



CITROEN C15

252019



PEUGEOT J7, J9

252011



SEAT INCA

252039



RENAULT EXPRESS, TRAFIC

252013



SEAT TERRA

252042



RENAULT TRAFIC

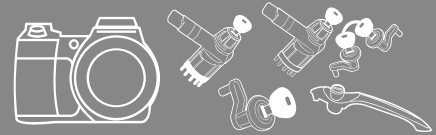

252045

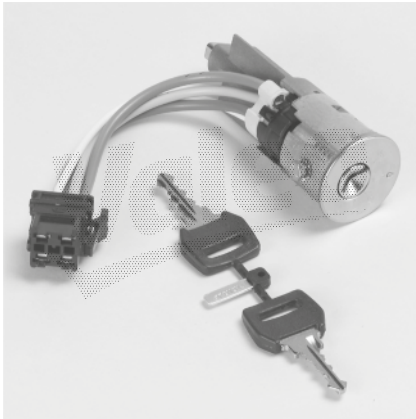

RENAULT MASTER

252132



RENAULT EXTRA

252085



RENAULT EXPRESS

252168

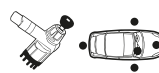

CITROEN C15

252129



PEUGEOT J9

252186



CITROEN C15



Valeo

252251



SEAT

INCA

252401



NISSAN

VANETTE

252373

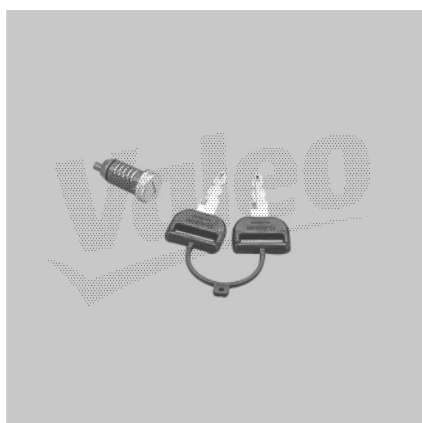

CITROEN

C15

252402

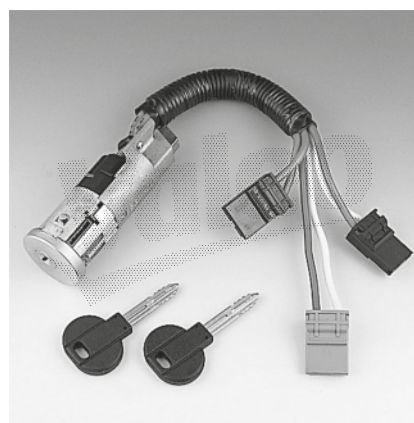

**CITROEN
FIAT
PEUGEOT**

DISPATCH, JUMPY
SCUDO
EXPERT

252388



CITROEN

C15

252415



RENAULT

EXTRA

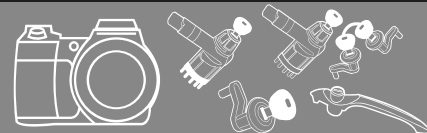

252427



NISSAN TRADE

252521



CITROEN BERLINGO
PEUGEOT PARTNER

252428



NISSAN VANETTE

252522



CITROEN BERLINGO
PEUGEOT PARTNER

252454



RENAULT TRAFIC

252526

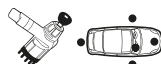

CITROEN BERLINGO
PEUGEOT PARTNER, RANCH

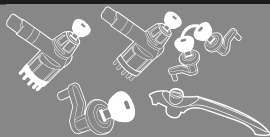

Valeo

252550



NISSAN TRADE, VANETTE

252614

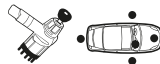

CITROEN DISPATCH, JUMPY
FIAT SCUDO
PEUGEOT EXPERT

252600



SEAT INCA
VOLKSWAGEN CADDY

252644



OPEL COMBO

252608



VOLKSWAGEN TRANSPORTER

2526364

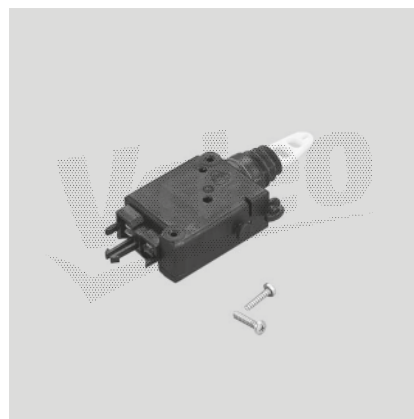

CITROEN BERLINGO
PEUGEOT PARTNER, RANCH

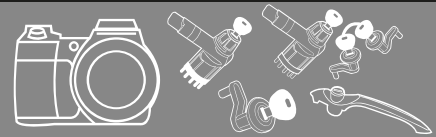

256411



RENAULT EXPRESS, EXTRA, RAPID

256523

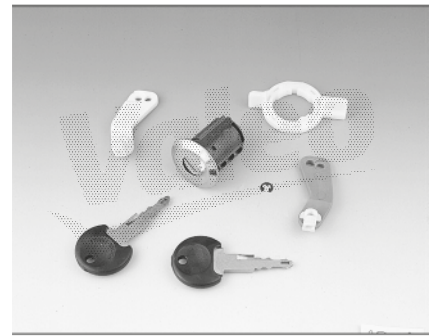

RENAULT MASTER
RENAULT TRUCKS MASCOTT

256466

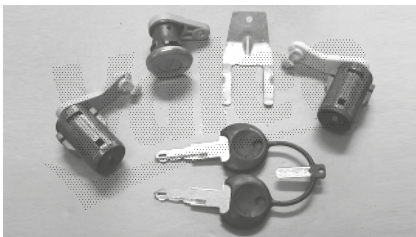

RENAULT TRUCKS KERAX, PREMIUM, SISU

256603



RENAULT EXPRESS

256499

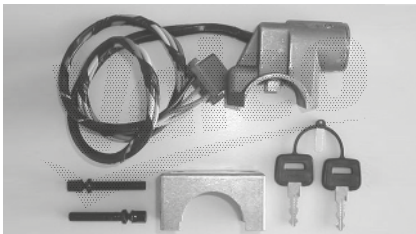

DAF 65 F, 95F

256749

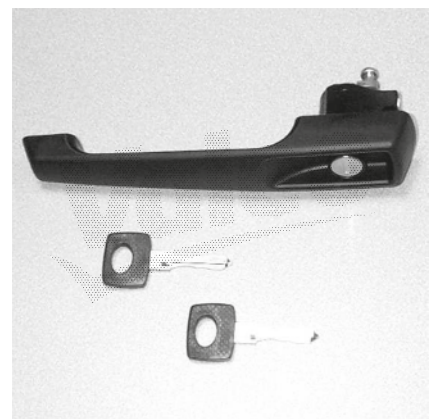

MERCEDES MB, SPRINTER, TRANSPORTER, 709 ... 2650, MEDIO, VARIO, SPRINTER



256750

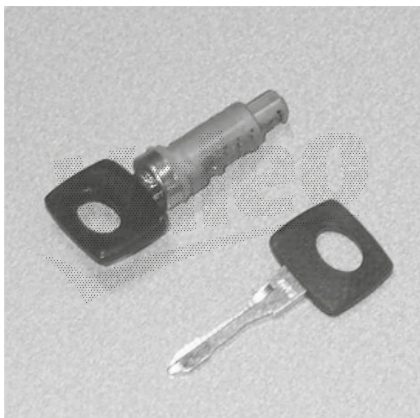
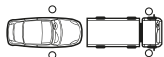

MERCEDES SPRINTER, TRANSPORTER, VITO, 709 ... 4150, ACTROS I, ACTROS II, ATEGO, AXOR, VARIO, O 404

256892



RENAULT KANGOO

256890

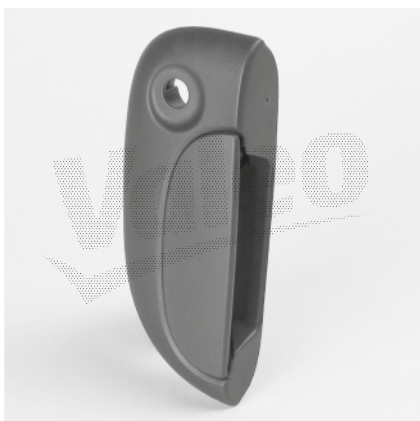

RENAULT KANGOO

256941

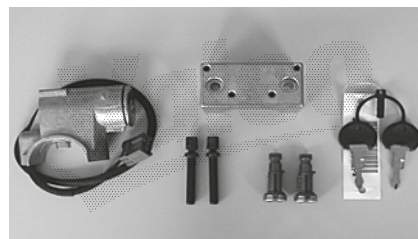
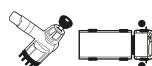

DAF XF 95

256891



RENAULT KANGOO

256967



CITROEN BERLINGO
PEUGEOT PARTNER

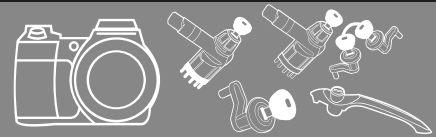

256968

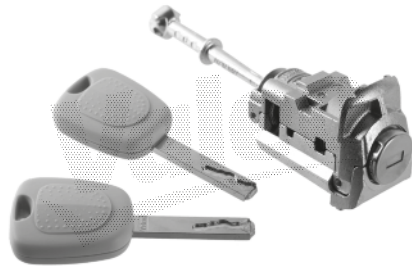

**CITROEN
PEUGEOT** BERLINGO
PARTNER

256977

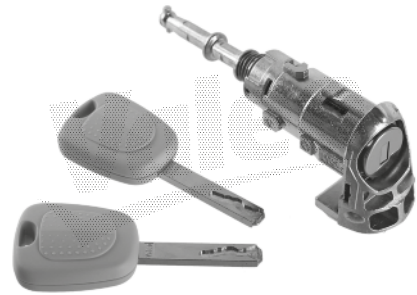

RENAULT KANGOO II

256969

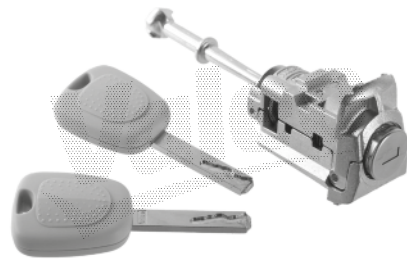

**CITROEN
PEUGEOT** BERLINGO
PARTNER

256978

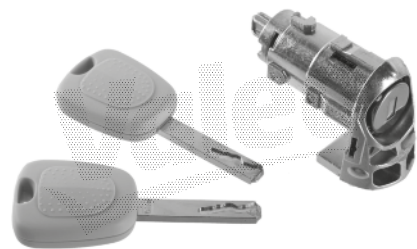

**RENAULT
RENAULT** KANGOO II
MASTER III

256970

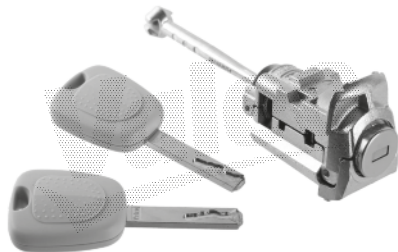

**CITROEN
PEUGEOT** BERLINGO
PARTNER





247500

B50

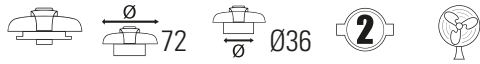

247507

B57

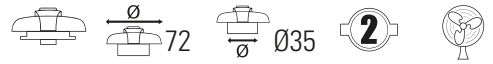

247503

B53

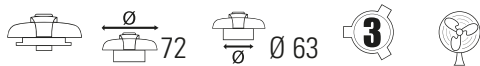

247511

B61



247504

B54

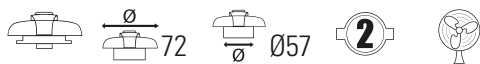

247518

B68





247525

B75

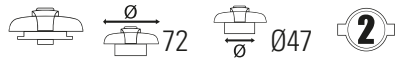

247538

B88

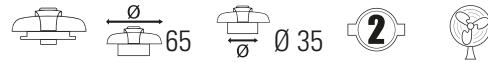

247528

B78



247547

B97

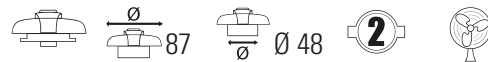

247529

B79

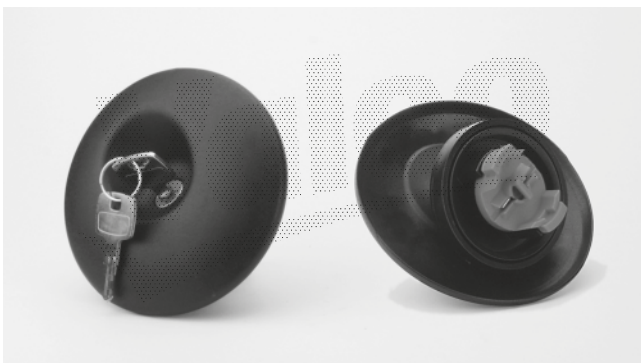

247548

B98

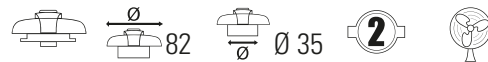



247558

B108

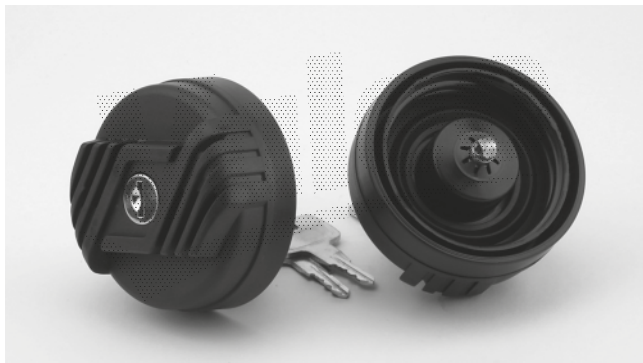

247602

B123



247561

B111



247603

B124



247601

B122

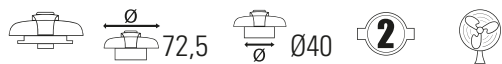

247605

B126

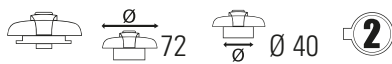



247606

B127

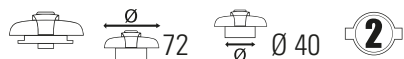

247611

B133

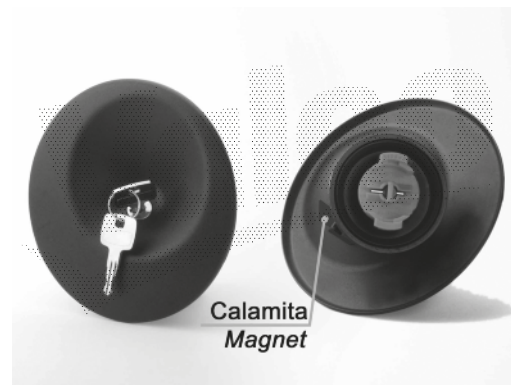

247607

B128

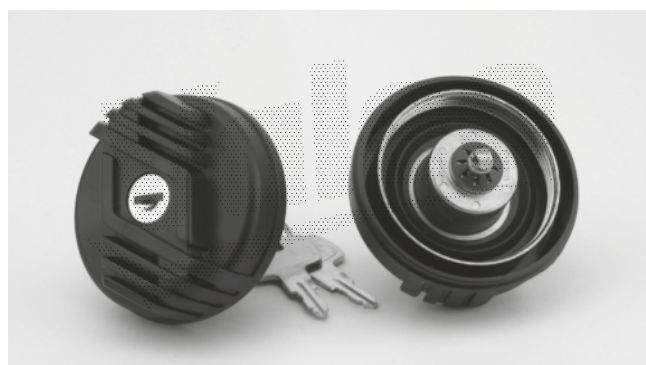

247613

B135



247610

B132



247700

B221

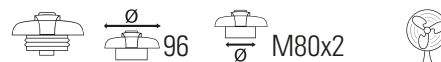



247702

B223

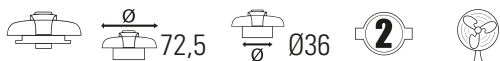

247705

B226



247703

B224

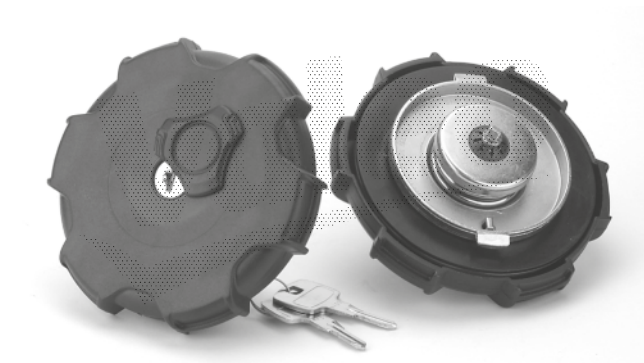
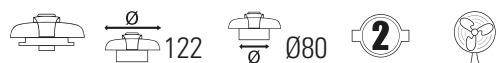

247706

B227

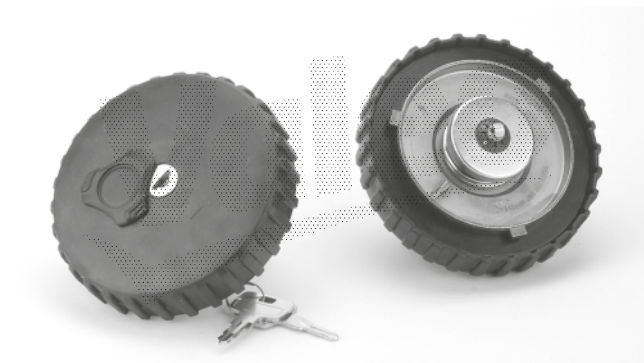
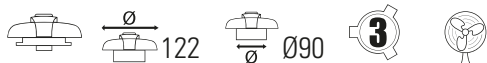

247704

B225

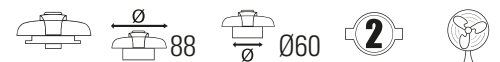

247707

B228

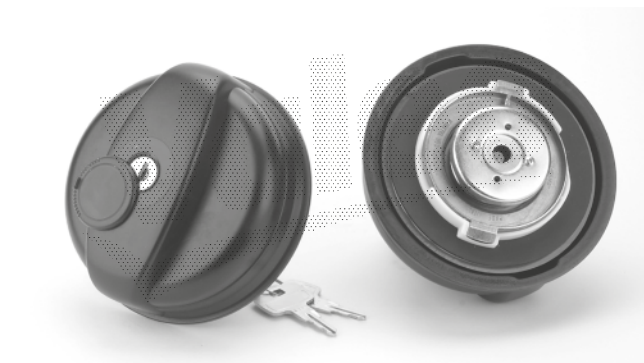



247708

B229

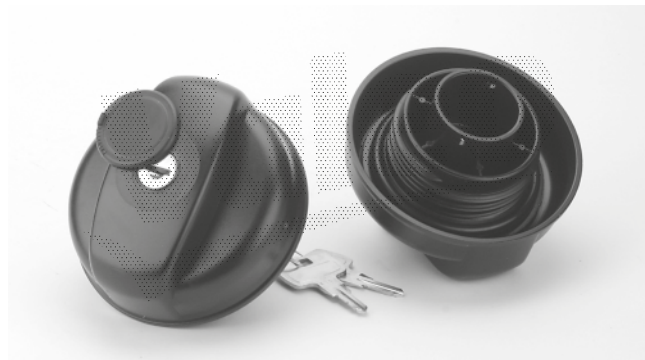

247711

B232



247709

B230

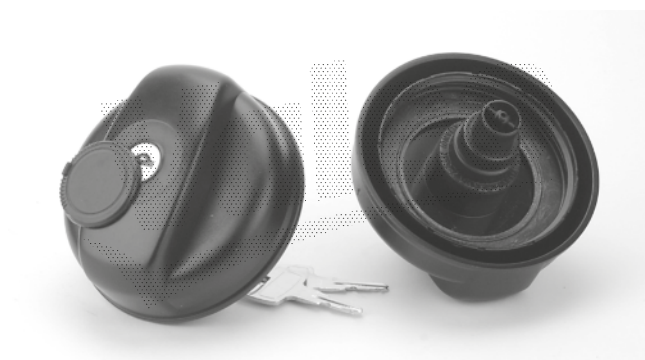
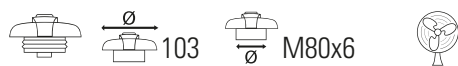

745368

B114



247710

B231

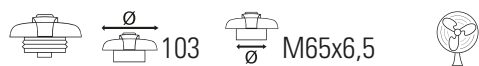

745370

B116

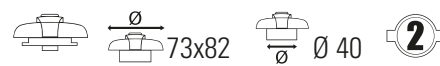



Valeo

745371

B117

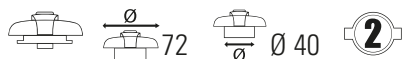

247712

B233



745373

B119

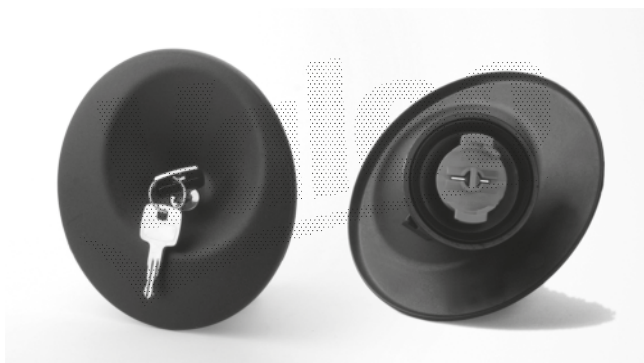

247713

B234



247617

B238

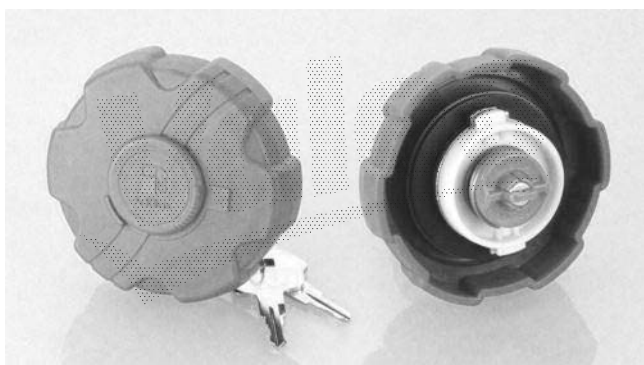

247714

B235





247715

n/a

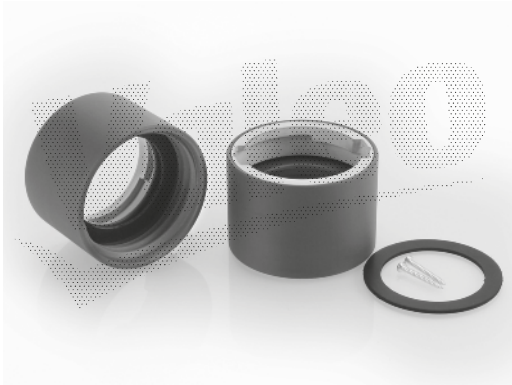
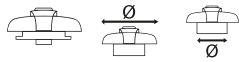

247718

B237

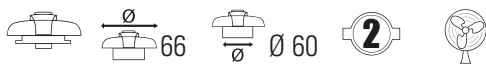









	Valeo		Valeo		Valeo		Valeo
CITROEN		RENAULT (...)					
86194954	252388	7701032141	252132				
95570866	252373	7701038354	256603				
95595343	252373	7701038355	256603				
96244156	252521	7701038361	256603				
4162F1	252168	7701038362	256603				
4162V1	252168	7701044087	252454				
9170G3	252522	7701470016	256603				
DAF		7701470944	256523				
1287785	256499	20926022/NON LOCK	247714				
1380452	256941	21075531/LOCK	247714				
9591067	256499	RENAULT TRUCKS					
1742568 /NON LOCK	247718	5001834847	256466				
IVECO		5001834847	256466				
2993918	247703	7701470944	256523				
2993919	247700	SCANIA					
2993920	247704	1481301(4M-001)/LOCK	247708				
2993923	247710	SCANIA					
500025735	247709	1759435/NON LOCK	247714				
500025779	247712	21075528/ LOCK	247714				
500043667	247703	SEAT					
MERCEDES		1L0905855	252011				
A0004702705002	247713	6K4837205	252251				
A6707600159	256749	6K4839205B	252600				
A6707600205	256750	SE028956000A	252013				
NISSAN		VOLKSWAGEN					
15066410	252427	357905855A	252608				
17251-9X427/LOCK	247617	6K4839205B	252600				
48700G5125	252428	VOLVO					
48700G5127	252401	20926021/ NON LOCK	247714				
OPEL							
914495	252644						
PEUGEOT							
416136	252019						
416237	252129						
96244156	252521						
4162F4	252614						
4162H9	252526						
4162L9	252614						
4162Q4	252526						
4162S1	252614						
9170G3	252522						
RENAULT							
7700303504	256892						
7700303549	256890						
7700303559	256891						
7700306570	252454						
7700739966	252045						
7700757260	252042						
7700772942	252039						
7700772942	252039						
7700772943	252415						
7700813973	252039						
7700813973	252039						





	Valeo		Valeo		Valeo		Valeo
BLAU		TRW (...)					
03035-SV-005	247507	601676	252132				
03035-SV-005	247538	601676	252415				
12045-SV-022	247525	602798	252045				
12045-SV-075	247601						
26035-SV-009	247511						
26040-SV-014	745371						
27035-SV-005	247500						
27040-SV-002	247503						
ERA							
660002	252007						
660006	252013						
660016	252039						
660017	252042						
660018	252045						
660026	252402						
660027	252132						
660027	252415						
660028	252454						
660033	252614						
660034	252644						
660125	252526						
FEBI BILSTEIN							
2750	252644						
FEBI BILSTEIN							
17254	256749						
HELLA							
8XY 004 715-001	247500						
8XY 004 716-001	745371						
8XY 004 720-001	247538						
8XY 004 725-001	247507						
8XY 005 067-001	247503						
8XY 007 103-001	247511						
8XY 007 747-001	247525						
8XY 008 238-001	247561						
8XY 008 530-001	247601						
JOURNEE							
XS 177	247503						
XS 233	247507						
XS 267	745371						
XS 291	247500						
XS 434	247538						
SISPA							
6051	247500						
6097	745371						
6101	247507						
6102	247503						
6104	247538						
6211	247525						
6227	247561						
6235	247601						
TRW							
601628	252039						
601632	252042						

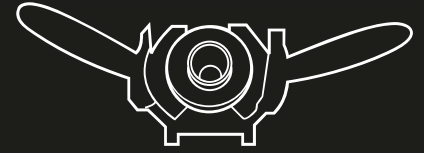

Steering column switches

Commutation sous volant

Conmutador de volante

Comutador de volante

Devioguida a sgancio

Stuurkolomschakelaars

Lenkstockschalter







Przełączniki kolumny kierownicy

Переключатель рулевой колонки









Far-korna-silecek kumanda kolları

Διακόπ της Τζμονιού



	Vehicle Vehículo Vehículo Viatura Veicolo Voertuig Fahrzeug Pojazd Автомобиль Αραç Όχημα
	Photo Photo Foto Foto Foto Foto Zdjęcie Фото Fotograf Φωτογραφία
	Wiring diagram Schéma technique Esquema Esquema Schema tecnico Bedradingsschema Montageanleitung Schemat Схема Çizim Τεχνικό Διάγραμμα
	OE reference Référence Constructeur Referencia constructor Referência constructor Riferimento Costruttore OE referentie OE-Nummer Referenja konstruktor OE номер OE referansı Κωδικός Κατασκευαστή
	Product Manufacturer reference Référence Equipementier Referencia competencia Referência fabricante Riferimento IAM IAM referentie Produktionsnummer Referenja producenta Номер производителя Parça üretici referansı Κωδικός Aftermarket
	Application date Date d'application Fecha de aplicación Data de aplicação Data d'applicazione Applicatie datum Baujahr Data produkcji samochodu Дата производства Uygulama tarihi Ημερομηνία κατασκευής
ch ▶	From chassis number Depuis N° de chassis Desde número de chassis Desde o n° de chassi Dal numero di telaio Van Chassisnummer Ab Fahrgestellnummer Nr. Od numeru nadwozia от номера шасси Şasi numarısından itibaren Από Σασί
▶ ch	To chassis number Jusqu'au N° de chassis Hasta número de chasis Até o n° de chassi Al numero di telaio Tot chassisnummer Bis Fahrgestellnummer Nr. Do numeru nadwozia до номера шасси Şasi numarasına kadar Μέχρι Σασί
AC	Air conditioning Climatisation Climatización Climatização Aria condizionata Airconditioning Klimaanlage Klimatyzacja Кондиционер Klima Κλιματισμός

AIR	Airbag Airbag Airbag Airbag Airbag Airbag Airbag Αварийная подушка безопасности Наваyастыği Αερόσακκος
DA	Power Assisted Steering Direction assistée Dirección asistida Direcção assistida Direzione assistita Stuurbekrachtiging Servolenkung Wspomaganie Kierownicy Усилитель рулевого управления Hidrolik direksiyon Υδραυλικό Τιμόνι
ESP	Electronic Stability Program Programme de Stabilité Electronique Programa de Estabilidad Electrónica Programa de Estabilidade Eletrónica Programma di Stabilità Elettronica Elektronisch Stabilitätsprogramm Elektronisches Stabilitätsprogramm System kontroli trakcji Система стабилизации курсовой устойчивости Elektronik denge sistemi Ηλεκτρονικό Σύστημα Σταθεροποίησης ESP
RESE	Post mounting radio Radio extra série Radio extra serie Radio extra serie Radio non di serie Radio booster Radiomachrüstung Niefabryczne radio Не заводская аудиосистема Kurulu radyo Ραδιόφωνο με extra εξοπλισμό
RTW	Radio / Telephon / CD changer Radio / Téléphone / CD Radio / Teléfono / CD Rádio / Telefone / CD Radio / Telefono / CD di serie Radio / Telefoon / Cd-wisselaar Radio / Telefon / CD Radio / Telefon / Zmieniarka CD Радио / Телефон / CD Radyo / Telefon / CD Ράδιο / Τηλέφωνο / CD
SUS	Suspension with electronic control Suspension pilotée Control de suspensión Control electrónico de suspensão Sospensioni controllate Electronisch actieve vering Elektronische Fahrwerkskontrolle Zawieszenie sterowane elektronicznie Электронно-регулируемая подвеска Elektronik kontrollü süspansiyon Ηλεκτρονικά Ελεγχόμενη Ανάρτηση
SPAIN	Spain Espanne España Espanha Spagna Spanje Spanien Hiszpania Испания ispanya Ισπανία
	Remote control for central locking Télécommande d'ouverture à distance Con mando de cierre centralizado Comando de fecho centralizado Comando di apertura a distanza Afstandsbediening Funkfernbedienung Zamek centralny z pilotem Центральный замок с пультом дистанционного управления Merkezi kilit için uzaktan kumanda Τηλεχειρισμός
	Control on wheel (radio or cruise control) Commande sur volant (radio ou régulateur de vitesse) Mando en el volante (radio o limitador de velocidad) Comando no volante (rádio ou controlo de velocidade) Comando al volante (radio o controllo di velocità) Switch op stuurwiel (Radiobediening of cruise control) Lenkradfernbedienung (Radio oder Tempomat) Sterowanie na kierownicy (radiem lub tempomatem) Пульт управление на рулевом колесе (аудио или климатическая системы) Direksiyon üzerindeki kumandalar (radyo ve hız sabitleyici) Τηλεχειριστήριο στο τιμόνι (Ραδιοφώνου η ρύθμισης ταχύτητας)

+/-	With / Without Avec / Sans Con / Sin Com / Sem Con / Senza Met / Zonder Mit / Ohne Z / Bez C / БЕЗ birlikte / ayrı Με / Χωρίς
	Lighting Eclairage Luces Luz Luci Verlichting Beleuchtung Światła Система освещения Αυτίνατμα Φωτισμός
	Automatic lighting (light sensor) Eclairage automatique Encendido automático luces Iluminação Automática (sensor de luz) Fari ad accensione automatica Automatische verlichting (sensor) Automatische Beleuchtung (Lichtsensor) Światła automatyczne (czujnik zmierzchu) Освещение автоматическое (датчик освещенности) Οτοματικ αυτίνατμα Αυτόματος Φωτισμός (με Αισθητήρες)
	Indicator Clignotant Indicador de dirección Indicador de direcção Indicatore di direzione Richtingaanzwijzer Blinker Kierunkowskaz Индикатор Sinyal Φάλαç
	Horn Avertisseur Bocina Buzina Avvisatore acustico Claxon Hupe Sygnał dźwiękowy Звуковой сигнал Korna Κόρνα
	Front fog-light Feu brouillard avant Antiniebla delantero Anti-nevoeiro dianteiro Fendinebbia Mistlamp voor Nebelscheinwerfer vorne Lampa przeciwmgielna przednia Передняя противотуманная фара On sis lambası Φανάç Ομίχλης Εμπ ρόσθιος
	Rear fog-light Feu brouillard arrière Antiniebla posterior Anti-nevoeiro posterior Retronebbia Mistlamp achter Nebelschussleuchte Lampa przeciwmgielna tylna Задняя противотуманная фара Arka sis lambası Φανάç Ομίχλης Оп ίσθιος
	Windscreen wiper / washer Essuie / lave-vitre avant Lava / Limpiaparabrisas Lava / Limpa-vidros Tergi / lavacrystallo Ruitenwisser en sproeier Scheibenwaschanlage Spryskiwacz szyby Омыватель ветрового стекла On cam yıkayıcı Υαλοκαθαριστήρες / Εκτοξευτής υγρού Εμπ ρός
	Single wiper (1 single wipe) Petite vitesse momentanée (1 seul balayage) Velocidad lenta momentánea (1 solo barrido) Velocidade lenta momentânea (1 só passagem) Bassa velocità momentanea (1 sola velocità) Enkele ruitenwisser Wischimpuls-schalter Jednorazowe uruchomienie wycieraczki Разовая работа стеклоочистителя Silencek zamanlayıcısı - Düşük Hız (Tek silme) Στιγμιαία αργή ταχύτητα (1 σκούπ ίσμο)



Intermittent wiper
Essuyage intermittent
Limpiaparabrisas intermitente
Limpa-vidros intermitente
Tergicristallo intermittente
Ruitenwisser met interval
Intervallschaltung
Przerzywana praca wycieraczki
Прерывание работы стеклоочистителя
Fasilali silme
Διακοπή τόμενος Καθαρισμός



Variable intermittent wiper
Essuyage intermittent réglable
Limpiaparabrisas intermitente regulable
Limpa-vidros intermitente regulável
Tergicristallo intermittente regolabile
Ruitenwisser met variable interval
Regelbare Intervallschaltung
Regulowana, przerywana praca wycieraczki
Стеклоочиститель с регулировкой частоты работы
Fasila ayarli silme
Ρυθμιζόμενος Διακοπή τόμενος Καθαρισμός



Rain sensitive wiper system
Essuyage automatique
Limpiaparabrisas con sensor de lluvia
Limpeza automática
Tergicristallo automatico
Ruitenwisser met regensensor
Wischen mit Regensensor
Wycieraczki automatyczne (czujnik deszczu)
Думающий стеклоочиститель
Οτοματικ silecek
Αυτόματος Καθαρισμός



Rear-screen wiper / washer
Essuie / lave-lunette arrière
Lava / Limpialuneta posterior
Lava / Limpa-vidros traseiro
Tergi / lavalunotto
Ruitenwisser achter/ ruitensproeier
Heckscheibenwaschanlage
Tylna wycieraczka/spryskiwacz
Стеклоочиститель/омыватель заднего стекла
Arka cam silme/yıkama
Πίσω Υαλοκαθαριστήρες / Εκτοξευτής υγρού



Clockspring (for Airbag)
Contacteur tournant (pour l'Airbag)
Contactador giratorio (para Airbag)
Contador giratorio (dispositivo de Airbag)
Dispositivo Airbag
Air Bag connector
Drehkontakt
Styk pierścieniowy
Рулевой контакт
Helezon bağlantı
Περστροφική επ αφή (Ενεργοπ οητής Αερόσακκου)



Cruise control
Régulateur de vitesse
Control velocidad
Controlo velocidade
Cruise control
Cruise control
Tempomat
Tempomatem
Круиз контроль
Hız sabitleme sistemi
Σύστημα ρύθμισης ταχύτητας



Radio control
Commande radio
Mando radio
Comando rádio
Comando radio
Radio control
Radiobediienung
Pilot radia
Радио контроль
Radyo kumandası
Ρύθμιση Ραδιοφώνου



Other functions
Autres fonctions
Otras funciones
Outras Funções
Altre funzioni
Andere fucties
Andere Funktionen
Inne funkcje
Другие функции
Diğer işlevler
Άλλες Λειτουργίες



Headlamp washer
Lave-projecteur
Lavafaros
Limpa-faróis
Lavaproiettori
Koplamp sproeier
Scheinwerfer-Waschanlage
Spryskiwacz reflektorów
Омыватель фар
Far yıkayıcı
Εκτοξευτής υγρού Φαναριού



On-board computer
Ordinateur de bord
Ordenador
Computador
Computer di bordo
Board computer
Bordcomputer
Komputer pokładowy
Бортовой компьютер
Yol bilgisayarı
Σύστημα πληροφοριών οδηγού



Rear-screen demist
Lunette arrière chauffante
Luneta posterior antivaho
Desembaciador traseiro
Lunotto termico
Achtterruitverwarming
Heckscheibenheizung
Podgrzewanie tylnej szyby
Обогрев заднего стекла
Arka cam rezistansı
Θερμανόμενο Πίσω Παμπ ρίζ



Hazard warning
Feu de détresse
Luces de emergencia
Luz de emergência
Emergenza
Waarschuwingslicht
Warnblinklicht
Światła awaryjne
Аварийный сигнал
Уяги işiği
Αλάριμ



Angle sensor
Capteur d'angle
Captador de ángulo
Ângulo do sensor
Sensore d'angolo
Hellingshoek
Abstandsensor
Czujnik kątowy
Датчик угла
Açı algılayıcı
Αισθητήρας Γωνίας



Day running lights (4 lamps)
Codes permanents (4 optiques)
Luz de cruce permanente (4 faros)
Luz de Intermitentes (4 farois)
Luci di ingombro (4 lampade)
Permanent stadslicht
Tagfahrlicht (4 Lampen)
Światła dzienne (4 żarówki)
Фонари дневного света (4 лампы)
4 ampullü aydınlatma
Μόνιμα Φανάρια





Pour / for



Valeo



CITROËN

Berlingo

	07/96 ▶ 12/02	251271																	
	07/96 ▶ 12/02	251280																	
	07/96 ▶ 12/02	251273																	
	07/96 ▶ 12/02	251270																	
	12/02 ▶	251494																	
	12/02 ▶	251496																	
	12/02 ▶	251495																	
	12/02 ▶	251497																	
	12/02 ▶	251491																	
	12/02 ▶	251492																	

C15

	10/84 ▶	251154																	
	10/84 ▶	251156																	

Dispatch

	09/95 ▶ 04/96	251279																	
	05/96 ▶ 12/03	251271																	
	09/95 ▶ 12/03	251273																	

Jumpy

	09/95 ▶ 04/96	251279																	
	05/96 ▶ 12/03	251271																	
	09/95 ▶ 12/03	251280																	
	09/95 ▶ 12/03	251273																	

FIAT

Doblò

Malibu (-), AIR (-)	10/00 ▶ 12/03	251472																	
Malibu (-), AIR (-)	10/00 ▶ 12/03	251474																	
Malibu (-), AIR (+)	10/00 ▶ 12/03	251473																	
Malibu (-), AIR (+)	10/00 ▶ 12/03	251508																	

Ducato

	ch 172001 ▶ 05/85	251362																	
--	-------------------	---------------	--	--	--	--	--	--	--	--	--	--	--	--	--	--	--	--	--



Pour / for		Valeo	☀	↔	🔊	🔊	👁️	↩️	👁️	🗑️	BAG	🔊	+ ...
FIAT													
Ducato (.../...)													
AIR (-)	02/94 ▶ 10/95	251370	☀	↔			👁️		👁️				
AIR (-)	11/95 ▶ 06/98	251378	☀	↔			👁️		👁️				
AIR (+), OE n° 1303037808	ch 5604859 ▶ 03/00	251368	☀	↔			👁️		👁️		BAG		
AIR (+), OE n° 1304147808	02/94 ▶ 12/01	251367	☀	↔			👁️		👁️		BAG		
AIR (-)	01/02 ▶	251573	☀	↔			👁️	↩️	👁️				
AIR (+)	01/02 ▶	251574	☀	↔			👁️	↩️	👁️		BAG		
Fiorino													
AIR (-)	08/93 ▶ 09/00	251365	☀	↔			👁️		👁️				
Scudo													
	02/96 ▶	251279	☀	↔	🔊								
	07/95 ▶	251271	☀	↔	🔊	🔊							
	07/95 ▶ 12/03	251273					👁️	↩️	👁️				☀
IRISBUS													
CityClass													
		251557	☀										
		251558					👁️		👁️				
EuroClass													
		251557	☀										
		251558					👁️		👁️				
EuroRider													
		251557	☀										
		251558					👁️		👁️				
TurboCity													
	02/86 ▶	251547	☀	↔	🔊		👁️						⚠️
	02/86 ▶	251548	☀	↔	🔊		👁️		👁️				
IVECO													
Daily I													
30-8	ch 311599 ▶ 12/89	251402	☀	↔	🔊		👁️						
35-8, OE n° 93803258, 93803689	01/78 ▶ 1991	251404	☀	↔	🔊		👁️						



Pour / for		Valeo	Headlight	Indicator	Bell	Washer	Wiper	Wiper	Wiper	Wiper	BAG	TH	Music	+ ...
IVECO (.../...)														
Daily I (.../...)														
35-8, OE n° 4802819	ch 431481 ▶ 1991	251402	Headlight	Indicator	Bell	Washer	Wiper	Wiper	Wiper	Wiper				
35-10	ch 15141 ▶ 1991	251402	Headlight	Indicator	Bell	Washer	Wiper	Wiper	Wiper	Wiper				
40-8	ch 311872 ▶ 1991	251402	Headlight	Indicator	Bell	Washer	Wiper	Wiper	Wiper	Wiper				
40-10 / 49-10	01/85 ▶ 12/89	251402	Headlight	Indicator	Bell	Washer	Wiper	Wiper	Wiper	Wiper				
Daily II														
	03/89 ▶ 03/96	251403	Headlight	Indicator	Bell	Washer	Wiper	Wiper	Wiper	Wiper				
Daily S2000														
	05/97 ▶	251550	Headlight	Indicator	Bell	Washer	Wiper	Wiper	Wiper	Wiper	BAG			
	05/97 ▶	251551	Headlight	Indicator	Bell	Washer	Wiper	Wiper	Wiper	Wiper	BAG	TH		
IVECO														
EuroCargo														
	01/83 ▶	251544	Headlight	Indicator	Bell	Washer	Wiper	Wiper	Wiper	Wiper				△
	05/86 ▶ 10/91	251543	Headlight	Indicator	Bell	Washer	Wiper	Wiper	Wiper	Wiper				△ △
	01/91 ▶	251557	Headlight											
	01/91 ▶	251558					Wiper	Wiper	Wiper	Wiper				
EuroFire														
	01/91 ▶	251557	Headlight											
	01/91 ▶	251558					Wiper	Wiper	Wiper	Wiper				
TurboStar														
OE n° 4784774	07/84 ▶	251544	Headlight	Indicator	Bell	Washer	Wiper	Wiper	Wiper	Wiper				△
	07/84 ▶	251543	Headlight	Indicator	Bell	Washer	Wiper	Wiper	Wiper	Wiper				△ △
TurboTech														
	07/88 ▶	251544	Headlight	Indicator	Bell	Washer	Wiper	Wiper	Wiper	Wiper				△
	01/90 ▶	251543	Headlight	Indicator	Bell	Washer	Wiper	Wiper	Wiper	Wiper				△ △
NISSAN														
Kubistar														
	09/03 ▶ 04/06	251586	Headlight	Indicator	Bell	Washer								
OPEL														
Movano														
	10/03 ▶ 10/06	251613					Wiper	Wiper	Wiper	Wiper				



Pour / for			Valeo												+ ...
OPEL (.../...)															
Vivaro															
	2009 ▶	251602													
	2009 ▶	251603													
	05/01 ▶	251613													
	05/01 ▶	251615													
PEUGEOT															
Expert															
	09/95 ▶ 04/96	251279													
	05/96 ▶ 12/03	251271													
	09/95 ▶ 12/03	251280													
	09/95 ▶ 12/03	251273													
J9															
	08/86 ▶ 1991	251154													
Partner															
	06/96 ▶ 11/02	251271													
	06/96 ▶ 11/02	251280													
	06/96 ▶ 11/02	251273													
	06/96 ▶ 11/02	251270													
	11/02 ▶	251494													
	11/02 ▶	251496													
	11/02 ▶	251495													
	11/02 ▶	251497													
	11/02 ▶	251491													
	11/02 ▶	251492													
Ranch															
	06/96 ▶ 11/02	251271													
	06/96 ▶ 11/02	251280													
	06/96 ▶ 11/02	251273													
	11/02 ▶	251494													
	11/02 ▶	251496													



Pour / for		Valeo													+
PEUGEOT (.../...)															
Ranch (.../...)															
	11/02 ▶	251495													
	11/02 ▶	251497													
	11/02 ▶	251491													
	11/02 ▶	251492													
RENAULT															
Express I															
	09/85 ▶ 08/91	251104													
	09/85 ▶ 08/91	251282													
Express II															
	09/91 ▶ 09/94	251104													
	09/91 ▶ 09/94	251282													
AC(-)	10/94 ▶ 08/97	251276													
AC(+)	10/94 ▶ 08/97	251275													
Extra I															
	09/85 ▶ 08/91	251282													
Extra II															
	09/91 ▶ 08/94	251282													
	09/91 ▶ 08/94	251104													
	09/94 ▶ 08/97	251275													
Kangoo I															
	09/97 ▶ 07/01	251438													
	09/97 ▶ 07/01	251439													
	02/97 ▶ 02/03	251608													
	09/97 ▶ 06/09	251609													
	09/97 ▶ 06/09	251611													
	09/97 ▶ 06/09	251612													
	12/99 ▶ 10/08	251586													
	08/01 ▶ 02/03	251565													
Kangoo II															
	03/03 ▶	251562													



Pour / for		Valeo											+ ...
RENAULT (.../...)													
Mascott													
	06/06 ▶ 10/08	251590											
	06/06 ▶ 10/08	251591											
Master													
	07/86 ▶ 09/97	251328											
	07/86 ▶ 09/97	251334											
	10/03 ▶	251614											
	06/06 ▶ 10/08	251590											
	06/06 ▶ 10/08	251591											
	10/08 ▶	251600											
	10/08 ▶	251601											
Rapid													
	09/85 ▶ 08/91	251104											
Trafic I													
	07/80 ▶ 09/94	251328											
	07/86 ▶ 07/92	251334											
Trafic II													
AIR (+)	04/01 ▶	251563											
	04/01 ▶	251444											
	04/01 ▶ 07/06	251613											
	04/01 ▶	251614											
	04/01 ▶ 07/06	251615											
	10/08 ▶	251602											
	10/08 ▶	251603											
RENAULT TRUCKS													
CBH, CLM													
280, 340, 350		645050											
CLR													
220		645050											
G													
OE n° 5000789126	10/82 ▶ 09/93	645050											



Valeo

Pour / for		Valeo										
RENAULT TRUCKS (.../...)												
G (.../...)												
<small>G170, G200, G210, G220, G230, G260, G270, G280, G290,</small> OE n° 5000788671		10/82 ▶ 09/93	645060									
JE												
9, 11, 13, 15			645130									
JK												
OE n° 5000623819		03/76 ▶ 06/80	645130									
JN												
OE n° 5000623819		06/80 ▶ 06/84	645130									
JP												
		1983 ▶ 06/84	645130									
JR/JX												
OE n° 5000623819		06/80 ▶ 06/84	645130									
Midliner												
<small>S90, S100, S110, S120, S130, S135, S150, S170, S220</small>		10/82 ▶ 01/00	645130									
PS												
130, 150			645130									
SH												
			645130									
R												
R310, R360, R370		10/80 ▶ 08/84 09/84 ▶	645010 645050	 								
VAUXHALL												
Movano												
		10/03 ▶ 10/06	251613									
Vivaro												
		08/01 ▶	251613									
		08/01 ▶	251615									
		2009 ▶	251602									
		2009 ▶	251603									





Valeo

251104

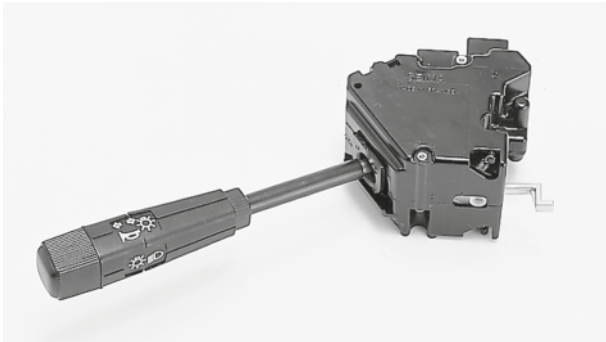

RENAULT

ESPACE I, EXPRESS I / II, EXTRA II, RAPID

251270

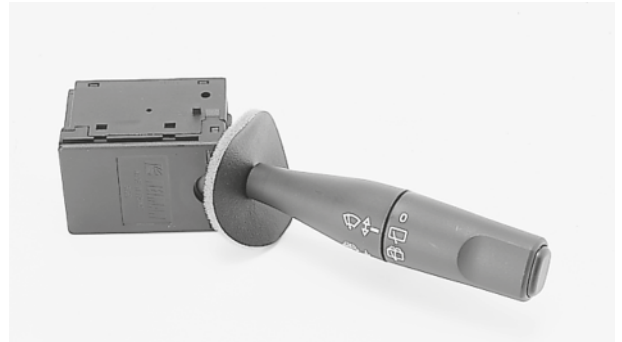

**CITROEN
PEUGEOT**

BERLINGO
PARTNER

251154



**CITROEN
PEUGEOT**

C15
J9

251271

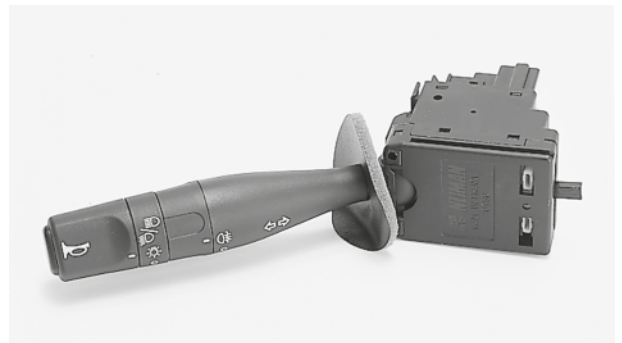

**CITROEN
FIAT
PEUGEOT**

BERLINGO, DISPATCH, JUMPY
SCUDO
EXPERT, PARTNER, RANCH

251156

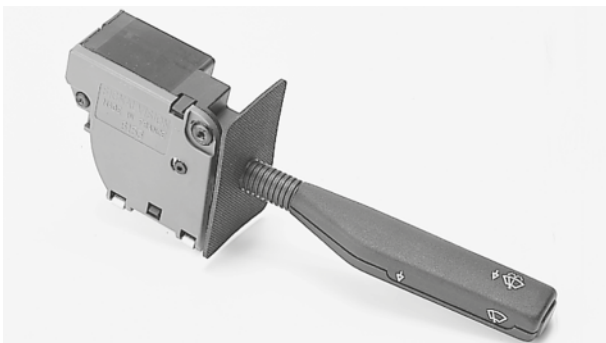
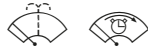

CITROEN

C15

251273



**CITROEN
FIAT
PEUGEOT**

BERLINGO, DISPATCH JUMPY
SCUDO
EXPERT, PARTNER, RANCH



251275

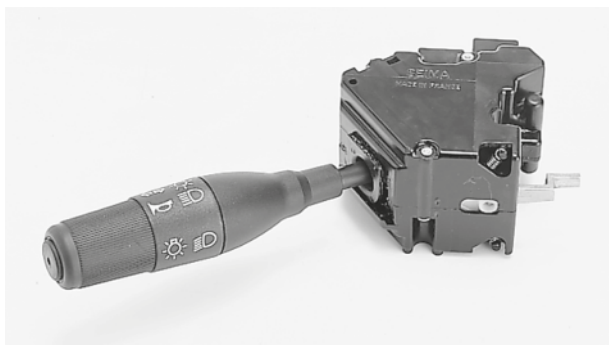

RENAULT EXPRESS II, EXTRA II

251280

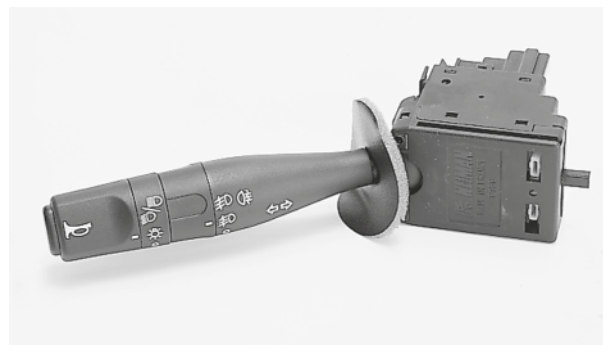

**CITROEN
PEUGEOT** BERLINGO, JUMPY, SAXO
EXPERT, PARTNER, RANCH

251276

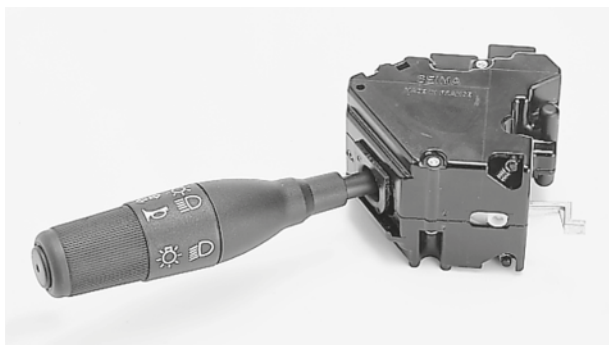

RENAULT EXPRESS II

251282

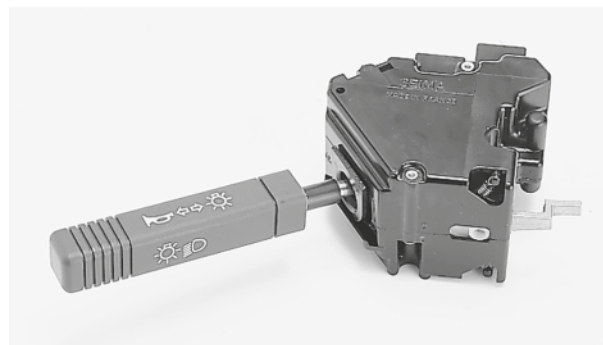

RENAULT EXPRESS I / II, EXTRA I / II

251279



**CITROEN
FIAT
PEUGEOT** DISPATCH, JUMPY
SCUDO
EXPERT

251328

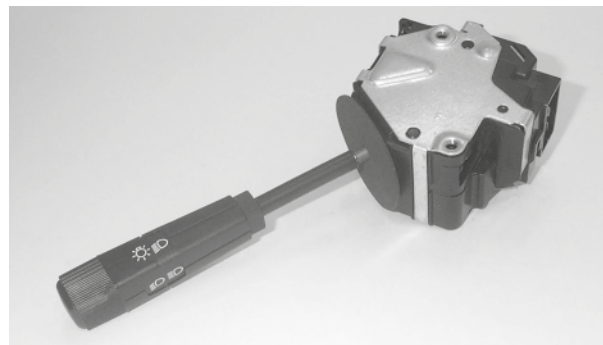

RENAULT MASTER, TRAFIC I



Valeo

251334

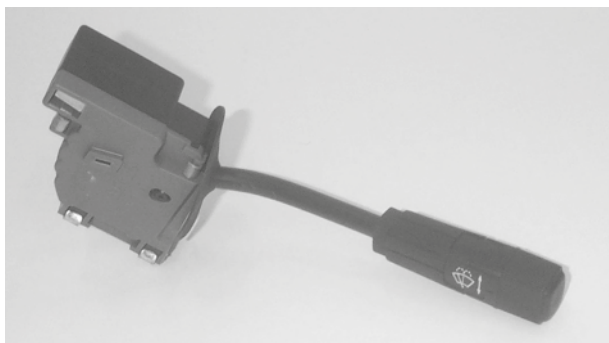

RENAULT MASTER, TRAFIC I

251367



FIAT DUCATO

251362

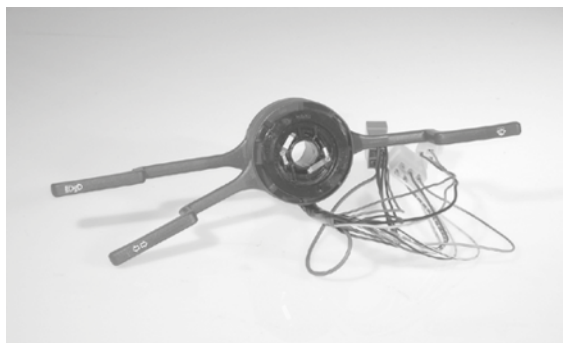
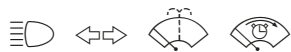

FIAT DUCATO

251368



FIAT DUCATO

251365

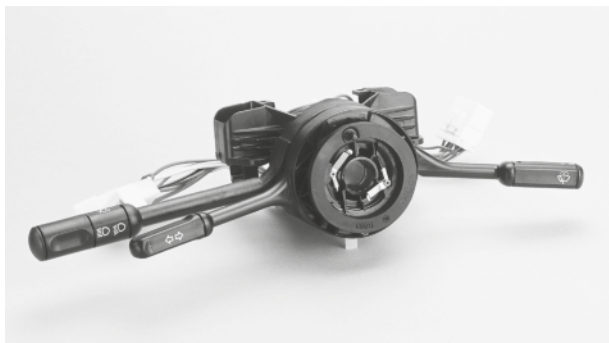
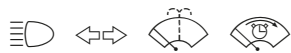

FIAT FIORINO

251370

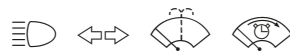

FIAT DUCATO



251378

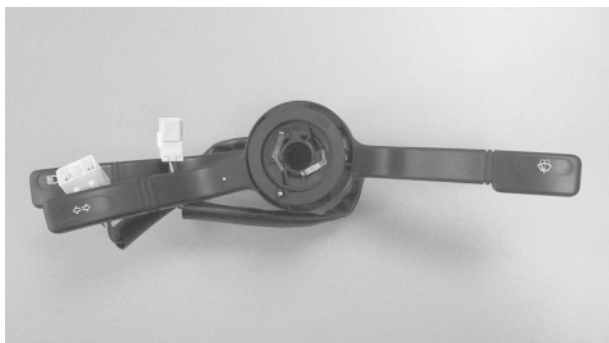
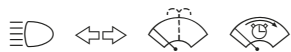

FIAT

DUCATO

251404

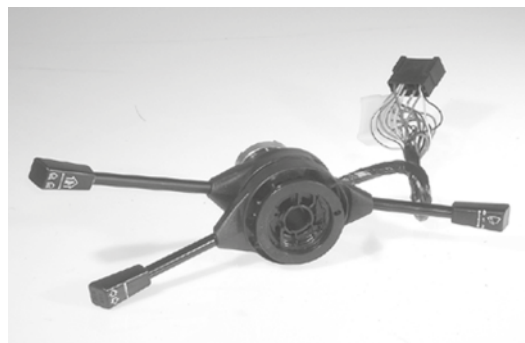

IVECO

DAILY I

251402

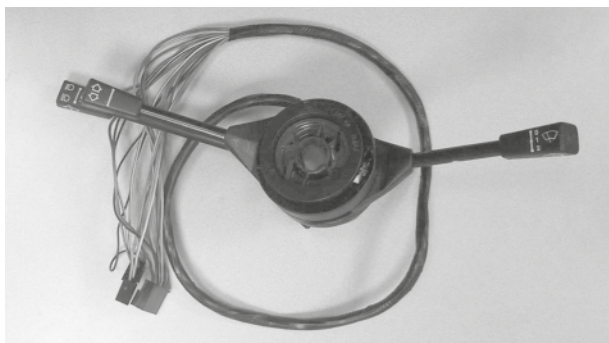

IVECO

DAILY I

251438

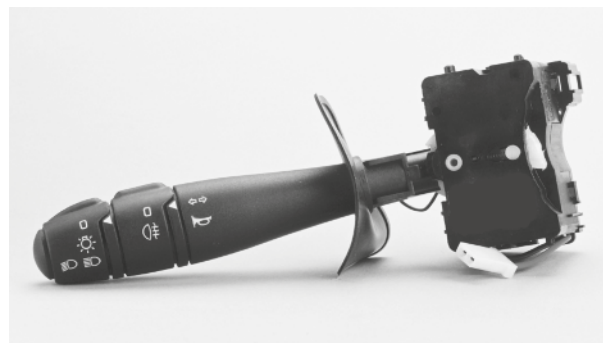

RENAULT

KANGOO I

251403



IVECO

DAILY II

251439

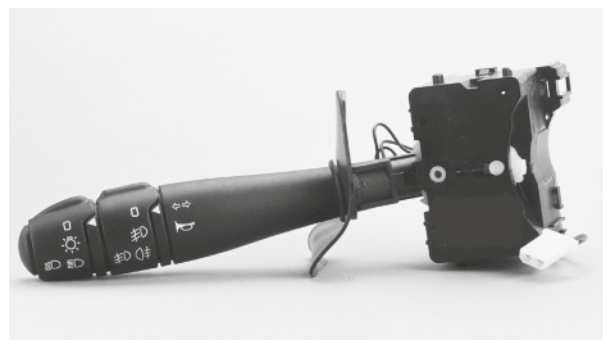

RENAULT

KANGOO I



251444



RENAULT

TRAFIC II

251474

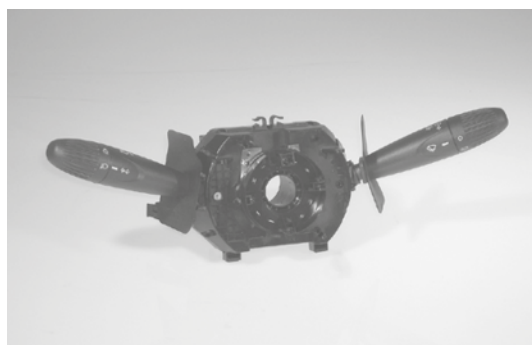

FIAT

DOBLÒ

251472



FIAT

DOBLÒ

251491

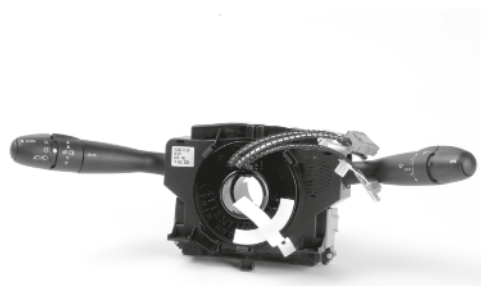

CITROEN
PEUGEOT

BERLINGO
PARTNER, RANCH

251473



FIAT

DOBLÒ

251492

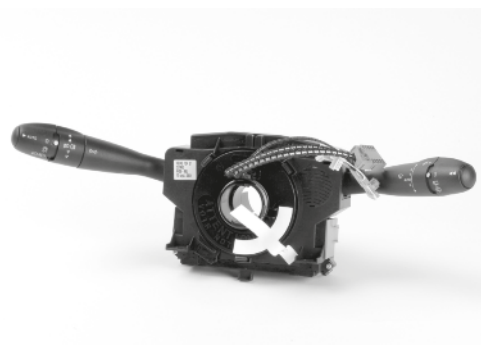

CITROEN
PEUGEOT

BERLINGO
PARTNER, RANCH



251494

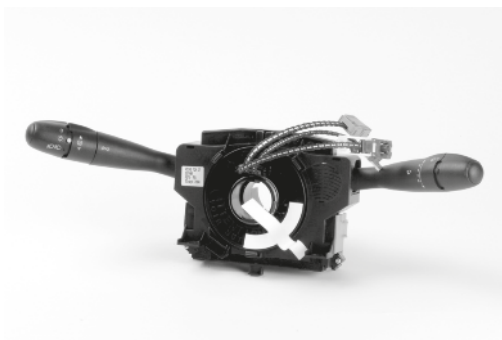

**CITROEN
PEUGEOT**

BERLINGO
PARTNER, RANCH

251497



**CITROEN
PEUGEOT**

BERLINGO
PARTNER, RANCH

251495

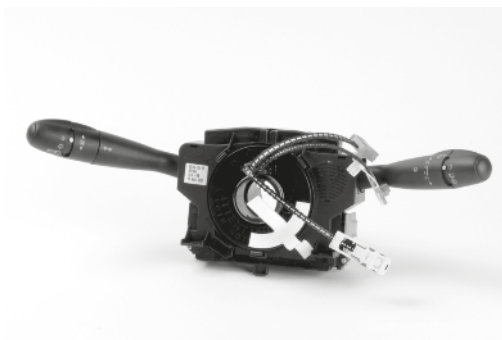

**CITROEN
PEUGEOT**

BERLINGO
PARTNER, RANCH

251508

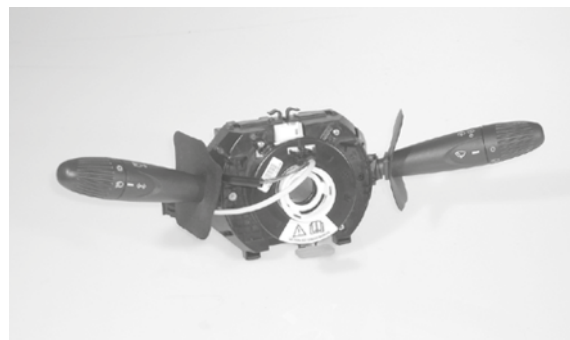

FIAT

DOBLÒ

251496

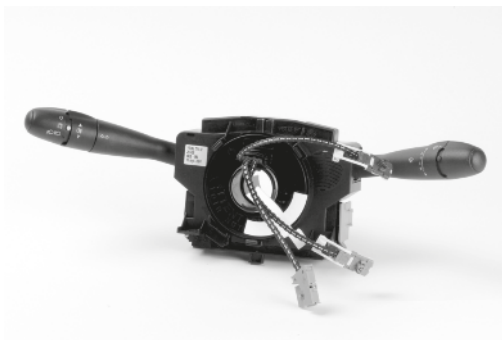
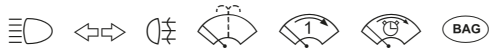

**CITROEN
PEUGEOT**

BERLINGO
PARTNER, RANCH

251543

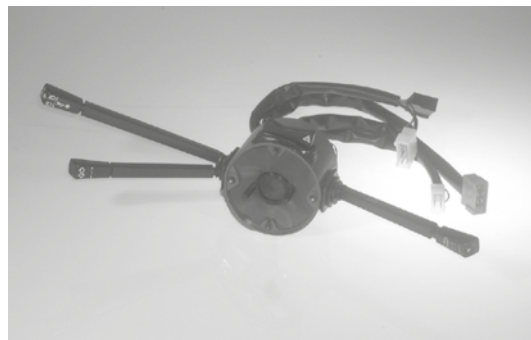

IVECO

EUROCARGO, TURBOSTAR, TURBOTECH



251544

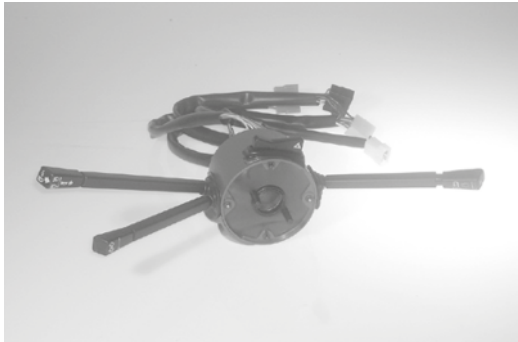

IVECO EUROCARGO, TURBOSTAR, TURBOTECH

251550

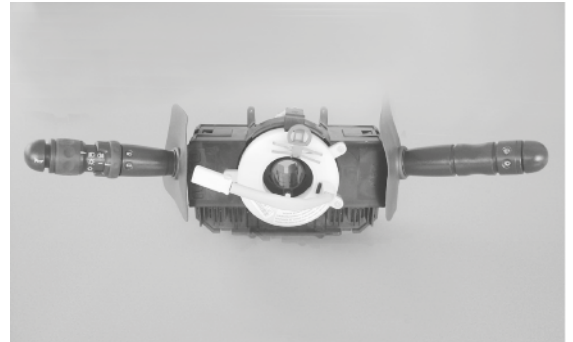

IVECO DAILY S2000

251547

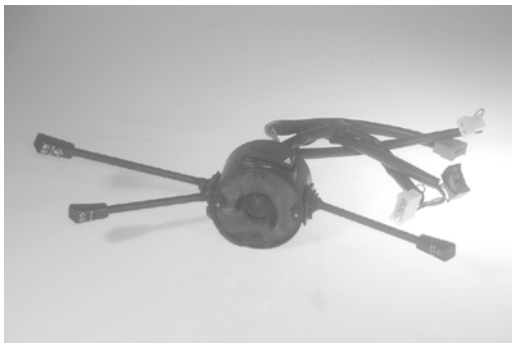

IRISBUS TURBOCITY

251551

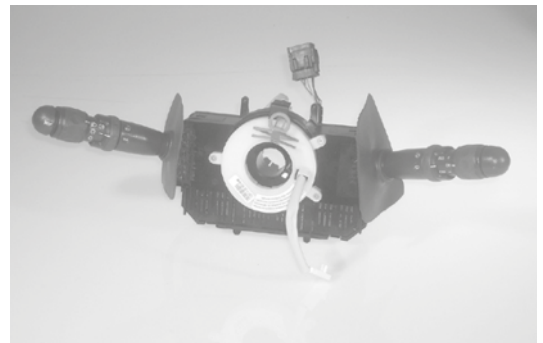

IVECO DAILY S2000

251548

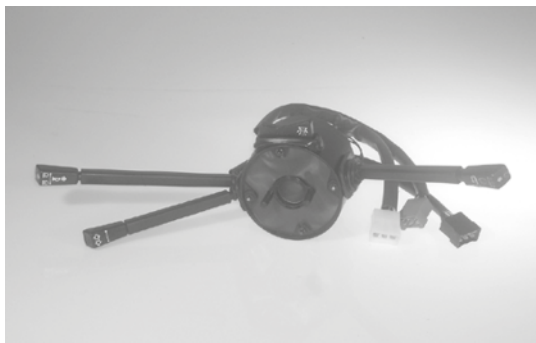

IRISBUS TURBOCITY

251557



IRISBUS / IVECO CITYCLASS, EUROCLASS, EURORIDER, EUROCARGO, EUROFIRE



251558



IRISBUS / IVECO CITYCLASS, EUROCLASS, EURORIDER, EUROARGO, EUROFIRE

251565

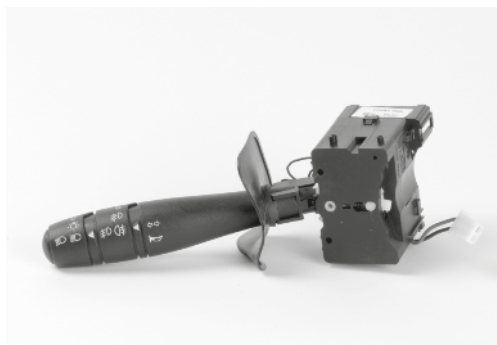

RENAULT KANGOO I

251562

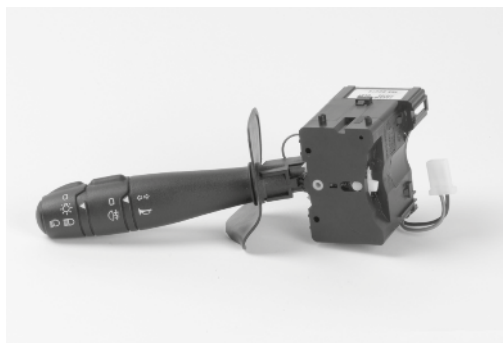

RENAULT KANGOO II

251573

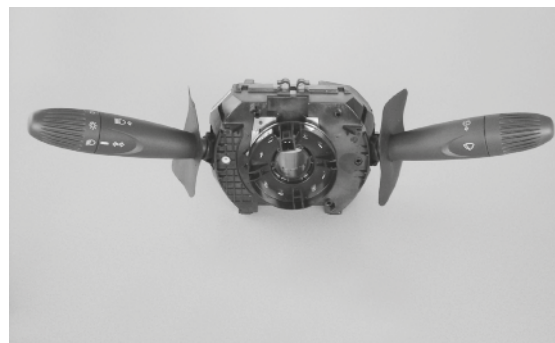

FIAT DUCATO

251563



RENAULT TRAFIC II

251574

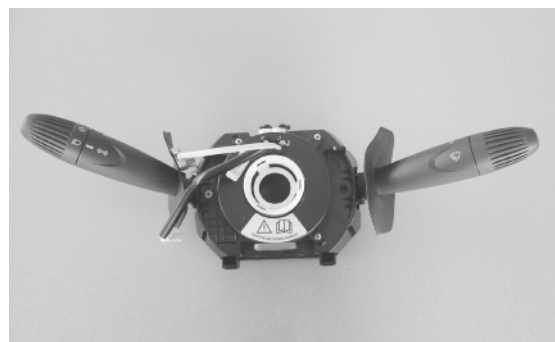

FIAT DUCATO



251586

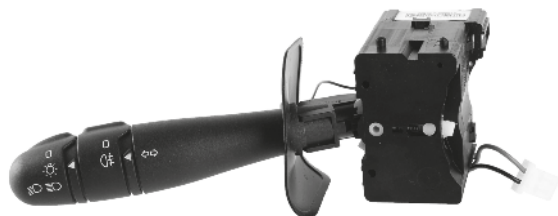

RENAULT
NISSAN

KANGOO I
KUBISTAR

251600



RENAULT

MASTER

251590



RENAULT
RENAULT

MASTER
MASCOTT

251601



RENAULT

MASTER

251591

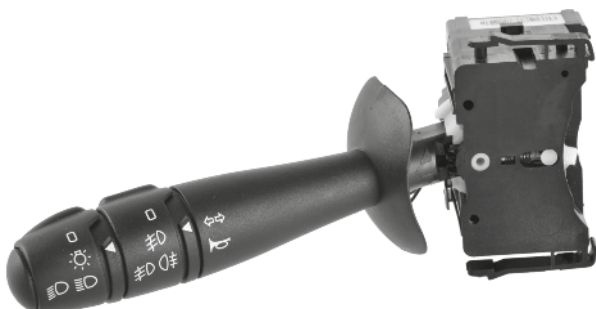

RENAULT
RENAULT

MASTER
MASCOTT

251602



RENAULT
OPEL
VAUXHALL

TRAFIC II
VIVARO
VIVARO



251603



RENAULT
OPEL
VAUXHALL

TRAFIC II
VIVARO
VIVARO

251611

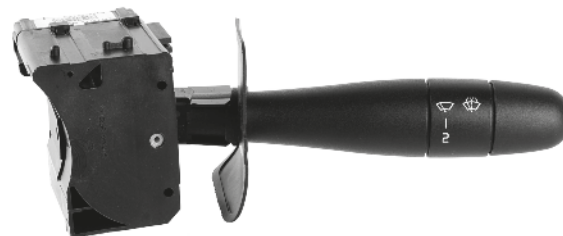

RENAULT

KANGOO I

251608



RENAULT

KANGOO I

251612



RENAULT

KANGOO I

251609



RENAULT

KANGOO I

251613

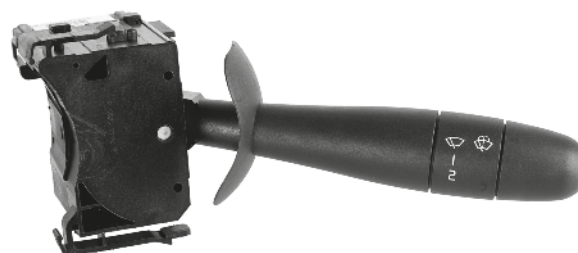

RENAULT
OPEL
VAUXHALL
OPEL/ VAUXHALL

TRAFIC II
MOVANO
MOVANO
VIVARO



251614



RENAULT
RENAULT

MASTER
TRAFIC II

645050

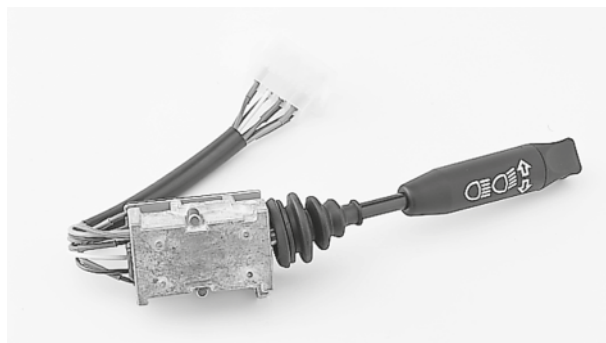

RENAULT TRUCKS CBH, CLM, CLR, G, R

251615



RENAULT
OPEL
VAUXHALL

TRAFIC II
VIVARO
VIVARO

645060

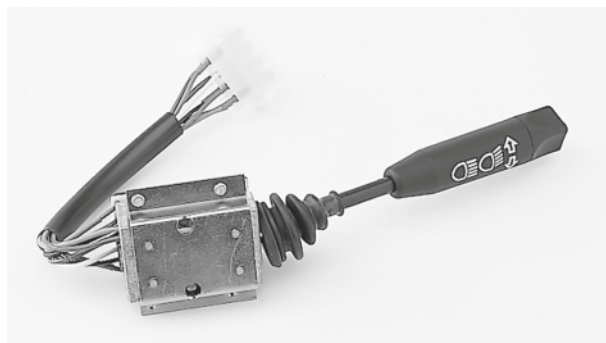

RENAULT TRUCKS G

645010

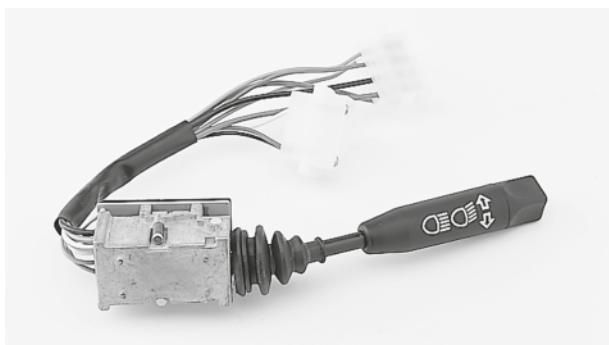

RENAULT TRUCKS R

645130

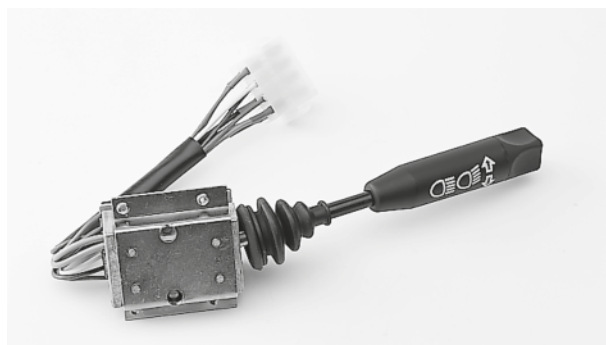

RENAULT TRUCKS JE, JK, JN, JP, JR/JX, MIDLINER, PS, SH



**ECLAIRAGE / LIGHTING / LUCES / LUCI / BELEUCHTUNG**

FRANCAIS	ENGLISH	ESPAÑOL	ITALIANO	DEUTSCH
Après contact / ap.contact	Ignition	Después de contacto	Dopo avviamento	Kontakt
Appel optique / appel opt.	Headlight flash	Ráfagas	Luci di richiamo	Lichthupe
Après contact phare	Headlamps only with ignition	Después de contacto luces	Dopo avviamento (faro)	Kontakt
Avertisseur / avvert.	Horn	Bocina	Avvisatore acustico	Hupe
Batterie / BAT	Battery	Batería	Batteria	Batterie
Brouillard	Fog light	Antiniebla	Fendinebbia	Nebelbeleuchtung
Brouillard avant / brouillard av.	Front fog-light	Antiniebla delantero	Fendinebbia anteriori	Nebelscheinwerfer
Brouillard arrière / brouillard ar. / sortie brouillard ar.	Rear fog-light	Antiniebla posterior	Retronebbia posteriore	Nebelschussleuchte
Centrale	Flasher unit	Centrale	Lampeggiatore	Blinkerrelais
Codes	Low Beam	Cruce	Anabbaglianti	Abblendlicht
Code (double optique)	Double optic low beam	Cruce óptica doble	Anabbagliante ottico doppio	Bei Fernlicht auch Abblendlicht eingeschaltet.
Code (simple optique)	Single optic low beam	Cruce óptica simple	Anabbagliante ottico semplice	Bei Fernlicht Abblendlicht ausgeschaltet.
Détrompeurs	Plug connector	Guías	Anti-errore (montaggio)	Verdrehschutz
Eclairage / ECL	Lighting	Iluminación	Luci	Beleuchtung
Indicateur / ind. / clignotant	Turn signal	Indicador de dirección	Indicatore di direzione	Blinker
Indicateur droit / ind.d / ind.droit / clignotant droit	Right turn signal	Indicador de dirección derecho	Indicatore di direzione destro	Blinker, rechts
Indicateur gauche / ind.g / ind.gauche / clignotant gauche	Left turn signal	Indicador de dirección izquierdo	Indicatore di direzione sinistro	Blinker, links
Lanterne / lant.	Side light	Posición	Luci di posizione	Standlicht
Phares	High beam	Faro	Abbaglianti	Fernlicht

**ESSUYAGE / WIPERS / LIMPIAPARABRISAS / TERGICRISTALLO / WISCHER**

FRANCAIS	ENGLISH	ESPAÑOL	ITALIANO	DEUTSCH
Après Contact / A.P.C. / A.C.	Ignition	Después de contacto	Dopo avviamento	Kontakt
Arrêt fixe AV / AR	Front cycle stop	Parada fija	Arresto automatico	Nullstellungsabschaltung für Wischer
Automatique / auto.	Automatic	Automatico	Automatico	Automatisch
Batterie / BAT	Battery	Batería	Batteria	Batterie
Cadencement	Intermittent wiper	Limpiaparabrisas regulable	Tergicristallo intermittente	Intervallschaltung
Défilement ordinateur / defi. ordi / def. ordi.	On board computer	Ordenador	Computer di bordo	Bordcomputer
Entrée temporisation / entrée tempo / entrée temporisateur	Temporizer	Entrada del temporizador	Temporizzatore	Verzögerungsschalter
Essuie avant / essuie av.	Front wiper	Limpiaparabrisas	Tergicristallo	Frontwischer
Essuie/lave vitre / E.V. LV.	Front wiper/ washer	Limpia / lavaparabrisas	Tergicristallo / lavavetro	Scheibenwaschanlage
Essuie lunette ar.	Rear-screen wiper	Limpialuneta posterior	Tergilunotto posteriore	Heckwischer
Essuie vitre arrière / essuie vitre ar. / E.V. arrière / essuie ar.	Rear-screen wiper	Limpialuneta posterior	Tergilunotto posteriore	Heckwischer
Grande vitesse / G.V.	Fast wipe	Gran velocidad	Alta velocità	Schnelles Wischen
Injection	Injection	Inyección	Iniezione	Injektion
Intermittence	Intermittent wiper	Limpiaparabrisas intermitente	Tergicristallo intermittente	Intervallschaltung
Intermittent rhéostaté / intern. rheost.	Variable intermittent wiper	Limpiaparabrisas intermitente regulable	Tergicristallo intermittente regulabile	Regelbare Intervallschaltung
Lave-vitre / lave avant	Front washer	Lavaparabrisas	Lavavetro	Scheibenwaschanlage
Lave-vitre ar / lave lunette ar. / lave ar. / lave hayon	Rear-screen washer	Lavaluneta posterior	Lavalunotto posteriore	Heckscheibenwaschanlage
Lunette arrière chauffante / LUN. CH.	Rear-screen demist	Luneta posterior antivaho	Lunotto termico posteriore	Heckscheibenheizung
Marche cadencée / M.C. / Cadencement / PV cadencée en MC / PV cadencée	Intermittent wiper	Limpiaparabrisas intermitente	Tergicristallo intermittente	Intervallschaltung
Masse	Negative	Masa (-)	Massa (-)	- Pol
Ordinateur	On-board computer	Ordenador	Computer di bordo	Bordcomputer
Petite vitesse / P.V.	Slow wipe	Velocidad lenta	Bassa velocità	Langsames Wischen
Pompe lave-vitre / borne pompe	Screen-washer pump	Bomba limpiaparabrisas	Pompetta lavavetro	Wischwasserpumpe

LUCI / LIGHTING / ECLAIRAGE / LUCES / BELEUCHTUNG

ITALIANO	ENGLISH	FRENCH	ESPAÑOL	DEUTSCH
Abbaglianti	High beam	Phares	Faro	Fernlicht
Alimentazione per luci e illuminazione	Lighting	Eclairage	Iluminación	Beleuchtung
Anabbaglianti	Low Beam	Codes	Cruce	Abblendlicht
Comando retronebbia	Rear fog-light	Brouillard arrière	Antiniebla posterior	Nebelschlussleuchte
(Ingresso) comando direzione	Turn signal	Clignotant	Indicador de dirección	Blinker
Consenso anabbagliante / abbagliante	Low beam / high beam consensus	Consensus codes / phares	Consenso cruce / faros	Einschaltkontrolle Fernlicht
Consenso retronebbia	Rear fog-light consensus	Consensus anti-brouillard arrière	Consenso antiniebla trasero	Einschaltkontrolle Nebelschlussleuchte
DIM-DIP	DIM-DIP (day-light)	DIM-DIP (éclairage de jour)	DIM-DIP (luz de día)	DIM-DIP (Tagfahrlicht)
Direzione destra	Right turn signal	Clignotant droit	Indicador de dirección derecho	Blinker, rechts
Direzione sinistra	Left turn signal	Clignotant gauche	Indicador de dirección izquierdo	Blinker, links
Luci di posizione	Side light	Lanternes	Posición	Standlicht
Massa	Negative	Masse	Masa (-)	- Pol

TERGICRISTALLO / WIPERS / ESSUYAGE / LIMPIAPARABRISAS / WISCHER

ITALIANO	ENGLISH	FRENCH	ESPAÑOL	DEUTSCH
Comando avvisatore	Horn	Avertisseur	Bocina	Hupe
Ingresso / Uscita intern. su leva	Input / Output intermittent wiper on lever	Entrée / Sortie intermittence sur manette	Entrada / Salida intermitencia sobre manecilla	Eingang / Ausgang Intervallschaltung
Illuminazione	Lighting	Eclairage	Iluminación	Beleuchtung
Lunotto termico	Rear-screen demist	Lunette arrière chauffante	Luneta posterior antivaho	Heckscheibenheizung
Massa	Negative	Masse (-)	Masa (-)	- Pol
(Alimentazione) pompa biugello	Bi-directional pump	Pompe bi-directionnelle	Bomba bi-direccional	Kombiwaschanlage vorne und hinten
(Alimentazione) pompa lavacrystallo	Screen-washer pump	Pompe lave-vitre	Bomba lavaparabrisas	Wischwasserpumpe
Tergilunotto	Rear-screen wiper	Essuie lunette arrière	Limpialuneta posterior	Heckwischer
Tergicristallo / Tergicristallo velocità continua	Front wiper	Essuie vitre	Limpiaparabrisas	Frontwischer
Tergicristallo velocità intermitt./tergicristallo inter.	Intermittent wiper	Essuyage intermittent	Limpiaparabrisas intermittente	Intervallschaltung



251104

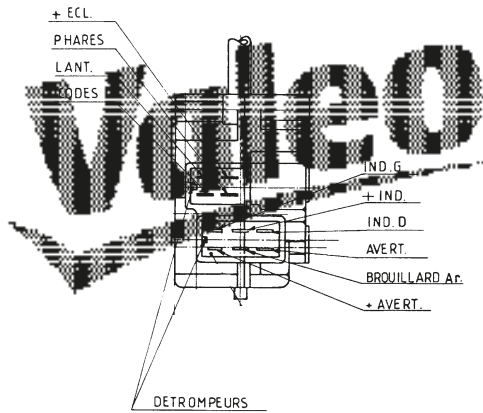

251270

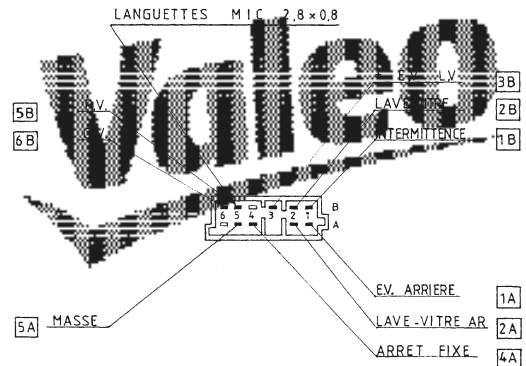

251154

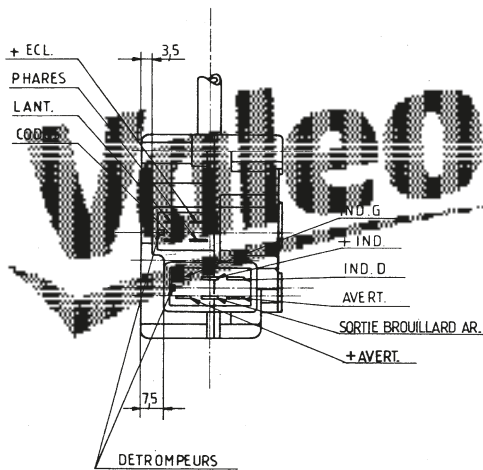

251271

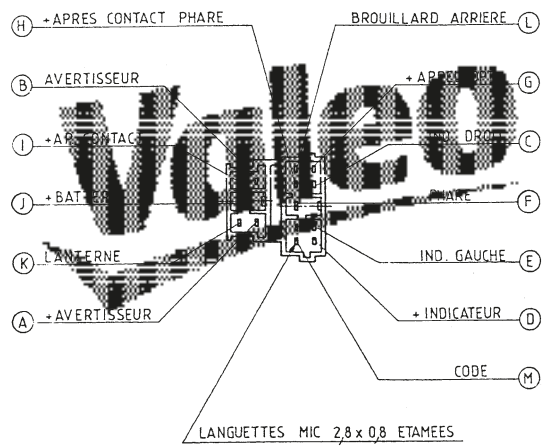

251156

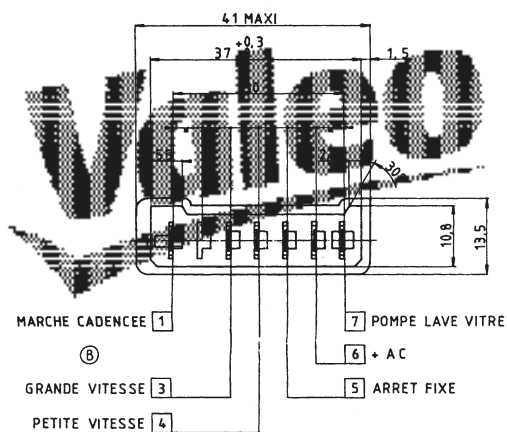

251273

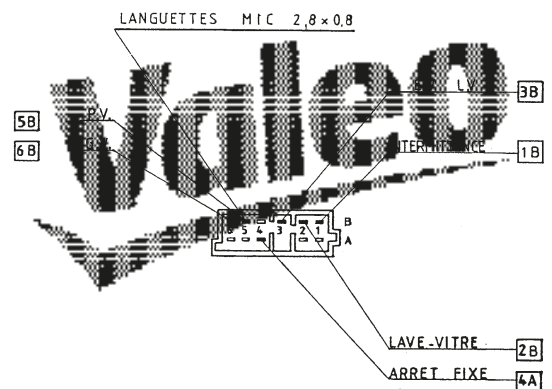



251275

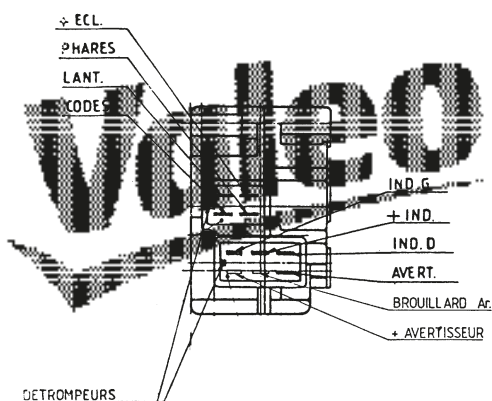

251280

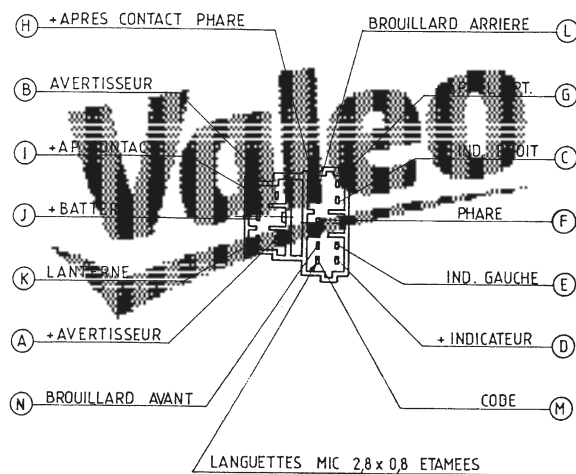

251276

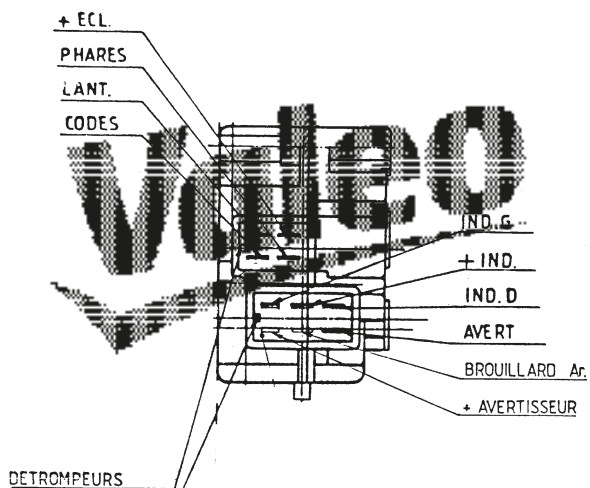

251282

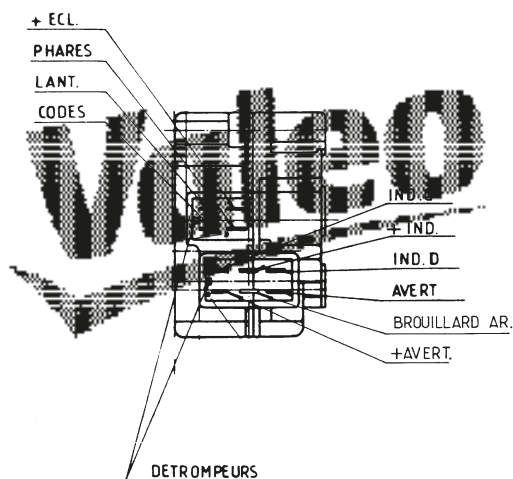

251279

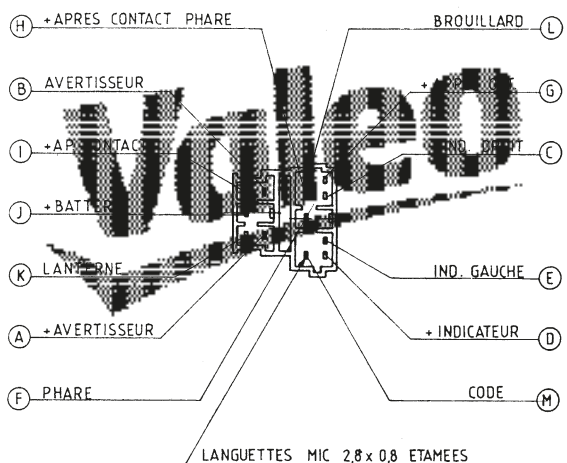

251328

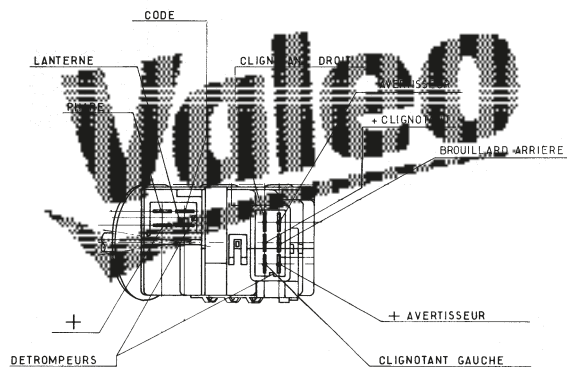



251334

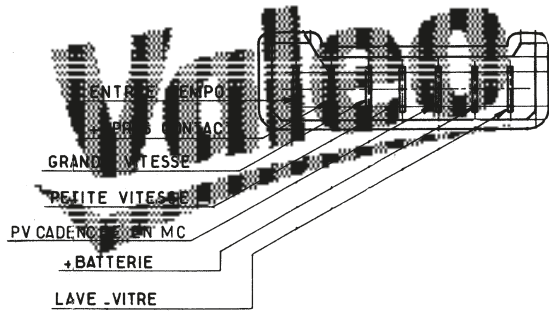

251444

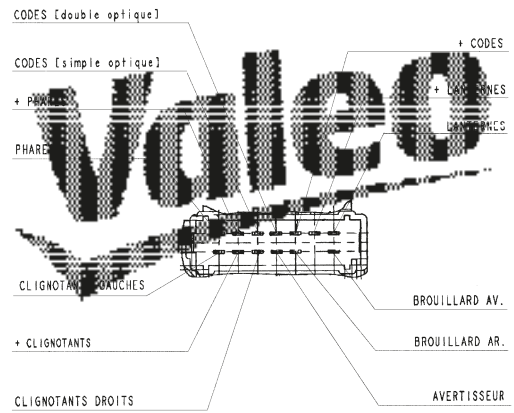

251438

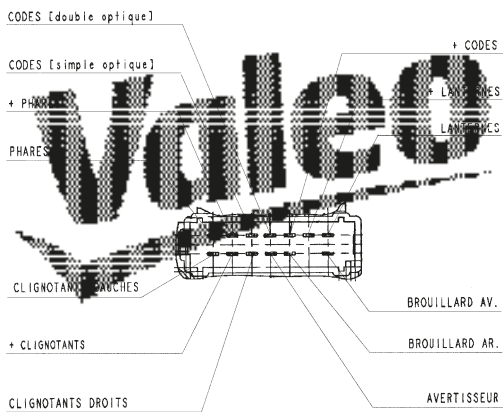

251562

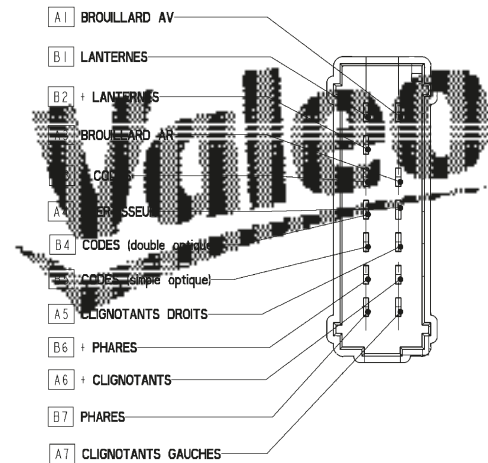

251439

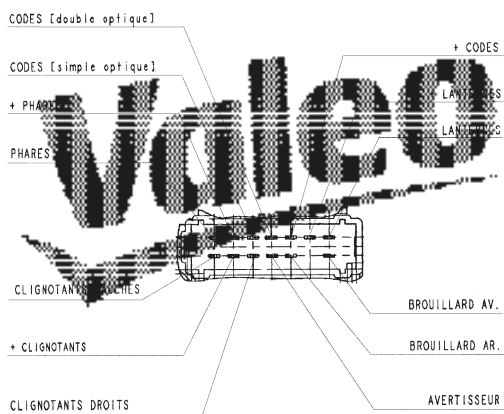

251563

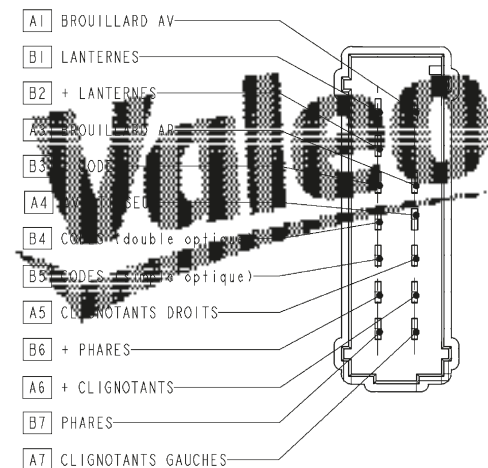



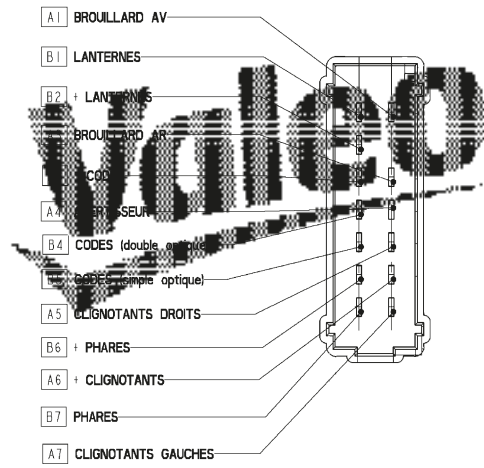

251565









Valeo

	Valeo		Valeo		Valeo
CITROEN		PEUGEOT (.../...)		RENAULT TRUCKS	
623991	251273	624230	251491	5000084872	645010
624230	251491	624231	251492	5000361688	645130
624231	251492	624232	251494	5000623819	645130
624232	251494	624233	251496	5000788671	645060
624233	251496	625342	251154	5000789126	645050
625342	251154	625359	251279	VAUXHALL	
625359	251279	625361	251280	93198617	251602
625361	251280	625369	251271	93198618	251603
625369	251271	96122254	251271	91160123	251613
96122254	251271	97518149	251154	93160241	251615
97518149	251154	6239G6	251270		
97533660	251156	6239JK	251496		
6239G6	251270	6239JR	251491		
6239JK	251496	6239P2	251491		
6239JR	251491	6239P3	251492		
6239P2	251491	6239Q0	251494		
6239P3	251492	6239Q1	251495		
6239Q0	251494	6239Q2	251496		
6239Q1	251495	6239Q3	251497		
6239Q2	251496	6239QK	251495		
6239Q3	251497	6239WQ	251497		
6239QK	251495	96049597ZL	251270		
6239WQ	251497	RENAULT			
96049597ZL	251270	6001030184	251276		
		6006000100	251334		
		7700305346	251275		
		7700760825	251104		
		7700777226	251282		
		7700779565	251328		
		7700779566	251104		
		7701044278	251438		
		7701044279	251439		
		7701045864	251438		
		7701045865	251439		
		7701048912	251563		
		7701048913	251444		
		7701053057	251562		
		7701053058	251565		
		7701068768	251586		
		7701057612	251590		
		7701057612	251590		
		7701057613	251591		
		7701057613	251591		
		7701071896	251600		
		7701071602	251601		
		7701072090	251602		
		7701072091	251603		
		7701044280	251608		
		7701049615	251609		
		7701053056	251611		
		7701053055	251612		
		7701050685	251613		
		7701059269	251614		
		7701048914	251615		
FIAT					
5996213	251362				
183028480	251365				
1301756808	251370				
1302631808	251378				
1303037808	251368				
1304147808	251367				
9612225469	251279				
9621180769	251273				
9623641569	251271				
IVECO					
4764379	251547				
4784774	251544				
4802819	251402				
4813404	251543				
4824230	251548				
4836417	251403				
4862412	251403				
93160486	251558				
93160488	251557				
93803258	251404				
93803689	251404				
500321203	251550				
500321204	251551				
OPEL					
93198617	251602				
93198618	251603				
91160123	251613				
93160241	251615				
PEUGEOT					
623991	251273				





	Valeo		Valeo
ERA		FEBI BILSTEIN (...)	
440026	251472	34928	251492
440039	251473		
440040	251474	KOSTAL	
440051	251156	111.2.329	251362
440053	251334		
		MAGNETI MARELLI	
440059	251378	DA41557	251362
440070	251362	DA42311	251402
440157	251104	DA43026	251370
440159	251154	DA43038	251365
440173	251270	DA43106	251368
440174	251271	DA43153	251550
440176	251273	DA43154	251551
440178	251276	DA43174	251367
440179	251280	DA43181	251573
440180	251282	DA43188	251472
440193	251328	DA43189	251473
440202	251365	DA43190	251474
440203	251370	DA43191	251508
440207	251404	DA50093	251270
440210	251438	DA50094	251279
440211	251439	DA50110	251491
440212	251508	DA50111	251439
440266	251543	DA50114	251565
440267	251403	DA50118	251438
440268	251550	DA50120	251563
440269	251551	DA50131	251496
440292	251573	DJ0069	251154
440293	251367	DJ0075	251104
440294	251368	DJ0076	251282
440295	251574	DJ0081	251328
440307	251491	DJ0097	251156
440308	251492	DJ0144	251334
440310	251494	DV41125	251404
440311	251495	DV41586	251547
440312	251496	DV41587	251544
440313	251497	DV42321	251548
440320	251565	DV42325	251543
440329	251279	DV42354	251403
440388	251557		
440389	251558		
440439	251444		
440210	251562		
FEBI BILSTEIN			
17947	251271		
19722	251270		
22071	251280		
22719	251370		
22769	251273		
33518	251438		
33519	251439		
34809	251495		
34810	251496		
34921	251497		
34927	251494		

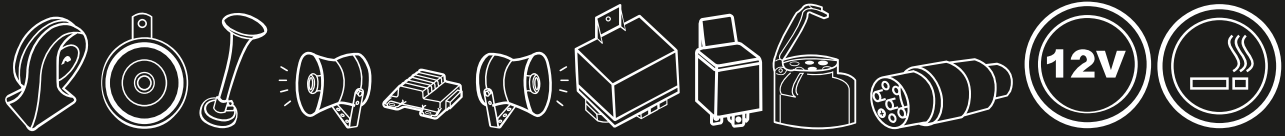

Electrical accessories

Accessoires électriques

Accesorios eléctricos

Acessórios elétricos

Accessori elettrici

Electrisches accessoires

Elektrisches Zubehör









Aksesoria elektryczne

Электрoприборы

Elektikli aksesuarlar





	Disc horn Electromagnétique à disque Bocina electromagnética de disco Buzina electromagnética de disco Elettromagnetico a disco Schijf hoorn Scheibenhupe Sygnal dźwiękowy (płaski) Disk elektromanyetik korna Электромагнитный - диск Electromagnetic horn Electromagnétique à trompe (escargot) Bocina electromagnética de caracol Buzina electromagnética de caracol Elettromagnetico a chiocciola Electromagnetische hoorn Elektromagnetische Hupe Sygnal dźwiękowy (ślimak) Salyangoz elektromanyetik korna Электромагнитный - рупор Emergency vehicle horn Avertisseur pour véhicule prioritaire Bocina para vehículo de emergencia Buzina para vehículos de emergência Segnalatore acustico di emergenza Sirene Sirene Sygnal dźwiękowy dla pojazdów uprzywilejowanych Geçiş üstünlüklü araç sireni Сигналы для спецмашин Reverse alarm Alarme de recul Alarma de marcha atrás Indicador sonoro de marcha-a-trás Segnalatore acustico di retromarcia Achteruitrij alarm Rückfahrwarnerr Dźwiękowy sygnalizator cofania Geri vites alarmı Сигналы заднего хода Jericho Jericho Bocina de aire comprimido Jericho Buzina de ar comprimido Jericho Jericho Jericho Jericho Jericho Jeriko Jericho Compressor Compresseur Compresor Compressor Compressore Compressor Kompressor Kompressor Kompresör Компрессор Trumpet Trompe Bocina electromagnética de trompeta Buzina electromagnética de trompeta Tromba Meertonige claxon Trompete Fanfar Trompet Трубы Module + 2 speakers Module + 2 haut-parleurs Módulo con 2 altavoces Módulo + 2 colunas Modulo + 2 altoparlanti Module + 2 speakers Modul + 2 Lautsprecher Modul + 2 sygnaly Modül + 2 hoparlör Модуль + 2 сигнала
	
	
	
	
	
	
	

	Colour Couleur Color Côr Colore Kleur Farbe Kolor Renk Цвет Sound pressure level at 2m Niveau sonore à 2m Nivel sonoro a 2 m Nivel sonoro a 2 m Livello di pressione sonora a 2m Geluidsdruk niveau na 2m Schalldruck bei 2m Poziom dźwięku przy 2m 2m'deki ses şiddeti Уровень звука при 2м Sound Type Type son Tipo de sonido Tipo de som Tipo di suono Geluidstype Tontyp Typ dźwięku Ses tipi Тип звука High Aigu Agudo Agudo Alto Hoog Hoch Wysoki Yüksek Высокий Medium Medium Medio Médio Medio Medium Mittel Sredni Orta Средний Low Grave Grave Grave Basso Laag Tief Niski Alçak Низкий High + low with relay Aigu + grave avec relais Agudo + grave con relés Agudo + grave com relés Alto + basso con relé Hoog + laag met relais Hoch + tief mit Relais Wysoki + niski z przekaźnikiem Röleli yüksek + alçak Низкий + высокий с реле Homologation Homologation Homologación Homologação Omologazione Homologatie Zulassung Homologacja Homologasyon Сертификация
dB	
	
	
	
	
	
	

	Polarity Polarité Polaridad Polaridade Polarità Polariteit Polarität Biegunowość İki kutuplu Полярность Single Polarity Unipolaire Unipolar Unipolar Polarità singola Enkele polariteit Einpolig Pojedyńcza Tek kutuplu Единичная Dual Polarity Bipolaire Bipolar bipolar Polarità doppia Dual polariteit Zweipolig Podwójna biegunowość Çift kutuplu двойная полярность Power Consumption Consommation en fonctionnement Consumo en funcionamiento Consumo em funcionamento Assorbimento di corrente Power consumptie Energieverbrauch bei Benutzung Zużycie prądu Güç tüketimi Расход тока Static Power Consumption Consommation au repos Consumo en reposo Consumo em repouso Assorbimento di corrente a riposo Statische power consumptie Energieverbrauch im Standby Stałe zużycie prądu Durağan haldeki tüketim Постоянный расход тока Day Jour Día Dia Giorno Dag Tag Dzień Gündüz День Night Nuit Noche Noite Notte Nacht Nacht Noc Gece Ночь Revolutions Cadence Cadencia Cadência Cadenza/frequenza Ritmes Drehzahlen Tempo Devir Темп
	
	
	
	
	
	
	



<p>Electronic / Electronique</p>	<p>Electronic Electronique Electrónica Electrónica Elettronico Elektronisch Elektronisch Elektroniczny Elektronik Электронный</p>	<p>UMH</p>	<p>Ambulance Unité Mobile Hospitalière Ambulancia Ambulancia Ambulância Unità mobile ospedaliera Mobiële ziekenhuis unit Krankenwagen Karetka pogotowia Hastane aracı Санитарный автомобиль</p>	
<p>Air powered / Electro- pneumatique</p>	<p>Air Powered Electropneumatique Electroneumáticas Electropneumáticas Elettropneumatico Electro-pneumatisch Elektropneumatisch Elektropneumatyczny Havali Электропневматический</p>	<p>Black / Noir</p>	<p>Black Noir Negro Preto Nero Zwart Schwarz Czarny Siyah Чёрный</p>	
<p>Tone / Ton</p>	<p>Tone Ton Tono Tom Tono Toon Ton Ton Seviye ТОН</p>	<p>Chromed / Chromé</p>	<p>Chromed Chromé Cromada Cromada Cromato Verchromd Verchromt Chromowany Krom Хромистый</p>	
<p>Cycles / Min.</p>	<p>Revolutions per minute Cycles par minute Ciclos por minuto Ciclos por minuto Cicli per minuto Cyclus per minuut Umdrehungen pro Minute Cykli na minutę Dakikadaki dönüş sayısı Циклов на минуту</p>	<p>Red / Rouge</p>	<p>Red Rouge Rojo Vermelho Rosso Rood Rot Czerwony Kırmızı Красный</p>	
<p>Ambulance</p>	<p>Ambulance Ambulance Ambulancia Ambulância Ambulanza Ambulance Krankenwagen Ambulans Sankurtaran Санитарный автомобиль</p>	<p>Fr</p>	<p>France France Francia Francia Francia Frankrijk Frankreich Francia Fransa Франция</p>	
<p>Gendarmerie</p>	<p>Police Station Gendarmerie Policia Esquadra de Policia Forze dell'ordine Politiebureau Polizei Policja Polis merkezi Полиция</p>			
<p>Police</p>	<p>Police Police Policia Policia Polizia Politie Polizei Policja Polis ГАИ</p>			
<p>Pompier</p>	<p>Fire brigade Pompier Bombero Bombeiro Pompieri brandweer Feuerwehr Straż pożarna İtfaiye Пожарный автомобиль</p>			



ELECTROMAGNETIC/ELECTROMAGNÉTIQUE/ELECTROMAGNÉTICAS
 ELECTROMAGNÉTICAS/ELETTROMAGNETICO/ELECTRO-MAGNETISCH
 ELEKTROMAGNETISCH/ELEKTROMAGNETYCZNY/ELEKTROMANYETIK/Электромагнитный

HK9

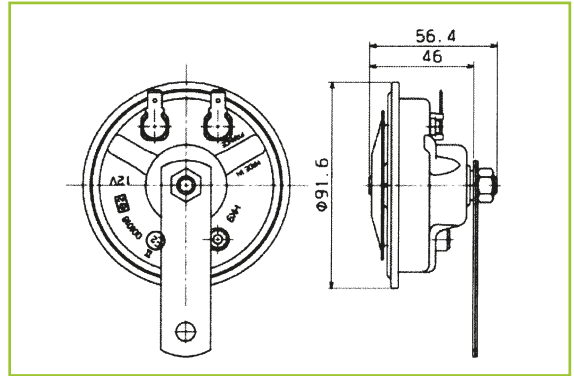

Valeo



U

I

479164

E200-1017



Chromed / Chrome

24 V

3-1,5A

479165

E200-1017



Chromed / Chrome

24 V

3-1,5A

AM80S - JPT

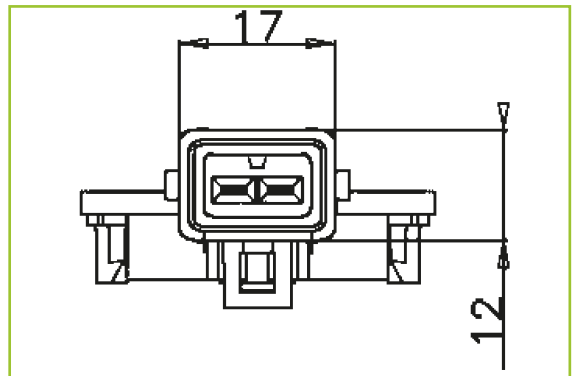
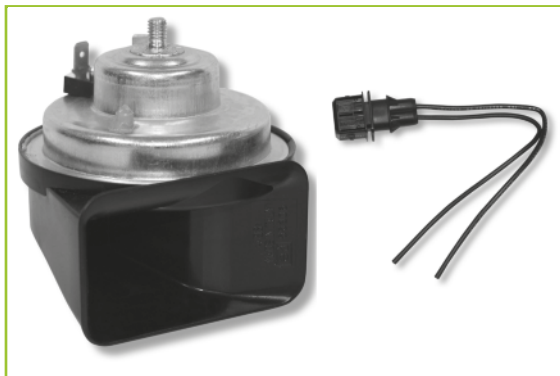

Valeo



U

I

479189

CEEECE55306-CCCA046522

Black / Chromed

12 V

4,5A

479190

CEEECE55306-CCCA046522

Black / Chromed

12 V

4,5A



Hi
Me
Lo

Hz

dB



H

425 Hz

114 db



L

340 Hz

114 db



Hi
Me
Lo

Hz

dB



H

500 Hz

107 db

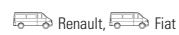

L

405 Hz

107 db

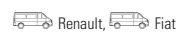



ELECTROMAGNETIC/ELECTROMAGNÉTIQUE/ELECTROMAGNÉTICAS
 ELECTROMAGNÉTICAS/ELETTROMAGNETICO/ELECTRO-MAGNETISCH
 ELEKTROMAGNETISCH/ELEKTROMAGNETYCZNY/ELEKTROMANYETIK/Электромагнитный

AM80S - USCAR

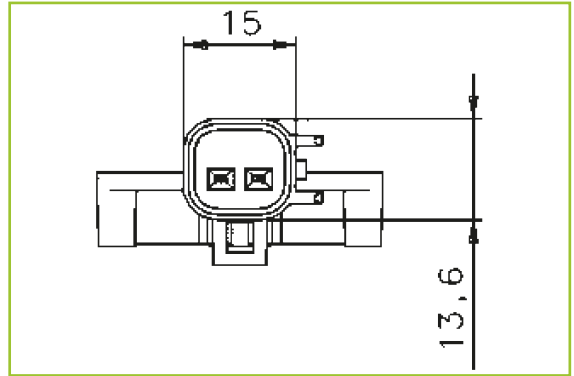

U

I

479191 CEEECE55306-CCCA046522

Black / Chromed

12 V

4,5A

479192 CEEECE55306-CCCA046522

Black / Chromed

12 V

4,5A

AM80S - SICMA II

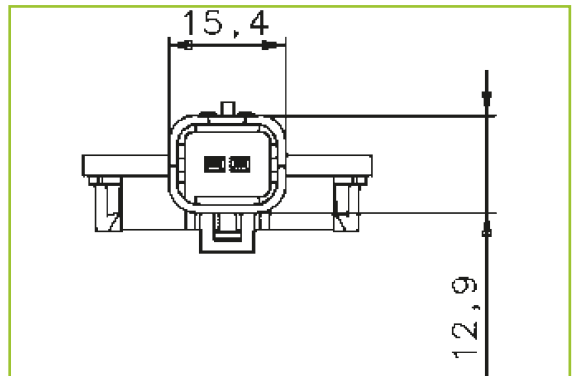

U

I

479193 CEEECE55306-CCCA046522

Black / Chromed

12 V

4,5A

479194 CEEECE55306-CCCA046522

Black / Chromed

12 V

4,5A



Hz

dB



H

500 Hz

107 db



Ford, Fiat

L

405 Hz

107 db



Ford, Fiat



Hz

dB



H

500 Hz

107 db



PSA

L

405 Hz

107 db



PSA



ELECTROMAGNETIC/ELECTROMAGNÉTIQUE/ELECTROMAGNÉTICAS
 ELECTROMAGNÉTICAS/ELETTROMAGNETICO/ELECTRO-MAGNETISCH
 ELEKTROMAGNETISCH/ELEKTROMAGNETYCZNY/ELEKTROMANYETIK/Электромагнитный

TR99R

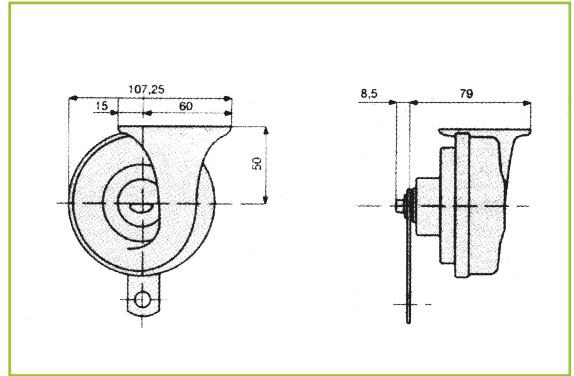
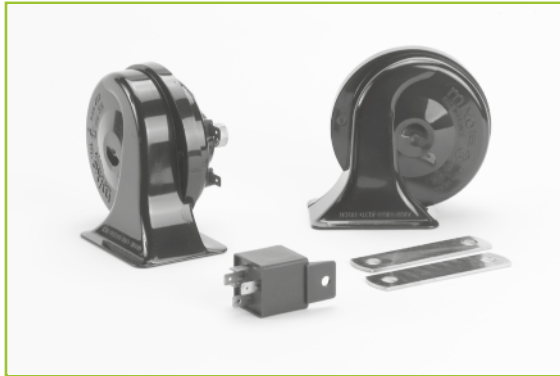

Valeo



U

I

479158

E2E2884



Black / Noir

24 V

2,5A

479159

E2E2884



Black / Noir

24 V

2,5A

479185

E2E2884



Black / Noir

24 V

5A

AIR POWERED/ELECTROPNEUMATIQUE/ELECTRONEUMÁTICAS
 ELECTROPNEUMÁTICAS/ELETTROPNEUMATICO/ELECTRO-PNEUMATISCH
 ELEKTROPNEUMATISCH/ELEKTROPNEUMAUTYCZNY/HAVALI/Электропневматический

JERICO - AIR

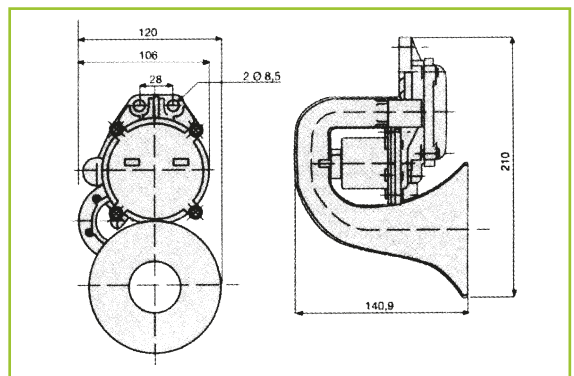

Valeo



U

I

479075

E200-816



Black / Noir

12-24 V

2A

479076

E200-816









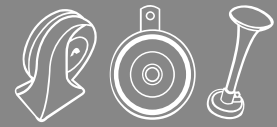











Black / Noir

12-24 V

2A



	Hz	dB				
H	500 +/- 35 HZ	110 db				
L	420 +/- 35 HZ	110 db				
L AND H	500 +/- 35 HZ, 420 +/- 35 HZ	112dd				

	Hz	dB				
	400 +/- 10 HZ	118 db				
	400 +/- 10 HZ	118 db				



AIR POWERED/ELECTROPNEUMATIQUE/ELECTRONEUMÁTICAS
ELECTROPNEUMÁTICAS/ELETTROPNEUMATICO/ELECTRO-PNEUMATISCH
ELEKTROPNEUMATISCH/ELEKTROPNEUMAUTYCZNY/HAVALI/Электропневматический

CR2 24V



Valeo



U

I

479172

CEEECE7007

Red trumpet, chromed compressor 24 V

10A

TA 150

Valeo



U

I

479183

CEE-ECE51520-51521

Stainless

24 V

5,5 A

TA 180

Valeo



U

I

479184

CEE-ECE51520-51521

Stainless

24 V

5,5 A



Hz

dB



L AND H L = 670 HZ AND H = 825 HZ

117 db



Hz

dB



L 150 HZ +/- 20HZ

118 db



Hz

dB



H 180 HZ +/- 20HZ

118 db



REVERSE ALARM/ALARME DE REcul/ALARMA DE MARCHA ATRÁS

INDICADORES SONOROS DE MARCHA-A-TRÁS/SEGNALATORI ACUSTICI DI RETROMARCIA/ACHTERUITRIJ ALARMEN

RÜCKFAHRWARNER/DŹWIĘKOWE SYGNALIZATORY COFANIA/GERI VITES ALARMLARI/сигналы заднего хода

630023



U

I

630023



Black / Noir

10-100 V

12-24A

630024



U

I

630024

CE



Black / Noir

10-100 V

12-24A



Hz

dB



2500 HZ

82 ou 92 db



Hz

dB



2500 HZ

82 ou 92 db





Valeo

REVERSE ALARM/ALARME DE REcul/ALARMA DE MARCHA ATRÁS

INDICADORES SONOROS DE MARCHA-A-TRÁS/SEGNALATORI ACUSTICI DI RETROMARCIA/ACHTERUITRIJ ALARMEN

RÜCKFAHRWARNER/DŹWIĘKOWE SYGNALIZATORY COFANIA/GERI VITES ALARMLARI/сигналы заднего хода

630025

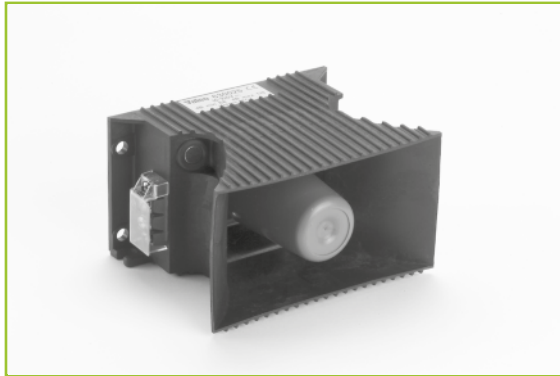

Valeo



U

I

630025

CE



Black / Noir

10-100 V

480-50A



Hz

dB



2500 +/-100 Hz

88 à 110 db







EMERGENCY VEHICLE HORNS/AVERTISSEURS PRIORITAIRES/BOCINA PARA VEHÍCULO DE EMERGENCIA

BUZINAS PARA VEÍCULOS DE EMERGÊNCIA/SEGNALATORI ACUSTICI DI EMERGENZA/SIRENES

SIRENEN/Sygnaly dźwiękowe dla pojazdów uprzywilejowanych/Geçis üstünlüklü araç sirenleri/Сигналы для спецмашин

ELECTRONIC/ELECTRONIQUE

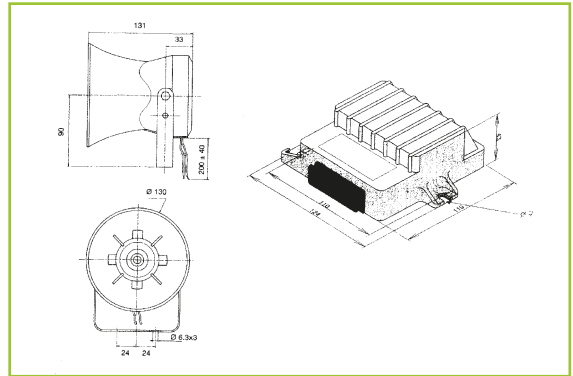
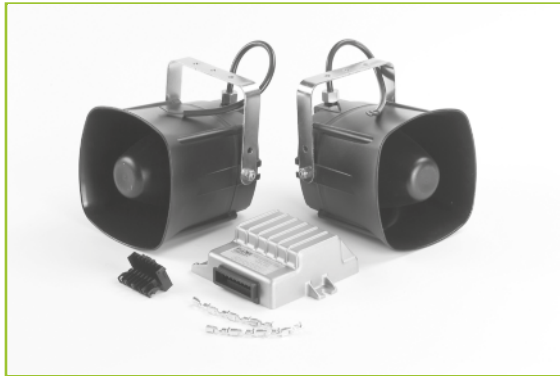

479127	TPSP04001		Black / Noir	12-24 V	12V 4+/-0,5A 24V 2+/-0,25A
479127	TPSP04001		Black / Noir	12-24 V	15mA
479129	TPPOL4009		Black / Noir	12-24 V	
479129	TPPOL4009		Black / Noir	12-24 V	
479131	TPGEN4007		Black / Noir	12-24 V	
479131	TPGEN4007		Black / Noir	12-24 V	
479133	TPUMH4010		Black / Noir	12-24 V	
479133	TPUMH4010		Black / Noir	12-24 V	
479135	TPASA4006		Black / Noir	12-24 V	12V 4+/- 0,5A 24V 2+/-0,25A
479135	TPASA4006		Black / Noir	12-24 V	15mA
479135	TPASA4006		Black / Noir	12-24 V	
479135	TPASA4006		Black / Noir	12-24 V	

ELECTRONIC MODULES



479179	TPPOL4009		Black	10.5-30V	4 +/-0,5A
479180	TPSP04001		Black	10.5-30V	4 +/-0,5A
479181	T.P.A.S.A.4006		Black	10.5-30V	2,5 +/- 0,5 A



Hz

dB



TONE/TON 1 : 435 +/-4 HZ	Jour : 117 +/- 5 db	28 +/- 1 cycles / min		Pompiers	FR
TONE/TON 2 : 488 +/-4 HZ	Nuit : 85 +/- 5 db	28 +/- 1 cycles / min		Pompiers	FR
TONE/TON 1 : 435 +/-4 HZ	Jour : 117 +/- 1 db	55 +/- 1 cycles / min		Police	FR
TONE/TON 2 : 488 +/-4 HZ	Nuit : 85 +/- 5 db	55 +/- 1 cycles / min		Police	FR
TONE/TON 1 : 435 +/-4 HZ	Jour : 117 +/- 1 db	55 +/- 1 cycles / min		Gendarmerie	FR
TONE/TON 2 : 732 +/-4 HZ	Nuit : 85 +/- 5 db	55 +/- 1 cycles / min		Gendarmerie	FR
TONE/TON 1 : 435 +/-4 HZ	Jour : 117 +/- 1 db	55 +/- 1 cycles / min		UMH	FR
TONE/TON 2 : 651 +/-7 HZ	Nuit : 85 +/- 5 db	55 +/- 1 cycles / min		UMH	FR
TONE/TON 1 : 420 +/- 4HZ	Jour : 108 +/- 1 db	30 +/- 1 cycles / min			FR
TONE/TON 2 : 516 +/- 5HZ	Nuit : 108 +/- 1 db	30 +/- 1 cycles / min			FR
TONE/TON 3 : 420 +/- 4HZ		30 +/- 1 cycles / min			FR
TONE/TON 4 : SILENCE 1,5S		30 +/- 1 cycles / min			FR



Hz

dB



L AND H	435 HZ - 580 HZ	117dB		Police
L AND H	488 HZ - 435 HZ	117 dB		Fire brigade
L AND H	420 HZ - 517 HZ	108 dB		



Valeo

EMERGENCY VEHICLE HORNS/AVERTISSEURS PRIORITAIRES/BOCINA PARA VEHÍCULO DE EMERGENCIA

BUZINAS PARA VEÍCULOS DE EMERGÊNCIA/SEGNALATORI ACUSTICI DI EMERGENZA/SIRENES

SIRENEN/Sygnaly dźwiękowe dla pojazdów uprzywilejowanych/Geçis üstünlüklü araç sirenleri/Сигналы для спецмашин

ELECTRONIC LOUDSPEAKER

Valeo



U

I

479182TPPOL4009-TPSP04001-T.P.A.S.A.4006-

Black

10.5-30V

POL, UMH, GEN, SPO : 4 +/- 0.5 A,

TPGEN4007-TPUMH4010

AMB : 2,5 +/- 0,5A



Hz

dB



L AND H UMH: 435 HZ - 651 HZ, 2HP(PLO,UMH,GEN,SPO): 117 +/- 1 dB,

Fire brigade / Police / Ambulance

AMB: 420 HZ - 517 HZ, 1HP (AMB) : 108 +/- 1 dB

SPO: 435 HZ - 488 HZ,

POL: 435 HZ - 580 HZ,

GEN: 435 HZ - 732 HZ

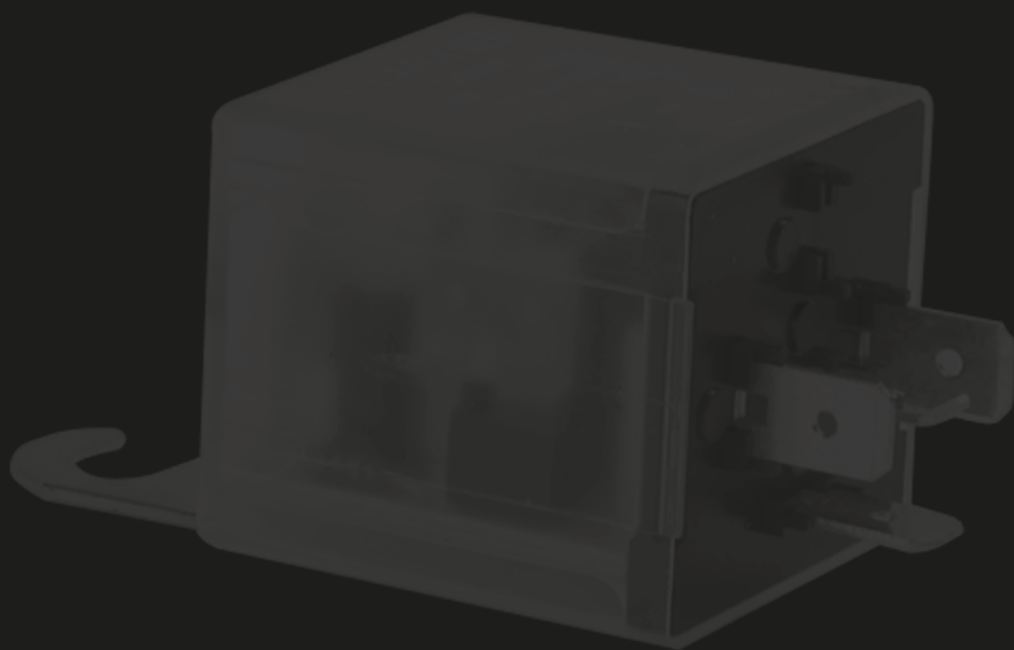



FIX.



DIN/SAE

CT

**Black /
Noir**

Flasher unit
Centrale clignotante
Central de intermitencia
Central de intermitente
Lampeggiatore
Knipperlicht relais
Blinkerrelais
Przerywacz
Flaşör üniteleri
Проблесковые приборы

Fixing
Fixation
Fijación
Fixação
Fissaggio
Fixation
Fixierung

Mocowanie
Takma

Крепление

Number of plugs
Nombre de fiches
Numero de conectores
Número de ligações
Numero di spine
Aantal kabelschoenen
Anzahl Steckverbinder

Ilość podłączeń

Bacak sayısı

Количество соединений

Standard Terminals
Norme de bornage
Norma de embornado
Terminais padrão
Terminali standard
Norme de bornage
Standard Datenverbindung

Standardowe gniazda

Standart kutup

Стандартный контакт

Technical code
Code technique
Código técnico
Código técnico
Codice tecnico
Technische code
technischer Code

Kod techniczny

Teknik kod

Технический код

Black
Noir
Negro
Preto

Nero
Zwart
Schwarz
Czarny
Siyah

Чёрный

**Grey /
Gris**



Grey
Gris
Gris
Cinzento
Grigio
Grijs
Gruu
Szary
Gri
Серый
Trailer
Remorque
Remolque
Reboques
Rimorchio
Aanhangwagens
Anhänger
Przyczepa
Römork
Прицеп



12 V

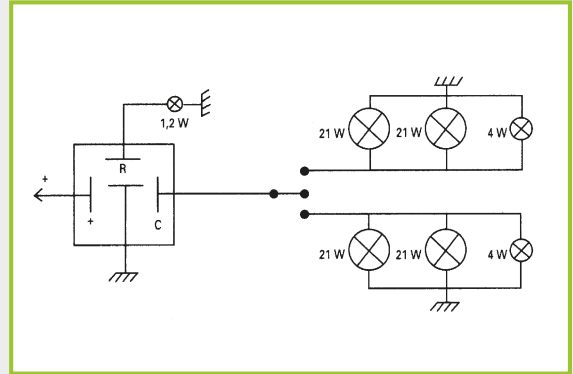
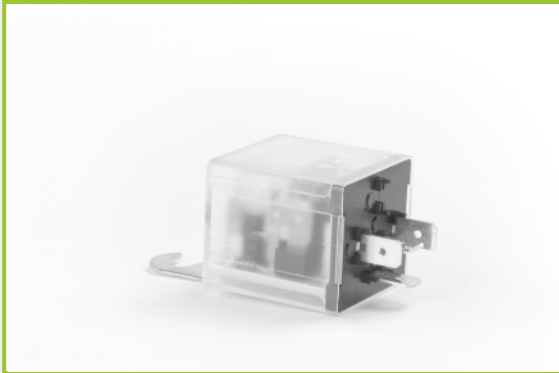

CT

U



FIX.



DIN/SAE



641421

739050

12 V

(+)

4

SAE

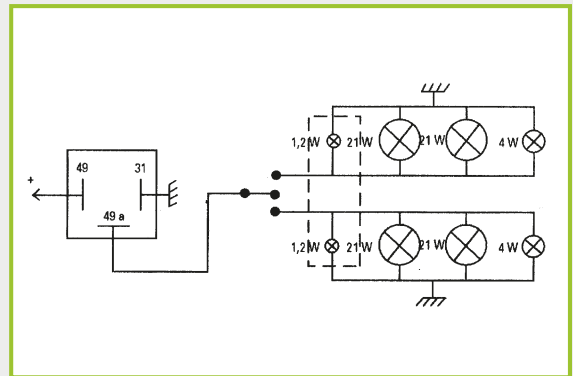
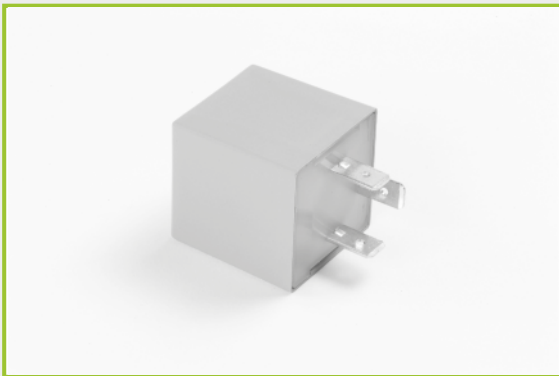

CT

U



FIX.



DIN/SAE



641422

739187

12 V

GREY/GRIS

(-)

3

DIN

CITROËN BERLINGO 07/96->12/02 JUMPY, PEUGEOT EXPERT

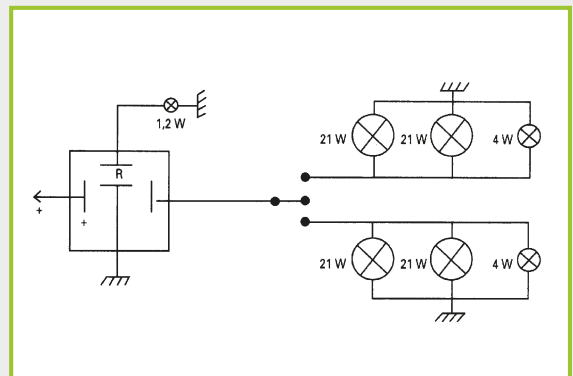

CT

U



FIX.



DIN/SAE



641424

739043

12 V

BLACK / NOIR

(-)

4

SAE

PSA, FIAT



12 V

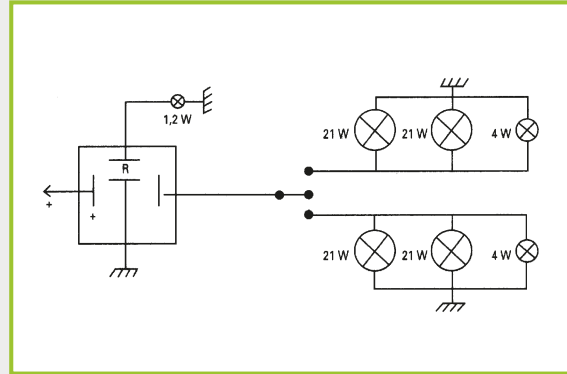
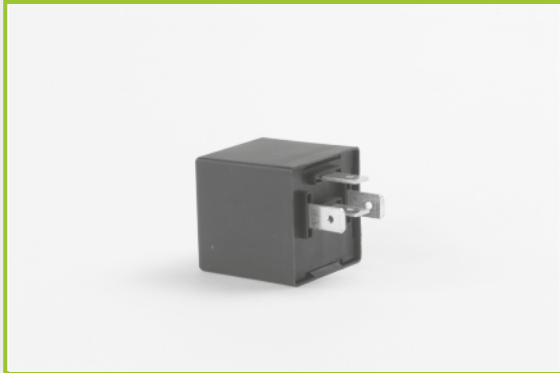

CT

U



FIX.



DIN/SAE



641426 54201045 12 V BLACK / NOIR (-) 4 SAE RENAULT EXPRESS / TRAFIC 03/89->02 / MASTER

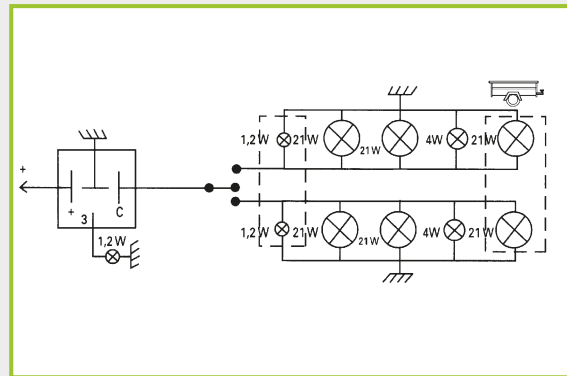

CT

U



FIX.



DIN/SAE



641427 54201044 12 V BLACK / NOIR (-) 4 SAE RENAULT TRAFIC 89-> / MASTER 81-> / MASCOTT

24 V

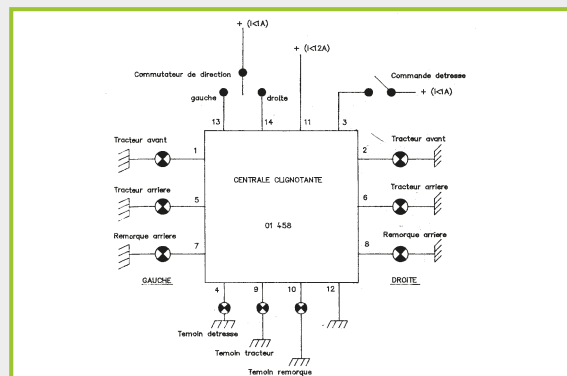

CT

U



FIX.



DIN/SAE



641428 739012 24 V BLACK / NOIR (+) 14 RENAULT TRUCKS



24 V



CT

U



FIX.



DIN/SAE



641429

739014

24 V

BLACK / NOIR

(+)

9

RENAULT TRUCKS



Compatibility DIN->SAE / Compatibilité DIN->SAE / Compatible DIN->SAE /
 Compatível DIN->SAE / Compatibilità DIN->SAE / Verglijkbare DIN->SAE / DIN->SAE Norm /
 Zgodność DIN->SAE / DIN->SAE normlarına uyumludur / Соответственно DIN->SAE

SAE	DIN	
-	31	Earth connection Masse Masa Massa Massa Aardleiding Masse Masa Toprak bağlantısı Macca
+	49	Positive battery Positif batterie Positivo Bateria Positivo da Bateria Polo positivo Pluspool van een batterij Pluspol der Batterie Plus do akumulatora Artı batarya Положительный ток аккумулятора
C	49a	Light Switch Commutateur lampe Conmutador lámpara Comutador de lâmpadas Commutatore lampada Verlichtingsswitch Lampenschalter Przełącznik podświetlany Aydınlatma anahtarı Переключатель подсвечиваемый
R		Vehicle indicator Voyant véhicule Indicador luminoso Indicador luminoso Veicolo viaggiante Controlelampje Kontrolllampe Oznaczenie pojazdu Sinyal lambaları Обозначение автомобиля

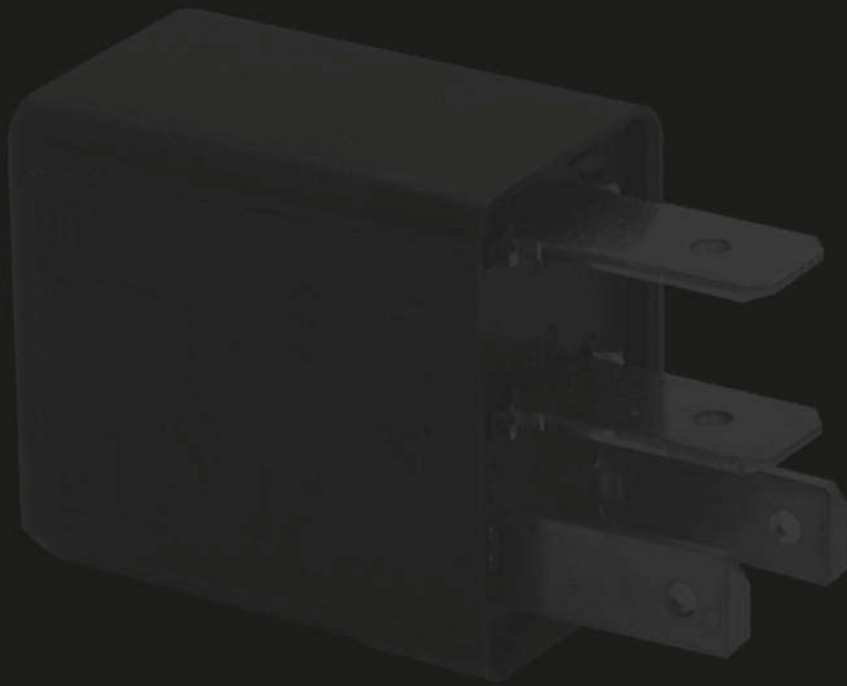



FIX.



Classic / Classique



Relay
Relais
Relé
Relé
Relé
Relais
Relais
Przełącznik
Реле
Реле
Fixing
Fixation
Fijación
Fixação
Fissaggio
Fixatie
Fixierung
Mocowanie
Такма
Крепление
Colour
Couleur
Color
Côr
Colore
Kleur
Farbe
Kolor
Renk
Цвет
Protection
Protection
Protección
Proteção
Protezione
Bescherming
Schutz
Chroniony
Koruma
Защита
Classic (No protection)
Classique (sans protection)
Clásico
Clássico
Classico
Classic
Klassisch (ohne Schutz)
Klasyczny (bez ochrony)
Klasik (korumasız)
Классический (без защиты)
Resistance
Resistencia
Resistencia
Resistência
Resistenza
Weerstand
Resistenz
Орор
Direnç
Сопротивление
Diode
Diode
Diodo
Diodo
Diodo
Diodo
Diodo
Diodo
Diodo
Diodo
Diyod
Диод
Fuse
Fusible
Fusible
Fusível
Fusibile
Zekering
Sicherung
Bezpiecznik
Sigorta
Предохранитель



DIN/SAE

CT



Standard Terminals
Norme de bornage
Norma de embornado
Terminais padrão
Terminali standard
Standaard uitgangen
Standard Datenverbindung
Standardowe gniazda
Standart kutup
Стандартный контакт
Technical code
Code technique
Código técnico
Código técnico
Codice tecnico
Technische code
Technischer Code
Kod techniczny
Teknik kod
Технический код
Connector for relay
Connecteur pour relais
Conector para relé
Ligação para relés
Connettore per relé
Stekkerverbinding voor relais
Relaisstecker
Gniazdo przełącznika
Rôle bağlantısı
Контакт для реле
Complete with lugs
Fourni avec cosses
Suministrado con terminal
Fornecido com terminal
Completo di morsetti
Compleet met kabelschoen
Komplett mit Öse
Kompletny z nóżkami
Kutusu ile beraber
Комплектный с соединениями
Dimension of lugs
Dimension des cosses
Dimensión del terminal
Dimensão do terminal
Dimensione dei morsetti
Dimensie van kabelschoen
Ösendimension
Wymiary nóżek
Kutu ölçüsü
Размер соединения
Number of plugs
Nombre de fiches
Numero de conectores
Número de ligações
Numero di spine
Aantal kabelschoenen
Anzahl Steckverbinder
Ilość podłączeń
Bacak sayısı
Количество соединения
High and low beam
Pour faisceaux de fils
Para conjunto de cables
Para conjunto de cabos
Per fascio di cavi
Hoge- en lage lichtbundel
Abblendlicht und Fernlicht
Światła mijania i drogowie
Kısa ve uzun ışık
Дальний и ближний свет
To Weld
A souder
A soldar
Para soldar
Da saldare
Lassen
Zu schweißen
Do lutowania
Kaynak
Сварка

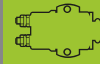

Micro-relay / Micro-relais

Cubic relay / Relais cubique

Power relay / Relais de puissance

Contact / Contacteur

Double contact / Double contacteur

Reverser / Inverseur



Coil relay contact
Contacteur à relais à bobine (d'appel isolée)
Contactor con relé y bobina
Ligação com relé e bobina
Contatto a relé con bobina
Relais met spoel
Relaispulenkontakt
Çevka
Rôle bobin bağlantısı
Катушка
Comfort relays
Temporisateurs de confort
Temporizadores de confort
Temporizadores de conforto
Temporizzadori di confort
Comfort relais
Komfort relais
Przełączniki
Devre anahtarları
Переключатели
Micro-relay
Micro-relais
Micro relé
Micro relé
Micro-relé
Micro-relais
Micro-Relais
Mikro przełącznik
Mikro röle
Микро реле
Cubic relay
Relais cubique
Relé cubico
Relé cubico
Relé cubico
Kubusvormig-relais
Würfel Relais
Przełącznik kostkowiec
Kúbik röle
Кубические реле
Power relay
Relais de puissance
Relé de potencia
Relé de potência
Relé di potenza
Bekrachtigingsrelais
Leistungsrelais
Przełącznik mocy
Yüksek güç röleleri
Высокоэффективные реле
Contact
Contacteur
Contactor
Contactor
Contatto
Contact
Kontakt
Złącze
Kontakt bağlantısı
Контакт
Double Contact
Double contacteur
Doble contactor
Contactor duplo
Doppio contatto
Dubbel contact
Doppelkontakt
Złącze podwójne
Çift kontaklı bağlantı
Двойной контакт
Reverser
Inverseur
Inversor
Inversor
Invertitore
Reverser
Umschalter
Zwrotny
Çevirici
Возвратный





<p>Functioning / Fonctionnement</p>	<p>Functioning Fonctionnement Funcionamiento Funcionamento Fuzionamento Functionering Funktion Funkcjonowanie Fonksjonowanie Действование</p>	<p>Blue / Bleu</p>	<p>Blue Bleu Azul Azul Azul Blauw Blau Blau Niebieski Mavi Голубой</p>	<p>For cubic relay / Pour relais cu- bique</p>	<p>For cubic relay Pour relais cubique Para relé cúbico Relé cúbico Per relé cubici Kubusvormig-relais Für Würfelrelais Przełącznik kostkowe Küçük röle Кубические реле</p>
<p>Permanent / Permanent</p>	<p>Permanent Permanent Permanente Permanente Permanente Permanent Permanent Staly Kalıcı Постоянный</p>	<p>Brown / Marron</p>	<p>Brown Marron Marrón Castanho Marrone Kastanje Kastanie Brazowy Kahverengi Бронзовый</p>	<p>For power relay / Pour relais de puissance</p>	<p>For power relay Pour relais de puissance Para relé de potencia Relé de potência Per relé di potenza Bekrachtigingsrelais Leistungsrelais Przełącznik mocy Yüksek güç röleleri Высокоэффективные реле</p>
<p>Closed / Fermé</p>	<p>Closed Fermé Cerrado Fechado Chiuso Gesloten Geschlossen Zamknięty Kapalı Закрыт</p>	<p>Green / Vert</p>	<p>Green Vert Verde Verde Verde Groen Grün Zielony Yeşil Зелёный</p>		
<p>Opened / Ouvert</p>	<p>Opened Ouvert Abierto Aberto Aperto Geopent Geöffnet Otwarty Açık Открыт</p>	<p>Grey / Gris</p>	<p>Grey Gris Gris Cinzento Grigio Grijs Grau Szary Gri Серый</p>		
<p>Conjunction voltage / Tension de conjonction</p>	<p>Conjunction voltage Tension de conjonction Tensión de conjunción Tensão de conjução Tensione di connessione Verbindungsspannung Schaltspannung Napięcie połączenia Bağlantı gerilimi Напряжение соединения</p>	<p>Purple / Violet</p>	<p>Purple Violet Violeta Violeta Viola Paars Violett Fioletowy Mor Фиолетовый</p>		
<p>Consumption under tension (cold) / Consumption bobine sous U à froid</p>	<p>Consumption under tension (cold) Consumation sous tension (U) à froid Consumo bajo tensión (U) en frío Consumo em tensão (U) a frio Consumo sotto tensione (U) a freddo Verbruik (koud) Verbrauch (kalt) Zużycie napięcia (U) Gerilim (U) altında tüketim (soğuk) Расход напряжения (U)</p>	<p>Yellow / Jaune</p>	<p>Yellow Jaune Amarillo Amarelo Giallo Geel Gelb Żółty Sarı Жёлтый</p>		
<p>Nominal voltage / Tension no- minale</p>	<p>Nominal voltage Tension nominale Tensión nominal Tensão nominal Tensione nominale Nominale spanning Nominalspannung Napięcie nominalne Nominal gerilim Напряжение номинальное</p>	<p>Red / Rouge</p>	<p>Red Rouge Rojo Vermelho Rosso Rood Rot Czerwony Kırmızı Красный</p>		
<p>Black / Noir</p>	<p>Black Noir Negro Preto Nero Zwart Schwarz Czarny Siyah Чёрный</p>	<p>For micro-relay / Pour micro- relais</p>	<p>For micro-relay Pour micro-relais Para micro relé Micro relé Per micro-relé Micro-relais Für Micro-Relais Mikro przełącznik Mikro röle Микро реле</p>		

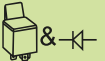

12V

	MICRO-RELAY / MICRO-RELAIS	CUBIC RELAY / RELAIS CUBIQUE	POWER RELAY / RELAIS DE PUISSANCE
Classic / Classique	643829 (T) 643832 (RT) 643833 (RT)	643501 (RT) / 643508 (RT) 643518 (RT) / 643601 (T) 643608 (T) / 643658 (T) 643815 (RT) / 643835 (T) 643836 (T) / 643840 (2T) 643843 (2T) / 643850 (RT) 643852 (RT) / 643853 (RT)	643856 (T)
Resistance / Résistance 	643823 (T) 643824 (RT) 643830 (T)	643510 (RT) / 643810 (2T) 643818 (RT) / 643841 (2T) 643844 (2T) / 643845 (2T) 643847 (2x1T) / 643851 (RT)	643819 (T) 643827 (T) 643855 (T)
Diode/ Diode 	643825 (RT)	643512 (RT) / 643837 (T) 643838 (T) / 643839 (T) 643848 (T) / 643849 (RT) 643854 (RT)	
Fuse/ Fusible 		643820 (2T) 643846 (2T)	

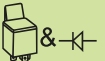
24V

	MICRO-RELAY / MICRO-RELAIS	CUBIC RELAY / RELAIS CUBIQUE	POWER RELAY / RELAIS DE PUISSANCE
Classic / Classique	643831 (RT) 643834 (RT)	643523 (RT) 643822 (RT)	643828 (T)
Resistance / Résistance 		643842 (2T)	
Diode / Diode 	643826 (RT)	643813 (RT)	
Fuse / Fusible 			





CONTACT / CONTACTEUR (T)

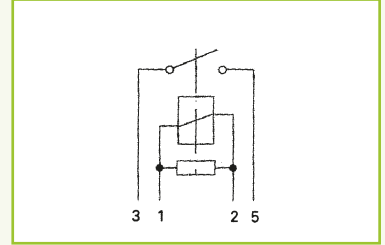
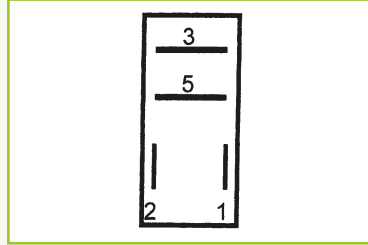

U

I

643823

SAE

4

Black / Noir

12 V

25 A

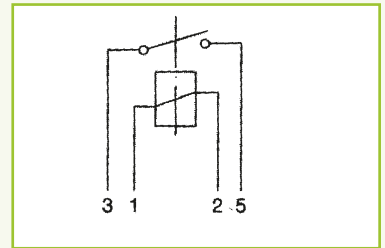
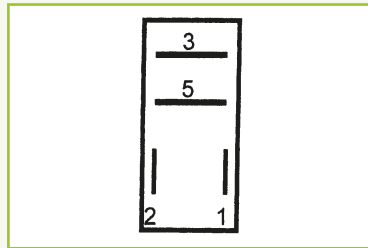
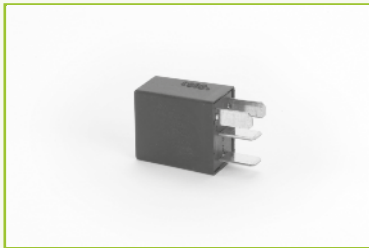

U

I

643829

SAE

4

Black / Noir

12 V

25 A

CONTACT / CONTACTEUR (RT)

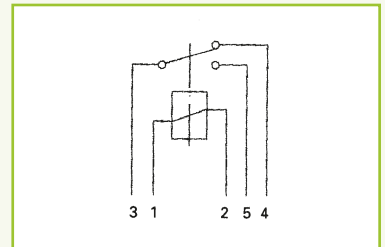
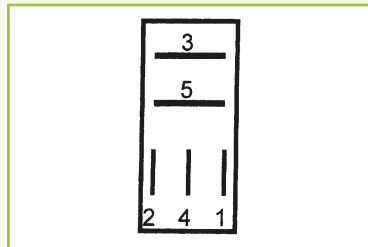

U

I

643831

SAE

5

Black / Noir

24 V

5/10 A



KRO PRZEKAZNIK/MIKRO RÖLE/Микро реле

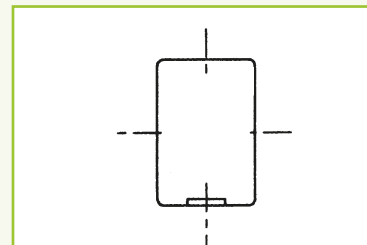
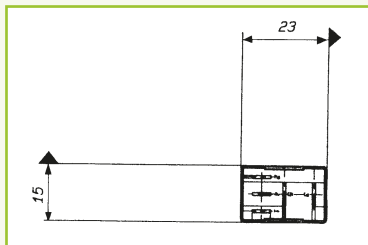
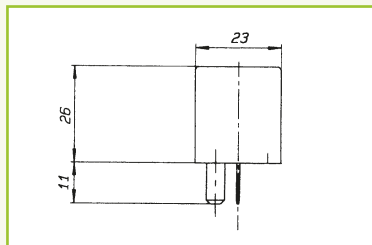

FIX.

CT



(-)

29200075

OPEL/...

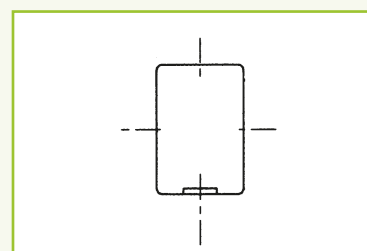
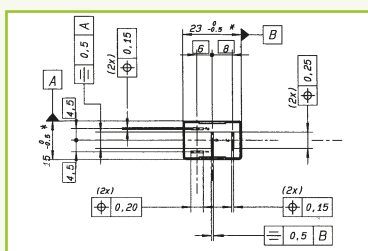
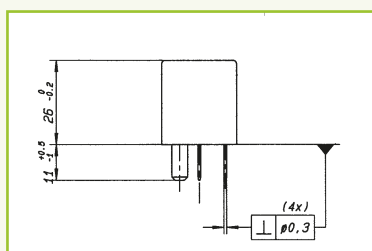

FIX.

CT



(-)

(-)

29200006

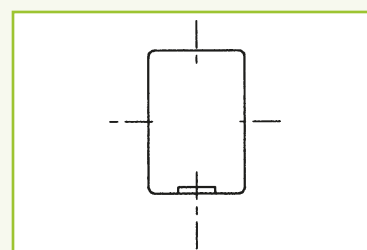
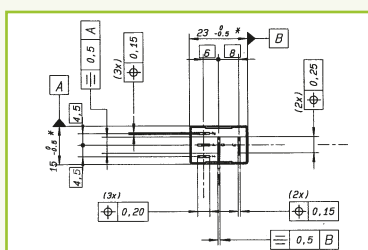
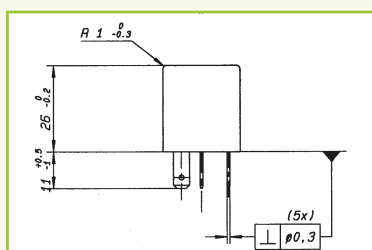

FIX.

CT



(-)

(-)

29401000



REVERSER / INVERSEUR (RT)

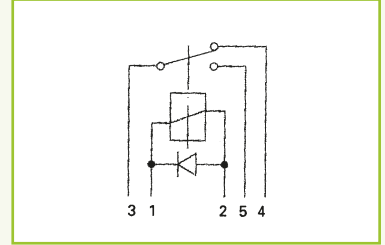
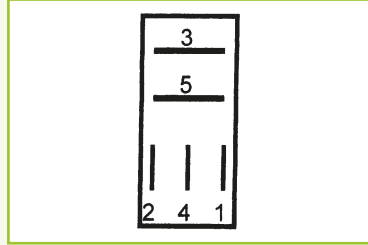

U

I

643825

SAE

5

Black / Noir

12 V

15/25 A

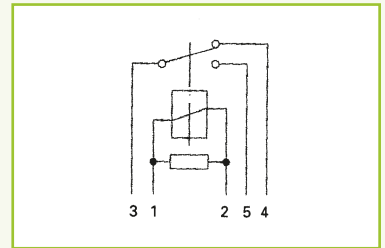
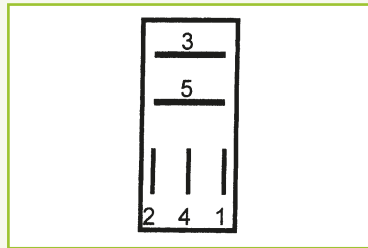

U

I

643824

SAE

5

Black / Noir

12 V

15/25 A

CONTACT / CONTACTEUR (T)

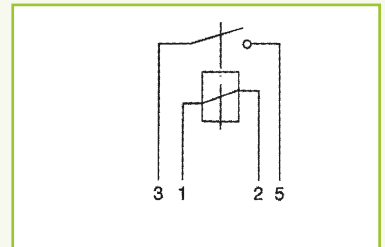
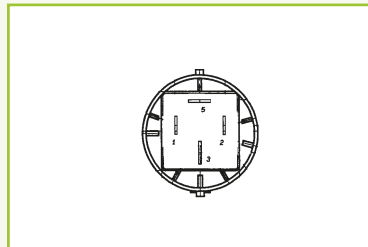

U

I

643835

SAE

4

Grey / Gris

12 V

45 A



KRO PRZEKAZNIK/MIKRO RÖLE/Микро реле

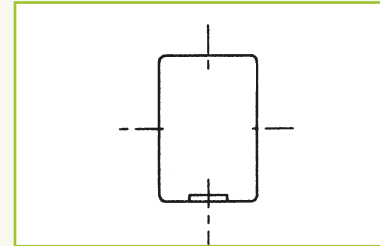
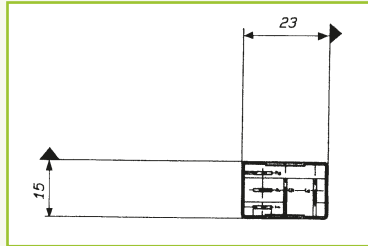
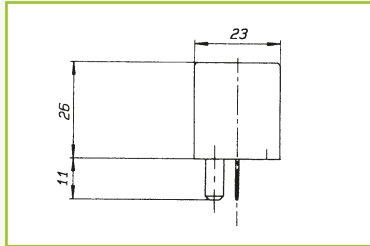

FIX.

CT



(-)

29201045

PSA/...

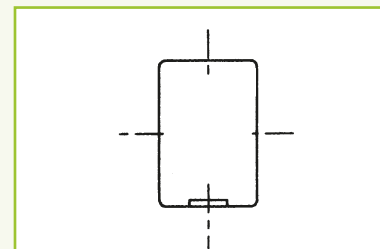
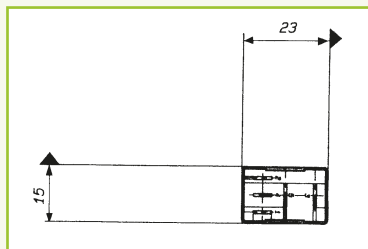
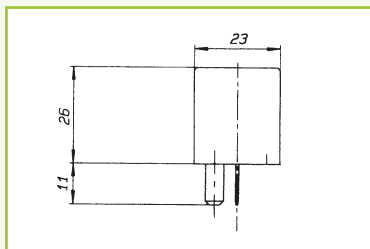

FIX.

CT



(-)

29201075

RENAULT/...

ELAIS/PRZEKAZNIK/MIKROI/KÜBIK RÖLE/Реле

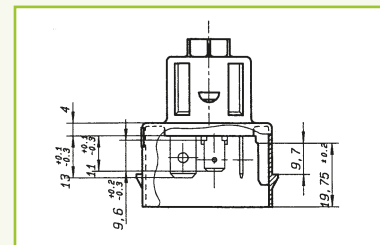
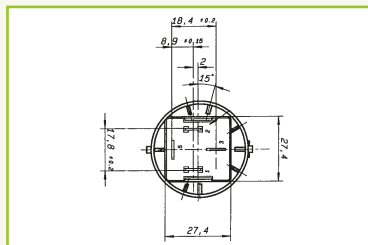
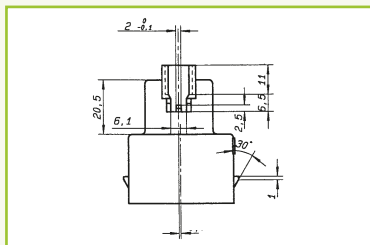

FIX.

CT



(-)

(-)

03652

PSA/...



CONTACT / CONTACTEUR (T)

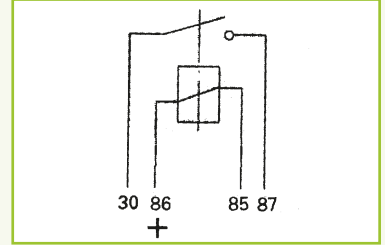
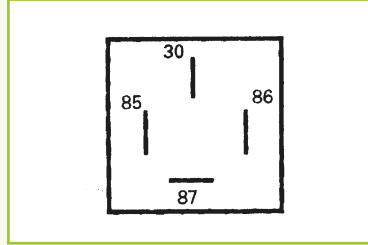
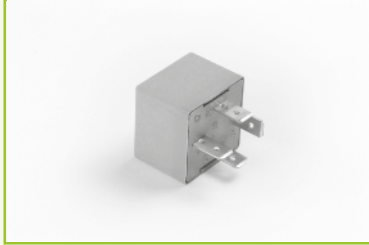

Valeo



U

I

643601

DIN

4

Green / Vert

12 V

25 A

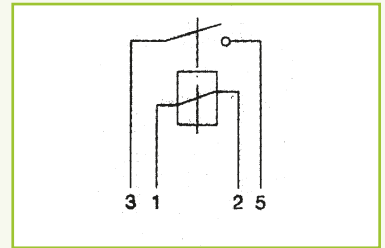
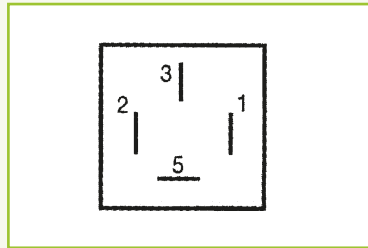
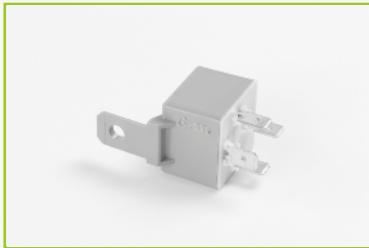

Valeo



U

I

643608

SAE

4

Green / Vert

12 V

25 A

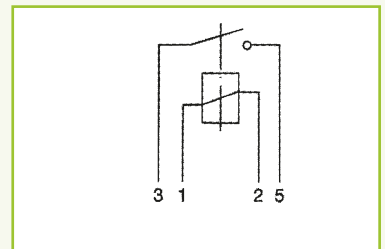
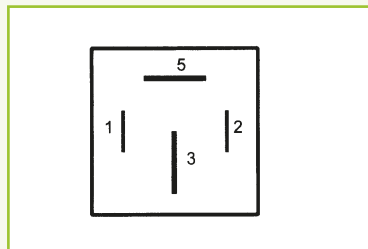
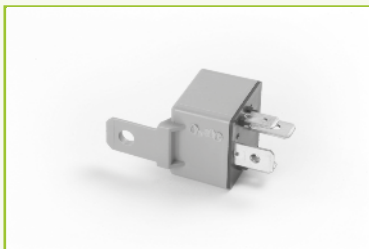

Valeo



U

I

643658

SAE

4

Green / Vert

12 V

50 A



ELAIS/PRZEKAZNIK/MIKROI/KÜBIK RÖLE/Реле

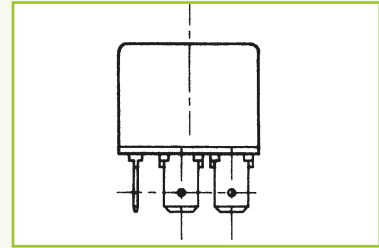
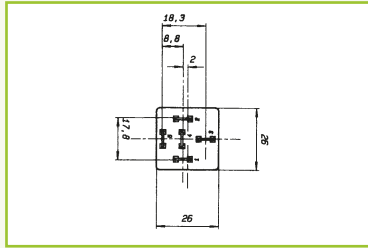
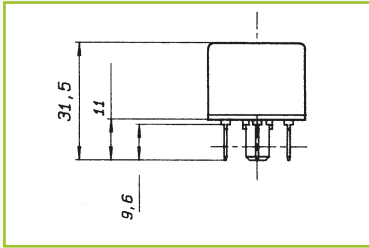

FIX.

CT



(-)

(-)

03601

PSA/...

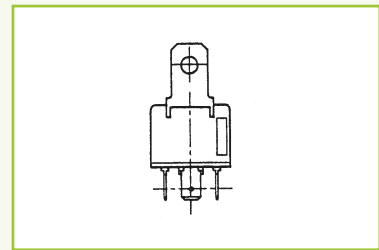
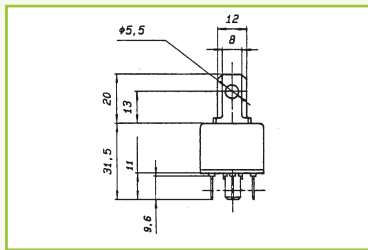
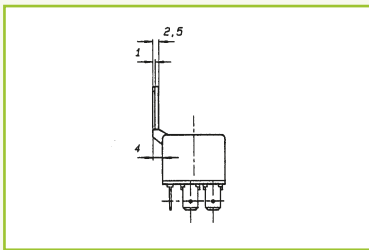

FIX.

CT



(-)

(+)

03608

PSA/...

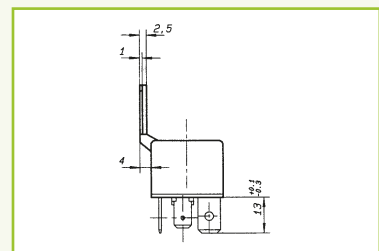
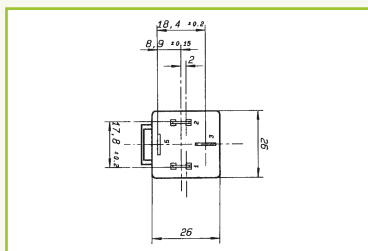
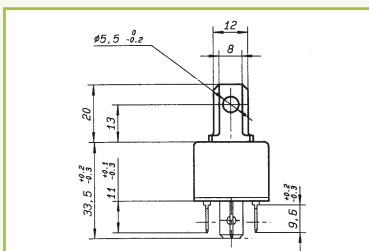

FIX.

CT



(-)

(+)

03658

PSA / RENAULT/...



CONTACT / CONTACTEUR (T)

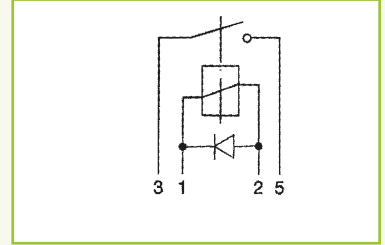
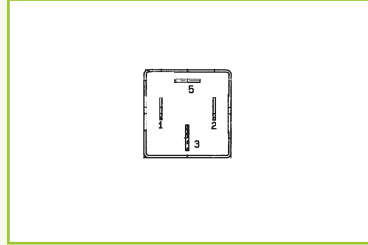
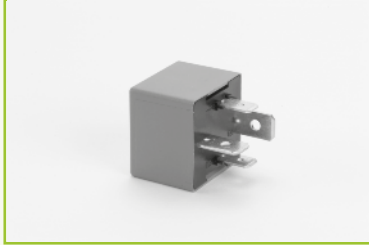

U

I

643838

SAE

4

Purple / Violet

12 V

50 A

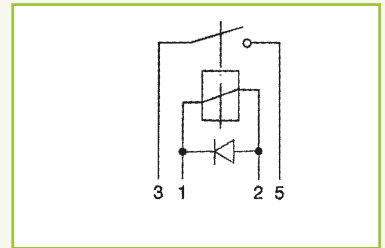
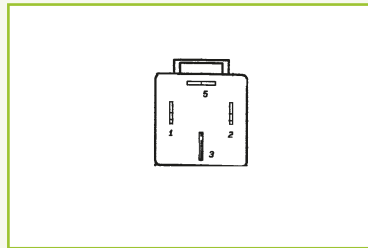
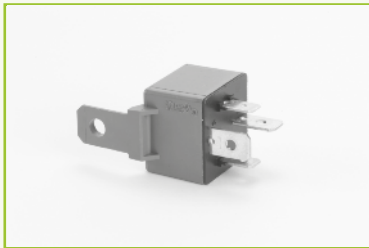

U

I

643839

SAE

4

Purple / Violet

12 V

50 A

REVERSER / CONTACTEUR (T)

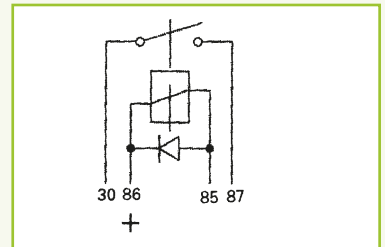
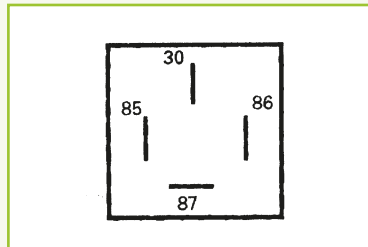

U

I

643848

DIN

4

Yellow / Jaune

12 V

40 A



ELAIS/PRZEKAZNIK/MIKROI/KÜBİK RÖLE/Реле

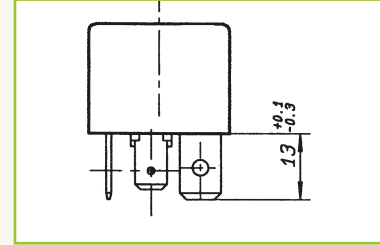
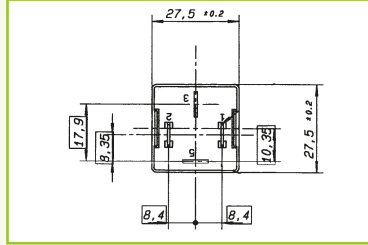
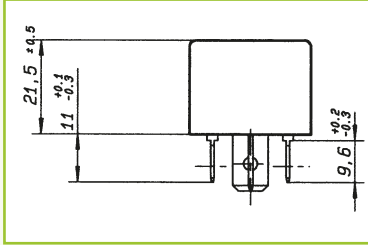

FIX.

CT



(-)

03525

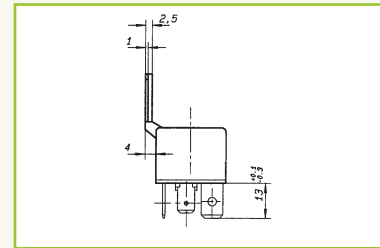
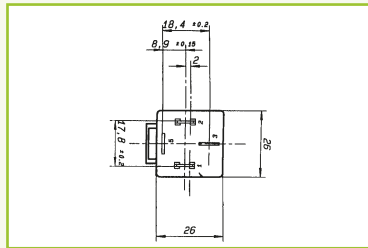
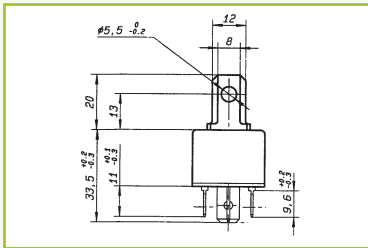

FIX.

CT



(+)

03520

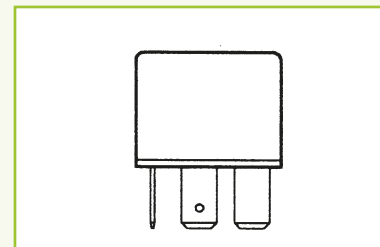
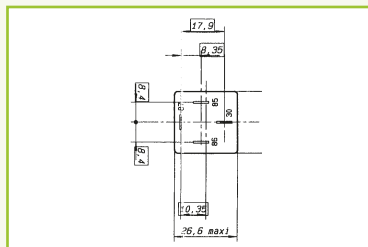
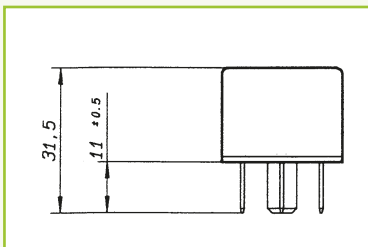

FIX.

CT



(-)

03544

PEUGEOT / RENAULT / ...



DOUBLE CONTACT / DOUBLE CONTACTEUR (2T)

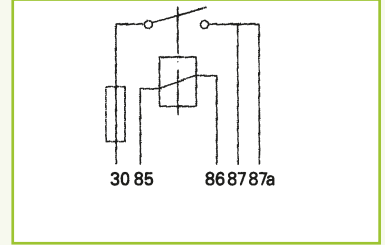
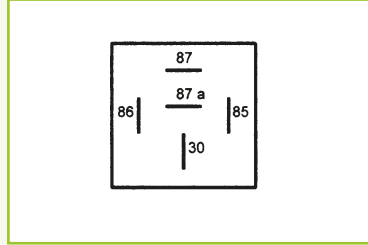
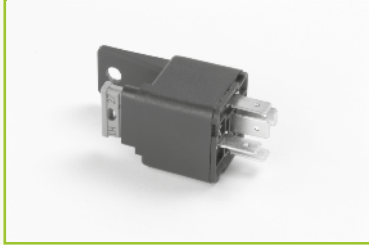

Valeo



U

I

643820

DIN

5

Black / Noir

12 V

15 A

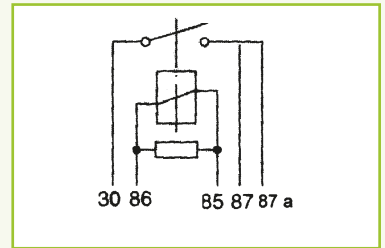
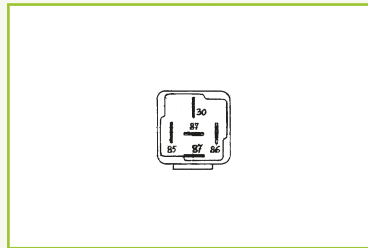

Valeo



U

I

643841

DIN

5

Green / Vert

12 V

2x15 A

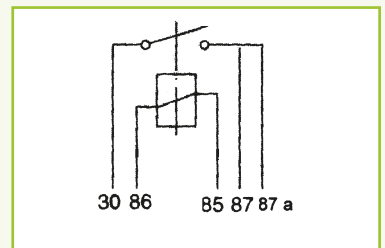
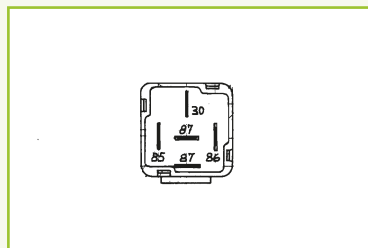

Valeo



U

I

643843

DIN

5

Brown / Marron

12 V

2x15 A



ELAIS/PRZEKAZNIK/MIKROI/KÜBIK RÖLE/Реле



FIX.

CT



(-)

0160940

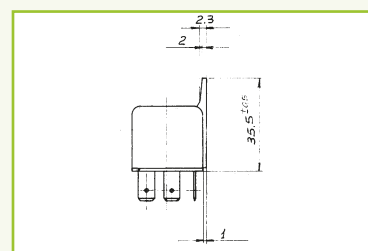
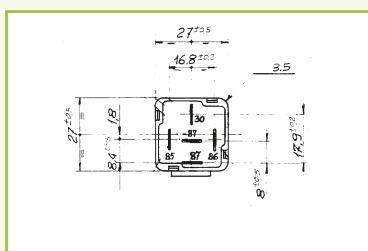
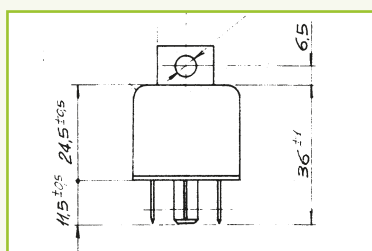

FIX.

CT



(+)

0103700

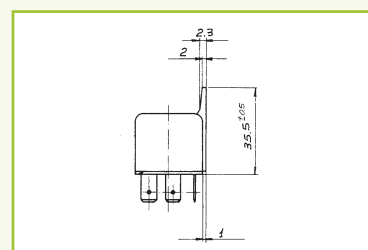
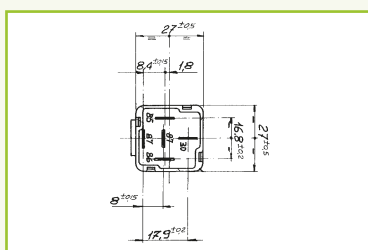
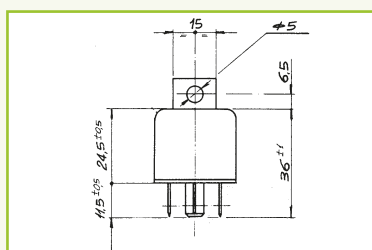

FIX.

CT



(-)

(+)

0108500



DOUBLE CONTACT / DOUBLE CONTACTEUR (2T)

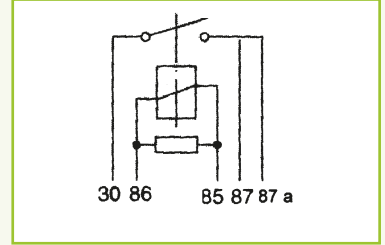
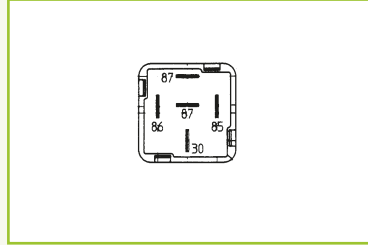

Valeo



U

I

643844

DIN

5

Black / Noir

12 V

40 A

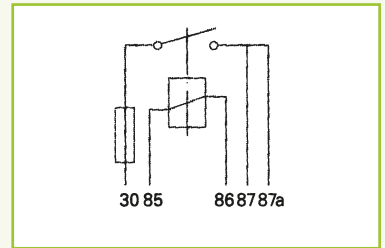
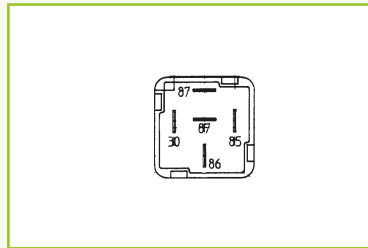
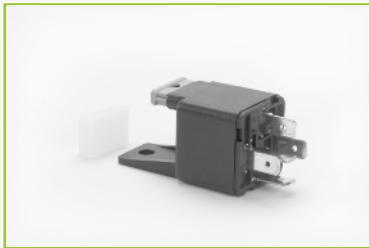

Valeo



U

I

643846

DIN

5

Black / Noir

12 V

30 A

REVERSER / INVERSEUR (RT)

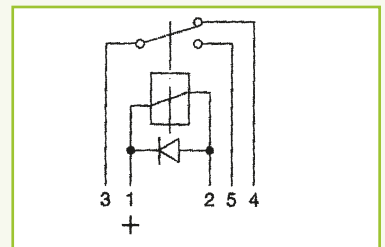
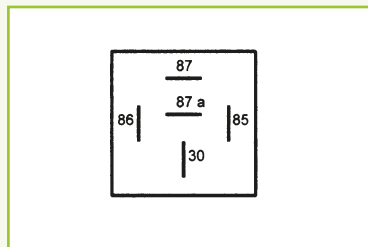

Valeo



U

I

643849

DIN

5

Brown / Marron

12 V

10/25 A



ELAIS/PRZEKAZNIK/MIKROI/KÜBİK RÖLE/Реле

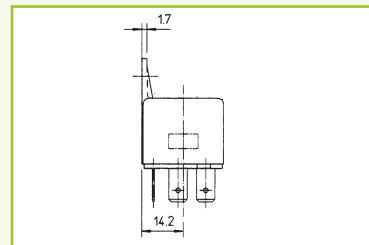
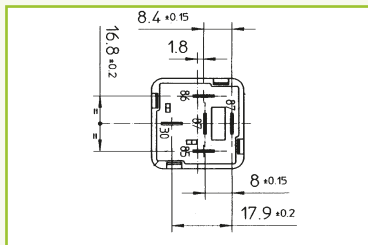
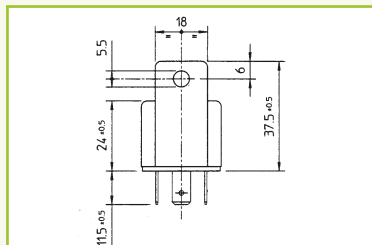

FIX.

CT



(+)

0125980

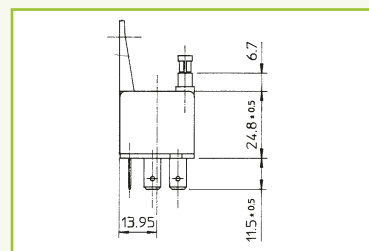
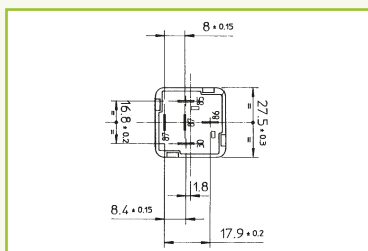
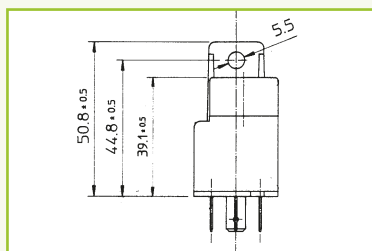

FIX.

CT



(+)

0160970

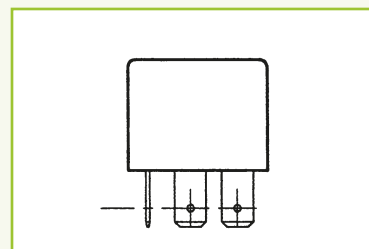
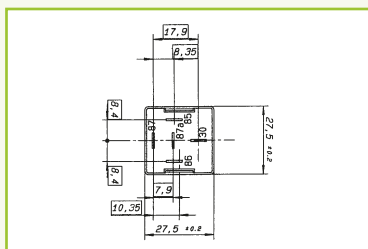
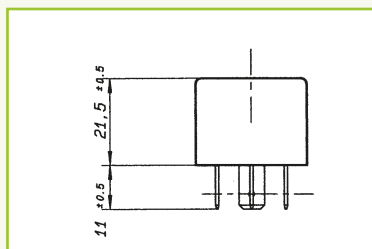

FIX.

CT



(-)

03612

RENAULT/ ...



REVERSER / INVERSEUR (RT)

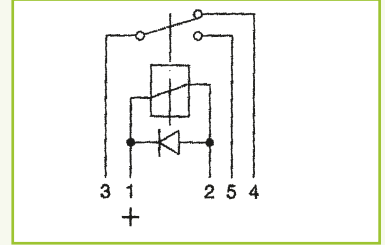
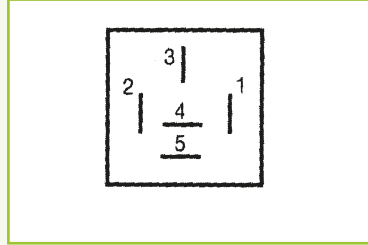
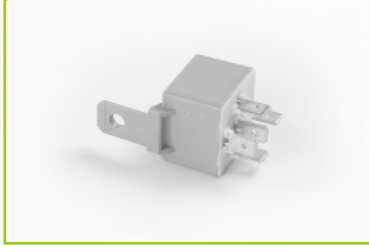

Valeo



U

I

643512

SAE

5

Grey / Gris

12 V

10/25 A

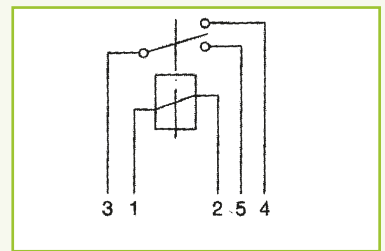
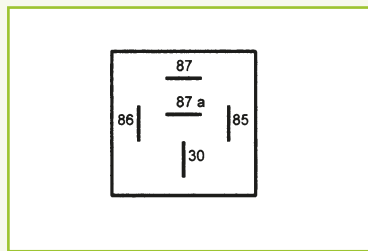
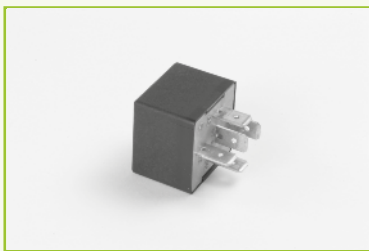

Valeo



U

I

643501

DIN

5

Black / Noir

12 V

10/25 A

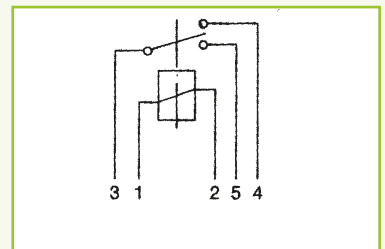
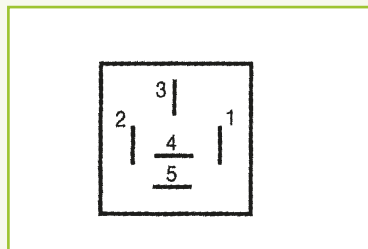

Valeo



U

I

643508

SAE

5

Black / Noir

12 V

10/25 A



ELAIS/PRZEKAZNIK/MIKROI/KÜBİK RÖLE/Реле

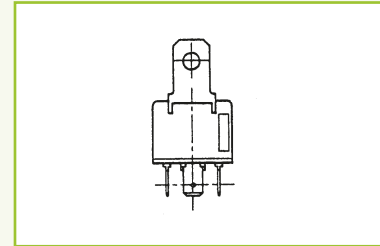
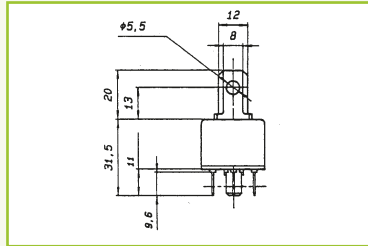
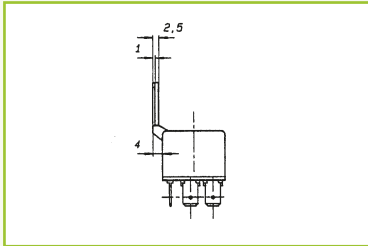

FIX.

CT



(+)

03512

PSA / RENAULT/...

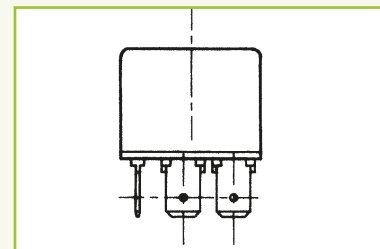
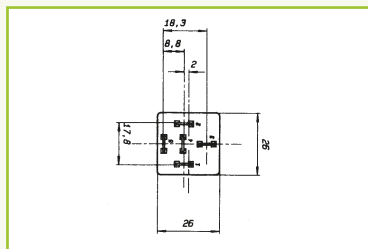
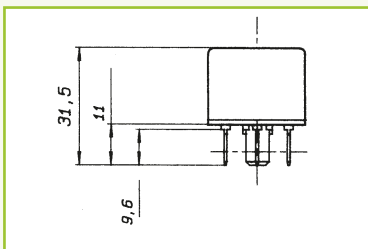

FIX.

CT



(-)

(-)

03501

PSA / RENAULT/...

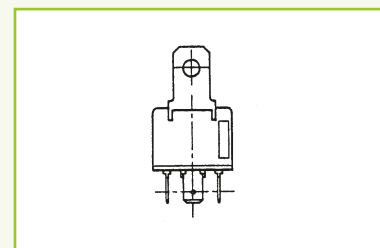
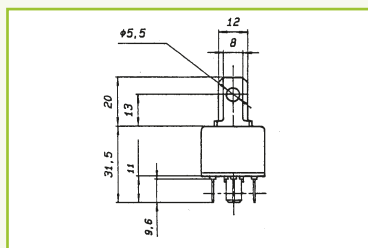
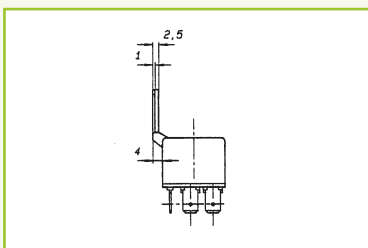

FIX.

CT



(-)

(+)

03508

PSA / RENAULT/...



REVERSER / INVERSEUR (RT)

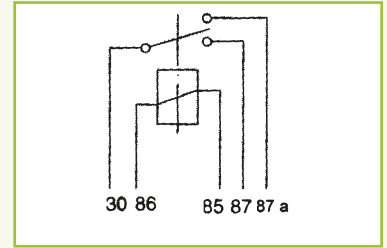
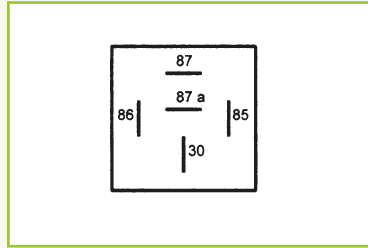
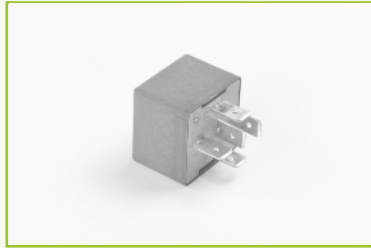

U

I

643523

DIN

5

Blue / Bleu

24 V

5/20 A

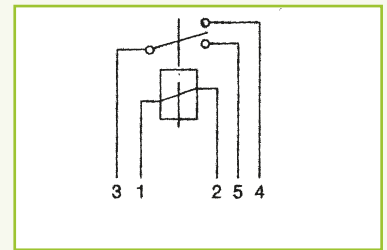
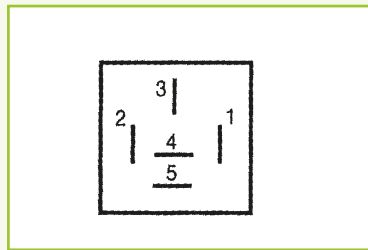

U

I

643815

SAE

5

Grey / Gris

12 V

15/40 A

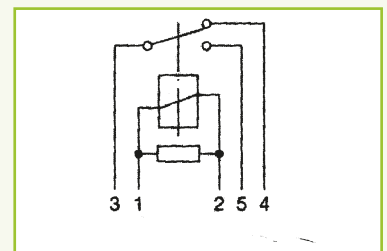
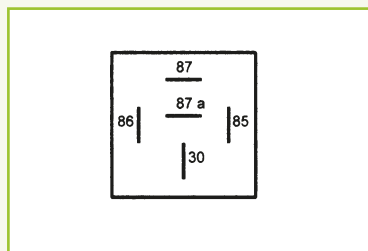
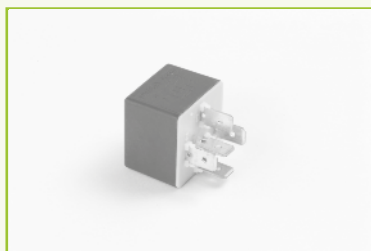

U

I

643818

SAE

5

Purple / Violet

12 V

10/25 A



ELAIS/PRZEKAZNIK/MIKROI/KÜBİK RÖLE/Реле

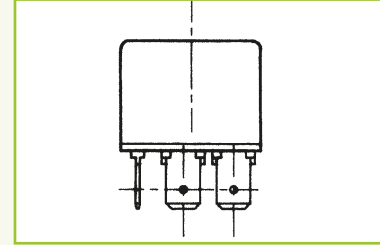
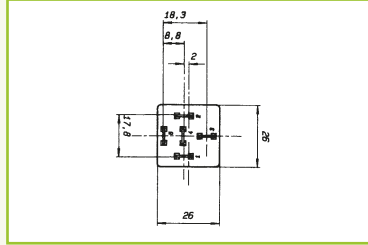
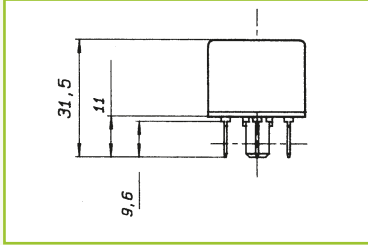

FIX.

CT



(-)

(-)

03523

RENAULT TRUCKS/...

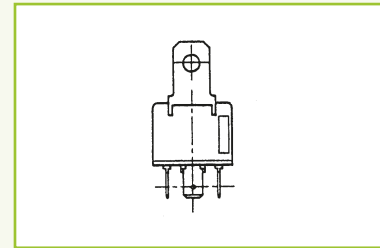
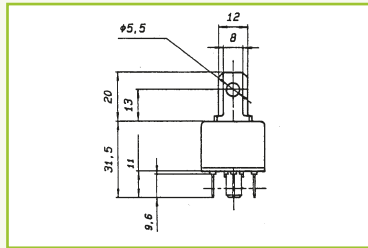
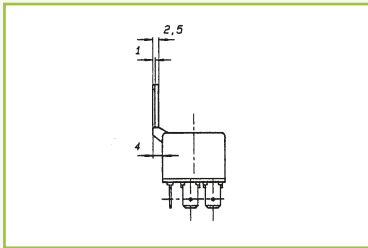

FIX.

CT



(-)

(+)

03535

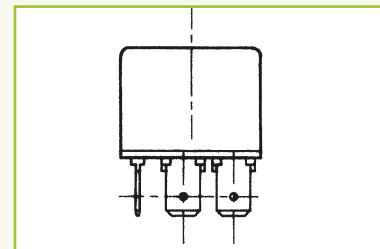
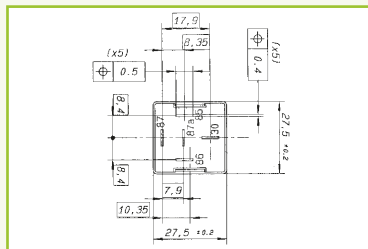
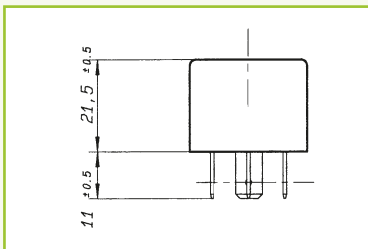

FIX.

CT



(-)

03517

PSA/...



REVERSER / INVERSEUR (RT)

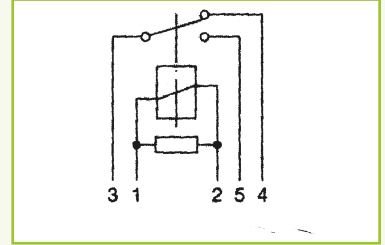
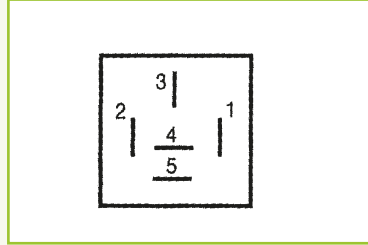

Valeo



U

I

643510

SAE

5

Purple / Violet

12 V

10/25 A

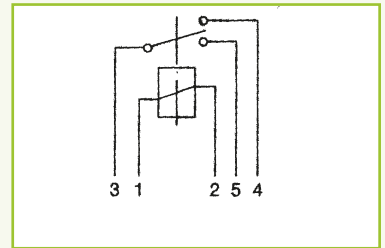
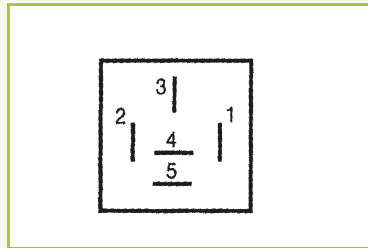
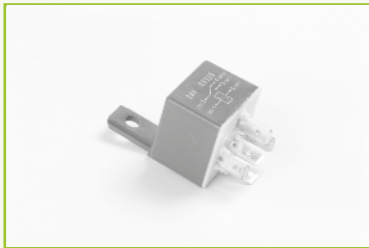

Valeo



U

I

643822

SAE

5

Blue / Bleu

24 V

5/20 A

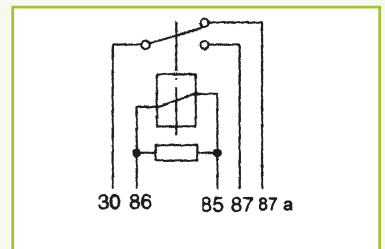
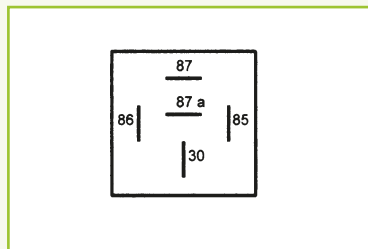
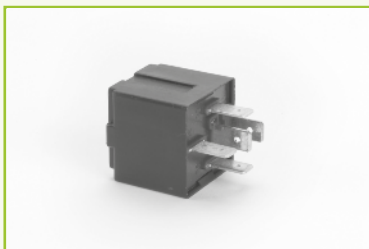

Valeo



U

I

643851

DIN

5

Black / Noir

12 V

15/30 A



ELAIS/PRZEKAZNIK/MIKROI/KÜBIK RÖLE/Реле

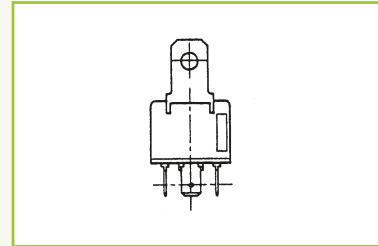
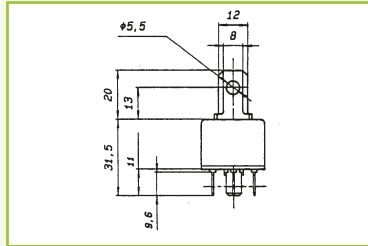
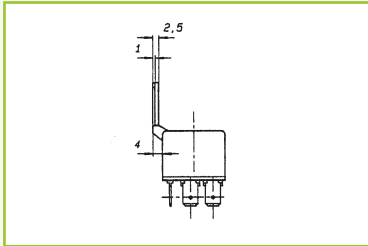

FIX.

CT



(+)

03510

PSA/...

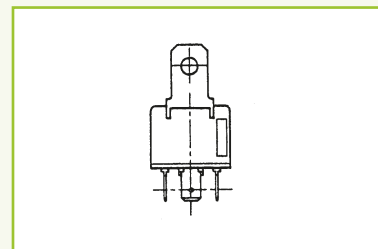
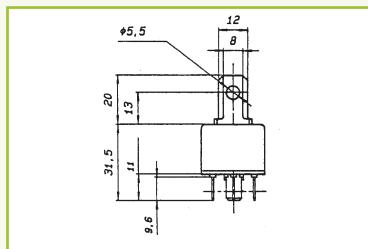
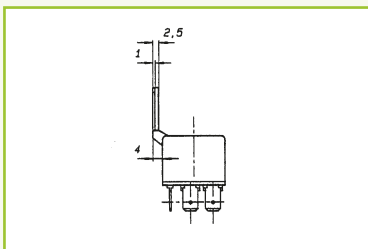

FIX.

CT



(-)

(+)

03526

RENAULT TRUCKS/...

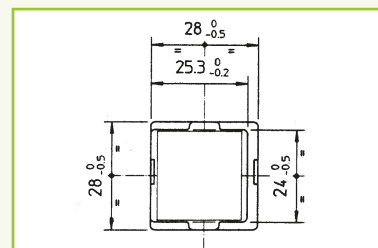
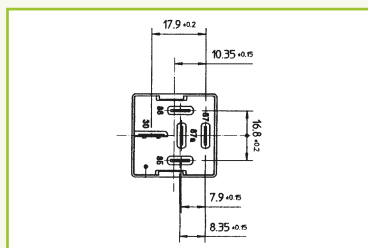
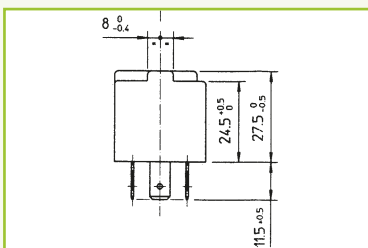

FIX.

CT



(-)

0106400



REVERSER / INVERSEUR (RT)

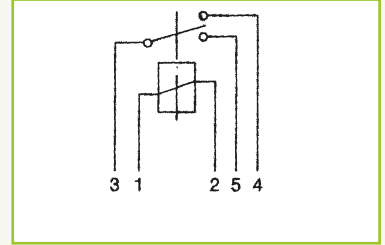
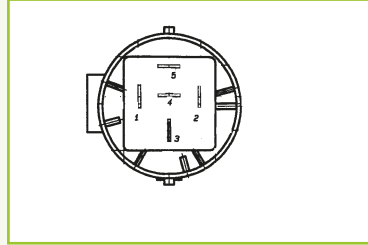

643853

SAE

5

Black / Noir

12 V

10/25 A

CONTACT / CONTACTEUR (T)

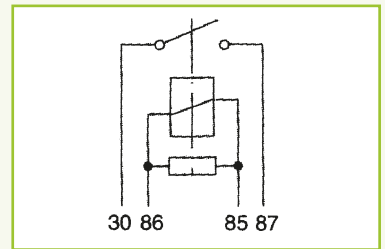
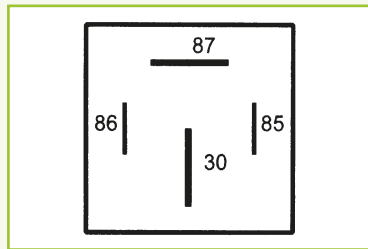

643855

DIN

4

Red / Rouge

12 V

70 A

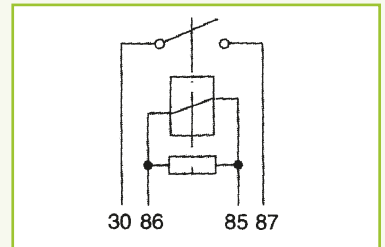
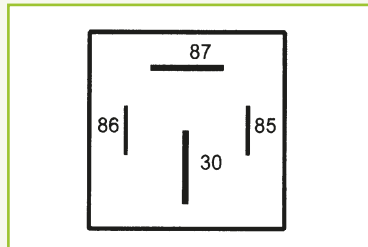

643827

DIN

4

Grey / Gris

12 V

70 A



RELAIS/PRZEKAZNIK/MIKROI/KÜBİK RÖLE/Реле

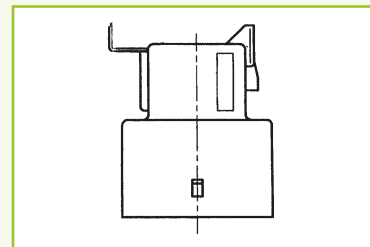
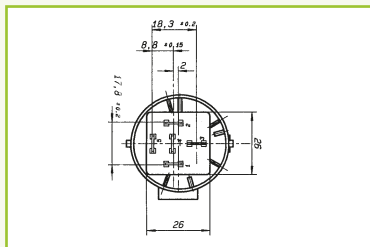
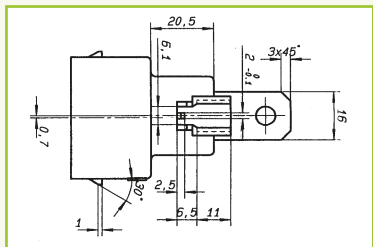

FIX.

CT



(-)

(+)

03514

TRIGGERRELAY/LEISTUNGSRELAIS/PRZEKAZNIK MOCY/YÜKSEK GÜÇ RÖLELERİ/Реле

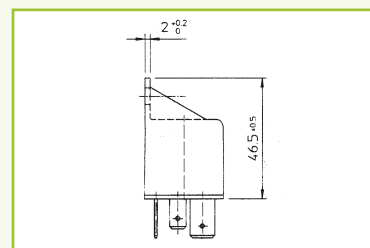
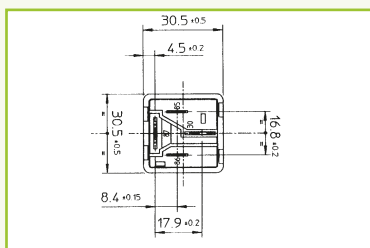
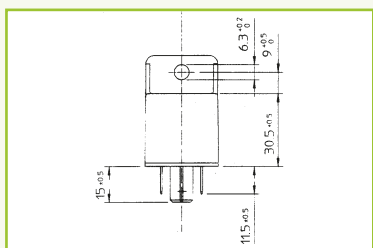

FIX.

CT



(+)

0138400

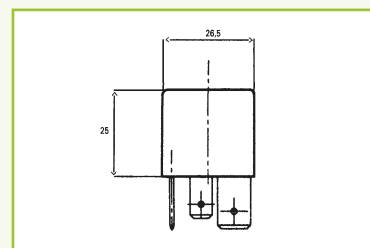
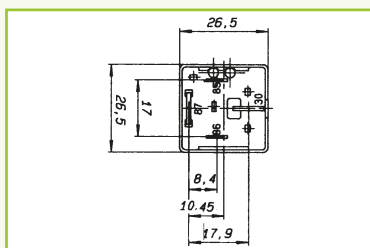
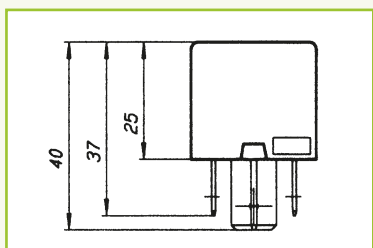

FIX.

CT



(-)

22204013

RENAULT/...



POWER RELAY/RELAIS DE PUISSANCE/RELÉ DE POTENCIA/RELÉ DE POTÊNCIA/RELÉ DI POTENZA/BEKRACHT

CONTACT / CONTACTEUR (T)

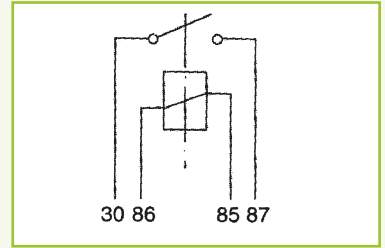
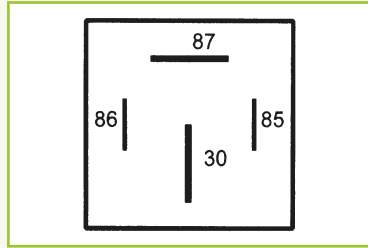

U

I

643828

DIN

4

Black / Noir

24 V

30 A

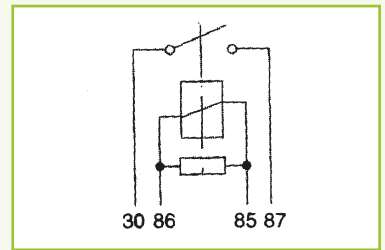
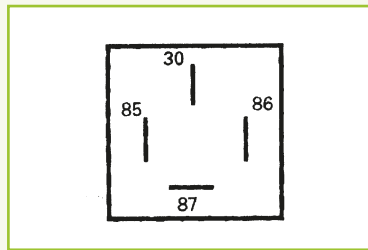
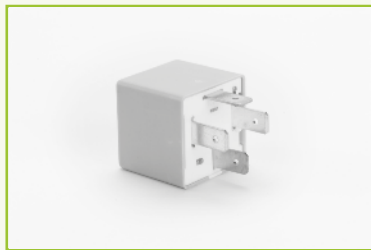

U

I

643819

DIN

4

Grey / Gris

12 V

40 A

COMFORT RELAYS / TEMPORISATEURS DE CONFORT / TEMPORIZADORES DE CONFORT / TEMPORIZZADORI

DOOR LOCK SWITCH / VERROUILLAGE AUTOMATIQUE DES PO

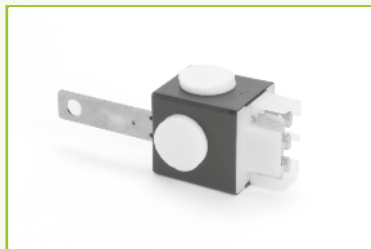

U

I

N/A

n/a

Black / Noir

12V

n/a



DIAGNOSISRELAY/LEISTUNGSRELAIS/PRZEKAZNIK MOCY/YÜKSEK GÜÇ RÖLELERİ/Реле

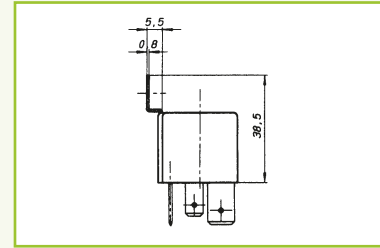
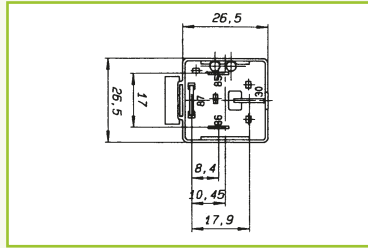
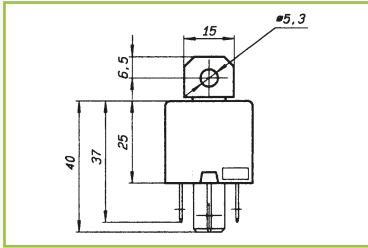

FIX.

CT



(-)

(+)

22400111

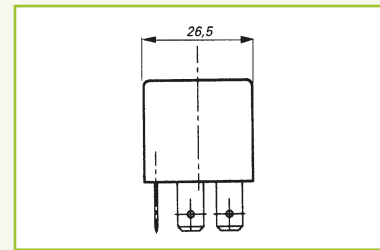
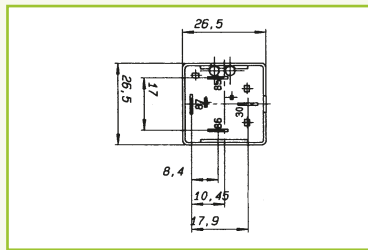
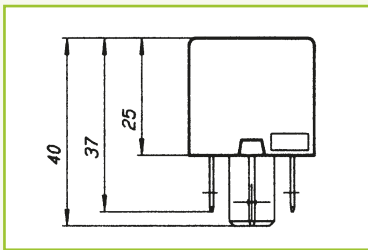

FIX.

CT



(-)

22200030

DI CONFORT / COMFORT RELAIS / KOMFORT RELAIS / PRZEŁĄZNIKI / Переключатели

ARTES



FIX.

CT



N/A

N/A

73602412

RENAULT / Express



FOR CUBIC RELAY / POUR RELAIS CUBIQUE



Valeo				+ / ...
649100	5	NO	6,3mm	
	4	NO	2,8mm	



Valeo				+ / ...
649200	5	YES	6,3mm	



Valeo				+ / ...
649600	5	YES	6,3mm	



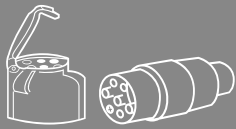

Plug
Fiche
Conector
Ficha
Connettore
stekkerdoos
Steckdosen
Gniazdo
Fişler
штепсели



Socket
Prise
Toma
Tomada
Presa
Stekker
Stecker
Złącze
Priz
Розетки



Adaptor
Adaptateur
Adaptador
Adattatore
Adaptor
Adapter
Adaptor
Adaptör
Адаптор



Number of pins plugs
Nombre de broches fiche
Numero de pines del conector
Número de pinos da ligação (fêmea)
Numero di prese di collegamento
Aantal stekkerdozen
Anzahl Verbindungssteckdosen
Liczba gniazd
Bağlantı priz sayısı
Количество розеток



Number of pins sockets
Nombre de broches prise
Numero de pines del conector
Número de pinos da ligação (macho)
Numero di spinotti di collegamento
Aantal stekker pinnen
Anzahl Verbindungsstifte
Liczba wtyczek
Bağlantı iğne sayısı
Количество штепсели



Type of connector
Type de contact
Tipo de conector
Tipo de ligação
Tipo di contatto
Type stekker
Verbindungstyp
Typ złącza
Bağlantı parçası tipi
Тип контакта



Type of lug
Type de cosse
Tipo de terminal
Tipo de terminal
Tipo di morsetto
Type kabelschoenen
Ösentyp
Typ nůzek
Kutu tipi
Тип соединения



Connection by screw
Connexion par vis
Conexión por tornillo
Ligação por parafuso
Connessione con vite
Schroef verbinding
Verbindung durch Schrauben
Połączenie wkrętem
Vidalı bağlantı
Подключение болтом



Connection by lugs
Connexion par cosses
Conexión con protección
Ligação por anel metálico
Connessione con morsetti
Stekkerverbinding
Ösenverbindung
Połączenie nóżkami
Kutulu bağlantı
Подключение соединениями



Diameter
Diamètre
Diámetro
Diámetro
Diámetro
Diameter
Durchmesser
Średnica
Çap
Диаметр



Battery connectivity
Connectique batterie
Conector de batería
Ligação da bateria
Connessione batteria
Batterij-aansluiting
Batterieanschluss
Podłączenie akumulatora
Batarya bağlantısı
Контакт для аккумулятора

**Fuses box /
Boitier
porte-
fusibles**

Fuses box
Boitier Porte-fusibles
Caja porta fusibles
Caixa porta-fusíveis
Scatola porta fusibili
Zekeringkast
Sicherungskasten
Skrzynka bezpieczników
Sigorta kutusu
Коробка предохранителей

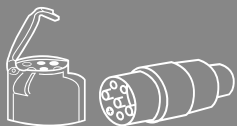

7 PINS / 7 BROCHES - 12 V

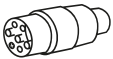
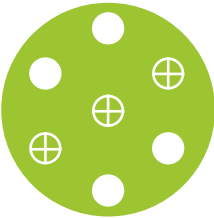
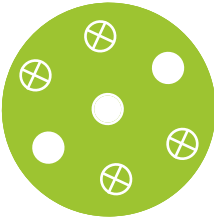
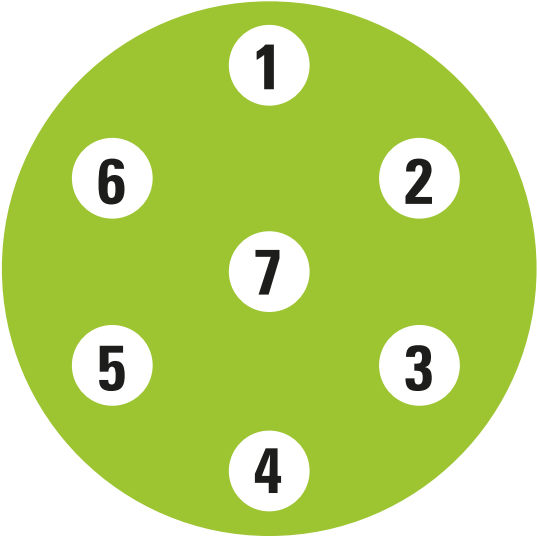
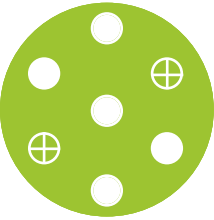
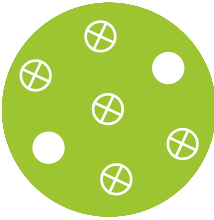

U	ISO/DIN			N°
12 V	ISO 1724 TYPE N			
12 V	ISO 3732 TYPE S			



N TYPE / TYPE N (ISO 1724)

	Function / Fonction / Función / Função / Funzione / Functie / Funktion / Funkcja / İşlev / Функция	Ø	
1	Left indicators	Linker knipperlicht	1,5 Yellow Geel
1	Indicateurs de direction gauche	Fahrtrichtungsanzeiger Links	1,5 Jaune Gelb
1	Indicador de dirección izquierda	Lewy kierunkowskaz	1,5 Amarillo Żółty
1	Pisca Esquerdo	Sağ göstergesi	1,5 Amarelo Sarı
1	Indicatore di direzione sinistro	Левый указатель поворота	1,5 Tuorlo Жёлтый
2	Rear fog light	Achter mistlamp	1,5 Blue Blauw
2	Feu de brouillard arrière	Nebelschlussleuchte	1,5 Bleu Blau
2	Antiniebla trasero	Tyłne światło przeciwmgielne	1,5 Azul Niebieski
2	Anti-nevoeiro traseiro	Arka sis lambası	1,5 Azul Mavi
2	Antinebbia posteriore	Задний противотуманный свет	1,5 Blu Голубой
3	Earth connection	Aardleiding	2,5 White Wit
3	Masse	Masse	2,5 Blanc Weiss
3	Masa	Masa	2,5 Blanco Biały
3	Massa	Toprak bağlantısı	2,5 Branco Beyaz
3	Massa	Масса	2,5 Bianco Белый
4	Right indicators	Rechter knipperlicht	1,5 Green Groen
4	Indicateurs de direction droit	Fahrtrichtungsanzeiger Rechts	1,5 Vert Grün
4	Indicador de dirección derecha	Prawy kierunkowskaz	1,5 Verde Zielony
4	Pisca Direito	Sol göstergesi	1,5 Verde Yeşil
4	Indicatore di direzione destro	Правый указатель поворота	1,5 Verde Зелёный
5	Side lights, side markers, numberplate light right	Zijverlichting, zijmarkering, nummerbordverlichting Rechts	1,5 Brown Kastanje
5	Feux de positions, feu d'encombement, éclairage plaque droite	Schlussleuchte, Umriss-Begrenzungsleuchte, Kennzeichenleuchte Rechts	1,5 Marron Kastanie
5	Luz de posición, luz de emergencia, iluminación matrícula Derecha	Obrysówki, światła pozycje, oświetlenie tablicy rejestracyjnej prawej	1,5 Marrón Brązowy
5	Luz de presença, luz de emergência, luz de matrícula Direita	Yan sinyaller, plaka lambası sol	1,5 Castanho Kahverengi
5	Luci di posizione, luci di ingombro, luci targa Destra	Стояночный свет, фонарь номерного знака Правый	1,5 Marrone Бронзовый
6	Stop lights	Remlichten	1,5 Red Rood
6	Feux stop	Bremslichter	1,5 Rouge Rot
6	Luz de freno	Światła stop	1,5 Rojo Czerwony
6	Luz de travão	Stop lambası	1,5 Vermelho Kırmızı
6	Luçe stop	Стоп-сигнал	1,5 Rosso Красный
7	Side lights, side markers, numberplate light left	Zijverlichting, zijmarkering, nummerbordverlichting links	1,5 Black Zwart
7	Feux de positions, feu d'encombement, éclairage plaque gauche	Schlussleuchte, Umriss-Begrenzungsleuchte, Kennzeichenleuchte Links	1,5 Noir Schwarz
7	Luz de posición, luz de emergencia, iluminación matrícula izquierda	Obrysówki, światła pozycje, oświetlenie tablicy rejestracyjnej lewej	1,5 Negro Czarny
7	Luz de presença, luz de emergência, luz de matrícula Esquerda	Yan sinyaller, plaka lambası sağ	1,5 Preto Siyah
7	Luci di posizione, luci di ingombro, luci targa sinistra	Стояночный свет, фонарь номерного знака Левый	1,5 Nero Чёрный

S TYPE / TYPE S (ISO 3732)

	Function / Fonction / Función / Função / Funzione / Functie / Funktion / Funkcja / İşlev / Функция	Ø	
1	Reversing lights	Achteruitrij-verlichting	1,5 Yellow Geel
1	Feux de marche arrière	Rückfahrleuchte	1,5 Jaune Gelb
1	Luz de marcha atrás	Światła cofania	1,5 Amarillo Żółty
1	Luz de marcha atrás	Geri vites lambası	1,5 Amarelo Sarı
1	Luci di retromarcia	Свет заднево хода	1,5 Tuorlo Жёлтый
2	Signal connection trailer	Knipperlichtaansluiting voor een aanhangwagen	
2	Signalisation raccordement remorque	Kontrollleuchte Anschluss Anhänger	
2	Testigo de conexión remolque	Złącze oświetlenia przyczepy	
2	Indicador de ligação do atrelado	Römork sinyalleri	
2	Indicatore di collegamento rimorchio	Соединение фар прицепа	
3	Return earth connection for contact 4	Retour aardleiding voor contact nr. 4	2,5 White Wit
3	Masse de retour pour contact n°4	Rückkehrmasse für Kontakt Nr.4	2,5 Blanc Weiss
3	Masa de retorno para contacto n° 4	Masa powrotna dla złącza 4	2,5 Blanco Biały
3	Massa de retorno para contacto 4	Topraklama için 4 numaralı bağlantıyı seçiniz	2,5 Branco Beyaz
3	Massa di ritorno per contatto n.4	Масса возврата для контакта 4	2,5 Bianco Белый
4	Positive direct current feed from battery	Directe positive voeding van de batterij	2,5 Green Groen
4	Positif d'alimentation directe de batterie	Pos.Stromspeisung direkt von Batterie	2,5 Vert Grün
4	Positivo de alimentación directa de la batería	Plus bezpośredni z akumulatora	2,5 Verde Zielony
4	Positivo de alimentação directa da bateria	Artı bağlantıyı aküden yapınız	2,5 Verde Yeşil
4	Positivo d'alimentazione diretta della batteria	Положительный ток с аккумулятора	2,5 Verde Зелёный
5	No allocation	Geen allocatie	1,5 Brown Kastanje
5	Aucune application	Kein Anschluss	1,5 Marron Kastanie
5	Ninguna aplicación1,5	Wolny	1,5 Marrón Brązowy
5	Sem aplicação	İlintisiz	1,5 Castanho Kahverengi
5	Nessuna applicazione	Свободный	1,5 Marrone Бронзовый
6	Positive ignition key	Positive contactsleutel	2,5 Red Rood
6	Positif d'alimentation sous clefs de mise en route	Pos.Stromspeisung mit Zündschlüssel	2,5 Rouge Rot
6	Positivo de alimentación con llave de puesta en marcha	Plus stacyjki	2,5 Rojo Czerwony
6	Positivo de alimentação com chave ligada	Artı ateşleme anahtarı	2,5 Vermelho Kırmızı
6	Positivo d'alimentazione sotto chiave inserita	Положительный ток замка зажигания	2,5 Rosso Красный
7	Return earth connection for contact 6	Retour aardleiding voor contact nr. 9	2,5 Black Zwart
7	Masse de retour pour contact n°6	Rückkehrmasse für Kontakt Nr.6	2,5 Noir Schwarz
7	Masa de retorno para contacto n° 6	Masa powrotna dla złącza 9	2,5 Negro Czarny
7	Massa de retorno para contacto 6	Topraklama için 6 numaralı bağlantıyı seçiniz	2,5 Preto Siyah
7	Massa di ritorno per contatto n.6	Розетка массы возврата №6	2,5 Nero Чёрный

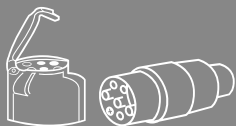

7 PINS / 7 BROCHES - 24 V

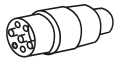
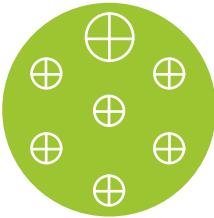
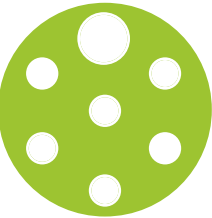
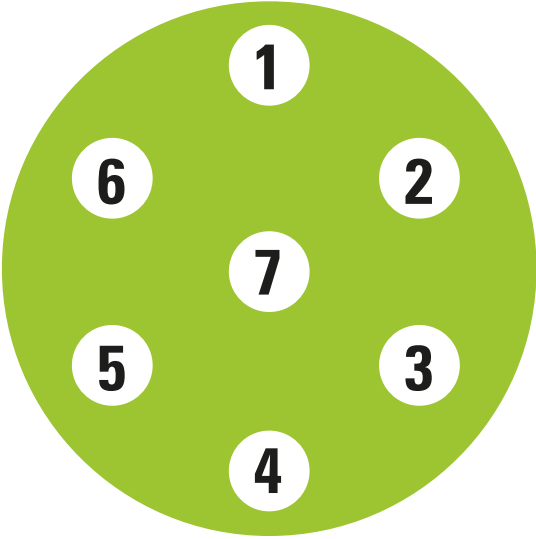
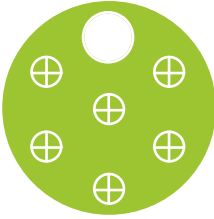
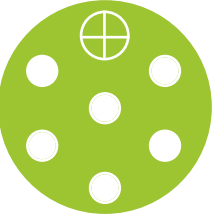

U	ISO/DIN			N°
24 V	ISO 1185 DIN 72579 TYPE N			
24 V	ISO 3731 TYPE S			

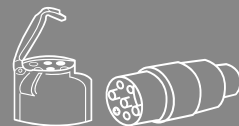

N TYPE / TYPE N (ISO 1185 / DIN 72579)

Function / Fonction / Función / Função / Funzione / Functie / Funktion / Funkcja / İşlev / Функция		Ø			
1	Earth connection	Aardleiding	2,5	White	Wit
1	Masse	Masse	2,5	Blanc	Weiss
1	Masa	Masa	2,5	Blanco	Biały
1	Massa	Toprak bağlantısı	2,5	Branco	Beyaz
1	Massa	Масса	2,5	Bianco	Белый
2	Side lights, side markers, numberplate light left	Zijverlichting, zijmarkering, nummerbordverlichting links	1,5	Black	Zwart
2	Feux de positions, feux d'encombrement, éclairage plaque gauche	Schlussleuchte, Umriss-Begrenzungsleuchte, Kennzeichenleuchte Links	1,5	Noir	Schwarz
2	Luz de posición, luz de emergencia, iluminación matricula izquierda	Obrysówki, światła pozycje, oświetlenie tablicy rejestracyjnej lewej	1,5	Negro	Czarny
2	Luz de presença, luz de emergência, luz de matrícula Esquerda	Yan sinyaller, plaka lambası sağ	1,5	Preto	Siyah
2	Luci di posizione, luci di ingombro, luci targa sinistra	Стояночный свет, фонарь номерного знака Левый	1,5	Nero	Чёрный
3	Left indicators	Linker knipperlicht	1,5	Yellow	Geel
3	Indicateurs de direction gauche	Fahrtrichtungsanzeiger Links	1,5	Jaune	Gelb
3	Indicador de dirección izquierda	Lewy kierunkowskaz	1,5	Amarillo	Zółty
3	Pisca Esquerdo	Sağ göstergesi	1,5	Amarelo	Sarı
3	Indicatore di direzione sinistro	Левый указатель поворота	1,5	Tuorlo	Жёлтый
4	Stop lights	Remlichten	1,5	Red	Rood
4	Feux stop	Bremslichter	1,5	Rouge	Rot
4	Luz de freno	Światła stop	1,5	Rojo	Czerwony
4	Luz de travão	Stop lambası	1,5	Vermelho	Kırmızı
4	Luce stop	Стоп-сигнал	1,5	Rosso	Красный
5	Right indicators	Rechter knipperlicht	1,5	Green	Groen
5	Indicateurs de direction droit	Fahrtrichtungsanzeiger Rechts	1,5	Vert	Grün
5	Indicador de dirección derecha	Prawy kierunkowskaz	1,5	Verde	Zielony
5	Pisca Direito	Sol göstergesi	1,5	Verde	Yeşil
5	Indicatore di direzione destro	Правый указатель поворота	1,5	Verde	Зелёный
6	Side lights, side markers, numberplate light right	Zijverlichting, zijmarkering, nummerbordverlichting Rechts	1,5	Brown	Kastanje
6	Feux de positions, feux d'encombrement, éclairage plaque droite	Schlussleuchte, Umriss-Begrenzungsleuchte, Kennzeichenleuchte Rechts	1,5	Marron	Kastanie
6	Luz de posición, luz de emergencia, iluminación matricula Derecha	Obrysówki, światła pozycje, oświetlenie tablicy rejestracyjnej prawej	1,5	Marrón	Brazowy
6	Luz de presença, luz de emergência, luz de matrícula Direita	Yan sinyaller, plaka lambası sol	1,5	Castanho	Kahverengi
6	Luci di posizione, luci di ingombro, luci targa Destra	Стояночный свет, фонарь номерного знака Правый	1,5	Marrone	Бронзовый
7	Control for the trailer braking system	Bediening voor de remverlichtten van aanhangwagen	1,5	Blue	Blauw
7	Contrôle freinage remorque	Kontrolle Bremsvorgang Anhänger	1,5	Bleu	Blau
7	Control freno remolque	Kontrola systemu hamulcowego przyczepy	1,5	Azul	Niebieski
7	Controlo de travão de atrelado	Römork fren sistemi kontrolü	1,5	Azul	Mavi
7	Controllo del sistema di frenata del rimorchio	Контроль тормозной системы прицепа	1,5	Blu	Голубой

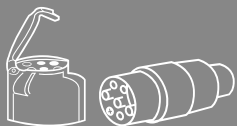

S TYPE / TYPE S (ISO 3731)

Function / Fonction / Función / Função / Funzione / Functie / Funktion / Funkcja / İşlev / Функция		Ø			
1	Earth connection	Aardleiding	1,5	White	Wit
1	Masse	Masse	1,5	Blanc	Weiss
1	Masa	Masa	1,5	Blanco	Biały
1	Massa	Toprak bağlantısı	1,5	Branco	Beyaz
1	Massa	Масса	1,5	Bianco	Белый
2	No allocation	Geen allocatie	1,5	Black	Zwart
2	Aucune application	Kein Anschluss	1,5	Noir	Schwarz
2	Ninguna aplicación	Wolny	1,5	Negro	Czarny
2	Sem aplicação	İlintisiz	1,5	Preto	Siyah
2	Nessuna applicazione	Свободный	1,5	Nero	Чёрный
3	Reversing lights	Achteruitrij-verlichting	1,5	Yellow	Geel
3	Feux de marche arrière	Rückfahrleuchte	1,5	Jaune	Gelb
3	Luz de marcha atrás	Światła cofania	1,5	Amarillo	Zółty
3	Luz de marcha atrás	Geri vites lambası	1,5	Amarelo	Sarı
3	Luci di retromarcia	Свет заднево хода	1,5	Tuorlo	Жёлтый
4	Positive direct current feed from battery	Directe positive voeding van de batterij	2,5	Red	Rood
4	Positif d'alimentation directe de batterie	Pos.Stromspeisung direkt von Batterie	2,5	Rouge	Rot
4	Positivo de alimentación directa de la batería	Plus bezpośredni z akumulatora	2,5	Rojo	Czerwony
4	Positivo de alimentação directa da bateria	Artı bağlantılı aküden yapınız	2,5	Vermelho	Kırmızı
4	Positivo d'alimentazione diretta della batteria	Положительный ток с аккумулятора	2,5	Rosso	Красный
5	Sensor with earth return	Sensor met aarde retour	1,5	Green	Groen
5	Capteur avec retour à la masse	Sensor mit Rückkehrmasse	1,5	Vert	Grün
5	Captador con retorno a la masa	Czujnik z masą powrotną	1,5	Verde	Zielony
5	Sensor com retorno de massa	Toprak dönüşlü algılayıcı	1,5	Verde	Yeşil
5	Sensore con collegamento alla massa	Датчик с массой возврата	1,5	Verde	Зелёный
6	Positive ignition key	Positive contactsleutel	2,5	Brown	Kastanje
6	Positif d'alimentation sous clefs de mise en route	Pos.Stromspeisung mit Zündschlüssel	2,5	Marron	Kastanie
6	Positivo de alimentación con llave de puesta en marcha	Plus stacyjki	2,5	Marrón	Brazowy
6	Positivo de alimentação com chave ligada	Artı ateşleme anahtarı	2,5	Castanho	Kahverengi
6	Positivo d'alimentazione sotto chiave inserita	Положительный ток замка зажигания	2,5	Marrone	Бронзовый
7	Rear fog light	Achter mistlamp	2,5	Blue	Blauw
7	Feu de brouillard arrière	Nebelschlussleuchte	2,5	Bleu	Blau
7	Antiniebla trasero	Tyłne światło przeciwmgielne	2,5	Azul	Niebieski
7	Anti-nevoeiro traseiro	Arka sis lambası	2,5	Azul	Mavi
7	Antinebbia posteriore	Задний противотуманный свет	2,5	Blu	Голубой



13 PINS / 13 BROCHES - 12 V

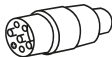
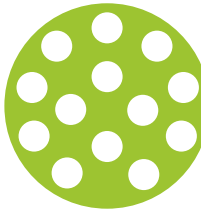

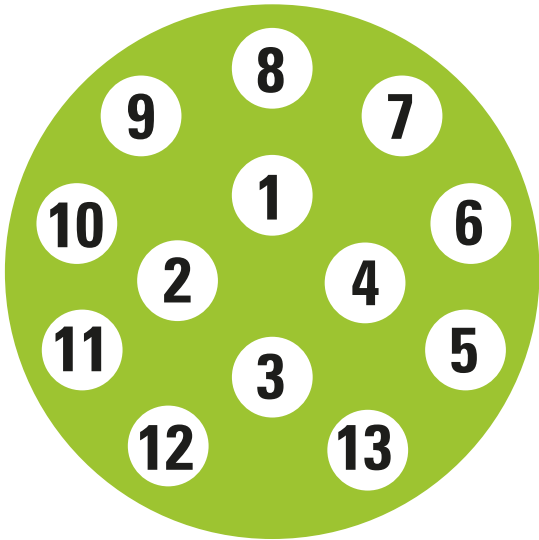
U	ISO/DIN			N°
12 V	ISO 11446 DIN 72570			

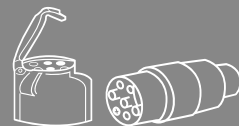
ISO 11446 / DIN 72570

Function / Fonction / Función / Função / Funzione / Functie / Funktion / Funkcja / İşlev / Функция		Ø			
1	Left indicators	Linker knipperlicht	1,5	Yellow	Geel
1	Indicateurs de direction gauche	Fahrtrichtungsanzeiger Links	1,5	Jaune	Gelb
1	Indicador de dirección izquierda	Lewy kierunkowskaz	1,5	Amarillo	Zółty
1	Pisca Esquerdo	Sağ göstergesi	1,5	Amarelo	Sarı
1	Indicatore di direzione sinistro	Левый указатель поворота	1,5	Tuorlo	Жёлтый
2	Rear fog light	Achter mistlamp	1,5	Blue	Blauw
2	Feu de brouillard arrière	Nebelschlussleuchte	1,5	Bleu	Blau
2	Antiniebla trasero	Tyłne światło przeciwmgielne	1,5	Azul	Niebieski
2	Anti-nevoeiro traseiro	Arka sis lambası	1,5	Azul	Mavi
2	Antinebbia posteriore	Задний противотуманный свет	1,5	Blu	Голубой
3	Earth for contacts 1 to 8	Massa voor contact 1 tot en met 8	2,5	White	Wit
3	Masse pour contact du n°1 au n°8	Masse für Kontakte 1 bis 8	2,5	Blanc	Weiss
3	Masa para contacto del n° 1 al n° 8	Masa dla złącz 1 do 8	2,5	Blanco	Biały
3	Massa para contacto do n.º 1 ao n.º 8	1'den 8'e kadar olan bağlantılar için toprak	2,5	Branco	Beyaz
3	Massa di contatto da n.1 a n. 8	Масса для контактов 1 до 8	2,5	Bianco	Белый
4	Right indicators	Rechter knipperlicht	1,5	Green	Groen
4	Indicateurs de direction droit	Fahrtrichtungsanzeiger Rechts	1,5	Vert	Grün
4	Indicador de dirección derecha	Prawy kierunkowskaz	1,5	Verde	Zielony
4	Pisca Direito	Sol göstergesi	1,5	Verde	Yeşil
4	Indicatore di direzione destro	Правый указатель поворота	1,5	Verde	Зелёный
5	Side lights, side markers, numberplate light right	Zijverlichting, zijmarkering, nummerbordverlichting Rechts	1,5	Brown	Kastanje
5	Feux de positions, feux d'encombement, éclairage plaque droite	Schlussleuchte, Umriss-Begrenzungsleuchte, Kennzeichenleuchte Rechts	1,5	Marron	Kastanie
5	Luz de posición, luz de emergencia, iluminación matricula Derecha	Obrysówki, światła pozycje, oświetlenie tablicy rejestracyjnej prawej	1,5	Marrón	Brazowy
5	Luz de presença, luz de emergência, luz de matrícula Direita	Yan sinyaller, plaka lambası sol	1,5	Castanho	Kahverengi
5	Luci di posizione, luci di ingombro, luci targa Destra	Стояночный свет, фонарь номерного знака Правый	1,5	Marrone	Бронзовый
6	Stop lights	Remlichten	1,5	Red	Rood
6	Feux stop	Bremslichter	1,5	Rouge	Rot
6	Luz de freno	Światła stop	1,5	Rojo	Czerwony
6	Luz de travão	Stop lambası	1,5	Vermelho	Kırmızı
6	Luce stop	Стоп-сигнал	1,5	Rosso	Красный
7	Side lights, side markers, numberplate light left	Zijverlichting, zijmarkering, nummerbordverlichting links	1,5	Black	Zwart
7	Feux de positions, feux d'encombement, éclairage plaque gauche	Schlussleuchte, Umriss-Begrenzungsleuchte, Kennzeichenleuchte Links	1,5	Noir	Schwarz
7	Luz de posición, luz de emergencia, iluminación matricula izquierda	Obrysówki, światła pozycje, oświetlenie tablicy rejestracyjnej lewej	1,5	Negro	Czarny
7	Luz de presença, luz de emergência, luz de matrícula Esquerda	Yan sinyaller, plaka lambası sağ	1,5	Preto	Siyah
7	Luci di posizione, luci di ingombro, luci targa sinistra	Стояночный свет, фонарь номерного знака Левый	1,5	Nero	Чёрный
8	Reversing lights	Achteruitrij-verlichting	1,5	Pink	Roze
8	Feux de marche arrière	Rückfahrleuchte	1,5	Rose	Rose
8	Luz de marcha atrás	Światła cofania	1,5	Rosa	Różowy
8	Luz de marcha atrás	Geri vites lambası	1,5	Rosa	Pembe
8	Luci di retromarcia	Свет заднево хода	1,5	Rosa	Розовый
9	Positive direct current feed from battery	Directe positive voeding van de batterij	2,5	Orange	Sinaasappel
9	Positif d'alimentation directe de batterie	Pos.Stromspeisung direkt von Batterie	2,5	Orange	Apfelsine
9	Positivo de alimentación directa de la batería	Plus bezpośredni z akumulatora	2,5	Naranja	Pomarańczowy
9	Positivo de alimentação directa da bateria	Artı bağlantıyı aküden yapınız	2,5	Laranja	Turuncu
9	Positivo d'alimentazione diretta della batteria	Положительный ток с аккумулятора	2,5	Arancione	Оранжевый
10	Positive ignition key	Positive contactsleutel	2,5	Grey	Grijs
10	Positif d'alimentation sous clefs de mise en route	Pos.Stromspeisung mit Zündschlüssel	2,5	Gris	Grau
10	Positivo de alimentación con llave de puesta en marcha	Plus stacyjki	2,5	Gris	Szary
10	Positivo de alimentação com chave ligada	Artı ateşleme anahtarı	2,5	Cinzent	Gri
10	Positivo d'alimentazione sotto chiave inserita	Положительный ток замка зажигания	2,5	Grigio	Серый
11	Return earth contact no.10	Retour massa contact nr. 10	2,5	White/Black	Wit/Zwart
11	Masse de retour pour contact pour n°10	Rückkehrmasse für Kontakt Nr.10	2,5	Blanc/Noir	Weiss/Schwarz
11	Masa de retorno para contacto n° 10	Masa powrotna złącza 10	2,5	Blanco/Negro	Biały/Czarny
11	Massa de retorno para contacto n.º 10	10 numaralı toprak bağlantısına dönünüz	2,5	Branco/Preto	Beyaz/Siyah
11	Massa di ritorno per contatto per n.10	Розетка массы возврата №10	2,5	Bianco/Nero	
Белый/Чёрный					
12	Signal connection trailer	Knipperlichtaansluiting voor een aanhangwagen			
12	Signalisation raccordement remorque	Kontrollleuchte Anschluss Anhänger			
12	testigo de conexión remolque	Złącze oświetlenia przyczepy			
12	Indicador de ligação do atrelado	Römork sinyalleri			
12	Indicatore di collegamento rimorchio	Соединение фар прицепа			
13	Return earth connection for contact 9	Retour aardleiding voor contact nr. 7	2,5	White/Red	Wit/Rood
13	Masse de retour pour contact n°9	Rückkehrmasse für Kontakt Nr.9	2,5	Blanc/Rouge	Weiss/Rot
13	Masa de retorno para contacto n° 9	Masa powrotna dla złącza 7	2,5	Blanco/Rojo	Biały/Czerwony
13	Massa de retorno para contacto 9	Topraklama için 9 numaralı bağlantıyı seçiniz	2,5	Branco/Vermelho	Beyaz/Kırmızı
13	Massa di ritorno per contatto n.9	Розетка массы возврата №9	2,5	Bianco/Rosso	
Белый/Красный					

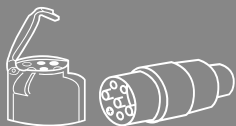

**7 PINS / BROCHES / CONECTOR / CONTACTOR / CONNESSO / VERBINDING /
VERBINDUNGSSTÜCK / KOŁEK STYKOWY / BAĞLANTI / ШТЕПСЕЛЬ**

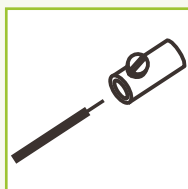

Valeo



U



ISO/DIN

083944



12V

N

ISO 1724

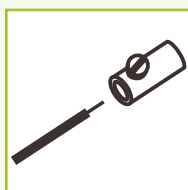

Valeo



U



ISO/DIN

251021



12V

S

ISO 3732

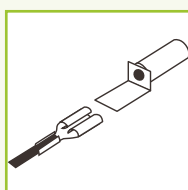

Valeo



U



ISO/DIN

084037



24V

N

ISO 1185 / DIN 72579



7 PINS / BROCHES / CONECTOR / CONTACTOR / CONNESSO / VERBINDING / VERBINDUNGSSTÜCK / KOŁEK STYKOWY / BAĞLANTI / ШТЕПСЕЛЬ

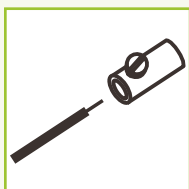

Valeo



U



ISO/DIN

083948



12V

N

ISO 1724

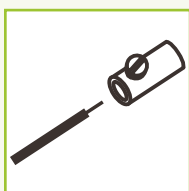

Valeo



U



ISO/DIN

251022



12V

S

ISO 3732

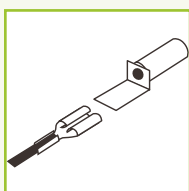

Valeo



U



ISO/DIN

084034



24V

N

ISO 1185 / DIN 72579

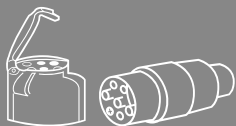

Valeo

**7 PINS / BROCHES / CONECTOR / CONTACTOR / CONNESSO / VERBINDING /
VERBINDUNGSSTÜCK / KOŁEK STYKOWY / BAĞLANTI / ШТЕПСЕЛЬ**

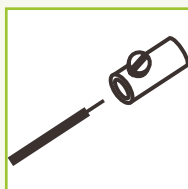

Valeo



U



ISO/DIN

084038



24V

N

ISO 1185 / DIN 72579

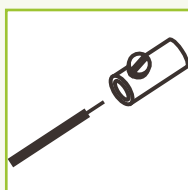

Valeo



U



ISO/DIN

084039



24V

S

ISO 3731

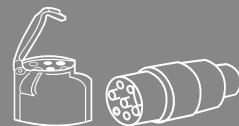

7 PINS / BROCHES / CONECTOR / CONTACTOR / CONNESSO / VERBINDING / VERBINDUNGSSTÜCK / KOŁEK STYKOWY / BAĞLANTI / ШТЕПСЕЛЬ

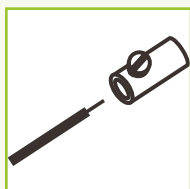

Valeo



U



ISO/DIN

084035



24V

N

ISO 1185 / DIN 72579

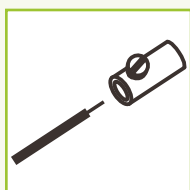

Valeo



U



ISO/DIN

084036



24V

S

ISO 3731

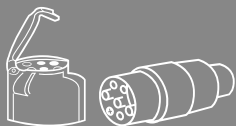

Valeo

**13 PINS / BROCHES / CONECTOR / CONTACTOR / CONNESSO / VERBINDING /
VERBINDUNGSSTÜCK / KOŁEK STYKOWY / BAĞLANTI / ШТЕПСЕЛЬ**

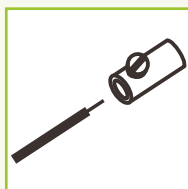

Valeo



U



ISO/DIN

251015



12V

ISO 11446 / DIN 72570

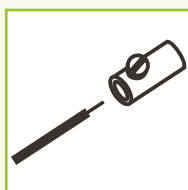

Valeo



U



ISO/DIN

251017



12V

ISO 11446 / DIN 72570

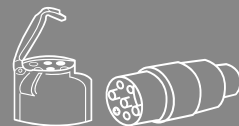

13 PINS / BROCHES / CONECTOR / CONTACTOR / CONNESSO / VERBINDING / VERBINDUNGSSTÜCK / KOŁEK STYKOWY / BAĞLANTI / ШТЕПСЕЛЬ

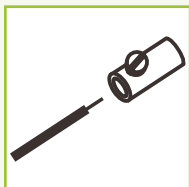

Valeo



U



ISO/DIN

251016



12V

ISO 11446 / DIN 72570

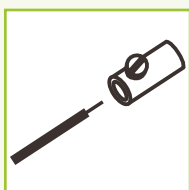

Valeo



U



ISO/DIN

251014



12V

ISO 11446 / DIN 72570



ADAPTOR / ADAPTATEUR / ADAPTADOR / ADAPTADOR / ADATTATORE /
ADAPTOR / ADAPTER / ADAPTOR / ADAPTÖR / АДАПТОР



Valeo



U

+/...

251018

13

7

12V



Valeo



U

+/...

251019

13

7

12V



Valeo



U

+/...

251020

7

13

12V

-



BATTERY CONNECTIVITY / CONNECTIQUE BATTERIE / CONECTOR DE BATERÍA / LIGAÇÃO DA BATERIA /
 CONNESSIONE BATTERIA / BATTERIJ-AANSLUITING / BATTERIEANSCHLUSS / PODŁĄCZENIE AKUMULATORA /
 BATARYA BAĞLANTISI / Контакт для аккумулятора



Valeo



084042

+

FUSES BOX / BOITIER PORTE-FUSIBLES / CAJA PORTA FUSIBLES / CAIXA PORTA-FUSÍVEIS /
 SCATOLA PORTA FUSIBILI / ZEKERINGKAST / SICHERUNGSKASTEN / SKRZYŃKA BEZPIECZNIKÓW
 SIGORTA KUTUSU / Коробка предохранителей

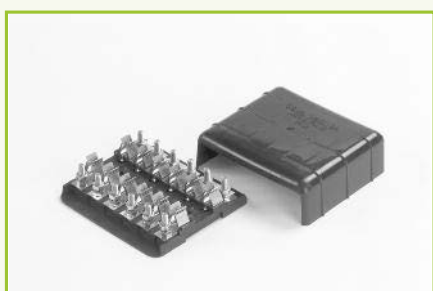

Valeo

084030

6



> **Valeo**



**12V****Valeo**

Cigar lighter
Allume-cigare
Encendedor
Isqueiro
Accendisigari
sigarettenaansteker
Zigarettenanzünder
Zapalniczka
Çakmak
прикуриватели

**12V**

Multifunctional plug
Prise multifonctions
Tomas multifunción
Tomadas multifunção
Presa multifunzione
Multi-functionele power aansluiting
12V Buchse
Wielofunkcyjne gniazda zasilania
Çok amaçlı priz
многофункциональные источники питания



Body colour
Couleur du corps
Color del cuerpo
Côr do corpo
Colore del corpo
Body kleur
Gehäusefarbe
Kolor korpusu
Ana renk
Цвет корпуса



Trim colour
Couleur bague éclairante
Color del anillo luminoso
Côr do anel luminoso
Colore della cornice
Afwerkings kleur
Leistenfarbe
Kolor tapicerki
Parça rengi
Цвет обивки

**Black /
Noir**

Black
Noir
Negro
Preto
Nero
Zwart
Schwarz
Czarny
Siyah
Чёрный

**Green /
Vert**

Green
Vert
Verde
Verde
Verde
Groen
Grün
Zielony
Yeşil
Зелёный

**Grey /
Gris**

Grey
Gris
Gris
Cinzento
Grigio
Grijs
Grau
Szary
Gri
Серый

**Red /
Rouge**

Red
Rouge
Rojo
Vermelho
Rosso
Rood
Rot
Czerwony
Kırmızı
Красный

**Yellow /
Jaune**

Yellow
Jaune
Amarillo
Amarelo
Giallo
Geel
Gelb
Żółty
Sarı
Жёлтый

**CIGAR LIGHTER / ALLUME-CIGARE / ENCENDEDOR / ISQUEIRO / ACCENDISIGARI /
CIGARETTENAANSTEKER / ZIGARETTENANZÜNDER / ZAPALNICZKA / ÇAKMAK / прикуриватели**



Valeo

U



634005

12V

Black / Noir

Yellow / Jaune

RENAULT Kangoo



Valeo

U



634011

12V

Black / Noir

Yellow / Jaune

CITROEN Berlingo (12/02>)

**MULTIFUNCTIONAL POWER OUTLET / PRISE MULTIFONCTIONS / TOMA MULTIFUNCIÓN / TOMA MULTIFUNÇÃO /
PRESA MULTIFUNZIONE / MULTI-FUNCTIONELE POWER AANSLUITING / 12V BUCHSE /
WIELOFUNKCYJNE GNIAZDA ZASILANIA / ÇOK İŞLEVLI GÜÇ ÇIKIŞI / МНОГОФУНКЦИОНАЛЬНЫЕ ИСТОЧНИКИ ПИТАНИЯ**



Valeo

U



634031

12V

Black / Noir

RENAULT Master / Trafic (89>09/94)





Valeo

BOSCH

332017100	643823
332017104	643823
332204122	643512
332204150	643508
332204151	643501
332204201	643523
332207102	643832
332207307	643832
332209150	643518
332209150	643508
332209152	643512
335200004	641422
335200022	641422
335200027	641422
335200038	641422
335200078	641422
335200081	641422
336251004	641422
3362510044	641422
0 332 204 122	643512
0 332 204 201	643523
0 332204122	643508
0 335 200 004	641422
0 335 200 022	641422
0 335 200 038	641422
0 335 200 049	641421
0 335 200 078	641422
0 335 200 078	641421
0 335 200 081	641422
0 336 251 004	641422
03 322 042 04	643822
CARTIER	
739012	641428
739043	641424
739043	641424
739050	641421
739187	641422
22204013	643827
22400111	643828
29201045	643825
54201044	641427
54201045	641426
0 3508	643508



Valeo

0 3510	643510
0 3510	643508
0 3512	643512
0 3517	643818
0 3518	643518
0 3523	643523
0 3526	643822
0 3576	643813
0 3601	643601
0 3608	643608
0 3658	643658
0 3701	643810
01 609 40	643820
HELLA	
48126230	643601
4AZ 001 879-011	641422
4AZ 001 879-011	641422
4AZ001879-041	641422
4DB 001 887-011	641422
4DB 001 890-000	641422
4DB 002 895-012	641422
4DB 002 895-023	641422
4DB 003 750-091	641422
4DB 003 750-092	641422
4DB 003 750-101	641422
4DB 003 750-651	641422
4DB 004 124 003	641421
4DB 007 218 001	641421
4DB 007 218-001	641426
4DB 007 218-001	641424
4DB004124-001	641421
4DB007218-001	641421
4RA 003 437 051	643828
4RA 003 510-267	643840
4RA 003 520-081	643508
4RD 003 314 051	643822
4RD 003 520-077	643523
4RD 003 520-081	643508
4RD 003 520-091	643822
4RD 003 520-097	643822
4RD 003 520-127	643822
4RD 003 520-131	643501
4RD 003 520-152	643501
4RD 007 703 011	643523



Valeo

4RD 940 020-094	643822
4RD003520-152	643501
4RD933332-041	643508
4RD933332-051	643501
LUCAS	
SRB500	643518
SRB500	643501
SRB501	643508
SRB506	643512
SRB510	643523
SRB512	643510
SRB520	643608
SRB520	643601
SRB525	643518
SRB525	643508
SRB525	643501
SRB535	643523
SRB535	643523
MARCO POLO	
102016749	643822
NAGARES	
ITA/4-12	641421
ITGS/3-12	641422
ITX/4-12	641426
R-8422	643813
RLAC/4-24	643828
RLP/52-12	643508
RLP/52-12D	643512
RLP/52-24	643822
RLPS/5-12	643810
RLPS/52-12R	643818
RLPS/52-12R	643510
RLPS/52-12R	643508
RLPS/52-24	643523
RLPS/85-12R	643825
RALUX	
134	643523
135	643822
139	643510
139	643508
165	643608
D-8444	641422
D-8489	641424



Valeo

D-8662	641426
R-3601	643601
R-8462	643827
R-8670	643508
SCHIER	
070100 00	643840
070100 10	643840
070200 00	643508
070400 00	643508
073100 00	643508
073200 00	643501
073300 00	643508
074200 00	643523
STRIEBEL	
898732	643508
898735	643508
899621	643508
899622	643840
899626	643523
899627	643501
899628	643501
899633	643508
899704	643508
899744	643501
899747	643501
899760	643508
899784	643523
899798	643523
899803	643508
899804	643508
899806	643508
899809	643508
899814	643508
899819	643508
899824	643508
899830	643508
899831	643508
899836	643508
899839	643523
899879	643508
SWF	
611005	643508
R500205	643508



R601126

Valeo

643508

TRIDON

EP 13.2N **641422**

EP 30 **641422**

EP 31 **641421**

EPD 31.2N **641422**

HD 13 **641421**

HD 63 **641421**

MD 12G **641422**

WEHRLE

21232 **643523**

21291 **643840**

7030212 **643508**

2020000 **643601**

2020001 **643819**

20200100 **643608**

20201000 **643501**

20201001 **643818**

20201100 **643508**

20201101 **643510**

20201103 **643512**

20207000 **643810**

20401000 **643523**

20401100 **643822**

22204013 **643827**

22400111 **643828**

29200075 **643823**

29201005 **643832**

29201045 **643825**

29201075 **643824**

29202045 **643825**

29401041 **643826**

54201136 **641426**

54201136 **641426**

54201136 **641424**

54201136 **641421**

54237001 **641422**

00 021 232 **643523**

00 021 234 **643508**



Window regulators

Lève-vitres

Elevalunas

Elevadores janela

Alzacristalli Elettrici

Raammechanismes

Fensterheber

Podnośników szyb

cam mekanizmasi

Γρύλοι Ηαραλύρων





Valeo

Pour/For



Valeo



CITROEN

Berlingo (96>2002)

		07/96 ▶ 12/02		850062		
		07/96 ▶ 12/02		850063		

Berlingo (2002>2008)

		11/02 ▶ 04/08		850062		
		11/02 ▶ 04/08		850063		

Berlingo (4/2008>)

		04/08 ▶		850932		
		04/08 ▶		850933		

CITROEN



Dispatch (95>2003)

		09/95 ▶ 12/03		850488		
		09/95 ▶ 12/03		850489		

Dispatch (2004>2006)

		01/04 ▶ 12/06		850488		
		01/04 ▶ 12/06		850489		



Pour / For

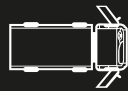













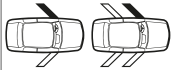

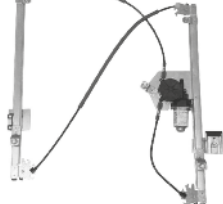

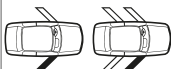







Valeo

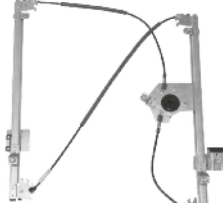













CITROEN  (.../...)













Dispatch (2007>)

  		01/07 ▶		850722	 	 
		01/07 ▶		850723	 	
 		01/07 ▶		850724	  	 
		01/07 ▶		850725	  	













Jumper (94>2001)

 		02/94 ▶ 12/01		850484	 	 
		02/94 ▶ 12/01		850485	 	

Jumper (2002>2006)

 		01/02 ▶ 06/06		850484	 	 
		01/02 ▶ 06/06		850485	 	

Jumper II (2006>)

 		07/06 ▶		NEW 851014	 	 
		07/06 ▶		NEW 851015	 	



Valeo

Pour/For

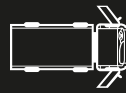

Valeo



CITROEN (.../...)

Jumper II (2006>) (.../...)

		07/06 ▶		850686		
		07/06 ▶		850687		

Jumpy (95>2003)

		09/95 ▶ 12/03		850488		
		09/95 ▶ 12/03		850489		

Jumpy (2004>2006)

		01/04 ▶ 12/06		850488		
		01/04 ▶ 12/06		850489		

Jumpy (2007>)

		01/07 ▶		850722		
		01/07 ▶		850723		
		01/07 ▶		850724		
		01/07 ▶		850725		



Pour / For								
------------	--	--	--	--	--	--	--	--

CITROEN (.../...)

Nemo (2007>)

			12/07 ▶		850726				
			12/07 ▶		850727				

CITROEN

Relay (94>2001)

			02/94 ▶ 12/01		850484				
			02/94 ▶ 12/01		850485				

Relay (2002>2006)

			01/02 ▶ 06/06		850484				
			01/02 ▶ 06/06		850485				

Relay II (2006>)

			07/06 ▶		850686				
			07/06 ▶		850687				

DAF

CF

					850948				
					850949				



Valeo

Pour/For

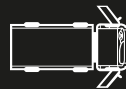











Valeo

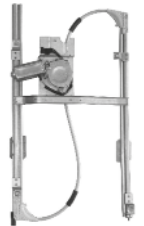









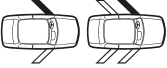

DAF (.../...)

LF





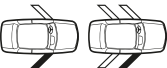



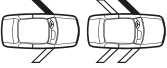

				850950			
				850951			

FIAT





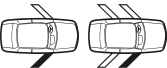



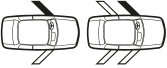

Doblo / Doblo Cargo (2000>2005)

		10/00 ▶ 12/05		850168			
		10/00 ▶ 12/05		850169			

Doblo II / Doblo Cargo II (2006>2008)



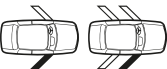







		01/06 ▶ 06/08		850168			
		01/06 ▶ 06/08		850169			

Doblo II / Doblo Cargo II (2008>)

		07/08 ▶		850832			
		07/08 ▶		850833			

FIAT

Ducato (94>2001)

		02/94 ▶ 12/01		850484			
		02/94 ▶ 12/01		850485			



Pour / For								
------------	--	--	--	--	--	--	--	--

FIAT (.../...)

Ducato (2002>2006)

		01/02 > 06/06		850484			
		01/02 > 06/06		850485			

Ducato (2006>)

		07/06 >		850686			
		07/06 >		850687			
		07/06 >		NEW 851014			
		07/06 >		NEW 851015			

FIAT

Fiorino (146) (88>93)

			03/88 > 06/93			850128			
			03/88 > 06/93			850129			

Fiorino (146) (93>2000)

			08/93 > 09/00			850128			
			08/93 > 09/00			850129			



Valeo

Pour/For

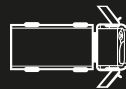

Valeo



FIAT  (.../...)

Fiorino (2007>)



12/07 ▶



850726



12/07 ▶



850727

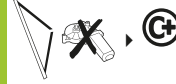

FIAT 

Marengo (159) (93>95)



03/93 ▶ 01/95



850130



03/93 ▶ 01/95



850131



Marengo (185) (95>)



01/95 ▶



850130



01/95 ▶



850131



Scudo (95>2003)



07/95 ▶ 12/03



850488



07/95 ▶ 12/03



850489



Scudo (2004>2006)



01/04 ▶ 12/06



850488



01/04 ▶ 12/06



850489





Pour / For							Valeo		
------------	--	--	--	--	--	--	--------------	--	--

FIAT (.../...)

Scudo (2007>)

				01/07 ▶		850722			
				01/07 ▶		850723			
				01/07 ▶		850724			
				01/07 ▶		850725			

FIAT

Strada Pick Up (99>2003)

			03/99 ▶ 03/03		850152			
			03/99 ▶ 03/03		850153			

Strada Pick Up (2003>2006)

			03/03 ▶ 05/06		850152			
			03/03 ▶ 05/06		850153			

FORD

Courrier (91>96)

			08/91 ▶ 09/96		850094			
			08/91 ▶ 09/96		850095			



Valeo

Pour/For



Valeo



FORD (…/…)

Courrier (96>)

		10/96 ▶		850106		
		10/96 ▶		850107		

FORD

Transit (94>99)

		09/94 ▶ 12/99		850486		
		09/94 ▶ 12/99		850487		

Transit (2000>)

		01/00 ▶		850496		
		01/00 ▶		850497		

Transit (2006>)

		04/06 ▶		850496		
		04/06 ▶		850497		

HYUNDAI

H100 (93>)

		07/93 ▶		850198		
		07/93 ▶		850199		

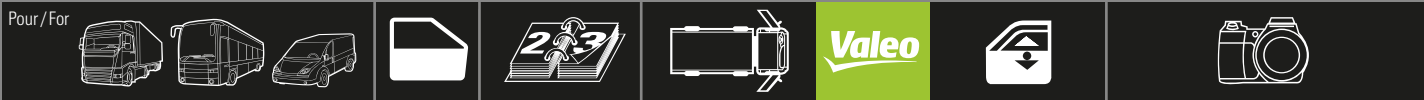

IVECO

Daily (89>96)

		1989 ▶ 03/96		850478		
		1989 ▶ 03/96		850479		

Daily (96>99)

		04/96 ▶ 05/99		850478		
		04/96 ▶ 05/99		850479		

Daily / Daily S2000 (99>2006)

		05/99 ▶ 2006		850494		
		05/99 ▶ 2006		850495		

Daily (2006>)

		04/06 ▶		850494		
		04/06 ▶		850495		

IVECO

Eurocargo

		01/91 ▶		850482		
		01/91 ▶		850483		



Valeo

Pour/For

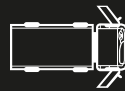

Valeo



IVECO (././...)

Eurostar



01/91 ▶

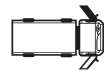

850482

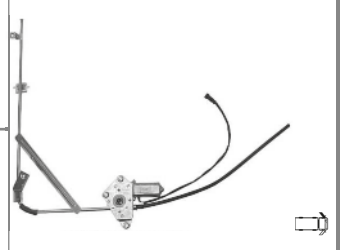
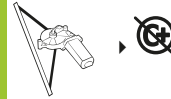

01/91 ▶

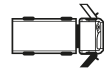

850483

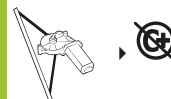

Eurotech



01/91 ▶



850482

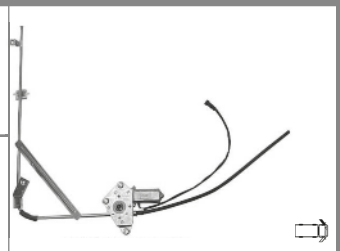
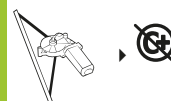

01/91 ▶

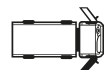

850483

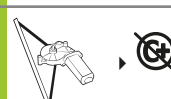

Eurotrakker



01/91 ▶



850482

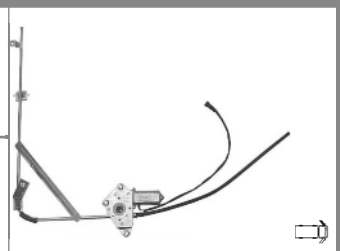
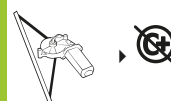

01/91 ▶

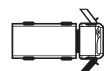

850483

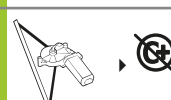

Magirus



1982 ▶ 1992



850482

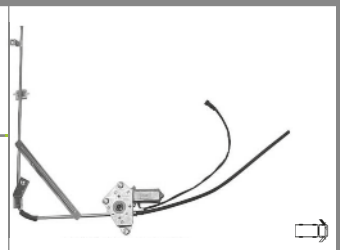
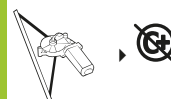

1982 ▶ 1992



850483

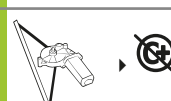

Stralis



01/02 ▶



850482

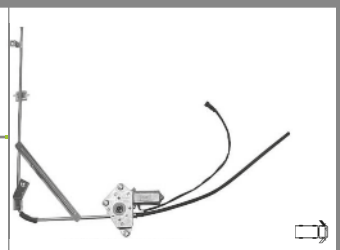

01/02 ▶

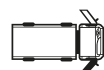

850483

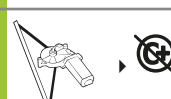



Pour / For							
------------	--	--	--	--	--	--	--

IVECO (.../...)

Turbostar (7/1988>)

			07/88 >		850952			
			07/88 >		850953			

MAN

TGS TGX

					850954			
					850955			

MERCEDES

Sprinter (95>)

			02/95 >		850490			
			02/95 >		850491			

Sprinter II (2006>)

			02/06 >		850690			
			02/06 >		850691			

Vito (96>2003)

			01/96 > 09/03		850248			
			01/96 > 09/03		850249			



Valeo

Pour/For

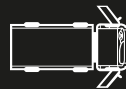













Valeo













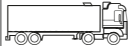

MERCEDES (.../...)

Vito (2003>)

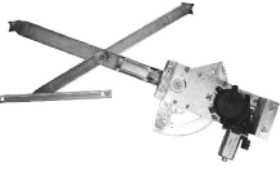











 		01/03 >		850766	 	
 		01/03 >		850767	 	

MERCEDES TRUCKS

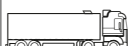
Actros (>3/2008)















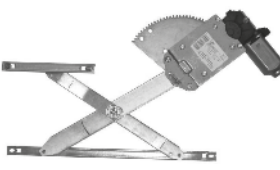

 		> 03/08		850964	 	
 		> 03/08		850965	 	

Atego Axor

 				850956	 	
 				850957	 	













MITSUBISHI

L200 (K6/7) (96>2005)

 	 	01/96 > 2005	 	850268	 	
 	 	01/96 > 2005	 	850269	 	

NISSAN

Kubistar (2003>)

 		09/03 >		850356	 	
 		09/03 >		850357	 	



Pour / For									
------------	--	--	--	--	--	--	--	--	--

NISSAN (.../...)

Primastar (2002>)

			09/02 ▶		850498			
			09/02 ▶		850499			

Vanette (C120 / C220) (86>94)

				09/86 ▶ 11/94			850078			
				09/86 ▶ 11/94			850079			

Vanette (GC22) (86>93)

				09/86 ▶ 03/93			850078			
				09/86 ▶ 03/93			850079			

Vanette Cargo (C23M) (92>2001)

				07/92 ▶ 11/01			850078			
				07/92 ▶ 11/01			850079			

NISSAN

Cabstar (2010>)

			01/10 ▶		NEW 851054			
			01/10 ▶		NEW 851055			



Valeo

Pour/For

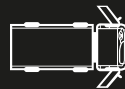

Valeo

















NISSAN (.../...)

Atleon















 12V 				NEW 851056		
 12V 				NEW 851057		
 24V 				NEW 851058		
 24V 				NEW 851059		

OPEL













Movano (98>2006)

  		2001 ▶ 10/06		850494	 	
  		2001 ▶ 10/06		850495	 	





Movano (2006>)

  		10/06 ▶		850494	 	
  		10/06 ▶		850495	 	

Vivaro (2001>2006)













 		05/01 ▶ 7/06		850498	 	
 		05/01 ▶ 7/06		850499	 	



Pour / For       **Valeo**  















OPEL  (.../...)

Vivaro (2006>)

 		07/06 ▶		850498	 	
 		07/06 ▶		850499	 	













PEUGEOT 

Bipper (2007>)













 		12/07 ▶		850726	  	
 		12/07 ▶		850727	  	

PEUGEOT 















Boxer I (94>2001)

 		02/94 ▶ 12/01		850484	 	
 		02/94 ▶ 12/01		850485	 	

Boxer I (2002>2006)

 		01/02 ▶ 06/06		850484	 	
 		01/02 ▶ 06/06		850485	 	

Boxer II (2006>)

 		07/06 ▶		850686	  	
 		07/06 ▶		850687	  	



Valeo

Pour/For

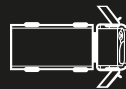













Valeo















PEUGEOT  (.../...)

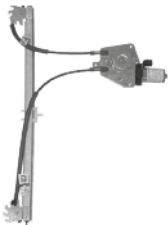











Boxer II (2006>) (.../...)

 		07/06 ▶		NEW 851014	 	
 		07/06 ▶		NEW 851015	 	

















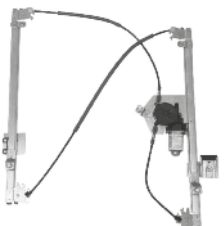

Expert I (95>2003)

















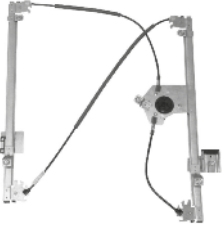

 		09/95 ▶ 12/03		850488	 	
 		09/95 ▶ 12/03		850489	 	

Expert I (2004>2006)

 		01/04 ▶ 12/06		850488	 	
 		01/04 ▶ 12/06		850489	 	

Expert II (2007>)

  	 	01/07 ▶	 	850722	 	
  	 	01/07 ▶	 	850723	 	

 	 	01/07 ▶	 	850724	  	
 	 	01/07 ▶	 	850725	  	



Pour / For								
------------	--	--	--	--	--	--	--	--

PEUGEOT (.../...)

Partner (96>2002)

			06/96 ▶ 11/02		850062			
			06/96 ▶ 11/02		850063			

Partner (2002>)

			11/02 ▶		850062			
			11/02 ▶		850063			

Ranch (96>2002)

			06/96 ▶ 11/02		850062			
			06/96 ▶ 11/02		850063			

Ranch (2002>)

			11/02 ▶		850062			
			11/02 ▶		850063			

RENAULT

Kangoo (97>2001)

			09/97 ▶ 07/01		850356			
			09/97 ▶ 07/01		850357			



Valeo

Pour/For

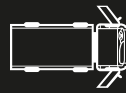













Valeo

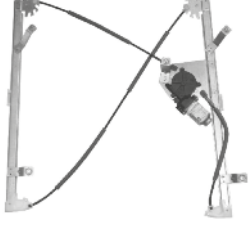















RENAULT (.../...)

Kangoo (2007>)















 		10/08 ▶		850866	 	
 		10/08 ▶		850867	 	

RENAULT















Mascott (98>2006)

  		03/98 ▶ 05/06		850494	 	
  		03/98 ▶ 05/06		850495	 	















Mascott (2006>)

  		06/06 ▶		850494	 	
  		06/06 ▶		850495	 	

Master (97>2006)

  		09/97 ▶ 2006		850494	 	
  		09/97 ▶ 2006		850495	 	

Master (2006>)













  		06/06 ▶		850494	 	
  		06/06 ▶		850495	 	















Pour / For         

RENAULT  (.../...)

Trafic II (2001>2006)











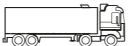

 		04/01 ▶ 07/06		850498	 	
 		04/01 ▶ 07/06		850499	 	

Trafic II (2006>)











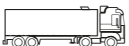

 		07/06 ▶		850498	 	
 		07/06 ▶		850499	 	

RENAULT TRUCKS 















Kerax Midlum Premium

 				850950	 	
 				850951	 	

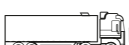
Magnum

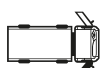
 				850958	 	
 				850959	 	

Maxity (2010>)

 		01/10 ▶		NEW 851054	  	
 		01/10 ▶		NEW 851055	  	



Valeo

Pour/For

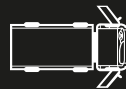

Valeo



SCANIA

3 Series (1989>1995)

		1989 ▶ 1995		850960		
		1989 ▶ 1995		850961		

4 Series (1996>2004)

		1996 ▶ 2004		851086		
		1996 ▶ 2004		851087		
		1996 ▶ 2004		851088		
		1996 ▶ 2004		851089		

SEAT

Inca (95>2003)

		11/95 ▶ 06/03		850390		
		11/95 ▶ 06/03		850391		

TOYOTA





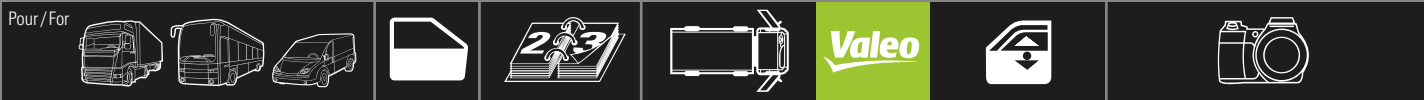







Hilux (8 / 9 / 10) (88>97)

		08/88 ▶ 08/97		850546		
		08/88 ▶ 08/97		850547		















VAUXHALL 













Movano (98>2006)

  		2001 ▶ 10/06		850494	 	 
		2001 ▶ 10/06		850495	 	













Movano (2006>)

  		10/06 ▶		850494	 	 
		10/06 ▶		850495	 	

Vivaro (2001>2006)













 		08/01 ▶ 06/06		850498	 	 
		08/01 ▶ 06/06		850499	 	

Vivaro (2006>)

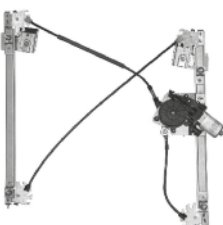
 		07/06 ▶		850498	 	 
		07/06 ▶		850499	 	

VOLKSWAGEN 

Caddy II (95>2004)

 		11/95 ▶ 01/04		850390	 	 
		11/95 ▶ 01/04		850391	 	



Valeo

Pour/For















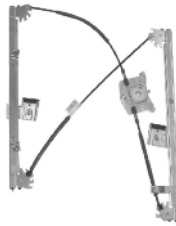

Valeo















VOLKSWAGEN (.../...)

Caddy III (2004>)













 		02/04 ▶		850560	  	
 		02/04 ▶		850561	  	

VOLKSWAGEN













Crafter (2006>)

 		04/06 ▶		850690	 	
 		04/06 ▶		850691	 	

LT II (96>2003)













 		05/96 ▶ 05/03		850492	 	
 		05/96 ▶ 05/03		850493	 	

LT III (2003>2006)

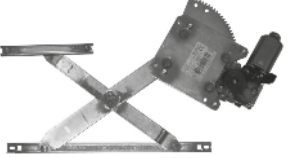



 		06/03 ▶ 02/06		850492	 	
 		06/03 ▶ 02/06		850493	 	

VOLKSWAGEN

Taro (89>97)













 		02/89 ▶ 03/97		850546	 	
 		02/89 ▶ 03/97		850547	 	















Pour / For       **Valeo**  

VOLKSWAGEN  (.../...)













Transporter (F70) (90>96)

 		09/90 ▶ 05/96		850442	 	
 		09/90 ▶ 05/96		850443	 	

Transporter (F7D) (96>2003)











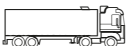

 		01/96 ▶ 06/03		850442	 	
 		01/96 ▶ 06/03		850443	 	

Transporter (2003>)

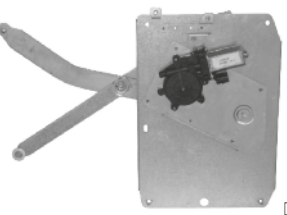
 		07/03 ▶		NEW 851084	 	
 		07/03 ▶		NEW 851085	 	

VOLVO TRUCKS 

FH

 				850962	 	
 				850963	 	



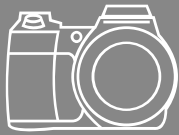

850062



850063



Pour/For

CITROEN Berlingo
PEUGEOT Partner
PEUGEOT Ranch

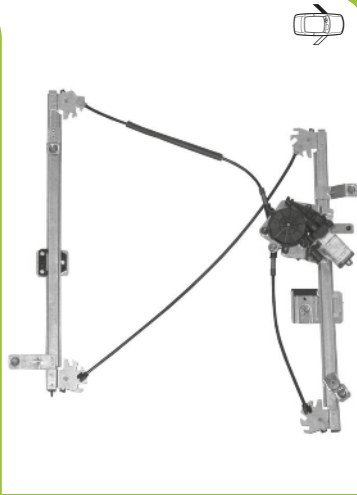

850106



850107



Pour/For

FORD Courier

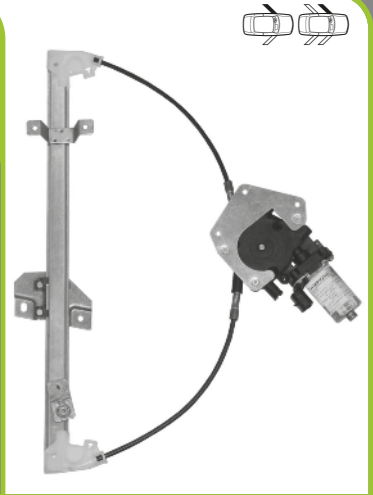

850078



850079



Pour/For

NISSAN Serena
NISSAN Vanette
NISSAN Vanette Cargo

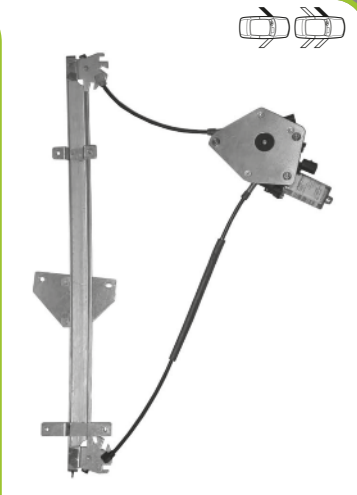

850128



850129



Pour/For

FIAT Duna
FIAT Fiorino

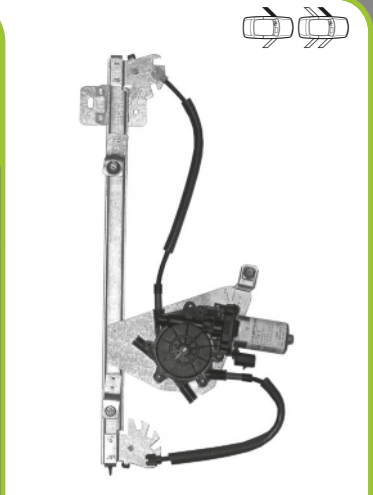

850094



850095

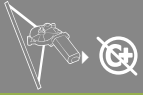

Pour/For

FORD Courier

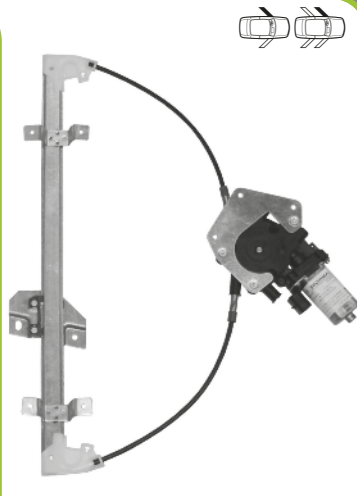

850130



850131



Pour/For

FIAT Marengo

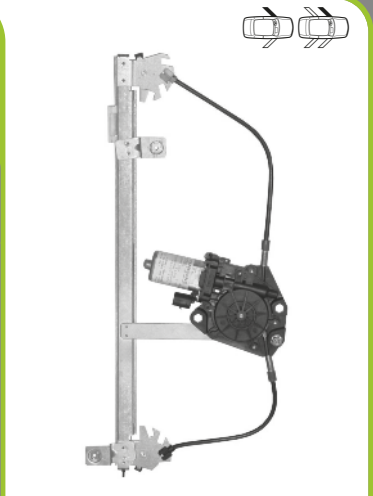



850152



850153



Pour/For

FIAT Strada pick-up



850248



850249



Pour/For

MERCEDES Vito



850168



850169



Pour/For

FIAT Doblo / Doblo Cargo
FIAT Doblo II / Doblo Cargo II



850268



850269



Pour/For

MITSUBISHI L200



850198



850199



Pour/For

HYUNDAI H100

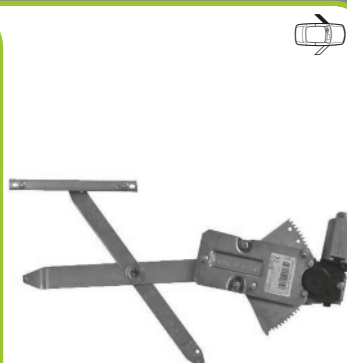

850356



850357



Pour/For

RENAULT Kangoo
NISSAN Kubistar



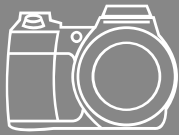

850390



850391



Pour/For

SEAT Cordoba
VOLKSWAGEN Caddy II

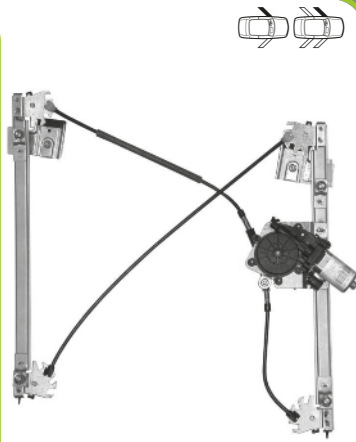

850482



850483



Pour/For

IVECO Eurocargo
IVECO Eurostar
IVECO Eurotech
IVECO Eurotrakker
IVECO Magirus
IVECO Stralis

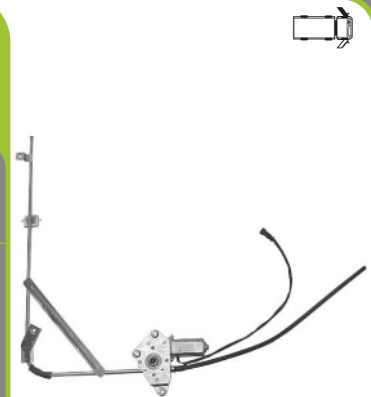

850442



850443

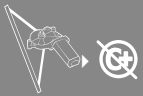

Pour/For

VOLKSWAGEN Transporter



850484



850485



Pour/For

CITROEN Jumper / Relay
FIAT Ducato
PEUGEOT Boxer I



850478



850479

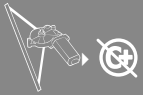

Pour/For

IVECO Daily / Eurocargo
IVECO Eurostar / Eurotech
IVECO Eurotrakker / Magirus/Stralis



850486



850487



Pour/For

FORD Transit

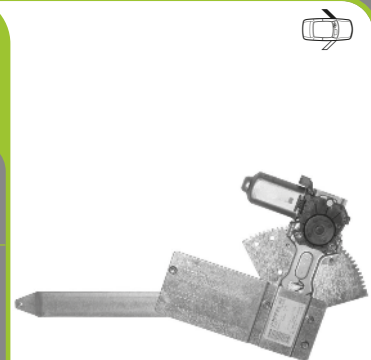



850488



850489



Pour/For
CITROEN Evasion / Synergie
CITROEN Jumpy / Dispatch
FIAT Scudo
FIAT Ulysse
LANCIA Zeta
PEUGEOT 806
PEUGEOT Expert



850494



850495



Pour/For
IVECO Daily / Daily S2000
OPEL Movano
RENAULT Mascott
RENAULT Master
RENAULT Traffic II
VAUXHALL Movano



850490



850491

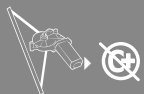

Pour/For

MERCEDES Sprinter

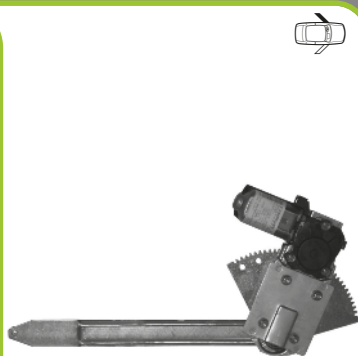

850496



850497



Pour/For

FORD Transit



850492



850493



Pour/For

VOLKSWAGEN LT II / LT III



850498



850499



Pour/For

NISSAN Primastar
OPEL Vivaro
RENAULT Traffic II
VAUXHALL Vivaro

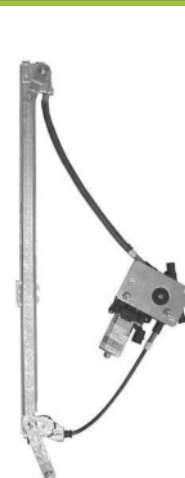

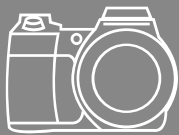

Valeo

850546



850547



Pour/For

TOYOTA 4Runner
TOYOTA Hilux
VOLKSWAGEN Taro

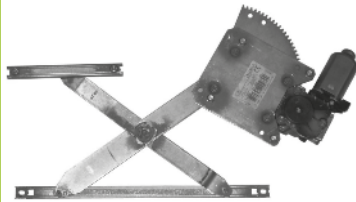

850690



850691



Pour/For

MERCEDES Sprinter II



850560



850561



Pour/For

VOLKSWAGEN Caddy III

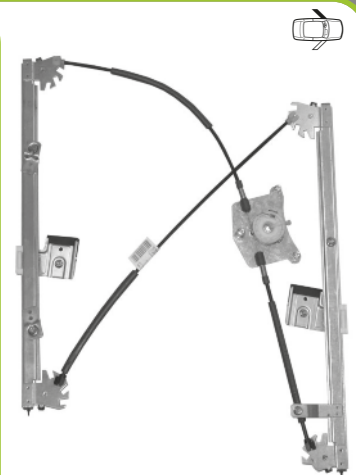

850722



850723



Pour/For

CITROEN Dispatch / Jumpy
FIAT Scudo
PEUGEOT Expert II

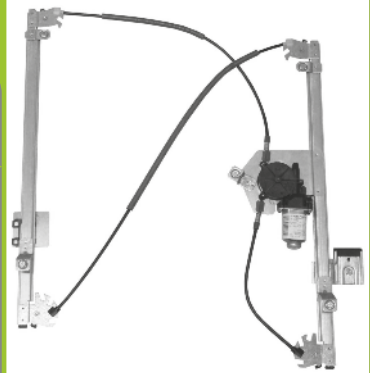

850686



850687



Pour/For

CITROEN Jumper II / Relay II
FIAT Ducato II
PEUGEOT Boxer II



850724



850725



Pour/For

CITROEN Dispatch / Jumpy
FIAT Scudo
PEUGEOT Expert II

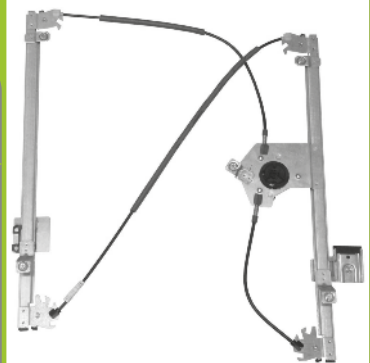



850726



850727



Pour/For

CITROEN Nemo
FIAT Fiorino
PEUGEOT Bipper

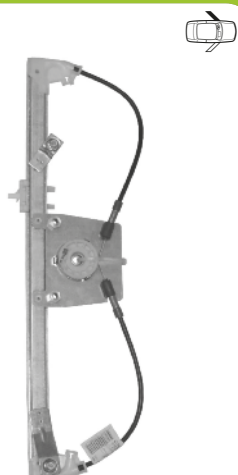

850866



850867



Pour/For

RENAULT Kangoo



850766



850767



Pour/For

MERCEDES Vito



850932



850933



Pour/For

CITROEN Berlingo



850832



850833



Pour/For

FIAT Doblo II / Doblo Cargo II



850948



850949



Pour/For

DAF CF

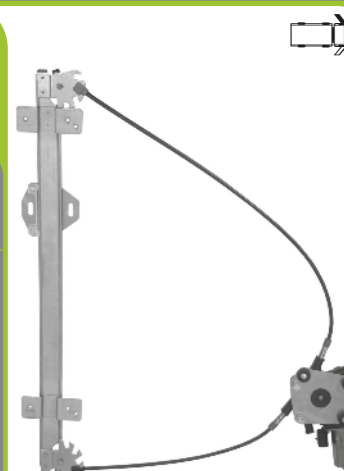

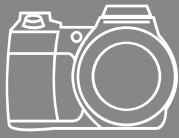

Valeo

850950



850951



Pour/For

DAF LF
RENAULT TRUCKS Kerax Midlum Premium

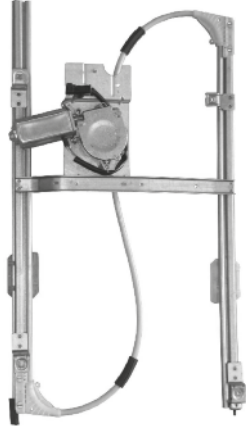

850956



850957



Pour/For

MERCEDES TRUCKS Atego Axor

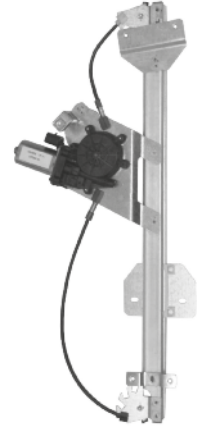

850952



850953



Pour/For

IVECO Turbostar



850958



850959



Pour/For

RENAULT TRUCKS Magnum

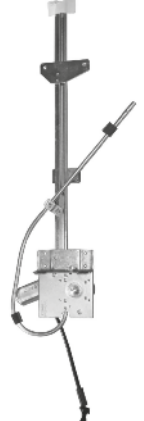

850954



850955



Pour/For

MAN TGS TGX



850960



850961



Pour/For

SCANIA 3 Series

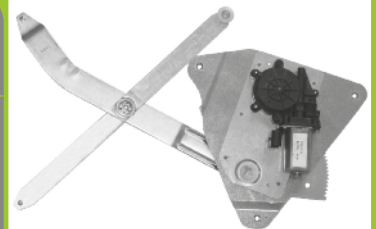



850962 

850963 



Pour/For

VOLVO TRUCKS FH

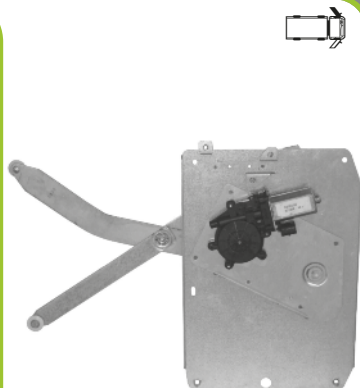

851054 

851055 



Pour/For

NISSAN Cabstar
RENAULT Maxity



850964 

850965 



Pour/For

MERCEDES TRUCKS Actros

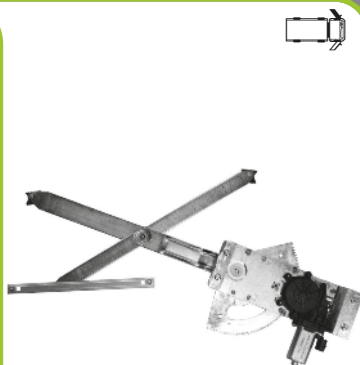

851056 

851057 



Pour/For

NISSAN Atleon



851014 

851015 



Pour/For

CITROEN Jumper
FIAT Ducato
PEUGEOT Boxer



851058 

851059 



Pour/For

NISSAN Atleon



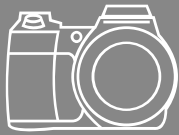

851084



851085



Pour/For

VOLKSWAGEN Transporter

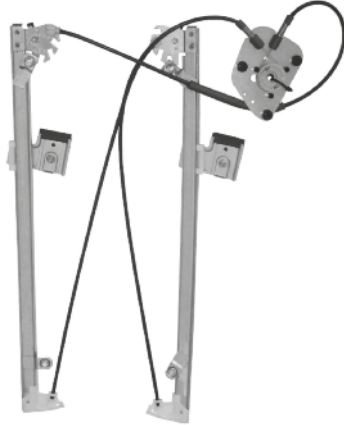

851086



851087

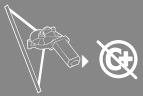

Pour/For

SCANIA 4 Series



851088



851089



Pour/For

SCANIA 4 Series







	Valeo
CITROEN	
922191HS	850488
9221EP	850726
9221ES	850932
9221H5	850488
9221X7	851014
9221Z5	850725
9221Z6	850722
9221Z6	850724
922290FS	850489
9222EN	850727
9222F5	850489
9222H3	850489
9222H3	850489
9222X6	851015
9222Z4	850723
DAF	
1374568	850948
1374569	850949
FIAT	
51830869	850833
51830870	850832
1340398080	851015
1340453080	851014
1354700080	850933
1354700080	850727
1354726080	850726
1462444080	850489
1462445080	850488
1484122080	850488
1488559080	850489
1498743080	850723
1499438080	850725
1499439080	850722
1499439080	850724
IVECO	
4817201	850953
4817202	850952
2997196	850482
98407722	850482
99487781	850482
99487780	850483
2997195	850483
98407721	850483
LANCIA	
1462444080	850489
1462445080	850488
1484120080	850488
1488559080	850489
MAN	
81626456054	850955
81626456055	850954
MERCEDES BENZ	
6397200046	850766
6397200146	850767

	Valeo
MERCEDES BENZ TRUCKS	
9737200346	850956
9737200446	850957
DX 0007250102	850965
SX 0007250002	850964
NISSAN	
807019X003	851058
807000T000	851055
807009X002	851057
807009X003	851059
807010T000	851054
807019X002	851056
PEUGEOT	
922334	850488
922434	850489
9221EP	850726
9221X7	851014
9221Z5	850725
9221Z6	850722
9221Z6	850724
9222EN	850727
9222X6	851015
9222Z4	850723
RENAULT	
8200497568	850866
8200497601	850867
807000T000	851055
807010T000	851054
RENAULT TRUCKS	
5010301993	850950
5010301994	850951
5010468940	850958
5010468940	850959
7421275875	850958
7421275875	850959
SCANIA	
1366849	851086
1366849	851088
1366850	851087
1366850	851089
1406613	850960
1406614	850961
1442294	851086
1442294	851088
1442295	851087
1442295	851089
VOLKSWAGEN	
7H0837753B	851084
7H0837754B	851085
VOLVO TRUCKS	
3176541	850962
3176542	850963









	Valeo
AC ROLCAR	
01.0118	850131
01.0119	850130
01.0500	850129
01.0501	850128
01.1350	850169
01.1351	850168
01.1501	850130
01.1850	850153
01.1851	850152
01.2502	850479
01.2503	850478
01.2506	850485
01.2507	850484
01.2508	850495
01.2509	850494
01.2514	850687
01.2515	850686
01.2606	850483
01.2607	850482
01.4078	850095
01.4079	850094
01.4080	850487
01.4081	850486
01.4084	850107
01.4085	850106
01.4090	850497
01.4091	850496
01.4134	850063
01.4135	850062
01.4243	850494
01.4310	850249
01.4311	850248
01.4324	850491
01.4325	850490
01.4334	850767
01.4335	850766
01.4358	850691
01.4359	850690
01.4548	850357
01.4549	850356
01.4556	850499
01.4557	850498
01.4610	850391
01.4611	850390
01.4758	850443
01.4759	850442
01.6904	850079
01.6905	850078
01.7170	850269
01.7171	850268
01.7232	850547
01.7233	850546
01.7253	850546
A1.1750	850489
A1.1751	850488

	Valeo
AC ROLCAR (...)	
A1.2507	850484
A1.2509	850494
A1.4611	850390
ELECTRIC LIFE	
ZR CT22 L	850062
ZR CT22 R	850063
ZR CT714 L	850932
ZR CT714 R	850933
ZR DN73 L	850078
ZR DN73 R	850079
ZR FR32 L B	850094
ZR FR32 R B	850095
ZR FR56 L	850106
ZR FR56 R	850107
ZR FT36 L B	850128
ZR FT36 R B	850129
ZR FT39 L	850130
ZR FT39 R	850131
ZR FT62 L B	850152
ZR FT62 R B	850153
ZR FT74 L	850168
ZR FT74 R	850169
ZR FT97 L	850832
ZR FT97 R	850833
ZR HY22 L	850198
ZR HY22 R	850199
ZR ME63 L B	850248
ZR ME63 R B	850249
ZR ME703 L	850766
ZR ME703 R	850767
ZR MI56 L	850268
ZR MI56 R	850269
ZR RN47 L	850356
ZR RN47 R	850357
ZR RN75 L	850866
ZR RN75 R	850867
ZR ST14 L B	850390
ZR ST14 R B	850391
ZR TY45 L	850546
ZR TY45 R	850547
ZR VK23 L B	850442
ZR VK23 R B	850443
ZR ZA110 L	850958
ZR ZA110 R	850959
ZR ZA124 L	850950
ZR ZA124 R	850951
ZR ZA125 L	850948
ZR ZA125 R	850949
ZR ZA13 L	850952
ZR ZA13 R	850953
ZR ZA16 L	850478
ZR ZA16 R	850479
ZR ZA19 L	850482
ZR ZA19 R	850483

	Valeo
ELECTRIC LIFE (...)	
ZR ZA21 L B	850484
ZR ZA21 R B	850485
ZR ZA22 L	850486
ZR ZA22 R	850487
ZR ZA24 L	850488
ZR ZA24 R	850489
ZR ZA25 L	850490
ZR ZA25 R	850491
ZR ZA26 L	850492
ZR ZA26 R	850493
ZR ZA29 L	850494
ZR ZA29 R	850495
ZR ZA31 L	850496
ZR ZA31 R	850497
ZR ZA32 L	850498
ZR ZA32 R	850499
ZR ZA42 L	850690
ZR ZA42 R	850691
ZR ZA45 L	850722
ZR ZA45 R	850723
ZR ZA48 L	850956
ZR ZA48 R	850957
ZR ZA50 L	850962
ZR ZA50 R	850963
ZR ZA59 L	850960
ZR ZA59 R	850961
ZR ZA61 L	850964
ZR ZA61 R	850965
ZR ZA702 L	850686
ZR ZA702 R	850687
ZR ZA703 L	850724
ZR ZA703 R	850725
ZR ZA704 L	850726
ZR ZA704 R	850727
ZR ZA705 L	850954
ZR ZA705 R	850955
LEMFORDE	
60090780	850357
60090790	850356
60091860	850495
60091870	850494
60270520	850391
60270530	850390
60450200	850199
60450210	850198
60491020	850095
60491030	850094
60491120	850107
60491130	850106
60500520	850063
60500530	850062
60700660	850131
60700670	850130
60800120	850129

	Valeo
LEMFORDE (...)	
60800130	850128
60800180	850497
60800190	850496
60806560	850832
60806570	850833
60807530	850866
60807540	850867
60808050	850726
60808060	850727
63470080	850269
63470090	850268
63510120	850547
63510130	850546
64100060	850491
64100070	850490
64300220	850443
64300230	850442
64300280	850493
64300290	850492
64400000	850489
64400010	850488
64420060	850079
64420070	850078
64490000	850487
64490010	850486
64700800	850479
64700810	850478
64801420	850498
64801430	850499
64803100	850561
64803110	850560
64804960	850687
64804970	850686
64804980	851015
64804990	851014
64805220	850691
64805230	850690
64806930	850766
64806940	850767
64808010	850722
64808030	850724
64808040	850725
65750020	850953
65750030	850952
LIFTEK	
LT CT22 L	850062
LT CT22 R	850063
LT CT714 L	850932
LT CT714 R	850933
LT DN73 L	850078
LT DN73 R	850079
LT FR32 L B	850094
LT FR32 R B	850095
LT FR56 L	850106
LT FR56 R	850107



	Valeo		Valeo		Valeo		Valeo
LIFTEK (.../...)		LIFTEK (.../...)		MAGNETI MARELLI (.../...)		MIRAGLIO (.../...)	
LT FT36 L B	850128	LT ZA25 R	850491	AC 320	850169	30/888	850498
LT FT36 R B	850129	LT ZA26 L	850492	AC 335	850486	30/985	851015
LT FT39 L	850130	LT ZA26 R	850493	AC 336	850487	30/986	851014
LT FT39 R	850131	LT ZA29 L	850494	AC 337	850496		
LT FT62 L B	850152	LT ZA29 R	850495	AC 338	850497		
LT FT62 R B	850153	LT ZA31 L	850496	AC 341	850494	PIMAX	850062
LT FT74 L	850168	LT ZA31 R	850497	AC 342	850495	PX 0722 L	850063
LT FT74 R	850169	LT ZA32 L	850498	AC 353	850248	PX 0722 R	850932
LT FT97 L	850832	LT ZA32 R	850499	AC 354	850249	PX 07714 L	850933
LT FT97 R	850833	LT ZA42 L	850690	AC 355	850490	PX 07714 R	850198
LT HY22 L	850198	LT ZA42 R	850691	AC 356	850491	PX 1022 L	850199
LT HY22 R	850199	LT ZA45 L	850722	AC 367	850268	PX 1022 R	850128
LT ME63 L B	850248	LT ZA45 R	850723	AC 368	850269	PX 1136 L	850129
LT ME63 R B	850249	LT ZA48 L	850956	AC 407	850442	PX 1136 R	850130
LT ME703 L	850766	LT ZA48 R	850957	AC 408	850443	PX 1139 L	850131
LT ME703 R	850767	LT ZA50 L	850962	AC 427	850498	PX 1162 L	850152
LT MI56 L	850268	LT ZA50 R	850963	AC 428	850499	PX 1162 R	850153
LT MI56 R	850269	LT ZA59 L	850960	AC 731	850724	PX 1174 L	850168
LT RN47 L	850356	LT ZA59 R	850961	AC 732	850725	PX 1174 R	850169
LT RN47 R	850357	LT ZA61 L	850964	AC 733	850722	PX 1197 L	850833
LT RN75 L	850866	LT ZA61 R	850965	AC 734	850723	PX 1197 R	850094
LT RN75 R	850867	LT ZA62 L	851056	AC 735	850726	PX 1332 L	850095
LT SC01 L	851086	LT ZA62 R	851057	AC 736	850727	PX 1332 R	850106
LT SC01 R	851087	LT ZA63 L	851058	AC 753	850766	PX 1356 L	850107
LT SC701 L	851088	LT ZA63 R	851059	AC 754	850767	PX 1356 R	
LT SC701 R	851089	LT ZA702 L	850686			PX 2456 L	850268
LT ST14 L B	850390	LT ZA702 R	850687			PX 2456 R	850269
LT ST14 R B	850391	LT ZA703 L	850724	30/1005	850495	PX 2763 L	850248
LT TY45 L	850546	LT ZA703 R	850725	30/1006	850494	PX 2763 R	850249
LT TY45 R	850547	LT ZA704 L	850726	30/744	850485	PX 27703 L	850766
LT VK23 L B	850442	LT ZA704 R	850727	30/745	850484	PX 27703 R	850767
LT VK23 R B	850443	LT ZA705 L	850954	30/746	850953	PX 2873 L	850078
LT VK720 L	851084	LT ZA705 R	850955	30/747	850952	PX 2873 R	850079
LT VK720 R	851085	LT ZA708 L	851054	30/748	850483	PX 4147 L	850356
LT ZA110 L	850958	LT ZA708 R	851055	30/749	850482	PX 4147 R	850357
LT ZA110 R	850959			30/751	850479	PX 4175 L	850866
LT ZA124 L	850950	MAGNETI MARELLI		30/752	850478	PX 4175 R	850867
LT ZA124 R	850951	AC 051	850130	30/761	850131	PX 4514 L	850390
LT ZA125 L	850948	AC 052	850131	30/762	850130	PX 4514 R	850391
LT ZA125 R	850949	AC 071	850488	30/781	850095	PX 5245 L	850546
LT ZA127 L	851014	AC 072	850489	30/782	850094	PX 5245 R	850547
LT ZA127 R	851015	AC 080	850478	30/821	850391	PX 5523 L	850442
LT ZA13 L	850952	AC 081	850479	30/822	850390	PX 5523 R	850443
LT ZA13 R	850953	AC 082	850482	30/829	850107	PX 55707 L	850560
LT ZA16 L	850478	AC 083	850483	30/830	850106	PX 55707 R	850561
LT ZA16 R	850479	AC 086	850484	30/837	850153	PX 56110 L	850958
LT ZA19 L	850482	AC 087	850485	30/838	850152	PX 56110 R	850959
LT ZA19 R	850483	AC 121	850062	30/855	850489	PX 56124 L	850950
LT ZA21 L B	850484	AC 122	850063	30/856	850488	PX 56124 R	850951
LT ZA21 R B	850485	AC 177	850094	30/871	850129	PX 56125 L	850948
LT ZA22 L	850486	AC 178	850095	30/872	850128	PX 56125 R	850949
LT ZA22 R	850487	AC 185	850106	30/881	850169	PX 56127 L	851014
LT ZA24 L	850488	AC 186	850107	30/882	850168	PX 56127 R	851015
LT ZA24 R	850489	AC 267	850356	30/885	850063	PX 5613 L	850952
LT ZA25 L	850490	AC 268	850357	30/886	850062	PX 5613 R	850953
		AC 319	850168	30/887	850499		



Valeo

PIMAX (.../...)

PX 5616 L	850478
PX 5616 R	850479
PX 5619 L	850482
PX 5619 R	850483
PX 5621 L	850484
PX 5621 R	850485
PX 5622 L	850486
PX 5622 R	850487
PX 5624 L	850488
PX 5624 R	850489
PX 5625 L	850490
PX 5625 R	850491
PX 5626 L	850492
PX 5626 R	850493
PX 5629 L	850494
PX 5629 R	850495
PX 5631 L	850496
PX 5631 R	850497
PX 5632 L	850498
PX 5632 R	850499
PX 5642 L	850690
PX 5642 R	850691
PX 5645 L	850722
PX 5645 R	850723
PX 5648 L	850956
PX 5648 R	850957
PX 5650 L	850962
PX 5650 R	850963
PX 5659 L	850960
PX 5659 R	850961
PX 5661 L	850964
PX 5661 R	850965
PX 56702 L	850686
PX 56702 R	850687
PX 56703 L	850724
PX 56703 R	850725
PX 56704 L	850726
PX 56704 R	850727
PX 56705 L	850954
PX 56705 R	850955

PMM

11001 L	850478
11001 R	850479
11004 L	850952
11004 R	850953
11013 L	850442
11013 R	850443
11015 L	850482
11015 R	850483
11020 L	850484
11020 R	850485
11021 L	850486
11021 R	850487
11022 L	850488
11022 R	850489



Valeo

PMM (.../...)

11023 L	850490
11023 R	850491
11024 L	850492
11024 R	850493
11052 L	850494
11052 R	850495
11062 L	850496
11062 R	850497
11064 L	850498
11064 R	850499
11092 L	850560
11092 R	850561
11142 L	850686
11142 R	850687
11152 L	850690
11152 R	850691
11174 L	850724
11174 R	850725
11176 L	850722
11176 R	850723
11192 L	850726
11192 R	850727
11202 L	850956
11202 R	850957
11212 L	850960
11212 R	850961
11222 L	850962
11222 R	850963
11232 L	850948
11232 R	850949
11242 L	850954
11242 R	850955
11252 L	850950
11252 R	850951
11282 L	850958
11282 R	850959
11292 L	850964
11292 R	850965
18062 L	850062
18062 R	850063
18252 L	850932
18252 R	850933
22104 L	850128
22104 R	850129
22114 L	850130
22114 R	850131
22172 L	850152
22172 R	850153
22204 L	850168
22204 R	850169
22374 L	850832
22374 R	850833
24084 L	850094
24084 R	850095
24104 L	850106



Valeo

PMM (.../...)

24104 R	850107
28052 L	850198
28052 R	850199
50104 L	850248
50104 R	850249
50194 L	850766
50194 R	850767
52104 L	850268
52104 R	850269
54054 L	850078
54054 R	850079
70142 L	850356
70142 R	850357
70332 L	850866
70332 R	850867
76062 L	850390
76062 R	850391
86054 L	850546
86054 R	850547

POLITECNICA

39080	850062
4811042	850130
4819080	850062
4819202	850484
4819203	850488
4819205	850488
48 19210	851014
4820080	850078
4820111	850356
4820120	850498
4824020	850128
4824030	850130
4824100	850152
4824120	850168
4824202	850484
4824203	850488
48 24210	851014
4824221	850478
4824222	850494
4825012	850094

POLITECNICA

4825014	850106
4825211	850486
4825212	850496
4829203	850488
4830042	850106
4833220	850490
4833230	850248
4833231	850766
4834072	850268
4837020	850128
4838201	850498
4838210	850494
4839202	850484
4839203	850488
48 39210	851014



Valeo

POLITECNICA (.../...)

4842080	850356
4842201	850498
4842211	850494
4848031	850390
4850059	850546
4854006	850546
4854051	850442
4854201	850492
4870012	850482
4870022	850482
4870032	850482
4911042	850131
4919080	850063
4919202	850485
4919203	850489
49 19210	851015
4920080	850079
4920111	850357
4920120	850499
4924020	850129
4924100	850153
4924120	850169
49 24210	851015
4924221	850479
4924222	850495
4925012	850095
4925014	850107
4925211	850487
4925212	850497
4933220	850491
4933230	850249
4933231	850767
4934072	850269
49 39210	851015
4948031	850391
4950059	850547
4954051	850443
4954201	850493
4970012	850483
ALE0025D	850129
ALE0025S	850128
ALE0026D	850131
ALE0026S	850130
ALE0037D	850153
ALE0037S	850152
ALE0045D	850169
ALE0045S	850168
ALE0099D	850833
ALE0099S	850832
ALE0320D	850095
ALE0320S	850094
ALE0326D	850107
ALE0326S	850106
ALE0348D	850249



	Valeo
RHIAG (.../...)	
ALE0348S	850248
ALE0380D	850391
ALE0380S	850390
ALE0387D	850443
ALE0387S	850442
ALE0431D	850561
ALE0431S	850560
ALE0483D	850767
ALE0483S	850766
ALE0608D	850063
ALE0608S	850062
ALE0645D	850357
ALE0645S	850356
ALE1000D	850479
ALE1000S	850478
ALE1002D	850483
ALE1002S	850482
ALE1003D	850485
ALE1003S	850484
ALE1004D	850487
ALE1004S	850486
ALE1005D	850489
ALE1005S	850488
ALE1006D	850491
ALE1006S	850490
ALE1007D	850493
ALE1007S	850492
ALE1008D	850495
ALE1008S	850494
ALE1009D	850497
ALE1009S	850496
ALE1010D	850499
ALE1010S	850498
ALE1012D	850687
ALE1012S	850686
ALE1014D	850691
ALE1014S	850690
ALE1016D	850725
ALE1016S	850724
ALE1017D	850723
ALE1017S	850722
ALE1018D	850727
ALE1018S	850726
ROLCAR	
12600	850953
12601	850952
14392	850957
14393	850956
14394	850965
14395	850964
01.2522	851015
01.2523	851014
SEIM	
900608	850722

	Valeo
SEIM (.../...)	
900609	850723
900644	850832
900645	850833
900768	850690
900769	850691
900822	850866
900823	850867
910004	850062
910005	850063
910016	850488
910017	850489
910018	850484
910019	850485
910060	850686
910061	850687
920036	850152
920037	850153
920076	850478
920077	850479
920200	850131
920201	850130
950134	850495
950135	850494
950346	850487
950347	850486
950348	850497
950349	850496
970012	850356
970013	850357
980002	850561
980003	850560
980004	850391
980005	850390
980060	850443
980061	850442
TECNOKIT	
TK 0722 L	850062
TK 0722 R	850063
TK 07714 L	850932
TK 07714 R	850933
TK 1022 L	850198
TK 1022 R	850199
TK 1136 L	850128
TK 1136 R	850129
TK 1139 L	850130
TK 1139 R	850131
TK 1162 L	850152
TK 1162 R	850153
TK 1174 L	850168
TK 1174 R	850169
TK 1197 L	850832
TK 1197 R	850833
TK 1332 L	850094
TK 1332 R	850095
TK 1356 L	850106

	Valeo
TECNOKIT (.../...)	
TK 1356 R	850107
TK 2456 L	850268
TK 2456 R	850269
TK 2763 L	850248
TK 2763 R	850249
TK 27703 L	850766
TK 27703 R	850767
TK 2873 L	850078
TK 2873 R	850079
TK 4147 L	850356
TK 4147 R	850357
TK 4175 L	850866
TK 4175 R	850867
TK 4514 L	850390
TK 4514 R	850391
TK 5245 L	850546
TK 5245 R	850547
TK 5523 L	850442
TK 5523 R	850443
TK 55707 L	850560
TK 55707 R	850561
TK 56110 L	850958
TK 56110 R	850959
TK 56124 L	850950
TK 56124 R	850951
TK 56125 L	850948
TK 56125 R	850949
TK 5613 L	850952
TK 5613 R	850953
TK 5616 L	850478
TK 5616 R	850479
TK 5619 L	850482
TK 5619 R	850483
TK 5621 L	850484
TK 5621 R	850485
TK 5622 L	850486
TK 5622 R	850487
TK 5624 L	850488
TK 5624 R	850489
TK 5625 L	850490
TK 5625 R	850491
TK 5626 L	850492
TK 5626 R	850493
TK 5629 L	850494
TK 5629 R	850495
TK 5631 L	850496
TK 5631 R	850497
TK 5632 L	850498
TK 5632 R	850499
TK 5642 L	850690
TK 5642 R	850691
TK 5645 L	850722
TK 5645 R	850723
TK 5648 L	850956
TK 5648 R	850957

	Valeo
TECNOKIT (.../...)	
TK 5650 L	850962
TK 5650 R	850963
TK 5659 L	850960
TK 5659 R	850961
TK 5661 L	850964
TK 5661 R	850965
TK 56702 L	850686
TK 56702 R	850687
TK 56703 L	850724
TK 56703 R	850725
TK 56704 L	850726
TK 56704 R	850727
TK 56705 L	850954
TK 56705 R	850955
VAN WEZEL	
155261	850130
155262	850131
903261	850062
903262	850063
945261	850488
945262	850489
947261	850484
947262	850485
1636261	850168
1636262	850169
1736261	850128
1736262	850129
1830263	850106
1830264	850107
1837263	850094
1837264	850095
1897261	850486
1897262	850487
1898261	850496
1898262	850497
3075261	850490
3075262	850491
3078261	850248
3078262	850249
3080263	850766
3080264	850767
3370261	850078
3370262	850079
3794261	850498
3794262	850499
3797261	850494
3797262	850495
4310261	850356
4310262	850357
4912263	850390
4912264	850391
5874261	850442
5874262	850443

EUROPE

FRANCE

VALEO SERVICE FRANCE
70, RUE PLEYEL
93285 SAINT-DENIS CEDEX - FRANCE
TEL. : (+33) 1 49 45 32 32
FAX : (+33) 1 49 45 37 36
S.A.S. au capital de 12 900 000 €
RCS Bobigny B 306 486 408

SPAIN, PORTUGAL

VALEO SERVICE ESPAÑA, S.A.
CALLE RIO ALMANZORA, N°5
AREA EMPRESARIAL ANDALUCIA C.L.A.
28906 GETAFE (MADRID) - ESPAÑA
TEL. : (+34) 91 495 85 00
FAX : (+34) 91 495 86 99
TEL. ATENCIÓN TÉCNICA :
902 011 799
TEL. ATENCIÓN AL CLIENTE :
900 122 657
Valeo Service España Sociedad Anónima
inscrita en el Registro Mercantil de Madrid,
Tomo 972 - Libro 941 de la sección 8ª,
Folio 25 - Hoja 65435 - Inscripción 1ª NIF. A28772978

ITALY

VALEO SERVICE ITALIA SPA
VIA ASTI 89
10026 SANTENA (TO) - ITALIA
TEL. : (+39) 011 94 95 1
FAX : (+39) 011 94 95 280
TEL. LINEA TECNICA : 800 805 046
N. iscrizione al Tribunale di Torino 2009/88 reg. soc.
C.C.I.A.A. 715107 - Capitale sociale € 2.600.000

UNITED KINGDOM

VALEO SERVICE UK LTD
HEMING ROAD - WASHFORD
REDDITCH - WORCS B98 0DZ - ENGLAND
TEL. : (+44) 1527 838 300
FAX : (+44) 1527 523 732
Registration Number : 956685

GERMANY

VALEO SERVICE DEUTSCHLAND GMBH
BRANDENBURGER STRASSE 46
40880 RATINGEN - DEUTSCHLAND
TEL. : (+49) 21 02 865 0
FAX : (+49) 21 02 865 142
Handelsregister Ratingen - HRB 3340

BENELUX

VALEO SERVICE BENELUX B.V.
HEIBLOEMWEG 1
5704 BS HELMOND - THE NETHERLANDS
TEL. BELGIUM (NL) : (+32) 2 366 99 17
TEL. BELGIUM (FR) : (+32) 2 355 14 46
TEL. NETHERLANDS : (+31) 492 580 894
FAX BELGIUM : (+32) 2 366 04 47
FAX NETHERLANDS : (+31) 492 580 828
K.v.K. Eindhoven 33113859

POLAND, LITHUANIA, LATVIA, ESTONIA, MOLDAVIA, BELARUS, UKRAINE

VALEO SERVICE EASTERN EUROPE Sp. z o.o.
UL. WOŁOSKA 9A
02-583 WARSZAWA - POLSKA
TEL. : (+48) 22 543 43 00
FAX : (+48) 22 543 43 05

RUSSIA

VALEO SERVICE CO LTD
RUSSIA, 105055, MOSCOW
RADIO STR, 24 - BUILD.2
TEL. : (+7) 495 981-06-96
FAX : (+7) 495 787-59-92

SWITZERLAND, AUSTRIA, SWEDEN, FINLAND, NORWAY, DENMARK, ICELAND, GREECE, EASTERN EUROPE

VALEO SERVICE EXPORT
70, RUE PLEYEL
93285 SAINT-DENIS CEDEX - FRANCE
TEL. : (+33) 01 49 45 32 32
FAX : (+33) 01 49 45 36 59

LIAISON OFFICE IN AUSTRIA
MÜHLGASSE 7
2380 PERCHTOLDSDORF - AUSTRIA
TEL. : (+43) 1 480 42 46
FAX : (+43) 1 480 42 34

LIAISON OFFICE IN CZECH REPUBLIC
DEDINSKA 29
16101 PRAGUE 6 - CZECH REPUBLIC
TEL. : (+420) 220 102 277
FAX : (+420) 220 102 278

LIAISON OFFICE IN HUNGARY
ROZSAKVARC UTCA 33
1188 BUDAPEST- HUNGARY
TEL. : (+36) 30 50 51 888

LIAISON OFFICE IN ROMANIA
STR.CA ROSETTI NR.17
SECTOR 2
02001 BUCURESTI - ROMANIA
TEL. : (+40) 215 27 03 80

LIAISON OFFICE IN SERBIA
BULEVAR ARSENJIJA CARNOJEVICA 99, LOKAL 4
11070 BELGRADE - SERBIA
TEL/FAX. : +381 (0)11 260 7754

LIAISON OFFICE IN GREECE
18, KALAMAKIOU AVENUE
174 55 ALIMOS - GREECE
TEL. : (+30) 210 45 27 447
FAX.: (+30) 210 45 27 449

SOUTH AMERICA

LATIN AMERICA (except Mexico)

VALEO CIBIE SERVICE LTDA
RUA SADAÉ TAKAGI, 2000
BAIRRO COOPERATIVA
09852-070 - SÃO BERNARDO DO CAMPO
SÃO PAULO - BRASIL
TEL. : (+55) 11 43 93 33 54
FAX : (+55) 11 43 93 33 55
C.N.P.J. : 57.010.662/0008-36
Inscrição Estadual : 635.331.124.114

MEXICO

LIAISON OFFICE IN MEXICO
MONTECITO 38, PISO 14 OFICINA 38.
TORRE WORLD TRADE CENTER
COLONIA NÁPOLES | 03810| MÉXICO, D.F.
TEL. : +52 (55) 90001588

ASIA, MIDDLE EAST, AUSTRALIA, NEW-ZEALAND

VALEO SERVICE EXPORT
70, RUE PLEYEL
93285 SAINT-DENIS CEDEX - FRANCE
TEL. : (+33) 01 49 45 32 32
FAX : (+33) 01 49 45 36 59

CHINA

**VALEO AUTO PART TRADING
(SHANGHAI) CO., LTD**
7 FLOOR, INNOV TOWER, 1801 HONG MEI ROAD,
CAOHEJING HI-TECH PARK, XUHUI
DISTRICT, SHANGHAI 200233, CHINA
TEL. : (+86) 21 5171 3576
MP : (+86) 139 1750 0406

TURKEY, IRAN, IRAQ, SYRIA, LEBANON, JORDAN, SAUDI ARABIA, UNITED ARABE EMIRATES, KUWAIT, BAHRAIN, QATAR, OMAN, YEMEN, EGYPT

VALEO OTOMOTIV DAĞITIM A.Ş.
AYDINEVLER SANAYİ CADDESİ
CENTRUM İS MERKEZİ N°3
KAT: 3, DAİRE N°302-303 KÜÇÜKYALI - MALTEPE
34854 İSTANBUL - TURKEY
TEL. : (+90) 216 518 75 75
FAX : (+90) 216 519 93 14

AFRICA, DOM-TOM

VALEO SERVICE EXPORT
70, RUE PLEYEL
93285 SAINT-DENIS CEDEX - FRANCE
TEL. : (+33) 01 49 45 32 32
FAX : (+33) 01 49 45 36 59
S.A.S. au capital de 12 900 000 €
RCS Bobigny B 306 486 408

LIAISON OFFICE IN TUNISIA
CENTRE D'AFFAIRES REGUS
IMMEUBLE CARTHAGE
RUE DU LAC DE CONSTANCE
1053 TUNIS - TUNISIA
TEL. : (216) 71 965 002
FAX : (216) 71 965 137
MOB: (216) 98 34 91 38

Truck by Valeo

Your solution provider

Wiping systems
99% European truck
park coverage

Braking systems
Only one supplier for
a full braking offer

Alternators & Starters
The OE quality for
the Aftermarket

Clutches
One truck out of two in Europe
are fitted with a Valeo clutch

Lighting systems
OE lighting for your
trucks & buses

Air Quality products
for professional drivers

Engine cooling
Irreproachable quality products

Climate Control
Most popular Trucks
covered by Valeo
O.E. offer!



valeo added

Automotive technology, naturally

