

BRAKE LINING

- for Passenger Car***
- for Bus***
- for Truck***

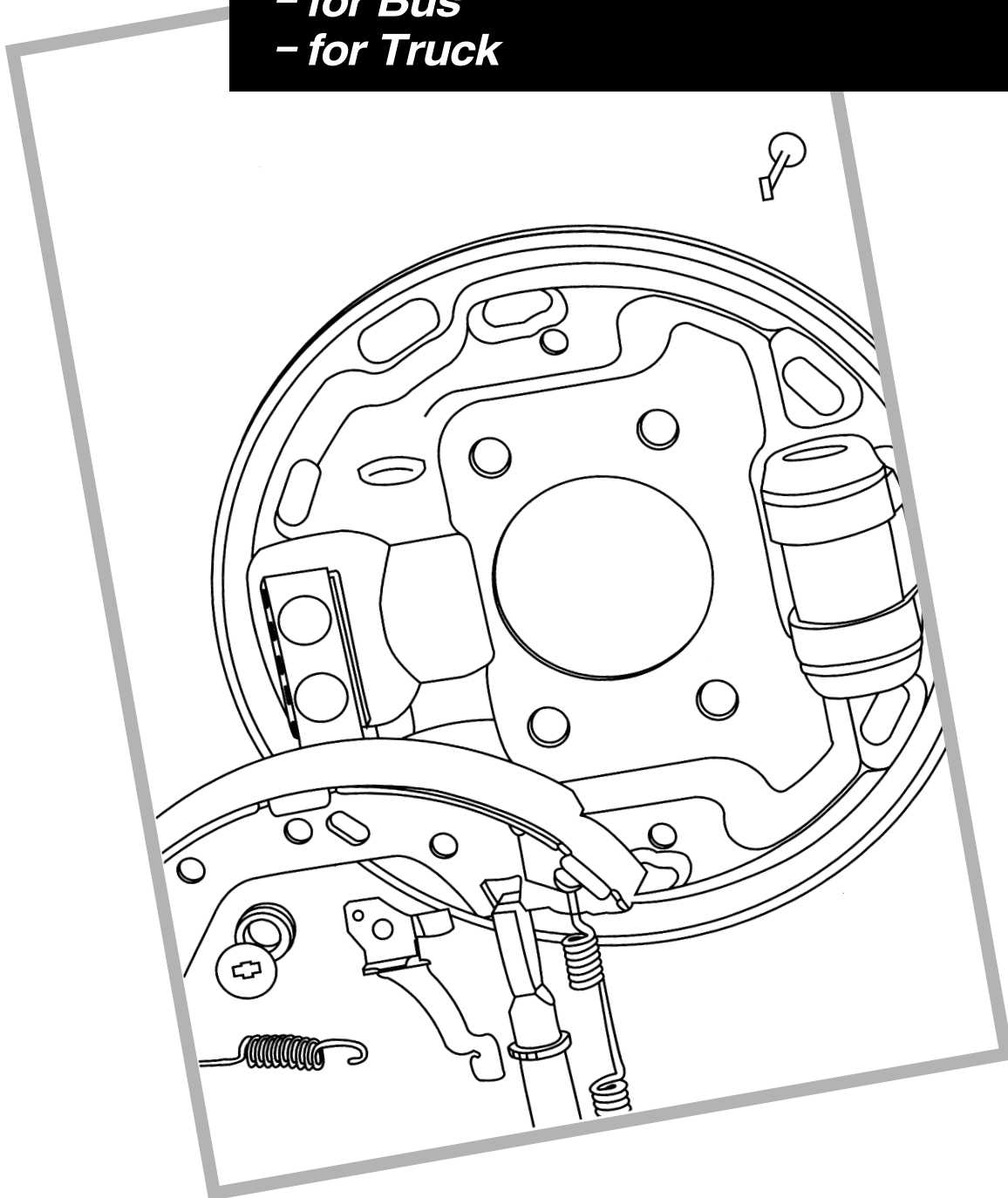

BRAKE LINING-for Passenger Car

MODEL	PART NO.	PO	YEAR	SPEC.					REMARK
				W	T	L	R	A	
ACCENT		RR		30.0	5.00	164	86	110	
AVANTE		RR		36.3	5.24	186	97	110	
AVELLA		RR		30.0	5.00	182	95	110	RIO
BRISA		RR		32.0	5.00	191	96	114	K303
CARNIVAL(SPORTAGE)		RR		55.0	6.00	248	119	120	SPORTAGE
CHAIRMAN		RR	95	19.8	4.60	159	78	117	W-CAR
CONCORD		RR		25.0	4.80	183	95	110	
CONCORD TAXI		RR		35.0	4.80	183	95	110	
NEW CORTINA		RR SEC		36.8	4.50	186	97	110	
NEW CORTINA		RR PRI		36.8	4.50	152	97	90	
CREDOS		RR		30.0	4.50	191	110	100	
EXCEL		RR		35.0	4.60	164	86	110	
ELANTRA		RR		36.3	4.94	186	97	110	
ESPERO		RR		45.0	5.50	185	95	112	LEMANS
GALLOPER		RR		55.35	4.95	233	121	110	
GALLOPER II		RR	97	52.0	5.10	274	131	120	
GRANDEUR 2.0(OLD)		RR		30.0	2.85	155	81	110	
GRANADA		RR		55.4	4.00	210	110	110	
HILLMAN		RR		42.6	4.50	211	110	110	
LEGANZA		RR		50.0	5.30	227.3	109	119	
LEMANS		RR		45.0	5.50	185	95	112	ESPERO
MAGNUS		RR		40.0	5.30	226	109	118	V-200
MAGNUS PARK'G		PARK'G	99	22.5	4.40	166	80	119	V-200
MATIZ		RR	99	30.0	4.30	164	86	110	
OLD PONY		RR	98	35.0	4.50	212	97	125	
NEW PONY		RR		36.3	4.95	152	96	90	
PONY EXCEL		RR SEC		29.6	3.90	166	86	110	
PONY EXCEL		RR PRI		29.6	6.45	133	85	90	
PRIDE		RR		24.5	4.00	149	81	106	
PRIDE VAN		RR		29.5	4.00	149	81	106	
REZZO		RR	00	50.0	5.30	226.3	109	118	A1-CAR
OLD ROYALE		RR		50.0	5.00	227	109	119	OPEL
NEW ROYALE		RR		50.0	5.80	226	109	119	

MODEL	PART NO.	PO	YEAR	SPEC.					REMARK
				W	T	L	R	A	
SHINJIN JEEP(OLD)		RR		52.0	5.60	270	120	129	
SHINJIN JEEP(NEW)		RR SEC		52.0	5.60	294	135	125	
SHINJIN JEEP(NEW)		RR PRI		52.0	5.60	260	135	110	
SONATA		RR		42.0	5.00	208	109	110	

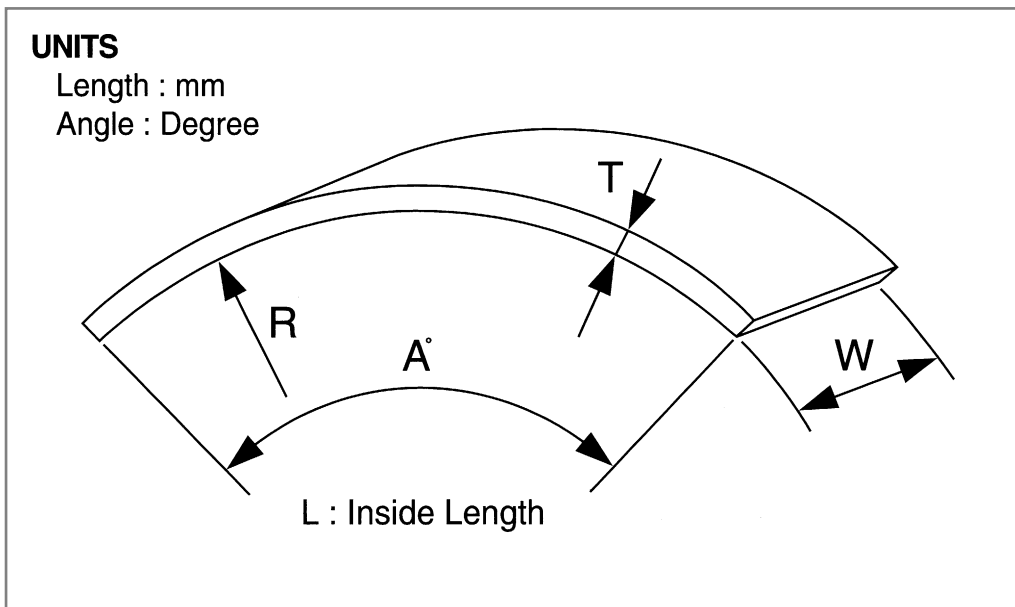

BRAKE LINING-for Bus

MODEL	PART NO.	PO	YEAR	SPEC.					REMARK
				W	T	L	R	A	
AC540		FR CAM		156.0	18.3/16.4	185	199	54	15TON CARGO
AC540		FR ANCHOR		156.0	17.5/11.3	181	199	53	15TON CARGO
AC540		RR CAM		207.5	18.3/16.4	185	199	54	15TON CARGO
AC540		RR ANCHOR		207.5	17.5/11.3	181	199	53	15TON CARGO
AM907		FR	82	127.0	15.30	195	189	59	KB900
AM907		RR	82	216.0	15.30	195	188	60	DAEWOO ROYALE
AM907 (NEW)		FR	93	147.0	15.3	195	189	59	AM939 (NEW)
AM927 (NEW)		FR CAM	88	147.0	17.98/15.46	193	197	58	AM937
AM927 (NEW)		FR ANCHOR	88	147.0	17.3/10.36	196	197	57	AM937
AM927 (NEW)		RR CAM	88	216.0	16.98/14.46	193	197	58	AM937
AM927 (NEW)		RR ANCHOR	88	216.0	16.3/9.36	196	197	57	AM937
AERO TOWN		FR	93	110.0	12.6	178	172	60	for A/S
AERO TOWN		RR	93	150.0	12.6	178	172	60	for A/S
BF101 (NEW)		FR	83	155.0	12.00	374	188	114	
BF101 (NEW)		RR CAM	87	176.0	14.70	194	190	59	
BF101 (NEW)		RR ANCHOR	87	176.0	14.70	194	190	59	
BH 120S		RR	83	202.0	15.5	193	190	58	
BS105		FR CAM	86	155.0	18.38/16.57	206	204	59	
BS105		FR ANCHOR	86	155.0	17.57/10.39	206	204	59	
BS105		RR CAM	86	203.0	18.38/16.57	206	204	59	
BS105		RR ANCHOR	86	203.0	17.57/10.39	206	204	59	
BS106 (OLD)		FR	91	155.0	16.0	191	189	59	
BS106 (OLD)		RR	91	203.0	16.0	191	189	59	
BS106 (NEW)		FR	94	155.0	19.0	190	186	59	
BS106 (NEW)		RR	93	220.0	19.0	190	186	59	
CHEVROLET BUS(OLD)		FR	92	139.0	11.70	375	188	114	
CHEVROLET BUS(OLD)		RR	82	176.0	14.70	194	190	59	
CHEVROLET BUS(NEW)		RR	85	176.0	14.70	194	190	59	
DA50		FR		128.0	15.0	186	190	56	
DAMAS		RR	91	39.0	5.5	200	104	110	S-CAR
FB485		FR CAM	82	152.4	19.18/ 15.75	186	203	53	
FB485		FR ANCHOR	82	152.4	18.62/ 11.35	192	203	55	
FB485		RR CAM	82	177.5	19.18/15.75	186	203	53	JINDO TRAILER
FB485		RR ANCHOR	82	177.5	18.62/11.35	192	203	55	

MODEL	PART NO.	PO	YEAR	SPEC.					REMARK
				W	T	L	R	A	
FORD MICRO (NEW)		FR	79	101.6	9.53	299	156	110	
FORD MICRO (NEW)		RR CAM	79	127.0	9.53	302	156	111	
FORD MICRO (NEW)		RR ANCHOR	79	127.0	9.53	342	156	126	
FUSO 905		FR	84	125.0	16.0	196	189	59	
FUSO 905		RR	84	190.0	16.0	184	194	54	
GRACE (10")		RR	94	55.35	4.95	233	121	110	1 TON PORTER
HA20		FR	80	128.0	15.00	186	190	56	DONG-A
HA20		RR	80	176.0	18.00	196	187	60	DONG-A
HA50		FR	82	150.0	15.00	184	185	57	DONG-A
HA50		RR	82	230.0	18.00	196	187	60	DONG-A
ISTANA		RR	95	55.35	5.1	233	121	110	L1-CAR
MA-PRO.		RR CAM	95	220.0	18.3/16.4	188	199	54	
MA-PRO.		RR ANCHOR	95	220.0	17.5/11.3	184	199	53	
RB520		FR CAM	84	152.4	19.18/16.54	189	203	53	
RB520		FR ANCHOR	84	152.4	18.62/12.14	195	203	55	
RB520		RR CAM	84	203.2	19.18/16.54	189	203	53	
RB520		RR ANCHOR	84	203.4	18.62/12.14	195	203	55	
DW ROYALE BUS		FR	87	127.0	14.5	195	188	60	
DW ROYALE BUS		RR	87	216.0	15.3	193	188	59	
SSANGYONG DA88 (DA85)		FR CAM	94	160.0	15.55/17.7	188	199	55	
SSANGYONG DA88 (DA85)		FR ANCHOR	94	160.0	10.18/16.9	188	199	55	
SSANGYONG DA88 (DA85)		RR CAM	94	220.0	15.55/17.7	188	199	55	
SSANGYONG DA88 (DA85)		RR ANCHOR	94	220.0	10.18/16.9	188	199	56	
STAREX		RR	95	52.0	5.1	274	131	120	
FUSO 905		SIDE	78	75	6	335	134	143	

BRAKE LINING-for Truck

MODEL	PART NO.	PO	YEAR	SPEC.					REMARK
				W	T	L	R	A	
AU-CAR LOW DECK		RR PRI.	96	45.0	5.20	202	105	110	
AU-CAR LOW DECK		RR SEC.	96	45.0	5.20	229	105	125	
AU-1.5TON		RR PRI.	97	60.0	5.20	234	122	110	
AU-1.5TON		RR SEC.	97	60.0	5.20	266	122	125	
BENZ		FR	99	142	16.8/12.7	178	199	52	FOR MALAY MARKET
BENZ 1625		FR CAM	92	162.0	14.48/17.78	177	200	51	FOR MALAY MARKET
BENZ 1625		FR ANCHOR	92	162.0	8.55/17.28	220	200	63	FOR BRASIL MARKET
BENZ 21TON		FR	92	183.0	17.0/13.0	178	200	51	
BENZ 21TON		RR	92	220.0	18.0/14.0	178	200	51	
BERING MIXER		RR CAM	98	220	17.3/19.3	185	199	54	
BERING MIXER		RR ANCHOR	98	220	18.5/12.3	181	199	53	
CERES		RR		45.0	5.50	240	125	110	
CHEVROLET 8TON		SIDE	80	59.5	5.00	275	127	124	
DW 15TON DUMP (OLD)		FR	84	140.0	16.0	192	188	59	
DW 15TON DUMP (OLD)		RR	84	177.5	16.0	192	188	59	
DW 15TON DUMP (NEW)		FR	84	140.0	15.0	192	188	59	
DW N/C TRUCK (F/AIR)		FR	93	155.0	16.50	191	189	58	SHT
DW N/C TRUCK (F/AIR)		RR	93	203.0	16.50	191	189	58	SHT
ASIA GRANTO 21.5TON		RR	95	220.0	17.6/12.8	163	205	46	
DW VANETTE		RR	88	60.0	4.20	220	105	121	
DW TRAILER		RR CAM	84	177.5	19.18/15.75	186	203	53	
DW TRAILER		RR ANCHOR	84	177.5	18.12/11.35	192	203	53	
DW 23TON		RR	98	220	16.5	191	189	58	
DW 23TON DUMP		RR	98	220	16.5	191	189	58	
FUSO 11TON		FR	78	125.0	16.00	196	189	60	
FUSO 11TON		RR	78	190.0	16.00	185	194	55	
FUSO 11TON		SIDE	78	75.0	6.00	335	134	143	THICKNESS 6.4/ 5.2/ 5.8
HD 2.5TON LOW DECK		RR PRI.		75.0	7.1	279	145	110	THICKNESS 8.8/ 9.9/ 9
HD 2.5TON LOW DECK		RR SEC.		75.0	10.7	320	145	126	
HD 2.5TON PARK'G		PARK'G	97	45	4.5	198	91	125	
HD 2.5TON HIGH DECK		RR	92	75.0	10.50	300	150	115	VOLUME UP
HD 3.5TON		FR, RR		85.0	8.50	305	152	115	
HD 3.5TON V/UP		FR	95	85.0	10.50	301	150	115	
HD 5TON		FR	94	120.0	12.5	145	148	56	

MODEL	PART NO.	PO	YEAR	SPEC.					REMARK
				W	T	L	R	A	
HD 5TON		RR	94	150.0	12.5	145	148	56	
HD 9.5TON		RR		150.0	12.5	145	148	56	
HD 20TON (OLD)		FR	90	151.8	18.5	198	193	59	
HD 20TON (OLD)		RR CAM	90	178.2	20.8/16.3	197	206	55	
HD 20TON (OLD)		RR ANCHOR	90	178.2	20.2/11.6	193	206	54	
HD 20TON (NEW)		FR	92	177.5	18.0	197	188	60	
HD 23TON		FR		176.0	15.50	192	188	59	
HD 23TON DUMP		RR CAM	98	220	18.3/16.4	184	199	53	
HD 23TON DUMP		RR ANCHOR	98	220	17.5/11.3	181	199	52	
HD 25TON C/G		FR CAM	98	156	17.3/19.3	185	199	54	
HD 25TON C/G		FR ANCHOR	98	156	18.5/12.3	181	199	53	
HD 25TON C/G		RR CAM	98	220	17.3/19.3	185	199	54	
HD 25TON C/G		RR ANCHOR	98	220	18.5/12.3	181	199	53	
HD SUPER TRUCK (AOH)		FR	95	156.0	16.50	191	189	58	
HD SUPER TRUCK (AOH)		RR	95	220.0	16.50	191	189	58	
HD SUPER TRUCK		FR	98	156	16.5	191	189	58	
HD SUPER TRUCK		RR	98	220	16.5	191	189	58	
HD 1000 (NEW)		FR	79	69.0	5.00	236	122	111	
HD 1000 (NEW)		RR	79	43.2	4.60	212	109	111	
HD PORTER (8.6")		RR PRI.		45.0	5.80	202	105	110	
HD PORTER (8.6")		RR SEC.		45.0	5.80	229	105	125	
HD 1TON (10")		RR		55.4	4.95	233	121	110	GRACE
HD 1.25TON		RR PRI.		55.0	5.80	202	105	110	
HD 1.25TON		RR SEC.		55.0	5.80	229	105	125	
HD LIBERO		RR PRI.	99	60	5.2	197	105	110	SR-CAR
HD LIBERO		RR SEC.	99	60	5.2	234	105	125	SR-CAR
HI- STAR		FR CAM	92	177.8	15.13/18.16	188	203	54	
HI- STAR		FR ANCHOR	92	177.8	10.72/17.4	194	203	55	
INTER 2.5TON			99	76	8.5	407	182	128	
IVECO- JURID		FR	96	177.5	19.3/15.3	198	196	58	
IVECO- JURID		RR	96	196.5	19.3/15.3	198	196	58	
IVECO-ROCKWELL		FR	96	177.5	19.5/12.7	196	201	56	
IVECO-ROCKWELL		RR	96	196.5	19.5/12.7	196	201	56	
ISUZU 8TON		FR	73	104.0	9.70	378	190	114	

MODEL	PART NO.	PO	YEAR	SPEC.					REMARK
				W	T	L	R	A	
ISUZU 8TON		RR	73	140.0	11.60	374	188	114	
JORDAN NICO		FR	93	75.0	9.50	327	150	125	
KB900		FR	78	127.0	15.30	195	189	59	
KB900		RR	78	203.0	15.30	195	189	59	
KIA		FR	87	50.8	6.74	328	171	110	
KIA BONGO		FR	85	55.0	6.30	217	108	115	
KIA BONGO		RR PRI	85	45.0	5.00	185	85	125	
KIA BONGO		RR SEC	85	45.0	5.00	163	85	110	AM907
KIA 1.4TON		RR	82	60.0	8.20	318	152	120	
KIA BOXER 4.5TON		FR	84	89.0	8.2	318	152	120	
KIA BOXER 4.5TON		RR	84	99.0	8.2	318	152	120	
KIA BOXER 4.5TON		SIDE	84	45.0	5.0	203	94	124	
KIA 5TON (OLD)		FR	89	110.0	13.0	294	147	115	
KIA 5TON (OLD)		RR	89	125.0	13.00	294	147	115	
KIA 5TON (NEW)		FR	94	110.0	12.50	178	172	60	
KIA 5TON (NEW)		RR	94	135.0	12.50	178	172	60	
KIA BESTA		RR PRI	88	50.0	5.30	250	123	117	
KIA BESTA		RR SEC	88	50.0	5.30	236	123	110	
MAN		FR	98	179	12.35/16.6	178	200	51	
MIGHTY 2.5TON		FRT/RR	86	75.0	8.5	305	152	115	
mitsubishi 15TON		FR	91	150.0	15.3	191	189	58	
MITSUBISHI 15TON		RR	91	220.0	15.3	191	189	58	
M-TRUCK		FR	97	140.0	15.0	191	189	58	
M-TRUCK		RR		200.0	15.0	191	189	58	
PB25		CENTER	99	35	5.5	178	85	120	
PB50		CENTER	99	50	4.5	220.8	97.3	130	
PB80		CENTER	99	75	6.8	338.9	146	133	
PUSHER 25TON (7")		RR CAM	98	177.5	17.21/20.57	186	203	52.5	
PUSHER 25TON (7")		RR ANCHOR	98	177.5	11.32/19.76	191.6	203	54	
PUSHER AXLE (6")		RR CAM	99	152.4	20.57/17.21	186	203	53	
PUSHER AXLE (6")		RR ANCHOR	99	152.4	19.76/11.3	192	203	55	
QING LING		FR	95	74.5	6.5	282	143	113	
RAVA 23TON		RR CAM	97	180	19.6/16.4	195	204	55	
RAVA 23TON		RR ANCHOR	97	180	18.9/11.6	195	204	55	

MODEL	PART NO.	PO	YEAR	SPEC.					REMARK
				W	T	L	R	A	
SCANIA 20TON		FR	91	177.0	19.0	232	188	71	
SCANIA 20TON		RR	91	202.0	19.0	232	188	71	
SCANIA 20TON (NEW)		RR	92	249.0	19.0	232	188	71	
SCANIA 39TON (OLD)		FR	96	126.5	18.70	195	186	60	
SCANIA 39TON (OLD)		RR	96	204.0	18.70	195	186	60	
SCANIA 39TON (NEW)		FR	95	176.0	18.00	196	187	60	
SILVER GRANT		FR	91	55.0	6.00	277	144	110	
SM 510		FR	93	150.0	17.00	191	189	58	FOR EXPORT
SM 510		RR	93	220.0	17.00	191	189	58	FOR EXPORT
S.M.Z 10.5TON		FR LEA D'G	81	152.0	14.5	192	190	59	
S.M.Z 10.5TON		FR TRAI L'G	81	152.0	14.50	192	190	59	
S.M.Z 10.5TON		RR LEA D'G	81	178.0	14.50	192	191	59	
S.M.Z 10.5TON		RR TRAI L'G	81	178.0	14.50	192	191	59	
S-PRO. (F/AIR)		FR		140.0	16.50	191	189	58	
S-PRO. (F/AIR)		RR		200.0	16.50	191	189	58	
SV110		RR	96	50.0	5.30	220	105	120	MS 1TON
TITAN 2.5TON		FR/ RR	81	75.0	8.2	318	152	120	
JUMBO TITAN		RR	81	75.0	8.20	304	152	115	
TC406		DAED	87	178.0	19.3/16.5	187	193	56	
UD 8TON		RR	97	177.5	16.5	196	187	60	
UD 39TON		FR	95	128.0	15	183	187	56	
VOLVO 20.5TON		FR	91	173.0	18.8/14.3	177	200	51	
VOLVO 20.5TON		RR	91	199.0	18.8/14.3	177	200	51	
ZY240		FR	82	126.6	15.50	212	203	60	
BPW 19094			97	199.6	17.9/12.5	203	206	57	