



DIFFERENTIAL SEALING KITS

SIMMERRING®-DICHTSÄTZE FÜR DAS DIFFERENTIALGETRIEBE

KITS DE JOINTS POUR DIFFÉRENTIELS

KIT TENUTA PER DIFFERENZIALE



CORTECO®

THE COMPANY

DAS UNTERNEHMEN | L'ENTREPRISE | SOCIETÀ

E

CORTECO as a member of the global Freudenberg Group is specialised in products for the Independent Aftermarket. The CORTECO range comprises automotive spare parts in the areas of sealing and vibration control technology as well as service parts. The Freudenberg Group is a leading Original Equipment Manufacturer and employs around 32,000 people in 55 countries. Independent garages trusting in CORTECO spare parts therefore profit from original quality made by Freudenberg.

More than 18,000 references support CORTECO's position as one of the leading companies in the Independent Aftermarket. The company sells spare parts and service kits worldwide from five European and a further four non-European locations.

F

CORTECO est le spécialiste au sein du groupe Freudenberg de la distribution de pièces de rechange automobile (aftermarket). Le groupe Freudenberg est un des leaders mondial en équipement d'origine et emploie 32.000 personnes dans 55 pays. Les gammes CORTECO s'appliquent notamment dans les domaines de l'étanchéité, des pièces antivibratoires et de la filtration d'habitacle. Ainsi, les clients utilisant des pièces CORTECO bénéficient d'une qualité "made by Freudenberg".

Acteur majeur de la rechange indépendante avec plus de 18.000 références, CORTECO s'appuie sur une logistique renforcée comprenant cinq sites européens et quatre hors Europe.

D

CORTECO ist der Spezialist der global aufgestellten Unternehmensgruppe Freudenberg für den freien Automobilersatzteilmarkt. Das CORTECO Sortiment umfasst Automobilersatzteile für die Dichtungs- und Schwingungstechnik sowie Serviceteile. Die Freudenberg Gruppe ist ein führender Erstausrüster der Automobilhersteller und beschäftigt rund 32.000 Mitarbeiter in 55 Ländern. Freie Werkstätten profitieren bei CORTECO somit von Ersatzteilen in Original-Qualität aus dem Hause Freudenberg.

Über 18.000 Referenzen unterstreichen die Position von CORTECO als eines der führenden Unternehmen im freien Ersatzteilhandel. Mit fünf Standorten in Europa und vier weiteren außereuropäischen Standorten vertreibt das Unternehmen weltweit Ersatzteile und Service Kits.

I

La CORTECO, società del gruppo Freudenberg, è specializzata nella distribuzione di prodotti tecnici per l'Aftermarket Indipendente. La gamma CORTECO comprende parti di ricambio per le linee di prodotto specializzate nel settore degli elementi di tenuta, smorzamento delle vibrazioni e parti di servizio per tutte le principali applicazioni del mercato "Automotive". Il Gruppo Freudenberg, di cui fa parte, è uno dei principali fornitori di componentistica di primo equipaggiamento e occupa circa 32.000 dipendenti in 55 paesi. E' proprio per questo che le officine indipendenti si fidano dei prodotti CORTECO, perché sono prodotti di qualità originale Freudenberg.

Più di 18.000 articoli disponibili a gamma permettono a CORTECO di posizionarsi tra i principali fornitori leader nel mercato dell'Aftermarket indipendente. Il gruppo CORTECO distribuisce da cinque siti Europei a ben quattro siti extra Europei le sue parti di ricambio singole o i suoi kit di manutenzione in tutte le parti del mondo.

CONTENT

INHALT | SOMMAIRE | INDICE

THE COMPANY

DAS UNTERNEHMEN | L'ENTREPRISE | SOCIETÀ

2

PRODUCT OVERVIEW

PRODUKTPROGRAMM | L'OFFRE PRODUITS | CATALOGO PRODOTTI

4

PRODUCT INFORMATION

PRODUKTINFORMATION | INFORMATIONS PRODUITS | INFORMAZIONE PRODOTTI

7

VEHICLE APPLICATIONS

FAHRZEUGANWENDUNGEN | APPLICATIONS | APPLICAZIONI



13

DISCLAIMER

RECHTLICHE HINWEISE | INFORMATIONS LÉGALES | AVVERTENZE

62

SIGNS AND SYMBOLS

ZEICHENERKLÄRUNG | SIGNES ET SYMBOLES | SEGNI E SIMBOLI

63

PRODUCT OVERVIEW

PRODUKTPROGRAMM | L'OFFRE PRODUITS | CATALOGO PRODOTTI

E

No matter which products you choose from the CORTECO product portfolio, you always get outstanding original quality. This high quality standard characterises our comprehensive spare parts range. CORTECO offers more than 18,000 products and service kits to garages - among them leading brands such as the Simmerring® radial shaft seal. Our extensive product programme comprises Simmerrings, valve stem seals, flat gaskets and engine kits, vibration control technology such as engine mounts, pulleys and suspension mounts as well as cabin air filters and brake hoses.

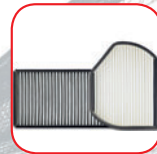

Cabin Air Filter
Innenraumfilter
Filtres d'habitacle
Filtri aria abitacolo



Gaskets and Head Bolts
Dichtungen und Zylinderkopfschrauben
Joints et kits de vis de culasse
Guarnizioni e bulloni testa



Radial Shaft Seals and Valve Stem Seals
Radialwellendichtringe und Ventilschaftabdichtungen
Bagues d'étanchéité et joints de queues de soupapes
Anelli di tenuta e paraolio valvole



Engine Mounts
Motorlager
Pièces anti-vibratoires pour moteurs et transmissions
Supporti motore

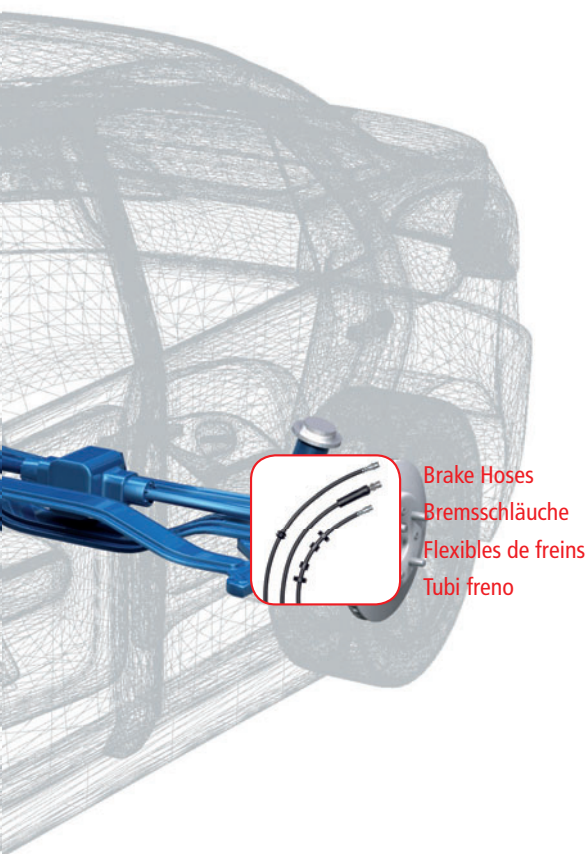

Brake Hoses
Bremschläuche
Flexibles de freins
Tubi freno

D

Für welches Produkt Sie sich aus der CORTECO-Produktfamilie auch entscheiden, Sie erhalten immer herausragende Original-Qualität. Dieser hohe Qualitätsstandard kennzeichnet unser umfangreiches Ersatzteil-Sortiment. CORTECO bietet Werkstätten mehr als 18.000 Produkte und Service Kits - unter ihnen führende Marken wie z. B. den Simmerring® Radialwellendichtring. Unser breites Produktsortiment umfasst Simmerringe, Ventilschaftabdichtungen, Flachdichtungen und Motorsätze, Schwingungstechnik wie Motorlager, Riemenscheiben und Fahrwerkslager sowie Innenraumfilter und Bremschläuche.

F

Quelque soit le produit CORTECO que vous choisissez, vous achetez toujours la qualité d'origine. CORTECO offre plus de 18.000 références de qualité, parmi lesquelles des marques leaders comme les bagues d'étanchéité Simmerring®. Nos gammes comprennent des bagues d'étanchéité dynamique, des joints de queue de soupapes, des joints et kits de joints, des pièces antivibratoires pour moteur, transmission ou châssis, des filtres d'habitacle ou encore des flexibles de freins.

I

Qualunque prodotto scegliate dalla gamma CORTECO, troverete sempre la necessaria qualità originale. La nostra gamma è caratterizzata da prodotti di alta qualità. CORTECO offre più di 18.000 parti di ricambio e kit riparazione alle officine, tra i quali importanti marchi depositati come Simmerring® e CORTECO® per gli anelli di tenuta. Il nostro programma di vendita include anelli di tenuta, paraolio stelo valvola, guarnizioni piane e kit guarnizioni motore, supporti motore, pulegge, supporti sospensioni ed anche ricambi di servizio come filtri aria abitacolo e tubi freno.

PRODUCT INFORMATION

PRODUKTINFORMATION | INFORMATIONS PRODUITS | INFORMAZIONE PRODOTTI

THE DIFFERENTIAL

What is it?

The Differential is very important even if it is at the end of the power train, because it has to distribute the torque to the driving wheels. The Differential allows the left and right side drive wheels to rotate at different speeds when cornering, thus greatly improving the handling of the vehicle and limiting wear to the tyres, brakes and suspension. Because of its position on the vehicle, the differential is exposed to the elements and the seals used in the unit must be made using the highest quality materials available. With time the components become worn and have to be changed during regular overhauls.

Overhauling the differential

If subjected to severe conditions, the differential must be checked more often than specified by the car manufacturer. It is recommended that all of the sealing parts are replaced to restore functionality, reduce fuel consumption and extend the life of the differential unit.



Why choose CORTECO's expertise?

Overhauling the differential is not a complex operation but, in order to guarantee reliability and service life, it must be done by experts with quality spare parts. For this reason, CORTECO, the aftermarket division of the Freudenberg Group, has launched its brand new Differential Overhaul Kits, so together with our Timing Belt Seal Kits and Clutch Oil Seal Kits, we now are able to offer a line of products dedicated to complete maintenance. Once again CORTECO offers its know-how to the customer, guaranteeing OE quality spare parts and providing a solution to searching through catalogues trying to find the right seals as all required parts are included in the kit.



Differential Overhaul Kits from CORTECO include all the sealing parts necessary for a successful maintenance routine:

- Dedicated Oil Seals
- Silicon Paste
- Flat Gaskets (where necessary)

SIMMERRING®-DICHTSÄTZE FÜR DAS DIFFERENTIALGETRIEBE



Aufbau und Funktion

Das Differentialgetriebe (Hinterachsgetriebe) ist ein Getriebe welches sich zwischen den angetriebenen Rädern befindet und am Ende des Antriebsstranges für den Ausgleich der Drehzahlen zwischen den zwei Rädern sorgt. Ein Differentialgetriebe besteht aus einem um die Abtriebswelle drehbaren Differentialkorb, den die Antriebswelle in Rotation versetzt. An den im Differentialkorb liegenden Enden der Abtriebswellen, sind Kegelräder angebracht, ebenso im sind ein bis vier Kegelräder an der Innenseite des Rotationskorbes drehbar befestigt. Jeder dieser Kegelräder ist mit beiden Abtriebskegelrädern verzahnt. Bei Kraftfahrzeugen sind die Abtriebswellen mit den angetriebenen Rädern verbunden.

Da die Räder einer Achse beim Fahren in Kurven unterschiedlich lange Wege zurücklegen, darf die Differenz bei starr gekoppelten Rädern nicht zu groß werden. Bei starr gekoppelten Rädern überträgt das äußere Rad in Kurven, eine kleinere Kraft als das innere Rad. Beim Differentialgetriebe übertragen beide Räder die gleiche Kraft. Aufgrund seiner Position im Fahrzeug hat das Hinterachsgetriebe einen wichtigsten Einfluss auf den Leistungszustand eines Fahrzeuges. Staub, Schmutz und andere Asphaltverunreinigungen sind ständig in Kontakt mit den Dichtungselementen. Durch eine zeitliche und mechanische Belastung werden diese Komponenten abgenutzt. Bei Instandsetzungsmaßnahmen am Differentialgetriebe, sollten alle Dichtungskomponenten gewechselt werden.

Instandsetzung des Getriebes

Bei extremen Umgebungsbedingungen muss das Differentialgetriebe öfters als von den Fahrzeugherstellern empfohlen, einer sorgfältigen und

korrekten Überprüfung unterzogen werden.

Während dieses Vorganges ist es zwingend erforderlich, zur Wiederherstellung der ordnungsgemäßen Funktionalität, alle entsprechenden Dichtungselemente zu wechseln.

Nur durch den Austausch allerdings Dichtungen, kann die Funktions- und Leistungsfähigkeit des Getriebes wieder dauerhaft gewährleistet werden.

Vorteile mit Produkten von corteco

Instandsetzungsarbeiten am Differentialgetriebe können ohne Probleme von Werkstätten durchgeführt werden. CORTECO bietet Ihnen als Aftermarketgesellschaft der Unternehmensgruppe Freudenberg alle für die Reparatur benötigten Ersatzteile in Originalqualität.

Zusammen mit den Simmerring® - Dichtringsätzen für den Zahnriemen oder Kupplungswechsel, erhalten Sie bei CORTECO alle für die jeweilige Anwendung benötigten Produkte aus einer Hand. Für Werkstätten ist es daher deutlich einfacher und die aufwendige Suche nach den richtigen Komponenten entfällt.

CORTECO bietet alle für den Instandsetzungsarbeiten am Differentialgetriebe benötigten Produkte in einem Set.

Das Differential-Kit beinhaltet:

- alle benötigten Dichtungen
- Silikondichmasse
- und die entsprechende Flachdichtung (wenn vom OE-Hersteller vorgesehen)



LE DIFFÉRENTIEL

Mode d'emploi

Situé sur le train roulant, le différentiel est un composant essentiel du véhicule puisqu'il repartit le couple sur les deux roues de l'essieu. Les différentiels sont généralement composés d'une cage métallique renfermant un jeu d'engrenages baigné dans un lubrifiant et permettant une différence de rotation entre les deux roues d'un même essieu. Ceci permet d'éviter des contraintes mécaniques excessives et des problèmes de comportement routier.

En raison de sa position sur le véhicule et de sa fonction, le différentiel est directement soumis aux conditions d'utilisation du véhicule. Par conséquent, les bagues d'étanchéité du différentiel doivent être d'une fiabilité irréprochable car elles sont soumises à toutes les poussières rencontrées sur la route. Néanmoins, au fil des kilomètres parcourus les bagues de différentiel s'usent et nécessitent un remplacement généralement réalisé lors de la maintenance du différentiel.

Maintenance d'un différentiel

En cas de conditions d'utilisation extrêmes, le différentiel doit être contrôlé à des intervalles plus courts que ceux prévus par le constructeur. Une inspection détaillée doit permettre de valider le bon fonctionnement des organes internes. Au cours de cette inspection, les différentes pièces d'étanchéité seront remplacées pour garantir une bonne protection contre les éléments extérieurs, le bon fonctionnement et la durée de vie du différentiel.



Optez pour l'expert, CORTECO

La maintenance d'un différentiel n'étant pas une opération complexe, elle nécessite néanmoins l'intervention d'un professionnel avec des pièces de qualité d'origine pour garantir fiabilité et longévité. C'est précisément pour cette raison que CORTECO en tant que division responsable de la rechange indépendante au sein du groupe freudenberg a décidé du lancement d'une gamme de kits de réparation pour différentiels. Ces kits viennent compléter l'offre de kits de bagues CORTECO existante pour la réparation d'embrayages et de la distribution.

Les kits CORTECO vous garantissent:

- L'ensemble des joints en qualité d'origine à remplacer lors de la rénovation d'un différentiel.
- Un gain de temps en vous évitant la recherche individuelle des pièces d'étanchéité.



Nos kits de rénovation sont destinés à répondre aux attentes des mécaniciens réparateurs en incluant l'ensemble des pièces d'étanchéité nécessaires pour le différentiel.

Nos kits de réparation incluent les éléments suivants:

- Un ensemble de bagues.
- De la pâte à joint silicone
- Un ou plusieurs joints plats (si prévu par le constructeur dans l'opération de maintenance)

IL DIFFERENZIALE



Cos'è

Nonostante si trovi alla fine della catena cinematica, il differenziale è un componente meccanico particolarmente importante, in quanto il suo compito è quello di distribuire il momento torcente proveniente dal cambio e di ripartirlo tra le ruote motrici. È solitamente costituito da una gabbia metallica dentro la quale si trovano due satelliti ed altrettanti planetari, questi ultimi solidali con i semiassi delle ruote. In caso di differente velocità di rotazione tra le due ruote motrici, il gruppo di ingranaggi satelliti-planetari ripartisce la coppia motrice in modo da evitare stress meccanici sia ai semiassi che alle ruote. Proprio per il suo compito e la sua posizione, il differenziale è uno degli elementi meccanici maggiormente esposti a quelle che sono le condizioni di utilizzo del veicolo. Polvere, fango ed impurità presenti sull'asfalto, infatti, sono costantemente in contatto con le tenute, che, per questa ragione, devono essere di assoluta qualità. Il passare del tempo, gli stress meccanici e l'usura logorano questi componenti che è indispensabile sostituire contestualmente alla revisione ed al recupero di tutte quelle che sono le parti interne alla scatola del differenziale.

Revisione e sostituzione

Se sottoposto a condizioni d'uso piuttosto gravose, il differenziale, contemporaneamente alla sostituzione dell'olio lubrificante e ad intervalli più frequenti rispetto a quanto previsto dalla casa madre, necessita anche di un'accurata revisione e del controllo dei giochi al suo interno. Durante questi interventi è indispensabile sostituire tutte le tenute a esso collegate in modo da ripristinarne la corretta funzionalità. Una ritrovata efficienza garantisce prestazioni ottimali ed una elevata protezione del differenziale dagli agenti esterni preservandone la vita e riducendo i consumi.

Perché affidarsi agli esperti CORTECO

La revisione del differenziale non è un'operazione complessa ma, perché siano garantite affidabilità e durata, deve poter contare su ricambi di sicuro valore e su manodopera esperta. Per questo CORTECO, divisione Aftermarket del Gruppo Freudenberg, ha lanciato sul mercato i nuovissimi Kit Anelli di Tenuta per Differenziale che, insieme ai Kit Anelli di Tenuta Distribuzione e Kit Anelli di Tenuta Frizione, vanno ad arricchire la gamma di soluzioni dedicate alla completa manutenzione del veicolo. Ancora una volta CORTECO mette a disposizione del meccanico il proprio know-how, con la certezza di:

- completare la manutenzione sul differenziale con particolari di qualità originale
- risparmiare tempo in quanto tutte le tenute necessarie sono presenti in unico kit dedicato

Questa linea, studiata per agevolare le esigenze del riparatore, include tutte le tenute necessarie alla completa manutenzione del differenziale. Il Kit Anelli di Tenuta per Differenziale CORTECO comprende:

- Anelli di Tenuta dedicati
- Pasta sigillante •
- Guarnizioni specifiche (dove previste dal costruttore)











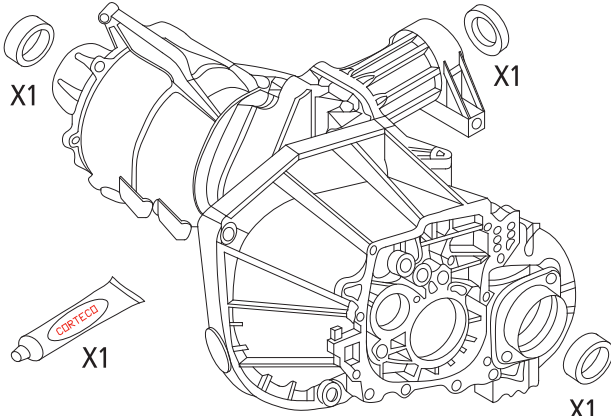





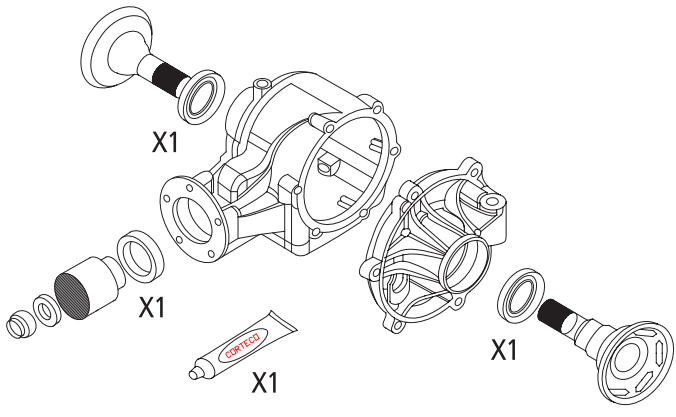







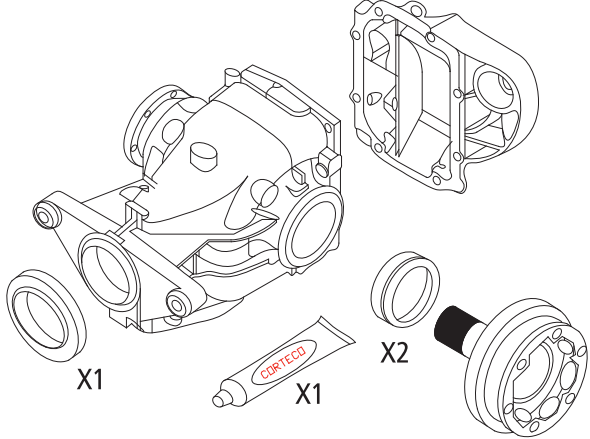





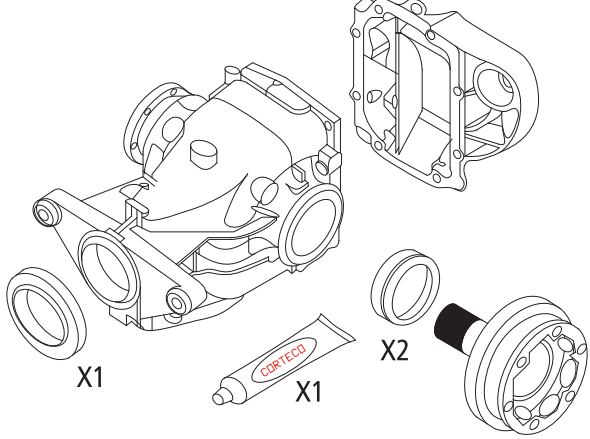





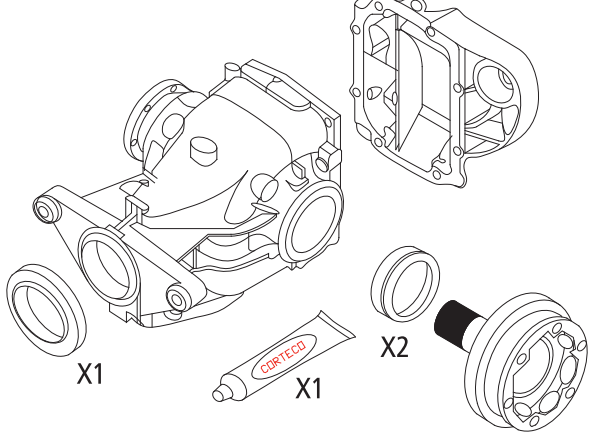

VEHICLE APPLICATIONS



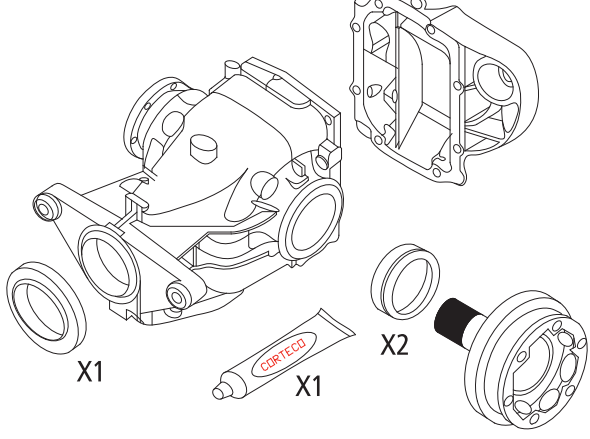













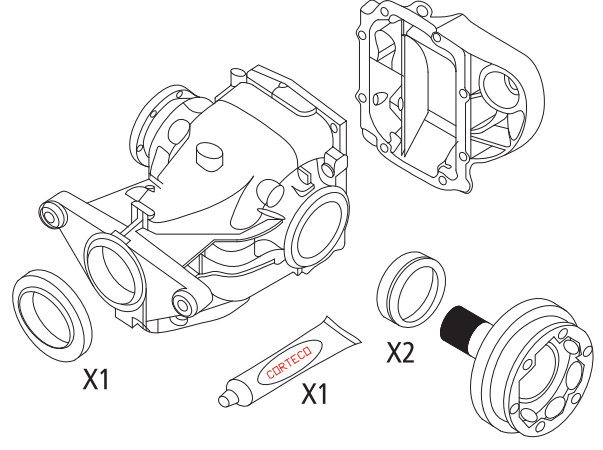





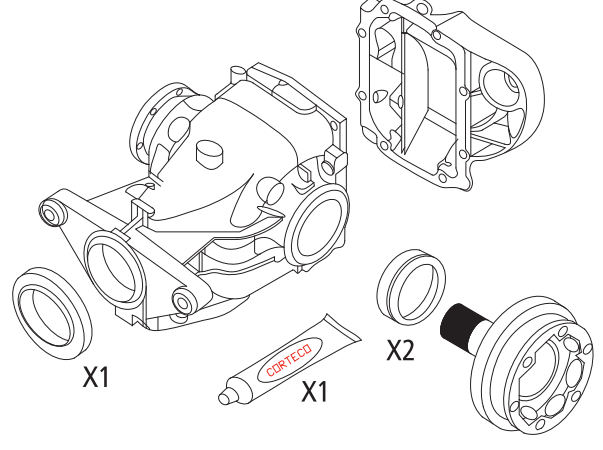

FAHRZEUGANWENDUNGEN | APPLICATIONS | APPLICAZIONI



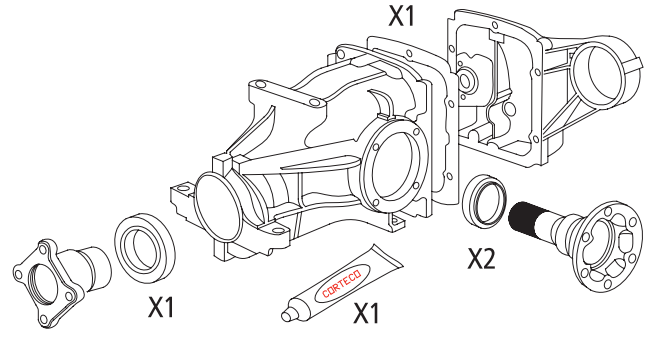





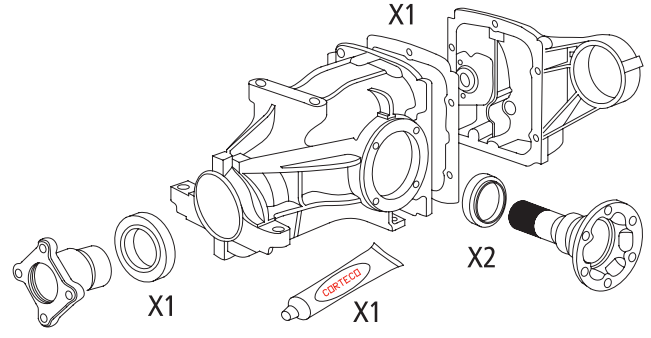

















Alfa Romeo

	19535943	
	156 (932) 1.9 JTD 16V 4x4 CrossWagon	
	01/04→12/06	
		
		
	19535939	
	156 (932) 1.9 JTD 16V 4x4 CrossWagon	
	01/04→12/06	
		
		









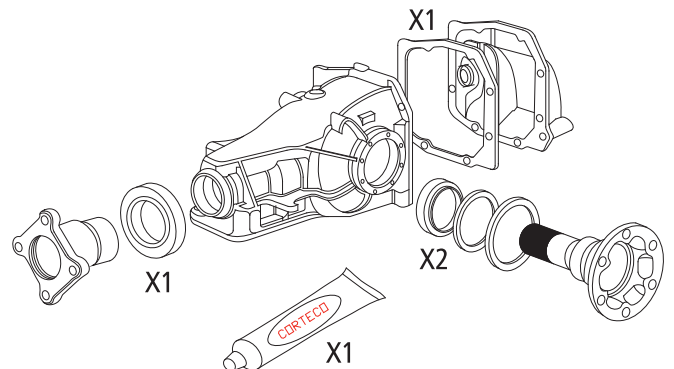
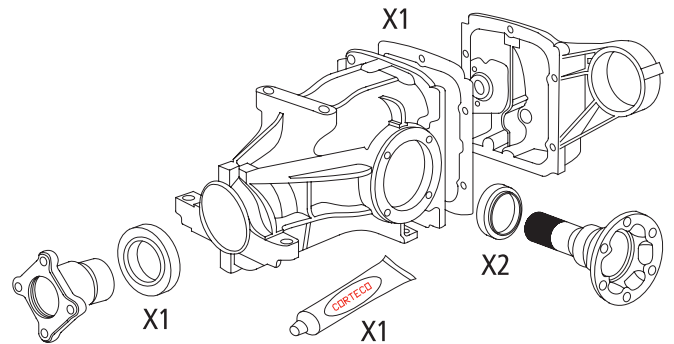
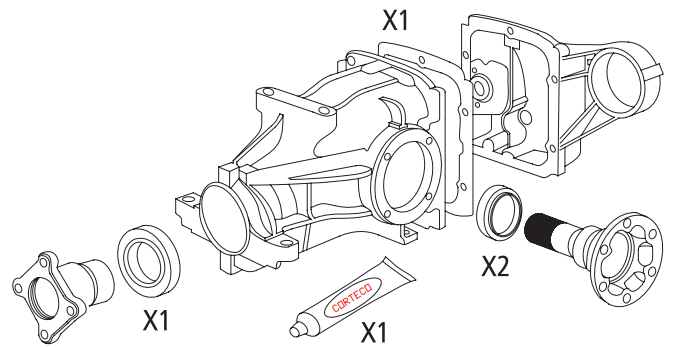
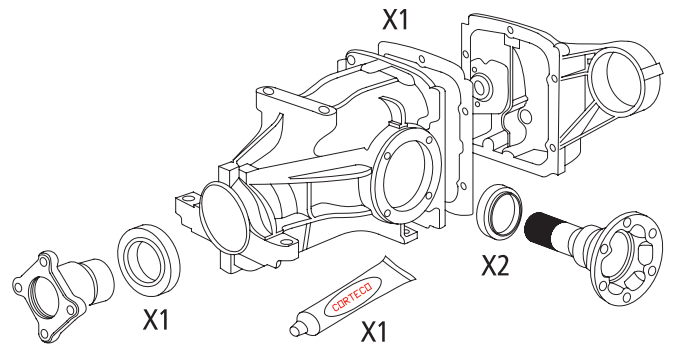

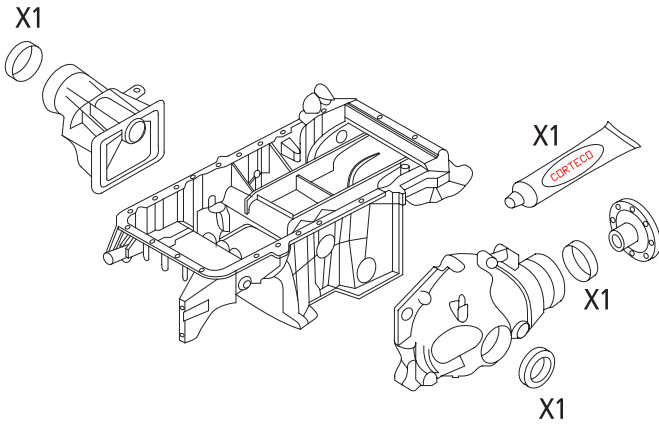





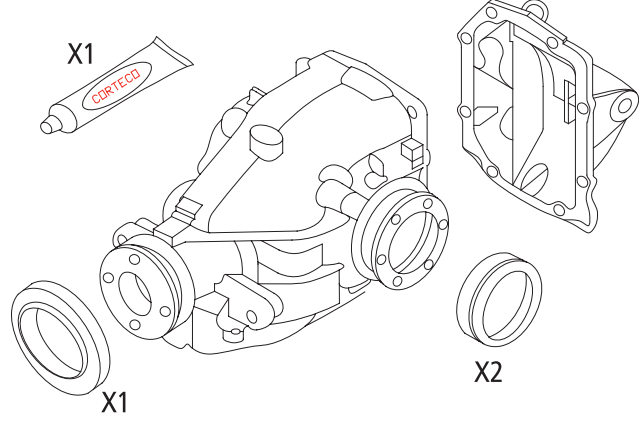





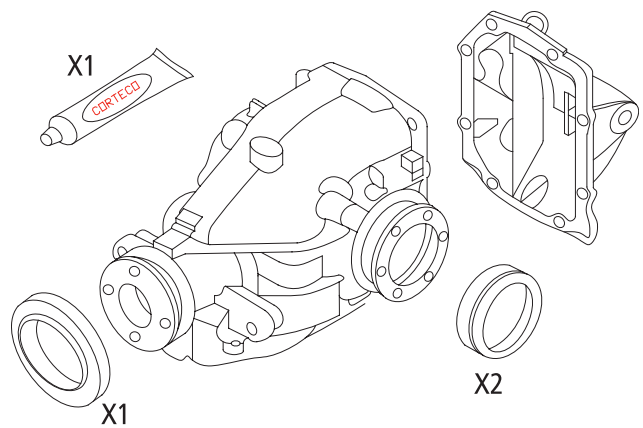

	19535940	
	1 Series (E87) 116i	
	09/04→	
		
		
	19535940	
	1 Series (E87) 118i	
	09/04→	
		
		
	19535940	
	1 Series (E87) 120i	
	09/04→	
		
		
	19535823	
	1 Series (E87) 130i	
	09/05→	
		
		



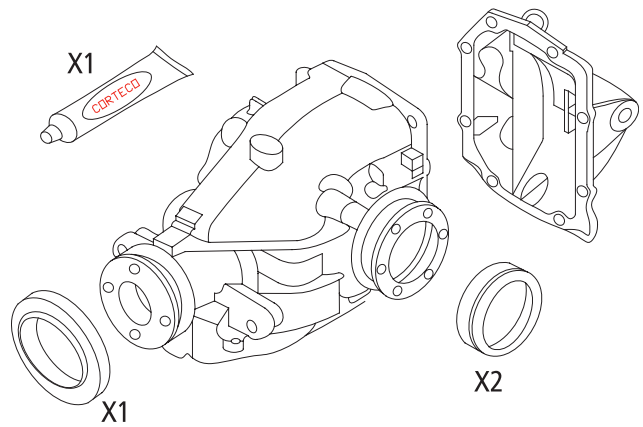







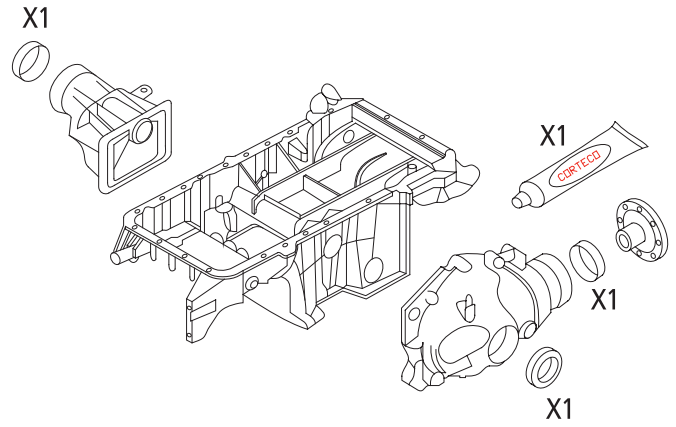





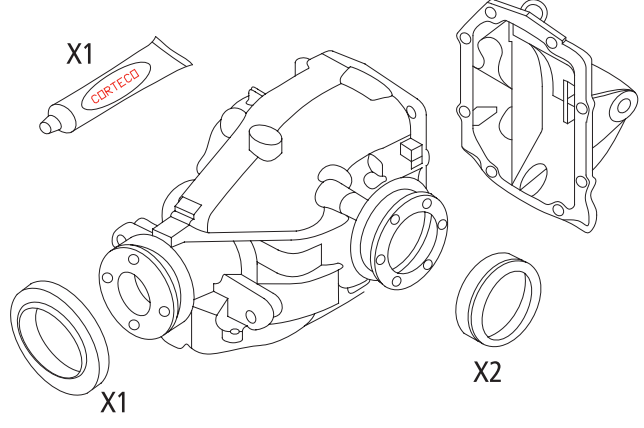





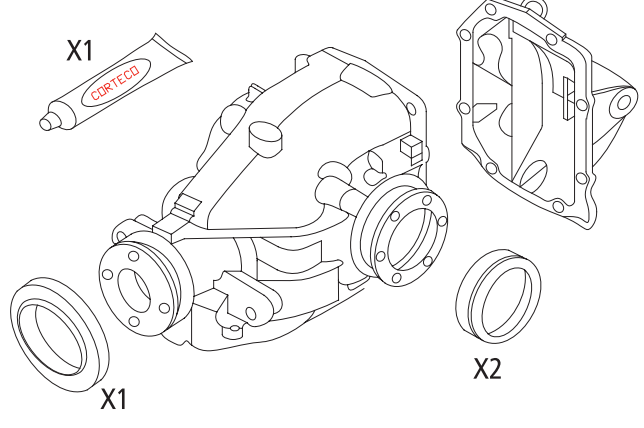

	<p>19535940</p>	
	<p>1 Series (E87) 118d</p>	
	<p>09/04→</p>	
		
		
	<p>19535823</p>	
	<p>1 Series (E81, E87) 120d</p>	
	<p>04/07→</p>	
		
		
	<p>19536199</p>	
	<p>3 Series (E30) 320 i.s.</p>	
	<p>01/87→12/90</p>	
		
		
	<p>19536199</p>	
	<p>3 Series (E30) M3</p>	
	<p>01/85→12/91</p>	
		
		



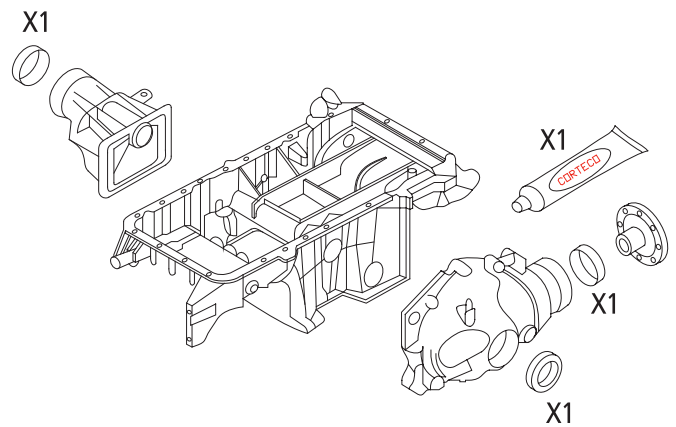







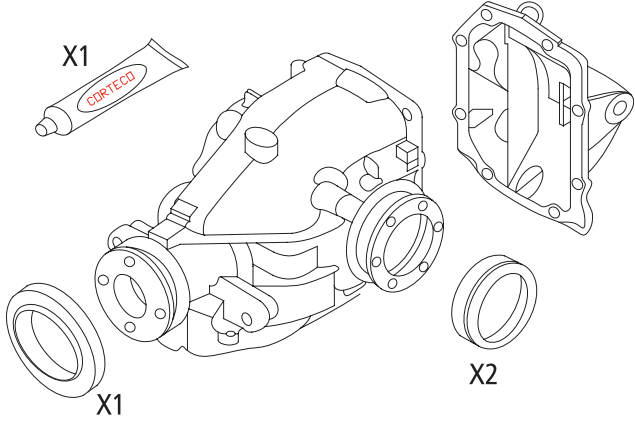





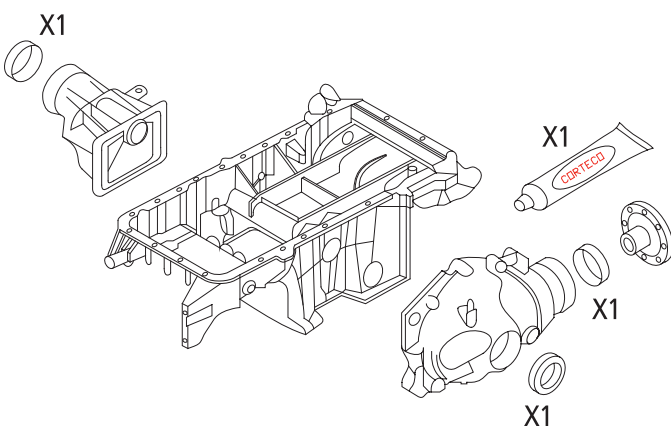





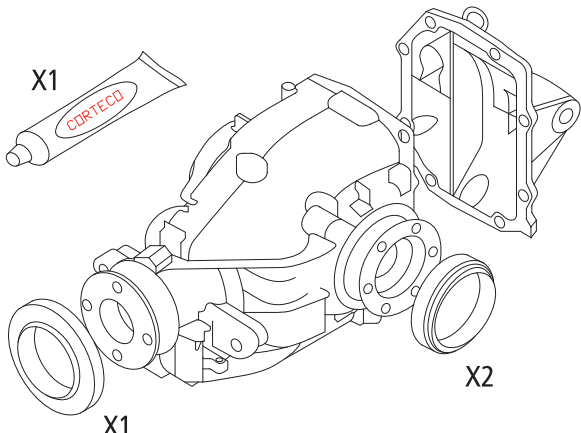

BMW



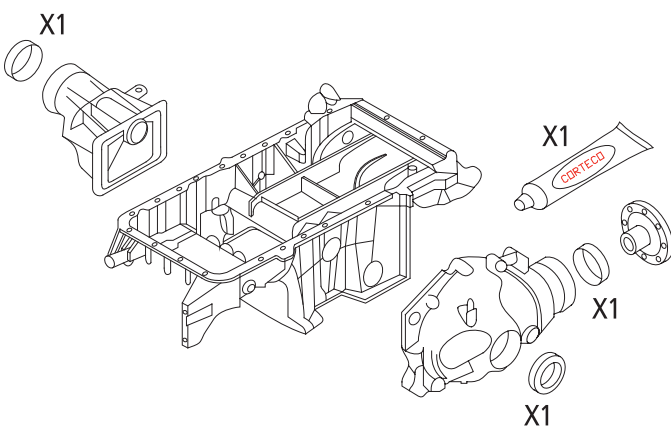







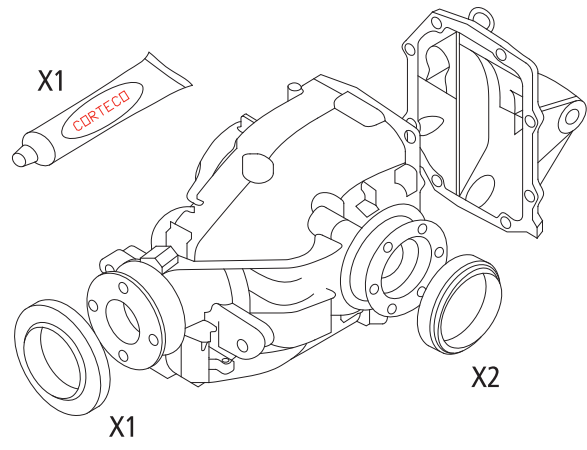





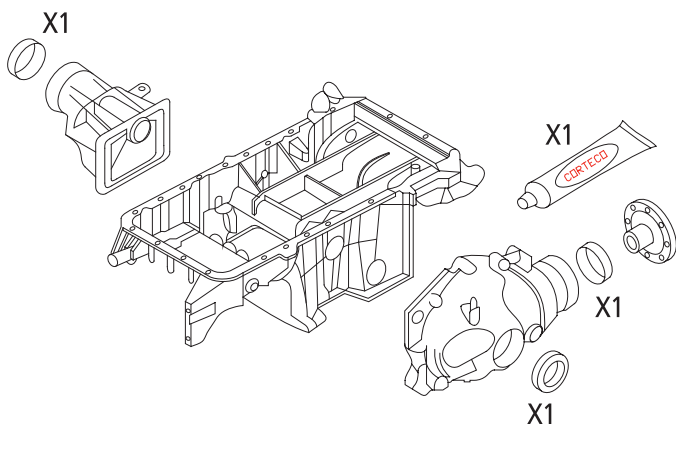





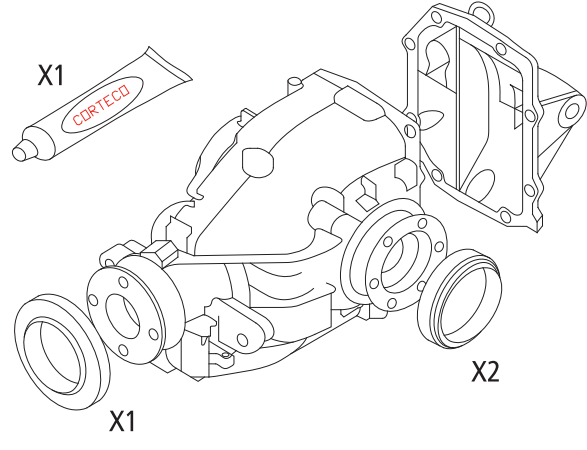

	19536200	
	3 Series (E36) 316i 1.6 Compact	
	01/98→12/00	
		
		
	19536200	
	3 Series (E36) 316i 1.9 Compact	
	01/98→12/00	
		
		
	19536199	
	3 Series (E36) 323 Ti 2.5 Compact	
	01/97→12/00	
		
		
	19536199	
	3 Series (E36) M3 3.0	
	01/92→12/95	
		
		



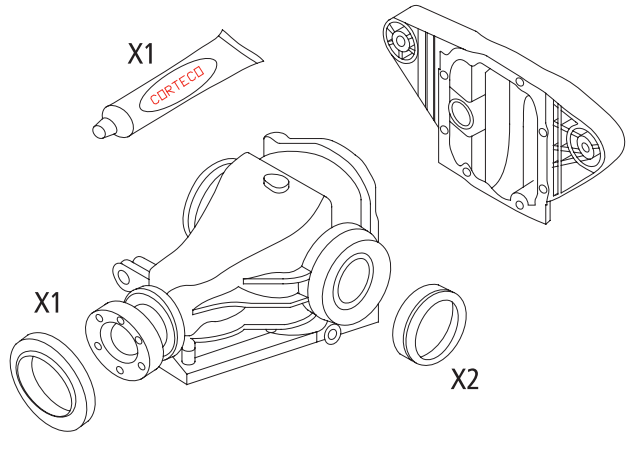







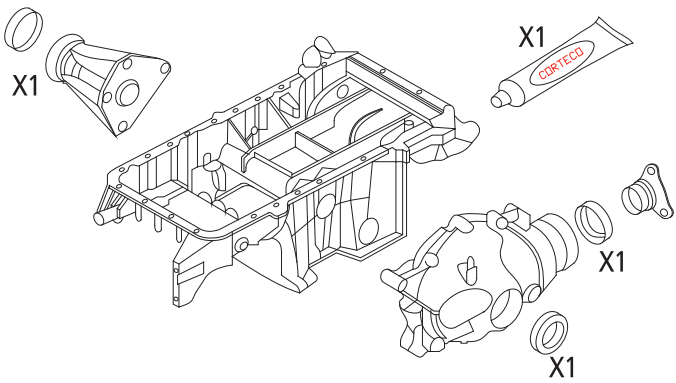





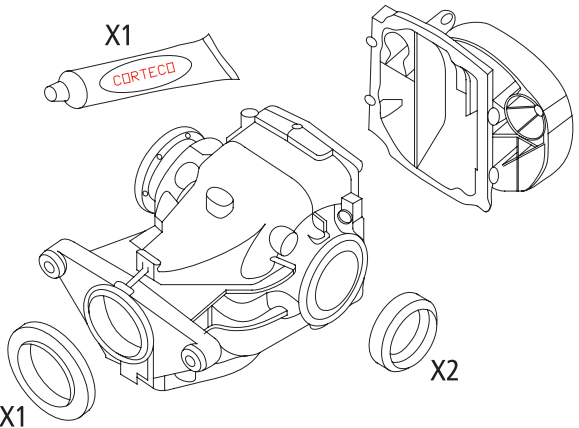





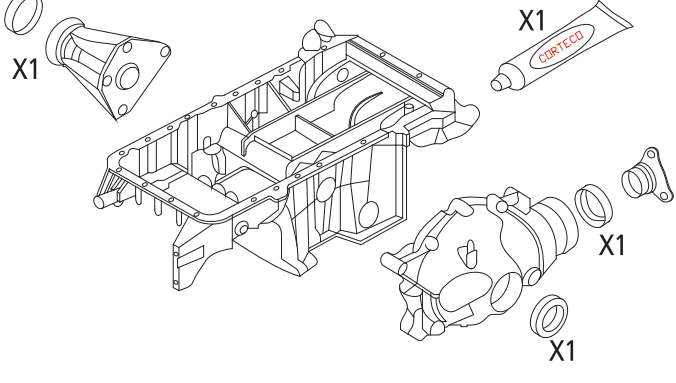



	<p>19535862</p>	
	<p>3 Series (E46) 325xi</p>	
	<p>01/00→12/03</p>	
		
		
	<p>19535823</p>	
	<p>3 Series (E46) 325xi</p>	
	<p>01/00→12/03</p>	
		
		
	<p>19535823</p>	
	<p>3 Series (E46) 328 Ci</p>	
	<p>01/97→12/00</p>	
		
		
	<p>19535823</p>	
	<p>3 Series (E46) 330 Ci</p>	
	<p>01/99→12/03</p>	
		
		

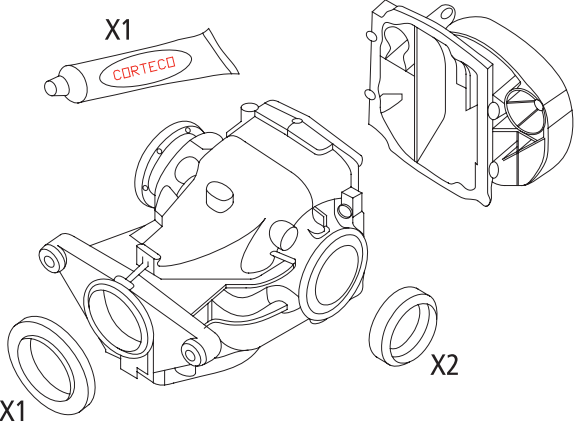















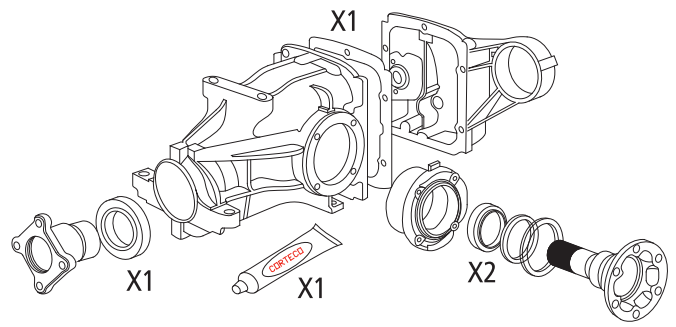





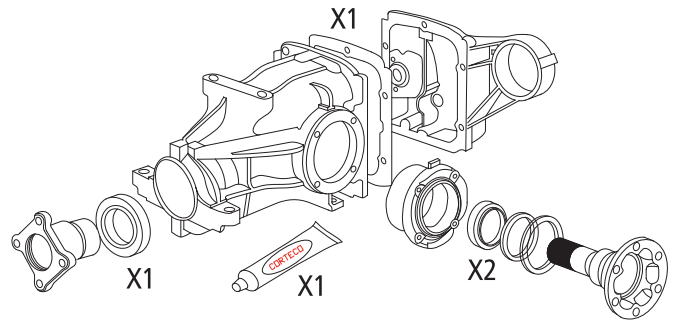

	19535862	
	3 Series (E46) 330xi	
	01/99→12/03	
		
		
	19535823	
	3 Series (E46) 330xi	
	01/99→12/03	
		
		
	19535823	
	3 Series (E46) 320d	
	09/01→02/05	
		
		
	19535862	
	3 Series (E46) 330xd	
	01/00→12/03	
		
		



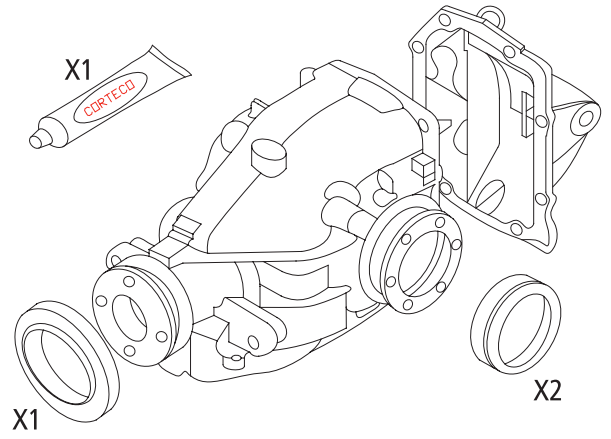

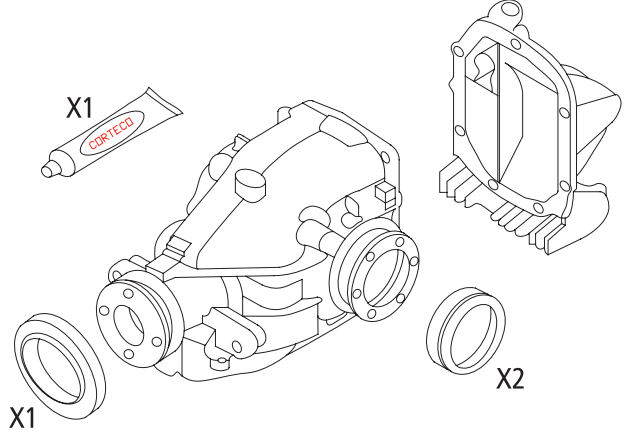

	<p>19535823</p>	
	<p>3 Series (E46) 330xd</p>	
	<p>01/00→12/03</p>	
		
		
	<p>19535862</p>	
	<p>X3 (E83) 2.0d</p>	
	<p>10/04→</p>	
		
		
	<p>19535823</p>	
	<p>X3 (E83) 2.0d</p>	
	<p>10/04→</p>	
		
		
	<p>19535862</p>	
	<p>X3 (E83) 3.0d</p>	
	<p>01/03→</p>	
		
		

	19535823	
	X3 (E83) 3.0d	
	01/03→	
		
		
	19535862	
	X3 (E83) 3.0d	
	01/06→	
		
		
	19535823	
	X3 (E83) 3.0d	
	01/06→	
		
		
	19535823	
	5 Series (E39) 525 Tds	
	10/95→12/00	
		
		

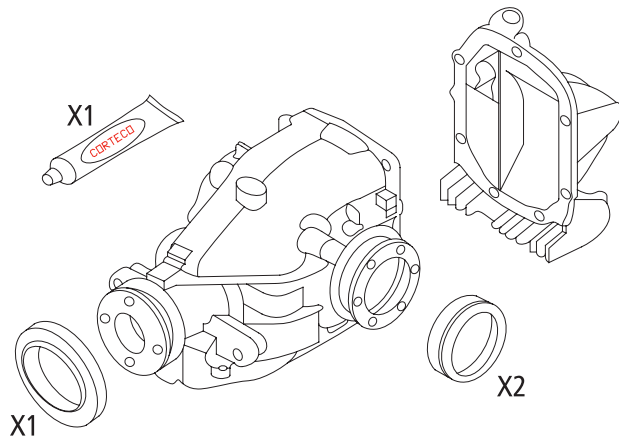









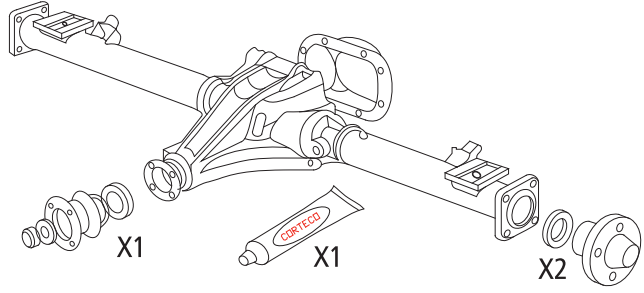





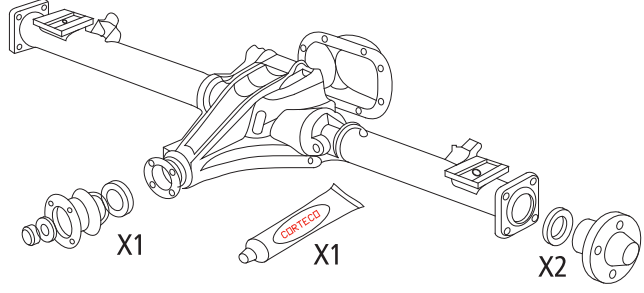

	19535862	
	X5 (E53) 4.6is	
	12/03→	
		
		
	19535823	
	X5 (E53) 4.6is	
	12/03→	
		
		
	19535862	
	X5 (E53) 3.0d	
	12/03→	
		
		
	19535823	
	X5 (E53) 3.0d	
	12/03→	
		
		

BMW

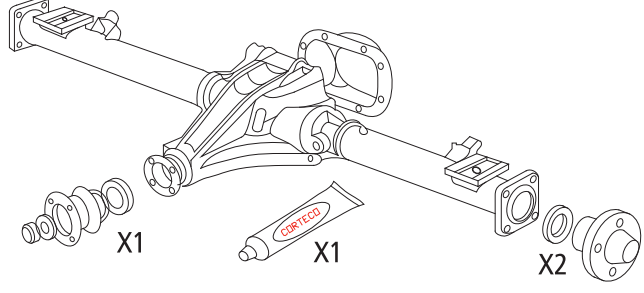









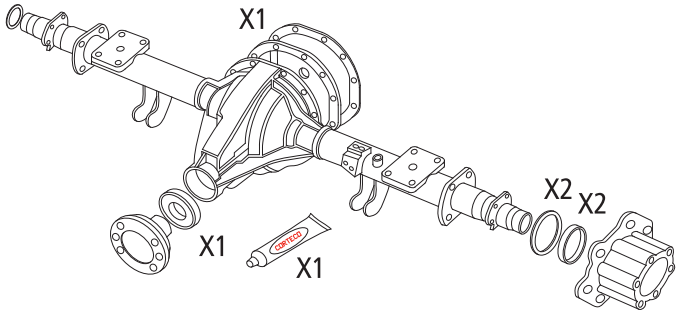





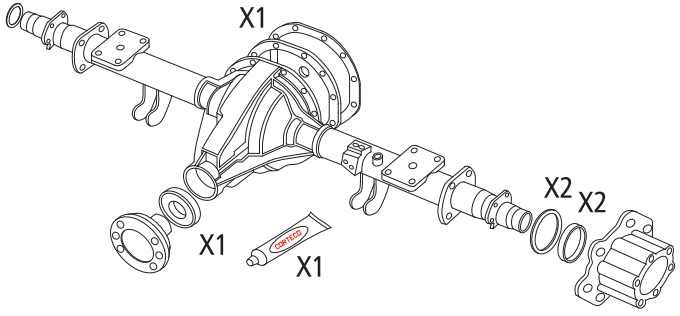





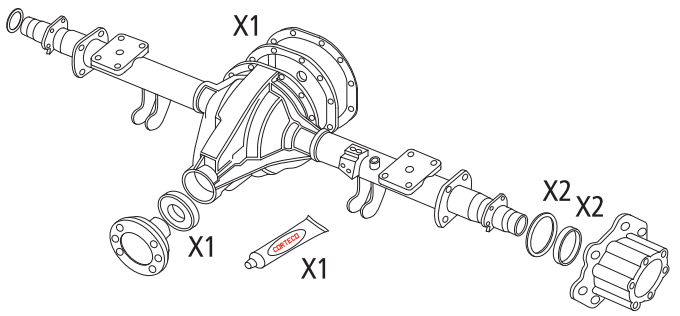

	19536199	
	Z3 (E36) 3.2 M Coupé	
	02/98→01/03	
		
		
	19536199	
	Z3 (E36) 3.2 M Roadster	
	03/97→01/03	
		
		
	19535823	
	Z4 (E85) Roadster 2.5 Si	
	01/04→	
		
		
	19535823	
	Z4 (E85) Roadster 3.0 i	
	01/02→	
		
		

	19535823	
	Z4 (E85) Roadster 3.0 Si	
	01/04→	
		
		

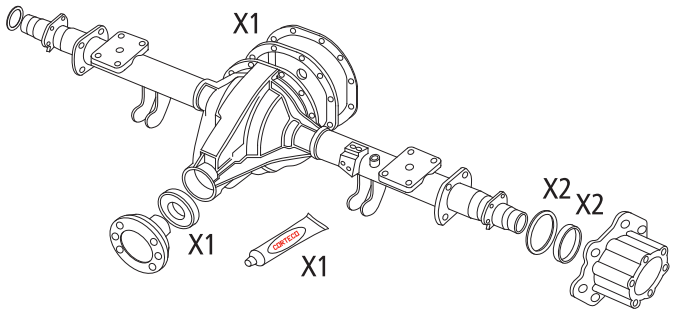















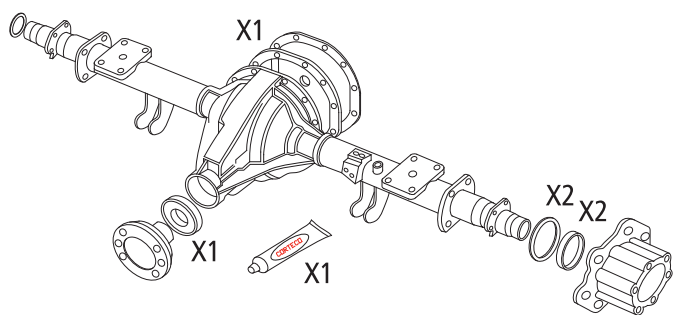





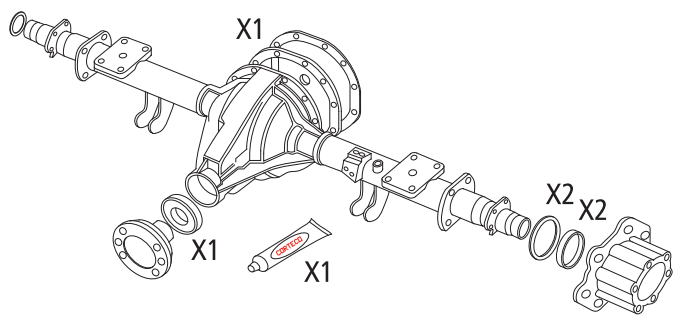

Fiat

	19535941	
	Panda 950 4x4	
	09/83→12/86	
		
		
	19535941	
	Panda 1.000 4x4	
	01/86→12/92	
		
		
	19535941	
	Panda 1.100 4x4	
	10/91→07/04	
		
		

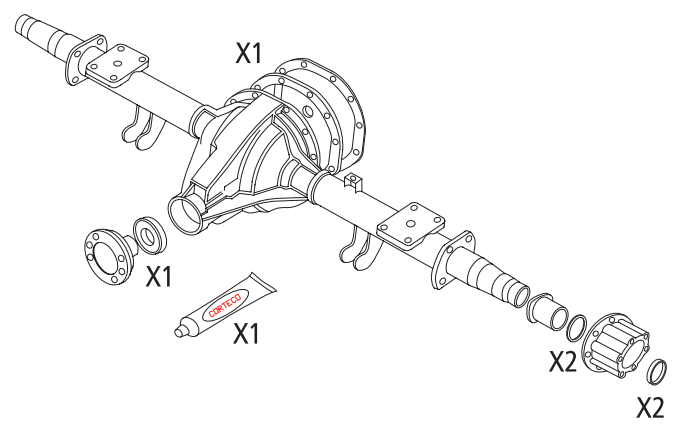



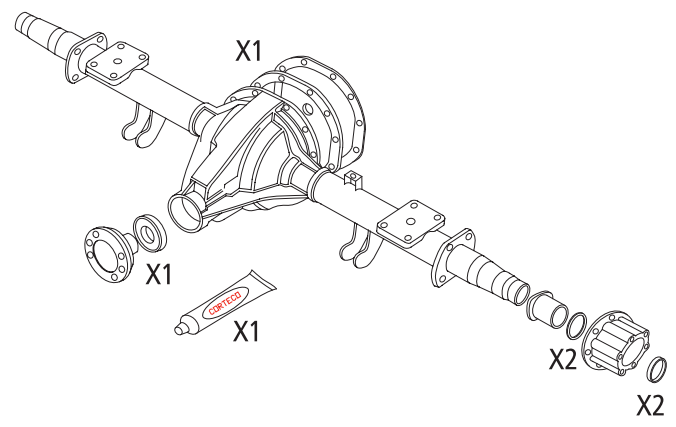

Ford L.T.

	19536195	
	Transit IV 2.0	
	09/91→09/94	
		
	Axle 53 DRW	
	19535195	
	Transit IV 2.5 Di / Td	
	09/91→09/94	
		
	Axle 53 DRW	
	19536195	
	Transit V 2.0	
	09/94→03/00	
		
	Axle 53 DRW (→03/97)	
	19536196	
	Transit V 2.0	
	09/94→03/00	
		
	Axle 53 DRW (04/97→)	

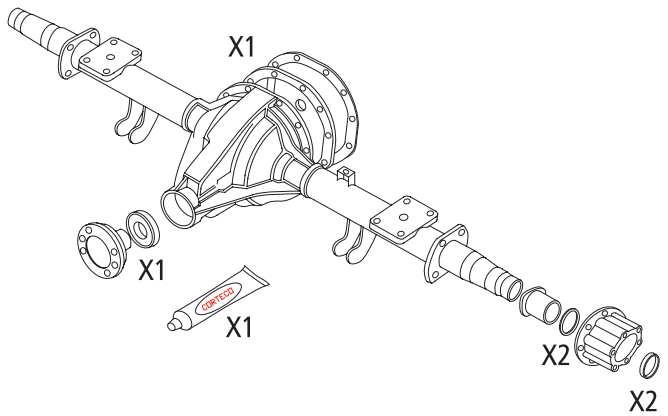









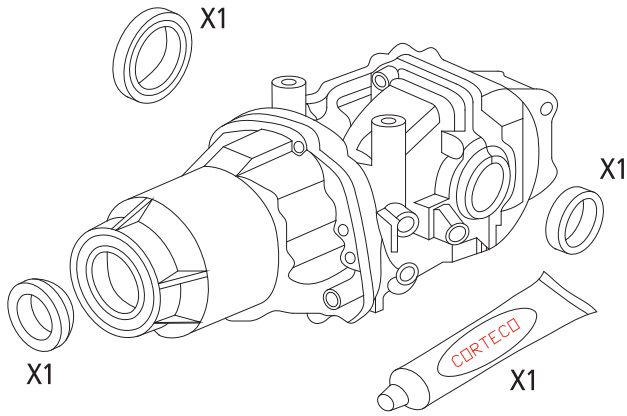





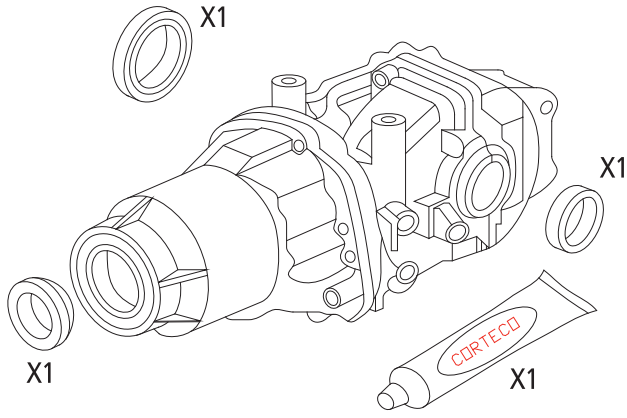

Ford L.T.

	19536195	
	Transit V 2.5 Di / Td	
	09/94 → 03/00	
		
	Axle 53 DRW (→03/97)	
	19536196	
	Transit V 2.5 Di / Td	
	09/94 → 03/00	
		
	Axle 53 DRW (04/97 →)	
	19536136	
	Transit VI 2.3 16V	
	04/01 →	
		
	DRW axle	
	19536136	
	Transit VI 2.4 Di	
	01/00 →	
		
	DRW Axle	

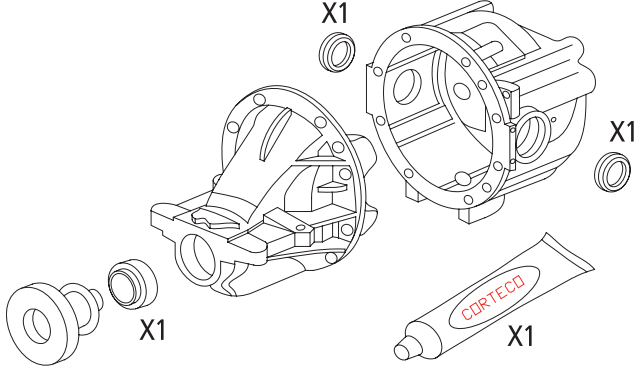









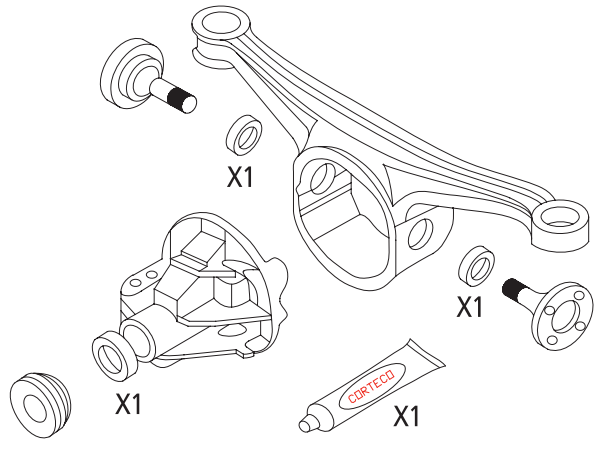





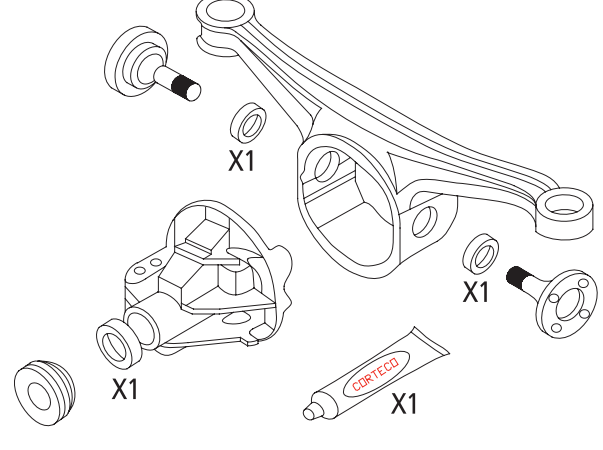





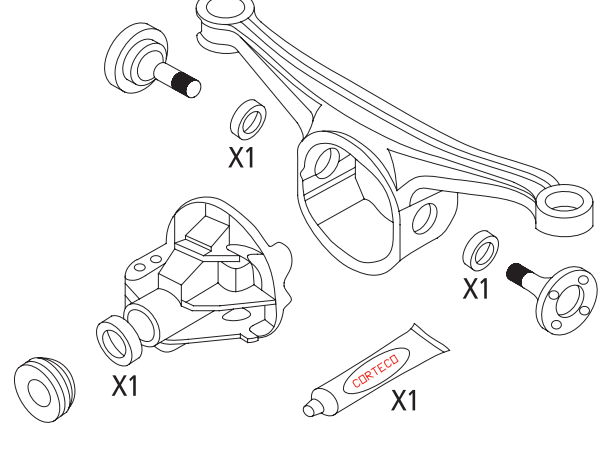

Ford L.T.

	19536136	
	Transit VI 2.4 TDCi	
	03/04→	
		
	DRW Axle	

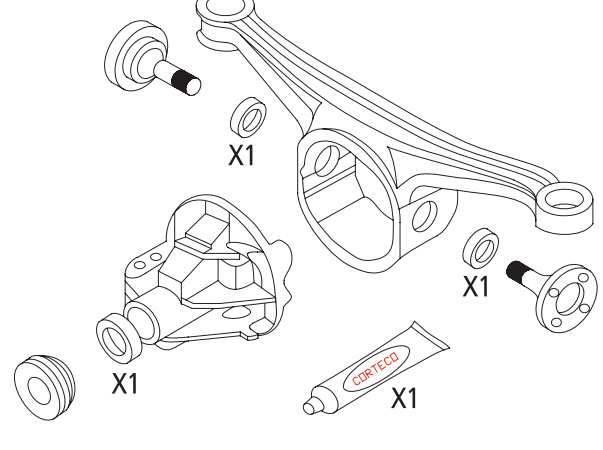









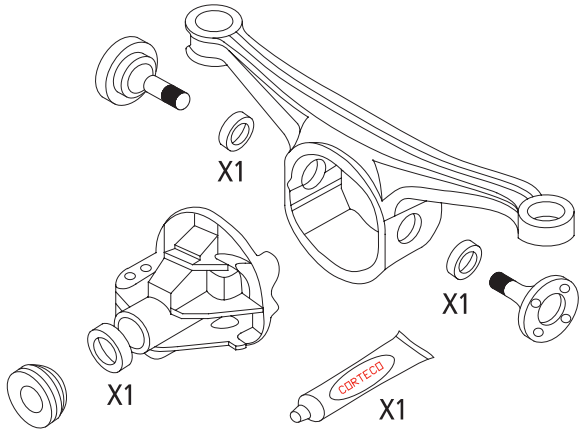

Honda

	19536172	
	CR-V II 2.0	
	07/02→09/06	
		
		
	19536172	
	CR-V II 2.2 CTDi	
	02/05→09/06	
		
		
	19536215	
	S2000	
	06/99→	
		
		

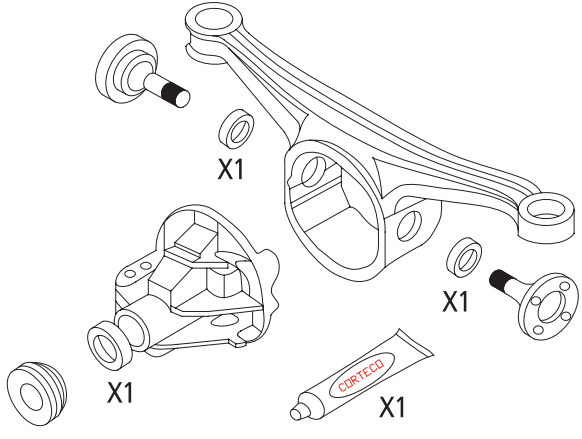









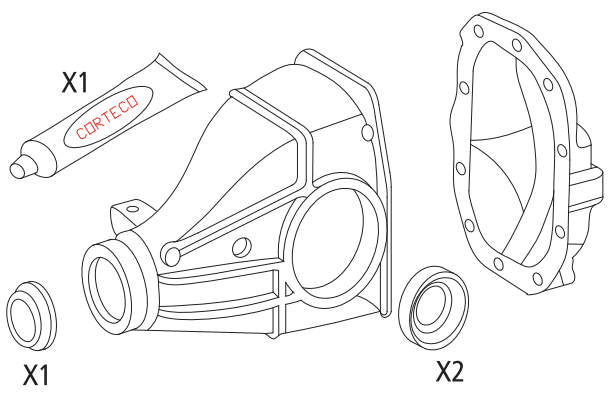





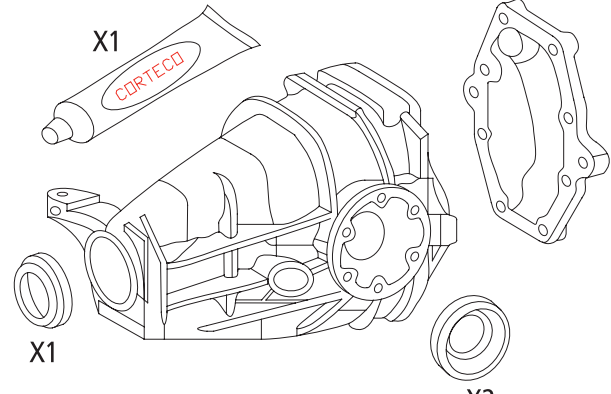





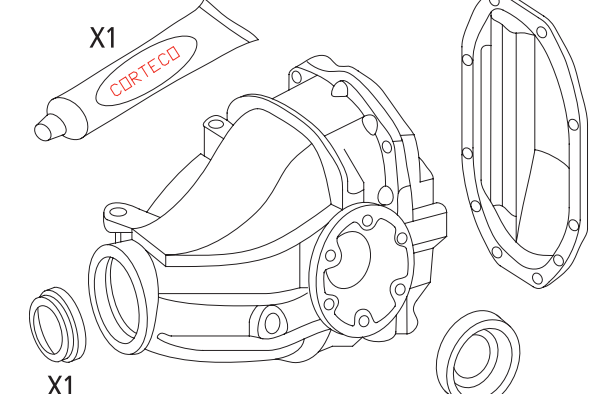

Mazda

	19535942			
	Miata 1.6			
	01/89→			
				
				
	19535861			
	MX-5 1.6 16V			
	05/90→01/94			
				
				
	19535861			
	MX-5 1.6 16V			
	02/94→04/98			
				
				
	19535861			
	MX-5 1.8 16V			
	02/94→04/98			
				
				

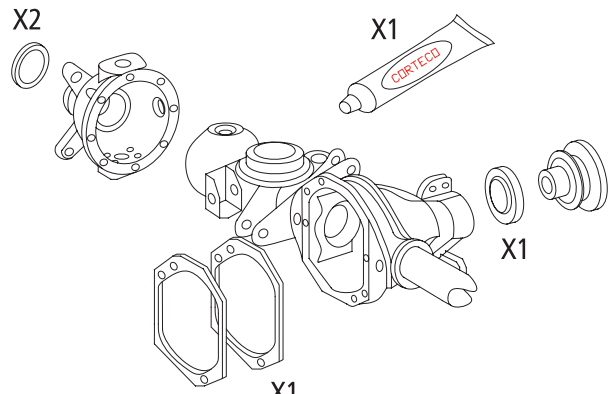









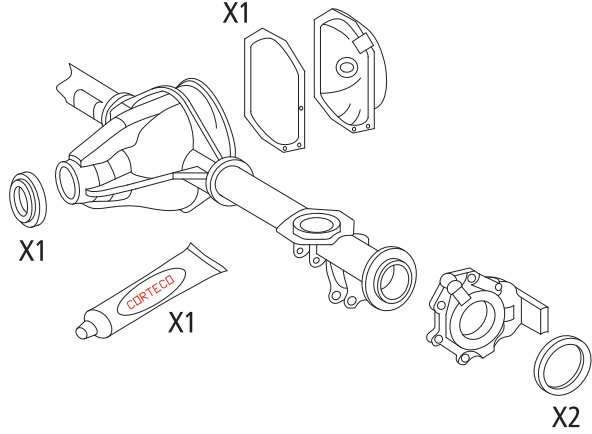

Mazda

	19535861	
	MX-5 II 1.6 16V	
	05/98→10/05	
		
		
	19535861	
	MX-5 II 1.8 16V	
	05/98→10/05	
		
		

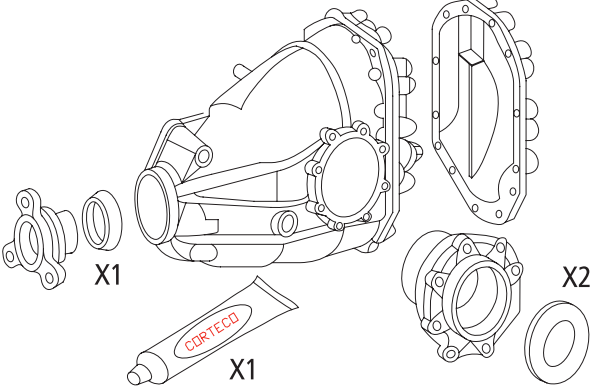















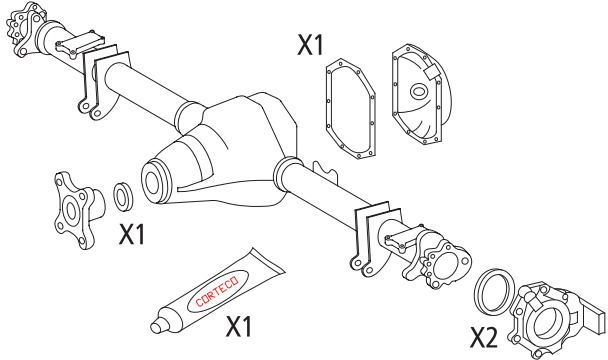





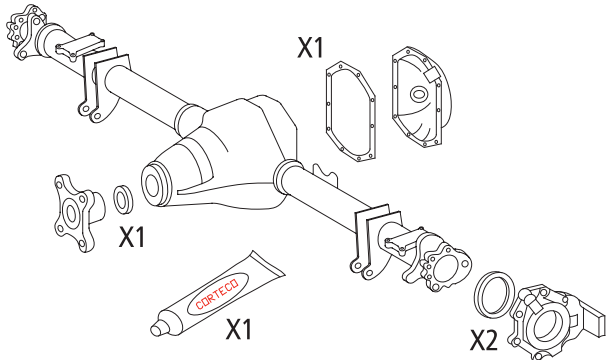

Mercedes

	19535825	
	C Class (W203) C220 CDI	
	02/04→	
		
		
	19535825	
	CLK (C208) CLK 200 Kompressor	
	06/97→06/00	
		
		
	19535815	
	E Class (W210) E270 CDI	
	07/99→03/02	
		
		
	19535844	
	G Class (W461) G270 CDI	
	08/06→	
		
		

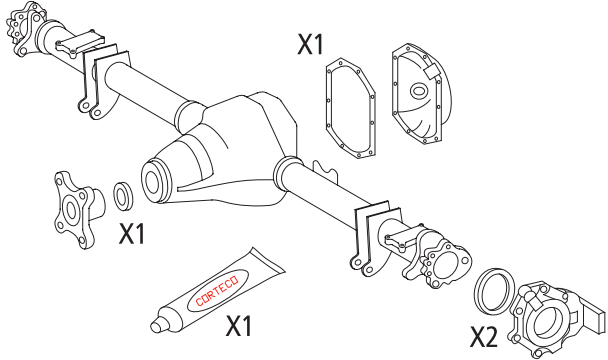





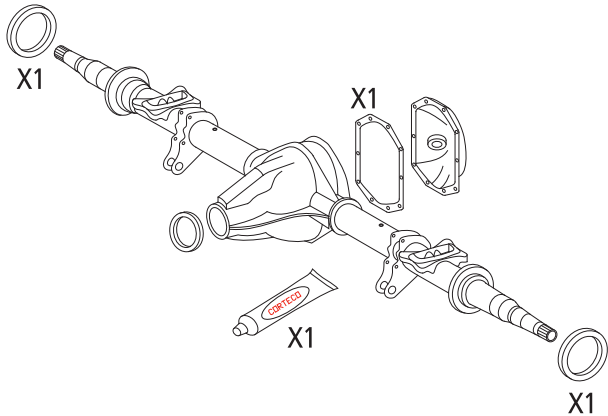









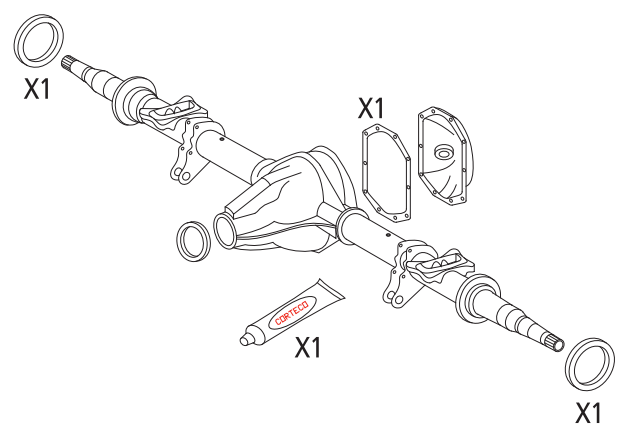





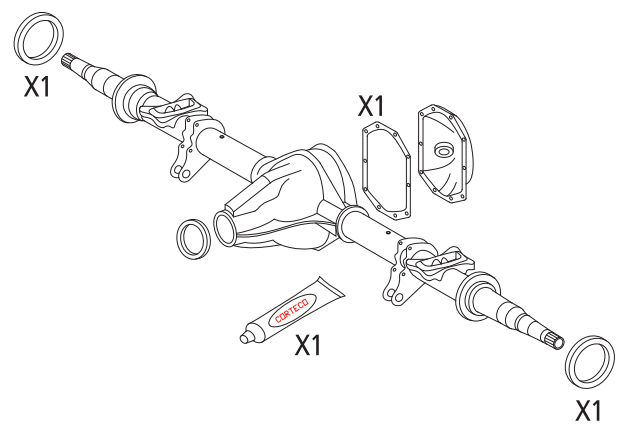

Mercedes

	19535845	
	G Class (W461) G270 CDI	
	08/06→	
		
		
	19535815	
	S Class (W220) S400 CDI	
	06/00→08/05	
		
		

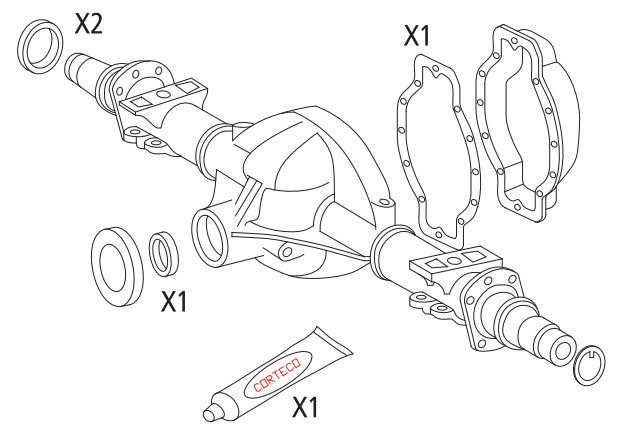





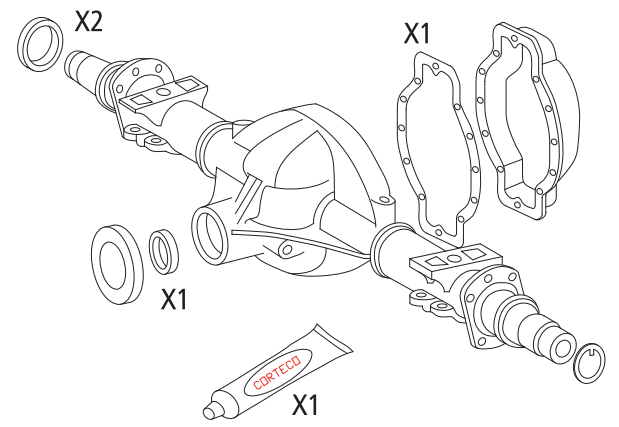



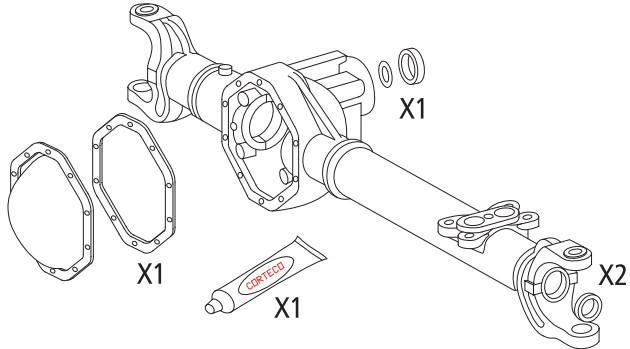





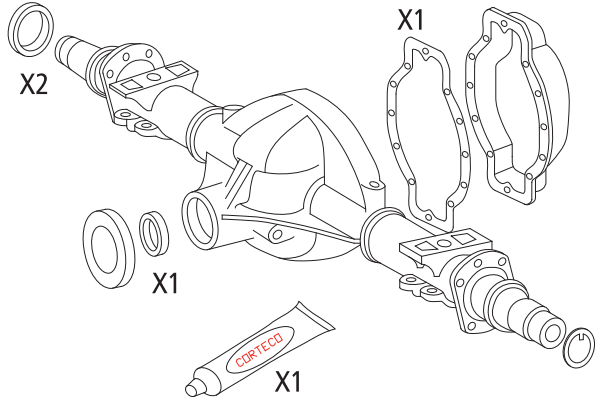





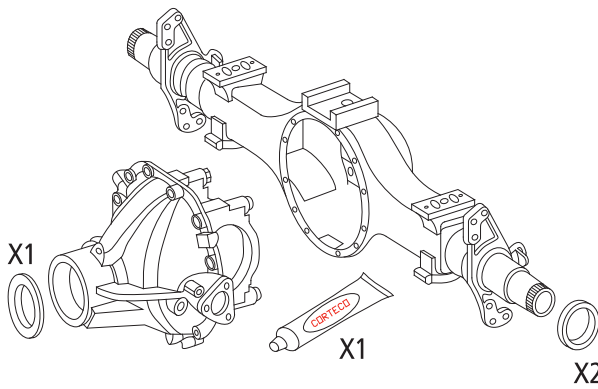

Mercedes L.T.

	19536170	
	Sprinter 216 2.7 CDI (901, 902)	
	01/95→05/06	
		
		
	19536170	
	Sprinter 316 2.7 CDI (903)	
	01/95→05/06	
		
		
	19536171	
	Sprinter 416 2.7 CDI (904)	
	02/96→05/06	
		
		
	19536169	
	T2/LN1 609D	
	04/86→12/94	
		
	Axle 741550 HL 0/6 3,9	

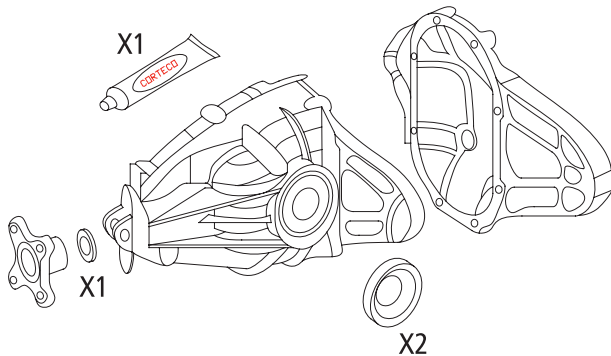





Mercedes L.T.

	19536169	
	T2/LN1 609D	
	04/86→12/94	
		
	Axle 741559 HL 0/6 3,9	
	19536221	
	T2/LN1 609D	
	04/86→12/94	
		
	Axle 742560 HL 1/8 4,7	
	19536223	
	T2/LN1 609D	
	04/86→12/94	
		
	Axle 742470 H 2/15 5,8	
	19536223	
	T2/LN1 609D	
	04/86→12/94	
		
	Axle 742486 H 2/15 5,8	

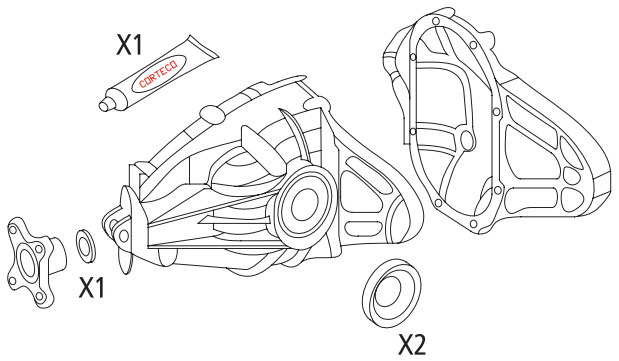









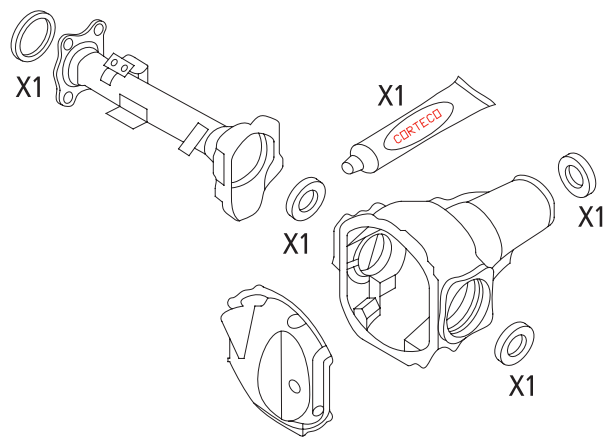





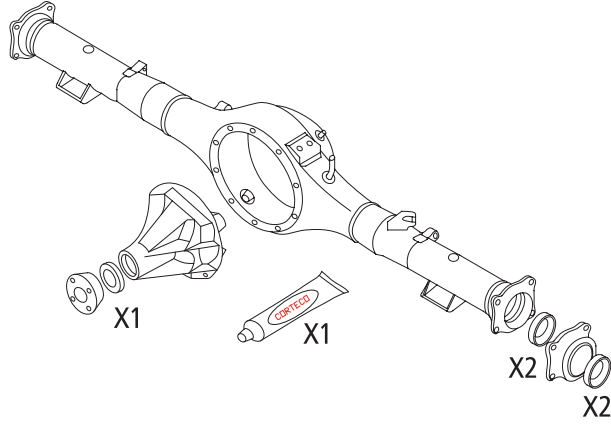





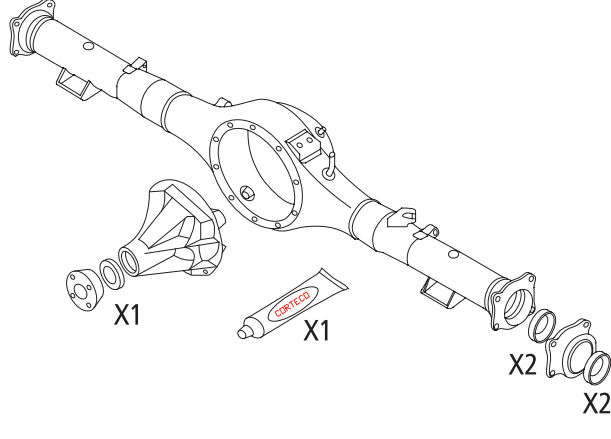

Mercedes L.T.

	19536222	
	T2/LN1 814DA	
	11/87→12/94	
		
	Axle 730351 AL 1/6 C3	
	19536223	
	T2/LN1 814DA	
	11/87→12/94	
		
	Axle 742485 HL 2/15 5,8	
	19536224	
	Vario	
	09/96→	
		
	Axle 742501 HL 2/41C 5,6	
	19535935	
	Viano (W639) 2.2 CDI	
	09/03→	
		
		

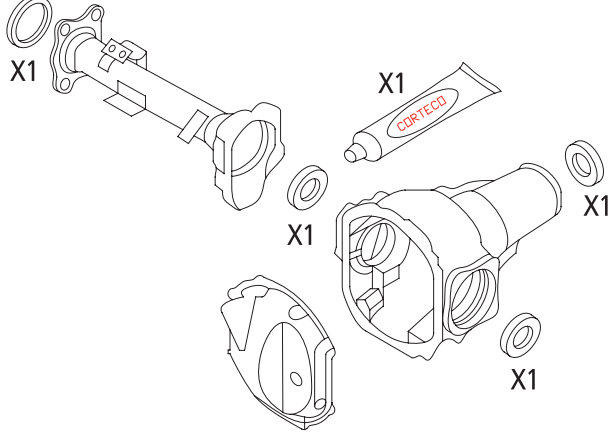























Mercedes L.T.

	19535935	
	Vito (W639) 109 / 111 / 115 2.2 CDI	
	09/03→	
		
		

Mitsubishi







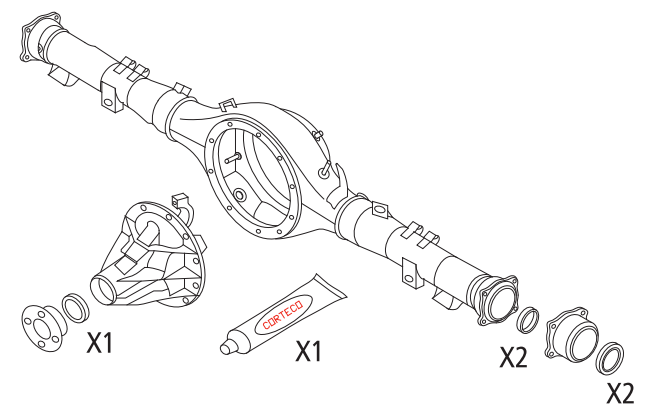
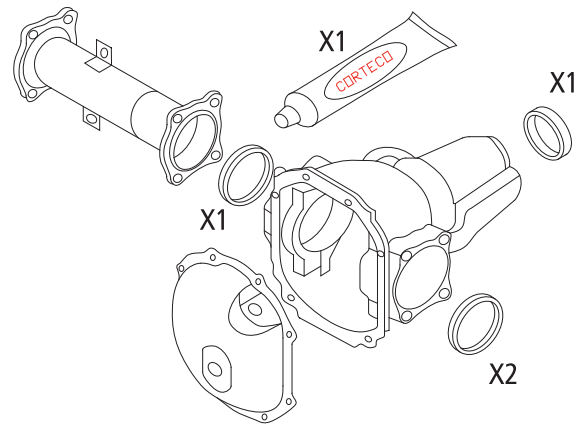
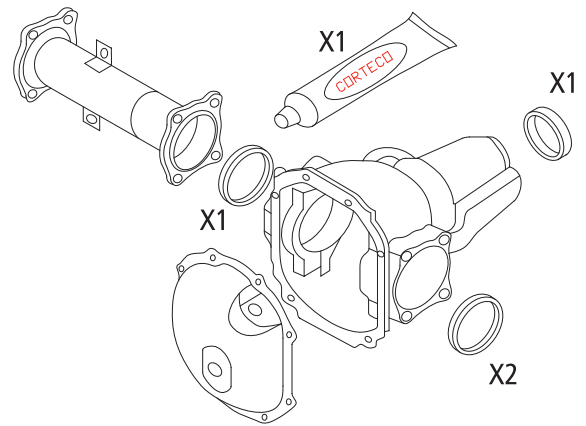
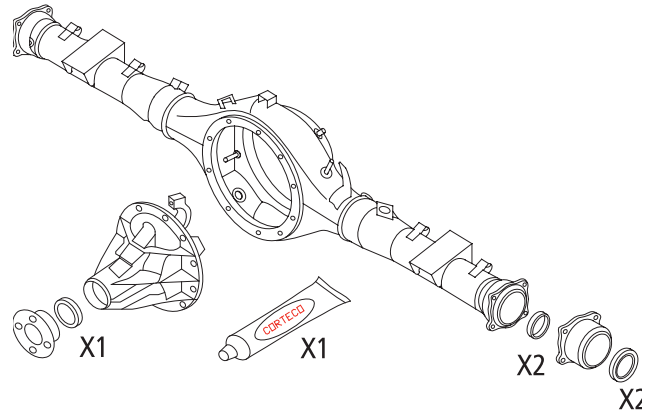



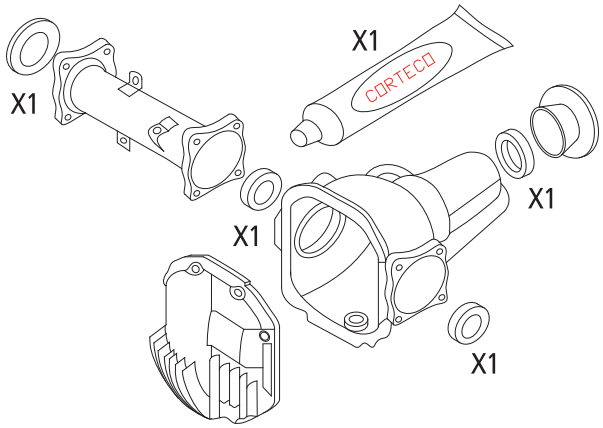





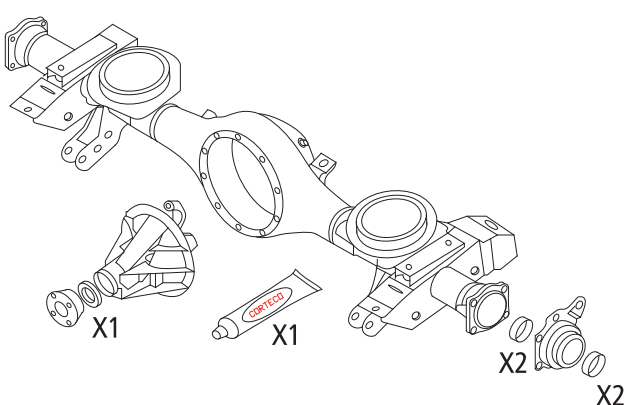





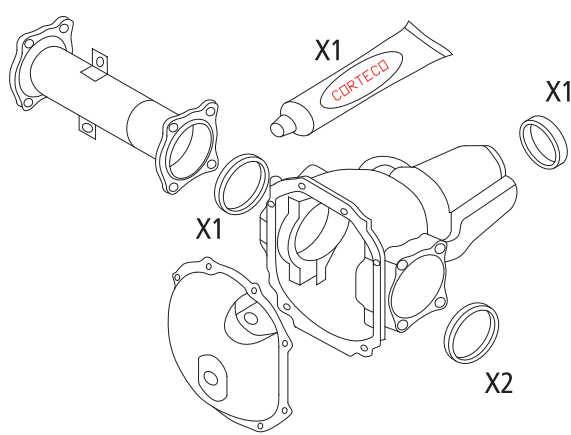

	19535826	
	L200 II 2.5 TD 4WD	
	06/96→	
		
		
	19536183	
	L200 II 2.5 TD 4WD	
	06/96→	
		
	LSD	
	19535816	
	L200 II 2.5 TD 4WD	
	06/96→	
		
	Diff Lock	
	19536138	
	L200 III 2.5 DI-D 4WD	
	05/06→	
		
		

Mitsubishi

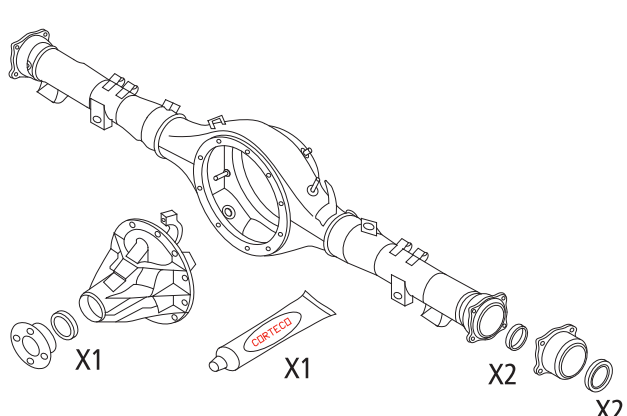























	19536184	
	L200 III 2.5 DI-D 4WD	
	05/06→	
		
		
	19536138	
	Pajero – Montero II 3.0 V6	
	12/90→04/00	
		
	MT	
	19535827	
	Pajero – Montero II 3.0 V6	
	12/90→04/00	
		
	AT	
	19535816	
	Pajero – Montero II 3.0 V6	
	12/90→04/00	
		
		



Mitsubishi







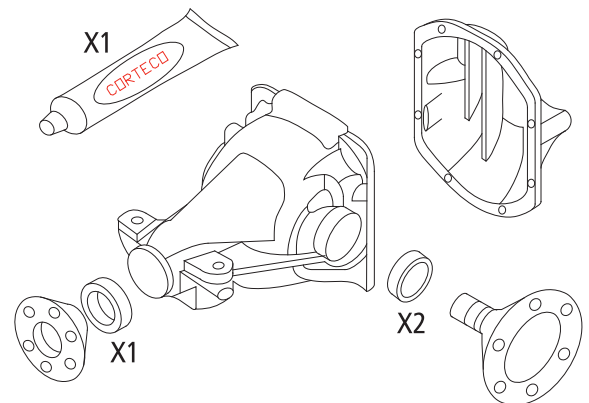
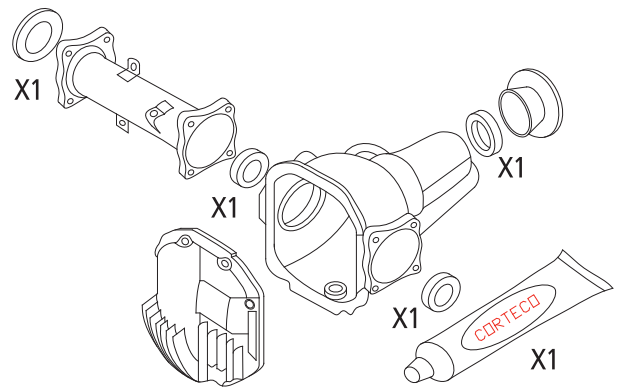
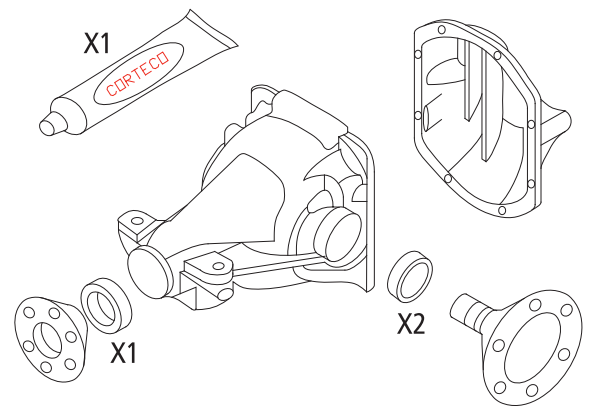
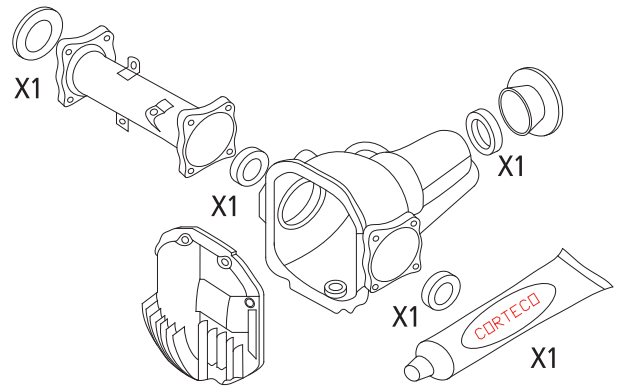



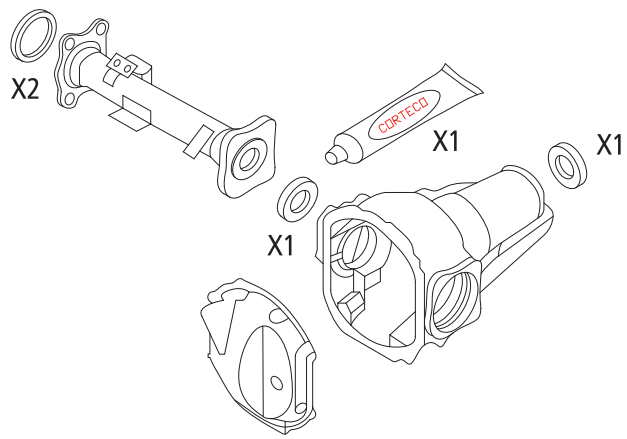

	19536138	
	Pajero – Montero II 3.5 V6 24 V	
	06/94 → 04/00	
		
		
	19535816	
	Pajero – Montero II 3.5 V6 24 V	
	06/94 → 04/00	
		
		
	19535827	
	Pajero – Montero II 2.5 TD	
	12/90 → 04/00	
		
		
	19535816	
	Pajero – Montero II 2.5 TD	
	12/90 → 04/00	
		
		

Mitsubishi

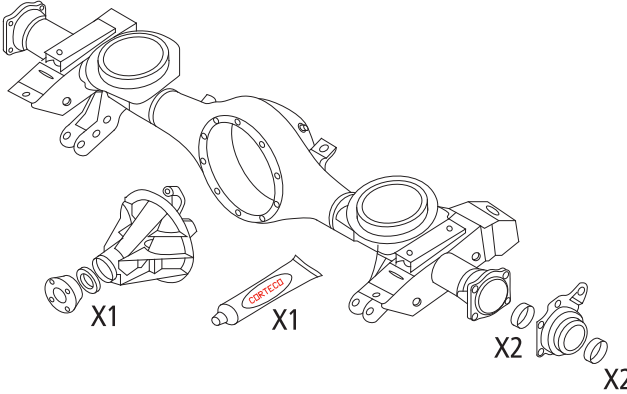















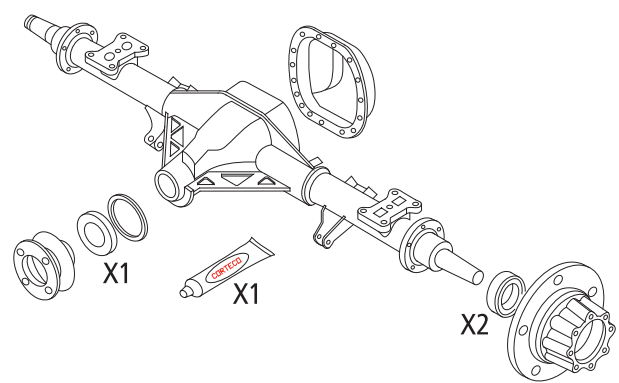





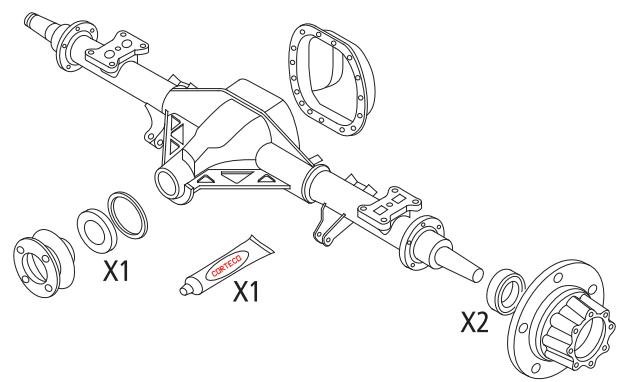

	19536138	
	Pajero – Montero III 3.2 Di-D	
	10/01 →	
		
		
	19536139	
	Pajero – Montero III 3.2 Di-D	
	10/01 →	
		
		
	19536138	
	Pajero – Montero IV 3.2 Di-D	
	02/07 →	
		
		
	19536139	
	Pajero – Montero IV 3.2 Di-D	
	02/07 →	
		
		



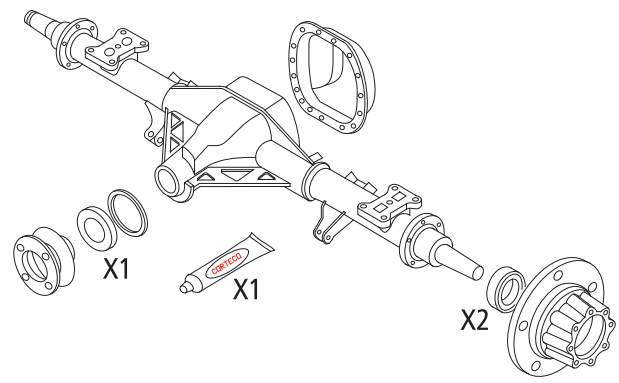





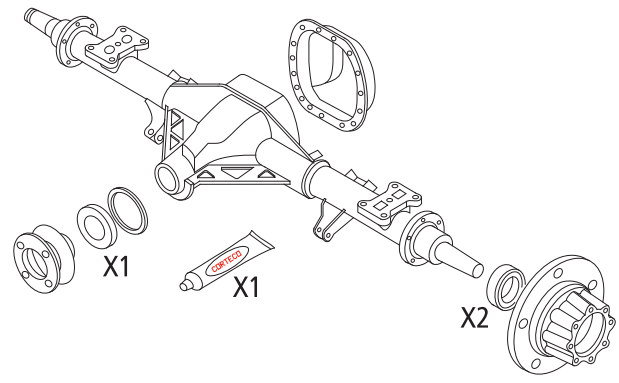



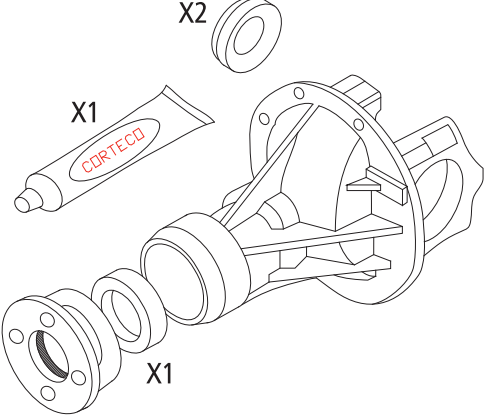





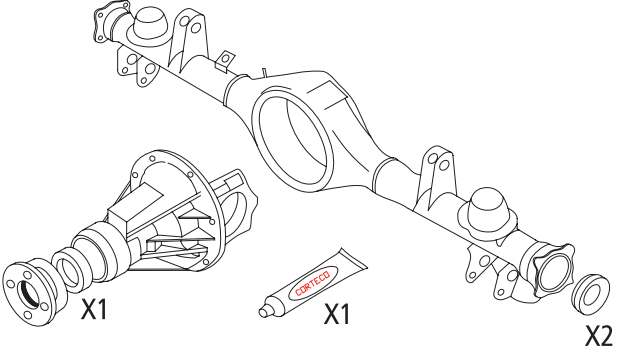





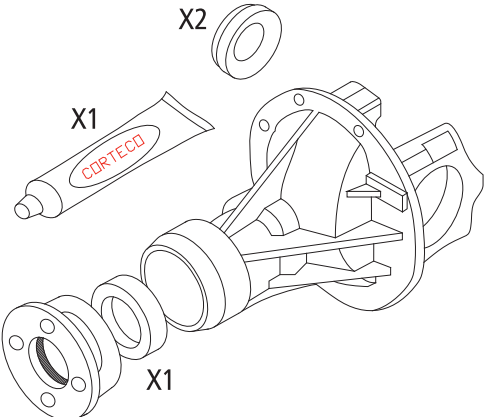

Mitsubishi

	19536138	
	Pajero – Montero Sport 2.5 TD	
	11/98→	
		
		
	19535816	
	Pajero – Montero Sport 2.5 TD	
	11/98→	
		
		

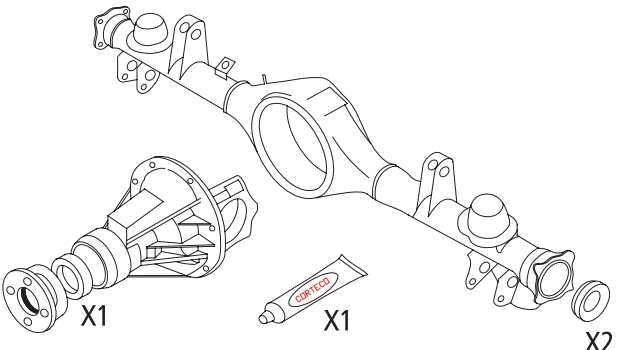









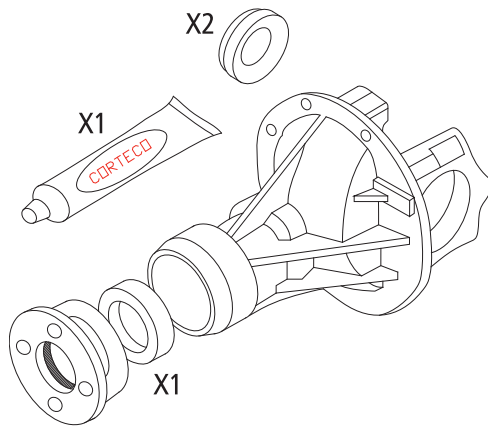





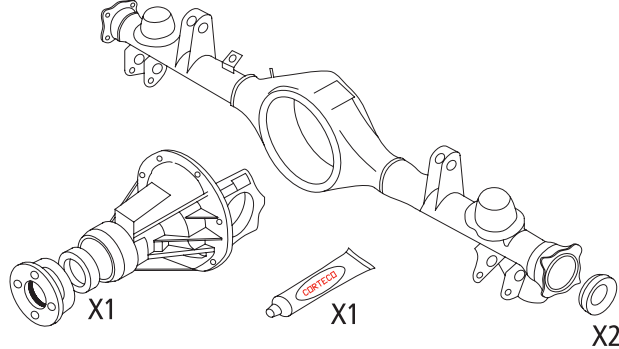





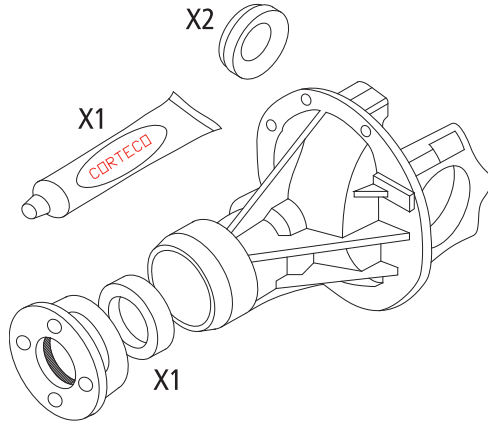

Renault Truck

	19536137	
	Mascott 120.35	
	05/04→	
		
	Axle 569.06	
	19536168	
	Mascott 120.35	
	05/04→	
		
	Axle 669.10	
	19536137	
	Mascott 160.35	
	05/04→	
		
	Axle 569.06	
	19536168	
	Mascott 160.35	
	05/04→	
		
	Axle 669.10	

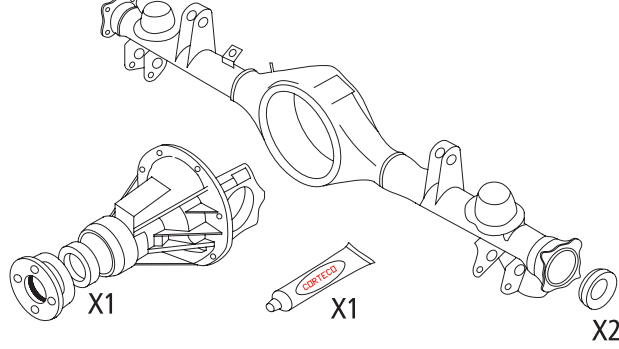









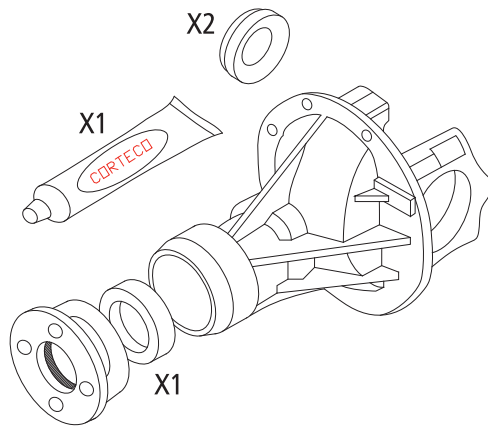





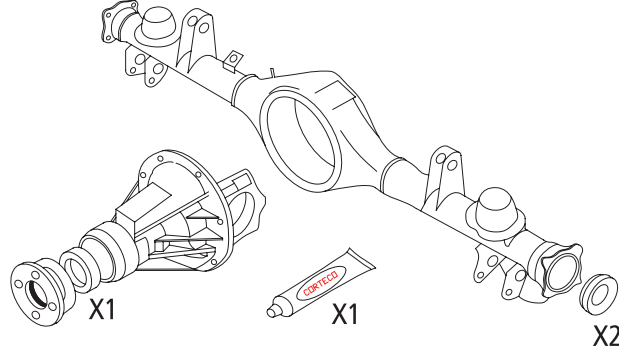





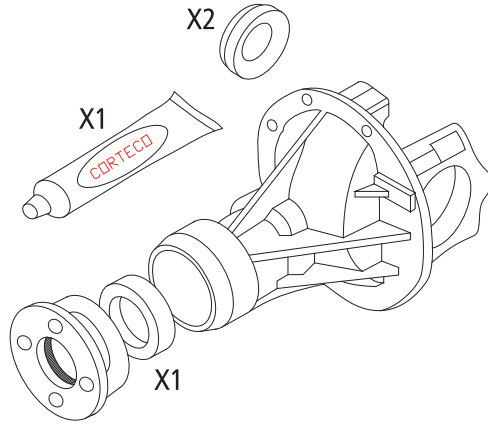

Suzuki

	19536212	
	Grand Vitara 1.6i 16V	
	03/98→	
		
		
	19536213	
	Grand Vitara 1.6i 16V	
	03/98→	
		
		
	19536212	
	Grand Vitara 2.0i 16V	
	03/98→	
		
		
	19536213	
	Grand Vitara 2.0i 16V	
	03/98→	
		
		

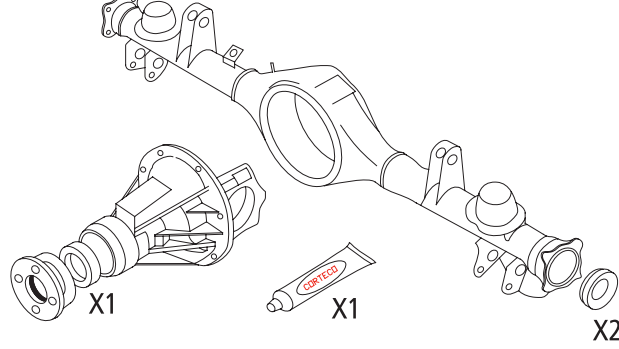









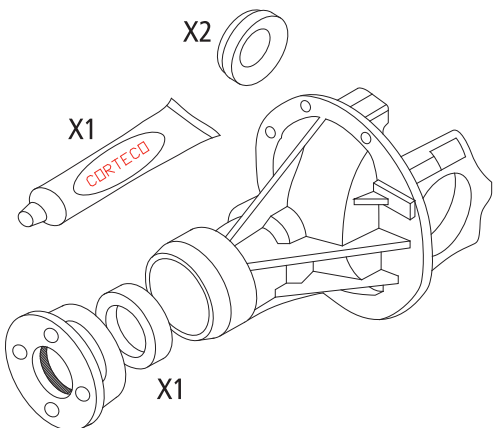





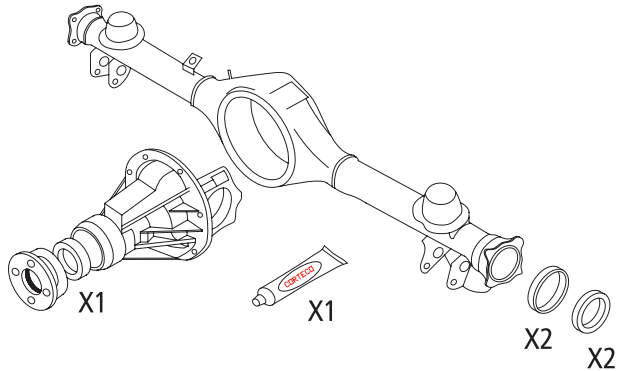





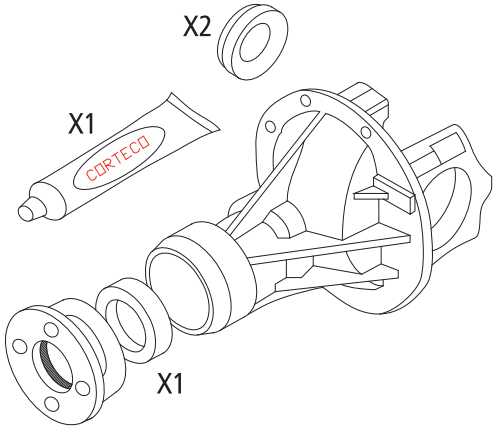

Suzuki

	19536212	
	Grand Vitara 2.5 V6 24V	
	04/98→	
		
		
	19536213	
	Grand Vitara 2.5 V6 24V	
	04/98→	
		
		
	19536212	
	Grand Vitara 2.5 V6 24V	
	04/01→	
		
		
	19536213	
	Grand Vitara 2.5 V6 24V	
	04/01→	
		
		

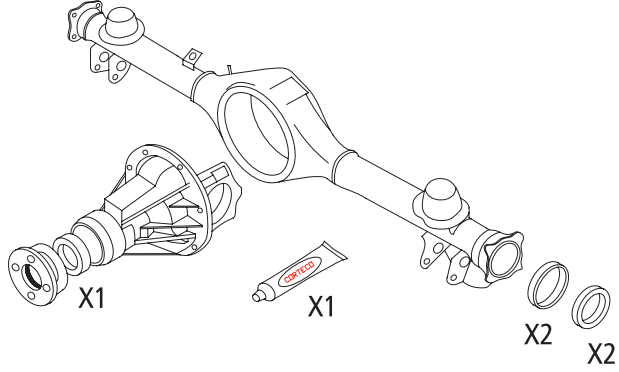









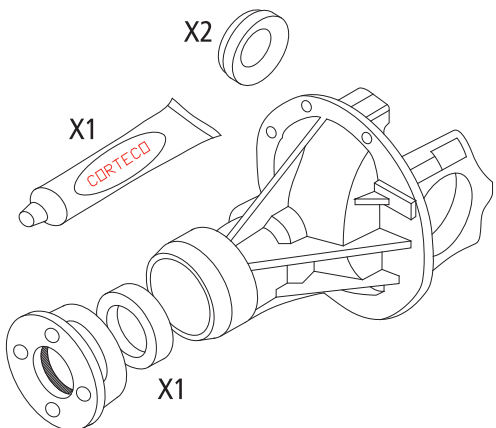





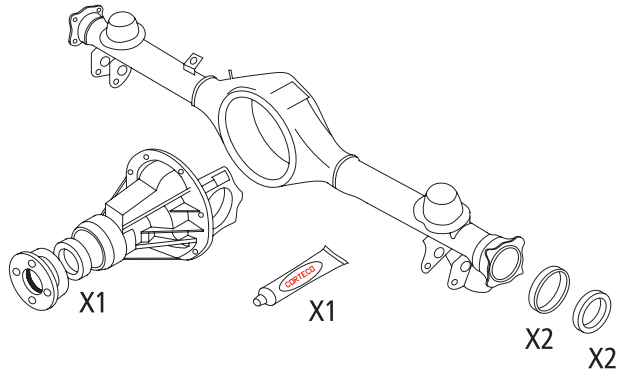





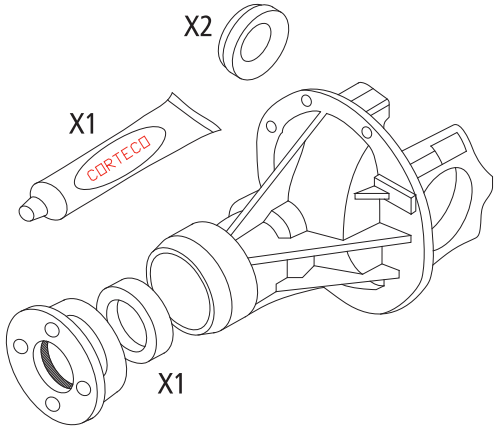

Suzuki

	19536212	
	Grand Vitara 2.0 TD	
	03/98→	
		
		
	19536213	
	Grand Vitara 2.0 TD	
	03/98→	
		
		
	19536212	
	Grand Vitara 2.0 HDi	
	07/01→	
		
		
	19536213	
	Grand Vitara 2.0 HDi	
	07/01→	
		
		

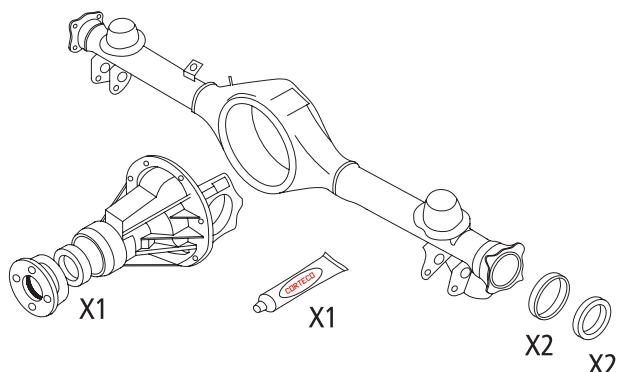









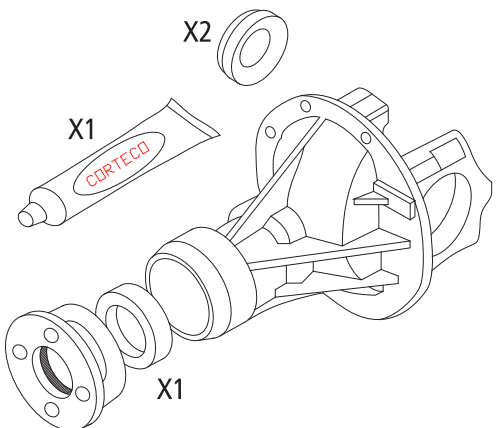





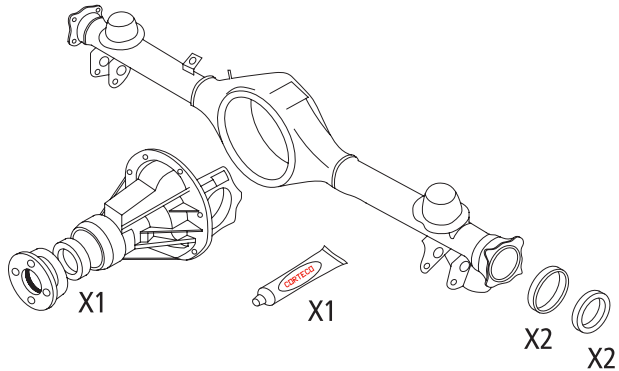





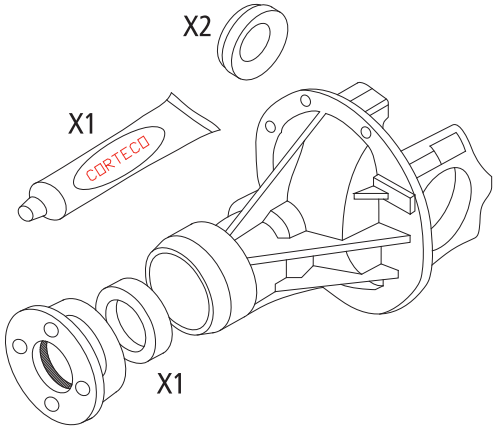

Suzuki

	19536212	
	Vitara 1.6	
	07/88→03/98	
		
		
	19536214	
	Vitara 1.6	
	07/88→03/98	
		
		
	19536212	
	Vitara 1.6i 16V	
	07/90→03/98	
		
		
	19536214	
	Vitara 1.6i 16V	
	07/90→03/98	
		
		

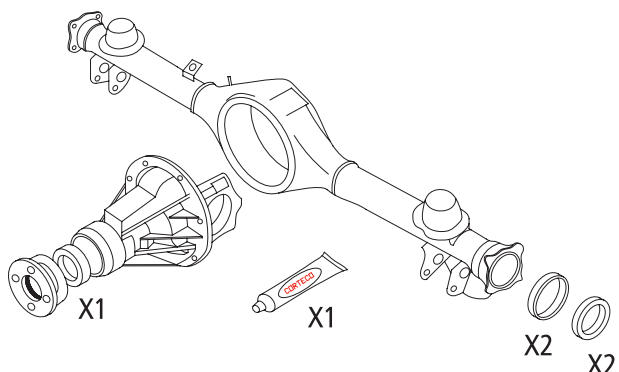









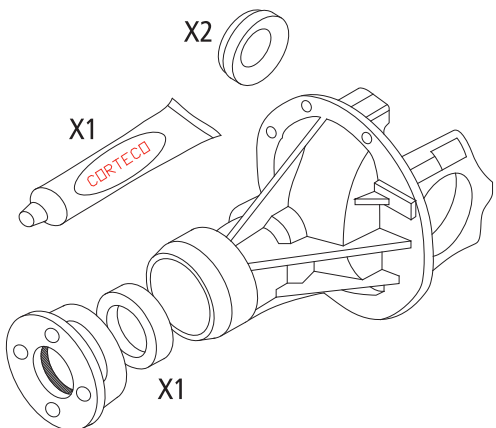





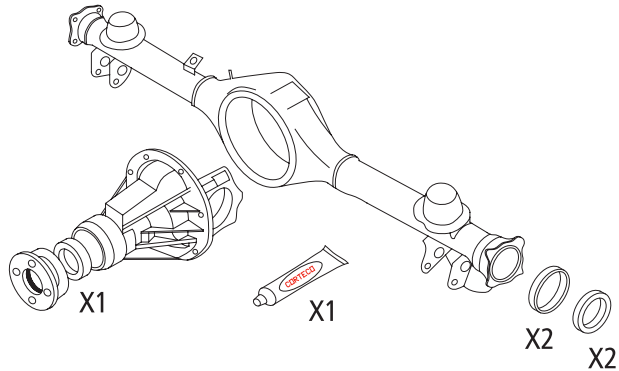





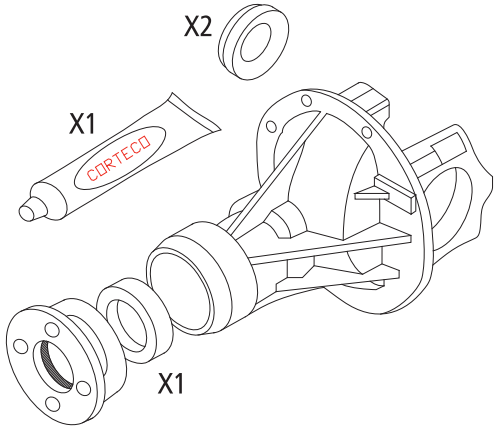

Suzuki

	19536212	
	Vitara 2.0 16V	
	12/96→03/98	
		
		
	19536214	
	Vitara 2.0 16V	
	12/96→03/98	
		
		
	19536212	
	Vitara 2.0 V6 24V	
	12/94→03/98	
		
		
	19536214	
	Vitara 2.0 V6 24V	
	12/94→03/98	
		
		

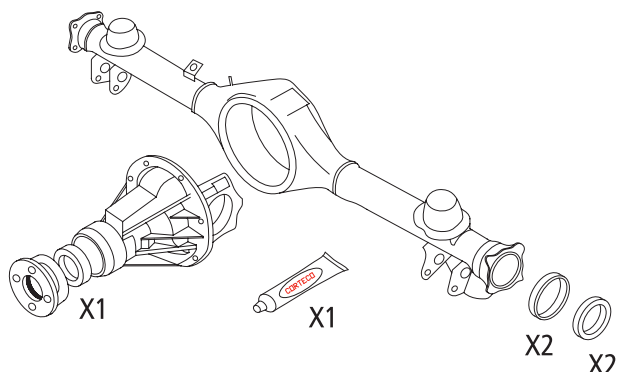























Suzuki

	19536212	
	Vitara 1.9 D	
	01/95→03/98	
		
		
	19536214	
	Vitara 1.9 D	
	01/95→03/98	
		
		
	19536212	
	Vitara 1.9 TD	
	08/96→03/98	
		
		
	19536214	
	Vitara 1.9 TD	
	08/96→03/98	
		
		

Suzuki







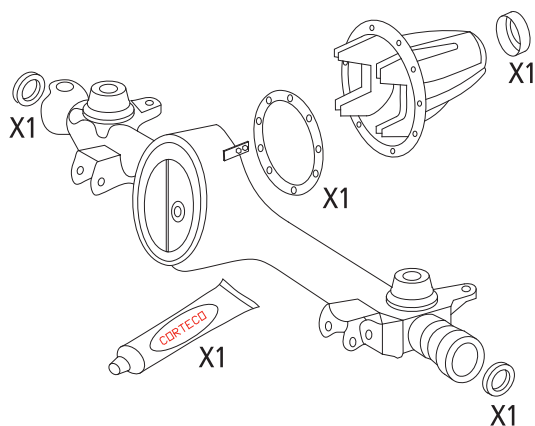
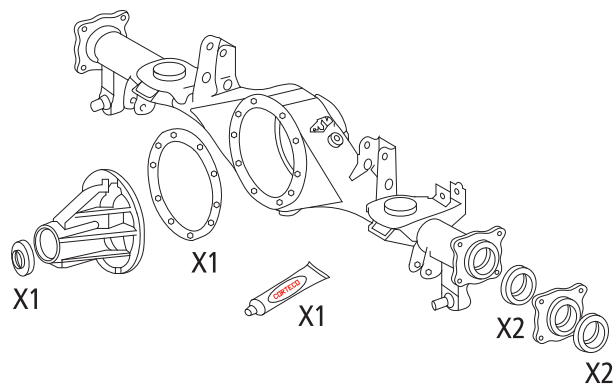
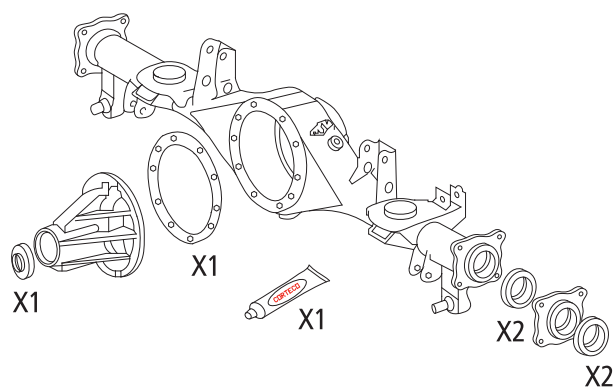
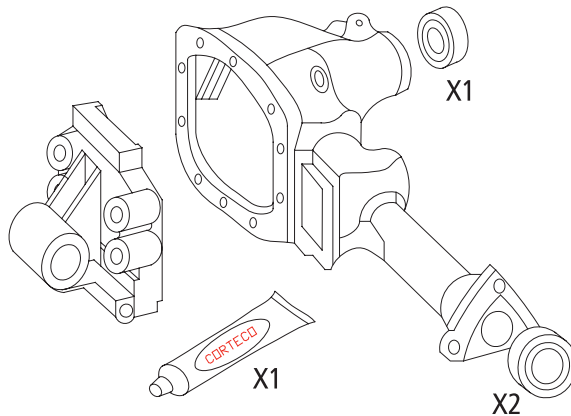









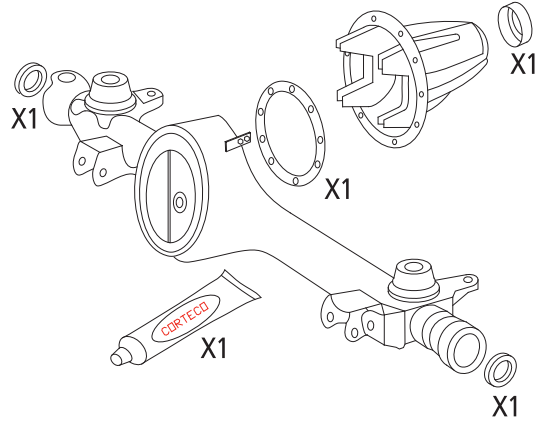





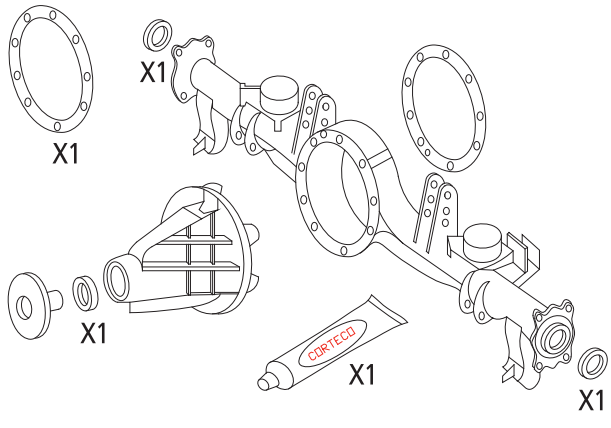

	19536212	
	Vitara 2.0 TD	
	12/94→03/98	
		
		
	19536214	
	Vitara 2.0 TD	
	12/94→03/98	
		
		
	19536212	
	Vitara 2.0 TD Intercooler	
	12/95→03/98	
		
		
	19536214	
	Vitara 2.0 TD Intercooler	
	12/95→03/98	
		
		

Toyota

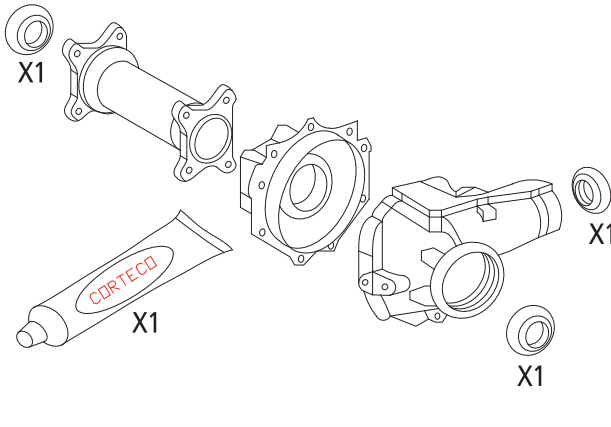





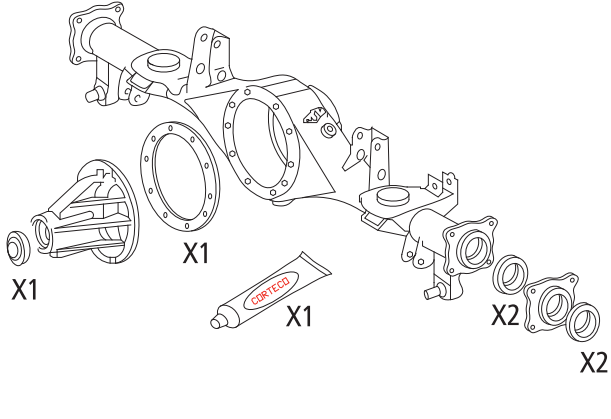







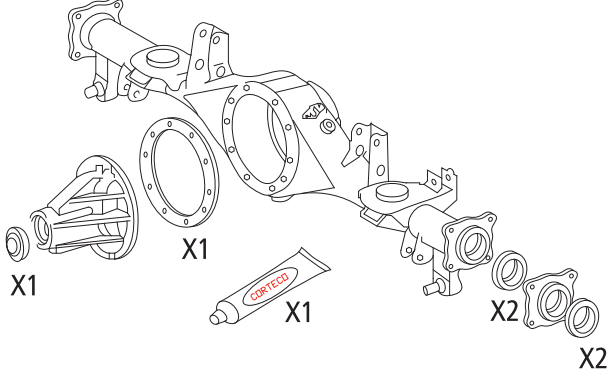





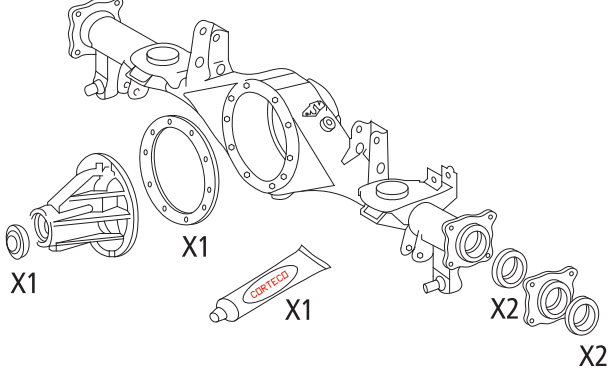

	19535828	
	Hi-Lux 2.5 D-4D 4WD	
	11/01→	
		
		
	19535846	
	Hi-Lux 2.5 D-4D 4WD	
	11/01→	
		
	LSD	
	19535847	
	Hi-Lux 2.5 D-4D 4WD	
	11/01→	
		
	Diff Lock	
	19535848	
	Land Cruiser (_J8_) 4.2 TD 24V	
	03/95→12/97	
		
		



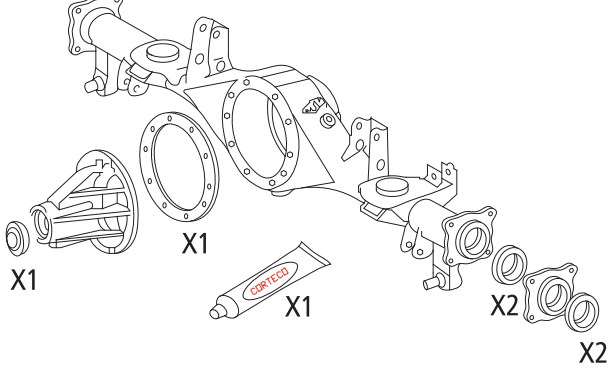





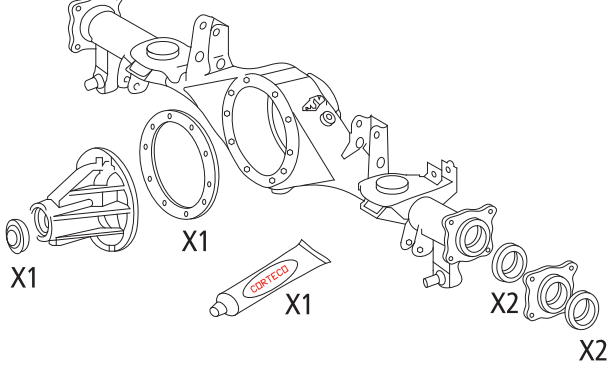



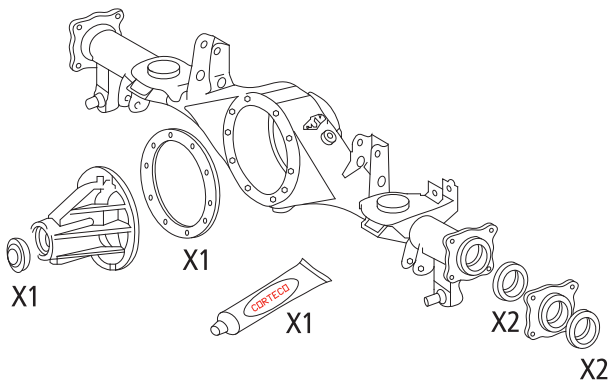





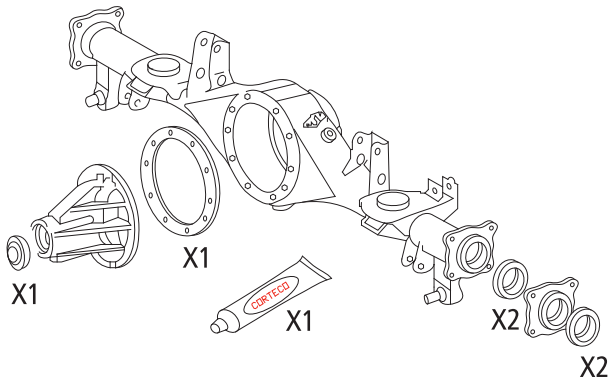





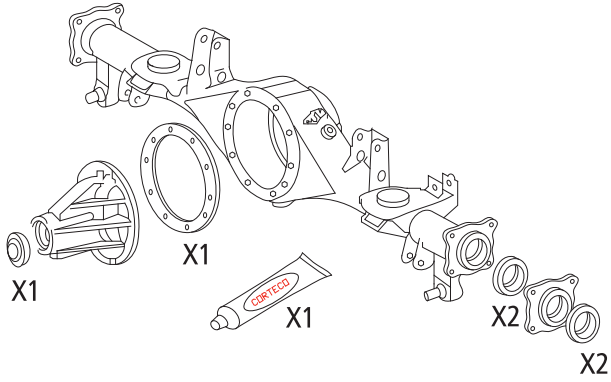

Toyota

	19535850	
	Land Cruiser (_J8_) 4.2 TD 24V	
	03/95→12/97	
		
	Diff Lock	
	19535851	
	Land Cruiser (_J8_) 4.2 TD 24V	
	03/95→12/97	
		
	Diff Lock	
	19536186	
	Land Cruiser (_J9_) 3.0 D-4D 4WD	
	10/00→	
		
		
	19536217	
	Land Cruiser (_J9_) 3.0 D-4D 4WD	
	10/00→	
		
	LSD – NO ABS /→01/2002	

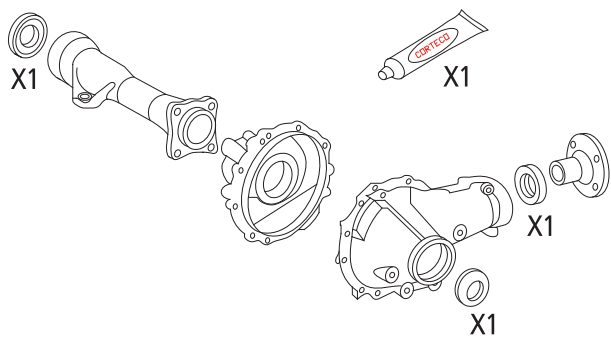









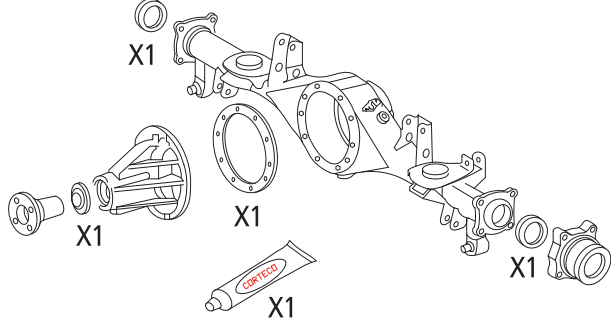

Toyota

	19536217	
	Land Cruiser (_J9_) 3.0 D-4D 4WD	
	10/00→	
		
i	Diff Lock – NO ABS /→01/2002	
	19536218	
	Land Cruiser (_J9_) 3.0 D-4D 4WD	
	10/00→	
		
i	LSD – ABS /→01/2002	
	19536218	
	Land Cruiser (_J9_) 3.0 D-4D 4WD	
	10/00→	
		
i	Diff Lock – ABS /→01/2002	
	19536219	
	Land Cruiser (_J9_) 3.0 D-4D 4WD	
	10/00→	
		
i	LSD – NO ABS / 02/2002→	





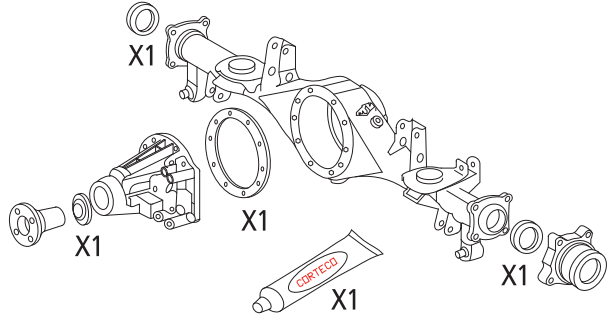











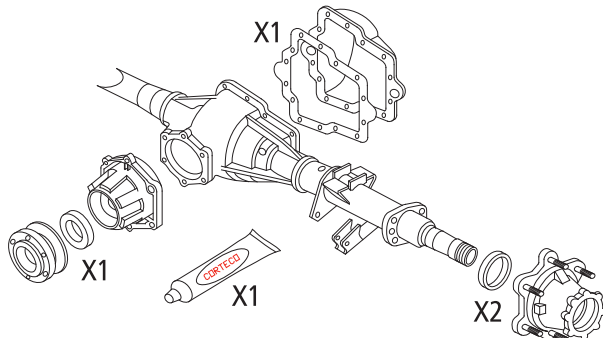





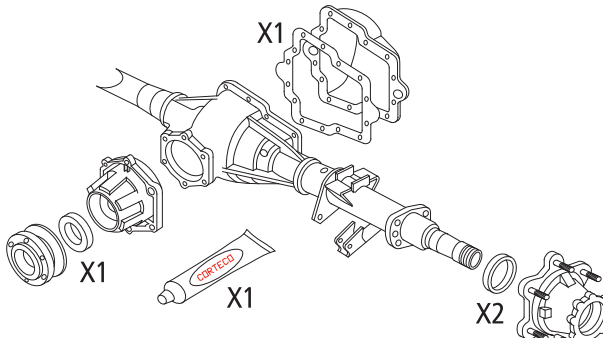

Toyota

	19536219	
	Land Cruiser (_J9_) 3.0 D-4D 4WD	
	10/00→	
		
	Diff Lock – NO ABS / 02/2002→	
	19536220	
	Land Cruiser (_J9_) 3.0 D-4D 4WD	
	10/00→	
		
	LSD – ABS / 02/2002→	
	19536220	
	Land Cruiser (_J9_) 3.0 D-4D 4WD	
	10/00→	
		
	Diff Lock – ABS / 02/2002→	
	19536187	
	Land Cruiser (_J12_) 3.0 D-4D 4WD	
	01/03→	
		
		

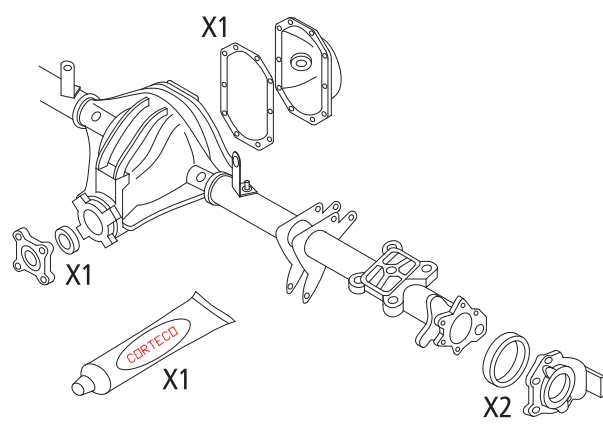





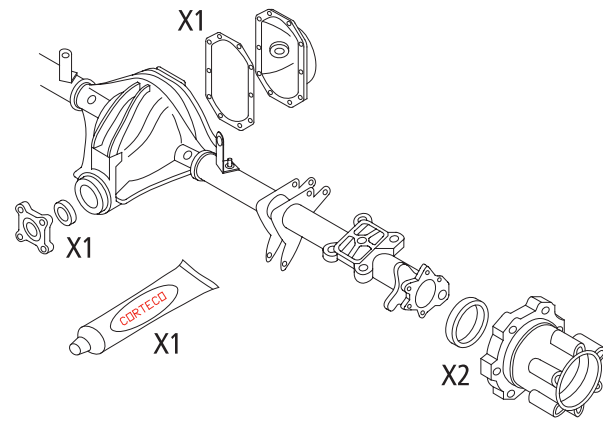









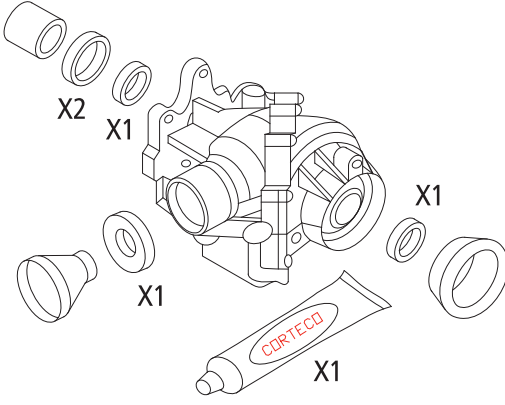





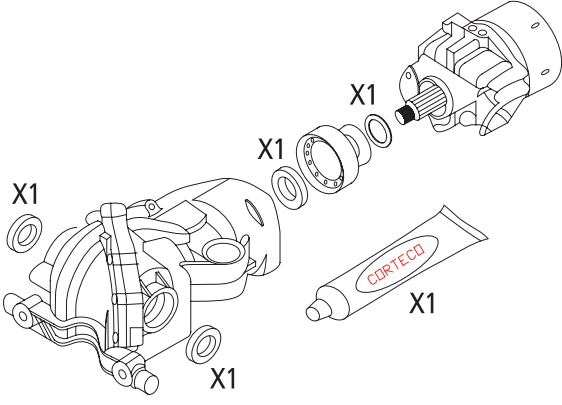

Toyota

	19536236	
	Land Cruiser (_J12_) 3.0 D-4D 4WD	
	01/03→	
		
	LSD	
	19536236	
	Land Cruiser (_J12_) 3.0 D-4D 4WD	
	01/03→	
		
	Diff Lock	

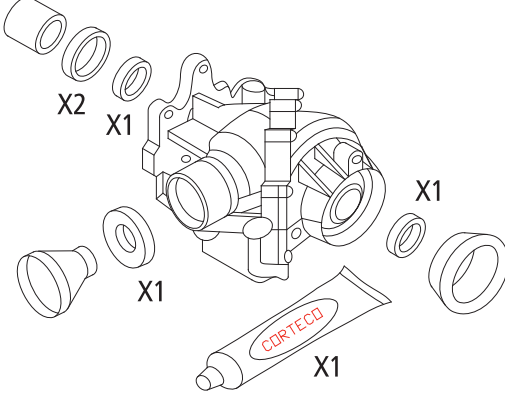
Volkswagen L.T.

	19536273	
	LT 40-55 (Type 21)	
	04/75→06/96	
		
	Single cab / Van	
	19536274	
	LT 40-55 (Type 21)	
	04/75→06/96	
		
	Double cab	
	19536204	
	LT 28-35	
	07/96→	
		
		
	19536203	
	LT 28-46	
	07/96→	
		
		

Volvo

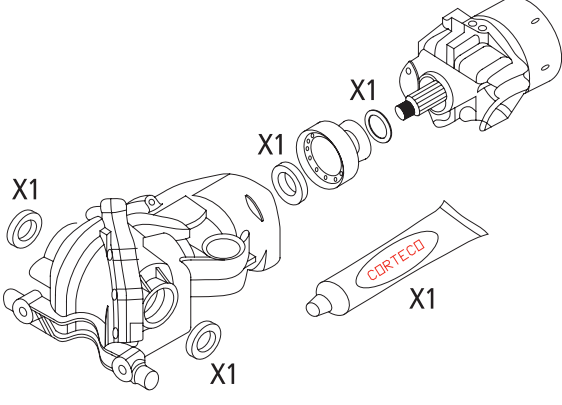
	19535954	
	XC90 2.5 T AWD	
	01/03→	
		
	AT	
	19535955	
	XC90 2.5 T AWD	
	01/03→	
		
		
	19535954	
	XC90 2.4 D5 AWD	
	10/02→	
		
	AT	
	19535955	
	XC90 2.4 D5 AWD	
	10/02→	
		
		

DISCLAIMER

RECHTLICHE HINWEISE | INFORMATIONS LÉGALES | AVVERTENZE

E

Every care has been taken to assure the information in this catalogue is correct, but we cannot accept any responsibility for errors. All particulars subject to alteration. This catalogue contains products in original quality. We reserve the right to make technical changes. Original numbers from automobile manufacturers only serve as a cross-reference comparison with the CORTECO-No. and should not be used in delivery notes and invoices to vehicle owners.

Full or partial reproduction permitted only with our written approval.

F

L'exactitude des données de ce catalogue a été vérifiée avec le plus grand soin. Néanmoins, tout droit à indemnité lié aux indications du présent catalogue est exclu. Ce catalogue comporte des produits de qualité d'équipement d'origine. Nous nous réservons le droit de procéder à des modifications de construction. Si nous référons dans nos documents au numéro de pièce de rechange du fabricant automobile, nous le faisons uniquement à des fins de comparaison. Il est interdit de faire usage de telles données dans des factures adressées au propriétaire du véhicule. Toute réimpression, même sous forme d'extraits, requiert notre autorisation.

D

Die Angaben in diesem Katalog wurden mit größter Sorgfalt auf ihre Richtigkeit überprüft. Trotzdem können Ersatzansprüche auf Grund von Angaben aus diesem Katalog nicht anerkannt werden. Alle Angaben erfolgen ohne Gewähr. Dieser Katalog enthält Produkte in Original-Qualität.

Konstruktionsänderungen bleiben vorbehalten. Soweit wir in unseren Unterlagen Bezug auf die Ersatzteilnummer des Fahrzeugherstellers nehmen, dient diese nur zu Vergleichszwecken. Eine Verwendung derartiger Angaben in Rechnungen an den Fahrzeugbesitzer ist nicht statthaft. Der Nachdruck, auch auszugsweise, ist nur mit unserer schriftlichen Genehmigung gestattet.



I

Ci siamo adoperati affinché i dati contenuti in questo catalogo siano i più esatti possibili. Tuttavia decliniamo ogni responsabilità per eventuali inesattezze e non verranno da noi riconosciuti diritti di risarcimento di qualsiasi sorta causati da errori od omissioni. Questo catalogo contiene prodotti di qualità "primo equipaggiamento". Ci riserviamo il diritto di apportare modifiche tecniche. I numeri originali e i nomi dei fabbricanti citati in questo catalogo servono esclusivamente a scopo comparativo e non possono essere utilizzati sui documenti di trasporto e fatture ai proprietari di autoveicoli. La riproduzione, anche sommaria, è concessa solo dietro nostra autorizzazione.

SIGNS AND SYMBOLS

ZEICHENERKLÄRUNG | SIGNES ET SYMBOLES | SEGNI E SIMBOLI

 Application
 Anwendung
 Application
 Applicazione

 Front
 Vorne
 Avant
 Anteriore

 Rear
 Hinten
 Arrière
 Posteriore

 Installation period
 Einbauzeitraum
 Période de montage
 Periodo di utilizzo

 Differential
 Differenzial
 Différentiel
 Differenziale

 CORTECO-Number
 CORTECO-Nummer
 Référence CORTECO
 Codice CORTECO

 Notes
 Notizen
 Notes
 Note

	E	D	F	I
ABS	Anti block System	Antiblockiersystem	Système anti blocage des roues	Anti Bloccaggio Ruote
Axle	Axle Type	Achstyp	Type d'essieu	Tipo Assale
AT	Automatic Gearbox	Automatikgetriebe	Boite de vitesse automatique	Cambio Automatico
Diff Lock	Differential Lock	Differenzialsperre	Différentiel blocable manuellement	Differenziale Bloccabile Manualmente
DRW	Doubled Rear Wheels	Verdoppelte Hinterräder	Roues arrière doublées	Ruote Posteriori Gemellate
LSD	Limited Slip Differential	Sperrdifferenzial	Différentiel à glissement limité	Differenziale Autobloccante

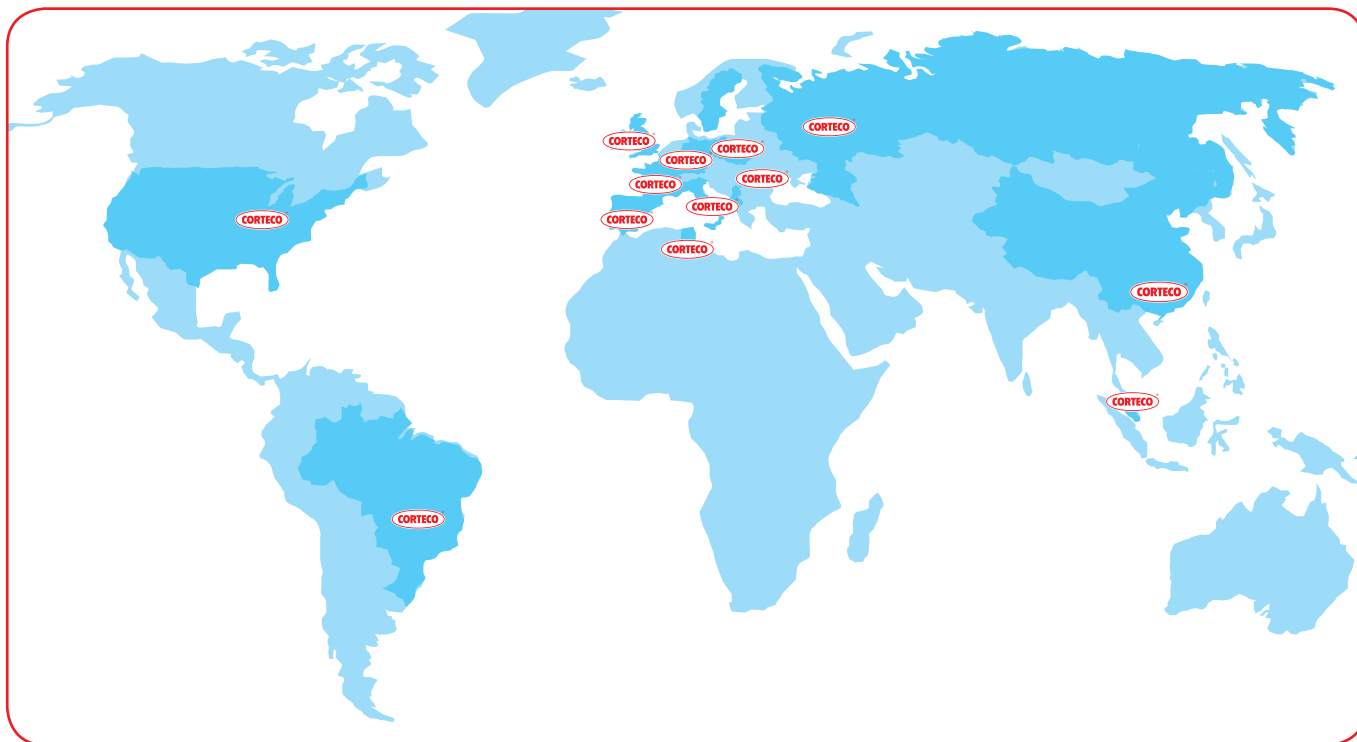

CORTECO GmbH

Badener Straße 10
69493 Hirschberg
Germany
Tel. +49-6201-259640
Fax +49-6201-2596411

CORTECO S.A.S.

Z.A. La Couture
87140 Nantiat
France
Tel. +33-5-55536800
Fax +33-5-55536888

CORTECO S.r.l.u.

Corso Torino 420/D
10064 Pinerolo (TO)
Italy
Tel. +39-0121-369269
Fax +39-0121-369299

CORTECO Ltd.

Unit 4, Elizabethan Way
Lutterworth-Leicestershire
LE17 4ND
United Kingdom
Tel. +44-1455-550000
Fax +44-1455-550066

CORTECO Spain & Portugal

Freudenberg Iberica
Pol. Ind. Can Volart
C/ Gurri 1
08150 Parets del Vallés (Barcelona)
España
Tel. +34-93-5738741
Fax +34-93-5624676

CORTECO Eastern Europe

Freudenberg Simrit
111141 Moscow, Elektrodnyaya str. 2,
Building 12-13-14
Russia
Tel. +7-495-3800650
Fax +7-495-3800651

CORTECO Poland

53-014 Wrocław
Ul. Warsztatowa 11
Poland
Tel. +48-71-3399755
Fax +48-71-3399700

CORTECO North Africa

Carthage Center - Bloc A - 2ème étage
Rue du Lac de Constance
1053 Tunis
Tunisia
Tel. +216-71-965049
Fax +216-71-965100

CORTECO Balkan States

Gajeva 27.
21208 Sremska Kamenica (Novi Sad)
Serbia
Tel. +381-21-465268
Fax +381-21-465268

CORTECO Asia

18 Tractor Road
Singapore 627976
Singapore
Tel. +65-6561-6651
Fax +65-6561-6862

CORTECO China Co. Ltd.

Room 3505, 35/F, Tower B,
Center Plaza,
No. 161 Lin He Xi Road
Tianhe District
Guangzhou, China
Tel. +86-2038-324968
Fax +86-2038-258548

CORTECO USA

11617 State Route 13
Milan, Ohio 44846
USA
Tel. +1-419-4992502
Fax +1-419-4992804

CORTECO South America

Av. Piraporinha, 411
09950-902 São Paulo / Diadema
Brasil
Tel. +55-11-40728010
Fax +55-11-40752535



The Perfect Change.