

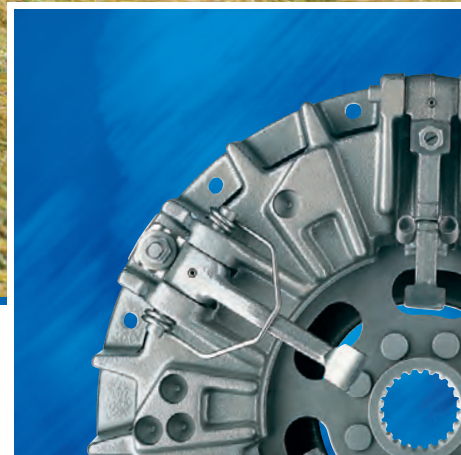

SACHS is a  
brand of ZF



2015 | 2016

# ***Kupplungen für Traktoren***

# ***Clutches for Tractors***

DE

EN

FR

ES

IT

PL

RU

EL



**SACHS**

	<b>DE</b>	<b>FR</b>	<b>IT</b>	<b>RU</b>
	<b>EN</b>	<b>ES</b>	<b>PL</b>	<b>EL</b>
	Produkte   Products	Produits   Productos	Prodotti   Produkty	Продукты   Προϊόντα
	Kit plus CSC   Kit plus CSC	Kit plus CSC   Kit plus CSC	Kit plus CSC   Kit plus CSC	Kit plus CSC   Kit plus CSC
	Kupplungssatz   Clutch kit	Kit d'embrayage   Kit de embrague	Kit frizione   Zestaw sprzęgła	Комплект сцепления   Σετ συμπλέκτη
	Druckplatte   Pressure plate	Mécanisme d'embrayage   Plato de presión	Spingidisco   Płytką dociskowa	Нажимной диск   Πλατό
	Kupplungsscheibe   Clutch disk	Disque d'embrayage   Disco de embrague	Disco frizione   Tarcza sprzęgła	Ведомый диск сцепления   Δίσκος συμπλέκτη
	Torsionsdämpfer   Torsion damper	Amortisseur de torsion   Amortiguador de torsión	Smorzatore torsionale   Tłumik drgań skrętnych	Гаситель крутильных колебаний   Αποσβεστήρας στρέψης
	Ausrücker   Releaser	Butée   Dispositivo de desembrague	Cuscinetto reggispinta   Wyrzęgnik	Выжимной подшипник   Έδρανο αποσύμπλεξης
	Haltefeder   Retaining spring	Ressort de retenue   Muelle de retención	Molla di fermo   Sprężyna ustalająca	Удерживающая пружина   Ελατήριο συγκράτησης
	Führungslager   Pilot bearing	Palier de guidage   Cojinete guía	Cuscinetto di guida   łożysko jezdne	Центрирующий подшипник   Έδρανο οδηγός
	Zentralausrücker (CSC)   Concentric slave cylinder (CSC)	Butée Hydraulique (CSC)   Dispositivo de desembrague (CSC)	Cuscinetto reggispinta coassiale (CSC)   Centralny wyrzęgnik (CSC)	Μυфта выключения (CSC)   Κεντρικό έδρανο αποσύμπλεξης (CSC)
	Lüfterkupplung   Fan clutch	Coupleur de ventilateur   Embrague del ventilador	Giunto ventola   Sprzęgło wentylatora	Μυфта вентилятора   Σύνδεσμος ανεμιστήρα
	Produkthinweise   Product information	Informations produit   Indicaciones del producto	Indicazioni prodotto   Informacje o produkcie	Указание к изделию   Υποδείξεις προϊόντος
	Nur als Satz lieferbar   Only available as kit	Uniquement disponible en kit   Solo disponible como kit	Disponibile solo come kit   Dostarczany tylko w komplecie	Поставляется только в комплекте   Παραδοτέο μόνο ως σετ
	Ohne Ausrücker   Without releaser	Sans butée   Sin dispositivo de desembrague	Senza cuscinetto reggispinta   Bez wyrzęgnika	Без выжимного подшипника   Χωρίς εξάρτημα αποσύμπλεξης
	Auslaufartikel   Article to be discontinued	Article jusqu'à épuisement   Hasta agotar existencias	Articolo fuori produzione   Artykuł już nieprodukowany	Снятое с производства изделие   Υπο κατάργηση
	Wahlweise   Alternatively	Alternative   Opcional	A scelta   Do wyboru	На выбор   Κατ' επιλογή
	Verstärkte Ausführung   Heavy duty version	Modèle renforcé   Versión reforzada	Versione rinforzata   Wersja wzmocniona	Усиленное исполнение   Ενισχυμένος τύπος
	Austauschteil   Remanufactured part	Élément de rechange   Pieza reacondicionada	Componente intercambiabile   Część wymienna	Сменяемая деталь   Εξάρτημα αντικατάστασης
	Fahrzeughinweise   Vehicle information	Indications de véhicule   Indicaciones del vehículo	Indicazioni veicolo   Informacje o pojeździe	Указания по автомобилю   Υποδείξεις οχήματος
	Bestückungswechsel   Fitting change	Remplacement des composants   Cambio de equipamiento	Sostituzione equipaggiamento   Wymiana uzbrojenia	Смена комплектующих   Αλλαγή εξοπλισμού
	Getriebeseitig   Transmission side	Côté transmission   Lado de la caja de cambios	Lato trasmissione   Po stronie skrzyni biegów	Со стороны коробки передач   Αφορά στο κιβώτιο ταχυτήτων
	Motorseitig   Engine side	Côté moteur   Lado del motor	Lato motore   Po stronie silnika	Со стороны двигателя   Από την πλευρά του κινητήρα

**DE****FR****IT****RU****EN****ES****PL****EL**

	Spalte i   Column i	Colonne i   Columna i	Colonna i   Kolumna i	Столбец i   Στήλη i
<b>Chass. ...</b>	Fahrgestellnummer   Chassis number	Numéro de châssis   Número de chasis	Numero di telaio   Numer nadwozia	Номер шасси   Αριθμός πλαισίου
<b>-&gt;Chass. ...</b>	Bis Fahrgestellnummer   To chassis number	Jusqu'au numéro de châssis   Hasta número de chasis	Fino al numero di telaio   Do numeru nadwozia	До номера шасси   Μέχρι αριθμό πλαισίου
<b>Chass. ...-&gt;</b>	Ab Fahrgestellnummer   From chassis number	À partir du numéro de châssis   Desde número de chasis	Da numero di telaio   Od numeru nadwozia	Начиная с номера шасси   Από αριθμό πλαισίου
<b>-&gt;02.1994</b>	Bis Baujahr   To construction year	Jusqu'à l'année de fabrication   Hasta año de construcción	Fino all'anno di costruzione   Do roku produkcji	До года изготовления   Μέχρι έτος κατασκευής
<b>03.1994-&gt;</b>	Ab Baujahr   From construction year	À partir de l'année de fabrication   Desde año de construcción	Da anno di costruzione   Od roku produkcji	Начиная с года изготовления   Από έτος κατασκευής
<b>-&gt; Mot. ...</b>	Bis Motornummer   To engine number	Jusqu'au numéro de moteur   Hasta número de motor	Fino al numero del motore   Do numeru silnika	До номера двигателя   Μέχρι αριθμό κινητήρα
<b>Mot. ...-&gt;</b>	Ab Motornummer   From engine number	À partir du numéro de moteur   Desde número de motor	Da numero del motore   Od numeru silnika	Начиная с номера двигателя   Από αριθμό κινητήρα
<b>Getr. ...</b> <b>GBox ...</b>	Getriebetyp   Transmission type	Type de transmission   Tipo de caja de cambios	Tipo di trasmissione   Typ skrzyni biegów	Тип коробки передач   Τύπος κιβωτίου ταχυτήτων

<b><i>DE</i></b>	<b>Deutsch</b>	<b>V3</b>
<b><i>EN</i></b>	<b>English</b>	<b>V5</b>
<b><i>FR</i></b>	<b>Français</b>	<b>V7</b>
<b><i>ES</i></b>	<b>Español</b>	<b>V11</b>
<b><i>IT</i></b>	<b>Italiano</b>	<b>V15</b>
<b><i>PL</i></b>	<b>Polski</b>	<b>V19</b>
<b><i>RU</i></b>	<b>Русский</b>	<b>V23</b>
<b><i>EL</i></b>	<b>Ελληνικά</b>	<b>V27</b>

# Allgemeine Informationen



Sämtliche in diesem Katalog aufgeführten Produkte dürfen nur durch ausgebildetes Personal einer Kfz-Fachwerkstatt verbaut werden.

Für Ihre Anforderungen benötigen wir die vollständige Bestellnummer, zum Beispiel:

Kupplungskit	3800 541 022
Kupplungsdruckplatte	1888 054 004
Kupplungsscheibe	1864 418 002

Im Zweifelsfall Typenbezeichnung und Baujahr des Fahrzeugs angeben, für das der gewünschte Artikel bestimmt ist.

Alle Rechte vorbehalten. Vervielfältigungen oder die Mitbenutzung dieses Kataloges, auch auszugsweise, für die Erstellung eines Eigenkataloges sind ohne ausdrückliche Zustimmung unzulässig.

Ersatzteilnummern der Fahrzeughersteller dienen nur zu Vergleichszwecken. Eine Verwendung derartiger Angaben in Rechnungen an den Fahrzeugbesitzer ist nicht statthaft.

Die aktuellen allgemeinen Geschäftsbedingungen finden Sie unter [www.zf.com/services/dokumente](http://www.zf.com/services/dokumente)

[www.zf.com/services/katalog](http://www.zf.com/services/katalog)

**WebCat**  
Online Katalog

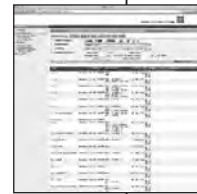

**InCat**  
Elektronischer Katalog



**PrintCat**  
Gedruckte Kataloge



## Inhaltsverzeichnis

<b>Index</b>	U2
<b>Symbole</b>	U3 - U4
<b>Allgemeine Informationen</b>	V3
<b>Katalogaufbau</b>	V4
<b>Kenngrößen</b>	V4
<b>Arithmetische Liste</b>	297 - 353
<b>Vergleichsliste</b>	354 - 369
<b>Neuaufnahmen</b>	370 - 372
<b>Geänderte Bestellnummern</b>	372 - 373
<b>Gestrichene Nummern</b>	373 - 374
<b>Torsionsdämpfer</b>	375 - 390
<b>Maßtabelle für Nabenprofile</b>	391
<b>Maßtabelle für Ausrücker und Führungslager</b>	392 - 393

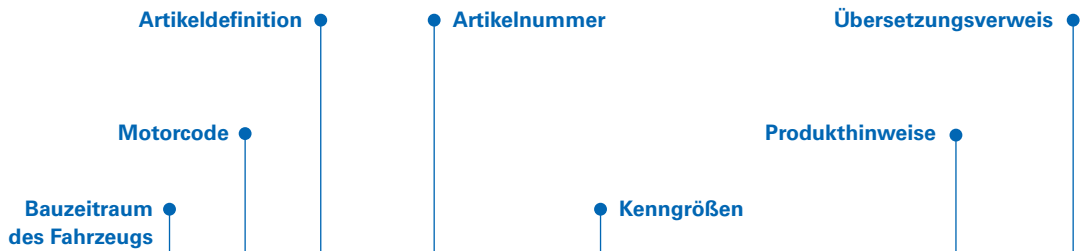

## EICHER

3105 - 3145						
3105 (3021/3022)	01.77 - 12.82	E-EDK-6	⚙️ 3482 012 211	GMF330		
			⚙️ 1864 352 101	330Z (44x48-23N)	Nur bei Altteil-Rückgabe lieferbar (Reparatur; Werk Bielefeld) / Please return old unit for repair (plant Bielefeld)	(33)
			⚙️ 3151 196 031			
3108 (3026)	01.82 - 12.90	E-EDL-6,	⚙️ 3482 002 234	GMF350X		
3125 (3028)	01.82 - 12.90	E-EDK-6,	⚙️ 1864 347 101 #	350Z (44x48-23N)		
3133 (3024)	01.77 - 12.82	E-EDL-6-T	⚙️			
3145 (3030)	01.82 - 12.90		⚙️ 3151 196 031			

## Kenngößen

⚙️ Kupplungsdruckplatten	
2/	Für 2-Scheibenausführung
400	Reibflächenaußendurchmesser 400 mm
Do	Doppelkupplung, abhängige Ausrückung
Du	Doppelkupplung, unabhängige Ausrückung
/E	XTend
F	Flaches Schwungrad
G	Kupplung mit Gußgehäuse
K	Schraubenfederkupplung
KM	Mit Membranfeder und Hebelsystem
M	Membranfederkupplung
N	Nebenantrieb
S	Schwenkbolzenausführung
T	Mit Tellerfeder
XTend	Mit automatischer Nachstellung
Z	Ausrückung auf Zug

⚙️ Ausrücklager	
...A	Außenring mitlaufend
G	Grafitanlaufring
GK	Grafitanlaufring und Kugellager
GR	Kugellager mit Blechkappe
GZ	Geberzylinder
HHIS	Konzentrischer Nehmerzylinder
...I	Innenring mitlaufend
KT	Teflonanlaufscheibe
KZ	Kugellager, zentralgeführt
NZ	Nehmerzylinder
...S	Selbstzentrierender Innenring
...Z	Ausrückung auf Zug

⚙️ Kupplungsscheiben	
200	Außendurchmesser 200 mm
CE	Anorganischer Sinterbelag
B/D/E/Z	Belagfederungen
BH/GS/GT/GV	Torsionsdämpfer für Nfz
/E	XTend
W/V	Vordämpfer für Nfz

⚙️ Lüfterkupplung	
VL	Leichter Einsatz
VM	Mittlerer Einsatz
VS	Schwerer Einsatz

# General Information



The products listed in this catalog must be installed in a workshop by qualified personnel only.

To fulfill your request, we need the complete order number, for example::

Clutch kit	3800 541 022
Clutch pressure plate	1888 054 004
Clutch disk	1864 418 002

In case of doubt, please provide the type description and the model year of the vehicle for which the desired item is intended.

All rights reserved. Duplication or joint use of this catalog, even in extracts, for the creation of your own catalog is prohibited, unless explicit consent is given.

Replacement part numbers from the vehicle manufacturer serve only for purposes of comparison. Use of such information in invoices to the vehicle owner is not permitted.

Current terms and conditions are available at [www.zf.com/services/documents](http://www.zf.com/services/documents)

[www.zf.com/services/catalog](http://www.zf.com/services/catalog)

**WebCat**  
Online catalog

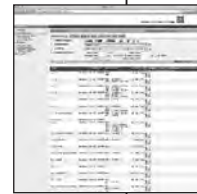

**InCat**  
Electronic catalog



**PrintCat**  
Printed catalogs



## Contents

<b>Index</b>	U2
<b>Symbols</b>	U3 - U4
<b>General Information</b>	V5
<b>Catalog structure</b>	V6
<b>Parameters</b>	V6
<b>Part number list</b>	297 - 353
<b>Cross reference list</b>	354 - 369
<b>New to range</b>	370 - 372
<b>Amended part numbers</b>	372 - 373
<b>Deleted numbers</b>	373 - 374
<b>Torsion damper</b>	375 - 390
<b>Measure table for hub profiles</b>	391
<b>Measure table for releaser and pilot bearing</b>	392 - 393

# Catalog structure

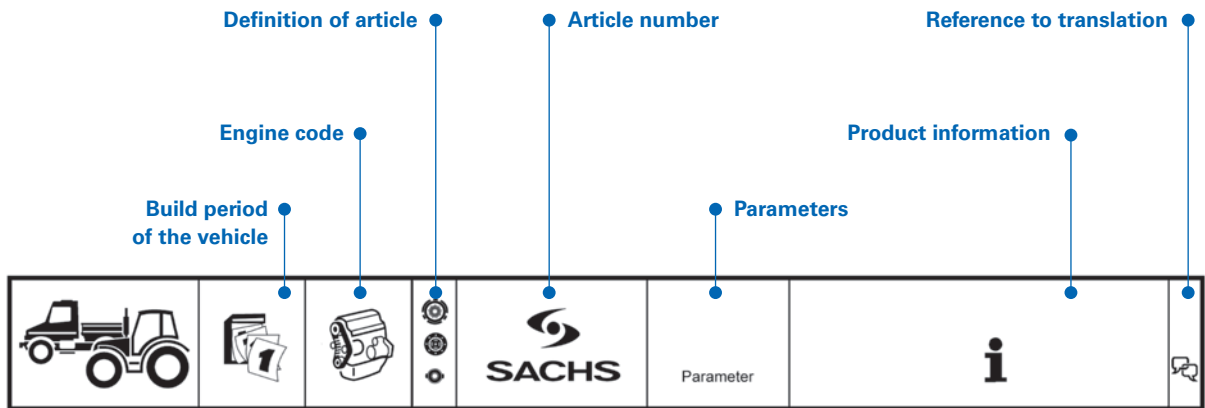

## EICHER

3105 - 3145						
3105 (3021/3022)	01.77 - 12.82	E-EDK-6	⚙️	3482 012 211	GMF330	
			⚙️	1864 352 101	330Z (44x48-23N)	Nur bei Altteil-Rückgabe lieferbar (Reparatur; Werk Bielefeld) / Please return old unit for repair (plant Bielefeld) (33)
			⚙️	3151 196 031		
3108 (3026)	01.82 - 12.90	E-EDL-6,	⚙️	3482 002 234	GMF350X	
3125 (3028)	01.82 - 12.90	E-EDK-6,				
3133 (3024)	01.77 - 12.82	E-EDL-6-T	⚙️	1864 347 101 #	350Z (44x48-23N)	
3145 (3030)	01.82 - 12.90		⚙️	3151 196 031		

## Parameters

⚙️ Clutch pressure plates	
2/	For twin disk design
400	Outer friction surface diameter 400 mm
Do	Double clutch, dependent disengagement
Du	Double clutch, independent disengagement
/E	XTend
F	Flat flywheel
G	Clutch with cast iron housing
K	Coil spring clutch
KM	With diaphragm spring and lever system
M	Diaphragm spring clutch
N	Power take-off (PTO)
S	Eye bolt design
T	With plate spring
XTend	With automatic adjustment
Z	Pull-type release

⚙️ Releasers	
...A	Running outer ring
G	Graphite thrust ring
GK	Graphite thrust ring and ball bearing
GR	Ball bearing with metal cap
GZ	Master cylinder
HHIS	Concentric slave cylinder
...I	Running inner ring
KT	Teflon coated thrust ring
KZ	Ball bearing, centrally guided
NZ	Slave cylinder
...S	Self-centering inner ring
...Z	Pull-type release

⚙️ Clutch disks	
200	Outer diameter 200 mm
CE	Non-organic sintered facing
B/D/E/Z	Cushion
BH/GS/GT/GV	Torsion dampers for CV
/E	XTend
W/V	Predamper for CV

⚙️ Fan clutch	
VL	Light use
VM	Medium use
VS	Heavy use



# Informations générales



Tous les produits mentionnés dans ce catalogue doivent exclusivement être montés par le personnel formé d'un atelier automobile qualifié.

Pour répondre à vos exigences, nous avons besoin de connaître le numéro de commande complet, par exemple :

**Kit d'embrayage** 3800 541 022  
**Mécanisme d'embrayage** 1888 054 004  
**Disque d'embrayage** 1864 418 002

En cas de doute, indiquez la désignation du modèle et l'année de construction du véhicule pour lequel la pièce souhaitée est destinée.

Tous droits réservés. La reproduction ou l'utilisation, même partielle, de ce catalogue pour l'élaboration de son propre catalogue est interdite sans notre autorisation expresse.

Les numéros de pièces détachées des constructeurs de véhicules sont uniquement indiqués aux fins de comparaison. Le report de ces données sur les factures destinées au propriétaire du véhicule est illicite.

Vous trouverez les conditions générales sur Internet [www.zf.com/services/documents](http://www.zf.com/services/documents)

[www.zf.com/services/catalog](http://www.zf.com/services/catalog)

## WebCat

Catalogue en ligne

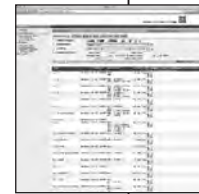

## InCat

Catalogue électronique



## PrintCat

Catalogues papier



## Sommaire

<b>Index</b>	U2
<b>Symboles</b>	U3 - U4
<b>Informations générales</b>	V7
<b>Structure du catalogue</b>	V8
<b>Caractéristiques</b>	V8
<b>Traductions</b>	V9 - V10
<b>Liste des pièces</b>	297 - 353
<b>Liste comparative</b>	354 - 369
<b>Nouveautés</b>	370 - 372
<b>Numéros de commande modifiés</b>	372 - 373
<b>Numéros barrés</b>	373 - 374
<b>Amortisseur de torsion</b>	375 - 390
<b>Table métrologique pour cannelures de moyeu</b>	391
<b>Table métrologique pour débrayeur et palier guide</b>	392 - 393

# Structure du catalogue

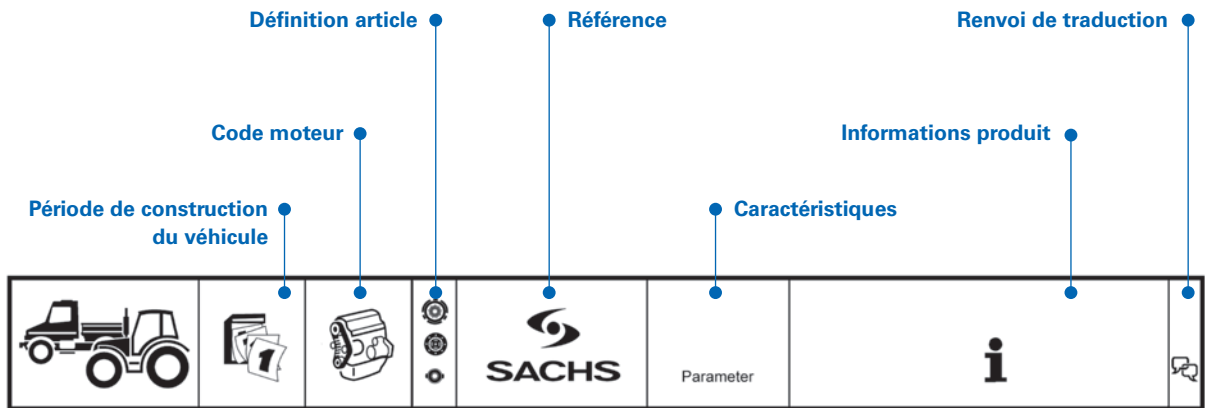

## EICHER

3105 - 3145						
3105 (3021/3022)	01.77 - 12.82	E-EDK-6	⊗	3482 012 211	GMF330	
			⊗	1864 352 101	330Z (44x48-23N)	Nur bei Altteil-Rückgabe lieferbar (Reparatur; Werk Bielefeld) / Please return old unit for repair (plant Bielefeld) (33)
			◇	3151 196 031		
3108 (3026)	01.82 - 12.90	E-EDL-6,	⊗	3482 002 234	GMF350X	
3125 (3028)	01.82 - 12.90	E-EDK-6,				
3133 (3024)	01.77 - 12.82	E-EDL-6-T	⊗	1864 347 101 #	350Z (44x48-23N)	
3145 (3030)	01.82 - 12.90		◇	3151 196 031		

## Caractéristiques

⊗ Plaques de pression embrayage	
2/	Pour modèle 2 disques
400	Diamètre extérieur surface de frottement 400 mm
Do	Embrayage double, débrayage dépendant
Du	Embrayage double, débrayage indépendant
/E	XTend
F	Volant moteur plat
G	Embrayage avec boîtier en fonte
K	Embrayage à ressort hélicoïdal
KM	Avec ressort à membrane et système levier
M	Embrayage à membrane
N	Prise de force
S	Modèle axe de pivotement
T	Avec rondelles-ressorts
XTend	Avec réglage automatique
Z	Débrayage en traction

⊗ Butée de débrayage	
...A	Bague extérieure entraînée
G	Bague de friction en graphite
GK	Bague de friction en graphite et roulement à billes
GR	Roulement à billes avec cache en tôle
GZ	Cylindre émetteur
HHIS	Cylindre récepteur concentrique
...I	Bague intérieure entraînée
KT	Rondelle de friction en téflon
KZ	Roulement à billes, guidage central
NZ	Cylindre récepteur
...S	Bague intérieure à centrage automatique
...Z	Débrayage en traction

⊗ Disques d'embrayage	
200	Diamètre extérieur 200 mm
CE	Garniture frittée anorganique
B/D/E/Z	Suspensions garnitures
BH/GS/GT/GV	Amortisseur de torsion pour VU
/E	XTend
W/V	Pré-amortisseur pour VU

⊗ Embrayage ventilateur	
VL	Utilisation légère
VM	Utilisation moyenne
VS	Utilisation lourde

# Traductions

- (1) Pièce d'écartement de 12 mm sur boîtier
- (2) 4 vitesses
- (3) 5 vitesses
- (4) 6 vitesses
- (5) Attention ! Les 3 vis rouges dans le boîtier doivent être retirées après le montage
- (6) Transmission intégrale
- (7) Nombre de garnitures
- (8) Diamètre extérieur [mm]
- (9) Version Borg & Beck
- (10) Largeur [mm]
- (11) Diesel
- (12) Plateau de pression avec 3 leviers
- (13) Plateau de pression avec 4 leviers
- (14) Manchon de pression KHD n° 238 4107 doit être aussi monté
- (15) La douille d'écartement KHD n° 0430 8044 doit éventuellement être montée
- (16) Pays de production du véhicule : Brésil
- (17) Fluide : Huile bio
- (18) Fluide : Liquide de frein
- (19) Fluide : Huile hydraulique
- (20) Fluide : Huile minérale
- (21) Type de transmission : Boîte-inverseur pour bateaux Hurth
- (22) Renouveler systématiquement
- (23) Compris dans 1881/1882/1888/3083/3088/3483/3488 ... ..
- (24) Compris dans 1888 ... ..
- (25) Diamètre intérieur [mm]
- (26) Avec embrayage différent selon le choix du client
- (27) Caractéristique
- (28) Roulement à billes
- (29) Version LUK
- (30) Disque d'embrayage amovible
- (31) Cannelure de moyeu
- (32) Non interchangeable avec VALEO
- (33) Disponible uniquement en cas de retour de pièce usagée (réparation; usine Bielefeld)
- (34) Ne monter que si l'embrayage précédent était de marque SACHS
- (35) À monter ensemble uniquement
- (36) Version SACHS
- (37) Volant moteur doit être modifié
- (38) Profondeur du volant moteur : 44,5 mm
- (39) Modèle spécial
- (40) Steyrmatic
- (41) Version VALEO
- (42) Transmission ZF
- (43) Kit de réparation alternatif
- (44) Comprend des vis de fixation pour plateau de pression
- (45) Comprend un disque d'embrayage
- (46) Comprend deux disques d'embrayage
- (47) Pour
- (48) Pour véhicules avec embrayage monodisque
- (49) Pour véhicules avec système de freinage à basse pression

DE

EN

FR

ES

IT

PL

RU

EL

# Traductions

- (50) Pour véhicules avec embrayage de pontage de convertisseur
- (51) Pour véhicules avec embrayage bi-disques
- (52) Pour véhicules avec commande d'embrayage hydraulique
- (53) Pour véhicules avec commande d'embrayage mécanique (par câble)
- (54) Pour arbre de prise de force avant
- (55) Pour tracteur à cabine fixe
- (56) Pour arbre de prise de force moteur
- (57) Pour prise de force
- (58) Pour numéro OE
- (59) Pour boîte de vitesses manuelle
- (60) Pour arbre de prise de force indépendant
- (61) Selon le modèle avec embrayage différent
- (62) Couple moteur max. transmissible [Nm]
- (63) Avec bague de friction
- (64) Avec boîte de vitesses
- (65) Avec prise de force
- (66) Avec Powermatic
- (67) Avec embrayage Rockford
- (68) Avec raccord pour tuyau de graissage
- (69) Avec capteur
- (70) Avec arbre pour prise de force
- (71) Avec frein de boîte de vitesses électrique
- (72) Avec frein de boîte de vitesses hydraulique
- (73) Avec arbre de prise de force hydraulique
- (74) Avec train inverseur mécanique
- (75) Pas pour
- (76) Pas pour numéro de châssis
- (77) Uniquement comme remplacement des numéros OE indiqués
- (78) Uniquement en combinaison avec
- (79) Sans bague de friction
- (80) Sans boîte de vitesses
- (81) Sans Powermatic
- (82) Sans raccord pour tuyau de graissage
- (83) Sans plaque intermédiaire
- (84) Grille H inversée

# Información general



Los productos indicados en este catálogo sólo los puede montar el personal cualificado de un taller mecánico.

Para poder tramitar su solicitud necesitamos el número de pedido completo, por ejemplo:

**Kit de embrague** 3800 541 022  
**Plato de presión del embrague** 1888 054 004  
**Disco de embrague** 1864 418 002

En caso de duda, se deberá indicar la designación del tipo y el año de construcción del vehículo, para el que se requiere el artículo deseado.

Quedan reservados todos los derechos. Queda prohibida la reproducción o el uso de este catálogo (también de forma parcial) para la elaboración de un catálogo propio sin consentimiento expreso.

Los números de las piezas de recambio del fabricante solo se usan para compararlos. No está permitido el empleo de este tipo de datos en las facturas emitidas al propietario del vehículo.

Puede encontrar las condiciones generales de contratación en [www.zf.com/services/documents](http://www.zf.com/services/documents)

[www.zf.com/services/catalog](http://www.zf.com/services/catalog)

**WebCat**  
Catálogo online

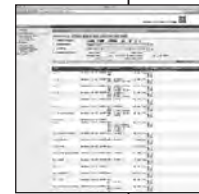

**InCat**  
Catálogo electrónico



**PrintCat**  
Catálogos impresos



## Índice

<b>Index</b>	U2
<b>Símbolos</b>	U3 - U4
<b>Información general</b>	V11
<b>Estructura del catálogo</b>	V12
<b>Parámetros</b>	V12
<b>Traducciones</b>	V13 - V14
<b>Lista aritmética</b>	297 - 353
<b>Lista comparativa</b>	354 - 369
<b>Novedades</b>	370 - 372
<b>Números de pedido modificados</b>	372 - 373
<b>Referencias eliminadas</b>	373 - 374
<b>Amortiguador de torsión</b>	375 - 390
<b>Tabla de medidas para perfiles del cubo</b>	391
<b>Tabla de medidas para dispositivos de desembrague y cojinetes de guía</b>	392 - 393

# Estructura del catálogo

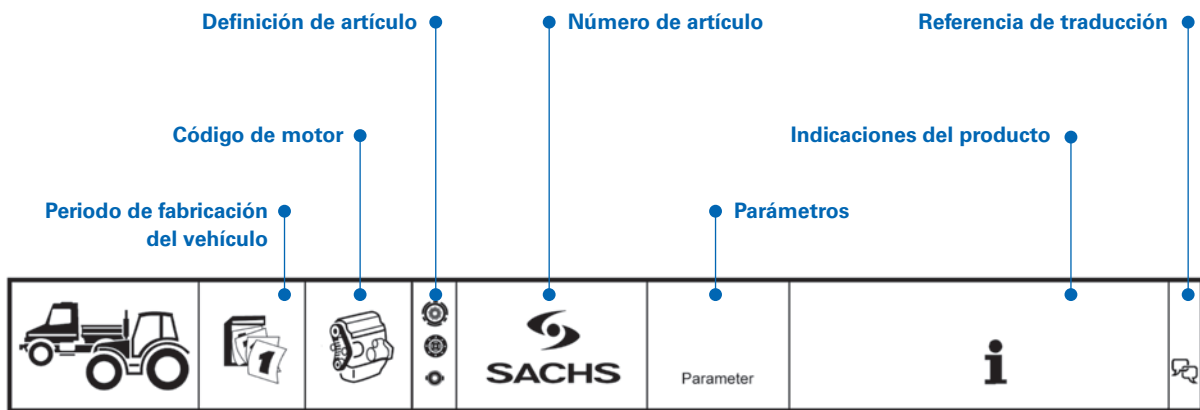

## EICHER

3105 - 3145						
3105 (3021/3022)	01.77 - 12.82	E-EDK-6	⊗	3482 012 211	GMF330	
			⊗	1864 352 101	330Z (44x48-23N)	Nur bei Altteil-Rückgabe lieferbar (Reparatur; Werk Bielefeld) / Please return old unit for repair (plant Bielefeld) (33)
			◇	3151 196 031		
3108 (3026)	01.82 - 12.90	E-EDL-6,	⊗	3482 002 234	GMF350X	
3125 (3028)	01.82 - 12.90	E-EDK-6,				
3133 (3024)	01.77 - 12.82	E-EDL-6-T	⊗	1864 347 101 #	350Z (44x48-23N)	
3145 (3030)	01.82 - 12.90		◇	3151 196 031		

## Parámetros

⊗ Platos de apriete del embrague	
2/	Para versión de 2 discos
400	Diámetro exterior de las superficies de fricción 400 mm
Do	Doble embrague, desembrague dependiente
Du	Doble embrague, desembrague independiente
/E	XTend
F	Volante motor plano
G	Embrague con cárter de fundición
K	Embrague de muelle helicoidal
KM	Con muelle de membrana y sistema de palanca
M	Embrague de muelle de membrana
N	Toma de fuerza
S	Modelo de pasador pivote
T	Con arandela Belleville
XTend	Con ajuste automático
Z	Desembrague de tracción

⊗ Cojinete de desembrague	
...A	Anillo exterior seguidor
G	Anillo de empuje de grafito
GK	Anillo de empuje de grafito y rodamiento de bolas
GR	Rodamiento de bolas con tapa de chapa
GZ	Cilindro principal
HHIS	Cilindro receptor concéntrico
...I	Anillo interior seguidor
KT	Arandela de tope de teflón
KZ	Rodamiento de bolas, centrado
NZ	Cilindro receptor
...S	Anillo interior autocentrante
...Z	Desembrague de tracción

⊗ Discos de embrague	
200	Diámetro exterior 200 mm
CE	Revestimiento sinterizado inorgánico
B/D/E/Z	Apoyos flexibles del revestimiento
BH/GS/GT/GV	Amortiguador de torsión para vehículos industriales
/E	XTend
W/V	Pre-amortiguador para vehículos industriales

⊗ Embrague del ventilador	
VL	Para vehículos ligeros
VM	Para vehículos medianos
VS	Para vehículos pesados

# Traducciones

- (1) Pieza distanciadora de 12 mm sobre la carcasa
- (2) 4 marchas
- (3) 5 marchas
- (4) 6 marchas
- (5) ¡Atención! Los 3 tornillos rojos en la carcasa deben retirarse después del montaje
- (6) Tracción a las cuatro ruedas
- (7) Número de forros
- (8) Diámetro exterior [mm]
- (9) Versión Borg & Beck
- (10) Ancho [mm]
- (11) Gasóleo
- (12) Plato de presión con 3 palancas
- (13) Plato de presión con 4 palancas
- (14) Debe montarse también el anillo de empuje con n.º KHD 238 4107
- (15) A lo mejor debe montarse también el casquillo distanciador con n.º KHD 0430 8044
- (16) País fabricante del vehículo: Brasil
- (17) Medio de llenado: Bioaceite
- (18) Medio de llenado: Líquido de frenos
- (19) Medio de llenado: Aceite hidráulico
- (20) Medio de llenado: Aceite mineral
- (21) Tipo de engranaje: Engranaje inversor de botes Hurth
- (22) Sustituir siempre
- (23) Incluido en 1881/1882/1888/3083/3088/3483/3488 ... ..
- (24) Incluido en 1888 ... ..
- (25) Diámetro interior [mm]
- (26) Equipado con diferente embrague (según petición del cliente)
- (27) Parámetro
- (28) Rodamiento de bolas
- (29) Versión LUK
- (30) Disco de embrague suelto
- (31) Perfil del buje
- (32) No intercambiable con VALEO
- (33) Sólo disponible para devolución de piezas usadas (reparación, fábrica en Bielefeld)
- (34) Solo instalar si lleva montado un Embrague SACHS
- (35) Montar solamente en conjunto
- (36) Versión SACHS
- (37) Se requiere un cambio del volante
- (38) Profundidad del disco volante: 44,5 mm
- (39) Modelo especial
- (40) Steyrmatic
- (41) Versión VALEO
- (42) Caja de cambios ZF
- (43) Kit de reparación opcional
- (44) Incluye tornillos de fijación del plato de presión
- (45) Incluye un disco de embrague
- (46) Incluye dos discos de embrague
- (47) Para
- (48) Para vehículos con embrague monodisco
- (49) Para vehículos con sistema de frenado de baja presión

DE

EN

FR

ES

IT

PL

RU

EL

DE

# Traducciones

EN

FR

ES

IT

PL

RU

EL

- (50) Para vehículos con convertidor de par
- (51) Para vehículos con embrague de disco doble
- (52) Para vehículos con accionamiento hidráulico del embrague
- (53) Para vehículos con accionamiento mecánico del embrague (cable de accionamiento)
- (54) Para el árbol de toma de fuerza frontal
- (55) Para el tractor de cabina
- (56) Para el árbol toma de fuerza del motor
- (57) Para mando auxiliar
- (58) Para número OE
- (59) Para caja de cambios
- (60) Para el árbol de toma de fuerza independiente
- (61) Con diferente embrague según versión
- (62) Máximo par motor transmisible [Nm]
- (63) Con anillo de empuje
- (64) Con caja de cambios de carga
- (65) Con mando auxiliar
- (66) Con Powermatic
- (67) Con embrague Rockford
- (68) Con conexión para tubo de engrase
- (69) Con sensor
- (70) Con árbol para mando auxiliar
- (71) Con freno de engranaje eléctrico
- (72) Con freno de engranaje hidráulico
- (73) Con árbol de toma de fuerza hidráulico
- (74) Con conmutación de inversión mecánica
- (75) No para
- (76) No para número de chasis
- (77) Solo como recambio para los números OE indicados
- (78) Solo en conexión con
- (79) Sin anillo de empuje
- (80) Sin caja de cambios de carga
- (81) Sin Powermatic
- (82) Sin conexión para tubo de engrase
- (83) Sin placa intermedia
- (84) Conmutación en H invertida



# Informazioni generali



Tutti i prodotti riportati in questo catalogo possono essere impiegati solo dal personale qualificato di una autofficina.

Per soddisfare le vostre richieste, abbiamo bisogno del numero di ordine completo, ad esempio:

**Kit frizione** 3800 541 022  
**Spingidisco della frizione** 1888 054 004  
**Disco frizione** 1864 418 002

In caso di dubbio fornire il nome del modello e l'anno di costruzione del veicolo per il quale è destinato l'articolo desiderato.

Tutti i diritti riservati. La riproduzione o la condivisione di questo catalogo, anche parziale, per la realizzazione di un proprio catalogo non sono consentite previo consenso espresso.

I numeri dei ricambi del produttore di veicoli servono solo a scopi comparativi. Un utilizzo di tali dati in fatture inviate ai proprietari dei veicoli non è consentito.

Le condizioni commerciali generali aggiornate sono reperibili all'indirizzo [www.zf.com/services/documents](http://www.zf.com/services/documents)

[www.zf.com/services/catalog](http://www.zf.com/services/catalog)

**WebCat**  
Catalogo online

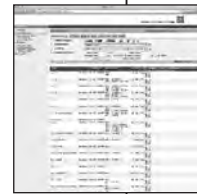

**InCat**  
Catalogo elettronico



**PrintCat**  
Cataloghi stampati



## Indice

<b>Index</b>	U2
<b>Simboli</b>	U3 - U4
<b>Informazioni generali</b>	V15
<b>Struttura del catalogo</b>	V16
<b>Grandezze caratteristiche</b>	V16
<b>Traduzioni</b>	V17 - V18
<b>Lista aritmetica</b>	297 - 353
<b>Elenco di confronto</b>	354 - 369
<b>Nuove acquisizioni</b>	370 - 372
<b>Numeri d'ordinazione modificati</b>	372 - 373
<b>Numeri eliminati</b>	373 - 374
<b>Smorzatore torsionale</b>	375 - 390
<b>Tabella misure per profili mozzo</b>	391
<b>Tabella misure per cuscinetto reggispinta e cuscinetto di guida</b>	392 - 393

# Struttura del catalogo

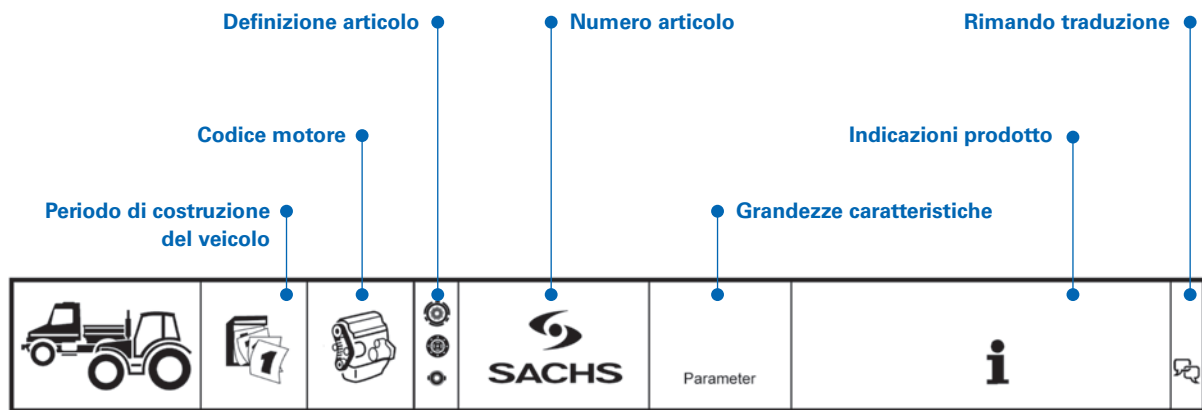

## EICHER

3105 - 3145						
3105 (3021/3022)	01.77 - 12.82	E-EDK-6	⚙️	3482 012 211	GMF330	
			⚙️	1864 352 101	330Z (44x48-23N)	Nur bei Altteil-Rückgabe lieferbar (Reparatur; Werk Bielefeld) / Please return old unit for repair (plant Bielefeld) (33)
			⚙️	3151 196 031		
3108 (3026)	01.82 - 12.90	E-EDL-6,	⚙️	3482 002 234	GMF350X	
3125 (3028)	01.82 - 12.90	E-EDK-6,	⚙️	1864 347 101 #	350Z (44x48-23N)	
3133 (3024)	01.77 - 12.82	E-EDL-6-T	⚙️			
3145 (3030)	01.82 - 12.90		⚙️	3151 196 031		

## Grandezze caratteristiche

### ⚙️ Dischi di spinta della frizione

<b>Z/</b>	Per versione a 2 dischi
<b>400</b>	Diametro esterno superficie di attrito 400 mm
<b>Do</b>	Doppia frizione, disinnesto azionato in modo dipendente
<b>Du</b>	Doppia frizione, disinnesto azionato in modo indipendente
<b>/E</b>	XTend
<b>F</b>	Volano piatto
<b>G</b>	Frizione con scatola in ghisa
<b>K</b>	Frizione a molla elicoidale
<b>KM</b>	Con molla a diaframma e sistema di leve
<b>M</b>	Frizione con molla a diaframma
<b>N</b>	Presa di forza
<b>S</b>	Orientamento del perno oscillante
<b>T</b>	Con molla a tazza
<b>XTend</b>	Con recupero automatico
<b>Z</b>	Disinnesto in trazione

### ⚙️ Cuscinetto di disinnesto

<b>...A</b>	Anello esterno mobile
<b>G</b>	Anello di guida in grafite
<b>GK</b>	Anello di guida in grafite e cuscinetto a sfere
<b>GR</b>	Cuscinetto a sfere con calotta in lamiera
<b>GZ</b>	Pompa idraulica
<b>HHIS</b>	Cilindro frizione concentrico
<b>...I</b>	Anello interno mobile
<b>KT</b>	Disco di scorrimento in teflon
<b>KZ</b>	Cuscinetto a sfere, centrante
<b>NZ</b>	Cilindro frizione
<b>...S</b>	Anello interno autocentrante
<b>...Z</b>	Disinnesto in trazione

### ⚙️ Dischi frizione

<b>200</b>	Diametro esterno 200 mm
<b>CE</b>	Pastiglia sinterizzata in materiale inorganico
<b>B/D/E/Z</b>	Sospensione pastiglia freno
<b>BH/GS/GT/GV</b>	Giunto torsionale per veicoli commerciali
<b>/E</b>	XTend
<b>W/V</b>	Preammortizzatore per veicoli commerciali

### ⚙️ Giunto ventola

<b>VL</b>	Impiego leggero
<b>VM</b>	Impiego di media difficoltà
<b>VS</b>	Impiego pesante

# Traduzioni

- (1) Distanziale 12 mm su scatola
- (2) 4 marce
- (3) 5 marce
- (4) 6 marce
- (5) Attenzione! Le 3 viti rosse nella scatola devono essere rimosse dopo il montaggio
- (6) Trazione integrale
- (7) Numero delle guarnizioni
- (8) Diametro esterno [mm]
- (9) Versione Borg & Beck
- (10) Larghezza [mm]
- (11) Diesel
- (12) Spingidisco con 3 leve
- (13) Spingidisco con 4 leve
- (14) È necessario montare insieme l'anello di spinta, n. KHD 238 4107
- (15) Potrebbe essere necessario montare insieme la boccola distanziatrice, n. KHD 0430 8044
- (16) Paese di produzione veicolo: Brasile
- (17) Fluido di riempimento: Bio-olio
- (18) Fluido di riempimento: Liquido freni
- (19) Fluido di riempimento: Olio idraulico
- (20) Fluido di riempimento: Olio minerale
- (21) Tipo di trasmissione: Invertitore marino Hurth
- (22) Sostituire sempre
- (23) Contenuto in 1881/1882/1888/3083/3088/3483/3488 ... ..
- (24) Contenuto in 1888 ... ..
- (25) Diametro interno [mm]
- (26) Su richiesta del cliente fornito con frizione diversa
- (27) Grandezza caratteristica
- (28) Cuscinetto a sfere
- (29) Versione LUK
- (30) Disco frizione sciolto
- (31) Profilo mozzo
- (32) Non intercambiabile con VALEO
- (33) Consegnabile solo in caso di restituzione del pezzo vecchio (riparazioni; stabilimento di Bielefeld)
- (34) Montare solamente se era montata una frizione SACHS
- (35) Solo da utilizzare congiuntamente
- (36) Versione SACHS
- (37) Modifica del volano necessaria
- (38) Profondità del volano: 44,5 mm
- (39) Versione speciale
- (40) Steyrmatic
- (41) Versione VALEO
- (42) Cambio ZF
- (43) Kit riparazione alternativo
- (44) Comprende le viti di fissaggio per spingidisco
- (45) Comprende un dischi frizione
- (46) Comprende due dischi frizione
- (47) Per
- (48) Per veicoli con frizione monodisco
- (49) Per veicoli con impianto frenante a bassa pressione

DE

EN

FR

ES

IT

PL

RU

EL

# Traduzioni

- (50) Per veicoli con convertitore di coppia-frizione
- (51) Per veicoli con frizione bidisco
- (52) Per veicoli con comando frizione idraulico
- (53) Per veicoli con comando frizione meccanico (tirante)
- (54) Per presa di forza anteriore
- (55) Per trattore con cabina
- (56) Per presa di forza del motore
- (57) Per presa di forza
- (58) Per codice OE
- (59) Per cambio manuale
- (60) Per albero della presa di forza indipendente
- (61) A seconda della versione con frizione diversa
- (62) Coppia motore max. trasmissibile [Nm]
- (63) Con anello di guida
- (64) Con cambio sotto carico
- (65) Con presa di forza
- (66) Con Powermatic
- (67) Con frizione Rockford
- (68) Con raccordo lubrificazione
- (69) Con sensore
- (70) Con albero per presa di forza
- (71) Con freno cambio elettrico
- (72) Con freno cambio idraulico
- (73) Con albero della presa di forza idraulico
- (74) Con invertitore meccanico
- (75) Non per
- (76) Non per numero telaio
- (77) Solo come ricambio per il numero OE indicato
- (78) Solo in combinazione con
- (79) Senza anello di guida
- (80) Senza cambio sotto carico
- (81) Senza Powermatic
- (82) Senza raccordo lubrificazione
- (83) Senza piastra intermedia
- (84) Innesto ad H invertito

# Ogólna informacja



Wszystkie produkty wymienione w tym katalogu mogą być montowane wyłącznie przez wykwalifikowany personel serwisu samochodowego.

W przypadku zamówień niezbędny jest pełny numer zamówieniowy, na przykład:

Zestaw sprzęgowy	3800 541 022
Tarcza dociskowa sprzęgła	1888 054 004
Tarcza sprzęgła	1864 418 002

W razie wątpliwości proszę podawać oznaczenie typu i rok produkcji pojazdu, dla którego przeznaczony jest żądany artykuł.

Wszelkie prawa zastrzeżone. Powielanie lub wykorzystywanie niniejszego katalogu, w całości lub częściowo, do sporządzenia innego katalogu jest niedozwolone bez uzyskania wyraźnej zgody. Numery części zamiennych producentów samochodów służą tylko do celów porównawczych.

Wykorzystywanie tego rodzaju danych na rachunkach wystawianych pod adresem posiadacza samochodu jest zabronione.

Aktualne ogólne warunki handlowe można znaleźć tutaj [www.zf.com/services/documents](http://www.zf.com/services/documents)

[www.zf.com/services/catalog](http://www.zf.com/services/catalog)

**WebCat**  
Katalog online

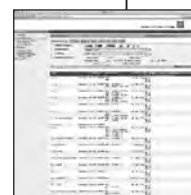

**InCat**  
Katalog elektroniczny



**PrintCat**  
Drukowane katalogi



## Spis treści

Index	U2
Symbole	U3 - U4
Ogólna informacja	V19
Struktura katalogu	V20
Parametry	V20
Tłumaczenia	V21 - V22
Lista z numerami	297 - 353
Lista porównawcza	354 - 369
Nowe produkty	370 - 372
Zmienione numery zamówienia	372 - 373
Numery skreślone	373 - 374
Tłumik drgań skrętnych	375 - 390
Tabela wymiarów profili piasty	391
Tabela wymiarów wyprężnika i łożysk prowadzących	392 - 393

# Struktura katalogu

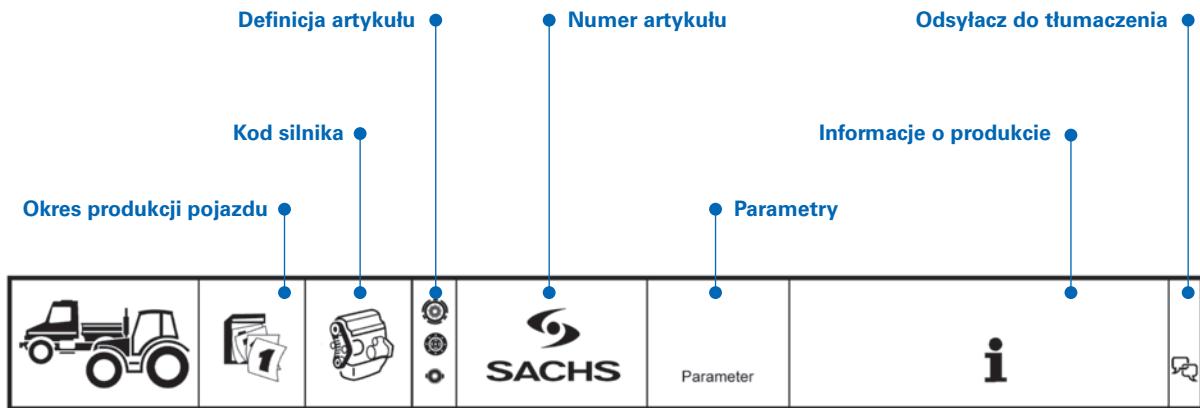

## EICHER

3105 - 3145						
3105 (3021/3022)	01.77 - 12.82	E-EDK-6	⚙️	3482 012 211	GMF330	
			⚙️	1864 352 101	330Z (44x48-23N)	Nur bei Altteil-Rückgabe lieferbar (Reparatur; Werk Bielefeld) / Please return old unit for repair (plant Bielefeld) (33)
			⚙️	3151 196 031		
3108 (3026)	01.82 - 12.90	E-EDL-6,	⚙️	3482 002 234	GMF350X	
3125 (3028)	01.82 - 12.90	E-EDK-6,	⚙️	1864 347 101 #	350Z (44x48-23N)	
3133 (3024)	01.77 - 12.82	E-EDL-6-T	⚙️			
3145 (3030)	01.82 - 12.90		⚙️	3151 196 031		

## Parametry

⚙️ Tarcze dociskowe sprzęgła	
2/	Do wersji z dwoma tarczami
400	Średnica zewnętrzna powierzchni tarcia 400 mm
Do	Podwójne sprzęgło, wyprężanie zależne
Du	Podwójne sprzęgło, wyprężanie niezależne
/E	XTend
F	Płaskie koło zamachowe
G	Sprzęgło z odlewaną obudową
K	Sprzęgło ze sprężyną śrubową
KM	Z sprężyną membranową i systemem dźwigniowym
M	Sprzęgło ze sprężyną membranową
N	Napęd dodatkowy
S	Wersja ze sworzniem obrotowym
T	Z sprężyną talerzową
XTend	Z automatycznym nastawianiem
Z	Wyprężanie przy naprężeniu

⚙️ Łożysko wyciskowe	
...A	Pierścień zewnętrzny współbieżny
G	Pierścień oporowy grafitowy
GK	Pierścień oporowy grafitowy i łożysko kulkowe
GR	Łożysko kulkowe z osłoną blaszaną
GZ	Pompa sprzęgłowa
HHIS	Koncentryczny cylinder odbiorczy
...I	Pierścień wewnętrzny współbieżny
KT	Teflonowa podkładka oporowa
KZ	Łożysko kulkowe, prowadzone centralnie
NZ	Cylinder odbiorczy
...S	Pierścień wewnętrzny samocentrujący
...Z	Wyprężanie przy naprężeniu

⚙️ Tarcza sprzęgła	
200	Średnica zewnętrzna 200 mm
CE	Nieorganiczna powłoka spiekana
B/D/E/Z	Uresorowania z powłoką
BH/GS/GT/GV	Tłumiki drgań skrętnych dla pojazdów użytkowych
/E	XTend
W/V	Tłumiki wstępne dla pojazdów użytkowych

⚙️ Sprzęgło wentylatora	
VL	Lekkie warunki pracy
VM	Średnio ciężkie warunki pracy
VS	Ciężkie warunki pracy

# Tłumaczenia

- (1) Element dystansowy 12 mm na obudowę
- (2) 4 biegów
- (3) 5 biegów
- (4) 6 biegów
- (5) Uwaga! Po dokonaniu montażu należy wyjąć 3 czerwone śruby w obudowie
- (6) Napęd na 4 koła
- (7) Liczba okładzin
- (8) Średnica zewnętrzna [mm]
- (9) Wersja Borg & Beck
- (10) Szerokość [mm]
- (11) Diesel
- (12) Tarcza dociskająca z 3 dźwigniami
- (13) Tarcza dociskająca z 4 dźwigniami
- (14) Należy zamontować także pierścień dociskający KHD nr 238 4107
- (15) Może istnieć konieczność zamontowania wraz z elementem tulei dystansowej KHD nr 0430 8044
- (16) Kraj produkcji pojazdu: Brazylia
- (17) Czynnik wypełniający: Oley bio
- (18) Czynnik wypełniający: Płyn hamulcowy
- (19) Czynnik wypełniający: Oley hydrauliczny
- (20) Czynnik wypełniający: Olej mineralny
- (21) Typ przekładni: Przekładnia nawrotna Hurth do łodzi
- (22) Zawsze wymieniać
- (23) Zawarte w 1881/1882/1888/3083/3088/3483/3488 ... ..
- (24) Zawarte w 1888 ... ..
- (25) Średnica wewnętrzna [mm]
- (26) Wyposażone w różne sprzęgła według życzenia klienta
- (27) Parametry
- (28) Łożysko kulkowe
- (29) Wersja LUK
- (30) Wolna tarcza sprzęgła
- (31) Profil piasty
- (32) Niewymienne z VALEO
- (33) Dostępne tylko w przypadku zwrotu zużytej części (naprawa; zakład Bielefeld)
- (34) Zamontować tylko wtedy, gdy wbudowane było sprzęgło SACHS
- (35) Montować tylko razem
- (36) Wersja SACHS
- (37) Wymagana zmiana stopnia wychylenia
- (38) Głębokość koła zamachowego: 44,5 mm
- (39) Wersja specjalna
- (40) Steyrmatic
- (41) Wersja VALEO
- (42) Przekładnia ZF
- (43) Alternatywny zestaw naprawczy
- (44) Zawiera śruby do mocowania tarczy dociskającej
- (45) Zawiera jedną tarczę sprzęgła
- (46) Zawiera dwie tarcze sprzęgła
- (47) Do
- (48) Do pojazdów z sprzęgłem jednotarczowym
- (49) Do pojazdów z niskociśnieniowym układem hamulcowym

# Tłumaczenia

(50) Do pojazdów z przekładnią hydrokinetyczną ze sprzęgłem ciernym

(51) Do pojazdów z sprzęgłem dwutarczowym

(52) Do pojazdów z hydraulicznym przełączaniem sprzęgła

(53) Do pojazdów z mechanicznym przełączaniem sprzęgła (ciężno)

(54) Do przedniego wału odbioru mocy

(55) Do ciągnika kabinowego

(56) Do wału odbioru mocy silnika

(57) Do napędu dodatkowego

(58) Do numeru OE

(59) Do mechanicznej skrzyni biegów

(60) Do niezależnego wału odbioru mocy

(61) W zależności od wykonania z różnymi sprzęgłami

(62) Maks. przenoszony moment silnika [Nm]

(63) Z pierścieniem rozruchowym

(64) Z przekładnią przełączalną

(65) Z napędem dodatkowym

(66) Z Powermatic

(67) Z sprzęgłem Rockford

(68) Z przyłączem rury smarowania

(69) Z czujnikiem

(70) Z wałem odbioru mocy do napędu pomocniczego

(71) Z elektrycznym hamulcem przekładniowym

(72) Z hydraulicznym hamulcem przekładniowym

(73) Z hydraulicznym wałem odbioru mocy

(74) Z mechanicznym przełączaniem nawrotnym

(75) Nie do

(76) Nie do podwozi o numerze

(77) Tylko jako zamiennik dla podanego numeru OE

(78) Tylko w połączeniu z

(79) Bez pierścienia rozruchowego

(80) Bez przekładni przełączalnej

(81) Bez Powermatic

(82) Bez przyłącza rury smarowania

(83) Bez tarczy pośredniej

(84) Odwrócony układ H



# Общая информация



Все приведенные в данном каталоге продукты разрешается устанавливать только обученному персоналу автомобильной мастерской.

Для удовлетворения вашего запроса нам необходим полный номер для заказа, например:

**Комплект сцепления** 3800 541 022  
**Нажимной диск сцепления** 1888 054 004  
**Ведомый диск сцепления** 1864 418 002

В случае сомнений необходимо указать обозначение типа и год выпуска автомобиля, для которого предназначено заказываемое изделие.

Все права защищены. Копирование либо совместное использование данного каталога в том числе частичное для составления собственного каталога недопустимо без особого на то согласия.

Номера запасных частей производителей автомобилей указаны исключительно в целях сравнения. Использование подобных данных в счетах, выставляемых владельцам автомобилей, недопустимо.

Действующие общие условия заключения сделок приведены на сайте [www.zf.com/services/documents](http://www.zf.com/services/documents)

[www.zf.com/services/catalog](http://www.zf.com/services/catalog)

## WebCat

Онлайн-каталог

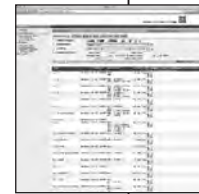

## InCat

Электронный каталог



## PrintCat

Печатные каталоги



## Оглавление

<b>Index</b>	U2
<b>Символы</b>	U3 - U4
<b>Общая информация</b>	V23
<b>Структура каталога</b>	V24
<b>Характеристики</b>	V24
<b>Переводы</b>	V25 - V26
<b>Арифметический список сравнительная таблица</b>	297 - 353 354 - 369
<b>Новинки</b>	370 - 372
<b>Измененные номера для заказа</b>	372 - 373
<b>Зачеркнутые номера</b>	373 - 374
<b>Гаситель крутильных колебаний</b>	375 - 390
<b>Таблица размеров профилей ступиц</b>	391
<b>Таблица размеров выжимного и упорного подшипников</b>	392 - 393

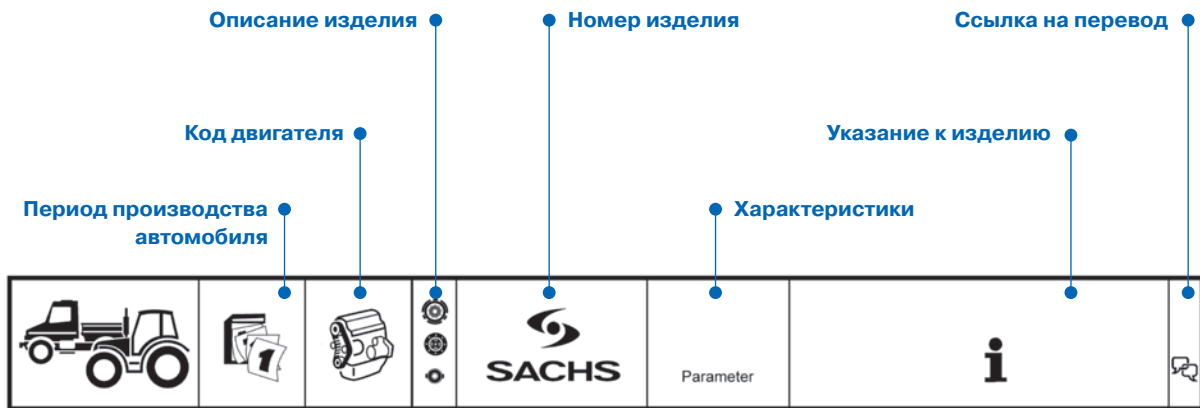

## EICHER

### 3105 - 3145

3105 (3021/3022)	01.77 - 12.82	E-EDK-6	⚙️ 3482 012 211	GMF330		
			⚙️ 1864 352 101	330Z (44x48-23N)	Nur bei Allteil-Rückgabe lieferbar (Reparatur; Werk Bielefeld) / Please return old unit for repair (plant Bielefeld)	(33)
			⚙️ 3151 196 031			
3108 (3026)	01.82 - 12.90	E-EDL-6,	⚙️ 3482 002 234	GMF350X		
3125 (3028)	01.82 - 12.90	E-EDK-6,	⚙️ 1864 347 101 #	350Z (44x48-23N)		
3133 (3024)	01.77 - 12.82	E-EDL-6-T	⚙️			
3145 (3030)	01.82 - 12.90		⚙️ 3151 196 031			

## Характеристики

### ⚙️ Нажимные диски сцепления

<b>2/</b>	Для исполнения с двумя шайбами
<b>400</b>	Наружный диаметр поверхности трения 400 мм
<b>Do</b>	Двойное сцепление, зависимое выключение
<b>Du</b>	Двойное сцепление, независимое выключение
<b>/E</b>	XTend
<b>F</b>	Плоский маховик
<b>G</b>	Сцепление с литым картером
<b>K</b>	Сцепление с витой пружиной
<b>KM</b>	С мембранной пружиной и системой рычагов
<b>M</b>	Сцепление с мембранной пружиной
<b>N</b>	Механизм отбора мощности
<b>S</b>	Исполнение откидного болта
<b>T</b>	С тарельчатой пружиной
<b>XTend</b>	С автоматической регулировкой
<b>Z</b>	Выключение при тяге

### ⚙️ Ведомые диски сцепления

<b>200</b>	Наружный диаметр 200 мм
<b>CE</b>	Накладка из неорганического спеченного материала
<b>B/D/E/Z</b>	Подпружинивание накладки
<b>BH/GS/GT/GV</b>	Гасители крутильных колебаний для грузовых а/м
<b>/E</b>	XTend
<b>W/V</b>	Первичный гаситель для грузовых а/м

### ⚙️ Выжимной подшипник

<b>...A</b>	Наружное кольцо, вращающееся совместно
<b>G</b>	Графитовое упорное кольцо
<b>GK</b>	Графитовое упорное кольцо и шарикоподшипник
<b>GR</b>	Шарикоподшипник с колпачком
<b>GZ</b>	Главный цилиндр
<b>HHIS</b>	Концентрический рабочий цилиндр
<b>...I</b>	Внутреннее кольцо, вращающееся совместно
<b>KT</b>	Тефлоновая регулировочная шайба
<b>KZ</b>	Шарикоподшипник, с центральным направлением
<b>NZ</b>	Рабочий цилиндр
<b>...S</b>	Самоцентрирующееся внутреннее кольцо
<b>...Z</b>	Выключение при тяге

### ⚙️ Муфта вентилятора

<b>VL</b>	Лёгкие условия эксплуатации
<b>VM</b>	Условия эксплуатации средней тяжести
<b>VS</b>	Тяжелые условия эксплуатации

# Переводы

DE

EN

FR

ES

IT

PL

RU

EL

- (1) Проставка 12 мм на корпусе
- (2) 4-ступенчатая
- (3) 5-ступенчатая
- (4) 6-ступенчатая
- (5) Внимание! После монтажа необходимо извлечь 3 красных винта внутри корпуса
- (6) Привод на все колеса
- (7) Количество накладок
- (8) Наружный диаметр [мм]
- (9) Исполнение Borg & Beck
- (10) Ширина [мм]
- (11) Дизель
- (12) Нажимной диск с 3 рычагами
- (13) Нажимной диск с 4 рычагами
- (14) Также необходимо установить упорное кольцо KHD № 238 4107
- (15) Возможно, потребуется установка распорной втулки KHD № 0430 8044
- (16) Страна-производитель: Бразилия
- (17) Рабочая среда: биомасло
- (18) Рабочая среда: тормозная жидкость
- (19) Рабочая среда: гидравлическая жидкость
- (20) Рабочая среда: минеральное масло
- (21) Тип коробки передач: реверсивная Hurth (для катеров и лодок)
- (22) Всегда заменять
- (23) Содержится в 1881/1882/1888/3083/3088/3483/3488 ... ..
- (24) Содержится в 1888 ... ..
- (25) Внутренний диаметр [мм]
- (26) С разным сцеплением по желанию заказчика
- (27) Характеристика
- (28) Шарикоподшипник
- (29) Версия LUK
- (30) Незакрепленный ведомый диск сцепления
- (31) Профиль ступицы
- (32) Взаимозаменяемость с VALEO не предусмотрена
- (33) Поставляется только при возврате старой детали (ремонт; завод в Bielefeld)
- (34) Устанавливать только, если ранее было установлено сцепление SACHS
- (35) Устанавливать только совместно
- (36) Версия SACHS
- (37) Требуется модификация маховика
- (38) Глубина маховика: 44,5 мм
- (39) Специальное исполнение
- (40) Steyrmatic
- (41) Версия VALEO
- (42) Коробка передач ZF
- (43) Альтернативный ремкомплект
- (44) включает винты крепления нажимного диска
- (45) Включает один диск сцепления
- (46) Включает два диска сцепления
- (47) Для
- (48) Для автомобилей с однодисковым сцеплением
- (49) Для автомобилей с тормозной системой низкого давления

# Переводы

- (50) Для автомобилей с блокировочной муфтой трансформатора
- (51) Для автомобилей с двухдисковым сцеплением
- (52) Для автомобилей с гидравлическим приводом управления сцеплением
- (53) Для автомобилей средств с механическим приводом управления сцеплением (тросовый привод)

- (54) Для переднего вала отбора мощности
- (55) Для трактора (с кабиной)
- (56) Для независимого вала отбора мощности
- (57) Для механизма отбора мощности
- (58) Для номера OE
- (59) Для механической коробки передач
- (60) Для независимого вала отбора мощности
- (61) В зависимости от исполнения с различным сцеплением
- (62) Макс. передаваемый крутящий момент двигателя [Нм]

- (63) С упорным кольцом
- (64) Для КПП, переключаемой под нагрузкой
- (65) С механизмом отбора мощности
- (66) С Powermatic
- (67) С сцеплением Rockford
- (68) С подключением трубопровода для смазочной линии
- (69) С датчиком
- (70) С валом для механизма отбора мощности
- (71) С электрическим трансмиссионным тормозом
- (72) С гидравлическим трансмиссионным тормозом
- (73) С гидравлическим валом отбора мощности

- (74) С механическим реверсированием
- (75) Не для
- (76) Не для шасси номера
- (77) Только в качестве замены указанного оригинального номера
- (78) Только в комбинации с
- (79) Без упорного кольца

- (80) Без коробки передач, переключаемой под нагрузкой
- (81) Без Powermatic
- (82) Без подключения трубопровода для смазочной линии
- (83) Без промежуточной пластины
- (84) Обратная H-схема (переключения)

# Γενικές πληροφορίες



Όλα τα εξαρτήματα αυτού του καταλόγου επιτρέπεται να τοποθετούνται μόνο από το εκπαιδευμένο προσωπικό ενός συνεργείου αυτοκινήτου.

Για τις απαιτήσεις σας χρειαζόμαστε τον πλήρη αριθμό παραγγελίας, για παράδειγμα:

**Σετ συμπλέκτη** 3800 541 022  
**Πλατό συμπλέκτη** 1888 054 004  
**Δίσκος συμπλέκτη** 1864 418 002

Εάν έχετε αμφιβολίες, δώστε την ονομασία τύπου και το έτος κατασκευής του οχήματος για το οποίο προορίζεται το επιθυμητό εξάρτημα.

Με την επιφύλαξη παντός δικαιώματος. Δεν επιτρέπεται η αναπαραγωγή ή η χρήση του παρόντος καταλόγου εν όλω ή εν μέρει για τη δημιουργία προσωπικού καταλόγου, χωρίς ρητή άδεια.

Οι κωδικοί εξαρτημάτων των κατασκευαστών οχημάτων παρέχονται μόνο για σκοπούς σύγκρισης. Δεν επιτρέπεται η αναφορά τέτοιου είδους στοιχείων σε παραστατικά αγοράς που απευθύνονται στον κάτοχο του οχήματος.

Οι ισχύοντες γενικοί όροι λειτουργίας υπάρχουν στη διεύθυνση [www.zf.com/services/documents](http://www.zf.com/services/documents)

[www.zf.com/services/catalog](http://www.zf.com/services/catalog)

## WebCat

Κατάλογος online

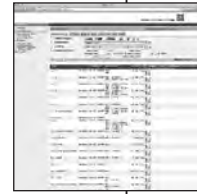

## InCat

Ηλεκτρονικός κατάλογος



## PrintCat

Τυπωμένοι κατάλογοι



## Περιεχόμενα

<b>Index</b>	U2
<b>Σύμβολα</b>	U3 - U4
<b>Γενικές πληροφορίες</b>	V27
<b>Δομή καταλόγου</b>	V28
<b>Κύρια μεγέθη</b>	V28
<b>Μεταφράσεις</b>	V29 - V30
<b>Αριθμητικός κατάλογος</b>	297 - 353
<b>Συγκριτικός κατάλογος</b>	354 - 369
<b>Νέες καταχωρίσεις</b>	370 - 372
<b>Τροποποιημένοι αριθμοί παραγγελίας</b>	372 - 373
<b>Διεγραμμένοι αριθμοί</b>	373 - 374
<b>Αποσβεστήρας στρέψης</b>	375 - 390
<b>Πίνακας διαστάσεων για προφίλ πλήμνης</b>	391
<b>Πίνακας διαστάσεων για έδρανα αποσύμπλεξης και έδρανα οδηγούς</b>	392 - 393

# Δομή καταλόγου

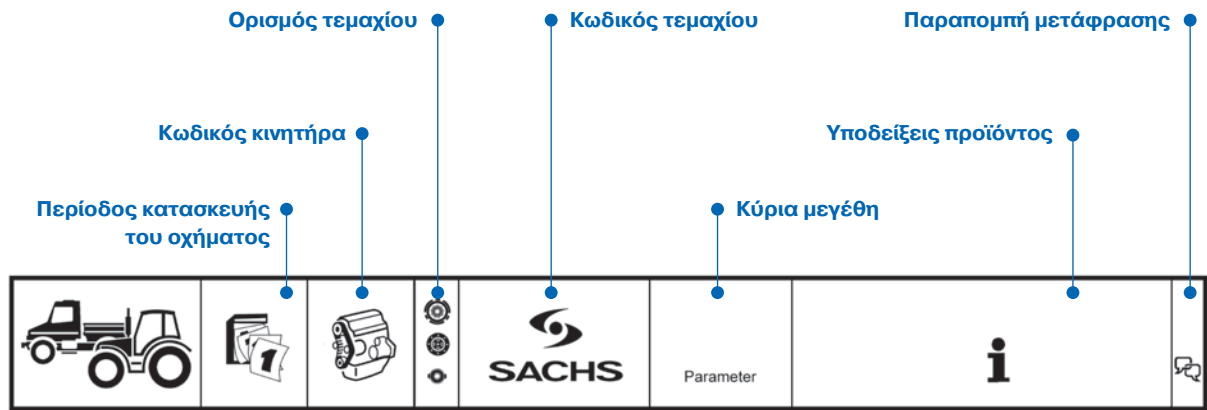

## EICHER

### 3105 - 3145

3105 (3021/3022)	01.77 - 12.82	E-EDK-6	⊗ 3482 012 211	GMF330		
			⊗ 1864 352 101	330Z (44x48-23N)	Nur bei Altteil-Rückgabe lieferbar (Reparatur; Werk Bielefeld) / Please return old unit for repair (plant Bielefeld)	(33)
			⊖ 3151 196 031			
3108 (3026)	01.82 - 12.90	E-EDL-6,	⊗ 3482 002 234	GMF350X		
3125 (3028)	01.82 - 12.90	E-EDK-6,				
3133 (3024)	01.77 - 12.82	E-EDL-6-T	⊗ 1864 347 101 #	350Z (44x48-23N)		
3145 (3030)	01.82 - 12.90		⊖ 3151 196 031			

## Κύρια μεγέθη

### ⊗ Πλατό συμπλέκτη

<b>2/</b>	Για τύπο 2 δίσκων
<b>400</b>	Εξωτερική διάμετρος επιφάνειας τριβής 400 mm
<b>Do</b>	Διπλός συμπλέκτης, εξαρτώμενη αποσύμπλεξη
<b>Du</b>	Διπλός συμπλέκτης, ανεξάρτητη αποσύμπλεξη
<b>/E</b>	XTend
<b>F</b>	Λεπτό βολάν
<b>G</b>	Συμπλέκτης με χυτό κέλυφος
<b>K</b>	Συμπλέκτης ελικοειδών ελατηρίων
<b>KM</b>	Με ελατήριο μεμβράνης και μοχλικό σύστημα
<b>M</b>	Συμπλέκτης ελατηρίων μεμβράνης
<b>N</b>	Δευτερεύων μηχανισμός κίνησης
<b>S</b>	Τύπος με πείρο στρέψης
<b>T</b>	Με δισκοειδές ελατήριο
<b>XTend</b>	Με αυτόματη ρύθμιση
<b>Z</b>	Αποσύμπλεξη με έλξη

### ⊗ Δίσκος συμπλέκτη

<b>200</b>	Εξωτερική διάμετρος 200 mm
<b>CE</b>	Ανόργανη επένδυση επίτηξης
<b>B/D/E/Z</b>	Ελατήρια επενδύσεων
<b>BH/GS/GT/GV</b>	Αποσβεστήρας στρέψης για οχήματα ΔΧ
<b>/E</b>	XTend
<b>W/V</b>	Αποσβεστήρας για οχήματα ΔΧ

### ⊗ Ρουλεμάν αποσύμπλεξης

<b>...A</b>	Παρασυρόμενος εξωτερικός δακτύλιος
<b>G</b>	Δακτύλιος εκκίνησης από γραφίτη
<b>GK</b>	Δακτύλιος εκκίνησης από γραφίτη με ένοσφαιρο ρουλεμάν
<b>GR</b>	Ένοσφαιρο ρουλεμάν με μεταλλικό πώμα
<b>GZ</b>	Κεντρική αντλία
<b>HHIS</b>	Ομόκεντρη βοηθητική αντλία
<b>...I</b>	Παρασυρόμενος εσωτερικός δακτύλιος
<b>KT</b>	Ροδέλα τεφλών
<b>KZ</b>	Ένοσφαιρο ρουλεμάν, κεντρικής οδήγησης
<b>NZ</b>	Βοηθητική αντλία
<b>...S</b>	Αυτοκεντραριζόμενος εσωτερικός δακτύλιος
<b>...Z</b>	Αποσύμπλεξη με έλξη

### ⊗ Σύνδεσμος ανεμιστήρα

<b>VL</b>	Μικρή χρήση
<b>VM</b>	Μεσαία χρήση
<b>VS</b>	Βαριά χρήση

# Μεταφράσεις

DE

EN

FR

ES

IT

PL

RU

EL

- (1) Αποστάτης 12 mm στο περίβλημα
- (2) 4 ταχυτήτων
- (3) 5 ταχυτήτων
- (4) 6 ταχυτήτων
- (5) Προσοχή ! Οι 3 κόκκινες βίδες, στο περίβλημα, πρέπει να απομακρυνθούν μετά τη συναρμολόγηση
- (6) Τετρακίνηση
- (7) Αριθμός των επενδύσεων
- (8) Εξωτερική διάμετρος [mm]
- (9) Έκδοση Borg & Beck
- (10) Πλάτος [mm]
- (11) Ντίτζελ
- (12) Πλατό με 3 μοχλούς
- (13) Πλατό με 4 μοχλούς
- (14) Ο δακτύλιος πίεσης, αρ. KHD 238 4107, πρέπει να τοποθετηθεί μαζί
- (15) Ενδεχομένως ο δακτύλιος αποστάτης, αρ. KHD 0430 8044, πρέπει να τοποθετηθεί μαζί
- (16) Χώρα κατασκευής οχήματος: Βραζιλία
- (17) Μέσο πλήρωσης: Βιολογικό λάδι
- (18) Μέσο πλήρωσης: Υγρό φρένων
- (19) Μέσο πλήρωσης: Υδραυλικό λάδι
- (20) Μέσο πλήρωσης: Ορυκτέλαιο
- (21) Τύπος κιβωτίου ταχυτήτων: Κιβώτιο αναστροφής σκάφους Hurth
- (22) Πάντοτε ανανέωση
- (23) Σε 1881/1882/1888/3083/3088/3483/3488 ... ..περιλαμβάνεται
- (24) Σε 1888 ... .. περιλαμβάνεται
- (25) Εσωτερική διάμετρος [mm]
- (26) Ανάλογα με την επιθυμία του πελάτη με διαφορετικό συμπλέκτη
- (27) Κύριο μέγεθος
- (28) Ρουλεμάν
- (29) Έκδοση LUK
- (30) Λασκαρισμένος δίσκος συμπλέκτη
- (31) Προφίλ πλήμνης
- (32) Δεν αντικαθίσταται με VALEO
- (33) Προσφέρεται μόνο σε επιστροφή παλαιού εξαρτήματος (επισκευή, εργοστάσιο Bielefeld)
- (34) Τοποθετήστε μόνο αν ήταν τοποθετημένος ο συμπλέκτης SACHS
- (35) Τοποθέτηση μόνο μαζί
- (36) Έκδοση SACHS
- (37) Αλλαγή σφονδύλου επιτυχής
- (38) Βάθος δίσκων σφονδύλου: 44,5 mm
- (39) Ειδική έκδοση
- (40) Steyrmatic
- (41) Έκδοση VALEO
- (42) Κιβώτιο ταχυτήτων ZF
- (43) Εναλλακτικό σετ επισκευής
- (44) Περιλαμβάνει βίδες στερέωσης του πλατό
- (45) Περιλαμβάνει ένα δίσκο συμπλέκτη
- (46) Περιλαμβάνει δύο δίσκους συμπλέκτη
- (47) Για
- (48) Για οχήματα με μονόδισκο συμπλέκτη
- (49) Για οχήματα με σύστημα πέδησης χαμηλής πίεσης

DE

# Μεταφράσεις

EN

- (50) Για οχήματα με μονάδα μετατροπέα-συμπλέκτη
- (51) Για οχήματα με συμπλέκτη διπλού δίσκου
- (52) Για οχήματα με υδραυλικό χειρισμό του συμπλέκτη
- (53) Για οχήματα με μηχανικό χειρισμό συμπλέκτη (ντίζα)
- (54) Για μπροστινό δυναμοδότη
- (55) Για ελκυστήρα με καμπίνα
- (56) Για δυναμοδότη κινητήρα
- (57) Για δυναμοδότη
- (58) Για αριθμό ΟΕ

FR

- (59) Για μηχανικό κιβώτιο ταχυτήτων
- (60) Για ανεξάρτητο δυναμοδότη
- (61) Ανάλογα με την έκδοση με διαφορετικό συμπλέκτη
- (62) Μέγιστη ωφέλιμη ροπή κινητήρα [Nm]
- (63) Με δακτύλιο εκκίνησης
- (64) Με κιβώτιο ταχυτήτων Powershift
- (65) Με δυναμοδότη
- (66) Με Powermatic

ES

- (67) Με συμπλέκτη Rockford
- (68) Με λιπαινόμενο σύνδεσμο σωλήνα
- (69) Με αισθητήρα
- (70) Με δυναμοδότη για βοηθητικό μηχανισμό κίνησης
- (71) Με ηλεκτρικό φρένο κιβωτίου ταχυτήτων
- (72) Με υδραυλικό φρένο κιβωτίου ταχυτήτων
- (73) Με υδραυλικό δυναμοδότη
- (74) Με μηχανική ζεύξη αναστροφής

IT

- (75) Όχι για
- (76) Όχι για αριθμό πλαισίου
- (77) Μόνο ως αντικατάσταση για τους αναφερόμενους αριθμούς ΟΕ (γνήσια ανταλλακτικά)
- (78) Μόνο σε συνδυασμό με
- (79) Χωρίς δακτύλιο εκκίνησης
- (80) Χωρίς κιβώτιο ταχυτήτων Powershift
- (81) Χωρίς Powermatic

PL

























- (82) Χωρίς λιπαινόμενο σύνδεσμο σωλήνα
- (83) Χωρίς ενδιάμεση πλάκα
- (84) Ανάστροφη ξεύξη Η

RU







EL



## AEBI

AEBI								
AM 30 AM 80 TP 1000				1882 155 009	K160			
					1864 006 147	160E (18x23-10N)		
					3151 994 801			
					1805 041 100			
AM 70				1864 072 201 ▲	140E (28x32-6N)			
					1859 600 001			
					1805 042 000			
TP 20				1882 315 003	KS180			
					1864 066 209	180E (18x23-10N)	->Chass. 6999	
					1864 315 101	180E (25x28-15N)	Chass. 7000->	
					1859 600 002			
					1805 041 100			
TP 25 - 50				1881 089 002	K225			
					1864 634 029	225Z (25x28-15N)		
					1859 600 001			
					1805 042 000			
TT 33				1882 315 003	KS180			
					1864 315 101	180E (25x28-15N)		
					1859 600 002			
					1805 041 100			
TT 77				1864 103 016	225 (36x40-20N)			
					3100 700 101  3151 021 001  2x 3130 010 200	KTI-1		









## AECHERLI

AECHERLI								
MA 60				1882 155 009	K160			
					1864 006 147	160E (18x23-10N)		
					3151 994 801			
					1805 041 100			
Tractor				1882 315 003	KS180			
					3151 270 602			
					1805 041 100			





## AGCO





LT-Serie							
LT 75 LT 75 A LT 90 LT 90 A				1866 600 016			





# AGRIA

AGRIA							
1900	- 12.71			<b>1882 315 002</b>	KS180		
2700				<b>1864 164 203 ▲#</b>	180E (22x25-14N)		
3800				<b>3159 140 004</b>			
4700			- 12.81		<b>1805 041 100</b>		
4800							
4900							
5700							
6700							
6900							
2800	- 12.71			<b>1882 315 002</b>	KS180		
				<b>1864 164 203 ▲#</b>	180E (22x25-14N)	<b>-&gt;Mot. 4104 755</b> <b>-&gt;Mot. 4106 122</b> <b>Mot. 4106 235-&gt;</b>	
				<b>3159 140 004</b>			
				<b>1805 041 100</b>			



# AGRIFULL



DERBY							
60				<b>1888 869 004 #</b>	DUT280 (280/35x40-14N)	enthält eine Kupplungsscheibe / This part number includes one clutch disc (45)	
80				<b>1888 600 140 ●#</b>	DUT280/ CERAM (280/35x40-14N)	enthält eine Kupplungsscheibe / This part number includes one clutch disc (45)	
					<b>1864 600 353 ▽</b>	280 (22x25-10N)	Lose Kupplungsscheibe / Loose clutch disc (30)
					<b>1863 838 000</b>	70/110/20	ohne Anlaufing / without thrust ring (79)
					<b>1863 838 001</b>	50/82/29	ohne Anlaufing / without thrust ring (79)
60 (RM 418)				<b>1864 600 353 ▽</b>	280 (22x25-10N)	Lose Kupplungsscheibe / Loose clutch disc (30)	
80 (RM 418)							
602 (RM 418)							



GRISO							
70				<b>1888 869 004 #</b>	DUT280 (280/35x40-14N)	enthält eine Kupplungsscheibe / This part number includes one clutch disc (45)	
75				<b>1888 600 140 ●#</b>	DUT280/ CERAM (280/35x40-14N)	enthält eine Kupplungsscheibe / This part number includes one clutch disc (45)	
					<b>1864 600 353 ▽</b>	280 (22x25-10N)	Lose Kupplungsscheibe / Loose clutch disc (30)
					<b>1863 838 000</b>	70/110/20	ohne Anlaufing / without thrust ring (79)
					<b>1863 838 001</b>	50/82/29	ohne Anlaufing / without thrust ring (79)

JOLLY							
45	01.75 -			<b>1888 887 001 #</b>	DUT225 (225/31x35-18N)	enthält eine Kupplungsscheibe / This part number includes one clutch disc (45)	
345	01.75 -			<b>1888 869 004 #</b>	DUT280 (280/35x40-14N)	enthält eine Kupplungsscheibe / This part number includes one clutch disc (45)	
50				<b>1888 600 140 ●#</b>	DUT280/ CERAM (280/35x40-14N)	enthält eine Kupplungsscheibe / This part number includes one clutch disc (45)	
					<b>1864 600 353 ▽</b>	280 (22x25-10N)	Lose Kupplungsscheibe / Loose clutch disc (30)
					<b>1863 838 000</b>	70/110/20	ohne Anlaufing / without thrust ring (79)
					<b>1863 838 001</b>	50/82/29	ohne Anlaufing / without thrust ring (79)



# AGRIFULL









RODEO							
90 95	01.76 - 01.76 -			1888 869 004 #	DUT280 (280/35x40-14N)	enthält eine Kupplungsscheibe / This part number includes one clutch disc	(45)
				1888 600 140 ●#	DUT280/ CERAM (280/35x40-14N)	enthält eine Kupplungsscheibe / This part number includes one clutch disc	(45)
			1864 600 353 ▽	280 (22x25-10N)	Lose Kupplungsscheibe / Loose clutch disc	(30)	
			1863 838 000	70/110/20	ohne Anlauftring / without thrust ring	(79)	
			1863 838 001	50/82/29	ohne Anlauftring / without thrust ring	(79)	

TORNADO							
80	01.76 -			1888 869 004 #	DUT280 (280/35x40-14N)	enthält eine Kupplungsscheibe / This part number includes one clutch disc	(45)
				1888 600 140 ●#	DUT280/ CERAM (280/35x40-14N)	enthält eine Kupplungsscheibe / This part number includes one clutch disc	(45)
			1864 600 353 ▽	280 (22x25-10N)	Lose Kupplungsscheibe / Loose clutch disc	(30)	
			1863 838 000	70/110/20	ohne Anlauftring / without thrust ring	(79)	
			1863 838 001	50/82/29	ohne Anlauftring / without thrust ring	(79)	

TOSELLI							
60,70,85	01.76 -			1888 869 004 #	DUT280 (280/35x40-14N)	enthält eine Kupplungsscheibe / This part number includes one clutch disc	(45)
				1888 600 140 ●#	DUT280/ CERAM (280/35x40-14N)	enthält eine Kupplungsscheibe / This part number includes one clutch disc	(45)
			1864 600 353 ▽	280 (22x25-10N)	Lose Kupplungsscheibe / Loose clutch disc	(30)	
			1863 838 000	70/110/20	ohne Anlauftring / without thrust ring	(79)	
			1863 838 001	50/82/29	ohne Anlauftring / without thrust ring	(79)	



VIGNETO							
235 345	01.75 - 01.75 -			1888 887 001 #	DUT225 (225/31x35-18N)	enthält eine Kupplungsscheibe / This part number includes one clutch disc	(45)



55 - 80							
55-46 55-66 60 II F,DT 65-46 70 II F,DT 80 II F,DT				1888 869 004 #	DUT280 (280/35x40-14N)	enthält eine Kupplungsscheibe / This part number includes one clutch disc	(45)
					1864 600 353 ▽	280 (22x25-10N)	Lose Kupplungsscheibe / Loose clutch disc
				1863 838 001	50/82/29	ohne Anlauftring / without thrust ring	(79)
				1863 838 000	70/110/20	ohne Anlauftring / without thrust ring	(79)



8045 - 80105							
8045 8050 8055 8060				1888 869 004 #	DUT280 (280/35x40-14N)	enthält eine Kupplungsscheibe / This part number includes one clutch disc	(45)
					1864 600 353 ▽	280 (22x25-10N)	Lose Kupplungsscheibe / Loose clutch disc
				1863 838 001	50/82/29	ohne Anlauftring / without thrust ring	(79)
				1863 838 000	70/110/20	ohne Anlauftring / without thrust ring	(79)
8065				1888 600 141 #	DUT280 (280/35x40-14N)	enthält eine Kupplungsscheibe / This part number includes one clutch disc	(45)
					1864 600 353 ▽	280 (22x25-10N)	Lose Kupplungsscheibe / Loose clutch disc
				1863 838 001	50/82/29	ohne Anlauftring / without thrust ring	(79)
				1863 838 000	70/110/20	ohne Anlauftring / without thrust ring	(79)
8085 8095 80105				1888 600 133 HD	DUT310/ 310 (310/40x45-16N)	enthält eine Kupplungsscheibe / This part number includes one clutch disc	(45)
					1864 914 003 ▽#	310 (24x28-10N)	Lose Kupplungsscheibe / Loose clutch disc
				1888 876 102 #	DUT310 (310/40x45-16N)	enthält eine Kupplungsscheibe / This part number includes one clutch disc	(45)

					Parameter		
---	--	--	--	--	-----------	---	---







## AKTIV FISCHER

S 830							
S 830				1881 059 208	KS200		
				1860 049 029	200Z (1"-10N)		









Snow Trac							
Snow Trac				1882 228 002	KM200		
				1861 271 236	200CD (18,3x20,4-24N)		
				3151 270 602			

Trac Master							
Trac Master				1882 228 002	KM200		
				1861 271 236	200CD (18,3x20,4-24N)		
				3151 270 602			









## ATM













TRAKTOR							
Traktor				3482 083 118	MFZ430		
				1878 080 034	430WGTZ (2" -10N)		
				3151 000 034			
Traktor Valtra		Valtra		3400 700 344 3482 083 118 1878 000 205 3151 000 034	MFZ430 430GTZ KZISZ-5		
Kirvoets K 3000 ATM		Minsk		3482 002 234	GMF350X	Getr. / GBox: Valtra	
				1878 001 143	350WGTZ (41x45-22N)	Getr. / GBox: Valtra	
				3182 001 105	HHIS-3	Getr. / GBox: Valtra Füllmedium: Bremsflüssigkeit / Fill Medium: Brake Fluid Immer erneuern / Renew everytime	(18) (22)

## BAUTZ

AL							
AL 122 AL 180				1882 315 003	KS180		
				1864 634 040	180E (23x29-10N)		
				1859 600 002			
				1805 041 100			
AL 240				1882 196 005	KS200		
				1864 634 039	200Z (23x29-10N)		
				1859 600 001			
				1805 042 000			

# BAUTZ



AS							
AS 120,122				1882 315 003	KS180		
				1864 634 040	180E (23x29-10N)		
				1859 600 002			
				1805 041 100			
AS 170,171,220				1882 196 005	KS200		
				1864 634 039	200Z (23x29-10N)		
				1859 600 001			
				1805 042 000			



AW							
AW 120,180,200				1882 315 003	KS180		
				1864 634 040	180E (23x29-10N)		
				1859 600 002			
				1805 041 100			
AW 240				1882 196 005	KS200		
				1864 634 039	200Z (23x29-10N)		
				1859 600 001			
				1805 042 000			
AW 300				1882 315 002	KS180		
				1864 634 040	180E (23x29-10N)		
				1859 600 002			
				1805 041 100			

# BKS





















































BKS (YALE)							
VDP 30/40				1864 634 025	250Z (1 1/8"-10N)		

# CASE IH



















A..							
AVJ 55	01.01-			1888 869 004 #	DUT280 (280/35x40-14N)	enthält eine Kupplungsscheibe / This part number includes one clutch disc	(45)
AVJ 60	01.01-			1864 600 353	280 (22x25-10N)		
AVJ 70	01.01-			1863 838 000	70/110/20	ohne Anlauftring / without thrust ring	(79)
				1863 838 001	50/82/29	ohne Anlauftring / without thrust ring	(79)



CS..								
CS 42	02.97-01.01			1888 998 101	DUT280 (280/44x49-24N)	enthält eine Kupplungsscheibe / This part number includes one clutch disc	(45)	
CS 48				1878 986 701 ▽#	290GSZ (25x28-15N)	Lose Kupplungsscheibe / Loose clutch disc	(30)	
CS 55					1863 855 000	106/140/25	mit Anlauftring / with thrust ring	(63)
CS 58			02.97-01.01		1863 837 002	65/97/23	mit Anlauftring / with thrust ring	(63)

# CASE IH

































CS..							
CS 64				<b>3800 541 002 #</b>  1888 998 101  1878 986 801  1863 837 002  1863 855 000	DUT280 290GSDC GR-4 GR-8	für Fahrzeuge mit Zweischeibenkupplung / for vehicles with double disc clutch (51)	
				 <b>1878 634 031 ●▽</b>	295GSPB (28x32-17N)	Lose Kupplungsscheibe / Loose clutch disc (30)	
CS 68 CS 75	03.99 - 03.04 03.99 - 03.04			<b>3800 541 002 #</b>  1888 998 101  1878 986 801  1863 837 002  1863 855 000	DUT280 290GSDC GR-4 GR-8	<b>Chass. DBD0040001-&gt;</b> für Fahrzeuge mit Zweischeibenkupplung / for vehicles with double disc clutch (51)	
				<b>1878 634 031 ●▽</b>	295GSPB (28x32-17N)	<b>Chass. DBD0040001-&gt;</b> Lose Kupplungsscheibe / Loose clutch disc (30)	
CS 78	03.96 - 01.04			<b>1888 059 201 #</b>	DUT330-310/ 295 (295/45x50-24N)	<b>-&gt;Chass. DBD0010380</b> enthält eine Kupplungsscheibe / This part number includes one clutch disc (45)	
				<b>1862 311 001 #</b>	310GSPB (28x32-17N)	<b>-&gt;Chass. DBD0010380</b>	
				<b>3800 541 001 #</b>  1888 998 001  1878 986 601  1863 837 002  1863 855 000	DUT310 327GSDC GR-4 GR-8	<b>Chass. DBD0010381 - Chass. DBD0010601</b> <b>Chass. DBD0055001-&gt;</b> für Fahrzeuge mit Zweischeibenkupplung / for vehicles with double disc clutch (51)	
				<b>1863 837 002</b>	65/97/23	mit Anlauftring / with thrust ring (63)	
				<b>1863 855 000</b>	106/140/25	mit Anlauftring / with thrust ring (63)	
CS 80 CS 90 CS 100	01.06 - 01.06 - 01.06 -			<b>3800 541 026 #</b>  1888 600 137  1878 634 037  1863 837 002  1863 855 000	DUT310/330 330GSPB GR-4 GR-8		
CS 86 CS 94	03.96 - 01.04 03.96 - 01.04			<b>3800 541 021 #</b>  1888 059 201  1878 634 036  1863 837 002  1863 855 000	DUT330-310/295 330GSPB GR-4 GR-8	<b>-&gt;Chass. DBD0010097</b> für Fahrzeuge mit Zweischeibenkupplung / for vehicles with double disc clutch (51)	
				<b>3800 541 001 #</b>  1888 998 001  1878 986 601  1863 837 002  1863 855 000	DUT310 327GSDC GR-4 GR-8	<b>Chass. DBD0010098 - Chass. DBD0010609</b> <b>Chass. DBD0055001-&gt;</b> für Fahrzeuge mit Zweischeibenkupplung / for vehicles with double disc clutch (51)	
C..							
C 50 C 60 C 70				<b>3800 541 015 ●</b>  3482 600 112  1878 600 550	MF310N 310CBC		
				<b>1863 600 101</b>	60/102/21,5	mit Anlauftring / with thrust ring (63)	
C DL 80 C DL 90 C DL 100				<b>3800 541 016 ●</b>  3482 600 112  1878 600 551	MF310N 310CBC		
				<b>1863 600 101</b>	60/102/21,5	mit Anlauftring / with thrust ring (63)	
CX..							
CX 50 CX 60 CX 70	01.98 - 01.98 - 01.98 -			<b>3800 541 015 ●</b>  3482 600 112  1878 600 550	MF310N 310CBC		
				<b>1863 600 101</b>	60/102/21,5	mit Anlauftring / with thrust ring (63)	
CX 80 CX 90 CX 100	01.98 - 01.98 - 01.98 -			<b>3800 541 016 ●</b>  3482 600 112  1878 600 551	MF310N 310CBC		
				<b>1863 600 101</b>	60/102/21,5	mit Anlauftring / with thrust ring (63)	

## CASE IH

D..							
D85 ,B (Loadstar Co.1700)				<b>1882 119 106</b>	HV250	Nur bei Altteil-Rückgabe lieferbar (Reparatur; Werk Bielefeld) / Please return old unit for repair (plant Bielefeld)	(33)
				<b>1878 634 051</b>	250B/ Z (1 1/4" -10N)		
				<b>1863 010 100</b>	60/96,6/26	mit Anlauftring / with thrust ring	(63)
D212 F D214 S D217 F,S D219				<b>1882 196 005</b>	KS200		
				<b>1860 049 027 #</b>	200Z (1 1/8"-10N)		
				<b>1864 634 031</b>	200Z (1 1/8"-10N)		
				<b>1805 042 000</b>			
D320 ,S D324 ,S D326				<b>1881 089 002</b>	K225		
				<b>1864 634 024</b>	225Z (1 1/4"-10N)		
				<b>1878 634 043 ●#</b>	225B/ Z (1 1/4" -10N)		
				<b>1859 600 003</b>			
DED 3.Zyl.	-01.56			<b>1881 089 002</b>	K225		
				<b>1864 634 024</b>	225Z (1 1/4"-10N)		
DLD 2.Zyl.	-01.56			<b>1882 196 005</b>	KS200		
				<b>1864 634 031</b>	200Z (1 1/8"-10N)		
				<b>1860 049 027 #</b>	200Z (1 1/8"-10N)		
DU66 ,D DU74				<b>1882 196 005</b>	KS200		
				<b>1860 049 027 #</b>	200Z (1 1/8"-10N)		
				<b>1864 634 031</b>	200Z (1 1/8"-10N)		
				<b>3100 700 101</b> ◊ 3151 021 001 ⌋ 2x 3130 010 200	KTI-1		
DU99 D				<b>1881 089 002</b>	K225		
				<b>1864 634 024</b>	225Z (1 1/4"-10N)		
				<b>3100 700 101</b> ◊ 3151 021 001 ⌋ 2x 3130 010 200	KTI-1		





























FARMALL							
55 C	04.11 -			<b>1863 838 001</b>	50/82/29	ohne Anlauftring / without thrust ring	(79)
65 C	04.11 -			<b>1863 858 002</b>	75/115/20	ohne Anlauftring / without thrust ring	(79)
75 C	04.11 -			<b>1863 869 014</b>	17/40/12		

# CASE IH



















JX							
JX 1060C	12.03-			1888 600 109	DUT280/ CERAM (280/35x40-14N)	->Chass. C4941 enthält eine Kupplungsscheibe / This part number includes one clutch disc	(45)
				1888 600 144	DUT280/ CERAM (280/35x40-14N)	->Chass. C4941 enthält eine Kupplungsscheibe / This part number includes one clutch disc	(45)
				1864 600 345	280C (22x25-10N)	->Chass. C4941 Anzahl der Beläge / Number of pads: 3	(7)
				1863 838 001	50/82/29	->Chass. C4941 ohne Anlauftring / without thrust ring	(79)
				1863 858 002	75/115/20	->Chass. C4941 ohne Anlauftring / without thrust ring	(79)
				1888 600 107	DUT280 (280/35x40-14N)	->Chass. D4941 enthält eine Kupplungsscheibe / This part number includes one clutch disc	(45)
				1864 600 345	280C (22x25-10N)	->Chass. D4941 Anzahl der Beläge / Number of pads: 3	(7)
				1863 838 001	50/82/29	->Chass. D4941 ohne Anlauftring / without thrust ring	(79)
				1863 858 002	75/115/20	->Chass. D4941 ohne Anlauftring / without thrust ring	(79)
JX 1060V	05.04-			1888 600 107	DUT280 (280/35x40-14N)	enthält eine Kupplungsscheibe / This part number includes one clutch disc	(45)
				1864 600 345	280C (22x25-10N)	Anzahl der Beläge / Number of pads: 3	(7)
				1863 838 001	50/82/29	ohne Anlauftring / without thrust ring	(79)
				1863 858 002	75/115/20	ohne Anlauftring / without thrust ring	(79)
JX 1070C	12.03-			1888 600 144	DUT280/ CERAM (280/35x40-14N)	->Chass. C4941 enthält eine Kupplungsscheibe / This part number includes one clutch disc	(45)
				1863 838 001	50/82/29	->Chass. C4941 ohne Anlauftring / without thrust ring	(79)
				1863 858 002	75/115/20	->Chass. C4941 ohne Anlauftring / without thrust ring	(79)
				1888 600 144	DUT280/ CERAM (280/35x40-14N)	->Chass. D4941 enthält eine Kupplungsscheibe / This part number includes one clutch disc	(45)
				1864 600 345	280C (22x25-10N)	->Chass. D4941 Anzahl der Beläge / Number of pads: 3	(7)
				1863 838 001	50/82/29	->Chass. D4941 ohne Anlauftring / without thrust ring	(79)
				1863 858 002	75/115/20	->Chass. D4941 ohne Anlauftring / without thrust ring	(79)
				1882 600 101	G280N		
				1864 600 345	280C (22x25-10N)	Anzahl der Beläge / Number of pads: 3	(7)
				1863 858 002	75/115/20	ohne Anlauftring / without thrust ring	(79)
JX 1070N	05.04-			1888 600 107	DUT280 (280/35x40-14N)	->Chass. C4941 enthält eine Kupplungsscheibe / This part number includes one clutch disc	(45)
				1863 838 001	50/82/29	->Chass. C4941 ohne Anlauftring / without thrust ring	(79)
				1863 858 002	75/115/20	->Chass. C4941 ohne Anlauftring / without thrust ring	(79)
				1888 600 107	DUT280 (280/35x40-14N)	->Chass. D4941 enthält eine Kupplungsscheibe / This part number includes one clutch disc	(45)
				1863 838 001	50/82/29	->Chass. D4941 ohne Anlauftring / without thrust ring	(79)
				1863 858 002	75/115/20	->Chass. D4941 ohne Anlauftring / without thrust ring	(79)
				1882 600 101	G280N		
				1864 600 345	280C (22x25-10N)	Anzahl der Beläge / Number of pads: 3	(7)
				1863 858 002	75/115/20	ohne Anlauftring / without thrust ring	(79)

























## CASE IH

JX							
<b>JX 1070U</b>	01.04-			<b>1866 600 013</b>		Getr. / GBox: Powershuttle	
				<b>1888 600 149</b>	DUT310/ CERAM (310/40x45-16N)	enthält eine Kupplungsscheibe / This part number includes one clutch disc	(45)
				<b>1864 600 302</b>	310 (22x25-10N)		
				<b>1863 838 001</b>	50/82/29	ohne Anlauffring / without thrust ring	(79)
				<b>3482 600 104</b>	MF310		
				<b>1878 600 518</b>	310GSDC (40x45-16N)	Anzahl der Beläge / Number of pads: 6	(7)
<b>JX 1070V</b>	05.04-			<b>1888 600 144</b>	DUT280/ CERAM (280/35x40-14N)	->Chass. D4941 enthält eine Kupplungsscheibe / This part number includes one clutch disc	(45)
				<b>1864 600 345</b>	280C (22x25-10N)	->Chass. D4941 Anzahl der Beläge / Number of pads: 3	(7)
				<b>1863 838 001</b>	50/82/29	->Chass. D4941 ohne Anlauffring / without thrust ring	(79)
				<b>1863 858 002</b>	75/115/20	->Chass. D4941 ohne Anlauffring / without thrust ring	(79)
				<b>1888 600 107</b>	DUT280 (280/35x40-14N)	->Chass. C4941 enthält eine Kupplungsscheibe / This part number includes one clutch disc	(45)
				<b>1863 838 001</b>	50/82/29	->Chass. C4941 ohne Anlauffring / without thrust ring	(79)
				<b>1863 858 002</b>	75/115/20	->Chass. C4941 ohne Anlauffring / without thrust ring	(79)
<b>JX 1075C</b>	12.03-			<b>1888 600 144</b>	DUT280/ CERAM (280/35x40-14N)	->Chass. D4941 enthält eine Kupplungsscheibe / This part number includes one clutch disc	(45)
				<b>1864 600 345</b>	280C (22x25-10N)	->Chass. D4941 Anzahl der Beläge / Number of pads: 3	(7)
				<b>1863 838 001</b>	50/82/29	->Chass. D4941 ohne Anlauffring / without thrust ring	(79)
				<b>1863 858 002</b>	75/115/20	->Chass. D4941 ohne Anlauffring / without thrust ring	(79)
				<b>1888 600 144</b>	DUT280/ CERAM (280/35x40-14N)	->Chass. C4941 enthält eine Kupplungsscheibe / This part number includes one clutch disc	(45)
				<b>1863 838 001</b>	50/82/29	->Chass. C4941 ohne Anlauffring / without thrust ring	(79)
				<b>1863 858 002</b>	75/115/20	->Chass. C4941 ohne Anlauffring / without thrust ring	(79)
<b>JX 1075N,V</b>	05.04-			<b>1888 600 109</b>	DUT280/ CERAM (280/35x40-14N)	->Chass. C4941 enthält eine Kupplungsscheibe / This part number includes one clutch disc	(45)
				<b>1864 600 345</b>	280C (22x25-10N)	->Chass. C4941 Anzahl der Beläge / Number of pads: 3	(7)
				<b>1863 838 001</b>	50/82/29	->Chass. C4941 ohne Anlauffring / without thrust ring	(79)
				<b>1863 858 002</b>	75/115/20	->Chass. C4941 ohne Anlauffring / without thrust ring	(79)
				<b>1888 600 144</b>	DUT280/ CERAM (280/35x40-14N)	->Chass. D4941 enthält eine Kupplungsscheibe / This part number includes one clutch disc	(45)
				<b>1864 600 345</b>	280C (22x25-10N)	->Chass. D4941 Anzahl der Beläge / Number of pads: 3	(7)
				<b>1863 838 001</b>	50/82/29	->Chass. D4941 ohne Anlauffring / without thrust ring	(79)
				<b>1863 858 002</b>	75/115/20	->Chass. D4941 ohne Anlauffring / without thrust ring	(79)

# CASE IH

JXU						
<b>JX 70 U</b>	05.02 -			<b>1888 600 106</b>	DUT310 (310/40x45-16N)	für Fahrzeuge mit Zweischeibenkupplung / for vehicles with double disc clutch enthält eine Kupplungsscheibe / This part number includes one clutch disc (51) (45)
				<b>1864 600 302</b>	310 (22x25-10N)	für Fahrzeuge mit Zweischeibenkupplung / for vehicles with double disc clutch Lose Kupplungsscheibe / Loose clutch disc (51) (30)
				<b>1863 838 001</b>	50/82/29	für Fahrzeuge mit Zweischeibenkupplung / for vehicles with double disc clutch ohne Anlauftring / without thrust ring (51) (79)
				<b>1863 858 002</b>	75/115/20	für Fahrzeuge mit Zweischeibenkupplung / for vehicles with double disc clutch ohne Anlauftring / without thrust ring (51) (79)
				<b>3482 600 104</b>	MF310	für Fahrzeuge mit Einscheibenkupplung / for vehicles with single disc clutch (48)
				<b>1878 600 518</b>	310GSDC (40x45-16N)	für Fahrzeuge mit Einscheibenkupplung / for vehicles with single disc clutch Anzahl der Beläge / Number of pads: 6 (48) (7)
				<b>1863 838 001</b>	50/82/29	für Fahrzeuge mit Einscheibenkupplung / for vehicles with single disc clutch ohne Anlauftring / without thrust ring (48) (79)
				<b>1866 600 020</b>		mit Zapfwelle für Nebenantrieb / with shaft for PTO (70) für Fahrzeuge mit Einscheibenkupplung / for vehicles with single disc clutch (48)
				<b>1863 869 019</b>	17/47/14	
				<b>1866 600 013</b>		Getr. / GBox: Powershuttle
<b>JX 75 U</b> <b>JX 85 U</b>	05.02 - 05.02 -			<b>1888 600 149</b>	DUT310/ CERAM (310/40x45-16N)	für Fahrzeuge mit Zweischeibenkupplung / for vehicles with double disc clutch enthält eine Kupplungsscheibe / This part number includes one clutch disc (51) (45)
				<b>1864 600 302</b>	310 (22x25-10N)	für Fahrzeuge mit Zweischeibenkupplung / for vehicles with double disc clutch Lose Kupplungsscheibe / Loose clutch disc (51) (30)
				<b>1863 838 001</b>	50/82/29	für Fahrzeuge mit Zweischeibenkupplung / for vehicles with double disc clutch ohne Anlauftring / without thrust ring (51) (79)
				<b>1863 858 002</b>	75/115/20	für Fahrzeuge mit Zweischeibenkupplung / for vehicles with double disc clutch ohne Anlauftring / without thrust ring (51) (79)
				<b>3482 600 104</b>	MF310	für Fahrzeuge mit hydraulischer Kupplungsbetätigung / for vehicles with hydraulic clutch actuation (52)
				<b>1878 600 518</b>	310GSDC (40x45-16N)	für Fahrzeuge mit hydraulischer Kupplungsbetätigung / for vehicles with hydraulic clutch actuation Anzahl der Beläge / Number of pads: 6 (52) (7)
				<b>1863 838 001</b>	50/82/29	für Fahrzeuge mit hydraulischer Kupplungsbetätigung / for vehicles with hydraulic clutch actuation ohne Anlauftring / without thrust ring (52) (79)
				<b>1863 869 019</b>	17/47/14	







# CASE IH

JXU											
JX 80 U JX 90 U	05.02 - 05.02 -			<b>1888 600 106</b>	DUT310 (310/40x45-16N)	für Fahrzeuge mit Zweischeibenkupplung / for vehicles with double disc clutch enthält eine Kupplungsscheibe / This part number includes one clutch disc	(51) (45)				
					<b>1888 600 149</b> ●	DUT310/ CERAM (310/40x45-16N)	für Fahrzeuge mit Zweischeibenkupplung / for vehicles with double disc clutch enthält eine Kupplungsscheibe / This part number includes one clutch disc	(51) (45)			
					<b>1864 600 302</b>	310 (22x25-10N)	für Fahrzeuge mit Zweischeibenkupplung / for vehicles with double disc clutch Lose Kupplungsscheibe / Loose clutch disc	(51) (30)			
					<b>1863 838 001</b>	50/82/29	für Fahrzeuge mit Zweischeibenkupplung / for vehicles with double disc clutch ohne Anlauftring / without thrust ring	(51) (79)			
					<b>1863 858 002</b>	75/115/20	für Fahrzeuge mit Zweischeibenkupplung / for vehicles with double disc clutch ohne Anlauftring / without thrust ring	(51) (79)			
					<b>3482 600 104</b>	MF310	für Fahrzeuge mit Einscheibenkupplung / for vehicles with single disc clutch	(48)			
					<b>1878 600 518</b>	310GSDC (40x45-16N)	für Fahrzeuge mit Einscheibenkupplung / for vehicles with single disc clutch Anzahl der Beläge / Number of pads: 6	(48) (7)			
					<b>1863 838 001</b>	50/82/29	für Fahrzeuge mit Einscheibenkupplung / for vehicles with single disc clutch ohne Anlauftring / without thrust ring	(48) (79)			
					<b>1866 600 020</b>		mit Zapfwelle für Nebenantrieb / with shaft for PTO für Fahrzeuge mit Einscheibenkupplung / for vehicles with single disc clutch	(70) (48)			
					<b>1863 869 019</b>	17/47/14					
					<b>1866 600 013</b>		Getr. / GBox: Powershuttle				
				JX 100 U	05.02 -			<b>1888 600 149</b>	DUT310/ CERAM (310/40x45-16N)	für Fahrzeuge mit Zweischeibenkupplung / for vehicles with double disc clutch enthält eine Kupplungsscheibe / This part number includes one clutch disc	(51) (45)
	<b>1864 600 302</b>	310 (22x25-10N)	für Fahrzeuge mit Zweischeibenkupplung / for vehicles with double disc clutch Lose Kupplungsscheibe / Loose clutch disc					(51) (30)			
	<b>1863 838 001</b>	50/82/29	für Fahrzeuge mit Zweischeibenkupplung / for vehicles with double disc clutch ohne Anlauftring / without thrust ring					(51) (79)			
	<b>1863 858 002</b>	75/115/20	für Fahrzeuge mit Zweischeibenkupplung / for vehicles with double disc clutch ohne Anlauftring / without thrust ring					(51) (79)			
	<b>3482 600 104</b>	MF310	für Fahrzeuge mit Einscheibenkupplung / for vehicles with single disc clutch					(48)			
	<b>1878 600 518</b>	310GSDC (40x45-16N)	für Fahrzeuge mit Einscheibenkupplung / for vehicles with single disc clutch Anzahl der Beläge / Number of pads: 6					(48) (7)			
	<b>1863 838 001</b>	50/82/29	für Fahrzeuge mit Einscheibenkupplung / for vehicles with single disc clutch ohne Anlauftring / without thrust ring					(48) (79)			
	<b>1866 600 020</b>		mit Zapfwelle für Nebenantrieb / with shaft for PTO für Fahrzeuge mit Einscheibenkupplung / for vehicles with single disc clutch					(70) (48)			
	<b>1863 869 019</b>	17/47/14									
	<b>1866 600 013</b>		Getr. / GBox: Powershuttle								
MAXXUM MX											
MX 80C MX 90C MX 100C	05.98 - 05.98 - 05.98 -							<b>1866 600 023</b>		Getr. / GBox: Powershift	
MX 100 MX 110 MX 120 MX 135 MX 150 MX 170	06.97 - 06.97 - 06.97 - 06.97 - 01.98 - 01.98 -			<b>1866 600 002</b>		Getr. / GBox: Powershift max. übertragbares Motormoment [Nm] / max. transmittable engine torque [Nm]: 900	(62)				



					Parameter		
---	--	--	--	--	-----------	---	---

## CASE IH



### MAXXUM MXM

<b>MXM 120</b>	06.02-			<b>3482 600 113</b>	M330	für Schaltgetriebe / for manual transmission	(59)
<b>MXM 130</b>	06.02-			<b>1878 600 552</b>	330CBC (45x50-18N)	für Schaltgetriebe / for manual transmission Anzahl der Beläge / Number of pads: 5	(59) (7)
<b>MXM 140</b>	06.02-			<b>3151 600 561</b>		für Schaltgetriebe / for manual transmission	(59)
				<b>1866 600 011</b>		mit Zapfwelle für Nebenantrieb / with shaft for PTO	(70)
				<b>1866 600 022</b>		Getr. / GBox: Full Power Shift	
<b>MXM 135</b>	06.02-			<b>1866 600 011</b>			
<b>MXM 150</b>	06.02-						
<b>MXM 165</b>	06.02-						
<b>MXM 180</b>	06.02-						
<b>MXM 190</b>	06.02-			<b>1866 600 022</b>			



### MAXXUM PRO, MAXXUM PLUS

<b>5120</b>				<b>1878 600 568</b>	276T (36,5x41-24N)	Getr. / GBox: Powershift	
<b>5130</b>				<b>1878 600 567</b>	276T (31,7x36,2-21N)	Getr. / GBox: Synchro	
<b>5140</b>							
<b>5150</b>				<b>1878 600 568</b>	276T (36,5x41-24N)	Getr. / GBox: Powershift	



### PJ

<b>PJ 55</b>	01.02-			<b>1888 998 501 #</b>	DUT280 (280/34x40-12N)	enthält eine Kupplungsscheibe / This part number includes one clutch disc	(45)
<b>PJ 65</b>	01.02-			<b>1864 996 101 ▽#</b>	280 (18,7x22,2-13N)	Lose Kupplungsscheibe / Loose clutch disc	(30)
<b>PJ 75</b>	01.02-			<b>1863 600 107</b>	65/100/18	ohne Anlauffring / without thrust ring	(79)
				<b>1863 838 001</b>	50/82/29	ohne Anlauffring / without thrust ring	(79)



### PJN

<b>PJN 55</b>	01.02-			<b>1888 998 501 #</b>	DUT280 (280/34x40-12N)	enthält eine Kupplungsscheibe / This part number includes one clutch disc	(45)
<b>PJN 65</b>	01.02-			<b>1864 996 101 ▽#</b>	280 (18,7x22,2-13N)	Lose Kupplungsscheibe / Loose clutch disc	(30)
<b>PJN 75</b>	01.02-			<b>1863 600 107</b>	65/100/18	ohne Anlauffring / without thrust ring	(79)
				<b>1863 838 001</b>	50/82/29	ohne Anlauffring / without thrust ring	(79)

































### PJV

<b>PJV 55</b>	01.02-			<b>1888 998 501 #</b>	DUT280 (280/34x40-12N)	enthält eine Kupplungsscheibe / This part number includes one clutch disc	(45)
<b>PJV 65</b>	01.02-			<b>1864 996 101 ▽#</b>	280 (18,7x22,2-13N)	Lose Kupplungsscheibe / Loose clutch disc	(30)
<b>PJV 75</b>	01.02-			<b>1863 600 107</b>	65/100/18	ohne Anlauffring / without thrust ring	(79)
				<b>1863 838 001</b>	50/82/29	ohne Anlauffring / without thrust ring	(79)

### PUMA



<b>115</b>	01.07-			<b>1866 600 022</b>		Getr. / GBox: Full Power Shift	
<b>125</b>	01.07-					Getr. / GBox: Semi Power Shift	
<b>140</b>	01.07-						
<b>155</b>	01.07-						
<b>165</b>	01.07-			<b>1866 600 022</b>		Getr. / GBox: Full Power Shift	
<b>180</b>	01.07-						
<b>195</b>	01.07-						
<b>210</b>	01.07-						









## CASE IH



QUANTUM							
<b>65 C</b> <b>75 C</b> <b>85 F</b> <b>85 N</b> <b>85 V</b>	04.08- 04.08- 10.10- 12.08- 12.08-			<b>1888 600 144</b>	DUT280/ CERAM (280/35x40-14N)	enthält eine Kupplungsscheibe / This part number includes one clutch disc	(45)
				<b>1864 600 303</b>	280C (22x25-10N)	Anzahl der Beläge / Number of pads: 4 Lose Kupplungsscheibe / Loose clutch disc	(7) (30)
				<b>1863 838 001</b>	50/82/29	ohne Anlauftring / without thrust ring	(79)
				<b>1863 858 002</b>	75/115/20	ohne Anlauftring / without thrust ring	(79)
				<b>1863 869 014</b>	17/40/12		
				<b>1882 600 101</b>	G280N	für / for: Powershuttle	(47)
				<b>1864 600 303</b>	280C (22x25-10N)	für / for: Powershuttle Anzahl der Beläge / Number of pads: 4	(47) (7)
				<b>1863 838 001</b>	50/82/29	für / for: Powershuttle ohne Anlauftring / without thrust ring	(47) (79)
				<b>1863 869 014</b>	17/40/12	für / for: Powershuttle	(47)
			<b>65 V</b> <b>75 F</b> <b>75 N</b> <b>75 V</b>	04.08- 10.10- 12.08- 12.08-			<b>1864 600 303</b>
	<b>1863 838 001</b>	50/82/29				ohne Anlauftring / without thrust ring	(79)
	<b>1863 858 002</b>	75/115/20				ohne Anlauftring / without thrust ring	(79)
	<b>1863 869 014</b>	17/40/12					
	<b>1882 600 101</b>	G280N				für / for: Powershuttle	(47)
	<b>1864 600 303</b>	280C (22x25-10N)				für / for: Powershuttle Anzahl der Beläge / Number of pads: 4	(47) (7)
	<b>1863 838 001</b>	50/82/29				für / for: Powershuttle ohne Anlauftring / without thrust ring	(47) (79)
	<b>1863 869 014</b>	17/40/12				für / for: Powershuttle	(47)
<b>85 C</b> <b>95 F</b> <b>95 N</b> <b>95 V</b>	01.07- 10.07- 12.08- 12.08-			<b>1888 600 144</b>	DUT280/ CERAM (280/35x40-14N)	enthält eine Kupplungsscheibe / This part number includes one clutch disc	(45)
				<b>1864 600 303</b>	280C (22x25-10N)	Anzahl der Beläge / Number of pads: 4 Lose Kupplungsscheibe / Loose clutch disc	(7) (30)
				<b>1863 838 001</b>	50/82/29	ohne Anlauftring / without thrust ring	(79)
				<b>1863 858 002</b>	75/115/20	ohne Anlauftring / without thrust ring	(79)
				<b>1863 869 019</b>	17/47/14		
				<b>1882 600 101</b>	G280N	für / for: Powershuttle	(47)
				<b>1864 600 303</b>	280C (22x25-10N)	für / for: Powershuttle Anzahl der Beläge / Number of pads: 4	(47) (7)
				<b>1863 838 001</b>	50/82/29	für / for: Powershuttle ohne Anlauftring / without thrust ring	(47) (79)
<b>95 C</b>	12.08-			<b>1864 600 303</b>	280C (22x25-10N)	Anzahl der Beläge / Number of pads: 4 Lose Kupplungsscheibe / Loose clutch disc	(7) (30)
				<b>1863 838 001</b>	50/82/29	ohne Anlauftring / without thrust ring	(79)
				<b>1863 858 002</b>	75/115/20	ohne Anlauftring / without thrust ring	(79)
				<b>1863 869 019</b>	17/47/14		
				<b>1864 600 303</b>	280C (22x25-10N)	für / for: Powershuttle Anzahl der Beläge / Number of pads: 4	(47) (7)
				<b>1863 838 001</b>	50/82/29	für / for: Powershuttle ohne Anlauftring / without thrust ring	(47) (79)
				<b>1863 869 019</b>	17/47/14	für / for: Powershuttle	(47)

					Parameter		
---	--	--	--	--	-----------	---	---



































## CASE IH

V..							
VJ 60 VJ 70				1888 869 004 #	DUT280 (280/35x40-14N)	enthält eine Kupplungsscheibe / This part number includes one clutch disc	(45)
				1864 600 353	280 (22x25-10N)		
				1863 838 000	70/110/20	ohne Anlauftring / without thrust ring	(79)
				1863 838 001	50/82/29	ohne Anlauftring / without thrust ring	(79)
VJ 80				3800 541 025 # 1888 998 502 1864 600 353	DUT280 280		
				1863 838 000	70/110/20	ohne Anlauftring / without thrust ring	(79)
				1863 838 001	50/82/29	ohne Anlauftring / without thrust ring	(79)

200 - 300								
206 238 B 248 258 ,L 268 ,B 278				3800 541 024 # 1882 600 116 1862 844 001 1863 600 101	XN280 280CC GR-4			
248 258				3800 541 006 # 3482 600 123 1862 716 003	M310 310CC			
				1863 600 101	60/102/21,5	mit Rockford-Kupplung / with Rockford-Clutch mit Anlauftring / with thrust ring	(67) (63)	
263 B 288 L				3800 541 006 # 3482 600 123 1862 716 003	M310 310CC			
				1863 600 101	60/102/21,5	mit Anlauftring / with thrust ring	(63)	
276 B				1862 844 001 #	280CC (1 1/8"-10N)	Anzahl der Beläge / Number of pads: 6	(7)	
278 L				3800 541 024 # 1882 600 116 1862 844 001 1863 600 101	XN280 280CC GR-4	->Chass. 809		
					3800 541 006 # 3482 600 123 1862 716 003	M310 310CC	Chass. 810->	
					1863 600 101	60/102/21,5	mit Anlauftring / with thrust ring	(63)
284 L				3800 541 024 # 1882 600 116 1862 844 001 1863 600 101	XN280 280CC GR-4	->Chass. 1335		
					3800 541 006 # 3482 600 123 1862 716 003	M310 310CC	Chass. 1336->	
					1863 600 101	60/102/21,5	mit Anlauftring / with thrust ring	(63)

































300 - 400								
320 S 322 324 S 326				1881 089 002	K225			
					1878 634 043 #	225B/ Z (1 1/4" -10N)		
					1859 600 003			
					1805 042 000			

## CASE IH

300 - 400							
323		1881 089 002	K225				
		1878 634 044 #	225B/ Z (21,7x25-13N)				
		1859 600 003					
		1805 042 000					
		1888 878 001 #	DUT250 (228/41x45-25N)	Nur zusammen verbauen / Only install together enthält eine Kupplungsscheibe / This part number includes one clutch disc	(35) (45)		
		1861 259 131 ▽#	250GSZ (21,7x25-13N)	Lose Kupplungsscheibe / Loose clutch disc Nur zusammen verbauen / Only install together	(30) (35)		
		1850 282 747	65/101,5/22	mit Anlauftring / with thrust ring	(63)		
		1863 839 000	75/115/20	ohne Anlauftring / without thrust ring	(79)		
353 383		1881 009 201 #	G250				
		1861 259 131 #	250GSZ (21,7x25-13N)				
		1859 600 003					
		1805 042 000					
		1888 878 001 #	DUT250 (228/41x45-25N)	Je nach Kundenwunsch mit unterschiedlicher Kupplung / Equipped with different clutch according to customer requirement enthält eine Kupplungsscheibe / This part number includes one clutch disc	(26) (45)		
		1861 259 131 ▽#	250GSZ (21,7x25-13N)	Lose Kupplungsscheibe / Loose clutch disc	(30)		
		1850 282 747	65/101,5/22	mit Anlauftring / with thrust ring	(63)		
		1863 839 000	75/115/20	ohne Anlauftring / without thrust ring	(79)		
353 D		1881 089 002	K225				
		1859 600 003					
385		3800 541 024 #					
		1882 600 116	XN280				
		1862 844 001	280CC				
		1863 600 101	GR-4				
	3800 541 006 #						
	3482 600 123	M310	mit Rockford-Kupplung / with Rockford-Clutch	(67)			
	1862 716 003	310CC					
	1863 600 101	60/102/21,5	mit Rockford-Kupplung / with Rockford-Clutch mit Anlauftring / with thrust ring	(67) (63)			
395		3800 541 024 #					
		1882 600 116	XN280				
		1862 844 001	280CC				
		1863 600 101	GR-4				
395		3800 541 006 #					
		3482 600 123	M310	mit Rockford-Kupplung / with Rockford-Clutch	(67)		
		1862 716 003	310CC				
	1863 600 101	60/102/21,5	mit Anlauftring / with thrust ring mit Rockford-Kupplung / with Rockford-Clutch	(63) (67)			

# CASE IH



## 400 - 500

423 440 453		1881 009 201 #	G250		
		1861 259 131 #	250GSZ (21,7x25-13N)		
		1859 600 003			
		1805 042 000			
		1888 878 001 #	DUT250 (228/41x45-25N)	Je nach Kundenwunsch mit unterschiedlicher Kupplung / Equipped with different clutch according to customer requirement enthält eine Kupplungsscheibe / This part number includes one clutch disc	(26) (45)
		1861 259 131 ▽#	250GSZ (21,7x25-13N)	Lose Kupplungsscheibe / Loose clutch disc	(30)
		1850 282 747	65/101,5/22	mit Anlauftring / with thrust ring	(63)
		1863 839 000	75/115/20	ohne Anlauftring / without thrust ring	(79)
423 D 453 D		1881 089 002	K225		
		1859 600 003			
430 432		1881 009 203 #	G250		
		1878 634 051	250B/ Z (1 1/4" -10N)		
		1859 600 003			
		1805 042 000			
433		1888 878 001 #	DUT250 (228/41x45-25N)	enthält eine Kupplungsscheibe / This part number includes one clutch disc	(45)
		1861 259 131 ▽#	250GSZ (21,7x25-13N)	Lose Kupplungsscheibe / Loose clutch disc	(30)
		1863 858 002	75/115/20	ohne Anlauftring / without thrust ring	(79)
		1850 282 747	65/101,5/22	mit Anlauftring / with thrust ring	(63)
436 439		1881 009 201 #	G250		
		1878 634 051	250B/ Z (1 1/4" -10N)		
		1859 600 003			
		1805 042 000			
444		1878 600 527	280CB (1 1/8"-10N)		
454 474 475 484 495		3800 541 024 #			
		1882 600 116	XN280		
		1862 844 001	280CC		
		1863 600 101	GR-4		
		3800 541 006 #	M310 310CC	mit Rockford-Kupplung / with Rockford-Clutch	(67)
485 L		1863 600 101	60/102/21,5	mit Rockford-Kupplung / with Rockford-Clutch mit Anlauftring / with thrust ring	(67) (63)
		3800 541 024 #		->Chass. 8250	
		1882 600 116	XN280	Chass. 8251->	
		1862 716 003 #	310CC (1 1/8"-10N)	Chass. 8251-> Anzahl der Beläge / Number of pads: 6	(7)
		1863 600 101	60/102/21,5	mit Anlauftring / with thrust ring	(63)





























# CASE IH

## 400 - 500















<b>485 XL</b>				3800 541 024 # ⊗ 1882 600 116 ⊗ 1862 844 001 ⊗ 1863 600 101	XN280 280CC GR-4	->Chass. 703	
				3800 541 006 # ⊗ 3482 600 123 ⊗ 1862 716 003	M310 310CC	Chass. 704->	
				1863 600 101	60/102/21,5	mit Anlauftring / with thrust ring	(63)

## 500 - 600















<b>523</b>				1880 096 208 #	G280		
				1878 634 045	280GSZ (1 1/4"-10N)	->Chass. 20469	
				1878 634 013	280GSZ (1 1/8" -10N)	Chass. 20470->	
				1859 600 003			
				1805 042 000			
				1888 048 142 #	DUT295-295/ 280 (280/41x45-22N)	enthält eine Kupplungsscheibe / This part number includes one clutch disc	(45)
				1878 634 035 ▽	295GSPDC (1 1/8"-10N)	Lose Kupplungsscheibe / Loose clutch disc	(30)
				3800 541 019 ●# ⊗ 1888 048 142 ⊗ 1878 634 018	DUT295-295/280 295GSB		
				3800 541 005 ●# ⊗ 1888 048 143 ⊗ 1878 634 035	DUT295/CERAM 295GSPDC		
				1863 839 000	75/115/20	ohne Anlauftring / without thrust ring	(79)
				1863 839 001	65/101,4/25	mit Anlauftring / with thrust ring	(63)
			<b>533</b>				1880 096 208 #
	1878 634 046	280GSZ (22x25-13N)					
<b>533 A</b>				1888 878 001 #	DUT250 (228/41x45-25N)	enthält eine Kupplungsscheibe / This part number includes one clutch disc	(45)
				1861 259 131 ▽#	250GSZ (21,7x25-13N)	Lose Kupplungsscheibe / Loose clutch disc	(30)
				1850 282 747	65/101,5/22	mit Anlauftring / with thrust ring	(63)
				1863 839 000	75/115/20	ohne Anlauftring / without thrust ring	(79)
				3800 541 018 ●# ⊗ 1888 879 001 ⊗ 1878 634 040	DUT290/228 290GTZ		
				1850 282 747	65/101,5/22	mit Anlauftring / with thrust ring	(63)
				1863 839 000	75/115/20	ohne Anlauftring / without thrust ring	(79)
<b>540 ,A</b>				1888 878 001 #	DUT250 (228/41x45-25N)	enthält eine Kupplungsscheibe / This part number includes one clutch disc	(45)
				1861 259 131 ▽#	250GSZ (21,7x25-13N)	Lose Kupplungsscheibe / Loose clutch disc	(30)
				1850 282 747	65/101,5/22	mit Anlauftring / with thrust ring	(63)
				1863 839 000	75/115/20	ohne Anlauftring / without thrust ring	(79)
				3800 541 018 HD●# ⊗ 1888 879 001 ⊗ 1878 634 040	DUT290/228 290GTZ		
				1850 282 747	65/101,5/22	mit Anlauftring / with thrust ring	(63)
	1863 839 000	75/115/20	ohne Anlauftring / without thrust ring	(79)			

# CASE IH

## 500 - 600



















































553 554 564	10.70-			<b>1888 048 142 #</b>	DUT295-295/ 280 (280/41x45-22N)	enthält eine Kupplungsscheibe / This part number includes one clutch disc	(45)
				<b>1878 634 035 ▽</b>	295GSPDC (1 1/8"-10N)	Lose Kupplungsscheibe / Loose clutch disc	(30)
				<b>3800 541 019 ●#⊖</b> ⊖ <b>1888 048 142</b> ⊖ <b>1878 634 018</b>	DUT295-295/280 295GSB		
				<b>3800 541 005 ●#⊖</b> ⊖ <b>1888 048 143</b> ⊖ <b>1878 634 035</b>	DUT295/CERAM 295GSPDC		
				<b>1863 839 000</b>	75/115/20	ohne Anlauftring / without thrust ring	(79)
				<b>1863 839 001</b>	65/101,4/25	mit Anlauftring / with thrust ring	(63)
553	- 10.70			<b>1880 096 208 #</b>	G280		
				<b>1878 634 045</b>	280GSZ (1 1/4"-10N)	->Chass. 20469	
				<b>1878 634 013</b>	280GSZ (1 1/8" -10N)	Chass. 20470->	
				<b>1859 600 003</b>			
				<b>1805 042 000</b>			
574				<b>3800 541 024 #</b> ⊖ <b>1882 600 116</b> ⊖ <b>1862 844 001</b> ⊖ <b>1863 600 101</b>	XN280 280CC GR-4		
584 585 595				<b>3800 541 024 #</b> ⊖ <b>1882 600 116</b> ⊖ <b>1862 844 001</b> ⊖ <b>1863 600 101</b>	XN280 280CC GR-4		
				<b>3800 541 006 #⊖</b> ⊖ <b>3482 600 123</b> ⊖ <b>1862 716 003</b>	M310 310CC	mit Rockford-Kupplung / with Rockford-Clutch	(67)
				<b>1863 600 101</b>	60/102/21,5	mit Rockford-Kupplung / with Rockford-Clutch mit Anlauftring / with thrust ring	(67) (63)

## 600 - 700





























624				<b>1880 096 208 #</b>	G280		
				<b>1878 634 045</b>	280GSZ (1 1/4"-10N)	->Chass. 20469	
				<b>1878 634 013</b>	280GSZ (1 1/8" -10N)	Chass. 20470->	
				<b>1859 600 003</b>			
				<b>1805 042 000</b>			
				<b>1888 048 142 #</b>	DUT295-295/ 280 (280/41x45-22N)	enthält eine Kupplungsscheibe / This part number includes one clutch disc	(45)
				<b>1878 634 035 ▽</b>	295GSPDC (1 1/8"-10N)	Lose Kupplungsscheibe / Loose clutch disc	(30)
				<b>3800 541 019 ●#⊖</b> ⊖ <b>1888 048 142</b> ⊖ <b>1878 634 018</b>	DUT295-295/280 295GSB		
				<b>3800 541 005 ●#⊖</b> ⊖ <b>1888 048 143</b> ⊖ <b>1878 634 035</b>	DUT295/CERAM 295GSPDC		
				<b>1863 839 000</b>	75/115/20	ohne Anlauftring / without thrust ring	(79)
				<b>1863 839 001</b>	65/101,4/25	mit Anlauftring / with thrust ring	(63)
633 644	- 04.78 - 08.78			<b>1888 878 001 #</b>	DUT250 (228/41x45-25N)	enthält eine Kupplungsscheibe / This part number includes one clutch disc	(45)
				<b>1861 259 131 ▽#</b>	250GSZ (21,7x25-13N)	Lose Kupplungsscheibe / Loose clutch disc	(30)
				<b>1850 282 747</b>	65/101,5/22	mit Anlauftring / with thrust ring	(63)
				<b>1863 839 000</b>	75/115/20	ohne Anlauftring / without thrust ring	(79)

## CASE IH



























### 600 - 700

633 640				 <b>3800 541 018 #</b>  1888 879 001  1878 634 040	DUT290/228 290GTZ		
				 <b>1888 879 002 ●#</b>	DUT290/ 228/ CERAM (228/41x45-25N)	enthält eine Kupplungsscheibe / This part number includes one clutch disc	(45)
				 <b>1878 634 040 ▽</b>	290GTZ	Lose Kupplungsscheibe / Loose clutch disc	(30)
				 <b>1862 650 001 ●▽#</b>	290CDC (21,5x25-13N)	Lose Kupplungsscheibe / Loose clutch disc	(30)
				 <b>1850 282 747</b>	65/101,5/22	mit Anlauftring / with thrust ring	(63)
				 <b>1863 839 000</b>	75/115/20	ohne Anlauftring / without thrust ring	(79)
644 654	09.78 - 09.78 -			 <b>1888 048 142 #</b>	DUT295-295/ 280 (280/41x45-22N)	enthält eine Kupplungsscheibe / This part number includes one clutch disc	(45)
				 <b>1878 634 035 ▽</b>	295GSPDC (1 1/8"-10N)	Lose Kupplungsscheibe / Loose clutch disc	(30)
				 <b>3800 541 019 ●#</b>  1888 048 142  1878 634 018	DUT295-295/280 295GSB		
				 <b>3800 541 005 ●#</b>  1888 048 143  1878 634 035	DUT295/CERAM 295GSPDC		
				 <b>1863 839 001</b>	65/101,4/25	mit Anlauftring / with thrust ring	(63)
				 <b>1863 839 000</b>	75/115/20	ohne Anlauftring / without thrust ring	(79)
654				 <b>1880 096 208 #</b>	G280		
				 <b>1878 634 045</b>	280GSZ (1 1/4"-10N)	->Chass. 20469	
				 <b>1878 634 013</b>	280GSZ (1 1/8" -10N)	Chass. 20470->	
				 <b>1859 600 003</b>			
				 <b>1805 042 000</b>			
674 684	- 12.81 - 12.81			 <b>3800 541 024 #</b>  1882 600 116  1862 844 001  1863 600 101	XN280 280CC GR-4		
685 L				 <b>3800 541 024 #</b>  1882 600 116  1862 844 001  1863 600 101	XN280 280CC GR-4	->Chass. 12349	
				 <b>3800 541 006 #</b>  3482 600 123  1862 716 003	M310 310CC	Chass. 12350->	
				 <b>1863 600 101</b>	60/102/21,5	mit Anlauftring / with thrust ring	(63)
685 XL				 <b>3800 541 024 #</b>  1882 600 116  1862 844 001  1863 600 101	XN280 280CC GR-4	->Chass. 3234	
				 <b>3800 541 006 #</b>  3482 600 123  1862 716 003	M310 310CC	Chass. 3235->	
				 <b>1863 600 101</b>	60/102/21,5	mit Anlauftring / with thrust ring	(63)
695				 <b>3800 541 024 #</b>  1882 600 116  1862 844 001  1863 600 101	XN280 280CC GR-4		
				 <b>3800 541 006 #</b>  3482 600 123  1862 716 003	M310 310CC		
				 <b>1863 600 101</b>	60/102/21,5	mit Anlauftring / with thrust ring	(63)





























# CASE IH

700 - 800							
724				1880 096 208 #	G280		
				1878 634 045	280GSZ (1 1/4"-10N)	->Chass. 20469	
				1878 634 013	280GSZ (1 1/8" -10N)	Chass. 20470->	
				1859 600 003			
				1805 042 000			
				1888 048 142 #	DUT295-295/ 280 (280/41x45-22N)	enthält eine Kupplungsscheibe / This part number includes one clutch disc	(45)
				1878 634 035 ▽	295GSPDC (1 1/8"-10N)	Lose Kupplungsscheibe / Loose clutch disc	(30)
				3800 541 019 ●# 1888 048 142 1878 634 018	DUT295-295/280 295GSB		
				3800 541 005 ●# 1888 048 143 1878 634 035	DUT295/CERAM 295GSPDC		
				1863 839 000	75/115/20	ohne Anlauftring / without thrust ring	(79)
				1863 839 001	65/101,4/25	mit Anlauftring / with thrust ring	(63)
733 740	05.78 -			3800 541 018 # 1888 879 001 1878 634 040	DUT290/228 290GTZ		
				1888 879 002 ●#	DUT290/ 228/ CERAM (228/41x45-25N)	enthält eine Kupplungsscheibe / This part number includes one clutch disc	(45)
				1862 650 001 ▽#	290CDC (21,5x25-13N)	Lose Kupplungsscheibe / Loose clutch disc	(30)
				1878 634 040 ●▽	290GTZ	Lose Kupplungsscheibe / Loose clutch disc	(30)
				1850 282 747	65/101,5/22	mit Anlauftring / with thrust ring	(63)
				1863 839 000	75/115/20	ohne Anlauftring / without thrust ring	(79)
734 XL,XLA 743 744 745 754	01.74-01.81			1888 048 142 #	DUT295-295/ 280 (280/41x45-22N)	enthält eine Kupplungsscheibe / This part number includes one clutch disc	(45)
				1878 634 035 ▽	295GSPDC (1 1/8"-10N)	Lose Kupplungsscheibe / Loose clutch disc	(30)
				3800 541 019 ●# 1888 048 142 1878 634 018	DUT295-295/280 295GSB		
				3800 541 005 ●# 1888 048 143 1878 634 035	DUT295/CERAM 295GSPDC		
				1863 839 001	65/101,4/25	mit Anlauftring / with thrust ring	(63)
				1863 839 000	75/115/20	ohne Anlauftring / without thrust ring	(79)
770 A 780				1864 600 349	250	Borg & Beck Version / Borg & Beck Version	(9)
784 795 L,XL				3800 541 024 # 1882 600 116 1862 844 001 1863 600 101	XN280 280CC GR-4		
785 L				3800 541 024 # 1882 600 116 1862 844 001 1863 600 101	XN280 280CC GR-4	->Chass. 16712	
				3800 541 006 # 3482 600 123 1862 716 003	M310 310CC	Chass. 16713->	
				1863 600 101	60/102/21,5	mit Anlauftring / with thrust ring	(63)

# CASE IH











700 - 800								
785 XL				3800 541 024 # ⊗ 1882 600 116 ⊗ 1862 844 001 ⊙ 1863 600 101	XN280 280CC GR-4	->Chass. 1840		
					3800 541 006 #⊙ ⊗ 3482 600 123 ⊗ 1862 716 003	M310 310CC	Chass. 1841->	
					1863 600 101	60/102/21,5	mit Anlauftring / with thrust ring	(63)
795				3800 541 006 #⊙ ⊗ 3482 600 123 ⊗ 1862 716 003	M310 310CC	mit Rockford-Kupplung / with Rockford-Clutch	(67)	
					1863 600 101	60/102/21,5	mit Rockford-Kupplung / with Rockford-Clutch mit Anlauftring / with thrust ring	(67) (63)
800 - 900								
824 S,XL,XLA 834 S,XL,XLA 844 S,XL,XLA 845 S,XL,XLA				1888 048 142 #	DUT295-295/ 280 (280/41x45-22N)	enthält eine Kupplungsscheibe / This part number includes one clutch disc	(45)	
					1878 634 035 ▽	295GSPDC (1 1/8"-10N)	Lose Kupplungsscheibe / Loose clutch disc	(30)
					3800 541 019 ●#⊙ ⊗ 1888 048 142 ⊗ 1878 634 018	DUT295-295/280 295GSB		
								3800 541 005 ●#⊙ ⊗ 1888 048 143 ⊗ 1878 634 035
					1863 839 001	65/101,4/25		
					1863 839 000	75/115/20	ohne Anlauftring / without thrust ring	(79)
833 A,E,H,V 840 A,E,H,V				1888 879 002 #	DUT290/ 228/ CERAM (228/41x45-25N)	enthält eine Kupplungsscheibe / This part number includes one clutch disc	(45)	
					1862 650 001 ▽#	290CDC (21,5x25-13N)	Lose Kupplungsscheibe / Loose clutch disc	(30)
					1878 634 040 ●▽	290GTZ	Lose Kupplungsscheibe / Loose clutch disc	(30)
					1850 282 747	65/101,5/22	mit Anlauftring / with thrust ring	(63)
					1863 858 002	75/115/20	ohne Anlauftring / without thrust ring	(79)
844 845				1880 083 132 #	G280			
				856 XL				3800 541 007 #⊙ ⊗ 1888 034 302 ⊗ 1861 784 001
	1878 634 019 ●▽	310GSB (1 1/8"-10N)	Lose Kupplungsscheibe / Loose clutch disc					(30)
	1863 839 001	65/101,4/25	mit Anlauftring / with thrust ring					(63)
880 A				1863 839 000	75/115/20	ohne Anlauftring / without thrust ring	(79)	
					1864 600 349	250	Borg & Beck Version / Borg & Beck Version	(9)
884				3800 541 024 # ⊗ 1882 600 116 ⊗ 1862 844 001 ⊙ 1863 600 101	XN280 280CC GR-4			
885 885 XL				3800 541 024 # ⊗ 1882 600 116 ⊗ 1862 844 001 ⊙ 1863 600 101	XN280 280CC GR-4	->Chass. 2990		
					3800 541 006 #⊙ ⊗ 3482 600 123 ⊗ 1862 716 003	M310 310CC	Chass. 2991->	
					1864 600 349	250	Borg & Beck Version / Borg & Beck Version	(9)
					1863 600 101	60/102/21,5	mit Anlauftring / with thrust ring	(63)

# CASE IH



















800 - 900							
885 L		3800 541 024 # ⊗ 1882 600 116 ⊗ 1862 844 001 ⊙ 1863 600 101	XN280 280CC GR-4	->Chass. 2691			
		3800 541 006 #⊙ ⊗ 3482 600 123 ⊗ 1862 716 003	M310 310CC	Chass. 2692->			
		1864 600 349	250	Borg & Beck Version / Borg & Beck Version			(9)
		1863 600 101	60/102/21,5	mit Anlauftring / with thrust ring			(63)
895		3800 541 006 #⊙ ⊗ 3482 600 123 ⊗ 1862 716 003	M310 310CC	mit Rockford-Kupplung / with Rockford-Clutch			(67)
		1863 600 101	60/102/21,5	mit Rockford-Kupplung / with Rockford-Clutch mit Anlauftring / with thrust ring			(67) (63)
900 - 1100							
900		1864 934 009 #	280 (1 1/8"-10N)				
		1863 866 001	69/103/22	mit Anlauftring / with thrust ring			(63)
933 940		1888 879 002 #	DUT290/ 228/ CERAM (228/41x45-25N)	enthält eine Kupplungsscheibe / This part number includes one clutch disc			(45)
		1862 650 001 ∇#	290CDC (21,5x25-13N)	Lose Kupplungsscheibe / Loose clutch disc			(30)
		1878 634 040 ●∇	290GTZ	Lose Kupplungsscheibe / Loose clutch disc			(30)
		1850 282 747	65/101,5/22	mit Anlauftring / with thrust ring			(63)
		1863 858 002	75/115/20	ohne Anlauftring / without thrust ring			(79)
946		1888 881 001 #	DUT280 (280/44x48-23N)	enthält eine Kupplungsscheibe / This part number includes one clutch disc			(45)
		1864 917 003 ∇#	280E (27x30-16N)	Lose Kupplungsscheibe / Loose clutch disc			(30)
		1863 839 001	65/101,4/25	mit Anlauftring / with thrust ring			(63)
		1863 839 000	75/115/20	ohne Anlauftring / without thrust ring			(79)
		1888 025 003 #	DUT295 (280/44x48-23N)	enthält eine Kupplungsscheibe / This part number includes one clutch disc			(45)
		1864 299 131 ▲∇#	295 (27x30-16N)	Lose Kupplungsscheibe / Loose clutch disc			(30)
		1863 123 000	65/101,5/17,5	mit Anlauftring / with thrust ring			(63)
955 ,XL 956 ,XL 1055 ,XL 1056 ,XL		3800 541 007 #⊙ ⊗ 1888 034 302 ⊗ 1861 784 001	DUT310 310GC				
		1878 634 019 ●∇	310GSB (1 1/8"-10N)	Lose Kupplungsscheibe / Loose clutch disc			(30)
		1863 839 001	65/101,4/25	mit Anlauftring / with thrust ring			(63)
		1863 839 000	75/115/20	ohne Anlauftring / without thrust ring			(79)
970		3800 541 003 # ⊗ 1888 050 101 ⊗ 1878 634 033 ⊙ 1863 837 002 1863 855 000	DUT295-295/280 295GSPB GR-4 GR-8	für Fahrzeuge mit Zweischeibenkupplung / for vehicles with double disc clutch			(51)
985 995		3800 541 006 #⊙ ⊗ 3482 600 123 ⊗ 1862 716 003	M310 310CC				
		1863 600 101	60/102/21,5	mit Anlauftring / with thrust ring			(63)
990 A 995 DB		1864 934 009 #	280 (1 1/8"-10N)	ohne Zwischenplatte / without intermediate plate			(83)

## CASE IH

### 900 - 1100



























<b>996</b>				<b>1888 907 001 #</b>	DO-280 (280/ 1 3/4"-10N)	enthält eine Kupplungsscheibe / This part number includes one clutch disc	(45)
				<b>1864 934 009 ▽#</b>	280 (1 1/8"-10N)	Lose Kupplungsscheibe / Loose clutch disc	(30)
				<b>1863 866 001</b>	69/103/22	mit Anlauftring / with thrust ring	(63)
				<b>1863 867 001</b>	76/114,5/19,4	ohne Anlauftring / without thrust ring	(79)
<b>1046</b>				<b>1888 881 001 #</b>	DUT280 (280/44x48-23N)	enthält eine Kupplungsscheibe / This part number includes one clutch disc	(45)
				<b>1864 917 003 ▽#</b>	280E (27x30-16N)	Lose Kupplungsscheibe / Loose clutch disc	(30)
				<b>1863 839 001</b>	65/101,4/25	mit Anlauftring / with thrust ring	(63)
				<b>1863 839 000</b>	75/115/20	ohne Anlauftring / without thrust ring	(79)
				<b>1863 839 001</b>	65/101,4/25	mit Anlauftring / with thrust ring	(63)
				<b>1863 839 000</b>	75/115/20	ohne Anlauftring / without thrust ring	(79)

### 1100 - 1300









<b>1190 1194</b>				<b>1888 600 143</b>	DUT305/ CERAM (305/ 1 3/4"-10N)	enthält eine Kupplungsscheibe / This part number includes one clutch disc	(45)
				<b>1864 600 349</b>	250	Borg & Beck Version / Borg & Beck Version	(9)
				<b>1864 943 002 ▽#</b>	305 (23,2x28,8-10N)	Lose Kupplungsscheibe / Loose clutch disc	(30)
				<b>1863 867 001</b>	76/114,5/19,4	ohne Anlauftring / without thrust ring	(79)
				<b>1863 866 001</b>	69/103/22	mit Anlauftring / with thrust ring	(63)
<b>1200 1290</b>				<b>1888 907 001 #</b>	DO-280 (280/ 1 3/4"-10N)	enthält eine Kupplungsscheibe / This part number includes one clutch disc	(45)
				<b>1864 934 009 ▽#</b>	280 (1 1/8"-10N)	Lose Kupplungsscheibe / Loose clutch disc	(30)
				<b>1863 866 001</b>	69/103/22	mit Anlauftring / with thrust ring	(63)
				<b>1863 867 001</b>	76/114,5/19,4	ohne Anlauftring / without thrust ring	(79)
<b>1210</b>				<b>1888 907 001 #</b>	DO-280 (280/ 1 3/4"-10N)	<b>-&gt;Chass. 1154230</b> enthält eine Kupplungsscheibe / This part number includes one clutch disc	(45)
				<b>1864 934 009 ▽#</b>	280 (1 1/8"-10N)	<b>-&gt;Chass. 1154230</b> Lose Kupplungsscheibe / Loose clutch disc	(30)
				<b>1888 600 143</b>	DUT305/ CERAM (305/ 1 3/4"-10N)	<b>Chass. 1154231-&gt;</b> enthält eine Kupplungsscheibe / This part number includes one clutch disc	(45)
				<b>1864 943 002 ▽#</b>	305 (23,2x28,8-10N)	<b>Chass. 1154231-&gt;</b> Lose Kupplungsscheibe / Loose clutch disc	(30)
				<b>1863 866 001</b>	69/103/22	mit Anlauftring / with thrust ring	(63)
				<b>1863 867 001</b>	76/114,5/19,4	ohne Anlauftring / without thrust ring	(79)
<b>1210 A</b>				<b>1888 897 003 #</b>	DUT305/ CERAM (305/ 1 3/4"-10N)	enthält eine Kupplungsscheibe / This part number includes one clutch disc	(45)
				<b>1864 943 002 ▽#</b>	305 (23,2x28,8-10N)	Lose Kupplungsscheibe / Loose clutch disc	(30)
				<b>1863 866 001</b>	69/103/22	mit Anlauftring / with thrust ring	(63)
				<b>1863 867 001</b>	76/114,5/19,4	ohne Anlauftring / without thrust ring	(79)

# CASE IH

## 1100 - 1300



















1212		<b>1888 907 001 #</b>	DO-280 (280/ 1 3/4"-10N)	enthält eine Kupplungsscheibe / This part number includes one clutch disc	(45)
		<b>1864 934 009 ▽#</b>	280 (1 1/8"-10N)	Lose Kupplungsscheibe / Loose clutch disc	(30)
		<b>1863 866 001</b>	69/103/22	mit Anlauftring / with thrust ring	(63)
		<b>1863 867 001</b>	76/114,5/19,4	ohne Anlauftring / without thrust ring	(79)
		<b>1888 600 143</b>	DUT305/ CERAM (305/ 1 3/4"-10N)	enthält eine Kupplungsscheibe / This part number includes one clutch disc	(45)
		<b>1864 943 002 ▽#</b>	305 (23,2x28,8-10N)	Lose Kupplungsscheibe / Loose clutch disc	(30)
		<b>1863 866 001</b>	69/103/22	mit Anlauftring / with thrust ring	(63)
		<b>1863 867 001</b>	76/114,5/19,4	ohne Anlauftring / without thrust ring	(79)
1246		<b>1850 280 743 #</b>	DUT310 (310/44x48-23N)	enthält eine Kupplungsscheibe / This part number includes one clutch disc	(45)
		<b>1863 839 000</b>	75/115/20	ohne Anlauftring / without thrust ring	(79)
		<b>1863 839 001</b>	65/101,4/25	mit Anlauftring / with thrust ring	(63)
1255 ,XL (mit / with Hydro Power)		<b>1888 864 002 #</b>	DUT350 (350/44x48-23N)	enthält eine Kupplungsscheibe / This part number includes one clutch disc	(45)
		<b>1864 941 001 ▽#</b>	350CERAM (27x30-16N)	Lose Kupplungsscheibe / Loose clutch disc	(30)
		<b>1863 839 000</b>	75/115/20	ohne Anlauftring / without thrust ring	(79)
		<b>1863 839 001</b>	65/101,4/25	mit Anlauftring / with thrust ring	(63)
1255 ,XL (ohne / without Hydro Power)		<b>1888 865 042 #</b>	DUT350 (350/44x48-23N)	enthält eine Kupplungsscheibe / This part number includes one clutch disc	(45)
		<b>1864 941 001 ▽#</b>	350CERAM (27x30-16N)	Lose Kupplungsscheibe / Loose clutch disc	(30)
		<b>1863 839 000</b>	75/115/20	ohne Anlauftring / without thrust ring	(79)
		<b>1863 839 001</b>	65/101,4/25	mit Anlauftring / with thrust ring	(63)
1294		<b>1888 907 001 #</b>	DO-280 (280/ 1 3/4"-10N)	<b>-&gt;Chass. 11059299</b> enthält eine Kupplungsscheibe / This part number includes one clutch disc	(45)
		<b>1864 934 009 ▽#</b>	280 (1 1/8"-10N)	<b>-&gt;Chass. 11059299</b> Lose Kupplungsscheibe / Loose clutch disc	(30)
		<b>1863 866 001</b>	69/103/22	mit Anlauftring / with thrust ring	(63)
		<b>1863 867 001</b>	76/114,5/19,4	ohne Anlauftring / without thrust ring	(79)
		<b>1888 897 003 #</b>	DUT305/ CERAM (305/ 1 3/4"-10N)	<b>Chass. 11059300-&gt;</b> enthält eine Kupplungsscheibe / This part number includes one clutch disc	(45)
		<b>1864 943 002 ▽#</b>	305 (23,2x28,8-10N)	<b>Chass. 11059300-&gt;</b> Lose Kupplungsscheibe / Loose clutch disc	(30)
		<b>1863 866 001</b>	69/103/22	mit Anlauftring / with thrust ring	(63)
		<b>1863 867 001</b>	76/114,5/19,4	ohne Anlauftring / without thrust ring	(79)



## 1300 - 1900













1390		<b>1888 907 001 #</b>	DO-280 (280/ 1 3/4"-10N)	enthält eine Kupplungsscheibe / This part number includes one clutch disc	(45)
		<b>1864 934 009 ▽#</b>	280 (1 1/8"-10N)	Lose Kupplungsscheibe / Loose clutch disc	(30)
		<b>1863 866 001</b>	69/103/22	mit Anlauftring / with thrust ring	(63)
		<b>1863 867 001</b>	76/114,5/19,4	ohne Anlauftring / without thrust ring	(79)
1394		<b>1888 600 143</b>	DUT305/ CERAM (305/ 1 3/4"-10N)	enthält eine Kupplungsscheibe / This part number includes one clutch disc	(45)
		<b>1888 897 003 #</b>	DUT305/ CERAM (305/ 1 3/4"-10N)	enthält eine Kupplungsscheibe / This part number includes one clutch disc	(45)
		<b>1864 943 002 ▽#</b>	305 (23,2x28,8-10N)	Lose Kupplungsscheibe / Loose clutch disc	(30)
		<b>1863 866 001</b>	69/103/22	mit Anlauftring / with thrust ring	(63)
		<b>1863 867 001</b>	76/114,5/19,4	ohne Anlauftring / without thrust ring	(79)





## CASE IH















1300 - 1900							
1410				<b>1888 600 143</b>	DUT305/ CERAM (305/ 1 3/4"-10N)	enthält eine Kupplungsscheibe / This part number includes one clutch disc	(45)
1412				<b>1864 943 002</b> ▽#	305 (23,2x28,8-10N)	Lose Kupplungsscheibe / Loose clutch disc	(30)
1490				<b>1863 866 001</b>	69/103/22	mit Anlauftring / with thrust ring	(63)
1494				<b>1863 867 001</b>	76/114,5/19,4	ohne Anlauftring / without thrust ring	(79)
1410 A				<b>1888 897 003</b> #	DUT305/ CERAM (305/ 1 3/4"-10N)	enthält eine Kupplungsscheibe / This part number includes one clutch disc	(45)
1412 A				<b>1864 943 002</b> ▽#	305 (23,2x28,8-10N)	Lose Kupplungsscheibe / Loose clutch disc	(30)
1490 A				<b>1863 866 001</b>	69/103/22	mit Anlauftring / with thrust ring	(63)
1494 A				<b>1863 867 001</b>	76/114,5/19,4	ohne Anlauftring / without thrust ring	(79)
1455 ,XL				<b>1888 865 042</b> #	DUT350 (350/44x48-23N)	enthält eine Kupplungsscheibe / This part number includes one clutch disc	(45)
				<b>1864 941 001</b> ▽#	350CERAM (27x30-16N)	Lose Kupplungsscheibe / Loose clutch disc	(30)
				<b>1863 839 000</b>	75/115/20	ohne Anlauftring / without thrust ring	(79)
				<b>1863 839 001</b>	65/101,4/25	mit Anlauftring / with thrust ring	(63)
1455 ,XL (mit / with Hydro Power)				<b>1888 864 002</b> #	DUT350 (350/44x48-23N)	enthält eine Kupplungsscheibe / This part number includes one clutch disc	(45)
				<b>1864 941 001</b> ▽#	350CERAM (27x30-16N)	Lose Kupplungsscheibe / Loose clutch disc	(30)
				<b>1863 839 000</b>	75/115/20	ohne Anlauftring / without thrust ring	(79)
				<b>1863 839 001</b>	65/101,4/25	mit Anlauftring / with thrust ring	(63)
1594	01.83 - 12.87			<b>1888 897 004</b> #	DUT305 (300/41x46-17N)	enthält eine Kupplungsscheibe / This part number includes one clutch disc	(45)
1690 ,T	01.80 -			<b>1863 866 001</b>	69/103/22	mit Anlauftring / with thrust ring	(63)
1694				<b>1863 867 001</b>	76/114,5/19,4	ohne Anlauftring / without thrust ring	(79)





2000 - 2300							
2120				<b>1888 998 501</b> #	DUT280 (280/34x40-12N)	enthält eine Kupplungsscheibe / This part number includes one clutch disc	(45)
2130				<b>1864 996 101</b> ▽#	280 (18,7x22,2-13N)	Lose Kupplungsscheibe / Loose clutch disc	(30)
2140							
2150							

2300 - 3500							
2400	01.70 -			<b>3800 541 024</b> #			
2500				<b>1882 600 116</b>	XN280		
3400				<b>1862 844 001</b>	280CC		
				<b>1863 600 101</b>	GR-4		
2520 CL				<b>1878 600 527</b>	280CB (1 1/8"-10N)		
2525 C							
2530 C							
3210				<b>3800 541 024</b> #			
3220				<b>1882 600 116</b>	XN280		
3230				<b>1862 844 001</b>	280CC		
				<b>1863 600 101</b>	GR-4		
				<b>3800 541 006</b> #	M310	mit Rockford-Kupplung / with Rockford-Clutch	(67)
				<b>3482 600 123</b>	310CC		
				<b>1862 716 003</b>			
				<b>1863 600 101</b>	60/102/21,5	mit Rockford-Kupplung / with Rockford-Clutch mit Anlauftring / with thrust ring	(67) (63)







					Parameter		
---	--	--	--	--	-----------	---	---

## CASE IH

2300 - 3500							
3434				3800 541 024 #	XN280 280CC GR-4		
				 1882 600 116			
				 1862 844 001			
				 1863 600 101			
				3800 541 006 #	M310 310CC	mit Rockford-Kupplung / with Rockford-Clutch	(67)
				 3482 600 123			
				 1862 716 003			
				1863 600 101	60/102/21,5	mit Rockford-Kupplung / with Rockford-Clutch mit Anlauftring / with thrust ring	(67) (63)
					1878 600 527	280CB (1 1/8"-10N)	12 mm Distanzstück auf Gehäuse / 12 mm spacers on pressing
3500				3800 541 024 #	XN280 280CC GR-4		
				 1882 600 116			
				 1862 844 001			
				1862 844 001 #	280CC (1 1/8"-10N)	Anzahl der Beläge / Number of pads: 6	(7)
					1863 600 101	60/102/21,5	mit Anlauftring / with thrust ring

4200 - 4525							
4210 4220 4230 4240				3800 541 006 #	M310 310CC		
				 3482 600 123			
				 1862 716 003			
4520 C 4525 C				1863 600 101	60/102/21,5	mit Anlauftring / with thrust ring	(63)
					1878 600 527	280CB (1 1/8"-10N)	

## CATERPILLAR

Lexion							
560 578		CaterpillarC9		1866 000 108	435/ 232GT	Chass. 57800011 - Chass. 57899999 max. übertragbares Motormoment [Nm] / max. transmittable engine torque [Nm]: 3415	(62)
570 R 574 575 R 574		CaterpillarC9		1866 000 108	435/ 232GT	Chass. 57400011 - Chass. 57499999 max. übertragbares Motormoment [Nm] / max. transmittable engine torque [Nm]: 3415	(62)
580 R 576 585 R 576		CaterpillarC13		1866 000 108	435/ 232GT	Chass. 57600011 - Chass. 57699999 max. übertragbares Motormoment [Nm] / max. transmittable engine torque [Nm]: 3415	(62)
590 R 579		CaterpillarC13		1866 000 108	435/ 232GT	Chass. 57900011 - Chass. 57999999 max. übertragbares Motormoment [Nm] / max. transmittable engine torque [Nm]: 3415	(62)
730 C48 740 C48 750 C48		CaterpillarC13 , CaterpillarC9		1866 000 108	435/ 232GT	Chass. C4800011 - Chass. C4899999 max. übertragbares Motormoment [Nm] / max. transmittable engine torque [Nm]: 3415	(62)
760 C49 770 C49		CaterpillarC13 , MBOM502LA		1866 000 108	435/ 232GT	Chass. C4900011 - Chass. C4999999 max. übertragbares Motormoment [Nm] / max. transmittable engine torque [Nm]: 3415	(62)

## CHALLENGER

MT-Serie							
MT 425 B MT 445 B MT 455 B MT 465 B		Cat.3054C		1866 600 016			



# CHALLENGER

MT-Serie						
MT 525 B		Cat.C6.6ACE	⊗	1866 600 017		Getr. / GBox: AutoPower VI
MT 535 B		RT				
MT 545 B						

# CLAAS

Ares						
540 RX/RZ			⊗	1866 600 024		Chass. CT32R0667 - Chass. CT32R839 mit mechanischer Wendeschaltung / with manual reverse gear unit (74)
550 RX/RZ				1866 600 024		
				1866 600 024		
546 RX/RZ			⊗	1866 600 024		Chass. CT533001 - Chass. CT5331300 Chass. CT5321500 - Chass. CT5322298
556 RX/RZ			⊗	1866 600 024		Chass. CT5311500 - Chass. CT5311730 Chass. CT5331500 - Chass. CT5332200





Columbus, Comet						
Columbus, Comet			⊗	1882 140 002	KS180J9	Nur bei Altteil-Rückgabe lieferbar (Reparatur; Werk Bielefeld) / Please return old unit for repair (plant Bielefeld) (33)
			⊗	1864 634 016	180E (23x29-10N)	
			⊗	1859 600 002		
			⌋	1805 041 100		

Compact						
25			⊗	1882 140 002	KS180J9	Chass. 73001150-> Nur bei Altteil-Rückgabe lieferbar (Reparatur; Werk Bielefeld) / Please return old unit for repair (plant Bielefeld) (33)
			⊗	1864 164 203 ▲#	180E (22x25-14N)	
			⊗	1859 600 002		
			⌋	1805 041 100		
30			⊗	1882 140 002	KS180J9	Nur bei Altteil-Rückgabe lieferbar (Reparatur; Werk Bielefeld) / Please return old unit for repair (plant Bielefeld) (33)
			⊗	1864 164 203 ▲#	180E (22x25-14N)	
			⊗	1859 600 002		
			⌋	1805 041 100		





Consul						
620			⊗	1881 089 007	K225	->Chass. 55008434 Getr. / GBox: ZF
			⊗	1860 039 024 #	225Z (23x29-10N)	->Chass. 55008434 Getr. / GBox: ZF
			⊗	1859 600 001		->Chass. 55008434 Getr. / GBox: ZF
			⌋	1805 042 000		->Chass. 55008434 Getr. / GBox: ZF
			⊗	1881 079 207	G250	Chass. 55008435 - Chass. 55010802 Getr. / GBox: ZF
			⊗	1864 052 103 #	250Z (36x42-8N)	Chass. 55008435 - Chass. 55010802 Getr. / GBox: ZF
			⊗	1859 600 005		Chass. 55008435 - Chass. 55010802 Getr. / GBox: ZF
			⌋	1805 042 000		Getr. / GBox: ZF

# CLAAS





















**Consul**

622				1881 079 207	G250	Chass. 55010803-> Getr. / GBox: Claas	
				1864 052 106 #	250Z (38x42-21N)	Chass. 55010803-> Getr. / GBox: Claas	
				1859 600 005		Chass. 55010803-> Getr. / GBox: Claas	
				1805 042 000		Chass. 55010803-> Getr. / GBox: Claas	

**Cosmos Corsar**

























Cosmos,Corsar				1882 140 002	KS180J9	Nur bei Altteil-Rückgabe lieferbar (Reparatur; Werk Bielefeld) / Please return old unit for repair (plant Bielefeld)	(33)
				1864 634 016	180E (23x29-10N)		
				1859 600 002			
				1805 041 100			

**Dominator**





38 48 58				1881 089 007	K225		
				1864 480 001	225DC (28x32-17N)	Anzahl der Beläge / Number of pads: 4	(7)
				3151 093 041			
				1805 042 000			
56 66 76				1880 096 208 #	G280		
				1864 320 101 #	280Z (38x42-21N)		
				1859 600 005			
				1805 042 000			
68				1880 096 208 #	G280		
				1864 320 101 #	280Z (38x42-21N)	->Chass. 15604334 Chass. 15605284->	
				1859 600 005			
				1805 042 000			
68 R/SR				1880 096 208 #	G280		
				1864 320 101 #	280Z (38x42-21N)	->Chass. 15500450	
				1859 600 005			
				1805 042 000			
78				1880 096 208 #	G280		
				1880 096 210	G280	für / for: 25 km/h	(47)
				1864 320 101 #	280Z (38x42-21N)	->Chass. 09101340	
				1859 600 005			
				1805 042 000			

# CLAAS





## Dominator



80		1881 079 207	G250	->Chass. 86002434
		1864 052 103 #	250Z (36x42-8N)	->Chass. 86002434
		1859 600 005		
		1805 042 000		
		1880 096 208 #	G280	Chass. 86002435->
		1864 320 101 #	280Z (38x42-21N)	Chass. 86002435->
		1859 600 005		
		1805 042 000		
85		1880 096 208 #	G280	Chass. 86002435->
		1864 320 101 #	280Z (38x42-21N)	Chass. 86002435->
		1859 600 005		Chass. 86002435->
		1805 042 000		Chass. 86002435->
86		1880 096 208 #	G280	->Chass. 08702061
		1880 096 210	G280	Chass. 08702062->
		1864 320 101 #	280Z (38x42-21N)	
		1859 600 005		
		1805 042 000		
88 S,SL		1880 096 210	G280	
		1864 320 101 #	280Z (38x42-21N)	
		1859 600 005		
		1805 042 000		
96 98 S,SL 106 108 S,SL 112 S,SL 115 CS		3482 008 038	MF310	
		1864 289 003	310Z (38x42-21N)	
		3151 000 395		
				

## Europa,Mercur

Europa,Mercur		1882 140 002	KS180J9	Nur bei Altteil-Rückgabe lieferbar (Reparatur; Werk Bielefeld) / Please return old unit for repair (plant Bielefeld)	(33)
		1864 634 016	180E (23x29-10N)		
		1859 600 002			
		1805 041 100			



## Gigant

630 640		1881 079 207	G250	
		1864 052 103 #	250Z (36x42-8N)	
		1859 600 005		
		1805 042 000		













					Parameter		
---	--	--	--	--	-----------	---	---

# CLAAS

## Huckepack

Huckepack	E89F		<b>1882 155 009</b>	K160		
			<b>1864 634 046</b>	160E (16x20-10N)		
			<b>3151 994 801</b>			
			<b>1805 041 100</b>			
	NWMMAKD9		<b>1882 315 002</b>	KS180		
			<b>1864 634 016</b>	180E (23x29-10N)		
			<b>3159 140 004</b>			
			<b>1805 041 100</b>			









## Jaguar

60 SF 70 SF				<b>1881 079 207</b>	G250		
				<b>1864 052 106 #</b>	250Z (38x42-21N)		
				<b>1859 600 005</b>			
				<b>1805 042 000</b>			
68 2LS/S				<b>1880 096 210</b>	G280		
				<b>1864 320 101 #</b>	280Z (38x42-21N)		
				<b>1859 600 005</b>			
810 495		MBOM460L A		<b>1866 000 108</b>	435/ 232GT	<b>Chass. 49500011 - Chass. 49599999</b> max. übertragbares Motormoment [Nm] / max. transmittable engine torque [Nm]: 3415	(62)
830 492 850 492 870 492 890 492		MBOM460LA, MBOM502LA		<b>1866 000 108</b>	435/ 232GT	<b>Chass. 49200011 - Chass. 49299999</b> max. übertragbares Motormoment [Nm] / max. transmittable engine torque [Nm]: 3415	(62)
860 880 900-830				<b>1864 501 001 #</b>	350Z (46x50-24N)		
900 493		MBOM502L A		<b>1866 000 108</b>	435/ 232GT	<b>Chass. 49300011 - Chass. 49399999</b> max. übertragbares Motormoment [Nm] / max. transmittable engine torque [Nm]: 3415	(62)
930 494 940 494 950 494 960 494 970 494 980 494		2xMBOM460L A, MBOM460LA, MBOM502LA		<b>1866 000 108</b>	435/ 232GT	<b>Chass. 49400011 - Chass. 49499999</b> max. übertragbares Motormoment [Nm] / max. transmittable engine torque [Nm]: 3415	(62)







# CLAAS







## Mercator

50		1881 079 207	G250	
		1864 052 103 #	250Z (36x42-8N)	->Chass. 57006849
		1864 052 106 #	250Z (38x42-21N)	Chass. 57006850->
		1859 600 005		
		1805 042 000		
60		1881 079 207	G250	
		1864 052 103 #	250Z (36x42-8N)	->Chass. 65002970
		1864 052 106 #	250Z (38x42-21N)	Chass. 65002971->
		1859 600 005		
		1805 042 000		
66 S		1881 079 207	G250	
		1864 052 103 #	250Z (36x42-8N)	
		1859 600 005		
		1805 042 000		
70		1881 079 207	G250	
		1864 052 103 #	250Z (36x42-8N)	->Chass. 67002411
		1864 052 106 #	250Z (38x42-21N)	Chass. 67002412->
		1859 600 005		
		1805 042 000		
75 ,R		1881 079 207	G250	
		1864 052 106 #	250Z (38x42-21N)	
		1859 600 005		
		1805 042 000		

## Protector

Protector		1881 079 207	G250	
		1864 052 103 #	250Z (36x42-8N)	
		1859 600 005		
		1805 042 000		



## Senator



85		1881 079 207	G250	
		1859 600 005		
		1805 042 000		
630 640		1881 079 207	G250	
		1864 052 103 #	250Z (36x42-8N)	
		1859 600 005		
		1805 042 000		





					Parameter		
---	--	--	--	--	-----------	---	---

## CLAAS

Super Aufbaumot.							
Super Aufbaumot. / Super body-engine		DBOM636		<b>1882 196 005</b>	KS200		
				<b>1861 123 236</b>	200PE (23x29-10N)		
				<b>3100 700 101</b> ◊ 3151 021 001 J 2x 3130 010 200	KTI-1		

Super Junior							
Super Junior		VWIndustrie12 2		<b>1881 065 101</b>	KS180		
				<b>1864 634 016</b>	180E (23x29-10N)		
				<b>3100 700 101</b> ◊ 3151 021 001 J 2x 3130 010 200	KTI-1		

Tucano							
320	01.07-	3126B, C6.6, , MBOM502L A, 906/926		<b>1866 000 150</b>	352/ 232NGT	max. übertragbares Motormoment [Nm] / max. transmittable engine torque [Nm]: 2030	(62)
330	01.07-						
340	01.07-						
430	01.07-						
440	01.07-						
450	01.07-	C9, C13, C10		<b>1866 000 108</b>	435/ 232GT	max. übertragbares Motormoment [Nm] / max. transmittable engine torque [Nm]: 3415	(62)
470	01.09-						
480	01.09-						

Xerion							
2500				<b>1864 501 001 #</b>	350Z (46x50-24N)	für Frontzapfwelle / for front PTO	(54)
3000							

## CLARK

BCE							
BCE 20				<b>1864 634 025</b>	250Z (1 1/8"-10N)		



DCE							
DCE 2024				<b>1864 634 025</b>	250Z (1 1/8"-10N)		

DF							
DF 20				<b>1864 634 025</b>	250Z (1 1/8"-10N)		







## COUNTY

COUNTY							
654				<b>3482 600 119</b>	MF330		
754							
854							
944							





## COUNTY





COUNTY							
1454				<b>3482 600 105</b>	MF330		
1494				<b>1878 600 519</b>	327CB (1 3/4"-10N)		
				<b>1863 600 118</b>	63,5/100,2/22	mit Anlauftring / with thrust ring	(63)









## CREDE

DFG							
1000				<b>1880 071 011</b>	K225		
1500				<b>1864 634 026</b>	225Z (26x32-10N)		
2000							
2511							
2700							
2500				<b>1880 071 011</b>	K225		
				<b>1864 634 026</b>	225Z (26x32-10N)		
				<b>1882 172 101</b>	G250	Nur bei Altteil-Rückgabe lieferbar (Reparatur; Werk Bielefeld) / Please return old unit for repair (plant Bielefeld)	(33)
				<b>1864 202 035 #</b>	250Z (26x32-10N)		
				<b>1863 100 030</b>	55/90,5/25	mit Anlauftring / with thrust ring	(63)

## DEUTZ-FAHR



1,2 ..							
1 DA				<b>1882 196 005</b>	KS200		
2 DA				<b>1864 634 039</b>	200Z (23x29-10N)		
2 DN				<b>1859 600 001</b>			
				<b>1805 042 000</b>			

A ..							
A2 L 514				<b>1881 010 101 #</b>	G250		
				<b>1864 202 035 #</b>	250Z (26x32-10N)		
A2 M 313				<b>1880 071 008</b>	K225		
				<b>1864 634 024</b>	225Z (1 1/4"-10N)		



AGROCOMPACT							
3.30 F,V				<b>1888 867 045 #</b>	DUT280/ CERAM (280/36x40-20N)	enthält eine Kupplungsscheibe / This part number includes one clutch disc	(45)
3.50 F,S,V				<b>1888 915 001 ●#</b>	DUT280 (280/36x40-20N)	enthält eine Kupplungsscheibe / This part number includes one clutch disc	(45)
				<b>1864 421 141 ▽#</b>	250 (28x32-17N)	Lose Kupplungsscheibe / Loose clutch disc	(30)
				<b>1863 837 000</b>	55/91,6/16,3	mit Anlauftring / with thrust ring	(63)
				<b>1863 838 000</b>	70/110/20	ohne Anlauftring / without thrust ring	(79)
3.70 F,V				<b>1888 867 045 #</b>	DUT280/ CERAM (280/36x40-20N)	enthält eine Kupplungsscheibe / This part number includes one clutch disc	(45)
3.90 F,V				<b>1864 421 141 ▽#</b>	250 (28x32-17N)	Lose Kupplungsscheibe / Loose clutch disc	(30)
				<b>1863 838 000</b>	70/110/20	ohne Anlauftring / without thrust ring	(79)
				<b>1863 837 000</b>	55/91,6/16,3	mit Anlauftring / with thrust ring	(63)

# DEUTZ-FAHR



## AGROCOMPACT

<b>70F3</b>				<b>1878 600 577</b>	280CB (36x40-24N)		
				<b>1863 100 030</b>	55/90,5/25	mit Anlauftring / with thrust ring	(63)
<b>70F4</b>				<b>1863 100 030</b>	55/90,5/25	mit Anlauftring / with thrust ring	(63)
<b>F80</b>							
<b>F90</b>							



## AGROKID

Agrokid 25 Agrokid 35 Agrokid 45	01.96- 01.96- 01.98-			<b>1888 600 129</b>	DUT225/ 225	enthält eine Kupplungsscheibe / This part number includes one clutch disc	(45)
				<b>1864 600 333</b> ▽	225 (17x20-12N)	Lose Kupplungsscheibe / Loose clutch disc	(30)
				<b>1863 869 018</b>	15/35/11		





## AGROLUX

<b>F60</b> <b>60</b>				<b>1878 600 577</b>	280CB (36x40-24N)		
				<b>1863 100 030</b>	55/90,5/25	mit Anlauftring / with thrust ring	(63)
<b>F70</b> <b>F80</b> <b>70</b>				<b>1863 100 030</b>	55/90,5/25	mit Anlauftring / with thrust ring	(63)

## AGROPLUS

<b>60</b>				<b>1878 600 577</b>	280CB (36x40-24N)		
				<b>1863 100 030</b>	55/90,5/25	mit Anlauftring / with thrust ring	(63)
<b>70</b> <b>80</b>				<b>1863 100 030</b>	55/90,5/25	mit Anlauftring / with thrust ring	(63)

## AGROPRIMA









<b>3.65</b>				<b>1888 867 045 #</b>	DUT280/ CERAM (280/36x40-20N)	enthält eine Kupplungsscheibe / This part number includes one clutch disc	(45)
				<b>1864 421 141</b> ▽#	250 (28x32-17N)	Lose Kupplungsscheibe / Loose clutch disc	(30)
				<b>1863 838 000</b>	70/110/20	ohne Anlauftring / without thrust ring	(79)
				<b>1863 837 000</b>	55/91,6/16,3	mit Anlauftring / with thrust ring	(63)
<b>4.31</b> <b>4.51</b> <b>4.56</b> <b>6.06</b> <b>6.07</b> <b>6.16</b>	01.89 - 12.95 01.89 - 12.95	BF4L913T		<b>1888 052 034 #</b>	DUT310/ CERAM (310/41x45-21N)	enthält eine Kupplungsscheibe / This part number includes one clutch disc	(45)
				<b>1864 451 041</b> ▽#	280/ 58 (31x35-16N)	Lose Kupplungsscheibe / Loose clutch disc	(30)
				<b>1863 600 119</b>	65/97/23	mit Anlauftring / with thrust ring	(63)
				<b>1863 855 000</b>	106/140/25	mit Anlauftring / with thrust ring	(63)
				<b>1863 869 023</b>	20/52/15		

## AGROSTAR

<b>4.61</b> <b>4.71</b>				<b>3482 925 001 #</b>	MF310	ohne Powermatic / without Powermatic	(81)
				<b>1861 990 001 #</b>	310GSPEC (41x45-21N)	Anzahl der Beläge / Number of pads: 8 ohne Powermatic / without Powermatic	(7) (81)
				<b>1863 600 119</b>	65/97/23	mit Anlauftring / with thrust ring	(63)
				<b>3482 998 401 #</b>	GMF330	mit Powermatic / with Powermatic	(66)
				<b>1878 987 502 #</b>	327GSDC (44x48-22N)	Anzahl der Beläge / Number of pads: 6 mit Powermatic / with Powermatic	(7) (66)
				<b>1863 600 119</b>	65/97/23	mit Anlauftring / with thrust ring	(63)

# DEUTZ-FAHR







## AGROSTAR

4.68				3482 998 401 #	GMF330		
4.78				1878 987 501 #	327GSDC (41x45-21N)	Anzahl der Beläge / Number of pads: 6 ohne Powermatic / without Powermatic	(7) (81)
6.08				1878 987 502 #	327GSDC (44x48-22N)	Anzahl der Beläge / Number of pads: 6 mit Powermatic / with Powermatic	(7) (66)
6.11				1863 600 119	65/97/23	mit Anlauftring / with thrust ring	(63)
6.21				3400 016 101 # 		Nabenprofil / Hub Profile: 2x310/44x48-22N mit Powermatic / with Powermatic	(31) (66)
6.28				3400 017 001 # 		Nabenprofil / Hub Profile: 2x310/41x45-21N ohne Powermatic / without Powermatic	(31) (81)
6.31				1863 855 000	106/140/25	mit Anlauftring / with thrust ring	(63)
6.38							





## AGROSUN

100	01.95-	BF6L913T		3400 700 458 			
120	01.95-						
140	01.95-						

## AGROTRON









4.70				3482 600 101	MF330	Getr. / GBox: Synchrosplit	
4.80				1878 600 515	327GSDC (41x45-21N)	Getr. / GBox: Synchrosplit Anzahl der Beläge / Number of pads: 5	(7)
4.85				1863 837 002	65/97/23	Getr. / GBox: Synchrosplit mit Anlauftring / with thrust ring	(63)
4.90							
4.95							
6.00							
6.05							
6.15							
6.20							
80							
85							
90							
100							
106							
110							
120	01.95-			3482 600 101	MF330		
				1878 600 515	327GSDC (41x45-21N)	Anzahl der Beläge / Number of pads: 5	(7)
				1863 837 002	65/97/23	mit Anlauftring / with thrust ring	(63)
120 MK3	01.00 - 12.03			1863 869 023	20/52/15		
135 MK3	01.00 - 12.03						
150 MK3	01.00 - 12.03						
165 MK3	01.00 - 12.03						
175 MK3	01.00 - 12.03						
TTV 1130							
TTV 1145							
TTV 1160							

## AGROXTRA























3.57	01.92-			1888 915 001 #	DUT280 (280/36x40-20N)	enthält eine Kupplungsscheibe / This part number includes one clutch disc	(45)
4.07	01.92-			1864 421 141 ∇#	250 (28x32-17N)		
				1863 839 000	75/115/20	ohne Anlauftring / without thrust ring	(79)
				1863 869 023	20/52/15		

# DEUTZ-FAHR





























**AGROXTRA**

4.17	01.91 -			<b>1888 867 045 #</b>	DUT280/ CERAM (280/36x40-20N)	enthält eine Kupplungsscheibe / This part number includes one clutch disc	(45)
				<b>1864 926 042 ▽#</b>	280 (28x32-17N)	Lose Kupplungsscheibe / Loose clutch disc	(30)
				<b>1863 839 000</b>	75/115/20	ohne Anlauftring / without thrust ring	(79)
				<b>1863 869 023</b>	20/52/15		
4.47 4.57 6.07 6.17	01.93 - 01.91 - 01.92 - 01.92 -			<b>1888 052 034 #</b>	DUT310/ CERAM (310/41x45-21N)	enthält eine Kupplungsscheibe / This part number includes one clutch disc	(45)
				<b>1864 451 041 ▽#</b>	280/ 58 (31x35-16N)	Lose Kupplungsscheibe / Loose clutch disc	(30)
				<b>1863 600 119</b>	65/97/23	mit Anlauftring / with thrust ring	(63)
				<b>1863 855 000</b>	106/140/25	mit Anlauftring / with thrust ring	(63)
				<b>1863 869 023</b>	20/52/15		































**D ..**

D 12 N D 17 N D 22 P D 25 1S D 90 ,H D 130 ,H D 131 ,H D 160 H D 180 H D 181				<b>1882 196 005</b>	KS200		
				<b>1864 634 039</b>	200Z (23x29-10N)		
				<b>1859 600 001</b>			
				<b>1805 042 000</b>			
D 15				<b>1881 044 001</b>	KF180	Nur bei Alteil-Rückgabe lieferbar (Reparatur; Werk Bielefeld) / Please return old unit for repair (plant Bielefeld)	(33)
				<b>1864 634 040</b>	180E (23x29-10N)		
				<b>1859 600 002</b>			
				<b>1805 041 200</b>			
				<b>1882 196 005</b>	KS200		
				<b>1864 634 039</b>	200Z (23x29-10N)		
				<b>1859 600 001</b>			
D 25				<b>1880 071 011</b>	K225		
				<b>1864 634 024</b>	225Z (1 1/4"-10N)		
				<b>1881 089 002</b>	K225		
				<b>1864 634 024</b>	225Z (1 1/4"-10N)		
				<b>1859 600 001</b>			
				<b>1805 042 000</b>			
D 25 ,1,D,S				<b>1882 196 005</b>	KS200		
				<b>1864 634 030</b>	200Z (26x32-10N)		
				<b>1859 600 006</b>			
				<b>1805 042 000</b>			
D 25 (28PS) D 30 (28PS)	- 01.65 - 01.65			<b>1882 148 105 #</b>	DO200 (Ge 200/26x32-10N) (Mo 200/21x26-10N)	enthält zwei Kupplungsscheiben / This part number includes both clutch discs Nur bei Alteil-Rückgabe lieferbar (Reparatur; Werk Bielefeld) / Please return old unit for repair (plant Bielefeld)	(46) (33)

# DEUTZ-FAHR















D ..							
D 25 ,2 (20PS) D 30 (28PS)				1881 059 208	KS200		
				1864 153 133	200Z (21x26-10N)		
				1863 837 000	55/91,6/16,3	mit Anlauftring / with thrust ring	(63)
D 28				1881 009 203 #	G250	<b>Chass. 20001-&gt;</b>	
				1864 202 035 #	250Z (26x32-10N)	<b>Chass. 20001-&gt;</b>	
				1859 600 001		<b>Chass. 20001-&gt;</b>	
				1805 042 000		<b>Chass. 20001-&gt;</b>	
D 28 U D 30 L				1881 009 203 #	G250		
				1864 202 035 #	250Z (26x32-10N)		
				1859 600 001			
				1805 042 000			
D 40 (38PS)				1881 009 201 #	G250		
				1864 202 035 #	250Z (26x32-10N)		
D 40 ,1S D 50 ,1S D 55				1863 010 100	60/96,6/26	mit Anlauftring / with thrust ring	(63)
D 40 ,2 D 40 L (35PS)				1882 160 104 #	DO225 (Ge 225/32x40-10N) (Mo 225/26x32-10N)	enthält zwei Kupplungsscheiben / This part number includes both clutch discs	(46)
				1863 837 001	50/82/17,2	mit Anlauftring / with thrust ring	(63)
D 40 UF		F3L712		1863 010 100	60/96,6/26	mit Anlauftring / with thrust ring	(63)
D 45 L D 400 ,A,B,C				1880 083 132 #	G280		
D 66 D 88				1882 315 003	KS180		
				1864 261 005 #	180E (23x29-10N)		
				1859 600 002			
				1805 041 200			
D 133 N,T D 177 N,T				1882 108 204 #	DO225 (Mo 225/23x29-10N) (Ge 200/46x50-8N)	enthält zwei Kupplungsscheiben / This part number includes both clutch discs	(46)
				3151 000 395			
D 270				1881 010 139 #	G250		
				1864 202 004 #	250Z (23x29-10N)		
				1863 010 100	60/96,6/26	mit Anlauftring / with thrust ring	(63)
D 270 H				1881 050 428 #	DO250 (Mo 250/23x29-10N) (Ge 225/46x50-8N)	enthält zwei Kupplungsscheiben / This part number includes both clutch discs Nur bei Altteil-Rückgabe lieferbar (Reparatur; Werk Bielefeld) / Please return old unit for repair (plant Bielefeld)	(46) (33)
				1863 101 100 ▲	65/101,5/26	mit Anlauftring / with thrust ring	(63)

# DEUTZ-FAHR













D 2000 - D 4...							
D 2505 D 2506 D 3005				<b>1881 059 208</b>	KS200		
				<b>1864 153 133</b>	200Z (21x26-10N)		
				<b>1863 840 000</b>	50/82/23	mit Anlauftring / with thrust ring	(63)
				<b>1882 148 105 #</b>	DO200 (Ge 200/26x32-10N) (Mo 200/21x26-10N)	enthält zwei Kupplungsscheiben / This part number includes both clutch discs Nur bei Altteil-Rückgabe lieferbar (Reparatur; Werk Bielefeld) / Please return old unit for repair (plant Bielefeld)	(46) (33)
				<b>1863 837 000</b>	55/91,6/16,3	mit Anlauftring / with thrust ring	(63)
D 2807 F D 3607 F				<b>1888 874 001 #</b>	DOT225 (225/40x36-20N)	enthält eine Kupplungsscheibe / This part number includes one clutch disc	(45)
				<b>1864 922 001 ∇#</b>	225 (32x28-17N)	Lose Kupplungsscheibe / Loose clutch disc	(30)
				<b>1863 837 001</b>	50/82/17,2	mit Anlauftring / with thrust ring	(63)
				<b>1863 869 018</b>	15/35/11		
D 3006 D 4006				<b>1882 160 104 #</b>	DO225 (Ge 225/32x40-10N) (Mo 225/26x32-10N)	Nur einbauen wenn SACHS-Kupplung eingebaut war / install only if SACHS CLUTCH has been installed enthält zwei Kupplungsscheiben / This part number includes both clutch discs	(34) (46)
				<b>1863 837 001</b>	50/82/17,2	mit Anlauftring / with thrust ring	(63)
D 3006 F D 4006 F D 4007 F D 4506 F	- 12.68			<b>1888 874 001 #</b>	DOT225 (225/40x36-20N)	enthält eine Kupplungsscheibe / This part number includes one clutch disc	(45)
				<b>1864 922 001 ∇#</b>	225 (32x28-17N)	Lose Kupplungsscheibe / Loose clutch disc	(30)
				<b>1863 837 001</b>	50/82/17,2	mit Anlauftring / with thrust ring	(63)
D 3007				<b>1881 010 139 #</b>	G250		
				<b>1864 202 035 #</b>	250Z (26x32-10N)		
D 3607				<b>1881 010 139 #</b>	G250		
				<b>1864 202 035 #</b>	250Z (26x32-10N)		
				<b>1863 869 018</b>	15/35/11		
D 3607 U				<b>1888 900 001 #</b>	DUT225 (225/40x36-20N)	enthält eine Kupplungsscheibe / This part number includes one clutch disc	(45)
				<b>1864 922 001 ∇#</b>	225 (32x28-17N)	Lose Kupplungsscheibe / Loose clutch disc	(30)
				<b>1863 837 000</b>	55/91,6/16,3	mit Anlauftring / with thrust ring	(63)
				<b>1863 838 000</b>	70/110/20	ohne Anlauftring / without thrust ring	(79)
				<b>1863 869 018</b>	15/35/11		
D 4005	- 12.68			<b>1882 160 104 #</b>	DO225 (Ge 225/32x40-10N) (Mo 225/26x32-10N)	enthält zwei Kupplungsscheiben / This part number includes both clutch discs	(46)
				<b>1863 837 001</b>	50/82/17,2	mit Anlauftring / with thrust ring	(63)
D 4006 U D 4007 U D 4506 S,U				<b>1888 900 001 #</b>	DUT225 (225/40x36-20N)	enthält eine Kupplungsscheibe / This part number includes one clutch disc	(45)
				<b>1864 922 001 ∇#</b>	225 (32x28-17N)	Lose Kupplungsscheibe / Loose clutch disc	(30)
				<b>1863 838 000</b>	70/110/20	ohne Anlauftring / without thrust ring	(79)
				<b>1863 837 000</b>	55/91,6/16,3	mit Anlauftring / with thrust ring	(63)

# DEUTZ-FAHR

## D 2000 - D 4...

D 4507 ,A,C D 4807 ,A,C				<b>1888 900 001 #</b>	DUT225 (225/40x36-20N)	->Chass. 7548/7814 enthält eine Kupplungsscheibe / This part number includes one clutch disc	(45)
				<b>1864 922 001 ▽#</b>	225 (32x28-17N)	->Chass. 7548/7814 Lose Kupplungsscheibe / Loose clutch disc	(30)
				<b>1863 837 000</b>	55/91,6/16,3	mit Anlauftring / with thrust ring	(63)
				<b>1863 838 000</b>	70/110/20	ohne Anlauftring / without thrust ring	(79)
				<b>1888 057 042 #</b>	DUT295-250/ 280 (280/36x40-20N)	Chass. 7548/7815-> enthält eine Kupplungsscheibe / This part number includes one clutch disc	(45)
				<b>1888 915 001 ●#</b>	DUT280 (280/36x40-20N)	Chass. 7548/7815-> enthält eine Kupplungsscheibe / This part number includes one clutch disc	(45)
				<b>1864 421 141 ▽#</b>	250 (28x32-17N)	Chass. 7548/7815-> Lose Kupplungsscheibe / Loose clutch disc	(30)
				<b>1863 837 000</b>	55/91,6/16,3	mit Anlauftring / with thrust ring	(63)
				<b>1863 838 000</b>	70/110/20	ohne Anlauftring / without thrust ring	(79)
D 4507 F D 4807 F				<b>1888 874 001 #</b>	DOT225 (225/40x36-20N)	->Chass. 7548/7814 enthält eine Kupplungsscheibe / This part number includes one clutch disc	(45)
				<b>1864 922 001 ▽#</b>	225 (32x28-17N)	->Chass. 7548/7814 Lose Kupplungsscheibe / Loose clutch disc	(30)
				<b>1863 837 001</b>	50/82/17,2	->Chass. 7548/7814 mit Anlauftring / with thrust ring	(63)
				<b>1888 884 001 #</b>	DOT280/ 228 (280/36x40-20N)	Chass. 7548/7815-> enthält eine Kupplungsscheibe / This part number includes one clutch disc	(45)
				<b>1863 837 000</b>	55/91,6/16,3	Chass. 7548/7815-> mit Anlauftring / with thrust ring	(63)

## D 5000 - D 6...

D 5006 F D 5206 F D 5207 F D 5506 F D 6007 F D 6206 F D 6207 F D 6507 F				<b>1888 884 001 #</b>	DOT280/ 228 (280/36x40-20N)	enthält eine Kupplungsscheibe / This part number includes one clutch disc	(45)
				<b>1863 837 000</b>	55/91,6/16,3	mit Anlauftring / with thrust ring	(63)
D 5006 U D 5206 U D 5207 U D 5506 U				<b>1888 057 042 #</b>	DUT295-250/ 280 (280/36x40-20N)	enthält eine Kupplungsscheibe / This part number includes one clutch disc	(45)
				<b>1888 915 001 ●#</b>	DUT280 (280/36x40-20N)	enthält eine Kupplungsscheibe / This part number includes one clutch disc	(45)
				<b>1864 421 141 ▽#</b>	250 (28x32-17N)	Lose Kupplungsscheibe / Loose clutch disc	(30)
				<b>1863 837 000</b>	55/91,6/16,3	mit Anlauftring / with thrust ring	(63)
D 5505 F				<b>1863 838 000</b>	70/110/20	ohne Anlauftring / without thrust ring	(79)
				<b>1863 010 100</b>	60/96,6/26	mit Anlauftring / with thrust ring	(63)
D 6006				<b>3082 121 031</b>	M228	für Frontzapfwelle / for front PTO	(54)
				<b>1864 634 010</b>	225C (27x30-16N)	für Frontzapfwelle / for front PTO Anzahl der Beläge / Number of pads: 4	(54) (7)
				<b>3100 700 101</b> ◊ 3151 021 001 ↓ 2x 3130 010 200	KTI-1	für Frontzapfwelle / for front PTO	(54)
D 6006 F				<b>1864 305 131 ▽#</b>	250 (26x32-10N)	Lose Kupplungsscheibe / Loose clutch disc	(30)
				<b>1863 837 002</b>	65/97/23	mit Anlauftring / with thrust ring	(63)





Parameter





# DEUTZ-FAHR

## D 5000 - D 6...

D 6006, U D 6806 U D 6807 ,A,C	- 01.82 - 01.82		☉	1888 026 102 #	DUT295 (295/36x42-8N)	enthält eine Kupplungsscheibe / This part number includes one clutch disc	(45)
			☉	1864 305 131 ▽#	250 (26x32-10N)	Lose Kupplungsscheibe / Loose clutch disc	(30)
			⊙	1863 100 030	55/90,5/25	mit Anlauftring / with thrust ring	(63)
			⊙	1863 838 000	70/110/20	ohne Anlauftring / without thrust ring	(79)
			☉	1863 869 023	20/52/15		
D 6007 ,A D 6206 U D 6207 ,A D 6507 ,A D 6907 ,C			☉	1888 867 045 #	DUT280/ CERAM (280/36x40-20N)	enthält eine Kupplungsscheibe / This part number includes one clutch disc	(45)
			☉	1864 926 042 ▽#	280 (28x32-17N)	Lose Kupplungsscheibe / Loose clutch disc	(30)
			⊙	1863 838 000	70/110/20	ohne Anlauftring / without thrust ring	(79)
			⊙	1863 837 000	55/91,6/16,3	mit Anlauftring / with thrust ring	(63)
			☉	1864 305 131 ▽#	250 (26x32-10N)	Lose Kupplungsscheibe / Loose clutch disc	(30)
D 6806 F D 6807			⊙	1863 837 002	65/97/23	Eventuell muss Distanzbüchse, KHD Nr. 0430 8044 mit verbaut werden / It may be necessary to install spacing sleeve KHD no. 0430 8044 mit Anlauftring / with thrust ring	(15) (63)
			☉	1888 889 001 #	DUT310/ 280 (310/36x42-8N)	enthält eine Kupplungsscheibe / This part number includes one clutch disc	(45)
D 6806 U D 6807 ,A,C,CA	02.82- 02.82-		☉	1864 926 004 ▽#	280 (26x32-10N)	Lose Kupplungsscheibe / Loose clutch disc	(30)
			⊙	1863 838 000	70/110/20	ohne Anlauftring / without thrust ring	(79)
			⊙	1863 100 030	55/90,5/25	mit Anlauftring / with thrust ring	(63)
			☉	1888 889 001 #	DUT310/ 280 (310/36x42-8N)	enthält eine Kupplungsscheibe / This part number includes one clutch disc	(45)



## D 7000 - D 8...



D 7006			☉	3082 121 031	M228	für Frontzapfwelle / for front PTO	(54)
			☉	1864 634 010	225C (27x30-16N)	für Frontzapfwelle / for front PTO Anzahl der Beläge / Number of pads: 4	(54) (7)
			⊙	3100 700 101 ⊙ 3151 021 001 ↓ 2x 3130 010 200	KTI-1	für Frontzapfwelle / for front PTO	(54)
D 7006 F D 7007 D 7206 F D 7207 D 7807 F			☉	1864 305 131 ▽#	250 (26x32-10N)	Lose Kupplungsscheibe / Loose clutch disc	(30)
			⊙	1863 837 002	65/97/23	Eventuell muss Distanzbüchse, KHD Nr. 0430 8044 mit verbaut werden / It may be necessary to install spacing sleeve KHD no. 0430 8044 mit Anlauftring / with thrust ring	(15) (63)
D 7006 U D 7007 ,A D 7206 ,A,U D 7207 ,A,C D 7807 ,A,C	- 01.82 - 01.82 - 01.82 - 01.82 - 01.82		☉	1888 026 102 #	DUT295 (295/36x42-8N)	enthält eine Kupplungsscheibe / This part number includes one clutch disc	(45)
			☉	1864 305 131 ▽#	250 (26x32-10N)	Lose Kupplungsscheibe / Loose clutch disc	(30)
			⊙	1863 838 000	70/110/20	ohne Anlauftring / without thrust ring	(79)
			⊙	1863 100 030	55/90,5/25	mit Anlauftring / with thrust ring	(63)
D 7006 U D 7007 ,A,C,CA D 7206 A,U D 7207 ,A,C D 7807 ,A,C,CA	02.82- 02.82- 02.82- 02.82- 02.82-		☉	1888 889 001 #	DUT310/ 280 (310/36x42-8N)	enthält eine Kupplungsscheibe / This part number includes one clutch disc	(45)
			☉	1864 926 004 ▽#	280 (26x32-10N)	Lose Kupplungsscheibe / Loose clutch disc	(30)
			⊙	1863 838 000	70/110/20	ohne Anlauftring / without thrust ring	(79)
			⊙	1863 100 030	55/90,5/25	mit Anlauftring / with thrust ring	(63)
D 7505 F D 7506			☉	1888 046 041 #	DOT327H-310 (295/44x48-23N)	enthält eine Kupplungsscheibe / This part number includes one clutch disc	(45)
			⊙	1863 837 002	65/97/23	Eventuell muss Distanzbüchse, KHD Nr. 0430 8044 mit verbaut werden / It may be necessary to install spacing sleeve KHD no. 0430 8044 mit Anlauftring / with thrust ring	(15) (63)
D 7505 U D 7506 U			⊙	1863 839 000	75/115/20	ohne Anlauftring / without thrust ring	(79)
			⊙	1863 837 002	65/97/23	Eventuell muss Distanzbüchse, KHD Nr. 0430 8044 mit verbaut werden / It may be necessary to install spacing sleeve KHD no. 0430 8044 mit Anlauftring / with thrust ring	(15) (63)
D 8006 F			☉	1888 046 041 #	DOT327H-310 (295/44x48-23N)	enthält eine Kupplungsscheibe / This part number includes one clutch disc	(45)
			⊙	1863 837 002	65/97/23	mit Anlauftring / with thrust ring	(63)

					Parameter		
---	--	--	--	--	-----------	---	---

# DEUTZ-FAHR



D 7000 - D 8...							
D 8006 U				1863 839 000	75/115/20	ohne Anlauftring / without thrust ring	(79)
				1863 837 002	65/97/23	mit Anlauftring / with thrust ring	(63)













D 9000 - D 13..								
D 9005 F				1888 046 041 #	DOT327H-310 (295/44x48-23N)	enthält eine Kupplungsscheibe / This part number includes one clutch disc	(45)	
D 9006 F					1863 837 002	65/97/23	mit Anlauftring / with thrust ring	(63)
D 10006 F				1863 839 000	75/115/20	ohne Anlauftring / without thrust ring	(79)	
D 9005 U				1863 837 000	55/91,6/16,3	mit Anlauftring / with thrust ring	(63)	
D 9006 U								
D 10006 U								
D 13006 U								

DK							
DK 75 B, BF				1881 039 532 #	G350KR		
DK 90				1882 325 134	G380		
DK 100 B							



















DL							
DL 75				1881 039 532 #	G350KR		

DR							
DR 120				1882 325 134	G380		

















DX 2...								
DX 2.30				1888 900 001 #	DUT225 (225/40x36-20N)	enthält eine Kupplungsscheibe / This part number includes one clutch disc	(45)	
DX 2.50					1864 922 001 ▽#	225 (32x28-17N)	Lose Kupplungsscheibe / Loose clutch disc	(30)
DX 2.70					1863 838 000	70/110/20	ohne Anlauftring / without thrust ring	(79)
				1863 837 000	55/91,6/16,3	mit Anlauftring / with thrust ring	(63)	

DX 3...								
DX 3.10				3082 121 031	M228	für Frontzapfwelle / for front PTO	(54)	
DX 3.30					1864 634 010	225C (27x30-16N)	für Frontzapfwelle / for front PTO Anzahl der Beläge / Number of pads: 4	(54) (7)
DX 3.50					3151 160 001		für Frontzapfwelle / for front PTO	(54)
DX 3.60								
DX 3.70								
DX 3.90								
DX 3.10 A,VA	01.84-			1888 057 042 #	DUT295-250/ 280 (280/36x40-20N)	enthält eine Kupplungsscheibe / This part number includes one clutch disc	(45)	
DX 3.30 A,FA,VA					1888 915 001 ●#	DUT280 (280/36x40-20N)	enthält eine Kupplungsscheibe / This part number includes one clutch disc	(45)
					1864 421 141 ▽#	250 (28x32-17N)	Lose Kupplungsscheibe / Loose clutch disc	(30)
					1863 837 000	55/91,6/16,3	mit Anlauftring / with thrust ring	(63)
					1863 838 000	70/110/20	ohne Anlauftring / without thrust ring	(79)
					1888 867 045 ●#	DUT280/ CERAM (280/36x40-20N)	enthält eine Kupplungsscheibe / This part number includes one clutch disc	(45)
					1864 926 042 ▽#	280 (28x32-17N)	Lose Kupplungsscheibe / Loose clutch disc	(30)
					1863 837 000	55/91,6/16,3	mit Anlauftring / with thrust ring	(63)
			1863 838 000	70/110/20	ohne Anlauftring / without thrust ring	(79)		





















# DEUTZ-FAHR

DX 3...						
DX 3.10 SC		1888 900 001 #	DUT225 (225/40x36-20N)	->Chass. 7724/0069 ->Chass. 7728/0026 enthält eine Kupplungsscheibe / This part number includes one clutch disc	(45)	
		1864 922 001 ▽#	225 (32x28-17N)	->Chass. 7724/0069 ->Chass. 7728/0026 Lose Kupplungsscheibe / Loose clutch disc	(30)	
		1863 838 000	70/110/20	ohne Anlauftring / without thrust ring	(79)	
		1863 837 000	55/91,6/16,3	mit Anlauftring / with thrust ring	(63)	
		1888 867 045 ●#	DUT280/ CERAM (280/36x40-20N)	Chass. 7724/0070-> Chass. 7728/0027-> enthält eine Kupplungsscheibe / This part number includes one clutch disc	(45)	
		1864 926 042 ▽#	280 (28x32-17N)	Chass. 7724/0070-> Chass. 7728/0027-> Lose Kupplungsscheibe / Loose clutch disc	(30)	
		1863 837 000	55/91,6/16,3	mit Anlauftring / with thrust ring	(63)	
		1863 838 000	70/110/20	ohne Anlauftring / without thrust ring	(79)	
		1888 057 042 #	DUT295-250/ 280 (280/36x40-20N)	Chass. 7724/0070 - Chass. 7724/3023 Chass. 7728/0027 - Chass. 7728/3010 enthält eine Kupplungsscheibe / This part number includes one clutch disc	(45)	
		1888 915 001 ●#	DUT280 (280/36x40-20N)	Chass. 7724/0070-> Chass. 7728/0027-> enthält eine Kupplungsscheibe / This part number includes one clutch disc	(45)	
		1864 421 141 ▽#	250 (28x32-17N)	Chass. 7724/0070-> Chass. 7728/0027-> Lose Kupplungsscheibe / Loose clutch disc	(30)	
		1863 837 000	55/91,6/16,3	mit Anlauftring / with thrust ring	(63)	
		1863 838 000	70/110/20	ohne Anlauftring / without thrust ring	(79)	
	DX 3.10 V		1888 867 045 ●#	DUT280/ CERAM (280/36x40-20N)	Chass. 7770/0306-> Chass. 7771/0306-> enthält eine Kupplungsscheibe / This part number includes one clutch disc	(45)
		1864 926 042 ▽#	280 (28x32-17N)	Chass. 7770/0306-> Chass. 7771/0306-> Lose Kupplungsscheibe / Loose clutch disc	(30)	
		1888 915 001 #	DUT280 (280/36x40-20N)	Chass. 7770/0306-> Chass. 7771/0306-> enthält eine Kupplungsscheibe / This part number includes one clutch disc	(45)	
		1864 421 141 ▽#	250 (28x32-17N)	Chass. 7770/0306-> Chass. 7771/0306-> Lose Kupplungsscheibe / Loose clutch disc	(30)	
		1863 837 000	55/91,6/16,3	mit Anlauftring / with thrust ring	(63)	
		1863 838 000	70/110/20	ohne Anlauftring / without thrust ring	(79)	





















# DEUTZ-FAHR

DX 3...							
DX 3.10 VC		1888 900 001 #	DUT225 (225/40x36-20N)	->Chass. 7722/0517 ->Chass. 7726/0191 enthält eine Kupplungsscheibe / This part number includes one clutch disc	(45)		
		1864 922 001 ▽#	225 (32x28-17N)	->Chass. 7722/0517 ->Chass. 7726/0191 Lose Kupplungsscheibe / Loose clutch disc	(30)		
		1888 867 045 ●#	DUT280/ CERAM (280/36x40-20N)	->Chass. 7722/0518 ->Chass. 7726/0192 enthält eine Kupplungsscheibe / This part number includes one clutch disc	(45)		
		1864 926 042 ▽#	280 (28x32-17N)	Chass. 7722/0518-> Chass. 7726/0192-> Lose Kupplungsscheibe / Loose clutch disc	(30)		
		1888 057 042 #	DUT295-250/ 280 (280/36x40-20N)	Chass. 7722/0518-> Chass. 7726/0192-> enthält eine Kupplungsscheibe / This part number includes one clutch disc	(45)		
		1888 915 001 ●#	DUT280 (280/36x40-20N)	Chass. 7722/0518-> Chass. 7726/0192-> enthält eine Kupplungsscheibe / This part number includes one clutch disc	(45)		
		1864 421 141 ▽#	250 (28x32-17N)	Chass. 7722/0518-> Chass. 7726/0192-> Lose Kupplungsscheibe / Loose clutch disc	(30)		
		1863 837 000	55/91,6/16,3	mit Anlauftring / with thrust ring	(63)		
	1863 838 000	70/110/20	ohne Anlauftring / without thrust ring	(79)			
DX 3.30 F,V		1888 867 045 ●#	DUT280/ CERAM (280/36x40-20N)	Chass. 7772/.... Chass. 7773/.... enthält eine Kupplungsscheibe / This part number includes one clutch disc	(45)		
		1864 926 042 ▽#	280 (28x32-17N)	Chass. 7772/.... Chass. 7773/.... Lose Kupplungsscheibe / Loose clutch disc	(30)		
		1888 057 042 #	DUT295-250/ 280 (280/36x40-20N)	->Chass. 7772/0304 ->Chass. 7773/0328 enthält eine Kupplungsscheibe / This part number includes one clutch disc	(45)		
		1888 915 001 ●#	DUT280 (280/36x40-20N)	Chass. 7772/.... Chass. 7773/.... enthält eine Kupplungsscheibe / This part number includes one clutch disc	(45)		
		1864 421 141 ▽#	250 (28x32-17N)	Chass. 7772/... Chass. 7773/.... Lose Kupplungsscheibe / Loose clutch disc	(30)		
		1863 837 000	55/91,6/16,3	mit Anlauftring / with thrust ring	(63)		
	1863 838 000	70/110/20	ohne Anlauftring / without thrust ring	(79)			





















# DEUTZ-FAHR

DX 3...							
<b>DX 3.10 V</b>	01.84-			<b>1888 867 045 ●#</b>	DUT280/ CERAM (280/36x40-20N)	->Chass. 7770/0305 ->Chass. 7771/0305 enthält eine Kupplungsscheibe / This part number includes one clutch disc	(45)
				<b>1864 926 042 ▽#</b>	280 (28x32-17N)	->Chass. 7770/0305 ->Chass. 7771/0305 Lose Kupplungsscheibe / Loose clutch disc	(30)
				<b>1888 057 042 #</b>	DUT295-250/ 280 (280/36x40-20N)	->Chass. 7771/0305 ->Chass. 7770/0305 enthält eine Kupplungsscheibe / This part number includes one clutch disc	(45)
				<b>1888 915 001 ●#</b>	DUT280 (280/36x40-20N)	->Chass. 7770/0305 ->Chass. 7771/0305 enthält eine Kupplungsscheibe / This part number includes one clutch disc	(45)
				<b>1864 421 141 ▽#</b>	250 (28x32-17N)	->Chass. 7771/0305 ->Chass. 7770/0305 Lose Kupplungsscheibe / Loose clutch disc	(30)
				<b>1863 837 000</b>	55/91,6/16,3	mit Anlauftring / with thrust ring	(63)
				<b>1863 838 000</b>	70/110/20	ohne Anlauftring / without thrust ring	(79)
<b>DX 3.30 SC</b>				<b>1888 867 045 ●#</b>	DUT280/ CERAM (280/36x40-20N)	<b>Chass. 7732/....</b> <b>Chass. 7736/....</b> enthält eine Kupplungsscheibe / This part number includes one clutch disc	(45)
				<b>1864 926 042 ▽#</b>	280 (28x32-17N)	<b>Chass. 7732/....</b> <b>Chass. 7736/....</b> Lose Kupplungsscheibe / Loose clutch disc	(30)
				<b>1888 057 042 #</b>	DUT295-250/ 280 (280/36x40-20N)	->Chass. 7732/3059 ->Chass. 7736/3060 enthält eine Kupplungsscheibe / This part number includes one clutch disc	(45)
				<b>1888 915 001 ●#</b>	DUT280 (280/36x40-20N)	<b>Chass. 7732/....</b> <b>Chass. 7736/....</b> enthält eine Kupplungsscheibe / This part number includes one clutch disc	(45)
				<b>1864 421 141 ▽#</b>	250 (28x32-17N)	<b>Chass. 7732/...</b> <b>Chass. 7736/....</b> Lose Kupplungsscheibe / Loose clutch disc	(30)
				<b>1863 837 000</b>	55/91,6/16,3	mit Anlauftring / with thrust ring	(63)
				<b>1863 838 000</b>	70/110/20	ohne Anlauftring / without thrust ring	(79)
<b>DX 3.30 VC</b>				<b>1888 867 045 ●#</b>	DUT280/ CERAM (280/36x40-20N)	<b>Chass. 7730/...</b> <b>Chass. 7734/...</b> enthält eine Kupplungsscheibe / This part number includes one clutch disc	(45)
				<b>1864 926 042 ▽#</b>	280 (28x32-17N)	<b>Chass. 7730/...</b> <b>Chass. 7734/...</b> Lose Kupplungsscheibe / Loose clutch disc	(30)
				<b>1888 057 042 #</b>	DUT295-250/ 280 (280/36x40-20N)	->Chass. 7730/3066 ->Chass. 7734/3103 enthält eine Kupplungsscheibe / This part number includes one clutch disc	(45)
				<b>1888 915 001 #</b>	DUT280 (280/36x40-20N)	<b>Chass. 7730/...</b> <b>Chass. 7734/...</b> enthält eine Kupplungsscheibe / This part number includes one clutch disc	(45)
				<b>1864 421 141 ▽#</b>	250 (28x32-17N)	<b>Chass. 7730/...</b> <b>Chass. 7734/....</b> Lose Kupplungsscheibe / Loose clutch disc	(30)
				<b>1863 837 000</b>	55/91,6/16,3	mit Anlauftring / with thrust ring	(63)
				<b>1863 838 000</b>	70/110/20	ohne Anlauftring / without thrust ring	(79)







# DEUTZ-FAHR

DX 3...							
DX 3.50 F,V		1888 867 045 ●#	DUT280/ CERAM (280/36x40-20N)	<b>Chass. 7774/....</b> <b>Chass. 7775/....</b> enthält eine Kupplungsscheibe / This part number includes one clutch disc	(45)		
		1864 926 042 ▽#	280 (28x32-17N)	<b>Chass. 7774/....</b> <b>Chass. 7775/....</b> Lose Kupplungsscheibe / Loose clutch disc	(30)		
		1888 057 042 #	DUT295-250/ 280 (280/36x40-20N)	<b>-&gt;Chass. 7775/0395</b> <b>-&gt;Chass. 7774/0353</b> enthält eine Kupplungsscheibe / This part number includes one clutch disc	(45)		
		1888 915 001 #	DUT280 (280/36x40-20N)	<b>Chass. 7774/....</b> <b>Chass. 7775/....</b> enthält eine Kupplungsscheibe / This part number includes one clutch disc	(45)		
		1864 421 141 ▽#	250 (28x32-17N)	<b>Chass. 7774/....</b> <b>Chass. 7775/....</b> Lose Kupplungsscheibe / Loose clutch disc	(30)		
		1863 837 000	55/91,6/16,3	mit Anlauftring / with thrust ring	(63)		
		1863 838 000	70/110/20	ohne Anlauftring / without thrust ring	(79)		
DX 3.50 S		1888 867 045 ●#	DUT280/ CERAM (280/36x40-20N)	<b>Chass. 7780/...</b> <b>Chass. 7781/...</b> enthält eine Kupplungsscheibe / This part number includes one clutch disc	(45)		
		1864 926 042 ▽#	280 (28x32-17N)	<b>Chass. 7780/....</b> <b>Chass. 7781/....</b> Lose Kupplungsscheibe / Loose clutch disc	(30)		
		1888 057 042 #	DUT295-250/ 280 (280/36x40-20N)	<b>-&gt;Chass. 7780/0008</b> <b>-&gt;Chass. 7781/0064</b> enthält eine Kupplungsscheibe / This part number includes one clutch disc	(45)		
		1888 915 001 ●#	DUT280 (280/36x40-20N)	<b>Chass. 7780/....</b> <b>Chass. 7781/....</b> enthält eine Kupplungsscheibe / This part number includes one clutch disc	(45)		
		1864 421 141 ▽#	250 (28x32-17N)	<b>Chass. 7780/....</b> <b>Chass. 7781/....</b> Lose Kupplungsscheibe / Loose clutch disc	(30)		
		1863 837 000	55/91,6/16,3	mit Anlauftring / with thrust ring	(63)		
		1863 838 000	70/110/20	ohne Anlauftring / without thrust ring	(79)		
DX 3.50 SC		1888 867 045 ●#	DUT280/ CERAM (280/36x40-20N)	<b>Chass. 7740/....</b> <b>Chass. 7744/....</b> enthält eine Kupplungsscheibe / This part number includes one clutch disc	(45)		
		1864 926 042 ▽#	280 (28x32-17N)	<b>Chass. 7740/....</b> <b>Chass. 7744/....</b> Lose Kupplungsscheibe / Loose clutch disc	(30)		
		1888 057 042 #	DUT295-250/ 280 (280/36x40-20N)	<b>-&gt;Chass. 7744/3352</b> <b>-&gt;Chass. 7740/3087</b> enthält eine Kupplungsscheibe / This part number includes one clutch disc	(45)		
		1888 915 001 ●#	DUT280 (280/36x40-20N)	<b>Chass. 7740/....</b> <b>Chass. 7744/....</b> enthält eine Kupplungsscheibe / This part number includes one clutch disc	(45)		
		1864 421 141 ▽#	250 (28x32-17N)	<b>Chass. 7740/....</b> <b>Chass. 7744/....</b> Lose Kupplungsscheibe / Loose clutch disc	(30)		
		1863 837 000	55/91,6/16,3	mit Anlauftring / with thrust ring	(63)		
		1863 838 000	70/110/20	ohne Anlauftring / without thrust ring	(79)		

# DEUTZ-FAHR

































DX 3...							
<b>DX 3.50 VC</b>				<b>1888 867 045 ●#</b>	DUT280/ CERAM (280/36x40-20N)	<b>Chass. 7738/....</b> <b>Chass. 7742/....</b> enthält eine Kupplungsscheibe / This part number includes one clutch disc	(45)
				<b>1864 926 042 ▽#</b>	280 (28x32-17N)	<b>Chass. 7738/....</b> <b>Chass. 7742/....</b> Lose Kupplungsscheibe / Loose clutch disc	(30)
				<b>1888 057 042 #</b>	DUT295-250/ 280 (280/36x40-20N)	<b>-&gt;Chass. 7738/3124</b> <b>-&gt;Chass. 7742/3138</b> enthält eine Kupplungsscheibe / This part number includes one clutch disc	(45)
				<b>1888 915 001 ●#</b>	DUT280 (280/36x40-20N)	<b>Chass. 7738/....</b> <b>Chass. 7742/....</b> enthält eine Kupplungsscheibe / This part number includes one clutch disc	(45)
				<b>1864 421 141 ▽#</b>	250 (28x32-17N)	<b>Chass. 7738/....</b> <b>Chass. 7742/....</b> Lose Kupplungsscheibe / Loose clutch disc	(30)
				<b>1863 837 000</b>	55/91,6/16,3	mit Anlauftring / with thrust ring	(63)
				<b>1863 838 000</b>	70/110/20	ohne Anlauftring / without thrust ring	(79)
<b>DX 3.60 SC</b>				<b>1888 867 045 ●#</b>	DUT280/ CERAM (280/36x40-20N)	<b>Chass. 7763/....</b> <b>Chass. 7765/....</b> enthält eine Kupplungsscheibe / This part number includes one clutch disc	(45)
				<b>1864 926 042 ▽#</b>	280 (28x32-17N)	<b>Chass. 7763/....</b> <b>Chass. 7765/....</b> Lose Kupplungsscheibe / Loose clutch disc	(30)
				<b>1888 057 042 #</b>	DUT295-250/ 280 (280/36x40-20N)	<b>-&gt;Chass. 7763/3491</b> <b>-&gt;Chass. 7765/3128</b> enthält eine Kupplungsscheibe / This part number includes one clutch disc	(45)
				<b>1888 915 001 ●#</b>	DUT280 (280/36x40-20N)	<b>Chass. 7763/....</b> <b>Chass. 7765/....</b> enthält eine Kupplungsscheibe / This part number includes one clutch disc	(45)
				<b>1864 421 141 ▽#</b>	250 (28x32-17N)	<b>Chass. 7763/....</b> <b>Chass. 7765/....</b> Lose Kupplungsscheibe / Loose clutch disc	(30)
				<b>1863 837 000</b>	55/91,6/16,3	mit Anlauftring / with thrust ring	(63)
				<b>1863 838 000</b>	70/110/20	ohne Anlauftring / without thrust ring	(79)
<b>DX 3.60 VC</b>				<b>1888 867 045 ●#</b>	DUT280/ CERAM (280/36x40-20N)	<b>Chass. 7764/....</b> <b>Chass. 7766/....</b> enthält eine Kupplungsscheibe / This part number includes one clutch disc	(45)
				<b>1864 926 042 ▽#</b>	280 (28x32-17N)	<b>Chass. 7764/....</b> <b>Chass. 7766/....</b> Lose Kupplungsscheibe / Loose clutch disc	(30)
				<b>1888 057 042 #</b>	DUT295-250/ 280 (280/36x40-20N)	<b>-&gt;Chass. 7764/3075</b> <b>-&gt;Chass. 7766/3106</b> enthält eine Kupplungsscheibe / This part number includes one clutch disc	(45)
				<b>1888 915 001 #</b>	DUT280 (280/36x40-20N)	<b>Chass. 7764/....</b> <b>Chass. 7766/....</b> enthält eine Kupplungsscheibe / This part number includes one clutch disc	(45)
				<b>1864 421 141 ▽#</b>	250 (28x32-17N)	<b>Chass. 7764/....</b> <b>Chass. 7766/....</b> Lose Kupplungsscheibe / Loose clutch disc	(30)
				<b>1863 837 000</b>	55/91,6/16,3	mit Anlauftring / with thrust ring	(63)
				<b>1863 838 000</b>	70/110/20	ohne Anlauftring / without thrust ring	(79)

# DEUTZ-FAHR

DX 3...							
DX 3.65 SC				1888 867 046 #	DUT280 (280/36x40-20N)	->Chass. 7768/1122 enthält eine Kupplungsscheibe / This part number includes one clutch disc	(45)
				1888 867 045 #	DUT280/ CERAM (280/36x40-20N)	Chass. 7768/1123-> enthält eine Kupplungsscheibe / This part number includes one clutch disc	(45)
				1864 926 042 ▽#	280 (28x32-17N)	Lose Kupplungsscheibe / Loose clutch disc	(30)
				1863 837 000	55/91,6/16,3	mit Anlauftring / with thrust ring	(63)
				1863 838 000	70/110/20	ohne Anlauftring / without thrust ring	(79)
DX 3.65 VC				1888 867 046 #	DUT280 (280/36x40-20N)	->Chass. 7767/0028 enthält eine Kupplungsscheibe / This part number includes one clutch disc	(45)
				1888 867 045 #	DUT280/ CERAM (280/36x40-20N)	Chass. 7767/0029-> enthält eine Kupplungsscheibe / This part number includes one clutch disc	(45)
				1864 926 042 ▽#	280 (28x32-17N)	Lose Kupplungsscheibe / Loose clutch disc	(30)
				1863 837 000	55/91,6/16,3	mit Anlauftring / with thrust ring	(63)
				1863 838 000	70/110/20	ohne Anlauftring / without thrust ring	(79)
DX 3.70 SC,VC DX 3.90 SC,VC				1888 889 001 #	DUT310/ 280 (310/36x42-8N)	enthält eine Kupplungsscheibe / This part number includes one clutch disc	(45)
				1864 926 004 ▽#	280 (26x32-10N)	Lose Kupplungsscheibe / Loose clutch disc	(30)
				1863 838 000	70/110/20	ohne Anlauftring / without thrust ring	(79)
				1863 100 030	55/90,5/25	mit Anlauftring / with thrust ring	(63)
DX 3.70 V,F				1888 867 045 #	DUT280/ CERAM (280/36x40-20N)	Chass. 7776/.... Chass. 7777/.... enthält eine Kupplungsscheibe / This part number includes one clutch disc	(45)
				1864 926 042 ▽#	280 (28x32-17N)	Chass. 7776/.... Chass. 7777/.... Lose Kupplungsscheibe / Loose clutch disc	(30)
				1863 838 000	70/110/20	ohne Anlauftring / without thrust ring	(79)
				1863 837 000	55/91,6/16,3	mit Anlauftring / with thrust ring	(63)
DX 3.80	01.85-			1888 867 045 #	DUT280/ CERAM (280/36x40-20N)	enthält eine Kupplungsscheibe / This part number includes one clutch disc	(45)
				1864 926 042 ▽#	280 (28x32-17N)	Lose Kupplungsscheibe / Loose clutch disc	(30)
				1863 838 000	70/110/20	ohne Anlauftring / without thrust ring	(79)
				1863 837 000	55/91,6/16,3	mit Anlauftring / with thrust ring	(63)
DX 3.90 F				1888 867 045 #	DUT280/ CERAM (280/36x40-20N)	Chass. 7778/.... Chass. 7779/.... enthält eine Kupplungsscheibe / This part number includes one clutch disc	(45)
				1864 926 042 ▽#	280 (28x32-17N)	Chass. 7778/.... Chass. 7779/.... Lose Kupplungsscheibe / Loose clutch disc	(30)
				1863 838 000	70/110/20	ohne Anlauftring / without thrust ring	(79)
				1863 837 000	55/91,6/16,3	mit Anlauftring / with thrust ring	(63)
DX 3.90 S				1888 867 045 #	DUT280/ CERAM (280/36x40-20N)	Chass. 7782/.... Chass. 7783/.... enthält eine Kupplungsscheibe / This part number includes one clutch disc	(45)
				1864 926 042 ▽#	280 (28x32-17N)	Chass. 7782/.... Chass. 7783/.... Lose Kupplungsscheibe / Loose clutch disc	(30)
				1863 838 000	70/110/20	ohne Anlauftring / without thrust ring	(79)
				1863 837 000	55/91,6/16,3	mit Anlauftring / with thrust ring	(63)















# DEUTZ-FAHR













DX 4...						
<b>DX 4.10</b>		<b>1888 052 034 #</b>	DUT310/ CERAM (310/41x45-21N)	enthält eine Kupplungsscheibe / This part number includes one clutch disc	(45)	
		<b>1864 451 041 ▽#</b>	280/ 58 (31x35-16N)	Lose Kupplungsscheibe / Loose clutch disc	(30)	
		<b>1863 600 119</b>	65/97/23	mit Anlauftring / with thrust ring	(63)	
		<b>1863 855 000</b>	106/140/25	mit Anlauftring / with thrust ring	(63)	
		<b>3082 121 031</b>	M228	<b>-&gt;Chass. 7444/0148</b> für Frontzapfwelle / for front PTO	(54)	
		<b>1864 634 010</b>	225C (27x30-16N)	für Frontzapfwelle / for front PTO Anzahl der Beläge / Number of pads: 4	(54) (7)	
		<b>3100 700 101</b> ◊ 3151 021 001 ⌋ 2x 3130 010 200	KTI-1	<b>-&gt;Chass. 7444/0148</b> für Frontzapfwelle / for front PTO	(54)	
		<b>3151 160 001</b>		<b>Chass. 7444/0149-&gt;</b> für Frontzapfwelle / for front PTO	(54)	
<b>DX 4.10 A</b>		<b>3082 121 031</b>	M228	<b>-&gt;Chass. 7445/0554</b> für Frontzapfwelle / for front PTO	(54)	
		<b>1864 634 010</b>	225C (27x30-16N)	für Frontzapfwelle / for front PTO Anzahl der Beläge / Number of pads: 4	(54) (7)	
		<b>3100 700 101</b> ◊ 3151 021 001 ⌋ 2x 3130 010 200	KTI-1	<b>-&gt;Chass. 7445/0554</b> für Frontzapfwelle / for front PTO	(54)	
		<b>3151 160 001</b>		<b>Chass. 7445/0555-&gt;</b> für Frontzapfwelle / for front PTO	(54)	
<b>DX 4.17 Hopfen</b>		<b>1888 867 045 #</b>	DUT280/ CERAM (280/36x40-20N)	enthält eine Kupplungsscheibe / This part number includes one clutch disc	(45)	
		<b>1864 926 042 #</b>	280 (28x32-17N)			
		<b>1863 837 000</b>	55/91,6/16,3	mit Anlauftring / with thrust ring	(63)	
<b>DX 4.30</b> <b>DX 4.31 ,A</b> <b>DX 4.50</b> <b>DX 4.51 ,A</b> <b>DX 4.57 Hopfen</b> <b>DX 4.70</b>		<b>1888 052 034 #</b>	DUT310/ CERAM (310/41x45-21N)	enthält eine Kupplungsscheibe / This part number includes one clutch disc	(45)	
		<b>1864 451 041 ▽#</b>	280/ 58 (31x35-16N)	Lose Kupplungsscheibe / Loose clutch disc	(30)	
		<b>1863 855 000</b>	106/140/25	mit Anlauftring / with thrust ring	(63)	
		<b>1863 600 119</b>	65/97/23	mit Anlauftring / with thrust ring	(63)	
		<b>3082 121 031</b>	M228	<b>-&gt;Chass. 7430/0501</b> für Frontzapfwelle / for front PTO	(54)	
<b>DX 4.30</b>		<b>1864 634 010</b>	225C (27x30-16N)	für Frontzapfwelle / for front PTO Anzahl der Beläge / Number of pads: 4	(54) (7)	
		<b>3100 700 101</b> ◊ 3151 021 001 ⌋ 2x 3130 010 200	KTI-1	<b>-&gt;Chass. 7430/0501</b> für Frontzapfwelle / for front PTO	(54)	
		<b>3151 160 001</b>		<b>Chass. 7430/0502-&gt;</b> für Frontzapfwelle / for front PTO	(54)	
		<b>3082 121 031</b>	M228	<b>-&gt;Chass. 7431/1401</b> für Frontzapfwelle / for front PTO	(54)	
<b>DX 4.30 A</b>		<b>1864 634 010</b>	225C (27x30-16N)	für Frontzapfwelle / for front PTO Anzahl der Beläge / Number of pads: 4	(54) (7)	
		<b>3100 700 101</b> ◊ 3151 021 001 ⌋ 2x 3130 010 200	KTI-1	<b>-&gt;Chass. 7431/1401</b> für Frontzapfwelle / for front PTO	(54)	
		<b>3151 160 001</b>		<b>Chass. 7431/1402-&gt;</b> für Frontzapfwelle / for front PTO	(54)	
		<b>3082 121 031</b>	M228	<b>-&gt;Chass. 7432/0405</b> für Frontzapfwelle / for front PTO	(54)	
<b>DX 4.50</b>		<b>1864 634 010</b>	225C (27x30-16N)	für Frontzapfwelle / for front PTO Anzahl der Beläge / Number of pads: 4	(54) (7)	
		<b>3100 700 101</b> ◊ 3151 021 001 ⌋ 2x 3130 010 200	KTI-1	<b>-&gt;Chass. 7432/0405</b> für Frontzapfwelle / for front PTO	(54)	
		<b>3151 160 001</b>		<b>Chass. 7432/0406-&gt;</b> für Frontzapfwelle / for front PTO	(54)	
		<b>3082 121 031</b>	M228	<b>-&gt;Chass. 7432/0405</b> für Frontzapfwelle / for front PTO	(54)	

# DEUTZ-FAHR







## DX 4...

DX 4.50 A		3082 121 031	M228	->Chass. 7433/2556 für Frontzapfwelle / for front PTO	(54)
		1864 634 010	225C (27x30-16N)	für Frontzapfwelle / for front PTO Anzahl der Beläge / Number of pads: 4	(54) (7)
		3100 700 101 ◊ 3151 021 001 ⌋ 2x 3130 010 200	KTI-1	->Chass. 7433/2556 für Frontzapfwelle / for front PTO	(54)
		3151 160 001		Chass. 7433/2557-> für Frontzapfwelle / for front PTO	(54)
DX 4.70		3082 121 031	M228	->Chass. 7434/0635 für Frontzapfwelle / for front PTO	(54)
		1864 634 010	225C (27x30-16N)	für Frontzapfwelle / for front PTO Anzahl der Beläge / Number of pads: 4	(54) (7)
		3100 700 101 ◊ 3151 021 001 ⌋ 2x 3130 010 200	KTI-1	->Chass. 7434/0635 für Frontzapfwelle / for front PTO	(54)
		3151 160 001		Chass. 7434/0636-> für Frontzapfwelle / for front PTO	(54)
DX 4.70 A		3082 121 031	M228	->Chass. 7435/2541 für Frontzapfwelle / for front PTO	(54)
		1864 634 010	225C (27x30-16N)	für Frontzapfwelle / for front PTO Anzahl der Beläge / Number of pads: 4	(54) (7)
		3100 700 101 ◊ 3151 021 001 ⌋ 2x 3130 010 200	KTI-1	->Chass. 7435/2541 für Frontzapfwelle / for front PTO	(54)
		3151 160 001		Chass. 7435/2542-> für Frontzapfwelle / for front PTO	(54)



























## DX 5...

DX 5.10		1888 889 001 #	DUT310/ 280 (310/36x42-8N)	enthält eine Kupplungsscheibe / This part number includes one clutch disc	(45)
		1864 926 004 ▽#	280 (26x32-10N)	Lose Kupplungsscheibe / Loose clutch disc	(30)
		1863 100 030	55/90,5/25	mit Anlauftring / with thrust ring	(63)
		1863 838 000	70/110/20	ohne Anlauftring / without thrust ring	(79)
		1888 052 034 #	DUT310/ CERAM (310/41x45-21N)	enthält eine Kupplungsscheibe / This part number includes one clutch disc	(45)
		1864 451 041 ▽#	280/ 58 (31x35-16N)	Lose Kupplungsscheibe / Loose clutch disc	(30)
		1863 855 000	106/140/25	mit Anlauftring / with thrust ring	(63)
DX 5.30 DX 5.50 DX 5.70		1863 837 000	55/91,6/16,3	mit Anlauftring / with thrust ring	(63)
		1888 052 034 #	DUT310/ CERAM (310/41x45-21N)	enthält eine Kupplungsscheibe / This part number includes one clutch disc	(45)
		1864 451 041 ▽#	280/ 58 (31x35-16N)	Lose Kupplungsscheibe / Loose clutch disc	(30)
		1863 855 000	106/140/25	mit Anlauftring / with thrust ring	(63)
		1863 600 119	65/97/23	mit Anlauftring / with thrust ring	(63)









## DX 6...

DX 6.05		1888 052 034 #	DUT310/ CERAM (310/41x45-21N)	enthält eine Kupplungsscheibe / This part number includes one clutch disc	(45)
		1864 451 041 ▽#	280/ 58 (31x35-16N)	Lose Kupplungsscheibe / Loose clutch disc	(30)
		1863 600 119	65/97/23	mit Anlauftring / with thrust ring	(63)
		1863 855 000	106/140/25	mit Anlauftring / with thrust ring	(63)
		1864 634 010	225C (27x30-16N)	für Frontzapfwelle / for front PTO Anzahl der Beläge / Number of pads: 4	(54) (7)
		3100 700 101 ◊ 3151 021 001 ⌋ 2x 3130 010 200	KTI-1	für Frontzapfwelle / for front PTO	(54)

# DEUTZ-FAHR

DX 6...							
<b>DX 6.10</b>				<b>3400 016 101 #</b>		<b>Chass. 7436/3117-&gt;</b> <b>Chass. 7437/3790-&gt;</b> Nabenprofil / Hub Profile: 2x310/44x48-22N mit Powermatic / with Powermatic	(31) (66)
				<b>1863 855 000</b>	106/140/25	<b>Chass. 7436/3117-&gt;</b> <b>Chass. 7437/3790-&gt;</b> mit Anlauftring / with thrust ring	(63)
				<b>1888 052 034 #</b>	DUT310/ CERAM (310/41x45-21N)	enthält eine Kupplungsscheibe / This part number includes one clutch disc	(45)
				<b>1863 100 030</b>	55/90,5/25	mit Anlauftring / with thrust ring	(63)
				<b>1863 838 000</b>	70/110/20	ohne Anlauftring / without thrust ring	(79)
<b>DX 6.10</b> <b>DX 6.30</b> <b>DX 6.50</b>				<b>1864 411 031</b>	250CE (31x35-16N)	für Frontzapfwelle / for front PTO Nur bei Altteil-Rückgabe lieferbar (Reparatur; Werk Bielefeld) / Please return old unit for repair (plant Bielefeld)	(54) (33)
				<b>3151 160 001 ●</b>		für Frontzapfwelle / for front PTO	(54)
				<b>3100 700 101</b> ◊ 3151 021 001 ↓ 2x 3130 010 200	KTI-1	für Frontzapfwelle / for front PTO	(54)
<b>DX 6.30</b>				<b>3400 016 101 #</b>		<b>Chass. 7438/3227-&gt;</b> <b>Chass. 7439/3929-&gt;</b> Nabenprofil / Hub Profile: 2x310/44x48-22N mit Powermatic / with Powermatic	(31) (66)
				<b>1863 855 000</b>	106/140/25	<b>Chass. 7438/3227-&gt;</b> <b>Chass. 7439/3929-&gt;</b> mit Anlauftring / with thrust ring	(63)
				<b>1888 052 034 #</b>	DUT310/ CERAM (310/41x45-21N)	enthält eine Kupplungsscheibe / This part number includes one clutch disc	(45)
				<b>1863 100 030</b>	55/90,5/25	mit Anlauftring / with thrust ring	(63)
				<b>1863 838 000</b>	70/110/20	ohne Anlauftring / without thrust ring	(79)
<b>DX 6.50</b>				<b>3400 016 101 #</b>		<b>Chass. 7440/0114-&gt;</b> <b>Chass. 7441/0744-&gt;</b> Nabenprofil / Hub Profile: 2x310/44x48-22N mit Powermatic / with Powermatic	(31) (66)
				<b>3400 017 001 #</b>		<b>Chass. 7439/0744-&gt;</b> <b>Chass. 7440/0114-&gt;</b> Nabenprofil / Hub Profile: 2x310/41x45-21N ohne Powermatic / without Powermatic	(31) (81)
				<b>3482 900 101 #</b>	GMF350	<b>Chass. 7440/0064 - Chass. 7440/0113</b> mit Powermatic / with Powermatic	(66)
				<b>3482 900 101 #</b>	GMF350	<b>Chass. 7440/0064-&gt;</b> <b>Chass. 7441/0357 - Chass. 7440/0113</b> <b>-&gt;Chass. 7441/0743</b> ohne Powermatic / without Powermatic	(81)
				<b>1864 900 102 #</b>	350DCE (44x48-22N)	<b>Chass. 7440/0065 - Chass. 7440/0113</b> <b>Chass. 7441/0358 - Chass. 7441/0743</b> Anzahl der Beläge / Number of pads: 7	(7)
				<b>1863 855 000</b>	106/140/25	<b>Chass. 7439/....</b> <b>Chass. 7440/....</b> <b>Chass. 7441/0744-&gt;</b> mit Anlauftring / with thrust ring	(63)
				<b>3400 016 101 #</b>		Nabenprofil / Hub Profile: 2x310/44x48-22N mit Powermatic / with Powermatic	(31) (66)
<b>DX 6.61</b>				<b>3400 017 001 #</b>		Nabenprofil / Hub Profile: 2x310/41x45-21N ohne Powermatic / without Powermatic	(31) (81)
				<b>1863 855 000</b>	106/140/25	mit Anlauftring / with thrust ring	(63)
				<b>3400 012 101 #</b>		Nabenprofil / Hub Profile: 2x310/31x35-16N	(31)
<b>DX 7.10</b>	02.84-			<b>1863 855 000</b>	106/140/25	mit Anlauftring / with thrust ring	(63)
		- 01.84		<b>3482 904 001</b>	GM320N		
<b>DX 7.10</b>				<b>1862 946 001 #</b>	350CB (31,2x35,6-16N)	Anzahl der Beläge / Number of pads: 7	(7)
				<b>1863 838 000</b>	70/110/20	Druckring KHD Nr. 238 4107 muss mit verbaut werden / Thrust collar KHD no. 238 4107 must also be installed	(14)

# DEUTZ-FAHR





















DX 36 - DX 92							
DX 36 V,VA DX 55 V				<b>1888 887 001 #</b>	DUT225 (225/31x35-18N)	enthält eine Kupplungsscheibe / This part number includes one clutch disc	(45)
DX 50 V,VA				<b>1888 887 001 #</b>	DUT225 (225/31x35-18N)	enthält eine Kupplungsscheibe / This part number includes one clutch disc	(45)
				<b>1863 010 100</b>	60/96,6/26	mit Anlauftring / with thrust ring	(63)
				<b>1863 839 000</b>	75/115/20	ohne Anlauftring / without thrust ring	(79)
DX 80 DX 86 DX 92				<b>1888 052 034 #</b>	DUT310/ CERAM (310/41x45-21N)	enthält eine Kupplungsscheibe / This part number includes one clutch disc	(45)
				<b>1864 451 041 ▽#</b>	280/ 58 (31x35-16N)	Lose Kupplungsscheibe / Loose clutch disc	(30)
				<b>1863 838 000</b>	70/110/20	ohne Anlauftring / without thrust ring	(79)
				<b>1863 100 030</b>	55/90,5/25	mit Anlauftring / with thrust ring	(63)
DX 85				<b>1888 801 001 #</b>	DUT295 (295/41x45-21N)	->Chass. 7816/0289 enthält eine Kupplungsscheibe / This part number includes one clutch disc	(45)
				<b>1888 052 034 #</b>	DUT310/ CERAM (310/41x45-21N)	Chass. 7816/0290-> enthält eine Kupplungsscheibe / This part number includes one clutch disc	(45)
				<b>1864 451 041 ▽#</b>	280/ 58 (31x35-16N)	Lose Kupplungsscheibe / Loose clutch disc	(30)
				<b>1863 100 030</b>	55/90,5/25	mit Anlauftring / with thrust ring	(63)
				<b>1863 838 000</b>	70/110/20	ohne Anlauftring / without thrust ring	(79)
DX 85 A				<b>1888 801 001 #</b>	DUT295 (295/41x45-21N)	->Chass. 7817/0083 enthält eine Kupplungsscheibe / This part number includes one clutch disc	(45)
				<b>1888 052 034 #</b>	DUT310/ CERAM (310/41x45-21N)	Chass. 7817/0084-> enthält eine Kupplungsscheibe / This part number includes one clutch disc	(45)
				<b>1864 451 041 ▽#</b>	280/ 58 (31x35-16N)	Lose Kupplungsscheibe / Loose clutch disc	(30)
				<b>1863 100 030</b>	55/90,5/25	mit Anlauftring / with thrust ring	(63)
				<b>1863 838 000</b>	70/110/20	ohne Anlauftring / without thrust ring	(79)
DX 90				<b>1888 801 001 #</b>	DUT295 (295/41x45-21N)	->Chass. 7818/0199 enthält eine Kupplungsscheibe / This part number includes one clutch disc	(45)
				<b>1888 052 034 #</b>	DUT310/ CERAM (310/41x45-21N)	Chass. 7818/0200-> enthält eine Kupplungsscheibe / This part number includes one clutch disc	(45)
				<b>1864 451 041 ▽#</b>	280/ 58 (31x35-16N)	Lose Kupplungsscheibe / Loose clutch disc	(30)
				<b>1863 100 030</b>	55/90,5/25	mit Anlauftring / with thrust ring	(63)
				<b>1863 838 000</b>	70/110/20	ohne Anlauftring / without thrust ring	(79)
DX 90 A				<b>1888 801 001 #</b>	DUT295 (295/41x45-21N)	->Chass. 7819/0187 enthält eine Kupplungsscheibe / This part number includes one clutch disc	(45)
				<b>1888 052 034 #</b>	DUT310/ CERAM (310/41x45-21N)	Chass. 7819/0188-> enthält eine Kupplungsscheibe / This part number includes one clutch disc	(45)
				<b>1864 451 041 ▽#</b>	280/ 58 (31x35-16N)	Lose Kupplungsscheibe / Loose clutch disc	(30)
				<b>1863 100 030</b>	55/90,5/25	mit Anlauftring / with thrust ring	(63)
				<b>1863 838 000</b>	70/110/20	ohne Anlauftring / without thrust ring	(79)
DX 110 - DX 160							
DX 110 ,A DX 120 ,A				<b>1888 052 034 #</b>	DUT310/ CERAM (310/41x45-21N)	enthält eine Kupplungsscheibe / This part number includes one clutch disc	(45)
				<b>1863 100 030</b>	55/90,5/25	mit Anlauftring / with thrust ring	(63)
				<b>1863 838 000</b>	70/110/20	ohne Anlauftring / without thrust ring	(79)
DX 140 ,A DX 160 ,A	- 01.84			<b>3482 904 001</b>	GM320N		
				<b>1862 946 001 #</b>	350CB (31,2x35,6-16N)	Anzahl der Beläge / Number of pads: 7	(7)
				<b>1863 838 000</b>	70/110/20	Druckring KHD Nr. 238 4107 muss mit verbaut werden / Thrust collar KHD no. 238 4107 must also be installed ohne Anlauftring / without thrust ring	(14) (79)

# DEUTZ-FAHR



## DX 110 - DX 160

DX 145 ,A	02.85 -		3400 016 101 # 		Nabenprofil / Hub Profile: 2x310/44x48-22N mit Powermatic / with Powermatic	(31) (66)
			3400 017 001 # 		Nabenprofil / Hub Profile: 2x310/41x45-21N ohne Powermatic / without Powermatic	(31) (81)
			 1863 855 000	106/140/25	mit Anlauftring / with thrust ring	(63)
DX 145 ,A			3482 900 101 #	GMF350	<b>Chass. 7440/....</b> <b>Chass. 7441/....</b> mit Powermatic / with Powermatic	(66)
			 1864 900 102 #	350DCE (44x48-22N)	<b>Chass. 7441/0606-&gt;</b> <b>Chass. 7440/0080-&gt;</b> Anzahl der Beläge / Number of pads: 7 mit Powermatic / with Powermatic	(7) (66)
			 3482 900 101 #	GMF350	ohne Powermatic / without Powermatic	(81)
DX 160 ,A	02.84 -		3400 012 101 # 		Nabenprofil / Hub Profile: 2x310/31x35-16N	(31)



































## INTRAC 01.72 - 12.90

6.05 6.30 6.60			3400 016 101 # 		Nabenprofil / Hub Profile: 2x310/44x48-22N mit Powermatic / with Powermatic	(31) (66)
			3400 017 001 # 		Nabenprofil / Hub Profile: 2x310/41x45-21N ohne Powermatic / without Powermatic	(31) (81)
			 1863 855 000	106/140/25	mit Anlauftring / with thrust ring	(63)
2002 2003			1888 057 042 #	DUT295-250/ 280 (280/36x40-20N)	enthält eine Kupplungsscheibe / This part number includes one clutch disc	(45)
			 1864 421 141 ▽#	250 (28x32-17N)	Lose Kupplungsscheibe / Loose clutch disc	(30)
			 1863 837 000	55/91,6/16,3	mit Anlauftring / with thrust ring	(63)
			 1863 838 000	70/110/20	ohne Anlauftring / without thrust ring	(79)
			 1888 915 001 ●#	DUT280 (280/36x40-20N)	enthält eine Kupplungsscheibe / This part number includes one clutch disc	(45)
			 1864 926 042 ●▽#	280 (28x32-17N)	Lose Kupplungsscheibe / Loose clutch disc	(30)
			 1863 838 000	70/110/20	ohne Anlauftring / without thrust ring	(79)
2004			1888 057 042 #	DUT295-250/ 280 (280/36x40-20N)	enthält eine Kupplungsscheibe / This part number includes one clutch disc	(45)
			 1888 915 001 ●#	DUT280 (280/36x40-20N)	enthält eine Kupplungsscheibe / This part number includes one clutch disc	(45)
			 1864 421 141 ▽#	250 (28x32-17N)	Lose Kupplungsscheibe / Loose clutch disc	(30)
			 1864 926 042 ●▽#	280 (28x32-17N)	Lose Kupplungsscheibe / Loose clutch disc	(30)
			 1863 837 000	55/91,6/16,3	mit Anlauftring / with thrust ring	(63)
			 1863 838 000	70/110/20	ohne Anlauftring / without thrust ring	(79)
			 1888 884 001 #	DOT280/ 228 (280/36x40-20N)	enthält eine Kupplungsscheibe / This part number includes one clutch disc	(45)
			 1863 837 000	55/91,6/16,3	mit Anlauftring / with thrust ring	(63)
			 1863 838 000	70/110/20	ohne Anlauftring / without thrust ring	(79)

## Kleinmährescher / small harvesting machine



























Porsche-Mot.			1881 065 101	KS180		
			 1864 121 536	180B (18,3x20,4-24N)		

# DEUTZ-FAHR



Mähdrescher / combine harvester							
M 60 M 66 ,S M 88 ,S		1864 634 039	200Z (23x29-10N)	->Chass. 1403			
		1859 600 001		->Chass. 1403			
		1805 042 000		->Chass. 1403			
		1881 089 010	K225	Chass. 1404-> Nur bei Altteil-Rückgabe lieferbar (Reparatur; Werk Bielefeld) / Please return old unit for repair (plant Bielefeld)	(33)		
		1860 039 024 #	225Z (23x29-10N)	Chass. 1404->			
		1859 600 001		Chass. 1404->			
		1805 042 000		Chass. 1404->			
		1882 321 001	KS200	->Chass. 1403 Nur bei Altteil-Rückgabe lieferbar (Reparatur; Werk Bielefeld) / Please return old unit for repair (plant Bielefeld)	(33)		
M 600 M 650 M 750		1882 321 001	KS200	Nur bei Altteil-Rückgabe lieferbar (Reparatur; Werk Bielefeld) / Please return old unit for repair (plant Bielefeld)	(33)		
		1864 634 039	200Z (23x29-10N)				
		1859 600 001					
		1805 042 000					
M 660 M 770		1881 089 007	K225	Getr. / GBox: Getrag			
		1864 078 010 #	225Z (23x29-10N)	Getr. / GBox: Getrag			
		3151 021 001		Getr. / GBox: Getrag			
		3130 010 100		Getr. / GBox: Getrag			
M 900		1881 089 007	K225	Getr. / GBox: 511/47			
		1864 078 010 #	225Z (23x29-10N)	Getr. / GBox: 511/47			
		3151 021 001		Getr. / GBox: 511/47			
		3130 010 100		Getr. / GBox: 511/47			
		1859 600 003					
		1805 042 000					
M 909		1881 089 007	K225				
		1860 039 024 #	225Z (23x29-10N)				
M 922 M 1002		1881 089 007	K225	Getr. / GBox: 511/47			
		1864 078 010 #	225Z (23x29-10N)	Getr. / GBox: 511/47			
		3151 021 001		Getr. / GBox: 511/47			
		3130 010 100		Getr. / GBox: 511/47			
		3082 007 338	MF240	Getr. / GBox: 3MD16			
		1864 394 102 ▲#	240B (27x30-16N)	Getr. / GBox: 3MD16			
		3151 045 001		Getr. / GBox: 3MD16			
M 980 M 1080		3082 007 338	MF240				
		1864 394 102 ▲#	240B (27x30-16N)				
		3151 045 001					

# DEUTZ-FAHR







## Mähdrescher / combine harvester























<b>M 1000</b>				<b>1860 062 037 #</b>	280Z (28x35-10N)		
<b>M 1200</b>				<b>1863 100 030</b>	55/90,5/25	mit Anlauftring / with thrust ring	(63)
<b>M 1300</b>				<b>1860 062 037 #</b>	280Z (28x35-10N)	Getr. / GBox: 3MD30	
<b>M 1102</b>				<b>3151 199 001</b>		Getr. / GBox: 3MD30	
<b>M 1202</b>							
<b>M 1300</b>				<b>1881 089 007</b>	K225		
<b>Korntankentleerer / grain tank emptier</b>				<b>1864 078 010 #</b>	225Z (23x29-10N)		
<b>M 1600</b>				<b>3100 700 101</b> ◊ 3151 021 001 ∩ 2x 3130 010 200	KTI-1		
<b>Korntankentleerer / grain tank emptier</b>							
<b>M 1320</b>				<b>1860 062 037 #</b>	280Z (28x35-10N)	Getr. / GBox: 3MD16	
<b>M 2480</b>				<b>3151 199 001</b>		Getr. / GBox: 3MD16	
<b>M 2580</b>							
<b>M 2680</b>							
<b>M 1322</b>				<b>1860 062 037 #</b>	280Z (28x35-10N)	Getr. / GBox: 3MD16	
				<b>3151 199 001</b>		Getr. / GBox: 3MD16	
				<b>3482 012 211</b>	GMF330		
				<b>1864 398 002</b>	330Z (28x35-10N)		
				<b>3151 199 001</b>			
<b>M 2385</b>				<b>1864 246 408 ▲</b>	250B (27x30-16N)	Getr. / GBox: 3MD16	
				<b>3151 045 001</b>		Getr. / GBox: 3MD16	
<b>M 2780</b>				<b>3482 012 211</b>	GMF330	Getr. / GBox: 3MD16	
				<b>1864 398 002</b>	330Z (28x35-10N)	Getr. / GBox: 3MD16	
				<b>3151 199 001</b>		Getr. / GBox: 3MD16	
<b>M 3480</b>				<b>1864 453 002</b>	(31x35-18N)	Nur bei Altteil-Rückgabe lieferbar (Reparatur; Werk Bielefeld) / Please return old unit for repair (plant Bielefeld)	(33)
<b>M 3540</b>							
<b>M 4030</b>				<b>3151 199 001</b>			
<b>M 3570</b>				<b>3482 008 034</b>	MF310	Getr. / GBox: 3MD16	
				<b>1864 097 002</b>	310Z (28x35-10N)	Getr. / GBox: 3MD16	
				<b>3151 199 001</b>		Getr. / GBox: 3MD16	
<b>M 3580</b>				<b>3482 012 211</b>	GMF330		
				<b>1864 398 002</b>	330Z (28x35-10N)		
				<b>3151 199 001</b>			





## Mot F1

<b>F 1 L 310</b>				<b>1881 065 101</b>	KS180		
				<b>1864 039 013 #</b>	180E (18x23-10N)		
				<b>3100 700 101</b> ◊ 3151 021 001 ∩ 2x 3130 010 200	KTI-1		

# DEUTZ-FAHR





Mot F1							
F 1 L 514 (15PS)				1882 196 005	KS200		
				1864 634 030	200Z (26x32-10N)		
				1859 600 001			
				1805 042 000			
F 1 L 612 (11PS)				1864 634 040	180E (23x29-10N)		
				1859 600 002			
				1805 041 100			

Mot F2							
F 2 L 310				1881 065 101	KS180		
				1864 039 013 #	180E (18x23-10N)		
				3100 700 101 ◊ 3151 021 001 J 2x 3130 010 200	KTI-1		
F 2 L 514	01.51 - 12.53			1864 202 035 #	250Z (26x32-10N)		
				1859 600 001			
				1805 042 000			
F 2 L 612 (18PS)	01.54 -			1882 196 005	KS200		
				1864 634 030	200Z (26x32-10N)		
				1859 600 006			
				1805 042 000			
F 2 L 612 (22/24PS)				1881 059 208	KS200		
				1864 634 030	200Z (26x32-10N)		
F 2 L 912				1881 010 139 #	G250		
				1864 202 035 #	250Z (26x32-10N)		
				1863 100 030	55/90,5/25	mit Anlauftring / with thrust ring	(63)
F 2 M 313				1880 071 008	K225		
				1864 634 024	225Z (1 1/4"-10N)		
F 2 M 414				1880 071 008	K225		
				1864 634 026	225Z (26x32-10N)		
				1881 089 002	K225		
				1864 634 024	225Z (1 1/4"-10N)		
				1859 600 001			
				1805 042 000			













Mot F3							
F 3 L 514 (45PS)				1880 092 416 #	G310		
				1864 340 101 #	310B (28x35-10N)		
				1863 100 030	55/90,5/25	mit Anlauftring / with thrust ring	(63)
F 3 L 514 (60/65PS)				1880 092 415 #	G310		





## DEUTZ-FAHR

Mot F3							
F 3 L 514 /4 (45PS)				<b>1863 100 030</b>	55/90,5/25	mit Anlauftring / with thrust ring	(63)
F 3 L 812				<b>1881 010 139 #</b>	G250		
F 3 L 912				<b>1864 202 035 #</b>	250Z (26x32-10N)		
				<b>1863 100 030</b>	55/90,5/25	mit Anlauftring / with thrust ring	(63)



## DEXHEIMER



AL...							
AL 222		Farymann22		<b>1882 313 001</b>	KS180	Nur bei Altteil-Rückgabe lieferbar (Reparatur; Werk Bielefeld) / Please return old unit for repair (plant Bielefeld)	(33)
AL 230				<b>1882 313 001</b>	KS180	Nur bei Altteil-Rückgabe lieferbar (Reparatur; Werk Bielefeld) / Please return old unit for repair (plant Bielefeld)	(33)
AL 232		MWM		<b>1860 039 025 #</b>	225Z (1 1/8"-10N)		
				<b>3151 045 001</b>			
AL 240				<b>1860 039 025 #</b>	225Z (1 1/8"-10N)		
				<b>3151 045 001</b>			
				<b>1882 162 001</b>	KS225S	Nur bei Altteil-Rückgabe lieferbar (Reparatur; Werk Bielefeld) / Please return old unit for repair (plant Bielefeld)	(33)
		MWM		<b>1888 024 114 #</b>	DUT250-250/ 250 (250/46x50-8N)	enthält eine Kupplungsscheibe / This part number includes one clutch disc	(45)
				<b>1864 254 002 ▽</b>	250Z (23x29-10N)	Lose Kupplungsscheibe / Loose clutch disc Nur bei Altteil-Rückgabe lieferbar (Reparatur; Werk Bielefeld) / Please return old unit for repair (plant Bielefeld)	(30) (33)
				<b>1863 123 000</b>	65/101,5/17,5	mit Anlauftring / with thrust ring	(63)
AL 345 AL 350 AL 370		MWM		<b>1888 024 114 #</b>	DUT250-250/ 250 (250/46x50-8N)	enthält eine Kupplungsscheibe / This part number includes one clutch disc	(45)
				<b>1864 254 002 ▽</b>	250Z (23x29-10N)	Lose Kupplungsscheibe / Loose clutch disc Nur bei Altteil-Rückgabe lieferbar (Reparatur; Werk Bielefeld) / Please return old unit for repair (plant Bielefeld)	(30) (33)
				<b>1863 123 000</b>	65/101,5/17,5	mit Anlauftring / with thrust ring	(63)

## EATON





VD,VDP							
20-50 F				<b>1864 634 025</b>	250Z (1 1/8"-10N)		
20-50 S 60-100 N				<b>1882 230 205</b>	HVB280		





  













VG,VGP							
20-50 F				<b>1864 634 025</b>	250Z (1 1/8"-10N)		
20-50 S				<b>1882 230 205</b>	HVB280		







					Parameter		
---	--	--	--	--	-----------	---	---

# EICHER



Büffel							
74 (3553) 74 A (3554)	01.74 - 12.78 01.74 - 12.77	P-A4.248		1888 903 004 #	DUT-280 (280/ 1 5/8"-25N)	enthält eine Kupplungsscheibe / This part number includes one clutch disc	(45)
				1878 993 101 ▽#	280CERAM (1 1/8"-10N)	Anzahl der Beläge / Number of pads: 6 Lose Kupplungsscheibe / Loose clutch disc	(7) (30)
				1863 855 000	106/140/25	mit Anlauftring / with thrust ring	(63)
				1863 837 002	65/97/23	mit Anlauftring / with thrust ring	(63)





EA							
EA 400	01.63 - 12.68	E-EDK3		1881 050 427 #	DO250 (Mo 250/23x29-10N) (Ge 225/46x50-8N)	enthält zwei Kupplungsscheiben / This part number includes both clutch discs Nur bei Altteil-Rückgabe lieferbar (Reparatur; Werk Bielefeld) / Please return old unit for repair (plant Bielefeld)	(46) (33)
				3151 000 395 3151 157 001 ●			
EA 600	01.63 - 12.69	E-EDK4		1881 051 310 #	DO280 (Mo 280/23x29-10N) (Ge 250/46x50-8N)	enthält zwei Kupplungsscheiben / This part number includes both clutch discs	(46)
				3151 000 395 3151 157 001 ●			





ED							
ED 13	01.56 - 12.60	E-ED1e		1881 089 002	K225		
				1864 634 026	225Z (26x32-10N)		
				1859 600 001			
				1805 042 000			
ED 15 ED 16 ,II ED 16 II ED 25 ,II ED 115	01.56 - 12.60 01.48 - 12.53 01.53 - 12.57	E-ED1e, E-ED1, E-ED1b		1881 089 002	K225		
				1864 634 024	225Z (1 1/4"-10N)		
				1859 600 001			
				1805 042 000			
ED 50 (Zapfwelle / implement power take off shaft) ED 50 ED 60				1864 340 101 #	310B (28x35-10N)		
				1863 600 123	65/101,5/26	mit Anlauftring / with thrust ring	(63)
ED 310 ED 500				1881 051 310 #	DO280 (Mo 280/23x29-10N) (Ge 250/46x50-8N)	enthält zwei Kupplungsscheiben / This part number includes both clutch discs	(46)
				3151 000 395 3151 157 001 ●			









EKL							
EKL 11 /II		F1L612		1864 634 040	180E (23x29-10N)		
				1859 600 002			
				1805 041 100			
EKL 15 /II				1881 089 002	K225		
				1864 634 024	225Z (1 1/4"-10N)		
				1859 600 001			
				1805 042 000			







# EICHER

EL								
EL 250 Z Farmexpress				1881 010 139 #	G250			
					1860 056 124 #	250Z (1 1/8"-10N)		
					1863 100 030	55/90,5/25	mit Anlauftring / with thrust ring	(63)

ELB								
ELB 340 ELB 360 ELB 424				1881 010 139 #	G250	4-Gang / 4 Speed 5-Gang / 5 Speed	(2) (3)	
					1860 056 124 #	250Z (1 1/8"-10N)	4-Gang / 4 Speed	(2)
					1864 202 035 #	250Z (26x32-10N)	5-Gang / 5 Speed	(3)
					1863 100 030	55/90,5/25	4-Gang / 4 Speed 5-Gang / 5 Speed mit Anlauftring / with thrust ring	(2) (3) (63)

ELK								
ELK 300				1881 010 139 #	G250	4-Gang / 4 Speed 5-Gang / 5 Speed	(2) (3)	
					1860 056 124 #	250Z (1 1/8"-10N)	4-Gang / 4 Speed	(2)
					1864 202 035 #	250Z (26x32-10N)	5-Gang / 5 Speed	(3)
					1863 100 030	55/90,5/25	4-Gang / 4 Speed 5-Gang / 5 Speed mit Anlauftring / with thrust ring	(2) (3) (63)

EM								
EM 200 EM 235 EM 295 EM 300	01.59 - 12.68			1881 050 427 #	DO250 (Mo 250/23x29-10N) (Ge 225/46x50-8N)	enthält zwei Kupplungsscheiben / This part number includes both clutch discs Nur bei Altteil-Rückgabe lieferbar (Reparatur; Werk Bielefeld) / Please return old unit for repair (plant Bielefeld)	(46) (33)	
					3151 000 395 3151 157 001 ●			
				EM 295 ,ED13				1881 089 002
	1864 634 026	225Z (26x32-10N)						
	1805 042 000							
	1859 600 001							
EM 500 EM 600				1881 051 310 #	DO280 (Mo 280/23x29-10N) (Ge 250/46x50-8N)	enthält zwei Kupplungsscheiben / This part number includes both clutch discs	(46)	
					3151 000 395 3151 157 001 ●			

ES								
ES 200 ES 201 ES 202				1882 140 002	KS180J9	Nur bei Altteil-Rückgabe lieferbar (Reparatur; Werk Bielefeld) / Please return old unit for repair (plant Bielefeld)	(33)	
					1864 261 005 #	180E (23x29-10N)		
					1859 600 001			
					1805 042 000			
ES 400				1881 050 427 #	DO250 (Mo 250/23x29-10N) (Ge 225/46x50-8N)	enthält zwei Kupplungsscheiben / This part number includes both clutch discs Nur bei Altteil-Rückgabe lieferbar (Reparatur; Werk Bielefeld) / Please return old unit for repair (plant Bielefeld)	(46) (33)	
					3151 000 395 3151 157 001 ●			



# EICHER

## ESA

ESA 300				<b>1881 010 139 #</b>	G250	4-Gang / 4 Speed 5-Gang / 5 Speed	(2) (3)
				<b>1860 056 124 #</b>	250Z (1 1/8"-10N)	4-Gang / 4 Speed	(2)
				<b>1864 202 035 #</b>	250Z (26x32-10N)	5-Gang / 5 Speed	(3)
				<b>1863 100 030</b>	55/90,5/25	4-Gang / 4 Speed 5-Gang / 5 Speed mit Anlauftring / with thrust ring	(2) (3) (63)

## ESB

ESB 300				<b>1881 010 139 #</b>	G250	4-Gang / 4 Speed 5-Gang / 5 Speed	(2) (3)
				<b>1860 056 124 #</b>	250Z (1 1/8"-10N)	4-Gang / 4 Speed	(2)
				<b>1864 202 035 #</b>	250Z (26x32-10N)	5-Gang / 5 Speed	(3)
				<b>1863 100 030</b>	55/90,5/25	4-Gang / 4 Speed 5-Gang / 5 Speed mit Anlauftring / with thrust ring	(2) (3) (63)

## EZ











EZ 540 EZ 600				<b>1881 010 139 #</b>	G250	4-Gang / 4 Speed 5-Gang / 5 Speed	(2) (3)
				<b>1860 056 124 #</b>	250Z (1 1/8"-10N)	4-Gang / 4 Speed	(2)
				<b>1864 202 035 #</b>	250Z (26x32-10N)	5-Gang / 5 Speed	(3)
				<b>1863 100 030</b>	55/90,5/25	4-Gang / 4 Speed 5-Gang / 5 Speed mit Anlauftring / with thrust ring	(2) (3) (63)

## Geräteträger / equipment rack















G 13 Multi	01.56 - 12.59	H-E89FG		<b>1882 155 009</b>	K160		
				<b>1864 006 147</b>	160E (18x23-10N)		
				<b>3159 140 004</b>			
				<b>1805 041 100</b>			
G 200 Kombi	01.59 - 12.62	E-EDK2a		<b>1882 140 002</b>	KS180J9	Nur bei Altteil-Rückgabe lieferbar (Reparatur; Werk Bielefeld) / Please return old unit for repair (plant Bielefeld)	(33)
				<b>1864 261 005 #</b>	180E (23x29-10N)		
				<b>1859 600 001</b>			
				<b>1805 042 000</b>			
G 280 Kombi	01.60 - 12.64	E-EDK2		<b>1881 050 427 #</b>	DO250 (Mo 250/23x29-10N) (Ge 225/46x50-8N)	enthält zwei Kupplungsscheiben / This part number includes both clutch discs Nur bei Altteil-Rückgabe lieferbar (Reparatur; Werk Bielefeld) / Please return old unit for repair (plant Bielefeld)	(46) (33)
				<b>1863 600 123</b>	65/101,5/26	mit Anlauftring / with thrust ring	(63)
G 220 Kombi	01.62 - 12.64	E-EDK2a		<b>1880 071 008</b>	K225		
				<b>1860 039 024 #</b>	225Z (23x29-10N)		
G 30 Kombi (3802) G 40 Kombi (3803)	01.64 - 12.66	E-EDK2-3, E-EDK3		<b>1881 050 427 #</b>	DO250 (Mo 250/23x29-10N) (Ge 225/46x50-8N)	enthält zwei Kupplungsscheiben / This part number includes both clutch discs Nur bei Altteil-Rückgabe lieferbar (Reparatur; Werk Bielefeld) / Please return old unit for repair (plant Bielefeld)	(46) (33)
				<b>3151 000 395</b> <b>3151 157 001 ●</b>			
G 300 Unisuper (3805) G 400 Unisuper (3806) G 250 Unisuper (3804)	01.66 - 12.68	E-EDK2-4		<b>1860 039 024 #</b>	225Z (23x29-10N)		

# EICHER



## Königstiger

Königstiger EM 300 Königstiger A EA 400	01.59 - 12.68	E-EDK3		1881 050 427 #	DO250 (Mo 250/23x29-10N) (Ge 225/46x50-8N)	enthält zwei Kupplungsscheiben / This part number includes both clutch discs Nur bei Altteil-Rückgabe lieferbar (Reparatur; Werk Bielefeld) / Please return old unit for repair (plant Bielefeld)	(46)
	01.63 - 12.68			 3151 000 395 3151 157 001 ●			
Königstiger I (3007) Königstiger I A (3010) Königstiger II (3015) Königstiger II A (3016)	01.68 - 12.71	E-EDK4-7, E-EDK3		1882 249 303 #	DUT250 (250/46x50-8N)	enthält eine Kupplungsscheibe / This part number includes one clutch disc	(45)
	01.68 - 12.73			 1864 257 101 ▽	250/ 50B (23x29-10N)	Lose Kupplungsscheibe / Loose clutch disc Nur bei Altteil-Rückgabe lieferbar (Reparatur; Werk Bielefeld) / Please return old unit for repair (plant Bielefeld)	(30) (33)
	01.68 - 12.72			 1863 123 000	65/101,5/17,5	mit Anlauftring / with thrust ring	(63)
	01.68 - 12.72			 1863 600 122	75/140/44,4	mit Anlauftring / with thrust ring	(63)
Königstiger 74 (3253) Königstiger 74 A (3254)	01.73 - 12.78	P-AD3.152		1888 024 104 #	DUT250 (250/38x44-25N)	enthält eine Kupplungsscheibe / This part number includes one clutch disc	(45)
	01.75 - 12.77			 1864 307 101 ▽	250/ 50B (1 1/8"-10N)	Lose Kupplungsscheibe / Loose clutch disc Nur bei Altteil-Rückgabe lieferbar (Reparatur; Werk Bielefeld) / Please return old unit for repair (plant Bielefeld)	(30) (33)
				 1863 837 002	65/97/23	mit Anlauftring / with thrust ring	(63)
				 1863 855 000	106/140/25	mit Anlauftring / with thrust ring	(63)



## L, LH



LH 12 /I				1882 155 009	K160		
				 1864 634 046	160E (16x20-10N)		
				 3151 994 801			
				 1805 041 100			
L 22		F2L612		1882 196 005	KS200		
				 1864 634 039	200Z (23x29-10N)		
				 1859 600 001			
				 1805 042 000			
L 28 (Zapfwelle / implement power take off shaft)				1881 050 427 #	DO250 (Mo 250/23x29-10N) (Ge 225/46x50-8N)	enthält zwei Kupplungsscheiben / This part number includes both clutch discs Nur bei Altteil-Rückgabe lieferbar (Reparatur; Werk Bielefeld) / Please return old unit for repair (plant Bielefeld)	(46) (33)
				 1863 600 123	65/101,5/26	mit Anlauftring / with thrust ring	(63)
L 60				1864 340 101 #	310B (28x35-10N)		
L 400 L 424				1881 010 139 #	G250		
				 1864 202 035 #	250Z (26x32-10N)		
				 1863 100 030	55/90,5/25	mit Anlauftring / with thrust ring	(63)

## M



























M 70 D6FL M 80 D6/7/8				1881 010 139 #	G250		
				 3151 045 001			

## Mammut

Mammut ED 310 Mammut ED 500	01.59 - 12.62	E-ED3b		1881 051 310 #	DO280 (Mo 280/23x29-10N) (Ge 250/46x50-8N)	enthält zwei Kupplungsscheiben / This part number includes both clutch discs	(46)
				 3151 000 395 3151 157 001 ●			







					Parameter		
---	--	--	--	--	-----------	---	---

# EICHER







Mammut								
<b>Mammut 3011</b> <b>Mammut A 3012</b> <b>Mammut AS 3422</b>	01.68 - 12.71	E-EDK4-8, E-EDK4		<b>1882 258 004</b>	DUT280 (280/46x50-8N)	Nur bei Altteil-Rückgabe lieferbar (Reparatur; Werk Bielefeld) / Please return old unit for repair (plant Bielefeld)	(33)	
	01.68 - 12.71				<b>1864 262 101</b> ▽#	280B (23x29-10N)	enthält eine Kupplungsscheibe / This part number includes one clutch disc	(45)
	01.70 - 12.73				<b>1863 123 000</b>	65/101,5/17,5	Lose Kupplungsscheibe / Loose clutch disc	(30)
<b>Mammut 74 (3353)</b> <b>Mammut 74 A (3354)</b>	01.73 - 12.78	P-AD4.203		<b>1888 024 104</b> #	DUT250 (250/38x44-25N)	mit Anlauftring / with thrust ring	(63)	
	01.74 - 12.78				<b>1864 307 101</b> ▽	250/ 50B (1 1/8"-10N)	enthält eine Kupplungsscheibe / This part number includes one clutch disc	(45)
					<b>1863 837 002</b>	65/97/23	Lose Kupplungsscheibe / Loose clutch disc	(30)
					<b>1863 855 000</b>	106/140/25	Nur bei Altteil-Rückgabe lieferbar (Reparatur; Werk Bielefeld) / Please return old unit for repair (plant Bielefeld)	(33)
<b>Mammut A 3422</b>	01.70 - 12.73	E-EDK4-8		<b>1888 903 004</b> #	DUT-280 (280/ 1 5/8"-25N)	mit Anlauftring / with thrust ring	(63)	
					<b>1864 600 344</b> ▽#	280B (1 1/8"-10N)	enthält eine Kupplungsscheibe / This part number includes one clutch disc	(45)
					<b>1878 993 101</b> ●▽#	280CERAM (1 1/8"-10N)	Lose Kupplungsscheibe / Loose clutch disc	(30)
					<b>1863 855 000</b>	106/140/25	Anzahl der Beläge / Number of pads: 6	(7)
					<b>1863 837 002</b>	65/97/23	Lose Kupplungsscheibe / Loose clutch disc	(30)
Mammut I								
<b>Mammut I EM 500</b>	01.64 - 12.68	E-EDK4		<b>1881 051 310</b> #	DO280 (Mo 280/23x29-10N) (Ge 250/46x50-8N)	enthält zwei Kupplungsscheiben / This part number includes both clutch discs	(46)	
					<b>3151 000 395</b>			
					<b>3151 157 001</b> ●			
Mammut II								
<b>Mammut II EM 600</b> <b>Mammut II A EA 600</b>	01.62 - 12.69	E-EDK4		<b>1881 051 310</b> #	DO280 (Mo 280/23x29-10N) (Ge 250/46x50-8N)	enthält zwei Kupplungsscheiben / This part number includes both clutch discs	(46)	
	01.63 - 12.69				<b>3151 000 395</b>			
					<b>3151 157 001</b> ●			
<b>Mammut II 3423</b> <b>Mammut II 3551</b> <b>Mammut II 74 (3453)</b>	01.71 - 12.73	E-EDK4-8, E-EDK4-10(T), P-A4.236		<b>1888 903 004</b> #	DUT-280 (280/ 1 5/8"-25N)	enthält eine Kupplungsscheibe / This part number includes one clutch disc	(45)	
	01.71 - 12.73				<b>1864 600 344</b> ▽#	280B (1 1/8"-10N)	Lose Kupplungsscheibe / Loose clutch disc	(30)
	01.74 - 12.78				<b>1878 993 101</b> ●▽#	280CERAM (1 1/8"-10N)	Anzahl der Beläge / Number of pads: 6	(7)
					<b>1863 855 000</b>	106/140/25	Lose Kupplungsscheibe / Loose clutch disc	(30)
					<b>1863 837 002</b>	65/97/23	mit Anlauftring / with thrust ring	(63)
Mot. / engine								
<b>2 Zyl. 32,36PS</b> <b>(stationär /</b> <b>stationery)</b>				<b>1880 083 132</b> #	G280			
					<b>1864 040 017</b> #	280Z (1 1/2"-10N)		
					<b>1863 100 030</b>	55/90,5/25	mit Anlauftring / with thrust ring	(63)

# EICHER















## Panther



<b>Panther EM 295</b>	01.58 - 12.68	E-EDK2a		<b>1881 089 002</b>	K225		
				<b>1864 634 026</b>	225Z (26x32-10N)		
				<b>1805 042 000</b>			
				<b>1859 600 001</b>			
				<b>1881 050 427 #</b>	DO250 (Mo 250/23x29-10N) (Ge 225/46x50-8N)	enthält zwei Kupplungsscheiben / This part number includes both clutch discs Nur bei Altteil-Rückgabe lieferbar (Reparatur; Werk Bielefeld) / Please return old unit for repair (plant Bielefeld)	(46) (33)
				<b>3151 000 395</b>			
				<b>3151 157 001 ●</b>			

## Puma







<b>Puma / ES 200</b> <b>Puma I / ES 201</b> <b>Puma I / ES 202</b>	01.60 - 12.61 01.62 - 12.64 01.65 - 12.70	E-EDK2, E-EDK2-3		<b>1882 140 002</b>	KS180J9	Nur bei Altteil-Rückgabe lieferbar (Reparatur; Werk Bielefeld) / Please return old unit for repair (plant Bielefeld)	(33)
				<b>1864 261 005 #</b>	180E (23x29-10N)		
				<b>1859 600 001</b>			
				<b>1805 042 000</b>			
<b>Puma II / ES 400</b>	01.63 - 12.70	E-EDK3-3		<b>1881 050 427 #</b>	DO250 (Mo 250/23x29-10N) (Ge 225/46x50-8N)	enthält zwei Kupplungsscheiben / This part number includes both clutch discs Nur bei Altteil-Rückgabe lieferbar (Reparatur; Werk Bielefeld) / Please return old unit for repair (plant Bielefeld)	(46) (33)
				<b>3151 000 395</b>			
				<b>3151 157 001 ●</b>			



## Schmalspur / narrow-gage type



<b>3705</b> <b>3706</b> <b>3708</b> <b>3713</b> <b>3714</b>	01.70 - 12.76 01.70 - 12.76 01.70 - 12.71 01.72 - 12.76 01.72 - 12.76	E-EDK2-3		<b>1881 089 007</b>	K225		
				<b>1860 039 024 #</b>	225Z (23x29-10N)		
				<b>1805 042 000</b>			
				<b>1882 249 303 #</b>	DUT250 (250/46x50-8N)	enthält eine Kupplungsscheibe / This part number includes one clutch disc	(45)
<b>3709</b> <b>3710 A</b> <b>3711</b> <b>3712 A</b> <b>342 S, AS</b> <b>352 S (3415)</b> <b>352 AS (3716)</b>	01.70 - 12.76 01.70 - 12.76 01.70 - 12.76 01.70 - 12.76 01.76 - 12.79 01.76 - 12.79 01.76 - 12.79	E-EDK3-3, E-EDK3-7, E-EDK3-4		<b>1864 257 101 ▽</b>	250/ 50B (23x29-10N)	Lose Kupplungsscheibe / Loose clutch disc Nur bei Altteil-Rückgabe lieferbar (Reparatur; Werk Bielefeld) / Please return old unit for repair (plant Bielefeld)	(30) (33)
				<b>1863 837 002</b>	65/97/23	mit Anlauftring / with thrust ring	(63)
				<b>1863 855 000</b>	106/140/25	mit Anlauftring / with thrust ring	(63)
				<b>1888 634 004</b>	DUT280/ 280 (280/46x50-8N)	enthält eine Kupplungsscheibe / This part number includes one clutch disc	(45)
				<b>1888 903 002</b>	DUT-280 (280/46x50-8N)	enthält eine Kupplungsscheibe / This part number includes one clutch disc	(45)
				<b>1864 634 002 ▽</b>	280B (23x29-10N)	Lose Kupplungsscheibe / Loose clutch disc	(30)
<b>635 K (3761)</b> <b>635 KA (3762)</b> <b>642 K (3761T)</b> <b>642 KA (3762T)</b> <b>645 K (3763)</b> <b>645 KA (3764)</b> <b>648 V (3765)</b> <b>648 VA (3766)</b>	01.86 - 12.93 01.86 - 12.93 01.86 - 12.93 01.86 - 12.93 01.86 - 12.97 01.86 - 12.97 01.87 - 12.92 01.87 - 12.92	E-EDL2-2, E-EDL3-7, E-EDL2-1		<b>1882 249 303 #</b>	DUT250 (250/46x50-8N)	enthält eine Kupplungsscheibe / This part number includes one clutch disc	(45)
				<b>1864 257 101 ▽</b>	250/ 50B (23x29-10N)	Lose Kupplungsscheibe / Loose clutch disc Nur bei Altteil-Rückgabe lieferbar (Reparatur; Werk Bielefeld) / Please return old unit for repair (plant Bielefeld)	(30) (33)
				<b>1863 123 000</b>	65/101,5/17,5	mit Anlauftring / with thrust ring	(63)
				<b>1863 600 122</b>	75/140/44,4	mit Anlauftring / with thrust ring	(63)







					Parameter		
---	--	--	--	--	-----------	---	---







# EICHER

Tiger								
Tiger EM 200 Tiger II EM 235	01.58 - 12.68 01.63 - 12.68	E-EDK2, E-EDK3a		1881 050 427 #	DO250 (Mo 250/23x29-10N) (Ge 225/46x50-8N)	enthält zwei Kupplungsscheiben / This part number includes both clutch discs Nur bei Altteil-Rückgabe lieferbar (Reparatur; Werk Bielefeld) / Please return old unit for repair (plant Bielefeld)	(46) (33)	
					3151 000 395 3151 157 001 ●			
Tiger I (3008) Tiger II (3009)	01.68 - 12.71 01.68 - 12.71	E-EDK2, E-EDK3-2		1882 249 303 #	DUT250 (250/46x50-8N)	enthält eine Kupplungsscheibe / This part number includes one clutch disc	(45)	
					1864 257 101 ▽	250/ 50B (23x29-10N)	Lose Kupplungsscheibe / Loose clutch disc Nur bei Altteil-Rückgabe lieferbar (Reparatur; Werk Bielefeld) / Please return old unit for repair (plant Bielefeld)	(30) (33)
					1863 123 000 1863 600 122	65/101,5/17,5 75/140/44,4	mit Anlauftring / with thrust ring mit Anlauftring / with thrust ring	(63) (63)
Tiger II (3151)	01.72 - 12.72	E-EDK3-4		1864 307 101 ▽	250/ 50B (1 1/8"-10N)	Nur bei Altteil-Rückgabe lieferbar (Reparatur; Werk Bielefeld) / Please return old unit for repair (plant Bielefeld) Lose Kupplungsscheibe / Loose clutch disc	(33) (30)	

Wotan I							
3017 3018 A	01.68 - 12.71 01.68 - 12.72	E-EDK-6		1888 064 041	DUT310/ 310 (310/41x45-22N)	enthält eine Kupplungsscheibe / This part number includes one clutch disc	(45)
					1864 244 042 ▽#	310 (25x28-15N)	Lose Kupplungsscheibe / Loose clutch disc

Wotan II							
3013 3014 A	01.68 - 12.71 01.68 - 12.76	E-EDK-6		1888 064 041	DUT310/ 310 (310/41x45-22N)	enthält eine Kupplungsscheibe / This part number includes one clutch disc	(45)
					1864 244 042 ▽#	310 (25x28-15N)	Lose Kupplungsscheibe / Loose clutch disc























365 - 666								
365 S 565 S 566 AS 656 S 666 AS				1888 634 004	DUT280/ 280 (280/46x50-8N)	enthält eine Kupplungsscheibe / This part number includes one clutch disc	(45)	
				1888 903 002	DUT-280 (280/46x50-8N)	enthält eine Kupplungsscheibe / This part number includes one clutch disc	(45)	
					1864 634 002 ▽	280B (23x29-10N)	Lose Kupplungsscheibe / Loose clutch disc	(30)
					1863 837 002 1863 855 000	65/97/23 106/140/25	mit Anlauftring / with thrust ring mit Anlauftring / with thrust ring	(63) (63)
				635 642 645 648				1882 249 303 #
	1864 257 101 ▽	250/ 50B (23x29-10N)	Lose Kupplungsscheibe / Loose clutch disc Nur bei Altteil-Rückgabe lieferbar (Reparatur; Werk Bielefeld) / Please return old unit for repair (plant Bielefeld)					(30) (33)
	1863 600 122 1863 123 000	75/140/44,4 65/101,5/17,5	mit Anlauftring / with thrust ring mit Anlauftring / with thrust ring					(63) (63)

3007 - 3088								
3007 3008 3009 3010 3015 3016				1882 249 303 #	DUT250 (250/46x50-8N)	enthält eine Kupplungsscheibe / This part number includes one clutch disc	(45)	
					1864 257 101 ▽	250/ 50B (23x29-10N)	Lose Kupplungsscheibe / Loose clutch disc Nur bei Altteil-Rückgabe lieferbar (Reparatur; Werk Bielefeld) / Please return old unit for repair (plant Bielefeld)	(30) (33)
					1863 600 122 1863 123 000	75/140/44,4 65/101,5/17,5	mit Anlauftring / with thrust ring mit Anlauftring / with thrust ring	(63) (63)
				3011 3012				1882 258 004
	1864 262 101 ▽#	280B (23x29-10N)	Lose Kupplungsscheibe / Loose clutch disc					(30)
	1863 123 000	65/101,5/17,5	mit Anlauftring / with thrust ring					(63)







# EICHER

## 3007 - 3088

<b>3021</b>				<b>3482 012 211</b>	GMF330		
<b>3022</b>				<b>1864 352 101</b>	330Z (44x48-23N)	Nur bei Altteil-Rückgabe lieferbar (Reparatur; Werk Bielefeld) / Please return old unit for repair (plant Bielefeld)	(33)
<b>3023</b>				<b>3151 196 031</b>			
<b>3048 ,S,AS</b> <b>(3257,3258)</b>	01.82 - 12.90	E-EDL3		<b>1888 024 104 #</b>	DUT250 (250/38x44-25N)	enthält eine Kupplungsscheibe / This part number includes one clutch disc	(45)
<b>3056 ,S,AS</b> <b>(3357,3358)</b>	01.82 - 12.90			<b>1864 307 101 ▽</b>	250/ 50B (1 1/8"-10N)	Lose Kupplungsscheibe / Loose clutch disc Nur bei Altteil-Rückgabe lieferbar (Reparatur; Werk Bielefeld) / Please return old unit for repair (plant Bielefeld)	(30) (33)
				<b>1863 837 002</b>	65/97/23	mit Anlauftring / with thrust ring	(63)
				<b>1863 855 000</b>	106/140/25	mit Anlauftring / with thrust ring	(63)
<b>3055</b>				<b>1888 036 001</b>	DOT250 (250/46x50-8N)	Nur bei Altteil-Rückgabe lieferbar (Reparatur; Werk Bielefeld) / Please return old unit for repair (plant Bielefeld) enthält eine Kupplungsscheibe / This part number includes one clutch disc	(33) (45)
				<b>1864 257 101 ▽</b>	250/ 50B (23x29-10N)	Lose Kupplungsscheibe / Loose clutch disc Nur bei Altteil-Rückgabe lieferbar (Reparatur; Werk Bielefeld) / Please return old unit for repair (plant Bielefeld)	(30) (33)
<b>3066 ,A (3457,3458)</b> <b>3085 ,A (3655,3656)</b>	01.82 - 12.90 01.78 - 12.82	E-EDL3, E-EDK4		<b>1888 903 004 #</b>	DUT-280 (280/ 1 5/8"-25N)	enthält eine Kupplungsscheibe / This part number includes one clutch disc	(45)
				<b>1878 993 101 ▽#</b>	280CERAM (1 1/8"-10N)	Anzahl der Beläge / Number of pads: 6 Lose Kupplungsscheibe / Loose clutch disc	(7) (30)
				<b>1863 855 000</b>	106/140/25	mit Anlauftring / with thrust ring	(63)
				<b>1863 837 002</b>	65/97/23	mit Anlauftring / with thrust ring	(63)
<b>3066 S,SA</b> <b>3075 S</b> <b>3088 S,AS</b>	- 12.83 - 12.83 - 12.83			<b>1888 903 004 #</b>	DUT-280 (280/ 1 5/8"-25N)	enthält eine Kupplungsscheibe / This part number includes one clutch disc	(45)
				<b>1864 600 344 ▽#</b>	280B (1 1/8"-10N)	Lose Kupplungsscheibe / Loose clutch disc	(30)
				<b>1878 993 101 ●▽#</b>	280CERAM (1 1/8"-10N)	Anzahl der Beläge / Number of pads: 6 Lose Kupplungsscheibe / Loose clutch disc	(7) (30)
				<b>1863 855 000</b>	106/140/25	mit Anlauftring / with thrust ring	(63)
				<b>1863 837 002</b>	65/97/23	mit Anlauftring / with thrust ring	(63)
<b>3075 S</b> <b>3085 S</b> <b>3088 S,AS</b>	01.84 - 01.84 - 01.84 -			<b>1888 903 004 #</b>	DUT-280 (280/ 1 5/8"-25N)	enthält eine Kupplungsscheibe / This part number includes one clutch disc	(45)
				<b>1864 600 344 ▽#</b>	280B (1 1/8"-10N)	Lose Kupplungsscheibe / Loose clutch disc	(30)
				<b>1863 855 000</b>	106/140/25	mit Anlauftring / with thrust ring	(63)
				<b>1863 837 002</b>	65/97/23	mit Anlauftring / with thrust ring	(63)

## 3105 - 3145







<b>3105 (3021/3022)</b>	01.77 - 12.82	E-EDK-6		<b>3482 012 211</b>	GMF330		
				<b>1864 352 101</b>	330Z (44x48-23N)	Nur bei Altteil-Rückgabe lieferbar (Reparatur; Werk Bielefeld) / Please return old unit for repair (plant Bielefeld)	(33)
				<b>3151 196 031</b>			
<b>3108 (3026)</b> <b>3125 (3028)</b> <b>3133 (3024)</b> <b>3145 (3030)</b>	01.82 - 12.90 01.82 - 12.90 01.77 - 12.82 01.82 - 12.90	E-EDL-6, E-EDK-6, E-EDL-6-T		<b>3482 002 234</b>	GMF350X		
				<b>1864 347 101 #</b>	350Z (44x48-23N)		
				<b>3151 196 031</b>			

## 3251 - 3660









<b>3251</b> <b>3351</b>				<b>1864 307 101 ▽</b>	250/ 50B (1 1/8"-10N)	Nur bei Altteil-Rückgabe lieferbar (Reparatur; Werk Bielefeld) / Please return old unit for repair (plant Bielefeld) Lose Kupplungsscheibe / Loose clutch disc	(33) (30)
----------------------------	--	--	---	-----------------------	--------------------------	---	--------------

# EICHER















## 3251 - 3660

3253				<b>1888 024 104 #</b>	DUT250 (250/38x44-25N)	enthält eine Kupplungsscheibe / This part number includes one clutch disc	(45)
3254 A				<b>1864 307 101 ▽</b>	250/ 50B (1 1/8"-10N)	Lose Kupplungsscheibe / Loose clutch disc	(30)
3255						Nur bei Altteil-Rückgabe lieferbar (Reparatur; Werk Bielefeld) / Please return old unit for repair (plant Bielefeld)	(33)
3256 A				<b>1863 855 000</b>	106/140/25	mit Anlauftring / with thrust ring	(63)
3257				<b>1863 837 002</b>	65/97/23	mit Anlauftring / with thrust ring	(63)
3258							
3353							
3354 A							
3355							
3356 A							
3357							
3358 AS							
3453	01.74 - 12.78			<b>1888 903 004 #</b>	DUT-280 (280/ 1 5/8"-25N)	enthält eine Kupplungsscheibe / This part number includes one clutch disc	(45)
3457				<b>1864 600 344 ▽#</b>	280B (1 1/8"-10N)	Lose Kupplungsscheibe / Loose clutch disc	(30)
3458				<b>1878 993 101 ●▽#</b>	280CERAM (1 1/8"-10N)	Anzahl der Beläge / Number of pads: 6	(7)
3553						Lose Kupplungsscheibe / Loose clutch disc	(30)
3555				<b>1863 855 000</b>	106/140/25	mit Anlauftring / with thrust ring	(63)
3556 A				<b>1863 837 002</b>	65/97/23	mit Anlauftring / with thrust ring	(63)
3557 A							
3558							
3655							
3656							
3657							
3658							
3660							











## 3705 - 4072





3705				<b>1881 089 007</b>	K225		
3706				<b>1860 039 024 #</b>	225Z (23x29-10N)		
3713				<b>1805 042 000</b>			
3714							
3752							
3755							
3756							
3709				<b>1882 249 303 #</b>	DUT250 (250/46x50-8N)	enthält eine Kupplungsscheibe / This part number includes one clutch disc	(45)
3710				<b>1864 257 101 ▽</b>	250/ 50B (23x29-10N)	Lose Kupplungsscheibe / Loose clutch disc	(30)
3711						Nur bei Altteil-Rückgabe lieferbar (Reparatur; Werk Bielefeld) / Please return old unit for repair (plant Bielefeld)	(33)
3712				<b>1863 855 000</b>	106/140/25	mit Anlauftring / with thrust ring	(63)
3757				<b>1863 837 002</b>	65/97/23	mit Anlauftring / with thrust ring	(63)
3758							
3759							
3760							
3761							
3762							
3763							
3764							
3765							
3766							
3767				<b>1888 634 004</b>	DUT280/ 280 (280/46x50-8N)	enthält eine Kupplungsscheibe / This part number includes one clutch disc	(45)
3768				<b>1888 903 002</b>	DUT-280 (280/46x50-8N)	enthält eine Kupplungsscheibe / This part number includes one clutch disc	(45)
				<b>1864 634 002 ▽</b>	280B (23x29-10N)	Lose Kupplungsscheibe / Loose clutch disc	(30)
				<b>1863 837 002</b>	65/97/23	mit Anlauftring / with thrust ring	(63)
				<b>1863 855 000</b>	106/140/25	mit Anlauftring / with thrust ring	(63)

## EICHER





3705 - 4072						
3941				1882 313 001	KS180	Nur bei Altteil-Rückgabe lieferbar (Reparatur; Werk Bielefeld) / Please return old unit for repair (plant Bielefeld) (33)
				1864 121 536	180B (18,3x20,4-24N)	
				3151 270 602		
				1805 041 100		
3951 3952 3955				1882 315 002	KS180	
				1864 634 022	180E (18x23-10N)	
				3151 270 602		
				1805 041 100		
4038 (3155)	01.78 - 12.82	P-AD3.152		1888 037 101 #	DOT250 (250/38x44-25N)	enthält eine Kupplungsscheibe / This part number includes one clutch disc (45)
				1864 307 101 ▽	250/ 50B (1 1/8"-10N)	Lose Kupplungsscheibe / Loose clutch disc Nur bei Altteil-Rückgabe lieferbar (Reparatur; Werk Bielefeld) / Please return old unit for repair (plant Bielefeld) (30) (33)
4072 ,A (3555,3556)	01.78 - 12.82	P-A4.248		1888 903 004 #	DUT-280 (280/ 1 5/8"-25N)	enthält eine Kupplungsscheibe / This part number includes one clutch disc (45)
				1864 600 344 ▽#	280B (1 1/8"-10N)	Lose Kupplungsscheibe / Loose clutch disc (30)
				1878 993 101 ●▽#	280CERAM (1 1/8"-10N)	Anzahl der Beläge / Number of pads: 6 (7) Lose Kupplungsscheibe / Loose clutch disc (30)
				1863 855 000	106/140/25	mit Anlauffring / with thrust ring (63)
				1863 837 002	65/97/23	mit Anlauffring / with thrust ring (63)



## EPPLER BUXBAUM









EM						
2 S				1881 065 101	KS180	
				1864 121 536	180B (18,3x20,4-24N)	
840				1882 196 005	KS200	
				1864 180 839	200B (18,3x20,4-24N)	
940 1000				1881 089 007	K225	
				1860 039 024 #	225Z (23x29-10N)	
				1859 600 001		
				1805 042 000		
1000 S 1240 S				1860 062 037 #	280Z (28x35-10N)	
				1863 100 030	55/90,5/25	mit Anlauffring / with thrust ring (63)

2..						
210 211 H,T,HT				1881 065 101	KS180	
				1864 121 536	180B (18,3x20,4-24N)	
250				1882 196 005	KS200	
				1864 180 839	200B (18,3x20,4-24N)	













## FAHRZEUGWERKE ESSLINGEN

BF							
BF 3		VWIndustrie		1881 065 101	KS180		
				1864 121 536	180B (18,3x20,4-24N)		
				1881 059 208	KS200		
				1864 634 039	200Z (23x29-10N)		







DF							
DF 3				1881 065 101	KS180		
				1864 121 536	180B (18,3x20,4-24N)		

DG							
DG 1	12.57 - - 12.57 - 12.57 - 12.57 - 12.57			1882 196 005	KS200	->08.1954	
DG 1,5				1864 634 039	200Z (23x29-10N)		
DG 2				3151 021 001		->08.1954	
DG 2,5				3130 010 100		->08.1954	
DG 3,2				3100 700 101 3151 021 001 2x 3130 010 200	KTI-1	->08.1954	
DG 3,2				1881 059 208	KS200	09.1954->	
DG 3,5				1881 010 139 #	G250		
				1864 202 035 #	250Z (26x32-10N)		









## FARNY & WEIDMANN

















A - V							
A 10 - A 40				1882 155 009	K160	Getr. / GBox: Hurth	
				3159 140 004		Getr. / GBox: Hurth	
				1805 041 200		Getr. / GBox: Hurth	
D 20 G 20				1882 315 003	KS180		
				3159 140 004			
G 10 P 10				1882 313 001	KS180	Nur bei Altteil-Rückgabe lieferbar (Reparatur; Werk Bielefeld) / Please return old unit for repair (plant Bielefeld)	(33)
				3159 140 004			
K 14 L 14				1882 155 009	K160		
				3159 140 004			
P 10 - P 30 S 10 - S 30				3082 043 132	M200		
				1882 313 001	KS180	Getr. / GBox: Hurth Nur bei Altteil-Rückgabe lieferbar (Reparatur; Werk Bielefeld) / Please return old unit for repair (plant Bielefeld)	(33)
R,P,S				1866 052 001	152/ 123NPC	max. übertragbares Motormoment [Nm] / max. transmittable engine torque [Nm]: 300 Getriebetyp: Hurth Bootswendegetriebe / Type of transmission: Hurth boat reversing gearing	(62) (21)

# FARNY & WEIDMANN







A - V							
Varimot (10PS)				1882 196 005	KS200		
				1864 634 030	200Z (26x32-10N)		
				1859 600 001			
				1805 042 000			
Varimot Betonmischer / Concrete Mixer (10PS)				1881 065 101	KS180		
				1864 121 536	180B (18,3x20,4-24N)		
				3151 270 602			

























# FENDT

AGROBIL							
S				1888 027 304 #	DUT250L (250/36x40-20N)	enthält eine Kupplungsscheibe / This part number includes one clutch disc	(45)
				1864 357 001 ▽#	250DC (26x32-10N)	Lose Kupplungsscheibe / Loose clutch disc	(30)
				1864 246 437 ●▽#	250B (26x32-10N)	Lose Kupplungsscheibe / Loose clutch disc	(30)
				1863 837 002	65/97/23	mit Anlauftring / with thrust ring	(63)
				1863 855 000	106/140/25	mit Anlauftring / with thrust ring	(63)
				1888 041 103 #	DUT280L-295 (280/36x40-20N)	enthält eine Kupplungsscheibe / This part number includes one clutch disc	(45)
				1863 837 002	65/97/23	mit Anlauftring / with thrust ring	(63)
				1863 855 000	106/140/25	mit Anlauftring / with thrust ring	(63)



























F							
F 12 GT,HG,HL				1882 315 002	KS180		
				1864 634 040	180E (23x29-10N)		
F 15				1882 315 002	KS180	6-Gang / 6 Speed	(4)
				1864 634 040	180E (23x29-10N)	6-Gang / 6 Speed	(4)
F 15 G,GH,G6,H6				1864 634 040	180E (23x29-10N)	Getr. / GBox: 8-Gang / 8-speed	
				1859 600 006		Getr. / GBox: 8-Gang / 8-speed	
				1805 042 000		Getr. / GBox: 8-Gang / 8-speed	
F 17 L,W				1882 196 005	KS200		
				1864 634 030	200Z (26x32-10N)		
				1859 600 006			
				1805 042 000			
F 18 F,G				1882 196 005	KS200		
				1859 600 001			
				1805 042 000			
F 20 G6,H6 F 24 L,L1,W,W1				1882 196 005	KS200		
				1859 600 006			
				1805 042 000			

# FENDT

F							
F 28 P		1881 089 002	K225				
		1864 634 024	225Z (1 1/4"-10N)				
		1859 600 001					
		1805 042 000					
F 220 /1		1890 006 101 #	DO225 (Ge 200/42x48-8N) (Mo 225/21x26-10N)	enthält zwei Kupplungsscheiben / This part number includes both clutch discs			(46)
		1863 010 100	60/96,6/26	mit Anlaufing / with thrust ring			(63)





















FARMER							
1 (FW237)		1881 089 002	K225				
		1864 634 024	225Z (1 1/4"-10N)				
		1859 600 006					
		1805 042 000					
1 E		1880 071 008	K225				
		1860 039 024 #	225Z (23x29-10N)				
		1890 006 101 #	DO225 (Ge 200/42x48-8N) (Mo 225/21x26-10N)	enthält zwei Kupplungsscheiben / This part number includes both clutch discs			(46)
		1863 010 100	60/96,6/26	mit Anlaufing / with thrust ring			(63)
2 ,D,E,DE		1881 050 428 #	DO250 (Mo 250/23x29-10N) (Ge 225/46x50-8N)	enthält zwei Kupplungsscheiben / This part number includes both clutch discs Nur bei Altteil-Rückgabe lieferbar (Reparatur; Werk Bielefeld) / Please return old unit for repair (plant Bielefeld)			(46) (33)
		3151 000 395					
2 S 3 S 4 S 101 S		1882 172 107	G250				
		1864 246 437 #	250B (26x32-10N)				
		1864 357 001 ●#	250DC (26x32-10N)				
		1863 840 000	50/82/23	mit Anlaufing / with thrust ring			(63)
5 S		1882 172 107	G250				
		1864 246 437 #	250B (26x32-10N)				
		1864 357 001 ●#	250DC (26x32-10N)	->Chass. 268/13617			
		1863 840 000	50/82/23	mit Anlaufing / with thrust ring			(63)
102 S 103 S,LS 104 S,LS 105 S,LS 106 S,LS		1882 172 107	G250				
		1864 246 437 #	250B (26x32-10N)				
		1863 840 000	50/82/23	mit Anlaufing / with thrust ring			(63)
103 S 200 S,LS 203 V 205 P		1888 027 304 #	DUT250L (250/36x40-20N)	enthält eine Kupplungsscheibe / This part number includes one clutch disc			(45)
		1864 246 437 ▽#	250B (26x32-10N)	Lose Kupplungsscheibe / Loose clutch disc			(30)
		1863 855 000	106/140/25	mit Anlaufing / with thrust ring			(63)
		1863 837 002	65/97/23	mit Anlaufing / with thrust ring			(63)

# FENDT

FARMER								
108 S,LS				<b>1882 172 107</b>	G250	<b>09.1975-&gt;</b>		
				<b>1864 246 437 #</b>	250B (26x32-10N)	<b>09.1975-&gt;</b>		
				<b>1864 357 001 ●#</b>	250DC (26x32-10N)	<b>09.1975-&gt;</b>		
					<b>1863 840 000</b>	50/82/23	<b>09.1975-&gt;</b> mit Anlauftring / with thrust ring	(63)
200 V				<b>1888 027 304 #</b>	DUT250L (250/36x40-20N)	enthält eine Kupplungsscheibe / This part number includes one clutch disc	(45)	
				<b>1864 246 437 ▽#</b>	250B (26x32-10N)	<b>-&gt;Chass. 145/1405</b> Lose Kupplungsscheibe / Loose clutch disc	(30)	
				<b>1861 723 201 ▽#</b>	250/ 145GSPZ (26x32-10N)	<b>Chass. 145/1406-&gt;</b> Lose Kupplungsscheibe / Loose clutch disc	(30)	
					<b>1863 855 000</b>	106/140/25	mit Anlauftring / with thrust ring	(63)
					<b>1863 837 002</b>	65/97/23	mit Anlauftring / with thrust ring	(63)
201 S 203 P,P-II				<b>1888 027 304 #</b>	DUT250L (250/36x40-20N)	enthält eine Kupplungsscheibe / This part number includes one clutch disc	(45)	
				<b>1861 723 201 ▽#</b>	250/ 145GSPZ (26x32-10N)	Lose Kupplungsscheibe / Loose clutch disc	(30)	
					<b>1863 855 000</b>	106/140/25	mit Anlauftring / with thrust ring	(63)
203 V-II				<b>1888 027 304 #</b>	DUT250L (250/36x40-20N)	enthält eine Kupplungsscheibe / This part number includes one clutch disc	(45)	
				<b>1864 246 437 ▽#</b>	250B (26x32-10N)	<b>-&gt;Chass. 155/1362</b> Lose Kupplungsscheibe / Loose clutch disc	(30)	
				<b>1861 723 201 ▽#</b>	250/ 145GSPZ (26x32-10N)	<b>Chass. 155/1363-&gt;</b> Lose Kupplungsscheibe / Loose clutch disc	(30)	
					<b>1863 855 000</b>	106/140/25	mit Anlauftring / with thrust ring	(63)
					<b>1863 837 002</b>	65/97/23	mit Anlauftring / with thrust ring	(63)
204 P-FL166 204 V-FL167 205 P-FL176				<b>1888 041 103 #</b>	DUT280L-295 (280/36x40-20N)	enthält eine Kupplungsscheibe / This part number includes one clutch disc	(45)	
				<b>1861 751 104 ▽#</b>	295GSPB (26x32-10N)	Lose Kupplungsscheibe / Loose clutch disc	(30)	
					<b>1863 855 000</b>	106/140/25	mit Anlauftring / with thrust ring	(63)
					<b>1863 837 002</b>	65/97/23	mit Anlauftring / with thrust ring	(63)
206 S 206 V / VA, F / FA, 207 S 207 V / VA, F / FA 208 S 208 VA / FA / PA 209 S 209 VA / FA / PA	01.03-			<b>1888 000 023</b>	DUT330L-330/ 295 (295/41x45-22N)	enthält eine Kupplungsscheibe / This part number includes one clutch disc	(45)	
	01.03-			<b>1864 482 031</b>	320B (26x32-10N)			
	01.03-			<b>1863 855 000</b>	106/140/25	mit Anlauftring / with thrust ring	(63)	
	01.03-			<b>3151 157 001</b>				
	01.03-				<b>1888 062 001 #</b>	DUT265L-265/ 250 (250/36x40-20N)	enthält eine Kupplungsscheibe / This part number includes one clutch disc	(45)
240 S 250 S,V				<b>1861 723 201 ▽#</b>	250/ 145GSPZ (26x32-10N)	Lose Kupplungsscheibe / Loose clutch disc	(30)	
				<b>1863 855 000</b>	106/140/25	mit Anlauftring / with thrust ring	(63)	
				<b>1863 837 002</b>	65/97/23	mit Anlauftring / with thrust ring	(63)	
					<b>1888 062 001 #</b>	DUT265L-265/ 250 (250/36x40-20N)	<b>-&gt;Chass. 246/0260</b> enthält eine Kupplungsscheibe / This part number includes one clutch disc	(45)
260 P				<b>1861 723 201 ▽#</b>	250/ 145GSPZ (26x32-10N)	<b>-&gt;Chass. 246/0260</b> Lose Kupplungsscheibe / Loose clutch disc	(30)	
				<b>1888 041 103 #</b>	DUT280L-295 (280/36x40-20N)	<b>Chass. 246/0261-&gt;</b> enthält eine Kupplungsscheibe / This part number includes one clutch disc	(45)	
				<b>1861 751 104 ▽#</b>	295GSPB (26x32-10N)	<b>Chass. 246/0261-&gt;</b> Lose Kupplungsscheibe / Loose clutch disc	(30)	
					<b>1863 837 002</b>	65/97/23	mit Anlauftring / with thrust ring	(63)
					<b>1863 855 000</b>	106/140/25	mit Anlauftring / with thrust ring	(63)













# FENDT

## FARMER





260 S		1888 062 001 #	DUT265L-265/ 250 (250/36x40-20N)	->Chass. 296/1249 enthält eine Kupplungsscheibe / This part number includes one clutch disc	(45)
		1861 723 201 ▽#	250/ 145GSPZ (26x32-10N)	->Chass. 296/1249 Lose Kupplungsscheibe / Loose clutch disc	(30)
		1888 041 103 #	DUT280L-295 (280/36x40-20N)	Chass. 296/1250-> enthält eine Kupplungsscheibe / This part number includes one clutch disc	(45)
		1861 751 104 ▽#	295GSPB (26x32-10N)	Chass. 296/1250-> Lose Kupplungsscheibe / Loose clutch disc	(30)
		1863 837 002	65/97/23	mit Anlauftring / with thrust ring	(63)
		1863 855 000	106/140/25	mit Anlauftring / with thrust ring	(63)
260 V		1888 062 001 #	DUT265L-265/ 250 (250/36x40-20N)	->Chass. 206/0875 enthält eine Kupplungsscheibe / This part number includes one clutch disc	(45)
		1861 723 201 ▽#	250/ 145GSPZ (26x32-10N)	->Chass. 206/0875 Lose Kupplungsscheibe / Loose clutch disc	(30)
		1888 041 103 #	DUT280L-295 (280/36x40-20N)	Chass. 206/0876 - Chass. 206/2792 enthält eine Kupplungsscheibe / This part number includes one clutch disc	(45)
		1888 068 001 #	DUT295L (280/36x40-20N)	Chass. 206/2793-> enthält eine Kupplungsscheibe / This part number includes one clutch disc	(45)
		1861 751 104 ▽#	295GSPB (26x32-10N)	Chass. 206/0876-> Lose Kupplungsscheibe / Loose clutch disc	(30)
		1863 837 002	65/97/23	mit Anlauftring / with thrust ring	(63)
270 P		1888 041 103 #	DUT280L-295 (280/36x40-20N)	->Chass. 247/0679 enthält eine Kupplungsscheibe / This part number includes one clutch disc	(45)
		1888 068 001 #	DUT295L (280/36x40-20N)	Chass. 247/0680-> enthält eine Kupplungsscheibe / This part number includes one clutch disc	(45)
		1861 751 104 ▽#	295GSPB (26x32-10N)	Lose Kupplungsscheibe / Loose clutch disc	(30)
		1863 837 002	65/97/23	mit Anlauftring / with thrust ring	(63)
		1863 855 000	106/140/25	mit Anlauftring / with thrust ring	(63)
270 V		1888 041 103 #	DUT280L-295 (280/36x40-20N)	->Chass. 270/7000 enthält eine Kupplungsscheibe / This part number includes one clutch disc	(45)
		1888 068 001 #	DUT295L (280/36x40-20N)	Chass. 270/7001-> enthält eine Kupplungsscheibe / This part number includes one clutch disc	(45)
		1861 751 104 ▽#	295GSPB (26x32-10N)	Lose Kupplungsscheibe / Loose clutch disc	(30)
		1863 837 002	65/97/23	mit Anlauftring / with thrust ring	(63)
		1863 855 000	106/140/25	mit Anlauftring / with thrust ring	(63)
275 S		1888 041 103 #	DUT280L-295 (280/36x40-20N)	->Chass. 297/4170 enthält eine Kupplungsscheibe / This part number includes one clutch disc	(45)
		1888 068 001 #	DUT295L (280/36x40-20N)	Chass. 297/4171-> enthält eine Kupplungsscheibe / This part number includes one clutch disc	(45)
		1861 751 104 ▽#	295GSPB (26x32-10N)	Lose Kupplungsscheibe / Loose clutch disc	(30)
		1863 837 002	65/97/23	mit Anlauftring / with thrust ring	(63)
		1863 855 000	106/140/25	mit Anlauftring / with thrust ring	(63)































# FENDT

FARMER											
275 V				1888 041 103 #	DUT280L-295 (280/36x40-20N)	->Chass. 208/1473 enthält eine Kupplungsscheibe / This part number includes one clutch disc (45)					
				1888 068 001 #	DUT295L (280/36x40-20N)	Chass. 208/1474-> enthält eine Kupplungsscheibe / This part number includes one clutch disc (45)					
				1861 751 104 ▽#	295GSPB (26x32-10N)	Lose Kupplungsscheibe / Loose clutch disc (30)					
				1863 855 000	106/140/25	mit Anlauftring / with thrust ring (63)					
				1863 837 002	65/97/23	mit Anlauftring / with thrust ring (63)					
280 P				1888 041 103 #	DUT280L-295 (280/36x40-20N)	->Chass. 248/1413 enthält eine Kupplungsscheibe / This part number includes one clutch disc (45)					
				1888 068 001 #	DUT295L (280/36x40-20N)	Chass. 248/1414-> enthält eine Kupplungsscheibe / This part number includes one clutch disc (45)					
				1861 751 104 ▽#	295GSPB (26x32-10N)	Lose Kupplungsscheibe / Loose clutch disc (30)					
				1863 837 002	65/97/23	mit Anlauftring / with thrust ring (63)					
				1863 855 000	106/140/25	mit Anlauftring / with thrust ring (63)					
280 S				1888 068 001 #	DUT295L (280/36x40-20N)	Chass. 297/7001-> enthält eine Kupplungsscheibe / This part number includes one clutch disc (45)					
				1861 751 104 ▽#	295GSPB (26x32-10N)	Chass. 297/7001-> Lose Kupplungsscheibe / Loose clutch disc (30)					
				1863 855 000	106/140/25	Chass. 297/7001-> mit Anlauftring / with thrust ring (63)					
				1863 837 002	65/97/23	Chass. 297/7001-> mit Anlauftring / with thrust ring (63)					
280 V				1888 068 001 #	DUT295L (280/36x40-20N)	Chass. 208/7001-> enthält eine Kupplungsscheibe / This part number includes one clutch disc (45)					
				1861 751 104 ▽#	295GSPB (26x32-10N)	Chass. 208/7001-> Lose Kupplungsscheibe / Loose clutch disc (30)					
				1863 855 000	106/140/25	Chass. 208/7001-> mit Anlauftring / with thrust ring (63)					
				1863 837 002	65/97/23	Chass. 208/7001-> mit Anlauftring / with thrust ring (63)					
303 S,LS,LSA 304 S,LS,LSA 305 S,LS,LSA 306 S,LS,LSA 307 LS,LSA 308 S,LS,LSA 309 S,LS,LSA				3800 541 012 #	GTF320N 320B	Nur zusammen verbauen / Only install together (35)					
				1882 347 102							
				1864 482 031							
								3151 000 395			
									3800 541 013 #	GTF330N 330B	
									1882 348 103		
									1864 477 101		
				3151 000 395							
					1863 869 027						
					20/42/12						
307 C 308 C 309 C				1888 000 023	DUT330L-330/ 295 (295/41x45-22N)	enthält eine Kupplungsscheibe / This part number includes one clutch disc (45)					
				1864 472 002 ▽#	330ZC (26x32-10N)	Anzahl der Beläge / Number of pads: 7 Lose Kupplungsscheibe / Loose clutch disc (7) (30)					
				1863 855 000	106/140/25	mit Anlauftring / with thrust ring (63)					
				3151 157 001							
				1863 869 027							
					20/42/12						
307 Ci 308 Ci 309 Ci				1882 348 103	GTF330N						
				1864 482 031	320B (26x32-10N)						
				3151 157 001							
				1863 869 027							
					20/42/12						
	Deutz			2100 038 031 ▲	VM121R						

# FENDT

FARMER							
310 LS,LSA 311 LS,LSA 312 LS,LSA					1882 348 103	GTF330N	
					1864 477 101	330B (26x32-10N)	
					3151 000 395		
					1863 869 027	20/42/12	

FAVORIT							
1 (FW 150/11) 2 (FW 150/11) 3 (FW 150/11)					1881 051 310 #	DO280 (Mo 280/23x29-10N) (Ge 250/46x50-8N)	enthält zwei Kupplungsscheiben / This part number includes both clutch discs (46)
					1863 600 123	65/101,5/26	mit Anlaufing / with thrust ring (63)
3 S					1864 634 002 ▽	280B (23x29-10N)	Lose Kupplungsscheibe / Loose clutch disc (30)
					1863 855 000	106/140/25	mit Anlaufing / with thrust ring (63)
					1863 837 002	65/97/23	mit Anlaufing / with thrust ring (63)
4 S					1880 092 415 #	G310	
					3151 000 395		
509 C 510 512 514 515					1863 869 027	20/42/12	
					1882 348 103	GTF330N	Chass. 511/0101->
					1864 477 101	330B (26x32-10N)	Chass. 511/0101->
					3151 000 395		Chass. 511/0101->
					1863 869 027	20/42/12	
600 LS (FW280)					1880 092 415 #	G310	
					1864 377 101	310B (26x32-10N)	
					3151 000 395		
610 LS					1880 092 415 #	G310	
					1864 377 101	310B (26x32-10N)	Chass. 281/1265->
					3151 000 395		
611 LS					1880 092 415 #	G310	->Chass. 282/0754
					1881 042 506 #	G350	Chass. 282/0755->
					1864 462 001 #	350ZC (41x45-22N)	Chass. 282/0755-> Anzahl der Beläge / Number of pads: 6 (7)
					3151 000 395		
611 LSA (382)					3482 050 301 #	GMFZ360	
					1864 456 001 #	360ZC (41x45-22N)	->Chass. 382/2737 Anzahl der Beläge / Number of pads: 6 (7)
					1864 300 006	350B (41x45-22N)	Chass. 382/2738->
					3151 156 003		
612					3482 050 301 #	GMFZ360	Chass. 383/0001->
					1864 456 001 #	360ZC (41x45-22N)	Chass. 383/0001-> Anzahl der Beläge / Number of pads: 6 (7)
					3151 156 003		Chass. 383/0001->



# FENDT

## FAVORIT

612 LS (283)			⊗	1881 042 506 #	G350		
614 LS (284)			⊗	1864 462 001 #	350ZC (41x45-22N)	Anzahl der Beläge / Number of pads: 6	(7)
615 LS (285)			⊙	3151 000 395			
612 LSA (383)			⊗	3482 050 301 #	GMFZ360		
614 LSA (384)			⊗	1864 456 001 #	360ZC (41x45-22N)	Anzahl der Beläge / Number of pads: 6	(7)
			⊙	3151 156 003			
615 LSA (385)			⊗	3482 050 301 #	GMFZ360	->Chass. 385/0152	
			⊗	1864 456 001 #	360ZC (41x45-22N)	->Chass. 385/0152 Anzahl der Beläge / Number of pads: 6	(7)
			⊙	3151 156 003		->Chass. 385/0152	

## FAVORIT VARIO 01.92 - 12.06

916 6 Zyl.	01.97 - 12.06	MAN	⊗	1863 869 027	20/42/12		
918 6 Zyl.	01.97 - 12.06						
920 6. Zyl	01.97 - 12.06						
924 6. Zyl	01.97 - 12.06						
926 6 Zyl.	01.96 - 12.06						



## FIX

2			⊗	1882 196 005	KS200		
			⊗	1864 634 028	200Z (23x29-10N)		
			⊙	3151 021 001			
			⌋	3130 014 000			
2 E			⊗	1880 071 008	K225		
			⊗	1860 039 024 #	225Z (23x29-10N)		

































## FL

FL 114			⊗	1882 315 002	KS180	6-Gang / 6 Speed	(4)
			⊗	1864 634 040	180E (23x29-10N)	6-Gang / 6 Speed	(4)
FL 120 FL 131			⊗	1880 071 008	K225		
			⊗	1860 039 024 #	225Z (23x29-10N)		
FL 236			⊗	1882 196 005	KS200		
			⊗	1864 634 030	200Z (26x32-10N)		
			⊙	1859 600 006			
			⌋	1805 042 000			
FL 237			⊗	1881 089 002	K225		
			⊗	1864 634 024	225Z (1 1/4"-10N)		
			⊙	1859 600 006			
			⌋	1805 042 000			

# FENDT





















FW							
FW 243 ,U				<b>1881 050 402 #</b>	DO250 (Ge 225/46x50-8N) (Mo 250/28x35-10N)	enthält zwei Kupplungsscheiben / This part number includes both clutch discs	(46)
				<b>1863 600 123</b>	65/101,5/26	mit Anlauftring / with thrust ring	(63)

## GERÄTETRÄGER / EQUIPMENT RACK

115 GT (FL116) 220 GT				<b>1882 196 005</b>	KS200		
				<b>1864 634 039</b>	200Z (23x29-10N)		
				<b>3151 093 041</b>			
				<b>1805 042 000</b>			
225 GT 230 GT 231 GT				<b>1890 006 101 #</b>	DO225 (Ge 200/42x48-8N) (Mo 225/21x26-10N)	enthält zwei Kupplungsscheiben / This part number includes both clutch discs	(46)
				<b>1863 010 100</b>	60/96,6/26	mit Anlauftring / with thrust ring	(63)
250 GT				<b>1888 027 304 #</b>	DUT250L (250/36x40-20N)	enthält eine Kupplungsscheibe / This part number includes one clutch disc	(45)
				<b>1861 723 201 ▽#</b>	250/ 145GSPZ (26x32-10N)	Lose Kupplungsscheibe / Loose clutch disc	(30)
				<b>1864 357 001 ●▽#</b>	250DC (26x32-10N)	Lose Kupplungsscheibe / Loose clutch disc	(30)
				<b>1863 855 000</b>	106/140/25	mit Anlauftring / with thrust ring	(63)
				<b>1863 837 002</b>	65/97/23	mit Anlauftring / with thrust ring	(63)
255 GT				<b>1888 041 103 #</b>	DUT280L-295 (280/36x40-20N)	->Chass. 255/0135 enthält eine Kupplungsscheibe / This part number includes one clutch disc	(45)
				<b>1861 751 104 ▽#</b>	295GSPB (26x32-10N)	Chass. 255/0136-> Lose Kupplungsscheibe / Loose clutch disc	(30)
				<b>1863 837 002</b>	65/97/23	mit Anlauftring / with thrust ring	(63)
				<b>1863 855 000</b>	106/140/25	mit Anlauftring / with thrust ring	(63)
275 GT				<b>1888 041 103 #</b>	DUT280L-295 (280/36x40-20N)	enthält eine Kupplungsscheibe / This part number includes one clutch disc	(45)
				<b>1861 751 104 ▽#</b>	295GSPB (26x32-10N)	Chass. 275/0540-> Lose Kupplungsscheibe / Loose clutch disc	(30)
				<b>1863 855 000</b>	106/140/25	mit Anlauftring / with thrust ring	(63)
				<b>1863 837 002</b>	65/97/23	mit Anlauftring / with thrust ring	(63)
275 GT (SA)				<b>1888 068 001 #</b>	DUT295L (280/36x40-20N)	enthält eine Kupplungsscheibe / This part number includes one clutch disc	(45)
				<b>1861 751 104 ▽#</b>	295GSPB (26x32-10N)	Lose Kupplungsscheibe / Loose clutch disc	(30)
				<b>1863 855 000</b>	106/140/25	mit Anlauftring / with thrust ring	(63)
				<b>1863 837 002</b>	65/97/23	mit Anlauftring / with thrust ring	(63)
345 GT				<b>1888 027 304 #</b>	DUT250L (250/36x40-20N)	enthält eine Kupplungsscheibe / This part number includes one clutch disc	(45)
				<b>1861 723 201 ▽#</b>	250/ 145GSPZ (26x32-10N)	Lose Kupplungsscheibe / Loose clutch disc	(30)
				<b>1888 041 103 #</b>	DUT280L-295 (280/36x40-20N)	enthält eine Kupplungsscheibe / This part number includes one clutch disc	(45)
				<b>1861 751 104 ▽#</b>	295GSPB (26x32-10N)	Lose Kupplungsscheibe / Loose clutch disc	(30)
				<b>3151 157 001</b>			
				<b>1863 855 000</b>	106/140/25	mit Anlauftring / with thrust ring	(63)
360 GT 365 GT				<b>1888 041 103 #</b>	DUT280L-295 (280/36x40-20N)	enthält eine Kupplungsscheibe / This part number includes one clutch disc	(45)
				<b>1861 751 104 ▽#</b>	295GSPB (26x32-10N)	Lose Kupplungsscheibe / Loose clutch disc	(30)
				<b>3151 157 001</b>			
				<b>1863 855 000</b>	106/140/25	mit Anlauftring / with thrust ring	(63)

# FENDT

## GERÄTETRÄGER / EQUIPMENT RACK

<b>370 GT</b>				<b>1888 068 001 #</b>	DUT295L (280/36x40-20N)	<b>Chass. 370/0101-&gt;</b> enthält eine Kupplungsscheibe / This part number includes one clutch disc	(45)
				<b>1861 751 104 ▽#</b>	295GSPB (26x32-10N)	<b>Chass. 370/0101-&gt;</b> Lose Kupplungsscheibe / Loose clutch disc	(30)
				<b>1863 855 000</b>	106/140/25	<b>Chass. 370/0101-&gt;</b> mit Anlauftring / with thrust ring	(63)
				<b>1863 837 002</b>	65/97/23	<b>Chass. 370/0101-&gt;</b> mit Anlauftring / with thrust ring	(63)
<b>380 GT</b>				<b>1888 051 401 #</b>	DUT320L-320/ 295 (295/36x40-20N)	<b>enthält eine Kupplungsscheibe / This part number includes one clutch disc</b>	(45)
				<b>1864 482 031 ▽</b>	320B (26x32-10N)	Lose Kupplungsscheibe / Loose clutch disc	(30)
				<b>1878 077 141 ●▽#</b>	320GTPB (26x32-10N)	Lose Kupplungsscheibe / Loose clutch disc	(30)
				<b>3151 157 001</b>			
				<b>1863 855 000</b>	106/140/25	mit Anlauftring / with thrust ring	(63)
<b>380 GT Turbo</b>				<b>1888 000 023</b>	DUT330L-330/ 295 (295/41x45-22N)	<b>enthält eine Kupplungsscheibe / This part number includes one clutch disc</b>	(45)
				<b>1864 472 002 ▽#</b>	330ZC (26x32-10N)	Anzahl der Beläge / Number of pads: 7 Lose Kupplungsscheibe / Loose clutch disc	(7) (30)
				<b>3151 157 001</b>			
				<b>1863 855 000</b>	106/140/25	mit Anlauftring / with thrust ring	(63)
<b>390 GT</b>				<b>1888 000 023</b>	DUT330L-330/ 295 (295/41x45-22N)	<b>Chass. 390/1001 - Chass. 390/0300</b> enthält eine Kupplungsscheibe / This part number includes one clutch disc	(45)
				<b>1864 472 002 ▽#</b>	330ZC (26x32-10N)	<b>Chass. 390/1001 - Chass. 390/0300</b> Anzahl der Beläge / Number of pads: 7 Lose Kupplungsscheibe / Loose clutch disc	(7) (30)
				<b>3151 157 001</b>			
				<b>1863 855 000</b>	106/140/25	mit Anlauftring / with thrust ring	(63)
<b>395 GT</b>				<b>1888 000 023</b>	DUT330L-330/ 295 (295/41x45-22N)	<b>-&gt;Chass. 390/0300</b> <b>Chass. 390/1001 - Chass. 395/0300</b> <b>Chass. 395/1001-&gt;</b> enthält eine Kupplungsscheibe / This part number includes one clutch disc	(45)
				<b>1864 472 002 ▽#</b>	330ZC (26x32-10N)	<b>-&gt;Chass. 390/0300</b> <b>Chass. 39071001 - Chass. 395/0300</b> <b>Chass. 395/1001-&gt;</b> Anzahl der Beläge / Number of pads: 7 Lose Kupplungsscheibe / Loose clutch disc	(7) (30)
				<b>3151 157 001</b>			
				<b>1863 855 000</b>	106/140/25	mit Anlauftring / with thrust ring	(63)

## VARIO 01.06 -



<b>712 Vario</b> 6. Zyl	01.06 -	DeutzTCD201 3L06, DeutzTCD201 2L064V		<b>1863 869 027</b>	20/42/12		
<b>714 Vario</b> 6. Zyl	01.06 -						
<b>716 Vario</b> 6. Zyl	01.06 -						
<b>718 Vario</b> 6. Zyl	01.06 -						
<b>818 Vario</b> 6. Zyl	01.06 - 12.10						
<b>820 Vario</b> 6. Zyl	01.06 - 12.10						
<b>924 Vario</b> 6. Zyl	01.06 - 12.10						
<b>924</b> 6. Zyl	01.11 -						
<b>930 Vario</b> 6. Zyl	01.06 - 12.10						
<b>930</b> 6. Zyl	01.11 -						







					Parameter		
---	--	--	--	--	-----------	---	---

# FENDT





<b>XYLON</b>							
Xylon 520,522,524				<b>1863 869 027</b>	20/42/12		

# FIATAGRI





























<b>A 90 - A 140</b>							
A 90 S,DT A 100 S,DT A 110 S,DT	01.84- 01.84-			<b>1888 600 133</b> HD	DUT310/ 310 (310/40x45-16N)	enthält eine Kupplungsscheibe / This part number includes one clutch disc	(45)
				<b>1888 876 102</b> #	DUT310 (310/40x45-16N)	enthält eine Kupplungsscheibe / This part number includes one clutch disc	(45)
				<b>1864 914 003</b> ▽#	310 (24x28-10N)	Lose Kupplungsscheibe / Loose clutch disc	(30)
				<b>1863 839 000</b>	75/115/20	ohne Anlauftring / without thrust ring	(79)
				<b>1863 838 001</b>	50/82/29	ohne Anlauftring / without thrust ring	(79)
A 140 DT				<b>3482 870 001</b> #	M350		
				<b>1862 724 002</b> #	350CC (45x50-18N)	Anzahl der Beläge / Number of pads: 8	(7)

<b>L-Serie</b>							
L 60				<b>1888 600 113</b>	DUT280 (280/40x45-16N)	enthält eine Kupplungsscheibe / This part number includes one clutch disc	(45)
				<b>1864 600 327</b>	280 (22x25-10N)		
				<b>1863 838 001</b>	50/82/29	ohne Anlauftring / without thrust ring	(79)
				<b>1863 858 001</b>	75/115/20	ohne Anlauftring / without thrust ring	(79)
L 65				<b>1888 600 106</b>	DUT310 (310/40x45-16N)	enthält eine Kupplungsscheibe / This part number includes one clutch disc	(45)
				<b>1864 600 302</b>	310 (22x25-10N)		
				<b>1863 838 001</b>	50/82/29	ohne Anlauftring / without thrust ring	(79)
				<b>1863 858 001</b>	75/115/20	ohne Anlauftring / without thrust ring	(79)
L 75 L 85				<b>1888 600 149</b>	DUT310/ CERAM (310/40x45-16N)	enthält eine Kupplungsscheibe / This part number includes one clutch disc	(45)
				<b>1864 600 302</b>	310 (22x25-10N)		
				<b>1863 838 001</b>	50/82/29	ohne Anlauftring / without thrust ring	(79)
				<b>1863 858 001</b>	75/115/20	ohne Anlauftring / without thrust ring	(79)
L 95				<b>3800 541 008</b> ☹  <b>3482 600 104</b>  <b>1878 600 518</b>	MF310 310GSDC		

<b>MATRESA</b>							
Matresa 880				<b>1888 885 002</b> #	DUT280 (280/40x45-16N)	enthält eine Kupplungsscheibe / This part number includes one clutch disc	(45)





<b>Winner Serie</b>							
F 100, TD	04.90 - 12.94			<b>3800 541 009</b> ☹  <b>3482 600 113</b>  <b>1878 600 552</b>	M330 330CBC		
F 110, TD	04.90 - 12.93						
F 115, TD	04.93 - 12.95						
F 120, TD	04.90 - 12.93						
F 130, TD	04.90 - 12.90			<b>3482 600 114</b>	M350		
F 140, TD	04.93 - 12.95			<b>1878 600 553</b>	350CBC (45x50-18N)	Anzahl der Beläge / Number of pads: 6	(7)
				<b>3151 600 561</b>			







# FIATAGRI

35... - 88-							
35-66 DT				<b>1888 600 125</b>	DUT230/ 230 (225/31x35-18N)	enthält eine Kupplungsscheibe / This part number includes one clutch disc	(45)
				<b>1864 600 330</b>	225 (14,4x17-9N)		
45-66 DT				<b>1864 916 001</b> ▽#	250 (19x22-13N)	Lose Kupplungsscheibe / Loose clutch disc	(30)
50-66 DT				<b>1863 838 000</b>	70/110/20	ohne Anlauftring / without thrust ring	(79)
50-86 DT				<b>1863 838 001</b>	50/82/29	ohne Anlauftring / without thrust ring	(79)
55-76 DT							
50-86S/V 55-66S 56-66S 60-86, D,F,S,V 70-86S,V	03.92- 12.92- 12.92- 03.92- 03.92-			<b>1888 600 131</b>	DUT280/ 280 (280/31x35-18N)	für Fahrzeuge mit Zweischeibenkupplung / for vehicles with double disc clutch enthält eine Kupplungsscheibe / This part number includes one clutch disc	(51) (45)
				<b>1864 600 337</b> ▽	280 (19x22-13N)	Lose Kupplungsscheibe / Loose clutch disc	(30)
				<b>1863 838 001</b>	50/82/29	ohne Anlauftring / without thrust ring	(79)
55-46 DT				<b>1888 600 140</b> #	DUT280/ CERAM (280/35x40-14N)	enthält eine Kupplungsscheibe / This part number includes one clutch disc	(45)
55-66 DT				<b>1888 600 141</b> ●#	DUT280 (280/35x40-14N)	enthält eine Kupplungsscheibe / This part number includes one clutch disc	(45)
55-90 DT				<b>1864 600 353</b> ▽	280 (22x25-10N)	Lose Kupplungsscheibe / Loose clutch disc	(30)
60-66 DT				<b>1863 838 001</b>	50/82/29	ohne Anlauftring / without thrust ring	(79)
60-76 DT				<b>1863 838 000</b>	70/110/20	ohne Anlauftring / without thrust ring	(79)
60-90 DT							
62-86 DT							
65-66 DT							
65-90 DT							
65-93 DT							
65-94 DT							
70-66 DT							
70-76 DT							
70-88 DT							
70-90 DT							
72-86 DT							
80-76 DT							
80-88 DT							
80-90 DT							
82-86 DT							
85-90 DT							
55-66 LP/S 80-66 /DT/F				<b>1888 869 004</b> #	DUT280 (280/35x40-14N)	enthält eine Kupplungsscheibe / This part number includes one clutch disc	(45)
				<b>1864 600 353</b>	280 (22x25-10N)		
				<b>1863 838 001</b>	50/82/29	ohne Anlauftring / without thrust ring	(79)
				<b>1863 838 000</b>	70/110/20	ohne Anlauftring / without thrust ring	(79)
72-93 DT 72-94 DT 80-66 DT				<b>1888 600 141</b> #	DUT280 (280/35x40-14N)	enthält eine Kupplungsscheibe / This part number includes one clutch disc	(45)
				<b>1888 600 140</b> ●#	DUT280/ CERAM (280/35x40-14N)	enthält eine Kupplungsscheibe / This part number includes one clutch disc	(45)
				<b>3800 541 025</b> ●#  <b>1888 998 502</b>  <b>1864 600 353</b>	DUT280 280		
				<b>1864 600 353</b> ▽	280 (22x25-10N)	Lose Kupplungsscheibe / Loose clutch disc	(30)
				<b>1863 838 001</b>	50/82/29	ohne Anlauftring / without thrust ring	(79)
				<b>1863 838 000</b>	70/110/20	ohne Anlauftring / without thrust ring	(79)
				<b>3800 541 025</b> #  <b>1888 998 502</b>  <b>1864 600 353</b>	DUT280 280		
82-93 DT 82-94 DT 88-93 DT 88-94 DT				<b>1863 838 000</b>	70/110/20	ohne Anlauftring / without thrust ring	(79)
				<b>1863 838 001</b>	50/82/29	ohne Anlauftring / without thrust ring	(79)

					Parameter		
---	--	--	--	--	-----------	---	---

## FIATAGRI

90.. - 180-..							
90-90 DT 90-95 DT 100-90 DT 110-90 DT	01.84-12.91 01.84- 01.84- 01.84-			1888 600 133 HD	DUT310/ 310 (310/40x45-16N)	enthält eine Kupplungsscheibe / This part number includes one clutch disc	(45)
				1888 876 102 #	DUT310 (310/40x45-16N)	enthält eine Kupplungsscheibe / This part number includes one clutch disc	(45)
				1864 914 003 ▽#	310 (24x28-10N)	Lose Kupplungsscheibe / Loose clutch disc	(30)
				1863 839 000	75/115/20	ohne Anlauftring / without thrust ring	(79)
				1863 838 001	50/82/29	ohne Anlauftring / without thrust ring	(79)
115-90 DT	01.84-			3482 870 001 #	M350	mit hydraulischer Zapfwelle / with hydraulic PTO shaft	(73)
				1862 724 002 #	350CC (45x50-18N)	Anzahl der Beläge / Number of pads: 8 mit hydraulischer Zapfwelle / with hydraulic PTO shaft	(7) (73)
130-90, DT 140-90, DT	01.84-12.90 01.84-12.95			3482 870 001 #	M350		
				1862 724 002 #	350CC (45x50-18N)	Anzahl der Beläge / Number of pads: 8	(7)
				1866 600 012		Getr. / GBox: Powershift	
160-90, DT 180-90, DT	01.84-12.95 01.84-12.95			1863 837 002	65/97/23	mit Anlauftring / with thrust ring	(63)
				1866 600 012		Getr. / GBox: Powershift	











366 - 480							
366 420				1864 916 001 ▽#	250 (19x22-13N)	Lose Kupplungsscheibe / Loose clutch disc	(30)
				1863 838 000	70/110/20	ohne Anlauftring / without thrust ring	(79)
				1863 838 001	50/82/29	ohne Anlauftring / without thrust ring	(79)
446 466				1888 600 140 #	DUT280/ CERAM (280/35x40-14N)	enthält eine Kupplungsscheibe / This part number includes one clutch disc	(45)
				1888 600 141 ●#	DUT280 (280/35x40-14N)	enthält eine Kupplungsscheibe / This part number includes one clutch disc	(45)
				1888 869 004 #	DUT280 (280/35x40-14N)	enthält eine Kupplungsscheibe / This part number includes one clutch disc	(45)
				1864 600 353 ▽	280 (22x25-10N)	Lose Kupplungsscheibe / Loose clutch disc	(30)
				1863 838 001	50/82/29	ohne Anlauftring / without thrust ring	(79)
				1863 838 000	70/110/20	ohne Anlauftring / without thrust ring	(79)
450 480				1888 600 140 #	DUT280/ CERAM (280/35x40-14N)	enthält eine Kupplungsscheibe / This part number includes one clutch disc	(45)
				1888 600 141 ●#	DUT280 (280/35x40-14N)	enthält eine Kupplungsscheibe / This part number includes one clutch disc	(45)
				1864 600 353 ▽	280 (22x25-10N)	Lose Kupplungsscheibe / Loose clutch disc	(30)
				1863 838 001	50/82/29	ohne Anlauftring / without thrust ring	(79)
				1863 838 000	70/110/20	ohne Anlauftring / without thrust ring	(79)
470 Schmalspur				1888 887 001 #	DUT225 (225/31x35-18N)	enthält eine Kupplungsscheibe / This part number includes one clutch disc	(45)
470 SSP				1888 887 001 #	DUT225 (225/31x35-18N)	Allrad / All-wheel Drive enthält eine Kupplungsscheibe / This part number includes one clutch disc	(6) (45)
470 DTVE				1888 869 004 #	DUT280 (280/35x40-14N)	enthält eine Kupplungsscheibe / This part number includes one clutch disc	(45)
				1864 600 353 ▽	280 (22x25-10N)	Lose Kupplungsscheibe / Loose clutch disc	(30)

500 - 580							
500, DT 540 550 580				1888 600 140 #	DUT280/ CERAM (280/35x40-14N)	enthält eine Kupplungsscheibe / This part number includes one clutch disc	(45)
				1888 600 141 ●#	DUT280 (280/35x40-14N)	enthält eine Kupplungsscheibe / This part number includes one clutch disc	(45)
				1864 600 353 ▽	280 (22x25-10N)	Lose Kupplungsscheibe / Loose clutch disc	(30)
				1863 838 001	50/82/29	ohne Anlauftring / without thrust ring	(79)
				1863 838 000	70/110/20	ohne Anlauftring / without thrust ring	(79)













# FIATAGRI













## 500 - 580



566				1888 600 140 #	DUT280/ CERAM (280/35x40-14N)	enthält eine Kupplungsscheibe / This part number includes one clutch disc	(45)
				1888 600 141 ●#	DUT280 (280/35x40-14N)	enthält eine Kupplungsscheibe / This part number includes one clutch disc	(45)
				1888 869 004 #	DUT280 (280/35x40-14N)	enthält eine Kupplungsscheibe / This part number includes one clutch disc	(45)
				1864 600 353 ▽	280 (22x25-10N)	Lose Kupplungsscheibe / Loose clutch disc	(30)
				1863 838 001	50/82/29	ohne Anlauffring / without thrust ring	(79)
				1863 838 000	70/110/20	ohne Anlauffring / without thrust ring	(79)
570				1888 869 004 #	DUT280 (280/35x40-14N)	enthält eine Kupplungsscheibe / This part number includes one clutch disc	(45)
				1864 600 353	280 (22x25-10N)		
				1863 838 001	50/82/29	ohne Anlauffring / without thrust ring	(79)
				1863 838 000	70/110/20	ohne Anlauffring / without thrust ring	(79)

## 600 - 780





600 640 666 670 680, DT 740, DT 766, DT				1888 600 140 #	DUT280/ CERAM (280/35x40-14N)	enthält eine Kupplungsscheibe / This part number includes one clutch disc	(45)
				1888 600 141 ●#	DUT280 (280/35x40-14N)	enthält eine Kupplungsscheibe / This part number includes one clutch disc	(45)
				1864 600 353 ▽	280 (22x25-10N)	Lose Kupplungsscheibe / Loose clutch disc	(30)
				1863 838 001	50/82/29	ohne Anlauffring / without thrust ring	(79)
				1863 838 000	70/110/20	ohne Anlauffring / without thrust ring	(79)
			780, DT				1888 600 140 #
	1888 600 141 ●#	DUT280 (280/35x40-14N)				Nicht mit VALEO austauschbar / Do not change with VALEO enthält eine Kupplungsscheibe / This part number includes one clutch disc	(32) (45)
	1864 600 353 ▽	280 (22x25-10N)				Lose Kupplungsscheibe / Loose clutch disc Nicht mit VALEO austauschbar / Do not change with VALEO	(30) (32)
	1863 838 001	50/82/29				Nicht mit VALEO austauschbar / Do not change with VALEO ohne Anlauffring / without thrust ring	(32) (79)
	1863 838 000	70/110/20				Nicht mit VALEO austauschbar / Do not change with VALEO ohne Anlauffring / without thrust ring	(32) (79)

## 880 - 1180











880/4,DT				1864 914 003 ▽#	310 (24x28-10N)	Lose Kupplungsscheibe / Loose clutch disc	(30)
				1863 838 000	70/110/20	ohne Anlauffring / without thrust ring	(79)
				1863 838 001	50/82/29	ohne Anlauffring / without thrust ring	(79)
880/5,DT 980,DT				1888 600 133 HD	DUT310/ 310 (310/40x45-16N)	enthält eine Kupplungsscheibe / This part number includes one clutch disc	(45)
				1888 876 102 #	DUT310 (310/40x45-16N)	enthält eine Kupplungsscheibe / This part number includes one clutch disc	(45)
				1864 914 003 ▽#	310 (24x28-10N)	Lose Kupplungsscheibe / Loose clutch disc	(30)
				1863 838 001	50/82/29	ohne Anlauffring / without thrust ring	(79)
				1863 838 000	70/110/20	ohne Anlauffring / without thrust ring	(79)
1180				1863 855 000	106/140/25	mit Anlauffring / with thrust ring	(63)
				1863 837 002	65/97/23	mit Anlauffring / with thrust ring	(63)
1180 DT	-10.83			3482 870 001 #	M350		
				1862 724 002 #	350CC (45x50-18N)	Anzahl der Beläge / Number of pads: 8	(7)



					Parameter		
---	--	--	--	--	-----------	---	---









## FIATAGRI

1280 - 4135							
1280	- 10.83			3482 870 001 #	M350		
1380	- 10.83						
1580	- 10.83			1862 724 002 #	350CC (45x50-18N)	Anzahl der Beläge / Number of pads: 8	(7)
1880	- 10.83						
4135	01.96 - 12.99			1888 600 131	DUT280/ 280 (280/31x35-18N)	für Fahrzeuge mit Zweischeibenkupplung / for vehicles with double disc clutch enthält eine Kupplungsscheibe / This part number includes one clutch disc	(51) (45)
				1864 600 337 ▽	280 (19x22-13N)	Lose Kupplungsscheibe / Loose clutch disc	(30)
				1863 838 001	50/82/29	ohne Anlauffring / without thrust ring	(79)

## FORD NEW HOLLAND





Fordson							
8009				1882 137 307 #	GF310		
				1864 355 102	310Z (1 3/8"-10N)		
8030	01.82 - 12.91			1882 230 209	HVB280	Nur bei Altteil-Rückgabe lieferbar (Reparatur; Werk Bielefeld) / Please return old unit for repair (plant Bielefeld)	(33)
8040	01.81 - 12.91						
8468				1864 330 204	280Z (1 3/8"-10N)		
8050	01.80 - 12.88			1882 137 307 #	GF310		
8060	01.82 - 12.87			1864 355 102	310Z (1 3/8"-10N)		
8070	01.78 - 12.86			3163 030 102			
8055	01.83 - 12.91			3482 008 110	MF310		
				1864 355 102	310Z (1 3/8"-10N)		
				3163 030 102			

Fordson TF							
42	01.83 - 12.93			1882 110 532 #	GF350		
				3163 030 102			









Fordson TX							
30	01.87 - 12.94			1882 137 307 #	GF310		
32	01.87 - 12.94			1864 355 102	310Z (1 3/8"-10N)		
				3163 030 102			
				1882 110 532 #	GF350	Je nach Kundenwunsch mit unterschiedlicher Kupplung / Equipped with different clutch according to customer requirement	(26)
				1864 300 007	350B (1 3/8"-10N)	Je nach Kundenwunsch mit unterschiedlicher Kupplung / Equipped with different clutch according to customer requirement	(26)
				3163 030 102			
34	01.87 - 12.94			1882 110 532 #	GF350		
				1864 300 007	350B (1 3/8"-10N)		
				3163 030 102			

# FORD NEW HOLLAND



















## Industrial

<b>335/340/345</b> <b>420/445/515</b> <b>532/535/540</b> <b>545/550/555</b>	01.75 - 12.78 01.75 - 12.78 01.75 - 12.78	    	<b>3482 600 109</b>	MF330N	Getr. / GBox: live drive	
			<b>1864 600 316</b>	330 (20x25-15N)	Getr. / GBox: live drive	
			<b>1878 600 526</b>	330CB (20,2x25,5-10N)	Getr. / GBox: live drive	
			<b>1864 600 343</b>	330E (1" - 10N)	Getr. / GBox: non live drive	
			<b>1863 600 118</b>	63,5/100,2/22	mit Anlauftring / with thrust ring	(63)

## TW



















<b>TW 5</b> <b>TW 10</b>	01.83 - 02.90 11.79 - 11.82	  	<b>1878 600 520</b>	321CBC (1 3/4"-10N)	Anzahl der Beläge / Number of pads: 7	(7)
			<b>1863 600 118</b>	63,5/100,2/22	mit Anlauftring / with thrust ring	(63)
			<b>1863 869 015</b>	36,5/68/15		
<b>TW 15</b> <b>TW 20</b> <b>TW 25</b> <b>TW 30</b> <b>TW 35</b>	01.83 - 02.90 11.79 - 11.82 01.83 - 02.90 11.79 - 11.82 01.83 - 02.90	    	<b>3482 600 124</b>	M350		
			<b>1878 600 578</b>	350BC (1 3/4"-10N)	Anzahl der Beläge / Number of pads: 6	(7)
			<b>1863 869 015</b>	36,5/68/15		

## TS-Serie















<b>TS 80</b>	01.97 - 12.03	   	<b>3482 600 105</b>	MF330	Getr. / GBox: 8x2	
			<b>1878 600 520</b>	321CBC (1 3/4"-10N)	Getr. / GBox: 8x2 Anzahl der Beläge / Number of pads: 7	(7)
			<b>1863 600 118</b>	63,5/100,2/22	Getr. / GBox: 8x2 mit Anlauftring / with thrust ring	(63)
			<b>1863 869 015</b>	36,5/68/15		
<b>TS 90</b> <b>TS 100</b> <b>TS 110</b>	01.97 - 12.03 01.97 - 12.03 01.97 - 12.03	        	<b>3482 600 105</b>	MF330	Getr. / GBox: 8x2	
			<b>1878 600 520</b>	321CBC (1 3/4"-10N)	Getr. / GBox: 8x2 Anzahl der Beläge / Number of pads: 7	(7)
			<b>1863 600 118</b>	63,5/100,2/22	Getr. / GBox: 8x2 mit Anlauftring / with thrust ring	(63)
			<b>3482 600 105</b>	MF330	Getr. / GBox: 12x12	
			<b>1878 600 519</b>	327CB (1 3/4"-10N)	Getr. / GBox: 12x12	
			<b>1878 600 520 ●</b>	321CBC (1 3/4"-10N)	Getr. / GBox: 12x12 Anzahl der Beläge / Number of pads: 7	(7)
			<b>3182 001 307</b>	HHIS-3	Getr. / GBox: 12x12 Füllmedium: Hydrauliköl / Fill Medium: Hydraulic Oil Füllmedium: Bioöl / Fill Medium: Bio Oil Immer erneuern / Renew everytime	(19) (17) (22)
			<b>1866 600 010</b>		Getr. / GBox: 16x16 für Motorzapfwelle / for engine PTO shaft	(56)
			<b>1863 869 015</b>	36,5/68/15		
<b>TS 115</b>	01.98 - 12.03	     	<b>3482 600 105</b>	MF330	Getr. / GBox: 12x12	
			<b>1878 600 519</b>	327CB (1 3/4"-10N)	Getr. / GBox: 12x12	
			<b>1878 600 520 ●</b>	321CBC (1 3/4"-10N)	Getr. / GBox: 12x12 Anzahl der Beläge / Number of pads: 7	(7)
			<b>3182 001 307</b>	HHIS-3	Getr. / GBox: 12x12 Füllmedium: Hydrauliköl / Fill Medium: Hydraulic Oil Füllmedium: Bioöl / Fill Medium: Bio Oil Immer erneuern / Renew everytime	(19) (17) (22)
			<b>1866 600 010</b>		Getr. / GBox: 16x16 für Motorzapfwelle / for engine PTO shaft	(56)
			<b>1863 869 015</b>	36,5/68/15		

## FORD NEW HOLLAND

### 230 - 545

















<b>230A</b>	01.81 - 12.83			<b>1882 600 103</b>	H280N	für Nebenantrieb / for PTO Druckplatte mit 4 Hebeln / pressure plate with 4 levers	(57) (13)
<b>334</b>	01.81 - 12.84			<b>1882 600 105</b>	H280	Druckplatte mit 3 Hebeln / pressure plate with 3 levers	(12)
<b>335</b>	01.75 -			<b>1878 600 524</b>	280CB (1" -10N)		
<b>530A</b>	01.81 - 12.83			<b>1863 600 118</b>	63,5/100,2/22	mit Anlauftring / with thrust ring	(63)
<b>231</b>	01.75 - 12.81			<b>1882 600 105</b>	H280	Druckplatte mit 3 Hebeln / pressure plate with 3 levers	(12)
				<b>1878 600 524</b>	280CB (1" -10N)		
				<b>1864 600 315</b>	280C (1" -10N)		
				<b>1863 600 118</b>	63,5/100,2/22	mit Anlauftring / with thrust ring	(63)
<b>233</b>	01.75 - 12.81			<b>1882 600 105</b>	H280	Druckplatte mit 3 Hebeln / pressure plate with 3 levers	(12)
				<b>1882 600 103</b>	H280N	für Nebenantrieb / for PTO Druckplatte mit 4 Hebeln / pressure plate with 4 levers	(57) (13)
				<b>1878 600 524</b>	280CB (1" -10N)		
				<b>1864 600 315</b>	280C (1" -10N)		
				<b>1863 600 118</b>	63,5/100,2/22	mit Anlauftring / with thrust ring	(63)
<b>234</b>	01.75 - 12.83			<b>1882 600 105</b>	H280	Druckplatte mit 3 Hebeln / pressure plate with 3 levers	(12)
				<b>1878 600 524</b>	280CB (1" -10N)		
				<b>1863 600 118</b>	63,5/100,2/22	mit Anlauftring / with thrust ring	(63)
<b>445 C/D</b> <b>545 C/D</b>	01.88 - 12.00 01.88 - 12.00			<b>3482 600 109</b>	MF330N		
				<b>1878 600 524</b>	280CB (1" -10N)		
				<b>1863 600 118</b>	63,5/100,2/22	mit Anlauftring / with thrust ring	(63)

### 2000 - 3000

















<b>2000</b>	01.64 - 12.75			<b>1882 600 105</b>	H280	Druckplatte mit 3 Hebeln / pressure plate with 3 levers	(12)	
<b>2100</b>	01.65 - 12.74			<b>1882 600 103</b>	H280N	für Nebenantrieb / for PTO Druckplatte mit 4 Hebeln / pressure plate with 4 levers	(57) (13)	
<b>2110</b>	01.83 - 12.87				<b>1864 600 315</b>	280C (1" -10N)		
<b>2120</b>	01.65 - 12.74				<b>1878 600 524</b>	280CB (1" -10N)		
<b>2150</b>	01.70 - 12.74				<b>1863 600 118</b>	63,5/100,2/22	mit Anlauftring / with thrust ring	(63)
<b>2300</b>	01.65 - 12.74				<b>1863 869 015</b>	36,5/68/15		
<b>2310</b>	01.82 - 12.85					<b>1882 600 105</b>	H280	Druckplatte mit 3 Hebeln / pressure plate with 3 levers
<b>2600</b>	01.75 - 12.81			<b>1882 600 103</b>	H280N	für Nebenantrieb / for PTO Druckplatte mit 4 Hebeln / pressure plate with 4 levers	(57) (13)	
					<b>1878 600 524</b>	280CB (1" -10N)		
				<b>1864 600 315</b>	280C (1" -10N)			
					<b>1863 600 118</b>	63,5/100,2/22	mit Anlauftring / with thrust ring	(63)
			<b>2610/N/V</b>	01.81 - 12.83			<b>1882 600 105</b>	H280
	<b>1878 600 524</b>	280CB (1" -10N)						
	<b>1863 600 118</b>	63,5/100,2/22				mit Anlauftring / with thrust ring	(63)	

## FORD NEW HOLLAND

### 2000 - 3000

































<b>2610</b>	01.82 - 12.83		<b>1882 600 106</b>	H280N		
			<b>1878 600 524</b>	280CB (1" -10N)		
			<b>1864 600 315</b>	280C (1" -10N)		
			<b>1863 600 118</b>	63,5/100,2/22	mit Anlauftring / with thrust ring	(63)
			<b>3482 600 109</b>	MF330N		
			<b>1878 600 526</b>	330CB (20,2x25,5-10N)		
			<b>1864 600 316</b>	330 (20x25-15N)		
			<b>1864 600 343</b>	330E (1" - 10N)		
			<b>1863 600 118</b>	63,5/100,2/22	mit Anlauftring / with thrust ring	(63)
<b>2810</b> <b>2910</b>	01.84 - 12.90 01.81 - 12.89		<b>1882 600 105</b>	H280	Druckplatte mit 3 Hebeln / pressure plate with 3 levers	(12)
			<b>1882 600 106</b>	H280N		
			<b>1878 600 524</b>	280CB (1" -10N)		
			<b>1863 600 118</b>	63,5/100,2/22	mit Anlauftring / with thrust ring	(63)
			<b>3482 600 109</b>	MF330N		
			<b>1878 600 526</b>	330CB (20,2x25,5-10N)		
			<b>1864 600 316</b>	330 (20x25-15N)		
			<b>1863 600 118</b>	63,5/100,2/22	mit Anlauftring / with thrust ring	(63)

### 3000 - 4000

<b>3000</b> <b>3055</b> <b>3100</b> <b>3110</b> <b>3120</b> <b>3150</b>	01.64 - 12.75 01.72 - 12.75 01.65 - 12.74 01.65 - 12.74 01.65 - 12.74 01.65 - 12.74		<b>1882 600 103</b>	H280N	für Nebenantrieb / for PTO Druckplatte mit 4 Hebeln / pressure plate with 4 levers	(57) (13)
			<b>1864 600 340</b>	280E (1" -15N)		
			<b>1878 600 524</b> ●	280CB (1" -10N)		
			<b>1863 600 118</b>	63,5/100,2/22	mit Anlauftring / with thrust ring	(63)
			<b>1882 600 112</b> ▲	H280	Druckplatte mit 4 Hebeln / pressure plate with 4 levers	(13)
			<b>1864 600 340</b>	280E (1" -15N)		
			<b>1863 600 118</b>	63,5/100,2/22	mit Anlauftring / with thrust ring	(63)
			<b>1882 600 105</b>	H280	Druckplatte mit 3 Hebeln / pressure plate with 3 levers	(12)
			<b>1864 600 315</b>	280C (1" -10N)	je nach Ausführung, mit unterschiedlicher Kupplung / depending on version, with different clutch	(61)
			<b>1878 600 524</b>	280CB (1" -10N)	je nach Ausführung, mit unterschiedlicher Kupplung / depending on version, with different clutch	(61)
			<b>1863 600 118</b>	63,5/100,2/22	mit Anlauftring / with thrust ring	(63)
			<b>1888 600 139</b>	DOT280/ 225 (225/44x48-29N)	enthält eine Kupplungsscheibe / This part number includes one clutch disc	(45)
			<b>1864 600 340</b>	280E (1" -15N)		
			<b>1878 600 524</b> ●	280CB (1" -10N)		
			<b>1864 600 315</b>	280C (1" -10N)	je nach Ausführung, mit unterschiedlicher Kupplung / depending on version, with different clutch	(61)
			<b>1863 600 118</b>	63,5/100,2/22	mit Anlauftring / with thrust ring	(63)
			<b>1863 869 015</b>	36,5/68/15		

# FORD NEW HOLLAND

## 3000 - 4000































3230 3430 3630	01.90 - 12.93 01.90 - 12.95			<b>3482 600 109</b>	MF330N			
				<b>1864 600 343</b>	330E (1" - 10N)	je nach Ausführung, mit unterschiedlicher Kupplung / depending on version, with different clutch	(61)	
				<b>1878 600 526</b>	330CB (20,2x25,5-10N)	je nach Ausführung, mit unterschiedlicher Kupplung / depending on version, with different clutch	(61)	
				<b>1863 600 118</b>	63,5/100,2/22	mit Anlauftring / with thrust ring	(63)	
				<b>3482 600 122</b>	MF330N	für / for: Synchro	(47)	
				<b>1864 600 343</b>	330E (1" - 10N)	für / for: Synchro je nach Ausführung, mit unterschiedlicher Kupplung / depending on version, with different clutch	(47) (61)	
				<b>1878 600 526</b>	330CB (20,2x25,5-10N)	für / for: Synchro je nach Ausführung, mit unterschiedlicher Kupplung / depending on version, with different clutch	(47) (61)	
				<b>1863 600 118</b>	63,5/100,2/22	für / for: Synchro mit Anlauftring / with thrust ring	(47) (63)	
3300 3310 3330	01.65 - 12.74 01.65 - 12.74 01.65 - 12.74			<b>1882 600 105</b>	H280	Druckplatte mit 3 Hebeln / pressure plate with 3 levers	(12)	
				<b>1882 600 103</b>	H280N	für Nebenantrieb / for PTO Druckplatte mit 4 Hebeln / pressure plate with 4 levers	(57) (13)	
				<b>1878 600 524</b>	280CB (1" -10N)			
				<b>1864 600 315</b>	280C (1" -10N)			
				<b>1863 600 118</b>	63,5/100,2/22	mit Anlauftring / with thrust ring	(63)	
				<b>1863 869 015</b>	36,5/68/15			
3400 3500	01.65 - 12.75 01.65 - 12.74			<b>1882 600 105</b>	H280	Druckplatte mit 3 Hebeln / pressure plate with 3 levers	(12)	
				<b>1882 600 103</b>	H280N	für Nebenantrieb / for PTO Druckplatte mit 4 Hebeln / pressure plate with 4 levers	(57) (13)	
				<b>1878 600 524</b>	280CB (1" -10N)			
				<b>1864 600 315</b>	280C (1" -10N)			
				<b>1863 600 118</b>	63,5/100,2/22	mit Anlauftring / with thrust ring	(63)	
				<b>3482 600 109</b>	MF330N			
				<b>1864 600 316</b>	330 (20x25-15N)			
				<b>1864 600 343</b>	330E (1" - 10N)			
				<b>1878 600 526</b>	330CB (20,2x25,5-10N)			
				<b>1863 600 118</b>	63,5/100,2/22	mit Anlauftring / with thrust ring	(63)	
3435 3830 3935	01.96 - 12.99 01.93 -			<b>1864 916 001 #</b>	250 (19x22-13N)			
3550	01.65 - 12.74			<b>1882 600 105</b>	H280	Druckplatte mit 3 Hebeln / pressure plate with 3 levers	(12)	
				<b>1864 600 315</b>	280C (1" -10N)			
				<b>1863 600 118</b>	63,5/100,2/22	mit Anlauftring / with thrust ring	(63)	
				<b>3482 600 109</b>	MF330N			
				<b>1864 600 316</b>	330 (20x25-15N)			
				<b>1864 600 343</b>	330E (1" - 10N)			
				<b>1878 600 526</b>	330CB (20,2x25,5-10N)			
				<b>1863 600 118</b>	63,5/100,2/22	mit Anlauftring / with thrust ring	(63)	

## FORD NEW HOLLAND

3000 - 4000							
<b>3600</b> <b>3610</b>	01.75 - 12.81 01.81 - 12.83			<b>1882 600 105</b>	H280	Druckplatte mit 3 Hebeln / pressure plate with 3 levers	(12)
				<b>1882 600 106</b>	H280N		
				<b>1864 600 315</b>	280C (1" -10N)		
				<b>1878 600 524</b>	280CB (1" -10N)		
				<b>1863 600 118</b>	63,5/100,2/22	mit Anlauftring / with thrust ring	(63)
				<b>3482 600 109</b>	MF330N		
				<b>1864 600 316</b>	330 (20x25-15N)		
				<b>1864 600 343</b>	330E (1" - 10N)		
				<b>1878 600 526</b>	330CB (20,2x25,5-10N)		
				<b>1863 600 118</b>	63,5/100,2/22	mit Anlauftring / with thrust ring	(63)
<b>3900 R</b>	01.75 - 12.81			<b>1882 600 105</b>	H280	Druckplatte mit 3 Hebeln / pressure plate with 3 levers	(12)
				<b>1878 600 524</b>	280CB (1" -10N)		
				<b>1863 600 118</b>	63,5/100,2/22	mit Anlauftring / with thrust ring	(63)
<b>3910</b>	01.83 - 12.89			<b>1882 600 106</b>	H280N		
				<b>1878 600 524</b>	280CB (1" -10N)		
				<b>1864 600 315</b>	280C (1" -10N)		
				<b>1863 600 118</b>	63,5/100,2/22	mit Anlauftring / with thrust ring	(63)
				<b>3482 600 109</b>	MF330N		
				<b>1864 600 316</b>	330 (20x25-15N)		
				<b>1864 600 343</b>	330E (1" - 10N)		
				<b>1878 600 526</b>	330CB (20,2x25,5-10N)		
				<b>1863 600 118</b>	63,5/100,2/22	mit Anlauftring / with thrust ring	(63)
			<b>3930</b>	01.90 - 12.95			<b>3482 600 109</b>
	<b>1878 600 526</b>	330CB (20,2x25,5-10N)					
	<b>1864 600 343</b>	330E (1" - 10N)					
	<b>1863 600 118</b>	63,5/100,2/22				mit Anlauftring / with thrust ring	(63)































# FORD NEW HOLLAND

## 4000 - 5000

4000 4110 4330 4340	01.64 - 12.75 01.81 - 12.89 01.65 - 12.74 01.65 - 12.74			<b>1882 600 105</b>	H280	Druckplatte mit 3 Hebeln / pressure plate with 3 levers	(12)
				<b>1882 600 103</b>	H280N	für Nebenantrieb / for PTO Druckplatte mit 4 Hebeln / pressure plate with 4 levers	(57) (13)
				<b>1882 600 106</b>	H280N		
				<b>1864 600 315</b>	280C (1" -10N)		
				<b>1878 600 524</b>	280CB (1" -10N)		
				<b>1863 600 118</b>	63,5/100,2/22	mit Anlauftring / with thrust ring	(63)
				<b>3482 600 109</b>	MF330N		
				<b>1878 600 526</b>	330CB (20,2x25,5-10N)		
				<b>1864 600 316</b>	330 (20x25-15N)		
				<b>1864 600 343</b>	330E (1" - 10N)		
				<b>1863 600 118</b>	63,5/100,2/22	mit Anlauftring / with thrust ring	(63)
						<b>1863 869 015</b>	36,5/68/15
4030 4230 4430	01.92 - 01.92 - 01.89 -			<b>1888 869 004 #</b>	DUT280 (280/35x40-14N)	enthält eine Kupplungsscheibe / This part number includes one clutch disc	(45)
				<b>1864 600 353</b>	280 (22x25-10N)		
				<b>1863 838 001</b>	50/82/29	ohne Anlauftring / without thrust ring	(79)
				<b>1863 838 000</b>	70/110/20	ohne Anlauftring / without thrust ring	(79)
4130	01.90 - 12.95			<b>1882 600 105</b>	H280	Druckplatte mit 3 Hebeln / pressure plate with 3 levers	(12)
				<b>1882 600 103</b>	H280N	für Nebenantrieb / for PTO Druckplatte mit 4 Hebeln / pressure plate with 4 levers	(57) (13)
				<b>1882 600 106</b>	H280N		
				<b>1864 600 315</b>	280C (1" -10N)		
				<b>1878 600 524</b>	280CB (1" -10N)		
				<b>1863 600 118</b>	63,5/100,2/22	mit Anlauftring / with thrust ring	(63)
				<b>3482 600 109</b>	MF330N		
				<b>1878 600 526</b>	330CB (20,2x25,5-10N)		
				<b>1864 600 316</b>	330 (20x25-15N)		
				<b>1864 600 343</b>	330E (1" - 10N)		
				<b>1863 600 118</b>	63,5/100,2/22	mit Anlauftring / with thrust ring	(63)
			4140	01.65 - 12.74			<b>1882 600 106</b>
	<b>1882 600 103</b>	H280N				für Nebenantrieb / for PTO Druckplatte mit 4 Hebeln / pressure plate with 4 levers	(57) (13)
	<b>1864 600 315</b>	280C (1" -10N)					
	<b>1878 600 524</b>	280CB (1" -10N)					
	<b>1863 600 118</b>	63,5/100,2/22				mit Anlauftring / with thrust ring	(63)
	<b>1863 869 015</b>	36,5/68/15					































# FORD NEW HOLLAND





























4000 - 5000								
<b>4200</b>	01.65 - 12.74			<b>1882 600 106</b>	H280N			
				<b>1882 600 105</b>	H280	Druckplatte mit 3 Hebeln / pressure plate with 3 levers	(12)	
					<b>1864 600 315</b>	280C (1" -10N)		
					<b>1878 600 524</b>	280CB (1" -10N)		
					<b>1863 600 118</b>	63,5/100,2/22	mit Anlauftring / with thrust ring	(63)
						<b>1863 869 015</b>	36,5/68/15	
<b>4300</b>				<b>1882 600 106</b>	H280N			
					<b>1864 600 315</b>	280C (1" -10N)		
						<b>1863 600 118</b>	63,5/100,2/22	mit Anlauftring / with thrust ring
<b>4400</b> <b>4410</b>	01.65 - 12.74 01.69 - 12.74			<b>1882 600 105</b>	H280	Druckplatte mit 3 Hebeln / pressure plate with 3 levers	(12)	
					<b>1882 600 106</b>	H280N		
						<b>1864 600 315</b>	280C (1" -10N)	
					<b>1878 600 524</b>	280CB (1" -10N)		
						<b>1863 600 118</b>	63,5/100,2/22	mit Anlauftring / with thrust ring
						<b>3482 600 109</b>	MF330N	
						<b>1864 600 316</b>	330 (20x25-15N)	
						<b>1864 600 343</b>	330E (1" - 10N)	
						<b>1878 600 526</b>	330CB (20,2x25,5-10N)	
						<b>1863 600 118</b>	63,5/100,2/22	mit Anlauftring / with thrust ring
					<b>4450</b>			
	<b>1864 600 316</b>	330 (20x25-15N)						
	<b>1878 600 526</b>	330CB (20,2x25,5-10N)						
	<b>1864 600 343</b>	330E (1" - 10N)						
		<b>1863 600 118</b>	63,5/100,2/22	mit Anlauftring / with thrust ring	(63)			
<b>4500</b> <b>4610</b>		01.65 - 12.74 01.81 - 12.89			<b>1882 600 106</b>	H280N		
					<b>1864 600 315</b>	280C (1" -10N)		
						<b>1878 600 524</b>	280CB (1" -10N)	
					<b>1863 600 118</b>	63,5/100,2/22	mit Anlauftring / with thrust ring	(63)
						<b>3482 600 109</b>	MF330N	
						<b>1864 600 316</b>	330 (20x25-15N)	
						<b>1864 600 343</b>	330E (1" - 10N)	
						<b>1878 600 526</b>	330CB (20,2x25,5-10N)	
						<b>1863 600 118</b>	63,5/100,2/22	mit Anlauftring / with thrust ring

# FORD NEW HOLLAND



























## 4000 - 5000

4600	01.75 - 12.76		1882 600 103	H280N	für Nebenantrieb / for PTO Druckplatte mit 4 Hebeln / pressure plate with 4 levers	(57) (13)
			1882 600 106	H280N		
			1864 600 315	280C (1" -10N)		
			1878 600 524	280CB (1" -10N)		
			1863 600 118	63,5/100,2/22	mit Anlauftring / with thrust ring	(63)
			3482 600 109	MF330N		
			1864 600 316	330 (20x25-15N)		
			1864 600 343	330E (1" - 10N)		
			1878 600 526	330CB (20,2x25,5-10N)		
			1863 600 118	63,5/100,2/22	mit Anlauftring / with thrust ring	(63)
			1863 869 015	36,5/68/15		
4630 4830	01.90 - 12.95 01.90 - 12.93		3482 600 109	MF330N		
			1878 600 526	330CB (20,2x25,5-10N)		
			1864 600 343	330E (1" - 10N)		
			1863 600 118	63,5/100,2/22	mit Anlauftring / with thrust ring	(63)
4635	01.96 - 12.98		3482 600 104	MF310		
			1888 600 113	DUT280 (280/40x45-16N)	enthält eine Kupplungsscheibe / This part number includes one clutch disc	(45)
			1864 600 327	280 (22x25-10N)		
			1863 838 001	50/82/29	ohne Anlauftring / without thrust ring	(79)
			1863 858 001	75/115/20	ohne Anlauftring / without thrust ring	(79)
4835	01.96 - 12.98		3482 600 104	MF310		
			1888 600 113	DUT280 (280/40x45-16N)	enthält eine Kupplungsscheibe / This part number includes one clutch disc	(45)
			1864 600 327	280 (22x25-10N)		
			1863 838 001	50/82/29	ohne Anlauftring / without thrust ring	(79)
			1863 858 001	75/115/20	ohne Anlauftring / without thrust ring	(79)
			1888 600 106	DUT310 (310/40x45-16N)	enthält eine Kupplungsscheibe / This part number includes one clutch disc	(45)
			1864 600 302	310 (22x25-10N)		
			1863 838 001	50/82/29	ohne Anlauftring / without thrust ring	(79)
			1863 858 001	75/115/20	ohne Anlauftring / without thrust ring	(79)

## FORD NEW HOLLAND











5000 - 6000								
<b>5000</b> <b>5100</b> <b>5200</b> <b>5340</b>	01.64 - 12.75 01.65 - 12.74 01.67 - 12.74 01.68 - 12.74			<b>1882 600 103</b>	H280N	für Nebenantrieb / for PTO Druckplatte mit 4 Hebeln / pressure plate with 4 levers	(57) (13)	
				<b>1864 600 315</b>	280C (1" -10N)			
				<b>1863 600 118</b>	63,5/100,2/22	mit Anlauftring / with thrust ring		(63)
				<b>3482 600 119</b>	MF330	je nach Ausführung, mit unterschiedlicher Kupplung / depending on version, with different clutch		(61)
				<b>1878 600 519</b>	327CB (1 3/4"-10N)	je nach Ausführung, mit unterschiedlicher Kupplung / depending on version, with different clutch		(61)
				<b>1864 600 304 ▲●</b>	330 (1 3/4"-10N)	je nach Ausführung, mit unterschiedlicher Kupplung / depending on version, with different clutch		(61)
				<b>1863 600 118</b>	63,5/100,2/22	mit Anlauftring / with thrust ring		(63)
				<b>3482 600 118</b>	MF310	je nach Ausführung, mit unterschiedlicher Kupplung / depending on version, with different clutch		(61)
				<b>1864 600 339</b>	310CB (1 3/4"-10N)	je nach Ausführung, mit unterschiedlicher Kupplung / depending on version, with different clutch		(61)
				<b>1863 600 118</b>	63,5/100,2/22	mit Anlauftring / with thrust ring		(63)
				<b>3482 600 118</b>	MF310	für / for: D-Power		(47)
				<b>1863 600 118</b>	63,5/100,2/22	für / for: D-Power mit Anlauftring / with thrust ring		(47) (63)
				<b>1863 869 015</b>	36,5/68/15	für / for: D-Power		(47)
			<b>5030</b>	01.93 - 12.95			<b>3482 600 109</b>	MF330N
	<b>1878 600 526</b>	330CB (20,2x25,5-10N)						
	<b>1864 600 343</b>	330E (1" - 10N)						
	<b>1863 600 118</b>	63,5/100,2/22				mit Anlauftring / with thrust ring		(63)
<b>5110</b>	01.88 - 12.91			<b>3482 600 119</b>	MF330			
				<b>1864 600 304 ▲</b>	330 (1 3/4"-10N)			
				<b>1863 600 118</b>	63,5/100,2/22	mit Anlauftring / with thrust ring		(63)
				<b>3482 600 119</b>	MF330	für / for: D-Power		(47)
				<b>1878 600 519</b>	327CB (1 3/4"-10N)	für / for: D-Power		(47)
				<b>1863 600 118</b>	63,5/100,2/22	für / for: D-Power mit Anlauftring / with thrust ring		(47) (63)
				<b>3482 600 105</b>	MF330			
				<b>1878 600 519</b>	327CB (1 3/4"-10N)	je nach Ausführung, mit unterschiedlicher Kupplung / depending on version, with different clutch		(61)
				<b>1864 600 304 ▲</b>	330 (1 3/4"-10N)	je nach Ausführung, mit unterschiedlicher Kupplung / depending on version, with different clutch		(61)
				<b>1863 600 118</b>	63,5/100,2/22	mit Anlauftring / with thrust ring		(63)
				<b>1863 869 015</b>	36,5/68/15			

# FORD NEW HOLLAND

















5000 - 6000							
5550				3482 600 119	MF330		
				1864 600 304 ▲	330 (1 3/4"-10N)		
				1863 600 118	63,5/100,2/22	mit Anlauftring / with thrust ring	(63)
				3482 600 119	MF330	für / for: D-Power	(47)
				1878 600 519	327CB (1 3/4"-10N)	für / for: D-Power	(47)
				1863 600 118	63,5/100,2/22	für / for: D-Power mit Anlauftring / with thrust ring	(47) (63)
				3482 600 105	MF330		
				1864 600 304 ▲	330 (1 3/4"-10N)		
				1863 600 118	63,5/100,2/22	mit Anlauftring / with thrust ring	(63)
5600 5610 5700	01.75 - 12.81 01.81 - 12.91 01.78 - 12.80			3482 600 119	MF330	je nach Ausführung, mit unterschiedlicher Kupplung / depending on version, with different clutch	(61)
				1878 600 519	327CB (1 3/4"-10N)	je nach Ausführung, mit unterschiedlicher Kupplung / depending on version, with different clutch	(61)
				1864 600 304 ▲●	330 (1 3/4"-10N)	je nach Ausführung, mit unterschiedlicher Kupplung / depending on version, with different clutch	(61)
				1863 600 118	63,5/100,2/22	mit Anlauftring / with thrust ring	(63)
				3482 600 118	MF310	je nach Ausführung, mit unterschiedlicher Kupplung / depending on version, with different clutch	(61)
				1864 600 339	310CB (1 3/4"-10N)	je nach Ausführung, mit unterschiedlicher Kupplung / depending on version, with different clutch	(61)
				1863 600 118	63,5/100,2/22	mit Anlauftring / with thrust ring	(63)
				3482 600 118	MF310	für / for: D-Power	(47)
				1863 600 118	63,5/100,2/22	für / for: D-Power mit Anlauftring / with thrust ring	(47) (63)
				1863 869 015	36,5/68/15		
5635	01.96 - 12.98			1888 600 149	DUT310/ CERAM (310/40x45-16N)	enthält eine Kupplungsscheibe / This part number includes one clutch disc	(45)
				1864 600 302	310 (22x25-10N)		
				1888 600 113	DUT280 (280/40x45-16N)	enthält eine Kupplungsscheibe / This part number includes one clutch disc	(45)
				1864 600 327	280 (22x25-10N)		
				1863 838 001	50/82/29	ohne Anlauftring / without thrust ring	(79)
				1863 858 001	75/115/20	ohne Anlauftring / without thrust ring	(79)
				3800 541 008 ☉ ☉ 3482 600 104 ☉ 1878 600 518	MF310 310GSDC		
				1863 600 118	63,5/100,2/22	mit Anlauftring / with thrust ring	(63)

## FORD NEW HOLLAND





























### 5000 - 6000

<b>5640</b>	01.92 - 12.97			<b>3482 600 105</b>	MF330	Getr. / GBox: 8x2	
				<b>1864 600 304 ▲</b>	330 (1 3/4"-10N)	Getr. / GBox: 8x2	
				<b>1863 600 118</b>	63,5/100,2/22	Getr. / GBox: 8x2 mit Anlauftring / with thrust ring	(63)
				<b>3482 600 105</b>	MF330	Getr. / GBox: 16x4 Getr. / GBox: 12x12	
				<b>1878 600 519</b>	327CB (1 3/4"-10N)	Getr. / GBox: 16x4 Getr. / GBox: 12x12	
				<b>1878 600 520 ●</b>	321CBC (1 3/4"-10N)	Getr. / GBox: 16x4 Getr. / GBox: 12x12 Anzahl der Beläge / Number of pads: 7	(7)
				<b>1863 600 118</b>	63,5/100,2/22	Getr. / GBox: 16x4 mit Anlauftring / with thrust ring	(63)
				<b>3182 001 307</b>	HHIS-3	Getr. / GBox: 12x12 Füllmedium: Hydrauliköl / Fill Medium: Hydraulic Oil Füllmedium: Bioöl / Fill Medium: Bio Oil Immer erneuern / Renew everytime	(19) (17) (22)
				<b>1866 600 010</b>		Getr. / GBox: 16x16	
	<b>1863 869 015</b>		36,5/68/15				

























### 6000 - 7000

<b>6410 6610 6710 6810</b>	01.88 - 12.91 01.81 - 12.88 01.81 - 12.85 01.88 - 12.91			<b>3482 600 119</b>	MF330		
				<b>1864 600 304 ▲</b>	330 (1 3/4"-10N)		
				<b>1863 600 118</b>	63,5/100,2/22	mit Anlauftring / with thrust ring	(63)
				<b>3482 600 105</b>	MF330		
				<b>1864 600 304 ▲</b>	330 (1 3/4"-10N)	je nach Ausführung, mit unterschiedlicher Kupplung / depending on version, with different clutch	(61)
				<b>1878 600 519</b>	327CB (1 3/4"-10N)	je nach Ausführung, mit unterschiedlicher Kupplung / depending on version, with different clutch	(61)
				<b>1878 600 520</b>	321CBC (1 3/4"-10N)	Anzahl der Beläge / Number of pads: 7 je nach Ausführung, mit unterschiedlicher Kupplung / depending on version, with different clutch	(7) (61)
				<b>1863 600 118</b>	63,5/100,2/22	mit Anlauftring / with thrust ring	(63)
				<b>3482 600 118</b>	MF310		
				<b>1864 600 339</b>	310CB (1 3/4"-10N)		
				<b>1863 600 118</b>	63,5/100,2/22	mit Anlauftring / with thrust ring	(63)
				<b>1863 869 015</b>		36,5/68/15	
			<b>6500</b>	01.83 - 12.88			<b>3482 600 118</b>
	<b>1864 600 339</b>	310CB (1 3/4"-10N)					
	<b>1863 600 118</b>	63,5/100,2/22				mit Anlauftring / with thrust ring	(63)
	<b>3482 600 118</b>	MF310				für / for: D-Power	(47)
	<b>1863 600 118</b>	63,5/100,2/22				für / for: D-Power mit Anlauftring / with thrust ring	(47) (63)

# FORD NEW HOLLAND

































6000 - 7000							
6600 6700	01.75 - 12.80 01.76 - 12.81			3482 600 119	MF330		
				1878 600 519	327CB (1 3/4"-10N)		
				1863 600 118	63,5/100,2/22	mit Anlauftring / with thrust ring	(63)
				3482 600 118	MF310		
				1864 600 339	310CB (1 3/4"-10N)		
				1863 600 118	63,5/100,2/22	mit Anlauftring / with thrust ring	(63)
				3482 600 118	MF310	für / for: D-Power	(47)
				1863 600 118	63,5/100,2/22	für / for: D-Power mit Anlauftring / with thrust ring	(47) (63)
				1863 869 015	36,5/68/15		
6635	01.96 - 12.98			1888 600 149	DUT310/ CERAM (310/40x45-16N)	enthält eine Kupplungsscheibe / This part number includes one clutch disc	(45)
				1864 600 302	310 (22x25-10N)		
				1888 600 113	DUT280 (280/40x45-16N)	enthält eine Kupplungsscheibe / This part number includes one clutch disc	(45)
				1864 600 327	280 (22x25-10N)		
				1863 838 001	50/82/29	ohne Anlauftring / without thrust ring	(79)
				1863 858 001	75/115/20	ohne Anlauftring / without thrust ring	(79)
				3800 541 008  3482 600 104  1878 600 518	MF310 310GSDC		
				1863 600 118	63,5/100,2/22	mit Anlauftring / with thrust ring	(63)
6640	01.92 - 12.97			3482 600 105	MF330	Getr. / GBox: 8x2	
				1864 600 304 ▲	330 (1 3/4"-10N)	Getr. / GBox: 8x2	
				1863 600 118	63,5/100,2/22	Getr. / GBox: 8x2 mit Anlauftring / with thrust ring	(63)
				3482 600 105	MF330	Getr. / GBox: 16x4 Getr. / GBox: 12x12	
				1878 600 519	327CB (1 3/4"-10N)	Getr. / GBox: 16x4 Getr. / GBox: 12x12	
				1878 600 520 ●	321CBC (1 3/4"-10N)	Getr. / GBox: 12x12 Getr. / GBox: 16x4 Anzahl der Beläge / Number of pads: 7	(7)
				1863 600 118	63,5/100,2/22	Getr. / GBox: 16x4 mit Anlauftring / with thrust ring	(63)
				3182 001 307	HHIS-3	Getr. / GBox: 12x12 Füllmedium: Hydrauliköl / Fill Medium: Hydraulic Oil Füllmedium: Bioöl / Fill Medium: Bio Oil Immer erneuern / Renew everytime	(19) (17) (22)
				1866 600 010		Getr. / GBox: 16x16	
	1863 869 015	36,5/68/15					

# FORD NEW HOLLAND

7000 - 8000							
7000 7010 7100	01.71 - 12.75 01.96 - 01.73 - 12.75			3482 600 119	MF330		
				1864 600 304 ▲	330 (1 3/4"-10N)		
				1863 600 118	63,5/100,2/22	mit Anlauftring / with thrust ring	(63)
				3482 600 119	MF330	für / for: D-Power	(47)
				1878 600 519	327CB (1 3/4"-10N)	für / for: D-Power	(47)
				1863 600 118	63,5/100,2/22	für / for: D-Power mit Anlauftring / with thrust ring	(47) (63)
				1863 869 015	36,5/68/15		
7200	01.73 - 12.75			3482 600 119	MF330		
				1864 600 304 ▲	330 (1 3/4"-10N)		
				1863 600 118	63,5/100,2/22	mit Anlauftring / with thrust ring	(63)
				3482 600 119	MF330	für / for: D-Power	(47)
				1878 600 519	327CB (1 3/4"-10N)	für / for: D-Power	(47)
				1863 600 118	63,5/100,2/22	für / for: D-Power mit Anlauftring / with thrust ring	(47) (63)
7600 7700	01.75 - 12.81 01.76 - 12.81			3482 600 119	MF330		
				1864 600 304 ▲	330 (1 3/4"-10N)		
				1863 600 118	63,5/100,2/22	mit Anlauftring / with thrust ring	(63)
				3482 600 119	MF330	für / for: D-Power	(47)
				1878 600 519	327CB (1 3/4"-10N)	für / for: D-Power	(47)
				1863 600 118	63,5/100,2/22	mit Anlauftring / with thrust ring	(63)
				3482 600 118	MF310		
				1864 600 339	310CB (1 3/4"-10N)		
				1863 600 118	63,5/100,2/22	mit Anlauftring / with thrust ring	(63)
				3482 600 118	MF310	für / for: D-Power	(47)
				1863 600 118	63,5/100,2/22	für / for: D-Power mit Anlauftring / with thrust ring	(47) (63)
				1863 869 015	36,5/68/15		











# FORD NEW HOLLAND

















## 7000 - 8000

<b>7610</b>	01.81 - 12.91		<b>3482 600 119</b>	MF330			
			<b>1864 600 304 ▲</b>	330 (1 3/4"-10N)			
			<b>1863 600 118</b>	63,5/100,2/22	mit Anlauftring / with thrust ring	(63)	
			<b>3482 600 119</b>	MF330	für / for: D-Power	(47)	
			<b>1878 600 519</b>	327CB (1 3/4"-10N)	für / for: D-Power	(47)	
			<b>1863 600 118</b>	63,5/100,2/22	für / for: D-Power mit Anlauftring / with thrust ring	(47) (63)	
			<b>3482 600 105</b>	MF330			
			<b>1864 600 304 ▲</b>	330 (1 3/4"-10N)	je nach Ausführung, mit unterschiedlicher Kupplung / depending on version, with different clutch	(61)	
			<b>1878 600 519</b>	327CB (1 3/4"-10N)	je nach Ausführung, mit unterschiedlicher Kupplung / depending on version, with different clutch	(61)	
			<b>1878 600 520</b>	321CBC (1 3/4"-10N)	Anzahl der Beläge / Number of pads: 7 je nach Ausführung, mit unterschiedlicher Kupplung / depending on version, with different clutch	(7) (61)	
			<b>1863 600 118</b>	63,5/100,2/22	mit Anlauftring / with thrust ring	(63)	
			<b>1863 869 015</b>	36,5/68/15			
<b>7635</b>	01.96 - 12.98		<b>1888 600 149</b>	DUT310/ CERAM (310/40x45-16N)	enthält eine Kupplungsscheibe / This part number includes one clutch disc	(45)	
			<b>1864 600 302</b>	310 (22x25-10N)			
			<b>1888 600 113</b>	DUT280 (280/40x45-16N)	enthält eine Kupplungsscheibe / This part number includes one clutch disc	(45)	
			<b>1864 600 327</b>	280 (22x25-10N)			
			<b>1863 838 001</b>	50/82/29	ohne Anlauftring / without thrust ring	(79)	
			<b>1863 858 001</b>	75/115/20	ohne Anlauftring / without thrust ring	(79)	
			<b>3800 541 008 ☹</b>  <b>3482 600 104</b>  <b>1878 600 518</b>	MF310 310GSDC			
			<b>1863 600 118</b>	63,5/100,2/22	mit Anlauftring / with thrust ring	(63)	
<b>7710</b> <b>7810</b> <b>7910</b>	01.81 - 12.88 01.88 - 12.91 01.85 - 12.87		<b>3482 600 119</b>	MF330			
			<b>1863 600 118</b>	63,5/100,2/22	mit Anlauftring / with thrust ring	(63)	
			<b>3482 600 119</b>	MF330	für / for: D-Power	(47)	
			<b>1863 600 118</b>	63,5/100,2/22	für / for: D-Power mit Anlauftring / with thrust ring	(47) (63)	
			<b>3482 600 105</b>	MF330			
			<b>1864 600 304 ▲</b>	330 (1 3/4"-10N)	je nach Ausführung, mit unterschiedlicher Kupplung / depending on version, with different clutch	(61)	
			<b>1878 600 519</b>	327CB (1 3/4"-10N)	je nach Ausführung, mit unterschiedlicher Kupplung / depending on version, with different clutch	(61)	
			<b>1878 600 520</b>	321CBC (1 3/4"-10N)	Anzahl der Beläge / Number of pads: 7 je nach Ausführung, mit unterschiedlicher Kupplung / depending on version, with different clutch	(7) (61)	
			<b>1863 600 118</b>	63,5/100,2/22	mit Anlauftring / with thrust ring	(63)	
			<b>1863 869 015</b>	36,5/68/15			



























## FORD NEW HOLLAND





7000 - 8000							
<b>7740</b>	01.92 - 12.97			<b>3482 600 105</b>	MF330	Getr. / GBox: 8x2	
<b>7840</b>	01.92 - 12.98			<b>1864 600 304 ▲</b>	330 (1 3/4"-10N)	Getr. / GBox: 8x2	
				<b>1863 600 118</b>	63,5/100,2/22	Getr. / GBox: 8x2 mit Anlauftring / with thrust ring	(63)
				<b>3482 600 105</b>	MF330	Getr. / GBox: 16x4 Getr. / GBox: 12x12	
				<b>1878 600 519</b>	327CB (1 3/4"-10N)	Getr. / GBox: 16x4 Getr. / GBox: 12x12	
				<b>1878 600 520 ●</b>	321CBC (1 3/4"-10N)	Getr. / GBox: 16x4 Getr. / GBox: 12x12 Anzahl der Beläge / Number of pads: 7	(7)
				<b>1863 600 118</b>	63,5/100,2/22	Getr. / GBox: 16x4 mit Anlauftring / with thrust ring	(63)
				<b>3182 001 307</b>	HHIS-3	Getr. / GBox: 12x12 Füllmedium: Hydrauliköl / Fill Medium: Hydraulic Oil Füllmedium: Bioöl / Fill Medium: Bio Oil Immer erneuern / Renew everytime	(19) (17) (22)
				<b>1866 600 010</b>		Getr. / GBox: 16x16	
				<b>1863 869 015</b>	36,5/68/15		

8000 - ....							
<b>8000</b>	01.68 - 12.72			<b>3482 600 105</b>	MF330		
<b>8400</b>	01.65 - 12.88			<b>1878 600 520</b>	321CBC (1 3/4"-10N)	Anzahl der Beläge / Number of pads: 7	(7)
<b>8600</b>	01.72 - 12.76			<b>1863 600 118</b>	63,5/100,2/22	mit Anlauftring / with thrust ring	(63)
<b>8010</b>	01.96 - 12.00			<b>3482 600 119</b>	MF330		
				<b>1864 600 304 ▲</b>	330 (1 3/4"-10N)	je nach Ausführung, mit unterschiedlicher Kupplung / depending on version, with different clutch	(61)
				<b>1878 600 519</b>	327CB (1 3/4"-10N)	je nach Ausführung, mit unterschiedlicher Kupplung / depending on version, with different clutch	(61)
				<b>1863 600 118</b>	63,5/100,2/22	mit Anlauftring / with thrust ring	(63)
				<b>1863 869 015</b>	36,5/68/15		
<b>8100</b>	01.78 - 12.81			<b>3482 600 119</b>	MF330		
				<b>1864 600 304 ▲</b>	330 (1 3/4"-10N)	je nach Ausführung, mit unterschiedlicher Kupplung / depending on version, with different clutch	(61)
				<b>1878 600 519</b>	327CB (1 3/4"-10N)	je nach Ausführung, mit unterschiedlicher Kupplung / depending on version, with different clutch	(61)
				<b>1863 600 118</b>	63,5/100,2/22	mit Anlauftring / with thrust ring	(63)
				<b>3482 600 105</b>	MF330		
				<b>1864 600 304 ▲</b>	330 (1 3/4"-10N)	je nach Ausführung, mit unterschiedlicher Kupplung / depending on version, with different clutch	(61)
				<b>1878 600 519</b>	327CB (1 3/4"-10N)	je nach Ausführung, mit unterschiedlicher Kupplung / depending on version, with different clutch	(61)
				<b>1878 600 520</b>	321CBC (1 3/4"-10N)	Anzahl der Beläge / Number of pads: 7 je nach Ausführung, mit unterschiedlicher Kupplung / depending on version, with different clutch	(7) (61)
				<b>1863 600 118</b>	63,5/100,2/22	mit Anlauftring / with thrust ring	(63)











## FORD NEW HOLLAND

8000 - ....							
8210	01.82 - 12.91			3482 600 119	MF330		
				1864 600 304 ▲	330 (1 3/4"-10N)	je nach Ausführung, mit unterschiedlicher Kupplung / depending on version, with different clutch	(61)
				1878 600 519	327CB (1 3/4"-10N)	je nach Ausführung, mit unterschiedlicher Kupplung / depending on version, with different clutch	(61)
				1863 600 118	63,5/100,2/22	mit Anlauftring / with thrust ring	(63)
				3482 600 105	MF330		
				1864 600 304 ▲	330 (1 3/4"-10N)	je nach Ausführung, mit unterschiedlicher Kupplung / depending on version, with different clutch	(61)
				1878 600 519	327CB (1 3/4"-10N)	je nach Ausführung, mit unterschiedlicher Kupplung / depending on version, with different clutch	(61)
				1878 600 520	321CBC (1 3/4"-10N)	Anzahl der Beläge / Number of pads: 7 je nach Ausführung, mit unterschiedlicher Kupplung / depending on version, with different clutch	(7) (61)
				1863 600 118	63,5/100,2/22	mit Anlauftring / with thrust ring	(63)
				1863 869 015	36,5/68/15		
8240 8340	01.92 - 12.97 01.92 - 12.94			3482 600 105	MF330	Getr. / GBox: 8x2	
				1864 600 304 ▲	330 (1 3/4"-10N)	Getr. / GBox: 8x2	
				1863 600 118	63,5/100,2/22	Getr. / GBox: 8x2 mit Anlauftring / with thrust ring	(63)
				3482 600 105	MF330	Getr. / GBox: 16x4 Getr. / GBox: 12x12	
				1878 600 519	327CB (1 3/4"-10N)	Getr. / GBox: 16x4 Getr. / GBox: 12x12	
				1878 600 520 ●	321CBC (1 3/4"-10N)	Getr. / GBox: 16x4 Getr. / GBox: 12x12 Anzahl der Beläge / Number of pads: 7	(7)
				1863 600 118	63,5/100,2/22	Getr. / GBox: 16x4 mit Anlauftring / with thrust ring	(63)
				3182 001 307	HHIS-3	Getr. / GBox: 12x12 Füllmedium: Hydrauliköl / Fill Medium: Hydraulic Oil Füllmedium: Bioöl / Fill Medium: Bio Oil Immer erneuern / Renew everytime	(19) (17) (22)
				1866 600 010		Getr. / GBox: 16x16	
				1863 869 015	36,5/68/15		
8530	01.90 - 12.93			3482 600 105	MF330		
				1878 600 520	321CBC (1 3/4"-10N)	Anzahl der Beläge / Number of pads: 7	(7)
				1863 600 118	63,5/100,2/22	mit Anlauftring / with thrust ring	(63)
				1863 869 015	36,5/68/15		



## FRISCH

F-Serie							
F 65 B		KHDF3L514		1888 027 304 #	DUT250L (250/36x40-20N)	enthält eine Kupplungsscheibe / This part number includes one clutch disc	(45)
				1864 246 437 ▽#	250B (26x32-10N)	Lose Kupplungsscheibe / Loose clutch disc	(30)
F 95		MWM225		1880 092 415 #	G310		
				1861 600 033 #	310GTD (32x40-10N)		

















# FUCHS

F-Serie							
F300				1881 059 208	KS200		
				1864 634 030	200Z (26x32-10N)		
F301		KHDF2L912		1881 059 208	KS200		
				1864 634 030	200Z (26x32-10N)	->Chass. 32-16905	
				1864 634 027	200Z (26x32-10N)	Chass. 32-16906->	
				1881 010 139 #	G250		
				1864 202 035 #	250Z (26x32-10N)		
F400		KHDF2L912		1881 010 139 #	G250		
				1864 202 035 #	250Z (26x32-10N)		
F500		KHDF2L912		1880 083 132 #	G280		
				1863 100 030	55/90,5/25	mit Anlauftring / with thrust ring	(63)

# GEDA



















Geda							
Geda 80		BF4M1012E		1882 000 003 #	GTF330N		
				1864 000 029	330B (28x35-10N)		

# GOLDONI







Star							
70 85 / C85				1888 600 128	DUT280/ 280 (280/31x35-18N)	enthält eine Kupplungsscheibe / This part number includes one clutch disc	(45)
				1864 600 332	280 (20,1x22,8-20N)		
75				1888 600 127	DUT250/ 250 (250/31x35-18N)	enthält eine Kupplungsscheibe / This part number includes one clutch disc	(45)
				1864 600 331	250 (20,1x22,8-20N)		
				1863 837 002	65/97/23	mit Anlauftring / with thrust ring	(63)
				1863 855 000	106/140/25	mit Anlauftring / with thrust ring	(63)
				1888 600 128	DUT280/ 280 (280/31x35-18N)	enthält eine Kupplungsscheibe / This part number includes one clutch disc	(45)
3050				1864 600 332	280 (20,1x22,8-20N)		
				1888 600 126	DUT230/ 230 (225/31x35-18N)	enthält eine Kupplungsscheibe / This part number includes one clutch disc	(45)
3070				1864 600 329 ▲	225 (20,1x22,8-20N)		
				1888 600 124 ▲	DUT230/ 230 (225/31x35-18N)	enthält eine Kupplungsscheibe / This part number includes one clutch disc	(45)
				1864 600 329 ▲	225 (20,1x22,8-20N)		
				1888 600 127	DUT250/ 250 (250/31x35-18N)	enthält eine Kupplungsscheibe / This part number includes one clutch disc	(45)
				1864 600 331	250 (20,1x22,8-20N)		
				1863 837 002	65/97/23	mit Anlauftring / with thrust ring	(63)
				1863 855 000	106/140/25	mit Anlauftring / with thrust ring	(63)

					Parameter		
---	--	--	--	--	-----------	---	---









## GOLDONI

Star							
V 3070				<b>1888 600 124 ▲</b>	DUT230/ 230 (225/31x35-18N)	enthält eine Kupplungsscheibe / This part number includes one clutch disc	(45)
				<b>1864 600 329 ▲</b>	225 (20,1x22,8-20N)		
662 - 4000							
662				<b>1888 600 127</b>	DUT250/ 250 (250/31x35-18N)	enthält eine Kupplungsscheibe / This part number includes one clutch disc	(45)
664				<b>1864 600 331</b>	250 (20,1x22,8-20N)		
762				<b>1863 837 002</b>	65/97/23	mit Anlauftring / with thrust ring	(63)
764				<b>1863 855 000</b>	106/140/25	mit Anlauftring / with thrust ring	(63)
772							
774							
3460							
3000	4000			<b>1888 600 125</b>	DUT230/ 230 (225/31x35-18N)	enthält eine Kupplungsscheibe / This part number includes one clutch disc	(45)
				<b>1864 600 330</b>	225 (14,4x17-9N)		
3045	3050			<b>1888 600 126</b>	DUT230/ 230 (225/31x35-18N)	enthält eine Kupplungsscheibe / This part number includes one clutch disc	(45)
				<b>1864 600 329 ▲</b>	225 (20,1x22,8-20N)		
3445							
3450							
3070				<b>1888 600 124 ▲</b>	DUT230/ 230 (225/31x35-18N)	enthält eine Kupplungsscheibe / This part number includes one clutch disc	(45)
				<b>1864 600 329 ▲</b>	225 (20,1x22,8-20N)		
				<b>1888 600 127</b>	DUT250/ 250 (250/31x35-18N)	enthält eine Kupplungsscheibe / This part number includes one clutch disc	(45)
				<b>1864 600 331</b>	250 (20,1x22,8-20N)		
				<b>1863 837 002</b>	65/97/23	mit Anlauftring / with thrust ring	(63)
				<b>1863 855 000</b>	106/140/25	mit Anlauftring / with thrust ring	(63)
3070 12V	3070 24V			<b>1888 600 124 ▲</b>	DUT230/ 230 (225/31x35-18N)	enthält eine Kupplungsscheibe / This part number includes one clutch disc	(45)
				<b>1864 600 329 ▲</b>	225 (20,1x22,8-20N)		



## GROSS





AK							
AK35		DBOM346		<b>1881 041 656 #</b>	G380		
				<b>1878 000 104</b>	380GTZ (36x45-10N)		
GK							
GK80				<b>1880 083 132 #</b>	G280		
				<b>1863 100 030</b>	55/90,5/25	mit Anlauftring / with thrust ring	(63)
GK81		KHDF4L912		<b>1881 010 139 #</b>	G250		
GK120				<b>1880 083 132 #</b>	G280		
UB							
UB 2	01.52-			<b>1881 010 139 #</b>	G250		
				<b>1860 056 124 #</b>	250Z (1 1/8"-10N)		



## GROSS



UB							
UB 2	- 12.51			1881 089 010	K225	Nur bei Altteil-Rückgabe lieferbar (Reparatur; Werk Bielefeld) / Please return old unit for repair (plant Bielefeld)	(33)
				1860 039 025 #	225Z (1 1/8"-10N)		
				1859 600 001			
UB475	11.62- 06.65- 11.62-			1880 083 132 #	G280	mit Anlaufing / with thrust ring	(63)
UB550				1863 100 030	55/90,5/25		
UB625				1881 010 139 #	G250		
UB600		KHDF4L912		1880 083 132 #	G280		
UB650				1880 083 132 #	G280		

## GRUNDNER









Pionier							
Pionier				1882 155 009	K160		
				3151 994 801			
				1805 041 100			

TK15							
TK15				1882 155 009	K160		
				1864 634 013	160 (23x28-6)		
				3151 994 801			
				1805 041 100			































U4G							
U4G				1882 155 009	K160		
				3151 994 801			
				1805 041 100			

3GD							
3GD				1882 155 009	K160		
				3151 994 801			
				1805 041 100			

## GUELDNER

A-Serie							
A 2 B, BL				1881 089 002	K225		
				1860 039 024 #	225Z (23x29-10N)		
				3100 700 101	KTI-1		
				3151 021 001 2x 3130 010 200			
A 2 K (12PS)				1882 196 005	KS200		
				1864 634 039	200Z (23x29-10N)		
				1859 600 001 ●			
				1805 042 000			

# GUELDNER











A-Serie								
A 2 K (14PS) A 2 KN/D 88E					1882 315 003	KS180		
					1864 261 005 #	180E (23x29-10N)		
					3159 140 004			
					1805 041 100			
A 2 L/D132W/L A 2 W					1882 196 005	KS200		
					1864 634 039	200Z (23x29-10N)		
					3100 700 101 ◊ 3151 021 001 J 2x 3130 010 200	KTI-1		
A 15 ABN (25PS) ABS (22PS) ADK (16PS) ADN (16PS) AF 15 AF 20 ALB ALD (16PS) ALK (16PS)					1882 196 005	KS200		
					1864 634 039	200Z (23x29-10N)		
					1859 600 001			
					1805 042 000			
A 20					1881 089 002	K225		
					1860 026 001	225Z (26x32-10N)	Nur bei Altteil-Rückgabe lieferbar (Reparatur; Werk Bielefeld) / Please return old unit for repair (plant Bielefeld)	(33)
					1859 600 001			
					1805 042 000			
A 25 AG 25					1881 089 002	K225		
					1864 634 026	225Z (26x32-10N)		
					1864 634 024	225Z (1 1/4"-10N)		
					1859 600 001			
					1805 042 000			
A 28					1881 089 002	K225		
					1864 634 026	225Z (26x32-10N)		
					1864 634 024	225Z (1 1/4"-10N)		
					1881 009 203 #	G250		
					1864 202 035 #	250Z (26x32-10N)		
					1859 600 001			
					1805 042 000			
AB ABL					1881 089 002	K225		
					1860 039 024 #	225Z (23x29-10N)		
					1859 600 001			
					1805 042 000			

# GUELDNER







## A-Serie

AF 30 AFN (35PS) AFS (20PS)		1881 009 203 #	G250		
		1864 202 035 #	250Z (26x32-10N)		
		1859 600 001			
		1805 042 000			
AK (11/13PS)		1882 315 003	KS180		
		1864 261 005 #	180E (23x29-10N)		
		1859 600 002			
		1805 041 100			







## Bootsmotor / boat engine



Bootsmot. / boat engine LK		1882 155 009	K160		
		1864 006 147	160E (18x23-10N)		
		3159 140 004			
		1805 041 100			
Bootsmot. / boat engine 2BS/2LB (WHF11)		1880 071 008	K225		
		1864 634 024	225Z (1 1/4"-10N)		
Bootsmot. / boat engine 2LK/2LD (WHF6,3)		1881 059 208	KS200		
		1860 049 018	200Z (1"-10N)	Nur bei Altteil-Rückgabe lieferbar (Reparatur; Werk Bielefeld) / Please return old unit for repair (plant Bielefeld)	(33)
Bootsmot. / boat engine 2LK/2LD (WHF8,5)		1881 059 208	KS200		
		1864 634 039	200Z (23x29-10N)		

## D-Serie





D 88E (11kw)		1882 315 002	KS180		
		1864 261 005 #	180E (23x29-10N)		
		3151 270 602			
D 132 L/W		1882 196 005	KS200		
		1864 634 039	200Z (23x29-10N)		
		3151 021 001			

## G-Serie







G 25		1882 108 204 #	DO225 (Mo 225/23x29-10N) (Ge 200/46x50-8N)	enthält zwei Kupplungsscheiben / This part number includes both clutch discs	(46)
		3151 000 395			
G 30 G 40 G 40 S		1881 050 428 #	DO250 (Mo 250/23x29-10N) (Ge 225/46x50-8N)	enthält zwei Kupplungsscheiben / This part number includes both clutch discs Nur bei Altteil-Rückgabe lieferbar (Reparatur; Werk Bielefeld) / Please return old unit for repair (plant Bielefeld)	(46) (33)
		3151 000 395			
G 45 G 50 G 50 S		1881 051 310 #	DO280 (Mo 280/23x29-10N) (Ge 250/46x50-8N)	enthält zwei Kupplungsscheiben / This part number includes both clutch discs	(46)
		3151 000 395			

					Parameter		
---	--	--	--	--	-----------	---	---



## GUELDNER

2LD							
2 LD				1881 089 002	K225		
				1860 039 025 #	225Z (1 1/8"-10N)		
				1859 600 001			
				1805 042 000			







## GUSS & ARMATURENWERK









Monax							
Bulldog 2-RAD				1880 096 208 #	G280		
				1859 600 003			
				1805 042 000			
106				1882 155 009	K160		
				1864 006 147	160E (18x23-10N)		
				3151 994 801			
				1805 041 100			

## GUTBROD

Atlas							
1000 /34				1864 121 536	180B (18,3x20,4-24N)		
				3151 270 602			
				1805 041 100			

GTA							
40				1888 887 001 #	DUT225 (225/31x35-18N)	enthält eine Kupplungsscheibe / This part number includes one clutch disc	(45)



KDW							
414 F2M414 (2 Zyl./cyl. KHD 25PS Mot./eng.) 415 E (12Zyl./cyl. MWM 15PS Mot./eng.)				1881 089 010	K225	Nur bei Altteil-Rückgabe lieferbar (Reparatur; Werk Bielefeld) / Please return old unit for repair (plant Bielefeld)	(33)
				1864 634 024	225Z (1 1/4"-10N)		
				1859 600 001			
				1805 042 000			
415 D (3Zyl./cyl. MWM 40PS Mot./eng.)				1880 096 208 #	G280		
				1859 600 003			
				1805 042 000			

1020 - 3000							
1020 1030 1031 1035 1040 ,D 1050 ,D 2500 DS				1881 069 101	K140		
				1864 048 204 #	140E (18x23-10N)		
				3151 994 801			
				1805 041 100			
				3000 237 001	MF160 160TB KZIS-00		
	01.72-			3082 144 242			
				1878 634 005			
				3151 151 241			





## GUTBROD

### 1020 - 3000



















3000 A,D,K		1864 006 147	160E (18x23-10N)		
		3151 994 801			
		1805 041 100			

## HAAS

### K-Serie





K 2 DPR (22PS)		1881 089 002	K225		
		1864 634 024	225Z (1 1/4"-10N)		
		1859 600 002			



### R-Serie

R 12 (12PS) R 17 (17PS)		1882 315 003	KS180		
		1864 634 040	180E (23x29-10N)		
		1859 600 002			
		1805 042 000			
R 20 (20PS) R 28 (20PS)		1881 089 002	K225		
		1864 634 024	225Z (1 1/4"-10N)		
		1859 600 001			
		1805 042 000			
R 22 (22PS)		1881 089 002	K225		
		1864 634 024	225Z (1 1/4"-10N)		
		1859 600 002			
		1805 041 100			
R 24 (24PS)		1882 196 005	KS200		
		1864 634 039	200Z (23x29-10N)		
		1859 600 001			
		1805 042 000			
R 33 (33PS) R 35 (35PS) R 40 (40PS)		1880 096 208 #	G280		
		1859 600 005			
		1805 042 000			





## HAKO

### Hakomobil



4000		1882 155 009	K160		
		1864 209 231	160B (18x22-6N)		
		3151 994 801			
		1805 041 100			





					Parameter		
---	--	--	--	--	-----------	---	---





# HAKO









Hakotrac							
D 12 V 12 2000				<b>1882 155 009</b>	K160		
				<b>1864 209 231</b>	160B (18x22-6N)		
				<b>3151 994 801</b>			
				<b>1805 041 100</b>			

# HANOMAG RHEINSTAHL





























Brillant							
500 (R448)		D28CR		<b>1881 051 310 #</b>	DO280 (Mo 280/23x29-10N) (Ge 250/46x50-8N)	enthält zwei Kupplungsscheiben / This part number includes both clutch discs	(46)
600				<b>1881 051 310 #</b>	DO280 (Mo 280/23x29-10N) (Ge 250/46x50-8N)	enthält zwei Kupplungsscheiben / This part number includes both clutch discs	(46)

Granit							
500				<b>1881 050 428 #</b>	DO250 (Mo 250/23x29-10N) (Ge 225/46x50-8N)	enthält zwei Kupplungsscheiben / This part number includes both clutch discs Nur bei Altteil-Rückgabe lieferbar (Reparatur; Werk Bielefeld) / Please return old unit for repair (plant Bielefeld)	(46) (33)
500 E 501	01.66- 01.66-			<b>1888 874 003 #</b>	DOT240 (225/45x50-24N)	enthält eine Kupplungsscheibe / This part number includes one clutch disc	(45)
				<b>1864 957 001 ▽</b>	240/ 40 (23x29-10N)	Lose Kupplungsscheibe / Loose clutch disc	(30)
				<b>1863 101 100 ▲</b>	65/101,5/26	mit Anlauftring / with thrust ring	(63)















K-Serie							
K 4				<b>1880 096 208 #</b>	G280		
				<b>1864 174 001</b>	280/ 58CERAM (26x32-10N)	Nur bei Altteil-Rückgabe lieferbar (Reparatur; Werk Bielefeld) / Please return old unit for repair (plant Bielefeld)	(33)
K 5				<b>1880 092 416 #</b>	G310		
				<b>1863 100 030</b>	55/90,5/25	mit Anlauftring / with thrust ring	(63)



Perfekt							
300		D14CR		<b>1882 108 204 #</b>	DO225 (Mo 225/23x29-10N) (Ge 200/46x50-8N)	enthält zwei Kupplungsscheiben / This part number includes both clutch discs	(46)
				<b>3151 000 395</b>			
400 400 E	10.69- 10.69-	D131		<b>1888 874 003 #</b>	DOT240 (225/45x50-24N)	enthält eine Kupplungsscheibe / This part number includes one clutch disc	(45)
				<b>1864 957 001 ▽</b>	240/ 40 (23x29-10N)	Lose Kupplungsscheibe / Loose clutch disc	(30)
				<b>1863 101 100 ▲</b>	65/101,5/26	mit Anlauftring / with thrust ring	(63)
400				<b>1882 108 204 #</b>	DO225 (Mo 225/23x29-10N) (Ge 200/46x50-8N)	->Mot. 1685290 enthält zwei Kupplungsscheiben / This part number includes both clutch discs	(46)
				<b>3151 000 395</b>		->Mot. 1685290	
400 E				<b>1882 108 204 #</b>	DO225 (Mo 225/23x29-10N) (Ge 200/46x50-8N)	->Mot. 1628093 enthält zwei Kupplungsscheiben / This part number includes both clutch discs	(46)
				<b>3151 000 395</b>		->Mot. 1628093	

# HANOMAG RHEINSTAHL

R-Serie							
R 13		D14S		1881 089 007	K225		
				1860 039 025 #	225Z (1 1/8"-10N)		
R 16 R 19 R 217 S		D14S		1881 089 007	K225		
				1860 039 025 #	225Z (1 1/8"-10N)		
				1859 600 006			
				1805 042 000			
R 18 R 24 R 224 R 228		D621S		1881 089 007	K225		
				1859 600 006			
				1805 042 000			
R 22 R 27		D21S		1881 089 007	K225		
				1860 039 025 #	225Z (1 1/8"-10N)		
R 25		D28		1881 009 203 #	G250		
				1864 202 035 #	250Z (26x32-10N)		
R 28		D21S		1881 009 201 #	G250		
				1864 202 035 #	250Z (26x32-10N)		
R 35		D28		1881 009 201 #	G250		
				1864 202 035 #	250Z (26x32-10N)		
			1881 050 402 #	DO250 (Ge 225/46x50-8N) (Mo 250/28x35-10N)	enthält zwei Kupplungsscheiben / This part number includes both clutch discs	(46)	
			3151 000 395				
R 45 R 332 Granit R 435 M R 440 R 445 /50				1881 050 402 #	DO250 (Ge 225/46x50-8N) (Mo 250/28x35-10N)	enthält zwei Kupplungsscheiben / This part number includes both clutch discs	(46)
				3151 000 395			
R 224 (Typ401)				1882 108 204 #	DO225 (Mo 225/23x29-10N) (Ge 200/46x50-8N)	enthält zwei Kupplungsscheiben / This part number includes both clutch discs	(46)
				3151 000 395			
R 324 S		D21S		1881 089 007	K225		
				1860 039 025 #	225Z (1 1/8"-10N)		
			1881 050 402 #	DO250 (Ge 225/46x50-8N) (Mo 250/28x35-10N)	enthält zwei Kupplungsscheiben / This part number includes both clutch discs	(46)	
			3151 000 395				
R 336		D21CR		1881 050 428 #	DO250 (Mo 250/23x29-10N) (Ge 225/46x50-8N)	enthält zwei Kupplungsscheiben / This part number includes both clutch discs Nur bei Altteil-Rückgabe lieferbar (Reparatur; Werk Bielefeld) / Please return old unit for repair (plant Bielefeld)	(46) (33)
				3151 000 395			



# HANOMAG RHEINSTAHL





R-Serie						
R 435		D28		1881 009 201 #	G250	
				1864 202 035 #	250Z (26x32-10N)	
R 435 /45		D28		1881 009 201 #	G250	
				1864 202 035 #	250Z (26x32-10N)	
				1859 600 006		
				1805 042 000		
			1881 050 402 #	DO250 (Ge 225/46x50-8N) (Mo 250/28x35-10N)	enthält zwei Kupplungsscheiben / This part number includes both clutch discs	(46)
			3151 000 395			
R 442 /50		D28S		1881 009 201 #	G250	
				1864 202 035 #	250Z (26x32-10N)	
				1859 600 006		
				1805 042 000		
			1881 050 402 #	DO250 (Ge 225/46x50-8N) (Mo 250/28x35-10N)	enthält zwei Kupplungsscheiben / This part number includes both clutch discs	(46)
			3151 000 395			

Robust						
Robust				1881 050 402 #	DO250 (Ge 225/46x50-8N) (Mo 250/28x35-10N)	enthält zwei Kupplungsscheiben / This part number includes both clutch discs
				3151 000 395		

# HARNISCHFEGER





AK-Serie						
AK 5-35				1863 100 030	55/90,5/25	mit Anlauftring / with thrust ring (63)

GH-Serie						
GH DG 750		KHDF10L413		1882 325 134	G380	Getr. / GBox: AK675/3
				1863 009 100	75/117/30	Getr. / GBox: AK675/3 mit Anlauftring / with thrust ring













T-Serie						
T 201		KHDF6L413V		1882 325 139	G380	
T 450 XL		KHDF8L413F		1882 325 139	G380	
				1878 000 957	380GTZ (1 3/4"-10N)	
				3151 000 515		

# HARNISCHFEGER

## T-Serie



T 600 XL		KHDF10L413 F		1882 320 131	GF420	Nur bei Altteil-Rückgabe lieferbar (Reparatur; Werk Bielefeld) / Please return old unit for repair (plant Bielefeld)	(33)
				3151 000 515			
		KHDF8L413F		1882 325 139	G380		
				1878 000 957	380GTZ (1 3/4"-10N)		
				3151 000 515			

## 105 - 430





105 A-TC				1880 083 132 #	G280		
105 B-TC				1863 100 030	55/90,5/25	mit Anlauftring / with thrust ring	(63)
105 TC							
155 A							
155 A-210							
155 A-TC							
325 TC 8 0"							
105 B-TC 6x6				1861 034 147 #	350 (32x40-10N)		
215				1880 083 132 #	G280		
218 TC		KHDF4L912		1863 100 030	55/90,5/25	mit Anlauftring / with thrust ring	(63)
325 TC 8 8"					1880 092 415 #	G310	
				1863 100 030	55/90,5/25	mit Anlauftring / with thrust ring	(63)
		DBOM326		1882 325 134	G380		
					1863 600 123	65/101,5/26	mit Anlauftring / with thrust ring
355 C-TC 6x6		DBOM326		1882 325 134	G380		
					1863 600 123	65/101,5/26	mit Anlauftring / with thrust ring
430 TC				1880 092 415 #	G310		
				1863 100 030	55/90,5/25	mit Anlauftring / with thrust ring	(63)

# HATZ

## A..-Serie

















A 2				1864 634 024	225Z (1 1/4"-10N)		
				1859 600 001			

## D..-Serie

















D 95				1881 009 201 #	G250		
				1864 202 035 #	250Z (26x32-10N)		
				1859 600 003			
				1805 042 000			
D 108				1863 100 030	55/90,5/25	mit Anlauftring / with thrust ring	(63)

# HATZ

## E..-Serie





E,ES 71 E,ES 75 E,ES 79 E 571 E 671				<b>1882 155 009</b>	K160		
				<b>1864 006 147</b>	160E (18x23-10N)		
				<b>3151 994 801</b>			
				<b>1805 041 100</b>			
E 80 G,FG E 85 G,FG E 89 G,FG E,ES 780 E,ES 785				<b>1882 315 002</b>	KS180		
				<b>1864 039 013 #</b>	180E (18x23-10N)		
				<b>3159 140 004</b>			
				<b>1805 041 100</b>			
E 108				<b>1882 314 001</b>	KS200		
				<b>1864 634 030</b>	200Z (26x32-10N)		
				<b>3100 700 101</b> ◊ <b>3151 021 001</b> ↓ <b>2x 3130 010 200</b>	KTI-1		
				<b>1881 010 101 #</b>	G250		
				<b>1864 202 035 #</b>	250Z (26x32-10N)		
				<b>1863 100 030</b>	55/90,5/25	mit Anlaufing / with thrust ring	(63)
E 950				<b>3082 025 531</b>	MF215		
				<b>3151 001 001</b>			

## T..-Serie











T 13 T 16				<b>1882 315 002</b>	KS180		
				<b>1864 634 040</b>	180E (23x29-10N)		
				<b>3159 140 004</b>			
				<b>1805 041 100</b>			
TL 10 TL 12				<b>1882 155 009</b>	K160		
				<b>1864 634 046</b>	160E (16x20-10N)		
				<b>3151 994 801</b>			
				<b>1805 041 100</b>			
TL 15 TL 18 TL 22				<b>1882 314 001</b>	KS200		
				<b>1864 634 039</b>	200Z (23x29-10N)		
				<b>1859 600 001</b>			
				<b>1805 042 000</b>			
TL 26 ,A2				<b>1864 634 024</b>	225Z (1 1/4"-10N)		
				<b>1859 600 001</b>			
				<b>1805 042 000</b>			
TL 35 TL 38				<b>1881 050 427 #</b>	DO250 (Mo 250/23x29-10N) (Ge 225/46x50-8N)	enthält zwei Kupplungsscheiben / This part number includes both clutch discs Nur bei Altteil-Rückgabe lieferbar (Reparatur; Werk Bielefeld) / Please return old unit for repair (plant Bielefeld)	(46) (33)
				<b>3151 000 395</b>			

# HATZ





## V..-Serie

<b>V 95</b>				<b>1881 009 201 #</b>	G250		
				<b>1864 202 035 #</b>	250Z (26x32-10N)		
				<b>1859 600 003</b>			
				<b>1805 042 000</b>			
<b>V 108</b>				<b>1863 100 030</b>	55/90,5/25	mit Anlauftring / with thrust ring	(63)

## Z..-Serie





<b>Z 108</b>				<b>1882 314 001</b>	KS200		
				<b>1864 634 030</b>	200Z (26x32-10N)		
				<b>3100 700 101</b> ◊ 3151 021 001 ↓ 2x 3130 010 200	KTI-1		
				<b>1881 010 101 #</b>	G250		
				<b>1864 202 035 #</b>	250Z (26x32-10N)		
				<b>1863 100 030</b>	55/90,5/25	mit Anlauftring / with thrust ring	(63)
<b>Z 788 Z 789 Z 790</b>				<b>1882 314 001</b>	KS200		
				<b>1864 634 027</b>	200Z (26x32-10N)		
				<b>1881 089 007</b>	K225		
				<b>1864 634 026</b>	225Z (26x32-10N)		
				<b>3100 700 101</b> ◊ 3151 021 001 ↓ 2x 3130 010 200	KTI-1		

## 715

































<b>715 J/H</b>		E85FG		<b>1882 315 002</b>	KS180		
				<b>1864 039 013 #</b>	180E (18x23-10N)		
				<b>3159 140 004</b>			
				<b>1805 041 100</b>			

# HIEBLE

## Bergmeister

<b>353, A 453, A</b>				<b>1888 878 001 #</b>	DUT250 (228/41x45-25N)	enthält eine Kupplungsscheibe / This part number includes one clutch disc	(45)
				<b>1861 259 131 ▽#</b>	250GSZ (21,7x25-13N)	Lose Kupplungsscheibe / Loose clutch disc	(30)
<b>553, A 654, A 754, A</b>				<b>1888 048 142 #</b>	DUT295-295/ 280 (280/41x45-22N)	enthält eine Kupplungsscheibe / This part number includes one clutch disc	(45)
				<b>1878 634 035 ▽</b>	295GSPDC (1 1/8"-10N)	Lose Kupplungsscheibe / Loose clutch disc	(30)
				<b>3800 541 019 ●#◊</b> ◊ 1888 048 142 ● 1878 634 018	DUT295-295/280 295GSB		

















# HOLDER

A.. - Serie							
A 8 B,D A 12 B,D				1882 155 009	K160		
				1864 634 009	(23x29-10N)		
				3151 994 801			
				1805 041 100			
A 10				1882 155 009	K160		
				1864 634 013	160 (23x28-6)		
				3151 994 801			
				1805 041 100			
A 15 B,D				1882 155 009	K160		
				1864 006 147	160E (18x23-10N)		
				3151 994 801			
				1805 041 100			
A 16	12.74-			1882 315 002	KS180		
				1864 066 209	180E (18x23-10N)		
				3151 270 602			
				1805 041 100			
A 20 A 21 S A 30				1882 315 002	KS180		
				1864 634 043	180E (23x29-10N)		
				1859 600 002			
				1805 041 100			
A 40 A 50 A 60 A 62 A 65				1861 674 331	240TPB (31x35-18N)		
				3151 083 001			
A 45/55				1882 196 005	KS200		
				1864 218 035	200Z (23x29-10N)		
				3100 700 101 ◊ 3151 021 001 J 2x 3130 010 200	KTI-1		
				3082 161 001 #	MF240		
A 440 S A 550 ,S A 560 Turbo A 760				1861 674 331	240TPB (31x35-18N)		
				3151 083 001			
				1882 196 005	KS200		
AG 3 AG 35 AM 2				1864 218 035	200Z (23x29-10N)		
				1859 600 001			
				1805 042 000			
							





# HOLDER













## B.. - Serie



<b>B 10 ,A,B,D</b>				<b>1882 155 009</b>	K160		
				<b>1864 634 013</b>	160 (23x28-6)		
				<b>3151 994 801</b>			
				<b>1805 041 100</b>			
<b>B 12 ,C BS 12 B</b>				<b>1882 315 002</b>	KS180		
				<b>1864 634 043</b>	180E (23x29-10N)		
				<b>1859 600 002</b>			
				<b>1805 041 100</b>			
<b>B 16</b>	12.74-	Hatz		<b>1882 315 002</b>	KS180	<b>12.1974-&gt;</b>	
				<b>1864 066 209</b>	180E (18x23-10N)	<b>12.1974-&gt;</b>	
				<b>3151 270 602</b>		<b>12.1974-&gt;</b>	
		Lombardini		<b>1882 155 009</b>	K160		
				<b>1864 006 147</b>	160E (18x23-10N)		
				<b>3151 994 801</b>			
				<b>1805 041 100</b>			
<b>BED 11</b>				<b>1882 005 002</b>	K160	Nur bei Altteil-Rückgabe lieferbar (Reparatur; Werk Bielefeld) / Please return old unit for repair (plant Bielefeld)	(33)
				<b>1864 634 013</b>	160 (23x28-6)		

## C.. - Serie







<b>C 62 C 65 C 500 Turbo</b>				<b>3082 161 001 #</b>	MF240		
				<b>1861 674 331</b>	240TPB (31x35-18N)		
				<b>3151 083 001</b>			









## E.. - Serie





<b>E 6</b>				<b>1881 069 101</b>	K140		
				<b>1864 051 202</b>	140E (16x20-10N)		
				<b>3159 140 004</b>			
				<b>1805 041 100</b>			
<b>E 8 (8PS)</b>				<b>1882 155 009</b>	K160		
				<b>1864 634 013</b>	160 (23x28-6)		
				<b>3151 994 801</b>			
				<b>1805 041 100</b>			
<b>E 8 B,D</b>				<b>1882 155 009</b>	K160		
				<b>1864 634 009</b>	(23x29-10N)		
				<b>3151 994 801</b>			
				<b>1805 041 100</b>			



					Parameter		
---	--	--	--	--	-----------	---	---

## HOLDER



E.. - Serie							
E 12 B		1882 315 002	KS180				
		1864 634 043	180E (23x29-10N)				
		1859 600 002					
		1805 041 100					
EB ED 10 ED 11 EF EF 11		1882 005 002	K160	Nur bei Altteil-Rückgabe lieferbar (Reparatur; Werk Bielefeld) / Please return old unit for repair (plant Bielefeld)			(33)
		1864 634 013	160 (23x28-6)				

P.. - Serie							
P 20		3082 112 031	MF190				
		1861 733 133 #	190TPB (17x20-17N)				
		3151 073 131					
P 60		1882 315 002	KS180				
		1864 634 043	180E (23x29-10N)				
		3100 700 101					
		3151 021 001	KTI-1				
		2x 3130 010 200					



504							
504		1882 155 009	K160				
		1864 634 013	160 (23x28-6)				
		3151 994 801					
		1805 041 100					

4100 - 5100							
4100 5100		3082 161 001 #	MF240				
		1861 674 331	240TPB (31x35-18N)				
		3151 083 001					

















## HURTH



HBW							
10		1866 052 001	152/ 123NPC	für / for: -20kpm max. übertragbares Motormoment [Nm] / max. transmittable engine torque [Nm]: 300			(47) (62)
		1866 050 002	122/ 100NC	für / for: -10kpm max. übertragbares Motormoment [Nm] / max. transmittable engine torque [Nm]: 154			(47) (62)
15 V 18		1866 052 002	152/ 123NPC	max. übertragbares Motormoment [Nm] / max. transmittable engine torque [Nm]: 300			(62)

## HÜRLIMANN

H-Serie							
H 305		1888 600 120	DUT250 (250/36x40-20N)	enthält eine Kupplungsscheibe / This part number includes one clutch disc			(45)
		1864 600 321	225 (22x25-10N)				







# HÜRLIMANN

H-Serie							
H 306				<b>1888 600 150</b>	DUT280/ CERAM (280/36x40-20N)	enthält eine Kupplungsscheibe / This part number includes one clutch disc (45)	
				<b>1864 600 318</b>	280CERAM (22x25-14N)		
				<b>1888 600 118</b>	DUT280/ CERAM (280/36x40-20N)	enthält eine Kupplungsscheibe / This part number includes one clutch disc (45)	
				<b>1864 600 324</b>	280CERAM (22x25-14N)	Anzahl der Beläge / Number of pads: 4 (7)	
H 307 H 476				<b>1888 600 118</b>	DUT280/ CERAM (280/36x40-20N)	enthält eine Kupplungsscheibe / This part number includes one clutch disc (45)	
				<b>1864 600 324</b>	280CERAM (22x25-14N)	Anzahl der Beläge / Number of pads: 4 (7)	
				<b>1888 600 119</b>	DUT280/ CERAM (280/36x40-20N)	enthält eine Kupplungsscheibe / This part number includes one clutch disc (45)	
				<b>1864 600 318</b>	280CERAM (22x25-14N)		
H 356 H 466/466.4				<b>1878 600 577</b>	280CB (36x40-24N)		
H 361/362/372				<b>1888 600 119</b>	DUT280/ CERAM (280/36x40-20N)	enthält eine Kupplungsscheibe / This part number includes one clutch disc (45)	
				<b>1864 600 318</b>	280CERAM (22x25-14N)		
H 480				<b>1888 600 118</b>	DUT280/ CERAM (280/36x40-20N)	enthält eine Kupplungsscheibe / This part number includes one clutch disc (45)	
H 481 H 491				<b>1888 600 118</b>	DUT280/ CERAM (280/36x40-20N)	enthält eine Kupplungsscheibe / This part number includes one clutch disc (45)	
				<b>1864 600 324</b>	280CERAM (22x25-14N)	Anzahl der Beläge / Number of pads: 4 (7)	
H XA 607				<b>1863 100 030</b>	55/90,5/25	mit Anlauftring / with thrust ring (63)	
H 6135 XB ELITE				<b>3482 600 111</b>	MF350		
				<b>1878 600 533</b>	350TC (41x45-21N)	Anzahl der Beläge / Number of pads: 6 (7)	





PRINCE						
Prince 325 Prince 335 Prince 345				<b>1888 600 129</b>	DUT225/ 225	enthält eine Kupplungsscheibe / This part number includes one clutch disc (45)
				<b>1864 600 333</b> ▽	225 (17x20-12N)	Lose Kupplungsscheibe / Loose clutch disc (30)



XT-Serie						
XT 908 XT 909 XT 910.4 XT 910.6	01.96- 01.96- 01.96- 01.96-			<b>1866 600 021</b>		Getr. / GBox: Fastdrive

# IMT

5000 - 6000						
5160 (180/200PS) 5200 (180/200PS)				<b>1878 002 706</b>	420GTZ (1 3/4" -10N)	
				<b>3151 000 515</b>		
				<b>1882 306 210</b>	G420N	für Nebenantrieb / for PTO (57)
				<b>3151 000 515</b>		
5270 5300				<b>1882 308 106</b>	G420	Nur bei Altteil-Rückgabe lieferbar (Reparatur; Werk Bielefeld) / Please return old unit for repair (plant Bielefeld) (33)
				<b>1878 002 706</b>	420GTZ (1 3/4" -10N)	
				<b>3151 000 515</b>		

# IRION



DGF							
1200				<b>1880 071 008</b>	K225		
1500				<b>1864 634 026</b>	225Z (26x32-10N)		
2000							
2500							
3000							
1200 K				<b>1882 172 101</b>	G250	Nur bei Altteil-Rückgabe lieferbar (Reparatur; Werk Bielefeld) / Please return old unit for repair (plant Bielefeld)	(33)
1500 K				<b>1864 202 035 #</b>	250Z (26x32-10N)		
2000 K							
2500 K							

HT							
1216				<b>1882 196 005</b>	KS200		
1225				<b>1860 049 027 #</b>	200Z (1 1/8"-10N)		
1231				<b>1864 634 031</b>	200Z (1 1/8"-10N)		
				<b>3100 700 101</b> ◊ 3151 021 001 ↓ 2x 3130 010 200	KTI-1		





# ISEKI

Iseki							
TX 2140				<b>1862 876 002</b>	180CB (18x20-18N)		
TX 2140 F							
TX 2160							
TX 2160 F							



# JCB

CONTRACTOR							
130 T				<b>3482 602 011</b>	GMF350N	mit Nebenantrieb / with PTO	(65)
150 T				<b>1878 600 830</b>	350BC (1 3/8"-10N)		
				<b>1863 600 115</b>	70/117		





# JCB



FASTRAC							
1115 S				3482 602 011	GMF350N	mit Nebenantrieb / with PTO	(65)
1125				1878 600 830	350BC (1 3/8"-10N)		
1135				1863 600 115	70/117		
125							
125-30							
125-40							
125-55							
125-65							
130T							
130T 30							
130T 40							
130T 55							
130T 65							
135 ,T							
145T							
145T 30							
145T 40							
145T 55							
145T 65							
150T							
150T 40							
150T 55							
150T 65							
155T							
185-Ti							
2115				3482 602 011	GMF350N	mit Nebenantrieb / with PTO	(65)
2125							
2135				3182 008 041	HHIS-3	Füllmedium: Mineralöl / Fill Medium: Mineral Oil nur als Ersatz für angegebene OE-Nr. / only for the listed OE-Numbers Immer erneuern / Renew everytime	(20) (77)
2150							
3155							(22)
3185							

# JENBACHER WERKE

JH							
JH 35				1880 071 008	K225		
				1864 634 026	225Z (26x32-10N)		























# JOHN DEERE

A							
1806				1882 315 003	KS180		
				1864 634 040	180E (23x29-10N)		
				1859 600 002			
				1805 041 100			

Mähdrescher / combine harvester							
930				1864 600 336	250 (26,1x32,2-10N)		
940							
1032							
1042							
955				1864 395 101 ▲#	305CERAM (1 3/8"-10N)	Chass. 269953->	

















# JOHN DEERE

## Mähdrescher / combine harvester









1052			 1864 600 336	250 (26,1x32,2-10N)			
			 3182 001 307	HHIS-3	für Fahrzeuge mit hydraulischer Kupplungsbetätigung / for vehicles with hydraulic clutch actuation Füllmedium: Hydrauliköl / Fill Medium: Hydraulic Oil Füllmedium: Bioöl / Fill Medium: Bio Oil Immer erneuern / Renew everytime	(52) (19) (17) (22)	
1055			 1864 395 101 ▲#	305CERAM (1 3/8"-10N)	->Chass. 044136	mit hydraulischer Getriebepbremse / with hydraulic gear brake	(72)
			 1864 395 101 ▲#	305CERAM (1 3/8"-10N)	->Chass. 044136	mit elektrischer Getriebepbremse / with electrical gear brake	(71)
			 3182 001 307	HHIS-3	->Chass. 044136	Füllmedium: Hydrauliköl / Fill Medium: Hydraulic Oil Füllmedium: Bioöl / Fill Medium: Bio Oil mit elektrischer Getriebepbremse / with electrical gear brake Immer erneuern / Renew everytime	(19) (17) (71) (22)
			 3482 008 034	MF310	Chass. 044137->	mit hydraulischer Getriebepbremse / with hydraulic gear brake	(72)
			 1864 461 001 #	310C (1 3/8"-10N)	Chass. 044137->	mit hydraulischer Getriebepbremse / with hydraulic gear brake	(72)
			 3482 008 034	MF310	Chass. 044137->	mit elektrischer Getriebepbremse / with electrical gear brake	(71)
			 1864 461 001 #	310C (1 3/8"-10N)	Chass. 044137->	mit elektrischer Getriebepbremse / with electrical gear brake	(71)
			 3182 001 307	HHIS-3	Chass. 044137->	Füllmedium: Hydrauliköl / Fill Medium: Hydraulic Oil Füllmedium: Bioöl / Fill Medium: Bio Oil mit elektrischer Getriebepbremse / with electrical gear brake Immer erneuern / Renew everytime	(19) (17) (71) (22)
1065 1068 H			 1864 395 101 ▲#	305CERAM (1 3/8"-10N)	mit hydraulischer Getriebepbremse / with hydraulic gear brake	(72)	
			 1864 395 101 ▲#	305CERAM (1 3/8"-10N)	mit elektrischer Getriebepbremse / with electrical gear brake	(71)	
			 3182 001 307	HHIS-3	Füllmedium: Hydrauliköl / Fill Medium: Hydraulic Oil Füllmedium: Bioöl / Fill Medium: Bio Oil mit elektrischer Getriebepbremse / with electrical gear brake Immer erneuern / Renew everytime	(19) (17) (71) (22)	
1068	10.85-		 3482 008 034	MF310			
			 1864 461 001 #	310C (1 3/8"-10N)			
			 3182 001 307	HHIS-3	10.1986->	Füllmedium: Hydrauliköl / Fill Medium: Hydraulic Oil Füllmedium: Bioöl / Fill Medium: Bio Oil Immer erneuern / Renew everytime	(19) (17) (22)
1072			 1864 395 101 ▲#	305CERAM (1 3/8"-10N)	->Chass. 044136		
			 3482 008 034	MF310	Chass. 044137->		
			 1864 461 001 #	310C (1 3/8"-10N)	Chass. 044137->		
1075 1188	10.86- 10.86-		 3482 012 211	GMF330			
			 3182 001 307	HHIS-3	Füllmedium: Hydrauliköl / Fill Medium: Hydraulic Oil Füllmedium: Bioöl / Fill Medium: Bio Oil Immer erneuern / Renew everytime	(19) (17) (22)	
1075 1085			 1864 395 101 ▲#	305CERAM (1 3/8"-10N)			

# JOHN DEERE

## Mähdrescher / combine harvester































1133 1144				<b>1864 600 336</b>	250 (26,1x32,2-10N)	für Fahrzeuge mit mech. Kupplungsbetätigung (Seilzug) / for vehicles with mech. clutch control (cable)	(53)
				<b>3182 001 307</b>	HHIS-3	für Fahrzeuge mit hydraulischer Kupplungsbetätigung / for vehicles with hydraulic clutch actuation Füllmedium: Hydrauliköl / Fill Medium: Hydraulic Oil Füllmedium: Bioöl / Fill Medium: Bio Oil Immer erneuern / Renew everytime	(52) (19) (17) (22)
1155 1157 1158 1169 4425 USA-Ausf.	10.86- 10.86-			<b>3482 008 034</b>	MF310		
				<b>1864 461 001 #</b>	310C (1 3/8"-10N)		
				<b>3182 001 307</b>	HHIS-3	Füllmedium: Hydrauliköl / Fill Medium: Hydraulic Oil Füllmedium: Bioöl / Fill Medium: Bio Oil Immer erneuern / Renew everytime	(19) (17) (22)
				<b>1864 461 001 #</b>	310C (1 3/8"-10N)		
1166	10.86-			<b>1864 395 101 ▲#</b>	305CERAM (1 3/8"-10N)	für / for: Reisausführung	(47)
				<b>3182 001 307</b>	HHIS-3	für / for: Reisausführung Füllmedium: Hydrauliköl / Fill Medium: Hydraulic Oil Füllmedium: Bioöl / Fill Medium: Bio Oil Immer erneuern / Renew everytime	(47) (19) (17) (22)
				<b>3482 008 034</b>	MF310		
				<b>1864 461 001 #</b>	310C (1 3/8"-10N)		
				<b>3182 001 307</b>	HHIS-3	Füllmedium: Hydrauliköl / Fill Medium: Hydraulic Oil Füllmedium: Bioöl / Fill Medium: Bio Oil Immer erneuern / Renew everytime	(19) (17) (22)
1174 1177	10.86-			<b>3482 012 211</b>	GMF330	Je nach Kundenwunsch mit unterschiedlicher Kupplung / Equipped with different clutch according to customer requirement	(26)
				<b>3182 001 307</b>	HHIS-3	Füllmedium: Hydrauliköl / Fill Medium: Hydraulic Oil Füllmedium: Bioöl / Fill Medium: Bio Oil Immer erneuern / Renew everytime	(19) (17) (22)
				<b>3482 008 034</b>	MF310	Je nach Kundenwunsch mit unterschiedlicher Kupplung / Equipped with different clutch according to customer requirement	(26)
				<b>1864 461 001 #</b>	310C (1 3/8"-10N)	Je nach Kundenwunsch mit unterschiedlicher Kupplung / Equipped with different clutch according to customer requirement	(26)
				<b>3182 001 307</b>	HHIS-3	Füllmedium: Hydrauliköl / Fill Medium: Hydraulic Oil Füllmedium: Bioöl / Fill Medium: Bio Oil Immer erneuern / Renew everytime	(19) (17) (22)

## T

100 200				<b>1882 196 005</b>	KS200		
				<b>1864 634 039</b>	200Z (23x29-10N)		
				<b>1859 600 001</b>			
				<b>1805 042 000</b>			
300 500 700				<b>1882 248 104 #</b>	G250		
				<b>1861 244 101 #</b>	250GSZ (26x32-10N)		
				<b>1859 600 003</b>			
				<b>1805 042 000</b>			
310 510 710				<b>3151 000 395</b>			





















# JOHN DEERE

## 820 - 1030































820 830				1888 053 101 #	DOT280H- (225/35x38-23N)	enthält eine Kupplungsscheibe / This part number includes one clutch disc	(45)
				1864 245 101 ▲▽#	250Z (22,3x25,8-15N)	Lose Kupplungsscheibe / Loose clutch disc	(30)
				3151 080 101			
				1863 869 018	15/35/11		
840				1888 053 101 #	DOT280H- (225/35x38-23N)	für Motorzapfwelle / for engine PTO shaft enthält eine Kupplungsscheibe / This part number includes one clutch disc	(56) (45)
				1861 686 033 ▽#	280GSPZ (22,3x25,8-15N)	Lose Kupplungsscheibe / Loose clutch disc	(30)
				3151 080 101			
				1882 284 306 #	XN280	->01.1983 für unabhängige Zapfwelle / for independent PTO shaft	(60)
				1861 686 033 #	280GSPZ (22,3x25,8-15N)	->01.1983	
				1864 239 033 ●#	280Z (22,3x25,8-15N)	->01.1983	
				3151 091 101		->01.1983	
				3482 039 402 #	GM320N	02.1983-> für unabhängige Zapfwelle / for independent PTO shaft	(60)
				3482 070 301	GM328N	02.1983-> für unabhängige Zapfwelle / for independent PTO shaft	(60)
				1861 924 103 #	280GTPZ (22,3x25,8-15N)	02.1983->	
				3151 091 101		02.1983->	
920	01.73-			1882 284 306 #	XN280		
				1864 239 033 #	280Z (22,3x25,8-15N)		
				1861 686 033 ●#	280GSPZ (22,3x25,8-15N)		
				1888 053 101 #	DOT280H- (225/35x38-23N)	für Fahrzeuge mit Zweischeibenkupplung / for vehicles with double disc clutch enthält eine Kupplungsscheibe / This part number includes one clutch disc	(51) (45)
				1864 245 101 ▲▽#	250Z (22,3x25,8-15N)	für Fahrzeuge mit Zweischeibenkupplung / for vehicles with double disc clutch Lose Kupplungsscheibe / Loose clutch disc	(51) (30)
				3151 080 101			
				1851 146 001 ▲		mit Schmierrohranschluß / with lubricating pipe coupling	(68)
				1863 869 018	15/35/11		
930 1020 ,V	01.73-			1882 284 306 #	XN280		
				1864 239 033 #	280Z (22,3x25,8-15N)		
				1861 686 033 ●#	280GSPZ (22,3x25,8-15N)		
				1888 053 101 #	DOT280H- (225/35x38-23N)	für Fahrzeuge mit Zweischeibenkupplung / for vehicles with double disc clutch enthält eine Kupplungsscheibe / This part number includes one clutch disc	(51) (45)
				1864 245 101 ▲▽#	250Z (22,3x25,8-15N)	für Fahrzeuge mit Zweischeibenkupplung / for vehicles with double disc clutch Lose Kupplungsscheibe / Loose clutch disc	(51) (30)
				3151 080 101			
				1851 146 001 ▲		mit Schmierrohranschluß / with lubricating pipe coupling	(68)



# JOHN DEERE

















820 - 1030							
940				<b>1888 053 101 #</b>	DOT280H- (225/35x38-23N)	für Motorzapfwelle / for engine PTO shaft enthält eine Kupplungsscheibe / This part number includes one clutch disc	(56) (45)
				<b>1861 686 033 ▽#</b>	280GSPZ (22,3x25,8-15N)	Lose Kupplungsscheibe / Loose clutch disc	(30)
				<b>3151 080 101</b>			
				<b>1882 284 306 #</b>	XN280	<b>-&gt;01.1983</b> für unabhängige Zapfwelle / for independent PTO shaft	(60)
				<b>1861 686 033 #</b>	280GSPZ (22,3x25,8-15N)	<b>-&gt;01.1983</b>	
				<b>1864 239 033 ●#</b>	280Z (22,3x25,8-15N)	<b>-&gt;01.1983</b>	
				<b>3151 091 101</b>		<b>-&gt;01.1983</b>	
				<b>3482 039 402 #</b>	GM320N	<b>02.1983-&gt;</b> für unabhängige Zapfwelle / for independent PTO shaft	(60)
				<b>3482 070 301</b>	GM328N	<b>02.1983-&gt;</b> für unabhängige Zapfwelle / for independent PTO shaft	(60)
				<b>1861 924 103 #</b>	280GTPZ (22,3x25,8-15N)	<b>02.1983-&gt;</b>	
				<b>3151 091 101</b>		<b>02.1983-&gt;</b>	
			1030	01.73 - 12.79			<b>1882 284 306 #</b>
	<b>1864 239 033 #</b>	280Z (22,3x25,8-15N)					
	<b>1861 686 033 ●#</b>	280GSPZ (22,3x25,8-15N)					
	<b>1851 146 001 ▲</b>					<b>-&gt;06.1976</b> mit Schmierrohranschluß / with lubricating pipe coupling	(68)
	<b>3151 080 101</b>					<b>07.1976-&gt;</b>	
	<b>1888 053 101 #</b>	DOT280H- (225/35x38-23N)				enthält eine Kupplungsscheibe / This part number includes one clutch disc	(45)
	<b>1864 239 033 #</b>	280Z (22,3x25,8-15N)					
	<b>1851 146 001 ▲</b>					<b>-&gt;Chass. 224436</b> mit Schmierrohranschluß / with lubricating pipe coupling	(68)
	<b>3151 080 101</b>					<b>Chass. 224437-&gt;</b>	
	<b>1863 869 018</b>	15/35/11					

# JOHN DEERE











1040 - 1550							
1040 1140				1888 053 101 #	DOT280H- (225/35x38-23N)	für Motorzapfwelle / for engine PTO shaft enthält eine Kupplungsscheibe / This part number includes one clutch disc	(56) (45)
				1861 686 033 ▽#	280GSPZ (22,3x25,8-15N)	Lose Kupplungsscheibe / Loose clutch disc	(30)
				3151 080 101			
				1882 284 306 #	XN280	->01.1983 für unabhängige Zapfwelle / for independent PTO shaft	(60)
				1861 686 033 #	280GSPZ (22,3x25,8-15N)	->01.1983	
				1864 239 033 ●#	280Z (22,3x25,8-15N)	->01.1983	
				3151 091 101		->01.1983	
				3482 039 402 #	GM320N	02.1983-> für unabhängige Zapfwelle / for independent PTO shaft	(60)
				1861 924 103 #	280GTPZ (22,3x25,8-15N)	02.1983->	
				3151 091 101		02.1983->	
				1863 869 018			
1120				1882 284 306 #	XN280		
				1864 239 033 #	280Z (22,3x25,8-15N)		
				1861 686 033 ●#	280GSPZ (22,3x25,8-15N)		
				1888 053 101 #	DOT280H- (225/35x38-23N)	für Fahrzeuge mit Zweischeibenkupplung / for vehicles with double disc clutch enthält eine Kupplungsscheibe / This part number includes one clutch disc	(51) (45)
				1864 245 101 ▲▽#	250Z (22,3x25,8-15N)	für Fahrzeuge mit Zweischeibenkupplung / for vehicles with double disc clutch Lose Kupplungsscheibe / Loose clutch disc	(51) (30)
				3151 080 101			
				1851 146 001 ▲		mit Schmierrohranschluß / with lubricating pipe coupling	(68)
				1863 869 018			
1130				1882 284 306 #	XN280		
				1864 239 033 #	280Z (22,3x25,8-15N)		
				1861 686 033 ●#	280GSPZ (22,3x25,8-15N)		
				1888 053 101 #	DOT280H- (225/35x38-23N)	für Fahrzeuge mit Zweischeibenkupplung / for vehicles with double disc clutch enthält eine Kupplungsscheibe / This part number includes one clutch disc	(51) (45)
				1864 245 101 ▲▽#	250Z (22,3x25,8-15N)	für Fahrzeuge mit Zweischeibenkupplung / for vehicles with double disc clutch Lose Kupplungsscheibe / Loose clutch disc	(51) (30)
				3151 080 101			
				1851 146 001 ▲		mit Schmierrohranschluß / with lubricating pipe coupling	(68)
1215 1315				1882 155 009	K160		
				1864 006 147	160E (18x23-10N)		
				3151 994 801			
				1805 041 100			

# JOHN DEERE

**1040 - 1550**



































<b>1350 1550</b>				<b>1888 053 101 #</b>	DOT280H- (225/35x38-23N)	Je nach Kundenwunsch mit unterschiedlicher Kupplung / Equipped with different clutch according to customer requirement enthält eine Kupplungsscheibe / This part number includes one clutch disc	(26) (45)
				<b>1864 245 101 ▲▽#</b>	250Z (22,3x25,8-15N)	Lose Kupplungsscheibe / Loose clutch disc	(30)
				<b>1864 239 033 ●▽#</b>	280Z (22,3x25,8-15N)	Lose Kupplungsscheibe / Loose clutch disc	(30)
				<b>3151 080 101</b>			
				<b>3163 026 100</b>		Kugellager / Ball Bearing	(28)
				<b>3482 070 301</b>	GM328N	Je nach Kundenwunsch mit unterschiedlicher Kupplung / Equipped with different clutch according to customer requirement	(26)
				<b>1861 924 103 #</b>	280GTPZ (22,3x25,8-15N)		
				<b>3151 091 101</b>			
<b>1530</b>				<b>1882 284 306 #</b>	XN280		
				<b>1864 239 033 #</b>	280Z (22,3x25,8-15N)		
				<b>1861 686 033 ●#</b>	280GSPZ (22,3x25,8-15N)		
				<b>1851 146 001 ▲</b>		-> <b>06.1976</b> mit Schmierrohranschluß / with lubricating pipe coupling	(68)
				<b>3151 080 101</b>		<b>07.1976-&gt;</b>	
				<b>1888 053 101 #</b>	DOT280H- (225/35x38-23N)	<b>07.1976-&gt;</b> enthält eine Kupplungsscheibe / This part number includes one clutch disc	(45)
				<b>1864 245 101 ▲▽#</b>	250Z (22,3x25,8-15N)	<b>07.1976-&gt;</b> Lose Kupplungsscheibe / Loose clutch disc	(30)
				<b>3151 080 101</b>		<b>07.1976-&gt;</b>	
				<b>1863 869 018</b>	15/35/11		

**1630 - 1950**

<b>1630</b>				<b>1882 284 306 #</b>	XN280		
				<b>1864 239 033 #</b>	280Z (22,3x25,8-15N)		
				<b>1861 686 033 ●#</b>	280GSPZ (22,3x25,8-15N)		
				<b>1851 146 001 ▲</b>		-> <b>06.1976</b> mit Schmierrohranschluß / with lubricating pipe coupling	(68)
				<b>3151 080 101</b>		<b>07.1976-&gt;</b>	
				<b>1863 869 018</b>	15/35/11		
<b>1630</b>				<b>1888 053 101 #</b>	DOT280H- (225/35x38-23N)	enthält eine Kupplungsscheibe / This part number includes one clutch disc	(45)
				<b>1861 686 033 ▽#</b>	280GSPZ (22,3x25,8-15N)	Lose Kupplungsscheibe / Loose clutch disc	(30)
				<b>1864 239 033 ●▽#</b>	280Z (22,3x25,8-15N)	Lose Kupplungsscheibe / Loose clutch disc	(30)
				<b>3163 026 100</b>		Kugellager / Ball Bearing	(28)
				<b>1863 869 018</b>	15/35/11		











# JOHN DEERE

## 1630 - 1950

















1635				1882 284 306 #	XN280		
				1861 686 033 #	280GSPZ (22,3x25,8-15N)		
				1851 146 001 ▲		mit Schmierrohranschluß / with lubricating pipe coupling	(68)
				1863 869 018	15/35/11		
1640 1840				1888 053 101 #	DOT280H- (225/35x38-23N)	für Motorzapfwelle / for engine PTO shaft enthält eine Kupplungsscheibe / This part number includes one clutch disc	(56) (45)
				1861 686 033 ▽#	280GSPZ (22,3x25,8-15N)	Lose Kupplungsscheibe / Loose clutch disc	(30)
				3163 026 100		Kugellager / Ball Bearing	(28)
				1863 869 018	15/35/11		
1640 1840	- 08.82 - 08.82			1882 284 306 #	XN280	für unabhängige Zapfwelle / for independent PTO shaft	(60)
				1861 686 033 #	280GSPZ (22,3x25,8-15N)		
				1864 239 033 ●#	280Z (22,3x25,8-15N)		
				3151 091 101			
				1863 869 018	15/35/11		
1640 1840	09.82 - 09.82 -	4Zyl.		3482 039 402 #	GM320N		
				3482 901 103	GM328N	für unabhängige Zapfwelle / for independent PTO shaft	(60)
				1862 140 004 #	320GTPB (22,3x25,8-15N)		
				3151 091 101			
				1863 869 018	15/35/11		
1745 F 1746 F 1845 F 1846 F				1888 600 127	DUT250/ 250 (250/31x35-18N)	enthält eine Kupplungsscheibe / This part number includes one clutch disc	(45)
				1864 600 331	250 (20,1x22,8-20N)		
				1863 837 002	65/97/23	mit Anlauftring / with thrust ring	(63)
				1863 855 000	106/140/25	mit Anlauftring / with thrust ring	(63)
				1888 053 101 #	DOT280H- (225/35x38-23N)	enthält eine Kupplungsscheibe / This part number includes one clutch disc	(45)
1750 1850 ,N				1861 686 033 ▽#	280GSPZ (22,3x25,8-15N)	Lose Kupplungsscheibe / Loose clutch disc	(30)
				1864 239 033 ●▽#	280Z (22,3x25,8-15N)	Lose Kupplungsscheibe / Loose clutch disc	(30)
				3151 080 101			
				3163 026 100		Kugellager / Ball Bearing	(28)
				3482 070 301	GM328N		
				1861 924 103 #	280GTPZ (22,3x25,8-15N)		
				3151 091 101			
				1882 284 306 #	XN280		
1830				1864 239 033 #	280Z (22,3x25,8-15N)		
				1861 686 033 ●#	280GSPZ (22,3x25,8-15N)		
				1851 146 001 ▲		->06.1976 mit Schmierrohranschluß / with lubricating pipe coupling	(68)
				3151 080 101		07.1976->	

# JOHN DEERE

## 1630 - 1950



















<b>1830</b>				<b>1888 053 101 #</b>	DOT280H- (225/35x38-23N)	enthält eine Kupplungsscheibe / This part number includes one clutch disc	(45)
				<b>1861 686 033 ∇#</b>	280GSPZ (22,3x25,8-15N)	Lose Kupplungsscheibe / Loose clutch disc	(30)
				<b>1864 239 033 ●∇#</b>	280Z (22,3x25,8-15N)	Lose Kupplungsscheibe / Loose clutch disc	(30)
				<b>3163 026 100</b>		Kugellager / Ball Bearing	(28)
<b>1950 ,N,F</b>				<b>1888 053 101 #</b>	DOT280H- (225/35x38-23N)	enthält eine Kupplungsscheibe / This part number includes one clutch disc	(45)
				<b>1861 686 033 ∇#</b>	280GSPZ (22,3x25,8-15N)	Lose Kupplungsscheibe / Loose clutch disc	(30)
				<b>1864 239 033 ●∇#</b>	280Z (22,3x25,8-15N)	Lose Kupplungsscheibe / Loose clutch disc	(30)
				<b>3163 026 100</b>		Kugellager / Ball Bearing	(28)
				<b>3482 070 301</b>	GM328N		
				<b>1861 924 103 #</b>	280GTPZ (22,3x25,8-15N)		
				<b>3151 091 101</b>			

## 2000 - 2040













<b>2000</b>				<b>1888 600 115</b>	DUT280/ 310 (280/42x45-28N)	enthält eine Kupplungsscheibe / This part number includes one clutch disc	(45)
				<b>1864 600 308</b>	310C (25x28-18N)	Anzahl der Beläge / Number of pads: 6	(7)
<b>2020</b>				<b>1888 053 101 #</b>	DOT280H- (225/35x38-23N)	enthält eine Kupplungsscheibe / This part number includes one clutch disc	(45)
				<b>1864 239 033 ∇#</b>	280Z (22,3x25,8-15N)	Lose Kupplungsscheibe / Loose clutch disc	(30)
				<b>1851 146 001 ▲</b>		-> <b>06.1976</b> mit Schmierrohranschluß / with lubricating pipe coupling	(68)
				<b>3151 080 101</b>		<b>07.1976-&gt;</b>	
<b>2020</b>				<b>1888 053 101 #</b>	DOT280H- (225/35x38-23N)	enthält eine Kupplungsscheibe / This part number includes one clutch disc	(45)
				<b>1861 686 033 ∇#</b>	280GSPZ (22,3x25,8-15N)	Lose Kupplungsscheibe / Loose clutch disc	(30)
				<b>1864 239 033 ●∇#</b>	280Z (22,3x25,8-15N)	Lose Kupplungsscheibe / Loose clutch disc	(30)
				<b>3151 080 101</b>			
				<b>3163 026 100</b>		Kugellager / Ball Bearing	(28)
				<b>1863 869 018</b>	15/35/11		
<b>2030</b>				<b>1882 284 306 #</b>	XN280		
				<b>1864 239 033 #</b>	280Z (22,3x25,8-15N)		
				<b>1861 686 033 ●#</b>	280GSPZ (22,3x25,8-15N)		
				<b>3151 080 101</b>			
				<b>1863 869 018</b>	15/35/11		

# JOHN DEERE

## 2000 - 2040

























2040				<b>1888 053 101 #</b>	DOT280H- (225/35x38-23N)	für Motorzapfwelle / for engine PTO shaft enthält eine Kupplungsscheibe / This part number includes one clutch disc	(56) (45)	
				<b>1861 686 033 ▽#</b>	280GSPZ (22,3x25,8-15N)	Lose Kupplungsscheibe / Loose clutch disc	(30)	
				<b>3163 026 100</b>		Kugellager / Ball Bearing	(28)	
				<b>1882 284 306 #</b>	XN280	<b>-&gt;08.1982</b> für unabhängige Zapfwelle / for independent PTO shaft	(60)	
				<b>1861 686 033 #</b>	280GSPZ (22,3x25,8-15N)	<b>-&gt;08.1982</b>		
				<b>1864 239 033 ●#</b>	280Z (22,3x25,8-15N)	<b>-&gt;08.1982</b>		
				<b>3151 091 101</b>		<b>-&gt;08.1982</b>		
				<b>1863 869 018</b>				
			4Zyl.		<b>3482 070 301</b>	GM328N	<b>09.1982-&gt;</b>	
					<b>1862 140 004 #</b>	320GTPB (22,3x25,8-15N)	<b>09.1982-&gt;</b>	
	<b>3151 091 101</b>			<b>09.1982-&gt;</b>				
2040 S				<b>3482 901 103</b>	GM328N			
				<b>1861 913 002 #</b>	320GSPDC (1 1/4"-10N)	Anzahl der Beläge / Number of pads: 5	(7)	
				<b>1862 140 005 ●#</b>	320GTPB (1 1/4"-10N)			
				<b>3151 091 101</b>				
				<b>3800 541 020 #</b>  <b>3482 901 103</b>  <b>1862 972 045</b>	GM328N 327GPSDC	<b>01.1986-&gt;</b>		
				<b>3182 001 104</b>	HHIS-3	<b>01.1986-&gt;</b> Füllmedium: Bremsflüssigkeit / Fill Medium: Brake Fluid Immer erneuern / Renew everytime	(18) (22)	

## 2100 - 2240

2100 2200				<b>1888 600 115</b>	DUT280/ 310 (280/42x45-28N)	enthält eine Kupplungsscheibe / This part number includes one clutch disc	(45)
				<b>1864 600 308</b>	310C (25x28-18N)	Anzahl der Beläge / Number of pads: 6	(7)
2120				<b>1888 053 101 #</b>	DOT280H- (225/35x38-23N)	enthält eine Kupplungsscheibe / This part number includes one clutch disc	(45)
				<b>1861 686 033 ▽#</b>	280GSPZ (22,3x25,8-15N)	Lose Kupplungsscheibe / Loose clutch disc	(30)
				<b>1864 239 033 ●▽#</b>	280Z (22,3x25,8-15N)	Lose Kupplungsscheibe / Loose clutch disc	(30)
				<b>3151 080 101</b>			
				<b>3163 026 100</b>		Kugellager / Ball Bearing	(28)
				<b>1888 053 101 #</b>	DOT280H- (225/35x38-23N)	enthält eine Kupplungsscheibe / This part number includes one clutch disc	(45)
				<b>1864 239 033 ▽#</b>	280Z (22,3x25,8-15N)	Lose Kupplungsscheibe / Loose clutch disc	(30)
				<b>1851 146 001 ▲</b>		<b>-&gt;06.1976</b> mit Schmierrohranschluß / with lubricating pipe coupling	(68)
				<b>3151 080 101</b>		<b>07.1976-&gt;</b>	
	<b>1863 869 018</b>	15/35/11					











# JOHN DEERE

## 2100 - 2240













<b>2130</b>		<b>1882 284 306 #</b>	XN280		
		<b>1861 686 033 #</b>	280GSPZ (22,3x25,8-15N)		
		<b>1864 239 033 ●#</b>	280Z (22,3x25,8-15N)		
		<b>1851 146 001 ▲</b>			<b>-&gt;06.1976</b> mit Schmierrohranschluß / with lubricating pipe coupling (68)
		<b>3151 080 101</b>			<b>07.1976-&gt;</b>
		<b>1882 600 121 #</b>	G320N		mit Lastschaltgetriebe / with power shift transmission (64)
		<b>1864 313 231 #</b>	300B (1 1/4"-10N)		mit Lastschaltgetriebe / with power shift transmission (64)
		<b>1864 634 007</b>	300B (1 1/4"-10N)		mit Lastschaltgetriebe / with power shift transmission (64)
		<b>3151 080 101</b>			mit Lastschaltgetriebe / with power shift transmission (64)
		<b>1882 271 403</b>	GN300		ohne Lastschaltgetriebe / without power shift transmission (80)
		<b>1866 011 202</b>	236/ 145GS		nur in Verbindung mit / only in connection with: 1882 271 403 (78) max. übertragbares Motormoment [Nm] / max. transmittable engine torque [Nm]: 560 (62) ohne Lastschaltgetriebe / without power shift transmission (80) In 1881/1882/1888/3083/3088/3483/3488 ... .. (23) enthalten / Contained in 1881, 1882, 1888, 3083, 3088, 3483, 3488 ... ..
		<b>1864 600 348 #</b>	330B (22,5x26-15N)		ohne Lastschaltgetriebe / without power shift transmission (80)
		<b>1851 146 001 ▲</b>			<b>-&gt;06.1976</b> mit Schmierrohranschluß / with lubricating pipe coupling (68) ohne Lastschaltgetriebe / without power shift transmission (80)
		<b>3151 080 101</b>			<b>07.1976-&gt;</b> ohne Lastschaltgetriebe / without power shift transmission (80)
	<b>1863 869 018</b>				
<b>2135</b>		<b>1882 271 403</b>	GN300		
		<b>1864 600 348 #</b>	330B (22,5x26-15N)		
		<b>1851 146 001 ▲</b>			mit Schmierrohranschluß / with lubricating pipe coupling (68)
		<b>1863 869 018</b>			
<b>2140</b>		<b>1882 339 103</b>	G320N		<b>-&gt;03.1981</b> Nur bei Altteil-Rückgabe lieferbar (Reparatur; Werk Bielefeld) / Please return old unit for repair (plant Bielefeld) (33)
		<b>1862 140 005 #</b>	320GTPB (1 1/4"-10N)		<b>-&gt;03.1981</b>
		<b>3151 091 101</b>			<b>-&gt;03.1981</b>
		<b>3482 901 103</b>	GM328N		<b>04.1981-&gt;</b>
		<b>1861 913 002 #</b>	320GSPDC (1 1/4"-10N)		<b>04.1981-&gt;</b> Anzahl der Beläge / Number of pads: 5 (7)
		<b>3151 091 101</b>			<b>04.1981-&gt;</b>
		<b>1863 869 018</b>			

# JOHN DEERE

## 2100 - 2240

2240				<b>1888 053 101 #</b>	DOT280H- (225/35x38-23N)	für Motorzapfwelle / for engine PTO shaft enthält eine Kupplungsscheibe / This part number includes one clutch disc	(56) (45)	
				<b>1861 686 033 ▽#</b>	280GSPZ (22,3x25,8-15N)	Lose Kupplungsscheibe / Loose clutch disc	(30)	
				<b>3163 026 100</b>		Kugellager / Ball Bearing	(28)	
				<b>1882 284 306 #</b>	XN280	<b>-&gt;08.1982</b> für unabhängige Zapfwelle / for independent PTO shaft	(60)	
				<b>1861 686 033 #</b>	280GSPZ (22,3x25,8-15N)	<b>-&gt;08.1982</b>		
				<b>1864 239 033 ●#</b>	280Z (22,3x25,8-15N)	<b>-&gt;08.1982</b>		
				<b>3151 091 101</b>		<b>-&gt;08.1982</b>		
				<b>1863 869 018</b>				
			4Zyl.		<b>3482 070 301</b>	GM328N	<b>09.1982-&gt;</b>	
					<b>1862 140 004 #</b>	320GTPB (22,3x25,8-15N)	<b>09.1982-&gt;</b>	
	<b>3151 091 101</b>			<b>09.1982-&gt;</b>				













## 2250 - 2850

2250 2450				<b>1888 053 101 #</b>	DOT280H- (225/35x38-23N)	Je nach Kundenwunsch mit unterschiedlicher Kupplung / Equipped with different clutch according to customer requirement enthält eine Kupplungsscheibe / This part number includes one clutch disc	(26) (45)
				<b>1861 686 033 ▽#</b>	280GSPZ (22,3x25,8-15N)	Lose Kupplungsscheibe / Loose clutch disc	(30)
				<b>1862 140 004 #</b>	320GTPB (22,3x25,8-15N)		
				<b>3151 091 101</b>			
				<b>3163 026 100</b>		Kugellager / Ball Bearing	(28)
				<b>3482 070 301</b>	GM328N	Je nach Kundenwunsch mit unterschiedlicher Kupplung / Equipped with different clutch according to customer requirement	(26)
				<b>3182 001 104</b>	HHIS-3	<b>-&gt;Chass. 649118</b> Füllmedium: Bremsflüssigkeit / Fill Medium: Brake Fluid für Kabinenschlepper / for cab tractor Immer erneuern / Renew everytime	(18) (55) (22)
				<b>3182 001 105</b>	HHIS-3	<b>Chass. 649119-&gt;</b> Füllmedium: Bremsflüssigkeit / Fill Medium: Brake Fluid für Kabinenschlepper / for cab tractor Immer erneuern / Renew everytime	(18) (55) (22)
2300 2400				<b>1888 600 115</b>	DUT280/ 310 (280/42x45-28N)	enthält eine Kupplungsscheibe / This part number includes one clutch disc	(45)
				<b>1864 600 308</b>	310C (25x28-18N)	Anzahl der Beläge / Number of pads: 6	(7)
2345 F 2346 F				<b>1888 600 127</b>	DUT250/ 250 (250/31x35-18N)	enthält eine Kupplungsscheibe / This part number includes one clutch disc	(45)
				<b>1864 600 331</b>	250 (20,1x22,8-20N)		















# JOHN DEERE

## 2250 - 2850























2650 2850				3800 541 020 # 3482 901 103 1862 972 045	GM328N 327GPSPDC		
				1878 987 201 ●#	327GSZ (1 1/4"-10N)		
				3151 091 101			
				3182 001 104	HHIS-3	->Chass. 649118 Füllmedium: Bremsflüssigkeit / Fill Medium: Brake Fluid für Kabinenschlepper / for cabintractor Immer erneuern / Renew everytime	(18) (55) (22)
				3182 001 105	HHIS-3	Chass. 649119-> Füllmedium: Bremsflüssigkeit / Fill Medium: Brake Fluid für Kabinenschlepper / for cabintractor Immer erneuern / Renew everytime	(18) (55) (22)
2650 N (25 km/h)				3482 070 301	GM328N		
				1862 140 004 #	320GTPB (22,3x25,8-15N)		
				3151 091 101			
2650 N (40 km/h)				3482 901 103	GM328N		
				1862 140 004 #	320GTPB (22,3x25,8-15N)		
				3151 091 101			
2700 2800				3482 600 107	MF330		
				1864 600 311	327C (27x30-18N)	Anzahl der Beläge / Number of pads: 5	(7)

## 2900 - 3650

2900				3482 600 107	MF330		
				1864 600 311	327C (27x30-18N)	Anzahl der Beläge / Number of pads: 5	(7)
2940 3140				1882 339 103	G320N	->03.1981 Nur bei Altteil-Rückgabe lieferbar (Reparatur; Werk Bielefeld) / Please return old unit for repair (plant Bielefeld)	(33)
				1862 140 005 #	320GTPB (1 1/4"-10N)	->03.1981	
				3482 901 103	GM328N	04.1981->	
				1861 913 002 #	320GSPDC (1 1/4"-10N)	04.1981-> Anzahl der Beläge / Number of pads: 5	(7)
				3151 091 101			
				1863 869 018	15/35/11		
3030				1882 600 121 #	G320N		
				1864 634 007 ●	300B (1 1/4"-10N)		
				1864 313 231 ●#	300B (1 1/4"-10N)		
				1851 146 001 ▲		mit Schmierrohranschluß / with lubricating pipe coupling	(68)























# JOHN DEERE

## 2900 - 3650

3040		1882 339 103	G320N	->03.1981 Nur bei Altteil-Rückgabe lieferbar (Reparatur; Werk Bielefeld) / Please return old unit for repair (plant Bielefeld)	(33)
		1862 140 005 #	320GTPB (1 1/4"-10N)	->03.1981	
		3482 901 103	GM328N	04.1981->	
		1861 913 002 #	320GSPDC (1 1/4"-10N)	04.1981-> Anzahl der Beläge / Number of pads: 5	(7)
		3151 091 101			
3050		3800 541 020 # 3482 901 103 1862 972 045	GM328N 327GPSDC		
		3800 541 011 HD# 3482 901 103 1878 995 301	GM328N 327GPSDC		
		1878 987 201 ●#	327GSZ (1 1/4"-10N)		
		3151 091 101			
		3182 001 104	HHIS-3	->Chass. 649118 Füllmedium: Bremsflüssigkeit / Fill Medium: Brake Fluid für Kabinenschlepper / for cabintractor Immer erneuern / Renew everytime	(18) (55) (22)
		3182 001 105	HHIS-3	Chass. 649119-> Füllmedium: Bremsflüssigkeit / Fill Medium: Brake Fluid für Kabinenschlepper / for cabintractor Immer erneuern / Renew everytime	(18) (55) (22)
3100 3110		1888 997 801 #	DUT280 (280/40x45-16N)	enthält eine Kupplungsscheibe / This part number includes one clutch disc	(45)
		1864 994 901 #	280 (22x25-13N)		
		1863 837 002	65/97/23	mit Anlauftring / with thrust ring	(63)
		1863 855 000	106/140/25	mit Anlauftring / with thrust ring	(63)
3120 3130		1882 600 121 #	G320N		
		1864 313 231 #	300B (1 1/4"-10N)		
		1864 634 007	300B (1 1/4"-10N)		
		3151 080 101			
3135		1882 600 121 #	G320N		
		1851 146 001 ▲		mit Schmierrohranschluß / with lubricating pipe coupling	(68)
		1863 869 018	15/35/11		



































# JOHN DEERE

## 2900 - 3650

<b>3200/X</b>				<b>1888 997 801 #</b>	DUT280 (280/40x45-16N)	<b>-&gt;Chass. 003138</b> enthält eine Kupplungsscheibe / This part number includes one clutch disc	(45)
				<b>1864 994 901 ▽#</b>	280 (22x25-13N)	<b>-&gt;Chass. 003138</b> Lose Kupplungsscheibe / Loose clutch disc	(30)
				<b>1863 837 002</b>	65/97/23	<b>-&gt;Chass. 003138</b> mit Anlauftring / with thrust ring	(63)
				<b>1863 855 000</b>	106/140/25	<b>-&gt;Chass. 003138</b> mit Anlauftring / with thrust ring	(63)
				<b>1888 600 104</b>	DUT310 (310/40x45-16N)	<b>Chass. 003139-&gt;</b> nicht für Fahrgestellnummer / not for chassis no.: 003141/003159/003168 enthält eine Kupplungsscheibe / This part number includes one clutch disc	(76) (45)
				<b>1864 994 901 #</b>	280 (22x25-13N)	<b>Chass. 003139-&gt;</b> nicht für Fahrgestellnummer / not for chassis no.: 003141/003159/003168	(76)
				<b>1863 837 002</b>	65/97/23	<b>Chass. 003139-&gt;</b> nicht für Fahrgestellnummer / not for chassis no.: 003141/003159/003168 mit Anlauftring / with thrust ring	(76) (63)
				<b>1863 855 000</b>	106/140/25	<b>Chass. 003139-&gt;</b> nicht für Fahrgestellnummer / not for chassis no.: 003141/003159/003168 mit Anlauftring / with thrust ring	(76) (63)
<b>3210/X</b>				<b>1888 600 104</b>	DUT310 (310/40x45-16N)	<b>Chass. 003139-&gt;</b> nicht für Fahrgestellnummer / not for chassis no.: 003141/003159/003168 enthält eine Kupplungsscheibe / This part number includes one clutch disc	(76) (45)
				<b>1864 994 901 #</b>	280 (22x25-13N)	<b>Chass. 003139-&gt;</b> nicht für Fahrgestellnummer / not for chassis no.: 003141/003159/003168	(76)
				<b>1863 837 002</b>	65/97/23	<b>Chass. 003139-&gt;</b> nicht für Fahrgestellnummer / not for chassis no.: 003141/003159/003168 mit Anlauftring / with thrust ring	(76) (63)
				<b>1863 855 000</b>	106/140/25	<b>Chass. 003139-&gt;</b> nicht für Fahrgestellnummer / not for chassis no.: 003141/003159/003168 mit Anlauftring / with thrust ring	(76) (63)
<b>3300/X</b>				<b>1888 600 142</b>	DUT310 (310/40x45-16N)	<b>-&gt;Chass. 003090</b> enthält eine Kupplungsscheibe / This part number includes one clutch disc	(45)
				<b>1888 997 901 #</b>	DUT310 (310/40x45-16N)	<b>-&gt;Chass. 003090</b> enthält eine Kupplungsscheibe / This part number includes one clutch disc	(45)
				<b>1864 994 901 ▽#</b>	280 (22x25-13N)	<b>-&gt;Chass. 003090</b> Lose Kupplungsscheibe / Loose clutch disc	(30)
				<b>1863 837 002</b>	65/97/23	<b>-&gt;Chass. 003090</b> mit Anlauftring / with thrust ring	(63)
				<b>1863 855 000</b>	106/140/25	<b>-&gt;Chass. 003090</b> mit Anlauftring / with thrust ring	(63)
				<b>1888 600 102</b>	DUT330 (327/40x45-16N)	<b>Chass. 003091-&gt;</b> enthält eine Kupplungsscheibe / This part number includes one clutch disc	(45)
				<b>1888 600 122</b>	DUT330/ CERAM (330/40x45-16N)	<b>Chass. 003091-&gt;</b> enthält eine Kupplungsscheibe / This part number includes one clutch disc	(45)
				<b>1864 918 005 #</b>	310 (21,5x25-13N)	<b>Chass. 003091-&gt;</b>	
				<b>1863 837 002</b>	65/97/23	<b>Chass. 003091-&gt;</b> mit Anlauftring / with thrust ring	(63)
				<b>1863 855 000</b>	106/140/25	<b>Chass. 003091-&gt;</b> mit Anlauftring / with thrust ring	(63)





# JOHN DEERE

## 2900 - 3650













3310/X		<b>1888 600 102</b>	DUT330 (327/40x45-16N)	<b>Chass. 003091-&gt;</b> enthält eine Kupplungsscheibe / This part number includes one clutch disc	(45)
		<b>1888 600 122</b>	DUT330/ CERAM (330/40x45-16N)	<b>Chass. 003091-&gt;</b> enthält eine Kupplungsscheibe / This part number includes one clutch disc	(45)
		<b>1864 918 005 #</b>	310 (21,5x25-13N)	<b>Chass. 003091-&gt;</b>	
		<b>1863 837 002</b>	65/97/23	<b>Chass. 003091-&gt;</b> mit Anlauftring / with thrust ring	(63)
		<b>1863 855 000</b>	106/140/25	<b>Chass. 003091-&gt;</b> mit Anlauftring / with thrust ring	(63)
3340		<b>3800 541 020 #</b>  <b>3482 901 103</b>  <b>1862 972 045</b>	GM328N 327GPSDC		
		<b>3151 091 101</b>			
		<b>1863 869 018</b>	15/35/11		
3350		<b>3482 901 103</b>	GM328N		
		<b>1878 987 201 ●#</b>	327GSZ (1 1/4"-10N)		
		<b>3800 541 011 HD●#</b>  <b>3482 901 103</b>  <b>1878 995 301</b>	GM328N 327GPSDCE		
		<b>3151 091 101</b>			
		<b>3182 001 104</b>	HHIS-3	<b>-&gt;Chass. 649118</b> Füllmedium: Bremsflüssigkeit / Fill Medium: Brake Fluid für Kabinenschlepper / for cabin tractor Immer erneuern / Renew everytime	(18) (55) (22)
		<b>3800 541 020 #</b>  <b>3482 901 103</b>  <b>1862 972 045</b>	GM328N 327GPSDC	<b>Chass. 649119-&gt;</b> für Kabinenschlepper / for cabin tractor	(55)
		<b>3182 001 105</b>	HHIS-3	<b>Chass. 649119-&gt;</b> Füllmedium: Bremsflüssigkeit / Fill Medium: Brake Fluid für Kabinenschlepper / for cabin tractor Immer erneuern / Renew everytime	(18) (55) (22)
3400/X		<b>1888 600 122</b>	DUT330/ CERAM (330/40x45-16N)	<b>-&gt;Chass. 003986</b> enthält eine Kupplungsscheibe / This part number includes one clutch disc	(45)
		<b>1888 895 002 #</b>	DUT330 (330/45x50-16N)	<b>-&gt;Chass. 003986</b> enthält eine Kupplungsscheibe / This part number includes one clutch disc	(45)
		<b>1864 918 005 ▽#</b>	310 (21,5x25-13N)	<b>-&gt;Chass. 003986</b> Lose Kupplungsscheibe / Loose clutch disc	(30)
		<b>1863 837 002</b>	65/97/23	<b>-&gt;Chass. 003986</b> mit Anlauftring / with thrust ring	(63)
		<b>1863 855 000</b>	106/140/25	<b>-&gt;Chass. 003986</b> mit Anlauftring / with thrust ring	(63)
		<b>1888 600 142</b>	DUT310 (310/40x45-16N)	<b>Chass. 003987-&gt;</b> enthält eine Kupplungsscheibe / This part number includes one clutch disc	(45)
		<b>1864 600 301</b>	280CERAM (25x32-13N)	<b>Chass. 003987-&gt;</b> Anzahl der Beläge / Number of pads: 4	(7)
		<b>1863 837 002</b>	65/97/23	<b>Chass. 003987-&gt;</b> mit Anlauftring / with thrust ring	(63)
		<b>1863 855 000</b>	106/140/25	<b>Chass. 003987-&gt;</b> mit Anlauftring / with thrust ring	(63)
3410/X		<b>1888 600 142</b>	DUT310 (310/40x45-16N)	<b>Chass. 003987-&gt;</b> enthält eine Kupplungsscheibe / This part number includes one clutch disc	(45)
		<b>1864 600 301</b>	280CERAM (25x32-13N)	<b>Chass. 003987-&gt;</b> Anzahl der Beläge / Number of pads: 4	(7)
		<b>1863 837 002</b>	65/97/23	<b>Chass. 003987-&gt;</b> mit Anlauftring / with thrust ring	(63)
		<b>1863 855 000</b>	106/140/25	<b>Chass. 003987-&gt;</b> mit Anlauftring / with thrust ring	(63)

# JOHN DEERE

## 2900 - 3650

3640	11.83-			3800 541 020 # 3482 901 103 1862 972 045	GM328N 327GPSDC		
				3182 001 104	HHIS-3	Füllmedium: Bremsflüssigkeit / Fill Medium: Brake Fluid Immer erneuern / Renew everytime	(18) (22)
3650				3482 901 104	GM328N		
				1862 972 004 #	327GPSDC (1 1/4"-10N)	Anzahl der Beläge / Number of pads: 6	(7)
				3182 001 104	HHIS-3	->Chass. 649118 Füllmedium: Bremsflüssigkeit / Fill Medium: Brake Fluid Immer erneuern / Renew everytime	(18) (22)
				3182 001 105	HHIS-3	Chass. 649119-> Füllmedium: Bremsflüssigkeit / Fill Medium: Brake Fluid Immer erneuern / Renew everytime	(18) (22)

## 5310 - 5610

5210				1888 600 136	DUT280/ 280	für / for: Collarshift für / for: Syncshuttle enthält eine Kupplungsscheibe / This part number includes one clutch disc	(47) (47) (45)
				1864 600 350 ▽	280CERAM (21,8x25,5-13N)	für / for: Collarshift für / for: Syncshuttle Anzahl der Beläge / Number of pads: 4 Lose Kupplungsscheibe / Loose clutch disc	(47) (47) (7) (30)
				1863 600 113	45/75/16	ohne Anlauftring / without thrust ring	(79)
5310 5410 5510				1888 600 123	DUT280 (280/34x40-12N)	enthält eine Kupplungsscheibe / This part number includes one clutch disc	(45)
				1864 600 351 ▽	280CERAM (19x22-13N)	Lose Kupplungsscheibe / Loose clutch disc	(30)
				1888 600 136	DUT280/ 280	für / for: Collarshift für / for: Syncshuttle enthält eine Kupplungsscheibe / This part number includes one clutch disc	(47) (47) (45)
				1864 600 350 ▽	280CERAM (21,8x25,5-13N)	für / for: Collarshift für / for: Syncshuttle Anzahl der Beläge / Number of pads: 4 Lose Kupplungsscheibe / Loose clutch disc	(47) (47) (7) (30)
				1863 600 113	45/75/16	ohne Anlauftring / without thrust ring	(79)
5415				1864 600 351	280CERAM (19x22-13N)		
				1863 600 113	45/75/16	ohne Anlauftring / without thrust ring	(79)
5425 5525				1864 600 350 ▽	280CERAM (21,8x25,5-13N)	für / for: Syncshuttle Anzahl der Beläge / Number of pads: 4 Lose Kupplungsscheibe / Loose clutch disc	(47) (7) (30)
				1863 600 113	45/75/16	ohne Anlauftring / without thrust ring	(79)
5515				1864 600 351	280CERAM (19x22-13N)		

# JOHN DEERE

## 6010 - 6920

6010			⊙	1863 600 113	45/75/16	ohne Anlauftring / without thrust ring	(79)
6020							
6110							
6120							
6215							
6220							
6310							
6320							
6410							
6415							
6510							
6520							
6610							
6615							
6620							
6715							
6810							
6820							
6910							
6920							

## 7220 - 8210

7220			⊙	1863 600 113	45/75/16	ohne Anlauftring / without thrust ring	(79)
7320							
7420							
7520							

# KÖDEL & BÖHM

## Cornet

Cornet			⊙	1881 089 007	K225		
			⊙	1860 039 024 #	225Z (23x29-10N)		
			⊙	1859 600 001			
			⌋	1805 042 000			

## Favorit









Favorit			⊙	1881 089 007	K225		
			⊙	1860 039 024 #	225Z (23x29-10N)		
			⊙	3100 700 101 ⊙ 3151 021 001 ⌋ 2x 3130 010 200	KTI-1		

## RZK-Serie









K 10			⊙	1882 315 002	KS180		
			⊙	1859 600 002			
			⌋	1805 041 100			
K 12			⊙	1882 196 005	KS200		
			⊙	1859 600 001			
			⌋	1805 042 000			

# KRAMER



















## K-Serie

<b>K 15</b>				<b>1882 315 002</b>	KS180		
				<b>1864 634 040</b>	180E (23x29-10N)		
				<b>1859 600 004</b>			
				<b>1805 042 000</b>			
<b>K 33</b>				<b>1881 009 203 #</b>	G250		
				<b>1864 202 035 #</b>	250Z (26x32-10N)		
				<b>1859 600 005</b>			
				<b>1805 042 000</b>			
<b>K 250</b>				<b>1863 010 100</b>	60/96,6/26	mit Anlauftring / with thrust ring	(63)

## KA-Serie









<b>KA 12 KA 15</b>				<b>1882 315 002</b>	KS180		
				<b>1864 634 040</b>	180E (23x29-10N)		
				<b>1859 600 004</b>			
				<b>1805 042 000</b>			
<b>KA 110</b>				<b>1864 634 040</b>	180E (23x29-10N)		
				<b>1859 600 004</b>			
				<b>1805 042 000</b>			
<b>KA 330</b>				<b>1863 010 100</b>	60/96,6/26	mit Anlauftring / with thrust ring	(63)

## KB-Serie























<b>KB 12</b>				<b>1882 315 002</b>	KS180		
				<b>1864 634 040</b>	180E (23x29-10N)		
				<b>1859 600 004</b>			
				<b>1805 042 000</b>			
<b>KB 17 KB 150 KB 180</b>				<b>1882 196 005</b>	KS200		
				<b>1864 634 039</b>	200Z (23x29-10N)		
				<b>1859 600 001</b>			
				<b>1805 042 000</b>			
<b>KB 22</b>				<b>1882 196 005</b>	KS200	<b>-&gt;Chass. 17207</b>	
				<b>1864 634 039</b>	200Z (23x29-10N)	<b>-&gt;Chass. 17207</b>	
				<b>1881 089 002</b>	K225	<b>Chass. 17208-&gt;</b>	
				<b>1860 039 024 #</b>	225Z (23x29-10N)	<b>Chass. 17208-&gt;</b>	
				<b>1859 600 001</b>			
				<b>1805 042 000</b>			
<b>KB 22 L KB 25 L KB 222</b>				<b>1882 196 005</b>	KS200		
				<b>1864 634 039</b>	200Z (23x29-10N)		
				<b>1859 600 006</b>			
				<b>1805 042 000</b>			

# KRAMER

## KB-Serie

KB 22 C KB 25 W KB 220 W KB 250 W		1881 089 002	K225		
		1860 039 024 #	225Z (23x29-10N)		
		1859 600 001			
		1805 042 000			
KB 28		1881 009 203 #	G250		
		1864 202 035 #	250Z (26x32-10N)		
		1859 600 001			
		1805 042 000			

## KL-Serie



KL KL 11 KL 150		1864 634 040	180E (23x29-10N)		
		1859 600 004			
		1805 042 000			
KL 12		1881 044 001	KF180	Nur bei Altteil-Rückgabe lieferbar (Reparatur; Werk Bielefeld) / Please return old unit for repair (plant Bielefeld)	(33)
		1864 634 040	180E (23x29-10N)		
		1859 600 004			
		1805 042 000			
KL 17 KL 180 KL 200		1882 196 005	KS200		
		1864 634 039	200Z (23x29-10N)		
		1859 600 001			
		1805 042 000			
KL 22 KL 25 KL 220 KL 250 KL 300		1882 196 005	KS200		
		1864 634 039	200Z (23x29-10N)		
		1859 600 006			
		1805 042 000			
KL 350 Export KL 450 Export		1881 010 139 #	G250		
		1863 100 030	55/90,5/25	mit Anlauftring / with thrust ring	(63)
		1863 010 100	60/96,6/26	mit Anlauftring / with thrust ring	(63)
KL 400		1881 010 139 #	G250		
		1864 202 004 #	250Z (23x29-10N)		
		1863 100 030	55/90,5/25	mit Anlauftring / with thrust ring	(63)
		1863 010 100	60/96,6/26	mit Anlauftring / with thrust ring	(63)
KL 414 KL 452 Export KL 514 a KL 600 /45 KL 600 /45 Export		1863 010 100	60/96,6/26	mit Anlauftring / with thrust ring	(63)



					Parameter		
---	--	--	--	--	-----------	---	---





## KRAMER

### KLS-Serie





















KLS 130		1864 634 040	180E (23x29-10N)		
		1859 600 004			
		1805 042 000			

## KRIEGER FAHRZEUGBAU

### Kruti Schlepper / Tractor

20 PS		1882 315 002	KS180		
		1864 634 040	180E (23x29-10N)		
		3151 270 602			
		1805 041 200			



### KS-Serie

KS 30 A,H KS 40 A,H		1882 162 001	KS225S	Nur bei Altteil-Rückgabe lieferbar (Reparatur; Werk Bielefeld) / Please return old unit for repair (plant Bielefeld)	(33)
		1860 039 025 #	225Z (1 1/8"-10N)		
		3151 045 001			
KS 33 A KS 42 A		1888 024 114 #	DUT250-250/ 250 (250/46x50-8N)	enthält eine Kupplungsscheibe / This part number includes one clutch disc	(45)
		1864 202 004 ▽#	250Z (23x29-10N)	Lose Kupplungsscheibe / Loose clutch disc	(30)
		1863 837 002	65/97/23	mit Anlauftring / with thrust ring	(63)
		1863 855 000	106/140/25	mit Anlauftring / with thrust ring	(63)
		1882 162 001	KS225S	Nur bei Altteil-Rückgabe lieferbar (Reparatur; Werk Bielefeld) / Please return old unit for repair (plant Bielefeld)	(33)
		1860 039 025 #	225Z (1 1/8"-10N)		
		3151 045 001			
KS 50 A		1881 010 139 #	G250		
		1864 310 104	250B (1 1/8"-10N)		
		3151 045 001			
		1888 024 114 #	DUT250-250/ 250 (250/46x50-8N)	enthält eine Kupplungsscheibe / This part number includes one clutch disc	(45)
		1864 202 004 ▽#	250Z (23x29-10N)	Lose Kupplungsscheibe / Loose clutch disc	(30)
		1863 837 002	65/97/23	mit Anlauftring / with thrust ring	(63)
		1863 855 000	106/140/25	mit Anlauftring / with thrust ring	(63)
KS 55 A KS 60 A KS 65 A		1888 024 114 #	DUT250-250/ 250 (250/46x50-8N)	enthält eine Kupplungsscheibe / This part number includes one clutch disc	(45)
		1864 202 004 ▽#	250Z (23x29-10N)	Lose Kupplungsscheibe / Loose clutch disc	(30)
		1863 837 002	65/97/23	mit Anlauftring / with thrust ring	(63)
		1863 855 000	106/140/25	mit Anlauftring / with thrust ring	(63)

## KUBOTA

### Kubota



HX 95 110 130 150		3482 926 001 #	M350		
----------------------------	---	----------------	------	--	--

					Parameter		
---	--	--	--	--	-----------	---	---





## KUBOTA



L-Serie							
235 DT				1863 869 033	15/32/9		
245 DT							
275 DT							
285 DT							
295 DT							
305 DT							
345 L							
2050 DT							
2250 DT							
2350 DT							
2550 DT							
3250 DT							







## KÄSSBOHRER

Pistenbully							
Pistenbully		OM352A		1882 252 331	GFX310		
				1861 303 248	310GSB (28x35-10N)		
		OM616		1882 252 331	GFX310		

## LAMBORGHINI

600 - 1706							
600/DT 700				1888 600 150	DUT280/ CERAM (280/36x40-20N)	enthält eine Kupplungsscheibe / This part number includes one clutch disc	(45)
				1864 600 318	280CERAM (22x25-14N)		
774-8/CROSS 874-90				1878 600 523	310CBC (36x40-24N)		
956/DT 1306/DT 1506/DT 1706/DT				3400 700 458 			

C-Serie							
C 65 C 635				1878 600 577	280CB (36x40-24N)		
C 352				1888 874 001 #	DOT225 (225/40x36-20N)	enthält eine Kupplungsscheibe / This part number includes one clutch disc	(45)



CRONO							
554-50/DT				1888 600 150	DUT280/ CERAM (280/36x40-20N)	enthält eine Kupplungsscheibe / This part number includes one clutch disc	(45)
				1864 600 318	280CERAM (22x25-14N)		
564-60/DT 564-70/DT				1888 600 150	DUT280/ CERAM (280/36x40-20N)	enthält eine Kupplungsscheibe / This part number includes one clutch disc	(45)
				1864 600 318	280CERAM (22x25-14N)		
				1888 600 118	DUT280/ CERAM (280/36x40-20N)	enthält eine Kupplungsscheibe / This part number includes one clutch disc	(45)
				1864 600 324	280CERAM (22x25-14N)	Anzahl der Beläge / Number of pads: 4	(7)







					Parameter		
---	--	--	--	--	-----------	---	---



# LAMBORGHINI





F-Serie							
F 660 PLUS/DT				1888 600 150	DUT280/ CERAM (280/36x40-20N)	enthält eine Kupplungsscheibe / This part number includes one clutch disc	(45)
				1864 600 318	280CERAM (22x25-14N)		
F 775 PLUS				1888 600 118	DUT280/ CERAM (280/36x40-20N)	enthält eine Kupplungsscheibe / This part number includes one clutch disc	(45)
				1864 600 324	280CERAM (22x25-14N)	Anzahl der Beläge / Number of pads: 4	(7)
				1888 600 119	DUT280/ CERAM (280/36x40-20N)	enthält eine Kupplungsscheibe / This part number includes one clutch disc	(45)
				1864 600 318	280CERAM (22x25-14N)		
F 880 PLUS/DT F 990 PLUS/DT				1888 600 118	DUT280/ CERAM (280/36x40-20N)	enthält eine Kupplungsscheibe / This part number includes one clutch disc	(45)
				1864 600 324	280CERAM (22x25-14N)	Anzahl der Beläge / Number of pads: 4	(7)

FORMULA							
105				1878 600 523	310CBC (36x40-24N)		
				3482 998 101	GMF330		
115				3482 998 101	GMF330	->Chass. 3129	
125				3482 998 101	GMF330		
135				3482 998 101	GMF330		
				3482 600 111	MF350		
				1878 600 533	350TC (41x45-21N)	Anzahl der Beläge / Number of pads: 6	(7)

GRANDPRIX / N							
774-80 874-90				3482 998 101	GMF330		
				1878 600 522	330CB (36,5x41-24N)		









GRIMPER							
555 560				1888 600 150	DUT280/ CERAM (280/36x40-20N)	enthält eine Kupplungsscheibe / This part number includes one clutch disc	(45)
				1864 600 318	280CERAM (22x25-14N)		
				1888 600 118	DUT280/ CERAM (280/36x40-20N)	enthält eine Kupplungsscheibe / This part number includes one clutch disc	(45)
				1864 600 324	280CERAM (22x25-14N)	Anzahl der Beläge / Number of pads: 4	(7)
570				1888 600 118	DUT280/ CERAM (280/36x40-20N)	enthält eine Kupplungsscheibe / This part number includes one clutch disc	(45)
				1864 600 324	280CERAM (22x25-14N)	Anzahl der Beläge / Number of pads: 4	(7)











N CROSS							
N CROSS 674-70				1878 600 523	310CBC (36x40-24N)		
				1863 100 030	55/90,5/25	mit Anlauftring / with thrust ring	(63)



PREMIUM							
150				3482 998 101	GMF330	->Chass. 1433	
				1878 600 522	330CB (36,5x41-24N)	->Chass. 1433	
160				3482 998 101	GMF330	->Chass. 2077	
				1878 600 522	330CB (36,5x41-24N)	->Chass. 2077	



					Parameter		
---	--	--	--	--	-----------	---	---

## LAMBORGHINI





PREMIUM							
850	01.96-			3482 998 101	GMF330		
				1878 600 522	330CB (36,5x41-24N)		
				1866 600 021		<b>Chass. 1810-&gt;</b> Getr. / GBox: Directronic	
950	01.96-			3482 998 101	GMF330		
				1878 600 522	330CB (36,5x41-24N)		
				1866 600 021		<b>Chass. 1860-&gt;</b> Getr. / GBox: Directronic	
1050	01.96-			1866 600 021		<b>Chass. 1439-&gt;</b> Getr. / GBox: Directronic	
1060	01.96-			1866 600 021		<b>Chass. 2081-&gt;</b> Getr. / GBox: Directronic	

R-SERIE							
R 573				1878 600 577	280CB (36x40-24N)		
				1863 100 030	55/90,5/25	mit Anlaufing / with thrust ring	(63)
R 613 V				1888 911 001 #	DUT-250/ 280 (250/36x40-20N)	enthält eine Kupplungsscheibe / This part number includes one clutch disc	(45)
				1862 654 002 ▽#	280TB (22x25-14N)	Lose Kupplungsscheibe / Loose clutch disc	(30)
R 674				3482 600 120	MF280	Borg & Beck Version / Borg & Beck Version	(9)
				1878 600 577	280CB (36x40-24N)		
				1863 100 030	55/90,5/25	mit Anlaufing / with thrust ring	(63)
R 874-90 GP				3482 998 101	GMF330		
R 956 R 1306/DT R 1356/DT R 1556/DT				3400 700 458 			





























RUNNER							
Runner 250 Runner 350 Runner 450				1888 600 129	DUT225/ 225	enthält eine Kupplungsscheibe / This part number includes one clutch disc	(45)
				1864 600 333 ▽	225 (17x20-12N)	Lose Kupplungsscheibe / Loose clutch disc	(30)

SPRINT							
664-60 674-70				1878 600 523	310CBC (36x40-24N)		
				1863 100 030	55/90,5/25	mit Anlaufing / with thrust ring	(63)

## LANDINI







Advantage							
55 F,L,GT 60 F,L,GT				1888 892 001 #	DUT280 (280/35x40-14N)	enthält eine Kupplungsscheibe / This part number includes one clutch disc	(45)
				1864 917 002 ▽#	280E (22x25-10N)	Lose Kupplungsscheibe / Loose clutch disc	(30)
				3800 541 017 	1888 880 001 1864 917 002	DUT280/CERAM 280E	







# LANDINI



Advantage							
65 F,L,GT 75 F,L,GT 85 F,L,GT		<b>1888 892 001 #</b>	DUT280 (280/35x40-14N)	enthält eine Kupplungsscheibe / This part number includes one clutch disc	(45)		
		<b>1864 917 002 ▽#</b>	280E (22x25-10N)	Lose Kupplungsscheibe / Loose clutch disc	(30)		
		<b>3800 541 017 #●#○</b> <b>1888 880 001</b> <b>1864 917 002</b>	DUT280/CERAM 280E				
		<b>1888 876 006 #</b>	DUT310 (310/35x40-14N)	enthält eine Kupplungsscheibe / This part number includes one clutch disc	(45)		
		<b>1864 959 001 ▽#</b>	310 (22x25-10N)	Lose Kupplungsscheibe / Loose clutch disc	(30)		
95 L,GT		<b>1888 876 006 #</b>	DUT310 (310/35x40-14N)	enthält eine Kupplungsscheibe / This part number includes one clutch disc	(45)		
		<b>1864 959 001 ▽#</b>	310 (22x25-10N)	Lose Kupplungsscheibe / Loose clutch disc	(30)		
Atlas							
70 R,DT 75 R,DT		<b>1888 892 001 #</b>	DUT280 (280/35x40-14N)	enthält eine Kupplungsscheibe / This part number includes one clutch disc	(45)		
		<b>1864 917 002 ▽#</b>	280E (22x25-10N)	Lose Kupplungsscheibe / Loose clutch disc	(30)		
		<b>1888 876 006 #</b>	DUT310 (310/35x40-14N)	enthält eine Kupplungsscheibe / This part number includes one clutch disc	(45)		
		<b>1864 959 001 ▽#</b>	310 (22x25-10N)	Lose Kupplungsscheibe / Loose clutch disc	(30)		
80 R,DT		<b>3800 541 017 #●#○</b> <b>1888 880 001</b> <b>1864 917 002</b>	DUT280/CERAM 280E				
		<b>1888 876 006 #</b>	DUT310 (310/35x40-14N)	enthält eine Kupplungsscheibe / This part number includes one clutch disc	(45)		
		<b>1864 959 001 ▽#</b>	310 (22x25-10N)	Lose Kupplungsscheibe / Loose clutch disc	(30)		
90 R,DT 100 R,DT		<b>1888 876 006 #</b>	DUT310 (310/35x40-14N)	enthält eine Kupplungsscheibe / This part number includes one clutch disc	(45)		
		<b>1864 959 001 ▽#</b>	310 (22x25-10N)	Lose Kupplungsscheibe / Loose clutch disc	(30)		
Blizzard							
50 60 ,DT		<b>1888 892 001 #</b>	DUT280 (280/35x40-14N)	enthält eine Kupplungsscheibe / This part number includes one clutch disc	(45)		
		<b>1864 917 002 ▽#</b>	280E (22x25-10N)	Lose Kupplungsscheibe / Loose clutch disc	(30)		
		<b>3800 541 017 #●#○</b> <b>1888 880 001</b> <b>1864 917 002</b>	DUT280/CERAM 280E				
		<b>1888 600 145</b>	DUT280/ 280 (280/35x40-14N)	enthält eine Kupplungsscheibe / This part number includes one clutch disc	(45)		
		<b>1864 917 002 #</b>	280E (22x25-10N)				
		<b>1863 838 001</b>	50/82/29	ohne Anlauftring / without thrust ring	(79)		
		<b>1863 600 117</b>	65/100/11	mit Anlauftring / with thrust ring	(63)		
		<b>1863 869 020</b>	20/47/14				
95 ,DT		<b>1888 876 006 #</b>	DUT310 (310/35x40-14N)	enthält eine Kupplungsscheibe / This part number includes one clutch disc	(45)		
		<b>1864 959 001 ▽#</b>	310 (22x25-10N)	Lose Kupplungsscheibe / Loose clutch disc	(30)		
CF							
55 CF 60 CF 70 CF 75 C,CF 80 CF 85 C		<b>1864 917 002 ▽#</b>	280E (22x25-10N)	Lose Kupplungsscheibe / Loose clutch disc	(30)		
		<b>3800 541 017 #●#○</b> <b>1888 880 001</b> <b>1864 917 002</b>	DUT280/CERAM 280E				



					Parameter		
---	--	--	--	--	-----------	---	---



# LANDINI



Ghibli							
80 R, DT 90 R, DT				<b>1888 876 006 #</b>	DUT310 (310/35x40-14N)	enthält eine Kupplungsscheibe / This part number includes one clutch disc	(45)
				<b>1864 959 001 ▽#</b>	310 (22x25-10N)	Lose Kupplungsscheibe / Loose clutch disc	(30)
100 R, DT		1004.40T		<b>1888 876 006 #</b>	DUT310 (310/35x40-14N)	enthält eine Kupplungsscheibe / This part number includes one clutch disc	(45)
				<b>1864 959 001 ▽#</b>	310 (22x25-10N)	Lose Kupplungsscheibe / Loose clutch disc	(30)
				<b>3482 600 116</b>	MF330	für Fahrzeuge mit Einscheibenkupplung / for vehicles with single disc clutch	(48)
				<b>1878 600 569</b>	330CBC (44x48-23N)	für Fahrzeuge mit Einscheibenkupplung / for vehicles with single disc clutch Anzahl der Beläge / Number of pads: 5	(48) (7)

Globus							
Techno 50/60/70 Top 55R/DT				<b>1888 600 121 ▲</b>	DUT280 (280/31x35-18N)	enthält eine Kupplungsscheibe / This part number includes one clutch disc	(45)
				<b>1864 600 320</b>	250 (19x22-18N)		
Top 55/DT, 60				<b>3482 600 110</b>	MF280		
				<b>1878 600 530</b>	280CB (31x35-18N)		
Top 70				<b>3482 600 110</b>	MF280		
				<b>1878 600 531</b>	280CBC (31x35-18N)		









Landinetta							
Landinetta				<b>1881 089 002</b>	K225		
				<b>1864 634 026</b>	225Z (26x32-10N)		
				<b>3100 700 101</b> ◊ 3151 021 001 J 2x 3130 010 200	KTI-1		













Legend Top							
Legend Top 105 Legend Top 115 Legend Top 120 Legend Top 130 Legend Top 140 Legend Top 145 Legend Top 160 Legend Top 165 Legend Top 180				<b>3482 600 117</b>	M350	nicht für / not for: Powershift	(75)
				<b>1878 600 571</b>	350CBC (48x52-24N)	nicht für / not for: Powershift	(75)
				<b>1866 600 003</b>		für / for: Powershift max. übertragbares Motormoment [Nm] / max. transmittable engine torque [Nm]: 1300	(47) (62)







Mistral							
Mistral 40 Mistral 45 Mistral 50 Mistral 55		4TNV84T-KLAN, 4TNE84-ELAN, 3TNE88-ELAN, 4TNE88-ELAN		<b>1888 600 130</b>	DUT230/ 230 (225/27x30-16N)	enthält eine Kupplungsscheibe / This part number includes one clutch disc	(45)
				<b>1864 600 335</b>	225 (14x17-9N)		







Mythos							
Mythos 90 Mythos 100 Mythos 110		1004.40T, 1006.6		<b>3482 600 116</b>	MF330	für Fahrzeuge mit Einscheibenkupplung / for vehicles with single disc clutch	(48)
				<b>1878 600 569</b>	330CBC (44x48-23N)	für Fahrzeuge mit Einscheibenkupplung / for vehicles with single disc clutch Anzahl der Beläge / Number of pads: 5	(48) (7)
				<b>1866 600 004</b>		für / for: Powershift max. übertragbares Motormoment [Nm] / max. transmittable engine torque [Nm]: 500	(47) (62)

# LANDINI































Rex						
60 65		<b>1888 600 145</b>	DUT280/ 280 (280/35x40-14N)	enthält eine Kupplungsscheibe / This part number includes one clutch disc	(45)	
		<b>1864 917 002</b> ▽#	280E (22x25-10N)	Lose Kupplungsscheibe / Loose clutch disc	(30)	
		<b>1863 838 001</b>	50/82/29	ohne Anlauftring / without thrust ring	(79)	
		<b>1863 600 117</b>	65/100/11	mit Anlauftring / with thrust ring	(63)	
		<b>1863 869 020</b>	20/47/14			
70 80 90		<b>1864 917 002</b> ▽#	280E (22x25-10N)	Lose Kupplungsscheibe / Loose clutch disc	(30)	
		<b>1888 876 006</b> #	DUT310 (310/35x40-14N)	enthält eine Kupplungsscheibe / This part number includes one clutch disc	(45)	
		<b>1864 959 001</b> ▽#	310 (22x25-10N)	Lose Kupplungsscheibe / Loose clutch disc	(30)	
100		<b>1888 876 006</b> #	DUT310 (310/35x40-14N)	enthält eine Kupplungsscheibe / This part number includes one clutch disc	(45)	
		<b>1864 959 001</b> ▽#	310 (22x25-10N)	Lose Kupplungsscheibe / Loose clutch disc	(30)	

Trekker						
CF 55 CF 60		<b>1888 600 145</b>	DUT280/ 280 (280/35x40-14N)	enthält eine Kupplungsscheibe / This part number includes one clutch disc	(45)	
		<b>1864 917 002</b> ▽#	280E (22x25-10N)	Lose Kupplungsscheibe / Loose clutch disc	(30)	
		<b>1863 838 001</b>	50/82/29	ohne Anlauftring / without thrust ring	(79)	
		<b>1863 600 117</b>	65/100/11	mit Anlauftring / with thrust ring	(63)	
		<b>1863 869 020</b>	20/47/14			
CF 65 CF 70 CF 75 CF 80 CF 85		<b>3800 541 017</b> # 	DUT280/CERAM 280E	enthält eine Kupplungsscheibe / This part number includes one clutch disc	(45)	
		<b>1888 880 001</b>				
		<b>1864 917 002</b>				
		<b>1888 876 006</b> #	DUT310 (310/35x40-14N)	enthält eine Kupplungsscheibe / This part number includes one clutch disc	(45)	
		<b>1864 959 001</b> ▽#	310 (22x25-10N)	Lose Kupplungsscheibe / Loose clutch disc	(30)	
CF 90 CF 95 CF 100		<b>1888 876 006</b> #	DUT310 (310/35x40-14N)	enthält eine Kupplungsscheibe / This part number includes one clutch disc	(45)	
		<b>1864 959 001</b> ▽#	310 (22x25-10N)	Lose Kupplungsscheibe / Loose clutch disc	(30)	

4...-Serie						
4530 4830 4860		<b>1888 892 001</b> #	DUT280 (280/35x40-14N)	enthält eine Kupplungsscheibe / This part number includes one clutch disc	(45)	
		<b>1864 917 002</b> ▽#	280E (22x25-10N)	Lose Kupplungsscheibe / Loose clutch disc	(30)	
		<b>3800 541 017</b> ●# 	DUT280/CERAM 280E			
	<b>1888 880 001</b>					
		<b>1864 917 002</b>				

5...-Serie						
5500 5530 5830 5840 5860		<b>1888 892 001</b> #	DUT280 (280/35x40-14N)	enthält eine Kupplungsscheibe / This part number includes one clutch disc	(45)	
		<b>1864 917 002</b> ▽#	280E (22x25-10N)	Lose Kupplungsscheibe / Loose clutch disc	(30)	
		<b>3800 541 017</b> ●# 	DUT280/CERAM 280E			
	<b>1888 880 001</b>					
		<b>1864 917 002</b>				

# LANDINI

6...-Serie							
6030				<b>1888 892 001 #</b>	DUT280 (280/35x40-14N)	enthält eine Kupplungsscheibe / This part number includes one clutch disc	(45)
6040				<b>1864 917 002 ▽#</b>	280E (22x25-10N)	Lose Kupplungsscheibe / Loose clutch disc	(30)
6060				<b>3800 541 017 ●#○</b>			
6500				<b>1888 880 001</b>	DUT280/CERAM		
6530				<b>1864 917 002</b>	280E		
6550							
6830							
6840							
6860				<b>1888 876 006 #</b>	DUT310 (310/35x40-14N)	enthält eine Kupplungsscheibe / This part number includes one clutch disc	(45)
6870				<b>1864 959 001 ▽#</b>	310 (22x25-10N)	Lose Kupplungsscheibe / Loose clutch disc	(30)
6880				<b>3800 541 017 #○</b>			
				<b>1888 880 001</b>	DUT280/CERAM		
				<b>1864 917 002</b>	280E		
7...-Serie							
7500				<b>3800 541 017 #○</b>			
7530				<b>1888 880 001</b>	DUT280/CERAM		
7550				<b>1864 917 002</b>	280E		
7830							
7860				<b>1888 876 006 #</b>	DUT310 (310/35x40-14N)	enthält eine Kupplungsscheibe / This part number includes one clutch disc	(45)
7870				<b>1864 959 001 ▽#</b>	310 (22x25-10N)	Lose Kupplungsscheibe / Loose clutch disc	(30)
7880							
8...-Serie							
8500				<b>3800 541 017 #○</b>			
8530				<b>1888 880 001</b>	DUT280/CERAM		
8550				<b>1864 917 002</b>	280E		
8830							
8870				<b>1888 876 006 #</b>	DUT310 (310/35x40-14N)	enthält eine Kupplungsscheibe / This part number includes one clutch disc	(45)
8880				<b>1864 959 001 ▽#</b>	310 (22x25-10N)	Lose Kupplungsscheibe / Loose clutch disc	(30)
9...-Serie							
9880				<b>1888 876 006 #</b>	DUT310 (310/35x40-14N)	enthält eine Kupplungsscheibe / This part number includes one clutch disc	(45)
				<b>1864 959 001 ▽#</b>	310 (22x25-10N)	Lose Kupplungsscheibe / Loose clutch disc	(30)
10-14...-Serie							
10000				<b>1864 914 005 ▽#</b>	310 (27x30-16N)	Lose Kupplungsscheibe / Loose clutch disc	(30)
12500				<b>1888 873 001 #</b>	DUT330 (330/44x48-23N)	enthält eine Kupplungsscheibe / This part number includes one clutch disc	(45)
13000				<b>1864 921 001 ▽#</b>	330 (27x30-16N)	Lose Kupplungsscheibe / Loose clutch disc	(30)
14500							
50 - 394							
50 V				<b>1888 600 145</b>	DUT280/ 280 (280/35x40-14N)	enthält eine Kupplungsscheibe / This part number includes one clutch disc	(45)
55 V				<b>1864 917 002 ▽#</b>	280E (22x25-10N)	Lose Kupplungsscheibe / Loose clutch disc	(30)
60 V				<b>1863 838 001</b>	50/82/29	ohne Anlauftring / without thrust ring	(79)
				<b>1863 600 117</b>	65/100/11	mit Anlauftring / with thrust ring	(63)
				<b>1863 869 020</b>	20/47/14		





# LANDINI































50 - 394						
65 ,F,L,V,GT 75 ,F,L,V,GT 85 ,F,L,V,GT				<b>1888 892 001 #</b>	DUT280 (280/35x40-14N)	enthält eine Kupplungsscheibe / This part number includes one clutch disc (45)
				<b>1864 917 002 ▽#</b>	280E (22x25-10N)	Lose Kupplungsscheibe / Loose clutch disc (30)
				<b>3800 541 017 ●#⊖</b> <b>1888 880 001</b> <b>1864 917 002</b>	DUT280/CERAM 280E	
				<b>1888 876 006 #</b>	DUT310 (310/35x40-14N)	enthält eine Kupplungsscheibe / This part number includes one clutch disc (45)
				<b>1864 959 001 ▽#</b>	310 (22x25-10N)	Lose Kupplungsscheibe / Loose clutch disc (30)
				<b>1863 600 117</b>	65/100/11	mit Anlauftring / with thrust ring (63)
				<b>1863 869 020</b>	20/47/14	
254 274 284 364 374 394				<b>3800 541 017 #⊖</b> <b>1888 880 001</b> <b>1864 917 002</b>	DUT280/CERAM 280E	

# LANZ+MARTI

Allradlader / all-wheel drive loader						
NI NA				<b>1881 059 208</b>	KS200	
				<b>1864 634 039</b>	200Z (23x29-10N)	
NI 22R				<b>1880 071 008</b>	K225	
				<b>1860 039 024 #</b>	225Z (23x29-10N)	

















D-Serie						
D 14 (15PS) D 18 (20PS) D 40				<b>1881 089 002</b>	K225	
				<b>1864 634 024</b>	225Z (1 1/4"-10N)	
				<b>1859 600 001</b>		
				<b>1805 042 000</b>		
D 15 D 20 D 22 D 47 D 215 D 225				<b>1881 089 002</b>	K225	
				<b>1864 634 026</b>	225Z (26x32-10N)	
				<b>1859 600 001</b>		
				<b>1805 042 000</b>		
D 16 D 112 (AKD412A) D 115 D 415 (AE1) D 420				<b>1882 196 005</b>	KS200	
				<b>1864 634 039</b>	200Z (23x29-10N)	
				<b>1859 600 001</b>		
				<b>1805 042 000</b>		
D 24				<b>1881 089 002</b>	K225	
				<b>1864 634 026</b>	225Z (26x32-10N)	
				<b>1859 600 001</b>		

# LANZ+MARTI







D-Serie							
D 30 25		1881 009 203 #	G250				
		1864 202 035 #	250Z (26x32-10N)				
		1859 600 001					
		1805 042 000					
D 32		1881 089 002	K225				
		1864 634 026	225Z (26x32-10N)				
		1881 009 203 #	G250				
		1864 202 035 #	250Z (26x32-10N)				
		1859 600 001					
		1805 042 000					
D 36		1881 009 203 #	G250				
		1864 202 035 #	250Z (26x32-10N)				
		1859 600 001					
		1805 042 000					
		1863 010 100	60/96,6/26	mit Anlaufing / with thrust ring			(63)
D 38		1880 096 208 #	G280				
		1859 600 003					
		1805 042 000					
		1863 010 100	60/96,6/26	mit Anlaufing / with thrust ring			(63)
D 38 Helamatic		1880 083 132 #	G280				
		1863 010 100	60/96,6/26	mit Anlaufing / with thrust ring			(63)
D 45 D 138 D 225 (Helamatic) D 434 D 438 D 532 D 534 D 538 ,S D 540 (238) D 548 (245)		1863 010 100	60/96,6/26	mit Anlaufing / with thrust ring			(63)
D 117 (AKD311Z) D 218 D 518		1882 196 005	KS200				
		1864 634 030	200Z (26x32-10N)				
		1859 600 001					
D 124		1881 089 002	K225				
		1860 039 024 #	225Z (23x29-10N)				
		1859 600 001					
		1805 042 000					
D 130		1881 050 428 #	DO250 (Mo 250/23x29-10N) (Ge 225/46x50-8N)	enthält zwei Kupplungsscheiben / This part number includes both clutch discs Nur bei Altteil-Rückgabe lieferbar (Reparatur; Werk Bielefeld) / Please return old unit for repair (plant Bielefeld)			(46) (33)
		3151 000 395					

# LANZ+MARTI







## D-Serie

<b>D 218 (Helamatic)</b>				<b>1881 059 208</b>	KS200		
				<b>1864 634 030</b>	200Z (26x32-10N)		
<b>D 230</b>				<b>1881 089 002</b>	K225		
				<b>1864 634 026</b>	225Z (26x32-10N)		
				<b>1859 600 001</b>			
				<b>1805 042 000</b>			
				<b>1863 010 100</b>	60/96,6/26	mit Anlauftring / with thrust ring	(63)
<b>D 254 ,A</b>				<b>1881 051 310 #</b>	DO280 (Mo 280/23x29-10N) (Ge 250/46x50-8N)	enthält zwei Kupplungsscheiben / This part number includes both clutch discs	(46)
				<b>3151 000 395</b>			
<b>D 260 ,A</b>				<b>1882 318 101 #</b>	GT310N		
				<b>1864 340 101 #</b>	310B (28x35-10N)		
<b>D 340 ,A</b>				<b>1881 050 427 #</b>	DO250 (Mo 250/23x29-10N) (Ge 225/46x50-8N)	enthält zwei Kupplungsscheiben / This part number includes both clutch discs Nur bei Altteil-Rückgabe lieferbar (Reparatur; Werk Bielefeld) / Please return old unit for repair (plant Bielefeld)	(46) (33)
				<b>3151 000 395</b>			
<b>D 416</b>				<b>1882 315 003</b>	KS180		
				<b>1864 634 040</b>	180E (23x29-10N)		
				<b>1859 600 002</b>			
				<b>1805 041 100</b>			

## Friedhofsbagger / cemetery dredger



<b>LNB,LNC</b>		MWMD327/2, 3		<b>1880 071 008</b>	K225		
				<b>1860 039 024 #</b>	225Z (23x29-10N)		
<b>NG</b>		KHDF2L411D		<b>1880 071 008</b>	K225		
				<b>1864 078 010 #</b>	225Z (23x29-10N)		
		KHDF2L511		<b>3082 121 031</b>	M228		
				<b>3151 045 001</b>			











## HG-Serie

<b>HG 25</b>				<b>1881 089 002</b>	K225		
				<b>1864 634 026</b>	225Z (26x32-10N)		
				<b>1881 009 203 #</b>	G250		
				<b>1864 202 035 #</b>	250Z (26x32-10N)		
				<b>1859 600 001</b>			
				<b>1805 042 000</b>			







					Parameter		
---	--	--	--	--	-----------	---	---

## LANZ+MARTI

L-Serie							
L 25				1881 089 002	K225		
				1864 634 026	225Z (26x32-10N)		
				1859 600 001			

VARIMONT							
Agrar 08				1881 065 101	KS180		
				1864 634 016	180E (23x29-10N)		
				3151 270 602			
Industrie / industry				1881 065 101	KS180		
				1864 634 016	180E (23x29-10N)		
Industrie / industry V14,LAF (14PS)				1881 065 101	KS180		
				1864 634 016	180E (23x29-10N)		
				3151 270 602			
				1805 041 100			
Kleinradlader / small-wheel loader NI, NV				1880 071 008	K225		
				1860 039 024 #	225Z (23x29-10N)		

## LIEBHERR

















Mobilbagger / mobile excavator							
A 312 A 314 A 316				1866 156 001	314/ 159NGS	max. übertragbares Motormoment [Nm] / max. transmittable engine torque [Nm]: 670	(62)
A 904 A 904 C, HD A 912 A 914, B A 922, HD A 924 B A 924 HD				1866 133 001	345/ 210NGS	max. übertragbares Motormoment [Nm] / max. transmittable engine torque [Nm]: 1420	(62)
A 932 LI A 934 B LI A 934 LI A 944 LI				1866 135 001	345/ 210NGS	max. übertragbares Motormoment [Nm] / max. transmittable engine torque [Nm]: 1584	(62)
A 934 C LI				1866 000 151	345/ 232NGT	max. übertragbares Motormoment [Nm] / max. transmittable engine torque [Nm]: 3415	(62)
A 942		KHD		1866 065 001	345/ 210GS	max. übertragbares Motormoment [Nm] / max. transmittable engine torque [Nm]: 1400	(62)
Radlader / wheel loader							
L 538 L 542				1866 000 079	466/ 232NGT	max. übertragbares Motormoment [Nm] / max. transmittable engine torque [Nm]: 2719	(62)



# LIEBHERR

## Radlader / wheel loader



















L 544				<b>1866 000 007</b>	345/ 254NGT	max. übertragbares Motormoment [Nm] / max. transmittable engine torque [Nm]: 2490	(62)
L 550							
L 554							
L 556							
L 564							
L 566							
L 574							
L 576							
L 580							

## Raupenbagger / crawler excavator





















R 317				<b>1866 156 001</b>	314/ 159NGS	max. übertragbares Motormoment [Nm] / max. transmittable engine torque [Nm]: 670	(62)
		BF4M1013C		<b>1866 000 021</b>	314/ 188NGT	max. übertragbares Motormoment [Nm] / max. transmittable engine torque [Nm]: 1240	(62)
R 321				<b>1866 136 001</b>	345/ 159NGS	max. übertragbares Motormoment [Nm] / max. transmittable engine torque [Nm]: 823	(62)
R 902 LI							
R 324				<b>1866 157 101</b>	345/ 232NGT	max. übertragbares Motormoment [Nm] / max. transmittable engine torque [Nm]: 2719	(62)
R 350				<b>1881 010 139 #</b>	G250		
R 400				<b>1864 202 035 #</b>	250Z (26x32-10N)		
R 500 N							
R 353				<b>1880 083 132 #</b>	G280		
				<b>1863 100 030</b>	55/90,5/25	mit Anlauftring / with thrust ring	(63)
R 900 LI				<b>1866 138 101</b>	314/ 159NGS	max. übertragbares Motormoment [Nm] / max. transmittable engine torque [Nm]: 670	(62)
R 912				<b>1866 133 001</b>	345/ 210NGS	max. übertragbares Motormoment [Nm] / max. transmittable engine torque [Nm]: 1420	(62)
R 932 LI, T				<b>1866 135 001</b>	345/ 210NGS	max. übertragbares Motormoment [Nm] / max. transmittable engine torque [Nm]: 1584	(62)
R 932 LI TR BAUER							
R 932 LI TR DELMAG							
R 934 B, T							
R 942 LI							
R 942 LI TR BAUER							
R 944							
R 934 C				<b>1866 135 001</b>	345/ 210NGS	max. übertragbares Motormoment [Nm] / max. transmittable engine torque [Nm]: 1584	(62)
				<b>1866 000 151</b>	345/ 232NGT	max. übertragbares Motormoment [Nm] / max. transmittable engine torque [Nm]: 3415	(62)
R 942				<b>1866 065 001</b>	345/ 210GS	max. übertragbares Motormoment [Nm] / max. transmittable engine torque [Nm]: 1400	(62)
R 944 C TU				<b>1866 000 151</b>	345/ 232NGT	max. übertragbares Motormoment [Nm] / max. transmittable engine torque [Nm]: 3415	(62)
R 952, LI				<b>1866 090 001</b>	390/ 210NGS	max. übertragbares Motormoment [Nm] / max. transmittable engine torque [Nm]: 1950	(62)
R 962-133 LC							
R 962-225 HD							
R 962-226 LC SL							
R 962-385 HD-EW							
R 964 B				<b>1866 148 001</b>	466/ 288NGT	max. übertragbares Motormoment [Nm] / max. transmittable engine torque [Nm]: 2789	(62)
R 964 LI							
R 974							
R 974 C				<b>1866 000 152</b>	466/ 288NGT	max. übertragbares Motormoment [Nm] / max. transmittable engine torque [Nm]: 4500	(62)
R 984 C							

					Parameter		
---	--	--	--	--	-----------	---	---

# LINDNER



















1000-Serie							
1048 1055 1065		AD3.152, AD4.236		<b>1888 018 208 #</b>	DUT280-280/ 280 (280/46x50-8N)	ZF-Getriebe / ZF Transmission umgekehrte H-Schaltung / reverse balanced H-section enthält eine Kupplungsscheibe / This part number includes one clutch disc	(42) (84) (45)
				<b>1864 262 101 ▽#</b>	280B (23x29-10N)	ZF-Getriebe / ZF Transmission Lose Kupplungsscheibe / Loose clutch disc umgekehrte H-Schaltung / reverse balanced H-section	(42) (30) (84)
				<b>1863 123 000</b>	65/101,5/17,5	ZF-Getriebe / ZF Transmission umgekehrte H-Schaltung / reverse balanced H-section mit Anlauftring / with thrust ring	(42) (84) (63)
				<b>1863 600 122</b>	75/140/44,4	ZF-Getriebe / ZF Transmission umgekehrte H-Schaltung / reverse balanced H-section mit Anlauftring / with thrust ring	(42) (84) (63)
1450 1500		1004-4, AD3.152S, AD4.236, AD4.248, T3.152.4		<b>1864 421 141 #</b>	250 (28x32-17N)	<b>-&gt;03.1987</b> für / for: H-Schaltung Getr. / GBox: Steyr	(47)
				<b>3151 157 001</b>		<b>-&gt;03.1987</b> für / for: H-Schaltung Getr. / GBox: Steyr	(47)
				<b>1863 101 100 ▲</b>	65/101,5/26	<b>-&gt;03.1987</b> für / for: H-Schaltung Getr. / GBox: Steyr mit Anlauftring / with thrust ring	(47) (63)
				<b>1888 050 101 #</b>	DUT295-295/ 280 (280/45x50-24N)	für / for: H-Schaltung Getr. / GBox: Steyr enthält eine Kupplungsscheibe / This part number includes one clutch disc	(47) (45)
				<b>1864 410 101 ▽#</b>	295B (28x32-17N)	für / for: H-Schaltung Getr. / GBox: Steyr	(47)
				<b>1863 123 000</b>	65/101,5/17,5	für / for: H-Schaltung Getr. / GBox: Steyr mit Anlauftring / with thrust ring	(47) (63)
				<b>1863 600 122</b>	75/140/44,4	für / for: H-Schaltung Getr. / GBox: Steyr mit Anlauftring / with thrust ring	(47) (63)
1600 1650 1700 1750		1004-4, AD3.152S, AD4.236, AD4.248, T3.152.4		<b>1888 050 101 #</b>	DUT295-295/ 280 (280/45x50-24N)	für / for: H-Schaltung Getr. / GBox: Steyr enthält eine Kupplungsscheibe / This part number includes one clutch disc	(47) (45)
				<b>1864 410 101 ▽#</b>	295B (28x32-17N)	für / for: H-Schaltung Getr. / GBox: Steyr	(47)
				<b>1863 123 000</b>	65/101,5/17,5	für / for: H-Schaltung Getr. / GBox: Steyr mit Anlauftring / with thrust ring	(47) (63)
				<b>1863 600 122</b>	75/140/44,4	für / for: H-Schaltung Getr. / GBox: Steyr mit Anlauftring / with thrust ring	(47) (63)
Bauernfreund							
22 A,N				<b>1881 065 101</b>	KS180		
				<b>1859 600 002</b>			
				<b>1805 041 100</b>			
30 35 ,A				<b>1882 108 204 #</b>	DO225 (Mo 225/23x29-10N) (Ge 200/46x50-8N)	enthält zwei Kupplungsscheiben / This part number includes both clutch discs	(46)
				<b>3151 000 395</b>			

# LINDNER



Bauernfreund							
45 420				<b>1881 050 428 #</b>	DO250 (Mo 250/23x29-10N) (Ge 225/46x50-8N)	ZF-Getriebe / ZF Transmission umgekehrte H-Schaltung / reverse balanced H-section enthält zwei Kupplungsscheiben / This part number includes both clutch discs Nur bei Altteil-Rückgabe lieferbar (Reparatur; Werk Bielefeld) / Please return old unit for repair (plant Bielefeld)	(42) (84) (46) (33)
				<b>1863 101 100 ▲</b>	65/101,5/26	ZF-Getriebe / ZF Transmission umgekehrte H-Schaltung / reverse balanced H-section mit Anlauftring / with thrust ring	(42) (84) (63)
				<b>3151 000 395</b>		ZF-Getriebe / ZF Transmission umgekehrte H-Schaltung / reverse balanced H-section	(42) (84)
250 320 350				<b>1882 196 005</b>	KS200		
				<b>1864 634 039</b>	200Z (23x29-10N)		
				<b>1859 600 001</b> <b>3100 700 101 ●</b> ◊ 3151 021 001 ∩ 2x 3130 010 200	KTI-1		
350 S 450 S				<b>1881 089 007</b>	K225		
				<b>1881 089 006</b>	K225		
				<b>1860 039 024 #</b>	225Z (23x29-10N)		
				<b>1859 600 001</b>			
				<b>3100 700 101 ●</b> ◊ 3151 021 001 ∩ 2x 3130 010 200	KTI-1		
				<b>1882 108 204 #</b>	DO225 (Mo 225/23x29-10N) (Ge 200/46x50-8N)	enthält zwei Kupplungsscheiben / This part number includes both clutch discs	(46)
				<b>3151 000 395</b>			
	<b>1863 101 100 ▲</b>	65/101,5/26	mit Anlauftring / with thrust ring	(63)			
450				<b>1881 050 428 #</b>	DO250 (Mo 250/23x29-10N) (Ge 225/46x50-8N)	ZF-Getriebe / ZF Transmission umgekehrte H-Schaltung / reverse balanced H-section enthält zwei Kupplungsscheiben / This part number includes both clutch discs Nur bei Altteil-Rückgabe lieferbar (Reparatur; Werk Bielefeld) / Please return old unit for repair (plant Bielefeld)	(42) (84) (46) (33)
				<b>1863 101 100 ▲</b>	65/101,5/26	ZF-Getriebe / ZF Transmission umgekehrte H-Schaltung / reverse balanced H-section mit Anlauftring / with thrust ring	(42) (84) (63)
				<b>3151 000 395</b>		ZF-Getriebe / ZF Transmission umgekehrte H-Schaltung / reverse balanced H-section	(42) (84)
				<b>1882 248 104 #</b>	G250		
				<b>1864 026 232 #</b>	250 (23x29-10N)		
				<b>3151 021 001</b>			

# LINDNER

## Bauernfreund



























520				<b>1881 050 428 #</b>	DO250 (Mo 250/23x29-10N) (Ge 225/46x50-8N)	ZF-Getriebe / ZF Transmission umgekehrte H-Schaltung / reverse balanced H-section enthält zwei Kupplungsscheiben / This part number includes both clutch discs Nur bei Altteil-Rückgabe lieferbar (Reparatur; Werk Bielefeld) / Please return old unit for repair (plant Bielefeld)	(42) (84) (46) (33)
				<b>1863 101 100 ▲</b>	65/101,5/26	ZF-Getriebe / ZF Transmission umgekehrte H-Schaltung / reverse balanced H-section mit Anlauftring / with thrust ring	(42) (84) (63)
				<b>3151 000 395</b>		ZF-Getriebe / ZF Transmission umgekehrte H-Schaltung / reverse balanced H-section	(42) (84)
				<b>1864 421 141 #</b>	250 (28x32-17N)	für / for: H-Schaltung Getr. / GBox: Steyr	(47)
				<b>3151 000 395</b>		für / for: H-Schaltung Getr. / GBox: Steyr	(47)
				<b>1863 101 100 ▲</b>	65/101,5/26	für / for: H-Schaltung Getr. / GBox: Steyr mit Anlauftring / with thrust ring	(47) (63)
				<b>1888 018 208 #</b>	DUT280-280/ 280 (280/46x50-8N)	für / for: H-Schaltung Getr. / GBox: Steyr enthält eine Kupplungsscheibe / This part number includes one clutch disc	(47) (45)
				<b>1864 262 101 ▽#</b>	280B (23x29-10N)	für / for: H-Schaltung Getr. / GBox: Steyr Lose Kupplungsscheibe / Loose clutch disc	(47) (30)
				<b>1863 123 000</b>	65/101,5/17,5	für / for: H-Schaltung Getr. / GBox: Steyr mit Anlauftring / with thrust ring	(47) (63)
	<b>1863 600 122</b>	75/140/44,4	für / for: H-Schaltung Getr. / GBox: Steyr mit Anlauftring / with thrust ring	(47) (63)			
520 S 620				<b>1888 018 208 #</b>	DUT280-280/ 280 (280/46x50-8N)	für / for: H-Schaltung Getr. / GBox: Steyr enthält eine Kupplungsscheibe / This part number includes one clutch disc	(47) (45)
				<b>1864 262 101 ▽#</b>	280B (23x29-10N)	für / for: H-Schaltung Getr. / GBox: Steyr Lose Kupplungsscheibe / Loose clutch disc	(47) (30)
				<b>1863 123 000</b>	65/101,5/17,5	für / for: H-Schaltung Getr. / GBox: Steyr mit Anlauftring / with thrust ring	(47) (63)
				<b>1863 600 122</b>	75/140/44,4	für / for: H-Schaltung Getr. / GBox: Steyr mit Anlauftring / with thrust ring	(47) (63)
550 SA,SN (58PS)				<b>1882 258 004</b>	DUT280 (280/46x50-8N)	Nur bei Altteil-Rückgabe lieferbar (Reparatur; Werk Bielefeld) / Please return old unit for repair (plant Bielefeld) enthält eine Kupplungsscheibe / This part number includes one clutch disc	(33) (45)
				<b>1864 262 101 #</b>	280B (23x29-10N)		
				<b>1863 123 000</b>	65/101,5/17,5	mit Anlauftring / with thrust ring	(63)
650				<b>3151 000 395</b>		für / for: H-Schaltung Getr. / GBox: Steyr	(47)
				<b>1863 101 100 ▲</b>	65/101,5/26	für / for: H-Schaltung Getr. / GBox: Steyr mit Anlauftring / with thrust ring	(47) (63)



## DB-Serie

14				<b>1881 065 101</b>	KS180		
				<b>1859 600 002</b>			
				<b>1805 041 100</b>			





# LINDNER

Geotrac							
<b>LS 63</b>	01.03-			<b>1888 600 135</b>	DUT290/ 280 (280/ 1" -10N)	enthält eine Kupplungsscheibe / This part number includes one clutch disc	(45)
<b>LS 73</b>	01.03-			<b>1878 600 573</b> ▲▽	290CB (28x32-17N)	Anzahl der Beläge / Number of pads: 5 Lose Kupplungsscheibe / Loose clutch disc	(7) (30)
<b>LS 83</b>	01.03-			<b>1888 050 101</b> #	DUT295-295/ 280 (280/45x50-24N)	Getr. / GBox: Steyr enthält eine Kupplungsscheibe / This part number includes one clutch disc	(45)
<b>50</b>		903.27, T		<b>1878 634 033</b> ▽	295GSPB (28x32-17N)	Getr. / GBox: Steyr Lose Kupplungsscheibe / Loose clutch disc	(30)
<b>60</b>				<b>1863 123 000</b>	65/101,5/17,5	Getr. / GBox: Steyr mit Anlauftring / with thrust ring	(63)
				<b>1863 600 122</b>	75/140/44,4	Getr. / GBox: Steyr mit Anlauftring / with thrust ring	(63)
				<b>1888 600 135</b>	DUT290/ 280 (280/ 1" -10N)	LUK-Version / LUK-version enthält eine Kupplungsscheibe / This part number includes one clutch disc	(29) (45)
				<b>1878 600 572</b> ▽	290CBC (28x32-17N)	Anzahl der Beläge / Number of pads: 5 Lose Kupplungsscheibe / Loose clutch disc LUK-Version / LUK-version	(7) (30) (29)
<b>63</b>				<b>1888 600 135</b>	DUT290/ 280 (280/ 1" -10N)	LUK-Version / LUK-version enthält eine Kupplungsscheibe / This part number includes one clutch disc	(29) (45)
<b>65</b>				<b>1878 600 572</b> ▽	290CBC (28x32-17N)	Anzahl der Beläge / Number of pads: 5 LUK-Version / LUK-version Lose Kupplungsscheibe / Loose clutch disc	(7) (29) (30)
<b>73</b>							
<b>85</b>							
<b>100</b>		- 12.02					
<b>70</b>		1004.4T, 1004C-4T		<b>1888 050 101</b> #	DUT295-295/ 280 (280/45x50-24N)	Getr. / GBox: Steyr enthält eine Kupplungsscheibe / This part number includes one clutch disc	(45)
<b>75</b>				<b>1864 410 101</b> ▽#	295B (28x32-17N)	Getr. / GBox: Steyr Lose Kupplungsscheibe / Loose clutch disc	(30)
<b>83</b>				<b>1863 123 000</b>	65/101,5/17,5	Getr. / GBox: Steyr mit Anlauftring / with thrust ring	(63)
				<b>1863 600 122</b>	75/140/44,4	Getr. / GBox: Steyr mit Anlauftring / with thrust ring	(63)
				<b>1888 600 135</b>	DUT290/ 280 (280/ 1" -10N)	enthält eine Kupplungsscheibe / This part number includes one clutch disc LUK-Version / LUK-version	(45) (29)
				<b>1878 600 572</b> ▽	290CBC (28x32-17N)	Anzahl der Beläge / Number of pads: 5 LUK-Version / LUK-version Lose Kupplungsscheibe / Loose clutch disc	(7) (29) (30)
<b>80</b>		1004.4T, 1004C-4T		<b>1888 059 201</b> #	DUT330-310/ 295 (295/45x50-24N)	Getr. / GBox: Steyr enthält eine Kupplungsscheibe / This part number includes one clutch disc	(45)
				<b>1864 439 101</b> ▽#	310B (28x32-17N)	Getr. / GBox: Steyr Lose Kupplungsscheibe / Loose clutch disc	(30)
				<b>1863 123 000</b>	65/101,5/17,5	Getr. / GBox: Steyr mit Anlauftring / with thrust ring	(63)
				<b>1863 600 122</b>	75/140/44,4	Getr. / GBox: Steyr mit Anlauftring / with thrust ring	(63)
				<b>1888 600 135</b>	DUT290/ 280 (280/ 1" -10N)	LUK-Version / LUK-version enthält eine Kupplungsscheibe / This part number includes one clutch disc	(29) (45)
				<b>1878 600 572</b> ▽	290CBC (28x32-17N)	Anzahl der Beläge / Number of pads: 5 LUK-Version / LUK-version Lose Kupplungsscheibe / Loose clutch disc	(7) (29) (30)
<b>93</b>		1004.4T, 1004C-4T		<b>1888 059 201</b> #	DUT330-310/ 295 (295/45x50-24N)	Getr. / GBox: Steyr enthält eine Kupplungsscheibe / This part number includes one clutch disc	(45)
				<b>1864 439 101</b> ▽#	310B (28x32-17N)	Getr. / GBox: Steyr Lose Kupplungsscheibe / Loose clutch disc	(30)
				<b>1863 123 000</b>	65/101,5/17,5	Getr. / GBox: Steyr mit Anlauftring / with thrust ring	(63)
				<b>1863 600 122</b>	75/140/44,4	Getr. / GBox: Steyr mit Anlauftring / with thrust ring	(63)
Junior							
<b>Junior (9PS)</b>				<b>1881 065 101</b>	KS180		
				<b>1859 600 002</b>			
				<b>1805 041 100</b>			







					Parameter		
---	--	--	--	--	-----------	---	---

# LINDNER







## LW-Serie

20 A,N		1881 065 101	KS180		
		1859 600 002			
		1805 041 100			

## T-Serie









2500		1882 196 005	KS200		
		1864 634 039	200Z (23x29-10N)		
		1859 600 001			
		3100 700 101 ◊ 3151 021 001 J 2x 3130 010 200	KTI-1		
3500 S		1881 089 007	K225		
		1860 039 024 #	225Z (23x29-10N)		
		3100 700 101 ◊ 3151 021 001 J 2x 3130 010 200	KTI-1		

## Unitrac

55		1888 600 135	DUT290/ 280 (280/ 1" -10N)	enthält eine Kupplungsscheibe / This part number includes one clutch disc	(45)		
60			1878 600 572 ▽	290CBC (28x32-17N)	Anzahl der Beläge / Number of pads: 5 Lose Kupplungsscheibe / Loose clutch disc	(7) (30)	
65				1888 050 101 #	DUT295-295/ 280 (280/45x50-24N)	enthält eine Kupplungsscheibe / This part number includes one clutch disc	(45)
78					1864 410 101 ▽#	295B (28x32-17N)	Lose Kupplungsscheibe / Loose clutch disc
100	1004.4		1888 600 135	DUT290/ 280 (280/ 1" -10N)	LUK-Version / LUK-version enthält eine Kupplungsscheibe / This part number includes one clutch disc	(29) (45)	
95				1878 600 572 ▽	290CBC (28x32-17N)	Anzahl der Beläge / Number of pads: 5 Lose Kupplungsscheibe / Loose clutch disc LUK-Version / LUK-version	(7) (30) (29)

# MAN

## A,B,C,F-Serie

2F1		1882 315 002	KS180		
		1864 261 005 #	180E (23x29-10N)		
		1859 600 002			
		1805 041 100			
32 /0,C40 40 A,O 330 430 ,A 440 A,AS		1881 010 139 #	G250		
			1864 202 035 #	250Z (26x32-10N)	
542		1881 050 402 #	DO250 (Ge 225/46x50-8N) (Mo 250/28x35-10N)	enthält zwei Kupplungsscheiben / This part number includes both clutch discs	(46)
			1863 600 123	65/101,5/26	mit Anlauffring / with thrust ring



## MAN

P,N-Serie						
2N1			⊗	1881 050 402 #	DO250 (Ge 225/46x50-8N) (Mo 250/28x35-10N)	enthält zwei Kupplungsscheiben / This part number includes both clutch discs (46)
2P1			⊙	1863 600 123	65/101,5/26	mit Anlauftring / with thrust ring (63)
4N2						
4P1						

## MANITOU

C-Serie						
Interindustrial MB 20/25/26/30,C 25/25C 25/45C 4RM 20/25/26/30,C			⊗	1878 600 527	280CB (1 1/8"-10N)	12 mm Distanzstück auf Gehäuse / 12 mm spacers on pressing (1)

J-Serie						
J-Serie			⊗	1880 096 208 #	G280	
			⊗	1878 634 046	280GSZ (22x25-13N)	
			⊙	1859 600 003		

Manitool						
Manitool			⊗	1880 096 208 #	G280	
			⊗	1878 634 046	280GSZ (22x25-13N)	
			⊙	1859 600 003		

N-Serie						
N-Serie			⊗	1880 096 208 #	G280	
			⊗	1878 634 046	280GSZ (22x25-13N)	
			⊙	1859 600 003		





P-Serie						
P-Serie			⊗	1882 600 116	XN280	
			⊙	1863 600 101	60/102/21,5	mit Anlauftring / with thrust ring (63)
			⊗	3800 541 006 # ⊗ 3482 600 123 ⊗ 1862 716 003	M310 310CC	mit Rockford-Kupplung / with Rockford-Clutch (67)
			⊙	1863 600 101	60/102/21,5	mit Rockford-Kupplung / with Rockford-Clutch mit Anlauftring / with thrust ring (67) (63)





## MARSHALL

Serie 200						
245			⊗	1888 600 132	DU280/ 280 (280/ 1 3/4"-10N)	enthält eine Kupplungsscheibe / This part number includes one clutch disc (45)
253			⊗	1864 600 338	280E (1 1/8"-10N)	
255			⊗	1878 600 570 HD	280CBC (1 1/8"-10N)	
262			⊙	1863 867 001	76/114,5/19,4	ohne Anlauftring / without thrust ring (79)
270			⊙	1863 600 106	63,6/102,7/20,3	mit Anlauftring / with thrust ring (63)
272						
282						









					Parameter		
---	--	--	--	--	-----------	---	---

# MARSHALL









Serie 300							
342				<b>1888 600 132</b>	DU280/ 280 (280/ 1 3/4"-10N)	enthält eine Kupplungsscheibe / This part number includes one clutch disc	(45)
344				<b>1864 600 338</b>	280E (1 1/8"-10N)		
345				<b>1878 600 570</b> HD	280CBC (1 1/8"-10N)		
345 Nuffield				<b>1863 867 001</b>	76/114,5/19,4	ohne Anlauftring / without thrust ring	(79)
384				<b>1863 600 106</b>	63,6/102,7/20,3	mit Anlauftring / with thrust ring	(63)

Serie 400 - 1000							
460				<b>1888 600 132</b>	DU280/ 280 (280/ 1 3/4"-10N)	enthält eine Kupplungsscheibe / This part number includes one clutch disc	(45)
462				<b>1864 600 338</b>	280E (1 1/8"-10N)		
465				<b>1878 600 570</b> HD	280CBC (1 1/8"-10N)		
465 Nuffield				<b>1863 867 001</b>	76/114,5/19,4	ohne Anlauftring / without thrust ring	(79)
472				<b>1863 600 106</b>	63,6/102,7/20,3	mit Anlauftring / with thrust ring	(63)
482							
502							
602							
604							
1042							
1060							

# MASCHINENBAU ULM (MBU)





G-Serie							
G 3		KHDF3-L912		<b>1881 010 101 #</b>	G250		
				<b>1864 202 035 #</b>	250Z (26x32-10N)		
				<b>1863 100 030</b>	55/90,5/25	mit Anlauftring / with thrust ring	(63)
G 4		KHDF4-L912		<b>1881 010 101 #</b>	G250		
				<b>1864 202 035 #</b>	250Z (26x32-10N)		
				<b>1863 100 030</b>	55/90,5/25	mit Anlauftring / with thrust ring	(63)
G 5		KHDF4-L912		<b>1864 202 035 #</b>	250Z (26x32-10N)		
				<b>1863 100 030</b>	55/90,5/25	mit Anlauftring / with thrust ring	(63)

# MASSEY FERGUSON



















16 - 507 (Mähdrescher / combine harvester)							
16				<b>1881 089 007</b>	K225		
20				<b>1864 078 010 #</b>	225Z (23x29-10N)		
25				<b>3100 700 101</b>	KTI-1		
330				<b>3151 021 001</b>			
430				<b>2x 3130 010 200</b>			
31				<b>1882 313 001</b>	KS180	Nur bei Altteil-Rückgabe lieferbar (Reparatur; Werk Bielefeld) / Please return old unit for repair (plant Bielefeld)	(33)
				<b>1864 634 040</b>	180E (23x29-10N)		
86				<b>1880 071 008</b>	K225		
87				<b>1864 634 026</b>	225Z (26x32-10N)		

# MASSEY FERGUSON















## 16 - 507 (Mähdrescher / combine harvester)

186				1880 071 008	K225		
187				1880 071 011 ●	K225		
206							
307				1864 634 033	225Z (28x35-10N)		
240				1880 071 011	K225		
440							
487				1864 634 033	225Z (28x35-10N)		
506							
507							

## 20 - 194













20 B/F/H				1888 998 801 #	DO250/ 300 (250/38x41-25N)	enthält eine Kupplungsscheibe / This part number includes one clutch disc	(45)
30 E				1864 937 001 #	300 (1 1/8"-10N)		
				1863 600 118	63,5/100,2/22	mit Anlauftring / with thrust ring	(63)
20 B/E/F/H				1882 998 901 #	G300		
30 D/H				1864 937 001 #	300 (1 1/8"-10N)		
				1863 600 118	63,5/100,2/22	mit Anlauftring / with thrust ring	(63)
30				1864 937 001 #	300 (1 1/8"-10N)		
40				1863 600 118	63,5/100,2/22	mit Anlauftring / with thrust ring	(63)
158 /MK III S							
35/X				1888 898 003	DO225/ 280 (225/ 1 3/4"-10N)	Achtung ! Die 3 roten Schrauben, im Gehäuse, müssen nach der Montage entfernt werden. / Note! The three red screws in the housing must be removed after installation.	(5)
135						enthält eine Kupplungsscheibe / This part number includes one clutch disc	(45)
						Schwungradtiefe: 44,5 mm / Depth of Flywheel: 44,5 mm	(38)
				1864 946 001 ▽	280B (1 1/8"-10N)	Lose Kupplungsscheibe / Loose clutch disc	(30)
						Schwungradtiefe: 44,5 mm / Depth of Flywheel: 44,5 mm	(38)
				1863 600 118	63,5/100,2/22	Schwungradtiefe: 44,5 mm / Depth of Flywheel: 44,5 mm mit Anlauftring / with thrust ring	(38) (63)
				1882 600 110	G280	Nur bei Altteil-Rückgabe lieferbar (Reparatur; Werk Bielefeld) / Please return old unit for repair (plant Bielefeld)	(33)
				1864 946 001	280B (1 1/8"-10N)		
				1863 600 118	63,5/100,2/22	mit Anlauftring / with thrust ring	(63)
40 B				1882 600 110	G280	Nur bei Altteil-Rückgabe lieferbar (Reparatur; Werk Bielefeld) / Please return old unit for repair (plant Bielefeld)	(33)
				1863 600 118	63,5/100,2/22	mit Anlauftring / with thrust ring	(63)
40 E				1882 998 902 #	G300		
50 E/EX				1863 600 118	63,5/100,2/22	mit Anlauftring / with thrust ring	(63)

# MASSEY FERGUSON

20 - 194							
50 60 ,S 65 ,S				<b>1888 634 003</b>	DO225/ 280 (225/ 1 3/4"-10N)	Achtung ! Die 3 roten Schrauben, im Gehäuse, müssen nach der Montage entfernt werden. / Note! The three red screws in the housing must be removed after installation. enthält eine Kupplungsscheibe / This part number includes one clutch disc	(5) (45)
				<b>1888 898 001</b>	DO225/ 280 (225/ 1 3/4"-10N)	Achtung ! Die 3 roten Schrauben, im Gehäuse, müssen nach der Montage entfernt werden. / Note! The three red screws in the housing must be removed after installation. enthält eine Kupplungsscheibe / This part number includes one clutch disc	(5) (45)
				<b>1864 946 001</b> ▽	280B (1 1/8"-10N)	Lose Kupplungsscheibe / Loose clutch disc	(30)
				<b>1863 600 118</b>	63,5/100,2/22	mit Anlauftring / with thrust ring	(63)
133				<b>1888 898 003</b>	DO225/ 280 (225/ 1 3/4"-10N)	->Chass. 217333 ->Chass. R392075 enthält eine Kupplungsscheibe / This part number includes one clutch disc	(45)
				<b>1864 946 001</b> ▽	280B (1 1/8"-10N)	->Chass. 217333 ->Chass. R392075 Lose Kupplungsscheibe / Loose clutch disc	(30)
				<b>1863 600 118</b>	63,5/100,2/22	mit Anlauftring / with thrust ring	(63)
				<b>1888 634 001</b>	DO250/ 300 (250/ 1 3/4"-10N)	<b>Chass. 217334 - Chass. C275040</b> enthält eine Kupplungsscheibe / This part number includes one clutch disc	(45)
				<b>1888 891 002</b>	DOT250/ 300 (250/ 1 3/4" -10N)	<b>Chass. 217334 - Chass. C275040</b> enthält eine Kupplungsscheibe / This part number includes one clutch disc	(45)
				<b>1888 998 801</b> #	DO250/ 300 (250/38x41-25N)	<b>Chass. 392076-&gt;</b> <b>Chass. C275041-&gt;</b> enthält eine Kupplungsscheibe / This part number includes one clutch disc	(45)
				<b>1864 937 001</b> ▽#	300 (1 1/8"-10N)	<b>Chass. 217334 - Chass. C275040</b> <b>Chass. 392076-&gt;</b> <b>Chass. C275041-&gt;</b> Lose Kupplungsscheibe / Loose clutch disc	(30)
	<b>1863 600 118</b>	63,5/100,2/22	mit Anlauftring / with thrust ring	(63)			
133 Made in France 140 Made in France 148 Made in GB 155				<b>1888 634 001</b>	DO250/ 300 (250/ 1 3/4"-10N)	Achtung ! Die 3 roten Schrauben, im Gehäuse, müssen nach der Montage entfernt werden. / Note! The three red screws in the housing must be removed after installation. enthält eine Kupplungsscheibe / This part number includes one clutch disc	(5) (45)
				<b>1888 891 002</b>	DOT250/ 300 (250/ 1 3/4" -10N)	Achtung ! Die 3 roten Schrauben, im Gehäuse, müssen nach der Montage entfernt werden. / Note! The three red screws in the housing must be removed after installation. enthält eine Kupplungsscheibe / This part number includes one clutch disc	(5) (45)
				<b>1864 937 001</b> ▽#	300 (1 1/8"-10N)	Lose Kupplungsscheibe / Loose clutch disc	(30)
				<b>1863 600 118</b>	63,5/100,2/22	mit Anlauftring / with thrust ring	(63)
134				<b>1888 892 001</b> #	DUT280 (280/35x40-14N)	enthält eine Kupplungsscheibe / This part number includes one clutch disc	(45)
				<b>1864 917 002</b> ▽#	280E (22x25-10N)	Lose Kupplungsscheibe / Loose clutch disc	(30)

# MASSEY FERGUSON

## 20 - 194

135 Made in France								
					<b>1888 898 003</b>	DO225/ 280 (225/ 1 3/4"-10N)	-> <b>Chass. 382042</b> Achtung ! Die 3 roten Schrauben, im Gehäuse, müssen nach der Montage entfernt werden. / Note! The three red screws in the housing must be removed after installation. enthält eine Kupplungsscheibe / This part number includes one clutch disc	(5) (45)
					<b>1864 946 001</b> ▽	280B (1 1/8"-10N)	-> <b>Chass. 382042</b> Lose Kupplungsscheibe / Loose clutch disc	(30)
					<b>1863 600 118</b>	63,5/100,2/22	mit Anlauftring / with thrust ring	(63)
					<b>1888 634 001</b>	DO250/ 300 (250/ 1 3/4"-10N)	Achtung ! Die 3 roten Schrauben, im Gehäuse, müssen nach der Montage entfernt werden. / Note! The three red screws in the housing must be removed after installation. enthält eine Kupplungsscheibe / This part number includes one clutch disc	(5)
								<b>1888 891 002</b>
					<b>1888 998 801</b> #	DO250/ 300 (250/38x41-25N)	<b>Chass. 382043-&gt;</b> Achtung ! Die 3 roten Schrauben, im Gehäuse, müssen nach der Montage entfernt werden. / Note! The three red screws in the housing must be removed after installation. enthält eine Kupplungsscheibe / This part number includes one clutch disc	(5) (45)
					<b>1864 937 001</b> ▽#	300 (1 1/8"-10N)	<b>Chass. 382043-&gt;</b> Lose Kupplungsscheibe / Loose clutch disc	(30)
					<b>1863 600 118</b>	63,5/100,2/22	mit Anlauftring / with thrust ring	(63)
135 Made in GB								
					<b>1888 898 003</b>	DO225/ 280 (225/ 1 3/4"-10N)	-> <b>Chass. 121069</b> Achtung ! Die 3 roten Schrauben, im Gehäuse, müssen nach der Montage entfernt werden. / Note! The three red screws in the housing must be removed after installation. enthält eine Kupplungsscheibe / This part number includes one clutch disc	(5) (45)
					<b>1864 946 001</b> ▽	280B (1 1/8"-10N)	-> <b>Chass. 121069</b> Lose Kupplungsscheibe / Loose clutch disc	(30)
					<b>1863 600 118</b>	63,5/100,2/22	mit Anlauftring / with thrust ring	(63)
					<b>1888 998 801</b> #	DO250/ 300 (250/38x41-25N)	<b>Chass. 439191-&gt;</b> Achtung ! Die 3 roten Schrauben, im Gehäuse, müssen nach der Montage entfernt werden. / Note! The three red screws in the housing must be removed after installation. enthält eine Kupplungsscheibe / This part number includes one clutch disc	(5)
								<b>1888 634 001</b>
					<b>1888 891 002</b>	DOT250/ 300 (250/ 1 3/4" -10N)	<b>Chass. 121070 - Chass. 439190</b> Achtung ! Die 3 roten Schrauben, im Gehäuse, müssen nach der Montage entfernt werden. / Note! The three red screws in the housing must be removed after installation. enthält eine Kupplungsscheibe / This part number includes one clutch disc	(5) (45)
					<b>1864 937 001</b> ▽#	300 (1 1/8"-10N)	<b>Chass. 121070 - Chass. 439190</b> <b>Chass. 439191-&gt;</b> Lose Kupplungsscheibe / Loose clutch disc	(30)
					<b>1863 600 118</b>	63,5/100,2/22	mit Anlauftring / with thrust ring	(63)



# MASSEY FERGUSON













## 20 - 194

135 Standard, Multipower			⊗	1888 898 003	DO225/ 280 (225/ 1 3/4"-10N)	->Chass. 273718 Achtung ! Die 3 roten Schrauben, im Gehäuse, müssen nach der Montage entfernt werden. / Note! The three red screws in the housing must be removed after installation. enthält eine Kupplungsscheibe / This part number includes one clutch disc	(5) (45)
			⊗	1864 946 001 ▽	280B (1 1/8"-10N)	->Chass. 273718 Lose Kupplungsscheibe / Loose clutch disc	(30)
			⊗	1863 600 118	63,5/100,2/22	->Chass. 273718 mit Anlauftring / with thrust ring	(63)
135 Weinberg / vineyard			⊗	1888 891 002	DOT250/ 300 (250/ 1 3/4" -10N)	->Chass. C275040 Achtung ! Die 3 roten Schrauben, im Gehäuse, müssen nach der Montage entfernt werden. / Note! The three red screws in the housing must be removed after installation. enthält eine Kupplungsscheibe / This part number includes one clutch disc	(5) (45)
				1888 634 001	DO250/ 300 (250/ 1 3/4"-10N)	->Chass. C275040 Achtung ! Die 3 roten Schrauben, im Gehäuse, müssen nach der Montage entfernt werden. / Note! The three red screws in the housing must be removed after installation. enthält eine Kupplungsscheibe / This part number includes one clutch disc	(5) (45)
			⊗	1888 998 801 #	DO250/ 300 (250/38x41-25N)	Chass. C275041-> Achtung ! Die 3 roten Schrauben, im Gehäuse, müssen nach der Montage entfernt werden. / Note! The three red screws in the housing must be removed after installation. enthält eine Kupplungsscheibe / This part number includes one clutch disc	(5) (45)
			⊗	1864 937 001 ▽#	300 (1 1/8"-10N)	Lose Kupplungsscheibe / Loose clutch disc	(30)
			⊗	1863 600 118	63,5/100,2/22	mit Anlauftring / with thrust ring	(63)
140			⊗	1888 898 003	DO225/ 280 (225/ 1 3/4"-10N)	->Chass. 382042 Achtung ! Die 3 roten Schrauben, im Gehäuse, müssen nach der Montage entfernt werden. / Note! The three red screws in the housing must be removed after installation. enthält eine Kupplungsscheibe / This part number includes one clutch disc	(5) (45)
			⊗	1864 946 001 ▽	280B (1 1/8"-10N)	->Chass. 382042 Lose Kupplungsscheibe / Loose clutch disc	(30)
			⊗	1863 600 118	63,5/100,2/22	mit Anlauftring / with thrust ring	(63)
			⊗	1888 998 801 #	DO250/ 300 (250/38x41-25N)	Chass. 382043-> Achtung ! Die 3 roten Schrauben, im Gehäuse, müssen nach der Montage entfernt werden. / Note! The three red screws in the housing must be removed after installation. enthält eine Kupplungsscheibe / This part number includes one clutch disc	(5) (45)
			⊗	1864 937 001 ▽#	300 (1 1/8"-10N)	Chass. 382043-> Lose Kupplungsscheibe / Loose clutch disc	(30)
			⊗	1863 600 118	63,5/100,2/22	mit Anlauftring / with thrust ring	(63)
145			⊗	1888 898 003	DO225/ 280 (225/ 1 3/4"-10N)	Achtung ! Die 3 roten Schrauben, im Gehäuse, müssen nach der Montage entfernt werden. / Note! The three red screws in the housing must be removed after installation. enthält eine Kupplungsscheibe / This part number includes one clutch disc	(5) (45)
			⊗	1864 946 001 ▽	280B (1 1/8"-10N)	Lose Kupplungsscheibe / Loose clutch disc	(30)
			⊗	1863 600 118	63,5/100,2/22	mit Anlauftring / with thrust ring	(63)



















# MASSEY FERGUSON

## 20 - 194

148				<b>1888 891 002</b>	DOT250/ 300 (250/ 1 3/4" -10N)	<b>-&gt;Chass. C190070</b> Achtung ! Die 3 roten Schrauben, im Gehäuse, müssen nach der Montage entfernt werden. / Note! The three red screws in the housing must be removed after installation. enthält eine Kupplungsscheibe / This part number includes one clutch disc	(5) (45)
			<b>1888 634 001</b>	DO250/ 300 (250/ 1 3/4" -10N)	<b>-&gt;Chass. C190070</b> Achtung ! Die 3 roten Schrauben, im Gehäuse, müssen nach der Montage entfernt werden. / Note! The three red screws in the housing must be removed after installation. enthält eine Kupplungsscheibe / This part number includes one clutch disc	(5) (45)	
				<b>1888 998 801 #</b>	DO250/ 300 (250/38x41-25N)	<b>Chass. C190071-&gt;</b> Achtung ! Die 3 roten Schrauben, im Gehäuse, müssen nach der Montage entfernt werden. / Note! The three red screws in the housing must be removed after installation. enthält eine Kupplungsscheibe / This part number includes one clutch disc	(5) (45)
				<b>1864 937 001</b> ▽#	300 (1 1/8"-10N)	Lose Kupplungsscheibe / Loose clutch disc	(30)
				<b>1863 600 118</b>	63,5/100,2/22	mit Anlauftring / with thrust ring	(63)
			148 Made in France				<b>1888 891 002</b>
<b>1888 634 001</b>	DO250/ 300 (250/ 1 3/4" -10N)	<b>-&gt;Chass. R389027</b> Achtung ! Die 3 roten Schrauben, im Gehäuse, müssen nach der Montage entfernt werden. / Note! The three red screws in the housing must be removed after installation. enthält eine Kupplungsscheibe / This part number includes one clutch disc				(5) (45)	
	<b>1888 998 801 #</b>	DO250/ 300 (250/38x41-25N)				<b>Chass. R389028-&gt;</b> Achtung ! Die 3 roten Schrauben, im Gehäuse, müssen nach der Montage entfernt werden. / Note! The three red screws in the housing must be removed after installation. enthält eine Kupplungsscheibe / This part number includes one clutch disc	(5) (45)
	<b>1864 937 001</b> ▽#	300 (1 1/8"-10N)				Lose Kupplungsscheibe / Loose clutch disc	(30)
	<b>1863 600 118</b>	63,5/100,2/22				mit Anlauftring / with thrust ring	(63)
152							<b>1888 891 002</b>
			<b>1888 634 001</b>	DO250/ 300 (250/ 1 3/4" -10N)	<b>-&gt;Chass. C247092</b> Achtung ! Die 3 roten Schrauben, im Gehäuse, müssen nach der Montage entfernt werden. / Note! The three red screws in the housing must be removed after installation. enthält eine Kupplungsscheibe / This part number includes one clutch disc	(5) (45)	
				<b>1888 998 801 #</b>	DO250/ 300 (250/38x41-25N)	<b>Chass. C247093-&gt;</b> Achtung ! Die 3 roten Schrauben, im Gehäuse, müssen nach der Montage entfernt werden. / Note! The three red screws in the housing must be removed after installation. enthält eine Kupplungsscheibe / This part number includes one clutch disc	(5) (45)
				<b>1864 937 001</b> ▽#	300 (1 1/8"-10N)	Lose Kupplungsscheibe / Loose clutch disc	(30)
				<b>1863 600 118</b>	63,5/100,2/22	mit Anlauftring / with thrust ring	(63)

# MASSEY FERGUSON





















20 - 194							
152 P3		<b>1888 998 801 #</b>	DO250/ 300 (250/38x41-25N)	Achtung ! Die 3 roten Schrauben, im Gehäuse, müssen nach der Montage entfernt werden. / Note! The three red screws in the housing must be removed after installation. enthält eine Kupplungsscheibe / This part number includes one clutch disc	(5)	(45)	
		<b>1864 937 001 ▽#</b>	300 (1 1/8"-10N)	Lose Kupplungsscheibe / Loose clutch disc	(30)		
		<b>1863 600 118</b>	63,5/100,2/22	mit Anlauftring / with thrust ring	(63)		
154 S,V 164 ,V 174 S,V		<b>1888 892 001 #</b>	DUT280 (280/35x40-14N)	enthält eine Kupplungsscheibe / This part number includes one clutch disc	(45)		
		<b>1864 917 002 ▽#</b>	280E (22x25-10N)	Lose Kupplungsscheibe / Loose clutch disc	(30)		
		<b>1888 876 006 HD#</b>	DUT310 (310/35x40-14N)	enthält eine Kupplungsscheibe / This part number includes one clutch disc	(45)		
		<b>1864 959 001 ▽#</b>	310 (22x25-10N)	Lose Kupplungsscheibe / Loose clutch disc	(30)		
157		<b>1864 937 001 ▽#</b>	300 (1 1/8"-10N)	Lose Kupplungsscheibe / Loose clutch disc	(30)		
158		<b>1888 891 002</b>	DOT250/ 300 (250/ 1 3/4" -10N)	Achtung ! Die 3 roten Schrauben, im Gehäuse, müssen nach der Montage entfernt werden. / Note! The three red screws in the housing must be removed after installation. enthält eine Kupplungsscheibe / This part number includes one clutch disc	(5)	(45)	
		<b>1888 998 801 #</b>	DO250/ 300 (250/38x41-25N)	Achtung ! Die 3 roten Schrauben, im Gehäuse, müssen nach der Montage entfernt werden. / Note! The three red screws in the housing must be removed after installation. enthält eine Kupplungsscheibe / This part number includes one clutch disc	(5)	(45)	
		<b>1888 634 001</b>	DO250/ 300 (250/ 1 3/4"-10N)	Achtung ! Die 3 roten Schrauben, im Gehäuse, müssen nach der Montage entfernt werden. / Note! The three red screws in the housing must be removed after installation. enthält eine Kupplungsscheibe / This part number includes one clutch disc	(5)	(45)	
		<b>1864 937 001 ▽#</b>	300 (1 1/8"-10N)	Lose Kupplungsscheibe / Loose clutch disc	(30)		
		<b>1863 600 118</b>	63,5/100,2/22	mit Anlauftring / with thrust ring	(63)		
	165 Made in France 168 Made in France 185 Made in France 188		<b>1888 891 004</b>	DO250/ 300 (250/38x41-25N)	Achtung ! Die 3 roten Schrauben, im Gehäuse, müssen nach der Montage entfernt werden. / Note! The three red screws in the housing must be removed after installation. enthält eine Kupplungsscheibe / This part number includes one clutch disc	(5)	(45)
		<b>1864 937 001 ▽#</b>	300 (1 1/8"-10N)	Lose Kupplungsscheibe / Loose clutch disc	(30)		
		<b>1863 600 118</b>	63,5/100,2/22	mit Anlauftring / with thrust ring	(63)		
165 Made in GB		<b>1888 634 003</b>	DO225/ 280 (225/ 1 3/4"-10N)	->Chass. 564618 Achtung ! Die 3 roten Schrauben, im Gehäuse, müssen nach der Montage entfernt werden. / Note! The three red screws in the housing must be removed after installation. enthält eine Kupplungsscheibe / This part number includes one clutch disc	(5)	(45)	
		<b>1888 898 001</b>	DO225/ 280 (225/ 1 3/4"-10N)	->Chass. 564618 Achtung ! Die 3 roten Schrauben, im Gehäuse, müssen nach der Montage entfernt werden. / Note! The three red screws in the housing must be removed after installation. enthält eine Kupplungsscheibe / This part number includes one clutch disc	(5)	(45)	
		<b>1864 946 001 ▽</b>	280B (1 1/8"-10N)	->Chass. 564618 Lose Kupplungsscheibe / Loose clutch disc	(30)		
		<b>1863 600 118</b>	63,5/100,2/22	->Chass. 564618 mit Anlauftring / with thrust ring	(63)		

# MASSEY FERGUSON































## 20 - 194

20 - 194							
165 MK2 Multipower				<b>1888 898 001</b>	DO225/ 280 (225/ 1 3/4"-10N)	<b>-&gt;Chass. 486848</b> Achtung ! Die 3 roten Schrauben, im Gehäuse, müssen nach der Montage entfernt werden. / Note! The three red screws in the housing must be removed after installation. enthält eine Kupplungsscheibe / This part number includes one clutch disc	(5) (45)
				<b>1888 634 003</b>	DO225/ 280 (225/ 1 3/4"-10N)	<b>-&gt;Chass. 486848</b> Achtung ! Die 3 roten Schrauben, im Gehäuse, müssen nach der Montage entfernt werden. / Note! The three red screws in the housing must be removed after installation. enthält eine Kupplungsscheibe / This part number includes one clutch disc	(5) (45)
				<b>1864 946 001</b> ▽	280B (1 1/8"-10N)	<b>-&gt;Chass. 486848</b> Lose Kupplungsscheibe / Loose clutch disc	(30)
				<b>1888 634 001</b>	DO250/ 300 (250/ 1 3/4"-10N)	<b>Chass. 486849-&gt;</b> Achtung ! Die 3 roten Schrauben, im Gehäuse, müssen nach der Montage entfernt werden. / Note! The three red screws in the housing must be removed after installation. enthält eine Kupplungsscheibe / This part number includes one clutch disc	(5) (45)
				<b>1888 891 002</b>	DOT250/ 300 (250/ 1 3/4" -10N)	<b>Chass. 486849-&gt;</b> Achtung ! Die 3 roten Schrauben, im Gehäuse, müssen nach der Montage entfernt werden. / Note! The three red screws in the housing must be removed after installation. enthält eine Kupplungsscheibe / This part number includes one clutch disc	(5) (45)
				<b>1864 937 001</b> ▽#	300 (1 1/8"-10N)	<b>Chass. 486849-&gt;</b> Lose Kupplungsscheibe / Loose clutch disc	(30)
				<b>1863 600 118</b>	63,5/100,2/22	mit Anlauftring / with thrust ring	(63)
165 MK2 Standard				<b>1888 898 001</b>	DO225/ 280 (225/ 1 3/4"-10N)	<b>-&gt;Chass. 669500</b> Achtung ! Die 3 roten Schrauben, im Gehäuse, müssen nach der Montage entfernt werden. / Note! The three red screws in the housing must be removed after installation. enthält eine Kupplungsscheibe / This part number includes one clutch disc	(5) (45)
				<b>1888 634 003</b>	DO225/ 280 (225/ 1 3/4"-10N)	<b>-&gt;Chass. 669500</b> Achtung ! Die 3 roten Schrauben, im Gehäuse, müssen nach der Montage entfernt werden. / Note! The three red screws in the housing must be removed after installation. enthält eine Kupplungsscheibe / This part number includes one clutch disc	(5) (45)
				<b>1864 946 001</b> ▽	280B (1 1/8"-10N)	<b>-&gt;Chass. 669500</b> Lose Kupplungsscheibe / Loose clutch disc	(30)
				<b>1888 634 001</b>	DO250/ 300 (250/ 1 3/4"-10N)	<b>Chass. 669501-&gt;</b> Achtung ! Die 3 roten Schrauben, im Gehäuse, müssen nach der Montage entfernt werden. / Note! The three red screws in the housing must be removed after installation. enthält eine Kupplungsscheibe / This part number includes one clutch disc	(5) (45)
				<b>1888 891 002</b>	DOT250/ 300 (250/ 1 3/4" -10N)	<b>Chass. 669501-&gt;</b> Achtung ! Die 3 roten Schrauben, im Gehäuse, müssen nach der Montage entfernt werden. / Note! The three red screws in the housing must be removed after installation. enthält eine Kupplungsscheibe / This part number includes one clutch disc	(5) (45)
				<b>1864 937 001</b> ▽#	300 (1 1/8"-10N)	<b>Chass. 669501-&gt;</b> Lose Kupplungsscheibe / Loose clutch disc	(30)
				<b>1863 600 118</b>	63,5/100,2/22	mit Anlauftring / with thrust ring	(63)

# MASSEY FERGUSON















20 - 194							
168		<b>1888 891 004</b>	DO250/ 300 (250/38x41-25N)	Achtung ! Die 3 roten Schrauben, im Gehäuse, müssen nach der Montage entfernt werden. / Note! The three red screws in the housing must be removed after installation. enthält eine Kupplungsscheibe / This part number includes one clutch disc	(5)		
		<b>1864 937 001</b> ▽#	300 (1 1/8"-10N)	Lose Kupplungsscheibe / Loose clutch disc	(30)		
		<b>1888 634 003</b>	DO225/ 280 (225/ 1 3/4"-10N)	Achtung ! Die 3 roten Schrauben, im Gehäuse, müssen nach der Montage entfernt werden. / Note! The three red screws in the housing must be removed after installation. enthält eine Kupplungsscheibe / This part number includes one clutch disc	(5)		
		<b>1888 898 001</b>	DO225/ 280 (225/ 1 3/4"-10N)	Achtung ! Die 3 roten Schrauben, im Gehäuse, müssen nach der Montage entfernt werden. / Note! The three red screws in the housing must be removed after installation. enthält eine Kupplungsscheibe / This part number includes one clutch disc	(5)		
		<b>1864 946 001</b> ▽	280B (1 1/8"-10N)	Lose Kupplungsscheibe / Loose clutch disc	(30)		
		<b>1863 600 118</b>	63,5/100,2/22	mit Anlauftring / with thrust ring	(63)		
	<b>168 Made in GB</b>		<b>1864 937 001</b> ▽#	300 (1 1/8"-10N)	-> <b>Chass. 255118</b> Lose Kupplungsscheibe / Loose clutch disc	(30)	
		<b>1863 600 118</b>	63,5/100,2/22	-> <b>Chass. 255118</b> mit Anlauftring / with thrust ring	(63)		
175 177 178		<b>1864 946 001</b> ▽	280B (1 1/8"-10N)	-> <b>Chass. 729573</b> Lose Kupplungsscheibe / Loose clutch disc	(30)		
		<b>1864 937 001</b> ▽#	300 (1 1/8"-10N)	<b>Chass. 729574-&gt;</b> Lose Kupplungsscheibe / Loose clutch disc	(30)		
		<b>1863 600 118</b>	63,5/100,2/22	mit Anlauftring / with thrust ring	(63)		
184 S		<b>3800 541 017</b> #☉ <b>1888 880 001</b> <b>1864 917 002</b>	DUT280/CERAM 280E				
		<b>1888 876 006</b> HD#	DUT310 (310/35x40-14N)	enthält eine Kupplungsscheibe / This part number includes one clutch disc	(45)		
		<b>1864 959 001</b> HD▽#	310 (22x25-10N)	Lose Kupplungsscheibe / Loose clutch disc	(30)		
<b>185 Made in GB</b> <b>188 Made in GB</b>		<b>1888 891 004</b>	DO250/ 300 (250/38x41-25N)	<b>Chass. 317619-&gt;</b> Achtung ! Die 3 roten Schrauben, im Gehäuse, müssen nach der Montage entfernt werden. / Note! The three red screws in the housing must be removed after installation. enthält eine Kupplungsscheibe / This part number includes one clutch disc	(5)		
		<b>1864 937 001</b> ▽#	300 (1 1/8"-10N)	Lose Kupplungsscheibe / Loose clutch disc	(30)		
		<b>1863 600 118</b>	63,5/100,2/22	mit Anlauftring / with thrust ring	(63)		
187		<b>1880 071 008</b>	K225				
		<b>1864 634 033</b>	225Z (28x35-10N)				
194 A,F,S		<b>3800 541 017</b> #☉ <b>1888 880 001</b> <b>1864 917 002</b>	DUT280/CERAM 280E				
194 F		<b>1888 876 006</b> HD#	DUT310 (310/35x40-14N)	enthält eine Kupplungsscheibe / This part number includes one clutch disc	(45)		
		<b>1864 959 001</b> ▽#	310 (22x25-10N)	Lose Kupplungsscheibe / Loose clutch disc	(30)		

# MASSEY FERGUSON







203 - 298							
203 205		<b>1888 898 003</b>	DO225/ 280 (225/ 1 3/4"-10N)	Achtung ! Die 3 roten Schrauben, im Gehäuse, müssen nach der Montage entfernt werden. / Note! The three red screws in the housing must be removed after installation. enthält eine Kupplungsscheibe / This part number includes one clutch disc	(5)		
		<b>1864 946 001</b> ▽	280B (1 1/8"-10N)	Lose Kupplungsscheibe / Loose clutch disc	(30)		
		<b>1863 600 118</b>	63,5/100,2/22	mit Anlauftring / with thrust ring	(63)		
230 235 240 245 250 255		<b>1888 998 801</b> #	DO250/ 300 (250/38x41-25N)	Achtung ! Die 3 roten Schrauben, im Gehäuse, müssen nach der Montage entfernt werden. / Note! The three red screws in the housing must be removed after installation. enthält eine Kupplungsscheibe / This part number includes one clutch disc	(5)		
		<b>1864 937 001</b> ▽#	300 (1 1/8"-10N)	Lose Kupplungsscheibe / Loose clutch disc	(30)		
		<b>1863 600 118</b>	63,5/100,2/22	mit Anlauftring / with thrust ring	(63)		
233 234 S 253 254 264		<b>1888 892 001</b> #	DUT280 (280/35x40-14N)	enthält eine Kupplungsscheibe / This part number includes one clutch disc	(45)		
		<b>1864 917 002</b> ▽#	280E (22x25-10N)	Lose Kupplungsscheibe / Loose clutch disc	(30)		
		<b>3800 541 017</b> #  <b>1888 880 001</b>  <b>1864 917 002</b>	DUT280/CERAM 280E				
233 S,CV 234 S,CV 253 A,SS 254 A,SS 264 CF,T		<b>1888 876 006</b> HD#	DUT310 (310/35x40-14N)	enthält eine Kupplungsscheibe / This part number includes one clutch disc	(45)		
		<b>1864 959 001</b> ▽#	310 (22x25-10N)	Lose Kupplungsscheibe / Loose clutch disc	(30)		
235 S		<b>1888 037 101</b> #	DOT250 (250/38x44-25N)	enthält eine Kupplungsscheibe / This part number includes one clutch disc	(45)		
		<b>1864 307 101</b> ▽	250/ 50B (1 1/8"-10N)	Lose Kupplungsscheibe / Loose clutch disc Nur bei Altteil-Rückgabe lieferbar (Reparatur; Werk Bielefeld) / Please return old unit for repair (plant Bielefeld)	(30) (33)		
		<b>1863 837 002</b>	65/97/23	mit Anlauftring / with thrust ring	(63)		
244 CF		<b>1888 892 001</b> #	DUT280 (280/35x40-14N)	enthält eine Kupplungsscheibe / This part number includes one clutch disc	(45)		
		<b>1864 917 002</b> ▽#	280E (22x25-10N)	Lose Kupplungsscheibe / Loose clutch disc	(30)		
260 265		<b>1864 937 001</b> #	300 (1 1/8"-10N)				
		<b>1863 600 118</b>	63,5/100,2/22	mit Anlauftring / with thrust ring	(63)		
261		<b>1888 998 801</b> #	DO250/ 300 (250/38x41-25N)	enthält eine Kupplungsscheibe / This part number includes one clutch disc	(45)		
		<b>1863 600 118</b>	63,5/100,2/22	mit Anlauftring / with thrust ring	(63)		
263 273 274		<b>1888 892 001</b> #	DUT280 (280/35x40-14N)	enthält eine Kupplungsscheibe / This part number includes one clutch disc	(45)		
		<b>1864 917 002</b> ▽#	280E (22x25-10N)	Lose Kupplungsscheibe / Loose clutch disc	(30)		
		<b>3800 541 017</b> #  <b>1888 880 001</b>  <b>1864 917 002</b>	DUT280/CERAM 280E				
		<b>1888 876 006</b> HD#	DUT310 (310/35x40-14N)	enthält eine Kupplungsscheibe / This part number includes one clutch disc	(45)		
		<b>1864 959 001</b> HD ▽#	310 (22x25-10N)	Lose Kupplungsscheibe / Loose clutch disc	(30)		
265 S		<b>1888 998 902</b> #	DUT350/ 330 (330/45x50-24N)	enthält eine Kupplungsscheibe / This part number includes one clutch disc	(45)		
		<b>1863 600 118</b>	63,5/100,2/22	mit Anlauftring / with thrust ring	(63)		

# MASSEY FERGUSON

## 203 - 298



























275				<b>1888 634 001</b>	DO250/ 300 (250/ 1 3/4"-10N)	Achtung ! Die 3 roten Schrauben, im Gehäuse, müssen nach der Montage entfernt werden. / Note! The three red screws in the housing must be removed after installation. enthält eine Kupplungsscheibe / This part number includes one clutch disc	(5) (45)
				<b>1888 891 002</b>	DOT250/ 300 (250/ 1 3/4" -10N)	Achtung ! Die 3 roten Schrauben, im Gehäuse, müssen nach der Montage entfernt werden. / Note! The three red screws in the housing must be removed after installation. enthält eine Kupplungsscheibe / This part number includes one clutch disc	(5) (45)
				<b>1864 937 001</b> ▽#	300 (1 1/8"-10N)	Lose Kupplungsscheibe / Loose clutch disc	(30)
				<b>1863 600 118</b>	63,5/100,2/22	mit Anlauftring / with thrust ring	(63)
283 284				<b>3800 541 017</b> # <b>1888 880 001</b> <b>1864 917 002</b>	DUT280/CERAM 280E		
				<b>1888 876 006</b> #	DUT310 (310/35x40-14N)	enthält eine Kupplungsscheibe / This part number includes one clutch disc	(45)
				<b>1864 959 001</b> ▽#	310 (22x25-10N)	Lose Kupplungsscheibe / Loose clutch disc	(30)
285 290				<b>1888 891 004</b>	DO250/ 300 (250/38x41-25N)	Achtung ! Die 3 roten Schrauben, im Gehäuse, müssen nach der Montage entfernt werden. / Note! The three red screws in the housing must be removed after installation. enthält eine Kupplungsscheibe / This part number includes one clutch disc	(5) (45)
				<b>1864 937 001</b> ▽#	300 (1 1/8"-10N)	Lose Kupplungsscheibe / Loose clutch disc	(30)
				<b>1863 600 118</b>	63,5/100,2/22	mit Anlauftring / with thrust ring	(63)
293 294				<b>3800 541 017</b> # <b>1888 880 001</b> <b>1864 917 002</b>	DUT280/CERAM 280E		
				<b>1888 876 006</b> HD#	DUT310 (310/35x40-14N)	enthält eine Kupplungsscheibe / This part number includes one clutch disc	(45)
				<b>1864 959 001</b> HD ▽#	310 (22x25-10N)	Lose Kupplungsscheibe / Loose clutch disc	(30)
298				<b>1882 818 001</b> #	GF330		
				<b>1864 974 001</b> #	330 (1 1/8"-10N)		
				<b>1864 973 001</b> ●#	327CE (1 1/8"-10N)		
				<b>1863 600 118</b>	63,5/100,2/22	mit Anlauftring / with thrust ring	(63)

## 307 - 399

307				<b>1880 071 008</b>	K225		
				<b>1864 634 033</b>	225Z (28x35-10N)		
333 334 353 354 F,V 363 364 F,V,CF				<b>1888 892 001</b> #	DUT280 (280/35x40-14N)	enthält eine Kupplungsscheibe / This part number includes one clutch disc	(45)
				<b>1864 917 002</b> ▽#	280E (22x25-10N)	Lose Kupplungsscheibe / Loose clutch disc	(30)
340				<b>1888 998 801</b> #	DO250/ 300 (250/38x41-25N)	Achtung ! Die 3 roten Schrauben, im Gehäuse, müssen nach der Montage entfernt werden. / Note! The three red screws in the housing must be removed after installation. enthält eine Kupplungsscheibe / This part number includes one clutch disc	(5) (45)
				<b>1864 937 001</b> ▽#	300 (1 1/8"-10N)	Lose Kupplungsscheibe / Loose clutch disc	(30)
				<b>1863 600 118</b>	63,5/100,2/22	mit Anlauftring / with thrust ring	(63)



































# MASSEY FERGUSON

## 307 - 399

342		1882 998 902 #	G300		
		1888 998 801 #	DO250/ 300 (250/38x41-25N)	Achtung ! Die 3 roten Schrauben, im Gehäuse, müssen nach der Montage entfernt werden. / Note! The three red screws in the housing must be removed after installation. enthält eine Kupplungsscheibe / This part number includes one clutch disc	(5) (45)
		1864 937 001 ▽#	300 (1 1/8"-10N)	Lose Kupplungsscheibe / Loose clutch disc	(30)
		1863 600 120	63,4/100/23	mit Anlauftring / with thrust ring	(63)
		1863 600 118	63,5/100,2/22	mit Anlauftring / with thrust ring	(63)
350		1888 998 801 #	DO250/ 300 (250/38x41-25N)	Achtung ! Die 3 roten Schrauben, im Gehäuse, müssen nach der Montage entfernt werden. / Note! The three red screws in the housing must be removed after installation. enthält eine Kupplungsscheibe / This part number includes one clutch disc	(5) (45)
		1863 600 118	63,5/100,2/22	mit Anlauftring / with thrust ring	(63)
354 S 364 S		1888 892 001 #	DUT280 (280/35x40-14N)	->Chass. P50186 enthält eine Kupplungsscheibe / This part number includes one clutch disc	(45)
		1864 917 002 ▽#	280E (22x25-10N)	->Chass. P50186 Lose Kupplungsscheibe / Loose clutch disc	(30)
355 360		1882 817 003 ▲#	HB310		
		1863 600 118	63,5/100,2/22	mit Anlauftring / with thrust ring	(63)
362 382		1882 820 001 #	G330		
		1862 586 001	305GSDC (25,5x29,4-21N)		
		1863 600 120	63,4/100/23	mit Anlauftring / with thrust ring	(63)
365		1882 817 003 ▲#	HB310		
		1863 600 118	63,5/100,2/22	mit Anlauftring / with thrust ring	(63)
		1863 600 120	63,4/100/23	mit Anlauftring / with thrust ring	(63)
367 CF 376 383 384 393 394 F 396 CF		3800 541 017 #☉	DUT280/CERAM 280E		
		1888 880 001			
		1864 917 002			
372 N		1862 586 001	305GSDC (25,5x29,4-21N)		
		1863 600 120	63,4/100/23	mit Anlauftring / with thrust ring	(63)
373		1888 892 001 #	DUT280 (280/35x40-14N)	enthält eine Kupplungsscheibe / This part number includes one clutch disc	(45)
		1864 917 002 #	280E (22x25-10N)		
		3800 541 017 ●#☉	DUT280/CERAM 280E		
		1888 880 001			
		1864 917 002			
	1888 876 006 #	DUT310 (310/35x40-14N)	enthält eine Kupplungsscheibe / This part number includes one clutch disc	(45)	
	1864 959 001 ▽#	310 (22x25-10N)	Lose Kupplungsscheibe / Loose clutch disc	(30)	

# MASSEY FERGUSON



## 307 - 399

374		1888 892 001 #	DUT280 (280/35x40-14N)	enthält eine Kupplungsscheibe / This part number includes one clutch disc	(45)
		1864 917 002 ▽#	280E (22x25-10N)	Lose Kupplungsscheibe / Loose clutch disc	(30)
		1888 876 006 HD#	DUT310 (310/35x40-14N)	enthält eine Kupplungsscheibe / This part number includes one clutch disc	(45)
		1864 959 001 ▽#	310 (22x25-10N)	Lose Kupplungsscheibe / Loose clutch disc	(30)
375		1882 817 003 ▲#	HB310		
		1863 600 118	63,5/100,2/22	mit Anlauftring / with thrust ring	(63)
		1882 820 001 #	G330		
		1862 586 001	305GSDC (25,5x29,4-21N)		
		1863 600 118	63,5/100,2/22	mit Anlauftring / with thrust ring	(63)
		1863 600 120	63,4/100/23	mit Anlauftring / with thrust ring	(63)
377		3800 541 017 # 1888 880 001 1864 917 002	DUT280/CERAM 280E		
		1888 876 006 #	DUT310 (310/35x40-14N)	enthält eine Kupplungsscheibe / This part number includes one clutch disc	(45)
		1864 959 001 ▽#	310 (22x25-10N)	Lose Kupplungsscheibe / Loose clutch disc	(30)
383 S 384 S 393 S		1888 876 006 HD#	DUT310 (310/35x40-14N)	enthält eine Kupplungsscheibe / This part number includes one clutch disc	(45)
		1864 959 001 ▽#	310 (22x25-10N)	Lose Kupplungsscheibe / Loose clutch disc	(30)
387		1880 071 011	K225		
		1864 634 033	225Z (28x35-10N)		
		1888 876 006 #	DUT310 (310/35x40-14N)	enthält eine Kupplungsscheibe / This part number includes one clutch disc	(45)
		1864 959 001 ▽#	310 (22x25-10N)	Lose Kupplungsscheibe / Loose clutch disc	(30)
390		1888 891 004	DO250/ 300 (250/38x41-25N)	enthält eine Kupplungsscheibe / This part number includes one clutch disc	(45)
		1863 600 118	63,5/100,2/22	mit Anlauftring / with thrust ring	(63)
		1882 820 001 #	G330		
		1862 586 001	305GSDC (25,5x29,4-21N)		
		1863 600 118	63,5/100,2/22	mit Anlauftring / with thrust ring	(63)
		1863 600 120	63,4/100/23	mit Anlauftring / with thrust ring	(63)
390 T 398 399		1882 819 001 #	G330		
		1878 600 534	330GS (25,5x29,4-21N)		
		3800 541 010 ●# 1882 819 001 1878 600 535	G330 330GSC		
		1863 600 118	63,5/100,2/22	mit Anlauftring / with thrust ring	(63)
		3482 931 001 ▲	GMF330N		
		1878 634 012	327GSDC (25,5x29,4-21N)		
		1863 600 118	63,5/100,2/22	mit Anlauftring / with thrust ring	(63)
		1863 600 120	63,4/100/23	mit Anlauftring / with thrust ring	(63)
394 397		1888 876 006 #	DUT310 (310/35x40-14N)	enthält eine Kupplungsscheibe / This part number includes one clutch disc	(45)
		1864 959 001 ▽#	310 (22x25-10N)	Lose Kupplungsscheibe / Loose clutch disc	(30)





















# MASSEY FERGUSON

## 307 - 399

































399 T		3482 931 001 ▲	GMF330N		
		1878 634 012	327GSDC (25,5x29,4-21N)		
		1863 600 120	63,4/100/23	mit Anlauftring / with thrust ring	(63)

## 407 - 1134

407		1880 071 011	K225		
		1864 634 033	225Z (28x35-10N)		
500		1888 634 001	DO250/ 300 (250/ 1 3/4"-10N)	Achtung ! Die 3 roten Schrauben, im Gehäuse, müssen nach der Montage entfernt werden. / Note! The three red screws in the housing must be removed after installation. enthält eine Kupplungsscheibe / This part number includes one clutch disc	(5) (45)
		1888 891 002	DOT250/ 300 (250/ 1 3/4" -10N)	Achtung ! Die 3 roten Schrauben, im Gehäuse, müssen nach der Montage entfernt werden. / Note! The three red screws in the housing must be removed after installation. enthält eine Kupplungsscheibe / This part number includes one clutch disc	(5) (45)
		1864 937 001 ▽#	300 (1 1/8"-10N)	Lose Kupplungsscheibe / Loose clutch disc	(30)
		1863 600 118	63,5/100,2/22	mit Anlauftring / with thrust ring	(63)
		1888 998 801 #	DO250/ 300 (250/38x41-25N)	->Chass. V39420 Achtung ! Die 3 roten Schrauben, im Gehäuse, müssen nach der Montage entfernt werden. / Note! The three red screws in the housing must be removed after installation. enthält eine Kupplungsscheibe / This part number includes one clutch disc	(5) (45)
550		1864 937 001 ▽#	300 (1 1/8"-10N)	->Chass. V39420 Lose Kupplungsscheibe / Loose clutch disc	(30)
		1863 600 118	63,5/100,2/22	->Chass. V39420 mit Anlauftring / with thrust ring	(63)
		1882 998 901 #	G300		
560 565 575 675		1864 937 001 ▽#	300 (1 1/8"-10N)	Lose Kupplungsscheibe / Loose clutch disc	(30)
		1863 600 118	63,5/100,2/22	mit Anlauftring / with thrust ring	(63)
		1882 998 902 #	G300		
590 690		1888 891 004	DO250/ 300 (250/38x41-25N)	Achtung ! Die 3 roten Schrauben, im Gehäuse, müssen nach der Montage entfernt werden. / Note! The three red screws in the housing must be removed after installation. enthält eine Kupplungsscheibe / This part number includes one clutch disc	(5) (45)
		1864 937 001 ▽#	300 (1 1/8"-10N)	Lose Kupplungsscheibe / Loose clutch disc	(30)
		1863 600 118	63,5/100,2/22	mit Anlauftring / with thrust ring	(63)
		1882 818 001 #	GF330		
592 698 Made in GB		1864 974 001 #	330 (1 1/8"-10N)		
		1864 973 001 ●#	327CE (1 1/8"-10N)		
		1863 600 118	63,5/100,2/22	mit Anlauftring / with thrust ring	(63)
595		1882 818 001 #	GF330	Chass. Z214005->	
		1864 974 001 #	330 (1 1/8"-10N)	Chass. Z214005->	
		1864 973 001 ●#	327CE (1 1/8"-10N)	Chass. Z214005->	
		1863 600 118	63,5/100,2/22	Chass. Z214005-> mit Anlauftring / with thrust ring	(63)









					Parameter		
---	--	--	--	--	-----------	---	---

# MASSEY FERGUSON















407 - 1134							
685		1864 937 001 ▽#	300 (1 1/8"-10N)	Lose Kupplungsscheibe / Loose clutch disc			(30)
		1863 600 118	63,5/100,2/22	mit Anlauftring / with thrust ring			(63)
685 ,S		1880 071 008	K225				
		1864 634 026	225Z (26x32-10N)				
698		1888 876 006 #	DUT310 (310/35x40-14N)	enthält eine Kupplungsscheibe / This part number includes one clutch disc			(45)
		1864 959 001 ▽#	310 (22x25-10N)	Lose Kupplungsscheibe / Loose clutch disc			(30)
698 Made in France		1882 819 001 #	G330				
		1878 600 534	330GS (25,5x29,4-21N)				
		3800 541 010 ●# 1882 819 001 1878 600 535	G330 330GSC				
		1863 600 118	63,5/100,2/22	mit Anlauftring / with thrust ring			(63)
		3482 931 001 ▲	GMF330N				
		1878 634 012	327GSDC (25,5x29,4-21N)				
		1863 600 118	63,5/100,2/22	mit Anlauftring / with thrust ring			(63)
698 T 1004 T		1882 819 001 #	G330				
		1864 974 001 #	330 (1 1/8"-10N)				
		1864 973 001 ●#	327CE (1 1/8"-10N)				
	1863 600 118	63,5/100,2/22	mit Anlauftring / with thrust ring			(63)	
699		1882 819 001 #	G330				
		1878 600 534	330GS (25,5x29,4-21N)				
		3800 541 010 ●# 1882 819 001 1878 600 535	G330 330GSC				
		1888 876 006 #	DUT310 (310/35x40-14N)	enthält eine Kupplungsscheibe / This part number includes one clutch disc			(45)
		1864 959 001 ▽#	310 (22x25-10N)	Lose Kupplungsscheibe / Loose clutch disc			(30)
	1863 600 118	63,5/100,2/22	mit Anlauftring / with thrust ring			(63)	
765		1888 634 003	DO225/ 280 (225/ 1 3/4"-10N)	enthält eine Kupplungsscheibe / This part number includes one clutch disc			(45)
		1888 898 001	DO225/ 280 (225/ 1 3/4"-10N)	enthält eine Kupplungsscheibe / This part number includes one clutch disc			(45)
		1863 600 118	63,5/100,2/22	mit Anlauftring / with thrust ring			(63)
1004		1882 818 001 #	GF330				
		1864 974 001 #	330 (1 1/8"-10N)				
		1864 973 001 ●#	327CE (1 1/8"-10N)				
1007		1888 876 006 #	DUT310 (310/35x40-14N)	enthält eine Kupplungsscheibe / This part number includes one clutch disc			(45)
		1864 959 001 ▽#	310 (22x25-10N)	Lose Kupplungsscheibe / Loose clutch disc			(30)
		1888 873 001 HD#	DUT330 (330/44x48-23N)	enthält eine Kupplungsscheibe / This part number includes one clutch disc			(45)
		1864 921 001 ▽#	330 (27x30-16N)	Lose Kupplungsscheibe / Loose clutch disc			(30)

# MASSEY FERGUSON

## 407 - 1134











1014				1888 873 001 #	DUT330 (330/44x48-23N)	<b>Chass. V44006-&gt;</b> enthält eine Kupplungsscheibe / This part number includes one clutch disc	(45)
				1864 914 005 ▽#	310 (27x30-16N)	<b>Chass. V44006-&gt;</b> Lose Kupplungsscheibe / Loose clutch disc	(30)
1014 4WD				1864 914 005 ▽#	310 (27x30-16N)	<b>-&gt;Chass. 22904564</b> Lose Kupplungsscheibe / Loose clutch disc	(30)
				1888 873 001 #	DUT330 (330/44x48-23N)	<b>Chass. 22904565-&gt;</b> enthält eine Kupplungsscheibe / This part number includes one clutch disc	(45)
				1864 921 001 ▽#	330 (27x30-16N)	<b>Chass. 22904565-&gt;</b> Lose Kupplungsscheibe / Loose clutch disc	(30)
1080				1863 600 118	63,5/100,2/22	mit Anlauftring / with thrust ring	(63)
1114 4WD 1134 4WD				1888 873 001 #	DUT330 (330/44x48-23N)	enthält eine Kupplungsscheibe / This part number includes one clutch disc	(45)
				1864 921 001 ▽#	330 (27x30-16N)	Lose Kupplungsscheibe / Loose clutch disc	(30)

## 2135 - 3690











2135 3303				1882 600 110	G280	Nur bei Altteil-Rückgabe lieferbar (Reparatur; Werk Bielefeld) / Please return old unit for repair (plant Bielefeld)	(33)		
				1863 600 118	63,5/100,2/22	mit Anlauftring / with thrust ring	(63)		
2200				1888 898 003	DO225/ 280 (225/ 1 3/4"-10N)	enthält eine Kupplungsscheibe / This part number includes one clutch disc	(45)		
				1864 946 001	280B (1 1/8"-10N)				
				1863 600 118	63,5/100,2/22	mit Anlauftring / with thrust ring	(63)		
2205				1888 600 121 ▲	DUT280 (280/31x35-18N)	enthält eine Kupplungsscheibe / This part number includes one clutch disc	(45)		
				1864 600 320	250 (19x22-18N)				
2210 2220				1888 600 121 ▲	DUT280 (280/31x35-18N)	enthält eine Kupplungsscheibe / This part number includes one clutch disc	(45)		
				1864 600 320	250 (19x22-18N)				
				3482 600 110	MF280				
				1878 600 530	280CB (31x35-18N)				
				1878 600 531 ●	280CBC (31x35-18N)				
2620 2625 2640 2645 2680 2685 2720 2725 3610 3630 3635 3645 3650 3655				3482 926 001 #	M350				
				1864 947 002 #	350 (46,6x51-23N)	Anzahl der Beläge / Number of pads: 8	(7)		

# MASSEY FERGUSON























## 2135 - 3690

3050				3800 541 014 ☹ 3482 998 101 1864 996 001	GMF330 330CERAM		
3055							
3060							
3065							
3070							
3075							
3080							
3090							
3085				3800 541 014 ☹ 3482 998 101 1864 996 001	GMF330 330CERAM		
3095				3482 998 201	GMF330N		
				1864 996 001	330CERAM (46,5x51-23N)	Anzahl der Beläge / Number of pads: 7	(7)
3115				3482 998 201	GMF330N		
3120				1864 996 001	330CERAM (46,5x51-23N)	Anzahl der Beläge / Number of pads: 7	(7)
3125							
3670				3400 126 401 #☹		Getr. / GBox: Dynashift	
				3482 926 001 #	M350		
				1864 947 002 #	350 (46,6x51-23N)	Anzahl der Beläge / Number of pads: 8	(7)
3680				3400 126 401 #☹		Getr. / GBox: Dynashift	
3690							

## 4215 - 8480







4215 LP 3 Zyl.	01.97 - 12.01			1888 998 902 #	DUT350/ 330 (330/45x50-24N)	enthält eine Kupplungsscheibe / This part number includes one clutch disc	(45)
				1863 600 120	63,4/100/23	mit Anlauftring / with thrust ring	(63)
4220 LP 3 Zyl.	01.97 - 12.01			1862 586 001	305GSDC (25,5x29,4-21N)		
				1863 600 120	63,4/100/23	mit Anlauftring / with thrust ring	(63)
4225 4 Zyl.	01.97 - 12.01			1863 600 120	63,4/100/23	mit Anlauftring / with thrust ring	(63)
4235 4 Zyl.	01.97 - 12.01			1866 600 025		->Chass. K37008 ->Mot. J46101 Getr. / GBox: Powershuttle	
				1866 600 018		->Chass. K37008 Mot. J46102-> Getr. / GBox: Powershuttle	
				1866 600 018		Chass. K37009 - Mot. M27503 Getr. / GBox: Powershuttle	
4245 LP 4 Zyl.	01.97 - 12.00			3482 931 001 ▲	GMF330N		
				1878 600 529	330CBCERAM (25,5x29,4-21N)	Anzahl der Beläge / Number of pads: 5	(7)
				1866 600 025		->Chass. K37008 ->Mot. J46101 Getr. / GBox: Powershuttle	
				1866 600 018		->Chass. K37008 Mot. J46102-> Getr. / GBox: Powershuttle	
				1863 600 120	63,4/100/23	mit Anlauftring / with thrust ring	(63)



# MASSEY FERGUSON

4215 - 8480							
4255 4 Zyl.	01.97 - 12.01			3482 931 001 ▲	GMF330N		
				1878 600 528	330CBCERAM (25,5x29,4-21N)	Anzahl der Beläge / Number of pads: 5	(7)
				1878 634 012 ●	327GSDC (25,5x29,4-21N)		
				1866 600 025		->Chass. K37008 ->Mot. J46101 Getr. / GBox: Powershuttle	
				1866 600 018		->Chass. K37008 Mot. J46102-> Getr. / GBox: Powershuttle	
				1866 600 018		Chass. K37009 - Mot. M27503 Getr. / GBox: Powershuttle	
				1863 600 120	63,4/100/23	mit Anlauftring / with thrust ring	(63)
4260 6 Zyl. 4270 6 Zyl.	01.97 - 12.01	Perkins		3482 931 001 ▲	GMF330N		
				1878 600 528	330CBCERAM (25,5x29,4-21N)	Anzahl der Beläge / Number of pads: 5	(7)
				1878 634 012 ●	327GSDC (25,5x29,4-21N)		
		1866 600 025		->Chass. K37008 ->Mot. J46108 Getr. / GBox: Powershuttle			
		1866 600 018		->Chass. K37008 Mot. J46109-> Getr. / GBox: Powershuttle			
		1866 600 018		Chass. K37009-> Getr. / GBox: Powershuttle			
		1863 600 120	63,4/100/23	mit Anlauftring / with thrust ring	(63)		
4265				3482 931 001 ▲	GMF330N		
				1878 600 528	330CBCERAM (25,5x29,4-21N)	Anzahl der Beläge / Number of pads: 5	(7)
				1878 634 012 ●	327GSDC (25,5x29,4-21N)		
				1866 600 018		->Mot. M27503 Getr. / GBox: Powershuttle	
				1863 600 120	63,4/100/23	mit Anlauftring / with thrust ring	(63)
4325 4 Zyl. 4335 4 Zyl. 4345 4 Zyl. 4355 4 Zyl. 4365 4 Zyl.	01.01 - 12.03			1863 600 120	63,4/100/23	mit Anlauftring / with thrust ring	(63)
	01.01 - 12.03			1866 600 018		->Mot. M27503 Getr. / GBox: Powershuttle	
	01.01 - 12.03						
	01.01 - 12.03						
	01.02 - 12.03						
4360 6 Zyl. 4370 6 Zyl.	01.01 - 12.02			1863 600 120	63,4/100/23	mit Anlauftring / with thrust ring	(63)
	01.01 - 12.03			1866 600 018		Getr. / GBox: Powershuttle	

# MASSEY FERGUSON



## 4215 - 8480

5425 4 Zyl.	01.04-	Perkins		1866 600 016			
5435 4 Zyl.	01.04-						
5445 4 Zyl.	01.04-						
5455 4 Zyl.	01.04-						
5460 4 Zyl.	01.04-						
6235 4 Zyl.							
6245 4 Zyl.	01.00-						
6255 4 Zyl.	01.00-						
6445 4 Zyl.	01.04-						
6455 4 Zyl.	01.04-						
6460 4 Zyl.	01.04-						
6470 4 Zyl.	01.04-						
5465 6 Zyl.	01.04- 12.07	Perkins1106C-E60TA		1866 600 017 1866 600 017		Getr. / GBox: Speedshift	
6170 6 Zyl.	01.95- 12.99	Perkins1006-6HR3,		1866 600 017		Chass. F058049->	
6180 6 Zyl.	01.95- 12.99	Perkins1006-6TLR2					
6190 6 Zyl.	01.96- 12.99	Perkins,		1866 600 017			
6260 6 Zyl.	01.99- 12.03	Perkins1006-60T,					
6270 6 Zyl.	01.99- 12.03	Perkins1006-6THR2					
6280 6 Zyl.	01.99- 12.03						
6290 6 Zyl.	01.99- 12.03						
6465 6 Zyl.	01.04-						
6475 6 Zyl.	01.04-						
6480 6 Zyl.	01.04-						
6485 6 Zyl.	01.04- 12.07	Sisu74.ETA,		1866 600 019		->Mot. N244038	
6490 6 Zyl.	01.04- 12.07	Sisu66.ETA					
6495 6 Zyl.	01.04- 12.07						
6497 6 Zyl.	01.07-						
6499 6 Zyl.	01.06-	Sisu74.ETA		1866 600 019 1866 600 019		->Mot. N244038 für / for: TIER3	(47)
7485 6 Zyl. Dyna-VT	01.04- 12.07	Sisu66.ETA		1866 600 019			
7490 Dyna-VT 6 Zyl.	01.04- 12.07						
7495 Dyna-VT 6 Zyl.	01.04- 12.07						





					Parameter		
---	--	--	--	--	-----------	---	---



## MASSEY FERGUSON



### 4215 - 8480

<b>8110</b> 6 Zyl.	01.96-	Perkins, Perkins1006 -6THR2, Valmet		<b>1866 600 015</b>		
<b>8120</b> 6 Zyl.	01.96-					
<b>8130</b>						
<b>8140</b> 6 Zyl.	01.96-					
<b>8150</b> 6 Zyl.	01.96-					
<b>8160</b> 6 Zyl.	01.96-					
<b>8210</b> 6 Zyl.	01.00-	Perkins, Sisu		<b>1866 600 014</b>		nur als Ersatz für angegebene OE-Nr. / only for the listed OE-Numbers (77)
<b>8220</b> 6 Zyl.	01.00-			<b>1866 600 019</b>		Getr. / GBox: Dynaschift nur als Ersatz für angegebene OE-Nr. / only for the listed OE-Numbers (77)
<b>8240</b> 6 Zyl.	01.00-			<b>1866 600 015</b>		nur als Ersatz für angegebene OE-Nr. / only for the listed OE-Numbers (77)
<b>8250</b> 6 Zyl.	01.00-					
<b>8260</b> 6 Zyl.	01.00-	Sisu, Valmet		<b>1866 600 014</b>		
<b>8270</b> 6 Zyl.						
<b>8280</b> 6 Zyl.						
<b>8280</b> 6 Zyl.						

## MC CORMICK

<b>F</b>							
<b>F 60</b> <b>F 60 F, VG</b>	01.01-			<b>1888 600 145</b>	DUT280/ 280 (280/35x40-14N)	enthält eine Kupplungsscheibe / This part number includes one clutch disc (45)	
	01.01-				<b>1864 917 002 #</b>	280E (22x25-10N)	
					<b>1863 838 001</b>	50/82/29	ohne Anlauftring / without thrust ring (79)
					<b>1863 600 117</b>	65/100/11	mit Anlauftring / with thrust ring (63)
					<b>1863 869 020</b>	20/47/14	

<b>GM</b>							
<b>GM 40</b> <b>GM 45</b> <b>GM 50</b> <b>GM 55</b>	01.03-	4TNV84T-KLAN, 4TNE84-ELAN, 3TNE88-ELAN, 4TNE88-ELAN		<b>1888 600 130</b>	DUT230/ 230 (225/27x30-16N)	enthält eine Kupplungsscheibe / This part number includes one clutch disc (45)	
	01.03-				<b>1864 600 335</b>	225 (14x17-9N)	
	01.03-						
	01.03-						









<b>GX</b>							
<b>GX 40</b> <b>GX 45</b> <b>GX 50</b> <b>GX 55</b>	01.03-	4TNV84T-KLAN, 4TNE84-ELAN, 3TNE88-ELAN, 4TNE88-ELAN		<b>1888 600 130</b>	DUT230/ 230 (225/27x30-16N)	enthält eine Kupplungsscheibe / This part number includes one clutch disc (45)	
	01.03-				<b>1864 600 335</b>	225 (14x17-9N)	
	01.03-						
	01.03-						





<b>MC</b>							
<b>MC 80</b> <b>MC 90</b> <b>MC 95</b> <b>MC 100</b> <b>MC 105</b> <b>MC 115</b>				<b>1866 600 023</b>			

					Parameter		
---	--	--	--	--	-----------	---	---





## MC CORMICK

MTX							
MTX 110	01.02-			1866 600 002		max. übertragbares Motormoment [Nm] / max. transmittable engine torque [Nm]: 900	(62)
MTX 120	01.03-						
MTX 125	01.02-						
MTX 135	01.03-						
MTX 140	01.02-						
MTX 150	01.03-						
MTX 155	01.03-						
MTX 165	01.03-						
MTX 175	01.03-						
MTX 185	01.03-						
MTX 200	01.03-						

T							
T 70				1888 880 001 #	DUT280/ CERAM (280/35x40-14N)	enthält eine Kupplungsscheibe / This part number includes one clutch disc	(45)
T 80				1864 917 002 ▽#	280E (22x25-10N)	Lose Kupplungsscheibe / Loose clutch disc	(30)
T 90				1863 838 001	50/82/29	ohne Anlauftring / without thrust ring	(79)
T 100				1863 600 117	65/100/11	mit Anlauftring / with thrust ring	(63)
				1863 869 020	20/47/14		
				1888 876 006 #	DUT310 (310/35x40-14N)	enthält eine Kupplungsscheibe / This part number includes one clutch disc	(45)
				1864 959 001 #	310 (22x25-10N)		
				1863 869 020	20/47/14		







V							
V 60	01.01-			1888 600 145	DUT280/ 280 (280/35x40-14N)	enthält eine Kupplungsscheibe / This part number includes one clutch disc	(45)
V 65	01.01-			1864 917 002 #	280E (22x25-10N)		
				1863 838 001	50/82/29	ohne Anlauftring / without thrust ring	(79)
				1863 600 117	65/100/11	mit Anlauftring / with thrust ring	(63)
				1863 869 020	20/47/14		

## MEILI







Dumper							
1000				1882 196 005	KS200		
				1864 634 031	200Z (1 1/8"-10N)		
				1860 049 027 #	200Z (1 1/8"-10N)		
				3100 700 101			
				3151 021 001	KTI-1		
				2x 3130 010 200			



## MEILI

DM-Serie								
25				<b>1882 108 204 #</b>	DO225 (Mo 225/23x29-10N) (Ge 200/46x50-8N)	enthält zwei Kupplungsscheiben / This part number includes both clutch discs	(46)	
				<b>3151 000 395</b>				
				<b>1882 196 005</b>	KS200			
				<b>1864 634 039</b>	200Z (23x29-10N)			
				<b>3100 700 101</b> ◦ 3151 021 001 ∩ 2x 3130 010 200	KTI-1			
36				<b>1882 108 204 #</b>	DO225 (Mo 225/23x29-10N) (Ge 200/46x50-8N)	enthält zwei Kupplungsscheiben / This part number includes both clutch discs	(46)	
				<b>3151 000 395</b>				

## MENGELE

Autobagger / car dredger							
Mot.KHD F2L612				<b>1881 059 208</b>	KS200		
				<b>1864 634 030</b>	200Z (26x32-10N)		
Mot.KHD F2L812				<b>1881 059 208</b>	KS200		
				<b>1864 634 027</b>	200Z (26x32-10N)		
Feldhäcksler / field chopper							
Mammut 6900 Mammut 7400 Mammut 7800				<b>1866 142 001</b>	352/ 210NGS	max. übertragbares Motormoment [Nm] / max. transmittable engine torque [Nm]: 2540	(62)
SF 5200 SF 5600 SF 6000 SF 6500 SF 6600 SF 7000				<b>1866 068 002</b>	352/ 210NGS	max. übertragbares Motormoment [Nm] / max. transmittable engine torque [Nm]: 2190	(62)
				<b>1866 068 001</b>	352/ 210NGS	max. übertragbares Motormoment [Nm] / max. transmittable engine torque [Nm]: 1410	(62)

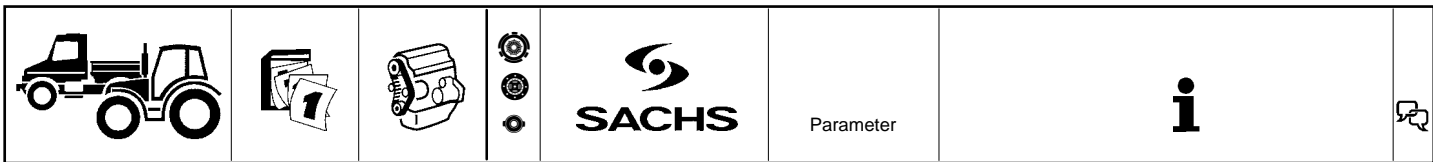

# MERCEDES-BENZ

MB-TRAC		07.73 - 12.91				
<b>65/70, 700, 800</b> 440.162 440.161 440.163 440.167/168	07.73 - 12.91	OM314.957, OM314.956	<b>1888 890 001 #</b>	DUT295 (280/45x50-24N)	für Fahrzeuge mit Zweischeibenkupplung / for vehicles with double disc clutch enthält eine Kupplungsscheibe / This part number includes one clutch disc	(51) (45)
			<b>1862 814 003 ▽#</b>	295GTB (26x32-10N)	für Fahrzeuge mit Zweischeibenkupplung / for vehicles with double disc clutch Lose Kupplungsscheibe / Loose clutch disc	(51) (30)
			<b>1863 838 002</b>	60/95/18	-> <b>Chass. 084 256</b> für Fahrzeuge mit Zweischeibenkupplung / for vehicles with double disc clutch ohne Anlauftring / without thrust ring	(51) (79)
			<b>1863 858 001</b>	75/115/20	-> <b>Chass. 084 256</b> für Fahrzeuge mit Zweischeibenkupplung / for vehicles with double disc clutch ohne Anlauftring / without thrust ring	(51) (79)
			<b>1863 837 002</b>	65/97/23	<b>Chass. 084 257-&gt;</b> für Fahrzeuge mit Zweischeibenkupplung / for vehicles with double disc clutch mit Anlauftring / with thrust ring	(51) (63)
			<b>1863 855 000</b>	106/140/25	<b>Chass. 084 257-&gt;</b> für Fahrzeuge mit Zweischeibenkupplung / for vehicles with double disc clutch mit Anlauftring / with thrust ring	(51) (63)
			<b>1882 229 131 #</b>	G280	-> <b>Chass. 091 605</b> 440.162-163 für Fahrzeuge mit Einscheibenkupplung / for vehicles with single disc clutch	(48)
			<b>1861 611 131 #</b>	280B/ Z (26x32-10N)	-> <b>Chass. 091 605</b> 440.162-163 für Fahrzeuge mit Einscheibenkupplung / for vehicles with single disc clutch	(48)
			<b>1863 838 002</b>	60/95/18	-> <b>Chass. 091 605</b> für Fahrzeuge mit Einscheibenkupplung / for vehicles with single disc clutch ohne Anlauftring / without thrust ring	(48) (79)
			<b>3482 008 032</b>	MF310	<b>Chass. 091 606-&gt;</b> 440.162-163 für Fahrzeuge mit Einscheibenkupplung / for vehicles with single disc clutch	(48)
			<b>1861 384 334 #</b>	310GSZ (26x32-10N)	<b>Chass. 091 606-&gt;</b> 440.162-163 für Fahrzeuge mit Einscheibenkupplung / for vehicles with single disc clutch	(48)
			<b>1863 837 002</b>	65/97/23	<b>Chass. 091 606-&gt;</b> für Fahrzeuge mit Einscheibenkupplung / for vehicles with single disc clutch mit Anlauftring / with thrust ring	(48) (63)
			<b>3482 008 032</b>	MF310	440.167-168 für Fahrzeuge mit Einscheibenkupplung / for vehicles with single disc clutch	(48)
			<b>1861 384 334 #</b>	310GSZ (26x32-10N)	440.167-168 für Fahrzeuge mit Einscheibenkupplung / for vehicles with single disc clutch	(48)
			<b>1863 837 002</b>	65/97/23	für Fahrzeuge mit Einscheibenkupplung / for vehicles with single disc clutch mit Anlauftring / with thrust ring	(48) (63)















# MERCEDES-BENZ

MB-TRAC		07.73 - 12.91					
700, 800 440.171/172	02.87 - 12.91	OM364.909, OM364.908		<b>1888 890 001 #</b>	DUT295 (280/45x50-24N)	für Fahrzeuge mit Zweis Scheibenkupplung / for vehicles with double disc clutch enthält eine Kupplungsscheibe / This part number includes one clutch disc	(51) (45)
				<b>1862 814 003 ▽#</b>	295GTB (26x32-10N)	für Fahrzeuge mit Zweis Scheibenkupplung / for vehicles with double disc clutch Lose Kupplungsscheibe / Loose clutch disc	(51) (30)
				<b>1863 838 002</b>	60/95/18	<b>-&gt;Chass. 084 256</b> für Fahrzeuge mit Zweis Scheibenkupplung / for vehicles with double disc clutch ohne Anlauftring / without thrust ring	(51) (79)
				<b>1863 858 001</b>	75/115/20	<b>-&gt;Chass. 084 256</b> für Fahrzeuge mit Zweis Scheibenkupplung / for vehicles with double disc clutch ohne Anlauftring / without thrust ring	(51) (79)
				<b>1863 837 002</b>	65/97/23	<b>Chass. 084 257-&gt;</b> für Fahrzeuge mit Zweis Scheibenkupplung / for vehicles with double disc clutch mit Anlauftring / with thrust ring	(51) (63)
				<b>1863 855 000</b>	106/140/25	<b>Chass. 084 257-&gt;</b> für Fahrzeuge mit Zweis Scheibenkupplung / for vehicles with double disc clutch mit Anlauftring / with thrust ring	(51) (63)
				<b>3482 008 038</b>	MF310	für Fahrzeuge mit Einscheibenkupplung / for vehicles with single disc clutch	(48)
				<b>1861 384 334 #</b>	310GSZ (26x32-10N)	für Fahrzeuge mit Einscheibenkupplung / for vehicles with single disc clutch	(48)
				<b>1863 837 002</b>	65/97/23	für Fahrzeuge mit Einscheibenkupplung / for vehicles with single disc clutch mit Anlauftring / with thrust ring	(48) (63)

# MERCEDES-BENZ

MB-TRAC		07.73 - 12.91					
900 440.169 440.164	09.81 - 12.91	OM314.970		<b>1888 890 001 #</b>	DUT295 (280/45x50-24N)	440.164 für Fahrzeuge mit Zweischeibenkupplung / for vehicles with double disc clutch enthält eine Kupplungsscheibe / This part number includes one clutch disc	(51) (45)
				<b>1862 814 003 ▽#</b>	295GTB (26x32-10N)	440.164 für Fahrzeuge mit Zweischeibenkupplung / for vehicles with double disc clutch Lose Kupplungsscheibe / Loose clutch disc	(51) (30)
				<b>1863 838 002</b>	60/95/18	->Chass. 084 256 440.164 für Fahrzeuge mit Zweischeibenkupplung / for vehicles with double disc clutch ohne Anlauftring / without thrust ring	(51) (79)
				<b>1863 858 001</b>	75/115/20	->Chass. 084 256 440.164 für Fahrzeuge mit Zweischeibenkupplung / for vehicles with double disc clutch ohne Anlauftring / without thrust ring	(51) (79)
				<b>1863 837 002</b>	65/97/23	Chass. 084 257-> 440.164 für Fahrzeuge mit Zweischeibenkupplung / for vehicles with double disc clutch mit Anlauftring / with thrust ring	(51) (63)
				<b>1863 855 000</b>	106/140/25	Chass. 084 257-> 440.164 für Fahrzeuge mit Zweischeibenkupplung / for vehicles with double disc clutch mit Anlauftring / with thrust ring	(51) (63)
				<b>3482 008 032</b>	MF310	für Fahrzeuge mit Einscheibenkupplung / for vehicles with single disc clutch	(48)
				<b>1861 384 334 #</b>	310GSZ (26x32-10N)	für Fahrzeuge mit Einscheibenkupplung / for vehicles with single disc clutch	(48)
				<b>1863 837 002</b>	65/97/23	für Fahrzeuge mit Einscheibenkupplung / for vehicles with single disc clutch mit Anlauftring / with thrust ring	(48) (63)
				<b>1888 067 031 #</b>	DUT330 (310/45x50-24N)	für / for: Turbo 440.169 für Fahrzeuge mit Zweischeibenkupplung / for vehicles with double disc clutch enthält eine Kupplungsscheibe / This part number includes one clutch disc	(47) (51) (45)
				<b>1862 812 006 ▽#</b>	330CTDC (26x32-10N)	für / for: Turbo 440.169 für Fahrzeuge mit Zweischeibenkupplung / for vehicles with double disc clutch Lose Kupplungsscheibe / Loose clutch disc	(47) (51) (30)
				<b>1863 837 002</b>	65/97/23	für / for: Turbo 440.169 für Fahrzeuge mit Zweischeibenkupplung / for vehicles with double disc clutch mit Anlauftring / with thrust ring	(47) (51) (63)
				<b>1863 855 000</b>	106/140/25	für / for: Turbo 440.169 für Fahrzeuge mit Zweischeibenkupplung / for vehicles with double disc clutch mit Anlauftring / with thrust ring	(47) (51) (63)
				<b>1888 998 201 #</b>	DUT330 (310/45x50-24N)	für / for: Turbo 440.169 für Fahrzeuge mit Zweischeibenkupplung / for vehicles with double disc clutch enthält eine Kupplungsscheibe / This part number includes one clutch disc für Fahrzeuge mit Niederdruck-Bremsanlage / for vehicles with low-pressure brakesystem	(47) (51) (45) (49)
				<b>1862 812 006 ▽#</b>	330CTDC (26x32-10N)	für / for: Turbo 440.169 für Fahrzeuge mit Zweischeibenkupplung / for vehicles with double disc clutch für Fahrzeuge mit Niederdruck-Bremsanlage / for vehicles with low-pressure brakesystem Lose Kupplungsscheibe / Loose clutch disc	(47) (51) (49) (30)
				<b>1863 837 002</b>	65/97/23	für / for: Turbo 440.169	(47)

## MERCEDES-BENZ

MB-TRAC		07.73 - 12.91					
<b>900</b> 440.169 440.164	09.81 - 12.91	OM314.970		<b>1863 855 000</b>	106/140/25	für / for: Turbo 440.169 für Fahrzeuge mit Zweischeibenkupplung / for vehicles with double disc clutch mit Anlauftring / with thrust ring für Fahrzeuge mit Niederdruck-Bremsanlage / for vehicles with low-pressure brakesystem	(47) (51) (63) (49)
<b>900</b> 440.173 <b>1000</b> 441.161	03.87 - 12.91 12.82 - 12.87	OM364.951, OM353.985		<b>1888 067 031 #</b>	DUT330 (310/45x50-24N)	für Fahrzeuge mit Zweischeibenkupplung / for vehicles with double disc clutch enthält eine Kupplungsscheibe / This part number includes one clutch disc	(51) (45)
				<b>1862 812 006 ▽#</b>	330CTDC (26x32-10N)	für Fahrzeuge mit Zweischeibenkupplung / for vehicles with double disc clutch Lose Kupplungsscheibe / Loose clutch disc	(51) (30)
				<b>1863 837 002</b>	65/97/23	für Fahrzeuge mit Zweischeibenkupplung / for vehicles with double disc clutch mit Anlauftring / with thrust ring	(51) (63)
				<b>1863 855 000</b>	106/140/25	für Fahrzeuge mit Zweischeibenkupplung / for vehicles with double disc clutch mit Anlauftring / with thrust ring	(51) (63)
				<b>1888 998 201 #</b>	DUT330 (310/45x50-24N)	für Fahrzeuge mit Zweischeibenkupplung / for vehicles with double disc clutch enthält eine Kupplungsscheibe / This part number includes one clutch disc für Fahrzeuge mit Niederdruck-Bremsanlage / for vehicles with low-pressure brakesystem	(51) (45) (49)
				<b>1862 812 006 ▽#</b>	330CTDC (26x32-10N)	für Fahrzeuge mit Zweischeibenkupplung / for vehicles with double disc clutch für Fahrzeuge mit Niederdruck-Bremsanlage / for vehicles with low-pressure brakesystem Lose Kupplungsscheibe / Loose clutch disc	(51) (49) (30)
				<b>1863 837 002</b>	65/97/23	für Fahrzeuge mit Zweischeibenkupplung / for vehicles with double disc clutch mit Anlauftring / with thrust ring für Fahrzeuge mit Niederdruck-Bremsanlage / for vehicles with low-pressure brakesystem	(51) (63) (49)
				<b>1863 855 000</b>	106/140/25	für Fahrzeuge mit Zweischeibenkupplung / for vehicles with double disc clutch mit Anlauftring / with thrust ring für Fahrzeuge mit Niederdruck-Bremsanlage / for vehicles with low-pressure brakesystem	(51) (63) (49)
				<b>3482 008 032</b>	MF310	für Fahrzeuge mit Einscheibenkupplung / for vehicles with single disc clutch	(48)
				<b>1861 384 334 #</b>	310GSZ (26x32-10N)	für Fahrzeuge mit Einscheibenkupplung / for vehicles with single disc clutch	(48)
				<b>1863 837 002</b>	65/97/23	für Fahrzeuge mit Einscheibenkupplung / for vehicles with single disc clutch mit Anlauftring / with thrust ring	(48) (63)

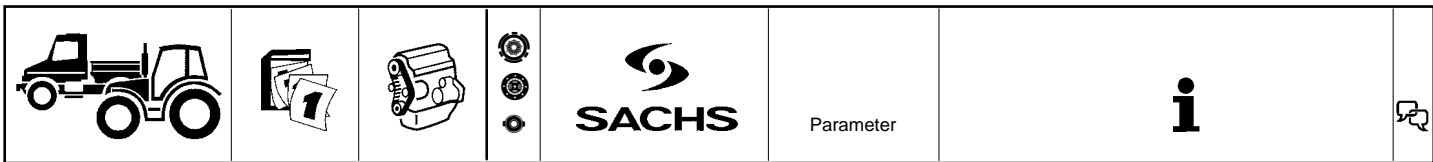

# MERCEDES-BENZ

















MB-TRAC		07.73 - 12.91			
1000, 1100 441.162/163	02.87 - 12.91	OM366.912, OM366.908	<b>1888 067 031 #</b> DUT330 (310/45x50-24N)	für Fahrzeuge mit Zweis Scheibenkupplung / for vehicles with double disc clutch enthält eine Kupplungsscheibe / This part number includes one clutch disc	(51) (45)
			<b>1862 812 006 ▽#</b> 330CTDC (26x32-10N)	für Fahrzeuge mit Zweis Scheibenkupplung / for vehicles with double disc clutch Lose Kupplungsscheibe / Loose clutch disc	(51) (30)
			<b>1863 837 002</b> 65/97/23	für Fahrzeuge mit Zweis Scheibenkupplung / for vehicles with double disc clutch mit Anlauftring / with thrust ring	(51) (63)
			<b>1863 855 000</b> 106/140/25	für Fahrzeuge mit Zweis Scheibenkupplung / for vehicles with double disc clutch mit Anlauftring / with thrust ring	(51) (63)
			<b>1888 998 201 #</b> DUT330 (310/45x50-24N)	für Fahrzeuge mit Zweis Scheibenkupplung / for vehicles with double disc clutch für Fahrzeuge mit Niederdruck-Bremsanlage / for vehicles with low-pressure brakesystem enthält eine Kupplungsscheibe / This part number includes one clutch disc	(51) (49) (45)
			<b>1862 812 006 ▽#</b> 330CTDC (26x32-10N)	für Fahrzeuge mit Zweis Scheibenkupplung / for vehicles with double disc clutch für Fahrzeuge mit Niederdruck-Bremsanlage / for vehicles with low-pressure brakesystem Lose Kupplungsscheibe / Loose clutch disc	(51) (49) (30)
			<b>1863 837 002</b> 65/97/23	für Fahrzeuge mit Zweis Scheibenkupplung / for vehicles with double disc clutch mit Anlauftring / with thrust ring für Fahrzeuge mit Niederdruck-Bremsanlage / for vehicles with low-pressure brakesystem	(51) (63) (49)
			<b>1863 855 000</b> 106/140/25	für Fahrzeuge mit Zweis Scheibenkupplung / for vehicles with double disc clutch mit Anlauftring / with thrust ring für Fahrzeuge mit Niederdruck-Bremsanlage / for vehicles with low-pressure brakesystem	(51) (63) (49)
			<b>3482 008 038</b> MF310	für Fahrzeuge mit Einscheibenkupplung / for vehicles with single disc clutch	(48)
			<b>1861 384 334 #</b> 310GSZ (26x32-10N)	für Fahrzeuge mit Einscheibenkupplung / for vehicles with single disc clutch	(48)
			<b>1863 837 002</b> 65/97/23	für Fahrzeuge mit Einscheibenkupplung / for vehicles with single disc clutch mit Anlauftring / with thrust ring	(48) (63)

# MERCEDES-BENZ

## MB-TRAC 07.73 - 12.91

<b>1100</b> 442.161 443.160	03.79 - 08.87	OM353.949		<b>1888 067 042 #</b>	DUT330/ 310 (310/41x45-22N)	442.161 für Fahrzeuge mit Zweischeibenkupplung / for vehicles with double disc clutch enthält eine Kupplungsscheibe / This part number includes one clutch disc enthält Druckplattenbefestigungsschrauben / includes bolt for pressure plate mounting	(51) (45) (44)
				<b>1861 741 042 ▽#</b>	327GSDC (36x40-20N)	442.161 für Fahrzeuge mit Zweischeibenkupplung / for vehicles with double disc clutch Anzahl der Beläge / Number of pads: 8 Lose Kupplungsscheibe / Loose clutch disc	(51) (7) (30)
				<b>1863 837 002</b>	65/97/23	442.161 für Fahrzeuge mit Zweischeibenkupplung / for vehicles with double disc clutch mit Anlauftring / with thrust ring	(51) (63)
				<b>1863 855 000</b>	106/140/25	442.161 für Fahrzeuge mit Zweischeibenkupplung / for vehicles with double disc clutch mit Anlauftring / with thrust ring	(51) (63)
				<b>3482 012 211</b>	GMF330	<b>-&gt;Chass. 010 812</b> 442.161 für Fahrzeuge mit Einscheibenkupplung / for vehicles with single disc clutch	(48)
				<b>1861 594 034 #</b>	330GSZ (36x40-20N)	<b>-&gt;Chass. 010 812</b> 442.161 für Fahrzeuge mit Einscheibenkupplung / for vehicles with single disc clutch	(48)
				<b>3151 051 031</b>		<b>-&gt;Chass. 010 812</b> 442.161 für Fahrzeuge mit Einscheibenkupplung / for vehicles with single disc clutch	(48)
				<b>3482 012 237</b>	GMF330	442.161 für Fahrzeuge mit Einscheibenkupplung / for vehicles with single disc clutch Nur zusammen verbauen / Only install together	(48) (35)
				<b>1861 667 034</b>	330GSB (36x40-20N)	442.161 für Fahrzeuge mit Einscheibenkupplung / for vehicles with single disc clutch Nur zusammen verbauen / Only install together	(48) (35)
				<b>3151 051 031</b>		442.161 für Fahrzeuge mit Einscheibenkupplung / for vehicles with single disc clutch Nur zusammen verbauen / Only install together	(48) (35)
				<b>1888 998 902 #</b>	DUT350/ 330 (330/45x50-24N)	443.160 für Fahrzeuge mit Zweischeibenkupplung / for vehicles with double disc clutch enthält eine Kupplungsscheibe / This part number includes one clutch disc	(51) (45)
				<b>1862 962 002 ▽#</b>	350GSDC (36x40-20N)	443.160 für Fahrzeuge mit Zweischeibenkupplung / for vehicles with double disc clutch Lose Kupplungsscheibe / Loose clutch disc	(51) (30)
				<b>1863 837 002</b>	65/97/23	443.160 für Fahrzeuge mit Zweischeibenkupplung / for vehicles with double disc clutch mit Anlauftring / with thrust ring	(51) (63)
				<b>1863 855 000</b>	106/140/25	443.160 für Fahrzeuge mit Zweischeibenkupplung / for vehicles with double disc clutch mit Anlauftring / with thrust ring	(51) (63)
				<b>3482 002 234</b>	GMF350X	443.160 für Fahrzeuge mit Einscheibenkupplung / for vehicles with single disc clutch	(48)
				<b>1861 956 133</b>	350GTD (36x40-20N)	443.160 für Fahrzeuge mit Einscheibenkupplung / for vehicles with single disc clutch	(48)
				<b>3151 051 031</b>		443.160 für Fahrzeuge mit Einscheibenkupplung / for vehicles with single disc clutch	(48)
				<b>3482 002 234</b>	GMF350X	443.160 für Fahrzeuge mit Wandlerschaltkupplung / for vehicles with converter and clutch unit	(50)
				<b>1861 713 133 #</b>	350GSZ (36x40-20N)	443.160 für Fahrzeuge mit Wandlerschaltkupplung / for	(50)

# MERCEDES-BENZ

MB-TRAC		07.73 - 12.91					
1300 443.161	03.76 - 08.87	OM353.957		<b>1888 067 042 #</b>	DUT330/ 310 (310/41x45-22N)	<b>-&gt;Chass. 114 457</b> für Fahrzeuge mit Zweischeibenkupplung / for vehicles with double disc clutch enthält eine Kupplungsscheibe / This part number includes one clutch disc enthält Druckplattenbefestigungsschrauben / includes bolt for pressure plate mounting	(51) (45) (44)
				<b>1861 741 042 ▽#</b>	327GSDC (36x40-20N)	<b>-&gt;Chass. 114 457</b> für Fahrzeuge mit Zweischeibenkupplung / for vehicles with double disc clutch Anzahl der Beläge / Number of pads: 8 Lose Kupplungsscheibe / Loose clutch disc	(51) (7) (30)
				<b>1863 837 002</b>	65/97/23	<b>-&gt;Chass. 114 457</b> für Fahrzeuge mit Zweischeibenkupplung / for vehicles with double disc clutch mit Anlauftring / with thrust ring	(51) (63)
				<b>1863 855 000</b>	106/140/25	<b>-&gt;Chass. 114 457</b> für Fahrzeuge mit Zweischeibenkupplung / for vehicles with double disc clutch mit Anlauftring / with thrust ring	(51) (63)
				<b>1888 998 902 #</b>	DUT350/ 330 (330/45x50-24N)	<b>Chass. 114 458-&gt;</b> für Fahrzeuge mit Zweischeibenkupplung / for vehicles with double disc clutch enthält eine Kupplungsscheibe / This part number includes one clutch disc	(51) (45)
				<b>1862 962 002 ▽#</b>	350GSDC (36x40-20N)	<b>Chass. 114 458-&gt;</b> für Fahrzeuge mit Zweischeibenkupplung / for vehicles with double disc clutch Lose Kupplungsscheibe / Loose clutch disc	(51) (30)
				<b>1863 837 002</b>	65/97/23	<b>Chass. 114 458-&gt;</b> für Fahrzeuge mit Zweischeibenkupplung / for vehicles with double disc clutch mit Anlauftring / with thrust ring	(51) (63)
				<b>1863 855 000</b>	106/140/25	<b>Chass. 114 458-&gt;</b> für Fahrzeuge mit Zweischeibenkupplung / for vehicles with double disc clutch mit Anlauftring / with thrust ring	(51) (63)
				<b>3482 012 211</b>	GMF330	<b>-&gt;Chass. 010 812</b> für Fahrzeuge mit Einscheibenkupplung / for vehicles with single disc clutch	(48)
				<b>1861 594 034 #</b>	330GSZ (36x40-20N)	<b>-&gt;Chass. 010 812</b> für Fahrzeuge mit Einscheibenkupplung / for vehicles with single disc clutch	(48)
				<b>3151 051 031</b>		<b>-&gt;Chass. 010 812</b> für Fahrzeuge mit Einscheibenkupplung / for vehicles with single disc clutch	(48)
				<b>3482 012 237</b>	GMF330	für Fahrzeuge mit Einscheibenkupplung / for vehicles with single disc clutch Nur zusammen verbauen / Only install together	(48) (35)
				<b>1861 667 034</b>	330GSB (36x40-20N)	für Fahrzeuge mit Einscheibenkupplung / for vehicles with single disc clutch Nur zusammen verbauen / Only install together	(48) (35)
				<b>3151 051 031</b>		für Fahrzeuge mit Einscheibenkupplung / for vehicles with single disc clutch Nur zusammen verbauen / Only install together	(48) (35)
				<b>3482 002 234</b>	GMF350X	für Fahrzeuge mit Wandlerschaltkupplung / for vehicles with converter and clutch unit	(50)
				<b>1861 713 133 #</b>	350GSZ (36x40-20N)	für Fahrzeuge mit Wandlerschaltkupplung / for vehicles with converter and clutch unit	(50)

















# MERCEDES-BENZ























MB-TRAC		07.73 - 12.91				
<b>1300 Turbo, 1400 Turbo</b> 443.163/164 <b>1600 Turbo</b> 443.166 <b>1800</b> 443.166	02.82 - 12.91	OM366.977, OM366.958, OM366.954	<b>1888 998 902 #</b>	DUT350/ 330 (330/45x50-24N)	für Fahrzeuge mit Zweischeibenkupplung / for vehicles with double disc clutch enthält eine Kupplungsscheibe / This part number includes one clutch disc	(51) (45)
	06.90 - 12.91		<b>1862 962 002 ▽#</b>	350GSDC (36x40-20N)	für Fahrzeuge mit Zweischeibenkupplung / for vehicles with double disc clutch Lose Kupplungsscheibe / Loose clutch disc	(51) (30)
	06.90 - 12.91		<b>1863 837 002</b>	65/97/23	für Fahrzeuge mit Zweischeibenkupplung / for vehicles with double disc clutch mit Anlauftring / with thrust ring	(51) (63)
			<b>1863 855 000</b>	106/140/25	für Fahrzeuge mit Zweischeibenkupplung / for vehicles with double disc clutch mit Anlauftring / with thrust ring	(51) (63)
			<b>3482 002 234</b>	GMF350X	für Fahrzeuge mit Einscheibenkupplung / for vehicles with single disc clutch	(48)
			<b>1861 956 133</b>	350GTD (36x40-20N)	für Fahrzeuge mit Einscheibenkupplung / for vehicles with single disc clutch	(48)
			<b>3151 051 031</b>		für Fahrzeuge mit Einscheibenkupplung / for vehicles with single disc clutch	(48)
			<b>3482 002 234</b>	GMF350X	für Fahrzeuge mit Wandlerschaltkupplung / for vehicles with converter and clutch unit	(50)
			<b>1861 713 133 #</b>	350GSZ (36x40-20N)	für Fahrzeuge mit Wandlerschaltkupplung / for vehicles with converter and clutch unit	(50)

# MERCEDES-BENZ

MB-TRAC		07.73 - 12.91				
1500 443.162	07.80 - 12.87	OM353.976	 <b>1888 067 042 #</b>	DUT330/ 310 (310/41x45-22N)	<b>-&gt;Chass. 114 457</b> für Fahrzeuge mit Zweischeibenkupplung / for vehicles with double disc clutch enthält eine Kupplungsscheibe / This part number includes one clutch disc enthält Druckplattenbefestigungsschrauben / includes bolt for pressure plate mounting	(51) (45) (44)
			 <b>1861 741 042 ▽#</b>	327GSDC (36x40-20N)	<b>-&gt;Chass. 114 457</b> für Fahrzeuge mit Zweischeibenkupplung / for vehicles with double disc clutch Anzahl der Beläge / Number of pads: 8 Lose Kupplungsscheibe / Loose clutch disc	(51) (7) (30)
			 <b>1863 837 002</b>	65/97/23	<b>-&gt;Chass. 114 457</b> für Fahrzeuge mit Zweischeibenkupplung / for vehicles with double disc clutch mit Anlauftring / with thrust ring	(51) (63)
			 <b>1863 855 000</b>	106/140/25	<b>-&gt;Chass. 114 457</b> für Fahrzeuge mit Zweischeibenkupplung / for vehicles with double disc clutch mit Anlauftring / with thrust ring	(51) (63)
			 <b>1888 998 902 #</b>	DUT350/ 330 (330/45x50-24N)	<b>Chass. 114 458-&gt;</b> für Fahrzeuge mit Zweischeibenkupplung / for vehicles with double disc clutch enthält eine Kupplungsscheibe / This part number includes one clutch disc	(51) (45)
			 <b>1862 962 002 ▽#</b>	350GSDC (36x40-20N)	<b>Chass. 114 458-&gt;</b> für Fahrzeuge mit Zweischeibenkupplung / for vehicles with double disc clutch Lose Kupplungsscheibe / Loose clutch disc	(51) (30)
			 <b>1863 837 002</b>	65/97/23	<b>Chass. 114 458-&gt;</b> für Fahrzeuge mit Zweischeibenkupplung / for vehicles with double disc clutch mit Anlauftring / with thrust ring	(51) (63)
			 <b>1863 855 000</b>	106/140/25	<b>Chass. 114 458-&gt;</b> für Fahrzeuge mit Zweischeibenkupplung / for vehicles with double disc clutch mit Anlauftring / with thrust ring	(51) (63)
			 <b>3482 012 237</b>	GMF330	<b>-&gt;Chass. 114 457</b> für Fahrzeuge mit Einscheibenkupplung / for vehicles with single disc clutch	(48)
			 <b>1861 667 034</b>	330GSB (36x40-20N)	<b>-&gt;Chass. 114 457</b> für Fahrzeuge mit Einscheibenkupplung / for vehicles with single disc clutch	(48)
			 <b>3151 051 031</b>		<b>-&gt;Chass. 114 457</b> für Fahrzeuge mit Einscheibenkupplung / for vehicles with single disc clutch	(48)
			 <b>3482 002 234</b>	GMF350X	<b>Chass. 114 458-&gt;</b> für Fahrzeuge mit Einscheibenkupplung / for vehicles with single disc clutch	(48)
			 <b>1861 956 133</b>	350GTD (36x40-20N)	<b>Chass. 114 458-&gt;</b> für Fahrzeuge mit Einscheibenkupplung / for vehicles with single disc clutch	(48)
			 <b>3151 051 031</b>		<b>Chass. 114 458-&gt;</b> für Fahrzeuge mit Einscheibenkupplung / for vehicles with single disc clutch	(48)
			 <b>3482 002 234</b>	GMF350X	für Fahrzeuge mit Wandlerschaltkupplung / for vehicles with converter and clutch unit	(50)
 <b>1861 713 133 #</b>	350GSZ (36x40-20N)	für Fahrzeuge mit Wandlerschaltkupplung / for vehicles with converter and clutch unit	(50)			

# MERCEDES-BENZ

## Unimog 32-100

<b>U 40</b> 421.123 421.122 <b>U 45</b> 421.123 421.122	01.66 - 04.71	OM621.931, OM615.911		<b>1882 231 131 #</b>	G250		
				<b>1861 840 133 #</b>	250TPZ (26x32-10N)		
				<b>1863 840 001</b>	55/90/18	ohne Anlauftring / without thrust ring	(79)
				<b>1888 893 001 #</b>	DOT240 (225/45x50-24N)	für / for: SA35334 01 für / for: SA35452 01 für Fahrzeuge mit Zweischeibenkupplung / for vehicles with double disc clutch enthält eine Kupplungsscheibe / This part number includes one clutch disc	(47) (47) (51) (45)
				<b>1862 718 002 ▽#</b>	240CC (26x32-10N)	für / for: SA35334 01 für / for: SA35452 01 für Fahrzeuge mit Zweischeibenkupplung / for vehicles with double disc clutch Lose Kupplungsscheibe / Loose clutch disc	(47) (47) (51) (30)
				<b>1863 869 010</b>	15/35/11	Kugellager / Ball Bearing	(28)
<b>U 52</b> 421.122-163 <b>U 60,T</b> 421.122-163				<b>1882 231 131 #</b>	G250		
				<b>1861 840 133 #</b>	250TPZ (26x32-10N)		
				<b>1863 840 001</b>	55/90/18	ohne Anlauftring / without thrust ring	(79)
				<b>1888 893 001 #</b>	DOT240 (225/45x50-24N)	<b>Chass. 002949 - Chass. 166589</b> enthält eine Kupplungsscheibe / This part number includes one clutch disc	(45)
				<b>1862 718 002 ▽#</b>	240CC (26x32-10N)	<b>Chass. 002949 - Chass. 166589</b> Lose Kupplungsscheibe / Loose clutch disc	(30)
				<b>1863 837 003</b>	65/100/18	<b>Chass. 002949 - Chass. 166589</b> ohne Anlauftring / without thrust ring	(79)
<b>U 54</b> 403.120/121	04.66 - 03.72	OM314.916		<b>1888 877 101 #</b>	DOT280 (Ge 280/45x50-24N) (Mo 280/26x32-10N)	für Fahrzeuge mit Zweischeibenkupplung / for vehicles with double disc clutch enthält zwei Kupplungsscheiben / This part number includes both clutch discs	(51) (46)
				<b>1882 229 131 #</b>	G280	<b>-&gt;Chass. 088736</b>	
				<b>1861 518 031 #</b>	280BDC (26x32-10N)	<b>-&gt;Chass. 088736</b> Anzahl der Beläge / Number of pads: 6	(7)
				<b>1861 611 131 ●#</b>	280B/ Z (26x32-10N)	<b>-&gt;Chass. 088736</b>	
				<b>1863 840 001</b>	55/90/18	<b>-&gt;Chass. 088736</b> ohne Anlauftring / without thrust ring	(79)
				<b>3482 008 032</b>	MF310	<b>Chass. 088737-&gt;</b>	
				<b>1861 384 334 #</b>	310GSZ (26x32-10N)	<b>Chass. 088737-&gt;</b>	
				<b>1863 840 001</b>	55/90/18	<b>Chass. 088737-&gt;</b> ohne Anlauftring / without thrust ring	(79)
<b>U 55,T</b> 421.130/131				<b>1882 231 131 #</b>	G250		
				<b>1861 840 133 #</b>	250TPZ (26x32-10N)		
				<b>1863 840 001</b>	55/90/18	ohne Anlauftring / without thrust ring	(79)





























# MERCEDES-BENZ

## Unimog 32-100





















<b>U 65 T, U 70 T</b> 406.130/131	01.62 - 01.88	OM352.919	<b>1888 877 101 #</b>	DOT280 (Ge 280/45x50-24N) (Mo 280/26x32-10N)	<b>Chass. 009059 - Chass. 088736</b> 406.130 enthält zwei Kupplungsscheiben / This part number includes both clutch discs	(46)	
			<b>1882 229 131 #</b>	G280	-> <b>Chass. 088736</b>		
			<b>1861 518 031 #</b>	280BDC (26x32-10N)	-> <b>Chass. 088736</b> Anzahl der Beläge / Number of pads: 6	(7)	
			<b>1861 611 131 ●#</b>	280B/ Z (26x32-10N)	-> <b>Chass. 088736</b>		
			<b>1863 840 001</b>	55/90/18	-> <b>Chass. 088736</b> ohne Anlauftring / without thrust ring	(79)	
			<b>3482 008 032</b>	MF310	<b>Chass. 088737-&gt;</b>		
			<b>1861 384 334 #</b>	310GSZ (26x32-10N)	<b>Chass. 088737-&gt;</b>		
			<b>1863 840 001</b>	55/90/18	<b>Chass. 088737-&gt;</b> ohne Anlauftring / without thrust ring	(79)	
<b>U 65, U 70</b> 406.121 406.120 <b>U 65, U 70</b> 406.120/121	01.62 - 01.88	OM352.919, OM312.954	<b>1888 877 101 #</b>	DOT280 (Ge 280/45x50-24N) (Mo 280/26x32-10N)	<b>Chass. 009059 - Chass. 088736</b> für Fahrzeuge mit Zweis Scheibenkupplung / for vehicles with double disc clutch enthält zwei Kupplungsscheiben / This part number includes both clutch discs	(51) (46)	
			<b>1882 229 131 #</b>	G280	-> <b>Chass. 088736</b>		
			<b>1861 518 031 #</b>	280BDC (26x32-10N)	-> <b>Chass. 088736</b> Anzahl der Beläge / Number of pads: 6	(7)	
			<b>1861 611 131 ●#</b>	280B/ Z (26x32-10N)	-> <b>Chass. 088736</b>		
			<b>1863 840 001</b>	55/90/18	-> <b>Chass. 088736</b> ohne Anlauftring / without thrust ring	(79)	
	01.62 - 01.88			<b>3482 008 032</b>	MF310	<b>Chass. 088737-&gt;</b>	
				<b>1861 384 334 #</b>	310GSZ (26x32-10N)	<b>Chass. 088737-&gt;</b>	
				<b>1863 840 001</b>	55/90/18	<b>Chass. 088737-&gt;</b> ohne Anlauftring / without thrust ring	(79)
				<b>1888 877 102 #</b>	DOT280 (280/45x50-24N)	<b>Chass. 088737-&gt;</b> für Fahrzeuge mit Zweis Scheibenkupplung / for vehicles with double disc clutch enthält eine Kupplungsscheibe / This part number includes one clutch disc	(51) (45)
				<b>1861 966 141 ▽#</b>	280GSPDCE/ CERAM (26x32-10N)	<b>Chass. 088737-&gt;</b> für Fahrzeuge mit Zweis Scheibenkupplung / for vehicles with double disc clutch Lose Kupplungsscheibe / Loose clutch disc	(51) (30)
			<b>1863 837 003</b>	65/100/18	<b>Chass. 088737-&gt;</b> für Fahrzeuge mit Zweis Scheibenkupplung / for vehicles with double disc clutch ohne Anlauftring / without thrust ring	(51) (79)	

# MERCEDES-BENZ

Unimog 32-100							
<b>U 66, U 72</b> 403.122/123	03.69 - 01.88	OM314.917		<b>1882 229 131 #</b>	G280	->Chass. 088736	
				<b>1861 518 031 #</b>	280BDC (26x32-10N)	->Chass. 088736 Anzahl der Beläge / Number of pads: 6	(7)
				<b>1861 611 131 ●#</b>	280B/ Z (26x32-10N)	->Chass. 088736	
				<b>1863 840 001</b>	55/90/18	->Chass. 088736 ohne Anlauftring / without thrust ring	(79)
				<b>3482 008 032</b>	MF310	Chass. 088737->	
				<b>1861 384 334 #</b>	310GSZ (26x32-10N)	Chass. 088737->	
				<b>1863 840 001</b>	55/90/18	Chass. 088737-> ohne Anlauftring / without thrust ring	(79)
				<b>1888 877 101 #</b>	DOT280 (Ge 280/45x50-24N) (Mo 280/26x32-10N)	Chass. 000760 - Chass. 088736 enthält zwei Kupplungsscheiben / This part number includes both clutch discs	(46)
				<b>1888 877 102 #</b>	DOT280 (280/45x50-24N)	Chass. 088737-> enthält eine Kupplungsscheibe / This part number includes one clutch disc	(45)
				<b>1861 966 141 ▽#</b>	280GSPDCE/ CERAM (26x32-10N)	Chass. 088737-> Lose Kupplungsscheibe / Loose clutch disc	(30)
	<b>1863 837 003</b>	65/100/18	Chass. 088737-> ohne Anlauftring / without thrust ring	(79)			
<b>U 72, U 80</b> 413.111 413.110	01.69 - 01.77	OM314.917		<b>1882 229 131 #</b>	G280	->Chass. 088736	
				<b>1861 518 031 #</b>	280BDC (26x32-10N)	->Chass. 088736 Anzahl der Beläge / Number of pads: 6	(7)
				<b>1861 611 131 ●#</b>	280B/ Z (26x32-10N)	->Chass. 088736	
				<b>1863 840 001</b>	55/90/18	->Chass. 088736 ohne Anlauftring / without thrust ring	(79)
				<b>3482 008 032</b>	MF310	Chass. 088737->	
				<b>1861 384 334 #</b>	310GSZ (26x32-10N)	Chass. 088737->	
				<b>1863 840 001</b>	55/90/18	Chass. 088737-> ohne Anlauftring / without thrust ring	(79)
				<b>1888 877 101 #</b>	DOT280 (Ge 280/45x50-24N) (Mo 280/26x32-10N)	->Chass. 088736 enthält zwei Kupplungsscheiben / This part number includes both clutch discs	(46)
<b>U 80 T, U 90 T</b> 416.130 416.133 406.133	05.66 -	OM352.903, OM352.984		<b>1882 229 131 #</b>	G280	->Chass. 088736	
				<b>1861 518 031 #</b>	280BDC (26x32-10N)	->Chass. 088736 Anzahl der Beläge / Number of pads: 6	(7)
				<b>1861 611 131 ●#</b>	280B/ Z (26x32-10N)	->Chass. 088736	
				<b>1863 840 001</b>	55/90/18	->Chass. 088736 ohne Anlauftring / without thrust ring	(79)
				<b>3482 008 032</b>	MF310	Chass. 088737->	
				<b>1861 384 334 #</b>	310GSZ (26x32-10N)	Chass. 088737->	
	<b>1863 840 001</b>	55/90/18	Chass. 088737-> ohne Anlauftring / without thrust ring	(79)			

# MERCEDES-BENZ

## Unimog 32-100

<b>U 80, U 84, U 90</b> 416.124-126 416.123 406.121 416.122 416.127	05.69 - 01.88	OM352.903, OM353.902		<b>1888 877 101 #</b>	DOT280 (Ge 280/45x50-24N) (Mo 280/26x32-10N)	<b>Chass. 009059 - Chass. 088736</b> 406.121 für Fahrzeuge mit Zweischeibenkupplung / for vehicles with double disc clutch enthält zwei Kupplungsscheiben / This part number includes both clutch discs	(51) (46)
				<b>1882 229 131 #</b>	G280	<b>-&gt;Chass. 088736</b> 406.121/122-125	
				<b>1861 518 031 #</b>	280BDC (26x32-10N)	<b>-&gt;Chass. 088736</b> 406.121/122-125 Anzahl der Beläge / Number of pads: 6	(7)
				<b>1861 611 131 ●#</b>	280B/ Z (26x32-10N)	<b>-&gt;Chass. 088736</b> 406.121/122-125	
				<b>1863 840 001</b>	55/90/18	<b>-&gt;Chass. 088736</b> 406.121/122-125 ohne Anlauftring / without thrust ring	(79)
				<b>3482 008 032</b>	MF310	<b>Chass. 088737-&gt;</b> 406.121/122-125	
				<b>1861 384 334 #</b>	310GSZ (26x32-10N)	<b>Chass. 088737-&gt;</b> 406.121/122-125	
				<b>1863 840 001</b>	55/90/18	<b>Chass. 088737-&gt;</b> 406.121/122-125 ohne Anlauftring / without thrust ring	(79)
				<b>1888 877 102 #</b>	DOT280 (280/45x50-24N)	<b>Chass. 088737-&gt;</b> 406.121 für Fahrzeuge mit Zweischeibenkupplung / for vehicles with double disc clutch enthält eine Kupplungsscheibe / This part number includes one clutch disc	(51) (45)
				<b>1861 966 141 ▽#</b>	280GSPDCE/ CERAM (26x32-10N)	<b>Chass. 088737-&gt;</b> 406.121 für Fahrzeuge mit Zweischeibenkupplung / for vehicles with double disc clutch Lose Kupplungsscheibe / Loose clutch disc	(51) (30)
				<b>1863 837 003</b>	65/100/18	<b>Chass. 088737-&gt;</b> 406.121 für Fahrzeuge mit Zweischeibenkupplung / for vehicles with double disc clutch ohne Anlauftring / without thrust ring	(51) (79)
				<b>1882 229 131 #</b>	G280	<b>-&gt;Chass. 003772</b> 406.126-127	
				<b>1861 518 031 #</b>	280BDC (26x32-10N)	<b>-&gt;Chass. 003772</b> 406.126-127 Anzahl der Beläge / Number of pads: 6	(7)
				<b>1861 611 131 ●#</b>	280B/ Z (26x32-10N)	<b>-&gt;Chass. 003772</b> 406.126-127	
				<b>1863 840 001</b>	55/90/18	<b>-&gt;Chass. 003772</b> 406.126-127 ohne Anlauftring / without thrust ring	(79)
				<b>1882 282 331</b>	GFX310	<b>Chass. 003773 - Chass. 088736</b> 406.126-127 Nur bei Altteil-Rückgabe lieferbar (Reparatur; Werk Bielefeld) / Please return old unit for repair (plant Bielefeld)	(33)
	<b>1861 384 334 #</b>	310GSZ (26x32-10N)	<b>Chass. 003773 - Chass. 088736</b> 406.126-127				
	<b>1863 840 001</b>	55/90/18	<b>Chass. 003773 - Chass. 088736</b> 406.126-127 ohne Anlauftring / without thrust ring	(79)			
<b>U 84</b> 406.143 406.145 406.142				<b>1882 282 331</b>	GFX310	<b>Chass. 003773 - Chass. 088736</b> Nur bei Altteil-Rückgabe lieferbar (Reparatur; Werk Bielefeld) / Please return old unit for repair (plant Bielefeld)	(33)
				<b>1861 384 334 #</b>	310GSZ (26x32-10N)	<b>Chass. 003773 - Chass. 088736</b>	
				<b>1863 840 001</b>	55/90/18	<b>Chass. 003773 - Chass. 088736</b> ohne Anlauftring / without thrust ring	(79)



# MERCEDES-BENZ

Unimog 32-100						
U 84 (406)			⊗	1888 067 042 #	DUT330/ 310 (310/41x45-22N)	enthält eine Kupplungsscheibe / This part number includes one clutch disc enthält Druckplattenbefestigungsschrauben / includes bolt for pressure plate mounting (45) (44)
			⊗	1861 741 042 ▽#	327GSDC (36x40-20N)	Anzahl der Beläge / Number of pads: 8 Lose Kupplungsscheibe / Loose clutch disc (7) (30)
			⊙	1863 837 002	65/97/23	mit Anlauftring / with thrust ring (63)
			⊙	1863 855 000	106/140/25	mit Anlauftring / with thrust ring (63)
U 90 408.101	07.96-	OM602	⊗	3082 269 031	M250	408.101
			⌘	3182 002 132	HHIS-3	408.101 Immer erneuern / Renew everytime (22)
U 94 403.120-123			⊗	1888 877 101 #	DOT280 (Ge 280/45x50-24N) (Mo 280/26x32-10N)	<b>Chass. 000760 - Chass. 088736</b> enthält zwei Kupplungsscheiben / This part number includes both clutch discs (46)

Unimog 100-500						
411	01.52-		⊗	1881 089 009 ▲	K225	
			⊗	1862 088 131	225B/ Z (26x32-10N)	Nur bei Alteil-Rückgabe lieferbar (Reparatur; Werk Bielefeld) / Please return old unit for repair (plant Bielefeld) (33)
			⊙	1859 600 001		
			⌘	1805 042 000		
S	01.54-		⊗	1862 088 131	225B/ Z (26x32-10N)	Nur bei Alteil-Rückgabe lieferbar (Reparatur; Werk Bielefeld) / Please return old unit for repair (plant Bielefeld) (33)
			⊙	3151 021 001		
			⌘	3130 010 100		
U 100,L,T 416.122-163 U 110,L,T 416.122-163 U 125 416.122-163			⊗	3482 008 032	MF310	<b>Chass. 088737-&gt;</b>
			⊗	1861 384 334 #	310GSZ (26x32-10N)	<b>Chass. 088737-&gt;</b>
			⊙	1863 840 001	55/90/18	<b>Chass. 088737-&gt;</b> ohne Anlauftring / without thrust ring (79)

























# MERCEDES-BENZ





















Unimog 100-500						
<b>U 100,L,T</b> 416.140-163 416.114-117 416.160 416.122-125 416.134 416.130-135				<b>1882 229 131 #</b> G280	<b>-&gt;Chass. 088736</b> 416.122-125/130-135/160	
				<b>1861 611 131 ●#</b> 280B/ Z (26x32-10N)	<b>-&gt;Chass. 088736</b> 416.122-125/130-135/160	
				<b>1861 518 031 #</b> 280BDC (26x32-10N)	<b>-&gt;Chass. 088736</b> 416.122-125/130-135/160 Anzahl der Beläge / Number of pads: 6	(7)
				<b>1863 840 001</b> 55/90/18	ohne Anlauftring / without thrust ring	(79)
				<b>1882 282 331</b> GFX310	<b>-&gt;Chass. 088736</b> 416.114-117/140-163 Nur bei Altteil-Rückgabe lieferbar (Reparatur; Werk Bielefeld) / Please return old unit for repair (plant Bielefeld)	(33)
				<b>1861 384 334 #</b> 310GSZ (26x32-10N)	<b>-&gt;Chass. 088736</b> 416.114-117/140-163	
				<b>1863 840 001</b> 55/90/18	<b>-&gt;Chass. 088736</b> 416.122-125/130-135/160/114-117/140-163 ohne Anlauftring / without thrust ring	(79)
				<b>1888 877 101 #</b> DOT280 (Ge 280/45x50-24N) (Mo 280/26x32-10N)	<b>Chass. 000562 - Chass. 088736</b> 416.114-117/134-135/140-163 enthält zwei Kupplungsscheiben / This part number includes both clutch discs	(46)
				<b>1888 877 102 #</b> DOT280 (280/45x50-24N)	<b>Chass. 088737 - Chass. 166589</b> 416.114-117/134-135/140-163 enthält eine Kupplungsscheibe / This part number includes one clutch disc	(45)
				<b>1888 877 103 #</b> DOT280 (280/45x50-24N)	<b>Chass. 166590-&gt;</b> 416.114-117/134-135/140-163 enthält eine Kupplungsscheibe / This part number includes one clutch disc	(45)
	<b>1861 966 141 ▽#</b> 280GSPDCE/ CERAM (26x32-10N)	<b>Chass. 088737-&gt;</b> 416.114-117/134-135/140-163 Lose Kupplungsscheibe / Loose clutch disc	(30)			
<b>U 100L</b> 408.215	11.92-	OM602		<b>3082 157 031</b> M240	408.215	
				<b>3151 069 032</b>	408.215	
<b>U 100L</b> 408.216	07.96-	OM602LA		<b>3082 269 031</b> M250	408.216	
				<b>3151 069 032</b>	408.216	
<b>U 110,L,T</b> 416.141 416.140				<b>1882 231 131 #</b> G250		
				<b>1861 840 133 #</b> 250TPZ (26x32-10N)		
				<b>1863 840 001</b> 55/90/18	ohne Anlauftring / without thrust ring	(79)















# MERCEDES-BENZ

Unimog 100-500							
<b>U 110,L,T</b> 416.122-125 416.140-163 416.134 416.130-135 416.114-117 416.160 416.135				<b>1882 229 131 #</b>	G280	-> <b>Chass. 088736</b> 416.122-125/130-135/160	
				<b>1861 518 031 #</b>	280BDC (26x32-10N)	-> <b>Chass. 088736</b> 416.122-125/130-135/160 Anzahl der Beläge / Number of pads: 6	(7)
				<b>1861 611 131 ●#</b>	280B/ Z (26x32-10N)	-> <b>Chass. 088736</b> 416.122-125/130-135/160	
				<b>1863 840 001</b>	55/90/18	-> <b>Chass. 088736</b> 416.114-117/140-163 ohne Anlauftring / without thrust ring	(79)
				<b>1882 282 331</b>	GFX310	-> <b>Chass. 088736</b> 416.114-117/140-163 Nur bei Altteil-Rückgabe lieferbar (Reparatur; Werk Bielefeld) / Please return old unit for repair (plant Bielefeld)	(33)
				<b>1861 384 334 #</b>	310GSZ (26x32-10N)	-> <b>Chass. 088736</b> 416.114-117/140-163	
				<b>1863 840 001</b>	55/90/18	-> <b>Chass. 088736</b> 416.122-125/130-135/160/114-117/140-163 ohne Anlauftring / without thrust ring	(79)
				<b>1888 877 102 #</b>	DOT280 (280/45x50-24N)	<b>Chass. 088737 - Chass. 166589</b> 416.114-117/134-135/140-163 enthält eine Kupplungsscheibe / This part number includes one clutch disc	(45)
				<b>1888 877 103 #</b>	DOT280 (280/45x50-24N)	<b>Chass. 166590-&gt;</b> 416.114-117/134-135/140-163 enthält eine Kupplungsscheibe / This part number includes one clutch disc	(45)
				<b>1861 966 141 ▽#</b>	280GSPDCE/ CERAM (26x32-10N)	416.114-117/134-135/140-163 Lose Kupplungsscheibe / Loose clutch disc	(30)
				<b>1888 067 042 #</b>	DUT330/ 310 (310/41x45-22N)	enthält eine Kupplungsscheibe / This part number includes one clutch disc enthält Druckplattenbefestigungsschrauben / includes bolt for pressure plate mounting	(45) (44)
				<b>1861 741 042 ▽#</b>	327GSDC (36x40-20N)	Anzahl der Beläge / Number of pads: 8 Lose Kupplungsscheibe / Loose clutch disc	(7) (30)
				<b>1863 837 002</b>	65/97/23	mit Anlauftring / with thrust ring	(63)
				<b>1863 855 000</b>	106/140/25	mit Anlauftring / with thrust ring	(63)
<b>U 110,U 110L</b> 418.100 418.115	02.92 -	OM364.958, OM364.955		<b>3482 012 211</b>	GMF330		
				<b>3182 002 131</b>	HHIS-3	Immer erneuern / Renew everytime	(22)
				<b>1888 998 201 #</b>	DUT330 (310/45x50-24N)	für Fahrzeuge mit Niederdruck-Bremsanlage / for vehicles with low-pressure brakesystem enthält eine Kupplungsscheibe / This part number includes one clutch disc	(49) (45)
				<b>1888 067 031 #</b>	DUT330 (310/45x50-24N)	<b>Chass. 183541-&gt;</b> enthält eine Kupplungsscheibe / This part number includes one clutch disc	(45)
<b>U 120</b> <b>U 125 (425)</b> <b>U 150 (425)</b>				<b>1888 067 042 #</b>	DUT330/ 310 (310/41x45-22N)	enthält eine Kupplungsscheibe / This part number includes one clutch disc enthält Druckplattenbefestigungsschrauben / includes bolt for pressure plate mounting	(45) (44)
				<b>1861 741 042 ▽#</b>	327GSDC (36x40-20N)	Anzahl der Beläge / Number of pads: 8 Lose Kupplungsscheibe / Loose clutch disc	(7) (30)
				<b>1863 837 002</b>	65/97/23	mit Anlauftring / with thrust ring	(63)
				<b>1863 855 000</b>	106/140/25	mit Anlauftring / with thrust ring	(63)

# MERCEDES-BENZ













Unimog 100-500							
<b>U 125</b> 416.114-117 416.140-163 416.135 416.134				<b>1882 282 331</b>	GFX310	-> <b>Chass. 088736</b> 416.114-117/140-163 Nur bei Altteil-Rückgabe lieferbar (Reparatur; Werk Bielefeld) / Please return old unit for repair (plant Bielefeld)	(33)
				<b>1861 384 334 #</b>	310GSZ (26x32-10N)	-> <b>Chass. 088736</b> 416.114-117/140-163	
				<b>1863 840 001</b>	55/90/18	-> <b>Chass. 088736</b> 416.114-117/140-163 ohne Anlauftring / without thrust ring	(79)
				<b>1888 877 101 #</b>	DOT280 (Ge 280/45x50-24N) (Mo 280/26x32-10N)	<b>Chass. 000562 - Chass. 088736</b> 416.114-117/134-135/140-163 enthält zwei Kupplungsscheiben / This part number includes both clutch discs	(46)
				<b>1888 877 102 #</b>	DOT280 (280/45x50-24N)	<b>Chass. 088737 - Chass. 166589</b> 416.114-117/134-135/140-163 enthält eine Kupplungsscheibe / This part number includes one clutch disc	(45)
				<b>1888 877 103 #</b>	DOT280 (280/45x50-24N)	<b>Chass. 166590-&gt;</b> 416.114-117/134-135/140-163 enthält eine Kupplungsscheibe / This part number includes one clutch disc	(45)
				<b>1861 966 141 ▽#</b>	280GSPDCE/ CERAM (26x32-10N)	416.114-117/134-135/140-163 Lose Kupplungsscheibe / Loose clutch disc	(30)
<b>U 130,U 140</b> 418.102 <b>U 140T</b> 418.000	07.92 -  07.92 -	OM364.985, OM364.982		<b>3482 012 211</b>	GMF330	für Fahrzeuge mit Einscheibenkupplung / for vehicles with single disc clutch	(48)
				<b>3182 002 131</b>	HHIS-3	für Fahrzeuge mit Einscheibenkupplung / for vehicles with single disc clutch Immer erneuern / Renew everytime	(48) (22)
				<b>1888 998 201 #</b>	DUT330 (310/45x50-24N)	-> <b>Chass. 183540</b> für Fahrzeuge mit Niederdruck-Bremsanlage / for vehicles with low-pressure brakesystem enthält eine Kupplungsscheibe / This part number includes one clutch disc	(49) (45)
				<b>3182 002 131</b>	HHIS-3	Immer erneuern / Renew everytime	(22)
				<b>1888 067 031 #</b>	DUT330 (310/45x50-24N)	enthält eine Kupplungsscheibe / This part number includes one clutch disc Sonderausführung / Special design	(45) (39)
				<b>1888 998 201 #</b>	DUT330 (310/45x50-24N)	für Fahrzeuge mit Niederdruck-Bremsanlage / for vehicles with low-pressure brakesystem enthält eine Kupplungsscheibe / This part number includes one clutch disc Sonderausführung / Special design	(49) (45) (39)
				<b>3182 003 131</b>	HHIS-3	Sonderausführung / Special design Immer erneuern / Renew everytime	(39) (22)
<b>U 140L</b> 418.117 418.237 418.217	07.92 -	OM364.985		<b>3482 012 211</b>	GMF330	418.117 für Fahrzeuge mit Einscheibenkupplung / for vehicles with single disc clutch	(48)
				<b>3182 002 131</b>	HHIS-3	418.117 für Fahrzeuge mit Einscheibenkupplung / for vehicles with single disc clutch Immer erneuern / Renew everytime	(48) (22)
				<b>1888 998 201 #</b>	DUT330 (310/45x50-24N)	-> <b>Chass. 183540</b> 418.117 für Fahrzeuge mit Niederdruck-Bremsanlage / for vehicles with low-pressure brakesystem enthält eine Kupplungsscheibe / This part number includes one clutch disc	(49) (45)
				<b>3182 002 131</b>	HHIS-3	418.117 Immer erneuern / Renew everytime	(22)
				<b>1888 067 031 #</b>	DUT330 (310/45x50-24N)	418.117 enthält eine Kupplungsscheibe / This part number includes one clutch disc Sonderausführung / Special design	(45) (39)
				<b>1888 998 201 #</b>	DUT330 (310/45x50-24N)	418.117 für Fahrzeuge mit Niederdruck-Bremsanlage / for vehicles with low-pressure brakesystem enthält eine Kupplungsscheibe / This part number includes one clutch disc Sonderausführung / Special design	(49) (45) (39)
				<b>3182 003 131</b>	HHIS-3	418.117 Sonderausführung / Special design	(39)

# MERCEDES-BENZ

Unimog 100-500								
<b>U 216</b> 405.090 <b>U 218</b> 405.090	05.13-	OM934		<b>3182 600 101</b>	HHIS-3	405.090 mit Sensor / with sensor Füllmedium: Bremsflüssigkeit / Fill Medium: Brake Fluid Immer erneuern / Renew everytime	(69) (18) (22)	
	05.13-				<b>1863 869 044</b>	25/55/15	405.090	
<b>U 300</b> 405.100/101	03.00-	OM904.927		<b>3482 000 462</b>	MF362	für Fahrzeuge mit Einscheibenkupplung / for vehicles with single disc clutch	(48)	
					<b>1878 600 560</b>	360CBC (36x40-18N)	für Fahrzeuge mit Einscheibenkupplung / for vehicles with single disc clutch Anzahl der Beläge / Number of pads: 9	(48) (7)
					<b>3182 600 101</b>	HHIS-3	für Fahrzeuge mit Einscheibenkupplung / for vehicles with single disc clutch mit Sensor / with sensor Füllmedium: Bremsflüssigkeit / Fill Medium: Brake Fluid Immer erneuern / Renew everytime	(48) (69) (18) (22)
					<b>3400 127 701</b> ●● <b>3482 000 462</b> <b>1878 052 842</b>	MF362 362WGTB	für Fahrzeuge mit Einscheibenkupplung / for vehicles with single disc clutch	(48)
					<b>1878 001 939</b> HD●	362WGTB (36x40-18N)	für Fahrzeuge mit Einscheibenkupplung / for vehicles with single disc clutch	(48)
					<b>3400 710 008</b> ● <b>3482 000 462</b> <b>1878 052 842</b> <b>3182 600 101</b>	MF362 362WGTB HHIS-3	für Fahrzeuge mit Einscheibenkupplung / for vehicles with single disc clutch mit Sensor / with sensor Füllmedium: Bremsflüssigkeit / Fill Medium: Brake Fluid	(48) (69) (18)
					<b>1888 916 001</b> #	DUT350 (330/45x50-24N)	für Fahrzeuge mit Zweischeibenkupplung / for vehicles with double disc clutch enthält eine Kupplungsscheibe / This part number includes one clutch disc	(51) (45)
					<b>1878 992 401</b> #	350GSDC (36x40-20N)	für Fahrzeuge mit Zweischeibenkupplung / for vehicles with double disc clutch Anzahl der Beläge / Number of pads: 8	(51) (7)
					<b>1863 837 002</b>	65/97/23	für Fahrzeuge mit Zweischeibenkupplung / for vehicles with double disc clutch mit Anlauftring / with thrust ring	(51) (63)
					<b>1863 855 000</b>	106/140/25	für Fahrzeuge mit Zweischeibenkupplung / for vehicles with double disc clutch mit Anlauftring / with thrust ring	(51) (63)
	904.927		<b>2300 146 031</b>		nur als Ersatz für angegebene OE-Nr. / only for the listed OE-Numbers	(77)		

























					Parameter		
---	--	--	--	--	-----------	---	---

# MERCEDES-BENZ

Unimog 100-500							
U 300 405.121 405.120	03.00 -	OM904.928		<b>3482 000 462</b>	MF362	für Fahrzeuge mit Einscheibenkupplung / for vehicles with single disc clutch	(48)
				<b>1878 600 560</b>	360CBC (36x40-18N)	für Fahrzeuge mit Einscheibenkupplung / for vehicles with single disc clutch Anzahl der Beläge / Number of pads: 9	(48) (7)
				<b>3182 600 101</b>	HHIS-3	für Fahrzeuge mit Einscheibenkupplung / for vehicles with single disc clutch mit Sensor / with sensor Füllmedium: Bremsflüssigkeit / Fill Medium: Brake Fluid Immer erneuern / Renew everytime	(48) (69) (18) (22)
				<b>3400 127 701</b> ●	MF362 362WGTB	für Fahrzeuge mit Einscheibenkupplung / for vehicles with single disc clutch	(48)
				<b>1878 001 939</b> HD●	362WGTB (36x40-18N)	für Fahrzeuge mit Einscheibenkupplung / for vehicles with single disc clutch	(48)
				<b>3400 710 008</b> ●	MF362 362WGTB HHIS-3	für Fahrzeuge mit Einscheibenkupplung / for vehicles with single disc clutch mit Sensor / with sensor Füllmedium: Bremsflüssigkeit / Fill Medium: Brake Fluid	(48) (69) (18)
				<b>1888 916 001</b> #	DUT350 (330/45x50-24N)	für Fahrzeuge mit Zweischeibenkupplung / for vehicles with double disc clutch enthält eine Kupplungsscheibe / This part number includes one clutch disc	(51) (45)
				<b>1878 992 401</b> #	350GSDC (36x40-20N)	für Fahrzeuge mit Zweischeibenkupplung / for vehicles with double disc clutch Anzahl der Beläge / Number of pads: 8	(51) (7)
				<b>1863 837 002</b>	65/97/23	für Fahrzeuge mit Zweischeibenkupplung / for vehicles with double disc clutch mit Anlauftring / with thrust ring	(51) (63)
				<b>1863 855 000</b>	106/140/25	für Fahrzeuge mit Zweischeibenkupplung / for vehicles with double disc clutch mit Anlauftring / with thrust ring	(51) (63)
		904.928		<b>2300 146 031</b>		nur als Ersatz für angegebene OE-Nr. / only for the listed OE-Numbers	(77)
U 318 405.104	05.13 -	OM934		<b>3182 600 101</b>	HHIS-3	405.104 mit Sensor / with sensor Füllmedium: Bremsflüssigkeit / Fill Medium: Brake Fluid Immer erneuern / Renew everytime	(69) (18) (22)
				<b>1863 869 044</b>	25/55/15	405.104	

# MERCEDES-BENZ

## Unimog 100-500

<b>U 400</b> 405.103 405.102	03.00-	OM904.928		<b>3482 000 462</b>	MF362		
				<b>1878 600 560</b>	360CBC (36x40-18N)	Anzahl der Beläge / Number of pads: 9	(7)
				<b>3182 600 101</b>	HHIS-3	mit Sensor / with sensor Füllmedium: Bremsflüssigkeit / Fill Medium: Brake Fluid Immer erneuern / Renew everytime	(69) (18) (22)
				<b>3400 127 701</b> ●● <b>3482 000 462</b> <b>1878 052 842</b>	MF362 362WGTB		
				<b>3400 700 484</b> HD●● <b>3482 000 462</b> <b>1878 001 939</b>	MF362 362WGTB		
				<b>3400 710 008</b> ● <b>3482 000 462</b> <b>1878 052 842</b> <b>3182 600 101</b>	MF362 362WGTB HHIS-3	mit Sensor / with sensor Füllmedium: Bremsflüssigkeit / Fill Medium: Brake Fluid	(69) (18)
				<b>1888 916 001</b> #	DUT350 (330/45x50-24N)	für Fahrzeuge mit Zweis Scheibenkupplung / for vehicles with double disc clutch enthält eine Kupplungsscheibe / This part number includes one clutch disc	(51) (45)
				<b>1878 992 401</b> #	350GSDC (36x40-20N)	für Fahrzeuge mit Zweis Scheibenkupplung / for vehicles with double disc clutch Anzahl der Beläge / Number of pads: 8	(51) (7)
				<b>1863 837 002</b>	65/97/23	für Fahrzeuge mit Zweis Scheibenkupplung / for vehicles with double disc clutch mit Anlauffring / with thrust ring	(51) (63)
				<b>1863 855 000</b>	106/140/25	für Fahrzeuge mit Zweis Scheibenkupplung / for vehicles with double disc clutch mit Anlauffring / with thrust ring	(51) (63)
	OM906		<b>3151 000 396</b>		für OE-Nummer / for OE number 001 250 99 15 für OE-Nummer / for OE number 002 250 00 15	(58) (58)	
	904.928		<b>2300 146 031</b>		nur als Ersatz für angegebene OE-Nr. / only for the listed OE-Numbers	(77)	
<b>U 400</b> 405.122/123 <b>U 500, UGN NA</b> 405.200 405.210 405.230 405.201 405.221	03.00-	OM906.935		<b>3482 000 463</b>	MF395		
				<b>1878 600 560</b>	360CBC (36x40-18N)	Anzahl der Beläge / Number of pads: 9	(7)
				<b>1878 052 842</b> ●	362WGTB (36x40-18N)		
				<b>1878 001 939</b> HD●	362WGTB (36x40-18N)		
				<b>3182 600 101</b>	HHIS-3	mit Sensor / with sensor Füllmedium: Bremsflüssigkeit / Fill Medium: Brake Fluid Immer erneuern / Renew everytime	(69) (18) (22)
				<b>1888 916 001</b> #	DUT350 (330/45x50-24N)	für Fahrzeuge mit Zweis Scheibenkupplung / for vehicles with double disc clutch enthält eine Kupplungsscheibe / This part number includes one clutch disc	(51) (45)
				<b>1878 992 401</b> #	350GSDC (36x40-20N)	für Fahrzeuge mit Zweis Scheibenkupplung / for vehicles with double disc clutch Anzahl der Beläge / Number of pads: 8	(51) (7)
				<b>1863 837 002</b>	65/97/23	für Fahrzeuge mit Zweis Scheibenkupplung / for vehicles with double disc clutch mit Anlauffring / with thrust ring	(51) (63)
				<b>1863 855 000</b>	106/140/25	für Fahrzeuge mit Zweis Scheibenkupplung / for vehicles with double disc clutch mit Anlauffring / with thrust ring	(51) (63)
				<b>2100 502 010</b>		für / for: SA 505033 23 für / for: SA 505033 37	(47) (47)
		OM906		<b>3151 000 396</b>		für OE-Nummer / for OE number 001 250 99 15 für OE-Nummer / for OE number 002 250 00 15	(58) (58)
		906.935		<b>2300 147 031</b>		nur als Ersatz für angegebene OE-Nr. / only for the listed OE-Numbers	(77)
				<b>2300 146 031</b>		nur als Ersatz für angegebene OE-Nr. / only for the listed OE-Numbers	(77)





















# MERCEDES-BENZ



















## Unimog 100-500

<b>U 423</b> 405.105 <b>U 423 L</b> 405.125	05.13-	OM934		<b>3182 600 101</b>	HHIS-3	405.105 mit Sensor / with sensor Füllmedium: Bremsflüssigkeit / Fill Medium: Brake Fluid Immer erneuern / Renew everytime	(69) (18) (22)
					<b>1863 869 044</b>	25/55/15	405.105
<b>U 427, U 427 L</b> 405.110 405.125 <b>U 430, U 430 L</b> 405.125 405.110	05.13-	OM936		<b>3182 600 101</b>	HHIS-3	405.110 mit Sensor / with sensor Füllmedium: Bremsflüssigkeit / Fill Medium: Brake Fluid Immer erneuern / Renew everytime	(69) (18) (22)
					<b>1863 869 044</b>	25/55/15	405.110
<b>U 500, UGN NA</b> 405.221 405.220 405.201 405.210 405.230	10.00-	OM906.967, OM906.955		<b>3482 000 463</b>	MF395		
				<b>1878 600 560</b>	360CBC (36x40-18N)	Anzahl der Beläge / Number of pads: 9	(7)
				<b>1878 052 842</b> ●	362WGTB (36x40-18N)		
				<b>1878 001 939</b> HD●	362WGTB (36x40-18N)		
				<b>3182 600 101</b>	HHIS-3	mit Sensor / with sensor Füllmedium: Bremsflüssigkeit / Fill Medium: Brake Fluid Immer erneuern / Renew everytime	(69) (18) (22)
				<b>1888 916 001</b> #	DUT350 (330/45x50-24N)	für Fahrzeuge mit Zweis Scheibenkupplung / for vehicles with double disc clutch enthält eine Kupplungsscheibe / This part number includes one clutch disc	(51) (45)
				<b>1878 992 401</b> #	350GSDC (36x40-20N)	für Fahrzeuge mit Zweis Scheibenkupplung / for vehicles with double disc clutch Anzahl der Beläge / Number of pads: 8	(51) (7)
				<b>1863 837 002</b>	65/97/23	für Fahrzeuge mit Zweis Scheibenkupplung / for vehicles with double disc clutch mit Anlauftring / with thrust ring	(51) (63)
				<b>1863 855 000</b>	106/140/25	für Fahrzeuge mit Zweis Scheibenkupplung / for vehicles with double disc clutch mit Anlauftring / with thrust ring	(51) (63)
				<b>3151 000 396</b>		für OE-Nummer / for OE number 001 250 99 15 für OE-Nummer / for OE number 002 250 00 15	(58) (58)
	OM906	906.955		<b>2300 146 031</b>		nur als Ersatz für angegebene OE-Nr. / only for the listed OE-Numbers	(77)
				<b>2300 147 031</b>		nur als Ersatz für angegebene OE-Nr. / only for the listed OE-Numbers	(77)
<b>U S 404</b> 404.115 404.113/114	01.55 - 12.76	M180.953, M180.952		<b>1862 088 131</b>	225B/ Z (26x32-10N)	Nur bei Alteil-Rückgabe lieferbar (Reparatur; Werk Bielefeld) / Please return old unit for repair (plant Bielefeld)	(33)
				<b>3151 021 001</b>			
				<b>1863 869 010</b>	15/35/11	Kugellager / Ball Bearing	(28)
<b>U S 404</b> 404.117	01.68 -	OM615.911		<b>1882 231 131</b> #	G250		
				<b>1861 840 133</b> #	250TPZ (26x32-10N)		
				<b>1863 840 001</b>	55/90/18	ohne Anlauftring / without thrust ring	(79)
				<b>1863 869 010</b>	15/35/11	Kugellager / Ball Bearing	(28)
<b>UX 100H, UX 100M</b> 409.100	09.96-	OM602.981, OM602.989		<b>3000 951 785</b> 3082 269 031 1878 600 501 3151 248 031	M250 250CD KZIS-0		

# MERCEDES-BENZ





















Unimog 500-900							
<b>U 52, U 60, U 600, U 600L</b> 421.141 421.128 421.162 421.140 421.129 421.163 <b>U 60T, U 600T</b> 421.133 421.132	01.77 - 05.88	OM616.911, OM616.931, OM616.915, OM616.932		<b>1882 231 131 #</b>	G250		
	01.77 - 05.88			<b>1861 840 133 #</b>	250TPZ (26x32-10N)		
				<b>1863 840 001</b>	55/90/18	ohne Anlauffring / without thrust ring	(79)
				<b>1888 893 001 #</b>	DOT240 (225/45x50-24N)	<b>Chass. 002949 - Chass. 166589</b> enthält eine Kupplungsscheibe / This part number includes one clutch disc	(45)
				<b>1862 718 002 ∇#</b>	240CC (26x32-10N)	<b>Chass. 002949 - Chass. 166589</b> Lose Kupplungsscheibe / Loose clutch disc	(30)
				<b>1863 837 003</b>	65/100/18	<b>Chass. 002949 - Chass. 166589</b> ohne Anlauffring / without thrust ring	(79)
				<b>1863 869 010</b>	15/35/11	Kugellager / Ball Bearing	(28)
<b>U 527, U 527 L</b> 405.222 405.202	05.13-	OM936		<b>3182 600 101</b>	HHIS-3	405.202 mit Sensor / with sensor Füllmedium: Bremsflüssigkeit / Fill Medium: Brake Fluid Immer erneuern / Renew everytime	(69) (18) (22)
				<b>1863 869 044</b>	25/55/15	405.202	
<b>U 530, U 530 L</b> 405.202 405.222	05.13-	OM936		<b>3182 600 101</b>	HHIS-3	mit Sensor / with sensor Füllmedium: Bremsflüssigkeit / Fill Medium: Brake Fluid Immer erneuern / Renew everytime	(69) (18) (22)
				<b>1863 869 044</b>	25/55/15		
<b>U 600</b> 407.200	05.88-	OM616.942, OM616.943		<b>1882 231 131 #</b>	G250		
				<b>1861 840 133 #</b>	250TPZ (26x32-10N)		
				<b>1863 840 001</b>	55/90/18	-> <b>Chass. 166588</b> ohne Anlauffring / without thrust ring	(79)
				<b>1863 837 002</b>	65/97/23	<b>Chass. 166589-&gt;</b> mit Anlauffring / with thrust ring	(63)
				<b>1888 893 001 #</b>	DOT240 (225/45x50-24N)	<b>Chass. 002949 - Chass. 166589</b> enthält eine Kupplungsscheibe / This part number includes one clutch disc	(45)
				<b>1862 718 002 ∇#</b>	240CC (26x32-10N)	<b>Chass. 002949 - Chass. 166589</b> Lose Kupplungsscheibe / Loose clutch disc	(30)
				<b>1863 837 003</b>	65/100/18	<b>Chass. 002949 - Chass. 166589</b> ohne Anlauffring / without thrust ring	(79)
	<b>1863 869 010</b>	15/35/11	Kugellager / Ball Bearing	(28)			

# MERCEDES-BENZ























Unimog 500-900							
U 600 407.100	05.88 -	OM616.942, OM616.943		<b>1882 231 131 #</b>	G250	für Fahrzeuge mit Einscheibenkupplung / for vehicles with single disc clutch	(48)
				<b>1861 840 133 #</b>	250TPZ (26x32-10N)	für Fahrzeuge mit Einscheibenkupplung / for vehicles with single disc clutch	(48)
				<b>1863 840 001</b>	55/90/18	für Fahrzeuge mit Einscheibenkupplung / for vehicles with single disc clutch ohne Anlauftring / without thrust ring	(48) (79)
				<b>1888 893 001 #</b>	DOT240 (225/45x50-24N)	->Chass. 166588 enthält eine Kupplungsscheibe / This part number includes one clutch disc Sonderausführung / Special design	(45) (39)
				<b>1862 718 002 ▽#</b>	240CC (26x32-10N)	->Chass. 166588 Lose Kupplungsscheibe / Loose clutch disc Sonderausführung / Special design	(30) (39)
				<b>1863 837 003</b>	65/100/18	->Chass. 166588 Sonderausführung / Special design ohne Anlauftring / without thrust ring	(39) (79)
				<b>1888 600 101 #</b>	DOT240 (225/45x50-24N)	Chass. 166590-> enthält eine Kupplungsscheibe / This part number includes one clutch disc	(45)
				<b>1862 718 002 #</b>	240CC (26x32-10N)	Chass. 166590->	
				<b>1863 837 002</b>	65/97/23	Chass. 166590-> mit Anlauftring / with thrust ring	(63)
				<b>1863 855 000</b>	106/140/25	Chass. 166590-> mit Anlauftring / with thrust ring	(63)
				<b>1863 869 010</b>	15/35/11	Kugellager / Ball Bearing	(28)
U 650,U 650L 407.211 407.210	05.88 -	OM616.942, OM616.943		<b>1882 231 131 #</b>	G250	für Fahrzeuge mit Einscheibenkupplung / for vehicles with single disc clutch	(48)
				<b>1861 840 133 #</b>	250TPZ (26x32-10N)	für Fahrzeuge mit Einscheibenkupplung / for vehicles with single disc clutch	(48)
				<b>1863 840 001</b>	55/90/18	->Chass. 166588 für Fahrzeuge mit Einscheibenkupplung / for vehicles with single disc clutch ohne Anlauftring / without thrust ring	(48) (79)
				<b>1863 837 002</b>	65/97/23	Chass. 166589-> für Fahrzeuge mit Einscheibenkupplung / for vehicles with single disc clutch mit Anlauftring / with thrust ring	(48) (63)
				<b>1888 893 001 #</b>	DOT240 (225/45x50-24N)	->Chass. 166588 Sonderausführung / Special design enthält eine Kupplungsscheibe / This part number includes one clutch disc	(39) (45)
				<b>1862 718 002 ▽#</b>	240CC (26x32-10N)	->Chass. 166588 Lose Kupplungsscheibe / Loose clutch disc Sonderausführung / Special design	(30) (39)
				<b>1863 837 003</b>	65/100/18	->Chass. 166588 Sonderausführung / Special design ohne Anlauftring / without thrust ring	(39) (79)
				<b>1863 869 010</b>	15/35/11	Kugellager / Ball Bearing	(28)



# MERCEDES-BENZ





















Unimog 500-900							
<b>U 650,U 650L</b> 407.111 407.110	05.88 -	OM616.942, OM616.943		<b>1882 231 131 #</b>	G250	für Fahrzeuge mit Einscheibenkupplung / for vehicles with single disc clutch	(48)
				<b>1861 840 133 #</b>	250TPZ (26x32-10N)	für Fahrzeuge mit Einscheibenkupplung / for vehicles with single disc clutch	(48)
				<b>1863 840 001</b>	55/90/18	-> <b>Chass. 166588</b> für Fahrzeuge mit Einscheibenkupplung / for vehicles with single disc clutch ohne Anlauftring / without thrust ring	(48) (79)
				<b>1863 837 002</b>	65/97/23	<b>Chass. 166589-&gt;</b> für Fahrzeuge mit Einscheibenkupplung / for vehicles with single disc clutch mit Anlauftring / with thrust ring	(48) (63)
				<b>1888 893 001 #</b>	DOT240 (225/45x50-24N)	-> <b>Chass. 166588</b> enthält eine Kupplungsscheibe / This part number includes one clutch disc Sonderausführung / Special design	(45) (39)
				<b>1862 718 002 ▽#</b>	240CC (26x32-10N)	-> <b>Chass. 166588</b> Lose Kupplungsscheibe / Loose clutch disc Sonderausführung / Special design	(30) (39)
				<b>1863 837 003</b>	65/100/18	-> <b>Chass. 166588</b> Sonderausführung / Special design ohne Anlauftring / without thrust ring	(39) (79)
				<b>1888 600 101 #</b>	DOT240 (225/45x50-24N)	<b>Chass. 166590-&gt;</b> enthält eine Kupplungsscheibe / This part number includes one clutch disc	(45)
				<b>1862 718 002 #</b>	240CC (26x32-10N)	<b>Chass. 166590-&gt;</b>	
				<b>1863 837 002</b>	65/97/23	<b>Chass. 166590-&gt;</b> mit Anlauftring / with thrust ring	(63)
				<b>1863 855 000</b>	106/140/25	<b>Chass. 166590-&gt;</b> mit Anlauftring / with thrust ring	(63)
				<b>1863 869 010</b>	15/35/11	Kugellager / Ball Bearing	(28)
			<b>U 800</b> 416.114-117 416.140-163 416.134/135				<b>1888 877 101 #</b>
	<b>1888 877 102 #</b>	DOT280 (280/45x50-24N)				<b>Chass. 088737 - Chass. 166589</b> enthält eine Kupplungsscheibe / This part number includes one clutch disc	(45)
	<b>1888 877 103 #</b>	DOT280 (280/45x50-24N)				<b>Chass. 166590-&gt;</b> enthält eine Kupplungsscheibe / This part number includes one clutch disc	(45)
	<b>1861 966 141 ▽#</b>	280GSPDCE/ CERAM (26x32-10N)				Lose Kupplungsscheibe / Loose clutch disc	(30)
<b>U 800,L</b> 403.120-123				<b>1888 877 101 #</b>	DOT280 (Ge 280/45x50-24N) (Mo 280/26x32-10N)	<b>Chass. 000760 - Chass. 088736</b> enthält zwei Kupplungsscheiben / This part number includes both clutch discs	(46)
				<b>1888 877 102 #</b>	DOT280 (280/45x50-24N)	<b>Chass. 088737-&gt;</b> enthält eine Kupplungsscheibe / This part number includes one clutch disc	(45)
				<b>1861 966 141 ▽#</b>	280GSPDCE/ CERAM (26x32-10N)	<b>Chass. 088737-&gt;</b> Lose Kupplungsscheibe / Loose clutch disc	(30)
				<b>1863 837 003</b>	65/100/18	<b>Chass. 088737-&gt;</b> ohne Anlauftring / without thrust ring	(79)

# MERCEDES-BENZ

























Unimog 500-900							
<b>U 800</b> 403.122 417.200	01.77 - 03.90	OM314.917		<b>1882 229 131 #</b>	G280	->Chass. 088736 403.122	
				<b>1861 518 031 #</b>	280BDC (26x32-10N)	->Chass. 088736 403.122 Anzahl der Beläge / Number of pads: 6	(7)
				<b>1861 611 131 ●#</b>	280B/ Z (26x32-10N)	->Chass. 088736 403.122	
				<b>1863 840 001</b>	55/90/18	->Chass. 088736 403.122 ohne Anlauftring / without thrust ring	(79)
				<b>3482 008 032</b>	MF310	Chass. 088737-> 403.122	
				<b>1861 384 334 #</b>	310GSZ (26x32-10N)	Chass. 088737-> 403.122	
				<b>1863 840 001</b>	55/90/18	Chass. 088737-> 403.122 ohne Anlauftring / without thrust ring	(79)
				<b>1888 893 001 #</b>	DOT240 (225/45x50-24N)	403.122 für Fahrzeuge mit Zweischeibenkupplung / for vehicles with double disc clutch enthält eine Kupplungsscheibe / This part number includes one clutch disc	(51) (45)
				<b>1862 718 002 ▽#</b>	240CC (26x32-10N)	403.122 für Fahrzeuge mit Zweischeibenkupplung / for vehicles with double disc clutch Lose Kupplungsscheibe / Loose clutch disc	(51) (30)
				<b>1863 837 003</b>	65/100/18	403.122 für Fahrzeuge mit Zweischeibenkupplung / for vehicles with double disc clutch ohne Anlauftring / without thrust ring	(51) (79)
				<b>3482 008 032</b>	MF310	417.200	
				<b>1861 384 334 #</b>	310GSZ (26x32-10N)	417.200	
				<b>1863 840 001</b>	55/90/18	->Chass. 166589 417.200 ohne Anlauftring / without thrust ring	(79)
				<b>1863 837 002</b>	65/97/23	Chass. 166590-> 417.200 mit Anlauftring / with thrust ring	(63)
<b>U 800L</b> 413.110/111	01.77 - 03.90	OM314.917		<b>1882 229 131 #</b>	G280	->Chass. 088736	
				<b>1861 518 031 #</b>	280BDC (26x32-10N)	->Chass. 088736 Anzahl der Beläge / Number of pads: 6	(7)
				<b>1861 611 131 ●#</b>	280B/ Z (26x32-10N)	->Chass. 088736	
				<b>1863 840 001</b>	55/90/18	->Chass. 088736 ohne Anlauftring / without thrust ring	(79)
				<b>3482 008 032</b>	MF310	Chass. 088737->	
				<b>1861 384 334 #</b>	310GSZ (26x32-10N)	Chass. 088737->	
				<b>1863 840 001</b>	55/90/18	Chass. 088737-> ohne Anlauftring / without thrust ring	(79)
				<b>1888 877 101 #</b>	DOT280 (Ge 280/45x50-24N) (Mo 280/26x32-10N)	->Chass. 088736 für Fahrzeuge mit Zweischeibenkupplung / for vehicles with double disc clutch enthält zwei Kupplungsscheiben / This part number includes both clutch discs	(51) (46)
	<b>1888 877 102 #</b>	DOT280 (280/45x50-24N)	Chass. 088737-> für Fahrzeuge mit Zweischeibenkupplung / for vehicles with double disc clutch enthält eine Kupplungsscheibe / This part number includes one clutch disc	(51) (45)			

# MERCEDES-BENZ

## Unimog 500-900













<b>U 800</b> 417.100	05.88 - 03.90	OM314.917		<b>3482 008 032</b>	MF310		
				<b>1861 384 334 #</b>	310GSZ (26x32-10N)		
				<b>1863 840 001</b>	55/90/18	<b>-&gt;Chass. 166589</b> ohne Anlauftring / without thrust ring	(79)
				<b>1863 837 002</b>	65/97/23	<b>Chass. 166590-&gt;</b> mit Anlauftring / with thrust ring	(63)
				<b>1888 877 102 #</b>	DOT280 (280/45x50-24N)	<b>-&gt;Chass. 166589</b> enthält eine Kupplungsscheibe / This part number includes one clutch disc	(45)
				<b>1888 877 103 #</b>	DOT280 (280/45x50-24N)	<b>Chass. 166590-&gt;</b> enthält eine Kupplungsscheibe / This part number includes one clutch disc	(45)
				<b>1861 966 141 ▽#</b>	280GSPDCE/ CERAM (26x32-10N)	Lose Kupplungsscheibe / Loose clutch disc	(30)
<b>U 900</b>				<b>1888 067 042 #</b>	DUT330/ 310 (310/41x45-22N)	enthält eine Kupplungsscheibe / This part number includes one clutch disc	(45)
				<b>1861 741 042 ▽#</b>	327GSDC (36x40-20N)	Anzahl der Beläge / Number of pads: 8 Lose Kupplungsscheibe / Loose clutch disc	(7) (30)
				<b>1863 837 002</b>	65/97/23	mit Anlauftring / with thrust ring	(63)
				<b>1863 855 000</b>	106/140/25	mit Anlauftring / with thrust ring	(63)
<b>U 900</b> 416.135 416.140-163 416.134 416.114-117				<b>1888 877 101 #</b>	DOT280 (Ge 280/45x50-24N) (Mo 280/26x32-10N)	<b>Chass. 000562 - Chass. 088736</b> enthält zwei Kupplungsscheiben / This part number includes both clutch discs	(46)
				<b>1888 877 102 #</b>	DOT280 (280/45x50-24N)	<b>Chass. 088737 - Chass. 166589</b> enthält eine Kupplungsscheibe / This part number includes one clutch disc	(45)
				<b>1888 877 103 #</b>	DOT280 (280/45x50-24N)	<b>Chass. 166590-&gt;</b> enthält eine Kupplungsscheibe / This part number includes one clutch disc	(45)
				<b>1861 966 141 ▽#</b>	280GSPDCE/ CERAM (26x32-10N)		
<b>U 900</b> 406.145				<b>1882 282 331</b>	GFX310	<b>Chass. 003773 - Chass. 088736</b> Nur bei Altteil-Rückgabe lieferbar (Reparatur; Werk Bielefeld) / Please return old unit for repair (plant Bielefeld)	(33)
				<b>1861 384 334 #</b>	310GSZ (26x32-10N)	<b>Chass. 003773 - Chass. 088736</b>	
				<b>1863 840 001</b>	55/90/18	<b>Chass. 003773 - Chass. 088736</b> ohne Anlauftring / without thrust ring	(79)
<b>U 900</b> 406.120				<b>1888 893 001 #</b>	DOT240 (225/45x50-24N)	enthält eine Kupplungsscheibe / This part number includes one clutch disc	(45)
				<b>1862 718 002 ▽#</b>	240CC (26x32-10N)	Lose Kupplungsscheibe / Loose clutch disc	(30)
				<b>1863 837 003</b>	65/100/18	ohne Anlauftring / without thrust ring	(79)

# MERCEDES-BENZ

Unimog 500-900							
<b>U 900</b> 406.120/121 417.201 417.101	01.77 -	OM353.902		<b>1882 229 131 #</b>	G280	-> <b>Chass. 088736</b> 406.120-121	
				<b>1861 518 031 #</b>	280BDC (26x32-10N)	-> <b>Chass. 088736</b> 406.120-121 Anzahl der Beläge / Number of pads: 6	(7)
				<b>1861 611 131 ●#</b>	280B/ Z (26x32-10N)	-> <b>Chass. 088736</b> 406.120-121	
				<b>1863 840 001</b>	55/90/18	-> <b>Chass. 088736</b> 406.120-121 ohne Anlauftring / without thrust ring	(79)
				<b>3482 008 032</b>	MF310	<b>Chass. 088737-&gt;</b> 406.120-121	
				<b>1861 384 334 #</b>	310GSZ (26x32-10N)	<b>Chass. 088737-&gt;</b> 406.120-121	
				<b>1863 840 001</b>	55/90/18	<b>Chass. 088737-&gt;</b> 406.120-121 ohne Anlauftring / without thrust ring	(79)
				<b>1888 877 101 #</b>	DOT280 (Ge 280/45x50-24N) (Mo 280/26x32-10N)	<b>Chass. 009059 - Chass. 088736</b> 406.120-121 enthält zwei Kupplungsscheiben / This part number includes both clutch discs	(46)
				<b>1888 877 102 #</b>	DOT280 (280/45x50-24N)	<b>Chass. 088737-&gt;</b> 406.120-121 enthält eine Kupplungsscheibe / This part number includes one clutch disc	(45)
				<b>1861 966 141 ▽#</b>	280GSPDCE/ CERAM (26x32-10N)	<b>Chass. 088737-&gt;</b> 406.120-121 Lose Kupplungsscheibe / Loose clutch disc	(30)
				<b>1863 837 003</b>	65/100/18	<b>Chass. 088737-&gt;</b> 406.120-121 ohne Anlauftring / without thrust ring	(79)
				<b>3482 008 032</b>	MF310	417.101/201	
				<b>1861 384 334 #</b>	310GSZ (26x32-10N)	417.101/201	
				<b>1863 840 001</b>	55/90/18	-> <b>Chass. 166588</b> 417.101/201 ohne Anlauftring / without thrust ring	(79)
				<b>1863 837 002</b>	65/97/23	<b>Chass. 166589-&gt;</b> 417.101/201 mit Anlauftring / with thrust ring	(63)
<b>U 900</b> 417.101 <b>U 900</b> 417.106	05.88 -	OM353.902, OM366.939, OM356.912		<b>3482 008 032</b>	MF310		
	11.88 -			<b>1861 384 334 #</b>	310GSZ (26x32-10N)		
				<b>1863 840 001</b>	55/90/18	ohne Anlauftring / without thrust ring	(79)
				<b>1888 877 102 #</b>	DOT280 (280/45x50-24N)	-> <b>Chass. 166589</b> enthält eine Kupplungsscheibe / This part number includes one clutch disc	(45)
				<b>1888 877 103 #</b>	DOT280 (280/45x50-24N)	<b>Chass. 166590-&gt;</b> enthält eine Kupplungsscheibe / This part number includes one clutch disc	(45)
	<b>1861 966 141 ▽#</b>	280GSPDCE/ CERAM (26x32-10N)	Lose Kupplungsscheibe / Loose clutch disc	(30)			
<b>U 900</b> 406.143 406.142	01.77 - 01.88	OM353.940		<b>1882 282 331</b>	GFX310	Nur bei Altteil-Rückgabe lieferbar (Reparatur; Werk Bielefeld) / Please return old unit for repair (plant Bielefeld)	(33)
				<b>1861 384 334 #</b>	310GSZ (26x32-10N)		
				<b>1863 840 001</b>	55/90/18	ohne Anlauftring / without thrust ring	(79)

# MERCEDES-BENZ

## Unimog 1000-1350

<b>U 100, U 110, U 1100L</b> 416.115/116 416.141 416.140 416.160 416.117	01.77 - 05.88 OM353.940, OM353.901, OM353.980		<b>1882 231 131 #</b>	G250	416.140-141	
			<b>1861 840 133 #</b>	250TPZ (26x32-10N)	416.140-141	
			<b>1863 840 001</b>	55/90/18	416.140-141 ohne Anlauftring / without thrust ring	(79)
			<b>1882 282 331</b>	GFX310	-> <b>Chass. 088736</b> für Fahrzeuge mit Einscheibenkupplung / for vehicles with single disc clutch Nur bei Altteil-Rückgabe lieferbar (Reparatur; Werk Bielefeld) / Please return old unit for repair (plant Bielefeld)	(48) (33)
			<b>1861 384 334 #</b>	310GSZ (26x32-10N)	-> <b>Chass. 088736</b> für Fahrzeuge mit Einscheibenkupplung / for vehicles with single disc clutch	(48)
			<b>1863 840 001</b>	55/90/18	-> <b>Chass. 088736</b> für Fahrzeuge mit Einscheibenkupplung / for vehicles with single disc clutch ohne Anlauftring / without thrust ring	(48) (79)
			<b>3482 008 032</b>	MF310	<b>Chass. 088737-&gt;</b> für Fahrzeuge mit Einscheibenkupplung / for vehicles with single disc clutch	(48)
			<b>1861 384 334 #</b>	310GSZ (26x32-10N)	<b>Chass. 088737-&gt;</b> für Fahrzeuge mit Einscheibenkupplung / for vehicles with single disc clutch	(48)
			<b>1863 840 001</b>	55/90/18	<b>Chass. 088737-&gt;</b> für Fahrzeuge mit Einscheibenkupplung / for vehicles with single disc clutch ohne Anlauftring / without thrust ring	(48) (79)
			<b>1888 877 101 #</b>	DOT280 (Ge 280/45x50-24N) (Mo 280/26x32-10N)	<b>Chass. 000562 - Chass. 088736</b> enthält zwei Kupplungsscheiben / This part number includes both clutch discs	(46)
			<b>1888 877 102 #</b>	DOT280 (280/45x50-24N)	<b>Chass. 088737 - Chass. 166589</b> enthält eine Kupplungsscheibe / This part number includes one clutch disc	(45)
			<b>1888 877 103 #</b>	DOT280 (280/45x50-24N)	<b>Chass. 166590-&gt;</b> enthält eine Kupplungsscheibe / This part number includes one clutch disc	(45)
			<b>1861 966 141 ▽#</b>	280GSPDCE/ CERAM (26x32-10N)	Lose Kupplungsscheibe / Loose clutch disc	(30)



























# MERCEDES-BENZ

## Unimog 1000-1350

<b>U 100, U 110T, U 1100T</b> 416.134/135 417.000	01.77 -	OM353.940, OM353.901, OM353.980		<b>3482 008 032</b>	MF310	417.000 für Fahrzeuge mit Einscheibenkupplung / for vehicles with single disc clutch	(48)
				<b>1861 384 334 #</b>	310GSZ (26x32-10N)	417.000 für Fahrzeuge mit Einscheibenkupplung / for vehicles with single disc clutch	(48)
				<b>1863 840 001</b>	55/90/18	<b>-&gt;Chass. 166589</b> 417.000 für Fahrzeuge mit Einscheibenkupplung / for vehicles with single disc clutch ohne Anlauftring / without thrust ring	(48) (79)
				<b>1863 837 002</b>	65/97/23	<b>Chass. 166590-&gt;</b> 417.000 für Fahrzeuge mit Einscheibenkupplung / for vehicles with single disc clutch mit Anlauftring / with thrust ring	(48) (63)
				<b>1888 877 102 #</b>	DOT280 (280/45x50-24N)	<b>-&gt;Chass. 166589</b> 417.000 enthält eine Kupplungsscheibe / This part number includes one clutch disc	(45)
				<b>1888 877 103 #</b>	DOT280 (280/45x50-24N)	<b>Chass. 166590-&gt;</b> 417.000 enthält eine Kupplungsscheibe / This part number includes one clutch disc	(45)
				<b>1861 966 141 ▽#</b>	280GSPDCE/ CERAM (26x32-10N)	417.000 Lose Kupplungsscheibe / Loose clutch disc	(30)
				<b>1882 229 131 #</b>	G280	<b>-&gt;Chass. 088736</b> 416.134-135 für Fahrzeuge mit Einscheibenkupplung / for vehicles with single disc clutch	(48)
				<b>1861 518 031 #</b>	280BDC (26x32-10N)	<b>-&gt;Chass. 088736</b> 416.134-135 für Fahrzeuge mit Einscheibenkupplung / for vehicles with single disc clutch Anzahl der Beläge / Number of pads: 6	(48) (7)
				<b>1861 611 131 ●#</b>	280B/ Z (26x32-10N)	<b>-&gt;Chass. 088736</b> 416.134-135 für Fahrzeuge mit Einscheibenkupplung / for vehicles with single disc clutch	(48)
				<b>1863 840 001</b>	55/90/18	<b>-&gt;Chass. 088736</b> 416.134-135 für Fahrzeuge mit Einscheibenkupplung / for vehicles with single disc clutch ohne Anlauftring / without thrust ring	(48) (79)
				<b>3482 008 032</b>	MF310	<b>Chass. 088737-&gt;</b> 416.134-135 für Fahrzeuge mit Einscheibenkupplung / for vehicles with single disc clutch	(48)
				<b>1861 384 334 #</b>	310GSZ (26x32-10N)	<b>Chass. 088737-&gt;</b> 416.134-135 für Fahrzeuge mit Einscheibenkupplung / for vehicles with single disc clutch	(48)
				<b>1863 840 001</b>	55/90/18	<b>Chass. 088737-&gt;</b> 416.134-135 für Fahrzeuge mit Einscheibenkupplung / for vehicles with single disc clutch ohne Anlauftring / without thrust ring	(48) (79)
				<b>1888 877 101 #</b>	DOT280 (Ge 280/45x50-24N) (Mo 280/26x32-10N)	<b>Chass. 000562 - Chass. 088736</b> 416.134-135 enthält zwei Kupplungsscheiben / This part number includes both clutch discs	(46)
				<b>1888 877 102 #</b>	DOT280 (280/45x50-24N)	<b>Chass. 088737 - Chass. 166589</b> 416.134-135 enthält eine Kupplungsscheibe / This part number includes one clutch disc	(45)
				<b>1888 877 103 #</b>	DOT280 (280/45x50-24N)	<b>Chass. 166590-&gt;</b> 416.134-135 enthält eine Kupplungsscheibe / This part number includes one clutch disc	(45)
				<b>1861 966 141 ▽#</b>	280GSPDCE/ CERAM (26x32-10N)	416.134-135 Lose Kupplungsscheibe / Loose clutch disc	(30)

























# MERCEDES-BENZ

## Unimog 1000-1350

<b>U 1000</b> 424.121	01.77 - 05.88	OM353.962		<b>3482 008 032</b>	MF310		
				<b>1861 603 034 #</b>	310GSZ (36x40-20N)		
				<b>3151 051 031</b>			
				<b>1888 067 042 #</b>	DUT330/ 310 (310/41x45-22N)	enthält eine Kupplungsscheibe / This part number includes one clutch disc enthält Druckplattenbefestigungsschrauben / includes bolt for pressure plate mounting	(45) (44)
				<b>1861 741 042 ▽#</b>	327GSDC (36x40-20N)	Anzahl der Beläge / Number of pads: 8 Lose Kupplungsscheibe / Loose clutch disc	(7) (30)
				<b>1863 837 002</b>	65/97/23	mit Anlauftring / with thrust ring	(63)
				<b>1863 855 000</b>	106/140/25	mit Anlauftring / with thrust ring	(63)
				<b>1888 893 001 #</b>	DOT240 (225/45x50-24N)	enthält eine Kupplungsscheibe / This part number includes one clutch disc	(45)
				<b>1862 718 002 ▽#</b>	240CC (26x32-10N)	Lose Kupplungsscheibe / Loose clutch disc	(30)
	<b>1863 837 003</b>	65/100/18	ohne Anlauftring / without thrust ring	(79)			
<b>U 1000</b> 427.100	01.88 -	OM356.914, OM366.915		<b>3482 008 038</b>	MF310		
				<b>1861 603 034 #</b>	310GSZ (36x40-20N)		
				<b>3151 051 031</b>		<b>-&gt;Chass. 173809</b>	
				<b>3182 002 131</b>	HHIS-3	<b>Chass. 173810-&gt;</b> Immer erneuern / Renew everytime	(22)
				<b>1888 067 031 #</b>	DUT330 (310/45x50-24N)	enthält eine Kupplungsscheibe / This part number includes one clutch disc Sonderausführung / Special design	(45) (39)
				<b>1888 998 201 #</b>	DUT330 (310/45x50-24N)	für Fahrzeuge mit Niederdruck-Bremsanlage / for vehicles with low-pressure brakesystem enthält eine Kupplungsscheibe / This part number includes one clutch disc Sonderausführung / Special design	(49) (45) (39)
				<b>1861 741 042 ▽#</b>	327GSDC (36x40-20N)	Anzahl der Beläge / Number of pads: 8 Lose Kupplungsscheibe / Loose clutch disc Sonderausführung / Special design	(7) (30) (39)
				<b>1863 837 002</b>	65/97/23	mit Anlauftring / with thrust ring	(63)
				<b>1863 855 000</b>	106/140/25	mit Anlauftring / with thrust ring	(63)
<b>U 1000T</b> 424.131	01.77 - 12.82	OM353.940, OM353.980		<b>3482 008 032</b>	MF310		
				<b>1861 603 034 #</b>	310GSZ (36x40-20N)		
				<b>3151 051 031</b>			
				<b>1888 067 042 #</b>	DUT330/ 310 (310/41x45-22N)	enthält eine Kupplungsscheibe / This part number includes one clutch disc enthält Druckplattenbefestigungsschrauben / includes bolt for pressure plate mounting	(45) (44)
				<b>1861 741 042 ▽#</b>	327GSDC (36x40-20N)	Anzahl der Beläge / Number of pads: 8 Lose Kupplungsscheibe / Loose clutch disc	(7) (30)
				<b>1863 837 002</b>	65/97/23	mit Anlauftring / with thrust ring	(63)
				<b>1863 855 000</b>	106/140/25	mit Anlauftring / with thrust ring	(63)



























# MERCEDES-BENZ

## Unimog 1000-1350

<b>U 1150,U 1150L</b> 417.210 417.220 417.211 <b>U 1150,U 1150L</b> 417.115 417.110/111 417.120 417.116 <b>U 1150L</b> 417.212	05.88 -	OM353.940, OM353.907		<b>3482 008 032</b>	MF310	für Fahrzeuge mit Einscheibenkupplung / for vehicles with single disc clutch	(48)
	05.88 -			<b>1861 384 334 #</b>	310GSZ (26x32-10N)	für Fahrzeuge mit Einscheibenkupplung / for vehicles with single disc clutch	(48)
				<b>1863 840 001</b>	55/90/18	<b>-&gt;Chass. 166589</b> für Fahrzeuge mit Einscheibenkupplung / for vehicles with single disc clutch ohne Anlauftring / without thrust ring	(48) (79)
	05.88 -			<b>1863 837 002</b>	65/97/23	<b>Chass. 166590-&gt;</b> für Fahrzeuge mit Einscheibenkupplung / for vehicles with single disc clutch mit Anlauftring / with thrust ring	(48) (63)
				<b>1888 877 102 #</b>	DOT280 (280/45x50-24N)	<b>-&gt;Chass. 166589</b> enthält eine Kupplungsscheibe / This part number includes one clutch disc	(45)
			<b>1888 877 103 #</b>	DOT280 (280/45x50-24N)	<b>Chass. 166590-&gt;</b> enthält eine Kupplungsscheibe / This part number includes one clutch disc	(45)	
			<b>1861 966 141 ▽#</b>	280GSPDCE/ CERAM (26x32-10N)	Lose Kupplungsscheibe / Loose clutch disc	(30)	
	<b>U 1200</b> 427.101 <b>U 1200T</b> 427.000 <b>U 1250,U 1250L</b> 427.110/111 <b>U 1250L</b> 427.111		01.88 -	OM356.950, OM356.954, OM366.955, OM366.949		<b>3482 012 237</b>	GMF330
01.88 -			<b>1861 667 034</b>		330GSB (36x40-20N)		
01.88 -			<b>3151 051 031</b>			<b>-&gt;Chass. 173809</b>	
05.88 -			<b>3182 002 131</b>		HHIS-3	<b>Chass. 173810-&gt;</b> Immer erneuern / Renew everytime	(22)
			<b>3800 710 002 #</b>  <b>1888 067 031</b>  <b>1861 741 042</b>  <b>3182 003 131</b>		DUT330 327GSDC HHIS-3	Sonderausführung / Special design	(39)
		<b>1888 998 201 #</b>	DUT330 (310/45x50-24N)		für Fahrzeuge mit Niederdruck-Bremsanlage / for vehicles with low-pressure brakesystem enthält eine Kupplungsscheibe / This part number includes one clutch disc Sonderausführung / Special design	(49) (45) (39)	
		<b>1861 741 042 ▽#</b>	327GSDC (36x40-20N)		Anzahl der Beläge / Number of pads: 8 Lose Kupplungsscheibe / Loose clutch disc Sonderausführung / Special design	(7) (30) (39)	
		<b>3182 003 131</b>	HHIS-3		Sonderausführung / Special design Immer erneuern / Renew everytime	(39) (22)	
<b>U 1200</b> 424.122 <b>U 1200T</b> 424.132 <b>U 1250</b> 424.127 424.126	02.82 - 05.88	OM353.973, OM353.995		<b>3482 012 237</b>	GMF330		
	01.83 - 05.88			<b>1861 667 034</b>	330GSB (36x40-20N)		
	12.84 - 05.88			<b>3151 051 031</b>			
				<b>1888 067 042 #</b>	DUT330/ 310 (310/41x45-22N)	enthält eine Kupplungsscheibe / This part number includes one clutch disc enthält Druckplattenbefestigungsschrauben / includes bolt for pressure plate mounting	(45) (44)
			<b>1861 741 042 ▽#</b>	327GSDC (36x40-20N)	Anzahl der Beläge / Number of pads: 8 Lose Kupplungsscheibe / Loose clutch disc	(7) (30)	
			<b>1863 837 002</b>	65/97/23	mit Anlauftring / with thrust ring	(63)	
			<b>1863 855 000</b>	106/140/25	mit Anlauftring / with thrust ring	(63)	































# MERCEDES-BENZ

Unimog 1000-1350							
<b>U 125, U 1100L</b> 416.163 416.114 416.162	01.77 - 01.88	OM353.907		<b>1882 282 331</b>	GFX310	-> <b>Chass. 088736</b> für Fahrzeuge mit Einscheibenkupplung / for vehicles with single disc clutch Nur bei Altteil-Rückgabe lieferbar (Reparatur; Werk Bielefeld) / Please return old unit for repair (plant Bielefeld)	(48) (33)
				<b>1861 384 334 #</b>	310GSZ (26x32-10N)	-> <b>Chass. 088736</b> für Fahrzeuge mit Einscheibenkupplung / for vehicles with single disc clutch	(48)
				<b>1863 840 001</b>	55/90/18	-> <b>Chass. 088736</b> für Fahrzeuge mit Einscheibenkupplung / for vehicles with single disc clutch ohne Anlauffring / without thrust ring	(48) (79)
				<b>3482 008 032</b>	MF310	<b>Chass. 088737-&gt;</b> für Fahrzeuge mit Einscheibenkupplung / for vehicles with single disc clutch	(48)
				<b>1861 384 334 #</b>	310GSZ (26x32-10N)	<b>Chass. 088737-&gt;</b> für Fahrzeuge mit Einscheibenkupplung / for vehicles with single disc clutch	(48)
				<b>1863 840 001</b>	55/90/18	<b>Chass. 088737-&gt;</b> für Fahrzeuge mit Einscheibenkupplung / for vehicles with single disc clutch ohne Anlauffring / without thrust ring	(48) (79)
				<b>1888 877 101 #</b>	DOT280 (Ge 280/45x50-24N) (Mo 280/26x32-10N)	<b>Chass. 000562 - Chass. 088736</b> enthält zwei Kupplungsscheiben / This part number includes both clutch discs	(46)
				<b>1888 877 102 #</b>	DOT280 (280/45x50-24N)	<b>Chass. 088737 - Chass. 166589</b> enthält eine Kupplungsscheibe / This part number includes one clutch disc	(45)
				<b>1888 877 103 #</b>	DOT280 (280/45x50-24N)	<b>Chass. 166590-&gt;</b> enthält eine Kupplungsscheibe / This part number includes one clutch disc	(45)
				<b>1861 966 141 ▽#</b>	280GSPDCE/ CERAM (26x32-10N)	Lose Kupplungsscheibe / Loose clutch disc	(30)
<b>U 1300</b> 425.121	01.77 - 12.84	OM353.973, OM353.995		<b>3482 012 211</b>	GMF330	-> <b>Chass. 001570</b>	
				<b>1861 594 034 #</b>	330GSZ (36x40-20N)	-> <b>Chass. 001570</b>	
				<b>3151 051 031</b>		-> <b>Chass. 001570</b>	
				<b>3482 012 237</b>	GMF330	<b>Chass. 001571-&gt;</b>	
				<b>1861 667 034</b>	330GSB (36x40-20N)	<b>Chass. 001571-&gt;</b>	
				<b>3151 051 031</b>		<b>Chass. 001571-&gt;</b>	
				<b>1888 893 001 #</b>	DOT240 (225/45x50-24N)	enthält eine Kupplungsscheibe / This part number includes one clutch disc	(45)
				<b>1862 718 002 ▽#</b>	240CC (26x32-10N)	Lose Kupplungsscheibe / Loose clutch disc	(30)
				<b>1863 837 003</b>	65/100/18	ohne Anlauffring / without thrust ring	(79)
				<b>1888 067 042 #</b>	DUT330/ 310 (310/41x45-22N)	enthält eine Kupplungsscheibe / This part number includes one clutch disc enthält Druckplattenbefestigungsschrauben / includes bolt for pressure plate mounting	(45) (44)
				<b>1861 741 042 ▽#</b>	327GSDC (36x40-20N)	Anzahl der Beläge / Number of pads: 8 Lose Kupplungsscheibe / Loose clutch disc	(7) (30)
				<b>1863 837 002</b>	65/97/23	mit Anlauffring / with thrust ring	(63)
				<b>1863 855 000</b>	106/140/25	mit Anlauffring / with thrust ring	(63)
<b>U 1300 L</b> 436.326 436.325	01.77 - 05.88	OM382.917		<b>3482 002 234</b>	GMF350X		
				<b>1861 956 133</b>	350GTD (36x40-20N)		
				<b>1861 713 133 ●#</b>	350GSZ (36x40-20N)		
				<b>3151 051 031</b>			













# MERCEDES-BENZ

## Unimog 1000-1350









<b>U 1300,L</b> 435.141 435.121 435.110 435.120 435.117 435.131 435.113 <b>U 1300,L</b> 425.110 425.121 425.131 425.120 425.141				<b>3482 012 237</b>	GMF330		
				<b>1861 667 034</b>	330GSB (36x40-20N)		
				<b>3151 051 031</b>			
<b>U 1300,U 1300L</b> 436.320 435.115 425.121 435.117 436.321	01.77 - 05.88	OM353.973, OM353.961		<b>3482 012 211</b>	GMF330	<b>-&gt;Chass. 001570</b> 425.121	
				<b>1861 594 034 #</b>	330GSZ (36x40-20N)	<b>-&gt;Chass. 001570</b> 425.121	
				<b>3151 051 031</b>		<b>-&gt;Chass. 001570</b> 425.121	
				<b>3482 012 237</b>	GMF330	<b>Chass. 001571-&gt;</b> 425.121	
				<b>1861 667 034</b>	330GSB (36x40-20N)	<b>Chass. 001571-&gt;</b> 425.121	
				<b>3151 051 031</b>		<b>Chass. 001571-&gt;</b> 425.121	
				<b>1888 893 001 #</b>	DOT240 (225/45x50-24N)	425.121 enthält eine Kupplungsscheibe / This part number includes one clutch disc	(45)
				<b>1862 718 002 ▽#</b>	240CC (26x32-10N)	425.121 Lose Kupplungsscheibe / Loose clutch disc	(30)
				<b>1863 837 003</b>	65/100/18	425.121 ohne Anlauftring / without thrust ring	(79)
				<b>1888 067 042 #</b>	DUT330/ 310 (310/41x45-22N)	425.121 enthält eine Kupplungsscheibe / This part number includes one clutch disc enthält Druckplattenbefestigungsschrauben / includes bolt for pressure plate mounting	(45) (44)
				<b>1861 741 042 ▽#</b>	327GSDC (36x40-20N)	425.121 Anzahl der Beläge / Number of pads: 8 Lose Kupplungsscheibe / Loose clutch disc	(7) (30)
				<b>1863 837 002</b>	65/97/23	425.121 mit Anlauftring / with thrust ring	(63)
				<b>1863 855 000</b>	106/140/25	425.121 mit Anlauftring / with thrust ring	(63)
				<b>3482 012 211</b>	GMF330	<b>-&gt;Chass. 002154</b> 435.115/117	
				<b>1861 594 034 #</b>	330GSZ (36x40-20N)	<b>-&gt;Chass. 002154</b> 435.117	
				<b>3482 012 237</b>	GMF330	<b>Chass. 002155-&gt;</b> 435.117	
				<b>1861 667 034</b>	330GSB (36x40-20N)	<b>Chass. 002155-&gt;</b> 435.117	
				<b>3151 051 031</b>		435.117	
				<b>1888 067 042 #</b>	DUT330/ 310 (310/41x45-22N)	435.117 enthält eine Kupplungsscheibe / This part number includes one clutch disc enthält Druckplattenbefestigungsschrauben / includes bolt for pressure plate mounting	(45) (44)
				<b>1861 741 042 ▽#</b>	327GSDC (36x40-20N)	435.117 Anzahl der Beläge / Number of pads: 8 Lose Kupplungsscheibe / Loose clutch disc	(7) (30)
				<b>1863 837 002</b>	65/97/23	435.117 mit Anlauftring / with thrust ring	(63)
				<b>1863 855 000</b>	106/140/25	435.117 mit Anlauftring / with thrust ring	(63)
				<b>3482 012 237</b>	GMF330	436.320-321	
				<b>1861 667 034</b>	330GSB (36x40-20N)	436.320-321	
				<b>3151 051 031</b>		436.320-321	

# MERCEDES-BENZ

## Unimog 1000-1350























<b>U 1350L</b> 437.110	05.88 -	OM366.955		<b>3482 012 237</b>	GMF330		
				<b>1861 667 034</b>	330GSB (36x40-20N)		
				<b>3151 051 031</b>		<b>-&gt;Chass. 173809</b>	
				<b>3182 002 131</b>	HHIS-3	<b>Chass. 173810-&gt;</b> Immer erneuern / Renew everytime (22)	
				<b>3800 710 002 #</b>  <b>1888 067 031</b>  <b>1861 741 042</b>  <b>3182 003 131</b>	DUT330 327GSDC HHIS-3	Sonderausführung / Special design (39)	
				<b>1861 594 034 ●▽#</b>	330GSZ (36x40-20N)	Lose Kupplungsscheibe / Loose clutch disc Sonderausführung / Special design (30) (39)	
				<b>1888 998 902 ●#</b>	DUT350/ 330 (330/45x50-24N)	enthält eine Kupplungsscheibe / This part number includes one clutch disc Sonderausführung / Special design (45) (39)	
				<b>1862 962 002 ▽#</b>	350GSDC (36x40-20N)	Lose Kupplungsscheibe / Loose clutch disc Sonderausführung / Special design (30) (39)	
				<b>3182 003 131</b>	HHIS-3	Sonderausführung / Special design Immer erneuern / Renew everytime (39) (22)	

## Unimog 1400-1750

<b>U 1400</b> 437.110 <b>U 1450</b> 437.110 <b>U 1600,L</b> 437.110				<b>1888 067 031 #</b>	DUT330 (310/45x50-24N)	enthält eine Kupplungsscheibe / This part number includes one clutch disc Sonderausführung / Special design (45) (39)
				<b>1861 741 042 ●▽#</b>	327GSDC (36x40-20N)	Anzahl der Beläge / Number of pads: 8 Lose Kupplungsscheibe / Loose clutch disc Sonderausführung / Special design (7) (30) (39)
				<b>1861 594 034 ▽#</b>	330GSZ (36x40-20N)	Lose Kupplungsscheibe / Loose clutch disc Sonderausführung / Special design (30) (39)
				<b>1888 998 902 ●#</b>	DUT350/ 330 (330/45x50-24N)	enthält eine Kupplungsscheibe / This part number includes one clutch disc Sonderausführung / Special design (45) (39)
				<b>1862 962 002 ▽#</b>	350GSDC (36x40-20N)	Lose Kupplungsscheibe / Loose clutch disc Sonderausführung / Special design (30) (39)
				<b>3482 012 237</b>	GMF330	
<b>U 1400</b> 424.127 424.132 424.126 424.122 <b>U 1450</b> 424.126/127 424.132 424.122 <b>U 1500</b> 435.117 435.120/121 435.131 435.141 435.113 435.110 <b>U 1700,U 1700L</b> 425.131 425.121 425.110 425.141 425.120				<b>1861 667 034</b>	330GSB (36x40-20N)	
				<b>3151 051 031</b>		































# MERCEDES-BENZ

## Unimog 1400-1750































<b>U 1400</b> 427.102 <b>U 1450,U 1450L</b> 427.112 427.111	01.88 -	OM357.912, OM366.948, OM366.955, OM366.956, OM366.947		<b>3482 012 237</b>	GMF330		
	01.88 -			<b>1861 667 034</b>	330GSB (36x40-20N)		
				<b>3151 051 031</b>			<b>-&gt;Chass. 173809</b>
				<b>3182 002 131</b>	HHIS-3		<b>Chass. 173810-&gt;</b> Immer erneuern / Renew everytime (22)
				<b>3482 106 133</b>	GMF350X		
				<b>1861 956 133</b>	350GTD (36x40-20N)		
				<b>1861 713 133 ●#</b>	350GSZ (36x40-20N)		
				<b>3182 002 131</b>	HHIS-3		Immer erneuern / Renew everytime (22)
				<b>3800 710 002 #</b> <b>1888 067 031</b> <b>1861 741 042</b> <b>3182 003 131</b>	DUT330 327GSDC HHIS-3		Sonderausführung / Special design (39)
				<b>1888 998 201 #</b>	DUT330 (310/45x50-24N)		für Fahrzeuge mit Niederdruck-Bremsanlage / for vehicles with low-pressure brakesystem enthält eine Kupplungsscheibe / This part number includes one clutch disc Sonderausführung / Special design (49) (45) (39)
				<b>1861 594 034 ▽#</b>	330GSZ (36x40-20N)		Lose Kupplungsscheibe / Loose clutch disc Sonderausführung / Special design (30) (39)
				<b>1861 741 042 ●▽#</b>	327GSDC (36x40-20N)		Anzahl der Beläge / Number of pads: 8 Lose Kupplungsscheibe / Loose clutch disc Sonderausführung / Special design (7) (30) (39)
				<b>3182 003 131</b>	HHIS-3		Sonderausführung / Special design Immer erneuern / Renew everytime (39) (22)
				<b>3800 710 003 ●#</b> <b>1888 998 902</b> <b>1862 962 002</b> <b>3182 003 131</b>	DUT350/330 350GSDC HHIS-3		Sonderausführung / Special design (39)
<b>U 1500</b> 425.141 <b>U 1500T</b> 425.131 <b>U 1550</b> 424.126 <b>U 1550 L</b> 424.127	01.77 - 05.88	OM353.958, OM353.995, OM353.961		<b>3482 012 237</b>	GMF330		für Fahrzeuge mit Einscheibenkupplung / for vehicles with single disc clutch (48)
	01.77 - 05.88			<b>1861 667 034</b>	330GSB (36x40-20N)		für Fahrzeuge mit Einscheibenkupplung / for vehicles with single disc clutch (48)
	01.86 - 05.88			<b>3151 051 031</b>			für Fahrzeuge mit Einscheibenkupplung / for vehicles with single disc clutch (48)
	02.86 - 05.88			<b>1888 067 042 #</b>	DUT330/ 310 (310/41x45-22N)		enthält eine Kupplungsscheibe / This part number includes one clutch disc enthält Druckplattenbefestigungsschrauben / includes bolt for pressure plate mounting (45) (44)
				<b>1861 741 042 ▽#</b>	327GSDC (36x40-20N)		Anzahl der Beläge / Number of pads: 8 Lose Kupplungsscheibe / Loose clutch disc (7) (30)
				<b>1863 837 002</b>	65/97/23		mit Anlauftring / with thrust ring (63)
				<b>1863 855 000</b>	106/140/25		mit Anlauftring / with thrust ring (63)
				<b>1888 998 902 #</b>	DUT350/ 330 (330/45x50-24N)		enthält eine Kupplungsscheibe / This part number includes one clutch disc (45)
<b>U 1550L</b> 437.000-160 <b>U 1550L/37</b> 437.120 437.125				<b>1862 962 002 ▽#</b>	350GSDC (36x40-20N)		Lose Kupplungsscheibe / Loose clutch disc (30)

# MERCEDES-BENZ

































**Unimog 1400-1750**

<b>U 1550L</b> 437.120 437.111 <b>U 1550L</b> 437.111	05.88 -	OM356.956, OM366.955, OM366.956		<b>3482 002 234</b>	GMF350X	<b>-&gt;Chass. 173809</b>	
	05.88 -			<b>3482 106 133</b>	GMF350X	<b>Chass. 173810-&gt;</b>	
				<b>1861 956 133</b>	350GTD (36x40-20N)		
				<b>1861 713 133 ●#</b>	350GSZ (36x40-20N)		
				<b>3151 051 031</b>		<b>-&gt;Chass. 173809</b>	
				<b>3182 002 131</b>	HHIS-3	<b>Chass. 173810-&gt;</b> Immer erneuern / Renew everytime	(22)
				<b>1888 998 902 #</b>	DUT350/ 330 (330/45x50-24N)	enthält eine Kupplungsscheibe / This part number includes one clutch disc Sonderausführung / Special design	(45) (39)
				<b>1862 962 002 ▽#</b>	350GSDC (36x40-20N)	Lose Kupplungsscheibe / Loose clutch disc Sonderausführung / Special design	(30) (39)
				<b>1863 855 000</b>	106/140/25	<b>-&gt;Chass. 186921</b> Sonderausführung / Special design mit Anlauftring / with thrust ring	(39) (63)
				<b>1863 837 002</b>	65/97/23	<b>-&gt;Chass. 186921</b> Sonderausführung / Special design mit Anlauftring / with thrust ring	(39) (63)
				<b>3800 710 003 #</b>  <b>1888 998 902</b>  <b>1862 962 002</b>  <b>3182 003 131</b>	DUT350/330 350GSDC HHIS-3	<b>Chass. 186922-&gt;</b>	
<b>U 1550L</b> 437.120 437.125 437.123 437.141	01.92 -	OM356.955, OM356.956		<b>3482 002 239 #</b>	GMF350X	<b>-&gt;Chass. 173809</b> 437.120/125	
				<b>3482 106 031</b>	GMF350X	<b>Chass. 173810-&gt;</b> 437.120/125	
				<b>1862 286 031 #</b>	360GSDC (36x40-20N)	437.125/120	
				<b>3151 051 031</b>		<b>-&gt;Chass. 173809</b> 437.120/125	
				<b>3182 002 131</b>	HHIS-3	<b>Chass. 173810-&gt;</b> 437.120/125 Immer erneuern / Renew everytime	(22)
				<b>1888 998 902 #</b>	DUT350/ 330 (330/45x50-24N)	437.120/125/123 enthält eine Kupplungsscheibe / This part number includes one clutch disc Sonderausführung / Special design	(45) (39)
				<b>1862 962 002 ▽#</b>	350GSDC (36x40-20N)	437.120/125/123 Lose Kupplungsscheibe / Loose clutch disc Sonderausführung / Special design	(30) (39)
				<b>1863 837 002</b>	65/97/23	<b>-&gt;Chass. 186921</b> 437.120/125/123 Sonderausführung / Special design mit Anlauftring / with thrust ring	(39) (63)
				<b>1863 855 000</b>	106/140/25	<b>-&gt;Chass. 186921</b> 437.120/125/123 Sonderausführung / Special design mit Anlauftring / with thrust ring	(39) (63)
				<b>3800 710 003 #</b>  <b>1888 998 902</b>  <b>1862 962 002</b>  <b>3182 003 131</b>	DUT350/330 350GSDC HHIS-3	<b>Chass. 186922-&gt;</b> 437.120/125/123 Sonderausführung / Special design	(39)
				<b>3482 106 133</b>	GMF350X	437.123/141	
				<b>1861 956 133</b>	350GTD (36x40-20N)	437.123/141	
				<b>1861 713 133 ●#</b>	350GSZ (36x40-20N)	437.123/141	
				<b>3182 002 131</b>	HHIS-3	437.123/141 Immer erneuern / Renew everytime	(22)

# MERCEDES-BENZ





































Unimog 1400-1750							
<b>U 1550L</b> 437.120 437.111 437.123	01.92 -	OM366.963		<b>3482 002 234</b>	GMF350X	-> <b>Chass. 173809</b> 437.111/120	
				<b>3482 106 133</b>	GMF350X	<b>Chass. 173810-&gt;</b> 437.111/120	
				<b>1861 956 133</b>	350GTD (36x40-20N)	437.111/120	
				<b>1861 713 133 ●#</b>	350GSZ (36x40-20N)	437.111/120	
				<b>3151 051 031</b>		-> <b>Chass. 173809</b> 437.111/120	
				<b>3182 002 131</b>	HHIS-3	<b>Chass. 173810-&gt;</b> 437.111/120 Immer erneuern / Renew everytime	(22)
				<b>1888 998 902 #</b>	DUT350/ 330 (330/45x50-24N)	437.111/120 enthält eine Kupplungsscheibe / This part number includes one clutch disc Sonderausführung / Special design	(45) (39)
				<b>1862 962 002 ▽#</b>	350GSDC (36x40-20N)	437.111/120 Lose Kupplungsscheibe / Loose clutch disc Sonderausführung / Special design	(30) (39)
				<b>1863 855 000</b>	106/140/25	-> <b>Chass. 186921</b> 437.111/120 Sonderausführung / Special design mit Anlauftring / with thrust ring	(39) (63)
				<b>1863 837 002</b>	65/97/23	-> <b>Chass. 186921</b> 437.111/120 Sonderausführung / Special design mit Anlauftring / with thrust ring	(39) (63)
				<b>3800 710 003 #</b>  <b>1888 998 902</b>  <b>1862 962 002</b>  <b>3182 003 131</b>	DUT350/330 350GSDC HHIS-3	<b>Chass. 186922-&gt;</b> 437.111/120	
				<b>3482 106 133</b>	GMF350X	437.123	
				<b>1861 956 133</b>	350GTD (36x40-20N)	437.123	
				<b>1861 713 133 ●#</b>	350GSZ (36x40-20N)	437.123	
				<b>3182 002 131</b>	HHIS-3	437.123 Immer erneuern / Renew everytime	(22)
				<b>3800 710 003 #</b>  <b>1888 998 902</b>  <b>1862 962 002</b>  <b>3182 003 131</b>	DUT350/330 350GSDC HHIS-3	437.123	
<b>U 1550L</b> 437.125 437.116 <b>U 1550L</b> 437.116 437.125	05.88 -	OM356.980, OM357.924, OM366.984, OM357.945, OM356.997		<b>3482 002 239 #</b>	GMF350X	-> <b>Chass. 173809</b>	
	05.88 -			<b>3482 106 031</b>	GMF350X	<b>Chass. 173810-&gt;</b>	
				<b>1862 286 031 #</b>	360GSDC (36x40-20N)		
				<b>3151 051 031</b>		-> <b>Chass. 173809</b>	
				<b>3182 002 131</b>	HHIS-3	<b>Chass. 173810-&gt;</b> Immer erneuern / Renew everytime	(22)
				<b>3800 710 003 #</b>  <b>1888 998 902</b>  <b>1862 962 002</b>  <b>3182 003 131</b>	DUT350/330 350GSDC HHIS-3	Sonderausführung / Special design	(39)

# MERCEDES-BENZ

Unimog 1400-1750						
<b>U 1600</b> 427.105	01.88 -	OM356.956, OM366.949		<b>3482 002 234</b>	GMF350X	<b>-&gt;Chass. 173809</b>
				<b>3482 106 133</b>	GMF350X	<b>Chass. 173810-&gt;</b>
				<b>1861 956 133</b>	350GTD (36x40-20N)	
				<b>1861 713 133 ●#</b>	350GSZ (36x40-20N)	
				<b>3151 051 031</b>		<b>-&gt;Chass. 173809</b>
				<b>3182 002 131</b>	HHIS-3	<b>Chass. 173810-&gt;</b> Immer erneuern / Renew everytime (22)
				<b>3800 710 002 #</b>  <b>1888 067 031</b>  <b>1861 741 042</b>  <b>3182 003 131</b>	DUT330 327GSDC HHIS-3	Sonderausführung / Special design (39)
				<b>1888 998 201 #</b>	DUT330 (310/45x50-24N)	für Fahrzeuge mit Niederdruck-Bremsanlage / for vehicles with low-pressure brakesystem enthält eine Kupplungsscheibe / This part number includes one clutch disc Sonderausführung / Special design (49) (45) (39)
				<b>1861 741 042 ▽#</b>	327GSDC (36x40-20N)	Anzahl der Beläge / Number of pads: 8 Lose Kupplungsscheibe / Loose clutch disc Sonderausführung / Special design (7) (30) (39)
				<b>3182 003 131</b>	HHIS-3	Sonderausführung / Special design Immer erneuern / Renew everytime (39) (22)
				<b>3800 710 003 ●#</b>  <b>1888 998 902</b>  <b>1862 962 002</b>  <b>3182 003 131</b>	DUT350/330 350GSDC HHIS-3	Sonderausführung / Special design (39)
			<b>U 1600</b> 427.107  <b>U 1600</b> 427.107	09.89 -  05.91 -	OM356.980, OM357.924, OM366.984, OM356.997, OM357.945	
	<b>3482 106 031</b>	GMF350X				<b>Chass. 173810-&gt;</b>
	<b>1862 286 031 #</b>	360GSDC (36x40-20N)				
	<b>3182 002 131</b>	HHIS-3				<b>Chass. 173810-&gt;</b> Immer erneuern / Renew everytime (22)
	<b>3151 051 031</b>					<b>-&gt;Chass. 173809</b>
	<b>1888 998 901 ▲#</b>	DUT350/ 330 (330/45x50-24N)				enthält eine Kupplungsscheibe / This part number includes one clutch disc Sonderausführung / Special design (45) (39)
	<b>1878 992 401 ▽#</b>	350GSDC (36x40-20N)				Anzahl der Beläge / Number of pads: 8 Lose Kupplungsscheibe / Loose clutch disc Sonderausführung / Special design (7) (30) (39)
	<b>1888 998 902 #</b>	DUT350/ 330 (330/45x50-24N)				enthält eine Kupplungsscheibe / This part number includes one clutch disc Sonderausführung / Special design (45) (39)
	<b>1862 962 002 ▽#</b>	350GSDC (36x40-20N)				Sonderausführung / Special design Lose Kupplungsscheibe / Loose clutch disc (39) (30)
	<b>1863 837 002</b>	65/97/23				<b>-&gt;Chass. 186921</b> Sonderausführung / Special design mit Anlauftring / with thrust ring (39) (63)
	<b>1863 855 000</b>	106/140/25				<b>-&gt;Chass. 186921</b> Sonderausführung / Special design mit Anlauftring / with thrust ring (39) (63)
	<b>3800 710 003 #</b>  <b>1888 998 902</b>  <b>1862 962 002</b>  <b>3182 003 131</b>	DUT350/330 350GSDC HHIS-3				<b>Chass. 186922-&gt;</b> Sonderausführung / Special design (39)

# MERCEDES-BENZ



























## Unimog 1400-1750

<b>U 1650,U 1650L</b> 427.116 427.115	01.88 -	OM356.956, OM366.948, OM366.949	 <b>3482 002 234</b>	GMF350X	<b>-&gt;Chass. 173809</b>	
			 <b>3482 106 133</b>	GMF350X	<b>Chass. 173810-&gt;</b>	
			 <b>1861 956 133</b>	350GTD (36x40-20N)		
			 <b>1861 713 133 ●#</b>	350GSZ (36x40-20N)		
			 <b>3151 051 031</b>		<b>-&gt;Chass. 173809</b>	
			 <b>3182 002 131</b>	HHIS-3	<b>Chass. 173810-&gt;</b> Immer erneuern / Renew everytime	(22)
			 <b>3482 012 237</b>	GMF330	Sonderausführung / Special design	(39)
			 <b>1861 667 034</b>	330GSB (36x40-20N)	Sonderausführung / Special design	(39)
			 <b>3182 002 131</b>	HHIS-3	Sonderausführung / Special design Immer erneuern / Renew everytime	(39) (22)
			 <b>3800 710 002 #</b>  <b>1888 067 031</b>  <b>1861 741 042</b>  <b>3182 003 131</b>	DUT330 327GSDC HHIS-3	Sonderausführung / Special design	(39)
			 <b>1888 998 201 #</b>	DUT330 (310/45x50-24N)	für Fahrzeuge mit Niederdruck-Bremsanlage / for vehicles with low-pressure brakesystem enthält eine Kupplungsscheibe / This part number includes one clutch disc Sonderausführung / Special design	(49) (45) (39)
			 <b>1861 741 042 ▽#</b>	327GSDC (36x40-20N)	Anzahl der Beläge / Number of pads: 8 Lose Kupplungsscheibe / Loose clutch disc Sonderausführung / Special design	(7) (30) (39)
			 <b>3182 003 131</b>	HHIS-3	Sonderausführung / Special design Immer erneuern / Renew everytime	(39) (22)
			 <b>3800 710 003 ●#</b>  <b>1888 998 902</b>  <b>1862 962 002</b>  <b>3182 003 131</b>	DUT350/330 350GSDC HHIS-3	Sonderausführung / Special design	(39)
<b>U 1650,U 1650L</b> 427.117/118 <b>U 1650,U 1650L</b> 427.117/118 <b>U 1700T</b> 437.000 <b>U 1750,U 1750L</b> 437.113 437.112 <b>U 1750,U 1750L</b> 437.131 437.130	09.89 -	OM356.980, OM357.924, OM366.984, OM356.957, OM366.963, OM356.997, OM356.981, OM357.945	 <b>3482 002 234</b>	GMF350X	<b>-&gt;Chass. 173809</b>	
	05.91 -		 <b>3482 106 133</b>	GMF350X	<b>Chass. 173810-&gt;</b>	
	09.88 -		 <b>1861 956 133</b>	350GTD (36x40-20N)		
	09.88 -		 <b>1861 713 133 ●#</b>	350GSZ (36x40-20N)		
	09.88 -		 <b>3151 051 031</b>		<b>-&gt;Chass. 173809</b>	
			 <b>3182 002 131</b>	HHIS-3	<b>Chass. 173810-&gt;</b> Immer erneuern / Renew everytime	(22)
			 <b>1888 998 902 #</b>	DUT350/ 330 (330/45x50-24N)	enthält eine Kupplungsscheibe / This part number includes one clutch disc	(45)
			 <b>1862 962 002 ▽#</b>	350GSDC (36x40-20N)	Lose Kupplungsscheibe / Loose clutch disc	(30)
			 <b>1888 998 902 #</b>	DUT350/ 330 (330/45x50-24N)	enthält eine Kupplungsscheibe / This part number includes one clutch disc Sonderausführung / Special design	(45) (39)
			 <b>1862 962 002 ▽#</b>	350GSDC (36x40-20N)	Lose Kupplungsscheibe / Loose clutch disc Sonderausführung / Special design	(30) (39)
			 <b>1863 837 002</b>	65/97/23	<b>-&gt;Chass. 186921</b> Sonderausführung / Special design mit Anlauftring / with thrust ring	(39) (63)
			 <b>1863 855 000</b>	106/140/25	<b>-&gt;Chass. 186921</b> Sonderausführung / Special design mit Anlauftring / with thrust ring	(39) (63)
			 <b>3800 710 003 #</b>  <b>1888 998 902</b>  <b>1862 962 002</b>  <b>3182 003 131</b>	DUT350/330 350GSDC HHIS-3	<b>Chass. 186922-&gt;</b> Sonderausführung / Special design	(39)





























# MERCEDES-BENZ

**Unimog 1400-1750**



























<b>U 1700, U 1700 L</b> 436.342/343 436.340/341 437.100	09.88 -	OM382.950, OM356.957, OM366.963		<b>3482 002 234</b>	GMF350X	436.340-341-342-343	
				<b>1861 956 133</b>	350GTD (36x40-20N)	436.340-341-342-343	
				<b>1861 713 133</b> ●#	350GSZ (36x40-20N)	436.340-341-342-343	
				<b>3151 051 031</b>		436.340-341-342-343	
				<b>3482 002 234</b>	GMF350X	<b>-&gt;Chass. 173809</b> 437.100	
				<b>3482 106 133</b>	GMF350X	<b>Chass. 173810-&gt;</b> 437.100	
				<b>1861 956 133</b>	350GTD (36x40-20N)	437.100	
				<b>1861 713 133</b> ●#	350GSZ (36x40-20N)	437.100	
				<b>3151 051 031</b>		<b>-&gt;Chass. 173809</b> 437.100	
				<b>3182 002 131</b>	HHIS-3	<b>Chass. 173810-&gt;</b> 437.100 Immer erneuern / Renew everytime	(22)
				<b>1888 998 902</b> #	DUT350/ 330 (330/45x50-24N)	437.100/110 enthält eine Kupplungsscheibe / This part number includes one clutch disc	(45)
				<b>1862 962 002</b> ▽#	350GSDC (36x40-20N)	437.100/110 Lose Kupplungsscheibe / Loose clutch disc	(30)
				<b>1888 998 902</b> #	DUT350/ 330 (330/45x50-24N)	437.100 enthält eine Kupplungsscheibe / This part number includes one clutch disc Sonderausführung / Special design	(45) (39)
				<b>1862 962 002</b> ▽#	350GSDC (36x40-20N)	437.100 Lose Kupplungsscheibe / Loose clutch disc Sonderausführung / Special design	(30) (39)
				<b>1863 837 002</b>	65/97/23	<b>-&gt;Chass. 186921</b> 437.100 Sonderausführung / Special design mit Anlauftring / with thrust ring	(39) (63)
				<b>1863 855 000</b>	106/140/25	<b>-&gt;Chass. 186921</b> 437.100 Sonderausführung / Special design mit Anlauftring / with thrust ring	(39) (63)
				<b>3800 710 003</b> #  <b>1888 998 902</b>  <b>1862 962 002</b>  <b>3182 003 131</b>	DUT350/330 350GSDC HHIS-3	<b>Chass. 186922-&gt;</b> 437.100 Sonderausführung / Special design	(39)
			<b>U 1700,U 1700L</b> 435.111 435.131 435.121 435.141 435.115 435.120 435.110 435.117 435.113				<b>3482 012 237</b>
	<b>1861 667 034</b>	330GSB (36x40-20N)				435.110/113/117/120-121/131/141	
	<b>3151 051 031</b>					435.110/113/117/120-121/131/141	
	<b>1888 067 042</b> #	DUT330/ 310 (310/41x45-22N)				435.110-111/113/115 enthält eine Kupplungsscheibe / This part number includes one clutch disc enthält Druckplattenbefestigungsschrauben / includes bolt for pressure plate mounting	(45) (44)
	<b>1861 741 042</b> #	327GSDC (36x40-20N)				435.110-111/113/115 Anzahl der Beläge / Number of pads: 8 Lose Kupplungsscheibe / Loose clutch disc	(7) (30)
	<b>1863 837 002</b>	65/97/23				435.110-111/113/115 mit Anlauftring / with thrust ring	(63)
	<b>1863 855 000</b>	106/140/25				435.110-111/113/115 mit Anlauftring / with thrust ring	(63)

# MERCEDES-BENZ

Unimog 1400-1750							
U 1700,U 1700L 435.111 435.110	05.78 - 09.88	OM353.959		3482 012 211	GMF330	->Chass. 002154 435.111	
				3482 012 237	GMF330	Chass. 002155-> 435.111	
				1861 594 034 #	330GSZ (36x40-20N)	->Chass. 002154 435.111	
				1861 667 034	330GSB (36x40-20N)	Chass. 002155-> 435.111	
				3151 051 031		435.111	
				3482 012 237	GMF330	435.110	
				1861 667 034	330GSB (36x40-20N)	435.110	
				3151 051 031		435.110	
				1888 067 042 #	DUT330/ 310 (310/41x45-22N)	enthält eine Kupplungsscheibe / This part number includes one clutch disc enthält Druckplattenbefestigungsschrauben / includes bolt for pressure plate mounting	(45) (44)
				1861 741 042 #	327GSDC (36x40-20N)	Anzahl der Beläge / Number of pads: 8 Lose Kupplungsscheibe / Loose clutch disc	(7) (30)
				1863 837 002	65/97/23	mit Anlauftring / with thrust ring	(63)
	1863 855 000	106/140/25	mit Anlauftring / with thrust ring	(63)			
U 1700L 435.113	05.78 - 09.88	OM353.959		3482 012 237	GMF330		
				1861 667 034	330GSB (36x40-20N)		
				3151 051 031			
				1888 067 042 #	DUT330/ 310 (310/41x45-22N)	enthält eine Kupplungsscheibe / This part number includes one clutch disc enthält Druckplattenbefestigungsschrauben / includes bolt for pressure plate mounting	(45) (44)
				1861 741 042 #	327GSDC (36x40-20N)	Anzahl der Beläge / Number of pads: 8 Lose Kupplungsscheibe / Loose clutch disc	(7) (30)
				1863 837 002	65/97/23	mit Anlauftring / with thrust ring	(63)
				1863 855 000	106/140/25	mit Anlauftring / with thrust ring	(63)
Unimog 1800-2050							
U 1800,T 437.000-160				1888 998 902 #	DUT350/ 330 (330/45x50-24N)	enthält eine Kupplungsscheibe / This part number includes one clutch disc	(45)
				1862 962 002 ▽#	350GSDC (36x40-20N)	Lose Kupplungsscheibe / Loose clutch disc	(30)
U 1800,T 437.002				3482 002 234	GMF350X	->Chass. 173809	
				3482 106 133	GMF350X	Chass. 173810->	
				1861 956 133	350GTD (36x40-20N)		
				1861 713 133 ●#	350GSZ (36x40-20N)		
				3151 051 031		->Chass. 173809	
				3182 002 131	HHIS-3	Chass. 173810-> Immer erneuern / Renew everytime	(22)

























# MERCEDES-BENZ

## Unimog 1800-2050

<b>U 1800,T</b> 437.102		<b>3482 106 031</b>	GMF350X		
		<b>1862 286 031 #</b>	360GSDC (36x40-20N)		
		<b>3151 051 031</b>		<b>-&gt;Chass. 173809</b>	
		<b>3182 002 131</b>	HHIS-3	<b>Chass. 173810-&gt;</b>	
				Immer erneuern / Renew everytime	(22)
		<b>1888 998 901 ▲#</b>	DUT350/ 330 (330/45x50-24N)	enthält eine Kupplungsscheibe / This part number includes one clutch disc	(45)
		<b>1878 992 401 ▽#</b>	350GSDC (36x40-20N)	Sonderausführung / Special design	(39)
		<b>3182 003 131</b>	HHIS-3	Anzahl der Beläge / Number of pads: 8 Lose Kupplungsscheibe / Loose clutch disc Sonderausführung / Special design	(7) (30) (39)
<b>U 1850 L/38</b> 437.133		<b>3800 710 003 #</b>	DUT350/330 350GSDC HHIS-3	Sonderausführung / Special design	(26)
		<b>1888 998 902</b>		Je nach Kundenwunsch mit unterschiedlicher Kupplung / Equipped with different clutch according to customer requirement	(39)
		<b>1862 962 002</b>		Sonderausführung / Special design	(39)
		<b>3182 003 131</b>		Immer erneuern / Renew everytime	(22)
		<b>3482 106 031</b>	GMF350X		
<b>U 1850,L</b> 437.115 437.114		<b>1862 286 031 #</b>	360GSDC (36x40-20N)		
		<b>3151 051 031</b>		<b>-&gt;Chass. 173809</b>	
		<b>3182 002 131</b>	HHIS-3	<b>Chass. 173810-&gt;</b>	
				Immer erneuern / Renew everytime	(22)
		<b>3800 710 003 #</b>	DUT350/330 350GSDC HHIS-3	Sonderausführung / Special design	(39)
		<b>1888 998 902</b>		Je nach Kundenwunsch mit unterschiedlicher Kupplung / Equipped with different clutch according to customer requirement	(26)
		<b>1862 962 002 ▽#</b>	350GSDC (36x40-20N)	Lose Kupplungsscheibe / Loose clutch disc	(30)
	<b>3182 003 131</b>		Immer erneuern / Renew everytime	(22)	
	<b>1888 998 902 #</b>	DUT350/ 330 (330/45x50-24N)	enthält eine Kupplungsscheibe / This part number includes one clutch disc	(45)	
	<b>1862 962 002 ▽#</b>	350GSDC (36x40-20N)	Lose Kupplungsscheibe / Loose clutch disc	(30)	
	<b>3182 003 131</b>		Immer erneuern / Renew everytime	(22)	
	<b>3800 710 003 #</b>	DUT350/330 350GSDC HHIS-3	Sonderausführung / Special design	(39)	
	<b>1888 998 902</b>		Je nach Kundenwunsch mit unterschiedlicher Kupplung / Equipped with different clutch according to customer requirement	(26)	
	<b>1862 962 002</b>		Sonderausführung / Special design	(39)	
	<b>3182 003 131</b>		Immer erneuern / Renew everytime	(22)	































# MERCEDES-BENZ

## Unimog 2100-2450

<b>U 2100</b> 437.105 <b>U 2100T</b> 437.002 <b>U 2150,U 2150L</b> 437.118 437.117 437.136 <b>U 2400</b> 437.105 <b>U 2450,U 2450L</b> 437.136 437.117/118	09.89 -	OM356.980, OM366.984, OM357.945, OM356.997		<b>3482 002 239 #</b>	GMF350X	<b>-&gt;Chass. 173809</b>	
	09.89 -			<b>3482 106 031</b>	GMF350X	<b>Chass. 173810-&gt;</b>	
	09.89 -			<b>1862 286 031 #</b>	360GSDC (36x40-20N)		
				<b>3151 051 031</b>		<b>-&gt;Chass. 173809</b>	
	05.91 -			<b>3182 002 131</b>	HHIS-3	<b>Chass. 173810-&gt;</b> Immer erneuern / Renew everytime	(22)
	05.91 -			<b>1888 998 902 #</b>	DUT350/ 330 (330/45x50-24N)	enthält eine Kupplungsscheibe / This part number includes one clutch disc	(45)
				<b>1862 962 002 ▽#</b>	350GSDC (36x40-20N)	Lose Kupplungsscheibe / Loose clutch disc	(30)
				<b>1888 998 901 ▲#</b>	DUT350/ 330 (330/45x50-24N)	enthält eine Kupplungsscheibe / This part number includes one clutch disc Sonderausführung / Special design	(45) (39)
				<b>1878 992 401 ▽#</b>	350GSDC (36x40-20N)	Anzahl der Beläge / Number of pads: 8 Lose Kupplungsscheibe / Loose clutch disc Sonderausführung / Special design	(7) (30) (39)
				<b>1888 998 902 #</b>	DUT350/ 330 (330/45x50-24N)	enthält eine Kupplungsscheibe / This part number includes one clutch disc Sonderausführung / Special design	(45) (39)
				<b>1862 962 002 ▽#</b>	350GSDC (36x40-20N)	Lose Kupplungsscheibe / Loose clutch disc Sonderausführung / Special design	(30) (39)
				<b>1863 837 002</b>	65/97/23	<b>-&gt;Chass. 186921</b> Sonderausführung / Special design mit Anlauftring / with thrust ring	(39) (63)
				<b>1863 855 000</b>	106/140/25	<b>-&gt;Chass. 186921</b> Sonderausführung / Special design mit Anlauftring / with thrust ring	(39) (63)
				<b>3800 710 003 #</b>  <b>1888 998 902</b>  <b>1862 962 002</b>  <b>3182 003 131</b>	DUT350/330 350GSDC HHIS-3	<b>Chass. 186922-&gt;</b> Sonderausführung / Special design	(39)
<b>U 2150</b> 437.135	09.89 -	OM366.984, OM356.997		<b>3482 002 239 #</b>	GMF350X	<b>-&gt;Chass. 173809</b>	
				<b>3482 106 031</b>	GMF350X	<b>Chass. 173810-&gt;</b>	
				<b>1862 286 031 #</b>	360GSDC (36x40-20N)		
				<b>3151 051 031</b>		<b>-&gt;Chass. 173809</b>	
				<b>3182 002 131</b>	HHIS-3	<b>Chass. 173810-&gt;</b> Immer erneuern / Renew everytime	(22)
				<b>1888 998 902 #</b>	DUT350/ 330 (330/45x50-24N)	enthält eine Kupplungsscheibe / This part number includes one clutch disc Sonderausführung / Special design	(45) (39)
				<b>1862 962 002 ▽#</b>	350GSDC (36x40-20N)	Lose Kupplungsscheibe / Loose clutch disc Sonderausführung / Special design	(30) (39)







# MERCEDES-BENZ

**Unimog 2100-2450**

















<b>U 2150,U 2150L</b> 437.118 437.136 437.171 437.117 437.170	09.89 -	OM357.924, OM366.984, OM356.997		<b>3482 002 239 #</b>	GMF350X	<b>-&gt;Chass. 173809</b> 437.117-118/136	
				<b>3482 106 031</b>	GMF350X	<b>Chass. 173810-&gt;</b> 437.117-118/136	
				<b>1862 286 031 #</b>	360GSDC (36x40-20N)	437.117-118/136	
				<b>3151 051 031</b>		<b>-&gt;Chass. 173809</b> 437.117-118/136	
				<b>3182 002 131</b>	HHIS-3	<b>Chass. 173810-&gt;</b> 437.117-118/136 Immer erneuern / Renew everytime	(22)
				<b>1888 998 902 #</b>	DUT350/ 330 (330/45x50-24N)	437.117-118/136 enthält eine Kupplungsscheibe / This part number includes one clutch disc	(45)
				<b>1862 962 002 ▽#</b>	350GSDC (36x40-20N)	437.117-118/136 Lose Kupplungsscheibe / Loose clutch disc	(30)
				<b>1888 998 901 ▲#</b>	DUT350/ 330 (330/45x50-24N)	437.117-118/136 enthält eine Kupplungsscheibe / This part number includes one clutch disc Sonderausführung / Special design	(45) (39)
				<b>1878 992 401 ▽#</b>	350GSDC (36x40-20N)	437.117-118/136 Anzahl der Beläge / Number of pads: 8 Lose Kupplungsscheibe / Loose clutch disc Sonderausführung / Special design	(7) (30) (39)
				<b>1888 998 902 #</b>	DUT350/ 330 (330/45x50-24N)	437.117-118/136 enthält eine Kupplungsscheibe / This part number includes one clutch disc Sonderausführung / Special design	(45) (39)
				<b>1862 962 002 ▽#</b>	350GSDC (36x40-20N)	437.117-118/136 Lose Kupplungsscheibe / Loose clutch disc Sonderausführung / Special design	(30) (39)
				<b>1863 837 002</b>	65/97/23	<b>-&gt;Chass. 186921</b> 437.117-118/136 Sonderausführung / Special design mit Anlauftring / with thrust ring	(39) (63)
				<b>1863 855 000</b>	106/140/25	<b>-&gt;Chass. 186921</b> 437.117-118/136 Sonderausführung / Special design mit Anlauftring / with thrust ring	(39) (63)
				<b>3800 710 003 #</b>  <b>1888 998 902</b>  <b>1862 962 002</b>  <b>3182 003 131</b>	DUT350/330 350GSDC HHIS-3	<b>Chass. 186922-&gt;</b> 437.117-118/136 Sonderausführung / Special design	(39)
				<b>3482 106 031</b>	GMF350X	437.170-171	
				<b>1862 286 031 #</b>	360GSDC (36x40-20N)	437.170-171	
	<b>3182 002 131</b>	HHIS-3	437.170-171 Immer erneuern / Renew everytime	(22)			
<b>U 2400TG</b> 437.182	07.93 -	OM356.980, OM357.945		<b>3482 106 031</b>	GMF350X		
				<b>1862 286 031 #</b>	360GSDC (36x40-20N)		
				<b>3182 002 131</b>	HHIS-3	Immer erneuern / Renew everytime	(22)
				<b>1888 998 902 #</b>	DUT350/ 330 (330/45x50-24N)	enthält eine Kupplungsscheibe / This part number includes one clutch disc	(45)
				<b>1862 962 002 #</b>	350GSDC (36x40-20N)		
				<b>1863 837 002</b>	65/97/23	<b>-&gt;Chass. 186921</b> mit Anlauftring / with thrust ring	(63)
				<b>1863 855 000</b>	106/140/25	<b>-&gt;Chass. 186921</b> mit Anlauftring / with thrust ring	(63)
				<b>3800 710 003 #</b>  <b>1888 998 902</b>  <b>1862 962 002</b>  <b>3182 003 131</b>	DUT350/330 350GSDC HHIS-3	<b>Chass. 186922-&gt;</b>	

# MERCEDES-BENZ







## Unimog 2100-2450

<b>U 2450L</b> 437.156	07.93 -	OM356.980, OM357.945	 <b>3482 106 031</b>	GMF350X		
			 <b>1862 286 031 #</b>	360GSDC (36x40-20N)		
			 <b>3182 002 131</b>	HHIS-3	Immer erneuern / Renew everytime	(22)
			 <b>3800 710 003 #</b>  <b>1888 998 902</b>  <b>1862 962 002</b>  <b>3182 003 131</b>	DUT350/330 350GSDC HHIS-3	Sonderausführung / Special design	(39)







## Unimog 2500-5023





<b>U 3000</b> 437.425 437.420 437.426 437.421 <b>U 3000</b> 437.420 437.425 <b>U 4000</b> 436.330 <b>U 4000</b> 437.420/421 437.425/426 436.330	09.02 -	OM900.920, OM904LA, OM904.953, OM904.952	 <b>3482 000 462</b>	MF362		
	09.02 -		 <b>1878 600 560</b>	360CBC (36x40-18N)	Anzahl der Beläge / Number of pads: 9 Je nach Kundenwunsch mit unterschiedlicher Kupplung / Equipped with different clutch according to customer requirement	(7) (26)
			 <b>1878 052 842</b>	362WGTB (36x40-18N)	Je nach Kundenwunsch mit unterschiedlicher Kupplung / Equipped with different clutch according to customer requirement	(26)
			 <b>1878 001 939 HD●</b>	362WGTB (36x40-18N)	Je nach Kundenwunsch mit unterschiedlicher Kupplung / Equipped with different clutch according to customer requirement	(26)
			 <b>3182 600 101</b>	HHIS-3	mit Sensor / with sensor Füllmedium: Bremsflüssigkeit / Fill Medium: Brake Fluid Immer erneuern / Renew everytime	(69) (18) (22)
<b>U 4023</b> 437.427	05.13 -	OM934	 <b>3182 600 101</b>	HHIS-3	mit Sensor / with sensor Füllmedium: Bremsflüssigkeit / Fill Medium: Brake Fluid Immer erneuern / Renew everytime	(69) (18) (22)
<b>U 5000</b> 437.430/431 437.435/436 437.465 437.460	09.02 -	OM924.916	 <b>3482 000 462</b>	MF362	437.430/435	
			 <b>1878 600 560</b>	360CBC (36x40-18N)	437.430/435 Anzahl der Beläge / Number of pads: 9 Je nach Kundenwunsch mit unterschiedlicher Kupplung / Equipped with different clutch according to customer requirement	(7) (26)
			 <b>1878 052 842</b>	362WGTB (36x40-18N)	437.430/435 Je nach Kundenwunsch mit unterschiedlicher Kupplung / Equipped with different clutch according to customer requirement	(26)
			 <b>1878 001 939 HD●</b>	362WGTB (36x40-18N)	437.430/435 Je nach Kundenwunsch mit unterschiedlicher Kupplung / Equipped with different clutch according to customer requirement	(26)
			 <b>3182 600 101</b>	HHIS-3	437.430/435 mit Sensor / with sensor Füllmedium: Bremsflüssigkeit / Fill Medium: Brake Fluid Immer erneuern / Renew everytime	(69) (18) (22)
	09.02 -	OM924.923	 <b>3482 000 462</b>	MF362	437.460/465	
			 <b>1878 600 560</b>	360CBC (36x40-18N)	437.460/465 Anzahl der Beläge / Number of pads: 9	(7)
			 <b>3182 600 101</b>	HHIS-3	437.460/465 mit Sensor / with sensor Füllmedium: Bremsflüssigkeit / Fill Medium: Brake Fluid Immer erneuern / Renew everytime	(69) (18) (22)
	09.02 -	OM924LA	 <b>3482 000 462</b>	MF362	437.431/436	
			 <b>1878 600 560</b>	360CBC (36x40-18N)	437.431/436 Anzahl der Beläge / Number of pads: 9	(7)
			 <b>3182 600 101</b>	HHIS-3	437.431/436 mit Sensor / with sensor Füllmedium: Bremsflüssigkeit / Fill Medium: Brake Fluid Immer erneuern / Renew everytime	(69) (18) (22)



## MERCEDES-BENZ

Unimog 2500-5023							
U 5000 437.470	11.02 -	OM906.935		3482 000 463	MF395		
				3182 600 101	HHIS-3	mit Sensor / with sensor Füllmedium: Bremsflüssigkeit / Fill Medium: Brake Fluid Immer erneuern / Renew everytime	(69) (18) (22)
				2100 502 010		für / for: SA 505033 23 für / for: SA 505033 37	(47) (47)
		906.935		2300 146 031		nur als Ersatz für angegebene OE-Nr. / only for the listed OE-Numbers	(77)
				2300 147 031		nur als Ersatz für angegebene OE-Nr. / only for the listed OE-Numbers	(77)
U 5023 437.437	05.13 -	OM934		3182 600 101	HHIS-3	437.437 mit Sensor / with sensor Füllmedium: Bremsflüssigkeit / Fill Medium: Brake Fluid Immer erneuern / Renew everytime	(69) (18) (22)
				1863 869 044		437.437	
					25/55/15		





## MIAG

A..-Serie							
AD22				1881 089 002	K225		
				1864 634 024	225Z (1 1/4"-10N)		
				1859 600 001			
				1805 042 000			
AD33				1880 096 208 #	G280		
				1859 600 005			
				1805 042 000			



L..-Serie							
LDK7 D				1863 100 030	55/90,5/25	mit Anlauffring / with thrust ring	(63)
LM1				1881 010 101 #	G250		
				1864 202 035 #	250Z (26x32-10N)		
LM20 D				1880 071 008	K225		
				1860 039 025 #	225Z (1 1/8"-10N)		



M..-Serie							
MSK35				1880 071 008	K225		
				1864 634 024	225Z (1 1/4"-10N)		

## MOT.MÜNCHEN SENDLING





A..-Serie							
AS7				1881 089 002	K225		
				1864 634 024	225Z (1 1/4"-10N)		
				1859 600 001			
				1805 042 000			







# MOT.MÜNCHEN SENDLING





A..-Serie							
AS7 A AS8				1882 196 005	KS200		
				1859 600 001			
				1805 042 000			

D..-Serie							
DC214 (18PS)				1882 196 005	KS200		
				1859 600 001			
				1805 042 000			

# MWM



























A..-Serie							
AKD 112E WHF8,5				1882 313 001	KS180	Nur bei Altteil-Rückgabe lieferbar (Reparatur; Werk Bielefeld) / Please return old unit for repair (plant Bielefeld)	(33)
				1864 634 040	180E (23x29-10N)		
AKD 112Z WHF8,5				1881 059 208	KS200		
				1864 634 039	200Z (23x29-10N)		



D..-Serie							
D 208-4 D 225-3 D 226-3 D 308-4 D 325-3 D 327-3				1881 010 101 #	G250		
				1864 202 035 #	250Z (26x32-10N)		
D 301-2				1882 315 003	KS180		
				1864 634 040	180E (23x29-10N)		
				1859 600 002			
				1805 041 100			

K..-Serie							
KD 12E WHF8,5 KD 211Z WHF8,5				1882 313 001	KS180	Nur bei Altteil-Rückgabe lieferbar (Reparatur; Werk Bielefeld) / Please return old unit for repair (plant Bielefeld)	(33)
				1864 634 040	180E (23x29-10N)		
KD 12Z WHF8,5				1881 059 208	KS200		
				1864 634 039	200Z (23x29-10N)		
KDW 415E,Z				1881 089 002	K225		
				1864 634 024	225Z (1 1/4"-10N)		































# NEW HOLLAND

T4000							
<b>T 4020</b> <b>T 4030</b>	04.08 - 04.08 -			<b>1888 600 144</b>	DUT280/ CERAM (280/35x40-14N)	enthält eine Kupplungsscheibe / This part number includes one clutch disc	(45)
				<b>1864 600 303</b>	280C (22x25-10N)	Anzahl der Beläge / Number of pads: 4 Lose Kupplungsscheibe / Loose clutch disc	(7) (30)
				<b>1863 838 001</b>	50/82/29	ohne Anlauftring / without thrust ring	(79)
				<b>1863 858 002</b>	75/115/20	ohne Anlauftring / without thrust ring	(79)
				<b>1863 869 014</b>	17/40/12		
				<b>1882 600 101</b>	G280N	für / for: Powershuttle	(47)
				<b>1864 600 303</b>	280C (22x25-10N)	für / for: Powershuttle Anzahl der Beläge / Number of pads: 4	(47) (7)
				<b>1863 838 001</b>	50/82/29	für / for: Powershuttle ohne Anlauftring / without thrust ring	(47) (79)
				<b>1863 869 014</b>	17/40/12	für / for: Powershuttle	(47)
<b>T 4030 F</b>	06.08 -			<b>1864 600 303</b>	280C (22x25-10N)	Anzahl der Beläge / Number of pads: 4	(7)
				<b>1863 838 001</b>	50/82/29	ohne Anlauftring / without thrust ring	(79)
				<b>1863 858 002</b>	75/115/20	ohne Anlauftring / without thrust ring	(79)
				<b>1863 869 014</b>	17/40/12		
				<b>1882 600 101</b>	G280N	für / for: Powershuttle	(47)
				<b>1864 600 303</b>	280C (22x25-10N)	für / for: Powershuttle Anzahl der Beläge / Number of pads: 4	(47) (7)
				<b>1863 838 001</b>	50/82/29	für / for: Powershuttle ohne Anlauftring / without thrust ring	(47) (79)
				<b>1863 869 014</b>	17/40/12	für / for: Powershuttle	(47)
<b>T 4040</b>	12.07 -			<b>1888 600 144</b>	DUT280/ CERAM (280/35x40-14N)	enthält eine Kupplungsscheibe / This part number includes one clutch disc	(45)
				<b>1864 600 303</b>	280C (22x25-10N)	Anzahl der Beläge / Number of pads: 4 Lose Kupplungsscheibe / Loose clutch disc	(7) (30)
				<b>1863 838 001</b>	50/82/29	ohne Anlauftring / without thrust ring	(79)
				<b>1863 858 002</b>	75/115/20	ohne Anlauftring / without thrust ring	(79)
				<b>1882 600 101</b>	G280N	für / for: Powershuttle	(47)
				<b>1864 600 303</b>	280C (22x25-10N)	für / for: Powershuttle Anzahl der Beläge / Number of pads: 4	(47) (7)
				<b>1863 838 001</b>	50/82/29	für / for: Powershuttle ohne Anlauftring / without thrust ring	(47) (79)
				<b>1888 600 144</b>	DUT280/ CERAM (280/35x40-14N)	für / for: 16x16 ShuttleCommand enthält eine Kupplungsscheibe / This part number includes one clutch disc	(47) (45)
				<b>1864 600 303</b>	280C (22x25-10N)	für / for: 16x16 ShuttleCommand Anzahl der Beläge / Number of pads: 4 Lose Kupplungsscheibe / Loose clutch disc	(47) (7) (30)
				<b>1863 838 001</b>	50/82/29	für / for: 16x16 ShuttleCommand ohne Anlauftring / without thrust ring	(47) (79)
				<b>1863 858 002</b>	75/115/20	für / for: 16x16 ShuttleCommand ohne Anlauftring / without thrust ring	(47) (79)























				Parameter		
---	--	--	--	-----------	---	---

# NEW HOLLAND





















T4000						
T 4040 F T 4050 F	06.08 - 06.08 -			<b>1888 600 144</b>	DUT280/ CERAM (280/35x40-14N)	enthält eine Kupplungsscheibe / This part number includes one clutch disc (45)
				<b>1864 600 303</b>	280C (22x25-10N)	Anzahl der Beläge / Number of pads: 4 Lose Kupplungsscheibe / Loose clutch disc (7) (30)
				<b>1863 838 001</b>	50/82/29	ohne Anlauffring / without thrust ring (79)
				<b>1863 858 002</b>	75/115/20	ohne Anlauffring / without thrust ring (79)
				<b>1863 869 014</b>	17/40/12	
				<b>1882 600 101</b>	G280N	für / for: Powershuttle (47)
				<b>1864 600 303</b>	280C (22x25-10N)	für / for: Powershuttle Anzahl der Beläge / Number of pads: 4 Lose Kupplungsscheibe / Loose clutch disc (47) (7) (30)
				<b>1863 838 001</b>	50/82/29	für / for: Powershuttle ohne Anlauffring / without thrust ring (47) (79)
T 4050	12.07 -			<b>1864 600 303</b>	280C (22x25-10N)	Anzahl der Beläge / Number of pads: 4 (7)
				<b>1863 838 001</b>	50/82/29	ohne Anlauffring / without thrust ring (79)
				<b>1863 858 002</b>	75/115/20	ohne Anlauffring / without thrust ring (79)
				<b>1864 600 303</b>	280C (22x25-10N)	für / for: Powershuttle Anzahl der Beläge / Number of pads: 4 (47) (7)
				<b>1863 838 001</b>	50/82/29	für / for: Powershuttle ohne Anlauffring / without thrust ring (47) (79)













TN - Series						
TN 55	09.99 - 12.03			<b>1888 600 107</b>	DUT280 (280/35x40-14N)	->Chass. C4737 enthält eine Kupplungsscheibe / This part number includes one clutch disc (45)
				<b>1864 600 346</b> ▲▽	330CE (41x45-22N)	->Chass. C4737 Anzahl der Beläge / Number of pads: 5 Lose Kupplungsscheibe / Loose clutch disc (7) (30)
				<b>1888 600 107</b>	DUT280 (280/35x40-14N)	->Chass. D4737 enthält eine Kupplungsscheibe / This part number includes one clutch disc (45)
				<b>1888 600 109</b> ●	DUT280/ CERAM (280/35x40-14N)	->Chass. D4737 enthält eine Kupplungsscheibe / This part number includes one clutch disc (45)
				<b>1864 600 345</b> ▽	280C (22x25-10N)	->Chass. D4737 Anzahl der Beläge / Number of pads: 3 Lose Kupplungsscheibe / Loose clutch disc (7) (30)
				<b>1863 838 001</b>	50/82/29	ohne Anlauffring / without thrust ring (79)
				<b>1863 858 002</b>	75/115/20	ohne Anlauffring / without thrust ring (79)
				<b>1863 869 019</b>	17/47/14	
TN 55 D/S	11.98 - 12.03			<b>1888 600 109</b>	DUT280/ CERAM (280/35x40-14N)	->Chass. C4737 enthält eine Kupplungsscheibe / This part number includes one clutch disc (45)
				<b>1864 600 303</b> ▽	280C (22x25-10N)	->Chass. C4737 Anzahl der Beläge / Number of pads: 4 Lose Kupplungsscheibe / Loose clutch disc (7) (30)
				<b>1888 600 109</b>	DUT280/ CERAM (280/35x40-14N)	->Chass. D4737 enthält eine Kupplungsscheibe / This part number includes one clutch disc (45)
				<b>1888 600 144</b> ●	DUT280/ CERAM (280/35x40-14N)	->Chass. D4737 enthält eine Kupplungsscheibe / This part number includes one clutch disc (45)
				<b>1864 600 345</b> ▽	280C (22x25-10N)	->Chass. D4737 Anzahl der Beläge / Number of pads: 3 Lose Kupplungsscheibe / Loose clutch disc (7) (30)
				<b>1863 838 001</b>	50/82/29	ohne Anlauffring / without thrust ring (79)
				<b>1863 858 002</b>	75/115/20	ohne Anlauffring / without thrust ring (79)
				<b>1863 869 019</b>	17/47/14	

# NEW HOLLAND

TN - Series							
TN 65	09.99 - 12.03			<b>1888 600 107</b>	DUT280 (280/35x40-14N)	->Chass. C4737 enthält eine Kupplungsscheibe / This part number includes one clutch disc	(45)
				<b>1864 600 303</b> ▽	280C (22x25-10N)	->Chass. C4737 Anzahl der Beläge / Number of pads: 4 Lose Kupplungsscheibe / Loose clutch disc	(7) (30)
				<b>1888 600 107</b>	DUT280 (280/35x40-14N)	->Chass. D4737 enthält eine Kupplungsscheibe / This part number includes one clutch disc	(45)
				<b>1888 600 109</b> ●	DUT280/ CERAM (280/35x40-14N)	->Chass. D4737 enthält eine Kupplungsscheibe / This part number includes one clutch disc	(45)
				<b>1864 600 345</b> ▽	280C (22x25-10N)	->Chass. D4737 Anzahl der Beläge / Number of pads: 3 Lose Kupplungsscheibe / Loose clutch disc	(7) (30)
				<b>1863 858 002</b>	75/115/20	ohne Anlauftring / without thrust ring	(79)
				<b>1863 838 001</b>	50/82/29	ohne Anlauftring / without thrust ring	(79)
				<b>1863 869 019</b>	17/47/14		
TN 65 D/S	11.98 - 12.03			<b>1888 600 109</b>	DUT280/ CERAM (280/35x40-14N)	->Chass. C4737 enthält eine Kupplungsscheibe / This part number includes one clutch disc	(45)
				<b>1864 600 303</b> ▽	280C (22x25-10N)	->Chass. C4737 Anzahl der Beläge / Number of pads: 4 Lose Kupplungsscheibe / Loose clutch disc	(7) (30)
				<b>1888 600 109</b>	DUT280/ CERAM (280/35x40-14N)	->Chass. D4737 enthält eine Kupplungsscheibe / This part number includes one clutch disc	(45)
				<b>1864 600 345</b> ▽	280C (22x25-10N)	->Chass. D4737 Anzahl der Beläge / Number of pads: 3 Lose Kupplungsscheibe / Loose clutch disc	(7) (30)
				<b>1863 838 001</b>	50/82/29	ohne Anlauftring / without thrust ring	(79)
				<b>1863 858 002</b>	75/115/20	ohne Anlauftring / without thrust ring	(79)
				<b>1863 869 019</b>	17/47/14		
			TN 65 F TN 70 D TN 70 S	09.97 - 10.01 06.00 - 12.03 06.00 - 12.03			<b>1888 600 144</b>
	<b>1864 600 345</b> ▽	280C (22x25-10N)				->Chass. D4737 Anzahl der Beläge / Number of pads: 3 Lose Kupplungsscheibe / Loose clutch disc	(7) (30)
	<b>1888 600 144</b>	DUT280/ CERAM (280/35x40-14N)				->Chass. C4737 enthält eine Kupplungsscheibe / This part number includes one clutch disc	(45)
	<b>1864 600 303</b> ▽	280C (22x25-10N)				->Chass. C4737 Anzahl der Beläge / Number of pads: 4 Lose Kupplungsscheibe / Loose clutch disc	(7) (30)
	<b>1863 838 001</b>	50/82/29				ohne Anlauftring / without thrust ring	(79)
	<b>1863 858 002</b>	75/115/20				ohne Anlauftring / without thrust ring	(79)
	<b>1863 869 019</b>	17/47/14					



# NEW HOLLAND

TN - Series							
TN 65 V TN 70	05.00 - 05.04 09.99 - 03.08			<b>1888 600 107</b>	DUT280 (280/35x40-14N)	-> <b>Chass. C4737</b> enthält eine Kupplungsscheibe / This part number includes one clutch disc	(45)
				<b>1864 600 303</b> ▽	280C (22x25-10N)	-> <b>Chass. C4737</b> Anzahl der Beläge / Number of pads: 4 Lose Kupplungsscheibe / Loose clutch disc	(7) (30)
				<b>1888 600 107</b>	DUT280 (280/35x40-14N)	-> <b>Chass. D4737</b> enthält eine Kupplungsscheibe / This part number includes one clutch disc	(45)
				<b>1864 600 345</b> ▽	280C (22x25-10N)	-> <b>Chass. D4737</b> Anzahl der Beläge / Number of pads: 3 Lose Kupplungsscheibe / Loose clutch disc	(7) (30)
				<b>1863 838 001</b>	50/82/29	ohne Anlauffring / without thrust ring	(79)
				<b>1863 858 002</b>	75/115/20	ohne Anlauffring / without thrust ring	(79)
				<b>1863 869 019</b>	17/47/14		
TN 70 A	12.03 -			<b>1888 600 109</b>	DUT280/ CERAM (280/35x40-14N)	enthält eine Kupplungsscheibe / This part number includes one clutch disc	(45)
				<b>1864 600 345</b> ▽	280C (22x25-10N)	Anzahl der Beläge / Number of pads: 3 Lose Kupplungsscheibe / Loose clutch disc	(7) (30)
				<b>1863 858 002</b>	75/115/20	ohne Anlauffring / without thrust ring	(79)
				<b>1863 838 001</b>	50/82/29	ohne Anlauffring / without thrust ring	(79)
				<b>1863 869 019</b>	17/47/14		
TN 70 F	10.01 - 01.04			<b>1888 600 144</b>	DUT280/ CERAM (280/35x40-14N)	enthält eine Kupplungsscheibe / This part number includes one clutch disc	(45)
				<b>1864 600 345</b> ▽	280C (22x25-10N)	Anzahl der Beläge / Number of pads: 3 Lose Kupplungsscheibe / Loose clutch disc	(7) (30)
				<b>1863 858 002</b>	75/115/20	ohne Anlauffring / without thrust ring	(79)
				<b>1863 838 001</b>	50/82/29	ohne Anlauffring / without thrust ring	(79)
				<b>1863 869 019</b>	17/47/14		
				<b>1882 600 101</b>	G280N	mit Lastschaltgetriebe / with power shift transmission	(64)
				<b>1864 600 303</b> ▽	280C (22x25-10N)	Anzahl der Beläge / Number of pads: 4 Lose Kupplungsscheibe / Loose clutch disc mit Lastschaltgetriebe / with power shift transmission	(7) (30) (64)
				<b>1863 858 002</b>	75/115/20	mit Lastschaltgetriebe / with power shift transmission ohne Anlauffring / without thrust ring	(64) (79)
				<b>1863 869 019</b>	17/47/14	mit Lastschaltgetriebe / with power shift transmission	(64)

TNDA - Series							
TN 60 DA TN 70 DA	12.03 - 12.03 -			<b>1888 600 109</b>	DUT280/ CERAM (280/35x40-14N)	-> <b>Chass. C4941</b> enthält eine Kupplungsscheibe / This part number includes one clutch disc	(45)
				<b>1888 600 144</b> ●	DUT280/ CERAM (280/35x40-14N)	-> <b>Chass. C4941</b> enthält eine Kupplungsscheibe / This part number includes one clutch disc	(45)
				<b>1888 600 107</b>	DUT280 (280/35x40-14N)	-> <b>Chass. D4941</b> enthält eine Kupplungsscheibe / This part number includes one clutch disc	(45)
				<b>1864 600 345</b> ▽	280C (22x25-10N)	Anzahl der Beläge / Number of pads: 3 Lose Kupplungsscheibe / Loose clutch disc	(7) (30)
				<b>1863 858 002</b>	75/115/20	ohne Anlauffring / without thrust ring	(79)
				<b>1863 838 001</b>	50/82/29	ohne Anlauffring / without thrust ring	(79)
				<b>1863 869 019</b>	17/47/14		
TN 75 DA	12.03 -			<b>1888 600 144</b>	DUT280/ CERAM (280/35x40-14N)	enthält eine Kupplungsscheibe / This part number includes one clutch disc	(45)
				<b>1864 600 345</b> ▽	280C (22x25-10N)	Anzahl der Beläge / Number of pads: 3 Lose Kupplungsscheibe / Loose clutch disc	(7) (30)
				<b>1863 838 001</b>	50/82/29	ohne Anlauffring / without thrust ring	(79)
				<b>1863 858 002</b>	75/115/20	ohne Anlauffring / without thrust ring	(79)
				<b>1863 869 019</b>	17/47/14		

# NEW HOLLAND

TNDA - Series							
TN 85 DA TN 95 DA	10.05 -			<b>1888 600 144</b>	DUT280/ CERAM (280/35x40-14N)	enthält eine Kupplungsscheibe / This part number includes one clutch disc	(45)
	10.05 -			<b>1864 600 303</b> ▽	280C (22x25-10N)	Anzahl der Beläge / Number of pads: 4 Lose Kupplungsscheibe / Loose clutch disc	(7) (30)
				<b>1863 838 001</b>	50/82/29	ohne Anlauftring / without thrust ring	(79)
				<b>1863 858 002</b>	75/115/20	ohne Anlauftring / without thrust ring	(79)
				<b>1863 869 019</b>	17/47/14		

TNSA - Series							
TN 60 SA TN 70 SA	12.03 - 12.03 -			<b>1888 600 109</b>	DUT280/ CERAM (280/35x40-14N)	<b>-&gt;Chass. C4941</b> enthält eine Kupplungsscheibe / This part number includes one clutch disc	(45)
				<b>1888 600 144</b> ●	DUT280/ CERAM (280/35x40-14N)	<b>-&gt;Chass. C4941</b> enthält eine Kupplungsscheibe / This part number includes one clutch disc	(45)
				<b>1888 600 107</b>	DUT280 (280/35x40-14N)	<b>-&gt;Chass. D4941</b> enthält eine Kupplungsscheibe / This part number includes one clutch disc	(45)
				<b>1864 600 345</b> ▽	280C (22x25-10N)	Anzahl der Beläge / Number of pads: 3 Lose Kupplungsscheibe / Loose clutch disc	(7) (30)
				<b>1863 858 002</b>	75/115/20	ohne Anlauftring / without thrust ring	(79)
				<b>1863 838 001</b>	50/82/29	ohne Anlauftring / without thrust ring	(79)
				<b>1863 869 019</b>	17/47/14		
TN 75 SA	12.03 -			<b>1888 600 144</b>	DUT280/ CERAM (280/35x40-14N)	<b>-&gt;Chass. C4941</b> enthält eine Kupplungsscheibe / This part number includes one clutch disc	(45)
				<b>1888 600 109</b>	DUT280/ CERAM (280/35x40-14N)	<b>-&gt;Chass. C4941</b> enthält eine Kupplungsscheibe / This part number includes one clutch disc	(45)
				<b>1888 600 144</b>	DUT280/ CERAM (280/35x40-14N)	<b>-&gt;Chass. D4941</b> enthält eine Kupplungsscheibe / This part number includes one clutch disc	(45)
				<b>1864 600 345</b> ▽	280C (22x25-10N)	Anzahl der Beläge / Number of pads: 3 Lose Kupplungsscheibe / Loose clutch disc	(7) (30)
				<b>1863 858 002</b>	75/115/20	ohne Anlauftring / without thrust ring	(79)
				<b>1863 838 001</b>	50/82/29	ohne Anlauftring / without thrust ring	(79)
				<b>1863 869 019</b>	17/47/14		
TN 85 SA	10.05 -			<b>1888 600 144</b>	DUT280/ CERAM (280/35x40-14N)	enthält eine Kupplungsscheibe / This part number includes one clutch disc	(45)
				<b>1864 600 303</b> ▽	280C (22x25-10N)	Anzahl der Beläge / Number of pads: 4 Lose Kupplungsscheibe / Loose clutch disc	(7) (30)
				<b>1863 858 002</b>	75/115/20	ohne Anlauftring / without thrust ring	(79)
				<b>1863 838 001</b>	50/82/29	ohne Anlauftring / without thrust ring	(79)
				<b>1863 869 019</b>	17/47/14		



# NEW HOLLAND

TNVA - Series							
TN 70 VA	05.04-			1888 600 107	DUT280 (280/35x40-14N)	->Chass. C4941 enthält eine Kupplungsscheibe / This part number includes one clutch disc	(45)
				1864 600 345 ▽	280C (22x25-10N)	->Chass. C4941 Anzahl der Beläge / Number of pads: 3 Lose Kupplungsscheibe / Loose clutch disc	(7) (30)
				1888 600 144	DUT280/ CERAM (280/35x40-14N)	->Chass. D4941 enthält eine Kupplungsscheibe / This part number includes one clutch disc	(45)
				1864 600 345 ▽	280C (22x25-10N)	->Chass. D4941 Anzahl der Beläge / Number of pads: 3 Lose Kupplungsscheibe / Loose clutch disc	(7) (30)
				1863 838 001	50/82/29	ohne Anlauftring / without thrust ring	(79)
				1863 858 002	75/115/20	ohne Anlauftring / without thrust ring	(79)
				1863 869 019	17/47/14		
				1882 600 101	G280N	mit Lastschaltgetriebe / with power shift transmission	(64)
				1864 600 303	280C (22x25-10N)	Anzahl der Beläge / Number of pads: 4 mit Lastschaltgetriebe / with power shift transmission	(7) (64)
				1863 858 002	75/115/20	mit Lastschaltgetriebe / with power shift transmission ohne Anlauftring / without thrust ring	(64) (79)
				1863 869 019	17/47/14	mit Lastschaltgetriebe / with power shift transmission	(64)

# NORDDEUTSCHE TRAKTORENFABRIK (NORDTRAK)

Stier							
241				1882 196 005	KS200		
				1864 634 039	200Z (23x29-10N)		
				1859 600 001			
				1805 042 000			

# NORDWESTDEUTSCHER FAHRZEUGBAU















BK							
BK 110				1881 039 531 #	G350		
				1863 100 030	55/90,5/25	mit Anlauftring / with thrust ring	(63)

HK							
HK (90PS)				1880 083 132 #	G280		
				1863 100 030	55/90,5/25	mit Anlauftring / with thrust ring	(63)













# NORMAG

F..-Serie							
F I-F III (15-28PS) F12 F16 F22				1881 089 010	K225	Nur bei Altteil-Rückgabe lieferbar (Reparatur; Werk Bielefeld) / Please return old unit for repair (plant Bielefeld)	(33)
				1860 039 024 #	225Z (23x29-10N)		
				1859 600 001			
				1805 042 000			













# NORMAG



NG...-Serie							
NG16 (16PS)		1881 089 010	K225	Nur bei Altteil-Rückgabe lieferbar (Reparatur; Werk Bielefeld) / Please return old unit for repair (plant Bielefeld)	(33)		
		1860 039 024 #	225Z (23x29-10N)				
		1859 600 001					
		1805 042 000					
NG23 (25PS)		1881 089 010	K225	Nur bei Altteil-Rückgabe lieferbar (Reparatur; Werk Bielefeld) / Please return old unit for repair (plant Bielefeld)	(33)		
		1864 634 026	225Z (26x32-10N)				
		1859 600 001					
		1805 042 000					
NG35 (35PS)		1881 009 201 #	G250				
		1864 202 035 #	250Z (26x32-10N)				
		1859 600 001					
		1805 042 000					
NG45		1880 083 132 #	G280				
		1863 100 030	55/90,5/25	mit Anlauffring / with thrust ring	(63)		











# ORENSTEIN KOPPEL





A...-Serie							
AS100		1882 155 009	K160				
		1864 634 046	160E (16x20-10N)				
		3151 994 801					
		1805 041 100					
AS100 S8		1882 315 002	KS180				
		1864 039 013 #	180E (18x23-10N)				
		3159 140 004					
		1805 041 200					
K...-Serie							
K300 S		1880 071 011	K225				
		1864 634 026	225Z (26x32-10N)				
K301 S		1882 162 001	KS225S	Nur bei Altteil-Rückgabe lieferbar (Reparatur; Werk Bielefeld) / Please return old unit for repair (plant Bielefeld)	(33)		
		1860 039 024 #	225Z (23x29-10N)				
KS4		1881 010 139 #	G250				

# ORENSTEIN KOPPEL

L..-Serie							
L4		F22511		3082 121 031	M228		
				1864 634 008	225Z (18x23-10N)		
				3151 021 001			
				3130 014 000			
				3100 700 101 ● ◦ 3151 021 001 ⌋ 2x 3130 010 200	KTI-1		
L4 A				1881 089 002	K225		
				1864 634 008	225Z (18x23-10N)		
				3151 021 001			
				3130 014 000			
				3100 700 101 ● ◦ 3151 021 001 ⌋ 2x 3130 010 200	KTI-1		
LS041				1881 010 101 #	G250		
				1864 202 035 #	250Z (26x32-10N)		









M..-Serie							
M3		F2L712, 812		1881 059 208	KS200		
				1864 634 030	200Z (26x32-10N)		

S..-Serie							
S10 Radlader / wheel loader		F1L410, 411		1882 315 002	KS180		
				1864 039 013 #	180E (18x23-10N)		
				3159 140 004			
				1805 041 200			
S16				1881 089 002	K225		
				1864 634 008	225Z (18x23-10N)		
				3151 021 001			
				3130 014 000			
				3100 700 101 ● ◦ 3151 021 001 ⌋ 2x 3130 010 200	KTI-1		
S18				1880 071 008	K225		
				1860 039 024 #	225Z (23x29-10N)		

T..-Serie							
T18 A				1881 089 002	K225		
				1860 039 024 #	225Z (23x29-10N)		
				1859 600 001			
				1805 042 000			













# OSTNER







Rex							
Rex 4 (1-1,5t)		1881 089 002	K225	Diesel / Diesel	(11)		
		1860 039 025 #	225Z (1 1/8"-10N)	Diesel / Diesel	(11)		
		1859 600 001		Diesel / Diesel	(11)		
		1805 042 000		Diesel / Diesel	(11)		
Rex (1,5t)		1881 009 201 #	G250	Diesel / Diesel	(11)		
		1860 056 124 #	250Z (1 1/8"-10N)	Diesel / Diesel	(11)		
		1859 600 001		Diesel / Diesel	(11)		
		1805 042 000		Diesel / Diesel	(11)		

# PAUS

RL							
RL 45		1866 024 001	360/ 159NGS	max. übertragbares Motormoment [Nm] / max. transmittable engine torque [Nm]: 660	(62)		









# PORSCHE

A..-Serie							
A 1A A 1C A 111		1882 315 003	KS180				
		1864 634 040	180E (23x29-10N)				
		1859 600 004					
		1805 041 100					
A 3A A 133		1881 009 201 #	G250				
		1864 202 035 #	250Z (26x32-10N)				
		1859 600 006					
		1805 042 000					
A 208		1881 059 208	KS200				
		1864 634 039	200Z (23x29-10N)				





L..-Serie							
L 310 Super L 318 (38PS) L 319 Super		1881 050 428 #	DO250 (Mo 250/23x29-10N) (Ge 225/46x50-8N)	enthält zwei Kupplungsscheiben / This part number includes both clutch discs Nur bei Altteil-Rückgabe lieferbar (Reparatur; Werk Bielefeld) / Please return old unit for repair (plant Bielefeld)	(46)		
		1863 600 123	65/101,5/26	mit Anlauftring / with thrust ring	(63)		
L 408		1881 051 204	DO280 (Ge 250/46x50-8N) (Mo 280/28x35-10N)	enthält zwei Kupplungsscheiben / This part number includes both clutch discs Nur bei Altteil-Rückgabe lieferbar (Reparatur; Werk Bielefeld) / Please return old unit for repair (plant Bielefeld)	(46)		
		1863 600 123	65/101,5/26	mit Anlauftring / with thrust ring	(63)		
L 419		1881 051 310 #	DO280 (Mo 280/23x29-10N) (Ge 250/46x50-8N)	enthält zwei Kupplungsscheiben / This part number includes both clutch discs	(46)		
		1863 600 123	65/101,5/26	mit Anlauftring / with thrust ring	(63)		

# PORSCHE





## N...-Serie

N 308 N 309 N 428 N 429		1881 009 201 #	G250		
		1864 202 035 #	250Z (26x32-10N)		
		1859 600 006			
		1805 042 000			
N 408		1881 051 204	DO280 (Ge 250/46x50-8N) (Mo 280/28x35-10N)	enthält zwei Kupplungsscheiben / This part number includes both clutch discs Nur bei Altteil-Rückgabe lieferbar (Reparatur; Werk Bielefeld) / Please return old unit for repair (plant Bielefeld)	(46) (33)
		1863 600 123	65/101,5/26	mit Anlauftring / with thrust ring	(63)
N 418 (50PS)		1881 051 310 #	DO280 (Mo 280/23x29-10N) (Ge 250/46x50-8N)	enthält zwei Kupplungsscheiben / This part number includes both clutch discs	(46)
		1863 600 123	65/101,5/26	mit Anlauftring / with thrust ring	(63)













## S...-Serie

S 309		1881 009 201 #	G250		
		1864 202 035 #	250Z (26x32-10N)		
		1859 600 006			
		1805 042 000			

## V...-Serie







V 309 V 429		1881 009 201 #	G250		
		1864 202 035 #	250Z (26x32-10N)		
		1859 600 006			
		1805 042 000			

## 108 - 312

108 Junior		1882 315 003	KS180		
		1864 634 040	180E (23x29-10N)		
		1859 600 004			
		1805 041 100			
217 Standard T 238 Standard Star		1882 196 005	KS200		
		1864 153 133	200Z (21x26-10N)		
		3100 700 101 ◊ 3151 021 001 ⌋ 2x 3130 010 200	KTI-1		
218 Standard H		1882 196 005	KS200		
		1864 634 039	200Z (23x29-10N)		
		3100 700 101 ◊ 3151 021 001 ⌋ 2x 3130 010 200	KTI-1		
308 A		1881 010 139 #	G250		
		1864 202 035 #	250Z (26x32-10N)		















## PORSCHE

### 108 - 312

308 Super		1881 009 201 #	G250		
		1864 202 035 #	250Z (26x32-10N)		
		3151 093 041			
		1805 042 000			
308 Super B 312 3A		1881 009 201 #	G250		
		1864 202 035 #	250Z (26x32-10N)		













## POTRATZ

### 800 - 1400

800 801		1882 315 002	KS180		
		1864 634 040	180E (23x29-10N)		
		3159 140 004			
		1805 041 100			
1000 D		1882 315 002	KS180	Allrad / All-wheel Drive	(6)
		1864 634 040	180E (23x29-10N)	Allrad / All-wheel Drive	(6)
		3159 140 004		Allrad / All-wheel Drive	(6)
		1805 041 100		Allrad / All-wheel Drive	(6)
1001 D 1400 K		1882 196 005	KS200		
		1864 634 030	200Z (26x32-10N)		
		3151 021 001			
		3130 014 000			
		3100 700 101  3151 021 001  2x 3130 010 200	KTI-1		





## PRIMUS





### P..-Serie

P 3 (30,36PS)		1881 009 203 #	G250		
		1864 202 035 #	250Z (26x32-10N)		
		1859 600 001			
		1805 042 000			
PD 1Z (17PS)		1882 315 003	KS180		
		1864 634 040	180E (23x29-10N)		
		1859 600 002			
		1805 041 100			
PD 2 (20,24PS)		1881 089 002	K225		
		1864 634 024	225Z (1 1/4"-10N)		
		1859 600 001			
		1805 042 000			



					Parameter		
---	--	--	--	--	-----------	---	---



## PRIMUS

P..-Serie							
PD 2L (24PS)				1882 196 005	KS200		
				1864 634 039	200Z (23x29-10N)		
				1859 600 001			
				1805 042 000			





U..-Serie							
U 22				1881 089 002	K225		
				1864 634 024	225Z (1 1/4"-10N)		
				1859 600 001			
				1805 042 000			

## PUTZMEISTER





Betonfördermaschine / Concrete hauling engine							
Betonfördermaschine / Concrete-transport machine				3082 170 103	M180		
				1860 023 012	180E (26x32-10N)		

Betonpumpe / Concrete-pump							
Betonpumpe / Concrete-pump				3082 199 102	M180		
				1860 023 012	180E (26x32-10N)		



## RAFFLENBEUL

D..-Serie							
D 6 D 7 D 8				1882 155 009	K160		
				3159 140 004			
				1805 041 100			
DB 12 (580ccm)				1882 313 001	KS180	Nur bei Altteil-Rückgabe lieferbar (Reparatur; Werk Bielefeld) / Please return old unit for repair (plant Bielefeld)	(33)

## RAPID

















Mot.-Mäher							
505 606				1882 155 009	K160		
				1864 339 131 #	160 (18x20-18N)		
				3151 994 801			
				1805 041 100			

## REFORM





Geräteträger / equipment rack							
Geräteträger				3082 147 033	MF240		
				1878 005 623	240TD (27x30-18N)		

# REFORM









**Metrac**

<b>G4 G5 G6 H4 H5 H6 2004 3004 4004</b>		V2203, V2403-M-T, V1903, V2403-M, VM-D754SE 3		<b>3082 058 031</b>	M215		
				<b>1861 994 003</b>	215CD (27x30-18N)		
				<b>3151 193 041</b>			
<b>2002</b>				<b>1881 065 101</b>	KS180		
				<b>1864 066 209</b>	180E (18x23-10N)		
				<b>3159 140 004</b>			
				<b>1805 041 100</b>			
<b>3000</b>				<b>1882 196 005</b>	KS200		
				<b>1864 634 039</b>	200Z (23x29-10N)		
				<b>3100 700 101</b>  <b>3151 021 001</b>  <b>2x 3130 010 200</b>	KTI-1		
				<b>3082 058 031</b>	M215		
<b>3003</b>				<b>3082 058 031</b>	M215		
				<b>1861 994 004</b>	215CD (23x29-10N)	je nach Ausführung, mit unterschiedlicher Kupplung / depending on version, with different clutch	(61)
				<b>1861 994 003</b>	215CD (27x30-18N)	je nach Ausführung, mit unterschiedlicher Kupplung / depending on version, with different clutch	(61)
				<b>3151 193 041</b>			

**Mot.-Mäher**

<b>M12</b>				<b>1882 155 009</b>	K160		
				<b>1864 006 147</b>	160E (18x23-10N)		
				<b>3151 994 801</b>			
				<b>1805 041 100</b>			

**Muli**

<b>30 400</b>				<b>3082 058 031</b>	M215		
				<b>1861 994 004</b>	215CD (23x29-10N)		
				<b>3151 193 041</b>			
<b>500 600</b>				<b>1888 069 001</b>	DUT250 (250/31x35-16N)	enthält eine Kupplungsscheibe / This part number includes one clutch disc	(45)
				<b>1864 202 006</b> ▽	250Z (22x25-15N)	Lose Kupplungsscheibe / Loose clutch disc	(30)
				<b>1878 076 401</b> ●▽	250TPZ (22x25-15N)	Lose Kupplungsscheibe / Loose clutch disc	(30)
<b>4000 5000 6000 7000</b>				<b>1864 202 006</b> ▽	250Z (22x25-15N)	Lose Kupplungsscheibe / Loose clutch disc	(30)
				<b>1878 076 401</b> ●▽	250TPZ (22x25-15N)	Lose Kupplungsscheibe / Loose clutch disc	(30)



# RENAULT AGRICULTURE

## 50.-Serie

50-12 LB (R3201) 50-12 V (R3215)			⊗	1888 998 501 #	DUT280 (280/34x40-12N)	enthält eine Kupplungsscheibe / This part number includes one clutch disc	(45)
			⊗	1864 996 101 ▽#	280 (18,7x22,2-13N)	Lose Kupplungsscheibe / Loose clutch disc	(30)

## 55.-Serie

55-12 F (R3246) 55-12 LB (R3221) 55-12 V (R3235) 55-14 LB (R3222) 55-14 V (R3237)			⊗	1888 998 501 #	DUT280 (280/34x40-12N)	enthält eine Kupplungsscheibe / This part number includes one clutch disc	(45)
			⊗	1864 996 101 ▽#	280 (18,7x22,2-13N)	Lose Kupplungsscheibe / Loose clutch disc	(30)

## 58.-Serie

58-12 (R3111) 58-14 (R3112)			⊗	1888 869 007 #	DUT280 (280/40x45-16N)	enthält eine Kupplungsscheibe / This part number includes one clutch disc	(45)
			⊗	1864 950 003 ▽#	280 (22x25-13N)	Lose Kupplungsscheibe / Loose clutch disc	(30)
			⊗	1863 837 002	65/97/23	mit Anlauftring / with thrust ring	(63)
			⊗	1863 855 000	106/140/25	mit Anlauftring / with thrust ring	(63)
58-32 (R3112) 58-34 (R3112)			⊗	1888 869 007 #	DUT280 (280/40x45-16N)	enthält eine Kupplungsscheibe / This part number includes one clutch disc	(45)
			⊗	1864 950 003 ▽#	280 (22x25-13N)	Lose Kupplungsscheibe / Loose clutch disc	(30)
			⊗	1888 868 010 #	DUT310 (280/40x45-16N)	Je nach Kundenwunsch mit unterschiedlicher Kupplung / Equipped with different clutch according to customer requirement enthält eine Kupplungsscheibe / This part number includes one clutch disc	(26) (45)
			⊗	1864 918 005 ▽#	310 (21,5x25-13N)	Lose Kupplungsscheibe / Loose clutch disc	(30)
			⊗	1863 837 002	65/97/23	mit Anlauftring / with thrust ring	(63)
			⊗	1863 855 000	106/140/25	mit Anlauftring / with thrust ring	(63)































## 61.-Serie

61-12 (R7711) 61-14 (R7712)			⊗	1888 869 007 #	DUT280 (280/40x45-16N)	enthält eine Kupplungsscheibe / This part number includes one clutch disc	(45)
			⊗	1864 950 003 ▽#	280 (22x25-13N)	Lose Kupplungsscheibe / Loose clutch disc	(30)
			⊗	1863 837 002	65/97/23	mit Anlauftring / with thrust ring	(63)
			⊗	1863 855 000	106/140/25	mit Anlauftring / with thrust ring	(63)

## 65.-Serie



























65-12 (R7711) 65-12 LS (R3121) 65-14 (R7712) 65-14 LS (R3122) 65-32 (R3121)			⊗	1888 869 007 #	DUT280 (280/40x45-16N)	enthält eine Kupplungsscheibe / This part number includes one clutch disc	(45)
			⊗	1864 950 003 ▽#	280 (22x25-13N)	Lose Kupplungsscheibe / Loose clutch disc	(30)
			⊗	1863 837 002	65/97/23	mit Anlauftring / with thrust ring	(63)
			⊗	1863 855 000	106/140/25	mit Anlauftring / with thrust ring	(63)
65-34 (R3122)			⊗	1888 868 010 #	DUT310 (280/40x45-16N)	Je nach Kundenwunsch mit unterschiedlicher Kupplung / Equipped with different clutch according to customer requirement enthält eine Kupplungsscheibe / This part number includes one clutch disc	(26) (45)
			⊗	1864 918 005 ▽#	310 (21,5x25-13N)	Lose Kupplungsscheibe / Loose clutch disc	(30)
			⊗	1888 869 007 #	DUT280 (280/40x45-16N)	enthält eine Kupplungsscheibe / This part number includes one clutch disc	(45)
			⊗	1864 950 003 ▽#	280 (22x25-13N)	Lose Kupplungsscheibe / Loose clutch disc	(30)
			⊗	1863 855 000	106/140/25	mit Anlauftring / with thrust ring	(63)
			⊗	1863 837 002	65/97/23	mit Anlauftring / with thrust ring	(63)

# RENAULT AGRICULTURE

68.-Serie						
68-12 (R7721)		1888 868 010 #	DUT310 (280/40x45-16N)	->Chass. 70592 enthält eine Kupplungsscheibe / This part number includes one clutch disc	(45)	
		1864 918 005 ▽#	310 (21,5x25-13N)	->Chass. 70592 Lose Kupplungsscheibe / Loose clutch disc	(30)	
		1888 869 007 #	DUT280 (280/40x45-16N)	Chass. 70593-> enthält eine Kupplungsscheibe / This part number includes one clutch disc	(45)	
		1864 950 003 ▽#	280 (22x25-13N)	Chass. 70593-> Lose Kupplungsscheibe / Loose clutch disc	(30)	
		1863 837 002	65/97/23	mit Anlauftring / with thrust ring	(63)	
		1863 855 000	106/140/25	mit Anlauftring / with thrust ring	(63)	
68-14 (R7722)		1888 868 010 #	DUT310 (280/40x45-16N)	->Chass. 70753 enthält eine Kupplungsscheibe / This part number includes one clutch disc	(45)	
		1864 918 005 ▽#	310 (21,5x25-13N)	->Chass. 70753 Lose Kupplungsscheibe / Loose clutch disc	(30)	
		1888 869 007 #	DUT280 (280/40x45-16N)	Chass. 70754-> enthält eine Kupplungsscheibe / This part number includes one clutch disc	(45)	
		1864 950 003 ▽#	280 (22x25-13N)	Chass. 70754-> Lose Kupplungsscheibe / Loose clutch disc	(30)	
		1863 837 002	65/97/23	mit Anlauftring / with thrust ring	(63)	
		1863 855 000	106/140/25	mit Anlauftring / with thrust ring	(63)	
70.-Serie						
70-12 (R3131) 70-14 (R3132) 70-32 PA (R3131) 70-34 PA (R3132)		1888 869 007 #	DUT280 (280/40x45-16N)	enthält eine Kupplungsscheibe / This part number includes one clutch disc	(45)	
		1864 950 003 ▽#	280 (22x25-13N)	Lose Kupplungsscheibe / Loose clutch disc	(30)	
		1863 837 002	65/97/23	mit Anlauftring / with thrust ring	(63)	
		1863 855 000	106/140/25	mit Anlauftring / with thrust ring	(63)	
70-12 F (R3266) 70-12 LB (R3241) 70-12 V (R3255) 70-14 F (R3268) 70-14 LB (R3242) 70-14 V (R3257)		1888 998 501 #	DUT280 (280/34x40-12N)	enthält eine Kupplungsscheibe / This part number includes one clutch disc	(45)	
		1864 996 101 ▽#	280 (18,7x22,2-13N)	Lose Kupplungsscheibe / Loose clutch disc	(30)	
75.-Serie						
75-12 (R3441,7731)		1888 869 007 #	DUT280 (280/40x45-16N)	Chass. 71193-> enthält eine Kupplungsscheibe / This part number includes one clutch disc	(45)	
		1864 950 003 ▽#	280 (22x25-13N)	Chass. 71193-> Lose Kupplungsscheibe / Loose clutch disc	(30)	
		1863 855 000	106/140/25	Chass. 71193-> mit Anlauftring / with thrust ring	(63)	
		1863 837 002	65/97/23	Chass. 71193-> mit Anlauftring / with thrust ring	(63)	
75-12 (R7731)		1888 868 010 #	DUT310 (280/40x45-16N)	->Chass. 71192 enthält eine Kupplungsscheibe / This part number includes one clutch disc	(45)	
		1864 918 005 ▽#	310 (21,5x25-13N)	->Chass. 71192 Lose Kupplungsscheibe / Loose clutch disc	(30)	
		1863 837 002	65/97/23	mit Anlauftring / with thrust ring	(63)	
		1863 855 000	106/140/25	mit Anlauftring / with thrust ring	(63)	
75-12 LS (R3141) 75-14 LS (R3142)		1888 868 010 #	DUT310 (280/40x45-16N)	enthält eine Kupplungsscheibe / This part number includes one clutch disc	(45)	
		1864 918 005 ▽#	310 (21,5x25-13N)	Lose Kupplungsscheibe / Loose clutch disc	(30)	
		1863 837 002	65/97/23	mit Anlauftring / with thrust ring	(63)	
		1863 855 000	106/140/25	mit Anlauftring / with thrust ring	(63)	

# RENAULT AGRICULTURE







## 75.-Serie

75-14 (R7732)		1888 868 010 #	DUT310 (280/40x45-16N)	->Chass. 72783 enthält eine Kupplungsscheibe / This part number includes one clutch disc	(45)
		1864 918 005 ▽#	310 (21,5x25-13N)	->Chass. 72783 Lose Kupplungsscheibe / Loose clutch disc	(30)
		1863 837 002	65/97/23	mit Anlauftring / with thrust ring	(63)
		1863 855 000	106/140/25	mit Anlauftring / with thrust ring	(63)
75-14 (R3142,7732)		1888 869 007 #	DUT280 (280/40x45-16N)	Chass. 72784-> enthält eine Kupplungsscheibe / This part number includes one clutch disc	(45)
		1864 950 003 ▽#	280 (22x25-13N)	Chass. 72784-> Lose Kupplungsscheibe / Loose clutch disc	(30)
		1863 837 002	65/97/23	mit Anlauftring / with thrust ring	(63)
		1863 855 000	106/140/25	mit Anlauftring / with thrust ring	(63)
75-32 (R3141)		1888 869 007 #	DUT280 (280/40x45-16N)	->Chass. C1232 enthält eine Kupplungsscheibe / This part number includes one clutch disc	(45)
		1864 950 003 ▽#	280 (22x25-13N)	->Chass. C1232 Lose Kupplungsscheibe / Loose clutch disc	(30)
		1888 868 010 #	DUT310 (280/40x45-16N)	Chass. C1233-> enthält eine Kupplungsscheibe / This part number includes one clutch disc	(45)
		1864 918 005 ▽#	310 (21,5x25-13N)	Chass. C1233-> Lose Kupplungsscheibe / Loose clutch disc	(30)
		1863 837 002	65/97/23	mit Anlauftring / with thrust ring	(63)
		1863 855 000	106/140/25	mit Anlauftring / with thrust ring	(63)
75-32 (R7721)		1888 869 007 #	DUT280 (280/40x45-16N)	->Chass. 71309 enthält eine Kupplungsscheibe / This part number includes one clutch disc	(45)
		1864 950 003 ▽#	280 (22x25-13N)	->Chass. 71309 Lose Kupplungsscheibe / Loose clutch disc	(30)
		1888 868 010 #	DUT310 (280/40x45-16N)	Chass. 71310-> enthält eine Kupplungsscheibe / This part number includes one clutch disc	(45)
		1864 918 005 ▽#	310 (21,5x25-13N)	Chass. 71310-> Lose Kupplungsscheibe / Loose clutch disc	(30)
		1863 837 002	65/97/23	mit Anlauftring / with thrust ring	(63)
		1863 855 000	106/140/25	mit Anlauftring / with thrust ring	(63)
75-34 (R3142)		1888 869 007 #	DUT280 (280/40x45-16N)	->Chass. C2614 enthält eine Kupplungsscheibe / This part number includes one clutch disc	(45)
		1864 950 003 ▽#	280 (22x25-13N)	->Chass. C2614 Lose Kupplungsscheibe / Loose clutch disc	(30)
		1888 868 010 #	DUT310 (280/40x45-16N)	Chass. C2615-> enthält eine Kupplungsscheibe / This part number includes one clutch disc	(45)
		1864 918 005 ▽#	310 (21,5x25-13N)	Chass. C2615-> Lose Kupplungsscheibe / Loose clutch disc	(30)
		1863 837 002	65/97/23	mit Anlauftring / with thrust ring	(63)
		1863 855 000	106/140/25	mit Anlauftring / with thrust ring	(63)















# RENAULT AGRICULTURE







## 75.-Serie

<b>75-34 (R7722)</b>				<b>1888 869 007 #</b>	DUT280 (280/40x45-16N)	-> <b>Chass. 71976</b> nicht für Fahrgestellnummer / not for chassis no.: 71950/51 enthält eine Kupplungsscheibe / This part number includes one clutch disc	(76) (45)
				<b>1864 950 003 ▽#</b>	280 (22x25-13N)	-> <b>Chass. 71976</b> nicht für Fahrgestellnummer / not for chassis no.: 71950/51 Lose Kupplungsscheibe / Loose clutch disc	(76) (30)
				<b>1888 868 010 #</b>	DUT310 (280/40x45-16N)	<b>Chass. 71977-&gt;</b> enthält eine Kupplungsscheibe / This part number includes one clutch disc	(45)
				<b>1864 918 005 ▽#</b>	310 (21,5x25-13N)	<b>Chass. 71977-&gt;</b> Lose Kupplungsscheibe / Loose clutch disc	(30)
				<b>1863 837 002</b>	65/97/23	nicht für Fahrgestellnummer / not for chassis no.: 71950/51 mit Anlauffring / with thrust ring	(76) (63)
				<b>1863 855 000</b>	106/140/25	nicht für Fahrgestellnummer / not for chassis no.: 71950/51 mit Anlauffring / with thrust ring	(76) (63)

## 77.-Serie

































<b>77-12 (R7721)</b>				<b>1888 868 010 #</b>	DUT310 (280/40x45-16N)	-> <b>Chass. 70592</b> enthält eine Kupplungsscheibe / This part number includes one clutch disc	(45)
				<b>1864 918 005 ▽#</b>	310 (21,5x25-13N)	-> <b>Chass. 70592</b> Lose Kupplungsscheibe / Loose clutch disc	(30)
				<b>1888 869 007 #</b>	DUT280 (280/40x45-16N)	<b>Chass. 70593-&gt;</b> enthält eine Kupplungsscheibe / This part number includes one clutch disc	(45)
				<b>1864 950 003 ▽#</b>	280 (22x25-13N)	<b>Chass. 70593-&gt;</b> Lose Kupplungsscheibe / Loose clutch disc	(30)
				<b>1863 837 002</b>	65/97/23	mit Anlauffring / with thrust ring	(63)
				<b>1863 855 000</b>	106/140/25	mit Anlauffring / with thrust ring	(63)
<b>77-14 (R7722)</b>				<b>1888 868 010 #</b>	DUT310 (280/40x45-16N)	-> <b>Chass. 70753</b> enthält eine Kupplungsscheibe / This part number includes one clutch disc	(45)
				<b>1864 918 005 ▽#</b>	310 (21,5x25-13N)	-> <b>Chass. 70753</b> Lose Kupplungsscheibe / Loose clutch disc	(30)
				<b>1888 869 007 #</b>	DUT280 (280/40x45-16N)	<b>Chass. 70754-&gt;</b> enthält eine Kupplungsscheibe / This part number includes one clutch disc	(45)
				<b>1864 950 003 ▽#</b>	280 (22x25-13N)	<b>Chass. 70754-&gt;</b> Lose Kupplungsscheibe / Loose clutch disc	(30)
				<b>1863 837 002</b>	65/97/23	mit Anlauffring / with thrust ring	(63)
				<b>1863 855 000</b>	106/140/25	mit Anlauffring / with thrust ring	(63)

## 80.-Serie

<b>80-12 (R3151) 80-14 (R3152)</b>				<b>1888 868 010 #</b>	DUT310 (280/40x45-16N)	enthält eine Kupplungsscheibe / This part number includes one clutch disc	(45)
				<b>1864 918 005 ▽#</b>	310 (21,5x25-13N)	Lose Kupplungsscheibe / Loose clutch disc	(30)
				<b>1863 837 002</b>	65/97/23	mit Anlauffring / with thrust ring	(63)
<b>80-12 (R7731)</b>				<b>1888 868 010 #</b>	DUT310 (280/40x45-16N)	-> <b>Chass. 71192</b> enthält eine Kupplungsscheibe / This part number includes one clutch disc	(45)
				<b>1864 918 005 ▽#</b>	310 (21,5x25-13N)	-> <b>Chass. 71192</b> Lose Kupplungsscheibe / Loose clutch disc	(30)
				<b>1863 837 002</b>	65/97/23	mit Anlauffring / with thrust ring	(63)
				<b>1863 855 000</b>	106/140/25	mit Anlauffring / with thrust ring	(63)







# RENAULT AGRICULTURE

## 80.-Serie























80-12 (R3152,7731)		1888 869 007 #	DUT280 (280/40x45-16N)	<b>Chass. 71193-&gt;</b> enthält eine Kupplungsscheibe / This part number includes one clutch disc	(45)
		1864 950 003 ▽#	280 (22x25-13N)	<b>Chass. 71193-&gt;</b> Lose Kupplungsscheibe / Loose clutch disc	(30)
		1863 837 002	65/97/23	mit Anlauftring / with thrust ring	(63)
		1863 855 000	106/140/25	mit Anlauftring / with thrust ring	(63)
80-12 (R7761)		1888 868 010 #	DUT310 (280/40x45-16N)	<b>-&gt;Chass. 70236</b> enthält eine Kupplungsscheibe / This part number includes one clutch disc	(45)
		1864 918 005 ▽#	310 (21,5x25-13N)	<b>-&gt;Chass. 70236</b> Lose Kupplungsscheibe / Loose clutch disc	(30)
		1888 869 007 #	DUT280 (280/40x45-16N)	<b>Chass. 70237-&gt;</b> enthält eine Kupplungsscheibe / This part number includes one clutch disc	(45)
		1864 950 003 ▽#	280 (22x25-13N)	<b>Chass. 70237-&gt;</b> Lose Kupplungsscheibe / Loose clutch disc	(30)
		1863 837 002	65/97/23	mit Anlauftring / with thrust ring	(63)
		1863 855 000	106/140/25	mit Anlauftring / with thrust ring	(63)
		1888 998 501 #	DUT280 (280/34x40-12N)	enthält eine Kupplungsscheibe / This part number includes one clutch disc	(45)
80-12 F (R3276) 80-12 V (R3275) 80-14 F (R3278) 80-14 LB (R3272) 80-14 V (R3277)		1864 996 101 ▽#	280 (18,7x22,2-13N)	Lose Kupplungsscheibe / Loose clutch disc	(30)
		1888 868 010 #	DUT310 (280/40x45-16N)	<b>-&gt;Chass. 72783</b> enthält eine Kupplungsscheibe / This part number includes one clutch disc	(45)
80-14 (R7732)		1864 918 005 ▽#	310 (21,5x25-13N)	<b>-&gt;Chass. 72783</b> Lose Kupplungsscheibe / Loose clutch disc	(30)
		1863 837 002	65/97/23	mit Anlauftring / with thrust ring	(63)
		1863 855 000	106/140/25	mit Anlauftring / with thrust ring	(63)
		1888 869 007 #	DUT280 (280/40x45-16N)	<b>Chass. 72784-&gt;</b> enthält eine Kupplungsscheibe / This part number includes one clutch disc	(45)
80-14 (R3152,7732)		1864 950 003 ▽#	280 (22x25-13N)	<b>Chass. 72784-&gt;</b> Lose Kupplungsscheibe / Loose clutch disc	(30)
		1863 837 002	65/97/23	mit Anlauftring / with thrust ring	(63)
		1863 855 000	106/140/25	mit Anlauftring / with thrust ring	(63)
		1888 868 010 #	DUT310 (280/40x45-16N)	<b>-&gt;Chass. 70940</b> enthält eine Kupplungsscheibe / This part number includes one clutch disc	(45)
80-14 (R7762)		1864 918 005 ▽#	310 (21,5x25-13N)	<b>-&gt;Chass. 70940</b> Lose Kupplungsscheibe / Loose clutch disc	(30)
		1888 869 007 #	DUT280 (280/40x45-16N)	<b>Chass. 70941-&gt;</b> enthält eine Kupplungsscheibe / This part number includes one clutch disc	(45)
		1864 950 003 ▽#	280 (22x25-13N)	<b>Chass. 70941-&gt;</b> Lose Kupplungsscheibe / Loose clutch disc	(30)
		1863 837 002	65/97/23	mit Anlauftring / with thrust ring	(63)
		1863 855 000	106/140/25	mit Anlauftring / with thrust ring	(63)
		1888 869 007 #	DUT280 (280/40x45-16N)	<b>-&gt;Chass. C0306</b> enthält eine Kupplungsscheibe / This part number includes one clutch disc	(45)
80-32 (R3151)		1864 950 003 ▽#	280 (22x25-13N)	<b>-&gt;Chass. C0306</b> Lose Kupplungsscheibe / Loose clutch disc	(30)
		1888 868 010 #	DUT310 (280/40x45-16N)	<b>Chass. C0307-&gt;</b> enthält eine Kupplungsscheibe / This part number includes one clutch disc	(45)
		1864 918 005 ▽#	310 (21,5x25-13N)	<b>Chass. C0307-&gt;</b> Lose Kupplungsscheibe / Loose clutch disc	(30)
		1863 837 002	65/97/23	mit Anlauftring / with thrust ring	(63)
		1863 855 000	106/140/25	mit Anlauftring / with thrust ring	(63)
		1888 869 007 #	DUT280 (280/40x45-16N)	<b>-&gt;Chass. C0306</b> enthält eine Kupplungsscheibe / This part number includes one clutch disc	(45)

# RENAULT AGRICULTURE

## 80.-Serie

























<b>80-34 (R3152)</b>				<b>1888 869 007 #</b>	DUT280 (280/40x45-16N)	-> <b>Chass. C0860</b> enthält eine Kupplungsscheibe / This part number includes one clutch disc	(45)
				<b>1864 950 003 ▽#</b>	280 (22x25-13N)	-> <b>Chass. C0860</b> Lose Kupplungsscheibe / Loose clutch disc	(30)
				<b>1888 868 010 #</b>	DUT310 (280/40x45-16N)	<b>Chass. C0861-&gt;</b> enthält eine Kupplungsscheibe / This part number includes one clutch disc	(45)
				<b>1864 918 005 ▽#</b>	310 (21,5x25-13N)	<b>Chass. C0861-&gt;</b> Lose Kupplungsscheibe / Loose clutch disc	(30)
				<b>1863 837 002</b>	65/97/23	mit Anlauftring / with thrust ring	(63)
				<b>1863 855 000</b>	106/140/25	mit Anlauftring / with thrust ring	(63)

## 85.-Serie

























<b>85-12 (R3161)</b>				<b>1888 868 010 #</b>	DUT310 (280/40x45-16N)	-> <b>Chass. 61C249</b> <b>Chass. 61C714-&gt;</b> enthält eine Kupplungsscheibe / This part number includes one clutch disc	(45)
				<b>1864 918 005 ▽#</b>	310 (21,5x25-13N)	-> <b>Chass. 61C249</b> <b>Chass. 61C714-&gt;</b> Lose Kupplungsscheibe / Loose clutch disc	(30)
				<b>1888 869 007 #</b>	DUT280 (280/40x45-16N)	<b>Chass. 61C250 - Chass. 713</b> enthält eine Kupplungsscheibe / This part number includes one clutch disc	(45)
				<b>1864 950 003 ▽#</b>	280 (22x25-13N)	<b>Chass. 61C250 - Chass. 713</b> Lose Kupplungsscheibe / Loose clutch disc	(30)
				<b>1863 837 002</b>	65/97/23	mit Anlauftring / with thrust ring	(63)
				<b>1863 855 000</b>	106/140/25	mit Anlauftring / with thrust ring	(63)
<b>85-12 (R7761)</b>				<b>1888 868 010 #</b>	DUT310 (280/40x45-16N)	-> <b>Chass. 70236</b> enthält eine Kupplungsscheibe / This part number includes one clutch disc	(45)
				<b>1864 918 005 ▽#</b>	310 (21,5x25-13N)	-> <b>Chass. 70236</b> Lose Kupplungsscheibe / Loose clutch disc	(30)
				<b>1888 869 007 #</b>	DUT280 (280/40x45-16N)	<b>Chass. 70237-&gt;</b> enthält eine Kupplungsscheibe / This part number includes one clutch disc	(45)
				<b>1864 950 003 ▽#</b>	280 (22x25-13N)	<b>Chass. 70237-&gt;</b> Lose Kupplungsscheibe / Loose clutch disc	(30)
				<b>1863 837 002</b>	65/97/23	mit Anlauftring / with thrust ring	(63)
				<b>1863 855 000</b>	106/140/25	mit Anlauftring / with thrust ring	(63)
<b>85-14 (R3162)</b>				<b>1888 868 010 #</b>	DUT310 (280/40x45-16N)	-> <b>Chass. 62C680</b> enthält eine Kupplungsscheibe / This part number includes one clutch disc	(45)
				<b>1864 918 005 ▽#</b>	310 (21,5x25-13N)	-> <b>Chass. 62C680</b> Lose Kupplungsscheibe / Loose clutch disc	(30)
				<b>1888 869 007 #</b>	DUT280 (280/40x45-16N)	<b>Chass. 62C681 - Chass. 1688</b> enthält eine Kupplungsscheibe / This part number includes one clutch disc	(45)
				<b>1864 950 003 ▽#</b>	280 (22x25-13N)	<b>Chass. 62C681 - Chass. 1688</b> Lose Kupplungsscheibe / Loose clutch disc	(30)
				<b>1863 837 002</b>	65/97/23	mit Anlauftring / with thrust ring	(63)
				<b>1863 855 000</b>	106/140/25	mit Anlauftring / with thrust ring	(63)
<b>85-14 (R3171,3172)</b>				<b>1888 868 010 #</b>	DUT310 (280/40x45-16N)	<b>Chass. 62C1689-></b> enthält eine Kupplungsscheibe / This part number includes one clutch disc	(45)
				<b>1864 918 005 ▽#</b>	310 (21,5x25-13N)	<b>Chass. 62C1689-></b> Lose Kupplungsscheibe / Loose clutch disc	(30)
				<b>1863 837 002</b>	65/97/23	mit Anlauftring / with thrust ring	(63)
				<b>1863 855 000</b>	106/140/25	mit Anlauftring / with thrust ring	(63)

# RENAULT AGRICULTURE



























## 85.-Serie

85-14 (R7762)		1888 868 010 #	DUT310 (280/40x45-16N)	->Chass. 70940 enthält eine Kupplungsscheibe / This part number includes one clutch disc	(45)
		1864 918 005 ▽#	310 (21,5x25-13N)	->Chass. 70940 Lose Kupplungsscheibe / Loose clutch disc	(30)
		1888 869 007 #	DUT280 (280/40x45-16N)	Chass. 70941-> enthält eine Kupplungsscheibe / This part number includes one clutch disc	(45)
		1864 950 003 ▽#	280 (22x25-13N)	Chass. 70941-> Lose Kupplungsscheibe / Loose clutch disc	(30)
		1863 837 002	65/97/23	mit Anlauftring / with thrust ring	(63)
		1863 855 000	106/140/25	mit Anlauftring / with thrust ring	(63)
85-32 (R3161)		1888 869 007 #	DUT280 (280/40x45-16N)	->Chass. C0713 enthält eine Kupplungsscheibe / This part number includes one clutch disc	(45)
		1864 950 003 ▽#	280 (22x25-13N)	->Chass. C0713 Lose Kupplungsscheibe / Loose clutch disc	(30)
		1888 868 010 #	DUT310 (280/40x45-16N)	Chass. C0714-> enthält eine Kupplungsscheibe / This part number includes one clutch disc	(45)
		1864 918 005 ▽#	310 (21,5x25-13N)	Chass. C0714-> Lose Kupplungsscheibe / Loose clutch disc	(30)
		1863 837 002	65/97/23	mit Anlauftring / with thrust ring	(63)
		1863 855 000	106/140/25	mit Anlauftring / with thrust ring	(63)
85-32 (R7761)		1888 869 007 #	DUT280 (280/40x45-16N)	->Chass. 70603 enthält eine Kupplungsscheibe / This part number includes one clutch disc	(45)
		1864 950 003 ▽#	280 (22x25-13N)	->Chass. 70603 Lose Kupplungsscheibe / Loose clutch disc	(30)
		1888 868 010 #	DUT310 (280/40x45-16N)	Chass. 70604-> enthält eine Kupplungsscheibe / This part number includes one clutch disc	(45)
		1864 918 005 ▽#	310 (21,5x25-13N)	Chass. 70604-> Lose Kupplungsscheibe / Loose clutch disc	(30)
		1863 837 002	65/97/23	mit Anlauftring / with thrust ring	(63)
		1863 855 000	106/140/25	mit Anlauftring / with thrust ring	(63)
85-34 (R3162)		1888 869 007 #	DUT280 (280/40x45-16N)	->Chass. C1668 enthält eine Kupplungsscheibe / This part number includes one clutch disc	(45)
		1864 950 003 ▽#	280 (22x25-13N)	->Chass. C1668 Lose Kupplungsscheibe / Loose clutch disc	(30)
		1888 868 010 #	DUT310 (280/40x45-16N)	Chass. C1669-> enthält eine Kupplungsscheibe / This part number includes one clutch disc	(45)
		1864 918 005 ▽#	310 (21,5x25-13N)	Chass. C1669-> Lose Kupplungsscheibe / Loose clutch disc	(30)
		1863 837 002	65/97/23	mit Anlauftring / with thrust ring	(63)
		1863 855 000	106/140/25	mit Anlauftring / with thrust ring	(63)

# RENAULT AGRICULTURE

85..-Serie							
<b>85-34 (R7762)</b>				<b>1888 869 007 #</b>	DUT280 (280/40x45-16N)	<b>-&gt;Chass. 71969</b> nicht für Fahrgestellnummer / not for chassis no.: 71950/51 enthält eine Kupplungsscheibe / This part number includes one clutch disc	(76) (45)
				<b>1864 950 003 ▽#</b>	280 (22x25-13N)	<b>-&gt;Chass. 71969</b> nicht für Fahrgestellnummer / not for chassis no.: 71950/51 Lose Kupplungsscheibe / Loose clutch disc	(76) (30)
				<b>1888 868 010 #</b>	DUT310 (280/40x45-16N)	<b>Chass. 71970-&gt;</b> <b>Chass. 71950/51</b> enthält eine Kupplungsscheibe / This part number includes one clutch disc	(45)
				<b>1864 918 005 ▽#</b>	310 (21,5x25-13N)	<b>Chass. 71970-&gt;</b> <b>Chass. 71950/51</b> Lose Kupplungsscheibe / Loose clutch disc	(30)
				<b>1863 837 002</b>	65/97/23	<b>Chass. 71950/51</b> mit Anlauftring / with thrust ring	(63)
				<b>1863 855 000</b>	106/140/25	nicht für Fahrgestellnummer / not for chassis no.: 71950/51 mit Anlauftring / with thrust ring	(76) (63)
<b>85-34 (R9034)</b>				<b>1888 868 010 #</b>	DUT310 (280/40x45-16N)	enthält eine Kupplungsscheibe / This part number includes one clutch disc	(45)
				<b>1864 918 005 ▽#</b>	310 (21,5x25-13N)	Lose Kupplungsscheibe / Loose clutch disc	(30)
				<b>1863 837 002</b>	65/97/23	mit Anlauftring / with thrust ring	(63)
				<b>1863 855 000</b>	106/140/25	mit Anlauftring / with thrust ring	(63)
90..-Serie							
<b>90-32 (R3171)</b>				<b>1888 868 010 #</b>	DUT310 (280/40x45-16N)	<b>-&gt;Chass. C0095</b> enthält eine Kupplungsscheibe / This part number includes one clutch disc	(45)
				<b>1888 895 002 #</b>	DUT330 (330/45x50-16N)	<b>Chass. C0096-&gt;</b> enthält eine Kupplungsscheibe / This part number includes one clutch disc	(45)
				<b>1864 918 005 ▽#</b>	310 (21,5x25-13N)	Lose Kupplungsscheibe / Loose clutch disc	(30)
				<b>1863 837 002</b>	65/97/23	mit Anlauftring / with thrust ring	(63)
				<b>1863 855 000</b>	106/140/25	mit Anlauftring / with thrust ring	(63)
<b>90-32 (R7771) 90-34 (R7771)</b>				<b>1888 868 010 #</b>	DUT310 (280/40x45-16N)	<b>-&gt;Chass. 70052</b> enthält eine Kupplungsscheibe / This part number includes one clutch disc	(45)
				<b>1888 895 002 #</b>	DUT330 (330/45x50-16N)	<b>Chass. 70053-&gt;</b> enthält eine Kupplungsscheibe / This part number includes one clutch disc	(45)
				<b>1864 918 005 ▽#</b>	310 (21,5x25-13N)	Lose Kupplungsscheibe / Loose clutch disc	(30)
				<b>1863 837 002</b>	65/97/23	mit Anlauftring / with thrust ring	(63)
				<b>1863 855 000</b>	106/140/25	mit Anlauftring / with thrust ring	(63)
<b>90-32 MA,ME,MS,MX (R3171)</b>				<b>1888 600 122</b>	DUT330/ CERAM (330/40x45-16N)	<b>Chass. C0096-&gt;</b> enthält eine Kupplungsscheibe / This part number includes one clutch disc	(45)
				<b>1888 895 002 #</b>	DUT330 (330/45x50-16N)	enthält eine Kupplungsscheibe / This part number includes one clutch disc	(45)
				<b>1864 918 005 ▽#</b>	310 (21,5x25-13N)	Lose Kupplungsscheibe / Loose clutch disc	(30)
				<b>1863 837 002</b>	65/97/23	mit Anlauftring / with thrust ring	(63)
				<b>1863 855 000</b>	106/140/25	mit Anlauftring / with thrust ring	(63)

# RENAULT AGRICULTURE

90..-Serie						
90-34 (R3172)		1888 868 010 #	DUT310 (280/40x45-16N)	->Chass. C2954 enthält eine Kupplungsscheibe / This part number includes one clutch disc	(45)	
		1888 895 002 #	DUT330 (330/45x50-16N)	Chass. C2955-> enthält eine Kupplungsscheibe / This part number includes one clutch disc	(45)	
		1864 918 005 ▽#	310 (21,5x25-13N)	Lose Kupplungsscheibe / Loose clutch disc	(30)	
		1863 837 002	65/97/23	mit Anlauftring / with thrust ring	(63)	
		1863 855 000	106/140/25	mit Anlauftring / with thrust ring	(63)	
90-34 (R7772)		1888 868 010 #	DUT310 (280/40x45-16N)	->Chass. 71510 nicht für Fahrgestellnummer / not for chassis no.: 71392 enthält eine Kupplungsscheibe / This part number includes one clutch disc	(76) (45)	
		1888 895 002 #	DUT330 (330/45x50-16N)	Chass. 71511-> Chass. 71392 enthält eine Kupplungsscheibe / This part number includes one clutch disc	(45)	
		1888 600 122	DUT330/ CERAM (330/40x45-16N)	Chass. 71511-> Chass. 71392 enthält eine Kupplungsscheibe / This part number includes one clutch disc	(45)	
		1864 918 005 ▽#	310 (21,5x25-13N)	Lose Kupplungsscheibe / Loose clutch disc	(30)	
		1863 837 002	65/97/23	mit Anlauftring / with thrust ring	(63)	
		1863 855 000	106/140/25	mit Anlauftring / with thrust ring	(63)	
90-34 MA,ME,MS,MX,FT (R3172)		1888 600 122	DUT330/ CERAM (330/40x45-16N)	enthält eine Kupplungsscheibe / This part number includes one clutch disc	(45)	
		1888 895 002 #	DUT330 (330/45x50-16N)	enthält eine Kupplungsscheibe / This part number includes one clutch disc	(45)	
		1864 918 005 ▽#	310 (21,5x25-13N)	Lose Kupplungsscheibe / Loose clutch disc	(30)	
		1863 837 002	65/97/23	mit Anlauftring / with thrust ring	(63)	
		1863 855 000	106/140/25	mit Anlauftring / with thrust ring	(63)	
92..-Serie						
92 (R7601) 92 Industrie (R7614)		1888 860 003 #	DUT280 (280/40x45-16N)	enthält eine Kupplungsscheibe / This part number includes one clutch disc	(45)	
		1862 844 004 ▽#	280TB (26,7x30-16N)	Lose Kupplungsscheibe / Loose clutch disc	(30)	
		1863 837 002	65/97/23	mit Anlauftring / with thrust ring	(63)	
		1863 855 000	106/140/25	mit Anlauftring / with thrust ring	(63)	
94..-Serie						
94 (R7611)		1888 860 003 #	DUT280 (280/40x45-16N)	enthält eine Kupplungsscheibe / This part number includes one clutch disc	(45)	
		1862 844 004 ▽#	280TB (26,7x30-16N)	Lose Kupplungsscheibe / Loose clutch disc	(30)	
		1863 837 002	65/97/23	mit Anlauftring / with thrust ring	(63)	
		1863 855 000	106/140/25	mit Anlauftring / with thrust ring	(63)	
95..-Serie						
95-12 (R7811) 95-14 (R7812)		1888 868 009 #	DUT310 (310/45x50-18N)	enthält eine Kupplungsscheibe / This part number includes one clutch disc	(45)	
		1862 715 001 ▽#	310CB (27x30-16N)	Lose Kupplungsscheibe / Loose clutch disc	(30)	
		1862 713 001 ●▽#	310CDC/ CERAM (27x30-16N)	Anzahl der Beläge / Number of pads: 8 Lose Kupplungsscheibe / Loose clutch disc	(7) (30)	
		1863 837 002	65/97/23	mit Anlauftring / with thrust ring	(63)	
		1863 855 000	106/140/25	mit Anlauftring / with thrust ring	(63)	



# RENAULT AGRICULTURE

95.-Serie						
95-12 TX (R7811) 95-14 TX (R7812)				<b>1888 868 009 #</b>	DUT310 (310/45x50-18N)	enthält eine Kupplungsscheibe / This part number includes one clutch disc (45)
				<b>1862 713 001 ▽#</b>	310CDC/ CERAM (27x30-16N)	Anzahl der Beläge / Number of pads: 8 Lose Kupplungsscheibe / Loose clutch disc (7) (30)
				<b>1863 837 002</b>	65/97/23	mit Anlauftring / with thrust ring (63)
				<b>1863 855 000</b>	106/140/25	mit Anlauftring / with thrust ring (63)













96.-Serie						
96 (R7631)				<b>1888 868 008 #</b>	DUT310 (310/40x45-16N)	enthält eine Kupplungsscheibe / This part number includes one clutch disc (45)
				<b>1862 715 001 ▽#</b>	310CB (27x30-16N)	Lose Kupplungsscheibe / Loose clutch disc (30)
				<b>1862 713 001 ●▽#</b>	310CDC/ CERAM (27x30-16N)	Anzahl der Beläge / Number of pads: 8 Lose Kupplungsscheibe / Loose clutch disc (7) (30)
				<b>1863 837 002</b>	65/97/23	mit Anlauftring / with thrust ring (63)
				<b>1863 855 000</b>	106/140/25	mit Anlauftring / with thrust ring (63)

98.-Serie						
98 (R7456)				<b>1888 860 003 #</b>	DUT280 (280/40x45-16N)	enthält eine Kupplungsscheibe / This part number includes one clutch disc (45)
				<b>1862 844 004 ▽#</b>	280TB (26,7x30-16N)	Lose Kupplungsscheibe / Loose clutch disc (30)
				<b>1863 837 002</b>	65/97/23	mit Anlauftring / with thrust ring (63)
				<b>1863 855 000</b>	106/140/25	mit Anlauftring / with thrust ring (63)
98 (R7651)				<b>1888 868 008 #</b>	DUT310 (310/40x45-16N)	enthält eine Kupplungsscheibe / This part number includes one clutch disc (45)
				<b>1862 715 001 ▽#</b>	310CB (27x30-16N)	Lose Kupplungsscheibe / Loose clutch disc (30)
				<b>1862 713 001 ●▽#</b>	310CDC/ CERAM (27x30-16N)	Anzahl der Beläge / Number of pads: 8 Lose Kupplungsscheibe / Loose clutch disc (7) (30)
				<b>1863 837 002</b>	65/97/23	mit Anlauftring / with thrust ring (63)
				<b>1863 855 000</b>	106/140/25	mit Anlauftring / with thrust ring (63)















103.-Serie						
103-12 (R7821) 103-14 (R7822)				<b>1888 868 009 #</b>	DUT310 (310/45x50-18N)	enthält eine Kupplungsscheibe / This part number includes one clutch disc (45)
				<b>1862 715 001 ▽#</b>	310CB (27x30-16N)	Lose Kupplungsscheibe / Loose clutch disc (30)
				<b>1862 713 001 ●▽#</b>	310CDC/ CERAM (27x30-16N)	Anzahl der Beläge / Number of pads: 8 Lose Kupplungsscheibe / Loose clutch disc (7) (30)
				<b>1863 837 002</b>	65/97/23	mit Anlauftring / with thrust ring (63)
				<b>1863 855 000</b>	106/140/25	mit Anlauftring / with thrust ring (63)
103-12 TX (R7821) 103-14 TX (R7822)				<b>1888 868 009 #</b>	DUT310 (310/45x50-18N)	enthält eine Kupplungsscheibe / This part number includes one clutch disc (45)
				<b>1862 713 001 ▽#</b>	310CDC/ CERAM (27x30-16N)	Anzahl der Beläge / Number of pads: 8 Lose Kupplungsscheibe / Loose clutch disc (7) (30)
				<b>1863 837 002</b>	65/97/23	mit Anlauftring / with thrust ring (63)
				<b>1863 855 000</b>	106/140/25	mit Anlauftring / with thrust ring (63)
103-52 (R7821)	02.89 - 07.92			<b>1888 868 009 #</b>	DUT310 (310/45x50-18N)	enthält eine Kupplungsscheibe / This part number includes one clutch disc (45)
				<b>1862 713 001 ▽#</b>	310CDC/ CERAM (27x30-16N)	Anzahl der Beläge / Number of pads: 8 Lose Kupplungsscheibe / Loose clutch disc (7) (30)
				<b>1863 837 002</b>	65/97/23	mit Anlauftring / with thrust ring (63)
				<b>1863 855 000</b>	106/140/25	mit Anlauftring / with thrust ring (63)
				<b>1866 600 005</b>		Getr. / GBox: Traktorshift
103-54 (R7822)	09.86 - 03.00			<b>1888 868 009 #</b>	DUT310 (310/45x50-18N)	enthält eine Kupplungsscheibe / This part number includes one clutch disc (45)
				<b>1862 713 001 ▽#</b>	310CDC/ CERAM (27x30-16N)	Anzahl der Beläge / Number of pads: 8 Lose Kupplungsscheibe / Loose clutch disc (7) (30)
				<b>1863 837 002</b>	65/97/23	mit Anlauftring / with thrust ring (63)
				<b>1863 855 000</b>	106/140/25	mit Anlauftring / with thrust ring (63)
			<b>1866 600 005</b>		Getr. / GBox: Traktorshift	

# RENAULT AGRICULTURE









## 106..-Serie

106-14 (R7832)				1888 868 009 #	DUT310 (310/45x50-18N)	->Chass. 51177 enthält eine Kupplungsscheibe / This part number includes one clutch disc	(45)
				1862 713 001 ●▽#	310CDC/ CERAM (27x30-16N)	->Chass. 51177 Anzahl der Beläge / Number of pads: 8 Lose Kupplungsscheibe / Loose clutch disc	(7) (30)
				1862 715 001 ▽#	310CB (27x30-16N)	->Chass. 51177 Lose Kupplungsscheibe / Loose clutch disc	(30)
				1888 868 011 #	DUT330 (330/45x50-18N)	Chass. 51178-> enthält eine Kupplungsscheibe / This part number includes one clutch disc	(45)
				1862 812 003 ▽#	330CB (27x30-16N)	Chass. 51178-> Lose Kupplungsscheibe / Loose clutch disc	(30)
				1863 837 002	65/97/23	mit Anlauftring / with thrust ring	(63)
				1863 855 000	106/140/25	mit Anlauftring / with thrust ring	(63)
106-54 (R7842)	01.92-02.00			1888 868 011 #	DUT330 (330/45x50-18N)	enthält eine Kupplungsscheibe / This part number includes one clutch disc	(45)
				1862 812 003 ▽#	330CB (27x30-16N)	Lose Kupplungsscheibe / Loose clutch disc	(30)
				1863 837 002	65/97/23	mit Anlauftring / with thrust ring	(63)
				1863 855 000	106/140/25	mit Anlauftring / with thrust ring	(63)
				1866 600 005		Getr. / GBox: Tractorshift	

## 110..-Serie

110-14 (R7912)				1888 868 011 #	DUT330 (330/45x50-18N)	enthält eine Kupplungsscheibe / This part number includes one clutch disc	(45)
				1862 812 003 ▽#	330CB (27x30-16N)	Lose Kupplungsscheibe / Loose clutch disc	(30)
				1863 837 002	65/97/23	mit Anlauftring / with thrust ring	(63)
				1863 855 000	106/140/25	mit Anlauftring / with thrust ring	(63)
110-14 RE,TS,TX (R7912)				1888 868 011 ●#	DUT330 (330/45x50-18N)	enthält eine Kupplungsscheibe / This part number includes one clutch disc	(45)
				1862 812 003 ▽#	330CB (27x30-16N)	Lose Kupplungsscheibe / Loose clutch disc	(30)
				1850 281 964 ▽#	327GSC (27x30-16N)	Anzahl der Beläge / Number of pads: 9 Lose Kupplungsscheibe / Loose clutch disc	(7) (30)
				1863 837 002	65/97/23	mit Anlauftring / with thrust ring	(63)
				1863 855 000	106/140/25	mit Anlauftring / with thrust ring	(63)
110-54 (R7912)	09.86-03.00			1888 868 011 #	DUT330 (330/45x50-18N)	enthält eine Kupplungsscheibe / This part number includes one clutch disc	(45)
				1862 812 003 ▽#	330CB (27x30-16N)	Lose Kupplungsscheibe / Loose clutch disc	(30)
				1863 837 002	65/97/23	mit Anlauftring / with thrust ring	(63)
				1863 855 000	106/140/25	mit Anlauftring / with thrust ring	(63)
				1866 600 005		Getr. / GBox: Tractorshift	















## 113..-Serie

113-12 (R7921) 113-14 (R7922)				1888 868 011 #	DUT330 (330/45x50-18N)	enthält eine Kupplungsscheibe / This part number includes one clutch disc	(45)
				1862 812 003 ▽#	330CB (27x30-16N)	Lose Kupplungsscheibe / Loose clutch disc	(30)
				1863 837 002	65/97/23	mit Anlauftring / with thrust ring	(63)
				1863 855 000	106/140/25	mit Anlauftring / with thrust ring	(63)
113-12 RE,TS,TX (R7921) 113-14 RE,TS,TX (R7922)				1888 868 011 ●#	DUT330 (330/45x50-18N)	enthält eine Kupplungsscheibe / This part number includes one clutch disc	(45)
				1862 812 003 ▽#	330CB (27x30-16N)	Lose Kupplungsscheibe / Loose clutch disc	(30)
				1850 281 964 ▽#	327GSC (27x30-16N)	Anzahl der Beläge / Number of pads: 9 Lose Kupplungsscheibe / Loose clutch disc	(7) (30)
				1863 837 002	65/97/23	mit Anlauftring / with thrust ring	(63)
				1863 855 000	106/140/25	mit Anlauftring / with thrust ring	(63)

















# RENAULT AGRICULTURE

## 120..-Serie

<b>120-14 (R7922)</b>				<b>1888 868 011 #</b>	DUT330 (330/45x50-18N)	enthält eine Kupplungsscheibe / This part number includes one clutch disc	(45)
				<b>1862 812 003 ∇#</b>	330CB (27x30-16N)	Lose Kupplungsscheibe / Loose clutch disc	(30)
				<b>1863 837 002</b>	65/97/23	mit Anlauftring / with thrust ring	(63)
				<b>1863 855 000</b>	106/140/25	mit Anlauftring / with thrust ring	(63)
<b>120-14 RE,TS,TX (R7922)</b>				<b>1888 868 011 ●#</b>	DUT330 (330/45x50-18N)	enthält eine Kupplungsscheibe / This part number includes one clutch disc	(45)
				<b>1862 812 003 ∇#</b>	330CB (27x30-16N)	Lose Kupplungsscheibe / Loose clutch disc	(30)
				<b>1850 281 964 ∇#</b>	327GSC (27x30-16N)	Anzahl der Beläge / Number of pads: 9 Lose Kupplungsscheibe / Loose clutch disc	(7) (30)
				<b>1863 837 002</b>	65/97/23	mit Anlauftring / with thrust ring	(63)
				<b>1863 855 000</b>	106/140/25	mit Anlauftring / with thrust ring	(63)
<b>120-54 (R7922)</b>				<b>1888 868 011 #</b>	DUT330 (330/45x50-18N)	enthält eine Kupplungsscheibe / This part number includes one clutch disc	(45)
				<b>1862 812 003 ∇#</b>	330CB (27x30-16N)	Lose Kupplungsscheibe / Loose clutch disc	(30)
				<b>1863 837 002</b>	65/97/23	mit Anlauftring / with thrust ring	(63)
				<b>1863 855 000</b>	106/140/25	mit Anlauftring / with thrust ring	(63)
				<b>1866 600 005</b>		<b>03.1998 - 06.1998</b> Getr. / GBox: Tractorshift	

## 133..-Serie

<b>133-14 (R7932)</b>				<b>1888 868 011 #</b>	DUT330 (330/45x50-18N)	enthält eine Kupplungsscheibe / This part number includes one clutch disc	(45)
				<b>1862 812 003 ∇#</b>	330CB (27x30-16N)	Lose Kupplungsscheibe / Loose clutch disc	(30)
				<b>1863 837 002</b>	65/97/23	mit Anlauftring / with thrust ring	(63)
				<b>1863 855 000</b>	106/140/25	mit Anlauftring / with thrust ring	(63)
<b>133-14 RE,TS,TX (R7932)</b>				<b>1888 868 011 ●#</b>	DUT330 (330/45x50-18N)	enthält eine Kupplungsscheibe / This part number includes one clutch disc	(45)
				<b>1862 812 003 ∇#</b>	330CB (27x30-16N)	Lose Kupplungsscheibe / Loose clutch disc	(30)
				<b>1850 281 964 ∇#</b>	327GSC (27x30-16N)	Anzahl der Beläge / Number of pads: 9 Lose Kupplungsscheibe / Loose clutch disc	(7) (30)
				<b>1863 837 002</b>	65/97/23	mit Anlauftring / with thrust ring	(63)
				<b>1863 855 000</b>	106/140/25	mit Anlauftring / with thrust ring	(63)
<b>133-54 (R7932)</b>				<b>1888 868 011 #</b>	DUT330 (330/45x50-18N)	enthält eine Kupplungsscheibe / This part number includes one clutch disc	(45)
				<b>1862 812 003 ∇#</b>	330CB (27x30-16N)	Lose Kupplungsscheibe / Loose clutch disc	(30)
				<b>1863 837 002</b>	65/97/23	mit Anlauftring / with thrust ring	(63)
				<b>1863 855 000</b>	106/140/25	mit Anlauftring / with thrust ring	(63)
				<b>1866 600 005</b>		Getr. / GBox: Tractorshift	

## 145..-Serie



<b>145-54 (R7942)</b>	03.87 - 02.94	MWMTD226-B6		<b>1866 600 005</b>		Getr. / GBox: Tractorshift	
-----------------------	---------------	-------------	---	---------------------	--	----------------------------	--

## 155..-Serie













<b>155-54 (R7952)</b>	03.87 - 02.94	MWMTD226-B6		<b>1866 600 005</b>		Getr. / GBox: Tractorshift	
-----------------------	---------------	-------------	---	---------------------	--	----------------------------	--

# RENAULT AGRICULTURE













## 175..-Serie

175-74 TZ (R3852)				<b>1882 262 006</b>	G350N	für Nebenantrieb / for PTO Nur bei Altteil-Rückgabe lieferbar (Reparatur; Werk Bielefeld) / Please return old unit for repair (plant Bielefeld)	(57) (33)
				<b>1861 613 101 #</b>	350WGSDC (28x35-10N)	Anzahl der Beläge / Number of pads: 12	(7)

## 3..-5..-Serie





























461 (R7441) 498 (R7466) 551 (R7451) 551 -4 (R7454) 556 (R7456) 581				<b>1888 860 003 #</b>	DUT280 (280/40x45-16N)	enthält eine Kupplungsscheibe / This part number includes one clutch disc	(45)
				<b>1862 844 004 ▽#</b>	280TB (26,7x30-16N)	Lose Kupplungsscheibe / Loose clutch disc	(30)
				<b>1863 837 002</b>	65/97/23	mit Anlauftring / with thrust ring	(63)
				<b>1863 855 000</b>	106/140/25	mit Anlauftring / with thrust ring	(63)
462 (R7442)				<b>1888 860 003 #</b>	DUT280 (280/40x45-16N)	<b>Chass. 22278-&gt;</b> enthält eine Kupplungsscheibe / This part number includes one clutch disc	(45)
				<b>1862 844 004 ▽#</b>	280TB (26,7x30-16N)	<b>Chass. 22278-&gt;</b> Lose Kupplungsscheibe / Loose clutch disc	(30)
				<b>1863 837 002</b>	65/97/23	<b>Chass. 22278-&gt;</b> mit Anlauftring / with thrust ring	(63)
				<b>1863 855 000</b>	106/140/25	<b>Chass. 22278-&gt;</b> mit Anlauftring / with thrust ring	(63)
496 (R7635) 498 (R7655)				<b>1888 868 008 #</b>	DUT310 (310/40x45-16N)	enthält eine Kupplungsscheibe / This part number includes one clutch disc	(45)
				<b>1862 715 001 ▽#</b>	310CB (27x30-16N)	Lose Kupplungsscheibe / Loose clutch disc	(30)
				<b>1862 713 001 ●▽#</b>	310CDC/ CERAM (27x30-16N)	Anzahl der Beläge / Number of pads: 8 Lose Kupplungsscheibe / Loose clutch disc	(7) (30)
				<b>1863 837 002</b>	65/97/23	mit Anlauftring / with thrust ring	(63)
				<b>1863 855 000</b>	106/140/25	mit Anlauftring / with thrust ring	(63)

## 6..-8..-Serie





























601 (R7491) 601 -4 (R7494) 651 (R7461) 651 -4 (R7464) 652 (R7462) 656 (R7466)				<b>1888 860 003 #</b>	DUT280 (280/40x45-16N)	enthält eine Kupplungsscheibe / This part number includes one clutch disc	(45)
				<b>1862 844 004 ▽#</b>	280TB (26,7x30-16N)	Lose Kupplungsscheibe / Loose clutch disc	(30)
				<b>1863 837 002</b>	65/97/23	mit Anlauftring / with thrust ring	(63)
				<b>1863 855 000</b>	106/140/25	mit Anlauftring / with thrust ring	(63)
650 MI				<b>1888 997 801 #</b>	DUT280 (280/40x45-16N)	enthält eine Kupplungsscheibe / This part number includes one clutch disc	(45)
				<b>1864 994 901 ▽#</b>	280 (22x25-13N)	Lose Kupplungsscheibe / Loose clutch disc	(30)
				<b>1863 837 002</b>	65/97/23	mit Anlauftring / with thrust ring	(63)
				<b>1863 855 000</b>	106/140/25	mit Anlauftring / with thrust ring	(63)
681 (R7491) 681 -4 (R7494) 751 -S4 (R7504) 751 S (R7501)				<b>1888 868 008 #</b>	DUT310 (310/40x45-16N)	enthält eine Kupplungsscheibe / This part number includes one clutch disc	(45)
				<b>1862 715 001 ▽#</b>	310CB (27x30-16N)	Lose Kupplungsscheibe / Loose clutch disc	(30)
				<b>1862 713 001 ●▽#</b>	310CDC/ CERAM (27x30-16N)	Anzahl der Beläge / Number of pads: 8 Lose Kupplungsscheibe / Loose clutch disc	(7) (30)
				<b>1863 837 002</b>	65/97/23	mit Anlauftring / with thrust ring	(63)
				<b>1863 855 000</b>	106/140/25	mit Anlauftring / with thrust ring	(63)

# RENAULT AGRICULTURE

## 6..-8..-Serie







751 (R7621)		1888 868 009 #	DUT310 (310/45x50-18N)	->Chass. 86014 enthält eine Kupplungsscheibe / This part number includes one clutch disc	(45)
		1862 713 001 ▽#	310CDC/ CERAM (27x30-16N)	->Chass. 86014 Anzahl der Beläge / Number of pads: 8 Lose Kupplungsscheibe / Loose clutch disc	(7) (30)
		1888 868 008 #	DUT310 (310/40x45-16N)	Chass. 86015-> enthält eine Kupplungsscheibe / This part number includes one clutch disc	(45)
		1862 713 001 ●▽#	310CDC/ CERAM (27x30-16N)	Chass. 86015-> Anzahl der Beläge / Number of pads: 8 Lose Kupplungsscheibe / Loose clutch disc	(7) (30)
		1862 715 001 ▽#	310CB (27x30-16N)	Chass. 86015-> Lose Kupplungsscheibe / Loose clutch disc	(30)
		1863 837 002	65/97/23	mit Anlauftring / with thrust ring	(63)
		1863 855 000	106/140/25	mit Anlauftring / with thrust ring	(63)
751 -4 (R7624)		1888 868 009 #	DUT310 (310/45x50-18N)	->Chass. 83074 enthält eine Kupplungsscheibe / This part number includes one clutch disc	(45)
		1862 713 001 ▽#	310CDC/ CERAM (27x30-16N)	->Chass. 83074 Anzahl der Beläge / Number of pads: 8 Lose Kupplungsscheibe / Loose clutch disc	(7) (30)
		1888 868 008 #	DUT310 (310/40x45-16N)	Chass. 83075-> enthält eine Kupplungsscheibe / This part number includes one clutch disc	(45)
		1862 713 001 ●▽#	310CDC/ CERAM (27x30-16N)	Chass. 83075-> Anzahl der Beläge / Number of pads: 8 Lose Kupplungsscheibe / Loose clutch disc	(7) (30)
		1862 715 001 ▽#	310CB (27x30-16N)	Chass. 83075-> Lose Kupplungsscheibe / Loose clutch disc	(30)
		1863 837 002	65/97/23	mit Anlauftring / with thrust ring	(63)
		1863 855 000	106/140/25	mit Anlauftring / with thrust ring	(63)
752 (R7622) 782 (R7622)		1888 868 008 #	DUT310 (310/40x45-16N)	->Chass. 80492 enthält eine Kupplungsscheibe / This part number includes one clutch disc	(45)
		1862 713 001 ●▽#	310CDC/ CERAM (27x30-16N)	->Chass. 80492 Anzahl der Beläge / Number of pads: 8 Lose Kupplungsscheibe / Loose clutch disc	(7) (30)
		1862 715 001 ▽#	310CB (27x30-16N)	->Chass. 80492 Lose Kupplungsscheibe / Loose clutch disc	(30)
		1888 868 009 #	DUT310 (310/45x50-18N)	Chass. 80493-> enthält eine Kupplungsscheibe / This part number includes one clutch disc	(45)
		1862 713 001 ▽#	310CDC/ CERAM (27x30-16N)	Chass. 80493-> Anzahl der Beläge / Number of pads: 8 Lose Kupplungsscheibe / Loose clutch disc	(7) (30)
		1863 837 002	65/97/23	mit Anlauftring / with thrust ring	(63)
		1863 855 000	106/140/25	mit Anlauftring / with thrust ring	(63)
752 -4 (R7624) 782 -4 (R7624)		1888 868 008 #	DUT310 (310/40x45-16N)	->Chass. 83074 enthält eine Kupplungsscheibe / This part number includes one clutch disc	(45)
		1862 713 001 ●▽#	310CDC/ CERAM (27x30-16N)	->Chass. 83074 Anzahl der Beläge / Number of pads: 8 Lose Kupplungsscheibe / Loose clutch disc	(7) (30)
		1862 715 001 ▽#	310CB (27x30-16N)	->Chass. 83074 Lose Kupplungsscheibe / Loose clutch disc	(30)
		1888 868 009 #	DUT310 (310/45x50-18N)	Chass. 83075-> enthält eine Kupplungsscheibe / This part number includes one clutch disc	(45)
		1862 713 001 ▽#	310CDC/ CERAM (27x30-16N)	Chass. 83075-> Anzahl der Beläge / Number of pads: 8 Lose Kupplungsscheibe / Loose clutch disc	(7) (30)
		1863 837 002	65/97/23	mit Anlauftring / with thrust ring	(63)
		1863 855 000	106/140/25	mit Anlauftring / with thrust ring	(63)

# RENAULT AGRICULTURE











6..-8..-Serie							
781 (R7591) 781 -4 (R7594)		1888 868 008 #	DUT310 (310/40x45-16N)	->Chass. 61182 enthält eine Kupplungsscheibe / This part number includes one clutch disc	(45)		
		1862 713 001 ●▽#	310CDC/ CERAM (27x30-16N)	->Chass. 61182 Anzahl der Beläge / Number of pads: 8 Lose Kupplungsscheibe / Loose clutch disc	(7) (30)		
		1862 715 001 ▽#	310CB (27x30-16N)	->Chass. 61182 Lose Kupplungsscheibe / Loose clutch disc	(30)		
		1888 868 009 #	DUT310 (310/45x50-18N)	Chass. 61183-> enthält eine Kupplungsscheibe / This part number includes one clutch disc	(45)		
		1862 713 001 ▽#	310CDC/ CERAM (27x30-16N)	Chass. 61183-> Anzahl der Beläge / Number of pads: 8 Lose Kupplungsscheibe / Loose clutch disc	(7) (30)		
		1863 837 002	65/97/23	mit Anlauftring / with thrust ring	(63)		
		1863 855 000	106/140/25	mit Anlauftring / with thrust ring	(63)		
851 (R7661)		1888 868 008 #	DUT310 (310/40x45-16N)	->Chass. 80898 enthält eine Kupplungsscheibe / This part number includes one clutch disc	(45)		
		1862 713 001 ●▽#	310CDC/ CERAM (27x30-16N)	->Chass. 80898 Anzahl der Beläge / Number of pads: 8 Lose Kupplungsscheibe / Loose clutch disc	(7) (30)		
		1862 715 001 ▽#	310CB (27x30-16N)	->Chass. 80898 Lose Kupplungsscheibe / Loose clutch disc	(30)		
		1888 868 009 #	DUT310 (310/45x50-18N)	Chass. 80899-> enthält eine Kupplungsscheibe / This part number includes one clutch disc	(45)		
		1862 713 001 ▽#	310CDC/ CERAM (27x30-16N)	Chass. 80899-> Anzahl der Beläge / Number of pads: 8 Lose Kupplungsscheibe / Loose clutch disc	(7) (30)		
		1863 837 002	65/97/23	mit Anlauftring / with thrust ring	(63)		
		1863 855 000	106/140/25	mit Anlauftring / with thrust ring	(63)		
851 -4 (R7664)		1888 868 008 #	DUT310 (310/40x45-16N)	->Chass. 81743 enthält eine Kupplungsscheibe / This part number includes one clutch disc	(45)		
		1862 713 001 ●▽#	310CDC/ CERAM (27x30-16N)	->Chass. 81743 Anzahl der Beläge / Number of pads: 8 Lose Kupplungsscheibe / Loose clutch disc	(7) (30)		
		1862 715 001 ▽#	310CB (27x30-16N)	->Chass. 81743 Lose Kupplungsscheibe / Loose clutch disc	(30)		
		1888 868 009 #	DUT310 (310/45x50-18N)	Chass. 81744-> enthält eine Kupplungsscheibe / This part number includes one clutch disc	(45)		
		1862 713 001 ▽#	310CDC/ CERAM (27x30-16N)	Chass. 81744-> Anzahl der Beläge / Number of pads: 8 Lose Kupplungsscheibe / Loose clutch disc	(7) (30)		
		1863 837 002	65/97/23	mit Anlauftring / with thrust ring	(63)		
		1863 855 000	106/140/25	mit Anlauftring / with thrust ring	(63)		
891 (R7681)		1888 868 008 #	DUT310 (310/40x45-16N)	->Chass. 80250 enthält eine Kupplungsscheibe / This part number includes one clutch disc	(45)		
		1862 713 001 ●▽#	310CDC/ CERAM (27x30-16N)	->Chass. 80250 Anzahl der Beläge / Number of pads: 8 Lose Kupplungsscheibe / Loose clutch disc	(7) (30)		
		1862 715 001 ▽#	310CB (27x30-16N)	->Chass. 80250 Lose Kupplungsscheibe / Loose clutch disc	(30)		
		1888 868 009 #	DUT310 (310/45x50-18N)	Chass. 80251-> enthält eine Kupplungsscheibe / This part number includes one clutch disc	(45)		
		1862 713 001 ▽#	310CDC/ CERAM (27x30-16N)	Chass. 80251-> Anzahl der Beläge / Number of pads: 8 Lose Kupplungsscheibe / Loose clutch disc	(7) (30)		
		1863 837 002	65/97/23	mit Anlauftring / with thrust ring	(63)		
		1863 855 000	106/140/25	mit Anlauftring / with thrust ring	(63)		

# RENAULT AGRICULTURE

## 6..-8..-Serie





















891 -4 (R7684)		1888 868 008 #	DUT310 (310/40x45-16N)	->Chass. 80951 enthält eine Kupplungsscheibe / This part number includes one clutch disc	(45)
		1862 713 001 ●▽#	310CDC/ CERAM (27x30-16N)	->Chass. 80951 Anzahl der Beläge / Number of pads: 8 Lose Kupplungsscheibe / Loose clutch disc	(7) (30)
		1862 715 001 ▽#	310CB (27x30-16N)	->Chass. 80951 Lose Kupplungsscheibe / Loose clutch disc	(30)
		1888 868 009 #	DUT310 (310/45x50-18N)	Chass. 80952-> enthält eine Kupplungsscheibe / This part number includes one clutch disc	(45)
		1862 713 001 ▽#	310CDC/ CERAM (27x30-16N)	Chass. 80952-> Anzahl der Beläge / Number of pads: 8 Lose Kupplungsscheibe / Loose clutch disc	(7) (30)
		1863 837 002	65/97/23	mit Anlauftring / with thrust ring	(63)
		1863 855 000	106/140/25	mit Anlauftring / with thrust ring	(63)

## 9..-11..-Serie

921 (R7641) 921 -4 (R7644)		1888 868 009 #	DUT310 (310/45x50-18N)	enthält eine Kupplungsscheibe / This part number includes one clutch disc	(45)
		1862 713 001 ▽#	310CDC/ CERAM (27x30-16N)	Anzahl der Beläge / Number of pads: 8 Lose Kupplungsscheibe / Loose clutch disc	(7) (30)
		1863 837 002	65/97/23	mit Anlauftring / with thrust ring	(63)
951 (R7641)		1863 855 000	106/140/25	mit Anlauftring / with thrust ring	(63)
		1888 868 009 #	DUT310 (310/45x50-18N)	->Chass. 81343 nicht für Fahrgestellnummer / not for chassis no.: 81339 enthält eine Kupplungsscheibe / This part number includes one clutch disc	(76) (45)
		1862 715 001 ▽#	310CB (27x30-16N)	->Chass. 81343 nicht für Fahrgestellnummer / not for chassis no.: 81339 Lose Kupplungsscheibe / Loose clutch disc	(76) (30)
		1888 868 011 ●#	DUT330 (330/45x50-18N)	Chass. 81344-> Chass. 81339 enthält eine Kupplungsscheibe / This part number includes one clutch disc	(45)
		1862 812 003 ▽#	330CB (27x30-16N)	Chass. 81344-> Chass. 81339 Lose Kupplungsscheibe / Loose clutch disc	(30)
		1850 281 964 ▽#	327GSC (27x30-16N)	Chass. 81344-> Chass. 81339 Anzahl der Beläge / Number of pads: 9 Lose Kupplungsscheibe / Loose clutch disc	(7) (30)
		1863 837 002	65/97/23	nicht für Fahrgestellnummer / not for chassis no.: 81339 mit Anlauftring / with thrust ring	(76) (63)
	1863 855 000	106/140/25	nicht für Fahrgestellnummer / not for chassis no.: 81339 mit Anlauftring / with thrust ring	(76) (63)	













# RENAULT AGRICULTURE

## 9..-11..-Serie











<b>951 -4 (R7644)</b>				1888 868 009 #	DUT310 (310/45x50-18N)	-> <b>Chass. 82292</b> nicht für Fahrgestellnummer / not for chassis no.: 82275 enthält eine Kupplungsscheibe / This part number includes one clutch disc	(76) (45)
				1862 715 001 ▽#	310CB (27x30-16N)	-> <b>Chass. 82292</b> nicht für Fahrgestellnummer / not for chassis no.: 82275 Lose Kupplungsscheibe / Loose clutch disc	(76) (30)
				1888 868 011 ●#	DUT330 (330/45x50-18N)	<b>Chass. 82293-&gt;</b> <b>Chass. 82275</b> enthält eine Kupplungsscheibe / This part number includes one clutch disc	(45)
				1862 812 003 ▽#	330CB (27x30-16N)	<b>Chass. 82293-&gt;</b> <b>Chass. 82275</b> Lose Kupplungsscheibe / Loose clutch disc	(30)
				1850 281 964 ▽#	327GSC (27x30-16N)	<b>Chass. 82293-&gt;</b> <b>Chass. 82275</b> Anzahl der Beläge / Number of pads: 9 Lose Kupplungsscheibe / Loose clutch disc	(7) (30)
				1863 837 002	65/97/23	nicht für Fahrgestellnummer / not for chassis no.: 82275 mit Anlauftring / with thrust ring	(76) (63)
				1863 855 000	106/140/25	nicht für Fahrgestellnummer / not for chassis no.: 82275 mit Anlauftring / with thrust ring	(76) (63)
<b>981 (R7641)</b>				1888 868 008 #	DUT310 (310/40x45-16N)	-> <b>Chass. 81343</b> nicht für Fahrgestellnummer / not for chassis no.: 81339 enthält eine Kupplungsscheibe / This part number includes one clutch disc	(76) (45)
				1862 715 001 ▽#	310CB (27x30-16N)	-> <b>Chass. 81343</b> nicht für Fahrgestellnummer / not for chassis no.: 81339 Lose Kupplungsscheibe / Loose clutch disc	(76) (30)
				1888 868 011 ●#	DUT330 (330/45x50-18N)	<b>Chass. 81344-&gt;</b> <b>Chass. 81339</b> enthält eine Kupplungsscheibe / This part number includes one clutch disc	(45)
				1862 812 003 ▽#	330CB (27x30-16N)	<b>Chass. 81344-&gt;</b> <b>Chass. 81339</b> Lose Kupplungsscheibe / Loose clutch disc	(30)
				1850 281 964 ▽#	327GSC (27x30-16N)	<b>Chass. 81344-&gt;</b> <b>Chass. 81339</b> Anzahl der Beläge / Number of pads: 9 Lose Kupplungsscheibe / Loose clutch disc	(7) (30)
				1863 837 002	65/97/23	nicht für Fahrgestellnummer / not for chassis no.: 81339 mit Anlauftring / with thrust ring	(76) (63)
				1863 855 000	106/140/25	nicht für Fahrgestellnummer / not for chassis no.: 81339 mit Anlauftring / with thrust ring	(76) (63)
<b>981 (R7681)</b>				1888 868 008 #	DUT310 (310/40x45-16N)	-> <b>Chass. 80250</b> enthält eine Kupplungsscheibe / This part number includes one clutch disc	(45)
				1862 715 001 ▽#	310CB (27x30-16N)	-> <b>Chass. 80250</b> Lose Kupplungsscheibe / Loose clutch disc	(30)
				1888 868 009 #	DUT310 (310/45x50-18N)	<b>Chass. 80251-&gt;</b> enthält eine Kupplungsscheibe / This part number includes one clutch disc	(45)
				1862 713 001 ▽#	310CDC/ CERAM (27x30-16N)	<b>Chass. 80251-&gt;</b> Anzahl der Beläge / Number of pads: 8 Lose Kupplungsscheibe / Loose clutch disc	(7) (30)
				1863 837 002	65/97/23	mit Anlauftring / with thrust ring	(63)
				1863 855 000	106/140/25	mit Anlauftring / with thrust ring	(63)

# RENAULT AGRICULTURE











## 9..-11..-Serie

981 -4 (R7644)				1888 868 008 #	DUT310 (310/40x45-16N)	->Chass. 82292 nicht für Fahrgestellnummer / not for chassis no.: 82275 enthält eine Kupplungsscheibe / This part number includes one clutch disc	(76) (45)
				1862 715 001 ▽#	310CB (27x30-16N)	->Chass. 82292 nicht für Fahrgestellnummer / not for chassis no.: 82275 Lose Kupplungsscheibe / Loose clutch disc	(76) (30)
				1888 868 011 ●#	DUT330 (330/45x50-18N)	Chass. 82293-> Chass. 82275 enthält eine Kupplungsscheibe / This part number includes one clutch disc	(45)
				1862 812 003 ▽#	330CB (27x30-16N)	Chass. 82293-> Chass. 82275 Lose Kupplungsscheibe / Loose clutch disc	(30)
				1850 281 964 ▽#	327GSC (27x30-16N)	Chass. 82293-> Chass. 82275 Anzahl der Beläge / Number of pads: 9 Lose Kupplungsscheibe / Loose clutch disc	(7) (30)
				1863 837 002	65/97/23	nicht für Fahrgestellnummer / not for chassis no.: 82275 mit Anlauftring / with thrust ring	(76) (63)
				1863 855 000	106/140/25	nicht für Fahrgestellnummer / not for chassis no.: 82275 mit Anlauftring / with thrust ring	(76) (63)
1151 -4 (R7674) 1181 -4 (R7674)				1888 868 011 ●#	DUT330 (330/45x50-18N)	enthält eine Kupplungsscheibe / This part number includes one clutch disc	(45)
				1862 812 003 ▽#	330CB (27x30-16N)	Lose Kupplungsscheibe / Loose clutch disc	(30)
				1850 281 964 ▽#	327GSC (27x30-16N)	Anzahl der Beläge / Number of pads: 9 Lose Kupplungsscheibe / Loose clutch disc	(7) (30)
				1863 837 002	65/97/23	mit Anlauftring / with thrust ring	(63)
				1863 855 000	106/140/25	mit Anlauftring / with thrust ring	(63)

## Ares

540 RX 4032	06.97 - 02.01			1866 600 006		->Chass. R 0698 Getr. / GBox: Revershift	
				1866 600 024		Chass. CT5310001 - Chass. CTZ531300	
				1866 600 024		Chass. R 0667 - Chass. R 839 mit mechanischer Wendeschaltung / with manual reverse gear unit	(74)
				1866 600 024		Chass. R 0699-> Getr. / GBox: Revershift	
546 RX/RZ 4 Zyl.				1866 600 024		Chass. CT5321500 - Chass. CT5322298 Chass. CT5330001 - Chass. CT5331300	
550 RX 4042	06.97 - 02.01			1866 600 006		->Chass. R 1776 Getr. / GBox: Revershift	
				1866 600 024		Chass. CT42R0050 - Chass. CT42R1578 mit mechanischer Wendeschaltung / with manual reverse gear unit	(74)
				1866 600 024		Chass. CT42R1777 - Chass. CT42R2448 Getr. / GBox: Revershift	
				1866 600 024		Chass. CT5320001 - Chass. CT5321400	
556 RX/RZ 4 Zyl.				1866 600 024		Chass. CT5311500 - Chass. CT5311730 Chass. CT5331500 - Chass. CT5332200	
610 RX 4062	01.97 - 02.01			1866 600 007		Chass. R1755->	
610 RZ 4062	01.97 - 02.01						



# RENAULT AGRICULTURE



Ares							
610 RX 8212	03.01 - 05.02			1866 600 007			
610 RZ 8212	03.01 - 05.02						
620 RX 8222	03.01 - 05.02						
620 RZ 8222	03.01 - 05.02						
626 RX 8222	06.02 - 05.03						
626 RZ 8222	06.02 - 05.03						
636 RZ 8232	06.02 - 05.03						
640 RZ 4122	10.97 - 02.01						
640 RZ 8242	03.01 - 05.02						
710 RZ 4212	07.97 - 11.00						
720 RZ 4222	07.97 - 05.99						
616 RX 8212	06.02 - 05.05			1866 600 007		->Chass. 12145	
616 RZ 8212	06.02 - 04.05						
620 RX 4072	06.97 - 02.01			1866 600 006		->Chass. R1129	
620 RZ 4072	06.97 - 02.01			1866 600 007		Chass. R1130->	
630 RX 4112	06.97 - 02.01			1866 600 006		->Chass. S1296	
630 RZ 4112	06.97 - 02.01			1866 600 007		Chass. S1297->	
630 RZ 8232	03.01 - 05.02			1866 600 007		Chass. S1297->	
656 RZ 8232	05.03 - 04.05			1866 600 007		->Chass. 32518	
696 RZ 8242	06.02 - 04.05			1866 600 007		->Chass. 42266	
715 RZ 4422	07.01 - 02.05			1866 600 026		Getr. / GBox: Revershift	
725 RZ 4422	03.99 - 05.02			1866 600 008		mit mechanischer Wendeschaltung / with manual reverse gear unit	(74)
735 RZ 4432	03.99 - 05.02						
816 RZ 4412	06.02 - 09.05						
836 RZ 4432	06.02 - 09.05						
815 RZ 4312	09.99 - 12.01			1866 600 009			
825 RZ 4322	09.99 - 05.02						
826 RZ 4322	06.02 - 03.03			1866 600 008		mit mechanischer Wendeschaltung / with manual reverse gear unit	(74)
				1866 600 026		Getr. / GBox: Revershift	
				1866 600 009		Getr. / GBox: Powershift	
826 RZ 4422	06.02 - 09.05			1866 600 026		Getr. / GBox: Quadrishift	
				1866 600 008		mit mechanischer Wendeschaltung / with manual reverse gear unit	(74)

















					Parameter		
---	--	--	--	--	-----------	---	---























# RENAULT AGRICULTURE

Atles							
915 RZ 4512	07.00 - 05.02			1866 600 009			
925 RZ 4522	07.00 - 05.02						
926 RZ 4522	06.02 - 09.05						
935 RZ 4532	07.00 - 05.02						
936 RZ 4532	06.02 - 09.05	DeutzBF6M10 13FC		1866 600 009			

























Celtis							
426 RC / RX	01.03 -			3482 600 115	MF310N	Getr. / GBox: Revershift	
436 RC / RX	01.03 -						
446 RC / RX	01.03 -			1864 600 334	310Z (21,7x25-13N)	Getr. / GBox: Revershift	
456 RC / RX	01.03 -						

Cergos							
330				1888 997 901 #	DUT310 (310/40x45-16N)	M3512 enthält eine Kupplungsscheibe / This part number includes one clutch disc	(45)
				1864 994 901 #	280 (22x25-13N)	M3512	
				1863 837 002	65/97/23	M3512 mit Anlauftring / with thrust ring	(63)
				1863 855 000	106/140/25	M3512 mit Anlauftring / with thrust ring	(63)
				3482 600 115	MF310N	Getr. / GBox: Revershift	
				1864 600 334	310Z (21,7x25-13N)	Getr. / GBox: Revershift	
335				3482 600 115	MF310N	Getr. / GBox: Revershift	
345							
355				1864 600 334	310Z (21,7x25-13N)	Getr. / GBox: Revershift	
340				1888 600 142	DUT310 (310/40x45-16N)	->Chass. G0428 M3522 enthält eine Kupplungsscheibe / This part number includes one clutch disc	(45)
				1864 600 301	280CERAM (25x32-13N)	->Chass. G0428 M3522 Anzahl der Beläge / Number of pads: 4	(7)
				1863 837 002	65/97/23	->Chass. G0428 M3522 mit Anlauftring / with thrust ring	(63)
				1863 855 000	106/140/25	->Chass. G0428 M3522 mit Anlauftring / with thrust ring	(63)
				3482 600 115	MF310N	Getr. / GBox: Revershift	
				1864 600 334	310Z (21,7x25-13N)	Getr. / GBox: Revershift	























# RENAULT AGRICULTURE

Cergos							
350		1888 600 142	DUT310 (310/40x45-16N)	->Chass. G0647 M3532 enthält eine Kupplungsscheibe / This part number includes one clutch disc	(45)		
		1864 600 301	280CERAM (25x32-13N)	->Chass. G0647 M3532 Anzahl der Beläge / Number of pads: 4	(7)		
		1863 837 002	65/97/23	->Chass. G0647 M3532 mit Anlauftring / with thrust ring	(63)		
		1863 855 000	106/140/25	->Chass. G0647 M3532 mit Anlauftring / with thrust ring	(63)		
		3482 600 115	MF310N	Getr. / GBox: Reversshift			
		1864 600 334	310Z (21,7x25-13N)	Getr. / GBox: Reversshift			
Ceres							
65		1888 869 007 #	DUT280 (280/40x45-16N)	R3311/3312/3411/3412 enthält eine Kupplungsscheibe / This part number includes one clutch disc	(45)		
		1864 950 003 ▽#	280 (22x25-13N)	R3311/3312/3411/3412 Lose Kupplungsscheibe / Loose clutch disc	(30)		
		1863 837 002	65/97/23	R3311/3312/3411/3412 mit Anlauftring / with thrust ring	(63)		
		1863 855 000	106/140/25	R3311/3312/3411/3412 mit Anlauftring / with thrust ring	(63)		
70 / X		1888 869 007 #	DUT280 (280/40x45-16N)	R3321/3322 enthält eine Kupplungsscheibe / This part number includes one clutch disc	(45)		
		1864 950 003 ▽#	280 (22x25-13N)	R3321/3322 Lose Kupplungsscheibe / Loose clutch disc	(30)		
		1863 837 002	65/97/23	R3321/3322 mit Anlauftring / with thrust ring	(63)		
		1863 855 000	106/140/25	R3321/3322 mit Anlauftring / with thrust ring	(63)		
75 / X		1888 869 007 #	DUT280 (280/40x45-16N)	R3331/3332/3421/3422 enthält eine Kupplungsscheibe / This part number includes one clutch disc	(45)		
		1864 950 003 ▽#	280 (22x25-13N)	R3331/3332/3421/3422 Lose Kupplungsscheibe / Loose clutch disc	(30)		
		1863 837 002	65/97/23	R3331/3332/3421/3422 mit Anlauftring / with thrust ring	(63)		
		1863 855 000	106/140/25	R3331/3332/3421/3422 mit Anlauftring / with thrust ring	(63)		
		1888 600 104	DUT310 (310/40x45-16N)	R3421/3422 enthält eine Kupplungsscheibe / This part number includes one clutch disc	(45)		
		1864 994 901 #	280 (22x25-13N)	R3421/3422			
		1863 837 002	65/97/23	R3421/3422 mit Anlauftring / with thrust ring	(63)		
		1863 855 000	106/140/25	R3421/3422 mit Anlauftring / with thrust ring	(63)		

# RENAULT AGRICULTURE





















Ceres						
85 / X		1888 868 010 #	DUT310 (280/40x45-16N)	->02.1995 R3341/3342 enthält eine Kupplungsscheibe / This part number includes one clutch disc	(45)	
		1864 918 005 ▽#	310 (21,5x25-13N)	->02.1995 R3341/3342 Lose Kupplungsscheibe / Loose clutch disc	(30)	
		1863 837 002	65/97/23	->02.1995 R3341/3342 mit Anlauftring / with thrust ring	(63)	
		1863 855 000	106/140/25	->02.1995 R3341/3342 mit Anlauftring / with thrust ring	(63)	
		1888 997 901 #	DUT310 (310/40x45-16N)	03.1995 - Chass. F0218 R3341/3342 enthält eine Kupplungsscheibe / This part number includes one clutch disc	(45)	
		1864 994 901 #	280 (22x25-13N)	03.1995-> R3341/3342		
		1863 837 002	65/97/23	03.1995-> R3341/3342 mit Anlauftring / with thrust ring	(63)	
		1863 855 000	106/140/25	03.1995-> R3341/3342 mit Anlauftring / with thrust ring	(63)	
		1888 600 102	DUT330 (327/40x45-16N)	Chass. F0219-> R3341/3342 enthält eine Kupplungsscheibe / This part number includes one clutch disc	(45)	
		1888 600 122	DUT330/ CERAM (330/40x45-16N)	Chass. F1184-> R3441/3442 enthält eine Kupplungsscheibe / This part number includes one clutch disc	(45)	
		1864 918 005 #	310 (21,5x25-13N)			
		1863 837 002	65/97/23	mit Anlauftring / with thrust ring	(63)	
		1863 855 000	106/140/25	mit Anlauftring / with thrust ring	(63)	
	95 / X		1888 600 142	DUT310 (310/40x45-16N)	R3371/3372/3471/3472 enthält eine Kupplungsscheibe / This part number includes one clutch disc	(45)
		1864 600 301	280CERAM (25x32-13N)	R3371/3372/3471/3472 Anzahl der Beläge / Number of pads: 4	(7)	
		1863 837 002	65/97/23	R3371/3372/3471/3472 mit Anlauftring / with thrust ring	(63)	
		1863 855 000	106/140/25	R3371/3372/3471/3472 mit Anlauftring / with thrust ring	(63)	
		1888 895 002 #	DUT330 (330/45x50-16N)	R3371/3372/3471/3472 enthält eine Kupplungsscheibe / This part number includes one clutch disc	(45)	
		1864 918 005 ▽#	310 (21,5x25-13N)	R3371/3372/3471/3472 Lose Kupplungsscheibe / Loose clutch disc	(30)	
		1863 837 002	65/97/23	R3371/3372/3471/3472 mit Anlauftring / with thrust ring	(63)	
		1863 855 000	106/140/25	R3371/3372/3471/3472 mit Anlauftring / with thrust ring	(63)	
		1888 600 122	DUT330/ CERAM (330/40x45-16N)	R3371/3372/3471/3472 enthält eine Kupplungsscheibe / This part number includes one clutch disc	(45)	
		1864 918 005 #	310 (21,5x25-13N)	R3371/3372/3471/3472		
		1863 837 002	65/97/23	R3371/3372/3471/3472 mit Anlauftring / with thrust ring	(63)	
		1863 855 000	106/140/25	R3371/3372/3471/3472 mit Anlauftring / with thrust ring	(63)	

# RENAULT AGRICULTURE



Ceres							
310		1888 997 801 #	DUT280 (280/40x45-16N)	enthält eine Kupplungsscheibe / This part number includes one clutch disc	(45)		
		1864 994 901 #	280 (22x25-13N)				
		1863 837 002	65/97/23	mit Anlauftring / with thrust ring	(63)		
		1863 855 000	106/140/25	mit Anlauftring / with thrust ring	(63)		
		3482 600 115	MF310N	Getr. / GBox: Revershift			
		1864 600 334	310Z (21,7x25-13N)	Getr. / GBox: Revershift			
320 / X		1888 600 104	DUT310 (310/40x45-16N)	R3421/3422 enthält eine Kupplungsscheibe / This part number includes one clutch disc	(45)		
		1864 994 901 #	280 (22x25-13N)	R3421/3422			
		1864 600 326 ●	280C (21,5x25-13N)	R3421/3422			
		1863 837 002	65/97/23	R3421/3422 mit Anlauftring / with thrust ring	(63)		
		1863 855 000	106/140/25	R3421/3422 mit Anlauftring / with thrust ring	(63)		
		3482 600 115	MF310N	Getr. / GBox: Revershift			
		1864 600 334	310Z (21,7x25-13N)	Getr. / GBox: Revershift			
325 / X		3482 600 115	MF310N	Getr. / GBox: Revershift			
330 / X		1864 600 334	310Z (21,7x25-13N)	Getr. / GBox: Revershift			
335 / X							
345 / X							
355 / X							
340 / X		1888 600 142	DUT310 (310/40x45-16N)	R3471/3472 enthält eine Kupplungsscheibe / This part number includes one clutch disc	(45)		
		1864 600 326	280C (21,5x25-13N)	R3471/3472			
		3482 600 115	MF310N	Getr. / GBox: Revershift			
		1864 600 334	310Z (21,7x25-13N)	Getr. / GBox: Revershift			
Dionis							
110 (R3235)		1888 998 501 #	DUT280 (280/34x40-12N)	enthält eine Kupplungsscheibe / This part number includes one clutch disc	(45)		
120 (R3285/R3287)		1864 996 101 #	280 (18,7x22,2-13N)				
130 (R3255/R3257)							
140 (R3275)							
Ergos							
85		3482 600 115	MF310N	Getr. / GBox: Revershift			
90		1864 600 334	310Z (21,7x25-13N)	Getr. / GBox: Revershift			
100							
110							

# RENAULT AGRICULTURE

























## Ergos

95		1888 600 122	DUT330/ CERAM (330/40x45-16N)	->Chass. G0142 T3571 enthält eine Kupplungsscheibe / This part number includes one clutch disc	(45)
		1864 918 005 #	310 (21,5x25-13N)	->Chass. G0142 T3571	
		1888 600 142	DUT310 (310/40x45-16N)	Chass. G0143 - Chass. G0198 T3571 enthält eine Kupplungsscheibe / This part number includes one clutch disc	(45)
		1864 600 301	280CERAM (25x32-13N)	Chass. G0143 - Chass. G0198 T3571 Anzahl der Beläge / Number of pads: 4	(7)
		1888 600 122	DUT330/ CERAM (330/40x45-16N)	->Chass. G0218 T3572 enthält eine Kupplungsscheibe / This part number includes one clutch disc	(45)
		1864 918 005 #	310 (21,5x25-13N)	->Chass. G0218 T3572	
		1888 600 142	DUT310 (310/40x45-16N)	Chass. G0219 - Chass. G0306 T3572 enthält eine Kupplungsscheibe / This part number includes one clutch disc	(45)
		1864 600 301	280CERAM (25x32-13N)	Chass. G0219 - Chass. G0306 T3572 Anzahl der Beläge / Number of pads: 4	(7)
		1863 837 002	65/97/23	T3571/T3572 mit Anlauftring / with thrust ring	(63)
		1863 855 000	106/140/25	T3571/T3572 mit Anlauftring / with thrust ring	(63)
		3482 600 115	MF310N	Getr. / GBox: Reversshift	
		1864 600 334	310Z (21,7x25-13N)	Getr. / GBox: Reversshift	
105		1888 600 142	DUT310 (310/40x45-16N)	Chass. G9999 - Chass. G0061 T3581 enthält eine Kupplungsscheibe / This part number includes one clutch disc	(45)
		1864 600 301	280CERAM (25x32-13N)	Chass. G9999 - Chass. G0061 T3581 Anzahl der Beläge / Number of pads: 4	(7)
		1888 600 142	DUT310 (310/40x45-16N)	Chass. G0125 - Chass. G0155 T3582 enthält eine Kupplungsscheibe / This part number includes one clutch disc	(45)
		1864 600 301	280CERAM (25x32-13N)	Chass. G0125 - Chass. G0155 T3582 Anzahl der Beläge / Number of pads: 4	(7)
		1863 837 002	65/97/23	T3581/T3582 mit Anlauftring / with thrust ring	(63)
		1863 855 000	106/140/25	T3581/T3582 mit Anlauftring / with thrust ring	(63)
		3482 600 115	MF310N	Getr. / GBox: Reversshift	
		1864 600 334	310Z (21,7x25-13N)	Getr. / GBox: Reversshift	





## Fructus

110 (R3246)		1888 998 501 #	DUT280 (280/34x40-12N)	enthält eine Kupplungsscheibe / This part number includes one clutch disc	(45)
120 (R3268/3288)		1864 996 101 ∇#	280 (18,7x22,2-13N)	Lose Kupplungsscheibe / Loose clutch disc	(30)
130 (R3266/3268)					
140 (R3278)					



# RENAULT AGRICULTURE



Pales							
210				1888 998 501 #	DUT280 (280/34x40-12N)	->Chass. CT21D5001 ->Chass. CT22D5000 ->Chass. CT41D5000 ->Chass. CT42D5001 ->Chass. CT72D5003 enthält eine Kupplungsscheibe / This part number includes one clutch disc (45)	
				1888 600 138	DUT280/ 280 (280/30x40-12N)	Chass. CT21D5002-> Chass. CT22D5001-> Chass. CT41D5001-> Chass. CT42D5002-> Chass. CT72D5004-> enthält eine Kupplungsscheibe / This part number includes one clutch disc (45)	
				1864 996 101 #	280 (18,7x22,2-13N)		
				1863 837 003	65/100/18	ohne Anlauftring / without thrust ring (79)	
220				1888 998 501 #	DUT280 (280/34x40-12N)	enthält eine Kupplungsscheibe / This part number includes one clutch disc (45)	
				1864 996 101 #	280 (18,7x22,2-13N)		
				1863 837 003	65/100/18	ohne Anlauftring / without thrust ring (79)	
Temis							
550 X H3912	06.00 - 03.05	DPS4045TRT 52		1862 713 001 #	310CDC/ CERAM (27x30-16N)	für Fahrzeuge mit Zweis Scheibenkupplung / for vehicles with double disc clutch Anzahl der Beläge / Number of pads: 8 (51) (7)	
				1863 855 000	106/140/25	für Fahrzeuge mit Zweis Scheibenkupplung / for vehicles with double disc clutch mit Anlauftring / with thrust ring (51) (63)	
				1863 837 002	65/97/23	für Fahrzeuge mit Zweis Scheibenkupplung / for vehicles with double disc clutch mit Anlauftring / with thrust ring (51) (63)	
				1863 869 014	17/40/12	für Fahrzeuge mit Zweis Scheibenkupplung / for vehicles with double disc clutch (51)	
				1866 600 005		Getr. / GBox: Tractonic	
610 X H3922	06.00 - 03.05	DPS4045TRT 52		1863 855 000	106/140/25	für Fahrzeuge mit Zweis Scheibenkupplung / for vehicles with double disc clutch mit Anlauftring / with thrust ring (51) (63)	
				1863 837 002	65/97/23	für Fahrzeuge mit Zweis Scheibenkupplung / for vehicles with double disc clutch mit Anlauftring / with thrust ring (51) (63)	
				1863 869 014	17/40/12	für Fahrzeuge mit Zweis Scheibenkupplung / for vehicles with double disc clutch (51)	
				1866 600 005		Getr. / GBox: Tractonic	
610 Z H3922	06.00 - 03.05	Iveco8064.05. 800		1863 855 000	106/140/25	für Fahrzeuge mit Zweis Scheibenkupplung / for vehicles with double disc clutch mit Anlauftring / with thrust ring (51) (63)	
				1863 837 002	65/97/23	für Fahrzeuge mit Zweis Scheibenkupplung / for vehicles with double disc clutch mit Anlauftring / with thrust ring (51) (63)	
				1863 869 014	17/40/12	für Fahrzeuge mit Zweis Scheibenkupplung / for vehicles with double disc clutch (51)	
				1866 600 005		Getr. / GBox: Tractonic	
630 X H3932 630 Z H3932	06.00 - 03.05	Iveco8065.05. 820		1863 855 000	106/140/25	für Fahrzeuge mit Zweis Scheibenkupplung / for vehicles with double disc clutch mit Anlauftring / with thrust ring (51) (63)	
				1863 837 002	65/97/23	für Fahrzeuge mit Zweis Scheibenkupplung / for vehicles with double disc clutch mit Anlauftring / with thrust ring (51) (63)	
	06.00 - 03.05				1863 869 014	17/40/12	für Fahrzeuge mit Zweis Scheibenkupplung / for vehicles with double disc clutch (51)
					1866 600 005		Getr. / GBox: Tractonic















## RENAULT AGRICULTURE



Temis							
650 X H3942 650 Z H3942	06.00 - 03.05	Iveco8065.05. 800		1863 855 000	106/140/25	für Fahrzeuge mit Zweischeibenkupplung / for vehicles with double disc clutch mit Anlauftring / with thrust ring (51)	(63)
				1863 837 002	65/97/23	für Fahrzeuge mit Zweischeibenkupplung / for vehicles with double disc clutch mit Anlauftring / with thrust ring (51)	(63)
		1863 869 014	17/40/12	für Fahrzeuge mit Zweischeibenkupplung / for vehicles with double disc clutch (51)			
		1866 600 005		Getr. / GBox: Tractonic			

## RITSCHER

Multitrac							
Multitrac				1882 315 003	KS180		
				1864 634 040	180E (23x29-10N)		
				3100 700 101 ◊ 3151 021 001 J 2x 3130 010 200	KTI-1		

York							
York				1882 315 003	KS180		
				3100 700 101 ◊ 3151 021 001 J 2x 3130 010 200	KTI-1		

5.-Serie							
512				1882 315 003	KS180		
				1864 634 040	180E (23x29-10N)		
				1859 600 002			
			J	1805 041 100			
515 /54 528 528 /20				1881 089 002	K225		
				1864 634 026	225Z (26x32-10N)		
				1859 600 001			
			J	1805 042 000			
524 L,W				1882 196 005	KS200		
				1864 634 030	200Z (26x32-10N)		
				3100 700 101 ◊ 3151 021 001 J 2x 3130 010 200	KTI-1		
			J	1805 042 000			
536 L,W				1881 009 203 #	G250		
				1864 202 035 #	250Z (26x32-10N)		
				1859 600 001			
			J	1805 042 000			
540				1880 096 208 #	G280		
				1859 600 003			
			J	1805 042 000			

				Parameter		
---	--	--	--	-----------	---	---



# RITSCHER

## 9..-Serie

936		1881 010 139 #	G250		
-----	---	----------------	------	--	--













# ROTHENBURGER METALLWERKE

## Industrieschlepper













Industrieschlepper		1882 196 005	KS200		
		1860 049 028	200Z (22x25-14N)		

# SAME



























## ANTARES

10		1878 600 523	310CBC (36x40-24N)		
		1863 100 030	55/90,5/25	mit Anlauftring / with thrust ring	(63)
100		3482 998 101	GMF330		
100 / 110 II		3482 998 101	GMF330	->Chass. 4243	
		1878 634 004	330CBC (41x45-21N)	->Chass. 4243	
127		3482 998 101	GMF330		
		1878 634 004	330CBC (41x45-21N)		
130		3482 998 101	GMF330	->Chass. 2026	
		1878 634 004	330CBC (41x45-21N)	->Chass. 2026	
		3482 600 111	MF350	Chass. 2027->	
		1878 600 533	350TC (41x45-21N)	Chass. 2027-> Anzahl der Beläge / Number of pads: 6	(7)
130 II / 130 V		3482 600 111	MF350		
		1878 600 533	350TC (41x45-21N)	Anzahl der Beläge / Number of pads: 6	(7)

## ARGON

50		1888 600 120	DUT250 (250/36x40-20N)	enthält eine Kupplungsscheibe / This part number includes one clutch disc	(45)
		1864 600 321	225 (22x25-10N)		
		1863 837 003	65/100/18	ohne Anlauftring / without thrust ring	(79)
		1863 838 001	50/82/29	ohne Anlauftring / without thrust ring	(79)
60		1888 600 150	DUT280/ CERAM (280/36x40-20N)	enthält eine Kupplungsscheibe / This part number includes one clutch disc	(45)
		1864 600 318	280CERAM (22x25-14N)		
		1863 838 001	50/82/29	ohne Anlauftring / without thrust ring	(79)
		1863 837 003	65/100/18	ohne Anlauftring / without thrust ring	(79)
		1888 600 118	DUT280/ CERAM (280/36x40-20N)	enthält eine Kupplungsscheibe / This part number includes one clutch disc	(45)
		1864 600 324	280CERAM (22x25-14N)	Anzahl der Beläge / Number of pads: 4	(7)
		1863 838 001	50/82/29	ohne Anlauftring / without thrust ring	(79)
		1863 837 003	65/100/18	ohne Anlauftring / without thrust ring	(79)

















ARGON							
60 / FRUTETTO				<b>1888 600 119</b>	DUT280/ CERAM (280/36x40-20N)	enthält eine Kupplungsscheibe / This part number includes one clutch disc (45)	
				<b>1864 600 318</b>	280CERAM (22x25-14N)		
				<b>1863 838 001</b>	50/82/29	ohne Anlaufing / without thrust ring (79)	
				<b>1863 837 003</b>	65/100/18	ohne Anlaufing / without thrust ring (79)	
70				<b>1888 600 118</b>	DUT280/ CERAM (280/36x40-20N)	enthält eine Kupplungsscheibe / This part number includes one clutch disc (45)	
				<b>1864 600 324</b>	280CERAM (22x25-14N)	Anzahl der Beläge / Number of pads: 4 (7)	
				<b>1863 838 001</b>	50/82/29	ohne Anlaufing / without thrust ring (79)	
				<b>1863 837 003</b>	65/100/18	ohne Anlaufing / without thrust ring (79)	
				<b>1888 600 119</b>	DUT280/ CERAM (280/36x40-20N)	enthält eine Kupplungsscheibe / This part number includes one clutch disc (45)	
				<b>1864 600 318</b>	280CERAM (22x25-14N)		
				<b>1863 838 001</b>	50/82/29	ohne Anlaufing / without thrust ring (79)	
				<b>1863 837 003</b>	65/100/18	ohne Anlaufing / without thrust ring (79)	
CONDOR							
Condor 55				<b>1888 911 001 #</b>	DUT-250/ 280 (250/36x40-20N)	Nicht mit VALEO austauschbar / Do not change with VALEO (32) enthält eine Kupplungsscheibe / This part number includes one clutch disc (45)	
				<b>1862 654 002 ▽#</b>	280TB (22x25-14N)	Lose Kupplungsscheibe / Loose clutch disc (30)	
CORSARO							
Corsaro 70/S				<b>1888 911 001 #</b>	DUT-250/ 280 (250/36x40-20N)	Nicht mit VALEO austauschbar / Do not change with VALEO (32) enthält eine Kupplungsscheibe / This part number includes one clutch disc (45)	
				<b>1862 654 002 ▽#</b>	280TB (22x25-14N)	Lose Kupplungsscheibe / Loose clutch disc (30)	
DORADO							
60/DT 70/DT				<b>1878 600 523</b>	310CBC (36x40-24N)		
				<b>1863 100 030</b>	55/90,5/25	mit Anlaufing / with thrust ring (63)	
EXPLORER							
55 60 65				<b>3482 600 120</b>	MF280	Borg & Beck Version / Borg & Beck Version (9)	
				<b>1878 600 577</b>	280CB (36x40-24N)		
70				<b>1878 600 523</b>	310CBC (36x40-24N)	VALEO-Version / VALEO-version (41)	
				<b>3482 600 120</b>	MF280	Borg & Beck Version / Borg & Beck Version (9)	
70 II/DT				<b>1878 600 523</b>	310CBC (36x40-24N)	->Chass. 22091	
75 80				<b>1878 600 523</b>	310CBC (36x40-24N)	VALEO-Version / VALEO-version (41)	
80 II/DT				<b>3482 998 101</b>	GMF330		
				<b>1878 600 522</b>	330CB (36,5x41-24N)		
90/DT				<b>1878 600 523</b>	310CBC (36x40-24N)		





					Parameter		
---	--	--	--	--	-----------	---	---

# SAME





## EXPLORER SPEZIAL

70				<b>1878 600 523</b>	310CBC (36x40-24N)		
				<b>1863 100 030</b>	55/90,5/25	mit Anlauftring / with thrust ring	(63)
				<b>1863 100 030</b>	55/90,5/25	mit Anlauftring / with thrust ring	(63)
70 II				<b>1878 600 523</b>	310CBC (36x40-24N)		
				<b>1863 100 030</b>	55/90,5/25	mit Anlauftring / with thrust ring	(63)
				<b>1863 100 030</b>	55/90,5/25	<b>Chass. 15583-&gt;</b> mit Anlauftring / with thrust ring	(63)
80				<b>3482 998 101</b>	GMF330	<b>-&gt;Chass. 15592</b>	
				<b>1878 600 522</b>	330CB (36,5x41-24N)	<b>-&gt;Chass. 15592</b>	
80/LP 80 II/LP				<b>3482 998 101</b>	GMF330		
				<b>1878 600 522</b>	330CB (36,5x41-24N)		
90				<b>3482 998 101</b>	GMF330	<b>-&gt;Chass. 2974</b>	
				<b>1878 600 522</b>	330CB (36,5x41-24N)	<b>-&gt;Chass. 2974</b>	
90/LP				<b>3482 998 101</b>	GMF330	<b>-&gt;Chass. 1075</b>	
				<b>1878 600 522</b>	330CB (36,5x41-24N)	<b>-&gt;Chass. 1075</b>	



## EXPLORER SPEZIAL BASSO

70 II				<b>1863 100 030</b>	55/90,5/25	<b>Chass. 15583-&gt;</b> mit Anlauftring / with thrust ring	(63)
80 II				<b>1863 100 030</b>	55/90,5/25	mit Anlauftring / with thrust ring	(63)
				<b>1878 600 523</b>	310CBC (36x40-24N)		
				<b>1863 100 030</b>	55/90,5/25	mit Anlauftring / with thrust ring	(63)



## EXPLORER TOP

90 II				<b>1863 100 030</b>	55/90,5/25	mit Anlauftring / with thrust ring	(63)
				<b>1878 600 523</b>	310CBC (36x40-24N)		
				<b>1863 100 030</b>	55/90,5/25	mit Anlauftring / with thrust ring	(63)
				<b>3482 998 101</b>	GMF330		
				<b>1878 600 522</b>	330CB (36,5x41-24N)		

## FALCON









50				<b>1888 911 001 #</b>	DUT-250/ 280 (250/36x40-20N)	Nicht mit VALEO austauschbar / Do not change with VALEO enthält eine Kupplungsscheibe / This part number includes one clutch disc	(32) (45)
				<b>1862 654 002 ▽#</b>	280TB (22x25-14N)	Lose Kupplungsscheibe / Loose clutch disc Nicht mit VALEO austauschbar / Do not change with VALEO	(30) (32)

## FRUTETTO

60				<b>1888 911 001 #</b>	DUT-250/ 280 (250/36x40-20N)	Nicht mit VALEO austauschbar / Do not change with VALEO enthält eine Kupplungsscheibe / This part number includes one clutch disc	(32) (45)
				<b>1862 654 002 ▽#</b>	280TB (22x25-14N)	Lose Kupplungsscheibe / Loose clutch disc Nicht mit VALEO austauschbar / Do not change with VALEO	(30) (32)

					Parameter		
---	--	--	--	--	-----------	---	---

# SAME



FRUTETTO							
60 II 75 II				<b>1888 600 119</b>	DUT280/ CERAM (280/36x40-20N)	enthält eine Kupplungsscheibe / This part number includes one clutch disc	(45)
				<b>1864 600 318</b>	280CERAM (22x25-14N)		
				<b>1863 838 000</b>	70/110/20	ohne Anlauftring / without thrust ring	(79)
				<b>1863 838 001</b>	50/82/29	ohne Anlauftring / without thrust ring	(79)
85 II				<b>1888 600 118</b>	DUT280/ CERAM (280/36x40-20N)	enthält eine Kupplungsscheibe / This part number includes one clutch disc	(45)
				<b>1864 600 324</b>	280CERAM (22x25-14N)	Anzahl der Beläge / Number of pads: 4	(7)
				<b>1863 838 000</b>	70/110/20	ohne Anlauftring / without thrust ring	(79)
				<b>1863 838 001</b>	50/82/29	ohne Anlauftring / without thrust ring	(79)

GALAXY							
170				<b>3400 700 458</b>			









GOLDEN COMPATTO							
75 85/DT				<b>1863 100 030</b>	55/90,5/25	mit Anlauftring / with thrust ring	(63)

HERCULES							
160				<b>3400 700 458</b>			

JAGUAR							
100				<b>3400 700 458</b>			

LASER							
90 / 100 110 130 150				<b>3400 700 458</b>			



LEOPARD							
90 T				<b>3400 700 458</b>		Chass. 20175->	

ROCK							
55 60				<b>1888 600 119</b>	DUT280/ CERAM (280/36x40-20N)	enthält eine Kupplungsscheibe / This part number includes one clutch disc	(45)
				<b>1864 600 318</b>	280CERAM (22x25-14N)		
				<b>1863 838 001</b>	50/82/29	ohne Anlauftring / without thrust ring	(79)
				<b>1888 600 118</b>	DUT280/ CERAM (280/36x40-20N)	enthält eine Kupplungsscheibe / This part number includes one clutch disc	(45)
				<b>1864 600 324</b>	280CERAM (22x25-14N)	Anzahl der Beläge / Number of pads: 4	(7)
				<b>1863 838 001</b>	50/82/29	ohne Anlauftring / without thrust ring	(79)
70				<b>1888 600 118</b>	DUT280/ CERAM (280/36x40-20N)	enthält eine Kupplungsscheibe / This part number includes one clutch disc	(45)
				<b>1864 600 324</b>	280CERAM (22x25-14N)	Anzahl der Beläge / Number of pads: 4	(7)
				<b>1863 838 001</b>	50/82/29	ohne Anlauftring / without thrust ring	(79)



					Parameter		
---	--	--	--	--	-----------	---	---

# SAME











## ROW CROP

90/DT				1878 600 523	310CBC (36x40-24N)	->Chass. 1357	
				1863 100 030	55/90,5/25	->Chass. 1357 mit Anlaufing / with thrust ring	(63)
				3482 998 101	GMF330	Chass. 1358->	



## SAME 65

Same 65				3482 600 120	MF280	Borg & Beck Version / Borg & Beck Version	(9)
				1878 600 577	280CB (36x40-24N)		



## SILVER

80	01.96-			3482 998 101	GMF330	->Chass. 2073	
				1878 600 522	330CB (36,5x41-24N)	->Chass. 2073	
				1866 600 021		Chass. 2146-> Getr. / GBox: Hydrive	
90	01.96-			3482 998 101	GMF330	->Chass. 2963	
				1878 600 522	330CB (36,5x41-24N)	->Chass. 2963	
				1866 600 021		Chass. 3043-> Getr. / GBox: Hydrive	
100.4	01.96-			3482 998 101	GMF330	->Chass. 1874	
				1878 600 522	330CB (36,5x41-24N)	->Chass. 1874	
				1866 600 021		->Chass. 1880 Getr. / GBox: Hydrive	
100.6	01.96-			3482 998 101	GMF330	->Chass. 3222	
				1866 600 021		Chass. 3234-> Getr. / GBox: Hydrive	



## SOLARIS

Solaris 25				1888 600 129	DUT225/ 225	enthält eine Kupplungsscheibe / This part number includes one clutch disc	(45)
Solaris 35				1864 600 333 ▽	225 (17x20-12N)	Lose Kupplungsscheibe / Loose clutch disc	(30)
Solaris 45							

## TAURUS

Taurus 60				1888 911 001 #	DUT-250/ 280 (250/36x40-20N)	Nicht mit VALEO austauschbar / Do not change with VALEO enthält eine Kupplungsscheibe / This part number includes one clutch disc	(32) (45)
				1862 654 002 ▽#	280TB (22x25-14N)	Lose Kupplungsscheibe / Loose clutch disc	(30)

## MINITAURUS

Minitaurus 60				1888 911 001 #	DUT-250/ 280 (250/36x40-20N)	Nicht mit VALEO austauschbar / Do not change with VALEO enthält eine Kupplungsscheibe / This part number includes one clutch disc	(32) (45)
				1862 654 002 ▽#	280TB (22x25-14N)	Lose Kupplungsscheibe / Loose clutch disc	(30)

## TIGER SIX

Tiger Six / 105				3400 700 458 			
-----------------	--	--	---	--	--	--	--











					Parameter		
---	--	--	--	--	-----------	---	---





# SAME

TITAN							
Titan				3400 700 458			

TRIDENT							
Trident 130				3400 700 458			







# SAMPO ROSENLEW

Sampo							
25-35				1882 196 005	KS200		
				1864 634 027	200Z (26x32-10N)		
				3100 700 101 ◊ 3151 021 001 ∩ 2x 3130 010 200	KTI-1		
				1859 600 001 ●			
				1805 042 000 ●			
40 410				1881 089 007	K225		
				1864 078 010 #	225Z (23x29-10N)		
				3100 700 101 ◊ 3151 021 001 ∩ 2x 3130 010 200	KTI-1		
				1859 600 001 ●			
				1805 042 000 ●			

600 Serie							
600 / 650 / 680 / 690				1881 089 007	K225		
				1864 078 010 #	225Z (23x29-10N)		
				1859 600 001			
				1805 042 000			

# SAURER

4..-Serie							
4 DF (D230F) 4 DM (D230M)				3151 000 515			

5..-Serie							
5 D,DF,DM				3482 124 522	GMF430	Allrad / All-wheel Drive	(6)
				1878 002 706	420GTZ (1 3/4" -10N)	Allrad / All-wheel Drive	(6)
				3151 000 515		Allrad / All-wheel Drive	(6)
5 DF6x4,DF8x4				3482 124 522	GMF430		
				1878 002 706	420GTZ (1 3/4" -10N)		
				3151 000 515			



# SAURER

D..-Serie						
290 B,F,N 330 B,F,N			⊗	3482 124 522	GMF430	
			⊗	1878 002 706	420GTZ (1 3/4" -10N)	
			⊙	3151 000 515		

# SCHANZLIN

Gigant						
25 250 300			⊗	1882 313 001	KS180	Nur bei Altteil-Rückgabe lieferbar (Reparatur; Werk Bielefeld) / Please return old unit for repair (plant Bielefeld) (33)
250 /A 300 /A 300 /B			⊗	3082 043 132	M200	
			⊗	1880 071 008	K225	
			⊗	1860 039 025 #	225Z (1 1/8"-10N)	
			⊙	3151 045 001		
350 450			⊗	1888 024 114 #	DUT250-250/ 250 (250/46x50-8N)	enthält eine Kupplungsscheibe / This part number includes one clutch disc (45)
			⊗	1864 634 025 ▽	250Z (1 1/8"-10N)	Lose Kupplungsscheibe / Loose clutch disc (30)
			⊙	1863 123 000	65/101,5/17,5	mit Anlauftring / with thrust ring (63)
600		DB60/68PS	⊗	1888 024 114 #	DUT250-250/ 250 (250/46x50-8N)	enthält eine Kupplungsscheibe / This part number includes one clutch disc (45)
			⊗	1864 634 025 ▽	250Z (1 1/8"-10N)	Lose Kupplungsscheibe / Loose clutch disc (30)
			⊙	1863 123 000	65/101,5/17,5	mit Anlauftring / with thrust ring (63)





Golftrac						
35 -2			⊗	3000 096 003 ⊗ 3082 046 531 ⊗ 1878 006 152 ⊙ 3151 193 041	MF190X 190TPB KZIS-0	

# SCHEID





















5..-Serie						
50.0 51.0 51.1			⊗	1882 196 005	KS200	->Chass. 49
			⊗	1864 634 030	200Z (26x32-10N)	->Chass. 49
			⊗	1881 089 007	K225	Chass. 50->
			⊗	1864 634 026	225Z (26x32-10N)	Chass. 50->
			⊙	3100 700 101 ⊙ 3151 021 001 ⌋ 2x 3130 010 200	KTI-1	





9..-Serie						
90.0 (7,5m) 90.1 (7,5m) 91.0 (7,5m) 91.1 (7,5m)			⊗	1882 196 005	KS200	
			⊗	1864 634 030	200Z (26x32-10N)	
			⊙	3100 700 101 ⊙ 3151 021 001 ⌋ 2x 3130 010 200	KTI-1	

# SCHLECHT

Verputzmaschine / fettling machine							
I	E				1881 089 002	K225	
					1864 634 026	225Z (26x32-10N)	
II	III		Hatz6PS		1881 065 101	KS180	
					3151 994 801		
					1805 041 200		

# SCHLÜTER

A...							
AS15 (15PS) ASFL160/161					1882 196 005	KS200	
					1864 634 039	200Z (23x29-10N)	
					1859 600 001		
					1805 042 000		
AS18 (22PS) AS22 (22PS)					1881 089 002	K225	
					1864 634 024	225Z (1 1/4"-10N)	
					1859 600 001		
					1805 042 000		
AS45 ASL180 ASF181 ASF350					1881 051 204	DO280 (Ge 250/46x50-8N) (Mo 280/28x35-10N)	enthält zwei Kupplungsscheiben / This part number includes both clutch discs Nur bei Altteil-Rückgabe lieferbar (Reparatur; Werk Bielefeld) / Please return old unit for repair (plant Bielefeld)
					1863 600 123	65/101,5/26	mit Anlauftring / with thrust ring
ASFL130 ASFL141 AV/A 127 AV/A1027					1882 315 002	KS180	
					1864 634 040	180E (23x29-10N)	
					1859 600 001		
					1805 042 000		
ASF181 (18PS) ASL180 (18PS) ASF240 (18PS)					1881 089 002	K225	
					1860 039 024 #	225Z (23x29-10N)	
					1859 600 001		
					1805 042 000		
AS261 (26PS)					1864 634 024	225Z (1 1/4"-10N)	
					1859 600 001		
					1805 042 000		

B...							
BA5808-10					1882 315 002	KS180	
					1864 634 040	180E (23x29-10N)	
					1859 600 001		
					1805 042 000		









# SCHLÜTER









COMPACT						
550 ,V (SF3510,V)			⊙	1863 600 123	65/101,5/26	mit Anlauftring / with thrust ring (63)
750 850 950 1050 V6 1150 TV6	07.83- 07.83- 07.83- 07.83- 07.83-		⊙	1888 894 003 #	DUT310 (310/44x48-23N)	enthält eine Kupplungsscheibe / This part number includes one clutch disc (45)
			⊙	1864 925 005 ▽#	310 (27x30-16N)	Lose Kupplungsscheibe / Loose clutch disc (30)
750 ,V (SF3700/701)			⊙	1888 894 004 #	DUT310 (310/44x48-23N)	<b>Chass. 701001 - Chass. 701055</b> enthält eine Kupplungsscheibe / This part number includes one clutch disc (45)
			⊙	1864 925 005 ▽#	310 (27x30-16N)	<b>Chass. 701001 - Chass. 701055</b> Lose Kupplungsscheibe / Loose clutch disc (30)
750 ,V (SF3700/702)			⊙	1888 894 004 #	DUT310 (310/44x48-23N)	<b>Chass. 702001 - Chass. 702021</b> enthält eine Kupplungsscheibe / This part number includes one clutch disc (45)
			⊙	1888 894 003 #	DUT310 (310/44x48-23N)	<b>Chass. 702022-&gt;</b> enthält eine Kupplungsscheibe / This part number includes one clutch disc (45)
			⊙	1864 925 005 ▽#	310 (27x30-16N)	Lose Kupplungsscheibe / Loose clutch disc (30)
850 ,V (SF4800/800)			⊙	1888 894 004 #	DUT310 (310/44x48-23N)	<b>Chass. 800419 - Chass. 800454</b> enthält eine Kupplungsscheibe / This part number includes one clutch disc (45)
			⊙	1864 925 005 ▽#	310 (27x30-16N)	<b>Chass. 800419 - Chass. 800454</b> Lose Kupplungsscheibe / Loose clutch disc (30)
850 ,V (SF4800/801)			⊙	1888 894 004 #	DUT310 (310/44x48-23N)	<b>Chass. 801001 - Chass. 801653</b> enthält eine Kupplungsscheibe / This part number includes one clutch disc (45)
			⊙	1864 925 005 ▽#	310 (27x30-16N)	<b>Chass. 801001 - Chass. 801653</b> Lose Kupplungsscheibe / Loose clutch disc (30)
850 ,V (SF4800/802)			⊙	1888 894 004 #	DUT310 (310/44x48-23N)	<b>Chass. 802002 - Chass. 802340</b> nicht für Fahrgestellnummer / not for chassis no.: 802287 enthält eine Kupplungsscheibe / This part number includes one clutch disc (45)
			⊙	1888 894 003 #	DUT310 (310/44x48-23N)	<b>Chass. 802341-&gt;</b> <b>Chass. und 802287</b> enthält eine Kupplungsscheibe / This part number includes one clutch disc (45)
			⊙	1864 925 005 ▽#	310 (27x30-16N)	nicht für Fahrgestellnummer / not for chassis no.: 802287 Lose Kupplungsscheibe / Loose clutch disc (30)
950 T,TV (SF4900/902)			⊙	1888 894 004 #	DUT310 (310/44x48-23N)	<b>Chass. 902001 - Chass. 902018</b> enthält eine Kupplungsscheibe / This part number includes one clutch disc (45)
			⊙	1864 925 005 ▽#	310 (27x30-16N)	<b>Chass. 902001 - Chass. 902018</b> Lose Kupplungsscheibe / Loose clutch disc (30)
1050 T,TV (SF4900/1001)			⊙	1888 894 004 #	DUT310 (310/44x48-23N)	<b>Chass. 1001001 - Chass. 1001055</b> enthält eine Kupplungsscheibe / This part number includes one clutch disc (45)
			⊙	1864 925 005 ▽#	310 (27x30-16N)	<b>Chass. 1001001 - Chass. 1001055</b> Lose Kupplungsscheibe / Loose clutch disc (30)
1050 T,TV (SF4900/1002)			⊙	1888 894 004 #	DUT310 (310/44x48-23N)	<b>Chass. 1002001 - Chass. 1002050</b> enthält eine Kupplungsscheibe / This part number includes one clutch disc (45)
			⊙	1888 894 003 #	DUT310 (310/44x48-23N)	<b>Chass. 1002051-&gt;</b> enthält eine Kupplungsscheibe / This part number includes one clutch disc (45)
			⊙	1864 925 005 ▽#	310 (27x30-16N)	Lose Kupplungsscheibe / Loose clutch disc (30)
1250 TV6 LS 1350 TV6 LS	01.92- 01.92-		⊙	1888 998 701 #	DUT350 (350/55x60-28N)	enthält eine Kupplungsscheibe / This part number includes one clutch disc (45)
			⊙	1878 987 401 ▽#	348GSDC (44x48-23N)	Anzahl der Beläge / Number of pads: 7 Lose Kupplungsscheibe / Loose clutch disc (7) (30)
1350	06.82-		⊙	1888 862 002 #	DUT350 (350/44x48-23N)	enthält eine Kupplungsscheibe / This part number includes one clutch disc (45)
			⊙	1864 904 003 ▽#	350CERAM (27x30-16N)	Anzahl der Beläge / Number of pads: 8 Lose Kupplungsscheibe / Loose clutch disc (7) (30)











# SCHLÜTER























D...							
D15				1881 089 002	K225		
DF15				1864 634 024	225Z (1 1/4"-10N)		
DS15				1859 600 001			
DF25				1805 042 000			
DS25 B							
DSU25							

EUROTRAC							
1300 LS	06.92-			1888 998 701 #	DUT350 (350/55x60-28N)	enthält eine Kupplungsscheibe / This part number includes one clutch disc	(45)
1600 LS	06.92-			1878 987 401 ▽#	348GSDC (44x48-23N)	Anzahl der Beläge / Number of pads: 7 Lose Kupplungsscheibe / Loose clutch disc	(7) (30)
1900 LS	06.92-						

S...							
S15				1882 315 002	KS180		
				1864 634 016	180E (23x29-10N)		
				1859 600 001			
				1805 042 000			
S30 (22kW) S40 (26kW)				1890 800 001 #	DO250/ 225 (Ge 225/46x50-8N) (Mo 250/23x29-10N)	enthält zwei Kupplungsscheiben / This part number includes both clutch discs Nur bei Altteil-Rückgabe lieferbar (Reparatur; Werk Bielefeld) / Please return old unit for repair (plant Bielefeld)	(46) (33)
				1863 600 123	65/101,5/26	mit Anlauftring / with thrust ring	(63)
S30 (33kW)				1863 600 123	65/101,5/26	mit Anlauftring / with thrust ring	(63)
SF10676	01.74-			1888 894 004 #	DUT310 (310/44x48-23N)	enthält eine Kupplungsscheibe / This part number includes one clutch disc	(45)
				1864 925 005 ▽#	310 (27x30-16N)	Lose Kupplungsscheibe / Loose clutch disc	(30)

SUPER							
350,350 V SF3410/350V 400,400 V SF3410/400V 450, V, S SF3400/450S SF3410/450V 500				1890 800 001 #	DO250/ 225 (Ge 225/46x50-8N) (Mo 250/23x29-10N)	enthält zwei Kupplungsscheiben / This part number includes both clutch discs Nur bei Altteil-Rückgabe lieferbar (Reparatur; Werk Bielefeld) / Please return old unit for repair (plant Bielefeld)	(46) (33)
				1863 600 123	65/101,5/26	mit Anlauftring / with thrust ring	(63)
550 S,550 SV SF4510/550S SF4510/550SV 550,550 V SF4510/550V 650,650 V				1890 800 001 #	DO250/ 225 (Ge 225/46x50-8N) (Mo 250/23x29-10N)	->Chass. 45935 enthält zwei Kupplungsscheiben / This part number includes both clutch discs Nur bei Altteil-Rückgabe lieferbar (Reparatur; Werk Bielefeld) / Please return old unit for repair (plant Bielefeld)	(46) (33)
				1863 600 123	65/101,5/26	mit Anlauftring / with thrust ring	(63)
850,850 V SF6810/852				1888 894 004 #	DUT310 (310/44x48-23N)	Chass. 852001 - Chass. 852083 enthält eine Kupplungsscheibe / This part number includes one clutch disc	(45)
				1864 925 005 ▽#	310 (27x30-16N)	Chass. 852001 - Chass. 852083 Lose Kupplungsscheibe / Loose clutch disc	(30)
950,950 V SF6900/950V				1888 998 601 #	DUT310 (330/41x45-22N)	Chass. 950347 - Chass. 950454 750260/261 / 850257/258/262-264 enthält eine Kupplungsscheibe / This part number includes one clutch disc	(45)
				1864 996 201 ▽#	310 (25x28-15N)	Chass. 950347 - Chass. 950454 750260/261 / 850257/258/262-264	

# SCHLÜTER



SUPER							
1050	07.83-			1888 894 003 #	DUT310 (310/44x48-23N)	enthält eine Kupplungsscheibe / This part number includes one clutch disc	(45)
				1864 925 005 ▽#	310 (27x30-16N)	Lose Kupplungsscheibe / Loose clutch disc	(30)
1050,1050 V SF6810/1050				1888 894 004 #	DUT310 (310/44x48-23N)	<b>Chass. 1050001 - Chass. 1050300</b> enthält eine Kupplungsscheibe / This part number includes one clutch disc	(45)
				1864 925 005 ▽#	310 (27x30-16N)	<b>Chass. 1050001 - Chass. 1050300</b> Lose Kupplungsscheibe / Loose clutch disc	(30)
1050,1050 V SF6810/1051				1888 894 004 #	DUT310 (310/44x48-23N)	<b>Chass. 1051001 - Chass. 1051151</b> enthält eine Kupplungsscheibe / This part number includes one clutch disc	(45)
				1864 925 005 ▽#	310 (27x30-16N)	<b>Chass. 1051001 - Chass. 1051151</b> Lose Kupplungsscheibe / Loose clutch disc	(30)
1050,1050 V SF6810/1052				1888 894 004 #	DUT310 (310/44x48-23N)	<b>Chass. 1052002 - Chass. 1052101</b> enthält eine Kupplungsscheibe / This part number includes one clutch disc	(45)
				1888 894 003 #	DUT310 (310/44x48-23N)	<b>Chass. 1052102-&gt;</b> enthält eine Kupplungsscheibe / This part number includes one clutch disc	(45)
				1864 925 005 ▽#	310 (27x30-16N)	Lose Kupplungsscheibe / Loose clutch disc	(30)
1150,1150 V SF6900/950V				1888 998 601 #	DUT310 (330/41x45-22N)	<b>Chass. 1150455 - Chass. 1150477</b> enthält eine Kupplungsscheibe / This part number includes one clutch disc	(45)
				1864 996 201 ▽#	310 (25x28-15N)	<b>Chass. 1150455 - Chass. 1150477</b> Lose Kupplungsscheibe / Loose clutch disc	(30)
1250 V SF6900/1251V				1888 998 601 #	DUT310 (330/41x45-22N)	<b>Chass. 1251001 - Chass. 1251014</b> enthält eine Kupplungsscheibe / This part number includes one clutch disc	(45)
				1864 996 201 ▽#	310 (25x28-15N)	<b>Chass. 1251001 - Chass. 1251014</b> Lose Kupplungsscheibe / Loose clutch disc	(30)
1250 V SF6900/1254				1888 883 041 #	DUT330 (330/44x48-23N)	<b>Chass. 1254001 - Chass. 1254141</b> enthält eine Kupplungsscheibe / This part number includes one clutch disc	(45)
				1864 932 041 ▽#	330 (27x30-16N)	<b>Chass. 1254001 - Chass. 1254141</b> Lose Kupplungsscheibe / Loose clutch disc	(30)
				1863 837 000	55/91,6/16,3	<b>Chass. 1254001 - Chass. 1254141</b> mit Anlauftring / with thrust ring	(63)
				1863 855 000	106/140/25	<b>Chass. 1254001 - Chass. 1254141</b> mit Anlauftring / with thrust ring	(63)
1250 V SF6900/1256				1888 883 041 #	DUT330 (330/44x48-23N)	<b>Chass. 1256001 - Chass. 1256055</b> enthält eine Kupplungsscheibe / This part number includes one clutch disc	(45)
				1864 932 041 ▽#	330 (27x30-16N)	<b>Chass. 1256001 - Chass. 1256055</b> Lose Kupplungsscheibe / Loose clutch disc	(30)
				1863 837 000	55/91,6/16,3	<b>Chass. 1256001 - Chass. 1256055</b> mit Anlauftring / with thrust ring	(63)
				1863 855 000	106/140/25	<b>Chass. 1256001 - Chass. 1256055</b> mit Anlauftring / with thrust ring	(63)
1250 V SF6900/1258				1888 883 041 #	DUT330 (330/44x48-23N)	<b>Chass. 1258001-&gt;</b> enthält eine Kupplungsscheibe / This part number includes one clutch disc	(45)
				1864 932 041 ▽#	330 (27x30-16N)	<b>Chass. 1258001-&gt;</b> Lose Kupplungsscheibe / Loose clutch disc	(30)
				1863 837 000	55/91,6/16,3	<b>Chass. 1258001-&gt;</b> mit Anlauftring / with thrust ring	(63)
				1863 855 000	106/140/25	<b>Chass. 1258001-&gt;</b> mit Anlauftring / with thrust ring	(63)
1250,1250 V SF6900/1250 SF6900/1250V				1888 998 601 #	DUT310 (330/41x45-22N)	<b>Chass. 1250001 - Chass. 1250656</b> <b>Chass. und 1500013</b> enthält eine Kupplungsscheibe / This part number includes one clutch disc	(45)
				1864 996 201 ▽#	310 (25x28-15N)	<b>Chass. 1250001 - Chass. 1250656</b> <b>Chass. und 1500013</b> Lose Kupplungsscheibe / Loose clutch disc	(30)



# SCHLÜTER

SUPER						
<b>1250 VL</b> <b>1500 TVL</b> <b>1600</b> <b>1800 TVL</b> <b>2000 TVL</b>	06.82- 06.82- 06.82- 06.82- 06.82-			<b>1888 862 002 #</b>	DUT350 (350/44x48-23N)	enthält eine Kupplungsscheibe / This part number includes one clutch disc (45)
				<b>1864 904 003 ▽#</b>	350CERAM (27x30-16N)	Anzahl der Beläge / Number of pads: 8 Lose Kupplungsscheibe / Loose clutch disc (7) (30)
<b>1250 VL</b> SF6900/1250VL				<b>1888 998 601 #</b>	DUT310 (330/41x45-22N)	<b>Chass. 1252001 - Chass. 1252045</b> enthält eine Kupplungsscheibe / This part number includes one clutch disc (45)
				<b>1864 996 201 ▽#</b>	310 (25x28-15N)	<b>Chass. 1252001 - Chass. 1252045</b> Lose Kupplungsscheibe / Loose clutch disc (30)
<b>1250 VL</b> SF6900/1253VL				<b>1888 998 601 #</b>	DUT310 (330/41x45-22N)	<b>Chass. 1253001 - Chass. 1253076</b> enthält eine Kupplungsscheibe / This part number includes one clutch disc (45)
				<b>1864 996 201 ▽#</b>	310 (25x28-15N)	<b>Chass. 1253001 - Chass. 1253076</b> Lose Kupplungsscheibe / Loose clutch disc (30)
<b>1250 VL</b> SF6900/1255				<b>1888 883 041 #</b>	DUT330 (330/44x48-23N)	<b>Chass. 1255001 - Chass. 1255381</b> enthält eine Kupplungsscheibe / This part number includes one clutch disc (45)
				<b>1864 932 041 ▽#</b>	330 (27x30-16N)	<b>Chass. 1255001 - Chass. 1255381</b> Lose Kupplungsscheibe / Loose clutch disc (30)
				<b>1863 837 000</b>	55/91,6/16,3	<b>Chass. 1255001 - Chass. 1255381</b> mit Anlauftring / with thrust ring (63)
				<b>1863 855 000</b>	106/140/25	<b>Chass. 1255001 - Chass. 1255381</b> mit Anlauftring / with thrust ring (63)
<b>1250 VL</b> SF6900/1257				<b>1888 883 041 #</b>	DUT330 (330/44x48-23N)	<b>Chass. 1257001 - Chass. 1257286</b> enthält eine Kupplungsscheibe / This part number includes one clutch disc (45)
				<b>1864 932 041 ▽#</b>	330 (27x30-16N)	<b>Chass. 1257001 - Chass. 1257286</b> Lose Kupplungsscheibe / Loose clutch disc (30)
				<b>1863 837 000</b>	55/91,6/16,3	<b>Chass. 1257001 - Chass. 1257286</b> mit Anlauftring / with thrust ring (63)
				<b>1863 855 000</b>	106/140/25	<b>Chass. 1257001 - Chass. 1257286</b> mit Anlauftring / with thrust ring (63)
<b>1250 VL</b> SF6900/1259				<b>1888 883 041 #</b>	DUT330 (330/44x48-23N)	<b>Chass. 1259001-&gt;</b> enthält eine Kupplungsscheibe / This part number includes one clutch disc (45)
				<b>1864 932 041 ▽#</b>	330 (27x30-16N)	<b>Chass. 1259001-&gt;</b> Lose Kupplungsscheibe / Loose clutch disc (30)
				<b>1863 837 000</b>	55/91,6/16,3	<b>Chass. 1259001-&gt;</b> mit Anlauftring / with thrust ring (63)
				<b>1863 855 000</b>	106/140/25	<b>Chass. 1259001-&gt;</b> mit Anlauftring / with thrust ring (63)
<b>1250 VL LS</b> <b>1500 VL LS</b>	01.92- 01.92-			<b>1888 998 701 #</b>	DUT350 (350/55x60-28N)	enthält eine Kupplungsscheibe / This part number includes one clutch disc (45)
				<b>1864 909 001 ▽</b>	350DC (44x48-23N)	Lose Kupplungsscheibe / Loose clutch disc (30)
<b>1500 TV</b> SF6950/1505 SF6950/1509 SF6950/1507 SF6950/1503				<b>1888 883 041 #</b>	DUT330 (330/44x48-23N)	<b>Chass. 1503001 - Chass. 1503003</b> <b>Chass. 1505001 - Chass. 1505011</b> <b>Chass. 1507001 - Chass. 1507011</b> <b>Chass. 1509001</b> enthält eine Kupplungsscheibe / This part number includes one clutch disc (45)
				<b>1864 932 041 ▽#</b>	330 (27x30-16N)	<b>Chass. 1503001 - Chass. 1503003</b> <b>Chass. 1505001 - Chass. 1505011</b> <b>Chass. 1507001 - Chass. 1507011</b> <b>Chass. 1509001</b> Lose Kupplungsscheibe / Loose clutch disc (30)
				<b>1863 837 000</b>	55/91,6/16,3	<b>Chass. 1503001 - Chass. 1503003</b> <b>Chass. 1505001 - Chass. 1505011</b> <b>Chass. 1507001 - Chass. 1507011</b> <b>Chass. 1509001</b> mit Anlauftring / with thrust ring (63)
				<b>1863 855 000</b>	106/140/25	<b>Chass. 1503001 - Chass. 1503003</b> <b>Chass. 1505001 - Chass. 1505011</b> <b>Chass. 1507001 - Chass. 1507011</b> <b>Chass. 1509001</b> mit Anlauftring / with thrust ring (63)

# SCHLÜTER

SUPER							
<b>1500 TVL</b> SF6950/1504 SF6950/1506 SF6950/1510 SF6950/1508				<b>1888 883 041 #</b>	DUT330 (330/44x48-23N)	<b>Chass. 1504001 - Chass. 1504042</b> <b>Chass. 1504049 - Chass. 1504072</b> <b>Chass. 1506001 - Chass. 1506255</b> <b>Chass. 1508001 - Chass. 1508253</b> <b>Chass. 1510001 - Chass. 1510168</b> <b>Chass. 1510219</b> nicht für Fahrgestellnummer / not for chassis no.: 1510050 (76) enthält eine Kupplungsscheibe / This part number includes one clutch disc (45)	
				<b>1864 932 041 ▽#</b>	330 (27x30-16N)	<b>Chass. 1504001 - Chass. 1504042</b> <b>Chass. 1504049 - Chass. 1504072</b> <b>Chass. 1506001 - Chass. 1506255</b> <b>Chass. 1508001 - Chass. 1508253</b> <b>Chass. 1510001 - Chass. 1510168</b> <b>Chass. 1510219</b> nicht für Fahrgestellnummer / not for chassis no.: 1510050 (76) Lose Kupplungsscheibe / Loose clutch disc (30)	
				<b>1863 837 000</b>	55/91,6/16,3	<b>Chass. 1504001 - Chass. 1504042</b> <b>Chass. 1504049 - Chass. 1504072</b> <b>Chass. 1506001 - Chass. 1506255</b> <b>Chass. 1508001 - Chass. 1508253</b> <b>Chass. 1510001 - Chass. 1510168</b> <b>Chass. 1510219</b> nicht für Fahrgestellnummer / not for chassis no.: 1510050 (76) mit Anlauftring / with thrust ring (63)	
				<b>1863 855 000</b>	106/140/25	<b>Chass. 1504001 - Chass. 1504042</b> <b>Chass. 1504049 - Chass. 1504072</b> <b>Chass. 1506001 - Chass. 1506255</b> <b>Chass. 1508001 - Chass. 1508253</b> <b>Chass. 1510001 - Chass. 1510168</b> <b>Chass. 1510219</b> nicht für Fahrgestellnummer / not for chassis no.: 1510050 (76) mit Anlauftring / with thrust ring (63)	
<b>2000 TVL</b> SF8106/2002 SF8106/2003 SF8106/2001				<b>1888 883 041 #</b>	DUT330 (330/44x48-23N)	<b>Chass. 2001002 - Chass. 2001035</b> <b>Chass. 2002001 - Chass. 2002118</b> <b>Chass. 2003001 - Chass. 2003046</b> <b>Chass. 2003072</b> nicht für Fahrgestellnummer / not for chassis no.: 2003002 (76) enthält eine Kupplungsscheibe / This part number includes one clutch disc (45)	
				<b>1864 932 041 ▽#</b>	330 (27x30-16N)	<b>Chass. 2001002 - Chass. 2001035</b> <b>Chass. 2002001 - Chass. 2002118</b> <b>Chass. 2003001 - Chass. 2003046</b> <b>Chass. 2003072</b> nicht für Fahrgestellnummer / not for chassis no.: 2003002 (76) Lose Kupplungsscheibe / Loose clutch disc (30)	
				<b>1863 837 002</b>	65/97/23	<b>Chass. 2001002 - Chass. 2001035</b> <b>Chass. 2002001 - Chass. 2002118</b> <b>Chass. 2003001 - Chass. 2003046</b> <b>Chass. 2003072</b> nicht für Fahrgestellnummer / not for chassis no.: 2003002 (76) mit Anlauftring / with thrust ring (63)	
				<b>1863 855 000</b>	106/140/25	<b>Chass. 2001002 - Chass. 2001035</b> <b>Chass. 2002001 - Chass. 2002118</b> <b>Chass. 2003001 - Chass. 2003046</b> <b>Chass. 2003072</b> nicht für Fahrgestellnummer / not for chassis no.: 2003002 (76) mit Anlauftring / with thrust ring (63)	



## SCHLÜTER

### SUPERTRAC

1700 TVL LS	01.92-		1888 998 701 #	DUT350 (350/55x60-28N)	enthält eine Kupplungsscheibe / This part number includes one clutch disc	(45)
1900 TVL LS	01.92-		1878 987 401 ▽#	348GSDC (44x48-23N)	Anzahl der Beläge / Number of pads: 7 Lose Kupplungsscheibe / Loose clutch disc	(7) (30)
2200 TVL LS	01.92-					

## SCHMOTZER

### Kombi

12 PS				1882 196 005	KS200		
				1864 634 030	200Z (26x32-10N)		
				1859 600 001			
				1805 042 000			
14 PS				1882 315 002	KS180		
				1860 023 012	180E (26x32-10N)		
				1859 600 002			
				1805 041 100			
17 PS 20 PS				1882 315 002	KS180		
				1864 634 040	180E (23x29-10N)		
				3151 270 602			
18 PS				1881 065 101	KS180		
				1864 634 016	180E (23x29-10N)		
				3151 270 602			

## SCHÖTTLER

### LO-Serie

16 25				1864 040 017 #	280Z (1 1/2"-10N)		
				1863 100 030	55/90,5/25	mit Anlauftring / with thrust ring	(63)



## SCHULTHEISS

### S-T



















S12 (12PS)				1882 315 003	KS180		
				1864 634 040	180E (23x29-10N)		
				1859 600 002			
				1805 041 100			
T5 (10PS)				1882 196 005	KS200		
				1864 634 030	200Z (26x32-10N)		
				1859 600 001			
				1805 042 000			

					Parameter		
---	--	--	--	--	-----------	---	---































# STEINBOCK



BFG,DFG,TFG							
1,25 1,6DA,2C,2,5R,3A		DBOM636, M136		<b>1881 010 101 #</b>	G250		
				<b>1864 202 035 #</b>	250Z (26x32-10N)		
2C/3/3,5		Ford17M, KHDF3L912 , Perkins4.20 3		<b>1863 100 030</b>	55/90,5/25	mit Anlauftring / with thrust ring	(63)

# STEYR





















80..							
8055 ,a		WD311.44, 45, 46, 47		<b>1888 043 101 #</b>	DUT280-280/ 280 (280/45x50-24N)	<b>-&gt;Chass. 10791</b> <b>Chass. 11004 - Chass. 11106</b> enthält eine Kupplungsscheibe / This part number includes one clutch disc	(45)
				<b>1888 050 302 #</b>	DUT295-295/ 280 (280/45x50-24N)	<b>Chass. 10792 - Chass. 11003</b> <b>Chass. 11107-&gt;</b> enthält eine Kupplungsscheibe / This part number includes one clutch disc	(45)
				<b>1864 366 102 ▽#</b>	280B (28x32-17N)	<b>Chass. 10792 - Chass. 11003</b> <b>Chass. 11107-&gt;</b> Lose Kupplungsscheibe / Loose clutch disc	(30)
				<b>1863 837 002</b>	65/97/23	<b>Chass. 10792 - Chass. 11003</b> <b>Chass. 11107-&gt;</b> mit Anlauftring / with thrust ring	(63)
8060 ,a		WD311.40, 41		<b>1888 018 207 #</b>	DUT280 (280/45x50-24N)	<b>-&gt;Chass. 21533</b> enthält eine Kupplungsscheibe / This part number includes one clutch disc	(45)
				<b>1864 366 102 ▽#</b>	280B (28x32-17N)	<b>-&gt;Chass. 21533</b> Lose Kupplungsscheibe / Loose clutch disc	(30)
				<b>1863 837 002</b>	65/97/23	<b>-&gt;Chass. 21533</b> mit Anlauftring / with thrust ring	(63)
				<b>1863 855 000</b>	106/140/25	<b>-&gt;Chass. 21533</b> mit Anlauftring / with thrust ring	(63)
8060 Schmalspur 8070 Schmalspur				<b>1888 043 101 #</b>	DUT280-280/ 280 (280/45x50-24N)	enthält eine Kupplungsscheibe / This part number includes one clutch disc	(45)
				<b>1864 366 102 ▽#</b>	280B (28x32-17N)	Lose Kupplungsscheibe / Loose clutch disc	(30)
8065 8075		WD411.47		<b>1888 050 302 #</b>	DUT295-295/ 280 (280/45x50-24N)	enthält eine Kupplungsscheibe / This part number includes one clutch disc	(45)
				<b>1864 366 102 ▽#</b>	280B (28x32-17N)	Lose Kupplungsscheibe / Loose clutch disc	(30)
8070 ,a		WD411.41, 42, 43, 44		<b>1888 018 207 #</b>	DUT280 (280/45x50-24N)	<b>-&gt;Chass. 21524</b> enthält eine Kupplungsscheibe / This part number includes one clutch disc	(45)
				<b>1864 366 102 ▽#</b>	280B (28x32-17N)	<b>-&gt;Chass. 21524</b> Lose Kupplungsscheibe / Loose clutch disc	(30)
				<b>1863 837 002</b>	65/97/23	<b>-&gt;Chass. 21524</b> mit Anlauftring / with thrust ring	(63)
				<b>1863 855 000</b>	106/140/25	<b>-&gt;Chass. 21524</b> mit Anlauftring / with thrust ring	(63)
8073				<b>1888 050 101 #</b>	DUT295-295/ 280 (280/45x50-24N)	enthält eine Kupplungsscheibe / This part number includes one clutch disc	(45)
				<b>1864 410 101 ▽#</b>	295B (28x32-17N)	Lose Kupplungsscheibe / Loose clutch disc	(30)
8075 ,a		WD411.45, 46		<b>1888 050 302 #</b>	DUT295-295/ 280 (280/45x50-24N)	enthält eine Kupplungsscheibe / This part number includes one clutch disc	(45)
				<b>1864 410 101 ▽#</b>	295B (28x32-17N)	Lose Kupplungsscheibe / Loose clutch disc	(30)
				<b>1863 837 002</b>	65/97/23	mit Anlauftring / with thrust ring	(63)

# STEYR

80..							
8080 ,a				<b>1888 059 201 #</b>	DUT330-310/ 295 (295/45x50-24N)	enthält eine Kupplungsscheibe / This part number includes one clutch disc	(45)
				<b>1888 059 202 ●#</b>	DUT310 (295/45x50-24N)	enthält eine Kupplungsscheibe / This part number includes one clutch disc	(45)
				<b>1864 439 101 ▽#</b>	310B (28x32-17N)	Lose Kupplungsscheibe / Loose clutch disc	(30)
				<b>1862 311 001 ▽#</b>	310GSPB (28x32-17N)	Lose Kupplungsscheibe / Loose clutch disc Steyrmatic / Steyrmatic	(30) (40)
				<b>1863 837 002</b>	65/97/23	mit Anlauftring / with thrust ring	(63)
				<b>1863 855 000</b>	106/140/25	mit Anlauftring / with thrust ring	(63)
8085 8090 ,a 8095 ap				<b>1888 059 201 #</b>	DUT330-310/ 295 (295/45x50-24N)	enthält eine Kupplungsscheibe / This part number includes one clutch disc	(45)
				<b>1888 059 202 ●#</b>	DUT310 (295/45x50-24N)	enthält eine Kupplungsscheibe / This part number includes one clutch disc	(45)
				<b>1862 311 001 ●▽#</b>	310GSPB (28x32-17N)	Lose Kupplungsscheibe / Loose clutch disc	(30)
				<b>1864 439 101 ▽#</b>	310B (28x32-17N)	Lose Kupplungsscheibe / Loose clutch disc	(30)
				<b>1863 837 002</b>	65/97/23	mit Anlauftring / with thrust ring	(63)
				<b>1863 855 000</b>	106/140/25	mit Anlauftring / with thrust ring	(63)
8085 a		WD411.45, 46		<b>1888 050 302 #</b>	DUT295-295/ 280 (280/45x50-24N)	enthält eine Kupplungsscheibe / This part number includes one clutch disc	(45)
				<b>1864 410 101 ▽#</b>	295B (28x32-17N)	Lose Kupplungsscheibe / Loose clutch disc	(30)
81..							
8100 ,a		WD611.40, 41		<b>1881 039 531 #</b>	G350	ohne Lastschaltgetriebe / without power shift transmission	(80)
				<b>1862 131 201 #</b>	350GTB (41x45-21N)	ohne Lastschaltgetriebe / without power shift transmission	(80)
				<b>1864 360 101 ●#</b>	350Z (41x45-21N)	ohne Lastschaltgetriebe / without power shift transmission	(80)
8110 ,a		WD611.42, 43		<b>1881 039 531 #</b>	G350	mit Lastschaltgetriebe / with power shift transmission	(64)
				<b>1862 131 201 #</b>	350GTB (41x45-21N)	mit Lastschaltgetriebe / with power shift transmission	(64)
				<b>1862 131 202 #</b>	350GTB (44x48-22N)	mit Lastschaltgetriebe / with power shift transmission	(64)
8120 ,a		WD611.85, 86		<b>1881 039 531 #</b>	G350	ohne Lastschaltgetriebe / without power shift transmission	(80)
				<b>1862 131 201 #</b>	350GTB (41x45-21N)	ohne Lastschaltgetriebe / without power shift transmission	(80)
				<b>1864 360 101 ●#</b>	350Z (41x45-21N)	ohne Lastschaltgetriebe / without power shift transmission	(80)
8130 ,a		WD611.87, 88		<b>1881 039 531 #</b>	G350	mit Lastschaltgetriebe / with power shift transmission	(64)
				<b>1862 131 201 #</b>	350GTB (41x45-21N)	mit Lastschaltgetriebe / with power shift transmission	(64)
				<b>1862 131 202 #</b>	350GTB (44x48-22N)	mit Lastschaltgetriebe / with power shift transmission	(64)
8140 ,a		WD612.40		<b>1882 262 006</b>	G350N	für Nebenantrieb / for PTO Nur bei Altteil-Rückgabe lieferbar (Reparatur; Werk Bielefeld) / Please return old unit for repair (plant Bielefeld)	(57) (33)
				<b>1861 691 101 #</b>	350WGSZ (28x35-10N)	für Nebenantrieb / for PTO	(57)
				<b>3151 082 001</b>		für Nebenantrieb / for PTO mit Schmierrohranschluß / with lubricating pipe coupling	(57) (68)
				<b>3151 111 032</b>		für Nebenantrieb / for PTO ohne Schmierrohranschluß / without lubricating pipe connection	(57) (82)







					Parameter		
---	--	--	--	--	-----------	---	---



















# STEYR

81..							
8150 ,a Turbo		WD612.87		1882 262 006	G350N	für Nebenantrieb / for PTO Nur bei Altteil-Rückgabe lieferbar (Reparatur; Werk Bielefeld) / Please return old unit for repair (plant Bielefeld)	(57) (33)
				1861 691 101 #	350WGSZ (28x35-10N)	für Nebenantrieb / for PTO	(57)
				3151 082 001		für Nebenantrieb / for PTO mit Schmierrohranschluß / with lubricating pipe coupling	(57) (68)
				3151 111 032		für Nebenantrieb / for PTO ohne Schmierrohranschluß / without lubricating pipe connection	(57) (82)
8160 a		WD612.85		1882 262 006	G350N	für Nebenantrieb / for PTO Nur bei Altteil-Rückgabe lieferbar (Reparatur; Werk Bielefeld) / Please return old unit for repair (plant Bielefeld)	(57) (33)
				1861 613 101 #	350WGSDC (28x35-10N)	für Nebenantrieb / for PTO Anzahl der Beläge / Number of pads: 12	(57) (7)
				3151 082 001		für Nebenantrieb / for PTO mit Schmierrohranschluß / with lubricating pipe coupling	(57) (68)
				3151 111 032		für Nebenantrieb / for PTO ohne Schmierrohranschluß / without lubricating pipe connection	(57) (82)
8170 a Turbo		WD612.89		1882 262 006	G350N	für Nebenantrieb / for PTO Nur bei Altteil-Rückgabe lieferbar (Reparatur; Werk Bielefeld) / Please return old unit for repair (plant Bielefeld)	(57) (33)
				1861 613 101 #	350WGSDC (28x35-10N)	für Nebenantrieb / for PTO Anzahl der Beläge / Number of pads: 12	(57) (7)
				3151 082 001		für Nebenantrieb / for PTO mit Schmierrohranschluß / with lubricating pipe coupling	(57) (68)
8180 a		WD612.96		1882 262 006	G350N	für Nebenantrieb / for PTO Nur bei Altteil-Rückgabe lieferbar (Reparatur; Werk Bielefeld) / Please return old unit for repair (plant Bielefeld)	(57) (33)
				1861 613 101 #	350WGSDC (28x35-10N)	für Nebenantrieb / for PTO Anzahl der Beläge / Number of pads: 12	(57) (7)
				3151 082 001		für Nebenantrieb / for PTO mit Schmierrohranschluß / with lubricating pipe coupling	(57) (68)
90..							
9078 / A	03.96 - 01.04			1888 059 201 #	DUT330-310/ 295 (295/45x50-24N)	->Chass. 04388 ->01.1999 enthält eine Kupplungsscheibe / This part number includes one clutch disc	(45)
				1862 311 001 ▽#	310GSPB (28x32-17N)	->Chass. 04388 ->01.1999 Lose Kupplungsscheibe / Loose clutch disc	(30)
				1888 998 001	DUT310 (310/45x50-24N)	Chass. 04389 - Chass. 04517 Chass. DBD0055001-> 01.1999-> enthält eine Kupplungsscheibe / This part number includes one clutch disc	(45)
				1878 986 601 #	327GSDC (28x32-17N)	Chass. 04389 - Chass. 04517 Chass. DBD0055001-> 01.1999-> Anzahl der Beläge / Number of pads: 5 Schwungradänderung erforderlich / Flywheel must be modified	(7) (37)
				1863 837 002	65/97/23	mit Anlauftring / with thrust ring	(63)
				1863 855 000	106/140/25	mit Anlauftring / with thrust ring	(63)









































# STEYR

90..							
9083 / A 9086 / A	09.94 - 01.99			3800 541 021 # ⊗ 1888 059 201 ⊗ 1878 634 036 ⊙ 1863 837 002 ⊙ 1863 855 000	DUT330-310/295 330GSPB GR-4 GR-8	->Chass. 04211 für Fahrzeuge mit Zweischeibenkupplung / for vehicles with double disc clutch	(51)
	03.96 - 01.99				3800 541 001 # ⊗ 1888 998 001 ⊗ 1878 986 601 ⊙ 1863 837 002 ⊙ 1863 855 000	DUT310 327GSDC GR-4 GR-8	Chass. 04212 - Chass. 04517 für Fahrzeuge mit Zweischeibenkupplung / for vehicles with double disc clutch
9094 / A	03.96 - 01.04			3800 541 021 # ⊗ 1888 059 201 ⊗ 1878 634 036 ⊙ 1863 837 002 ⊙ 1863 855 000	DUT330-310/295 330GSPB GR-4 GR-8	->Chass. 04211 für Fahrzeuge mit Zweischeibenkupplung / for vehicles with double disc clutch	(51)
					3800 541 001 # ⊗ 1888 998 001 ⊗ 1878 986 601 ⊙ 1863 837 002 ⊙ 1863 855 000	DUT310 327GSDC GR-4 GR-8	Chass. 04212 - Chass. 04517 Chass. DBD0055001-> für Fahrzeuge mit Zweischeibenkupplung / for vehicles with double disc clutch
9155 9170 9190				3400 126 401 # 		mit Lastschaltgetriebe / with power shift transmission	(64)























60 - 991							
50 650 ,A		WD407.40		3151 000 395		->Mot. 2535	
60 295 658				1882 318 101 #	GT310N		
				1864 340 101 #	310B (28x35-10N)		
180 A 180 N 182				1881 050 402 #	DO250 (Ge 225/46x50-8N) (Mo 250/28x35-10N)	enthält zwei Kupplungsscheiben / This part number includes both clutch discs	(46)
188				1881 089 002	K225		
				1860 039 024 #	225Z (23x29-10N)		
				3100 700 101 ⊙ 3151 021 001 ⌘ 2x 3130 010 200	KTI-1		
430 ,B,N		WD210.40		1881 089 002	K225		
				1860 039 024 #	225Z (23x29-10N)		
586 591 680 691		WD612.01		1861 600 034 #	310GTD (28x35-10N)		
667		Valmet320.80		3800 541 022 ▲#⊙ ⊗ 1888 054 004 ⊗ 1864 418 002	DUT295-280/295 280		
690		WD610.18		1880 092 415 #	G310		
				1861 600 034 #	310GTD (28x35-10N)		
760 ,A		WD408.40		1882 318 101 #	GT310N		
				1864 340 101 #	310B (28x35-10N)		
				3151 000 395			
768 ,A		WD408.43		1882 318 101 #	GT310N		
				1864 340 101 #	310B (28x35-10N)		
				3151 000 395			

# STEYR























60 - 991							
780		WD612.01		1864 340 101 #	310B (28x35-10N)		
780 E		WD609.60, 610.70		1880 092 415 #	G310		
				1864 340 101 #	310B (28x35-10N)		
790		WD610.18		1880 092 415 #	G310		
				1864 340 101 #	310B (28x35-10N)		
870 ,A		WD410.40		1881 039 531 #	G350	Mot. 18760->	
				1864 347 102 #	350Z (41x45-22N)	Mot. 18760->	
890		610.70, WD609.60, 610.18,		1880 092 415 #	G310		
				1864 340 101 #	310B (28x35-10N)		
942 ,A		WD308.48		1888 050 101 #	DUT295-295/ 280 (280/45x50-24N)	enthält eine Kupplungsscheibe / This part number includes one clutch disc	(45)
				1864 412 101 #	280/ 58 (45x50-24N)	Lose Kupplungsscheibe / Loose clutch disc	(30)
				1863 837 002	65/97/23	mit Anlauftring / with thrust ring	(63)
				1863 855 000	106/140/25	mit Anlauftring / with thrust ring	(63)
948 ,A Turbo		WD308.85		1888 050 101 #	DUT295-295/ 280 (280/45x50-24N)	enthält eine Kupplungsscheibe / This part number includes one clutch disc	(45)
				1864 412 101 #	280/ 58 (45x50-24N)	Lose Kupplungsscheibe / Loose clutch disc	(30)
				1863 837 002	65/97/23	mit Anlauftring / with thrust ring	(63)
				1863 855 000	106/140/25	mit Anlauftring / with thrust ring	(63)
955 ,A	- 01.98	MWMMDT226/3 , WD301.42/43		1888 050 101 #	DUT295-295/ 280 (280/45x50-24N)	enthält eine Kupplungsscheibe / This part number includes one clutch disc	(45)
				1862 421 001 ▽#	280GSPB (28x32-17N)	Lose Kupplungsscheibe / Loose clutch disc	(30)
				1863 837 002	65/97/23	mit Anlauftring / with thrust ring	(63)
				1863 855 000	106/140/25	mit Anlauftring / with thrust ring	(63)
964 A		WD301.82, 83		3800 541 002 #  1888 998 101  1878 986 801  1863 837 002  1863 855 000	DUT280 290GSDC GR-4 GR-8	für Fahrzeuge mit Zweischeibenkupplung / for vehicles with double disc clutch	(51)
				1878 634 031 ●▽	295GSPB (28x32-17N)	Lose Kupplungsscheibe / Loose clutch disc	(30)
970 A		WD301.87		3800 541 002 #  1888 998 101  1878 986 801  1863 837 002  1863 855 000	DUT280 290GSDC GR-4 GR-8	für Fahrzeuge mit Zweischeibenkupplung / for vehicles with double disc clutch	(51)
				1878 634 031 ●▽	295GSPB (28x32-17N)	Lose Kupplungsscheibe / Loose clutch disc	(30)
980 ,A		WD412.40		1881 039 531 #	G350		
				1864 347 102 #	350Z (41x45-22N)		
988 ,A		WD412.41		1881 039 531 #	G350		
				1864 347 102 #	350Z (41x45-22N)		
990 mit NMV 80/3		WD614.01/20		1882 261 013 #	G380N	für Nebenantrieb / for PTO	(57)

# STEYR

**1090 - 2891**

















<b>1090 ,a</b>		WD610.42		<b>1881 039 531 #</b>	G350		
				<b>1864 347 102 #</b>	350Z (41x45-22N)		
<b>1100 ,a</b>		WD610.40		<b>1881 039 531 #</b>	G350		
				<b>1864 347 102 #</b>	350Z (41x45-22N)		
<b>1108 ,a</b>		WD610.44		<b>1881 039 531 #</b>	G350		
				<b>1864 347 102 #</b>	350Z (41x45-22N)		
<b>1200 ,a</b>		WD610.43		<b>1881 039 531 #</b>	G350	Getr. / GBox: ZF	
				<b>1864 347 102 #</b>	350Z (41x45-22N)	Getr. / GBox: ZF	
				<b>1882 262 006</b>	G350N	Getr. / GBox: Steyr für Nebenantrieb / for PTO Nur bei Altteil-Rückgabe lieferbar (Reparatur; Werk Bielefeld) / Please return old unit for repair (plant Bielefeld)	(57) (33)
				<b>1864 347 101 #</b>	350Z (44x48-23N)	Getr. / GBox: Steyr	
				<b>3151 111 032</b>		Getr. / GBox: Steyr ohne Schmierrohranschluß / without lubricating pipe connection	(82)
<b>1290 mit NMV 80/3 1490 mit NMV 80/3</b>		WD614.01/20		<b>1882 261 013 #</b>	G380N	für Nebenantrieb / for PTO	(57)
<b>1400 a</b>		WD612.85		<b>1882 262 006</b>	G350N	für Nebenantrieb / for PTO Nur bei Altteil-Rückgabe lieferbar (Reparatur; Werk Bielefeld) / Please return old unit for repair (plant Bielefeld)	(57) (33)
				<b>1861 613 101 #</b>	350WGSDC (28x35-10N)	für Nebenantrieb / for PTO Anzahl der Beläge / Number of pads: 12	(57) (7)
		WD610.43		<b>1864 347 101 #</b>	350Z (44x48-23N)	Getr. / GBox: Steyr	
				<b>3151 111 032</b>		Getr. / GBox: Steyr ohne Schmierrohranschluß / without lubricating pipe connection	(82)
<b>1600 a</b>		WD612.85		<b>1882 262 006</b>	G350N	für Nebenantrieb / for PTO Nur bei Altteil-Rückgabe lieferbar (Reparatur; Werk Bielefeld) / Please return old unit for repair (plant Bielefeld)	(57) (33)
				<b>1861 613 101 #</b>	350WGSDC (28x35-10N)	für Nebenantrieb / for PTO Anzahl der Beläge / Number of pads: 12	(57) (7)
<b>1881</b>		WD815.66		<b>1888 015 515 #</b>	GF2/ 380 (380/ 2"-10N)	enthält eine Kupplungsscheibe / This part number includes one clutch disc	(45)
				<b>1878 000 968</b> ▽	380GTZ (2"-10N)	Lose Kupplungsscheibe / Loose clutch disc	(30)
				<b>3151 186 001</b>			
				<b>1882 280 213</b>	GF2/ 380	In 1888 ... .. enthalten / Contained in 1888 ... ..	(24)
				<b>1859 212 000</b>	GF2/ 380	In 1888 ... .. enthalten / Contained in 1888 ... ..	(24)

# STEYR





























Kompakt							
360 370	04.03- 04.03-			1888 600 109	DUT280/ CERAM (280/35x40-14N)	->Chass. C4941 enthält eine Kupplungsscheibe / This part number includes one clutch disc	(45)
				1888 600 144 ●	DUT280/ CERAM (280/35x40-14N)	->Chass. C4941 enthält eine Kupplungsscheibe / This part number includes one clutch disc	(45)
				1864 600 345	280C (22x25-10N)	->Chass. C4941 Anzahl der Beläge / Number of pads: 3	(7)
				1863 838 001	50/82/29	->Chass. C4941 ohne Anlauftring / without thrust ring	(79)
				1863 858 002	75/115/20	->Chass. C4941 ohne Anlauftring / without thrust ring	(79)
				1888 600 107	DUT280 (280/35x40-14N)	->Chass. D4941 enthält eine Kupplungsscheibe / This part number includes one clutch disc	(45)
				1864 600 345	280C (22x25-10N)	->Chass. D4941 Anzahl der Beläge / Number of pads: 3	(7)
				1863 838 001	50/82/29	->Chass. D4941 ohne Anlauftring / without thrust ring	(79)
				1863 858 002	75/115/20	->Chass. D4941 ohne Anlauftring / without thrust ring	(79)
375	04.03-			1888 600 144	DUT280/ CERAM (280/35x40-14N)	enthält eine Kupplungsscheibe / This part number includes one clutch disc	(45)
				1864 600 345	280C (22x25-10N)	Anzahl der Beläge / Number of pads: 3	(7)
				1863 838 001	50/82/29	ohne Anlauftring / without thrust ring	(79)
				1863 858 002	75/115/20	ohne Anlauftring / without thrust ring	(79)
485 495	10.05- 10.05-			1888 600 144	DUT280/ CERAM (280/35x40-14N)	enthält eine Kupplungsscheibe / This part number includes one clutch disc	(45)
				1864 600 303	280C (22x25-10N)	Anzahl der Beläge / Number of pads: 4	(7)
				1863 838 001	50/82/29	ohne Anlauftring / without thrust ring	(79)
				1863 858 002	75/115/20	ohne Anlauftring / without thrust ring	(79)
4055 S 4065 S	04.11- 04.11-			1863 838 001	50/82/29	ohne Anlauftring / without thrust ring	(79)
				1863 858 002	75/115/20	ohne Anlauftring / without thrust ring	(79)
				1863 869 014	17/40/12		
4065 4075	04.08- 04.08-			1888 600 144	DUT280/ CERAM (280/35x40-14N)	enthält eine Kupplungsscheibe / This part number includes one clutch disc	(45)
				1864 600 303	280C (22x25-10N)	Anzahl der Beläge / Number of pads: 4 Lose Kupplungsscheibe / Loose clutch disc	(7) (30)
				1863 838 001	50/82/29	ohne Anlauftring / without thrust ring	(79)
				1863 858 002	75/115/20	ohne Anlauftring / without thrust ring	(79)
				1863 869 014	17/40/12		
				1882 600 101	G280N	für / for: Powershuttle	(47)
				1864 600 303	280C (22x25-10N)	für / for: Powershuttle Anzahl der Beläge / Number of pads: 4	(47) (7)
				1863 838 001	50/82/29	für / for: Powershuttle ohne Anlauftring / without thrust ring	(47) (79)
				1863 869 014	17/40/12	für / for: Powershuttle	(47)

# STEYR

## Kompakt

4085	01.07-			<b>1888 600 144</b>	DUT280/ CERAM (280/35x40-14N)	enthält eine Kupplungsscheibe / This part number includes one clutch disc	(45)
				<b>1864 600 303</b>	280C (22x25-10N)	Anzahl der Beläge / Number of pads: 4 Lose Kupplungsscheibe / Loose clutch disc	(7) (30)
				<b>1863 838 001</b>	50/82/29	ohne Anlauftring / without thrust ring	(79)
				<b>1863 858 002</b>	75/115/20	ohne Anlauftring / without thrust ring	(79)
				<b>1863 869 019</b>	17/47/14		
				<b>1882 600 101</b>	G280N	für / for: Powershuttle	(47)
				<b>1864 600 303</b>	280C (22x25-10N)	für / for: Powershuttle Anzahl der Beläge / Number of pads: 4	(47) (7)
				<b>1863 838 001</b>	50/82/29	für / for: Powershuttle ohne Anlauftring / without thrust ring	(47) (79)
				<b>1863 869 019</b>	17/47/14	für / for: Powershuttle	(47)
4095	01.07-			<b>1864 600 303</b>	280C (22x25-10N)	Anzahl der Beläge / Number of pads: 4 Lose Kupplungsscheibe / Loose clutch disc	(7) (30)
				<b>1863 838 001</b>	50/82/29	ohne Anlauftring / without thrust ring	(79)
				<b>1863 858 002</b>	75/115/20	ohne Anlauftring / without thrust ring	(79)
				<b>1863 869 019</b>	17/47/14		
				<b>1864 600 303</b>	280C (22x25-10N)	für / for: Powershuttle Anzahl der Beläge / Number of pads: 4	(47) (7)
				<b>1863 838 001</b>	50/82/29	für / for: Powershuttle ohne Anlauftring / without thrust ring	(47) (79)
				<b>1863 869 019</b>	17/47/14	für / for: Powershuttle	(47)



## M Reihe

M948 M958		Perkins903.27 , T		<b>1888 998 101</b>	DUT280 (280/44x49-24N)	enthält eine Kupplungsscheibe / This part number includes one clutch disc	(45)
				<b>1878 986 701</b> ▽#	290GSZ (25x28-15N)	Lose Kupplungsscheibe / Loose clutch disc	(30)
M952 M963				<b>1888 998 101</b>	DUT280 (280/44x49-24N)	enthält eine Kupplungsscheibe / This part number includes one clutch disc	(45)
				<b>1863 837 002</b>	65/97/23	mit Anlauftring / with thrust ring	(63)
				<b>1863 855 000</b>	106/140/25	mit Anlauftring / with thrust ring	(63)
M964 M975				<b>3800 541 002</b> #  <b>1888 998 101</b>  <b>1878 986 801</b>  <b>1863 837 002</b>  <b>1863 855 000</b>	DUT280 290GSDC GR-4 GR-8	für Fahrzeuge mit Zweischeibenkupplung / for vehicles with double disc clutch	(51)
				<b>1878 634 031</b> ●▽	295GSPB (28x32-17N)	Lose Kupplungsscheibe / Loose clutch disc	(30)
M968 a, Turbo		WD301.89		<b>3800 541 002</b> #  <b>1888 998 101</b>  <b>1878 986 801</b>  <b>1863 837 002</b>  <b>1863 855 000</b>	DUT280 290GSDC GR-4 GR-8	für Fahrzeuge mit Zweischeibenkupplung / for vehicles with double disc clutch	(51)
				<b>1878 634 031</b> ●▽	295GSPB (28x32-17N)	Lose Kupplungsscheibe / Loose clutch disc	(30)
M975 a, Turbo		WD301.88		<b>3800 541 002</b> #  <b>1888 998 101</b>  <b>1878 986 801</b>  <b>1863 837 002</b>  <b>1863 855 000</b>	DUT280 290GSDC GR-4 GR-8	für Fahrzeuge mit Zweischeibenkupplung / for vehicles with double disc clutch	(51)
				<b>1878 634 031</b> ●▽	295GSPB (28x32-17N)	Lose Kupplungsscheibe / Loose clutch disc	(30)
M9083 a		WD401.83		<b>3800 541 001</b> #  <b>1888 998 001</b>  <b>1878 986 601</b>  <b>1863 837 002</b>  <b>1863 855 000</b>	DUT310 327GSDC GR-4 GR-8	für Fahrzeuge mit Zweischeibenkupplung / for vehicles with double disc clutch Schwungradänderung erforderlich / Flywheel must be modified	(51) (37)



					Parameter		
---	--	--	--	--	-----------	---	---

# STEYR

## M Reihe



M9086 a		WD401.82		3800 541 001 #	DUT310 327GSDC GR-4 GR-8	für Fahrzeuge mit Zweischeibenkupplung / for vehicles with double disc clutch Schwungradänderung erforderlich / Flywheel must be modified	(51) (37)
				1888 998 001 1878 986 601 1863 837 002 1863 855 000			
M9090 M9100				1888 998 001	DUT310 (310/45x50-24N)	enthält eine Kupplungsscheibe / This part number includes one clutch disc	(45)
				1878 986 601 ▽#	327GSDC (28x32-17N)	Anzahl der Beläge / Number of pads: 5 Schwungradänderung erforderlich / Flywheel must be modified	(7) (37)
				1878 600 574 ▽	330CB (28x32-17N)	Lose Kupplungsscheibe / Loose clutch disc	(30)
				1863 855 000	106/140/25	mit Anlauftring / with thrust ring	(63)
M9094 a		WD401.85		1863 837 002	65/97/23	mit Anlauftring / with thrust ring	(63)
				3800 541 001 # 1888 998 001 1878 986 601 1863 837 002 1863 855 000	DUT310 327GSDC GR-4 GR-8	für Fahrzeuge mit Zweischeibenkupplung / for vehicles with double disc clutch Schwungradänderung erforderlich / Flywheel must be modified	(51) (37)

## T Reihe





T 80	01.50 - 12.60			1882 230 238	HVB280		
				1864 634 035	(20,7x25,92-10N)		
T 188				1881 089 002	K225		
				1860 039 024 #	225Z (23x29-10N)		
				3100 700 101 3151 021 001 2x 3130 010 200	KTI-1		
T 190		WD306a		1881 089 006	K225	->Mot. 11611	
				1861 775 035	228TPD (23x29-10N)	->Mot. 11611	
				3151 093 042		->Mot. 11611	
				1805 042 000		->Mot. 11611	

# STILL



## DFG

102 122 1002 1202				1881 089 002	K225		
				1862 088 131	225B/ Z (26x32-10N)	Nur bei Altteil-Rückgabe lieferbar (Reparatur; Werk Bielefeld) / Please return old unit for repair (plant Bielefeld)	(33)
				3100 700 101 3151 021 001 2x 3130 010 200	KTI-1		
1001 V 1201 V				1881 089 002	K225		
				1860 039 024 #	225Z (23x29-10N)		
				3100 700 101 3151 021 001 2x 3130 010 200	KTI-1		
1002 L 1202 L 1502 L,V 1604 L,V				1881 010 101 #	G250		
				1864 202 035 #	250Z (26x32-10N)		



# STOLBERGER

ROB							
II/20				1881 010 101 #	G250		
II/25 K				1864 202 035 #	250Z (26x32-10N)		
II/RL				1863 100 030	55/90,5/25	mit Anlauftring / with thrust ring	(63)
III/36				1880 083 132 #	G280		
IV S,G							



# TRUCO



AY							
4050/84/86				1878 001 138	420GTZ (1 3/4"-10N)		
				3151 000 515			



BK							
1044/01				1880 092 415 #	G310		

HFT							
644				1880 092 415 #	G310		
1066							
1366							
1644				1878 001 138	420GTZ (1 3/4"-10N)		
2666				3151 000 515			

15..							
1520/66 SL				1881 041 656 #	G380		

25..							
2530/84 L/86				1878 001 138	420GTZ (1 3/4"-10N)		
				3151 000 515			

30..							
3040/84-86				1861 206 211 #	420GS (36x45-10N)		
				3151 000 515			



45..							
4555/84-106				1861 206 211 #	420GS (36x45-10N)		
				3151 000 515			
4555/84-106 /10				1882 325 134	G380		



60..							
6070/84-106				1882 325 134	G380		



100..							
100120/106-126				1882 325 134	G380		

					Parameter		
---	--	--	--	--	-----------	---	---





# UNIVERSAL





SD-Serie							
530				1888 600 140 #	DUT280/ CERAM (280/35x40-14N)	enthält eine Kupplungsscheibe / This part number includes one clutch disc	(45)
640				1864 600 353 ▽	280 (22x25-10N)	Lose Kupplungsscheibe / Loose clutch disc	(30)
750							



Universal							
453 /DT				1888 600 140 #	DUT280/ CERAM (280/35x40-14N)	enthält eine Kupplungsscheibe / This part number includes one clutch disc	(45)
530 /DT				1864 600 353	280 (22x25-10N)		
532 /L /DT							
640 /DT							
642 /L /DT							
703 /DT							
704 /DT							

U-Serie							
533 ,DT				1888 600 140 #	DUT280/ CERAM (280/35x40-14N)	enthält eine Kupplungsscheibe / This part number includes one clutch disc	(45)
603 ,DT				1864 600 353 ▽	280 (22x25-10N)	Lose Kupplungsscheibe / Loose clutch disc	(30)
643							
723 ,DT							
850 ,DT							
853 ,DT							
1010							

# URSUS (D)

B28							
32				1881 089 002	K225		
				1864 634 024	225Z (1 1/4"-10N)		
				1859 600 001			
				1805 042 000			

C10							
Bambi				1882 155 009	K160		
				1864 006 147	160E (18x23-10N)		
				3159 140 004			
				1805 041 100			

Schlepper / Tractor							
Schlepper				1882 196 005	KS200		
				1864 634 031	200Z (1 1/8"-10N)		
				1860 049 027 #	200Z (1 1/8"-10N)		





Parameter



# VALMET

## Mega / Mezzo

6000				<b>3482 012 211</b>	GMF330		
6100				<b>1862 361 101 #</b>	330WGSZX (41x45-22N)		
6200				<b>1864 352 301 ●</b>	330Z (41x45-22N)		
6300							
6400				<b>3182 001 105</b>	HHIS-3	Füllmedium: Bremsflüssigkeit / Fill Medium: Brake Fluid Immer erneuern / Renew everytime	(18) (22)
6600							
6800							
6900							
8000							
8100							
8200				<b>3482 002 234</b>	GMF350X		
				<b>1878 001 143</b>	350WGTZ (41x45-22N)		
				<b>3482 012 211</b>	GMF330		
				<b>1862 361 101 #</b>	330WGSZX (41x45-22N)		
				<b>3182 001 105</b>	HHIS-3	Füllmedium: Bremsflüssigkeit / Fill Medium: Brake Fluid Immer erneuern / Renew everytime	(18) (22)
8400				<b>3482 002 234</b>	GMF350X	->12.1993	
				<b>1878 001 143</b>	350WGTZ (41x45-22N)	->12.1993	
				<b>3482 012 211</b>	GMF330	01.1994->	
				<b>1862 361 101 #</b>	330WGSZX (41x45-22N)	01.1994->	
				<b>3182 001 105</b>	HHIS-3	Füllmedium: Bremsflüssigkeit / Fill Medium: Brake Fluid Immer erneuern / Renew everytime	(18) (22)

## MK

<b>MK 2</b>				<b>3482 046 031 #</b>	MF280		
-------------	--	--	--	-----------------------	-------	--	--







## 2..-4..

<b>205</b>				<b>3482 046 031 #</b>	MF280		
<b>255</b>	- 12.95			<b>3800 541 022 ▲#☉</b> <b>1888 054 004</b> <b>1864 418 002</b>	DUT295-280/295 280	SACHS-Version / SACHS-version	(36)
<b>355</b>	- 12.95						
<b>365</b>	- 12.95			<b>1888 600 116</b>	DUT280/ CERAM (280/41x45-22N)	enthält eine Kupplungsscheibe / This part number includes one clutch disc LUK-Version / LUK-version	(45) (29)
<b>405</b>	- 12.95						
<b>415</b>				<b>1864 600 323 ▽</b>	280 (22,5x25-18N)	Lose Kupplungsscheibe / Loose clutch disc LUK-Version / LUK-version	(30) (29)
<b>455</b>	- 12.95						
<b>305</b>	- 12.95			<b>3800 541 022 ▲#☉</b> <b>1888 054 004</b> <b>1864 418 002</b>	DUT295-280/295 280		
<b>365</b>	01.96-			<b>1888 054 004 #</b>	DUT295-280/ 295 (280/41x45-22N)	enthält eine Kupplungsscheibe / This part number includes one clutch disc	(45)
				<b>1864 418 002 ▽#</b>	280 (22,5x25-18N)	Lose Kupplungsscheibe / Loose clutch disc	(30)
				<b>3182 001 105</b>	HHIS-3	Füllmedium: Bremsflüssigkeit / Fill Medium: Brake Fluid Immer erneuern / Renew everytime	(18) (22)





















					Parameter		
---	--	--	--	--	-----------	---	---

## VALMET





### 2..-4..

465	01.96-			<b>3800 541 022 ▲#</b>  <b>1888 054 004</b>  <b>1864 418 002</b>	DUT295-280/295 280	SACHS-Version / SACHS-version	(36)
				<b>3182 001 105</b>	HHIS-3	Füllmedium: Bremsflüssigkeit / Fill Medium: Brake Fluid SACHS-Version / SACHS-version Immer erneuern / Renew everytime	(18) (36) (22)
				<b>1888 600 116</b>	DUT280/ CERAM (280/41x45-22N)	enthält eine Kupplungsscheibe / This part number includes one clutch disc LUK-Version / LUK-version	(45) (29)
				<b>1864 600 323 ▽</b>	280 (22,5x25-18N)	Lose Kupplungsscheibe / Loose clutch disc LUK-Version / LUK-version	(30) (29)

### 5..-7..

505 605 705				<b>3482 008 038</b>	MF310		
				<b>1861 447 102</b>	310GSZ (41x45-22N)		
555 655				<b>1888 600 116</b>	DUT280/ CERAM (280/41x45-22N)	enthält eine Kupplungsscheibe / This part number includes one clutch disc	(45)
				<b>1864 600 323</b>	280 (22,5x25-18N)		
565 665	01.96- 01.96-			<b>3800 541 022 ▲#</b>  <b>1888 054 004</b>  <b>1864 418 002</b>	DUT295-280/295 280	SACHS-Version / SACHS-version	(36)
				<b>3182 001 105</b>	HHIS-3	Füllmedium: Bremsflüssigkeit / Fill Medium: Brake Fluid SACHS-Version / SACHS-version Immer erneuern / Renew everytime	(18) (36) (22)
				<b>1888 600 116</b>	DUT280/ CERAM (280/41x45-22N)	enthält eine Kupplungsscheibe / This part number includes one clutch disc LUK-Version / LUK-version	(45) (29)
				<b>1864 600 323 ▽</b>	280 (22,5x25-18N)	LUK-Version / LUK-version Lose Kupplungsscheibe / Loose clutch disc	(29) (30)
600				<b>3800 541 022 ▲#</b>  <b>1888 054 004</b>  <b>1864 418 002</b>	DUT295-280/295 280		
700 702 703				<b>1882 236 212 ▲#</b>	DUT310 (Ge 310/41x45-22N)	enthält eine Kupplungsscheibe / This part number includes one clutch disc	(45)
755				<b>3482 012 211</b>	GMF330		
				<b>1864 352 301</b>	330Z (41x45-22N)		
765	01.96-			<b>3800 541 022 ▲#</b>  <b>1888 054 004</b>  <b>1864 418 002</b>	DUT295-280/295 280		
				<b>3182 001 105</b>	HHIS-3	Füllmedium: Bremsflüssigkeit / Fill Medium: Brake Fluid Immer erneuern / Renew everytime	(18) (22)

### 8...-12..

800				<b>3800 541 022 ▲#</b>  <b>1888 054 004</b>  <b>1864 418 002</b>	DUT295-280/295 280		
				<b>3182 001 105</b>	HHIS-3	Füllmedium: Bremsflüssigkeit / Fill Medium: Brake Fluid Immer erneuern / Renew everytime	(18) (22)
802 900 903 1100 1102 1103 1203				<b>1882 236 212 ▲#</b>	DUT310 (Ge 310/41x45-22N)	enthält eine Kupplungsscheibe / This part number includes one clutch disc	(45)



## VALMET

8...-12..						
805				<b>3482 008 038</b>	MF310	
				<b>1861 447 102</b>	310GSZ (41x45-22N)	
855				<b>3482 012 211</b>	GMF330	
				<b>1864 352 301</b>	330Z (41x45-22N)	
865	01.96-			<b>3800 541 022 ▲#</b> <b>1888 054 004</b> <b>1864 418 002</b>	DUT295-280/295 280	SACHS-Version / SACHS-version (36)
				<b>1888 600 116</b>	DUT280/ CERAM (280/41x45-22N)	enthält eine Kupplungsscheibe / This part number includes one clutch disc LUK-Version / LUK-version (29)
				<b>1864 600 323 ▽</b>	280 (22,5x25-18N)	LUK-Version / LUK-version (29) Lose Kupplungsscheibe / Loose clutch disc (30)
905				<b>3482 012 211</b>	GMF330	
				<b>1862 233 133</b>	330GSZ (41x45-22N)	
8050 8150 8450 8550 8750				<b>3482 002 234</b>	GMF350X	
				<b>1878 001 143</b>	350WGTZ (41x45-22N)	
				<b>3182 001 105</b>	HHIS-3	Füllmedium: Bremsflüssigkeit / Fill Medium: Brake Fluid (18) Immer erneuern / Renew everytime (22)

## VALMET BRASILIEN

1.. - 2..						
118 128				<b>3482 012 211</b>	GMF330	Fahrzeugproduktionsland: Brasilien / Vehicle Production Country: Brazil (16)

## VALTRA

255 - 903						
255				<b>1863 600 111</b>	70/132,4/93,6	
305				<b>1863 600 110</b>	55/92,4/51	
355						
365						
405						
415						
455						
465						
502						
504						
505						
562						
565						
600						
602						
604						
655						
800						
865						
900						
700				<b>1863 600 112</b>	55/102,4/29,4	

					Parameter		
---	--	--	--	--	-----------	---	---

# VALTRA

## 255 - 903

700 MK II 702 703 802 903				<b>1863 600 111</b>	70/132,4/93,6		
---------------------------------------	--	--	---	---------------------	---------------	--	--

## C - Serie

C 90 C 100 C 110 C 120 ,E C 130 C 150		Sisu44.EWA, Sisu44.DT		<b>1866 000 154</b>	352NWGT	max. übertragbares Motormoment [Nm] / max. transmittable engine torque [Nm]: 2719	(62)
--	--	--------------------------	---	---------------------	---------	---	------

## HI - Serie

6250 HI 6350 HI 6550 HI 6650 HI 6750 HI 6850 HI 8050 HI 8150 HI 8350 HI 8450 HI 8550 HI 8750 HI 8950 HI 6 Zyl.		Sisu66.EWA, Sisu44.DT, Sisu420, Sisu620, Sisu, Sisu634, Sisu44.ET		<b>1866 000 154</b>	352NWGT	max. übertragbares Motormoment [Nm] / max. transmittable engine torque [Nm]: 2719	(62)
---	--	--	---	---------------------	---------	---	------

## M - Serie

M 120 M 120 E M 130 M 150		Sisu44.EWA		<b>1866 000 154</b>	352NWGT	max. übertragbares Motormoment [Nm] / max. transmittable engine torque [Nm]: 2719	(62)
------------------------------------	--	------------	---	---------------------	---------	---	------

## T - Serie



T 120 T 130 T 140, E T 150 T 160 T 170 T 180 T 190		Sisu74.ETA, Sisu66.ET, Sisu66.ETA		<b>1866 000 154</b>	352NWGT	max. übertragbares Motormoment [Nm] / max. transmittable engine torque [Nm]: 2719	(62)
---	--	---	---	---------------------	---------	---	------

## XM - Serie

XM 130 XM 150		Sisu44.EWA		<b>1866 000 154</b>	352NWGT	max. übertragbares Motormoment [Nm] / max. transmittable engine torque [Nm]: 2719	(62)
------------------	--	------------	---	---------------------	---------	---	------



# VME





## S/SI-Serie



S830				<b>1881 059 208</b>	KS200		
				<b>1860 049 029</b>	200Z (1"-10N)		

					Parameter		
---	--	--	--	--	-----------	---	---



## VME















S/SI-Serie							
SI257				1882 313 001	KS180	Nur bei Altteil-Rückgabe lieferbar (Reparatur; Werk Bielefeld) / Please return old unit for repair (plant Bielefeld)	(33)
				1864 634 041	180E (1"-10N)		

T-Serie							
T320	01.65-			1888 898 003	DO225/ 280 (225/ 1 3/4"-10N)	enthält eine Kupplungsscheibe / This part number includes one clutch disc	(45)
T400	01.65-			1864 946 001 ▽	280B (1 1/8"-10N)	Lose Kupplungsscheibe / Loose clutch disc	(30)
T430	01.65-			1882 600 116	XN280		
T500	01.65-			1862 844 001 #	280CC (1 1/8"-10N)	Anzahl der Beläge / Number of pads: 6	(7)

22..-Serie							
2200 2204 A	01.79- 12.80			1882 600 116	XN280		
	01.79-			1862 844 001 #	280CC (1 1/8"-10N)	Anzahl der Beläge / Number of pads: 6	(7)

## VÖGELE

Ivo							
Trecker		MWMKDW4 15		1881 089 002	K225		
				1860 039 025 #	225Z (1 1/8"-10N)		

Super							
80/82				1881 010 139 #	G250		
				1864 202 035 #	250Z (26x32-10N)		
				3151 045 001			
		KHDF3L912		1881 010 139 #	G250		
				1864 202 035 #	250Z (26x32-10N)		
				1863 100 030	55/90,5/25	mit Anlauftring / with thrust ring	(63)
140/142		KHDF3L912		1881 010 139 #	G250		
				1864 202 035 #	250Z (26x32-10N)		
				1863 100 030	55/90,5/25	mit Anlauftring / with thrust ring	(63)
150		KHDF4L912		3151 199 001			
160/164		KHDF5L912		1863 100 030	55/90,5/25	mit Anlauftring / with thrust ring	(63)
170/174		KHDF4L912		1863 100 030	55/90,5/25	mit Anlauftring / with thrust ring	(63)
200 1700/1704		KHDF6L912		1863 100 030	55/90,5/25	mit Anlauftring / with thrust ring	(63)
200/204		KHDF4L514		1861 034 147 #	350 (32x40-10N)		
		KHDF6L912		1863 100 030	55/90,5/25	mit Anlauftring / with thrust ring	(63)

VTM							
651		KHDF6L912		1866 024 001	360/ 159NGS	max. übertragbares Motormoment [Nm] / max. transmittable engine torque [Nm]: 660	(62)





# VOLK

8..-20..						
800				1881 069 101	K140	
				3151 994 801		
1000				1882 155 009	K160	
				3151 994 801		
				1805 041 100		
2000 V				1882 313 001	KS180	Nur bei Altteil-Rückgabe lieferbar (Reparatur; Werk Bielefeld) / Please return old unit for repair (plant Bielefeld) (33)
				1864 634 016	180E (23x29-10N)	





# VOLVO

Traktor						
T 320				1888 898 003	DO225/ 280 (225/ 1 3/4"-10N)	enthält eine Kupplungsscheibe / This part number includes one clutch disc (45)
T 400				1864 946 001	280B (1 1/8"-10N)	
T 430						
T 500				1882 600 116	XN280	
				1862 844 001 #	280CC (1 1/8"-10N)	Anzahl der Beläge / Number of pads: 6 (7)
2200 2WD				1862 844 001 #	280CC (1 1/8"-10N)	->12.1980 Anzahl der Beläge / Number of pads: 6 (7)
				1864 600 352	280 (1 1/8"-10N)	01.1980->
2204 4WD				1862 844 001 #	280CC (1 1/8"-10N)	Anzahl der Beläge / Number of pads: 6 (7)

# VOLVO PENTA



Benzinmotor							
230A				<b>1866 032 231</b>	287/ 133NTP	max. übertragbares Motormoment [Nm] / max. transmittable engine torque [Nm]: 425	(62)
230B							
250A							
250B							
251A							
AQ115A							
AQ115B							
AQ120B							
AQ125A							
AQ125B							
AQ130A							
AQ130B							
AQ130C							
AQ130D							
AQ131A							
AQ131B							
AQ131C							
AQ131D							
AQ140A							
AQ145A							
AQ145B							
AQ151A							
AQ151B							
AQ151C							
AQ171A							
AQ171C							
BB115A							
BB115B							
BB115C							
BB140A							
MB20A							
MB20B							
MB20C							
AQ165A				<b>1866 018 131</b>	287/ 133NTP	max. übertragbares Motormoment [Nm] / max. transmittable engine torque [Nm]: 425	(62)
AQ170A							
AQ170B							
AQ170C							
AQD21A							
BB165A							
BB170A							
BB170B							
BB170C							

# VOLVO PENTA

















Dieselmotor							
AD31A AD31B AD31D AD31XD AQAD30A AQAD31A MD30A MD31A TAMD30A TAMD31A TAMD31B TAMD31D TMD30A TMD31A TMD31B TMD31D				<b>1866 032 231</b>	287/ 133NTP	max. übertragbares Motormoment [Nm] / max. transmittable engine torque [Nm]: 425	(62)
AD41A AD41B AD41D AQAD41A D41A D41B D41D KAD42A KAD42B TAMD41A TAMD41B TMD41A TMD41B				<b>1866 118 001</b>	287/ 159NGS	max. übertragbares Motormoment [Nm] / max. transmittable engine torque [Nm]: 820	(62)
AQAD40A AQAD40B MD40A TAMD40A TAMD40B TMD40A TMD40B TMD40C				<b>1866 032 231</b>	287/ 133NTP	max. übertragbares Motormoment [Nm] / max. transmittable engine torque [Nm]: 425	(62)
				<b>1866 018 131</b>	287/ 133NTP	max. übertragbares Motormoment [Nm] / max. transmittable engine torque [Nm]: 425	(62)
AQD21B AQD40A MD21B				<b>1866 018 131</b>	287/ 133NTP	max. übertragbares Motormoment [Nm] / max. transmittable engine torque [Nm]: 425	(62)
D3-190				<b>1866 000 140</b>	275/ 188NWGTP	max. übertragbares Motormoment [Nm] / max. transmittable engine torque [Nm]: 800	(62)





# VOLVO PENTA



Dieselmotor							
D4-210A-A				1866 000 239	314/ 212NWGTP	max. übertragbares Motormoment [Nm] / max. transmittable engine torque [Nm]: 1500	(62)
D4-210A-B							
D4-225A-B							
D4-225A-C							
D4-260A-A							
D4-260A-B							
D4-260A-C							
D4-300A-A							
D4-300A-C							
D6-280A-A							
D6-280A-B							
D6-310A-A							
D6-310A-B							
D6-330A-B							
D6-350A-A							
D6-350A-B							
D6-370A-B							
DPH-A							
DPH-B							
DPR-A							
DPR-B							
DP-D				1866 118 001	287/ 159NGS	max. übertragbares Motormoment [Nm] / max. transmittable engine torque [Nm]: 820	(62)
DP-D1				1866 032 231	287/ 133NTP	max. übertragbares Motormoment [Nm] / max. transmittable engine torque [Nm]: 425	(62)
DP-D2							
DP-E							
DP-G							
DPX							

# WAHL









W12-W133							
W12 (12PS) W17 (17PS)				1882 315 003	KS180		
				1864 634 040	180E (23x29-10N)		
				1859 600 001			
				1805 042 000			
W15 (15PS)				1881 089 002	K225		
				1860 039 024 #	225Z (23x29-10N)		
				1859 600 001			
				1805 042 000			
W22 (22PS)				1882 196 005	KS200		
				1864 634 039	200Z (23x29-10N)		
				1859 600 001			
				1805 042 000			
W28 (28PS)				1881 089 002	K225		
				1864 634 024	225Z (1 1/4"-10N)		
				1859 600 001			
				1805 042 000			

					Parameter		
---	--	--	--	--	-----------	---	---







## WAHL

W12-W133							
W133 (25PS)				1882 108 204 #	DO225 (Mo 225/23x29-10N) (Ge 200/46x50-8N)	enthält zwei Kupplungsscheiben / This part number includes both clutch discs	(46)
				3151 000 395			



## WARCHALOWSKI

WT25-WT44							
WT25				1881 065 101	KS180		
				1864 634 040	180E (23x29-10N)		
WT30				1881 065 101	KS180		
				1864 634 041	180E (1"-10N)		
				3151 270 602			
WT40				1882 108 204 #	DO225 (Mo 225/23x29-10N) (Ge 200/46x50-8N)	enthält zwei Kupplungsscheiben / This part number includes both clutch discs	(46)
				3151 000 395			
WT44				1881 050 428 #	DO250 (Mo 250/23x29-10N) (Ge 225/46x50-8N)	enthält zwei Kupplungsscheiben / This part number includes both clutch discs Nur bei Altteil-Rückgabe lieferbar (Reparatur; Werk Bielefeld) / Please return old unit for repair (plant Bielefeld)	(46) (33)
				3151 000 395			

## WEHRHAHN





W3...-W4...							
W3000				1882 196 005	KS200		
				1864 634 031	200Z (1 1/8"-10N)		
				1860 049 027 #	200Z (1 1/8"-10N)		
				1859 600 001			
				1805 042 000			
W4000				1881 009 201 #	G250		
				1859 600 001			
				1805 042 000			

## ZANDONA





Traktor							
Traktor / Tractor				1880 096 208 #	G280		
				1859 600 005			
				1805 042 000			

# ZETOR





## FORTERRA

9641	01.00-			<b>3482 600 107</b>	MF330		
10641	01.06-						
11441	01.06-			<b>1864 600 312</b>	327 (27x30-18N)		
12441	01.07-			<b>1864 600 311 ●</b>	327C (27x30-18N)	Anzahl der Beläge / Number of pads: 5	(7)
				<b>1863 869 023</b>	20/52/15		











## 3000-4000

3011				<b>1888 600 114</b>	DUT280 (280/42x45-28N)	enthält eine Kupplungsscheibe / This part number includes one clutch disc	(45)
3045							
3511				<b>1864 600 306 ●</b>	280 (22x25-16N)		
3545							
3320 / 3321				<b>1888 600 115</b>	DUT280/ 310 (280/42x45-28N)	enthält eine Kupplungsscheibe / This part number includes one clutch disc	(45)
3340 / 3341				<b>1864 600 307</b>	310 (25x28-18N)		
				<b>1864 600 308 ●</b>	310C (25x28-18N)	Anzahl der Beläge / Number of pads: 6	(7)

## 4000-5000

4320 / 4321				<b>1888 600 115</b>	DUT280/ 310 (280/42x45-28N)	enthält eine Kupplungsscheibe / This part number includes one clutch disc	(45)
4340 / 4341				<b>1864 600 307</b>	310 (25x28-18N)		
				<b>1864 600 308 ●</b>	310C (25x28-18N)	Anzahl der Beläge / Number of pads: 6	(7)
4712				<b>1888 600 114</b>	DUT280 (280/42x45-28N)	enthält eine Kupplungsscheibe / This part number includes one clutch disc	(45)
4718							
4911				<b>1864 600 306 ●</b>	280 (22x25-16N)		



## 5000-6000

5011				<b>1888 600 114</b>	DUT280 (280/42x45-28N)	enthält eine Kupplungsscheibe / This part number includes one clutch disc	(45)
				<b>1864 600 306 ●</b>	280 (22x25-16N)		
				<b>1888 600 115</b>	DUT280/ 310 (280/42x45-28N)	enthält eine Kupplungsscheibe / This part number includes one clutch disc	(45)
				<b>1864 600 307</b>	310 (25x28-18N)		
				<b>1864 600 308 ●</b>	310C (25x28-18N)	Anzahl der Beläge / Number of pads: 6	(7)
5211				<b>1888 600 114</b>	DUT280 (280/42x45-28N)	enthält eine Kupplungsscheibe / This part number includes one clutch disc	(45)
5245							
5213				<b>1864 600 309</b>	280 (25x28-18N)		
5243				<b>1864 600 310 ●</b>	280C (25x28-18N)	Anzahl der Beläge / Number of pads: 6	(7)
5511							
5545				<b>1888 600 115</b>	DUT280/ 310 (280/42x45-28N)	enthält eine Kupplungsscheibe / This part number includes one clutch disc	(45)
5611				<b>1864 600 307</b>	310 (25x28-18N)		
5645							
5647				<b>1864 600 308 ●</b>	310C (25x28-18N)	Anzahl der Beläge / Number of pads: 6	(7)
5711							
5718							
5745							
5748							
5911							
5945							













					Parameter		
---	--	--	--	--	-----------	---	---

# ZETOR













## 5000-6000

5320 / 5321 5340 / HORAL 5341		<b>1888 600 115</b>	DUT280/ 310 (280/42x45-28N)	enthält eine Kupplungsscheibe / This part number includes one clutch disc	(45)
		<b>1864 600 307</b>	310 (25x28-18N)		
		<b>1864 600 308 ●</b>	310C (25x28-18N)	Anzahl der Beläge / Number of pads: 6	(7)



## 6000-7000

6011 6045 6211 6245		<b>1888 600 114</b>	DUT280 (280/42x45-28N)	enthält eine Kupplungsscheibe / This part number includes one clutch disc	(45)
		<b>1864 600 309</b>	280 (25x28-18N)		
		<b>1864 600 310 ●</b>	280C (25x28-18N)	Anzahl der Beläge / Number of pads: 6	(7)
		<b>1888 600 115</b>	DUT280/ 310 (280/42x45-28N)	enthält eine Kupplungsscheibe / This part number includes one clutch disc	(45)
		<b>1864 600 307</b>	310 (25x28-18N)		
		<b>1864 600 308 ●</b>	310C (25x28-18N)	Anzahl der Beläge / Number of pads: 6	(7)
6320 / 6321 6340 / 6341		<b>1888 600 115</b>	DUT280/ 310 (280/42x45-28N)	enthält eine Kupplungsscheibe / This part number includes one clutch disc	(45)
		<b>1864 600 307</b>	310 (25x28-18N)		
		<b>1864 600 308 ●</b>	310C (25x28-18N)	Anzahl der Beläge / Number of pads: 6	(7)
6711 6718 6745 6748 6911 6945		<b>1888 600 114</b>	DUT280 (280/42x45-28N)	enthält eine Kupplungsscheibe / This part number includes one clutch disc	(45)
		<b>1864 600 309</b>	280 (25x28-18N)		
		<b>1864 600 310 ●</b>	280C (25x28-18N)	Anzahl der Beläge / Number of pads: 6	(7)







## 7000-8000



7011 7045 7211 7245 7711 7745		<b>1888 600 114</b>	DUT280 (280/42x45-28N)	enthält eine Kupplungsscheibe / This part number includes one clutch disc	(45)
		<b>1864 600 309</b>	280 (25x28-18N)		
		<b>1864 600 310 ●</b>	280C (25x28-18N)	Anzahl der Beläge / Number of pads: 6	(7)
		<b>1888 600 115</b>	DUT280/ 310 (280/42x45-28N)	enthält eine Kupplungsscheibe / This part number includes one clutch disc	(45)
		<b>1864 600 307</b>	310 (25x28-18N)		
		<b>1864 600 308 ●</b>	310C (25x28-18N)	Anzahl der Beläge / Number of pads: 6	(7)
7320 T / 7321 7340 T / 7341		<b>1888 600 115</b>	DUT280/ 310 (280/42x45-28N)	enthält eine Kupplungsscheibe / This part number includes one clutch disc	(45)
		<b>1864 600 307</b>	310 (25x28-18N)		
		<b>1864 600 308 ●</b>	310C (25x28-18N)	Anzahl der Beläge / Number of pads: 6	(7)
7520 7540		<b>3482 600 107</b>	MF330		
		<b>1864 600 312</b>	327 (27x30-18N)		
		<b>1864 600 311 ●</b>	327C (27x30-18N)	Anzahl der Beläge / Number of pads: 5	(7)







# ZETOR





8000-10000							
8011				3482 600 107	MF330		
8045				1864 600 312	327 (27x30-18N)		
8520				1864 600 311 ●	327C (27x30-18N)	Anzahl der Beläge / Number of pads: 5	(7)
8540							
8620							
8621							
8640							
8641							
9540							
10520							
10540							

# ZETTELMAYER

A..							
A2				1881 009 201 #	G250		
				1864 202 035 #	250Z (26x32-10N)		
				3100 700 101 ◊ 3151 021 001 ↓ 2x 3130 010 200	KTI-1		
A4,A5				1880 096 208 #	G280		
				1859 600 005			
				1805 042 000			

L..							
L500,L501				1881 009 201 #	G250		
				1864 202 035 #	250Z (26x32-10N)		
				3100 700 101 ◊ 3151 021 001 ↓ 2x 3130 010 200	KTI-1		

V..							
VTH				1882 155 009	K160		
				1864 006 147	160E (18x23-10N)		
VT7				1882 196 005	KS200		
				1864 634 030	200Z (26x32-10N)		
				1859 600 001			
				1805 042 000			

Z..							
Z1,Z2				1881 089 002	K225		
				1864 634 026	225Z (26x32-10N)		
				1859 600 001			
				1805 042 000			



# ZF









## Schaltgetriebe / Manual Transmission

3MD16			⊗	1881 089 007	K225		
			⊗	1860 039 024 #	225Z (23x29-10N)		
			⊙	1859 600 001			
			∩	1805 042 000			
3MD30			⊗	1860 062 037 #	280Z (28x35-10N)		
			⊙	1863 100 030	55/90,5/25	mit Anlauftring / with thrust ring	(63)

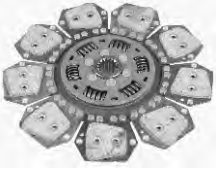







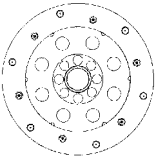

# ZIEGLER

## Mot.



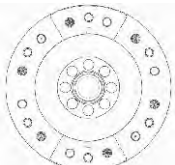









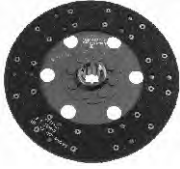

TS8			⊗	1881 065 101	KS180		
			⊗	1864 121 536	180B (18,3x20,4-24N)		
			⊙	3151 270 602			
			∩	1805 041 100			

Artikelnummer Article No.	Seite Page	Hersteller Manufacturer	Artikelnummer Article No.	Seite Page	Hersteller Manufacturer	
<b>1805 041 100</b> 	1	AEBI	<b>1850 280 743 #</b> (310/44x48-23N) 	24	CASE IH	
	1	AECHERLI				
	2	AGRIA				
	4 5	BAUTZ				
	27 28 29	CLAAS				
	30					
	56	DEUTZ-FAHR				
	58 60 61	EICHER				
	67					
	101	GRUNDNER	<b>1850 281 964 #</b> (27x30-16N) 	248 249 253	RENAULT	
	102 103	GUELDNER		254 255	AGRICULTURE	
	104	GUSS & ARMATURENWERK				
	104 105	GUTBROD				
	105	HAAS				
	105 106	HAKO				
	109 110 111	HATZ				
	112 113 114	HOLDER	<b>1850 282 747</b> 	15 16 17	CASE IH	
	117 122	JOHN DEERE		18 19 20		
	134	KÖDEL & BÖHM	21 22			
	147 148	LANZ+MARTI				
	150 152 153	LINDNER				
	154					
	154	MAN				
	224	MWM	<b>1851 146 001 ▲</b> 	120 121 122	JOHN DEERE	
	231	ORENSTEIN		123 124 125		
	233 234	KOPPEL	126 127 129			
	235	PORSCHE	130			
235	POTRATZ					
236	PRIMUS	<b>1859 212 000</b> 	283	STEYR		
236	RAFFLENBEUL					
236	RAPID					
237	REFORM					
263	RITSCHER					
277	SCHMOTZER					
277	SCHULTHEISS					
288	URSUS (D)					
294	VOLK					
302	ZIEGLER					
<b>1805 041 200</b> 	37 38		DEUTZ-FAHR	<b>1859 600 001</b> 	1	AEBI
	68		FARNY & WEIDMANN		4 5	BAUTZ
	137	KRIEGER	27		CLAAS	
	231 232	FAHRZEUGBAU	34 37 38		DEUTZ-FAHR	
	271	ORENSTEIN	53 54 55			
<b>1805 042 000</b> 	271	KOPPEL	56			
	1	SCHLECHT	58 59 60	EICHER		
	4 5	AEBI	61 62 63			
	7 14 15	BAUTZ	67	EPPLE BUXBAUM		
	16 17 18	CASE IH	69	FARNY & WEIDMANN		
	19 20		69 70	FENDT		
	27 28 29	CLAAS	100 101	GROSS		
	30 31 32		101 102 103	GUELDNER		
	34 37 38	DEUTZ-FAHR	104			
	53 54 55		104	GUTBROD		
	56		105	HAAS		
	58 59 60	EICHER	109 110	HATZ		
	61 62 63		112	HOLDER		
	66		119	JOHN DEERE		
	67	EPPLE BUXBAUM	134	KÖDEL & BÖHM		
	69	FARNY & WEIDMANN	135 136	KRAMER		
	69 70 75	FENDT	145 146 147	LANZ+MARTI		
			148			















Arithmetische Liste / Part number list









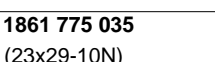





Artikelnummer Article No.	Seite Page	Hersteller Manufacturer	Artikelnummer Article No.	Seite Page	Hersteller Manufacturer		
<b>1859 600 002</b> 	1	AEBI	<b>1860 026 001</b> (26x32-10N) 	102	GUELDNER		
	4 5	BAUTZ					
	27 28 29	CLAAS					
	37 38 56	DEUTZ-FAHR					
	58	EICHER					
	103	GUELDNER					
	105	HAAS					
	112 113 114	HOLDER					
	117	JOHN DEERE					
	134	KÖDEL & BÖHM					
	147	LANZ+MARTI					
	150 152 153	LINDNER					
	154	MAN					
	154	MWM					
	224	PRIMUS					
235	RITSCHER						
263	SCHMOTZER						
277	SCHMOTZER						
277	SCHULTHEISS						
<b>1859 600 003</b> 	7 14 15	CASE IH	<b>1860 039 024 #</b> (23x29-10N) 	27	CLAAS		
	16 17 18			53 54	DEUTZ-FAHR		
	19 20			60 63 66	EICHER		
	54	DEUTZ-FAHR		67	EPPLE BUXBAUM		
	104	GUSS & ARMATURENWERK		70 75	FENDT		
	104	GUTBROD		101 102	GUELDNER		
	109 111	HATZ		134	KÖDEL & BÖHM		
	119	JOHN DEERE		135 136	KRAMER		
	146	LANZ+MARTI		145 146 147	LANZ+MARTI		
	155	MANITOU		148			
	263	RITSCHER		151 154	LINDNER		
				230 231	NORMAG		
				231 232	ORENSTEIN		
					KOPPEL		
				271	SCHLÜTER		
		281 286	STEYR				
		286	STILL				
		297	WAHL				
		302	ZF				
<b>1859 600 004</b> 	135 136 137	KRAMER	<b>1860 039 025 #</b> (1 1/8"-10N) 	57	DEXHEIMER		
	233 234	PORSCHE		100 101	GROSS		
				104	GUELDNER		
				107	HANOMAG		
				137	RHEINSTAHL		
					KRIEGER		
					FAHRZEUGBAU		
				223	MIAG		
				233	OSTNER		
				270	SCHANZLIN		
				293	VÖGELE		
					GUELDNER		
	<b>1859 600 005</b> 	27 28 29		CLAAS	<b>1860 049 018</b> (1"-10N) 	103	GUELDNER
		30 31 32					
		105		HAAS			
135		KRAMER					
223		MIAG					
298		ZANDONA					
301		ZETTELMEYER					
<b>1859 600 006</b> 		37 56	DEUTZ-FAHR	<b>1860 049 027 #</b> (1 1/8"-10N) 		7	CASE IH
		69 70 75	FENDT			116	IRION
		107 108	HANOMAG			176	MEILI
			RHEINSTAHL			288	URSUS (D)
		135 136	KRAMER			298	WEHRHAHN
		233 234	PORSCHE				
<b>1860 023 012</b> (26x32-10N) 	236	PUTZMEISTER	<b>1860 049 028</b> (22x25-14N) 	264	ROTHENBURGER		
	277	SCHMOTZER			METALLWERKE		







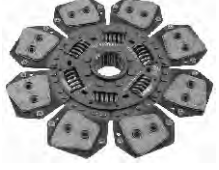









Artikelnummer Article No.	Seite Page	Hersteller Manufacturer	Artikelnummer Article No.	Seite Page	Hersteller Manufacturer
1860 049 029 (1"-10N)	4 292	AKTIV FISCHER VME	1861 259 131 # (21,7x25-13N)	14 15 16 17 18 111	CASE IH  HIEBLE
					
1860 056 124 # (1 1/8"-10N)	59 60 100 233	EICHER GROSS OSTNER	1861 271 236 (18,3x20,4-24N)	4	AKTIV FISCHER
					
1860 062 037 # (28x35-10N)	54 55 67 302	DEUTZ-FAHR EPPLE BUXBAUM ZF	1861 303 248 (28x35-10N)	138	KÄSSBOHRER
					
1861 034 147 # (32x40-10N)	109 293	HARNISCHFEGER VÖGELE	1861 384 334 # (26x32-10N)	178 179 180 181 182 187 188 189 190 191 192 193 194 201 202 203 204 205 206 207 208 209	MERCEDES-BENZ
					
1861 123 236 (23x29-10N)	33	CLAAS	1861 447 102 (41x45-22N)	290 291	VALMET
					
1861 206 211 # (36x45-10N)	287	TRUCO	1861 518 031 # (26x32-10N)	187 188 189 190 191 192 193 201 202 203 204 205 206	MERCEDES-BENZ
					
1861 244 101 # (26x32-10N)	119	JOHN DEERE	1861 594 034 # (36x40-20N)	182 183 184 209 210 211 212 217 218	MERCEDES-BENZ
					













Arithmetische Liste / Part number list

Artikelnummer Article No.	Seite Page	Hersteller Manufacturer	Artikelnummer Article No.	Seite Page	Hersteller Manufacturer
1861 600 033 # (32x40-10N) 	98	FRISCH	1861 686 033 # (22,3x25,8-15N) 	120 121 122 123 124 125 126 127 128	JOHN DEERE
1861 600 034 # (28x35-10N) 	281	STEYR	1861 691 101 # (28x35-10N) 	279 280	STEYR
1861 603 034 # (36x40-20N) 	207	MERCEDES-BENZ	1861 713 133 # (36x40-20N) 	183 184 185 186 209 211 212 213 214 215 216 217 218	MERCEDES-BENZ
1861 611 131 # (26x32-10N) 	178 187 188 189 190 191 192 193 201 202 203 204 206	MERCEDES-BENZ	1861 723 201 # (26x32-10N) 	71 72 76	FENDT
1861 613 101 # (28x35-10N) 	249 250 280 283	RENAULT AGRICULTURE STEYR	1861 733 133 # (17x20-17N) 	114	HOLDER
1861 667 034 (36x40-20N) 	183 184 185 186 208 209 210 211 212 216 217 218	MERCEDES-BENZ	1861 741 042 # (36x40-20N) 	182 183 184 185 186 190 191 193 203 207 208 209 210 211 212 215 216 217 218	MERCEDES-BENZ
1861 674 331 (31x35-18N) 	112 113 114	HOLDER	1861 751 104 # (26x32-10N) 	71 72 73 76 77	FENDT
			1861 775 035 (23x29-10N) 	286	STEYR





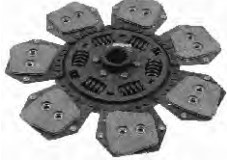











Artikelnummer Article No.	Seite Page	Hersteller Manufacturer	Artikelnummer Article No.	Seite Page	Hersteller Manufacturer
<b>1861 784 001</b> (1 1/8"-10N)	21 22	<b>CASE IH</b>	<b>1861 994 003</b> (27x30-18N)	237	<b>REFORM</b>
					
<b>1861 840 133 #</b> (26x32-10N)	186 187 192 198 199 200 201 204 205	<b>MERCEDES-BENZ</b>	<b>1861 994 004</b> (23x29-10N)	237	<b>REFORM</b>
					
<b>1861 913 002 #</b> (1 1/4"-10N)	126 127 129 130	<b>JOHN DEERE</b>	<b>1862 088 131</b> (26x32-10N)	191 198 286	<b>MERCEDES-BENZ STILL</b>
					
<b>1861 924 103 #</b> (22,3x25,8-15N)	120 121 122 123 124 125	<b>JOHN DEERE</b>	<b>1862 131 201 #</b> (41x45-21N)	279	<b>STEYR</b>
					
<b>1861 956 133</b> (36x40-20N)	183 185 186 209 211 212 213 214 215 216 217 218	<b>MERCEDES-BENZ</b>	<b>1862 131 202 #</b> (44x48-22N)	279	<b>STEYR</b>
					
<b>1861 966 141 #</b> (26x32-10N)	188 189 190 191 192 193 194 201 203 204 205 206 208 209	<b>MERCEDES-BENZ</b>	<b>1862 140 004 #</b> (22,3x25,8-15N)	124 126 128 129	<b>JOHN DEERE</b>
					
<b>1861 990 001 #</b> (41x45-21N)	35	<b>DEUTZ-FAHR</b>	<b>1862 140 005 #</b> (1 1/4"-10N)	126 127 129 130	<b>JOHN DEERE</b>
					

Arithmetische Liste / Part number list











Artikelnummer Article No.	Seite Page	Hersteller Manufacturer	Artikelnummer Article No.	Seite Page	Hersteller Manufacturer
1862 233 133 (41x45-22N)	291	VALMET	1862 654 002 # (22x25-14N)	140 265 266 268	LAMBORGHINI SAME
					
1862 286 031 # (36x40-20N)	213 214 215 218 219 220 221 222	MERCEDES-BENZ	1862 713 001 # (27x30-16N)	246 247 248 250 251 252 253 254 262	RENAULT AGRICULTURE
					
1862 311 001 # (28x32-17N)	6 279 280	CASE IH STEYR	1862 715 001 # (27x30-16N)	246 247 248 250 251 252 253 254 255	RENAULT AGRICULTURE
					
1862 361 101 # (41x45-22N)	288 289	VALMET	1862 716 003 # (1 1/8"-10N)	14 15 16 17 18 19 20 21 22 25 26 155	CASE IH  MANITOU
					
1862 421 001 # (28x32-17N)	282	STEYR	1862 718 002 # (26x32-10N)	186 187 199 200 201 202 203 207 209 210	MERCEDES-BENZ
					
1862 586 001 (25,5x29,4-21N)	167 168 172	MASSEY FERGUSON	1862 724 002 # (45x50-18N)	78 80 81 82	FIATAGRI
					
1862 650 001 # (21,5x25-13N)	19 20 21 22	CASE IH	1862 812 003 # (27x30-16N)	248 249 253 254 255	RENAULT AGRICULTURE
					

Artikelnummer Article No.	Seite Page	Hersteller Manufacturer	Artikelnummer Article No.	Seite Page	Hersteller Manufacturer
1862 812 006 # (26x32-10N) 	179 180 181 182	MERCEDES-BENZ	1862 972 004 # (1 1/4"-10N) 	133	JOHN DEERE
1862 814 003 # (26x32-10N) 	177 178 179 180	MERCEDES-BENZ	1862 972 045 (1 1/4"-10N) 	126 128 129 130 132 133	JOHN DEERE
1862 844 001 # (1 1/8"-10N) 	14 15 16 17 18 19 20 21 22 25 26 293 294	CASE IH    VME VOLVO	1863 009 100 	108	HARNISCHFEGER
1862 844 004 # (26,7x30-16N) 	246 247 250	RENAULT AGRICULTURE	1863 010 100 	6 7 38 40 52 70 76 135 136 146 147	CASE IH DEUTZ-FAHR FENDT KRAMER LANZ+MARTI
1862 876 002 (18x20-18N) 	116	ISEKI	1863 100 030 	34 35 40 41 48 50 51 52 54 55 56 57 59 60 61 62 67 99 100 101 106	CREDE DEUTZ-FAHR      EICHER  EPPLE BUXBAUM FUCHS GROSS HANOMAG RHEINSTAHL HARNISCHFEGER HATZ HÜRLIMANN KRAMER LAMBORGHINI LIEBHERR MASCHINENBAU ULM (MBU) MIAG NORDWESTDEUTSC HER FAHRZEUGBAU NORMAG SAME
1862 946 001 # (31,2x35,6-16N) 	51 52	DEUTZ-FAHR	108 109 109 110 111 115 136 139 140 149 156		
1862 962 002 # (36x40-20N) 	183 184 185 186 211 212 213 214 215 216 217 218 219 220 221 222	MERCEDES-BENZ	223 230  231 264 265 266 267 268 277 278 287 293 302		SCHÖTTLER STEINBOCK STOLBERGER VÖGELE ZF













Arithmetische Liste / Part number list

Artikelnummer Article No.	Seite Page	Hersteller Manufacturer	Artikelnummer Article No.	Seite Page	Hersteller Manufacturer
1863 101 100 ▲ 	38 106 150 151 152	DEUTZ-FAHR HANOMAG RHEINSTAHL LINDNER	1863 600 113 	133 134	JOHN DEERE
1863 123 000 	22 57 61 62 63 64 150 152 153 270	CASE IH DEXHEIMER EICHER  LINDNER SCHANZLIN	1863 600 115 	116 117	JCB
1863 600 101 	6 14 15 16 17 18 19 20 21 22 25 26 155	CASE IH   MANITOU	1863 600 117 	141 143 144 145 175 176	LANDINI  MC CORMICK
1863 600 106 	155 156	MARSHALL	1863 600 118 	33 34 83 84 85 86 87 88 89 90 91 92 93 94 95 96 97 98 157 158 159 160 161 162 163 164 165 166 167 168 169 170 171	COUNTY FORD NEW HOLLAND  MASSEY FERGUSON
1863 600 107 	12	CASE IH	1863 600 119 	35 36 37 48 49 50	DEUTZ-FAHR
1863 600 110 	291	VALTRA	1863 600 120 	167 168 169 172 173	MASSEY FERGUSON
1863 600 111 	291 292	VALTRA	1863 600 122 	61 63 64 150 152 153	EICHER LINDNER
1863 600 112 	291	VALTRA	1863 600 123 	58 60 61 74 76 109 154 155 233 234 271 272 273	EICHER FENDT HARNISCHFEGER MAN PORSCHE SCHLÜTER















Arithmetische Liste / Part number list

Artikelnummer Article No.	Seite Page	Hersteller Manufacturer	Artikelnummer Article No.	Seite Page	Hersteller Manufacturer	
<b>1863 837 000</b> 	34 35 38	<b>DEUTZ-FAHR</b>	<b>1863 837 003</b> 	187 188 189	<b>MERCEDES-BENZ</b>	
	39 40 41			190 199 200		
	42 43 44			201 202 203		
	45 46 47			204 207 209		
	48 49 50	210				
	53	262		<b>RENAULT AGRICULTURE SAME</b>		
	274 275 276	264 265				
<b>1863 837 001</b> 	38 39 40	<b>DEUTZ-FAHR</b>	<b>1863 838 000</b> 	2 3	<b>AGRIFULL</b>	
<b>1863 837 002</b> 	5 6 22	<b>CASE IH DEUTZ-FAHR</b>	<b>1863 838 001</b> 	5 13 14	<b>CASE IH DEUTZ-FAHR</b>	
	36 40 41			34 35 39		
	42			40 41 42		
	57 58 61	43 44 45		<b>FIATAGRI FORD NEW HOLLAND SAME</b>		
	62 63 64	46 47 48				
	65 66 67	49 50 51 52				
	69 70 71	53				
	72 73 74	79 80 81		<b>FIATAGRI FORD NEW HOLLAND SAME</b>		
	76 77	88				
	80 81	266 267				
	99 100	<b>FENDT</b>		<b>1863 838 002</b> 	2 3	<b>AGRIFULL CASE IH</b>
	124 130 131				5 7 8	
	132	9 10 11			<b>FIATAGRI</b>	
	137	12 13 14				
	165	78 79 80				
	177 178 179	81 82				<b>FORD NEW HOLLAND LANDINI MC CORMICK NEW HOLLAND</b>
	180 181 182	88 90 92				
183 184 185	94 96					
186 191 193	141 143 144					
195 196 197	175 176	<b>SAME STEYR</b>				
198 199 200	224 225 226					
201 202 203	227 228 229					
204 205 206	230					
207 208 209	264 265 267	<b>MERCEDES-BENZ</b>				
210 212 213	283 284 285					
214 215 216	<b>KRIEGER FAHRZEUGBAU MASSEY FERGUSON MERCEDES-BENZ</b>	<b>1863 839 000</b> 	15 16 17		<b>CASE IH</b>	
217 218 220			18 19 20			
221	21 22 23		<b>DEUTZ-FAHR</b>			
238 239 240	24 25					
241 242 243	36 37 41					
244 245 246	42 52					
247 248 249	78 80			<b>FIATAGRI</b>		
250 251 252	<b>RENALT AGRICULTURE</b>		<b>1863 839 001</b> 	17 18 19	<b>CASE IH</b>	
253 254 255				20 21 22		
257 258 259	23 24 25			<b>DEUTZ-FAHR FENDT</b>		
260 261 262	<b>1863 840 000</b> 				38 39	
263					70 71	
276					<b>SCHLÜTER STEYR</b>	<b>DEUTZ-FAHR FENDT</b>
278 279 280						
281 282 285						
286						









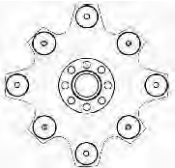

Arithmetische Liste / Part number list











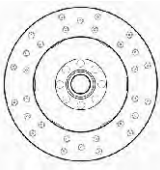

Artikelnummer Article No.	Seite Page	Hersteller Manufacturer	Artikelnummer Article No.	Seite Page	Hersteller Manufacturer
<b>1863 840 001</b> 	186 187 188 189 190 191 192 193 194 198 199 200 201 202 203 204 205 206 207 208 209	<b>MERCEDES-BENZ</b>	<b>1863 866 001</b> 	22 23 24 25	<b>CASE IH</b>
<b>1863 855 000</b> 	5 6 22 35 36 37 48 49 50 51 53 57 58 61 62 63 64 65 66 67 69 70 71 72 73 74 76 77 81 99 100 124 130 131 132 137  177 178 179 180 181 182 183 184 185 186 191 193 195 196 197 198 199 200 201 203 207 208 209 210 212 213 214 215 216 217 218 220 221 238 239 240 241 242 243 244 245 246 247 248 249 250 251 252 253 254 255 257 258 259 260 261 262 263 274 275 276 278 279 280 281 282 285 286	<b>CASE IH</b> <b>DEUTZ-FAHR</b>  <b>EICHER</b>  <b>FENDT</b>  <b>FIATAGRI</b> <b>GOLDONI</b> <b>JOHN DEERE</b>  <b>KRIEGER</b> <b>FAHRZEUGBAU</b> <b>MERCEDES-BENZ</b>          <b>RENAULT</b> <b>AGRICULTURE</b>       <b>SCHLÜTER</b> <b>STEYR</b>	<b>1863 867 001</b> 	22 23 24 25 155 156	<b>CASE IH</b>  <b>MARSHALL</b>
			<b>1863 869 010</b> 	187 198 199 200 201	<b>MERCEDES-BENZ</b>
			<b>1863 869 014</b> 	7 13 225 226 262 263  284	<b>CASE IH</b> <b>NEW HOLLAND</b> <b>RENAULT</b> <b>AGRICULTURE</b> <b>STEYR</b>
			<b>1863 869 015</b> 	83 84 85 86 88 89 90 91 92 93 94 95 96 97 98	<b>FORD NEW</b> <b>HOLLAND</b>
			<b>1863 869 018</b> 	35 39 119 120 121 122 123 124 125 126 127 128 129 130 132	<b>DEUTZ-FAHR</b> <b>JOHN DEERE</b>
			<b>1863 869 019</b> 	10 11 13 226 227 228 229 230 284 285	<b>CASE IH</b> <b>NEW HOLLAND</b>  <b>STEYR</b>
<b>1863 858 001</b> 	78 90 92 94 96 177 178 179 180	<b>FIATAGRI</b> <b>FORD NEW</b> <b>HOLLAND</b> <b>MERCEDES-BENZ</b>	<b>1863 869 020</b> 	141 143 144 145 175 176	<b>LANDINI</b>  <b>MC CORMICK</b>
<b>1863 858 002</b> 	7 8 9 10 11 12 13 16 21 22 224 225 226 227 228 229 230 284 285	<b>CASE IH</b>    <b>NEW HOLLAND</b>    <b>STEYR</b>			















Artikelnummer Article No.	Seite Page	Hersteller Manufacturer	Artikelnummer Article No.	Seite Page	Hersteller Manufacturer
1863 869 023 	35 36 37 41 299	DEUTZ-FAHR  ZETOR	1864 039 013 # (18x23-10N) 	55 56 110 111 231 232	DEUTZ-FAHR HATZ ORENSTEIN KOPPEL
1863 869 027 	73 74 75 77 78	FENDT	1864 040 017 # (1 1/2"-10N) 	62 277	EICHER SCHÖTTLER
1863 869 033 	138	KUBOTA	1864 048 204 # (18x23-10N) 	104	GUTBROD
1863 869 044 	195 196 197 198 199 222 223	MERCEDES-BENZ	1864 051 202 (16x20-10N) 	113	HOLDER
1864 000 029 (28x35-10N) 	99	GEDA	1864 052 103 # (36x42-8N) 	27 28 29 31 32	CLAAS
1864 006 147 (18x23-10N) 	1 1 60 103 104 104 105 109 110 112 113 122 237 288 301	AEBI AECHERLI EICHER GUELDNER GUSS & ARMATURENWERK GUTBROD HATZ HOLDER JOHN DEERE REFORM URSUS (D) ZETTELMAYER	1864 052 106 # (38x42-21N) 	27 28 30 31 32	CLAAS
1864 026 232 # (23x29-10N) 	151	LINDNER	1864 066 209 (18x23-10N) 	1 112 113 237	AEBI HOLDER REFORM







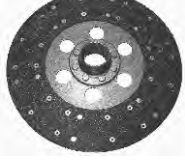



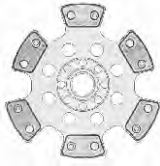

Arithmetische Liste / Part number list

Artikelnummer Article No.	Seite Page	Hersteller Manufacturer	Artikelnummer Article No.	Seite Page	Hersteller Manufacturer
1864 072 201 ▲ (28x32-6N) 	1	AEBI	1864 174 001 (26x32-10N) 	106	HANOMAG RHEINSTAHL
1864 078 010 # (23x29-10N) 	54 55 147 156 269	DEUTZ-FAHR LANZ+MARTI MASSEY FERGUSON SAMPO ROSENLEW	1864 180 839 (18,3x20,4-24N) 	67	EPPL E BUXBAUM
1864 097 002 (28x35-10N) 	55	DEUTZ-FAHR	1864 202 004 # (23x29-10N) 	38 136 137	DEUTZ-FAHR KRAMER KRIEGER FAHRZEUGBAU
1864 103 016 (36x40-20N) 	1	AEBI	1864 202 006 (22x25-15N) 	237	REFORM
1864 121 536 (18,3x20,4-24N) 	53 66 67 67 68 69 104 302	DEUTZ-FAHR EICHER EPPL E BUXBAUM FAHRZEUGWERK E ESSLINGEN FARNY & WEIDMANN GUTBROD ZIEGLER	1864 202 035 # (26x32-10N) 	34 34 38 39 56 57 59 60 61 68 99 102 103 107 108 109 110 111 116 135 136 145 146 147 149 154 156	CREDE DEUTZ-FAHR  EICHER FAHRZEUGWERK E ESSLINGEN FUCHS GUELDNER HANOMAG RHEINSTAHL HATZ IRION KRAMER LANZ+MARTI LIEBHERR MAN MASCHINENBAU ULM (MBU) MIAG MWM NORMAG ORENSTEIN KOPPEL PORSCHE PRIMUS RITSCHER STEINBOCK STILL STOLBERGER VÖGELE
1864 153 133 (21x26-10N) 	38 39 234	DEUTZ-FAHR PORSCHE		223 224 231 232 233 234 235 235 263 278 286 287 293	
1864 164 203 ▲# (22x25-14N) 	2 27	AGRIA CLAAS			



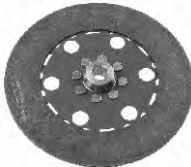







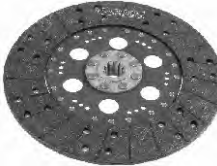

Artikelnummer Article No.	Seite Page	Hersteller Manufacturer	Artikelnummer Article No.	Seite Page	Hersteller Manufacturer
<b>1864 209 231</b> (18x22-6N)	105 106	<b>HAKO</b>	<b>1864 254 002</b> (23x29-10N)	57	<b>DEXHEIMER</b>
					
<b>1864 218 035</b> (23x29-10N)	112	<b>HOLDER</b>	<b>1864 257 101</b> (23x29-10N)	61 63 64 65 66	<b>EICHER</b>
					
<b>1864 239 033 #</b> (22,3x25,8-15N)	120 121 122 123 124 125 126 127 128	<b>JOHN DEERE</b>	<b>1864 261 005 #</b> (23x29-10N)	38 59 60 63 102 103 154	<b>DEUTZ-FAHR EICHER GUELDNER MAN</b>
					
<b>1864 244 042 #</b> (25x28-15N)	64	<b>EICHER</b>	<b>1864 262 101 #</b> (23x29-10N)	61 62 64 150 152	<b>EICHER LINDNER</b>
					
<b>1864 245 101 ▲#</b> (22,3x25,8-15N)	119 120 122 123	<b>JOHN DEERE</b>	<b>1864 289 003</b> (38x42-21N)	29	<b>CLAAS</b>
					
<b>1864 246 408 ▲</b> (27x30-16N)	55	<b>DEUTZ-FAHR</b>	<b>1864 299 131 ▲#</b> (27x30-16N)	22	<b>CASE IH</b>
					
<b>1864 246 437 #</b> (26x32-10N)	69 70 71 98	<b>FENDT FRISCH</b>	<b>1864 300 006</b> (41x45-22N)	74	<b>FENDT</b>
					















Arithmetische Liste / Part number list

Artikelnummer Article No.	Seite Page	Hersteller Manufacturer	Artikelnummer Article No.	Seite Page	Hersteller Manufacturer
1864 300 007 (1 3/8"-10N)	82	FORD NEW HOLLAND	1864 330 204 (1 3/8"-10N)	82	FORD NEW HOLLAND
					
1864 305 131 # (26x32-10N)	40 41	DEUTZ-FAHR	1864 339 131 # (18x20-18N)	236	RAPID
					
1864 307 101 (1 1/8"-10N)	61 62 64 65 66 67 165	EICHER  MASSEY FERGUSON	1864 340 101 # (28x35-10N)	56 58 61 147 281 282	DEUTZ-FAHR EICHER LANZ+MARTI STEYR
					
1864 310 104 (1 1/8"-10N)	137	KRIEGER FAHRZEUGBAU	1864 347 101 # (44x48-23N)	65 283	EICHER STEYR
					
1864 313 231 # (1 1/4"-10N)	127 129 130	JOHN DEERE	1864 347 102 # (41x45-22N)	282 283	STEYR
					
1864 315 101 (25x28-15N)	1	AEBI	1864 352 101 (44x48-23N)	65	EICHER
					
1864 320 101 # (38x42-21N)	28 29 30	CLAAS	1864 352 301 (41x45-22N)	288 289 290 291	VALMET
					













Artikelnummer Article No.	Seite Page	Hersteller Manufacturer	Artikelnummer Article No.	Seite Page	Hersteller Manufacturer
1864 355 102 (1 3/8"-10N)	82	FORD NEW HOLLAND	1864 398 002 (28x35-10N)	55	DEUTZ-FAHR
					
1864 357 001 # (26x32-10N)	69 70 71 76	FENDT	1864 410 101 # (28x32-17N)	150 153 154 278 279	LINDNER STEYR
					
1864 360 101 # (41x45-21N)	279	STEYR	1864 411 031 (31x35-16N)	51	DEUTZ-FAHR
					
1864 366 102 # (28x32-17N)	278	STEYR	1864 412 101 # (45x50-24N)	282	STEYR
					
1864 377 101 (26x32-10N)	74	FENDT	1864 418 002 # (22,5x25-18N)	281 289 290 291	STEYR VALMET
					
1864 394 102 ▲# (27x30-16N)	54	DEUTZ-FAHR	1864 421 141 # (28x32-17N)	34 35 36 40 42 43 44 45 46 47 53 150 152	DEUTZ-FAHR    LINDNER
					
1864 395 101 ▲# (1 3/8"-10N)	117 118 119	JOHN DEERE	1864 439 101 # (28x32-17N)	153 278 279	LINDNER STEYR
					

Arithmetische Liste / Part number list



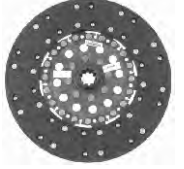









Artikelnummer Article No.	Seite Page	Hersteller Manufacturer	Artikelnummer Article No.	Seite Page	Hersteller Manufacturer
1864 451 041 # (31x35-16N)	35 37 48 49 50 52	DEUTZ-FAHR	1864 480 001 (28x32-17N)	28	CLAAS
					
1864 453 002 (31x35-18N)	55	DEUTZ-FAHR	1864 482 031 (26x32-10N)	71 73 77	FENDT
					
1864 456 001 # (41x45-22N)	74 75	FENDT	1864 501 001 # (46x50-24N)	30 33	CLAAS
					
1864 461 001 # (1 3/8"-10N)	118 119	JOHN DEERE	1864 600 301 (25x32-13N)	132 257 258 259 260 261	JOHN DEERE RENAULT AGRICULTURE
					
1864 462 001 # (41x45-22N)	74 75	FENDT	1864 600 302 (22x25-10N)	9 10 11 78 90 92 94 96	CASE IH FIATAGRI FORD NEW HOLLAND
					
1864 472 002 # (26x32-10N)	73 77	FENDT	1864 600 303 (22x25-10N)	12 13 224 225 226 227 228 229 230 284 285	CASE IH NEW HOLLAND  STEYR
					
1864 477 101 (26x32-10N)	73 74	FENDT	1864 600 304 ▲ (1 3/4"-10N)	90 91 92 93 94 95 96 97 98	FORD NEW HOLLAND
					

Artikelnummer Article No.	Seite Page	Hersteller Manufacturer	Artikelnummer Article No.	Seite Page	Hersteller Manufacturer
<b>1864 600 306</b> (22x25-16N)	299	<b>ZETOR</b>	<b>1864 600 315</b> (1" -10N)	84 85 86 87 88 89 90 91	<b>FORD NEW HOLLAND</b>
					
<b>1864 600 307</b> (25x28-18N)	299 300	<b>ZETOR</b>	<b>1864 600 316</b> (20x25-15N)	82 83 85 86 87 88 89 90	<b>FORD NEW HOLLAND</b>
					
<b>1864 600 308</b> (25x28-18N)	125 126 128 299 300	<b>JOHN DEERE</b> <b>ZETOR</b>	<b>1864 600 318</b> (22x25-14N)	115 138 139 264 265 266 267	<b>HÜRLIMANN</b> <b>LAMBORGHINI</b> <b>SAME</b>
					
<b>1864 600 309</b> (25x28-18N)	299 300	<b>ZETOR</b>	<b>1864 600 320</b> (19x22-18N)	142 171	<b>LANDINI</b> <b>MASSEY FERGUSON</b>
					
<b>1864 600 310</b> (25x28-18N)	299 300	<b>ZETOR</b>	<b>1864 600 321</b> (22x25-10N)	114 264	<b>HÜRLIMANN</b> <b>SAME</b>
					
<b>1864 600 311</b> (27x30-18N)	129 299 300 301	<b>JOHN DEERE</b> <b>ZETOR</b>	<b>1864 600 323</b> (22,5x25-18N)	289 290 291	<b>VALMET</b>
					
<b>1864 600 312</b> (27x30-18N)	299 300 301	<b>ZETOR</b>	<b>1864 600 324</b> (22x25-14N)	115 138 139 264 265 267	<b>HÜRLIMANN</b> <b>LAMBORGHINI</b> <b>SAME</b>
					



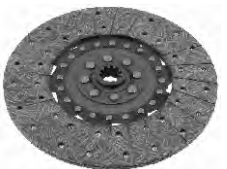



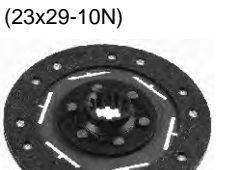



Arithmetische Liste / Part number list













Artikelnummer Article No.	Seite Page	Hersteller Manufacturer	Artikelnummer Article No.	Seite Page	Hersteller Manufacturer
<b>1864 600 326</b> (21,5x25-13N)	260	<b>RENAULT AGRICULTURE</b>	<b>1864 600 334</b> (21,7x25-13N)	257 258 260 261	<b>RENAULT AGRICULTURE</b>
					
<b>1864 600 327</b> (22x25-10N)	78 90 92 94 96	<b>FIATAGRI FORD NEW HOLLAND</b>	<b>1864 600 335</b> (14x17-9N)	142 175	<b>LANDINI MC CORMICK</b>
					
<b>1864 600 329 ▲</b> (20,1x22,8-20N)	99 100	<b>GOLDONI</b>	<b>1864 600 336</b> (26,1x32,2-10N)	117 118 119	<b>JOHN DEERE</b>
					
<b>1864 600 330</b> (14,4x17-9N)	78 79 100	<b>FIATAGRI GOLDONI</b>	<b>1864 600 337</b> (19x22-13N)	79 82	<b>FIATAGRI</b>
					
<b>1864 600 331</b> (20,1x22,8-20N)	99 100 124 128	<b>GOLDONI JOHN DEERE</b>	<b>1864 600 338</b> (1 1/8"-10N)	155 156	<b>MARSHALL</b>
					
<b>1864 600 332</b> (20,1x22,8-20N)	99	<b>GOLDONI</b>	<b>1864 600 339</b> (1 3/4"-10N)	91 92 93 94 95	<b>FORD NEW HOLLAND</b>
					
<b>1864 600 333</b> (17x20-12N)	35 115 140 268	<b>DEUTZ-FAHR HÜRLIMANN LAMBORGHINI SAME</b>	<b>1864 600 340</b> (1" -15N)	85	<b>FORD NEW HOLLAND</b>
					

















Artikelnummer Article No.	Seite Page	Hersteller Manufacturer	Artikelnummer Article No.	Seite Page	Hersteller Manufacturer
<b>1864 600 343</b> (1" - 10N)	83 85 86 87 88 89 90 91	<b>FORD NEW HOLLAND</b>	<b>1864 600 351</b> (19x22-13N)	133	<b>JOHN DEERE</b>
					
<b>1864 600 344 #</b> (1 1/8"-10N)	62 65 66 67	<b>EICHER</b>	<b>1864 600 352</b> (1 1/8"-10N)	294	<b>VOLVO</b>
					
<b>1864 600 345</b> (22x25-10N)	7 8 9 226 227 228 229 230 283 284	<b>CASE IH NEW HOLLAND</b>  <b>STEYR</b>	<b>1864 600 353</b> (22x25-10N)	2 3 5 13 14 79 80 81 88 288	<b>AGRIFULL CASE IH FIATAGRI FORD NEW HOLLAND UNIVERSAL</b>
					
<b>1864 600 346 ▲</b> (41x45-22N)	226	<b>NEW HOLLAND</b>	<b>1864 634 002</b> (23x29-10N)	63 64 66 74	<b>EICHER FENDT</b>
					
<b>1864 600 348 #</b> (22,5x26-15N)	127	<b>JOHN DEERE</b>	<b>1864 634 007</b> (1 1/4"-10N)	127 129 130	<b>JOHN DEERE</b>
					
<b>1864 600 349</b>	20 21 22 23	<b>CASE IH</b>	<b>1864 634 008</b> (18x23-10N)	231 232	<b>ORENSTEIN KOPPEL</b>
					
<b>1864 600 350</b> (21,8x25,5-13N)	133	<b>JOHN DEERE</b>	<b>1864 634 009</b> (23x29-10N)	111 112 113	<b>HOLDER</b>
					















Arithmetische Liste / Part number list

Artikelnummer Article No.	Seite Page	Hersteller Manufacturer	Artikelnummer Article No.	Seite Page	Hersteller Manufacturer
<b>1864 634 010</b> (27x30-16N)	40 41 42 49 50	DEUTZ-FAHR	<b>1864 634 026</b> (26x32-10N)	34 56 58 59 62 63 102 111 116 117	CREDE DEUTZ-FAHR EICHER  GUELDNER HATZ IRION JENBACHER WERKE LANDINI LANZ+MARTI
				142 145 146 147 148 156 170  231 231	MASSEY FERGUSON NORMAG ORENSTEIN KOPPEL RITSCHER SCHEID SCHLECHT ZETTELMEYER
<b>1864 634 013</b> (23x28-6)	101 112 113 114	GRUNDNER HOLDER		263 270 271 301	
			<b>1864 634 027</b> (26x32-10N)	99 111 177 269	FUCHS HATZ MENGELE SAMPO ROSENLEW
<b>1864 634 016</b> (23x29-10N)	27 28 29 30 33 148 273 277 294	CLAAS  LANZ+MARTI SCHLÜTER SCHMOTZER VOLK			
			<b>1864 634 028</b> (23x29-10N)	75	FENDT
<b>1864 634 022</b> (18x23-10N)	67	EICHER			
<b>1864 634 024</b> (1 1/4"-10N)	7 34 37 56 58 69 70 75 102 103 104 105 109 110 145 223 223  224 235 236 271 273 288 297	CASE IH DEUTZ-FAHR EICHER FENDT GUELDNER GUTBROD HAAS HATZ LANZ+MARTI MIAG MOT.MÜNCHEN SENDLING MWM PRIMUS SCHLÜTER URSUS (D) WAHL	<b>1864 634 029</b> (25x28-15N)	1	AEBI
					
<b>1864 634 025</b> (1 1/8"-10N)	5 33 57 270	BKS CLARK EATON SCHANZLIN	<b>1864 634 030</b> (26x32-10N)	37 55 56 69  69 75 99 110 111 146 147 177 232  235 263 270 277 277 301	DEUTZ-FAHR FARNY & WEIDMANN FENDT FUCHS HATZ LANZ+MARTI MENGELE ORENSTEIN KOPPEL POTRATZ RITSCHER SCHEID SCHMOTZER SCHULTHEISS ZETTELMEYER
					















Artikelnummer Article No.	Seite Page	Hersteller Manufacturer	Artikelnummer Article No.	Seite Page	Hersteller Manufacturer
<b>1864 634 031</b> (1 1/8"-10N)	7 116 176 288 298	<b>CASE IH IRION MEILI URSUS (D) WEHRHAHN</b>	<b>1864 634 041</b> (1"-10N)	293 298	<b>VME WARCHALOWSKI</b>
			<b>1864 634 043</b> (23x29-10N)	112 113 114	<b>HOLDER</b>
<b>1864 634 033</b> (28x35-10N)	157 164 166 168 169	<b>MASSEY FERGUSON</b>			
			<b>1864 634 046</b> (16x20-10N)	30 61 110 231	<b>CLAAS EICHER HATZ ORENSTEIN KOPPEL</b>
<b>1864 634 035</b> (20,7x25,92-10N)	286	<b>STEYR</b>			
			<b>1864 900 102 #</b> (44x48-22N)	51 53	<b>DEUTZ-FAHR</b>
<b>1864 634 039</b> (23x29-10N)	4 5 34 37 53 54 61 68 76 101 102 103 105 110 119 135 136 145 151 154 176 177 224 230 233 234 236 237 271 297	<b>BAUTZ DEUTZ-FAHR  EICHER FAHRZEUGWERK E ESSLINGEN FENDT GUELDNER HAAS HATZ JOHN DEERE KRAMER LANZ+MARTI LINDNER MEILI MWM NORDDEUTSCHE TRAKTORENFABRI K (NORDTRAK) PORSCH PRIMUS REFORM SCHLÜTER WAHL</b>			
			<b>1864 904 003 #</b> (27x30-16N)	272 274 275	<b>SCHLÜTER</b>
<b>1864 634 040</b> (23x29-10N)	4 5 37 56 58 69 75 105 110 117 135 136 137 137 147 156 224 233 234	<b>BAUTZ DEUTZ-FAHR EICHER FENDT HAAS HATZ JOHN DEERE KRAMER KRIEGER FAHRZEUGBAU LANZ+MARTI MASSEY FERGUSON MWM PORSCH</b>			
			<b>1864 909 001</b> (44x48-23N)	275	<b>SCHLÜTER</b>
					
			<b>1864 914 003 #</b> (24x28-10N)	3 78 80 81	<b>AGRIFULL FIATAGRI</b>
					
			<b>1864 914 005 #</b> (27x30-16N)	144 170 171	<b>LANDINI MASSEY FERGUSON</b>
					















Arithmetische Liste / Part number list

Artikelnummer Article No.	Seite Page	Hersteller Manufacturer	Artikelnummer Article No.	Seite Page	Hersteller Manufacturer
1864 916 001 # (19x22-13N)	79 80 86	FIATAGRI FORD NEW HOLLAND	1864 926 004 # (26x32-10N)	41 48 50	DEUTZ-FAHR
					
1864 917 002 # (22x25-10N)	140 141 143 144 145 158 162 164 165 166 167 168 175 176	LANDINI  MASSEY FERGUSON  MC CORMICK	1864 926 042 # (28x32-17N)	36 37 41 42 43 44 45 46 47 48 49 53	DEUTZ-FAHR
					
1864 917 003 # (27x30-16N)	22 23	CASE IH	1864 932 041 # (27x30-16N)	274 275 276	SCHLÜTER
					
1864 918 005 # (21,5x25-13N)	131 132 238 239 240 241 242 243 244 245 246 258 259 260 261	JOHN DEERE RENAULT AGRICULTURE	1864 934 009 # (1 1/8"-10N)	22 23 24	CASE IH
					
1864 921 001 # (27x30-16N)	144 170 171	LANDINI MASSEY FERGUSON	1864 937 001 # (1 1/8"-10N)	157 158 159 160 161 162 163 164 165 166 167 169 170	MASSEY FERGUSON
					
1864 922 001 # (32x28-17N)	39 40 42 43 44	DEUTZ-FAHR	1864 941 001 # (27x30-16N)	24 25	CASE IH
					
1864 925 005 # (27x30-16N)	272 273 274	SCHLÜTER	1864 943 002 # (23,2x28,8-10N)	23 24 25	CASE IH
					















Artikelnummer Article No.	Seite Page	Hersteller Manufacturer	Artikelnummer Article No.	Seite Page	Hersteller Manufacturer
<b>1864 946 001</b> (1 1/8"-10N)	157 158 159 160 162 163 164 165 171 293 294	<b>MASSEY FERGUSON</b>  <b>VME VOLVO</b>	<b>1864 994 901 #</b> (22x25-13N)	130 131 250 257 258 259 260	<b>JOHN DEERE RENAULT AGRICULTURE</b>
					
<b>1864 947 002 #</b> (46,6x51-23N)	171 172	<b>MASSEY FERGUSON</b>	<b>1864 996 001</b> (46,5x51-23N)	171 172	<b>MASSEY FERGUSON</b>
					
<b>1864 950 003 #</b> (22x25-13N)	238 239 240 241 242 243 244 245 258	<b>RENAULT AGRICULTURE</b>	<b>1864 996 101 #</b> (18,7x22,2-13N)	12 25 238 239 242 260 261 262	<b>CASE IH RENAULT AGRICULTURE</b>
					
<b>1864 957 001</b> (23x29-10N)	106	<b>HANOMAG RHEINSTAHL</b>	<b>1864 996 201 #</b> (25x28-15N)	273 274 275	<b>SCHLÜTER</b>
					
<b>1864 959 001 #</b> (22x25-10N)	141 142 143 144 145 162 164 165 166 167 168 170 176	<b>LANDINI</b>  <b>MASSEY FERGUSON</b>  <b>MC CORMICK</b>	<b>1866 000 007</b> (54x60-18N)	148 149	<b>LIEBHERR</b>
					
<b>1864 973 001 #</b> (1 1/8"-10N)	166 169 170	<b>MASSEY FERGUSON</b>	<b>1866 000 021</b> (41x45-21N)	149	<b>LIEBHERR</b>
					
<b>1864 974 001 #</b> (1 1/8"-10N)	166 169 170	<b>MASSEY FERGUSON</b>	<b>1866 000 079</b> (36x40 -18N)	148	<b>LIEBHERR</b>
					

Arithmetische Liste / Part number list















Artikelnummer Article No.	Seite Page	Hersteller Manufacturer	Artikelnummer Article No.	Seite Page	Hersteller Manufacturer
<b>1866 000 108</b> (46x50-24N)	26 30 31 33	<b>CATERPILLAR</b> <b>CLAAS</b>	<b>1866 011 202</b> (35x38,5-23N)	127	<b>JOHN DEERE</b>
					
<b>1866 000 140</b> (31,8x34,3-26N)	296	<b>VOLVO PENTA</b>	<b>1866 018 131</b> (31,8x34,3-26N)	295 296	<b>VOLVO PENTA</b>
					
<b>1866 000 150</b> (45x50-24N)	30 31 33	<b>CLAAS</b>	<b>1866 024 001</b> (31,8x35-21N)	233 293	<b>PAUS</b> <b>VÖGELE</b>
					
<b>1866 000 151</b> (46x50-24N)	148 149	<b>LIEBHERR</b>	<b>1866 032 231</b> (31,8x34,3-26N)	294 295 296 297	<b>VOLVO PENTA</b>
					
<b>1866 000 152</b> (64x70-22N)	149	<b>LIEBHERR</b>	<b>1866 050 002</b> (23x29-10N)	114	<b>HURTH</b>
					
<b>1866 000 154</b> (41x45-20N)	292	<b>VALTRA</b>	<b>1866 052 001</b> (23x29-10N)	68 114	<b>FARNY &amp; WEIDMANN</b> <b>HURTH</b>
					
<b>1866 000 239</b> (31,8x34,3-26N)	296 297	<b>VOLVO PENTA</b>	<b>1866 052 002</b> (31,8x34,3-26N)	114	<b>HURTH</b>
					

Artikelnummer Article No.	Seite Page	Hersteller Manufacturer	Artikelnummer Article No.	Seite Page	Hersteller Manufacturer
1866 065 001 (41x45-22N)	148 149	LIEBHERR	1866 136 001 (31x35-16N)	149	LIEBHERR
					
1866 068 001 (41x45-22N)	177	MENGELE	1866 138 101 (31x35-16N)	149	LIEBHERR
					
1866 068 002 (41x45-22N)	177	MENGELE	1866 142 001 (45x50-24N)	177	MENGELE
					
1866 090 001 (54x60-18N)	149	LIEBHERR	1866 148 001 (64x70-22N)	149	LIEBHERR
					
1866 118 001 (31,8x34,3-26N)	296 297	VOLVO PENTA	1866 156 001 (36x40-18N)	148 149	LIEBHERR
					
1866 133 001 (36x40-18N)	148 149	LIEBHERR	1866 157 101 (46x50-24N)	149	LIEBHERR
					
1866 135 001 (46x50-24N)	148 149	LIEBHERR	1866 600 002	11 176	CASE IH MC CORMICK
					















Arithmetische Liste / Part number list















Artikelnummer Article No.	Seite Page	Hersteller Manufacturer	Artikelnummer Article No.	Seite Page	Hersteller Manufacturer
<b>1866 600 003</b> (50,4x54,6-26N)	142	<b>LANDINI</b>	<b>1866 600 010</b> (1 1/8"-10N)	83 92 93 94 97 98	<b>FORD NEW HOLLAND</b>
					
<b>1866 600 004</b> (31x35-16N)	142	<b>LANDINI</b>	<b>1866 600 011</b> (35x40-14N)	12	<b>CASE IH</b>
					
<b>1866 600 005</b> (31x35-16N)	247 248 249 262 263	<b>RENAULT AGRICULTURE</b>	<b>1866 600 012</b> (35x40-14N)	80	<b>FIATAGRI</b>
					
<b>1866 600 006</b> (39x42,5-26N)	255 256	<b>RENAULT AGRICULTURE</b>	<b>1866 600 013</b> (35x40-14N)	8 9 10 11	<b>CASE IH</b>
					
<b>1866 600 007</b> (39x42,5-26N)	255 256	<b>RENAULT AGRICULTURE</b>	<b>1866 600 014</b> (39x42,5-26N)	175	<b>MASSEY FERGUSON</b>
					
<b>1866 600 008</b> (39x42,5-26N)	256	<b>RENAULT AGRICULTURE</b>	<b>1866 600 015</b> (39x42,5-26N)	174 175	<b>MASSEY FERGUSON</b>
					
<b>1866 600 009</b> (39x42,5-26N)	256 257	<b>RENAULT AGRICULTURE</b>	<b>1866 600 016</b> (39x42,5-26N)	1 26 173 174	<b>AGCO CHALLENGER MASSEY FERGUSON</b>
					

















Artikelnummer Article No.	Seite Page	Hersteller Manufacturer	Artikelnummer Article No.	Seite Page	Hersteller Manufacturer
<b>1866 600 017</b> (39x42,5-26N)	26 27 174	<b>CHALLENGER MASSEY FERGUSON</b>	<b>1866 600 024</b> (39x42,5-26N)	27 255	<b>CLAAS RENAULT AGRICULTURE</b>
					
<b>1866 600 018</b> (38,2x41,5-25N)	172 173	<b>MASSEY FERGUSON</b>	<b>1866 600 025</b> (38,2x41,5-25N)	172 173	<b>MASSEY FERGUSON</b>
					
<b>1866 600 019</b> (39x42,5-26N)	174 175	<b>MASSEY FERGUSON</b>	<b>1866 600 026</b> (39x42,5-26N)	256	<b>RENAULT AGRICULTURE</b>
					
<b>1866 600 020</b> (22x25-10N)	10 11	<b>CASE IH</b>	<b>1878 000 104</b> (36x45-10N)	100	<b>GROSS</b>
					
<b>1866 600 021</b> (46x50-24N)	115 140 268	<b>HÜRLIMANN LAMBORGHINI SAME</b>	<b>1878 000 205</b> (2"-10N)	4	<b>ATM</b>
					
<b>1866 600 022</b> (35x40-14N)	12	<b>CASE IH</b>	<b>1878 000 957</b> (1 3/4"-10N)	108 109	<b>HARNISCHFEGER</b>
					
<b>1866 600 023</b> (38,3x45,6-13N)	11 175	<b>CASE IH MC CORMICK</b>	<b>1878 000 968</b> (2"-10N)	283	<b>STEYR</b>
					













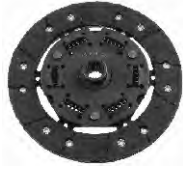

Arithmetische Liste / Part number list

Artikelnummer Article No.	Seite Page	Hersteller Manufacturer	Artikelnummer Article No.	Seite Page	Hersteller Manufacturer
<b>1878 001 138</b> (1 3/4"-10N)	287	TRUCO	<b>1878 076 401</b> (22x25-15N)	237	REFORM
					
<b>1878 001 143</b> (41x45-22N)	4 289 291	ATM VALMET	<b>1878 077 141 #</b> (26x32-10N)	77	FENDT
					
<b>1878 001 939</b> (36x40-18N)	195 196 197 198 222	MERCEDES-BENZ	<b>1878 080 034</b> (2" -10N)	4	ATM
					
<b>1878 002 706</b> (1 3/4" -10N)	115 269 270	IMT SAURER	<b>1878 600 501</b> (26,5x28,9-26N)	198	MERCEDES-BENZ
					
<b>1878 005 623</b> (27x30-18N)	236	REFORM	<b>1878 600 515</b> (41x45-21N)	36	DEUTZ-FAHR
					
<b>1878 006 152</b> (18,3x20,4-24N)	270	SCHANZLIN	<b>1878 600 518</b> (40x45-16N)	9 10 11 78 92 94 96	CASE IH FIATAGRI FORD NEW HOLLAND
					
<b>1878 052 842</b> (36x40-18N)	195 196 197 198 222	MERCEDES-BENZ	<b>1878 600 519</b> (1 3/4"-10N)	33 34 83 90 91 92 93 94 95 96 97 98	COUNTY FORD NEW HOLLAND
					















Artikelnummer Article No.	Seite Page	Hersteller Manufacturer	Artikelnummer Article No.	Seite Page	Hersteller Manufacturer
<b>1878 600 520</b> (1 3/4"-10N)	83 92 93 94 95 96 97 98	<b>FORD NEW HOLLAND</b>	<b>1878 600 529</b> (25,5x29,4-21N)	172	<b>MASSEY FERGUSON</b>
					
<b>1878 600 522</b> (36,5x41-24N)	139 140 265 266 268	<b>LAMBORGHINI SAME</b>	<b>1878 600 530</b> (31x35-18N)	142 171	<b>LANDINI MASSEY FERGUSON</b>
					
<b>1878 600 523</b> (36x40-24N)	138 139 140 264 265 266 268	<b>LAMBORGHINI SAME</b>	<b>1878 600 531</b> (31x35-18N)	142 171	<b>LANDINI MASSEY FERGUSON</b>
					
<b>1878 600 524</b> (1" -10N)	84 85 86 87 88 89 90	<b>FORD NEW HOLLAND</b>	<b>1878 600 533</b> (41x45-21N)	115 139 264	<b>HÜRLIMANN LAMBORGHINI SAME</b>
					
<b>1878 600 526</b> (20,2x25,5-10N)	83 85 86 87 88 89 90 91	<b>FORD NEW HOLLAND</b>	<b>1878 600 534</b> (25,5x29,4-21N)	168 170	<b>MASSEY FERGUSON</b>
					
<b>1878 600 527</b> (1 1/8"-10N)	16 25 26 155	<b>CASE IH MANITOU</b>	<b>1878 600 535</b> (25,5x29,4-21N)	168 170	<b>MASSEY FERGUSON</b>
					
<b>1878 600 528</b> (25,5x29,4-21N)	172 173	<b>MASSEY FERGUSON</b>	<b>1878 600 550</b> (1 1/8"-10N)	6	<b>CASE IH</b>
					





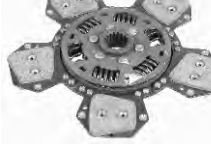

Arithmetische Liste / Part number list

Artikelnummer Article No.	Seite Page	Hersteller Manufacturer	Artikelnummer Article No.	Seite Page	Hersteller Manufacturer
1878 600 551 (1 1/8"-10N)	6	CASE IH	1878 600 570 (1 1/8"-10N)	155 156	MARSHALL
					
1878 600 552 (45x50-18N)	12 78	CASE IH FIATAGRI	1878 600 571 (48x52-24N)	142	LANDINI
					
1878 600 553 (45x50-18N)	78	FIATAGRI	1878 600 572 (28x32-17N)	153 154	LINDNER
					
1878 600 560 (36x40-18N)	195 196 197 198 222	MERCEDES-BENZ	1878 600 573 ▲ (28x32-17N)	153	LINDNER
					
1878 600 567 (31,7x36,2-21N)	12	CASE IH	1878 600 574 (28x32-17N)	286	STEYR
					
1878 600 568 (36,5x41-24N)	12	CASE IH	1878 600 577 (36x40-24N)	34 35 115 138 140 265 268	DEUTZ-FAHR HÜRLIMANN LAMBORGHINI SAME
					
1878 600 569 (44x48-23N)	142	LANDINI	1878 600 578 (1 3/4"-10N)	83	FORD NEW HOLLAND
					













Artikelnummer Article No.	Seite Page	Hersteller Manufacturer	Artikelnummer Article No.	Seite Page	Hersteller Manufacturer
1878 600 830 (1 3/8"-10N) 	116 117	JCB	1878 634 031 (28x32-17N) 	6 282 285	CASE IH STEYR
1878 634 004 (41x45-21N) 	264	SAME	1878 634 033 (28x32-17N) 	22 153	CASE IH LINDNER
1878 634 005 (15,2x17,3-20N) 	104	GUTBROD	1878 634 035 (1 1/8"-10N) 	17 18 19 20 21 111	CASE IH HIEBLE
1878 634 012 (25,5x29,4-21N) 	168 169 170 172 173	MASSEY FERGUSON	1878 634 036 (28x32-17N) 	6 280 281	CASE IH STEYR
1878 634 013 (1 1/8" -10N) 	17 18 19 20	CASE IH	1878 634 037 (28x32-17N) 	6	CASE IH
1878 634 018 (1 1/8"-10N) 	17 18 19 20 21 111	CASE IH HIEBLE	1878 634 040 	17 18 19 20 21 22	CASE IH
1878 634 019 (1 1/8"-10N) 	21 22	CASE IH	1878 634 043 # (1 1/4" -10N) 	7 14	CASE IH

Arithmetische Liste / Part number list

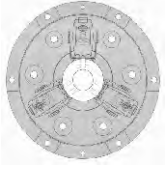









Artikelnummer Article No.	Seite Page	Hersteller Manufacturer	Artikelnummer Article No.	Seite Page	Hersteller Manufacturer
1878 634 044 # (21,7x25-13N)	14 15	CASE IH	1878 987 201 # (1 1/4"-10N)	128 129 130 132	JOHN DEERE
					
1878 634 045 (1 1/4"-10N)	17 18 19 20	CASE IH	1878 987 401 # (44x48-23N)	272 273 277	SCHLÜTER
					
1878 634 046 (22x25-13N)	17 155	CASE IH MANITOU	1878 987 501 # (41x45-21N)	35 36	DEUTZ-FAHR
					
1878 634 051 (1 1/4" -10N)	6 7 16	CASE IH	1878 987 502 # (44x48-22N)	35 36	DEUTZ-FAHR
					
1878 986 601 # (28x32-17N)	6 280 281 285 286	CASE IH STEYR	1878 992 401 # (36x40-20N)	195 196 197 198 215 218 219 220 221	MERCEDES-BENZ
					
1878 986 701 # (25x28-15N)	5 285	CASE IH STEYR	1878 993 101 # (1 1/8"-10N)	57 58 62 65 66 67	EICHER
					
1878 986 801 (28x32-17N)	5 6 282 285	CASE IH STEYR	1878 995 301 (1 1/4"-10N)	130 132	JOHN DEERE
					

Artikelnummer Article No.	Seite Page	Hersteller Manufacturer	Artikelnummer Article No.	Seite Page	Hersteller Manufacturer	
1880 071 008	34 56 60 70 75 103 116 117	DEUTZ-FAHR EICHER FENDT GUELDNER IRION JENBACHER WERKE LANZ+MARTI MASSEY FERGUSON MIAG ORENSTEIN KOPPEL SCHANZLIN	1880 096 210	28 29 30	CLAAS	
	145 147 148 156 157 164 166 170 223 232		1881 009 201 #	15 16 38 107 108 109 111 231 233 233 234 235 298 301	CASE IH DEUTZ-FAHR HANOMAG RHEINSTAHL HATZ NORMAG OSTNER PORSCHE WEHRHAHN ZETTELMEYER	
1880 071 011	34 37 156 157 168 169 231	CREDE DEUTZ-FAHR MASSEY FERGUSON ORENSTEIN KOPPEL		1881 009 203 #	16 38 102 103 107 135 136 145 146 147 235 263	CASE IH DEUTZ-FAHR GUELDNER HANOMAG RHEINSTAHL KRAMER LANZ+MARTI PRIMUS RITSCHER
1880 083 132 #	21 38 62 99 100 101 109 146 149 230 231 287	CASE IH DEUTZ-FAHR EICHER FUCHS GROSS HARNISCHFEGER LANZ+MARTI LIEBHERR NORDWESTDEUTSC HER FAHRZEUGBAU NORMAG STOLBERGER		1881 010 101 #	34 110 111 156 223 224 232 278 286 287	DEUTZ-FAHR HATZ MASCHINENBAU ULM (MBU) MIAG MWM ORENSTEIN KOPPEL STEINBOCK STILL STOLBERGER
1880 092 415 #	56 74 98 109 281 282 287	DEUTZ-FAHR FENDT FRISCH HARNISCHFEGER STEYR TRUCO		1881 010 139 #	38 39 56 57 59 60 61 68 99 100 101 136 137 149 154 231 234 264 293	DEUTZ-FAHR EICHER FAHRZEUGWERK E ESSLINGEN FUCHS GROSS KRAMER KRIEGER FAHRZEUGBAU LIEBHERR MAN ORENSTEIN KOPPEL PORSCHE RITSCHER VÖGELE
1880 092 416 #	56 106	DEUTZ-FAHR HANOMAG RHEINSTAHL		1881 039 531 #	230 279 282 283	NORDWESTDEUTSC HER FAHRZEUGBAU STEYR
1880 096 208 #	17 18 19 20 28 29 104 104 105 106 146 155 223 263 298 301	CASE IH CLAAS GUSS & ARMATURENWERK GUTBROD HAAS HANOMAG RHEINSTAHL LANZ+MARTI MANITOU MIAG RITSCHER ZANDONA ZETTELMEYER				



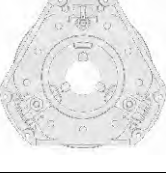









Arithmetische Liste / Part number list

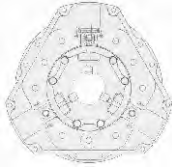











Artikelnummer Article No.	Seite Page	Hersteller Manufacturer	Artikelnummer Article No.	Seite Page	Hersteller Manufacturer
1881 039 532 # 	42	DEUTZ-FAHR	1881 051 204 (Ge 250/46x50-8N) (Mo 280/28x35-10N) 	233 234 271	PORSCHE SCHLÜTER
1881 041 656 # 	100 287	GROSS TRUCO	1881 051 310 # (Mo 280/23x29-10N) (Ge 250/46x50-8N) 	58 59 61 62 74 103 106 147 233 234	EICHER  FENDT GUELDNER HANOMAG RHEINSTAHL LANZ+MARTI PORSCHE
1881 042 506 # 	74 75	FENDT	1881 059 208 	4 37 38 39 56 68 99 103 145 146 147 177 224 232 233 292	AKTIV FISCHER DEUTZ-FAHR  FAHRZEUGWERK E ESSLINGEN FUCHS GUELDNER LANZ+MARTI MENGELE MWM ORENSTEIN KOPPEL PORSCHE VME
1881 044 001 	37 136	DEUTZ-FAHR KRAMER	1881 065 101 	33 53 55 56 67 68 69 148 150 152 153 154 237 271 277 298 302	CLAAS DEUTZ-FAHR EPPLER BUXBAUM FAHRZEUGWERK E ESSLINGEN FARNY & WEIDMANN LANZ+MARTI LINDNER
1881 050 402 # (Ge 225/46x50-8N) (Mo 250/28x35-10N) 	76 107 108 154 155 281	FENDT HANOMAG RHEINSTAHL MAN STEYR	1881 069 101 	104 113 294	GUTBROD HOLDER VOLK
1881 050 427 # (Mo 250/23x29-10N) (Ge 225/46x50-8N) 	58 59 60 61 62 63 64 110 147	EICHER  HATZ LANZ+MARTI	1881 079 207 	27 28 29 30 31 32	CLAAS
1881 050 428 # (Mo 250/23x29-10N) (Ge 225/46x50-8N) 	38 70 103 106 107 146 150 151 152 233 298	DEUTZ-FAHR FENDT GUELDNER HANOMAG RHEINSTAHL LANZ+MARTI LINDNER PORSCHE WARHALOWSKI			















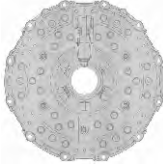



Artikelnummer Article No.	Seite Page	Hersteller Manufacturer	Artikelnummer Article No.	Seite Page	Hersteller Manufacturer	
	1	AEBI		53 54	DEUTZ-FAHR GROSS GUTBROD NORMAG	
	7 14 15	CASE IH		100 101		
	16			104		
	37 56	DEUTZ-FAHR EICHER		230 231		
	58 59 62		<hr/>			
	63	FENDT	1882 000 003 #	99	GEDA	
	69 70 75	GUELDNER		<hr/>		
	101 102 104	HAAS		1882 005 002	113 114	HOLDER
	105	KRAMER			<hr/>	
	135 136	LANDINI			1882 108 204 #	38
	142	LANZ+MARTI	(Mo 225/23x29-10N)		103	GUELDNER
	145 146 147	MIAG	(Ge 200/46x50-8N)		106 107	HANOMAG
	148	MOT.MÜNCHEN		150 151	RHEINSTAHL	
	223	SENDLING		176 177	LINDNER	
	223	MWM		297 298	MEILI	
	224	ORENSTEIN		298	WAHL WARCHALOWSKI	
	232	KOPPEL	<hr/>			
	233	OSTNER	1882 110 532 #	82	FORD NEW HOLLAND	
	235 236	PRIMUS		<hr/>		
	263	RITSCHER		1882 119 106	6 7	CASE IH
271	SCHLECHT			<hr/>		
271 273	SCHLÜTER			1882 137 307 #	82	FORD NEW HOLLAND
281 286	STEYR			<hr/>		
286	STILL			1882 140 002	27 28 29	CLAAS
288	URSUS (D)	59 60 63		EICHER		
293	VÖGELE	<hr/>				
297	WAHL	<hr/>				
301	ZETTELMEYER	<hr/>				
<hr/>			<hr/>			
1881 089 006	151 286	LINDNER STEYR	<hr/>			
	27 28	CLAAS	<hr/>			
	54 55	DEUTZ-FAHR	<hr/>			
	63 66	EICHER	<hr/>			
	67	EPPLE BUXBAUM	<hr/>			
	107	HANOMAG	<hr/>			
	111	RHEINSTAHL	<hr/>			
	134	HATZ	<hr/>			
	151 154	KÖDEL & BÖHM	<hr/>			
	156	LINDNER	<hr/>			
	269	MASSEY FERGUSON	<hr/>			
	270	SAMPO	<hr/>			
	302	ROSENLEW SCHEID ZF	<hr/>			
1881 089 009 ▲	191	MERCEDES-BENZ	<hr/>			
	<hr/>					
	<hr/>					















Arithmetische Liste / Part number list

Artikelnummer Article No.	Seite Page	Hersteller Manufacturer	Artikelnummer Article No.	Seite Page	Hersteller Manufacturer
1882 148 105 # (Ge 200/26x32-10N) (Mo 200/21x26-10N) 	37 38 39	DEUTZ-FAHR	1882 228 002 	4	AKTIV FISCHER
1882 155 009 	1 1 30 60 61 68  101 103 104  105 106 109 110 111 112 113 114 122 231  236 236 237 288 294 301	AEBI AECHERLI CLAAS EICHER FARNY & WEIDMANN GRUNDNER GUELDNER GUSS & ARMATURENWERK HAKO HATZ HOLDER  JOHN DEERE ORENSTEIN KOPPEL RAFFLENBEUL RAPID REFORM URSUS (D) VOLK ZETTELMEYER	1882 229 131 # 	177 178 187 188 189 190 191 192 193 201 202 203 204 205 206	MERCEDES-BENZ
1882 160 104 # (Ge 225/32x40-10N) (Mo 225/26x32-10N) 	38 39	DEUTZ-FAHR	1882 230 205 	57	EATON
1882 162 001	57 137  231	DEXHEIMER KRIEGER FAHRZEUGBAU ORENSTEIN KOPPEL	1882 230 209 	82	FORD NEW HOLLAND STEYR
1882 172 101	34 116	CREDE IRION	1882 230 238 1882 231 131 # 	286 186 187 192 198 199 200 201 204 205	MERCEDES-BENZ
1882 172 107 	70 71	FENDT	1882 236 212 ▲# (Ge 310/41x45-22N) 	290	VALMET
1882 196 005 	4 5 7 33 34 37 55 56 61 67 68	BAUTZ CASE IH CLAAS DEUTZ-FAHR  EICHER EPPLE BUXBAUM FAHRZEUGWERK E ESSELINGEN	1882 248 104 # 	119 151	JOHN DEERE LINDNER
			1882 249 303 # (250/46x50-8N) 	61 63 64 66	EICHER
			1882 252 331 	138	KÄSSBOHRER











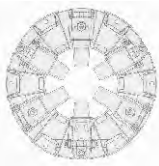



Artikelnummer Article No.	Seite Page	Hersteller Manufacturer	Artikelnummer Article No.	Seite Page	Hersteller Manufacturer
1882 258 004 (280/46x50-8N)	61 62 64 152	EICHER LINDNER	1882 308 106	115	IMT
					
1882 261 013 #	282 283	STEYR	1882 313 001	57 66 67 68  156  224 236 270 292 293 294	DEXHEIMER EICHER FARNY & WEIDMANN MASSEY FERGUSON MWM RAFFLENBEUL SCHANZLIN VME VOLK
					
1882 262 006	249 250 279 280 283	RENAULT AGRICULTURE STEYR	1882 314 001	110 111	HATZ
					
1882 271 403	127	JOHN DEERE	1882 315 002	2 5 30 67 69 75 103 110 111 112 113 114 134 135 137  154 231 232  235 271 273 277	AGRIA BAUTZ CLAAS EICHER FENDT GUELDNER HATZ HOLDER KÖDEL & BÖHM KRAMER KRIEGER FAHRZEUGBAU MAN ORENSTEIN KOPPEL POTRATZ SCHLÜTER SCHMOTZER
					
1882 280 213	283	STEYR	1882 315 003	1 1 4 5 38 68  101 102 103 105 117 147 224 233 234 235 263 277 297	AEBI AECHERLI BAUTZ DEUTZ-FAHR FARNY & WEIDMANN GUELDNER HAAS JOHN DEERE LANZ+MARTI MWM PORSCHE PRIMUS RITSCHER SCHULTHEISS WAHL
					
1882 282 331	190 191 192 193 194 203 204 205 208 209	MERCEDES-BENZ			
					
1882 284 306 #	120 121 122 123 124 125 126 127 128	JOHN DEERE			
					
1882 306 210	115	IMT			
					















Arithmetische Liste / Part number list

Artikelnummer Article No.	Seite Page	Hersteller Manufacturer	Artikelnummer Article No.	Seite Page	Hersteller Manufacturer
1882 318 101 # 	147 281	LANZ+MARTI STEYR	1882 600 103 	84 85 86 87 88 89 90 91	FORD NEW HOLLAND
1882 320 131 	108 109	HARNISCHFEGER	1882 600 105 	84 85 86 87 88 89	FORD NEW HOLLAND
1882 321 001 1882 325 134 	54 42 108 109 287	DEUTZ-FAHR DEUTZ-FAHR HARNISCHFEGER TRUCO	1882 600 106 	84 85 87 88 89 90	FORD NEW HOLLAND
1882 325 139 	108 109	HARNISCHFEGER	1882 600 110 	157 171	MASSEY FERGUSON
1882 339 103 	127 129 130	JOHN DEERE	1882 600 112 ▲ 	85	FORD NEW HOLLAND
1882 347 102 	73	FENDT	1882 600 116 	14 15 16 17 18 19 20 21 22 25 26 155 293 294	CASE IH     MANITOU VME VOLVO
1882 348 103 	73 74	FENDT	1882 600 121 # 	127 129 130	JOHN DEERE
1882 600 101 	8 13 225 226 228 229 230 284 285	CASE IH NEW HOLLAND  STEYR	1882 817 003 ▲# 	167 168	MASSEY FERGUSON















Artikelnummer Article No.	Seite Page	Hersteller Manufacturer	Artikelnummer Article No.	Seite Page	Hersteller Manufacturer
1882 818 001 # 	166 169 170	MASSEY FERGUSON	1888 018 208 # (280/46x50-8N) 	150 152	LINDNER
1882 819 001 # 	168 170	MASSEY FERGUSON	1888 024 104 # (250/38x44-25N) 	61 62 65 66	EICHER
1882 820 001 # 	167 168	MASSEY FERGUSON	1888 024 114 # (250/46x50-8N) 	57 137 270	DEXHEIMER KRIEGER FAHRZEUGBAU SCHANZLIN
1882 998 901 # 	157 169	MASSEY FERGUSON	1888 025 003 # (280/44x48-23N) 	22	CASE IH
1882 998 902 # 	157 166 167 169	MASSEY FERGUSON	1888 026 102 # (295/36x42-8N) 	40 41	DEUTZ-FAHR
1888 000 023 (295/41x45-22N) 	71 73 77	FENDT	1888 027 304 # (250/36x40-20N) 	69 70 71 76 98	FENDT  FRISCH
1888 015 515 # (380/ 2"-10N) 	283	STEYR	1888 034 302 (310/41x45-22N) 	21 22	CASE IH
1888 018 207 # (280/45x50-24N) 	278	STEYR			

Arithmetische Liste / Part number list















Artikelnummer Article No.	Seite Page	Hersteller Manufacturer	Artikelnummer Article No.	Seite Page	Hersteller Manufacturer
1888 036 001 (250/46x50-8N) 	65	EICHER	1888 050 101 # (280/45x50-24N) 	22 150 153 154 278 282	CASE IH LINDNER STEYR
1888 037 101 # (250/38x44-25N) 	67 165	EICHER MASSEY FERGUSON	1888 050 302 # (280/45x50-24N) 	278 279	STEYR
1888 041 103 # (280/36x40-20N) 	69 71 72 73 76	FENDT	1888 051 401 # (295/36x40-20N) 	77	FENDT
1888 043 101 # (280/45x50-24N) 	278	STEYR	1888 052 034 # (310/41x45-21N) 	35 37 48 49 50 51 52	DEUTZ-FAHR
1888 046 041 # (295/44x48-23N) 	41 42	DEUTZ-FAHR	1888 053 101 # (225/35x38-23N) 	119 120 121 122 123 124 125 126 127 128	JOHN DEERE
1888 048 142 # (280/41x45-22N) 	17 18 19 20 21 111	CASE IH HIEBLE	1888 054 004 # (280/41x45-22N) 	281 289 290 291	STEYR VALMET
1888 048 143 (280/41x45-22N) 	17 18 19 20 21	CASE IH	1888 057 042 # (280/36x40-20N) 	39 40 42 43 44 45 46 47 53	DEUTZ-FAHR

Artikelnummer Article No.	Seite Page	Hersteller Manufacturer	Artikelnummer Article No.	Seite Page	Hersteller Manufacturer
1888 059 201 # (295/45x50-24N) 	6 153 278 279 280 281	CASE IH LINDNER STEYR	1888 069 001 (250/31x35-16N) 	237	REFORM
1888 059 202 # (295/45x50-24N) 	278 279	STEYR	1888 600 101 # (225/45x50-24N) 	199 200 201	MERCEDES-BENZ
1888 062 001 # (250/36x40-20N) 	71 72	FENDT	1888 600 102 (327/40x45-16N) 	131 132 259	JOHN DEERE RENAULT AGRICULTURE
1888 064 041 (310/41x45-22N) 	64	EICHER	1888 600 104 (310/40x45-16N) 	130 131 258 260	JOHN DEERE RENAULT AGRICULTURE
1888 067 031 # (310/45x50-24N) 	179 180 181 182 193 194 207 208 211 212 214 215 216	MERCEDES-BENZ	1888 600 106 (310/40x45-16N) 	9 10 11 78 90	CASE IH FIATAGRI FORD NEW HOLLAND
1888 067 042 # (310/41x45-22N) 	182 183 184 185 186 190 191 193 203 207 208 209 210 212 217 218	MERCEDES-BENZ	1888 600 107 (280/35x40-14N) 	8 9 226 227 228 229 230 284	CASE IH NEW HOLLAND  STEYR
1888 068 001 # (280/36x40-20N) 	72 73 76 77	FENDT	1888 600 109 (280/35x40-14N) 	7 8 9 226 227 228 229 283 284	CASE IH NEW HOLLAND  STEYR















Arithmetische Liste / Part number list















Artikelnummer Article No.	Seite Page	Hersteller Manufacturer	Artikelnummer Article No.	Seite Page	Hersteller Manufacturer
<b>1888 600 113</b> (280/40x45-16N)	78 90 92 94 96	<b>FIATAGRI</b> <b>FORD NEW</b> <b>HOLLAND</b>	<b>1888 600 121 ▲</b> (280/31x35-18N)	142 171	<b>LANDINI</b> <b>MASSEY</b> <b>FERGUSON</b>
					
<b>1888 600 114</b> (280/42x45-28N)	299 300	<b>ZETOR</b>	<b>1888 600 122</b> (330/40x45-16N)	131 132 245 246 259 260 261	<b>JOHN DEERE</b> <b>RENAULT</b> <b>AGRICULTURE</b>
					
<b>1888 600 115</b> (280/42x45-28N)	125 126 128 299 300	<b>JOHN DEERE</b> <b>ZETOR</b>	<b>1888 600 123</b> (280/34x40-12N)	133	<b>JOHN DEERE</b>
					
<b>1888 600 116</b> (280/41x45-22N)	289 290 291	<b>VALMET</b>	<b>1888 600 124 ▲</b> (225/31x35-18N)	99 100	<b>GOLDONI</b>
					
<b>1888 600 118</b> (280/36x40-20N)	115 138 139 264 265 267	<b>HÜRLIMANN</b> <b>LAMBORGHINI</b> <b>SAME</b>	<b>1888 600 125</b> (225/31x35-18N)	78 79 100	<b>FIATAGRI</b> <b>GOLDONI</b>
					
<b>1888 600 119</b> (280/36x40-20N)	115 139 264 265 266 267	<b>HÜRLIMANN</b> <b>LAMBORGHINI</b> <b>SAME</b>	<b>1888 600 126</b> (225/31x35-18N)	99 100	<b>GOLDONI</b>
					
<b>1888 600 120</b> (250/36x40-20N)	114 264	<b>HÜRLIMANN</b> <b>SAME</b>	<b>1888 600 127</b> (250/31x35-18N)	99 100 124 128	<b>GOLDONI</b> <b>JOHN DEERE</b>
					

















Artikelnummer Article No.	Seite Page	Hersteller Manufacturer	Artikelnummer Article No.	Seite Page	Hersteller Manufacturer
<b>1888 600 128</b> (280/31x35-18N)	99	<b>GOLDONI</b>	<b>1888 600 136</b>	133	<b>JOHN DEERE</b>
					
<b>1888 600 129</b>	35 115 140 268	<b>DEUTZ-FAHR HÜRLIMANN LAMBORGHINI SAME</b>	<b>1888 600 137</b> (310/45x50-24N)	6	<b>CASE IH</b>
					
<b>1888 600 130</b> (225/27x30-16N)	142 175	<b>LANDINI MC CORMICK</b>	<b>1888 600 138</b> (280/30x40-12N)	261 262	<b>RENAULT AGRICULTURE</b>
					
<b>1888 600 131</b> (280/31x35-18N)	79 82	<b>FIATAGRI</b>	<b>1888 600 139</b> (225/44x48-29N)	85	<b>FORD NEW HOLLAND</b>
					
<b>1888 600 132</b> (280/ 1 3/4"-10N)	155 156	<b>MARSHALL</b>	<b>1888 600 140 #</b> (280/35x40-14N)	2 3 79 80 81 288	<b>AGRIFULL FIATAGRI UNIVERSAL</b>
					
<b>1888 600 133</b> (310/40x45-16N)	3 78 80 81	<b>AGRIFULL FIATAGRI</b>	<b>1888 600 141 #</b> (280/35x40-14N)	3 79 80 81	<b>AGRIFULL FIATAGRI</b>
					
<b>1888 600 135</b> (280/ 1" -10N)	153 154	<b>LINDNER</b>	<b>1888 600 142</b> (310/40x45-16N)	131 132 257 258 259 260 261	<b>JOHN DEERE RENAULT AGRICULTURE</b>
					















Arithmetische Liste / Part number list

Artikelnummer Article No.	Seite Page	Hersteller Manufacturer	Artikelnummer Article No.	Seite Page	Hersteller Manufacturer
<b>1888 600 143</b> (305/ 1 3/4"-10N)	23 24 25	<b>CASE IH</b>	<b>1888 634 004</b> (280/46x50-8N)	63 64 66	<b>EICHER</b>
					
<b>1888 600 144</b> (280/35x40-14N)	7 8 9 12 13 224 225 226 227 228 229 230 283 284 285	<b>CASE IH</b>  <b>NEW HOLLAND</b>  <b>STEYR</b>	<b>1888 801 001 #</b> (295/41x45-21N)	52	<b>DEUTZ-FAHR</b>
					
<b>1888 600 145</b> (280/35x40-14N)	141 143 144 175 176	<b>LANDINI</b> <b>MC CORMICK</b>	<b>1888 860 003 #</b> (280/40x45-16N)	246 247 250	<b>RENAULT</b> <b>AGRICULTURE</b>
					
<b>1888 600 149</b> (310/40x45-16N)	9 10 11 78 92 94 96	<b>CASE IH</b> <b>FIATAGRI</b> <b>FORD NEW</b> <b>HOLLAND</b>	<b>1888 862 002 #</b> (350/44x48-23N)	272 274 275	<b>SCHLÜTER</b>
					
<b>1888 600 150</b> (280/36x40-20N)	114 115 138 139 264	<b>HÜRLIMANN</b> <b>LAMBORGHINI</b> <b>SAME</b>	<b>1888 864 002 #</b> (350/44x48-23N)	24 25	<b>CASE IH</b>
					
<b>1888 634 001</b> (250/ 1 3/4"-10N)	158 159 160 161 162 163 165 166 169	<b>MASSEY</b> <b>FERGUSON</b>	<b>1888 865 042 #</b> (350/44x48-23N)	24 25	<b>CASE IH</b>
					
<b>1888 634 003</b> (225/ 1 3/4"-10N)	157 158 162 163 164 170	<b>MASSEY</b> <b>FERGUSON</b>	<b>1888 867 045 #</b> (280/36x40-20N)	34 35 36 37 41 42 43 44 45 46 47 48 49	<b>DEUTZ-FAHR</b>
					















Artikelnummer Article No.	Seite Page	Hersteller Manufacturer	Artikelnummer Article No.	Seite Page	Hersteller Manufacturer
<b>1888 867 046 #</b> (280/36x40-20N) 	47 48	<b>DEUTZ-FAHR</b>	<b>1888 873 001 #</b> (330/44x48-23N) 	144 170 171	<b>LANDINI MASSEY FERGUSON</b>
<b>1888 868 008 #</b> (310/40x45-16N) 	247 250 251 252 253 254 255	<b>RENAULT AGRICULTURE</b>	<b>1888 874 001 #</b> (225/40x36-20N) 	39 40 138	<b>DEUTZ-FAHR LAMBORGHINI</b>
<b>1888 868 009 #</b> (310/45x50-18N) 	246 247 248 250 251 252 253 254	<b>RENAULT AGRICULTURE</b>	<b>1888 874 003 #</b> (225/45x50-24N) 	106	<b>HANOMAG RHEINSTAHL</b>
<b>1888 868 010 #</b> (280/40x45-16N) 	238 239 240 241 242 243 244 245 246 258 259	<b>RENAULT AGRICULTURE</b>	<b>1888 876 006 #</b> (310/35x40-14N) 	141 142 143 144 145 162 164 165 166 167 168 170 176	<b>LANDINI  MASSEY FERGUSON  MC CORMICK</b>
<b>1888 868 011 #</b> (330/45x50-18N) 	248 249 253 254 255	<b>RENAULT AGRICULTURE</b>	<b>1888 876 102 #</b> (310/40x45-16N) 	3 78 80 81	<b>AGRIFULL FIATAGRI</b>
<b>1888 869 004 #</b> (280/35x40-14N) 	2 3 5 13 14 79 80 81 88	<b>AGRIFULL CASE IH FIATAGRI FORD NEW HOLLAND</b>	<b>1888 877 101 #</b> (Ge 280/45x50-24N) (Mo 280/26x32-10N) 	187 188 189 190 191 192 193 194 201 202 203 204 205 206 209	<b>MERCEDES-BENZ</b>
<b>1888 869 007 #</b> (280/40x45-16N) 	238 239 240 241 242 243 244 245 258	<b>RENAULT AGRICULTURE</b>	<b>1888 877 102 #</b> (280/45x50-24N) 	188 189 190 191 192 193 194 201 202 203 204 205 206 207 208 209	<b>MERCEDES-BENZ</b>













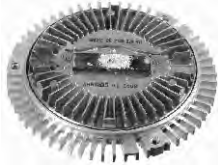

Arithmetische Liste / Part number list

Artikelnummer Article No.	Seite Page	Hersteller Manufacturer	Artikelnummer Article No.	Seite Page	Hersteller Manufacturer
1888 877 103 # (280/45x50-24N) 	191 192 193 194 201 203 204 205 206 207 208 209	MERCEDES-BENZ	1888 884 001 # (280/36x40-20N) 	40 53	DEUTZ-FAHR
1888 878 001 # (228/41x45-25N) 	14 15 16 17 18 111	CASE IH  HIEBLE	1888 885 002 # (280/40x45-16N) 	78	FIATAGRI
1888 879 001 (228/41x45-25N) 	17 18 19 20	CASE IH	1888 887 001 # (225/31x35-18N) 	2 3 52 80 104	AGRIFULL DEUTZ-FAHR FIATAGRI GUTBROD
1888 879 002 # (228/41x45-25N) 	18 19 20 21 22	CASE IH	1888 889 001 # (310/36x42-8N) 	41 48 50	DEUTZ-FAHR
1888 880 001 # (280/35x40-14N) 	140 141 143 144 145 164 165 166 167 168 176	LANDINI  MASSEY FERGUSON MC CORMICK	1888 890 001 # (280/45x50-24N) 	177 178 179 180	MERCEDES-BENZ
1888 881 001 # (280/44x48-23N) 	22 23	CASE IH	1888 891 002 (250/ 1 3/4" -10N) 	158 159 160 161 162 163 165 166 169	MASSEY FERGUSON
1888 883 041 # (330/44x48-23N) 	274 275 276	SCHLÜTER	1888 891 004 (250/38x41-25N) 	162 163 164 166 168 169	MASSEY FERGUSON

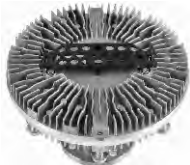











Artikelnummer Article No.	Seite Page	Hersteller Manufacturer	Artikelnummer Article No.	Seite Page	Hersteller Manufacturer
<b>1888 892 001 #</b> (280/35x40-14N) 	140 141 143 144 145 158 162 165 166 167 168	<b>LANDINI</b>  <b>MASSEY FERGUSON</b>	<b>1888 898 001</b> (225/ 1 3/4"-10N) 	157 158 162 163 164 170	<b>MASSEY FERGUSON</b>
<b>1888 893 001 #</b> (225/45x50-24N) 	186 187 198 199 200 201 202 203 207 209 210	<b>MERCEDES-BENZ</b>	<b>1888 898 003</b> (225/ 1 3/4"-10N) 	157 158 159 160 164 165 171 293 294	<b>MASSEY FERGUSON</b>  <b>VME VOLVO</b>
<b>1888 894 003 #</b> (310/44x48-23N) 	272 273 274	<b>SCHLÜTER</b>	<b>1888 900 001 #</b> (225/40x36-20N) 	39 40 42 43 44	<b>DEUTZ-FAHR</b>
<b>1888 894 004 #</b> (310/44x48-23N) 	272 273 274	<b>SCHLÜTER</b>	<b>1888 903 002</b> (280/46x50-8N) 	63 64 66	<b>EICHER</b>
<b>1888 895 002 #</b> (330/45x50-16N) 	132 245 246 259	<b>JOHN DEERE</b> <b>RENAULT AGRICULTURE</b>	<b>1888 903 004 #</b> (280/ 1 5/8"-25N) 	57 58 62 65 66 67	<b>EICHER</b>
<b>1888 897 003 #</b> (305/ 1 3/4"-10N) 	23 24 25	<b>CASE IH</b>	<b>1888 907 001 #</b> (280/ 1 3/4"-10N) 	22 23 24	<b>CASE IH</b>
<b>1888 897 004 #</b> (300/41x46-17N) 	25	<b>CASE IH</b>	<b>1888 911 001 #</b> (250/36x40-20N) 	140 265 266 268	<b>LAMBORGHINI SAME</b>

Arithmetische Liste / Part number list













Artikelnummer Article No.	Seite Page	Hersteller Manufacturer	Artikelnummer Article No.	Seite Page	Hersteller Manufacturer
1888 915 001 # (280/36x40-20N) 	34 36 40 42 43 44 45 46 47 53	DEUTZ-FAHR	1888 998 501 # (280/34x40-12N) 	12 25 238 239 242 260 261 262	CASE IH RENAULT AGRICULTURE
1888 916 001 # (330/45x50-24N) 	195 196 197 198	MERCEDES-BENZ	1888 998 502 (280/35x40-14N) 	14 79	CASE IH FIATAGRI
1888 997 801 # (280/40x45-16N) 	130 131 250 259 260	JOHN DEERE RENAULT AGRICULTURE	1888 998 601 # (330/41x45-22N) 	273 274 275	SCHLÜTER
1888 997 901 # (310/40x45-16N) 	131 257 258 259	JOHN DEERE RENAULT AGRICULTURE	1888 998 701 # (350/55x60-28N) 	272 273 275 277	SCHLÜTER
1888 998 001 (310/45x50-24N) 	6 280 281 285 286	CASE IH STEYR	1888 998 801 # (250/38x41-25N) 	157 158 159 160 161 162 165 166 167 169	MASSEY FERGUSON
1888 998 101 (280/44x49-24N) 	5 6 282 285	CASE IH STEYR	1888 998 901 ▲# (330/45x50-24N) 	215 218 219 220 221	MERCEDES-BENZ
1888 998 201 # (310/45x50-24N) 	180 181 182 193 194 207 208 211 212 215 216	MERCEDES-BENZ	1888 998 902 # (330/45x50-24N) 	165 172  183 184 185 186 211 212 213 214 215 216 217 218 219 220 221 222	MASSEY FERGUSON MERCEDES-BENZ

Artikelnummer Article No.	Seite Page	Hersteller Manufacturer	Artikelnummer Article No.	Seite Page	Hersteller Manufacturer
1890 006 101 # (Ge 200/42x48-8N) (Mo 225/21x26-10N)	70 76	FENDT	3082 007 338	54	DEUTZ-FAHR
					
1890 800 001 # (Ge 225/46x50-8N) (Mo 250/23x29-10N)	273	SCHLÜTER	3082 025 531	110	HATZ
					
2100 038 031 ▲	73	FENDT	3082 043 132	68 270	FARNY & WEIDMANN SCHANZLIN
					
2100 502 010	197 223	MERCEDES-BENZ	3082 046 531	270	SCHANZLIN
2300 146 031	195 196 197 198 223	MERCEDES-BENZ			
			3082 058 031	237	REFORM
2300 147 031	197 198 223	MERCEDES-BENZ			
			3082 112 031	114	HOLDER
3000 096 003	270	SCHANZLIN			
			3082 121 031	40 41 42 49 50 147 231 232	DEUTZ-FAHR  LANZ+MARTI ORENSTEIN KOPPEL
3000 237 001	104	GUTBROD			
3000 951 785	198	MERCEDES-BENZ	3082 144 242	104	GUTBROD
					















Arithmetische Liste / Part number list















Artikelnummer Article No.	Seite Page	Hersteller Manufacturer	Artikelnummer Article No.	Seite Page	Hersteller Manufacturer
3082 147 033	236	REFORM	3130 010 100	54 68 191	DEUTZ-FAHR FAHRZEUGWERK E ESSLINGEN MERCEDES-BENZ
					
3082 157 031	192	MERCEDES-BENZ	3130 010 200	1 7 33 40 41 49 50 51 55 56 68	AEBI CASE IH CLAAS DEUTZ-FAHR
					
3082 161 001 #	112 113 114	HOLDER		101 102 110 111 112 114 116 134 142 151 154 156	FAHRZEUGWERK E ESSLINGEN GUELDNER HATZ HOLDER IRION KÖDEL & BÖHM LANDINI LINDNER MASSEY FERGUSON MEILI ORENSTEIN KOPPEL PORSCHE POTRATZ REFORM RITSCHER SAMPO ROSENLEW SCHEID STEYR STILL ZETTELMEYER
				176 177 232	
3082 170 103	236	PUTZMEISTER		234 235 237 263 269	
				270 281 286 286 301	
3082 199 102	236	PUTZMEISTER			
					
3082 269 031	191 192 198	MERCEDES-BENZ	3130 014 000	75 231 232 235	FENDT ORENSTEIN KOPPEL POTRATZ
					
3100 700 101	1 7 33 40 41 49 50 51 55 56 68	AEBI CASE IH CLAAS DEUTZ-FAHR	3151 000 034	4	ATM
					
	101 102 110 111 112 114 116 134 142 151 154 156	FAHRZEUGWERK E ESSLINGEN GUELDNER HATZ HOLDER IRION KÖDEL & BÖHM LANDINI LINDNER MASSEY FERGUSON MEILI ORENSTEIN KOPPEL	3151 000 395	29 38 58 59 60 61 62 63 64 70 73 74 75 103 106 107 108	CLAAS DEUTZ-FAHR EICHER
	176 177 231 232			110 119	FENDT  GUELDNER HANOMAG RHEINSTAHL HATZ JOHN DEERE





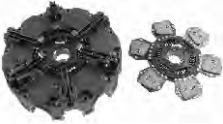













Artikelnummer Article No.	Seite Page	Hersteller Manufacturer	Artikelnummer Article No.	Seite Page	Hersteller Manufacturer
3151 000 396 	196 197 198	MERCEDES-BENZ	3151 051 031 	182 183 184 185 186 207 208 209 210 211 212 213 214 215 216 217 218 219 220 221	MERCEDES-BENZ
3151 000 515 	108 109 115 269 270 287	HARNISCHFEGER IMT SAURER TRUCO	3151 069 032 	192	MERCEDES-BENZ
3151 001 001 	110	HATZ	3151 073 131 	114	HOLDER
3151 021 001 	1 7 33 40 41 49 50 51 54 55 56 68  75 101 102 103 110 111 112 114 116 134 142 151 154 156  176 177 191 198 231 232  234 235 237 263 269  270 281 286 286 301	AEBI CASE IH CLAAS DEUTZ-FAHR  FAHRZEUGWERK E ESSLINGEN FENDT GUELDNER HATZ HOLDER IRION KÖDEL & BÖHM LANDINI LINDNER MASSEY FERGUSON MEILI MERCEDÉS-BENZ ORENSTEIN KOPPEL PORSCHE POTRATZ REFORM RITSCHER SAMPO ROSENLEW SCHEID STEYR STILL ZETTELMEYER	3151 080 101 	119 120 121 122 123 124 125 126 127 130	JOHN DEERE
			3151 082 001 	279 280	STEYR
			3151 083 001 	112 113 114	HOLDER
			3151 091 101 	120 121 122 123 124 125 126 127 128 129 130 132	JOHN DEERE
			3151 093 041 	28 76 234 235	CLAAS FENDT PORSCHE
3151 045 001 	54 55 57 61 137  147 270 293	DEUTZ-FAHR DEXHEIMER EICHER KRIEGER FAHRZEUGBAU LANZ+MARTI SCHANZLIN VÖGELE			

















Arithmetische Liste / Part number list

Artikelnummer Article No.	Seite Page	Hersteller Manufacturer	Artikelnummer Article No.	Seite Page	Hersteller Manufacturer
3151 093 042	286	STEYR	3151 196 031	65	EICHER
					
3151 111 032	279 280 283	STEYR	3151 199 001	55 293	DEUTZ-FAHR VÖGELE
					
3151 151 241	104	GUTBROD	3151 248 031	198	MERCEDES-BENZ
					
3151 156 003	74 75	FENDT	3151 270 602	1 4 67 69 103 104 112 113 137 148 277 298 302	AECHERLI AKTIV FISCHER EICHER FARNY & WEIDMANN GUELDNER GUTBROD HOLDER KRIEGER FAHRZEUGBAU LANZ+MARTI SCHMOTZER WARCHALOWSKI ZIEGLER
					
3151 157 001	58 59 60 61 62 63 64 71 73 76 77 150	EICHER  FENDT  LINDNER	3151 600 561	12 78	CASE IH FIATAGRI
					
3151 160 001	42 49 50 51	DEUTZ-FAHR	3151 994 801	1 1 30 61 101 104 104 105 105 106 109 110 111 112 113 114 122 231 236 237 271 294	AEBI AECHERLI CLAAS EICHER GRUNDNER GUSS & ARMATURENWERK GUTBROD HAKO HATZ HOLDER  JOHN DEERE ORENSTEIN KOPPEL RAPID REFORM SCHLECHT VOLK
					
3151 186 001	283	STEYR			
					
3151 193 041	237 270	REFORM SCHANZLIN			
					

















Artikelnummer Article No.	Seite Page	Hersteller Manufacturer	Artikelnummer Article No.	Seite Page	Hersteller Manufacturer
3159 140 004 	2 30 60 68 102 103 110 111 113 231 232 235 236 237 288	AGRIA CLAAS EICHER FARNY & WEIDMANN GUELDNER HATZ HOLDER ORENSTEIN KOPPEL POTRATZ RAFFLENBEUL REFORM URSUS (D)	3182 002 132 	191	MERCEDES-BENZ
3163 026 100 	123 124 125 126 127 128	JOHN DEERE	3182 003 131 	194 208 211 212 213 214 215 216 217 218 219 220 221 222	MERCEDES-BENZ
3163 030 102 	82	FORD NEW HOLLAND	3182 008 041 	117	JCB
3182 001 104 	126 128 129 130 132 133	JOHN DEERE	3182 600 101 	194 195 196 197 198 199 222 223	MERCEDES-BENZ
3182 001 105 	4 128 129 130 132 133 288 289 290 291	ATM JOHN DEERE  VALMET	3400 012 101 #☐ (2x310/31x35-16N) 	51 53	DEUTZ-FAHR
3182 001 307 	83 92 93 94 97 98 118 119	FORD NEW HOLLAND JOHN DEERE	3400 016 101 #☐ (2x310/44x48-22N) 	36 50 51 52 53	DEUTZ-FAHR
3182 002 131 	193 194 207 208 211 212 213 214 215 216 217 218 219 220 221 222	MERCEDES-BENZ	3400 017 001 #☐ (2x310/41x45-21N) 	36 51 52 53	DEUTZ-FAHR
			3400 126 401 #☐ 	172 281	MASSEY FERGUSON STEYR







Arithmetische Liste / Part number list

Artikelnummer Article No.	Seite Page	Hersteller Manufacturer	Artikelnummer Article No.	Seite Page	Hersteller Manufacturer
3400 127 701 	195 196 197	MERCEDES-BENZ	3482 008 032 	178 179 180 181 187 188 189 190 191 201 202 203 204 205 206 207 208 209	MERCEDES-BENZ
3400 700 344 	4	ATM	3482 008 034 	55 118 119	DEUTZ-FAHR JOHN DEERE
3400 700 458 	36 138 140 267 268 269	DEUTZ-FAHR LAMBORGHINI SAME	3482 008 038 	29 179 182 207 290 291	CLAAS MERCEDES-BENZ VALMET
3400 700 484 	196 197	MERCEDES-BENZ	3482 008 110 	82	FORD NEW HOLLAND
3400 710 008	195 196 197	MERCEDES-BENZ	3482 012 211 	55 64 65 118 119 182 183 184 193 194 209 210 217 218 288 289 290 291 291	DEUTZ-FAHR EICHER JOHN DEERE MERCEDES-BENZ  VALMET  VALMET BRASILLEN MERCEDES-BENZ
3482 000 462 	195 196 197 222	MERCEDES-BENZ	3482 012 237 	182 183 184 185 186 208 209 210 211 212 216 217 218	MERCEDES-BENZ
3482 000 463 	197 198 222 223	MERCEDES-BENZ	3482 039 402 # 	120 121 122 124	JOHN DEERE
3482 002 234 	4 65 183 184 185 186 209 212 213 214 215 216 217 218 289 291	ATM EICHER MERCEDES-BENZ  VALMET	3482 046 031 # 	289	VALMET
3482 002 239 # 	213 214 215 219 220 221	MERCEDES-BENZ			

Artikelnummer Article No.	Seite Page	Hersteller Manufacturer	Artikelnummer Article No.	Seite Page	Hersteller Manufacturer
3482 050 301 # 	74 75	FENDT	3482 600 105 	33 34 83 91 92 93 94 95 96 97 98	COUNTY FORD NEW HOLLAND
3482 070 301 	120 121 123 124 125 126 128 129	JOHN DEERE	3482 600 107 	129 299 300 301	JOHN DEERE ZETOR
3482 083 118 	4	ATM	3482 600 109 	82 83 84 85 86 87 88 89 90 91	FORD NEW HOLLAND
3482 106 031 	213 214 215 218 219 220 221 222	MERCEDES-BENZ	3482 600 110 	142 171	LANDINI MASSEY FERGUSON
3482 106 133 	211 212 213 214 215 216 217 218	MERCEDES-BENZ	3482 600 111 	115 139 264	HÜRLIMANN LAMBORGHINI SAME
3482 124 522 	269 270	SAURER	3482 600 112 	6	CASE IH
3482 600 101 	36	DEUTZ-FAHR	3482 600 113 	12 78	CASE IH FIATAGRI
3482 600 104 	9 10 11 78 90 92 94 96	CASE IH FIATAGRI FORD NEW HOLLAND	3482 600 114 	78	FIATAGRI

Arithmetische Liste / Part number list

Artikelnummer Article No.	Seite Page	Hersteller Manufacturer	Artikelnummer Article No.	Seite Page	Hersteller Manufacturer
3482 600 115 	257 258 260 261	RENAULT AGRICULTURE	3482 600 124 	83	FORD NEW HOLLAND
3482 600 116 	142	LANDINI	3482 602 011 	116 117	JCB
3482 600 117 	142	LANDINI	3482 870 001 # 	78 80 81 82	FIATAGRI
3482 600 118 	91 92 93 94 95	FORD NEW HOLLAND	3482 900 101 # 	51 53	DEUTZ-FAHR
3482 600 119 	33 90 91 92 93 94 95 96 97 98	COUNTY FORD NEW HOLLAND	3482 901 103 	124 126 127 128 129 130 132 133	JOHN DEERE
3482 600 120 	140 265 268	LAMBORGHINI SAME	3482 901 104 	133	JOHN DEERE
3482 600 122 	86	FORD NEW HOLLAND	3482 904 001 	51 52	DEUTZ-FAHR
3482 600 123 	14 15 16 17 18 19 20 21 22 25 26 155	CASE IH    MANITOU	3482 925 001 # 	35	DEUTZ-FAHR

Artikelnummer Article No.	Seite Page	Hersteller Manufacturer	Artikelnummer Article No.	Seite Page	Hersteller Manufacturer
3482 926 001 # 	137 171 172	KUBOTA MASSEY FERGUSON	3800 541 014 ☉ 	171 172	MASSEY FERGUSON
3482 931 001 ▲ 	168 169 170 172 173	MASSEY FERGUSON	3800 541 015 ☉	6	CASE IH
3482 998 101 	139 140 171 172 264 265 266 268	LAMBORGHINI MASSEY FERGUSON SAME	3800 541 016 ☉	6	CASE IH
3482 998 201 	172	MASSEY FERGUSON	3800 541 017 #☉	140 141 143 144 145 164 165 166 167 168	LANDINI MASSEY FERGUSON
3482 998 401 # 	35 36	DEUTZ-FAHR	3800 541 018 #☉	17 18 19 20	CASE IH
3800 541 001 #	6 280 281 285 286	CASE IH STEYR	3800 541 019 #☉	17 18 19 20 21 111	CASE IH HIEBLE
3800 541 002 #	5 6 282 285	CASE IH STEYR	3800 541 020 #☉	126 128 129 130 132 133	JOHN DEERE
3800 541 003 #	22	CASE IH	3800 541 021 #	6 280 281	CASE IH STEYR
3800 541 005 #☉	17 18 19 20 21	CASE IH	3800 541 022 ▲#☉	281 289 290 291	STEYR VALMET
3800 541 006 #☉	14 15 16 17 18 19 20 21 22 25 26 155	CASE IH MANITOU	3800 541 024 #	14 15 16 17 18 19 20 21 22 25 26	CASE IH
3800 541 007 #☉	21 22	CASE IH	3800 541 025 #☉	14 79	CASE IH FIATAGRI
3800 541 008 ☉	78 92 94 96	FIATAGRI FORD NEW HOLLAND	3800 541 026 #	6	CASE IH
3800 541 009 ☉	78	FIATAGRI	3800 710 002 #	208 211 212 214 215 216	MERCEDES-BENZ
3800 541 010 #☉	168 170	MASSEY FERGUSON	3800 710 003 #	212 213 214 215 216 217 219 220 221 222	MERCEDES-BENZ
3800 541 011 #☉	130 132	JOHN DEERE			
3800 541 012 #☉	73	FENDT			
3800 541 013 ☉	73	FENDT			

Vergleichsliste / Cross reference list

Vergleichs-Nr. Compare No.	Artikelnummer Article No.
-------------------------------	------------------------------

**AEBI**

8 58 72352	1859 600 001
8 58 72353	1805 042 000
8 58 74935	1864 103 016
8 58 74936	3082 121 031

**AGRIA**

LO 253	1882 315 002
LO 253	1882 315 002
1842 25696-1	1805 041 100
256 96	1805 041 100
36898	1882 315 003
369 01	1864 164 203
380 369 991	1882 155 009
380 369 991	1882 155 009
436 64	1882 315 002
465 630 698	1881 069 101
470 43 6641	1882 315 002
470 436 641	1882 315 002
480 256 961	1805 041 100
480 257 391	1859 600 002
480 368 981	1882 315 003
480 369 011	1864 164 203
490 570 221	3159 140 004
507 22	3159 140 004
50722-1 1342	3159 140 004
50722-1-1342	3159 140 004
50722-11343	3159 140 004

**AGRIFULL**

00.13.2415.4	1888 887 001
5086.0	1888 887 001
511 2084	1863 858 002
511 3076	1888 876 102
511 8200	1888 876 102
512 2347	1888 876 102
99-05104880-0	1864 914 003
99-05113076-0	1888 876 102
99-44901419-0	1888 600 140

**CASE IH**

A190182	1878 600 568
A190183	1878 600 567
B506200	3800 541 006
K923374	1864 600 349
120 9160 007	3130 014 000
120 9160 721	1805 042 000
120 9160 725	3151 093 042
120 9160 901	1881 089 002
120 9160 903	1860 039 024
126 9350 EX	3800 541 007
127 885	1880 096 208
128 8021 0081	3151 000 395
130 1001 60002	1878 634 033
130 1001 60003	1862 421 001
130 1001 60902	1862 421 001
130 6A16 0901	1881 089 006
131 1001 60708	1888 043 101
131 1001 60902	1888 043 101
132 0671 60902	1864 418 002
135 506 A2	1888 048 143
135 506 A2	3800 541 005
135 506 EX	1888 048 143

Vergleichs-Nr. Compare No.	Artikelnummer Article No.
-------------------------------	------------------------------

**CASE IH**

135 508 A1	1888 034 302
135 508 EX	1888 034 302
139 7210 118	3151 082 001
140 1001 60002	1888 059 201
140 1001 60901	1888 059 201
140 6A16 0727	1864 026 232
140 8001 60753	1864 340 101
140 8001 60905	1864 340 101
140 8001 60906	1882 318 101
141 1001 60085	1862 311 001
141 1001 60091	1888 050 302
141 1001 60093	1864 412 101
141 1001 600941	1864 410 101
141 1001 600951	1888 050 101
141 1001 60871	1888 018 207
141 1001 60920	1862 311 001
141 1001 60921	1864 366 102
141 1001 60922	1864 412 101
141 1001 60923	1888 050 302
141 1001 60924	1864 410 101
141 1001 60938	1888 018 207
153 9018 C1	1864 943 002
161 OT16 0903	1864 347 102
161 0001 60004	1882 230 238
161 0001 60901	1882 230 238
161 1001 60013	1862 131 202
161 1001 60014	1862 131 201
161 1001 60904	1862 131 201
161 1001 60905	1862 131 202
161 2001 60004	1882 262 006
161 2001 60009	1861 613 101
161 2001 60901	1882 262 006
161 2001 60905	1861 613 101
161 4160 0181	1881 039 531
161 4160 902	1881 039 531
169 4004 C1	3800 541 007
169 4004 C91	3800 541 007
185 631 A1	1888 034 302
185 631 A2	3800 541 007
191 259 A2	1861 784 001
194 4263 C1	1862 844 001
196 4053 C1	1888 878 001
196 4053 EX	1888 878 001
196 4054 C1	1888 879 001
196 4054 EX	1888 879 001
196 4055 C1	1888 879 002
196 4055 EX	1888 879 002
196 4058 C2	1888 865 042
196 4058 EX	1888 865 042
196 4059 C1	1888 864 002
196 4059 EX	1888 864 002
196 4060 C2	1888 865 042
196 4060 EX	1888 865 042
196 4061 C1	1888 864 002
196 4061 EX	1888 864 002
196 4090 C1	1864 941 001
196 4090 EX	1864 941 001
196 4146 C1	1861 259 131
196 4146 EX	1861 259 131
196 4150 C1	1878 634 040
196 4150 EX	1878 634 040

Vergleichs-Nr. Compare No.	Artikelnummer Article No.
-------------------------------	------------------------------

**CASE IH**

196 4154 C1	1862 650 001
196 4154 EX	1862 650 001
196 4223 C2	1878 634 035
196 4224 C1	1878 634 035
196 4224 EX	1878 634 035
196 6557 C1	1863 838 001
196 6616 C1	1863 869 014
196 6618 C1	1863 600 107
196 8356 EX	1861 784 001
1964 004 EX	3800 541 007
1964 057 C1	3800 541 007
1964 057 EX	3800 541 007
198 4811 C1	1888 998 501
198 4813 C1	1864 996 101
203 0039 18	3800 541 005
203 1097 09	3800 541 007
209 1600 06	3151 021 001
209 1607 24	1860 039 024
223 807A 1	3482 600 112
293 248A 1	1862 844 001
297 662 A1	1888 998 501
305 4379 R1	1863 010 100
305 4382 R91	1882 119 106
305 4384 R91	1863 010 100
305 7150 R92	1880 096 208
305 7151 R92	1878 634 045
305 8405 R92	1878 634 035
305 8676 R91	1861 259 131
305 9214 R93	1878 634 013
306 2713 R91	1878 600 527
307 4827 R91	1862 844 001
307 4827 R91	1878 600 570
312 1506 R92	1862 844 001
312 1507 R95	1862 844 001
313 1797 R91	1888 878 001
313 3444 R91	1863 100 030
313 3744 R91	1863 100 030
313 4147 R91	1863 839 001
313 4875 R91	1888 878 001
313 4891 R91	1861 259 131
313 6858 R11	1859 600 003
313 7633 R97	1888 048 142
313 7666 R96	1888 048 142
313 7666 R97	1888 048 142
313 7666 R98	1888 048 142
313 7677 R2	1878 634 035
313 9819 R91	1881 009 201
314 1044 R91	1888 025 003
314 1044 R92	1888 025 003
314 1044 R93	1888 025 003
314 1177 EX	1864 917 003
314 1177 R91	1864 917 003
314 1177 R92	1864 917 003
314 1565 EX	1888 881 001
314 1565 R91	1888 881 001
314 1565 R92	1888 881 001
314 1565 R93	1888 881 001
314 1565 R94	1888 881 001
314 2129 R91	1880 096 208
314 2798 R91	1863 839 001
314 5303 R1	1880 083 132



Vergleichsliste / Cross reference list

Vergleichs-Nr. Compare No.	Artikelnummer Article No.
<b>CASE IH</b>	
314 6056 R91	1863 839 000
314 6449 EX	1850 280 743
314 6449 R91	1850 280 743
314 6449 R92	1850 280 743
314 6449 R93	1850 280 743
314 6449 R94	1850 280 743
314 6449 R95	1850 280 743
314 6449 R96	1850 280 743
314 6449 R97	1850 280 743
314 7877 R91	1863 839 001
321 6396 R91	1888 879 001
321 6396 R92	1888 879 001
321 6396 R93	1888 879 001
321 6397 R1	1861 259 131
321 6398 R91	1888 878 001
321 6398 R92	1888 878 001
321 6398 R93	1888 878 001
321 6398 R94	1888 878 001
321 6399 R1	1888 878 001
321 8393 R91	1863 869 020
322 4423 R91	1861 784 001
322 4423 R92	1861 784 001
322 4423 R93	1861 784 001
322 4545 R91	1888 879 001
322 4545 R92	1888 879 001
322 4546 EX	1878 634 040
322 4546 R91	1878 634 040
322 4546 R92	1878 634 040
322 5094 R1	1878 634 035
322 5094 R3	1878 634 035
322 5950 R1	1878 634 035
322 5978 R91	1861 259 131
322 6551 R91	1888 865 042
322 6551 R92	1888 865 042
322 6551 R93	1888 865 042
322 6551 R94	1888 865 042
322 6551 R95	1888 865 042
322 6551 R96	1888 865 042
322 6551 R97	1888 865 042
322 6552 R97	1888 864 002
3220 805 R91	3800 541 007
3220 805 R92	3800 541 007
3220 805 R93	3800 541 007
3220 807 EX	3800 541 007
3220 807 R91	3800 541 007
3220 807 R92	3800 541 007
3220 807 R93	3800 541 007
3220 807 R94	3800 541 007
323 0722 EX	1864 941 001
323 0722 R91	1864 941 001
323 0726 EX	1864 909 001
323 0726 R3	1864 909 001
323 0726 R91	1864 909 001
323 0985 EX	1888 865 042
323 0985 R97	1888 865 042
323 0985 R98	1888 865 042
323 0986 EX	1888 864 002
323 0986 R97	1888 864 002
323 2790 R91	1880 096 208
323 2791 R92	1878 634 046
323 4724 R93	1861 784 001

Vergleichs-Nr. Compare No.	Artikelnummer Article No.
<b>CASE IH</b>	
3234 724 EX	3800 541 007
3234 724 R91	3800 541 007
3234 724 R92	3800 541 007
324 4926 R91	3482 012 211
330 732A 1	1878 600 551
332 123A 1	1878 600 550
340 4116 EX	1862 650 001
340 4116 EX	1888 879 002
340 4116 R91	1862 650 001
340 4116 R91	1888 879 002
341 719 A1	3800 541 015
341 719A 1	1878 600 550
341 723 A1	3800 541 016
341 723A 1	1878 600 551
347 952 A1	1866 600 023
354 430 A1	1861 775 035
354 431A 1	1878 634 033
376 596 A1	1866 600 002
411 0016 0085	1862 311 001
411 0016 0104	1888 059 201
431 6258 R1	1861 259 131
451 350 A1	1866 600 023
471 2670 1	1866 600 013
471 2709 7	1866 600 022
471 3370 9	1863 869 019
471 3444 0	3182 001 105
471 3487 4	1864 600 303
471 3488 0	1888 600 109
471 3488 2	1864 600 345
471 3488 9	1888 600 107
471 3567 0	1863 838 001
509 2788	1864 600 353
513 9337	1888 600 140
514 4009	1888 876 102
514 4738	1888 876 102
514 4739	1888 876 102
514 5709	1888 600 140
514 5710	1888 600 140
515 4703	1864 600 353
515 4879	1888 869 004
516 7936	1878 600 518
516 7937	1864 600 302
517 1137	1888 869 004
517 9851	1878 600 518
518 9825	1878 600 518
519 6819	1864 600 345
519 6822	1888 600 113
519 7980	1863 838 001
537 290 R91	1863 869 020
538 961 R91	1863 869 020
611 0016 0014	1862 131 201
620 153	1863 866 001
69844 C91	1863 869 020
70127 C91	1863 869 020
70716 C1	1882 600 116
70795 C91	1863 869 020
712 317 R95	1882 196 005
712 679 R1	1805 042 000
712 711 EX	1860 049 027
712 711 EX	1864 634 031
715 575 R11	1859 600 003

Vergleichs-Nr. Compare No.	Artikelnummer Article No.
<b>CASE IH</b>	
715 713 R93	1881 089 002
715 714 R91	1878 634 043
715 716 R91	1878 634 051
715 741 R91	1878 634 043
751 846 R93	1863 869 020
751 847 R93	1863 869 020
751 848 R93	1863 869 020
786 518 R91	1881 009 201
786 532 R91	1850 282 747
787 513 R91	1881 089 002
787 514 R91	1881 089 002
787 516 R91	1861 259 131
787 517 R91	1881 009 201
818 166 75	1863 869 015
822 8525 R91	1863 869 020
839 925 60	1863 869 015
850 26C2	1862 716 003
85025 C1	3482 600 123
85104 C91	1863 600 101
85104 C92	1863 600 101
8730 2871	1866 600 022
8730 4267	1866 600 011
8754 2609	1866 600 022
8772 9147	1863 869 014
915 827	1864 934 009
92602 C91	1882 600 116
92602 C92	1882 600 116
956 051	1888 600 143
956 051	1888 897 003
957 435	1888 907 001
997 5291	1863 869 018
<b>CLAAS</b>	
00 0077 472 0	1866 000 108
00 0077 472 0	1866 140 101
00 0077 474 0	1864 501 001
00 0084 662 0	3182 002 131
00 0176 482 0	1881 089 007
00 0507 906 0	1864 634 016
00 0609 421 0	3151 157 001
00 0609 421 1	3151 157 001
00 0609 425 1	1864 289 003
00 0609 426 0	3482 008 038
00 0631 663 0	1859 600 005
00 0631 884 0	1881 079 207
00 0643 605 0	1880 096 210
00 0643 605 1	1880 096 210
00 0649 860 0	3151 160 001
00 0655 021 0	1864 052 103
00 0655 021 3	1864 052 103
00 0655 024 1	1881 079 207
00 0655 024 1	1881 079 207
00 0655 027 0	1881 079 207
00 0655 043 1	1864 052 106
00 0655 043 2	1864 052 106
00 0664 712 0	1866 000 108
00 0679 955 0	1880 096 208
00 0679 955 1	1880 096 208
00 0679 995 0	1880 096 208
00 0679 995 1	1880 096 208
00 0679 996 1	1864 320 101

Vergleichsliste / Cross reference list

Vergleichs-Nr. Compare No.	Artikelnummer Article No.
-------------------------------	------------------------------

**CLAAS**

00 0679 999 0	1881 079 207
00 0694 082 0	1864 480 001
00 0694 082 1	1864 480 001
00 0694 177 0	3151 045 001
00 0694 179 0	3082 007 338
00 0712 611 0	1881 089 007
00 0712 612 0	1860 039 024
00 0712 612 1	1860 039 024
00 0712 612 1	1860 039 024
00 0712 613 0	1859 600 001
00 0751 007 0	1882 140 002
00 0751 007 1	1882 140 002
00 0751 011 0	1859 600 002
00 0762 042 0	3151 270 602
00 0762 042 0	3159 140 004
00 0789 067 0	1864 164 203
00 0789 067 1	1864 164 203
00 0932 378 0	1859 600 003
00 1118 914 0	1888 600 142
00 1130 965 0	1888 998 501
06647110	1866 000 150
606.837.0	3151 093 041
77 0103 052 5	1863 869 019

**CLARK**

00846620	3182 002 131
0170600010	1864 634 025
06094251	1864 289 003
06941770	3151 045 001
06941790	3082 007 338
320 2163	1882 230 205
3702163	1882 230 205
3752340	1864 634 025
4107381	3151 021 001

**DEUTZ-FAHR**

K 18035	1881 039 532
01/06233600	1864 634 040
01/06235265	1864 634 039
01/06235267	1859 600 001
01/06236668	1860 039 024
01/06238387	1859 600 003
01/06238395	3151 045 001
01/06238396	3082 007 338
01/06257464	1881 089 007
01/06257465	3151 021 001
01/06260127	1864 246 408
01/06276681	3482 012 211
01/06276681	3482 012 211
01/06543600	1864 398 002
01/06543611	1864 394 102
01/06543617	1864 097 002
0110 1461	1863 838 000
0110 1700	1863 839 000
0110 9032	1863 869 018
0113 6449	1863 838 000
0117 2721	3151 000 515
0117 2861	3082 121 031
0117 2863	1864 394 102
0117 2865	3151 045 001
0117 3290	1878 002 706
0117 9108	1888 042 012

Vergleichs-Nr. Compare No.	Artikelnummer Article No.
-------------------------------	------------------------------

**DEUTZ-FAHR**

0126 0070	1863 837 000
0126 0401	1864 202 035
0126 0426	1864 078 010
0126 0427	1864 634 016
0126 0463	1863 837 002
0126 0549	1882 248 104
0126 1333	1882 325 134
0126 1558	3151 157 001
0126 1629	1864 634 010
0126 1630	1864 634 010
0126 1631	3082 121 031
0126 1760	3151 021 001
0126 1760 KZ	3151 021 001
0126 1896	1880 092 415
0126 1902	1878 000 957
0126 2142	1880 092 415
0126 2631	3082 121 031
0126 6379	1805 041 100
0126 6383	1805 042 000
0126 6388	1859 600 001
0126 6389	1859 600 006
0126 6390	1859 600 002
0126 6393	1863 100 030
0126 6397	1863 009 100
0126 6399	1863 100 030
0126 6400	1863 840 000
0126 6401	1863 837 001
0126 6425	1881 059 208
0126 6448	1881 010 139
0126 6463	1880 083 132
0126 6475	1880 083 132
0126 6530	1864 026 232
0126 6600	1881 065 101
0127 2047	1881 039 532
0127 8622	1882 325 134
0131 9256	1864 634 016
0143 2106	1863 101 100
0212 1203	1859 600 002
0212 2102	1864 261 005
0224 6044	1881 039 532
0230 5329	1888 900 001
0230 7628	1864 922 001
0231 3468	1864 421 141
0231 6766	1888 884 001
0231 6768	1888 874 001
0233 7655	3151 021 001
0233 7656	3151 021 001
0237 6202	1864 305 131
0237 6203	1864 305 131
0238 0398	1888 884 001
0238 1234	1888 057 042
0238 5464	1888 046 041
0238 8299	1888 046 041
0238 8802	1863 837 002
0291 3024	1864 922 001
0291 3031	1864 421 141
0291 3034	1864 922 001
0291 3228	1888 874 001
0291 3230	1888 900 001
0291 3234	1888 884 001
0291 3235	1888 884 001

Vergleichs-Nr. Compare No.	Artikelnummer Article No.
-------------------------------	------------------------------

**DEUTZ-FAHR**

0291 3325	1888 884 001
0291 3342	1888 046 041
0291 3357	1888 046 041
0292 2101	3151 157 001
0294 0100	1888 052 034
0294 0103	1888 801 001
0294 0104	1864 451 041
0294 0106	3482 904 001
0294 0107	1862 946 001
0294 0108	1888 887 001
0294 0120	1864 153 133
0294 0159	1888 026 102
0294 0160	1888 057 042
0294 0165	1888 052 034
0294 0167	1888 889 001
0294 0169	1864 926 004
0294 0170	1861 990 001
0294 0171	1888 052 034
0294 0172	1861 990 001
0294 0182	1864 900 102
0294 0183	3482 900 101
0294 0184	3482 900 101
0294 0209	3482 900 101
0294 0216	1888 026 102
0294 0217	1888 884 001
0294 0218	1888 874 001
0294 0220	1888 046 041
0294 0222	1888 057 042
0294 0223	1888 052 034
0294 0224	1888 900 001
0294 0225	1888 801 001
0294 0226	1888 889 001
0294 0227	1888 052 034
0294 0276	3482 904 001
0294 0277	3482 900 101
0294 0280	3400 016 101
0294 0281	3400 016 101
0294 0283	3400 017 001
0294 0284	3400 017 001
0294 0289	1888 052 034
0294 0294	3400 016 101
0294 0295	3400 017 001
0294 0309	1888 867 045
0294 0351	1888 867 045
0294 0353	1888 889 001
0294 0355	1888 052 034
0294 0392	1888 900 001
0294 0394	1888 801 001
0294 0403	1888 026 102
0294 0408	1888 052 034
0294 0421	1888 052 034
0294 0734	1888 052 034
0294 0735	1888 867 045
0294 0738	1888 915 001
0294 1267	1888 052 034
0382 1201	1882 315 003
0430 2031	1864 634 010
0430 8445	1888 900 001
0430 8446	1888 874 001
0431 4882	1864 451 041
0431 5562	1888 801 001

Vergleichsliste / Cross reference list

Vergleichs-Nr. Compare No.	Artikelnummer Article No.
-------------------------------	------------------------------

**DEUTZ-FAHR**

0431 5565	3482 904 001
0431 5567	1862 946 001
0431 5568	1888 052 034
0431 5571	1888 801 001
0433 4402	1863 855 000
0433 7322	1888 052 034
0433 9891	1888 026 102
0434 1141	1888 057 042
0434 1323	1861 990 001
0434 2210	1888 052 034
0434 2333	1861 990 001
0434 2464	1888 889 001
0434 2501	1864 926 004
0434 2543	1888 052 034
0434 4441	1864 900 102
0434 4441	3482 900 101
0434 4443	3482 900 101
0434 4489	1864 900 102
0434 9656	3482 900 101
0435 0562	1888 884 001
0435 0867	1888 057 042
0435 0868	1888 900 001
0435 0869	1888 889 001
0435 0872	1888 052 034
0435 0875	1888 026 102
0435 1259	1888 874 001
0435 1607	3400 017 001
0435 2144	1864 411 031
0435 2608	3400 016 101
0435 3450	3400 017 001
0435 3452	3400 017 001
0435 3786	3400 016 101
0435 3788	3400 016 101
0435 6405	3151 160 001
0435 8932	1888 052 034
0435 9388	1864 900 102
0435 9410	1862 946 001
0435 9491	1888 052 034
0436 0390	3482 900 101
0436 0393	3482 904 001
0436 0621	1888 052 034
0436 0623	1888 052 034
0436 0625	1888 052 034
0436 2644	1863 837 002
0436 2689	3400 012 101
0436 2691	3400 016 101
0436 7205	1888 867 045
0437 1472	1888 052 034
0437 2114	1888 052 034
0437 8220	1863 838 000
0437 8231	1888 867 046
0437 8763	1864 421 141
0437 8767	1888 867 046
0437 8771	1888 889 001
0437 8777	1888 052 034
0437 8779	1864 451 041
0437 8781	1888 052 034
0438 1284	1864 922 001
0438 1291	1888 874 001
0438 3378	1863 600 119
0438 3896	1878 987 501

Vergleichs-Nr. Compare No.	Artikelnummer Article No.
-------------------------------	------------------------------

**DEUTZ-FAHR**

0438 4061	3482 925 001
0438 5887	1888 052 034
0438 5897	3400 016 101
0438 5904	3400 017 001
0438 6358	1888 026 102
0438 6364	1864 305 131
0438 6629	1888 052 034
0438 6637	1861 990 001
0438 7064	1863 839 000
0438 8445	3482 925 001
0439 3071	1888 052 034
0439 3084	1878 987 502
0439 8421	3482 998 401
0439 9886	1878 987 502
0440 1103	1888 915 001
0440 1112	1888 052 034
0440 1834	1878 987 501
0440 1836	1878 987 502
0623 3600	1864 634 040
0623 8381	1864 078 010
0623 8387	1859 600 003
0623 8394	1864 394 102
0623 8395	3151 045 001
0625 7414	3130 010 100
0625 7465	3151 021 001
0626 0127	1864 246 408
0627 5626	1860 062 037
0627 6678	3151 199 001
0627 6680	1864 398 002
0627 6681	3482 012 211
0652 3985	3482 008 034
0653 2257	1864 453 002
0654 3065	1864 078 010
0654 3075	1860 062 037
0654 3600	1864 398 002
0654 3611	1864 394 102
0654 3617	1864 097 002
0890 351	3151 045 001
1000 0693	1888 887 001
1-0004-300-804.00	3159 140 004
1-1103-002-510.00	1864 121 536
1-1104-030-803.00	1864 121 536
1-1104-300-804.00	3151 270 602
1-1106-300-118.00	1805 042 000
1-1106-300-806.11	1882 321 001
1-1106-300-808.00	1859 600 001
1-1110-300-811.00	1860 039 024
1-1114-300-520.01	1864 078 010
1-1114-300-560.00	1859 600 003
1-1114-300-560.01	1859 600 003
1-1116-300-560.00	1860 062 037
1136-02-04.90	1882 160 104
1-2107-270-560.00	1881 089 007
1-2107-270-570.00	3151 021 001
1-2114-300-510.00	1881 089 007
1-2121-300-520.00	1864 246 408
1-2123-300-620.00	3151 199 001
1-2123-300-620.01	3151 199 001
1-2123-300-640.00	1864 398 002
126 1760 KZ	3151 021 001
212 2102	1864 261 005

Vergleichs-Nr. Compare No.	Artikelnummer Article No.
-------------------------------	------------------------------

**DEUTZ-FAHR**

2925 7012	1864 634 016
2925 7013	1882 315 002
2925 7014	3151 270 602
7950-030-600.00	1882 315 002
8739-44-01.20	1863 100 030
8739-44-02.50	1859 600 001
8739-44-02.90	1859 600 002
8739-44-05.20	1863 100 030
8739-47-04.10	1881 059 208
8739-47-04.20	1882 196 005
8739-47-10.30	1880 092 415
8739-47-16.70	1864 026 232
8739-47-24.10	1881 065 101
8739-47-24.10	1881 065 101
8739-47-27.10	1880 071 008
8739-47-50.29	1864 153 133
8739-47-50.45	1864 202 035
8751-52-51.64	1881 039 532
8751-52-51.92	1882 325 134
9231 7048	1864 926 042
<b>EATON</b>	
411 010 120	1864 634 025
<b>EICHER</b>	
127 237	3159 140 004
127 248	1882 249 303
127 281	1864 307 101
148 181	1864 244 042
148 291	3151 157 001
148 302	1882 313 001
148 313	1864 121 536
148 335	1864 634 022
148 735	1805 042 000
151 041	1805 041 100
1620 432 M1	1805 042 000
1620 433 M1	1881 089 007
1621 290 M1	1882 249 303
1621 755 M1	1864 307 101
1622 273 M1	1864 600 344
1622 273 M2	1864 600 344
175 522 M91	1880 083 132
275 022	1888 024 104
3007 605 0001	1882 249 303
3017 605 0002	1888 064 041
3022 605 0007	3151 196 031
3024 605 0003-2	1864 347 101
3024 605 0004	3482 002 234
3140 507 M1	3151 196 031
3140 569 M1	3482 002 234
3140 570 M1	1864 347 101
3141 909 M1	3482 012 211
3141 910 M1	1864 352 101
3165 118 M91	1888 903 002
3165 118 M92	1888 903 002
3165 119 M1	1864 634 002
3166 767 M2	1888 037 101
3168 436 M1	1888 024 104
3168 918 M1	1888 903 004
3168 935 M1	1878 993 101
3168 935 M2	1878 993 101
3188 894 M1	1864 600 344

Vergleichsliste / Cross reference list

Vergleichs-Nr. Compare No.	Artikelnummer Article No.
-------------------------------	------------------------------

**EICHER**

3195 396 M1	1888 903 004
3195 433 M1	1888 903 004
3197 263 M1	1864 347 101
3198 032 M1	1864 600 344
3705 605 0001	1881 089 007
3707 605 0001	1882 249 303
533 621	1881 089 009
706 134	1863 100 030
706 145	1863 009 100
706 178	1863 100 030
706 222	1864 634 046
706 574	1864 634 024
706 596	1863 600 122
706 629	1863 123 000
706 684	1864 121 536
706 695	1864 202 035
706 805	1859 600 005
706 816	1859 600 003
706 827	1859 600 002
706 838	3151 994 801
706 937	1863 123 000
706 981	1882 313 001
706 992	1880 071 008
707 058	1864 307 101
707 157	1864 261 005
707 333	1864 026 232
707 443	1882 140 002
707 454	1882 196 005
707 465	1881 089 007
707 487	1881 089 007
707 498	1882 155 009
707 553	1881 050 427
707 652	1881 010 139
707 685	1881 009 203
707 840	1881 089 002
708 750	1860 039 024
708 772	1864 634 026
712 932	1888 903 004
714 417	1888 064 041

**FARNY & WEIDMANN**

03 10 01 0160	1882 155 009
03 10 01 0180	1882 313 001
03 10 01 2160	3151 270 602
03 10 01 3003	1866 052 001
03 10 03 0180	1882 315 003
167.097.2	1866 050 002
167.100.2	1866 052 001
167.103.2	1866 052 002
533.007.2	1882 155 009
533.016.2	3159 140 004
533.019.2	1882 315 003
533.020.2	1805 041 200

**FENDT**

E099.103.100.030	1888 000 023
E117.108.100.020	1888 000 023
E117.108.100.030	1888 000 023
E198.100.100.010	1882 347 102
E198.100.100.020	1882 348 103
E199.104.100.010	1882 348 103
E205.100.100.010	1888 062 001

Vergleichs-Nr. Compare No.	Artikelnummer Article No.
-------------------------------	------------------------------

**FENDT**

E205.100.100.020	1888 027 304
E207.100.100.010	1888 041 103
E207.100.100.020	1888 068 001
E210.103.100.020	1888 000 023
E210.103.100.040	1888 000 023
E231.103.100.010	1890 006 101
E285.100.103.050	1881 042 506
E312.100.101.010	1882 348 103
E380.100.100.030	1888 051 401
E382.100.100.010	3482 050 301
E384.100.100.020	3482 050 301
E384.102.100.010	3482 050 301
E384.102.100.020	3482 050 301
E385.100.100.010	3482 050 301
E385.100.100.011	3482 050 301
E385.103.100.020	3482 050 301
F015.100.100.020	1859 600 006
F015.100.100.040	1805 042 000
F015.100.100.220	1864 634 040
F015.100.100.230	1881 089 002
F016.100.100.010	1881 089 002
F016.100.100.031	1864 634 039
F020.100.100.021	1882 196 005
F025.100.100.020	1859 600 001
F025.100.100.041	1864 634 026
F025.100.100.180	1864 634 024
F040.100.100.030	1859 600 003
F040.100.100.330	1863 600 123
F112.100.100.011	1882 315 002
F112.100.100.090	1882 315 002
F120.100.100.010	1864 634 028
F120.100.100.011	1864 634 028
F120.106.100.001	3151 021 001
F120.106.100.011	3151 021 001
F120.106.100.020	3130 014 000
F131.100.100.010	1880 071 008
F131.100.100.020	1860 039 024
F138.151.100.030	1864 103 016
F139.100.100.013	1881 050 428
F139.100.100.014	1881 050 428
F139.103.100.010	1864 026 232
F139.103.100.011	1864 026 232
F165.100.100.031	1864 634 002
F178.100.100.040	1882 347 102
F178.100.101.010	1882 347 102
F178.100.101.020	1882 347 102
F178.100.420.011	1864 377 101
F181.100.100.060	1880 092 415
F181.100.101.040	1880 092 415
F181.100.101.060	1880 092 415
F183.100.100.020	1864 300 006
F183.100.100.021	1864 300 006
F218.100.100.010	3151 157 001
F225.100.100.012	1890 006 101
F225.100.100.013	1890 006 101
F225.100.100.021	1864 163 203
F225.100.100.022	1864 163 203
F231.103.100.010	1890 006 101
F281.100.100.010	3151 157 001
F281.100.101.010	1880 092 415
F285.100.100.005	1881 042 506

Vergleichs-Nr. Compare No.	Artikelnummer Article No.
-------------------------------	------------------------------

**FENDT**

F285.100.100.010	1881 042 506
F285.100.103.010	1864 462 001
F285.100.103.050	1881 042 506
G117.200.040.110	2100 038 031
G385.100.100.030	3151 156 003
G385.103.100.010	3151 156 003
H186.126.420.010	1864 482 031
H199.100.420.020	1864 477 101
H199.100.420.030	1864 477 101
H199.104.420.010	1864 477 101
H199.104.420.020	1864 477 101
H205.100.420.020	1861 723 201
H207.100.420.010	1861 751 104
H207.100.420.020	1861 751 104
H210.103.420.020	1864 482 031
H285.100.103.010	1864 462 001
H382.100.420.030	1864 300 006
H385.103.420.010	1864 456 001
H395.100.420.010	1864 472 002
H395.100.420.020	1864 472 002
X345.100.100.020	1851 146 001
X600.197.100	1863 855 000
X606.715.411	1863 869 023
X607.305.302	1863 869 027
X612.197.000	1863 837 002
X612.197.000.000	1863 837 002
X612.197.100	1863 855 000
X612.197.100.000	1863 855 000
X623.577.008.001	1863 840 000
X623.577.400	1863 600 123
X623.577.500	1863 837 001
X805.230.002	1888 027 304
X805.230.003	1888 027 304
X805.230.004	1888 027 304
X805.230.007	1888 027 304
X805.230.022	1888 041 103
X805.230.026	1888 041 103
X805.230.052	1882 172 107
X805.230.052.000	1882 172 107
X805.230.103.010	1864 246 437
X805.230.110	1864 357 001
X805.230.110.000	1864 357 001
Z178.100.420.011	1864 377 101
Z186.126.420.010	1864 482 031
Z199.104.420.020	1864 477 101
Z205.100.100.010	1888 062 001
Z205.100.100.020	1888 027 304
Z205.100.420.020	1861 723 201
Z207.100.100.010	1888 041 103
Z207.100.100.020	1888 068 001
Z207.100.420.020	1861 751 104
Z210.103.100.040	1888 000 023
Z231.103.100.010	1890 006 101
Z281.100.101.010	1880 092 415
Z285.100.103.010	1864 462 001
Z285.100.103.050	1881 042 506
Z312.100.101.010	1882 348 103
Z380.100.100.030	1888 051 401
Z382.100.420.030	1864 300 006
Z385.103.100.020	3482 050 301
Z385.103.420.010	1864 456 001

Vergleichsliste / Cross reference list

Vergleichs-Nr. Compare No.	Artikelnummer Article No.
-------------------------------	------------------------------

**FENDT**

Z395.100.420.020	1864 472 002
Z805.230.052.000	1882 172 107
Z805.230.103.010	1864 246 437
Z805.230.110.000	1864 357 001
155.102.420.010	1861 723 201
178.100.420.010	1864 377 101
178.100.420.011	1864 377 101
285.100.103.010	1864 462 001
345.100.100.020	3151 157 001
385.100.100.030	3151 156 003
385.100.100.150	3151 156 003

**FIATAGRI**

0341 9028	1863 100 030
127 1902	1863 101 100
132 4154	1888 887 001
449 07617	1864 600 330
4490 9044	1864 600 337
4490 9045	1888 600 131
4712 3372	1882 600 101
4713 4898	1888 600 109
4713 4899	1888 600 107
510 4880	1864 914 003
511 2400	3482 870 001
511 2564	3482 870 001
511 2819	1888 876 102
511 2843	3482 870 001
511 3076	1888 876 102
511 3135	3482 870 001
511 4473	1888 876 102
511 4522	1864 914 003
511 8200	1888 876 102
511 8453	1862 724 002
512 0567	1888 876 102
512 0568	1888 876 102
512 2028	1863 838 001
512 2347	1888 876 102
512 2348	1888 876 102
512 3061	3482 870 001
512 3062	3482 870 001
512 4029	1862 724 002
512 4031	3482 870 001
512 4399	3482 870 001
512 8074	1864 916 001
516 2897	1888 600 140
516 2900	1888 998 502
516 3936	1888 600 133
516 7925	1864 600 327
517 1494	1888 600 131
518 1421	1888 600 144
518 6548	1882 600 101
518 6550	1882 600 101
518 6552	1888 600 107
519 6770	1882 600 101
519 6809	1888 600 109
519 6813	1888 600 144
519 6816	1888 600 107
519 6818	1888 600 109
8820 3018	1888 876 102
8820 3027	3482 870 001
8820 3028	3482 870 001

Vergleichs-Nr. Compare No.	Artikelnummer Article No.
-------------------------------	------------------------------

**FIATAGRI**

8820 3034	1888 600 140
996 7339	3151 600 561

**FORD NEW HOLLAND**

C5NN N779 B	1863 869 015
C5NN 7563 AC	3482 600 109
C5NN 7563 U	1882 600 103
C5NN 7563 V	1882 600 103
C5NN 7600 A	1863 869 014
C5NN-7580-A	1863 600 118
C5NN-7580-B	1863 600 118
C7NN 7550 AA	1864 600 340
C7NN 7550 AC	1864 600 315
C7NN 7550 AD	1864 600 315
C7NN 7550 H	1864 600 316
C7NN 7550 V	1864 600 340
C7NN 7563 B	3482 600 118
D0 NN 7563 A	1882 600 105
D1NN 7550 A	1878 600 524
D1NN 7550 C	1878 600 520
D2NN 7550 C	1878 600 520
D2NN 7563 B	3482 600 119
D8NN 7550 A	1864 600 340
D8NN 7550 CA	1864 600 340
D8NN 7563 AB	3482 600 119
D8NN 7563 DB	1882 600 106
D9NN 7550 AA	1864 600 304
D9NN 7550 AB	1878 600 520
ED.FONN-7580-AA	3182 001 307
E0NN 7563 CA	3482 600 118
E0NN 7563 CAB	3482 600 118
E3NN 7550 AA	1878 600 524
E3NN 7550 BA	1864 600 343
E3NN 7550 CA	1864 600 339
E3NN 7550 DA	1864 600 304
E5NN 7550 AA	1878 600 526
E5NN 7550 BB	1864 600 340
E7NN 7550 BA	1878 600 526
E7NN 7550 DA	1864 600 339
E9NN 7550 BA	1878 600 520
FONN-7580 AA	3182 001 307
F0NN N779 AA	1863 869 015
F1NN 7550 BA	1878 600 520
1042 972	1863 869 018
1072 135	1863 869 018
1805 417	1863 869 014
1815 763	3482 600 109
1815 765	1882 600 103
1816 102	1864 600 316
1820 826	1864 600 340
1820 827	1864 600 340
1822 440	1882 600 103
1826 106	1878 600 520
1862 926	1864 600 340
2000 E-7580-A	1863 600 118
2144 1794	3163 030 102
2490 5360	1863 838 000
3916 951	1864 600 340
3925 716	3482 600 118
3927 137	3482 600 119
3933 520	1863 600 118

Vergleichs-Nr. Compare No.	Artikelnummer Article No.
-------------------------------	------------------------------

**FORD NEW HOLLAND**

3935 271	1882 600 106
3937 180	1864 600 343
3937 183	1864 600 339
3937 184	1864 600 304
3971 654	1864 600 339
3992 560	1863 869 015
4044 7069	3482 008 110
4045 0248	1882 110 532
4107 05	1882 137 307
4401 6827	1863 855 000
4470 69	3482 008 110
4490 7615	1888 600 125
4561 55	1864 330 204
4712 3372	1882 600 101
4713 4898	1888 600 109
4713 4899	1888 600 107
4713 4901	1888 600 144
4713 4905	1888 600 144
5106 854	1864 600 353
5119 875	1863 838 001
5120 853	1863 837 002
5150 078	3482 600 114
5150 079	3482 600 114
5150 080	1878 600 553
5150 646	1888 600 140
5153 359	1866 600 012
5154 417	3482 600 113
5154 418	3482 600 113
5154 703	1864 600 353
5165 648	1878 600 553
5165 650	1878 600 552
5167 923	1888 600 113
5167 925	1864 600 327
5167 933	1888 600 106
5167 935	1888 600 149
5167 936	1878 600 518
5167 937	1864 600 302
5167 939	3482 600 104
5170 404	1888 869 004
5176 450	1864 600 303
5177 618	3482 600 113
5177 620	3482 600 114
5179 850	1888 600 149
5179 851	1878 600 518
518 1872	1866 600 020
5181 421	1888 600 144
5181 424	1888 600 144
5186 548	1882 600 101
5186 550	1882 600 101
5186 552	1888 600 107
5187 845	1866 600 011
5187 958	1866 600 013
5189 823	3482 600 104
5189 825	1878 600 518
5189 875	1888 600 149
5196 770	1882 600 101
5196 807	1888 600 144
5196 809	1888 600 109
5196 813	1888 600 144
5196 816	1888 600 107
5196 818	1888 600 109

Vergleichsliste / Cross reference list

Vergleichs-Nr. Compare No.	Artikelnummer Article No.
-------------------------------	------------------------------

**FORD NEW HOLLAND**

6088 497	1863 869 018
8043 9138	1882 230 209
8045 0248	1882 110 532
8182 4316	1864 600 341
8182 4316	1878 600 524
8182 5076	1864 600 343
8186 2926	1878 600 524
8186 4436	3182 001 307
8186 6447	1864 600 343
8200 1667	1878 600 520
8200 4604	1878 600 526
8200 5471	3182 001 307
8200 6015	1864 600 343
8200 6046	3482 600 119
8200 6626	1878 600 524
8200 8857	1866 600 010
8201 0859	1863 600 118
8201 1590	3482 600 105
8201 1591	1878 600 520
8201 1592	1878 600 519
8201 1593	1878 600 519
8201 1594	1864 600 304
8201 3944	3482 600 122
8201 3945	3482 600 109
8392 5716	3482 600 118
8393 5271	1882 600 106
8393 7180	1864 600 343
8394 8791	1878 600 524
8394 8819	1878 600 524
8397 1428	1864 600 341
8397 1428	1878 600 524
8663 4432	1878 600 519
8663 4443	3482 600 109
8663 4454	1882 600 106
8663 4458	3482 600 118
8734 5759	1863 838 001
8754 1562	1863 838 001
8773 2504	1888 600 144
8820 3038	3482 600 113
8820 3039	3482 600 114
8950 9944	1864 330 204
8951 2094	1864 494 001
9224 46	1864 300 007
9410 704	1864 355 102
9410 705	1882 137 307
9439 138	1882 230 209
9439 139	1864 330 204
9509 942	1864 355 102
9509 944	1864 330 204
9513 721	1864 300 007
974F 7600 AA	1863 869 018

**FORTSCHRITT**

02-114585	1866 142 001
-----------	--------------

**FRISCH**

131-0122	1863 100 030
131-0849	1881 039 532
131-1031	1863 100 030
131-1416	1861 600 033
412-5480	1863 100 030
415-6538	1863 101 100

Vergleichs-Nr. Compare No.	Artikelnummer Article No.
-------------------------------	------------------------------

**FUCHS**

00-038.008	1881 010 139
00-038.011	1863 100 030
5264637625	1866 122 006

**GOLDONI**

23666	1888 600 127
29694	1888 600 127
31457	1888 600 128
31457	1888 600 131
35290	1888 600 127
35386	1888 600 126
35388	1888 600 124
6200155	1863 837 002
6300068	1864 600 331
6300082	1864 600 329
6300091	1864 600 332

**GUELDNER**

101 232 01.10	1864 261 005
101 232 02.00	1882 155 009
102 232 02.00	1882 315 003
102 232 03.00	1859 600 002
104 232 02.20	1881 059 208
106 232 02.20	1881 089 002
107 232 03.00	1859 600 001
118 230 29.05	1881 050 428

**GUTBROD**

090.08.014	3151 994 801
090.08.014	3151 994 801
090.08.015	1881 069 101
090.08.021-0	1805 041 100
090.08.233	3151 994 801
090.08.233-0	3151 994 801
090.88.014-0	3151 994 801
097.04.690-B	3151 157 001

**HAKO**

90-00522-4	1805 041 100
90-00523-2	3151 994 801
90-00541-4	1864 209 231
90-04723-4	1882 155 009
90-08161-3	1882 155 009
90-17232-1	1881 065 101
90-27606-4	1864 209 231

**HARNISCHFEGER**

122 122	1882 325 139
122 222	1878 000 957
122 222	1882 325 139
122 222	3151 000 515
123 614	3151 000 515
2215 Z 20	1880 092 415
223 897	1880 092 415
272 113	1882 325 134
290 525	1863 100 030
296 544	1880 083 132

**HATZ**

400 038 00	1882 155 009
400 039 00	1882 155 009
400 039 00.98.4	1882 155 009
400 040 00	1882 315 002
400 040 00.098.2	1882 315 002

Vergleichs-Nr. Compare No.	Artikelnummer Article No.
-------------------------------	------------------------------

**HATZ**

400 040 00.98.2	1882 315 002
400 041 00	1882 314 001
400 041 00.098.2	1882 314 001
400 042 00	1881 089 002
400 043 00	1881 009 201
400 077 00	1881 009 203
400 092 00	1805 041 100
400 092 00.098.4	1805 041 100
400 093 00	1805 042 000
400 093 00.989	1805 042 000
400 150 00	3151 270 602
400 150 00.098.9	3159 140 004
400 150 00.989	3159 140 004
400 151 01	3151 021 001
400 151 01.098.3	3151 021 001
400 151 01.983	3151 021 001
400 153 00	3151 994 801
400 153 00.989	3151 994 801
400 170 01.193	1864 634 030
400 172 00	1864 634 046
400 172 01.989	1864 634 046
400 173 00	1864 006 147
400 173 01.016.3	1864 006 147
400 173 01.163	1864 006 147
400 174 01.027.3	1864 039 013
400 174 01.273	1864 039 013
400 176 00	1864 202 035
400 176 02.051.2	1864 202 035
400 176 60.251.2	1864 202 035
400 177 01.032.3	1864 634 027
400 177 01.323	1864 634 027
400 571 00	1881 010 101
400 571 01.512	1881 010 139
400 572 00	3151 199 001
400 604 00	1882 314 001
400 792 00	3082 025 531
400 792 00.989	3082 025 531
400 794 00	3151 001 001
400 794 00.989	3151 001 001
400 834 00.989	3130 014 000
400 896 00	1881 089 002
400 897 00	1864 634 026
400 959 00.011.8	1864 634 041
501 592 00	1881 059 208
501 592 00.989	1881 059 208
501 593 00.989	3151 045 001

**HOLDER**

A040A31	1864 218 035
A040A31	1864 218 035
A040A32	1882 196 005
A11040A07	3151 270 602
A11040A31	1864 634 009
A11040A32	1882 155 009
A20040A32	1882 315 002
A450408005	3151 021 001
A450408006	3151 021 001
A450408035	1882 196 005
B 16 040 80 06	3151 270 602
B12040A06	1859 600 002
B12040A31	1864 634 043

Vergleichsliste / Cross reference list

Vergleichs-Nr. Compare No.	Artikelnummer Article No.	Vergleichs-Nr. Compare No.	Artikelnummer Article No.	Vergleichs-Nr. Compare No.	Artikelnummer Article No.
<b>HOLDER</b>		<b>JCB</b>		<b>JOHN DEERE</b>	
B12040A32	1882 315 002	476/02500	3482 602 011	AL 39242	3182 001 104
B160408006	3151 270 602	476/02600	1878 600 830	AL 39245	3482 901 103
B160408031	1864 066 209	477/00160	3482 602 011	AL 39541	3151 091 101
B160408032	1882 315 002	477/00161	1878 600 830	AL 39592	3482 039 402
E500401031	1864 051 202	477/01415	1878 600 830	AL 39618	1882 284 306
E500401032	1881 069 101	477/01734	1878 600 830	AL 39624	1888 053 101
014380	1805 041 200	916/50200	1863 600 115	AL 40882	1888 053 101
014381	3130 010 100	<b>JOHN DEERE</b>		AL 41714	3482 070 301
106077	1864 066 209	AH 64100	1864 600 336	AL 55140	1888 053 101
106941	1882 315 002	AL 11665	1882 196 005	AL 55240	3482 901 103
109435	3151 083 001	AL 11726	1859 600 001	AL 56167	1882 284 306
111441	1864 006 147	AL 1200016	1864 600 348	AL 56308	1862 140 004
112008	3151 021 001	AL 120013	1861 924 103	AL 56308 E	1862 140 004
112017	1864 218 035	AL 120018	1861 686 033	AL 56540	3163 045 001
112017	1864 218 035	AL 120022	1888 053 101	AL 57415	1862 972 045
112018	1882 196 005	AL 120025	1882 600 121	AL 59324	3482 901 103
115066	3159 140 004	AL 120027	3482 070 301	AL 60308 A	3482 901 104
118606	3151 994 801	AL 120028	3182 001 105	AL 61754	1862 972 045
118606	3151 994 801	AL 120029	3182 001 104	AL 62237	1862 972 004
118690	3082 112 031	AL 120065	1864 600 336	AL 64338	1861 924 103
118691	1861 733 133	AL 120117	1888 600 123	AL 64340	1862 140 004
118692	3151 073 131	AL 120118	1864 600 351	AL 64759	1862 972 045
118692	3151 073 131	AL 16333	3151 157 001	AL 64948	3482 901 103
118800	3082 161 001	AL 17317	3151 021 001	AL 64948	3800 541 011
120379	1864 634 043	AL 17471	1882 248 104	AL 65354	1862 140 004
120843	1861 674 331	AL 17503	1864 634 039	AL 65877	1861 924 103
12208	3151 021 001	AL 19084	1882 284 306	AL 65891	3482 901 103
123033	1882 155 009	AL 23094	1864 600 348	AL 65892	3482 901 104
123033	1882 155 009	AL 23095	1882 271 403	AL 66088	3182 001 105
123037	1859 600 002	AL 23097	1864 313 231	AL 66180	1861 686 033
2A048132	1882 196 005	AL 23097	1864 634 007	AL 66181	1861 686 033
203382	1864 051 202	AL 23098	1882 600 121	AL 67046	3482 070 301
203383	1881 069 101	AL 23511	1864 239 033	AL 67173	3482 901 104
206746	1882 155 009	AL 23902	1866 011 202	AL 67184	3482 901 103
22088	1882 315 002	AL 26774	1864 313 231	AL 67525	1864 239 033
5040400031	1864 634 013	AL 26774	1864 634 007	AL 68022	1862 972 045
5049940065	1805 041 100	AL 27231	3151 080 101	AL 68023	1862 972 004
5070400006	3151 994 801	AL 28039	1882 600 121	AL 68484	3482 901 104
5070400032	1882 155 009	AL 28860	3151 091 101	AL 68485	3482 901 103
60010400000	3082 007 338	AL 30151	1888 053 101	AL 68486	3482 901 104
60010400132	3159 140 004	AL 30451	1864 600 348	AL 69935	1878 987 201
60010400231	3082 007 338	AL 30452	1864 313 231	AL 70272	1878 995 301
60200400106	3151 083 001	AL 30452	1864 634 007	AL 70273	1862 972 004
<b>HURTH</b>		AL 30777	3151 080 101	AL 70432	1866 146 001
115082	3151 994 801	AL 31436	1861 686 033	AL 71210	3800 541 011
115082	3151 994 801	AL 32965	1882 284 306	AL 71222	3182 001 105
3306316001	1866 050 002	AL 33126	1862 140 005	ALY 27846	1864 313 231
3306316003	1866 052 001	AL 33127	1882 339 103	ALY 27846	1864 634 007
3307316001	1866 052 002	AL 33315	1861 686 033	ALY 35669 C	3151 091 101
94 724 601 03	1866 052 002	AL 34903	1861 686 033	ALY 38407 A	1861 913 002
94 744 601 02	1866 050 002	AL 36133	1862 972 045	AR 528 L	1881 010 139
94 744 601 03	1866 052 001	AL 36374	1882 284 306	AR 529 L	1864 202 035
<b>JCB</b>		AL 36525	1862 140 004	AT 24699	1851 146 001
02/350041	1864 600 338	AL 37192	1882 284 306	AT 25481	1864 245 101
331/14487	1878 600 830	AL 37703	1861 756 201	AT 25482	1888 053 101
331/15902	3182 008 041	AL 37707	1882 284 306	AT 26781	1882 600 121
331/19970	3182 008 041	AL 38197	3482 070 301	AT 27792	1888 053 101
331/19970	3182 008 041	AL 38557	3482 039 402	AT 27793	1888 053 101
447/02500	1878 600 830	AL 39123	1861 924 103	AT 27794	1888 053 101
456/00108	3182 008 041	AL 39168	1861 913 002	AZ 20825	1863 869 020
				AZ 25131	1864 600 336

Vergleichsliste / Cross reference list

Vergleichs-Nr. Compare No.	Artikelnummer Article No.
-------------------------------	------------------------------

**JOHN DEERE**

AZ 35258	1864 355 102
AZ 35261	3482 008 034
AZ 36461	3182 001 307
AZ 36712	3482 012 211
AZ 37630	3163 045 001
AZ 40096	1864 395 101
AZ 42031	1864 461 001
AZ 46129	1863 600 107
AZY 61355	3482 012 211
CH 18554	1863 600 107
CH 18562	1863 600 113
ER 026007	1863 600 113
ER 027659	1863 600 107
ER 199071	1864 600 351
FG 6200155	1863 837 002
FG 6300056	1863 855 000
JD 10107	1863 869 018
JD 10243	3163 026 100
JD 33004	1863 600 113
L 13321	1805 042 000
RE 211277	1888 600 136
RE 227648	1864 600 350
RE 72534	1888 600 136
RE 72536	1864 600 350
170 50 009	1862 876 002
37 50 067	1861 733 133
37 80 073	3082 112 031
6.0321/01	3151 994 801
6.0321/17	1859 600 002
6.3140/21	1882 155 009

**KÄSSBOHRER**

003 250 88 04	3482 124 522
003 250 98 04	3482 008 038
005 250 19 04	3482 124 522
017 250 87 03	1878 080 034
8.383.000.133.0	3130 010 100
8.383.022.000	1882 110 532
8.383.067.000	1881 041 656
8.383.067.000	1881 041 656
8.383.121.000	1881 039 531
8.383.130.000	1862 088 131
8.383.130.000	1862 088 131
8.383.131.000	3151 021 001
8.383.154.000	3151 157 001
8.383.155.000	1882 252 331
8.383.156.000	1861 303 248
8.383.189.000	3151 000 515
8.383.211.000	3482 012 211
8.383.211.000	3482 012 211
8.383.211.000 C	3482 012 211
8.383.225.000	1878 000 968
8.383.225.000 D	1878 000 968
8.383.262.000	1878 000 968
8.383.275.000	1861 303 248
8.383.275.000.0	1861 303 248
8.383.336.000	1878 080 034
8.383.336.000	1878 080 034
8.383.336.000 C	1878 080 034
8.383.336.000 C	1878 080 034
8.383.350.000	1878 080 034

Vergleichs-Nr. Compare No.	Artikelnummer Article No.
-------------------------------	------------------------------

**KÄSSBOHRER**

8.383.350.000	1878 080 034
---------------	--------------

**KRAMER**

0 22 212 00 60	1859 600 001
0 22 212 01 60	1859 600 006
0 33 212 01 35	1863 100 030
0 45 212 00 35	1863 010 100
00 994 27 15	1863 101 100
0153 000 211 H	1859 600 004
0155 000 211 H	1859 600 004
0160 500 211	1864 634 039
0160 500 211 H	1864 634 039
0196 000 211 H	1882 196 005
022 212 00 80	1805 042 000
045 212 05 03	1880 083 132
22 212 01 60	1859 600 006
33 212 00 35	1863 010 100
33 212 01 35	1863 100 030
45 212 00 35	1863 010 100

**KRIEGER FAHRZEUGBAU**

201101	1888 024 114
203383	1881 069 101
206746	1882 155 009

**KUBOTA**

08101-16013	1863 600 117
08121-06002	1863 869 033
08121-06203	1863 869 014

**LANDINI**

1423 473 M93	1863 838 001
1424 135 M91	1864 917 002
1426 390 M94	1864 921 001
3105 233 M91	1864 959 001
3105 233 M92	1864 959 001
3105 367 M91	1864 914 005
3301 234 M91	1864 914 005
3303 137 M92	1888 873 001
3303 137 M93	1888 873 001
3303 137 M95	1888 873 001
3532 501 M91	1888 876 006
3532 501 M93	1888 876 006
3533 765 M91	1888 873 001
3538 591 M91	1888 600 145
3538 591 M92	1888 600 145
3540 443 M91	1878 600 571
3540 478 M91	1888 876 006
3540 865 M91	3482 600 110
3540 866 M92	1878 600 530
3541 803 M91	1878 600 531
3547 076 M91	1888 876 006
3559 802 M91	3482 600 117
3559 828 M91	3482 600 116
3657 986 M91	3482 600 116
3657 987 M91	1878 600 569
3667 112 M91	1878 600 569
3667 112 M91	3482 600 116
3676 788 M1	1864 917 002
4202 164 JA	1864 600 335
4202 164 M91	1864 600 335
4202 165 J9A	1888 600 130
4202 165 J9B	1888 600 130

Vergleichs-Nr. Compare No.	Artikelnummer Article No.
-------------------------------	------------------------------

**LANDINI**

975 522 M91	1880 083 132
-------------	--------------

**LIEBHERR**

1000-3465	1866 157 101
1001-6633	1866 000 007
1002-2829	1866 000 021
1011-6024	1866 000 151
1013-6818	1866 000 007
1022-1026	1866 000 152
1022-8100	1866 000 079
5001-041	1863 100 030
5006-801	1866 136 001
5007-636	1866 138 101
5009-663	1866 156 001
5030-103	1881 010 139
5030-103	3151 045 001
5030-106	1881 010 139
5030-108	3151 157 001
5030-114	1881 010 139
5030-166	3151 000 515
5031-005	1864 202 035
5031-040	1863 100 030
5031-100	1880 083 132
5031-118	1881 010 139
5031-18308	3482 083 118
5031-18408	3151 000 034
5031-301	1881 010 139
5031-317	1878 000 104
5031-325	3151 157 001
5031-32508	3151 157 001
5031-328	1881 010 139
5031-32808	1881 010 139
5031-329	3151 045 001
5031-32908	3151 045 001
5031-338	1881 010 139
5031-403	1881 010 139
5602-880	1866 065 001
5603-280	1866 068 001
5603-810	1866 090 001
5607-974	1866 133 001
5608-138	1866 135 001
5608-851	1866 148 001
5611-081	1866 148 001

**MAN**

81.30000.6587	3151 000 034
81.30000.6600	3151 000 034
81.30000.6602	1878 080 034
81.30301.0031	1861 034 147
81.30301.0038	1861 206 211
81.30301.0046	1861 034 147
81.30301.0060	1861 206 211
81.30301.0088	1878 000 104
81.30301.0155	1878 000 104
81.30301.0187	1861 206 211
81.30301.0213	1878 002 706
81.30301.0235	1878 000 968
81.30301.0283	1878 000 957
81.30301.0284	1878 000 957
81.30301.0285	1878 000 957
81.30301.0291	1878 002 706
81.30301.0304	1861 034 147



Vergleichsliste / Cross reference list

Vergleichs-Nr. Compare No.	Artikelnummer Article No.
<b>MAN</b>	
81.30301.0314	1878 000 968
81.30301.0340	1861 600 033
81.30301.0343	1878 002 706
81.30301.0355	1878 080 034
81.30301.0364	1878 080 034
81.30301.0376	1878 080 034
81.30301.0381	1878 080 034
81.30301.0382	1878 080 034
81.30301.0385	1878 080 034
81.30301.0386	1878 080 034
81.30301.0388	1878 080 034
81.30301.0440	1878 080 034
81.30301.0459	1878 080 034
81.30301.0500	1878 080 034
81.30301.0509	1878 080 034
81.30301.0582	1878 080 034
81.30301.0583	1878 080 034
81.30301.9031	1861 034 147
81.30301.9038	1861 206 211
81.30301.9046	1861 034 147
81.30301.9060	1861 206 211
81.30301.9088	1878 000 104
81.30301.9155	1878 000 104
81.30301.9187	1861 206 211
81.30301.9213	1878 002 706
81.30301.9235	1878 000 968
81.30301.9284	1878 000 957
81.30301.9291	1878 002 706
81.30301.9304	1861 034 147
81.30301.9340	1861 600 033
81.30301.9343	1878 002 706
81.30301.9381	1878 080 034
81.30301.9386	1878 080 034
81.30302.0002	1859 212 000
81.30302.9002	1859 212 000
81.30305.0007	1880 083 132
81.30305.0022	1880 092 415
81.30305.0029	1882 261 013
81.30305.0060	1881 039 531
81.30305.0064	1880 092 415
81.30305.0080	1881 041 656
81.30305.0108	1882 280 213
81.30305.0111	3482 124 522
81.30305.0112	3482 008 110
81.30305.6007	1880 083 132
81.30305.6018	1880 092 416
81.30305.9007	1880 083 132
81.30305.9064	1880 092 415
81.30305.9112	3482 008 110
81.30401.7009	1882 110 532
81.30401.7013	1881 039 532
81.30550.0026	3151 157 001
81.30550.0035	3151 000 515
81.30550.0036	3151 111 032
81.30550.0040	1863 009 100
81.30550.0041	3151 157 001
81.30550.0044	3151 199 001
81.30550.0049	3151 000 515
81.30550.0050	3151 000 395
81.30550.0060	3151 199 001
81.30550.0063	3151 000 034

Vergleichs-Nr. Compare No.	Artikelnummer Article No.
<b>MAN</b>	
81.30550.0067	3151 000 034
81.30550.0069	3151 000 395
81.30550.0071	3151 000 034
81.30550.0072	3151 157 001
81.30550.0073	3151 000 034
81.30550.0077	3151 000 034
81.30550.0078	3151 000 395
81.30550.0087	3151 000 034
81.30550.0088	3151 000 034
81.30550.0094	3151 000 034
81.30550.0103	3151 000 034
81.30550.0106	3151 000 034
81.30550.0107	3151 000 034
81.30550.0109	3151 000 034
81.30550.0110	3151 000 034
81.30550.0112	3151 000 515
81.30550.0116	3151 000 034
81.30550.0261	3151 000 515
81.30550.0262	3151 000 395
81.30550.6013	1863 009 100
81.30550.6019	3151 157 001
81.30550.7000	1863 100 030
81.30550.7004	1863 101 100
81.97640.0015	1805 042 000
88.30302.0005	1859 212 000
88.30304.0003	1882 325 134
88.30305.0001	1881 039 531
88.30305.0002	1881 041 656
88.30305.0003	1882 325 134
88.30305.9002	1881 041 656
88.30305.9003	1882 325 134
88.30305.9018	1880 092 415
88.30305.9064	1880 092 415
90.39260.01	1861 600 033
90.39260.9.01	1861 600 033
90.39370.01	1861 600 033
90.39370.9.01	1861 600 033
90.43802.10	1880 092 415
90.44562.01	1882 325 134
90.90392.6001	1861 600 033
90.90392.9001	1861 600 033
90.90393.7001	1861 600 033
90.90393.9001	1861 600 033
90.90438.0210	1880 092 415
90.90440.2201	1881 039 531
90.90440.4213	1881 041 656
90.90445.6201	1882 325 134
<b>MARSHALL</b>	
CTJ8260	1864 600 338
NT 6780	1863 600 106
3541 803 M91	1862 844 001
3541 803 M91	1878 600 570
37H 2447	1888 600 132
<b>MASSEY FERGUSON</b>	
1136 553	1863 869 020
1423 467 M92	1888 880 001
1423 467 M93	1888 880 001
1423 467 M94	1888 880 001
1423 468 M92	1888 892 001
1423 468 M93	1888 892 001

Vergleichs-Nr. Compare No.	Artikelnummer Article No.
<b>MASSEY FERGUSON</b>	
1423 473 M93	1863 838 001
1424 135 M91	1864 917 002
1424 135 T	1864 917 002
1425 135 M91	1864 917 002
1426 390 M92	1864 921 001
1426 390 M93	1864 921 001
1426 390 T	1864 921 001
1442 381 X 1	1863 600 117
1603 572 M1	1880 071 011
1620 433 M1	1881 089 007
1621 755 M1	1864 307 101
1671 691 M91	1864 974 001
1671 692 M91	1882 818 001
1671 692 M92	1882 818 001
1688 187 M91	1864 973 001
1688 187 M91	1864 974 001
1688 207 M91	1878 600 535
1688 208 M91	1882 819 001
1700 849 M 1	1882 313 001
1719 877 M91	1880 083 132
1722 158 M1	1864 634 033
1722 159 M1	1880 071 011
1851 651 M93	1888 898 003
1853 003 M95	1882 600 110
1866 042 M93	1864 937 001
1867 436 M91	1882 998 902
1867 436 M92	1882 998 902
1867 438 M91	1888 998 801
1867 438 M92	1888 998 801
1867 440 M91	1888 998 801
1867 440 M92	1888 998 801
1868 005 M 91	1888 891 004
1868 005 T	1888 891 004
1868 225 M1	1863 600 118
195 174 M1	1863 869 014
195 508 M1	1863 600 118
3001 642 X1	1863 837 002
3104 363 M91	1882 313 001
3105 233 M91	1864 959 001
3105 233 M92	1864 959 001
3106 161 M1	1864 634 033
3106 383 M1	1864 078 010
3106 391 M1	1888 037 101
3106 391 T	1888 037 101
3301 234 M91	1864 914 005
3303 000 T	1888 892 001
3303 001 M94	1888 880 001
3303 001 T	1888 880 001
3303 137 M92	1888 873 001
3303 137 T	1888 873 001
3304 583 M91	1888 880 001
3304 583 M93	1888 892 001
3311 352 M92	1864 959 001
3311 943 M91	1864 959 001
3381 122 M2	3482 926 001
3382 762 M1	3482 998 101
3388 927 M1	1864 947 002
339 599 X1	1863 869 020
3405 678 M91	1864 937 001
3499 492 R91	1882 819 001
3523 192 T	1888 876 006

Vergleichsliste / Cross reference list

Vergleichs-Nr. Compare No.	Artikelnummer Article No.
-------------------------------	------------------------------

**MASSEY FERGUSON**

3532 192 M92	1888 876 006
3532 192 M93	1888 876 006
3532 192 M94	1888 876 006
3532 192 492	1888 876 006
3532 193 M91	1888 876 006
3532 501 M91	1888 876 006
3532 501 M92	1888 876 006
3532 501 M93	1888 876 006
3533 765 M91	1888 873 001
3538 591 M91	1888 600 145
3540 479 M91	1888 892 001
3540 865 M91	3482 600 110
3540 866 M92	1878 600 530
3541 803 M91	1878 600 531
3547 076 M91	1888 876 006
3553 259 M91	1888 600 121
3580 944 M92	3400 126 401
3580 946 M2	3400 126 401
3595 554 M91	1878 600 534
3595 554 M91	1878 600 535
3596 265 M91	1882 817 003
3596 265 M92	1882 817 003
3599 461 M91	1878 600 534
3599 461 M91	1878 600 535
3599 461 M92	1878 600 534
3599 461 M92	1878 600 535
3599 462 M91	1864 937 001
3599 462 M92	1864 937 001
3599 492 M91	1882 819 001
3599 494 M91	1882 817 003
3599 494 M92	1882 817 003
3599 496 M92	1882 998 902
3599 496 M93	1882 998 902
3610 268 M 91	1888 891 004
3610 269 M91	1882 998 901
3610 281 M91	1864 974 001
3610 281 M92	1864 974 001
3611 842 M91	1864 937 001
3613 976 M91	1878 634 012
3615 366 M1	1864 996 001
3615 367 M1	1864 947 002
3618 886 M1	3482 998 201
362 040 M92	1864 946 001
362 0410 M91	1864 946 001
362 0410 M92	1864 946 001
3620 412 M91	1864 974 001
3620 413 M91	1882 818 001
3620 416 M91	1882 600 110
3620 416 R91	1882 600 110
3648 843 M91	1866 600 004
3652 970 M91	1866 600 003
3697 163 M91	1862 586 001
3700 527 M1	1863 600 120
3701 009 M91	1862 586 001
3701 011 M91	1878 634 012
3701 014 M91	1882 820 001
3701 015 M91	3482 931 001
3713 264 M91	3400 126 401
3713 266 M1	3400 126 401
3713 903 M91	3800 541 014
3762 356 M91	1878 600 528

Vergleichs-Nr. Compare No.	Artikelnummer Article No.
-------------------------------	------------------------------

**MASSEY FERGUSON**

3772 439 M91	1878 600 529
3772 439 M92	1878 600 529
379 364 H1	1866 600 019
379 648 H1	1866 600 019
3790 734 M2	1866 600 017
3790 734 M3	1866 600 017
3790 735 M2	1866 600 015
3792 346 M1	1866 600 014
3792 448 H2	1866 600 016
3792 448 M2	1866 600 016
3793 648 M1	1866 600 019
3815 739 M2	1866 600 025
3820 069 M1	1866 600 018
3918 835 M1	1864 996 001
415 279 M1	1880 071 008
415 280 M1	1864 634 033
417 401 M1	1864 634 026
417 404 M1	1864 634 026
417 540 M1	1864 634 040
417 541 M 1	1882 313 001
828 123 M1	1863 869 014
828 123 M2	1863 869 014
832 953 M94	1863 869 014
832 960 M2	1863 869 014
832 960 M3	1863 869 014
833 084 M1	1863 600 118
886 384 M93	1888 898 003
886 384 T	1888 898 003
886 386	1888 898 003
886 386 M91	1888 898 003
886 388 M91	1888 898 001
886 388 M93	1888 898 001
886 390 M91	1888 898 001
887 878 T	1888 891 002
887 879 M91	1888 891 002
887 879 T	1888 891 002
887 881 M91	1888 891 002
887 889 M91	1864 937 001
887 889 M92	1864 937 001
887 889 M93	1864 937 001
887 889 M94	1864 937 001
890 302 M91	1864 946 001
891 983 T	1888 898 001
892 862 M1	1863 600 118
975 522 M91	1880 083 132

**MENGELE**

02-114585	1866 142 001
02-116646	1866 142 001
98-039641	1866 068 002
98-041436	1866 068 001

**MERCEDES-BENZ**

000 250 01 15	3151 021 001
000 250 04 03	1861 123 236
000 250 05 04	1881 089 009
000 250 09 03	1862 088 131
000 250 11 03	1862 088 131
000 250 12 03	1862 088 131
000 250 14 03	1860 062 037
000 250 15 03	1862 088 131
000 250 21 03	1861 123 236

Vergleichs-Nr. Compare No.	Artikelnummer Article No.
-------------------------------	------------------------------

**MERCEDES-BENZ**

000 250 22 03	1861 123 236
000 250 31 04	1882 110 532
000 250 32 15	3151 021 001
000 250 35 04	1882 230 238
000 250 38 04	1882 229 131
000 250 39 03	1861 123 236
000 250 40 03	1861 123 236
000 250 41 03	1861 123 236
000 250 41 04	1881 041 656
000 250 44 15	3151 051 031
000 250 45 03	1861 123 236
000 250 50 04	1882 230 238
000 250 61 03	1861 611 131
000 250 62 03	1861 775 035
000 250 64 04	1882 229 131
000 250 65 04	1881 039 532
000 250 67 03	1861 775 035
000 250 69 15	3151 069 032
000 250 78 04	1882 229 131
000 250 79 04	1882 229 131
000 250 81 04	1882 231 131
000 250 84 03	1861 518 031
000 250 86 01	1880 071 008
000 250 92 03	1878 000 104
000 250 94 15	3151 210 031
000 254 01 94	1805 042 000
000 254 03 94	3130 010 100
000 625 40 62 04	1863 869 020
000 981 43 20	1863 869 020
000 981 45 20	1863 869 020
000 981 66 27	1863 837 002
000 981 67 25	1863 840 001
000 981 67 27	1863 837 002
000 981 70 25	1863 837 003
000 981 75 25	1863 840 001
000 981 96 27	1863 837 002
000 981 97 27	1863 855 000
001 250 01 15	3151 248 031
001 250 02 15	3151 248 031
001 250 03 04	1882 252 331
001 250 13 01	1862 718 002
001 250 25 15	3151 248 031
001 250 41 04	3082 121 031
001 250 42 04	3082 121 031
001 250 42 04	3082 121 031
001 250 43 15	3182 003 131
001 250 44 15	3182 002 131
001 250 48 03	1861 518 031
001 250 49 03	1861 518 031
001 250 55 03	1878 000 104
001 250 58 03	1878 000 104
001 250 59 03	1861 303 248
001 250 60 03	1861 303 248
001 250 67 03	1878 000 104
001 250 69 03	1861 840 133
001 250 72 15	3151 248 031
001 250 76 03	1861 518 031
001 250 78 04	1882 282 331
001 250 83 03	1878 000 104
001 250 86 03	1861 611 131
001 250 87 04	1882 231 131

Vergleichsliste / Cross reference list

Vergleichs-Nr. Compare No.	Artikelnummer Article No.
-------------------------------	------------------------------

**MERCEDES-BENZ**

001 250 99 15	3151 000 396
001 981 32 27	1863 855 000
001 981 33 27	1863 837 002
002 250 00 15	3151 000 396
002 250 03 04	3482 124 522
002 250 04 03	1861 303 248
002 250 04 04	3482 124 522
002 250 05 03	1878 000 104
002 250 05 15	3151 248 031
002 250 11 15	3182 002 132
002 250 16 04	1882 282 331
002 250 24 15	3182 600 101
002 250 25 03	1861 384 334
002 250 25 15	3182 600 101
002 250 28 15	3182 600 101
002 250 30 15	3182 600 101
002 250 30 15	3182 600 101
002 250 34 03	1861 303 248
002 250 39 03	1861 303 248
002 250 43 03	1861 840 133
002 250 46 04	3082 121 031
002 250 47 04	3082 121 031
002 250 48 15	3182 003 131
002 250 52 15	3182 600 101
002 250 62 15	3182 600 101
002 250 65 15	3151 000 396
002 250 70 04	3482 008 038
002 250 71 04	3482 008 038
002 250 72 04	3082 121 031
002 250 72 15	3182 600 101
002 250 73 04	3082 121 031
002 250 76 15	3182 600 101
002 250 81 01	1888 893 001
002 250 81 04	3482 124 522
002 250 83 01	1888 877 101
002 250 87 04	3482 012 211
002 250 88 03	1861 303 248
002 250 89 01	1888 893 001
002 250 94 04	1882 252 331
002 250 99 03	1878 002 706
002 981 12 25	1863 858 001
002 981 13 25	1863 838 002
003 250 00 03	1878 002 706
003 250 06 04	3482 008 032
003 250 11 03	1862 718 002
003 250 13 03	1862 718 002
003 250 13 04	1882 230 238
003 250 14 04	1881 041 656
003 250 22 03	1861 611 131
003 250 24 01	1888 877 101
003 250 26 03	1861 966 141
003 250 37 04	3082 121 031
003 250 38 03	1862 088 131
003 250 39 03	1861 840 133
003 250 41 03	1861 518 031
003 250 42 03	1861 384 334
003 250 48 04	3482 002 234
003 250 50 03	1862 718 002
003 250 51 03	1878 000 104
003 250 53 03	1861 966 141
003 250 54 04	3482 012 211

Vergleichs-Nr. Compare No.	Artikelnummer Article No.
-------------------------------	------------------------------

**MERCEDES-BENZ**

003 250 59 04	3482 012 237
003 250 65 04	3482 008 038
003 250 66 04	3082 121 031
003 250 79 03	1878 002 706
003 250 79 04	3082 121 031
003 250 80 04	3082 121 031
003 250 82 03	1861 303 248
003 250 83 03	1861 303 248
003 250 84 04	3482 002 234
003 250 86 03	1861 303 248
003 250 88 04	3482 124 522
003 250 88 04	3482 124 522
003 250 91 04	3082 121 031
003 250 96 04	3482 046 031
003 250 98 01	1888 067 042
003 250 98 04	3482 008 038
004 250 00 04	3482 124 522
004 250 07 04	3482 012 237
004 250 11 04	3482 008 038
004 250 20 04	3082 157 031
004 250 23 03	1861 611 131
004 250 26 03	1861 594 034
004 250 27 03	1861 594 034
004 250 28 03	1861 603 034
004 250 29 03	1861 603 034
004 250 30 03	1861 594 034
004 250 42 03	1861 384 334
004 250 47 03	1861 611 131
004 250 49 03	1861 303 248
004 250 63 05	1863 600 123
004 250 69 03	1861 966 141
004 250 71 03	1861 594 034
004 250 80 01	1888 067 042
004 250 81 01	1888 067 042
004 250 86 03	1861 384 334
004 250 97 01	1888 893 001
004 250 98 03	1861 667 034
005 250 01 03	1878 002 706
005 250 02 03	1878 002 706
005 250 03 01	1888 067 031
005 250 06 03	1861 303 248
005 250 06 04	3482 002 239
005 250 07 03	1861 303 248
005 250 08 04	3482 012 237
005 250 17 01	1888 890 001
005 250 17 03	1861 775 035
005 250 19 04	3482 124 522
005 250 33 01	1888 877 102
005 250 46 04	3482 106 031
005 250 47 04	3482 106 133
005 250 49 01	1888 877 102
005 250 54 03	1861 741 042
005 250 59 03	1861 775 035
005 250 70 03	1861 840 133
005 250 71 03	1862 812 006
005 250 80 03	1861 775 035
005 250 86 01	1888 067 031
005 250 89 03	1861 840 133
005 250 90 03	1862 814 003
006 250 07 04	3082 269 031
006 250 10 04	3482 008 038

Vergleichs-Nr. Compare No.	Artikelnummer Article No.
-------------------------------	------------------------------

**MERCEDES-BENZ**

006 250 14 03	1861 667 034
006 250 17 03	1878 002 706
006 250 19 03	1862 962 002
006 250 25 04	3082 269 031
006 250 26 04	3082 269 031
006 250 27 04	3082 269 031
006 250 28 04	3482 106 133
006 250 30 04	3482 000 462
006 250 34 04	3482 000 463
006 250 50 03	1861 775 035
006 250 62 03	1861 956 133
006 250 67 04	3482 000 462
006 250 78 03	1861 384 334
007 250 15 04	3482 000 463
007 250 38 03	1878 000 104
007 250 42 03	1878 002 706
007 250 43 03	1878 002 706
007 250 67 03	1878 002 706
007 250 68 03	1878 002 706
007 250 69 03	1878 002 706
007 250 88 01	1888 877 102
007 250 89 01	1888 890 001
007 250 90 01	1888 067 031
007 250 92 01	1888 893 001
008 250 42 03	1861 713 133
008 250 43 03	1861 384 334
008 250 70 03	1862 812 006
008 250 72 03	1861 303 248
008 250 80 03	1878 000 968
008 250 84 01	1888 877 102
009 250 12 03	1861 303 248
009 250 13 03	1861 303 248
009 250 14 03	1861 741 042
009 250 23 03	1861 775 035
009 250 24 03	1861 775 035
009 250 52 03	1861 956 133
009 250 53 03	1861 956 133
009 250 55 03	1861 384 334
009 250 56 03	1861 384 334
009 250 57 03	1861 667 034
009 250 58 03	1861 840 133
009 250 59 03	1861 840 133
009 250 60 03	1861 603 034
009 250 61 03	1861 603 034
009 250 62 03	1861 713 133
009 250 63 03	1861 713 133
009 250 64 03	1861 713 133
009 250 65 03	1861 713 133
009 250 66 03	1862 814 003
009 250 67 03	1861 594 034
009 250 68 03	1862 812 006
009 250 73 01	1888 998 902
009 250 80 03	1861 713 133
009 250 81 03	1862 718 002
009 250 82 03	1861 966 141
009 250 84 03	1862 812 006
009 250 85 03	1862 962 002
009 250 92 03	1861 775 035
009 250 93 03	1860 062 037
009 250 95 01	1888 877 101
009 250 96 01	1888 067 042

Vergleichsliste / Cross reference list

Vergleichs-Nr. Compare No.	Artikelnummer Article No.
-------------------------------	------------------------------

**MERCEDES-BENZ**

009 250 97 01	1888 067 031
010 250 12 03	1861 123 236
010 250 18 03	1878 002 706
010 250 27 03	1861 775 035
010 250 29 03	1861 775 035
010 250 35 03	1861 775 035
010 250 49 03	1861 775 035
010 250 82 03	1862 814 003
010 250 83 03	1861 741 042
010 250 84 03	1862 962 002
010 250 86 03	1861 303 248
011 250 27 03	1862 286 031
011 250 70 03	1862 088 131
011 250 71 03	1861 611 131
011 250 72 03	1861 594 034
012 250 15 01	1888 600 101
012 250 16 01	1888 877 103
012 250 36 03	1861 384 334
013 250 36 01	1888 998 901
013 250 82 03	1861 303 248
013 250 92 03	1861 303 248
014 250 79 01	1888 998 902
014 250 80 01	1888 916 001
015 250 19 03	1878 600 501
015 250 25 03	1862 286 031
015 250 26 03	1878 992 401
015 250 57 01	1888 998 201
016 250 35 03	1878 080 034
016 250 36 03	1878 080 034
016 250 37 03	1878 080 034
016 250 46 03	1878 080 034
017 250 05 03	1878 052 842
017 250 06 03	1878 052 842
017 250 87 03	1878 080 034
018 250 19 01	3800 710 002
018 250 20 01	3800 710 003
018 250 20 03	1878 080 034
018 250 35 03	1878 000 205
018 250 45 01	1862 962 002
018 250 92 03	1878 052 842
018 250 94 01	3400 127 701
018 250 94 03	1878 080 034
019 250 42 03	1878 052 842
019 250 59 01	3000 951 785
019 250 64 01	1878 600 560
019 250 64 01	3482 000 462
019 250 66 03	1878 080 034
019 250 91 03	1878 052 842
020 250 31 03	1878 600 560
020 250 58 03	1878 080 034
021 250 34 01	3400 127 701
021 250 35 01	3400 127 701
021 250 60 03	1878 052 842
021 250 61 03	1878 052 842
022 250 81 01	1878 600 560
022 250 81 01	3482 000 462
022 250 97 03	1878 600 560
024 250 17 03	1878 052 842
024 250 21 03	1878 052 842
025 250 23 01	3400 127 701
025 250 25 01	3400 127 701

Vergleichs-Nr. Compare No.	Artikelnummer Article No.
-------------------------------	------------------------------

**MERCEDES-BENZ**

102 980 03 15	1863 869 010
102 981 01 25	1863 869 010
115 980 00 15	1863 869 010
115 980 01 15	1863 869 010
121 250 01 04	1881 059 208
121 250 02 04	1881 059 208
121 250 03 04	1881 059 208
136 250 00 04	1881 059 208
136 250 04 03	1861 123 236
136 250 05 03	1861 123 236
180 250 03 03	1861 123 236
180 250 03 04	1881 059 208
180 250 04 04	1881 059 208
180 250 06 04	1881 059 208
180 250 07 04	1881 059 208
187 250 05 03	1861 123 236
303 250 00 05	1861 034 147
304 250 01 04	1881 039 532
304 252 00 05	1861 034 147
317 250 02 04	1881 041 656
317 250 04 03	1878 000 104
319 250 03 03	1861 123 236
319 250 04 03	1861 123 236
319 250 06 03	1861 123 236
319 250 07 03	1861 123 236
319 250 09 03	1861 123 236
319 250 10 03	1861 123 236
319 250 13 03	1861 123 236
330 250 00 04	1881 039 532
344 250 72 03	1878 000 104
345 250 74 03	1861 303 248
345 250 75 03	1861 303 248
366 200 13 22	2300 146 031
443 250 00 15	1863 837 002
443 250 00 15	1863 855 000
608 250 00 15	3151 270 602
621 250 00 03	1861 775 035
685 250 04 03	1878 001 939
906 200 05 22	2300 147 031
906 200 08 22	2300 147 031
906 200 09 22	2300 146 031
906 200 10 23	2300 147 031
906 200 12 22	2100 502 010
906 200 18 22	2300 147 031
906 200 20 22	2100 502 010
906 981 14 25	1863 869 044

**MIAG**

FZ.2-2147	1880 071 008
-----------	--------------

**MWM**

6.0310.62.2.0001	1882 313 001
6.0310.62.2.0002	1881 059 208
6.0310.63.2.2201	1880 071 008
6.0310.63.2.3101	1880 092 415

**NEW HOLLAND**

D5NN 7563BA	3482 600 124
E5NN 7550 CA	1878 600 578
2490 5350	1863 600 107
28 042 740	1863 869 020
28 043 280	1863 869 019

Vergleichs-Nr. Compare No.	Artikelnummer Article No.
-------------------------------	------------------------------

**NEW HOLLAND**

4712 7081	1863 858 002
4713 4873	1882 600 101
4713 4884	1882 600 101
4999 811	1888 600 141
5003 11249	1863 869 019
5149 611	3151 600 561
5154 535	1888 600 141
5154 835	1888 600 141
5182 556	1888 600 109
8029 941	1863 869 019
8072 7874	1863 869 019
8391 4224	1878 600 578
8395 5477	1878 600 578
8663 4434	1864 600 304
8663 4447	3482 600 105
8663 7524	1878 600 519
8773 2490	1882 600 101
8773 2503	1888 600 144
8773 2506	1888 600 144

**ORENSTEIN KOPPEL**

D 15 174	1805 041 200
0015 175	1805 042 000
0015 257	3151 994 801
0015 293	1882 155 009
0015 294	1882 315 002
0036 741	1881 089 002
015 174	1805 041 100
015 174-031	1805 041 100
015 174-031	1805 042 000
015 175	3130 014 000
015 254	3151 270 602
015 254	3159 140 004
015 255	3151 021 001
015 256	1859 600 001
015 257	3151 994 801
015 262	1860 039 024
015 267	1864 202 035
015 274	1864 039 013
015 275	1864 202 035
015 283	1880 071 008
015 284	1881 059 208
015 293	1882 155 009
015 294	1882 315 002
015 295-071	1881 010 101
024 484	1880 071 011
036 741	1881 089 002
053 0248	3130 010 200
089 0184	1863 100 030
089 0209	1881 039 532
089 0275	1882 325 134
089 0385	1881 041 656
089 0427	3163 026 100
089 0481	1863 100 030
244 484	1880 071 011
271 898	3082 121 031
410 0430	1880 092 415
412 5480	1863 100 030
415 6538	1863 101 100
591 480	3151 021 001
591 482	3130 014 000

Vergleichsliste / Cross reference list

Vergleichs-Nr. Compare No.	Artikelnummer Article No.	Vergleichs-Nr. Compare No.	Artikelnummer Article No.	Vergleichs-Nr. Compare No.	Artikelnummer Article No.
<b>ORENSTEIN KOPPEL</b>		<b>REFORM</b>		<b>RENAULT AGRICULTURE</b>	
840 7402	3151 157 001	210.180.102	1864 066 209	7700 050 636	1866 600 008
841 1968	1863 009 100	210.180.102.0	1864 066 209	7700 052 211	1864 600 334
<b>PAUS</b>		210.181.101	3151 270 602	7700 052 774	1866 600 007
1 848 491 087	1866 024 001	210.181.101	3159 140 004	7700 052 918	1888 600 104
<b>PORSCHE</b>		210.181.101.0	3151 270 602	7700 052 918	1888 600 142
000 2010 104	1864 202 035	211.180.101	1882 196 005	7700 052 919	1864 600 326
000 2010 133	1864 202 035	211.180.101.0	1882 196 005	7700 052 921	1888 997 901
000 2032 001	1859 600 004	211.180.102	1864 153 133	7700 053 637	1866 600 009
000 2032 002	1859 600 001	211.180.104	1860 039 024	7700 058 654	1888 600 142
000 2032 002	3151 021 001	211.180.105	3082 058 031	7700 062 283	1864 600 334
000 2032 003	3151 093 041	211.180.106	1861 994 004	7700 062 284	1888 600 142
000 2032 109	1864 153 133	211.181.106	3151 021 001	7700 062 285	1888 600 142
019 141 165	3151 193 041	211.181.110	3151 193 041	7700 062 286	3482 600 115
035 141 117 E	3082 025 531	211.181.303	1805 042 000	7700 065 620	1866 600 026
059 141 117 A	3082 025 531	211.181.316	3130 010 200	7700 067 039	1866 600 007
113 141 165 B	3151 193 041	215.181.124	1864 202 006	7700 067 040	1866 600 024
616 16 013 1	1864 121 536	215.181.131	1888 069 001	7700 072 030	3482 600 115
616.116.012.00	3082 170 103	215.181.134	1878 076 401	7700 515 750	1863 855 000
616.116.012.01	3082 170 103	221.180.101	1864 634 039	7700 515 751	1863 837 002
616.116.013.01	1864 121 536	225.181.100	1881 065 101	7700 516 127	1888 860 003
616.116.124.00	1882 228 002	225.181.101	1861 994 003	7700 528 384	1862 844 004
616.116.141.00	1864 121 536	225.181.109	3151 270 602	7700 573 504	1862 844 004
<b>POTRATZ</b>		226.181.103	1878 005 623	7700 573 505	1888 860 003
C 3.026.05.1	3151 021 001	226.181.104	3082 147 033	7700 573 506	1888 868 009
C 3.026.06.2	3130 010 100	<b>RENAULT AGRICULTURE</b>		7700 620 323	1863 869 014
F 14.182.00	1882 314 001	0854 673 000	3151 994 801	7700 653 343	1863 855 000
1.026.04	1882 315 002	5000 271 136	1880 092 415	7700 653 344	1863 837 002
1.026.05	3151 270 602	5000 791 029	1864 330 204	7700 666 659	1888 868 009
3.026.04	1882 196 005	6000 100 506	1863 838 001	7700 666 660	1862 713 001
3.026.05	3151 021 001	6000 102 851	1864 996 101	7700 666 661	1850 281 964
3.026.06	1805 042 000	6000 103 468	1888 998 501	7700 671 152	1888 860 003
<b>PUTZMEISTER</b>		6000 105 184	1888 600 138	7700 673 152	1888 860 003
002063003	1860 023 012	6000 127 659	1863 600 107	7700 673 249	1862 715 001
01052002	1864 634 046	6005 005 225	1862 812 003	7700 677 103	1862 844 004
063106006	3082 170 103	7700 002 662	1888 868 010	7700 677 104	1888 868 008
063284009	3082 199 102	7700 005 571	1888 860 003	7700 704 257	1864 950 003
63106006	3082 170 103	7700 014 551	1888 869 007	7700 704 260	1864 918 005
63284009	3082 199 102	7700 014 722	1888 868 010	7701 006 067	1863 101 100
<b>RAPID</b>		7700 017 815	1888 868 011	7701 009 950	1880 092 415
205.160-4	1881 010 139	7700 017 816	1862 812 003	7701 012 193	1863 101 100
205.161-4	3151 199 001	7700 019 282	1866 600 005	<b>SAME</b>	
218.308	3151 193 041	7700 022 623	1864 950 003	0.008.5596.3	1878 600 533
44.218	1864 339 131	7700 022 624	1864 918 005	0.008.5596.3/10	1878 600 533
55.948	3151 994 801	7700 022 625	1888 868 011	0.009.4556.1	1863 869 018
55.948	3151 994 801	7700 022 628	1888 869 007	0.011.3942.4	1866 600 021
95.234-2	1882 196 005	7700 024 660	1861 613 101	008.4184.3	3482 998 101
96.470	1882 155 009	7700 024 661	1882 262 006	008.5596.3	1878 600 533
<b>REFORM</b>		7700 025 600	1888 868 011	008.9937.3	1878 600 522
MHK1201001	1882 155 009	7700 025 603	1888 868 010	009.9769.3	1878 634 004
MHK1201002	1864 634 046	7700 025 605	1888 869 007	009.9770.3	1878 600 523
MHK1201010	1805 041 100	7700 026 953	1888 895 002	0.255.2350.3	3482 600 120
MHK1201016	3151 994 801	7700 032 701	1888 997 801	119.063.3	1864 600 321
110.181.310	3151 994 801	7700 032 702	1864 994 901	119.067.3	1864 600 318
120.101.0	1805 041 100	7700 036 301	1888 997 901	119.073.3	1864 600 324
151.222.100	1864 006 147	7700 040 759	1864 600 301	122.564.4	1888 600 120
151.222.121	1882 155 009	7700 043 010	1888 600 104	122.567.4	1888 600 150
155.222.100	1864 006 147	7700 043 010	1888 600 142	122.571.4	1888 600 119
210.180.101	1882 315 003	7700 043 011	1888 600 102	122.574.4	1888 600 118
		7700 046 278	1888 600 142	194.2210.4	1888 911 001
		7700 046 743	1866 600 006	194.2213.3	1862 654 002

Vergleichsliste / Cross reference list

Vergleichs-Nr. Compare No.	Artikelnummer Article No.
-------------------------------	------------------------------

**SAME**

2.2021.017.0	1863 600 107
2.2021.018.0	1863 838 000
2.2041.008.0	1863 869 020
2.2999.003.0	1863 600 123
2.2999.153.0	1863 838 001
255.230.3	3482 600 120
270.2330.3/10	1878 600 577

**SAMPO ROSENLEW**

048 0425	3130 010 200
048 0425	3151 021 001
048 0426	3130 010 200
048 0558	1881 089 007
048 0559	1864 078 010
049 2787	1859 600 001
049 2787	1881 089 007
049 2791	1864 078 010
049 2791	1881 089 007

**SAURER**

950.2641.030	3482 124 522
953.2614.001	3151 000 515
953.2628.030	1878 002 706

**SCHANZLIN**

00.9918.01.3881	1888 024 114
-----------------	--------------

**SCHLÜTER**

001 1251	1888 883 041
001 1251	1888 883 041
3400.04.02.002	1890 800 001

**STEINBOCK**

014 524	1881 010 101
026203	1866 066 001
050 616	1880 092 416
126 307	1864 202 035
135 365	1863 100 030

**STEYR**

B512172	3800 541 001
B512293	3800 541 002
B512294	3800 541 003
120.91.60.721	1805 042 000
130.10.01.60002	1878 634 033
130.6A.16.0903	1861 775 035
132 0000 200 0021	1888 998 101
132 0000 200 0031	1878 986 801
132 0000 200 0041	1878 986 701
132 0000 200 02	1888 998 101
132 0000 200 03	1878 986 801
132 0000 200 41	1878 986 701
133.70.02.10065	1863 837 002
133.70.02.10066	1863 855 000
140.10.01.60002	1888 059 201
140.10.01.60004	1888 998 001
140.10.01.600041	1888 998 001
140.10.01.60005	1878 986 601
140.10.01.60012	1878 986 601
140.10.01.60014	1888 998 001
140.6A.16.0727	1864 026 232
141.10.01.600951	1888 050 101
141.10.01.60921	1864 366 102
161.00.01.60004	1882 230 238

Vergleichs-Nr. Compare No.	Artikelnummer Article No.
-------------------------------	------------------------------

**STEYR**

161.00.01.60903	1861 600 034
161.20.01.60004	1882 262 006
161.40.01.60018	1881 039 531
161.41.60.0181	1881 039 531
190 0033 100 75	1863 869 014
209.16.00.03	1881 089 002
209.16.00.05	3151 021 001
209.16.00.06	3151 021 001
209.16.00.07	3130 014 000
209.16.07.21	1805 042 000
209.16.07.24	1860 039 024
209.16.09.01	1881 089 002
209.16.09.02	1860 039 024
209.16.09.03	1860 039 024
301.00.16.0003	1862 421 001
306.A1.60.003	1861 775 035
306.A1.60.901	1881 089 006
311.00.16.0902	1888 043 101
337.00.21.0065	1863 837 002
337.00.21.0066	1863 855 000
354 311 A1	1888 998 001
356.03.17	1882 155 009
397.21.0118	3151 082 001
4S2614A	3151 157 001
4S2641	1881 039 531
401.00.16.0002	1888 059 201
401.00.16.0901	1888 059 202
406.A1.60.717	1864 026 232
406.A1.60.902	1864 026 232
407.00.16.0015	1864 026 232
407.16.00.15	1864 026 232
408.00.16.0001	1882 318 101
408.00.16.0002	1882 318 101
408.00.16.0003	1882 318 101
408.00.16.0007	1882 318 101
408.00.16.0753	1864 340 101
408.00.16.0754	1882 318 101
408.00.16.0903	1882 318 101
408.00.16.0906	1882 318 101
411.00.16.0004	1888 059 202
411.00.16.0007	1864 366 102
411.00.16.0024	1888 050 302
411.00.16.0028	1864 410 101
411.00.16.0029	1864 412 101
411.00.16.0030	1888 050 302
411.00.16.0039	1888 050 101
411.00.16.0040	1888 050 302
411.00.16.0085	1862 311 001
411.00.16.0091	1888 050 302
411.00.16.0094	1864 410 101
411.00.16.0095	1888 050 101
411.00.16.0104	1888 059 201
411.00.16.0105	1864 439 101
411.00.16.033	1888 059 201
411.00.16.0923	1888 050 302
411.00.16.0925	1888 050 101
497.00.16.0712	3400 126 401
497.00.16.0715	3400 126 401
497.00.16.0901	3400 126 401
5 G 2610 B	1882 325 134
508.11.60.010	1882 155 009

Vergleichs-Nr. Compare No.	Artikelnummer Article No.
-------------------------------	------------------------------

**STEYR**

525.42.60.14A00	3151 157 001
527.12.60.10000	3082 121 031
609.E1.60.001	1880 092 415
609.F1.60.001	1861 600 034
610.T1.60.004	1864 347 102
610.00.16.0004	1882 230 238
610.00.16.0005	1861 600 034
610.00.16.0006	1861 600 034
611.00.16.0001	1864 360 101
611.00.16.0008	1862 131 201
611.00.16.0013	1862 131 202
611.00.16.0014	1862 131 201
612.00.16.0004	1882 262 006
612.00.16.0008	1882 262 006
612.00.16.0009	1861 613 101
614.00.16.0018	1881 039 531
614.16.00.02	1881 039 531
614.16.00.18	1881 039 531
614.60.16.0001	1882 261 013
700.21.63.010	1882 155 009
700.31.63.030	3151 994 801
716.11.10.022	3082 161 001
792.00.16.0002	3151 156 003
792.00.16.0007	3151 156 003
815.00.16.0017	1878 002 706
815.60.16.0003	3482 124 522
815.60.16.0006	3482 124 522
853.03.05.0001	3482 124 522
853.03.05.9001	3482 124 522
8753 3027	1878 600 574
8753 3027	1878 634 037
875.33.02.6	1888 600 137
990.00.21.0029	3151 111 032
990.00.21.0032	3151 157 001
990.00.21.0050	3151 157 001
990.00.21.0706	3163 026 100
990.02.10.032	3151 157 001
991.14.16.0007	1878 000 968
991.14.16.0011	1888 015 515
991.14.16.0017	1878 002 706
991.14.16.0020	1878 002 706
991.14.16.0022	3151 186 001
991.14.16.0030	1878 002 706
991.14.16.0031	1888 015 515
991.14.16.0032	1878 000 968

**STILL**

014 706	1881 089 002
014 707	1862 088 131
014 709	3151 021 001
014 741	1881 089 002
032 269	1864 202 035
034 746	1805 042 000
039 979	1881 059 208
039 984	1881 010 139
503 514	1881 010 101
511 803	1864 202 035

**TRUCO**

J 32000106	1880 092 415
J 32000163	1882 325 134
J 32000227	1881 041 656

Vergleichsliste / Cross reference list

Vergleichs-Nr. Compare No.	Artikelnummer Article No.
-------------------------------	------------------------------

**TRUCO**

J 32000276	1880 083 132
J 32000292	1882 306 210
J 33020510	1866 024 001
J 33030143	1861 206 211
J 34000153	3151 000 515
J 34000200	1863 009 100
J 34000313	3151 199 001

**VALMET**

11992553	1864 600 352
300364	3482 008 038
30049200	1861 447 102
30049210	1861 447 102
30208100	1863 010 100
30208110	1863 010 100
303429	3482 012 211
30342900	3482 012 211
303430	1862 233 133
30343010	1862 233 133
307543	1888 054 004
30754320	1888 054 004
309607	1864 418 002
30960710	1864 418 002
31068800	3482 046 031
31597300	3182 001 105
318878	1864 352 301
31887800	1864 352 301
32043000	1864 600 323
32043110	1888 600 116
325927	1862 361 101
32592700	1862 361 101
327729	1862 361 101
32772900	1862 361 101
328313	1878 001 143
32831300	1878 001 143
328314	3482 002 234
32831400	3482 002 234
718010	1882 236 212
80882500	1864 600 346
889810	1882 236 212
889810V	1882 236 212

**VALTRA**

30208100	1863 010 100
30208110	1863 010 100
33494300	3163 045 001
33676410	1866 000 154
35303500	1866 000 154
582970	1863 600 111
582990	1863 600 110
725160	1863 600 112

**VME**

4461682	1881 059 208
---------	--------------

**VÖGELE**

45 1022 0010 0	1866 024 001
46 1022 2004 E	1864 202 035
46 1022 2007 E 01	3151 199 001
46 1022 2007 E 02	3151 199 001
46 1022 2009 E 01	3151 045 001
49 1018 0026	1881 010 139

Vergleichs-Nr. Compare No.	Artikelnummer Article No.
-------------------------------	------------------------------

**VOLVO**

1526023	1888 015 515
1655409	1888 015 515
1655410	1888 015 515
1655417	1859 212 000
1667929	1878 000 968
21581138	1866 000 239
267043	1859 212 000
267181	1882 280 213
267182	1859 212 000
267238	1888 015 515
267446	1878 000 968
355022	1882 325 134
364239	1882 280 213
3807988	1866 000 140
382853	1882 280 213
3886887	1866 000 239
446168	1881 059 208
4461682	1881 059 208
5001387	1882 280 213
5001389	1882 280 213
5001490	1882 325 134
685611	3151 199 001
6856112	3151 199 001
8112124	1878 000 968
8112136	1882 325 134
824991	1866 018 131
841893	1866 018 131
855389	1866 032 231
855617	1866 118 001

**ZETOR**

PE 971 105	1863 869 023
PE 971 115	1863 869 023
16.021.901	3482 600 107
16.021.902	1864 600 312
16.021.903	1864 600 311
16.021.905	3482 600 107
4901 1155	1864 600 306
4901 1155 C	1864 600 306
6701 1123	1864 600 309
7001 1186	1864 600 309
7001 1189	1864 600 309
7201 0011	1888 600 114
7201 1152	1864 600 309
7901 0011	1888 600 115
7901 1120	1864 600 307
7901 1140	1864 600 308
971 105	1863 869 023

**ZETTELMAYER**

K 1316	1881 009 201
V 2973	1882 155 009
V 2986	1864 006 147
0010134000	1859 600 001
001013401	3151 021 001
0010134018	3151 021 001
0021475903	3082 025 531
0050133004	1881 069 101
0050134400	3151 994 801
00501346	1805 041 100
00502576	1882 196 005
0050285009	1864 634 030

Vergleichs-Nr. Compare No.	Artikelnummer Article No.
-------------------------------	------------------------------

**ZETTELMAYER**

00502855	1805 042 000
0050298607	1864 006 147
00503791	1881 069 101

**ZF**

0501 002 847	3151 000 395
0501 005 910	3151 000 034
0501 006 339	3482 083 118
0501 006 350	3151 199 001
0501 007 693	3151 000 515
0501 008 367	3151 000 395
0501 205 429	3151 000 515
0501 212 986	1878 080 034
0501 216 559	3482 000 463
0501 218 752	3151 000 515
0501 300 130	1859 600 001
0501 300 131	1805 042 000
0501 300 478	1860 039 024
0501 300 844	1860 062 037
0501 303 688	3151 157 001
0501 315 711	3151 082 001
5840 302 184	1861 613 101

**Neuaufnahmen / New to range**

Artikelnummer Article No.	Seite Page	Hersteller Manufacturer
1859 600 001	1	AEBI
1859 600 001	4 5	BAUTZ
1859 600 001	27	CLAAS
1859 600 001	34 37 38 53 54 55 56	DEUTZ-FAHR
1859 600 001	58 59 60 61 62 63	EICHER
1859 600 001	67	EPPLE BUXBAUM
1859 600 001	69	FARNY & WEIDMANN
1859 600 001	69 70	FENDT
1859 600 001	100 101	GROSS
1859 600 001	101 102 103 104	GUELDNER
1859 600 001	104	GUTBROD
1859 600 001	105	HAAS
1859 600 001	109 110	HATZ
1859 600 001	112	HOLDER
1859 600 001	119	JOHN DEERE
1859 600 001	134	KÖDEL & BÖHM
1859 600 001	135 136	KRAMER
1859 600 001	145 146 147 148	LANZ+MARTI
1859 600 001	151 154	LINDNER
1859 600 001	191	MERCEDES-BENZ
1859 600 001	223	MIAG
1859 600 001	223 224	MOT.MÜNCHEN SENDLING
1859 600 001	230	NORDDEUTSCHE TRAKTORENFABRIK (NORDTRAK)
1859 600 001	230 231	NORMAG
1859 600 001	232	ORENSTEIN KOPPEL
1859 600 001	233	OSTNER
1859 600 001	235 236	PRIMUS
1859 600 001	263	RITSCHER
1859 600 001	269	SAMPO ROSENLEW
1859 600 001	271 273	SCHLÜTER
1859 600 001	277	SCHMOTZER
1859 600 001	277	SCHULTHEISS
1859 600 001	288	URSUS (D)
1859 600 001	297	WAHL
1859 600 001	298	WEHRHAHN
1859 600 001	301	ZETTELMEYER
1859 600 001	302	ZF
1859 600 002	1	AEBI
1859 600 002	4 5	BAUTZ
1859 600 002	27 28 29	CLAAS
1859 600 002	37 38 56	DEUTZ-FAHR
1859 600 002	58	EICHER
1859 600 002	103	GUELDNER
1859 600 002	105	HAAS
1859 600 002	112 113 114	HOLDER
1859 600 002	117	JOHN DEERE
1859 600 002	134	KÖDEL & BÖHM
1859 600 002	147	LANZ+MARTI
1859 600 002	150 152 153 154	LINDNER
1859 600 002	154	MAN
1859 600 002	224	MWM
1859 600 002	235	PRIMUS
1859 600 002	263	RITSCHER
1859 600 002	277	SCHMOTZER
1859 600 002	277	SCHULTHEISS

Artikelnummer Article No.	Seite Page	Hersteller Manufacturer
1859 600 003	7 14 15 16 17 18 19 20	CASE IH
1859 600 003	54	DEUTZ-FAHR
1859 600 003	104	GUSS & ARMATURENWERK
1859 600 003	104	GUTBROD
1859 600 003	109 111	HATZ
1859 600 003	119	JOHN DEERE
1859 600 003	146	LANZ+MARTI
1859 600 003	155	MANITOU
1859 600 003	263	RITSCHER
1859 600 004	135 136 137	KRAMER
1859 600 004	233 234	PORSCHE
1859 600 005	27 28 29 30 31 32	CLAAS
1859 600 005	105	HAAS
1859 600 005	135	KRAMER
1859 600 005	223	MIAG
1859 600 005	298	ZANDONA
1859 600 005	301	ZETTELMEYER
1859 600 006	37 56	DEUTZ-FAHR
1859 600 006	69 70 75	FENDT
1859 600 006	107 108	HANOMAG RHEINSTAHL
1859 600 006	135 136	KRAMER
1859 600 006	233 234	PORSCHE
1863 600 123	58 60 61	EICHER
1863 600 123	74 76	FENDT
1863 600 123	109	HARNISCHFEGER
1863 600 123	154 155	MAN
1863 600 123	233 234	PORSCHE
1863 600 123	271 272 273	SCHLÜTER
1863 869 044	195 196 197 198 199 222 223	MERCEDES-BENZ
1864 634 007	127 129 130	JOHN DEERE
1864 634 013	101	GRUNDNER
1864 634 013	112 113 114	HOLDER
1864 634 016	27 28 29 30 33	CLAAS
1864 634 016	148	LANZ+MARTI
1864 634 016	273	SCHLÜTER
1864 634 016	277	SCHMOTZER
1864 634 016	294	VOLK
1864 634 022	67	EICHER
1864 634 024	7	CASE IH
1864 634 024	34 37 56	DEUTZ-FAHR
1864 634 024	58	EICHER
1864 634 024	69 70 75	FENDT
1864 634 024	102 103	GUELDNER
1864 634 024	104	GUTBROD
1864 634 024	105	HAAS
1864 634 024	109 110	HATZ
1864 634 024	145	LANZ+MARTI
1864 634 024	223	MIAG
1864 634 024	223	MOT.MÜNCHEN SENDLING
1864 634 024	224	MWM
1864 634 024	235 236	PRIMUS
1864 634 024	271 273	SCHLÜTER
1864 634 024	288	URSUS (D)
1864 634 024	297	WAHL
1864 634 025	5	BKS



## Neuaufnahmen / New to range

Artikelnummer Article No.	Seite Page	Hersteller Manufacturer
1864 634 025	33	CLARK
1864 634 025	57	EATON
1864 634 025	270	SCHANZLIN
1864 634 026	34	CREDE
1864 634 026	56	DEUTZ-FAHR
1864 634 026	58 59 62 63	EICHER
1864 634 026	102	GUELDNER
1864 634 026	111	HATZ
1864 634 026	116	IRION
1864 634 026	117	JENBACHER WERKE
1864 634 026	142	LANDINI
1864 634 026	145 146 147 148	LANZ+MARTI
1864 634 026	156 170	MASSEY FERGUSON
1864 634 026	231	NORMAG
1864 634 026	231	ORENSTEIN KOPPEL
1864 634 026	263	RITSCHER
1864 634 026	270	SCHEID
1864 634 026	271	SCHLECHT
1864 634 026	301	ZETTELMEYER
1864 634 027	99	FUCHS
1864 634 027	111	HATZ
1864 634 027	177	MENGELE
1864 634 027	269	SAMPO ROSENLEW
1864 634 028	75	FENDT
1864 634 029	1	AEBI
1864 634 030	37 55 56	DEUTZ-FAHR
1864 634 030	69	FARNY & WEIDMANN
1864 634 030	69 75	FENDT
1864 634 030	99	FUCHS
1864 634 030	110 111	HATZ
1864 634 030	146 147	LANZ+MARTI
1864 634 030	177	MENGELE
1864 634 030	232	ORENSTEIN KOPPEL
1864 634 030	235	POTRATZ
1864 634 030	263	RITSCHER
1864 634 030	270	SCHEID
1864 634 030	277	SCHMOTZER
1864 634 030	277	SCHULTHEISS
1864 634 030	301	ZETTELMEYER
1864 634 031	7	CASE IH
1864 634 031	116	IRION
1864 634 031	176	MEILI
1864 634 031	288	URSUS (D)
1864 634 031	298	WEHRHAHN
1864 634 033	157 164 166 168 169	MASSEY FERGUSON
1864 634 035	286	STEYR
1864 634 039	4 5	BAUTZ
1864 634 039	34 37 53 54	DEUTZ-FAHR
1864 634 039	61	EICHER
1864 634 039	68	FAHRZEUGWERKE ESSLINGEN
1864 634 039	76	FENDT
1864 634 039	101 102 103	GUELDNER
1864 634 039	105	HAAS
1864 634 039	110	HATZ
1864 634 039	119	JOHN DEERE
1864 634 039	135 136	KRAMER
1864 634 039	145	LANZ+MARTI
1864 634 039	151 154	LINDNER

Artikelnummer Article No.	Seite Page	Hersteller Manufacturer
1864 634 039	176 177	MEILI
1864 634 039	224	MWM
1864 634 039	230	NORDDEUTSCHE TRAKTORENFABRIK (NORDTRAK)
1864 634 039	233 234	PORSCHE
1864 634 039	236	PRIMUS
1864 634 039	237	REFORM
1864 634 039	271	SCHLÜTER
1864 634 039	297	WAHL
1864 634 040	4 5	BAUTZ
1864 634 040	37 56	DEUTZ-FAHR
1864 634 040	58	EICHER
1864 634 040	69 75	FENDT
1864 634 040	105	HAAS
1864 634 040	110	HATZ
1864 634 040	117	JOHN DEERE
1864 634 040	135 136 137	KRAMER
1864 634 040	137	KRIEGER FAHRZEUGBAU
1864 634 040	147	LANZ+MARTI
1864 634 040	156	MASSEY FERGUSON
1864 634 040	224	MWM
1864 634 040	233 234	PORSCHE
1864 634 040	235	POTRATZ
1864 634 040	235	PRIMUS
1864 634 040	263	RITSCHER
1864 634 040	271	SCHLÜTER
1864 634 040	277	SCHMOTZER
1864 634 040	277	SCHULTHEISS
1864 634 040	297	WAHL
1864 634 040	298	WARCHALOWSKI
1864 634 041	293	VME
1864 634 041	298	WARCHALOWSKI
1864 634 043	112 113 114	HOLDER
1864 634 046	30	CLAAS
1864 634 046	61	EICHER
1864 634 046	110	HATZ
1864 634 046	231	ORENSTEIN KOPPEL
1866 000 150	30 31 33	CLAAS
1866 118 001	296 297	VOLVO PENTA
1878 001 939	195 196 197 198 222	MERCEDES-BENZ
1878 005 623	236	REFORM
1878 634 040	17 18 19 20 21 22	CASE IH
1878 634 043 #	7 14	CASE IH
1878 634 044 #	14 15	CASE IH
1878 634 045	17 18 19 20	CASE IH
1878 634 046	17	CASE IH
1878 634 046	155	MANITOU
1878 634 051	6 7 16	CASE IH
1882 160 104 #	38 39	DEUTZ-FAHR
1882 160 104 #	38 39	DEUTZ-FAHR
1882 261 013 #	282 283	STEYR
1882 600 121 #	127 129 130	JOHN DEERE
1888 024 114 #	57	DEXHEIMER
1888 024 114 #	137	KRIEGER FAHRZEUGBAU
1888 024 114 #	270	SCHANZLIN
1888 054 004 #	281	STEYR
1888 054 004 #	289 290 291	VALMET

**Neuaufnahmen / New to range**

Artikelnummer Article No.	Seite Page	Hersteller Manufacturer
1888 600 144	7 8 9 12 13	CASE IH
1888 600 144	224 225 226 227 228 229 230	NEW HOLLAND
1888 600 144	283 284 285	STEYR
1888 600 149	9 10 11	CASE IH
1888 600 149	78	FIATAGRI
1888 600 149	92 94 96	FORD NEW HOLLAND
1888 600 150	114 115	HÜRLIMANN
1888 600 150	138 139	LAMBORGHINI
1888 600 150	264	SAME
1888 880 001 #	140 141 143 144 145	LANDINI
1888 880 001 #	164 165 166 167 168	MASSEY FERGUSON
1888 880 001 #	176	MC CORMICK
1890 006 101 #	70 76	FENDT
1890 006 101 #	70 76	FENDT
2300 146 031	195 196 197 198 223	MERCEDES-BENZ
2300 147 031	197 198 223	MERCEDES-BENZ
3800 541 017 #☉	140 141 143 144 145	LANDINI
3800 541 017 #☉	164 165 166 167 168	MASSEY FERGUSON

Artikelnummer Article No.	Seite Page	Hersteller Manufacturer
------------------------------	---------------	----------------------------

**Geänderte Bestellnummer / Amended part numbers**

Artikelnummer alt Article No. old	Artikelnummer neu Article No. new	Artikelnummer alt Article No. old	Artikelnummer neu Article No. new	Artikelnummer alt Article No. old	Artikelnummer neu Article No. new
1850 481 124	1864 600 344	1878 634 016	1878 002 706		
1859 029 000	1859 600 001	1882 271 504	1882 600 121		
1859 102 000	1859 600 002	1888 025 004	1888 881 001		
1859 103 001	1859 600 003	1888 600 104	1888 600 142		
1859 104 000	1859 600 004	1888 600 105	1888 600 149		
1859 105 000	3151 093 041	1888 600 117	1888 600 150		
1859 107 100	1859 600 005	1888 600 128	1888 600 131		
1859 109 001	1859 600 006	3151 000 512	3151 000 515		
1860 023 011	1864 634 041				
1860 023 040	1864 634 040				
1860 039 022	1864 634 029				
1860 039 027	1864 634 026				
1860 039 028	1864 634 024				
1860 049 027	1864 634 031				
1860 049 055	1864 634 030				
1860 049 056	1864 634 039				
1861 070 101	1878 634 043				
1861 260 101	1878 634 045				
1861 266 001	1878 634 044				
1861 456 339	1878 006 152				
1861 755 131	1878 634 046				
1861 915 101	1861 784 001				
1862 001 201	1878 634 051				
1862 756 001	1878 634 040				
1863 600 119	1863 837 002				
1864 006 118	1864 634 046				
1864 039 045	1864 634 016				
1864 066 210	1864 634 043				
1864 137 005	1864 634 027				
1864 137 006	1864 634 028				
1864 254 003	1864 634 025				
1864 258 101	1864 634 033				
1864 261 004	1864 634 022				
1864 600 305	1864 600 306				
1864 973 001	1864 974 001				
1866 118 031	1866 118 001				
1866 600 001	1866 600 023				
1878 600 534	1878 600 535				
1878 600 570	1862 844 001				

**Geänderte Bestellnummer / Amended part numbers**

<b>Artikelnummer neu</b> <b>Article No. new</b>	<b>Artikelnummer alt</b> <b>Article No. old</b>	<b>Artikelnummer neu</b> <b>Article No. new</b>	<b>Artikelnummer alt</b> <b>Article No. old</b>	<b>Artikelnummer neu</b> <b>Article No. new</b>	<b>Artikelnummer alt</b> <b>Article No. old</b>
1859 600 001	1859 029 000				
1859 600 002	1859 102 000				
1859 600 003	1859 103 001				
1859 600 004	1859 104 000				
1859 600 005	1859 107 100				
1859 600 006	1859 109 001				
1861 784 001	1861 915 101				
1862 844 001	1878 600 570				
1863 837 002	1863 600 119				
1864 600 306	1864 600 305				
1864 600 344	1850 481 124				
1864 634 016	1864 039 045				
1864 634 022	1864 261 004				
1864 634 024	1860 039 028				
1864 634 025	1864 254 003				
1864 634 026	1860 039 027				
1864 634 027	1864 137 005				
1864 634 028	1864 137 006				
1864 634 029	1860 039 022				
1864 634 030	1860 049 055				
1864 634 031	1860 049 027				
1864 634 033	1864 258 101				
1864 634 039	1860 049 056				
1864 634 040	1860 023 040				
1864 634 041	1860 023 011				
1864 634 043	1864 066 210				
1864 634 046	1864 006 118				
1864 974 001	1864 973 001				
1866 118 001	1866 118 031				
1866 600 023	1866 600 001				
1878 002 706	1878 634 016				
1878 006 152	1861 456 339				
1878 600 535	1878 600 534				
1878 634 040	1862 756 001				
1878 634 043	1861 070 101				
1878 634 044	1861 266 001				
1878 634 045	1861 260 101				
1878 634 046	1861 755 131				
1878 634 051	1862 001 201				
1882 600 121	1882 271 504				
1888 600 131	1888 600 128				
1888 600 142	1888 600 104				
1888 600 149	1888 600 105				
1888 600 150	1888 600 117				
1888 881 001	1888 025 004				
3151 000 515	3151 000 512				
3151 093 041	1859 105 000				

**Gestrichene Nummern / Deleted references**

<b>Artikelnummer</b> <b>Article No.</b>	<b>Artikelnummer</b> <b>Article No.</b>	<b>Artikelnummer</b> <b>Article No.</b>
1850 280 181	1864 998 501	1888 023 102
1850 280 385	1865 006 001	1888 876 003
1850 480 055	1866 026 131	1890 801 001
1861 561 002	1866 031 101	1896 094 100
1861 562 231	1866 050 001	2100 500 015
1861 696 044	1874 000 047	2100 500 016
1861 732 031	1878 002 103	2100 500 019
1861 845 132	1878 003 248	2100 500 025
1861 981 202	1878 053 831	2100 500 026
1862 039 015	1878 600 633	2100 500 027
1862 141 042	1878 600 671	2100 500 029
1862 408 031	1878 600 919	2100 500 030
1864 000 236	1878 600 931	2100 500 033
1864 093 031	1878 600 934	2100 500 034
1864 103 018	1878 989 301	2100 500 035
1864 122 146	1881 050 427	2100 500 041
1864 338 001	1881 050 428	2100 500 047
1864 498 001	1881 050 429	2100 500 052
1864 600 319	1882 021 101	2100 500 057
1864 922 003	1882 288 104	2100 500 061

**Gestrichene Nummern / Deleted references**

<b>Artikelnummer</b> <b>Article No.</b>	<b>Artikelnummer</b> <b>Article No.</b>	<b>Artikelnummer</b> <b>Article No.</b>
2100 500 065	3082 878 002	
2100 500 067	3082 999 450	
2100 500 072	3089 998 901	
2100 500 073	3151 104 001	
2100 500 074	3151 192 041	
2100 500 080	3400 700 419	
2100 500 105	3488 000 087	
2100 500 106	3488 007 631	
2100 500 107	6284 600 615	
2100 500 109	6284 600 654	
2100 500 110		
2100 500 111		
2100 500 113		
2100 500 116		
2100 500 117		
2100 500 118		
2100 500 119		
2100 500 120		
2100 500 121		
2100 500 123		
2100 500 124		
2100 500 127		
2100 501 005		
2100 501 023		
2100 501 038		
2290 601 029		
2290 601 036		
3000 047 008		
3000 047 009		
3000 047 010		
3000 101 002		
3000 169 002		
3000 189 001		
3000 257 001		
3000 306 001		
3000 388 001		
3000 427 001		
3000 534 001		
3000 535 001		
3000 603 001		
3000 857 501		
3000 950 625		
3000 950 695		
3000 951 155		
3000 951 441		
3000 951 442		
3000 951 719		
3000 951 733		
3000 951 735		
3000 954 099		
3000 960 701		
3000 963 001		
3000 990 092		
3000 990 254		
3032 000 216		
3072 000 013		
3082 000 304		
3082 001 492		
3082 001 498		
3082 001 499		
3082 001 503		
3082 098 131		
3082 240 031		
3082 600 594		
3082 600 754		
3082 642 901		
3082 850 002		

**1866 000 007**

**Torsionsdämpfer, Kupplung / Torsion Damper, clutch**

**LIEBHERR**  
1013-6818  
1001-6633



KenngroÙe / Parameter: 345/254NGT  
Durchmesser [mm] / Diameter [mm]: 345  
Nabenprofil / Hub Profile: 54x60-18N  
Zähnezahl / Number of Teeth: 18  
max. übertragbares Motormoment [Nm] / max. transmittable engine torque [Nm]: 2490

**1866 000 021**

**Torsionsdämpfer, Kupplung / Torsion Damper, clutch**

**LIEBHERR**  
1002-2829



KenngroÙe / Parameter: 314/188NGT  
Durchmesser [mm] / Diameter [mm]: 314  
Nabenprofil / Hub Profile: 41x45-21N  
Zähnezahl / Number of Teeth: 21  
max. übertragbares Motormoment [Nm] / max. transmittable engine torque [Nm]: 1240

**1866 000 030**

**Torsionsdämpfer, Kupplung / Torsion Damper, clutch**

**KÄSSBOHRER**  
8.383.348.00  
8.383.343.000.0



KenngroÙe / Parameter: 352/232NGT  
Durchmesser [mm] / Diameter [mm]: 352  
Nabenprofil / Hub Profile: 41x45-21N  
Zähnezahl / Number of Teeth: 21  
max. übertragbares Motormoment [Nm] / max. transmittable engine torque [Nm]: 2030

**1866 000 062**

**Torsionsdämpfer, Kupplung / Torsion Damper, clutch**

**LIEBHERR**  
1010-0069



KenngroÙe / Parameter: 466/232NGT  
Durchmesser [mm] / Diameter [mm]: 466  
Nabenprofil / Hub Profile: 36x40-18N  
Zähnezahl / Number of Teeth: 18  
max. übertragbares Motormoment [Nm] / max. transmittable engine torque [Nm]: 2719

**1866 000 072**

**Torsionsdämpfer, Kupplung / Torsion Damper, clutch**



KenngroÙe / Parameter: 468/254NGTP  
Durchmesser [mm] / Diameter [mm]: 468  
Nabenprofil / Hub Profile: 64x70-32N  
Zähnezahl / Number of Teeth: 32  
max. übertragbares Motormoment [Nm] / max. transmittable engine torque [Nm]: 3007

**1866 000 079**

**Torsionsdämpfer, Kupplung / Torsion Damper, clutch**

**LIEBHERR**  
1022-8100



KenngroÙe / Parameter: 466/232NGT  
 Durchmesser [mm] / Diameter [mm]: 466  
 Nabenprofil / Hub Profile: 36x40 -18N  
 Zähnezah! / Number of Teeth: 18  
 max. übertragbares Motormoment [Nm] / max. transmittable engine torque [Nm]: 2719

**1866 000 084**

**Torsionsdämpfer, Kupplung / Torsion Damper, clutch**



KenngroÙe / Parameter: 352/210NGS  
 Durchmesser [mm] / Diameter [mm]: 352  
 Nabenprofil / Hub Profile: 46x50-24N  
 Zähnezah! / Number of Teeth: 24

**1866 000 108**

**Torsionsdämpfer, Kupplung / Torsion Damper, clutch**

**CLAAS**  
00 0664 712 0



KenngroÙe / Parameter: 435/232GT  
 Durchmesser [mm] / Diameter [mm]: 435  
 Nabenprofil / Hub Profile: 46x50-24N  
 Zähnezah! / Number of Teeth: 24  
 max. übertragbares Motormoment [Nm] / max. transmittable engine torque [Nm]: 3415

**1866 000 140**

**Torsionsdämpfer, Kupplung / Torsion Damper, clutch**

**VOLVO**  
3807988



KenngroÙe / Parameter: 275/188NWGTP  
 Durchmesser [mm] / Diameter [mm]: 275  
 Nabenprofil / Hub Profile: 31,8x34,3-26N  
 Zähnezah! / Number of Teeth: 26  
 max. übertragbares Motormoment [Nm] / max. transmittable engine torque [Nm]: 800

**1866 000 150**

**Torsionsdämpfer, Kupplung / Torsion Damper, clutch**

**CLAAS**  
06647110



KenngroÙe / Parameter: 352/232NGT  
 Durchmesser [mm] / Diameter [mm]: 352  
 Nabenprofil / Hub Profile: 45x50-24N  
 Zähnezah! / Number of Teeth: 24  
 max. übertragbares Motormoment [Nm] / max. transmittable engine torque [Nm]: 2030

**1866 000 151**

**Torsionsdämpfer, Kupplung / Torsion Damper, clutch**

**LIEBHERR**  
1011-6024



KenngroÙe / Parameter: 345/232NGT  
Durchmesser [mm] / Diameter [mm]: 345  
Nabenprofil / Hub Profile: 46x50-24N  
Zähnezahl / Number of Teeth: 24  
max. übertragbares Motormoment [Nm] / max. transmittable engine torque [Nm]: 3415

**1866 000 152**

**Torsionsdämpfer, Kupplung / Torsion Damper, clutch**

**LIEBHERR**  
1022-1026



KenngroÙe / Parameter: 466/288NGT  
Durchmesser [mm] / Diameter [mm]: 466  
Nabenprofil / Hub Profile: 64x70-22N  
Zähnezahl / Number of Teeth: 22  
max. übertragbares Motormoment [Nm] / max. transmittable engine torque [Nm]: 4500

**1866 000 153**

**Torsionsdämpfer, Kupplung / Torsion Damper, clutch**

**LIEBHERR**  
1021-8079



KenngroÙe / Parameter: 466/232NGT  
Durchmesser [mm] / Diameter [mm]: 466  
Nabenprofil / Hub Profile: 46x50-24N  
Zähnezahl / Number of Teeth: 24  
max. übertragbares Motormoment [Nm] / max. transmittable engine torque [Nm]: 2030

**1866 000 154**

**Torsionsdämpfer, Kupplung / Torsion Damper, clutch**

**VALTRA**  
33676410  
35303500



KenngroÙe / Parameter: 352NWGT  
Durchmesser [mm] / Diameter [mm]: 352  
Nabenprofil / Hub Profile: 41x45-20N  
Zähnezahl / Number of Teeth: 20  
max. übertragbares Motormoment [Nm] / max. transmittable engine torque [Nm]: 2719

**1866 000 175**

**Torsionsdämpfer, Kupplung / Torsion Damper, clutch**

**KÄSSBOHRER**  
8.383.347.000.0



KenngroÙe / Parameter: 466/254NGT  
Durchmesser [mm] / Diameter [mm]: 466  
Nabenprofil / Hub Profile: 46x50-24N  
Zähnezahl / Number of Teeth: 24  
max. übertragbares Motormoment [Nm] / max. transmittable engine torque [Nm]: 3021

**1866 000 189**

**Torsionsdämpfer, Kupplung / Torsion Damper, clutch**



KenngroÙe / Parameter: 314/188NGT  
 Durchmesser [mm] / Diameter [mm]: 314  
 Nabenprofil / Hub Profile: 31x35-10N  
 Zähnezah! / Number of Teeth: 10  
 max. übertragbares Motormoment [Nm] / max. transmittable engine torque [Nm]: 1042

**1866 000 239**

**Torsionsdämpfer, Kupplung / Torsion Damper, clutch**



KenngroÙe / Parameter: 314/212NWGTP  
 Durchmesser [mm] / Diameter [mm]: 314  
 Nabenprofil / Hub Profile: 31,8x34,3-26N  
 Zähnezah! / Number of Teeth: 26  
 max. übertragbares Motormoment [Nm] / max. transmittable engine torque [Nm]: 1500

**VOLVO**  
 21581138  
 3886887

**1866 000 323**

**Torsionsdämpfer, Kupplung / Torsion Damper, clutch**

KenngroÙe / Parameter: 345/212GT  
 Durchmesser [mm] / Diameter [mm]: 345  
 Nabenprofil / Hub Profile: 41x45-22N  
 Zähnezah! / Number of Teeth: 22  
 max. übertragbares Motormoment [Nm] / max. transmittable engine torque [Nm]: 2500

**1866 000 337**

**Torsionsdämpfer, Kupplung / Torsion Damper, clutch**

KenngroÙe / Parameter: 345/212GT  
 Durchmesser [mm] / Diameter [mm]: 345  
 Nabenprofil / Hub Profile: 46x50-24N  
 Zähnezah! / Number of Teeth: 24  
 max. übertragbares Motormoment [Nm] / max. transmittable engine torque [Nm]: 2500

**1866 011 202**

**Torsionsdämpfer, Kupplung / Torsion Damper, clutch**



KenngroÙe / Parameter: 236/145GS  
 Durchmesser [mm] / Diameter [mm]: 236  
 Nabenprofil / Hub Profile: 35x38,5-23N  
 Zähnezah! / Number of Teeth: 23  
 max. übertragbares Motormoment [Nm] / max. transmittable engine torque [Nm]: 560

**JOHN DEERE**  
 AL 23902



**1866 018 131**

**Torsionsdämpfer, Kupplung / Torsion Damper, clutch**



KenngroÙe / Parameter: 287/133NTP  
 Durchmesser [mm] / Diameter [mm]: 287  
 Nabenprofil / Hub Profile: 31,8x34,3-26N  
 Zähnezahl / Number of Teeth: 26  
 max. übertragbares Motormoment [Nm] / max. transmittable engine torque [Nm]: 425

**VOLVO**  
 841893  
 824991

**1866 021 101**

**Torsionsdämpfer, Kupplung / Torsion Damper, clutch**



KenngroÙe / Parameter: 267/133NTP  
 Durchmesser [mm] / Diameter [mm]: 267  
 Nabenprofil / Hub Profile: 31,8x34,3-26N  
 Zähnezahl / Number of Teeth: 26  
 max. übertragbares Motormoment [Nm] / max. transmittable engine torque [Nm]: 425

**1866 024 001**

**Torsionsdämpfer, Kupplung / Torsion Damper, clutch**



KenngroÙe / Parameter: 360/159NGS  
 Durchmesser [mm] / Diameter [mm]: 360  
 Nabenprofil / Hub Profile: 31,8x35-21N  
 Zähnezahl / Number of Teeth: 21  
 max. übertragbares Motormoment [Nm] / max. transmittable engine torque [Nm]: 660

**PAUS**  
 1 848 491 087  
**TRUCO**  
 J 33020510  
**VÖGELE**  
 45 1022 0010 0

**1866 030 102**

**Torsionsdämpfer, Kupplung / Torsion Damper, clutch**



KenngroÙe / Parameter: 250/210GS  
 Durchmesser [mm] / Diameter [mm]: 250  
 Nabenprofil / Hub Profile: 64x70-32N  
 Zähnezahl / Number of Teeth: 32  
 max. übertragbares Motormoment [Nm] / max. transmittable engine torque [Nm]: 2200

**ASTRA**  
 104671  
**IRISBUS**  
 104671  
**MAGIRUS-DEUTZ**  
 4248 3478 /U-E

**1866 032 231**

**Torsionsdämpfer, Kupplung / Torsion Damper, clutch**



KenngroÙe / Parameter: 287/133NTP  
 Durchmesser [mm] / Diameter [mm]: 287  
 Nabenprofil / Hub Profile: 31,8x34,3-26N  
 Zähnezahl / Number of Teeth: 26  
 max. übertragbares Motormoment [Nm] / max. transmittable engine torque [Nm]: 425

**VOLVO**  
 855389

**1866 050 002**

**Torsionsdämpfer, Kupplung / Torsion Damper, clutch**



KenngroÙe / Parameter: 122/100NC  
 Durchmesser [mm] / Diameter [mm]: 122  
 Nabenprofil / Hub Profile: 23x29-10N  
 Zähnezahl / Number of Teeth: 10  
 max. übertragbares Motormoment [Nm] / max. transmittable engine torque [Nm]: 154

**ASIA MOTORS**  
 322 381 0  
**BMW**  
 1 329 048  
**FARNY & WEIDMANN**  
 167.097.2  
**HURTH**  
 3306316001  
 94 744 601 02

**1866 052 001**

**Torsionsdämpfer, Kupplung / Torsion Damper, clutch**



KenngroÙe / Parameter: 152/123NPC  
 Durchmesser [mm] / Diameter [mm]: 152  
 Nabenprofil / Hub Profile: 23x29-10N  
 Zähnezahl / Number of Teeth: 10  
 max. übertragbares Motormoment [Nm] / max. transmittable engine torque [Nm]: 300

**FARNY & WEIDMANN**  
 03 10 01 3003  
 167.100.2  
**HURTH**  
 94 744 601 03  
 3306316003

**1866 052 002**

**Torsionsdämpfer, Kupplung / Torsion Damper, clutch**



KenngroÙe / Parameter: 152/123NPC  
 Durchmesser [mm] / Diameter [mm]: 152  
 Nabenprofil / Hub Profile: 31,8x34,3-26N  
 Zähnezahl / Number of Teeth: 26  
 max. übertragbares Motormoment [Nm] / max. transmittable engine torque [Nm]: 300

**ASIA MOTORS**  
 322 380  
**FARNY & WEIDMANN**  
 167.103.2  
**HURTH**  
 94 724 601 03  
 3307316001

**1866 061 001**

**Torsionsdämpfer, Kupplung / Torsion Damper, clutch**



KenngroÙe / Parameter: 157/123NCP  
 Durchmesser [mm] / Diameter [mm]: 157  
 Nabenprofil / Hub Profile: 23x29-10N  
 Zähnezahl / Number of Teeth: 10  
 max. übertragbares Motormoment [Nm] / max. transmittable engine torque [Nm]: 265

**HURTH**  
 3306316002

**1866 061 002**

**Torsionsdämpfer, Kupplung / Torsion Damper, clutch**



KenngroÙe / Parameter: 157/123NCP  
 Durchmesser [mm] / Diameter [mm]: 157  
 Nabenprofil / Hub Profile: 31,8x34,3-26N  
 Zähnezahl / Number of Teeth: 26  
 max. übertragbares Motormoment [Nm] / max. transmittable engine torque [Nm]: 265

**HURTH**  
 3307316002

**1866 065 001**

**Torsionsdämpfer, Kupplung / Torsion Damper, clutch**

**LIEBHERR**  
5602-880



KenngroÙe / Parameter: 345/210GS  
 Durchmesser [mm] / Diameter [mm]: 345  
 Nabenprofil / Hub Profile: 41x45-22N  
 Zähnezahl / Number of Teeth: 22  
 max. übertragbares Motormoment [Nm] / max. transmittable engine torque [Nm]: 1400

**1866 066 001**

**Torsionsdämpfer, Kupplung / Torsion Damper, clutch**

**STEINBOCK**  
026203



KenngroÙe / Parameter: 290/159GS  
 Durchmesser [mm] / Diameter [mm]: 290  
 Nabenprofil / Hub Profile: 26x30-14N  
 Zähnezahl / Number of Teeth: 14  
 max. übertragbares Motormoment [Nm] / max. transmittable engine torque [Nm]: 305

**1866 068 001**

**Torsionsdämpfer, Kupplung / Torsion Damper, clutch**

**LIEBHERR**  
5603-280  
**MENGELE**  
98-041436



KenngroÙe / Parameter: 352/210NGS  
 Durchmesser [mm] / Diameter [mm]: 352  
 Nabenprofil / Hub Profile: 41x45-22N  
 Zähnezahl / Number of Teeth: 22  
 max. übertragbares Motormoment [Nm] / max. transmittable engine torque [Nm]: 1410

**1866 068 002**

**Torsionsdämpfer, Kupplung / Torsion Damper, clutch**

**MENGELE**  
98-039641



KenngroÙe / Parameter: 352/210NGS  
 Durchmesser [mm] / Diameter [mm]: 352  
 Nabenprofil / Hub Profile: 41x45-22N  
 Zähnezahl / Number of Teeth: 22  
 max. übertragbares Motormoment [Nm] / max. transmittable engine torque [Nm]: 2190

**1866 090 001**

**Torsionsdämpfer, Kupplung / Torsion Damper, clutch**

**LIEBHERR**  
5603-810



KenngroÙe / Parameter: 390/210NGS  
 Durchmesser [mm] / Diameter [mm]: 390  
 Nabenprofil / Hub Profile: 54x60-18N  
 Zähnezahl / Number of Teeth: 18  
 max. übertragbares Motormoment [Nm] / max. transmittable engine torque [Nm]: 1950

**1866 104 001**

**Torsionsdämpfer, Kupplung / Torsion Damper, clutch**



KenngroÙe / Parameter: 267/100NC  
 Durchmesser [mm] / Diameter [mm]: 267  
 Nabenprofil / Hub Profile: 23x29-10N  
 Zähnezahl / Number of Teeth: 10  
 max. übertragbares Motormoment [Nm] / max. transmittable engine torque [Nm]: 98

**1866 107 001**

**Torsionsdämpfer, Kupplung / Torsion Damper, clutch**



KenngroÙe / Parameter: 190/145NG  
 Durchmesser [mm] / Diameter [mm]: 190  
 Nabenprofil / Hub Profile: 31,8x34,3-26N  
 Zähnezahl / Number of Teeth: 26  
 max. übertragbares Motormoment [Nm] / max. transmittable engine torque [Nm]: 645

**FARNY & WEIDMANN**  
 167.104.2  
**FIAT**  
 08105631  
**IRISBUS**  
 08105631  
**IVECO**  
 08105631

**1866 118 001**

**Torsionsdämpfer, Kupplung / Torsion Damper, clutch**



KenngroÙe / Parameter: 287/159NGS  
 Durchmesser [mm] / Diameter [mm]: 287  
 Nabenprofil / Hub Profile: 31,8x34,3-26N  
 Zähnezahl / Number of Teeth: 26  
 max. übertragbares Motormoment [Nm] / max. transmittable engine torque [Nm]: 820

**1866 122 002**

**Torsionsdämpfer, Kupplung / Torsion Damper, clutch**



KenngroÙe / Parameter: 352/159NGS  
 Durchmesser [mm] / Diameter [mm]: 352  
 Nabenprofil / Hub Profile: 26x30-14N  
 Zähnezahl / Number of Teeth: 14  
 max. übertragbares Motormoment [Nm] / max. transmittable engine torque [Nm]: 370

**1866 130 001**

**Torsionsdämpfer, Kupplung / Torsion Damper, clutch**



KenngroÙe / Parameter: 250/210NGS  
 Durchmesser [mm] / Diameter [mm]: 250  
 Nabenprofil / Hub Profile: 64x70-32N  
 Zähnezahl / Number of Teeth: 32  
 max. übertragbares Motormoment [Nm] / max. transmittable engine torque [Nm]: 2180

**IRISBUS**  
 112319

**1866 133 001**

**Torsionsdämpfer, Kupplung / Torsion Damper, clutch**

**LIEBHERR**  
5607-974



KenngroÙe / Parameter: 345/210NGS  
 Durchmesser [mm] / Diameter [mm]: 345  
 Nabenprofil / Hub Profile: 36x40-18N  
 Zähnezahl / Number of Teeth: 18  
 max. übertragbares Motormoment [Nm] / max. transmittable engine torque [Nm]: 1420

**1866 135 001**

**Torsionsdämpfer, Kupplung / Torsion Damper, clutch**

**LIEBHERR**  
5608-138



KenngroÙe / Parameter: 345/210NGS  
 Durchmesser [mm] / Diameter [mm]: 345  
 Nabenprofil / Hub Profile: 46x50-24N  
 Zähnezahl / Number of Teeth: 24  
 max. übertragbares Motormoment [Nm] / max. transmittable engine torque [Nm]: 1584

**1866 136 001**

**Torsionsdämpfer, Kupplung / Torsion Damper, clutch**

**LIEBHERR**  
5006-801



KenngroÙe / Parameter: 345/159NGS  
 Durchmesser [mm] / Diameter [mm]: 345  
 Nabenprofil / Hub Profile: 31x35-16N  
 Zähnezahl / Number of Teeth: 16  
 max. übertragbares Motormoment [Nm] / max. transmittable engine torque [Nm]: 823

**1866 138 101**

**Torsionsdämpfer, Kupplung / Torsion Damper, clutch**

**LIEBHERR**  
5007-636



KenngroÙe / Parameter: 314/159NGS  
 Durchmesser [mm] / Diameter [mm]: 314  
 Nabenprofil / Hub Profile: 31x35-16N  
 Zähnezahl / Number of Teeth: 16  
 max. übertragbares Motormoment [Nm] / max. transmittable engine torque [Nm]: 670

**1866 142 001**

**Torsionsdämpfer, Kupplung / Torsion Damper, clutch**

**FORTSCHRITT**  
02-114585  
**MENGELE**  
02-114585  
02-116646



KenngroÙe / Parameter: 352/210NGS  
 Durchmesser [mm] / Diameter [mm]: 352  
 Nabenprofil / Hub Profile: 45x50-24N  
 Zähnezahl / Number of Teeth: 24  
 max. übertragbares Motormoment [Nm] / max. transmittable engine torque [Nm]: 2540

**1866 148 001**

**Torsionsdämpfer, Kupplung / Torsion Damper, clutch**

**LIEBHERR**  
5611-081  
5608-851



KenngroÙe / Parameter: 466/288NGT  
Durchmesser [mm] / Diameter [mm]: 466  
Nabenprofil / Hub Profile: 64x70-22N  
Zähnezahl / Number of Teeth: 22  
max. übertragbares Motormoment [Nm] / max. transmittable engine torque [Nm]: 2789

**1866 156 001**

**Torsionsdämpfer, Kupplung / Torsion Damper, clutch**

**LIEBHERR**  
5009-663



KenngroÙe / Parameter: 314/159NGS  
Durchmesser [mm] / Diameter [mm]: 314  
Nabenprofil / Hub Profile: 36x40-18N  
Zähnezahl / Number of Teeth: 18  
max. übertragbares Motormoment [Nm] / max. transmittable engine torque [Nm]: 670

**1866 157 101**

**Torsionsdämpfer, Kupplung / Torsion Damper, clutch**

**LIEBHERR**  
1000-3465



KenngroÙe / Parameter: 345/232NGT  
Durchmesser [mm] / Diameter [mm]: 345  
Nabenprofil / Hub Profile: 46x50-24N  
Zähnezahl / Number of Teeth: 24  
max. übertragbares Motormoment [Nm] / max. transmittable engine torque [Nm]: 2719

**1866 157 103**

**Torsionsdämpfer, Kupplung / Torsion Damper, clutch**

**LIEBHERR**  
1001-6872



KenngroÙe / Parameter: 345/232NGT  
Durchmesser [mm] / Diameter [mm]: 345  
Nabenprofil / Hub Profile: 46x50-24N  
Zähnezahl / Number of Teeth: 24  
max. übertragbares Motormoment [Nm] / max. transmittable engine torque [Nm]: 1810

**1866 157 631**

**Torsionsdämpfer, Kupplung / Torsion Damper, clutch**

KenngroÙe / Parameter: 431/254NGT  
Durchmesser [mm] / Diameter [mm]: 431  
Nabenprofil / Hub Profile: 36x50-18N  
Zähnezahl / Number of Teeth: 18  
max. übertragbares Motormoment [Nm] / max. transmittable engine torque [Nm]: 3550

**1866 600 002**

**Torsionsdämpfer, Kupplung / Torsion Damper, clutch**

**CASE IH**  
376 596 A1



Durchmesser [mm] / Diameter [mm]: 354  
max. übertragbares Motormoment [Nm] / max. transmittable engine torque [Nm]: 900

**1866 600 003**

**Torsionsdämpfer, Kupplung / Torsion Damper, clutch**

**MASSEY FERGUSON**  
3652 970 M91



Durchmesser [mm] / Diameter [mm]: 295  
Nabenprofil / Hub Profile: 50,4x54,6-26N  
Zähnezahl / Number of Teeth: 26  
max. übertragbares Motormoment [Nm] / max. transmittable engine torque [Nm]: 1300

**1866 600 004**

**Torsionsdämpfer, Kupplung / Torsion Damper, clutch**

**MASSEY FERGUSON**  
3648 843 M91



Durchmesser [mm] / Diameter [mm]: 263  
Nabenprofil / Hub Profile: 31x35-16N  
Zähnezahl / Number of Teeth: 16  
max. übertragbares Motormoment [Nm] / max. transmittable engine torque [Nm]: 500

**1866 600 005**

**Torsionsdämpfer, Kupplung / Torsion Damper, clutch**

**RENAULT AGRICULTURE**  
7700 019 282



Durchmesser [mm] / Diameter [mm]: 225  
Nabenprofil / Hub Profile: 31x35-16N  
Zähnezahl / Number of Teeth: 16

**1866 600 006**

**Torsionsdämpfer, Kupplung / Torsion Damper, clutch**

**RENAULT AGRICULTURE**  
7700 046 743



Durchmesser [mm] / Diameter [mm]: 263  
Nabenprofil / Hub Profile: 39x42,5-26N  
Zähnezahl / Number of Teeth: 26

**1866 600 007**

**Torsionsdämpfer, Kupplung / Torsion Damper, clutch**



Durchmesser [mm] / Diameter [mm]: 295  
 Nabenprofil / Hub Profile: 39x42,5-26N  
 Zähnezahl / Number of Teeth: 26

**RENAULT  
 AGRICULTURE**  
 7700 067 039  
 7700 052 774

**1866 600 008**

**Torsionsdämpfer, Kupplung / Torsion Damper, clutch**



Durchmesser [mm] / Diameter [mm]: 348  
 Nabenprofil / Hub Profile: 39x42,5-26N  
 Zähnezahl / Number of Teeth: 26

**RENAULT  
 AGRICULTURE**  
 7700 050 636

**1866 600 009**

**Torsionsdämpfer, Kupplung / Torsion Damper, clutch**



Durchmesser [mm] / Diameter [mm]: 352  
 Nabenprofil / Hub Profile: 39x42,5-26N  
 Zähnezahl / Number of Teeth: 26

**RENAULT  
 AGRICULTURE**  
 7700 053 637

**1866 600 010**

**Torsionsdämpfer, Kupplung / Torsion Damper, clutch**



Durchmesser [mm] / Diameter [mm]: 263  
 Nabenprofil / Hub Profile: 1 1/8"-10N  
 Zähnezahl / Number of Teeth: 10

**FORD NEW HOLLAND**  
 8200 8857

**1866 600 011**

**Torsionsdämpfer, Kupplung / Torsion Damper, clutch**



Durchmesser [mm] / Diameter [mm]: 348  
 Nabenprofil / Hub Profile: 35x40-14N  
 Zähnezahl / Number of Teeth: 14

**CASE IH**  
 8730 4267  
**FORD NEW HOLLAND**  
 5187 845



**1866 600 012**

**Torsionsdämpfer, Kupplung / Torsion Damper, clutch**

**FORD NEW HOLLAND**  
5153 359



Durchmesser [mm] / Diameter [mm]: 350  
Nabenprofil / Hub Profile: 35x40-14N  
Zähnezahl / Number of Teeth: 14

**1866 600 013**

**Torsionsdämpfer, Kupplung / Torsion Damper, clutch**

**CASE IH**  
471 2670 1  
**FORD NEW HOLLAND**  
5187 958



Durchmesser [mm] / Diameter [mm]: 263  
Nabenprofil / Hub Profile: 35x40-14N  
Zähnezahl / Number of Teeth: 14

**1866 600 014**

**Torsionsdämpfer, Kupplung / Torsion Damper, clutch**

**MASSEY FERGUSON**  
3792 346 M1



Durchmesser [mm] / Diameter [mm]: 352  
Nabenprofil / Hub Profile: 39x42,5-26N  
Zähnezahl / Number of Teeth: 26

**1866 600 015**

**Torsionsdämpfer, Kupplung / Torsion Damper, clutch**

**MASSEY FERGUSON**  
3790 735 M2



Durchmesser [mm] / Diameter [mm]: 348  
Nabenprofil / Hub Profile: 39x42,5-26N  
Zähnezahl / Number of Teeth: 26

**1866 600 016**

**Torsionsdämpfer, Kupplung / Torsion Damper, clutch**

**MASSEY FERGUSON**  
3792 448 M2  
3792 448 H2



Durchmesser [mm] / Diameter [mm]: 295  
Nabenprofil / Hub Profile: 39x42,5-26N  
Zähnezahl / Number of Teeth: 26

**1866 600 017**

**Torsionsdämpfer, Kupplung / Torsion Damper, clutch**

**MASSEY FERGUSON**  
3790 734 M2  
3790 734 M3



Durchmesser [mm] / Diameter [mm]: 295  
Nabenprofil / Hub Profile: 39x42,5-26N  
Zähnezahl / Number of Teeth: 26

**1866 600 018**

**Torsionsdämpfer, Kupplung / Torsion Damper, clutch**

**MASSEY FERGUSON**  
3820 069 M1



Durchmesser [mm] / Diameter [mm]: 320  
Nabenprofil / Hub Profile: 38,2x41,5-25N  
Zähnezahl / Number of Teeth: 25

**1866 600 019**

**Torsionsdämpfer, Kupplung / Torsion Damper, clutch**

**MASSEY FERGUSON**  
379 648 H1  
379 364 H1  
3793 648 M1



Durchmesser [mm] / Diameter [mm]: 348  
Nabenprofil / Hub Profile: 39x42,5-26N  
Zähnezahl / Number of Teeth: 26

**1866 600 020**

**Torsionsdämpfer, Kupplung / Torsion Damper, clutch**

**FORD NEW HOLLAND**  
518 1872



Durchmesser [mm] / Diameter [mm]: 116  
Nabenprofil / Hub Profile: 22x25-10N  
Zähnezahl / Number of Teeth: 10

**1866 600 021**

**Torsionsdämpfer, Kupplung / Torsion Damper, clutch**

**SAME**  
0.011.3942.4



Durchmesser [mm] / Diameter [mm]: 263  
Nabenprofil / Hub Profile: 46x50-24N  
Zähnezahl / Number of Teeth: 24

**1866 600 022**

**Torsionsdämpfer, Kupplung / Torsion Damper, clutch**



Durchmesser [mm] / Diameter [mm]: 348  
 Nabenprofil / Hub Profile: 35x40-14N  
 Zähnezahl / Number of Teeth: 14

**CASE IH**  
 471 2709 7  
 8730 2871  
 8754 2609

**1866 600 023**

**Torsionsdämpfer, Kupplung / Torsion Damper, clutch**



Durchmesser [mm] / Diameter [mm]: 354  
 Nabenprofil / Hub Profile: 38,3x45,6-13N  
 Zähnezahl / Number of Teeth: 13

**CASE IH**  
 451 350 A1

**1866 600 024**

**Torsionsdämpfer, Kupplung / Torsion Damper, clutch**



Durchmesser [mm] / Diameter [mm]: 295  
 Nabenprofil / Hub Profile: 39x42,5-26N  
 Zähnezahl / Number of Teeth: 26

**RENAULT  
 AGRICULTURE**  
 7700 067 040

**1866 600 025**

**Torsionsdämpfer, Kupplung / Torsion Damper, clutch**



Durchmesser [mm] / Diameter [mm]: 295  
 Nabenprofil / Hub Profile: 38,2x41,5-25N  
 Zähnezahl / Number of Teeth: 25

**MASSEY FERGUSON**  
 3815 739 M2

**1866 600 026**

**Torsionsdämpfer, Kupplung / Torsion Damper, clutch**



Durchmesser [mm] / Diameter [mm]: 348  
 Nabenprofil / Hub Profile: 39x42,5-26N  
 Zähnezahl / Number of Teeth: 26

**RENAULT  
 AGRICULTURE**  
 7700 065 620

**1866 600 027**

**Torsionsdämpfer, Kupplung / Torsion Damper, clutch**



Durchmesser [mm] / Diameter [mm]: 348

Nabenprofil / Hub Profile: 39x42,5-26N

Zähnezahl / Number of Teeth: 26

**RENAULT  
AGRICULTURE**  
7700 078 337  
7700 067 161

© ZF Friedrichshafen AG, ZF Services - 17.11.14

# Maßtabelle für Nabenprofile

## Measure table for hub profiles

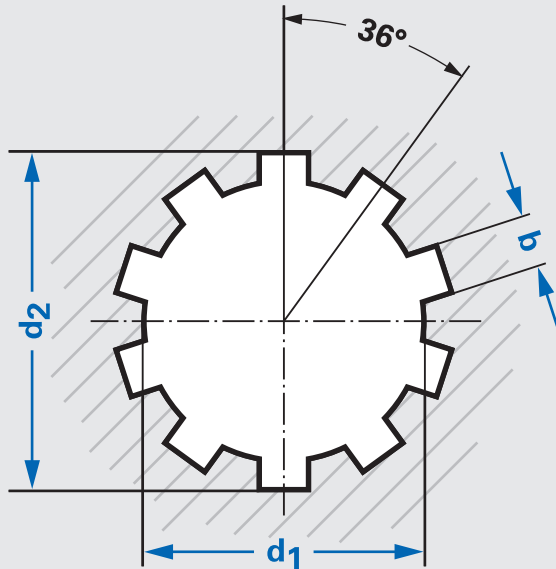

Profiles in inches	$\varnothing d_1$ [mm]	$\varnothing d_2$ [mm]	<b>b</b> [mm]
5/8 "	13,70	16,10	2,50
7/8 "	19,10	22,20	3,45
1 "	20,60	25,80	3,93
1 1/8 "	23,40	28,90	4,45
1 1/4 "	25,80	32,10	4,93
1 3/8 "	28,70	35,20	5,43
1 1/2 "	30,70	38,40	5,89
1 5/8 "	33,40	41,30	6,40
1 3/4 "	36,00	44,50	6,88
2 SAE "	41,10	50,80	7,88

# Maßtabelle für Ausrücker und Führungslager

## Measure table for releaser and pilot bearing

 SACHS	Aussendurchmesser Outer diameter [mm]	Innendurchmesser Inner diameter [mm]	Breite Width [mm]	<b>i</b>
1863 869 001	21,00	15,00	15,00	
1863 869 006	21,00	15,00	15,00	
1863 869 005	24,00	15,00	26,00	
1863 869 002	24,00	18,00	16,00	
1863 600 103	26,00	14,00	8,00	
1863 869 035	28,00	12,00	8,00	
1863 869 012	28,00	16,00	26,00	
1863 600 102	30,00	10,00	9,00	
1863 821 001	32,00	12,00	10,00	
1863 600 104	32,00	15,00	9,00	
1863 606 243	32,00	15,00	9,00	
1863 869 033	32,00	15,00	9,00	
1863 869 036	32,00	15,00	10,00	
1863 869 010	35,00	15,00	11,00	
1863 869 018	35,00	15,00	11,00	
1863 869 016	40,00	16,00	11,00	
1863 869 009	40,00	17,00	12,00	
1863 869 014	40,00	17,00	12,00	
1863 870 301	40,00	17,00	12,00	
1863 870 201	40,00	17,00	20,00	
1863 869 027	42,00	20,00	12,00	
1863 869 019	47,00	17,00	14,00	
1863 869 020	47,00	20,00	14,00	
1863 869 031	48,00	15,00	11,00	
1863 869 011	50,00	16,00	26,00	
1863 869 017	51,00	22,00	14,00	
1863 869 023	52,00	20,00	15,00	
1863 869 039	52,00	25,00	15,00	
1863 841 001	56,60	35,00	15,00	
1863 863 001	57,20	42,00	24,80	mit Anlaufring / with thrust ring
1863 820 001	60,00	33,00	16,30	
1863 869 038	62,00	25,00	17,00	
1863 869 028	62,00	25,00	24,00	
1863 869 029	62,00	25,00	27,00	
1863 805 002	66,60	37,00	20,90	
1863 805 001	67,00	38,00	17,20	
1863 836 001	67,30	40,00	19,50	
1863 869 015	68,00	36,50	15,00	
1863 869 026	68,00	40,00	15,00	
1863 600 109	68,00	40,00	19,00	
1863 869 037	72,00	30,00	19,00	
1863 810 001	75,00	40,00	18,40	
1863 600 113	75,00	45,00	16,00	
1863 600 108	76,60	45,00	22,30	
1863 011 100	76,60	45,00	23,00	mit Anlaufring / with thrust ring

# Maßtabelle für Ausrücker und Führungslager

## Measure table for releaser and pilot bearing

 SACHS	Aussendurchmesser Outer diameter [mm]	Innendurchmesser Inner diameter [mm]	Breite Width [mm]	<b>i</b>
1863 600 116	81,00	40,00	19,00	
1863 860 001	81,20	42,00	19,50	
1863 837 001	82,00	50,00	17,20	mit Anlauftring / with thrust ring
1863 840 000	82,00	50,00	23,00	mit Anlauftring / with thrust ring
1863 838 001	82,00	50,00	29,00	
1863 840 001	90,00	55,00	18,00	
1863 100 030	90,50	55,00	25,00	mit Anlauftring / with thrust ring
1863 837 000	91,60	55,00	16,30	mit Anlauftring / with thrust ring
1863 856 001	92,00	52,50	26,00	
1863 600 110	92,40	55,00	51,00	
1863 838 002	95,00	60,00	18,00	
1863 010 100	96,60	60,00	26,00	mit Anlauftring / with thrust ring
1863 600 119	97,00	65,00	23,00	mit Anlauftring / with thrust ring
1863 837 002	97,00	65,00	23,00	mit Anlauftring / with thrust ring
1863 600 101	100,00	60,00	21,50	mit Anlauftring / with thrust ring
1863 600 120	100,00	63,40	23,00	mit Anlauftring / with thrust ring
1863 600 117	100,00	65,00	11,00	mit Anlauftring / with thrust ring
1863 600 107	100,00	65,00	18,00	
1863 837 003	100,00	65,00	18,00	
1863 600 118	100,20	63,50	22,00	mit Anlauftring / with thrust ring
1863 839 001	101,40	65,00	25,00	mit Anlauftring / with thrust ring
1863 123 000	101,50	65,00	17,50	mit Anlauftring / with thrust ring
1850 282 747	101,50	65,00	22,00	mit Anlauftring / with thrust ring
1863 007 102	101,50	65,00	26,00	mit Anlauftring / with thrust ring
1863 101 100	101,50	65,00	26,00	mit Anlauftring / with thrust ring
1863 600 123	101,50	65,00	26,00	mit Anlauftring / with thrust ring
1863 600 112	102,40	55,00	29,40	
1863 600 106	102,70	63,60	20,30	mit Anlauftring / with thrust ring
1863 866 001	103,00	69,00	22,00	mit Anlauftring / with thrust ring
1863 838 000	110,00	70,00	20,00	
1863 867 001	114,50	76,00	19,40	
1863 839 000	115,00	75,00	20,00	
1863 858 001	115,00	75,00	20,00	
1863 858 002	115,00	75,00	20,00	
1863 600 115	117,00	70,00	26,90	
1863 009 100	117,00	75,00	30,00	mit Anlauftring / with thrust ring
1863 600 111	132,40	70,00	93,60	
1863 600 122	140,00	75,00	44,40	mit Anlauftring / with thrust ring
1863 855 000	140,00	106,00	25,00	mit Anlauftring / with thrust ring

**DE** *Kupplungen für Traktoren*

**EN** *Clutches for Tractors*

**FR** *Embrayages pour tracteurs*

**ES** *Embragues para tractores*

**IT** *Frizioni per trattori*

**PL** *Sprzęgła do traktorów*

**RU** *Сцепления для тракторов*

**EL** *Συμπλκτες για τρακτρ*



12229 IN

