

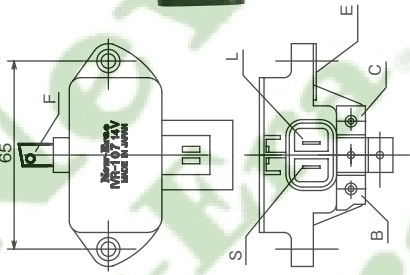







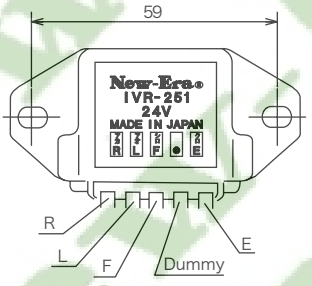

# VOLTAGE REGULATORS

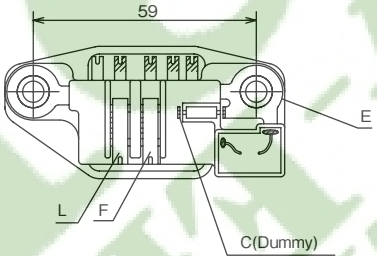
VOLTAGE REGULATORS

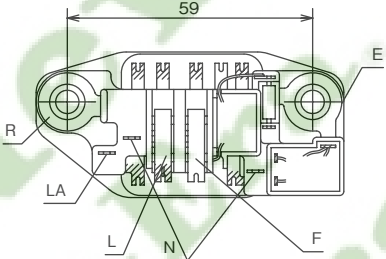
New-Era No.	Ref.No.	Application
<b>IVR-107</b>  	<b>AC12V</b> 9-191-067-049 9-191-067-059	TOYOTA CAMRY (Australia) SXV10 (5SFE) 98~01
<b>IVR-251</b>  	<b>AC24V</b> 27700-1370 1510 23500-99005  1291-004-00 SF 005-00 SF	HINO MIDDLE TRUCK HEAVY DUTY TRUCK BUS AIR SERVO SNOW-PLOW ENGINE UNIVERSAL USE  MITSUBISHI CONSTRUCTION  NISSAN HEAVY DUTY TRUCK HEAVY DUTY TRUCK (OPTION)  BUS  BUS (OPTION) SNOW-PLOW CONSTRUCTION MACHINE  EH500, EH700, EL100 W04D, H06C, H06CT, H07C EK100, EF550, EF750 EP100 W06D EL100 EF750 W04C-T1  MACHINE S6A  PE6, PE6T, RD8 RE8  RD10 PE6H RD8 PD PE6 PE6T PE6, PE6T, PE6A PE6TA  80~83 83~ 81~ 84~ 83~ 81~ 82~ 84~  82~  79~ 82~ 79~83  79~ 80~ 84~ 80~ 83~ 84~
<b>IVR-252</b>  	<b>AC24V</b> 27700-1600 23500-Z9003  1291-007-00X0 SF	HINO TRUCK  NISSAN TRUCK  GENERATOR NE6  FD FF: H06CT, H07C FD: W06E FD: H06CT, H07C SH72, SS72 FD: W06E H06C-T1  P-CM87: FE6B, FE6T P-CL86: FE6B, FE6T P-CP87: FE6B, FE6T CW54 TYPE RF8 CD54 TYPE RF8 CM87, CL80: FE6A, FE6B, FE6T CM88, CP88: FE6TA  86~ 86~92 86~92 87~88 86~88 87~88  88~ 88~ 88~ 90~ 90~ 88~ 88~90 88~89 88~

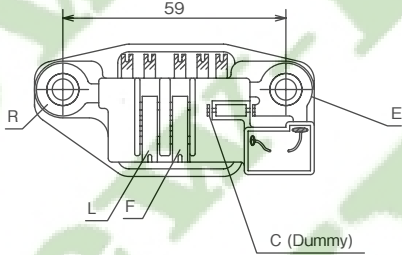

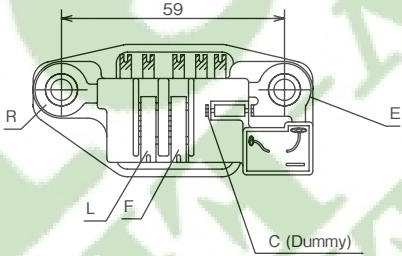

# VOLTAGE REGULATORS

New-Era No.	Ref.No.	Application
<b>IVR-253</b>  	<b>AC24V</b> 27700-1700 1990 23500-Z9007  1291-008-00X0 SF 20X9 SF	HINO BUS, TRUCK TRUCK  NISSAN TRUCK  TRUCK  F17D, F17E, K13D, K13U H07CT (A), H07D, W06E, U-FD2H, 3H, U-FD3W, U-F 2H, 3H H07CT (A), H07D, W06E, U-FD2H, 3H, U-FD3W, U-FF2H, 3H F17D, F17E, K13D, F20C, P09C  PF6, RF8, RE8, RE10, RF10, U-CK, U-CG, U-CV, U-CW FE6B, FE6T CM, CL, CP FE6A, FE6B, FE6T, CM, CL NF6TA, PE6T, PF6TA (B) U-CV, U-CK, U-CD, U-G FE6TA, CM, CL, CP  89~ 89~ 89~ 89~ 89~ 89~ 90~ 90~ 89~ 90~
<b>IVR-254</b>  	<b>AC24V</b> 27700-1590	HINO TRUCK  FS, FN, FR (EF550, EF750, EK100, EP100TC) P-FR, P-FS, P-SH (F17C)  85~92 87~89
<b>IVR-255</b>  	<b>AC24V</b> 27700-1690  1291-006-10X0 SF	HINO TRUCK  FS, FN, FR (EF550, EF750, EK100, EP100TC) P-FR, P-FS, P-SH (F17C)  88~92 88~91

VOLTAGE REGULATORS

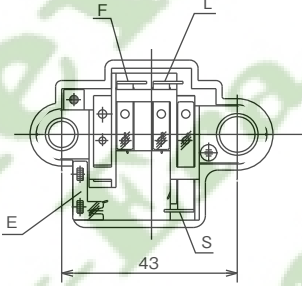

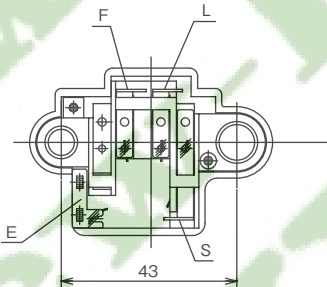
# VOLTAGE REGULATORS

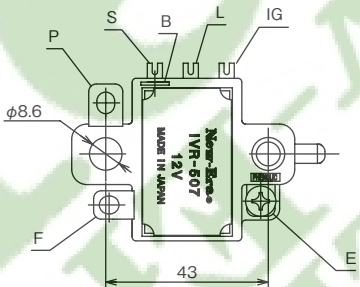
New-Era No.	Ref.No.	Application
<b>IVR-505</b>  	<b>AC12V</b> 27700-57060 27700-64030	DAIHATSU CHARADE CHARADE DIESEL  ISUZU ELF  TOYOTA CORONA CORONA MARK II MARK II CHASER CHASER CRESTA CRESTA CARINA CARINA CAMRY VISTA CAMRY VISTA
	126000-0180 ND 0770 ND	E-G11 (CB12, 33, 34, 22) N-G30 (CL10)  NKR  CT141 (2C) CT141 (2C) LX70 (2L, 2L-T) LX70Y (2L) LX70 (2L, 2L-T) LX70Y (2L) LX70 (2L, 2L-T) LX70Y (2L) CT150MT (2C-L) CT150AT (2C-L) CV20MT (2C-T) CV20MT (2C-T) CV20AT (2C-T) CV20AT (2C-T)
<b>IVR-506</b>  	<b>AC24V</b> 27700-57051	ISUZU FORWARD  MAZDA TITAN4100  TOYOTA LAND CRUISER LAND CRUISER LAND CRUISER COASTER COASTER COASTER
	126000-0200 ND 0260 ND 0810 ND	P-FR12 (6BG1)  K-WEX, WEY, WEZ (2B) K-WE11D, N-WE14L, T K-WE17T  BJ71, 74V (13B-T) HJ60V (2H) HJ61V (2H) BB2#, 3# (3B) HB30 (2H) HB31 (12H-T)
<b>IVR-507</b>  	<b>AC12V</b> 27700-64040 64110	TOYOTA CORONA, CARINA  COROLLA, SPRINTER  CAMRY, VISTA CAMRY, VISTA CROWN HIACE  HI-LUX  DYNA, TOYOACE (Refr igerator)
	126000-0920 ND 1460 ND	CT170 (2C) CT176V (2C) CE90 (1C) CE96V (1C) CE97G (1C) CV20 (2C-T) CV30 (2C-T) LS130 (2L, -T, -THE) LH51G (2L, 2L-T) LH51V (2L) LH80 (2L) LH80VH (2L) LN130G (2L-T) LN131V (3L)  LY50, 60 (2L) LY5# (2L) LY6# (3L) LY51, 61 (3L)

VOLTAGE REGULATORS

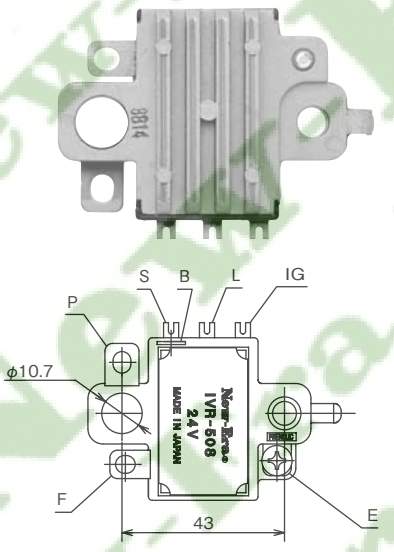
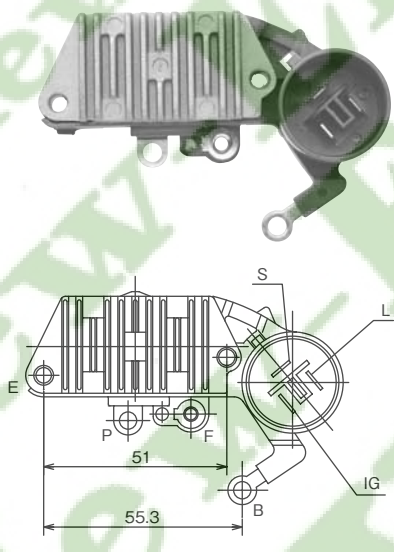

# VOLTAGE REGULATORS

VOLTAGE REGULATORS

New-Era No.	Ref.No.	Application
<b>IVR-508</b> 	<b>AC24V</b> 27700-58010  126000-7000 ND 7001 ND	TOYOTA COASTER BB2#, 3# (3B) HB31 (12H-T) HB30 (2H) 87~ 87~ 87~
<b>IVR-510J</b> 	<b>AC12V</b> 31150-PDI-004 27700-63020 63021 72040  126000-0340 ND 0400 ND 0510 ND	DAIHATSU DELTA WIDE E-YB21B (3Y-EU) 83~  HONDA ACCORD 1800 1600 VIGOR 1800 CITY 1200 E-AD (ES) 83~ E-AC (EY) E-AD GES E-AA CER 82~  ISUZU FLORIAN ASKA E-JJ120, 110 (4ZC1, 4ZB1) 83~  TOYOTA SOARER 2800 2000 MARK II, CHASER 2000 1800 CRESTA 2000 VISTA, CAMRY 2000 1800 CORONA 1800 CELICA XX 2000 CARINA 1600 COROLLA, SPRINTER 1600 TOWNACE 2000 CELICA, SUPRA CRESSIDA CAMRY COROLLA, TERCEL COROLLA (FRONT WHEEL DRIVE) (REAR WHEEL DRIVE w/FUEL INJECTION) [USA] E-MZ11 (5M-GEU) 84 E-GZ10 (1G-GEU) 83~ E-GX61 (1G-GEU) 82~84 E-SX60 (2Y-PU) 83~84 E-GX61 (1G-GEU) 82~84 E-MX61 (M-TEU) 81~83 E-SV11 (2S-ELU) 82~ E-SV10 (1S-LU) 82~84 E-ST150 (1S-LU) 83~ E-GA61 (1G-GEU) 82~ E-AA63 (4A-GEU) 83~ E-AE82 (4A-ELU) 83~ E-AE86 (4A-GEU) 83~ E-YR21G (3Y-EU) 83~ [USA] 84~ [USA] 84~ [USA] 83~ [USA] 85~ [USA] 84~ [USA] 85~

# VOLTAGE REGULATORS

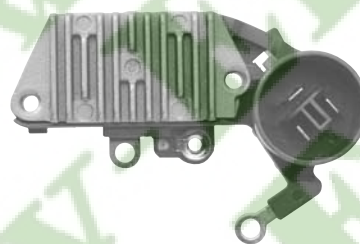
VOLTAGE REGULATORS

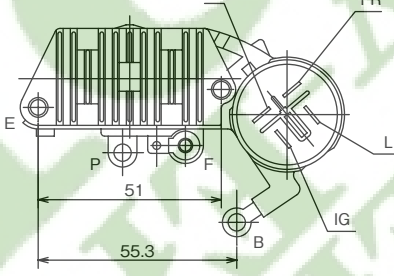
New-Era No.	Ref.No.	Application
<b>IVR-511J</b>  	<b>AC12V</b> 31150-PE0-003 32500-82610 GM# 96052000  126000-0410 ND 0430 ND	HONDA BALLADE SPORTS CR-X E-AE E-AF (EV, EW) 83~  SUZUKI CULTUS  GM SPRINT
<b>IVR-512</b>  	<b>AC12V</b> 31150-PE0-921  126000-0440 ND	HONDA CIVIC CIVIC BALLADE AG, A.J, MT (EV) VJ (EV) AE, A.J, MT (EV) 83. 9~ 83. 10~ 83. 7~  ISUZU GEMINI JT190 (4XE1) 88. 3~
<b>IVR-513J</b>  	<b>AC12V</b> 31150-PD6-014  126000-0540 ND	HONDA ACCORD, VIGOR (A20A3) PRELUDE ACCORD, VIGOR VIGOR LEGEND ACCORD, VIGOR LEGEND PRELUDE LEYLAND(U.K) LAND ROVER 825 CA6 (USA) BA1 (B20A) CA3 (B20A) CA3 (B20A) KA5 (C20A) CA3 (B20A) KA1 (C20A) KA2 (C25A) KA3 (C27A) BA4, 5 PGM-F1 (B20A) 88. 4~ 85 ~87 85 ~88 85. 6~ 88. 10~ 88. 8~ 88. 10~ 88. 10~ 88. 10~ 87. 4~

# VOLTAGE REGULATORS

VOLTAGE REGULATORS

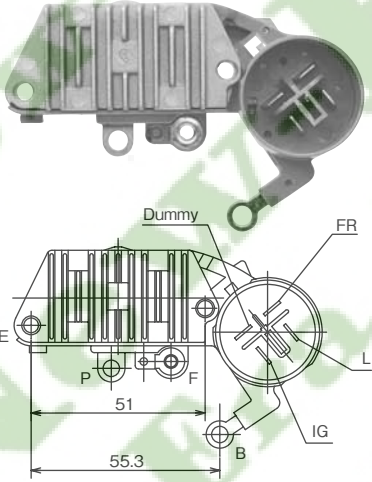
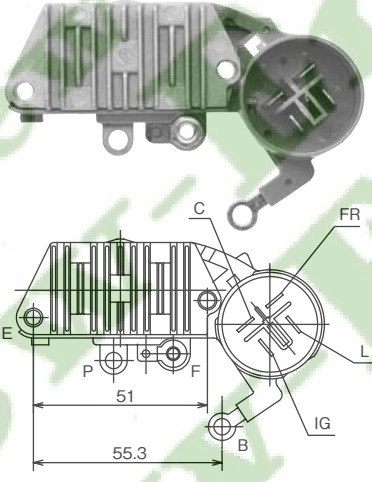
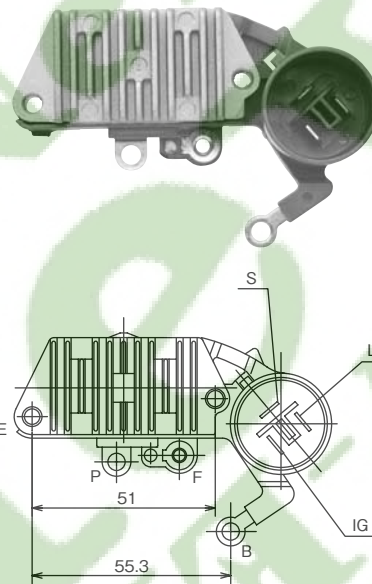
New-Era No.	Ref.No.	Application
<b>IVR-514J</b> 	<b>AC12V</b> 31150-PE7-662  126000-0570 ND	HONDA QUINT DA6 (B16A) DA8 (B16A) 89.4~
<b>IVR-515</b> 	<b>AC12V</b> 31150-PM4-003  126000-0940 ND	HONDA CONCERTO CIVIC CR-X QUINT (INTEGRA) MA2 PGM-F1 (ZC) MA3 4WD (ZC) EF3 (ZC) EF5, MA3 (ZC) EF7 (ZC) DA5 (ZC) DA7 PGM-F1 (ZC) 88~ 88~ 87~ 88~ 87~ 89~ 89~
<b>IVR-516</b> 	<b>AC12V</b> 31150-PD2-014 27700-70030 54050 10061  126000-0700 ND 1530 ND 0731 ND 0732 ND	HONDA ACCORD CA2 (B18A) 85~88 TOYOTA CROWN SOARER SUPRA SUPRA CORONA CELICA CELICA MR2 MR2 MARK II COROLLA SPRINTER TARCEL CAMRY CAMRY V6 HIACE LITEACE TOWNACE MASTERACE VAN GS131 (1G-GE) GZ20 (1G-GTEU) GA70 (1G-GTEU) ST165 (3S-GTE) ST165 (3S-GTE) (4A-FE) W/O POWER STRG GX70G (1G-EU) AE91 (5A-FE) AE95G (4A-FE) (4A-FE) AE91 (5A-FE) YH62V (3Y) YM30G (3Y-U) YM40G (4Y-U) YR20G (2Y-U) YR20G (2Y-U) PICK-UP 4RUNNER 4CYL PICK-UP 4RUNNER 4X4 87~88 86~88 87~88 88~92 87~89 86~89 90~92 89~91 92 86~88 88~89 88~90 90~92 88~89 90~91 90~91 88~89 87~89 86~88 86~88 86~ 86~ 90~91 89 88~89

# VOLTAGE REGULATORS

New-Era No.	Ref.No.	Application
IVR-517	AC12V 27060-87715-000 27700-87601-000 8-94455160-0 32500-60B11 86510 GM# 96055618 96067082	DAIHATSU CHARADE ROCKY G102S MT G112S MT (HC-E) G100S MT, AT (CB37) G100S MT (CB70) F300S MT (HD-E) 90. 11~93. 1 90. 11~93. 1 90. 11~93. 1 92. 5~93. 8
		ISUZU JEMINNET RODEO BIG HORN AA43Z (G10) UBS12 (4ZC1) UBS25DW MT (6VD1) 86. 7~ 86. 9~ 92. 10~
IVRS-517	AC12V 27700-87601-000 32500-86511	DAIHATSU CHARADE ROCKY G102S, G112S (HC-E) G100S (CB37, CB70) F300S MT (HD-E) 90~93 90~93 92~93
		SUZUKI GEMINNET JIMMY CULTUS AA43Z (G10) JB31W (G13BA) AA33S, AB33S (G13B) 86~ 93~95 86~88
IVR-518	AC12V 27700-10050 10080	TOYOTA LITEAGE TOWNACE, LITEAGE CORONA CARINA COROLLA, SPRINTER DYNA, TOYOACE DYNA, TOYOACE YM31V (2Y-J) YM-55, 60 (2Y) ET176V, MT (3E) ET176V, MT (3E) EE106V, MT (2E) YY51 (2Y) YY52, 61 (3Y) 90. 8~92. 1 89. 1~ 91. 8~92. 11 91. 8~92. 11 91. 9~92. 5 89. 1~93. 9 89. 1~93. 9

VOLTAGE REGULATORS



# VOLTAGE REGULATORS

VOLTAGE REGULATORS

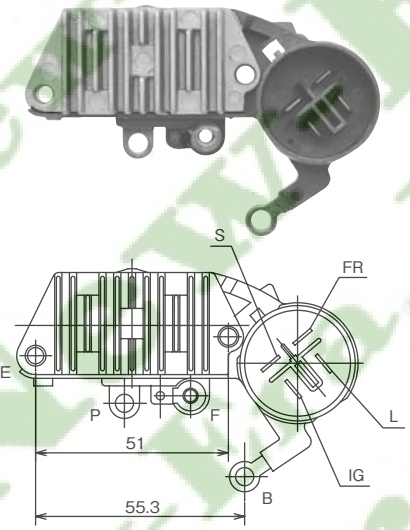
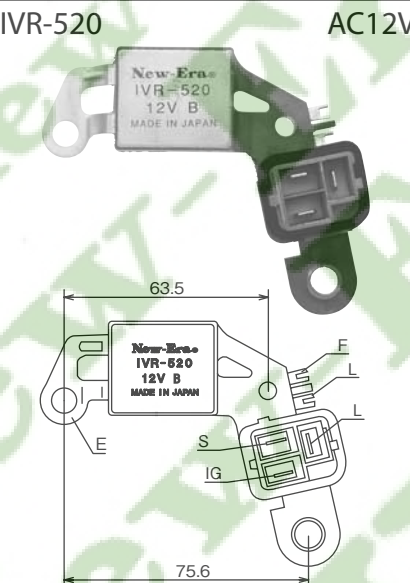
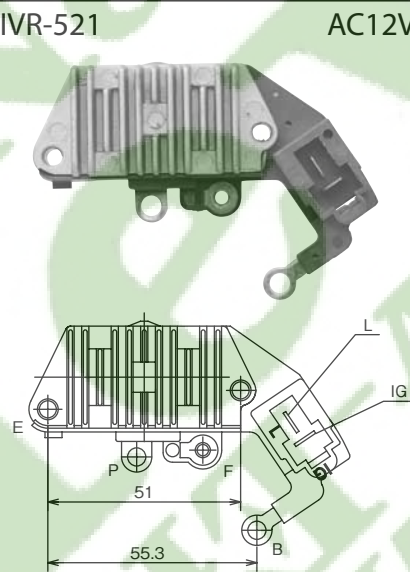
New-Era No.	Ref.No.	Application
<b>IVR-519</b> 	<b>AC12V</b> 31150-PD6-0240  126000-1060 ND	HONDA VIGOR (ACURA) ACCORD, VIGOR (ACURA)  LEGEND (ACURA)  PRELUDE CA3 (B20A) 85. 6~ CA3 (B20A) 85. 6~88. 7 CA3 (B20A) 88. 8~ CA6 (A20A3) 88. 4~ KA1 (C20A) 85. 11~88. 10 KA1 (C20A) 88. 10~ KA2 (C25A) 85. 11~88. 10 KA2 (C25A) 88. 10~ KA3 (C27A) 87. 2~88. 10 KA3 (C27A) 88. 10~ KA6 (C20A) 88. 10~ BA4, 5 PGM-F1 (B20A) 87. 4~ BA4, 5 (B20A) 89. 11~ BA7 PGM-F1 (B21A) 90. 11~ BA4 PGM-F1 (B20A) 87. 4~89. 10 BA4 PGM-F1 (B20A) 89. 11~91. 8 BA5 PGM-F1 (B20A) 87. 4~89. 10 BA5 PGM-F1 (B20A) 89. 11~91. 8
<b>IVR-520</b> 	<b>AC12V</b> 27700-43010  126000-0170 ND 0450 ND	TOYOTA CORONA MARK II E-RX63 (18R-GEU) 80~82 E-MX60, 61, 63 (5M-EU, GEU) 80~83 E-GX60, 61 (1G-EU) 81~ CORONA E-TT132 (3T-EU) 81~ E-TT142 (4T-GTEU) 81~ CHASER E-RX63 (18R-GEU) 80~82 E-GX60, 61 (1G-EU) 81~ CROWN E-MS110, 112 (M-U, 5M-EU) 80~82 E-MS112 (5M-GEU) 81~83 SOARER E-MZ10, 11 (M-U, TEU) 80~83 E-GZ10 (1G, EU) 81 CRESSIDA GX6#, MX62X (1GE, 5ME) [USA] 80~83 CRESTA E-MX60, 61 (5M-GEU) 81~83 CELICA, CARINA E-TA63, 64 (3T-EU, GTEU) 81~ E-MA61, E-TA63 (5H-GEU, ST-E) 81~ CELICA E-GA61 (1G-EU) 81~ COROLLA, SPRINTER E-TE71 (2T-GEU) 81~83 TERCEL AL-21, 25 (3A, 3AC) [USA] 82~ COROLLA (exc TERCEL) [USA] 81~82 CORONA [USA] 81~82
<b>IVR-521</b> 	<b>AC12V</b> 27700-87702-000 32500-85510  126000-0371 ND	DAIHATSU CHARADE G100S MT (CB37) 87. 1~ G11 (CB12, 33, 34) (CB35) 83. 1~86. 4 85. 2~86. 4 G100S AT TURBO (CB50) (CB51) 86. 1~87. 1 87. 1~88. 8 89. 8~ APPLAUSE A101S, 16RI AT (HD)  MITSUBISHI MINICAB U11T, U12T (G23B) 85. 3~86. 4 U11V, U12V, (G23B) 85. 4~86. 4  SUZUKI FRONTE CB71S (1C) (F5A) 84. 10~86. 7 ALTO CA71V (1C) (F5A) 84. 10~86. 3 CC71V (1C) (F5A) 84. 10~86. 3

# VOLTAGE REGULATORS

New-Era No.	Ref.No.	Application
IVR-522 	AC12V 27700-87207-000 87209-000 87703-000 31150-PE9-941 MD604751 MD604589 23815-KA080 32500-85250/1 KUBOTA# 15881-64601 27700-96301	DAIHATSU MIRA (KANCIL)  L200 (EF-CL) 90. 3~ L200 (EF-HL) 90. 3~ L210 (EP-CL) 90. 3~ L200 (EF-XL) 90. 3~92. 8 L200 AT (EF-XL) 92. 8~ L200 3AT (EF-JL) 90. 3~91. 5
		HONDA TODAY  JA1 CAB, JWZ CAB (E05A) 88. 2~90. 2 JA2 CAB, JA3 CAB (E07A) 90. 2~ ACTY HA1 A/C, HA2 A/C HH1 A/C (E05A) 88. 5~ HA3, HA4, HH3 (E07A) 90. 4~
	MAZDA CAROL  AA6PA (F6A) 90. 2~ AA6RA (F6A) 90. 2~	
	MITSUBISHI MINICAB  U14T, U14TP, U14V U15T, U15V (3G81) 87. 5~ U41T, U41TP, U42T-PS, U41V SOHC MT, U41V SOHC AT, U41V DOHC AT, U41V DOHC TBO MT, U41V DOHC TBO AT, U42V SOHC MT, U42V SOHC AT, U42V DOHC AT, U42V DOHC TBO MT, U42V DOHC TBO AT (3G83) 90. 12~	
	SUBARU REX  KH1, KH1-PS, KH1-AC (EN05A) 89. 6~ KH3-AC, KH3-PS, KP3-AC, KP3-PS, KP4-AC, KP4-PS (EN07A) 90. 4~ VIVIO KK3 PS, KK4 PS, KW3 PS (EN07) 92. 3~	
	SUZUKI CARRY EVERY CERVO  DA41V, DB41V (F5B) 89. 5~ DA51V, DB51V (F6A) 90. 3~ CG72V (F5B) 80. 1~ CH72V (F5B) 88. 1~ CN31S, CP31S (F6B) 90. 7~ FRONTE ALTO CN11S, CP11S (F5B) 88. 9~ CL11V (F5B) 88. 9~ CL11S SE, CP11S SE CP11S SM (F5B) 89. 10~90. 2	
	IHI  S753 93. 7~	
	ISEKI TRACTOR TU185  (E3AF1-D01K) 86. 8~ TU205 (E3AF1-DK) 86. 8~ TU225 (E3AF1-D01K) 86. 8~	
	KUBOTA TRACTOR TRACTOR  A35 (D100) 88. 8~ F2402 (D100) 88. 11~	
	TOYOTA SHOVEL LOADER (DIESEL)  3SDK3 (3TN66) 87. 12~ 3SDK4 (3TNA68) 87. 12~ 3SDK5 (3TN82) 87. 12~ FORKLIFT FG5 (AB) 91. 9~	
	126000-1160 ND 0600 ND	

# VOLTAGE REGULATORS

VOLTAGE REGULATORS

New-Era No.	Ref.No.	Application
<b>IVR-523</b> 	<b>AC12V</b> 27700-70040  126000-1520 ND	TOYOTA CROWN MARK II · CHASER · CRESTA  YS130 (3Y-PE) 91. 12~ GS130, GS130H (1G-GP) 91. 12~  YX80 (3Y-P) 94. 9~ YX80Y (3Y-P) 93. 2~94. 9
		TOYOTA ARISTO (LEXUS GS 300) CROWN CORSA · COROLLA II · TERCEL  STARLET NP80 (1N) CORONA AT190AT, AT190MT  COROLLA · SPRINTER  MARK II · CHASER · CRESTA  MARK II · CHASER · CRESTA  CAMRY · VISTA  HILUX  WINDOM (LEXUS ES 300) CARINA MR2 TOWN ACE · LITE ACE
<b>IVR-524</b> 	<b>AC12V</b> 27700-40050 65010 74030  126000-1580 ND 1640 ND 7100 ND	UZS143 (1UZ-FE) 92. 10~  UZS143, UZS145 (1UZ-FE) 92. 10~ UZS141, UZS147 (1UZ-FE) 93. 8~ NL40 (1N-T) 92. 8~ NL50 (1N-T) 94. 9~ EL41AT (4E-FE) 93. 5~ EL43AT (5E-FE, 5E-FHE) 93. 5~  (4A-FE) 92. 1~ CT190AT, CT190MT (2C) 92. 2~92. 3 CT190YMT (2C) 93. 2~ CT195 (2C) 92. 11~ ST180, ST181 (4S-FE) 92. 8~ ST182 (3S-FE) 92. 11~  AE100AT, AE100GAT, AE100MT, AE100GMT (5A-FE) 92. 5~ AE101AT, AE101MT (4A-GE) 92. 5~ AE104AT (4A-FE) 92. 5~ SX80MT (4S-FE) 93. 2~ SX90AT, SX90MT (4S-FE) 92. 10~ GX70GMT (1G-FE) 93. 2~ GX90MT (1G-FE) 92. 10~  GX70GAT GX81AT (1G-FE) 93. 2~94. 9 GX90AT (1G-FE) 94. 9~ VZV32, VZV33 (4VZ-FE) 92. 6~ SV30AT (4S-FE) 92. 6~ CV30 (2C-T) 92. 6~ VZN130G (3VZ-E) 92. 8~ LN130GAT, LN130GMT, LN130WAT, LN130WMT (2L-TE) 92. 8~93. 8 LN131V (3L) 92. 8~93. 8 LN108, LN112 (2L-TE) 95. 8~ KZN130GAT, KZN130WAT, KZN130GMT, KZN130WMT (1KZ-TE) 93. 8~ VCV10 (3VZ-FE) 92. 6~  CT190AT (2C) 92. 11~ SW20MT, SW20AT (3S-GE) 92. 11~ SW20 (3S-GTE) 92. 11~ CR22G, CR29G (3C-T) 93. 9~ CR31GAT, CR38GAT, CR31GMT (3C-T) 93. 9~ YR21GMT, YR30G (3Y-EU) 93. 9~

CONTINUED

# VOLTAGE REGULATORS

New-Era No.	Ref.No.	Application
<b>IVR-524</b>  	<b>AC12V</b> 27700-40050 65010 74030	TOWN ACE·LITE ACE TRUCK CM55, CM60, CM61, CM65 (2C) 93. 10~ CM55SJL, CM65JL, TS, MT, AT (2C) 93. 10~ TOWN ACE·LITE ACE V. W. CR27VAT (REFRIGERATOR CAR) CR36VMT (2C) 93. 9~ UCF-10, UCF11 (1UZ-FE) CELSIOR (LEXUS LS 400) 92. 8~94. 10 SUPRA 93. 5~ SOARER 94. 1~ HIACE LH129VMT, LH123VMT, LH119VMT, GL (3L) 93. 8~ LH129S, (3L) 93. 8~95. 8 KZH126G, KZH116G, KZH120GAT, KZH111GAT (1KZ-TE) 93. 8~ KZH120GMT (1KZ-TE) 93. 8~95. 8 LAND CRUISER HZJ81V (1HZ) 92. 8~ HDJ81V (1HD-T) 92. 8~95. 1 HDJ81V (1HD-FT) 95. 1~ HZJ75 (1HZ) 92. 12~ ESTIMA CXR21G, CXR20G, CXR11G (3C-TE) 93. 8~95. 1 CXR10G (3C-TE) 95. 1~
	126000-1580 ND 1640 ND 7100 ND	
<b>IVR-525</b>  	<b>AC12V</b> 8-97032091-0	ISUZU GEMINI JT191F (4XE1) 90~92 JT151F (4XC1) 90~92 JT191S (4XE1) 92~ JT191F (4XE1) 92~ JT151F (4XC1) 92~ PIAZZA JT2221F (4XF1-W) 91~
	126000-1200 ND	
<b>IVR-526</b>  	<b>AC12V</b> 32500-86210	HONDA CITY GA1 (D12A) 86. 10~88. 10 SUZUKI SWIFT 1300CC (SF413)
	126000-0840 ND	

VOLTAGE REGULATORS

# VOLTAGE REGULATORS

VOLTAGE REGULATORS

New-Era No.	Ref.No.	Application
<b>IVR-527</b> 	<b>AC24V</b> 27700-58020  126000-7010 ND 7011 ND 2340 ND	<b>DAIHATSU</b> DELTA V98, 98D, 99 (B) 88~ V115, 116, 118, 119 (14B) 88~93 <b>HINO</b> RANGER HV98, 98D, 99 (B) 88~ HV115, 116, 118, 119 (14B) 88~ <b>TOYOTA</b> DYNA, TOYOACE BU60, BU70, 70VH, 83 (B) 88~93 BU68DH (3B) 89~93 BU61, 84 (11B) 88~93 BU66, 66D, 66H, 67, 67D, 87, 87V, 88, 91, 94, 96, 73, 74, 78, 72, 72D, 72DH, 72H (14B) 88~93 <b>COASTER</b> BU88, 91, 94, 96 (14B-T) 89~93 BB20, 21 (3B) 82~93 BB26V, 31 (3B) 88~93 BB23, 24 (14B) 88~93 HDB30, 31 (1HD-T) 90~93 HZB30, 31 (1HZ) 90~93 HZB36V (1HZ) 90~93 <b>LAND CRUISER</b> BJ70, 70V, 73V (3B) 88~90 HZJ73HV, 73V, 77HV (1HZ) 90~92 PZJ70, 70V, 77V, 77HV (1PZ) 90~92
		<b>DAIHATSU</b> DELTA V98, 98D (B) 93~95 BU100N (3B) 95~ V115, 116, 118, 118D, 119 (14B) 93~95 BU102J, 102N, 102P, 102U, 107N, 112M, 112N, 112T, 112U, 142N, 147N, 162J, 162M, 162N, 162U, 172N, 212N, 222N (15B-F) 95~ <b>HINO</b> RANGER BU100M (3B) 95~ BU102E, 102M, 102T, 102X, 107M, 112M, 112T, 112X, 142M, 147M, 162M, 162T, 162X, 172M, 182M, 202M, 212M, 222M (15B-F) 95~ <b>MEGA-CRUISER</b> XZU130 (J05C) 95~96 BXD20 (15B-FT) 96~ <b>TOYOTA</b> DYNA, TOYOACE BU60, 70V, 70VH, 83 (B) 93~95 BU68DH (3B) 93~95 BU100, 100A, 120V, 140 (3B) 95~ BU61, 84 (11B) 93~95 <b>DYNA, TOYOACE</b> BU66, 66D, 66H, 67, 67D, 72, 72D, 72DH, 72H, 73, 74, 78, 87, 87V, 88, 91, 94, 96 (14B) 93~95 BU88, 91, 94 (14B-T) 93~95 BU102, 102A, 102D, 102H, 107, 112, 112A, 112D, 132, 137, 142, 147, 202, 162, 162A, 162D, 172, 182, 212, 222 (15B-F) 95~ BU212, 222 (15B-FT) 95~ XZU130 (J05C) 96~ <b>COASTER</b> BU40, 46V (3B) 93~ BB55 (15B-F) 95~ HDB50, 51 (1HD-FT) 95~ HDB40, 41, 50, 56 (1HZ) 93~ HZB50, 51 (1HZ) 93~ <b>LAND CRUISER</b> HZJ70, 70V, 77HV (1HZ) 92~ PZJ70, 70V, 77V, 77HV (1PZ) 92~94
<b>IVR-528</b> 	<b>AC24V</b> 27700-58040 58060  126000-7120 ND 2390 ND	<b>DAIHATSU</b> DELTA V98, 98D (B) 93~95 BU100N (3B) 95~ V115, 116, 118, 118D, 119 (14B) 93~95 BU102J, 102N, 102P, 102U, 107N, 112M, 112N, 112T, 112U, 142N, 147N, 162J, 162M, 162N, 162U, 172N, 212N, 222N (15B-F) 95~ <b>HINO</b> RANGER BU100M (3B) 95~ BU102E, 102M, 102T, 102X, 107M, 112M, 112T, 112X, 142M, 147M, 162M, 162T, 162X, 172M, 182M, 202M, 212M, 222M (15B-F) 95~ <b>MEGA-CRUISER</b> XZU130 (J05C) 95~96 BXD20 (15B-FT) 96~ <b>TOYOTA</b> DYNA, TOYOACE BU60, 70V, 70VH, 83 (B) 93~95 BU68DH (3B) 93~95 BU100, 100A, 120V, 140 (3B) 95~ BU61, 84 (11B) 93~95 <b>DYNA, TOYOACE</b> BU66, 66D, 66H, 67, 67D, 72, 72D, 72DH, 72H, 73, 74, 78, 87, 87V, 88, 91, 94, 96 (14B) 93~95 BU88, 91, 94 (14B-T) 93~95 BU102, 102A, 102D, 102H, 107, 112, 112A, 112D, 132, 137, 142, 147, 202, 162, 162A, 162D, 172, 182, 212, 222 (15B-F) 95~ BU212, 222 (15B-FT) 95~ XZU130 (J05C) 96~ <b>COASTER</b> BU40, 46V (3B) 93~ BB55 (15B-F) 95~ HDB50, 51 (1HD-FT) 95~ HDB40, 41, 50, 56 (1HZ) 93~ HZB50, 51 (1HZ) 93~ <b>LAND CRUISER</b> HZJ70, 70V, 77HV (1HZ) 92~ PZJ70, 70V, 77V, 77HV (1PZ) 92~94

# VOLTAGE REGULATORS

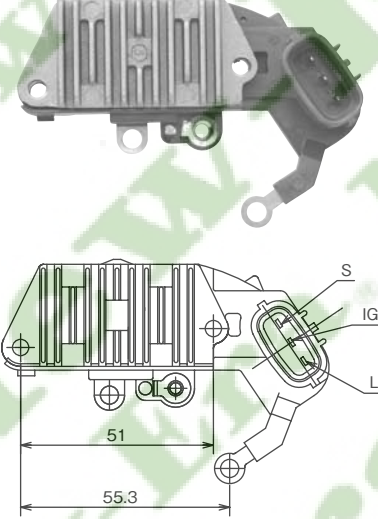
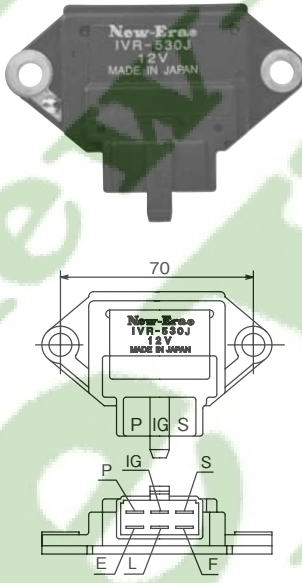
New-Era No.	Ref.No.	Application
<b>IVR-529</b> 	<b>AC12V</b> 27700-11070 66040	TOYOTA CARDINA COROLLA, SPRINTER  CORSA, COROLLA II  CYNOS  DYNA, TOYOACE  HIACE  LAND CRUISER MARK II, CHASER QUICK DELIVERY SERA STARLET  TOWNACE, LITEACE  ET196V (5E-FE) 92~93 EE101 (4E-FE) 92~95 EE102V (4E-FE) 97~ EE103V (5E-FE) 97~ EE104G (5E-FE) 97~ EE106V (2E) 92~94 EE107V (3E) 92~94 EE108G (3E) 92~94 EE111 (4E-FE) 95~ EL41 (4E-FE) 92~94 EL43 (5E-FE) 92~94 EL43 (5E-FHE) 92~94 EL45 (5E-FE) 92~94 EL44 (5E-FE) 92~95 EL44 (5E-FHE) 92~95 RZU100 (3RZ-FE) 95~97 RZU100A (3RZ-FE) 95~97 RZU100A (3RZ-FP) 95~97 RZU100H (3RZ-FP) 95~97 RZH100G (1RZ-E) 93~95 RZH112V (1RZ-E) 93~ RZH124B (1RZ-E) 93~ FZJ80G (1FZ-FE) 92~98 YX78V (3Y-E) 93~97 RZU68VH (3RZ-FP) 96~ EXY10 (5E-FHE) 92~95 EP82 (4E-FE) 92~96 EP82 (4E-FTE) 92~93 EP-85 (4E-FE) 92~93 EP91 (4E-FTE) 96~ YM55 (2Y) 93~ YR25V (2Y-J) 93~96
	126000-1750 ND 1730 ND	
<b>IVR-530J</b> 	<b>AC12V</b> 31400-SA5-004 SB0-004	HONDA ACCROD 1800 VIGOR 1800 PRELUDE 1800  E-SZ (EK) 81~ E-SZ 81~ E-SN (EK) 82~
	126000-0301 ND 0302 ND 0420 ND	

VOLTAGE REGULATORS

# VOLTAGE REGULATORS

VOLTAGE REGULATORS

New-Era No.	Ref.No.	Application
<b>IVR-531</b> 	<b>AC12V</b> 19279-64601	MITSUBISHI CATERPILLAR  126000-1940 ND
<b>IVR-532</b> 	<b>AC12V</b> 126000-0760 ND 0990 ND	SUBARU SAMBER  INDUSTRIAL USE  KR1 (EK23) 86~90 KR2 (EK23) 86~88 KR5 (EK23) 88~90 KR6 (EK23) 88~90 KT1 (EK23) 86~90 KT2 (EK23) 86~88 KT6 (EK23) 88~90 FD20-11 (4D95S) 88 FD20DC-11 (4D95S) 88 FD20SDC-11 (4D95S) 88 FD20ST-11 (4D95S) 88 FD20T-11 (4D95S) 88 FD20WC-11 (4D95S) 88 FD30H-11 (4D95L) 88
<b>IVR-533</b> 	<b>AC12V</b> 27700-16010 50010 76020  126000-0610 ND 1440 ND 1441 ND 1450 ND	TOYOTA CAMRY, VISTA  CARINA  CELICA CELSIOR COROLLA CORONA  CORSA CROWN  SV21, 25 (3S-FE) 88~90 SV21 (3S-GE) 88~90 SV22 (4S-FI) 88~90 AT-160 (4A-GELU) 88 AT171 (4A-GE) 88~92 ST162 (3S-GELU) 88~89 ST170, 170G (4S-FE) 90~92 ST170, 170G, 180, 181 (4S-FI) 88~90 ST182, 183 (3S-FE, GE) 89~91 ST182, 183, 183C (3S-GE) 89~91 ST185, 185H (3S-GTE) 89~91 UCF10, 11 (1UZ-FE) 89~92 AE92 (4A-GE) 87~91 ST170 (4S-FE) 89~92 ST170, 180, 181 (4S-FI) 87~89 ST171, 182, 183 (3S-FE, GE) 87~92 NL40 (1N-T) 90~92 GS130, 130G, 131 (1G-FE) 88~93 GS131H, 136V (1G-FE) 88~93 GS130G, 131, 131H (1G-GZE) 88~91 GS131 (1G-GE) 88~91 LS130, 131 (2L-T) 89~91 LS130, 130G, 130W (2L-THE) 89~93

CONTINUED

# VOLTAGE REGULATORS

New-Era No.	Ref.No.	Application
IVR-533	AC12V 27700-16010	CROWN DELIBOY DELTA WIDE ESTIMA HIACE HILUX LAND CRUISER MARK II, CHASER SOARER STARLET SUPRA TOWNACE
	50010 76020	
IVR-535	AC12V 31150-P2T-0030	HONDA CR-X CIVIC DOMANI INTEGRA ASCOT, RAFAGA STEP WAGON PRELUDE S-MX INSPIRE SABER CR-V S-MX
CONTINUED	126000-0610 ND 1440 ND 1441 ND 1450 ND	LS131, 131H, 141 (2L-THE) 89~93 LS130, 136V (2L) 89~93 MS135, 135Z, 137 (7M-GE) 88~91 UZS131 (1UZ-FE) 89~91 CXC10V (2C) 91~94 CB27V (2C) 90~93 YB21G (3Y-EU) 88~91 CXR10G, 11G (3C-T) 92~93 CXR20G, 21G (3C-T) 92~93 TCR10G, 10W (2TZ-FE) 90~93 TCR11G, 11W (2TZ-FE) 90~93 TCR20G, 20W (2TZ-FE) 90~93 TCR21G, 21W (2TZ-FE) 90~93 LH100G, 102V (2L) 89~93 LH110G, 140G (2L) 89~93 LH100G, 120G (2L-T, TE) 89~93 LH102V, 107G, 107W (3L) 89~93 LH109V, 110G (3L) 89~93 LH113K, 113V, 115B (3L) 89~93 LH117G, 119V (3L) 89~93 LH123V, 125B (3L) 89~93 LH129S, 129V (3L) 89~93 LN130G, 130W (2L-TE) 90~92 LN131V (3L) 90~92 FJ80G (3F-E) 90~92 HDJ81V (1HD-T) 90~92 HJ61V (12H-T) 89~90 HZJ81V (1HZ) 90~92 LJ71G, 78G, 78W (2L-TE) 90~93 GX70G, 80Z, 81 (1G-FE) 88~95 GX81 (1G-GE, GTE, GZE) 88~93 LX76V, 80, 80Y (2L) 88~93 LX80, 80Y (2L-T) 88~93 MX83 (7M-GE) 89~93 SX80, 80Y (4S-FE, F1) 88~93 GZ20 (1G-FE, GEU, GTEU) 89~91 MZ20, 21 (7M-GTEU) 88~91 EP71 (2E-ELU, LU) 86~88 NP80 (1N) 89~92 GA70 (1G-FE, GEU) 88~93 GA70, 70H (1G-GTEU) 88~93 MA70 (7M-GTEU) 88~90 CM30G, 31V, 36V (2C) 90~93 CM41V, 51 (2C) 90~93 CM52, 55, 60, 61, 65 (2C) 90~93 CR27V, 36V (2C) 90~93 YR21G, 30G, 36G (3Y-EU) 88~92
	126000-2090 ND	EG2 (B16A) 95~ EJ4 (D16A) 95~97 EK4 (B16A) 95~ MA4 (ZC) 95~96 MA5 (B18B) 95~97 MA6 (ZC) 95~97 MA7 (D15B) 95~97 DB8, DC2 (B18C) 95~ DB6, DB9 (ZC) 95~ CE4 (G20A) 95~ CE5 (G25A) 95~ RF1 (B20B) 96~99 RF2 (B20B) 96~99 BB5 96~98 BB7 (F22B) 96~98 RH2 (B20B) 96~99 UA4 (J25A) 01~02 UA4 (J25A) 01~02 RD1 (B20B) 95~97 RD2 (B20B) 98~ EL2, EL3 (B20B) 96~ RH1 (B20B) 99~ RH2 (B20B) 99~

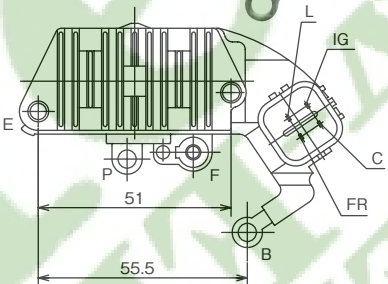
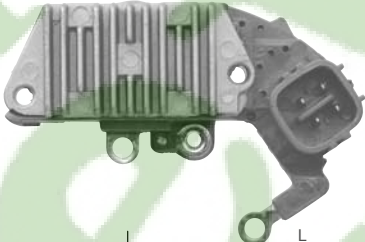
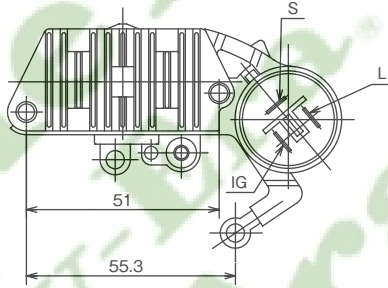
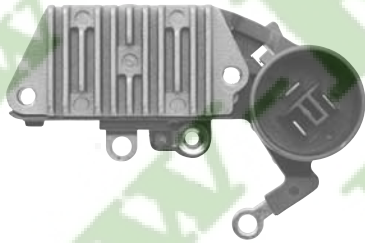



VOLTAGE REGULATORS

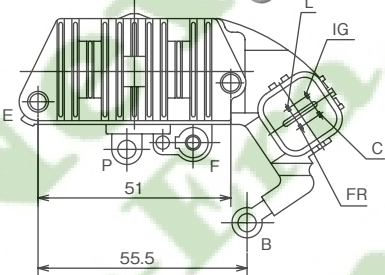
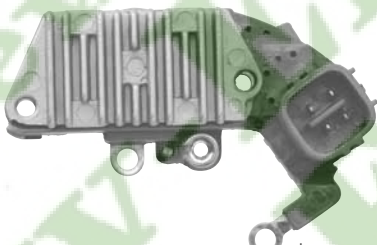
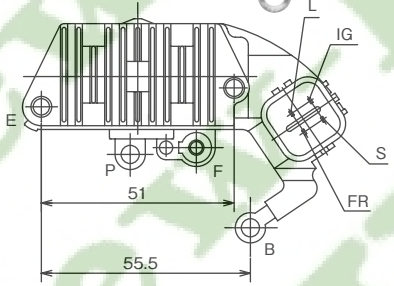

# VOLTAGE REGULATORS

VOLTAGE REGULATORS

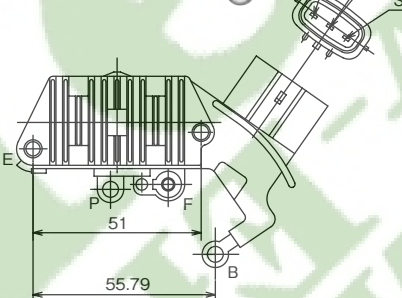
New-Era No.	Ref.No.	Application
<b>IVR-535</b>  	<b>AC12V</b> 31150-P2T-0030	HONDA ACCORD  TORNEO  OLTHIA  CF3 (F18B) 97~ CF4 (F20B) 97~ CF5 (F20B) 97~ CF6 (F23A) 97~ CF7 (F23A) 97~ CL3 (F20B) 00~ CF3 (F18B) 97~ CF4 (F20B) 97~ CF5 (F20B) 97~ CL3 (F20B) 00~ CE5 (G25A) 95~ EL1 (B18B) 96~
<b>IVR-536</b>  	<b>AC12V</b> 31150-P5A-0030 P5G-0030	HONDA LEGEND INSPIRE, SAVRE  KA9 (C35A) 96~ UA3 (G32A) 96~
<b>IVR-538</b>  	<b>AC12V</b> KJ01-18-W70 27700-62010	MAZDA EUNOS800 MILLENIA  TOYOTA ESTIMA  IPSUM CALDINA  CARINA CORONA  CAMRY (USA) LEXUS  TA3A/3P/3Y/3Z (KJ-ZEM) 93~  TCR10W (2TZ-FZE) 94~ TCR11W TCR20W TCR24W CXM10G (3C-TE) 97~ CT190G (2C-T) 96~97 CT196V/198V (2C) 96~98 CT197V/199V (3C-E) 98~ CT216G (3C-TE) 97~ CT210/215 (2C-T) 96~ CT210/215 (2C-T) 96~97 CT211/216 (3C-TE) 97~ SC300, ES300

# VOLTAGE REGULATORS

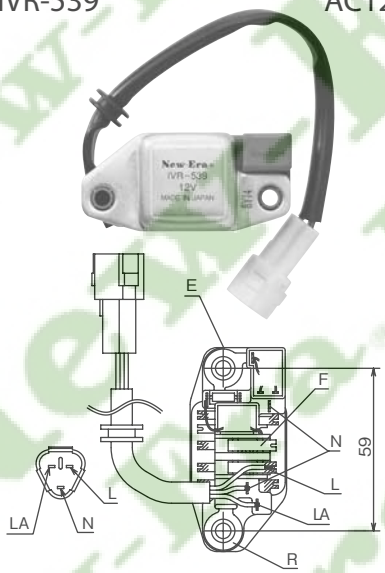
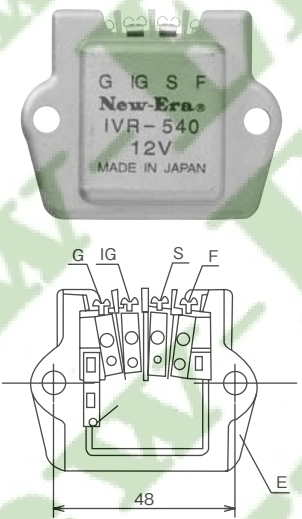
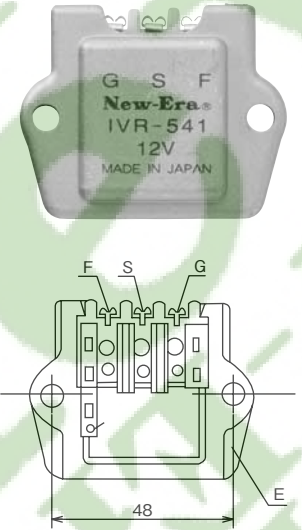
New-Era No.		Ref.No.	Application
IVR-539	AC12V	HINO	HC06C (FD2218) (LP) (FE2618) (FF3018) (FF3020) (SG3320) (SG3323) (SG5523)
		126000-8000 ND	95~
IVR-540	AC12V	AR88018	JOHN DEERE ALL AGRICULTURAL TRACTORS W/CAB
		126000-0050 ND	
4 TERMINALS			
IVR-541	AC12V	7N5961	MITSUBISHI INDUSTRIAL MACHINE (D03) CATERPILLAR
		126000-0020 ND	79~

# VOLTAGE REGULATORS

VOLTAGE REGULATORS

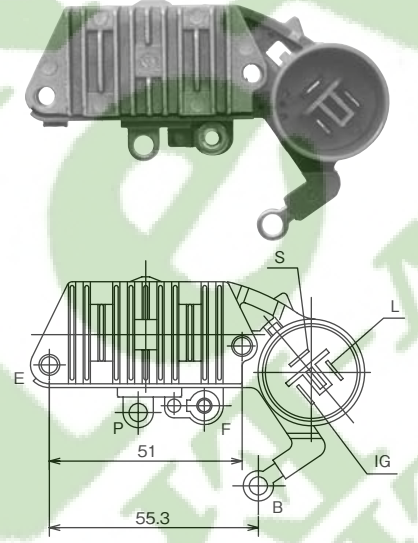
New-Era No.	Ref.No.	Application
<b>IVR-542</b> 	<b>AC12V</b> 31150-PD6-0240  126000-1060 ND	Same as IVR-519 Low Regulated Voltage 14.5±0.3V
<b>IVR-543</b> 	<b>AC12V</b> 27700-35040 40050 50020 50030 54060 65010 74030 74040 74050  126000-1580 ND 1640 ND 1660 ND 1670 ND 2050 ND 2200 ND 2290 ND 7100 ND	TOYOTA CAMRY SXU20 (MADE IN AUSTRALIA)  Same as IVR-524 Low Regulated Voltage 14.5±0.3V  95~98
<b>IVR-544</b> 	<b>AC12V</b> 27700-16010 50010 76020  126000-0610 ND 1441 ND 1450 ND	Same as IVR-533 Low Regulated Voltage 14.5±0.3V



# VOLTAGE REGULATORS

VOLTAGE REGULATORS

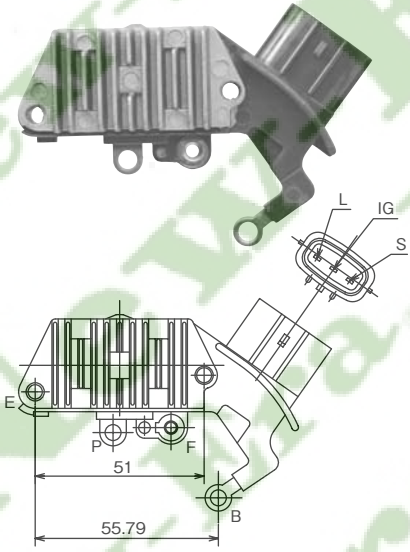
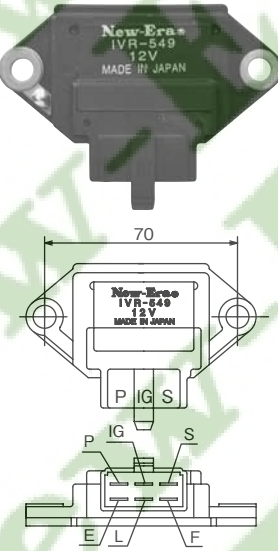
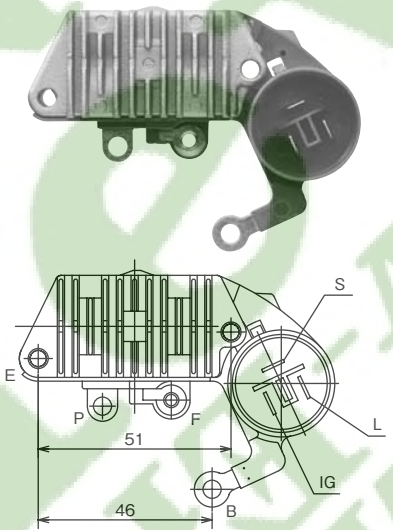
New-Era No.	Ref.No.	Application
<b>IVR-548</b> 	<b>AC12V</b> KJ01-18-W70 27700-62010  126000-1870 ND	Same as IVR-538 Low Regulated Voltage 14.5±0.3V
<b>IVR-549</b> 	<b>AC12V</b> 31400-SA5-004 SB0-004  126000-0301 ND 0302 ND 0420 ND	HONDA ACCORD 1800 E-SZ (EK) 81~ VIGOR 1800 E-SZ 81~ PRELUDE 1800 E-SN (EK) 82~  Same as IVR-530J Low Regulated Voltage 14.5±0.3V
<b>IVR-5000</b> 	<b>AC24V</b> 27700-78303-71A  126000-2360 ND	TOYOTA Folklift 4SD20 (14Z) 3SD15 (1DZ) 5FD20 (1Z) 4SD20 (14Z) 5FD23 (1Z) SDK10 (1Z) 5FD25 (1Z) 5FD20 (1Z) 5FD28 (1Z) 5FD23 (1Z) 5FD30 (1Z) 5FD25 (1Z) 5FD33 (11Z) 5FD28 (1Z) 5FD35 (11Z) 5FD30 (1Z) 5FD38 (11Z) 5FD33 (11Z) 5FD40 (11Z) 5FD35 (11Z) 5FD45 (11Z) 5FD38 (11Z) 5FD50 (12Z, 14Z) 5FD40 (11Z) 5FD60 (12Z, 14Z) 5FD45 (11Z) 5FD70 (12Z, 14Z) 5FD50 (12Z, 14Z) 5FDE35 (11Z) 5FD60 (12Z, 14Z) 6FD33 (13Z) 5FD70 (12Z, 14Z) 6FD35 (13Z) 5FDE35 (11Z) 6FD40 (13Z) 6FD33 (13Z) 6FD45 (13Z) 6FD35 (13Z) 6FDA50 (13Z) 6FD40 (13Z) 6FDE35 (13Z) 6FD45 (13Z) 2JD21 (1Z) 6FDA50 (13Z) 2JD25 (1Z) 6FDE35 (13Z)

# VOLTAGE REGULATORS

VOLTAGE REGULATORS

New-Era No.	Ref.No.	Application
<p>IVR-5001</p>	<p>AC12V TG989-082-0040</p> <p>126000-09204D ND</p>	<p>ISUZU PICK UP D-MAX (THAILAND)</p>
<p>IVR-5002</p>	<p>AC12V 8-97183613-0</p> <p>126000-2480 ND</p>	<p>ISUZU RODEO BIGHORN (TROOPER) INDUSTRIAL USE</p> <p>UBS26GW (6VE1) 01~ (6VD1) 98~</p>
<p>IVR-5003</p>	<p>AC12V 27700-11060</p> <p>126000-1630 ND</p>	<p>TOYOTA CALDINA COROLLA CORSA CYNOS STARLET</p> <p>ET196V (5E-FE) 92~ EE102V (4E-FE) 94~97 EE103V, 104G (5E-FE) 94~97 EL51 (4E-FE) 94~99 EL53, EL55 (5E-FE) 94~99 EL52 (4E-FE) 95~99 EL54 (5E-FHE) 95~99 EP85, 91, 95 (4E-FE) 96~99</p>

# VOLTAGE REGULATORS

VOLTAGE REGULATORS

New-Era No.	Ref.No.	Application
<b>IVR-5004</b> <b>AC12V</b> 	27700-21010 21020	TOYOTA BB WILL-VI VITZ FUN CARGO PLATZ COROLLA PROBOX NCP30 (2NZ-FE) 00~02 NCP31, 35 (1NZ-FE) 00~02 NCP34 (1NZ-FE) 01~02 NCP19 (2NZ-FE) 00~01 NCP10 (2NZ-FE) 99~03 NCP15 (2NZ-FE) 99~05 NCP13 (1NZ-FE) 00~03 NCP20 (2NZ-FE) 99~02 NCP21, 25 (1NZ-FE) 99~02 NCP12 (1NZ-FE) 99~02 NCP16 (2NZ-FE) 99~ NZE120 (2NZ-FE) 00~ NCP50V (2NZ-FE) 02~ NCP51V, 55V (1NZ-FE) 02~ NCP58G, 59G (1NZ-FE) 02~ NCP52V (1NZ-FNE) 03 NLP51V (1ND-TV) 02~
	126000-3130/1 ND 3170/1 ND	
<b>IVR-5005</b> <b>AC12V</b> 	32500-60G10	SUZUKI ESCUDO CULTUS ESCUDO PROCEED WAGON R JIMNY TA51W, TD51W (J20A) 96~97 GC41W (J18A) 96~98 GA11S (G13B) 94~97 GA21S, GB21S, GC21W, (G15A) 94~97 GD21S GB31S, GD31S, GD31W (G16A) 96~97 TA11W, TD11W (H20A) 95~97 TD61W (H25A) 96~97 TJ62W (H25A) 98~ TF11W, TJ11W (H20A) 95~ MA61S, MB61S (K10A) 97 JB33W (J13B) 98~00
	126000-1970/1 ND	
<b>IVR-5006</b> <b>AC12V</b> 	27700-21040	TOYOTA BB CALDINA CAMRY COROLLA SPACIO FUNCARGO IPSUM IST NOAH OPA PLATZ PORTE PREMIO PROBOX VISTA WILL-CYPHA WILL-VS NCP30 (2NZ-FE) 02~ NCP31, 34, 35 (1NZ-FE) 02~ ST246W (3S-GTE) 02~ AZT241W, 246W (1AZ-FSE) 02~ ZZT241W (1ZZ-FE) 02~ AZV50, 50G (1AZ-FSE) 01~03 ZZE122, 122G, 124, 124G (1ZZ-FE) 02~ NZE121, 121G, 124, 124G (1NZ-FE) 00~ NZE121N (1NZ-FE) 01~ NCP20 (2NZ-FE) 02~03 NCP21, 25 (1NZ-FE) 02~03 ACM21W, 26W (2AZ-FE) 01~03 NCP60 (2NZ-FE) 02~03 NCP61, 65 (1NZ-FE) 02~03 AZR60G, 65G (1AZ-FSE) 01~04 ACT10 (1AZ-FSE) 02~ ZCT10, 15 (1ZZ-FE) 02~ NCP12 (1NZ-FE) 02~ NNP10, 11 (2NZ-FE) 04~ NZT240 (1NZ-FE) 01~ AZT240 (1AZ-FSE) 01~ ZZT240, 245 (1ZZ-FE) 01~ NCP58G (1NZ-FE) 02~03 AZV50, 50G (1AZ-FSE) 01~03 AZV55, 55G (1AZ-FSE) 02~03 NCP70 (2NZ-FE) 02~03 NCP75 (1NZ-FE) 02~ NZE127 (1NZ-FE) 02~04
	126000-3370 ND	

# VOLTAGE REGULATORS

New-Era No.	Ref.No.	Application
<b>IVR-5007</b>  	<b>AC12V</b> 27700-13120  126000-2280 ND	DAIHATSU DELTA KR41J (5K) 96~  TOYOTA LITEACE ESCAVATOR KR42V (7K) 96~98 5SD7, 10, 12, 15 (1DZ, 2Z) 00~03 5SG10, 12 (4Y, 5K) 01~03 5SGL7, 10 (4Y, 5K) 01~03 FOLKLIFT 7FD10, 14, 15, 18, (1DZ) 00~03 7FD20, 25 7FD20, 23, 25, 28, (2Z) 00~03 7FD30 7FG10, 14, 15, 18, (5K) 01~03 7FG20, 23, 25, 7FG15, 18, 20, 23, (4Y) 01~03 7FG25, 28, 30 7FGJ35 (4Y) 01~03 7FGK20, 25 (4Y, 5K) 01~03  KI JANG
		<b>IVR-5008</b>  

VOLTAGE REGULATORS







# VOLTAGE REGULATORS

VOLTAGE REGULATORS

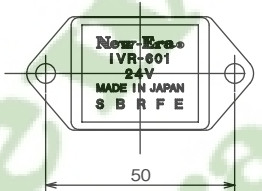
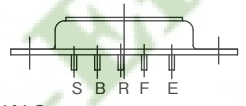
New-Era No.	Ref.No.	Application
IVR-5009 	AC12V 8-94239099-0          126000-0270 ND	ISUZU FARGO PIAZZA TRACTOR  JR120/130 (4ZB1) (G200) (D3200)  81~87 81~88 84~93
IVR-5010 	AC12V          126000-7160 ND -1760 ND -1130 ND	VOLVO 940 740          90~97 91~92
IVR-5011 	AC12V 27700-31040          126000-3720 ND	TOYOTA FJ CRUISER 4 RUNNER FORTUNER HILUX LAND CRUISER PRADO HILUX (USA) TUNDRA (USA)  (1GR-FE) (1GR-FE) (1GR-FE) (1GR-FE) (1GR-FE) (1GR-FE) (1GR-FE)

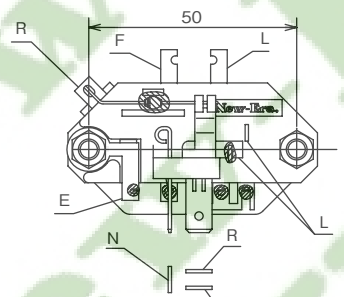

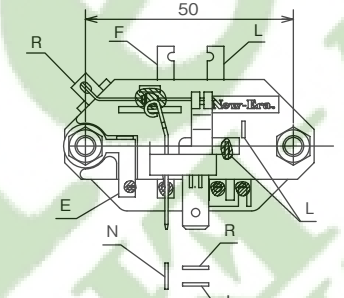

# VOLTAGE REGULATORS

New-Era No.	Ref.No.	Application
<b>IVR-601</b>    5 TERMINALS	<b>AC24V</b> 1-81260004-0 81260005-0 81270001-0 8-94173052-0  7-44000-0900 NK 0901 NK 0920 NK 0905 NK 0903 NK 0906 NK	ISUZU TRUCK V8 TRUCK V10 TRUCK V10 TRACTOR V12 TRUCK V12 TRACTOR FORWARD ENGINE FOR UNIVERSAL USE  KOMATSU ENGINE FOR UNIVERSAL USE  DUMP TRUCK MOTOR GRADER  NISSAN FD33  6QA1, 6RA1, 6RB1 84~ 84~ 84~ 10PC1 84~ 10PC1 84~ 12PC1 84~ 12PC1 84~ 6BD1, 6BG1 4BC2-A, 4BD1, 4BD1-T  4D95L, 6D95L, 6D125-1, S6D105, S6D105-1 S6D123 S125 84~ 84~  84~ 84~
<b>IVR-602</b>   WITH HOLDER	<b>AC24V</b> 1-81270001-0  7-44000-0900 NK	ISUZU V8TRUCK V10TRUCK 980 V12TRUCK V10TRACTOR V12TRACTOR TRUCK  FORWARD840  KOMATSU WHEEL LOADER  SKW462, 482 (8PC1) CV17, CX17 (8PC1) CX19 (10PC1) 88~90 84~90 88~90 CX19 (10PC1) (10P) 88.11~ CX21 (12PC1) 88~90 EX19 (10PC1) 88~90 EX21 (12PC1) 88~90 CV14 (6QA1) 88~90 CX17 (6RA1) 88~90 CX18 (6RB1) 88~90 FSR-11 (6BD1-T) 88~90 FRR-11 (6BD1-T) 88~90 FTR-11 (6BD1-T) 88~90 FSR-12 (6BG1) 87~90 FRR-12 (6BG1) 87~90 FTR-12 (6BG1) 87~90 WA200 (6D105) 88~
<b>IVR-603</b>   WITH HOLDER	<b>AC24V</b> 1-81260004-0  7-44000-0901 NK	ISUZU FORWARD840  FSR-11 (6BD1) 87~ FRR-11 (6BD1) 87~ FTR-11 (6BD1) 87~ FSR-12 (6BG1) 87~ FRR-12 (6BG1) 87~ FTR-12 (6BG1) 87~

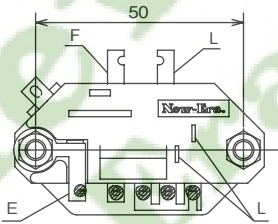

VOLTAGE REGULATORS

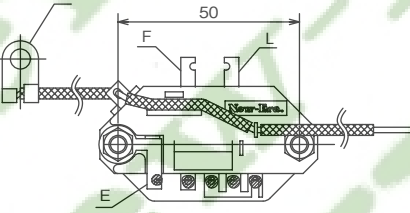
# VOLTAGE REGULATORS

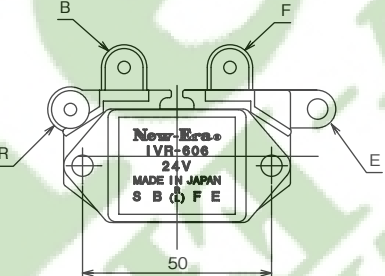
VOLTAGE REGULATORS

New-Era No.		Ref.No.	Application			
IVR-604	AC24V		KOMATSU BULLDOZER	D175A-1 (SA6D170)	88 ~	
				D375A-1 (SA6D170)	88 ~	
			DUMP TRUCK	D85-21 (6D140)	91 ~	
				HD205-3 (S6D140)	91 ~	
			MOTOR GRADER	HA250 (S6D125)	91 ~	
				GD625A-1 (S6D105)	88 ~	
			MOTOR SCRAPER	GD655A-5 (S6D105)	88 ~	
				WS23-2-F, R (S6D140)	88 ~	
			NISSAN DIESEL	(PE-6)	84 ~	
WITH HOLDER		7-44000-0907 NK				
IVR-605	AC24V		KOMATSU S6D105 GD70SR-4	(6D125-1)		
						
						
WITH HOLDER		7-44000-0906 NK				
IVR-606	AC24V	1-81260015-0	ISUZU Marine Vessel	(6HE1TMC)	01 ~	
			KOMATSU Construction Machinery	D155AX-5	(S6D140E-2B)	98 ~
				WA70-1	(4D95L-W-1)	98 ~
			WA70	(4D95L)	98 ~	
				D355A-3	(SA6D155-1)	98 ~
			PC200-5	(4D95L)	98 ~	
				D31	(SA6D102E-1J)	98 ~
			D37	(SA6D102E-1K)	98 ~	
				D66	(SA6D110)	98 ~
			WA450	(SA6D125)	98 ~	
				PC300	(SA6D108)	98 ~
			D85-21	(S6D125E-2)	98 ~	
				D155A-2	(S6D155)	98 ~
		0-35719-0151 NK				

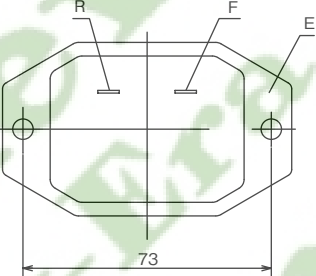

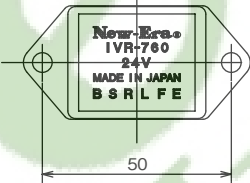
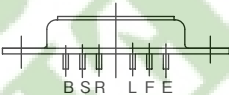

# VOLTAGE REGULATORS

New-Era No.	Ref.No.	Application
<b>IVR-621</b>  	<b>AC24V</b> 1-81251004-0 81251024-0 6-00821328-0 00821335-0 00821544-1  0-33000-2280 NK 2290 NK 2841 NK 3230 NK 1-44000-0580 NK 0730 NK	ISUZU ENGINE FOR UNIVERSAL USE [DA220, DA120, DA640] 78~86 [DA640TPR, DH100, E120] [6BB1, 6BD1, 6BF1] 80~86  KOMATSU BULLDOZER D31-16 78~81 D21-5[4D94] 78~83 D40-2, D45-2 81~ D40-3, D41-3[6D105] 82~ D50-16, D53-6 82~ D57, D60, 65-8, D75-5 84~  POWER SHOVEL 12HT-1, 15HT-3 78~80 20HT-1, 10HT  DOZER SHOVEL PC100, PC120, PC200, PC220 81~ D60S-6, D65-S6 78~80 75S-3 78~81  MOTOR GRADER GD37-6H 78~80 CD22H-28 78~81 GD505A 82~ GD200, 300A-1 84~ GD600, 605R-3 GD705R-3  PAY LOADER JH30B, JH60A 78~ 510, 515, JH63 81~ 530, 540  FORKLIFT FD35-1, FD50-2 78~ FD60-2, FD100-3, FD150-2 FD40HT 86~  ENGINE GENERATOR EG30-2, EG45, 45S-1 81~ EG75, 75S-2 EG100, 100S-2 EG150, 175-2, 200-2 EG170, S-2 84~ EG200-3, EC200Z EG260T-1 EG480B-1, EG500BS-1 86~ EG580B-1, EG600BS-1 EC105V 81~ EC35V, 50Z 78~ EC75-2 84~  COMPRESSOR CD40[4D105-3] 86~ CD60[S4D105-3]
		<b>IVR-760</b>   

VOLTAGE REGULATORS

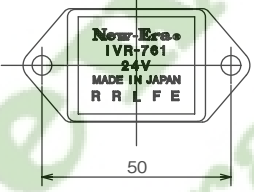
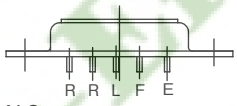

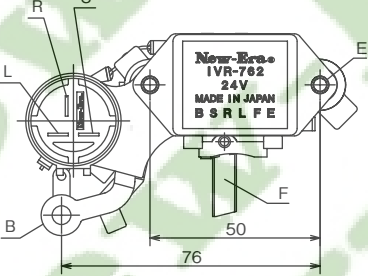

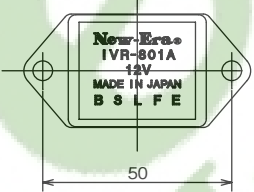
# VOLTAGE REGULATORS

VOLTAGE REGULATORS

New-Era No.	Ref.No.	Application
<b>IVR-761</b> <b>AC24V</b>    5 TERMINALS	5-81251016-0 23500-99008  TR2Z-47 HI	ISUZU STREET SWEEPER (4FB1) 88. 6~ SPECIAL TRUCK FOR HEIGHT OPERATION (4JB1) 86. 6~ HEAVY DUTY TRUCK P-CXM19, Z19 (10PC1) 87. 9~ ENGINE (C3, 4B) 82. 7~ ENGINE FOR UNIVERSAL USE (C240) 83. 6~ ENGINE FOR CONSTRUCTION (6RB1) 89. 5~  NISSAN FORKLIFT WF03 WF03 (TD42) 88. 10~ FORKLIFT WF03 (TD42) 89. 4~ BUS CD17 89. 12~ TRUCK CV46 (PE6T) 88. 11~ CD53, CW53 (RE8) 88. 11~ CD46 (PE6) 88. 9~ CD46, CV46 (PE6T) 88. 9~ TRUCK CONDOR CM (FD6) 83. 1~ P-CM86 (FD6, FD6T) 84. 9~ P-CM87 (FE6) 88. 4~
<b>IVR-762</b> <b>AC24V</b>   WITH BRUSH HOLDER	8-94156590-0  L225-8315 HI	ISUZU ELF P-NKR58, P-NPR (4BE1, 4BC2) 90. 6~93. 3 NKR63 (4BE2) 93. 4~ NKR, NPR (4BD1) 90. 6~ P-NPR58 (4BE1) 90. 8~93. 3 U-PR59, U-NPS59 (4BD1-T) 90. 3~ (OPTION) NPR, NKR (4BE1) 90. 7~ (FIRE ENGINE) P-NKR57 (4BE1) 87~90 (REFRIGERATOR CAR) NKR (4BC2) 88. 5~90 ELF 250 NKR (4BE1, 4BG1) 90. 5~ ELF VAN NKR63 (4BE2) 93. 4~ NKR58 (4BE1)
<b>IVR-801</b> <b>AC12V</b>   5 TERMINALS	23215-B9800 Q4601 P2500 Q4602 F2500  TR1Z-27 HI 33 HI 48 HI 56 HI 65 HI	NISSAN SUNNY 1200STD E-B310 (A12) 77~ CALIFORNIA B310 (A14E) 77~ E-GB310 (A13) 80~ E-PB310 (A15) 81~ E-GB310 (A13S) E-PB310 (A15S) SENTRA E-MN10 (E15E) (E16) 82~ BLUEBIRD E-RG810 (L20E) 77~ RG810E (L20E) 78~ E-PJ811 (Z18E) 80~ BLUEBIRD 1600 E-J910, E-KJ910 79~ 1800 EP-910, E-PK910 VIOLET, STANZA E-PA11 (L16E, Z16E) 77~ CEDRIC E430 (L20E) 79~ E430 (L20E, L28E) 80~ 200SX S110 81~83 S12 84 720 L20B 80~ Z-20 83~ Z-24 82~ PULSAR E15T, E16 (A12, 14) 82~ LANGLEY (A14) 78~ PULSAR 1200 E-YN10 (A12A) 80~81

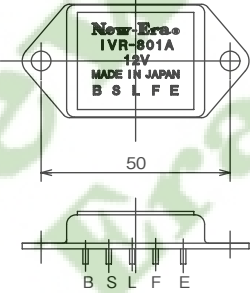
CONTINUED

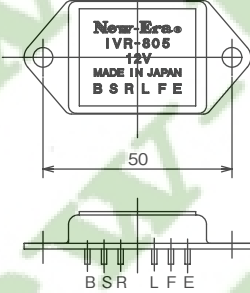
# VOLTAGE REGULATORS

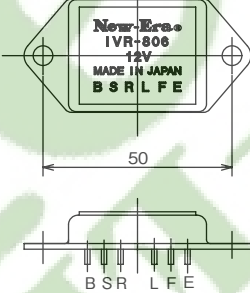
New-Era No.	Ref.No.	Application
<b>IVR-801</b>   5 TERMINALS	<b>AC12V</b> 23215-B9800 Q4601 P2500 Q4602 F2500  TR1Z-27 HI 33 HI 48 HI 56 HI 65 HI	NISSAN EXC MAXIMA, 810 (DIESEL) [USA] 81 MAXIMA, PICK UP (GAS), SENTRA, STANZA, 82 200SX, 210, 280ZX, 310 [USA] MAXIMA, PICK UP, SENTRA (GAS), PULSAR, 83~85 STANZA, 280ZX, 200SX (CA20E, Z22E, ENGS) [USA] KOSHAKU (CA20S) [CHINA] [HONG KONG] 84~85
<b>IVR-805</b>   6 TERMINALS	<b>AC12V</b> 23215-W1701 54A00  TR1Z-64 HI 64A HI	NISSAN ATLAS F22, H40, N-AH40 88. 5~ (TD23, TD27) CARAVAN E24 (TD23) 88. 4~ DATSUN TRUCK N-D21 88. 5~ (TD23, TD27) CARAVAN E-KE23 (TD23, TD27) ATLAS N-F22, N-EF22 (TD23) 88. 4~ FORKLIFT SD25 86. 7~ BLUEBIRD (Taxi) 910 (LD20 II) 89. 5~ VANNET N-G22, N-KUC22 (LD20) 89. 5~ CEDRIC Q-UY31 (RD28) 89. 10~ SUNNY Q-SB12 (GD17) 89. 10~ AVENIR (VAN) S-VSW10 (CD20) 90. 4~
<b>IVR-806</b>   6 TERMINALS	<b>AC12V</b> 8-94250964-0 94237728-0 RF01-24-520 23215-W1700  TR1Z-43 HI 53 HI	ISUZU RODEO BIG HORN N-UBS52 (C223) 85. 2~ FARGO N-WFR51 (4FC1) 85. 9~ BIG HORN Q-UBS52F (4JA1, 4JB1) 87. 10~ FARGO N-WFR/S62 series (4FC1, 4FD1) 88. 12~ FARGO WAGON N-WF51D series (4FC1, 4FD1, 4FG1) 88. 12~ FARGO N-WFR62/S series (4FC1, 4FD1) 88. 12~ ASKA DIESEL N-JJ510 (4FC1) 86. 3~ GEMINI JT641F (4EE1T) 90. 2~ NEW VAN TRUCK WFR (4FB1, 4FC1) 80~  MAZDA BONGO TRUCK U-SD29M, SD29T, SD2AT (R2) 90. 4~ BONGO TRUCK DIESEL P322 (RF) 90. 4~ BONGO VAN N-SR2AV, U-SR29V (R2) 90. 4~ BONGO VAN S-SSF8V (RF) TRUCK N-SEF8T (RF) 90. 3~  NISSAN LAUREL K-EJC31 (LD28) CEDRIC, GLORIA DIESEL 280D K-H430 (LD28) 80. 12~ DATSUN TRUCK K-S720, K-SG720 (SD22) 80. 10~

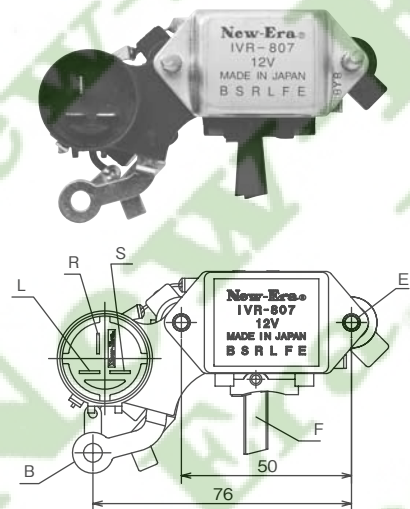
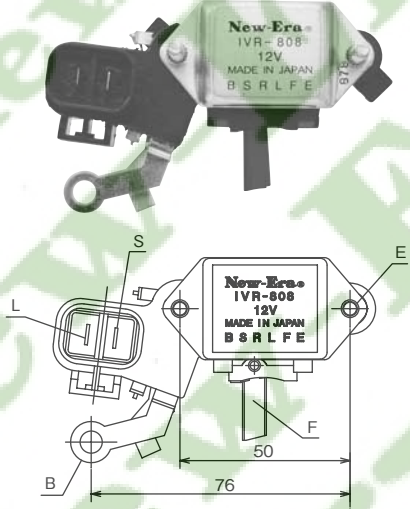
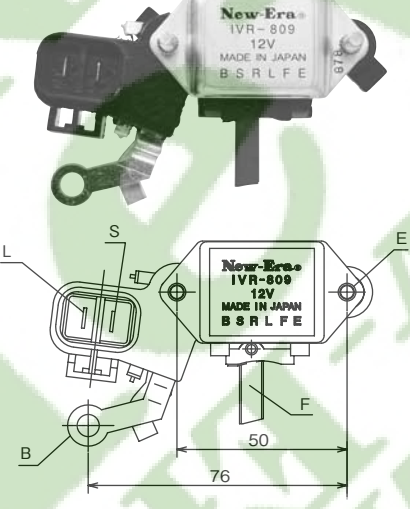

# VOLTAGE REGULATORS

VOLTAGE REGULATORS

New-Era No.	Ref.No.	Application
<b>IVR-807</b>  WITH BRUSH HOLDER	<b>AC12V</b> 8-94167410-0  L150-33155 HI	ISUZU BIG HORN  BIG HORN WAGON FARGO  FARGO WAGON ELF  ELF 150 NEW ELF  Q-UB552F (4JA1, 4JB1) 87~ KD-UBS69DW (4JG2) 94~ KD-UBS25GW (4JG2) 94~ Q-UBS69 (4JG2) 91~ N-WFR62/S (4FC1, 4FD1) 88~90 N-WFR/S62 (4FC1, 4FD1) 88~ N-WF51D (4FC1, 4FD1, 4FG1) 88~ NHR69 (4JG2) 93~ NKR69 (4JG2) 93~ P-NHR (4JA1, 4JB1) 84~ NHR, NKR (4JA1, 4JB1) 84~
<b>IVR-808</b>  WITH BRUSH HOLDER	<b>AC12V</b> 23528-05E06  L160-23153 HI	NISSAN VANETTE VANETTE VAN  VANETTE TRUCK SAFARI  DATSUN TRUCK CARAVAN  ATLAS  N-KUC22 (LD20·II) 89~91 S-VUSNC22 (LD20) 94~ S-VUSNC22 (LD20·II) 91~ S-UGJC22 (LD20·II) 93~ S-VRV60 (TD42) 94~ N-D21 (TD23) 94~ E-KE23 (TD23) 88~ E-VYE23 (TD23) 94~ E-KE23 (TD27) 94~ E24 (LD20) 93~ N-VYE23 (SD23) 94~ Q-KRME24 (TD27) 94~ N-EF22 (TD23) 94~ N-EF22 (SD23) 94~ N-AH40 (TD27) 94~ H40 (TD27) 88~94
<b>IVR-809</b>  WITH BRUSH HOLDER	<b>AC12V</b> 23528-18G01 V7200  L150-93155 HI L160-63153 HI	NISSAN SUNNY  PULSER  AD VAN LAUREL  CEDRIC CARAVAN  SAFARI ATLAS  TRUCK  B12 (CD17) 93~ B13 (CD17) 93~ B14 (CD17) 93~ Q-SB12 (CD17) 89~92 Q-SB13 (CD17) 91~92 N13 (CD17) 93~ N14 (CD17) 93~ N15 (CD17) 93~ Q-SN14 91~92 S-VSNY10 (CD17) 93~ Y-SC34 (RD28) 93~ Q-SC33 (RD28) 93~ Q-UY31 (RD28) 93~ E-KE23 (TD23, 27, 42) 86~ N-VYE23 (TD23) 94~ U-Y60 (TD23, 27, 42) 88~ U-F22 (TD23, 27, 42) 88~ N-AH40 (TD23, 27) 86~ N-EF22 (TD23) 94~ N-EF22 (TD25) 94~ N-D21 (TD23, 27, 42) 86~

# VOLTAGE REGULATORS

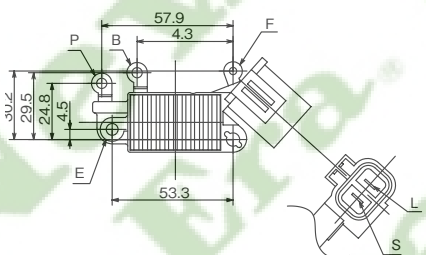
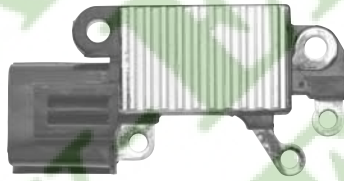
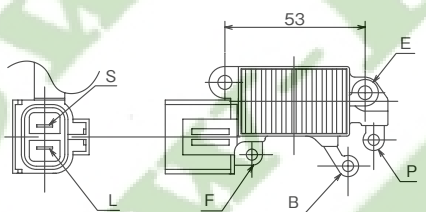

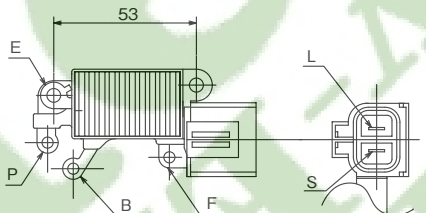
VOLTAGE REGULATORS

New-Era No.	Ref.No.	Application
<b>IVR-840</b>  	<b>AC12V</b> 23215-0C400	NISSAN CEDRIC, GLORIA BLUEBIRD BLUEBIRD VANETTE AVENIR WAGON VANETTE LARGO LARGO LARGO Q-UY32 (RD28) 91~95 Q-SU13 (CD20) 91~96 E-SNU13 (CD20) 93~99 Q-KVC23 (CD20T) 91~94 Y-SW10 (CD20T) 92~96 Q-VW30 (CD20T) 93~96 E-W30 (KA24DE) 96~97 KD-VW30 (CD20ETi) 96~97
	TR1Z-108B HI	
<b>IVR-841</b>  	<b>AC12V</b> 23215-0C001 85L00 70T00	NISSAN PULSAR PRESEA CEFIRO, ALTIMA VANETTE SUNNY LAUREL SKYLINE E-EN14 (GA16DE) 94~98 E-FN14 (GA15DS) 90~ E-EN14 (GA16DS) 94~98 E-FNN14 (GA15DS) 94~98 E-HR10 (SR20DE) 94~98 E-PR10 (SR18DE) 93~94 R10 (GA15DS) 93~94 E-LNA31 (RB25DET) 91~95 E-LA31 (RB25DET) 90~ E-EA31 (RB25DE) 91~95 A31 (RB20E) 90~ A31 (RB20DET) 91~95 A31 (RB20DE) 90~ A31 (RB25DE) 91~95 E-KAC23 (GA16DE) 90~ E-EB13 (GA16DS) 91~95 E-FB13 (GA15DS) 90~ C34 (RB20E) 94~95 R33 (RB20E) 94~95
	L180G-6340 HI 2340 HI 7340 HI	
<b>IVR-842</b>  	<b>AC12V</b> 23215-64J02	NISSAN TERRANO SAFARI PULSAR CEDRIC, GLORIA FAIRLADY Z PRESEA AVENIR WHYD21 (TD42) 93~ Y60 (TB42) 94~ N14 (SR18DE, SR20DET) 94~ Y32 (VG20E, VG30E) 94~ Z32 (VG30DE) 94~ R10 (SR18DE, SR20DE) 94~ W10 (SR18DE, SR20DE) 94~
	L180G-5340 HI	

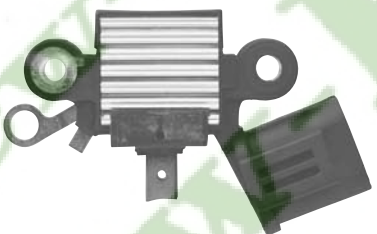
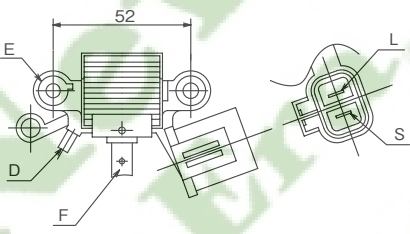

# VOLTAGE REGULATORS

VOLTAGE REGULATORS

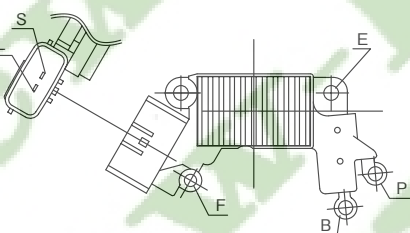
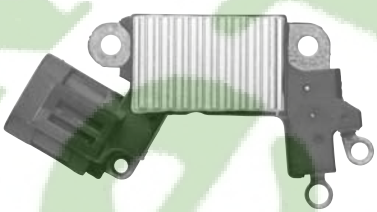
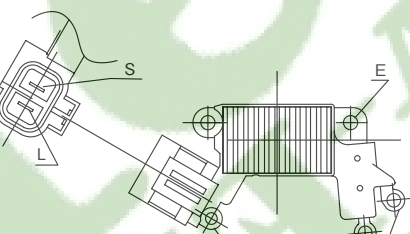

New-Era No.		Ref.No.	Application	
<b>IVR-843</b>  	<b>AC12V</b>	23133-58S01	NISSAN SUNNY SUNNY CALIFORNIA SKYLINE  DATSUN VANNET CEDRIC, GLORIA	E-HB12 (E15S) 85~96 E-WHB12 (E15S) 85~96 E-HR31 85~90 (RB20E, RB20ET, RB20D) E-C120 (CA18ET, CA20S) 85~90 E-Y31 (VG20DET) 94~95 E-Y31 (VG30E, VG30ET) 87~91 E-PAY31 (VG30ET) 87~92 E-FY31 (VG30DET) 88~94
		L160-43154 HI		
<b>IVR-844</b>  	<b>AC12V</b>	23215-31U05 31U02	NISSAN CEFIRO	E-HA32 (VQ30DE) 94~96 E-PA32 (VQ25DE) 94~96 E-A32 (VQ20DE) 94~96 AH32 (VQ30DE) 94~97 AH32 (VQ25DE) 94~97 AH32 (VQ20DE) 94~97
		L1100G-3340 HI L1100G-9340 HI		
<b>IVR-845</b>  	<b>AC12V</b>	23215-3C001 -7F700	NISSAN SUNNY PULSAR TERRANO  GARAVAN  LAUREL SKYLINE  MISTRAL	E-EB14 (GA16DE) 93~97 E-EN14 (GA16DE) 93~97 R50 (TD27T i) 96 (TD32ET) 96 N-E24 (TD27T i) 96 E24 (QD32ET) 96 E-HC34 (RB20E) 94~96 E-HR33 (RB20E) 94~96 E-HR33 (RB20DE) 96 KD-R20, KD-KR20 (TD27TE) 96~97
		L180G-33401 HI -3340 HI L1100G-6340 HI		

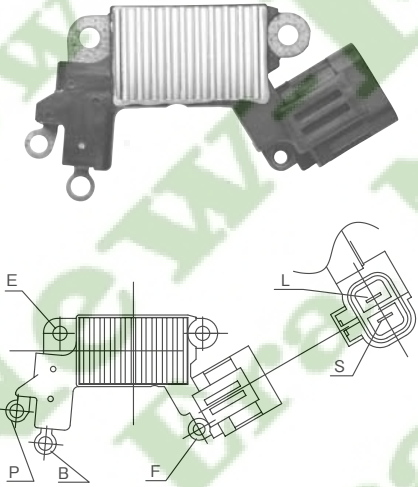
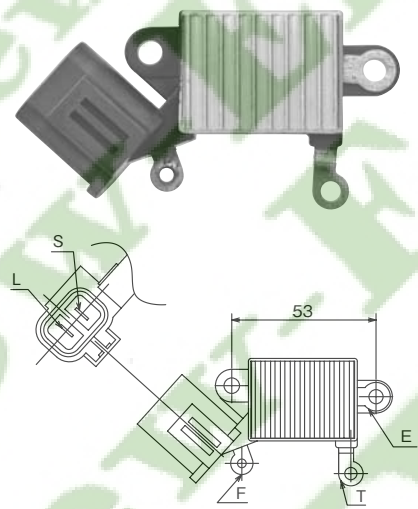
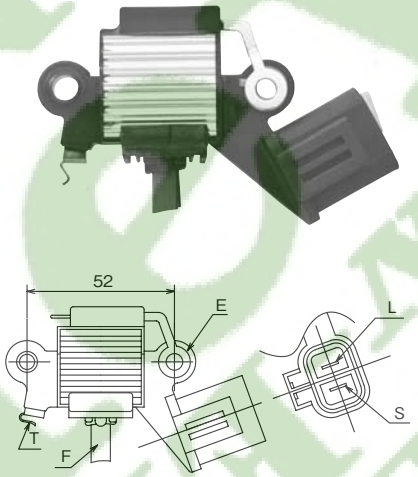
# VOLTAGE REGULATORS

New-Era No.		Ref.No.	Application		
<b>IVR-846</b> 	<b>AC12V</b>	23215-0M801 0M800	NISSAN SUNNY (MT)	E-EB14 (GA16DE) E-FB14 (GA15DE) E-B14 (GA13DE)	96~97 96~97 96~97
		BLUEBIRD	E-HNU13 (SR20DET) E-HNU13/-HU13 (SR20DE) E-EU13/-ENU13 (SR18DE)	93~96 93~96 93~96	
			VANETTE SELENA	E-KBC23 (SR20DE)	94~96
			LARGO	E-CW30/-W30 (KA24DE)	95~96
			TERRANO	E-WHYD21 (VG30E)	94~96
			SAFARI	E-WGY60 (TB42E)	95~97
		L180G-23401 HI L170G-6315 HI			
<b>IVR-847</b> 	<b>AC12V</b>	23215-1P000	NISSAN CARAVAN	E24 (TD27T1) N-E24 (TD27T1)	90~96
		SAFARI VAN	U-VRGY60 (TD42) Y60 (TD42)	94~95	
		TR1Z-257 HI			
<b>IVR-848</b> 	<b>AC12V</b>	23133-F6500	NISSAN SKYLINE	E-HR31 (RB20DE-T)	86~93
		CARAVAN	L-E23 (Z20S)	87~90	
			FAIRLADY Z	E-Z32 (VG30DE)	88~93
			LEOPARD	E-UF31 (VG30DE) E-UF31 (VG20ET)	94~ 86~91
		L190-4315 HI			

VOLTAGE REGULATORS

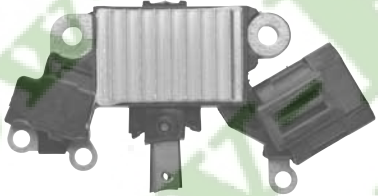
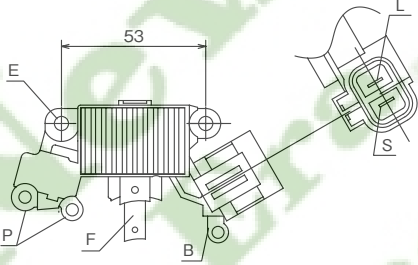
# VOLTAGE REGULATORS

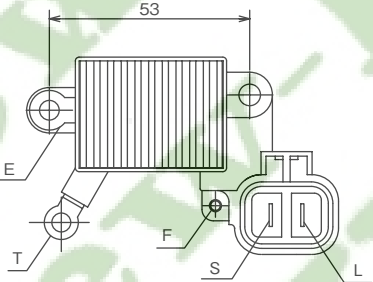
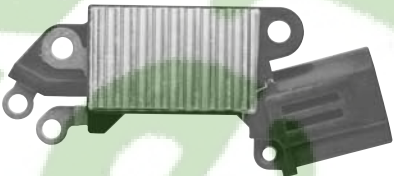
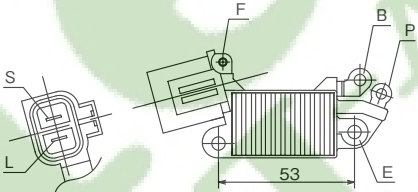
New-Era No.		Ref.No.	Application		
<b>IVR-849</b>  	<b>AC12V</b>	23215-5V100	NISSAN SUNNY PULSAR  BLUEBIRD  CEDRIC SERENA LARGO SAFARI  PRESIDENT	B14 (GA15DE) N15 (GA15DE) N15 (GA) U13 (SR20DE) U13 (SR18DE) U13 (SR20DE)  E-HU14 (VG30E) C23 (SR20DE) W30 (KA24D) Y61 (TB) Y61 (TB42) E-PHG50 (VH45DE) F-PG50	97~99 97~99 00 97~98  96~ 97~99 97 97~99 99~ 97~
		L190G-7340 HI			
<b>IVR-850</b>  	<b>AC12V</b>	23215-60U00	NISSAN INFINITI  PRESIDENT INFINITI	E-HG50 (VH45DE)  E-JHG50 (VH45DE) E-HG50 (VH45DE)	89~90  90~94
		L1110-2315 HI			
<b>IVR-851</b>  	<b>AC12V</b>	23215-1P100	NISSAN CEDRIC / GLORIA  CIMA  CIMA	E-PY32 (VG30DET)  E-FY32 (VH41DE) E-FGY32 (VH41DE)	91~95  91~97 91~95
		L1110G-4340 HI			

VOLTAGE REGULATORS

# VOLTAGE REGULATORS

VOLTAGE REGULATORS

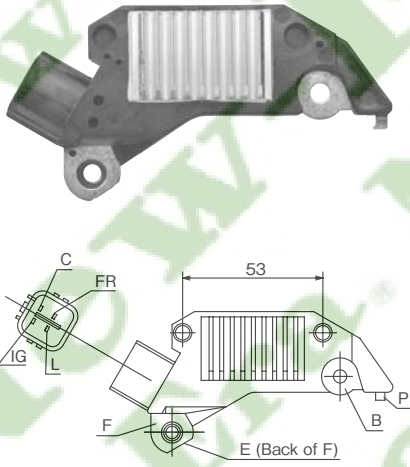
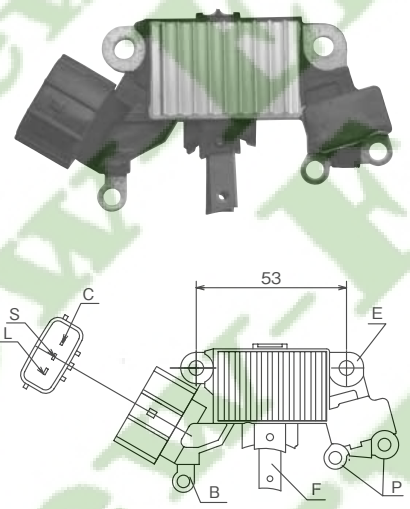
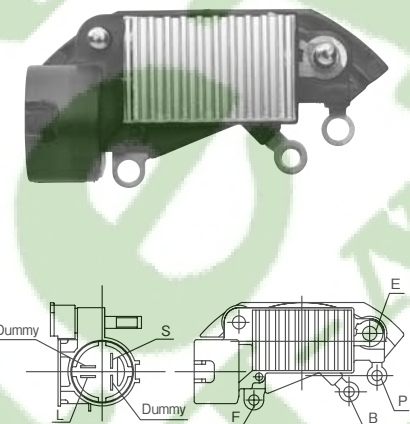
New-Era No.	Ref.No.	Application
<p>IVR-852 AC12V</p> 	<p>31150-P8A-A01</p> <p>19009715 DR</p>	<p>HONDA ACURA CL ACCORD (USA)</p> <p>3L 3L</p> <p>97~99 98~99</p>
<p>IVR-853 AC12V</p> 	<p>Rear Cover Assy 23727-AA210 (LR1100G-93001)</p>	<p>SUBARU LEGACY</p> <p>GF-BH5 (EJ20)</p> <p>98.8~01</p>
<p>IVR-854 AC12V</p> 	<p>23815-AA010</p> <p>L170-23152 HI</p>	<p>SUBARU LEGACY (2WD) LEGACY (4WD)</p> <p>E-BC4 (EJ20) E-BC5 (EJ20)</p> <p>88~ 89~</p>

# VOLTAGE REGULATORS

VOLTAGE REGULATORS

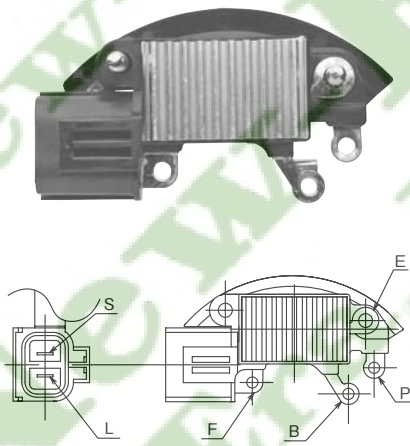
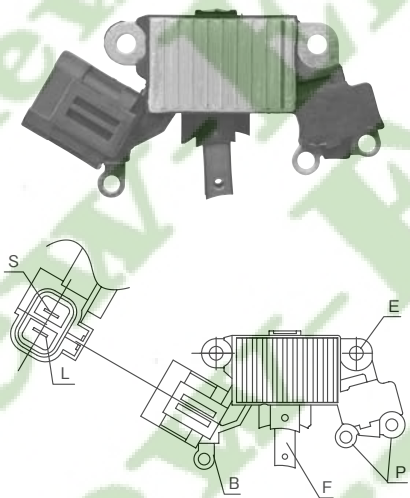
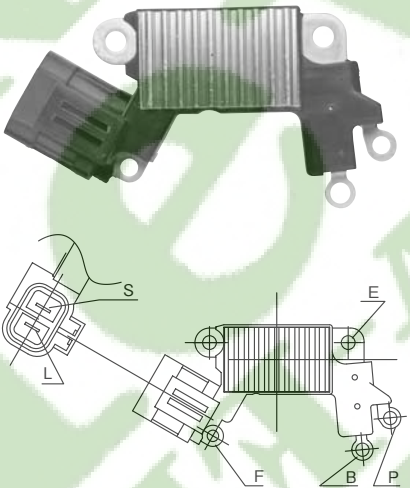
New-Era No.	Ref.No.	Application
<b>IVR-855</b> 	<b>AC12V</b> 23215-85L00  L180G-2340 HI	NISSAN CEFIRO  E-CA31 (RB20DE) 90~
<b>IVR-856</b> 	<b>AC12V</b> 23215-0V000 2J602  L180G-63401 HI L190G-8340 H	NISSAN DATSUN TRUCK  ATLAS  CARAVAN  SERENA SUNNY PULSAR PULSAR BLUEBIRD SKYLINE LAUREL  SAFARI AVENIR BLUEBIRD TERRANO SERENA LARGO  D21 (TD23, TD25, TD27, QD32) U-BGD21 (TD27) F23 (TD23, TD25, TD27, QD32) E24 (TD23, TD25, TD27, QD32) C23 (GA16DE) E-EB14 (GA16DE) E-EN14 (GA16DE) KD-SN15 (CD20) KD-SU14 (CD20) R33 C34 (RB20E, RB25DE, RB25DET) Y60 (TD42T) W10 (CD20T) U13 (CD20T) R50 (TD32, TD27ETi) C23 (CD20) W30 (CD20)  97~ 95~97 96~ 96~97 97~99 93~97 93~97 97~00 96~97 96~97 96~97 95~97 97~00 97~00 96~ 96~99 96~99
<b>IVR-857</b> 	<b>AC12V</b> 23815-AA100  L185G-4340 HI	SUBARU LEGACY  (DOHC) E-BD4, E-BG4, E-BD5, E-BG5 (EJ20) 96~

# VOLTAGE REGULATORS

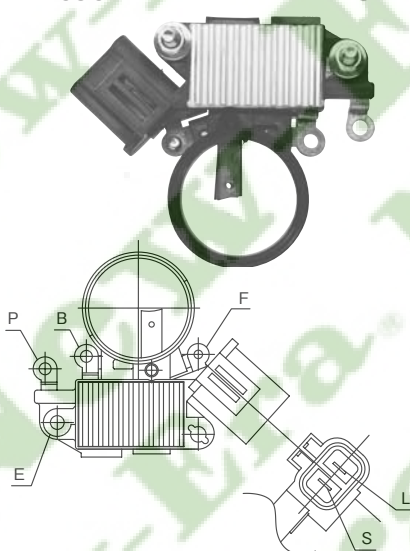
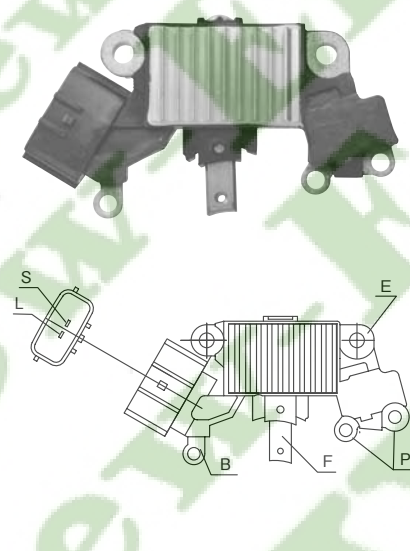
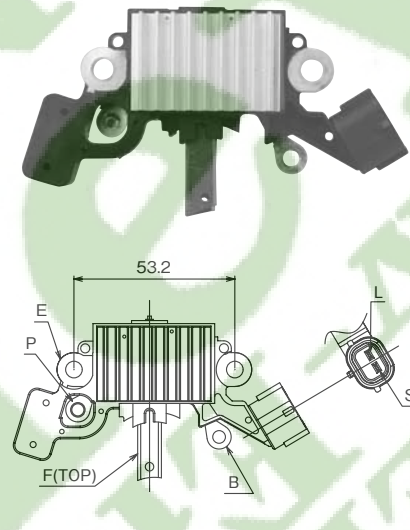



New-Era No.	Ref.No.	Application
<b>IVR-858</b> 	<b>AC12V</b> 23135-0C400  L190G-2315 HI	NISSAN CEDRIC, GLORIA BLUEBIRD BLUEBIRD VANETTE AVENIR WAGON VANETTE LARGO LARGO LARGO Q-UY32 (RD28) 91~95 Q-SU13 (CD20) 91~96 E-SNU13 (CD20) 93~99 Q-KVC23 (CD20T) 91~94 Y-SW10 (CD20T) 92~96 Q-VW30 (CD20T) 93~96 E-W30 (KA24DE) 96~97 KD-VW30 (CD20ET1) 96~97
<b>IVR-859</b> 	<b>AC12V</b> 23215-2Y005 2Y001  L1110G-53402 HI 43402 HI	NISSAN CEFIRO  PRESAGE A33 (VQ20DE, VQ25E-D1, VQ30DE) 99~ U30 (VQ30DE) 98~
<b>IVR-860</b> 	<b>AC12V</b>	NISSAN CUBE  Regulator for Rectifier Assembly DIVR-860600 Z10 (GG13DE) 97~99

# VOLTAGE REGULATORS

VOLTAGE REGULATORS

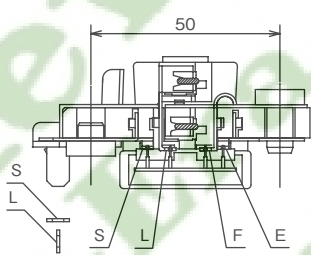
New-Era No.		Ref.No.	Application		
IVR-861	AC12V	RF01-24-521	MAZDA		
			BONGO BRAWNY VAN	SR2AV (R2)	90~
IVR-901H	AC12V	8173-24-520 N221-24-520 MD607372 MD607570	MAZDA	E-CB23C	78~
			COSMO RE		79~
IVR-861	AC12V	L150-73154 HI	BONGO BRAWNY TRUCK	SR29V (R2)	90~
				SD2AT (R2)	90~
IVR-901H	AC12V	L150-73154 HI		SD29T (R2)	90~
				SD29M (R2)	90~
IVR-901H	AC12V	L150-73154 HI	SAVANNA RX-7		79~80
			FAMILIA 1500, 1300 BD1051, BD1031		80~82
IVR-901H	AC12V	L150-73154 HI	BONGO		80~
			323, 1500, 1300	[USA]	80~82
IVR-901H	AC12V	L150-73154 HI	323	[GENERAL] [EC]	81~
			FAMILIA	[EC] [USA]	82~
IVR-901H	AC12V	L150-73154 HI	RX7	[USA]	79~80
				[NORTH AMERICA]	79
IVR-901H	AC12V	L150-73154 HI	RX4	LA82S [GENERAL]	80~
			RX3	[NORTH AMERICA]	79~80
IVR-901H	AC12V	L150-73154 HI		[GENERAL]	79
				[USA]	81
IVR-901H	AC12V	L150-73154 HI	929 2000	[EC]	79~82
			121 2000	E-HBPHE	81~83
IVR-901H	AC12V	L150-73154 HI	CAPELLA 2000, 1800, 1600	[USA]	81~83
				[NORTH AMERICA]	78
IVR-901H	AC12V	L150-73154 HI	LUCE ROTARY	LA82S	80~
			E2000 TRUCK	[USA]	81~
IVR-901H	AC12V	L150-73154 HI	B2000 PICK UP	[USA]	81~
			GLC FRONT WHEEL DRIVE	[USA]	83~
IVR-901H	AC12V	L150-73154 HI	FORD		
			TELSTAR 2000, 1800, 1600		82~83
IVR-901H	AC12V	L150-73154 HI	VIRGO	[USA]	82~83
			COURIER 2000	[USA]	81~
IVR-901H	AC12V	L150-73154 HI	MITSUBISHI		
			DEBONAIR EXECUTIVE	G-A32K (4G54, G54B)	78~81
IVR-901H	AC12V	L150-73154 HI	GALANT Σ 2300D	E-A167A	79
			GALANT Σ Λ 2000	E-A164A, EA-163A (4G6)	79~
IVR-901H	AC12V	L150-73154 HI	ETERNA Σ Λ 2600, 2000	E-A164A, EA-163A (4G6)	79~
			LANCER EX 1600, 1400		78~79
IVR-901H	AC12V	L150-73154 HI	MIRAGE 1400, 1200	E-A155A, E-A156A	78~79
			TREDIA, CORDIA 1600 TURBO		81~83
IVR-901H	AC12V	L150-73154 HI	STARION	A182A	81~
			GALANT Σ, Λ	[NORTH AMERICA]	78~79
IVR-901H	AC12V	L150-73154 HI	FORTE	[NORTH AMERICA]	78~
			MIRAGE	[NORTH AMERICA]	79~
IVR-901H	AC12V	L150-73154 HI		[EC]	80~
			CANTER		80~
IVR-901H	AC12V	L150-73154 HI	LIGHT BUS ROSA		80~
			DELICA STAR WAGON 1800 L1300		79
IVR-901H	AC12V	L150-73154 HI	TRUCK, TRUCK 4WD	LO23G [USA]	83~84
			STARION 2600 TURBO	[USA]	83~
IVR-901H	AC12V	L150-73154 HI	PLYMOUTH CRICKET		78~79

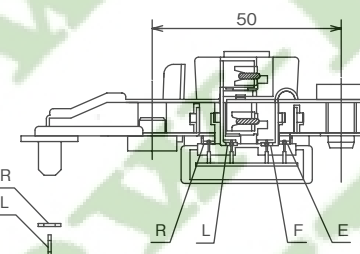
# VOLTAGE REGULATORS

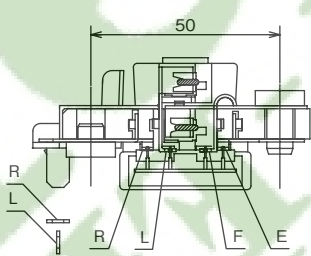
New-Era No.	Ref.No.	Application
<b>IVR-902H</b>  	<b>AC12V</b> 23215-P3017 W7110	NISSAN BLUEBIRD 1800 (COLD) 79~ 2000 79~ STANZA 1800 80~ 1600 80~ SKYLINE 1800 79~ 2000GTE (COLD) H-GC210 79~ 2000 80~ SILVIA 2000 79~ LAUREL 2000, 1800 79~ VIOLET 1600 80~ FAIRLADY 2000Z (COLD) 79~ CEDRIC 2000 VAN 81~ PULSAR 1500 82~ SUNNY 1500 82~ 130Y 85~ CARAVAN (COLD) 80~ HOMY (COLD) 80~ MARCH [NORTH AMERICA] 83~ A866T00870 MI 02970 MI
<b>IVR-903H</b>  	<b>AC12V</b> SE21-24-520 MD607619	MAZDA E3000 81~ E2000 82~ LIGHT BUS 81~ MITSUBISHI GALANT Σ Λ 2300 DIESEL 81~ PAJERO L043G 81~ DELICA 2300 SL 82~ TRUCK, TRUCK AWD L023G[USA]
<b>IVR-904H</b>  	<b>AC12V</b> FE05-24-520	MAZDA CAPELLA 2000 E-GCEP 82~ FAMILIA 1500, 1300 TURBO E-BR1051, BD10 82~ FORD TELSTAR 2000, 1800, 1600 82~ LASER 1500 82~ A866T02270 MI 04070 MI



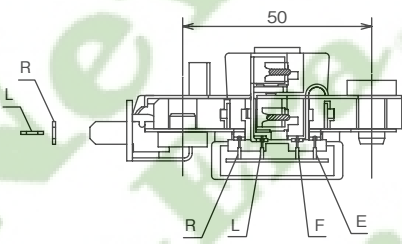
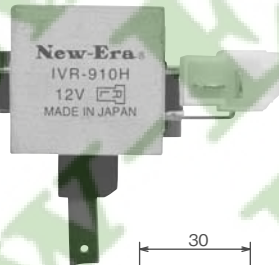
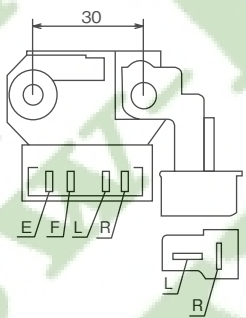
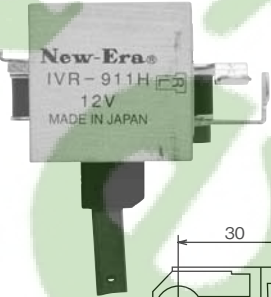
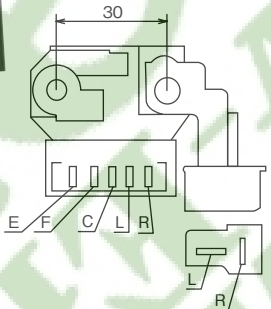

# VOLTAGE REGULATORS

VOLTAGE REGULATORS

New-Era No.	Ref.No.	Application
<b>IVR-905</b>  	<b>AC12V</b> ME700556  A866T06570 MI	MITSUBISHI CANTER GUTS  CANTER 20 CANTER  FB308 (4DR7) 89~ FB300 (4DR5) 83~92 FE320 (4DR) 83~92 FB100 (4DR) 83~92
<b>IVR-910H</b>  	<b>AC12V</b> S501-24-520  A866X02470 MI	MAZDA B2200 PICK UP [GENERAL] 80~83 E3000 DIESEL TRUCK [GENERAL] 81 B DIESEL [PHI] 81~ TITAN 3000 DIESEL E-WE100 81~ TA3H4 80 2500 DIESEL XA, EXR15 80 PROCEED 2200 DIESEL 80~83
<b>IVR-911H</b>  	<b>AC12V</b> 8599-24-520  A866X02170 MI	MAZDA B2200 PICK UP [USA] [AUSTRALIA] 80~83 [USA] 82~ E2500 DIESEL 80~81 LUCE 2200 DIESEL 80~81 TITAN 2500 DIESEL 80~81 PROCEED 2200 DIESEL 80~83  FORD COURIER 2000 DIESEL [USA] 82~

# VOLTAGE REGULATORS

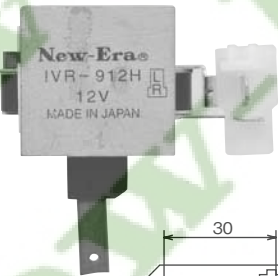
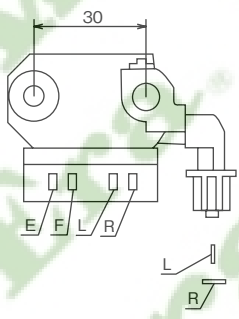
VOLTAGE REGULATORS

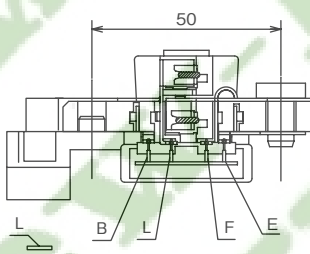
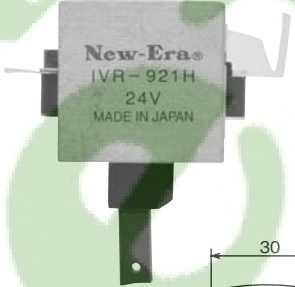
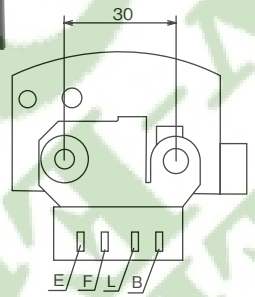
New-Era No.	Ref.No.	Application
IVR-912H  	AC12V MD607500	MITSUBISHI GALANT Σ 2300D (GOLD) ETERNA Σ 2300D (GOLD) K-A167A K-A167A K-A167A 80~81 80~81
IVR-913  	AC12V A866X01670 MI	CTRON CITROEN BX PEUGEOT 205, 305, 405, 605.
IVR-921H  	AC24V ME700091 A866T01070 MI	MITSUBISHI CANTER FUSO LARGE TRUCK LARGE BUS FE110, 111, 211 T656, FK115, FM215 MP117M, 118M, 517M, 518 79~ 80~ 81~ MIDDLE BUS LIGHT BUS ROSA (FORKLIFT) MK103H BH212 79~80 80~ 81~

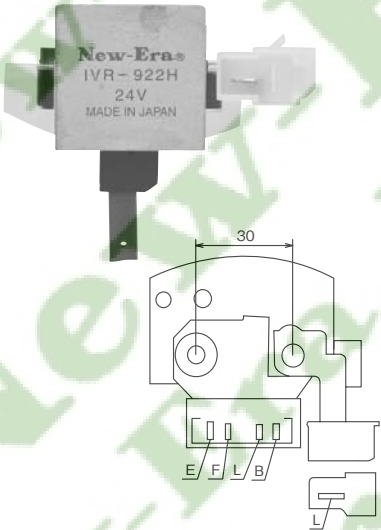
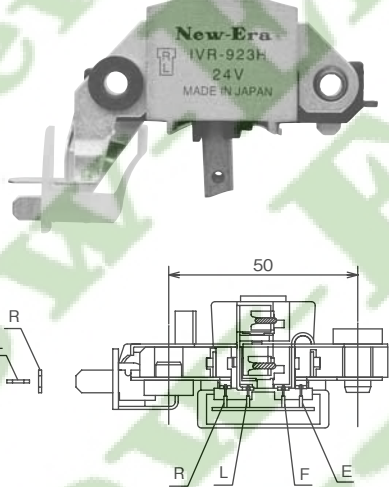
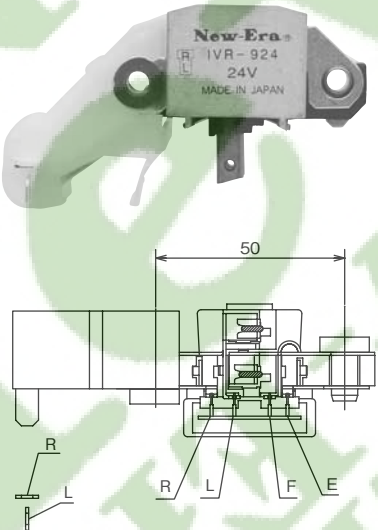

# VOLTAGE REGULATORS

VOLTAGE REGULATORS

New-Era No.	Ref.No.	Application
<b>IVR-922H</b> 	<b>AC24V</b> SE01-24-520	MAZDA TITAN 3000 DIESEL TITAN 2500 DIESEL E3000 DIESEL TRUCK HA, TA3H XA, EXR [EC] 81~82 81~82 81~82
<b>IVR-923H</b> 	<b>AC24V</b> ME700571	MITSUBISHI CANTER20, 30 FE101B, 101E, 111B 121B, 211E 83~
<b>IVR-924H</b> 	<b>AC24V</b> SE17-24-520	MAZDA TITAN 3000, 2500 DIESEL (COLD) 3000, 2500 DIESEL 3500 DIESEL E3500 LIGHT BUS TA3, TB3, EXR (HA) N-WEF, N-WE5 (XA) P-WEL (SL) [GENERAL] 83~ 83~ 83~ 84~

# VOLTAGE REGULATORS

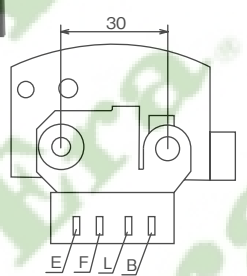
VOLTAGE REGULATORS

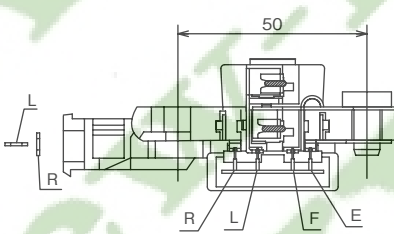
New-Era No.	Ref.No.	Application
<b>IVR-925H</b>  	<b>AC24V</b> ME700228  A866T03170 MI	MITSUBISHI TRUCK (6D1, 6D2) (8DC7) 80~ 81~
<b>IVR-926</b>  	<b>AC24V</b> ME700635  A866T06870 MI	MITSUBISHI FUSO TRUCK REARDUMP TRUCK (OFFLOAD) CRANE TRUCK LARGE TRUCK TRUCK LARGE TRUCK MIDDLE TRUCK LARGE TRUCK MIDDLE TRUCK LARGE TRUCK CANTER CANTER MIDDLE TRUCK MIDDLE TRUCK MIDDLE TRUCK LARGE TRUCK LIGHT BUS ROSA LARGE BUS MIDDLE BUS LIGHT BUS TRUCK LIGHT BUS LARGE BUS INDUSTRIAL USE LARGE TRUCK CANTER FU415, FV415FS415 (8DC) D320, D200 (10DC) K252, K400 (8DC2, 6DC2) FS, FT, FU, FV (6D20) P-FT418V, FU-418 (6D22) FP, FT (6D1, 6D2) FK (6D14, 6D15) P-FK515 (6D14, 6D15) FK115, FK116 (6D14, 6D15) FK (6D31) OPTION FK, FM, K-FP, FT (6D14, 6D10) FB300 (4DR5) 20, 30, 35FE, FE314, FE434, 444 (4D31T) FK (6D31) FK330 (6D31) (TAIPEI) FK330 (6D31) DIESEL FT (6D1, 6D2) BE434, 435 (4D32, 4D31T) MK, MP, MM (6D1, 6D2) MM, MK515, MK116J, F (6D14, 6D15) P-MK126F (6D15) FW425, FN425 (8DC9, 8DC11) BK215F (6D14) MP218, MP618 (6D22) (6D1) OPTION FK335, 345, 337 (6D14, 6D16) 20, 30, FE305, 325, 425, FB315, 435 (4D32) 84~85 84~85 84~85 84~89 83~88 83~ 83~ 80~84 87~ 84~ 84~ 84~ 87~ 89~ 89~ 83~88 86~ 84~88 84~88 84~88 85~ 84~87 85~ 85~ 87~90 84~

# VOLTAGE REGULATORS

New-Era No.	Ref.No.	Application	
IVR-940	AC12V	E356-18-W70 FE65-24-520 MD611032 MD611146	MAZDA CAPELLA 2000, 1800, 1600 [SAUDI ARABIA] 83~ COSMO 12A, 13B 83~ COSMO 2000 FE 83~ LUCE 12A, 13B 83~ LUCE 2000 FE RX-7 [GENERAL] 83~ SAVANNA RX-7 12A 83~ 323, 626, 929
		FORD NO. E8GY-10-316	MITSUBISHI CHARIOT 1800 [SWEDEN] 84~ CHARIOT 1800 (COLD) [EC] [SWEDEN] 84~ ETERNA, GALANT Σ 1800 G37B 83~ ETERNA, GALANT Σ 2000 G63B 83~ LANCER F10RE 1500, 1300 G15B, B13B [EC] MIRAGE 1500, 1300 G15B, G13B [EC]
		A866X05470 MI 05471 MI 05472 MI	
IVR-942	AC12V	RFG1-18-W70 MD618735 MD619167 TF35-18-W70 23215-K8470	MAZDA TELSTAR 2000 DIESEL GVFRF, GVFWF, GEFRF 92~95 CAPELLA CARGO 2000 DIESEL WAGON GVFR, GVFW 92~95 CRONOS 2000 DIESEL GEFP 92~95 BONGO (OPTION) (NORTH AMERICA) 95~ SPECTRON 2000 DIESEL WAGON SSF8WF 93~ BONGO BRAUNY 2000 DIESEL WAGON SRF9W 93~ BONGO 2000 DIESEL WAGON SSF8W, SSF8R 93~
		MITSUBISHI LANCER CB8A, CD8A (4D68) 93~ CB8W, CD8W (4D68) PAJERO, MONTERO V47WG (4D56) 94~ L400 PA5W, PB5W (4D56) 94~ PC5W (4D56) PO5T, PO5V (4D56) P15T, P25T (4D56) P25W (4D56) PA5V, PB5V (4D56) PD5V (4D56)	
		A866X24472 MI 24972 MI 25572 MI	RVR/CHARIOT N28W, N38W, N48W (4D68) 92~97 ETERNA/GALANT E57A, E77A (4D68) 92~ LIVERO CB8W (4D68) 92~ MIRAGE/LANCER CB8A, CD8A (4D68) 92~99 PAJERO V24C, V24W (4D56) 93~99 CHALLENGER K94W, K94WG (4D56) 93~99 STRADA K74T (4D56) 98~99 KUDA DIESEL (INDONESIA)

VOLTAGE REGULATORS

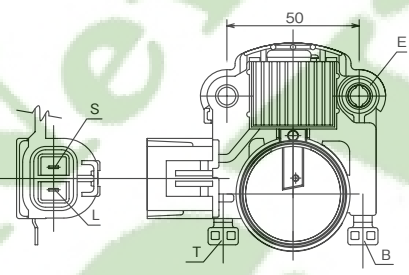
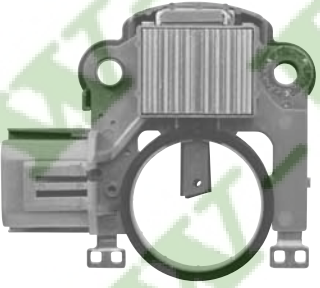
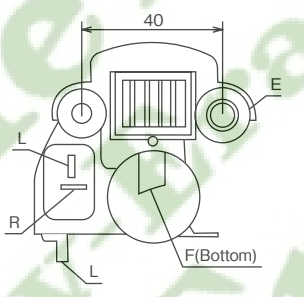

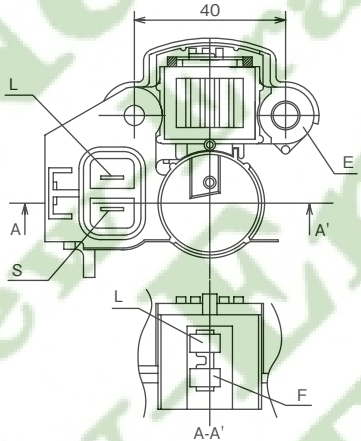

# VOLTAGE REGULATORS

New-Era No.	Ref.No.	Application
IVR-946	AC12V	MITSUBISHI
		CHARRIOT
		D05W (G37B) 85~94
		N33W, N43W (4G63) 87~00
		F11A (G671) 86~96
		L036P/PY (G33B) 86~94
		L063P/PY (G32B) 86~94
		P01V (G33B) 86~94
		P02V (G32B) 86~94
		P03W (G63B) 86~00
		P04W, P24W (4G64) 86~00
		P12V (G32B) 86~94
		P13V (G63B) 86~00
		P23V (G63B) 86~96
		P23W (G63B) 86~00
		F11A (G671) 86~96
		F07W (G672) 86~96
		ECLIPSE D22A, D27A (4G63) 87~00
		ETERNA, GALANT E33A, E39A (4G63) 87~98
		E35A (4G67) 87~98
		ETERNA Σ, GALANT Σ E11A (G32B) 85~94
		E12A (G37B) 85~94
		E17A (G671) 86~96
		E18A (G672) 86~96
		ETERNA, GALANT E32A/E37A (4G37) 85~00
		FORKLIFT (4G63) 86~96
		GALANT (4G63) 91~96
		E31A (4G32) 85~00
		E38A (4G63) 87~94
		LIBERO CARGO CB1A (4G13) 87~96
		CB2A, CD2V (4G15) 87~96
		MIRAGE C51A, CA1A (4G13) 87~96
		C52A, C82A (4G15) 87~96
		C53A, C63A (4G61) 87~00
		C73A, C83A (4G61) 87~00
		MIRAGE, LANCER C11V (G13B) 87~96
		C12V, C12W (G15B) 87~96
		C32V (G15B) 89~93
		C61A, CB1A (4G13) 87~96
		C62A, C72A (4G15) 87~96
		C63A, C73A (4G61) 87~00
		PAJERO L041GV (G63B) 86~98
		L141G/GW (G672) 88~97
		L146GW (G672) 88~97
		V23C/W, V43W (G672) 90~97
		RVR N13W, N23W (4G63) 87~96
		STALION A187A (G54B) 87~97
		NISSAN
		BLUEBIRD 2000 E-YU11 (CA20S) 84~86
		1800 E-U11 (CA18E) 84~86
		1600 E-RU11 (CA16S) 84~86
		LAUREL 2000 E-HJC32, -KHC32 (RB20E) 84~89
		FAIRLADY Z E-HZ31, HGZ31, GZ31 (VG30, E, DE) 84~89
		FAIRLADY Z E-HZ31, HGZ31, GZ31 (VG20DE, E) 84~89
		GEDRIC, GLORIA E-Y30, PY30, RY30 (VG30, E) 84~89
		E-Y30, PY30, RY30 (VG20E, E, T) 84~89
		HYUNDAI
		ACCENT 1.5L 95~99
		ELANTRA 1.6L 92~95
		1.8L 93~95
		EXCEL 1.5L 90~93
		SCOUPE 1.5L 91~95
		SONATA 2.0L 92~98
		3.0L 90~95
		A866X05272 MI
		09071 MI
		09771 MI
		09782 MI
		09072 MI
		12472 MI

VOLTAGE REGULATORS

# VOLTAGE REGULATORS

New-Era No.	Ref.No.	Application
IVR-947	AC12V MD611481	MITSUBISHI PAJERO 2500 DIESEL VAN (E. C.) V14V, V34V, L044G, L144G L044GV, L049GV (4D56) 86~
		MITSUBISHI PAJERO 2500 DIESEL WAGON 4WD (E. C.) L044GV, L049GV (4D56) 86~ DIESEL (E. C.) (COLD) Q-L044GV, Q-L049GV (4D56) 86~ DIESEL WAGON L149GV, L144GV (4D56) 87~ DIESEL VAN L044GV, L049GV (4D56) 87~ DIESEL WAGON L044GV, L049GV (4D56) 87~ DIESEL VAN L044GV, L049GV (4D56) 87~ DIESEL WAGON V24C, V24V (4D56) 89~ DELICA 2300 VAN 4WD, 2WD (E. C.) (4D55) L144GV, V24V (4D56) 86~ 2500 DIESEL (E. C.) Q-P15W (4D56) 86~ 2500 PICK-UP, VAN (E. C.) N-L039P, L06P (4D56) 86~ DIESEL VAN P45V, P05V, P15V, P25V (4D56) 86~ MIRAGE 1800 DIESEL (E. C.) C64A, C74A (4D65) 87~ LANCER 1800 DIESEL (E. C.) C64A, C74A (4D65) 87~ ETERNA SAVA 1800 DIESEL E34A (4D65) 87~ GARANT 1800 DIESEL E34A (4D65) 87~
IVR-948	AC24V ME701399	MITSUBISHI CANTER FE517, 537, 567, 53C 95~ FE648, 568 95~ FE516, 566 95~
	A866X09171 MI	
	A866X28372 MI	

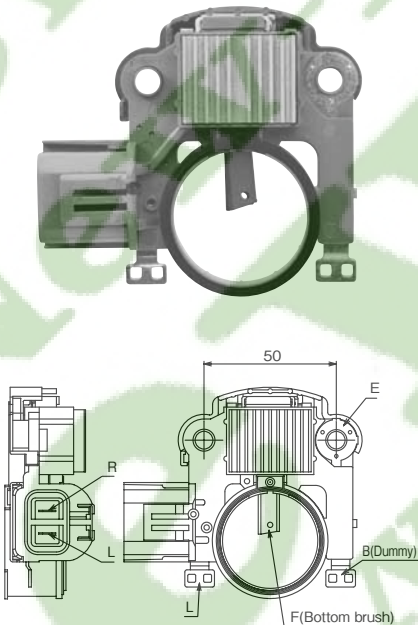
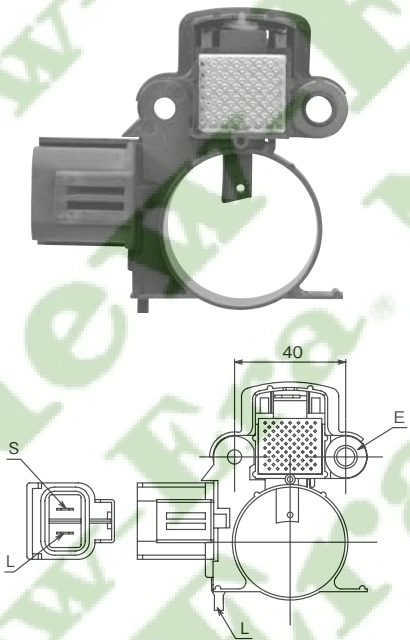

VOLTAGE REGULATORS





# VOLTAGE REGULATORS

VOLTAGE REGULATORS

New-Era No.	Ref.No.	Application
IVR-949	AC12V MD618569 MD618696 F81E-18-W70 23815-KA110	MITSUBISHI GALANT CHARIOT RVR LANCER DEBONAIR MIRAGE LIBERO PAJERO DELICA GTO FORKLIFT SUBARU DOMINGO
		E52A, E72A (4G93) 92~98 N33W, N43W (4G63, 4G64) 92~00 N13W, N23W (4G63) 92~00 N11W, N21W (4G93) 91~98 CD9A, CE9A (4G63) 92~00 CD5A (4G93) 91~98 S26A, S27A (6G74) 92~98 S22A (6G72, 6G74) 92~97 CA1A, CB1A (4G13) 93~98 CA3A, CB3A, (4G91) 91~98 CC3A, CD3A CA4A, CC4A (4G92) 91~96 CD2V, CB1V, (4G13, 4G15) 93~98 CB2V CB5W, CD5W (4G93) 91~99 V25W, V25C, (6G74) 93~97 V45W V23C, V23W, (6G72) 94~97 V43W PB6W, PD6W, (6G72) 94~97 PF6W PO2T, PO6V (4G92) 94~98 Z15A, Z16A (6G72) 95~97 (4G15, 4G63, 4G64) 94~98 FA7, FA8 (EF12E) 93~98
	A866X22272 MI 23182 MI	
IVR-950	AC12V JE48-18-W70 B64J-18-W70A	MAZDA REVUE FESTIVA FAMILIA EUNOS LASER AUTOZAM PRESSO PROCEED CAPELLA CRONOS TELSTAR EFINI MX-6 CREF SENTIA CUSTOM CAB BONGO FORD
		DB3PA, DB5PA, (B3, B5) 90~97 D23PF, D25PF (B3, B5) 90~97 BG5P, BG5S, BG6R (B5, B6) 91~96 BG6Z, BG8R, BG8Z (B6, BP) BG8P, BG8S, BG3P (BP, B3) BG3S, BG5P (B3, B5) BG5S (B5) BG5PE, BG8PE (B5, BP) 91~96 CAPP (FP) 91~97 CA8PE, CAEPE (K8, KF) BG3PF (B3) 91~96 EC5SA (B5) 91~97 EC5S (B5) 91~97 EC8SE (K8) UJL6R (WL) 95~97 GVFV (RF) 92~97 CG2PP, CG2SP, (FP, FS) 91~97 CG2SR GESR (FS) 91~97 GE8P, GEEP (K8, KF) GESRF (FS) 91~97 CG2PPF, CG2SPF (FP, FS) GE8PF, GEEPF (K8, KF) GE5PF (KL) GESR (FS) 91~97 GE8P, GEEP (K8, KF) FD3S (13B) MBEP, MB5P (KF, KL) HD5S, HDES (J5, JE) 91~98 LVLR (WL) 95~97 GEEB, GE5B (KF, KL) 91~97 GESRA (FS) 91~97 GE5PA, GEEPA, (KL, KF) HDES, HD5P, (JE, J5) 91~98 HDEP, HD5S HBEY (FE) 92~97 SGEW, SG5W (FE, J5) 95~97 SGEWF, SG5WF (FE, J5) 95~97
	A866X20472 MI 20972 MI	

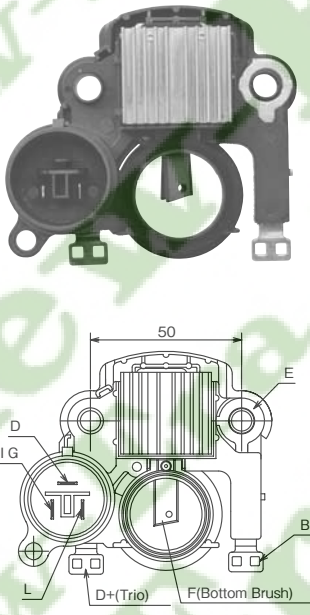
# VOLTAGE REGULATORS

New-Era No.	Ref.No.	Application
IVR-951	AC12V 32500-60F30	SUZUKI JIMNY JA11C, JA11V, (F6A) 92~96 JA12C, JA12V, JA12W
		ESCUDO TA01R, TA01W, (G16A) 92~96 TD01W
	ALTO CR22S, HA11S (F6A) 91~96 CR22S, CS22S (F6A) 92~96	
	CERVO MODE CN22S, CP22S (F6A) 92~96	
	CARA PG6SS (F6A) 92~96	
	CULTUS AA34S, AB34S, (G13B) 92~93 AF34S, AK34S	
	A866X23772 MI	
IVR-952	AC12V B675-18-W70A	MAZDA ETUDE BFMP, (B6) 86~95 BFSP (B5)
		CAPELLA CARGO GV6V (B6) 86~95
	FAMILIA BF3V, BFTP, BW3W (E3) 86~95 BF5V, BW5W (E5) BF6M, BFMP, BFMR (B6) BWMR BFSP, BFSR (B5) BFTP (B3)	
	CAPELLA GD6P (B6) 86~95 GD8A, GD8B, GD8P, (F8) 87~94 GD8R, GD8S GDEA, GDEB, (FE) GDEP, GDES (F8) GV8W	
	TELSTAR GVERF (FE) 87~94	
	PROVE BT21C, BT21L (F2) 87~94	
	PERSONA MA8P (F8) 87~94 MAEP (FE)	
A866X12782 MI 12770 MI 12772 MI 12780 MI		

VOLTAGE REGULATORS

# VOLTAGE REGULATORS

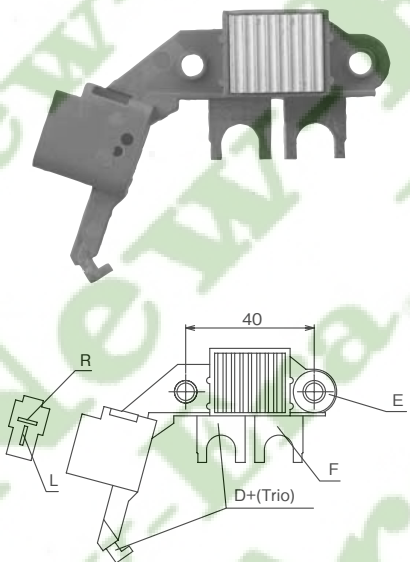
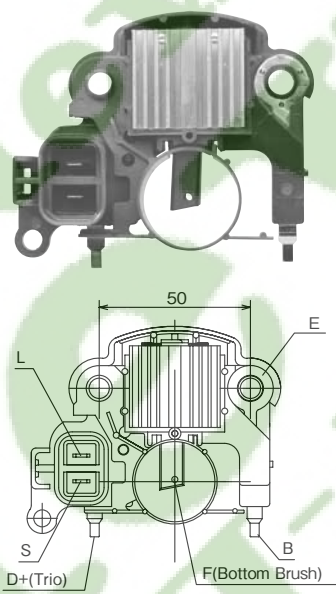
New-Era No.	Ref.No.	Application
<b>IVR-953</b> 	<b>AC24V</b> ME701196 ME700783	<b>MITSUBISHI (FUSO)</b> AEROSTAR MP218, MP618 (6D22) 85~97 AERO MIDDY MJ117, MD527, MK117, (6D16) 87~95 MK517, MM117, MM527 (6D16) MK527, MM517 (6D16) MK115 (6D14) MK525 (6D14T) THE GREAT FU418, FP418, FT418, (6D22) 85~99 FU418, FP418, FU478, FT418 (6D22T) FV418, FS418, FU428, FU418 (6D22T) FN428, FP418, FU478, FS478 (6D22T) FW419, FP449, FU419, FV419 (8DC11) FP419, FW429 (8DC11) FP413, FU413, FT413, FV413 (8DC8) FP445, FP415, FS415 (8DC9T) FT415, FV415 (8DC9T) FS415, FV415, FP415 (8DC9) FW455, FW445, FU415, FS425 (8DC9) FV416, FS416, FU416 (8DC10) FU410, FS410, FU440, FU470 (6D40) FT410 (6D40T) FP414, FV414 (10DC11) FP411, FU411, FV411 (8M20) FIGHTER FK415, FK425, FK345, FK335 (6D14) 87~95 FK615 (6D14) FK415, FK515, FM515, MK595 (6D14T) FK416, FK516, FM516 (6D15T2) FM656 (6D15T3) FK567, FK517, FK467, FL417 (6D16) FK417, FK427, FK617 (6D16) FL618 (6D17) INDUSTRY (6D143) 90~97 TADANO (6D152) TADANO (6D161) TADANO, KATO (6D221) (6D311)
	A866X19972 MI 08871 M	
<b>IVR-954</b> 	<b>AC12V</b> JE15-18-W70A	<b>MAZDA</b> LUCE HCEP FE 88~98 HC2J F2 HC3S 13B 88~95 HCFS JF 88~98 HCSS JE 88~96 MPV LVEW JE 88~98 LV5W G5 RX-7 FC3S 13B 88~98
	A866X17072 MI	

VOLTAGE REGULATORS



# VOLTAGE REGULATORS

VOLTAGE REGULATORS

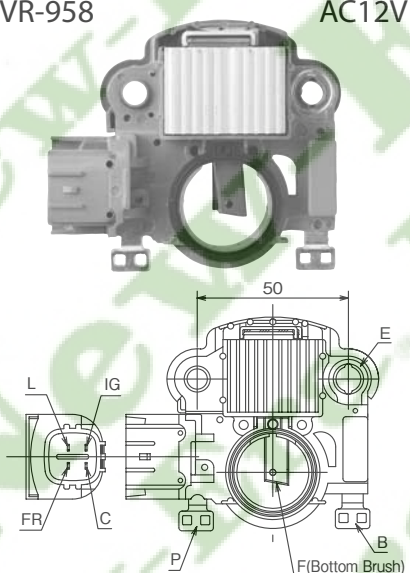
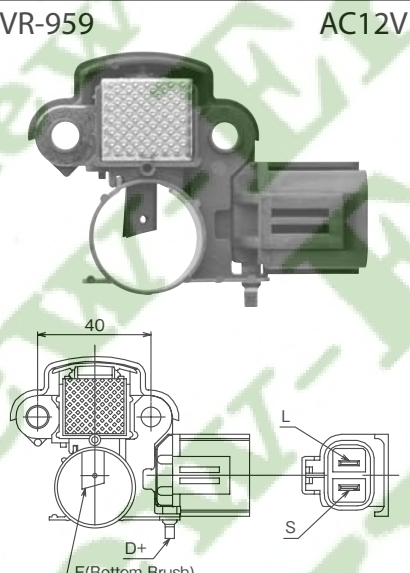
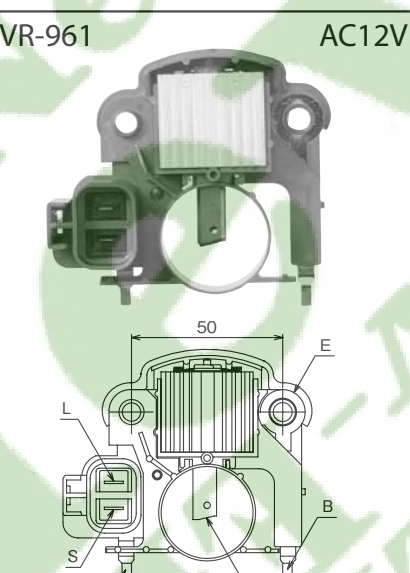
New-Era No.	Ref.No.	Application
<b>IVR-958</b> 	<b>AC12V</b> 31150-PLM-A01	HONDA CIVIC 1.7L 01~05 ACURA EL 1.7L 01~03
<b>IVR-959</b> 	<b>AC12V</b> 23125-58510	NISSAN SUNNY PULSAR LAUREL LANGREY PRAIRIE E-HB12, (E15E, E13S, 85~87 E-B12, E15ET) EHNN13 (E15S) 85~ E-HB12L (E15S, E15E) 86~ E-BHN13 (E15E) 86~ E-N12, E-B12 (E15E, E13E) 86~87
<b>IVR-961</b> 	<b>AC12V</b> MD611743	MITSUBISHI Σ DIAMANTE DEBONAIR V GTO (3000GT) F13A, F15A, (6G73, 72) 92~ F25A, F27A F13A, F15A, (6G73, 72) 92~ F25A, F27A S11A, S12A (6G71, 72) 86~95 F17A, F16A, (6G72) 92~00 Z15A, Z16A

# VOLTAGE REGULATORS

VOLTAGE REGULATORS

New-Era No.		Ref.No.	Application	
IVR-962	AC12V	04314-P08-J02	HONDA Civic	2DR DX 95
		A866X26641 MI		
IVR-963	AC12V	Z599-18-W70	MAZDA LANTIS FAMILIA	CBA8P (BP) 96~98 BHA6R (B6) 96~00 BJ3P, BHA3P/S, (B3) 96~ BJ5P, BJ5W, (ZL) 96~ E-N12, E-B12 (E15E, E13E) 96~98 BHALP/S, (Z5) 96~00 BHA8P/S, (BP) 96~00 BJ8W (FP) 96~00 BJFW, BJFP (FS) 99~00 BHALPF, BHALSF (Z5) 96~00 BHA8PF (BP) 96~00 BHA6RF (B6) 96~00 BHA3PF (B3) 96~00 CAPELLA GFEP, GFER (FS) 96~00 GF8P, GW8W (FP) 96~00 TELSTER GW8WF, GF8PF (FP) 96~99 GW5WF, GW5RF (FS) 96~99 PREMACY GFERF (FS) 96~99 CP8W (FP) 98~00 CPEW (FS) 99~00 MPV LWEW (FS) 99~00 DEMIO DW5W (B5) 98~ DW3W (B3) 98~ FORD FESTIVA DW5WF (B5) 98~ DW3WF (B3) 98~
		A866X35472 MI		
IVR-964	AC12V	F2G8-18-W70	MAZDA PICK-UP 2. 2L B2200	90~93
		A866X18972 MI		

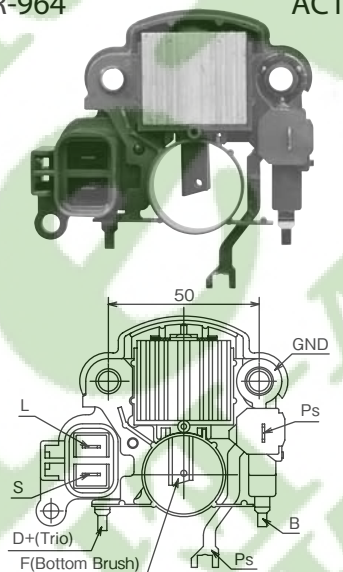
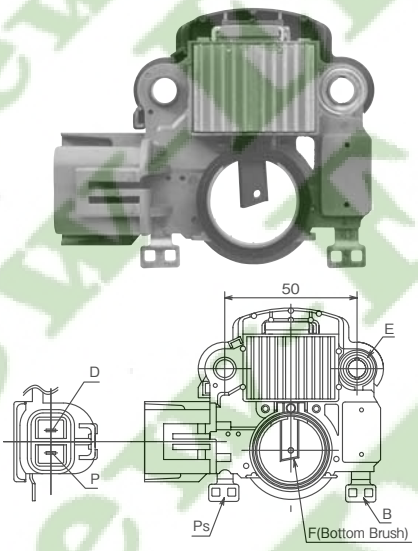
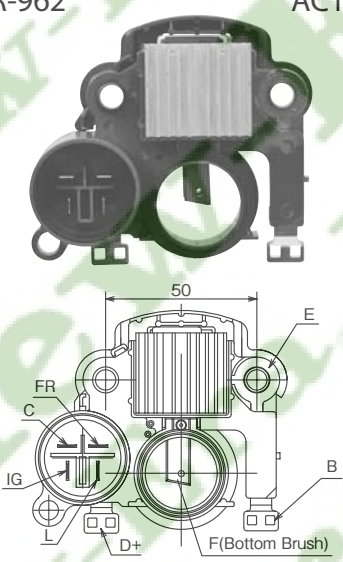

# VOLTAGE REGULATORS

VOLTAGE REGULATORS

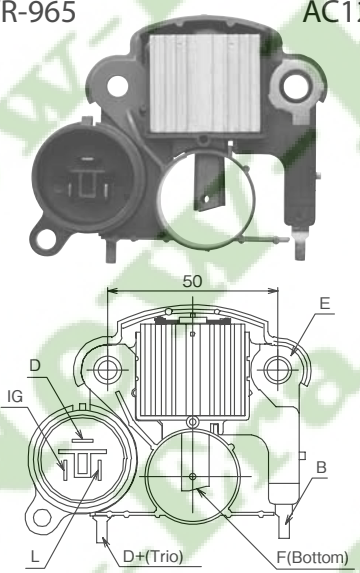
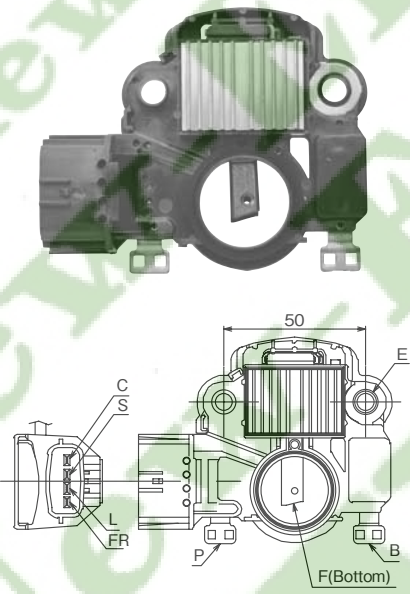
New-Era No.	Ref.No.	Application
<b>IVR-965</b> 	<b>AC12V</b> 32500-60A10  A866X11872 MI	SUZUKI JIMNY ESCUDE  CULTUS  ALTO ALTO WORKS CERVO MODE  JA11V, JA11C (F6A) 90~92 TA01 (G16A) 88~92 TA01R, TA01V (G16A) 88~92 TA01W, TD01W (G16A) 88~92 AA34S (G13B) 88~92 AF34S (G13B) 91~92 AB34S (G13B) 91~92 AK34S (G13B) 91~92 CR22S, CS22S (F6A) 90~92 CN21S, CP21S (F6A) 90~92 CN21S, CN21S (F6A) 90~92 CP21S, CP22S (F6A) 90~92
<b>IVR-966</b> 	<b>AC12V</b> MD619268  A866X34172 MI	MITSUBISHI MIRAGE, ASTY  LANCER  GALANT  DION  PAJERO 10 MIRAGE DINGO  LANCER CEDIA LANCER CEDIA WAGON LEGNUM  RVR  ASPIRE FTO DIAMANTE  AIRTRECK  CJ4A, CK4A, (4G92) 95~97 CJ4A (4G13, 4G15) 98~ CJ1A, CJ2A, CK1A, CK2A CL2A, CM2A (4G15) 98~ CK6A (6A11) 95~97 CK4A (4G92) 95~ CK1A, CK2A, CM2A (4G13, 4G15) 95~00 CK6A (6A11) 95~06 CK5AR (4G93) 95~00 CN9A, CP9A (4G63) 96~99 EA1A, EA7A, EC1A, EC7A (4G93, 4G94) 96~06 EC5A (6A13) 96~06 CR6W (4G94) 96~06 CR9W (4G63) 97~06 H76W (4G93) 96~06 CQ5A, CQ1A, CQ2A (4G93, 4G13, 4G15) 96~06 CS5A, CS5AR, CS2A (4G93, 4G15) 96~06 CS2W (4G15) 98~ EA1W, EA7W, EC1W (4G93, 4G94) 96~06 EA4W, EA5W, EC4W, EC5W (6A12, 6A13) 96~06 N61W, N71W (4G93) 98~05 N73WG (6G63) 97~06 EA1A, EC1A (4G93) 98~05 DE3A (6A12) 95~06 F34A (6A13) 02~06 F31A, F36A (6G73, 6G72) 96~99 F41A, F46A, F47A (6G73, 6G72) 96~99 CU2W (4G63) 01~06







# VOLTAGE REGULATORS

New-Era No.	Ref.No.	Application
IVR-967 	AC12V E8PZ-103-13A 103-16A 103-16B GRE792 793  A866X13971 MI 13970 MI	FORD TEMPO THUNDERBIRD  MERCURY TOPAZ  88~89  88~90
IVR-968 	AC12V 23815-AA020  A866X17272 MI	SUBARU (FUJI) LEGACY  LEGACY WAGON  BC2, BC3 (EJ20S) 88~99 BC5 (EJ20G) 88~99 BF3 (EJ18S) 88~99 BF5 (EJ20G) 88~99 BFA (EJ20D) 88~99
IVR-969 	AC12V 31150-PE0-9270  A866X08270 MI 08271 MI	HONDA CIVIC CR-X

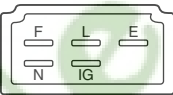
VOLTAGE REGULATORS

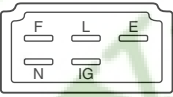

# VOLTAGE REGULATORS

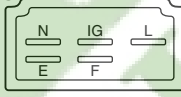

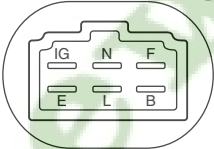
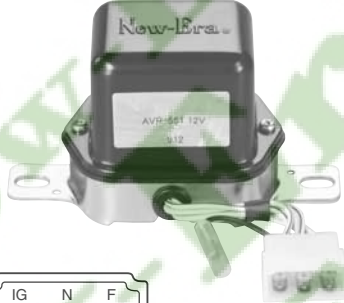
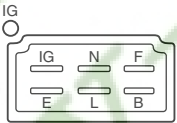

New-Era No.	Ref.No.	Application	
<b>AVR-201</b>  	<b>AC24V</b> 6301-3200-52 27700-1120A  0512-159-1210 SF 026000-1790 ND 1791 ND	HINO  RANGER LIGHT BUS PM  EC100B, DM100B KM500 (DQ100) DQ100, EC100, EH100, EH300 (OPTION) DM100 EC100, EH100, EH300, DQ300 KR, KL400, KL500, EC100 KL300, 321D, 340, WB310, KL300-340	
<b>AVR-203</b>  	<b>AC24V</b> 6301-3200-42 27700-1040  0512-159-0910 SF	HINO  KL (EC100) KR (EC100, EH100) KM (DM100) EC100B, DM100B KM500 (DQ100) EC100, EH100, EH300, DQ100 DQ100, EC100, EH100, EH300 (OPTION) DM100 EC100, EH100, EH300, DQ100 KQ (EL100)	
<b>AVR-204</b>  	<b>AC24V</b> 6071-3200-10 11 27700-1280  0512-159-0230 SF RS1011-24B SF	HINO TRUCK BUS  TRACTOR  KB381, 312 (EB100) KG301, 311 (EA100) RG300, 320 (DK20) KF300, 380, HE335 (ED100)	67~71 66~71 70~74 ~73
<b>AVR-511</b>  	<b>AC24V</b> 1-8125-1026-0 9-8225-0112-0  026000-1860 ND 1861 ND	ISUZU FORWARD  TRUCK  SBR, SCR (6BB1, 6BD1) F/SDR, F/SCR (6BF1, 6BD1) TW-D (DA640)	78~ 80~85 78~

VOLTAGE REGULATORS

# VOLTAGE REGULATORS



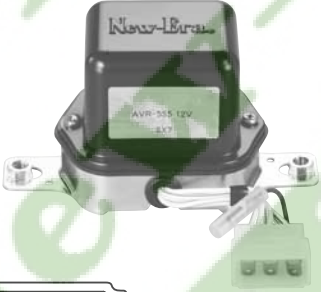
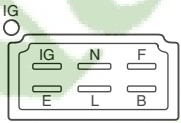

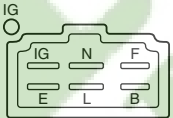

New-Era No.	Ref.No.	Application
<b>AVR-512</b>   W/DIODE	<b>AC24V</b> 27700-57010 57020 57021 57040	DAIHATSU DELTA DIESEL 2000 3000 TOYOTA COASTER DIESEL DYNA DIESEL TOYOACE DIESEL LAND CRUISER DIESEL DYNA DIESEL
	026000-3790 ND 3840 ND 3890 ND 3960 ND	K-V10, 12 (B) 80~83 N-V10, 12, 13, 15 (B) 83~ K-V17, 18 (B) 80~83 N-V40, 42, 47, 48 (3B) 83~ K-V48 (3B) 80~83 K-BB11 (2B) 80~81 K-BU20, 30, 35 (B), 36 (3B) 80~82 K-BY30 (B) 80~82 K-BJ60V (2B) 80~ K-BJ41, 44 (3B) 80~ K-BJ60V (3B) 80~ K-BU40, 50 (3B) 82~
<b>AVR-551</b>  	<b>AC12V</b> 27700-22010 22011 22012 31010 31011 33010 33011 40020 40021 51010 51011 51012 36010 32500-56010	DAIHATSU CONSORTE CHARMANT CHARADE DELTA 1500 2000 750 TAFT JEEP DELTA DIESEL 2000 SUZUKI FRONTE COUPE JIMNY 55 8 CARRY 55 FRONTE 7-S CERVO FRONTE 7-S CERVO ALTO TOYOTA CORONA MARK II CORONA CARINA CELICA CORONA LAND CRUISER PICK UP STARLET DYNA COASTER STOUT HI LUX TOYOACE DIESEL TOYOACE HI ACE LARGE TRUCK 4200
	026000-1740 ND 1742 ND 1751 ND 1800 ND 1801 ND 1810 ND 1871 ND 2430 ND 2431 ND	EP30, 30D, 30N, 30NB, 31S ~76 EP40, 42, 45, 47 A10, 20 77~ SV17T, SV18L DV23T, DV26T2 KD10 F10 78~ V20, 23, 25, 26 (DG) 77~79 LC10W 73~76 LC20FG 75~76 H-SJ10 (V), (LJ-50) 76~81 H-SJ20 (F8A) 76~ H-ST10 (T5A) ST20 (LJ-50) 76~79 (T4A) 76~ (T4A) 76~ C-SS11 (AB10) 77~79 E-SS20 (T5A) 77~79 H-SH10 (LJ50) 76~79 MX10, 20, 27 72~74 RT40, 50, 60, 70, 80, 90 65~74 RT100, 110, TT-100, 110 PT36, PT40, PT86V [USA] 73~74 RA21 [USA] 73~74 MX13, 23, 29 73~74 RT85, 95, 104, 114, 118 [USA] 73~74 (F ENG FJ55) (2F ENG FJ55) [USA] 73~74 RN22, 27 [USA] 73~74 KP40 73~74 JK171, 176, RK171, 176 74~ JU10, 12, 15, RU10, 12, 15 69~74 RK171B, JU18, RU18, 19 69~74 RK101 67~74 RN10, 20, 22, 25 68~74 JY16 (2J) 72~74 RK32, 41, 42, PY10, 12, 14 67~74 RH10, 11, 15, 16 67~74 FA101 (2F) 75~79

# VOLTAGE REGULATORS

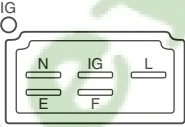
New-Era No.	Ref.No.	Application
<b>AVR-553</b> 	<b>AC12V</b> 27700-40010 40011  026000-0810 ND 0811 ND 1410 ND	TOYOTA CROWN LAND CRUISER  RS40 FJ40  63~64 64~71
<b>AVR-554</b>  	<b>AC12V</b> 27700-60080 60090  026000-2370 ND 2371 ND	TOYOTA LAND CRUISER DYNA LAND CRUISER  FJ40, 43, 45, 55, 56 (F, 2F) FC22D (F ENG FJ40, 2F ENG FJ40) [USA]  75~78 73~79
<b>AVR-555</b>  	<b>AC12V</b> 27700-41010 41011 41012 41020  026000-1650 ND 1810 ND 2310 ND 2550 ND	TOYOTA CROWN  HIACE  MS50, 60, 70 RS-50, 56, 60, 66 RH18VC (5R) RH10, 20, 30, 40 (12R, 16R, 18R)  74~ 78~
<b>AVR-556</b>  	<b>AC24V</b> 27700-47010  026000-1690 ND	TOYOTA LAND CRUISER TRUCK  FJ40-B (F) DA1# (2D)  68~

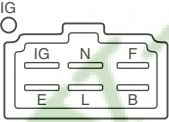
VOLTAGE REGULATORS

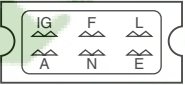
# VOLTAGE REGULATORS



New-Era No.	Ref.No.	Application
<b>AVR-557</b>  	<b>AC12V</b> 9-8225-0110-0  026000-1990 ND	ISUZU ELF 250 JOURNEY BUS ELF JOURNEY BUS ELF 150  ELF JOURNEY ELF  TLD23HB (C240) 73~75 BLD24 (C240) 73~75 TLG12, 22 (G201) 74~ BLG24 (G201) 73~75 COLD-STORAGE CAR (G161) 74~ KA-51 75~ (C240PM, C221PM, P0-5) 75~ TLG12, 22, 32 (G201) 75~ K-BLD35 (4BA-1) 75~ TLD (C240) 80~
<b>AVR-558</b>  	<b>AC12V</b> 27700-26020 28010 38010 38020 2770A-38020  026000-2540 ND 2680 ND	DAIHATSU DELTA 750 DELTA WIDE DELTA  HINO RANGER  TOYOTA CROWN  CROWN 2000  CARINA MARK II CORONA DYNA TOYOACE PICK UP  V30 (DG5R)  HV10 (DG) 78~  C-RS100 (5R-U) 76~ E-MS105 (M-U) C-MS100 (M-U) 76~ H-MS87V (M-J) 75~76 H-TA16, 17 (T-J, 2T-J) 75~79 RX12, 22, 28 (18R-G (R)) 75~77 RT104, 114, 120 (16R, 18R) 75~77 JU10, 20, K-JU20 (2J) 73~ K-JY20, 30 (2J) 73~ RN23, 28[USA] 73~79
<b>AVR-559</b>  	<b>AC12V</b> MD011810 MD011811  026000-1940 ND	MITSUBISHI GALANT FTO 1400 DELICA DELICA VAN  A61  T120, 120V
<b>AVR-562</b>  	<b>AC12V</b> 31400-642-004 657-003 657-004 657-671 657-672 659-003  026000-2411 ND 2580 ND 2900 ND	HONDA CIVIC 1200, 1300, 1500B-SC, SF, E-SK, SP (EE, EJ, ED, EC) E-SG, SH 75~79 B-SJ, BSM (EF, EK) 76~78 E-SN (EK) 78~79  ACCORD 1600, 1800 PRELUDE 1800

VOLTAGE REGULATORS

W/RUBBER SHEET



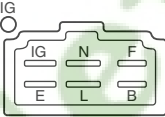

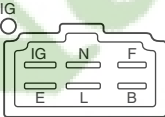

# VOLTAGE REGULATORS

VOLTAGE REGULATORS

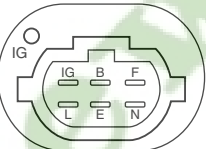
New-Era No.	Ref.No.	Application
<b>AVR-565</b>  	<b>AC12V</b> 27700-24010 36010 40041 44020	DAIHATSU CHARADE (COLD) E-G10 (CB10, 11, 31, 32) 77~83 CHARMANT H-A10, H-A20V (3K-HJ, T-J) 75~79 DELTA DIESEL 1500 K-V24, 26 (DG) 79~83 1750 N-V54, 56 (DL) 83~ 2000 K-V24, 26 (DG) 79~80 K-V20, 23, 25 (DG) 80~83 F50 (DG) 78~80 K-F50, 50V (DG) 80~  TAFT 2000  TOYOTA COROLLA TE3#, 4# (T, 2T) 75~ B-KE50, 60 (3K-U) SPRINTER H-TE36 (2T-J), H-KE26, 36 (3K-U) 75~ PUBLICA H-KP27 (2K), B-HP5# (4K-J) 75~ STARLET B-KP50, 51 (3K), H-KP37 (4K-J) 75~  HIACE PH10 (5R) 72~ DYNA RU-10, 12, 15 (5R) 72~ CORONA 1800 H-RT137V (16R-J) 78~79 1600 H-TT137V (2T-J) 78~79 CARINA [USA] 75~79 CELICA RA21 [USA] 75~79 CORONA MX13, 23, 29 [USA] 75~79 RT85, 95, 104, 114, 118 [USA] 75~79 (F ENG FJ55, 2F ENG FJ55) [USA] 75~79 LAND CRUISER RN22, 27 [USA] 75~79 PICK UP
	026000-2432 ND 3880 ND	
<b>AVR-566</b>  	<b>AC12V</b> 27700-13010 13020 15010 36020	DAIHATSU CHARMANT E-A30 (4K-U), JA40V (12T-J) 78~81 J-A30 (4K-J), E-A40 (12T-U) 78~81 DELTA 750 H-KD11 (4K-J) 78~79 1500, 2000 V3#, J-V3# (5R) 77~83 WIDE H-TB10V, J-TB11V (2T-J) 78~82 E-TB15G (13T-U) 78~79 E-YB20G (2Y-U) 82~ E-YB21G (3Y-EU) 83~ H-F20, J-F20 (12R-J) 76~81  TAFT  TOYOTA CROWN G-RS100 (5R-U), 76~ C-MS100, 102 (M) CORONA A-RT100, C, E-RT120, 130 (12R-U) 75~80  CELICA 2000 E-RA46 (21R-U) 78~81 1800 E-TA46 (13T-U) 77~78 1600 E-TA41 (12T-U) 77~79 CELICA CAMRY 2000 E-RA56 (21R-U) 80~82 CARINA 2000 E-RA46 (21R-U) 78~79 1800 E-TA46 (13T-U) 77~79 1600 E-TA41 (12T-U) 78~79 COROLLA-SPRINTER 1800 E-TE70 (13T-U) 79~80 COROLLA 1600 J-TE73V (12T-J) 79~81 COROLLA-SPRINTER 1300 E-KE70 (4K-U) 79~80 CORSA-TERCEL E-AL10 (1A-U) 78~79 COROLLA II 1500 E-AL12W, RD 79~80 COASTER RB11 (20R) 77~79 LAND CRUISER FJ53, 56 (2F) 77~ TOYOACE JY16 (2J) 73~79
	026000-3190 ND 3330 ND 3350 ND	

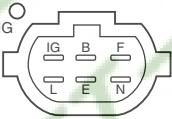

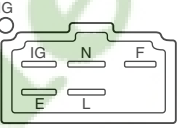

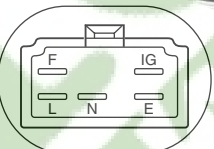

W/BOTTOM PLATE

# VOLTAGE REGULATORS

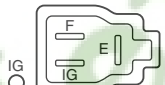
New-Era No.	Ref.No.	Application
<b>AVR-569</b>   W/BOTTOM PLATE	<b>AC12V</b> 27700-24020 38040 38050 38060  026000-2960 ND 3210 ND	TOYOTA CELICA RA24, 29, 42L 76~ RT105L, 115L, 119 77~ CORONA MX32, 36 4M 77~ CRESSIDA TE31, 51 76~77 COROLLA RN23, 28 76~78 HI LUX RA24, 29[USA] 73~79 CELICA KE30 (W/O H. D. REAR DEFODGER) [USA] 73~79 COROLLA (2F ENG FJ40, FJ55) [USA] 73~79 LAND CRUISER [USA] 80
<b>AVR-570</b>   W/BOTTOM PLATE	<b>AC12V</b> 27700-26030 28020 38120  026000-3320 ND 3610 ND 3680 ND	TOYOTA PICK UP RN32, 42 78~79 COROLLA TE31, 51 77~ TE31, 51[USA] 73~79 CORONA RT105, 115, 119 (NON-INTEGRAL TYPE) [USA] 73~79 CRESSIDA (55AMP NON-INTEGRAL TYPE) [USA] 75~79 PICK UP (55AMP NON-INTEGRAL TYPE) [USA] 75~79 COROLLA RN23, 28, RN32, 42 (40AMP) [USA] 73~79 (50AMP) [USA] 80~
<b>AVR-573</b>   W/DIODE & BOTTOM PLATE	<b>AC24V</b> 27700-46010 46011 46012 56050  026000-1670 ND 1671 ND 3040 ND 3540 ND	DAIHATSU DELTA DIESEL 2000 V10, V12 (B) 77~79 K-V10 (B) 79~80  TOYOTA DYNA, COASTER BU 72~77 LAND CRUISER BJ40, 43 DYNA JU10, 20, BJ40, 43 TOYOACE K-YJ20, 30 JY16 COASTER BB10 DYNA BU20, 30 LAND CRUISER BJ41, 44 COASTER BB10, 11
<b>AVR-574</b>   W/RUBBER SHEET	<b>AC12V</b> 31400-657-673  026000-3270 ND	HONDA CIVIC 1200 75~ ACCORD 76~79 PRELUDE 80~ CIVIC 1200, 1500 SB, SL, SG, E, N, D 72~ ACCORD 1600 SS, EL 79~ PRELUDE 1600 SN, EL 79~ QUINT SN, EL 79~ CVCC [USA] 75~77 ACCORD, CIVIC [USA] 76~77 ACCORD, PRELUDE [USA] 80

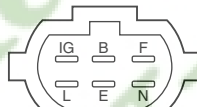
VOLTAGE REGULATORS





# VOLTAGE REGULATORS

New-Era No.	Ref.No.	Application
<b>AVR-575</b>   W/BOTTOM PLATE	<b>AC24V</b> 27700-77005  026000-3140 ND	TOYOTA TRUCK, BUS  DA115, 118 DA100, 11#, K-DA120, 125  77~83 77~
<b>AVR-577</b>   W/CONDENSER & BOTTOM PLATE	<b>AC12V</b> 27700-27010 27020 27030 27040 27050  026000-3310 ND 3430 ND 3660 ND	DAIHATSU DELTA WIDE E-TB15G (13T-U A/T) 81~82  TOYOTA MARK II 2000 1800 E-RX40, 41, 60 (21R-U) C-TX30 (3T-U) E-TX40, 60 (13T-U) 78~82 77~79 77~82  CHASER 2000 1800 E-RX40, 41, 60 (21R-U) E-TX40, 60 (13T-U) E-SX60 (1S-U) 78~82 77~82 82~84  CORONA CELICA E-TT131 (13T-U), E-TT130 (12T-U) 78~81  CARINA E-TA46 (13T-U), E-TA41 (12T-U) 79~81  COROLLA, SPRINTER E-TA46 (13T-U), E-TA41 (12T-U) E-TE70 (13T-U), E-AE70 (3A-U) 79~81 79~80
<b>AVR-578</b>   W/DIODE & BOTTOM PLATE	<b>AC12V</b> 27700-13060 35010  026000-3851 ND	TOYOTA COROLLA LAND CRUISER PICK UP STARLET 1200  (TERCEL) [USA] (NON-INTEGRAL TYPE) [USA] (GAS, NON-INTEGRAL TYPE) [USA] [USA] (4K-C)  81~82 81~84 81~83  81~82 81~
<b>AVR-579</b>   W/DIODE	<b>AC12V</b> 32500-56011  026000-3670 ND	SUZUKI FRONTE 7-S ALTO CARRY 55WIDE 800CC CERVO JIMNY  E-SS30 (T5B) E-SS40 (F5A) H-SS30V (T5B) H-ST30 (LJ50) ST80/K/V, ST90/K/V SC80 SS80F, SS80AF H-SJ30 (LJ-50)  79~81 79~81 79~ 79~ 80~ 80~ 83~ 81~

VOLTAGE REGULATORS

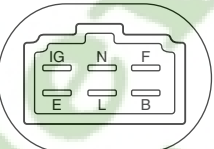
# VOLTAGE REGULATORS

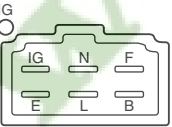
VOLTAGE REGULATORS

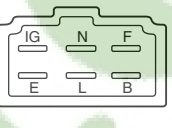



New-Era No.	Ref.No.	Application
<b>AVR-580</b>  	<b>AC12V</b> 27700-13050	DAIHATSU DELTA WIDE DELTA 750  TOYOTA LITEAGE STARLET TOWNAGE HILUX  STOUT
		J-KB12V (4K-J) 77~82 J-KD20 (OPT10N) 79~  J-KM20, 20V (4K-J) 79~ E-KP61, J-KP62V J-KR12V (4K-J) 79~ RN46 82~ (18R) 81~ (5R) 81~
<b>AVR-583</b>  	<b>AC12V</b> 27700-13040 15011 35030 87701  026000-3810 ND  026000-3700 ND 3701 ND 3860 ND 3861 ND 3980 ND 4120 ND 4190 ND	DAIHATSU DELTA 750 (COLD) DELTA WIDE VAN DELTA WIDE WAGON CHARMANT 1500 DELTA WIDE  DELTA WIDE DIESEL  TOYOTA CORONA 1500 CARINA 1500 COROLLA, SPRINTER 1500  1300  CORSA, TERCEL, COROLLA II 1500  1300
		J-KD20 (4K-J) 79~82 J-TB11V E-TB15G E-A55 (3A-U) 81~ H-KB11V (4K-J) 78~79 J-KB12V (4K-J) 79~82 L-KB26V (4K-J) 82~ L-YB26V (1Y-J) 82~ N-CB21G (2C) 83~  E-AT140 (3A-U) 82~ E-AA60 (3A-U) 81~  E-AE70, 85 (3A-U) 81~  E-KE70, 73G (4K-U) 81~83  E-AL12, 21 (3A-U) 79~ E-AL11, 20 80~
<b>AVR-586</b>  	<b>AC12V</b> 27700-41021  026000-3750 ND 3751 ND	TOYOTA HIAGE DIESEL HILUX
		(18R, 21R) 12R, 12RJ 79~ LH11R, JR. (L) 82~ (12R-J) 80~

W/DIODE



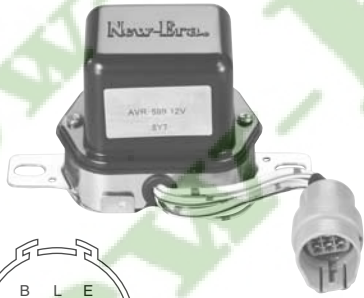
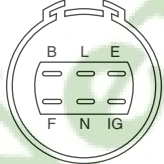

# VOLTAGE REGULATORS

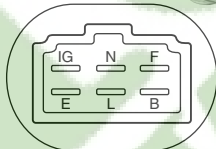

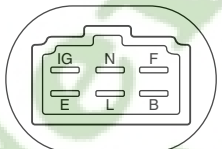

VOLTAGE REGULATORS

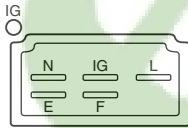
New-Era No.	Ref.No.	Application
<b>AVR-589</b>  	<b>AC12V</b> 27700-13090 63010 63040 72030	TOYOTA MARK II, CHASER, CRESTA E-SX60 (1S-U) 82~84 E-LX60, 67V-X, D (L) 82~84 E-TX67V-X (13T-J) 82~84 CORONA 1800 E-ST140 (1S-U) 82~ E-AT140 (3A-U) 82~ E-CT140, 147 (1C) 83~ E-KT147 (5K-J) 83~ E-TT147V (12T-J) 82~83 CORONA 1500 DIESEL (COLD) N-CT140, 147V (1C) 82~ CELICA 1800 E-SA60 (1S-U) 81~85 CARINA 1800 E-SA60 (1S-U) 81~83 E-AA60 (3A-U) 81~83 E-CA60, 37V (1C) 82~ E-KA67V (5K-J) 83~ E-TA67V (12T-J) 81~83 DIESEL N-CA60, 37V (1C) 82 COROLLA, SPRINTER DIESEL NGE70 M/T (1C) 82~83 STARLET [USA] 81~82 COROLLA [USA] 83 TERCEL (GAS 50AMP) [USA] 83~85 HILUX E-LN5#, 6# (2L#) 83~85 E-LN5#, 6# (2L#) 85~ E-YN56 (3Y-P) 84~ E-YN5# (2Y-J) 83~85 E-YN5# (2Y-J) 85~ E-Y6# (3Y-J) 83~84 KIJANG DIESEL (7K)
W/CONDENSER & DIODE & BOTTOM PLATE	026000-4050 ND 4051 ND 4070 ND 4180 ND 4300 ND	
<b>AVR-592</b>  	<b>AC12V</b> 27700-87504 87505	DAIHATSU HI-JET 550 J-S40 (AB20) 79~81 HI-JET 55 WIDE J-S60 (AB20) J-S65 (V) (C) (AB20) 81~82 M-S65, 66 (AB20) 82~
W/DIODE & BOTTOM PLATE	026000-3170 ND 4080 ND	
<b>AVR-593</b>  	<b>AC12V</b> 27700-15030	TOYOTA COROLLA (3A-2U, 2A-LU, 3A-LU) 83~ DIESEL A-CE80 (1C-L) 83~ SPRINTER 1500 E-AE81 (3A-LU) 83~ 1300 E-AE80 (2A-LU) 83~ DIESEL N-CE80M/T (1C-L) 83~ SPRINTER TRUENO 83~
W/DIODE & BOTTOM PLATE	026000-4200 ND	

# VOLTAGE REGULATORS

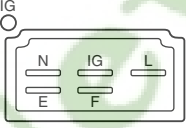
New-Era No.	Ref.No.	Application
<b>AVR-595</b>  	<b>AC12V</b> 27700-15020	TOYOTA COROLLA II TERCEL CORSA CORSA, TERCEL, COROLLA II 1300 E-AL20 (2A-U) 80~ E-AL20 (2A-U) 80~ E-AL20 (2A-U) 80~ E-AL20DX (M/T, STD) (2A-U) 82~
W/DIODE & BOTTOM PLATE	026000-4130 ND	
<b>AVR-613</b> 	<b>AC24V</b> 9-8225-0086-0 0096-0 0079-0	ISUZU DA640, DH100 DA120P-114 E120, TMC DA120P DH100 BX, BA, DA640 DH100 BA, BX, DA640 V170 D920, 8MA-1/E120
	0-41000-0030 NK	
<b>AVR-615</b>  	<b>AC24V</b> 9-8225-0129-0 0112-0 0114-0 0134-0	ISUZU TRUCK TX, TWS (DA 640) 76~81 SFR (DA640) 76~ TD, SLR (DH100) SPM, TMK (E120) 76~ BUS CCM, ECM (6BD1) 80~ CLM, CLA (DH100H) 80~ CJM, CJA (6QA2) 80~81 CPM, CPA (E120H) 80~81 DX BUS BU-K (E120H) 76~78 BH (8MA1), CRA (10PA1) 76~ TRUCK SKW (8PA1) 76~84 SK, SM (8PB1) 80~84 SRM, VRR (10PA1) 76~ SSZ, SSK, VSR (10PB1) 80~ SSH, SSZ, SSK, VSR (10PB1) 81~ SR (10PA1), SS, VS (10PB1) 82~ TRACTOR TRUCK VWR, VWZ (8MA1) 76~78 VTR, VTZ (12PA1) 76~81 VT (12PA1) 82~ BUS BA, BS (DA640), BU-D (D920H) 76~79 BU (DH100H) 76~79 INDUSTRIAL MACHINE (DA220, DA640, 8MA1) 78~
	0-41000-2390 NK	

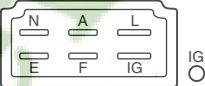



# VOLTAGE REGULATORS

New-Era No.	Ref.No.	Application
<b>AVR-615EX</b>  	<b>AC24V</b> 9-8225-0129-0 0112-0 0114-0 0134-0  0-41000-2390 NK	ISUZU TRUCK TX, TWS (DA 640) 76~81 SFR (DA640) 76~ TD, SLR (DH100) SPM, TMK (E120) 76~ BUS CCM, ECM (6BD1) 80~ CLM, CLA (DH100H) 80~ CJM, CJA (6QA2) 80~81 CPM, CPA (E120H) 80~81 DX BUS BU-K (E120H) 76~78 TRUCK BH (8MA1), CRA (10PA1) 76~ SKW (8PA1) 76~84 SK, SM (8PB1) 80~84 SRM, VRR (10PA1) 76~ SSZ, SSK, VSR (10PB1) 80~ SSH, SSZ, SSK, VSR (10PB1) 81~ SR (10PA1), SS, VS (10PB1) 82~ TRACTOR VWR, VWZ (8MA1) 76~78 TRUCK VTR, VTZ (12PA1) 76~81 VT (12PA1) 82~ BUS BA, BS (DA640), BU-D (D920H) 76~79 BU (DH100H) 76~79 INDUSTRIAL MACHINE (DA220, DA640, 8MA1) 78~
		<b>AVR-712</b>  
<b>AVR-713</b>  	<b>AC24V</b> 9-8225-0134-0  TL2Z-15 HI	ISUZU ELF 150 KAD 73~ 250 TLD (C240) ~82 350 TLD (4BA1, 4BC1) 77~78 TRUCK KS (4BB1) 78~ BUS TX, TV, BA 73~ BU, BL, TW 73~

VOLTAGE REGULATORS

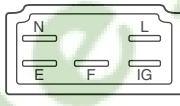

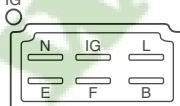

# VOLTAGE REGULATORS

VOLTAGE REGULATORS



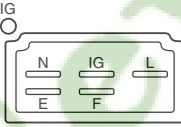

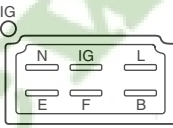
New-Era No.	Ref.No.	Application
<b>AVR-714</b>  	<b>AC24V</b> 23500-J5502	NISSAN CARAVAN CABSTAR, HOMER CABALL PATROL RSE20, RE20, KRSE20 (SD22) 77~ QCF20, F20 (SD22) 77~ K-YC341 (ED33) 80~ J-G60 (SD33) 79~
	TL2Z-26 HI	
<b>AVR-715</b>  	<b>AC24V</b> TL2Z-27 HI	ISUZU ELF 150 78~ 250 78~ 250 WIDE 80~ KAD (C190) TLD (C240, 4BA1, 4BC1) KTD (4BA1, 4BC1)
	TL2Z-27 HI	
<b>AVR-811</b>  	<b>AC12V</b> 23500-14602 14802/4 14814 16500 16502/3/4 16510 16512/3/4 29900/1/2 29905 29911 29912 73000 73010/1 86400 89900/1 89904 89910 89911 L0400 L0410 N3310 N3300	NISSAN CHERRY, PULSAR 100A, 120A, 140A, F10, F11 75~ N10 (A12, 14) SUNNY 1200, 1400, 1000 120Y, 140Y, B210 66~ 1600 B310, HB310 (L14, 16) 77~ BLUEBIRD 1300, 1400 160B, 180B, 510, 610 72~ VIOLET 140J, 160J, 710, J710 72~ SKYLINE 1600, 1800 C111, C211 73~ LAUREL 1800, 2000 C130, SC230 75~ AUSTER 1400, 1600 B-A10, H-VA10 77~78 CEDRIC 2000 ALL 130, N230S, 330, V330 70~ GLORIA 2000 ALL 230GA, N230S, 330 70~ DATSUN TRUCK 520, 620, 720 72~ (J15, L18, SD22) PATROL G60 (P40) 72~ NEW SILVIA S11 (L18) 78~ STANZA 1600 GPA10 79~ CABSTAR ALL A320, QF20 (SD22) 72~ HOMER, CARAVAN ALL E20, F20 (SD22) 72~ CABALL CH2, C240, QC141, C240 72~ CLIPPER ALL T650, T40, YC340 72~ MICROBUS DIESEL QGHC240 76~ FORKLIFT SD22 74~ PULSAR 1200 E-YN10 (A12A) 79~80 PICK UP 510, 240Z, 1200 [USA] 73
	TL1Z-57D HI 61D HI	

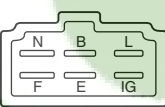
# VOLTAGE REGULATORS

VOLTAGE REGULATORS

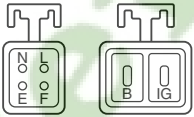
New-Era No.	Ref.No.	Application
<b>AVR-815</b>  	<b>AC12V</b> 9-8225-0110-0 3102-0 3107-0 8-9402-1595-0	ISUZU ELF 150 250 150 250 150 250 117 COUPE PICK UP KAD (C190) 78~ TLD (C240) TLD (4BA1) 77~ KAD9 (C190) 73~ TLD9 (C240) 75~ KAD (C190) 78~ TLD (C240) ECG. 1. PA90E 72~ XE, PA95TE (G180WET) 73~ KBD 76~80
	TL1Z-08 HI	
<b>AVR-821</b>  	<b>AC12V</b> 8-9420-2581-0 5956-0 2581-1	ISUZU ELF 150 FASTER FLORIAN DIESEL FLORIAN-VAN DIESEL CHEV. LUV GEMINI 1600 117 COUPE W/AIR-CON CAR 1600, 1800 FLORIAN 1800 CHEV. TROOPER, CARIBE 442 TOYOTA LAND CRUISER KAD (C190) 78~ KB20 (G161) 74~ PAD30 (C190G) 78~ PA30D (C190) 78~ KB30 74 PF50 (G161) 74~79 A-PA95 (G180) 74~79 (G180) 74~76 77~ FJ40, 43, 53, 56 (F. 2F) 77~
	TL1Z-87 HI 026000-2510 ND	
<b>AVR-823</b>  	<b>AC12V</b> 23500-29912 89911	NISSAN CEDRIC, GLORIA 2000 N230, N330 (H20) 78~80 CEDRIC, GLORIA 2000 (COLD) 430 (L20) 79~80 SKYLINE 1600, 1800 (COLD) (L16, Z16S) 76~79 BLUEBIRD 1600 (COLD) (Z16S) 79~80 STANZA 1600, 1800 (COLD) (Z16S, Z18) 79~80 VIOLET, AUSTER 1600, 1400 (COLD) (Z16S, A14S) 77~80 1800 PICK UP [SAUDI ARABIA] 78~ [AUSTRALIA]
	RQB-2B5 MI RLB-2B5 MI	

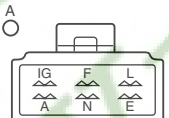

# VOLTAGE REGULATORS

New-Era No.	Ref.No.	Application
AVR-824	AC12V 23500-25G10	NISSAN PICK UP (720) 5~
 		
	RQB-2B8 MI	
AVR-951	AC12V 0259-18-391 391A 391B D27Z-10316A 367210 K437300 K437301 K457300 K467300 K467310 T200839 T206533 MD001810 MD601810 30668-26600	MAZDA 929 1800 [CANADA] 76~77 121 1800 [EC] [WEST GERMANY] [GENERAL] 75~77 929 2000 [SWEDEN] [AUSTRALIA] 77~79 121 1800 [AUSTRALIA] 75~77  MITSUBISHI COLT 1000 A20, A81 63~68 1000F K467300 A21, A82 66~68 1100 1100F T200839 A22, A25 65~66 T206533 A51, A52 69~ GALANT (DODGE COLT) 73~ LANCER ALL 68~ DELICA T100, J30 67~ JEEP J20, J30 67~69 JUPITER T11G, T11LPG 67~69 JUPITER JUNIOR T50, T51 67~69 MINICA A101, LA23, 2G10, 1V44 70~ (WATER COOLING CARS ALL TYPE) NEW COLT 1200, 1500 A23, A27 68~70
 		
	RLB-2220A MI	
AVR-952	AC12V MD001811 MD001821	MITSUBISHI CANTER 2T (4G52, 4G53, 4G54) 74~75 CANTER, ROSA (4G53, 4G54) 74 COLT Σ (4G52, 4G54) 78 DEBONAIR (A31) 73~75 DODGE CHALLENGER (4G37) 77~79 DODGE COLT (4G32) EXECUTIVE DEBONAIR SE (4G54, 4G54B) 76~78 FORKLIFT KE42 73~76 (4G32, 4G33) 77~78 FORTE 1600 (4G32) 78~79 GALANT (4G52) 73~74 4G32, 4G52, G52B) 73~78 (4G32, G32B) 74~80 (4G32, G32B) 75~79 1850, 2000 (4G51, 4G52) 74~78 (COLD) (4G51, 4G52) 75~78 2000 (4G52) 77~ COUPE (4G32) 74~77 GTO A57 72~74 (4G52) 72~77 GTO (COLD) (4G52) 75~77 Λ, SAPPORO C-A123A 75~ Σ B-A121A, C-A122A 75~ (COLD) (4G32, G52B) 75~78 (COLD) (4G52, G52B) 75~79
 		
	RQB-2D1 MI	

VOLTAGE REGULATORS

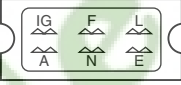

CONTINUED

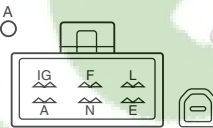
# VOLTAGE REGULATORS

New-Era No.	Ref.No.	Application
<b>AVR-952</b>  	<b>AC12V</b> MD001811 MD001821	MITSUBISHI GALANT ETERNA 1600 (COLD) (G32B) JEEP (4G53, 4G54) (4G52, 4G53, 4G54) (4G53) LANCER (4G36) 1600 (G32B, 4G32) CELESTE B-A73M, B-A72M (4G32, G32B) LIGHT BUS (4G53) ROSA (4G35) MINICA (2G23, 2G23B) (2G23) MIRAGE 1400, 1200 (G32B, G11B, G12B) PLYMOUTH ARROW (4G32Z) (4G52, 4G54) SAPPORO (4G37)
	RQB-2D1 MI	
<b>AVR-953</b> 	<b>AC12V</b> 0222-18-391 2090-18-940 940A 2329-18-940 940B	MAZDA LUCE 1500 SUA, SUAV (UB) FAMILIA 1200 MT#, ST# (TB) PRESTO 1000, 1300 SPC, STB CAPELLA SU2A, SNA SAVANNA RX, GR, SX, GS, GS11 CHANTEZ L, LX, GL, GL11, GF, GF11, KMA# FAMILIA 1000 (PC)
	RL-2122P MI	
<b>AVR-954</b>  	<b>AC12V</b> 0453-18-391	MAZDA RX4 COSMO RX5 (13B, 12B) [USA] [CANADA] [GENERAL] [EC] [WEST GERMANY] [SWEDEN] [AUSTRALIA] [UK]
	RLB-2220A5 MI	

VOLTAGE REGULATORS

# VOLTAGE REGULATORS

New-Era No.	Ref.No.	Application
<p>AVR-958</p> <p>AC12V</p>   <p>W/CONDENSER</p>	<p>ME037121-01</p> <p>RMS-2C7 MI</p>	<p>MITSUBISHI TRUCK</p> <p>FK115, FH215, FP117</p> <p>76~</p>

VOLTAGE REGULATORS