



BEDFORD MIDI 2.0D/TD MOT. ISUZU 4FC1/4FC1T dia. cil. 84,00 mm	GB	F	Japanparts Code	i	NEW
CINGHIA DISTRIBUZIONE 137 denti	TIMING BELT 137 tooth	COURROIE DE DISTRIBUTION 137	JDD904	137 T	*
CUSCINETTO TENDICINGHIA	TENSIONER BEARING	GALET TENDEUR/ROULEMENT	JBE901		*
SERIE GUARNIZIONI SMERIGLIO	CYLINDER HEADSETS	KIT JOINTS DE CULASSES	JKG902		*
SERIE GUARNIZIONI MOTORE	FULL GASKET SET	KIT POCHETTE JOINT MOTEUR	JKM902		*
VALVOLA ASPIRAZIONE	INLET ENGINE VALVES	SOUPAPES D'ADMISSION	JVVIZ000	39x8x132,5	**
VALVOLA SCARICO	EXHAUST ENGINE VALVES	SOUPAPES D'ECHAPPEMENT	JVVIZ001	34x8x132,5	**
KIT PISTONI STD C/SEGMENTI Mot.4FC1 aspirato	PISTON KIT WITH RINGS	PISTONS AVEC SEGMENT	JKI903	Pist. pin 25mm	*
KIT PISTONI +050 C/SEGMENTI Mot.4FC1 aspirato	PISTON KIT WITH RINGS +0,50	PISTONS AVEC SEGMENT +0,50	JKI903M	NO TURBO	*
KIT PISTONI STD C/SEGMENTI Mot.4FC1T turbo	PISTON KIT WITH RINGS	PISTONS AVEC SEGMENT	JKI999	TURBO	**
KIT PISTONI +050 C/SEGMENTI Mot.4FC1T turbo	PISTON KIT WITH RINGS +0,50	PISTONS AVEC SEGMENT +0,50	JKI999M		**
SERIE SEGMENTI STD Mot.4FC1/4FC1T	PISTON RINGS	SEGMENTS DE PISTON	JRC17650	2,5 - 2,4	*
SERIE SEGMENTI +050 Mot.4FC1-4FC1T	PISTON RINGS +0,50	SEGMENTS DE PISTON +0,50	JRC17650M	TURBO / NO TURBO	*
SERIE BRONZINE BANCO STD	MAIN BEARING	COUSSINET DE PALIER	JMS1616GP		*
SERIE BRONZINE BANCO +025	MAIN BEARING +0,25	COUSSINET DE PALIER +0,25	JMS1616G2		*
SERIE BRONZINE BANCO +050	MAIN BEARING +0,50	COUSSINET DE PALIER +0,50	JMS1616G5		*
SERIE BRONZINE BIELLA STD	CON ROD BEARING	COUSSINET DE BIELLE	JCB1616GP		*
SERIE BRONZINE BIELLA +025	CON ROD BEARING 0,25	COUSSINET DE BIELLE 0,25	JCB1616G2		*
SERIE BRONZINE BIELLA +050	CON ROD BEARING +0,50	COUSSINET DE BIELLE 0,50	JCB1616G5		*
SERIE BOCCOLE BIELLA	PISTON PIN BUSHING	BAGUE TETE DE BIELLE	JPB1166J		*
SERIE RASAMENTI --> 82	THRUST WASHER	CALE LATERALE	JTW1030GP	--> '82	*
SERIE RASAMENTI 82 -->	THRUST WASHER	CALE LATERALE	JTW1616A	82 -->	*
SERIE BRONZINE ALBERO DISTRIBUZIONE	CAMSHAFT BEARING	COUSSINET ARBRE A CAMES	JSH1166B		*
POMPA ACQUA Mot. 4FC1 aspirato	WATER PUMP	POMPE E EAU	JPQ903	NO TURBO	*
POMPA ACQUA Mot. 4FC1T turbo	WATER PUMP	POMPE E EAU	JPQ910	TURBO	*
TERMOSTATO	THRMOSTATES	THERMOSTATE	JVT500		*
CANDELETTA PRERISCALDAMENTO 5 VOLT Cod. NGK Y104R	GLOW PLUGS	BOUGIES DE PRECHAUFFAGGE	JCE900	NGK Y104R	*



BEDFORD MIDI 2.2D Mot. ISUZU 4FD1 dia. cil. 88,00 mm	GB	F	Japanparts Code	i	NEW
CINGHIA DISTRIBUZIONE 137 denti	TIMING BELT 137 tooth	COURROIE DE DISTRIBUZIONE 137	JDD904	137 T	*
CUSCINETTO TENDICINGHIA	TENSIONER BEARING	GALET TENDEUR/ROULEMENT	JBE901		*
SERIE GUARNIZIONI SMERIGLIO	CYLINDER HEADSETS	KIT JOINTS DE CULASSES	JKG998		*
SERIE GUARNIZIONI MOTORE	FULL GASKET SET	KIT POCHETTE JOINT MOTEUR	JKM998		*
VALVOLA ASPIRAZIONE	INLET ENGINE VALVES	SOUPAPES D'ADMISSION	JVVIZ000		**
VALVOLA SCARICO	EXHAUST ENGINE VALVES	SOUPAPES D'ECHAPPEMENT	JVVIZ001		**
KIT PISTONI STD C/SEGMENTI	PISTON KIT WITH RINGS	PISTONS AVEC SEGMENT	JKI998		**
KIT PISTONI +050 C/SEGMENTI	PISTON KIT WITH RINGS +0,50	PISTONS AVEC SEGMENT +0,50	JKI998M		**
SERIE SEGMENTI STD	PISTON RINGS	SEGMENTS DE PISTON	JRC17999		**
SERIE SEGMENTI +050	PISTON RINGS +0,50	SEGMENTS DE PISTON +0,50	JRC17999M		**
SERIE BRONZINE BANCO STD	MAIN BEARING	COUSSINET DE PALIER	JMS1616GP		*
SERIE BRONZINE BANCO +025	MAIN BEARING +0,25	COUSSINET DE PALIER +0,25	JMS1616G2		*
SERIE BRONZINE BANCO +050	MAIN BEARING +0,50	COUSSINET DE PALIER +0,50	JMS1616G5		*
SERIE BRONZINE BIELLA STD	CON ROD BEARING	COUSSINET DE BIELLE	JCB1616GP		*
SERIE BRONZINE BIELLA +025	CON ROD BEARING 0,25	COUSSINET DE BIELLE 0,25	JCB1616G2		*
SERIE BRONZINE BIELLA +050	CON ROD BEARING +0,50	COUSSINET DE BIELLE 0,50	JCB1616G5		*
SERIE BOCCOLE BIELLA	PISTON PIN BUSHING	BAGUE TETE DE BIELLE	JPB1166J		*
SERIE RASAMENTI	THRUST WASHER	CALE LATERALE	JTW1616A		*
POMPA ACQUA	WATER PUMP	POMPE E EAU	JPQ915		*
TERMOSTATO	THRMOSTATES	THERMOSTATE	JVT500		*
CANDELETTA PRERISCALDAMENTO 5 VOLT	GLOW PLUGS	BOUGIES DE PRECHAUFFAGGE	JCE900	NGK Y104R	*



BEDFORD RASCAL 1.0 Mot. SUZUKI F10A dia. cil. 65,50 mm	GB	F	Japanparts Code	i	NEW
CINGHIA DISTRIBUZIONE 88 denti	TIMING BELT 88 tooth	COURROIE DE DISTRIBUTION	JDD201	86 T	*
CUSCINETTO TENDICINGHIA DISTRIBUZIONE	TENSIONER BEARING	GALET TENDEUR/ROULEMENT	JBE802		*
SERIE GUARNIZIONI SMERIGLIO	CYLINDER HEADSETS	KIT JOINTS DE CULASSES	JKG808		*
SERIE GUARNIZIONI MOTORE	FULL GASKET SET	KIT POCHEFFE JOINT MOTEUR	JKM808		*
VALVOLA ASPIRAZIONE	INLET ENGINE VALVES	SOUPAPES D'ADMISSION	JVVSZ000	31,6 x 7 x 110,2	*
VALVOLA SCARICO	EXHAUST ENGINE VALVES	SOUPAPES D'ECHAPPEMENT	JVVSZ001	27,5 x 7 x 109,6	*
KIT PISTONI STD C/SEGMENTI	PISTON KIT WITH RINGS	PISTONS AVEC	JKI800	HC=24,5/-2	*
KIT PISTONI +050 C/SEGMENTI	PISTON KIT WITH RINGS +0,50	PISTONS AVEC SEGMENT +0,50	JKI800M		*
SERIE CANNE CILINDRO dia.int. 65,50 mm / dia. est. 68,00 mm	SET CYLINDER LINERS	CHEMISES DE CYLINDRE	JCCSZ001	i.d. 65,5mm o.d. 68,0mm	**
SERIE SEGMENTI STD	PISTON RINGS	SEGMENTS DE PISTON	JRC27470	1,5 - 1,5 - 2,8	*
SERIE SEGMENTI +050	PISTON RINGS +0,50	SEGMENTS DE PISTON +0,50	JRC27470M		*
SERIE SEGMENTI STD ROOF SPIRAL	PISTON RINGS ROOF SPIRAL	SEGMENTS DE PISTON SPIRAL	JRS27470	1,5 - 1,5 - 2,8	*
SERIE SEGMENTI +050 ROOF SPIRAL	PISTON RINGS 0,50 ROOF SPIRAL	SEGMENTS DE PISTON 0,50 SPIRAL	JRS27470M	Roof Spiral	*
SERIE BRONZINE BANCO STD	MAIN BEARING	COUSSINET DE PALIER	JMS1179A	i.d. 49,974 o.d. 53,997	*
SERIE BRONZINE BANCO +025	MAIN BEARING +0,25	COUSSINET DE PALIER +0,25	JMS1179A2		*
SERIE BRONZINE BANCO +050	MAIN BEARING +0,50	COUSSINET DE PALIER +0,50	JMS1179A5		*
SERIE BRONZINE BIELLA STD	CON ROD BEARING	COUSSINET DE BIELLE	JCB1179A	i.d. 37,98 o.d. 40,998	*
SERIE BRONZINE BIELLA +025	CON ROD BEARING +0,25	COUSSINET DE BIELLE +0,25	JCB1179A2		*
SERIE BRONZINE BIELLA +050	CON ROD BEARING +0,50	COUSSINET DE BIELLE +0,50	JCB1179A5		*
SERIE BOCCOLE BIELLA	PISTON PIN BUSHING	BAGUE TETE DE BIELLE	JPB1179J		*
BIELLA MOTORE	CONECTING ROD	BIELLES	JBISZ000		**
ALBERO MOTORE	CRANKSHAFT	VILEBREQUINS	JXXSZ004		**
SERIE RASAMENTI STD	THRUST WASHER	CALE LATERALE	JTW1179A		*



BEDFORD RASCAL 1.0 Mot. SUZUKI F10A dia. cil. 65,50 mm	GB	F	Japanparts Code	i	NEW
---	-----------	----------	----------------------------	----------	------------

TESTATA NUDA F10A 11110-80002	CYLINDERHEADS	CULASSES	JXXSZ001		*
-------------------------------	---------------	----------	----------	--	---



JXX-SZ001 11110-80002

ALBERO DISTRIBUZIONE	CAMSHAFT	ARBRES A CAMES	JAASZ000		*
----------------------	----------	----------------	----------	--	---



JAA-SZ000

BILANCIERI VALVOLE	VALVE ROCKER ARM	CULBUTEUR	JBZSZ000		*
--------------------	------------------	-----------	----------	--	---

POMPA ACQUA	WATER PUMP	POMPE E EAU	JPQ800		*
TERMOSTATO	THERMOSTATES	THERMOSTATE	JVT200		*

POMPA OLIO COMPLETA	OIL PUMP	POMPE A HUILE	JXXOLS1		**
---------------------	----------	---------------	---------	--	----



DAIHATSU FEROZA F300 MOT. HDC/HDE dia. cil. 76,00 mm	GB	F	Japanparts Code	i	NEW
CINGHIA DISTRIBUZIONE 95 denti	TIMING BELT 95 tooth	COURROIE DE DISTRIBUTION	JDD610	95 T	*
CUSCINETTO TENDICINGHIA DISTRIBUZIONE	TENSIONER BEARING	GALET TENDEUR/ROULEMENT	JBE600		*
SERIE GUARNIZIONI SMERIGLIO motore carburatori	CYLINDER HEADSETS	KIT JOINTS DE CULASSES	JKG608	Carburator	*
SERIE GUARNIZIONI MOTORE motore carburatori	FULL GASKET SET	KIT POCHETTE JOINT MOTEUR	JKM608	Carburator	*
SERIE GUARNIZIONI SMERIGLIO motore iniezione	CYLINDER HEADSETS	KIT JOINTS DE CULASSES	JKG607	Injection	*
SERIE GUARNIZIONI MOTORE motore iniezione	FULL GASKET SET	KIT POCHETTE JOINT MOTEUR	JKM607	Injection	*
VALVOLA ASPIRAZIONE	INLET ENGINE VALVES	SOUPAPES D'ADMISSION	JVVDA000	30 x 6,57 x 112,7	**
VALVOLA SCARICO	EXHAUST ENGINE VALVES	SOUPAPES D'ECHAPPEMENT	JVVDA001	26 x 6,56 x 114,5	**
KIT PISTONI STD C/SEGMENTI	PISTON KIT WITH RINGS	PISTONS AVEC SEGMENT	JKI699	Carburator	**
KIT PISTONI +050 C/SEGMENTI	PISTON KIT WITH RINGS +0,50	PISTONS AVEC SEGMENT +0,50	JKI699M	Carburator	**
SERIE SEGMENTI STD	PISTON RINGS	SEGMENTS DE PISTON	JRC12999		**
SERIE SEGMENTI +050	PISTON RINGS +0,50	SEGMENTS DE PISTON +0,50	JRC12999M		**
SERIE BRONZINE BANCO STD	MAIN BEARING	COUSSINET DE PALIER	JMS2511A		*
SERIE BRONZINE BANCO +025	MAIN BEARING +0,25	COUSSINET DE PALIER +0,25	JMS2511A2		*
SERIE BRONZINE BANCO +050	MAIN BEARING +0,50	COUSSINET DE PALIER +0,50	JMS2511A5		*
SERIE BRONZINE BIELLA STD	CON ROD BEARING	COUSSINET DE BIELLE	JCB2511A		*
SERIE BRONZINE BIELLA +025	CON ROD BEARING +0,25	COUSSINET DE BIELLE +0,25	JCB2511A2		*
SERIE BRONZINE BIELLA +050	CON ROD BEARING +0,50	COUSSINET DE BIELLE +0,50	JCB2511A5		*
SERIE RASAMENTI STD	THRUST WASHER	CALE LATERALE	JTW2511A		*
BIELLA MOTORE	CONECTING ROD	BIELLES	JBIDA000		**
ALBERO MOTORE	CRANKSHAFT	VILEBREQUINS	JXXDA004		**
POMPA OLIO COMPLETA	OIL PUMP	POMPE A HUILE	JXXOLD1		**
POMPA ACQUA	WATER PUMP	POMPE E EAU	JPQ610		*
TERMOSTATO	THERMOSTATES	THERMOSTATE	JVT601		*



DAIHATSU ROCKY 2.8D/TD F70-75 MOT. DL dia. cil. 92,00 mm	(GB)	(F)	Japanparts Code	i	NEW
CINGHIA DISTRIBUZIONE 108 denti	TIMING BELT 108 tooth	COURROIE DE DISTRIBUTION 108	JDD615	108 T	*
SERIE GUARNIZIONI SMERIGLIO	CYLINDER HEADSETS	KIT JOINTS DE CULASSES	JKG609		*
SERIE GUARNIZIONI MOTORE	FULL GASKET SET	KIT POCHEFFE JOINT MOTEUR	JKM609		*
VALVOLA ASPIRAZIONE	INLET ENGINE VALVES	SOUPAPES D'ADMISSION	JVVDA008		**
VALVOLA SCARICO	EXHAUST ENGINE VALVES	SOUPAPES D'ECHAPPEMENT	JVVDA009		**
KIT PISTONI STD C/SEGMENTI --> 87	PISTON KIT WITH RINGS	PISTONS AVEC SEGMENT	JKI605	Pist. pin 26mm	*
KIT PISTONI +050 C/SEGMENTI --> 87	PISTON KIT WITH RINGS +0,50	PISTONS AVEC SEGMENT +0,50	JKI605M	--> '87	*
KIT PISTONI STD C/SEGMENTI 87 -->	PISTON KIT WITH RINGS	PISTONS AVEC SEGMENT	JKI606	Pist. pin 28mm	*
KIT PISTONI +050 C/SEGMENTI 87 -->	PISTON KIT WITH RINGS +0,50	PISTONS AVEC SEGMENT +0,50	JKI606M	'87 -->	*
SERIE CANNE CILINDRO d. int. 92,00 mm / dia. est. 96,15 mm	SET CYLINDER LINERS	CHEMISES DE CYLINDRE	JCCDA01	i.d. 92,0mm o.d.96,15mm	**
SERIE BRONZINE BANCO STD --> 87	MAIN BEARING	COUSSINET DE PALIER	JMS1158A	--> '87	*
SERIE BRONZINE BANCO +025 --> 87	MAIN BEARING +0,25	COUSSINET DE PALIER +0,25	JMS1158A2	--> '87	*
SERIE BRONZINE BANCO +050 --> 87	MAIN BEARING +0,50	COUSSINET DE PALIER +0,50	JMS1158A5	--> '87	*
SERIE BRONZINE BANCO STD 87 -->	MAIN BEARING	COUSSINET DE PALIER	JMS2502A	'87 -->	*
SERIE BRONZINE BANCO +025 87 -->	MAIN BEARING +0,25	COUSSINET DE PALIER +0,25	JMS2502A2	'87 -->	*
SERIE BRONZINE BANCO +050 87 -->	MAIN BEARING +0,50	COUSSINET DE PALIER +0,50	JMS2502A5	'87 -->	*
SERIE BRONZINE BIELLA STD	CON ROD BEARING	COUSSINET DE BIELLE	JCB1158A		*
SERIE BRONZINE BIELLA +025	CON ROD BEARING 0,25	COUSSINET DE BIELLE 0,25	JCB1158A2		*
SERIE BRONZINE BIELLA +050	CON ROD BEARING +0,50	COUSSINET DE BIELLE 0,50	JCB1158A5		*
SERIE BOCCOLE BIELLA --> 87	PISTON PIN BUSHING	BAGUE TETE DE BIELLE	JPB2502J	--> 87	*
SERIE BOCCOLE BIELLA --> 87	PISTON PIN BUSHING	BAGUE TETE DE BIELLE	JPB2511J	'87 -->	*
SERIE BRONZINE ALBERO DISTRIBUZIONE ->87	CAMSHAFT BEARING	COUSSINET ARBRE A CAMES	JSH1158A	--> 87	*
SERIE BRONZINE ALBERO DISTRIBUZIONE 87->	CAMSHAFT BEARING	COUSSINET ARBRE A CAMES	JSH2502A	'87 -->	*
POMPA ACQUA	WATER PUMP	POMPE E EAU	JPQ609		*
TERMOSTATO	THRMOSTATES	THERMOSTATE	JVT205		*
CANDELETTA PRERISCALDAMENTO 7 VOLT	GLOW PLUGS	BOUGIES DE PRECHAUFFAGGE	JCE016	NGK Y146R	*



HYUNDAI H100 Mot. 4D56 dia.cil. 91,10 mm		GB	F	Japanparts Code	i	NEW
CINGHIA DISTRIBUZIONE 163 denti	TIMING BELT 163 tooth	COURROIE DE DISTRIBUTION	JDD505	163 T	*	
CINGHIA CONTROLBERI 83 denti	TIMING BELT 83 tooth	COURROIE DE DISTRIBUTION	JDD506	83 T	*	
CUSCINETTO TENDICINGHIA CONTROLBERI	TENSIONER BEARING	GALET TENDEUR/ROULEMENT	JBE500		*	
CUSCINETTO TENDICINGHIA DISTRIBUZIONE	TENSIONER BEARING	GALET TENDEUR/ROULEMENT	JBE501		*	
SERIE GUARNIZIONI SMERIGLIO	CYLINDER HEADSETS	KIT JOINTS DE CULASSES	JKG537		*	
SERIE GUARNIZIONI MOTORE	FULL GASKET SET	KIT POCHEFFE JOINT MOTEUR	JKM537		*	
VALVOLA ASPIRAZIONE	INLET ENGINE VALVES	SOUPAPES D'ADMISSION	JVVMi000	40 x 8 x 136,5	*	
VALVOLA SCARICO	EXHAUST ENGINE VALVES	SOUPAPES D'ECHAPPEMENT	JVVMi001	34 x 8 x 136,5	*	
KIT PISTONI STD C/SEGMENTI	PISTON KIT WITH RINGS	PISTONS AVEC SEGMENT	JKI513	HC=48,7/-2,1 spin. 29	*	
KIT PISTONI +050 C/SEGMENTI	PISTON KIT WITH RINGS +0,50	PISTONS AVEC SEGMENT +0,50	JKI513M		*	
SERIE SEGMENTI STD	PISTON RINGS	SEGMENTS DE PISTON	JRC41324	2,5 - 2 -4	*	
SERIE SEGMENTI +050	PISTON RINGS +0,50	SEGMENTS DE PISTON +0,50	JRC41324M		*	
SERIE CANNE CILINDRO	CYLINDER LINERS	CHEMISES DE CYLINDRE	JXXCA500		*	
SERIE BRONZINE BANCO STD	MAIN BEARING	COUSSINET DE PALIER	JMS1131GP		*	
SERIE BRONZINE BANCO +025	MAIN BEARING +0,25	COUSSINET DE PALIER 0,25	JMS1131G2		*	
SERIE BRONZINE BANCO +050	MAIN BEARING +0,50	COUSSINET DE PALIER +0,50	JMS1131G5		*	
SERIE BRONZINE BIELLA STD	CON ROD BEARING	COUSSINET DE BIELLE	JCB1131GP		*	
SERIE BRONZINE BIELLA +025	CON ROD BEARING 0,25	COUSSINET DE BIELLE 0,25	JCB1131G2		*	
SERIE BRONZINE BIELLA +050	CON ROD BEARING 0,50	COUSSINET DE BIELLE 0,50	JCB1131G5		*	
SERIE BOCCOLE BIELLA	PISTON PIN BUSHING	BAGUE TETE DE BIELLE	JPB1802J		*	
BIELLA MOTORE	CONECTING ROD	BIELLES	JXXMI002		*	



JXX - MI002



HYUNDAI H100 Mot. 4D56 dia.cil. 91,10 mm	GB	F	Japanparts Code	i	NEW
ALBERO DISTRIBUZIONE	CAM SHAFT	ARBRES A CAMES	JXXMI003		*



JXX - MI003

ALBERO MOTORE	CRANKSHAFT	VILEBREQUINS	JXXMI004		*
---------------	------------	--------------	-----------------	--	---



JXX - MI004

Testata Mot. Nuda diametro iniettore 19mm	CYLINDERHEADS	CULASSES	JXXMI001		*
---	---------------	----------	-----------------	--	---



**JXX-MI001 BARE
HEAD**



HYUNDAI H100 Mot. 4D56 dia.cil. 91,10 mm	(GB)	(F)	Japanparts Code	i	NEW
--	------	-----	--------------------	---	-----

TESTATA MOTORE completa diametro iniettori 19mm non intercooler	COMPLETE CYLINDERHEADS	CULASSES COMPLETE	JXXMI007		*
--	---------------------------	-------------------	----------	--	---



JXX-MI007 COMPLETE

MONOBLOCCO MOTORE (Nudo - Senza parti rotanti)	NACKED ENGINE BLOCK	BLOC MOTEUR	JXXMI006		*
---	---------------------	-------------	----------	--	---

MOTORE ALLEGGERITO (senza testata)	FULL ENGINE WITHOUT HEAD		JXXMI005		*
------------------------------------	-----------------------------	--	----------	--	---

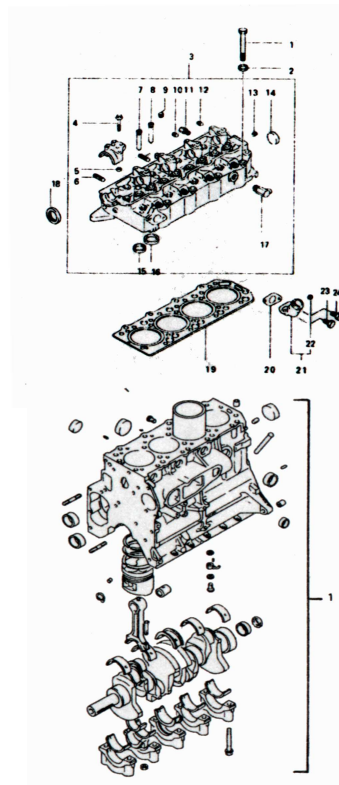

JXX-MI007

JKG-537

JXX-MI005



HYUNDAI H100 Mot. 4D56 dia.cil. 91,10 mm	GB	F	Japanparts Code	i	NEW
MOTORE COMPLETO NO INTERCOOLER	FULL ENGINE	MOTEUR COMPLE'	JXXMI008	NO I.C.	*
MOTORE COMPLETO INTERCOOLER	FULL ENGINE INTERCOOLER	MOTEUR COMPLE'	JXXMI008 I	I.C.	*

**VEDI FOTO NEL FLOPPY
DISC**

BILANCIERI VALVOLE ASPIRAZIONE	INLET VALVE ROCKER	CULBUTEUR	JBZMI000		**
BILANCIERI VALVOLE SCARICO	EXHAUST VALVE ROCKER	CULBUTEUR	JBZMI001		**
POMPA ACQUA	WATER PUMP	POMPE E EAU	JPQ506		*
TERMOSTATO	THRMOSTATES	THERMOSTATE	JVT597		*
CANDELETTA PRERISCALDAMENTO 6 volt RAPIDA	GLOW PLUGS 6V	Bougies de Prechauffage 6V	JCE501	6 Volts	*





ISUZU TROOPER 2.2D/1D Mot. C223/223T dia. cil. 88.00 mm		(GB)	(F)	Japanparts Code	i	NEW
CINGHIA DISTRIBUZIONE 87 denti	TIMING BELT 87 tooth	COURROIE DE DISTRIBUTION	JDD901	87 T	*	
SERIE GUARNIZIONI SMERIGLIO Mot. C223 aspirato	CYLINDER HEAD SETS	KIT JOINTS DE CULASSES	JKG904	NO TURBO	*	
SERIE GUARNIZIONI SMERIGLIO Mot. C223T turbo	CYLINDER HEAD SETS	KIT JOINTS DE CULASSES	JKG905	TURBO	*	
SERIE GUARNIZIONI MOTORE Mot. C223T turbo	FULL GASKET SET	KIT POCHETTE JOINT MOTEUR	JKM997	TURBO	*	
KIT PISTONI STD C/SEGMENTI Mot. C223 aspirato	PISTON KIT WITH RINGS	PISTONS AVEC SEGMENT	JKI908	Pist. pin 27mm	*	
KIT PISTONI +050 C/SEGMENTI Mot. C223 aspirato	PISTON KIT WITH RINGS +0,50	PISTONS AVEC SEGMENT +0,50	JKI908M	NO TURBO	*	
SERIE SEGMENTI STD Mot. C223 aspirato	PISTON RINGS	SEGMENTS DE PISTON	JRC17400	2 - 2 - 4	*	
SERIE SEGMENTI +050 Mot. C223 aspirato	PISTON RINGS +0,50	SEGMENTS DE PISTON +0,50	JRC17400M	NO TURBO	*	
SERIE SEGMENTI STD Mot. C223T turbo	PISTON RINGS	SEGMENTS DE PISTON	JRC12090	2,5 - 2,4	*	
SERIE SEGMENTI +050 Mot. C223T turbo	PISTON RINGS +0,50	SEGMENTS DE PISTON +0,50	JRC12090M	TURBO	*	
SERIE BRONZINE BANCO STD Mot. C223 aspirato	MAIN BEARING	COUSSINET DE PALIER	JMS1605GP	NO TURBO	*	
SERIE BRONZINE BANCO +025 Mot. C223 aspirato	MAIN BEARING +0,25	COUSSINET DE PALIER +0,25	JMS1605G2	NO TURBO	*	
SERIE BRONZINE BANCO +050 Mot. C223 aspirato	MAIN BEARING +0,50	COUSSINET DE PALIER +0,50	JMS1605G5	NO TURBO	*	
SERIE BRONZINE BIELLA STD Mot. C223 aspirato	CON ROD BEARING	COUSSINET DE BIELLE	JCB1070GP	NO TURBO	*	
SERIE BRONZINE BIELLA +025 Mot. C223 aspirato	CON ROD BEARING 0,25	COUSSINET DE BIELLE 0,25	JCB1070G2	NO TURBO	*	
SERIE BRONZINE BIELLA +050 Mot. C223 aspirato	CON ROD BEARING +0,50	COUSSINET DE BIELLE 0,50	JCB1070G5	NO TURBO	*	
SERIE BOCCOLE BIELLA Mot. C223 aspirato	PISTON PIN BUSHING	BAGUE TETE DE BIELLE	JPB1605J	NO TURBO	*	
ALBERO DISTRIBUZIONE	CAMSHAFT	ARBRES A CAMES	JAAIS002	D / TD		
SERIE RASAMENTI Mot. C223 aspirato	THRUST WASHER	CALE LATERALE	JTW1622GP	NO TURBO	*	
SERIE BRONZINE ALBERO DISTRIBUZIONE Mot. C223 aspirato	CAMSHAFT BEARING	COUSSINET ARBRE A CAMES	JSH1605B	NO TURBO	*	
POMPA ACQUA	WATER PUMP	POMPE E EAU	JPQ902		*	
TERMOSTATO	THRMOSTATES	THERMOSTATE	JVT500		*	
CANDELETTA PRERISCALDAMENTO	GLOW PLUGS	BOUGIES DE PRECHAUFFAGGE	JCE900	NGK Y904M	*	



ISUZU TROOPER 2.8TD Mot. 4JB1T dia. cil. 93,00 mm		GB	F	Japanparts Code	i	NEW
CINGHIA DISTRIBUZIONE 119 denti	TIMING BELT 119 tooth	COURROIE DE DISTRIBUTION	JDD906	119 T	*	
CUSCINETTO TENDICINGHIA Mot. 4JA1 Asp. -->92	TENS. BEARING -->92 no turbo	GALET TENDEUR/ROULEMENT	JBE907	NO TURBO > 92	*	
CUSCINETTO TENDICINGHIA Mot. 4JA1 Asp. -->92	TENS. BEARING -->92 no turbo	GALET TENDEUR/ROULEMENT	JBE908	NO TURBO > 92	*	
SERIE GUARNIZIONI SMERIGLIO NO INTERCOOLER	CYLINDER HEAD SETS	KIT JOINTS DE CULASSES	JKG996	NO I.C.	*	
SERIE GUARNIZIONI MOTORE NO INTERCOOLER	FULL GASKET SET	KIT POCLETTE JOINT MOTEUR	JKM996	NO I.C.	*	
VALVOLA ASPIRAZIONE	INLET ENGINE VALVES	SOUPAPES D'ADMISSION	JVVIZ002		*	
VALVOLA SCARICO	EXHAUST ENGINE VALVES	SOUPAPES D'ECHAPPEMENT	JVVIZ003		*	
KIT PISTONI STD C/SEGMENTI NO INTERCOOLER	PISTON KIT WITH RINGS	PISTONS AVEC SEGMENT	JKI924	Pist. Pin. 34mm	*	
KIT PISTONI +050 C/SEGMENTI NO INTERCOOLER	PISTON KIT WITH RINGS +0,50	PISTONS AVEC SEGMENT +0,50	JKI924M	NO I.C.	*	
POMPA ACQUA	WATER PUMP	POMPE E EAU	JPQ906		*	
TERMOSTATO	THRMOSTATES	THERMOSTATE	JVT500		*	
CANDELETTA PRERISCALDAMENTO	GLOW PLUGS	BOUGIES DE PRECHAUFFAGGE	JCE902	NGK Y904M	*	



MAZDA 626 2000D 626KOMBI 2000D E2000			Japanparts Code	i	NEW
CINGHIA DISTRIBUZIONE 162 denti	TIMING BELT 162 tooth	COURROIE DE DISTRIBUTION 162	JDD314	162 T	
TENDICINGHIA CONTROALBERI RF03-12-700A	TENSIONER BEARING	GALET TENDEUR/ROULEMENT	JBE317		
TENDICINGHIA DISTRIBUZIONE RF03-12-720	TENSIONER BEARING	GALET TENDEUR/ROULEMENT	JBE318		
TENDICINGHIA DISTRIBUZIONE RF03-12-700C	TENSIONER BEARING	GALET TENDEUR/ROULEMENT	JBE319		
SERIE GUARNIZIONI SMERIGLIO FINO '88	CYLINDER HEADSETS UNTIL '88	KIT JOINTS DE CULASSES '88	JKG332	--> '88	
SERIE GUARNIZIONI SMERIGLIO DOPO '89	CYLINDER HEADSETS AFTER '89	KIT JOINTS DE CULASSES '89	JKG339	'88 -->	
KIT PISTONI STD C/SEGMENTI RF	PISTON KIT WITH RINGS	PISTONS AVEC SEGMENT	JKI399		
KIT PISTONI +050 C/SEGMENTI RF	PISTON KIT WITH RINGS +0,50	PISTONS AVEC SEGMENT +0,50	JKI399M		
SERIE SEGMENTI STD	PISTON RINGS	SEGMENTS DE PISTON	JRW30670		
SERIE SEGMENTI +050	PISTON RINGS +0,50	SEGMENTS DE PISTON +0,50	JRW30670M		
SERIE CANNE CILINDRO RF	SET CYLINDER LINERS	CHEMISES DE CYLINDRE	JCCMZ001		
SERIE BRONZINE BANCO STD	MAIN BEARING	COUSSINET DE PALIER	JMS2007A		
SERIE BRONZINE BANCO +025	MAIN BEARING 0,25	COUSSINET DE PALIER 0,25	JMS2007A2		
SERIE BRONZINE BANCO +050	MAIN BEARING 0,50	COUSSINET DE PALIER 0,50	JMS2007A5		
SERIE BRONZINE BIELLA STD	CON ROD BEARING	COUSSINET DE BIELLE	JCB2004A		
SERIE BRONZINE BIELLA +025	CON ROD BEARING +0,25	COUSSINET DE BIELLE +0,25	JCB2004A2		
SERIE BRONZINE BIELLA +050	CON ROD BEARING +0,50	COUSSINET DE BIELLE +0,50	JCB2004A5		
SERIE BOCCOLE BIELLA	PISTON PIN BUSHING	BAGUE TETE DE BIELLE	JPB2007J		
SERIE RASAMENTI	THRUST WASHER	CALE LATERALE	JTW2007A		
POMPA ACQUA --> '88	WATER PUMP until '88	POMPE E EAU	JPQ308	--> '88	
TERMOSTATO PER PQ-308	THRMOSTATES	THERMOSTATE	JVT600	--> '88	
POMPA ACQUA '88 -->	WATER PUMP after '88	POMPE E EAU	JPQ316	'88 -->	
TERMOSTATO PER PQ-316	THRMOSTATES	THERMOSTATE	JVT305	'88 -->	
CANDELETTE S501-18-140	GLOW PLUGS	BOUGIES DE PRECHAUFFAGGE	JCE300	NGK Y107R	
CANDELETTE S210-18-140	GLOW PLUGS	BOUGIES DE PRECHAUFFAGGE	JCE302		



MITSUBISHI PAJERO 2300D/TD 2346cc MOTORE 4D55/4D55T dia. cil. 91.10 mm		(GB)	(F)	Japanparts Code	i	NEW
CINGHIA DISTRIBUZIONE 163 denti	TIMING BELT 163 tooth	COURROIE DE DISTRIBUTION	JDD505	163 T		
CINGHIA CONTROLBERI 83 denti	TIMING BELT 83 tooth	COURROIE DE DISTRIBUTION	JDD506	83 T		
CUSCINETTO TENDICINGHIA CONTROLBERI	TENSIONER BEARING	GALET TENDEUR/ROULEMENT	JBE500			
CUSCINETTO TENDICINGHIA DISTRIBUZIONE	TENSIONER BEARING	GALET TENDEUR/ROULEMENT	JBE501			
SERIE GUARNIZIONI SMERIGLIO	CYLINDER HEADSETS	KIT JOINTS DE CULASSES	JKG537			
SERIE GUARNIZIONI MOTORE	FULL GASKET SET	KIT POCHETTE JOINT MOTEUR	JKM537			
VALVOLA ASPIRAZIONE	INLET ENGINE VALVES	SOUPAPES D'ADMISSION	JVVMi002	40 x 8 x 136,5		
VALVOLA SCARICO	EXHAUST ENGINE VALVES	SOUPAPES D'ECHAPPEMENT	JVVMi003	34 x 8 x 136,5		
KIT PISTONI STD C/SEGMENTI	PISTON KIT WITH RINGS	PISTONS AVEC SEGMENT	JKI512	HC=48,5/-2,5 spin. 29	*	
KIT PISTONI +050 C/SEGMENTI	PISTON KIT WITH RINGS +0,50	PISTONS AVEC SEGMENT +0,50	JKI512M		*	
SERIE SEGMENTI STD	PISTON RINGS	SEGMENTS DE PISTON	JRC41324	2,5 - 2 -4		
SERIE SEGMENTI +050	PISTON RINGS +0,50	SEGMENTS DE PISTON +0,50	JRC41324M			
SERIE CANNE CILINDRO	CYLINDER LINERS	CHEMISES DE CYLINDRE	JXXCA500			
SERIE BRONZINE BANCO STD	MAIN BEARING	COUSSINET DE PALIER	JMS1131GP			
SERIE BRONZINE BANCO +025	MAIN BEARING +0,25	COUSSINET DE PALIER +0,25	JMS1131G2			
SERIE BRONZINE BANCO +050	MAIN BEARING +0,50	COUSSINET DE PALIER +0,50	JMS1131G5			
SERIE BRONZINE BIELLA STD	CON ROD BEARING	COUSSINET DE BIELLE	JCB1131GP			
SERIE BRONZINE BIELLA +025	CON ROD BEARING 0,25	COUSSINET DE BIELLE 0,25	JCB1131G2			
SERIE BRONZINE BIELLA +050	CON ROD BEARING +0,50	COUSSINET DE BIELLE 0,50	JCB1131G5			
SERIE BOCCOLE BIELLA	PISTON PIN BUSHING	BAGUE TETE DE BIELLE	JPB1802J			
BIELLA MOTORE	CONECTING ROD	BIELLES	JXXMI002			



XX-MI002

JXX-MI002



MITSUBISHI PAJERO 2300D/TD 2346cc MOTORE 4D55/4D55T dia. cil. 91.10 mm	GB	F	Japanparts Code	i	NEW
---	-----------	----------	----------------------------------	----------	------------

ALBERO DISTRIBUZIONE AD. MD050140 NO INTERCOOLER	CAMSHAFT NO INTERCOOLER	ARBRES A CAMES NO INTERCOOLER	JXXMI003	NO I.C.	
--	-------------------------	-------------------------------	----------	---------	--



JXX-MI003

BILANCIERI VALVOLE ASPIRAZIONE	INLET VALVE ROCKER ARM	CULBUTEUR	JBZMI000		**
BILANCIERI VALVOLE SCARICO	EXHAUST VALVE ROCKER ARM	CULBUTEUR	JBZMI001		**

TESTATA MOTORE NUDA dia. iniettore 19mm AD. MD185922	CYLINDERHEADS	CULASSES	JXXMI001	Nozzle 19,00 mm	
---	---------------	----------	----------	-----------------	--



JXX-MI001 BARE HEAD



MITSUBISHI PAJERO 2300D/TD 2346cc MOTORE 4D55/4D55T dia. cil. 91.10 mm	(GB)	(F)	Japanparts Code	i	NEW
---	------	-----	----------------------------------	----------	------------

TESTATA MOTORE COMPLETA diam.iniettore 19mm	COMPLETE CYLINDERHEADS	CULASSES COMPLETE	JXXMI007	Nozzle 19,00 mm	
--	---------------------------	-------------------	----------	--------------------	--



JXX-MI007 COMPLETE

TURBINA raffreddata ad aria	TURBO CHARGER Air cooling system	TURBO (Climatisation)	JXXTURBO	Air cooling system	*
-----------------------------	-------------------------------------	-----------------------	-----------------	-----------------------	---

POMPA ACQUA TERMOSTATO	WATER PUMP THRMOSTATES	POMPE E EAU THERMOSTATE	JPQ506 JVT102		
---------------------------	---------------------------	----------------------------	------------------	--	--

POMPA OLIO COMPLETA	OIL PUMP	POMPE A HUILE	JXXOLIO		
---------------------	----------	---------------	---------	--	--



JXX-OLIO

CANDELETTA PRERISCALDAMENTO 12 volt	GLOW PLUGS	BOUGIES DE PRECHAUFFAGGE	JCE000	NGK Y115T1	
-------------------------------------	------------	-----------------------------	--------	------------	--



MITSUBISHI PAJERO E L200-300 2500TD --> '91 2477cc MOT 4D56T dia. cil. 91,10mm				Japanparts Code	i	NEW
CINGHIA DISTRIBUZIONE 163 denti	TIMING BELT 163 tooth	COURROIE DE DISTRIBUTION	JDD505	163 T		
CINGHIA CONTROLBERI 83 denti	TIMING BELT 83 tooth	COURROIE DE DISTRIBUTION	JDD506	83 T		
CUSCINETTO TENDICINGHIA CONTROLBERI	TENSIONER BEARING	GALET TENDEUR/ROULEMENT	JBE500			
CUSCINETTO TENDICINGHIA DISTRIBUZIONE	TENSIONER BEARING	GALET TENDEUR/ROULEMENT	JBE501			
SERIE GUARNIZIONI SMERIGLIO	CYLINDER HEADSETS	KIT JOINTS DE CULASSES	JKG537			
SERIE GUARNIZIONI MOTORE	FULL GASKET SET	KIT POCHEFFE JOINT MOTEUR	JKM537			
VALVOLA ASPIRAZIONE	INLET ENGINE VALVES	SOUPAPES D'ADMISSION	JVVM1000	40 x 8 x 136,5		
VALVOLA SCARICO	EXHAUST ENGINE VALVES	SOUPAPES D'ECHAPPEMENT	JVVM1001	34 x 8 x 136,5		
KIT PISTONI STD C/SEGMENTI non intercooler	PISTON KIT WITH RINGS	PISTONS AVEC SEGMENT	JKI513	HC=48,7/-2,1 spin. 29		
KIT PISTONI +050 C/SEGMENTI non intercooler	PISTON KIT WITH RINGS +0,50	PISTONS AVEC SEGMENT +0,50	JKI513M			
SERIE SEGMENTI STD	PISTON RINGS	SEGMENTS DE PISTON	JRC41324	2,5 - 2 - 4		
SERIE SEGMENTI +050	PISTON RINGS +0,50	SEGMENTS DE PISTON +0,50	JRC41324M			
SERIE CANNE CILINDRO	CYLINDER LINERS	CHEMISES DE CYLINDRE	JXXCA500			
SERIE BRONZINE BANCO STD	MAIN BEARING	COUSSINET DE PALIER	JMS1131GP			
SERIE BRONZINE BANCO +025	MAIN BEARING +0,25	COUSSINET DE PALIER 0,25	JMS1131G2			
SERIE BRONZINE BANCO +050	MAIN BEARING +0,50	COUSSINET DE PALIER +0,50	JMS1131G5			
SERIE BRONZINE BIELLA STD	CON ROD BEARING	COUSSINET DE BIELLE	JCB1131GP			
SERIE BRONZINE BIELLA +025	CON ROD BEARING 0,25	COUSSINET DE BIELLE 0,25	JCB1131G2			
SERIE BRONZINE BIELLA +050	CON ROD BEARING 0,50	COUSSINET DE BIELLE 0,50	JCB1131G5			
SERIE BOCCOLE BIELLA	PISTON PIN BUSHING	BAGUE TETE DE BIELLE	JPB1802J			



MITSUBISHI PAJERO E L200-300 2500TD --> '91 2477cc MOT 4D56T dia. cil. 91,10mm			Japanparts Code	<i>i</i>	NEW
---	---	--	----------------------------------	----------	------------

BIELLA MOTORE	CONECTING ROD	BIELLES	JXXMI002		
---------------	---------------	---------	----------	--	--



JXX-MI002

ALBERO DISTRIBUZIONE AD. MD050140 NO INTERCOOLER	CAM SHAFT NO INTERCOOLER	ARBRES A CAMES NO INTERCOOLER	JXXMI003	NO I.C.	
--	--------------------------	-------------------------------	----------	---------	--



JXX-MI003

ALBERO MOTORE AD. MD102601	CRANKSHAFT	VILEBREQUINS	JXXMI004		
----------------------------	------------	--------------	----------	--	--



JXX - MI004



MITSUBISHI PAJERO E L200-300 2500TD --> '91 2477cc MOT 4D56T dia. cil. 91,10mm	GB	F	Japanparts Code	i	NEW
---	-----------	----------	----------------------------------	----------	------------

Test. Mot. Nuda diam. Iniet.19mm NO INTERCOOLER AD. MD 185922	CYLINDERHEADS	CULASSES	JXXMI001	Nozzle 19,00 mm	
--	---------------	----------	----------	--------------------	--



JXX-MI001 BARE HEAD

TESTATA MOTORE completa dia. iniettori 19mm non intercooler	COMPLETE CYLINDERHEADS	CULASSES COMPLETE	JXXMI007	Nozzle 19,00 mm	
--	---------------------------	----------------------	----------	--------------------	--



JXX-MI007 COMPLETE

MONOBLOCCO MOTORE (nudo)	ENGINE BLOCK	BLOC MOTEUR	JXXMI006		
--------------------------	--------------	-------------	----------	--	--

MOTORE ALLEGGERITO (senza testata)	FULL ENGINE WITHOUT HEAD	BLOC EMBIELLE'	JXXMI005		
------------------------------------	-----------------------------	----------------	----------	--	--



MITSUBISHI PAJERO E L200-300 2500TD --> '91 2477cc MOT 4D56T dia. cil. 91,10mm	GB	F	Japanparts Code	i	NEW
---	-----------	----------	---------------------------	----------	------------

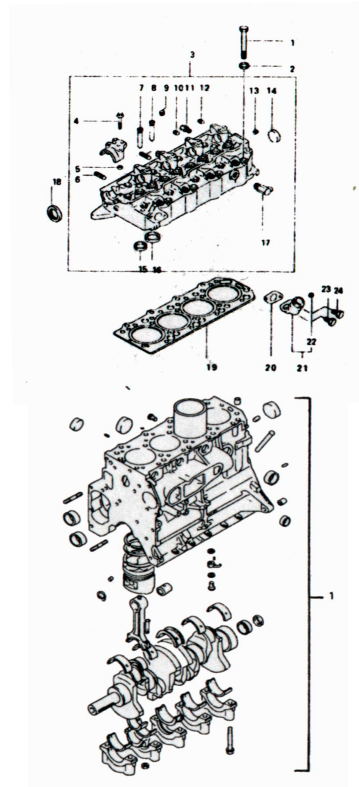

JXX-MI007

JKG-537

JXX-MI005

MOTORE COMPLETO NO INTERCOOLER	FULL ENGINE	MOTEUR COMPLE'	JXXMI008	NO I.C.	
--------------------------------	-------------	----------------	----------	---------	--

VEDI FOTO NEL DISCHETTO

TURBINA raffreddata ad aria	TURBO CHARGER Air cooling system	TURBO (Climatisation)	JXXTURBO	Air cooling system	*
-----------------------------	-------------------------------------	-----------------------	-----------------	--------------------	---

BILANCIERI VALVOLE ASPIRAZIONE ->88 / PAJERO -->91	L200	INLET VALVE ROCKER	CULBUTEUR	JBZMI000	L200 -->88 PAJERO->91	**
BILANCIERI VALVOLE SCARICO >88 / PAJERO -->91	L200	EXHAUST VALVE ROCKER	CULBUTEUR	JBZMI001	L200 -->88 PAJERO->91	**

BILANCIERI VALVOLE ASPIRAZIONE 88-->	L200	INLET VALVE ROCKER	CULBUTEUR	JBZMI002	L200 88 -->	**
BILANCIERI VALVOLE SCARICO ->88	L200	EXHAUST VALVE ROCKER	CULBUTEUR	JBZMI003	L200 88 -->	**

POMPA ACQUA THERMOSTATO	WATER PUMP THERMOSTATES	POMPE E EAU THERMOSTATE	JPQ506 JVT102		
----------------------------	----------------------------	----------------------------	------------------	--	--



MITSUBISHI PAJERO E L200-300 2500TD --> '91 2477cc MOT 4D56T dia. cil. 91,10mm			Japanparts Code	<i>i</i>	NEW
---	---	--	----------------------------------	----------	------------



POMPA OLIO COMPLETA	OIL PUMP	POMPE A HUILE	JXXOLIO		
---------------------	----------	---------------	---------	--	--



JXX-OLIO

CANDELETTA PRERISCALDAMENTO 12 volt	GLOW PLUGS 12V	Bougies de Prechauffage12V	JCE000	NGK Y115T1	
CANDELETTA PRERISCALDAMENTO 6 volt RAPIDA	GLOW PLUGS 6V	Bougies de Prechauffage 6V	JCE501	MD092392	



mitsubishi pajero 2500TD INTERCOOLER '91 --> 2477cc MOT. 4D56T dia.cil 91,10mm				Japanparts Code	i	NEW
CINGHIA DISTRIBUZIONE 163 DENTI --> 11.93	TIMING BELT --> 11.93	COURROIE DE DISTRIBUTION --> 11.93	JDD505	163 T > 11.93	-	
CINGHIA CONTROLBERI 83 DENTI --> 11.93	TIMING BELT --> 11.93	COURROIE DE DISTRIBUTION --> 11.93	JDD506	83 T > 11.93	-	
CINGHIA DISTRIBUZIONE 163 DENTI 11.93 -->	TIMING BELT 11.93 -->	COURROIE DE DISTRIBUTION 11.93 -->	JDD588	163 T 11.93 -->		*
CINGHIA CONTROLBERI 99 DENTI 11.93 -->	TIMING BELT 11.93 -->	COURROIE DE DISTRIBUTION 11.93 -->	JDD587	99 T 11.93 -->		*
CUSCINETTO TENDICINGHIA CONTROLBERI	TENSIONER BEARING	GALET TENDEUR/ROULEMENT	JBE500			
CUSCINETTO TENDICINGHIA DISTRIBUZIONE	TENSIONER BEARING	GALET TENDEUR/ROULEMENT	JBE501			
SERIE GUARNIZIONI SMERIGLIO	CYLINDER HEADSETS	KIT JOINTS DE CULASSES	JKG537			
SERIE GUARNIZIONI MOTORE	FULL GASKET SET	KIT POCHEE JOINT MOTEUR	JKM537			
VALVOLA ASPIRAZIONE --> 91	INLET ENGINE VALVES > 91	SOUPAPES D'ADMISSION --> 91	JVVM1000	40x8x136,5 > '91	-	
VALVOLA SCARICO --> 91	EXHAUST ENGINE VALVES --> 91	SOUPAPES D'ECHAPPEMENT --> 91	JVVM1001	34x8x136,5 > '91	-	
KIT PISTONI STD C/SEGMENTI INTERCOOLER (Con galleria per il passaggio dell'olio)	PISTON KIT WITH RINGS (With groove)	PISTONS AVEC SEGMENT	JKI516	I.C. - WITH GROOVE		**
KIT PISTONI +050 C/SEGMENTI INTERCOOLER (Con galleria per il passaggio dell'olio)	PISTON KIT WITH RINGS +0,50 (With groove)	PISTONS AVEC SEGMENT +0,50	JKI516M	I.C. - WITH GROOVE		**
SERIE SEGMENTI STD	PISTON RINGS	SEGMENTS DE PISTON	JRC41324	2,5 - 2 - 4		
SERIE SEGMENTI +050	PISTON RINGS +0,50	SEGMENTS DE PISTON +0,50	JRC41324M			
SERIE CANNE CILINDRO	CYLINDER LINERS	CHEMISES DE CYLINDRE	JXXCA500			
SERIE BRONZINE BANCO STD	MAIN BEARING	COUSSINET DE PALIER	JMS1131GP			
SERIE BRONZINE BANCO +025	MAIN BEARING +0,25	COUSSINET DE PALIER 0,25	JMS1131G2			
SERIE BRONZINE BANCO +050	MAIN BEARING +0,50	COUSSINET DE PALIER +0,50	JMS1131G5			
SERIE BRONZINE BIELLA STD	CON ROD BEARING	COUSSINET DE BIELLE	JCB1131GP			
SERIE BRONZINE BIELLA +025	CON ROD BEARING 0,25	COUSSINET DE BIELLE 0,25	JCB1131G2			
SERIE BRONZINE BIELLA +050	CON ROD BEARING 0,50	COUSSINET DE BIELLE 0,50	JCB1131G5			
SERIE BOCCOLE BIELLA	PISTON PIN BUSHING	BAGUE TETE DE BIELLE	JPB1802J			



MITSUBISHI PAJERO 2500TD INTERCOOLER '91 --> 2477cc MOT. 4D56T dia.cil 91,10mm	(GB)	(F)	Japanparts Code	i	NEW
--	------	-----	--------------------	---	-----

BIELLA MOTORE	CONECTING ROD	BIELLES	JXXMI002		
---------------	---------------	---------	----------	--	--



JXX-MI002

ALBERO DISTRIBUZIONE AD. MD137163 per INTERCOOLER	CAM SHAFT INTERCOOLER	ARBRES A CMES INTERCOOLER	JXXMI022	I.C.	**
--	--------------------------	------------------------------	-----------------	------	----

ALBERO MOTORE AD. MD102601	CRANKSHAFT	VILEBREQUINS	JXXMI004		
----------------------------	------------	--------------	----------	--	--



JXX - MI004



MITSUBISHI PAJERO 2500TD INTERCOOLER '91 --> 2477cc MOT. 4D56T dia.cil 91,10mm	(GB)	(F)	Japanparts Code	i	NEW
--	------	-----	----------------------------------	----------	------------

TESTATA MOTORE NUDA diametro iniettore 19mm INTERCOOLER MD303750	CYLINDERHEADS	CULASSES	JXXMI021	Nozzle 19,00 mm	**
---	---------------	----------	----------	--------------------	----



JXX-MI021

TESTATA MOTORE COMPLETA CON VALVOLE INCASSATE - diametro iniettori 19mm - INTERCOOLER	COMPLETE CYLINDERHEADS	CULASSES COMPLETE	JXXMI019	Nozzle 19,00 mm	**
---	---------------------------	-------------------	----------	--------------------	----



JXX-MI019

MONOBLOCCO MOTORE (Nudo - Senza parti rotanti)	NACKED ENGINE BLOCK	BLOC MOTEUR	JXXMI006		
---	---------------------	-------------	----------	--	--



MITSUBISHI PAJERO 2500TD INTERCOOLER '91 --> 2477cc MOT. 4D56T dia.cil 91,10mm	GB	F	Japanparts Code	i	NEW
--	-----------	----------	----------------------------------	----------	------------

MOTORE ALLEGGERITO (senza testata)	FULL ENGINE WITHOUT CYLINDER HEAD	BLOC EMBIELLE'	JXXMI005		
------------------------------------	-----------------------------------	----------------	----------	--	--

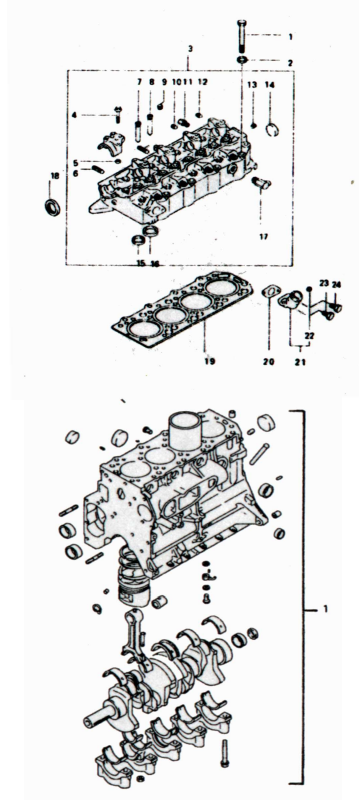

JXX-MI019

JKG-537

JXX-MI005

MOTORE COMPLETO INTERCOOLER	FULL ENGINE INTERCOOLER	MOTEUR COMPLE' INTERCOOLER	JXXMI008 I	I.C.	
-----------------------------	-------------------------	----------------------------	------------	------	--

VEDI FOTO FLOPPY
DISC

TURBINA raffreddata ad aria	TURBO CHARGER Air cooling system	TURBO (Climatisation)	JXXTURBO	Air cooling system	*
-----------------------------	-------------------------------------	-----------------------	-----------------	--------------------	---

BILANCIERI VALVOLE ASPIRAZIONE 91 -->	INLET VALVE ROCKER	CULBUTEUR	JBZMI002	--> '91	**
BILANCIERI VALVOLE SCARICO 91 -->	EXHAUST VALVE ROCKER	CULBUTEUR	JBZMI003	--> '91	**

POMPA ACQUA TERMOSTATO	WATER PUMP THRMOSTATES	POMPE E EAU THERMOSTATE	JPQ529 JVT102		
---------------------------	---------------------------	----------------------------	------------------	--	--



MITSUBISHI PAJERO 2500TD INTERCOOLER '91 --> 2477cc MOT. 4D56T dia.cil 91,10mm	(GB)	(F)	Japanparts Code	i	NEW
--	------	-----	----------------------------	----------	------------

POMPA OLIO COMPLETA TD	OIL PUMP	POMPE A HUILE	JXXOLIO	NO I.C.	
POMPA OLIO COMPLETA TD INTERCOOLER	OIL PUMP INTERCOOLER	POMPE A HUILE INTERCOOLER	JXXOLM1	I.C.	**



JXX-OLIO

CANDELETTA PRERISCALDAMENTO 12 volt	GLOW PLUGS 12V	Bougies DE	JCE000	NGK Y115T1	
CANDELETTA PRERISCALDAMENTO 6 volt	GLOW PLUGS 6V	Bougies DE	JCE501	MD092392	



MITSUBISHI SPACE WAGON 1.8D/TD MOT. 4D65/4D65T dia. cil. 80,60 mm		GB	F	Japanparts Code	i	NEW
KIT PISTONI STD C/SEGMENTI Mot. Aspirato 1.8D	PISTON KIT WITH RINGS	PISTONS AVEC SEGMENT	JKI510	1.8D NO TURBO	*	
KIT PISTONI +050 C/SEGMENTI Mot. Aspirato 1.8D	PISTON KIT WITH RINGS +0,50	PISTONS AVEC SEGMENT +0,50	JKI510M	1.8D NO TURBO	*	
KIT PISTONI STD C/SEGMENTI Mot. Turbo 1.8TD	PISTON KIT WITH RINGS	PISTONS AVEC SEGMENT	JKI511	1.8TD TURBO	*	
KIT PISTONI +050 C/SEGMENTI Mot. Turbo 1.8TD	PISTON KIT WITH RINGS +0,50	PISTONS AVEC SEGMENT +0,50	JKI511M	1.8TD TURBO	*	
SERIE GUARNIZIONI SMERIGLIO Mot. 1.8D/TD	CYLINDER HEADSETS	KIT JOINTS DE CULASSES	JKG535	1.8D/TD		
SERIE GUARNIZIONI MOTORE Mot. 1.8D/TD	FULL GASKET SET	KIT POCHETTE JOINT MOTEUR	JKM535	1.8D/TD		
SERIE BRONZINE BANCO STD	MAIN BEARING	COUSSINET DE PALIER	JMS1821A	1.8D/TD	*	
SERIE BRONZINE BANCO +025	MAIN BEARING +0,25	COUSSINET DE PALIER 0,25	JMS1821A2	1.8D/TD	*	
SERIE BRONZINE BANCO +050	MAIN BEARING +0,50	COUSSINET DE PALIER +0,50	JMS1821A5	1.8D/TD	*	
SERIE BRONZINE BIELLA STD	CON ROD BEARING	COUSSINET DE BIELLE	JCB1085A	1.8D/TD	*	
SERIE BRONZINE BIELLA +025	CON ROD BEARING 0,25	COUSSINET DE BIELLE 0,25	JCB1085A2	1.8D/TD	*	
SERIE BRONZINE BIELLA +050	CON ROD BEARING 0,50	COUSSINET DE BIELLE 0,50	JCB1085A5	1.8D/TD	*	
POMPA ACQUA Mot. 1.8D/TD --> 05.91	WATER PUMP	POMPE E EAU	JPQ513	1.8D/TD --> 05.91	*	
POMPA ACQUA Mot. 1.8D/TD 05.91 -->	WATER PUMP	POMPE E EAU	JPQ532	1.8D/TD 05.91 -->	*	
CANDELETTA PRERISCALDAMENTO 12 volt	GLOW PLUGS 12V	Bougies DE	JCE000	NGK Y115T1		
CANDELETTA PRERISCALDAMENTO 6 volt	GLOW PLUGS 6V	Bougies DE	JCE501	MD092392		



MITSUBISHI SPACE WAGON 2.0TD MOT. 4D68T	GB	F	Japanparts Code	i	NEW
--	-----------	----------	----------------------------	----------	------------

KIT PISTONI STD C/SEGMENTI	PISTON KIT WITH RINGS	PISTONS AVEC SEGMENT	JKI517		**
KIT PISTONI +050 C/SEGMENTI	PISTON KIT WITH RINGS +0,50	PISTONS AVEC SEGMENT +0,50	JKI517M		**

SERIE BRONZINE BANCO STD	MAIN BEARING	COUSSINET DE PALIER	JMS1821A		*
SERIE BRONZINE BANCO +025	MAIN BEARING +0,25	COUSSINET DE PALIER 0,25	JMS1821A2		*
SERIE BRONZINE BANCO +050	MAIN BEARING +0,50	COUSSINET DE PALIER +0,50	JMS1821A5		*

SERIE BRONZINE BIELLA STD	CON ROD BEARING	COUSSINET DE BIELLE	JCB1085A		*
SERIE BRONZINE BIELLA +025	CON ROD BEARING 0,25	COUSSINET DE BIELLE 0,25	JCB1085A2		*
SERIE BRONZINE BIELLA +050	CON ROD BEARING 0,50	COUSSINET DE BIELLE 0,50	JCB1085A5		*

SERIE BOCCOLE BIELLA	PISTON PIN BUSHING	BAGUE TETE DE BIELLE	JPB1821J		*
----------------------	--------------------	----------------------	-----------------	--	---

TESTATA MOTORE NUDA AD. MD326939	NACKED CYLINDERHEAD	CULASSES	JXXMI020	ADAP. MD326939	*
----------------------------------	---------------------	----------	-----------------	----------------	---

POMPA ACQUA	WATER PUMP	POMPE E EAU	JPQ530		*
-------------	------------	-------------	---------------	--	---

CANDELETTA PRERISCALDAMENTO 12 volt	GLOW PLUGS 12V	Bougies DE	JCE000	NGK Y115T1	
CANDELETTA PRERISCALDAMENTO 6 volt	GLOW PLUGS 6V	Bougies DE	JCE501	MD092392	



NISSAN KING-CAB / PICK-UP 2.5D MOT. SD25 dia.cil. 89.00 mm.		GB	F	Japanparts Code	i	NEW
SERIE GUARNIZIONI SMERIGLIO	CYLINDER HEADSETS	KIT JOINTS DE CULASSES	JKG134		*	
SERIE GUARNIZIONI MOTORE	FULL GASKET SET	KIT POCHETTE JOINT MOTEUR	JKM134		*	
VALVOLA ASPIRAZIONE	INLET ENGINE VALVES	SOUPAPES D'ADMISSION	JVNI000	40 x 8 x 117	*	
VALVOLA SCARICO	EXHAUST ENGINE VALVES	SOUPAPES D'ECHAPPEMENT	JVNI001	34 x 8 x 117	*	
KIT PISTONI STD C/SEGMENTI	PISTON KIT WITH RINGS	PISTONS AVEC SEGMENT	JKI107	Pist. pin 26 mm	*	
KIT PISTONI +050 C/SEGMENTI	PISTON KIT WITH RINGS +0,50	PISTONS AVEC SEGMENT +0,50	JKI107M	Pist. pin 26 mm	*	
SERIE SEGMENTI STD	PISTON RINGS	SEGMENTS DE PISTON	JRC24750	2,5 - 2 - 4,5	*	
SERIE SEGMENTI +050	PISTON RINGS +0,50	SEGMENTS DE PISTON +0,50	JRC24750M		*	
SERIE CANNE CILINDRO diam. int. 89,00 mm / dia. est. 92,00 mm	CYLINDER LINERS	CHEMISES DE CYLINDRE	JCCNI005		**	
SERIE BRONZINE BANCO STD	MAIN BEARING	COUSSINET DE PALIER	JMS1182GP		*	
SERIE BRONZINE BANCO +025	MAIN BEARING +0,25	COUSSINET DE PALIER +0,25	JMS1182G2		*	
SERIE BRONZINE BANCO +050	MAIN BEARING +0,50	COUSSINET DE PALIER +0,50	JMS1182G5		*	
SERIE BRONZINE BIELLA STD	CON ROD BEARING	COUSSINET DE BIELLE	JCB1029GP		*	
SERIE BRONZINE BIELLA +025	CON ROD BEARING +0,25	COUSSINET DE BIELLE 0,25	JCB1029G2		*	
SERIE BRONZINE BIELLA +050	CON ROD BEARING +0,50	COUSSINET DE BIELLE +0,50	JCB1029G5		*	
SERIE RASAMENTI STD	THRUST WASHER	CALE LATERALE	JTW1028GP		*	
SERIE BOCCOLE BIELLA	PISTON PIN BUSHING	BAGUE TETE DE BIELLE	JPB1182J	Pist. pin 26 mm	*	
SERIE BRONZINE ALBERO DISTRIBUZIONE	CAMSHAFT BEARING	COUSSINET ARBRE A CAMES	JSH1003B		*	
POMPA ACQUA	WATER PUMP	POMPE E EAU	JPQ121		*	
TERMOSTATO	THRMOSTATES	THERMOSTATE	JVT500		*	
CANDELETTA PRERISCALDAMENTO 11 VOLT	GLOW PLUGS	BOUGIES DE PRECHAUFFAGGE	JCE105	--> '85 NGK Y705RS	*	
CANDELETTA PRERISCALDAMENTO 11 VOLT	GLOW PLUGS	BOUGIES DE PRECHAUFFAGGE	JCE107	85 --> NGK Y707RS	*	





NISSAN KING-CAB / PICK-UP 2.5TD MOT. TD25 dia. cil. 93,00 mm		GB	F	Japanparts Code	i	NEW
SERIE GUARNIZIONI SMERIGLIO	CYLINDER HEADSETS	KIT JOINTS DE CULASSES	JKG145		*	
SERIE GUARNIZIONI MOTORE	FULL GASKET SET	KIT POCHETTE JOINT MOTEUR	JKM145		*	
VALVOLA ASPIRAZIONE	INLET ENGINE VALVES	SOUPAPES D'ADMISSION	JVVNI014		**	
VALVOLA SCARICO	EXHAUST ENGINE VALVES	SOUPAPES D'ECHAPPEMENT	JVVNI015		**	
KIT PISTONI STD C/SEGMENTI	PISTON KIT WITH RINGS	PISTONS AVEC SEGMENT	JKI108	Pist. pin 28 mm	*	
KIT PISTONI +050 C/SEGMENTI	PISTON KIT WITH RINGS +0,50	PISTONS AVEC SEGMENT +0,50	JKI108M	Pist. pin 28 mm	*	
SERIE SEGMENTI STD	PISTON RINGS	SEGMENTS DE PISTON	JRC50000	2,5 - 2 - 4	*	
SERIE SEGMENTI +050	PISTON RINGS +0,50	SEGMENTS DE PISTON +0,50	JRC50000M		*	
SERIE CANNE CILINDRO diam. int. 89,00 mm / dia. est. 92,00 mm	CYLINDER LINERS	CHEMISES DE CYLINDRE	JCCNI004	i.d. 89,0mm o.d. 92,0mm	**	
SERIE BRONZINE BANCO STD	MAIN BEARING	COUSSINET DE PALIER	JMS1190GP		*	
SERIE BRONZINE BANCO +025	MAIN BEARING +0,25	COUSSINET DE PALIER +0,25	JMS1190G2		*	
SERIE BRONZINE BANCO +050	MAIN BEARING +0,50	COUSSINET DE PALIER +0,50	JMS1190G5		*	
SERIE BRONZINE BIELLA STD	CON ROD BEARING	COUSSINET DE BIELLE	JCB1190GP		*	
SERIE BRONZINE BIELLA +025	CON ROD BEARING +0,25	COUSSINET DE BIELLE 0,25	JCB1190G2		*	
SERIE BRONZINE BIELLA +050	CON ROD BEARING +0,50	COUSSINET DE BIELLE +0,50	JCB1190G5		*	
SERIE RASAMENTI STD	THRUST WASHER	CALE LATERALE	JTW1028GP		*	
SERIE BOCCOLE BIELLA	PISTON PIN BUSHING	BAGUE TETE DE BIELLE	JPB1190J	Pist. pin 28 mm	*	
SERIE BRONZINE ALBERO DISTRIBUZIONE	CAMSHAFT BEARING	COUSSINET ARBRE A	JSH1190B		*	
POMPA ACQUA	WATER PUMP	POMPE E EAU	JPQ129		*	
TERMOSTATO	THRMOSTATES	THERMOSTATE	JVT500		*	
CANDELETTA PRERISCALDAMENTO 11 VOLT	GLOW PLUGS	BOUGIES DE PRECHAUFFAGGE	JCE107	NGK Y707RS	*	



NISSAN MICRA 1.0i 16v Mot. CG10 tipo K11/1.3i 16V Mot. CG13 tipo K11 dia. cil. 71,00 mm		GB	F	Japanparts Code	i	NEW
CATENA DISTRIBUZIONE 1a	TIMING CHAIN 1st	CHAINE DE DISTRIBUTION	JCH198	1.0cc / 1.3cc	*	
CATENA DISTRIBUZIONE 2a	TIMING CHAIN 2nd	CHAINE DE DISTRIBUTION	JCH197	1.0cc / 1.3cc	*	
SERIE GUARNIZIONI SMERIGLIO	CYLINDER HEADSETS	KIT JOINTS DE CULASSES	JKG197	1.0cc / 1.3cc	*	
SERIE GUARNIZIONI MOTORE	FULL GASKET SET	KIT POCHETTE JOINT MOTEUR	JKM195	1.0cc / 1.3cc	*	
SERIE SEGMENTI STD	PISTON RINGS	SEGMENTS DE PISTON	JRC19999	1.0cc / 1.3cc	**	
SERIE SEGMENTI	PISTON RINGS +0,50	SEGMENTS DE PISTON +0,50	JRC19999M	1.0cc / 1.3cc	**	
VALVOLA ASPIRAZIONE	INLET ENGINE VALVES	SOUPAPES D'ADMISSION	JVVNI020	27,5 x 5,5 x 95,8 / 1.0 / 1.3cc	**	
VALVOLA SCARICO	EXHAUST ENGINE VALVES	SOUPAPES D'ECHAPPEMENT	JVVNI021	22,5 x 5,5 x 95,8 / 1.0cc / 1.3cc	**	
SERIE BRONZINE BANCO STD Mot. 1.0i 16V	MAIN BEARING	COUSSINET DE PALIER	JMS1999A	1.0cc	**	
SERIE BRONZINE BANCO +025 Mot. 1.0i 16V	MAIN BEARING +0,25	COUSSINET DE PALIER +0,25	JMS1999A2	1.0cc	**	
SERIE BRONZINE BANCO +050 Mot. 1.0i 16V	MAIN BEARING +0,50	COUSSINET DE PALIER +0,50	JMS1999A5	1.0cc	**	
SERIE BRONZINE BANCO STD Mot. 1.3i 16V	MAIN BEARING	COUSSINET DE PALIER	JMS1998A	1.3cc	**	
SERIE BRONZINE BANCO +025 Mot. 1.3i 16V	MAIN BEARING +0,25	COUSSINET DE PALIER +0,25	JMS1998A2	1.3cc	**	
SERIE BRONZINE BANCO +050 Mot. 1.3i 16V	MAIN BEARING +0,50	COUSSINET DE PALIER +0,50	JMS1998A5	1.3cc	**	
SERIE BRONZINE BIELLA STD Mot. 1.0i 16V	CON ROD BEARING	COUSSINET DE BIELLE	JCB1999A	1.0cc	**	
SERIE BRONZINE BIELLA +025 Mot. 1.0i 16V	CON ROD BEARING 0,25	COUSSINET DE BIELLE 0,25	JCB1999A2	1.0cc	**	
SERIE BRONZINE BIELLA +050 Mot. 1.0i 16V	CON ROD BEARING +0,50	COUSSINET DE BIELLE +0,50	JCB1999A5	1.0cc	**	
SERIE BRONZINE BIELLA STD Mot. 1.3i 16V	CON ROD BEARING	COUSSINET DE BIELLE	JCB1998A	1.3cc	**	
SERIE BRONZINE BIELLA +025 Mot. 1.3i 16V	CON ROD BEARING 0,25	COUSSINET DE BIELLE 0,25	JCB1998A2	1.3cc	**	
SERIE BRONZINE BIELLA +050 Mot. 1.3i 16V	CON ROD BEARING +0,50	COUSSINET DE BIELLE +0,50	JCB1998A5	1.3cc	**	
SERIE BOCCOLE BIELLA Mot. 1.0i 16V	PISTON PIN BUSHING	BAGUE TETE DE BIELLE	JPB1999J	1.0cc	**	
SERIE BOCCOLE BIELLA Mot. 1.3i 16V	PISTON PIN BUSHING	BAGUE TETE DE BIELLE	JPB1998J	1.3cc	**	
POMPA ACQUA	WATER PUMP	POMPE E EAU	JPQ197	1.0cc / 1.3cc	*	
TERMOSTATO	THRMOSTATES	THERMOSTATE	JVT198	1.0cc / 1.3cc	*	



NISSAN PATROL 2800TD 6cil. 2826cc Mot.RD28T (9/'88>) dia.cil.85,00mm				Japanparts Code	i	NEW
CINGHIA DISTRIBUZIONE 149 denti	TIMING BELT 149 tooth	COURROIE DE DISTRIBUTION	JDD116	149 T		
CUSCINETTO TENDICINGHIA DISTRIBUZIONE	TENSIONER BEARING	GALET TENDEUR/ROULEMENT	JBE100			
CUSCINETTO TENDICINGHIA DISTRIBUZIONE	TENSIONER BEARING	GALET TENDEUR/ROULEMENT	JBE101			
SERIE GUARNIZIONI SMERIGLIO CON G.T. 1,50mm	CYLINDER HEAD SET	KIT JOINTS DE CULASSES	JKG124	w/ cyl. head 1,50mm		
SERIE GUARNIZIONI MOTORE CON G.T. 1,50mm	FULL GASKET SET	KIT POCHETTE JOINT MOTEUR	JKM124	w/ cyl. head 1,50mm		
SERIE GUARNIZIONI SMERIGLIO	CYLINDER HEAD SET	KIT JOINTS DE CULASSES	JKG124S §	w/o cyl. Head		
SERIE GUARNIZIONI MOTORE	FULL GASKET SET	KIT POCHETTE JOINT MOTEUR	JKM124S §	w/o cyl. Head		
GUARNIZIONE TESTATA 1,42	CYLINDER HEAD GASKET	JOINT DE CULASSE	JGT124A	H= 1,42 mm	**	
GUARNIZIONE TESTATA 1,50	CYLINDER HEAD GASKET	JOINT DE CULASSE	JGT124B	H= 1,50 mm	**	
GUARNIZIONE TESTATA 1,58	CYLINDER HEAD GASKET	JOINT DE CULASSE	JGT124C	H= 1,58 mm	**	
§ NB: FORNITE SENZA GUARNIZIONE TESTA	without CYL. HEAD GASKET					
VALVOLA ASPIRAZIONE altezza valvola 101,8	INLET ENGINE VALVES	SOUPAPES D'ADMISSION	JVVNI002	39x7x101,8		
VALVOLA SCARICO altezza valvola 101,6	EXHAUST ENGINE VALVES	SOUPAPES D'ECHAPPEMENT	JVVNI003	32x7x101,6		
VALVOLA ASPIRAZIONE altezza valvola 102,7	INLET ENGINE VALVES	SOUPAPES D'ADMISSION	JVVNI018	102,7	**	
VALVOLA SCARICO altezza valvola 102,7	EXHAUST ENGINE VALVES	SOUPAPES D'ECHAPPEMENT	JVVNI019	102,7	**	
KIT PISTONI STD C/SEGMENTI	PISTON KIT WITH RINGS	PISTONS AVEC SEGMENT	JKI121	Pist. Pin 28 mm		
KIT PISTONI +050 C/SEGMENTI	PISTON KIT WITH RINGS +0,50	PISTONS AVEC SEGMENT +0,50	JKI121M	Pist. Pin 28 mm		
SERIE SEGMENTI STD	PISTON RINGS	SEGMENTS DE PISTON	JRC50003	2 - 2 - 4	*	
SERIE SEGMENTI +050	PISTON RINGS +0,50	SEGMENTS DE PISTON +0,50	JRC50003M		*	
SERIE CANNE CILINDRO	CYLINDER LINERS	CHEMISES DE CILINDRE	JCCNI002		**	



NISSAN PATROL 2800TD 6cil. 2826cc Mot.RD28T (9/'88>) dia.cil.85,00mm	GB	F	Japanparts Code	i	NEW
--	-----------	----------	----------------------------	----------	------------

TESTATA NUDA RD28T 11040-34504 11040-34J04	CYLINDERHEADS	CULASSES	JXXNS001	NEW	
--	---------------	----------	----------	-----	--

TESTATA NUDA RD28T 11040-34504 11040-34J04 REVISIONATA DISPONIBILE SOLO SU RICHIESTA	CYLINDERHEADS REBUILT AVAILABLE ONLY UNDER REQUEST	CULASSES RECONDITIONEE' DISPONIBLES SEULEMENT SUR DEMANDE	JXXNS001R	REBUILT	**
---	---	---	-----------	---------	----



**JXX-NS001 NACKED
11040-34J04**



NISSAN PATROL 2800TD 6cil. 2826cc Mot.RD28T (9/'88>) dia.cil.85,00mm	GB	F	Japanparts Code	i	NEW
SERIE BRONZINE BANCO STD	MAIN BEARING	COUSSINET DE PALIER	JMS1203GP		
SERIE BRONZINE BANCO +025	MAIN BEARING +0,25	COUSSINET DE PALIER +0,25	JMS1203G2		
SERIE BRONZINE BANCO +050	MAIN BEARING +0,50	COUSSINET DE PALIER +0,50	JMS1203G5		
SERIE BRONZINE BIELLA STD	CON ROD BEARING	COUSSINET DE BIELLE	JCB1207A		
SERIE BRONZINE BIELLA +025	CON ROD BEARING +0,25	COUSSINET DE BIELLE 0,25	JCB1207A2		
SERIE BRONZINE BIELLA +050	CON ROD BEARING +0,50	COUSSINET DE BIELLE +0,50	JCB1207A5		
ALBERO DISTRIBUZIONE	CAMSHAFT	ARBRES A CAMES	JAANS002	GR Model	**
SERIE BOCCOLE BIELLA Mot. ASPIRATO	PISTON PIN BUSHING NO TURBO	BAGUE TETE DE BIELLE NO TURBO	JPB1207J	NO TURBO	
SERIE BOCCOLE BIELLA Mot. TURBO	PISTON PIN BUSHING TURBO	BAGUE TETE DE BIELLE TURBO	JPB1212J	TURBO	**
POMPA ACQUA THERMOSTATO	WATER PUMP THRMOSTATES	POMPE E EAU THERMOSTATE	JPQ125 JVT106		
POMPA OLIO	OIL PUMP	POMPE A HUILE	JXXOLN1		**



JXX-OLN1

CANDELETTA PRERISCALDAMENTO (verde) X3	GLOW PLUGS	BOUGIES DE PRECHAUFFAGGE	JCE113	NGK CZ-01	
CANDELETTA PRERISCALDAMENTO (gialla) X3	GLOW PLUGS	BOUGIES DE PRECHAUFFAGGE	JCE114	NGK CZ-01	



NISSAN PATROL 2.8TD 4WD ENG. A4.28T EBRO dia. cil.94,00mm	(GB)	(F)	Japanparts Code	i	NEW
--	------	-----	--------------------	---	-----



KIT PISTONI STD C/SEGMENTI	PISTON KIT WITH RINGS	PISTONS AVEC SEGMENT	JKI123	Pist. pin 34 mm	*
KIT PISTONI +050 C/SEGMENTI	PISTON KIT WITH RINGS +0,50	PISTONS AVEC SEGMENT +0,50	JKI123M	Pist. pin 34 mm	*
POMPA ACQUA	WATER PUMP	POMPE E EAU	JPQ196		*



NISSAN PATROL 3300TD 6cil. MOTORE SD33T (8/'84>) dia.cil. 83,00mm			Japanparts Code	i	NEW
SERIE GUARNIZIONI SMERIGLIO Mot. SD33	CYLINDER HEADSETS	KIT JOINTS DE CULASSES	JKG147	ENG. SD33 NO TURBO	*
SERIE GUARNIZIONI MOTORE Mot. SD33	FULL GASKET SET	KIT POCHETTE JOINT MOTEUR	JKM147	ENG. SD33 NO TURBO	*
SERIE GUARNIZIONI SMERIGLIO Mot. SD33T	CYLINDER HEADSETS	KIT JOINTS DE CULASSES	JKG176	ENG. SD33T TURBO	
SERIE GUARNIZIONI MOTORE Mot. SD33T	FULL GASKET SET	KIT POCHETTE JOINT MOTEUR	JKM176	ENG. SD33T TURBO	
VALVOLA ASPIRAZIONE	INLET ENGINE VALVES	SOUPAPES D'ADMISSION	JVVNI004	38 x 8 x 117 SD33/SD33T	
VALVOLA SCARICO	EXHAUST ENGINE VALVES	SOUPAPES D'ECHAPPEMENT	JVVNI005	32 x 8 x 117 SD33/SD33T	
KIT PISTONI STD C/SEGMENTI pistoni a 5 fasce Mot. Aspirato	PISTON KIT WITH RINGS	PISTONS AVEC SEGMENT	JKI104	Pist. pin 26 mm with 5 RINGS	*
KIT PISTONI +050 C/SEGMENTI pistoni a 5 fasce Mot. Aspirato	PISTON KIT WITH RINGS +0,50	PISTONS AVEC SEGMENT +0,50	JKI104M	Pist. pin 26 mm with 5 RINGS	*
KIT PISTONI STD C/SEGMENTI pistoni a 3 fasce Mot. TURBO	PISTON KIT WITH RINGS	PISTONS AVEC SEGMENT	JKI120	Pist. pin 26 mm with 3 RINGS	
KIT PISTONI +050 C/SEGMENTI pistoni a 3 fasce Mot. TURBO	PISTON KIT WITH RINGS +0,50	PISTONS AVEC SEGMENT +0,50	JKI120M	Pist. pin 26 mm with 3 RINGS	
SERIE SEGMENTI STD (Set per 2 CIL.) pistone a 5 fasce	PISTON RINGS	SEGMENTS DE PISTON	JRC24060	2,5 - 2 - 2 - 4,5 - 4,5 set sold for 2 cyl. 5 rings model	*
SERIE SEGMENTI +050 (Set per 2 CIL.) pistone a 5 fasce	PISTON RINGS +0,50	SEGMENTS DE PISTON +0,50	JRC24060M	2,5 - 2 - 2 - 4,5 - 4,5 set sold for 2 cyl. 5 rings model	*
SERIE SEGMENTI STD pistone a 3 fasce	PISTON RINGS	SEGMENTS DE PISTON	JRC500001	2,5 - 2 - 4 3 rings model	
SERIE SEGMENTI +050 pistone a 3 fasce	PISTON RINGS +0,50	SEGMENTS DE PISTON +0,50	JRC500001M	2,5 - 2 - 4 3 rings model	
SERIE CANNE CILINDRO	CYLINDER LINERS	CHEMISES DE CYLINDRE	JCCNI001		
TESTATA NUDA SD33T 11041-C8702	CYLINDERHEADS	CULASSES	J XXNS002	NEW	
TESTATA NUDA SD33T 11041-C8702 REVISIONATA DISPONIBILE SOLO SU RICHIESTA	CYLINDERHEADS REBUILT AVAILABLE ONLY UNDER REQUEST	CULASSES RECONDITIONEE' DISPONIBLES SEULEMENT SUR DEMANDE	J XXNS002R	REBUILT	**



XX-NS002



XX-NS002

JXX-NS002 11041-C8702 NISSAN NEW SD33T



NISSAN PATROL 3300TD 6cil. MOTORE SD33T (8/'84>) dia.cil. 83,00mm		GB	F	Japanparts Code	i	NEW
SERIE BRONZINE BANCO STD	MAIN BEARING	COUSSINET DE PALIER	JMS1058GP	SD33/SD33T		
SERIE BRONZINE BANCO +025	MAIN BEARING +0,25	COUSSINET DE PALIER +0,25	JMS1058G2	SD33/SD33T		
SERIE BRONZINE BANCO +050	MAIN BEARING +0,50	COUSSINET DE PALIER +0,50	JMS1058G5	SD33/SD33T		
SERIE BRONZINE BIELLA STD	CON ROD BEARING	COUSSINET DE BIELLE	JCB1058GP	SD33/SD33T		
SERIE BRONZINE BIELLA +025	CON ROD BEARING 0,25	COUSSINET DE BIELLE 0,25	JCB1058G2	SD33/SD33T		
SERIE BRONZINE BIELLA +050	CON ROD BEARING +0,50	COUSSINET DE BIELLE +0,50	JCB1058G5	SD33/SD33T		
SERIE RASAMENTI STD	THRUST WASHER	CALE LATERALE	JTW1028GP	SD33/SD33T		
SERIE BOCCOLE BIELLA	PISTON PIN BUSHING	BAGUE TETE DE BIELLE	JPB1058J	SD33/SD33T		
SERIE BRONZINE ALBERO DISTRIBUZIONE --> 79	CAMSHAFT BEARING --> 79	COUSSINET ARBRE A CAMES --> 79	JSH1004B	--> '79 SD33		
SERIE BRONZINE ALBERO DISTRIBUZIONE 79 -->	CAMSHAFT BEARING 79 -->	COUSSINET ARBRE A CAMES 79 -->	JSH1191B	79 --> SD33/SD33T		
POMPA ACQUA	WATER PUMP	POMPE E EAU	JPQ106	SD33/SD33T		
TERMOSTATO	THRMOSTATES	THERMOSTATE	JVT500	SD33/SD33T		
CANDELETTA PRERISCALDAMENTO 24volt	GLOW PLUGS	BOUGIES DE PRECHAUFFAGGE	JCE038	NGK Y755RS		



NISSAN PRIMERA 1.6 Mot. GA16 P10 dia. cil. 76,00 mm		GB	F	Japanparts Code	i	NEW
CATENA DISTRIBUZIONE 1a	TIMING CHAIN 1st	CHAINE DE DISTRIBUTION	JCH196	1 st	*	
CATENA DISTRIBUZIONE 2a	TIMING CHAIN 2nd	CHAINE DE DISTRIBUTION	JCH195	2 nd	*	
SERIE GUARNIZIONI SMERIGLIO Mot. GA16DE	CYLINDER HEADSETS	KIT JOINTS DE CULASSES	JKG175	ENG. GA16DE	*	
SERIE GUARNIZIONI MOTORE Mot. GA16DE	FULL GASKET SET	KIT POCHETTE JOINT MOTEUR	JKM175	ENG. GA16DE	*	
SERIE SEGMENTI STD	PISTON RINGS	SEGMENTS DE PISTON	JRC30574	1,5 - 1,5 - 2,8	*	
SERIE SEGMENTI	PISTON RINGS +0,50	SEGMENTS DE PISTON +0,50	JRC30574M		*	
SERIE BRONZINE BANCO STD	MAIN BEARING	COUSSINET DE PALIER	JMS1208A		*	
SERIE BRONZINE BANCO +025	MAIN BEARING +0,25	COUSSINET DE PALIER +0,25	JMS1208A2		*	
SERIE BRONZINE BANCO +050	MAIN BEARING +0,50	COUSSINET DE PALIER +0,50	JMS1208A5		*	
SERIE BRONZINE BIELLA STD	CON ROD BEARING	COUSSINET DE BIELLE	JCB1208A		*	
SERIE BRONZINE BIELLA +025	CON ROD BEARING 0,25	COUSSINET DE BIELLE	JCB1208A2		*	
SERIE BRONZINE BIELLA +050	CON ROD BEARING	COUSSINET DE BIELLE	JCB1208A5		*	
SERIE RASAMENTI STD	THRUST WASHER	CALE LATERALE	JTW1208A		*	
SERIE BOCCOLE BIELLA	PISTON PIN BUSHING	BAGUE TETE DE BIELLE	JPB1208J		*	
POMPA ACQUA	WATER PUMP	POMPE E EAU	JPQ199		*	
TERMOSTATO	THRMOSTATES	THERMOSTATE	JVT199		*	



NISSAN TERRANO prima serie/seconda serie (II) 2.7D/TD Mot. TD27/TD27T dia.cil.96 mm	(GB)	(F)	Japanparts Code	i	NEW
--	------	-----	------------------------	---	------------



SERIE GUARNIZIONI SMERIGLIO per 1a serie	CYLINDER HEADSETS	KIT JOINTS DE CULASSES	JKG145	1st edition	*
SERIE GUARNIZIONI MOTORE per 1a serie	FULL GASKET SET	KIT POCHELETTE JOINT MOTEUR	JKM145	1st edition	*

VALVOLA ASPIRAZIONE	INLET ENGINE VALVES	SOUPAPES D'ADMISSION	JVVNI016		**
VALVOLA SCARICO	EXHAUST ENGINE VALVES	SOUPAPES D'ECHAPPEMENT	JVVNI017		**

KIT PISTONI STD C/SEGMENTI Mot. TD27 1a serie	PISTON KIT WITH RINGS	PISTONS AVEC SEGMENT	JKI109	Pist. pin 28 mm 1st edition	*
KIT PISTONI +050 C/SEGMENTI Mot. TD27 1a serie	PISTON KIT WITH RINGS +0,50	PISTONS AVEC SEGMENT +0,50	JKI109M	Pist. pin 28 mm 1st edition	*

KIT PISTONI STD C/SEGMENTI Mot. TD27T 2a serie	PISTON KIT WITH RINGS	PISTONS AVEC SEGMENT	JKI125	Pist. pin 30 mm 2nd edition Made in Spain	*
KIT PISTONI +050 C/SEG. Mot. TD27T 2a serie	PISTON KIT WITH RINGS +0,50	PISTONS AVEC SEGMENT +0,50	JKI125M	Pist. pin 30 mm 2nd edition Made in Spain	*

SERIE CANNE CILINDRO 1a serie --> 93	CYLINDER LINERS	CHEMISES DE CYLINDRE	JCCNI006	1st edition > '93	**
SERIE CANNE CILINDRO 2a serie 93 -->	CYLINDER LINERS	CHEMISES DE CYLINDRE	JCCNI007	2nd edition '93 -->	**

SERIE BRONZINE BANCO STD per 1a serie	MAIN BEARING	COUSSINET DE PALIER	JMS1190GP	1st edition	*
SERIE BRONZINE BANCO +025 per 1a serie	MAIN BEARING +0,25	COUSSINET DE PALIER +0,25	JMS1190G2	1st edition	*
SERIE BRONZINE BANCO +050 per 1a serie	MAIN BEARING +0,50	COUSSINET DE PALIER +0,50	JMS1190G5	1st edition	*



NISSAN TERRANO prima serie/seconda serie (II) 2.7D/TD Mot. TD27/TD27T dia.cil.96 mm		GB	F	Japanparts Code	i	NEW
SERIE BRONZINE BIELLA STD per 1a serie	CON ROD BEARING	COUSSINET DE BIELLE	JCB1190GP	1st edition	*	
SERIE BRONZINE BIELLA +025 per 1a serie	CON ROD BEARING 0,25	COUSSINET DE BIELLE 0,25	JCB1190G2	1st edition	*	
SERIE BRONZINE BIELLA +050 per 1a serie	CON ROD BEARING +0,50	COUSSINET DE BIELLE +0,50	JCB119G5	1st edition	*	
SERIE RASAMENTI STD per 1a serie	THRUST WASHER	CALE LATERALE	JTW1028GP	1st edition	*	
SERIE BOCCOLE BIELLA per 1a serie	PISTON PIN BUSHING	BAGUE TETE DE BIELLE	JPB1190J	1st edition	*	
SERIE BRONZINE ALBERO DISTRIBUZIONE per 1a serie	CAMSHAFT BEARING	COUSSINET ARBRE A CAMES	JSH1190B	1st edition	*	
POMPA ACQUA	WATER PUMP	POMPE E EAU	JPQ136	1st/nd edition	*	
TERMOSTATO	THERMOSTATES	THERMOSTATE	JVT500	1st/nd edition	*	
CANDELETTA PRERISCALDAMENTO	GLOW PLUGS	BOUGIES DE PRECHAUFFAGGE	JCE116	NGK Y712RS	*	



NISSAN TRADE/PATROL 2.8D ENG. A4.28/A4.28II EBRO dia. cil. 94,00mm			Japanparts Code	i	NEW
---	---	--	----------------------------	----------	------------

KIT PISTONI STD C/SEGMENTI	PISTON KIT WITH RINGS	PISTONS AVEC SEGMENT	JKI122	Pist. pin 34 mm	
KIT PISTONI +050 C/SEGMENTI	PISTON KIT WITH RINGS +0,50	PISTONS AVEC SEGMENT +0,50	JKI122M	Pist. pin 34 mm	

SERIE CANNE CILINDRO dia. int. 94,00 mm / dia. est. 97,50 mm	SET CYLINDER LINERS	CHEMISES DE CYLINDRE	JCCNI003	i.d. 94,0mm o.d. 97,5mm	**
---	---------------------	-------------------------	-----------------	----------------------------	-----------

TESTATA NUDA	CYLINDERHEADS	CULASSES	J XXNS003		**
--------------	---------------	----------	-----------	--	-----------

ALBERO DISTRIBUZIONE	CAMSHAFT	ARBRES A CAMES	JAANS001	A4.28 / A4.28II	**
----------------------	----------	----------------	-----------------	-----------------	-----------

POMPA ACQUA	WATER PUMP	POMPE E EAU	JPQ196		*
-------------	------------	-------------	---------------	--	----------

CANDELETTA PRERISCALDAMENTO	GLOW PLUGS	BOUGIES DE	JCE111	NGK CY-01	*
CANDELETTA PRERISCALDAMENTO	GLOW PLUGS	BOUGIES DE PRECHAUFFAGGE	JCE120	NGK Y902-R	*



NISSAN VANETTE/TRADE 2000D LD20II dia. cil. 85,00 Made in Spain / VANETTE 2.0D LD20 Made in Japan		GB	F	Japanparts Code	i	NEW
CINGHIA DISTRIBUZIONE pompa iniezione 69 denti quadri	TIMING BELT 69 square tooth	COURROIE DE DISTRIBUTION	JDD102	69 square T	*	
CINGHIA DISTRIBUZIONE 141 denti	TIMING BELT 141 tooth	COURROIE DE DISTRIBUTION	JDD118	141 T	*	
CINGHIA DISTRIBUZIONE 69 denti tondi	TIMING BELT 69 round tooth	COURROIE DE DISTRIBUTION	JDD199	69 round T	*	
CUSCINETTO TENDICINGHIA	TENSIONER BEARING	GALET TENDEUR/ROULEMENT	JBE112		*	
CUSCINETTO TENDICINGHIA	TENSIONER BEARING	GALET TENDEUR/ROULEMENT	JBE113		*	
SERIE GUARNIZIONI SMERIGLIO Mot. LD20	CYLINDER HEAD SET	KIT JOINTS DE CULASSES	JKG128	LD20 Japan		
SERIE GUARNIZIONI MOTORE Mot. LD20	FULL GASKET SET	KIT POCHETTE JOINT MOTEUR	JKM128	LD20 Japan		
SERIE GUARNIZIONI SMERIGLIO Mot. LD20II Con G.T. 1,20 mm	CYLINDER HEAD SET	KIT JOINTS DE CULASSES	JKG190	LD20II Spain with cyl. Head 1,20mm		
SERIE GUARNIZIONI MOTORE Mot. LD20II Con G.T. 1,20 mm	FULL GASKET SET	KIT POCHETTE JOINT MOTEUR	JKM190	LD20II Spain with cyl. Head 1,20mm		
SERIE GUARNIZIONI SMERIGLIO Mot. LD20II	CYLINDER HEAD SET	KIT JOINTS DE CULASSES	JKG190S §	LD20II Spain w/o cyl. Head	**	
SERIE GUARNIZIONI MOTORE Mot. LD20II	FULL GASKET SET	KIT POCHETTE JOINT MOTEUR	JKM190S §	LD20II Spain w/o cyl. Head	**	
§ NB: FORNITE SENZA GUARNIZIONE TESTA without CYL. HEAD GASKET						
GUARNIZIONE TESTATA 1,15	CYLINDER HEAD GASKET	JOINT DE CULASSES	JGT190A	Only cyl. Head H= 1,15 mm	**	
GUARNIZIONE TESTATA 1,20	CYLINDER HEAD GASKET	JOINT DE CULASSES	JGT190B	Only cyl. Head H= 1,20 mm	**	
GUARNIZIONE TESTATA 1,25	CYLINDER HEAD GASKET	JOINT DE CULASSES	JGT190C	Only cyl. Head H= 1,25 mm	**	
VALVOLA ASPIRAZIONE VANETTE LD20II	INLET ENGINE VALVES	SOUPAPES D'ADMISSION	JVVNI012	LD20II Spain	**	
VALVOLA SCARICO VANETTE LD20II	EXHAUST ENGINE VALVES	SOUPAPES D'ECHAPPEMENT	JVVNI013	LD20II Spain	**	
KIT PISTONI STD C/SEGMENTI Mot. LD20	PISTON KIT WITH RINGS	PISTONS AVEC SEGMENT	JKI105	HC=46,5/-2,7 spin. 25 LD20 Japan	*	
KIT PISTONI +050 C/SEGMENTI Mot. LD20	PISTON KIT WITH RINGS +0,50	PISTONS AVEC SEGMENT +0,50	JKI105M	HC=46,5/-2,7 spin. 25 LD20 Japan	*	
KIT PISTONI STD C/SEGMENTI Mot. LD20II	PISTON KIT WITH RINGS	PISTONS AVEC SEGMENT	JKI119	Pist. pin 25 mm LD20II Spain		
KIT PISTONI +050 C/Segmenti Mot. LD20II	PISTON KIT WITH RINGS +0,50	PISTONS AVEC SEGMENT +0,50	JKI119M	Pist. pin 25 mm LD20II Spain		
SERIE SEGMENTI STD Mot. LD20	PISTON RINGS	SEGMENTS DE PISTON	JRC23601	2 - 2 - 4 LD20 Japan	*	
SERIE SEGMENTI +050 Mot. LD20	PISTON RINGS +0,50	SEGMENTS DE PISTON +0,50	JRC23601M	2 - 2 - 4 LD20 Japan	*	
SERIE SEGMENTI STD Mot. LD20II	PISTON RINGS	SEGMENTS DE PISTON	JRC50002	2 - 2 - 4 LD20II Spain	*	
SERIE SEGMENTI +050 Mot. LD20II	PISTON RINGS +0,50	SEGMENTS DE PISTON +0,50	JRC50002M	2 - 2 - 4 LD20II Spain	*	



NISSAN VANETTE/TRADE 2000D LD20II dia. cil. 85,00 Made in Spain / VANETTE 2.0D LD20 Made in Japan	GB	F	Japanparts Code	i	NEW
--	-----------	----------	------------------------	----------	------------

TESTATA NUDA	CYLINDERHEADS	CULASSES	J XXNS004		**
--------------	---------------	----------	-----------	--	----

SERIE BRONZINE BANCO STD --> 10.83	MAIN BEARING	COUSSINET DE PALIER	JMS1183GP	LD20 / II --> 10.83	*
SERIE BRONZINE BANCO +025 --> 10.83	MAIN BEARING +0,25	COUSSINET DE PALIER +0,25	JMS1183G2	LD20 / II --> 10.83	*
SERIE BRONZINE BANCO +050 --> 10.83	MAIN BEARING +0,50	COUSSINET DE PALIER +0,50	JMS1183G5	LD20 / II --> 10.83	*

SERIE BRONZINE BANCO STD 10.83 -->	MAIN BEARING	COUSSINET DE PALIER	JMS1997GP	LD20 / II 10.83 -->	*
SERIE BRONZINE BANCO +025 10.83 -->	MAIN BEARING +0,25	COUSSINET DE PALIER +0,25	JMS1997G2	LD20 / II 10.83 -->	*
SERIE BRONZINE BANCO +050 10.83 -->	MAIN BEARING +0,50	COUSSINET DE PALIER +0,50	JMS1997G5	LD20 / II 10.83 -->	*

SERIE BRONZINE BIELLA STD	CON ROD BEARING	COUSSINET DE BIELLE	JCB1044GP	LD20 / II	*
SERIE BRONZINE BIELLA +025	CON ROD BEARING 0,25	COUSSINET DE BIELLE 0,25	JCB1044G2	LD20 / II	*
SERIE BRONZINE BIELLA +050	CON ROD BEARING +0,50	COUSSINET DE BIELLE +0,50	JCB1044G5	LD20 / II	*

SERIE BOCCOLE BIELLA	PISTON PIN BUSHING	BAGUE TETE DE BIELLE	JPB1189J	LD20 / II	*
----------------------	--------------------	----------------------	-----------------	-----------	---

ALBERO DISTRIBUZIONE	CAMSHAFT	ARBRES A CAMES	JAANS000	LD20 / II	**
----------------------	----------	----------------	-----------------	-----------	----

POMPA ACQUA	WATER PUMP	POMPE E EAU	JPQ132	LD20 / II	*
TERMOSTATO	THRMOSTATES	THERMOSTATE	JVT102	LD20 / II	*

CANDELETTA PRERISCALDAMENTO	GLOW PLUGS	BOUGIES DE PRECHAUFFAGGE	JCE111	NGK CY-01	*
-----------------------------	------------	--------------------------	---------------	-----------	---



OPEL CORSA / KADETT 1500D 1487cc MOTORE 4EC1 dia. cil. 76,00mm		GB	F	Japanparts Code	i	NEW
CINGHIA DISTRIBUZIONE 136 denti	TIMING BELT 136 tooth	COURROIE DE DISTRIBUTION	JDD907	136 T		
CUSCINETTO TENDICINGHIA DISTRIBUZIONE	TENSIONER BEARING	GALET TENDEUR/ROULEMENT	JBE912			
CUSCINETTO TENDICINGHIA DISTRIBUZIONE	TENSIONER BEARING	GALET TENDEUR/ROULEMENT	JBE913			
SERIE GUARNIZIONI SMERIGLIO Con G.T. 1,40 mm	CYLINDER HEADSETS	KIT JOINTS DE CULASSES	JKG907	w/ cyl. Head 1,40mm		
SERIE GUARNIZIONI MOTORE Con G.T. 1,40 mm	FULL GASKET SET	KIT POCHEFFE JOINT	JKM907	w/ cyl. Head 1,40mm		
SERIE GUARNIZIONI SMERIGLIO	CYLINDER HEADSETS	KIT JOINTS DE CULASSES	JKG907S §	w/o cyl. Head	**	
SERIE GUARNIZIONI MOTORE	FULL GASKET SET	KIT POCHEFFE JOINT	JKM907S §	w/o cyl. Head	**	
§ NB: FORNITE SENZA GUARNIZIONE TESTA without CYL. HEAD GASKET						
GUARNIZIONE MOTOTRE 1,35	CYLINDER HEAD GASKET	JOINT DE CULASSES	JGT907A	Only cyl. Head H= 1,35 mm	**	
GUARNIZIONE MOTOTRE 1,40	CYLINDER HEAD GASKET	JOINT DE CULASSES	JGT907B	Only cyl. Head H= 1,40 MM	**	
GUARNIZIONE MOTOTRE 1,45	CYLINDER HEAD GASKET	JOINT DE CULASSES	JGT907C	Only cyl. Head H= 1,45 mm	**	
VALVOLA ASPIRAZIONE	INLET ENGINE VALVES	SOUPAPES D'ADMISSION	JVVIZ006	34,6 x 7 x 104,1	**	
VALVOLA SCARICO	EXHAUST ENGINE VALVES	SOUPAPES D'ECHAPPEMENT	JVVIZ007	30,6 x 7 x 104	**	
KIT PISTONI STD S/SEGMENTI	PISTON KIT WITH RINGS	PISTONS AVEC SEGMENT	JKI927	Pist. pin 22 mm		
KIT PISTONI +050 S/SEGMENTI	PISTON KIT WITH RINGS +0,50	PISTONS AVEC SEGMENT +0,50	JKI927M	Pist. pin 22 mm		
SERIE SEGMENTI STD	PISTON RINGS	SEGMENTS DE PISTON	JRC17880	2 - 1,5 - 3		
SERIE SEGMENTI +050	PISTON RINGS +0,50	SEGMENTS DE PISTON +0,50	JRC17880M			
SERIE BRONZINE BANCO STD	MAIN BEARING	COUSSINET DE PALIER	JMS1624GP			
SERIE BRONZINE BANCO +025	MAIN BEARING +0,25	COUSSINET DE PALIER	JMS1624G2			
SERIE BRONZINE BANCO +050	MAIN BEARING +0,50	COUSSINET DE PALIER	JMS1624G5			
SERIE BRONZINE BIELLA STD	CON ROD BEARING	COUSSINET DE BIELLE	JCB1624A			
SERIE BRONZINE BIELLA +025	CON ROD BEARING +0,25	COUSSINET DE BIELLE +0,25	JCB1624A2			
SERIE BRONZINE BIELLA +050	CON ROD BEARING +0,50	COUSSINET DE BIELLE +0,50	JCB1624A5			



OPEL CORSA / KADETT 1500D 1487cc MOTORE 4EC1 dia. cil. 76,00mm			Japanparts Code	i	NEW
---	--	--	--------------------	---	-----

SERIE RASAMENTI STD	THRUST WASHER	CALE LATERALE	JTW1625GP		
---------------------	---------------	---------------	-----------	--	--

TESTATA NUDA 4EC1T 970.435.23	CYLINDERHEADS	CULASSES	JXXIS001	TURBO	
-------------------------------	---------------	----------	----------	-------	--

TESTATA NUDA 4EC1T 970.435.23 REVISIONATA DISPONIBILE SOLO SU RICHIESTA	CYLINDERHEADS REBUILT AVAILABLE ONLY UNDER REQUEST	CULASSES RECONDITIONEE' DISPONIBLES SEULEMENT SUR DEMANDE	JXXIS001R	TURBO	**
---	---	---	-----------	-------	----



JXX-IS001

SERIE BOCCOLE BIELLA	PISTON PIN BUSHING	BAGUE TETE DE BIELLE	JPB1624J		
----------------------	--------------------	----------------------	----------	--	--

BILANCIERI VALVOLE	ROCKER ARMS	CULBUTEUR	JBZIS000		**
--------------------	-------------	-----------	----------	--	----

ALBERO DISTRIBUZIONE	CAMSHAFT	ARBRES A CAMMES	JAAIS000		**
----------------------	----------	-----------------	----------	--	----

POMPA ACQUA	WATER PUMP	POMPE E EAU	JPQ909		
-------------	------------	-------------	--------	--	--

CANDELETTA PRERISCALDAMENTO 5 volt	GLOW PLUGS	BOUGIES DE PRECHAUFFAGGE	JCE999	NGK Y104R --> '89	
CANDELETTA PRERISCALDAMENTO	GLOW PLUGS	BOUGIES DE PRECHAUFFAGGE	JCE908	NGK Y710R '89 -->	



OPEL CORSA / KADETT 1500TD 1487cc MOTORE 4EC1T dia. cil. 76,00mm		GB	F	Japanparts Code	i	NEW
CINGHIA DISTRIBUZIONE 136 denti --> 90	TIMING BELT 136 tooth -->90	COURROIE DE DISTRIBUTION	JDD907	136 T --> '90		
CINGHIA DISTRIBUZIONE 137 denti 90 -->	TIMING BELT 137 tooth 90	COURROIE DE DISTRIBUTION	JDD904	137 T '90 -->		
CUSCINETTO TENDICINGHIA DISTRIBUZIONE	TENSIONER BEARING	GALET TENDEUR/ROULEMENT	JBE-912			
CUSCINETTO TENDICINGHIA DISTRIBUZIONE	TENSIONER BEARING	GALET TENDEUR/ROULEMENT	JBE-913			
SERIE GUARNIZIONI SMERIGLIO Con G.T. 1,40 mm	CYLINDER HEADSETS	KIT JOINTS DE CULASSES	JKG906	w/ cyl. Head 1,40 mm		
SERIE GUARNIZIONI MOTORE Con G.T. 1,40 mm	FULL GASKET SET	KIT POCHETTE JOINT	JKM906	w/ cyl. Head 1,40 mm		
SERIE GUARNIZIONI SMERIGLIO	CYLINDER HEADSETS	KIT JOINTS DE CULASSES	JKG906S §	w/o cyl. Head	**	
SERIE GUARNIZIONI MOTORE	FULL GASKET SET	KIT POCHETTE JOINT	JKM906S §	w/o cyl. Head	**	
§ NB: FORNITE SENZA GUARNIZIONE TESTA		without CYL. HEAD GASKET				
GUARNIZIONE MOTOTRE 1,35 mm	CYLINDER HEAD GASKET	JOINTS DE CULASSE	JGT906A	Only cyl. Head H= 1,35 mm	**	
GUARNIZIONE MOTOTRE 1,40 mm	CYLINDER HEAD GASKET	JOINTS DE CULASSE	JGT906B	Only cyl. Head H= 1,40 mm	**	
GUARNIZIONE MOTOTRE 1,45 mm	CYLINDER HEAD GASKET	JOINTS DE CULASSE	JGT906C	Only cyl. Head H= 1,45 mm	**	
VALVOLA ASPIRAZIONE	INLET ENGINE VALVES	SOUPAPES D'ADMISSION	JVVIZ006	34,6 x 7 x 104,1	**	
VALVOLA SCARICO	EXHAUST ENGINE VALVES	SOUPAPES D'ECHAPPEMENT	JVVIZ008	30,6 x 7 x 104	**	
KIT PISTONI STD S/SEGMENTI	PISTON KIT WITH RINGS	PISTONS AVEC SEGMENT	JKI926	Pist. pin 25 mm		
KIT PISTONI +050 S/SEGMENTI	PISTON KIT WITH RINGS +0,50	PISTONS AVEC SEGMENT +0,50	JKI926M	Pist. pin 25 mm		
SERIE SEGMENTI STD	PISTON RINGS	SEGMENTS DE PISTON	J RC17880	2 - 1,5 - 3		
SERIE SEGMENTI +050	PISTON RINGS +0,50	SEGMENTS DE PISTON +0,50	J RC17880M			
SERIE CANNE CILINDRO	SET CYLINDER LINEES	CHEMISES DE CYLINDRE	JCCIS000		**	
SERIE BRONZINE BANCO STD	MAIN BEARING	COUSSINET DE PALIER	JMS1625GP			
SERIE BRONZINE BANCO +025	MAIN BEARING +0,25	COUSSINET DE PALIER +0,25	JMS1625G2			
SERIE BRONZINE BANCO +050	MAIN BEARING +0,50	COUSSINET DE PALIER +0,50	JMS1625G5			
SERIE BRONZINE BIELLA STD	CON ROD BEARING	COUSSINET DE BIELLE	JCB1624A			
SERIE BRONZINE BIELLA +025	CON ROD BEARING +0,25	COUSSINET DE BIELLE +0,25	JCB1624A2			
SERIE BRONZINE BIELLA +050	CON ROD BEARING +0,50	COUSSINET DE BIELLE +0,50	JCB1624A5			



OPEL CORSA / KADETT 1500TD 1487cc MOTORE 4EC1T dia. cil. 76,00mm			Japanparts Code	i	NEW
---	--	--	--------------------	---	-----

SERIE RASAMENTI STD	THRUST WASHER	CALE LATERALE	JTW1625GP		
---------------------	---------------	---------------	-----------	--	--

TESTATA NUDA 4EC1T 970.435.23	CYLINDERHEADS	CULASSES	JXXIS001	NEW	
-------------------------------	---------------	----------	----------	-----	--

TESTATA NUDA 4EC1T 970.435.23 REVISIONATA DISPONIBILE SOLO SU RICHIESTA	CYLINDERHEADS REBUILT AVAILABLE ONLY UNDER REQUEST	CULASSES RECONDITIONEE' DISPONIBLES SEULEMENT SUR DEMANDE	JXXIS001R	REBUILT	**
---	---	---	-----------	---------	----



JXX-IS001

SERIE BOCCOLE BIELLA	PISTON PIN BUSHING	BAGUE TETE DE BIELLE	JPB1625J		
----------------------	--------------------	----------------------	----------	--	--

BILANCIERI VALVOLE	ROCKER ARMS	CULBUTEUR	JBZIS000		**
--------------------	-------------	-----------	----------	--	----

ALBERO DISTRIBUZIONE	CAMSHAFT	ARBRES A CAMES	JAAIS000		**
----------------------	----------	----------------	----------	--	----

POMPA ACQUA --> 93	WATER PUMP -->93	POMPE E EAU --> 93	JPQ909	--> '93	
POMPA ACQUA 93 -->	WATER PUMP 93 -->	POMPE E EAU 93 -->	JPQ908	'93 -->	

CANDELETTA PRERISCALDAMENTO 5 volt	GLOW PLUGS 5v	BOUGIES DE PRECHAUFFAGGE	JCE999	NGK Y104 --> 90	
CANDELETTA PRERISCALDAMENTO	GLOW PLUGS	BOUGIES DE PRECHAUFFAGGE	JCE907	NGK Y711 '90 -->	



OPEL ASTRA / VECTRA 1700TD MOTORE 4EE1T dia.cil.79,00 mm		(GB)	(F)	Japanparts Code	i	NEW
CINGHIA DISTRIBUZIONE 146 denti --> 90	TIMING BELT 146 tooth -->90	COURROIE DE DISTRIBUTION	JDD998	146 T --> 90		
CUSCINETTO TENDICINGHIA DISTRIBUZIONE	TENSIONER BEARING	GALET TENDEUR/ROULEMENT	J BE-913			
SERIE GUARNIZIONI SMERIGLIO Con G.T. 1,40 mm	CYLINDER HEAD SET	KIT JOINTS DE CULASSES	JKG995	w/ cyl. Head 1,40mm		
SERIE GUARNIZIONI MOTORE G.T. 1,40 mm	Con FULL GASKET SET	KIT POCLETTE JOINT	JKM995	w/ cyl. Head 1,40mm		
SERIE GUARNIZIONI SMERIGLIO	CYLINDER HEAD SET	KIT JOINTS DE CULASSES	JKG995S §			**
SERIE GUARNIZIONI MOTORE	FULL GASKET SET	KIT POCLETTE JOINT	JKM995S §			**
§ NB: FORNITE SENZA GUARNIZIONE TESTA		without CYL. HEAD GASKET				
GUARNIZIONE MOTOTRE 1,30	CYLINDER HEAD GASKET	JOINTS DE CULASSE	JGT995A	Only cyl. Head H= 1,30 mm		**
GUARNIZIONE MOTOTRE 1,40	CYLINDER HEAD GASKET	JOINTS DE CULASSE	JGT995B	Only cyl. Head H= 1,40 mm		**
GUARNIZIONE MOTOTRE 1,50	CYLINDER HEAD GASKET	JOINTS DE CULASSE	JGT995C	Only cyl. Head H= 1,50 mm		**
VALVOLA ASPIRAZIONE	INLET ENGINE VALVES	SOUPAPES D'ADMISSION	JVVIZ006	34,6 x 7 x 104,1		**
VALVOLA SCARICO	EXHAUST ENGINE VALVES	SOUPAPES D'ECHAPPEMENT	JVVIZ008	30,6 x 7 x 104		**
KIT PISTONI STD C/SEGMENTI	PISTON KIT WITH RINGS	PISTONS AVEC SEGMENT	JKI925	Pist. pin 27mm		
KIT PISTONI +050 C/SEGMENTI	PISTON KIT WITH RINGS +0,50	PISTONS AVEC SEGMENT +0,50	JKI925M	Pist. pin 27mm		
SERIE SEGMENTI STD SERIE SEGMENTI +050	PISTON RINGS PISTON RINGS +0,50	SEGMENTS DE PISTON SEGMENTS DE PISTON +0,50	JRC17800 JRC17800M	2 - 1,5 - 3		
SERIE CANNE CILINDRO diam. int. 79,50 mm / dia. est. 83,50 mm	SET CYLINDER LINERS	CHEMISES DE CYLINDRE	JCCIS001	i.d. 79,5mm o.d. 83,5mm		**
BRONZINE BANCO STD BRONZINE BANCO +025 BRONZINE BANCO +050	MAIN BEARING MAIN BEARING +0,25 MAIN BEARING +0,50	COUSSINET DE PALIER COUSSINET DE PALIER +0,25 COUSSINET DE PALIER +0,50	JMS1625GP JMS1625G2 JMS1625G5			
BRONZINE BIELLA STD BRONZINE BIELLA +025 BRONZINE BIELLA +050	CON ROD BEARING CON ROD BEARING +0,25 CON ROD BEARING +0,50	COUSSINET DE BIELLE COUSSINET DE BIELLE +0,25 COUSSINET DE BIELLE +0,50	JCB1624A JCB1624A2 JCB1624A5			



OPEL ASTRA / VECTRA 1700TD MOTORE 4EE1T dia.cil.79,00 mm	GB	F	Japanparts Code	i	NEW
---	-----------	----------	----------------------------------	----------	------------

SERIE RASAMENTI STD	THRUST WASHER	CALE LATERALE	JTW1625GP		
---------------------	---------------	---------------	-----------	--	--

SERIE BOCCOLE BIELLA	PISTON PIN BUSHING	BAGUE TETE DE BIELLE	JPB1625J		
----------------------	--------------------	----------------------	----------	--	--

TESTATA NUDA 4EE1-T OPEL 607044 ISUZU 97043767	CYLINDERHEADS	CULASSES	JXXIS002	NEW	
---	---------------	----------	----------	-----	--

TESTATA NUDA 4EE1-T 607044 ISUZU 97043767 REVISIONATA DISPONIBILE SOLO SU RICHIESTA	OPEL	CYLINDERHEADS REBUILT AVAILABLE ONLY UNDER REQUEST	CULASSES RECONDITIONEE' DISPONIBLES SEULEMENT SUR DEMANDE	JXXIS002R	REBUILT	**
---	------	---	---	-----------	---------	----



JXX-IS002

BILANCIERI VALVOLE	ROCKER ARMS	CULBUTEUR	JBZIS001		**
--------------------	-------------	-----------	----------	--	----

ALBERO DISTRIBUZIONE	CAMSHAFT	ARBRES A CAMMES	JAAIS001		**
----------------------	----------	-----------------	----------	--	----

POMPA ACQUA	WATER PUMP	POMPE E EAU	JPQ993		
-------------	------------	-------------	--------	--	--

CANDELETTA PRERISCALDAMENTO Y711RS	GLOW PLUGS	BOUGIES DE PRECHAUFFAGGE	JCE907	NGK Y711RS	
------------------------------------	------------	-----------------------------	--------	------------	--

CANDELETTA PRERISCALDAMENTO CY-03	GLOW PLUGS	BOUGIES DE PRECHAUFFAGGE	JCE997	NGK CY-03	*
-----------------------------------	------------	-----------------------------	--------	-----------	---



SUZUKI MARUTI 800 3 CIL. MOTORE F8B dia.cil. 68,50 mm	(GB)	(F)	Japanparts Code	i	NEW
--	------	-----	----------------------------	---	------------



CINGHIA DISTRIBUZIONE 88 denti	TIMING BELT 88 tooth	COURROIE DE DISTRIBUTION	JDD201	88 T	*
CUSCINETTO TENDICINGHIA	TENSIONER BEARING	GALET TENDEUR/ROULEMENT	JBE803		*
CUSCINETTO TENDICINGHIA	TENSIONER BEARING	GALET TENDEUR/ROULEMENT	JBE899		*
SERIE GUARNIZIONI SMERIGLIO	CYLINDER HEADSETS	KIT JOINTS DE CULASSES	JKG801		*
SERIE GUARNIZIONI MOTORE	FULL GASKET SET	KIT POCHETTE JOINT MOTEUR	JKM801		*
KIT PISTONI STD C/SEGMENTI	PISTON KIT WITH RINGS	PISTONS AVEC SEGMENT	JKI899		*
KIT PISTONI +050 C/SEGMENTI	PISTON KIT WITH RINGS +0,50	PISTONS AVEC SEGMENT +0,50	JKI899M		*
SERIE SEGMENTI STD	PISTON RINGS	SEGMENTS DE PISTON	JRC27830	1,5 - 1,5 -2,75	*
SERIE SEGMENTI +050	PISTON RINGS +0,50	SEGMENTS DE PISTON +0,50	JRC27830M		*
BRONZINE BANCO STD	MAIN BEARING	COUSSINET DE PALIER	JMS2401A		*
BRONZINE BANCO +025	MAIN BEARING +0,25	COUSSINET DE PALIER +0,25	JMS2401A2		*
BRONZINE BANCO +050	MAIN BEARING +0,50	COUSSINET DE PALIER +0,50	JMS2401A5		*



SUZUKI MARUTI 800 3 CIL. MOTORE F8B dia.cil. 68,50 mm		GB	F	Japanparts Code	i	NEW
BRONZINE BIELLA STD	CON ROD BEARING	COUSSINET DE BIELLE	JCB2401A		*	
BRONZINE BIELLA +025	CON ROD BEARING +0,25	COUSSINET DE BIELLE +0,25	JCB2401A2		*	
BRONZINE BIELLA +050	CON ROD BEARING +0,50	COUSSINET DE BIELLE +0,50	JCB2401A5		*	
SERIE RASAMENTI STD	THRUST WASHER	CALE LATERALE	JTW1179A		*	
BIELLA MOTORE	CONECTING ROD	BIELLES	JBISZ000		**	
SERIE BOCCOLE BIELLA	PISTON PIN BUSHING	BAGUE TETE DE BIELLE	JPB2401J		*	
BILANCIERI VALVOLE	VALVE ROCKER ARM	CULBUTEUR	JBZSZ000		*	
POMPA ACQUA	WATER PUMP	POMPE E EAU	JPQ800		*	
TERMOSTATO	THRMOSTATES	THERMOSTATE	JVT800		*	
POMPA OLIO	OIL PUMP	POMPE A HUILLE	XXOLS3		**	



SUZUKI SUPER CARRY 1000 970cc MOTORE F10A dia.cil. 65,50 mm		GB	F	Japanparts Code	i	NEW
CINGHIA DISTRIBUZIONE 88 denti	TIMING BELT 88 tooth	COURROIE DE DISTRIBUTION	JDD201	88 T		
CUSCINETTO TENDICINGHIA DISTRIBUZIONE	TENSIONER BEARING	GALET TENDEUR/ROULEMENT	JBE802			
SERIE GUARNIZIONI SMERIGLIO	CYLINDER HEADSETS	KIT JOINTS DE CULASSES	JKG808			
SERIE GUARNIZIONI MOTORE	FULL GASKET SET	KIT POCHETTE JOINT MOTEUR	JKM808			
VALVOLA ASPIRAZIONE	INLET ENGINE VALVES	SOUPAPES D'ADMISSION	JVVSZ000	31,6 x 7 x 110,2		
VALVOLA SCARICO	EXHAUST ENGINE VALVES	SOUPAPES D'ECHAPPEMENT	JVVSZ001	27,5 x 7 x 109,6		
KIT PISTONI STD C/SEGMENTI	PISTON KIT WITH RINGS	PISTONS AVEC SEGMENT	JKI800	HC=24,5/-2 Pist. pin 16		
KIT PISTONI +050 C/SEGMENTI	PISTON KIT WITH RINGS +0,50	PISTONS AVEC SEGMENT +0,50	JKI800M			
SERIE CANNE CILINDRO diam. int. 65,50 mm / dia. est. 68,00 mm	SET CYLINDER LINERS	CHEMISES DE CYLINDRE	JCCSZ001			**
SERIE SEGMENTI STD	PISTON RINGS	SEGMENTS DE PISTON	JRC27470	1,5 - 1,5 - 2,8		
SERIE SEGMENTI +050	PISTON RINGS +0,50	SEGMENTS DE PISTON +0,50	JRC27470M			
SERIE SEGMENTI STD ROOF SPIRAL	PISTON RINGS ROOF SPIRAL	SEGMENTS DE PISTON SPIRAL	JRS27470	1,5 - 1,5 - 2,8 Roof spiral		
SERIE SEGMENTI +050 ROOF SPIRAL	PISTON RINGS 0,50 ROOF SPIRAL	SEGMENTS DE PISTON 0,50 SPIRAL	JRS27470M	1,5 - 1,5 - 2,8 Roof spiral		
SERIE BRONZINE BANCO STD	MAIN BEARING	COUSSINET DE PALIER	JMS1179A	i.d. 49,974 o.d. 53,997		
SERIE BRONZINE BANCO +025	MAIN BEARING +0,25	COUSSINET DE PALIER +0,25	JMS1179A2			
SERIE BRONZINE BANCO +050	MAIN BEARING +0,50	COUSSINET DE PALIER +0,50	JMS1179A5			
SERIE BRONZINE BIELLA STD	CON ROD BEARING	COUSSINET DE BIELLE	JCB1179A	i.d. 37,98 o.d. 40,998		
SERIE BRONZINE BIELLA +025	CON ROD BEARING +0,25	COUSSINET DE BIELLE +0,25	JCB1179A2			
SERIE BRONZINE BIELLA +050	CON ROD BEARING +0,50	COUSSINET DE BIELLE +0,50	JCB1179A5			



SUZUKI SUPER CARRY 1000 970cc MOTORE F10A dia.cil. 65,50 mm	GB	F	Japanparts Code	i	NEW
--	-----------	----------	----------------------------------	----------	------------

SERIE BOCCOLE BIELLA	PISTON PIN BUSHING	BAGUE TETE DE BIELLE	JPB1179J		
BIELLA MOTORE	CONECTING ROD	BIELLES	JBISZ000		**
ALBERO MOTORE	CRANKSHAFT	VILEBREQUINS	JXXSZ004		**
SERIE RASAMENTI STD	THRUST WASHER	CALE LATERALE	JTW1179A		
TESTATA NUDA F10A 11110-80002	CYLINDERHEADS	CULASSES	JXXSZ001		



JXX-SZ001 11110-80002

ALBERO DISTRIBUZIONE	CAMSHAFT	ARBRES A CAMES	JAASZ000		
----------------------	----------	----------------	----------	--	--



JAA-SZ000

BILANCIERI VALVOLE	VALVE ROCKER ARM	CULBUTEUR	JBZSZ000		
POMPA ACQUA THERMOSTATO	WATER PUMP THERMOSTATES	POMPE E EAU THERMOSTATE	JPQ800 JVT200		
POMPA OLIO COMPLETA	OIL PUMP	POMPE A HUILE	JXXOLS1		**



SUZUKI SAMURAI LJ80 MOTORE F8A dia.cil. 62,00 mm	(GB)	(F)	Japanparts Code	i	NEW
--	------	-----	--------------------	---	-----



CINGHIA DISTRIBUZIONE 84 denti	TIMING BELT 84 tooth	COURROIE DE DISTRIBUTION	JDD401	84 T	*
SERIE GUARNIZIONI SMERIGLIO	CYLINDER HEADSETS	KIT JOINTS DE CULASSES	JKG809		*
SERIE GUARNIZIONI MOTORE	FULL GASKET SET	KIT POCHESTE JOINT MOTEUR	JKM809		*
VALVOLA ASPIRAZIONE	INLET ENGINE VALVES	SOUPAPES D'ADMISSION	JVVSZ000	31,6 x 7 x 110,2	*
VALVOLA SCARICO	ENGINE VALVE	SOUPAPES D'ECHAPPEMENT	JVVSZ001	27,5 x 7 x 109,6	*
KIT PISTONI STD C/SEGMENTI	PISTON KIT WITH RINGS	PISTONS AVEC SEGMENT	JKI898		*
KIT PISTONI +050 C/SEGMENTI	PISTON KIT WITH RINGS +0,50	PISTONS AVEC SEGMENT +0,50	JKI898M		*
SERIE SEGMENTI STD	PISTON RINGS	SEGMENTS DE PISTON	JRC27220	1,5 - 1,5 - 2,75	*
SERIE SEGMENTI +050	PISTON RINGS +0,50	SEGMENTS DE PISTON +0,50	JRC27220M		*
SERIE BRONZINE BANCO STD	MAIN BEARING	COUSSINET DE PALIER	JMS1179A	i.d. 49,974 o.d. 53,997	*
SERIE BRONZINE BANCO +025	MAIN BEARING +0,25	COUSSINET DE PALIER +0,25	JMS1179A2		*
SERIE BRONZINE BANCO +050	MAIN BEARING +0,50	COUSSINET DE PALIER +0,50	JMS1179A5		*



SUZUKI SAMURAI LJ80 MOTORE F8A dia.cil. 62,00 mm		GB	F	Japanparts Code	i	NEW
SERIE BRONZINE BIELLA STD	CON ROD BEARING	COUSSINET DE BIELLE	JCB1179A	i.d. 37,98 o.d. 40,998	*	
SERIE BRONZINE BIELLA +025	CON ROD BEARING +0,25	COUSSINET DE BIELLE +0,25	JCB1179A2		*	
SERIE BRONZINE BIELLA +050	CON ROD BEARING +0,50	COUSSINET DE BIELLE +0,50	JCB1179A5		*	
SERIE BOCCOLE BIELLA	PISTON PIN BUSHING	BAGUE TETE DE BIELLE	JPB1179J		*	
BIELLA MOTORE	CONECTING ROD	BIELLES	JBISZ000		**	
SERIE RASAMENTI STD	THRUST WASHER	CALE LATERALE	JTW1179A		*	
BILANCIERI VALVOLE	VALVE ROCKER ARM	CULBUTEUR	JBZSZ000		*	
POMPA OLIO COMPLETA	OIL PUMP	POMPE A HUILE	JXXOLS1		**	
POMPA ACQUA THERMOSTATO	WATER PUMP THERMOSTATES	POMPE E EAU THERMOSTATE	JPQ800 JVT200		*	



SUZUKI SAMURAI SJ 410 970cc MOTORE F10A dia.cil. 65,50 mm	GB	F	Japanparts Code	i	NEW
--	-----------	----------	----------------------------------	----------	------------

CINGHIA DISTRIBUZIONE 84 denti	TIMING BELT 84 tooth	COURROIE DE DISTRIBUTION	JDD401	84 T	
CINGHIA DISTRIBUZIONE 88 denti	TIMING BELT 88 tooth	COURROIE DE DISTRIBUTION	JDD201	88 T	
CINGHIA DISTRIBUZIONE 89 denti	TIMING BELT 89 tooth	COURROIE DE DISTRIBUTION	JDD800	89 T	

CUSCINETTO TENDICINGHIA DISTRIBUZIONE	TENSIONER BEARING	GALET TENDEUR/ROULEMENT	JBE802		
---------------------------------------	-------------------	-------------------------	--------	--	--

SERIE GUARNIZIONI SMERIGLIO	CYLINDER HEADSETS	KIT JOINTS DE CULASSES	JKG803		
SERIE GUARNIZIONI MOTORE	FULL GASKET SET	KIT POCHETTE JOINT MOTEUR	JKM803		

VALVOLA ASPIRAZIONE	INLET ENGINE VALVES	SOUPAPES D'ADMISSION	JVVSZ000	31,6 x 7 x 110,2	
VALVOLA SCARICO	ENGINE VALVE	SOUPAPES D'ECHAPPEMENT	JVVSZ001	27,5 x 7 x 109,6	

KIT PISTONI STD C/SEGMENTI	PISTON KIT WITH RINGS	PISTONS AVEC SEGMENT	JKI800	HC=24,5/-2 Pist. pin 16	
KIT PISTONI +050 C/SEGMENTI	PISTON KIT WITH RINGS +0,50	PISTONS AVEC SEGMENT +0,50	JKI800M		

SERIE SEGMENTI STD	PISTON RINGS	SEGMENTS DE PISTON	JRC27470	1,5 - 1,5 - 2,8	
SERIE SEGMENTI +050	PISTON RINGS 0,50	SEGMENTS DE PISTON 0,50	JRC27470M		

SERIE SEGMENTI STD ROOF SPIRAL	PISTON RINGS ROOF SPIRAL	SEGMENTS DE PISTON SPIRAL	JRS27470	1,5 - 1,5 - 2,8 Roof spiral	
SERIE SEGMENTI +050 ROOF SPIRAL	PISTON RINGS 0,50 ROOF SPIRAL	Segments DE PISTON 0,50 SPIRAL	JRS27470M	1,5 - 1,5 - 2,8 Roof spiral	

SERIE CANNE CILINDRO diam. int. 65,50 mm / dia. est. 68,00 mm	SET CYLINDER LINERS	CHEMISES DE CYLINDRE	JCCSZ001	i.d. 66,5mm o.d. 68,0mm	**
--	---------------------	----------------------	-----------------	----------------------------	----

SERIE BRONZINE BANCO STD	MAIN BEARING	COUSSINET DE PALIER	JMS1179A	i.d. 49,974 o.d. 53,997	
SERIE BRONZINE BANCO +025	MAIN BEARING 0,25	COUSSINET DE PALIER 0,25	JMS1179A2		
SERIE BRONZINE BANCO +050	MAIN BEARING 0,50	COUSSINET DE PALIER 0,50	JMS1179A5		

SERIE BRONZINE BIELLA STD	CON ROD BEARING	COUSSINET DE BIELLE	JCB1179A	i.d. 37,98 o.d. 40,998	
SERIE BRONZINE BIELLA +025	CON ROD BEARING 0,25	COUSSINET DE BIELLE 0,25	JCB1179A2		
SERIE BRONZINE BIELLA +050	CON ROD BEARING 0,50	COUSSINET DE BIELLE 0,50	JCB1179A5		



SUZUKI SAMURAI SJ 410 970cc MOTORE F10A dia.cil. 65,50 mm	GB	F	Japanparts Code	i	NEW
--	-----------	----------	----------------------------	----------	------------

SERIE BOCCOLE BIELLA	PISTON PIN BUSHING	BAGUE TETE DE BIELLE	JPB1179J		
----------------------	--------------------	----------------------	----------	--	--

BIELLA MOTORE	CONECTING ROD	BIELLES	JBISZ000		**
---------------	---------------	---------	-----------------	--	-----------

ALBERO MOTORE	CRANKSHAFT	VILEBREQUINS	JXXSZ004		**
---------------	------------	--------------	-----------------	--	-----------

SERIE RASAMENTI STD	THRUST WASHER	CALE LATERALE	JTW1179A		
---------------------	---------------	---------------	----------	--	--

TESTATA NUDA F10A 11110-80002	CYLINDERHEADS	CULASSES	JXXSZ001		
-------------------------------	---------------	----------	----------	--	--



JXX-SZ001 11110-80002

ALBERO DISTRIBUZIONE	CAMSHAFT	ARBRES A CAMES	JAASZ000		
----------------------	----------	----------------	----------	--	--



JAA- SZ000



SUZUKI SAMURAI SJ 410 970cc MOTORE F10A dia.cil. 65,50 mm	GB	F	Japanparts Code	i	NEW
--	-----------	----------	----------------------------------	----------	------------

BILANCIERI VALVOLE	VALVE ROCKER ARM	CULBUTEUR	JBZSZ000		
--------------------	------------------	-----------	----------	--	--

POMPA ACQUA TERMOSTATO	WATER PUMP THERMOSTATES	POMPE E EAU THERMOSTATE	JPQ800 JVT200		
---------------------------	----------------------------	----------------------------	------------------	--	--

POMPA OLIO COMPLETA	OIL PUMP	POMPE A HUILE	JXXOLS1		**
---------------------	----------	---------------	---------	--	----



SUZUKI SAMURAI SJ413 1300CC G13A dia. cil. 74,00 mm		GB	F	Japanparts Code	i	NEW
CINGHIA DISTRIBUZIONE 88denti	TIMING BELT 88tooth	COURROIE DE DISTRIBUTION	JDD201	88 T		
CINGHIA DISTRIBUZIONE 89denti	TIMING BELT 89tooth	COURROIE DE DISTRIBUTION	JDD800	89 T		
CUSCINETTO TENDICINGHIA DISTRIBUZIONE	TENSIONER BEARING	GALET TENDEUR/ROULEMENT	JBE800			
SERIE GUARNIZIONI SMERIGLIO	CYLINDER HEADSETS	KIT JOINTS DE CULASSES	JKG804			
SERIE GUARNIZIONI MOTORE	FULL GASKET SET	KIT POCLETTE JOINT MOTEUR	JKM804			
VALVOLA ASPIRAZIONE	INLET ENGINE VALVES	SOUPAPES D'ADMISSION	JVVSZ002	36 x 7 x 115,5		
VALVOLA SCARICO	EXHAUST ENGINE VALVES	SOUPAPES D'ECHAPPEMENT	JVVSZ003	30 x 7 x 114,5		
KIT PISTONI STD C/SEGMENTI	PISTON KIT WITH RINGS	PISTONS AVEC SEGMENT	JKI805	HC=28,3/-1,35 Pist. pin 17		
KIT PISTONI +050 C/SEGMENTI	PISTON KIT WITH RINGS +0,50	PISTONS AVEC SEGMENT +0,50	JKI805M			
SERIE SEGMENTI STD	PISTON RINGS	SEGMENTS DE PISTON	JRC33444	1,2 - 1,5 - 2,8		
SERIE SEGMENTI +050	PISTON RINGS +0,50	SEGMENTS DE PISTON +0,50	JRC33444M			
SERIE SEGMENTI STD ROOF SPIRAL	PISTON RINGS ROOF SPIRAL	SEGMENTS DE PISTON SPIRAL	JRS33444	1,2 - 1,5 - 2,8		
SERIE SEGMENTI +050 ROOF SPIRAL	PISTON RINGS 0,50 ROOF SPIRAL	SEGMENTS DE PISTON 0,50 SPIRAL	JRS33444M			
SERIE BRONZINE BANCO STD	MAIN BEARING	COUSSINET DE PALIER	JMS2404A	i.d. 44,980 o.d. 48,999		
SERIE BRONZINE BANCO +025	MAIN BEARING +0,25	COUSSINET DE PALIER +0,25	JMS2404A2			
SERIE BRONZINE BANCO +050	MAIN BEARING +0,50	COUSSINET DE PALIER +0,50	JMS2404A5			
SERIE BRONZINE BIELLA STD	CON ROD BEARING	COUSSINET DE BIELLE	JCB2404A	i.d. 41,998 o.d. 45,044		
SERIE BRONZINE BIELLA +025	CON ROD BEARING +0,25	COUSSINET DE BIELLE +0,25	JCB2404A2			
SERIE BRONZINE BIELLA +050	CON ROD BEARING +0,50	COUSSINET DE BIELLE +0,50	JCB2404A5			
SERIE RASAMENTI STD	THRUST WASHER	CALE LATERALE	JTW2403A			
BIELLA MOTORE	CONECTING ROD	BIELLES	JBISZ001			**
ALBERO MOTORE	CRANKSHAFT	VILEBREQUINS	JXXSZ005			**



SUZUKI SAMURAI SJ413 1300CC G13A dia. cil. 74,00 mm	GB	F	Japanparts Code	i	NEW
---	-----------	----------	---------------------------	----------	------------

TESTATA NUDA G13A 11110- 82602	CYLINDERHEADS	CULASSES	JXXSZ002		
--------------------------------	---------------	----------	----------	--	--



JXX-SZ002 11110-82602

BILANCIERI VALVOLE	VALVE ROCKER ARM	CULBUTEUR	JBZSZ001		**
--------------------	------------------	-----------	-----------------	--	-----------

ALBERO DISTRIBUZIONE	CAMSHAFT	ARBRES A CAMES	JAASZ001		
----------------------	----------	----------------	----------	--	--



JAA-SZ001

POMPA ACQUA THERMOSTATO	WATER PUMP THERMOSTATES	POMPE E EAU THERMOSTATE	JPQ803 JVT200		
----------------------------	----------------------------	----------------------------	------------------	--	--

POMPA OLIO COMPLETA	OIL PUMP	POMPE A HUILE	XX-OLS2		**
---------------------	----------	---------------	----------------	--	-----------



SUZUKI VITARA 1600 Mot. G16A/G16B dia. cil. 75,00 mm	(GB)	(F)	Japanparts Code	i	NEW
--	------	-----	---------------------------	---	------------



CINGHIA DISTRIBUZIONE Mot. 8 valvole 95 denti	TIMING BELT 95 tooth	COURROIE DE DISTRIBUTION	JDD805	96 T (8 V)	*
CINGHIA DISTRIBUZIONE Mot. 16 valvole 103 denti	TIMING BELT 103 tooth	COURROIE DE DISTRIBUTION	JDD803	103 T (16 V)	*

CUSCINETTO TENDICINGHIA Mot. 8 valvole	TENSIONER BEARING	GALET TENDEUR/ROULEMENT	JBE800	ENG. 8 V	*
CUSCINETTO TENDICINGHIA Mot. 16 valvole	TENSIONER BEARING	GALET TENDEUR/ROULEMENT	JBE801	ENG. 16 V	*

SERIE GUARNIZIONI SMERIGLIO Mot. 8 valvole	CYLINDER HEADSETS	KIT JOINTS DE CULASSES	JKG814	ENG. 8 V	*
SERIE GUARNIZIONI MOTORE Mot. 8 valvole	FULL GASKET SET	KIT POCHETTE JOINT MOTEUR	JKM814	ENG. 8 V	*

SERIE GUARNIZIONI SMERIGLIO Mot. 16 valvole	CYLINDER HEADSETS	KIT JOINTS DE CULASSES	JKG899	ENG. 16 V	*
SERIE GUARNIZIONI MOTORE Mot. 16 valvole	FULL GASKET SET	KIT POCHETTE JOINT MOTEUR	JKM899	ENG. 16 V	*

VALVOLA ASPIRAZIONE Mot. 8 valvole	INLET ENGINE VALVES	SOUPAPES D'ADMISSION	JVVSZ005	36,6x7x115,5 (8 V)	**
VALVOLA SCARICO Mot. 8 valvole	EXHAUST ENGINE VALVES	SOUPAPES D'ECHAPPEMENT	JVVSZ006	32,6x7x114,4 (8 V)	**

VALVOLA ASPIRAZIONE Mot. 16 valvole	INLET ENGINE VALVES	SOUPAPES D'ADMISSION	JVVSZ007	29x5,5x105,3 (16 V)	**
VALVOLA SCARICO Mot. 16 valvole	EXHAUST ENGINE VALVES	SOUPAPES D'ECHAPPEMENT	JVVSZ008	24,1x5,5x104,5 (16 V)	**



SUZUKI VITARA 1600 Mot. G16A/G16B dia. cil. 75,00 mm	GB	F	Japanparts Code	i	NEW
KIT PISTONI STD C/SEGMENTI Mot. G16A 8 valvole	PISTON KIT WITH RINGS	PISTONS AVEC SEGMENT	JKI806	Pist. pin 19mm (8 V)	
KIT PISTONI +050 C/SEGMENTI Mot. G16A 8 valvole	PISTON KIT WITH RINGS +0,50	PISTONS AVEC SEGMENT +0,50	JKI806M	Pist. pin 19mm (8 V)	
KIT PISTONI STD C/SEGMENTI Mot. G16B 16 valvole	PISTON KIT WITH RINGS	PISTONS AVEC SEGMENT	JKI807	16 V	**
KIT PISTONI +050 C/SEGMENTI Mot. G16B 16 valvole	PISTON KIT WITH RINGS +0,50	PISTONS AVEC SEGMENT +0,50	JKI807M	16 V	**
SERIE SEGMENTI STD	PISTON RINGS ROOF SPIRAL	SEGMENTS DE PISTON	JRC34004	1,2 - 1,5 - 2,8 (8 v / 16 v)	*
SERIE SEGMENTI +050	PISTON RINGS 0,50 ROOF SPIRAL	SEGMENTS DE PISTON 0,50	JRC34004M	1,2 - 1,5 - 2,8 (8 v / 16 v)	*
SERIE SEGMENTI STD ROOF SPIRAL	PISTON RINGS ROOF SPIRAL	SEGMENTS DE PISTON SPIRAL	JRS34004	1,2 - 1,5 - 2,8 Roof spiral (8 V / 16 V)	
SERIE SEGMENTI +050 ROOF SPIRAL	PISTON RINGS 0,50 ROOF SPIRAL	SEGMENTS DE PISTON 0,50 SPIRAL	JRS34004M	1,2 - 1,5 - 2,8 Roof spiral (8 V / 16 V)	
SERIE BRONZINE BANCO STD	MAIN BEARING	COUSSINET DE PALIER	JMS2405GP	8 V - 16 V	*
SERIE BRONZINE BANCO +025	MAIN BEARING +0,25	COUSSINET DE PALIER +0,25	JMS2405G2		*
SERIE BRONZINE BANCO +050	MAIN BEARING +0,50	COUSSINET DE PALIER +0,50	JMS2405G5		*
SERIE BRONZINE BIELLA STD	CON ROD BEARING	COUSSINET DE BIELLE	JCB2405A	8 V - 16 V	*
SERIE BRONZINE BIELLA +025	CON ROD BEARING +0,25	COUSSINET DE BIELLE +0,25	JCB2405A2		*
SERIE BRONZINE BIELLA +050	CON ROD BEARING +0,50	COUSSINET DE BIELLE +0,50	JCB2405A5		*
SERIE RASAMENTI STD	THRUST WASHER	CALE LATERALE	JTW2405GP	8 V - 16 V	*
BIELLA MOTORE	CONECTING ROD	BIELLES	JBISZ002	8 V - 16 V	**
ALBERO DISTRIBUZIONE	CAMSHAFT	ARBRES A CAMES	JAASZ002	8 V - 16 V	**
BILANCIERI VALVOLE Mot. G16A 8 valvole	VALVE ROCKER ARM	CULBUTEUR	JBZSZ001	8 V	**
POMPA OLIO COMPLETA	OIL PUMP	POMPE A HUILE	XX-OLS4	8 V - 16 V	**
POMPA ACQUA	WATER PUMP	POMPE E EAU	JPQ805	8 V - 16 V	*
TERMOSTATO	THERMOSTATES	THERMOSTATE	JVT200	8 V - 16 V	*



TOYOTA BJ40 3000D 2977cc MOTORE B (11/75)> dia.cil. 95,00mm		GB	F	Japanparts Code	i	NEW
SERIE GUARNIZIONI SMERIGLIO	CYLINDER HEADSETS	KIT JOINTS DE CULASSES	JKG235			
SERIE GUARNIZIONI MOTORE	FULL GASKET SET	KIT POCHETTE JOINT MOTEUR	JKM235			
VALVOLA ASPIRAZIONE	INLET ENGINE VALVES	SOUPAPES D'ADMISSION	JVVTO000	45 x 9 x 128,1		
VALVOLA SCARICO	EXHAUST ENGINE VALVES	SOUPAPES D'ECHAPPEMENT	JVVTO001	37,5 x 9 x 128		
KIT PISTONI STD C/SEGMENTI (3 fasce)	PISTON KIT WITH RINGS	PISTONS AVEC SEGMENT	JKI211	Pist. pin 29mm 3 Rings model		
KIT PISTONI +050 C/SEGMENTI (3 fasce)	PISTON KIT WITH RINGS +0,50	PISTONS AVEC SEGMENT +0,50	JKI211M	Pist. pin 29mm 3 Rings model		
SERIE SEGMENTI STD per pistone a 3 fasce	PISTON KIT WITH RINGS	PISTONS AVEC SEGMENT	JRCTO003	2,3 - 2,5 - 4,5 3 Rings model		
TESTATA NUDA B 11101-56034	CYLINDERHEADS	CULASSES	JXXTY001			



JXX-TY001 - TOYOTA B NEW - 11101-56034 11111-56030

SERIE CANNE CILINDRO	CYLINDER LINERS	CHEMISES DE CYLINDRE	JCCTO000			
SERIE BRONZINE BANCO STD	MAIN BEARING	COUSSINET DE PALIER	JMS1121GP			
SERIE BRONZINE BANCO +025	MAIN BEARING +0,25	COUSSINET DE PALIER +0,25	JMS1121G2			
SERIE BRONZINE BANCO +050	MAIN BEARING +0,50	COUSSINET DE PALIER +0,50	JMS1121G5			
SERIE BRONZINE BIELLA STD	CON ROD BEARING	COUSSINET DE BIELLE	JCB1121A			
SERIE BRONZINE BIELLA +025	CON ROD BEARING +0,25	COUSSINET DE BIELLE +0,25	JCB1121A2			
SERIE BRONZINE BIELLA +050	CON ROD BEARING +0,50	COUSSINET DE BIELLE +0,50	JCB1121A5			
POMPA ACQUA	WATER PUMP	POMPE E EAU	JPQ291			
TERMOSTATO	THERMOSTATES	THERMOSTATE	JVT205			
CANDELETTA PRERISCALDAMENTO 20,5 volt	GLOW PLUGS	BOUGIES DE PRECHAUFFAGGE	JCE006	DENSO 0671100-1360		



TOYOTA HI-LUX 2400D LN65 MOTORE 2L (>12/'89) dia.cil. 92,00mm		GB	F	Japanparts Code		NEW
CINGHIA DISTRIBUZIONE 130 denti	TIMING BELT 130 tooth	COURROIE DE DISTRIBUTION	JDD206	130 T		
CUSCINETTO TENDICINGHIA DISTRIBUZIONE	TENSIONER BEARING	GALET TENDEUR/ROULEMENT	JBE200			
CUSCINETTO TENDICINGHIA DISTRIBUZIONE	TENSIONER BEARING	GALET TENDEUR/ROULEMENT	JBE201			
SERIE GUARNIZIONI SMERIGLIO	CYLINDER HEADSETS	KIT JOINTS DE CULASSES	JKG209			
SERIE GUARNIZIONI MOTORE	FULL GASKET SET	KIT POCHETTE JOINT MOTEUR	JKM209			
VALVOLA ASPIRAZIONE	INLET ENGINE VALVES	SOUPAPES D'ADMISSION	JVVTO004	42,5 x 8,5 x 123		
VALVOLA SCARICO	EXHAUST ENGINE VALVES	SOUPAPES D'ECHAPPEMENT	JVVTO005	35 x 8,5 x 123		
KIT PISTONI STD C/SEGMENTI	PISTON KIT WITH RINGS	PISTONS AVEC SEGMENT	JKI208	Pist. pin 28mm		
KIT PISTONI +050 C/SEGMENTI	PISTON KIT WITH RINGS +0,50	PISTONS AVEC SEGMENT +0,50	JKI208M	Pist. pin 28mm		
SERIE SEGMENTI STD	PISTON RINGS	SEGMENTS DE PISTON	JRC28740	2 - 2 - 4		
SERIE SEGMENTI +025	PISTON RINGS +0,25	SEGMENTS DE PISTON +0,25	JRC28740V			
SERIE SEGMENTI +050	PISTON RINGS 0,50	SEGMENTS DE PISTON +0,50	JRC28740M			
TESTATA NUDA 3 SUPPORTI 2LT AD. 11101-54062	CYLINDERHEADS	CULASSES	JXXTY002	3 SUPPORTI		
TESTATA NUDA 3 SUPPORTI 2LT AD. 11101-54062 REVISIONATA DISPONIBILE SOLO SU RICHIESTA	CYLINDERHEADS REBUILT AVAILABLE ONLY UNDER REQUEST	CULASSES RECONDITIONNEE' DISPONIBLES SEULEMENT SUR DEMANDE	JXXTY002R	3 SUPPORTI		**



JXX-TY002 - TOYOTA 2LT 3 SUPPORTI NEW 11101-54062



TOYOTA HI-LUX 2400D LN65 MOTORE 2L (>12/'89) dia.cil. 92,00mm	GB	F	Japanparts Code		NEW
SERIE BRONZINE BANCO STD SERIE BRONZINE BANCO +025 SERIE BRONZINE BANCO +050	MAIN BEARING MAIN BEARING +0,25 MAIN BEARING + 0,50	COUSSINET DE PALIER COUSSINET DE PALIER +0,25 COUSSINET DE PALIER +0,50	JMS1406A JMS1406A2 JMS1406A5		
SERIE BRONZINE BIELLA STD SERIE BRONZINE BIELLA +025 SERIE BRONZINE BIELLA +050	CON ROD BEARING CON ROD BEARING +0,25 CON ROD BEARING +0,50	COUSSINET DE BIELLE COUSSINET DE BIELLE 0,25 COUSSINET DE BIELLE +0,50	JCB140GP JCB1406G2 JCB1406G5		
SERIE RASAMENTI STD	THRUST WASHER	CALE LATERALE	JTW1161A		
SERIE BOCCOLE BIELLA	PISTON PIN BUSHING	BAGUE TETE DE BIELLE	JPB1063J		
KIT INGRANAGGI POMPA OLIO	OIL PUMP GEAR KIT	KIT POMPE A HUILE	JGKNI000		**
POMPA ACQUA THERMOSTATO	WATER PUMP THERMOSTATES	POMPE E EAU THERMOSTATE	JPQ232 JVT201		
CANDELETTA PRERISCALDAMENTO 6 volt	GLOW PLUGS	BOUGIES DE PRECHAUFFAGGE	JCE012	DENSO 067100-1370	



TOYOTA HI-LUX 2400D LN85-105-110 MOTORE 2L (>12/'89) dia.cil. 92,00mm		GB	F	Japanparts Code	i	NEW
CINGHIA DISTRIBUZIONE 129 denti	TIMING BELT 129 tooth	COURROIE DE DISTRIBUTION	JDD219	129 T		
CUSCINETTO TENDICINGHIA DISTRIBUZIONE	TENSIONER BEARING	GALET TENDEUR/ROULEMENT	JBE202			
CUSCINETTO TENDICINGHIA DISTRIBUZIONE	TENSIONER BEARING	GALET TENDEUR/ROULEMENT	JBE203			
SERIE GUARNIZIONI SMERIGLIO Con G.T. misura DO	CYLINDER HEADSETS	KIT JOINTS DE CULASSES	JKG294	w/ Cyl. Head size DO	**	
SERIE GUARNIZIONI MOTORE Con G.T. misura DO	FULL GASKET SET	KIT POCLETTE JOINT	JKM294	w/ Cyl. Head size DO	**	
SERIE GUARNIZIONI SMERIGLIO	CYLINDER HEADSETS	KIT JOINTS DE CULASSES	JKG294S §	w/o Cyl. Head	**	
SERIE GUARNIZIONI MOTORE	FULL GASKET SET	KIT POCLETTE JOINT	JKM294S §	w/o Cyl. Head	**	
§ NB: FORNITE SENZA GUARNIZIONE TESTA without CYL. HEAD GASKET						
GUARNIZIONE MOTORE BO	CYLINDER HEAD GASKET	JOINT DE CULASSES	JGT261A	Head Gasket only size BO	**	
GUARNIZIONE MOTORE DO	CYLINDER HEAD GASKET	JOINT DE CULASSES	JGT261B	Head Gasket only size DO	**	
GUARNIZIONE MOTORE FO	CYLINDER HEAD GASKET	JOINT DE CULASSES	JGT261C	Head Gasket only size FO	**	
KIT PISTONI STD C/SEGMENTI	PISTON KIT WITH RINGS	PISTONS AVEC SEGMENT	JKI220	Pist. pin 27mm		
KIT PISTONI +050 C/SEGMENTI	PISTON KIT WITH RINGS +0,50	PISTONS AVEC SEGMENT +0,50	JKI220M	Pist. pin 27mm		
SERIE SEGMENTI STD	PISTON RINGS	SEGMENTS DE PISTON	JRC28740	2 - 2 - 4		
SERIE SEGMENTI +050	PISTON RINGS +0,50	SEGMENTS DE PISTON +0,50	JRC28740M			
TESTATA NUDA 2LII 11101-54111	CYLINDERHEADS	CULASSES	JXXTY003	NEW		
TESTATA NUDA 2LII 11101-54111 REVISIONATA DISPONIBILE SOLO SU RICHIESTA	CYLINDERHEADS REBUILT AVAILABLE ONLY UNDER REQUEST	CULASSES RECONDITIONEE' DISPONIBLES SEULEMENT SUR DEMANDE	JXXTY003R	REBUILT	**	



XX-TY003



XX-TY003

JXX-TY003 - TOYOTA 2L II NEW 11101-54111



TOYOTA HI-LUX 2400D LN85-105-110 MOTORE 2L (>12/'89) dia.cil. 92,00mm		GB	F	Japanparts Code	i	NEW
SERIE BRONZINE BANCO STD	MAIN BEARING	COUSSINET DE PALIER	JMS1406A			
SERIE BRONZINE BANCO +025	MAIN BEARING +0,25	COUSSINET DE PALIER +0,25	JMS1406A2			
SERIE BRONZINE BANCO +050	MAIN BEARING +0,50	COUSSINET DE PALIER +0,50	JMS1406A5			
SERIE BRONZINE BIELLA STD	CON ROD BEARING	COUSSINET DE BIELLE	JCB1406GP			
SERIE BRONZINE BIELLA +025	CON ROD BEARING +0,25	COUSSINET DE BIELLE +0,25	JCB1406G2			
SERIE BRONZINE BIELLA +050	CON ROD BEARING +0,50	COUSSINET DE BIELLE +0,50	JCB1406G5			
SERIE RASAMENTI STD	THRUST WASHER	CALE LATERALE	JTW1161A			
SERIE BOCCOLE BIELLA	PISTON PIN BUSHING	BAGUE TETE DE BIELLE	JPB1063J			
BILANCIERI VALVOLE ASPIRAZIONE	INLET ROCKER ARM	CURBUTEUR	JBZTY000			**
BILANCIERI VALVOLE SCARICO	EXHAUST ROCKER ARM	CURBUTEUR	JBZTY001			**
POMPA ACQUA	WATER PUMP	POMPE E EAU	JPQ253			
CANDELETTA PRERISCALDAMENTO 6volt	GLOW PLUGS	BOUGIES DE PRECHAUFFAGGE	JCE208	DENSO 067100-1500		



TOYOTA LJ70-LJ73 2400TD MOTORE 2LT (>12/'89) dia.cil. 92,00mm		GB	F	Japanparts Code	i	NEW
CINGHIA DISTRIBUZIONE 130 denti	TIMING BELT 130 tooth	COURROIE DE DISTRIBUTION	JDD206	130 T		
CUSCINETTO TENDICINGHIA DISTRIBUZIONE	TENSIONER BEARING	GALET TENDEUR/ROULEMENT	JBE200			
CUSCINETTO TENDICINGHIA DISTRIBUZIONE	TENSIONER BEARING	GALET TENDEUR/ROULEMENT	JBE201			
SERIE GUARNIZIONI SMERIGLIO	CYLINDER HEADSETS	KIT JOINTS DE CULASSES	JKG246			
SERIE GUARNIZIONI MOTORE	FULL GASKET SET	KIT POCHETTE JOINT MOTEUR	JKM246			
VALVOLA ASPIRAZIONE	INLET ENGINE VALVES	SOUPAPES D'ADMISSION	JVVT0004	42,5 x 8,5 x 123		
VALVOLA SCARICO	EXHAUST ENGINE VALVES	SOUPAPES D'ECHAPPEMENT	JVVT0005	35 x 8,5 x 123		
KIT PISTONI STD C/SEGMENTI	PISTON KIT WITH RINGS	PISTONS AVEC SEGMENT	JKI209	Pist. pin 29mm		
KIT PISTONI +050 C/SEGMENTI	PISTON KIT WITH RINGS +0,50	PISTONS AVEC SEGMENT +0,50	JKI209M	Pist. pin 29mm		
SERIE SEGMENTI STD	PISTON RINGS	SEGMENTS DE PISTON	JRC28740	2 - 2 - 4		
SERIE SEGMENTI +025	PISTON RINGS +0,25	SEGMENTS DE PISTON 0,25	JRC28740V			
SERIE SEGMENTI +050	PISTON RINGS +0,50	SEGMENTS DE PISTON +0,50	JRC28740M			
SERIE CANNE CILINDRO diam. int. 92,00 mm / dia. est. 96,00 mm	SET CYLINDER LINERS	CHEMISES DE CYLINDRE	JCCT0001	i.d. 92,0mm o.d. 96,0mm	**	
TESTATA NUDA 2LT AD. 11101-54062	CYLINDERHEADS	CULASSES	JXXTY002	NEW 3 SUPPORTI		
TESTATA NUDA 2LT AD. 11101-54062 REVISIONATA DISPONIBILE SOLO SU RICHIESTA	CYLINDERHEADS REBUILT AVAILABLE ONLY UNDER REQUEST	CULASSES RECONDITIONEE' DISPONIBLES SEULEMENT SUR DEMANDE	JXXTY002R	REBUILT 3 SUPPORTI	**	



JXX-TY002 - TOYOTA 2LT 3 SUPPORTI NEW 11101-54062



TOYOTA LJ70-LJ73 2400TD MOTORE 2LT (>12/'89) dia.cil. 92,00mm		GB	F	Japanparts Code	i	NEW
SERIE BRONZINE BANCO STD	MAIN BEARING	COUSSINET DE PALIER	JMS1406A			
SERIE BRONZINE BANCO +025	MAIN BEARING +0,25	COUSSINET DE PALIER +0,25	JMS1406A2			
SERIE BRONZINE BANCO +050	MAIN BEARING +0,50	COUSSINET DE PALIER +0,50	JMS1406A5			
SERIE BRONZINE BIELLA STD	CON ROD BEARING	COUSSINET DE BIELLE	JCB1411A			
SERIE BRONZINE BIELLA +025	CON ROD BEARING +0,25	COUSSINET DE BIELLE +0,25	JCB1411A2			
SERIE BRONZINE BIELLA +050	CON ROD BEARING +0,50	COUSSINET DE BIELLE +0,50	JCB1411A5			
SERIE RASAMENTI STD	THRUST WASHER	CALE LATERALE	JTW1161A			
SERIE BOCCOLE BIELLA	PISTON PIN BUSHING	BAGUE TETE DE BIELLE	JPB1411J			
TURBINA AD. 17201-54030	TURBO CHARGER	TURBO	JXXTUTY1		**	
SERIE BRONZINE ALBERO DISTRIBUZIONE	CAMSHAFT BEARING	COUSSINET ARBRE A CAMES	JSH1431A			
ALBERO MOTORE 6 FORI --> 05.88 (Rigenerato misura STD)	CRANKSHAFT6 HOLES (STD REBUILT)	VILEBREQUINS (STD RECONDITIONNE)	JABTY000	6 HOLES STD REBUILT --> 05.88	**	
ALBERO MOTORE 8 FORI 05.88 --> (Rigenerato misura STD)	CRANKSHAFT 8 HOLES (STD REBUILT)	VILEBREQUINS (STD RECONDITIONNE)	JABTY001	8 HOLES STD REBUILT 05.88 -->	**	
BILANCIERI VALVOLE ASPIRAZIONE	INLET ROCKER ARMS	CURBUTEUR	JBZTY000		**	
BILANCIERI VALVOLE SCARICO	EXAUST ROCKER ARMS	CURBUTEUR	JBZTY001		**	
KIT INGRANAGGI POMPA OLIO	OIL PUMP GEAR KIT	KIT POMPE A HUILE	JGKNI000		**	
POMPA ACQUA THERMOSTATO	WATER PUMP THERMOSTATES	POMPE E EAU THERMOSTATE	JPQ232 JVT201			
CANDELETTA PRERISCALDAMENTO 6volt	GLOW PLUGS	BOUGIES DE PRECHAUFFAGGE	JCE208	DENSO 067100-1500		



TOYOTA LAND CRUISER LJ70 4 RUNNER LN130 2400TD (1/90>) MOT. 2LT dia. cil. 92.00 mm		GB	F	Japanparts Code	i	NEW
CINGHIA DISTRIBUZIONE 129 denti	TIMING BELT 129 tooth	COURROIE DE DISTRIBUTION	JDD219	129 T		
CUSCINETTO TENDICINGHIA DISTRIBUZIONE	TENSIONER BEARING	GALET TENDEUR/ROULEMENT	JBE202			
CUSCINETTO TENDICINGHIA DISTRIBUZIONE	TENSIONER BEARING	GALET TENDEUR/ROULEMENT	JBE203			
SERIE GUARNIZIONI SMERIGLIO Con G.T. misura DO	CYLINDER HEADSETS	KIT JOINTS DE CULASSES	JKG261	w/ Cyl. Head size DO		
SERIE GUARNIZIONI MOTORE Con G.T. misura DO	FULL GASKET SET	KIT POCLETTE JOINT	JKM261	w/ Cyl. Head size DO		
SERIE GUARNIZIONI SMERIGLIO	CYLINDER HEADSETS	KIT JOINTS DE CULASSES	JKG261S §	w/o Cyl. Head		**
SERIE GUARNIZIONI MOTORE	FULL GASKET SET	KIT POCLETTE JOINT	JKM261S §	w/o Cyl. Head		**
§ NB: FORNITE SENZA GUARNIZIONE TESTA without CYL. HEAD GASKET						
GUARNIZIONE MOTORE BO	CYLINDER HEAD GASKET	JOINT DE CULASSES	JGT261A	Head Gasket only size BO		**
GUARNIZIONE MOTORE DO	CYLINDER HEAD GASKET	JOINT DE CULASSES	JGT261B	Head Gasket only size DO		**
GUARNIZIONE MOTORE FO	CYLINDER HEAD GASKET	JOINT DE CULASSES	JGT261C	Head Gasket only size FO		**
VALVOLA ASPIRAZIONE	INLET ENGINE VALVES	SOUPAPES D'ADMISSION	JVVT0006	42,5 x 8,5 x 123		**
VALVOLA SCARICO	EXHAUST ENGINE VALVES	SOUPAPES D'ECHAPPEMENT	JVVT0007	35 x 8,5 x 123		**
KIT Pistoni STD C/SEGMENTI (Con galleria per passaggio dell'olio)	PISTON KIT WITH RINGS (With groove)	PISTONS AVEC SEGMENT	JKI222	With groove		**
KIT Pistoni +050 C/SEGMENTI (Con galleria per il passaggio dell'olio)	PISTON KIT WITH RINGS +0,50 (With groove)	PISTONS AVEC SEGMENT +0,50	JKI222M	With groove		**
SERIE SEGMENTI STD	PISTON RINGS	SEGMENTS DE PISTON	JRC28740	2 - 2 - 4		
SERIE SEGMENTI +050	PISTON RINGS +0,50	SEGMENTS DE PISTON + 0,50	JRC28740M			
TESTATA NUDA 5 supporti albero distrib. 2LT II 11101-54121	CYLINDERHEADS	CULASSES	JXXTY004	5 SUPPORTI		



JXX-TY004 - TOYOTA 2LT 5 SUPPORTI NEW 11101-54121



TOYOTA LAND CRUISER LJ70 4 RUNNER LN130 2400TD (1/90>) MOT. 2LT dia. cil. 92.00 mm	GB	F	Japanparts Code	i	NEW
--	-----------	----------	----------------------------	----------	------------

SERIE BRONZINE BANCO STD	MAIN BEARING	COUSSINET DE PALIER	JMS1406A		
SERIE BRONZINE BANCO +025	MAIN BEARING +0,25	COUSSINET DE PALIER +0,25	JMS1406A2		
SERIE BRONZINE BANCO +050	MAIN BEARING + 0,50	COUSSINET DE PALIER +0,50	JMS1406A5		

SERIE BRONZINE BIELLA STD	CON ROD BEARING	COUSSINET DE BIELLE	JCB1411A		
SERIE BRONZINE BIELLA +025	CON ROD BEARING +0,25	COUSSINET DE BIELLE +0,25	JCB1411A2		
SERIE BRONZINE BIELLA +050	CON ROD BEARING +0,50	COUSSINET DE BIELLE +0,50	JCB1411A5		

SERIE RASAMENTI STD	THRUST WASHER	CALE LATERALE	JTW1161A		
---------------------	---------------	---------------	----------	--	--

ALBERO MOTORE (Rigenerato a misura STD)	CRANKSHAFT (STD REBUILT)	VILEBREQUINS (STD RECONDITIONNE)	JABTY002	STD REBUILT	**
--	------------------------------	-------------------------------------	-----------------	-------------	-----------

SERIE BOCCOLE BIELLA	PISTON PIN BUSHING	BAGUE TETE DE BIELLE	JPB1411J		
----------------------	--------------------	----------------------	----------	--	--

BIELLA MOTORE	CONECTING ROD	BIELLES	JBITY000		**
---------------	---------------	---------	-----------------	--	-----------

TURBINA AD. 17201-54060	TURBO CHARGER	TURBO	JXXTUTY2		**
-------------------------	---------------	-------	-----------------	--	-----------

POMPA ACQUA THERMOSTATO	WATER PUMP THERMOSTATES	POMPE E EAU THERMOSTATE	JPQ253 JVT210		
----------------------------	----------------------------	----------------------------	------------------	--	--

CANDELETTA PRERISCALDAMNETO 11 volt	GLOW PLUGS	BOUGIES DE PRECHAUFFAGGE	JCE207	DENSO 067100-1710	
-------------------------------------	------------	-----------------------------	--------	----------------------	--



TOYOTA LAND CRUISER 3.0D MOT. 1KZT	(GB)	(F)	Japanparts Code	i	NEW
---------------------------------------	------	-----	--------------------	---	-----

TESTATA NUDA 11101-69126	CYLINDERHEADS	CULASSES	JXXTY005		*
--------------------------	---------------	----------	----------	--	---



VOLKSWAGEN TARO 2400D 2466cc MOTORE 2L diam.cil. STD 92,00mm		GB	F	Japanparts Code	i	NEW
CINGHIA DISTRIBUZIONE 129 denti	TIMING BELT 129 tooth	COURROIE DE DISTRIBUTION	JDD299	129 T		
CUSCINETTO TENDICINGHIA DISTRIBUZIONE	TENSIONER BEARING	GALET TENDEUR/ROULEMENT	JBE202			
CUSCINETTO TENDICIGNHIA DISTRIBUZIONE	TENSIONER BEARING	GALET TENDEUR/ROULEMENT	JBE203			
SERIE GUARNIZIONI SMERIGLIO Con G.T. misura DO	CYLINDER HEADSETS	KIT JOINTS DE CULASSES	JKG294	w/ Cyl. Head size DO	**	
SERIE GUARNIZIONI MOTORE Con G.T. misura DO	FULL GASKET SET	KIT POCLETTE JOINT	JKM294	w/ Cyl. Head size DO	**	
SERIE GUARNIZIONI SMERIGLIO	CYLINDER HEADSETS	KIT JOINTS DE CULASSES	JKG294S §	w/o Cyl. Head	**	
SERIE GUARNIZIONI MOTORE	FULL GASKET SET	KIT POCLETTE JOINT	JKM294S §	w/o Cyl. Head	**	
§ NB: FORNITE SENZA GUARNIZIONE TESTA without CYL. HEAD GASKET						
GUARNIZIONE MOTORE BO	CYLINDER HEAD GASKET	JOINT DE CULASSES	JGT261A	Head Gasket only size BO	**	
GUARNIZIONE MOTORE DO	CYLINDER HEAD GASKET	JOINT DE CULASSES	JGT261B	Head Gasket only size DO	**	
GUARNIZIONE MOTORE FO	CYLINDER HEAD GASKET	JOINT DE CULASSES	JGT261C	Head Gasket only size FO	**	
VALVOLA ASPIRAZIONE	INLET ENGINE VALVES	SOUPAPES D'ADMISSION	JVVT0004	42,5 x 8,5 x 123		
VALVOLA SCARICO	EXHAUST ENGINE VALVES	SOUPAPES D'ECHAPPEMENT	JVVT0005	35 x 8,5 x 123		
KIT PISTONI STD C/SEGMENTI	PISTON KIT WITH RINGS	PISTONS AVEC SEGMENT	JKI220	Pist. pin 27mm		
KIT PISTONI +050 C/SEGMENTI	PISTON KIT WITH RINGS +0,50	PISTONS AVEC SEGMENT +0,50	JKI220M	Pist. pin 27mm		
SERIE SEGMENTI STD	PISTON RINGS	SEGMENTS DE PISTON	J RC28740	2 - 2 - 4		
SERIE SEGMENTI +050	PISTON RINGS +0,50	SEGMENTS DE PISTON +0,50	JRC28740M			
TESTATA NUDA 2L2 11101-54111	CYLINDERHEADS	CULASSES	JXXTY003	NEW		
TESTATA NUDA 2L2 11101-54111 REVISIONATA DISPONIBILE SOLO SU RICHIESTA	CYLINDERHEADS REBUILT AVAILABLE ONLY UNDER REQUEST	CULASSES RECONDITIONEE' DISPONIBLES SEULEMENT SUR DEMANDE	JXXTY003R	REBUILT	**	



XX-TY003



XX-TY003

JXX-TY003 - TOYOTA 2L II NEW 11101-54111



VOLKSWAGEN TARO 2400D 2466cc MOTORE 2L diam.cil. STD 92,00mm		GB	F	Japanparts Code	i	NEW
SERIE BRONZINE BANCO STD	MAIN BEARING	COUSSINET DE PALIER	JMS1406A			
SERIE BRONZINE BANCO +025	MAIN BEARING +0,25	COUSSINET DE PALIER +0,25	JMS1406A2			
SERIE BRONZINE BANCO +050	MAIN BEARING +0,50	COUSSINET DE PALIER + 0,50	JMS1406A5			
SERIE BRONZINE BIELLA STD	CON ROD BEARING	COUSSINET DE BIELLE	JCB1406GP			
SERIE BRONZINE BIELLA +025	CON ROD BEARING +0,25	COUSSINET DE BIELLE + 0,25	JCB1406G2			
SERIE BRONZINE BIELLA +050	CON ROD BEARING +0,50	COUSSINET DE BIELLE +0,50	JCB1406G5			
SERIE RASAMENTI STD	THRUST WASHER	CALE LATERALE	JTW1161A			
SERIE BOCCOLE BIELLA	PISTON PIN BUSHING	BAGUE TETE DE BIELLE	JPB1063J			
POMPA ACQUA THERMOSTATO	WATER PUMP THERMOSTATES	POMPE E EAU THERMOSTATE	JPQ253 JVT201			
CANDELETTA PRERISCALDAMENTO 6 volt	GLOW PLUGS 6 volt	BOUGIES DE PRECHAUFFAGGE	JCE208	DENSO 067100-1500		
CANDELETTA PRERISCALDAMENTO 7 volt	GLOW PLUGS 7 volt	BOUGIES DE PRECHAUFFAGGE	JCE012	DENSO 067100-1370		



KIA SPORTAGE / BESTA 2.2D MOT. R2	GB	F	Japanparts Code	i	NEW
TESTATA	CYLINDERHEADS	CULASSES	JXXMZ002	OEM R263-10-100	*

**VEDI FOTO NEL
DISCHETTO**

