

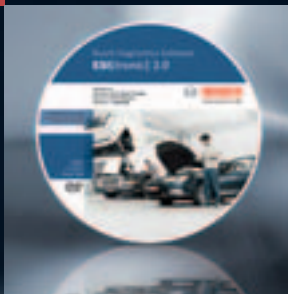

**Inclusive batteries
for Start-Stop systems
and leisure applications**

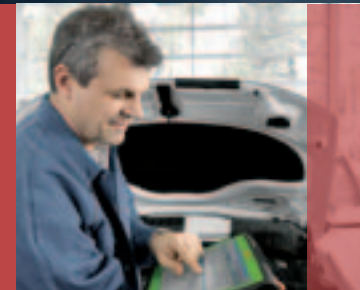

de

**Sichere Diagnose.
Zeitsparende Reparatur.
Bosch-Diagnostics und
Ersatzteile.**

Aus einer Hand: Diagnostics, Teile und Services. Bosch bietet der Werkstatt ein Komplettprogramm zur Steigerung von Effizienz und Qualität in der täglichen Arbeit. Vom weltweit aktiven Entwickler und führenden Hersteller von Kfz-Systemtechnik kommen die Ersatzteile in bekannter Originalqualität. Kompetenz und Qualität – für die Zukunft Ihrer Werkstatt.

en

**Reliable diagnosis.
Time-saving repairs.
Bosch diagnostics and
service parts.**

From a single source: Diagnostics, parts and services. Bosch has a complete program available which increases efficiency and quality in the workshop's daily work. The service parts from the globally active development expert and leading manufacturer of automotive system technology are in renowned Bosch OE quality. Competence and quality: Assuring your workshop's future success.

fr

**Diagnostic fiable.
Réparation rapide.
Diagnostics et pièces
de rechange Bosch.**

À partir d'une source unique: diagnostic, pièces et services. Bosch propose aux réparateurs une gamme complète qui améliore au quotidien l'efficacité et la qualité du travail. En tant que concepteur présent dans le monde entier et leader dans la fabrication de systèmes pour automobiles, ses pièces de rechange sont reconnues pour offrir la qualité des pièces d'origine.

it

Diagnosi sicure. Riparazioni rapide. Diagnostica, ricambi e formazione: tutto da un unico fornitore.

Tutto da un unico fornitore: diagnostics, componenti e service. Bosch offre all'officina un programma completo per migliorare l'efficienza e la qualità nel lavoro quotidiano. Lo sviluppatore attivo a livello mondiale e costruttore leader di sistemi automobilistici offre ricambi di comprovata qualità originale. Competenza e qualità, quindi, per il futuro dell'officina.

es

**Diagnóstico seguro.
Ahorro de tiempo en la
reparación. Diagnosis
Bosch y piezas de recambio.**

De un solo proveedor: diagnósticos, repuestos y servicios. Bosch ofrece al taller un programa completo para incrementar la eficiencia y la calidad del trabajo diario. De activos desarrolladores de todo el mundo y fabricantes de sistemas técnicos para el automóvil proceden los repuestos en la conocida calidad original. Competencia y calidad para el futuro de su taller.



2013 | 2014



Bosch parts fast and easy on:
www.bosch-automotive-catalog.com

2013 | 2014



BOSCH

☎ 1 987 720 213/201309

AA/MK12 – 09.2013 – int

© 2013 Robert Bosch GmbH
Automotive Aftermarket
Postfach 41 09 60
76225 Karlsruhe

Token fee: € 5,00

www.bosch.de/aa

Editorial closing: 01.07.2013

Subject to change without notice.
Please direct questions and
comments to our Authorized
Representative in your country.
This edition supersedes all
previous editions.



BOSCH



BOSCH



de Bosch-Batterien Gesamtprogramm	en Overall Bosch batteries range	fr Batteries Bosch gamme générale	it Gamma completa batterie Bosch	es Programa completo de baterías Bosch
pt Baterias Bosch Programa completo	fi Bosch-akut Tuotevalikoima	pl Akumulatory Bosch Pełny asortyment	cs Akumulátory Bosch Celkový program	ru Программа аккумуляторов Bosch

de Werkstattsausrüstung komplett. Mit modernen Batterie-Service- geräten von Bosch	en Complete workshop equipment. With the modern battery servicing equipment from Bosch	fr Un équipement d'atelier complet. Avec les appareils modernes pour maintenance des batteries Bosch	it L'equipaggiamento completo per l'officina. Bosch fornisce le apparecchiature più moderne per il «Service batteria»	es Equipamiento de taller completo. Con modernos equipos de servicio de baterías de Bosch
---	---	---	--	--



Battery charger BAT 490

Bosch batteries S5, S4, S3

Battery charger BSL 2470

de Übersichtliches, einfaches und kompaktes Batterienprogramm, welches die optimale Batterie für jedes Fahrzeug bereithält. ▶ Erstausrüstungsoptimiertes Programm ▶ Sichere Versorgung der elektronischen Verbraucher ▶ Höchste Lebensdauer dank zukunftsweisender Technologien	en Clear, simple and compact battery range, that includes the perfect battery for every vehicle. ▶ Range optimized for OE ▶ Reliable power supply for electronic consumers ▶ Maximum service life thanks to pioneering technologies	fr Une gamme de batteries claire, simple et compacte, qui comporte une batterie parfaitement adaptée à chaque véhicule. ▶ Gamme optimisée de qualité première monte ▶ Alimentation fiable des appareils électroniques ▶ Durée de vie maximale grâce à des technologies de pointe	it Programma di batterie chiaro, semplice e compatto che mette a disposizione la batteria ottimale per ogni veicolo. ▶ Programma ottimizzato per il primo equipaggiamento ▶ Alimentazione affidabile delle utenze elettroniche ▶ Massima durata grazie all'impiego di tecnologie all'avanguardia	es Programa de baterías claro, sencillo y compacto, que ofrece la batería óptima para cada vehículo ▶ Programa optimizado de acuerdo a las altas exigencias de calidad de primer equipo ▶ Suministro fiable para todos los componentes ▶ Máxima vida útil gracias a tecnologías de vanguardia
pt Programa de baterias claro, simples e compacto que contém a bateria ideal para cada veículo. ▶ Programa otimizado para equipamento original ▶ Alimentação segura dos consumidores eletrónicos ▶ Máxima durabilidade graças a tecnologias pioneiras	fi Kompakti ja selkeä akkuvalikoima, josta löytyy oikeantyyppinen akku jokaiseen ajoneuvoon. ▶ Optimoitu alkuperäisöimittajan valikoima ▶ Turvaa luotettavasti elektronisten järjestelmien virransaannin ▶ Erittäin pitkä käyttöikä kiitos edistyksellisen teknologian	pl Przejrzysto, prosty i dopasowany asortyment akumulatorów, w którym znajduje się optymalny akumulator dla każdego pojazdu. ▶ Asortyment optymalny pod względem wyposażenia serijnego ▶ Bezpieczne zasilanie odbiorników elektronicznych ▶ Najdłuższy okres użytkowania dzięki technologii przyszłości	cs Přehledný, jednoduchý a kompaktní program akumulátorů, v němž je k výběru optimální akumulátor pro každé vozidlo. ▶ Program optimalizovaný pro OE ▶ Bezpečné napájení všech elektronických spotřebičů ▶ Nejvyšší životnost díky nejnovějším technologiím	ru Наглядная, простая и компактная программа аккумуляторов, в которой найдется оптимальный аккумулятор для каждого транспортного средства. ▶ Оптимизированная с точки зрения первичной комплектации программа ▶ Надежное питание потребителей электроэнергии ▶ Максимальный срок службы благодаря применению передовых технологий

Systemvernetzung bestimmt zunehmend das Werkstattgeschäft. Im Auto der Zukunft werden die komplexen Systeme miteinander vernetzt. Bosch-Prüftechnik liefert qualifizierte Diagnoseinformationen, für Komponenten-Austausch und Instandsetzung.	Workshop business is being increasingly influenced by system networking. Complex systems will be networked with each other in future automobiles. Bosch test equipment and technology provides qualified diagnosis information for component exchange and repair.	Le travail en atelier de plus en plus marqué par l'interconnexion des systèmes. Sur l'automobile du futur, les systèmes complexes sont connectés entre-eux. Les équipements de contrôle Bosch fournissent des informations de qualité pour le diagnostic, le remplacement des composants et la réparation.	L'interconnessione dei diversi sistemi caratterizza in misura crescente le attività di officina. Negli autoveicoli i sistemi complessi sono sempre più interconnessi. L'attrezzatura diagnostica Bosch fornisce valide indicazioni per la riparazione o sostituzione dei componenti.	La interconexión de sistemas determina cada vez el negocio de los talleres. En los coches del futuro, los complejos sistemas estarán interconectados. La técnica de pruebas de Bosch proporciona informaciones de diagnóstico cualificadas para el intercambio de componentes y la reparación.
Die Batterie – Zentrum der Energieversorgung für innovative Fahrzeugkomponenten. Auch der Batterieservice stellt heute höchste Ansprüche an eingesetzte Prüfgeräte. Beim Ladevorgang dürfen keine Spannungsspitzen auftreten, die zu Fehlfunktionen von Sensoren führen. Mit Bosch-Batterieladern lassen sich Starterbatterien auch in eingebautem Zustand schonend aufladen. Hohe Leistungsreserven ermöglichen erfolgreiche Starthilfe.	The battery – the center of the energy supply for innovative automotive components. Battery service makes high demands on the test equipment used. There must be no voltage peaks during the charging process, since this could lead to sensor malfunction. Bosch battery chargers are perfect for the careful charging of starter batteries without removing them from the vehicle. High energy reserves ensure successful start-assist measures.	La batterie – élément central de l'alimentation en énergie des composants novateurs des véhicules. La maintenance des batteries est très exigeante vis à vis des appareils de contrôle utilisés. Aucun pic de tension susceptible d'occasionner des dysfonctionnements des capteurs ne doit se produire durant la charge. Avec les chargeurs Bosch, la charge des batteries de démarrage, même restées installées dans le véhicule se fait aisément. Grâce à leurs grandes réserves de puissance, ils constituent des auxiliaires de démarrage efficaces.	La batteria: centrale d'alimentazione elettrica dei componenti più innovativi del veicolo. Anche gli strumenti impiegati per il «Service batteria» devono rispondere a requisiti particolarmente esigenti. Durante la ricarica non si devono verificare picchi di tensione che causerebbero anomalie di funzionamento dei sensori. Con i caricabatteria Bosch, le batterie di avviamento possono essere caricate senza alcun rischio anche se collegate alla rete di bordo. Elevate riserve di potenza garantiscono avviamenti affidabili.	La batería es el centro de la alimentación de energía para los innovadores componentes de los vehículos. También el servicio técnico de baterías actual hace necesario que los equipos de prueba utilizados cumplan las más altas exigencias. Durante el proceso de carga no deben producirse picos de corriente que podrían producir el funcionamiento incorrecto de los sensores. Los cargadores de baterías de Bosch permiten cargar las baterías de arranque moderadamente, incluso cuando están montadas. Grandes reservas de potencia ofrecen una ayuda de arranque eficiente.

de	en	fr	it	es	
Inhalt	Content	Contenu	Contenuto	Contenido	
pt	fi	pl	cs	ru	
Conteúdo	Sisältö	Spis treści	Obsah	Содержание	
Produkt- informationen	Product informations	Informations produit	Informazioni sul prodotto	Informaciones productos	A 2
Informações de produtos	Tuotetiedot	Informacje o produkcie	Informace o produktu	Информация о продукте	
Technische Legende	Tecnical legend	Légende technique	Legenda tecnica	Leyenda técnica	A 29
Legenda técnica	Tekninen erittely	Opis techniczny	Technická legenda	Технические условные	
Programmübersicht	Product range	Aperçude la gamme	Panoramica del programma	Relación programa	A 30
Vista geral do programa	Tuotevalikoimat	Przegląd asortymentu	Přehled výrobního programu	Обзор программ	
				S6 AGM – S5 EFB	A 34
				S5 – S4 – S3	A 36
				T5 – T4 – T3	A 48
				M6 – M4	A 58
				L5 – L4	A 72
				Optima	A 76
Bosch Batterietypen- Gegenüberstellungen	Cross-reference Battery types	Table de correspondance Types de batterie Bosch	Comparazione Batterie Bosch	Equivalencias Baterías Bosch	A 82
Comparações dos tipos de baterias	Akkutyyppien keskinäinen vertailu	Typy akumulatorów - porównanie	Porovnání typů akumulátorů	Сравнения типов аккумуляторов	
Verwendung	Applications	Affectations	Impiego	Aplicación	B 2
Utilização	Käyttö	Przeznaczenie	Použití	Применение	
					B 241
					B 278
					B 291
Gegenüberstellung	Cross-reference	Table de correspondance	Comparazione	Equivalencias	C 2
Comparação	Vertailu	Porównanie	Porovnání	Сравнение	



de

Höchste Leistungs-technologie für Start-Stop-Systeme

en

Top power technology for Start-Stop systems

fr

Une technologie de pointe pour les systèmes Start-Stop

it

Tecnologia ad elevate prestazioni per sistemi Start-Stop

es

La tecnología de potencia más avanzada para sistemas Start-Stop



Motor mit Start-Stop-System: Viele Starts brauchen mehr Energie

Das Start-Stop-System führt zu einem vollkommen neuen Belastungsprofil der Batterie.

- ▶ Häufige Stopps und Starts mit Weiterversorgung der elektrischen Verbraucher während der Stopp-Phase
- ▶ Moderate Entladetiefe und höhere Anforderungen an Zyklenfestigkeit
- ▶ Kraftstoffeinsparung und CO₂-Reduktion
- ▶ Batterie: S6 mit AGM-Technologie¹⁾ oder S5 mit EFB-Technologie²⁾

Motor mit Start-Stop-System und Bremsenergierückgewinnung: Volle Ladung für viele Starts

Der Einsatz von Start-Stop in Verbindung mit Bremsenergie-rückgewinnung (Recuperation) erfordert eine Batterie mit Spitzenleistung.

- ▶ Häufige Stopps und Starts mit Weiterversorgung der elektrischen Verbraucher während der Stopp-Phase
- ▶ Nochmals höhere Anforderungen an Zyklenfestigkeit und Entladetiefe
- ▶ Schnelle und hohe Ladungs-aufnahme
- ▶ Hohe Kraftstoffeinsparung und CO₂-Reduktion
- ▶ Batterie: AGM-Technologie

Engine with Start-Stop system: Many starts need more energy

The Start-Stop system leads to a completely new load profile for the battery.

- ▶ Frequent stops and starts with continued supply of the electrical consumer units during the stop phase
- ▶ Moderate discharge levels and higher requirements for deep-cycle resistance
- ▶ Fuel saving and CO₂ reduction
- ▶ Batterie: S6 with AGM technology¹⁾ or S5 with EFB technology²⁾

Engine with Start-Stop system and brake energy recuperation: Full charging for many starts

The deployment of Start-Stop in conjunction with brake energy recuperation requires a battery with top performance.

- ▶ Frequent stops and starts with continued supply of the electrical consumer units during the stop phase
- ▶ Even higher requirements for deep-cycle resistance and discharge level
- ▶ Fast and high charge acceptance
- ▶ High fuel saving and CO₂ reduction
- ▶ Batterie: AGM technology

Moteur avec système Start-Stop: les nombreux démarrages nécessitent plus d'énergie

Avec le système Start-Stop, la batterie subit un nouveau type de sollicitations.

- ▶ Arrêts et démarrages fréquents avec maintien de l'alimentation des appareils électriques durant la phase d'arrêt
- ▶ Profondeur de décharge modérée et exigences supérieures concernant la résistance au cyclage
- ▶ Economies de carburant et réduction du CO₂
- ▶ Batterie: S6 avec technologie AGM¹⁾ ou S5 avec technologie EFB²⁾

Moteur avec système Start-Stop et récupération de l'énergie de freinage: pleine charge pour de nombreux démarrages

Le système Start-Stop associé à la récupération de l'énergie de freinage exige de la batterie des performances maximales.

- ▶ Arrêts et démarrages fréquents avec maintien de l'alimentation des appareils électriques durant la phase d'arrêt
- ▶ Exigences encore supérieures quant à la résistance en régime cyclique et à la profondeur de décharge
- ▶ Prise de charge rapide et élevée
- ▶ Importantes économies de carburant et réduction du CO₂
- ▶ Batterie: technologie AGM

Motori con sistema Start-Stop: molti avviamenti richiedono più energia

Il sistema Start-Stop determina un profilo di sollecitazione della batteria del tutto nuovo.

- ▶ Frequenti arresti e avviamenti del motore ed alimentazione elettrica degli utilizzatori elettrici anche durante la fase di arresto
- ▶ Profondità di scarica moderata e requisiti più severi per quanto riguarda la resistenza ai cicli di scarica e ricarica
- ▶ Risparmio di carburante e riduzione CO₂
- ▶ Batteria: S6 con tecnologia AGM¹⁾ o S5 con tecnologia EFB²⁾

Motori con sistema Start-Stop e recupero di energia in frenata: piena carica per tante partenze

L'impiego di un sistema Start-Stop combinato al recupero di energia in frenata richiede una batteria con prestazioni eccellenti.

- ▶ Frequenti arresti e avviamenti del motore ed alimentazione elettrica degli utilizzatori elettrici anche durante la fase di arresto
- ▶ Requisiti ancora più severi per quanto riguarda la resistenza ai cicli di scarica e ricarica
- ▶ Assorbimento rapido ed elevato della carica
- ▶ Elevato risparmio di carburante e riduzione CO₂
- ▶ Batteria: tecnologia AGM

Motor con sistema Start-Stop: muchos arranques necesitan más energía

El sistema Start-Stop origina un perfil de carga de la batería totalmente nuevo.

- ▶ Paradas y arranques frecuentes, sin interrupción de la alimentación de los consumidores eléctricos durante la fase de parada
- ▶ Profundidad de descarga moderada y grandes exigencias de resistencia a ciclo profundo
- ▶ Ahorro de combustible y reducción de CO₂
- ▶ Batería: S6 con tecnología AGM¹⁾ o S5 con tecnología EFB²⁾

Motor con sistema Start-Stop y recuperación de energía de frenado: carga completa para muchos arranques

El uso del sistema Start-Stop en combinación con la recuperación de energía de frenado exige una batería con prestaciones excelentes.

- ▶ Paradas y arranques frecuentes, sin interrupción de la alimentación de los consumidores eléctricos durante la fase de parada
- ▶ Exigencias aún mayores en cuanto a la estabilidad del ciclo y la profundidad de descarga
- ▶ Rápida y elevada aceptación de carga
- ▶ Gran ahorro de combustible y reducción de CO₂
- ▶ Batería: tecnología AGM

¹⁾ Säure ist komplett in Mikroglasfaser-matten gebunden

²⁾ Mit zusätzlichem Polyester-Scrim zwischen Platte und Separator

¹⁾ Acid is completely bound in absorbed glass mats

²⁾ With additional polyester scrim between plate and separator

¹⁾ L'acide est entièrement lié dans des matelas en microfibre de verre

²⁾ Gaze polyester supplémentaire entre la plaque et le séparateur

¹⁾ L'acido è trattenuto completamente in strati di feltro di microfibra di vetro

²⁾ Con un ulteriore rivestimento in poliestere tra elettrodo e separatore

¹⁾ El ácido está fijado por completo en esteras de microfibra de vidrio

²⁾ Con scrim de poliéster adicional entre la placa y el separador

pt

Máxima tecnologia de potência para sistemas Start-Stop

fi

Huipputehoa ja -teknologiaa Start-Stop-järjestelmiin

pl

Najwydajniejsza technologia dla systemów Start-Stop

cs

Nejvyšší výkon pro systémy Start-Stop

ru

Технология максимальной мощности для систем Старт-Стоп



Attention: In many vehicles battery replacement requires a suitable diagnostics tester such as the Bosch KTS series.

Load diagram - battery in conventional vehicle

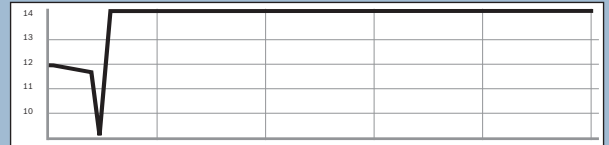

Characteristic: A start operation followed by recharging

Load diagram - battery for Start-Stop system

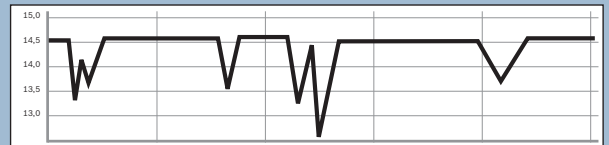

Characteristic: Large number of start operations, resulting in higher load on the battery

Load diagram - battery for Start-Stop system/recuperation



Characteristic: Many start operations, high load on the battery, additional power called up by passive boost

Motor com sistema Start-Stop: Muitos arranques precisam de mais energia

Motor com sistema Start-Stop: Muitos arranques precisam de mais energia.

- ▶ O sistema Start-Stop trouxe um perfil de carga da bateria totalmente novo.
- ▶ Paradas e partidas frequentes com alimentação contínua dos consumidores elétricos durante a fase de parada
- ▶ Profundidade moderada de descarga e elevadas exigências na resistência aos ciclos
- ▶ Economia de combustível e redução de CO₂
- ▶ Bateria: S6 com tecnologia AGM¹⁾ ou S5 com tecnologia EFB²⁾

Motor com sistema Start-Stop e recuperação de energia de travagem: Carga total para muitos arranques

A utilização do sistema Start-Stop em combinação com a recuperação de energia de frenagem (recuperação) necessita de uma bateria com potência de ponta.

- ▶ Paradas e arranques frequentes com alimentação contínua dos consumidores elétricos durante a fase de parada
- ▶ Exigências ainda mais elevadas na resistência aos ciclos e profundidade de descarga
- ▶ Aceitação rápida e elevada de carga
- ▶ Elevada poupança de combustível e redução de CO₂
- ▶ Bateria: tecnologia AGM

Automaattiset Start-Stop-järjestelmät. Toistuvat käynnistykset vaativat paljon energiaa

Mootorin automaattiset sammutukset ja käynnistykset merkitsevät akulle aivan uutta kuormitusprofiilia.

- ▶ Toistuvat sammutukset ja käynnistykset, joista huolimatta akun on huolehdittava auton sähkölaitteiden jatkuvasta toiminnasta
- ▶ Kohtuullinen purkausaste, suuremmat vaatimukset syklinkestävyydelle
- ▶ Polttoainetta säästyy ja CO₂-päästöt vähenevät
- ▶ Akku: S6 tai AGM-teknologia¹⁾ / S5 tai EFB-teknologia²⁾

Automaattiset Start-Stop-järjestelmät ja jarrutusenergian talteenotto. Täysi varaus tiheään toistuville käynnistyksille

Automaattinen Start-Stop yhdessä jarrutusenergian talteenotto-järjestelmän kanssa vaatii auton akulta huippusuorituksia.

- ▶ Toistuvat sammutukset ja käynnistykset, joista huolimatta akun on huolehdittava auton sähkölaitteiden jatkuvasta toiminnasta
- ▶ Entistä tiukemmat vaatimukset purkausluvulle ja syklinkestävyydelle
- ▶ Nopea ja tehokas latausvaihe
- ▶ Polttoainetta säästyy ja CO₂-päästöt vähenevät
- ▶ Akku: AGM-teknologia

Silnik z systemem Start-Stop: częste rozruchy wymagają większej ilości energii

System Start-Stop powoduje całkowicie nowy profil obciążenia akumulatora.

- ▶ Częste zatrzymania i rozruchy z nieprzerwanym zasilaniem odbiorników elektrycznych w fazie zatrzymania
- ▶ Praca w stanie niepełnego naładowania i wymóg zwiększonej odporności cyklicznej
- ▶ Oszczędność paliwa i zmniejszenie emisji CO₂
- ▶ Akumulator: S6 se technologia AGM¹⁾ lub S5 se technologia EFB²⁾

Silnik z systemem Start-Stop i odzyskiem energii hamowania: Pełna moc dla wielokrotnych rozruchów

Zastosowanie systemu Start-Stop w połączeniu z odzyskiwaniem energii hamowania wymaga akumulatora o najwyższych parametrach.

- ▶ Częste zatrzymania i rozruchy z nieprzerwanym zasilaniem odbiorników elektrycznych w fazie zatrzymania
- ▶ Jeszcze większa odporność cykliczna i możliwy poziom rozładowania
- ▶ Skrócony czas ładowania
- ▶ Duża oszczędność paliwa i zmniejszenie emisji CO₂
- ▶ Akumulator: technologia AGM

Motor se systémem Start-Stop: více startování spotřebuje více energie

Systém Start-Stop vede ke zcela novému zatěžování startovacího akumulátoru.

- ▶ Časté zastavování a startování spolu s následným napájením elektrických spotřebičů během fáze zastavení
- ▶ Mírná hloubka vybíjení a vyšší požadavky na cyklickou odolnost
- ▶ Úspora paliva a snížení CO₂
- ▶ Akumulátor: S6 pomocí technologie AGM¹⁾ nebo S5 pomocí technologie EFB²⁾

Motor se systémem Start-Stop a s recuperací při brzdění: plně nabití pro více startování

Použití funkce Start-Stop ve spojení s recuperací (zpětným získáváním energie) při brzdění vyžaduje akumulátor se špičkovým výkonem.

- ▶ Časté zastavování a startování spolu s následným napájením elektrických spotřebičů během fáze zastavení
- ▶ Ještě vyšší požadavky na cyklickou odolnost a hloubku vybíjení
- ▶ Rychlý a vysoký příjem energie při nabíjení
- ▶ Vysoká úspora paliva a snížení CO₂
- ▶ Akumulátor: technologie AGM

Двигатель с системой Старт-Стоп: для многочисленных запусков двигателя необходимо больше энергии

Использование системы Старт-Стоп ведет к совершенно новому уровню нагрузки аккумулятора.

- ▶ Частые отключения и запуски двигателя с непрерывным энергообеспечением потребителей электроэнергии во время фазы остановки
- ▶ Средняя глубина разрядки и более высокие требования к циклической устойчивости
- ▶ Экономия выбросов CO₂
- ▶ Аккумулятор: S6 с технология AGM¹⁾ или S5 с технология EFB²⁾

Двигатель с системой Старт-Стоп и регенерацией энергии торможения: полная зарядка для частого запуска двигателя

Для применения системы Старт-Стоп в сочетании с регенерацией энергии торможения (рекуперацией) необходим аккумулятор с максимальной мощностью.

- ▶ Частые отключения и запуски двигателя с непрерывным энергообеспечением потребителей электроэнергии во время фазы остановки
- ▶ Еще более высокие требования к циклической устойчивости и глубине разрядки
- ▶ Быстрое и высокое потребление зарядного тока
- ▶ Значительная экономия топлива и снижение выбросов CO₂
- ▶ Аккумулятор: технология AGM

¹⁾ O ácido está totalmente aglutinado nas esteiras de microfibras de vidro

²⁾ Com "scrim" de poliéster adicional entre a placa e o separador

¹⁾ Happo on imeytetty kokonaan mikrohuokoiseen lasikuituun

²⁾ Lisänä polyesteriverkko plus-/minuslevyn ja erotinlevyn välissä

¹⁾ Kwas jest całkowicie związany w matach z mikrowłókna szklanego

²⁾ Dodatkowa warstwa poliestru między płytą a separatorem

¹⁾ Kyselina je kompletně vázána v rohožích ze skleněného mikrovlnáka

²⁾ S dodatkovým polyesterovým plátnem mezi deskou a separátorem

¹⁾ Кислота полностью абсорбирована в сепараторы из стекловолокна

²⁾ С дополнительной полиэфирной пленкой между пластиной и сепаратором

de

Maßgeschneidert für Start-Stopp-Technologie

en

Tailor-made for Start-Stop technology

fr

Conçue sur mesure pour la technologie Start-Stop

it

Tagliata su misura per la tecnologia Start-Stop

es

A la medida de la tecnología Start-Stop

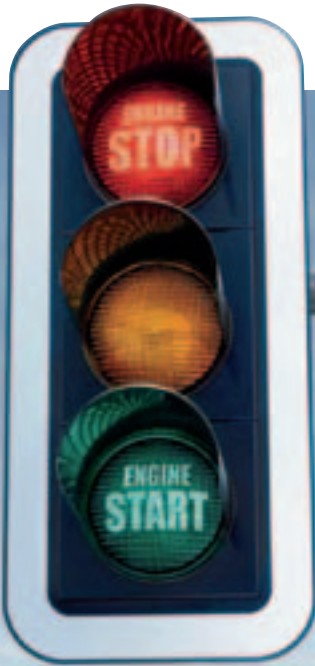

AGM battery technology

Cover with safety valve and central degassing

Positive plate set

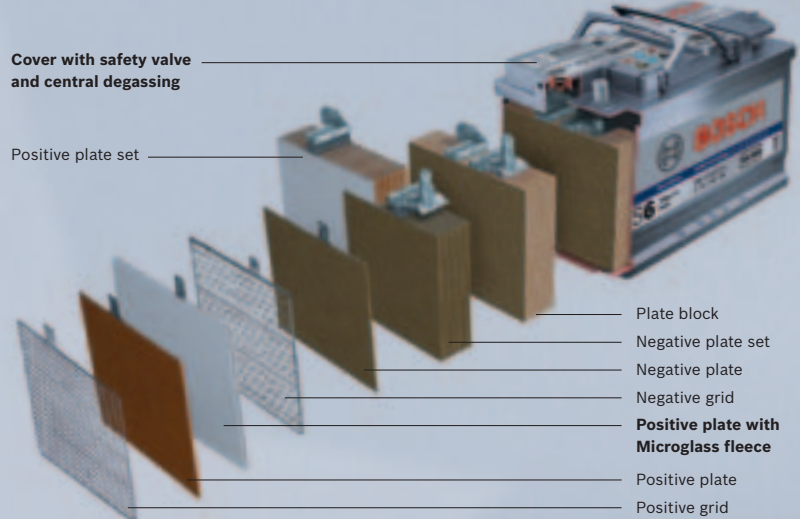

Plate block

Negative plate set

Negative plate

Negative grid

Positive plate with Microglass fleece

Positive plate

Positive grid

S6 mit AGM-Technologie: für Start-Stopp-System und Rekuperation

AGM-Technologie (Absorbent Glass Mat) ist die Top-Technologie im Markt. Die Säure ist komplett in Mikroglasfasermatten gebunden. Das sorgt für Spitzenleistung.

Die Vorteile:

- ▶ Konstante Power auch bei Kurzfahrten, Stop-and-go-Verkehr oder hohem Verbrauch im Standbetrieb
- ▶ Bis zu 4-mal höhere Zyklenfestigkeit im Vergleich zu herkömmlichen Starterbatterien
- ▶ In jeder Lage einbaubar, 100% auslauf- und kippsicher

S5 mit EFB-Technologie: für Start-Stopp-System

EFB-Technologie (Enhanced Flooded Battery) von Bosch erfüllt alle Ansprüche, die zwischen herkömmlichen Starterbatterien und der S6 AGM-Technologie liegen.

Die Vorteile:

- ▶ Doppelte Zyklenfestigkeit im Vergleich zu herkömmlichen Starterbatterien
- ▶ Hohe Kurzstreckenfestigkeit

S6 with AGM technology: for Start-Stop system and recuperation

AGM technology (Absorbent Glass Mat) is the top technology on the market. The acid is completely bound in microglass fiber mats. This ensures the highest performance.

The advantages:

- ▶ Constant power even for short distances, stop-and-go traffic or high consumption with the car at a standstill
- ▶ Up to 4 times higher deep-cycle resistance in comparison with conventional starter batteries
- ▶ Can be installed in any location, secured 100% against leaks and tilting

S5 with EFB technology: for Start-Stop system

The S5 EFB technology (Enhanced Flooded Battery) from Bosch meets all the demands between conventional starter batteries and S6 AGM technology.

The advantages:

- ▶ Two times higher cycling performance compared to conventional starter batteries
- ▶ Perfect for short-distance urban driving conditions

S6 à technologie AGM : pour le système Start-Stop et la récupération

La technologie AGM (Absorbent Glass Mat) est la plus évoluée des technologies commercialisées. L'acide est hermétiquement emprisonné dans des matelas en microfibre de verre. Cette technologie garantit des puissances de pointe.

Avantages:

- ▶ Une puissance constante même dans le cas de petits trajets, de démarrages et arrêts répétés ou de consommation élevée du véhicule à l'arrêt
- ▶ Résistance en régime cyclique jusqu'à 4 fois supérieure à celle des batteries de démarrage conventionnelles
- ▶ Montage possible en toute position, parfaitement étanche et à l'épreuve du basculement

S5 à technologie EFB : pour le système Start-Stop

La batterie S5 à technologie EFB (Enhanced Flooded Battery) de Bosch répond à toutes les exigences que imposent les batteries de démarrage conventionnelles et la technologie AGM.

Avantages:

- ▶ Résistance en régime cyclique doublée par rapport aux batteries de démarrage conventionnelles
- ▶ Bonne tenue aux petits trajets

S6 con tecnologia AGM: per sistemi start-stop e recupero energetico

La tecnologia AGM (Absorbent Glass Mat) è la tecnologia d'avanguardia attualmente presente sul mercato. L'acido è trattenuto completamente in strati di feltro di microfibra di vetro. Per prestazioni al top.

I vantaggi:

- ▶ Potenza costante anche se impiegata prevalentemente su tragitti brevi, traffico stop-and-go o consumo elevato a veicolo fermo
- ▶ Resistenza ai cicli di scarica e ricarica anche quadruplicata rispetto alle batterie di avviamento convenzionali
- ▶ Montabile in qualsiasi posizione, ermetica e resistente al ribaltamento al 100%

S5 con tecnologia EFB: per sistemi start-stop

La batteria S5 con tecnologia EFB (Enhanced Flooded Battery) di Bosch soddisfa tutti i requisiti che si collocano tra le batterie di avviamento convenzionali e la batteria S6 con tecnologia AGM.

I vantaggi:

- ▶ Resistenza ai cicli di scarica e ricarica doppia rispetto alle batterie di avviamento convenzionali
- ▶ Elevata resistenza ai tragitti brevi

S6 con tecnología AGM: para el sistema Start-Stop y de recuperación

La tecnología AGM (Absorbent Glass Mat) es la tecnología de vanguardia del mercado. El ácido está fijado por completo en esteras de microfibra de vidrio. Proporciona un rendimiento de primera.

Las ventajas:

- ▶ Potencia constante también en recorridos cortos, tráfico con paradas y arranques frecuentes o consumo elevado a vehículo parado
- ▶ Resistencia a ciclos hasta cuatro veces superior en comparación con las baterías de arranque convencionales
- ▶ Montaje posible en cualquier posición, seguridad total contra derrames y vuelco

S5 con tecnología EFB: para el sistema Start-Stop

La batería S5 con tecnología EFB (Enhanced Flooded Battery) de Bosch satisface todas las exigencias ubicadas entre las baterías de arranque convencionales y las S6 con tecnología AGM.

Las ventajas:

- ▶ Doble resistencia a ciclos en comparación con baterías de arranque convencionales
- ▶ Perfecta para recorridos cortos urbanos

pt

Concebida à medida para a tecnologia Start-Stop

fi

Räätälöity Start-Stop-tekniikkaa varten

pl

Idealnie dopasowany do technologii Start-Stop

cs

Zhotoveno na míru technologie Start-Stop

ru

Идеальное решение для технологии Старт-Стоп

EFB battery technology

Paste with higher density and additives for improved charge acceptance

Positive plate set

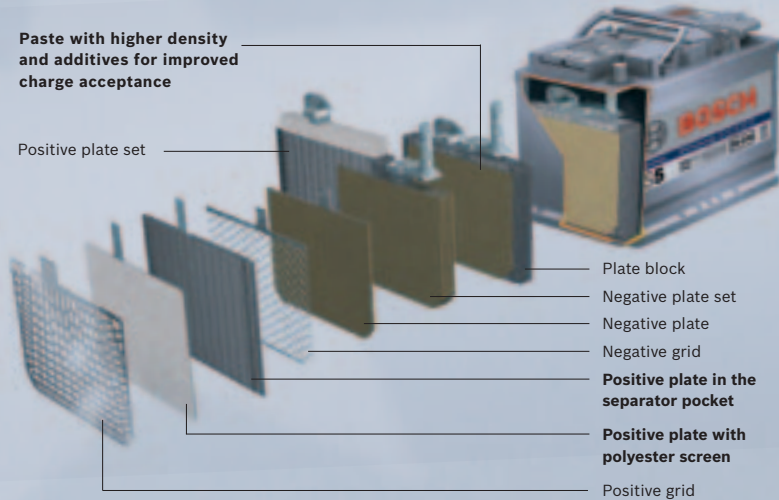

Plate block

Negative plate set

Negative plate

Negative grid

Positive plate in the separator pocket

Positive plate with polyester screen

Positive grid



S6 com tecnologia AGM: para sistema start-stop e recuperação

A tecnologia AGM (Absorbent Glas Mat) é a mais avançada tecnologia existente no mercado. O ácido está totalmente aglutinado nas esteiras de micro-fibra de vidro. Isto garante uma potência de ponta.

As vantagens:

- ▶ Potência constante em viagens curtas e trânsito pára-arranca (Stop-and-go) ou elevado consumo com o veículo parado
- ▶ Com uma resistência aos ciclos 4 vezes superior em comparação com as baterias de arranque convencionais
- ▶ Pode ser instalada em qualquer posição, 100 % à prova de vazamentos e viragens

S5 com tecnologia EFB: para sistema start-stop

A S5 com tecnologia EFB (Enhanced Flooded Battery) da Bosch preenche todas as pretensões existentes entre as baterias de partida convencionais e a S6 com tecnologia AGM.

As vantagens:

- ▶ Dupla resistência aos ciclos em comparação com as baterias de arranque convencionais
- ▶ Elevada resistência em trajetos curtos

S6 AGM-tekniikkalla: Start-Stop-järjestelmiin ja jarrutusenergian talteenottoon

AGM-tekniikka (Absorbent Glas Mat = mikrohuokoinen lasikuitumatto) edustaa markkinoiden ykkösluokkaa. Happo on imeytetty kokonaan mikrohuokoiseen lasikuituun. Takaa huippuluokan suorituskyvyn.

Sarjan edut:

- ▶ Vakaa voimanlähte myös lyhyissä ajoissa, stop & go -liikenteessä ja suurella virrankulutuksella, kun moottori on joutokäynnillä
- ▶ Jopa nelinkertainen syklinkestävyys perinteisiin käynnistys-akkuihin verrattuna
- ▶ Asento vapaasti valittavissa, 100 %:n kalliustus- ja vuotovarma

S5 EFB-tekniikkalla: Start-Stop-järjestelmiin

EFB-tekniikkaan (Enhanced Flooded Battery = erikoishappo-akku) perustuvat Bosch S5 EFB-akut paikkaavat ne aukot, jotka jäävät tavanomaisten käynnistys-akkujen ja S6 AGM-tekniikan väliin.

Sarjan edut:

- ▶ Kaksinkertainen syklinkestävyys tavanomaisiin käynnistys-akkuihin verrattuna
- ▶ Sitkeän kestävä lyhyissä ajoissa

S6 z technologią AGM: do systemu start-stop i regeneracji

Technologia AGM (Absorbent Glas Mat) to najlepsza technologia na rynku. Kwas jest całkowicie związany w matach z mikrowłókna szklanego. Zapewnia najlepszą moc.

Zalety:

- ▶ Stabilna moc również podczas jazdy na krótkich dystansach, postoju w korku oraz przy dużym obciążeniu w trybie zatrzymania
- ▶ Do 4 razy większa odporność cykliczna w porównaniu do standardowych akumulatorów rozruchowych
- ▶ Montaż możliwy w każdym położeniu, w 100 % zabezpieczony przed wyciekami

S5 z technologią EFB: do systemu start-stop

Technologia S5 EFB (Enhanced Flooded Battery) firmy Bosch wypełnia lukę, istniejącą między tradycyjnymi akumulatorami rozruchowymi a technologią S6 AGM.

Zalety:

- ▶ Podwójna odporność cykliczna w porównaniu do tradycyjnych akumulatorów rozruchowych
- ▶ Odporność na użytkowanie na krótkich dystansach

S6 s technologií AGM: pro systém Start-Stop a regeneraci

Technologie AGM (Absorbent Glas Mat) je nejlepší technologie na trhu. Veškerá kyselina je vázána v rohožích ze skleněného mikrovlákna. To zajistí špičkový výkon.

Přednosti:

- ▶ Konstantní výkon i při krátkých jízdách, při provozu brzda-plyn nebo při vysoké spotřebě ve statickém provozu
- ▶ Až 4krát vyšší cyklická odolnost v porovnání s běžnými startovacími akumulátory
- ▶ Lze instalovat v kterékoli poloze, 100 % bezpečné proti vytečení a naklonění

S5 s technologií EFB: pro systém Start-Stop

Technologie S5 EFB (Enhanced Flooded Battery) firmy Bosch splňuje všechny nároky, které spadají do oblasti mezi konvenčními startovacími akumulátory a technologií S6 AGM.

Přednosti:

- ▶ Dvojnásobná cyklická odolnost v porovnání s běžnými startovacími akumulátory
- ▶ Vysoká odolnost při krátkých jízdách

S6 с технологией AGM: для систем start-stop в т.ч. с рекуперацией

Технология AGM (Absorbent Glas Mat) - это ведущая технология на рынке. Электролит полностью связывается в микростекловолоконных сепараторах. Обеспечивает максимум мощности.

Преимущества:

- ▶ Постоянная мощность также и при езде на короткие расстояния, с частыми остановками или с высоким энергопотреблением в автономном режиме
- ▶ В 4 раза большая циклическая устойчивость по сравнению с обычными стартерными аккумуляторами
- ▶ Устанавливается в любом положении, 100% герметичность

S5 с технологией EFB: для систем стар-стоп

Технология S5 EFB (Enhanced Flooded Battery) компании Bosch отвечает промежуточным требованиям между обычными стартерными аккумуляторами и АКБ с технологией S6 AGM.

Преимущества:

- ▶ Двойная циклическая устойчивость по сравнению с обычными стартерными аккумуляторами
- ▶ Высокая работоспособность при езде на короткие расстояния

de

Service und Diagnose für Start-Stopp-Systeme

en

Service and diagnosis for Start-Stop systems

fr

Entretien et diagnostic pour systèmes Start-Stop

it

Service e diagnosi per sistemi start-stop

es

Servicio y diagnóstico de los sistemas Start-Stop



Effizienz in der Werkstatt: Service und Diagnose für Start-Stopp-Systeme

Als Systemhersteller mit umfassender Kompetenz bietet Bosch

- ▶ Optimale technische Lösungen in Erstausrüstungsqualität
- ▶ Ersatzteile
- ▶ Diagnosetechnik der ersten Wahl
- ▶ Schulungen

Efficiency in the workshop: Service and diagnosis for Start-Stop systems

As a system manufacturer with comprehensive expertise, Bosch offers

- ▶ Optimal technical solutions in original equipment quality
- ▶ Replacement parts
- ▶ First-choice diagnosis technology
- ▶ Training courses

Efficacité dans l'atelier : entretien et diagnostic pour systèmes Start-Stop

En tant que fournisseur d'équipements aux compétences étendues, Bosch offre les avantages suivants :

- ▶ solutions techniques optimales de qualité première monte
- ▶ pièces de rechange
- ▶ technique de diagnostic de premier choix
- ▶ formations

Efficienza in officina: service e diagnosi per sistemi start-stop

In qualità di costruttore di sistemi con una competenza a tutto campo Bosch offre

- ▶ Soluzioni tecniche ottimizzate con qualità identica al primo equipaggiamento
- ▶ Ricambi
- ▶ Tecnica di diagnosi di prima scelta
- ▶ Corsi di formazione

Eficacia en el taller: servicio y diagnóstico de los sistemas Start-Stop

Como fabricante de sistemas con una amplia competencia Bosch ofrece

- ▶ Soluciones técnicas óptimas en calidad de primeros equipamientos
- ▶ Piezas de recambio
- ▶ Tecnología de diagnóstico: la primera elección
- ▶ Cursos de formación

1 KTS 340: Diagnosetests mit zugehöriger Diagnosesoftware ESI[tronic]

KTS 340: Diagnosis tests with accompanying diagnosis software ESI[tronic]

KTS 340 : contrôles de diagnostic à l'aide du logiciel de diagnostic approprié ESI[tronic]

KTS 340: test di diagnosi con il relativo software di diagnosi ESI[tronic]

KTS 340: Pruebas para diagnóstico con el software de diagnóstico ESI[tronic] correspondiente

2 BAT 131: Überprüfung des Zustands von Start-Stopp-Batterien mit AGM-Technologie

BAT 131: Tests the condition of Start-Stop batteries with AGM technology

BAT 131 : contrôle de l'état des batteries Start-Stop à l'aide de la technologie AGM

BAT 131: controllo dello stato delle batterie start-stop con tecnologia AGM

BAT 131: comprobación del estado de las baterías de Start-Stop con tecnología AGM

3 BAT 490: Zuverlässig Start-Stopp-Batterien laden

BAT 490: Reliably charges Start-Stop batteries

BAT 490 : chargement fiable des batteries Start-Stop

BAT 490: ricarica affidabile delle batterie start-stop

BAT 490: carga fiable de las baterías Start-Stop

4 FSA 740 Edition: Funktionsfähigkeit relevanter Sensoren des Start-Stopp-Systems testen

FSA 740 Edition: Tests functionality of relevant sensors in the Start-Stop system

FSA 740 Edition : contrôle du fonctionnement des capteurs correspondants du système Start-Stop

FSA 740 Edition: test dei sensori fondamentali per il funzionamento del sistema start-stop

FSA 740 Edition: comprobar la capacidad de funcionamiento de los sensores relevantes del sistema Start-Stop

5 Schulungen im Bosch Service Trainings Center:

- ▶ Funktionsprinzip des Start-Stopp-Systems
- ▶ Vernetzung mit anderen Fahrzeugsystemen
- ▶ Diagnose und Reparatur der Komponenten
- ▶ Batteriewechsel mit Diagnosetester

Training courses in the Bosch Service Training Center:

- ▶ Operating principle of the Start-Stop system
- ▶ Networking with other vehicle systems
- ▶ Component diagnosis and repair
- ▶ Battery change with diagnostic tester

Formations dans le centre de formation Bosch Service :

- ▶ principe de fonctionnement du système Start-Stop
- ▶ interconnexion avec d'autres systèmes automobiles
- ▶ diagnostic et réparation des composants
- ▶ remplacement de la batterie à l'aide du testeur de diagnostic

Corsi di formazione sul Bosch Service Centri di formazione:

- ▶ Principio di funzionamento del sistema start-stop
- ▶ Interconnessione con altri sistemi automobilistici
- ▶ Diagnosi e riparazione di componenti
- ▶ Sostituzione batterie con tester di diagnosi

Cursos de formación en Bosch Service Centros de formación:

- ▶ Principio de funcionamiento del sistema Start-Stop
- ▶ Conexión con otros sistemas de vehículo
- ▶ Diagnóstico y reparación de componentes
- ▶ Cambio de batería con tester para diagnóstico

pt

Serviço de assistência e diagnóstico para sistemas start-stop

fi

Huolto ja diagnoosi Start-Stop-järjestelmissä

pl

Serwis i diagnostyka do systemów start-stop

cs

Servis a diagnostika pro systémy Start-Stop

ru

Техобслуживание и диагностика систем старт-стоп

4

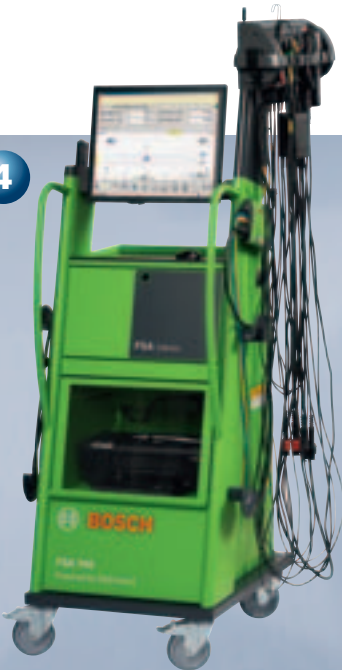

5



Eficácia na oficina: serviço de assistência e diagnóstico para sistemas start-stop

Como fabricante de sistemas com abrangente competência, a Bosch oferece

- ▶ ótimas soluções técnicas com qualidade de equipamento original
- ▶ peças de reposição
- ▶ técnica de diagnóstico de primeira água
- ▶ treinamentos

KTS 340: testes de diagnose com o respectivo software de diagnose ESI[tronic]

BAT 131: verificação do estado das baterias start-stop com tecnologia AGM

BAT 490: arregar baterias start-stop de modo fiável

FSA 740 Edition: testar a operacionalidade de sensores relevantes do sistema start-stop

Treinamentos na assistência técnica da Bosch Centro de treinamento:

- ▶ princípio de funcionamento do sistema start-stop
- ▶ ligação em rede com outros sistemas de veículo
- ▶ diagnósticos e reparo dos componentes
- ▶ troca da bateria com aparelho de teste de diagnose

Tehokkuutta korjaamoon: Huolto ja diagnoosi Start-Stop-järjestelmissä

Järjestelmätoimittajana Bosch tarjoaa kattavaa osaamista

- ▶ Optimaaliset tekniset ratkaisut alkuperäistoimittajan laatusa
- ▶ Varaosat
- ▶ Ykkösluokan diagnositekologiaa
- ▶ Koulutusta

KTS 340: Diagnositestit ESI[tronic]-diagnosiohjelmistolla

BAT 131: Start-Stop-ajoneuvoissa AGM-tyyppin akkujen kunnon tarkastus

BAT 490: Start-Stop-akkujen luotettava varaos

FSA 740 Edition: Start-Stop-järjestelmien oleellisten tunnistimien toimintakyvyn testaus

Koulutusta Bosch-huoltoon Trainings Center:

- ▶ Start-Stop-järjestelmän toimintaperiaate
- ▶ Verkotus auton muihin järjestelmiin
- ▶ Komponenttien diagnoosi ja korjaus
- ▶ Akun vaihto diagnoositestereillä

Wydatnosc w stacji obsługi: serwis i diagnostyka do systemów start-stop

Jako producent systemów posiadający szerokie kompetencje, firma Bosch zapewnia

- ▶ optymalne rozwiązania techniczne w jakości wyposażenia fabrycznego
- ▶ części zamienne
- ▶ technologie diagnostyczna pierwszego wyboru
- ▶ szkolenia

KTS 340: testy diagnostyczne z odpowiednim oprogramowaniem diagnostycznym ESI[tronic]

BAT 131: kontrola stanu akumulatorów start-stop z tecnologia AGM

BAT 490: niezawodne ładowanie akumulatorów start-stop

FSA 740 Edition: testowanie sprawności odpowiednich czujników systemu start-stop

Szkolenia Bosch Service Centrum szkoleniowe:

- ▶ zasada działania systemu start-stop
- ▶ połączenie w sieć z innymi systemami pojazdu
- ▶ diagnostyka i naprawa elementów
- ▶ wymiana akumulatora z testerem diagnostycznym

Efektivnost v servisní dílně: Servis a diagnostika pro systémy Start-Stop

Jako výrobce systému s rozsáhlou kompetencí nabízí společnost Bosch

- ▶ Optimální technická řešení v kvalitě originálního vybavení
- ▶ Náhradní díly
- ▶ Diagnostickou techniku první volby
- ▶ Školení

KTS 340: Diagnostické testy s příslušným diagnostickým softwarem ESI[tronic]

BAT 131: Prezkoušení stavu akumulátoru Start-Stop pomocí technologie AGM

BAT 490: Spolehlivé nabíjení akumulátoru Start-Stop

FSA 740 Edition: Testování funkční způsobilosti relevantních snímací systému Start-Stop

Školení v servisu Bosch Školící středisko:

- ▶ Princip funkce systému Start-Stop
- ▶ Síťové propojení s jinými systémy vozidla
- ▶ Diagnostika a opravy komponent
- ▶ Výměna akumulátorů s diagnostickým testerem

Эффективность на СТО: Техобслуживание и диагностика систем старт-стоп

Являясь системным производителем с комплексной компетенцией, Bosch предлагает

- ▶ Оптимальные технические решения с качеством конвейерной комплектации
- ▶ Запчасти
- ▶ Диагностическое оборудование
- ▶ Обучения и тренинги

KTS 340: диагностическое тестирование с помощью соответствующего программного обеспечения ESI[tronic]

BAT 131: проверка состояния аккумуляторов систем старт-стоп с технологией AGM

BAT 490: надежная зарядка для аккумуляторов систем старт-стоп

FSA 740 Edition: тестирование работоспособности соответствующих датчиков системы старт-стоп

Обучение в сервисной службе Bosch Учебный центр:

- ▶ Принцип работы системы старт-стоп
- ▶ Взаимодействие с другими автомобильными системами
- ▶ Диагностика и ремонт компонентов
- ▶ Замена аккумулятора с использованием диагностического тестера

de

PowerFrame®-Technologie:
Mehr Leistung vom Start weg

en

PowerFrame® technology:
More power, right from the start

fr

Technologie PowerFrame® :
Plus de puissance dès le démarrage

it

Tecnologia PowerFrame®:
più potenza per un avviamento affidabile

es

Tecnología PowerFrame®:
Más potencia desde el arranque

SAE J240 durability test (75°C) after 8 weeks:

Standard grid:



Severe corrosion.
The grid becomes brittle.

PowerFrame®:



Minimal corrosion. The grid is completely intact.

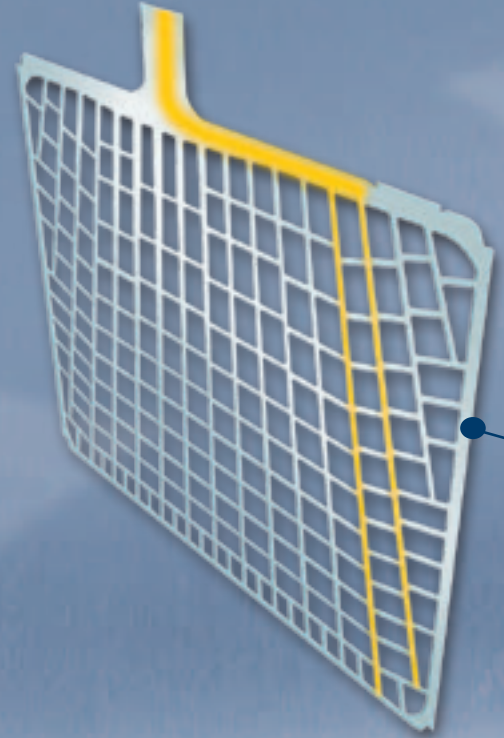

PowerFrame®-Technologie steht für die revolutionäre Weiterentwicklung der Bosch-Batterien durch das patentierte Stanverfahren. Leistung und Qualität der Batteriekomponenten sind im Vergleich zu der herkömmlichen Produktionsmethode wesentlich verbessert.

Entscheidend für Leistung und Zuverlässigkeit einer Batterie ist das Gitter. Es ist verantwortlich für den optimalen Stromfluss.

Vorteile für den Autofahrer ab dem ersten Start:

- ▶ Längere Lebensdauer dank minimaler Korrosion
- ▶ Zuverlässige Startkraft durch Gitter mit optimalem Stromfluss

PowerFrame® technology represents a revolutionary new development for Bosch batteries, employing a patented stamping process. Compared to conventional production methods, the battery components offer far superior performance and quality.

The grid is of crucial importance to the power and reliability of a battery. It is responsible for an optimum current flow.

Motorists enjoy the benefits right from the start:

- ▶ Longer service life thanks to minimum corrosion
- ▶ Reliable starting power thanks to a grid with optimum current flow

Les batteries Bosch ont connu un développement révolutionnaire grâce au procédé de poinçonnage breveté appliqué à la »PowerFrame®«. La puissance et la qualité des composants des batteries sont considérablement améliorées par rapport à la méthode de production conventionnelle.

La grille est d'importance capitale pour la puissance et la fiabilité d'une batterie dont elle assure la circulation optimale du courant.

Avantages pour l'automobiliste dès le premier démarrage:

- ▶ une durée de vie plus longue grâce à une corrosion minimale
- ▶ une capacité de démarrage élevée grâce à la grille et la circulation optimale du courant

La tecnologia "PowerFrame®" rappresenta il perfezionamento rivoluzionario delle batterie Bosch, grazie al nuovo metodo brevettato di punzonatura. Il rendimento e la qualità dei componenti della batteria risultano notevolmente migliorati rispetto al metodo di produzione convenzionale.

Un fattore decisivo per il rendimento e l'affidabilità di una batteria è costituito dalla griglia. La griglia garantisce il flusso ottimale della corrente.

Vantaggi per gli automobilisti fin dal primo avviamento:

- ▶ Ciclo di vita più lungo grazie alla corrosione minima
- ▶ Potenza di avviamento affidabile grazie alla griglia che garantisce un flusso ottimale della corrente

La tecnología de "PowerFrame®" representa el revolucionario perfeccionamiento de las baterías Bosch mediante un procedimiento patentado de estampado, punzonado y cortado. El rendimiento y la calidad de los componentes de la batería se han mejorado notablemente en comparación con el método de producción convencional.

El factor decisivo para la potencia y la fiabilidad de una batería es su rejilla. Ella garantiza un flujo de corriente óptimo.

Ventajas para el conductor desde el primer arranque:

- ▶ Mayor vida útil gracias a una corrosión mínima
- ▶ Potencia de arranque fiable gracias a una rejilla con un flujo de corriente óptimo

pt

Tecnologia PowerFrame®:
Mais potência desde a partida

fi

PowerFrame®-teknologia:
Lisää tehoa heti käynnistyksellä

pl

Technologia PowerFrame®:
Większa moc rozruchu już od pierwszego startu

cs

Technologie PowerFrame®:
Více výkonu již od startu

ru

Технология PowerFrame®:
больше мощности уже на старте

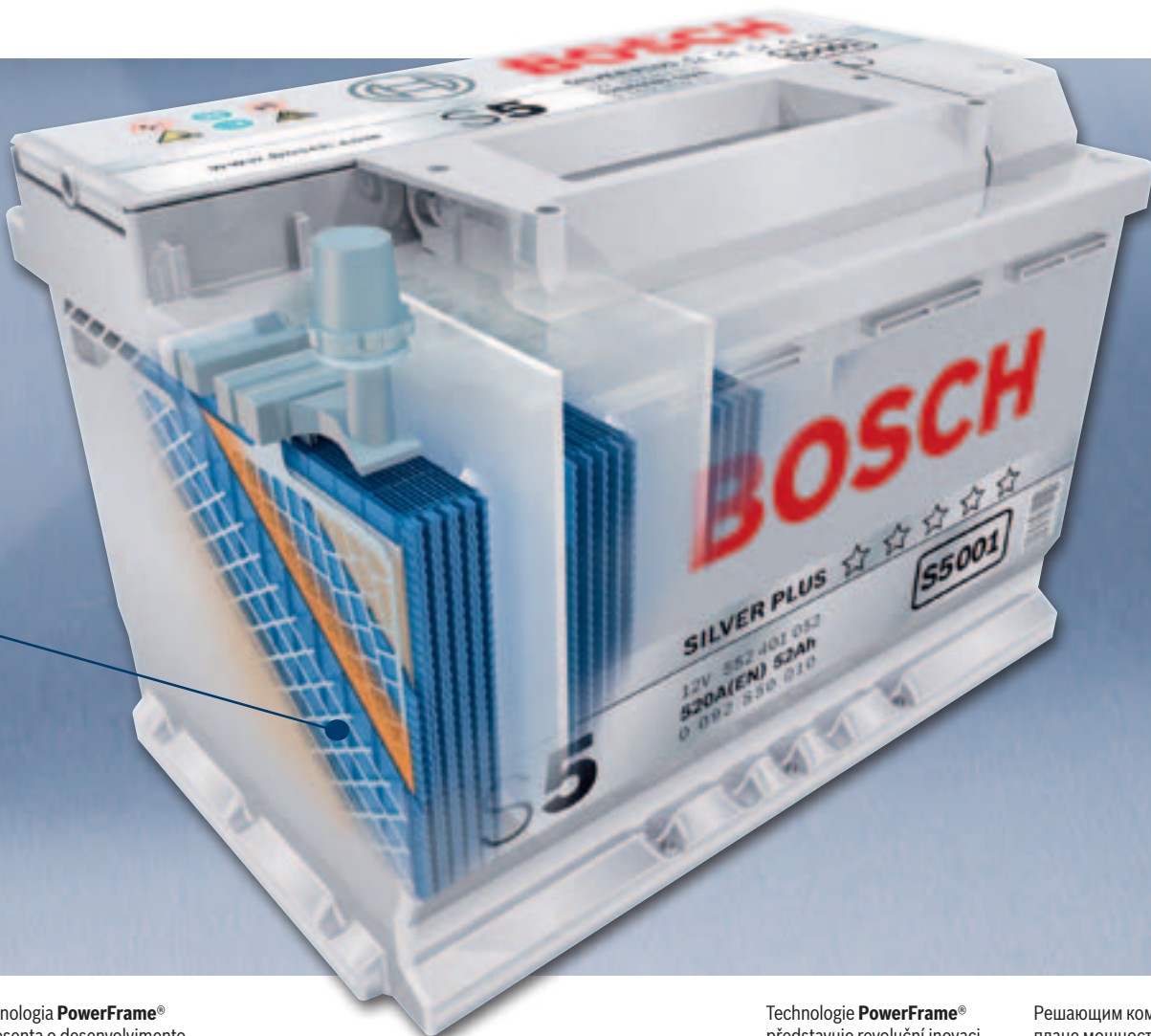

A tecnologia **PowerFrame®** representa o desenvolvimento revolucionário das baterias Bosch graças ao procedimento patenteado de estampagem e perfurado. A potência e a qualidade dos componentes da bateria estão consideravelmente melhoradas em comparação com os métodos de produção convencionais.

A grelha é decisiva para a potência e fiabilidade de uma bateria. Dela depende o fluxo de corrente ideal.

Vantagens para o automobilista a partir do primeiro arranque:

- ▶ Maior vida útil graças a uma corrosão mínima
- ▶ Força de partida fiável graças à grelha com fluxo de corrente ideal

PowerFrame®-teknologia merkitsee Bosch-akkujen kehityksessä mullistavaa uudistusta – patentilla suojattu stansattu ristikkorakenne. Akun osien laatu ja kestävyys ovat perinteisiin tuotantomenetelmiin verrattuina olennaisesti paremmat.

Akun tehon ja luotettavuuden kannalta akun ristikkorakenne on ratkaiseva tekijä. Siitä riippuu, miten tehokas virrantuotto on.

Edut autoilijan kannalta heti ensikäynnistyksestä lähtien:

- ▶ Pitempi elinikä kiitos minimaalisen korroosion
- ▶ Luotettavan käynnistyksen takaa virtaoptimoitu ristikko

Opatentowana metoda **PowerFrame®** to rewolucyjny krok w rozwoju akumulatorów Bosch. Nowa technologia znacząco poprawia wydajność i jakość elementów akumulatora.

Decydujące znaczenie dla wydajności i niezawodności akumulatora ma kratka. Odpowiada ona za optymalny przepływ prądu.

Zalety technologii wytłaczania kratki dla kierowców:

- ▶ Dłuższy okres użytkowania dzięki minimalnej korozji
- ▶ Wysoka moc rozruchu dzięki optymalnemu przepływowi prądu w kratce.

Technologie **PowerFrame®** představuje revoluční inovaci akumulátorů Bosch díky patentovanému způsobu lisování mřížek. Výkon a kvalita komponentů akumulátorů jsou v porovnání s běžnými výrobními metodami podstatně zlepšeny.

Pro výkon a spolehlivost akumulátoru je rozhodující mřížka. Zodpovídá za optimální tok proudu.

Výhody pro řidiče již od prvního nastartování:

- ▶ Delší životnost díky minimální korozji mřížek
- ▶ Spolehlivá startovací síla díky použití mřížky s optimálním tokem proudu

Решающим компонентом в плане мощности и надежности аккумулятора является решетка. Она отвечает за оптимальное прохождение тока.

Технология **PowerFrame®** - это революционное усовершенствование аккумуляторов Bosch благодаря запатентованному методу штамповки решетки. Значительно улучшены мощность и качество компонентов аккумулятора по сравнению с обычным методом изготовления решеток.

Преимущества для автовладельцев:

- ▶ Более долгий срок службы благодаря минимальной коррозии
- ▶ Надежная стартовая мощность благодаря решетке с оптимальным прохождением тока

de

Bosch-Batterien
S6 – S5 – S4 – S3

en

Bosch batteries
S6 – S5 – S4 – S3

fr

Batteries Bosch
S6 – S5 – S4 – S3

it

Batterie Bosch
S6 – S5 – S4 – S3

es

Baterías Bosch
S6 – S5 – S4 – S3

Clear assignment of the Bosch battery types



	S6 (AGM)	S5 (EFB)
Application	For modern vehicles with start-stop and recuperation	For modern vehicles with start-stop
Primary function	High number of engine starts with "high" depth of discharge and "extended" engine off periods	High number of engine starts with "low" depth of discharge and "moderate" engine off periods
Technology	AGM – Absorbent Glass Mat	EFB – Enhanced Flooded Battery
Start-Stop system	✓	✓
Recuperation	✓	–
High quantity of consumers	✓✓✓✓	✓✓✓✓
Frequent short distance	✓✓✓✓	✓✓✓✓
Vibration proof	✓	–
Cold cranking power	135 %	115 %

Die Auswahl der richtigen Batterie wird heutzutage von unterschiedlichen Faktoren beeinflusst: Fahrzeugklasse, Anzahl der elektrischen Verbraucher, Fahrverhalten und klimatische Verhältnisse. Bosch-Batterien erfüllen jede Leistungsanforderung.

Mit erhöhter Kaltstartleistung sichern Bosch-Batterien die elektrische Versorgung des Bordnetzes zuverlässig. Das Batterie-Programm von Bosch erfüllt die Anforderungen der internationalen Erstausrüster und übertrifft diese sogar.

Nowadays there are many factors involved when selecting a battery: class of vehicle, number of electrical consumers, driving behavior and climatic conditions. Bosch batteries comply with all manner of performance requirements.

With their enhanced cold-start performance Bosch batteries ensure that the vehicle's electric system never runs out of power. The range of Bosch batteries not only complies in full with the requirements of international original equipment manufacturers, it's better!

Différents facteurs influent aujourd'hui sur le choix de la bonne batterie: la classe du véhicule, le nombre de consommateurs électriques, le comportement routier et les conditions climatiques. Les batteries Bosch couvrent par leurs performances toutes les exigences.

Grâce à leur capacité de démarrage à froid supérieure, les batteries Bosch assurent une alimentation fiable du réseau de bord. La gamme de batteries Bosch remplit et surclasse même les exigences des équipementiers internationaux.

Al giorno d'oggi la scelta della batteria giusta viene influenzata da una molteplicità di fattori diversi: categoria di veicolo, fabbisogno elettrico, stile di guida e condizioni climatiche. Le batterie Bosch sono in grado di soddisfare qualsiasi fabbisogno di potenza.

Grazie alla loro elevata capacità di avviamento a freddo, le batterie garantiscono un'alimentazione elettrica affidabile della rete di bordo. La gamma di batterie Bosch non solo soddisfa i requisiti dei costruttori automobilistici internazionali, ma li supera persino.

La elección de la batería idónea está influenciada actualmente por diferentes factores: la clase del vehículo, la cantidad de componentes eléctricos, el comportamiento de marcha y las condiciones climáticas. Las baterías Bosch cumplen todos estos requisitos.

Mediante una mayor capacidad de arranque en frío, las baterías Bosch garantizan la alimentación de la red de a bordo. El programa de baterías de Bosch cumple todas las sofisticadas exigencias de los fabricantes de primeros equipos e incluso las supera.

pt

Baterias Bosch
S6 – S5 – S4 – S3

fi

Bosch-akut
S6 – S5 – S4 – S3

pl

Akumulatory Bosch
S6 – S5 – S4 – S3

cs

Akumulátory Bosch
S6 – S5 – S4 – S3

ru

Аккумуляторы Bosch
S6 – S5 – S4 – S3



S5

For new vehicles

Engine start

PowerFrame®

-

-

✓✓

✓✓

-

130 %

S4

For all vehicles,
also for Asian vehicles

Engine start

PowerFrame®

-

-

✓

✓

-

115 %

S3

For older vehicles

Engine start

PowerFrame®

-

-

-

-

-

100 %

A seleção da bateria correta é influenciada hoje em dia por diferentes fatores: Classe do veículo, número de consumidores elétricos, comportamento de condução e condições climáticas. As baterias Bosch preenchem todas as exigências de performance.

Com uma maior potência de arranque a frio as baterias Bosch asseguram de forma fiável a alimentação do sistema elétrico do veículo. O programa de baterias da Bosch não só cumpre os requisitos dos fornecedores internacionais de equipamento original, como os supera.

Akkutyypin valintaan vaikuttavat nykyään monet eri tekijät: ajoneuvoluokka, sähkökuluttajien lukumäärä, ajotyylit ja ilmastolliset olosuhteet. Bosch-akut täyttävät kaikki suoritusvaatimukset.

Tehostetuilla kylmäkäynnistösominaisuuksillaan Bosch-akut takaavat luotettavasti auton sähkölaitteiden virransaannin. Bosch-akkuvalikoima täyttää kansainvälisten OEM-valmistajien vaatimukset ja jopa ylittää ne.

Na wybór właściwego akumulatora wpływ mają dzisiaj różne czynniki: klasa pojazdu, liczba odbiorników elektrycznych, styl jazdy kierowcy i warunki klimatyczne. Akumulatory Bosch spełniają każde wymaganie.

Dzięki poprawionej zdolności startowej akumulatory Bosch zapewniają niezawodne zasilanie elektrycznej sieci pokładowej. Akumulatory Bosch spełniają i przewyższają wymagania producentów samochodów z całego świata.

Výběr správného akumulátoru je v současné době ovlivňován různými faktory: Třída vozidla, počet elektrických spotřebičů, jízdní vlastnosti a klimatické podmínky. Akumulátory Bosch splňují každý požadavek na výkon.

Díky zvýšenému výkonu při startování za studena zajišťují akumulátory Bosch spolehlivé elektrické napájení palubní sítě. Program akumulátorů Bosch splňuje požadavky mezinárodních výrobců prvního vybavení a dokonce je v mnoha případech překračuje.

Выбор правильного аккумулятора сегодня зависит от различных факторов: класса автомобиля, числа потребителей электроэнергии, стиля вождения и климатических условий. В программе аккумуляторов Bosch есть решение для любых требований.

Благодаря повышенному току холодного пуска аккумуляторы Bosch надежно обеспечивают электропитание бортовой сети. Программа аккумуляторов Bosch отвечает требованиям международных производителей первичной комплектации и даже превышает их.

de

Bosch-Batterien T5 – T4 – T3 für Nutzfahrzeuge

en

Bosch commercial- vehicle batteries T5 – T4 – T3

fr

Batteries Bosch T5 – T4 – T3 pour véhicules utilitaires

it

Batterie Bosch T5 – T4 – T3 per veicoli commerciali

es

Baterías Bosch T5 – T4 – T3 para vehículos industriales



Die T-Batterien von Bosch verfügen über höchste Kraftreserven. Das bietet Ihnen entscheidende Vorteile: Sie

- ▶ meistern die hohen Belastungen im Betrieb von Nutzfahrzeugen
- ▶ sorgen für zuverlässige Energieversorgung zu jeder Zeit
- ▶ sind absolut wartungsfrei

T5 Heavy Duty Extra und T4 Heavy Duty

- ▶ Bis zu 30% mehr Startkraft und Lebensdauer dank Silver-Technologie ¹⁾
- ▶ Sehr rüttel- und zyklusfest
- ▶ Sicherheit auch beim Einbau im Fahrzeuginnenraum
- ▶ Gefüllt und geladen bis zu 18 Monate lagerfähig
- ▶ T5 Heavy Duty Extra: maximale Leistung, extra rüttel- und zyklusfest

T3 Startkraft ohne Kompromisse

- ▶ Hybridtechnologie ²⁾
- ▶ Rüttelfest
- ▶ Gefüllt und geladen bis zu 12 Monate lagerfähig

The T batteries from Bosch offer maximum power reserves. This provides you with crucial advantages: They

- ▶ cope effortlessly with the high loads when operating commercial vehicles
- ▶ ensure a reliable power supply at all times
- ▶ are completely maintenance-free

T5 Heavy Duty Extra and T4 Heavy Duty

- ▶ Up to 30% more starting power and service life thanks to silver technology ¹⁾
- ▶ Excellent vibration and deep-cycle resistance
- ▶ Safe enough to fit in the cab
- ▶ Store for up to 18 months when filled and charged
- ▶ T5 Heavy Duty Extra: maximum power, extra vibration and deep-cycle resistance

T3 Starting power without compromise

- ▶ Hybrid technology ²⁾
- ▶ Vibration resistant
- ▶ Store for up to 12 months when filled and charged

Les batteries T disposent de réserves de puissance très élevées. Les avantages qui en résultent sont les suivants: Elles

- ▶ font face aux sollicitations importantes rencontrées sur les véhicules utilitaires
- ▶ assurent une alimentation fiable à tout moment
- ▶ N'exigent aucun entretien

T5 Heavy Duty Extra et T4 Heavy Duty

- ▶ Capacité de démarrage et durée de vie accrues de 30% grâce à la technologie Silver ¹⁾
- ▶ Très résistantes aux secousses et aux sollicitations cycliques
- ▶ Sécurité même en cas de montage dans l'habitacle
- ▶ Stockage jusqu'à 18 mois des batteries remplies et chargées
- ▶ T5 Heavy Duty Extra: puissance maximale, extrême résistance aux secousses et aux sollicitations cycliques

T3 pour une puissance de démarrage sans compromis

- ▶ Technologie hybride ²⁾
- ▶ A l'épreuve des secousses
- ▶ Stockage jusqu'à 12 mois des batteries remplies et chargées

Le batterie T di Bosch dispongono di eccezionali riserve di potenza. I vantaggi decisivi per voi: queste batterie

- ▶ affrontano senza problemi le sollecitazioni elevate caratteristiche dei veicoli commerciali
- ▶ garantiscono l'alimentazione elettrica affidabile in qualsiasi momento
- ▶ sono assolutamente esenti da manutenzione

T5 Heavy Duty Extra e T4 Heavy Duty

- ▶ Aumento della potenza di avviamento e della durata fino al 30% grazie alla tecnologia Silver ¹⁾
- ▶ Molto resistenti alle vibrazioni e ai cicli di carica e scarica
- ▶ Sicurezza assoluta anche in caso di montaggio nell'abitacolo
- ▶ Batteria immagazzinabile fino a 18 mesi se riempita e caricata
- ▶ T5 Heavy Duty Extra: prestazioni massime, estremamente resistente alle vibrazioni e ai cicli di carica e scarica

T3 Potenza di avviamento senza compromessi

- ▶ Tecnologia ibrida ²⁾
- ▶ Resistente alle vibrazioni
- ▶ Batteria riempita e caricata immagazzinabile fino a 12 mesi

Las baterías T de Bosch disponen de reservas de potencia máximas. Esto le ofrece ventajas decisivas: Estas baterías

- ▶ soportan las grandes sollicitaciones en el funcionamiento en vehículos industriales
- ▶ garantizan una alimentación fiable de energía en todo momento
- ▶ Eabsolutamente sin mantenimiento

T5 Heavy Duty Extra y T4 Heavy Duty

- ▶ Hasta un 30% más de potencia de arranque y de vida útil gracias a la tecnología de plata ¹⁾
- ▶ Sumamente resistentes a las vibraciones y a los ciclos
- ▶ Seguridad también en caso de montaje dentro del habitáculo del vehículo
- ▶ Llena y cargada puede almacenarse hasta 18 meses
- ▶ T5 Heavy Duty Extra: rendimiento máximo, sumamente resistentes a las vibraciones y a los ciclos

T3 Potencia de arranque sin compromisos

- ▶ Tecnología híbrida ²⁾
- ▶ Resistente a vibraciones
- ▶ Llena y cargada puede almacenarse hasta 12 meses

¹⁾ Spezielle Silberlegierung sorgt für drastisch erhöhte Korrosionsbeständigkeit

²⁾ Sorgt für hohe Kraftreserven und hervorragende Leistungswerte

¹⁾ Special silver alloy ensures dramatically increased corrosion resistance

²⁾ Ensures high power reserves and outstanding performance values

¹⁾ Alliage d'argent spécial garantissant une résistance à la corrosion fortement accrue

²⁾ Réserves de puissance élevées et caractéristiques de puissance remarquables

¹⁾ La speciale lega di argento offre una resistenza alla corrosione drasticamente maggiore

²⁾ Garantisce elevate riserve di forza e prestazioni eccellenti

¹⁾ Aleación de plata especial para una resistencia a la corrosión incrementada drásticamente

²⁾ Suministra elevadas reservas de fuerza y unos valores de potencia excelentes

pt

Baterias Bosch T5 - T4 - T3 para veículos comerciais e camiões

fi

Bosch-akut T5 - T4 - T3 hyötyajoneuvoihin

pl

Akumulatory Bosch T5 - T4 - T3 do samochodów dostawczych

cs

Akumulátory Bosch T5 - T4 - T3 pro užitková vozidla

ru

Аккумуляторы Bosch T5 - T4 - T3 для коммерческого транспорта



Clear assignment of the Bosch truck battery types

Features	T5 Heavy duty extra	T4 Heavy duty	T3
Technologies	Silver technology* Labyrinth cover**	Silver technology* Labyrinth cover**	
Absolutely maintenance-free	✓***	✓***	Maintenance-free, can be refilled with water
Installation in cab	✓	✓	Not possible
Cycle stability (compared to EN standard)	up to 400 %	up to 300 %	Exceeds EN standard
Service life	130 % thanks to silver technology and glass mat	120 %, thanks to silver technology	100 %
Vibration resistance****	10 x more vibr.-resistant	10 x more vibr.-resistant	Highly vibration-resistant
Starting power	130 %	120 %	100 %
Storage time	18 month	15 month	Up to 12 month

* Special silver alloy ensures dramatically increased corrosion resistance
 ** Reliably routes condensed water back into the battery; high operational safety thanks to flame arrester
 *** Reduce your fleet operation costs with absolutely maintenance free batteries from Bosch.
 **** in comparison with conventional starter batteries

As baterias T da Bosch dispõem de reservas de potência máximas. Isto oferece-lhe vantagens decisivas: Elas

- suportam as grandes solicitações dos veículos comerciais e camiões
- asseguram uma alimentação fiável de energia em qualquer altura
- são absolutamente isentas de manutenção

T5 Heavy Duty Extra e T4 Heavy Duty

- Até mais 30% de potência de arranque e vida útil graças à tecnologia de prata ¹⁾
- Muito resistente à vibração e aos ciclos
- Segurança mesmo na montagem no habitáculo do veículo
- Armazenável até 18 meses quando cheia e carregada
- T5 Heavy Duty Extra: potência máxima, extra resistente à vibração e aos ciclos

Força de partida total T3

- Tecnologia híbrida ²⁾
- Resistente à vibração
- Armazenável até 12 meses quando cheia e carregada

T-sarjan Bosch-akkujen voimavarat ovat huippuluokkaa. Niillä on merkittäviä etuja: Ne

- hallitsevat ajotilanteissa hyötyajoneuvon kohdistuvan korkean kuormituksen
- huolehtivat luotettavasti energiantuosta joka tilanteessa
- ovat täysin huoltovapaat

T5 Heavy Duty Extra ja T4 Heavy Duty

- Erittäin hyvä tärinä- ja sykkinkestävyys
- Turvallinen myös ajoneuvon sisätilaan asennettuna
- Täytettynä ja varattuna varastointikelpoinen jopa 18 kk
- T5 Heavy Duty Extra: enimmäisteho, erityisen hyvä tärinä- ja sykkinkestävyys

T3 kompromissitonta käynnistysvoimaa

- Hybriditeknologia ²⁾
- Tärinänkestävä
- Täytettynä ja varattuna varastointikelpoinen jopa 12 kk

Akumulatory Bosch linii T oferują kierowcom największe rezerwy mocy. Zapewnia to znaczne korzyści: Akumulatory te

- są w stanie sprostać wymaganiom stawianym przez wszystkie odbiorniki elektryczne samochodów użytkowych
- zapewniają niezawodne i nieprzerwane zasilanie w energię
- są całkowicie bezobsługowe

T5 Heavy Duty Extra i T4 Heavy Duty

- Do 30% większa moc rozruchowa i okres użytkowania dzięki technologii Silver ¹⁾
- Bardzo odporne na wstrząsy i pracę cykliczną
- Bezpieczne również w przypadku montażu we wnętrzu pojazdu
- Napełnione i naładowane; okres przechowywania do 18 miesięcy
- T5 Heavy Duty Extra: maksymalna wydajność, wyjątkowo odporne na wstrząsy i pracę cykliczną

T3 Moc rozruchowa bez kompromisów

- Technologia hybrydowa ²⁾
- Odporne na wstrząsy
- Napełnione i naładowane; okres przechowywania do 12 miesięcy

Akumulátory řady T firmy Bosch disponují nejvyššími výkonovými rezervami. To přináší rozhodující výhody:

- zvládají vysoká zatížení při provozu užitkových vozidel
- zajišťují spolehlivé zásobování energií v kterékoli době
- jsou absolutně bezúdržbové

T5 Heavy Duty Extra a T4 Heavy Duty

- Velmi odolné otřesům a cyklům
- Bezpečné i při vestavbě ve vnitřním prostoru vozidla
- Naplněno a nabit až pro 18měsíční skladovatelnost
- T5 Heavy Duty Extra: maximální výkon, zvláště odolné otřesům a cyklům

T3 Startovací síla bez kompromisů

- Hybridní technologie ²⁾
- Odolné otřesům
- Naplněno a nabit až pro 12měsíční skladovatelnost

Аккумуляторы компании Bosch серии T имеют максимальные резервы мощности. Это дает им неоспоримые преимущества: они

- справляются с высокими нагрузками, возникающими при эксплуатации коммерческих автомобилей
- обеспечивают надежное электропитание в любое время
- Абсолютно необслуживаемые

T5 Heavy Duty Extra и T4 Heavy Duty

- На 30% больше стартовая мощность и больший срок службы благодаря использованию серебряной технологии
- Очень высокая устойчивость к вибрациям и циклическим нагрузкам
- Безопасны даже при установке в кабине автомобиля (если это предусмотрено конструкцией)
- В залитом и заряженном состоянии могут храниться на складе до 18 месяцев
- T5: Максимальная мощность, экстремальная устойчивость к вибрациям и циклическим нагрузкам

Стартовая мощность T3 без компромиссов

- Гибридная технология
- Виброустойчивость
- В залитом и заряженном состоянии могут храниться на складе до 12 месяцев

¹⁾ A liga de prata especial assegura uma resistência à corrosão drasticamente superior

²⁾ Garante elevadas reservas e excelentes valores ao nível da potência

¹⁾ Erikoistyyppinen hopeaseos suojaa erittäin tehokkaasti korroosiolta

²⁾ Takaa korkean varaustason ja erinomaiset teholuokemat

¹⁾ Specjalny stop srebra zapewnia o wiele większą odporność na korozję

²⁾ Zapewnia due rezerwy energii, umożliwiające uzyskanie doskonałych wartości mocy

¹⁾ Speciální slitina stříbra zajišťují zásadně zvýšenou odolnost proti korozi

²⁾ Zajišťují vysoké výkonové rezervy a vynikající výkonové hodnoty

de

Bosch-Batterien M6 – M4 für Motorräder

en

Bosch motorcycle batteries M6 – M4

fr

Batteries Bosch M6 – M4 pour motocyclettes

it

Batterie Bosch M6 – M4 per motocicli

es

Baterías Bosch M6 – M4 para motocicletas



Die Bosch-Batterien M4 und M6 sind besonders robust und überzeugen durch ihre zuverlässige Startkraft. Neben dem Einsatz bei Motorrädern sind sie auch für Jetskis, ATV-Quads, Schneemobile und Rasenmäher geeignet.

Freshpack im Lieferumfang enthalten. Vorteil: Einfache und sichere Befüllung und Aktivierung der Batterien.

M6 mit AGM-Technologie ¹⁾

- ▶ AGM-Technologie (Absorbent Glass Mat) erfüllt höchste Ansprüche an Lebensdauer und Kaltstartkraft
- ▶ 20% mehr Lebensdauer und bis zu 4-mal höhere Zyklenfestigkeit
- ▶ Absolut wartungsfrei
- ▶ Absolut kipp-, auslaufsicher bis 45° Kippwinkel
- ▶ Extrem rüttelfest
- ▶ Optimal für Extrembelastungen wie lange Geländestrecken – ideal z. B. für Enduros

M4 für sichere Startleistung

- ▶ Wartungsfrei nach EN
- ▶ Zuverlässige Startkraft
- ▶ Lange Lebensdauer

The Bosch M4 and M6 batteries are exceptionally robust and provide reliable starting power. As well as motorcycles, they are suitable for use on jet skis, ATV quad bikes, snowmobiles and lawnmowers.

Freshpack included in scope of delivery. Easy, reliable filling and battery activation.

M6 with AGM-technology ¹⁾

- ▶ AGM technology (Absorbent Glass Mat) fulfills the highest requirements in terms of service life and cold starting performance
- ▶ 20% longer service life and up to 4 times higher cycle stability
- ▶ Totally maintenance-free
- ▶ Totally tilt and leak-proof up to a tilt angle of 45°
- ▶ Extremely vibration-resistant
- ▶ Optimized for extreme loads such as long off-road courses – ideal for enduros, for example

M4 for safe starting performance

- ▶ Maintenance-free to EN standards
- ▶ Reliable starting power
- ▶ Long service life

Les batteries Bosch M4 et M6 se distinguent par leur robustesse et leur capacité de démarrage fiable. Outre les motocyclettes modernes, elles sont utilisables sur les jetskis, les quads, les scooters des neiges et les tondeuses à gazon.

Pack acide et aide de remplissage compris. Avantage : activation simple et sûre des batteries.

M6 avec technologie AGM ¹⁾

- ▶ La technologie AGM (Absorbent Glass Mat) répond aux exigences les plus élevées en termes de durée de vie et de capacité de démarrage à froid
- ▶ Durée de vie prolongée de 20 % et résistance aux cycles jusqu'à 4 fois supérieure
- ▶ Sans aucun entretien
- ▶ Totalement étanche et à l'épreuve du basculement
- ▶ Extrêmement résistantes aux secousses
- ▶ S'adapte parfaitement aux charges extrêmes et à tous les types de terrains, idéal par ex. pour les enduros

M4 pour un démarrage fiable en toutes circonstances

- ▶ Sans entretien selon EN
- ▶ Démarrage fiable
- ▶ Longue durée de vie

Le batterie M4 e M6 di Bosch sono particolarmente resistenti e convincono grazie alla loro potenza di avviamento affidabile. Oltre che all'impiego nei motocicli si prestano anche per l'uso con acquascooter, ATV/quad, motoslitte e tagliaerba.

Confezione di acido compreso nella dotazione. Il vantaggio: attivazione semplice e sicura delle batterie.

M6 con tecnologia AGM ¹⁾

- ▶ La tecnologia AGM (Absorbent Glass Mat) soddisfa i requisiti più severi in termini di durata e potenza di avviamento a freddo
- ▶ 20% di durata in più e resistenza ai cicli fino a 4 volte maggiore
- ▶ Assolutamente esente da manutenzione
- ▶ Assolutamente resistente al ribaltamento, assolutamente ermetica
- ▶ Estremamente resistente alle vibrazioni
- ▶ Ottimale per sollecitazioni estreme come lunghi tragitti su sterrato – ideale ad es. per enduro

M4 per una potenza di avviamento sicura

- ▶ Esente da manutenzione secondo EN
- ▶ Potenza di avviamento affidabile
- ▶ Ciclo di vita lungo

Las baterías Bosch M4 y M6 son especialmente robustas y convienen por su potencia de arranque fiable. Además de utilizarse en motocicletas son adecuadas también para motos acuáticas, ATV-Quads, motos de nieve y cortadoras de césped.

Pack de ácido (freshpack) incluido en el suministro. Ventaja: activación sencilla y segura de las baterías.

M6 como tecnología AGM ¹⁾

- ▶ La tecnología AGM (Absorbent Glass Mat) satisface las más elevadas exigencias en cuanto a duración y arranque en frío
- ▶ 20% más de duración y una estabilidad de ciclos hasta 4 veces mayor
- ▶ Absolutamente libres de mantenimiento
- ▶ Absoluta seguridad contra vuelcos y fugas
- ▶ Extremadamente resistente a vibraciones
- ▶ Óptima para esfuerzos extremos como largos trayectos campo a través, ideal para, por ejemplo, enduro

M4 para una potencia de arranque segura

- ▶ Libre de mantenimiento según EN
- ▶ Potencia de arranque fiable
- ▶ Larga vida útil

¹⁾ Säure ist komplett in Mikroglasfaser-matten gebunden

¹⁾ Acid is completely bound in absorbed glass mats

¹⁾ L'acide est entièrement lié dans des matelas en microfibre de verre

¹⁾ L'acido è trattenuto completamente in strati di feltro di microfibra di vetro

¹⁾ El ácido está fijado por completo en esteras de microfibra de vidrio

pt

**Baterias Bosch
M6 – M4
para motocicletas**

fi

**Bosch-akut
M6 – M4
moottoripyöriin**

pl

**Akumulatory Bosch
M6 – M4 do
motocykli**

cs

**Akumulátory Bosch
M6 – M4 pro
motocykly**

ru

**Аккумуляторы
Bosch M6 – M4 для
мотоциклов**



As baterias Bosch M4 e M6 são especialmente robustas e convencem graças à sua potência de arranque fiável. Além da utilização em motos, também são adequadas para Jetskis, moto-quadro, motos de neve e cortadores de relva. Freshpack incluído no embalagem. Vantagem: Ativação simples e segura das baterias.

M6 com tecnologia AGM ¹⁾

- ▶ A tecnologia AGM (Absorbent Glass Mat) preenche os mais altos requisitos em termos de vida útil e força de partida a frio
- ▶ Vida útil 20% mais longa e resistência aos ciclos até 4 vezes superior
- ▶ Absolutamente isenta de manutenção
- ▶ Totalmente resistente contra viragem e fugas
- ▶ Extremamente resistente a vibrações
- ▶ Ótimo para solicitações extremas, como longos trajetos fora de estrada. Ideal p. ex. para enduros

M4 para uma potência de partida segura

- ▶ Isenta de manutenção segundo EN
- ▶ Força de partida fiável
- ▶ Longa vida útil

Boschin M4- ja M6-akut ovat erityisen vankkarakenteisia ja vakuuttavat luotettavalla käynnistysteholla. Paitsi moottoripyöriin nämä akut soveltuvat myös vesiskoottereihin, mönkijöihin, moottorikelkkoihin ja ruohonleikkureihin. Freshpack-happopakkaus kuuluu hintaan. Etu: Helppo ja turvallinen tapa aktivoida akku.

M6 tai teknologia AGM ¹⁾

- ▶ AGM-teknologia (Absorbent Glass Mat) täyttää korkeimmatkin vaatimukset käyttäjälle ja kylmäkäynnistyskestävyydelle
- ▶ 20% pitempi käyttöikä ja jopa 4-kertainen syklinkestävyys
- ▶ Täysin huoltovapaa
- ▶ Täysin kallistus- ja vuotovarma
- ▶ Äärimmäisen tärinänkestävä
- ▶ Optimaalinen raskaassa käytössä kuten pitkissä maastoajoissa - ihanteellinen esim. Enduro-pyöriin

M4 luotettavaan käynnistystehoon

- ▶ Huoltovapaa EN-normin mukaan
- ▶ Luotettava käynnistysteho
- ▶ Pitkä hyötykäyttöikä

Akumulatory Bosch M4 i M6 są nadzwyczaj wytrzymałe i przekonują swoją niezawodnością. Oprócz zastosowania w motocyklach są przeznaczone również do skuterów wodnych, quadów, skuterów śnieżnych i kosiarek. Zawierają dołączony zbiornik z elektrolitem - FreshPack. Zaleta: proste i bezpieczne uruchomienie akumulatora w domu.

M6 z technologią AGM ¹⁾

- ▶ Technologia AGM (Absorbent Glass Mat) spełnia najwyższe wymagania wytrzymałości i siły rozruchu na zimno
- ▶ 20% dłuższa żywotność i nawet czterokrotnie większa stabilność cyklu
- ▶ Całkowita bezobsługowość
- ▶ Zabezpieczenie przed wyciekami elektrolitu
- ▶ Niezwykła odporność na wstrząsy
- ▶ Optymalna do bardzo duych obciążeń, takich jak długie trasy terenowe – idealna np. do rajdów enduro

M4 zapewnia bezpieczną moc rozruchową

- ▶ Bezobsługowe zgodnie z normą EN
- ▶ Niezawodna moc rozruchu
- ▶ Wydłużony okres użytkowania

Akumulátory Bosch M4 a M6 jsou zvláště robustní a přesvědčí svou spolehlivou startovací silou. Kromě použití pro motocykly jsou vhodné také pro sněžné skútry, čtyřkolky, sněhové rolby a žací stroje. Freshpack je obsahem dodávky. Výhoda: jednoduchá a bezpečná aktivace akumulátorů.

M6 pomocí technologie AGM ¹⁾

- ▶ Technologie AGM (Absorbent Glass Mat) splňuje maximální nároky na životnost a energii pro studený start
- ▶ O 20 % vyšší životnost a až 4krát vyšší cyklická odolnost
- ▶ Absolutně bezúdržbový
- ▶ Absolutně bezpečný při převrácení, proti vytečení
- ▶ Zvláště odolné ořesům
- ▶ Optimální pro extrémní zatížení jako dlouhé terénní trasy – ideální např. pro typy Enduro

M4 pro bezpečný výkon při startování

- ▶ Bezúdržbový podle EN
- ▶ Spolehlivá startovací síla
- ▶ Dlouhá životnost

Аккумуляторы M4 и M6 компании Bosch отличаются особой прочностью и надежной стартовой мощностью. Они подходят не только для мотоциклов, но и для скутеров квадроциклов ATV, снегоходов и газонокосилок. Набор для заливки Freshpack входит в комплект поставки. Преимущество: простая и надежная активация аккумуляторов.

M6 в технология AGM

- ▶ Технология AGM (Absorbent Glass Mat) удовлетворяет высочайшим требованиям к сроку службы и току холодного пуска
- ▶ Срок службы больше на 20%, циклическая устойчивость выше в 4 раза
- ▶ Абсолютно необслуживаемые
- ▶ Абсолютная герметичность
- ▶ Экстремальная виброустойчивость
- ▶ Оптимально подходит для экстремальных нагрузок, таких как длительное движение по бездорожью;

M4 для надежной стартовой мощности

- ▶ Не требуют обслуживания согласно нормам EN
- ▶ Надежная стартовая мощность
- ▶ Длительный срок службы

¹⁾ O ácido está totalmente aglutinado nas esteiras de microfibras de vidro

¹⁾ Happo on imeytetty kokonaan mikrohuokoiseen lasikuituun

¹⁾ Kwas jest całkowicie związany w matach z mikrowłókna szklanego

¹⁾ Kyselina je kompletně vázána v rohožích ze skleněného mikrovlákna

de

**Bosch-Batterie
L5 – L4
für Freizeit-
anwendungen**

en

**Bosch battery
L5 – L4
for leisure
applications**

fr

**Batterie Bosch
L5 – L4
pour les applications
de loisirs**





it

**Batteria Bosch
L5 – L4
per applicazioni
del tempo libero**

es

**Baterías Bosch
L5 – L4
para aplicaciones
de ocio**



	L5 Deep Cycle	L4
Technologies	Labyrinth cap Deep-Cycle technology	Standard
Applications		
Caravans 	✓	–
Motorhomes 	✓	✓
Electric boats 	✓	–
Motor boats 	✓	–
Sailing yachts 	✓	–
Starting power	● ● ○	● ● ○
Cycle resistance	● ● ○	● ○ ○
Charge acceptance	● ● ○	● ● ○
Vibration proof	● ● ○	● ○ ○

Wird für mobile Anwendungen über lange Zeit Strom benötigt, so sind herkömmliche Starterbatterien dafür nicht geeignet. L-Batterien sind hingegen speziell auf die Anforderungen von Langzeitentladung ausgelegt. Sie liefern genau dort Energie, wo kein Stromnetz mehr verfügbar ist. Sie versorgen Boote, Wohnmobile, Golf-Caddies usw. mit tragbarer Energie. Und zwar zuverlässig und leistungsstark.

- ▶ Sehr zyklenfest
- ▶ Tiefentladefest
- ▶ Lange Einsatzdauer
- ▶ Absolut wartungsfrei
- ▶ L5 und L4 auslaufsicher bis 55° Kippwinkel
- ▶ Extrem rüttelfest
- ▶ Geringe Selbstentladung
- ▶ Hoher Energiedurchsatz
- ▶ Zentralentgasung

When it comes to providing power for mobile applications over a long period, conventional starter batteries are often not suitable. By contrast, L-batteries are specially designed for the requirements of long-term discharge. They provide power where no mains supply is available. They supply boats, mobile homes, golf carts etc. with portable power. Reliably and with high power.

- ▶ Excellent deep-cycle resistance
- ▶ Deep-discharge resistant
- ▶ Long service life
- ▶ Totally maintenance-free
- ▶ L5 and L4 leak-proof up to 55° tilt angle
- ▶ Extremely vibration-resistant
- ▶ Low self discharge
- ▶ High power throughput
- ▶ Central degassing

Les batteries de démarrage conventionnelles ne conviennent pas pour les applications mobiles qui nécessitent du courant sur une durée prolongée. Les batteries L, elles, sont spécialement conçues pour répondre aux exigences résultant d'une décharge sur une longue durée. Elles délivrent leur énergie là où il n'y a plus de réseau électrique. Elles alimentent en énergie mobile les bateaux, les mobile homes, les caddies de golf etc. Le tout avec une parfaite fiabilité et des performances élevées.

- ▶ Très résistantes aux sollicitations cycliques
- ▶ A l'épreuve des décharges profondes
- ▶ Autonomie élevée
- ▶ Sans aucun entretien
- ▶ L5 et L4 l'épreuve du basculement angle d'inclinaison max. 55°
- ▶ Extrêmement résistantes aux secousses
- ▶ Décharge spontanée réduite
- ▶ Rendement énergétique élevé
- ▶ Dégazage central

Se nell'ambito di applicazioni mobili è richiesta l'alimentazione elettrica per un tempo prolungato, le convenzionali batterie di avviamento non sono idonee. Le batterie L sono invece appositamente concepite per impieghi caratterizzati da una scarica prolungata. Queste batterie mettono a disposizione l'energia necessaria nei luoghi dove non è disponibile alcuna rete elettrica. Esse provvedono all'alimentazione di imbarcazioni, camper, caddy da golf, ecc, con energia portatile. E lo fanno con estrema affidabilità e potenza.

- ▶ Molto resistenti ai cicli di carica e scarica
- ▶ Resistenti alla scarica profonda
- ▶ Durata di impiego lunga
- ▶ Assolutamente esente da manutenzione
- ▶ L5 e L4 assolutamente ermetiche angolo di inclinazione fino a 55°
- ▶ Estremamente resistenti alle vibrazioni
- ▶ Autoscarica ridotta
- ▶ Elevata potenza
- ▶ Degassamento centrale

Quando se requiere corriente durante periodos prolongados para aplicaciones móviles, las baterías de arranque convencionales no satisfacen los requerimientos. Las baterías L, en cambio, están diseñadas especialmente para cumplir las exigencias de una descarga prolongada. Suministran energía en los lugares en los que no se dispone de ninguna red eléctrica. Alimentan a botes, caravanas, carros eléctricos de golf, etc., con energía portátil. Y lo hacen de forma fiable y potente.

- ▶ Sumamente resistentes a los ciclos
- ▶ Resistentes a la descarga profunda
- ▶ Utilizables durante periodos prolongados
- ▶ Absolutamente libres de mantenimiento
- ▶ L5 y L4 seguridad contra fugas hasta un ángulo de inclinación de 55°
- ▶ Extremadamente resistente a vibraciones
- ▶ Reducida autodescarga
- ▶ Gran caudal de energía
- ▶ Desgasificación central

pt

**Baterias Bosch
L5 – L4
para aplicações
de lazer**

fi

**Bosch-akut
L5 – L4
vapaa-ajan
viettoon**

pl

**Akumulatory Bosch
L5 – L4
do zastosowań
trakcyjnych**

cs

**Akumulátor Bosch
L5 – L4
pro volnočasové
aplikace**

ru

**Аккумуляторы
Bosch L5 – L4
для привода
и освещения**



Se for necessária corrente durante longos períodos de tempo para aplicações móveis, as baterias de partida convencionais não são adequadas para o efeito. As baterias L foram concebidas especialmente para as exigências de uma descarga prolongada. Elas fornecem energia onde não existe rede elétrica. Elas alimentam barcos, caravanas, carrinhos elétricos de golfe, etc., com energia portátil. E de forma fiável e potente.

- ▶ Muito resistente aos ciclos
- ▶ Resistente à descarga profunda
- ▶ Longa autonomia
- ▶ Absolutamente isenta de manutenção
- ▶ L5 e L4 resistente contra fugas ângulo máx. de inclinação de 55°
- ▶ Extremamente resistente a vibrações
- ▶ Autodescarga reduzida
- ▶ Elevado rendimento energético
- ▶ Saída de gases central

Mikäli akkuvirtaa tarvitaan liikkeellä ollessa moneen eri kohteeseen pitemmän ajan, perinteiset käynnistysakut eivät siihen pysty. L-akut sen sijaan on suunniteltu nimenomaan kestämään pitkäaikaiset purkausjaksot. Ne huolehtivat energiantuotosta siellä, missä verkkovirtaa ei ole saatavilla. Veneessä, matkailuautossa, golfcaddyssä ym. tämä akku on kannattava energiapakkas. Ja todella luotettava ja tehokas.

- ▶ Erittäin hyvä syklinkesto
- ▶ Syväpurkauksia kestävä
- ▶ Pitkä hyötykäyttöikä
- ▶ Täysin huoltovapaa
- ▶ L5 ja L4 vuotovarma jopa 55° asteen kippauskulma
- ▶ Äärimmäisen tärinänkestävä
- ▶ Alhainen itsepurkausaste
- ▶ Korkea energian hyötyste
- ▶ Keskitetty kaasunpoisto

Jeśli w przypadku zastosowań mobilnych potrzebny jest przez dłuższy czas prąd, to tradycyjne akumulatory rozruchowe nie są do tego przeznaczone. Akumulatory L zostały zaprojektowane specjalnie do zastosowań związanych z długim czasem rozładowania. Dostarczają one energię dokładnie tam, gdzie nie ma sieci elektrycznej. Zasilają łodzie, pojazdy kempingowe, wózki golfowe itp. Są niezawodne i bardzo wydajne.

- ▶ Odporne na pracę cykliczną
- ▶ Odporne na głębokie rozładowania
- ▶ Długi okres użytkowania
- ▶ Absolutnie bezobsługowe
- ▶ L5 i L4 Zabezpieczone przy przechyłach kat pochylenia do 55°
- ▶ Wyjątkowo odporne na wstrząsy
- ▶ Minimalne samorozładowanie
- ▶ Duża przepustowość energetyczna
- ▶ centralne odgazowanie

Jestliže je u mobilních aplikací požadována el. energie po delší dobu, nejsou k tomu běžné startovací akumulátory vhodné. Akumulátory L4 jsou naproti tomu dimenzovány speciálně ke splnění požadavku dlouhodobého vybíjení. Dodávají energii přesně tam, kde není k dispozici žádná elektrická síť. Napájejí čluny, obytná vozidla, golfové vozíky apod. mobilní energií. A to spolehlivě a výkonně.

- ▶ Velmi odolné cyklům
- ▶ Odolné proti hlubokému vybití
- ▶ Dlouhá doba použití
- ▶ Absolutně bezúdržbový
- ▶ L5 a L4 bezpečné proti vytečení do úhlu sklápění 55°
- ▶ Zvláště odolné otřesům
- ▶ Nízké samovybíjení
- ▶ Vysoký průtok energie
- ▶ Centrální odplynění

Если в случае отсутствия электросети длительное время требуется электропитание, то обычные стартерные аккумуляторы не подходят для этого. А вот аккумуляторы серии L специально приспособлены к условиям длительной разрядки. Они являются источником мобильной электроэнергии для яхт, катеров, жилых автомобилей, гольф-каров и т.д., обеспечивая надежность и высокую мощность.

- ▶ Чрезвычайно высокая устойчивость к циклическим нагрузкам
- ▶ Стойкость к глубокому разряду
- ▶ Длительный срок эксплуатации
- ▶ Абсолютно необслуживаемые
- ▶ L5 и L4 Герметичность при наклонах до 55°
- ▶ Экстремальная виброустойчивость
- ▶ Небольшая саморазрядка
- ▶ Высокая производительность
- ▶ Центральный газоотвод

de

**Batterierücknahme-
system von Bosch**

en

**Battery Collection
System von Bosch**

fr

**Système de
collecte de batteries
de Bosch**

it

**Battery Collection
System di Bosch**

es

**El sistema de
reciclaje de baterías****Das Batterierücknahme-
system: einfach, effizient und
nachhaltig****Vorteile des Systems:**

- ▶ **Einfach und kostenlos:**
Altbatterien werden ohne Sorgen für den Endverbraucher zurückgenommen
- ▶ **Effizient:**
Bei der Lieferung neuer Batterien an die Werkstatt/ den Händler werden gleichzeitig die Altbatterien abgeholt
- ▶ **Nachhaltig:**
Die Altbatterien werden recycelt und für die Herstellung neuer Batterien verwendet
- ▶ **Einhaltung der gesetzlichen Vorschriften:**
Eingeschränkte Lagerung von Gefahrgut in den Werkstätten und dokumentierter Entsorgungsprozess
- ▶ **Image:**
Umweltfreundliches Image für Sie und die Werkstatt sowie besserer Service für den Endverbraucher

**The battery collection system:
simple, efficient and sustainable****The system's benefits:**

- ▶ **Simple and free:**
Old batteries are recovered without worries for the end consumer
- ▶ **Efficient:**
When delivering the new batteries to the workshop/ retailer, old batteries are collected at the same time
- ▶ **Sustainable:**
The old batteries are recycled and used for manufacturing of new batteries
- ▶ **Legal compliance:**
Limited stocking of dangerous goods in the workshops and a documented disposal process
- ▶ **Image:**
Environmentally friendly image for yourself, the workshop and increased service for the end consumer

**Système de collecte de batteries :
simplicité, efficacité et
durabilité****Avantages du système :**

- ▶ **Simplicité et gratuité :**
les batteries usagées sont récupérées sans que le consommateur final n'ait à se soucier de quoi que ce soit
- ▶ **Efficacité :**
les batteries usagées sont collectées lors de la livraison des nouvelles batteries à l'atelier ou chez le détaillant
- ▶ **Durabilité :**
les batteries usagées sont recyclées et intégrées dans la production de nouvelles batteries
- ▶ **Respect des obligations légales :**
limitation du stockage de substances dangereuses dans les ateliers et processus d'élimination documenté
- ▶ **Image :**
les ateliers et vous-même acquérez l'image d'entreprises soucieuses de l'environnement et offrez au client final un service supplémentaire

**Sistema di raccolta delle
batterie: semplice, efficiente e
sostenibile****I vantaggi del sistema:**

- ▶ **Semplice e gratuito:**
le vecchie batterie vengono ritirate senza problemi per il consumatore finale
- ▶ **Efficiente:**
le vecchie batterie vengono raccolte al momento della consegna delle nuove batterie all'officina / al distributore
- ▶ **Sostenibile:**
le vecchie batterie vengono riciclate e utilizzate per la produzione di nuove batterie
- ▶ **Conformità legale:**
stock limitato di merci pericolose nelle officine e un processo di smaltimento documentato
- ▶ **Immagine:**
un'immagine ecologica per voi e l'officina e servizi maggiori per il consumatore finale

**El sistema de reciclaje de
baterías: sencillo, eficiente y
sostenible****Las ventajas del sistema:**

- ▶ **Sencillo y gratuito:**
Se recuperan las baterías viejas sin problemas para el consumidor final
- ▶ **Efficiente:**
Cuando se suministran las baterías viejas al taller/minorista, se recogen al mismo tiempo las baterías viejas
- ▶ **Sostenible:**
Las baterías viejas se reciclan y se usan para la fabricación de baterías nuevas
- ▶ **Conformidad legal:**
Almacenamiento limitado de mercancías peligrosas en los talleres y un proceso de eliminación documentado
- ▶ **Imagen:**
Imagen de respeto del medio ambiente para usted, el taller y más servicios para el consumidor final

pt

Recolha de baterias Sistema da Bosch

fi

Akkualikoima Bosch-järjestelmä

pl

System odbierania akumulatorów firmy Bosch

cs

Systém zpětného odběru akumulátorů od společnosti Bosch

ru

Система сбора аккумуляторов от Bosch

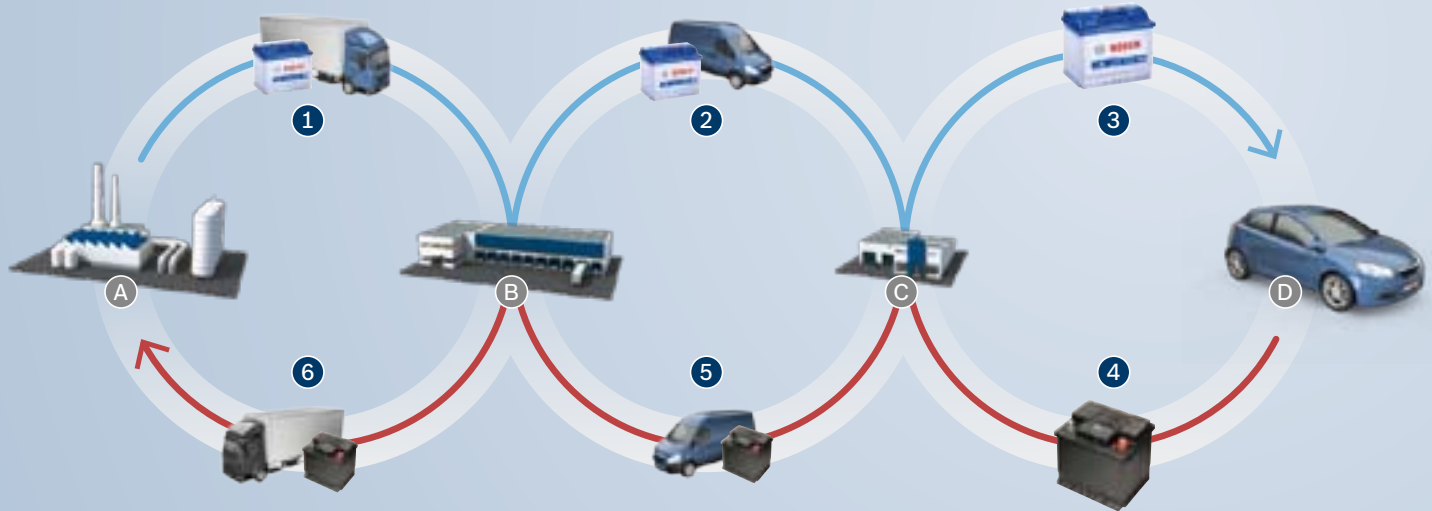

Commercial levels

- (A) Factory/Recycling plant
- (B) Wholesaler/Distributor
- (C) Workshop/Retailer
- (D) End consumer

Battery collection cycle

- ① New batteries are delivered directly to the wholesaler/distributor
- ② The wholesaler/distributor delivers the new batteries to the workshops/retailers
- ③ The workshop mounts the new battery in the customer's vehicle
- ④ The old battery is recovered right away by the workshop
- ⑤ The wholesaler/distributor collects the old batteries
- ⑥ The old batteries are picked up from the wholesaler/distributor, using specially designed containers

O sistema de recolha de baterias: simples, eficaz e sustentável

Os benefícios do sistema:

- ▶ **Simple e gratuito:**
As baterias usadas são recuperadas sem preocupações para o consumidor final
- ▶ **Eficaz:**
Por ocasião da entrega das baterias novas na oficina/ao varejista, as baterias usadas são simultaneamente recolhidas
- ▶ **Sustentável:**
As baterias usadas são recicladas e utilizadas para o fabrico de baterias novas
- ▶ **Conformidade jurídica:**
Armazenamento limitado de materiais perigosos em oficinas e um processo de descarte documentado
- ▶ **Imagem:**
Uma imagem ecológica para você e para a oficina e um melhor serviço para o cliente final

Akkualikoimat: selkeät, tehokkaat ja kestävät

Järjestelmän edut:

- ▶ **Selkeä ratkaisu:**
Käytetyt akut johdetaan kierrätykseen, käyttäjän ei tarvitse huolehtia niistä
- ▶ **Tehokas:**
Kun korjaamoon tai jälleenmyyjälle toimitetaan uusia akkuja, käytetyt akut kerätään samalla talteen
- ▶ **Kestävää kehitystä:**
Käytetyt akut johdetaan uusiokäyttöön ja hyödynnetään uusia akkuja valmistettaessa
- ▶ **Lakisääteiset määräykset:**
Rajoitukset koskien vaarallisten tuotteiden varastointia korjaamoissa sekä niiden hävittämiseen liittyvä dokumentointi
- ▶ **Imago:**
Ympäristöystävällinen omakuva sekä yritykselle että korjaamolle, loppusiakkaseen kohdistuvien palvelujen tehostaminen

System odbierania akumulatorów: prosty, sprawny i ekologiczny

Korzysci płynące z systemu:

- ▶ **Prosto i bez kłopotu:**
stare akumulatory są odzyskiwane bez adnych staran ze strony klienta końcowego
- ▶ **Sprawnie:**
podczas dostawy nowych akumulatorów do stacji obsługi/sprzedawcy stare akumulatory są jednocześnie odbierane
- ▶ **Ekologicznie:**
stare akumulatory są poddawane recyklingowi i uywane do produkcji nowych
- ▶ **Zgodnie z przepisami prawa:**
ograniczone składowanie produktów niebezpiecznych w stacjach obsługi i udokumentowany proces utylizacji
- ▶ **Wizerunek:**
wizerunek Twojej firmy i stacji obsługi jako przyjaznych środowisku, zwiększona wartość usług dla klienta końcowego

Systém zpětného odběru akumulátorů: jednoduchý, efektivní a udržitelný

Výhody systému:

- ▶ **Je jednoduchý a zdarma:**
Použité akumulátory se recyklují, aniž by to zatěžovalo koncové zákazníky
- ▶ **Účinnost:**
Při každé dodávce nových akumulátorů do servisních dílen/prodejen, se současně odebírají použité akumulátory
- ▶ **Udržitelnost:**
Použité akumulátory se recyklují a používají k výrobě nových akumulátorů
- ▶ **Dodržování zákonných předpisů:**
Omezené možnosti skladování nebezpečných látek v jednotlivých servisních dílnách a dokumentace veškerých postupů při jejich likvidaci
- ▶ **Image:**
Získáte image někoho, kdo pečuje o životní prostředí a zároveň z kvalitní služby poskytované koncovým zákazníkům

Система сбора аккумуляторов: простая, эффективная и экологически безопасная

Преимущества системы:

- ▶ **Простота и доступность:**
Старые аккумуляторы перерабатываются без забот для конечного пользователя
- ▶ **Эффективность:**
Одновременно с доставкой новых аккумуляторов на СТО/дилера выполняется сбор старых аккумуляторов
- ▶ **Защита окружающей среды:**
Старые аккумуляторы перерабатываются и используются для производства новых
- ▶ **Соответствие законодательным требованиям:**
Сокращение запасов опасных грузов на СТО и документированный процесс утилизации
- ▶ **Улучшение имиджа:**
Создайте своей СТО имидж предприятия, заботящегося об окружающей среде; повысьте уровень обслуживания конечных потребителей

de Batterie-Zubehör	en Battery accessories	fr Accessoires pour batteries	it Accessori per batterie	es Accesorios para baterías
-------------------------------	----------------------------------	--	--	--



Batteriepolklemmen mit verzinnter Oberfläche Battery pole terminals with tin-plated surface Bornes de batterie étamées Morsetti batteria con superficie stagnata Bornes de los polos de la batería con superficie cincada Terminais dos pólos da bateria com superfície estanhada Akkunapojen pinta on tinattu Zaciski biegunów akumulatora z cynkową powierzchnią Svorky pólu akumulátoru s pozinkovaným povrchem Клеммы полюсных выводов с оцинкованной поверхностью	Leiterquerschnitt mm ² Cable cross-section mm ² Section du conducteur mm ² Sezione del conduttore mm ² Sección de cable mm ² Seção transversal do cabo mm ² Johdinpöikkipinta mm ² Przekrój przewodu w mm ² Průřez vodiče mm ² Поперечное сечение, mm ²	Pol Terminal Pôle Polo Polo Pólo Napa Biegun Pól Полюсный вывод	Bestellnummer * Order number * Référence * Numero d'ordinazione * Referencia de pedido * Referência * Tilausnumero* Nr katalogowy * Objednací číslo * Номер для заказа *
①	16,0 – 70,0	+	1 901 315 100
		-	1 901 315 102
		- +	1 901 315 120
②	16,0 – 70,0	+	1 901 315 104
		-	1 901 315 105
		- +	1 901 315 125
③	70,0 – 120,0	+	1 901 315 101
		-	1 901 315 103

* DIN 72 331

pt

Acessórios da bateria

fi

Akun lisävarusteet

pl

Wyposażenie dodat-
kowe akumulatora

cs

Příslušenství
akumulátoru

ru

Принадлежности
для аккумуляторов

④ **Bodenleisten-Adapter**
von B13 auf B14 (Set bestehend
aus 2 Adaptern)

0 189 999 020

⑤ **Ford Pol-Adapter Set**
von Pol 1 auf Pol 19
(Set bestehend aus 1 x Pluspol-
Adapter und 1 x Minuspol-
Adapter)

0 189 999 021

④ **Adaptador das barras de
fixação**
de B13 para B14 (conjunto
composto por 2 adaptadores)

0 189 999 020

⑤ **Conjunto de adaptadores de
pólos Ford**
de pólo 1 ao pólo 19 (conjunto
composto por 1 x adaptador de
pólo positivo e 1 x adaptador de
pólo negativo)

0 189 999 021

④ **Bottom-rail adapter**
from B13 to B14 (Set consisting
of 2 adapters)

0 189 999 020

⑤ **Ford terminal-adapter set**
from terminal 1 to terminal 19
(Set consists of 1 x positive-
terminal adapter and
1 x negative-terminal adapter)

0 189 999 021

④ **Pohjakiinnityksen sovitin**
koosta B13 kokoon B14
(sarjassa 2 sovitinta)

0 189 999 020

⑤ **Ford-napasovitusarja**
navalta 1 navalle 19 (sarjassa 1
x plusnavan ja 1 x miinusnavan
sovitin)

0 189 999 021

④ **Adaptateurs pour rebord de
fixation de B13 à B14**
(kit comprenant 2 adaptateurs)

0 189 999 020

⑤ **Kit adaptateur de pôle Ford**
de pôle 1 à pôle 19 (kit com-
prenant 1 adaptateur de pôle
positif et 1 adaptateur de pôle
négatif)

0 189 999 021

④ **Adapter listew podłożowych**
z B13 na B14 (zestaw
składający się z 2 adapterów)

0 189 999 020

⑤ **Zestaw adaptera biegun
Ford**
z biegun 1 na biegun 19 (zestaw
składający się z 1-go adaptera
biegun dodatniego i 1-go
adaptera biegun ujemnego)

0 189 999 021

④ **Adattatore listello
di fissaggio da B13 a B14**
(kit comprendente 2 adattatori)

0 189 999 020

⑤ **Kit adattatori poli Ford**
da polo 1 a polo 19 (kit com-
posto da 1 x adattatore polo
positivo e 1 x adattatore polo
negativo)

0 189 999 021

④ **Adaptér pro podlahové lišty**
z B13 na B14 (sada se skládá ze
2 adaptérů)

0 189 999 020

⑤ **Pólový adaptér Ford**
z pólu 1 na pól 19 (sada se
skládá z 1 x adaptéru pro pól
plus 1 x adaptéru pro pól minus)

0 189 999 021

④ **Listón de sujeción**
de B13 a B14
(juego de 2 adaptadores)

0 189 999 020

⑤ **Juego adaptador terminal
Ford** de polo 1 a polo 19
(juego de 1 x adaptador polo
positivo y 1 x adaptador polo
negativo)

0 189 999 021

④ **Адаптер к нижней части
корпуса**
с В13 на В14 (комплект,
состоящий из 2 адаптеров)

0 189 999 020

⑤ **Комплект адаптеров для
клемм Ford**
с клеммы 1 на клемму 19
(комплект, состоящий из 1
адаптера положительного
полюса и 1 адаптера
отрицательного полюса)

0 189 999 021

de

Die kompakten Batterielader C3 und C7

en

The compact battery chargers C3 and C7

fr

Les chargeurs de batteries compacts C3 et C7

it

I caricabatterie compatti C3 e C7

es

Los cargadores de baterías compactos C3 y C7



Die kompakten Batterielader C3 und C7: volle Leistung auf Knopfdruck

C3

- ▶ Mit dem C3 von Bosch lassen sich schwache Pkw-Batterien und Batterien von Motorrollern, Mopeds und Scootern automatisch, schnell und sicher laden

C7

- ▶ Der C7 von Bosch lädt stark beanspruchte Starterbatterien von Transportern, Campern und großen Motorrädern.
- ▶ Mit 7A Stromstärke ist er eine ideale Lösung für große 12- oder 24-V-Batterien

Einfache Bedienung

- ▶ Die kompakten Bosch-Batterielader sind über einen einzigen Knopf leicht und bequem zu bedienen
- ▶ Die Memory Funktion speichert die letzte Geräteeinstellung

Zubehör

- ▶ Wandhalterung, Mobilhaken, Kabeladapter oder Kleineladerkabel inklusive Stecker mit Sicherung
- ▶ Das praktische Zubehör gewährleistet optimales Arbeiten mit den Bosch-Batterieladern

Compact battery chargers C3 and C7: full power at the push of a button

C3

- ▶ With the C3 from Bosch, weak passenger car batteries and scooter and moped batteries can be charged automatically, quickly and safely

C7

- ▶ The C7 from Bosch charges hard-working starter batteries in vans, campers and large motorbikes
- ▶ With a current intensity of 7A, it is the ideal solution for large 12 or 24-V batteries

Easy to use

- ▶ Compact Bosch battery chargers are easy and convenient to use, with a single button.
- ▶ The memory function saves the last device setting

Accessories

- ▶ Wall bracket, mobile hook, cable adapter or small charger cable including plug with fuse
- ▶ These practical accessories guarantee optimum work with Bosch battery chargers

Chargeurs de batterie compacts C3 et C7 : puissance maximale d'une simple pression sur un bouton

C3

- ▶ Le chargeur C3 de Bosch permet de charger les batteries pour voitures particulières et les batteries des scooters et cyclomoteurs automatiquement, rapidement et en toute sécurité

C7

- ▶ Le chargeur C7 de Bosch charge les batteries de démarrage fortement sollicitées des camionnettes, des mobile-homes et des motos de grosses cylindrées
- ▶ Avec une intensité du courant de 7 A, il constitue la solution idéale pour les grandes batteries de 12 ou 24 V

Utilisation simple

- ▶ Les chargeurs de batterie Bosch compacts peuvent être utilisés facilement au moyen d'un simple bouton
- ▶ La fonction « Memory » permet d'enregistrer la dernière configuration de l'appareil

Accessoires

- ▶ Fixation murale, crochet pour montage, adaptateur pour câble ou câble pour chargeur portatif avec connecteur et fusible
- ▶ Notre gamme d'accessoires pratiques permet un travail optimal avec les chargeurs de batterie Bosch

I caricabatterie compatti C3 e C7: piena potenza con la semplice pressione di un pulsante

C3

- ▶ Con il caricabatterie C3 di Bosch è possibile ricaricare le batterie auto e le batterie di motocicli e scooter in modo automatico, rapido e sicuro

C7

- ▶ Il caricabatterie C7 di Bosch carica le batterie d'avviamento sottoposte a forti sollecitazioni di furgoni, camper e grandi motocicli
- ▶ Con un'intensità di corrente di 7A rappresenta la soluzione ideale per grandi batterie da 12 o 24 V

Uso semplicissimo

- ▶ I caricabatterie Bosch compatti si utilizzano in modo comodo e semplice con la pressione di un pulsante
- ▶ La funzione Memory memorizza l'ultima impostazione dell'apparecchio

- ▶ La funzione Memory memorizza l'ultima impostazione dell'apparecchio

Accessori

- ▶ Supporto a parete, ganci mobili, adattatore cavi o piccolo cavo di carica con spina e fusibile
- ▶ I pratici accessori per utilizzare in modo ottimale i caricabatterie Bosch

Los cargadores de baterías compactos C3 y C7: potencia total con solo pulsar un botón

C3

- ▶ Con el C3 de Bosch se pueden cargar de forma segura, rápida y automática las baterías desgastadas de turismos, ciclomotores, motocicletas y scooters

C7

- ▶ El C7 de Bosch carga baterías de arranque sometidas a mucho esfuerzo de furgonetas, caravanas y motos
- ▶ Con la intensidad de corriente 7A, es una solución ideal para baterías grandes de 12 o 24-V

Manejo sencillo

- ▶ Los cargadores compactos de batería de Bosch se manejan de forma cómoda y sencilla mediante un único botón
- ▶ La función de memoria almacena los últimos ajustes del dispositivo

Accesorio

- ▶ Soporte de pared, gancho móvil, adaptador de cable o cable de cargador pequeño incluido conector con fusible
- ▶ El práctico accesorio garantiza un trabajo óptimo con los cargadores de batería de Bosch

pt

Os carregadores de baterias compactos C3 e C7

fi

Kompaktit akkuvaraajat C3 ja C7: täysi teho yhdellä nupin painalluksella

pl

Ładowarki do akumulatorów C3 i C7

cs

Kompaktní nabíjecí zařízení akumulátorů, C3 a C7

ru

Компактные зарядные устройства аккумуляторов C3 и C7



Compactos carregadores de bateria C3 e C7: potência total ao alcance de um botão

C3

- ▶ O C3 da Bosch permite carregar de modo automático, rápido e seguro baterias fracas de veículos de passeio e baterias de lambretas, scooters e outros ciclomotores

C7

- ▶ O C7 da Bosch carrega baterias de partida sob grande esforço de furgões, trailers e motos grandes
- ▶ Com uma intensidade de corrente de 7 A, esta é a solução ideal para baterias grandes de 12 ou 24 V

Operação simples

- ▶ Os compactos carregadores de bateria Bosch são fáceis e práticos de operar, com um único botão
- ▶ A função de memória salva o último ajuste do aparelho

Acessórios

- ▶ Suportes de parede, ganchos para utilização móvel, adaptadores de cabos ou cabos de carregador pequenos incluindo conector com fusível
- ▶ Os acessórios práticos asseguram um ótimo trabalho com os carregadores de bateria Bosch

Kompaktit akkuvaraajat C3 ja C7: täysi teho yhdellä nupin painalluksella

C3

- ▶ Bosch-akkuvaraajalla C3 purkautunut akku on nopea ja turvallinen varata automaattisesti henkilöautoissa, mutta myös vespoissa, mopedeissa ja skoottereissa

C7

- ▶ Bosch-varaaja C7 on suunniteltu raskaassa käytössä olevien käynnistysakkujen varaukseen pakettiautoissa, matkailuautoissa ja suuren kokoluokan moottoripyörissä
- ▶ 7 ampeerin varausvirta on ihanteellinen ratkaisu suurien 12 ja 24 voltin akkujen tapauksessa

Yksinkertainen käyttö

- ▶ Kompaktien Bosch-akkuvaraajien toiminnot käynnistetään yhdellä ainoalla nupin painalluksella
- ▶ Muistitoiminto tallentaa viimeiset laiteasetukset

Lisävarusteet

- ▶ Seinäteline, siirrettävät koukut, kaapelidapterit sekä pienvaraajakaapelit + pistoke ja sulake
- ▶ Käytännölliset lisävarusteet takaavat optimaaliset toimenpiteet Bosch-akkuvaraajia käsiteltäessä

Kompaktowe prostowniki do akumulatorów C3 i C7: pełna moc za jednym naciśnięciem przycisku

C3

- ▶ Prostownik Bosch C3 umoliwia automatyczne, szybkie i pewne ładowanie słabych akumulatorów samochodów osobowych oraz akumulatorów motocykli, motorowerów i skuterów

C7

- ▶ Prostownik C7 umoliwia ładowanie intensywnie wykorzystywanych akumulatorów rozruchowych w pojazdach dostawczych, kempingowych i dych motocyklach
- ▶ Nateenie prądu 7 A stanowi idealne rozwiązanie dla dych akumulatorów 12 lub 24 V

Łatwa obsługa

- ▶ Kompaktowe prostowniki do akumulatorów Bosch są łatwe i wygodne w obsłudze dzięki zastosowaniu pojedynczego przycisku
- ▶ Funkcja pamięci zapisuje ostatnie ustawienie urządzenia

Wyposażenie dodatkowe

- ▶ Mocowanie ścienne, przenosny haczyk, przejściówka kablowa lub kabel do małych ładowarek z wtyczka zawierająca bezpiecznik
- ▶ Praktyczne wyposażenie dodatkowe zapewnia optymalną pracę z prostownikami do akumulatorów firmy Bosch

Kompaktní zařízení pro nabíjení akumulátorů C3 a C7: Plný výkon stisknutím tlačítka.

C3

- ▶ Pomocí C3 od společnosti Bosch lze automaticky, rychle a bezpečně nabíjet slabé akumulátory osobních vozidel a akumulátory mopedů a skútrů

C7

- ▶ C7 od společnosti Bosch nabije silně namáhané startovací akumulátory dodávkových vozidel, obytných automobilů a velkých motocyklů
- ▶ S intenzitou proudu 7 A je ideálním řešením pro velké akumulátory 12 nebo 24 V

Jednoduché ovládání

- ▶ Kompaktní zařízení pro nabíjení akumulátorů Bosch lze snadno a pohodlně ovládat jediným tlačítkem
- ▶ Funkce Memory (paměť) ukládá poslední nastavení zařízení

Příslušenství

- ▶ Držák na stěnu, mobilní háky, kabelový adaptér nebo kabel pro malá nabíjecí zařízení včetně konektoru se zajištěním
- ▶ Praktické příslušenství zaručuje optimální práci se zařízením pro nabíjení akumulátorů Bosch

Компактные зарядные устройства C3 и C7: запуск одним нажатием кнопки

C3

- ▶ С помощью C3 от Bosch можно быстро и надежно заряжать в автоматическом режиме аккумуляторы для легковых

C7

- ▶ C7 от Bosch позволяет заряжать стартерные аккумуляторы небольших фургонов, туристических автомобилей и больших мотоциклов.
- ▶ С током силой 7 А, это устройство - идеальное решение для больших 12- или 24-вольтовых аккумуляторов.

Простое управление

- ▶ Компактным зарядным устройством Bosch можно легко управлять с помощью единственной кнопки.
- ▶ Функция памяти позволяет сохранять результаты последней настройки устройства

Принадлежности

- ▶ Настенное крепление, переносной крюк, кабельный адаптер или кабель для малогабаритного зарядного устройства, в т. ч. разъем с предохранителем
- ▶ Практичные принадлежности гарантируют оптимальную работу

de

Batterietester von Bosch – BAT 131 für alle 6 V und 12 V Starter-Batterien

en

Battery tester from Bosch – BAT 131 for all 6 V and 12 V starter batteries

fr

Testeur de batterie Bosch – BAT 131 pour toutes les batteries de démarrage de 6 V et de 12 V

it

Tester per batterie Bosch – BAT 131 per tutte le batterie di avviamento da 6 V e 12 V

es

Comprobador de baterías de Bosch – BAT 131 para todas las baterías de arranque de 6 V y 12 V



Schnell, präzise und verlässlich

Der neue tragbare Batterietester BAT 131 eignet sich optimal zum Testen von Starter-Batterien (Blei-Säure-, Gel- und Vlies-Batterien/AGM).

Der Kaltstartstrom ist wahlweise nach den Normen EN, EN2, DIN, SAE, IEC und JIS von 100-2000 A einstellbar.

Fast, precise and reliable

The new portable battery tester BAT 131 is perfectly convenient for testing starter batteries (lead acid, gel and fleece batteries / AGM).

The cold start current can be set as required between 100 and 2,000 A according to the standards EN, EN2, DIN, SAE, IEC and JIS.

Rapide, précis, fiable

Le nouveau testeur de batterie portatif BAT 131 de Bosch est idéal pour tester les batteries de démarrage (batteries au plomb-acide, au gel et AGM).

Le courant démarrage à froid est réglable au choix selon les normes EN, EN2, DIN, SAE, IEC et JIS de 100 à 2 000 A.

Rapido, preciso ed affidabile

Il nuovo tester portatile per batterie BAT 131 si presta in modo ottimale per il controllo di batterie di avviamento (al piombo-acido, gel e AGM).

La corrente di avviamento a bassa temperatura è impostabile a scelta, secondo le norme EN, EN2, DIN, SAE, IEC e JIS, da 100 a 2000 A.

Rápido, preciso y fiable

El nuevo comprobador de baterías portátil BAT 131 es óptimo para la comprobación de baterías de arranque (baterías de plomo-ácido, gel y AGM).

La corriente de arranque en frío se puede ajustar opcionalmente según las normas EN, EN2, DIN, SAE, IEC y JIS entre 100 y 2000 A.

Vorteile auf einen Blick

- ▶ Menügeführte intuitive Bedienung
- ▶ Test des Batteriezustands und Erkennung von Batterie-defekten
- ▶ Optimierter Testalgorithmus für die Überprüfung neuer Batterien
- ▶ Erweiterter Test des Start- / Ladesystems für 12 V und 24 V Batterien.
- ▶ Integrierter Drucker stellt Messergebnisse übersichtlich und grafisch dar
- ▶ USB-Anschluss zur Speicherung der Testergebnisse
- ▶ Austauschbares, 3 m langes Kabel

Advantages at a glance

- ▶ Menu-guided intuitive operation
- ▶ Test of battery condition and identification of defective batteries
- ▶ Optimized test algorithm for testing new batteries
- ▶ Extended test of the 12 V and 24 V starting/ charging system for batteries.
- ▶ Integrated printer provides graphical printouts
- ▶ USB port for transferring the test results
- ▶ 3 m replaceable cable

Les avantages

- ▶ Utilisation intuitive à l'aide de menus
- ▶ Test de l'état de la batterie et détection de défauts ses
- ▶ Algorithme de test optimisé pour le contrôle des batteries neuves
- ▶ Test étendu du système de démarrage/charge pour les batteries de 12 V et 24V
- ▶ Graphique des résultats clair grâce à l'imprimante intégrée
- ▶ Port USB pour l'enregistrement des résultats des tests
- ▶ Câble de 3 m amovible

Ecco un riepilogo dei vantaggi decisivi

- ▶ Comando intuitivo guidato da menu
- ▶ Test dello stato della batteria e riconoscimento di difetti della batteria
- ▶ Algoritmo di controllo ottimizzato per il controllo di batterie nuove
- ▶ Test ampliato del sistema di avviamento/carica per batterie da 12 V e 24V.
- ▶ La stampante integrata consente una chiara rappresentazione grafica dei risultati di misura
- ▶ Presa USB per il salvataggio dei risultati dei test
- ▶ Cavo lungo 3 m, sostituibile

Las ventajas de un vistazo

- ▶ Manejo intuitivo guiado por menú
- ▶ Prueba del estado de la batería y detección de defectos en la misma
- ▶ Algoritmo optimizado para comprobación de baterías nuevas
- ▶ Comprobación extendida del sistema de arranque/carga para baterías de 12 V y 24 V
- ▶ Impresora integrada presenta los resultados de las mediciones de forma gráfica e intuitiva
- ▶ Puerto USB para almacenar los resultados de las pruebas
- ▶ Cable de 3 m de longitud, sustituible

Technische Daten BAT 131

Menüsprachen: 24
Maße mit Drucker: (BxHxT): ca. 270x113x50 mm
Gewicht mit Drucker: ca. 700 g
Betriebstemperatur: 0° – 40° C

Technical data BAT 131

Menu languages: 24
Dims. inclusive printer: (B x W x T) approx. 270x113x50 mm
Weight inclusive printer: approx. 700 g
Operating temperature: 0° – 40° C

Caractéristiques techniques BAT 131

Langues des menus : 24
Dimensions avec imprimante : (LxHxP) : env. 270x113x50 mm
Poids avec imprimante : env. 700 g
Température de service : 0° – 40° C

Dati tecnici BAT 131

Lingue del menu: 24
Dimensioni con stampante (Lxaxp): ca. 270x113x50 mm
Peso con stampante: ca. 700 g
Temperatura di esercizio: 0° – 40° C

Datos técnicos de BAT 131

Idiomas: 24
Medidas con impresora: (ancho x alto x profundo): aprox. 270x113x50 mm
Peso con impresora: aprox. 700 g
Temperatura de servicio: 0° – 40° C

pt

Aparelho de teste para baterias da Bosch – BAT 131 para todas as baterias de partida de 6 V e 12 V

fi

Bosch-akutesteri BAT 131 kaikkiin 6 V ja 12 V käynnistysakuihin

pl

Tester akumulatorów – Bosch BAT 131 do wszystkich akumulatorów rozruchowych 6 V i 12 V

cs

Tester akumulátorů Bosch – BAT 131 pro všechny startovací akumulátory 6 V a 12 V

ru

Тестер БАТ 131 от Bosch – для всех стартерных аккумуляторов 6 В и 12 В



Rápido, preciso e fiável

O novo aparelho de teste para baterias portátil BAT 131 é ideal para testar baterias de partida (baterias de chumbo-ácido, de gel e AGM).

A corrente de partida a frio é ajustável opcionalmente de 100 – 2 000 A segundo as normas EN, EN2, DIN, SAE, IEC e JIS.

Resumo das vantagens

- ▶ Utilização intuitiva guiada por menu
- ▶ Teste do estado da bateria e deteção de defeitos na mesma
- ▶ Algoritmo de teste otimizado para a verificação de baterias novas
- ▶ Teste ampliado do sistema de partida / carga para baterias de 12 V e 24 V.
- ▶ Impressora integrada apresenta resultados de medição de forma clara e gráfica
- ▶ Conexão USB para a memorização dos resultados de teste
- ▶ Substituível, cabo com 3 m de comprimento

Dados técnicos BAT 131

Idiomas: 24
Dimensões com impressora: (LxAxP): aprox. 270x113x50 mm
Peso com impressora: aprox. 700 g
Temperatura de serviço: 0° – 40° C

Nopea, tarkka ja luotettava

Uusi kannettava akutesteri BAT 131 soveltuu ihanteellisesti käynnistysakujen testaukseen (lyijy-, happo-, geeli ja kuituakut / AGM).

Kylmäkäynnistysvirta voidaan säätää valinnaisesti eri standardien mukaan: EN, EN2, DIN, SAE, IEC ja JIS alueelle 100 – 2 000 A.

Vilkaiseppa etuja

- ▶ Valikko-ohjatut, intuitiiviset toiminnot
- ▶ Akun kunnon tarkastus ja vikojen tunnistus
- ▶ Optimoitu testialgoritmi uusien akkujen tarkastukseen
- ▶ Laajennettu testi käynnistys-/varausjärjestelmiin 12 V ja 24 V.
- ▶ Yhdysrakenteinen printteli tulostaa mittaustulokset selkeään, graafiseen muotoon
- ▶ USB-portti testitulosten tallentamista varten
- ▶ Vaihdettava 3 m:n pituinen kaapeli

Tekniset tiedot – BAT 131

Valikkokielet: 24
Printterin mitat (LxKxS): n. 270x113x50 mm
Printterin paino: n. 700 g
Käyttölämpötila: 0° – 40° C

Szybko, precyzyjnie i niezawodnie

Nowy przenośny tester akumulatorów BAT 131 jest przeznaczony do testowania ołowio-w kwasowych akumulatorów rozruchowych (z elektrolitem płynnym, żelowych i AGM). Testowy prąd zimnego rozruchu można ustawić od 100 do 2000 A według norm EN, EN2, DIN, SAE, IEC i JIS.

Najważniejsze zalety

- ▶ Intuicyjne menu
- ▶ Test stanu akumulatora i rozpoznawanie uszkodzeń akumulatora
- ▶ Optymalny algorytm testu do sprawdzania nowych akumulatorów
- ▶ Rozszerzony test startowy/ładowania dla akumulatorów 12 V i 24 V.
- ▶ Zintegrowana drukarka przedstawia wyniki pomiarów w sposób przejrzysty i graficznie
- ▶ Port USB do zapisywania wyników testów
- ▶ Wymienny kabel 3 m

Dane techniczne BAT 131

Języki menu: 24
Wymiary z drukarką (SxWxG): ok. 270x113x50 mm
Masa z drukarką: ok. 700 g
Temperatura robocza: 0° – 40° C

Rychlý, přesný a spolehlivý

Nový, přenosný tester akumulátorů BAT 131 je optimálně vhodný k testování startovacích akumulátorů (akumulátory olovo-kyselina, gel a AGM). Vybíjecí proud za studena je volitelně nastavitelný podle norem EN, EN2, DIN, SAE, IEC a JIS v rozsahu 100 - 2 000 A.

Stručný přehled výhod

- ▶ Intuitivní ovládání pomocí menu
- ▶ Test stavu akumulátoru a rozpoznání vad akumulátoru
- ▶ Optimalizovaný testovací algoritmus pro kontrolu nových akumulátorů
- ▶ Rozšířený test startovacího/nabíjecího systému pro akumulátory 12 V a 24 V.
- ▶ Integrovaná tiskárna znázorňuje výsledky měření v přehledném grafickém provedení
- ▶ Přípojka USB pro uložení výsledků testu
- ▶ Výměnný kabel délka 3 m

Technické údaje BAT 131

Jazyky menu: 24
Rozměry s tiskárnou (ŠxVxH): cca 270x113x50 mm
Hmotnost s tiskárnou: cca 700 g
Provozní teplota: 0° – 40° C

Быстро, точно и надежно

Новый переносной тестер БАТ 131 оптимально подходит для проверки стартерных аккумуляторов (свинцово-кислотных, гелевых и со стекловолоконными сепараторами/AGM). Ток холодного пуска согласно нормам EN, EN2, DIN, SAE, IEC и JIS выбирается в диапазоне 100 – 2000 А.

Основные преимущества

- ▶ Интуитивно-понятное меню с подсказками
- ▶ Проверка состояния аккумулятора и распознавание поврежденного аккумулятора
- ▶ Оптимизированный алгоритм проверки новых аккумуляторов
- ▶ Расширенная проверка стартеров/генераторов 12 В и 24 В
- ▶ Наглядное графическое представление результатов измерения с помощью встроенного принтера
- ▶ Разъем USB для сохранения результатов проверки
- ▶ Сменный кабель длиной 3 м

Технические данные БАТ 131

Языки меню: 24 (включая русский)
Размеры с принтером: (ШxВxГ): 270x113x50 мм
Вес с принтером: 700 г
Рабочая температура: 0° – 40° C

de

Das Multitalent Elektroniklader BAT 490

en

The multitalent Electronic charger BAT 490

fr

BAT 490, le chargeur électronique aux mul- tiples talents

it

L'autentico tuttofare Caricabatterie elettronico BAT 490

es

El multitalento: cargador electrónico BAT 490



Kompakter und solide verarbeiteter Hochfrequenzlader mit vielseitigen Anwendungsmöglichkeiten. Der Allrounder für Werkstatt, Service-Station und Batteriehandel.

Leistungsstarker Batterielader zum Laden von 12 V- oder 24 V-Blei-Säure-Batterien, besonders von Batterien mit fixiertem Elektrolyt (Gel-Batterien oder Vlies-Batterien / AGM).

Der Pufferbetrieb des BAT 490, mit Stromstärken bis 90 A, stabilisiert das Bordnetz während der Diagnose und Reprogrammierung von Steuergeräten und macht das Gerät somit unverzichtbar in jeder modernen Werkstatt.

Compact and solid high-frequency charger with versatile application. An "all-rounder" for the workshop, service station, and battery retail outlets.

The powerful battery charger is suitable for charging all 12-/24-V lead-acid batteries, particularly batteries with fixed electrolyte (gel batteries or fleece batteries / AGM).

The floating-mode operation of the BAT 490, with intensities of current up to 90 A, stabilizes the vehicle electrical system during diagnosis and reprogramming of control units, thus making the device essential in every modern workshop.

Chargeur haute fréquence compact et robuste, aux possibilités d'utilisation multiples.

Un chargeur polyvalent pour le garage, la station-service et le commerce de batteries.

Chargeur puissant pour les batteries au plomb-acide de 12 V ou 24 V, en particulier les batteries à électrolyte fixé (batteries au gel ou batteries à feutre / AGM).

En mode tampon, avec des intensités jusqu'à 90 A, le BAT 490 stabilise le réseau de bord pendant le diagnostic et la reprogrammation des centrales de commande, rendant cet appareil indispensable dans tout atelier moderne.

Caricabatterie ad alta frequenza compatto e resistente con numerose possibilità di impiego grazie alla sua elevata versatilità. Il tuttofare per officine, stazioni di servizio e rivenditori di batterie. Caricabatterie potente per il caricamento di batterie al piombo-acido da 12 V o da 24 V, in particolare di batterie con elettrolita fissato (batterie al gel o batterie AGM).

L'esercizio tampone del BAT 490, con intensità di corrente fino a 90 A, stabilizza la rete di bordo durante gli interventi di diagnosi o la riprogrammazione di centraline e rende l'apparecchio uno strumento indispensabile in ogni autofficina moderna.

Cargador de alta frecuencia, compacto y robusto, con versatilidad de aplicaciones.

El cargador polivalente para el taller, la estación de servicio y el sector comercial de las baterías. Potente cargador para baterías de 12 V o 24 V de plomo-ácido, y especialmente para baterías con electrolito fijado (baterías de gel o baterías AGM).

El régimen de compensación del BAT 490, con intensidades de corriente de hasta 90 A, estabiliza la red del vehículo durante el diagnóstico y la reprogramación de las unidades de control, haciendo este instrumento imprescindible para cualquier taller moderno.

Produkteigenschaften Hochfrequenzlader BAT 490

- ▶ Ladebetrieb für 12 V- /24 V- Blei-Säure-Batterien
- ▶ Mit automatischer 12 V- /24 V-Umschaltung
- ▶ Variable Ladestromstärke im Expertenmodus (0 – 90 A)
- ▶ Kürzere Ladezeiten dank optimiertem Ladeverlauf
- ▶ Stufenlos einstellbarer, geregelter Ladestrom
- ▶ Laden am Bordnetz
- ▶ Pufferbetrieb und Stützbetrieb
- ▶ Sägezahnhalterungsladung
- ▶ Schutz vor Verpolung, Überladung und Kurzschlüssen
- ▶ Solides Gehäuse

Product features of high-frequency charger BAT 490

- ▶ Charging mode for 12-/24-V lead-acid batteries
- ▶ Automatic detection of 12 V- or 24 V- System
- ▶ Variable charge current intensity in the expert mode (0 – 90 A)
- ▶ Shorter charging times due to optimized charging process
- ▶ Infinitely variable, regulated charging current
- ▶ Charging at vehicle electrical system
- ▶ Floating-mode operation and backup mode
- ▶ Sawtooth trickle charge
- ▶ Protection against reverse polarity, overcharge and short circuits
- ▶ Solid housing

Caractéristiques du chargeur haute fréquence BAT 490

- ▶ Charge des batteries au plomb-acide de 12 V/24 V
- ▶ Sélection automatique 12 V/24 V
- ▶ Intensité de charge variable en mode Expert (0 – 90 A)
- ▶ Temps de charge réduits grâce à une courbe de charge optimisée
- ▶ Courant de charge réglé, réglable en continu
- ▶ Charge sur le réseau de bord
- ▶ Mode tampon et soutien
- ▶ Charge de maintien en dents de scie
- ▶ Protection contre l'inversion de polarité, la surcharge et les courts-circuits
- ▶ Robuste boîtier

Caratteristiche del prodotto caricabatterie ad alta frequenza BAT 490

- ▶ Esercizio di carica per batterie al piombo-acido da 12 V/24 V
- ▶ Con commutazione automatica 12 V/24 V
- ▶ Intensità variabile della corrente di carica nella modalità esperto (0 – 90 A)
- ▶ Tempi di carica più brevi grazie all'andamento ottimizzato della carica
- ▶ Corrente di carica regolata, impostabile in modo continuo
- ▶ Caricamento con la rete di bordo collegata
- ▶ Esercizio tampone e di sostegno
- ▶ Carica di mantenimento a dente di sega
- ▶ Protezione dall'inversione di polarità, da sovraccarica e cortocircuito
- ▶ Custodia robusta

Características del cargador de alta frecuencia BAT 490

- ▶ Modo de carga para baterías de ácido-plomo de 12 V/24 V
- ▶ Conmutación automática de 12 V/24 V
- ▶ Intensidad de carga variable en el modo de experto (0 – 90 A)
- ▶ Tiempos de carga más cortos gracias al proceso de carga optimado
- ▶ Corriente de carga regulada, ajustable sin escalonamientos
- ▶ Carga en la red eléctrica del vehículo
- ▶ Servicio de compensación (o "búfer") y de apoyo
- ▶ Carga de conservación de diente de sierra
- ▶ Protección contra polaridad incorrecta, sobrecarga y cortocircuitos
- ▶ Caja robusta

230 V	0 687 000 049
100 V	0 687 000 050

230 V	0 687 000 049
100 V	0 687 000 050

230 V	0 687 000 049
100 V	0 687 000 050

230 V	0 687 000 049
100 V	0 687 000 050

230 V	0 687 000 049
100 V	0 687 000 050

pt

O carregador eletrônico multi-funções BAT 490

fi

Monilahjakas elektroninen varaaja BAT 490

pl

Elektroniczny prostownik Multitalent BAT 490

cs

Univerzální elektronické nabíjecí zařízení BAT 490

ru

Многофункциональное электронное зарядное устройство BAT 490



Carregador de alta frequência compacto e sólido com diversificadas possibilidades de utilização.

O "Allrounder" para a oficina, estações de serviço e comércio de baterias.

O potente carregador de baterias para carregar baterias de chumbo-ácido de 12 V ou 24 V, especialmente baterias com eletrólito fixado (baterias de gel ou baterias AGM).

Na função buffer da BAT 490, com intensidades de corrente até 90 A, o sistema elétrico do veículo estabiliza durante o diagnóstico e reprogramação das unidades de comando tornando o aparelho irremovível em qualquer oficina moderna.

Características do produto Carregador de alta frequência BAT 490

- ▶ Modo de carregamento para baterias de chumbo-ácido de 12 V / 24 V
- ▶ Com comutação 12 V / 24 V automática
- ▶ Intensidade de corrente de carregamento variável no modo Peritos (0 - 90 A)
- ▶ Tempos de carregamento mais curtos graças ao progresso de carregamento otimizado
- ▶ Ajuste contínuo, corrente de carga regulada
- ▶ Carregamento no sistema elétrico do veículo
- ▶ Função buffer e função de suporte
- ▶ Carga de manutenção dente de serra
- ▶ Proteção contra inversão de polaridade, sobrecarga e curtos-circuitos
- ▶ Caixa sólida

Kompakti ja vankkatekoinen korkeataajuusvaraaja manipuloisiin sovelluksiin. Todellinen yleismies korjaamoihin, huoltamoihin ja alan liikkeisiin. Tehopaketti varaa sekä 12 V että 24 V lyijyhappoakut – ihanteellinen varsinkin akkuihin, joissa on sidottu elektrolyytti (geeli- ja kuituakut / AGM). BAT 490 -mallin puskuritoiminto – 90 ampeerin virtaan saakka – stabiloi auton sähkölaitteiston diagnoosin ja ohjainlaitteiden uudelleenohjelmoinnin ajaksi, mikä tekee testeristä välttämättömän apulaisen jokaiseen ajan tasalla olevaan korjaamoon.

Korkeataajuusvaraaja BAT 490 tuoteseloste

- ▶ Varaukskäyttötä 12 V / 24 V lyijy-happo-akkuja varten
- ▶ Automaattinen vaihto 12 V / 24 V varaukselle
- ▶ Virran voimakkuutta voidaan säätää expert-tasolla (0 – 90 A)
- ▶ Latausajat lyhenevät optimoidun varaukskäyrän ansiosta
- ▶ Säätävän varausvirran portaaton asetus
- ▶ Varaus suoraan ajoneuvossa
- ▶ Puskuroiva ja tasoitava käyttötila
- ▶ Sahalaitteiden ylläpitövarausta
- ▶ Suojattu vääriltä napaisuksilta, ylivaraukselta ja oikosuluilta
- ▶ Vankkatekoinen kotelo

Kompaktowa i solidnie wykonana ładowarka akumulatorów prądem wysokiej częstotliwości o wielofunkcyjnych zastosowaniach. Wszechstronne urządzenie, nadające się do warsztatów samochodowych, stacji serwisowych oraz punktów sprzedaży akumulatorów. Wydajna ładowarka przeznaczona do akumulatorów kwasowo-olowiowych 12V lub 24V oraz szczególnie do akumulatorów z niepalnym elektrolitem (żelowych lub włókninowych typu AGM). Ładowanie buforowe za pomocą urządzenia BAT 490, prądem o natężeniu do 90 A, stabilizuje napięcie w instalacji samochodu podczas diagnozowania i reprogramowania sterowników. Urządzenie jest więc niezastąpione w każdym nowoczesnym warsztacie samochodowym.

Charakterystyka ładowarki BAT 490

- ▶ Tryb ładowania akumulatorów ołowiowo-kwasowych 12 V / 24 V
- ▶ Z automatycznym przełączeniem 12 V / 24 V
- ▶ Zmienny prąd ładowania w trybie Expert (0 - 90 A)
- ▶ Krótkie czasy ładowania dzięki zoptymalizowanemu przebiegowi ładowania
- ▶ Płynnie ustawiany, regulowany prąd ładowania
- ▶ Ładowanie bez odłączania od instalacji
- ▶ Ładowanie buforowe i ładowanie podtrzymujące
- ▶ Ładowanie konserwacyjne w postaci "piły"
- ▶ Ochrona przed zamianą biegunów, przeładowaniem i zwarciami
- ▶ Wytrzymała obudowa

Kompaktní a solidně zpracované nabíjecí zařízení, pracující na principu spínáného zdroje s všestrannými možnostmi použití. Všestranný nástroj pro servisní dílnu, servisní stanici a prodejnu akumulatorů. Výkonné nabíjecí zařízení akumulatorů olovo-kyselina 12 V nebo 24 V, zejména akumulatorů se stabilizovaným elektrolytem (akumulátory gel nebo AGM). Dobíjecí provoz BAT 490, s intenzitou proudu do 90 A, stabilizují palubní síť během diagnostiky a přeprogramování řídicích jednotek, což zařízení činí nepostradatelným v každé moderní servisní dílně.

Vlastnosti produktu vysokofrekvenční nabíjecí zařízení BAT 490

- ▶ Nabíjecí provoz pro akumulátory olovo-kyselina 12 V / 24 V
- ▶ S automatickým přepínáním 12 V / 24 V
- ▶ Variabilní intenzita nabíjecího proudu v režimu Expert (0 – 90 A)
- ▶ Kratší doby nabíjení díky optimalizovanému postupu nabíjení
- ▶ Plynule nastavitelný, regulovaný nabíjecí proud
- ▶ Nabíjení na palubní síti
- ▶ Dobíjecí provoz a podpůrný provoz
- ▶ Udržovací nabíjení s pilovitým průběhem proudu
- ▶ Ochrana proti přepólování, přebíjení a zkratům
- ▶ Robustní konstrukce

Компактное и надежное зарядное устройство с импульсным преобразователем напряжения. Универсальный помощник для СТО и магазинов. Мощное устройство для зарядки аккумуляторов 12 В или 24 В, (свинцово-кислотных, гелевых, со стекловолоконными сепараторами/AGM). Буферный режим BAT 490, обеспечивающий ток потребления до 90 А, поддерживает стабильное электропитание бортовой сети во время диагностики и программирования блоков управления, что делает устройство незаменимым помощником на любой современной СТО.

Особенности BAT 490

- ▶ Оптимальные режимы зарядки свинцово-кислотных аккумуляторов 12 В / 24 В
- ▶ Автоматическое переключение 12 В / 24 В
- ▶ Регулировка зарядного тока в пределах 0 – 90 А в экспертном режиме
- ▶ Уменьшенное время зарядки благодаря оптимизированному процессу зарядки
- ▶ Плавно настраиваемый, регулируемый зарядный ток
- ▶ Зарядка аккумулятора в бортовой сети
- ▶ Буферный режим и поддерживающий режим
- ▶ Постоянный импульсный подзаряд
- ▶ Защита от подключения с неправильной полярностью (переплюсовки), перезарядки и короткого замыкания
- ▶ Прочный корпус

230 V	0 687 000 049
100 V	0 687 000 050

230 V	0 687 000 049
100 V	0 687 000 050

230 V	0 687 000 049
100 V	0 687 000 050

230 V	0 687 000 049
100 V	0 687 000 050

230 V	0 687 000 049
100 V	0 687 000 050

de

"Online"-Katalog für Kraftfahrzeug-Ausrüstung

en

"Online" Catalogue for Automotive Parts

fr

Catalogue »online« de pièces détachées et de rechange

it

Catalogo »online« per ricambi di automobili

es

Catálogo »online« de los componentes del automóvil

The screenshot shows the 'Vehicle search' page of the Bosch Automotive Aftermarket Product Catalog. The page includes a navigation menu on the left with 'Automotive Aftermarket Product Catalog' and 'Choose your country' (set to Great Britain). The main search area has two tabs: 'Search by description' and 'Search by regional key numbers'. Below these are sections for 'Vehicle fleet' (currently Great Britain), 'Kind of vehicle' (Passenger car, Commercial vehicle, Motorcycle), 'Drive type' (Petrol, Diesel, Electric), and 'Other characteristics' (Make, Model range, Type, Motor number). There are also input fields for Litres, kW, HP, and Year. A red callout box at the bottom of the screenshot states '75 Countries 28 Languages'. An inset image shows a person's hands typing on a laptop that displays the same website interface.

www.bosch-automotive-catalog.com

Einfacher und schneller Zugriff auf Kfz-Ausrüstungsdaten von Bosch.

Easy and quick access to vehicle application data from Bosch.

Accès facile et rapide aux données de rechange automobile Bosch.

Ricerca semplice e veloce dei dati Bosch di equipaggiamento veicoli.

Fácil y rápido acceso a la información de equipamiento Bosch para vehículos.

de
Technische
Legende

en
Technical
legend

fr
Légende
technique

it
Legenda
tecnica

es
Leyenda
técnica

pt
Legenda
técnica

fi
Tekninen
erittely

pl
Opis
techniczny

cs
Technická
legenda

ru
Технические
условные
обозначения

L

Schaltung, Layout, Schéma, Circuito, Circuito,
Circuito, Kytkenä, Przelączanie, Zapojení, Схема

T

Endpole, Terminal posts, Bornes, Polo terminale,
Terminales, Pólos finais, Navat, Bieguny krańcowe,
Koncové póly, Конечные полюса

B

Bodenbefestigung, Bottom rail, Fixations par la batterie,
Fissaggio alla base, Fijación en el suelo, Fixação ao piso,
Pohjakiinnitys, Mocowanie do podłoża, Upevnění k pod-
laze, Напольное крепление

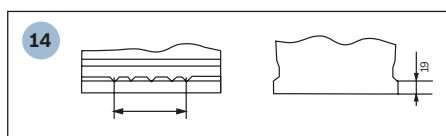
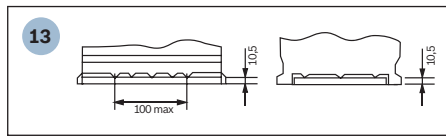
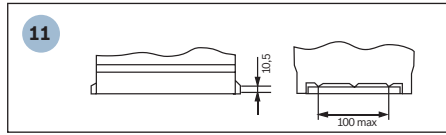
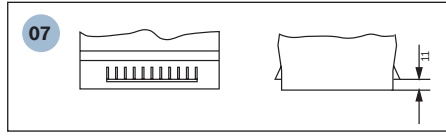
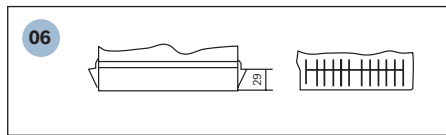
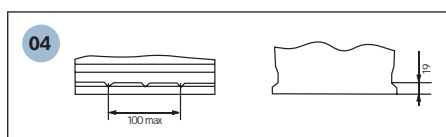
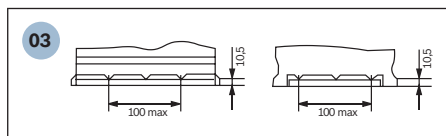
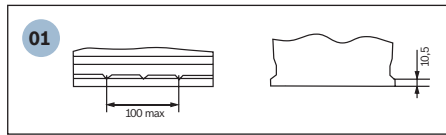
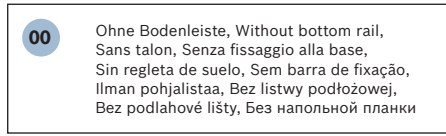
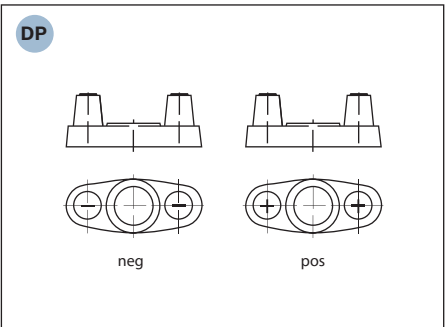
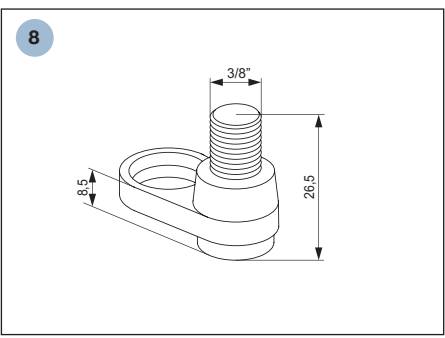
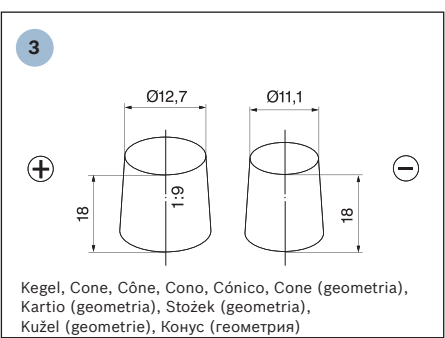
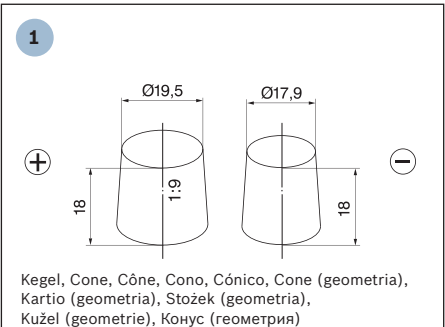
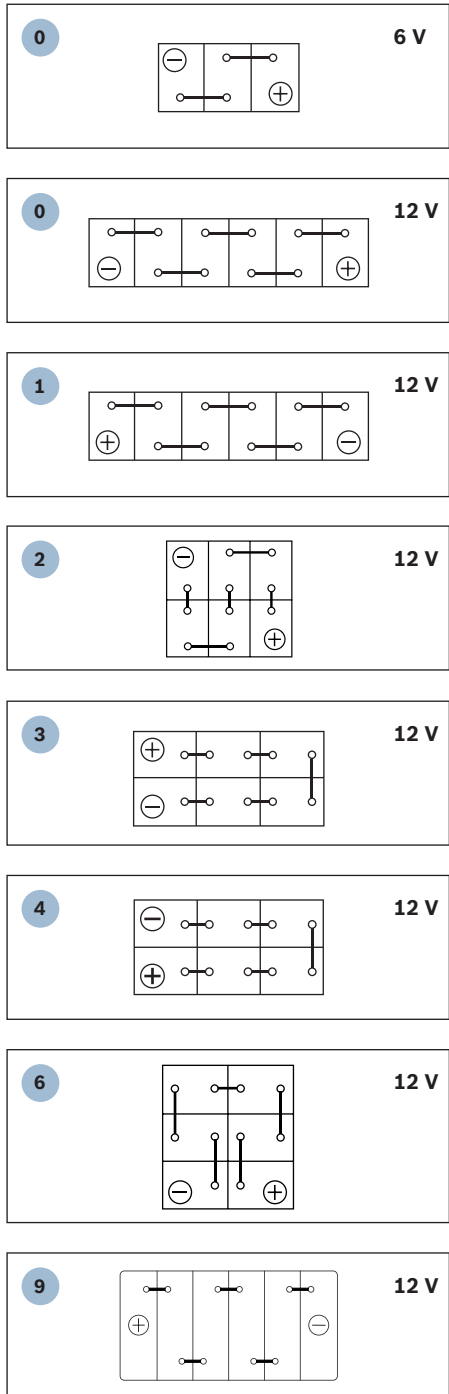

<div style="border: 1px solid black; padding: 2px; width: 20px; margin: 0 auto;">de</div> <p>Programmübersicht Pkw, Nfz</p>	<div style="border: 1px solid black; padding: 2px; width: 20px; margin: 0 auto;">en</div> <p>Product range Cars, commercial vehicles</p>	<div style="border: 1px solid black; padding: 2px; width: 20px; margin: 0 auto;">fr</div> <p>Aperçu de la gamme véhicules particuliers, véhicules utilitaires</p>	<div style="border: 1px solid black; padding: 2px; width: 20px; margin: 0 auto;">it</div> <p>Panoramica del programma per autovetture, veicoli commerciali</p>	<div style="border: 1px solid black; padding: 2px; width: 20px; margin: 0 auto;">es</div> <p>Relación programa Turismos, vehículos industriales</p>
--	---	--	---	--

			AGM Technology EFB-Technology Asia Type Vibration Proof Heavy Duty Heavy Duty Extra	Ah 20 h	A(EN)		L	T	B	EAN		
--	--	--	--	-------------------	--------------	--	----------	----------	----------	------------	--	--



Start/Stopp S6 AGM / 12 V

560 901 068	0 092 S60 050	S6 005	•	60	680	242 x 175 x 190	0	1	B13	4047 024 684 584	17,50	57
570 901 076	0 092 S60 080	S6 008	•	70	760	278 x 175 x 190	0	1	B13	4047 024 684 591	20,40	48
580 901 080	0 092 S60 110	S6 011	•	80	800	315 x 175 x 190	0	1	B13	4047 024 684 607	22,76	36
595 901 085	0 092 S60 130	S6 013	•	95	850	353 x 175 x 190	0	1	B13	4047 024 684 614	26,40	36
605 901 095	0 092 S60 150	S6 015	•	105	950	393 x 175 x 190	0	1	B13	4047 024 684 621	29,40	36

Start/Stopp S5 EFB / 12 V

560 500 056	0 092 S5E 050	S5 E05	•	60	560	242 x 175 x 190	0	1	B13	4047 024 684 638	16,67	60
565 500 065	0 092 S5E 070	S5 E07	•	65	650	278 x 175 x 175	0	1	B13	4047 024 684 645	18,63	48
570 500 065	0 092 S5E 080	S5 E08	•	70	650	278 x 175 x 190	0	1	B13	4047 024 684 652	19,14	48
575 500 073	0 092 S5E 100	S5 E10	•	75	730	315 x 175 x 175	0	1	B13	4047 024 684 669	21,19	48
580 500 073	0 092 S5E 110	S5 E11	•	80	730	315 x 175 x 190	0	1	B13	4047 024 684 676	21,78	42

S5 / 12 V

552 401 052	0 092 S50 010	S5 001		52	520	207 x 175 x 175	0	1	B13	4047 023 479 426	12,27	72
554 400 053	0 092 S50 020	S5 002		54	530	207 x 175 x 190	0	1	B13	4047 023 479 419	12,65	72
561 400 060	0 092 S50 040	S5 004		61	600	242 x 175 x 175	0	1	B13	4047 023 479 334	14,34	63
563 400 061	0 092 S50 050	S5 005		63	610	242 x 175 x 190	0	1	B13	4047 023 479 358	14,78	63
563 401 061	0 092 S50 060	S5 006		63	610	242 x 175 x 190	1	1	B13	4047 023 479 365	14,78	63
574 402 075	0 092 S50 070	S5 007		74	750	278 x 175 x 175	0	1	B13	4047 023 479 563	17,11	48
577 400 078	0 092 S50 080	S5 008		77	780	278 x 175 x 190	0	1	B13	4047 023 479 617	17,94	48
585 200 080	0 092 S50 100	S5 010		85	800	315 x 175 x 175	0	1	B13	4047 023 573230	19,02	42
585 400 080	0 092 S50 110	S5 011		85	800	315 x 175 x 190	0	1	B13	4047 024 937598	19,76	36
600 402 083	0 092 S50 130	S5 013		100	830	353 x 175 x 190	0	1	B13	4047 023 479 495	21,92	36
610 402 092	0 092 S50 150	S5 015		110	920	393 x 175 x 190	0	1	B13	4047 024 016 989	25,10	36

S4 / 12 V

544 401 042	0 092 S40 001	S4 000		44	420	175 x 175 x 190	0	1	B13	4047 024 937 567	10,46	72
544 402 044	0 092 S40 010	S4 001		44	440	207 x 175 x 175	0	1	B13	4047 023 479 372	11,29	72
552 400 047	0 092 S40 020	S4 002		52	470	207 x 175 x 190	0	1	B13	4047 023 479 389	12,40	72
560 409 054	0 092 S40 040	S4 004		60	540	242 x 175 x 175	0	1	B13	4047 023 479 297	13,89	63
560 408 054	0 092 S40 050	S4 005		60	540	242 x 175 x 190	0	1	B13	4047 023 479 310	15,00	63
560 127 054	0 092 S40 060	S4 006		60	540	242 x 175 x 190	1	1	B03	4047 023 479 327	14,34	63
572 409 068	0 092 S40 070	S4 007		72	680	278 x 175 x 175	0	1	B13	4047 023 479 549	17,05	48
574 012 068	0 092 S40 080	S4 008		74	680	278 x 175 x 190	0	1	B13	4047 023 479 594	17,87	48
574 013 068	0 092 S40 090	S4 009		74	680	278 x 175 x 190	1	1	B13	4047 023 479 600	17,87	48
580 406 074	0 092 S40 100	S4 010		80	740	315 x 175 x 175	0	1	B13	4047 023 479 648	19,21	42
580 400 074	0 092 S40 110	S4 011		80	740	315 x 175 x 190	0	1	B13	4047 024 937581	19,10	36
595 402 080	0 092 S40 130	S4 013	•	95	800	353 x 175 x 190	0	1	B13	4047 023 479 471	21,32	36
540 126 033	0 092 S40 180	S4 018	•	40	330	187 x 127 x 227	0	3	B00	4047 023 479 990	10,10	84
540 127 033	0 092 S40 190	S4 019	•	40	330	187 x 127 x 227	1	3	B00	4047 023 479 808	10,10	84
545 155 033	0 092 S40 200	S4 020	•	45	330	238 x 129 x 227	0	3	B00	4047 023 479 822	11,68	72
545 156 033	0 092 S40 210	S4 021	•	45	330	238 x 129 x 227	0	1	B00	4047 023 479 839	11,68	72
545 157 033	0 092 S40 220	S4 022	•	45	330	238 x 129 x 227	1	3	B00	4047 023 479 846	11,68	72
545 158 033	0 092 S40 230	S4 023	•	45	330	238 x 129 x 227	1	1	B00	4047 023 479 853	11,68	72
560 410 054	0 092 S40 240	S4 024	•	60	540	232 x 173 x 225	0	1	B00	4047 023 479 877	14,54	54
560 411 054	0 092 S40 250	S4 025	•	60	540	232 x 173 x 225	1	1	B00	4047 023 479 884	14,54	54
570 412 063	0 092 S40 260	S4 026	•	70	630	261 x 175 x 220	0	1	B01	4047 023 479 730	17,32	48
570 413 063	0 092 S40 270	S4 027	•	70	630	261 x 175 x 220	1	1	B01	4047 023 479 747	17,32	48
595 404 083	0 092 S40 280	S4 028	•	95	830	306 x 173 x 225	0	1	B01	4047 023 479 891	20,23	39
595 405 083	0 092 S40 290	S4 029	•	95	830	306 x 173 x 225	1	1	B01	4047 023 479 907	20,23	39
540 125 033	0 092 S40 300	S4 030	•	40	330	187 x 127 x 227	0	3	B01	4047 024 891 012	10,10	84

pt

Vista geral do programa veículos de passeio, veículos utilitários

fi

Tuotevalikoimat – henkilöautot, hyötyajoneuvot

pl

Przegląd asortymentu – samochody osobowe, samochody dostawcze

cs

Přehled výrobního programu pro osobní a užitková vozidla

ru

Обзор программ для легковых и коммерческих автомобилей

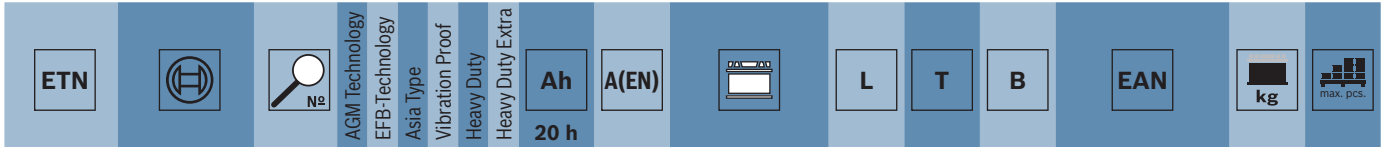
**S3 / 12 V**

540 406 034	0 092 S30 000	S3 000						40	340	175 x 175 x 190	0	1	B13	4047 024 659 407	9,88	72
541 400 036	0 092 S30 010	S3 001						41	360	207 x 175 x 175	0	1	B13	4047 023 479 204	10,68	72
545 412 040	0 092 S30 020	S3 002						45	400	207 x 175 x 190	0	1	B13	4047 023 479 228	11,43	72
545 413 040	0 092 S30 030	S3 003						45	400	207 x 175 x 190	1	1	B13	4047 023 479 242	11,43	72
545 077 030	0 092 S30 160	S3 016						45	300	220 x 135 x 225	0	1	B01	4047 023 573 278	11,32	78
545 079 030	0 092 S30 170	S3 017						45	300	220 x 135 x 225	1	1	B01	4047 023 573 261	11,32	78
553 401 050	0 092 S30 041	S3 004						53	500	242 x 175 x 175	0	1	B13	4047 024 937574	13,27	63
556 400 048	0 092 S30 050	S3 005						56	480	242 x 175 x 190	0	1	B13	4047 023 479 266	13,70	63
556 401 048	0 092 S30 060	S3 006						56	480	242 x 175 x 190	1	1	B13	4047 023 479 280	13,70	63
570 144 064	0 092 S30 070	S3 007						70	640	278 x 175 x 175	0	1	B13	4047 023 479 525	16,00	48
570 409 064	0 092 S30 080	S3 008						70	640	278 x 175 x 190	0	1	B13	4047 023 479 570	16,60	48
588 403 074	0 092 S30 120	S3 012						88	740	353 x 175 x 175	0	1	B13	4047 023 479 457	20,25	36
590 122 072	0 092 S30 130	S3 013						90	720	353 x 175 x 190	0	1	B13	4047 023 479 464	20,78	36

S3 / 6 V

066 017 036	0 092 S30 600	S3 060						66	360	178 x 175 x 188	0	1	B04	4047 024 437 708	11,90	96
077 015 036	0 092 S30 610	S3 061						77	360	216 x 170 x 191	0	1	B06	4047 024 437 692	11,90	96

de

Programmübersicht

Pkw, Nfz
(Fortsetzung)

en

Product range

Cars, commercial vehicles
(continued)

fr

Aperçu de la gamme véhicules
particuliers, véhicules utili-
taires (suite)

it

Panoramica del programma
per autovetture, veicoli com-
merciali (seguito)

es

Relación programa
Turismos, vehículos industri-
ales (continuación)

pt

Vista geral do programa
veículos de passeio, veículos
utilitários (continuação)

fi

Tuotevalikoimat – henkilö-
autot, hyötyajoneuvot
(jatkoa)

pl

Przegląd asortymentu –
samochody osobowe, samochody
dostawcze (ciąg dalszy)

cs

Přehled výrobního programu
pro osobní a užitková vozidla
(pokračování)

ru

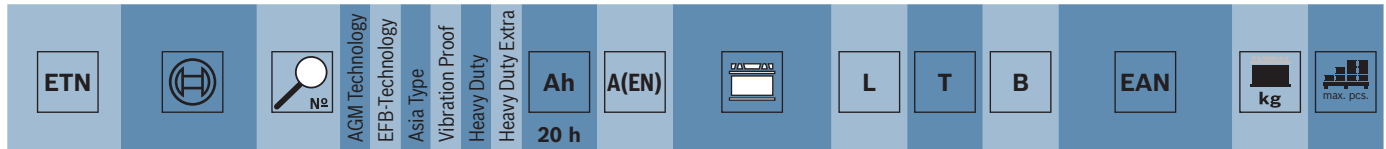
Обзор программ для
легковых и коммерческих
автомобилей (продолжение)

Commercial Vehicle T5 / 12 V

645 400 080	0092	T50 750	T5 075					145	800	513 x 189 x 223	3	1	B00	4047 024 344754	36,62	24
680 108 100	0092	T50 770	T5 077					180	1000	513 x 223 x 223	3	1	B00	4047 024 345041	45,10	21
725 103 115	0092	T50 800	T5 080					225	1150	518 x 276 x 242	3	1	B00	4047 024 345058	58,10	12

Commercial Vehicle T4 / 12 V

640 103 080	0092	T40 750	T4 075					140	800	513 x 189 x 223	3	1	B00	4047 024 345 003	35,76	24
640 400 080	0092	T40 760	T4 076					140	800	513 x 189 x 223	3	1	B03	4047 024 345 010	35,76	24
670 103 100	0092	T40 770	T4 077					170	1000	513 x 223 x 223	3	1	B00	4047 024 345 027	45,30	21
670 104 100	0092	T40 780	T4 078					170	1000	513 x 223 x 223	3	1	B03	4047 024 344 723	44,20	21
715 400 115	0092	T40 800	T4 080					215	1150	518 x 276 x 242	3	1	B00	4047 024 345 034	56,75	12

Commercial Vehicle T3 / 6 V

070 011 030	0092	T30 600	T3 060					70	300	175 x 167 x 220	0	1	B00	4047 024 345 126	9,35	72
112 025 051	0092	T30 610	T3 061					112	510	260 x 175 x 236	0	1	B01	4047 024 344 716	16,50	57
140 023 072	0092	T30 620	T3 062					140	720	260 x 175 x 236	0	1	B01	4047 024 345 133	19,50	57
150 030 076	0092	T30 630	T3 063					150	760	333 x 175 x 235	0	1	B11	4047 024 345 140	23,80	36
200 023 095	0092	T30 640	T3 064					200	950	403 x 175 x 238	0	20	B11	4047 024 345 157	31,00	24

Commercial Vehicle T3 / 12 V

545 200 030	0092	T30 010	T3 001					45	300	207 x 175 x 175	0	1	B13	4047 024 344 761	11,05	72
555 064 042	0092	T30 050	T3 005					55	420	246 x 175 x 190	0	1	B13	4047 024 344 778	14,20	57
566 047 051	0092	T30 080	T3 008					66	510	278 x 175 x 190	0	1	B03	4047 024 344 785	16,80	51
588 038 068	0092	T30 130	T3 013					88	680	353 x 175 x 190	0	1	B13	4047 024 344 792	21,00	36
590 040 048	0092	T30 300	T3 030					90	480	350 x 175 x 239	0	1	B00	4047 024 344 808	25,20	36
590 041 048	0092	T30 310	T3 031					90	480	350 x 174 x 189	1	1	B00	4047 024 344 815	25,20	36
600 035 060	0092	T30 710	T3 071					100	600	413 x 175 x 220	1	1	B00	4047 024 344 921	27,43	36
600 047 060	0092	T30 720	T3 072					100	600	413 x 175 x 220	0	1	B00	4047 024 344 938	26,70	36
600 123 072	0092	T30 320	T3 032					100	720	313 x 175 x 205	0	1	B03	4047 024 344 822	24,90	36
602 102 068	0092	T30 330	T3 033					102	680	330 x 172 x 240	9	1	B01	4047 024 345 065	24,42	36
602 103 068	0092	T30 340	T3 034					102	680	330 x 172 x 240	9	8	B01	4047 024 345 072	24,42	36
610 047 068	0092	T30 350	T3 035					110	680	350 x 175 x 239	0	1	B00	4047 024 344 839	28,58	24
610 048 068	0092	T30 360	T3 036					110	680	350 x 175 x 239	1	1	B00	4047 024 344 846	28,58	24
610 404 068	0092	T30 370	T3 037					110	680	347 x 173 x 234	0	1	B01	4047 024 344 853	28,58	36
610 013 076	0092	T30 380	T3 038					110	760	514 x 175 x 210	3	1	B03	4047 024 344 860	32,31	27
610 050 085	0092	T30 730	T3 073					110	850	413 x 175 x 220	0	1	B03	4047 024 344 945	27,80	24
620 045 068	0092	T30 750	T3 075					120	680	513 x 189 x 215	3	1	B00	4047 024 344 952	33,64	24
620 109 076	0092	T30 390	T3 039					120	760	510 x 175 x 235	4	1	B03	4047 024 345 089	35,12	24
625 023 000	0092	T30 420	T3 042					125		286 x 269 x 230	2	1	B00	4047 024 345 096	36,80	24
625 012 072	0092	T30 400	T3 040					125	720	349 x 175 x 285	0	1	B00	4047 024 344 877	31,22	24
625 014 072	0092	T30 410	T3 041					125	720	349 x 175 x 285	1	1	B00	4047 024 344 884	31,22	24
630 014 068	0092	T30 430	T3 043					130	680	514 x 218 x 208	3	1	B00	4047 024 344 891	37,83	24
635 042 068	0092	T30 440	T3 044					135	680	360 x 253 x 240	6	1	B11	4047 024 345 102	42,30	24
635 052 100	0092	T30 450	T3 045					135	1000	514 x 175 x 210	3	1	B03	4047 024 344 907	35,46	27
643 107 090	0092	T30 460	T3 046					143	900	508 x 174 x 205	0	1	B01	4047 024 345 119	36,50	21
643 033 095	0092	T30 470	T3 047					143	950	514 x 218 x 210	3	1	B03	4047 024 344 747	39,85	21
655 013 090	0092	T30 770	T3 077					155	900	513 x 223 x 223	3	1	B00	4047 024 344 969	40,98	21
655 104 090	0092	T30 480	T3 048					155	900	514 x 218 x 210	4	1	B03	4047 024 344 914	42,88	21
680 033 110	0092	T30 790	T3 079					180	1100	513 x 223 x 223	4	1	B03	4047 024 344 976	44,99	21
700 038 105	0092	T30 800	T3 080					200	1050	518 x 276 x 242	3	1	B00	4047 024 344 983	53,61	12
720 018 115	0092	T30 810	T3 081					220	1150	518 x 291 x 242	3	1	B00	4047 024 344 990	56,79	12

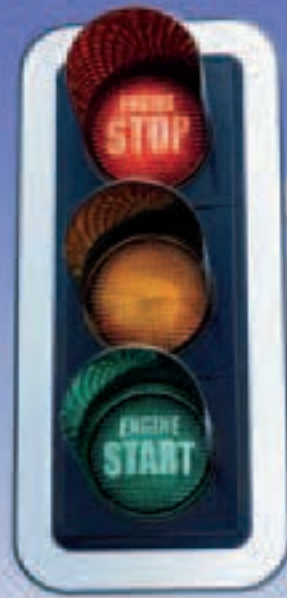

Bosch S5 – S4 – S3

Batterien für Pkw
Batteries for cars
Batteries pour véhicules particuliers
Batterie per autovetture
Baterías para turismos



Bosch Start/Stop S6 AGM – S5 EFB



BOSCH

A34









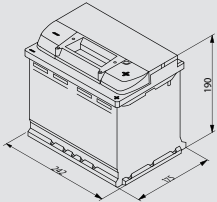
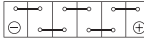
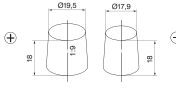
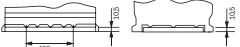

de Bosch-Batterie S6-S5 E für Pkw 12 V	en Bosch battery S6-S5 E for cars 12 V	fr Batterie Bosch S6-S5 E pour véhicules particuliers 12 V	it Batteria Bosch S6-S5 E per autovetture 12 V	es Batería Bosch S6-S5 E para turismos 12 V
---	---	---	---	--

	ETN Bosch Reference Short code	Ah 20 h	A(EN)		L	T	B	EAN	kg	
	S6 (12 V)									

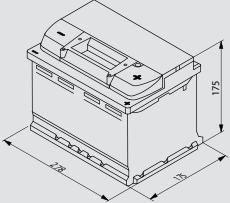
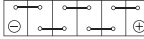
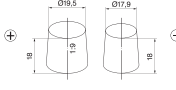
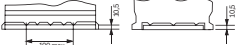
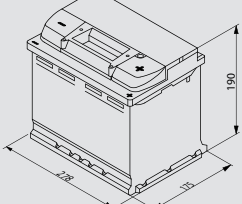

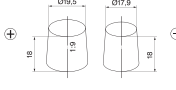
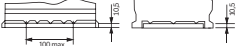
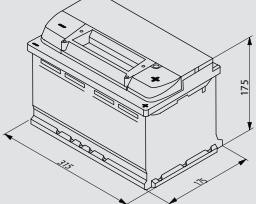
560 901 068 0 092 S60 050 S6 005	60	680			4 047 024 684 584	17,50	57
570 901 076 0 092 S60 080 S6 008	70	760			4 047 024 684 591	20,40	48
580 901 080 0 092 S60 110 S6 011	80	800			4 047 024 684 607	22,76	36
595 901 085 0 092 S60 130 S6 013	95	850			4 047 024 684 614	26,40	36
605 901 095 0 092 S60 150 S6 015	105	950			4 047 024 684 621	29,40	36

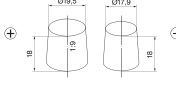
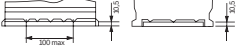
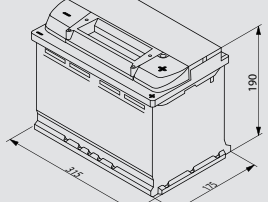
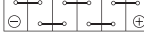
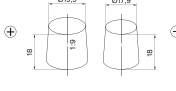
pt Bateria Bosch S6-S5 E para veículos de passeio 12 V	fi Bosch-akut S6-S5 E, 12 V: henkiöautot	pl Akumulator Bosch S6-S5 E do samochodów osobowych 12 V	cs Akumulátory Bosch S6-S5 E pro osobní vozy 12 V	ru Аккумуляторы Bosch S6-S5 E для легковых автомобилей 12 В
---	---	---	--	--

ETN Bosch Reference Short code	Ah 20 h	A(EN)		L	T	B	EAN	kg		
S5 E (12 V)										
560 500 056 0 092 S5 E 050 S5 E05	60	560	 242 x 175 x 190	  	4 047 024 684 638	16,67	60			
565 500 065 0 092 S5 E 070 S5 E07	65	650	 278 x 175 x 175	  	4 047 024 684 645	18,63	48			
570 500 065 0 092 S5 E 080 S5 E08	70	650	 278 x 175 x 190	  	4 047 024 684 652	19,14	48			
575 500 073 0 092 S5 E 100 S5 E10	75	730	 315 x 175 x 175	  	4 047 024 684 669	21,19	48			
580 500 073 0 092 S5 E 110 S5 E11	80	730	 315 x 175 x 190	  	4 047 024 684 676	21,78	42			





de	en	fr	it	es
Bosch-Batterie S5-S4-S3 für Pkw 12 V	Bosch battery S5-S4-S3 for cars 12 V	Batterie Bosch S5-S4-S3 pour véhicules particuliers 12 V	Batteria Bosch S5-S4-S3 per autovetture 12 V	Batería Bosch S5-S4-S3 para turismos 12 V

	ETN Bosch Reference Short code	Ah 20 h	A(EN)		L	T	B	EAN	 kg	 max. pcs.
	S5 (12 V)									





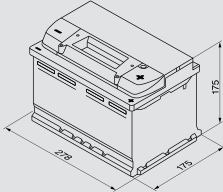
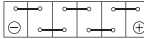
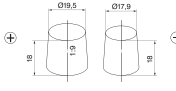
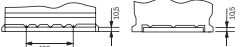
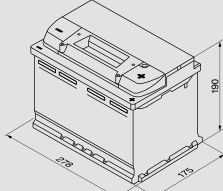
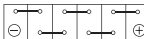
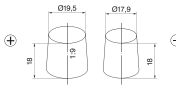
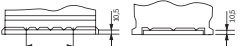
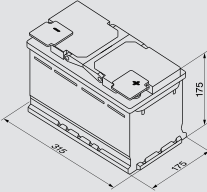

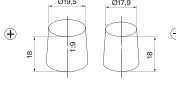
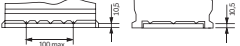
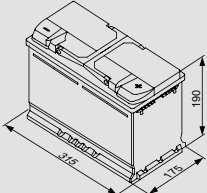
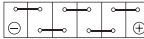
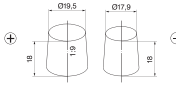
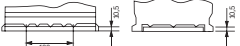
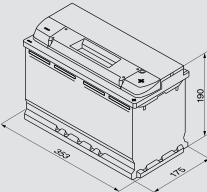
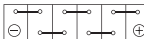
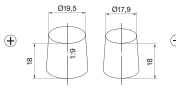
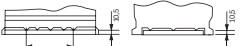

552 401 052 0 092 S50 010 S5 001	52	520	 207 x 175 x 175	 100 max	4 047 023 479 426	12,27	72
554 400 053 0 092 S50 020 S5 002	54	530	 207 x 175 x 190	 100 max	4 047 023 479 419	12,65	72
561 400 060 0 092 S50 040 S5 004	61	600	 242 x 175 x 175	 100 max	4 047 023 479 334	14,34	63
563 400 061 0 092 S50 050 S5 005	63	610	 242 x 175 x 190	 100 max	4 047 023 479 358	14,78	63
563 401 061 0 092 S50 060 S5 006	63	610	 242 x 175 x 190	 100 max	4 047 023 479 365	14,78	63



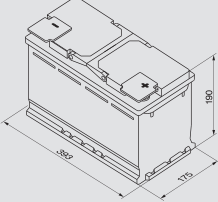
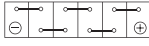
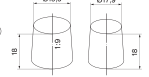
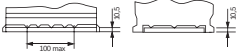
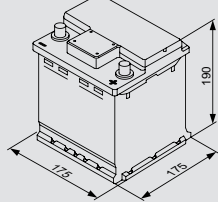
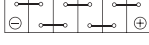
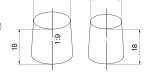
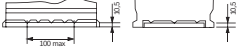
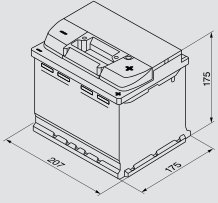

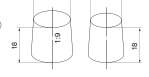
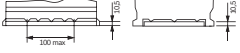
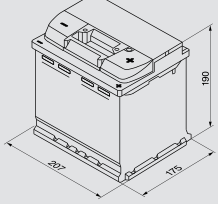
pt Bateria Bosch S5-S4-S3 para veículos de passeio 12 V	fi Bosch-akut S5-S4-S3, 12 V: henkiöautot	pl Akumulator Bosch S5-S4-S3 do samochodów osobowych 12 V	cs Akumulátory Bosch S5-S4-S3 pro osobní vozy 12 V	ru Аккумуляторы Bosch S5-S4-S3 для легковых автомобилей 12 В
--	--	--	---	---

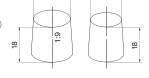
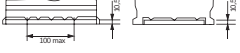
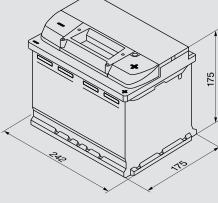
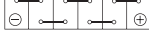
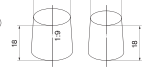
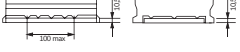
ETN Bosch Reference Short code	Ah 20 h	A(EN)		L	T	B	EAN	kg		
S5 (12 V)										
574 402 075 0 092 S50 070 S5 007	74	750	 278 x 175 x 175	  			4 047 023 479 563	17,11	48	
577 400 078 0 092 S50 080 S5 008	77	780	 278 x 175 x 190	  			4 047 023 479 617	17,94	48	
585 200 080 0 092 S50 100 S5 010	85	800	 315 x 175 x 175	  			4 047 023 573 230	19,02	42	
585 400 080 0 092 S50 110 S5 011	85	800	 315 x 175 x 190	  			4047 024 937 598	19,76	36	
600 402 083 0 092 S50 130 S5 013	100	830	 353 x 175 x 190	  			4 047 023 479 495	21,92	36	

de Bosch-Batterie S5-S4-S3 für Pkw 12 V (Fortsetzung)	en Bosch battery S5-S4-S3 for cars 12 V (continued)	fr Batterie Bosch S5-S4-S3 pour véhicules particuliers 12 V (suite)	it Batteria Bosch S5-S4-S3 per autovetture 12 V (seguito)	es Batería Bosch S5-S4-S3 para turismos 12 V (continuación)
---	---	---	---	---

ETN Bosch Reference Short code	Ah 20 h	A(EN)		L	T	B	EAN	kg	 max. pcs.
S5 (12 V)									
610 402 092 0 092 S50 150 S5 015	110	920					4 047 024 016 989	25,10	36
S4 (12 V)									
544 401 042 0 092 S40 001 S4 000	44	420					4047 024 937 567	10,46	72
544 402 044 0 092 S40 010 S4 001	44	440					4 047 023 479 372	11,29	72
552 400 047 0 092 S40 020 S4 002	52	470					4 047 023 479 389	12,40	72
560 409 054 0 092 S40 040 S4 004	60	540					4 047 023 479 297	13,89	63

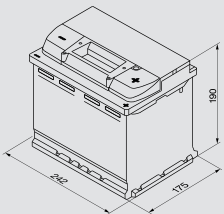
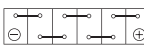
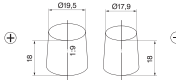
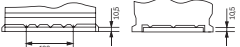
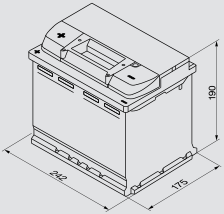
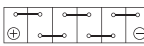
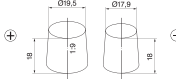
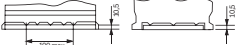
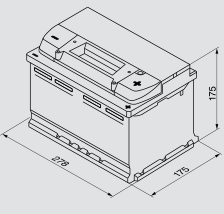
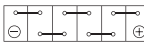
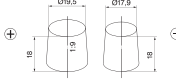
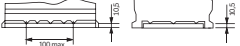
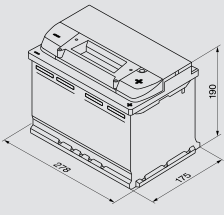
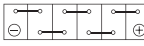
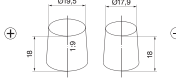
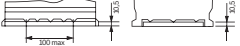
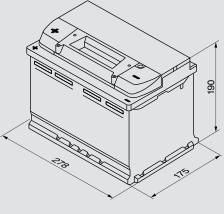
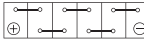
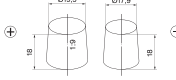
pt Bateria Bosch S5-S4-S3 para veículos de passeio 12 V (continuação)	fi Bosch-akut S5-S4-S3, 12 V: henkilöautot (jatkoa)	pl Akumulator Bosch S5-S4-S3 do samochodów osobowych 12 V (ciąg dalszy)	cs Akumulátory Bosch S5-S4-S3 pro osobní vozy 12 V (pokračování)	ru Аккумуляторы Bosch S5-S4-S3 для легковых автомобилей 12 В (продолжение)
---	---	---	--	--

ETN Bosch Reference Short code	Ah 20 h	A(EN)		L	T	B	EAN	kg		
S4 (12 V)										
560 408 054 0 092 S40 050 S4 005	60	540	 242 x 175 x 190	  			4 047 023 479 310	15,00	63	
560 127 054 0 092 S40 060 S4 006	60	540	 242 x 175 x 190	  			4 047 023 479 327	14,34	63	
572 409 068 0 092 S40 070 S4 007	72	680	 278 x 175 x 175	  			4 047 023 479 549	17,05	48	
574 012 068 0 092 S40 080 S4 008	74	680	 278 x 175 x 190	  			4 047 023 479 594	17,87	48	
574 013 068 0 092 S40 090 S4 009	74	680	 278 x 175 x 190	  			4 047 023 479 600	17,87	48	

A 40

de Bosch-Batterie S5-S4-S3 für Pkw 12 V (Fortsetzung)	en Bosch battery S5-S4-S3 for cars 12 V (continued)	fr Batterie Bosch S5-S4-S3 pour véhicules particuliers 12 V (suite)	it Batteria Bosch S5-S4-S3 per autovetture 12 V (seguito)	es Batería Bosch S5-S4-S3 para turismos 12 V (continuación)
---	---	---	---	---

	ETN Bosch Reference Short code	Ah 20 h	A(EN)		L	T	B	EAN	kg	
--	--------------------------------------	-------------------	--------------	--	----------	----------	----------	------------	-----------	--

S4 (12 V)







580 406 074 0 092 S40 100 S4 010	80	740	 315 x 175 x 175		4 047 023 479 648	19,21	42
580 400 074 0 092 S40 110 S4 011	80	740	 315 x 175 x 190		4 047 024 937 581	19,10	36
595 402 080 0 092 S40 130 S4 013	95	800	 353 x 175 x 190		4 047 023 479 471	21,32	36

S4 (12 V) Asiatische Typen / Asiatic models / Types asiatiques / Tipi asiatici / Tipos asiáticos / Para vehículos asiáticos / Ajoneuvot Aasian maista / Do pojazdów azjatyckich / Pro asijská vozidla / Для азиатских автомобилей

540 126 033 0 092 S40 180 S4 018	40	330	 187 x 127 x 227 JIS		4 047 023 479 990	10,10	84
540 127 033 0 092 S40 190 S4 019	40	330	 187 x 127 x 227 JIS		4 047 023 479 808	10,10	84

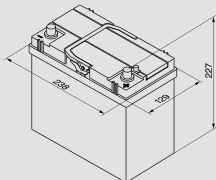
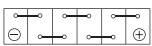
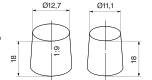
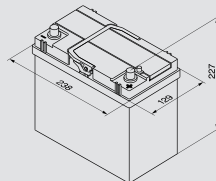
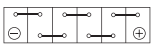
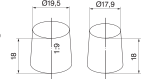
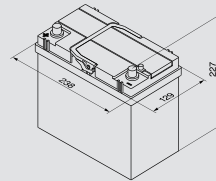
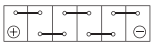

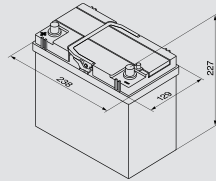
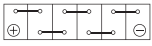
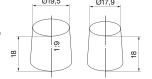
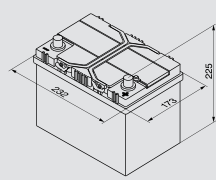
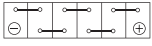
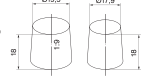





pt Bateria Bosch S5-S4-S3 para veículos de passeio 12 V (continuação)	fi Bosch-akut S5-S4-S3, 12 V: henkiöautot (jatkoa)	pl Akumulator Bosch S5-S4-S3 do samochodów osobowych 12 V (ciąg dalszy)	cs Akumulátory Bosch S5-S4-S3 pro osobní vozy 12 V (pokračování)	ru Аккумуляторы Bosch S5-S4-S3 для легковых автомобилей 12 В (продолжение)
---	--	---	--	--

ETN Bosch Reference Short code	Ah 20 h	A(EN)		L	T	B	EAN	kg	 max. pcs.	
S4 (12 V) Asiatische Typen / Asiatic models / Types asiatiques / Tipi asiatici / Tipos asiáticos / Para vehículos asiáticos / Ajoneuvot Aasian maista / Do pojazdów azjatyckich / Pro asijská vozidla / Для азиатских автомобилей										
545 155 033 0 092 S40 200 S4 020	45	330	 238 x 129 x 227 JIS	 			4 047 023 479 822	11,68	72	
545 156 033 0 092 S40 210 S4 021	45	330	 238 x 129 x 227 JIS	 			4 047 023 479 839	11,68	72	
545 157 033 0 092 S40 220 S4 022	45	330	 238 x 129 x 227 JIS	 			4 047 023 479 846	11,68	72	
545 158 033 0 092 S40 230 S4 023	45	330	 238 x 129 x 227 JIS	 			4 047 023 479 853	11,68	72	
560 410 054 0 092 S40 240 S4 024	60	540	 232 x 173 x 225 JIS	 			4 047 023 479 877	14,54	54	

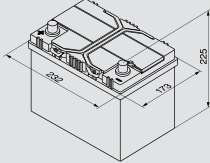
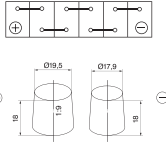
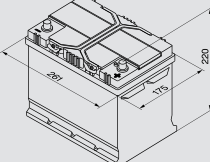
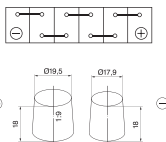
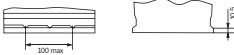
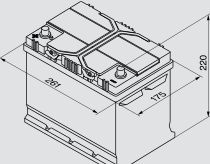
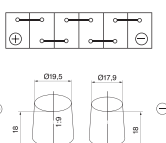
JIS (= Japanese Industrial Standard) = für asiatische Fahrzeuge / for Asiatic vehicles / pour véhicules asiatiques / per veicoli asiatici / para vehículos asiáticos / Para vehículos asiáticos / Ajoneuvot Aasian maista / Do pojazdów azjatyckich / Pro asijská vozidla / Для азиатских автомобилей

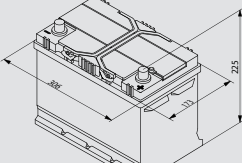
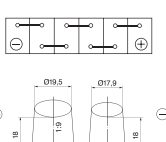

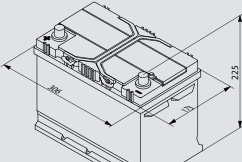
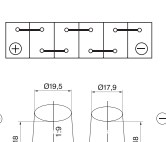
A42



de Bosch-Batterie S5-S4-S3 für Pkw 12 V (Fortsetzung)	en Bosch battery S5-S4-S3 for cars 12 V (continued)	fr Batterie Bosch S5-S4-S3 pour véhicules particuliers 12 V (suite)	it Batteria Bosch S5-S4-S3 per autovetture 12 V (seguito)	es Batería Bosch S5-S4-S3 para turismos 12 V (continuación)
---	---	---	---	---

ETN Bosch Reference Short code	Ah	A(EN)		L	T	B	EAN	 kg	 max. pcs	
	20 h									
S4 (12 V) Asiatische Typen / Asiatic models / Types asiatiques / Tipi asiatici / Tipos asiáticos / Para vehículos asiáticos / Ajoneuvot Aasian maista / Do pojazdów azjatyckich / Pro asijská vozidla / Для азиатских автомобилей										
560 411 054 0 092 S40 250 S4 025	60	540	 232 x 173 x 225 JIS				4 047 023 479 884	14,54	54	
570 412 063 0 092 S40 260 S4 026	70	630	 261 x 175 x 220 JIS				4 047 023 479 730	17,32	48	
570 413 063 0 092 S40 270 S4 027	70	630	 261 x 175 x 220 JIS				4 047 023 479 747	17,32	48	
595 404 083 0 092 S40 280 S4 028	95	830	 306 x 173 x 225 JIS				4 047 023 479 891	20,23	39	
595 405 083 0 092 S40 290 S4 029	95	830	 306 x 173 x 225 JIS				4 047 023 479 907	20,23	39	

JIS (= Japanese Industrial Standard) = für asiatische Fahrzeuge / for Asiatic vehicles / pour véhicules asiatiques / per veicoli asiatici / para vehículos asiáticos / Para vehículos asiáticos / Ajoneuvot Aasian maista / Do pojazdów azjatyckich / Pro asijská vozidla / Для азиатских автомобилей

pt Bateria Bosch S5-S4-S3 para veículos de passeio 12 V (continuação)	fi Bosch-akut S5-S4-S3, 12 V: henkiöautot (jatkoa)	pl Akumulator Bosch S5-S4-S3 do samochodów osobowych 12 V (ciąg dalszy)	cs Akumulátory Bosch S5-S4-S3 pro osobní vozy 12 V (pokračování)	ru Аккумуляторы Bosch S5-S4-S3 для легковых автомобилей 12 В (продолжение)
---	--	---	--	--

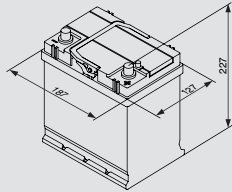
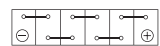
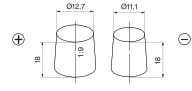

ETN Bosch Reference Short code	Ah 20 h	A(EN)		L	T	B	EAN	kg	
S4 (12 V) Asiatische Typen / Asiatic models / Types asiatiques / Tipi asiatici / Tipos asiáticos / Para vehículos asiáticos / Ajoneuvot Aasian maista / Do pojazdów azjatyckich / Pro asijská vozidla / Для азиатских автомобилей									

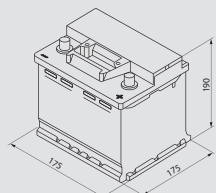
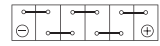
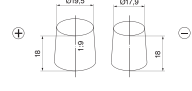
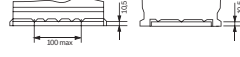

540 125 033 0 092 S40 300 S4 030	40	330	 330 x 187 x 127 JIS	  	4 047 024 891 012	10,10	84
---	----	-----	--	--	-------------------	-------	----

JIS (= Japanese Industrial Standard) = für asiatische Fahrzeuge / for Asiatic vehicles / pour véhicules asiatiques / per veicoli asiatici / para vehículos asiáticos / Para vehículos asiáticos/ Ajoneuvot Aasian maista / Do pojazdów azjatyckich / Pro asijská vozidla / Для азиатских автомобилей

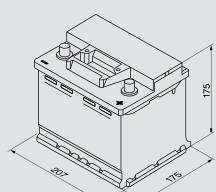
S3 (12 V)									
------------------	--	--	--	--	--	--	--	--	--

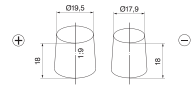
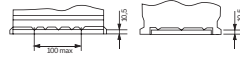
540 406 034 0 092 S30 000 S3 000	40	340	 175 x 175 x 190	  	4 047 024 659 407	9,88	72
---	----	-----	---	---	-------------------	------	----

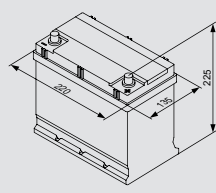
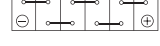
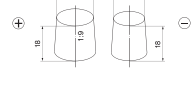
541 400 036 0 092 S30 010 S3 001	41	360	 207 x 175 x 175	  	4 047 023 479 204	10,68	72
---	----	-----	--	--	-------------------	-------	----

545 077 030 0 092 S30 160 S3 016	45	300	 220 x 135 x 225	  	4 047 023 573 278	11,32	78
---	----	-----	--	--	-------------------	-------	----

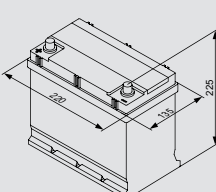
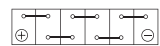
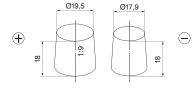
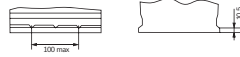
545 079 030 0 092 S30 170 S3 017	45	300	 220 x 135 x 225	  	4 047 023 573 261	11,32	78
---	----	-----	--	--	-------------------	-------	----

A44

de Bosch-Batterie S5-S4-S3 für Pkw 12 V (Fortsetzung)	en Bosch battery S5-S4-S3 for cars 12 V (continued)	fr Batterie Bosch S5-S4-S3 pour véhicules particuliers 12 V (suite)	it Batteria Bosch S5-S4-S3 per autovetture 12 V (seguito)	es Batería Bosch S5-S4-S3 para turismos 12 V (continuación)
---	---	---	---	---









	ETN Bosch Reference Short code	Ah 20 h	A(EN)		L	T	B	EAN	kg	
--	--------------------------------------	-------------------	--------------	--	----------	----------	----------	------------	-----------	--

S3 (12 V)

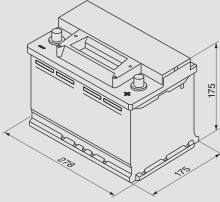
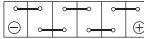
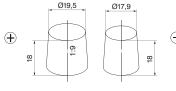
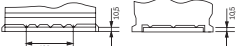
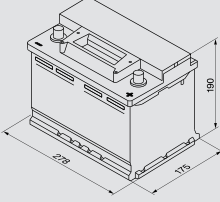
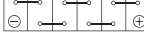
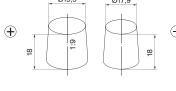

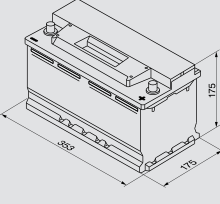
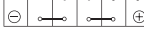
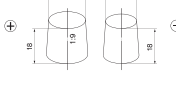
545 412 040 0 092 S30 020 S3 002	45	400	 207 x 175 x 190		4 047 023 479 228	11,43	72
545 413 040 0 092 S30 030 S3 003	45	400	 207 x 175 x 190		4 047 023 479 242	11,43	72
553 401 050 0 092 S30 041 S3 004	53	500	 242 x 175 x 175		4 047 024 937 574	13,27	63
556 400 048 0 092 S30 050 S3 005	56	480	 242 x 175 x 190		4 047 023 479 266	13,70	63
556 401 048 0 092 S30 060 S3 006	56	480	 242 x 175 x 190		4 047 023 479 280	13,70	63

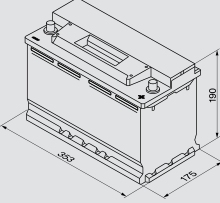
pt Bateria Bosch S5-S4-S3 para veículos de passeio 12 V (continuação)	fi Bosch-akut S5-S4-S3, 12 V: henkilöautot (jatkoa)	pl Akumulator Bosch S5-S4-S3 do samochodów osobowych 12 V (ciąg dalszy)	cs Akumulátory Bosch S5-S4-S3 pro osobní vozy 12 V (pokračování)	ru Аккумуляторы Bosch S5-S4-S3 для легковых автомобилей 12 В (продолжение)
---	---	---	--	--

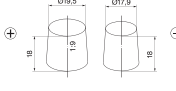
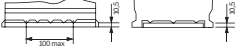
ETN Bosch Reference Short code	Ah 20 h	A(EN)		L	T	B	EAN	kg	 max. pcs.
S3 (12 V)									
570 144 064 0 092 S30 070 S3 007	70	640	 278 x 175 x 175	  			4 047 023 479 525	16,00	48
570 409 064 0 092 S30 080 S3 008	70	640	 278 x 175 x 190	  			4 047 023 479 570	16,60	48
588 403 074 0 092 S30 120 S3 012	88	740	 353 x 175 x 175	  			4 047 023 479 457	20,25	36
590 122 072 0 092 S30 130 S3 013	90	720	 353 x 175 x 190	  			4 047 023 479 464	20,78	36



Bosch T5 – T4 – T3

Batterien für Nutzfahrzeuge
Batteries for commercial vehicles
Batteries pour véhicules utilitaires
Batterie per veicoli commerciali
Baterías para vehículos industriales



BOSCH

A48

de Bosch-Batterien T5-T4-T3 für Nutzfahrzeuge 6 V/12 V	en Bosch batteries T5-T4-T3 for commercial vehicles 6 V/12 V	fr Batteries Bosch T5-T4-T3 pour véhicules utilitaires 6 V/12 V	it Batterie Bosch T5-T4-T3 per veicoli commerciali 6 V/12 V	es Bosch Baterías T5-T4-T3 para vehículos industriales 6 V/12 V
---	---	--	--	--

 ETN Bosch Reference Short code	Ah 20 h	A(EN)		L	T	B	EAN	 kg	 max. pcs.
--	-------------------	--------------	---	----------	----------	----------	------------	--	---

T5 (12 V)

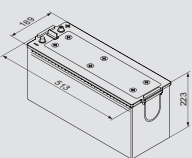
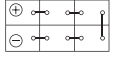
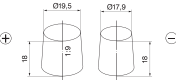
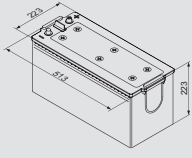
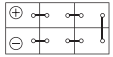
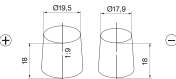
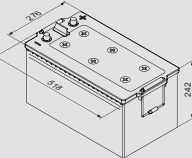
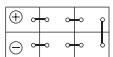
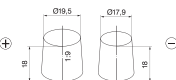

645 400 080 0 092 T50 750 T5 075	145	800	 513 x 189 x 223 HDE	 	4 047 024 344 754	36,62	24
680 108 100 0 092 T50 770 T5 077	180	1000	 513 x 223 x 223 HDE	 	4 047 024 345 041	45,10	21
725 103 115 0 092 T50 800 T5 080	225	1150	 518 x 276 x 242 HDE	 	4 047 024 345 058	58,10	12

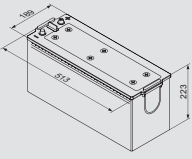
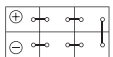
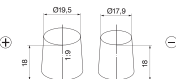
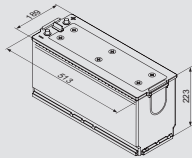
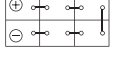
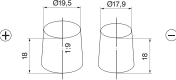
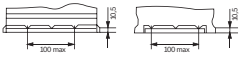

T4 (12 V)

640 103 080 0 092 T40 750 T4 075	140	800	 513 x 189 x 223 HD	 	4 047 024 345 003	35,76	24
640 400 080 0 092 T40 760 T4 076	140	800	 513 x 189 x 223 HD	  	4 047 024 345 010	35,76	24

HD = Heavy Duty, HDE = Heavy Duty Extra

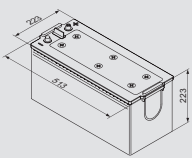
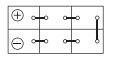
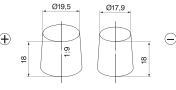
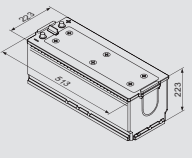
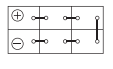
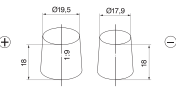
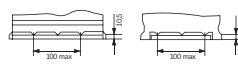
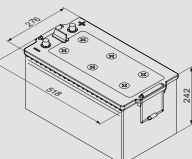
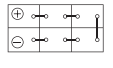
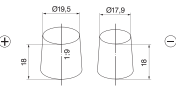

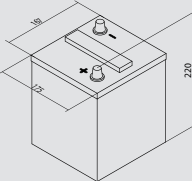
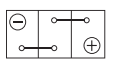

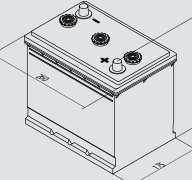
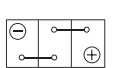
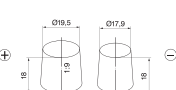
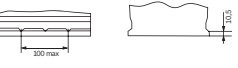







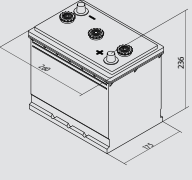

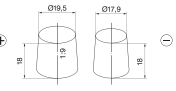

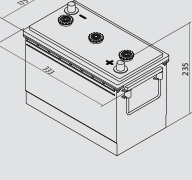
pt Baterias Bosch T5-T4-T3 para veículos utilitários 6 V/12 V	fi Bosch-akut T5-T4-T3, 6 V/12 V: hyötyajoneuvot	pl Akumulatory Bosch T5-T4-T3 do samochodów dostawczych 6 V/12 V	cs Akumulátory Bosch T5-T4-T3 pro užitková vozidla 6 V/12 V	ru Аккумуляторы Bosch T5-T4-T3 для коммерческих автомобилей 6 В/12 В
--	---	---	--	---

ETN Bosch Reference Short code	Ah 20 h	A(EN)		L	T	B	EAN	 kg	 max. pcs.	
T4 (12 V)										
670 103 100 0 092 T40 770 T4 077	170	1000	 513 x 223 x 223 HD	 			4 047 024 345 027	45,30	21	
670 104 100 0 092 T40 780 T4 078	170	1000	 513 x 223 x 223 HD	  			4 047 024 344 723	44,20	21	
715 400 115 0 092 T40 800 T4 080	215	1150	 518 x 276 x 242 HD	 			4 047 024 345 034	56,75	12	

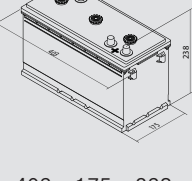
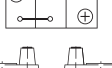
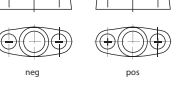
T3 (6 V)										
070 011 030 0 092 T30 600 T3 060	70	300	 175 x 167 x 220	 			4 047 024 345 126	9,35	72	
112 025 051 0 092 T30 610 T3 061	112	510	 260 x 175 x 236 Rf	  			4 047 024 344 716	16,50	57	

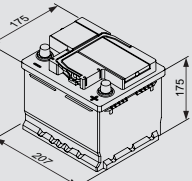
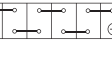
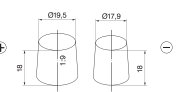

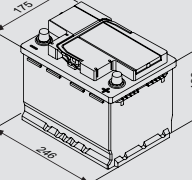
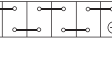
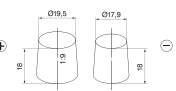





A50

de Bosch-Batterien T5-T4-T3 für Nutzfahrzeuge 6 V/12 V (Fortsetzung)	en Bosch batteries T5-T4-T3 for commercial vehicles 6 V/12 V (continued)	fr Batteries Bosch T5-T4-T3 pour véhicules utilitaires 6 V/12 V (suite)	it Batterie Bosch T5-T4-T3 per veicoli commerciali 6 V/12 V (seguito)	es Bosch Baterías T5-T4-T3 para vehículos industriales 6 V/12 V (continuación)
--	--	---	---	--

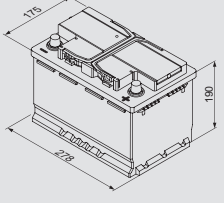
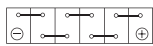
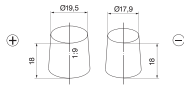
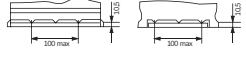
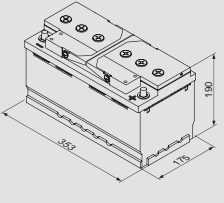
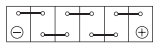
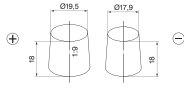
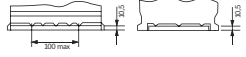
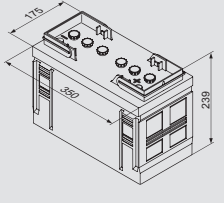
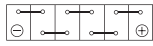
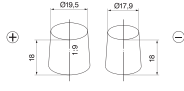

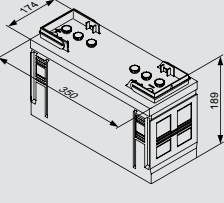
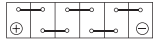
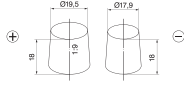

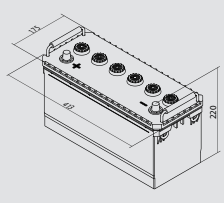
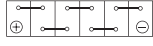
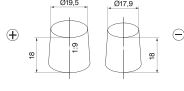



ETN Bosch Reference Short code	Ah	A(EN)	L x W x H 	L	T	B	EAN	kg 	max. pcs. 	
	20 h									
T3 (6 V)										
140 023 072 0 092 T30 620 T3 062	140	720	 260 x 175 x 236 Rf	  			4 047 024 345 133	19,50	57	
150 030 076 0 092 T30 630 T3 063	150	760	 333 x 175 x 235 Rf	  			4 047 024 345 140	23,80	36	
200 023 095 0 092 T30 640 T3 064	200	950	 403 x 175 x 238 Rf	  			4 047 024 345 157	31,00	24	
T3 (12 V)										
545 200 030 0 092 T30 010 T3 001	45	300	 207 x 175 x 175 Rf	  			4 047 024 344 761	11,05	72	
555 064 042 0 092 T30 050 T3 005	55	420	 246 x 175 x 190 Rf	  			4 047 024 344 778	14,20	57	

HD = Heavy Duty
Rf = Rüttelfest / Vibration resistant / Résistant aux fortes vibrations / Resistente alle vibrazioni / Resistente a sacudidas / resistente à vibração / tārinānkeštvā / odporny na wstrząsy / Odolné otřesům / вибростойкость

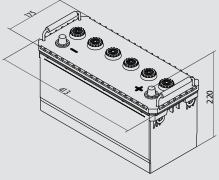
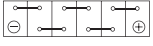
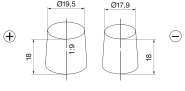
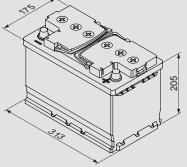
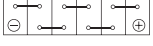
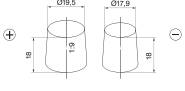
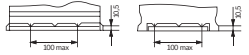
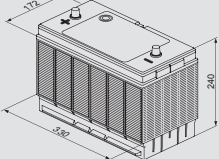
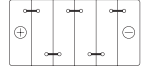
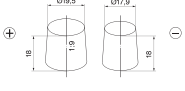
pt Baterias Bosch T5-T4-T3 para veículos utilitários 6 V/12 V (continuação)	fi Bosch-akut T5-T4-T3, 6 V/12 V: hyötyajoneuvot (jatkoa)	pl Akumulatory Bosch T5-T4-T3 do samochodów dostawczych 6 V/12 V (ciąg dalszy)	cs Akumulátory Bosch T5-T4-T3 pro užitková vozidla 6 V/12 V (pokračování)	ru Аккумуляторы Bosch T5-T4-T3 для коммерческих автомобилей 6 В/12 В (продолжение)
---	---	--	---	--

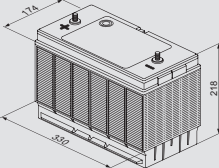

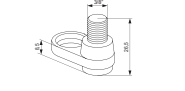

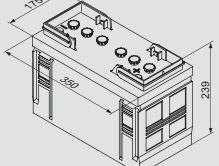
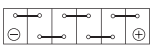
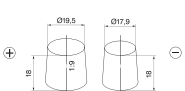



ETN Bosch Reference Short code	Ah 20 h	A(EN)		L	T	B	EAN	 kg	 max. pcs.
T3 (12 V)									
566 047 051 0 092 T30 080 T3 008	66	510	 278 x 175 x 190 HD	  			4 047 024 344 785	16,80	51
588 038 068 0 092 T30 130 T3 013	88	680	 353 x 175 x 190 HD	  			4 047 024 344 792	21,00	36
590 040 048 0 092 T30 300 T3 030	90	480	 350 x 175 x 239 Rf	  			4 047 024 344 808	25,20	36
590 041 048 0 092 T30 310 T3 031	90	480	 350 x 174 x 189 Rf	  			4 047 024 344 815	25,20	36
600 035 060 0 092 T30 710 T3 071	100	600	 413 x 175 x 220 Rf	  			4 047 024 344 921	27,43	36

de Bosch-Batterien T5-T4-T3 für Nutzfahrzeuge 6 V/12 V (Fortsetzung)	en Bosch batteries T5-T4-T3 for commercial vehicles 6 V/12 V (continued)	fr Batteries Bosch T5-T4-T3 pour véhicules utilitaires 6 V/12 V (suite)	it Batterie Bosch T5-T4-T3 per veicoli commerciali 6 V/12 V (seguito)	es Bosch Baterías T5-T4-T3 para vehículos industriales 6 V/12 V (continuación)
--	--	---	---	--

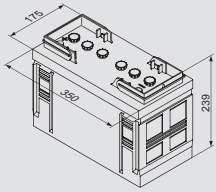
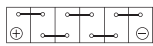
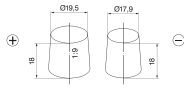
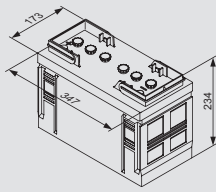
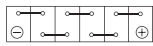
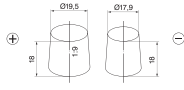
ETN Bosch Reference Short code	Ah 20 h	A(EN)		L	T	B	EAN	 kg	 max. pcs.
600 047 060 0 092 T30 720 T3 072	100	600					4 047 024 344 938	26,70	36
			413 x 175 x 220 HD						
600 123 072 0 092 T30 320 T3 032	100	720					4 047 024 344 822	24,90	36
			313 x 175 x 205						
602 102 068 0 092 T30 330 T3 033	102	680					4 047 024 345 065	24,42	36
			330 x 172 x 240 Rf						
602 103 068 0 092 T30 340 T3 034	102	680					4 047 024 345 072	24,42	36
			330 x 172 x 240 Rf						
610 047 068 0 092 T30 350 T3 035	110	680					4 047 024 344 839	28,58	24
			350 x 175 x 239 HD						

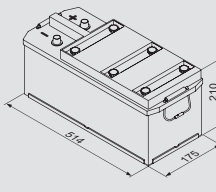
Rf = Rüttelfest / Vibration resistant / Résistant aux fortes vibrations / Resistente alle vibrazioni / Resistente a sacudidas / resistente à vibração / tärinänkestävä / odporny na wstrząsy / Odolné otřesům / вибростойкость
HD = Heavy Duty

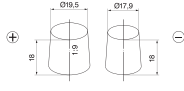
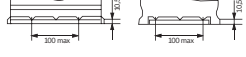
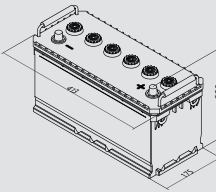
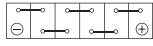
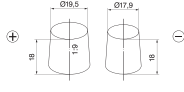
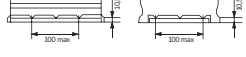
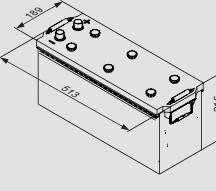
pt Baterias Bosch T5-T4-T3 para veículos utilitários 6 V/12 V (continuação)	fi Bosch-akut T5-T4-T3, 6 V/12 V: hyötyajoneuvot (jatkoa)	pl Akumulatory Bosch T5-T4-T3 do samochodów dostawczych 6 V/12 V (ciąg dalszy)	cs Akumulátory Bosch T5-T4-T3 pro užitková vozidla 6 V/12 V (pokračování)	ru Аккумуляторы Bosch T5-T4-T3 для коммерческих автомобилей 6 В/12 В (продолжение)
---	---	--	---	--

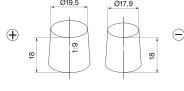
ETN Bosch Reference Short code	Ah 20 h	A(EN)		L	T	B	EAN	 kg	 max. pcs.
T3 (12 V)									
610 048 068 0 092 T30 360 T3 036	110	680	 350 x 175 x 239 HD	 			4 047 024 344 846	28,58	24
610 404 068 0 092 T30 370 T3 037	110	680	 347 x 173 x 234 HD	  			4 047 024 344 853	28,58	36
610 013 076 0 092 T30 380 T3 038	110	760	 514 x 175 x 210 HD	  			4 047 024 344 860	32,31	27
610 050 085 0 092 T30 730 T3 073	110	850	 413 x 175 x 220 HD	  			4 047 024 344 945	27,80	24
620 045 068 0 092 T30 750 T3 075	120	680	 513 x 189 x 215 HD	 			4 047 024 344 952	33,64	24

A54

de Bosch-Batterien T5-T4-T3 für Nutzfahrzeuge 6 V/12 V (Fortsetzung)	en Bosch batteries T5-T4-T3 for commercial vehicles 6 V/12 V (continued)	fr Batteries Bosch T5-T4-T3 pour véhicules utilitaires 6 V/12 V (suite)	it Batterie Bosch T5-T4-T3 per veicoli commerciali 6 V/12 V (seguito)	es Bosch Baterías T5-T4-T3 para vehículos industriales 6 V/12 V (continuación)
--	--	---	---	--

 ETN Bosch Reference Short code	Ah 20 h	A(EN)		L	T	B	EAN	 kg	 max. pcs.
--	-------------------	--------------	---	----------	----------	----------	------------	--	---





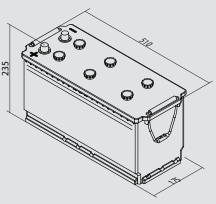
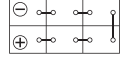
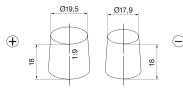
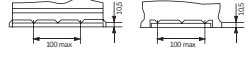
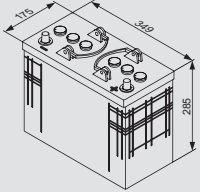
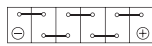
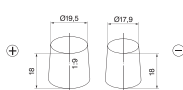
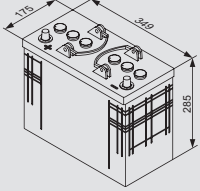
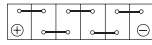
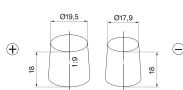
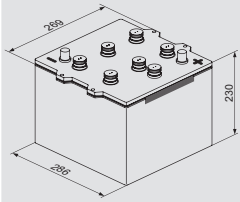
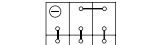
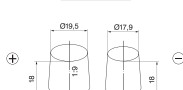
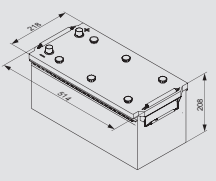
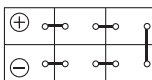
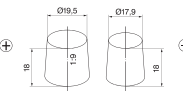





T3 (12 V)

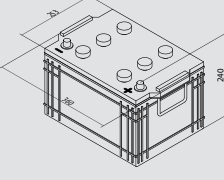

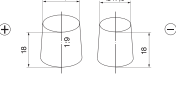
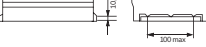
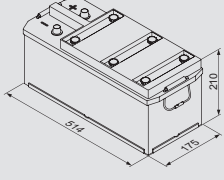
620 109 076 0 092 T30 390 T3 039	120	760	 510 x 175 x 235 HD	  	4 047 024 345 089	35,12	24
625 012 072 0 092 T30 400 T3 040	125	720	 349 x 175 x 285 Rf	 	4 047 024 344 877	31,22	24
625 014 072 0 092 T30 410 T3 041	125	720	 349 x 175 x 285 Rf	 	4 047 024 344 884	31,22	24
625 023 000 0 092 T30 420 T3 042	125		 286 x 269 x 230 Rf	 	4 047 024 345 096	36,80	24
630 014 068 0 092 T30 430 T3 043	130	680	 514 x 218 x 208 HD	 	4 047 024 344 891	37,83	24

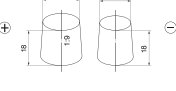
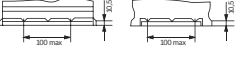
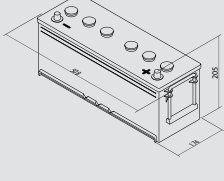
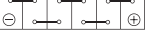
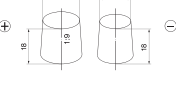
Rf = Rüttelfest / Vibration resistant / Résistant aux fortes vibrations / Resistente alle vibrazioni / Resistente a sacudidas / resistente à vibração / tārinānkestävä / odporny na wstrząsy / Odolné otřesům / вибростойкость
HD = Heavy Duty

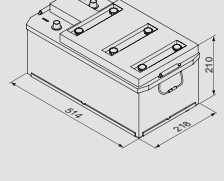
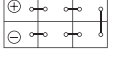
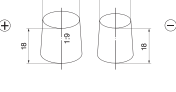
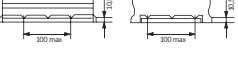
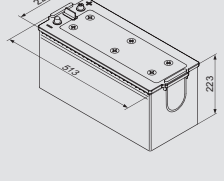
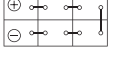
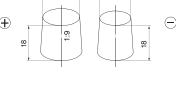
pt Baterias Bosch T5-T4-T3 para veículos utilitários 6 V/12 V (continuação)	fi Bosch-akut T5-T4-T3, 6 V/12 V: hyötyajoneuvot (jatkoa)	pl Akumulatory Bosch T5-T4-T3 do samochodów dostawczych 6 V/12 V (ciąg dalszy)	cs Akumulátory Bosch T5-T4-T3 pro užitková vozidla 6 V/12 V (pokračování)	ru Аккумуляторы Bosch T5-T4-T3 для коммерческих автомобилей 6 В/12 В (продолжение)
---	---	--	---	--

ETN Bosch Reference Short code	Ah 20 h	A(EN)		L	T	B	EAN	 kg	 max. pcs.	
T3 (12 V)										
635 042 068 0 092 T30 440 T3 044	135	680	 360 x 253 x 240 Rf	  			4 047 024 345 102	42,30	24	
635 052 100 0 092 T30 450 T3 045	135	1000	 514 x 175 x 210 HD	  			4 047 024 344 907	35,46	27	
643 107 090 0 092 T30 460 T3 046	143	900	 508 x 174 x 205 Rf	  			4 047 024 345 119	36,50	21	
643 033 095 0 092 T30 470 T3 047	143	950	 514 x 218 x 210 HD	  			4 047 024 344 747	39,85	21	
655 013 090 0 092 T30 770 T3 077	155	900	 513 x 223 x 223 HD	  			4 047 024 344 969	40,98	21	

A56

de Bosch-Batterien T5-T4-T3 für Nutzfahrzeuge 6 V/12 V (Fortsetzung)	en Bosch batteries T5-T4-T3 for commercial vehicles 6 V/12 V (continued)	fr Batteries Bosch T5-T4-T3 pour véhicules utilitaires 6 V/12 V (suite)	it Batterie Bosch T5-T4-T3 per veicoli commerciali 6 V/12 V (seguito)	es Bosch Baterías T5-T4-T3 para vehículos industriales 6 V/12 V (continuación)
--	--	---	---	--

ETN Bosch Reference Short code	Ah	A(EN)	L x W x H 	L	T	B	EAN	kg 	max. pcs. 	
	20 h									
T3 (12 V)										
655 104 090 0 092 T30 480 T3 048	155	900	 514 x 218 x 210 HD				4 047 024 344 914	42,88	21	
680 033 110 0 092 T30 790 T3 079	180	1100	 513 x 223 x 223 HD				4 047 024 344 976	44,99	21	
700 038 105 0 092 T30 800 T3 080	200	1050	 518 x 276 x 242 HD				4 047 024 344 983	53,61	12	
720 018 115 0 092 T30 810 T3 081	220	1150	 518 x 291 x 242 HD				4 047 024 344 990	56,79	12	

Rf = Rüttelfest / Vibration resistant / Résistant aux fortes vibrations / Resistente alle vibrazioni / Resistente a sacudidas / resistente à vibração / tārinānkestāvē / odporny na wstrząsy / Odolné otřesům / вибростойкость
HD = Heavy Duty



Bosch M6 – M4

Batterien für Motorräder
Batteries for motorcycles
Batteries pour motos
Batterie per motocicli
Baterías para motocicletas



BOSCH

de

Bosch-Batterien
M6 – M4
für Motorräder
6 V/12 V

en

Bosch batteries
M6 – M4
for motorcycles
6 V/12 V

fr

Batteries Bosch
M6 – M4
pour motocyclettes 6
V/12 V

it

Batterie Bosch
M6 – M4
per motocicli
6 V/12 V

es

Bosch Baterías
M6 – M4
para motocicletas
6 V/12 V



ETN
Bosch Reference
Short code
Japanese Part no.

Ah
20 h

A
-18 °C



EAN



M6 (12 V)



503 014 003
0 092 **M60 010**
M6 001
YT4L-4
YT4L-BS

3

30

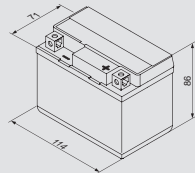

114 x 71 x 86



4 047 024 284 913

1,30

1,50

180

503 903 004
0 092 **M60 030**
M6 003
YTR4A-BS

3

40

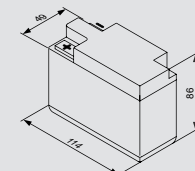

114 x 49 x 86



4 047 024 284 357

0,90

1,08

280

504 012 003
0 092 **M60 040**
M6 004
YTX5L-4
YTX5L-BS

4

80

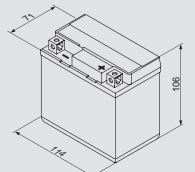

114 x 71 x 106



4 047 024 284 920

1,50

1,90

156

506 014 005
0 092 **M60 060**
M6 006
YTX7L-4
YTX7L-BS

6

100

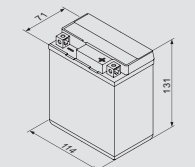

114 x 71 x 131



4 047 024 284 258

2,10

2,50

120

506 015 005
0 092 **M60 070**
M6 007
YTX7A-4
YTX7A-BS

6

105

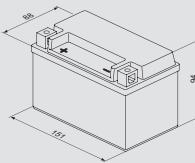

151 x 88 x 94



4 047 024 284 241

2,20

2,63

120

507 901 012
0 092 **M60 080**
M6 008
YT7B-4
YT7B-BS

7

120

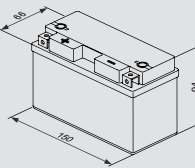

150 x 66 x 94



4 047 024 284 371

2,30

2,70

144

pt

Baterias Bosch
M6 – M4
para motos
6 V/12 V

fi

Bosch-akut
M6 – M4,
6 V/12 V:
moottoripyörät

pl















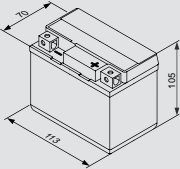

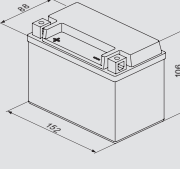
Akumulatory Bosch
M6 – M4
do motocykli
6 V/12 V

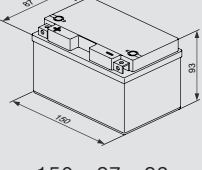
cs

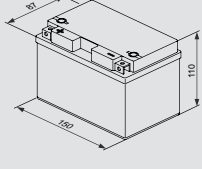
Bosch-Batterien
M6 – M4
pro motocykly
6 V/12 V

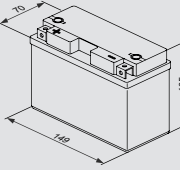
ru

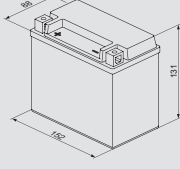
Bosch-Batterien
M6 – M4
для мотоциклов
6 V/12 V

ETN Bosch Reference Short code Japanese Part no.	Ah 20 h	A -18 °C		L	T	EAN	 kg	 kg	 max. pcs.	
M6 (12 V)										
507 902 011 0 092 M60 090 M6 009 YTZ7S-4 YTZ7S-BS	5	120	 113 x 70 x 105	- +		4 047 024 284 388	1,70	2,10	240	
508 012 008 0 092 M60 100 M6 010 YTX9-4 YTX9-BS	8	135	 152 x 88 x 106	+ -		4 047 024 284 234	2,50	3,08	120	
508 901 015 0 092 M60 110 M6 011 YTZ10S-4 YTZ10S-BS	8	150	 150 x 87 x 93	+ -		4 047 024 284 227	2,70	3,20	120	
509 901 020 0 092 M60 120 M6 012 YTZ12S-4 YTZ12S-BS	9	200	 150 x 87 x 110	+ -		4 047 024 284 135	2,80	3,70	96	
509 902 008 0 092 M60 130 M6 013 YT9B-4 YT9B-BS	8	115	 149 x 70 x 105	+ -		4 047 024 284 395	2,90	3,40	160	
510 012 009 0 092 M60 140 M6 014 YTX12-4 YTX12-BS	10	150	 152 x 88 x 131	+ -		4 047 024 284 142	3,40	4,15	96	

A 60

de

**Bosch-Batterien
M6 – M4
für Motorräder
6 V/12 V**
(Fortsetzung)

en

**Bosch batteries
M6 – M4
for motorcycles
6 V/12 V**
(continued)

fr

**Batteries Bosch
M6 – M4
pour motocyclettes
6 V/12 V**
(suite)

it

**Batterie Bosch
M6 – M4
per motocicli
6 V/12 V**
(seguito)

es

**Bosch Baterías
M6 – M4
para motocicletas
6 V/12 V**
(continuación)



ETN
Bosch Reference
Short code
Japanese Part no.

Ah
20 h

A
-18 °C



L

T

EAN



M6 (12 V)



511 901 014
0 092 **M60 160**
M6 016
YT12A-4
YT12A-BS

11

160

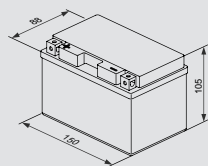

150 x 88 x 105

+ -



4 047 024 284 166

3,50

4,10

96

511 902 023
0 092 **M60 170**
M6 017
YTZ14S-4
YTZ14S-BS

11

230

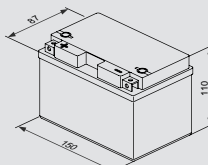

150 x 87 x 110

+ -



4 047 024 284 173

3,00

3,90

96

512 014 010
0 092 **M60 180**
M6 018
YTX14-4
YTX14-BS

12

200

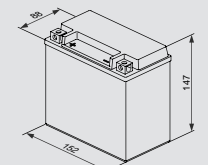

152 x 88 x 147

+ -



4 047 024 284 180

3,80

4,51

96

512 901 019
0 092 **M60 190**
M6 019
YT12B-4
YT12B-BS

12

215

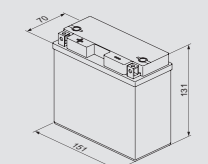

151 x 70 x 131

+ -



4 047 024 284 098

3,30

4,00

96

512 903 013
0 092 **M60 200**
M6 020
YT14B-4
YT14B-BS

12

190

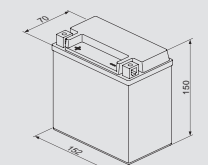

152 x 70 x 150

+ -



4 047 024 284 401

5,60

6,40

128

514 901 022
0 092 **M60 210**
M6 021
YTX16-4-1
YTX16-BS-1

14

210

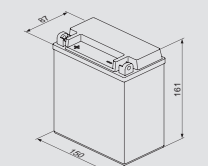

150 x 87 x 161

+ -



4 047 024 284 081

4,30

5,30

63

pt

**Baterias Bosch
M6 – M4
para motos
6 V/12 V
(continuação)**

fi

**Bosch-akut
M6 – M4,
6 V/12 V:
moottoripyörät
(jatkoa)**

pl











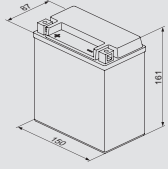

**Akumulatory Bosch
M6 – M4
do motocykli
6 V/12 V
(ciąg dalszy)**

cs

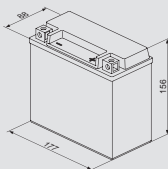
**Akumulátory Bosch
M6 – M4
pro motocykly
6 V/12 V
(pokračování)**

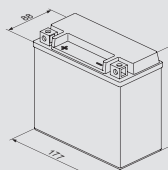
ru

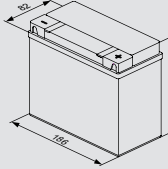
**Аккумуляторы
Bosch M6 – M4
для мотоциклов
6 В/12 В
(продолжение)**

ETN Bosch Reference Short code Japanese Part no.	Ah 20 h	A -18 °C		L	T	EAN			
M6 (12 V)									
514 902 022 0 092 M60 220 M6 022 YTX16-4 YTX16-BS	14	210				4 047 024 284 197	4,30	5,30	63
518 901 026 0 092 M60 230 M6 023 YTX20L-4 YTX20L-BS	18	250				4 047 024 284 203	5,30	6,50	54
518 902 026 0 092 M60 240 M6 024 YTX20-4 YTX20-BS	18	250				4 047 024 284 210	5,30	6,50	54
519 901 017 0 092 M60 450 ¹⁾ M6 045 -	19	170				4 047 024 284 296		6,40	108

¹⁾ Gelbatterie / Gel battery / Batterie à gel / Batteria al gel / Bateria de gel / Bateria de gel / Geeliakku / Akumulator żelowy / Gelový akumulátor / Аккумулятор Gel

A62

de Bosch-Batterien M6 – M4 für Motorräder 6 V/12 V	en Bosch batteries M6 – M4 for motorcycles 6 V/12 V	fr Batteries Bosch M6 – M4 pour motocyclettes 6 V/12 V	it Batterie Bosch M6 – M4 per motocicli 6 V/12 V	es Bosch Baterías M6 – M4 para motocicletas 6 V/12 V
---	--	---	---	---



ETN
Bosch Reference
Short code
Japanese Part no.

Ah
20 h

A
-18°C



L

T

EAN

kg

kg

max. pcs.

M4 (12 V)



503 012 001
0 092 **M4F 150** ³⁾
M4 F15
YB3L-A

3

30

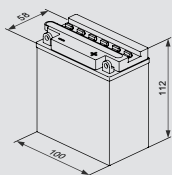

100 x 58 x 112



4 047 024 510 524

1,10

1,41

480

503 013 001
0 092 **M4F 160** ³⁾
M4 F16
YB3L-B

3

30

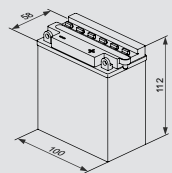

100 x 58 x 112



4 047 024 510 630

1,10

1,41

480

504 011 002
0 092 **M4F 170** ³⁾
M4 F17
YB4L-B

4

50

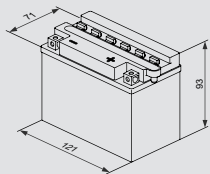

121 x 71 x 93



4 047 024 284 890

1,20

1,52

400

505 012 003
0 092 **M4F 180** ³⁾
M4 F18
12N5-3B ²⁾
YB5L-B

5

60

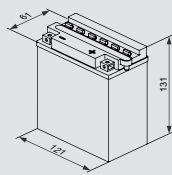

121 x 61 x 131



4 047 024 510 531

1,30

2,11

300

506 011 004
0 092 **M4F 190** ³⁾
M4 F19
12N5.5-3B

5,5

55

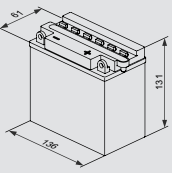

136 x 61 x 131



4 047 024 510 623

1,60

2,14

300

506 012 004
0 092 **M4F 200** ³⁾
M4 F20
12N5.5A-3B

6

58

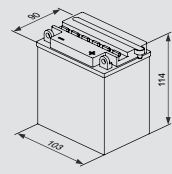

103 x 90 x 114



4 047 024 772 564

1,80

2,16

240

pt

**Baterias Bosch
M6 – M4
para motos
6 V/12 V**

fi

**Bosch-akut
M6 – M4,
6 V/12 V:
moottoripyörät**

pl

**Akumulatory Bosch
M6 – M4
do motocykli
6 V/12 V**

cs

**Akumulátory Bosch
M6 – M4
pro motocykly
6 V/12 V**

ru

**Аккумуляторы
Bosch M6 – M4
для мотоциклов
6 В/12 В**

ETN

Bosch Reference
Short code
Japanese Part no.

Ah

A
-18 °C

L

T

EAN

kg

kg

max. pcs.

**M4 (12 V)**

507 012 004 0 092 M4F 210 ³⁾ M4 F21 12N7-3B ²⁾ YB7L-B	7	74				4 047 024 510 562	2,10	2,71	225
507 013 004 0 092 M4F 220 M4 F22 12N7-4A	7	74				4 047 024 772 571	2,05	2,86	96
507 101 008 0 092 M4F 230 ³⁾ M4 F23 GM7CZ-3D YB7C-A	8	110				4 047 024 752 719	2,10	2,69	240
508 013 008 0 092 M4F 240 ³⁾ M4 F24 YB7-A	8	110				4 047 024 510 555	2,10	2,83	225
509 014 008 0 092 M4F 250 ³⁾ M4 F25 12N9-4B-1 ²⁾ YB9-B	9	85				4 047 024 284 289	2,30	3,04	225

²⁾ Typen mit niedrigeren Leistungswerten als Bosch. / Types with lower power output values than Bosch. / Types présentant des performances inférieures à Bosch. / Tipi con valori di potenza inferiori rispetto a Bosch. / Tipos con valores de potencia inferiores a los de Bosch. / Tipos com valores de potência mais baixos do que Bosch. / Tehoarvoiltaan Bosch-akkuja alhaisemmat tyypit. / Typy z niższą wartością mocy niż Bosch. / Typy nižšími výkonovými hodnotami než Bosch. / Типы с более низкими значениями мощности, чем Bosch.

³⁾ Batterie mit Zentralentgasung, deshalb 7–10 mm Überstand. / Battery with central gassing, consequently 7–10 mm projection. / Batterie avec dégazage central, donc saillie de 7–10 mm. / Batteria con degassamento centralizzato, sporgenza di 7–10 mm. / Bateria con desgasificación centralizada. Por tanto, 7–10 mm de protrusión. / Bateria com saída de gases central, por isso 7–10 mm de saliência. / Akussa keskitetty kaasunpoisto, siksi 7–10 mm:n ulottuma yli reunan. / Akumulator z centralnym odgazowaniem, dlatego jest występ 7–10 mm. / Akumulátor s centrálnym odplyňením, preto pŕesah 7–10 mm. / Аккумулятор с централизованным удалением газов, поэтому выступ на 7–10 мм.

A 64

de

**Bosch-Batterien
M6 – M4
für Motorräder
6 V/12 V**
(Fortsetzung)

en

**Bosch batteries
M6 – M4
for motorcycles
6 V/12 V**
(continued)

fr

**Batteries Bosch
M6 – M4
pour motocyclettes
6 V/12 V**
(suite)

it

**Batterie Bosch
M6 – M4
per motocicli
6 V/12 V**
(seguito)

es

**Bosch Baterías
M6 – M4
para motocicletas
6 V/12 V**
(continuación)

ETN
Bosch Reference
Short code
Japanese Part no.

Ah

20 h

A
-18°C



L

T

EAN



M4 (12 V)

509 015 008
0 092 **M4F 260** ³⁾
M4 F26
12N9-3B ²⁾
YB9L-B

9

85

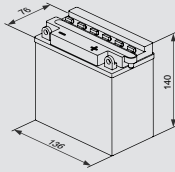

136 x 76 x 140



4 047 024 510 548

2,30

3,04

225

509 016 008
0 092 **M4F 270** ³⁾
M4 F27
YB9L-A2

9

130

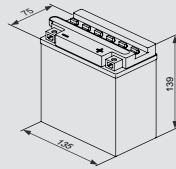

135 x 75 x 139



4 047 024 752 726

2,20

2,97

225

511 012 009
0 092 **M4F 280** ³⁾
M4 F28
12N10-3A ²⁾
12N10-3A-1 ²⁾
12N10-3A-2 ²⁾
YB10L-A2

11

150

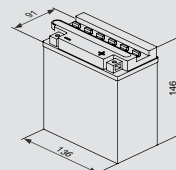

136 x 91 x 146



4 047 024 284 661

3,10

4,03

140

511 013 009
0 092 **M4F 290** ³⁾
M4 F29
12N10-3B ²⁾
YB10L-B
YB10L-B2

11

150

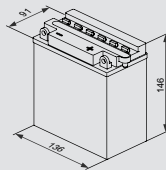

136 x 91 x 146



4 047 024 284 678

3,10

4,03

140

512 011 012
0 092 **M4F 300** ³⁾
M4 F30
12N12A-4A-1 ²⁾
YB12A-A

12

160

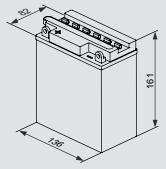

136 x 82 x 161



4 047 024 284 685

3,20

4,02

180

512 013 012
0 092 **M4F 320** ³⁾
M4 F32
YB12AL-A
YB12AL-A2
(with adapter)

12

160

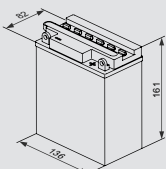

136 x 82 x 161



4 047 024 510 593

3,20

4,07

180

pt

**Baterias Bosch
M6 – M4
para motos
6 V/12 V**
(continuação)

fi

**Bosch-akut
M6 – M4,
6 V/12 V:
moottoripyörät**
(jatkoa)

pl





**Akumulatory Bosch
M6 – M4
do motocykli
6 V/12 V**
(ciąg dalszy)

cs









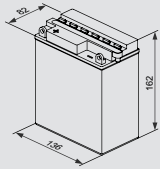

**Akumulátory Bosch
M6 – M4
pro motocykly
6 V/12 V**
(pokračování)

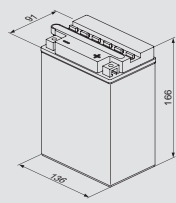
ru

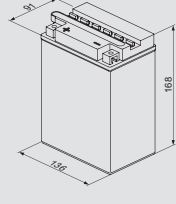
**Аккумуляторы
Bosch M6 – M4
для мотоциклов
6 В/12 В**
(продолжение)

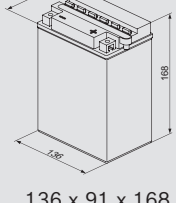
ETN Bosch Reference Short code Japanese Part no.	Ah 20 h	A -18 °C		L	T	EAN			
---	------------	-------------	---	---	---	-----	---	---	---

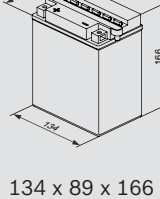
M4 (12 V)

512 015 012 0 092 M4F 330 ³⁾ M4 F33 YB12A-B	12	160				4 047 024 752 733	3,20	4,02	180
514 011 014 0 092 M4F 340 ³⁾ M4 F34 12N14-3A YB14L-A2	14	190				4 047 024 284 906	3,30	4,51	140
514 012 014 0 092 M4F 350 ³⁾ M4 F35 YB14-A2	14	190				4 047 024 510 708	3,50	4,53	140
514 013 014 0 092 M4F 360 ³⁾ M4 F36 YB14L-B2	14	190				4 047 024 510 647	3,50	4,51	140
514 014 014 0 092 M4F 370 ³⁾ M4 F37 YB14-B2	14	190				4 047 024 772 588	3,50	4,53	140

²⁾ Typen mit niedrigeren Leistungswerten als Bosch. / Types with lower power output values than Bosch. / Types présentant des performances inférieures à Bosch. / Tipi con valori di potenza inferiori rispetto a Bosch. / Tipos con valores de potencia inferiores a los de Bosch. / Tipos con valores de potência mais baixos do que Bosch. / Tehoarvoiltaan Bosch-akkuja alhaisemmat tyypit. / Typy z niższą wartością mocy niż Bosch. / Typy nižšími výkonovými hodnotami než Bosch. / Типы с более низкими значениями мощности, чем Bosch.

³⁾ Batterie mit Zentralentgasung, deshalb 7–10 mm Überstand. / Battery with central gassing, consequently 7–10 mm projection. / Batterie avec dégazage central, donc saillie de 7–10 mm. / Batteria con degassamento centralizzato, sporgenza di 7–10 mm. / Bateria con desgasificación centralizada. Por tanto, 7–10 mm de protrusión. / Bateria com saída de gases central, por isso 7–10 mm de saliência. / Akussa keskitetty kaasunpoisto, siksi 7–10 mm:n ulottuma yli reunan. / Akumulator z centralnym odgazowaniem, dlatego jest występ 7–10 mm. / Akumulátor s centrálním odplyňním, proto přesah 7–10 mm. / Аккумулятор с централизованным удалением газов, поэтому выступ на 7–10 мм.

A 66

de Bosch-Batterien M6 – M4 für Motorräder 6 V/12 V (Fortsetzung)	en Bosch batteries M6 – M4 for motorcycles 6 V/12 V (continued)	fr Batteries Bosch M6 – M4 pour motocyclettes 6 V/12 V (suite)	it Batterie Bosch M6 – M4 per motocicli 6 V/12 V (seguito)	es Bosch Baterías M6 – M4 para motocicletas 6 V/12 V (continuación)
--	---	--	--	---



ETN
Bosch Reference
Short code
Japanese Part no.

Ah
20 h

A
-18°C



L

T

EAN

kg

kg

max. pcs.

M4 (12 V)



514 401 019 0 092 M4F 380 ³⁾ M4 F38 YB14A-A2	14	190			4 047 024 772 595	2,50	4,51	140
516 015 016 0 092 M4F 390 ³⁾ M4 F39 YB16B-A YB16B-A1	16	200			4 047 024 510 609	3,90	5,17	120
516 016 012 0 092 M4F 400 ³⁾ M4 F40 YB16AL-A2	16	180			4 047 024 510 661	3,90	5,25	140
518 014 015 0 092 M4F 410 ³⁾ M4 F41 51814	18	100			4 047 024 510 654	4,50	5,69	120
518 015 018 0 092 M4F 420 ³⁾ M4 F42 YB18L-A	18	200			4 047 024 510 678	4,30	5,70	120
519 011 019 0 092 M4F 430 ³⁾ M4 F43 YB16L-B	19	240			4 047 024 510 685	4,60	6,11	120

pt

**Baterias Bosch
M6 – M4
para motos
6 V/12 V**
(continuação)

fi

**Bosch-akut
M6 – M4,
6 V/12 V:
moottoripyörät**
(jatkoa)

pl

**Akumulatory Bosch
M6 – M4
do motocykli
6 V/12 V**
(ciąg dalszy)

cs











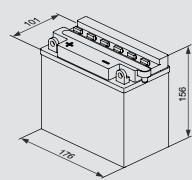

**Akumulátory Bosch
M6 – M4
pro motocykly
6 V/12 V**
(pokračování)

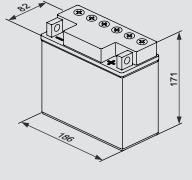
ru

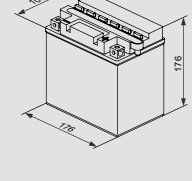
**Аккумуляторы
Bosch M6 – M4
для мотоциклов
6 В/12 В**
(продолжение)

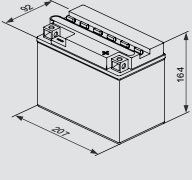
ETN Bosch Reference Short code Japanese Part no.	Ah 20 h	A -18 °C		L	T	EAN				
---	------------	-------------	---	---	---	-----	---	---	---	---

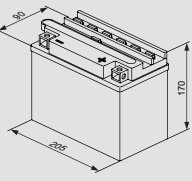
M4 (12 V)





519 012 019 0 092 M4F 440 ³⁾ M4 F44 YB16-B	19	240				4 047 024 510 692	4,60	6,10	120	
			176 x 101 x 156							
519 013 017 0 092 M4F 450 ³⁾ M4 F45 51913	19	100				4 047 024 284 128	4,50	5,69	120	
			186 x 82 x 171							
519 014 018 0 092 M4F 460 ³⁾ M4 F46 YB16CL-B	19	240				4 047 024 510 739	4,60	6,21	120	
			176 x 101 x 176							
520 012 020 0 092 M4F 470 ³⁾ M4 F47 Y50-N18L-A Y50N18L-A2	20	260				4 047 024 510 715	4,70	6,40	120	
			207 x 92 x 164							
520 016 020 0 092 M4F 480 ³⁾ M4 F48 SY50-N18L-AT	20	260				4 047 024 772 601	4,70	6,40	120	
			205 x 90 x 170							

²⁾ Typen mit niedrigeren Leistungswerten als Bosch. / Types with lower power output values than Bosch. / Types présentant des performances inférieures à Bosch. / Tipi con valori di potenza inferiori rispetto a Bosch. / Tipos con valores de potencia inferiores a los de Bosch. / Tipos com valores de potência mais baixos do que Bosch. / Tehoarvoiltaan Bosch-akkuja alhaisemmat tyypit. / Typy z niższą wartością mocy niż Bosch. / Typy niżšími výkonovými hodnotami než Bosch. / Типы с более низкими значениями мощности, чем Bosch.







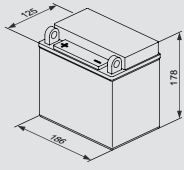

³⁾ Batterie mit Zentralentgasung, deshalb 7–10 mm Überstand. / Battery with central gassing, consequently 7–10 mm projection. / Batterie avec dégazage central, donc saillie de 7–10 mm. / Batteria con degassamento centralizzato, sporgenza di 7–10 mm. / Bateria con desgasificación centralizada. Por tanto, 7–10 mm de protrusión. / Bateria com saída de gases central, por isso 7–10 mm de saliência. / Akussa keskitetty kaasunpoisto, siksi 7–10 mm:n ulottuma yli reunan. / Akumulator z centralnym odgazowaniem, dlatego jest występ 7–10 mm. / Akumulátor s centrálním odplyňením, preto pŕesah 7–10 mm. / Аккумулятор с централизованным удалением газов, поэтому выступ на 7–10 мм.

A 68

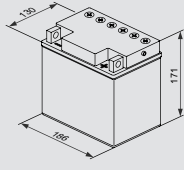
de Bosch-Batterien M6 – M4 für Motorräder 6 V/12 V (Fortsetzung)	en Bosch batteries M6 – M4 for motorcycles 6 V/12 V (continued)	fr Batteries Bosch M6 – M4 pour motocyclettes 6 V/12 V (suite)	it Batterie Bosch M6 – M4 per motocicli 6 V/12 V (seguito)	es Bosch Baterías M6 – M4 para motocicletas 6 V/12 V (continuación)
--	---	--	--	---

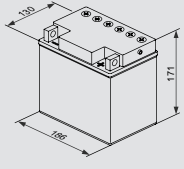
	ETN Bosch Reference Short code Japanese Part no.	Ah 20 h	A -18°C		L	T	EAN			
	M4 (12 V)									

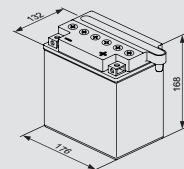

524 101 020 0 092 M4F 510 ³⁾ M4 F51 12N24-4	24	200	 186 x 125 x 178			4 047 024 510 746	6,50	8,52	136
525 015 022 0 092 M4F 520 ³⁾ M4 F52 52515 Y60-N24LA ²⁾	25	300	 186 x 130 x 171			4 047 024 510 722	5,50	7,75	128
530 030 030 0 092 M4F 540 ³⁾ M4 F54 53030	30	180	 186 x 130 x 171			4 047 024 284 074	6,50	8,55	128
530 400 030 0 092 M4F 600 ³⁾ M4 F60 YB30L-B	30	300	 176 x 132 x 168			4 047 024 772 632	6,75	8,98	48

pt

**Baterias Bosch
M6 – M4
para motos
6 V/12 V
(continuação)**

fi

**Bosch-akut
M6 – M4,
6 V/12 V:
moottoripyörät
(jatkoa)**

pl





**Akumulatory Bosch
M6 – M4
do motocykli
6 V/12 V
(ciąg dalszy)**

cs









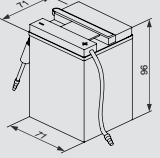

**Akumulátory Bosch
M6 – M4
pro motocykly
6 V/12 V
(pokračování)**

ru

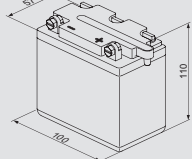
**Аккумуляторы
Bosch M6 – M4
для мотоциклов
6 В/12 В
(продолжение)**

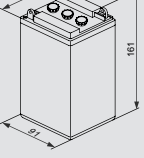
ETN Bosch Reference Short code Japanese Part no.	Ah 20 h	A -18 °C		L	T	EAN				
---	------------	-------------	---	---	---	-----	---	---	---	---

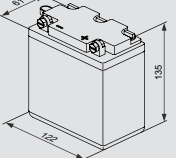
M4 (6 V)

004 014 001 0 092 M4F 040 ³⁾ M4 F04 6N4-2A-2 6N4-2A-4 6N4-2A-7 6N4A-2A-4	4	10	 71 x 71 x 96			4 047 024 772 540	0,50	0,75	420	
006 012 003 0 092 M4F 070 ³⁾ M4 F07 6N6-3B-1	6	30	 100 x 57 x 110			4 047 024 752 702	0,80	1,07	480	
008 011 004 0 092 M4F 100 ³⁾ M4 F10 B49-6	8	40	 95 x 85 x 166			4 047 024 772 557	1,50	2,10	120	
012 014 008 0 092 M4F 120 ³⁾ M4 F12 6N11A-3A	12	80	 122 x 61 x 135			4 047 024 510 517	1,60	2,06	300	

²⁾ Typen mit niedrigeren Leistungswerten als Bosch. / Types with lower power output values than Bosch. / Types présentant des performances inférieures à Bosch. / Tipi con valori di potenza inferiori rispetto a Bosch. / Tipos con valores de potencia inferiores a los de Bosch. / Tipos con valores de potência mais baixos do que Bosch. / Tehoarvoiltaan Bosch-akkuja alhaisemmat tyypit. / Typy z niższą wartością mocy niż Bosch. / Typy niżšími výkonovými hodnotami než Bosch. / Типы с более низкими значениями мощности, чем Bosch.

³⁾ Batterie mit Zentralentgasung, deshalb 7–10 mm Überstand. / Battery with central gassing, consequently 7–10 mm projection. / Batterie avec dégazage central, donc saillie de 7–10 mm. / Batteria con degassamento centralizzato, sporgenza di 7–10 mm. / Bateria con desgasificación centralizada. Por tanto, 7–10 mm de protrusión. / Bateria com saída de gases central, por isso 7–10 mm de saliência. / Akussa keskitetty kaasunpoisto, siksi 7–10 mm:n ulottuma yli reunan. / Akumulator z centralnym odgazowaniem, dlatego jest występ 7–10 mm. / Akumulátor s centrálním odplyňením, proto přesah 7–10 mm. / Аккумулятор с централизованным удалением газов, поэтому выступ на 7–10 мм.



Bosch L5, L4

Batterien für Freizeitanwendungen

Batteries for leisure applications

Batteries pour les applications de loisirs

Batterie per applicazioni del tempo libero

Baterías para aplicaciones de ocio



BOSCH







A72

de Bosch-Batterien L5, L4 für Freizeit- anwendungen	en Bosch batteries L5, L4 for leisure applicatiions	fr Batterie Bosch L5, L4 pour les applications de loisirs	it Batteria Bosch L5, L4 per applicazioni del tempo libero	es Batería Bosch L5, L4 para aplicaciones de ocio
--	--	--	---	--

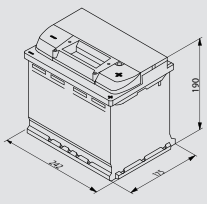
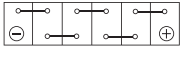
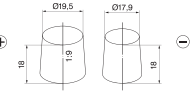
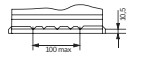
ETN Bosch Reference Short code	Ah 20 h	Ah 5 h	RC @25A min	A(EN)		L	T	B	EAN		

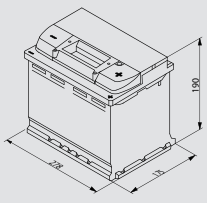
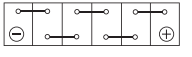
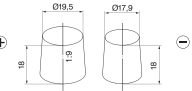
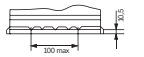
L5 (12 V)

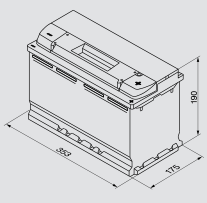
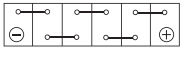
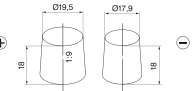
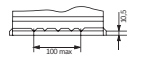
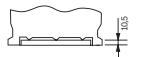
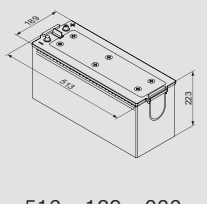
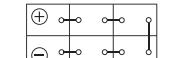
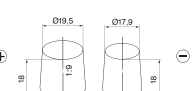



930 060 056 0 092 L50 050 L5 005	60	51	109	560	 242 x 175 x 190	   	4 047 024 776 852	16,93	63
930 075 065 0 092 L50 080 L5 008	75	64	141	650	 278 x 175 x 190	   	4 047 024 776 869	18,91	48
930 090 080 0 092 L50 130 L5 013	90	77	174	800	 353 x 175 x 190	   	4 047 024 776 876	23,73	36
930 140 080 0 092 L50 750 L5 075	140	119	284	800	 513 x 189 x 223	   	4 047 024 776 883	35,76	24

pt Bateria Bosch L5, L4 para aplicações de lazer	fi Bosch-akku L5, L4 vapaa-ajan viettoon	pl Akumulator Bosch L5, L4 do zastosowań w wolnym czasie	cs Akumulátory Bosch L5, L4 pro volnočasové aplikace	ru Аккумулятор Bosch L5, L4 для бытового использования
---	---	---	---	---

ETN Bosch Reference Short code	Ah 20 h	Ah 5 h	RC @25A min	A(EN)		L	T	B	EAN	 kg	 max. pcs	
--------------------------------------	-------------------	------------------	--------------------------	--------------	---	----------	----------	----------	------------	--	--	---

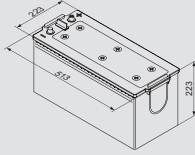
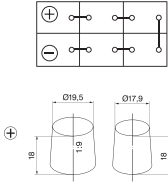
L5 (12 V)

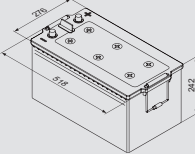
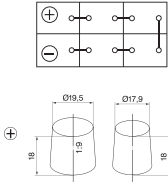
930 180 100 0 092 L50 770 L5 077	180	153	377	1000	 513 x 223 x 223		4 047 024 776 890	45,10	21	 
930 230 115 0 092 L50 800 L5 080	230	196	499	1150	 518 x 276 x 242		4 047 024 776 906	56,75	12	

L5 (8 V)

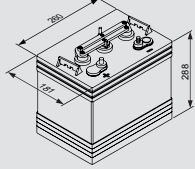
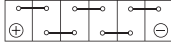
400 170 000 0 092 L50 G40 L5 0G4	170	138	337		 260 x 181 x 288		4 047 024 996 458	31,00	40	
---	-----	-----	-----	--	--	--	-------------------	-------	----	--

L5 (6 V)

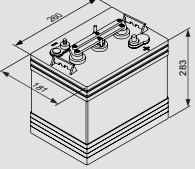
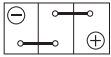
300 208 000 0 092 L50 G10 L5 0G1	208	163	415		 260 x 181 x 288		4 047 024 996 427	28,80	40	
---	-----	-----	-----	--	--	--	-------------------	-------	----	--

A74

de

Bosch-Batterien
L5, L4
für Freizeit-
anwendungen
 (Fortsetzung)

en

Bosch batteries
L5, L4
for leisure
applicatiions
 (continued)

fr

Batterie Bosch
L5, L4
pour les applications
de loisirs
 (suite)

it

Batteria Bosch
L5, L4
per applicazioni
del tempo libero
 (seguito)v

es

Batería Bosch
L5, L4
para aplicaciones
de ocio
 (continuación)

 ETN Bosch Reference Short code	Ah 20 h	Ah 5 h	RC @25A min	A(EN)		L	T	B	EAN	 kg	 max. pcs

L5 (6 V)



300 216 000

0 092 **L50 G20**

216

174

445

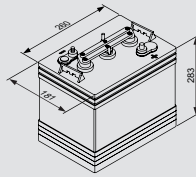

260 x 181 x 283

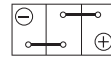

4 047 024 996 434

29,20

40



L5 0G2

300 232 000

0 092 **L50 G30**

232

183

474

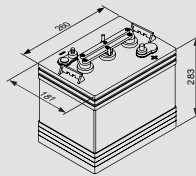

260 x 181 x 283

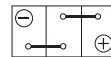

4 047 024 996 441

30,20

40

L5 0G3

L4 (12 V)

812 071 000

0 092 **L40 270**

75

60

124

600

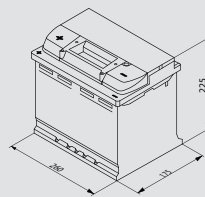

260 x 175 x 225

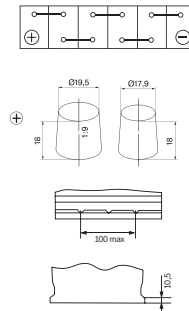

4 047 024 776 838

17,32

48

L4 027

811 053 057

0 092 **L40 330**

105

85

190

570

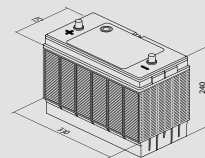

330 x 175 x 240

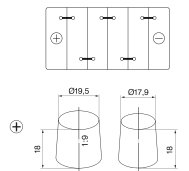

4 047 024 776 845

24,11

36

L4 033



OPTIMA

Batterien für Boote, Landwirtschaft und Baustelle
Batteries for boats, agriculturals and construction
Batteries pour bateaux, matériels agricoles
et engins de chantier

Batterie per imbarcazioni, agricoltura e cantiere
Baterías para barcos, máquinas agrícolas y de construcción



BOSCH

de

**OPTIMA
Red Top**

en

**OPTIMA
Red Top**

fr

**OPTIMA
Red Top**

it

**OPTIMA
Red Top**

es

**OPTIMA
Red Top**



Optima Reference
Bosch Reference
Short code

Ah
20 h

A(EN)



L

T

B

EAN



12 V



RT C 4,2

0 098 001 287

50

815

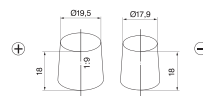

4 016 987 113 455

19,30

48

8001-287

254 x 175 x 200

RT S 4,2

0 098 002 250

50

815

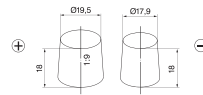

4 016 987 113 462

19,30

48

8002-250

254 x 175 x 200

RT R 4,2

0 098 003 251

50

815

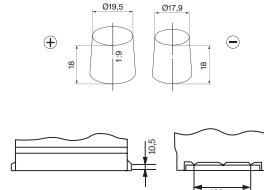

4 016 987 113 479

19,30

48

8003-251

254 x 175 x 200

RT U 4,2

0 098 004 250

50

815

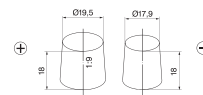

4 016 987 113 486

19,70

48

8004-250

254 x 175 x 200

& 21)

RT F 4,2

0 098 078 209

50

815

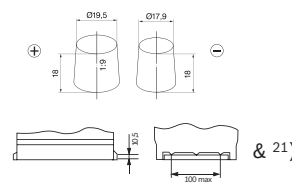

4 016 987 128 237

19,60

48

8078-209

254 x 185 x 184

& 21)

pt

OPTIMA
Red Top

fi

OPTIMA
Red Top

pl





OPTIMA
Red Top

cs

OPTIMA
Red Top

ru

OPTIMA
Red Top

Optima Reference Bosch Reference Short code	Ah 20 h	A(EN)		L	T	B	EAN			
---	------------	-------	---	---	---	---	-----	---	---	---

12 V

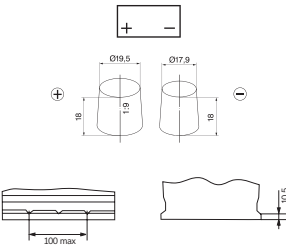
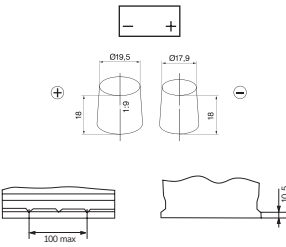
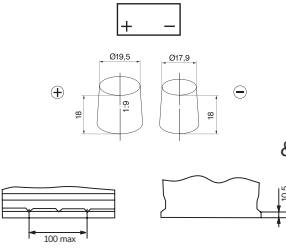
RT S 3,7 0 098 020 255 8020-255	44	730	237 x 171 x 197		4 016 987 113 554	16,10	48
RT R 3,7 0 098 035 255 8035-255	44	730	237 x 171 x 197		4 016 987 113 578	16,10	48
RT U 3,7 0 098 022 255 8022-255	44	730	237 x 171 x 197		4 016 987 113 561	16,80	48

6 V

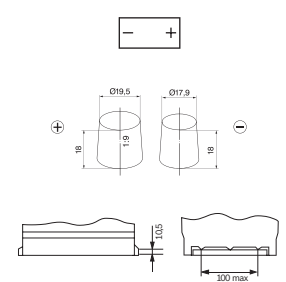
RT S 2,1 0 098 010 355 8010-355	50	815	252 x 90 x 206		4 016 987 113 516	9,30	48
--	----	-----	----------------	--	-------------------	------	----

²¹⁾ 3/16"-16 UNC-2B korrosionsfestes Innengewinde / 3/16"-16 UNC-2B non-corroding female thread / Filet femelle anticorrosion 3/16"-16 UNC-2B / Filettatura interna anticorrosiva 3/16"-16 UNC-2B / Rosca interior resistente a la corrosión de 3/16"-16 UNC-2B / 3/16"-16 UNC-2B Rosca interior resistente à corrosão / 3/16"-16 UNC-2B korroosionkestävä sisäkierre / 3/16"-16 UNC-2B antykorozyjny gwint wewnętrzny / 3/16"-16 UNC-2B korozivzdorný vnitřní závit / 3/16"-16 UNC-2B Коррозионностойкая внутренняя резьба

Rf = Rüttelfest / Vibration resistant / Résistant aux fortes vibrations / Resistente alle vibrazioni / Resistente a sacudidas / resistente à vibração / tärinänkestävä / odporny na wstrząsy / Odolné otřesům / вибростойкость

A78

de

OPTIMA
Yellow Top

en

OPTIMA
Yellow Top

fr

OPTIMA
Yellow Top

it

OPTIMA
Yellow Top

es

OPTIMA
Yellow Top



Optima Reference
Bosch Reference
Short code

Ah
20 h

A(EN)



L

T

B

EAN

kg

max. pcs.

12 V



YT S 5,5

0 098 051 187

75

975

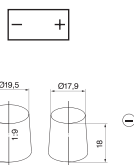

4 016 987 113 585

30,40

36

8051-187

325 x 165 x 238



YT R 5,0

0 098 037 327

66

845

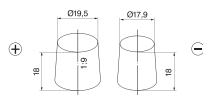

4 016 987 141 038

22,50

36

8037-327

309 x 172 x 219

YT S 4,2

0 098 012 254

55

765

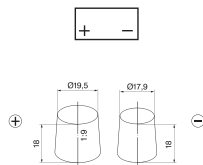

4 016 987 113 523

21,80

48

8012-254

254 x 175 x 200

YT U 4,2

0 098 014 254

55

765

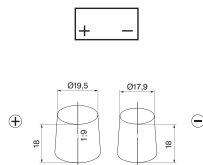

4 016 987 113 530

22,10

48

8014-254

254 x 175 x 200

& 21)

YT R 3,7

0 098 040 222

48

660

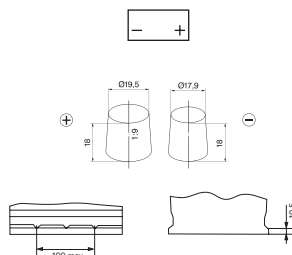

4 016 987 114 667

17,40

48

8040-222

237 x 171 x 197

pt

OPTIMA
Yellow Top

fi

OPTIMA
Yellow Top

pl





OPTIMA
Yellow Top

cs

OPTIMA
Yellow Top

ru

OPTIMA
Yellow Top

Optima Reference Bosch Reference Short code	Ah 20 h	A(EN)		L	T	B	EAN			
---	------------	-------	---	---	---	---	-----	---	---	---

12 V

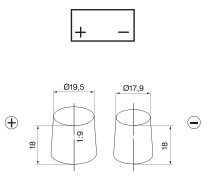
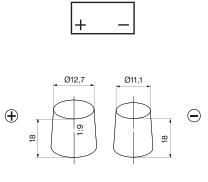
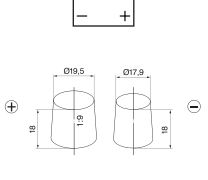
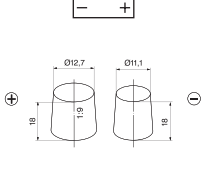
YT S 2,7 0 098 071 176 8071-176	38	460	237 x 129 x 227		4 016 987 113 615	12,50	64
YT S 2,7 J 0 098 070 176 8070-176	38	460	237 x 129 x 227		4 016 987 113 608	12,50	64
YT R 2,7 0 098 073 176 8073-176	38	460	237 x 129 x 227		4 016 987 113 639	12,50	64
YT R 2,7 J 0 098 072 176 8072-176	38	460	237 x 129 x 227		4 016 987 113 622	12,50	64

6 V

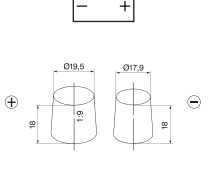
YT S 2,1 0 098 018 356 8018-356	55	765	252 x 90 x 206		4 016 987 124 093	10,60	48
---------------------------------------	----	-----	----------------	--	-------------------	-------	----

²¹⁾ 3/16 UNC-2B korrosionsfestes Innengewinde / 3/16 UNC-2B non-corroding female thread / Filet femelle anticorrosion 3/16 UNC-2B / Filettatura interna anticorrosiva 3/16 UNC-2B / Rosca interior resistente a la corrosión de 3/16 UNC-2B / 3/16 UNC-2B Rosca interior resistente à corrosão / 3/16 UNC-2B korroosionkestävä sisäkierre / 3/16 UNC-2B antykorozyjny gwint wewnętrzny / 3/16 UNC-2B korozivzdorný vnitřní závit / 3/16 UNC-2B Коррозионностойкая внутренняя резьба

A 80

de

**OPTIMA
Blue Top**

en

**OPTIMA
Blue Top**

fr

**OPTIMA
Blue Top**

it

**OPTIMA
Blue Top**

es

**OPTIMA
Blue Top**

pt

**OPTIMA
Blue Top**

fi

**OPTIMA
Blue Top**

pl

**OPTIMA
Blue Top**

cs

**OPTIMA
Blue Top**

ru

**OPTIMA
Blue Top**



Optima Reference
Bosch Reference
Short code

Ah

20 h

A(EN)



L

T

B

EAN



12 V



BT DCM 5,5

0 098 052 188

75

975

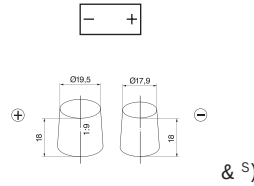

4 016 987 113 592

30,40

36

8052-188

325 x 165 x 238

& ^{S)}



BT DCM 5,0

0 098 027 227

66

845

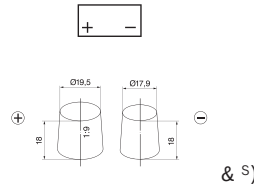

4 016 987 130 346

22,70

36

8027-227

309 x 172 x 221

& ^{S)}

BT DCM 4,2

0 098 016 253

55

765

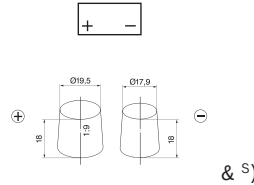

4 016 987 113 547

22,10

48

8016-253

254 x 175 x 200

& ^{S)}

BT SLIM 4,2

0 098 006 252

50

815

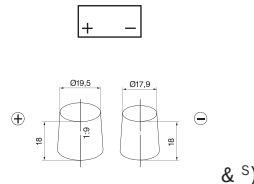

4 016 987 113 493

19,50

48

8006-252

254 x 175 x 200

& ^{S)}

^{S)} 5/16"-18 UNC-2A korrosionsfester Gewindepol
 5/16"-18 UNC-2A non-corroding terminal post
 Borne anticorrosion 5/16"-18 UNC-2A
 Polo anticorrosivo 5/16"-18 UNC-2A
 Polo roscada a prueba de corrosión de 5/16"-18 UNC-2A
 5/16"-18 UNC-2A Pólo rosca resistente à corrosão
 5/16"-18 UNC-2A korroosionkestävä kierrenapa
 5/16"-18 UNC-2A antykorozyjny biegun gwintowany
 5/16"-18 UNC-2A korozivzdorný závitový pól
 5/16"-18 UNC-2A Коррозионнстойкий резьбовой полюс

de	en	fr	it	es
Gegenüberstellung Bosch-Batterien	Cross-reference Bosch batteries	Table de correspondance Batteries Bosch	Comparazione Batterie Bosch	Equivalencias Baterías Bosch



Bosch High Tec →

Bosch S6 – S5 – S4 – S3

0 092 S60 010	570 901 076	S6 001	0 092 S60 080	570 901 076	S6 080
0 092 S60 020	595 901 085	S6 002	0 092 S60 130	595 901 085	S6 130
0 097 H57 0P1	570 901 076	70H	0 092 S60 080	570 901 076	S6 080
0 097 H59 5P1	595 901 085	95H	0 092 S60 130	595 901 085	S6 130

Bosch Silver Plus →

Bosch S6 – S5 – S4 – S3

0 093 T54 32Z	543 107 048	4PT	0 092 S40 010	544 402 044	S4 001
0 093 T54 42X	544 105 045	4CT	0 092 S40 020	552 400 047	S4 002
0 093 T54 42Y	544 106 045	4DT	0 092 S30 030	545 413 040	S3 003
0 093 T54 52T	545 101 048	4ET	0 092 S40 010**	544 402 044	S4 001
0 093 T55 52Z	555 107 054	5DT	0 092 S40 050	560 408 054	S4 005
0 093 T56 22V	562 103 060	6CT	0 092 S50 050	563 400 061	S5 005
0 093 T56 32U	563 102 060	6DT	0 092 S30 070**	570 144 064	S3 007
0 093 T56 62T	566 101 064	6FT	0 092 S30 080	570 409 064	S3 008
0 093 T58 82Z	588 107 085	8AT	0 092 S40 130	595 402 080	S4 013

Bosch Silver →

Bosch S6 – S5 – S4 – S3

0 093 S53 6RV	536 054 030	3F	0 092 S30 010	541 400 036	S3 001
0 093 S54 030	540 108 033	4F	0 092 S40 000	542 400 039	S4 000
0 093 S54 03K	540 128 036	4FN	0 092 S40 000	542 400 039	S4 000
0 093 S54 05K	540 200 036	4HN	0 092 S30 010	541 400 036	S3 001
0 093 S54 30J	543 019 039	4B	0 092 S40 010*	544 402 044	S4 001
0 093 S54 30N	543 023 039	4P	0 092 S40 010	544 402 044	S4 001
0 093 S54 41N	544 059 036	4C	0 092 S30 020	545 412 040	S3 002
0 093 S54 41N	544 059 036	4CN	0 092 S30 020	545 412 040	S3 002
0 093 S54 41S	544 064 036	4D	0 092 S30 030	545 413 040	S3 003
0 093 S54 41S	544 064 036	4DN	0 092 S30 030	545 413 040	S3 003
0 093 S54 41X	544 069 036	4S	0 092 S40 010**	544 402 044	S4 001
0 093 S54 50J	545 019 036	4E	0 092 S40 010**	544 402 044	S4 001
0 093 S54 525	545 077 030	4K	0 092 S30 160	545 077 030	S3 016
0 093 S54 525	545 077 030	4KN	0 092 S30 160	545 077 030	S3 016
0 093 S54 527	545 079 030	4L	0 092 S30 170	545 079 030	S3 017
0 093 S54 527	545 079 030	4LN	0 092 S30 170	545 079 030	S3 017
0 093 S54 54R	545 171 042	4PN	0 092 S40 010	544 402 044	S4 001
0 093 S54 54S	545 172 042	4BN	0 092 S40 010*	544 402 044	S4 001
0 093 S54 54T	545 173 042	4EN	0 092 S40 010**	544 402 044	S4 001
0 093 S55 01K	550 056 054	5B	0 092 S30 040	553 400 047	S3 004
0 093 S55 01L	550 057 054	5C	0 092 S30 040*	553 400 047	S3 004
0 093 S55 01Y	550 070 033	5H	0 092 S40 020	552 400 047	S4 002
0 093 S55 040	550 144 039	5K	0 092 S40 020	552 400 047	S4 002
0 093 S55 04A	550 154 042	5KN	0 092 S40 020	552 400 047	S4 002
0 093 S55 04B	550 155 054	5LN	0 092 S50 010	552 401 052	S5 001
0 093 S55 51N	555 059 042	5D	0 092 S30 050	556 400 048	S3 005
0 093 S55 51N	555 059 042	5DN	0 092 S30 050	556 400 048	S3 005
0 093 S55 51T	555 065 042	5E	0 092 S30 060	556 401 048	S3 006
0 093 S55 51T	555 065 042	5EN	0 092 S30 060	556 401 048	S3 006
0 093 S55 54B	555 155 054	5BN	0 092 S40 040	560 409 054	S4 004
0 093 S55 54C	555 156 054	5CN	0 092 S40 040*	560 409 054	S4 004
0 093 S56 025	560 077 060	6H	0 092 S50 040	561 400 060	S5 004

pt

Comparação
das baterias Bosch

fi

Bosch-akkujen
vertailu

pl

Porównanie
akumulatorów Bosch

cs

Porovnání
akumulátorů Bosch

ru

Сравнение
аккумуляторов
Bosch



	ETN			ETN	
0 093 S56 02R	560 099 028	6B	0 092 S40 270	570 413 063	S4 027
0 093 S56 0S0	560 098 028	6A	0 092 S40 260	570 412 063	S4 026
0 093 S56 0S6	560 170 064	6HN	0 092 S50 040	561 400 060	S5 004
0 093 S56 20J	562 019 048	6C	0 092 S40 050	560 408 054	S4 005
0 093 S56 20J	562 019 048	6CN	0 092 S40 050	560 408 054	S4 005
0 093 S56 20L	562 021 048	6M	0 092 S50 060	563 401 061	S5 006
0 093 S56 22V	562 103 060	6PN	0 092 S50 050	563 400 061	S5 005
0 093 S56 22W	562 104 060	6MN	0 092 S50 060	563 401 061	S5 006
0 093 S56 2B4	562 400 048	6NN	0 092 S40 060	560 127 054	S4 006
0 093 S56 3RS	563 018 051	6D	0 092 S30 070**	570 144 064	S3 007
0 093 S56 40K	564 020 064	6E	0 092 S30 070**	570 144 064	S3 007
0 093 S56 615	566 041 051	6F	0 092 S30 080	570 409 064	S3 008
0 093 S57 020	570 072 051	7A	0 092 S40 270	570 413 063	S4 027
0 093 S57 021	570 073 051	7BA	0 092 S40 260	570 412 063	S4 026
0 093 S57 040	570 144 064	7EN	0 092 S40 070	572 409 068	S4 007
0 093 S57 041	570 145 064	7DN	0 092 S40 070*	572 409 068	S4 007
0 093 S57 042	570 146 064	7GN	0 092 S40 070**	572 409 068	S4 007
0 093 S57 10D	571 013 068	7E	0 092 S40 070	572 409 068	S4 007
0 093 S57 10E	571 014 068	7D	0 092 S40 070*	572 409 068	S4 007
0 093 S57 20U	572 030 064	7G	0 092 S40 070**	572 409 068	S4 007
0 093 S57 40C	574 012 068	7C	0 092 S40 080	574 012 068	S4 008
0 093 S57 40C	574 012 068	7CN	0 092 S40 080	574 012 068	S4 008
0 093 S57 40D	574 013 068	7F	0 092 S40 090	574 013 068	S4 009
0 093 S57 40D	574 013 068	7FN	0 092 S40 090	574 013 068	S4 009
0 093 S57 53D	575 121 072	7HN	0 092 S50 070	574 402 075	S5 007
0 093 S58 017	580 043 064	8C	0 092 S40 100	580 406 074	S4 010
0 093 S58 03E	580 122 072	8CN	0 092 S40 100	580 406 074	S4 010
0 093 S58 50F	585 015 076	8B	0 092 S30 120	588 403 074	S3 012
0 093 S58 50F	585 015 076	8BN	0 092 S30 120	588 403 074	S3 012
0 093 S58 55K	585 200 080	8DN	0 092 S50 100	585 200 080	S5 010
0 093 S58 80X	588 033 064	8A	0 092 S30 130	590 122 072	S3 013
0 093 S59 03E	590 122 072	9BN	0 092 S30 130	590 122 072	S3 013
0 093 S59 03F	590 123 072	9AN	0 092 S30 130**	590 122 072	S3 013
0 093 S59 2RU	592 026 076	9A	0 092 S40 130**	595 402 080	S4 013
0 093 S59 55K	595 200 085	9CN	0 092 S50 130	600 402 083	S5 013
0 093 S60 018	600 044 076	1A	0 092 S50 130	600 402 083	S5 013
0 093 S60 03N	600 131 080	1AN	0 092 S50 130	600 402 083	S5 013
0 093 S61 05K	610 200 085	1BN	0 092 S50 150	610 402 092	S5 015
Bosch Asia Silver →			Bosch S6 – S5 – S4 – S3		
0 093 A54 03J	540 127 033	4CA	0 092 S40 190	540 127 033	S4 019
0 093 A54 0S1	540 126 033	4BA	0 092 S40 180	540 126 033	S4 018
0 093 A54 54B	545 155 033	4DA	0 092 S40 200	545 155 033	S4 020
0 093 A54 54C	545 156 033	4EA	0 092 S40 210	545 156 033	S4 021
0 093 A54 54D	545 157 033	4FA	0 092 S40 220	545 157 033	S4 022

** Ford-Pol-Adapter erforderlich (s. S. 11) / Ford terminal adapter required (s. p. 11) / Adaptateur de pôle Ford nécessaire (v. p. 11) /
Necessari adattatori poli Ford (v. p. 11) / Se requiere adaptador terminal Ford (v. p. 11)

Necessário adaptador de pólos Ford (v. pág. 11) / Ford-napasovitin tarpeen (ks. sivu 11) / Niezbędny adapter biegun Ford (p. str. 11) /
Pólóvú adaptér Ford nutný (viz str. 11) / Необходим адаптер полюса Ford (см. стр. 11)

** Bodenleisten-Adapter erforderlich (s. S. 11) / Bottom rail adapter required (s. p. 11) / Adaptateur pour rebord de fixation
nécessaire (v. p. 11) / Necessario adattatore listello di fissaggio (v. p. 11) / Se requiere adaptador regleta de suelo (v. p. 11)

Necessário adaptador de barras de fixação (v. pág. 11) / Pohjalistan sovitin tarpeen (ks. sivu 11) / Niezbędny adapter listew podłożowych (p. str. 11) /
Adaptér pro upínací lišty nutný (viz str. 11) / Необходим адаптер напольной планки (см. стр. 11)

de Gegenüberstellung Bosch-Batterien (Fortsetzung)	en Cross-reference Bosch batteries (continued)	fr Table de correspondance Batteries Bosch (suite)	it Comparazione Batterie Bosch (seguito)	es Equivalencias Baterías Bosch (continuación)
--	--	--	--	--

**Bosch Asia Silver →****Bosch S6 – S5 – S4 – S3**

0 093 A54 54E	545 158 033	4GA	0 092 S40 230	545 158 033	S4 023
0 093 A56 04G	560 160 042	6AA	0 092 S40 260	570 412 063	S4 026
0 093 A56 04H	560 161 042	6BA	0 092 S40 270	570 413 063	S4 027
0 093 A56 04J	560 163 042	6EA	0 092 S40 250	560 411 054	S4 025
0 093 A56 0S4	560 162 042	6DA	0 092 S40 240	560 410 054	S4 024
0 093 A57 03T	570 137 057	7BA	0 092 S40 260	570 412 063	S4 026
0 093 A57 03U	570 138 057	7AA	0 092 S40 270	570 413 063	S4 027
0 093 A59 52W	595 104 068	9BA	0 092 S40 280	595 404 083	S4 028
0 093 A59 52X	595 105 068	9CA	0 092 S40 290	595 405 083	S4 029

Bosch Standard →**Bosch S6 – S5 – S4 – S3**

0 180 606 60H	066 017 036		0 092 S30 600	066 017 036	S3 060
0 180 607 70F	077 015 036		0 092 S30 610	077 015 036	S3 061
0 180 654 525	545 077 030		0 092 S30 160	545 077 030	S3 016
0 180 654 527	545 079 030		0 092 S30 170	545 079 030	S3 017
0 180 655 015	550 041 036		0 092 S40 240	560 410 054	S4 024
0 180 655 016	550 042 036		0 092 S40 250	560 411 054	S4 025
0 180 656 025	560 077 060		0 092 S50 040**	561 400 060	S5 004
0 180 657 513	575 039 064		0 092 S40 100	580 406 074	S4 010
0 180 658 017	580 043 064		0 092 S40 100	580 406 074	S4 010
0 180 660 018	600 044 076		0 092 S50 130	600 402 083	S5 013
0 180 653 50K	535 020 024		0 092 S40 180	540 126 033	S4 018
0 180 653 50M	535 022 024		0 092 S40 190	540 127 033	S4 019
0 180 653 6RV	536 054 030		0 092 S30 010	541 400 036	S3 001
0 180 653 82U	538 102 030		0 092 S40 000	542 400 039	S4 000
0 180 654 30H	543 017 033		0 092 S40 010*	544 402 044	S4 001
0 180 654 3RT	543 024 033		0 092 S40 010	544 402 044	S4 001
0 180 654 41N	544 059 036		0 092 S30 020	545 412 040	S3 002
0 180 654 41S	544 064 036		0 092 S30 030	545 413 040	S3 003
0 180 654 41X	544 069 036		0 092 S40 010**	544 402 044	S4 001
0 180 654 50J	545 019 036		0 092 S40 010**	544 402 044	S4 001
0 180 654 50N	545 023 030		0 092 S40 210	545 156 033	S4 021
0 180 654 50O	545 024 030		0 092 S40 230	545 158 033	S4 023
0 180 654 51F	545 051 030		0 092 S40 220	545 157 033	S4 022
0 180 654 52C	545 084 030		0 092 S40 200	545 155 033	S4 020
0 180 655 01I	550 054 039		0 092 S40 020	552 400 047	S4 002
0 180 655 01K	550 056 054		0 092 S30 040	553 400 047	S3 004
0 180 655 01L	550 057 054		0 092 S30 040*	553 400 047	S3 004
0 180 655 01U	550 066 033		0 092 S40 020	552 400 047	S4 002
0 180 655 51N	555 059 042		0 092 S30 050	556 400 048	S3 005
0 180 655 51T	555 065 042		0 092 S30 060	556 401 048	S3 006
0 180 656 01C	560 048 028		0 092 S40 260	570 412 063	S4 026
0 180 656 01D	560 049 028		0 092 S40 270	570 413 063	S4 027
0 180 656 01W	560 068 039		0 092 S40 240	560 410 054	S4 024
0 180 656 01X	560 069 039		0 092 S40 250	560 411 054	S4 025
0 180 656 20J	562 019 048		0 092 S40 050	560 408 054	S4 005
0 180 656 3RS	563 018 051		0 092 S30 070**	570 144 064	S3 007
0 180 656 40K	564 020 064		0 092 S30 070**	570 144 064	S3 007

pt

Comparação das baterias Bosch
(continuação)

fi

Bosch-akkujen vertailu
(jatkoa)

pl

Porównanie akumulatorów Bosch
(ciąg dalszy)

cs

Porovnání akumulátorů Bosch
(pokračování)

ru

Сравнение аккумуляторов Bosch
(продолжение)



ETN



ETN



0 180 656 50U	565 030 054		0 092 S30 070	570 144 064	S3 007
0 180 657 00T	570 029 054		0 092 S40 260	570 412 063	S4 026
0 180 657 00T	570 024 054		0 092 S40 270	570 413 063	S4 027
0 180 657 10D	571 013 068		0 092 S40 070	572 409 068	S4 007
0 180 657 10E	571 014 068		0 092 S40 070*	572 409 068	S4 007
0 180 657 20U	572 030 064		0 092 S40 070**	572 409 068	S4 007
0 180 657 40C	574 012 068		0 092 S40 080	574 012 068	S4 008
0 180 657 40D	574 013 068		0 092 S40 090	574 013 068	S4 009
0 180 658 50F	585 015 076		0 092 S30 120	588 403 074	S3 012
0 180 658 50L	585 021 054		0 092 S40 280	595 404 083	S4 028
0 180 658 50M	585 022 054		0 092 S40 290	595 405 083	S4 029
0 180 659 20Q	592 026 076		0 092 S40 130**	595 402 080	S4 013
0 180 659 50I	595 018 064		0 092 S40 280	595 404 083	S4 028
0 180 659 50J	595 019 064		0 092 S40 290	595 405 083	S4 029

** Ford-Pol-Adapter erforderlich (s. S. 11) / Ford terminal adapter required (s. p. 11) / Adaptateur de pôle Ford nécessaire (v. p. 11) / Necessari adattatori poli Ford (v. p. 11) / Se requiere adaptador terminal Ford (v. p. 11) / Necessário adaptador de pólos Ford (v. pág. 11) / Ford-napasovitin tarpeen (ks. sivu 11) / Niezbędny adapter biegun Ford (p. str. 11) / Pólóv adapter Ford nutný (viz str. 11) / Необходим адаптер полюса Ford (см. стр. 11)

** Bodenleisten-Adapter erforderlich (s. S. 11) / Bottom rail adapter required (s. p. 11) / Adaptateur pour rebord de fixation nécessaire (v. p. 11) / Necessario adattatore listello di fissaggio (v. p. 11) / Se requiere adaptador regleta de suelo (v. p. 11) / Necessário adaptador de barras de fixação (v. pág. 11) / Pohjalistan sovitin tarpeen (ks. sivu 11) / Niezbędny adapter listew podłozowych (p. str. 11) / Adaptér pro upínací lišty nutný (viz str. 11) / Необходим адаптер напольной планки (см. стр. 11)

de	en	fr	it	es
Gegenüberstellung Bosch-Batterien	Cross-reference Bosch batteries	Table de correspondance Batteries Bosch	Comparazione Batterie Bosch	Equivalencias Baterías Bosch

**Bosch Tecmaxx →****T5 – T4**

0 093 X64 02V	640 103 080	14T1	0 092 T40 750	640 103 080	T4 075
0 093 X64 0B4	640 400 080	14T2	0 092 T40 760	640 400 080	T4 076
0 093 X67 02V	670 103 100	17T1	0 092 T40 770	670 103 100	T4 077
0 093 X67 02W	670 104 100	17T2	0 092 T40 780	670 104 100	T4 078
0 093 X68 030	680 108 100	18T2	0 092 T50 770	680 108 100	T5 077
0 093 X72 52V	725 103 115	22T1	0 092 T50 800	725 103 115	T5 080

Bosch Standard →**T5 – T4 – T3**

0 180 607 00B	070 011 030		0 092 T30 600	070 011 030	T3 060
0 180 611 20P	112 025 051		0 092 T30 610	112 025 051	T3 061
0 180 614 00N	140 023 072		0 092 T30 620	140 023 072	T3 062
0 180 615 00U	150 030 076		0 092 T30 630	150 030 076	T3 063
0 180 618 00R	180 027 100		0 092 T30 640	200 023 095	T3 064
0 180 620 00N	200 023 095		0 092 T30 640	200 023 095	T3 064
0 180 655 51S	555 064 042	05A	0 092 T30 050	555 064 042	T3 005
0 180 656 61B	566 047 051	06A	0 092 T30 080	566 047 051	T3 008
0 180 658 812	588 038 068	08A	0 092 T30 130	588 038 068	T3 013
0 180 659 014	590 040 048	09A	0 092 T30 300	590 040 048	T3 030
0 180 659 015	590 041 048	09B	0 092 T30 310	590 041 048	T3 031
0 180 660 00Z	600 035 060	10B	0 092 T30 710	600 035 060	T3 071
0 180 660 01B	600 047 060	10A	0 092 T30 720	600 047 060	T3 072
0 180 660 22U	602 102 068	10C	0 092 T30 330	602 102 068	T3 033
0 180 660 22V	602 103 068	10D	0 092 T30 340	602 103 068	T3 034
0 180 661 00D	610 013 076	11B	0 092 T30 380	610 013 076	T3 038
0 180 661 01B	610 047 068	11C	0 092 T30 350	610 047 068	T3 035
0 180 661 01C	610 048 068	11D	0 092 T30 360	610 048 068	T3 036
0 180 661 01D	610 049 068	11A	0 092 T30 390	620 109 076	T3 039
0 180 661 01E	610 050 085	11E	0 092 T30 730	610 050 085	T3 073
0 180 662 019	620 045 068	12C	0 092 T30 750	620 045 068	T3 075
0 180 662 01A	620 046 068	12D	0 092 T30 390	620 109 076	T3 039
0 180 662 031	620 109 076		0 092 T30 390	620 109 076	T3 039
0 180 662 50C	625 012 072	12A	0 092 T30 400	625 012 072	T3 040
0 180 662 50E	625 014 072	12B	0 092 T30 410	625 014 072	T3 041
0 180 662 50N	625 023 000	12E	0 092 T30 420	625 023 000	T3 042
0 180 663 00E	630 014 068	13D	0 092 T30 430	630 014 068	T3 043
0 180 663 20B	632 011 085	13E	0 092 T30 460	643 107 090	T3 046
0 180 663 516	635 042 068	13B	0 092 T30 440	635 042 068	T3 044
0 180 663 519	635 045 068	13C	0 092 T50 750	645 400 080	T5 075
0 180 663 51G	635 052 100	13A	0 092 T30 450	635 052 100	T3 045
0 180 664 00Y	640 034 095	14E	0 092 T40 750	640 103 080	T4 075
0 180 664 00Y	640 034 095	14E	0 092 T40 750	640 103 080	T4 075
0 180 664 00Z	640 035 076	14A	0 092 T40 750	640 103 080	T4 075
0 180 664 010	640 036 076	14B	0 092 T40 760	640 400 080	T4 076
0 180 664 30X	643 033 095	14C	0 092 T30 470	643 033 095	T3 047
0 180 664 30Y	643 034 090	14D	0 092 T30 480	655 104 090	T3 048
0 180 664 32Z	643 107 090		0 092 T30 460	643 107 090	T3 046
0 180 665 50D	655 013 090	15A	0 092 T30 770	655 013 090	T3 077
0 180 665 52W	655 104 090		0 092 T30 480	655 104 090	T3 048
0 180 667 00N	670 023 080	17A	0 092 T40 780	670 104 100	T4 078

pt

Comparação
das baterias Bosch

fi

Bosch-akkujen
vertailu

pl

Porównanie
akumulatorów Bosch

cs

Porovnání
akumulátorů Bosch

ru

Сравнение
аккумуляторов
Bosch



ETN



ETN



0 180 667 016	670 042 115		0 092 T40 770	670 103 100	T4 077
0 180 667 017	670 043 100	17B	0 092 T40 770	670 103 100	T4 077
0 180 667 018	670 044 100	16A	0 092 T30 790	680 033 110	T3 079
0 180 667 019	670 045 100	17C	0 092 T40 780	670 104 100	T4 078
0 180 667 01A	670 046 110	17D	0 092 T30 790	680 033 110	T3 079
0 180 668 00W	680 032 100	18A	0 092 T50 770	680 108 100	T5 077
0 180 668 00X	680 033 110	18B	0 092 T30 790	680 033 110	T3 079
0 180 670 012	700 038 105	20A	0 092 T30 800	700 038 105	T3 080
0 180 671 50E	715 014 115	21A	0 092 T40 800	715 400 115	T4 080
0 180 672 00P	720 025 145	22B	0 092 T30 810	720 018 115	T3 081
0 180 672 50C	725 012 115	22A	0 092 T50 800	725 103 115	T5 080
0 180 755 51S	555 064 042	05A	0 092 T30 050	555 064 042	T3 005
0 180 756 61B	566 047 051	06A	0 092 T30 080	566 047 051	T3 008
0 180 758 812	588 038 068	08A	0 092 T30 130	588 038 068	T3 013
0 180 760 03F	600 123 072		0 092 T30 320	600 123 072	T3 032

de Gegenüberstellung Bosch-Batterien (Fortsetzung)	en Cross-reference Bosch batteries (continued)	fr Table de correspondance Batteries Bosch (suite)	it Comparazione Batterie Bosch (seguito)	es Equivalencias Baterías Bosch (continuación)
--	--	--	--	--



ETN



Nº



ETN



Nº

Bosch AS →**M6**

0 097 051 9P1	519 901 017		0 092 M60 450	519 901 017	M6 045
0 097 250 30E	503 014 003	3AS	0 092 M60 010	503 014 003	M6 001
0 097 250 3P3	503 903 004		0 092 M60 030	503 903 004	M6 003
0 097 250 40C	504 012 003	4AS	0 092 M60 040	504 012 003	M6 004
0 097 250 60E	506 014 005	6AS1	0 092 M60 060	506 014 005	M6 006
0 097 250 60F	506 015 005	6AS2	0 092 M60 070	506 015 005	M6 007
0 097 250 7P1	507 901 012	7AS	0 092 M60 080	507 901 012	M6 008
0 097 250 7P2	507 902 011		0 092 M60 090	507 902 011	M6 009
0 097 250 80C	508 012 008	8AS	0 092 M60 100	508 012 008	M6 010
0 097 250 8P1	508 901 015		0 092 M60 110	508 901 015	M6 011
0 097 250 9P1	509 901 020		0 092 M60 120	509 901 020	M6 012
0 097 250 9P2	509 902 008		0 092 M60 130	509 902 008	M6 013
0 097 251 00C	510 012 009	10AS	0 092 M60 140	510 012 009	M6 014
0 097 251 1P1	511 901 014		0 092 M60 160	511 901 014	M6 016
0 097 251 1P2	511 902 023		0 092 M60 170	511 902 023	M6 017
0 097 251 20E	512 014 010	12AS	0 092 M60 180	512 014 010	M6 018
0 097 251 2P1	512 901 019	12AS1	0 092 M60 190	512 901 019	M6 019
0 097 251 2P3	512 903 013		0 092 M60 200	512 903 013	M6 020
0 097 251 4P1	514 901 022	14AS1	0 092 M60 210	514 901 022	M6 021
0 097 251 4P2	514 902 022	14AS2	0 092 M60 220	514 902 022	M6 022
0 097 251 8P1	518 901 026	18AS1	0 092 M60 230	518 901 026	M6 023
0 097 251 8P2	518 902 026	18AS2	0 092 M60 240	518 902 026	M6 024

Bosch Standard →**M4**

0 180 000 40E	004 014 001		0 092 M4F 040	004 014 001	M4 F04
0 180 000 60C	006 012 003		0 092 M4F 070	006 012 003	M4 F07
0 180 000 80B	008 011 004		0 092 M4F 100	008 011 004	M4 F10
0 180 001 20E	012 014 008		0 092 M4F 120	012 014 008	M4 F12
0 180 050 30C	503 012 001		0 092 M4F 150	503 012 001	M4 F15
0 180 050 30D	503 013 001		0 092 M4F 160	503 013 001	M4 F16
0 180 050 40B	504 011 002		0 092 M4F 170	504 011 002	M4 F17
0 180 050 50C	505 012 003		0 092 M4F 180	505 012 003	M4 F18
0 180 050 60B	506 011 004		0 092 M4F 190	506 011 004	M4 F19
0 180 050 60C	506 012 004		0 092 M4F 200	506 012 004	M4 F20
0 180 050 70C	507 012 004		0 092 M4F 210	507 012 004	M4 F21
0 180 050 72T	507 101 008		0 092 M4F 230	507 101 008	M4 F23
0 180 050 80D	508 013 008		0 092 M4F 240	508 013 008	M4 F24
0 180 050 90E	509 014 008		0 092 M4F 250	509 014 008	M4 F25
0 180 050 90F	509 015 008		0 092 M4F 260	509 015 008	M4 F26
0 180 050 90G	509 016 008		0 092 M4F 270	509 016 008	M4 F27
0 180 051 10C	511 012 009		0 092 M4F 280	511 012 009	M4 F28
0 180 051 10D	511 013 009		0 092 M4F 290	511 013 009	M4 F29
0 180 051 20B	512 011 012		0 092 M4F 300	512 011 012	M4 F30
0 180 051 20D	512 013 012		0 092 M4F 320	512 013 012	M4 F32
0 180 051 20F	512 015 012		0 092 M4F 330	512 015 012	M4 F33
0 180 051 40B	514 011 014		0 092 M4F 340	514 011 014	M4 F34
0 180 051 40C	514 012 014		0 092 M4F 350	514 012 014	M4 F35
0 180 051 40D	514 013 014		0 092 M4F 360	514 013 014	M4 F36
0 180 051 40E	514 014 014		0 092 M4F 370	514 014 014	M4 F37

pt

Comparação das baterias Bosch
(continuação)

fi

Bosch-akkujen vertailu
(jatkoa)

pl

Porównanie akumulatorów Bosch
(ciąg dalszy)

cs

Porovnání akumulátorů Bosch
(pokračování)

ru

Сравнение аккумуляторов Bosch
(продолжение)



ETN



№



ETN



№

0 180 051 60F	516 015 016		0 092 M4F 390	516 015 016	M4 F39
0 180 051 60G	516 016 012		0 092 M4F 400	516 016 012	M4 F40
0 180 051 80E	518 014 015		0 092 M4F 410	518 014 015	M4 F41
0 180 051 80F	518 015 018		0 092 M4F 420	518 015 018	M4 F42
0 180 051 90B	519 011 019		0 092 M4F 430	519 011 019	M4 F43
0 180 051 90C	519 012 019		0 092 M4F 440	519 012 019	M4 F44
0 180 051 90D	519 013 017		0 092 M4F 450	519 013 017	M4 F45
0 180 051 90E	519 014 018		0 092 M4F 460	519 014 018	M4 F46
0 180 052 00C	520 012 020		0 092 M4F 470	520 012 020	M4 F47
0 180 052 00G	520 016 020		0 092 M4F 480	520 016 020	M4 F48
0 180 052 42T	524 101 020		0 092 M4F 510	524 101 020	M4 F51
0 180 052 50F	525 015 022		0 092 M4F 520	525 015 022	M4 F52
0 180 053 00U	530 030 030		0 092 M4F 540	530 030 030	M4 F54
0 180 450 40B	504 011 002	041	0 092 M4F 170	504 011 002	M4 F17
0 180 450 90E	509 014 008	091	0 092 M4F 250	509 014 008	M4 F25
0 180 451 40B	514 011 014	141	0 092 M4F 340	514 011 014	M4 F34
0 180 451 90D	519 013 017	191	0 092 M4F 450	519 013 017	M4 F45
0 180 453 00U	530 030 030	301	0 092 M4F 540	530 030 030	M4 F54

A 90

de Gegenüberstellung Bosch-Batterien	en Cross-reference Bosch batteries	fr Table de correspondance Batteries Bosch	it Comparazione Batterie Bosch	es Equivalencias Baterías Bosch
pt Comparação das baterias Bosch	fi Bosch-akkujen vertailu	pl Porównanie akumulatorów Bosch	cs Porovnání akumulátorů Bosch	ru Сравнение аккумуляторов Bosch



Bosch Standard →			L4 – L5		
0 180 081 270			0 092 L40 270	812 071 000	L4 027
0 180 095 502			0 092 L50 050	930 060 056	L5 005
0 180 095 551			0 092 L40 270	812 071 000	L4 027
0 180 095 602			0 092 L50 080	930 075 065	L5 008
0 180 095 752			0 092 L50 130	930 090 080	L5 013
0 180 096 051			0 092 L50 750	930 140 080	L5 075
0 180 096 351			0 092 L50 770	930 180 100	L5 077
0 180 096 801			0 092 L50 800	930 230 115	L5 080

L4 →			L4 – L5		
0 092 L40 110	955 002 000	L4 011	0 092 L50 050	930 060 056	L5 005
0 092 L40 130	812 071 000	L4 013	0 092 L40 270	812 071 000	L4 027
0 092 L40 140	956 002 000	L4 014	0 092 L50 080	930 075 065	L5 008
0 092 L40 150	957 052 000	L4 015	0 092 L50 130	930 090 080	L5 013
0 092 L40 160	811 053 057	L4 016	0 092 L40 330	811 053 057	L4 033
0 092 L40 210	960 051 000	L4 021	0 092 L50 750	930 140 080	L5 075
0 092 L40 230	963 051 000	L4 023	0 092 L50 770	930 180 100	L5 077
0 092 L40 240	968 001 000	L4 024	0 092 L50 800	930 230 115	L5 080

de

Verwendungsteil

en

Applications

fr

Affectations

it

Impiego

es

Aplicación

Benutzerhinweise

In diesem Katalog sind die Daten von Fahrzeugen, Motoren und Geräten für den europäischen Markt von Baujahr 1985 bis einschließlich 2013 erfasst. Diese wurden aus Hersteller- und Importeurangaben, aus Fahrzeuguntersuchungen sowie aus Unterlagen von Bosch nach bestem Wissen sorgfältig zusammengestellt und geben den Stand zum Zeitpunkt der Drucklegung wieder.

Zwangsläufige Abweichungen durch länderspezifische technische Änderungen können nie ganz ausgeschlossen werden. Bosch kann daher insoweit nicht für die Vollständigkeit und Fehlerfreiheit der Daten haften. Für Irrtümer und Druckfehler, die zu Schäden am Eigentum oder Vermögen führen, haftet Bosch nur bei grob fahrlässiger Pflichtverletzung und bei Vorsatz für unmittelbare Schäden. Bei Personenschäden haftet Bosch auch bei leichter Fahrlässigkeit.

Notes for users

This catalog contains the data from the vehicles, engines, and equipment for the European market from year of manufacture 1985 up to and including the year 2013. This data has been assembled from information provided by manufacturers and importers, and taken from Bosch documentation, as well as from investigations made on vehicles. It has been compiled to the best of our knowledge and belief, and reflects the status at the date of going to print.

It is impossible to avoid deviations caused by technical changes resulting from the conditions and regulations applying in a particular country. Bosch can therefore accept no liability for the completeness and faultlessness of the data. In case of mistakes and misprints which result in damage to property or assets, Bosch is only liable for immediate damages insofar as a gross breach of duty or wrongful intent apply. If personal injury is involved, Bosch is liable also in case of ordinary negligence.

A l'attention de l'utilisateur

Le présent catalogue mentionne les données spécifiques de véhicules, moteurs et appareils pour le marché européen depuis l'année de fabrication 1985 jusqu'au millésime 2013 inclus. Ces informations ont été rassemblées soigneusement et en toute impartialité à partir des indications des constructeurs et importateurs, des contrôles techniques des véhicules et de la documentation Bosch, et matérialisent le stade des connaissances au moment de la mise sous presse.

Il n'est jamais possible d'exclure totalement les divergences éventuelles dues aux modifications techniques, spécifiques des différents pays considérés. En aucun cas, Bosch n'engage sa responsabilité en ce qui concerne l'intégralité et l'exactitude des données. En ce qui concerne les erreurs et les fautes d'impression, qui peuvent entraîner des dommages à la propriété ou à la fortune, Bosch n'engage sa responsabilité pour les dommages directs qu'en cas d'atteinte et de négligence graves et intentionnelles envers ses obligations. En cas de dommages causés aux personnes, Bosch engage sa responsabilité aussi en cas de légère négligence.

Avvertenze per la consultazione

Nella seguente parte di catalogo sono contemplati veicoli, motori ed apparecchi a partire dall'anno di costruzione 1985 fino all'anno 2013. Tali informazioni sono state rilevate dalle documentazioni di Case Auto, Importatori, da verifiche eseguite sui veicoli, così come da documentazione Bosch.

Eventuali discordanze dovute a specifiche esigenze del Paese e variazioni tecniche non possono essere previste. Per questo Bosch non si assume alcuna responsabilità per mancanze ed eventuali errori riferite ai dati. Per danni a cose o danni patrimoniali, dovuti ad errori o refusi di stampa, Bosch è responsabile solo in caso di dolo o colpa grave. Per danni alla persona, Bosch è responsabile anche in caso di colpa meno grave.

Avertencia al usuario

Los datos recogidos en este catálogo para vehículos, motores y maquinaria del mercado europeo abarcan los años de fabricación entre 1985 y 2013, inclusive. Estos datos han sido recogidos del fondo documental de Bosch, así como de las inspecciones de vehículos, datos de fabricantes e importadores.

No obstante, y debido al cuantioso material de información, no se puede excluir la posibilidad de modificaciones, diferencias propias de aplicaciones específicas de los países, fallos, equivocaciones o errores. En caso de inexactitudes y errores de imprenta, la responsabilidad de Bosch se limita al daño inmediato, con posibles perjuicios patrimoniales, a no ser que el daño previsible y típico del contrato sea de mayor cuantía o se deba a dolo o culpa intencionada o a negligencia grave.

pt

Aplicação

fi

Sovelluskohteet

pl

Aplikacja

cs

Používaný díl

ru

Применение

Instruções de utilização

Este catálogo contém os dados de veículos, motores e aparelhos para o mercado europeu desde o ano de fabricação de 1985 até 2013 inclusive. Estes foram reunidos com base nas indicações de fabricantes e importadores, inspeções de veículos e na documentação da Bosch de modo criterioso e da melhor forma possível, refletindo o estado da altura da impressão.

Não é possível excluir inteiramente as divergências inevitáveis em virtude das alterações técnicas específicas de países. Por conseguinte, a Bosch não pode garantir que os dados estejam completos e isentos de erros. No que respeita a equívocos e erros de impressão, que resultem em danos na propriedade ou no património, a Bosch apenas se responsabiliza por danos diretos no caso de violação gravemente negligente de obrigações e dolo. Se houver danos pessoais, a Bosch será responsabilizada mesmo em casos de negligência ligeira.

Ohjeita käyttäjälle

Oheiseen esitteeseen on koostettu ajoneuvo-, moottori- ja laitekohtaisia tietoja, jotka kattavat Euroopan maissa markkinoidut mallit vm. 1985 lähtien – vm. 2013 mukaan lukien. Tiedot on kerätty valikoiden valmistajien ja maahantuojien laatimista tiedoista, katsastusdokumenteista sekä Bosch-dokumenteista ja ne vastaavat painatusajankohdan tietämystasoa.

Maakohtaisten teknisten muutosten aiheuttamia poikkeuksia ei voida koskaan täysin sulkea pois. Bosch ei siten voi taata tietojen täydellisyyttä ja virheettömyyttä. Bosch vastaa omaisuus- tai varallisuusvahinkoihin johtavista erehdyksistä ja painovirheistä vain, jos ne on aiheutettu tahallisesti ja törkeästi huolimattomuudesta ja johtavat välittömiin vahinkoihin. Henkilövahinkojen yhteydessä Bosch vastaa vain, jos kyse on lievistä huolimattomuudesta.

Wskazówki dla użytkownika

W tym katalogu zawarte są dane pojazdów, silników i urządzeń na rynek europejski, wyprodukowanych od roku 1985 do 2013 włącznie. Zostały one zebrane przy zachowaniu najwyższej staranności i w najlepszej wierze na podstawie danych producentów i importerów, na podstawie badań pojazdów oraz dokumentacji Bosch.

Przedstawione dane odzwierciedlają stan wiedzy w momencie druku. Ewentualne odstępstwa warunkowane przez zmiany techniczne w poszczególnych krajach nigdy nie mogą zostać całkowicie wykluczone. Dlatego Bosch nie odpowiada za kompletność i bezbłądność danych. Za pomyłki i błędy w druku, które prowadzą do szkód własnościowych lub majątkowych, Bosch odpowiada tylko w przypadku rażącego nieumyślnego naruszenia zobowiązań, a za szkody pośrednie w przypadku działania umyślnego. W przypadku szkód osobowych Bosch odpowiada także w przypadku zaniedbania.

Pokyny pro uživatele

V tomto katalogu jsou zahrnuty údaje vozidel, motorů a přístrojů pro evropský trh počínajíc rokem výroby 1985 do roku 2013 včetně. Tyto údaje byly pečlivě sestaveny na základě údajů výrobce a importérů, z prohlídek vozidel a také z podkladů firmy Bosch podle nejlepšího svědomí a daném stavu v okamžiku tisku.

Nevyhnutelné odchylky v důsledku technických změn dané země nelze nikdy zcela vyloučit. Společnosti Bosch proto nemůže ručit za úplnost a bezchybnost údajů. Za omyly a tiskové chyby, které vedou ke škodám na majetku nebo jmění, přebírá společnost Bosch odpovědnost jen v případě hrubého nedbalého porušení povinnosti a za přímé škody v případě úmyslného jednání. Při škodách na zdraví osob ručí společnost Bosch také v případech lehké nedbalosti.

Указания для пользователей

Этот каталог содержит данные транспортных средств, двигателей и устройств для европейского рынка, выпущенных с 1985 по 2013 г. включительно. Эти данные были тщательно и по лучшему разумению собраны на основе сведений, полученных от производителей и импортеров, результатов исследований автомобильной промышленности и документации Bosch, и являются актуальными на момент сдачи в печать.

Нельзя полностью исключить наличие расхождений, вызванных внесением технических изменений, обусловленных национальными требованиями определенной страны. Поэтому Bosch не несет ответственности за полноту и достоверность всех данных. Bosch не несет ответственности за ошибки и опечатки, ставшие причиной нанесения ущерба имуществу, за исключением случаев грубого и халатного нарушения обязанностей или преднамеренного нанесения ущерба. В случае причинения вреда людям Bosch несет ответственность даже в случае незначительной халатности.

B2 | AUDI

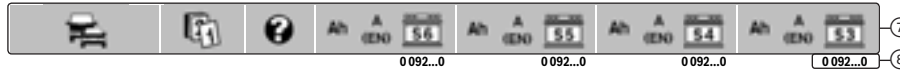

AUDI		0 092...0		0 092...0		0 092...0		0 092...0	
1.2	TDI 3L [8Z0]	09.99-08.05	70	760	S6 001	77	780	S5 008	74 680 S4 008 70 640 S3 008
1.4	[8Z0]	09.99-04.02	70	760	S6 001	77	780	S5 008	74 680 S4 008 70 640 S3 008
		11.01-08.05	70	760	S6 001	77	780	S5 008	74 680 S4 008
	TDI [8Z0]	09.99-08.03	70	760	S6 001	77	780	S5 008	74 680 S4 008 70 640 S3 008
		05.03-08.05	70	760	S6 001	77	780	S5 008	74 680 S4 008
		01.02-08.05	70	760	S6 001	85	800	S5 010	74 680 S4 008
1.6	FSI [8Z0]	09.96-06.01				63	610	S5 005	52 470 S4 002 45 400 S3 002
		05.00-06.03				63	610	S5 005	52 470 S4 002
	[8P1]	05.03-05.05				63	610	S5 005	52 470 S4 002
	FSI [8P1]	08.03->				63	610	S5 005	60 540 S4 005
1.8	[8L1]	09.96-04.03				63	610	S5 005	60 540 S4 005 56 480 S3 005
	quattro [8L1]	08.98-06.99				63	610	S5 005	60 540 S4 005 56 480 S3 005
	T [8L1]	12.96-06.03				63	610	S5 005	60 540 S4 005 56 480 S3 005
		05.00-06.03				63	610	S5 005	60 540 S4 005
	T quattro [8L1]	08.97-06.03				63	610	S5 005	60 540 S4 005 56 480 S3 005
		09.00-06.03				63	610	S5 005	60 540 S4 005
1.9	TDI [8L1]	09.96-06.01	70	760	S6 001	77	780	S5 008	74 680 S4 008 70 640 S3 008
		05.00-06.03	70	760	S6 001	77	780	S5 008	74 680 S4 008
	TDI [8P1]	06.03-05.06	70	760	S6 001	77	780	S5 008	74 680 S4 008
	TDI quattro [8L1]	05.00-06.03	70	760	S6 001	77	780	S5 008	74 680 S4 008
2.0	FSI [8P1]	05.03-10.05	70	760	S6 001	77	780	S5 008	60 540 S4 005
	TDI [8P1]	05.03->	70	760	S6 001	85	800	S5 010	74 680 S4 008
	TDI quattro [8P1]	05.03->	70	760	S6 001	85	800	S5 010	74 680 S4 008
	FSI, TFSI quattro [8P1]	09.04-10.05	70	760	S6 001	77	780	S5 008	60 540 S4 005
3.2	quattro [8P1]	07.03-10.05	70	760	S6 001	85	800	S5 010	74 680 S4 008
1.6	[8PA]	09.04-05.05				63	610	S5 005	52 470 S4 002
	FSI [8PA]	09.04-05.07				63	610	S5 005	60 540 S4 005
1.9	TDI [8PA]	09.04-05.06	70	760	S6 001	77	780	S5 008	74 680 S4 008
2.0	FSI [8PA]	09.04-10.05	70	760	S6 001	77	780	S5 008	60 540 S4 005
	TDI [8PA]	09.04->	70	760	S6 001	85	800	S5 010	74 680 S4 008
	TFSI, TFSI quattro [8PA]	09.04-10.05	70	760	S6 001	77	780	S5 008	60 540 S4 005
3.2	quattro [8PA]	09.04-10.05	70	760	S6 001	85	800	S5 010	74 680 S4 008
1.6	[8D2; B5]	11.94-06.00	VAD	70	760	S6 001	77	780	S5 008 60 540 S4 005 45 400 S3 002
		06.00-10.00	VAD	70	760	S6 001	77	780	S5 008 60 540 S4 005
	[8E2; B6]	10.00-12.04				77	780	S5 008	60 540 S4 005
1.6/2.0	[8EC; B7]	11.04->	70	760	S6 001	77	780	S5 008	60 540 S4 005
1.8	[8D2; B5]	11.94-10.00	(VAD)	70	760	S6 001	77	780	S5 008 60 540 S4 005 45 400 S3 002
		06.00-10.00	VAD	70	760	S6 001	77	780	S5 008 60 540 S4 005
	quattro [8D2; B5]	11.94-10.01	VAD	70	760	S6 001	77	780	S5 008 60 540 S4 005 45 400 S3 002
	T [8D2; B5]	11.94-06.00	VAD	70	760	S6 001	77	780	S5 008 60 540 S4 005 45 400 S3 002
		06.00-10.00	VAD	70	760	S6 001	77	780	S5 008 60 540 S4 005
	T quattro [8D2; B5]	11.94-10.00	VAD	70	760	S6 001	77	780	S5 008 60 540 S4 005 45 400 S3 002
		06.00-10.00	VAD	70	760	S6 001	77	780	S5 008 60 540 S4 005
	T quattro [8E2; B6]	12.00-12.04				77	780	S5 008	60 540 S4 005
1.8/2.0	FSI, T [8E2; B6]	12.00-12.04	70	760	S6 001	77	780	S5 008	60 540 S4 005
	T, T quattro, TFSI, TFSI quattro [8EC; B7]	11.04->	70	760	S6 001	77	780	S5 008	60 540 S4 005
1.9	TDI [8D2; B5]	11.94-11.00	VAD	70	760	S6 001	77	780	S5 008 74 680 S4 008 70 640 S3 008
	TDI [8E2; B6]	12.00-12.04	70	760	S6 001	77	780	S5 008	74 680 S4 008
	TDI quattro [8D2; B5]	07.96-12.98	VAD	70	760	S6 001	77	780	S5 008 74 680 S4 008 70 640 S3 008
		08.99-01.00	VAD	70	760	S6 001	77	780	S5 008 74 680 S4 008 70 640 S3 008
		01.00-10.00	VAD	70	760	S6 001	77	780	S5 008 74 680 S4 008
	TDI quattro [8E2; B6]	04.01-12.04	70	760	S6 001	77	780	S5 008	74 680 S4 008
1.9/2.0	TDI [8EC; B7]	11.04->	70	760	S6 001	77	780	S5 008	74 680 S4 008
2.0	TDI quattro [8EC; B7]	01.06->	70	760	S6 001	77	780	S5 008	74 680 S4 008
2.0/2.4	[8E2; B6]	12.00-12.04	70	760	S6 001	77	780	S5 008	60 540 S4 005
2.4	[8D2; B5]	07.95-07.97	VAD	70	760	S6 001	77	780	S5 008 60 540 S4 005 56 480 S3 005
		08.97-10.00	VAD	70	760	S6 001	77	780	S5 008 60 540 S4 005 45 400 S3 002
		06.00-10.00	VAD	70	760	S6 001	77	780	S5 008 60 540 S4 005
	quattro [8D2; B5]	08.97-07.98	VAD	70	760	S6 001	100	830	S5 013 74 680 S4 008 70 640 S3 008
		08.97-12.98	VAD	70	760	S6 001	77	780	S5 008 60 540 S4 005 45 400 S3 002
		02.99-10.00	VAD	70	760	S6 001	77	780	S5 008 60 540 S4 005 45 400 S3 002
2.5	TDI [8D2; B5]	08.97-10.00	VAD	95	850	S6 002	77	780	S5 008 74 680 S4 008 70 640 S3 008
	TDI [8EC; B7]	11.04-05.06	95	850	S6 002	100	830	S5 013	74 680 S4 008

① **Fahrzeugmarke**
Hervorhebung der Hersteller im Graubalken

② **Fahrzeugmodell**
Alphanumerisch aufsteigend

③ **Modelldetail**
Besondere Fahrzeugmerkmale

④ **Volt/Amperestunde**

⑤ **Sonderfall**
Erläuterung siehe Katalogende

⑥ **Produktionszeitraum**
Einbauzeitraum des jeweiligen Produktes

⑦ **Bildzeichen**
Erläuterung siehe Katalogende

⑧ **Konstanter Teil**
der 10-stelligen Bestellnummer

⑨ **Variabler Teil/ Kurzsuchnummer**
der 10-stelligen Bestellnummer

en

How to use this catalog

fr

Consignes d'utilisation

it

Istruzioni d'uso

es

Indicaciones de uso**① Vehicle brand**

Manufacturer indicated in bold print within gray bar

① Marque du véhicule

Mise en avant des constructeurs sur fond gris

① Marca del veicolo

Evidenziata con fondo grigio

① Marca de vehículo

Fabricante destacado en la franja gris

② Vehicle model

in alphabetical order

② Modèle du véhicule

par ordre alphanumérique croissant

② Modello del veicolo

In ordine alfabetico

② Modelo de vehículo

Orden alfanumérico creciente

③ Model specifics

special vehicle information

③ Détails du modèle

Caractéristiques du véhicule

③ Dettagli modello

Particolari caratteristiche

③ Detalle de modelo

Características especiales de vehículo

④ Voltage/Ampere hours**④ Volt/Ampère-heure****④ Volt/Ampere-ore****④ Voltios/amperios-horas****⑤ Special version**

See end of catalog for explanation

⑤ Cas particulier

Explication, voir la fin du catalogue

⑤ Caso specifico

Indicazioni a fine catalogo

⑤ Caso especial

Explicación, véase la parte final del catálogo

⑥ Production period

Mounting period for each product

⑥ Période de fabrication

Première et dernière date de montage du produit considéré.

⑥ Periodo di produzione

Prima e ultima data di montaggio del rispettivo prodotto

⑥ Intervalo de producción

Periodo de montaje de dicho producto

⑦ Explanation of symbols

See end of catalog for explanation

⑦ Légende des symboles

Explication, voir la fin du catalogue

⑦ Legenda dei simboli

Indicazioni a fine catalogo

⑦ Explicación de símbolo gráfico

Explicación, véase la parte final del catálogo

⑧ Constant component
of 10-digit order number

⑧ Partie constante
de la référence à 10 chiffres

⑧ Parte fissa
del numero di ordinazione a 10 cifre

⑧ Parte constante
de la referencia de pedido de 10 caracteres

**⑨ Variable component/
Short code**
of 10-digit order number

**⑨ Partie variable/
Référence simplifiée**
de la référence à 10 chiffres

**⑨ Parte variabile/
Codice breve**
del numero di ordinazione a 10 cifre

**⑨ Parte variable/
Código breve**
de la referencia de pedido de 10 caracteres

B2 | AUDI



1 **AUDI**

A2

1.2 TDI 3L [8Z0] 09.99-08.05 70 760 **S6 001** 77 780 **S5 008** 74 680 **S4 008** 70 640 **S3 008**

1.4 [8Z0] 09.99-04.02 70 760 **S6 001** 77 780 **S5 008** 74 680 **S4 008** 70 640 **S3 008**

11.01-08.05 70 760 **S6 001** 77 780 **S5 008** 74 680 **S4 008**

TDI [8Z0] 09.99-08.03 70 760 **S6 001** 77 780 **S5 008** 74 680 **S4 008** 70 640 **S3 008**

05.03-08.05 70 760 **S6 001** 77 780 **S5 008** 74 680 **S4 008**

01.02-08.05 70 760 **S6 001** 85 800 **S5 010** 74 680 **S4 008**

2 **A3**

1.6 [8L1] 09.96-06.01 63 610 **S5 005** 52 470 **S4 002** 45 400 **S3 002**

05.00-06.03 63 610 **S5 005** 52 470 **S4 002**

[8P1] 05.03-05.05 63 610 **S5 005** 52 470 **S4 002**

FSI [8P1] 08.03-> 63 610 **S5 005** 60 540 **S4 005**

1.8 [8L1] 09.96-04.03 63 610 **S5 005** 60 540 **S4 005** 56 480 **S3 005**

quattro [8L1] 08.98-06.99 63 610 **S5 005** 60 540 **S4 005** 56 480 **S3 005**

T [8L1] 12.96-06.03 63 610 **S5 005** 60 540 **S4 005** 56 480 **S3 005**

05.00-06.03 63 610 **S5 005** 60 540 **S4 005**

T quattro [8L1] 08.97-06.03 63 610 **S5 005** 60 540 **S4 005** 56 480 **S3 005**

09.00-06.03 63 610 **S5 005** 60 540 **S4 005**

3 **1.9 TDI [8L1]** 09.96-06.01 70 760 **S6 001** 77 780 **S5 008** 74 680 **S4 008** 70 640 **S3 008**

05.00-06.03 70 760 **S6 001** 77 780 **S5 008** 74 680 **S4 008**

06.03-05.06 70 760 **S6 001** 77 780 **S5 008** 74 680 **S4 008**

TDI [8P1] 05.00-06.03 70 760 **S6 001** 77 780 **S5 008** 74 680 **S4 008**

TDI quattro [8L1] 05.03-10.05 70 760 **S6 001** 77 780 **S5 008** 60 540 **S4 005**

2.0 FSI [8P1] 05.03-> 70 760 **S6 001** 85 800 **S5 010** 74 680 **S4 008**

05.03-> 70 760 **S6 001** 85 800 **S5 010** 74 680 **S4 008**

TDI quattro [8P1] 09.04-10.05 70 760 **S6 001** 77 780 **S5 008** 60 540 **S4 005**

TFSI, TFSl quattro [8P1] 07.03-10.05 70 760 **S6 001** 85 800 **S5 010** 74 680 **S4 008**

3.2 quattro [8P1] 09.04-10.05 70 760 **S6 001** 85 800 **S5 010** 74 680 **S4 008**

A3 Sportback

1.6 [8PA] 09.04-05.05 63 610 **S5 005** 52 470 **S4 002**

FSI [8PA] 09.04-05.07 63 610 **S5 005** 60 540 **S4 005**

1.9 TDI [8PA] 09.04-05.06 70 760 **S6 001** 77 780 **S5 008** 74 680 **S4 008**

2.0 FSI [8PA] 09.04-10.05 70 760 **S6 001** 77 780 **S5 008** 60 540 **S4 005**

TDI [8PA] 09.04-> 70 760 **S6 001** 85 800 **S5 010** 74 680 **S4 008**

TFSl, TFSl quattro [8PA] 09.04-10.05 70 760 **S6 001** 77 780 **S5 008** 60 540 **S4 005**

3.2 quattro [8PA] 09.04-10.05 70 760 **S6 001** 85 800 **S5 010** 74 680 **S4 008**

A4

1.6 [8D2; B5] 11.94-06.00 VAD 70 760 **S6 001** 77 780 **S5 008** 60 540 **S4 005** 45 400 **S3 002**

06.00-10.00 VAD 70 760 **S6 001** 77 780 **S5 008** 60 540 **S4 005**

10.00-12.04 77 780 **S5 008** 60 540 **S4 005**

5 **1.6/2.0** [8EC; B7] 11.04-> 70 760 **S6 001** 77 780 **S5 008** 60 540 **S4 005**

1.8 [8D2; B5] 11.94-10.00 (VAD) 70 760 **S6 001** 77 780 **S5 008** 60 540 **S4 005** 45 400 **S3 002**

06.00-10.00 VAD 70 760 **S6 001** 77 780 **S5 008** 60 540 **S4 005**

quattro [8D2; B5] 11.94-10.01 VAD 70 760 **S6 001** 77 780 **S5 008** 60 540 **S4 005** 45 400 **S3 002**

T [8D2; B5] 11.94-06.00 VAD 70 760 **S6 001** 77 780 **S5 008** 60 540 **S4 005** 45 400 **S3 002**

06.00-10.00 VAD 70 760 **S6 001** 77 780 **S5 008** 60 540 **S4 005**

T quattro [8D2; B5] 11.94-10.00 VAD 70 760 **S6 001** 77 780 **S5 008** 60 540 **S4 005** 45 400 **S3 002**

06.00-10.00 VAD 70 760 **S6 001** 77 780 **S5 008** 60 540 **S4 005**

T quattro [8E2; B6] 12.00-12.04 77 780 **S5 008** 60 540 **S4 005**

1.8/2.0 FSI, T [8E2; B6] 12.00-12.04 70 760 **S6 001** 77 780 **S5 008** 60 540 **S4 005**

T, T quattro, TFSl, TFSl quattro [8EC; B7] 11.04-> 70 760 **S6 001** 77 780 **S5 008** 60 540 **S4 005**

1.9 TDI [8D2; B5] 11.94-11.00 VAD 70 760 **S6 001** 77 780 **S5 008** 74 680 **S4 008** 70 640 **S3 008**

TDI [8E2; B6] 12.00-12.04 70 760 **S6 001** 77 780 **S5 008** 74 680 **S4 008**

TDI quattro [8D2; B5] 07.96-12.98 VAD 70 760 **S6 001** 77 780 **S5 008** 74 680 **S4 008** 70 640 **S3 008**

08.99-01.00 VAD 70 760 **S6 001** 77 780 **S5 008** 74 680 **S4 008**

01.00-10.00 VAD 70 760 **S6 001** 77 780 **S5 008** 74 680 **S4 008**

TDI quattro [8E2; B6] 04.01-12.04 70 760 **S6 001** 77 780 **S5 008** 74 680 **S4 008**

1.9/2.0 TDI [8EC; B7] 11.04-> 70 760 **S6 001** 77 780 **S5 008** 74 680 **S4 008**

2.0 TDI quattro [8EC; B7] 01.06-> 70 760 **S6 001** 77 780 **S5 008** 74 680 **S4 008**

2.0/2.4 [8E2; B6] 12.00-12.04 70 760 **S6 001** 77 780 **S5 008** 60 540 **S4 005**

2.4 [8D2; B5] 07.95-07.97 VAD 70 760 **S6 001** 77 780 **S5 008** 60 540 **S4 005** 56 480 **S3 005**

08.97-10.00 VAD 70 760 **S6 001** 77 780 **S5 008** 60 540 **S4 005** 45 400 **S3 002**

06.00-10.00 VAD 70 760 **S6 001** 77 780 **S5 008** 60 540 **S4 005**

quattro [8D2; B5] 08.97-07.98 VAD 70 760 **S6 001** 100 830 **S5 013** 74 680 **S4 008** 70 640 **S3 008**

08.97-12.98 VAD 70 760 **S6 001** 77 780 **S5 008** 60 540 **S4 005** 45 400 **S3 002**

02.99-10.00 VAD 70 760 **S6 001** 77 780 **S5 008** 60 540 **S4 005** 45 400 **S3 002**

2.5 TDI [8D2; B5] 08.97-10.00 VAD 95 850 **S6 002** 77 780 **S5 008** 74 680 **S4 008** 70 640 **S3 008**

TDI [8EC; B7] 11.04-05.06 95 850 **S6 002** 100 830 **S5 013** 74 680 **S4 008**

1 **Marca do veículo**
Destaque dos fabricantes na barra cinzenta

2 **Modelo de veículo**
Por ordem alfanumérica ascendente

3 **Pormenor do modelo**
Características especiais do veículo

4 **Volt/ampere-hora**

5 **Situação especial**
Explicação ver final do catálogo

6 **Período de produção**
Período de montagem do respetivo produto

7 **Pictogramas**
Explicação ver final do catálogo

8 **Parte constante**
do n.º de referência de 10 algarismos

9 **Parte variável/número de busca abreviado**
do n.º de referência de 10 algarismos

fi

Käyttöön liittyvät ohjeet

pl

Wskazówki dotyczące korzystania

cs

Upozornění při použití

ru

Указания по использованию

① **Automerkki,**
almistajan korostus harmaassa palkissa

② **Ajoneuvomalli**
Aakkosnumeerisesti nouseva

③ **Mallin yksityiskohta**
Ajoneuvon erikoisominaisuudet

④ **Voltti/ampeeritunti**

⑤ **Erikoistapaus,**
katso selitys luettelon lopusta

⑥ **Tuotantokausi,**
kunkin tuotteen asennusaika

⑦ **Kuvamerkki,**
katso selitys luettelon lopusta

⑧ **vakio-osa**
10-numeroisen tilausnumeron

⑨ **vaihtuva osa /
lyhythaun numero**
10-numeroisen tilausnumeron

① **Marka pojazdu**
Nazwa producenta na szarym pasku

② **Model pojazdu**
Alfanumerycznie, rosnaço

③ **Szczegół modelu**
Szczegółowe właściwoći pojazdu

④ **Wolt/amperogodzina**

⑤ **Przypadek specjalny,**
patrz objaśnienie – koniec katalogu

⑥ **Okres produkcji**
Okres montażu danego produktu

⑦ **Rysunek**
Objaśnienie, patrz objaśnienie – koniec katalogu

⑧ **Część stała**
10-znakowy numer katalogowy

⑨ **Część zmienna / Skrót**
10-znakowego numeru katalogowego

① **Značka vozidla**
zvýraznění výrobce v šedém sloupci

② **Model vozidla**
alfanumericky vzestupně

③ **Detail modelu**
Zvláštní vlastnosti vozidla

④ **Volt/ampérhodina**

⑤ **Zvláštní případ**
vysvětlení viz konec katalogu

⑥ **Období produkce**
období instalace příslušného výrobku

⑦ **Piktogram**
vysvětlení viz konec katalogu

⑧ **Konstantní část**
10-místného objednáčícího čísla

⑨ **Variabilní část/krátké
vyhledávací číslo**
10-místného objednáčícího čísla

① **Марка автомобиля**
Имя производителя на серой полосе

② **Модель автомобиля**
Буквенно-цифровые обозначения с сортировкой по возрастанию

③ **Информация о модели**
Особые характеристики автомобиля

④ **Вольт/ампер-часы**

⑤ **Особый случай**
Пояснение см. в конце каталога

⑥ **Период производства**
Период выпуска продукта

⑦ **Графический знак**
Пояснение см. в конце каталога

⑧ **Постоянная часть**
10-значного номера для заказа

⑨ **Переменная часть/
короткий код для поиска**
10-значного номера для заказа

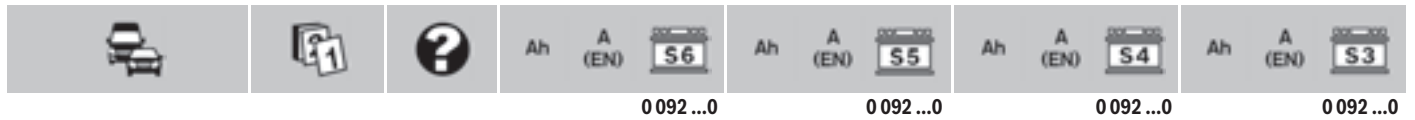

ALFA ROMEO

Arna														
1.2/ 1.3/ 1.5	01.85-12.86											45	400	S3 003
Brera														
1.8 TBi [939]	05.09-12.10				54	530	S5 002		52	530	S4 002			
2.2/ 3.2 JTS, JTS 24V, JTS 24V Q4 [939]	01.06-12.10				63	610	S5 005		60	610	S4 005			
Diesel														
2.0 JTDM [939]	02.09-12.10				77	780	S5 008		74	780	S4 008			
2.4 JTDM 20V [939]	04.06-12.10		70	760	S6 008		77	780	S5 008		74	780	S4 008	
Giulietta														
1.4 TB, TB BiFuel [940]	04.10→	SSJ			60	560	S5 E05			560				
1.6/ 1.8/ 2.0 [116]	10.77-04.85				63	610	S5 006		60	610	S4 006	45	400	S3 003
1.8 TBi [940]	05.10→				63	610	S5 005		60	610	S4 005			
Diesel														
1.6/ 2.0 JTDM [940]	04.10→	SSJ			70	650	S5 E08			650				
2.0 D Turbo [116]	03.83-04.85								70		S4 027			
GT														
1.8/ 2.0/ 3.2 JTS, TS, V6 [937]	10.03-12.10				63	610	S5 005		60	610	S4 005			
Diesel														
1.9 JTD 16V [937]	10.03-12.10				63	610	S5 005		60	610	S4 005			
GTV														
1.8 T.S. 16V [916]	05.98-12.00		70	760	S6 008		77	780	S5 008		60	780	S4 005	56 480 S3 005
2.0 [116]	07.78-01.86								70		S4 027			
JTS [916]	04.03-12.05		70	760	S6 008		77	780	S5 008		60	780	S4 005	
T.S. 16V [916]	04.95-07.00		70	760	S6 008		77	780	S5 008		60	780	S4 005	56 480 S3 005
	08.00-12.05		70	760	S6 008		77	780	S5 008		60	780	S4 005	
V6 Turbo [916]	05.98-07.00		70	760	S6 008		77	780	S5 008		60	780	S4 005	56 480 S3 005
3.0 V6 24V [916]	05.98-07.00		70	760	S6 008		77	780	S5 008		60	780	S4 005	56 480 S3 005
	08.00-12.05		70	760	S6 008		77	780	S5 008		60	780	S4 005	
3.2 V6 24V [916]	04.03-12.05		70	760	S6 008		77	780	S5 008		60	780	S4 005	
GTV 6														
2.5 i.e. [116]	11.80-02.87								70		S4 027			
Mito														
1.4 [955]	10.09→	SSJ			60	560	S5 E05			560				
i.e. Turbo [955]	08.08→				54	530	S5 002		52	530	S4 002			
i.e. 16V [955]	08.08→				77	780	S5 008		60	780	S4 005			
		SSJ			60	560	S5 E05			560				
		XXX										53	470	S3 004
16V Turbo [955]	10.09→	SSJ			60	560	S5 E05			560				
Diesel														
1.3 JTD [955]	10.08→				77	780	S5 008		60	780	S4 005			
		SSJ			60	560	S5 E05			560				
		XXX										53	470	S3 004
1.6 JTD [955]	08.08→	BWD,SSJ			70	650	S5 E08			650				
	09.08→				77	780	S5 008		60	780	S4 005			
		SSJ			60	560	S5 E05			560				
		XXX										53	470	S3 004
MiTo														
0.9 i.e. [955]	07.11→	SSJ			60	560	S5 E05			560				
1.4 i.e. [955]	05.08→				54	530	S5 002		52	530	S4 002			
	06.11→	SSJ			60	560	S5 E05			560				
LPG [955]	07.11→				54	530	S5 002		52	530	S4 002			
		SSJ			60	560	S5 E05			560				
Turbo [955]	10.09→	SSJ			60	560	S5 E05			560				
Diesel														
1.3 JTD [955]	03.11→	SSJ			60	560	S5 E05			560				

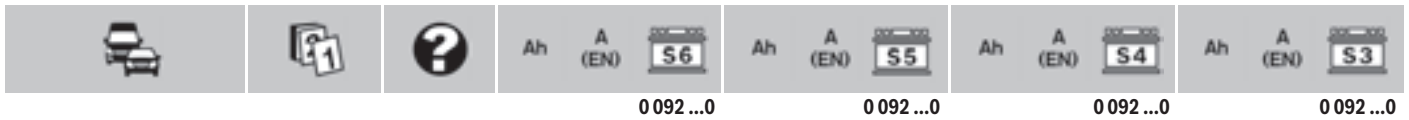

Spider											
1.6 [105; 115]	11.79-12.94				63	610	S5 005		610		
1.8 TBi [939]	05.09-12.10				54	530	S5 002	52	530	S4 002	
T.S. 16V [916]	05.98-07.00				63	610	S5 005		610		
2.0 [105]	04.71-12.89							70		S4 027	
i.e. [105]	10.81-12.89				63	610	S5 005		610		
i.e. [115]	01.90-12.94				63	610	S5 005		610		
JTS [916]	04.03-02.06	70	760	S6 008	77	780	S5 008	60	780	S4 005	
T.S. 16V [916]	04.95-07.00	70	760	S6 008	77	780	S5 008	60	780	S4 005	56 480 S3 005
	08.00-02.06	70	760	S6 008	77	780	S5 008	60	780	S4 005	
2.0/ 3.0 V6 Turbo, V6 12V [916]	04.95-12.00	70	760	S6 008	77	780	S5 008	60	780	S4 005	56 480 S3 005
2.2/ 3.2 JTS, JTS 24V, JTS 24V Q4 [939]	03.06-12.10	70	760	S6 008	77	780	S5 008	60	780	S4 005	
3.0/ 3.2 V6 24V [916]	08.00-02.06	70	760	S6 008	77	780	S5 008	60	780	S4 005	
Diesel											
2.0 JTDM [939]	04.09-12.10				77	780	S5 008	74	780	S4 008	
	05.09-12.10				85	800	S5 010	80	800	S4 010	
2.4 JTDM 20V [939]	03.07-12.10	70	760	S6 008	77	780	S5 008	74	780	S4 008	
Sprint											
1.3/ 1.5/ 1.7 , i.e.	07.79-12.89				54	530	S5 002	52	530	S4 002	45 400 S3 002
6											
2.0/ 2.5 , i.e. [119]	09.83-12.86							70		S4 027	
Diesel											
2.5 D Turbo [119]	06.83-02.87							70		S4 027	
33											
1500	10.83-12.85				54	530	S5 002	52	530	S4 002	45 400 S3 002
33 Berlina											
1.2/ 1.3/ 1.4/ 1.5/ 1.7 , i.e., i.e. 4x4, i.e. 16V, i.e. 16V 4x4, 4x4 [905; 907]	06.83-10.94				54	530	S5 002	52	530	S4 002	45 400 S3 002
Diesel											
1.8 D Turbo [905]	09.86-12.89	70	760	S6 008	77	780	S5 008	74	780	S4 008	70 640 S3 008
D Turbo [907]	02.90-10.94	70	760	S6 008	77	780	S5 008	74	780	S4 008	70 640 S3 008
33 Break											
1.5 , 4x4 [905]	01.85-12.90				54	530	S5 002	52	530	S4 002	45 400 S3 002
33 Sport Wagon											
1.3/ 1.5/ 1.7 , i.e., i.e. 4x4, i.e. 16V, i.e. 16V 4x4, 4x4 [905; 907]	09.84-10.94				54	530	S5 002	52	530	S4 002	45 400 S3 002
Diesel											
1.8 D Turbo [905; 907]	04.88-10.94	70	760	S6 008	77	780	S5 008	74	780	S4 008	70 640 S3 008
75											
1.6/ 1.8/ 2.0 , i.e., Turbo, Turbo i.e., Twin Spark [162]	05.85-02.92				63	610	S5 005		610		
2.5 V6 [162]	09.85-02.92	70	760	S6 008	63	610	S5 005	60	610	S4 005	56 480 S3 005
3.0 V6 [162]	01.87-02.92	70	760	S6 008	77	780	S5 008	60	780	S4 005	56 480 S3 005
Diesel											
2.0/ 2.4 TD [162]	05.85-02.92	70	760	S6 008	77	780	S5 008	74	780	S4 008	70 640 S3 008
75 ES Coupe Zagato											
3.0 [162]	03.89-02.92	70	760	S6 008	77	780	S5 008	74	780	S4 008	70 640 S3 008
90											
1.8/ 2.0/ 2.5 , i.e., i.e. V6 [162]	10.84-12.90	70	760	S6 008	77	780	S5 008	60	780	S4 005	56 480 S3 005
Diesel											
2.4 D Turbo [162]	10.84-01.87	70	760	S6 008	77	780	S5 008	60	780	S4 005	56 480 S3 005
145											
1.3/ 1.6/ 1.7 i.e., i.e. 16V [930 MY95; 930 MY97; 930 MY99]	04.94-11.96				63	610	S5 005	52	610	S4 002	45 400 S3 002

				Ah A (EN) S6		Ah A (EN) S5		Ah A (EN) S4		Ah A (EN) S3		
				0092...0		0092...0		0092...0		0092...0		
◀ ALFA ROMEO												
1.4/1.6/1.8 i.e. 16V T.S. [930 MY95; 930 MY97; 930 MY99]	11.96-12.00			63	610	S5 005		52	610	S4 002	45 400	S3 002
2.0 i.e. 16V T.S. [930 MY95; 930 MY97; 930 MY99]	10.95-12.00			63	610	S5 005			610			
Diesel												
1.9 JTD, TD [930 MY95; 930 MY97; 930 MY99]	04.94-12.00	70	760	S6 008	77	780	S5 008	74	780	S4 008	70 640	S3 008
146												
1.3/1.4/1.6/1.7/1.8 i.e., i.e. 16V, i.e. 16V T.S. [930 MY95; 930 MY97; 930 MY99]	12.94-12.00			63	610	S5 005		52	610	S4 002	45 400	S3 002
2.0 ti 16V T.S. [930 MY95; 930 MY97; 930 MY99]	10.95-12.00			63	610	S5 005			610			
Diesel												
1.9 JTD, TD [930 MY95; 930 MY97; 930 MY99]	12.94-12.00	70	760	S6 008	77	780	S5 008	74	780	S4 008	70 640	S3 008
147												
1.6/2.0/3.2 GTA, TS 16V, TS 16V ECO [937]	11.00-12.10			63	610	S5 005		60	610	S4 005		
Diesel												
1.9 JTD, JTDM [937]	11.00-12.10	70	760	S6 008	77	780	S5 008	74	780	S4 008		
JTDM 16V [937]	10.02-12.10	70	760	S6 008	77	780	S5 008	74	780	S4 008		
	10.07-12.10			77	780	S5 008		74	780	S4 008		
155												
1.6/1.7/1.8/2.0/2.5 i V6, i 16V T.S., T.S., T.S. 16V, Turbo 4x4, V6 [167 MY92; 167 MY96]	02.92-10.97			63	610	S5 005			610			
Diesel												
1.9/2.5 TD [167 MY92; 167 MY96]	04.93-10.97	70	760	S6 008	77	780	S5 008	74	780	S4 008	70 640	S3 008
156 Berlina												
1.6 TS 16V [932]	10.97-09.00			63	610	S5 005		52	610	S4 002	45 400	S3 002
	09.00-10.05			63	610	S5 005		52	610	S4 002		
1.8 TS 16V [932]	10.97-09.00			63	610	S5 005		52	610	S4 002	45 400	S3 002
	09.00-10.05			63	610	S5 005		52	610	S4 002		
2.0 JTS 16V [932]	01.02-12.05			63	610	S5 005		60	610	S4 005		
TS 16V [932]	10.97-09.00			63	610	S5 005			610			
	09.00-10.05			63	610	S5 005		60	610	S4 005		
2.5 24V [932]	10.97-12.01			63	610	S5 005			610			
	09.00-10.05	70	760	S6 008	63	610	S5 005	60	610	S4 005		
3.2 GTA [932]	03.02-10.05	70	760	S6 008	77	780	S5 008	74	780	S4 008		
Diesel												
1.9 JTD [932]	10.97-09.00	70	760	S6 008	77	780	S5 008	74	780	S4 008	70 640	S3 008
	09.00-10.05	70	760	S6 008	77	780	S5 008	74	780	S4 008		
JTD 16V [932]	10.02-10.05	70	760	S6 008	77	780	S5 008	74	780	S4 008		
	07.04-12.05	70	760	S6 008	77	780	S5 008	74	780	S4 008	70 640	S3 008
2.4 JTD [932]	10.97-09.00	70	760	S6 008	77	780	S5 008	74	780	S4 008	70 640	S3 008
	09.00-10.05	70	760	S6 008	77	780	S5 008	74	780	S4 008		
JTD 20V [932]	10.04-10.05	70	760	S6 008	77	780	S5 008	74	780	S4 008		
156 Sport Wagon												
1.6/1.8 TS 16V [932]	06.00-12.05			63	610	S5 005		52	610	S4 002		
2.0 TS 16V [932]	06.00-10.05			63	610	S5 005		60	610	S4 005		
2.0/2.5 JTS 16V, 24V [932]	06.00-12.05	70	760	S6 008	63	610	S5 005	60	610	S4 005		
3.2 GTA [932]	03.02-10.05	70	760	S6 008	77	780	S5 008	74	780	S4 008		
Diesel												
1.9/2.4 JTD, JTD 16V, JTD 20V [932]	06.00-12.05	70	760	S6 008	77	780	S5 008	74	780	S4 008		

			Ah A (EN) S6	Ah A (EN) S5	Ah A (EN) S4	Ah A (EN) S3
			0 092 ...0	0 092 ...0	0 092 ...0	0 092 ...0



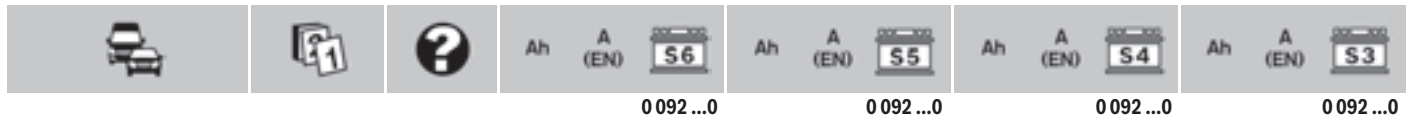

156 Sport Wagon Q4										
Diesel										
1.9 JTD 16V 4x4 [932]	10.04-12.05	70	760	S6 008	77	780	S5 008	74	780	S4 008
159										
Diesel										
2.0 JTDM 16V [939]	06.10→				77	780	S5 008	74	780	S4 008
159 Berlina										
1.8 i [939]	03.06-11.11				63	610	S5 005	60	610	S4 005
TBi [939]	05.09-11.11				63	610	S5 005	60	610	S4 005
1.9/2.2 JTS [939]	06.05-12.08				63	610	S5 005	60	610	S4 005
3.2 JTS [939]	08.07-12.08	70	760	S6 008	77	780	S5 008	74	780	S4 008
Diesel										
1.9 JTDM 8V [939]	06.05-12.08				63	610	S5 005	60	610	S4 005
JTDM 16V [939]	06.05-12.08				63	610	S5 005	60	610	S4 005
2.0 JTDM [939]	05.09→				77	780	S5 008	74	780	S4 008
JTDM 16V [939]	05.09-12.10				77	780	S5 008	74	780	S4 008
2.4 JTD 20V, JTDM 20V [939]	06.05-12.08	70	760	S6 008	77	780	S5 008	74	780	S4 008
159 Berlina Q4										
3.2 JTS [939]	01.06-12.08	70	760	S6 008	77	780	S5 008	74	780	S4 008
Diesel										
2.4 JTD 20V [939]	09.06-12.08	70	760	S6 008	77	780	S5 008	74	780	S4 008
159 Sport Wagon										
1.8 i [939]	03.06-12.08				63	610	S5 005	60	610	S4 005
TBi [939]	05.09-12.10				63	610	S5 005	60	610	S4 005
1.9/2.2 JTS [939]	03.06-12.08				63	610	S5 005	60	610	S4 005
3.2 JTS [939]	08.07-12.08	70	760	S6 008	77	780	S5 008	74	780	S4 008
Diesel										
1.9 JTDM 8V [939]	03.06-12.08				63	610	S5 005	60	610	S4 005
JTDM 16V [939]	03.06-12.08				63	610	S5 005	60	610	S4 005
2.0 JTDM [939]	05.09→				77	780	S5 008	74	780	S4 008
JTDM 16V [939]	05.09→				77	780	S5 008	74	780	S4 008
2.4 JTD 20V, JTDM 20V [939]	03.06-12.08	70	760	S6 008	77	780	S5 008	74	780	S4 008
159 Sport Wagon Q4										
3.2 JTS [939]	03.06-12.08	70	760	S6 008	77	780	S5 008	74	780	S4 008
Diesel										
2.4 JTD 20V [939]	09.06-12.08	70	760	S6 008	77	780	S5 008	74	780	S4 008
164										
2.0 T.S., Turbo i.e., Twin Spark, V6 Turbo, V6 Turbo i.e. [164]	06.87-10.98							60		S4 005 56 480 S3 005
3.0 i.e. [164]	06.87-09.92	70	760	S6 008	63	610	S5 005	60	610	S4 005 56 480 S3 005
Q4 4x4, V6 12V, V6 24V, V6 24V Q.V., V6 24V Q.V. G.D. [164]	09.92-10.98	70	760	S6 008	63	610	S5 005	60	610	S4 005
Diesel										
2.5 D Turbo [164]	06.87-10.98	95	850	S6 013	100	830	S5 013	95	830	S4 013 90 720 S3 013
166										
2.0/2.5/3.0/3.2 T.S. 16V, Turbo V6, V6 24V [936]	07.98-10.07	70	760	S6 008	77	780	S5 008	74	780	S4 008
Diesel										
2.4 JTD [936]	10.98-09.00	95	850	S6 013	100	830	S5 013	95	830	S4 013 90 720 S3 013
	09.00-10.07	95	850	S6 013	100	830	S5 013	95	830	S4 013
JTD 20V, JTDM 20V [936]	06.03-10.07	95	850	S6 013	100	830	S5 013	95	830	S4 013





ALPINA (B.BOVENSIEPEN KG)

B 3														
2.7 [E 30]	08.87-06.92	70	760	S6 008	77	780	S5 008	74	780	S4 008	70	640	S3 008	
3.0 [E 36]	04.93-02.96	70	760	S6 008	77	780	S5 008	74	780	S4 008	70	640	S3 008	
Biturbo, S Biturbo [E 90]	07.07→	80	800	S6 011										
3.2 [E 36]	04.96-03.99	70	760	S6 008	77	780	S5 008	74	780	S4 008	70	640	S3 008	
3.3 , S [E 46]	03.99-01.06				85	800	S5 010	80	800	S4 010				
B 3 Cabrio														
2.7 [E 30]	08.87-06.92	70	760	S6 008	77	780	S5 008	74	780	S4 008	70	640	S3 008	
3.0 [E 36]	04.93-02.96	70	760	S6 008	77	780	S5 008	74	780	S4 008	70	640	S3 008	
S Biturbo [E 93]	03.10→	80	800	S6 011										
3.2 [E 36]	04.96-03.99	70	760	S6 008	77	780	S5 008	74	780	S4 008	70	640	S3 008	
3.3 , S [E 46]	09.00-01.06				85	800	S5 010	80	800	S4 010				
B 3 Coupé														
3.0 Biturbo, S Biturbo [E 92]	01.08→	80	800	S6 011										
GT3 [E 92]	12.11→	95	850	S6 013										
3.2 [E 36]	04.96-03.99	70	760	S6 008	77	780	S5 008	74	780	S4 008	70	640	S3 008	
3.3 , S [E 46]	03.99-01.06				85	800	S5 010	80	800	S4 010				
B 3 Touring														
2.7 [E 30]	08.87-06.92	70	760	S6 008	77	780	S5 008	74	780	S4 008	70	640	S3 008	
3.0 [E 36]	04.93-02.96	70	760	S6 008	77	780	S5 008	74	780	S4 008	70	640	S3 008	
Biturbo, S Biturbo [E 91]	10.08→	80	800	S6 011										
3.2 [E 36]	04.96-03.99	70	760	S6 008	77	780	S5 008	74	780	S4 008	70	640	S3 008	
3.3 , S [E 46]	02.00-01.06				85	800	S5 010	80	800	S4 010				
B 5														
4.4 [E 60]	03.05-10.07	95	850	S6 013	110	920	S5 015	95	920	S4 013				
Biturbo [F 10]	09.10→	95	850	S6 013										
S [E 60]	10.07-05.10	95	850	S6 013										
B 5 Touring														
4.4 [E 61]	03.05-10.07	95	850	S6 013	110	920	S5 015	95	920	S4 013				
Biturbo [F 11]	03.11→	95	850	S6 013										
B 6														
2.8 [E 30]	03.84-07.86	70	760	S6 008	77	780	S5 008	74	780	S4 008	70	640	S3 008	
[E 36]	03.92-07.93	VAD	95	850	S6 013	100	830	S5 013	95	830	S4 013	90	720	S3 013
3.5 [E 30]	11.85-07.87	70	760	S6 008	77	780	S5 008	74	780	S4 008	70	640	S3 008	
	11.87-12.90	70	760	S6 008	77	780	S5 008	74	780	S4 008	70	640	S3 008	
S [E 30]	11.87-12.90	70	760	S6 008	77	780	S5 008	74	780	S4 008	70	640	S3 008	
B 6 Cabrio														
4.4 , S [E 64]	04.06-08.10	95	850	S6 013										
Biturbo [F 12]	09.11→	95	850	S6 013										
B 6 Coupé														
4.4 , S [E 63]	04.06-08.10	95	850	S6 013										
Biturbo [F 13]	09.11→	95	850	S6 013										
B 7														
4.4 [E 65/66]	12.03-06.08	95	850	S6 013										
Biturbo [F 01/02]	06.09-06.12	95	850	S6 013										
B 8														
4.6 [E 36]	01.95-11.98	95	850	S6 013	100	830	S5 013	95	830	S4 013	90	720	S3 013	
B 8 Cabrio														
4.6 [E 36]	01.95-11.98	95	850	S6 013	100	830	S5 013	95	830	S4 013	90	720	S3 013	
B 8 Coupé														
4.6 [E 36]	01.95-11.98	95	850	S6 013	100	830	S5 013	95	830	S4 013	90	720	S3 013	
B 8 Touring														
4.6 [E 36]	01.95-11.98	95	850	S6 013	100	830	S5 013	95	830	S4 013	90	720	S3 013	
B 10														
3.0/ 3.5/ 4.0/ 4.6 , Biturbo [E 34]	04.88-10.95				77	780	S5 008	60	780	S4 005	56	480	S3 005	
3.2 [E 39]	08.97-12.98	95	850	S6 013	100	830	S5 013	95	830	S4 013	90	720	S3 013	
3.3 [E 39]	02.99-10.03	95	850	S6 013	100	830	S5 013	95	830	S4 013	90	720	S3 013	
4.6/ 4.8 S V8, V8 [E 39]	01.97-05.04	95	850	S6 013	110	920	S5 015	920						

			Ah A (EN) 	Ah A (EN) 	Ah A (EN) 	Ah A (EN) 
			0 092 ...0	0 092 ...0	0 092 ...0	0 092 ...0

B 10 Touring													
3.0/ 4.0/ 4.6 [E 34]	11.93-05.96	95	850	S6 013	100	830	S5 013	74	830	S4 008	70	640	S3 008
3.2 [E 39]	08.97-12.98	95	850	S6 013	100	830	S5 013	95	830	S4 013	90	720	S3 013
3.3 [E 39]	02.99-10.03	95	850	S6 013	100	830	S5 013	95	830	S4 013	90	720	S3 013
4.6/ 4.8 S V8, V8 [E 39]	01.97-05.04	95	850	S6 013	110	920	S5 015		920				
B 12													
6.0 [E 38]	07.99-07.01	95	850	S6 013									
D 10													
Diesel													
3.0 Biturbo [E 39]	04.00-10.03	95	850	S6 013	100	830	S5 013	95	830	S4 013			
D 10 Touring													
Diesel													
3.0 Biturbo [E 39]	04.00-10.03	95	850	S6 013	100	830	S5 013	95	830	S4 013			
D3													
Diesel													
2.0 [E 90]	12.05-04.08	95	850	S6 013									
Biturbo [E 90]	10.08→	95	850	S6 013									
D3 Coupé													
Diesel													
2.0 Biturbo [E 92]	04.08→	95	850	S6 013									
D3 Touring													
Diesel													
2.0 , Biturbo [E 91]	05.06→	95	850	S6 013									
D5													
Diesel													
3.0 Biturbo [F 10]	09.11→	95	850	S6 013									
D5 Touring													
Diesel													
3.0 Biturbo [F 11]	09.11→	95	850	S6 013									
Roadster													
S [Z4]	07.03-12.05				85	800	S5 010	80	800	S4 010			
V8 [Z8]	06.02-10.03	95	850	S6 013	110	920	S5 015	95	920	S4 013			

AMC (AMERICAN MOTORS CORP.)

Alliance													
2.0 i Renault	01.87-06.87				54	530	S5 002	52	530	S4 002	45	400	S3 002
Encore													
1.7 Renault	08.84-06.87										45	400	S3 002

ARO

ARO 10													
1.2/ 1.3/ 1.4/ 1.6, i 16V, Spartana	09.80-12.06										45	400	S3 003
Diesel													
1.6 D	09.80-12.89				63	610	S5 005	60	610	S4 005	56	480	S3 005
D Turbo	09.80-12.89				63	610	S5 005	60	610	S4 005	56	480	S3 005
1.9 D	09.90-12.06				63	610	S5 005	60	610	S4 005	56	480	S3 005
ARO 240-244													
3.0 V6	01.98-12.06							74		S4 008	70	640	S3 008

ASIA (ASIA MOTORS)

Rocsta													
1.8 i [CA]	02.94-12.98							60		S4 024			
Diesel													
2.2 D [CA]	08.94-12.98							60		S4 024			



			Ah A (EN) S6 0092 ...0	Ah A (EN) S5 0092 ...0	Ah A (EN) S4 0092 ...0	Ah A (EN) S3 0092 ...0
--	--	--	---------------------------	---------------------------	---------------------------	---------------------------

ASTON MARTIN







Cygnnet												
1.3	04.11→									60		S4025
DB7 Cabrio												
3.2/5.9	Volante, V12 Volante	03.94-08.02	70	760	S6 008	77	780	S5 008	74	780	S4 008	70 640 S3 008
5.9	AR1 Volante	03.02→	95	850	S6 013	100	830	S5 013	95	830	S4 013	
DB7 Coupé												
3.2	Vantage	03.94-02.99	70	760	S6 008	77	780	S5 008	74	780	S4 008	70 640 S3 008
5.9	V12 Vantage	03.99-08.02	70	760	S6 008	77	780	S5 008	74	780	S4 008	70 640 S3 008
		AGM	95	850	S6 013							
	V12 Zagato	09.02-12.03	95	850	S6 013	100	830	S5 013	95	830	S4 013	
6.0	V12 Vantage	10.02-10.03				77	780	S5 008	74	780	S4 008	
DB9 Cabrio												
5.9	Volante	04.04-12.07	AGM	95	850	S6 013						
DB9 Coupé												
4.2	Vantage	06.05-12.07	95	850	S6 013	100	830	S5 013	95	830	S4 013	
5.9	Vantage	01.04-12.07	AGM	95	850	S6 013						
Lagonda												
5.3/6.3		01.76-12.99								70		S4027
Vanquish												
5.9		09.01-08.04	95	850	S6 013	100	830	S5 013	95	830	S4 013	
		09.04-08.07	AGM	95	850	S6 013						
Vantage Coupe												
4.3	V8	03.05-09.08				100	830	S5 013	95	830	S4 013	
			AGM	95	850	S6 013						
4.7	V8 S	06.11→	95	850	S6 013	100	830	S5 013	95	830	S4 013	
Vantage Roadster												
4.3	V8	04.07-09.08	AGM	95	850	S6 013						
4.7	V8	09.12→				100	830	S5 013	95	830	S4 013	
Virage Cabrio												
5.3	Volante	09.90-12.95							70		S4027	
		01.97-12.00				85	800	S5 010	74	800	S4008	
Virage Coupé												
5.3	Kompressor, V8, V8 Limited Edition	10.88-12.99							70		S4027	
Virage Saloon												
5.3	V8	10.88-12.95							70		S4027	
Virage Shooting Brake												
5.3	V8	10.88-12.95							70		S4027	
V8 Cabrio												
5.3	Volante	01.78-12.89							70		S4027	
V8 Coupe												
5.3	, Vantage	01.69-12.89							70		S4027	
	32V Kompressor	10.92-12.99							70		S4027	
V8 Zagato Cabrio												
5.3	Volante	01.86-12.89							70		S4027	
V8 Zagato Coupe												
5.3	Vantage	01.86-12.89							70		S4027	

AUDI

A1												
1.2	TFSI [8X1]	05.10→	SSJ	60	680	S6 005						
1.4	TFSI [8X1]	05.10→	KZO,SSJ	70	760	S6 008						
			KZO,SSJ	80	800	S6 011						
		01.11→	BWD,SSJ	70	760	S6 008						
		02.13→		70	760	S6 008						
2.0	TFSI quattro [8X1]	03.12→		80	800	S6 011						
Diesel												
1.6	TDI [8X1]	05.10→	KZO,SSJ	70	760	S6 008						

				Ah A (EN) S6	Ah A (EN) S5	Ah A (EN) S4	Ah A (EN) S3							
				0 092 ...0	0 092 ...0	0 092 ...0	0 092 ...0							
1.6 TDI [8X1]	05.10→	KZO,SSJ	80	800	S6 011									
	03.11→	BWD,SSJ	60	680	S6 005									
2.0 TDI [8X1]	09.11→	BWD	70	760	S6 008									
		BWD,KZO,SSJ	70	760	S6 008									
		BWD,KZO,SSJ	80	800	S6 011									
A1 Sportback														
1.2 TFSI [8XA]	01.12→	SSJ	60	680	S6 005									
1.4 TFSI [8XA]	11.11→	KZO,SSJ	70	760	S6 008									
		KZO,SSJ	80	800	S6 011									
	02.13→		70	760	S6 008									
Diesel														
1.6 TDI [8XA]	11.11→	BWD,KZO,SSJ	70	760	S6 008									
		BWD,KZO,SSJ	80	800	S6 011									
		KZO,SSJ	70	760	S6 008									
		KZO,SSJ	80	800	S6 011									
2.0 TDI [8XA]	09.11→	BWD	70	760	S6 008									
	05.12→		70	760	S6 008									
A2														
1.4 [8Z0]	09.99-04.02		70	760	S6 008	77	780	S5 008	74	780	S4 008	70	640	S3 008
	11.01-08.05		70	760	S6 008	77	780	S5 008	74	780	S4 008			
1.6 FSI [8Z0]	01.02-08.05		70	760	S6 008	85	800	S5 011	74	800	S4 008	70	640	S3 008
Diesel														
1.2 TDI 3L [8Z0]	03.01-08.05		70	760	S6 008	85	800	S5 011	74	800	S4 008	70	640	S3 008
1.4 TDI [8Z0]	09.99-08.05		70	760	S6 008	85	800	S5 010	74	800	S4 008	70	640	S3 008
A3														
1.2 TFSI [8P1]	04.10-03.13	BWD				77	780	S5 008	60	780	S4 005	45	400	S3 002
		BWD,SSJ	70	760	S6 008									
1.2/ 1.4/ 1.8 FSI, FSI quattro, TFSI [8V1]	04.12→		70	760	S6 008									
1.4 TFSI [8P1]	09.07-03.13					63	610	S5 005	52	610	S4 002			
		SSJ	70	760	S6 008									
	04.10-03.13	BWD				63	610	S5 005	52	610	S4 002			
		BWD,SSJ	70	760	S6 008									
1.6 [8L1]	09.96-06.01					63	610	S5 005	52	610	S4 002	45	400	S3 002
	05.00-06.03					63	610	S5 005	52	610	S4 002			
[8P1]	05.03→					63	610	S5 005	52	610	S4 002	45	400	S3 002
	05.10→	BWD				63	610	S5 005	52	610	S4 002			
FSI [8P1]	08.03-09.07					63	610	S5 005	60	610	S4 005			
1.8 [8L1]	09.96-06.03					63	610	S5 005	60	610	S4 005	56	480	S3 005
quattro, T, T quattro [8L1]	12.96-06.03					63	610	S5 005	60	610	S4 005	56	480	S3 005
TFSI [8P1]	11.06-05.08					63	610	S5 005	60	610	S4 005			
	07.08-08.12					63	610	S5 005	60	610	S4 005			
TFSI quattro [8P1]	07.08→	BWD				77	780	S5 008	60	780	S4 005			
2.0 FSI [8P1]	05.03-06.08		70	760	S6 008	77	780	S5 008	60	780	S4 005	56	480	S3 005
TFSI [8P1]	09.04-06.08		70	760	S6 008	77	780	S5 008	60	780	S4 005	56	480	S3 005
	07.08→	BWD	70	760	S6 008	77	780	S5 008	60	780	S4 005	56	480	S3 005
TFSI quattro [8P1]	09.04-06.08		70	760	S6 008	77	780	S5 008	60	780	S4 005	56	480	S3 005
	07.08→	BWD	70	760	S6 008	77	780	S5 008	60	780	S4 005	56	480	S3 005
3.2 quattro [8P1]	07.03-05.09		70	760	S6 008	85	800	S5 011	74	800	S4 008			
	11.05-05.09		70	760	S6 008	85	800	S5 010	80	800	S4 011			
			70	760	S6 008	85	800	S5 011	80	800	S4 011			
Diesel														
1.6 TDI [8P1]	05.09→	BWD				77	780	S5 008	60	780	S4 005			
		BWD,SSJ	70	760	S6 008									
	11.09→	BWD,KZO,SSJ	70	760	S6 008									
		BWD,KZO,SSJ	80	800	S6 011									
1.9 TDI [8P1]	06.03-05.10		70	760	S6 008	85	800	S5 011	74	800	S4 008	70	640	S3 008
TDI, TDI quattro [8L1]	09.96-06.03		70	760	S6 008	77	780	S5 008	74	780	S4 008			
2.0 TDI [8P1]	05.03-06.08		70	760	S6 008	85	800	S5 010	74	800	S4 008	70	640	S3 008
			70	760	S6 008	85	800	S5 011	74	800	S4 008	70	640	S3 008
	03.06-06.08					85	800	S5 011	74	800	S4 008	70	640	S3 008
		SSJ	70	760	S6 008									
	06.06-06.08					85	800	S5 010	80	800	S4 010			

				Ah A (EN) S6	Ah A (EN) S5	Ah A (EN) S4	Ah A (EN) S3
				0 092 ...0	0 092 ...0	0 092 ...0	0 092 ...0
◀ AUDI							
2.0 TDI [8P1]	07.08→	BWD	70 760	S6 008	85 800	S5 011	74 800 S4 008 70 640 S3 008
	09.08→	BWD			85 800	S5 011	74 800 S4 008 70 640 S3 008
		BWD,SSJ	70 760	S6 008			
TDI quattro [8P1]	05.03-06.08		70 760	S6 008	85 800	S5 010	74 800 S4 008 70 640 S3 008
			70 760	S6 008	85 800	S5 011	74 800 S4 008 70 640 S3 008
	03.06-06.08				85 800	S5 011	74 800 S4 008 70 640 S3 008
		SSJ	70 760	S6 008			
	07.08→	BWD			85 800	S5 011	74 800 S4 008 70 640 S3 008
		BWD,SSJ	70 760	S6 008			
	09.08→	BWD	70 760	S6 008	85 800	S5 011	74 800 S4 008 70 640 S3 008
TDI, TDI quattro [8V1]	04.12→		70 760	S6 008			
A3 Cabriolet							
1.2 TFSI [8P7]	03.10→	BWD			63 610	S5 005	610 70 640 S3 008
		BWD,SSJ	70 760	S6 008			
1.4 TFSI [8P7]	02.11→	BWD	70 760	S6 008			
1.6 [8P7]	09.08-05.10	BWD			63 610	S5 005	52 610 S4 002
1.8/ 2.0 TFSI [8P7]	04.08→				63 610	S5 005	60 610 S4 005
Diesel							
1.6 TDI [8P7]	05.09→	BWD			63 610	S5 005	610 70 640 S3 008
		BWD,KZO,SSJ	70 760	S6 008			
		BWD,KZO,SSJ	80 800	S6 011			
1.9 TDI [8P7]	04.08-05.09	BWD	70 760	S6 008	85 800	S5 011	74 800 S4 008 70 640 S3 008
2.0 TDI [8P7]	04.08-05.10		70 760	S6 008	85 800	S5 010	74 800 S4 008
	04.08→	BWD			85 800	S5 011	74 800 S4 008 70 640 S3 008
		BWD,SSJ	70 760	S6 008			
	11.09→	BWD			77 780	S5 008	74 780 S4 008
A3 Sportback							
1.2 TFSI [8PA]	11.09-08.12	BWD			77 780	S5 008	60 780 S4 005 45 400 S3 002
		BWD,SSJ	70 760	S6 008			
1.4 TFSI [8PA]	06.07-08.12	BWD			63 610	S5 005	52 610 S4 002
		BWD,SSJ	70 760	S6 008			
	04.10→	SSJ	70 760	S6 008			
1.4/ 1.8 TFSI [8VA]	09.12→		70 760	S6 008			
1.6 [8PA]	09.04→				63 610	S5 005	52 610 S4 002 45 400 S3 002
	05.10→	BWD			63 610	S5 005	52 610 S4 002
FSI [8PA]	09.04-09.07				63 610	S5 005	60 610 S4 005
1.8 TFSI [8PA]	11.06-08.12				63 610	S5 005	60 610 S4 005
TFSI quattro [8PA]	07.08→	BWD			77 780	S5 008	60 780 S4 005
2.0 FSI [8PA]	09.04-01.05		70 760	S6 008	77 780	S5 008	60 780 S4 005
	09.04-06.08		70 760	S6 008	77 780	S5 008	60 780 S4 005 56 480 S3 005
TFSI [8PA]	09.04→		70 760	S6 008	77 780	S5 008	60 780 S4 005 56 480 S3 005
	07.08→	BWD	70 760	S6 008	77 780	S5 008	60 780 S4 005 56 480 S3 005
TFSI quattro [8PA]	09.04-05.09		70 760	S6 008	77 780	S5 008	60 780 S4 005 56 480 S3 005
	07.08→	BWD	70 760	S6 008	77 780	S5 008	60 780 S4 005 56 480 S3 005
3.2 quattro [8PA]	09.04-05.09		70 760	S6 008	85 800	S5 011	74 800 S4 008
Diesel							
1.6 TDI [8PA]	05.09→	BWD			77 780	S5 008	60 780 S4 005
		BWD,SSJ	70 760	S6 008			
1.6/ 2.0 TDI, TDI quattro [8VA]	10.12→		70 760	S6 008			
1.9 TDI [8PA]	09.04-05.10		70 760	S6 008	85 800	S5 011	74 800 S4 008 70 640 S3 008
2.0 TDI [8PA]	09.04-06.08		70 760	S6 008	85 800	S5 010	74 800 S4 008 70 640 S3 008
			70 760	S6 008	85 800	S5 011	74 800 S4 008 70 640 S3 008
	03.06-06.08				85 800	S5 011	74 800 S4 008 70 640 S3 008
		SSJ	70 760	S6 008			
	06.06-06.08				85 800	S5 010	80 800 S4 010
	07.08→	BWD			85 800	S5 011	74 800 S4 008 70 640 S3 008
			70 760	S6 008	85 800	S5 011	74 800 S4 008 70 640 S3 008
		BWD,SSJ	70 760	S6 008			
	09.09→				85 800	S5 011	80 800 S4 011
TDI quattro [8PA]	09.04-06.08		70 760	S6 008	85 800	S5 010	74 800 S4 008 70 640 S3 008
			70 760	S6 008	85 800	S5 011	74 800 S4 008 70 640 S3 008
	03.06-06.08				85 800	S5 011	74 800 S4 008 70 640 S3 008

				Ah	A (EN)		Ah	A (EN)		Ah	A (EN)		Ah	A (EN)		
				0 092 ...0			0 092 ...0			0 092 ...0			0 092 ...0			
2.0 TDI quattro [8PA]	03.06-06.08	SSJ	70	760	S6 008											
	07.08→	BWD				85	800	S5 011	74	800	S4 008	70	640	S3 008		
			70	760	S6 008	85	800	S5 011	74	800	S4 008	70	640	S3 008		
		BWD,SSJ	70	760	S6 008											
A4																
1.6 [8D2; B5]	11.94-10.00	VAD	70	760	S6 008	77	780	S5 008	60	780	S4 005	45	400	S3 002		
1.6/ 1.8/ 2.0, T, TFSI [8EC; B7]	11.04-06.08		70	760	S6 008	77	780	S5 008	60	780	S4 005	56	480	S3 005		
1.6/ 2.0/ 2.4, FSI [8E2; B6]	10.00-12.04		70	760	S6 008	77	780	S5 008	60	780	S4 005					
1.8 [8D2; B5]	11.94-04.99								44		S4 001					
	11.94-10.00	VAD	70	760	S6 008	77	780	S5 008	60	780	S4 005	45	400	S3 002		
quattro [8D2; B5]	11.94-04.99								44		S4 001					
	11.94-10.01	VAD	70	760	S6 008	77	780	S5 008	60	780	S4 005	45	400	S3 002		
T [8D2; B5]	11.94-12.98								44		S4 001					
	11.94-10.00	VAD	70	760	S6 008	77	780	S5 008	60	780	S4 005	45	400	S3 002		
T [8E2; B6]	12.00-08.05		70	760	S6 008	77	780	S5 008	60	780	S4 005					
	07.02-12.04		70	760	S6 008	77	780	S5 008	44	780	S4 001					
T quattro [8D2; B5]	11.94-10.00								44		S4 001					
		VAD	70	760	S6 008	77	780	S5 008	60	780	S4 005	45	400	S3 002		
T quattro [8EC; B7]	11.04-06.08		70	760	S6 008	77	780	S5 008	60	780	S4 005					
T quattro [8E2; B6]	12.00-06.02		70	760	S6 008	77	780	S5 008	60	780	S4 005	56	480	S3 005		
	07.01-12.04		70	760	S6 008	77	780	S5 008	60	780	S4 005					
TFSI [8K2; B8]	11.07→	BWD	70	760	S6 008	77	780	S5 008	60	780	S4 005	56	480	S3 005		
	11.11→	BWD	80	800	S6 011											
TFSI quattro [8K2; B8]	09.08-03.12	BWD				63	610	S5 005	52	610	S4 002					
	11.11→	BWD	80	800	S6 011											
2.0 TFSI [8K2; B8]	06.08→					77	780	S5 008	74	780	S4 008	70	640	S3 008		
			70	760	S6 008	77	780	S5 008	74	780	S4 008	70	640	S3 008		
			BWD,KZO,SSJ	70	760	S6 008										
			BWD,KZO,SSJ	105	950	S6 015										
	08.08→	KZO,SSJ	70	760	S6 008											
			KZO,SSJ	105	950	S6 015										
	09.08-03.12		70	760	S6 008	77	780	S5 008	74	780	S4 008	70	640	S3 008		
	TFSI flexible fuel [8K2; B8]	11.09→	BWD				77	780	S5 008	74	780	S4 008				
			BWD,KZO,SSJ	70	760	S6 008										
			BWD,KZO,SSJ	105	950	S6 015										
TFSI quattro [8EC; B7]	11.04-06.08		70	760	S6 008	77	780	S5 008	60	780	S4 005					
	01.05-05.06		70	760	S6 008	77	780	S5 008	60	780	S4 005	56	480	S3 005		
TFSI quattro [8K2; B8]	06.08→	BWD				77	780	S5 008	74	780	S4 008	70	640	S3 008		
		BWD,KZO,SSJ	70	760	S6 008											
		BWD,KZO,SSJ	105	950	S6 015											
08.08→	KZO,SSJ	70	760	S6 008												
		KZO,SSJ	105	950	S6 015											
TFSI quattro flexible fuel [8K2; B8]	11.09→	BWD				77	780	S5 008	74	780	S4 008					
	03.12→					77	780	S5 008	74	780	S4 008	70	640	S3 008		
		KZO,SSJ	70	760	S6 008											
		KZO,SSJ	105	950	S6 015											
2.4 [8D2; B5]	07.95-10.00					85	800	S5 011	80	800	S4 011					
		VAD	70	760	S6 008	77	780	S5 008	60	780	S4 005	45	400	S3 002		
	quattro [8D2; B5]	08.97-12.98				85	800	S5 011	80	800	S4 011					
		VAD	70	760	S6 008	77	780	S5 008	60	780	S4 005	45	400	S3 002		
	02.99-10.00					85	800	S5 011	80	800	S4 011					
	VAD	70	760	S6 008	77	780	S5 008	60	780	S4 005	45	400	S3 002			
2.6 [8D2; B5]	11.94-07.98					85	800	S5 011	80	800	S4 011					
		VAD	70	760	S6 008	77	780	S5 008	60	780	S4 005	45	400	S3 002		
quattro [8D2; B5]	11.94-07.98				85	800	S5 011	80	800	S4 011						
		VAD	70	760	S6 008	77	780	S5 008	60	780	S4 005	45	400	S3 002		
2.8 [8D2; B5]	11.94-06.00					85	800	S5 011	80	800	S4 011					
	11.94-10.00	VAD	70	760	S6 008	77	780	S5 008	60	780	S4 005	45	400	S3 002		
	quattro [8D2; B5]	11.94-07.98				85	800	S5 011	80	800	S4 011					
		VAD	70	760	S6 008	77	780	S5 008	60	780	S4 005	45	400	S3 002		
	02.99-10.00					85	800	S5 011	80	800	S4 011					
		VAD	70	760	S6 008	77	780	S5 008	60	780	S4 005	45	400	S3 002		

		Ah A (EN) S6			Ah A (EN) S5			Ah A (EN) S4			Ah A (EN) S3		
		0092 ...0			0092 ...0			0092 ...0			0092 ...0		
◀ AUDI													
3.0 TFSI quattro [8K2; B8]	02.12→		80	800	S6 011								
3.0/3.2 , FSI, FSI quattro, quattro [8EC; B7; 8E2; B6]	12.00-06.08		95	850	S6 013	100	830	S5 013	95	830	S4 013		
3.2 FSI, FSI quattro [8K2; B8]	01.08-03.12	BWD	70	760	S6 008	77	780	S5 008	74	780	S4 008		
Diesel													
1.9 TDI [8D2; B5]	11.94-11.00					85	800	S5 011	80	800	S4 011		
		VAD	70	760	S6 008	77	780	S5 008	74	780	S4 008	70 640 S3 008	
TDI [8E2; B6]	12.00-12.04		70	760	S6 008	77	780	S5 008	80	780	S4 011		
			70	760	S6 008	85	800	S5 011	74	800	S4 008		
			70	760	S6 008	85	800	S5 011	80	800	S4 011		
TDI quattro [8D2; B5]	06.04-12.04		70	760	S6 008	77	780	S5 008	74	780	S4 008		
	07.96-12.98					85	800	S5 011	80	800	S4 011		
		VAD	70	760	S6 008	77	780	S5 008	74	780	S4 008	70 640 S3 008	
	08.99-10.00					85	800	S5 011	80	800	S4 011		
		VAD	70	760	S6 008	77	780	S5 008	74	780	S4 008	70 640 S3 008	
TDI quattro [8E2; B6]	04.01-12.04		70	760	S6 008	77	780	S5 008	80	780	S4 011		
			70	760	S6 008	85	800	S5 011	74	800	S4 008		
			70	760	S6 008	85	800	S5 011	80	800	S4 011		
1.9/2.0 TDI [8EC; B7]	11.04-06.08		70	760	S6 008	85	800	S5 011	74	800	S4 008	70 640 S3 008	
2.0 TDI [8K2; B8]	11.07→	BWD				77	780	S5 008	74	780	S4 008	70 640 S3 008	
		BWD,KZO,SSJ	70	760	S6 008								
		BWD,KZO,SSJ	105	950	S6 015								
	01.08-03.12	BWD				77	780	S5 008	60	780	S4 005		
		BWD,SSJ	95	850	S6 013								
	01.08→	BWD	70	760	S6 008	77	780	S5 008	74	780	S4 008		
	11.11→	BWD	80	800	S6 011								
	01.12→					77	780	S5 008	60	780	S4 005		
		KZO,SSJ	70	760	S6 008								
		KZO,SSJ	105	950	S6 015								
TDI quattro [8EC; B7]	01.06-06.08		70	760	S6 008	77	780	S5 008	80	780	S4 011		
			70	760	S6 008	85	800	S5 011	74	800	S4 008		
			70	760	S6 008	85	800	S5 011	80	800	S4 011		
TDI quattro [8K2; B8]	06.08-03.12	BWD				77	780	S5 008	74	780	S4 008	70 640 S3 008	
	06.08→	BWD,KZO,SSJ	70	760	S6 008								
		BWD,KZO,SSJ	105	950	S6 015								
	05.09→	BWD				77	780	S5 008	74	780	S4 008		
	11.11→		80	800	S6 011								
2.5 TDI [8D2; B5]	08.97-10.00	VAD	95	850	S6 013	77	780	S5 008	74	780	S4 008	70 640 S3 008	
TDI [8E2; B6]	04.01-12.04		95	850	S6 013	100	830	S5 013	74	830	S4 008		
TDI quattro [8D2; B5]	11.97-10.00	VAD	95	850	S6 013	77	780	S5 008	74	780	S4 008	70 640 S3 008	
TDI quattro [8E2; B6]	12.00-12.04		95	850	S6 013	100	830	S5 013	74	830	S4 008		
2.5/2.7 TDI [8EC; B7]	11.04-06.08		95	850	S6 013	100	830	S5 013	74	830	S4 008	70 640 S3 008	
2.7 TDI [8K2; B8]	11.07-03.12	BWD	70	760	S6 008	77	780	S5 008	74	780	S4 008	70 640 S3 008	
			95	850	S6 013	100	830	S5 013	74	830	S4 008	70 640 S3 008	
3.0 TDI [8K2; B8]	11.11→	BWD	80	800	S6 011								
TDI quattro [8EC; B7]	01.05-06.08		95	850	S6 013	100	830	S5 013	74	830	S4 008		
TDI quattro [8K2; B8]	11.07-03.12	BWD	95	850	S6 013	100	830	S5 013	74	830	S4 008	70 640 S3 008	
	11.11→	BWD	80	800	S6 011								
A4 Avant													
1.6 [8E5; B6]	09.01-12.04		70	760	S6 008	77	780	S5 008	60	780	S4 005		
1.6/1.8 [8D5; B5]	11.94-09.01	VAD	70	760	S6 008	77	780	S5 008	60	780	S4 005	45 400 S3 002	
, T, T quattro [8ED; B7]	11.04-06.08		70	760	S6 008	77	780	S5 008	60	780	S4 005		
1.8 quattro [8D5; B5]	11.94-04.99								44		S4 001		
	11.94-09.01	VAD	70	760	S6 008	77	780	S5 008	60	780	S4 005	45 400 S3 002	
T [8D5; B5]	10.95-09.01								44		S4 001		
		VAD	70	760	S6 008	77	780	S5 008	60	780	S4 005	45 400 S3 002	
T [8E5; B6]	09.01-12.04		70	760	S6 008	77	780	S5 008	60	780	S4 005		
	07.02-12.04		70	760	S6 008	77	780	S5 008	44	780	S4 001		
T quattro [8D5; B5]	02.96-09.01	VAD	70	760	S6 008	77	780	S5 008	60	780	S4 005	45 400 S3 002	
	08.97-09.01								44		S4 001		
T quattro [8E5; B6]	09.01-06.02		70	760	S6 008	77	780	S5 008	44	780	S4 001		
	09.01-12.04		70	760	S6 008	77	780	S5 008	60	780	S4 005		
TFSI [8K5; B8]	11.07→	BWD	70	760	S6 008	77	780	S5 008	60	780	S4 005	56 480 S3 005	



		0 092 ...0			0 092 ...0			0 092 ...0			0 092 ...0		
1.8	TFSI [8K5; B8]	11.11→	BWD	80	800	S6 011							
	TFSI quattro [8K5; B8]	09.08-03.12	BWD				63	610	S5 005	52	610	S4 002	
		11.11→	BWD	80	800	S6 011							
2.0	FSI [8ED; B7; 8E5; B6]	09.01-12.04		70	760	S6 008			S5 008	60	780	S4 005	
	TFSI [8K5; B8]	06.08→	BWD						S5 008	74	780	S4 008	
				70	760	S6 008			S5 008	74	780	S4 008	
			BWD,KZO,SSJ	70	760	S6 008							
			BWD,KZO,SSJ	105	950	S6 015							
	TFSI flexible fuel [8K5; B8]	11.09→	BWD						S5 008	74	780	S4 008	
			BWD,KZO,SSJ	70	760	S6 008							
			BWD,KZO,SSJ	105	950	S6 015							
	TFSI quattro [8K5; B8]	06.08→	BWD						S5 008	74	780	S4 008	
			BWD,KZO,SSJ	70	760	S6 008							
			BWD,KZO,SSJ	105	950	S6 015							
	TFSI quattro flexible fuel [8K5; B8]	11.09→	BWD						S5 008	74	780	S4 008	
	TFSI, TFSI quattro [8ED; B7; 8E5; B6]	11.04-06.08		70	760	S6 008			S5 008	60	780	S4 005	
2.0/2.4	[8ED; B7; 8E5; B6]	09.01-06.08		70	760	S6 008			S5 008	60	780	S4 005	
2.4	[8D5; B5]	08.97-09.01							S5 011	80	800	S4 011	
			VAD	70	760	S6 008			S5 008	60	780	S4 005	
	quattro [8D5; B5]	08.97-09.01								80		S4 011	
			VAD	70	760	S6 008			S5 008	60	780	S4 005	
										80		S4 011	
2.6	[8D5; B5]	11.94-07.98							S5 011	80	800	S4 011	
			VAD	70	760	S6 008			S5 008	60	780	S4 005	
	quattro [8D5; B5]	11.94-07.98								80		S4 011	
			VAD	70	760	S6 008			S5 008	60	780	S4 005	
										80		S4 011	
2.8	[8D5; B5]	03.96-09.01							S5 011	80	800	S4 011	
			VAD	70	760	S6 008			S5 008	60	780	S4 005	
	quattro [8D5; B5]	03.96-09.01								80		S4 011	
			VAD	70	760	S6 008			S5 008	60	780	S4 005	
										80		S4 011	
3.0	[8ED; B7; 8E5; B6]	09.01-05.06		95	850	S6 013			S5 013	95	830	S4 013	
	TFSI quattro [8K5; B8]	02.12→		80	800	S6 011							
3.0/3.2	FSI quattro, quattro [8ED; B7; 8E5; B6]	09.01-06.08		95	850	S6 013			S5 013	95	830	S4 013	
3.2	FSI [8ED; B7; 8E5; B6]	01.05-06.08		95	850	S6 013			S5 013	95	830	S4 013	
	FSI, FSI quattro [8K5; B8]	04.08-03.12	BWD	70	760	S6 008			S5 008	74	780	S4 008	
Diesel													
1.9	TDI [8D5; B5]	01.95-09.01							S5 011	80	800	S4 011	
			VAD	70	760	S6 008			S5 008	74	780	S4 008	
	TDI [8ED; B7]	11.04-06.08		70	760	S6 008			S5 008	80	780	S4 011	
				70	760	S6 008			S5 011	85	800	S4 008	
				70	760	S6 008			S5 011	80	800	S4 011	
	TDI [8E5; B6]	09.01-12.04		70	760	S6 008			S5 008	80	780	S4 011	
				70	760	S6 008			S5 011	85	800	S4 008	
				70	760	S6 008			S5 011	80	800	S4 011	
		06.04-12.04		70	760	S6 008			S5 008	74	780	S4 008	
	TDI quattro [8D5; B5]	07.96-01.00							S5 011	80	800	S4 011	
			VAD	70	760	S6 008			S5 008	74	780	S4 008	
		01.00-09.01		70	760	S6 008			S5 008	80	780	S4 011	
				70	760	S6 008			S5 011	85	800	S4 008	
				70	760	S6 008			S5 011	80	800	S4 011	
	TDI quattro [8E5; B6]	09.01-12.04		70	760	S6 008			S5 008	80	780	S4 011	
				70	760	S6 008			S5 011	85	800	S4 008	
				70	760	S6 008			S5 011	80	800	S4 011	
2.0	TDI [8ED; B7]	11.04-06.08		70	760	S6 008			S5 008	80	780	S4 011	
				70	760	S6 008			S5 011	85	800	S4 008	
				70	760	S6 008			S5 011	80	800	S4 011	
	TDI [8K5; B8]	04.08-03.12	BWD,SSJ	95	850	S6 013							
		04.08→	BWD						S5 008	74	780	S4 008	
									S5 008	74	780	S4 008	
				70	760	S6 008			S5 008	74	780	S4 008	
			BWD,KZO,SSJ	70	760	S6 008							

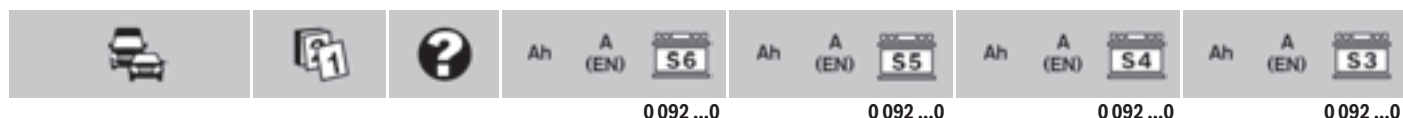

◀ AUDI

			0092 ...0			0092 ...0			0092 ...0			0092 ...0		
2.0 TDI [8K5; B8]	04.08→	BWD,KZO,SSJ	105	950	S6 015									
	11.11→	BWD	80	800	S6 011									
	01.12→					77	780	S5 008	74	780	S4 008			
		KZO,SSJ	70	760	S6 008									
		KZO,SSJ	105	950	S6 015									
	TDI quattro [8ED; B7]	01.06-06.08				70	760	S6 008	77	780	S5 008	80	780	S4 011
						70	760	S6 008	85	800	S5 011	74	800	S4 008
						70	760	S6 008	85	800	S5 011	80	800	S4 011
	TDI quattro [8K5; B8]	06.08-03.12	BWD						77	780	S5 008	74	780	S4 008
		06.08→	BWD,KZO,SSJ	70	760	S6 008								
		BWD,KZO,SSJ	105	950	S6 015									
	05.09→	BWD						77	780	S5 008	60	780	S4 005	
	11.11→	BWD	80	800	S6 011									
2.5 TDI [8D5; B5]	11.97-09.01	VAD	95	850	S6 013	77	780	S5 008	74	780	S4 008	70	640	S3 008
TDI [8ED; B7]	11.04-05.06		95	850	S6 013	85	800	S5 011	74	800	S4 008			
			95	850	S6 013	85	800	S5 011	80	800	S4 011			
			95	850	S6 013	100	830	S5 013	80	830	S4 011			
TDI [8E5; B6]	09.01-12.04		95	850	S6 013	100	830	S5 013	74	830	S4 008			
TDI quattro [8D5; B5]	11.97-06.00	VAD	95	850	S6 013	77	780	S5 008	74	780	S4 008	70	640	S3 008
TDI quattro [8E5; B6]	09.01-12.04		95	850	S6 013	100	830	S5 013	74	830	S4 008			
2.7 TDI [8ED; B7]	11.05-06.08		95	850	S6 013	100	830	S5 013	74	830	S4 008			
TDI [8K5; B8]	04.08-05.08					85	800	S5 011		800				
			95	850	S6 013	100	830	S5 013	74	830	S4 008			
		KZO,SSJ	95	850	S6 013									
		KZO,SSJ	80	800	S6 011									
	06.08-03.12	BWD				85	800	S5 011		800				
			95	850	S6 013	100	830	S5 013	74	830	S4 008			
		BWD,KZO,SSJ	95	850	S6 013									
		BWD,KZO,SSJ	80	800	S6 011									
3.0 TDI [8K5; B8]	11.11→	BWD	80	800	S6 011									
TDI quattro [8ED; B7]	01.05-06.08		95	850	S6 013	100	830	S5 013	74	830	S4 008			
TDI quattro [8K5; B8]	04.08-05.08	BWD	95	850	S6 013	100	830	S5 013	74	830	S4 008			
	04.08-03.12	BWD	70	760	S6 008	77	780	S5 008	74	780	S4 008			
	11.09-03.12		70	760	S6 008	77	780	S5 008	74	780	S4 008			
	11.11→	BWD	80	800	S6 011									
	01.12→		80	800	S6 011									
A4 Avant Allroad														
2.0 TFSI [8KH]	04.09-05.13	BWD				77	780	S5 008	60	780	S4 005			
		BWD,KZO,SSJ	70	760	S6 008									
		BWD,KZO,SSJ	105	950	S6 015									
TFSI flexible fuel [8KH]	03.12→	BWD				77	780	S5 008	60	780	S4 005			
		BWD,KZO,SSJ	70	760	S6 008									
		BWD,KZO,SSJ	105	950	S6 015									
Diesel														
2.0 TDI [8KH]	04.09→	BWD				77	780	S5 008	60	780	S4 005			
			70	760	S6 008	77	780	S5 008	74	780	S4 008			
		BWD,KZO,SSJ	70	760	S6 008									
		BWD,KZO,SSJ	105	950	S6 015									
	09.09→	BWD	95	850	S6 013	100	830	S5 013	95	830	S4 013			
		BWD,SSJ	105	950	S6 015									
	11.11→	BWD	80	800	S6 011									
3.0 TDI [8KH]	04.09→	BWD	95	850	S6 013	100	830	S5 013	74	830	S4 008			
	01.12→	BWD	80	800	S6 011									
A4 Cabriolet														
1.8 T [8HE; B7]	01.06-03.09		70	760	S6 008	77	780	S5 008	60	780	S4 005			
T, T quattro [8H7; B6]	04.02-06.06		70	760	S6 008	77	780	S5 008	60	780	S4 005	56	480	S3 005
2.0 TFSI [8HE; B7]	01.06-03.09		70	760	S6 008	77	780	S5 008	60	780	S4 005			
	08.06-03.09		70	760	S6 008	77	780	S5 008	60	780	S4 005	56	480	S3 005
2.0/2.4 [8H7; B6]	04.02-12.05		70	760	S6 008	77	780	S5 008	60	780	S4 005			
3.0/3.2/4.2 , FSI, FSI quattro, quattro [8HE; B7; 8H7; B6]	04.02-03.09		95	850	S6 013	100	830	S5 013	95	830	S4 013			

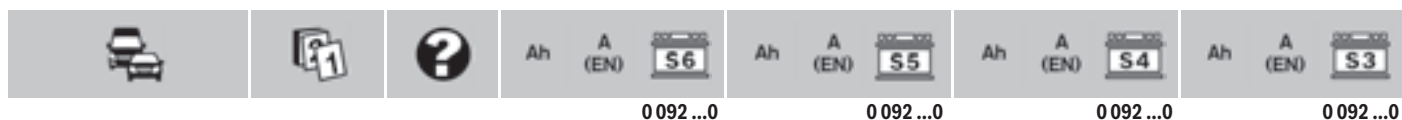



0 092 ...0

0 092 ...0

0 092 ...0

0 092 ...0

Diesel														
2.0 TDI [8HE; B7]	01.06-03.09		70	760	S6 008	77	780	S5 008	74	780	S4 008			
			70	760	S6 008	77	780	S5 008	80	780	S4 011			
			70	760	S6 008	85	800	S5 011	74	800	S4 008			
2.5 TDI [8H7; B6]	08.02-12.05		95	850	S6 013	100	830	S5 013	74	830	S4 008			
2.7 TDI [8HE; B7]	11.05-03.09		95	850	S6 013	100	830	S5 013	74	830	S4 008			
3.0 TDI quattro [8HE; B7]	01.06-03.09		95	850	S6 013	100	830	S5 013	74	830	S4 008	70	640	S3 008
A4 Sportback														
Diesel														
2.0 TDI quattro [8TA]	01.12→	BWD	80	800	S6 011									
A5 Cabriolet														
1.8 TFSI [8F7]	09.09→	BWD	70	760	S6 008	77	780	S5 008	74	780	S4 008			
	09.11→	BWD	80	800	S6 011									
2.0 TFSI [8F7]	03.09→	BWD				77	780	S5 008	74	780	S4 008			
			70	760	S6 008	77	780	S5 008	74	780	S4 008			
			BWD,KZO,SSJ	70	760	S6 008								
			BWD,KZO,SSJ	105	950	S6 015								
	05.09→		70	760	S6 008	77	780	S5 008	74	780	S4 008			
TFSI quattro [8F7]	03.09→	BWD				77	780	S5 008	74	780	S4 008			
			70	760	S6 008									
			105	950	S6 015									
3.0 FSI quattro [8F7]	11.11→	BWD	80	800	S6 011									
3.2 FSI [8F7]	03.09→	BWD	80	800	S6 011	77	780	S5 008	74	780	S4 008			
FSI quattro [8F7]	03.09→	BWD	80	800	S6 011	77	780	S5 008	74	780	S4 008			
Diesel														
2.0 TDI [8F7]	05.09→	BWD				77	780	S5 008	74	780	S4 008			
			70	760	S6 008	77	780	S5 008	74	780	S4 008			
			70	760	S6 008									
			105	950	S6 015									
	10.11→	BWD	80	800	S6 011									
TDI quattro [8F7]	01.12→		80	800	S6 011									
2.7 TDI [8F7]	03.09→	BWD	80	800	S6 011	77	780	S5 008	74	780	S4 008			
3.0 TDI [8F7]	09.11→	BWD	80	800	S6 011									
TDI quattro [8F7]	03.09→	BWD	95	850	S6 013	110	920	S5 015	95	920	S4 013			
	10.11→	BWD	80	800	S6 011									
A5 Coupé														
1.8 TFSI [8T3]	10.07-11.08	BWD				110	920	S5 015		920				
	05.09-09.11	BWD	70	760	S6 008	77	780	S5 008	74	780	S4 008			
2.0 TFSI [8T3]	06.08→	BWD				77	780	S5 008	74	780	S4 008			
			70	760	S6 008									
			105	950	S6 015									
TFSI quattro [8T3]	06.08-05.13	BWD				77	780	S5 008	74	780	S4 008			
			70	760	S6 008									
			105	950	S6 015									
3.0 TFSI quattro [8T3]	12.11→	BWD	80	800	S6 011									
3.2 FSI [8T3]	06.07-03.12	BWD	95	850	S6 013	110	920	S5 015	95	920	S4 013			
FSI quattro [8T3]	11.07-03.12	BWD				110	920	S5 015		920				
Diesel														
2.0 TDI [8T3]	01.08-03.12	BWD				77	780	S5 008	74	780	S4 008			
			70	760	S6 008	77	780	S5 008	74	780	S4 008			
			70	760	S6 008									
			105	950	S6 015									
	08.11→	BWD	80	800	S6 011									
TDI quattro [8T3]	08.08-03.12	BWD				77	780	S5 008	74	780	S4 008			
			70	760	S6 008									
			105	950	S6 015									
	08.11→	BWD	80	800	S6 011									
2.7 TDI [8T3]	07.07-05.08	BWD				110	920	S5 015		920				
	09.07-03.12	BWD	80	800	S6 011	85	800	S5 010	80	800	S4 010			
	06.08-03.12		95	850	S6 013	110	920	S5 015		920				
3.0 TDI [8T3]	10.11→	BWD	80	800	S6 011									
TDI quattro [8T3]	06.07-05.08	BWD				110	920	S5 015		920				
	03.08-05.10	BWD	95	850	S6 013	110	920	S5 015	95	920	S4 013			







				Ah A (EN) S6	Ah A (EN) S5	Ah A (EN) S4	Ah A (EN) S3							
				0092 ...0	0092 ...0	0092 ...0	0092 ...0							
◀ AUDI														
3.0 TDI quattro [8T3]	03.08-03.12		95	850	S6 013	110	920	S5 015	920					
	08.11→	BWD	80	800	S6 011									
A5 Sportback														
1.8 TFSI [8TA]	11.09-09.11	BWD	70	760	S6 008	77	780	S5 008	74	780	S4 008			
	08.11→	BWD	80	800	S6 011									
2.0 TFSI [8TA]	09.09→	BWD				77	780	S5 008	74	780	S4 008			
		BWD,KZO,SSJ	70	760	S6 008									
		BWD,KZO,SSJ	105	950	S6 015									
TFSI quattro [8TA]	09.09-05.13	BWD				77	780	S5 008	74	780	S4 008			
		BWD,KZO,SSJ	70	760	S6 008									
		BWD,KZO,SSJ	105	950	S6 015									
3.0 TFSI quattro [8TA]	12.11→	BWD	80	800	S6 011									
3.2 FSI quattro [8TA]	09.09-03.12	BWD	80	800	S6 011	85	800	S5 010	80	800	S4 010			
Diesel														
2.0 TDI [8TA]	09.09-03.12	BWD				77	780	S5 008	74	780	S4 008			
						110	920	S5 015	80	920	S4 010			
			70	760	S6 008	77	780	S5 008	74	780	S4 008			
		BWD,KZO,SSJ	70	760	S6 008									
		BWD,KZO,SSJ	105	950	S6 015									
		BWD,SSJ	70	760	S6 008									
	08.11→	BWD	80	800	S6 011									
	11.11→					85	800	S5 011	80	800	S4 011			
TDI quattro [8TA]	09.09-03.12	BWD				77	780	S5 008	74	780	S4 008			
		BWD,KZO,SSJ	70	760	S6 008									
		BWD,KZO,SSJ	105	950	S6 015									
2.7 TDI [8TA]	09.09-03.12	BWD	80	800	S6 011	77	780	S5 008	74	780	S4 008			
			80	800	S6 011	85	800	S5 010	80	800	S4 010			
3.0 TDI [8TA]	10.11→	BWD	80	800	S6 011									
TDI quattro [8TA]	09.09-03.12	BWD	95	850	S6 013	110	920	S5 015	95	920	S4 013			
	08.11→	BWD	80	800	S6 011									
A6														
1.8 [4A2; C4]	06.94-10.97	VAD	70	760	S6 008	77	780	S5 008	60	780	S4 005	45	400	S3 002
[4B2; C5]	05.97-04.01	VAD	70	760	S6 008	77	780	S5 008	60	780	S4 005	45	400	S3 002
quattro [4A2; C4]	10.95-10.97	VAD	70	760	S6 008	77	780	S5 008	60	780	S4 005	45	400	S3 002
T [4B2; C5]	04.97-05.99		70	760	S6 008	100	830	S5 013	74	830	S4 008	70	640	S3 008
	11.97-04.01	VAD	70	760	S6 008	100	830	S5 013	74	830	S4 008	70	640	S3 008
T quattro [4B2; C5]	04.97-01.99		70	760	S6 008	100	830	S5 013	74	830	S4 008	70	640	S3 008
	06.97-05.01	VAD	70	760	S6 008	100	830	S5 013	74	830	S4 008	70	640	S3 008
	05.00-05.04		70	760	S6 008	100	830	S5 013	74	830	S4 008			
2.0 [4A2; C4]	06.94-10.97					85	800	S5 011	80	800	S4 011			
		VAD	70	760	S6 008	77	780	S5 008	60	780	S4 005	45	400	S3 002
[4B2; C5]	06.01-05.04	VAD	70	760	S6 008	77	780	S5 008	60	780	S4 005			
FSI [4G2; C7]	03.11→		80	800	S6 011									
	05.11→	BWD	80	800	S6 011									
quattro [4A2; C4]	06.94-10.97					85	800	S5 011	80	800	S4 011			
		VAD	70	760	S6 008	100	830	S5 013	74	830	S4 008	70	640	S3 008
TFSI [4F2; C6]	06.05→	BWD,VAD	95	850	S6 013	100	830	S5 013	74	830	S4 008	70	640	S3 008
	01.07→		95	850	S6 013	100	830	S5 013	74	830	S4 008	70	640	S3 008
TFSI Hybrid [4G2; C7]	11.11→	BWD	80	800	S6 011									
2.3 [4A2; C4]	06.94-10.97					85	800	S5 011	80	800	S4 011			
		VAD	70	760	S6 008	100	830	S5 013	74	830	S4 008	70	640	S3 008
quattro [4A2; C4]	08.94-07.95					85	800	S5 011	80	800	S4 011			
		VAD	70	760	S6 008	100	830	S5 013	74	830	S4 008	70	640	S3 008
2.4 [4A2; C4]	07.95-10.97					85	800	S5 011	80	800	S4 011			
		VAD	70	760	S6 008	100	830	S5 013	74	830	S4 008	70	640	S3 008
[4B2; C5]	04.97-04.01		70	760	S6 008	100	830	S5 013	74	830	S4 008	70	640	S3 008
	06.01-05.04		70	760	S6 008	100	830	S5 013	74	830	S4 008			
quattro [4B2; C5]	04.97-09.01	VAD	70	760	S6 008	100	830	S5 013	74	830	S4 008	70	640	S3 008
	06.00-05.04		70	760	S6 008	100	830	S5 013	74	830	S4 008			
2.4/ 3.0 [4F2; C6]	04.04-10.08	BWD	95	850	S6 013	100	830	S5 013	80	830	S4 010			
2.4/ 3.0/ 4.2 quattro [4F2; C6]	04.04-10.08	BWD	95	850	S6 013	100	830	S5 013	80	830	S4 010			

						Ah A (EN) S6		Ah A (EN) S5		Ah A (EN) S4		Ah A (EN) S3	
				0 092 ...0		0 092 ...0		0 092 ...0		0 092 ...0		0 092 ...0	
2.6	[4A2; C4]	06.94-10.97				85	800	S5 011	80	800	S4 011		
		VAD	70	760	S6 008	100	830	S5 013	74	830	S4 008	70	640 S3 008
	quattro [4A2; C4]	06.94-10.97				85	800	S5 011	80	800	S4 011		
		VAD	70	760	S6 008	100	830	S5 013	74	830	S4 008	70	640 S3 008
2.7	Biturbo [4B2; C5]	02.99-05.01	VAD	70	760	S6 008	100	830	S5 013	74	830	S4 008	70 640 S3 008
	Biturbo quattro [4B2; C5]	10.97-08.00	VAD	70	760	S6 008	100	830	S5 013	74	830	S4 008	70 640 S3 008
		09.00-05.04		70	760	S6 008	100	830	S5 013	74	830	S4 008	
2.8	[4A2; C4]	06.94-10.97				85	800	S5 011	80	800	S4 011		
		VAD	70	760	S6 008	100	830	S5 013	74	830	S4 008	70	640 S3 008
	[4B2; C5]	04.97-07.98	VAD			85	800	S5 011	74	800	S4 008	70	640 S3 008
		06.97-04.01	VAD	70	760	S6 008	100	830	S5 013	74	830	S4 008	70 640 S3 008
	FSI [4F2; C6]	11.06-10.08	BWD	95	850	S6 013	100	830	S5 013	80	830	S4 010	
		10.08→	BWD				100	830	S5 013	95	830	S4 013	
	FSI [4G2; C7]	11.10→	BWD	80	800	S6 011							
	FSI quattro [4F2; C6]	11.06-10.08	BWD	95	850	S6 013	100	830	S5 013	80	830	S4 010	
	FSI quattro [4F2; C6]	10.08→	BWD				100	830	S5 013	95	830	S4 013	
	FSI quattro [4G2; C7]	11.10→	BWD	70	760	S6 008							
			BWD,KZO,SSJ	80	800	S6 011							
			BWD,KZO,SSJ	105	950	S6 015							
	quattro [4A2; C4]	06.94-10.97				85	800	S5 011	80	800	S4 011		
		VAD	70	760	S6 008	100	830	S5 013	74	830	S4 008	70	640 S3 008
	quattro [4B2; C5]	04.97-05.01		70	760	S6 008	100	830	S5 013	74	830	S4 008	70 640 S3 008
		07.99-05.01				100	830	S5 013	95	830	S4 013		
3.0	[4B2; C5]	06.01-05.04		70	760	S6 008	100	830	S5 013	74	830	S4 008	
	quattro [4B2; C5]	06.01-05.04		70	760	S6 008	100	830	S5 013	74	830	S4 008	
	TFSI quattro [4F2; C6]	10.08→	BWD	80	800	S6 011	85	800	S5 010	80	800	S4 010	
				95	850	S6 013	100	830	S5 013	74	830	S4 008	
	TFSI quattro [4G2; C7]	11.10→	BWD,KZO,SSJ	70	760	S6 008							
			BWD,KZO,SSJ	105	950	S6 015							
		11.11→	BWD	80	800	S6 011							
3.2	FSI [4F2; C6]	04.04-10.08	BWD	95	850	S6 013	100	830	S5 013	80	830	S4 010	
		06.06-05.09		95	850	S6 013	100	830	S5 013	80	830	S4 010	
		03.09→	BWD	95	850	S6 013	100	830	S5 013	74	830	S4 008	
	FSI quattro [4F2; C6]	04.04-10.08	BWD	95	850	S6 013	100	830	S5 013	80	830	S4 010	
4.2	FSI quattro [4F2; C6]	06.06→	BWD	95	850	S6 013			80		S4 010		
	quattro [4B4; C5]	04.99-05.04		70	760	S6 008	100	830	S5 013	74	830	S4 008	
Diesel													
1.9	TDI [4A2; C4]	06.94-10.97				85	800	S5 011	80	800	S4 011		
		VAD	70	760	S6 008	100	830	S5 013	74	830	S4 008	70	640 S3 008
	TDI [4B2; C5]	04.97-04.01		70	760	S6 008	85	800	S5 011	74	800	S4 008	70 640 S3 008
				70	760	S6 008	100	830	S5 013	74	830	S4 008	70 640 S3 008
		08.99-10.00		70	760	S6 008	85	800	S5 011	80	800	S4 011	70 640 S3 008
				70	760	S6 008	100	830	S5 013	80	830	S4 011	70 640 S3 008
		06.01-05.04		95	850	S6 013	100	830	S5 013	74	830	S4 008	
2.0	TDI [4F2; C6]	07.04-06.08	BWD	95	850	S6 013	100	830	S5 013	80	830	S4 010	
		10.08→	BWD				100	830	S5 013	95	830	S4 013	
	TDI [4G2; C7]	02.11→	BWD	80	800	S6 011							
		01.12→		80	800	S6 011							
	TDI e [4F2; C6]	10.08→	BWD	95	850	S6 013	100	830	S5 013	80	830	S4 010	
2.5	TDI [4A2; C4]	06.94-10.97				85	800	S5 011	80	800	S4 011		
		VAD	95	850	S6 013	100	830	S5 013	74	830	S4 008	70	640 S3 008
	TDI [4B2; C5]	04.97-08.03	VAD	95	850	S6 013	100	830	S5 013	74	830	S4 008	70 640 S3 008
		06.01-05.04	VAD	95	850	S6 013	100	830	S5 013	74	830	S4 008	
	TDI quattro [4A2; C4]	07.95-10.97				85	800	S5 011	80	800	S4 011		
		VAD	95	850	S6 013	100	830	S5 013	74	830	S4 008		
	TDI quattro [4B2; C5]	07.97-08.03	VAD	95	850	S6 013	100	830	S5 013	74	830	S4 008	70 640 S3 008
		02.03-05.04		95	850	S6 013	100	830	S5 013	74	830	S4 008	
2.7	TDI [4F2; C6]	11.04-05.09	BWD	95	850	S6 013	100	830	S5 013	80	830	S4 010	
		10.08→	BWD				100	830	S5 013	95	830	S4 013	
	TDI quattro [4F2; C6]	06.05→	BWD	95	850	S6 013	100	830	S5 013	80	830	S4 010	
		10.08→	BWD				100	830	S5 013	95	830	S4 013	



				Ah A (EN) S6	Ah A (EN) S5	Ah A (EN) S4	Ah A (EN) S3
				0092 ...0	0092 ...0	0092 ...0	0092 ...0
◀ AUDI							
3.0 TDI [4G2; C7]	11.10→	BWD	80	800	S6 011		
TDI quattro [4F2; C6]	04.04→	BWD	95	850	S6 013	100 830	S5 013 80 830 S4 010
	10.08→	BWD				100 830	S5 013 95 830 S4 013
TDI quattro [4G2; C7]	11.10→	BWD, KZO, SSJ	70	760	S6 008		
		BWD, KZO, SSJ	105	950	S6 015		
	02.11→	BWD	80	800	S6 011		
	04.12→	KZO, SSJ	70	760	S6 008		
		KZO, SSJ	105	950	S6 015		
A6 Avant							
1.8 [4A5; C4]	10.95-10.97	VAD	70	760	S6 008	77 780	S5 008 60 780 S4 005 45 400 S3 002
[4B5; C5]	02.98-04.01		70	760	S6 008	77 780	S5 008 60 780 S4 005 45 400 S3 002
	01.99-04.01	VAD	70	760	S6 008	77 780	S5 008 60 780 S4 005 45 400 S3 002
quattro [4A5; C4]	07.96-10.97	VAD	70	760	S6 008	77 780	S5 008 60 780 S4 005 45 400 S3 002
T [4B5; C5]	02.98-04.01	VAD	70	760	S6 008	100 830	S5 013 74 830 S4 008 70 640 S3 008
	05.00-04.01		70	760	S6 008	100 830	S5 013 74 830 S4 008
T quattro [4B5; C5]	02.98-05.01	VAD	70	760	S6 008	100 830	S5 013 74 830 S4 008 70 640 S3 008
	05.00-01.05		70	760	S6 008	100 830	S5 013 74 830 S4 008
2.0 [4A5; C4]	06.94-10.97	VAD	70	760	S6 008	77 780	S5 008 60 780 S4 005 45 400 S3 002
	07.96-10.97					85 800	S5 011 80 800 S4 011
[4B5; C5]	06.01-01.05		70	760	S6 008	77 780	S5 008 60 780 S4 005
quattro [4A5; C4]	06.94-10.97					85 800	S5 011 80 800 S4 011
		VAD	70	760	S6 008	100 830	S5 013 74 830 S4 008 70 640 S3 008
TFSI [4F5; C6]	06.05→	BWD	95	850	S6 013	100 830	S5 013 74 830 S4 008 70 640 S3 008
2.0/2.8/3.0 FSI, FSI quattro, TFSI quattro [4G5; C7]	05.11→	BWD	80	800	S6 011		
2.3 [4A5; C4]	06.94-06.96					85 800	S5 011 80 800 S4 011
		VAD	70	760	S6 008	100 830	S5 013 74 830 S4 008 70 640 S3 008
quattro [4A5; C4]	08.94-06.95					85 800	S5 011 80 800 S4 011
		VAD	70	760	S6 008	100 830	S5 013 74 830 S4 008 70 640 S3 008
2.4 [4A5; C4]	07.96-10.97		70	760	S6 008	85 800	S5 011 74 800 S4 008 70 640 S3 008
			70	760	S6 008	85 800	S5 011 80 800 S4 011 70 640 S3 008
			70	760	S6 008	100 830	S5 013 80 830 S4 011 70 640 S3 008
[4B5; C5]	04.97-04.01		70	760	S6 008	100 830	S5 013 74 830 S4 008 70 640 S3 008
	02.98-04.01	VAD	70	760	S6 008	100 830	S5 013 74 830 S4 008 70 640 S3 008
	06.00-04.01		70	760	S6 008	100 830	S5 013 74 830 S4 008
	06.01-01.05		70	760	S6 008	100 830	S5 013 74 830 S4 008
[4B5; C5]	06.00-04.01		70	760	S6 008	100 830	S5 013 74 830 S4 008
[4F5; C6]	03.05-10.08	BWD	95	850	S6 013	100 830	S5 013 80 830 S4 010
quattro [4B5; C5]	04.97-06.99		70	760	S6 008	100 830	S5 013 74 830 S4 008 70 640 S3 008
	08.98-05.01	VAD	70	760	S6 008	100 830	S5 013 74 830 S4 008 70 640 S3 008
	06.00-01.05		70	760	S6 008	100 830	S5 013 74 830 S4 008
2.4/3.0/4.2 quattro [4F5; C6]	03.05-10.08	BWD	95	850	S6 013	100 830	S5 013 80 830 S4 010
2.6 [4A5; C4]	06.94-07.96					85 800	S5 011 80 800 S4 011
		VAD	70	760	S6 008	100 830	S5 013 74 830 S4 008 70 640 S3 008
quattro [4A5; C4]	06.94-10.97					85 800	S5 011 80 800 S4 011
		VAD	70	760	S6 008	100 830	S5 013 74 830 S4 008 70 640 S3 008
2.7 Biturbo [4B5; C5]	02.99-05.01		70	760	S6 008	100 830	S5 013 74 830 S4 008
Biturbo quattro [4B5; C5]	02.99-08.00		70	760	S6 008	100 830	S5 013 74 830 S4 008 70 640 S3 008
	09.00-01.05		70	760	S6 008	100 830	S5 013 74 830 S4 008
2.8 [4A5; C4]	06.94-10.97					85 800	S5 011 80 800 S4 011
		VAD	70	760	S6 008	100 830	S5 013 74 830 S4 008 70 640 S3 008
[4B5; C5]	02.98-04.01		70	760	S6 008	100 830	S5 013 74 830 S4 008 70 640 S3 008
FSI [4F5; C6]	11.06-10.08	BWD	95	850	S6 013	100 830	S5 013 80 830 S4 010
	10.08→						80 S4 011
		BWD	95	850	S6 013		80 S4 010
FSI quattro [4F5; C6]	11.06-10.08	BWD	95	850	S6 013	100 830	S5 013 80 830 S4 010
FSI quattro [4F5; C6]	10.08→						80 S4 011
		BWD	95	850	S6 013		80 S4 010
quattro [4A5; C4]	06.94-12.98					85 800	S5 011 80 800 S4 011
		VAD	70	760	S6 008	100 830	S5 013 74 830 S4 008 70 640 S3 008
quattro [4B5; C5]	02.98-05.01		70	760	S6 008	100 830	S5 013 74 830 S4 008 70 640 S3 008

						Ah A (EN) S6		Ah A (EN) S5		Ah A (EN) S4		Ah A (EN) S3	
				0 092 ...0		0 092 ...0		0 092 ...0		0 092 ...0			
3.0	[4B5; C5]	06.01-01.05		70	760	S6 008	100	830	S5 013	74	830	S4 008	
	[4F5; C6]	03.05-05.06								80		S4 011	
			BWD	95	850	S6 013				80		S4 010	
	quattro [4B5; C5]	06.01-01.05		70	760	S6 008	100	830	S5 013	74	830	S4 008	
	TFSI quattro [4F5; C6]	10.08→								80		S4 011	
			BWD	80	800	S6 011	85	800	S5 010	80	800	S4 010	
3.2	FSI [4F5; C6]	03.05-10.08	BWD	95	850	S6 013	100	830	S5 013	80	830	S4 010	
	FSI quattro [4F5; C6]	03.05-10.08	BWD	95	850	S6 013	100	830	S5 013	80	830	S4 010	
4.2	FSI quattro [4F5; C6]	06.06→	BWD	95	850	S6 013				80		S4 010	
	quattro [4B; C5; 4B6; C5]	04.99-01.05		70	760	S6 008	100	830	S5 013	74	830	S4 008	
Diesel													
1.9	TDI [4A5; C4]	07.94-10.97						85	800	S5 011	80	800	S4 011
			VAD	95	850	S6 013	100	830	S5 013	74	830	S4 008	70 640 S3 008
	TDI [4B5; C5]	02.98-04.01						85	800	S5 011	80	800	S4 011
			VAD	95	850	S6 013	100	830	S5 013	74	830	S4 008	70 640 S3 008
		06.01-01.05		95	850	S6 013	100	830	S5 013	74	830	S4 008	
2.0	TDI [4F5; C6]	06.05-11.05		95	850	S6 013	100	830	S5 013	80	830	S4 010	
		06.05-10.08	BWD	95	850	S6 013	100	830	S5 013	80	830	S4 010	
		11.08→	BWD	95	850	S6 013				80		S4 010	
	TDI [4G5; C7]	05.11→	BWD	80	800	S6 011							
		01.12→		80	800	S6 011							
	TDI e [4F5; C6]	10.08→	BWD	95	850	S6 013	100	830	S5 013	80	830	S4 010	
2.5	TDI [4A5; C4]	06.94-10.97						85	800	S5 011	80	800	S4 011
			VAD	95	850	S6 013	100	830	S5 013	74	830	S4 008	70 640 S3 008
	TDI [4B5; C5]	02.98-01.05	VAD	95	850	S6 013	100	830	S5 013	74	830	S4 008	
		10.99-01.05	VAD	95	850	S6 013	85	800	S5 011	74	800	S4 008	
	TDI quattro [4A5; C4]	07.96-10.97						85	800	S5 011	80	800	S4 011
			VAD	95	850	S6 013	100	830	S5 013	74	830	S4 008	70 640 S3 008
	TDI quattro [4B5; C5]	02.98-08.03	VAD	95	850	S6 013	100	830	S5 013	74	830	S4 008	70 640 S3 008
		02.03-01.05	VAD	95	850	S6 013	100	830	S5 013	74	830	S4 008	
2.7	TDI [4F5; C6]	03.05-05.09	BWD	95	850	S6 013	100	830	S5 013	80	830	S4 010	
		10.08→	BWD	95	850	S6 013				80		S4 010	
	TDI quattro [4F5; C6]	06.05→	BWD	95	850	S6 013	100	830	S5 013	80	830	S4 010	
		10.08→	BWD	95	850	S6 013				80		S4 010	
3.0	TDI [4G5; C7]	05.11→	BWD	95	850	S6 013							
	TDI quattro [4F5; C6]	03.05→	BWD	95	850	S6 013	100	830	S5 013	80	830	S4 010	
		10.08→	BWD	95	850	S6 013				80		S4 010	
	TDI quattro [4G5; C7]	12.11→	BWD	80	800	S6 011							
		04.12→		95	850	S6 013							
A6 Avant Allroad													
2.7/4.2, T	[4BH; C5]	05.00-08.05		95	850	S6 013	100	830	S5 013	74	830	S4 008	70 640 S3 008
3.0	TFSI [4FH; C6]	10.08-08.11	BWD	95	850	S6 013	100	830	S5 013	74	830	S4 008	
	TFSI [4GH; C7]	01.12→		80	800	S6 011							
3.2	FSI [4FH; C6]	05.06-10.08	BWD	95	850	S6 013				95		S4 013	
4.2	FSI [4FH; C6]	05.06-12.10	BWD	95	850	S6 013				80		S4 010	
Diesel													
2.5	TDI [4BH; C5]	05.00-08.05						85	800	S5 011	74	800	S4 008
		06.03-08.05		95	850	S6 013	100	830	S5 013	74	830	S4 008	70 640 S3 008
2.7	TDI [4FH; C6]	05.06-10.08	BWD	95	850	S6 013				95		S4 013	
		10.08-08.11	BWD	95	850	S6 013	100	830	S5 013	74	830	S4 008	
				95	850	S6 013	100	830	S5 013	95	830	S4 013	90 720 S3 013
3.0	TDI [4FH; C6]	05.06-10.08	BWD	95	850	S6 013				95		S4 013	
		10.08-08.11	BWD	95	850	S6 013	100	830	S5 013	74	830	S4 008	
				95	850	S6 013	100	830	S5 013	95	830	S4 013	90 720 S3 013
	TDI [4GH; C7]	01.12→		80	800	S6 011							
				95	850	S6 013							
A7 Sportback													
2.8	FSI [4GA]	02.11→	BWD	80	800	S6 011							
	FSI quattro [4GA]	10.10→	BWD							80		S4 010	
			BWD, KZO, SSJ	70	760	S6 008							
			BWD, KZO, SSJ	105	950	S6 015							



		Ah A (EN) S6			Ah A (EN) S5			Ah A (EN) S4			Ah A (EN) S3		
		0092 ...0			0092 ...0			0092 ...0			0092 ...0		
◀ AUDI													
3.0 TFSI quattro [4GA]	07.10→	BWD					80			S4 010			
		BWD,KZØ,SSJ	70	760	S6 008								
		BWD,KZO,SSJ	105	950	S6 015								
	01.11→	BWD	70	760	S6 008	110	920	S5 015	80	920	S4 010		
		BWD,SSJ	70	760	S6 008								
4.0 TFSI quattro [4GA]	04.12→		95	850	S6 013								
Diesel													
3.0 TDI [4GA]	11.10→	BWD	95	850	S6 013								
TDI quattro [4GA]	07.10→	BWD						80		S4 010			
		BWD,KZØ,SSJ	70	760	S6 008								
		BWD,KZO,SSJ	105	950	S6 015								
	12.10→	BWD	95	850	S6 013								
	11.11→					85	800	S5 011	80	800	S4 011		
A8													
2.0 TFSI Hybrid [4H; D4]	02.12→		95	850	S6 013								
2.8 [4D2; D2]	06.94-03.96		95	850	S6 013	100	830	S5 013	74	830	S4 008	70 640 S3 008	
	06.94-12.98		70	760	S6 008	100	830	S5 013	74	830	S4 008	70 640 S3 008	
	10.97-09.02		95	850	S6 013	100	830	S5 013	74	830	S4 008	70 640 S3 008	
FSI [4E; D3]	09.07-07.10		95	850	S6 013	110	920	S5 015	95	920	S4 013		
	01.09-07.10		95	850	S6 013	110	920	S5 015		920			
quattro [4D2; D2]	09.94-04.99		95	850	S6 013	100	830	S5 013	74	830	S4 008	70 640 S3 008	
	05.00-09.02		95	850	S6 013	100	830	S5 013	74	830	S4 008	70 640 S3 008	
3.0 [4E; D3]	07.03-05.06		95	850	S6 013	110	920	S5 015	95	920	S4 013		
quattro [4E; D3]	11.03-05.06	BWD	95	850	S6 013	110	920	S5 015	95	920	S4 013		
TFSI quattro [H4; D4]	11.11→	BWD	95	850	S6 013								
TFSI quattro [4H; D4]	06.10→	BWD	95	850	S6 013								
	03.12→		95	850	S6 013								
3.2 FSI [4E; D3]	06.05-07.10		95	850	S6 013	110	920	S5 015	95	920	S4 013		
3.2/ 4.2 FSI quattro [4E; D3]	06.05-07.10		95	850	S6 013	110	920	S5 015	95	920	S4 013		
3.7 [4D2; D2]	07.95-09.02		95	850	S6 013	110	920	S5 015	95	920	S4 013	90 720 S3 013	
3.7/ 4.2 quattro [4D2; D2]	06.94-08.03		95	850	S6 013	110	920	S5 015	95	920	S4 013	90 720 S3 013	
3.7/ 4.2/ 6.0 quattro [4E; D3]	11.02-07.10		95	850	S6 013	110	920	S5 015	95	920	S4 013		
4.0 FSI quattro [4H; D4]	05.12→		95	850	S6 013								
4.2/ 6.3 FSI quattro [4H; D4]	11.09→	BWD	95	850	S6 013								
6.0 quattro [4D2; D2]	03.01-08.02		95	850	S6 013	110	920	S5 015	95	920	S4 013		
Diesel													
2.5/ 3.3 TDI, TDI quattro [4D2; D2]	06.97-09.02		95	850	S6 013	110	920	S5 015	95	920	S4 013	90 720 S3 013	
3.0 TDI quattro [4H; D4]	07.10→	BWD				100	830	S5 013	95	830	S4 013		
		BWD,KZØ,SSJ	95	850	S6 013								
		BWD,KZO,SSJ	105	950	S6 015								
	08.10→	BWD	95	850	S6 013								
	03.12→					100	830	S5 013	95	830	S4 013		
		KZO,SSJ	95	850	S6 013								
		KZO,SSJ	105	950	S6 015								
3.0/ 4.0/ 4.2 TDI quattro [4E; D3]	05.03-07.10		95	850	S6 013	110	920	S5 015	95	920	S4 013		
4.2 TDI quattro [4H; D4]	11.09→	BWD	95	850	S6 013								
Cabriolet													
1.8/ 2.0/ 2.3/ 2.6/ 2.8 [8G7; B4]	06.91-08.00	VAD				74	750	S5 007	72	750	S4 007	70 640 S3 007	
Diesel													
1.9 TDI [8G7; B4]	07.95-08.00	VAD				74	750	S5 007	72	750	S4 007	70 640 S3 007	
Coupé													
1.8 GT [85; B2]	09.82-07.88	VAD				74	750	S5 007	60	750	S4 004		
		VAD,XXX									53 470	S3 004	
2.0 [89; B3]	05.89-07.91	VAD				74	750	S5 007	60	750	S4 004		
		VAD,XXX									53 470	S3 004	
	09.91-12.95	VAD				74	750	S5 007	60	750	S4 004		
		VAD,XXX									53 470	S3 004	
GT [85; B2]	08.83-07.86	VAD				74	750	S5 007	60	750	S4 004		
		VAD,XXX									53 470	S3 004	

				Ah	A (EN)		Ah	A (EN)		Ah	A (EN)		Ah	A (EN)	
				0 092 ...0			0 092 ...0			0 092 ...0			0 092 ...0		
2.0 GT 5E [85; B2]	09.83-07.88	VAD		74	750	S5 007	60	750	S4 004						
		VAD,XXX											53	470	S3 004
2.2 [89; B3]	11.88-07.91	VAD		74	750	S5 007	60	750	S4 004						
		VAD,XXX											53	470	S3 004
GT [85; B2]	01.84-07.88	VAD		74	750	S5 007	60	750	S4 004						
		VAD,XXX											53	470	S3 004
S2 T quattro [89; B3]	10.92-12.95	VAD		74	750	S5 007	60	750	S4 004						
		VAD,XXX											53	470	S3 004
2.3 [89; B3]	11.88-07.94	VAD		74	750	S5 007	60	750	S4 004						
		VAD,XXX											53	470	S3 004
GT [85; B2]	08.86-07.88	VAD		74	750	S5 007	60	750	S4 004						
		VAD,XXX											53	470	S3 004
2.6 [89; B3]	08.92-12.95	VAD		74	750	S5 007	60	750	S4 004						
		VAD,XXX											53	470	S3 004
2.8 [89; B3]	09.91-12.95	VAD		74	750	S5 007	60	750	S4 004						
		VAD,XXX											53	470	S3 004
quattro [89; B3]	08.91-12.95	VAD		74	750	S5 007	60	750	S4 004						
		VAD,XXX											53	470	S3 004
Quattro															
2.2/ 2.3 Turbo, Turbo Sport [85; B2]	07.80-07.91	VAD		74	750	S5 007	72	750	S4 007	70	640				S3 007
Q3															
2.0 TFSI quattro [8UB]	06.11→	SSJ	70	760	S6 008										
Diesel															
2.0 TDI [8UB]	09.11→		70	760	S6 008										
		SSJ	70	760	S6 008										
TDI quattro [8UB]	06.11→		70	760	S6 008										
		SSJ	70	760	S6 008										
	01.12→		80	800	S6 011										
Q5															
2.0 TFSI Hybrid quattro [8RB]	06.11→	BWD,KZO,SSJ	70	760	S6 008										
		BWD,KZO,SSJ	105	950	S6 015										
TFSI quattro [8RB]	11.08-09.12	BWD				77	780	S5 008	74	780	S4 008				
		BWD,KZO,SSJ	70	760	S6 008										
		BWD,KZO,SSJ	105	950	S6 015										
	06.12→		70	760	S6 008										
TFSI quattro flexible fuel [8RB]	07.12→		70	760	S6 008										
3.0 TFSI quattro [8RB]	06.12→		80	800	S6 011										
3.2 FSI quattro [8RB]	11.08-09.12	BWD	80	800	S6 011	85	800	S5 010	80	800	S4 010				
Diesel															
2.0 TDI [8RB]	11.10→	BWD	70	760	S6 008										
		BWD,KZO,SSJ	70	760	S6 008										
		BWD,KZO,SSJ	105	950	S6 015										
TDI quattro [8RB]	11.08-09.12	BWD				110	920	S5 015	80	920	S4 010				
		BWD,SSJ	70	760	S6 008										
	11.08→	BWD				77	780	S5 008	74	780	S4 008				
		BWD,KZO,SSJ	70	760	S6 008										
		BWD,KZO,SSJ	105	950	S6 015										
	08.09→	BWD	80	800	S6 011	85	800	S5 010	80	800	S4 010				
	10.10-09.12					77	780	S5 008	74	780	S4 008				
		KZO,SSJ	70	760	S6 008										
		KZO,SSJ	105	950	S6 015										
	06.12→		80	800	S6 011										
3.0 TDI quattro [8RB]	11.08-09.12	BWD				100	830	S5 013	95	830	S4 013				
		BWD,SSJ	95	850	S6 013										
	06.12→		95	850	S6 013										
Q7															
3.0 TFSI [4LB]	05.10→		95	850	S6 013										
3.6/ 4.2 FSI [4LB]	03.06-05.10	BWD	95	850	S6 013	110	920	S5 015	95	920	S4 013				
Diesel															
3.0 TDI [4LB]	03.06-05.11		95	850	S6 013	110	920	S5 015	95	920	S4 013				
	08.06-05.11	BWD	95	850	S6 013	110	920	S5 015	95	920	S4 013				



				Ah	A (EN)		Ah	A (EN)		Ah	A (EN)		Ah	A (EN)	
				0092 ...0			0092 ...0			0092 ...0			0092 ...0		
◀ AUDI															
3.0 TDI [4LB]	05.10→	KZO,SSJ	95	850	S6 013										
		KZO,SSJ	105	950	S6 015										
	05.12→		95	850	S6 013	110	920	S5 015	95	920	S4 013				
4.2 TDI [4LB]	03.07-06.09	BWD	95	850	S6 013	110	920	S5 015	95	920	S4 013				
	06.09→		95	850	S6 013	110	920	S5 015	95	920	S4 013				
6.0 TDI [4LB]	09.08→					110	920	S5 015		920					
RS3 Sportback															
2.5 TFSI quattro [8PA]	01.11→	BWD	80	800	S6 011										
RS4															
4.2 quattro [8EC; B7]	11.05-06.08		95	850	S6 013	110	920	S5 015		920					
RS4 Avant															
2.7 quattro [8D5; B5]	05.00-09.01					85	800	S5 011	74	800	S4 008	70	640	S3 008	
4.2 quattro [8ED; B7]	05.06-06.08		95	850	S6 013	110	920	S5 015		920					
quattro [8K5; B8]	05.12→		95	850	S6 013										
RS4 Cabriolet															
4.2 quattro [8HE; B7]	05.06-01.08		95	850	S6 013	110	920	S5 015		920					
RS5 Coupé															
4.2 FSI quattro [8T3]	03.10→	BWD	95	850	S6 013	110	920	S5 015		920					
RS6															
4.2 quattro [4B4]	07.02-04.04					110	920	S5 015		920					
5.0 TFSI quattro [4F2; C6]	09.08-08.10	BWD				110	920	S5 015		920					
RS6 Avant															
4.2 quattro [4B6]	05.02-09.04		95	850	S6 013	110	920	S5 015		920					
5.0 TFSI quattro [4F5; C6]	04.08-08.10	BWD				110	920	S5 015		920					
R8															
4.2 FSI quattro [423]	04.07-09.10					110	920	S5 015		920					
	09.10→					110	920	S5 015	95	920	S4 013				
5.2 FSI GT quattro [422]	11.10-10.12		95	850	S6 013										
FSI quattro [423]	04.09-07.12					110	920	S5 015	95	920	S4 013				
	09.12→		95	850	S6 013	110	920	S5 015		920					
R8 Spyder															
4.2/5.2 FSI quattro [429]	02.10→					110	920	S5 015	95	920	S4 013				
R8 Spyder GT															
5.2 FSI quattro [427]	11.11-10.12		95	850	S6 013	110	920	S5 015		920					
SQ5															
Diesel															
3.0 quattro [8RB]	12.12→		95	850	S6 013										
S3															
1.8 quattro [8L1]	08.98-06.03		70	760	S6 008	77	780	S5 008	74	780	S4 008	70	640	S3 008	
2.0 TFSI quattro [8P1]	11.06-06.08		70	760	S6 008	85	800	S5 011	74	800	S4 008	70	640	S3 008	
	07.08→	BWD	70	760	S6 008	85	800	S5 011	74	800	S4 008	70	640	S3 008	
FSI quattro [8V1]	11.12→		70	760	S6 008										
S3 Sportback															
2.0 TFSI quattro [8PA]	07.08→		70	760	S6 008	77	780	S5 008	74	780	S4 008				
TFSI quattro [8VA]	05.13→		70	760	S6 008										
S4															
2.2 quattro [4A2; C4]	07.92-07.94								44		S4 001				
		VAD				85	800	S5 010	72	800	S4 007	70	640	S3 007	
2.7 Biturbo quattro [8D2; B5]	10.97-10.00	VAD	70	760	S6 008	85	800	S5 010	72	800	S4 007	70	640	S3 007	
	10.97-09.01					85	800	S5 011	80	800	S4 011				
	11.00-09.01	VAD	70	760	S6 008	85	800	S5 010	72	800	S4 007				
3.0 TFSI quattro [8K2; B8]	03.09→	BWD	80	800	S6 011	85	800	S5 010	80	800	S4 010				
	05.09-03.12		80	800	S6 011	85	800	S5 010	80	800	S4 010				
4.2 quattro [4A2; C4]	07.92-07.94	VAD				74	750	S5 007	72	750	S4 007	70	640	S3 007	
quattro [8EC; B7; 8E2; B6]	03.03-06.08		95	850	S6 013	100	830	S5 013	95	830	S4 013				
S4 Avant															
2.2 quattro [4A5; C4]	07.92-07.94	VAD				85	800	S5 010	72	800	S4 007	70	640	S3 007	
2.7 Biturbo quattro [8D5; B5]	10.97-09.01					85	800	S5 011	80	800	S4 011				
		VAD	70	760	S6 008	85	800	S5 010	72	800	S4 007	70	640	S3 007	
quattro [8D5; B5]	06.00-08.02	VAD	70	760	S6 008	85	800	S5 010	72	800	S4 007				
3.0 TFSI quattro [8K5; B8]	03.09→	BWD	80	800	S6 011	85	800	S5 010	80	800	S4 010				

				Ah A (EN) S6	Ah A (EN) S5	Ah A (EN) S4	Ah A (EN) S3							
				0 092 ...0	0 092 ...0	0 092 ...0	0 092 ...0							
4.2 quattro [4A5; C4]	10.92-07.94	VAD		74	750	S5 007	72	750	S4 007	70	640	S3 007		
quattro [8ED; B7; 8E5; B6]	03.03-06.08		95	850	S6 013	100	830	S5 013	95	830	S4 013			
S4 Cabriolet														
4.2 quattro [8HE; B7]	01.06-03.09		95	850	S6 013	100	830	S5 013	95	830	S4 013			
quattro [8H7; B7]	02.04-12.05		95	850	S6 013	100	830	S5 013	95	830	S4 013	90	720	S3 013
S5 Cabriolet														
3.0 TFSI quattro [8F7]	05.09→	BWD	80	800	S6 011	77	780	S5 008	74	780	S4 008			
S5 Coupé														
3.0 TFSI quattro [8T3]	09.11→	BWD	80	800	S6 011									
4.2 quattro [8T3]	06.07→	BWD	95	850	S6 013	110	920	S5 015		920				
S5 Sportback														
3.0 TFSI quattro [8TA]	01.10→	BWD	80	800	S6 011	77	780	S5 008	74	780	S4 008			
S6														
4.0 TFSI quattro [4G2; C7]	04.12→		95	850	S6 013									
4.2 Plus quattro, quattro [4A2; C4]	09.94-10.97	VAD	95	850	S6 013	100	830	S5 013	95	830	S4 013	90	720	S3 013
quattro [4B4; C5]	09.99-05.04		95	850	S6 013	100	830	S5 013	95	830	S4 013			
5.2 FSI quattro [4F2; C6]	06.06-08.11	BWD				110	920	S5 015		920				
S6 Avant														
4.0 TFSI quattro [4G5; C7]	04.12→		95	850	S6 013									
4.2 Plus quattro, quattro [4A5; C4]	09.94-10.97	VAD	95	850	S6 013	100	830	S5 013	95	830	S4 013	90	720	S3 013
quattro [4B; C5; 4B6; C5]	09.99-01.05		95	850	S6 013	100	830	S5 013	95	830	S4 013			
5.2 FSI quattro [4F5; C6]	06.06→	BWD				110	920	S5 015		920				
S8														
4.0 FSI quattro [4H; D4]	04.12→		95	850	S6 013									
4.2 quattro [4D2]	09.96-12.98		70	760	S6 008	100	830	S5 013	74	830	S4 008	70	640	S3 008
			95	850	S6 013	100	830	S5 013	74	830	S4 008	70	640	S3 008
	05.99-09.02		95	850	S6 013	110	920	S5 015	95	920	S4 013	90	720	S3 013
	09.00-09.02		95	850	S6 013	110	920	S5 015	95	920	S4 013			
5.2 FSI quattro [4E2]	06.06-07.10	BWD				110	920	S5 015		920				
TT Coupé														
1.8 T [8N3]	07.98-09.00					63	610	S5 005	60	610	S4 005	56	480	S3 005
	09.00-06.06					63	610	S5 005	60	610	S4 005			
T quattro [8N3]	07.98-08.02					63	610	S5 005	60	610	S4 005	56	480	S3 005
	09.00-06.06					63	610	S5 005	60	610	S4 005			
TFSI [8J3]	06.08→					85	800	S5 010	80	800	S4 010			
2.0 TFSI [8J3]	07.06-06.10					85	800	S5 011	80	800	S4 010			
	06.09→	BWD				85	800	S5 010	80	800	S4 010			
TFSI quattro [8J3]	06.08-06.10					85	800	S5 011	80	800	S4 011			
	05.10→	BWD				85	800	S5 010	80	800	S4 010			
3.2 quattro [8J3]	07.06-06.10					85	800	S5 011	80	800	S4 010			
quattro [8N3]	07.03-06.06					63	610	S5 005	60	610	S4 005			
Diesel														
2.0 TDI quattro [8J3]	06.08-06.10					85	800	S5 010	80	800	S4 010			
	05.10→	BWD				85	800	S5 010	80	800	S4 010			
TT Roadster														
1.8 T [8N9]	04.99-06.06					63	610	S5 005	60	610	S4 005			
	01.01-06.06		70	760	S6 008	63	610	S5 005	60	610	S4 005			
	09.05-06.06					63	610	S5 005	52	610	S4 002			
			80	800	S6 011	63	610	S5 005		610				
			80	800	S6 011	70	650	S5 E08		650				
T quattro [8N9]	03.99-06.06		70	760	S6 008	63	610	S5 005	60	610	S4 005			
	07.99-05.05					63	610	S5 005	52	610	S4 002			
	09.05-06.06					63	610	S5 005	52	610	S4 002			
TFSI [8J9]	06.08→					85	800	S5 010	80	800	S4 010			
2.0 TFSI [8J9]	02.07-06.10		70	760	S6 008	85	800	S5 011	80	800	S4 010			
	05.10→	BWD				85	800	S5 010	80	800	S4 010			
TFSI Convertible quattro [8J9]	06.08-06.10					85	800	S5 011	80	800	S4 011			
TFSI quattro [8J9]	06.08-06.10					85	800	S5 011	80	800	S4 011			
	05.10→	BWD				85	800	S5 010	80	800	S4 010			

				Ah A (EN) S6	Ah A (EN) S5	Ah A (EN) S4	Ah A (EN) S3							
				0092 ...0	0092 ...0	0092 ...0	0092 ...0							
◀ AUDI														
3.2 quattro [8J9]	02.07-06.10		70	760	S6 008	85	800	S5 011	80	800	S4 010			
	03.07→					85	800	S5 011	80	800	S4 011			
quattro [8N9]	07.03-06.06		70	760	S6 008									
Diesel														
2.0 TDI quattro [8J9]	06.08-06.10					85	800	S5 010	80	800	S4 010			
	05.10→	BWD				85	800	S5 010	80	800	S4 010			
TT RS Coupé														
2.5 TFSI quattro [8J3]	07.09→	BWD				85	800	S5 010	80	800	S4 010			
	05.11→	BWD	80	800	S6 011									
TT RS Roadster														
2.5 TFSI quattro [8J9]	07.09→	BWD				85	800	S5 010	80	800	S4 010			
	03.12→		80	800	S6 011									
TTS Coupé														
2.0 TFSI quattro [8J3]	05.08→					85	800	S5 010	80	800	S4 010			
						85	800	S5 011	80	800	S4 010			
TTS Roadster														
2.0 TFSI quattro [8J9]	05.08→					85	800	S5 010	80	800	S4 010			
			70	760	S6 008	85	800	S5 011	80	800	S4 010			
V8														
3.6/4.2 quattro [44; 4C; D11]	10.88-11.93	VAD	95	850	S6 013	100	830	S5 013	95	830	S4 013	90	720	S3 013
80														
1.3/1.6 [81; 85; B2]	08.81-03.87	VAD				61	600	S5 004	44	600	S4 001	41	360	S3 001
1.4/1.6/1.8 [89; 8A2; B3]	08.86-12.91	VAD				61	600	S5 004	44	600	S4 001	41	360	S3 001
1.6 [8C2; B4]	01.92-08.94	VAD				61	600	S5 004	44	600	S4 001	41	360	S3 001
1.8 [81; 85; B2]	01.83-03.87	VAD				74	750	S5 007	60	750	S4 004			
		VAD,XXX										53	470	S3 004
	08.83-03.87								44		S4 001			
E [89; 8A2; B3]	09.86-12.91	VAD				74	750	S5 007	60	750	S4 004			
		VAD,XXX										53	470	S3 004
quattro [81; 85; B2]	08.84-08.86	VAD				74	750	S5 007	60	750	S4 004			
		VAD,XXX										53	470	S3 004
quattro [89; 8A2; B3]	09.86-09.91	VAD				74	750	S5 007	60	750	S4 004			
		VAD,XXX										53	470	S3 004
S [89; 8A2; B3]	08.86-12.91	VAD				74	750	S5 007	60	750	S4 004			
		VAD,XXX										53	470	S3 004
S quattro [89; 8A2; B3]	08.90-08.91	VAD				74	750	S5 007	60	750	S4 004			
		VAD,XXX										53	470	S3 004
1.9 E [89; 8A2; B3]	02.87-07.88	VAD				74	750	S5 007	60	750	S4 004			
		VAD,XXX										53	470	S3 004
quattro [89; 8A2; B3]	09.86-07.88	VAD				74	750	S5 007	60	750	S4 004			
		VAD,XXX										53	470	S3 004
2.0 [8C2; B4]	09.91-05.95	VAD				74	750	S5 007	60	750	S4 004			
		VAD,XXX										53	470	S3 004
[89; 8A2; B3]	03.90-12.91	VAD				74	750	S5 007	60	750	S4 004			
		VAD,XXX										53	470	S3 004
E [8C2; B4]	09.91-05.95	VAD				74	750	S5 007	60	750	S4 004			
		VAD,XXX										53	470	S3 004
E [89; 8A2; B3]	08.88-10.90								44		S4 001			
		VAD				74	750	S5 007	60	750	S4 004			
		VAD,XXX										53	470	S3 004
quattro [8C2; B4]	09.91-05.95	VAD				74	750	S5 007	60	750	S4 004			
		VAD,XXX										53	470	S3 004
quattro [89; 8A2; B3]	08.88-09.91	VAD				74	750	S5 007	60	750	S4 004			
		VAD,XXX										53	470	S3 004
16V quattro [89; 8A2; B3]	03.90-08.91	VAD				74	750	S5 007	60	750	S4 004			
		VAD,XXX										53	470	S3 004
2.2 S2 quattro [8C2; B4]	02.93-05.95	VAD				74	750	S5 007	60	750	S4 004			
		VAD,XXX										53	470	S3 004
2.3 [8C2; B4]	09.90-11.94	VAD				74	750	S5 007	60	750	S4 004			
		VAD,XXX										53	470	S3 004
quattro [8C2; B4]	09.91-11.94	VAD				74	750	S5 007	60	750	S4 004			
		VAD,XXX										53	470	S3 004

				Ah A (EN) S6	Ah A (EN) S5	Ah A (EN) S4	Ah A (EN) S3				
				0 092 ...0	0 092 ...0	0 092 ...0	0 092 ...0				
2.3 quattro [89; 8A2; B3]	04.87-08.91	VAD		74	750	S5 007	60	750	S4 004		
		VAD,XXX								53	470
											S3 004
2.6 E [8C2; B4]	07.92-05.95	VAD		74	750	S5 007	60	750	S4 004		
		VAD,XXX								53	470
											S3 004
quattro [8C2; B4]	07.92-05.95	VAD		74	750	S5 007	60	750	S4 004		
		VAD,XXX								53	470
											S3 004
2.8 E [8C2; B4]	09.91-05.95	VAD		74	750	S5 007	60	750	S4 004		
		VAD,XXX								53	470
											S3 004
quattro [8C2; B4]	09.91-05.95	VAD		74	750	S5 007	60	750	S4 004		
		VAD,XXX								53	470
											S3 004
Diesel											
1.6/ 1.9 D, TD, TDI [8C2; B4; 81; 85; B2; 89; 8A2; B3]	08.81-05.95	VAD		74	750	S5 007	72	750	S4 007	70	640
											S3 007
80 Avant											
1.6 [8C5; B4]	03.92-07.95	VAD		74	750	S5 007	60	750	S4 004		
		VAD,XXX								53	470
											S3 004
2.0 [8C5; B4]	08.92-07.95	VAD		74	750	S5 007	60	750	S4 004		
		VAD,XXX								53	470
											S3 004
E [8C5; B4]	08.92-07.95	VAD		74	750	S5 007	60	750	S4 004		
		VAD,XXX								53	470
											S3 004
2.2 RS2 quattro [8C5; B4]	03.94-07.95	VAD		74	750	S5 007	60	750	S4 004		
		VAD,XXX								53	470
											S3 004
S2 quattro [8C5; B4]	07.94-07.95	VAD		74	750	S5 007	60	750	S4 004		
		VAD,XXX								53	470
											S3 004
2.6 quattro [8C5; B4]	08.92-07.95	VAD		74	750	S5 007	60	750	S4 004		
		VAD,XXX								53	470
											S3 004
Diesel											
1.9 TD, TDI [8C5; B4]	08.92-07.95	VAD		74	750	S5 007	72	750	S4 007	70	640
											S3 007
90											
1.8 [81; 85; B2]	06.84-03.87	VAD		74	750	S5 007	60	750	S4 004		
		VAD,XXX								53	470
											S3 004
E [89; 8A2; B3]	08.89-12.91	VAD		74	750	S5 007	60	750	S4 004		
		VAD,XXX								53	470
											S3 004
2.0 [81; 85; B2]	10.84-03.87	VAD		74	750	S5 007	60	750	S4 004		
		VAD,XXX								53	470
											S3 004
[89; 8A2; B3]	05.87-12.91	VAD		74	750	S5 007	60	750	S4 004		
		VAD,XXX								53	470
											S3 004
quattro [89; 8A2; B3]	01.88-09.91	VAD		74	750	S5 007	60	750	S4 004		
		VAD,XXX								53	470
											S3 004
2.2 [81; 85; B2]	10.84-03.87	VAD		74	750	S5 007	60	750	S4 004		
		VAD,XXX								53	470
											S3 004
E [89; 8A2; B3]	04.87-12.91	VAD		74	750	S5 007	60	750	S4 004		
		VAD,XXX								53	470
											S3 004
quattro [81; 85; B2]	08.84-03.87	VAD		74	750	S5 007	60	750	S4 004		
		VAD,XXX								53	470
											S3 004
quattro [89; 8A2; B3]	04.87-09.91	VAD		74	750	S5 007	60	750	S4 004		
		VAD,XXX								53	470
											S3 004
2.3 [89; 8A2; B3]	08.88-12.91	VAD		74	750	S5 007	60	750	S4 004		
		VAD,XXX								53	470
											S3 004
E [89; 8A2; B3]	04.87-12.91	VAD		74	750	S5 007	60	750	S4 004		
		VAD,XXX								53	470
											S3 004
quattro [89; 8A2; B3]	04.87-09.91	VAD		74	750	S5 007	60	750	S4 004		
		VAD,XXX								53	470
											S3 004
2.8 [89; 8A2; B3]	01.92-05.95	VAD		74	750	S5 007	72	750	S4 007	70	640
											S3 007
Diesel											
1.6 TD [89; 8A2; B3]	07.87-12.91	VAD		74	750	S5 007	60	750	S4 004		
											S3 004
100											
1.6 [4A2; C4]	03.92-01.94	VAD		61	600	S5 004	60	600	S4 004	41	360
											S3 001
1.8 [44; 44Q; C3]	08.82-12.90	VAD		74	750	S5 007	60	750	S4 004	41	360
											S3 001
quattro [44; 44Q; C3]	08.85-11.90	VAD		74	750	S5 007	60	750	S4 004	41	360
											S3 001
2.0 [4A2; C4]	12.90-07.94	VAD		74	750	S5 007	60	750	S4 004		
		VAD,XXX								53	470
											S3 004

			0092 ...0			0092 ...0			0092 ...0			0092 ...0		
			Ah A (EN) S6			Ah A (EN) S5			Ah A (EN) S4			Ah A (EN) S3		
◀ AUDI														
2.0 [44; 44Q; C3]	08.84-12.90	VAD	74	750	S5 007	60	750	S4 004						
		VAD,XXX									53	470	S3 004	
quattro [4A2; C4]	12.90-07.94	VAD	85	800	S5 010	72	800	S4 007	70	640	S3 007			
2.2 [44; 44Q; C3]	08.84-12.90	VAD	74	750	S5 007	60	750	S4 004						
		VAD,XXX									53	470	S3 004	
quattro [44; 44Q; C3]	08.84-11.90	VAD	74	750	S5 007	60	750	S4 004						
		VAD,XXX									53	470	S3 004	
quattro Turbo [44; 44Q; C3]	03.86-11.90	VAD	74	750	S5 007	60	750	S4 004						
		VAD,XXX									53	470	S3 004	
turbo [44; 44Q; C3]	05.86-12.90	VAD	74	750	S5 007	60	750	S4 004						
		VAD,XXX									53	470	S3 004	
2.3 [4A2; C4]	12.90-07.94	VAD	85	800	S5 010	72	800	S4 007	70	640	S3 007			
[44; 44Q; C3]	10.86-12.90	VAD	74	750	S5 007	60	750	S4 004						
		VAD,XXX									53	470	S3 004	
quattro [4A2; C4]	12.90-07.94	VAD	74	750	S5 007	60	750	S4 004						
		VAD,XXX									53	470	S3 004	
quattro [44; 44Q; C3]	08.86-08.91	VAD	74	750	S5 007	60	750	S4 004						
		VAD,XXX									53	470	S3 004	
2.6 [4A2; C4]	04.92-07.94					44		S4 001						
		VAD	85	800	S5 010	72	800	S4 007	70	640	S3 007			
E [4A2; C4]	01.92-12.98	VAD	85	800	S5 010	72	800	S4 007	70	640	S3 007			
quattro [4A2; C4]	03.92-07.94					44		S4 001						
		VAD	85	800	S5 010	72	800	S4 007	70	640	S3 007			
2.8 [4A2; C4]	12.90-07.94					44		S4 001						
		VAD	85	800	S5 010	72	800	S4 007	70	640	S3 007			
quattro [4A2; C4]	12.90-07.94					44		S4 001						
		VAD	85	800	S5 010	72	800	S4 007	70	640	S3 007			
Diesel														
2.0/ 2.4/ 2.5 D, TD, TDI [44; 44Q; C3]	08.80-12.90	VAD	74	750	S5 007	72	750	S4 007	70	640	S3 007			
2.4/ 2.5 D, TDI [4A2; C4]	05.91-07.94	VAD	85	800	S5 010	72	800	S4 007	70	640	S3 007			
100 Avant														
1.6 [4A5; C4]	03.92-07.93	VAD	61	600	S5 004	60	600	S4 004	41	360	S3 001			
1.8 [44; 44Q; C3]	05.83-07.89	VAD	74	750	S5 007	60	750	S4 004	41	360	S3 001			
quattro [44; 44Q; C3]	10.84-11.90	VAD	74	750	S5 007	60	750	S4 004						
		VAD,XXX									53	470	S3 004	
2.0 [44; 44Q; C3]	08.86-12.90	VAD	74	750	S5 007	60	750	S4 004						
		VAD,XXX									53	470	S3 004	
2.0/ 2.3/ 2.6/ 2.8 [4A5; C4]	08.91-07.94	VAD	85	800	S5 010	72	800	S4 007	70	640	S3 007			
2.2 [44; 44Q; C3]	08.84-07.89	VAD	74	750	S5 007	60	750	S4 004						
		VAD,XXX									53	470	S3 004	
quattro [44; 44Q; C3]	08.84-11.90	VAD	74	750	S5 007	60	750	S4 004						
		VAD,XXX									53	470	S3 004	
quattro Turbo [44; 44Q; C3]	03.86-11.90	VAD	74	750	S5 007	60	750	S4 004						
		VAD,XXX									53	470	S3 004	
Turbo [44; 44Q; C3]	08.88-07.89	VAD	74	750	S5 007	60	750	S4 004						
		VAD,XXX									53	470	S3 004	
2.3 [44; 44Q; C3]	01.88-07.89	VAD	74	750	S5 007	60	750	S4 004						
		VAD,XXX									53	470	S3 004	
quattro [4A5; C4]	12.90-07.94	VAD	74	750	S5 007	60	750	S4 004						
		VAD,XXX									53	470	S3 004	
quattro [44; 44Q; C3]	08.86-11.90	VAD	74	750	S5 007	60	750	S4 004						
		VAD,XXX									53	470	S3 004	
2.6/ 2.8 quattro [4A5; C4]	12.90-07.94	VAD	85	800	S5 010	72	800	S4 007	70	640	S3 007			
Diesel														
2.0/ 2.4/ 2.5 D, TD, TDI [44; 44Q; C3]	05.83-12.90	VAD	74	750	S5 007	72	750	S4 007	70	640	S3 007			
2.4/ 2.5 D, TDI [4A5; C4]	08.91-07.94	VAD	85	800	S5 010	72	800	S4 007	70	640	S3 007			
200														
2.2 [44; C3]	08.84-07.85	VAD	74	750	S5 007	60	750	S4 004						
		VAD,XXX									53	470	S3 004	
Turbo [44; C3]	08.83-12.91	VAD	74	750	S5 007	60	750	S4 004						
		VAD,XXX									53	470	S3 004	

			Ah A (EN) S6	Ah A (EN) S5	Ah A (EN) S4	Ah A (EN) S3
			0 092 ...0	0 092 ...0	0 092 ...0	0 092 ...0

2.2 Turbo quattro [44, C3]	11.84-12.90	VAD	74	750	S5 007	60	750	S4 004			
		VAD,XXX							53	470	S3 004
200 Avant											
2.2 Turbo quattro [44, C3]	11.84-11.90	VAD	74	750	S5 007	60	750	S4 004			
		VAD,XXX							53	470	S3 004
5000 Diesel											
2.0 D Turbo [44]	06.83-07.85	VAD	100	830	S5 013	95	830	S4 013	90	720	S3 013

AUSTIN

Maestro											
1.3	03.83-09.92		52	520	S5 001	44	520	S4 001	41	360	S3 001
LS	03.83-09.92		52	520	S5 001	44	520	S4 001	41	360	S3 001
1.6	03.83-09.92		63	610	S5 005	52	610	S4 002	45	400	S3 002
1.6/ 2.0 i, MG	10.84-09.92		63	610	S5 005	52	610	S4 002	45	400	S3 002
Maestro 500/700 Diesel											
1.3/ 1.6 City L	09.84-09.92		63	610	S5 005	52	610	S4 002	45	400	S3 002
2.0 City L	09.84-09.92		63	610	S5 005	52	610	S4 002	45	400	S3 002
Metro											
1.0/ 1.3 , HLE	10.80-04.90					44		S4 001	45	300	S3 017
1.3/ 310 Turbo, 1.0 City L, 1.3 City L	08.83-04.90		52	520	S5 001	44	520	S4 001	41	360	S3 001
6R4 3.0	03.85-12.86					52		S4 002	45	400	S3 002
Mini											
1.0 City	01.82-09.92								45	300	S3 017
Montego Diesel											
1.3/ 1.6/ 2.0 , i, Turbo	04.84-08.88		61	600	S5 004	44	600	S4 001	41	360	S3 001
2.0 DSL Turbo	07.88-09.92		61	600	S5 004	44	600	S4 001	41	360	S3 001
Montego Estate											
1.3/ 1.6/ 2.0 , i	04.84-08.91		61	600	S5 004	44	600	S4 001	41	360	S3 001

AUTOBIANCHI

A 112											
	03.84-12.86		54	530	S5 002	52	530	S4 002	45	400	S3 002
Y 10											
1.0/ 1.1/ 1.3 , fire, fire i.e., fire i.e. 4x4, fire 4x4, GT i.e., i.e., i.e. ECVT, i.e. Selectronic, i.e. 4x4, turbo [; R.92]	03.85-12.95					45		S4 023			

BARKAS

B 1000-Serie											
0.9/ 1.3	01.75-12.90		54	530	S5 002	52	530	S4 002	45	400	S3 002

BEDFORD

MIDI Diesel											
1.8/ 2.0	02.85-08.92					70		S4 027			
2.0/ 2.2 D, D Turbo	02.85-08.92					70		S4 027			
Rascal											
99170, 99180	02.86-06.93								45	300	S3 017

			Ah A (EN) S6	Ah A (EN) S5	Ah A (EN) S4	Ah A (EN) S3
			0092 ...0	0092 ...0	0092 ...0	0092 ...0

◀ BEDFORD







Serie CF										
2 /230	05.84-07.87		52	520	S5 001	60	520	S4 004		
		XXX							53	470 S3 004
/250	05.84-07.87		52	520	S5 001	60	520	S4 004		
		XXX							53	470 S3 004
/280	05.84-07.87		52	520	S5 001	60	520	S4 004		
		XXX							53	470 S3 004
/350	05.84-07.87		52	520	S5 001	60	520	S4 004		
		XXX							53	470 S3 004
Serie K										
B	11.80-01.88						70	S4 027		
Diesel										
B	11.80-01.88						70	S4 027		

BENTLEY

Arnage										
4.4/ 6.8 , T	04.98-08.08						70	S4 027		
Azure										
6.8 , Mulliner, T	09.95-12.11						70	S4 027		
Brooklands										
6.8 , R	07.92-12.98						70	S4 027		
Continental Cabrio										
6.8	07.84-12.90	ZE					70	S4 027		
R	03.91-08.99						70	S4 027		
Continental Coupé										
6.8 , R, T Mulliner	03.91-08.03						70	S4 027		
Continental Flying Spur										
6.0	03.05→		95	850	S6 013	63	610	S5 005	60	610 S4 005
FFV Speed	09.08→					77	780	S5 008	74	780 S4 008
Continental GT										
6.0	06.03-10.10					63	610	S5 005	60	610 S4 005
Speed	09.07→					77	780	S5 008	74	780 S4 008
Continental Supersports Cabrio										
6.0	03.10→					77	780	S5 008	74	780 S4 008
ISR	03.11→		95	850	S6 013	100	830	S5 013	95	830 S4 013
Eight										
6.8	09.83-09.92						70	S4 027		
Mulsanne										
6.8	01.81-08.87						70	S4 027		
	09.09→		95	850	S6 013	100	830	S5 013	95	830 S4 013
Turbo	04.82-09.85						70	S4 027		
	10.86-05.90						70	S4 027		
Turbo R										
6.8 , V8	03.85-03.97						70	S4 027		
Turbo RT										
6.8	10.97-10.99						70	S4 027		
Turbo S										
6.8	07.95-07.99						70	S4 027		

BMW

Serie X										
X1 18i sDrive [E 84]	03.10→	AHB,BWD	70	760	S6 008					
20i sDrive, 20i xDrive, 25i xDrive [E 84]	03.10→	AHB,BWD	80	800	S6 011					
28i xDrive [E 84]	10.09-08.11	AHB,BWD				85	800	S5 010	74	800 S4 008
		AHB,BWD,SSJ	70	760	S6 008					
	03.11→	AHB,BWD	80	800	S6 011					

				Ah	A (EN)		Ah	A (EN)		Ah	A (EN)		Ah	A (EN)	
				0 092 ...0			0 092 ...0			0 092 ...0			0 092 ...0		
X 3	2.0i [E 83]	09.05-08.08	AHB,BWD	70	760	S6 008	77	780	S5 008	60	780	S4 005	56	480	S3 005
	2.5 si, 2.5i, 3.0 si [E 83]	03.04-08.08	AHB,BWD	95	850	S6 013	100	830	S5 013	80	830	S4 010	70	640	S3 008
	3.0i [E 83]	01.04-08.06	AHB,BWD	95	850	S6 013	100	830	S5 013	80	830	S4 010	70	640	S3 008
		09.06-08.08		95	850	S6 013	100	830	S5 013	80	830	S4 010			
	20i xDrive [E 83]	09.08-08.10	AHB,BWD				77	780	S5 008	60	780	S4 005			
			AHB,BWD,SSJ	70	760	S6 008	60	560	S5 E05		560				
	20i xDrive [F 25]	09.11→	AHB,BWD	95	850	S6 013									
	25i xDrive [E 83]	09.08-08.10	AHB,BWD				100	830	S5 013	95	830	S4 013			
			AHB,BWD,SSJ	70	760	S6 008									
	28i xDrive [F 25]	11.10-03.12	AHB,BWD	80	800	S6 011									
		04.12→		80	800	S6 011									
	30i xDrive [E 83]	09.08-08.10	AHB,BWD				100	830	S5 013	80	830	S4 010			
			AHB,BWD,SSJ	70	760	S6 008									
	35i xDrive [F 25]	10.10→	AHB,BWD,SSJ	95	850	S6 013									
X 5	M, 30 i xDrive, 35 i xDrive, 50 i xDrive [E 70]	10.08→	AHB,BWD	95	850	S6 013									
	3.0 i [E 53]	10.99-09.06		95	850	S6 013	100	830	S5 013	95	830	S4 013			
	3.0 si, 4.8 i [E 70]	11.06-09.08	AHB,BWD	95	850	S6 013	100	830	S5 013	80	830	S4 010	70	640	S3 008
	4.4 i [E 53]	03.99-09.03	AHB,BWD	95	850	S6 013	100	830	S5 013	95	830	S4 013	90	720	S3 013
		10.03-10.06		95	850	S6 013	100	830	S5 013	95	830	S4 013			
	4.6 is [E 53]	02.02-09.03		95	850	S6 013	100	830	S5 013	95	830	S4 013			
	4.8 is [E 53]	03.04-10.06		95	850	S6 013	100	830	S5 013	95	830	S4 013			
	48 i xDrive [E 70]	10.08-03.10	AHB,BWD,JEA	95	850	S6 013	100	830	S5 013	95	830	S4 013			
X 6	Active Hybrid [E 72]	12.09-10.11	AHB,BWD	95	850	S6 013									
	M [E 71]	09.09→	AHB,BWD	95	850	S6 013									
	35i xDrive [E 71]	03.08-03.10	AHB,BWD	95	850	S6 013	100	830	S5 013	95	830	S4 013			
		04.10→	AHB,BWD	95	850	S6 013									
	50i xDrive [E 71]	05.08→	AHB,BWD	95	850	S6 013									
Diesel															
X 1	16 d sDrive, 25 d xDrive [E 84]	07.12→		80	800	S6 011									
	18 d sDrive [E 84]	11.09-06.12	AHB,BWD,SSJ	70	760	S6 008									
				80	800	S6 011									
	18 d xDrive, 20 d sDrive, 20 d xDrive [E 84]	10.09-06.12	AHB,BWD,SSJ	80	800	S6 011									
	23 d xDrive [E 84]	10.09-06.12	AHB,BWD,SSJ	80	800	S6 011									
			BWD				85	800	S5 010	74	800	S4 008			
X 3	2.0 d [E 83]	10.04-09.07	AHB,BWD	95	850	S6 013	100	830	S5 013	80	830	S4 010			
		09.07-08.08	AHB,BWD	95	850	S6 013	100	830	S5 013	95	830	S4 013			
	3.0 d, 3.0 sd [E 83]	01.04-08.08		95	850	S6 013	100	830	S5 013	95	830	S4 013			
	18 d sDrive [F25]	10.12→		80	800	S6 011									
	18 d xDrive [E 83]	05.09-08.10	AHB,BWD,SSJ	80	800	S6 011									
	20 d xDrive [E 83]	09.08-08.10	AHB,BWD	80	800	S6 011									
	20 d xDrive [F 25]	10.10→	AHB,BWD,SSJ	95	850	S6 013									
	30 d xDrive [E 83]	09.08-08.10	AHB,BWD				100	830	S5 013	95	830	S4 013			
			AHB,BWD,SSJ	95	850	S6 013									
	30 d xDrive [F 25]	04.11→	AHB,BWD	80	800	S6 011									
	35 d xDrive [E 83]	09.08-08.10	AHB,BWD				100	830	S5 013	95	830	S4 013			
			AHB,BWD,SSJ	95	850	S6 013									
	35 d xDrive [F 25]	09.11→	AHB,BWD	95	850	S6 013									
X 5	M50d [E 70]	04.12→	AHB,BWD	95	850	S6 013									
	3.0 d [E 53]	03.01-09.03	AHB,BWD	95	850	S6 013	100	830	S5 013	95	830	S4 013	90	720	S3 013
		10.03-10.06		95	850	S6 013	100	830	S5 013	95	830	S4 013			
	3.0 d [E 70]	03.07-09.08	AHB,BWD	95	850	S6 013	100	830	S5 013	80	830	S4 010	70	640	S3 008
	3.0 sd [E 70]	10.07-09.08	AHB,BWD	95	850	S6 013	100	830	S5 013	95	830	S4 013	90	720	S3 013
	30 d xDrive [E 70]	10.08-03.10	AHB,BWD	95	850	S6 013									
		04.10→	AHB,BWD,SSJ	95	850	S6 013									
	35 d xDrive, 40 d xDrive [E 70]	10.08→	AHB,BWD	95	850	S6 013									
X 6	M50d, 30 d xDrive, 40 d xDrive [E 71]	05.08→	AHB,BWD	95	850	S6 013									
	35 d xDrive [E 71]	05.08-03.10	AHB,BWD	95	850	S6 013	100	830	S5 013	95	830	S4 013			

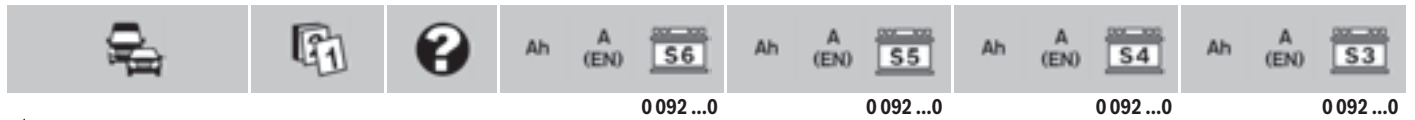

◀ BMW

Serie Z														
Z1 [E30]	07.88-06.91					61	600	S5 004	60	600	S4 004	53	500	S3 004
Z3 M 3.2, 1.8, 1.9, 2.0, 2.2i, 2.5, 2.8, 3.0i [E 36/7]	03.95-09.02		70	760	S6 008	77	780	S5 008	60	780	S4 005			
Z4 M 3.2 [E 85]	02.06-08.08	AHB,BWD	70	760	S6 008	77	780	S5 008	60	780	S4 005			
2.0i, 2.2i, 2.5 si, 2.5i, 3.0 si, 3.0i [E 85]	10.02-03.09	AHB,BWD	70	760	S6 008	77	780	S5 008	60	780	S4 005	56	480	S3 005
20i sDrive, 28i sDrive [E 89]	09.11→	AHB,BWD	80	800	S6 011									
23i sDrive, 30i sDrive, 35i sDrive [E 89]	04.09→	AHB,BWD	70	760	S6 008									
35is sDrive [E 89]	03.10→		70	760	S6 008									
Z8 [E 52]	03.00-07.03		95	850	S6 013	100	830	S5 013	95	830	S4 013	90	720	S3 013
Serie Z Coupé														
Z3 M 3.2, 2.8, 3.0i [E 36/8]	09.97-06.02		70	760	S6 008	77	780	S5 008	60	780	S4 005			
Z4 M 3.2 [E 86]	03.06-08.08					63	610	S5 005	60	610	S4 005			
3.0 si [E 86]	03.06-08.08		70	760	S6 008	77	780	S5 008	60	780	S4 005			
Serie 1														
M 135 i xDrive [F 20]	11.12→		80	800	S6 011									
M 135/ 114 i [F 20]	07.12→		80	800	S6 011									
116 i [E 81]	09.07-11.11	AHB,BWD	70	760	S6 008									
	09.07-12.11	AHB,BWD				54	530	S5 002	52	530	S4 002			
	03.09-12.11	AHB,BWD,SSJ	95	850	S6 013									
i [E 87]	09.04-06.11					54	530	S5 002	52	530	S4 002			
	03.09-06.11		80	800	S6 011									
		KZO,SSJ	70	760	S6 008									
		KZO,SSJ	95	850	S6 013									
116/ 118 i [F 20]	09.11→	AHB,BWD,SSJ	80	800	S6 011									
118 i [E 81]	05.07-12.11		70	760	S6 008									
		AHB,BWD,SSJ	95	850	S6 013									
i [E 87]	11.04-03.07					54	530	S5 002	52	530	S4 002			
	03.07-06.11		70	760	S6 008									
		KZO,SSJ	70	760	S6 008									
		KZO,SSJ	95	850	S6 013									
120 i [E 81]	05.07-12.11		70	760	S6 008									
		KZO,SSJ	70	760	S6 008									
		KZO,SSJ	95	850	S6 013									
i [E 87]	09.04-03.07					63	610	S5 005	52	610	S4 002			
	03.07-06.11		70	760	S6 008									
		KZO,SSJ	70	760	S6 008									
		KZO,SSJ	95	850	S6 013									
125 i [F 20]	03.12→	AHB,BWD	80	800	S6 011									
130 i [E 81]	05.07-08.09	AHB,BWD				63	610	S5 005	52	610	S4 002			
	09.09-12.11	AHB,BWD	70	760	S6 008	77	780	S5 008	60	780	S4 005			
i [E 87]	09.05-06.11					63	610	S5 005	52	610	S4 002			
Diesel														
114 d [F 20]	11.12→		80	800	S6 011									
116 d [E 81]	03.09-12.11	AHB,BWD,SSJ	95	850	S6 013									
d [E 87]	03.09-06.11	BWD,KZO,SSJ	70	760	S6 008									
		BWD,KZO,SSJ	95	850	S6 013									
d ed [F 20]	03.12→	AHB,BWD	80	800	S6 011									
116/ 118 d [F 20]	09.11→	AHB,BWD,SSJ	80	800	S6 011									
118 d [E 81]	05.07-12.11	AHB,BWD				85	800	S5 010	80	800	S4 010			
		AHB,BWD,SSJ	95	850	S6 013									
d [E 87]	09.04-03.07					85	800	S5 010	80	800	S4 010			
	03.07-06.11	BWD				85	800	S5 010	80	800	S4 010			
		BWD,SSJ	80	800	S6 011									
120 d [E 81]	05.07-12.11	AHB,BWD				85	800	S5 010	80	800	S4 010			
		AHB,BWD,SSJ	95	850	S6 013									
d [E 87]	09.04-03.07					85	800	S5 010	80	800	S4 010			
	03.07-06.11	BWD				85	800	S5 010	80	800	S4 010			
		BWD,KZO,SSJ	70	760	S6 008									
		BWD,KZO,SSJ	95	850	S6 013									



			Ah	A (EN)	S6	Ah	A (EN)	S5	Ah	A (EN)	S4	Ah	A (EN)	S3
			0 092 ...0			0 092 ...0			0 092 ...0			0 092 ...0		
120 d xDrive [F 20]	11.12→		80	800	S6 011									
120/125 d [F 20]	09.11→	AHB,BWD	80	800	S6 011									
123 d [E 81]	09.07-12.11	AHB,BWD,SSJ	95	850	S6 013									
d [E 87]	09.07-06.11	KZO,SSJ	70	760	S6 008									
		KZO,SSJ	95	850	S6 013									
Serie 1 Cabrio														
118 i [E 88]	03.08→	AHB,BWD				63	610	S5 005	60	610	S4 005			
		AHB,BWD,SSJ	95	850	S6 013									
120 i [E 88]	03.08→	AHB,BWD				63	610	S5 005	60	610	S4 005			
			70	760	S6 008									
		AHB,BWD,SSJ	95	850	S6 013									
125 i [E 88]	03.08→	AHB,BWD				63	610	S5 005	60	610	S4 005			
135 i [E 88]	03.08→	AHB,BWD				85	800	S5 010	80	800	S4 010			
Diesel														
118/123 d [E 88]	09.08→	AHB,BWD,SSJ	95	850	S6 013									
120 d [E 88]	03.08→	AHB,BWD,SSJ	80	800	S6 011									
Serie 1 Coupé														
M [E 82]	04.11→	AHB,BWD	80	800	S6 011									
120 i [E 82]	09.09→	AHB,BWD				85	800	S5 010	74	800	S4 008			
		AHB,BWD,SSJ	70	760	S6 008									
125 i [E 82]	03.08→	AHB,BWD,SSJ	95	850	S6 013									
135 i [E 82]	10.07→	AHB,BWD	70	760	S6 008									
Diesel														
118 d [E 82]	09.09→	AHB,BWD				100	830	S5 013	80	830	S4 010			
		AHB,BWD,SSJ	70	760	S6 008									
			95	850	S6 013									
120/123 d [E 82]	10.07→	AHB,BWD,SSJ	95	850	S6 013									
Serie 3														
ActiveHybrid [F 30]	09.12→		95	850	S6 013									
M 3 [E 30]	07.86-12.90		95	850	S6 013	100	830	S5 013	95	830	S4 013	90	720	S3 013
[E 36]	01.94-09.95		70	760	S6 008	77	780	S5 008	74	780	S4 008	70	640	S3 008
[E 90]	11.07-10.11	AHB,BWD				85	800	S5 010	74	800	S4 008			
		AHB,BWD,SSJ	70	760	S6 008									
Evolution I, Evolution II [E 30]	02.87-10.89		95	850	S6 013	100	830	S5 013	95	830	S4 013	90	720	S3 013
Evolution III [E 30]	12.89-12.90		95	850	S6 013	100	830	S5 013	95	830	S4 013	90	720	S3 013
3.2 [E 36]	10.95-06.98		70	760	S6 008	74	750	S5 007	72	750	S4 007	70	640	S3 007
316 [E 30]	09.82-12.88					63	610	S5 005	52	610	S4 002	45	400	S3 002
i [E 36]	09.90-12.98					63	610	S5 005	60	610	S4 005	56	480	S3 005
i [E 46]	04.98-09.02					77	780	S5 008	60	780	S4 005	56	480	S3 005
		SSJ	70	760	S6 008									
	04.98-03.05		70	760	S6 008	77	780	S5 008	60	780	S4 005	56	480	S3 005
i [E 90]	09.05-10.11					63	610	S5 005	52	610	S4 002			
	09.07-10.11	AHB,BWD,SSJ	95	850	S6 013									
i [F 30]	07.12→		95	850	S6 013									
316/318/320/323 i [E 30]	09.82-12.91					63	610	S5 005	52	610	S4 002	45	400	S3 002
318 i [E 36]	12.90-12.98					61	600	S5 004	60	600	S4 004	53	500	S3 004
		XXX										53	470	S3 004
	09.95-08.98					61	600	S5 004	60	600	S4 004			
i [E 46]	04.98-09.01		70	760	S6 008	77	780	S5 008	60	780	S4 005	56	480	S3 005
	09.01-03.05		70	760	S6 008	77	780	S5 008	60	780	S4 005			
i [E 90]	09.05-10.11	AHB,BWD				63	610	S5 005	52	610	S4 002			
	09.07-10.11	AHB,BWD,SSJ	95	850	S6 013									
is [E 36]	03.93-12.96					61	600	S5 004	60	600	S4 004	53	500	S3 004
	03.93-12.98	XXX										53	470	S3 004
	03.95-12.98					61	600	S5 004	60	600	S4 004			
318/320 is [E 30]	01.88-12.91					63	610	S5 005	52	610	S4 002	45	400	S3 002
320 i [E 46]	04.98-03.05		70	760	S6 008	85	800	S5 010	74	800	S4 008	70	640	S3 008
i [E 90]	03.05-12.11	AHB,BWD				63	610	S5 005	52	610	S4 002			
	09.07-12.11	AHB,BWD,SSJ	95	850	S6 013									
i [F 30]	03.12→	AHB,BWD	95	850	S6 013									
si [E 90]	03.06-09.06		70	760	S6 008	63	610	S5 005	52	610	S4 002			
320/323/325/328 i [E 36]	09.90-12.98					74	750	S5 007	72	750	S4 007	70	640	S3 007



◀ BMW

			Ah	A (EN)	S6	Ah	A (EN)	S5	Ah	A (EN)	S4	Ah	A (EN)	S3
			0092 ...0			0092 ...0			0092 ...0			0092 ...0		
320/335 i xDrive [F 30]	07.12→		95	850	S6 013									
323 i [E 46]	04.98-09.00		70	760	S6 008	85	800	S5 010	74	800	S4 008	70	640	S3 008
	03.99-12.03		70	760	S6 008	77	780	S5 008	74	780	S4 008	70	640	S3 008
	09.05-12.11		95	850	S6 013	85	800	S5 010	74	800	S4 008			
325 e [E 30]	09.83-07.88		70	760	S6 008	77	780	S5 008	60	780	S4 005	56	480	S3 005
	09.85-12.91		70	760	S6 008	77	780	S5 008	60	780	S4 005	56	480	S3 005
	09.00-03.05		70	760	S6 008	85	800	S5 010	74	800	S4 008	70	640	S3 008
	09.02-12.04					85	800	S5 010	80	800	S4 010			
	03.05-12.11	AHB,BWD	95	850	S6 013	85	800	S5 010	74	800	S4 008	70	640	S3 008
	09.05-08.06		95	850	S6 013	85	800	S5 010	74	800	S4 008			
	09.07-12.11	BWD	95	850	S6 013	85	800	S5 010	74	800	S4 008			
	09.08-10.11	AHB,BWD	80	800	S6 011									
			95	850	S6 013	85	800	S5 010	74	800	S4 008	70	640	S3 008
	03.86-02.91		70	760	S6 008	77	780	S5 008	60	780	S4 005	56	480	S3 005
	09.05-08.08	AHB,BWD	95	850	S6 013	85	800	S5 010	74	800	S4 008	70	640	S3 008
	09.07-08.08	AHB,BWD	70	760	S6 008	77	780	S5 008	74	780	S4 008			
325/330 xi [E 46]	07.00-03.05		70	760	S6 008	85	800	S5 010	74	800	S4 008	70	640	S3 008
328 i [E 90]	09.06-12.11		95	850	S6 013	85	800	S5 010	74	800	S4 008			
328/330 i [E 46]	04.98-04.05		70	760	S6 008	85	800	S5 010	74	800	S4 008	70	640	S3 008
328/335 i [F 30]	02.12→	AHB,BWD,SSJ	95	850	S6 013									
330 i [E 90]	03.05-12.11	AHB,BWD	95	850	S6 013	85	800	S5 010	74	800	S4 008	70	640	S3 008
	09.07-10.11	AHB,BWD	80	800	S6 011	77	780	S5 008	74	780	S4 008			
	09.05-09.07	AHB,BWD	95	850	S6 013	85	800	S5 010	74	800	S4 008	70	640	S3 008
	09.07-08.08	AHB,BWD	70	760	S6 008	77	780	S5 008	74	780	S4 008			
330/335 i xDrive [E 90]	09.08-10.11	AHB,BWD	80	800	S6 011									
335 i [E 90]	09.06-12.11	AHB,BWD	95	850	S6 013	85	800	S5 010	74	800	S4 008	70	640	S3 008
	03.07-08.08	AHB,BWD	70	760	S6 008	77	780	S5 008	74	780	S4 008			
Diesel														
316 d [E 90]	09.09-10.11	AHB,BWD				85	800	S5 010	74	800	S4 008			
		AHB,BWD,SSJ	95	850	S6 013									
	03.12→		95	850	S6 013									
318 d [E 46]	09.01-03.03		70	760	S6 008	85	800	S5 010	80	800	S4 010			
	03.03-03.05					85	800	S5 010	80	800	S4 010			
	09.05-09.07	AHB,BWD	95	850	S6 013	100	830	S5 013	80	830	S4 010			
	09.07-10.11	BWD,KZO,SSJ	70	760	S6 008									
		BWD,KZO,SSJ	95	850	S6 013									
	03.12→	AHB,BWD	95	850	S6 013									
318/325 td, tds [E 36]	09.91-12.98		95	850	S6 013	100	830	S5 013	80	830	S4 010			
320 d [E 46]	04.98-03.05		95	850	S6 013	85	800	S5 010	80	800	S4 010			
	03.05-09.07	AHB,BWD				100	830	S5 013	80	830	S4 010			
		AHB,BWD,SSJ	95	850	S6 013									
	09.05-09.07	AHB,BWD	95	850	S6 013	100	830	S5 013	80	830	S4 010			
	09.07-03.10	BWD,SSJ	95	850	S6 013									
	03.10-12.11	AHB,BWD,SSJ	95	850	S6 013									
	02.12→	AHB,BWD,SSJ	95	850	S6 013									
	03.10-11.11	BWD	95	850	S6 013									
		BWD,SSJ	95	850	S6 013									
	02.12→	AHB,BWD,SSJ	95	850	S6 013									
	09.08-10.11	AHB,BWD	95	850	S6 013									
	07.12→		95	850	S6 013									
324 d, td [E 30]	09.85-12.90		95	850	S6 013	100	830	S5 013	95	830	S4 013	90	720	S3 013
325 d [E 90]	09.06-02.10		95	850	S6 013	100	830	S5 013	80	830	S4 010			
	03.10-10.11	AHB,BWD	95	850	S6 013									
330 d [E 46]	10.99-03.05		95	850	S6 013	100	830	S5 013	95	830	S4 013	90	720	S3 013
	09.05-08.08		95	850	S6 013	100	830	S5 013	80	830	S4 010			
	09.08-12.11	AHB,BWD,SSJ	95	850	S6 013									
	09.08-10.11	AHB,BWD,SSJ	95	850	S6 013									
	07.00-03.05		95	850	S6 013	100	830	S5 013	80	830	S4 010			
	09.05-08.08		95	850	S6 013	100	830	S5 013	80	830	S4 010			
335 d [E 90]	09.06-10.11		95	850	S6 013	100	830	S5 013	80	830	S4 010			



0 092 ...0

0 092 ...0

0 092 ...0



0 092 ...0



Serie 3 Cabrio

M 3 [E 30]	03.88-09.91		95	850	S6 013	100	830	S5 013	95	830	S4 013	90	720	S3 013
[E 46]	04.01-08.06					85	800	S5 010	80	800	S4 010			
[E 93]	03.08→	AHB,BWD				85	800	S5 010	74	800	S4 008			
		AHB,BWD,SSJ	70	760	S6 008									
, 3.2 [E 36]	01.94-12.99		70	760	S6 008	77	780	S5 008	74	780	S4 008	70	640	S3 008
318 i [E 36]	01.94-12.99					61	600	S5 004	60	600	S4 004	53	500	S3 004
		XXX										53	470	S3 004
i [E 93]	03.10→	AHB,BWD	95	850	S6 013									
318/ 320 i [E 30]	04.86-12.93					63	610	S5 005	52	610	S4 002	45	400	S3 002
318/ 320/ 325/ 330 i [E 46]	05.00-08.06					85	800	S5 010	80	800	S4 010			
320 i [E 93]	03.07→					63	610	S5 005	52	610	S4 002			
						63	610	S5 005	52	610	S4 002	45	400	S3 002
		KZO,SSJ	70	760	S6 008									
		KZO,SSJ	95	850	S6 013									
320/ 323/ 325/ 328 i [E 36]	03.93-12.99					74	750	S5 007	72	750	S4 007	70	640	S3 007
323 i [E 46]	03.00-09.00		70	760	S6 008	85	800	S5 010	74	800	S4 008	70	640	S3 008
i [E 93]	09.07-04.12	AHB,BWD				77	780	S5 008	60	780	S4 005			
325 i [E 30]	09.85-01.93		70	760	S6 008	77	780	S5 008	60	780	S4 005	56	480	S3 005
325/ 330 i [E 93]	03.07→		70	760	S6 008	77	780	S5 008	74	780	S4 008			
335 i [E 93]	03.07-02.10		70	760	S6 008	77	780	S5 008	74	780	S4 008			
	03.10→	AHB,BWD	70	760	S6 008	77	780	S5 008	74	780	S4 008	70	640	S3 008
Diesel														
320 d [E 93]	03.08-02.10	BWD,SSJ	95	850	S6 013									
	03.10→	AHB,BWD,SSJ	95	850	S6 013									
320/ 330 d [E 46]	01.05-08.06		95	850	S6 013	85	800	S5 010	80	800	S4 010			
325 d [E 93]	09.07-02.10	AHB,BWD	95	850	S6 013	85	800	S5 010	80	800	S4 010			
	03.10→	AHB,BWD	95	850	S6 013									
330 d [E 93]	03.07-02.09		95	850	S6 013	85	800	S5 010	80	800	S4 010			
	03.09→	BWD,SSJ	95	850	S6 013									
Serie 3 Compact														
316 g [E 36]	11.95-09.00					63	610	S5 005	60	610	S4 005	56	480	S3 005
i [E 36]	03.94-09.00					61	600	S5 004	60	600	S4 004			
		XXX										53	470	S3 004
	12.98-09.00					63	610	S5 005	60	610	S4 005	56	480	S3 005
ti [E 46]	06.01-12.04		70	760	S6 008	77	780	S5 008	60	780	S4 005	56	480	S3 005
	03.02-12.04					63	610	S5 005	52	610	S4 002			
318 ti [E 36]	09.94-09.96					61	600	S5 004	60	600	S4 004	53	500	S3 004
	09.94-09.00	XXX										53	470	S3 004
	12.95-09.00					61	600	S5 004	60	600	S4 004			
ti [E 46]	09.01-12.04		70	760	S6 008	77	780	S5 008	60	780	S4 005	56	480	S3 005
323 ti [E 36]	06.97-09.00					74	750	S5 007	72	750	S4 007	70	640	S3 007
325 ti [E 46]	06.01-12.04		70	760	S6 008	85	800	S5 010	74	800	S4 008	70	640	S3 008
Diesel														
318 td [E 46]	03.03-12.04					85	800	S5 010	80	800	S4 010			
tds [E 36]	01.95-09.00		95	850	S6 013	100	830	S5 013	80	830	S4 010			
320 td [E 46]	09.01-12.04		70	760	S6 008	77	780	S5 008	74	780	S4 008			
Serie 3 Coupé														
M 3 [E 92]	05.07→	BWD	70	760	S6 008	77	780	S5 008	74	780	S4 008			
, CSL [E 46]	09.00-05.06		70	760	S6 008	85	800	S5 010	74	800	S4 008	70	640	S3 008
, 3.2 [E 36]	09.92-12.98		70	760	S6 008	74	750	S5 007	72	750	S4 007	70	640	S3 007
316 i [E 36]	09.93-12.99					63	610	S5 005	60	610	S4 004	56	480	S3 005
i [E 46]	10.99-09.02		70	760	S6 008	77	780	S5 008	60	780	S4 005	56	480	S3 005
	03.02-05.06		70	760	S6 008	77	780	S5 008	60	780	S4 005			
i [E 92]	09.07→	AHB,BWD				63	610	S5 005	52	610	S4 002			
		BWD,SSJ	70	760	S6 008									
318 i [E 46]	04.99-05.06		70	760	S6 008	77	780	S5 008	60	780	S4 005	56	480	S3 005
i [E 92]	03.10→	AHB,BWD	95	850	S6 013									
is [E 36]	03.92-09.96					63	610	S5 005	60	610	S4 005	53	500	S3 004
	03.92-08.99					63	610	S5 005	60	610	S4 005	56	480	S3 005
320 i [E 46]	04.98-09.01		70	760	S6 008	85	800	S5 010	74	800	S4 008	70	640	S3 008
	09.00-05.06		70	760	S6 008	77	780	S5 008	74	780	S4 008			

					Ah A (EN) S6	Ah A (EN) S5	Ah A (EN) S4	Ah A (EN) S3					
◀ BMW					0092 ...0	0092 ...0	0092 ...0	0092 ...0					
320 i [E 92]	03.07→				70 760 S6 008	77 780 S5 008	74 780 S4 008						
		AHB,BWD				77 780 S5 008	74 780 S4 008		70	640		S3 008	
		AHB,BWD,SSJ	95	850	S6 013								
320/323/325/328 i [E 36]	03.92-06.99				70 760 S6 008	77 780 S5 008	74 780 S4 008		70	640		S3 008	
323 i [E 46]	04.98-09.00				70 760 S6 008	85 800 S5 010	74 800 S4 008		70	640		S3 008	
i [E 92]	09.06-02.12				95 850 S6 013	85 800 S5 010	74 800 S4 008						
325 i [E 46]	09.00-05.06				70 760 S6 008	85 800 S5 010	74 800 S4 008		70	640		S3 008	
	09.02-05.06					85 800 S5 010	80 800 S4 010						
i [E 92]	09.06→	AHB,BWD	95	850	S6 013	85 800 S5 010	74 800 S4 008		70	640		S3 008	
	09.07→	AHB,BWD	80	800	S6 011	77 780 S5 008	74 780 S4 008						
ixDrive [E 92]	09.08→		95	850	S6 013	85 800 S5 010	74 800 S4 008						
		AHB,BWD	80	800	S6 011								
xi [E 92]	09.06-08.08	AHB,BWD	95	850	S6 013	85 800 S5 010	74 800 S4 008		70	640		S3 008	
	09.07-08.08	AHB,BWD	70	760	S6 008	77 780 S5 008	74 780 S4 008						
328 i [E 46]	04.98-09.00				70 760 S6 008	85 800 S5 010	74 800 S4 008		70	640		S3 008	
330 i [E 46]	05.00-05.06				70 760 S6 008	77 780 S5 008	74 780 S4 008						
		AHB,BWD				77 780 S5 008	60 780 S4 005						
i [E 92]	09.06→	AHB,BWD	95	850	S6 013	85 800 S5 010	74 800 S4 008		70	640		S3 008	
xi [E 92]	09.06-08.08	AHB,BWD	95	850	S6 013	85 800 S5 010	74 800 S4 008		70	640		S3 008	
330/335 ixDrive [E 92]	09.08→	AHB,BWD	80	800	S6 011								
335 i [E 92]	09.06-02.10				95 850 S6 013	85 800 S5 010	74 800 S4 008						
	03.10→	AHB,BWD	70	760	S6 008	77 780 S5 008	74 780 S4 008		70	640		S3 008	
xi [E 92]	09.07-08.08	AHB,BWD	70	760	S6 008	77 780 S5 008	74 780 S4 008						
Diesel													
320 d [E 46]	09.03-05.06				70 760 S6 008	85 800 S5 010	74 800 S4 008		70	640		S3 008	
d [E 92]	03.07-02.10	BWD	95	850	S6 013	100 830 S5 013	95 830 S4 013						
		BWD,SSJ	95	850	S6 013								
	03.10→	AHB,BWD,SSJ	95	850	S6 013								
d xDrive [E 92]	09.08-02.10	BWD,SSJ	95	850	S6 013								
	03.10→	AHB,BWD,SSJ	95	850	S6 013								
325 d [E 92]	03.07-02.10	BWD	95	850	S6 013	100 830 S5 013	95 830 S4 013						
	03.10→	AHB,BWD	95	850	S6 013								
330 d [E 46]	03.03-05.06				95 850 S6 013	100 830 S5 013	95 830 S4 013						
d [E 92]	09.06-08.08	BWD	95	850	S6 013	100 830 S5 013	95 830 S4 013						
	09.08→	BWD,SSJ	95	850	S6 013								
d xDrive [E 92]	09.08→	BWD,SSJ	95	850	S6 013								
xd [E 92]	09.06-08.08	BWD	95	850	S6 013	100 830 S5 013	95 830 S4 013						
335 d [E 92]	09.06→	BWD	95	850	S6 013	100 830 S5 013	95 830 S4 013						
Serie 3 Touring													
316 i [E 36]	01.96-12.99					63 610 S5 005	60 610 S4 005		56	480		S3 005	
i [E 91]	09.08→	AHB,BWD,SSJ	95	850	S6 013								
316/318 i [E 46]	10.99-09.05				70 760 S6 008	77 780 S5 008	60 780 S4 005		56	480		S3 005	
316/318/320 i [E 30]	01.88-06.94					63 610 S5 005	52 610 S4 002		45	400		S3 002	
318 i [E 36]	07.95-12.99					61 600 S5 004	60 600 S4 004		53	500		S3 004	
		XXX							53	470		S3 004	
i [E 91]	03.06-03.10	AHB,BWD				63 610 S5 005	52 610 S4 002						
	09.07→	AHB,BWD	80	800	S6 011								
320 i [E 46]	10.99-09.05				70 760 S6 008	85 800 S5 010	74 800 S4 008		70	640		S3 008	
i [E 91]	09.05-05.12					63 610 S5 005	52 610 S4 002						
	09.07-06.12	AHB,BWD,SSJ	95	850	S6 013								
320/323/328 i [E 36]	03.95-12.99					74 750 S5 007	72 750 S4 007		70	640		S3 007	
320/328 i [F 31]	09.12→				95 850 S6 013								
323 i [E 46]	10.98-09.00				70 760 S6 008	77 780 S5 008	74 780 S4 008		70	640		S3 008	
i [E 91]	09.05-05.12				70 760 S6 008	77 780 S5 008	74 780 S4 008						
325 i [E 30]	07.87-12.93				70 760 S6 008	77 780 S5 008	60 780 S4 005		56	480		S3 005	
i [E 46]	09.00-09.05				70 760 S6 008	85 800 S5 010	74 800 S4 008		70	640		S3 008	
	09.02-01.05					85 800 S5 010	80 800 S4 010						
i [E 91]	09.05→		95	850	S6 013	77 780 S5 008	74 780 S4 008						
ixDrive [E 91]	09.08→		95	850	S6 013	77 780 S5 008	74 780 S4 008						
		AHB,BWD	80	800	S6 011								
ix [E 30]	06.88-03.93				70 760 S6 008	77 780 S5 008	60 780 S4 005		56	480		S3 005	
xi [E 91]	09.05-08.08				95 850 S6 013	77 780 S5 008	74 780 S4 008						
	09.07-08.08	AHB,BWD	70	760	S6 008	77 780 S5 008	74 780 S4 008						

			Ah A (EN) S6			Ah A (EN) S5			Ah A (EN) S4			Ah A (EN) S3		
			0 092 ...0			0 092 ...0			0 092 ...0			0 092 ...0		
325/ 330 xi [E 46]	07.00-09.05		70	760	S6 008	85	800	S5 010	74	800	S4 008	70	640	S3 008
328/ 330 i [E 46]	10.99-09.05		70	760	S6 008	85	800	S5 010	74	800	S4 008	70	640	S3 008
330 i [E 91]	09.05→		95	850	S6 013	77	780	S5 008	74	780	S4 008			
	09.07→	AHB,BWD	80	800	S6 011	77	780	S5 008	74	780	S4 008			
xi [E 91]	09.05-09.07		95	850	S6 013	77	780	S5 008	74	780	S4 008			
	09.07-08.08	AHB,BWD	70	760	S6 008	77	780	S5 008	74	780	S4 008			
330/ 335 i xDrive [E 91]	09.08→	AHB,BWD	80	800	S6 011									
335 i [E 91]	09.06-02.10		95	850	S6 013	85	800	S5 010	74	800	S4 008			
	03.10→	AHB,BWD	95	850	S6 013	77	780	S5 008	74	780	S4 008	70	640	S3 008
xi [E 91]	03.07-08.08	AHB,BWD	70	760	S6 008	77	780	S5 008	74	780	S4 008			
Diesel														
316 d [E 91]	03.10→	AHB,BWD,SSJ	95	850	S6 013									
316/ 318/ 320/ 330 d [F 31]	09.12→		95	850	S6 013									
318 d [E 46]	03.02-09.05		70	760	S6 008	85	800	S5 010	80	800	S4 010			
d [E 91]	03.06-09.07	AHB,BWD	95	850	S6 013	100	830	S5 013	80	830	S4 010			
	09.07→	BWD,KZO,SSJ	70	760	S6 008									
		BWD,KZO,SSJ	95	850	S6 013									
318/ 325 tds [E 36]	03.95-12.99		95	850	S6 013	100	830	S5 013	80	830	S4 010			
320 d [E 46]	10.99-09.01					85	800	S5 010	80	800	S4 010			
	09.01-09.05		95	850	S6 013	85	800	S5 010	80	800	S4 010			
d [E 91]	09.05-08.07	AHB,BWD	95	850	S6 013	100	830	S5 013	80	830	S4 010			
	09.07-02.10	BWD,SSJ	95	850	S6 013									
	03.10→	AHB,BWD,SSJ	95	850	S6 013									
d xDrive [E 91]	09.08→	AHB,BWD	95	850	S6 013									
324 td [E 30]	01.88-12.93		95	850	S6 013	100	830	S5 013	95	830	S4 013	90	720	S3 013
325 d [E 91]	09.06-02.10		95	850	S6 013	100	830	S5 013	80	830	S4 010			
	03.10→	AHB,BWD	95	850	S6 013									
330 d [E 46]	10.99-03.03		95	850	S6 013	100	830	S5 013	95	830	S4 013	90	720	S3 013
		AHB,BWD	95	850	S6 013	100	830	S5 013	95	830	S4 013	90	720	S3 013
	03.03-09.05		95	850	S6 013	100	830	S5 013	95	830	S4 013			
d [E 91]	09.05-08.08		95	850	S6 013	100	830	S5 013	95	830	S4 013			
	09.08-06.12	AHB,BWD,SSJ	95	850	S6 013									
d xDrive [E 91]	09.08→	AHB,BWD,SSJ	95	850	S6 013									
xd [E 46]	07.00-09.05		95	850	S6 013	100	830	S5 013	95	830	S4 013			
xd [E 91]	09.05-08.08	AHB,BWD	95	850	S6 013	100	830	S5 013	95	830	S4 013	90	720	S3 013
335 d [E 91]	09.06→		95	850	S6 013	100	830	S5 013	95	830	S4 013			
Serie 5														
Active Hybrid/ M 5 [F 10]	09.11→	AHB,BWD	95	850	S6 013									
M 5 [E 28]	01.85-12.87		95	850	S6 013	100	830	S5 013	74	830	S4 008	70	640	S3 008
[E 39]	10.98-07.03		95	850	S6 013	110	920	S5 015	95	920	S4 013			
[E 60]	11.04-12.09	BWD	95	850	S6 013	110	920	S5 015	95	920	S4 013			
3.6, 3.8 [E 34]	10.88-12.95		95	850	S6 013	100	830	S5 013	74	830	S4 008	70	640	S3 008
M 535/ 535 i [E 28]	09.84-12.87		95	850	S6 013	100	830	S5 013	74	830	S4 008	70	640	S3 008
518/ 520 i [E 28; E 34]	09.82-12.95					63	610	S5 005	52	610	S4 002	45	400	S3 002
520/ 523 i [F 10]	03.10→	AHB,BWD	95	850	S6 013									
520/ 523/ 525/ 530 i [E 60]	07.03-02.10	AHB,BWD	95	850	S6 013	110	920	S5 015	80	920	S4 010			
520/ 525/ 530 i [E 39]	09.95-07.03		95	850	S6 013	100	830	S5 013	95	830	S4 013			
523 i [E 39]	09.95-09.00		95	850	S6 013	100	830	S5 013	95	830	S4 013	70	640	S3 008
525 i [E 34]	01.88-12.95		70	760	S6 008	77	780	S5 008	60	780	S4 005	56	480	S3 005
i xDrive [E 60]	09.08-02.10	AHB,BWD	80	800	S6 011									
ix [E 34]	09.91-12.95		70	760	S6 008	77	780	S5 008	60	780	S4 005	56	480	S3 005
525/ 528 e [E 28]	09.81-12.87		70	760	S6 008	77	780	S5 008	60	780	S4 005	56	480	S3 005
i [E 28]	06.81-12.87		70	760	S6 008	77	780	S5 008	60	780	S4 005	56	480	S3 005
525/ 530 xi [E 60]	03.05-08.08	AHB,BWD	95	850	S6 013	110	920	S5 015	80	920	S4 010			
528 i [F 10]	03.10-08.11	AHB,BWD	95	850	S6 013									
	09.11→	AHB,BWD	80	800	S6 011									
i xDrive [F 10]	09.11→	AHB,BWD	80	800	S6 011									
528/ 535 i [E 39]	09.95-11.12		95	850	S6 013	100	830	S5 013	74	830	S4 008	70	640	S3 008
530 i [E 34]	01.88-12.90		70	760	S6 008	77	780	S5 008	60	780	S4 005	56	480	S3 005
	09.92-12.95		95	850	S6 013	100	830	S5 013	74	830	S4 008	70	640	S3 008
i xDrive [E 60]	09.08-02.10		95	850	S6 013	110	920	S5 015	80	920	S4 010			
		AHB,BWD	80	800	S6 011									
530/ 535/ 550 i [F 10]	03.10→	AHB,BWD	95	850	S6 013									

				Ah A (EN) S6	Ah A (EN) S5	Ah A (EN) S4	Ah A (EN) S3
				0092 ...0	0092 ...0	0092 ...0	0092 ...0
◀ BMW							
535/ 540 i [E 34]	01.88-09.95			95 850 S6 013	100 830 S5 013	74 830 S4 008	70 640 S3 008
535/ 550 i xDrive [F 10]	09.10→	AHB,BWD		95 850 S6 013			
540 i [E 39]	01.96-07.03			95 850 S6 013	100 830 S5 013	95 830 S4 013	90 720 S3 013
540/ 545/ 550 i [E 60]	09.03-02.10	AHB,BWD		95 850 S6 013	110 920 S5 015	95 920 S4 013	
Diesel							
520 d [F 10]	05.10→	AHB,BWD,SSJ		105 950 S6 015			
520/ 525 d [E 39]	04.00-07.03			95 850 S6 013	100 830 S5 013	95 830 S4 013	
d [E 60]	05.04-02.10	AHB,BWD		95 850 S6 013	110 920 S5 015	95 920 S4 013	
524 d, td [E 28]	03.83-12.87			95 850 S6 013	100 830 S5 013	95 830 S4 013	90 720 S3 013
524/ 525 td, tds [E 34]	03.88-12.95			95 850 S6 013	100 830 S5 013	95 830 S4 013	90 720 S3 013
525 d xDrive [E 60]	09.08-02.10	AHB,BWD		95 850 S6 013			
td, tds [E 39]	01.96-09.00			95 850 S6 013	100 830 S5 013	95 830 S4 013	90 720 S3 013
xd [E 60]	09.07-08.08	AHB,BWD		95 850 S6 013	100 830 S5 013	95 830 S4 013	
525/ 530/ 535 d [F 10]	03.10→	AHB,BWD		95 850 S6 013			
525/ 530/ 535/ 550 d xDrive [F 10]	03.11→	AHB,BWD		95 850 S6 013			
530 d [E 39]	08.98-07.03			95 850 S6 013	100 830 S5 013	95 830 S4 013	90 720 S3 013
d [E 60]	07.03-09.05	BWD		95 850 S6 013	110 920 S5 015	95 920 S4 013	
	09.05-02.10	AHB,BWD		95 850 S6 013	110 920 S5 015	95 920 S4 013	
d xDrive [E 60]	09.08-02.10	AHB,BWD		95 850 S6 013	110 920 S5 015	920	
xd [E 60]	09.05-08.08	AHB,BWD		95 850 S6 013	110 920 S5 015	95 920 S4 013	
535 d [E 60]	09.04-02.10	AHB,BWD		95 850 S6 013	110 920 S5 015	95 920 S4 013	
Serie 5 GT							
535/ 550 i, i xDrive [F 07]	10.09→	AHB,BWD		95 850 S6 013			
Diesel							
530/ 535 d, d xDrive [F 07]	10.09-06.12	AHB,BWD		95 850 S6 013			
Serie 5 Touring							
M 5 [E 34]	04.92-12.95			95 850 S6 013	100 830 S5 013	74 830 S4 008	70 640 S3 008
[E 61]	03.07-08.10	AHB,BWD		95 850 S6 013	110 920 S5 015	920	
518 g [E 34]	11.95-06.96				63 610 S5 005	52 610 S4 002	45 400 S3 002
518/ 520 i [E 34]	11.91-12.96				63 610 S5 005	52 610 S4 002	45 400 S3 002
520 i [E 61]	09.07-08.10	AHB,BWD		95 850 S6 013	85 800 S5 010	80 800 S4 010	
i [F 11]	09.11→	AHB,BWD		80 800 S6 011			
520/ 523/ 525/ 528/ 530/ 540 i [E 39]	12.96-05.04			95 850 S6 013	100 830 S5 013	95 830 S4 013	
523 i [E 61]	03.05-08.10	AHB,BWD		95 850 S6 013	110 920 S5 015	80 920 S4 010	
	03.07-08.10	BWD		95 850 S6 013	100 830 S5 013	95 830 S4 013	
i [F 11]	09.10-08.11	AHB,BWD		95 850 S6 013			
525 i [E 34]	11.91-12.96			70 760 S6 008	77 780 S5 008	60 780 S4 005	56 480 S3 005
i [E 61]	05.04-08.10	AHB,BWD		95 850 S6 013	110 920 S5 015	80 920 S4 010	
	03.07-08.10	AHB,BWD		95 850 S6 013	110 920 S5 015	95 920 S4 013	90 720 S3 013
i xDrive [E 61]	09.08-08.10	AHB,BWD		95 850 S6 013			
ix [E 34]	02.92-12.96			70 760 S6 008	77 780 S5 008	60 780 S4 005	56 480 S3 005
xi [E 61]	03.05-03.07	AHB,BWD		95 850 S6 013	110 920 S5 015	80 920 S4 010	
	03.07-08.08	AHB,BWD		95 850 S6 013	110 920 S5 015	95 920 S4 013	90 720 S3 013
528 i [F 11]	09.10-08.11	AHB,BWD		95 850 S6 013			
	09.11→	AHB,BWD		80 800 S6 011			
i xDrive [F 11]	09.11→	AHB,BWD		80 800 S6 011			
530 i [E 61]	03.05-08.10	AHB,BWD		95 850 S6 013	110 920 S5 015	80 920 S4 010	
	03.07-08.10	AHB,BWD		95 850 S6 013	110 920 S5 015	95 920 S4 013	90 720 S3 013
i xDrive [E 61]	09.08-08.10			95 850 S6 013	110 920 S5 015	95 920 S4 013	
		AHB,BWD		95 850 S6 013			
xi [E 61]	03.05-08.08	AHB,BWD		95 850 S6 013	110 920 S5 015	80 920 S4 010	
	03.07-08.08	AHB,BWD		95 850 S6 013	110 920 S5 015	95 920 S4 013	90 720 S3 013
530/ 535/ 550 i [F 11]	09.10→	AHB,BWD		95 850 S6 013			
530/ 540 i [E 34]	09.92-12.96			95 850 S6 013	100 830 S5 013	74 830 S4 008	
535 i xDrive [F 11]	09.11→	AHB,BWD		95 850 S6 013			
545/ 550 i [E 61]	05.04-08.10	AHB,BWD		95 850 S6 013	110 920 S5 015	95 920 S4 013	
Diesel							
520 d [E 61]	09.05-02.08	AHB,BWD		95 850 S6 013	110 920 S5 015	95 920 S4 013	
	09.07-08.10	BWD,SSJ		95 850 S6 013			
d [F 11]	09.10→	AHB,BWD,SSJ		105 950 S6 015			
520/ 525 d [E 39]	04.00-05.04			95 850 S6 013	110 920 S5 015	95 920 S4 013	

				Ah A (EN) S6	Ah A (EN) S5	Ah A (EN) S4	Ah A (EN) S3							
				0 092 ...0	0 092 ...0	0 092 ...0	0 092 ...0							
525 d [E 61]	05.04-03.07	BWD	95	850	S6 013	110	920	S5 015	95	920	S4 013			
	12.04-03.07	AHB,BWD	95	850	S6 013	110	920	S5 015	95	920	S4 013			
	03.07-08.10	AHB,BWD	95	850	S6 013	100	830	S5 013	95	830	S4 013	90	720	S3 013
d [F 11]	09.10-08.11	AHB,BWD	95	850	S6 013									
	09.11→	AHB,BWD,SSJ	105	950	S6 015									
d xDrive [E 61]	09.08-08.10	AHB,BWD	95	850	S6 013									
d xDrive [F 11]	09.11→	AHB,BWD,SSJ	105	950	S6 015									
td, tds [E 34]	12.91-12.96		95	850	S6 013	100	830	S5 013	95	830	S4 013	90	720	S3 013
tds [E 39]	03.97-09.00		95	850	S6 013	100	830	S5 013	95	830	S4 013	90	720	S3 013
xd [E 61]	09.07-08.08	AHB,BWD	95	850	S6 013	100	830	S5 013	95	830	S4 013			
530 d [E 39]	08.98-05.04		95	850	S6 013	100	830	S5 013	95	830	S4 013			
d [E 61]	05.04-03.07	AHB,BWD	95	850	S6 013	110	920	S5 015	95	920	S4 013			
	03.07-08.10	AHB,BWD	95	850	S6 013	100	830	S5 013	95	830	S4 013	90	720	S3 013
d xDrive [E 61]	09.08-08.10	AHB,BWD	95	850	S6 013	110	920	S5 015		920				
xd [E 61]	09.05-03.07	AHB,BWD	95	850	S6 013	110	920	S5 015	95	920	S4 013			
	03.07-08.08	AHB,BWD	95	850	S6 013	100	830	S5 013	95	830	S4 013	90	720	S3 013
530/ 535 d [F 11]	09.10→	AHB,BWD	95	850	S6 013									
530/ 535/ 550 d xDrive [F 11]	03.11→	AHB,BWD	95	850	S6 013									
535 d [E 61]	09.04-03.07	AHB,BWD	95	850	S6 013	110	920	S5 015	95	920	S4 013			
	03.07-08.10	AHB,BWD	95	850	S6 013	100	830	S5 013	95	830	S4 013	90	720	S3 013
Serie 6														
M 6 [E 63]	03.05-07.10	BWD	95	850	S6 013	110	920	S5 015		920				
M 6/ M 635/ 628/ 635 , CSI [E 24]	05.82-04.89		70	760	S6 008	77	780	S5 008	74	780	S4 008	70	640	S3 008
630 i [E 63]	09.04-07.10	AHB,BWD	95	850	S6 013	110	920	S5 015	80	920	S4 010			
	09.07-07.10	AHB,BWD	95	850	S6 013	85	800	S5 010	80	800	S4 010			
645 i [E 63]	01.04-09.05	AHB,BWD	95	850	S6 013	110	920	S5 015	95	920	S4 013			
650 i [E 63]	09.05-07.10	BWD	95	850	S6 013	110	920	S5 015	95	920	S4 013			
Diesel														
635 d [E 63]	09.07-07.10	AHB,BWD	95	850	S6 013	110	920	S5 015	95	920	S4 013			
Serie 6 Cabrio														
M 6 [E 64]	11.06-07.10	BWD				110	920	S5 015		920				
[F 12]	03.12→	AHB,BWD	95	850	S6 013									
630 i [E 64]	09.04-07.10	AHB,BWD	95	850	S6 013	110	920	S5 015	95	920	S4 013			
	09.07-07.10	AHB,BWD	95	850	S6 013									
640 i [F 12]	03.11→	AHB,BWD,SSJ	105	950	S6 015									
645 i [E 64]	04.04-09.05	BWD	95	850	S6 013	110	920	S5 015	95	920	S4 013			
650 i [E 64]	09.05-07.10	AHB,BWD	95	850	S6 013	110	920	S5 015	95	920	S4 013			
i [F 12]	03.11-06.12	AHB,BWD	95	850	S6 013									
i xDrive [F 12]	09.11-06.12	AHB,BWD	95	850	S6 013									
Diesel														
635 d [E 64]	09.07-07.10	AHB,BWD	95	850	S6 013	85	800	S5 010	80	800	S4 010			
640 d [F 12]	09.11→	AHB,BWD	95	850	S6 013									
d xDrive [F 12]	03.12→		95	850	S6 013									
Serie 6 Coupé														
M 6 [F 13]	09.12→		95	850	S6 013									
640 i [F 13]	10.11→	AHB,BWD,SSJ	105	950	S6 015									
650 i [F 13]	10.11-06.12	AHB,BWD	95	850	S6 013									
	07.12→		95	850	S6 013									
i xDrive [F 13]	10.11-06.12	AHB,BWD	95	850	S6 013									
	07.12→		95	850	S6 013									
Diesel														
640 d [F 13]	10.11→	AHB,BWD,SSJ	105	950	S6 015									
d xDrive [F 13]	03.12→	AHB,BWD	95	850	S6 013									
Serie 7														
Active Hybrid/ 730 , Li [F 02; F 04]	05.09→	AHB,BWD	95	850	S6 013									
ActiveHybrid/ AktiveHybrid , L [F 04]	07.12→		95	850	S6 013									
728/ 730/ 735/ 740/ 750 i, iL [E 38]	06.94-10.01		95	850	S6 013	100	830	S5 013	95	830	S4 013	90	720	S3 013

				Ah A (EN) S6	Ah A (EN) S5	Ah A (EN) S4	Ah A (EN) S3
				0 092 ...0	0 092 ...0	0 092 ...0	0 092 ...0
BMW							
728/732/735/745 i, i, iL	07.78-12.92			70 760 S6 008	77 780 S5 008	74 780 S4 008	70 640 S3 008
[E 23; E 32]							
730 i [E 65; E 66]	03.03-10.08			95 850 S6 013	85 800 S5 010	80 800 S4 010	
i [F 01]	09.09→	AHB,BWD		95 850 S6 013			
i, iL [E 32]	09.86-06.94			70 760 S6 008	85 800 S5 010	80 800 S4 010	70 640 S3 008
	09.91-10.94			70 760 S6 008	85 800 S5 010	80 800 S4 010	
Li [E 65; E 66]	03.03-10.08			95 850 S6 013	85 800 S5 010	80 800 S4 010	
735 i [E 65; E 66]	11.01-03.05			95 850 S6 013	100 830 S5 013	95 830 S4 013	
Li [E 65; E 66]	03.02-03.05			95 850 S6 013	100 830 S5 013	95 830 S4 013	
740 i [F 01]	11.08-06.12	AHB,BWD		95 850 S6 013			
	07.12→			95 850 S6 013			
Li [F 02]	11.08-06.12	AHB,BWD		95 850 S6 013			
	07.12→			95 850 S6 013			
740/750 i [E 65; E 66]	04.05-10.08			95 850 S6 013			
i, iL [E 32]	09.87-10.94			70 760 S6 008	85 800 S5 010	80 800 S4 010	70 640 S3 008
Li [E 65; E 66]	04.05-10.08			95 850 S6 013			
745/760 i [E 65; E 66]	11.01-10.08			95 850 S6 013	100 830 S5 013	830	
Li [E 65; E 66]	03.02-10.08			95 850 S6 013	100 830 S5 013	830	
750 i [F 01]	11.08-06.12	AHB,BWD		95 850 S6 013			
	07.12→			95 850 S6 013			
i xDrive [F 01]	09.09-06.12	AHB,BWD		95 850 S6 013			
	07.12→			95 850 S6 013			
Li [F 02]	11.08-06.12	AHB,BWD		95 850 S6 013			
	07.12→			95 850 S6 013			
LixDrive [F 02]	09.09-06.12	AHB,BWD		95 850 S6 013			
	07.12→			95 850 S6 013			
760 i, Li [F 01; F 02]	09.09→	AHB,BWD		95 850 S6 013			
Diesel							
725 tds [E 38]	01.96-12.00			95 850 S6 013	100 830 S5 013	95 830 S4 013	90 720 S3 013
730 d [F 01]	11.08-06.12	AHB,BWD,SSJ		95 850 S6 013			
	07.12→			95 850 S6 013			
d, Ld [E 65; E 66]	10.02-10.08	AGM		95 850 S6 013			
d xDrive [F 01]	07.12→			95 850 S6 013			
Ld [F 02]	03.09-06.12	AHB,BWD,SSJ		95 850 S6 013			
	07.12→			95 850 S6 013			
730/740 d [E 38]	08.98-12.01			95 850 S6 013	100 830 S5 013	95 830 S4 013	
740 d [E 65]	10.02-03.05			95 850 S6 013	100 830 S5 013	95 830 S4 013	
d [F 01]	09.09-06.12	AHB,BWD		95 850 S6 013			
	07.12→			95 850 S6 013			
d xDrive [F 01]	09.10-06.12	AHB,BWD		95 850 S6 013			
	07.12→			95 850 S6 013			
745 d [E 65]	03.05-10.08			95 850 S6 013			
750 d xDrive, Ld xDrive	07.12→			95 850 S6 013			
[F 01; F 02]							
Serie 8							
840/850 Ci, CSi, i, i, Ci [E 31]	07.89-12.99	ZE			74 750 S5 007	72 750 S4 007	70 640 S3 007

BOGDAN

2110							
211010	12.09→				63 610 S5 006	60 610 S4 006	56 480 S3 006
2111							
211120	12.09→				63 610 S5 006	60 610 S4 006	56 480 S3 006
2310							
231010	12.09→				63 610 S5 006	60 610 S4 006	56 480 S3 006

			Ah A (EN) S6 0 092 ...0	Ah A (EN) S5 0 092 ...0	Ah A (EN) S4 0 092 ...0	Ah A (EN) S3 0 092 ...0
--	--	--	----------------------------	----------------------------	----------------------------	----------------------------

BRISTOL

Beaufighter						
5.9 V8 Turbo	01.80-12.89				70	S4 027
Blenheim						
5.9	03.94-10.99				70	S4 027
Blenheim 3S						
5.9	03.02→				70	S4 027
Britannia						
5.9 , Brigand Turbo	10.82-12.89				70	S4 027

BUGATTI

Veyron Coupé						
16.4 AWD, Super Sport	09.05-12.12	100	830	S5 013		830
Veyron Roadster						
16.4 , Super Sport Vitesse	03.09→	100	830	S5 013		830

BUICK

LeSabre						
3.8	09.99-08.05				70	S4 027
Park Avenue						
3.8 i	09.89-08.94				70	S4 027
Park Avenue Ultra						
3.8 , i	09.90-08.05				70	S4 027
Skylark						
3.3	09.88-08.93				70	S4 027
Skylark Coupé						
2.3	09.87-08.95				70	S4 027



CADILLAC

BLS													
2.0/ 2.8	10.05→	70	760	S6 008	77	780	S5 008	74	780	S4 008	70	640	S3 008
Flexpower, 4x4	04.06→				77	780	S5 008	74	780	S4 008			
Diesel													
1.9	10.05→	70	760	S6 008	77	780	S5 008	74	780	S4 008	70	640	S3 008
	10.07→				85	800	S5 010	74	800	S4 008			
BLS Wagon													
2.0/ 2.8 , Flexpower, 4x4	10.07→				77	780	S5 008	74	780	S4 008			
Diesel													
1.9	10.07→				85	800	S5 010	74	800	S4 008			
CTS													
2.6/ 2.8	09.02-08.07									70			S4 027
2.8 i	04.06→				77	780	S5 008	74	780	S4 008			
CTS-V													
5.7	09.03-08.05				63	610	S5 006			610			
CTS-V Wagon													
6.2	09.10-08.14	70	760	S6 008	77	780	S5 008	74	780	S4 008			
SRX													
3.0	09.09→				77	780	S5 008	74	780	S4 008			
XLR													
4.6	09.03-08.09				61	600	S5 004	60	600	S4 004	53	500	S3 004

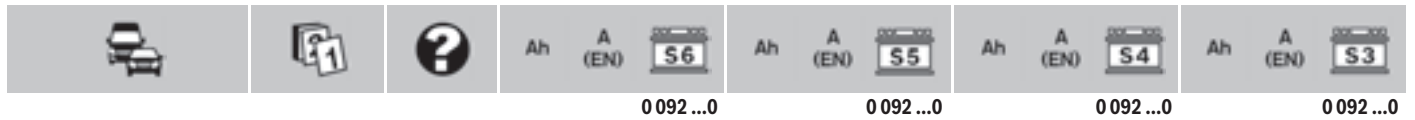



CHEVROLET										
Alero Coupé										
2.2/ 2.4/ 3.4	01.99-12.04	63	610	S5 006	610					
Aveo										
1.2/ 1.4/ 1.6, i [KL1S, T250; KL1S, T255; KL1T, T300]	02.06→				60	S4 025				
Diesel										
1.3 D [KL1T, T300]	09.11→	60	560	S5 E05	560					
Aveo Hatchback										
1.2/ 1.4/ 1.5/ 1.6, i [; KL1S, T255; KL1T, T300]	02.03→				60	S4 025				
Diesel										
1.3 D [KL1T, T300]	09.11→	60	560	S5 E05	560					
Beretta										
2.0 i	09.86-08.89							45	400	S3 003
2.2 i	09.91-08.96							45	400	S3 003
Beretta Convertible										
2.2 i	09.89-08.91	63	610	S5 006	60	610	S4 006	56	480	S3 006
Camaro Convertible										
3.4/ 5.7 i, i Z28	09.92-08.97					70	S4 027			
6.2	09.10→	80	730	S5 E11	80	730	S4 010			
		85	800	S5 010	80	800	S4 010			
Camaro Coupé										
2.5/ 2.8/ 3.4/ 5.0/ 5.7 i, i Z28	12.81→					70	S4 027			
5.0	09.79-08.87	63	610	S5 006	60	610	S4 006	56	480	S3 006
6.2	09.11→	80	730	S5 E11	80	730	S4 010			
		85	800	S5 010	80	800	S4 010			
Caprice										
4.3/ 5.0 i, i Classic	08.88-08.96	63	610	S5 006	60	610	S4 006	56	480	S3 006
Caprice Station Wagon										
5.0/ 5.7, i	09.87-12.00	63	610	S5 006	60	610	S4 006	56	480	S3 006
Captiva										
2.4 [KL1C, C100]	10.06-02.11	63	610	S5 006	60	610	S4 006	56	480	S3 006
[KL1C, C140]	04.11→				60	S4 025				
4x4 [KL1C, C100]	10.06-02.11	63	610	S5 006	60	610	S4 006			
4x4 [KL1C, C140]	04.11→				60	S4 025				
3.0 4x4 [KL1C, C140]	04.11→				70	S4 027				
3.2 4x4 [KL1C, C100]	10.06-02.11				74	S4 009				
Diesel										
2.0 CDRI, CDRI 4x4 [KL1C, C100]	10.06-02.11				95	S4 029				
2.2 CDRI [KL1C, C140]	04.11→				60	S4 025				
CDRI 4x4 [KL1C, C140]	04.11→				60	S4 025				
					95	S4 029				
Corsica										
2.2 i	09.89-08.96							45	400	S3 003
Corvette Cabrio										
5.7	09.91-08.04					70	S4 027	56	480	S3 006
	03.02→	63	610	S5 006	610					
Corvette Convertible										
6.2, Grand Sport	01.11→	63	610	S5 006	610					
7.0 427	09.12→	61	600	S5 004	600					
Corvette Coupé										
5.7	02.83-05.85	63	610	S5 006	70	610	S4 027			
	08.85-08.95	63	610	S5 006	70	610	S4 027			
	01.97-08.04	63	610	S5 006	70	610	S4 027			
6.2	12.11→	63	610	S5 006	610					
Grant Sport	01.11→	63	610	S5 006	610					
ZR1	12.11→	61	600	S5 004	600					
7.0 Z06	09.11→				74	S4 009				

			Ah A (EN) S6	Ah A (EN) S5	Ah A (EN) S4	Ah A (EN) S3
			0 092 ...0	0 092 ...0	0 092 ...0	0 092 ...0

Cruze							
1.6/ 1.8 [KL1J,J300]	05.09→	63	610	S5 006	60	610	S4 006
Diesel							
1.7 CDI [KL1J,J300]	01.12→				80		S4 010
2.0 CDI [KL1J,J300]	05.09→	85	800	S5 010	80	800	S4 010
	10.10→				80		S4 010
Cruze Hatchback							
1.4/ 1.6/ 1.8 , Turbo	07.11→	63	610	S5 006	60	610	S4 006
[KL1J,J305]							
Diesel							
1.7/ 2.0 CDI [KL1J,J305]	07.11→				80		S4 010
Cruze Station Wagon							
1.4/ 1.6/ 1.8 , Turbo	07.12→	63	610	S5 006	60	610	S4 006
[KL1J,J308]							
Diesel							
1.7/ 2.0 CDI [KL1J,J308]	07.12→				80		S4 010
Epica							
2.0/ 2.5 [KL1L,V250]	06.06-12.11				70		S4 027
Diesel							
2.0 CDRi [KL1L,V250]	09.06-12.11				70		S4 027
Evanda							
2.0 i [KLAL,V200]	02.05-09.06				60		S4 025
HHR							
2.4	09.05→	61	600	S5 004	60	600	S4 004
Impala							
3.8	01.84-08.85				70		S4 027
Kalos							
1.2 [KL1S, T200]	02.05-08.06				52		S4 002 45 400 S3 003
1.4 [KL1S, T200]	02.05-08.06				60		S4 025
Kalos Hatchback							
1.2/ 1.4 [KL1S, T200]	02.05-04.08				60		S4 025
Lacetti							
1.4 [KL1N, J200]	02.05→	63	610	S5 006	60	610	S4 006 56 480 S3 006
1.6 [KL1N, J200]	02.05→	63	610	S5 006	60	610	S4 006
1.8 [KL1N, J200]	02.05-08.05	63	610	S5 006	60	610	S4 006
	08.05→	63	610	S5 006	60	610	S4 006 56 480 S3 006
Diesel							
2.0 D [KL1N, J200]	09.06→	63	610	S5 006	60	610	S4 006 56 480 S3 006
Lanos							
1.5/ 1.6 i	01.04→	63	610	S5 006	60	610	S4 006 56 480 S3 006
Lumina APV							
3.1/ 3.8 , i	09.88-08.96	63	610	S5 006	60	610	S4 006 56 480 S3 006
Malibu							
2.4/ 3.1	09.96-08.99	63	610	S5 006	60	610	S4 006 56 480 S3 006
Matiz							
0.8/ 1.0 i [KL1K, M200]	02.05-12.10				40		S4 018
Niva							
1.7 i	09.02→	63	610	S5 006	60	610	S4 006 56 480 S3 006
1.8 MT [212360]	09.04→	74	750	S5 007	60	750	S4 004
Nubira							
1.4/ 1.6 i [KL1N, J200]	02.05→				60		S4 025
1.8 i [KL1N, J200]	02.05-08.05				60		S4 004
	08.05→				60		S4 025
Nubira Wagon							
1.6/ 1.8 i [KL1N, J200]	02.05→				60		S4 025
Diesel							
2.0 D [KL1N, J200]	09.06→				70		S4 027
Orlando							
1.4/ 1.8 , Turbo [KL1Y,J309]	10.10→	63	610	S5 006	60	610	S4 006
Diesel							
2.0 CRDi [KL1Y,J309]	10.10→				80		S4 010
Rezzo							
1.6/ 2.0 i [KL1U, U100]	02.05-05.09				70		S4 027



			Ah A (EN) S6	Ah A (EN) S5	Ah A (EN) S4	Ah A (EN) S3
			0092 ...0	0092 ...0	0092 ...0	0092 ...0

◀ CHEVROLET

Sens												
1.3 Si [TF698]	01.02→			63	610	S5 006	60	610	S4 006	56	480	S3 006
Spark												
0.8 i [KL1K,M200]	02.05-12.10						40		S4 018			
1.0 i [KL1K,M200]	02.05-12.10						40		S4 019			
1.0/ 1.2 i [KL1M,M300; KL1M,M300]	12.09→						40		S4 019			
Tahoe												
6.0 i	09.99→			74	750	S5 007		750				
Trans Sport												
3.4 AWD	10.01→			63	610	S5 006		610				
Trax												
1.4/ 1.6 , Turbo AWD	11.12→			70	760	S6 008						
Diesel												
1.7 CDI, CDI AWD	11.12→			70	760	S6 008						

CHRYSLER

Cherokee												
Diesel												
3.1 D	01.00-12.01			85	800	S5 010	80	800	S4 010			
Crossfire Coupé												
3.2 , SRT-6 [ZH]	09.03-08.08			70	760	S6 008	77	780	S5 008	74	780	S4 008
Crossfire Roadster												
3.2 , SRT-6 [ZH]	09.04-08.08			70	760	S6 008	77	780	S5 008	74	780	S4 008
Delta												
1.4	06.11→			60	560	S5 E05	60	560	S4 005			
				63	610	S5 005	60	610	S4 005			
Diesel												
1.6	06.11→			63	610	S5 005	60	610	S4 005			
2.0	06.11→			77	780	S5 008	74	780	S4 008			
Grand Voyager												
3.8 [RS]	09.07→						74		S4 009			
Horizon												
1.1/ 1.3/ 1.4	01.78-06.86									45	300	S3 017
Le Baron												
2.2/ 2.5 i	09.85-08.95						74		S4 009			
Le Baron Coupé												
2.2 i Turbo	01.88-08.95									66	360	S3 D60
										66	360	S3 060
2.5 i Turbo	09.88-08.93									66	360	S3 D60
										66	360	S3 060
3.0 i	05.89-08.93									66	360	S3 D60
										66	360	S3 060
Le Baron GTS												
2.2 i	01.88-08.95						74		S4 009			
Neon												
1.6/ 1.8/ 2.0/ 2.4 , i, i4x4, i 16V [; PL]	06.94-12.05			63	610	S5 006	60	610	S4 006			
Neon Coupé												
2.0 i 16V [PL]	09.95-08.99			63	610	S5 006	60	610	S4 006			
New Yorker												
3.0 i	09.87-08.92						70		S4 027			
PT Cruiser												
1.6 [PT]	10.02-12.07			61	600	S5 004	60	600	S4 004			
		XXX								53	470	S3 004
2.0 [PT]	06.00-12.05			61	600	S5 004	60	600	S4 004			
		XXX								53	470	S3 004
2.4 [PT]	06.00-12.10			61	600	S5 004	60	600	S4 004			
		XXX								53	470	S3 004
	09.00-08.10									53	500	S3 004
Turbo [PT]	09.02-12.09			61	600	S5 004	60	600	S4 004	53	500	S3 004

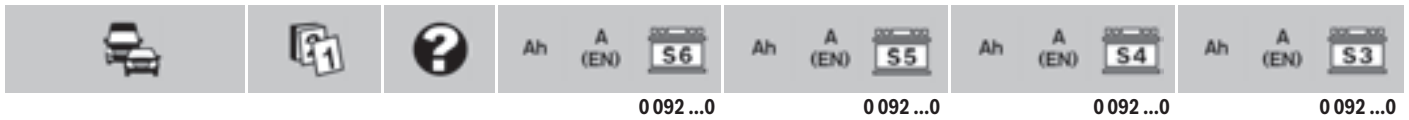

Diesel		0 092 ...0		0 092 ...0		0 092 ...0		0 092 ...0					
2.2 CRD [PT]	09.02-12.09	70	760	S6 008	77	780	S5 008	74	780	S4 008			
PT Cruiser Cabrio													
2.0 [PT]	09.00-12.05				61	600	S5 004	60	600	S4 004			
									53	470	S3 004		
2.4 [PT]	01.04-12.10				61	600	S5 004	60	600	S4 004			
									53	470	S3 004		
Turbo [PT]	01.03-12.09				61	600	S5 004	60	600	S4 004			
									53	470	S3 004		
Saratoga													
3.0 i	09.89-12.95							74		S4 009			
Sebring													
2.0 [JR]	09.00-08.06				63	610	S5 006	60	610	S4 006			
2.0/ 2.4 [JS]	09.06→				63	610	S5 006		610				
Sebring Convertible													
2.0 [JR]	01.01-08.06				63	610	S5 006	60	610	S4 006			
2.0/ 2.4/ 2.7 [JS]	09.06→				63	610	S5 006		610				
Stratus													
2.0/ 2.4/ 2.5 i 16V, i 24V [JA; JX]	08.95-04.01							74		S4 009			
Stratus Cabrio													
2.0/ 2.4/ 2.5 i 16V, i 24V [JA; JX]	08.95-04.01							74		S4 009			
2.5 i 24V [JA]	08.97-04.01				63	610	S5 006		610				
Viper Convertible													
8.0 GTS	06.97→							74		S4 009			
Viper Coupé													
8.0 GTS, GTS Lemans, RT/10	08.92→							74		S4 009			
Vision													
3.5 i	09.93-12.97							74		S4 009			
Voyager													
2.0/ 2.4/ 3.0/ 3.3/ 3.8 , i, i AWD, i V6, i V6 AWD, i 4x4 [GS; RG; RS; RT]	01.95→							74		S4 009			
Diesel													
2.5 CRD [RG]	09.00-08.01				85	800	S5 010	80	800	S4 010			
	09.01-08.07							74		S4 009			
TD [ES; GS]	04.92-12.00							74		S4 009			
2.5/ 2.8 CRD 4x4 [RG]	09.00-12.07				85	800	S5 010	80	800	S4 010			
2.8 CRD [RG]	08.04-12.07							74		S4 009			
Ypsilon													
0.9/ 1.2	06.11→				60	560	S5 E05		560				
Diesel													
1.3	06.11→				60	560	S5 E05		560				
300													
2.7/ 3.5/ 5.7/ 6.1 , SRT-8 [LX]	09.04-08.10				85	800	S5 010	80	800	S4 010			
Diesel													
3.0 CRD [LE]	01.11→				100	830	S5 013	95	830	S4 013			
300C													
2.7 [LE]	10.04-08.10								88	740	S3 012		
					85	800	S5 010	80	800	S4 010	88	740	S3 012
3.5/ 5.7 [LE]	10.04-08.10				85	800	S5 010	80	800	S4 010			
6.1 SRT-8 [LE]	01.05-08.10				85	800	S5 010	80	800	S4 010			
Diesel													
3.0 CRD [LE]	10.05-08.10	95	850	S6 013	100	830	S5 013	95	830	S4 013			
300C Touring													
2.7/ 3.5/ 5.7/ 6.1 , 4x4 [LE; LX]	10.04→				85	800	S5 010	80	800	S4 010			
Diesel													
3.0 CRD [LE]	10.05-08.10	95	850	S6 013	100	830	S5 013	95	830	S4 013			
300M													
2.7/ 3.5 [LH]	06.98-12.04				63	610	S5 006	60	610	S4 006			



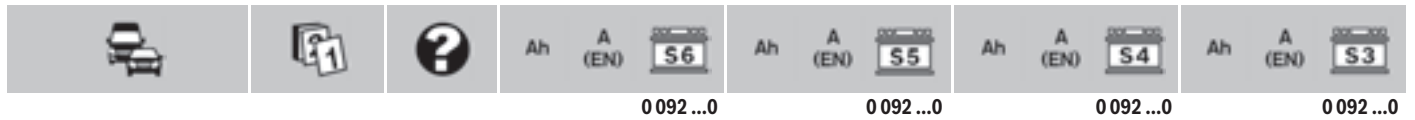

CITROEN



AX															
1.0/ 1.1/ 1.3/ 1.4 , GT, i, Sport	10.86-12.98					54	530	S5 002	52	530	S4 002	45	400	S3 002	
Diesel															
1.4/ 1.5 D	09.88-12.97					63	610	S5 005	60	610	S4 005				
Axel															
11	07.84-03.91								44		S4 000	40	340	S3 000	
					XXX				42		S4 000				
12	07.84-03.91				XXX				42		S4 000				
Berlingo															
1.1/ 1.4/ 1.6/ 1.8 , i, i 16V [M49; M59]	07.96-04.08					63	610	S5 005	60	610	S4 005	56	480	S3 005	
1.4 i [M59]	11.02-03.10					54	530	S5 002		530					
1.6 [B9]	05.08-11.11								60		S4 005	56	480	S3 005	
VTi [B9]	11.09→					63	610	S5 005	60	610	S4 005				
16V [B9]	05.08-11.11					63	610	S5 005	60	610	S4 005	56	480	S3 005	
Diesel															
1.6 HDi [B9]	05.08→					77	780	S5 008	74	780	S4 008	70	640	S3 008	
	03.10→					63	610	S5 005	60	610	S4 005				
	10.10→		SSJ	70	760	S6 008									
HDi [M59]	07.05-04.08			70	760	S6 008	77	780	S5 008	74	780	S4 008	70	640	S3 008
	09.05-04.08			70	760	S6 008	77	780	S5 008	74	780	S4 008			
1.8 D [M49]	07.96-11.02			70	760	S6 008	77	780	S5 008	74	780	S4 008			
1.9 D [M49]	07.96-11.02			70	760	S6 008	77	780	S5 008	74	780	S4 008			
	07.98-11.02			70	760	S6 008	77	780	S5 008	74	780	S4 008	70	640	S3 008
D [M59]	11.02-04.08			70	760	S6 008	77	780	S5 008	74	780	S4 008	70	640	S3 008
2.0 HDi [M49]	12.99-11.02			70	760	S6 008	77	780	S5 008	74	780	S4 008	70	640	S3 008
HDi [M59]	11.02-04.08			70	760	S6 008	77	780	S5 008	74	780	S4 008	70	640	S3 008
Berlingo Electricque															
[M49; M59]	10.98-04.08					63	610	S5 005	60	610	S4 005				
BX															
11/ 14/ 15/ 16 [X56]	10.82-12.94					54	530	S5 002	52	530	S4 002	45	400	S3 002	
14/ 16 i [X56]	03.86-12.94					54	530	S5 002	52	530	S4 002	45	400	S3 002	
19 [X56]	10.84-09.93					63	610	S5 005	60	610	S4 005	56	480	S3 005	
i [X56]	03.86-12.94					63	610	S5 005	60	610	S4 005	56	480	S3 005	
i 16S [X56]	07.87-03.93					63	610	S5 005	60	610	S4 005	56	480	S3 005	
Sport [X56]	05.85-06.86					63	610	S5 005	60	610	S4 005	56	480	S3 005	
Diesel															
17/ 19 D, D Turbo [X56]	09.83-12.94			70	760	S6 008	77	780	S5 008	74	780	S4 008	70	640	S3 008
C															
25 E 1.8	11.81-03.94					63	610	S5 005	60	610	S4 005	56	480	S3 005	
E 2.0	09.81-03.94					63	610	S5 005	60	610	S4 005	56	480	S3 005	
35 E 2.0	11.73-12.92								70		S4 027				
Diesel															
25/ 35/ 45 1.9 D, 1.9 D Turbo, 2.5 D, 2.5 D Turbo	01.80-03.94					100	830	S5 013	95	830	S4 013	90	720	S3 013	
C 15															
E 1.0/ E 1.1/ E 1.3/ E 1.4 , i	10.84-12.97					54	530	S5 002	52	530	S4 002	45	400	S3 002	
Diesel															
1.8/ 1.9 D	07.86-12.05					63	610	S5 005	52	610	S4 002				
C-Crosser															
2.0 [I4]	11.10→					63	610	S5 005	60	610	S4 005				
4x4 [I4]	11.10→					63	610	S5 005	60	610	S4 005				
2.4 4x4 [I4]	11.07→			70	760	S6 008	77	780	S5 008	74	780	S4 008	70	640	S3 008
Diesel															
2.2 HDi 4x4 [I4]	09.07→								95		S4 028				
C-Elysee															
1.2/ 1.6 VTi	09.12→					54	530	S5 002	52	530	S4 002				
Diesel															
1.6 HDi	09.12→					63	610	S5 005	60	610	S4 005				



			Ah	A (EN)	S6	Ah	A (EN)	S5	Ah	A (EN)	S4	Ah	A (EN)	S3
			0 092 ...0			0 092 ...0			0 092 ...0			0 092 ...0		
CX														
20/ 22/ 25 , Injection, Injection Turbo, Injection Turbo 2	07.82-12.92		63	610	S5 005	60	610	S4 005	56	480	S3 005			
Diesel														
25 D, D Turbo, D Turbo 2	07.82-12.92		70	760	S6 008	77	780	S5 008	74	780	S4 008	70	640	S3 008
C1														
1.0 [B0]	06.05→								40	340	S3 000			
		XXX							42		S4 000			
Diesel														
1.4 HDi [B0]	06.05→		54	530	S5 002	52	530	S4 002						
C2														
1.1 [A6]	09.03-12.09		54	530	S5 002		530		40	340	S3 000			
		XXX							42		S4 000			
1.4 [A6]	09.03-12.09		54	530	S5 002	44	530	S4 000	40	340	S3 000			
		XXX							42		S4 000			
16V [A6]	12.05-12.08		54	530	S5 002		530		40	340	S3 000			
		SSJ	60	560	S5 E05		560							
		XXX							42		S4 000			
1.6 [A6]	09.03-12.09		54	530	S5 002		530		40	340	S3 000			
		XXX							42		S4 000			
VTS [A6]	10.04-05.09		54	530	S5 002		530		40	340	S3 000			
		XXX							42		S4 000			
Diesel														
1.4 HDi [A6]	09.03-12.09		63	610	S5 005	60	610	S4 005						
1.6 HDi [A6]	07.07-05.09	XXX							42		S4 000			
C3														
1.1 i [A8]	01.02-08.05		54	530	S5 002		530		40	340	S3 000			
		XXX							42		S4 000			
i [A31]	09.05-09.09		54	530	S5 002		530		40	340	S3 000			
		XXX							42		S4 000			
1.1/ 1.4 [A51]	09.09→	BWD	54	530	S5 002	52	530	S4 002						
1.4 i [A8]	01.02-08.05		54	530	S5 002		530		40	340	S3 000			
		XXX							42		S4 000			
i [A31]	09.05-09.09		54	530	S5 002		530		40	340	S3 000			
		XXX							42		S4 000			
i 16V [A8]	10.03-08.05		54	530	S5 002		530		40	340	S3 000			
		SSJ	60	560	S5 E05		560							
		XXX							42		S4 000			
i 16V [A31]	09.05-09.09		54	530	S5 002		530		40	340	S3 000			
		SSJ	60	560	S5 E05		560							
		XXX							42		S4 000			
VTi [A51]	09.09→		52	520	S5 001	44	520	S4 001						
1.6 i [A8; A31]	01.02-05.09		54	530	S5 002	52	530	S4 002						
VTi [A51]	09.09→	BWD	54	530	S5 002	52	530	S4 002						
Diesel														
1.4 HDi [A51]	09.09→	BWD	63	610	S5 005	60	610	S4 005						
1.4/ 1.6 HDi, HDi 16V [A8; A31]	01.02-12.09		63	610	S5 005	60	610	S4 005						
1.6 HDi [A51]	09.09→	BWD	63	610	S5 005	60	610	S4 005						
			70	760	S6 008	63	610	S5 005	60	610	S4 005			
C3 Picasso														
1.4 [A58]	02.09→		61	600	S5 004	60	600	S4 004						
VTi [A58]	01.10→	BWD				60		S4 005						
VTi LPG [A58]	06.11→	BWD	63	610	S5 005	60	610	S4 005						
1.6 [A58]	02.09→	BWD	63	610	S5 005	60	610	S4 005						
VTi [A58]	01.10→	BWD	63	610	S5 005	60	610	S4 005						
Diesel														
1.6 HDi [A58]	02.09-12.11		61	600	S5 004	60	600	S4 004						
	02.09→	BWD	63	610	S5 005	60	610	S4 005						
C3-Pluriel														
1.4 [A42]	05.03-10.12		54	530	S5 002		530		40	340	S3 000			
		XXX							42		S4 000			

								Ah A (EN) S6		Ah A (EN) S5		Ah A (EN) S4		Ah A (EN) S3	
								0092 ...0		0092 ...0		0092 ...0		0092 ...0	
◀ CITROEN															
1.6 16V [A42]	05.03-10.12					54	530	S5 002	52	530	S4 002				
Diesel															
1.4 HDi [A42]	10.03-01.10					63	610	S5 005	60	610	S4 005				
C4															
1.4 [B5]	11.04-09.10					54	530	S5 002		530		40	340	S3 000	
		XXX							42		S4 000				
[B71]	09.10→	BWD				54	530	S5 002	52	530	S4 002				
1.6 [B5]	11.04-09.10					54	530	S5 002		530		40	340	S3 000	
		XXX							42		S4 000				
i BioFlex [B5]	09.07-07.08					54	530	S5 002		530		40	340	S3 000	
		XXX							42		S4 000				
LPG, THP, VTi [B71]	09.10→	BWD				63	610	S5 005	60	610	S4 005				
THP [B5]	07.08-07.09					63	610	S5 005	60	610	S4 005	56	480	S3 005	
	07.08-09.10					63	610	S5 005	60	610	S4 005				
2.0 [B5]	11.04-07.08					63	610	S5 005	60	610	S4 005				
Diesel															
1.6 HDi [B5]	11.04-09.10					63	610	S5 005	60	610	S4 005				
HDi [B71]	09.10→	BWD	70	760	S6 008	63	610	S5 005	60	610	S4 005				
		BWD,SSJ	70	760	S6 008										
2.0 HDi [B5]	11.04-01.10					63	610	S5 005	60	610	S4 005				
	07.08-09.10					77	780	S5 008	74	780	S4 008				
HDi [B71]	09.10→	BWD				77	780	S5 008	74	780	S4 008				
C4 Aircross															
1.6	03.12→		70	760	S6 008										
Diesel															
1.6/ 1.8 HDi, HDi 4x4	03.12→		70	760	S6 008										
C4 Coupé															
1.4 [B5]	11.04-07.10					54	530	S5 002		530		40	340	S3 000	
		XXX							42		S4 000				
1.6 [B5]	11.04-07.10					54	530	S5 002		530		40	340	S3 000	
		XXX							42		S4 000				
THP [B5]	07.08-07.10					63	610	S5 005	60	610	S4 005				
2.0 [B5]	11.04-03.08					63	610	S5 005	60	610	S4 005	56	480	S3 005	
	11.04-07.08					63	610	S5 005	60	610	S4 005				
Diesel															
1.6 HDi [B5]	11.04-07.10					63	610	S5 005	60	610	S4 005				
2.0 HDi [B5]	11.04-07.09					63	610	S5 005	60	610	S4 005				
	07.08-07.10					77	780	S5 008	74	780	S4 008				
C4 Grand Picasso															
1.6 [B58]	07.08→	BWD				63	610	S5 005	60	610	S4 005	56	480	S3 005	
THP [B58]	07.08-11.09	BWD				63	610	S5 005	60	610	S4 005	56	480	S3 005	
	07.08→	BWD				63	610	S5 005	60	610	S4 005				
1.8/ 2.0 [B58]	10.06-10.08	BWD	70	760	S6 008	77	780	S5 008	74	780	S4 008				
Diesel															
1.6 HDi [B58]	10.06-12.11	BWD	70	760	S6 008	77	780	S5 008	74	780	S4 008				
	05.10→	BWD				63	610	S5 005	60	610	S4 005				
2.0 HDi [B58]	10.06-12.11	BWD				63	610	S5 005	60	610	S4 005				
	10.06→	BWD	70	760	S6 008	77	780	S5 008	74	780	S4 008				
	09.10→					77	780	S5 008	74	780	S4 008				
C4 Picasso															
1.6 THP [B58]	07.08-11.09	BWD				63	610	S5 005	60	610	S4 005	56	480	S3 005	
	07.08→	BWD				63	610	S5 005	60	610	S4 005				
1.6/ 2.0 [B58]	02.07→	BWD				63	610	S5 005	60	610	S4 005	56	480	S3 005	
1.8 [B58]	02.07-12.11	BWD				63	610	S5 005	60	610	S4 005				
Diesel															
1.6 HDi [B58]	02.07-12.11	BWD				77	780	S5 008	74	780	S4 008	70	640	S3 008	
	05.10→	BWD				63	610	S5 005	60	610	S4 005				
2.0 HDi [B58]	02.07-12.11	BWD				77	780	S5 008	74	780	S4 008	70	640	S3 008	
	07.09→	BWD	70	760	S6 008	77	780	S5 008	74	780	S4 008				
	09.10→					77	780	S5 008	74	780	S4 008				
C4 Sedan															
1.6 [B5]	07.06-12.10								44		S4 000	40	340	S3 000	
2.0 [B5]	07.06-12.10					63	610	S5 005	60	610	S4 005				

			Ah A (EN) S6	Ah A (EN) S5	Ah A (EN) S4	Ah A (EN) S3
			0 092 ...0	0 092 ...0	0 092 ...0	0 092 ...0

Diesel												
1.6 HDi [B5]	07.06-12.10					63	610	S5 005	60	610	S4 005	
C5												
1.6 [X7]	09.10→	BWD				63	610	S5 005	60	610	S4 005	
THP [X7]	09.09→	BWD				63	610	S5 005	60	610	S4 005	56 480 S3 005
1.8 [X7]	04.08-01.11	BWD							60		S4 005	56 480 S3 005
i [X3]	10.04-09.05					63	610	S5 005	60	610	S4 005	56 480 S3 005
	09.05-03.08		70	760	S6 008	63	610	S5 005	60	610	S4 005	
i 16V [X4]	03.01-09.04					63	610	S5 005	60	610	S4 005	56 480 S3 005
2.0 [X7]	04.08-01.10	BWD				63	610	S5 005	60	610	S4 005	56 480 S3 005
HPi [X4]	03.01-09.04		70	760	S6 008	77	780	S5 008	74	780	S4 008	
i [X3]	10.04-03.08		70	760	S6 008	63	610	S5 005	60	610	S4 005	56 480 S3 005
i 16V [X4]	03.01-09.04		70	760	S6 008	63	610	S5 005	60	610	S4 005	
3.0 [X7]	04.08-04.09	BWD				77	780	S5 008	60	780	S4 005	
i [X3]	10.04-04.07		70	760	S6 008	77	780	S5 008	74	780	S4 008	
i [X4]	03.01-09.04		70	760	S6 008	77	780	S5 008	74	780	S4 008	70 640 S3 008
Diesel												
1.6 HDi [X7]	04.08-07.10	BWD	70	760	S6 008	77	780	S5 008	60	780	S4 005	70 640 S3 008
	03.10→	BWD,SSJ				70	650	S5 E08		650		
	03.12→		70	760	S6 008	63	610	S5 005	60	610	S4 005	
1.6/ 2.0/ 2.2 HDi [X3; X4]	03.01-03.08		70	760	S6 008	77	780	S5 008	74	780	S4 008	
2.0 HDi [X7]	04.08→	BWD	70	760	S6 008	77	780	S5 008	74	780	S4 008	70 640 S3 008
	09.09→		70	760	S6 008	77	780	S5 008	74	780	S4 008	70 640 S3 008
2.2 HDi [X4]	03.01-09.04		70	760	S6 008	77	780	S5 008	74	780	S4 008	70 640 S3 008
HDi [X7]	04.08-09.09	BWD	70	760	S6 008	77	780	S5 008	74	780	S4 008	70 640 S3 008
	07.10→	BWD	70	760	S6 008	77	780	S5 008	74	780	S4 008	
2.7 HDi [X7]	04.08-07.09	BWD	70	760	S6 008	77	780	S5 008	74	780	S4 008	70 640 S3 008
3.0 HDi 24V [X7]	07.09→	BWD	70	760	S6 008	77	780	S5 008	74	780	S4 008	70 640 S3 008
C5 Break												
1.8 i [X3]	10.04-08.05		70	760	S6 008	63	610	S5 005	60	610	S4 005	56 480 S3 005
	09.05-03.08		70	760	S6 008	63	610	S5 005	60	610	S4 005	
i 16V [X4]	06.01-09.04		70	760	S6 008	63	610	S5 005	60	610	S4 005	
2.0 HPi [X4]	06.01-09.04		70	760	S6 008	77	780	S5 008	74	780	S4 008	
i [X3]	10.04-09.07		70	760	S6 008	63	610	S5 005	60	610	S4 005	56 480 S3 005
i 16V [X4]	06.01-09.04					63	610	S5 005	60	610	S4 005	56 480 S3 005
3.0 i [X3; X4]	06.01-04.07		70	760	S6 008	77	780	S5 008	74	780	S4 008	
Diesel												
1.6/ 2.0/ 2.2 HDi [X3; X4]	06.01-03.08		70	760	S6 008	77	780	S5 008	74	780	S4 008	
C5 Tourer												
1.6 [X7]	09.10→	BWD				63	610	S5 005	60	610	S4 005	
THP [X7]	09.09→					63	610	S5 005	60	610	S4 005	
1.8 [X7]	04.08-01.11	BWD				63	610	S5 005	60	610	S4 005	56 480 S3 005
2.0 [X7]	04.08-01.10	BWD				63	610	S5 005	60	610	S4 005	
3.0 24V [X7]	04.08-04.09	BWD				77	780	S5 008	60	780	S4 005	
Diesel												
1.6 HDi [X7]	04.08-07.10	BWD	70	760	S6 008	77	780	S5 008	74	780	S4 008	
	03.10→	BWD,SSJ				70	650	S5 E08		650		
	03.12→		70	760	S6 008	63	610	S5 005	60	610	S4 005	
2.0 HDi [X7]	04.08→	BWD	70	760	S6 008	77	780	S5 008	74	780	S4 008	
	09.09→		70	760	S6 008	77	780	S5 008	74	780	S4 008	
2.2 HDi [X7]	04.08-09.09	BWD	70	760	S6 008	77	780	S5 008	74	780	S4 008	70 640 S3 008
	07.10→	BWD	70	760	S6 008	77	780	S5 008	74	780	S4 008	
2.7 HDi [X7]	04.08-07.09	BWD	70	760	S6 008	77	780	S5 008	74	780	S4 008	70 640 S3 008
3.0 HDi 24V [X7]	07.09→		70	760	S6 008	77	780	S5 008	74	780	S4 008	
C6												
3.0 [X6]	11.05-02.09					74	750	S5 007	72	750	S4 007	
Diesel												
2.2 HDi [X6]	06.06-07.10					74	750	S5 007	72	750	S4 007	
2.7 HDi [X6]	11.05-07.09					100	830	S5 013		830		
3.0 HDi 24V [X6]	07.09→	BWD	70	760	S6 008	77	780	S5 008	74	780	S4 008	
C8												
2.0 16V [V3]	06.02-05.10		70	760	S6 008	77	780	S5 008	74	780	S4 008	70 640 S3 008
2.2 16V [V3]	06.02-05.06		70	760	S6 008	77	780	S5 008	74	780	S4 008	

			Ah A (EN) S6	Ah A (EN) S5	Ah A (EN) S4	Ah A (EN) S3
			0092 ...0	0092 ...0	0092 ...0	0092 ...0
◀ CITROEN						
3.0 [V3]	10.02-05.06		70 760 S6 008	77 780 S5 008	74 780 S4 008	70 640 S3 008
Diesel						
2.0 HDi [V3]	06.02-12.06		70 760 S6 008	77 780 S5 008	74 780 S4 008	70 640 S3 008
	06.02→		70 760 S6 008	77 780 S5 008	74 780 S4 008	
2.2 HDi [V3]	06.02-07.06		70 760 S6 008	77 780 S5 008	74 780 S4 008	70 640 S3 008
	09.07-05.10		70 760 S6 008	77 780 S5 008	74 780 S4 008	
DS3						
1.4 VTi [A55]	01.10→	BWD		54 530 S5 002	52 530 S4 002	
1.6 THP [A55]	01.10→	BWD		54 530 S5 002	52 530 S4 002	
				63 610 S5 005	60 610 S4 005	
THP Racing [A55]	10.10→	BWD		54 530 S5 002	52 530 S4 002	
				63 610 S5 005	60 610 S4 005	
VTi [A55]	01.10→	BWD			60 S4 005	
Diesel						
1.4 HDi 8V [A55]	03.10→	BWD,SSJ	70 760 S6 008			
1.6 HDi [A55]	11.09→			61 600 S5 004	60 600 S4 004	
	01.10→	BWD,SSJ		70 650 S5 E08	650	
DS4						
1.6 , THP [B75]	03.11→	BWD		63 610 S5 005	60 610 S4 005	
Diesel						
1.6 HDi [B75]	03.11→	BWD,SSJ	70 760 S6 008			
2.0 HDi 16V [B75]	03.11→	BWD		77 780 S5 008	74 780 S4 008	
DS5						
1.6 THP [B81]	09.11→	BWD		63 610 S5 005	60 610 S4 005	
Diesel						
1.6 HDi [B81]	09.11→	BWD,SSJ	70 760 S6 008			
2.0 HDi [B81]	09.11→	BWD	70 760 S6 008	77 780 S5 008	74 780 S4 008	
HDi Hybrid4 4x4 [B81]	09.11→	BWD	70 760 S6 008	77 780 S5 008	74 780 S4 008	
Dyane						
400	01.81-06.87					45 400 S3 002
		XXX		42	S4 000	
Evasion						
1.8/ 2.0 i, i Turbo, i 16V [U60]	06.94-07.02			63 610 S5 005	60 610 S4 005	56 480 S3 005
Diesel						
1.9/ 2.1 D Turbo [U60]	10.94-07.02		70 760 S6 008	63 610 S5 005	60 610 S4 005	
2.0 HDi [U60]	01.99-07.02		70 760 S6 008	77 780 S5 008	74 780 S4 008	70 640 S3 008
GSA						
1.1/ 1.2/ 1.3	09.79-07.86			54 530 S5 002	52 530 S4 002	45 400 S3 002
Jumper						
2.0 , i [23]	02.94-02.02		70 760 S6 008	77 780 S5 008	74 780 S4 008	70 640 S3 008
i [U5]	02.02-05.06		70 760 S6 008	77 780 S5 008	60 780 S4 005	56 480 S3 005
Diesel						
1.9 D [23]	02.94-02.02		95 850 S6 013	100 830 S5 013	95 830 S4 013	90 720 S3 013
	01.99-02.02		70 760 S6 008	77 780 S5 008	74 780 S4 008	70 640 S3 008
1.9/ 2.0/ 2.5/ 2.8 D Turbo, HDi, TDi [23]	02.94-02.02		95 850 S6 013	100 830 S5 013	95 830 S4 013	90 720 S3 013
2.0 HDi [U5]	02.02-05.06		70 760 S6 008	77 780 S5 008	74 780 S4 008	70 640 S3 008
2.2 HDi [U9]	06.06→			110 920 S5 015	920	
	06.11→		95 850 S6 013	110 920 S5 015	95 920 S4 013	
2.2/ 2.8 HDi [U5]	02.02-05.06		95 850 S6 013	100 830 S5 013	95 830 S4 013	
2.5/ 2.8 D [23]	02.94-02.02		95 850 S6 013	100 830 S5 013	95 830 S4 013	90 720 S3 013
3.0 HDi [U6]	03.11→			110 920 S5 015	920	
HDi [U9]	06.06→			110 920 S5 015	920	
Jumpy						
1.6 i [U64]	10.95-01.07			63 610 S5 006	60 610 S4 006	
2.0 i [U64]	04.00-01.07			63 610 S5 005	60 610 S4 005	
16V [G9]	02.07→		70 760 S6 008	77 780 S5 008	60 780 S4 005	
Diesel						
1.6 HDi [G9]	02.07→		70 760 S6 008	77 780 S5 008	74 780 S4 008	70 640 S3 008
1.9 D, D Turbo [U64]	10.95-01.07			63 610 S5 005	60 610 S4 005	
2.0 HDi [G9]	02.07→		70 760 S6 008	77 780 S5 008	74 780 S4 008	
	04.10→			77 780 S5 008	74 780 S4 008	

				Ah A (EN) S6	Ah A (EN) S5	Ah A (EN) S4	Ah A (EN) S3							
				0 092 ...0	0 092 ...0	0 092 ...0	0 092 ...0							
2.0 HDi [U64]	10.99-01.07			63	610	S5 005	60	610	S4 005					
	06.00-01.07			77	780	S5 008	74	780	S4 008					
LNA														
0.7/1.0/1.1	07.82-04.85							45	300	S3 016				
Mehari														
0.6	05.68-12.85						44	S4 000	40	340	S3 000			
							44	S4 000	45	400	S3 002			
		XXX					42	S4 000						
Nemo														
1.4 [A9]	02.08→			54	530	S5 002	52	530	S4 002					
Diesel														
1.3 HDi [A9]	08.10→	SSJ		60	560	S5 E05		560						
1.4 HDi [A9]	02.08→			63	610	S5 005	60	610	S4 005					
Picasso														
1.6 i	06.02-02.07			63	610	S5 005	52	610	S4 002	45	400	S3 002		
Saxo														
Electrique [S8]	01.97-09.03			54	530	S5 002	52	530	S4 002	45	400	S3 002		
1.0 i [S8]	02.96-09.03						44	S4 000	40	340	S3 000			
		XXX					42	S4 000						
1.1 i [S8]	02.96-09.03						44	S4 000	40	340	S3 000			
		XXX					42	S4 000						
	03.00-09.03								40	340	S3 000			
1.4/1.6 i [S8]	02.96-09.03			54	530	S5 002	52	530	S4 002	45	400	S3 002		
1.6 i 16V [S8]	07.96-09.03			54	530	S5 002	52	530	S4 002	45	400	S3 002		
Diesel														
1.5 D [S8]	07.96-09.03			63	610	S5 005	60	610	S4 005					
Visa														
0.6 [VD]	07.82-03.91						44	S4 000	40	340	S3 000			
		XXX					42	S4 000						
1.0 [VD]	02.84-03.91						44	S4 000	40	340	S3 000			
		XXX					42	S4 000						
1.1/1.4 [VD]	09.78-03.91			54	530	S5 002	52	530	S4 002	45	400	S3 002		
1.6 i [VD]	01.85-03.91			54	530	S5 002	52	530	S4 002	45	400	S3 002		
Diesel														
1.8 D [VD]	04.84-03.91			63	610	S5 005	60	610	S4 005					
Xantia														
1.6/1.8 i [X1]	03.93-01.98			63	610	S5 005	52	610	S4 002	45	400	S3 002		
i [X2]	10.97-12.01			63	610	S5 005	52	610	S4 002	45	400	S3 002		
1.8 i 16V [X2]	12.97-12.01			63	610	S5 005	52	610	S4 002	45	400	S3 002		
1.8/2.0 i Turbo, i 16V [X1]	03.93-12.98			63	610	S5 005	60	610	S4 005	56	480	S3 005		
2.0 i [X1]	03.93-01.98			63	610	S5 005	60	610	S4 005	56	480	S3 005		
i [X2]	12.97-12.01			63	610	S5 005	60	610	S4 005	56	480	S3 005		
i Turbo [X2]	12.97-12.01			63	610	S5 005	60	610	S4 005	56	480	S3 005		
i 16V [X2]	12.97-12.01			63	610	S5 005	60	610	S4 005	56	480	S3 005		
3.0 i [X1]	10.96-01.98		70	760	S6 008	77	780	S5 008	74	780	S4 008	70	640	S3 008
i [X2]	12.97-12.01		70	760	S6 008	77	780	S5 008	74	780	S4 008	70	640	S3 008
Diesel														
1.9 D, D Turbo [X1]	07.93-01.98			63	610	S5 005	60	610	S4 005					
D Turbo [X2]	12.97-12.01			63	610	S5 005	60	610	S4 005					
2.0 HDi [X2]	10.98-12.01		70	760	S6 008	77	780	S5 008	74	780	S4 008	70	640	S3 008
2.1 D Turbo [X1; X2]	05.95-12.01		70	760	S6 008	77	780	S5 008	74	780	S4 008	70	640	S3 008
Xantia Break														
1.8 i [X1]	09.95-01.98			63	610	S5 005	52	610	S4 002	45	400	S3 002		
i [X2]	12.97-12.01			63	610	S5 005	52	610	S4 002	45	400	S3 002		
i 16V [X1]	04.97-01.98			63	610	S5 005	60	610	S4 005	56	480	S3 005		
i 16V [X2]	12.97-12.01			63	610	S5 005	52	610	S4 002	45	400	S3 002		
2.0 i, i Turbo, i 16V [X1; X2]	09.95-12.01			63	610	S5 005	60	610	S4 005	56	480	S3 005		
3.0 i [X2]	01.98-12.01		70	760	S6 008	77	780	S5 008	74	780	S4 008	70	640	S3 008
Diesel														
1.9 D Turbo [X1; X2]	09.95-12.01			63	610	S5 005	60	610	S4 005					
2.0 HDi [X1; X2]	10.98-12.01		70	760	S6 008	77	780	S5 008	74	780	S4 008	70	640	S3 008
2.1 D Turbo [X1; X2]	06.96-12.01		70	760	S6 008	77	780	S5 008	74	780	S4 008	70	640	S3 008

			Ah A (EN) S6			Ah A (EN) S5			Ah A (EN) S4			Ah A (EN) S3		
			0092 ...0			0092 ...0			0092 ...0			0092 ...0		
◀ CITROEN														
XM														
2.0 [Y3]	05.89-06.94	70	760	S6 008	77	780	S5 008	60	780	S4 005	56	480	S3 005	
i [Y3]	05.89-06.94	70	760	S6 008	77	780	S5 008	60	780	S4 005	56	480	S3 005	
i [Y4]	07.94-10.00	70	760	S6 008	77	780	S5 008	60	780	S4 005	56	480	S3 005	
i 16V [Y4]	07.94-10.00	70	760	S6 008	77	780	S5 008	60	780	S4 005	56	480	S3 005	
2.0/3.0 i Turbo, i 24V [Y3]	05.89-06.94	70	760	S6 008	77	780	S5 008	74	780	S4 008	70	640	S3 008	
i Turbo, i 24V [Y4]	07.94-10.00	70	760	S6 008	77	780	S5 008	74	780	S4 008	70	640	S3 008	
3.0 i [Y3]	05.89-06.94	70	760	S6 008	77	780	S5 008	74	780	S4 008	70	640	S3 008	
i [Y4]	07.94-10.00	70	760	S6 008	77	780	S5 008	74	780	S4 008	70	640	S3 008	
Diesel														
2.1/2.5 D, D Turbo [Y3; Y4]	05.89-10.00	70	760	S6 008	77	780	S5 008	74	780	S4 008	70	640	S3 008	
Xsara														
1.4 i [N6]	07.97-08.00				63	610	S5 006	60	610	S4 006				
i [N7]	09.00-12.05				63	610	S5 005	52	610	S4 002	45	400	S3 002	
1.6 i 16V [N7]	09.00-12.05				63	610	S5 005	52	610	S4 002	45	400	S3 002	
1.6/1.8 i [N6]	07.97-08.00				63	610	S5 005	52	610	S4 002	45	400	S3 002	
1.8 i 16V [N6]	07.97-08.00				63	610	S5 005	60	610	S4 005				
2.0 i 16V [N6]	07.97-08.00				63	610	S5 005	60	610	S4 005	56	480	S3 005	
					63	610	S5 006	60	610	S4 006				
i 16V [N7]	09.00-12.05				63	610	S5 005	60	610	S4 005				
Diesel														
1.4 HDi [N6; N7]	01.03-12.05				63	610	S5 005	60	610	S4 005				
1.5/1.8/1.9 D, D Turbo [N6; N7]	07.97-12.05				63	610	S5 005	60	610	S4 005				
2.0 HDi [N6; N7]	02.99-12.05	70	760	S6 008	77	780	S5 008	74	780	S4 008				
Xsara Break														
1.4 i [N7]	09.00-12.05				63	610	S5 005	52	610	S4 002	45	400	S3 002	
1.4/1.6/1.8 i [N6]	10.97-08.00				63	610	S5 005	52	610	S4 002	45	400	S3 002	
1.6 i 16V [N7]	09.00-03.10				63	610	S5 005	52	610	S4 002	45	400	S3 002	
1.8/2.0 i 16V [N6]	04.98-08.00				63	610	S5 005	60	610	S4 005	56	480	S3 005	
2.0 i 16V [N7]	09.00-01.07				63	610	S5 005	60	610	S4 005				
Diesel														
1.4 HDi [N7]	01.03-12.05				63	610	S5 005	60	610	S4 005				
1.5/1.8/1.9 D, D Turbo [N6]	10.97-08.00				63	610	S5 005	60	610	S4 005				
1.9 D [N7]	09.00-12.05				63	610	S5 005	60	610	S4 005				
2.0 HDi [N6]	02.99-08.00	70	760	S6 008	77	780	S5 008	74	780	S4 008				
HDi [N7]	09.00-03.10	70	760	S6 008	77	780	S5 008	74	780	S4 008				
		70	760	S6 008	77	780	S5 008	74	780	S4 008	70	640	S3 008	
Xsara Coupé														
1.4 i [N7]	09.00-12.05				63	610	S5 005	52	610	S4 002	45	400	S3 002	
1.4/1.6/1.8 i [N6]	07.97-08.00				63	610	S5 005	52	610	S4 002	45	400	S3 002	
1.6 i 16V [N7]	09.00-12.05				63	610	S5 005	52	610	S4 002	45	400	S3 002	
1.8/2.0 i 16V [N6]	07.97-08.00				63	610	S5 005	60	610	S4 005	56	480	S3 005	
2.0 i 16V [N7]	09.00-12.05				63	610	S5 005	60	610	S4 005				
Diesel														
1.4/1.8/1.9 D, D Turbo, HDi [N6; N7]	07.97-12.05				63	610	S5 005	60	610	S4 005				
2.0 HDi [N6]	02.99-08.00	70	760	S6 008	77	780	S5 008	74	780	S4 008	70	640	S3 008	
HDi [N7]	09.00-12.05	70	760	S6 008	77	780	S5 008	74	780	S4 008				
		70	760	S6 008	77	780	S5 008	74	780	S4 008	70	640	S3 008	
Xsara Picasso														
1.6 i 16V [N68]	03.05-04.10				63	610	S5 005	52	610	S4 002	45	400	S3 002	
1.6/1.8 i [N68]	01.00-04.10				63	610	S5 005	52	610	S4 002	45	400	S3 002	
2.0 i 16V [N68]	03.01-04.10				63	610	S5 005	60	610	S4 005	56	480	S3 005	
Diesel														
1.6 HDi [N68]	05.04-04.10	70	760	S6 008	77	780	S5 008	74	780	S4 008	70	640	S3 008	
2.0 HDi [N68]	01.00-04.10	70	760	S6 008	77	780	S5 008	74	780	S4 008				
ZX														
1.1/1.4/1.6/1.8/1.9/2.0 , i, i 8V, i 16V [; N20/N21]	03.91→				54	530	S5 002	52	530	S4 002	45	400	S3 002	
Diesel														
1.4/1.5/1.8/1.9 D, D Turbo [N20/N21]	03.91-10.97				63	610	S5 005	60	610	S4 005				



2 CV									
6	07.79-07.90				44	S4 000	40	340	S3 000
					44	S4 000	45	400	S3 002
	XXX				42	S4 000			

DACIA

Dokker									
1.2/ 1.6 [FE/FK]	07.12→			54	530	S5 002	52	530	S4 002
Diesel									
1.5 dCi [FE/FK]	07.12→			63	610	S5 005	60	610	S4 005
Duster									
1.6 , 4x4 [HS]	10.09→			63	610	S5 005	60	610	S4 005
Diesel									
1.5 dCi, dCi 4x4 [HS]	10.09→			63	610	S5 005	60	610	S4 005
Lodgy									
1.2/ 1.6 [JS]	03.12→			54	530	S5 002	52	530	S4 002
Diesel									
1.5 dCi [JS]	03.12→			63	610	S5 005	60	610	S4 005
Logan									
1.2/ 1.4 [LS]	07.04→			54	530	S5 002	52	530	S4 002
1.6 [LS]	07.04→			63	610	S5 005	60	610	S4 005
	11.10→			54	530	S5 002	52	530	S4 002
16V [LS]	12.05→			63	610	S5 005	60	610	S4 005
Diesel									
1.5 dCi [LS]	06.05→			61	600	S5 004	60	600	S4 004
	10.05→			61	600	S5 004		600	
	XXX							53	470 S3 004
Logan MCV									
1.4 [KS/FS]	01.07→			54	530	S5 002	52	530	S4 002
1.6 [KS/FS]	01.07→			63	610	S5 005	60	610	S4 005
	11.10→			54	530	S5 002	52	530	S4 002
16V [KS/FS]	01.07→			63	610	S5 005	60	610	S4 005
Diesel									
1.5 dCi [KS/FS]	01.07→	70	760	S6 008	77	780	S5 008	74	780 S4 008
	11.10→			61	600	S5 004		600	
	XXX							53	470 S3 004
Logan Pick-Up									
1.6 [US]	01.07→			54	530	S5 002	52	530	S4 002
Diesel									
1.5 dCi [US]	01.07→			61	600	S5 004		600	
	XXX							53	470 S3 004
Sandero									
1.2 [BS]	06.08→			54	530	S5 002	52	530	S4 002
1.4 [BS]	06.08→						52	S4 002	45 400 S3 002
1.6 [BS]	06.08→			54	530	S5 002	52	530	S4 002
	11.10→			54	530	S5 002	52	530	S4 002
16V [BS]	11.10→			54	530	S5 002	52	530	S4 002
Diesel									
1.5 dCi [BS]	06.08→			63	610	S5 005	60	610	S4 005
Serie 1200									
1210 1.2	01.84-12.90			54	530	S5 002	52	530	S4 002
Serie 1300									
1304/ 1305/ 1307/ 1309/ 1310/ 1325 1.3, 1.4, 1.4	01.79-06.04			54	530	S5 002	52	530	S4 002
Double Cabin, 1.4 Liberta, 1.4 Pick Up, 1.6									
Diesel									
1310 1.6 D Turbo	01.87-12.97			63	610	S5 005	60	610	S4 005
Solenza									
1.4 i	04.03-04.05			54	530	S5 002	52	530	S4 002

			Ah A (EN) S6 0092 ...0	Ah A (EN) S5 0092 ...0	Ah A (EN) S4 0092 ...0	Ah A (EN) S3 0092 ...0
--	--	--	------------------------	------------------------	------------------------	------------------------

◀ DACIA

Diesel										
1.9 D	04.03-04.05	61	600	S5 004	60	600	S4 004			
Super Nova										
1.4 i	10.00-09.03	54	530	S5 002	52	530	S4 002	45	400	S3 002

DAEWOO

Brougham										
2.0 i, LPG	09.91-12.95	63	610	S5 005	60	610	S4 005	56	480	S3 005
Cielo										
1.5 i	08.94-08.97	63	610	S5 005	60	610	S4 005	56	480	S3 005
Espero										
1.5/ 1.8/ 2.0 i [KLEJ]	09.91-10.99	63	610	S5 005	60	610	S4 005	56	480	S3 005
Evanda										
2.0 i	03.03-01.05				60		S4 025			
Kalos										
1.4 [KLAS]	09.02-01.05				60		S4 025			
	04.03-01.05				52		S4 002	45	400	S3 003
Kalos Hatchback										
1.2/ 1.4 [KLAS]	09.02-01.05				60		S4 025			
Korando										
2.3 i 16V [KJ]	07.96-12.00				40		S4 018			
3.2 i 24V [KJ]	07.96-12.00				95		S4 029			
Diesel										
2.2/ 2.3/ 2.9 D, TD Intercooler [KJ; K4]	10.86-12.00				95		S4 029			
Lacetti										
1.4/ 1.6/ 1.8 i [KLAN]	03.04-01.05	63	610	S5 005	60	610	S4 006			
Lanos										
1.4/ 1.5/ 1.6 i [KLAT]	11.96-09.03	63	610	S5 005	60	610	S4 006	56	480	S3 006
Lanos Hatchback										
1.4/ 1.5/ 1.6 i [KLAT]	11.96-09.03	63	610	S5 005	60	610	S4 006	56	480	S3 006
Leganza										
1.8 i	03.97-07.02				40		S4 018			
1.8/ 2.0 i [KLAV, V100]	03.97-12.02	63	610	S5 006	60	610	S4 006	56	480	S3 006
Matiz										
0.8	01.01→				40		S4 019			
i	11.98-02.02				40		S4 018			
0.8/ 1.0, i [; KLYA]	04.98→				40		S4 018			
Musso										
2.0/ 2.3/ 3.2 i 16V, i 24V [MJ]	01.96-12.00				95		S4 029			
Diesel										
2.3/ 2.9 D, TD Intercooler [MJ]	07.93-12.00				95		S4 029			
New Matiz										
0.8 i	03.06→				40		S4 019			
New Prince										
2.0 i	04.96-02.97				70		S4 026			
LPG	04.96-02.97				70		S4 027			
Nexia										
1.5/ 1.6, i [; KLETN]	04.94→	63	610	S5 005	60	610	S4 005	56	480	S3 005
Nexia Hatchback										
1.5 i [KLETN]	11.94-08.97	63	610	S5 005	60	610	S4 005	56	480	S3 005
Nubira										
1.6 i [KLAJ, J100]	09.97-09.99	63	610	S5 006	60	610	S4 025			
i [KLAJ, 150, 190]	10.99-06.03	63	610	S5 006		610				
1.6/ 1.8/ 2.0 i [J200, KLAN; KLAJ, J100; KLAJ, 150, 190]	09.97-01.05				60		S4 025			
Nubira Hatchback										
1.6/ 2.0 i [KLAJ, J100]	09.97-09.99				60		S4 025			

			Ah A (EN) S6	Ah A (EN) S5	Ah A (EN) S4	Ah A (EN) S3
			0 092 ...0	0 092 ...0	0 092 ...0	0 092 ...0

Nubira I											
1.5 i	02.97-02.99					60				S4 025	
Nubira II											
1.5 i	03.99-11.02					60				S4 025	
Nubira Station Wagon											
1.6 i [KLAJ, J100]	09.97-09.99					60				S4 025	
1.6/ 1.8 i [J200, KLAN]	03.04-01.05					60				S4 025	
1.6/ 2.0 i [KLAJ, 150, 190]	08.99-06.03					60				S4 025	
2.0 i [KLAJ, J100]	09.97-09.99					40				S4 018	
Prince											
1.8/ 2.0 i, LPG	01.91-03.96		63	610	S5 005	60	610	S4 024	56	480	S3 005
Rezzo											
1.6/ 1.8/ 2.0 i [KLAU]	09.00-01.05					70				S4 027	
Royal											
1.9/ 2.0 Prince, Salon	09.80-12.87					70				S4 026	
Sens											
1.3 Si [TF698]	01.02→		63	610	S5 005	60	610	S4 006	56	480	S3 006
Super Salon											
2.0 i	09.91-12.95		63	610	S5 005	60	610	S4 024	56	480	S3 005
Tico											
0.8 [KLY3]	06.91-01.05					40				S4 018	
	01.96-01.05					45				S4 021	

DAF

V											
Diesel											
400 BN, EN, ET	12.86-12.93		52	520	S5 001	44	520	S4 001	41	360	S3 001

DAIHATSU

Cab Van											
1.0 , 4WD	01.85-12.95					40				S4 019	
Charade Hatchback											
Diesel											
1.0 D, D Turbo [G1; G3]	10.83-12.92					70				S4 026	
Charmant											
1.3/ 1.6	12.81-07.87					45				S4 021	
Copen											
0.7/ 1.3 [80; 81]	05.02→					40				S4 018	
Cuore											
Mira Turbo, 4WD	10.80-08.85					40				S4 018	
1.0/ 850 , i, i 12V [; L2; L5; L7]	08.94→					40				S4 018	
Feroza											
1.6 i 16V 4WD, 4WD	10.88-10.99					40				S4 019	
F70											
Diesel											
2.8 D	08.84-03.87					70				S4 027	
Hijet											
1.0	01.84-04.86		63	610	S5 005	60	610	S4 005	56	480	S3 006
	05.86-11.92					40				S4 018	
4WD	12.86-11.92					40				S4 019	
850	05.86-11.92					40				S4 018	
Hijet Pick-up											
1.0/ 1.3 , i, 16V	12.92→					40				S4 019	
Diesel											
1.2/ 1.4 D	03.96→		63	610	S5 005	60	610	S4 005	56	480	S3 005
Hijet Van											
1.0 i	03.95-05.98		63	610	S5 005	60	610	S4 005	56	480	S3 006
1.0/ 1.3 , 16V	12.92→					40				S4 018	

			Ah A (EN) S6	Ah A (EN) S5	Ah A (EN) S4	Ah A (EN) S3
			0092 ...0	0092 ...0	0092 ...0	0092 ...0

◀ DAIHATSU

Diesel												
1.2/ 1.4D	03.96→			63	610	S5 005	60	610	S4 005	56	480	S3 005
Materia												
1.3/ 1.5 , 4WD	09.06→						40		S4 018			
Move												
1.0/ 850 , i 12V	01.97-09.02						40		S4 018			
Rocky												
2.0/ 2.2 4WD	04.84-06.01						95		S4 029			
Diesel												
2.8 D Turbo 4WD	04.84-07.93						70		S4 027			
	05.93-03.02						95		S4 029			
D 4WD	04.84-06.01						95		S4 029			
Sirion I												
1.0 12V [M1]	05.00-07.04	JEA					40		S4 018			
Sirion II												
1.0/ 1.3/ 1.5 , 4WD [M3]	10.04→						40		S4 018			
Terios												
1.3 i 4WD [J1]	03.97-12.05						45		S4 022			
1.3/ 1.5 i 4WD [J2]	01.06→						40		S4 018			
Trevis												
1.0 [L6]	08.06→						40		S4 018			
YRV												
1.0 , 4WD [M2]	08.00-07.05						40		S4 018			

DAIMLER LTD.

Double-Six												
5.3 HE	01.81-12.92						70		S4 027			
6.0	02.93-12.99		95	850	S6 013	100	830	S5 013	95	830	S4 013	
Sovereign												
3.4/ 4.2	09.74-12.89						70		S4 027			
4.0												
32V/ 32V Kompressor	09.89-12.02		95	850	S6 013	100	830	S5 013	95	830	S4 013	

DODGE

Avenger												
2.0 [JS]	09.07-08.11			54	530	S5 002	52	530	S4 002			
2.4 [JS]	09.07-08.11			63	610	S5 006		610				
2.7 FlexFuel [JS]	09.07-08.10			63	610	S5 006		610				
Diesel												
2.0 CRD [JS]	09.07-08.10			54	530	S5 002	52	530	S4 002			
Caliber												
1.8/ 2.0 [PM]	09.06-12.10						60		S4 025			
[P3]	09.06-08.09						60		S4 025			
2.4 [PM]	09.06-08.11						60		S4 006			
SRT-4, 4x4 [PM]	09.06-08.10						60		S4 025			
Diesel												
2.0 CRD [PM; P3]	01.06-08.09						74		S4 009			
Caravan												
2.4/ 3.3/ 3.8 , 4x4 [RS]	09.00-08.07						70		S4 027			
Challenger												
6.1 [LC]	09.07-08.10			80	730	S5 E11		730				
				85	800	S5 010		800				
Journey												
2.4/ 2.7/ 3.5 , FlexFuel, 4x4 [JC]	09.08-12.10						60		S4 025			
Neon												
2.0 [PL]	09.99-08.05						70		S4 027			
Nitro												
4.0 4x4 [KA]	09.06-08.11			74	750	S5 007		750				



Diesel											
2.8 CRD, CRD 4x4 [KA]	09.06-08.09									95	S4 029
Viper Convertible											
8.3 SRT-10 [ZB]	09.02-08.06		100	830	S5 013				95	830	S4 013
8.4 SRT-10 [ZB]	09.07-08.10		100	830	S5 013				95	830	S4 013
Viper Coupé											
8.3 SRT-10 [ZB]	09.02-08.06		100	830	S5 013				95	830	S4 013
8.4 SRT-10 [ZB]	09.07-08.10		100	830	S5 013				95	830	S4 013

FERRARI

California																	
4.3	01.09→		70	760	S6 008		77	780	S5 008		74	780	S4 008		70	640	S3 008
F 40																	
	04.88-06.92										70	S4 027					
F 50																	
V12	07.95-10.97		70	760	S6 008		77	780	S5 008		74	780	S4 008				
F 355																	
Spider	05.94-10.10		70	760	S6 008		77	780	S5 008		74	780	S4 008				
F 360																	
Modena/ Spider , Challenge Stradale	03.99-12.05						74	750	S5 007		72	750	S4 007				
F 430																	
Coupé/ Scuderia/ Spider	01.05-12.09		70	760	S6 008		77	780	S5 008		74	780	S4 008				
FF																	
	09.11→		95	850	S6 013		100	830	S5 013		95	830	S4 013				
Mondial																	
T/8	01.88-02.94		70	760	S6 008		77	780	S5 008		74	780	S4 008		70	640	S3 008
8 Quattrovalvole	06.82-06.85		70	760	S6 008		77	780	S5 008		74	780	S4 008		70	640	S3 008
	09.85-12.87		70	760	S6 008		77	780	S5 008		74	780	S4 008		70	640	S3 008
Testarossa																	
4.9	10.84-10.91		70	760	S6 008		77	780	S5 008		74	780	S4 008		70	640	S3 008
208																	
GTB/ GTS Turbo	06.82-10.90										70	S4 027					
308																	
GTB/ GTS Quattrovalvole	07.81-06.85										70	S4 027					
328																	
GTB/ GTS	09.85-09.89										70	S4 027					
348																	
TB/ TS	02.90-04.94		70	760	S6 008		77	780	S5 008		74	780	S4 008		70	640	S3 008
400																	
4.8 i, i Automatic	05.79-03.85										70	S4 027					
412																	
4.9 i	06.85-12.88										70	S4 027					
456																	
GT/ GT/GTR 2+2, 48V	01.93-12.04		70	760	S6 008		77	780	S5 008		74	780	S4 008				
458 Italia																	
[F 142]	03.10→		70	760	S6 008		77	780	S5 008		74	780	S4 008		70	640	S3 008
512																	
M/ TR	01.92→										74	S4 009					
550																	
Barchetta	10.00-01.05										74	S4 009					
Maranello																	
Barchetta	10.96-12.03		70	760	S6 008		77	780	S5 008		74	780	S4 008				
	10.00-12.05		70	760	S6 008		77	780	S5 008		74	780	S4 008				
599																	
GTB Fiorano	01.06-12.12		95	850	S6 013		100	830	S5 013		95	830	S4 013				
GTO	04.10-12.12						100	830	S5 013		95	830	S4 013				



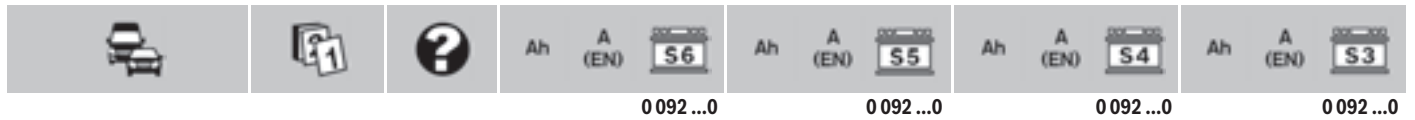

FIAT

Albea												
1.2 i.e. 8V [172]	01.02→				54	530	S5 002		52	530	S4 002	
1.2/ 1.6 i.e. 16V, i.e. 16V LPG [172]	01.02→				54	530	S5 002		52	530	S4 002	
1.4 i.e. 8V [172]	07.06→				63	610	S5 005		52	610	S4 002	45 400 S3 002
Diesel												
1.3 JTD 16V [172]	07.03→				63	610	S5 005			610		
Argenta												
100/ 110/ 120/ 135 , i.e., Volumex [132 MY83]	06.83-11.85											45 400 S3 003
Diesel												
2500 D, D Turbo [132 MY83]	06.83-11.85	70	760	S6 008	77	780	S5 008		74	780	S4 008	70 640 S3 008
Barchetta												
1.8 i.e. 16V [183]	01.95-02.05				63	610	S5 005		52	610	S4 002	45 400 S3 002
Brava												
1.2/ 1.6 16V [182 MY 98]	11.98-12.01				54	530	S5 002		52	530	S4 002	45 400 S3 002
1.4 12V [182 MY 95]	10.95-10.98				54	530	S5 002		52	530	S4 002	45 400 S3 002
1.6 16V [182 MY 95]	10.95-10.98				54	530	S5 002		52	530	S4 002	45 400 S3 002
1.8 16V [182 MY 95]	10.95-10.98				63	610	S5 005		60	610	S4 005	56 480 S3 005
16V [182 MY 98]	11.98-09.01				63	610	S5 005		60	610	S4 005	56 480 S3 005
Diesel												
1.9 D [182 MY 95]	10.95-10.98				63	610	S5 005			610		
JTD	01.01-12.02				63	610	S5 005			610		
JTD [182 MY 98]	11.98-09.01				63	610	S5 005		60	610	S4 005	
	08.00-09.01				63	610	S5 005		60	610	S4 005	56 480 S3 005
TD [182 MY 95]	03.96-10.98				63	610	S5 005		60	610	S4 005	
TD [182 MY 98]	11.98-09.01				63	610	S5 005		60	610	S4 005	
Bravo												
1.2/ 1.6 16V [182 MY98]	11.98-09.01				54	530	S5 002		52	530	S4 002	45 400 S3 002
1.4 [198 MY10]	03.10→				54	530	S5 002		52	530	S4 002	45 400 S3 002
LPG [198 MY10]	03.10→				54	530	S5 002		52	530	S4 002	
Turbo [198 MY10]	03.10→				54	530	S5 002		52	530	S4 002	45 400 S3 002
		SSJ			60	560	S5 E05			560		
Turbo 16V, 16V LPG [198 MY07]	07.07-12.09				54	530	S5 002		52	530	S4 002	
16V [198 MY07]	03.07-12.09				63	610	S5 005		52	610	S4 002	
1.4/ 1.6 12V, 16V [182 MY95]	10.95-10.98				54	530	S5 002		52	530	S4 002	45 400 S3 002
1.8/ 2.0 16V, 20V [182 MY95; 182 MY98]	10.95-09.01				63	610	S5 005		60	610	S4 005	56 480 S3 005
Diesel												
1.6 Multijet [198 MY10]	03.10→				63	610	S5 005			610		
					63	610	S5 005		60	610	S4 005	
1.6/ 1.9/ 2.0 Multijet [198 MY07]	03.07-12.09				63	610	S5 005			610		
1.9 D, JTD, TD [182 MY95; 182 MY98]	10.95-09.01				63	610	S5 005		60	610	S4 005	
2.0 Multijet [198 MY10]	03.10→				63	610	S5 005		60	610	S4 005	
					77	780	S5 008		74	780	S4 008	
Campagnola												
2.0	06.74-10.86											45 400 S3 003
Diesel												
2.5 D	06.79-10.86	70	760	S6 008	77	780	S5 008		74	780	S4 008	70 640 S3 008
Cinquecento												
1.1 i.e [170]	10.94-07.98								44		S4 000	40 340 S3 000
		XXX							42		S4 000	
700 [170]	07.91-07.98								44		S4 000	40 340 S3 000
		XXX							42		S4 000	
900 [170]	07.91-07.98								44		S4 000	40 340 S3 000
		XXX							42		S4 000	

						Ah A (EN) S6		Ah A (EN) S5		Ah A (EN) S4		Ah A (EN) S3	
				0 092 ...0		0 092 ...0		0 092 ...0		0 092 ...0		0 092 ...0	
900 i.e [170]	07.91-07.98									44	S4 000	40	340 S3 000
										42	S4 000		
Coupé													
1.8 16V [175 MY96]	10.96-09.00	70	760	S6 008	63	610	S5 005	52	610	S4 002	45	400	S3 002
1.8/ 2.0 i 16V, i 16V Turbo [175 MY93]	02.94-09.96	70	760	S6 008	63	610	S5 005	52	610	S4 002	45	400	S3 002
2.0 20V [175 MY96]	10.96-03.98	70	760	S6 008	63	610	S5 005	52	610	S4 002	45	400	S3 002
	04.98-09.00				63	610	S5 005	52	610	S4 002	45	400	S3 002
20V Turbo [175 MY96]	10.96-09.00	70	760	S6 008	63	610	S5 005	52	610	S4 002	45	400	S3 002
Croma													
1.6/ 2.0/ 2.5, i.e., i.e. Turbo, i.e. 16V [154 MY85; 154 MY90]	12.85-12.96				63	610	S5 005	52	610	S4 002	45	400	S3 002
1.8/ 2.2 i.e. [194 MY05]	06.05-12.10				63	610	S5 005		610				
Diesel													
1.9/ 2.4 JTD, JTD 8V, JTD 16V [194 MY05]	06.05-12.10				63	610	S5 005		610				
1.9/ 2.5 D, TD, TD i.d., TDI [154 MY85; 154 MY90]	12.85-12.96	70	760	S6 008	77	780	S5 008	74	780	S4 008	70	640	S3 008
Doblo													
1.2/ 1.6 i.e. 8V, i.e. 16V Bipower [223 MY00]	07.00-09.05				54	530	S5 002	52	530	S4 002			
1.4 [263 MY10]	02.10→				77	780	S5 008	74	780	S4 008	56	480	S3 005
				SSJ	65	650	S5 E07		650				
	10.11→				63	610	S5 005		610				
Natural Power [263 MY10]	06.10→				60	560	S5 E05		560				
1.4/ 1.6 i.e., i.e. 16V Bipower [223 MY05]	10.05-12.10				54	530	S5 002	52	530	S4 002			
1.6 i.e. 16V [223 MY00]	10.01-09.05				54	530	S5 002	52	530	S4 002	45	400	S3 002
Diesel													
1.3 Multijet [223 MY05]	10.05-12.10				63	610	S5 005	60	610	S4 005			
Multijet [263 MY10]	02.10→				60	560	S5 E05		560				
Multijet DPF [263 MY10]	02.10→				60	560	S5 E05		560				
1.3/ 1.9 D, JTD, JTD 16V [223 MY00]	07.00-09.05				63	610	S5 005		610				
1.6 Multijet [263 MY10]	02.10→				54	530	S5 002	44	530	S4 000	40	340	S3 000
				SSJ	60	560	S5 E05		560				
				XXX				42		S4 000			
1.9 Multijet [223 MY05]	10.05-12.10				63	610	S5 005		610				
2.0 Multijet [263 MY10]	02.10→			SSJ	70	650	S5 E08		650				
Doblo Cargo													
1.2/ 1.4/ 1.6 i.e., i.e. 8V, i.e. 16V [223..]	07.00-12.10				54	530	S5 002	52	530	S4 002			
1.4 [263..]	02.10→				77	780	S5 008	74	780	S4 008	56	480	S3 005
				SSJ	70	650	S5 E08		650				
	10.11→				63	610	S5 005		610				
Natural Power [263..]	06.10→				60	560	S5 E05		560				
1.6 i.e. 16V Bipower [223..]	01.03-09.05				54	530	S5 002	52	530	S4 002	45	400	S3 002
	10.05-12.10				54	530	S5 002	52	530	S4 002			
Diesel													
1.3/ 1.9 D, JTD, JTD 16V, Multijet [223..; 263.; 263..]	07.00→				63	610	S5 005		610				
1.6 Multijet [263..]	02.10→				54	530	S5 002		530				
					54	530	S5 002	44	530	S4 000	40	340	S3 000
					60	560	S5 E05		560				
				SSJ	60	560	S5 E05		560				
				XXX				42		S4 000			
2.0 Multijet [263..]	02.10→				70	650	S5 E08		650				
Ducato													
Diesel													
2.8 D	04.99-05.05	95	850	S6 013	100	830	S5 013	95	830	S4 013	90	720	S3 013

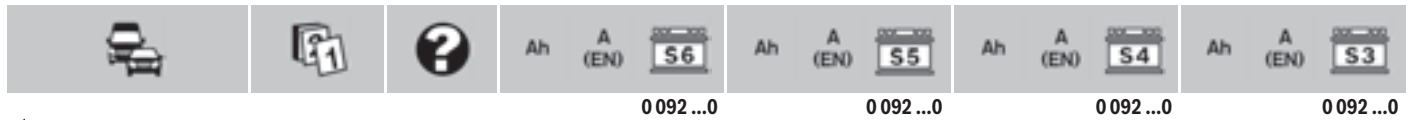

◀ FIAT

Ducato 10													
1.8/ 2.0 [280..]	09.81-06.90								74		S4009		
2.0 [290..]	07.90-02.94	70	760	S6 008	77	780	S5 008	74	780	S4 008	70	640	S3 008
, i.e. [230..]	03.94-03.02				63	610	S5 005	60	610	S4 005	56	480	S3 005
i.e. Bipower CNG 4x4 [230..]	03.94-03.02	70	760	S6 008	77	780	S5 008	74	780	S4 008	70	640	S3 008
Diesel													
1.9/ 2.0/ 2.5/ 2.8 D, JTD, JTD EGR, JTD EGR 4x4, JTD 4x4, TD, TD CAT, TD ECO, TD EGR, TD EGR 4x4, TD 4x4 [230..; 280..; 290..]	05.81-03.02	95	850	S6 013	100	830	S5 013	95	830	S4 013	90	720	S3 013
Ducato 11													
2.0 i.e. [244..]	04.02-08.06	70	760	S6 008	77	780	S5 008	74	780	S4 008			
i.e. 4x4 [244..]	04.02-08.06	70	760	S6 008	77	780	S5 008	74	780	S4 008	70	640	S3 008
Diesel													
2.0/ 2.3/ 2.8 JTD, JTD EGR, JTD EGR 4x4, TD, TD EGR, TD EGR 4x4 [244..]	04.02-08.06	95	850	S6 013	100	830	S5 013	95	830	S4 013			
2.8 JTD 4x4 [244..]	04.02-08.06	95	850	S6 013	100	830	S5 013	95	830	S4 013	90	720	S3 013
100/ 120/ 160 Multijet [250..]	06.06→				110	920	S5 015		920				
130 Multijet [250..]	06.06→	95	850	S6 013	100	830	S5 013	95	830	S4 013	90	720	S3 013
Ducato 12													
2.0 4x4 [290..]	07.90-02.94	70	760	S6 008	77	780	S5 008	74	780	S4 008	70	640	S3 008
Diesel													
2.5 D 4x4, TD 4x4 [290..]	07.90-02.94	95	850	S6 013	100	830	S5 013	95	830	S4 013	90	720	S3 013
Ducato 13													
2.0 [280..]	09.81-12.85							74		S4009			
Diesel													
2.5 D [280..]	05.81-12.85	95	850	S6 013	100	830	S5 013	95	830	S4 013	90	720	S3 013
Ducato 14													
2.0 [280..]	01.86-06.90							74		S4009			
[290..]	07.90-02.94	70	760	S6 008	77	780	S5 008	74	780	S4 008	70	640	S3 008
, i.e. [230..]	03.94-03.02	70	760	S6 008	77	780	S5 008	74	780	S4 008	70	640	S3 008
i.e. Bipower CNG 4x4 [230..]	03.94-03.02							74		S4009			
Diesel													
1.9/ 2.0/ 2.5/ 2.8 D, D 4x4, JTD, JTD EGR, JTD EGR 4x4, JTD 4x4, TD, TD CAT, TD ECO, TD ECO 4x4, TD EGR, TD EGR 4x4, TD 4x4 [230..; 280..; 290..]	01.86-03.02	95	850	S6 013	100	830	S5 013	95	830	S4 013	90	720	S3 013
Ducato 15													
2.0 i.e., i.e. Bipower CNG, i.e. Bipower CNG 4x4, i.e. Bipower LPG, i.e. Bipower LPG 4x4, i.e. 4x4 [244..]	04.02-08.06	70	760	S6 008	77	780	S5 008	74	780	S4 008			
Diesel													
2.0/ 2.3/ 2.8 JTD, JTD CGV, JTD EGR, JTD EGR 4x4, JTD 4x4, TD, TD EGR, TD EGR 4x4, TD 4x4 [244..]	04.02-08.06	95	850	S6 013	100	830	S5 013	95	830	S4 013			
100/ 120/ 160 Multijet [250..]	06.06→				110	920	S5 015		920				
130 Multijet [250..]	06.06→	95	850	S6 013	100	830	S5 013	95	830	S4 013	90	720	S3 013
Ducato 17													
140 Natural Power [250..]	06.06→	70	760	S6 008	77	780	S5 008	74	780	S4 008			
Diesel													
100/ 120/ 160 Multijet [250..]	06.06→				110	920	S5 015		920				

			Ah A (EN) S6			Ah A (EN) S5			Ah A (EN) S4			Ah A (EN) S3		
			0 092 ...0			0 092 ...0			0 092 ...0			0 092 ...0		
120/ 160 Multijet Maxi [250..]	06.06→					110	920	S5 015		920				
130 Multijet [250..]	06.06→	95	850	S6 013	100	830	S5 013	95	830	S4 013	90	720	S3 013	
Multijet Maxi [250..]	06.06→	95	850	S6 013	100	830	S5 013	95	830	S4 013	90	720	S3 013	
Ducato 18														
2.0 Maxi [280..]	06.86-06.90								74	S4 009				
i.e. Bipower CNG, Maxi [230..; 290..]	07.90-03.02	70	760	S6 008	77	780	S5 008	74	780	S4 008	70	640	S3 008	
i.e., i.e. Bipower CNG, i.e. Bipower CNG 4x4, i.e. Bipower LPG, i.e. Bipower LPG 4x4, i.e. 4x4 [244..]	04.02-08.06	70	760	S6 008	77	780	S5 008	74	780	S4 008				
Diesel														
2.3 JTD [244..]	04.02-08.06	95	850	S6 013	100	830	S5 013	95	830	S4 013				
2.5 D Maxi, TD Maxi [280..]	01.86-06.90	95	850	S6 013	100	830	S5 013	95	830	S4 013	90	720	S3 013	
D Maxi, TD Maxi [290..]	07.90-02.94	95	850	S6 013	100	830	S5 013	95	830	S4 013	90	720	S3 013	
2.5/ 2.8 D, D 4x4, JTD EGR 4x4, JTD 4x4, TD, TD ECO, TD EGR, TD EGR 4x4, TD 4x4 [230..]	03.94-03.02	95	850	S6 013	100	830	S5 013	95	830	S4 013	90	720	S3 013	
2.8 JTD [244..]	04.02-08.06	95	850	S6 013	100	830	S5 013	95	830	S4 013	90	720	S3 013	
JTD CGV, JTD EGR, JTD EGR 4x4, JTD 4x4, TD [244..]	04.02-08.06	95	850	S6 013	100	830	S5 013	95	830	S4 013				
JTD, JTD EGR [230..]	08.00-03.02	95	850	S6 013	100	830	S5 013	95	830	S4 013				
TD 4x4 [244..]	10.02-08.06	95	850	S6 013	100	830	S5 013	95	830	S4 013	90	720	S3 013	
Ducato 20														
140 Natural Power [250..]	09.09→	70	760	S6 008	77	780	S5 008	74	780	S4 008				
Diesel														
120/ 160 Multijet Maxi [250..]	06.06→				110	920	S5 015		920					
130 Multijet Maxi [250..]	06.06→	95	850	S6 013	100	830	S5 013	95	830	S4 013	90	720	S3 013	
150/ 160 Multijet [250..]	09.10→				110	920	S5 015		920					
Ducato 110														
Diesel														
2.3 Multijet [250..]	10.11→	95	850	S6 013	100	830	S5 013	95	830	S4 013				
Ducato 115														
Diesel														
2.0 Multijet [250..]	06.11→	70	760	S6 008	77	780	S5 008	74	780	S4 008				
Ducato 130														
Diesel														
2.3 Multijet [250..]	06.11→	95	850	S6 013	100	830	S5 013	95	830	S4 013	90	720	S3 013	
Ducato 150														
Diesel														
2.3 Multijet [250..]	06.11→				100	830	S5 013	95	830	S4 013				
Ducato 180														
Diesel														
3.0 Multijet [250..]	06.11→				110	920	S5 015		920					
Duna														
60/ 70 [155]	10.86-12.90				63	610	S5 005	52	610	S4 002	45	400	S3 002	
Diesel														
1.7 D [155]	10.86-12.90	70	760	S6 008	77	780	S5 008	60	780	S4 005	56	480	S3 005	
Duna Weekend														
60/ 70 [155]	10.86-12.90				63	610	S5 005	52	610	S4 002	45	400	S3 002	
Diesel														
1.7 D [155]	10.86-12.90	70	760	S6 008	77	780	S5 008	60	780	S4 005	56	480	S3 005	
Fiorino														
1.1/ 1.3 [146..]	01.88-12.01				63	610	S5 005	52	610	S4 002	45	400	S3 002	
1.4 [225..]														
	12.07→				54	530	S5 002	52	530	S4 002				
	06.10→				54	530	S5 002	52	530	S4 002	45	400	S3 002	
i.e. [146..]	09.93-06.95				77	780	S5 008	74	780	S4 008	70	640	S3 008	
	06.95-12.01				63	610	S5 005	52	610	S4 002	45	400	S3 002	
Natural Power [225..]	10.09→				63	610	S5 005		610					
1.5 i.e. [146..]	01.88-08.93				63	610	S5 005	52	610	S4 002	45	400	S3 002	

			Ah	A (EN)	S6	Ah	A (EN)	S5	Ah	A (EN)	S4	Ah	A (EN)	S3
			0092 ...0			0092 ...0			0092 ...0			0092 ...0		
◀ FIAT														
1.6 i.e. [146..]	09.93-12.01		70	760	S6 008	77	780	S5 008	74	780	S4 008	70	640	S3 008
Diesel														
1.3 D [146..; 147..]	04.82-08.93					77	780	S5 008	74	780	S4 008	70	640	S3 008
Multijet [225..]	12.07→					63	610	S5 005		610				
	06.10→					54	530	S5 002	52	530	S4 002	45	400	S3 002
1.7 D, TDS [146..]	01.88-12.01		70	760	S6 008	77	780	S5 008	74	780	S4 008	70	640	S3 008
Freemont														
3.6 4x4 [JC]	08.11→		70	760	S6 008	77	780	S5 008	74	780	S4 008			
Diesel														
2.0 JTD [JC]	06.11→					77	780	S5 008	74	780	S4 008			
JTD 4x4 [JC]	06.11→		70	760	S6 008	77	780	S5 008	74	780	S4 008			
Grande Punto														
Diesel														
1.3 Multijet [199]	07.08-12.11					63	610	S5 005		610				
	04.10-12.11					54	530	S5 002	52	530	S4 002	45	400	S3 002
Idea														
1.2 16V [350]	01.04-12.12					54	530	S5 002	52	530	S4 002	45	400	S3 002
	SSJ					60	560	S5 E05		560				
1.4 8V, 8V LPG [350]	11.04-12.12					54	530	S5 002	52	530	S4 002			
16V [350]	01.04-12.12					54	530	S5 002	52	530	S4 002			
Diesel														
1.3 Multijet [350]	11.04-11.10					63	610	S5 005		610				
Multijet [350]	01.04-11.10					63	610	S5 005	60	610	S4 005			
	05.08-12.12	SSJ				60	560	S5 E05		560				
1.6 Multijet [350]	04.08-12.12	SSJ				70	650	S5 E08		650				
1.9 Multijet [350]	01.04-12.12					63	610	S5 005	60	610	S4 005			
Linea														
1.4 , Turbo [323]	03.07→					63	610	S5 005		610				
1.6/ 1.9 , 16V [; 323]	07.08→					54	530	S5 002	52	530	S4 002			
Diesel														
1.3 Multijet [323]	03.07→					63	610	S5 005		610				
	09.09→					54	530	S5 002	52	530	S4 002			
1.3/ 1.6 JTD, Multijet [110; 323]	10.08→					63	610	S5 005	60	610	S4 005	56	480	S3 005
Marea														
1.2 i 16V [185]	03.99-09.02					54	530	S5 002	52	530	S4 002	45	400	S3 002
1.4 i 12V [185]	10.96-02.99					54	530	S5 002	52	530	S4 002	45	400	S3 002
1.6 i 16V [185]	10.96-12.02					54	530	S5 002	52	530	S4 002	45	400	S3 002
	05.01-12.02					54	530	S5 002	52	530	S4 002			
i 16V BI-Power [185]	10.97-09.02					54	530	S5 002	52	530	S4 002	45	400	S3 002
1.8 i 16V [185]	10.96-09.02					54	530	S5 002	52	530	S4 002	45	400	S3 002
2.0 i 20V [185]	10.96-09.02					54	530	S5 002	52	530	S4 002	45	400	S3 002
	10.00-12.02					54	530	S5 002	52	530	S4 002			
Diesel														
1.9 JTD	01.01-12.07					63	610	S5 005		610				
JTD [185]	03.99-09.02					63	610	S5 005		610				
JTD S.W. [185]	10.01-09.02					63	610	S5 005		610				
TD [185]	10.96-09.02					63	610	S5 005		610				
2.4 JTD [185]	03.99-09.02					63	610	S5 005	60	610	S4 005			
TD [185]	10.96-02.99					63	610	S5 005	60	610	S4 005			
Marea Weekend														
Diesel														
1.9 JTD	01.01-12.07					63	610	S5 005		610				
Marengo														
Diesel														
1.9 D, D Turbo [259..]	02.90-12.96					100	830	S5 013	95	830	S4 013	90	720	S3 013
JTD, TD [285..]	01.97-09.02					63	610	S5 005		610				
2000 D [138..]	01.86-07.89					100	830	S5 013	95	830	S4 013	90	720	S3 013
Multipla														
1.6 Blupower, 16V, 16V Bipower CNG, 16V LPG [186..]	01.99-12.10					63	610	S5 005	52	610	S4 002	45	400	S3 002







Diesel		0 092 ...0		0 092 ...0		0 092 ...0		0 092 ...0	
1.9 JTD [186..]	01.99-03.02	63	610	S5 005		610			
	04.02-12.10	63	610	S5 005	60	610	S4 005		
	10.03-12.10	63	610	S5 005		610			
Palio		0 092 ...0		0 092 ...0		0 092 ...0		0 092 ...0	
1.2 i.e. 8V [178..]	11.99→	54	530	S5 002	52	530	S4 002	45	400
	01.01-09.01	54	530	S5 002	52	530	S4 002		
1.2/1.6 i.e. 16V, i.e. 16V Sport [178..]	03.98→	54	530	S5 002	52	530	S4 002	45	400
1.4 i.e. [178..]	03.98-09.01	54	530	S5 002	52	530	S4 002	45	400
	07.03→	54	530	S5 002	52	530	S4 002	45	400
Diesel		0 092 ...0		0 092 ...0		0 092 ...0		0 092 ...0	
1.3/1.9 D, JTD 16V [178..]	01.03→	63	610	S5 005		610			
Palio Weekend		0 092 ...0		0 092 ...0		0 092 ...0		0 092 ...0	
1.2 i.e. 8V [178..]	03.99-09.01	54	530	S5 002	52	530	S4 002	45	400
	10.01→	54	530	S5 002	52	530	S4 002		
i.e. 16V [178..]	10.01→	54	530	S5 002	52	530	S4 002		
1.2/1.4 i.e. [178..]	11.97-02.02	54	530	S5 002	52	530	S4 002	45	400
1.6 i.e. 8V [178..]	06.01-09.02	54	530	S5 002	52	530	S4 002	45	400
i.e. 16V [178..]	11.97→	54	530	S5 002	52	530	S4 002	45	400
75/100 1.2 i.e., 1.6 i.e. 16V [178..]	09.97-09.04	54	530	S5 002	52	530	S4 002	45	400
Diesel		0 092 ...0		0 092 ...0		0 092 ...0		0 092 ...0	
1.7 TD [178..]	09.97-10.00	63	610	S5 005	60	610	S4 005		
1.9 D [178..]	11.00-09.01	63	610	S5 005		610			
	04.03-09.04	63	610	S5 005		610			
JTD [178..]	10.01-09.04	63	610	S5 005		610			
	06.02-12.08	63	610	S5 005	60	610	S4 005		
Panda		0 092 ...0		0 092 ...0		0 092 ...0		0 092 ...0	
0.9 [312..]	02.12→	60	560	S5 E05		560			
	SSJ	65	650	S5 E07		650			
Natural Power, 4x4 [312..]	06.12→	60	560	S5 E05		560			
1.1 i.e. [169..]	10.03-12.09							40	340
	XXX				42		S4 000		
1.2 [169..]	09.10-12.12	54	530	S5 002	52	530	S4 002		
	SSJ	60	560	S5 E05		560			
[312..]	02.12→	54	530	S5 002	52	530	S4 002		
i.e. [169..]	10.03-12.09							44	340
	XXX				42		S4 000		
i.e. LPG [169..]	12.06-12.09							40	340
	XXX				42		S4 000		
i.e. Natural Power [169..]	12.06-12.09							40	340
	XXX				42		S4 000		
i.e. 4x4 [169..]	10.04-12.09							40	340
	XXX				42		S4 000		
LPG [169]	01.09-12.12							40	340
	XXX				42		S4 000		
LPG [312..]	05.12→	54	530	S5 002	52	530	S4 002		
Natural Power [169..]	01.09-12.10							40	340
	XXX				42		S4 000		
4x4 [169..]	09.10-12.12	54	530	S5 002	52	530	S4 002		
1.4 [169..]	01.09-09.10	54	530	S5 002	52	530	S4 002	45	400
i.e. 16V [169..]	10.06-12.09	54	530	S5 002	52	530	S4 002		
Natural Power [169..]	09.10-12.12	54	530	S5 002	52	530	S4 002		
30 [141..]	03.80-12.85	54	530	S5 002	44	530	S4 000	40	340
	XXX				42		S4 000		
34/48 [141..]	02.81-12.85							45	400
45 [141..]	09.82-12.85	54	530	S5 002	44	530	S4 000	40	340
	XXX				42		S4 000		
48 4x4 [141..]	04.83-12.85	54	530	S5 002	44	530	S4 000	40	340
	XXX				42		S4 000		

								Ah A (EN) S6		Ah A (EN) S5		Ah A (EN) S4		Ah A (EN) S3	
◀ FIAT				0092 ...0		0092 ...0		0092 ...0		0092 ...0					
750 [141..]	01.86-07.92			54	530	S5 002	44	530	S4 000	40	340	S3 000			
		XXX					42		S4 000						
fire [141..]	01.86-12.92			54	530	S5 002	44	530	S4 000	40	340	S3 000			
		XXX					42		S4 000						
900 [141..]	01.86-03.92			54	530	S5 002	44	530	S4 000	40	340	S3 000			
		XXX					42		S4 000						
i.e. [141..]	04.92-09.03			54	530	S5 002	44	530	S4 000	40	340	S3 000			
		XXX					42		S4 000						
1000 [141..]	01.86-03.97			54	530	S5 002	44	530	S4 000	40	340	S3 000			
		XXX					42		S4 000						
ACT [141..]	10.87-06.90			54	530	S5 002	44	530	S4 000	40	340	S3 000			
		XXX					42		S4 000						
i.e. [141..]	01.86-09.03			54	530	S5 002	44	530	S4 000	40	340	S3 000			
		XXX					42		S4 000						
i.e. 4x4 [141..]	01.86-04.92			54	530	S5 002	44	530	S4 000	40	340	S3 000			
		XXX					42		S4 000						
Selecta [141..]	07.90-03.97			54	530	S5 002	44	530	S4 000	40	340	S3 000			
		XXX					42		S4 000						
4x4 [141..]	01.86-12.95			54	530	S5 002	44	530	S4 000	40	340	S3 000			
		XXX					42		S4 000						
1100 i.e. [141..]	04.92-09.03			54	530	S5 002	44	530	S4 000	40	340	S3 000			
		XXX					42		S4 000						
	12.00-09.03			54	530	S5 002		530		40	340	S3 000			
i.e. Selecta [141..]	01.86-09.03			54	530	S5 002	44	530	S4 000	40	340	S3 000			
		XXX					42		S4 000						
i.e. 4x4 [141..]	03.92-09.03			54	530	S5 002	44	530	S4 000	40	340	S3 000			
		XXX					42		S4 000						
Diesel															
1.3 [312..]	02.12→	SSJ		65	650	S5 E07		650							
D [141..]	07.90-08.92			54	530	S5 002	52	530	S4 002						
JTD, JTD 4x4 [169..]	01.04-12.09			54	530	S5 002	52	530	S4 002						
Multijet 4x4 [169..]	03.10-12.12						60		S4 005						
Multijet 4x4 [312..]	06.12→			60	560	S5 E05		560							
1300 D [141..]	03.86-12.89			54	530	S5 002	52	530	S4 002						
Panda Van															
1000 ACT [241..]	10.87-05.91			54	530	S5 002	44	530	S4 000	40	340	S3 000			
		XXX					42		S4 000						
Punto															
0.9 [199]	03.12→			60	560	S5 E05		560							
1.2 [199]	01.12→						44		S4 000	40	340	S3 000			
				54	530	S5 002	52	530	S4 002						
				60	560	S5 E05	52	560	S4 002						
Bipower [188]	07.03-12.10									40	340	S3 000			
		XXX					42		S4 000						
i 8V [188]	07.99-06.03									40	340	S3 000			
		XXX					42		S4 000						
i 8V Bipower [188]	11.02-06.03			54	530	S5 002	44	530	S4 000	40	340	S3 000			
		XXX					42		S4 000						
i 16V [188]	07.99-06.03									40	340	S3 000			
		XXX					42		S4 000						
i.e. 8V [188]	07.03-12.10									40	340	S3 000			
		XXX					42		S4 000						
i.e. 16V [188]	07.03-12.10									40	340	S3 000			
		XXX					42		S4 000						
LPG [188]	08.07-12.10			54	530	S5 002	52	530	S4 002						
1.4 [199]	01.12→						44		S4 000	40	340	S3 000			
				54	530	S5 002	52	530	S4 002						
				60	560	S5 E05	52	560	S4 002						
Abarth SS, LPG [199]	01.12→			54	530	S5 002	52	530	S4 002						
i.e. 16V [188]	07.03-12.10			54	530	S5 002		530		40	340	S3 000			
		XXX					42		S4 000						
Natural Power [199]	01.12→			54	530	S5 002	52	530	S4 002						
				60	560	S5 E05	52	560	S4 002						

					Ah A (EN) S6	Ah A (EN) S5	Ah A (EN) S4	Ah A (EN) S3					
					0 092 ...0	0 092 ...0	0 092 ...0	0 092 ...0					
1.8 i 16V [188]	07.99-06.03				54	530	S5 002	530	40	340	S3 000		
		XXX						42			S4 000		
	09.00-06.03				54	530	S5 002	44	530	S4 000	40	340	S3 000
i.e. 16V [188]	07.03-12.10				54	530	S5 002	530	40	340	S3 000		
		XXX						42			S4 000		
55 1.1 i.e. [176]	08.93-04.97				54	530	S5 002	44	530	S4 000	40	340	S3 000
	08.93-08.99	XXX						42			S4 000		
	05.97-08.99				54	530	S5 002	530	40	340	S3 000		
60 1.2 i.e. [176]	08.93-05.94				54	530	S5 002	44	530	S4 000	40	340	S3 000
		XXX						42			S4 000		
	06.95-04.97				54	530	S5 002	44	530	S4 000	40	340	S3 000
	06.95-08.99	XXX						42			S4 000		
	05.97-08.99				54	530	S5 002	530	40	340	S3 000		
1.2 i.e. Selecta [176]	06.94-04.97				54	530	S5 002	44	530	S4 000	40	340	S3 000
		XXX						42			S4 000		
75 1.2 i.e. [176]	08.93-04.97				54	530	S5 002	44	530	S4 000	40	340	S3 000
	08.93-08.99	XXX						42			S4 000		
	05.97-08.99				54	530	S5 002	530	40	340	S3 000		
85 1.2 i.e. 16V [176]	05.97-08.99				54	530	S5 002	530	40	340	S3 000		
		XXX						42			S4 000		
90 1.6 i.e. [176]	01.94-04.97				54	530	S5 002	44	530	S4 000	40	340	S3 000
		XXX						42			S4 000		
Diesel													
1.3 MJTD 16V [188]	07.03-12.10				54	530	S5 002	52	530	S4 002			
	Multijet [199]	01.12→			60	560	S5 E05	560					
		SSJ			60	560	S5 E05	560					
1.7 D, TD [176]	08.93-08.99				63	610	S5 005	610					
1.9 D [188]	07.99-06.03				63	610	S5 005	60	610	S4 005			
	JTD [188]	07.99-06.03			63	610	S5 005	610					
	JTD 8V [188]	07.03-12.10			54	530	S5 002	52	530	S4 002			
					63	610	S5 005	52	610	S4 002			
Punto Cabrio													
60 1.2 i.e. [176]	04.94-04.97				54	530	S5 002	44	530	S4 000	40	340	S3 000
	04.94-08.99	XXX						42			S4 000		
	05.97-08.99				54	530	S5 002	530	40	340	S3 000		
85 1.2 i.e. 16V [176]	05.97-08.99				54	530	S5 002	530	40	340	S3 000		
		XXX						42			S4 000		
90 1.6 i.e. [176]	04.94-04.97				54	530	S5 002	44	530	S4 000	40	340	S3 000
		XXX						42			S4 000		
Punto Evo													
1.2 8V [199]	10.09-12.11				54	530	S5 002	44	530	S4 000	40	340	S3 000
					54	530	S5 002	52	530	S4 002	40	340	S3 000
	09.10-12.11	SSJ			60	560	S5 E05	560					
1.4 Abarth [199]	06.10→	SSJ			65	650	S5 E07	650					
	LPG [199]	10.09-12.11			54	530	S5 002	52	530	S4 002			
	8V [199]	10.09-12.11			54	530	S5 002	44	530	S4 000	40	340	S3 000
					54	530	S5 002	52	530	S4 002			
			BWD,SSJ			60	560	S5 E05	560				
			XXX						42			S4 000	
	8V Natural [199]	10.09-12.11							44		S4 000	40	340
16V [199]	10.09-12.11				54	530	S5 002	530	40	340	S3 000		
		SSJ			65	650	S5 E07	650					
		XXX						42			S4 000		
Diesel													
1.3 Multijet [199]	10.09-12.11				54	530	S5 002	52	530	S4 002			
					60	560	S5 E05	560					
					60	560	S5 E05	52	560	S4 002			
					63	610	S5 005	610					
			BWD,SSJ			60	560	S5 E05	560				
	05.10-12.11	SSJ			65	650	S5 E07	650					
1.6 Multijet [199]	10.09-12.11				54	530	S5 002	530	40	340	S3 000		
		SSJ			70	650	S5 E08	650					
		XXX						42			S4 000		

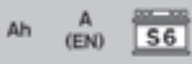
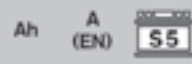
		Ah		A (EN)		S6		Ah		A (EN)		S5		Ah		A (EN)		S4		Ah		A (EN)		S3	
						0092 ...0						0092 ...0				0092 ...0				0092 ...0				0092 ...0	
FIAT																									
Punto Grande																									
1.2 [199]	10.05-12.11			54	530			S5 002	44	530	S4 000	40	340	S3 000											
		XXX								42	S4 000														
	09.10-12.11									44	S4 000	40	340	S3 000											
		SSJ		60	560	S5 E05				560															
1.4 [199]	10.05-12.11			54	530	S5 002			44	530	S4 000	40	340	S3 000											
		XXX								42	S4 000														
	03.06-12.09			54	530	S5 002				530		40	340	S3 000											
	06.06-12.11			54	530	S5 002			52	530	S4 002														
	06.07-12.09			63	610	S5 005				610															
Abarth [199]	10.07→			63	610	S5 005				610															
Abarth SS [199]	10.07→			54	530	S5 002			52	530	S4 002														
				60	560	S5 E05			52	560	S4 002														
CNG, LPG [199]	09.08-12.11								44		S4 000	40	340	S3 000											
Diesel																									
1.3/ 1.6/ 1.9 Multijet, Multijet [199]	10.05-12.11			63	610	S5 005				610															
Punto GT																									
1.4 i.e. Turbo [176]	08.93-04.97			54	530	S5 002			44	530	S4 000	40	340	S3 000											
	08.93-08.99	XXX								42	S4 000														
	05.97-08.99			54	530	S5 002				530		40	340	S3 000											
Punto Van																									
1.1 i.e. [276]	05.97-08.99			54	530	S5 002				530		40	340	S3 000											
		XXX								42	S4 000														
1.2 Bipower [288]	07.03-12.10									42	S4 000		40	340	S3 000										
i 8V [288]	07.99-12.10									42	S4 000		40	340	S3 000										
		XXX								42	S4 000														
Diesel																									
1.3 MJTD 16V [288]	07.03-12.10			54	530	S5 002				530															
		XXX								42	S4 000														
1.7 D, TD, TD SOFT [276]	05.97-08.99			63	610	S5 005				610															
1.9 D [288]	05.99-06.03			54	530	S5 002				530															
		XXX								42	S4 000														
JTD [288]	05.99-06.03			63	610	S5 005				610															
JTD 8V [288]	07.03-12.10			54	530	S5 002			52	530	S4 002														
Qubo																									
1.4 [300..]	09.08→			54	530	S5 002			52	530	S4 002	45	400	S3 002											
Natural Power [300..]	10.09→			54	530	S5 002			52	530	S4 002														
Diesel																									
1.3 Multijet [300..]	09.08→			63	610	S5 005			60	610	S4 005	56	480	S3 005											
	09.10→	SSJ		60	560	S5 E05				560															
Regata																									
60/ 70/ 75/ 85/ 90/ 100 , c.a., ES, i.e., S.i.e. [138..]	09.83-06.90			54	530	S5 002			52	530	S4 002	45	400	S3 002											
Diesel																									
1.7/ 1.9 D, D Super, D Turbo [138..]	09.83-07.89			63	610	S5 005				610															
Ritmo																									
1.1/ 60/ 70/ 75/ 85/ 90/ 100/ 125/ 130 , ES, i.e., TC Abarth [138A..]	10.82-12.88			63	610	S5 005			52	610	S4 002	45	400	S3 002											
105 TC [138A..]	10.82-04.85			63	610	S5 006			60	610	S4 006	45	400	S3 003											
Diesel																									
1.7/ 1.9 D, D Turbo [138A..]	10.82-12.87			63	610	S5 005			60	610	S4 005														
Scudo																									
1.6 i [222..]	10.95-05.00			63	610	S5 005			60	610	S4 005	56	480	S3 005											
2.0 [272..]	03.07→		70	760	S6 008			77	780	S5 008	74	780	S4 008												
16V [222..]	05.00-05.04			63	610	S5 005			60	610	S4 005	56	480	S3 005											
	06.04-01.07			63	610	S5 005				610															
Diesel																									
1.6 D Multijet [272..]	01.07→		70	760	S6 008			77	780	S5 008	74	780	S4 008												

																						
		0 092 ...0			0 092 ...0			0 092 ...0			0 092 ...0											
1.9/2.0 D, TD, 8V JTD, 16V JTD [222..]	10.95-01.07	70	760	S6 008	77	780	S5 008	74	780	S4 008	70	640	S3 008									
2.0 D [272..]	04.11→				77	780	S5 008	74	780	S4 008												
D Multijet [272..]	01.07→				77	780	S5 008	74	780	S4 008												
		70	760	S6 008	77	780	S5 008	74	780	S4 008												
Sedici																						
1.6 [189]	09.06→				54	530	S5 002	44	530	S4 001												
	08.09→				54	530	S5 002	52	530	S4 002												
4x4 [189]	05.06→				63	610	S5 005	52	610	S4 002												
	08.09→				54	530	S5 002	52	530	S4 002												
Diesel																						
1.9 JTD [189]	05.06→				63	610	S5 005		610													
1.9/2.0 JTD 4x4 [189]	05.06→				63	610	S5 005		610													
2.0 JTD [189]	08.09→				77	780	S5 008	74	780	S4 008												
Seicento																						
Elettra [187..]	10.98-12.03							44		S4 001	40	340	S3 000									
900 [187..]	03.98-12.03										40	340	S3 000									
	XXX							42		S4 000												
1100 [187..]	03.98-12.10										40	340	S3 000									
	XXX							42		S4 000												
Siena																						
1.2/1.4/1.6 i.e., i.e. 8V, i.e. 16V [178..]	04.97-12.01				54	530	S5 002	52	530	S4 002	45	400	S3 002									
Stilo																						
1.2/1.4/1.6 16V [192..]	10.01-12.07				63	610	S5 005	52	610	S4 002	45	400	S3 002									
1.8 16V [192..]	10.01-12.03				63	610	S5 005	52	610	S4 002	45	400	S3 002									
	01.04-12.07				63	610	S5 005	52	610	S4 002												
2.4 20V [192..]	10.01-12.07				63	610	S5 005		610													
Diesel																						
1.9 JTD 8V, JTD 16V [192..]	10.01-12.07				63	610	S5 005	60	610	S4 005												
Stilo Multi Wagon																						
1.4 16V [192..]	01.04-12.07				63	610	S5 005	52	610	S4 002	45	400	S3 002									
1.6 16V [192..]	10.02-12.07				63	610	S5 005	52	610	S4 002	45	400	S3 002									
	07.05-12.07				63	610	S5 005	52	610	S4 002												
16V Natural Power [192..]	04.06-12.07				63	610	S5 005	52	610	S4 002												
1.8 16V [192..]	10.02-12.07				63	610	S5 005	52	610	S4 002	45	400	S3 002									
2.4 20V [192..]	01.04-12.07				63	610	S5 005		610													
Diesel																						
1.9 JTD 8V, JTD 16V [192..]	10.02-12.07				63	610	S5 005	60	610	S4 005												
Strada																						
1.2 MPI 8V [278]	03.99-06.05				63	610	S5 005	52	610	S4 002	45	400	S3 002									
60/70/85/105/130 TC, TC Abarth, 1.1, 1.3, 1.5	12.81-06.88										45	400	S3 003									
Diesel																						
1.3 JTD [278]	07.05→				63	610	S5 005		610													
Multijet [278]	12.11→				54	530	S5 002	52	530	S4 002												
1.7 TDS [278]	03.99-03.03				63	610	S5 005	60	610	S4 005												
1.9 D [278]	11.00-06.05				63	610	S5 005	60	610	S4 005												
JTD [278]	04.03-06.05				63	610	S5 005	60	610	S4 005												
Talento																						
2.0	07.90-12.94	70	760	S6 008	77	780	S5 008	74	780	S4 008	70	640	S3 008									
Diesel																						
1.9 D	03.88-12.94	70	760	S6 008	77	780	S5 008	74	780	S4 008	70	640	S3 008									
Tempra																						
1.4/1.6/1.8/2.0 , i.e., i.e. Selecta [159]	02.90-12.96				63	610	S5 005	60	610	S4 005	56	480	S3 005									
Diesel																						
1.9 D, TD [159]	02.90-12.96	70	760	S6 008	77	780	S5 008	60	780	S4 005												
Tempra SW																						
1.4/1.6/1.8/2.0 , i.e., i.e. Selecta, i.e. 4x4 [159]	06.90-12.96				63	610	S5 005	60	610	S4 005	56	480	S3 005									
Diesel																						
1.9 D, TD [159]	02.90-12.96	70	760	S6 008	77	780	S5 008	60	780	S4 005												

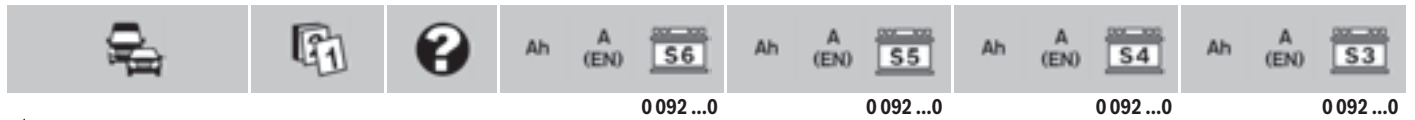

◀ FIAT

Tipo													
1.1/ 1.4 [160..]	07.87-10.95				63	610	S5 005	52	610	S4 002	45	400	S3 002
i.e. [160..]	05.89-10.95				63	610	S5 005	52	610	S4 002	45	400	S3 002
1.6 [160..]	07.87-12.92				63	610	S5 005	60	610	S4 005	56	480	S3 005
	03.93-10.95				63	610	S5 005	60	610	S4 005	56	480	S3 005
1.6/ 1.8/ 2.0 i.e. [160..]	02.88-10.95				63	610	S5 005	60	610	S4 005	56	480	S3 005
i.e. GT, i.e. Selecta, i.e. 16V [160..]	06.89-10.95				63	610	S5 005	60	610	S4 005	56	480	S3 005
Diesel													
1.7/ 1.9 D, D Turbo, TD [160..]	07.87-10.95	70	760	S6 008	77	780	S5 008	60	780	S4 005			
Ulysse													
1.8/ 2.0 i.e., i.e. Turbo, i.e. 16V [220..]	09.94-09.02				63	610	S5 005	60	610	S4 005	56	480	S3 005
2.0/ 3.0 V6 24V, 16V [179..]	10.02-10.05	70	760	S6 008	77	780	S5 008	74	780	S4 008			
Diesel													
1.9/ 2.0/ 2.1 JTD 8V, JTD 16V, TD [220..]	01.95-09.02	70	760	S6 008	77	780	S5 008	74	780	S4 008	70	640	S3 008
2.0 16V JTD [179..]	10.02-12.10	70	760	S6 008	77	780	S5 008	74	780	S4 008			
2.2 16V JTD [179..]	10.02-09.07	70	760	S6 008	77	780	S5 008	74	780	S4 008			
	10.07-12.10	70	760	S6 008	77	780	S5 008	74	780	S4 008	70	640	S3 008
Uno													
0.9 [146..]	01.83-05.85				54	530	S5 002	52	530	S4 002	45	400	S3 002
	09.89-09.92				54	530	S5 002	52	530	S4 002	45	400	S3 002
0.9/ 1.0 ES, fire, fire i.e. [146..]	01.83-08.89				54	530	S5 002	52	530	S4 002	45	400	S3 002
0.9/ 1.0/ 1.1/ 1.3 Matic, Selecta, Sting, Super, SX, Trend [146..]	01.83-03.94				54	530	S5 002	52	530	S4 002	45	400	S3 002
1.0 [146..]	09.89-03.94				54	530	S5 002	52	530	S4 002	45	400	S3 002
	01.98-05.00				54	530	S5 002	52	530	S4 002	45	400	S3 002
Base [146..]	09.89-03.94				54	530	S5 002	52	530	S4 002	45	400	S3 002
DAV-15 [146..]	09.89-03.94				54	530	S5 002	52	530	S4 002	45	400	S3 002
i.e. [146..]	09.89-03.94				54	530	S5 002	52	530	S4 002	45	400	S3 002
	01.96-12.02				54	530	S5 002	52	530	S4 002	45	400	S3 002
1.1 CS [146..]	09.87-09.91				52	520	S5 001	44	520	S4 001	41	360	S3 001
i.e. [146..]	09.89-03.94				54	530	S5 002	52	530	S4 002	45	400	S3 002
1.1/ 1.3 [146..]	01.83-09.92				54	530	S5 002	52	530	S4 002	45	400	S3 002
1.3 Turbo i.e. [146..]	04.85-03.91				54	530	S5 002	52	530	S4 002	45	400	S3 002
1.4 [146..]	09.89-09.92				52	520	S5 001	44	520	S4 001	41	360	S3 001
DAV-15 [146..]	09.89-03.94				63	610	S5 005	60	610	S4 005	56	480	S3 005
Turbo i.e. [146..]	09.89-12.93				63	610	S5 005	60	610	S4 005	56	480	S3 005
1.4/ 1.5 i.e. [146..]	10.85-03.94				63	610	S5 005	60	610	S4 005	56	480	S3 005
1.5 i.e. Selecta [146..]	05.92-03.94				63	610	S5 005	60	610	S4 005	56	480	S3 005
Diesel													
1.3/ 1.4/ 1.7/ 1.9 D, D Turbo, TD [146..]	06.83-03.94				63	610	S5 005	60	610	S4 005	56	480	S3 005
Uno Van													
0.9 [246..]	09.89-03.94				52	520	S5 001	44	520	S4 001	41	360	S3 001
1.0 [246..]	04.92-09.92				54	530	S5 002	52	530	S4 002	45	400	S3 002
i.e. [246..]	09.89-03.94				54	530	S5 002	52	530	S4 002	45	400	S3 002
Diesel													
1.7 D [246..]	01.91-03.94				63	610	S5 005	60	610	S4 005	56	480	S3 005
X 1/9													
1500	11.78-12.89				54	530	S5 002	44	530	S4 000	40	340	S3 000
				XXX				42		S4 000			
i.e.	06.80-12.88				54	530	S5 002	44	530	S4 000	40	340	S3 000
				XXX				42		S4 000			
124													
2000 Spider i.e., Spider Volumex	06.79-04.85				63	610	S5 006	60	610	S4 006	45	400	S3 003
126													
BIS/ Maluch/ 650	12.84-09.00										45	400	S3 003



127										
Panorama	03.81-12.86			63	610	S5 006	60	610	S4 006	
Pick Up/ 1050	03.81-12.86									45 400 S3 003
1050 Panorama	06.83-12.86									45 400 S3 003
Diesel										
1300 D, D Panorama	06.83-12.86			63	610	S5 006	60	610	S4 006	
242										
Diesel										
E	11.79-05.85						95		S4 013	90 720 S3 013
500										
0.9 [312]	09.10→	SSJ		60	560	S5 E05		560		
	09.12→			60	560	S5 E05		560		
1.2 [312]	07.07→									40 340 S3 000
		SSJ		60	560	S5 E05		560		
		XXX					42		S4 000	
LPG [312]	09.10→						44		S4 000	40 340 S3 000
1.4 [312]	07.07→									40 340 S3 000
		SSJ		60	560	S5 E05		560		
		XXX					42		S4 000	
Abarth [312]	05.08→									40 340 S3 000
							52		S4 002	
		SSJ		60	560	S5 E05		560		
		XXX					42		S4 000	
Diesel										
1.3 MJTD, Multijet [312]	07.07→			54	530	S5 002	52	530	S4 002	
500C										
0.9 [312]	09.10→	SSJ		60	560	S5 E05		560		
	09.12→			60	560	S5 E05		560		
1.2 [312]	07.09→									40 340 S3 000
		SSJ		60	560	S5 E05		560		
		XXX					42		S4 000	
1.4 [312]	07.09→									40 340 S3 000
		SSJ		60	560	S5 E05		560		
		XXX					42		S4 000	
Abarth [312]	09.09→			54	530	S5 002	52	530	S4 002	
	05.11→			60	560	S5 E05		560		
Diesel										
1.3 Multijet [312]	07.09→			54	530	S5 002	52	530	S4 002	
500L										
0.9/ 1.4 [199]	09.12→			60	560	S5 E05		560		
Diesel										
1.3 Multijet [199]	09.12→			60	560	S5 E05		560		
900										
E Furgone	12.79-12.87									45 400 S3 003

FORD

A										
0407/ 0510 , V6	01.86-12.99			61	600	S5 004	44	600	S4 001	41 360 S3 001
Diesel										
0407	01.86-12.99			61	600	S5 004	44	600	S4 001	41 360 S3 001
B-Max										
1.4	08.12→			61	600	S5 004		600		
		XXX								53 470 S3 004
1.6 Ti-VCT	08.12→			61	600	S5 004		600		
		XXX								53 470 S3 004
Bronco II										
2.9	01.88-08.90						70		S4 026	

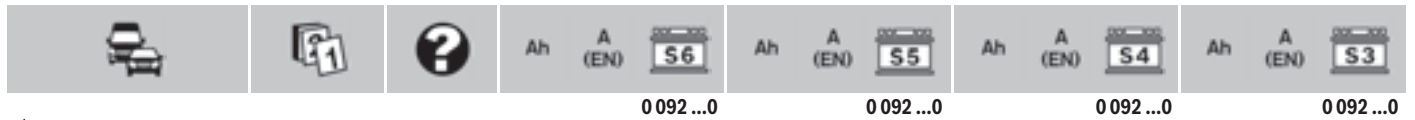



◀ FORD

Capri III												
1.3/ 1.6/ 2.0/ 2.3 [78]	01.78-04.87	FAD		61	600	S5 004	44	600	S4 001	41	360	S3 001
2.8 i [78]	01.81-04.87	FAD		61	600	S5 004	60	600	S4 004			
		FAD,XXX								53	470	S3 004
i Turbo [78]	01.81-04.87	FAD		61	600	S5 004	60	600	S4 004			
		FAD,XXX								53	470	S3 004
C-MAX												
1.6 [07]	03.07-07.10			61	600	S5 004	60	600	S4 004			
		XXX								53	470	S3 004
EcoBoost [11]	08.10→			75	730	S5 E10		730				
Ti-VCT [11]	08.10→			61	600	S5 004		600				
		XXX								53	470	S3 004
Ti-VCT FlexiFuel [11]	08.10→			61	600	S5 004		600				
		XXX								53	470	S3 004
1.8 [07]	03.07-07.10			61	600	S5 004	60	600	S4 004	53	500	S3 004
FFV [07]	03.07-07.10			61	600	S5 004	60	600	S4 004			
		XXX								53	470	S3 004
2.0 [07]	03.07-07.10			61	600	S5 004	60	600	S4 004			
		XXX								53	470	S3 004
CNG, LPG [07]	03.07-07.10			61	600	S5 004	60	600	S4 004	53	500	S3 004
Diesel												
1.6/ 1.8/ 2.0 TDCi [07; 11]	03.07→			74	750	S5 007	72	750	S4 007			
Cougar												
2.0 i	08.98-12.00			61	600	S5 004	60	600	S4 004			
		XXX								53	470	S3 004
2.5 i	08.98-12.00			61	600	S5 004	60	600	S4 004			
		XXX								53	470	S3 004
i ST200	01.00-12.00			61	600	S5 004	60	600	S4 004			
		XXX								53	470	S3 004
Econovan												
1.4	08.85-12.99						60		S4 024			
Diesel												
2.0 D	02.86-12.99						60		S4 024			
Escort												
1.6 i 16V	12.97-01.00			61	600	S5 004	44	600	S4 001	41	360	S3 001
Escort III												
1.1/ 1.3/ 1.6, i [81]	08.80-12.85	FAD		61	600	S5 004	44	600	S4 001	41	360	S3 001
Diesel												
1.6 D [81]	02.84-12.85	FAD		74	750	S5 007	60	750	S4 004			
		FAD,XXX								53	470	S3 004
Escort III Cabrio												
1.3/ 1.6 [81]	08.80-12.85	FAD		61	600	S5 004	44	600	S4 001	41	360	S3 001
Escort III Express												
1.1/ 1.3 35, 55 [81]	12.80-12.85	FAD		61	600	S5 004	44	600	S4 001	41	360	S3 001
Diesel												
1.6 D 35 [81]	02.84-12.85	FAD		74	750	S5 007	60	750	S4 004			
		FAD,XXX								53	470	S3 004
D 55 [81]	02.84-12.85	FAD		74	750	S5 007	60	750	S4 004			
		FAD,XXX								53	470	S3 004
Escort III RS												
1.6 Turbo [81]	10.84-12.85	FAD		61	600	S5 004	44	600	S4 001	41	360	S3 001
Escort III Turnier												
1.1/ 1.3/ 1.6 [81]	08.80-12.85	FAD		61	600	S5 004	44	600	S4 001	41	360	S3 001
Diesel												
1.6 D [81]	02.84-12.85	FAD		74	750	S5 007	60	750	S4 004			
		FAD,XXX								53	470	S3 004
Escort III XR3												
1.6 [81]	08.80-02.85	FAD		61	600	S5 004	44	600	S4 001	41	360	S3 001
Escort III XR3i												
1.6 i [81]	10.82-12.85	FAD		61	600	S5 004	44	600	S4 001	41	360	S3 001
Escort III XR3i Cabrio												
1.6 i [81]	10.82-12.85	FAD		61	600	S5 004	44	600	S4 001	41	360	S3 001



Escort IV											
1.1/ 1.3/ 1.4/ 1.6, i [86]	01.86-07.90	FAD	61	600	S5 004	44	600	S4 001	41	360	S3 001
Diesel											
1.6 D [86]	01.86-12.88	FAD	74	750	S5 007	60	750	S4 004			
		FAD,XXX							53	470	S3 004
1.8 D [86]	01.89-07.90	FAD	74	750	S5 007	60	750	S4 004			
		FAD,XXX							53	470	S3 004
Escort IV Cabrio											
1.4/ 1.6, i [86]	01.86-07.90	FAD	61	600	S5 004	44	600	S4 001	41	360	S3 001
Escort IV Express											
1.1/ 1.3/ 1.4/ 1.6, i [86]	01.86-07.90	FAD	61	600	S5 004	44	600	S4 001	41	360	S3 001
Diesel											
1.6 D [86]	01.86-12.88	FAD	74	750	S5 007	60	750	S4 004			
		FAD,XXX							53	470	S3 004
1.8 D [86]	01.89-07.90	FAD	74	750	S5 007	60	750	S4 004			
		FAD,XXX							53	470	S3 004
Escort IV RS											
1.6 RS Turbo [86]	01.86-07.90	FAD	61	600	S5 004	44	600	S4 001	41	360	S3 001
Escort IV Turnier											
1.1/ 1.3/ 1.4/ 1.6, i [86]	01.86-07.90	FAD	61	600	S5 004	44	600	S4 001	41	360	S3 001
Diesel											
1.6 D [86]	01.86-12.88	FAD	74	750	S5 007	60	750	S4 004			
		FAD,XXX							53	470	S3 004
1.8 D [86]	01.89-07.90	FAD	74	750	S5 007	60	750	S4 004			
		FAD,XXX							53	470	S3 004
Escort IV XR3i											
1.6 i [86]	01.86-07.90	FAD	61	600	S5 004	44	600	S4 001	41	360	S3 001
Escort IV XR3i Cabrio											
1.6 i [86]	01.86-07.90	FAD	61	600	S5 004	44	600	S4 001	41	360	S3 001
Escort VII											
1.3 i [95]	01.95-09.96	FAD	61	600	S5 004	44	600	S4 001	41	360	S3 001
1.4 i [95]	01.95-09.96	FAD	61	600	S5 004	60	600	S4 004			
		FAD,XXX							53	470	S3 004
	01.95-09.01								53	500	S3 004
	10.96-09.01		61	600	S5 004	60	600	S4 004			
		XXX							53	470	S3 004
1.6 i 16V [95]	01.95-09.01								53	500	S3 004
		FAD	61	600	S5 004	60	600	S4 004			
		FAD,XXX							53	470	S3 004
	08.96-01.00		61	600	S5 004	44	600	S4 001	41	360	S3 001
i 16V 4x4 [95]	01.95-09.01								53	500	S3 004
		FAD	61	600	S5 004	60	600	S4 004			
		FAD,XXX							53	470	S3 004
1.8 i 16V [95]	01.95-09.96	FAD	61	600	S5 004	60	600	S4 004			
		FAD,XXX							53	470	S3 004
	09.95-09.01								53	500	S3 004
	09.96-01.00		61	600	S5 004	44	600	S4 001	41	360	S3 001
Diesel											
1.8 D [95]	01.95-09.96	FAD	74	750	S5 007	60	750	S4 004			
		FAD,XXX							53	470	S3 004
TD [95]	01.95-09.96	FAD	74	750	S5 007	60	750	S4 004			
		FAD,XXX							53	470	S3 004
Escort VII Cabrio											
1.4 i [95]	01.95-09.96	FAD	61	600	S5 004	60	600	S4 004			
		FAD,XXX							53	470	S3 004
	01.95-09.01								53	500	S3 004
Diesel											
1.8 TD [95]	01.95-09.96	FAD	74	750	S5 007	60	750	S4 004			
		FAD,XXX							53	470	S3 004
Escort VII Express											
1.4 i 55 [95]	01.95-09.96	FAD	61	600	S5 004	60	600	S4 004			
		FAD,XXX							53	470	S3 004
	01.95-09.01								53	500	S3 004



				Ah A (EN) S6	Ah A (EN) S5	Ah A (EN) S4	Ah A (EN) S3
				0092 ...0	0092 ...0	0092 ...0	0092 ...0
◀ FORD							
1.4 i [95]	01.95-09.96	FAD		61	600	S5 004	60 600 S4 004
		FAD,XXX					53 470 S3 004
	01.95-09.01						53 500 S3 004
Diesel							
1.8 D 55 [95]	01.95-09.96	FAD		74	750	S5 007	60 750 S4 004
		FAD,XXX					53 470 S3 004
D 75 [95]	01.95-09.96	FAD		74	750	S5 007	60 750 S4 004
		FAD,XXX					53 470 S3 004
TD [95]	10.95-09.96	FAD		74	750	S5 007	60 750 S4 004
		FAD,XXX					53 470 S3 004
Escort VII RS							
2.0 i Cosworth [95]	01.95-12.95						53 500 S3 004
		FAD		74	750	S5 007	72 750 S4 007
							70 640 S3 007
2000 [95]	01.95-08.96						53 500 S3 004
		FAD		74	750	S5 007	72 750 S4 007
							70 640 S3 007
4x4 [95]	01.95-08.96						53 500 S3 004
		FAD		74	750	S5 007	72 750 S4 007
							70 640 S3 007
Escort VII Turnier							
1.3 i [95]	01.95-09.96	FAD		61	600	S5 004	44 600 S4 001
							41 360 S3 001
1.4 i [95]	01.95-09.96	FAD		61	600	S5 004	60 600 S4 004
		FAD,XXX					53 470 S3 004
	01.95-09.01						53 500 S3 004
1.6 i 16V [95]	01.95-09.96	FAD		61	600	S5 004	60 600 S4 004
		FAD,XXX					53 470 S3 004
	01.95-09.01						53 500 S3 004
1.8 i 16V [95]	01.95-09.96	FAD		61	600	S5 004	60 600 S4 004
		FAD,XXX					53 470 S3 004
	01.95-09.01						53 500 S3 004
Diesel							
1.8 D [95]	01.95-09.96	FAD		74	750	S5 007	60 750 S4 004
		FAD,XXX					53 470 S3 004
TD [95]	01.95-09.96	FAD		74	750	S5 007	60 750 S4 004
		FAD,XXX					53 470 S3 004
Escort VII XR3i Cabrio							
1.6 i [95]	01.95-09.96	FAD		61	600	S5 004	60 600 S4 004
		FAD,XXX					53 470 S3 004
	01.95-09.01						53 500 S3 004
1.8 i [95]	01.95-09.01						53 500 S3 004
		FAD		74	750	S5 007	60 750 S4 004
		FAD,XXX					53 470 S3 004
Escort V/VI							
1.1 [91]	08.90-12.94	FAD		61	600	S5 004	60 600 S4 004
		FAD,XXX					53 470 S3 004
1.3 [91]	08.90-12.94	FAD		61	600	S5 004	60 600 S4 004
		FAD,XXX					53 470 S3 004
i [91]	05.91-12.94	FAD		61	600	S5 004	60 600 S4 004
		FAD,XXX					53 470 S3 004
1.4 [91]	08.90-12.94	FAD		61	600	S5 004	60 600 S4 004
		FAD,XXX					53 470 S3 004
i [91]	08.90-12.94	FAD		61	600	S5 004	60 600 S4 004
		FAD,XXX					53 470 S3 004
1.6 [91]	08.90-12.94	FAD		61	600	S5 004	60 600 S4 004
		FAD,XXX					53 470 S3 004
i [91]	08.90-09.92	FAD		61	600	S5 004	60 600 S4 004
		FAD,XXX					53 470 S3 004
i 16V [91]	09.92-12.94	FAD		61	600	S5 004	60 600 S4 004
		FAD,XXX					53 470 S3 004
1.8 i 16V [91]	03.92-12.94	FAD		61	600	S5 004	60 600 S4 004
		FAD,XXX					53 470 S3 004
Diesel							
1.8 D, TD [91]	08.90-12.94	FAD		74	750	S5 007	72 750 S4 007
							70 640 S3 007



Escort V/VI Cabrio											
1.4 i [91]	08.90-12.94	FAD FAD,XXX	61	600	S5 004	60	600	S4 004	53	470	S3 004
1.6 i [91]	08.90-09.92	FAD FAD,XXX	61	600	S5 004	60	600	S4 004	53	470	S3 004
i 16V [91]	02.93-12.94	FAD FAD,XXX	61	600	S5 004	60	600	S4 004	53	470	S3 004
Escort V/VI Express											
1.3 [91]	08.90-12.94	FAD FAD,XXX	61	600	S5 004	60	600	S4 004	53	470	S3 004
1.4 i [91]	08.90-12.94	FAD FAD,XXX	61	600	S5 004	60	600	S4 004	53	470	S3 004
Diesel											
1.8 D [91]	08.90-12.94	FAD	74	750	S5 007	72	750	S4 007	70	640	S3 007
Escort V/VI RS											
2.0 i Cosworth [91]	04.92-12.94	FAD FAD,XXX	61	600	S5 004	60	600	S4 004	53	470	S3 004
2000 [91]	05.91-12.94	FAD FAD,XXX	61	600	S5 004	60	600	S4 004	53	470	S3 004
Escort V/VI Turnier											
1.3 [91]	08.90-12.94	FAD FAD,XXX	61	600	S5 004	60	600	S4 004	53	470	S3 004
i [91]	08.90-12.94	FAD FAD,XXX	61	600	S5 004	60	600	S4 004	53	470	S3 004
1.4 [91]	08.90-09.92	FAD FAD,XXX	61	600	S5 004	60	600	S4 004	53	470	S3 004
i [91]	08.90-12.94	FAD FAD,XXX	61	600	S5 004	60	600	S4 004	53	470	S3 004
1.6 [91]	08.90-12.94	FAD FAD,XXX	61	600	S5 004	60	600	S4 004	53	470	S3 004
i [91]	08.90-09.92	FAD FAD,XXX	61	600	S5 004	60	600	S4 004	53	470	S3 004
i 16V [91]	09.92-12.94	FAD FAD,XXX	61	600	S5 004	60	600	S4 004	53	470	S3 004
1.8 i 16V [91]	02.92-12.94	FAD FAD,XXX	61	600	S5 004	60	600	S4 004	53	470	S3 004
Diesel											
1.8 D, TD [91]	08.90-12.94	FAD	74	750	S5 007	72	750	S4 007	70	640	S3 007
Escort V/VI XR3i											
1.8 i [91]	02.92-12.94	FAD FAD,XXX	61	600	S5 004	60	600	S4 004	53	470	S3 004
Escort V/VI XR3i Cabrio											
1.8 i [91]	02.92-12.94	FAD FAD,XXX	61	600	S5 004	60	600	S4 004	53	470	S3 004
Explorer											
4.0/ 5.0, i, 4x4	01.91-08.10		74	750	S5 007	72	750	S4 007	70	640	S3 007
Explorer Sport Trac											
4.0 FFV 4x4	09.02-08.05		74	750	S5 007	72	750	S4 007	70	640	S3 007
Fiesta II											
0.9/ 1.1/ 1.3/ 1.4/ 1.6, i, XR2 [84]	08.83-02.89	FAD	61	600	S5 004	44	600	S4 001	41	360	S3 001
Diesel											
1.6 D [84]	04.84-02.89	FAD FAD,XXX	74	750	S5 007	60	750	S4 004	53	470	S3 004
Fiesta III											
1.0/ 1.1/ 1.3/ 1.4 [89]	03.89-12.96	FAD	61	600	S5 004	44	600	S4 001	41	360	S3 001
1.1/ 1.3/ 1.4 i [89]	03.89-12.96	FAD	61	600	S5 004	44	600	S4 001	41	360	S3 001
1.6 [89]	03.89-12.96	FAD FAD,XXX	61	600	S5 004	60	600	S4 004	53	470	S3 004
i 16V [89]	02.94-12.96	FAD FAD,XXX	61	600	S5 004	60	600	S4 004	53	470	S3 004
Turbo [89]	07.90-12.96	FAD FAD,XXX	61	600	S5 004	60	600	S4 004	53	470	S3 004



				Ah A (EN) S6		Ah A (EN) S5		Ah A (EN) S4		Ah A (EN) S3	
				0092 ...0		0092 ...0		0092 ...0		0092 ...0	
◀ FORD											
1.6 XR2i [89]	03.89-12.96	FAD		61	600	S5 004	60	600	S4 004		
		FAD,XXX								53	470 S3 004
1.8 i 16V [89]	02.92-12.96	FAD		61	600	S5 004	60	600	S4 004		
		FAD,XXX								53	470 S3 004
XR2i 16V [89]	02.92-12.96	FAD		61	600	S5 004	60	600	S4 004		
		FAD,XXX								53	470 S3 004
Diesel											
1.8 D [89]	03.89-12.96	FAD		74	750	S5 007	72	750	S4 007	70	640 S3 007
Fiesta III Courier											
1.3 i [89]	09.91-08.96	FAD		61	600	S5 004	44	600	S4 001	41	360 S3 001
Diesel											
1.8 D [89]	09.91-08.96	FAD		74	750	S5 007	72	750	S4 007	70	640 S3 007
Fiesta IV											
1.25 i 16V [96]	11.95-12.02			61	600	S5 004	44	600	S4 001	41	360 S3 001
1.3 i [96]	11.95-12.02			61	600	S5 004	44	600	S4 001	41	360 S3 001
1.4 i 16V [96]	01.96-12.00			61	600	S5 004	60	600	S4 004	53	500 S3 004
		XXX								53	470 S3 004
1.6 i 16V [96]	02.00-12.02			61	600	S5 004	60	600	S4 004		
		XXX								53	470 S3 004
Diesel											
1.8 D [96]	10.95-06.01			74	750	S5 007	60	750	S4 004		
		XXX								53	470 S3 004
TD [96]	02.00-12.02			74	750	S5 007	60	750	S4 004		
		XXX								53	470 S3 004
Fiesta IV Courier											
1.3 i [96]	11.95-12.02			61	600	S5 004	44	600	S4 001	41	360 S3 001
1.4 i [96]	01.96-12.00			61	600	S5 004	60	600	S4 004	53	500 S3 004
		XXX								53	470 S3 004
Diesel											
1.8 D [96]	10.95-06.01			74	750	S5 007	60	750	S4 004		
		XXX								53	470 S3 004
TD [96]	02.00-12.02			74	750	S5 007	60	750	S4 004		
Fiesta V											
1.25/ 1.3 i [02]	11.01-09.08			52	520	S5 001	44	520	S4 001	41	360 S3 001
1.4 i [02]	11.01-09.08			61	600	S5 004	44	600	S4 001		
1.6 i [02]	11.01-09.08			61	600	S5 004	44	600	S4 001	53	500 S3 004
2.0 i ST150 [02]	11.04-09.08			61	600	S5 004	60	600	S4 004		
		XXX								53	470 S3 004
Diesel											
1.4/ 1.6 TDCi [02]	11.01-09.08			74	750	S5 007	60	750	S4 004		
Fiesta VI											
1.25 i [08]	07.08-11.12			52	520	S5 001	44	520	S4 001	41	360 S3 001
1.4 i [08]	07.08-11.12			61	600	S5 004	44	600	S4 001		
LPG [08]	05.09-11.12			52	520	S5 001	44	520	S4 001		
1.6 Ti-VCT [08]	07.08-11.12			61	600	S5 004	60	600	S4 004		
Ti-VCT Sport S [08]	01.11-11.12			61	600	S5 004	600				
		XXX								53	470 S3 004
Diesel											
1.4 TDCi [08]	07.08-11.12			63	610	S5 006	60	610	S4 006		
	09.10-11.12						72	S4 007			
1.6 TDCi [08]	07.08-11.12			63	610	S5 006	60	610	S4 006		
	01.09-11.12			61	600	S5 004	60	600	S4 004		
	03.10-11.12			61	600	S5 004	600				
		XXX								53	470 S3 004
Focus											
1.6 i	06.00-06.04			61	600	S5 004	44	600	S4 001		
2.0 i	08.04-→						60	S4 004			
Focus C-MAX											
1.6 [04]	09.03-03.07			61	600	S5 004	60	600	S4 004		
		XXX								53	470 S3 004
Ti-VCT [04]	07.04-03.07			61	600	S5 004	60	600	S4 004		
		XXX								53	470 S3 004

								Ah A (EN)		Ah A (EN)		Ah A (EN)		Ah A (EN)	
				0 092 ...0		0 092 ...0		0 092 ...0		0 092 ...0		0 092 ...0		0 092 ...0	
1.8 [04]	06.03-03.07			74	750	S5 007	60	750	S4 004						
		XXX										53	470	S3 004	
FFV [04]	05.05-03.07			74	750	S5 007	60	750	S4 004						
		XXX										53	470	S3 004	
2.0 [04]	04.04-03.07			74	750	S5 007	60	750	S4 004						
		XXX										53	470	S3 004	
CNG [04]	11.05-03.07			74	750	S5 007	60	750	S4 004						
		XXX										53	470	S3 004	
Diesel															
1.6/ 1.8/ 2.0 TDCi [04]	06.03-03.07			74	750	S5 007	72	750	S4 007						
Focus I															
1.4 i [99]	08.98-05.05			61	600	S5 004	44	600	S4 001	41	360	S3 001			
	12.00-05.05			61	600	S5 004	44	600	S4 001						
1.6 i [99]	08.98-05.05			61	600	S5 004	44	600	S4 001	41	360	S3 001			
	09.02-05.05			61	600	S5 004	44	600	S4 001						
i FFV [99]	10.01-05.05			61	600	S5 004	44	600	S4 001						
1.8 i [99]	08.98-05.05			61	600	S5 004	60	600	S4 004						
		XXX										53	470	S3 004	
2.0 i [99]	08.98-05.05			61	600	S5 004	60	600	S4 004						
		XXX										53	470	S3 004	
i RS [99]	09.02-05.05			74	750	S5 007	60	750	S4 004						
		XXX										53	470	S3 004	
i ST170 [99]	02.02-05.05			74	750	S5 007	60	750	S4 004						
		XXX										53	470	S3 004	
Diesel															
1.8 TDCi [99]	05.01-05.05			74	750	S5 007	72	750	S4 007						
TDDi [99]	01.99-05.05			74	750	S5 007	72	750	S4 007	70	640	S3 007			
Focus I Turnier															
1.4 i [99]	11.98-05.05			61	600	S5 004	44	600	S4 001	41	360	S3 001			
	12.00-05.05			61	600	S5 004	44	600	S4 001						
1.6 i [99]	11.98-05.05			61	600	S5 004	44	600	S4 001	41	360	S3 001			
				74	750	S5 007	72	750	S4 007						
	09.02-05.05			61	600	S5 004	44	600	S4 001						
i FFV [99]	10.01-05.05			61	600	S5 004	44	600	S4 001						
1.8 i [99]	11.98-05.05			61	600	S5 004	60	600	S4 004						
		XXX										53	470	S3 004	
2.0 i [99]	11.98-05.05			61	600	S5 004	60	600	S4 004						
		XXX										53	470	S3 004	
i ST170 [99]	02.02-05.05			74	750	S5 007	60	750	S4 004						
		XXX										53	470	S3 004	
Diesel															
1.8 TDCi [99]	05.01-05.05			74	750	S5 007	72	750	S4 007						
TDDi [99]	01.99-05.05			74	750	S5 007	72	750	S4 007	70	640	S3 007			
Focus II															
1.4 i [04]	07.04-01.08			61	600	S5 004	60	600	S4 004						
		XXX										53	470	S3 004	
i [08]	12.07-12.11			61	600	S5 004	60	600	S4 004						
		XXX										53	470	S3 004	
1.6 i [04]	07.04-01.08			61	600	S5 004	60	600	S4 004						
		XXX										53	470	S3 004	
i [08]	12.07-12.11			61	600	S5 004	60	600	S4 004						
		XXX										53	470	S3 004	
Ti-VCT [04]	07.04-01.08			61	600	S5 004	60	600	S4 004						
		XXX										53	470	S3 004	
Ti-VCT [08]	12.07-12.11			61	600	S5 004	60	600	S4 004						
		XXX										53	470	S3 004	
1.8 FFV [04]	07.04-01.08			61	600	S5 004	60	600	S4 004						
		XXX										53	470	S3 004	
	05.05-01.08			74	750	S5 007	60	750	S4 004						
Flexifuel [08]	12.07-12.11			74	750	S5 007	60	750	S4 004						
		XXX										53	470	S3 004	

								Ah A (EN)		Ah A (EN)		Ah A (EN)		Ah A (EN)	
◀ FORD				0092 ...0		0092 ...0		0092 ...0		0092 ...0					
1.8 i [04]	05.05-01.08			61	600	S5 004	60	600	S4 004						
				74	750	S5 007	60	750	S4 004	53	500	S3 004			
			XXX							53	470	S3 004			
i [08]	12.07-12.11			61	600	S5 004	60	600	S4 004						
			XXX							53	470	S3 004			
2.0 CNG [08]	01.08-12.11			61	600	S5 004		600							
			XXX							53	470	S3 004			
i [04]	07.04-01.08			74	750	S5 007	60	750	S4 004						
			XXX							53	470	S3 004			
i [08]	12.07-12.11			74	750	S5 007	60	750	S4 004						
			XXX							53	470	S3 004			
LPG [08]	01.08-12.11			61	600	S5 004		600							
			XXX							53	470	S3 004			
2.5 i RS [08]	01.09-12.11			74	750	S5 007	72	750	S4 007	70	640	S3 007			
i RS 500 [08]	04.10-12.11			74	750	S5 007	72	750	S4 007						
i ST [04]	10.05-01.08			74	750	S5 007	60	750	S4 004						
			XXX							53	470	S3 004			
i ST [08]	12.07-12.11			74	750	S5 007	60	750	S4 004						
			XXX							53	470	S3 004			
Diesel															
1.6/ 1.8/ 2.0 TDCi [04]	07.04-01.08			74	750	S5 007	72	750	S4 007						
TDCi [08]	12.07-12.11			74	750	S5 007	72	750	S4 007	70	640	S3 007			
Focus II Cabriolet															
1.6 i [06]	07.06-07.10			61	600	S5 004	60	600	S4 004						
			XXX							53	470	S3 004			
2.0 i [06]	07.06-07.10			74	750	S5 007	60	750	S4 004						
			XXX							53	470	S3 004			
Diesel															
2.0 TDCi [06]	07.06-07.10			85	800	S5 010	72	800	S4 007						
Focus II Turnier															
1.4 i [04]	07.04-01.08			61	600	S5 004	60	600	S4 004						
			XXX							53	470	S3 004			
i [08]	12.07-12.11			61	600	S5 004	60	600	S4 004						
			XXX							53	470	S3 004			
1.6 i [04]	07.04-01.08			61	600	S5 004	60	600	S4 004						
			XXX							53	470	S3 004			
i [08]	12.07-12.11			61	600	S5 004	60	600	S4 004						
			XXX							53	470	S3 004			
Ti-VCT [04]	07.04-01.08			61	600	S5 004	60	600	S4 004						
			XXX							53	470	S3 004			
Ti-VCT [08]	12.07-12.11			61	600	S5 004	60	600	S4 004						
			XXX							53	470	S3 004			
1.8 FFV [04]	05.05-01.08			61	600	S5 004	60	600	S4 004						
			XXX							53	470	S3 004			
Flexifuel [08]	12.07-12.11			61	600	S5 004	60	600	S4 004						
			XXX							53	470	S3 004			
i [04]	05.05-01.08			61	600	S5 004	60	600	S4 004						
			XXX							53	470	S3 004			
i [08]	12.07-12.11			61	600	S5 004	60	600	S4 004						
			XXX							53	470	S3 004			
2.0 i [04]	07.04-01.08			74	750	S5 007	60	750	S4 004						
			XXX							53	470	S3 004			
i [08]	12.07-12.11			74	750	S5 007	60	750	S4 004						
			XXX							53	470	S3 004			
LPG [08]	01.08-12.11			61	600	S5 004		600							
			XXX							53	470	S3 004			
Diesel															
1.6/ 1.8/ 2.0 TDCi [08]	12.07-12.11			74	750	S5 007	72	750	S4 007	70	640	S3 007			
TDCi, TDCi [04]	07.04-01.08			74	750	S5 007	72	750	S4 007						
Focus III															
1.6 EcoBoost [11]	01.11→	SSJ		75	730	S5 E10		730							
Ti-VCT [11]	01.11→			61	600	S5 004		600							
			XXX							53	470	S3 004			

						Ah A (EN) S6		Ah A (EN) S5		Ah A (EN) S4		Ah A (EN) S3	
				0 092 ...0		0 092 ...0		0 092 ...0		0 092 ...0		0 092 ...0	
1.6 Ti-VCT FlexiFuel [11]	01.11→			61	600	S5 004		600					
		XXX										53	470 S3 004
2.0 EcoBoost ST [11]	06.12→			74	750	S5 007		72	750	S4 007			
Diesel													
1.6 TDCi [11]	01.11→	SSJ		75	730	S5 E10		730					
2.0 TDCi [11]	01.11→			74	750	S5 007		72	750	S4 007			
Focus III Turnier													
1.6 Ti-VCT [11]	01.11→			61	600	S5 004		600					
		XXX										53	470 S3 004
Ti-VCT FlexiFuel [11]	01.11→			61	600	S5 004		600					
		XXX										53	470 S3 004
2.0 EcoBoost ST [11]	06.12→			74	750	S5 007		72	750	S4 007			
Diesel													
1.6 TDCi [11]	01.11→	SSJ		75	730	S5 E10		730					
2.0 TDCi [11]	01.11→			74	750	S5 007		72	750	S4 007			
Fusion													
1.25/ 1.4 i [02]	10.02-06.12			61	600	S5 004		44	600	S4 001			
1.6 i [02]	10.02-06.12			61	600	S5 004		60	600	S4 004		53	500 S3 004
i 16V [B256]	11.04-01.10			61	600	S5 004		60	600	S4 004			
Diesel													
1.4/ 1.6 TDCi [02]	10.02-06.12			74	750	S5 007		60	750	S4 004			
Galaxy													
1.6 EcoBoost [06]	11.10→	SSJ		75	730	S5 E10		730					
2.0 [06]	03.06→			74	750	S5 007		60	750	S4 004			
		XXX										53	470 S3 004
EcoBoost SCTi [06]	03.10→			74	750	S5 007		72	750	S4 007			
FlexiFuel [06]	03.08→			61	600	S5 004		60	600	S4 004			
		XXX										53	470 S3 004
i [95]	02.95-03.00	VAD	70	760	S6 008		77	780	S5 008		60	780	S4 005 56 480 S3 005
2.0/ 2.3 i [00]	04.00-08.06		70	760	S6 008		77	780	S5 008		60	780	S4 005
2.3 [06]	09.07→			74	750	S5 007		60	750	S4 004			
		XXX										53	470 S3 004
i 16V [95]	01.97-03.00	VAD	70	760	S6 008		77	780	S5 008		60	780	S4 005 56 480 S3 005
2.8 i [00]	04.00-08.06		95	850	S6 013		100	830	S5 013		95	830	S4 013 90 720 S3 013
i [95]	02.95-03.00	VAD					100	830	S5 013		95	830	S4 013 90 720 S3 013
i 4x4 [95]	07.96-03.00	VAD					100	830	S5 013		95	830	S4 013 90 720 S3 013
Diesel													
1.6 TDCi [06]	02.11→	SSJ		75	730	S5 E10		730					
1.8 TDCi [06]	03.06-03.10			85	800	S5 010		80	800	S4 010			
1.9 TDI [00]	04.00-08.06		70	760	S6 008		100	830	S5 013		95	830	S4 013
TDI [95]	02.95-03.00	VAD					100	830	S5 013		95	830	S4 013 90 720 S3 013
2.0 TDCi [06]	03.06→			85	800	S5 010		80	800	S4 010			
	03.10→			74	750	S5 007		72	750	S4 007			
2.2 TDCi [06]	11.10→			74	750	S5 007		72	750	S4 007			
Granada II													
1.6 [78;82]	08.81-04.85	FAD		74	750	S5 007		60	750	S4 004			
		FAD,XXX										53	470 S3 004
2.0 [78;82]	08.77-04.85	FAD		74	750	S5 007		60	750	S4 004			
		FAD,XXX										53	470 S3 004
2.3 [78;82]	06.79-04.85	FAD		74	750	S5 007		60	750	S4 004			
		FAD,XXX										53	470 S3 004
2.6 [78;82]	08.77-04.85	FAD		74	750	S5 007		60	750	S4 004			
		FAD,XXX										53	470 S3 004
2.8 [78;82]	08.77-04.85	FAD		74	750	S5 007		60	750	S4 004			
		FAD,XXX										53	470 S3 004
i [78;82]	08.77-04.85	FAD		74	750	S5 007		60	750	S4 004			
		FAD,XXX										53	470 S3 004
Diesel													
2.5 D [78;82]	08.82-04.85	FAD		74	750	S5 007		72	750	S4 007		70	640 S3 007
Granada II Turnier													
2.0 [78;82]	08.77-04.85	FAD		74	750	S5 007		60	750	S4 004			
		FAD,XXX										53	470 S3 004

				Ah A (EN) S6	Ah A (EN) S5	Ah A (EN) S4	Ah A (EN) S3	
				0092 ...0	0092 ...0	0092 ...0	0092 ...0	
◀ FORD								
2.3 [78;82]	06.79-04.85	FAD		74	750	S5 007	60 750 S4 004	
		FAD,XXX						53 470 S3 004
2.8 [78;82]	08.77-04.85	FAD		74	750	S5 007	60 750 S4 004	
		FAD,XXX						53 470 S3 004
i [78;82]	08.77-04.85	FAD		74	750	S5 007	60 750 S4 004	
		FAD,XXX						53 470 S3 004
Diesel								
2.5 D [78;82]	08.82-04.85	FAD		74	750	S5 007	72 750 S4 007	70 640 S3 007
Granada III								
1.8 [85]	05.85-01.92	FAD		74	750	S5 007	60 750 S4 004	
		FAD,XXX						53 470 S3 004
2.0 [85]	05.85-01.89	FAD		74	750	S5 007	60 750 S4 004	
		FAD,XXX						53 470 S3 004
	05.89-01.92	FAD		74	750	S5 007	60 750 S4 004	
		FAD,XXX						53 470 S3 004
i [85]	05.85-01.92	FAD		74	750	S5 007	60 750 S4 004	
		FAD,XXX						53 470 S3 004
i [92]	02.92-09.94	FAD		74	750	S5 007	60 750 S4 004	
		FAD,XXX						53 470 S3 004
2.4 i [85]	09.86-08.89	FAD		74	750	S5 007	60 750 S4 004	
		FAD,XXX						53 470 S3 004
i [92]	02.92-09.94	FAD		74	750	S5 007	60 750 S4 004	
		FAD,XXX						53 470 S3 004
2.8 i 4x4 [85]	10.85-08.87	FAD		74	750	S5 007	72 750 S4 007	70 640 S3 007
2.8/ 2.9 i [85]	05.85-01.92	FAD		74	750	S5 007	72 750 S4 007	70 640 S3 007
2.9 i [92]	02.92-09.94	FAD		74	750	S5 007	72 750 S4 007	70 640 S3 007
i 4x4, i 24V [92]	02.92-09.94	FAD		74	750	S5 007	72 750 S4 007	70 640 S3 007
Diesel								
2.5 D, D Turbo [85; 92]	05.85-09.94	FAD		74	750	S5 007	72 750 S4 007	70 640 S3 007
Granada III Estate								
2.0 i [92]	02.92-09.94	FAD		74	750	S5 007	60 750 S4 004	
		FAD,XXX						53 470 S3 004
2.4 i [92]	02.92-09.94	FAD		74	750	S5 007	60 750 S4 004	
		FAD,XXX						53 470 S3 004
2.9 i [92]	02.92-09.94	FAD		74	750	S5 007	72 750 S4 007	70 640 S3 007
i 4x4 [92]	02.92-09.94	FAD		74	750	S5 007	72 750 S4 007	70 640 S3 007
Diesel								
2.5 D Turbo [92]	02.92-09.94	FAD		74	750	S5 007	72 750 S4 007	70 640 S3 007
GT								
5.4	09.04-08.06			85	800	S5 010	80 800 S4 010	
Ka								
1.2 [08]	09.08→			52	520	S5 001	44 520 S4 001	
		SSJ		60	560	S5 E05	560	
1.3 i	10.05→			52	520	S5 001	44 520 S4 001	
i [97]	09.96-10.02			52	520	S5 001	44 520 S4 001	41 360 S3 001
	10.02-09.08			52	520	S5 001	44 520 S4 001	
1.6 i [97]	07.03-09.08			52	520	S5 001	44 520 S4 001	
Diesel								
1.3 TDCi [08]	09.08→						60 S4 005	56 480 S3 005
		SSJ		65	650	S5 E07	650	
Kuga								
2.5 i 4x4 [08]	12.08-11.12			74	750	S5 007	72 750 S4 007	70 640 S3 007
Diesel								
2.0 TDCi [08]	02.08-11.12			74	750	S5 007	72 750 S4 007	
	05.10-11.12			74	750	S5 007	72 750 S4 007	70 640 S3 007
TDCi 4x4 [08]	02.08-11.12			74	750	S5 007	72 750 S4 007	
	05.10-11.12			74	750	S5 007	72 750 S4 007	70 640 S3 007
Maverick								
2.0/ 2.3 i [1EZ, 1N2]	10.00-01.07			63	610	S5 005	60 610 S4 005	
i 4x4 [1EZ, 1N2]	10.00-01.07			63	610	S5 005	60 610 S4 005	
2.4 i [UDS, UNS]	06.93-12.98						95 S4 029	
3.0 i [1EZ, 1N2]	07.01-01.07			74	750	S5 007	72 750 S4 007	
i 4x4 [1EZ, 1N2]	07.01-01.07			74	750	S5 007	72 750 S4 007	



Diesel										
2.7 TD [UDS, UNS]	06.93-12.98						95			S4 029
Metrostar										
2.0 i	03.01-07.07		61	600	S5 004		60	600		S4 004
Mondeo										
1.6 i [97]	08.98-09.00		61	600	S5 004		60	600	S4 004	53 500 S3 004
		XXX								53 470 S3 004
Mondeo I										
1.6 i [93]	01.93-07.96		61	600	S5 004		60	600	S4 004	53 500 S3 004
		XXX								53 470 S3 004
1.8 i [93]	01.93-07.96		74	750	S5 007		60	750	S4 004	53 500 S3 004
		XXX								53 470 S3 004
i4x4 [93]	01.93-07.96		74	750	S5 007		60	750	S4 004	53 500 S3 004
		XXX								53 470 S3 004
2.0 i [93]	01.93-07.96		74	750	S5 007		60	750	S4 004	53 500 S3 004
		XXX								53 470 S3 004
i4x4 [93]	07.93-07.96		74	750	S5 007		60	750	S4 004	53 500 S3 004
		XXX								53 470 S3 004
2.5 i [93]	08.94-07.96		74	750	S5 007		60	750	S4 004	53 500 S3 004
		XXX								53 470 S3 004
Diesel										
1.8 TD [93]	06.93-07.96		74	750	S5 007		60	750	S4 004	
		XXX								53 470 S3 004
Mondeo I Turnier										
1.6 i [93]	04.93-07.96		61	600	S5 004		60	600	S4 004	53 500 S3 004
		XXX								53 470 S3 004
1.8 i [93]	04.93-07.96		74	750	S5 007		60	750	S4 004	53 500 S3 004
		XXX								53 470 S3 004
2.0 i [93]	04.93-07.96		74	750	S5 007		60	750	S4 004	53 500 S3 004
		XXX								53 470 S3 004
i4x4 [93]	07.93-07.96		74	750	S5 007		60	750	S4 004	53 500 S3 004
		XXX								53 470 S3 004
2.5 i [93]	08.94-07.96		74	750	S5 007		60	750	S4 004	53 500 S3 004
		XXX								53 470 S3 004
Diesel										
1.8 TD [93]	06.93-07.96		74	750	S5 007		60	750	S4 004	
		XXX								53 470 S3 004
Mondeo II										
1.6 i [97]	08.96-09.00		61	600	S5 004		60	600	S4 004	53 500 S3 004
		XXX								53 470 S3 004
1.8 i [97]	08.96-09.00		61	600	S5 004		60	600	S4 004	53 500 S3 004
		XXX								53 470 S3 004
2.0 i [97]	08.96-09.00		61	600	S5 004		60	600	S4 004	53 500 S3 004
		XXX								53 470 S3 004
2.5 i [97]	08.96-09.00		74	750	S5 007		60	750	S4 004	53 500 S3 004
		XXX								53 470 S3 004
iST200 [97]	09.99-09.00		74	750	S5 007		60	750	S4 004	53 500 S3 004
		XXX								53 470 S3 004
Diesel										
1.8 TD [97]	08.96-09.00		74	750	S5 007		60	750	S4 004	
		XXX								53 470 S3 004
Mondeo II Turnier										
1.6 i [97]	08.96-09.00		61	600	S5 004		60	600	S4 004	53 500 S3 004
		XXX								53 470 S3 004
1.8 i [97]	08.96-09.00		61	600	S5 004		60	600	S4 004	53 500 S3 004
		XXX								53 470 S3 004
2.0 i [97]	08.96-09.00		61	600	S5 004		60	600	S4 004	53 500 S3 004
		XXX								53 470 S3 004
2.5 i [97]	08.96-09.00		74	750	S5 007		60	750	S4 004	53 500 S3 004
		XXX								53 470 S3 004
iST200 [97]	09.99-09.00		74	750	S5 007		60	750	S4 004	53 500 S3 004
		XXX								53 470 S3 004



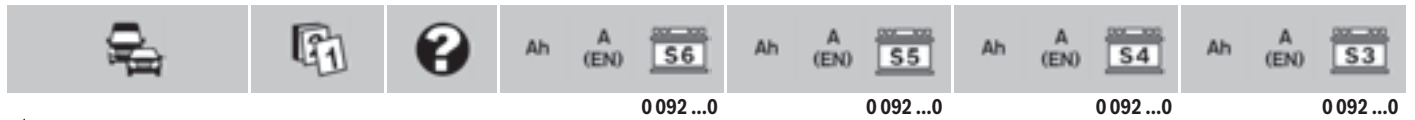



◀ FORD

Diesel												
1.8 TD [97]	08.96-09.00		74	750	S5 007	60	750	S4 004		53	470	S3 004
		XXX										
Mondeo III												
1.8/ 2.0 i [01]	10.00-03.07		61	600	S5 004	44	600	S4 001	41	360	S3 001	
2.5 i [01]	10.00-03.07		61	600	S5 004	60	600	S4 004				
		XXX								53	470	S3 004
3.0 i [01]	08.04-03.07		74	750	S5 007	60	750	S4 004				
		XXX								53	470	S3 004
iST220 [01]	02.02-03.07		74	750	S5 007	60	750	S4 004				
		XXX								53	470	S3 004
Diesel												
2.0 TDDi [01]	10.00-08.02		74	750	S5 007	72	750	S4 007	70	640	S3 007	
	10.00-03.07		74	750	S5 007	72	750	S4 007				
2.0/ 2.2 TDCi [01]	10.01-03.07		74	750	S5 007	72	750	S4 007				
Mondeo III Turnier												
1.8/ 2.0 i [01]	10.00-03.07		61	600	S5 004	44	600	S4 001	41	360	S3 001	
2.5 i [01]	10.00-03.07		61	600	S5 004	60	600	S4 004				
		XXX								53	470	S3 004
3.0 i [01]	08.04-03.07		74	750	S5 007	60	750	S4 004				
		XXX								53	470	S3 004
iST220 [01]	02.02-03.07		74	750	S5 007	60	750	S4 004				
		XXX								53	470	S3 004
Diesel												
2.0 TDDi [01]	10.00-08.02		74	750	S5 007	72	750	S4 007				
	10.00-03.07		74	750	S5 007	72	750	S4 007	70	640	S3 007	
2.0/ 2.2 TDCi [01]	10.01-03.07		74	750	S5 007	72	750	S4 007				
Mondeo IV												
1.6 EcoBoost [07]	11.10→	SSJ	75	730	S5 E10		730					
Ti-VCT [07]	02.07-08.10		61	600	S5 004	44	600	S4 001	41	360	S3 001	
			61	600	S5 004	60	600	S4 004				
			74	750	S5 007	60	750	S4 004				
	02.07→	XXX								53	470	S3 004
	09.10→		61	600	S5 004		600					
2.0 [07]	02.07→		74	750	S5 007	60	750	S4 004				
		XXX								53	470	S3 004
EcoBoost SCTi [07]	03.10→		74	750	S5 007	72	750	S4 007				
Flexifuel [07]	02.08→		74	750	S5 007	60	750	S4 004				
		XXX								53	470	S3 004
LPG [07]	04.09→		61	600	S5 004	60	600	S4 004	53	500	S3 004	
2.3 [07]	09.07→		74	750	S5 007	72	750	S4 007	53	500	S3 004	
			74	750	S5 007	72	750	S4 007	70	640	S3 007	
2.5 [07]	02.07-03.10		74	750	S5 007	60	750	S4 004				
Diesel												
1.6 TDCi [07]	02.11→	SSJ	75	730	S5 E10		730					
1.8 TDCi [07]	02.07-11.10		85	800	S5 010	72	800	S4 007				
1.8/ 2.0 TDCi eco [07]	02.07→		85	800	S5 010	72	800	S4 007				
2.0 TDCi [07]	02.07→		85	800	S5 010	72	800	S4 007				
	03.10→					60		S4 004				
2.2 TDCi [07]	03.08-11.10		85	800	S5 010	72	800	S4 007	70	640	S3 007	
	11.10→		74	750	S5 007	72	750	S4 007				
Mondeo IV Turnier												
1.6 EcoBoost [07]	11.10→	SSJ	75	730	S5 E10		730					
Ti-VCT [07]	02.07-08.10		61	600	S5 004	44	600	S4 001	41	360	S3 001	
	09.10→		61	600	S5 004		600					
		XXX								53	470	S3 004
2.0 [07]	02.07→		74	750	S5 007	60	750	S4 004				
		XXX								53	470	S3 004
EcoBoost SCTi [07]	03.10→		74	750	S5 007	72	750	S4 007				
Flexifuel [07]	02.08→		74	750	S5 007	60	750	S4 004				
		XXX								53	470	S3 004
LPG [07]	04.09→		61	600	S5 004	60	600	S4 004	53	500	S3 004	

		0 092 ...0			0 092 ...0			0 092 ...0			0 092 ...0					
2.3 [07]	09.07→		74	750	S5 007	72	750	S4 007	53	500	S3 004					
			74	750	S5 007	72	750	S4 007	70	640	S3 007					
2.5 [07]	02.07-03.10		74	750	S5 007	60	750	S4 004								
Diesel																
1.6 TDCi [07]	02.11→	SSJ	75	730	S5 E10		730									
1.8 TDCi [07]	02.07-11.10		85	800	S5 010	72	800	S4 007								
1.8/ 2.0 TDCi eco [07]	02.07→		85	800	S5 010	72	800	S4 007								
2.0 TDCi [07]	02.07→		85	800	S5 010	72	800	S4 007								
	03.10→		74	750	S5 007	72	750	S4 007								
2.2 TDCi [07]	03.08-11.10		85	800	S5 010	72	800	S4 007	70	640	S3 007					
	11.10→		74	750	S5 007	72	750	S4 007								
Mustang Convertible																
5.0	09.93-08.94		63	610	S5 005	60	610	S4 005								
Mustang Coupé																
3.8	09.93-08.98		63	610	S5 005	60	610	S4 005								
Mustang Hatchback																
5.0	09.91-08.94		63	610	S5 005	60	610	S4 005								
Orion I																
1.3/ 1.6 , i [81]	05.83-12.85	FAD	61	600	S5 004	44	600	S4 001	41	360	S3 001					
Diesel																
1.6 D [81]	04.84-12.85	FAD	74	750	S5 007	60	750	S4 004								
		FAD,XXX							53	470	S3 004					
Orion II																
1.3/ 1.4/ 1.6 , i [86]	01.86-07.90	FAD	61	600	S5 004	44	600	S4 001	41	360	S3 001					
Diesel																
1.6 D [86]	04.86-01.89	FAD	74	750	S5 007	60	750	S4 004								
		FAD,XXX							53	470	S3 004					
1.8 D [86]	01.89-07.90	FAD	74	750	S5 007	60	750	S4 004								
		FAD,XXX							53	470	S3 004					
Orion III																
1.3 [91]	07.90-12.93	FAD	61	600	S5 004	60	600	S4 004								
		FAD,XXX							53	470	S3 004					
i [91]	05.91-12.93	FAD	61	600	S5 004	60	600	S4 004								
		FAD,XXX							53	470	S3 004					
1.4 [91]	07.90-12.93	FAD	61	600	S5 004	60	600	S4 004								
		FAD,XXX							53	470	S3 004					
i [91]	07.90-12.93	FAD	61	600	S5 004	60	600	S4 004								
		FAD,XXX							53	470	S3 004					
1.6 [91]	07.90-12.93								53	500	S3 004					
		FAD	61	600	S5 004	60	600	S4 004								
		FAD,XXX							53	470	S3 004					
i [91]	07.90-09.92								53	500	S3 004					
		FAD	61	600	S5 004	60	600	S4 004								
		FAD,XXX							53	470	S3 004					
i 16V [91]	09.92-12.93								53	500	S3 004					
		FAD	61	600	S5 004	60	600	S4 004								
		FAD,XXX							53	470	S3 004					
1.8 i 16V [91]	02.92-12.93								53	500	S3 004					
		FAD	61	600	S5 004	60	600	S4 004								
		FAD,XXX							53	470	S3 004					
Diesel																
1.8 D, TD [91]	07.90-12.93	FAD	74	750	S5 007	72	750	S4 007	70	640	S3 007					
P 100																
1.6 L	04.82-09.87	FAD	61	600	S5 004	60	600	S4 004								
		FAD,XXX							53	470	S3 004					
2.0 L	01.88-12.92	FAD	61	600	S5 004	60	600	S4 004								
		FAD,XXX							53	470	S3 004					
Diesel																
1.8 L TD	02.89-12.92	FAD	74	750	S5 007	60	750	S4 004								
		FAD,XXX							53	470	S3 004					
Probe																
2.0 i 16V	09.92-08.97		61	600	S5 004	60	600	S4 004								
		XXX							53	470	S3 004					



				Ah A (EN) S6	Ah A (EN) S5	Ah A (EN) S4	Ah A (EN) S3	
				0092...0	0092...0	0092...0	0092...0	
◀ FORD								
2.2 iGT	09.88-08.92			61	600	S5 004	60 600 S4 004	53 470 S3 004
		XXX						
iLX Turbo	09.88-08.92			61	600	S5 004	60 600 S4 004	53 470 S3 004
		XXX						
2.5 i24V	09.92-08.97			61	600	S5 004	60 600 S4 004	53 470 S3 004
		XXX						
3.0 iGT	09.89-08.92			61	600	S5 004	60 600 S4 004	53 470 S3 004
		XXX						
Puma								
1.4 i [ECT]	01.98-11.00			61	600	S5 004	44 600 S4 001	41 360 S3 001
1.6 i [ECT]	08.00-12.01			61	600	S5 004	60 600 S4 004	53 470 S3 004
		XXX						
1.7 i [ECT]	06.97-12.01			61	600	S5 004	60 600 S4 004	53 470 S3 004
		XXX						
iST160 [ECT]	06.99-12.01			61	600	S5 004	60 600 S4 004	53 500 S3 004
Ranger								
2.5 4x4 [12]	09.11→			74	750	S5 007	72 750 S4 007	
Diesel								
2.2 TDCi [12]	09.11→			74	750	S5 007	72 750 S4 007	
TDCi 4x4 [12]	09.11→			74	750	S5 007	72 750 S4 007	
2.5/3.0 D, D 4x4, TD, TD 4x4, TDCi, TDCi 4x4 [06; 99]	01.99-12.11						95 S4 029	
3.2 TDCi 4x4 [12]	09.11→			85	800	S5 010	80 800 S4 010	
Scorpio I								
1.8 [85]	05.85-01.92	FAD		74	750	S5 007	60 750 S4 004	53 470 S3 004
		FAD,XXX						
2.0 [85]	05.85-01.92	FAD		74	750	S5 007	60 750 S4 004	53 470 S3 004
		FAD,XXX						
i [85]	05.85-01.92	FAD		74	750	S5 007	60 750 S4 004	53 470 S3 004
		FAD,XXX						
i [92]	02.92-09.94	FAD		74	750	S5 007	60 750 S4 004	53 470 S3 004
		FAD,XXX						
2.4 i [85]	09.86-01.92	FAD		74	750	S5 007	60 750 S4 004	53 470 S3 004
		FAD,XXX						
i [92]	02.92-09.94	FAD		74	750	S5 007	60 750 S4 004	53 470 S3 004
		FAD,XXX						
2.8 i [85]	05.85-12.88	FAD		74	750	S5 007	72 750 S4 007	70 640 S3 007
i 4x4 [85]	10.85-12.88	FAD		74	750	S5 007	72 750 S4 007	70 640 S3 007
2.9 i, i 4x4, i 24V [85; 92]	09.86-09.94	FAD		74	750	S5 007	72 750 S4 007	70 640 S3 007
Diesel								
2.5 D, TD [85]	12.85-01.92	FAD		74	750	S5 007	72 750 S4 007	70 640 S3 007
TD [92]	03.92-09.94	FAD		74	750	S5 007	72 750 S4 007	70 640 S3 007
Scorpio I Turnier								
2.0 i [92]	02.92-09.94	FAD		74	750	S5 007	60 750 S4 004	53 470 S3 004
		FAD,XXX						
2.4 i [92]	02.92-09.94	FAD		74	750	S5 007	60 750 S4 004	53 470 S3 004
		FAD,XXX						
2.9 i [92]	02.92-09.94	FAD		74	750	S5 007	72 750 S4 007	70 640 S3 007
i 4x4, i 24V [92]	02.92-09.94	FAD		74	750	S5 007	72 750 S4 007	70 640 S3 007
Diesel								
2.5 TD [92]	03.92-09.94	FAD		74	750	S5 007	72 750 S4 007	70 640 S3 007
Scorpio II								
2.0 i [95]	10.94-12.98	FAD		74	750	S5 007	60 750 S4 004	53 470 S3 004
		FAD,XXX						
i 16V [95]	10.94-04.96	FAD		74	750	S5 007	60 750 S4 004	53 470 S3 004
		FAD,XXX						
2.3 i 16V [95]	05.96-12.98	FAD		74	750	S5 007	60 750 S4 004	53 470 S3 004
		FAD,XXX						
2.9 i [95]	10.94-08.96	FAD		74	750	S5 007	72 750 S4 007	70 640 S3 007
i 24V [95]	10.94-07.98	FAD		74	750	S5 007	72 750 S4 007	70 640 S3 007
Diesel								
2.5 TD [95]	10.94-12.98	FAD		74	750	S5 007	72 750 S4 007	70 640 S3 007



Scorpio II Turnier											
2.0 i [95]	10.94-12.98	FAD	74	750	S5 007	60	750	S4 004			
		FAD,XXX							53	470	S3 004
i 16V [95]	10.94-04.96	FAD	74	750	S5 007	60	750	S4 004			
		FAD,XXX							53	470	S3 004
2.3 i 16V [95]	05.96-12.98	FAD	74	750	S5 007	60	750	S4 004			
		FAD,XXX							53	470	S3 004
2.9 i [95]	10.94-08.96	FAD	74	750	S5 007	72	750	S4 007	70	640	S3 007
i 24V [95]	10.94-07.98	FAD	74	750	S5 007	72	750	S4 007	70	640	S3 007
Diesel											
2.5 TD [95]	10.94-12.98	FAD	74	750	S5 007	72	750	S4 007	70	640	S3 007
Sierra I											
1.3 [82]	08.82-12.86	FAD	61	600	S5 004	60	600	S4 004			
		FAD,XXX							53	470	S3 004
1.6 [82]	08.82-12.86	FAD	61	600	S5 004	60	600	S4 004			
		FAD,XXX							53	470	S3 004
1.8 [82]	10.84-12.86	FAD	61	600	S5 004	60	600	S4 004			
		FAD,XXX							53	470	S3 004
2.0 [82]	08.82-12.86	FAD	61	600	S5 004	60	600	S4 004			
		FAD,XXX							53	470	S3 004
i [82]	03.85-12.86	FAD	61	600	S5 004	60	600	S4 004			
		FAD,XXX							53	470	S3 004
RS Cosworth [82]	01.86-12.86	FAD	61	600	S5 004	60	600	S4 004			
		FAD,XXX							53	470	S3 004
2.3 [82]	08.82-12.86	FAD	61	600	S5 004	60	600	S4 004			
		FAD,XXX							53	470	S3 004
2.8 i XR4, i XR4 4x4 [82]	08.82-12.86	FAD	74	750	S5 007	72	750	S4 007	70	640	S3 007
Diesel											
2.3 D [82]	08.82-12.86	FAD	74	750	S5 007	72	750	S4 007	70	640	S3 007
Sierra I Turnier											
1.6 [82]	08.82-12.86	FAD	61	600	S5 004	60	600	S4 004			
		FAD,XXX							53	470	S3 004
1.8 [82]	10.84-12.86	FAD	61	600	S5 004	60	600	S4 004			
		FAD,XXX							53	470	S3 004
2.0 [82]	08.82-12.86	FAD	61	600	S5 004	60	600	S4 004			
		FAD,XXX							53	470	S3 004
i [82]	03.85-12.86	FAD	61	600	S5 004	60	600	S4 004			
		FAD,XXX							53	470	S3 004
2.3 [82]	08.82-12.86	FAD	61	600	S5 004	60	600	S4 004			
		FAD,XXX							53	470	S3 004
2.8 i XR4, i XR4 4x4 [82]	08.82-12.86	FAD	74	750	S5 007	72	750	S4 007	70	640	S3 007
Diesel											
2.3 D [82]	08.82-12.86	FAD	74	750	S5 007	72	750	S4 007	70	640	S3 007
Sierra II											
1.6 [87]	01.87-02.93	FAD	61	600	S5 004	60	600	S4 004			
		FAD,XXX							53	470	S3 004
i [87]	10.89-02.93	FAD	61	600	S5 004	60	600	S4 004			
		FAD,XXX							53	470	S3 004
Sapphire [87]	02.87-02.93	FAD	61	600	S5 004	60	600	S4 004			
		FAD,XXX							53	470	S3 004
1.8 [87]	01.87-02.93	FAD	61	600	S5 004	60	600	S4 004			
		FAD,XXX							53	470	S3 004
i [87]	04.92-02.93	FAD	61	600	S5 004	60	600	S4 004			
		FAD,XXX							53	470	S3 004
Sapphire [87]	03.87-02.93	FAD	61	600	S5 004	60	600	S4 004			
		FAD,XXX							53	470	S3 004
2.0 [87]	01.87-02.93	FAD	61	600	S5 004	60	600	S4 004			
		FAD,XXX							53	470	S3 004
i [87]	01.87-02.93	FAD	61	600	S5 004	60	600	S4 004			
		FAD,XXX							53	470	S3 004
i 4x4 [87]	01.90-02.93	FAD	61	600	S5 004	60	600	S4 004			
		FAD,XXX							53	470	S3 004



				Ah A (EN) S6	Ah A (EN) S5	Ah A (EN) S4	Ah A (EN) S3	
				0092 ...0	0092 ...0	0092 ...0	0092 ...0	
◀ FORD								
2.0 RS Cosworth [87]	11.87-01.90	FAD		61	600	S5 004	60 600 S4 004	
		FAD,XXX						53 470 S3 004
RS Cosworth 4x4 [87]	02.90-02.93	FAD		61	600	S5 004	60 600 S4 004	
		FAD,XXX						53 470 S3 004
Sapphire [87]	05.89-02.93	FAD		61	600	S5 004	60 600 S4 004	
		FAD,XXX						53 470 S3 004
XR4i [87]	01.90-02.93	FAD		61	600	S5 004	60 600 S4 004	
		FAD,XXX						53 470 S3 004
2.8/2.9 i [87]	01.87-02.93	FAD		74	750	S5 007	72 750 S4 007	70 640 S3 007
i XR 4x4 [87]	01.87-02.93	FAD		74	750	S5 007	72 750 S4 007	70 640 S3 007
Diesel								
1.8/2.3 D, TD [87]	01.87-02.93	FAD		74	750	S5 007	72 750 S4 007	70 640 S3 007
Sierra II Turnier								
1.6 [87]	01.87-02.93	FAD		61	600	S5 004	60 600 S4 004	
		FAD,XXX						53 470 S3 004
i [87]	10.89-02.93	FAD		61	600	S5 004	60 600 S4 004	
		FAD,XXX						53 470 S3 004
1.8 [87]	01.87-02.93	FAD		61	600	S5 004	60 600 S4 004	
		FAD,XXX						53 470 S3 004
i [87]	04.92-02.93	FAD		61	600	S5 004	60 600 S4 004	
		FAD,XXX						53 470 S3 004
2.0 [87]	01.87-02.93	FAD		61	600	S5 004	60 600 S4 004	
		FAD,XXX						53 470 S3 004
i [87]	01.87-02.93	FAD		61	600	S5 004	60 600 S4 004	
		FAD,XXX						53 470 S3 004
i 4x4 [87]	05.89-02.93	FAD		61	600	S5 004	60 600 S4 004	
		FAD,XXX						53 470 S3 004
2.8/2.9 i 4x4 [87]	01.87-02.93	FAD		74	750	S5 007	72 750 S4 007	70 640 S3 007
2.9 i [87]	08.88-02.93	FAD		74	750	S5 007	72 750 S4 007	70 640 S3 007
Diesel								
1.8/2.3 D, TD [87]	01.87-02.93	FAD		74	750	S5 007	72 750 S4 007	70 640 S3 007
S-MAX								
2.0 [06]	03.06→			74	750	S5 007	60 750 S4 004	
		XXX						53 470 S3 004
EcoBoost SCTi [06]	03.10→			74	750	S5 007	72 750 S4 007	
FlexiFuel [06]	03.08→			74	750	S5 007	60 750 S4 004	
		XXX						53 470 S3 004
2.3 [06]	09.07→			74	750	S5 007	60 750 S4 004	
		XXX						53 470 S3 004
2.5 [06]	03.06-03.10			74	750	S5 007	60 750 S4 004	
		XXX						53 470 S3 004
Diesel								
1.8/2.0/2.2 TDCi [06]	03.06→			85	800	S5 010	80 800 S4 010	
Streetka								
1.6 i	12.02-12.05			52	520	S5 001	44 520 S4 001	
Taurus								
1.6/2.0	10.88-12.99	FAD		61	600	S5 004	44 600 S4 001	41 360 S3 001
Taurus								
3.0 , 24V	09.95-08.07			74	750	S5 007	72 750 S4 007	70 640 S3 007
Taurus Wagon								
3.0	09.99-12.04			74	750	S5 007	72 750 S4 007	
Tourneo Connect								
1.8 i [02]	05.02-06.10			61	600	S5 004	60 600 S4 004	
		XXX						53 470 S3 004
LPG [02]	06.03-06.10			61	600	S5 004	60 600 S4 004	
		XXX						53 470 S3 004
Diesel								
1.8 TDCi, TDDi [02]	05.02→			85	800	S5 010	80 800 S4 010	
Transit								
FT 80/100/120 1.6, 100/120 2.0, 130/160/190 2.0 [78]	04.78-12.85			61	600	S5 004	44 600 S4 001	



			Ah	A (EN)	S6	Ah	A (EN)	S5	Ah	A (EN)	S4	Ah	A (EN)	S3
			0 092 ...0			0 092 ...0			0 092 ...0			0 092 ...0		
FT 080/ FT 100/ FT 120/ FT 150/ FT 190 2.0i [95]	08.94-07.00		74	750	S5 007	60	750	S4 004	53	500	S3 004			
FT 260 K/S 2.3i [00]	08.01-07.06		74	750	S5 007	60	750	S4 004				53	470	S3 004
		XXX												
FT 280 K/S 2.3i [00]	08.01-07.06		74	750	S5 007	60	750	S4 004				53	470	S3 004
		XXX												
FT 280 L 2.3i [00]	08.01-07.06		74	750	S5 007	60	750	S4 004				53	470	S3 004
		XXX												
FT 280 M 2.3i [00]	08.01-07.06		74	750	S5 007	60	750	S4 004				53	470	S3 004
		XXX												
FT 300 2.3i [06]	04.06-09.11		61	600	S5 004	60	600	S4 004				53	470	S3 004
		XXX												
FT 300 K/S 2.3i [00]	08.00-07.06		74	750	S5 007	60	750	S4 004				53	470	S3 004
		XXX												
FT 300 L 2.3i [00]	08.00-07.06		74	750	S5 007	60	750	S4 004				53	470	S3 004
		XXX												
FT 300 M 2.3i [00]	08.00-07.06		74	750	S5 007	60	750	S4 004				53	470	S3 004
		XXX												
FT 330 2.3i [06]	04.06-09.11		61	600	S5 004	60	600	S4 004				53	470	S3 004
		XXX												
FT 330/ FT 350 2.3i CNG, 2.3i LPG [06]	04.06-09.11											53	500	S3 004
FT 330 K/S 2.3i [00]	12.00-07.06		74	750	S5 007	60	750	S4 004				53	470	S3 004
		XXX												
FT 330 L 2.3i [00]	12.00-07.06		74	750	S5 007	60	750	S4 004				53	470	S3 004
		XXX												
	08.01-07.06		61	600	S5 004	60	600	S4 004						
FT 330 M 2.3i [00]	12.00-07.06		74	750	S5 007	60	750	S4 004				53	470	S3 004
		XXX												
	08.01-07.06		61	600	S5 004	60	600	S4 004						
FT 350 2.3i [06]	04.06-09.11		61	600	S5 004	60	600	S4 004				53	470	S3 004
		XXX												
FT 350 EL 2.3i [00]	12.00-07.06		74	750	S5 007	60	750	S4 004				53	470	S3 004
		XXX												
	08.01-07.06		61	600	S5 004	60	600	S4 004						
FT 350 L 2.3i [00]	12.00-07.06		74	750	S5 007	60	750	S4 004				53	470	S3 004
		XXX												
	08.01-07.06		70	760	S6 008	74	750	S5 007	60	750	S4 004			
FT 350 M 2.3i [00]	12.00-07.06		61	600	S5 004	60	600	S4 004				53	470	S3 004
		XXX												
1.6 80-120 [86]	01.86-07.91	FAD	74	750	S5 007	60	750	S4 004				53	470	S3 004
		FAD,XXX												
100 L [86]	01.86-07.91	FAD	74	750	S5 007	60	750	S4 004				53	470	S3 004
		FAD,XXX												
130-190 [86]	01.86-07.91	FAD	74	750	S5 007	60	750	S4 004				53	470	S3 004
		FAD,XXX												
2.0 iLWB 100-190 [92]	08.91-07.94	FAD	74	750	S5 007	60	750	S4 004				53	470	S3 004
		FAD,XXX												
iSWB 80-150 [92]	08.91-07.94	FAD	74	750	S5 007	60	750	S4 004				53	470	S3 004
		FAD,XXX												
i80-120 [86]	10.88-07.91	FAD	74	750	S5 007	60	750	S4 004				53	470	S3 004
		FAD,XXX												
i100 L [86]	10.88-07.91	FAD	74	750	S5 007	60	750	S4 004				53	470	S3 004
		FAD,XXX												
i130-190 [86]	10.88-07.91	FAD	74	750	S5 007	60	750	S4 004				53	470	S3 004
		FAD,XXX												
LWB 100-190 [92]	08.91-07.94	FAD	74	750	S5 007	60	750	S4 004				53	470	S3 004
		FAD,XXX												
SWB 80-150 [92]	08.91-07.94	FAD	74	750	S5 007	60	750	S4 004				53	470	S3 004
		FAD,XXX												
80-120 [86]	01.86-07.91	FAD	74	750	S5 007	60	750	S4 004				53	470	S3 004
		FAD,XXX												
100 L [86]	01.86-07.91	FAD	74	750	S5 007	60	750	S4 004						



			Ah	A (EN)	S6	Ah	A (EN)	S5	Ah	A (EN)	S4	Ah	A (EN)	S3
			0 092 ...0		0 092 ...0		0 092 ...0		0 092 ...0		0 092 ...0		0 092 ...0	
◀ FORD														
2.0 100 L [86]	01.86-07.91	FAD,XXX										53	470	S3 004
130-190 [86]	01.86-07.91	FAD	74	750	S5 007	60	750	S4 004						
		FAD,XXX										53	470	S3 004
2.9 V6 [86]	05.88-07.91	FAD	74	750	S5 007	60	750	S4 004						
		FAD,XXX										53	470	S3 004
V6 LWB 100 L-190 [92]	08.91-07.94	FAD	74	750	S5 007	60	750	S4 004						
3.0 [78]	08.83-12.85	FAD	74	750	S5 007	60	750	S4 004						
V6 [86]	01.86-07.91	FAD	74	750	S5 007	60	750	S4 004						
		FAD,XXX										53	470	S3 004
Diesel														
FT/VAN/ 2.5 , D 80-120, D 100 L, D 130-190, DI LWB 100 L, DI LWB 100-190, DI SWB 80-120, DI SWB 80-150, DI Turbo LWB 100-190, DI Turbo LWB 150-190 L, DI Turbo SWB 80-150, DI Turbo SWB 150 S, 80-190 [78; 86; 92]	04.78-07.94	FAD	74	750	S5 007	60	750	S4 004						
FT 080/ FT 100/ FT 120/ FT 150/ FT 190 2.5 D, 2.5 DI, 2.5 TD, 2.5 TDI [95]			74	750	S5 007	60	750	S4 004						
FT 240 K/S/ FT 260 K/S/ FT 280 K/S/ FT 280 L/ FT 280 M/ FT 280 S/ FT 300 K/S/ FT 300 L/ FT 300 M/ FT 300 S/ FT 310 S/ FT 330 K/S/ FT 330 L/ FT 330 M/ FT 330 S/ FT 350 E/ FT 350 EL/ FT 350 L/ FT 350 M/ FT 430 E/ FT 430 EL/ FT 430 M 2.0 TDE, 2.4 TD, 2.4 TDCi, 2.4 TDE, 2.4 TDI [00]	01.00-07.06		85	800	S5 010	80	800	S4 010						
FT 240 K/S/ FT 260 K/S/ FT 280 K/S/ FT 280 M/ FT TD 300 K/S/ FT 300 L/ FT 300 M 2.0 [00]	08.00-07.06		85	800	S5 010	80	800	S4 010						
FT 250 2.2 TDCi [12]	09.11→		85	800	S5 010	80	800	S4 010						
FT 260 2.2 TDCi [06]	04.06-09.11		74	750	S5 007	80	750	S4 010						
			85	800	S5 010	80	800	S4 010						
	10.07-09.11		85	800	S5 010	80	800	S4 010	70	640	S3 007			
2.2 TDCi [12]	09.11→		85	800	S5 010	80	800	S4 010						
			85	800	S5 010	80	800	S4 010	70	640	S3 007			
FT 260 K/S/ FT 300 S 2.0 TDCi [00]	05.02-07.06		85	800	S5 010	80	800	S4 010						
FT 280 2.2 TDCi [06]	04.06-09.11		74	750	S5 007	80	750	S4 010						
			85	800	S5 010	80	800	S4 010						
	10.07-09.11		85	800	S5 010	80	800	S4 010	70	640	S3 007			
2.2 TDCi [12]	09.11→		85	800	S5 010	80	800	S4 010						
			85	800	S5 010	80	800	S4 010	70	640	S3 007			
FT 280 K/S/ FT 280 M/ FT 300 K/S/ FT 300 L/ FT 300M/ FT 330 K/S/ FT 330 L/ FT 330 M/ FT 350 EL/ FT 350 L/ FT 350 M 2.0 TDCi [00]	05.02-07.06		74	750	S5 007	72	750	S4 007						
FT 300 2.2 TDCi [06]	04.06-09.11		74	750	S5 007	80	750	S4 010						
			85	800	S5 010	80	800	S4 010						
2.2 TDCi [12]	09.11→		85	800	S5 010	80	800	S4 010						
FT 300/ FT 330/ FT 350/ FT 430/ FT 460 2.4 TDCi, 2.4 TDCi 4x4, 3.2 TDCi [06]	07.06-09.11		85	800	S5 010	80	800	S4 010						

		Ah A (EN) S6			Ah A (EN) S5			Ah A (EN) S4			Ah A (EN) S3		
		0 092 ...0			0 092 ...0			0 092 ...0			0 092 ...0		
FT 330 2.2 TDCi [06]	04.06-09.11	85	800	S5 010	80	800	S4 010						
	10.07-09.11	85	800	S5 010	80	800	S4 010	70	640	S3 007			
2.2 TDCi [12]	09.11→	85	800	S5 010	80	800	S4 010						
		85	800	S5 010	80	800	S4 010	70	640	S3 007			
FT 350 2.2 TDCi [06]	04.06-09.11	85	800	S5 010	80	800	S4 010						
	10.07-09.11	85	800	S5 010	80	800	S4 010	70	640	S3 007			
2.2 TDCi [12]	09.11→	85	800	S5 010	80	800	S4 010						
		85	800	S5 010	80	800	S4 010	70	640	S3 007			
FT 350/ FT 430 2.2 TDCi HDT [12]	09.11→	74	750	S5 007	72	750	S4 007						
FT 370/ FT 430 2.2 TDCi [12]	09.11→	85	800	S5 010	80	800	S4 010						
FT 460 2.2 TDCi [12]	09.11→	74	750	S5 007	72	750	S4 007						
		85	800	S5 010	80	800	S4 010						
Transit Connect													
1.8 i [02]	05.02-06.10	61	600	S5 004	60	600	S4 004						
		XXX						53	470	S3 004			
LPG [02]	06.03-06.10	61	600	S5 004	60	600	S4 004	53	500	S3 004			
Diesel													
1.8 TDCi [02]	05.02→	85	800	S5 010	72	800	S4 007						
	08.06→	74	750	S5 007	72	750	S4 007						
		85	800	S5 010	80	800	S4 010						
TDDi [02]	05.02-06.10	74	750	S5 007	72	750	S4 007						
Transit Euroline													
2.0 i [95]	08.94-07.00	74	750	S5 007	60	750	S4 004	53	500	S3 004			
Diesel													
2.0/ 2.2 TDCi, TDE [00; 06]	08.00-09.11	85	800	S5 010	80	800	S4 010						
2.5 D, DI, TD, TDI [95]	08.94-08.00	74	750	S5 007	60	750	S4 004						
Transit Nugget													
2.0 i [95]	08.94-07.00	74	750	S5 007	60	750	S4 004	53	500	S3 004			
Diesel													
2.0 TDCi [00]	05.02-07.06	74	750	S5 007	72	750	S4 007						
TDE [00]	08.00-07.06	85	800	S5 010	80	800	S4 010						
2.2 TDCi [06]	04.06-09.11	85	800	S5 010	80	800	S4 010						
2.5 D, DI, TD, TDI [95]	08.94-08.00	74	750	S5 007	60	750	S4 004						
Transit Tourneo													
2.0 i [95]	08.94-07.00	74	750	S5 007	60	750	S4 004	53	500	S3 004			
Diesel													
2.0/ 2.2 TDCi, TDE [00; 06]	08.00-09.11	85	800	S5 010	80	800	S4 010						
2.5 D, DI, TD, TDI [95]	08.94-08.00	74	750	S5 007	60	750	S4 004						
Windstar													
3.0 i	02.99-08.03						95	S4 029					
3.8	09.94-12.98						95	S4 029					

FS LUBLIN

Zuk

2.1	01.94-04.98	60	S4 024				
------------	-------------	----	---------------	--	--	--	--

FSM

126

P el.	12.94-12.00	45	400	S3 003				
fl	07.77-09.87	45	400	S3 003				

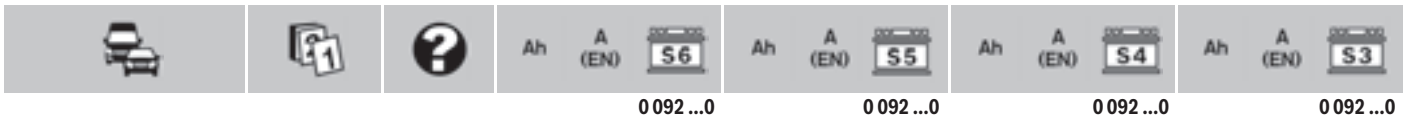

FSO

Lanos											
1.4/ 1.5/ 1.6 , 16V	05.04→			63	610	S5 006	60	610	S4 006		
Polonez											
1.5	05.78-12.88								45	400	S3 003
Polonez Atu											
1.4/ 1.6 , 16V	01.96-12.02								45	400	S3 003
Polonez Caro											
1.4/ 1.5/ 1.6 , 16V	05.87-12.02								45	400	S3 003
Diesel											
1.9 D	01.93-12.02			63	610	S5 006	60	610	S4 006		

GAZ

Gazel										
2.4 L DOHC	07.05→			61	600	S5 004	60	600	S4 004	
Diesel										
2.1/ 2.8 TD	07.10→			61	600	S5 004	60	600	S4 004	
Sobol										
2.4 L DOHC	01.94→			61	600	S5 004	60	600	S4 004	
Diesel										
2.1/ 2.8 TD	07.10→			61	600	S5 004	60	600	S4 004	
Volga										
2.4 L	07.05→			61	600	S5 004	60	600	S4 004	
2.4/ 2.5	01.86-01.08			63	610	S5 006	60	610	S4 006	

HOLDEN

Astra										
1.8 i [G]	09.00-08.09			74	750	S5 007	72	750	S4 007	

HONDA

Accord											
2.0 [CU/CW]	07.08→								45	S4 022	
2.0/ 2.4/ 3.0 , i, i 4WD	01.98-11.08								45	S4 021	
										[; CL/CN/CM]	
2.4 [CU/CW]	07.08→								60	S4 025	
iV-Tec	01.00-10.06								60	S4 025	
Diesel											
2.2 CTDI [CL/CN/CM]	01.04-06.08		70	760	S6 008	77	780	S5 008	74	780	S4 008
i-DTEC, i-DTEC Type S	07.08→								60	S4 025	
										[CU/CW]	
Accord Aerodeck											
2.0/ 2.2/ 2.3 i, i 16V	01.91-12.02								60	S4 025	
										[CB/CC/CD/CE; CG]	
Accord Coupé											
1.6/ 1.8 12V [AC/AD/SY]	09.83-10.85								45	S4 022	
2.0/ 2.2/ 2.3/ 3.0 i LS, i 16V,	01.92-12.02								60	S4 025	
i 24V, 16V [CB/CC/CD/CE;										CD; CG]	
Accord Hatchback											
1.6 i [CG/CH/CL]	10.98-02.03	JEA							60	S4 024	
									60	S4 025	
1.8/ 2.0/ 2.3 i [CG/CH/CL]	10.98-02.03	JEA							60	S4 024	
2.0 , i [CA/CB/CD]	07.87-12.89								60	S4 025	





Diesel											
2.0 TDi [CG/CH/CL]	01.99-10.00			74	750	S5 007		72	750	S4 007	
Accord Sedan											
1.6/ 1.8 12V [AC/AD/SY]	09.83-10.85							45		S4 022	
1.6/ 1.8/ 2.0/ 2.2 , i, i 4WS [CA/CB/CD]	11.85-12.99							60		S4 025	
1.6/ 1.8/ 2.0/ 2.2/ 2.3 i, i Typ R [CG/CH/CL]	10.98-02.03	JEA						60		S4 024	
1.8 i 16V [CC; CE/CF]	09.93-10.98							60		S4 025	
2.0 i 16V [CA/CB/CD]	10.86-05.93							60		S4 025	
16V [CA/CB/CD]	01.90-05.93							60		S4 025	
2.0/ 2.2 i 16V [CE/CF]	09.95-10.98							60		S4 025	
2.0/ 2.3 i 16V [CC]	03.93-09.95							60		S4 025	
2.2 i 16V [CA/CB/CD]	01.90-05.93							60		S4 025	53 500 S3 004
2.3 16V [CA/CB/CD]	12.97-04.99							60		S4 025	
Diesel											
2.0 D Turbo [CE/CF]	09.95-10.98			74	750	S5 007		72	750	S4 007	70 640 S3 007
TDi [CG/CH/CL]	01.99-02.03			74	750	S5 007		72	750	S4 007	70 640 S3 007
Accord Tourer											
2.0/ 2.4 [CL/CN/CM]	02.03-08.08							45		S4 021	
[CU/CW]	09.08→							60		S4 025	
Diesel											
2.2 CTDi [CL/CN/CM]	01.04-08.08		70 760 S6 008	77	780	S5 008		74	780	S4 008	70 640 S3 008
i-DTEC, i-DTEC Type S [CU/CW]	09.08→							60		S4 025	
Accord Wagon											
2.4 i	11.02-11.08							60		S4 025	
Acty											
TN 550	11.85-08.86							45		S4 023	
Ballade											
1.5	10.86-12.89							40		S4 019	
								45		S4 023	
i	10.86-12.89							40		S4 019	
								45		S4 023	
Capa											
1.5 i 16V	04.98→							45		S4 023	
Civic											
1.8 CNG	01.06→							45		S4 021	
2.0 i	05.03→							45		S4 023	
Civic Aerodeck											
1.4 i 16V [MB/MC]	03.98-02.01							45		S4 023	
1.6 i 16V [MB/MC]	03.99-12.00							45		S4 022	
Civic Coupé											
1.5/ 1.6 [EJ]	09.92-08.00							45		S4 021	
1.6 i 16V	01.94-12.95							45		S4 021	
	01.94-08.00							45		S4 023	
i 16V [EK]	02.01-12.04							45		S4 023	
1.7 i, i VTEC	05.01-12.05							45		S4 023	
Civic CRX											
1.4/ 1.6 , i, i 16V [ED/EE]	10.87-05.92							45		S4 023	
1.5 i [AF]	10.83-10.85							40		S4 019	
	10.83-12.85							45		S4 023	
1.6 i 16V [AF]	03.86-10.87							40		S4 019	
								45		S4 023	
Civic Fastback											
1.4 i 16V [MB/MC]	03.97-02.01							45		S4 021	
								45		S4 023	
1.4/ 1.5 i 16V [MA]	09.94-01.97							45		S4 021	
1.5 i 16V [MB/MC]	03.97-02.01							45		S4 023	
1.6 i 16V [MB/MC]	09.94-01.97							45		S4 023	
	03.97-02.01							45		S4 023	
1.8 i 16V [MB/MC]	03.97-02.01							45		S4 023	



		Ah		A (EN)		S6		Ah		A (EN)		S5		Ah		A (EN)		S4		Ah		A (EN)		S3									
						0092 ...0						0092 ...0				0092 ...0				0092 ...0				0092 ...0									
◀ HONDA																																	
Diesel																																	
2.0 D [MB/MC]	03.97-02.01																										45	S4 023					
Civic Hatchback																																	
1.2/1.3 [A; EC/ED/EE]	10.83-09.91																										45	S4 023					
1.3/1.4/1.5/1.6, i, i 16V, 16V [EC/ED/EE]	10.87-09.91																										45	S4 021					
1.3/1.5/1.6 i 16V, 16V [EG/EH]	12.92-09.95																										45	S4 021					
1.4 [EU/EP]	02.01-12.05																										45	S4 023					
[FK/FN]	10.08-12.11	SSJ						60	560	S5 E05																	560						
i 16V [EJ/EK]	10.95-02.01																										45	S4 021					
																											45	S4 023					
1.5, i [A]	10.83-10.87																										45	S4 023					
i 16V [EJ/EK]	10.95-02.01																										45	S4 023					
1.6/2.0 i, i 16V, Type R, VSA [EJ/EK; EU/EP]	10.95-12.05																										45	S4 023					
1.8 [FK/FN]	09.05-12.11																										45	S4 021					
	09.11→																										60	S4 024					
2.0 Type R [FK/FN]	01.07-12.11																										60	S4 024					
Diesel																																	
1.7 CTDi [EU/EP]	01.02-12.05							63	610	S5 005																	60	610	S4 005				
2.2 CTDi [FK/FN]	09.05-12.11							70	760	S6 008																	74	780	S4 008				
i-DTEC [FK/FN]	09.11→																										60	S4 024					
Civic Hybrid																																	
1.3 [ES]	01.02-12.05																										45	S4 023					
[FD]	01.06-12.10																										45	S4 021					
Civic Sedan																																	
1.2 [EC/ED/EE]	10.87-09.91																										45	S4 023					
1.4 [EC/ED/EE]	10.87-09.91																										45	S4 021					
1.4/1.6/1.7, i, i 16V [EJ/EK; ES]	10.95-12.06																										45	S4 023					
1.5 [A]	10.83-10.87																										45	S4 023					
i 16V [EG/EH]	10.91-09.95																										45	S4 023					
	12.92-09.95																										45	S4 021					
i 16V [EJ/EK]	10.95-02.01																										45	S4 023					
1.5/1.6 i, i 4WD [EC/ED/EE]	10.87-09.91																										45	S4 021					
1.6 [EG/EH]	12.92-09.93																										45	S4 021					
[FB]	09.11→																										45	S4 022					
i VTEC [FD6]	06.06-08.10																										45	S4 021					
i 16V [EG/EH]	12.92-09.95																										45	S4 021					
i 16V 4WD [EG/EH]	12.92-09.95																										45	S4 021					
1.8 [FB]	09.11→																										45	S4 021					
i [FD]	09.05-08.10																										45	S4 021					
Civic Shuttle																																	
1.4 [EC/ED/EE]	01.88-09.89																										40	S4 019					
																											45	S4 021					
																											45	S4 023					
1.5, 4WD [A]	10.83-10.87																										45	S4 023					
1.5/1.6 i 16V, i 16V 4WD [EC/ED/EE]	01.88-06.95																										45	S4 022					
Civic Wagon																																	
1.5 [A]	10.83-10.87																										45	S4 023					
Civic Sedan																																	
1.4 i 16V [EJ/EK]	10.95-10.98																										45	S4 023					
Concerto Hatchback																																	
1.4/1.5/1.6 EX 16V, GL 16V, i, i 16V, 16V	11.88-03.95							54	530	S5 002																	52	530	S4 002	45	400	S3 002	
Concerto Sedan																																	
1.4/1.5/1.6 GL 16V, i 16V, 16V	08.89-03.95							54	530	S5 002																		52	530	S4 002	45	400	S3 002
CR-V																																	
2.0 i 4WD [RE]	09.06-12.12							54	530	S5 002																		52	530	S4 002	45	400	S3 002
i 4WD, i 16V 4WD [RD]	10.95-09.06																										45	S4 021					

						Ah A (EN) S6		Ah A (EN) S5		Ah A (EN) S4		Ah A (EN) S3		
				0 092 ...0		0 092 ...0		0 092 ...0		0 092 ...0		0 092 ...0		
2.0 i 16V	08.04→	JEA								45	S4 021			
i 16V 4WD	10.95-01.99									45	S4 021			
	02.99-12.01	JEA								45	S4 021			
2.4 i 4WD [New]	05.04→				63	610	S5 005			60	610	S4 005		
4x4 [RE]	09.09-12.09				63	610	S5 005			60	610	S4 005		
Diesel														
2.2 CTDi 4x4 [RD]	02.05-09.06		70	760	S6 008			77	780	S5 008		74	780	S4 008
CTDi 4x4 [RE]	01.07-12.09							77	780	S5 008		74	780	S4 008
i-DTEC 4x4 [RE]	01.10-12.12							77	780	S5 008		74	780	S4 008
CR-Z														
1.5 Hybrid [ZF]	03.10→									40		S4 030		
FR-V														
1.7/ 2.0 i [BE]	01.05-12.06									45		S4 021		
1.8 [BE]	01.07-06.09									45		S4 023		
Diesel														
2.2 CTDi [BE]	07.05-06.09		70	760	S6 008			77	780	S5 008		74	780	S4 008
HR-V														
1.6 i 16V, i 16V VTEC 4WD, i 16V 4WD [GH]	12.98-12.05									45		S4 021		
Insight Coupé														
1.0 i [ZE]	01.00-12.06									40		S4 019		
Insight Hatchback														
1.3 Hybrid [ZE]	03.09→	SSJ								40		S4 018		
Integra														
1.8 i, i 16V [; DA]	06.89-10.99									45		S4 021		
Integra Type R														
1.8 i 16V [DC]	01.98-10.01									45		S4 021		
2.0 i	02.02→									45		S4 021		
Jazz														
1.2 [AA]	10.83-10.86									40		S4 019		
	01.85-10.86									40		S4 030		
[GD]	03.02-12.08									40		S4 018		
[GE/GG]	10.08→	ASB								40		S4 018		
Automatic [AA]	09.84-10.86									40		S4 019		
1.3/ 1.4/ 1.5, Hybrid, i [; GE/GG; GP]	10.08→									40		S4 030		
Legend														
2.5 i	01.86-12.87									60		S4 024		
2.7 i 24V	01.88-12.90									60		S4 024		
3.2/ 3.5 i 24V	01.91-12.04									70		S4 027		
3.5 i 4WD	10.04-09.08									70		S4 027		
3.7 4WD [KB]	09.08-12.10									70		S4 026		
Legend Coupé														
2.7 i 24V	10.87-02.91									60		S4 024		
3.2 i 24V	01.91-04.96									70		S4 027		
Legend Sedan														
2.5 i	05.86-12.87									60		S4 024		
2.7 i	01.87-02.91									70		S4 026		
3.2 i 24V	03.91-04.96									70		S4 027		
Logo														
1.3 i	10.96→									45		S4 023		
NSX Coupé														
3.0/ 3.2 i 24V [NA]	06.90-09.05									60		S4 024		
NSX-T Cabrio														
3.0/ 3.2 i 24V [NA]	01.95-09.05									60		S4 024		
Odyssey														
2.3 16V [RA]	03.00→									60		S4 024		
Prelude														
1.8/ 2.0, i, i 16V [AB]	08.83-04.87									45		S4 023		
2.0, i 16V, i 16V EX, i 16V 4WS, 4WS [BA]	04.86-01.92									70		S4 027		
i 16V [BB]	02.92-12.99									60		S4 024		
2.2/ 2.3 i 16V [BB]	09.91→									70		S4 026		



			Ah A (EN) S6	Ah A (EN) S5	Ah A (EN) S4	Ah A (EN) S3
			0092 ...0	0092 ...0	0092 ...0	0092 ...0

◀ HONDA

2.2/ 2.3 i 16V 4WD, i 16V 4WS, i 24V [BB]	02.92-12.01				70	S4 026			
Quint Integra									
1.6 , i	02.85-12.99				45	S4 023			
Shuttle									
2.2/ 2.3 i 16V	01.95-05.01				60	S4 024			
Stream									
1.7/ 2.0 i, i 16V [RN]	05.01-07.06				45	S4 021			
2.0 i	10.00-07.06				45	S4 023			
S2000									
2.0/ 2.2 i, 16V	04.99-09.09				45	S4 023			

HYUNDAI

Accent										
1.3 [LC]	05.99-09.02	54	530	S5 002	52	530	S4 002	45	400	S3 002
i	08.99→	54	530	S5 002	52	530	S4 002			
i [X3]	04.94-07.99							45	300	S3 016
1.3/ 1.5/ 1.6 i [LC]	08.99-03.06	54	530	S5 002	52	530	S4 002			
1.4/ 1.6 [MC, MCT]	04.06-02.12	54	530	S5 002	52	530	S4 002	45	400	S3 002
1.5 [X3]	08.96-07.97				70		S4 026			
i [X3]	04.94-07.99							45	300	S3 016
	09.97-12.00				60		S4 004			
i 16V [X3]	11.95-07.99							45	300	S3 016
Diesel										
1.5 CRDi [LC; MC, MCT]	01.02-02.12				70		S4 026			
Accent Hatchback										
1.3 i [LC]	08.99-03.06	54	530	S5 002	52	530	S4 002	45	400	S3 002
		54	530	S5 002	52	530	S4 002	45	400	S3 002
1.3/ 1.5 i [X3]	07.94-07.99							45	300	S3 016
1.4/ 1.6 [MC]	04.06-02.12	54	530	S5 002	52	530	S4 002	45	400	S3 002
1.5/ 1.6 i [LC]	08.99-03.06	54	530	S5 002	52	530	S4 002			
Diesel										
1.5 CRDi [LC; MC]	01.02-02.12				70		S4 026			
Atos										
0.8 i [MX]	09.97-06.01				40		S4 018			
					40		S4 030			
1.0 i [MX]	12.97-12.03				40		S4 018			
Atos Prime										
1.0 i [MX]	09.99-12.03				40		S4 018			
1.1 i [MX]	06.03-03.08				40		S4 018			
					40		S4 030			
Avante										
1.5 i [J2]	03.95→				60		S4 025	45	300	S3 017
Coupé										
1.6 i [GK]	03.02-08.09				70		S4 026			
1.6/ 1.8/ 2.0 i [RD]	05.96-04.02				70		S4 026			
2.0 i [GK]	10.01-08.09				60		S4 024			
i F2 Evolution [RD]	01.99-05.99				60		S4 024			
2.0/ 2.7 i, i V6 [FX; GK]	07.96→				70		S4 026			
Elantra										
1.5 i	10.90-03.95				45		S4 021	45	300	S3 017
i [J1]	10.90-04.95				60		S4 025	45	300	S3 017
	01.94-04.95				45		S4 021	45	300	S3 017
i [J2]	07.96-09.00	54	530	S5 002	52	530	S4 002	45	400	S3 002
1.6 [HD]	08.06-06.11	54	530	S5 002	52	530	S4 002			
i	04.04→	63	610	S5 005	60	610	S4 005	56	480	S3 005
i 16V [J2]	05.95-05.98							45	300	S3 016
	06.98-09.00	54	530	S5 002	52	530	S4 002	45	400	S3 002
16V [XD]	06.00-08.06	63	610	S5 005	52	610	S4 002	45	400	S3 002
1.6/ 1.8 i 16V [J1]	10.90-04.95				60		S4 025			
1.8 i 16V [J2]	05.95-09.00	63	610	S5 005	60	610	S4 005	56	480	S3 005

			Ah A (EN) S6			Ah A (EN) S5			Ah A (EN) S4			Ah A (EN) S3		
			0 092 ...0			0 092 ...0			0 092 ...0			0 092 ...0		
1.8/ 2.0 16V [XD]	06.00-09.06		63	610	S5 005	60	610	S4 005						
Diesel														
1.6/ 2.0 CRDi [HD; XD]	06.01-06.11					70		S4 027						
Elantra Hatchback														
1.6 16V [XD]	06.00-08.06		54	530	S5 002	52	530	S4 002						
1.8/ 2.0 16V [XD]	06.00-09.06		63	610	S5 005	60	610	S4 005						
Diesel														
2.0 CRDi [XD]	06.01-08.06					70		S4 027						
Excel														
1.3/ 1.5 i, i 16V [X2; X3]	04.89-07.99								45	300	S3 017			
Excel Hatchback														
1.3/ 1.5 i [X2]	04.89-07.94								45	300	S3 017			
1.5 i [X3]	11.95-07.99								45	300	S3 016			
Galloper I														
3.0 iV6	09.91-01.97								70		S4 027			
Diesel														
2.5 D Interc., D Turbo	09.91-01.97								95		S4 029			
Galloper II														
3.0 iV6	02.97-08.01								70		S4 027			
Diesel														
2.5 D Turbo	02.97-09.02								95		S4 029			
Genesis														
3.8 [BH]	05.08→		100	830	S5 013	95	830	S4 013						
Genesis Coupé														
2.0/ 3.8 , T, 24V [; BK]	09.10→								70		S4 026			
Getz														
1.1/ 1.3/ 1.4 [TB]	09.02-06.09		54	530	S5 002	52	530	S4 002	45	400	S3 002			
1.6 [TB]	09.02-06.09		54	530	S5 002	52	530	S4 002						
Diesel														
1.5 CRDi [TB]	05.03-06.09								70		S4 026			
Grace														
2.4 i Super	10.95→								60		S4 024			
Diesel									60		S4 025			
2.5 D	10.95→								95		S4 028			
Grandeur														
2.0 i	07.86-08.92		70	760	S6 008	77	780	S5 008	74	780	S4 008			
2.7/ 3.3 , 24V [TG]	07.05→		70	760	S6 008	77	780	S5 008	74	780	S4 008	70	640	
Diesel														
2.2 CRDi [TG]	07.06-11.10		70	760	S6 008	77	780	S5 008	74	780	S4 008			
H 100														
2.4 i	07.93-03.00								95		S4 028			
Diesel														
2.5 TD	07.93-03.00								95		S4 028			
	05.05→								95		S4 029			
2.5/ 2.6 D, Intercooler, TCI	02.93→								95		S4 028			
H-1														
2.4	06.01-12.06								74		S4 009			
i	10.97-05.07								74		S4 009			
	10.08→								95		S4 029			
Diesel														
2.5 CRDi Cargo	03.08→								74		S4 009			
	12.08→								95		S4 029			
CRDi, D, TCI	10.97-12.06								95		S4 028			
CRDi Travel	03.08→								95		S4 029			
ix20														
1.4/ 1.6 [JC]	10.10→		60	680	S6 005									
Diesel														
1.4 CRDi [JC]	10.10→		60	680	S6 005									
1.6 CRDi [JC]	05.11→								60		S4 024			
ix35														
1.6 GDI [LM,EL]	09.10→		70	650	S5 E08				650					
2.0 i [LM,EL]	01.10→								60		S4 024			

		Ah A (EN) S6		Ah A (EN) S5		Ah A (EN) S4		Ah A (EN) S3	
		0 092 ...0		0 092 ...0		0 092 ...0		0 092 ...0	
◀ HYUNDAI									
2.0 i 4x4 [LM,EL]	01.10→					60			S4 024
2.4 i 4x4 [LM,EL]	11.10→			63	610	S5 005	60	610	S4 005
Diesel									
1.7 CRDi [LM,EL]	09.10→		80	800	S6 011				
		SSJ					70		S4 026
2.0 CRDi [LM,EL]	01.10→						95		S4 028
				77	780	S5 008	74	780	S4 008
CRDi 4x4 [LM,EL]	01.10→			77	780	S5 008	74	780	S4 008
ix55									
3.8 4x4 [EN]	09.08→						95		S4 028
Diesel									
3.0 V6 CRDi 4x4 [EN]	04.09→						95		S4 028
i10									
1.1 [PA]	03.08-09.10						40		S4 018
	10.10→						40		S4 030
1.2 [PA]	08.08→						40		S4 030
Diesel									
1.1 CRDi [PA]	03.08-12.10						60		S4 024
i20									
1.2 [PB/PBT]	01.09-03.12		54	530	S5 002	52	530	S4 002	45 400 S3 002
	03.12→		54	530	S5 002	52	530	S4 002	
1.4/ 1.6 [PB/PBT]	01.09→		54	530	S5 002	52	530	S4 002	
Diesel									
1.1 CRDi [PB/PBT]	03.12→		54	530	S5 002	52	530	S4 002	
1.4/ 1.6 CRDi [PB/PBT]	10.08→						60		S4 024
i30									
1.4 [FD/FDH]	09.07-12.11		54	530	S5 002	52	530	S4 002	45 400 S3 002
		SSJ	60	680	S6 005				
1.4/ 1.6 [GD]	12.11→		54	530	S5 002	52	530	S4 002	
LPG [FD/FDH]	03.09-12.10	SSJ	60	680	S6 005				
1.6 [FD/FDH]	09.07→		54	530	S5 002	52	530	S4 002	45 400 S3 002
		SSJ	60	680	S6 005				
2.0 [FD/FDH]	09.07→		54	530	S5 002	52	530	S4 002	45 400 S3 002
Diesel									
1.4 CRDi [GD]	12.11→		70	760	S6 008				
1.6 CRDi [FD/FDH]	09.07→		70	760	S6 008				
	10.07-12.11						70		S4 026
		SSJ	70	760	S6 008				
	11.08-12.11						60		S4 024
CRDi [GD]	12.11→						60		S4 024
			70	760	S6 008				
2.0 CRDi [FD/FDH]	09.07-03.11						70		S4 026
i30 CW									
1.4 [FD/FDH]	08.09-09.12		54	530	S5 002	52	530	S4 002	
		SSJ	60	680	S6 005				
1.4/ 1.6 LPG [FD/FDH]	03.09-12.10	SSJ	60	680	S6 005				
1.6 [FD/FDH]	03.08-09.12		54	530	S5 002	52	530	S4 002	45 400 S3 002
		SSJ	60	680	S6 005				
2.0 [FD/FDH]	03.08-03.11		54	530	S5 002	52	530	S4 002	45 400 S3 002
Diesel									
1.4/ 1.6 CRDi [GD]	03.12→						60		S4 024
1.6 CRDi [FD/FDH]	02.08-09.12						70		S4 026
		SSJ	70	760	S6 008				
2.0 CRDi [FD/FDH]	03.08-03.11						70		S4 026
i40									
1.6 GDI [VF]	04.11→		70	760	S6 008				
2.0 GDI [VF]	04.11→		63	610	S5 005	60	610	S4 005	
Diesel									
1.7 CRDi [VF]	04.11→		80	800	S6 011				
i40 CW									
1.6/ 2.0 GDI [VF]	04.11→		63	610	S5 005	60	610	S4 005	
Diesel									
1.7 CRDi [VF]	04.11→		70	760	S6 008				

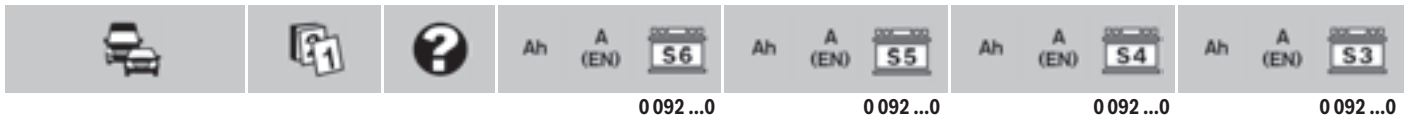

Lantra												
1.5 i [J2]	07.96-09.00		54	530	S5 002		52	530	S4 002	45	400	S3 002
1.5/1.6/1.8 i, i 16V [J1]	10.90-04.95									45	300	S3 017
1.6 i 16V [J2]	05.95-05.98									45	300	S3 016
	06.98-09.00		54	530	S5 002		52	530	S4 002	45	400	S3 002
1.8/ 2.0 i 16V [J2]	05.95-09.00		63	610	S5 005		60	610	S4 005	56	480	S3 005
Lantra Kombi												
1.5 i [J2]	07.96-09.00									45	300	S3 016
1.6 i [J2]	05.95-05.98									45	300	S3 016
	06.98-09.00		54	530	S5 002		52	530	S4 002	45	400	S3 002
1.8/ 2.0 i [J2]	05.95-09.00		63	610	S5 005		60	610	S4 005	56	480	S3 005
Matrix												
1.6 i [FC]	08.01-04.10		63	610	S5 005		60	610	S4 005			
	01.02-12.05		63	610	S5 005		60	610	S4 005	56	480	S3 005
1.8 i [FC]	08.01-04.10		63	610	S5 005		60	610	S4 005			
Diesel												
1.5 CRDi [FC]	07.01-04.10							70	S4 026			
Pony												
1.2/ 1.3/ 1.4/ 1.5 i [X1; X2; X3]	05.82-07.99							60	S4 025	45	300	S3 017
Porter												
Diesel												
2.6 D	09.00-12.03		63	610	S5 006		60	610	S4 006			
Santa Fe												
2.0/ 2.4/ 2.7 i, i 4x4 [SM]	09.99-12.05		63	610	S5 005		60	610	S4 005			
2.4 i	12.00→		63	610	S5 005		60	610	S4 005			
i 4x4 [CM]	11.09-12.12		63	610	S5 005		60	610	S4 005			
2.4/ 2.7 i [CM]	03.06-12.12		63	610	S5 005		60	610	S4 005			
2.7 i 4x4 [CM]	03.06-11.09							95	S4 028			
Diesel												
2.0 CRDi 4x4, CRDi-VGT 4x4 [SM]	01.01-12.05							95	S4 028			
2.0/ 2.2 CRDi, CRDi 4x4 [CM]	03.06-12.12							95	S4 028			
Santamo												
2.0 i	05.99-12.02							60	S4 025			
Satellite												
Diesel												
2.5 D Turbo, D Turbo 4WD	10.97-08.02							95	S4 028			
Satnta Fe												
Diesel												
2.0 CRDi [DM]	04.01-12.05							95	S4 028			
Scoupe												
1.5	02.90-06.92							60	S4 025	45	300	S3 017
i	02.90-12.93							60	S4 025	45	300	S3 017
	01.94-05.95							45	S4 023			
i Turbo GT	04.91-12.93							60	S4 025	45	300	S3 017
	01.94-08.95							45	S4 023			
Solaris												
1.4/ 1.6 [RB]	01.11→		54	530	S5 002		52	530	S4 002			
Solaris Hatchback												
1.4/ 1.6 [RB]	01.11→		54	530	S5 002		52	530	S4 002			
Sonata												
1.8 i [Y3]	07.93-06.98		63	610	S5 006		60	610	S4 006	56	480	S3 006
i GLS [Y3]	07.96-05.98		63	610	S5 006		60	610	S4 006	56	480	S3 006
1.8/ 2.0/ 2.4/ 3.0 i, i 16V [Y2; Y3]	06.88-06.98							70	S4 027			
2.0 [NF]	12.05-12.07							70	S4 026			
	01.08-12.10							60	S4 024			
[YF]	09.10→							70	S4 026			
i [EF]	03.98-03.01		63	610	S5 005		60	610	S4 005	56	480	S3 005
	04.01-11.04		63	610	S5 005		60	610	S4 005			
i [Y3]	07.92-06.98		63	610	S5 006		60	610	S4 006	56	480	S3 006
	09.97→		63	610	S5 005		60	610	S4 005			

			Ah	A (EN)	S6	Ah	A (EN)	S5	Ah	A (EN)	S4	Ah	A (EN)	S3
			0 092 ...0			0 092 ...0			0 092 ...0			0 092 ...0		
HYUNDAI														
2.4/ 2.5 i [EF]	03.98-03.01		77	780	S5 008	74	780	S4 008	70	640	S3 008			
2.4/ 3.3 [NF]	08.04-12.10						70	S4 026						
2.7 i [EF]	04.01→		63	610	S5 005	60	610	S4 005						
	10.02-07.05						70	S4 026						
Diesel														
2.0 CRDi [NF]	01.06-12.10						95	S4 028						
Sonata I														
2.4 i [Y2]	01.89-10.93						70	S4 027						
Sonata II														
3.0 i [Y3]	11.93-04.98						70	S4 027						
Starex														
2.4 i, i 4WD	10.97-05.07						74	S4 009						
Diesel														
2.5 CRDi	10.02-01.07						95	S4 028						
D, D Turbo, D Turbo 4WD	10.97-08.02						95	S4 028						
TCI	10.02-12.07						74	S4 009						
Stellar														
1.4 i	09.83-12.86		54	530	S5 002	52	530	S4 002	45	400	S3 002			
Stellar Prima														
1.6/ 1.8 i	09.83-12.89		54	530	S5 002	52	530	S4 002	45	400	S3 002			
2.0 i	10.85-01.88						60	S4 025						
Terracan														
3.5 i V6 [HP]	07.01-10.06						95	S4 028						
Diesel														
2.5/ 2.9 CRDi, D Turbo [HP]	02.01-10.06						95	S4 028						
Trajjet														
2.0 i [FO]	01.00-06.07		63	610	S5 005	60	610	S4 005						
	01.04-06.07		63	610	S5 005	60	610	S4 005	56	480	S3 005			
2.7 i [FO]	01.00-06.07		63	610	S5 005	60	610	S4 005	56	480	S3 005			
Diesel														
2.0 CRDi [FO]	01.01-06.07						95	S4 028						
Tucson														
2.0/ 2.7 i, i 4x4 [JM]	08.04-03.10						95	S4 028						
Diesel														
2.0 CRDi, CRDi 4x4, VGT CRDi [; JM]	04.04→						95	S4 028						
Veloster														
1.6 GDI	06.11→		54	530	S5 002		530							
			60	560	S5 E05		560							
GDI Turbo	02.12→		54	530	S5 002		530							
			60	560	S5 E05		560							
Verna														
1.5 i Lean Burn [LC]	07.99-03.06		54	530	S5 002	52	530	S4 002	45	400	S3 002			
XG														
25/ 30 2.5i, 3.0i [F]	12.98-12.05		77	780	S5 008	74	780	S4 008	70	640	S3 008			
35 3.5i [F]	08.02-12.05		77	780	S5 008	74	780	S4 008						

INFINITI

EX

37 4x4 [J50]	06.08→						60	S4 024						
Diesel														
30 d 4x4 [J50]	04.10→		85	800	S5 010	80	800	S4 010						
FX														
35 i [S50]	11.02-08.08		70	760	S6 008	70	650	S5 E08		650				
			70	760	S6 008	77	780	S5 008		780				
37 4x4 [S51]	07.08→						60	S4 024						
45 4x4 [S50]	07.06-08.08	BWD					70	S4 027						
50 4x4 [S51]	07.08→						70	S4 026						
Diesel														
30 d 4x4 [S51]	03.10→		85	800	S5 010	80	800	S4 010						

			Ah A (EN)  0 092 ...0	Ah A (EN)  0 092 ...0	Ah A (EN)  0 092 ...0	Ah A (EN)  0 092 ...0
---	---	---	--	---	--	--

G						
25 [V36]	01.10→				70	S4 026
37 [V36]	07.08→				60	S4 024
4x4 [V36]	07.08→				60	S4 024
G Cabrio						
37 [HV36]	06.09→				60	S4 024
G Coupé						
37 [CV36]	10.07→				60	S4 024
M						
35 [Y50]	09.05-08.08				60	S4 024
35/37 , h, 4x4 [Y51]	05.10→				70	S4 026
Diesel						
30 d [Y51]	07.10→	85	800	S5 010	80	800 S4 010

INNOCENTI (NUOVA INNOCENTI)

Mini						
TRE/ 650	04.82-04.86				45	300 S3 017
TRE/ 990 Matic, Turbo, Turbo de Tomaso	10.83-12.90				45	300 S3 017
550	01.90-06.90	52	520	S5 001	44	520 S4 001 41 360 S3 001
990	05.86-06.90				45	300 S3 017
Diesel						
TRE/ 990 D	01.84-12.90	54	530	S5 002	52	530 S4 002

IRAN KHODRO

Samand						
1.8 i	07.01→				74	S4 008 70 640 S3 008

ISUZU

Aska						
1.8/ 2.0 , i Turbo	04.83-12.93				60	S4 025
Diesel						
2.0 D, D Turbo	04.83-12.93				60	S4 025
Campo						
2.2 Sports-Cab	01.89-12.90				95	S4 028
D-Max						
Diesel						
2.5 D Turbo	05.02-10.04				95	S4 028
	01.07→				70	S4 026
	04.12→				70	S4 027
D Turbo 4x4	05.02-10.04				95	S4 029
	01.07→				70	S4 026
	04.12→				70	S4 027
3.0 D Turbo	01.07→				95	S4 029
D Turbo 4x4	05.02→				95	S4 029
	01.07→				95	S4 028
Elf						
150/ 250 1.6, 2.0	01.74-10.88				60	S4 025
Diesel						
150/ 250/ 350 2.5 D, 2.8 D, 3.3 D, 3.9 D, 3.9 D Turbo	10.86-12.96				95	S4 029
Gemini						
1.5/ 1.6 , GTI, i Turbo	11.84-12.93				60	S4 024
Diesel						
1.5 D, D Turbo	10.85-12.93				70	S4 026

			Ah A (EN) S6	Ah A (EN) S5	Ah A (EN) S4	Ah A (EN) S3
			0092 ...0	0092 ...0	0092 ...0	0092 ...0

◀ ISUZU

KAD						
Diesel						
2.0 D	01.85-12.95				95	S4 029
KAG						
1.6	01.85-12.95				60	S4 025
Midi						
2.0 , 4WD	01.89-12.99				95	S4 029
Diesel						
2.0/ 2.2/ 2.4 D, D Turbo, D 4WD	01.89-12.99				95	S4 029
Piazza						
2.0 i, i Turbo	06.81-12.90				70	S4 027
Pick Up						
Diesel						
2.5 TD	11.98→				60	S4 025
3.1 TD	05.97→				70	S4 027
Pick-Up						
1.9 [KB]	01.83-12.88				70	S4 027
	06.85-12.93				95	S4 028
Diesel						
2.2 D [KB]	04.86-12.90				95	S4 028
Rodeo D-Max						
Diesel						
3.0 D Turbo 4WD I-TEQ	10.04→				95	S4 028
Serie N						
Diesel						
NHR/ NKR/ NPR/ NQR 2.5 D, 2.8 D, 3.1 D, 3.3 D, 3.9 D, 3.9 D Turbo, 4.7 D Turbo	01.81→				95	S4 029
TL, TLD						
Diesel						
2.8 D	01.75-02.86				95	S4 029
Trooper						
2.0/ 2.2/ 2.6 , i [UBS]	02.81-08.91				95	S4 029
3.2/ 3.5 i 4WD, i 24V 4WD, i 24V 4x4 [UB]	04.92-09.04				95	S4 029
Diesel						
2.2/ 2.8 D, D Turbo, D Turbo Interc. [UBS]	02.81-12.91				95	S4 029
3.0 D Turbo 4WD [UB]	04.00-08.03				95	S4 029
3.1 D Turbo Interc. [UB]	04.92-12.97				95	S4 029
WFR, WFS						
1.8/ 2.0	06.83-12.96				60	S4 025
Diesel						
2.0/ 2.2 D, D Turbo	02.83-12.96				95	S4 029

IVECO



Daily						
35 C/ 35 S/ 50 C 11 [00]	09.02-08.06		100	830	S5 013	95 830 S4 013
Diesel						
A40/ A45/ A49/ 30/ 35/ 40/ 42/ 45/ 49/ 54/ 59/ 66	07.89-12.00	95	850	S6 013	100 830 S5 013	95 830 S4 013 90 720 S3 013
-8, -10, -10 Turbo, -10 Turbo I.D., -10 Turbo 4x4, -12 Turbo[; 96]						
29 L/ 35 C/ 35 S/ 50 C 9, 10, 11, 12 [00]	05.99-03.06		100	830	S5 013	95 830 S4 013
29 L/ 35 C/ 40 C/ 50 C 13 [00]	05.99-03.06		100	830	S5 013	95 830 S4 013
35 C/ 35 S/ 40 C/ 50 C/ 65 C 14, 15, 17 [00]	05.00-03.06		100	830	S5 013	95 830 S4 013

			Ah A (EN) S6	Ah A (EN) S5	Ah A (EN) S4	Ah A (EN) S3
			0 092 ...0	0 092 ...0	0 092 ...0	0 092 ...0

35 S 13 [00]	05.99-03.06	95	850	S6 013	100	830	S5 013	95	830	S4 013
Daily, Grinta										
30/ 35 -9	12.81-12.87							95		S4 013
Diesel										
30/ 35/ 40 -8, -8 Duty, -10 Turbo, -10 Turbo 4x4	04.78-09.90	95	850	S6 013	100	830	S5 013	95	830	S4 013
Massif										
Diesel										
3.0	06.08→				100	830	S5 013	95	830	S4 013

JAGUAR

Daimler										
3.6	10.86-08.89				61	600	S5 004	60	600	S4 004
	10.86-12.90	95	850	S6 013	61	600	S5 004	60	600	S4 004
				XXX					53	470
4.0	09.89-10.98	95	850	S6 013	100	830	S5 013	95	830	S4 013
	09.89-10.99				100	830	S5 013	95	830	S4 013
	Kompressor, 32V				100	830	S5 013	95	830	S4 013
4.2	10.83-10.95							70		S4 027
5.3 HE	10.86-12.92	95	850	S6 013				70		S4 027
	V12	95	850	S6 013				70		S4 027
	V12 Coupé, V12 HE	95	850	S6 013				70		S4 027
6.0 V12	12.93-12.94	95	850	S6 013	100	830	S5 013	95	830	S4 013
F-TYPE										
3.0/ 5.0 V6, V8	10.12→	95	850	S6 013						
F-TYPE S										
3.0 V6	10.12→	95	850	S6 013						
Sovereign										
2.9	10.86-08.90				63	610	S5 005	60	610	S4 005
3.2 24V	09.90-08.99				63	610	S5 005	60	610	S4 005
3.6	10.86-08.89				63	610	S5 005	60	610	S4 005
		95	850	S6 013	63	610	S5 005	60	610	S4 005
4.0	09.89-08.99	70	760	S6 008	77	780	S5 008	74	780	S4 008
	32V	70	760	S6 008	77	780	S5 008	74	780	S4 008
6.0 XJ 81	03.93-12.95	70	760	S6 008	77	780	S5 008	74	780	S4 008
S-Type										
2.5/ 3.0/ 4.0/ 4.2 V8 32V, V8 32V R, 24V, 32V	10.98-03.08	95	850	S6 013	100	830	S5 013	95	830	S4 013
Diesel										
2.7 D	06.04-03.08	95	850	S6 013	100	830	S5 013	95	830	S4 013
XF										
2.0 EcoBoost	09.12→				74	750	S5 007	72	750	S4 007
3.0 V6 Supercharged	03.12→				85	800	S5 010	80	800	S4 010
3.0/ 4.2/ 5.0 Supercharged, V6, V8	03.08→	95	850	S6 013	100	830	S5 013	95	830	S4 013
Diesel										
2.2 D	09.11→	80	800	S6 011						
				SSJ	85	800	S5 010	800		
2.7 D	03.08-02.09	95	850	S6 013	100	830	S5 013	95	830	S4 013
3.0 D	03.09-08.11				85	800	S5 010	80	800	S4 010
	D V6, D V6S	95	850	S6 013	100	830	S5 013	95	830	S4 013
XF SPORTBRAKE										
2.0 EcoBoost	08.12→				77	780	S5 008	74	780	S4 008
Diesel										
2.2 D	09.12→	80	800	S6 011						
3.0 D	09.12→				85	800	S5 010	80	800	S4 010
	D V6				85	800	S5 010	80	800	S4 010
XJ										
3.0 V6	08.11→				100	830	S5 013	95	830	S4 013
	V6 Supercharged				85	800	S5 010	80	800	S4 010
5.0 V8, V8 Supercharged	11.09→	95	850	S6 013						

			Ah A (EN) S6	Ah A (EN) S5	Ah A (EN) S4	Ah A (EN) S3
◀ JAGUAR			0092 ...0	0092 ...0	0092 ...0	0092 ...0
Diesel						
3.0 DV6	08.10→	95	850	S6 013		
XJ S Cabrio						
3.6/4.0/5.3/6.0	09.81-12.97	70	760	S6 008	77 780 S5 008	74 780 S4 008 70 640 S3 008
XJ S Coupé						
3.6/4.0/5.3/6.0, i, V12, V12 HE	09.75-12.97	70	760	S6 008	77 780 S5 008	74 780 S4 008 70 640 S3 008
XJ 6						
2.5 32V	03.03-03.05	70	760	S6 008	77 780 S5 008	74 780 S4 008
2.9/3.2/3.4/3.6/4.0/4.2, Kompressor	05.75-12.98	70	760	S6 008	77 780 S5 008	74 780 S4 008 70 640 S3 008
3.0 24V	03.03-07.10	70	760	S6 008	77 780 S5 008	74 780 S4 008 70 640 S3 008
3.2/4.0 24V	10.90-12.98	70	760	S6 008	77 780 S5 008	74 780 S4 008 70 640 S3 008
4.0 24V Kompressor	10.94-12.98	70	760	S6 008	77 780 S5 008	74 780 S4 008 70 640 S3 008
4.2 32V V8 S/C	03.03-07.10	70	760	S6 008	77 780 S5 008	74 780 S4 008 70 640 S3 008
Diesel						
2.7 DV6	10.05-07.10	70	760	S6 008	77 780 S5 008	74 780 S4 008 70 640 S3 008
XJ 8						
3.2/4.0 V8 32V	09.97-08.02	70	760	S6 008	77 780 S5 008	74 780 S4 008 70 640 S3 008
3.5/4.2 32V	03.03-07.10	70	760	S6 008	77 780 S5 008	74 780 S4 008 70 640 S3 008
XJ 12						
5.3/6.0, HE	05.75-12.99	70	760	S6 008	77 780 S5 008	74 780 S4 008 70 640 S3 008
XJR Convertible						
4.2 32V V8 S/C	03.03-03.09	70	760	S6 008	77 780 S5 008	74 780 S4 008 70 640 S3 008
XJR Coupé						
4.2 32V V8 S/C	03.03-03.09	70	760	S6 008	77 780 S5 008	74 780 S4 008 70 640 S3 008
XJR 8						
4.0 V8 32V Kompressor	09.97-09.02	70	760	S6 008	77 780 S5 008	74 780 S4 008 70 640 S3 008
XK Convertible						
3.5/5.0 AWD, R	03.08→	95	850	S6 013	100 830 S5 013	95 830 S4 013 90 720 S3 013
4.2 R 32V	03.06-02.09	95	850	S6 013		
32V	03.06-02.09				100 830 S5 013	95 830 S4 013 90 720 S3 013
5.0	02.09→	95	850	S6 013	100 830 S5 013	95 830 S4 013
		95	850	S6 013	100 830 S5 013	95 830 S4 013 90 720 S3 013
R-S	01.11→	95	850	S6 013	100 830 S5 013	95 830 S4 013
XK Coupé						
3.5	07.07-02.09	95	850	S6 013	100 830 S5 013	95 830 S4 013 90 720 S3 013
4.2 R 32V	03.06-02.09	95	850	S6 013	100 830 S5 013	95 830 S4 013
32V	03.06-02.09				100 830 S5 013	95 830 S4 013 90 720 S3 013
5.0	02.09→	95	850	S6 013	100 830 S5 013	95 830 S4 013
R	01.09→	95	850	S6 013	100 830 S5 013	95 830 S4 013 90 720 S3 013
	09.10→	95	850	S6 013		
R-S	01.11→	95	850	S6 013		
XK 8 Convertible						
4.0 R 32V	03.98-09.02	95	850	S6 013	100 830 S5 013	95 830 S4 013 90 720 S3 013
32V	03.96-09.02	95	850	S6 013	100 830 S5 013	95 830 S4 013
4.2 R 32V	03.03-02.09	95	850	S6 013	100 830 S5 013	95 830 S4 013 90 720 S3 013
32V	03.03-02.09	95	850	S6 013	100 830 S5 013	95 830 S4 013 90 720 S3 013
XK 8 Coupé						
4.0 R 32V	03.98-09.02	95	850	S6 013	100 830 S5 013	95 830 S4 013 90 720 S3 013
32V	03.96-09.02	95	850	S6 013	100 830 S5 013	95 830 S4 013
4.2 R 32V	03.03-02.09	95	850	S6 013	100 830 S5 013	95 830 S4 013 90 720 S3 013
32V	03.03-02.09	95	850	S6 013	100 830 S5 013	95 830 S4 013 90 720 S3 013
X-Type						
2.0/2.5/3.0	03.01-11.09	70	760	S6 008	77 780 S5 008	74 780 S4 008 70 640 S3 008
Diesel						
2.0 D	09.03-10.05	70	760	S6 008	77 780 S5 008	74 780 S4 008 70 640 S3 008
2.2 D	09.05-11.09				74 750 S5 007	750
X-Type Estate						
2.0/2.5/3.0	03.03-12.09	70	760	S6 008	77 780 S5 008	74 780 S4 008 70 640 S3 008
Diesel						
2.0 D	09.03-10.05				85 800 S5 011	80 800 S4 010
2.2 D	09.05-12.09				74 750 S5 007	750

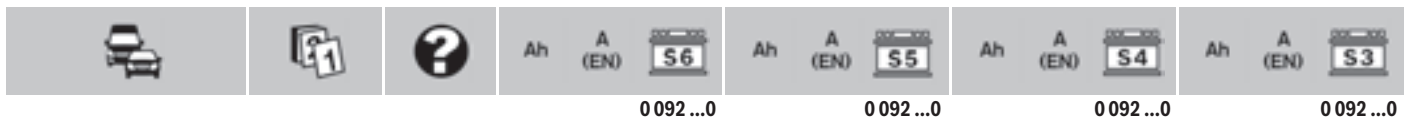

JEEP

Cherokee											
2.4 4x4 [KJ]	03.01-12.07								74	S4 008	70 640 S3 008
2.5/ 3.7/ 4.0 , i, i 4x4, 4x4 [KJ; XJ]	09.86-12.07								74	S4 009	
Diesel											
2.1 D Turbo [XJ]	04.84-08.95								95	S4 028	
2.5 D Turbo [XJ]	09.88-12.01	VAD						74 750	72 750	S4 007	70 640 S3 007
2.5/ 2.8 CRD, CRD 4x4 [KJ]	03.01-12.07								74	S4 009	
CJ7											
2.0	10.83-12.86							63 610	60 610	S4 005	56 480 S3 005
2.5/ 4.2	01.72-12.87								70	S4 027	
Diesel											
2.1/ 2.4 D	10.82-12.87							63 610	60 610	S4 005	56 480 S3 005
Commander											
3.7/ 4.7/ 5.7 4x4 [XH; XK]	09.05→		70 760	S6 008		77 780	S5 008		74 780	S4 008	
Diesel											
3.0 CRD 4x4 [XH]	01.06→					100 830	S5 013		830		
Compass											
2.0 AWD [PK]	05.11→					77 780	S5 008		74 780	S4 008	
2.4 , 4x4 [MK]	10.06→					61 600	S5 004		60 600	S4 004	
Diesel											
2.0 CRD, CRD 4x4 [MK]	10.06→					61 600	S5 004		60 600	S4 004	
Grand Cherokee											
3.6/ 3.7/ 4.7/ 5.7 , FFV 4x4, 4x4 [WK]	09.03→					85 800	S5 010		80 800	S4 010	
4.0/ 4.7/ 5.7/ 6.1 , i, i 4WD, SRT-8 4x4, V8, 4x4 [; WG; WH; WJ; WK]	10.98-09.10		70 760	S6 008		77 780	S5 008		74 780	S4 008	
4.0/ 5.2/ 5.9 , i [ZG; ZJ]	09.92-04.99								70	S4 027	
4.7 i [WG]	09.00-12.04					75 730	S5 E10		80 730	S4 010	
						85 800	S5 010		80 800	S4 010	
i Overland [WG]	10.01-12.04					75 730	S5 E10		80 730	S4 010	
						85 800	S5 010		80 800	S4 010	
6.1 SRT-8 4x4 [WH]	01.06-09.10		70 760	S6 008		77 780	S5 008		80 780	S4 010	
			70 760	S6 008		85 800	S5 010		74 800	S4 008	
			70 760	S6 008		85 800	S5 010		80 800	S4 010	
Diesel											
2.5 TD [ZG]	01.96-04.99	VAD				74 750	S5 007		72 750	S4 007	70 640 S3 007
2.7 CRD [WG]	10.01-12.04	VAD	95 850	S6 013		100 830	S5 013		95 830	S4 013	
3.0 CRD [WH]	03.05-10.11		95 850	S6 013		100 830	S5 013		830		
CRDi AWD [WK2]	04.11→					100 830	S5 013		95 830	S4 013	
			95 850	S6 013		100 830	S5 013		95 830	S4 013	
3.1 TD [WG]	09.00-12.02								74	S4 009	
Liberty											
3.7 [KK]	09.07→								80	S4 010	
Diesel											
2.8 CRD 4x4 [KK]	01.08→					77 780	S5 008		74 780	S4 008	
Patriot											
2.4 [MK]	10.06→								74	S4 009	
Diesel											
2.0 CRD, CRD 4x4 [MK]	10.06→					63 610	S5 006		610		
Wagoneer											
Diesel											
2.1 D Turbo [SJ]	01.88-12.94								70	S4 027	
Wrangler											
2.4/ 2.5/ 4.0 [TJ]	09.96-12.07					63 610	S5 006		60 610	S4 006	
2.5/ 4.0/ 4.2 i 4x4, 4x4 [YJ]	01.86-08.96								74	S4 009	
3.8 4x4 [JK]	01.07→								70	S4 027	
Diesel											
2.8 CRD [JK]	01.07→								74	S4 009	



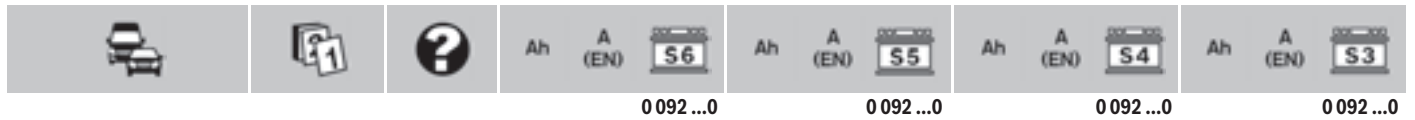

JENSEN

S Cabrio			
4.6 V8	10.98→	70	S4027
S Coupé			
4.6 V8	10.00→	70	S4027

KIA

Avella			
1.3 i	03.94→	45	S4021
Capital			
1.5/1.8 i, LPG	03.89-06.95	60	S4024
Carens			
1.6 [FG]	02.09→	63 610	S5005 60 610 S4005
i [FC]	09.02-12.06	63 610	S5005 60 610 S4005
1.8 i [FC]	04.99-05.02	63 610	S5005 60 610 S4005
	09.02-12.06	63 610	S5005 60 610 S4005
2.0 CVT, i [FC; FG]	08.04→	63 610	S5005 60 610 S4005
Diesel			
1.6 CRDi [FG]	09.10→	63 610	S5005 60 610 S4005
2.0 CRDi, CRDi VGT [FC; FG]	04.02→		70 S4026
Carnival			
2.5 V6 [UP]	06.98-06.06		70 S4026
2.7 V6 [MB]	04.06→		60 S4024
Diesel			
2.2/2.9 CRDi, D Turbo [MB; UP]	06.98→		95 S4028
Carnival II			
2.5 i V6	10.01-12.05		60 S4024
Cee'd			
1.4 [ED/FF2]	11.06-08.09	BWD,SSJ	60 680 S6005
	11.06→		60 S4024
	09.09→	SSJ	60 680 S6005
1.6 [ED/FF2]	11.06-01.08	SSJ	60 680 S6005
	11.06-12.12		60 S4024
	02.08-12.12	BWD,SSJ	60 680 S6005
GDi [JD]	05.12→		60 S4024
2.0 [ED/FF2]	11.06-12.12		60 S4024
Diesel			
1.4 CRDi [JD]	05.12→		70 650 S5E08 60 650 S4024
1.6 CRDi [ED/FF2]	11.06-12.12		60 S4024
		SSJ	70 760 S6008
	09.10→		70 S4026
CRDi [JD]	05.12→		70 650 S5E08 60 650 S4024
			70 760 S6008 60 S4024
2.0 CRDi [ED/FF2]	09.07-12.12		60 S4024
Cee'd Sporty Wagon			
1.4 [ED/FF2]	09.07→		60 S4024
		SSJ	60 680 S6005
[JD]	08.12→		70 650 S5E08 60 650 S4024
1.6 [ED/FF2]	09.07-12.12		60 S4024
		BWD,SSJ	60 680 S6005
[JD]	08.12→		70 760 S6008 60 S4024
2.0 [ED/FF2]	09.07-12.12		60 S4024
Diesel			
1.4/1.6 [JD]	08.12→		70 760 S6008 70 S4026
1.6 CRDi [ED/FF2]	09.07-12.12		60 S4024
		SSJ	70 760 S6008
	09.10→		70 S4026
2.0 CRDi [ED/FF2]	09.07-12.12		60 S4024

			Ah A (EN) 	Ah A (EN) 	Ah A (EN) 	Ah A (EN) 
			0 092 ...0	0 092 ...0	0 092 ...0	0 092 ...0

Cerato									
1.6 i [FE]	10.04-11.09		54	530	S5 002	52	530	S4 002	
	05.06-11.09		63	610	S5 005	60	610	S4 005	56 480 S3 005
2.0 [TD]	12.08→		63	610	S5 005	60	610	S4 005	
i [FE]	10.04-11.09		63	610	S5 005	60	610	S4 005	56 480 S3 005
Diesel									
1.5/ 1.6/ 2.0 CRDi [FE]	03.04-11.09					70		S4 026	
Cerato Hatchback									
1.6/ 2.0 i [FE]	03.04-11.09		63	610	S5 005	60	610	S4 005	56 480 S3 005
Diesel									
1.5/ 1.6/ 2.0 CRDi [FE]	03.04-11.09					70		S4 026	
Clarus									
1.8/ 2.0 i 16V [GC]	05.96-11.01					45		S4 021	
Clarus Kombi									
1.8/ 2.0 i [GC]	06.98-11.01					45		S4 021	
Concord									
1.8/ 2.0 i	10.87-06.95					60		S4 024	
Creato									
1.6 [TD]	08.10→		63	610	S5 005	60	610	S4 005	
Joice									
2.0 i [MT]	08.99-03.03					70		S4 027	
Magentis									
2.0 [GE]	07.08-04.10					70		S4 027	
i [GE]	02.06-08.08		63	610	S5 005	60	610	S4 005	
2.0/ 2.5 i [GD]	09.00-12.05		63	610	S5 005	60	610	S4 005	
2.7 [GE]	09.06-08.08		63	610	S5 005	60	610	S4 005	
	07.08-04.10					70		S4 027	
Diesel									
2.0 CRDi [GE]	02.06-08.08					70		S4 026	
	07.08-04.10					95		S4 028	
Opirus									
3.5/ 3.8 i, i V6 [LD]	09.03→					70		S4 026	
Optima									
2.0/ 2.4 [TF]	03.12→					60		S4 024	
Diesel									
1.7 CRDi [TF]	09.11→		70	760	S6 008				
Picanto									
1.0/ 1.1 i [BA]	05.04-01.11					40		S4 018	
1.0/ 1.2, Bi-Fuel [TA]	05.11→					40		S4 018	
Diesel									
1.1 CRDi [BA]	11.05-01.11					60		S4 024	
Pride									
1.1/ 1.3 i [DA]	01.90-02.00					60		S4 024	
Pro Cee'd									
1.4 [ED]	10.07-12.12					60		S4 024	
	09.09-12.12	SSJ	60	680	S6 005				
1.6 [ED]	03.08-12.12					60		S4 024	
		SSJ	60	680	S6 005				
2.0 [ED]	03.08-12.12					60		S4 024	
Diesel									
1.6 CRDi [ED]	03.08-12.12					60		S4 024	
	09.10-12.12					70		S4 026	
2.0 CRDi [ED]	03.08-12.12					70		S4 026	
Retona									
2.0 i [CE]	04.98-12.00					95		S4 028	
Diesel									
2.0 TD [CE]	04.98-12.00					95		S4 028	
Rio									
1.2 [UB]	11.11→		60	560	S5 E05		560		
1.3/ 1.4/ 1.5/ 1.6, i [DC; JB, DE; UB]	07.00→					60		S4 024	

		Ah A (EN) S6		Ah A (EN) S5		Ah A (EN) S4		Ah A (EN) S3	
		0092 ...0		0092 ...0		0092 ...0		0092 ...0	
◀ KIA									
Diesel									
1.5 CRDi [JB, DE]	03.05-09.11							70	S4 026
Rio Hatchback									
1.2 [UB]	06.11→		60	560	S5 E05		560		
1.4/ 1.6, i [JB, DE; UB]	03.05→						60		S4 024
Diesel									
1.1/ 1.4 CRDi [UB]	06.11→						60		S4 024
1.5 CRDi [JB, DE]	03.05-09.11						70		S4 026
Rio Kombi									
1.3/ 1.5 i [DC]	09.02-02.05						60		S4 024
Sedona									
2.5 i V6	06.98-09.05						70		S4 026
Diesel									
2.9 D Turbo [UP]	06.98-09.01						60		S4 024
Sephia I									
1.5 i [FA]	01.92-10.94						60		S4 024
	09.96-12.97						60		S4 024
	10.97-12.00						60		S4 025
i 16V [FA]	01.92-10.94						60		S4 024
	10.97-12.00						60		S4 025
1.6 i [FA]	07.93-12.97						60		S4 024
i 16V [FA]	09.95-08.97						60		S4 024
	01.98-12.00						60		S4 025
1.8 i 16V [FA]	03.95-08.98						60		S4 024
	01.98-12.00						60		S4 025
Sephia I Hatchback									
1.5 i [FA]	09.96-12.97						60		S4 024
1.5/ 1.6 i 16V [FA]	01.98-12.00						60		S4 025
1.8 i 16V [FA]	09.96-12.00						60		S4 024
Sephia I Leo									
1.5/ 1.8 i, i 16V [FA]	09.96-09.97						60		S4 024
Sephia II									
1.8 i 16V	08.97-05.00						60		S4 025
Shuma									
1.5 i	12.97-05.00		63	610	S5 006		60	610	S4 006 56 480 S3 006
Shuma I									
1.5/ 1.6 i 16V [FB]	01.98-12.00		63	610	S5 005		60	610	S4 005 56 480 S3 005
1.8 i 16V [FB]	01.98-12.00		63	610	S5 006		60	610	S4 006 56 480 S3 006
Shuma I Hatchback									
1.5/ 1.6 i 16V [FB]	01.98-12.00		63	610	S5 005		60	610	S4 005 56 480 S3 005
1.8 i 16V [FB]	01.98-12.00						60		S4 025
Shuma II									
1.6/ 1.8 i 16V [FB]	01.01-08.04		63	610	S5 005		60	610	S4 005
Shuma II Hatchback									
1.6/ 1.8 i 16V [FB]	01.01-08.04		63	610	S5 005		60	610	S4 005
Sorento									
2.4/ 3.3/ 3.5/ 3.8, i, 4x4 [JC; XM]	03.03→						70		S4 027
Diesel									
2.0 CRDi [XM]	10.10→						95		S4 028
CRDi 4x4 [XM]	10.10→						95		S4 028
2.2 CRDi [XM]	09.09→						95		S4 029
CRDi 4x4 [XM]	09.09→						95		S4 029
2.5 CRDi [JC]	07.02-08.09						95		S4 029
Soul									
1.6 GDi [AM]	08.11→		54	530	S5 002		52	530	S4 002
i CVVT [AM]	01.09-07.11		61	600	S5 004		600		
		XXX					53		S3 004
Diesel									
1.6 CRDi [AM]	01.09→		63	610	S5 005		60	610	S4 005
Sportage									
1.6 GDi [SL]	07.10→		70	650	S5 E08		650		

								Ah A (EN) S6		Ah A (EN) S5		Ah A (EN) S4		Ah A (EN) S3		
								0 092 ...0		0 092 ...0		0 092 ...0		0 092 ...0		
2.0	i [JE]	09.04-05.10								60				S4 024		
	, 4x4 [SL]	07.10→								60				S4 025		
	i [JA]	11.98-08.04								60				S4 025		
		10.00-08.04								63	610	S5 006	60	610	S4 006	56 480 S3 006
	i 4x4 [JA]	07.93-08.04								60				S4 025		
		11.98-08.04								63	610	S5 006	60	610	S4 006	56 480 S3 006
	i 4x4 [JE]	09.04-04.07								60				S4 024		
	4x4 [JE]	05.07-05.10								60				S4 024		
2.7	i 4x4 [JE]	09.04-04.07								70				S4 026		
	4x4 [JE]	05.07-05.10								70				S4 026		
Diesel																
1.7	CRDi [SL]	09.10→			80	800	S6 011									
2.0	CRDi [SL]	07.10→								95				S4 028		
	CRDi, CRDi 4x4 [JE]	09.04-05.10								95				S4 028		
	CRDi 4x4 [SL]	07.10→								95				S4 028		
		01.11→			70	760	S6 008									
2.0/ 2.2	TD 4x4, 4x4 [JA]	05.93-08.04								95				S4 029		
Venga																
1.4	[YN]	12.09→	SSJ		60	680	S6 005									
1.6	[YN]	12.09→	BWD						63	610	S5 005	60	610	S4 005		
			BWD,SSJ		60	680	S6 005		60	560	S5 E05		560			
Diesel																
1.4	CRDi [YN]	12.09→								60	560	S5 E05		560		
					70	760	S6 008									
1.6	CRDi [YN]	12.09→							70	650	S5 E08	74	650	S4 008		
									77	780	S5 008	74	780	S4 008		
					70	760	S6 008									

LADA

Forma															
1.3/ 1.5		09.91-12.00							63	610	S5 006	60	610	S4 006	56 480 S3 006
Kalina															
1.4/ 1.6		11.04→							63	610	S5 006	60	610	S4 006	56 480 S3 006
Kalina Hatchback															
1.4/ 1.6		07.06→							63	610	S5 006	60	610	S4 006	56 480 S3 006
Kalina Kombi															
1.4/ 1.6		07.07→							63	610	S5 006	60	610	S4 006	56 480 S3 006
Niva															
1.6/ 1.7		12.76-12.99							63	610	S5 006	60	610	S4 006	56 480 S3 006
1.7	i	01.93→							63	610	S5 006	60	610	S4 006	56 480 S3 006
		06.07→							63	610	S5 006	60	610	S4 006	
1.8/ 2.0	i	01.99→							63	610	S5 006	60	610	S4 006	56 480 S3 006
Diesel															
1.5/ 1.8/ 1.9	D, TD	01.93→							63	610	S5 006	60	610	S4 006	56 480 S3 006
Niva Estate															
1.6	4x4	09.87-12.99							63	610	S5 006	60	610	S4 006	56 480 S3 006
Oka															
0.8		01.99→								40				S4 018	
Priora															
1.6	8V	09.08→							63	610	S5 006	60	610	S4 006	
1.6/ 1.8	, 16V	11.06→							63	610	S5 006	60	610	S4 006	56 480 S3 006
Priora Hatchback															
1.6	8V	09.08→							63	610	S5 006	60	610	S4 006	
1.6/ 1.8	, 16V	01.08→							63	610	S5 006	60	610	S4 006	56 480 S3 006
Priora Kombi															
1.6		01.08→							63	610	S5 006	60	610	S4 006	56 480 S3 006
Sagona															
Diesel															
1.5	D	07.95→								70				S4 027	
Samara															
1.1/ 1.3/ 1.5/ 1.6/ 2.6	, i	09.91→							63	610	S5 006	60	610	S4 006	56 480 S3 006

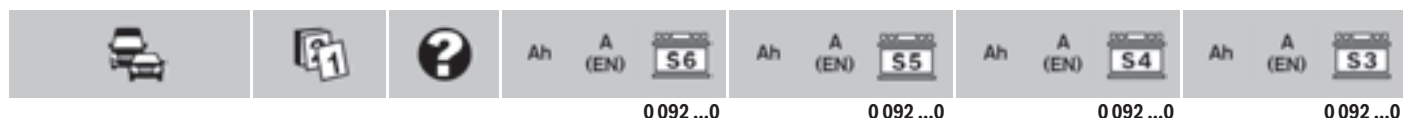

◀ LADA

Diesel		0092 ...0		0092 ...0		0092 ...0		0092 ...0		
1.5 D	01.95→			70				S4027		
Samara Fun										
1.1/ 1.3/ 1.5	09.88→	63	610	S5 006	60	610	S4 006	56	480	S3 006
Samara Hatchback										
1.1/ 1.3/ 1.5	01.84→	63	610	S5 006	60	610	S4 006	56	480	S3 006
1.3 i	01.86→	63	610	S5 006	60	610	S4 006	56	480	S3 006
1.5 i	01.84→	63	610	S5 006	60	610	S4 006			
Serie 110										
1.5 i 16V	01.96-12.04	63	610	S5 006	60	610	S4 006	56	480	S3 006
1.5/ 1.6/ 2.0 , GTI, i8V	01.96→	63	610	S5 006	60	610	S4 006	56	480	S3 006
1.5/ 2.0/ 2.6 Wankel, 16V, 16V Premier	01.96-12.00	63	610	S5 006	60	610	S4 006	56	480	S3 006
1.6 i	01.05→				60		S4 006	56	480	S3 006
i 16V	01.05→				60		S4 006	56	480	S3 006
Serie 111										
1.5	01.96-12.04	63	610	S5 006	60	610	S4 006	56	480	S3 006
i	01.96-12.04	63	610	S5 006	60	610	S4 006	56	480	S3 006
i 8V, i 16V	01.96-12.04	63	610	S5 006	60	610	S4 006	56	480	S3 006
1.6 i	01.05→				60		S4 006			
					60		S4 006	56	480	S3 006
		63	610	S5 006	60	610	S4 006	56	480	S3 006
Serie 112										
1.5 i	01.96-12.04	63	610	S5 006	60	610	S4 006	56	480	S3 006
i 8V, i 16V	01.96-12.04	63	610	S5 006	60	610	S4 006	56	480	S3 006
1.6 i	01.05→				60		S4 006	56	480	S3 006
		63	610	S5 006	60	610	S4 006	56	480	S3 006
Serie 114										
1.6 i	12.08→	63	610	S5 006	60	610	S4 006	56	480	S3 006
Serie 115										
1.3/ 1.5 , i	01.98→	63	610	S5 006	60	610	S4 006	56	480	S3 006
Serie 2100										
2101/ 2105/ 2106/ 2107/ 2107-02 1.2, 1.3, 1.5, 1.6	01.70→	63	610	S5 006	60	610	S4 006	56	480	S3 006
Diesel										
2104 1.5 TD	01.97-12.00	63	610	S5 006	60	610	S4 006	56	480	S3 006
Serie 2100 Kombi										
2104 1.5	01.88-12.93	63	610	S5 006	60	610	S4 006	56	480	S3 006
	08.94-12.00	63	610	S5 006	60	610	S4 006	56	480	S3 006
1.7	08.94-12.00	63	610	S5 006	60	610	S4 006	56	480	S3 006
Serie 2113										
1.6 i	01.07→	63	610	S5 006	60	610	S4 006	56	480	S3 006
Serie 2114										
1.5/ 1.6 i	10.01→	63	610	S5 006	60	610	S4 006	56	480	S3 006
Serie 2115										
1.6 i	01.07→	63	610	S5 006	60	610	S4 006	56	480	S3 006
Serie 2120										
1.7/ 1.8	01.97→	63	610	S5 006	60	610	S4 006	56	480	S3 006
Serie 21000										
21011/ 21053-20/ 21074/ 21077/ 21093/ 21099 1.3, 1.5i, 1.6, 1500	05.78→	63	610	S5 006	60	610	S4 006	56	480	S3 006
21041-30/ 210540/ 210740 1.6i	12.05→				60		S4 006	56	480	S3 006
Serie 21000 Coupé										
21043-20 1.5i	06.02→	63	610	S5 006	60	610	S4 006	56	480	S3 006
Toscana										
1.4/ 1.5 4x4	01.86-12.00	63	610	S5 006	60	610	S4 006	56	480	S3 006
1.7 i	06.07→	63	610	S5 006	60	610	S4 006			

			Ah A (EN) S6	Ah A (EN) S5	Ah A (EN) S4	Ah A (EN) S3
			0 092 ...0	0 092 ...0	0 092 ...0	0 092 ...0

LAMBORGHINI (S+L+H)

Countach										
Quattrovalvole/ 5 S	05.82-07.90	70	760	S6 008	77	780	S5 008	74	780	S4 008
Diablo										
5.7 , SE, VT 4x4	01.90-12.01	70	760	S6 008	77	780	S5 008	74	780	S4 008
Diablo GT										
6.0 AWD	10.99-12.01	70	760	S6 008	77	780	S5 008	74	780	S4 008
Diablo Roadster										
5.7	01.98-12.01	70	760	S6 008	77	780	S5 008	74	780	S4 008
Jalpa										
3.5	05.82-12.87							60		S4 025
Murcielago										
6.2	11.01-02.06	70	760	S6 008	77	780	S5 008	74	780	S4 008
Murcielago LP 640										
6.5	03.06-08.10	70	760	S6 008	77	780	S5 008	74	780	S4 008
Murcielago Roadster										
6.2	03.04-10.06	70	760	S6 008	77	780	S5 008	74	780	S4 008 70 640 S3 008
Serie LM										
002 AWD	01.86-12.95	70	760	S6 008	77	780	S5 008	74	780	S4 008

LANCIA

A 112										
	03.84-12.86				54	530	S5 002		530	
		XXX						42		S4 000
Dedra Berlina										
1.6 i [835]	01.89-10.94				54	530	S5 002		530	
		XXX						42		S4 000
	04.93-10.94				54	530	S5 002	44	530	S4 000 40 340 S3 000
	10.94-04.98				63	610	S5 005	60	610	S4 005
1.6/ 1.8/ 2.0 i Automatic, i 4x4 Integrale, i 16V [835]	06.90-10.99				63	610	S5 005	60	610	S4 005 56 480 S3 005
1.8/ 2.0 i [835]	01.89-12.95				63	610	S5 005	60	610	S4 005 56 480 S3 005
Diesel										
1.9 TD [835]	01.89-10.99	70	760	S6 008	77	780	S5 008	74	780	S4 008 70 640 S3 008
Dedra Station Wagon										
1.6/ 1.8/ 2.0 i, i 16V, i 16V 4x4 [835]	10.94-10.99				63	610	S5 005	60	610	S4 005 56 480 S3 005
Diesel										
1.9 TD [835]	10.94-10.99	70	760	S6 008	77	780	S5 008	74	780	S4 008 70 640 S3 008
Delta										
1.1/ 1.3/ 1.5/ 1.6 , HF Turbo, i, i HF Turbo [831]	09.79-08.92				54	530	S5 002	52	530	S4 002 45 400 S3 002
1.4 i [836]	06.93-12.99				54	530	S5 002	44	530	S4 000 40 340 S3 000
		XXX						42		S4 000
i LPG [844]	12.09→				63	610	S5 006	60	610	S4 006 56 480 S3 006
i 16V [844]	07.08→				63	610	S5 005	52	610	S4 002 45 400 S3 002
	08.10→	SSJ			60	560	S5 E05		560	
1.6 i [836]	06.93-12.99				54	530	S5 002	44	530	S4 000 40 340 S3 000
		XXX						42		S4 000
i 16V HPE [836]	01.96-12.99				54	530	S5 002	44	530	S4 000 40 340 S3 000
		XXX						42		S4 000
1.8 i [836]	06.93-12.99				63	610	S5 005	52	610	S4 002 45 400 S3 002
TBi [844]	05.09→				63	610	S5 005	60	610	S4 005
1.8/ 2.0 i GT 16V, i 16V, i 16V Turbo HPE [836]	06.93-12.99				63	610	S5 005	52	610	S4 002 45 400 S3 002
2.0 i HF Turbo Int. 4x4, i Turbo 8V Int. 4x4, i Turbo 16V Int. 4x4 [831]	05.86-01.94				63	610	S5 006	60	610	S4 006 56 480 S3 006

		Ah A (EN) S6			Ah A (EN) S5			Ah A (EN) S4			Ah A (EN) S3		
		0092 ...0			0092 ...0			0092 ...0			0092 ...0		
LANCIA													
Diesel													
1.6 JTD [844]	07.08→				63	610	S5 006	60	610	S4 006	56	480	S3 006
1.9 JTD [844]	08.08→	70	760	S6 008	77	780	S5 008	74	780	S4 008	70	640	S3 008
TD [831]	06.86-06.91	70	760	S6 008	77	780	S5 008	74	780	S4 008	70	640	S3 008
TD [836]	07.94-12.99	70	760	S6 008	77	780	S5 008	74	780	S4 008	70	640	S3 008
2.0 MJTD [844]	08.08→				77	780	S5 008	60	780	S4 005			
Kappa Berlina													
2.0/2.4/3.0 i Turbo 16V, i Turbo 20V, i 20V, i 24V [838]	11.94-12.00				63	610	S5 005	60	610	S4 005	56	480	S3 005
Diesel													
2.4 JTD, TD [838]	11.94-12.00	70	760	S6 008	77	780	S5 008	74	780	S4 008	70	640	S3 008
Kappa Coupé													
2.0/2.4/3.0 i Turbo 16V, i Turbo 20V, i 20V, i 24V V6 [838]	04.97-06.00	70	760	S6 008	77	780	S5 008	60	780	S4 005	56	480	S3 005
Kappa Station Wagon													
2.0/2.4/3.0 i Turbo 16V, i Turbo 20V, i 20V, i 24V [838]	11.94-12.00				63	610	S5 005	60	610	S4 005	56	480	S3 005
Diesel													
2.4 D Turbo, JTD [838]	06.96-12.00	70	760	S6 008	77	780	S5 008	74	780	S4 008	70	640	S3 008
Lybra Berlina													
1.6 i 16V [839]	10.99-09.05				63	610	S5 005	52	610	S4 002	45	400	S3 002
1.8 i 16V [839]	10.99-02.02				63	610	S5 005	52	610	S4 002	45	400	S3 002
	03.02-09.05				63	610	S5 005	52	610	S4 002			
2.0 i 20V [839]	10.99-09.00				63	610	S5 005	52	610	S4 002	45	400	S3 002
	10.00-09.05				63	610	S5 005	52	610	S4 002			
Diesel													
1.9/2.4 JTD [839]	10.99-11.06	70	760	S6 008	77	780	S5 008	60	780	S4 005	70	640	S3 008
Lybra Station Wagon													
1.6 i 16V [839]	10.99-09.05				63	610	S5 005	52	610	S4 002	45	400	S3 002
1.8 i 16V [839]	10.99-09.00				63	610	S5 005	52	610	S4 002	45	400	S3 002
	09.00-09.05				63	610	S5 005	52	610	S4 002			
2.0 i 20V [839]	10.99-09.05				63	610	S5 005	52	610	S4 002	45	400	S3 002
Diesel													
1.9/2.4 JTD [839]	10.99-11.06	70	760	S6 008	77	780	S5 008	60	780	S4 005	56	480	S3 005
Musa													
1.4 [184]	03.05→				63	610	S5 005	52	610	S4 002	45	400	S3 002
LPG [184]	03.09→				60	560	S5 E05		560				
16V [184]	10.04→				63	610	S5 005	52	610	S4 002			
		SSJ	60	680	S6 005	60	560	S5 E05		560			
	03.05→				54	530	S5 002	52	530	S4 002			
Diesel													
1.3 MJTD [184]	10.04→				63	610	S5 005	60	610	S4 005	56	480	S3 005
MJTD 16V [184]	01.06→				63	610	S5 005	60	610	S4 005			
	02.10→				54	530	S5 002	52	530	S4 002	45	400	S3 002
		BWD,SSJ			60	560	S5 E05		560				
1.6 JTD [184]	10.07→				63	610	S5 005	60	610	S4 005	56	480	S3 005
		BWD,SSJ			70	650	S5 E08		650				
	09.08→				63	610	S5 005	60	610	S4 005			
		SSJ			60	560	S5 E05		560				
1.9 JTD [184]	10.04→				63	610	S5 005	60	610	S4 005			
Phedra													
2.0/3.0 16V, 24V [180]	09.02-09.05	70	760	S6 008	77	780	S5 008	74	780	S4 008			
Diesel													
2.0 JTD 16V [180]	09.02-12.10	70	760	S6 008	77	780	S5 008	74	780	S4 008			
2.2 JTD 16V [180]	09.02-09.07	70	760	S6 008	77	780	S5 008	74	780	S4 008			
	03.08-12.10				77	780	S5 008	60	780	S4 005			
Prisma													
1.3	12.82-12.89				54	530	S5 002	44	530	S4 000	40	340	S3 000
		XXX						42		S4 000			

			Ah A (EN) S6			Ah A (EN) S5			Ah A (EN) S4			Ah A (EN) S3		
			0 092 ...0			0 092 ...0			0 092 ...0			0 092 ...0		
1.5	12.82-12.89		54	530	S5 002	44	530	S4 000	40	340	S3 000			
		XXX				42		S4 000						
i.e.	12.85-12.86		54	530	S5 002	44	530	S4 000	40	340	S3 000			
		XXX				42		S4 000						
1.6	12.82-12.89		54	530	S5 002	44	530	S4 000	40	340	S3 000			
		XXX				42		S4 000						
i.e.	05.86-12.89		54	530	S5 002	44	530	S4 000	40	340	S3 000			
		XXX				42		S4 000						
2.0 i.e. Integrale, i.e. 4WD	04.86-12.89		63	610	S5 005	60	610	S4 005	56	480	S3 005			
Diesel														
1.9 D, D Turbo	06.84-12.89		70	760	S6 008	77	780	S5 008	74	780	S4 008	70	640	
Thema														
3.6 VVT	11.11→		100	830	S5 013	95	830	S4 013						
Diesel														
3.0 CRD	11.11→		100	830	S5 013	95	830	S4 013						
Thema Berlina														
2.0/ 2.8/ 2.9/ 3.0/ 8.32 , i.e.,	11.84-11.94		63	610	S5 005	52	610	S4 002	45	400	S3 002			
i.e. Turbo, i.e. Turbo 16V,														
i.e. 16V, i.e. 16V Turbo,														
6 V PRV [104]														
Diesel														
2.5 TD [104]	11.84-11.94		70	760	S6 008	77	780	S5 008	74	780	S4 008	70	640	
Thema Station Wagon														
2.0/ 3.0 i.e., i.e. Turbo, i.e.	11.84-11.94		63	610	S5 005	52	610	S4 002	45	400	S3 002			
Turbo 16V, i.e. 16V,														
i.e. 16V Turbo [104]														
Diesel														
2.5 TD [104]	11.84-11.94		70	760	S6 008	77	780	S5 008	74	780	S4 008	70	640	
Thesis														
2.0/ 2.4 Turbo 20V, 20V	04.02-12.09		95	850	S6 013	100	830	S5 013	95	830	S4 013			
[841]														
3.0/ 3.2 V6 24V [841]	04.02-12.09		95	850	S6 013	100	830	S5 013	95	830	S4 013	90	720	
Diesel														
2.4 JTD 10V [841]	04.02-02.05		95	850	S6 013	100	830	S5 013	95	830	S4 013			
JTD 20V [841]	06.03-02.06		95	850	S6 013	100	830	S5 013	95	830	S4 013			
	06.03-12.09		95	850	S6 013	100	830	S5 013	95	830	S4 013	90	720	
Voyager														
3.6 [RT]	09.11→		80	800	S6 011	85	800	S5 010	80	800	S4 010			
Diesel														
2.8 CRD [RT]	09.11→								74		S4 009			
Y														
1.1 i.e. [840]	04.97-06.00		54	530	S5 002	44	530	S4 000	40	340	S3 000			
		XXX				42		S4 000						
1.2 i8V [840]	06.00-06.03		54	530	S5 002		530		40	340	S3 000			
		XXX				42		S4 000						
i 16V [840]	06.00-06.03		54	530	S5 002		530		40	340	S3 000			
		XXX				42		S4 000						
i.e. 8V [840]	01.96-06.00		54	530	S5 002	44	530	S4 000	40	340	S3 000			
		XXX				42		S4 000						
i.e. 16V [840]	04.97-06.00		54	530	S5 002	44	530	S4 000	40	340	S3 000			
		XXX				42		S4 000						
1.4 i.e. 12V [840]	01.96-06.00		54	530	S5 002	44	530	S4 000	40	340	S3 000			
		XXX				42		S4 000						
Y 10														
1.0 fire [156]	03.85-06.91		54	530	S5 002	44	530	S4 000	40	340	S3 000			
		XXX				42		S4 000						
fire 4x4 [156]	09.86-02.89		54	530	S5 002	44	530	S4 000	40	340	S3 000			
		XXX				42		S4 000						
i fire [156]	10.87-02.92		54	530	S5 002	44	530	S4 000	40	340	S3 000			
		XXX				42		S4 000						
i fire 4x4 [156]	10.87-07.89		54	530	S5 002	44	530	S4 000	40	340	S3 000			
		XXX				42		S4 000						

			Ah	A (EN)	S6	Ah	A (EN)	S5	Ah	A (EN)	S4	Ah	A (EN)	S3
			0 092 ...0			0 092 ...0			0 092 ...0			0 092 ...0		
LANCIA														
1.1 [156]	03.85-02.89		54	530	S5 002	44	530	S4 000	40	340	S3 000			
		XXX				42		S4 000						
i [156]	09.92-12.95		54	530	S5 002	44	530	S4 000	40	340	S3 000			
		XXX				42		S4 000						
i fire LX [156]	03.89-09.92		54	530	S5 002	44	530	S4 000	40	340	S3 000			
		XXX				42		S4 000						
i fire 4x4 [156]	01.89-09.92		54	530	S5 002	44	530	S4 000	40	340	S3 000			
		XXX				42		S4 000						
i Selectronic [156]	09.92-12.95		54	530	S5 002	44	530	S4 000	40	340	S3 000			
		XXX				42		S4 000						
i 4x4 [156]	09.92-12.95		54	530	S5 002	44	530	S4 000	40	340	S3 000			
		XXX				42		S4 000						
Turbo [156]	03.85-02.89		54	530	S5 002	44	530	S4 000	40	340	S3 000			
		XXX				42		S4 000						
1.3 i [156]	09.92-12.95		54	530	S5 002	44	530	S4 000	40	340	S3 000			
		XXX				42		S4 000						
i GT [156]	11.87-09.92		54	530	S5 002	44	530	S4 000	40	340	S3 000			
		XXX				42		S4 000						
Ypsilon														
0.9/1.2 , 8V [846]	06.11→	SSJ	60	560	S5 E05		560							
1.2 8V [843]	06.03-11.11		54	530	S5 002		530		40	340	S3 000			
		XXX				42		S4 000						
	08.10-11.11		60	560	S5 E05		560							
16V [843]	06.03-09.06		54	530	S5 002		530		40	340	S3 000			
		XXX				42		S4 000						
1.4 LPG [843]	03.09-11.11					44		S4 000	40	340	S3 000			
8V [843]	10.06-11.11		54	530	S5 002		530		40	340	S3 000			
		XXX				42		S4 000						
16V [843]	06.03-11.11		54	530	S5 002		530		40	340	S3 000			
		XXX				42		S4 000						
Diesel														
1.3 JTD 16V, Multijet, Multijet 16V [843]	06.03-11.11		63	610	S5 005	60	610	S4 005						
Multijet 16V [846]	06.11→	SSJ	60	560	S5 E05		560							
ZETA														
2.0 i.e. Turbo [122]	09.94-06.99		63	610	S5 005	60	610	S4 005	56	480	S3 005			
16V [122]	06.99-10.00		63	610	S5 005	60	610	S4 005	56	480	S3 005			
	10.00-06.02		63	610	S5 005	60	610	S4 005						
Diesel														
2.0 JTD [122]	06.99-06.02		63	610	S5 005	60	610	S4 005						
2.1 TD [122]	05.96-06.99		63	610	S5 005	52	610	S4 002						

LAND ROVER GROUP

Defender 90														
2.5/ 2.8/ 3.5/ 4.0 AWD, 4WD	08.90-09.04					70		S4 027						
Diesel														
2.2/ 2.4 Td4 AWD	05.07→					70		S4 027						
2.5 D AWD	08.90-09.01					70		S4 027						
D Turbo AWD	08.90-12.01		63	610	S5 005	60	610	S4 005						
Defender 110														
2.5/ 3.5/ 4.0 AWD, i AWD	08.90-12.01					70		S4 027						
Diesel														
2.2/ 2.4 Td4 AWD	08.07→					70		S4 027						
2.5 D AWD	08.90-09.01					70		S4 027						
D Turbo AWD	08.90-12.01		63	610	S5 005	60	610	S4 005						
Defender 130														
Diesel														
2.2/ 2.4 Td4 AWD	08.07→					70		S4 027						
2.5 D AWD, D Turbo AWD	08.90-12.01					70		S4 027						

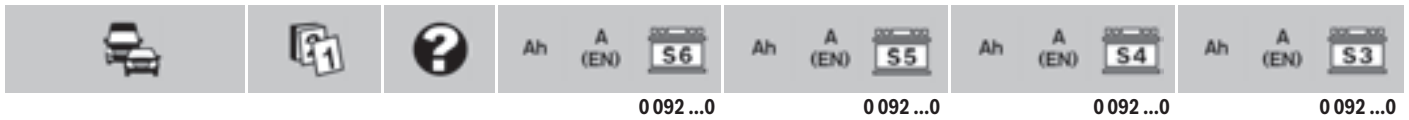

Discovery I											
2.0/ 3.5/ 3.9 AWD, i AWD, i V8 AWD, i 16V AWD	09.89-12.98								70		S4 027
Diesel											
2.5 TDi AWD	09.89-12.98								70		S4 027
Discovery II											
4.0/ 4.6 i AWD	10.98-12.04								70		S4 027
Discovery III											
4.0 AWD	09.04-08.09					100	830	S5 013	95	830	S4 013
4.4 AWD	09.04-08.09		95	850	S6 013	100	830	S5 013	95	830	S4 013
Diesel											
2.7 TDV6 AWD	09.04-08.09		95	850	S6 013	100	830	S5 013	95	830	S4 013
Discovery IV											
5.0 V8 AWD	09.09→		95	850	S6 013	100	830	S5 013	95	830	S4 013
Diesel											
2.7 TDV6 AWD	09.09-08.10					100	830	S5 013	95	830	S4 013
3.0 TDV6 AWD	09.09→		95	850	S6 013	100	830	S5 013	95	830	S4 013
	09.10→					100	830	S5 013	95	830	S4 013
Freelander											
1.8/ 2.5 i 16V AWD, V6 AWD [LN]	09.97-03.07					63	610	S5 005	60	610	S4 005 56 480 S3 005
Diesel											
2.0 D AWD [LN]	09.97-09.03		70	760	S6 008	77	780	S5 008	74	780	S4 008 70 640 S3 008
TD4 AWD [LN]	09.01-03.07		70	760	S6 008	77	780	S5 008	74	780	S4 008
Freelander II											
3.2 i6 AWD	10.06-11.12	BWD	70	760	S6 008	77	780	S5 008	74	780	S4 008
Diesel											
2.2 Td4 AWD	10.06→					77	780	S5 008	74	780	S4 008
		SSJ	80	800	S6 011						
Freelander 2											
2.0 Si4 AWD [LF]	10.12→								70		S4 027
Diesel											
2.2 eD4 [LF]	09.10→	BWD,SSJ	70	760	S6 008						
SD4 AWD [LF]	09.10→	BWD	70	760	S6 008						
Land Rover											
2.3	01.72-12.85								70		S4 027
Diesel											
2.3/ 2.5 D	01.72-12.85								95		S4 029
Land Rover 90											
2.3/ 2.5/ 3.5	09.83-08.90								70		S4 027
Diesel											
2.3/ 2.5 D, D Turbo	09.83-08.90								70		S4 027
Land Rover 110											
2.3/ 2.5/ 3.5	09.83-07.90								70		S4 027
Diesel											
2.3/ 2.5/ 3.9 D, D Turbo	09.83-07.90								70		S4 027
Range Rover Evoque											
2.0 Si4 AWD	09.11→					74	750	S5 007	72	750	S4 007
Diesel											
2.2 eD4	09.12→					85	800	S5 010	80	800	S4 010
SD4 AWD, TD4 AWD	09.11→	SSJ	80	800	S6 011						
Range Rover I											
3.5/ 3.9/ 4.3 AWD, i AWD, i Classic AWD, Vogue LSE AWD	06.70-04.96								70		S4 027
Diesel											
2.4/ 2.5/ 3.0/ 3.6 D Turbo AWD, TDi Classic AWD	04.86-09.95								70		S4 027
Range Rover II											
4.0/ 4.6 i V8 AWD	09.94-08.02								70		S4 027
Diesel											
2.5 TDi AWD	10.94-04.96								70		S4 027



			Ah A (EN) S6	Ah A (EN) S5	Ah A (EN) S4	Ah A (EN) S3
			0092 ...0	0092 ...0	0092 ...0	0092 ...0

◀ LAND ROVER GROUP

Range Rover III										
4.2 AWD	03.05-08.09	95	850	S6 013	110	920	S5 015	95	920	S4 013
4.4 V8 AWD	03.02-08.09	95	850	S6 013	110	920	S5 015	95	920	S4 013
	05.05-08.09	95	850	S6 013	100	830	S5 013	95	830	S4 013
Diesel										
3.0 Td6 AWD	03.02-09.06	95	850	S6 013	110	920	S5 015	95	920	S4 013
3.6 TDV8 AWD	09.06-08.09	95	850	S6 013	110	920	S5 015		920	
Range Rover IV										
5.0 V8 AWD	09.09-01.13	95	850	S6 013	100	830	S5 013	95	830	S4 013
V8 SC AWD	09.09-01.13	95	850	S6 013	110	920	S5 015	95	920	S4 013
V8 Supercharged AWD	02.13→	95	850	S6 013						
Diesel										
3.0/4.4 SDV8 AWD, V6 AWD	02.13→	95	850	S6 013						
3.6 TDV8 AWD	09.09-01.13	95	850	S6 013	110	920	S5 015		920	
4.4 TDV8 AWD	09.10-01.13	95	850	S6 013	100	830	S5 013	95	830	S4 013
Range Rover Sport I										
4.2/4.4 Supercharged V8 AWD, V8 AWD	03.05-08.09	95	850	S6 013	110	920	S5 015	95	920	S4 013
Diesel										
2.7 TDV6 AWD	03.05-08.09	95	850	S6 013	110	920	S5 015	95	920	S4 013
3.6 TDV8 AWD	01.07-08.09	95	850	S6 013	110	920	S5 015		920	
Range Rover Sport II										
5.0 V8 AWD	09.09-08.13	95	850	S6 013	100	830	S5 013	95	830	S4 013
V8 SC AWD	09.09-08.13	95	850	S6 013	110	920	S5 015	95	920	S4 013
Diesel										
3.0 SDV6 AWD, TDV6 AWD	09.09-08.13	95	850	S6 013	100	830	S5 013	95	830	S4 013
3.6 TDV8 AWD	09.09-08.13	95	850	S6 013	110	920	S5 015		920	

LDV GROUP LIMITED

Maxus										
Diesel										
2.5	01.05→					95	S4 013	90	720	S3 013
CRD	10.05→					70	S4 027			
Pilot										
Diesel										
1.9 D	06.01-10.05					70	S4 027			

LEXUS

CT										
200h i	12.10→					40	S4 030			
ES										
300/330 i [V]	07.91→					60	S4 024			
GS										
250/350/450h, i, i4x4 [L1; S1]	02.06→					70	S4 026			
300/430 [S1]	01.05-12.11					70	S4 027			
i [S1]	03.93-01.07					70	S4 027			
460 [S1]	09.07-12.11					95	S4 029			
IS										
200 i [E1]	01.99-07.05					60	S4 025			
250 Ci [E2]	04.09→					70	S4 027			
i [E2]	08.05→					70	S4 027			
4x4 [E2]	08.05-05.13					70	S4 027			
300 i [E1]	07.01-07.05					95	S4 028			
350 i [E2]	08.10→					60	S4 025			
Diesel										
220 d [E2]	11.05→					95	S4 029			
	08.10→					95	S4 028			

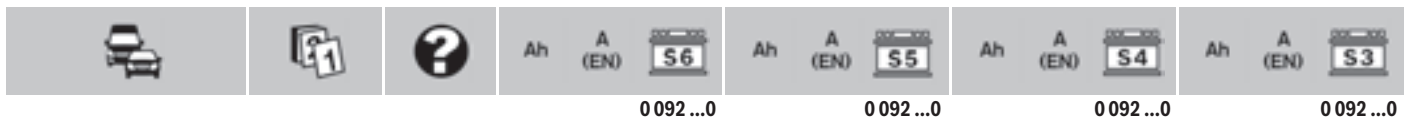

IS F										
5.0 [E2]	12.07→							60		S4 025
IS Wagon										
200 i [E1]	08.02-07.05							70		S4 027
300 i [E1]	07.01-07.05							95		S4 028
LS										
400 i [F1; F2]	12.89-08.00							95		S4 028
430 i [F3]	08.00-08.06							70		S4 026
460 i [F4]	08.06→							95		S4 029
		70	760	S6 008	70	650	S5 E08		650	
		70	760	S6 008	77	780	S5 008		780	
460/ 600h i 4x4, 4x4 [F4]	04.07→							95		S4 029
460L i [F4]	09.08→							95		S4 029
RX										
2.7/ 300/ 350/ 400h/ 450h i, i 4x4, 4x4 [; L1; U1; U3]	01.98→							70		S4 026
SC Cabrio										
430 [Z4]	05.01-08.10							70		S4 026
								74		S4 009
SC Coupé										
400 i	09.91-08.95							70		S4 026
430 i	08.05-07.10							70		S4 026

LONDON TAXIS INTERNATIONAL LTI

TX										
Diesel										
2.4/ 2.5 D LTI [TX2; TX4]	10.02→							70	760	S6 008

LOTUS

Eclat																			
2.2	05.80-08.86							70	760	S6 008	77	780	S5 008	60	780	S4 005	56	480	S3 005
Elan																			
1.6 i DOHC 16V, i Turbo 16V	09.89-09.99							70	760	S6 008	77	780	S5 008	60	780	S4 005	56	480	S3 005
Elise																			
1.6	03.10→										54	530	S5 002	52	530	S4 002			
1.8 R	01.04→													44		S4 001			
16V, 340 R	01.96-02.10										52	520	S5 001	44	520	S4 001			
Esprit																			
2.0 GT3 16V	01.97-12.02										61	600	S5 004	60	600	S4 004	53	500	S3 004
																	53	470	S3 004
2.2 S 3	05.80-06.92										61	600	S5 004	60	600	S4 004	53	500	S3 004
																	53	470	S3 004
S4	09.90-01.92																53	500	S3 004
	05.93-07.96																53	500	S3 004
Turbo	02.80-07.92										61	600	S5 004	60	600	S4 004	53	500	S3 004
																	53	470	S3 004
Turbo SE	05.89-01.93										61	600	S5 004	60	600	S4 004	53	500	S3 004
																	53	470	S3 004
Turbo S4	01.93-12.01										61	600	S5 004	60	600	S4 004	53	500	S3 004
																	53	470	S3 004
Turbo 16V	01.94-12.02										61	600	S5 004	60	600	S4 004	53	500	S3 004
																	53	470	S3 004
3.5 V8 32V Twin Turbo	03.96-09.03										61	600	S5 004	60	600	S4 004	53	500	S3 004
																	53	470	S3 004
Europa S																			
2.0 Turbo	07.06-10.10										61	600	S5 004		600				
																	53	470	S3 004

			Ah A (EN) S6	Ah A (EN) S5	Ah A (EN) S4	Ah A (EN) S3
			0092 ...0	0092 ...0	0092 ...0	0092 ...0

◀ LOTUS

Europa SE										
2.0 Turbo	10.08-10.10				61	600	S5 004		600	
		XXX							53	470 S3 004
Evora										
3.5 , S	05.09→							70		S4 026
Excel										
2.2 , SE	10.83-07.92				63	610	S5 005	60	610	S4 005 56 480 S3 005
Exige										
1.8 , 240	10.03→				52	520	S5 001	44	520	S4 001

MASERATI

Biturbo										
Coupé/ Spider/ 2.0/ 2.5/ 4.24V/ 222/ 425/ 2500 , E, i, S, SE, Si, 24V, 2800	12.81-12.01				63	610	S5 006	60	610	S4 006 56 480 S3 006
Ghibli										
2.0 i Biturbo	02.92-12.01								88	740 S3 012
Karif										
2.8	04.88-12.01		70	760	S6 008	77	780	S5 008	74	780 S4 008 70 640 S3 008
Kyalami										
4.1/ 4.9	04.76-12.85							70		S4 027
Quattroporte										
2.0/ 2.8/ 3.2 i BiTurbo	03.94-12.00							70		S4 027
4.1/ 4.9	08.76-12.89							70		S4 027
4.2 V8 32V	03.04→		95	850	S6 013	100	830	S5 013	95	830 S4 013
Shamal										
3.2	09.89-12.01		70	760	S6 008	77	780	S5 008	74	780 S4 008 70 640 S3 008
Spyder										
4.2 Coupé, GT	12.01→		70	760	S6 008	77	780	S5 008	74	780 S4 008
228										
2.8 , Biturbo	12.84-12.90				63	610	S5 005	60	610	S4 005 56 480 S3 005
420										
2.0 , i	03.85-12.01				63	610	S5 006	60	610	S4 006 56 480 S3 006
430										
2.8	02.88-12.01				63	610	S5 006	60	610	S4 006 56 480 S3 006
3200 GT										
	10.98→				63	610	S5 006	60	610	S4 006 56 480 S3 006

MAYBACH

Serie 240										
57/ 62 , S	09.02→		95	850	S6 013	100	830	S5 013	95	830 S4 013

MAZDA

BT-50										
Diesel										
2.5/ 3.0 D Turbo, D Turbo 4x4 [UN]	03.06→								95	S4 029
CX-7										
2.3 MZR DISI Turbo 4x4 [ER] Diesel	05.07→		70	760	S6 008	77	780	S5 008	74	780 S4 008 70 640 S3 008
CX-9										
2.2 MZR CD 4x4 [ER] Diesel	06.09→							95		S4 028
Demio										
3.7 4x4 [TB]	06.08→							70		S4 026
Demio										
1.3/ 1.5 i, i 16V [DW]	07.96-02.03							45		S4 021

			Ah A (EN) S6	Ah A (EN) S5	Ah A (EN) S4	Ah A (EN) S3
			0 092 ...0	0 092 ...0	0 092 ...0	0 092 ...0

MPV										
2.0/ 2.3/ 2.5/ 3.0 i, i 16V, i 24V [LV; LW]	07.94→						60		S4 024	
Diesel										
2.0 D Turbo [LW]	03.02-06.04						95		S4 028	
2.5 12V D Turbo [LV]	03.96-05.99						95		S4 028	
MX-3										
1.6/ 1.8 i [; EC]	05.91-02.98						60		S4 024	
MX-5										
1.6 i [NB]	01.98-07.05	BAW		52	520	S5 001	44	520	S4 001	41 360 S3 001
1.6/ 1.8 i, i 16V [NA]	08.89-11.97	BAW		52	520	S5 001	44	520	S4 001	41 360 S3 001
1.8 i [NB]	01.98-07.05	BAW		52	520	S5 001	44	520	S4 001	41 360 S3 001
	09.00-07.05			52	520	S5 001	44	520	S4 001	41 360 S3 001
1.8/ 2.0 [NC]	07.05→						45		S4 021	
MX-6										
2.0/ 2.5 i, i 4WS [GE]	07.91-06.97						60		S4 024	
2.2 i Turbo 2WS [GD]	09.89-06.91						70		S4 026	
Premacy										
1.8/ 2.0 i [CP]	03.99-05.05						60		S4 024	
Diesel										
2.0 D Turbo [CP]	06.99-05.05						60		S4 024	
RX-7 Cabrio										
Turbo [FC]	10.85-11.91						60		S4 024	
RX-7 Coupé										
[SA]	03.78-08.85						60		S4 025	
Biturbo [FD]	01.92→						70		S4 026	
Turbo [FC]	09.85-11.91						60		S4 024	
RX-8										
[FE; SE]	04.03-04.12						70		S4 026	
Serie B										
1800/ 2000/ 2200 [; UF]	01.82-03.96						60		S4 025	
2200/ 2600 , 4x4 [UN]	02.99-03.06						95		S4 029	
2600 , i [UF]	12.86-03.96						95		S4 029	
Diesel										
2200 D [UF]	01.90-04.95						95		S4 029	
2500 D, D Turbo, D Turbo 4x4, D 4x4, 12V D, 12V D 4x4 [; UF; UN]	03.96-11.06						95		S4 029	
Serie E										
1.4	03.84-08.88						45		S4 021	
							70		S4 026	
2.0	01.84-03.95						60		S4 024	
	02.03-12.06						60		S4 024	
i	08.91-04.97						60		S4 024	
4WD	03.86-07.89						60		S4 024	
Diesel										
2.2 D, D 4WD	01.84-12.01						70		S4 026	
Tribute										
2.0 i, i 4WD	12.00→			63	610	S5 005	60	610	S4 005	56 480 S3 005
i 4x4 [EP]	02.01-12.03			63	610	S5 005	60	610	S4 005	
2.0/ 2.3 i [EP]	02.01-05.04			63	610	S5 005	60	610	S4 005	
2.3 i 4x4 [EP]	12.03-05.04			63	610	S5 005	60	610	S4 005	56 480 S3 005
3.0 i, i 4WD, i 4x4 [; EP]	12.00→			63	610	S5 005	60	610	S4 005	56 480 S3 005
Xedos-6										
1.6/ 2.0 i [CA]	01.92-02.99						60		S4 024	
Xedos-9										
2.0 i [TA]	09.93-07.98			61	600	S5 004	60	600	S4 004	53 500 S3 004
	09.93-07.00	XXX								53 470 S3 004
	08.98-07.00			61	600	S5 004	60	600	S4 004	
2.3 i Kompressor [TA]	12.94-07.98			61	600	S5 004	60	600	S4 004	53 500 S3 004
	12.94-07.00	XXX								53 470 S3 004
	08.98-07.00			61	600	S5 004	60	600	S4 004	

				Ah A (EN) S6	Ah A (EN) S5	Ah A (EN) S4	Ah A (EN) S3
				0092 ...0	0092 ...0	0092 ...0	0092 ...0
◀ MAZDA							
2.5 i [TA]	07.93-07.98			61	600	S5 004	60 600 S4 004 53 500 S3 004
	07.93-11.02	XXX					53 470 S3 004
	08.98-11.02			61	600	S5 004	60 600 S4 004
i 4WS [TA]	07.93-07.98			61	600	S5 004	60 600 S4 004 53 500 S3 004
		XXX					53 470 S3 004
2							
1.25 [DY]	02.03-06.07			52	520	S5 001	44 520 S4 001 41 360 S3 001
1.3 [DE]	06.07→			63	610	S5 005	60 610 S4 005 56 480 S3 005
1.4/ 1.6 [DY]	02.03-06.07						45 S4 021
1.5 [DE]	06.07→			63	610	S5 005	60 610 S4 005
Diesel							
1.4 CD [DE]	08.07-09.10			63	610	S5 005	60 610 S4 005 56 480 S3 005
D Turbo [DY]	02.03-06.07			52	520	S5 001	44 520 S4 001 41 360 S3 001
1.6 CD [DE]	11.08→			63	610	S5 005	60 610 S4 005
3							
1.6 [BK]	07.03-12.08			61	600	S5 004	60 600 S4 004
		XXX					53 470 S3 004
1.6/ 2.0 MZR, MZR DISI [BL]	12.08→			63	610	S5 006	610
2.0 [BK]	07.03-12.08			61	600	S5 004	60 600 S4 004
		XXX					53 470 S3 004
Diesel							
1.6 MZR-CD [BL]	10.10→			63	610	S5 006	610
1.6/ 2.0 MZ-CD, MZR-CD [BK]	12.03-12.08						70 S4 026
2.2 MZR-CD [BL]	01.09-07.11						95 S4 028
3 Hatchback							
1.4 [BK]	08.03-12.08			61	600	S5 004	60 600 S4 004
		XXX					53 470 S3 004
1.6 [BK]	10.03-12.08			61	600	S5 004	60 600 S4 004
		XXX					53 470 S3 004
MZR [BL]	12.08→			63	610	S5 005	60 610 S4 005
2.0 [BK]	07.03-12.08						60 S4 004
MZR [BL]	12.08→			63	610	S5 006	610
MZR DISI [BL]	12.08→	SSJ	80 800	S6 011			
2.3 MPS [BK]	07.06-12.08			61	600	S5 004	60 600 S4 004
		XXX					53 470 S3 004
MPS [BL]	09.09→						60 S4 024
Diesel							
1.6 MZ-CD [BK]	12.03-12.08						70 S4 026
MZR-CD [BL]	12.08-07.11						70 S4 026
	10.10→			63	610	S5 006	610
2.0 MZR-CD [BK]	12.06-12.08						95 S4 028
2.2 MZR-CD [BL]	01.09→						95 S4 028
5							
1.8/ 2.0 [CR]	02.05-12.11						60 S4 024
2.0 [CW]	09.10→						60 S4 024
DISI [CW]	06.10→		80 800	S6 011			
Diesel							
1.6 CD [CW]	06.10→						70 S4 026
2.0 CD [CR]	03.05-12.11						95 S4 028
6							
1.8/ 2.0/ 2.5 MZR [GH]	08.07→			63	610	S5 005	60 610 S4 005
2.0 MZR DISI [GH]	04.10→						60 S4 024
2.3 , MPS 4x4 [GG/GY]	02.02-08.07						60 S4 024
Diesel							
2.0 MZR-CD [GH]	11.07-01.10						95 S4 028
2.2 MZR-CD [GH]	01.09→						70 S4 026
	04.10→						95 S4 028
6 Fastback							
1.8/ 2.0/ 2.3 [GG/GY]	04.02-08.08						60 S4 024
1.8/ 2.0/ 2.5 MZR [GH]	08.07→			63	610	S5 005	60 610 S4 005
2.0 MZR DISI [GH]	04.10→						60 S4 024



Diesel													
2.0 D Turbo [GG/GY]	06.02-08.07										70	S4 026	
MZR-CD	[GH]	11.07-01.10	63	610	S5 005	60	610					S4 005	
2.2 MZR-CD [GH]	01.09→										70	S4 026	
	04.10→										95	S4 028	
6 Sedan													
1.8/ 2.0 [GG/GY]	02.02-08.07										60	S4 024	
Diesel													
2.0 D Turbo [GG/GY]	06.02-08.07										70	S4 026	
6 Wagon													
1.8/ 2.0/ 2.3 , 4x4 [GG/GY]	06.02-12.07										60	S4 024	
1.8/ 2.0/ 2.5 MZR [GH]	12.07→										60	S4 005	
2.0 MZR DISI [GH]	04.10→										60	S4 024	
Diesel													
2.0 D Turbo [GG/GY]	06.02-12.07										70	S4 026	
MZR-CD	[GH]	12.07-01.10									60	S4 005	
2.2 MZR-CD [GH]	10.08→										70	S4 026	
	04.10→										95	S4 028	
121													
1.1/ 1.3 , i [DA; DB]	12.86-11.97										45	S4 021	
1.25/ 1.3 i, i 16V	01.96-01.02		63	610	S5 005	60	610					S4 005	
	[JA/JB; Soho]										56	480 S3 005	
Diesel													
1.8 D [JA/JB]	01.96-01.02		70	760	S6 008	77	780	S5 008	74	780	S4 008	70	640 S3 008
323													
1.1/ 1.3/ 1.5/ 1.6/ 1.8 , GT, i,	10.81-12.95										60	S4 024	
	i Turbo	[BD; BF; BG; P3/Y1]											
1.3/ 1.5/ 1.6 i [BJ]	05.98-09.03										45	S4 021	
1.8 i [BJ]	05.98-09.03										45	S4 021	
	07.98-11.00										60	S4 024	
2.0 i [BJ]	09.00-08.03										60	S4 024	
Diesel													
1.7 D [BF]	04.85-05.89										60	S4 024	
2.0 D, D Turbo [BJ]	05.98-09.03										60	S4 024	
323 Astina Hatchback													
1.8/ 2.0 i [BA]	05.94-09.95										60	S4 024	
323 F Hatchback													
1.3/ 1.5/ 1.8/ 2.0 i [BA]	05.94-07.98										60	S4 024	
Diesel													
2.0 D [BA]	10.96-05.98										60	S4 024	
323 Hatchback													
P 1.3/ P 1.5 i [BA]	10.96-09.00										45	S4 021	
P 1.3/ P 1.5/ 1.1/ 1.3/ 1.5/ 1.6/ 1.8/ 2.0 , i, i, i Turbo 4x4,	09.81→										60	S4 024	
	i 16V, i 16V Turbo, i 16V Turbo 4WD, i 16V 4x4, i 16V 4x4 Turbo, 16V [BA; BD; BD/FA; BF; BG; BJ; P3/Y1]												
Diesel													
P 2.0 D [BA]	03.97-09.00										60	S4 024	
1.7 D [BG]	06.89-02.96										60	S4 024	
2.0 D [BJ]	06.98-09.99										60	S4 024	
	D Turbo [BJ]	08.98-01.01									60	S4 024	
		11.00-09.03									95	S4 028	
323 Sedan													
1.1 [BD]	07.82-10.85										60	S4 024	
1.3/ 1.5/ 1.8 i [BA]	06.94-06.98										45	S4 021	
1.3/ 1.6/ 1.8 i, i 16V, i 16V GT, i 16V 4x4, i 16V 4x4 Turbo, 16V [BG]	06.89-02.97										60	S4 024	
1.5 Saloon [BD/FA]	09.82-05.85										60	S4 024	
1.6 i [BF]	07.85-07.87										45	S4 021	



			Ah A (EN) S6	Ah A (EN) S5	Ah A (EN) S4	Ah A (EN) S3
			0092 ...0	0092 ...0	0092 ...0	0092 ...0

◀ MAZDA

Diesel			
1.7 D [BG]	06.89-05.94	60	S4 024
D Turbo [BA]	08.95-12.96	60	S4 024
2.0 D [BA]	03.97-06.98	60	S4 024
323 Wagon			
1.3/ 1.5 [BD/FA]	11.80-10.85	60	S4 024
1.3/ 1.5/ 1.6, i, i 4x4 [BW]	01.86-10.95	60	S4 024
Diesel			
1.7 D [BW]	04.86-06.95	60	S4 024
626			
1.6/ 1.8/ 2.0 [GD]	07.87-07.91	60	S4 024
, i, i Turbo [GC]	10.82-06.87	60	S4 024
1.6/ 2.0, i [Y2]	08.83-12.92	60	S4 025
1.8/ 2.0 i 16V, 16V [GF]	05.97-04.02	60	S4 024
1.8/ 2.0/ 2.5 i, i 16V, i 16V 4x4, i 24V [GE]	08.91-06.97	60	S4 024
2.0 i [GD]	06.87-07.91	60	S4 024
2.0/ 2.2 i 12V 4x4, i 16V, 12V [GD]	06.87-07.91	60	S4 024
2.2 i [GD]	08.88-09.91	60	S4 024
		70	S4 026
Diesel			
2.0 D [GC]	07.85-06.87	70	S4 026
D [GD]	07.87-07.91	70	S4 026
D Comprex [GE]	03.92-03.97	70	S4 026
16V D Turbo [GF]	04.98-07.02	95	S4 028
626 Coupé			
1.6/ 1.8/ 2.0/ 2.2, i, i 12V, i 16V, 12V [GC; GD]	11.82-05.92	60	S4 024
Diesel			
2.0 D [GC]	11.82-06.87	70	S4 026
626 Fastback			
1.8/ 2.0 i 16V [GF]	08.99-04.02	60	S4 024
Diesel			
2.0 16V D Turbo [GF]	08.99-07.00	95	S4 028
626 Hatchback			
1.8/ 2.0 i 16V, 16V [GF]	04.97-10.99	60	S4 024
1.8/ 2.0/ 2.5 i, i 16V, i 16V 4x4, i 24V, i 24V 4WS [GE]	09.91-06.97	60	S4 024
2.0 [GC]	12.82-06.87	60	S4 024
		70	S4 026
i [GD]	06.87-08.89	60	S4 024
2.2 i [GD]	09.89-09.91	60	S4 024
		70	S4 026
i Turbo 2WS [GD]	09.89-09.91	60	S4 024
		70	S4 026
i 12V [GD]	11.87-07.91	60	S4 024
		70	S4 026
Diesel			
2.0 D [GC]	11.82-07.85	70	S4 026
	07.85-06.87	60	S4 024
D Comprex [GE]	03.92-03.97	70	S4 026
16V D Turbo [GF]	04.98-08.99	95	S4 028
	10.00-07.02	95	S4 028
626 Wagon			
1.8/ 2.0/ 2.2, i, i 4WD, i 12V, i 16V, 12V [GV; GW]	03.88-04.02	60	S4 024
Diesel			
2.0 D, D Comprex [GV]	03.88-10.97	70	S4 026
D Turbo, 16V D Turbo [GW]	05.98-04.02	95	S4 028



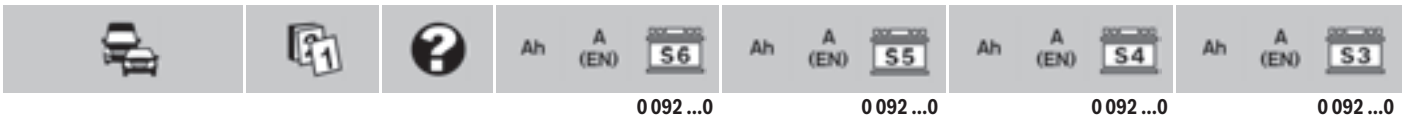

929												
2.0/ 2.2/ 3.0 , i, i 12V, i 18V, i 24V, 12V [HB; HC]	07.83-12.95							60				S4 024
929 Coupé												
2.0 , i [HB]	11.83-12.87							60				S4 024
929 Hardtop												
2.0/ 3.0 , i, i Turbo, i 18V, i 24V [HB; HC]	10.83-06.91							60				S4 024
929 Sedan												
3.0 i 24V 4WS [HD]	05.91-11.93							60				S4 024
929 Wagon												
2.0 [HV/LA]	12.81-12.88							60				S4 024

MERCEDES-BENZ

MB														
Diesel														
100 D	09.87-01.96		70	760	S6 008	77	780	S5 008	74	780	S4 008	70	640	S3 008
O 309														
B	08.82-02.89					100	830	S5 013	74	830	S4 008			
Diesel														
D	01.70-02.89					100	830	S5 013	74	830	S4 008			
Serie A														
140/ 160 [168]	10.97-08.04		70	760	S6 008	63	610	S5 005	60	610	S4 005			
150 [169]	09.04-04.09		70	760	S6 008	63	610	S5 005	60	610	S4 005			
		SSJ	70	760	S6 008									
160 [169]	04.09-10.11		70	760	S6 008	63	610	S5 005	60	610	S4 005			
		SSJ	70	760	S6 008									
170 [169]	09.04-04.09		70	760	S6 008	63	610	S5 005	60	610	S4 005			
		SSJ	70	760	S6 008									
180 [169]	04.09-10.11		70	760	S6 008	63	610	S5 005	60	610	S4 005			
		SSJ	70	760	S6 008									
190/ 200/ 210 , Evolution, Turbo [168; 169]	03.99-10.11		70	760	S6 008	63	610	S5 005	60	610	S4 005			
Diesel														
160/ 170/ 180/ 200 CDI [168; 169]	07.98-10.11		70	760	S6 008	77	780	S5 008	74	780	S4 008			
Serie B														
150 [245]	04.05-04.09		70	760	S6 008	63	610	S5 005	60	610	S4 005			
		SSJ	70	760	S6 008									
160 [245]	04.09-04.11		70	760	S6 008	63	610	S5 005	60	610	S4 005			
		SSJ	70	760	S6 008									
170 [245]	04.05-04.09		70	760	S6 008	63	610	S5 005	60	610	S4 005			
		SSJ	70	760	S6 008									
180 [245]	04.09-04.11		70	760	S6 008	63	610	S5 005	60	610	S4 005			
		SSJ	70	760	S6 008									
200 [245]	04.05-04.11		70	760	S6 008	63	610	S5 005	60	610	S4 005			
Turbo [245]	04.05-10.10		70	760	S6 008	63	610	S5 005	60	610	S4 005			
Diesel														
180/ 200 CDI [245]	04.05-05.11		70	760	S6 008	77	780	S5 008	74	780	S4 008			
Serie C														
32 AMG KOMPRESSOR [203]	01.01-01.04					100	830	S5 013	74	830	S4 008			
36 AMG [202]	01.94-05.97					100	830	S5 013	74	830	S4 008			
43 AMG/ 55 AMG/ 320 , 4MATIC [202; 203]	11.97-08.07					100	830	S5 013	74	830	S4 008			
180 [202]	03.93-04.00		70	760	S6 008	77	780	S5 008	60	780	S4 005			
CGI [204]	01.09-04.12					63	610	S5 005		610				
		SSJ	80	800	S6 011									
KOMPRESSOR [203]	09.02-07.07		70	760	S6 008	77	780	S5 008	60	780	S4 005			
KOMPRESSOR [204]	01.07-10.08	SSJ	70	760	S6 008									
	01.07-04.10		70	760	S6 008	77	780	S5 008	60	780	S4 005			
180/ 230/ 240 [203]	05.00-07.07		70	760	S6 008	77	780	S5 008	60	780	S4 005			

		Ah A (EN) S6			Ah A (EN) S5			Ah A (EN) S4			Ah A (EN) S3		
		0092 ...0			0092 ...0			0092 ...0			0092 ...0		
◀ MERCEDES-BENZ													
200 CGI [204]	04.09→				63	610	S5 005		610				
					85	800	S5 011		800				
		SSJ	80	800	S6 011								
CGI KOMPRESSOR [203]	04.03-04.05		70	760	S6 008	77	780	S5 008	60	780	S4 005		
KOMPRESSOR [203]	05.00-08.02		70	760	S6 008	100	830	S5 013	74	830	S4 008		
	09.02-02.07		70	760	S6 008	77	780	S5 008	60	780	S4 005		
KOMPRESSOR [204]	03.07-04.10		70	760	S6 008	77	780	S5 008	60	780	S4 005		
		SSJ	70	760	S6 008								
200/ 220/ 230/ 240 [202]	03.93-04.00		70	760	S6 008	77	780	S5 008	60	780	S4 005	56 480 S3 005	
200/ 230 KOMPRESSOR [202]	09.95-04.00		70	760	S6 008	77	780	S5 008	60	780	S4 005	56 480 S3 005	
230 [204]	08.07-04.09		70	760	S6 008	77	780	S5 008	60	780	S4 005		
KOMPRESSOR [203]	02.04-05.05		70	760	S6 008	77	780	S5 008	60	780	S4 005		
4MATIC [204]	08.07-04.09		70	760	S6 008	77	780	S5 008	60	780	S4 005		
240 4MATIC [203]	09.02-06.05		70	760	S6 008	77	780	S5 008	60	780	S4 005		
250 CGI [204]	04.09→	BWD,SSJ	80	800	S6 011								
280 [202]	05.93-08.00		70	760	S6 008	100	830	S5 013	74	830	S4 008	70 640 S3 008	
[204]	03.07-04.09		70	760	S6 008	77	780	S5 008	80	780	S4 011		
			70	760	S6 008	85	800	S5 011	60	800	S4 005		
			70	760	S6 008	85	800	S5 011	80	800	S4 011		
4MATIC [204]	07.07-04.09		70	760	S6 008	77	780	S5 008	80	780	S4 011		
			70	760	S6 008	85	800	S5 011	60	800	S4 005		
			70	760	S6 008	85	800	S5 011	80	800	S4 011		
280/ 350 [203]	06.05-02.07		70	760	S6 008	100	830	S5 013	74	830	S4 008		
4MATIC [203]	07.05-08.07		70	760	S6 008	100	830	S5 013	74	830	S4 008		
300 [204]	05.09-01.11					85	800	S5 011		800			
4MATIC [204]	05.09-01.11		70	760	S6 008	77	780	S5 008	60	780	S4 005		
			70	760	S6 008	85	800	S5 011	60	800	S4 005		
350 [204]	03.07-12.10		70	760	S6 008	77	780	S5 008	80	780	S4 011		
			70	760	S6 008	85	800	S5 011	60	800	S4 005		
			70	760	S6 008	85	800	S5 011	80	800	S4 011		
4MATIC [204]	07.07-12.10		70	760	S6 008	77	780	S5 008	80	780	S4 011		
			70	760	S6 008	85	800	S5 011	60	800	S4 005		
			70	760	S6 008	85	800	S5 011	80	800	S4 011		
Diesel													
30 AMG/ 200/ 220/ 270/ 320 CDI [203]	05.00-07.07					100	830	S5 013	74	830	S4 008		
200 CDI [204]	01.07-12.10	SSJ	80	800	S6 011								
	01.07→		95	850	S6 013	85	800	S5 010	80	800	S4 011		
			95	850	S6 013	85	800	S5 011	80	800	S4 010		
			95	850	S6 013	85	800	S5 011	80	800	S4 011		
200/ 220 CDI [202]	12.97-04.00					100	830	S5 013	74	830	S4 008		
200/ 220/ 250 D, D Turbo [202]	03.93-04.00	BAW				100	830	S5 013	74	830	S4 008		
220 CDI [204]	03.07-04.09		95	850	S6 013	85	800	S5 010	80	800	S4 011		
			95	850	S6 013	85	800	S5 011	80	800	S4 010		
			95	850	S6 013	85	800	S5 011	80	800	S4 011		
		SSJ	80	800	S6 011								
	12.08→					85	800	S5 011	80	800	S4 011		
		BWD,SSJ	80	800	S6 011								
250 CDI [204]	09.08→	BWD,SSJ	80	800	S6 011								
320 CDI [204]	06.07-04.09		95	850	S6 013	85	800	S5 010	80	800	S4 011		
			95	850	S6 013	85	800	S5 011	80	800	S4 010		
			95	850	S6 013	85	800	S5 011	80	800	S4 011		
CDI 4MATIC [204]	07.07-04.09		95	850	S6 013	85	800	S5 010	80	800	S4 011		
			95	850	S6 013	85	800	S5 011	80	800	S4 010		
			95	850	S6 013	85	800	S5 011	80	800	S4 011		
Serie C (Sportcoupe)													
160/ 180/ 200/ 230 CGI KOMPRESSOR, KOMPRESSOR [203]	01.01-02.08		70	760	S6 008	77	780	S5 008	60	780	S4 005		
180 [203]	01.01-08.02		70	760	S6 008	77	780	S5 008	60	780	S4 005		
230 [203]	06.05-02.08		70	760	S6 008	77	780	S5 008	60	780	S4 005		

		0 092 ...0			0 092 ...0			0 092 ...0			0 092 ...0					
320/ 350 [203]	09.02-02.08				100	830	S5 013	74	830	S4 008						
Diesel																
30 AMG/ 200/ 220 CDI [203]	01.01-02.08				100	830	S5 013	74	830	S4 008						
Serie C (T-Modell)																
32 AMG/ 43 AMG/ 55 AMG/ 320 , KOMPRESSOR, 4MATIC [202; 203]	10.97-08.07				100	830	S5 013	74	830	S4 008						
180 [203]	01.01-08.02		70	760	S6 008	77	780	S5 008	60	780	S4 005					
CGI [204]	10.09-04.12					63	610	S5 005		610						
		SSJ	60	680	S6 005											
KOMPRESSOR [204]	09.07-08.08		70	760	S6 008	77	780	S5 008	60	780	S4 005					
			70	760	S6 008	85	800	S5 011	60	800	S4 005					
KOMPRESSOR	09.08-04.10		70	760	S6 008	77	780	S5 008	60	780	S4 005					
BlueEFFICIENCY [204]																
180/ 200 [202]	05.96-02.01		70	760	S6 008	77	780	S5 008	60	780	S4 005					
CGI KOMPRESSOR, KOMPRESSOR [203]	01.01-08.07		70	760	S6 008	77	780	S5 008	60	780	S4 005					
200 CGI [204]	04.09→					63	610	S5 005		610						
		SSJ	60	680	S6 005											
KOMPRESSOR [202]	05.96-02.01		70	760	S6 008	77	780	S5 008	60	780	S4 005					
KOMPRESSOR [204]	09.07-04.10		70	760	S6 008	77	780	S5 008	60	780	S4 005					
230 [202]	05.96-05.97		70	760	S6 008	77	780	S5 008	60	780	S4 005	56	480	S3 005		
KOMPRESSOR [202]	06.97-02.01		70	760	S6 008	77	780	S5 008	60	780	S4 005	56	480	S3 005		
230/ 240/ 300 , KOMPRESSOR, 4MATIC [202; 203; 204]	06.97-01.11		70	760	S6 008	77	780	S5 008	60	780	S4 005					
250 CGI [204]	04.09→					63	610	S5 005		610						
		SSJ	80	800	S6 011											
280 [204]	09.07-03.09		70	760	S6 008	77	780	S5 008	80	780	S4 011					
			70	760	S6 008	85	800	S5 011	60	800	S4 005					
			70	760	S6 008	85	800	S5 011	80	800	S4 011					
280/ 350 [203]	06.05-08.07		70	760	S6 008	100	830	S5 013	74	830	S4 008					
4MATIC [203]	07.05-08.07		70	760	S6 008	100	830	S5 013	74	830	S4 008					
350 [204]	09.07-12.10		70	760	S6 008	77	780	S5 008	80	780	S4 011					
			70	760	S6 008	85	800	S5 011	60	800	S4 005					
			70	760	S6 008	85	800	S5 011	80	800	S4 011					
Diesel																
30 AMG/ 200/ 220/ 270/ 320 CDI [202; 203]	12.97-08.07					100	830	S5 013	74	830	S4 008					
200 CDI [204]	09.07-10.09		95	850	S6 013	85	800	S5 010	80	800	S4 011					
			95	850	S6 013	85	800	S5 011	80	800	S4 010					
			95	850	S6 013	85	800	S5 011	80	800	S4 011					
		SSJ	80	800	S6 011											
	01.11→					85	800	S5 011	80	800	S4 011					
220 CDI [204]	09.07-03.09		95	850	S6 013	85	800	S5 010	80	800	S4 011					
			95	850	S6 013	85	800	S5 011	80	800	S4 010					
			95	850	S6 013	85	800	S5 011	80	800	S4 011					
	09.07→	SSJ	80	800	S6 011											
	04.09→					85	800	S5 011	80	800	S4 011					
250 D Turbo [202]	05.96-02.01		70	760	S6 008	100	830	S5 013	74	830	S4 008					
320 CDI [204]	09.07-04.09		95	850	S6 013	85	800	S5 010	80	800	S4 010					
320/ 350 CDI 4MATIC [204]	09.07-10.09		95	850	S6 013	85	800	S5 010	80	800	S4 010					
Serie CL (Coupé)																
55 AMG/ 63 AMG/ 65 AMG/ 500/ 600 , KOMPRESSOR, 4MATIC [215; 216]	09.99→		95	850	S6 013	100	830	S5 013		830						
420/ 500/ 600 [140]	06.96-08.99		95	850	S6 013	100	830	S5 013	95	830	S4 013	90	720	S3 013		
Serie CLC																
160 [203]	02.09-10.10	SSJ	70	760	S6 008											
180/ 200 KOMPRESSOR [203]	03.08-05.10		70	760	S6 008	77	780	S5 008	60	780	S4 005					
230 [203]	03.08-05.10		70	760	S6 008	77	780	S5 008	60	780	S4 005					
350 [203]	03.08-05.10					100	830	S5 013	74	830	S4 008					

						Ah A (EN) S6		Ah A (EN) S5		Ah A (EN) S4		Ah A (EN) S3	
						0092...0		0092...0		0092...0		0092...0	
◀ MERCEDES-BENZ													
Diesel													
200/220 CDI [203]	03.08-05.10			100	830	S5 013	74	830	S4 008				
Serie CLK (Cabrio)													
55 AMG/280/320/350/500 [209]	09.01-12.09	70	760	S6 008	100	830	S5 013	74	830	S4 008			
63 AMG [209]	09.06-12.09	95	850	S6 013	100	830	S5 013	95	830	S4 013	90	720	S3 013
200 [208]	06.98-06.00	70	760	S6 008	77	780	S5 008	60	780	S4 005			
KOMPRESSOR [209]	02.03-09.06	70	760	S6 008	77	780	S5 008		780				
	10.06-12.09	70	760	S6 008	77	780	S5 008	60	780	S4 005			
200/230 KOMPRESSOR [208]	09.96-01.03	70	760	S6 008	77	780	S5 008	60	780	S4 005			
240 [209]	02.03-03.05	70	760	S6 008	77	780	S5 008		780				
320/430 [208]	06.98-01.03			100	830	S5 013	74	830	S4 008				
Diesel													
320 CDI [209]	04.05-12.09	95	850	S6 013	100	830	S5 013	95	830	S4 013	90	720	S3 013
Serie CLK (Coupé)													
55 AMG/320/430 [208; 209]	01.97-08.06			100	830	S5 013	74	830	S4 008				
63 AMG [209]	09.06-04.09	95	850	S6 013	100	830	S5 013	95	830	S4 013	90	720	S3 013
200 [208; 209]	06.97-06.00	70	760	S6 008	77	780	S5 008	60	780	S4 005			
200/230 CGI KOMPRESSOR, KOMPRESSOR [208; 209]	06.97-04.09	70	760	S6 008	77	780	S5 008	60	780	S4 005			
240/320 [209]	05.02-03.05	70	760	S6 008	77	780	S5 008	60	780	S4 005			
280/350 [209]	04.05-04.09	70	760	S6 008	100	830	S5 013	74	830	S4 008			
500 [209]	05.02-07.06	70	760	S6 008	77	780	S5 008	60	780	S4 005			
	09.06-04.09	70	760	S6 008	100	830	S5 013	74	830	S4 008			
Diesel													
220/270/320 CDI [209]	09.02-04.09			100	830	S5 013	74	830	S4 008				
Serie CLS													
55 AMG/63 AMG/350/500 , CGI [219]	06.04-02.11	AGM,BWD	95	850	S6 013								
Diesel													
320 CDI [219]	05.05-04.09	AGM,BWD	95	850	S6 013								
350 CDI [219]	05.09-09.09	AGM	95	850	S6 013								
Serie E													
55 AMG/63 AMG/200/230/240/280/320/350/500 , CGI, KOMPRESSOR, KOMPRESSOR NGT, 4MATIC [211]	03.02-03.09	AGM,BWD	95	850	S6 013								
55 AMG/280/320/420/430 [210]	06.95-08.03		70	760	S6 008	100	830	S5 013	74	830	S4 008		
60 AMG/280/300/320/420/500 , 4MATIC [124]	07.93-06.95		70	760	S6 008	100	830	S5 013	74	830	S4 008	70	640
200 CGI [212]	04.09→				63	610	S5 005		610				
		SSJ	80	800	S6 011								
200/220 , KOMPRESSOR [124; 210]	07.93-03.02		70	760	S6 008	77	780	S5 008	60	780	S4 005		
230/240 [210]	06.95-03.02		70	760	S6 008	77	780	S5 008	60	780	S4 005		
250 CGI [212]	04.09→				63	610	S5 005		610				
		SSJ	80	800	S6 011								
280/320/430 4MATIC [210]	03.97-01.03		70	760	S6 008	100	830	S5 013	74	830	S4 008		
Diesel													
200 CDI [212]	04.09→				63	610	S5 005		610				
		SSJ	80	800	S6 011								
200/220/250/270/290/300/320 CDI, D, D Turbo [210]	06.95-03.02		70	760	S6 008	100	830	S5 013	74	830	S4 008		
200/220/270/280/300/320/400/420 BlueTec, CDI, CDI 4MATIC [211]	03.02-03.09	AGM,BWD	95	850	S6 013								
200/250/300 D, D Turbo, D Turbo 4MATIC [124]	07.93-06.95	BAW	70	760	S6 008	100	830	S5 013	74	830	S4 008	70	640

				Ah A (EN) S6	Ah A (EN) S5	Ah A (EN) S4	Ah A (EN) S3
				0 092 ...0	0 092 ...0	0 092 ...0	0 092 ...0
220 CDI [212]	12.08→	SSJ	80 800	S6 011			
250 CDI [212]	12.08→				63 610	S5 005	610
		SSJ	80 800	S6 011			
Serie E (Cabrio)							
36 AMG [124]	07.93-06.98		70 760	S6 008	100 830	S5 013	74 830 S4 008
200/ 220 [124]	07.93-06.98		70 760	S6 008	77 780	S5 008	60 780 S4 005
200/ 250 CGI [207]	01.10→	SSJ	80 800	S6 011			
320 [124]	05.93-06.98		70 760	S6 008	100 830	S5 013	74 830 S4 008 70 640 S3 008
Diesel							
220/ 250 CDI [207]	01.10→	SSJ	80 800	S6 011			
Serie E (Coupé)							
36 AMG/ 320 [124]	07.93-06.98		70 760	S6 008	100 830	S5 013	74 830 S4 008 70 640 S3 008
200/ 220 [124]	07.93-06.97		70 760	S6 008	77 780	S5 008	60 780 S4 005
200/ 250 CGI [207]	02.09→	SSJ	80 800	S6 011			
Diesel							
220/ 250 CDI [207]	02.09→	SSJ	80 800	S6 011			
Serie E (T-Modell)							
36 AMG/ 280 [124]	07.93-05.96		70 760	S6 008	100 830	S5 013	74 830 S4 008 70 640 S3 008
55 AMG KOMPRESSOR [211]	09.03-05.06	AGM,BWD	95 850	S6 013			
55 AMG/ 280/ 320/ 420/ 430 [210]	05.96-01.03		70 760	S6 008	100 830	S5 013	74 830 S4 008
63 AMG/ 230/ 240/ 280/ 320/ 350/ 500 , CGI [211]	02.03-08.09	AGM,BWD	95 850	S6 013			
200 CGI [212]	08.09→				63 610	S5 005	610
		SSJ	80 800	S6 011			
KOMPRESSOR [210]	09.97-05.99		70 760	S6 008	77 780	S5 008	60 780 S4 005
	07.99-01.03		70 760	S6 008	77 780	S5 008	60 780 S4 005
KOMPRESSOR [211]	02.03-03.06	AGM,BWD,KZO	70 760	S6 008			
		AGM,BWD,KZO	95 850	S6 013			
	04.06-08.09	AGM,BWD	95 850	S6 013			
200/ 220 [124]	07.93-05.96		70 760	S6 008	77 780	S5 008	60 780 S4 005
200/ 230/ 240 [210]	05.96-01.03		70 760	S6 008	77 780	S5 008	60 780 S4 005
240/ 280/ 320/ 350/ 500 4MATIC [211]	09.03-08.09	AGM,BWD	95 850	S6 013			
250 CGI [212]	08.09→				63 610	S5 005	610
		SSJ	80 800	S6 011			
280/ 320/ 430 4MATIC [210]	03.97-02.03		70 760	S6 008	100 830	S5 013	74 830 S4 008
300 4MATIC [124]	07.93-06.95		70 760	S6 008	100 830	S5 013	74 830 S4 008 70 640 S3 008
320 [124]	07.93-05.96		70 760	S6 008	100 830	S5 013	74 830 S4 008
Diesel							
200 CDI [211]	04.07-08.09	AGM,BWD	95 850	S6 013			
CDI [212]	08.09→				63 610	S5 005	610
		SSJ	80 800	S6 011			
220 CDI [211]	02.03-03.06	AGM,BWD	70 760	S6 008			
	02.03-08.09	AGM,BWD	95 850	S6 013			
CDI [212]	08.09→				63 610	S5 005	610
		SSJ	80 800	S6 011			
220/ 250/ 270/ 290/ 300/ 320 CDI, D, D Turbo [210]	05.96-01.03		70 760	S6 008	100 830	S5 013	74 830 S4 008
250 CDI [212]	08.09→	SSJ	80 800	S6 011			
D Turbo [124]	07.93-06.95		70 760	S6 008	100 830	S5 013	74 830 S4 008 70 640 S3 008
250/ 300 D [124]	07.93-05.96	BAW	70 760	S6 008	100 830	S5 013	74 830 S4 008 70 640 S3 008
270/ 280/ 320 CDI [211]	02.03-08.09	AGM,BWD	95 850	S6 013			
280/ 320 CDI 4MATIC [211]	04.05-08.09	AGM,BWD	95 850	S6 013			
300 D Turbo [124]	07.93-05.96	BAW	70 760	S6 008	100 830	S5 013	74 830 S4 008 70 640 S3 008
D Turbo 4MATIC [124]	07.93-05.96		70 760	S6 008	100 830	S5 013	74 830 S4 008 70 640 S3 008
Serie G							
55 AMG KOMPRESSOR [463]	04.04→		95 850	S6 013	100 830	S5 013	95 830 S4 013 90 720 S3 013
55 AMG/ 320/ 500 [463]	06.97-08.06		95 850	S6 013	100 830	S5 013	95 830 S4 013 90 720 S3 013
200 E [463]	01.90-07.93		70 760	S6 008	77 780	S5 008	74 780 S4 008
230 [461]	04.92-09.95	ZE	70 760	S6 008	77 780	S5 008	60 780 S4 005
[463]	06.90-06.95		70 760	S6 008	100 830	S5 013	74 830 S4 008 70 640 S3 008
E [461]	10.89-09.95		70 760	S6 008	100 830	S5 013	74 830 S4 008 70 640 S3 008



			Ah A (EN) S6			Ah A (EN) S5			Ah A (EN) S4			Ah A (EN) S3		
			0092 ...0			0092 ...0			0092 ...0			0092 ...0		
◀ MERCEDES-BENZ														
230 E [463]	09.89-06.93		70	760	S6 008	100	830	S5 013	74	830	S4 008	70	640	S3 008
230/280 E [460]	11.79-08.92		70	760	S6 008	100	830	S5 013	74	830	S4 008	70	640	S3 008
280/300 E [461; 463]	09.89-07.97		70	760	S6 008	100	830	S5 013	74	830	S4 008			
500 AMG E [463]	03.93-09.01		95	850	S6 013	100	830	S5 013	95	830	S4 013	90	720	S3 013
Diesel														
240/250/300 D [461]	04.90-11.97	ZE	70	760	S6 008	77	780	S5 008	74	780	S4 008			
240/300 D [460]	03.79-08.91		95	850	S6 013	100	830	S5 013	95	830	S4 013	90	720	S3 013
250 D [460; 463]	09.87-07.93		95	850	S6 013	100	830	S5 013	95	830	S4 013	90	720	S3 013
270/400 CDI [463]	12.00-08.06		95	850	S6 013	100	830	S5 013	95	830	S4 013			
290 D [461]	04.92-09.97		95	850	S6 013	100	830	S5 013	95	830	S4 013	90	720	S3 013
DT [461]	04.97-09.01	ZE	95	850	S6 013	100	830	S5 013	95	830	S4 013	90	720	S3 013
300/350 D, D Turbo [463]	09.89-11.00		95	850	S6 013	100	830	S5 013	95	830	S4 013	90	720	S3 013
320 CDI [463]	09.06→		95	850	S6 013	100	830	S5 013	95	830	S4 013	90	720	S3 013
Serie GL														
450/500 4MATIC [164]	02.06→		95	850	S6 013	100	830	S5 013	95	830	S4 013			
Diesel														
320/420 CDI 4MATIC [164]	02.06-04.09		95	850	S6 013	100	830	S5 013	95	830	S4 013			
Serie GLK														
Diesel														
200 CDI [204]	07.10→					63	610	S5 005		610				
			SSJ	80	800	S6 011								
220 CDI [204]	04.09→					63	610	S5 005		610				
			SSJ	80	800	S6 011								
CDI 4MATIC [204]	06.08→					63	610	S5 005		610				
			SSJ	80	800	S6 011								
250 CDI 4MATIC [204]	04.09→					63	610	S5 005		610				
			SSJ	80	800	S6 011								
Serie ML														
55 AMG/320 [163]	03.98-06.05					100	830	S5 013		830				
63 AMG/350/500, 4MATIC [164]	09.05-07.11	AGM	95	850	S6 013									
350 [163]	08.02-06.05		95	850	S6 013	100	830	S5 013	95	830	S4 013			
430 [163]	09.98-07.02		95	850	S6 013	100	830	S5 013	95	830	S4 013	90	720	S3 013
500 [163]	09.01-06.05		95	850	S6 013	85	800	S5 010	80	800	S4 010			
Diesel														
270 CDI [163]	11.99-06.05					100	830	S5 013		830				
280/300/320/350/420/450 CDI 4MATIC [164]	03.05-01.11	AGM	95	850	S6 013									
400 CDI [163]	09.01-06.05		95	850	S6 013	100	830	S5 013	95	830	S4 013			
Serie R														
63 AMG 4MATIC [251]	04.06-08.07		95	850	S6 013									
280/350 [251]	05.07-05.10	AGM	95	850	S6 013									
350/500 4MATIC [251]	09.05→	AGM	95	850	S6 013									
Diesel														
280/320 CDI, CDI 4MATIC [251]	09.05-04.09	AGM	95	850	S6 013									
Serie S														
55 AMG/280/320/430 [220]	10.98-01.06		95	850	S6 013	100	830	S5 013	95	830	S4 013	90	720	S3 013
55 AMG/350/430/500 KOMPRESSOR, 4MATIC [220]	09.02-08.06	AGM	95	850	S6 013									
63 AMG/65 AMG/350/450/500/600, 4MATIC [221]	09.05→	AGM	95	850	S6 013									
65 AMG/350 [220]	09.02-08.06	AGM	95	850	S6 013									
260/280/300/380/420/500/560 S, SE, SEL [126]	10.79-08.91		70	760	S6 008	100	830	S5 013	74	830	S4 008	70	640	S3 008
280/300/320/400/420/500/600, SE, SE, SEL, SE 2.8, SEL, SEL 3.2 [140]	02.91-02.99		95	850	S6 013	100	830	S5 013	95	830	S4 013	90	720	S3 013
500 [220]	10.98-08.06		95	850	S6 013	100	830	S5 013	95	830	S4 013	90	720	S3 013
	06.00-08.05		95	850	S6 013	100	830	S5 013	95	830	S4 013			

			Ah A (EN) S6			Ah A (EN) S5			Ah A (EN) S4			Ah A (EN) S3		
			0 092 ...0	0 092 ...0	0 092 ...0	0 092 ...0	0 092 ...0	0 092 ...0						
600 [220]	08.99-08.05		95	850	S6 013	100	830	S5 013	95	830	S4 013	90	720	S3 013
	09.02-01.06	AGM	95	850	S6 013									
Diesel														
300 SD Turbo [126]	09.80-08.85		95	850	S6 013	100	830	S5 013	95	830	S4 013	90	720	S3 013
300/350 D Turbo, SD Turbo [140]	09.91-09.98		95	850	S6 013	100	830	S5 013	95	830	S4 013	90	720	S3 013
320 CDI [220]	06.99-08.02		95	850	S6 013	100	830	S5 013	95	830	S4 013	90	720	S3 013
	09.02-08.05	AGM	95	850	S6 013									
320/420/450 CDI, CDI 4MATIC [221]	12.05-06.10	AGM	95	850	S6 013									
350 SDL Turbo [126]	03.90-06.91		95	850	S6 013	100	830	S5 013	95	830	S4 013	90	720	S3 013
400 CDI [220]	06.99-08.03		95	850	S6 013	100	830	S5 013	95	830	S4 013	90	720	S3 013
	09.03-08.05	AGM	95	850	S6 013									
Serie S (Coupé)														
380/420/500/560 SE [126]	10.81-06.91		70	760	S6 008	100	830	S5 013	74	830	S4 008	70	640	S3 008
420/500/600 [140]	09.92-09.97		95	850	S6 013	100	830	S5 013	95	830	S4 013	90	720	S3 013
Serie SL														
55 AMG/65 AMG [230]	10.01-12.11	AGM,BWD	70	760	S6 008									
60 AMG [129]	07.93-06.98		95	850	S6 013	100	830	S5 013		830				
280 [107]	06.76-07.85		70	760	S6 008	77	780	S5 008	60	780	S4 005	56	480	S3 005
	01.08-04.09	BWD	70	760	S6 008									
280/300/320/500/600 [129]	03.89-09.04	BAW	95	850	S6 013	100	830	S5 013		830				
300 [107]	09.85-08.89		70	760	S6 008	77	780	S5 008	60	780	S4 005	56	480	S3 005
	03.89-06.93	BAW	95	850	S6 013	100	830	S5 013		830				
350 [230]	03.03-12.07	AGM,BWD	70	760	S6 008									
	01.08-12.11	BWD	70	760	S6 008									
380 [107]	07.80-08.85		70	760	S6 008	77	780	S5 008	60	780	S4 005			
420/500 [107]	05.80-08.89		70	760	S6 008	100	830	S5 013	74	830	S4 008	70	640	S3 008
500/600 [230]	10.01-11.12	AGM,BWD	70	760	S6 008									
560 [107]	09.85-08.89		70	760	S6 008	100	830	S5 013	74	830	S4 008			
Serie SLK														
32 AMG/200/230/320 , KOMPRESSOR [170]	09.96-03.04		70	760	S6 008	77	780	S5 008	60	780	S4 005			
55 AMG/200/280/300/350 , KOMPRESSOR [171]	04.04-02.11		70	760	S6 008	77	780	S5 008	74	780	S4 008			
Serie SLR (Coupé)														
5.4 , 722 Edition [199]	04.04-12.09	AGM,BWD	70	760	S6 008									
Serie SLR (Roadster)														
5.4 [199]	04.07-12.09	AGM,BWD	70	760	S6 008									
Serie V														
200/230/280 [638 TON]	04.96-09.03		95	850	S6 013	100	830	S5 013	95	830	S4 013	90	720	S3 013
Diesel														
200/220/230 CDI, TD [638 TON]	04.96-09.03		95	850	S6 013	100	830	S5 013	95	830	S4 013	90	720	S3 013
Serie 123														
200/230/250/280 , E	02.76-12.85		70	760	S6 008	77	780	S5 008	60	780	S4 005	56	480	S3 005
Diesel														
200/300 D, D Turbo	02.76-11.85		95	850	S6 013	100	830	S5 013	74	830	S4 008	70	640	S3 008
Serie 123 (Coupé)														
230/280 E	03.77-12.85		70	760	S6 008	77	780	S5 008	60	780	S4 005	56	480	S3 005
Diesel														
300 D Turbo	09.81-07.85		95	850	S6 013	100	830	S5 013	74	830	S4 008	70	640	S3 008
Serie 123 (T-Modell)														
200/230/250 , E	02.76-12.85		70	760	S6 008	77	780	S5 008	60	780	S4 005	56	480	S3 005
Diesel														
300 D	09.77-11.85		95	850	S6 013	77	780	S5 008	60	780	S4 005	56	480	S3 005
	10.80-07.85		95	850	S6 013	100	830	S5 013	74	830	S4 008	70	640	S3 008
Serie 124														
200	12.84-10.90		70	760	S6 008	77	780	S5 008	60	780	S4 005			
200/220 E	06.86-06.93		70	760	S6 008	77	780	S5 008	60	780	S4 005			
230 E	12.84-06.93		70	760	S6 008	77	780	S5 008	60	780	S4 005	56	480	S3 005
260/280/300/320/400 E	01.85-08.93		70	760	S6 008	100	830	S5 013	74	830	S4 008	70	640	S3 008

		Ah A (EN) S6			Ah A (EN) S5			Ah A (EN) S4			Ah A (EN) S3			
		0092 ...0			0092 ...0			0092 ...0			0092 ...0			
◀ MERCEDES-BENZ														
260/300 E 4MATIC, E-24V	09.86-08.93	70	760	S6 008	100	830	S5 013	74	830	S4 008	70	640	S3 008	
500 E	01.91-06.93	95	850	S6 013	100	830	S5 013	74	830	S4 008	70	640	S3 008	
500 AMG E 6.0	01.91-06.93	95	850	S6 013	100	830	S5 013	74	830	S4 008	70	640	S3 008	
Diesel														
200/250/300 D, D Turbo, D Turbo 4MATIC, D 4MATIC	12.84-06.93	BAW	95	850	S6 013	100	830	S5 013	74	830	S4 008	70	640	S3 008
Serie 124 (Cabrio)														
200/220 E	06.91-06.93	70	760	S6 008	77	780	S5 008	60	780	S4 005				
300 E	04.92-04.93	70	760	S6 008	100	830	S5 013	74	830	S4 008	70	640	S3 008	
E-24V	04.92-06.93	70	760	S6 008	100	830	S5 013	74	830	S4 008	70	640	S3 008	
Serie 124 (Coupé)														
200/220/230 E	03.87-06.93	70	760	S6 008	77	780	S5 008	60	780	S4 005	56	480	S3 005	
300/300 AMG E 3.4, E-24V	09.87-06.93	70	760	S6 008	100	830	S5 013	74	830	S4 008	70	640	S3 008	
300/320 E	03.87-06.93	70	760	S6 008	100	830	S5 013	74	830	S4 008	70	640	S3 008	
Serie 124 (T-Modell)														
200	09.85-05.90	70	760	S6 008	77	780	S5 008	60	780	S4 005				
200/220 E	09.88-06.93	70	760	S6 008	77	780	S5 008	60	780	S4 005				
230 E	09.85-08.93	70	760	S6 008	77	780	S5 008	60	780	S4 005	56	480	S3 005	
260/280/300/320 E	09.85-06.93	70	760	S6 008	100	830	S5 013	74	830	S4 008	70	640	S3 008	
300 E 4MATIC, E-24V	09.86-06.93	70	760	S6 008	100	830	S5 013	74	830	S4 008	70	640	S3 008	
Diesel														
200/250/300 D	01.85-06.93	70	760	S6 008	100	830	S5 013	74	830	S4 008	70	640	S3 008	
250 D Turbo	09.90-06.93	70	760	S6 008	77	780	S5 008	74	780	S4 008				
300 D Turbo	09.86-06.93	95	850	S6 013	100	830	S5 013	74	830	S4 008	70	640	S3 008	
D Turbo 4MATIC	09.86-08.89	70	760	S6 008	100	830	S5 013	74	830	S4 008	70	640	S3 008	
	09.89-06.93	95	850	S6 013	100	830	S5 013	74	830	S4 008	70	640	S3 008	
Serie 190														
190 E 1.8 [201]	03.90-08.93	70	760	S6 008										
	09.91-04.94	70	760	S6 008	63	610	S5 005	60	610	S4 005	56	480	S3 005	
190/190 E 2.0, 2.3, 2.3-16, 2.5-16, 2.5-16 Evolution I, 2.5-16 Evolution II, 2.6 [201]	10.82-09.93	70	760	S6 008	77	780	S5 008	60	780	S4 005	56	480	S3 005	
Diesel														
190 D 2.0, 2.2, 2.5, 2.5 Turbo [201]	09.83-08.93	BAW	70	760	S6 008	100	830	S5 013	74	830	S4 008			
Sprinter														
214/224/314/324/414/424/524, James Cook, NGT [NCV3; T1N]	02.95→				100	830	S5 013	74	830	S4 008				
Diesel														
208/210/211/212/213/216/308/310/311/312/313 CDI, CDI 4x4, D, D James Cook [T1N]	02.95-05.06				100	830	S5 013	74	830	S4 008				
209/211 CDI [NCV3]	04.06-09.11				100	830	S5 013	74	830	S4 008				
210 CDI [NCV3]	03.09→				77	780	S5 008	74	780	S4 008				
		SSJ	70	760	S6 008									
213 CDI [NCV3]	04.06-09.11				100	830	S5 013	74	830	S4 008				
	03.09→				77	780	S5 008	74	780	S4 008				
		SSJ	70	760	S6 008									
215/309/311 CDI [NCV3]	04.06-12.11				100	830	S5 013	74	830	S4 008				
218/318/418/518 CDI [NCV3]	04.06-03.09	95	850	S6 013	100	830	S5 013		830					
310 CDI [NCV3]	03.09→				77	780	S5 008	74	780	S4 008				
		SSJ	70	760	S6 008									
D	09.96-05.01		70	760	S6 008	77	780	S5 008	74	780	S4 008	70	640	S3 008
313 CDI	06.01-05.12				100	830	S5 013	74	830	S4 008				
CDI [NCV3]	04.06-09.11				100	830	S5 013	74	830	S4 008				
	03.09→				77	780	S5 008	74	780	S4 008				
		SSJ	70	760	S6 008									
315 CDI [NCV3]	04.06-09.11				100	830	S5 013	74	830	S4 008				

			Ah A (EN) S6	Ah A (EN) S5	Ah A (EN) S4	Ah A (EN) S3
			0 092 ...0	0 092 ...0	0 092 ...0	0 092 ...0

316/ 408/ 410/ 411/ 412/ 413/ 415/ 416/ 509/ 511/ 515/ 616 CDI, CDI James Cook, D [NCV3; T1N]	02.95-09.11				100	830	S5 013	74	830	S4 008		
413 CDI [NCV3]	03.09→				77	780	S5 008	74	780	S4 008		
		SSJ	70	760			S6 008					
510 CDI [NCV3]	03.09→				77	780	S5 008	74	780	S4 008		
		SSJ	70	760			S6 008					
513 CDI [NCV3]	03.09→				77	780	S5 008	74	780	S4 008		
		SSJ	70	760			S6 008					
Vaneo												
1.6/ 1.9 [414]	02.02-08.05		70	760	S6 008	77	780	S5 008	74	780	S4 008	
Diesel												
1.7 CDI [414]	02.02-08.05		70	760	S6 008	77	780	S5 008	74	780	S4 008	
Vario												
Diesel												
512/ 612/ 613/ 614/ 615/ 616/ 618/ 810/ 812/ 813/ 814/ 815/ 816/ 818 , D, DA, D/DA, DT [T2W]	01.96→				100	830	S5 013	74	830	S4 008		
Viano												
3.2/ 3.7 [639 TON]	09.03-12.07		70	760	S6 008	100	830	S5 013	74	830	S4 008	
Diesel												
2.0 CDI [639 TON]	09.03-08.10					100	830	S5 013	74	830	S4 008	
	07.10→					77	780	S5 008	74	780	S4 008	
		SSJ	70	760	S6 008							
2.2 CDI [639 TON]	09.03-12.10					100	830	S5 013	74	830	S4 008	
	07.10→					77	780	S5 008	74	780	S4 008	
		SSJ	70	760	S6 008							
3.0 CDI [639 TON]	04.06-08.10					100	830	S5 013	74	830	S4 008	
Vito												
113/ 114/ 119/ 122/ 123 [638 TON; 639 TON]	11.95-12.10					100	830	S5 013	74	830	S4 008	
Diesel												
108/ 110/ 112 CDI, D [638 TON]	11.95-09.03		95	850	S6 013	100	830	S5 013	95	830	S4 013	90 720 S3 013
109/ 111/ 115/ 120 CDI [639 TON]	10.03-07.10					100	830	S5 013	74	830	S4 008	
110 CDI [639 TON]	07.10→					77	780	S5 008	74	780	S4 008	
		SSJ	70	760	S6 008							
113 CDI [639 TON]	07.10→					77	780	S5 008	74	780	S4 008	
		SSJ	70	760	S6 008							
116 CDI [639 TON]	07.10→					77	780	S5 008	74	780	S4 008	
		SSJ	70	760	S6 008							
2t												
210 [T1]	08.82-06.95					100	830	S5 013	74	830	S4 008	
Diesel												
207/ 208/ 209/ 210 D [T1]	08.77-06.95					100	830	S5 013	74	830	S4 008	
3t												
310 [T1]	08.82-06.95					100	830	S5 013	74	830	S4 008	
Diesel												
307/ 308/ 309/ 310 D [T1]	08.77-06.95					100	830	S5 013	74	830	S4 008	
4t												
410 [T1]	08.82-06.95					100	830	S5 013	74	830	S4 008	
Diesel												
407/ 408/ 409/ 410 D [T1]	07.81-06.95					100	830	S5 013	74	830	S4 008	

METROCAB

Taxi												
2.4/ 2.5 D, TD	01.91→								95		S4 028	

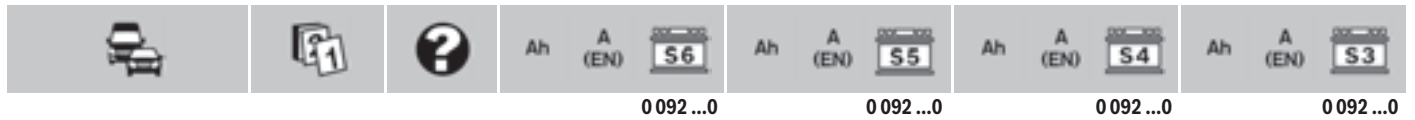

MG

MG TF

115/ 120/ 135/ 160 1.6i	03.02→		63	610	S5 005	60	610	S4 005	56	480	S3 005
16V, 1.8i 16V, 1.8i 16V Stepspeed											

MG 6

1.8 , T	11.10→		63	610	S5 005	60	610	S4 005			
----------------	--------	--	----	-----	---------------	----	-----	---------------	--	--	--

MGF

1.6 i 16V	10.01-03.02		61	600	S5 004	60	600	S4 004			
		XXX							53	470	S3 004
1.8 i 16V	10.95-03.02		61	600	S5 004	60	600	S4 004	53	500	S3 004
		XXX							53	470	S3 004
16V Trophy	03.01-03.02		61	600	S5 004	60	600	S4 004			
		XXX							53	470	S3 004

RV8

3.9	09.92-12.95		61	600	S5 004	60	600	S4 004	53	500	S3 004
		XXX							53	470	S3 004

X Power

4.6 SV	01.03-05.05		74	750	S5 007	72	750	S4 007			
---------------	-------------	--	----	-----	---------------	----	-----	---------------	--	--	--

X Power SV-R

5.0 Supercharged	01.05-05.05		74	750	S5 007	72	750	S4 007			
-------------------------	-------------	--	----	-----	---------------	----	-----	---------------	--	--	--

ZR

105 1.4i 16V	10.01-05.05		61	600	S5 004	60	600	S4 004			
		XXX							53	470	S3 004
120 1.8i 16V	10.01-05.05		61	600	S5 004	60	600	S4 004			
		XXX							53	470	S3 004
160 1.8i 16V	10.01-05.05		61	600	S5 004	60	600	S4 004			
		XXX							53	470	S3 004

Diesel

2.0 D Turbo	10.01-05.05		61	600	S5 004	60	600	S4 004			
		XXX							53	470	S3 004

ZS

110/ 120/ 180 1.6i 16V, 1.8i 16V, 2.5i 24V	10.01-05.05		54	530	S5 002	52	530	S4 002	45	400	S3 002
---	-------------	--	----	-----	---------------	----	-----	---------------	----	-----	---------------

Diesel

2.0 TD	10.01-05.05		74	750	S5 007	72	750	S4 007	70	640	S3 007
---------------	-------------	--	----	-----	---------------	----	-----	---------------	----	-----	---------------

ZT

1.8/ 160/ 180/ 190 i 16V, T 16V, 2.5i 24V	10.01-05.05		63	610	S5 005	60	610	S4 005	56	480	S3 005
260 4.6i Power Supercharged	03.02-05.05		63	610	S5 005	60	610	S4 005	56	480	S3 005
385/ 500 4.6i Power Supercharged	03.02-05.05		52	520	S5 001	72	520	S4 007	70	640	S3 007

Diesel

135/ 190 2.0 CDT, 2.0 CDTi	10.01-05.05	70	760	S6 008	77	780	S5 008	74	780	S4 008	70	640	S3 008
-----------------------------------	-------------	----	-----	---------------	----	-----	---------------	----	-----	---------------	----	-----	---------------

ZT-Tourer

160/ 180/ 190/ 260 1.8 T 16V, 1.8i 16V, 2.5i 24V, 4.6i Power Supercharged	10.01-05.05		63	610	S5 005	60	610	S4 005	56	480	S3 005
--	-------------	--	----	-----	---------------	----	-----	---------------	----	-----	---------------

Diesel

135/ 190 2.0 CDT, 2.0 CDTi	10.01-05.05	70	760	S6 008	77	780	S5 008	74	780	S4 008	70	640	S3 008
-----------------------------------	-------------	----	-----	---------------	----	-----	---------------	----	-----	---------------	----	-----	---------------

MINI (BMW)

Mini

Cooper [R 56]	11.06-08.10	BWD	70	760	S6 008						
	03.10→		70	760	S6 008						
S [R 56]	11.06-07.10	BWD	70	760	S6 008						
	03.10→		70	760	S6 008						
		SSJ	70	760	S6 008						

						Ah A (EN) S6		Ah A (EN) S5		Ah A (EN) S4		Ah A (EN) S3		
						0 092 ...0		0 092 ...0		0 092 ...0		0 092 ...0		
Cooper/ John Cooper Works/ One , S, 1.4i, 1.6i [R 50; R 53]	06.01-11.07			63	610	\$5 005		52	610	\$4 002		45	400	\$3 002
John Cooper Works [R 56]	07.08-06.12	BWD	70	760	\$6 008									
	07.12→		70	760	\$6 008									
One [R 56]	03.07-02.10	BWD	70	760	\$6 008									
	03.09→	SSJ	70	760	\$6 008									
	03.10→		70	760	\$6 008									
Diesel														
Cooper D [R 56]	03.07-07.10	BWD	70	760	\$6 008									
	08.10→	SSJ	70	760	\$6 008									
	03.11→					85	800	\$5 010	80	800	\$4 010			
SD [R 56]	03.11→		80	800	\$6 011									
One D [R 56]	09.09→	SSJ	70	760	\$6 008									
1.4 D [R 50]	03.03-09.05		70	760	\$6 008	77	780	\$5 008	74	780	\$4 008	70	640	\$3 008
	09.05-11.06		70	760	\$6 008	77	780	\$5 008	74	780	\$4 008			
Mini Cabrio														
Cooper S [R 57]	03.09-07.10	BWD	70	760	\$6 008									
	03.10→	SSJ	70	760	\$6 008									
Cooper/ John Cooper Works/ One , S [R 52]	07.04-07.08					63	610	\$5 005	52	610	\$4 002	45	400	\$3 002
Cooper/ One [R 57]	03.09→	SSJ	70	760	\$6 008									
John Cooper Works [R 57]	03.09-07.12	BWD	70	760	\$6 008									
Diesel														
Cooper D [R 57]	09.10→	SSJ	70	760	\$6 008									
	03.11→		70	760	\$6 008									
SD [R 57]	03.11→	SSJ	70	760	\$6 008									
Mini Clubman														
Cooper [R 55]	11.07-07.10	BWD	70	760	\$6 008									
	03.10→		70	760	\$6 008									
S [R 55]	11.07-07.10	BWD	70	760	\$6 008									
	03.10→		70	760	\$6 008									
		SSJ	70	760	\$6 008									
John Cooper Works [R 55]	07.08-06.12	BWD	70	760	\$6 008									
One [R 55]	03.09-02.10		70	760	\$6 008									
	03.10→	SSJ	70	760	\$6 008									
Diesel														
Cooper D [R 55]	11.07-07.10	SSJ	70	760	\$6 008									
	09.10→	SSJ	70	760	\$6 008									
	03.11→					85	800	\$5 010	80	800	\$4 010			
SD [R 55]	03.11→	SSJ	80	800	\$6 011									
One D [R 55]	09.10→	SSJ	70	760	\$6 008									
Mini Clubvan														
Cooper/ One [R 55]	02.13→	SSJ	70	760	\$6 008									
Diesel														
Cooper D [R 55]	02.13→	SSJ	70	760	\$6 008									
Mini Countryman														
Cooper S [R 60]	09.10→		70	760	\$6 008									
		SSJ	70	760	\$6 008									
S ALL4 [R 60]	09.10→	SSJ	70	760	\$6 008									
Cooper/ One [R 60]	09.10→	SSJ	70	760	\$6 008									
Cooper Works All4 [R 60]	11.12→		70	760	\$6 008									
Diesel														
Cooper D [R 60]	09.10→	SSJ	70	760	\$6 008									
	03.11→					85	800	\$5 010	80	800	\$4 010			
D ALL4 [R 60]	09.10→	SSJ	70	760	\$6 008									
	03.11→					85	800	\$5 010	80	800	\$4 010			
SD [R 60]	03.11→	SSJ	70	760	\$6 008									
SD ALL4 [R 60]	03.11→		80	800	\$6 011									
One D [R 60]	09.10→	SSJ	70	760	\$6 008									
Mini Coupé														
Cooper [R 58]	09.11→	BWD							74		\$4 008			
		BWD,SSJ	70	760	\$6 008	70	650	\$5 E08		650				

			Ah A (EN) S6	Ah A (EN) S5	Ah A (EN) S4	Ah A (EN) S3
			0 092 ...0	0 092 ...0	0 092 ...0	0 092 ...0

◀ MINI

Cooper S [R 58]	09.11→		70	760	S6 008						
		BWD						74		S4 008	
		BWD,SSJ	70	760	S6 008	70	650	S5 E08		650	
John Cooper Works [R 58]	09.11-07.12										
		BWD						74		S4 008	
		BWD,SSJ	70	760	S6 008	70	650	S5 E08		650	
Diesel											
Cooper SD [R 58]	09.11→		80	800	S6 011						
Mini Roadster											
Cooper [R 59]	02.12→	SSJ	70	760	S6 008						
S [R 59]	02.12→		70	760	S6 008						
		SSJ	70	760	S6 008						
John Cooper Works [R 59]	02.12-06.12		70	760	S6 008						
Diesel											
Cooper SD [R 59]	02.12→	SSJ	70	760	S6 008						

MITSUBISHI

ASX											
1.8 [GA]	05.10→		70	760	S6 008						
Diesel											
1.8 DI-D 4x4 [GA]	04.10→	BWD						70		S4 027	
Canter 35											
Diesel											
2.3/2.5 D [FB]	01.86-09.96							95		S4 029	
Carisma											
1.3/1.6 i 16V [DA]	05.96-12.03					63	610	S5 005	60	610	S4 005
											56 480 S3 005
1.8 GDI [DA]	05.97-02.99					77	780	S5 008	74	780	S4 008
	03.99-12.03					77	780	S5 008	74	780	S4 008
i 16V [DA]	05.96-02.99					77	780	S5 008	74	780	S4 008
											70 640 S3 008
Diesel											
1.9 D Turbo [DA]	05.96-06.00					77	780	S5 008	74	780	S4 008
											70 640 S3 008
DI-D [DA]	07.00-12.03					77	780	S5 008	74	780	S4 008
Carisma Hatchback											
1.6 i 16V [DA]	05.95-12.03					63	610	S5 005	60	610	S4 005
											56 480 S3 005
1.8 GDI [DA]	05.97-02.99					77	780	S5 008	74	780	S4 008
	03.99-12.03					77	780	S5 008	74	780	S4 008
i 16V [DA]	05.95-02.99					77	780	S5 008	74	780	S4 008
											70 640 S3 008
2.0 16V GT EVO VI [DA]	11.99-12.03					77	780	S5 008	74	780	S4 008
											70 640 S3 008
Diesel											
1.9 D Turbo [DA]	05.96-06.00					77	780	S5 008	74	780	S4 008
											70 640 S3 008
DI-D [DA]	07.00-12.03					77	780	S5 008	74	780	S4 008
Challenger											
3.0 i 4x4 [PA]	02.98→								70		S4 027
Colt											
1.1/1.3 [CZ]	04.04→					54	530	S5 002	52	530	S4 002
											45 400 S3 002
1.2/1.3 [CA/CC; C1; C5]	11.83-05.92								40		S4 019
1.3 i 12V, 12V [CA/CC; C1; C5]	04.88-11.95								40		S4 019
1.3/1.5/1.6 , i 12V, i 16V [CJ]	11.95-06.03								60		S4 025
1.5 [CA/CC; C1; C5]	01.84-05.92								45		S4 023
[CZ]	04.04-06.10					54	530	S5 002	52	530	S4 002
Turbo [CZ]	01.05→					77	780	S5 008	74	780	S4 008
1.5/1.6/1.8 i, i Turbo, i 16V, i 16V 2WD, i 16V 4WD [CA/CC; C1; C5]	11.83-12.96								45		S4 023
1.8 i [CA/CC]	12.91-11.95								70		S4 027
Diesel											
1.5 DI-D [CZ]	08.04-09.08					63	610	S5 005	60	610	S4 005
1.8 D [C1; C5]	11.83-05.92								70		S4 027
Colt Cabrio											
1.5 , Turbo [CZ]	03.06-07.08					63	610	S5 005	60	610	S4 005

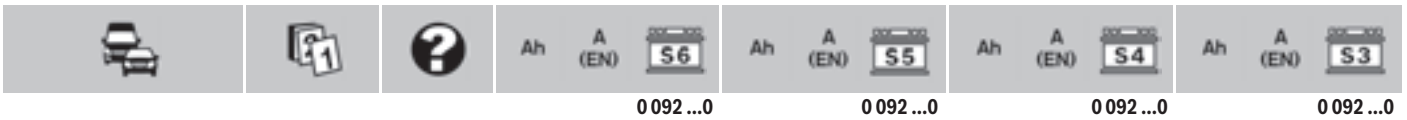

Cordia			
1.6 [AA, AB]	10.82-10.86	60	S4 025
Cordia Coupé			
1.8 , i Turbo [AA, AB; AC]	10.84-12.89	60	S4 025
Eclipse			
1.8 i [D2/3]	01.90-03.94	70	S4 027
2.0 i 16V [D2/3]	01.90-03.94	70	S4 027
	08.95-04.99	70	S4 027
i 16V Turbo, i 16V 4WD [D2/3]	08.90-03.94	70	S4 027
2.4 i 16V [D2/3]	09.98-12.00	70	S4 027
Eclipse Spyder			
2.0 i Turbo, Turbo [; D2/D3]	09.95-09.00	70	S4 027
Express L200			
1.6 [MD]	01.86→	70	S4 027
Galant			
1.6/ 1.8/ 2.0/ 2.4/ 2.5 , GDI,	05.84-12.03	60	S4 025
i, i Turbo, i Turbo AWD, i V6-24, i V6-24 4WS, i 4WD, i 4WD 4WS, i 16V, i 16V 4WD, i 16V 4WD 4WS [; EA; E1; E3; E5...8; H]			
Diesel			
1.8/ 2.0 D Turbo	05.84-02.00	60	S4 025
[EA; E1; E3; E5...8]			
Galant Hatchback			
1.8/ 2.0/ 2.5 , i, i V6-24,	11.88-05.96	60	S4 025
i V6-24 4WS, i 4WD, i 4WD 4WS, i 16V, i 16V 4WD, i 16V 4WD 4WS [E3; E5...8]			
Diesel			
1.8/ 2.0 D Turbo [E3; E5...8]	11.88-10.96	60	S4 025
Galant Sedan			
2.0 i, i 16V [E3]	07.90-10.92	60	S4 025
Galant Station Wagon			
2.0/ 2.4/ 2.5 GDI, i V6-24, i	10.96-09.02	60	S4 025
16V [; EA]			
Diesel			
2.0 D Turbo [EA]	10.96-02.00	60	S4 025
Galloper			
3.0 V6 4x4	09.98-12.01	70	S4 027
Diesel			
2.5 TD Interc. 4x4, TD 4x4	05.98-12.01	70	S4 027
Grandis			
2.4 , i, i 4WD, i 16V	10.97→	60	S4 024
Diesel			
2.0 DI-D	06.05-11.10	60	S4 024
Jeep			
Diesel			
2.7 D	01.74-08.89	95	S4 029
L 200			
1.6/ 2.0/ 2.4/ 2.6 , i 2WD,	11.86-12.07	70	S4 027
i 4WD, i 16V, 2WD, 4WD, 4x4 [; KO-K3; K6/K7]			
3.0 i V6 4x4 [KO-K3]	06.90-05.91	60	S4 025
Diesel			
2.5 D	09.86-06.92	70	S4 027
D, D Turbo Interc. 2WD,	06.95-12.07	70	S4 027
D 2WD, D 4WD [K6/K7]			
D Turbo Interc. 4WD	01.96-12.07	95	S4 029
[K6/K7]			
D Turbo 4WD, D 2WD,	10.84-03.01	70	S4 027
D 4WD [KO-K3]			
DI-D, DI-D 4x4 [KA; KB]	12.05→	95	S4 028



			Ah	A (EN)	S6	Ah	A (EN)	S5	Ah	A (EN)	S4	Ah	A (EN)	S3
			0092 ...0			0092 ...0			0092 ...0			0092 ...0		
◀ MITSUBISHI														
L 200 Forte														
2.4 i [K7]	01.96→													
Diesel														
2.5 D Turbo Interc. [K7]	01.97→													
L 300														
Diesel														
2.3 D Wagon [L]	04.83-10.86													
L 300 Truck														
1.6/2.0 , i 16V, 16V [L; P]	05.80-04.00													
Diesel														
2.3 D [L]	04.83-10.86													
2.5 D [L]	11.86-05.94													
D Turbo [P]	06.94-12.01													
L 300 Van														
1.6/2.0/2.4 i 2WD, i 4WD, 2WD, 4WD [L; P]	05.80-12.01													
Diesel														
2.3 D [L]	04.83-10.86													
2.5 D Turbo 4WD, D 2WD [P]	11.86-12.01													
L 300 Wagon														
1.4/1.6/1.8/2.0/2.4 , i, i 2WD, i 4WD, 2WD, 4WD [L; P]	05.80-08.97													
Diesel														
2.5 D Turbo 4WD, D 2WD long, D 2WD short [P]	11.86-12.00													
L 400														
2.0/2.4 i	12.94-03.01													
Diesel														
2.5 D Turbo 2WD, D Turbo 4WD	12.94-03.01													
Lancer														
1.2 [C1/C3]	11.83-06.88													
[C6/C7]	04.88-05.92													
1.3 , i [CA/CB/CD]	12.91-12.96													
, i [C1/C3; C6/C7]	04.88-07.95													
1.3/1.5/2.0 , i Turbo Evo4, i 12V [CK/CP/CN]	11.95-05.01													
1.3/1.6 i [CS/CT]	06.03-04.10		63	610	S5 005	60	610	S4 005	56	480	S3 005			
1.5 [CC]	10.92-06.96													
[C1/C3]	11.83-02.89													
	07.93-12.94													
, i, 8V, 12V [CA/CB/CD; C6/C7]	04.88-10.96													
1.5/1.6/1.8 [CY/CZ]	03.07→		63	610	S5 005	60	610	S4 005						
1.6 i [CB]	10.90-09.92													
1.6/1.8 i 16V, i 16V 4WD [CA/CB/CD]	05.92-12.96													
1.6/2.0 i Turbo Evo5/6, i 16V [CK/CP/CN]	11.95-09.00													
2.0 EvoX FQ-330 4x4, EvoX FQ-360 4x4, i Turbo EvoX 4WD, Ralliart 4x4 [CY/CZ]	03.07→		77	780	S5 008	74	780	S4 008						
i [CS/CT]	06.02-04.10		63	610	S5 005	60	610	S4 005						
i Turbo Evo8 4x4 [CS/CT]	09.02-07.05													
i Turbo Evo9 4x4 [CS/CT]	08.05-06.07													
Diesel														
1.8 D [C1/C3; C6/C7]	11.83-05.92													
DI-D [CY/CZ]	07.10→	BWD	77	780	S5 008	74	780	S4 008						
2.0 D [CA/CB/CD]	05.92-12.96													
DI-D [CY/CZ]	02.08-08.10		77	780	S5 008	74	780	S4 008						



Lancer Hatchback										
1.3/ 1.5 i [C6/C7]	05.89-07.95								45	S4 022
1.6/ 1.8 i 4WD, i 16V, i 16V 4WD [C6/C7]	04.88-07.95								60	S4 025
Diesel										
1.8 D [C6/C7]	04.88-05.92								60	S4 025
2.0 D [C6/C7]	06.92-07.95								70	S4 027
Lancer Sedan										
1.5 , i [CA/CB/CD; C1/C3]	01.89-12.97								45	S4 022
1.6 i 16V [CA/CB/CD]	01.93-12.96								70	S4 027
1.8 i [CK/CP/CN]	05.96-05.01								60	S4 025
Lancer Sportback										
1.5/ 1.6/ 1.8 [CX]	07.08→			63	610	S5 005		60	610	S4 005
2.0 Ralliart 4x4 [CX]	07.08-09.11			77	780	S5 008		74	780	S4 008
Diesel										
1.8/ 2.0 DI-D [CX]	08.08→	BWD		77	780	S5 008		74	780	S4 008
Lancer Station Wagon										
1.5 , i [C1/C3]	06.85-05.92								45	S4 022
1.6 i 16V, i 16V 4WD [CA/CB/CD]	06.92-09.00								70	S4 027
1.6/ 2.0 i [CS/CT]	06.03-06.08			63	610	S5 005		60	610	S4 005 56 480 S3 005
1.8 i 4WD, 4WD [C1/C3]	06.86-05.92								60	S4 025
Diesel										
1.8 D [C1/C3]	07.85-05.92								60	S4 025
2.0 D [CA/CB/CD]	06.92-05.96								70	S4 027
Minica										
500/ 550/ 660/ 800 , Turbo, 16V, 16V Toppo, 16V 4WD, 16V 4WD Toppo	10.84→								45	S4 023
Outlander										
2.0/ 2.4 , i Turbo 4WD, i 2WD, i 4WD, i 4x4, 4x4 [CU; CW]	02.03-12.12								70	S4 026
2.4/ 3.0 , i 4WD, 4x4 [; CW]	05.03→								95	S4 028
Diesel										
2.0/ 2.2 DI-D, DI-D 4x4 [CW]	02.07-12.12								95	S4 028
Pajero										
1.8/ 2.4/ 2.6/ 3.0/ 3.5/ 3000 , GDI, i, i V6, i 4WD, i 16V, i 24V, V6, V6 24V, V6-24, 4WD [; L; N; NH/NJ; NH/ NJ/NK; NJ/NK/NL; V]	12.82→								70	S4 027
3.5 GDI [V60; V70]	02.00-08.06								95	S4 028
3.8 [V80; V90]	09.06→								60	S4 025
Diesel										
2.3/ 2.5 TD, TD Interc. [L]	12.82-06.91								95	S4 029
2.5 TD [V]	04.91-05.99								70	S4 027
TD Interc. [V60; V70]	02.00-08.06								95	S4 029
2.5/ 2.8 D, TD Interc., TD 4WD [V]	12.90-06.00								95	S4 029
3.2 D Turbo 4WD	10.08-08.10	BWD							70	S4 026
DI-D [V80; V90]	09.06→	BWD							70	S4 026
									95	S4 028
DI-D 4WD [V60; V70]	02.00-08.06	BWD							95	S4 028
Pajero Cabrio										
2.4/ 3000 i, V6, V6 24V [V]	12.90-05.01								70	S4 027
Diesel										
2.5 TD Interc. [V]	12.90-05.01								95	S4 029
Pajero Pinin										
1.8/ 2.0 , GDI [H]	10.99-02.05			63	610	S5 005		60	610	S4 005 56 480 S3 005
Pajero Sport										
3.0 i V6 [K]	07.96-02.09								95	S4 029
Diesel										
2.5 TD, TD+ [K]	08.98-02.09	BWD							95	S4 029



			Ah A (EN) S6	Ah A (EN) S5	Ah A (EN) S4	Ah A (EN) S3
			0092 ...0	0092 ...0	0092 ...0	0092 ...0

◀ MITSUBISHI

Proudia														
3.5 24V	10.99→												95	S4 028
Santamo														
2.0 , 4x4	05.99-12.02												70	S4 027
Sapporo														
2.4 i [E1]	05.87-08.89												60	S4 025
Sigma														
3.0 i, i 24V, i 24V 4WS	12.90-03.96												70	S4 027
Sigma Wagon														
3.0	01.93-07.96												70	S4 027
Space Gear														
2.0/ 2.4/ 3.0 i, i 2WD, i 4WD, i 24V	12.94-03.01												70	S4 027
Diesel														
2.5/ 2.8 D Turbo, D Turbo Interc. 2WD, D Turbo Interc. 4WD, D Turbo 2WD long, D Turbo 2WD short	06.94-03.01												95	S4 029
Space Runner														
1.8/ 2.0/ 2.4 GDI, i, i 16V, i 16V 4WD	06.91-08.02												70	S4 027
Diesel														
2.0 D Turbo	06.92-05.99												70	S4 027
Space Wagon														
1.8/ 2.0 , i 2WD, i 4WD, 2WD, 4WD [D]	10.83-04.91												60	S4 025
1.8/ 2.0/ 2.4 GDI, GDI 4WD, i 16V, i 16V 4WD [N]	05.91-01.04												70	S4 027
Diesel														
1.8 D Turbo [D]	06.85-04.91												70	S4 027
1.8/ 2.0 D Turbo [N]	05.91-11.00												95	S4 029
Spacestar														
1.3/ 1.6 i [DG]	06.98-12.04					63	610	S5 005	60	610	S4 005	56	480	S3 005
1.8 GDI [DG]	08.98-08.02	70	760	S6 008	77	780	S5 008	74	780	S4 008	70	640	S3 008	
i [DG]	09.02-12.04	60	680	S6 005	63	610	S5 005	60	610	S4 005				
Diesel														
1.9 DI-D [DG]	06.00-12.04	70	760	S6 008	77	780	S5 008	74	780	S4 008	70	640	S3 008	
	09.02-12.04	70	760	S6 008	77	780	S5 008	74	780	S4 008				
Starion														
2.0/ 2.6 i Turbo, i Turbo Intercooler	02.82-06.90												70	S4 027
Tredia														
1.5/ 1.8/ 2.0 , i Turbo, 4WD	09.84-09.87												70	S4 027
3000 GT														
3.0 i 24V, i 24V Bi-Turbo 4WD 4WS	04.90-12.00												70	S4 027

MORGAN

Aero 8															
4.4 32V	03.00→												45	300	S3 017
Plus 4															
1.8/ 2.0 , i, 16V	01.85-10.99												45	300	S3 017
Plus 8															
3.5/ 3.9/ 4.6 , i, V8 4/4	09.68-09.04												40	S4 019	
1600/ 1800 , i, 16V	01.82→												45	300	S3 017



MOSKWITSCH

Aleko												
1.5/ 1.6	01.86-12.00			63	610	S5 006	60	610	S4 006	56	480	S3 006
1.7/ 1.8/ 2.0	01.86-12.00						70		S4 027			
2140												
	03.76-12.86			63	610	S5 006	60	610	S4 006	56	480	S3 006

NISSAN

Almera												
1.6 [B10]	01.06→						60		S4 024			
i [H14/15/17]	01.00→			52	520	S5 001	44	520	S4 001	41	360	S3 001
Almera Hatchback												
1.4/ 1.6/ 2.0 i [N15]	07.95-04.00						60		S4 024			
1.5 i [N16E]	01.00-07.02			52	520	S5 001	44	520	S4 001			
	08.02-11.06			54	530	S5 002	44	530	S4 001			
1.8 i [N16E]	01.00-07.02			52	520	S5 001	44	520	S4 001			
	08.02-11.06			54	530	S5 002	44	530	S4 001			
Diesel												
1.5 D Turbo [N16E]	10.02-11.06			74	750	S5 007	72	750	S4 007			
2.0 D [N15]	07.95-04.00						95		S4 028			
2.2 D Turbo [N16E]	01.00-11.06			74	750	S5 007	72	750	S4 007	70	640	S3 007
Almera Sedan												
1.4/ 1.6 i [N15]	07.95-04.00						60		S4 024			
1.5 i [N16]	04.00-03.01			54	530	S5 002	44	530	S4 001			
i [N16E]	03.01-07.02			52	520	S5 001	44	520	S4 001			
	08.02-11.06			54	530	S5 002	44	530	S4 001			
1.8 i [N16; N16E]	04.00-11.06			54	530	S5 002	44	530	S4 001			
Diesel												
1.5 D Turbo [N16E]	10.02-11.06			74	750	S5 007	72	750	S4 007			
2.0 D [N15]	07.95-04.00						95		S4 028			
2.2 D Turbo [N16]	04.00-03.01			74	750	S5 007	72	750	S4 007			
D Turbo [N16E]	03.01-11.06			74	750	S5 007	72	750	S4 007	70	640	S3 007
Almera Tino												
1.8/ 2.0 i [V10M]	05.00-12.05			52	520	S5 001	44	520	S4 001			
Diesel												
2.2 D Turbo [V10M]	05.00-01.03			74	750	S5 007	72	750	S4 007	70	640	S3 007
	02.03-12.05	70	760	S6 008	74	750	S5 007	72	750	S4 007		
Altima												
2.5 [L31]	09.01-12.06						70		S4 026			
Bluebird Hatchback												
1.6/ 1.8/ 2.0 , i, i Turbo [T12; T72]	12.85-04.90						60		S4 024			
Diesel												
2.0 D [T12; T72]	12.85-04.90						95		S4 028			
Bluebird Kombi												
1.8/ 2.0 , i [U11]	11.83-09.90						60		S4 024			
Diesel												
2.0 D, D Turbo [U11]	11.83-05.90						95		S4 028			
Bluebird Sedan												
1.6 [U11]	11.83-04.90						60		S4 025			
1.6/ 1.8/ 2.0 , i, i Turbo [T12; T72; U11]	11.83-04.90						60		S4 024			
Diesel												
2.0 D, D Turbo [T12; T72; U11]	11.83-04.90						95		S4 028			
Cabstar												
1.6/ 2.0/ 2.2/ 2.8 [F22]	03.85-06.92						60		S4 025			



		0092 ...0		0092 ...0		0092 ...0		0092 ...0		
		Ah	A (EN)	Ah	A (EN)	Ah	A (EN)	Ah	A (EN)	
NISSAN										
Diesel										
2.0/ 2.3/ 2.5/ 2.7/ 3.3 D,	12.81-06.92			70					S4 027	
D Turbo [F22]										
Cabstar E										
Diesel										
2.3/ 2.7/ 3.0 D, D Turbo [TLO]	10.98-08.06			95					S4 028	
Cedric Kombi										
2.8 [430]	01.80-06.87			60					S4 025	
Diesel										
2.8 D [430]	01.80-09.85			70					S4 027	
Cedric Sedan										
2.0/ 2.8/ 3.0, i, i Turbo, i 24V	01.80-05.91			60					S4 025	
Turbo [; 430]										
Diesel										
2.8 D	07.87-05.91			95					S4 029	
D [430]	01.80-09.85			70					S4 027	
Cherry										
1.3/ 1.5 [N12]	05.82-05.86			45					S4 022	
Cherry Coupé										
1.5 i Turbo [N12]	07.83-05.86			45					S4 022	
Cherry Hatchback										
1.0/ 1.3/ 1.5/ 1.6, i Turbo	05.82-05.86			45					S4 022	
[N12]										
Diesel										
1.7 D [N12]	10.82-05.86			95					S4 028	
Cube										
1.6 [Z12]	08.09-03.11			45					S4 021	
Diesel										
1.5 dCi [Z12]	10.09-03.11					45	300		S3 016	
Dualis										
2.0 i 4WD	05.07→	63	610	S5 005	60	610	S4 005	56	480	S3 005
Evalia										
1.6 [M20M]	01.11→	61	600	S5 004		600				
XXX										
Diesel										
1.5 dCi [M20M]	10.10→	63	610	S5 005	60	610	S4 005			
Gloria										
2.0/ 2.4/ 2.8/ 3.0, i, i Turbo,	06.79-12.97			60					S4 025	
i 24V Turbo [; 430]										
Diesel										
2.8 D [430]	06.79-06.87			70					S4 027	
Interstar										
Diesel										
1.9/ 2.5/ 3.0 D Turbo dCi 80,	07.02-06.10	100	830	S5 013	95	830	S4 013			
D Turbo dCi 100, D Turbo dCi 120, D Turbo dCi 140 [X70]										
2.2 D Turbo dCi 90 [X70]	07.02-06.10	95	850	S6 013	100	830	S5 013	95	830	S4 013
2.5 D Turbo dCi 150 [X70]	09.06-06.10	95	850	S6 013	100	830	S5 013	95	830	S4 013
90 720 S3 013										
Juke										
1.6 , DIG-T, DIG-T 4x4 [F15]	07.10→			60					S4 025	
Diesel										
1.5 dCi [F15]	07.10→	63	610	S5 005	60	610	S4 005			
Kubistar										
1.1/ 1.6 i, i 8V, i 16V [X76]	07.03-03.09	52	520	S5 001	44	520	S4 001			
Diesel										
1.5 D Turbo 60 [X76]	07.03-03.09	70	760	S6 008	77	780	S5 008	74	780	S4 008
D Turbo 70, D Turbo 80 [X76]										
77 780 S5 008 74 780 S4 008										
Laurel										
2.0/ 2.4/ 3.0, Hardtop, i	01.85-10.90			60					S4 025	
[C32]										
2.0/ 2.5 i, i Turbo	01.93-12.03			60					S4 025	



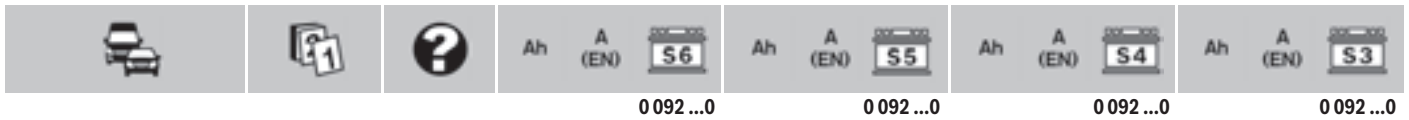

Diesel															
2.8 D	01.93-08.02													70	S4 027
D [C32]	01.85-10.90													70	S4 027
Leopard															
1.8/ 2.0/ 3.0, i, i Turbo	08.84-03.86													70	S4 027
Leopard Coupé															
2.0/ 3.0 i, i Turbo	04.86-12.96													70	S4 027
Liberta															
2.0 [T12]	07.86-06.90													60	S4 024
Maxima															
3.0 i	01.95-12.01													60	S4 024
i [A32]	02.95-09.99													60	S4 024
i [J30]	09.88-06.94													60	S4 024
Maxima QX															
2.0 i [CA33]	01.00-01.06	70	760	S6 008	77	780	S5 008	74	780	S4 008	70	640	S3 008		
2.0/ 2.5/ 3.0 i [A32]	10.94-01.00												60	S4 024	
2.5 i [CA33]	01.00-01.06	70	760	S6 008	77	780	S5 008	74	780	S4 008					
3.0 i [CA33]	01.96→	70	760	S6 008	77	780	S5 008	74	780	S4 008					
	01.00-01.06	70	760	S6 008	77	780	S5 008	74	780	S4 008	70	640	S3 008		
Micra															
1.0 i [K12E]	11.02-05.05				52	520	S5 001	44	520	S4 001	41	360	S3 001		
1.0/ 1.2 [K10]	12.82-07.92							45		S4 022					
1.0/ 1.3/ 1.4 i [K11E]	08.92-10.02							45		S4 021					
1.2 DIG-S [K13K]	03.11→	SSJ			60	560	S5 E05		560						
i [K12E]	11.02-10.10				52	520	S5 001	44	520	S4 001	41	360	S3 001		
	06.05-10.10	BWD			54	530	S5 002	44	530	S4 001					
i [K13K]	07.10→							40		S4 018					
1.4/ 1.6 i [K12E]	11.02-10.10				52	520	S5 001	44	520	S4 001	41	360	S3 001		
Diesel															
1.5 D [K11E]	02.98-10.02				61	600	S5 004	60	600	S4 004					
D Turbo [K12E]	02.03-10.10				61	600	S5 004	60	600	S4 004					
	08.03-10.10	XXX									53	470	S3 004		
Micra CC															
1.4/ 1.6 i [K12E]	09.05-10.10				61	600	S5 004	60	600	S4 004					
Murano															
3.5 i 4x4 [Z50]	11.04-12.08							60		S4 024					
4x4 [Z51]	06.08→	BWD						60		S4 024					
Diesel															
2.5 dCi 4x4 [Z51]	05.10→							60		S4 025					
Navara															
Diesel															
2.5 dCi [D40]	05.05-12.09	70	760	S6 008	77	780	S5 008	74	780	S4 008	70	640	S3 008		
	01.10→				77	780	S5 008	74	780	S4 008					
dCi 4x4 [D40]	05.05-12.09	70	760	S6 008	77	780	S5 008	74	780	S4 008	70	640	S3 008		
	01.10→				77	780	S5 008	74	780	S4 008					
3.0 dCi 4x4 [D40]	05.10→							95		S4 029					
Note															
1.4/ 1.6 [E11; E11E]	01.06→				54	530	S5 002	44	530	S4 001					
Diesel															
1.5 dCi 70, dCi 86, dCi 105 [E11]	01.06→				61	600	S5 004	60	600	S4 004					
dCi 90 [E11]	11.10→				61	600	S5 004		600						
		XXX									53	470	S3 004		
NV200															
1.6 [M20; M20M]	08.09→				63	610	S5 005	60	610	S4 005					
Diesel															
1.5 dCi [M20; M20M]	08.09→				63	610	S5 005	60	610	S4 005					
NV400															
Diesel															
2.3 dCi 100 FWD, dCi 125 FWD, dCi 125 RWD, dCi 150 FWD, dCi 150 RWD [X62]	09.11→				110	920	S5 015	95	920	S4 013					



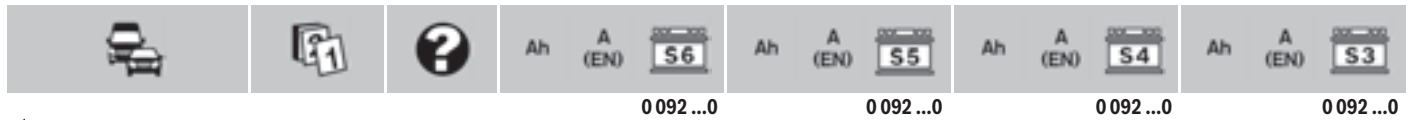

◀ NISSAN

Pathfinder													
2.4/ 3.0/ 3.3/ 3.5 i, i 4WD, i 4x4 [; D21; R50]	09.89→									70		S4 027	
4.0 4x4 [R51]	06.05-08.12			63	610	S5 005			60	610		S4 005	
Diesel													
2.5 dCi 4x4 [R51]	01.05-12.09			70	760	S6 008			77	780	S5 008	74 780 S4 008	70 640 S3 008
	01.10→								77	780	S5 008	74 780 S4 008	
3.0 dCi 4x4 [R51]	05.10→										95	S4 029	
3.2 D Turbo 4x4	09.97-12.07										95	S4 029	
Patrol													
2.8/ 3.0 [260]	07.85-05.98										70	S4 027	
2.8/ 4.0 [160]	11.79-08.87										70	S4 027	
5.6 4x4 [Y62]	03.10→			85	800	S5 010			80	800		S4 010	
Diesel													
2.7 D Turbo [260]	05.98-12.05										95	S4 029	
2.8 D [260]	10.84-05.98										70	S4 027	
2.8/ 3.2 D Turbo [260]	02.86-05.98										95	S4 028	
3.2 D [260]	06.85-03.89										95	S4 029	
3.3 D [160]	11.79-08.88										70	S4 027	
D Turbo [160]	07.83-08.88										95	S4 029	
Patrol GR													
4.2 , i [Y60]	08.87-09.97										70	S4 026	
4.8 , i 4x4 [Y61]	10.02→										95	S4 028	
Diesel													
2.8/ 3.0/ 4.2 D, D Turbo, D Turbo 4x4, dCi 4x4, Di Hardtop 4x4, Di 4x4 [Y60; Y61]	08.87→										95	S4 028	
Pickup													
1.6/ 1.8/ 2.0 [D21; 720]	08.79-09.95										60	S4 025	
2.2 4WD [720]	04.83-09.85										70	S4 027	
2.4 i [D22]	02.98-01.08										60	S4 025	
i 4WD [D22]	02.98-11.01										60	S4 025	
	11.01-01.08										60	S4 024	
2.4/ 3.0 , i, i 2WD, i 4WD, i 4x4, 4WD [D21]	09.85-02.98										60	S4 025	
Diesel													
2.3/ 2.5 D, D 4WD, D 4x4 [720]	01.83-09.85										70	S4 027	
2.3/ 2.5/ 2.7 D, D 4WD [D21]	09.85-02.98										95	S4 029	
2.5 dCi, dCi 4x4 [D22]	02.08-12.11	BWD									95	S4 029	
2.5/ 2.7/ 3.2 D, D Turbo, D Turbo 4WD, D 2WD, D 4WD [D22]	02.97→										95	S4 029	
Pintara													
2.0 i [U12]	08.89-10.92										70	S4 027	
Pixo Hatchback													
1.0 [UA0]	03.09→										40	S4 018	
Prairie													
1.5/ 1.8/ 2.0 , i 4WD, 4WD [M10]	09.82-09.88										60	S4 024	
Prairie Pro													
2.0/ 2.4 , i, i 4WD, 4WD [M11]	10.88-07.94										60	S4 024	
Primastar													
2.0 i [X83]	02.03-11.11			85	800	S5 010			80	800		S4 010	
Diesel													
1.9/ 2.5 dCi 80, dCi 100, dCi 135 [X83]	07.02-11.11			85	800	S5 010			80	800		S4 010	
2.0 dCi 90 [X83]	10.06→			70	760	S6 008			85	800	S5 010	74 800 S4 008	70 640 S3 008
dCi 115 [X83]	10.06→			70	760	S6 008			85	800	S5 010	74 800 S4 008	70 640 S3 008
				70	760	S6 008			85	800	S5 010	80 800 S4 010	70 640 S3 008
2.5 dCi 150 [X83]	10.06→			70	760	S6 008			85	800	S5 010	74 800 S4 008	70 640 S3 008



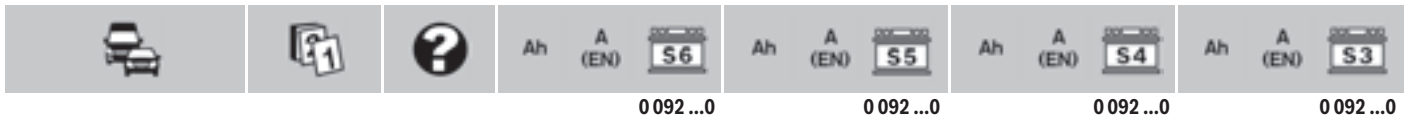

Primer						Ah A (EN) S6		Ah A (EN) S5		Ah A (EN) S4		Ah A (EN) S3	
				0 092 ...0		0 092 ...0		0 092 ...0		0 092 ...0		0 092 ...0	
1.6/ 1.8/ 2.0 [P12E]	12.01-07.10			63	610	S5 005		60	610	S4 005			
Diesel													
1.9/ 2.2 D Turbo [P12E]	12.01-09.10	70	760	S6 008	77	780	S5 008	74	780	S4 008			
Primer Hatchback													
1.6/ 1.8/ 2.0 [P12E]	05.02-07.10			63	610	S5 005		60	610	S4 005			
i, iGT [P11E]	06.96-12.01			63	610	S5 005		60	610	S4 005	56	480	S3 005
1.6/ 2.0 , i, i 4WD [P10E]	06.90-06.96			63	610	S5 005		52	610	S4 002	45	400	S3 002
2.0 i	07.91-11.96			63	610	S5 005		52	610	S4 002	45	400	S3 002
	11.96-09.98			63	610	S5 005		60	610	S4 005	56	480	S3 005
Diesel													
1.9/ 2.2 D Turbo [P12E]	05.02-09.10	70	760	S6 008	77	780	S5 008	74	780	S4 008			
2.0 D, D Turbo [P10E; P11E]	01.91-12.01	70	760	S6 008	77	780	S5 008	74	780	S4 008	70	640	S3 008
Primer Sedan													
1.6/ 1.8/ 2.0 i, iGT [P11E]	06.96-12.01			63	610	S5 005		60	610	S4 005	56	480	S3 005
1.6/ 2.0 , i, i 4WD [P10E]	06.90-06.96			63	610	S5 005		52	610	S4 002	45	400	S3 002
Diesel													
2.0 D, D Turbo [P10E; P11E]	01.91-12.01	70	760	S6 008	77	780	S5 008	74	780	S4 008	70	640	S3 008
Primer Wagon													
1.6/ 1.8/ 2.0 , i	01.98-06.10			63	610	S5 005		60	610	S4 005	56	480	S3 005
[P12E; WP11E]													
1.6/ 2.0 , i [W10]	07.90-12.97							70		S4 026			
1.8/ 2.0 [P12E]	12.01-07.10			63	610	S5 005		60	610	S4 005			
Diesel													
1.9/ 2.2 D Turbo [P12E]	12.01-09.10	70	760	S6 008	77	780	S5 008	74	780	S4 008			
2.0 D [W10]	07.90-04.96							95		S4 028			
D Turbo [WP11E]	01.98-12.01	70	760	S6 008	77	780	S5 008	74	780	S4 008	70	640	S3 008
Pulsar													
1.6 , i [N14]	08.91-05.95							60		S4 024			
Pulsar Coupé													
1.5 i Turbo [N12]	08.83-05.86							45		S4 021			
Pulsar Hatchback													
1.0/ 1.3/ 1.4/ 1.5/ 1.6/ 1.8	04.82-08.90							45		S4 021			
, i, i Turbo, i 4WD, 4WD													
[N12; N13]													
2.0 i [N14]	08.91-05.95							60		S4 024			
Diesel													
1.7 D [N12]	04.82-05.86							60		S4 024			
Pulsar Sedan													
1.5 [N12]	04.82-05.86							45		S4 021			
Qashqai													
1.6 [J10]	12.06→							60		S4 024			
	11.10→			63	610	S5 005		60	610	S4 005	56	480	S3 005
2.0 [J10]	12.06→	BWD		63	610	S5 005		60	610	S4 005			
4x4 [J10]	12.06→	BWD		63	610	S5 005		60	610	S4 005			
Diesel													
1.5 dCi [J10]	12.06→			77	780	S5 008		74	780	S4 008	70	640	S3 008
		SSJ	70	760	S6 008								
	01.10→			77	780	S5 008		74	780	S4 008			
1.6 dCi [J10]	07.11→	SSJ	70	760	S6 008								
dCi 4x4 [J10]	07.11→	SSJ	70	760	S6 008								
2.0 dCi [J10]	04.07→	BWD	70	760	S6 008	77	780	S5 008	74	780	S4 008	70	640
dCi 4x4 [J10]	04.07→	BWD	70	760	S6 008	77	780	S5 008	74	780	S4 008	70	640
Qashqai+2													
1.6 [JJ10]	08.08→							60		S4 024			
	11.10→			63	610	S5 005		60	610	S4 005	56	480	S3 005
2.0 [JJ10]	08.08→	BWD		63	610	S5 005		60	610	S4 005	56	480	S3 005
4x4 [JJ10]	08.08→	BWD		63	610	S5 005		60	610	S4 005	56	480	S3 005
Diesel													
1.5 dCi [JJ10]	08.08→	BWD	70	760	S6 008	77	780	S5 008	74	780	S4 008	70	640
	01.10→			77	780	S5 008		74	780	S4 008			
1.6 dCi [JJ10]	07.11→	SSJ	70	760	S6 008								
dCi 4x4 [JJ10]	07.11→	SSJ	70	760	S6 008								



			Ah		A (EN)	S6	Ah		A (EN)	S5	Ah		A (EN)	S4	Ah		A (EN)	S3
						0092 ...0				0092 ...0				0092 ...0				0092 ...0
◀ NISSAN																		
2.0 dCi [JJ10]	08.08→	BWD	70	760	S6 008	77	780	S5 008	74	780	S4 008	70	640	S3 008				
dCi 4x4 [JJ10]	08.08→	BWD	70	760	S6 008	77	780	S5 008	74	780	S4 008	70	640	S3 008				
Quest																		
3.5 [V42]	05.03-08.11								60		S4 024							
Serena																		
1.6/ 2.0 i [C23M]	07.92-11.01								60		S4 025							
Diesel																		
2.0/ 2.3 D [C23M]	07.92-11.01								95		S4 029							
Silvia Hatchback																		
1.8/ 2.0 i, i Turbo [S12]	08.84-04.88								60		S4 025							
Skyline Coupé																		
2.0/ 2.6 i Turbo, i 24V, i 24V Turbo	05.89-07.93								60		S4 025							
2.4 , i [C210]	10.77-08.85								60		S4 025							
Skyline GT-R																		
2.6 i Turbo 4WD [R33]	08.97-09.99								70		S4 027							
Skyline Kombi																		
1.8 [C210]	10.77-08.85								60		S4 025							
Diesel																		
2.0 D	09.85-04.89								95		S4 029							
Skyline Sedan																		
1.8/ 2.0 , i, i Turbo, i 24V, i 24V Turbo [: C210]	10.77-07.93								60		S4 025							
Diesel																		
2.8 D	09.85-04.89								95		S4 029							
Stanza Coupé																		
1.6/ 1.8 [T11]	08.81-12.85								60		S4 025							
Diesel																		
1.7 D Turbo [T11]	02.84-12.85								70		S4 027							
Stanza Hatchback																		
1.6/ 1.8 [T11; T12]	08.81-11.86								60		S4 025							
Stanza Sedan																		
1.6 [T12]	12.85-11.86								60		S4 025							
Diesel																		
1.7 D Turbo [T11]	02.84-12.85								70		S4 027							
Sunny																		
1.3 i	01.94→								45		S4 021							
									60		S4 024							
1.3/ 1.5/ 1.6 , i, i 12V, 12V [B12]	01.86-09.90								60		S4 024							
1.4 12V [B12; N13]	10.88-08.91								60		S4 024							
1.5 i 16V	01.94→								45		S4 021							
									60		S4 024							
1.5/ 1.6 , i, 12V [N13]	06.86-08.90								60		S4 024							
1.6 i	01.94→								45		S4 021							
									60		S4 024							
1.8 i	01.94→								45		S4 021							
									60		S4 024							
Diesel																		
2.0 D	01.94→								95		S4 028							
Sunny Coupé																		
1.3 i	06.94→								60		S4 024							
1.3/ 1.5 [B11]	03.82-05.88								45		S4 022							
1.5	09.87-01.90								60		S4 024							
i 16V	06.94→								60		S4 024							
1.6 i	08.86-01.90								60		S4 024							
	06.94→								60		S4 024							
1.6/ 1.8 i [B12]	02.87-09.90								60		S4 024							
1.8 i	06.94→								60		S4 024							
Sunny Hatchback																		
1.0/ 1.3/ 1.8 , i [N13]	06.86-08.90								60		S4 024							
1.4/ 1.6/ 2.0 , i, i Turbo 4x4 [N14]	10.90-05.95								60		S4 024							



Diesel											
1.7 D [N13]	06.86-08.90						95			S4 028	
2.0 D [N14]	10.90-05.95						95			S4 028	
Sunny Liftback											
2.0 i [N14]	10.90-05.95						60			S4 024	
Sunny Sedan											
1.3/ 1.5 [B11]	03.82-05.88						45			S4 022	
1.3/ 1.6 , i 4WD, 4WD, 12V 4WD [N13]	06.86-08.90						60			S4 024	
1.4/ 1.6 , i, i 4WD, 4WD [N14]	10.90-10.95						60			S4 024	
Diesel											
1.7 D [B11]	03.82-05.88						95			S4 028	
D [B12]	01.86-04.90						95			S4 028	
D [N13]	06.86-08.90						95			S4 028	
2.0 D [N14]	10.90-05.95						95			S4 028	
Sunny Wagon											
1.3/ 1.5/ 1.6 [B11]	03.82-08.90						45			S4 022	
1.5/ 1.6 i 4WD, i 12V 4WD, 4WD, 12V 4WD [B12]	01.86-09.90						60			S4 024	
1.6 , i, i 4WD, 4WD [Y10]	11.90-03.00						60			S4 024	
Diesel											
1.7 D [B11]	03.82-10.85						95			S4 028	
D [B12]	01.86-09.90						95			S4 028	
1.7/ 2.0 D [Y10]	11.90-03.00						95			S4 028	
Teana											
2.0 [J31]	04.06-02.08						60			S4 024	
2.5/ 3.5 [J32]	02.08→		85	800	S5 010		80	800		S4 010	
Terrano I											
2.4 [WD21]	08.86-11.95						60			S4 024	
i [WD21]	08.87-07.92						60			S4 024	
3.0 i 4WD [WD21]	01.90-10.95						95			S4 029	
3.0/ 3.3 i [WD21]	01.90-12.05						95			S4 029	
Diesel											
2.7/ 3.2 D, D Turbo [WD21]	08.87-12.06						70			S4 026	
Terrano II											
2.4 i 4x4 [R20]	02.93-12.06		63	610	S5 006		60	610		S4 006	
Diesel											
2.7 D Turbo 4x4 [R20]	02.93→						95			S4 029	
3.0 D Turbo 4x4 [R20]	02.02-12.06		77	780	S5 008		74	780		S4 008	
Tiida											
1.6/ 1.8 , i [, C11]	01.05→	BWD	63	610	S5 005		52	610		S4 002	
Diesel											
1.5 dCi [C11]	02.07-03.10	BWD	63	610	S5 005		60	610		S4 005	
Tiida Hatchback											
1.6/ 1.8 [C11]	03.07→		63	610	S5 005		60	610	56	480	S3 005
Diesel											
1.5 dCi [C11]	03.07-03.10		63	610	S5 005		60	610		S4 005	
Urvan											
1.8/ 2.0 [E23]	04.82-02.87						60			S4 025	
2.0 [E24]	11.86-01.95						60			S4 024	
2.4 [E24]	11.86-06.97						60			S4 025	
i [E24]	05.89-11.95						60			S4 024	
Diesel											
2.3 D [E23]	04.82-02.87						70			S4 027	
D [E24]	11.86-03.89						70			S4 027	
							95			S4 029	
2.5 D [E24]	12.88-06.97						95			S4 029	
Vanette											
1.5/ 2.0/ 2.4 , i [, C120; C220; GC22]	10.78-12.96						60			S4 025	
Diesel											
2.0 D [, C120; C220; GC22]	06.81-11.94						70			S4 027	



			Ah A (EN) S6	Ah A (EN) S5	Ah A (EN) S4	Ah A (EN) S3
			0092 ...0	0092 ...0	0092 ...0	0092 ...0

◀ NISSAN

Vanette Cargo											
1.6 i [C23M]	07.92-11.01						60			S4 025	
Diesel											
2.0 D [C23M]	07.92-09.94						95			S4 029	
2.3 D [C23M]	09.94-11.01						70			S4 027	
X-Trail											
2.0 i Turbo	06.01-08.07		70	760	S6 008	77	780	S5 008	74	780	S4 008
4x2 [T30]	02.05-03.07		70	760	S6 008	77	780	S5 008	74	780	S4 008
4x4 [T30]	06.01-03.07		70	760	S6 008	77	780	S5 008	74	780	S4 008
									70	640	S3 008
2.0/ 2.5, 4x4 [T31]	04.07→	BWD							60		S4 024
2.5 4x4 [T30]	09.02-03.07		70	760	S6 008	77	780	S5 008	74	780	S4 008
4x4 [T31R]	10.09→								70		S4 026
Diesel											
2.0 dCi, dCi 4x4 [T31]	04.07→	BWD							70		S4 026
2.2 D Turbo 4x2 [T30]	02.05-03.07								95		S4 028
D Turbo 4x4 [T30]	06.01-03.07								70		S4 026
100 NX											
1.6/ 2.0, i [B13]	08.90-10.94								60		S4 024
200 SX											
1.8/ 2.0/ 2.4 i, i Turbo [S13; S14]	07.88-12.99								60		S4 025
300 ZX											
3.0 i, i Biturbo [Z32]	01.90-08.96								70		S4 026
i, i Turbo [Z31]	01.84-06.89								70		S4 027
350 Z Cabriolet											
3.5 [Z33]	09.03-01.07								60		S4 024
	09.06-04.09	BWD							60		S4 024
350 Z Coupé											
3.5 [Z33]	09.02-01.07								60		S4 024
	09.06-04.09	BWD							60		S4 024
370 Z Coupé											
3.7 [Z34]	04.09→	BWD							60		S4 024

OPEL

Agila															
1.0/ 1.2 i, Twinport [A]	06.00-02.08						52	520	S5 001	44	440	S4 001	41	360	S3 001
Twinport [B]	03.08→						52	520	S5 001	44	440	S4 001			
Diesel															
1.3 CDTI [A]	08.03-02.08						61	600	S5 004	60	540	S4 004			
		XXX											53	470	S3 004
CDTI [B]	03.08→						61	600	S5 004	60	540	S4 004			
Antara															
2.4	05.06→									60	540	S4 006	56	480	S3 006
4x4	05.06→									60	540	S4 006	56	480	S3 006
	11.10→									70	630	S4 027			
3.0 V6	01.12→									70	630	S4 027			
3.2 V6 4x4	05.06→									74	680	S4 009			
Diesel															
2.0/ 2.2 CDTI, CDTI 4x4	05.06→									95	830	S4 029			
Arena															
Diesel															
1.9/ 2.5 D	03.98-08.01		70	760	S6 008	77	780	S5 008	74	680	S4 008	70	640	S3 008	
Ascona															
1.3/ 1.6/ 1.8/ 2.0, i, S [C]	09.81-08.88						61	600	S5 004	44	440	S4 001	41	360	S3 001
Diesel															
1.6 D [C]	03.82-08.88						74	750	S5 007	60	540	S4 004			
Astra															
1.2 i Twinport [H]	03.07-03.09						61	600	S5 004	44	440	S4 001	41	360	S3 001
1.2/ 1.4/ 1.6/ 1.8/ 2.0, i, i Twinport, Twinport [F; G]	09.91-07.09						61	600	S5 004	44	440	S4 001	41	360	S3 001

								Ah A (EN) S6		Ah A (EN) S5		Ah A (EN) S4		Ah A (EN) S3	
				0 092 ...0		0 092 ...0		0 092 ...0		0 092 ...0		0 092 ...0		0 092 ...0	
1.4 i [H]	09.04-09.05			61	600	S5 004									
			XXX										53	470	S3 004
i [J]	09.09→			61	600	S5 004		44	440	S4 001		41	360	S3 001	
				74	750	S5 007		60	540	S4 004					
i Turbo [J]	09.09→			61	600	S5 004									
			XXX										53	470	S3 004
Twinport [H]	03.04-03.10			61	600	S5 004									
			XXX										53	470	S3 004
1.6 [H]	01.07-03.10			61	600	S5 004		44	440	S4 001		41	360	S3 001	
	07.10→			61	600	S5 004		44	440	S4 001		41	360	S3 001	
i [J]	09.09→			61	600	S5 004		44	440	S4 001		41	360	S3 001	
i Turbo [J]	09.09→			61	600	S5 004		44	440	S4 001		41	360	S3 001	
Turbo [H]	02.07-03.10			74	750	S5 007		60	540	S4 004					
			XXX										53	470	S3 004
Twinport [H]	03.04-03.09			61	600	S5 004		44	440	S4 001		41	360	S3 001	
1.8 [H]	07.10→			61	600	S5 004		44	440	S4 001		41	360	S3 001	
i [G]	09.97-01.04			74	750	S5 007		60	540	S4 004					
			XXX										53	470	S3 004
	03.01-01.04			74	750	S5 007		60	540	S4 004		53	500	S3 004	
i [H]	03.04-03.10			61	600	S5 004		44	440	S4 001		41	360	S3 001	
2.0 i [G]	09.97-01.04			74	750	S5 007		60	540	S4 004					
			XXX										53	470	S3 004
Turbo [G]	09.02-01.04			74	750	S5 007		60	540	S4 004					
			XXX										53	470	S3 004
Turbo [H]	03.04-03.10			74	750	S5 007		60	540	S4 004					
			XXX										53	470	S3 004
2.2 i [G]	09.00-01.04			74	750	S5 007		72	680	S4 007					
Diesel															
1.3 CDTI [H]	08.05-03.10			74	750	S5 007		60	540	S4 004					
CDTI [J]	09.09→			61	600	S5 004		44	440	S4 001		41	360	S3 001	
			SSJ	70	760	S6 008									
1.7 CDTI [G]	03.03-01.04			74	750	S5 007		72	680	S4 007					
CDTI [H]	03.04→			74	750	S5 007		60	540	S4 004		70	640	S3 007	
	02.07-03.10			74	750	S5 007		60	540	S4 004					
CDTI [J]	09.09→											70	640	S3 007	
	07.11→			61	600	S5 004									
				70	650	S5 E08									
			XXX										53	470	S3 004
D, TD [F]	12.91-02.98			74	750	S5 007		60	540	S4 004					
1.7/ 2.0/ 2.2 DT, DTI, DTL [G]	03.98-01.05											70	640	S3 007	
1.9 CDTI [H]	04.04-03.10			74	750	S5 007		60	540	S4 004		70	640	S3 007	
2.0 CDTI [J]	09.09→											70	640	S3 007	
	09.11→			74	750	S5 007		72	680	S4 007					
	08.12→			70	760	S6 008									
Astra Cabrio															
1.4/ 1.6 i [G]	09.97-08.05			61	600	S5 004		44	440	S4 001		41	360	S3 001	
1.4/ 1.6/ 1.8/ 2.0, i [F]	09.91-08.98			61	600	S5 004		44	440	S4 001		41	360	S3 001	
1.6 Twinport [G]	03.03-08.05			61	600	S5 004		44	440	S4 001		41	360	S3 001	
1.8 i [G]	09.00-08.05			74	750	S5 007		60	540	S4 004		53	500	S3 004	
2.0 Turbo [G]	03.02-08.05			74	750	S5 007		60	540	S4 004		53	500	S3 004	
2.2 i [G]	09.00-08.05											70	640	S3 007	
Diesel															
1.7 CDTI [G]	03.03-08.05			74	750	S5 007		60	540	S4 004					
2.2 DTI [G]	03.02-08.05											70	640	S3 007	
Astra Caravan															
1.2 Twinport [H]	03.07-03.09			61	600	S5 004		44	440	S4 001					
1.2/ 1.4/ 1.6/ 1.8/ 2.0, i, i CNG, i Twinport, Twinport [F, G]	09.91-07.09			61	600	S5 004		44	440	S4 001		41	360	S3 001	
1.4 [H]	09.04-09.05			61	600	S5 004									
			XXX										53	470	S3 004
Twinport [H]	08.04-03.10			63	610	S5 005		44	440	S4 001		41	360	S3 001	

		0092 ...0			0092 ...0			0092 ...0			0092 ...0		
		Ah	A (EN)	S6	Ah	A (EN)	S5	Ah	A (EN)	S4	Ah	A (EN)	S3
◀ OPEL													
1.6 [H]	03.07-03.10				61	600	S5 004						
	XXX										53	470	S3 004
	01.11→				61	600	S5 004	44	440	S4 001			
Turbo [H]	09.07-03.10				74	750	S5 007	60	540	S4 004			
	XXX										53	470	S3 004
Twinport [H]	08.04-03.07				63	610	S5 005	44	440	S4 001	41	360	S3 001
	09.07-03.09				61	600	S5 004	44	440	S4 001			
1.8 i [G]	09.97-06.04				74	750	S5 007	60	540	S4 004			
	XXX										53	470	S3 004
	03.01-06.04				74	750	S5 007	60	540	S4 004	53	500	S3 004
i [H]	08.04-03.10				63	610	S5 005	44	440	S4 001	41	360	S3 001
	01.11→				63	610	S5 005	44	440	S4 001	41	360	S3 001
2.0 i [G]	09.97-06.04				74	750	S5 007	60	540	S4 004			
	XXX										53	470	S3 004
	10.99-09.02				74	750	S5 007	60	540	S4 004	53	500	S3 004
Turbo [G]	09.01-06.04				74	750	S5 007	60	540	S4 004			
	XXX										53	470	S3 004
Turbo [H]	08.04-03.10				74	750	S5 007	60	540	S4 004			
	XXX										53	470	S3 004
	09.05-03.10				74	750	S5 007	60	540	S4 004	53	500	S3 004
2.2 i [G]	09.00-06.04										70	640	S3 007
Diesel													
1.3 CDTI [H]	08.05-03.10				61	600	S5 004						
	XXX										53	470	S3 004
1.7 CDTI [H]	08.04→				74	750	S5 007	60	540	S4 004			
	02.07-03.10				61	600	S5 004						
	XXX										53	470	S3 004
D, TD [F]	12.91-02.98				74	750	S5 007	60	540	S4 004			
1.7/2.0 CDTI, DT, DTL [G]	03.98-07.09										70	640	S3 007
1.7/2.0/2.2 DTI [G]	09.00-06.04				74	750	S5 007	72	680	S4 007			
1.9 CDTI [H]	09.04-03.10				74	750	S5 007	72	680	S4 007			
	09.04-07.10				74	750	S5 007	60	540	S4 004			
Astra Classic													
1.4/1.6 i [F]	09.97-08.02				61	600	S5 004	44	440	S4 001	41	360	S3 001
Astra Classic Caravan													
1.4/1.6 i [F]	09.97-08.02				61	600	S5 004	44	440	S4 001	41	360	S3 001
Astra Coupé													
1.6 Twinport [G]	03.03-02.05				61	600	S5 004	44	440	S4 001	41	360	S3 001
1.8 i [G]	09.97-08.00										53	470	S3 004
	09.97-02.05				74	750	S5 007	60	540	S4 004	53	500	S3 004
2.0 Turbo [G]	09.00-02.05				74	750	S5 007	60	540	S4 004	53	500	S3 004
2.2 i [G]	09.00-02.05										70	640	S3 007
Diesel													
1.7 CDTI [G]	03.03-02.05				74	750	S5 007	60	540	S4 004			
2.2 DTI [G]	03.02-02.05				74	750	S5 007	72	680	S4 007			
Astra Estate													
1.6 i [F]	10.93-12.98				61	600	S5 004	44	440	S4 001	41	360	S3 001
Astra GTC													
1.4 [J]	09.11→				61	600	S5 004						
	XXX										53	470	S3 004
Turbo [J]	09.11→				70	760	S6 008						
					70	760	S6 008	61	600	S5 004			
	XXX										53	470	S3 004
Twinport [H]	03.05-03.09				61	600	S5 004	44	440	S4 001	41	360	S3 001
	09.05-02.09				61	600	S5 004						
	XXX										53	470	S3 004
1.6 i [H]	12.06-09.09				61	600	S5 004	44	440	S4 001	41	360	S3 001
	01.11→				61	600	S5 004	44	440	S4 001			
Turbo [H]	02.07-09.10				63	610	S5 006	60	540	S4 004			
	XXX										53	470	S3 004
	01.11→				63	610	S5 006	60	540	S4 004			
	XXX										53	470	S3 004

								Ah A (EN)		Ah A (EN)		Ah A (EN)		Ah A (EN)	
				0 092 ...0		0 092 ...0		0 092 ...0		0 092 ...0		0 092 ...0		0 092 ...0	
1.6 Turbo [J]	09.11→				61	600			S5 004						
		XXX											53	470	S3 004
Twinport [H]	03.05-03.08				61	600			S5 004	44	440	S4 001	41	360	S3 001
1.8 [J]	11.11→				61	600			S5 004						
		XXX											53	470	S3 004
i [H]	03.05-12.10				61	600			S5 004	44	440	S4 001	41	360	S3 001
	01.11→				61	600			S5 004	44	440	S4 001			
2.0 Turbo [H]	03.05-09.09				74	750			S5 007	60	540	S4 004			
		XXX											53	470	S3 004
Turbo [J]	06.12→			70	760			S6 008							
Diesel															
1.3 CDTI [H]	06.05-02.09				74	750			S5 007	60	540	S4 004			
1.7 [J]	11.11→			70	760			S6 008							
CDTI [H]	03.05-03.07												70	640	S3 007
	09.05→				74	750			S5 007	60	540	S4 004	70	640	S3 007
1.9 [H]	07.05-07.10				74	750			S5 007	60	540	S4 004	70	640	S3 007
CDTI [H]	03.05-09.09				74	750			S5 007	60	540	S4 004	70	640	S3 007
2.0 [J]	09.11→			70	760			S6 008	61	600	S5 004				
		XXX											53	470	S3 004
	08.12→			70	760			S6 008							
Astra Limousine															
1.4 [J]	09.12→				61	600			S5 004						
		XXX											53	470	S3 004
Turbo [J]	09.12→			70	760			S6 008	61	600	S5 004				
		XXX											53	470	S3 004
1.6 [J]	09.12→				61	600			S5 004						
		XXX											53	470	S3 004
Turbo [J]	09.12→				61	600			S5 004						
		XXX											53	470	S3 004
Diesel															
1.3 CDTI [J]	09.12→				60	560			S5 E05						
1.7 CDTI [J]	09.12→			70	760			S6 008							
Astra Sports Tourer															
1.4 i [J]	09.10→				61	600			S5 004						
		XXX											53	470	S3 004
i Turbo [J]	09.10→				61	600			S5 004	60	540	S4 004			
		SSJ		60	680			S6 005							
		XXX											53	470	S3 004
1.6 i [J]	09.10→				61	600			S5 004						
		XXX											53	470	S3 004
i Turbo [J]	09.10→				61	600			S5 004						
		XXX											53	470	S3 004
Diesel															
1.3 CDTI [J]	09.10→	SSJ		70	760			S6 008							
1.7 CDTI [J]	09.10→				61	600			S5 004						
					61	600			S5 004	60	540	S4 004			
		SSJ		80	800			S6 011							
		XXX											53	470	S3 004
	07.11→				70	650			S5 E08						
2.0 CDTI [J]	09.10→				74	750			S5 007	72	680	S4 007			
	09.11→			70	760			S6 008							
Astra TwinTop															
1.6 i Turbo [H]	02.07-10.10				74	750			S5 007	60	540	S4 004			
		XXX											53	470	S3 004
Turbo [H]	02.07-10.10				74	750			S5 007	60	540	S4 004			
		XXX											53	470	S3 004
1.6/ 1.8 i [H]	09.05-10.10				61	600			S5 004	44	440	S4 001	41	360	S3 001
2.0 i Turbo [H]	09.05-10.10				74	750			S5 007	60	540	S4 004			
		XXX											53	470	S3 004
Diesel															
1.9 CDTi [H]	09.05-10.10				74	750			S5 007	60	540	S4 004	70	640	S3 007



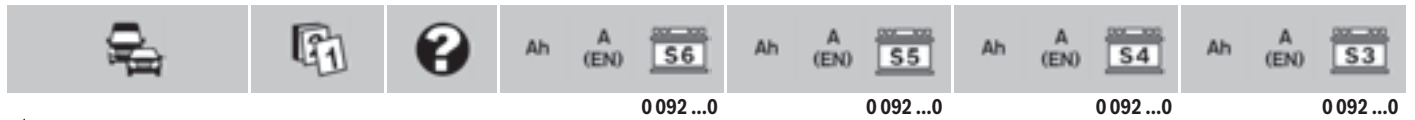

◀ OPEL

Bedford-Blitz											
2.0 CF	08.84-07.87		61	600	S5 004	60	540	S4 004	41	360	S3 001
Diesel											
2.3 D CF	09.80-07.87		61	600	S5 004	60	540	S4 004	41	360	S3 001
Calibra											
2.0 i	06.90-03.97		74	750	S5 007	60	540	S4 004	53	500	S3 004
		XXX							53	470	S3 004
i Turbo	03.92-03.97		74	750	S5 007	60	540	S4 004	53	500	S3 004
		XXX							53	470	S3 004
2.5 i V6	04.93-03.97		74	750	S5 007	60	540	S4 004	53	500	S3 004
		XXX							53	470	S3 004
Campo Pick-Up											
2.3 , i [TF0]	09.91-09.96								70	640	S3 007
Diesel											
2.2/2.5/3.1 D, Di, DTi, TD, TDS [TF0; TF1]	08.87-08.03								70	640	S3 007
Combo											
1.2 i	09.94-10.01		61	600	S5 004	44	440	S4 001	41	360	S3 001
1.4 [D]	02.12→		61	600	S5 004						
		XXX							53	470	S3 004
i	09.94-10.01		61	600	S5 004	44	440	S4 001	41	360	S3 001
	08.08→		61	600	S5 004	44	440	S4 001	41	360	S3 001
1.4/ 1.6 i, i Twinport [Tour]	10.01-01.12		61	600	S5 004	44	440	S4 001	41	360	S3 001
1.6 CNG [Tour]	04.05-05.06		52	520	S5 001	44	440	S4 001	41	360	S3 001
	06.06-01.12		61	600	S5 004	44	440	S4 001	41	360	S3 001
Diesel											
1.3 [D]	02.12→		60	560	S5 E05						
			61	600	S5 004						
		XXX							53	470	S3 004
CDTI [Tour]	09.04-01.12		74	750	S5 007	60	540	S4 004			
		XXX							53	470	S3 004
1.6/ 2.0 [D]	02.12→		74	750	S5 007	72	680	S4 007			
1.7 CDTI [Tour]	09.04-01.12		74	750	S5 007	60	540	S4 004			
		XXX							53	470	S3 004
D	09.94-10.01		74	750	S5 007	60	540	S4 004	53	500	S3 004
		XXX							53	470	S3 004
Di [Tour]	10.01-08.04		74	750	S5 007	60	540	S4 004			
		XXX							53	470	S3 004
DTI [Tour]	10.01-08.04		74	750	S5 007	60	540	S4 004			
		XXX							53	470	S3 004
Corsa											
1.0 Twinport [D]	07.06-10.09		54	530	S5 002				40	340	S3 000
		XXX				42	390	S4 000			
	12.09→		54	530	S5 002						
		XXX				42	390	S4 000			
1.0/ 1.2 i [B]	03.93-09.00		61	600	S5 004	44	440	S4 001	41	360	S3 001
1.0/ 1.2/ 1.3/ 1.4/ 1.6 , i, S, Sprint R [A]	09.82-08.94		61	600	S5 004	44	440	S4 001	41	360	S3 001
1.0/ 1.2/ 1.4/ 1.8 i Twinport, i 12V, i 16V, Twinport [C]	09.00-09.06		61	600	S5 004	44	440	S4 001	41	360	S3 001
1.2 i Twinport [D]	07.06→		54	530	S5 002	52	470	S4 002			
1.2/ 1.4 LPG [D]	09.09→		63	610	S5 005	52	470	S4 002	45	400	S3 002
1.4 i [B]	03.93-09.00		61	600	S5 004	44	440	S4 001	41	360	S3 001
	03.00-12.03		61	600	S5 004	44	440	S4 001			
i, i Sail	01.00-12.06		61	600	S5 004	44	440	S4 001			
i Utility [B]	08.00-12.02		61	600	S5 004	44	440	S4 001			
Twinport [D]	07.06-11.10					52	470	S4 002	45	400	S3 002
	12.09→		54	530	S5 002	52	470	S4 002			
Twinport Turbo [D]	07.12→		70	760	S6 008	61	600	S5 004			
		XXX							53	470	S3 004
1.6 GSI [B]	03.93-08.00		61	600	S5 004	44	440	S4 001	41	360	S3 001
i [B]	06.98-08.00		61	600	S5 004	44	440	S4 001	41	360	S3 001
i [C]	09.01-08.05		61	600	S5 004	44	440	S4 001			

		Ah A (EN) S6			Ah A (EN) S5			Ah A (EN) S4			Ah A (EN) S3		
		0 092 ...0			0 092 ...0			0 092 ...0			0 092 ...0		
1.6 i GSI [B]	03.93-08.99				61	600	S5 004	44	440	S4 001	41	360	S3 001
i OPC Turbo [D]	02.07→				63	610	S5 005	44	440	S4 001	41	360	S3 001
	10.11→				61	600	S5 004						
				XXX							53	470	S3 004
i Turbo [D]	02.07→				63	610	S5 005	44	440	S4 001	41	360	S3 001
Diesel													
1.3 CDTI [C]	09.03-09.06				74	750	S5 007	60	540	S4 004	70	640	S3 007
	09.05-09.06				74	750	S5 007	60	540	S4 004			
CDTI [D]	07.06-07.10				74	750	S5 007	72	680	S4 007			
	07.06→										70	640	S3 007
	12.09→				54	530	S5 002	52	470	S4 002			
1.5/ 1.7 D, TD, XD, XTD [A; B]	09.87-08.00				74	750	S5 007	60	540	S4 004			
1.7 CDTI [C]	09.03-09.06				74	750	S5 007	60	540	S4 004	70	640	S3 007
CDTI [D]	07.06→										70	640	S3 007
	12.09→				74	750	S5 007	72	680	S4 007			
DI, DTI [C]	09.00-08.03				74	750	S5 007	60	540	S4 004			
Corsa Hatchback													
1.4 i Swing	07.01-09.03				61	600	S5 004	44	440	S4 001			
Frontera													
2.0/ 2.2/ 2.4 i [A]	09.91-08.98	70	760	S6 008	77	780	S5 008	74	680	S4 008	70	640	S3 008
2.2 i [B]	09.98-12.00	70	760	S6 008	77	780	S5 008	70	630	S4 026	70	640	S3 008
	09.00-09.04	70	760	S6 008	77	780	S5 008	70	630	S4 026			
3.2 i [B]	09.98-09.04	70	760	S6 008	77	780	S5 008	70	630	S4 026	70	640	S3 008
Diesel													
2.2 DTI [B]	09.98-10.02	70	760	S6 008	77	780	S5 008	70	630	S4 026	70	640	S3 008
	09.02-09.04	70	760	S6 008	77	780	S5 008	70	630	S4 026			
2.3/ 2.5/ 2.8 TD, TDI, TDS Turbo [A]	09.91-08.98	70	760	S6 008	77	780	S5 008	74	680	S4 008	70	640	S3 008
GT													
2.0 Turbo [B]	06.07-12.09										70	640	S3 007
Insignia													
1.4 Turbo [68]	09.11→				61	600	S5 004						
				XXX							53	470	S3 004
Turbo [69]	09.11→				61	600	S5 004						
				XXX							53	470	S3 004
1.6/ 1.8 [68; 69]	09.08→				61	600	S5 004	60	540	S4 004			
1.8 [68]	09.08→				74	750	S5 007	60	540	S4 004			
2.0 Turbo [68]	09.08→										70	640	S3 007
	01.11→				74	750	S5 007	72	680	S4 007			
Turbo [69]	09.08→										70	640	S3 007
	01.11→				74	750	S5 007	72	680	S4 007			
Turbo 4x4 [68]	09.08→										70	640	S3 007
	03.12→				74	750	S5 007	72	680	S4 007			
Turbo 4x4 [69]	09.08→										70	640	S3 007
	03.12→				74	750	S5 007	72	680	S4 007			
2.8 Turbo 4x4 [68; 69]	09.08→				85	800	S5 010	80	740	S4 010			
Diesel													
2.0 CDTI [68]	09.08→	70	760	S6 008	77	780	S5 008	74	680	S4 008	70	640	S3 008
	07.09→				80	730	S5 E11	80	740	S4 010			
					85	800	S5 010	80	740	S4 010			
CDTI [69]	09.08→	70	760	S6 008	77	780	S5 008	74	680	S4 008	70	640	S3 008
CDTI 4x4 [68]	07.09→				80	730	S5 E11	80	740	S4 010			
					85	800	S5 010	80	740	S4 010			
CDTI 4x4 [69]	07.09→				80	730	S5 E11	80	740	S4 010			
					85	800	S5 010	80	740	S4 010			
Insignia Sports Tourer													
1.4 [35]	09.11→	70	760	S6 008	61	600	S5 004						
				XXX							53	470	S3 004
1.6/ 1.8 [35]	02.09→				61	600	S5 004	60	540	S4 004			
2.0 Turbo [35]	02.09→										70	640	S3 007
	01.11→				74	750	S5 007	72	680	S4 007			
Turbo 4x4 [35]	02.09→										70	640	S3 007
	03.12→				74	750	S5 007	72	680	S4 007			



			Ah A (EN) S6			Ah A (EN) S5			Ah A (EN) S4			Ah A (EN) S3		
			0092 ...0			0092 ...0			0092 ...0			0092 ...0		
◀ OPEL														
2.8 Turbo 4x4 [35]	02.09→				85	800	S5 010	80	740	S4 010				
Diesel														
2.0 CDTI [35]	02.09→	70	760	S6 008	77	780	S5 008	74	680	S4 008	70	640	S3 008	
	07.09→				80	730	S5 E11	80	740	S4 010				
					85	800	S5 010	80	740	S4 010				
CDTI 4x4 [35]	07.09→	70	760	S6 008	77	780	S5 008	74	680	S4 008	70	640	S3 008	
	06.10→				85	800	S5 010	80	740	S4 010				
Kadett														
1.2/1.3/1.8 S [E]	09.84-08.91				61	600	S5 004	44	440	S4 001	41	360	S3 001	
1.3/1.4/1.6 i [E]	09.85-08.93				61	600	S5 004	44	440	S4 001	41	360	S3 001	
1.3/1.4/1.6/1.8 [E]	09.84-08.91				61	600	S5 004	44	440	S4 001	41	360	S3 001	
1.8 i [E]	09.84-08.91				61	600	S5 004	44	440	S4 001	41	360	S3 001	
					61	600	S5 004	44	440	S4 001	53	500	S3 004	
2.0 i [E]	09.86-08.91				74	750	S5 007	60	540	S4 004				
					74	750	S5 007	60	540	S4 004				
	XXX										53	500	S3 004	
	XXX										53	470	S3 004	
Diesel														
1.5/1.6/1.7 D, D/DR, TD [E]	09.84-08.91				74	750	S5 007	60	540	S4 004	53	500	S3 004	
Manta														
1.3 S [B]	08.79-08.86				61	600	S5 004	44	440	S4 001	41	360	S3 001	
1.8 S [B]	07.82-08.87				74	750	S5 007	60	540	S4 004	53	500	S3 004	
	XXX										53	470	S3 004	
2.0 i [B]	09.81-08.88				74	750	S5 007	60	540	S4 004	53	500	S3 004	
	XXX										53	470	S3 004	
S [B]	08.77-08.85				74	750	S5 007	60	540	S4 004	53	500	S3 004	
	XXX										53	470	S3 004	
Meriva														
1.4 ecoFLEX, Ecotec [B]	04.10→								44	440	S4 001	41	360	S3 001
i Twinport [A]	07.04-03.10				61	600	S5 004							
	XXX										53	470	S3 004	
1.6 i [A]	03.03-09.05				74	750	S5 007	60	540	S4 004				
	XXX										53	470	S3 004	
i OPC Turbo [A]	09.05-03.10				74	750	S5 007	60	540	S4 004				
	XXX										53	470	S3 004	
i 16V Twinport [A]	03.03-03.10				74	750	S5 007	60	540	S4 004				
	XXX										53	470	S3 004	
1.8 i 16V [A]	03.03-03.10				74	750	S5 007	60	540	S4 004				
	XXX										53	470	S3 004	
Diesel														
1.3 CDTI [A]	09.03-03.10										70	640	S3 007	
CDTI [B]	04.10→				60	560	S5 E05							
					61	600	S5 004							
					74	750	S5 007	60	540	S4 004				
	SSJ	70	760	S6 008										
	XXX										53	470	S3 004	
1.7 CDTI [A]	09.03-09.09				74	750	S5 007	72	680	S4 007				
	09.06-03.10										70	640	S3 007	
CDTI [B]	06.10→										70	640	S3 007	
					74	750	S5 007	72	680	S4 007				
DTI [A]	03.03-09.05				74	750	S5 007	72	680	S4 007				
Mokka														
1.4/1.6 Turbo ecoFLEX, Turbo ecoFLEX 4x4	09.12→	70	760	S6 008										
Diesel														
1.7 CDTI ecoFLEX	09.12→	70	760	S6 008										
		70	760	S6 008	61	600	S5 004							
	XXX										53	470	S3 004	
Monterey														
3.2 i [A]	04.92-12.97								70	630	S4 026			
3.5 i V6 [B]	02.98-12.99								70	630	S4 026			
Diesel														
3.0 DTI [B]	02.98-12.99								70	630	S4 026			
3.1 TD [A]	09.91-12.97								70	630	S4 026			



Monza													
2.2 i [A]	11.84-08.86				74	750	S5 007	60	540	S4 004	53	500	S3 004
		XXX									53	470	S3 004
2.5 i [A]	05.81-08.86				74	750	S5 007	60	540	S4 004	53	500	S3 004
		XXX									53	470	S3 004
3.0 i [A]	01.83-08.86				74	750	S5 007	60	540	S4 004	53	500	S3 004
		XXX									53	470	S3 004
Movano													
Diesel													
1.9 DTI [A]	10.01-10.05	100	830	S5 013	95	850	S6 013	95	800	S4 013	90	720	S3 013
1.9/ 2.5 D [A]	10.98-10.01	100	830	S5 013	95	850	S6 013	95	800	S4 013	90	720	S3 013
2.2 DTI [A]	09.00-10.05	100	830	S5 013	95	850	S6 013	95	800	S4 013	90	720	S3 013
	03.01-10.05	95	850	S6 013	100	830	S5 013						
2.3 CDTI FWD, CDTI RWD [B]	04.10→				100	830	S5 013	95	800	S4 013			
2.5 DTI [A]	10.01-06.10	100	830	S5 013	95	850	S6 013	95	800	S4 013	90	720	S3 013
2.8 DTI [A]	06.98-10.01	100	830	S5 013	95	850	S6 013	95	800	S4 013	90	720	S3 013
	06.99-09.02	95	850	S6 013	100	830	S5 013						
3.0 CDTI [A]	03.03-10.05	100	830	S5 013	95	850	S6 013	95	800	S4 013	90	720	S3 013
Omega													
1.8 [A]	09.86-03.94				61	600	S5 004	44	440	S4 001	41	360	S3 001
i [A]	09.86-03.94				61	600	S5 004	44	440	S4 001	41	360	S3 001
S [A]	09.86-03.94				61	600	S5 004	44	440	S4 001	41	360	S3 001
2.0 i [A]	09.86-03.94				74	750	S5 007	60	540	S4 004	53	500	S3 004
		XXX									53	470	S3 004
i [B]	09.93-08.99				74	750	S5 007	60	540	S4 004	53	500	S3 004
		XXX									53	470	S3 004
2.2/ 2.5 i [B]	04.94-09.03										70	640	S3 007
2.4 i [A]	09.88-03.94				74	750	S5 007	60	540	S4 004	53	500	S3 004
		XXX									53	470	S3 004
2.6 i [A]	09.90-03.94				74	750	S5 007	60	540	S4 004	53	500	S3 004
		XXX									53	470	S3 004
i [B]	09.00-09.03				74	750	S5 007	72	680	S4 007	53	500	S3 004
3.0 i [A]	03.87-03.94				74	750	S5 007	60	540	S4 004	53	500	S3 004
		XXX									53	470	S3 004
i Evol. 500 [A]	12.90-03.94				74	750	S5 007	60	540	S4 004	53	500	S3 004
		XXX									53	470	S3 004
3.0/ 3.2 i [B]	04.94-09.03				74	750	S5 007	72	680	S4 007			
3.6 i [A]	01.90-03.94				74	750	S5 007	60	540	S4 004	53	500	S3 004
		XXX									53	470	S3 004
Diesel													
2.0 DTI Turbo [B]	09.97-08.00				85	800	S5 010	72	680	S4 007	70	640	S3 007
2.2 DTI [B]	06.00-07.03				85	800	S5 010	72	680	S4 007			
2.3 D, TD [A]	09.86-03.94										70	640	S3 007
2.5 DTI Turbo [B]	06.01-09.03				85	800	S5 010	80	740	S4 010			
TD [B]	04.94-02.01				85	800	S5 010	80	740	S4 010			
Rekord													
1.8 [E]	11.82-08.86				61	600	S5 004	44	440	S4 001	41	360	S3 001
i [E]	05.85-08.86				61	600	S5 004	44	440	S4 001	41	360	S3 001
S [E]	11.82-08.86				61	600	S5 004	44	440	S4 001	41	360	S3 001
2.0 S [E]	11.82-08.86				74	750	S5 007	60	540	S4 004	53	500	S3 004
		XXX									53	470	S3 004
2.2 i [E]	11.84-08.86				74	750	S5 007	60	540	S4 004	53	500	S3 004
		XXX									53	470	S3 004
Diesel													
2.3 D, TD [E]	11.82-08.86	ZE									70	640	S3 007
Senator													
2.2 i [A]	11.84-08.87				74	750	S5 007	60	540	S4 004	53	500	S3 004
		XXX									53	470	S3 004
2.5 i [A]	09.84-08.87				74	750	S5 007	60	540	S4 004	53	500	S3 004
		XXX									53	470	S3 004
i [B]	09.87-12.89				74	750	S5 007	60	540	S4 004	53	500	S3 004
		XXX									53	470	S3 004



				Ah A (EN) S6	Ah A (EN) S5	Ah A (EN) S4	Ah A (EN) S3							
				0092 ...0	0092 ...0	0092 ...0	0092 ...0							
◀ OPEL														
2.6 i [B]	09.90-09.93			74	750	S5 007	60	540	S4 004	53	500	S3 004		
		XXX								53	470	S3 004		
3.0 i [A]	01.83-08.87			74	750	S5 007	60	540	S4 004	53	500	S3 004		
		XXX								53	470	S3 004		
i [B]	09.87-09.93			74	750	S5 007	60	540	S4 004	53	500	S3 004		
		XXX								53	470	S3 004		
i 24V [B]	09.89-09.93			74	750	S5 007	60	540	S4 004	53	500	S3 004		
		XXX								53	470	S3 004		
3.6 i [B]	08.89-09.93			74	750	S5 007	60	540	S4 004	53	500	S3 004		
		XXX								53	470	S3 004		
4.0 i [B]	01.91-09.93			74	750	S5 007	60	540	S4 004	53	500	S3 004		
		XXX								53	470	S3 004		
Diesel														
2.3 D Complex, TD [A]	11.84-08.87	ZE								70	640	S3 007		
Signum														
1.8 i	05.03-02.05			74	750	S5 007	60	540	S4 004					
		XXX								53	470	S3 004		
	09.05-09.08			74	750	S5 007	60	540	S4 004					
		XXX								53	470	S3 004		
2.0/ 2.2/ 2.8 Direct, Turbo, V6 Turbo	05.03-09.08									70	640	S3 007		
3.2 V6	05.03-09.05			74	750	S5 007	72	680	S4 007					
Diesel														
1.9 CDTI	04.04-09.08									70	640	S3 007		
2.0/ 2.2 DTI	05.03-09.05			74	750	S5 007	72	680	S4 007					
3.0 CDTI	05.03-09.05			74	750	S5 007	72	680	S4 007					
	09.05-09.08									88	740	S3 012		
Sintra														
2.2 i 16V	09.96-09.99									53	500	S3 004		
		JEA		61	600	S5 004	60	540	S4 004					
		JEA,XXX								53	470	S3 004		
3.0 i 24V	09.96-09.99									53	500	S3 004		
		JEA		61	600	S5 004	60	540	S4 004					
		JEA,XXX								53	470	S3 004		
Diesel														
2.2 TD	09.97-09.99	JEA		74	750	S5 007	60	540	S4 004					
Speedster														
2.0 Turbo	04.03-09.06			52	520	S5 001	44	440	S4 001	41	360	S3 001		
2.2 i	09.00-09.06			52	520	S5 001	44	440	S4 001					
Tigra														
1.4/ 1.6 i, i 16V [A]	09.94-08.99			61	600	S5 004	44	440	S4 001	41	360	S3 001		
Tigra TwinTop														
1.4 i [B]	06.04-12.09			74	750	S5 007	60	540	S4 004					
		XXX								53	470	S3 004		
1.8 i [B]	06.04-12.09			74	750	S5 007	60	540	S4 004					
		XXX								53	470	S3 004		
Diesel														
1.3 CDTI [B]	06.04-03.09			74	750	S5 007	60	540	S4 004					
Vectra														
1.4/ 1.8 [A]	09.88-08.95			61	600	S5 004	44	440	S4 001	41	360	S3 001		
1.6 i [B]	09.95-07.03			61	600	S5 004	44	440	S4 001	41	360	S3 001		
i [C]	09.01-10.08		70	760	S6 008	77	780	S5 008	44	440	S4 001	56	480	S3 005
i GTS [C]	09.01-07.05		70	760	S6 008	77	780	S5 008	60	540	S4 005			
	08.05-10.08		70	760	S6 008	77	780	S5 008	60	540	S4 005	56	480	S3 005
i KAT [A]	09.88-08.95			61	600	S5 004	44	440	S4 001					
i 16V [B]	09.95-09.02			61	600	S5 004	44	440	S4 001	41	360	S3 001		
1.6/ 1.8 i [A]	03.90-08.95			61	600	S5 004	44	440	S4 001	41	360	S3 001		
S, S 4x4, 4x4 [A]	09.88-08.95			61	600	S5 004	44	440	S4 001	41	360	S3 001		
1.8 i [C]	09.01-10.08		70	760	S6 008	77	780	S5 008	60	540	S4 005	56	480	S3 005
i GTS [C]	09.01-08.05			63	610	S5 005	60	540	S4 005					
	09.01-10.08		70	760	S6 008	77	780	S5 008	60	540	S4 005	56	480	S3 005
i 16V [B]	09.95-09.00			61	600	S5 004	44	440	S4 001	41	360	S3 001		
	09.00-09.03			61	600	S5 004	44	440	S4 001					

			Ah A (EN) S6			Ah A (EN) S5			Ah A (EN) S4			Ah A (EN) S3		
			0 092 ...0			0 092 ...0			0 092 ...0			0 092 ...0		
2.0 i [A]	09.88-08.95					74	750	S5 007	60	540	S4 004	53	500	S3 004
		XXX										53	470	S3 004
i [B]	09.95-09.02					74	750	S5 007	60	540	S4 004	53	500	S3 004
		XXX										53	470	S3 004
i 4x4 [A]	01.89-08.95					74	750	S5 007	60	540	S4 004	53	500	S3 004
		XXX										53	470	S3 004
i 4x4 Turbo [A]	09.92-08.95					74	750	S5 007	60	540	S4 004	53	500	S3 004
		XXX										53	470	S3 004
i 16V [A]	09.92-08.95					74	750	S5 007	60	540	S4 004	53	500	S3 004
		XXX										53	470	S3 004
i 16V [B]	09.95-09.02					74	750	S5 007	60	540	S4 004	53	500	S3 004
		XXX										53	470	S3 004
Turbo [C]	03.03-10.08		70	760	S6 008	77	780	S5 008	74	680	S4 008	70	640	S3 008
Turbo GTS [C]	03.03-10.08		70	760	S6 008	77	780	S5 008	72	680	S4 007	70	640	S3 007
2.2 Direct, Direct GTS [C]	09.03-10.08		70	760	S6 008	77	780	S5 008	72	680	S4 007	70	640	S3 007
i [B]	06.00-09.02					74	750	S5 007	60	540	S4 004	53	500	S3 004
i 16V [B]	09.00-09.03					74	750	S5 007	60	540	S4 004	53	500	S3 004
2.2/3.2 i [C]	09.01-09.05		70	760	S6 008	77	780	S5 008	72	680	S4 007	70	640	S3 007
i GTS [C]	09.01-09.05		70	760	S6 008	77	780	S5 008	72	680	S4 007	70	640	S3 007
2.5 i [A]	02.93-08.95					74	750	S5 007	60	540	S4 004	53	500	S3 004
		XXX										53	470	S3 004
i V6 [B]	09.95-09.00					74	750	S5 007	60	540	S4 004	53	500	S3 004
		XXX										53	470	S3 004
2.6 V6 [B]	09.00-09.02					74	750	S5 007	60	540	S4 004	53	500	S3 004
2.8 GTS Turbo [C]	08.05-09.07		70	760	S6 008	77	780	S5 008	72	680	S4 007	70	640	S3 007
	09.05-10.08											70	640	S3 007
Turbo [C]	08.05-10.08		70	760	S6 008	77	780	S5 008	72	680	S4 007	70	640	S3 007
2000 i 16V [A]	09.89-08.92					74	750	S5 007	60	540	S4 004	53	500	S3 004
		XXX										53	470	S3 004
i 16V 4x4 [A]	09.89-08.92					74	750	S5 007	60	540	S4 004	53	500	S3 004
		XXX										53	470	S3 004
Diesel														
1.7/2.0 D, DI, DTI, TD [A; B]	10.88-09.03											70	640	S3 007
1.9 CDTI [C]	04.04-10.08					85	800	S5 010	80	740	S4 010			
CDTI GTS [C]	04.04-10.08					85	800	S5 010	80	740	S4 010			
2.0/2.2 DTI, DTI GTS [C]	04.02-09.05					85	800	S5 010	80	740	S4 010			
2.2 DTI [B]	09.00-09.03					74	750	S5 007	72	680	S4 007			
3.0 CDTI [C]	03.03-10.08					85	800	S5 010	80	740	S4 010	88	740	S3 012
CDTI GTS [C]	03.03-10.08											88	740	S3 012
Vectra Caravan														
1.6 i [B]	09.95-09.00					61	600	S5 004	44	440	S4 001	41	360	S3 001
i [C]	09.03-05.04		70	760	S6 008	77	780	S5 008	60	540	S4 005			
	06.04-10.08		70	760	S6 008	77	780	S5 008	60	540	S4 005	56	480	S3 005
i 16V [B]	09.96-09.02					61	600	S5 004	44	440	S4 001	41	360	S3 001
1.8 i [C]	09.03-08.05		70	760	S6 008	77	780	S5 008	60	540	S4 005			
	09.03-10.08		70	760	S6 008	77	780	S5 008	60	540	S4 005	56	480	S3 005
i 16V [B]	09.95-09.00					61	600	S5 004	44	440	S4 001	41	360	S3 001
	09.00-09.03					61	600	S5 004	44	440	S4 001			
2.0 i [B]	09.95-09.02					74	750	S5 007	60	540	S4 004	53	500	S3 004
		XXX										53	470	S3 004
i 16V [B]	09.95-09.02					74	750	S5 007	60	540	S4 004	53	500	S3 004
		XXX										53	470	S3 004
Turbo [C]	09.03-10.08		70	760	S6 008	77	780	S5 008	72	680	S4 007	70	640	S3 007
2.2 Direct [C]	09.03-10.08		70	760	S6 008	77	780	S5 008	72	680	S4 007	70	640	S3 007
i [C]	09.03-09.05		70	760	S6 008	77	780	S5 008	74	680	S4 008			
i 16V [B]	09.00-09.03					74	750	S5 007	60	540	S4 004	53	500	S3 004
2.5 i V6 [B]	09.96-06.00					74	750	S5 007	60	540	S4 004	53	500	S3 004
		XXX										53	470	S3 004
2.6 V6 [B]	09.00-09.02					74	750	S5 007	60	540	S4 004	53	500	S3 004
2.8 Turbo [C]	08.05-09.07		70	760	S6 008	77	780	S5 008	72	680	S4 007	70	640	S3 007
	08.05-10.08											70	640	S3 007
3.2 i [C]	09.03-09.05		70	760	S6 008	77	780	S5 008	72	680	S4 007	70	640	S3 007



			Ah A (EN) S6	Ah A (EN) S5	Ah A (EN) S4	Ah A (EN) S3
			0092 ...0	0092 ...0	0092 ...0	0092 ...0

◀ OPEL

Diesel										
1.7 TD [B]	09.95-09.98								70 640	S3 007
1.9 CDTI [C]	04.04-10.08			85 800	S5 010	80 740	S4 010			
2.0 DI [B]	09.96-08.00								70 640	S3 007
DTI [B]	09.97-09.03								70 640	S3 007
2.0/2.2 DTI [C]	09.03-09.05			85 800	S5 010	80 740	S4 010			
2.2 DTI [B]	09.00-09.03			74 750	S5 007	72 680	S4 007			
3.0 CDTI [C]	09.03-08.05	70 760	S6 008			80 740	S4 010			
	08.05-10.08			85 800	S5 010	80 740	S4 010	88 740		S3 012
Vivaro										
2.0 16V	03.01→	70 760	S6 008	77 780	S5 008	74 680	S4 008			
Diesel										
1.9 CDTI	03.01-08.06			85 800	S5 010	80 740	S4 010	88 740		S3 012
DTI	03.01-08.06			85 800	S5 010	80 740	S4 010	88 740		S3 012
2.0 CDTI	08.06→	70 760	S6 008	85 800	S5 010	74 680	S4 008	70 640		S3 008
2.5 CDTI	09.02-08.06			85 800	S5 010	80 740	S4 010			
	08.06→	95 850	S6 013	100 830	S5 013	74 680	S4 008	70 640		S3 008
Zafira										
1.4 Turbo [C]	01.12→			61 600	S5 004					
	XXX							53 470		S3 004
1.6 CNG [B]	09.05-03.10			61 600	S5 004	44 440	S4 001	41 360		S3 001
CNG [C]	01.12→			61 600	S5 004					
	XXX							53 470		S3 004
CNG Turbo [B]	03.09-07.10			61 600	S5 004	44 440	S4 001	41 360		S3 001
	07.10→			52 520	S5 001	44 440	S4 001			
i [A]	03.99-07.05			61 600	S5 004	44 440	S4 001	41 360		S3 001
i [B]	07.05→			61 600	S5 004	44 440	S4 001	41 360		S3 001
	03.06-02.09			61 600	S5 004	44 440	S4 001			
	01.11→			61 600	S5 004	44 440	S4 001			
i CNG [A]	09.01-07.05			61 600	S5 004	44 440	S4 001	41 360		S3 001
1.8 [C]	01.12→			61 600	S5 004					
	XXX							53 470		S3 004
i [A]	03.99-07.05			74 750	S5 007	60 540	S4 004			
	XXX							53 470		S3 004
i [B]	07.05-02.10			61 600	S5 004					
	XXX							53 470		S3 004
	01.11→			61 600	S5 004					
	XXX							53 470		S3 004
2.0 i Turbo [B]	07.05→			74 750	S5 007	60 540	S4 004			
	XXX							53 470		S3 004
Turbo [A]	09.01-07.05			74 750	S5 007	60 540	S4 004			
	XXX							53 470		S3 004
2.2 [A]	09.00-07.05							70 640		S3 007
i Direct [B]	07.05→			74 750	S5 007	60 540	S4 004			
	XXX							53 470		S3 004
Diesel										
1.7 CDTI [B]	03.08→			63 610	S5 005	60 540	S4 005			
				74 750	S5 007	60 540	S4 005			
1.9 CDTI [B]	07.05→			74 750	S5 007	60 540	S4 004			
2.0 CDTI [C]	01.12→			74 750	S5 007	72 680	S4 007			
	08.12→	70 760	S6 008							
2.0/2.2 DI, DTI [A]	03.99-07.05							70 640		S3 007

PEUGEOT

Bipper										
1.4 [A9]	02.08→			54 530	S5 002	52 470	S4 002			
	04.10→			54 530	S5 002	52 470	S4 002	45 400		S3 002
Diesel										
1.3 HDi [A9]	08.10→	SSJ		60 560	S5 E05					
1.4 HDi [A9]	02.08→			63 610	S5 005	60 540	S4 005	56 480		S3 005

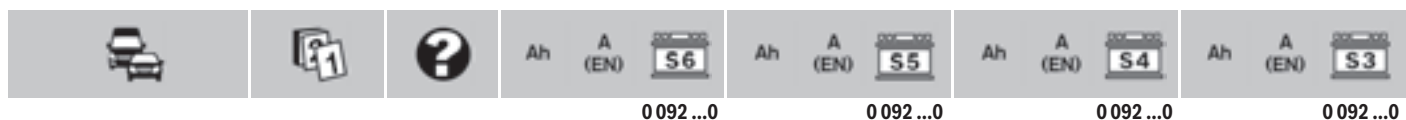

Boxer														
2.0 i [U3; U5]	02.94-05.06		70	760	S6 008	77	780	S5 008	74	680	S4 008	70	640	S3 008
Diesel														
1.9/ 2.0/ 2.2 D, D Turbo, HDi [U3; U5]	02.94-05.06		70	760	S6 008	77	780	S5 008	74	680	S4 008	70	640	S3 008
2.2 HDi [U9]	06.06→					110	920	S5 015						
	06.11→					100	830	S5 013	74	680	S4 008			
2.5 D [U3]	02.94-02.02		95	850	S6 013	100	830	S5 013	95	800	S4 013	70	640	S3 008
	01.99-02.02					100	830	S5 013	95	800	S4 013	90	720	S3 013
D Turbo [U3]	02.94-02.02		95	850	S6 013	100	830	S5 013	95	800	S4 013	70	640	S3 008
TDi [U3]	10.96-02.02		95	850	S6 013	100	830	S5 013	95	800	S4 013	70	640	S3 008
2.8 D [U3]	01.99-02.02					100	830	S5 013	95	800	S4 013			
D Turbo [U3]	10.99-02.02					100	830	S5 013	95	800	S4 013	90	720	S3 013
D Turbo [U5]	02.02-05.06					100	830	S5 013	95	800	S4 013	90	720	S3 013
HDi [U3]	09.00-02.02					100	830	S5 013	95	800	S4 013	90	720	S3 013
HDi [U5]	02.02-05.06		95	850	S6 013	100	830	S5 013	95	800	S4 013	90	720	S3 013
3.0 HDi [U9]	06.06→					110	920	S5 015						
	03.11→					100	830	S5 013	95	800	S4 013	90	720	S3 013
Expert														
1.6/ 1.8/ 2.0 i, i 16V [U64]	09.95-01.07					63	610	S5 005	60	540	S4 005	56	480	S3 005
2.0 16V [G9]	02.07→		70	760	S6 008	77	780	S5 008	74	680	S4 008	70	640	S3 008
Diesel														
1.6 HDi [G9]	02.07→		70	760	S6 008	77	780	S5 008	74	680	S4 008	70	640	S3 008
1.9 D [U64]	09.95-05.00		70	760	S6 008	63	610	S5 005	60	540	S4 005	56	480	S3 005
	06.98-01.07					70	760	S6 008	63	610	S5 005			
D Turbo [U64]	09.95-05.00		70	760	S6 008	63	610	S5 005	60	540	S4 005	56	480	S3 005
2.0 HDi [G9]	02.07→		70	760	S6 008	77	780	S5 008	74	680	S4 008	70	640	S3 008
	04.10→					77	780	S5 008	74	680	S4 008			
HDi [U64]	10.99-01.07		70	760	S6 008	77	780	S5 008	74	680	S4 008	70	640	S3 008
J 5														
1.8	09.81-12.93					63	610	S5 005	60	540	S4 005	56	480	S3 005
2.0	09.81-12.93		70	760	S6 008	77	780	S5 008	74	680	S4 008	70	640	S3 008
Diesel														
1.9/ 2.5 D, D Turbo	09.81-12.93		95	850	S6 013	100	830	S5 013	95	800	S4 013	90	720	S3 013
J 9														
1.6/ 2.0	10.80-06.87								70	630	S4 027			
Diesel														
2.1/ 2.5 D	10.80-06.87								70	630	S4 027			
Partner														
Electrique [M4]	01.98-08.02					54	530	S5 002	52	470	S4 002			
1.1/ 1.4/ 1.6 i, i 16V [M5]	09.02-04.08					63	610	S5 005	52	470	S4 002	45	400	S3 002
1.1/ 1.4/ 1.6/ 1.8 i, i 16V [M4]	07.96-08.02					63	610	S5 005	52	470	S4 002	45	400	S3 002
1.4 [M4]	11.96-08.02					63	610	S5 005	52	470	S4 002	45	400	S3 002
1.6 VTi [B9]	09.09→					54	530	S5 002	52	470	S4 002			
	03.10→					63	610	S5 005	60	540	S4 005			
16V [B9]	05.08-02.12								60	540	S4 005			
						54	530	S5 002	52	470	S4 002			
Diesel														
1.6 HDi [B9]	05.08→					63	610	S5 005	60	540	S4 005			
	10.10→	SSJ				70	650	S5 E08						
1.6/ 2.0 HDi, HDi [; M4; M5]	12.99→		70	760	S6 008	77	780	S5 008	60	540	S4 005			
1.8/ 1.9 D [M4; M5]	07.96-03.07					63	610	S5 005	60	540	S4 005			
1.9 D	10.99→					63	610	S5 005	60	540	S4 005			
Ranch														
1.4 i [M4]	07.97-08.02					54	530	S5 002	52	470	S4 002	45	400	S3 002
						63	610	S5 005	52	470	S4 002	45	400	S3 002
Diesel														
1.9 D [M4]	07.97-08.02					63	610	S5 005	60	540	S4 005			
RCZ														
1.6 THP [T75]	01.10→	BWD				77	780	S5 008	60	540	S4 005			
						77	780	S5 008	74	680	S4 008			



		Ah A (EN) S6		Ah A (EN) S5		Ah A (EN) S4		Ah A (EN) S3	
		0092 ...0		0092 ...0		0092 ...0		0092 ...0	
PEUGEOT									
Diesel									
2.0 HDi [T75]	01.10→	BWD	77	780	S5 008	74	680	S4 008	
104									
1.0/1.1/1.4	07.76-06.88								45 300 S3 016
106									
1.0 [S1]	09.91-04.96		54	530	S5 002	44	420	S4 000	40 340 S3 000
		XXX				42	390	S4 000	
i [S1]	07.92-04.96		54	530	S5 002	44	420	S4 000	40 340 S3 000
		XXX	54	530	S5 002	44	420	S4 000	40 340 S3 000
		XXX				42	390	S4 000	
i [S2]	05.96-05.05		54	530	S5 002	44	420	S4 000	40 340 S3 000
		XXX	54	530	S5 002	44	420	S4 000	40 340 S3 000
		XXX				42	390	S4 000	
1.1 [S1]	09.91-04.96		54	530	S5 002	44	420	S4 000	40 340 S3 000
		XXX				42	390	S4 000	
i [S1]	09.91-04.96		54	530	S5 002	44	420	S4 000	40 340 S3 000
		XXX				42	390	S4 000	
i [S2]	05.96-05.05		54	530	S5 002	44	420	S4 000	40 340 S3 000
		XXX				42	390	S4 000	
	03.00-05.05		54	530	S5 002				40 340 S3 000
1.3/1.4/1.6, i, i 16S [S1; S2]	09.91-05.05		54	530	S5 002	52	470	S4 002	45 400 S3 002
Diesel									
1.4/1.5 D [S1; S2]	09.92-05.05		63	610	S5 005	60	540	S4 005	56 480 S3 005
107									
1.0 [B0]	06.05→		54	530	S5 002				40 340 S3 000
		XXX				42	390	S4 000	
Diesel									
1.4 HDi [B0]	06.05→		54	530	S5 002				40 340 S3 000
		XXX				42	390	S4 000	
205									
1.0/1.1/1.3/1.4/1.6/1.9, i	02.83-09.98		54	530	S5 002	52	470	S4 002	45 400 S3 002
Diesel									
1.8 D	10.83-10.87	70 760 S6 008	77	780	S5 008	74	680	S4 008	70 640 S3 008
	07.87-12.98	60 680 S6 005	63	610	S5 005	60	540	S4 005	56 480 S3 005
D Turbo	01.90-09.98	70 760 S6 008	77	780	S5 008	74	680	S4 008	70 640 S3 008
1.9 D	10.87-09.98	70 760 S6 008	77	780	S5 008	74	680	S4 008	70 640 S3 008
205 Pickup									
1.1	10.87-12.90		54	530	S5 002	52	470	S4 002	45 400 S3 002
Diesel									
1.8 D	05.85-09.98	70 760 S6 008	77	780	S5 008	74	680	S4 008	70 640 S3 008
206									
1.1 i [T1]	06.98-10.05								40 340 S3 000
1.4/1.6 i [T1]	06.98-02.09		54	530	S5 002	52	470	S4 002	45 400 S3 002
i 16V [T1]	03.00-08.07		54	530	S5 002	52	470	S4 002	45 400 S3 002
2.0 i RC, i S16 [T1]	01.99-08.06		63	610	S5 005	60	540	S4 005	56 480 S3 005
Diesel									
1.4 HDi [T1]	09.01-02.09		63	610	S5 005	60	540	S4 005	
1.6/2.0 HDi [T1]	04.99-03.07		63	610	S5 005	60	540	S4 005	56 480 S3 005
1.9 D [T1]	06.98-10.01		63	610	S5 005	60	540	S4 005	
	02.99-03.06		63	610	S5 005	60	540	S4 005	56 480 S3 005
206+									
1.1 [T3E]	03.09→		54	530	S5 002	52	470	S4 002	
1.4 [T3E]	03.09→		54	530	S5 002	52	470	S4 002	45 400 S3 002
	04.10→		54	530	S5 002	52	470	S4 002	
Diesel									
1.4 HDi [T3E]	03.09→		63	610	S5 005	60	540	S4 005	
206 CC									
1.6 i 16V [T1]	09.00-03.07		54	530	S5 002	52	470	S4 002	45 400 S3 002
2.0 i S16 [T1]	09.00-03.07		63	610	S5 005	60	540	S4 005	56 480 S3 005
Diesel									
1.6 HDi [T1]	06.05-03.07		63	610	S5 005	60	540	S4 005	56 480 S3 005

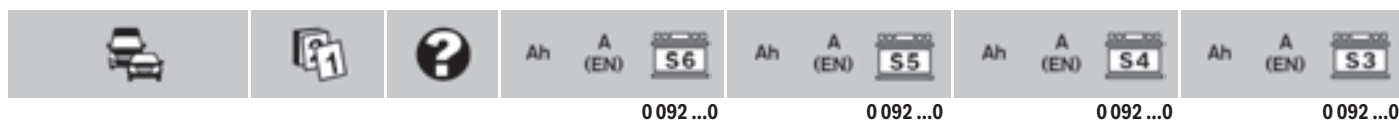

206 Sedan														
1.4 [T1]	02.06-03.09				54	530	S5 002	52	470	S4 002	45	400	S3 002	
1.6 16V [T1]	03.07-12.10				63	610	S5 005	60	540	S4 005	56	480	S3 005	
Diesel														
1.4 HDi 16V [T1]	09.08-12.10				63	610	S5 005	60	540	S4 005				
206 SW														
1.1 i [T1]	03.02-10.05										40	340	S3 000	
		XXX						42	390	S4 000				
1.4 i [T1]	03.02-12.06				54	530	S5 002	52	470	S4 002	45	400	S3 002	
1.4/ 1.6 i 16V [T1]	03.02-12.06				54	530	S5 002	52	470	S4 002	45	400	S3 002	
2.0 iS16 [T1]	03.02-10.05				63	610	S5 005	60	540	S4 005	56	480	S3 005	
Diesel														
1.4/ 1.6/ 2.0 HDi [T1]	03.02-12.06				63	610	S5 005	60	540	S4 005	56	480	S3 005	
207														
1.4 [A7]	05.06-04.12	BWD			63	610	S5 005	52	470	S4 002	45	400	S3 002	
VTi [A7]	07.09-04.12	BWD			63	610	S5 005	52	470	S4 002	45	400	S3 002	
16V [A7]	05.06-06.08	BWD			63	610	S5 005	52	470	S4 002	45	400	S3 002	
1.6 [A7]	03.07-06.09	BWD			61	600	S5 004	60	540	S4 004				
		BWD,XXX									53	470	S3 004	
i [A7]	05.06-08.07	BWD			63	610	S5 005	52	470	S4 002	45	400	S3 002	
RC [A7]	04.07-02.11	BWD			61	600	S5 004	60	540	S4 004				
		BWD,XXX									53	470	S3 004	
THP [A7]	07.06-04.10	BWD			63	610	S5 005	60	540	S4 005	56	480	S3 005	
	04.10-12.11	BWD						52	470	S4 002				
VTi [A7]	07.09-12.11	BWD			61	600	S5 004	60	540	S4 004				
		BWD,XXX									53	470	S3 004	
Diesel														
1.4 HDi [A7]	05.06-12.11	BWD			63	610	S5 005	60	540	S4 005	56	480	S3 005	
1.6 HDi [A7]	05.06-04.11	BWD			63	610	S5 005	60	540	S4 005	56	480	S3 005	
	04.10-12.11	BWD						52	470	S4 002				
	04.10-04.12	BWD			63	610	S5 005	60	540	S4 005				
207 CC														
1.6 [A7]	03.07-06.09	BWD			63	610	S5 005	60	540	S4 005	56	480	S3 005	
THP [A7]	03.07→	BWD			63	610	S5 005	60	540	S4 005	56	480	S3 005	
	07.10→	BWD			54	530	S5 002	52	470	S4 002				
VTi [A7]	07.09→	BWD			63	610	S5 005	60	540	S4 005	56	480	S3 005	
Diesel														
1.6 HDi [A7]	03.07-02.11	BWD	70	760	S6 008	77	780	S5 008	74	680	S4 008	70	640	S3 008
	02.10→	BWD				63	610	S5 005	60	540	S4 005			
207 SW														
1.4/ 1.6, VTi [A7]	06.07→	BWD			63	610	S5 005	52	470	S4 002	45	400	S3 002	
1.6 THPRC [A7]	11.07-06.09	BWD			54	530	S5 002	52	470	S4 002				
Diesel														
1.6 HDi [A7]	06.07-04.11	BWD			63	610	S5 005	60	540	S4 005	56	480	S3 005	
	04.10→	BWD			63	610	S5 005	60	540	S4 005				
208														
1.0/ 1.2/ 1.6 VTi	01.12→				54	530	S5 002	52	470	S4 002				
1.6 HTP	01.12→				63	610	S5 005	60	540	S4 005				
Diesel														
1.4/ 1.6 HDi	01.12→	SSJ	70	760	S6 008									
305														
1.1/ 1.3/ 1.5/ 1.6/ 1.9, i	07.82-07.90				63	610	S5 005	60	540	S4 005	56	480	S3 005	
Diesel														
1.8 D	10.82-06.88				77	780	S5 008	74	680	S4 008	70	640	S3 008	
1.9 D	10.82-07.90		70	760	S6 008	77	780	S5 008	74	680	S4 008	70	640	S3 008
306														
1.1/ 1.4/ 1.6/ 1.8, i [, N3]	01.93-03.07				54	530	S5 002	52	470	S4 002	45	400	S3 002	
1.4 [N5]	05.97-10.03				54	530	S5 002	52	470	S4 002	45	400	S3 002	
1.4/ 1.6 i [N5]	05.97-10.03				54	530	S5 002	52	470	S4 002	45	400	S3 002	
1.8 i [N5]	05.97-10.03				54	530	S5 002	52	470	S4 002	45	400	S3 002	
					63	610	S5 005	52	470	S4 002	45	400	S3 002	
1.8/ 2.0 i 16V [N5]	05.97-10.03				63	610	S5 005	52	470	S4 002	45	400	S3 002	
2.0 i, i 16V [N3]	08.93-04.97				63	610	S5 005	52	470	S4 002	45	400	S3 002	



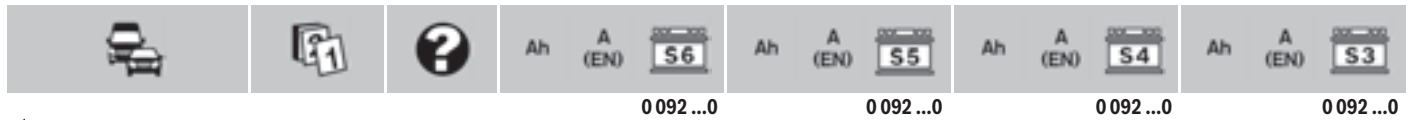

◀ PEUGEOT

Diesel		0092 ...0		0092 ...0		0092 ...0		0092 ...0		
1.8/ 1.9/ 2.0 D, D Turbo, HDi	05.93→	63	610	\$5 005	60	540	\$4 005	56	480	\$3 005
[; N3; N5]										
306 Break		0092 ...0		0092 ...0		0092 ...0		0092 ...0		
1.4/ 1.6/ 1.8 , i [N5]	05.97-03.02	54	530	\$5 002	52	470	\$4 002	45	400	\$3 002
1.8/ 2.0 i 16V [N5]	05.97-03.02	63	610	\$5 005	52	470	\$4 002	45	400	\$3 002
Diesel		0092 ...0		0092 ...0		0092 ...0		0092 ...0		
1.9/ 2.0 D, D Turbo, HDi [N5]	05.97-03.02	63	610	\$5 005	60	540	\$4 005	56	480	\$3 005
306 Cabriolet		0092 ...0		0092 ...0		0092 ...0		0092 ...0		
1.6/ 1.8 i [N3]	01.93-04.97	54	530	\$5 002	52	470	\$4 002	45	400	\$3 002
i [N5]	05.97-10.03	54	530	\$5 002	52	470	\$4 002	45	400	\$3 002
1.8/ 2.0 i 16V [N5]	05.97-10.03	63	610	\$5 005	52	470	\$4 002	45	400	\$3 002
2.0 i [N3]	08.93-04.97	63	610	\$5 005	52	470	\$4 002	45	400	\$3 002
307		0092 ...0		0092 ...0		0092 ...0		0092 ...0		
1.4 i [T5]	08.00-05.05	54	530	\$5 002				40	340	\$3 000
	XXX				42	390	\$4 000			
i [T6]	06.05-08.07	54	530	\$5 002				40	340	\$3 000
	XXX				42	390	\$4 000			
i 16V [T5]	11.03-05.05	54	530	\$5 002				40	340	\$3 000
	XXX				42	390	\$4 000			
1.6 i [T5]	08.00-05.05	54	530	\$5 002				40	340	\$3 000
	XXX				42	390	\$4 000			
i [T6]	06.05-08.07	54	530	\$5 002				40	340	\$3 000
	XXX				42	390	\$4 000			
i 16V [T5]	06.04-04.06	54	530	\$5 002						
	XXX				42	390	\$4 000			
2.0 i [T5]	08.00-05.05	63	610	\$5 005	60	540	\$4 005	56	480	\$3 005
i [T6]	06.05-08.07	63	610	\$5 005	60	540	\$4 005	56	480	\$3 005
i 16V [T5]	06.04-04.06	63	610	\$5 005	60	540	\$4 005			
Diesel		0092 ...0		0092 ...0		0092 ...0		0092 ...0		
1.4/ 1.6 HDi [T5]	10.01-05.05	63	610	\$5 005	60	540	\$4 005			
1.6 HDi [T6]	06.05-08.07	63	610	\$5 005	60	540	\$4 005			
2.0 HDi [T5]	08.00-05.05	63	610	\$5 005	60	540	\$4 005			
	03.02-05.05	70	760	\$6 008	77	780	\$5 008	60	540	\$4 005
HDi [T6]	06.05-08.07	70	760	\$6 008	77	780	\$5 008	60	540	\$4 005
307 Break/SW		0092 ...0		0092 ...0		0092 ...0		0092 ...0		
1.4 i [T5]	03.02-05.05	54	530	\$5 002	44	420	\$4 000	45	400	\$3 002
		54	530	\$5 002	52	470	\$4 002	40	340	\$3 000
		54	530	\$5 002	52	470	\$4 002	45	400	\$3 002
i [T6]	06.05-05.08	54	530	\$5 002				40	340	\$3 000
	XXX				42	390	\$4 000			
i 16V [T5]	11.03-05.05	54	530	\$5 002				40	340	\$3 000
	XXX				42	390	\$4 000			
1.6 i [T5]	03.02-05.05	54	530	\$5 002				40	340	\$3 000
	XXX				42	390	\$4 000			
i 16V [T6]	06.05-05.08	54	530	\$5 002				40	340	\$3 000
	XXX				42	390	\$4 000			
i 16V BioFlex [T6]	09.07-12.09	63	610	\$5 005	52	470	\$4 002			
2.0 i [T5; T6]	03.02-05.08	63	610	\$5 005	60	540	\$4 005	56	480	\$3 005
Diesel		0092 ...0		0092 ...0		0092 ...0		0092 ...0		
1.4/ 1.6 HDi [T5]	03.02-05.05	63	610	\$5 005	60	540	\$4 005			
1.6 HDi [T6]	06.05-05.08	63	610	\$5 005	60	540	\$4 005			
2.0 HDi [T5]	03.02-05.05	63	610	\$5 005	60	540	\$4 005			
		70	760	\$6 008	77	780	\$5 008	60	540	\$4 005
HDi [T6]	06.05-05.08	70	760	\$6 008	77	780	\$5 008	60	540	\$4 005
307 CC		0092 ...0		0092 ...0		0092 ...0		0092 ...0		
1.6 i [T6]	06.05-03.09	54	530	\$5 002				40	340	\$3 000
	XXX				42	390	\$4 000			
2.0 i [T6]	06.05-03.09	63	610	\$5 005	60	540	\$4 005	56	480	\$3 005
i, i Sport [T5]	10.03-05.05	63	610	\$5 005	60	540	\$4 005	56	480	\$3 005
i Sport [T6]	06.05-03.09	63	610	\$5 005	60	540	\$4 005	56	480	\$3 005
Diesel		0092 ...0		0092 ...0		0092 ...0		0092 ...0		
2.0 HDi [T6]	06.05-03.09	70	760	\$6 008	77	780	\$5 008	60	540	\$4 005



307 Sedan											
1.6 i16V [T6]	08.06→					54	530	S5 002			
		XXX							42	390	S4 000
2.0 i16V [T6]	08.06→					63	610	S5 005	60	540	S4 005
308											
1.4 [T7]	09.07-03.10	BWD				63	610	S5 005	60	540	S4 005
VTi [T7]	04.10→	BWD				54	530	S5 002	52	470	S4 002
1.6 [T7]	09.07→	BWD	70	760	S6 008	77	780	S5 008	60	540	S4 005
	07.08-04.12	BWD				63	610	S5 005	60	540	S4 005
GTi THP [T7]	05.10→	BWD				63	610	S5 005	60	540	S4 005
THP [T7]	09.07-04.10	BWD	70	760	S6 008	77	780	S5 008	60	540	S4 005
	11.07→	BWD				63	610	S5 005	60	540	S4 005
	03.08-04.10	BWD				63	610	S5 005	60	540	S4 005
VTi [T7]	12.09→	BWD	70	760	S6 008	77	780	S5 008	60	540	S4 005
2.0 [T7]	07.08-04.12	BWD				63	610	S5 005	60	540	S4 005
Diesel											
1.6 HDi [T7]	09.07-03.10	BWD	70	760	S6 008	77	780	S5 008	74	680	S4 008
	04.10-03.13	BWD,SSJ				70	650	S5 E08			
	04.10→	BWD				63	610	S5 005	60	540	S4 005
2.0 HDi [T7]	09.07→	BWD	70	760	S6 008	77	780	S5 008	74	680	S4 008
	10.10→	BWD				63	610	S5 005	60	540	S4 005
308 CC											
1.6 THP, THP GTi, VTi [T7]	03.09→	BWD				63	610	S5 005	60	540	S4 005
Diesel											
1.6 HDi [T7]	03.09-03.13	BWD				63	610	S5 005	60	540	S4 005
2.0 HDi [T7]	03.09→	BWD				77	780	S5 008	74	680	S4 008
308 SW											
1.4 [T7]	05.08-03.10	BWD				54	530	S5 002	52	470	S4 002
VTi [T7]	04.10→	BWD				54	530	S5 002	52	470	S4 002
1.6 [T7]	05.08→	BWD				63	610	S5 005	60	540	S4 005
		BWD,SSJ				60	560	S5 E05			
BioFlex [T7]	03.09-04.12	BWD				63	610	S5 005	60	540	S4 005
THP [T7]	05.08-04.10	BWD				63	610	S5 005	60	540	S4 005
	05.08→	BWD				63	610	S5 005	60	540	S4 005
VTi [T7]	12.09→	BWD				63	610	S5 005	60	540	S4 005
		BWD,SSJ				60	560	S5 E05			
2.0 [T7]	05.08-04.12	BWD				63	610	S5 005	60	540	S4 005
Diesel											
1.6 HDi [T7]	05.08-03.10	BWD				63	610	S5 005	60	540	S4 005
	04.10-03.13	BWD,SSJ				70	650	S5 E08			
	06.10→	BWD				63	610	S5 005	60	540	S4 005
2.0 HDi [T7]	05.08→	BWD				77	780	S5 008	74	680	S4 008
	10.10→	BWD				63	610	S5 005	60	540	S4 005
309											
1.1/ 1.3	10.85-12.93					54	530	S5 002	52	470	S4 002
1.1/ 1.4/ 1.6 i	11.85-12.93					54	530	S5 002	52	470	S4 002
1.4	10.86-12.93					54	530	S5 002	52	470	S4 002
	08.95-09.99					54	530	S5 002	52	470	S4 002
1.6	10.85-12.93					54	530	S5 002	52	470	S4 002
1.9	10.85-12.93					63	610	S5 005	60	540	S4 005
GTi	10.86-12.93					63	610	S5 005	60	540	S4 005
i	03.86-12.93					63	610	S5 005	60	540	S4 005
i16V	02.90-12.93					63	610	S5 005	60	540	S4 005
Diesel											
1.5	02.97-09.99		70	760	S6 008	77	780	S5 008	60	540	S4 005
1.8/ 1.9 D, D Turbo	06.86-12.93		70	760	S6 008	77	780	S5 008	60	540	S4 005
405											
1.4 [15]	07.87-06.88					54	530	S5 002	44	420	S4 000
						54	530	S5 002	44	420	S4 000
	07.87-12.92	XXX							42	390	S4 000
	11.87-12.92					54	530	S5 002			45 400 S3 002
1.4/ 1.6/ 1.8, i [4; 15]	07.87-04.97					54	530	S5 002	52	470	S4 002



				Ah A (EN) S6		Ah A (EN) S5		Ah A (EN) S4		Ah A (EN) S3				
				0092 ...0		0092 ...0		0092 ...0		0092 ...0				
◀ PEUGEOT														
1.9 [15]	07.87-12.92			63	610	\$5 005	60	540	\$4 005	56	480	\$3 005		
i, i 16V [15]	07.87-12.92			63	610	\$5 005	60	540	\$4 005	56	480	\$3 005		
1.9/2.0, i, i Mi16, i T16 4x4, i 4x4 [4]	06.92-04.97			63	610	\$5 005	60	540	\$4 005	56	480	\$3 005		
Diesel														
1.8 D [15]	10.90-12.92			77	780	\$5 008	74	680	\$4 008	70	640	\$3 008		
D Turbo [15]	03.88-12.92	70	760	\$6 008	77	780	\$5 008	74	680	\$4 008	70	640	\$3 008	
1.9 D [15]	03.88-12.92	70	760	\$6 008	77	780	\$5 008	74	680	\$4 008	70	640	\$3 008	
D, D Turbo [4]	06.92-04.97	70	760	\$6 008	77	780	\$5 008	74	680	\$4 008	70	640	\$3 008	
405 Break														
1.4/1.6 [4; 15]	07.88-04.97			54	530	\$5 002	52	470	\$4 002	45	400	\$3 002		
1.4/1.6/1.8 i [4; 15]	07.89-04.97			54	530	\$5 002	52	470	\$4 002	45	400	\$3 002		
1.9 [4; 15]	07.88-04.97			63	610	\$5 005	60	540	\$4 005	56	480	\$3 005		
1.9/2.0 i [4; 15]	07.88-04.97			63	610	\$5 005	60	540	\$4 005	56	480	\$3 005		
2.0 i 4x4 [4; 15]	06.92-04.97			63	610	\$5 005	60	540	\$4 005	56	480	\$3 005		
Diesel														
1.8/1.9 D, D Turbo [4; 15]	07.88-04.97	70	760	\$6 008	77	780	\$5 008	74	680	\$4 008	70	640	\$3 008	
406														
1.6/1.8 i [D8; D9]	10.95-06.04			63	610	\$5 005	52	470	\$4 002	45	400	\$3 002		
1.8/2.0/2.2 i Turbo, i 16V [D8; D9]	10.95-06.04			63	610	\$5 005	52	470	\$4 002	45	400	\$3 002		
2.0 HPI [D8; D9]	10.00-06.04			63	610	\$5 005	52	470	\$4 002	45	400	\$3 002		
3.0 i [D8; D9]	08.96-06.04	70	760	\$6 008	77	780	\$5 008	60	540	\$4 005	56	480	\$3 005	
Diesel														
1.9/2.0/2.1/2.2 D Turbo, HDi [D8; D9]	12.95-06.04	70	760	\$6 008	77	780	\$5 008	60	540	\$4 005	56	480	\$3 005	
406 Break														
1.8 i [D8; D9]	10.96-06.04			63	610	\$5 005	52	470	\$4 002	45	400	\$3 002		
1.8/2.0/2.2 i Turbo, i 16V [D8; D9]	10.96-06.04			63	610	\$5 005	52	470	\$4 002	45	400	\$3 002		
2.0 HPI [D8; D9]	10.00-06.04			63	610	\$5 005	52	470	\$4 002	45	400	\$3 002		
3.0 i [D8; D9]	10.96-06.04	70	760	\$6 008	77	780	\$5 008	60	540	\$4 005	56	480	\$3 005	
Diesel														
1.9/2.0/2.1/2.2 D Turbo, HDi [D8; D9]	10.96-06.04	70	760	\$6 008	77	780	\$5 008	60	540	\$4 005	56	480	\$3 005	
406 Coupé														
1.8/2.0/2.2 i 16V [D8; D9]	03.97-02.05			63	610	\$5 005	52	470	\$4 002	45	400	\$3 002		
3.0 i [D8; D9]	03.97-02.05	70	760	\$6 008	77	780	\$5 008	60	540	\$4 005	56	480	\$3 005	
Diesel														
2.2 HDi [D9]	03.00-02.05	70	760	\$6 008	77	780	\$5 008	60	540	\$4 005	56	480	\$3 005	
		70	760	\$6 008	77	780	\$5 008	74	680	\$4 008	56	480	\$3 005	
407														
1.8 [D2]	05.04-02.11	BWD		63	610	\$5 005	52	470	\$4 002	45	400	\$3 002		
2.0/2.2/3.0 [D2]	05.04-02.11	BWD		63	610	\$5 005	60	540	\$4 005	56	480	\$3 005		
Diesel														
1.6 HDi [D2]	05.04-02.11	BWD	70	760	\$6 008	77	780	\$5 008	74	680	\$4 008	70	640	\$3 008
2.0 HDi [D2]	05.04-02.11	BWD	70	760	\$6 008	77	780	\$5 008	74	680	\$4 008	70	640	\$3 008
	11.09-02.11	BWD		77	780	\$5 008	74	680	\$4 008					
2.2/2.7 HDi [D2]	05.06-07.10	BWD	70	760	\$6 008	77	780	\$5 008	74	680	\$4 008	70	640	\$3 008
407 Coupé														
2.2/3.0 [D2]	10.05-06.09	BWD		63	610	\$5 005	60	540	\$4 005	56	480	\$3 005		
Diesel														
2.0/2.7 HDi [D2]	10.05-06.09	BWD	70	760	\$6 008	77	780	\$5 008	74	680	\$4 008	70	640	\$3 008
2.0/3.0 HDi 16V, HDi 24V [D2]	07.09->	BWD		77	780	\$5 008	74	680	\$4 008					
407 SW														
1.8 [D2]	05.04-02.11	BWD		63	610	\$5 005	52	470	\$4 002	45	400	\$3 002		
2.0/2.2/3.0 [D2]	05.04-02.11	BWD		63	610	\$5 005	60	540	\$4 005	56	480	\$3 005		
Diesel														
1.6 HDi [D2]	05.04-02.11	BWD	70	760	\$6 008	77	780	\$5 008	74	680	\$4 008	70	640	\$3 008
2.0 HDi [D2]	05.04-02.11	BWD	70	760	\$6 008	77	780	\$5 008	74	680	\$4 008	70	640	\$3 008
	11.09-02.11	BWD		77	780	\$5 008	74	680	\$4 008					
2.2/2.7 HDi [D2]	09.06-07.10	BWD	70	760	\$6 008	77	780	\$5 008	74	680	\$4 008	70	640	\$3 008



504											
1.6/ 2.0	01.71-12.90						70	630	S4 027		
504 Pickup											
1.6/ 1.8/ 2.0	09.79-12.90						70	630	S4 027		
Diesel											
1.9/ 2.1/ 2.3/ 2.5 D	10.79-12.90						70	630	S4 027		
505											
1.8/ 2.0	05.79-12.93				63	610	S5 005	60	540	S4 005 56 480 S3 005	
2.0 i	08.79-12.89				63	610	S5 005	60	540	S4 005 56 480 S3 005	
2.2 i	08.83-12.93	70	760	S6 008	77	780	S5 008	74	680	S4 008 70 640 S3 008	
2.2/ 2.8 i Turbo, i V6	10.82-12.93	70	760	S6 008	77	780	S5 008	74	680	S4 008 70 640 S3 008	
Diesel											
2.3 D	09.79-09.86				77	780	S5 008	74	680	S4 008 70 640 S3 008	
2.3/ 2.5 D Turbo	09.80-12.93	70	760	S6 008	77	780	S5 008	74	680	S4 008 70 640 S3 008	
2.5 D	06.81-12.93	70	760	S6 008	77	780	S5 008	74	680	S4 008 70 640 S3 008	
508											
1.6 THP, VTi [W2]	10.10→	BWD			63	610	S5 005	60	540	S4 005	
Diesel											
1.6 HDi [W2]	10.10→	BWD,SSJ			70	650	S5 E08				
	02.12→		70	760	S6 008						
2.0/ 2.2 HDi [W2]	10.10→	BWD			77	780	S5 008	74	680	S4 008	
508 RXH SW											
Diesel											
2.0 HDi HYbrid4 4x4 [W2]	09.11→		70	760	S6 008						
508 SW											
1.6 THP, VTi [W2]	10.10→	BWD			63	610	S5 005	60	540	S4 005	
Diesel											
1.6 HDi [W2]	10.10→	BWD			63	610	S5 005	60	540	S4 005	
		SSJ	70	760	S6 008	70	650	S5 E08			
	02.12→		70	760	S6 008						
2.0/ 2.2 HDi [W2]	10.10→	BWD			77	780	S5 008	74	680	S4 008	
604											
2.7/ 2.8 i V6, V6	08.75-06.86				63	610	S5 005	60	540	S4 005 56 480 S3 005	
Diesel											
2.5 D Turbo	06.83-06.86		95	850	S6 013	100	830	S5 013	95	800	S4 013 90 720 S3 013
605											
2.0/ 3.0, i, i Turbo, i 16V, i 24V [Y30]	06.89-05.99				63	610	S5 005	52	470	S4 002 45 400 S3 002	
Diesel											
2.1/ 2.5 D, D Turbo [Y30]	06.89-05.99		70	760	S6 008	77	780	S5 008	74	680	S4 008 70 640 S3 008
607											
2.0/ 2.2/ 3.0, i, i 16V [Z8; Z9]	03.00-01.09		70	760	S6 008	77	780	S5 008	74	680	S4 008 70 640 S3 008
Diesel											
2.0 HDi [Z9]	12.04-12.07		70	760	S6 008	77	780	S5 008	74	680	S4 008
	03.06-12.09		70	760	S6 008	77	780	S5 008	74	680	S4 008 70 640 S3 008
2.0/ 2.2 HDi [Z8]	03.00-11.04		70	760	S6 008	77	780	S5 008	74	680	S4 008 70 640 S3 008
2.2/ 2.7 HDi [Z9]	12.04-12.10		70	760	S6 008	77	780	S5 008	74	680	S4 008 70 640 S3 008
806											
1.8/ 2.0 i, i Turbo, i 16V [U60]	06.94-08.02				63	610	S5 005	60	540	S4 005 56 480 S3 005	
Diesel											
1.9/ 2.0/ 2.1 D Turbo, HDi [U60]	12.94-08.02		70	760	S6 008	77	780	S5 008	74	680	S4 008 70 640 S3 008
807											
2.0/ 2.2/ 3.0 i, i 16V [V2]	06.02-05.10				63	610	S5 005	60	540	S4 005 56 480 S3 005	
Diesel											
2.0 HDi [V2]	06.02-05.10		70	760	S6 008	77	780	S5 008	74	680	S4 008 70 640 S3 008
	06.10→				63	610	S5 005	60	540	S4 005	
2.2 HDi [V2]	06.02-07.06		70	760	S6 008	77	780	S5 008	74	680	S4 008 70 640 S3 008
	09.07-05.10		70	760	S6 008	77	780	S5 008	74	680	S4 008 70 640 S3 008
1007											
1.4/ 1.6 [A8]	04.05-02.11				63	610	S5 005	52	470	S4 002 45 400 S3 002	
Diesel											
1.4/ 1.6 HDi [A8]	04.05-02.11				63	610	S5 005	60	540	S4 005 56 480 S3 005	



			Ah A (EN) S6	Ah A (EN) S5	Ah A (EN) S4	Ah A (EN) S3
			0092 ...0	0092 ...0	0092 ...0	0092 ...0

◀ PEUGEOT

3008									
1.6 [T8]	05.09→	BWD					60	540	S4 005
						63	610	S5 005	60 540 S4 005
Diesel									
1.6 HDi [T8]	05.09→	BWD				63	610	S5 005	60 540 S4 005
	11.09→	SSJ	70	760	S6 008	70	650	S5 E08	
2.0 HDi [T8]	05.09→	BWD							60 540 S4 005
						77	780	S5 008	74 680 S4 008
HDi HYbrid4 4x4 [T8]	09.10→	BWD	70	760	S6 008				
4007									
2.0 [I3]	11.10→					77	780	S5 008	74 680 S4 008
4x4 [I3]	11.10→					77	780	S5 008	74 680 S4 008
2.4 4x4 [I3]	11.07→								95 830 S4 028
Diesel									
2.2 HDi 4x4 [I3]	09.07→								95 830 S4 028
4008									
Diesel									
1.6/ 1.8 HDi 4x4 [J3]	03.12→		70	760	S6 008				
5008									
1.6 [T8]	09.09→	BWD				63	610	S5 005	60 540 S4 005
THP [T8]	09.09→	BWD							60 540 S4 005
Diesel									
1.6 HDi [T8]	09.09→	BWD				63	610	S5 005	60 540 S4 005
	11.09→	SSJ	70	760	S6 008	70	650	S5 E08	
2.0 HDi [T8]	09.09→	BWD							60 540 S4 005
						77	780	S5 008	74 680 S4 008

PIAGGIO

Porter									
1.0/ 1.3	10.94→								45 300 S3 016
Diesel									
1.4	10.99→					63	610	S5 005	60 540 S4 005 56 480 S3 005

PONTIAC

Bonneville									
3.8	09.86-08.88					70	630	S4 027	
	09.94-05.05					70	630	S4 027	
Fiero Coupé									
2.8	09.84-08.88					70	630	S4 027	
Firebird Convertible									
3.4	09.93-08.95					70	630	S4 027	
Firebird Coupe									
5.7	10.97-12.02					63	610	S5 006	
Firebird Coupé									
3.1/ 3.2/ 3.4/ 3.8/ 5.0/ 5.7	09.84-08.02					70	630	S4 027	
Grand Am									
2.3/ 2.4/ 3.1/ 3.3/ 3.4, V6, 8V, 16V	09.87-08.05					70	630	S4 027	
Grand Am Coupé									
2.3/ 2.4/ 2.5/ 3.4, 16V	09.84-08.05					70	630	S4 027	
Grand Prix									
3.1/ 3.8, Turbo	09.96-08.03					70	630	S4 027	
Grand Prix Coupé									
2.8/ 3.1, Turbo	09.87-08.93					70	630	S4 027	
Trans Sport									
2.3/ 3.1/ 3.4/ 3.8, 16V	09.89-08.99					63	610	S5 006	60 540 S4 006 56 480 S3 006

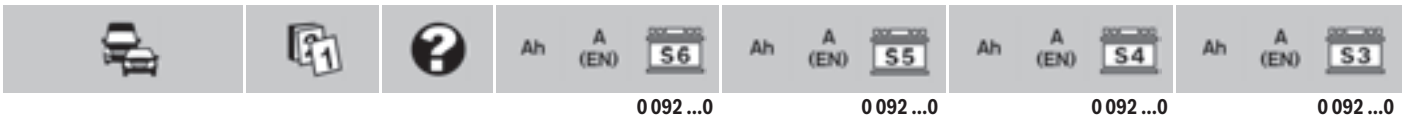

PORSCHE

Boxster											
2.5 [986]	10.96-08.99					85	800	S5 010	80	740	S4 011
						85	800	S5 011	80	740	S4 010
						85	800	S5 011	80	740	S4 011
2.7 [986]	09.99-08.04					85	800	S5 011	80	740	S4 010
2.7/ 2.9/ 3.2/ 3.4 , S [987]	09.04→					85	800	S5 011	80	740	S4 010
2.7/ 3.4 , S [981]	04.12→	80	800	S6 011							
3.2 S [986]	09.99-08.04					85	800	S5 011	80	740	S4 010
3.4 Spyder [987]	09.10→					85	800	S5 010	80	740	S4 010
						85	800	S5 010	80	740	S4 011
Carrera GT											
5.7	10.04-04.06					85	800	S5 011	80	740	S4 010
Cayenne											
3.0/ 4.8 S , S Hybrid [92A]	09.10→	SSJ	105	950	S6 015						
3.2/ 3.6/ 4.5/ 4.8 , GTS, S, Turbo, Turbo S [9PA]	09.02-08.10		95	850	S6 013	110	920	S5 015			
3.6 [92A]	09.10→					77	780	S5 008			
		SSJ	95	850	S6 013						
4.8 GTS [92A]	04.12→		95	850	S6 013						
Turbo [92A]	09.10→	SSJ	95	850	S6 013						
Diesel											
3.0 [9PA]	09.08-08.10		95	850	S6 013	110	920	S5 015			
[92A]	09.10-08.11					77	780	S5 008			
		SSJ	95	850	S6 013						
	06.11→		95	850	S6 013	110	920	S5 015			
Cayman											
2.7/ 2.9/ 3.4 , S, S Sport [987C]	11.05-12.12		70	760	S6 008	85	800	S5 011	80	740	S4 010
3.4 R [987C]	02.10-12.12					85	800	S5 010	80	740	S4 010
Panamera											
3.0/ 4.8 S Hybrid, Turbo S [970]	03.11→		95	850	S6 013						
3.6/ 4.8 , GTS, S [970]	03.09→	SSJ	95	850	S6 013						
Turbo, 4, 4S [970]	03.09→	SSJ	105	950	S6 015						
Diesel											
3.0 [970]	08.11→		95	850	S6 013						
911											
3.3 Turbo	08.82-08.88		70	760	S6 008	85	800	S5 010	74	680	S4 008
			70	760	S6 008	85	800	S5 011	74	680	S4 008
Turbo [964]	12.90-08.92		70	760	S6 008	85	800	S5 010	74	680	S4 008
			70	760	S6 008	85	800	S5 011	74	680	S4 008
Turbo S [964]	12.90-08.92		70	760	S6 008	85	800	S5 010	74	680	S4 008
			70	760	S6 008	85	800	S5 011	74	680	S4 008
			70	760	S6 008	85	800	S5 011	74	680	S4 008
3.4 24V Carrera, 24V Carrera 4 [996]	09.97-08.01		70	760	S6 008	77	780	S5 008	74	680	S4 008
3.4/ 3.8 Carrera, Carrera S, Carrera 4S [991]	12.11→		95	850	S6 013						
3.6 Carrera [997]	08.04-05.08		70	760	S6 008	77	780	S5 008	74	680	S4 008
	06.08→		70	760	S6 008	85	800	S5 011	74	680	S4 008
Carrera, Carrera 4 [996]	09.01-07.04		70	760	S6 008	77	780	S5 008	74	680	S4 008
Carrera 2, Carrera 2RS, Carrera 4 [964]	09.89-08.93		70	760	S6 008	77	780	S5 008	74	680	S4 008
Carrera 4 [993]	09.94-08.95		95	850	S6 013						
	09.95-08.97		70	760	S6 008	77	780	S5 008	74	680	S4 008
Carrera 4 [997]	08.04-05.08		70	760	S6 008	77	780	S5 008	74	680	S4 008
	06.08→		70	760	S6 008	85	800	S5 011	74	680	S4 008
Carrera 4S [993]	09.95-08.97		70	760	S6 008	77	780	S5 008	74	680	S4 008
Carrera 4S [996]	09.01-07.04		70	760	S6 008	77	780	S5 008	74	680	S4 008
	06.02-07.04		70	760	S6 008	77	780	S5 008	74	680	S4 008
GT2 [996]	06.01-09.05		70	760	S6 008	85	800	S5 011	74	680	S4 008

				Ah A (EN) S6	Ah A (EN) S5	Ah A (EN) S4	Ah A (EN) S3
				0092 ...0	0092 ...0	0092 ...0	0092 ...0
◀ PORSCHE							
3.6 GT2 RS [997]	09.10-08.11		95 850	S6 013	100 830	S5 013	95 800 S4 013
GT3 [996]	03.99-08.01		70 760	S6 008	85 800	S5 010	74 680 S4 008 70 640 S3 008
	10.03-09.05		70 760	S6 008	85 800	S5 010	74 680 S4 008
Turbo [964]	02.93-08.93		70 760	S6 008	85 800	S5 010	74 680 S4 008 70 640 S3 008
			70 760	S6 008	85 800	S5 011	74 680 S4 008 70 640 S3 008
Turbo [993]	03.95-08.97		70 760	S6 008	85 800	S5 010	74 680 S4 008 70 640 S3 008
			70 760	S6 008	85 800	S5 011	74 680 S4 008 70 640 S3 008
Turbo Carrera [997]	03.06-08.09		70 760	S6 008	85 800	S5 010	74 680 S4 008
			70 760	S6 008	85 800	S5 011	74 680 S4 008
Turbo GT2 Carrera [993]	01.95-05.97		70 760	S6 008	85 800	S5 010	74 680 S4 008 70 640 S3 008
			70 760	S6 008	85 800	S5 011	74 680 S4 008 70 640 S3 008
Turbo GT2 4 [993]	06.97-08.97		70 760	S6 008	85 800	S5 011	74 680 S4 008 70 640 S3 008
Turbo, Turbo S [996]	06.00-09.05		70 760	S6 008	85 800	S5 011	74 680 S4 008 70 640 S3 008
3.6/ 3.8 Carrera, Carrera RS [993]	09.93-08.97		70 760	S6 008	77 780	S5 008	74 680 S4 008 70 640 S3 008
GT2, GT3 [997]	03.06-08.11		70 760	S6 008	85 800	S5 011	74 680 S4 008 70 640 S3 008
3.8 Carrera GTS, Carrera 4 GTS, Turbo, Turbo S [997]	10.09→		70 760	S6 008	77 780	S5 008	74 680 S4 008
Carrera S [997]	08.04-05.08		70 760	S6 008	77 780	S5 008	74 680 S4 008 70 640 S3 008
	06.08→		70 760	S6 008	85 800	S5 011	74 680 S4 008 70 640 S3 008
Carrera 4S [997]	10.05-05.08		70 760	S6 008	77 780	S5 008	74 680 S4 008 70 640 S3 008
	06.08→		70 760	S6 008	85 800	S5 011	74 680 S4 008 70 640 S3 008
GT3 RS [997]	08.10-08.11		70 760	S6 008	85 800	S5 010	74 680 S4 008
4.0 GT3 RS [997]	07.11-08.12		95 850	S6 013			
911 Cabriolet							
3.4/ 3.6 Carrera 4, Carrera 4S, 24V Carrera, 24V Carrera 4 [996]	02.98-07.04		70 760	S6 008	77 780	S5 008	74 680 S4 008 70 640 S3 008
3.4/ 3.8 Carrera, Carrera S, Carrera 4S [991]	03.12→		95 850	S6 013			
3.6 Carrera [996]	09.01-07.04		70 760	S6 008	77 780	S5 008	74 680 S4 008
	06.02-07.04		70 760	S6 008	77 780	S5 008	74 680 S4 008 70 640 S3 008
Carrera [997]	04.05-05.08		70 760	S6 008	77 780	S5 008	74 680 S4 008 70 640 S3 008
	06.08→		70 760	S6 008	85 800	S5 011	74 680 S4 008 70 640 S3 008
Carrera 4 [997]	08.04-05.08		70 760	S6 008	77 780	S5 008	74 680 S4 008 70 640 S3 008
	06.08→		70 760	S6 008	85 800	S5 011	74 680 S4 008 70 640 S3 008
Turbo Carrera [997]	08.07-08.09		70 760	S6 008	85 800	S5 010	74 680 S4 008 70 640 S3 008
Turbo, Turbo S [996]	10.03-09.05		70 760	S6 008	85 800	S5 011	74 680 S4 008 70 640 S3 008
3.8 Carrera [997]	06.08→		70 760	S6 008	85 800	S5 011	74 680 S4 008 70 640 S3 008
Carrera GTS [997]	10.10→		70 760	S6 008	77 780	S5 008	74 680 S4 008
Carrera S [997]	04.05-05.08		70 760	S6 008	77 780	S5 008	74 680 S4 008
	06.08→		70 760	S6 008	85 800	S5 011	74 680 S4 008 70 640 S3 008
Carrera 4 GTS, Turbo, Turbo S [997]	10.09→		70 760	S6 008	77 780	S5 008	74 680 S4 008
Carrera 4S [997]	10.05-05.08		70 760	S6 008	77 780	S5 008	74 680 S4 008 70 640 S3 008
	06.08→		70 760	S6 008	85 800	S5 011	74 680 S4 008 70 640 S3 008
911 Coupe/Targa							
3.2 Carrera	08.83-07.89		70 760	S6 008	77 780	S5 008	74 680 S4 008 70 640 S3 008
	08.86-07.89		70 760	S6 008	85 800	S5 011	74 680 S4 008 70 640 S3 008
911 Speedster							
3.8 [997]	10.10→		70 760	S6 008	85 800	S5 010	74 680 S4 008 70 640 S3 008
911 Targa							
3.6 , 4 [993]	09.95-08.97		70 760	S6 008	77 780	S5 008	74 680 S4 008 70 640 S3 008
Carrera [996]	12.01-07.04		70 760	S6 008	77 780	S5 008	74 680 S4 008 70 640 S3 008
			70 760	S6 008	85 800	S5 011	74 680 S4 008 70 640 S3 008
3.6/ 3.8 4, 4S [997]	08.06→		70 760	S6 008	85 800	S5 011	74 680 S4 008 70 640 S3 008
924							
2.0	01.76-06.85	VAD			74 750	S5 007	60 540 S4 004 41 360 S3 001
2.5 S	09.85-07.88	VAD			74 750	S5 007	60 540 S4 004
		VAD,XXX					53 470 S3 004

			Ah A (EN) S6	Ah A (EN) S5	Ah A (EN) S4	Ah A (EN) S3
			0 092 ...0	0 092 ...0	0 092 ...0	0 092 ...0

928														
4.7 S	08.83-07.86		70	760	S6 008	85	800	S5 010	74	680	S4 008	70	640	S3 008
5.0 GT	01.89-07.91		70	760	S6 008	77	780	S5 008	74	680	S4 008	70	640	S3 008
S4	08.86-07.91		70	760	S6 008	77	780	S5 008	74	680	S4 008	70	640	S3 008
			70	760	S6 008	85	800	S5 011	74	680	S4 008	70	640	S3 008
S4/CS	08.87-07.89		70	760	S6 008	77	780	S5 008	74	680	S4 008	70	640	S3 008
			70	760	S6 008	85	800	S5 011	74	680	S4 008	70	640	S3 008
5.4 GTS	08.91-11.95		70	760	S6 008	85	800	S5 010	74	680	S4 008	70	640	S3 008
			70	760	S6 008	85	800	S5 011	74	680	S4 008	70	640	S3 008
944														
2.5	01.85-07.88	VAD				74	750	S5 007	60	540	S4 004			
		VAD,XXX										53	470	S3 004
S	08.86-07.88	VAD				74	750	S5 007	60	540	S4 004			
		VAD,XXX										53	470	S3 004
Turbo [951]	08.85-07.91	VAD				74	750	S5 007	60	540	S4 004			
		VAD,XXX										53	470	S3 004
2.7	11.88-07.89	VAD				74	750	S5 007	60	540	S4 004			
		VAD,XXX										53	470	S3 004
3.0 S2	12.88-07.91	VAD				74	750	S5 007	72	680	S4 007	70	640	S3 007
959														
2.8	05.86-07.88		70	760	S6 008	77	780	S5 008	74	680	S4 008	70	640	S3 008
968														
3.0 , Turbo S	08.91-11.95	VAD				74	750	S5 007	72	680	S4 007	70	640	S3 007

PROTON

Arena														
1.5 i	01.01-01.07								60	540	S4 025			
GEN2														
1.3/ 1.6 i	02.04→								60	540	S4 025			
Persona														
1.3/ 1.5/ 1.6/ 1.8 i, i 12V, i 16V [C90 CC0; C90 CC1]	01.93→								60	540	S4 025			
Diesel														
2.0 D, D Turbo [C90 CC1]	12.95→								60	540	S4 025			
Persona Hatchback														
1.3/ 1.5/ 1.6 i, i 16V [C90 CC1]	12.95→								60	540	S4 025			
Diesel														
2.0 D, D Turbo [C90 CC1]	12.95→								60	540	S4 025			
Waja														
1.6 i, i CAMPRO [CF1]	09.00→								60	540	S4 025			
Wira Aeroback														
1.5	05.93-06.01								60	540	S4 025			

RELIANT

Scimitar														
2.9 GTE	10.88-10.98											45	300	S3 017
Scimitar Cabrio														
1.4/ 1.6/ 1.8 SS 1, Turbo SS 1	09.84-11.92											45	300	S3 017
1.4/ 1.8/ 2.0 i Turbo, i 16V	10.93-10.00											45	300	S3 017
2.8	03.80-12.85											45	300	S3 017
Scimitar Kombi														
2.8	10.80-09.86											45	300	S3 017

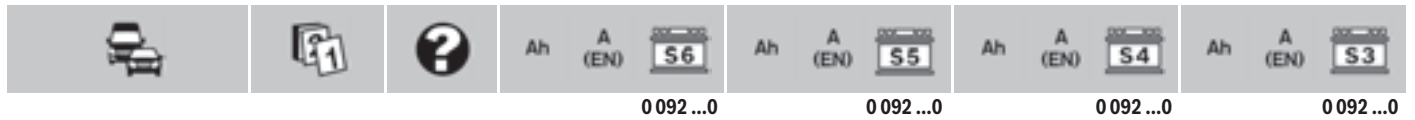

RENAULT

Alpine														
A 310 V6	09.76-06.85	VAD				63	610	S5 005	60	540	S4 005	56	480	S3 005
A 610/ 2.5/ 2.9 , i Turbo, 3.0i Turbo [; D503]	03.85-12.95								70	630	S4 026			
Avantime														
2.0 16V Turbo [XEO]	09.01-12.03		70	760	S6 008	77	780	S5 008	74	680	S4 008			
3.0 V6 24V [XEO]	09.01-12.03		70	760	S6 008	77	780	S5 008	72	680	S4 007			
Diesel														
2.2 DCI [XEO]	12.01-12.03					74	750	S5 007	72	680	S4 007			
Clio I														
1.1/ 1.2/ 1.4 [X57]	06.90-02.98					54	530	S5 002	52	470	S4 002	45	400	S3 002
1.2 i [X57]	06.90-02.98					54	530	S5 002	52	470	S4 002	45	400	S3 002
1.4 i [X57]	04.90-02.98					63	610	S5 005	52	470	S4 002	45	400	S3 002
1.7 [X57]	06.90-03.96					63	610	S5 005	52	470	S4 002	45	400	S3 002
1.8 i [X57]	06.90-02.98					63	610	S5 005	52	470	S4 002	45	400	S3 002
						63	610	S5 005	52	470	S4 002	53	500	S3 004
i 16V [X57]	03.91-03.96					63	610	S5 005	52	470	S4 002	45	400	S3 002
						63	610	S5 005	52	470	S4 002	53	500	S3 004
2.0 i Williams [X57]	07.92-03.96					54	530	S5 002	52	470	S4 002	45	400	S3 002
Diesel														
1.9 D [; X57]	06.90→		70	760	S6 008	77	780	S5 008	74	680	S4 008	70	640	S3 007
Clio II														
1.0 i [BB./CB./SB.]	03.99-11.04					52	520	S5 001	44	440	S4 001	41	360	S3 001
i 16V [BB./CB./SB.]	06.01-11.04					54	530	S5 002	52	470	S4 002			
1.2 [BB./CB./SB.]	10.99→					52	520	S5 001	44	440	S4 001	41	360	S3 001
i [BB./CB./SB.]	03.98-10.07					54	530	S5 002	52	470	S4 002	45	400	S3 002
i 16V [BB./CB./SB.]	03.00-03.04					54	530	S5 002	52	470	S4 002			
	04.04-10.07					52	520	S5 001	44	440	S4 001	41	360	S3 001
16V [BB./CB./SB.]	10.03→					52	520	S5 001	44	440	S4 001	41	360	S3 001
1.4 i 16V [BB./CB./SB.]	10.99-10.07					63	610	S5 005	52	470	S4 002	45	400	S3 002
	05.00-10.07					63	610	S5 005	44	440	S4 001	41	360	S3 001
1.4/ 1.6 i [BB./CB./SB.]	03.98-10.07					63	610	S5 005	52	470	S4 002	45	400	S3 002
1.6 i 16V [BB./CB./SB.]	06.98-10.07					63	610	S5 005	52	470	S4 002	45	400	S3 002
2.0 16V [BB./CB./SB.]	03.99-10.07					54	530	S5 002	52	470	S4 002	45	400	S3 002
3.0 24V Sport [BB./CB./SB.]	09.00-06.05					74	750	S5 007	72	680	S4 007			
Diesel														
1.5 dCi [BB./CB./SB.]	06.01-10.07		70	760	S6 008	77	780	S5 008	74	680	S4 008			
	06.01→					61	600	S5 004	60	540	S4 004			
1.9 D [BB./CB./SB.]	03.98-10.07					63	610	S5 005	60	540	S4 005	56	480	S3 005
D DTI [BB./CB./SB.]	03.99-10.07		70	760	S6 008	77	780	S5 008	60	540	S4 005	70	640	S3 008
	08.00-10.07		70	760	S6 008	77	780	S5 008	60	540	S4 005			
Clio III														
1.2 [BR/CR]	06.05→					61	600	S5 004	44	440	S4 001	41	360	S3 001
	08.07→					61	600	S5 004	60	540	S4 004			
TCe [BR/CR]	08.07→					61	600	S5 004	44	440	S4 001	41	360	S3 001
1.4 [BR/CR]	06.05→					61	600	S5 004	44	440	S4 001	41	360	S3 001
1.6 [BR/CR]	06.05→					61	600	S5 004	60	540	S4 004			
												53	470	S3 004
2.0 [BR/CR]	06.05→					61	600	S5 004	60	540	S4 004			
												53	470	S3 004
R.S. [BR/CR]	11.09→					61	600	S5 004	60	540	S4 004			
												53	470	S3 004
Sport [BR/CR]	12.05→					61	600	S5 004	60	540	S4 004			
												53	470	S3 004
Diesel														
1.5 dCi [BR/CR]	06.05→					74	750	S5 007	60	540	S4 004			
						74	750	S5 007	60	540	S4 004	70	640	S3 007
	11.05→					74	750	S5 007	72	680	S4 007			

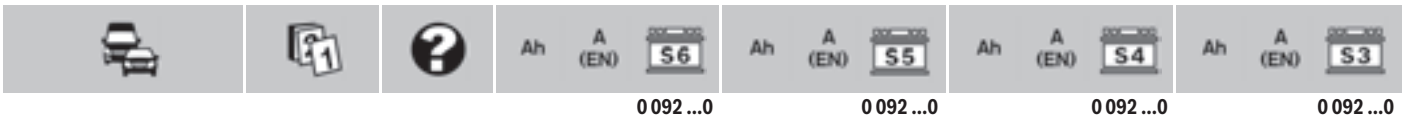

Clio III Grandtour														
1.2 [KR]	08.07→				52	520	S5 001	44	440	S4 001	41	360	S3 001	
TCe [KR]	08.07→				61	600	S5 004	60	540	S4 004				
				XXX							53	470	S3 004	
1.4 [KR]	08.07→				52	520	S5 001	44	440	S4 001				
1.6 [KR]	08.07→				74	750	S5 007	60	540	S4 005	56	480	S3 005	
16V [KR]	08.07-01.10				63	610	S5 005	60	540	S4 005				
Diesel														
1.5 dCi [KR]	08.07→				85	800	S5 011	60	540	S4 005	56	480	S3 005	
	11.10→				74	750	S5 007	72	680	S4 007				
Clio IV														
0.9 [BH]	05.12→		70	760	S6 008									
1.2 [BH]	05.12→					54	530	S5 002	52	470	S4 002			
Diesel														
1.5 dCi [BH]	05.12→		70	760	S6 008									
Duster														
1.6 [HS]	03.12→				54	530	S5 002	52	470	S4 002				
2.0 [HS]	03.12→				63	610	S5 005	60	540	S4 005				
Diesel														
1.5 dCi 4x4 [HS]	03.12→				63	610	S5 005	60	540	S4 005				
Espace I														
2.0 [J11/13]	07.84-12.90				63	610	S5 005	52	470	S4 002	45	400	S3 002	
i [J11/13]	06.87-12.90				63	610	S5 005	52	470	S4 002	45	400	S3 002	
i Quadra [J11/13]	01.88-12.90				63	610	S5 005	52	470	S4 002	45	400	S3 002	
2.2 i [J11/13]	07.86-12.90				63	610	S5 005	52	470	S4 002	45	400	S3 002	
					63	610	S5 005	52	470	S4 002	53	500	S3 004	
i Quadra [J11/13]	01.88-12.90				63	610	S5 005	52	470	S4 002	45	400	S3 002	
					63	610	S5 005	52	470	S4 002	53	500	S3 004	
Diesel														
2.1 D Turbo [J11/13]	10.84-12.90		70	760	S6 008	77	780	S5 008	74	680	S4 008	70	640	S3 007
Espace II														
2.0/ 2.2/ 2.9 i, i 4x4 [J63]	01.91-09.96		70	760	S6 008	77	780	S5 008	74	680	S4 008	70	640	S3 007
Diesel														
2.1 D Turbo, D Turbo 4x4 [J63]	01.91-09.96		70	760	S6 008	77	780	S5 008	74	680	S4 008	70	640	S3 007
Espace III														
2.0 i [JEO]	10.96-10.02		70	760	S6 008	77	780	S5 008	60	540	S4 005	53	500	S3 004
i GPL [JEO]	02.98-10.02		70	760	S6 008	77	780	S5 008	60	540	S4 004			
				XXX							53	470	S3 004	
i 16V [JEO]	10.98-10.02		70	760	S6 008	77	780	S5 008	60	540	S4 004			
				XXX							53	470	S3 004	
3.0 i V6, i V6 24V [JEO]	10.96-10.02		70	760	S6 008	77	780	S5 008	74	680	S4 008	70	640	S3 007
Diesel														
1.9/ 2.2 D Turbo, dCi, dTi [JEO]	10.96-10.02		70	760	S6 008	77	780	S5 008	74	680	S4 008	70	640	S3 007
Espace IV														
2.0/ 3.5, TCe, Turbo, 16V [JKO]	11.02→				74	750	S5 007	72	680	S4 007				
Diesel														
1.9 dCi [JKO]	11.02-12.06		70	760	S6 008	85	800	S5 011	74	680	S4 008	70	640	S3 007
2.0 dCi [JKO]	05.05→				70	760	S6 008	85	800	S5 010	80	740	S4 010	
					70	760	S6 008	85	800	S5 011	80	740	S4 010	
					70	760	S6 008	85	800	S5 011	80	740	S4 010	
					70	760	S6 008	85	800	S5 011	80	740	S4 010	
	01.12→				70	760	S6 008	85	800	S5 010	80	740	S4 010	
2.2 dCi [JKO]	11.02-12.06		70	760	S6 008	85	800	S5 010	80	740	S4 011			
					70	760	S6 008	85	800	S5 011	80	740	S4 010	
					70	760	S6 008	85	800	S5 011	80	740	S4 011	
	11.02→				85	800	S5 011	80	740	S4 010				
3.0 dCi [JKO]	11.02→				85	800	S5 011	80	740	S4 010				
Express, Extra, Rapid														
1.0/ 1.1/ 1.2/ 1.4, i [F40]	03.86-10.97				54	530	S5 002	52	470	S4 002	45	400	S3 002	



			Ah	A (EN)	S6	Ah	A (EN)	S5	Ah	A (EN)	S4	Ah	A (EN)	S3			
		0092 ...0				0092 ...0				0092 ...0				0092 ...0			
RENAULT																	
Diesel																	
1.6/ 1.9 D [F40]	03.86-10.97	70	760	S6 008	77	780	S5 008	74	680	S4 008	70	640	S3 007				
Fluence																	
1.6/ 2.0 [L3]	11.09→				52	520	S5 001	44	440	S4 001	41	360	S3 001				
Diesel																	
1.5 dCi [L3]	11.09→	70	760	S6 008	77	780	S5 008	74	680	S4 008	70	640	S3 007				
1.6 dCi [L3]	11.12→				52	520	S5 001	44	440	S4 001	41	360	S3 001				
Fuego																	
1.4/ 1.6	03.80-10.85										45	300	S3 016				
1.6/ 2.2 i, i Turbo, Turbo	09.83-10.85				54	530	S5 002	52	470	S4 002	45	400	S3 002				
2.0	10.80-10.85				54	530	S5 002	52	470	S4 002	45	400	S3 002				
Kangoo																	
Diesel																	
1.9 D	01.99→				63	610	S5 005	60	540	S4 005							
Kangoo I																	
1.0 i [FC./KC.]	09.98-12.07				63	610	S5 005	52	470	S4 002	45	400	S3 002				
i 16V [FC./KC.]	02.01-12.07				63	610	S5 005	52	470	S4 002							
1.2 GPL [FC./KC.]	10.97-12.07				63	610	S5 005	44	440	S4 001	41	360	S3 001				
i [FC./KC.]	10.97-12.07				63	610	S5 005	44	440	S4 001	41	360	S3 001				
	03.02-12.07				61	600	S5 004	44	440	S4 001	41	360	S3 001				
					63	610	S5 005	52	470	S4 002	45	400	S3 002				
i 16V [FC./KC.]	05.00-12.07				61	600	S5 004	44	440	S4 001	41	360	S3 001				
1.4 i [FC./KC.]	10.97-12.07				63	610	S5 005	44	440	S4 001	41	360	S3 001				
1.6 i [FC./KC.]	09.99-12.07				63	610	S5 005	52	470	S4 002	45	400	S3 002				
	09.01-12.07				63	610	S5 005	52	470	S4 002							
i 4x4 [FC./KC.]	06.00-12.07				63	610	S5 005	52	470	S4 002							
					63	610	S5 005	52	470	S4 002	45	400	S3 002				
Diesel																	
1.5 DCI [FC./KC.]	05.00-12.07	70	760	S6 008	77	780	S5 008	60	540	S4 005	70	640	S3 008				
	02.01-12.07	70	760	S6 008	77	780	S5 008	72	680	S4 007	70	640	S3 007				
		70	760	S6 008	77	780	S5 008	74	680	S4 008	70	640	S3 007				
	04.05-12.07	70	760	S6 008	77	780	S5 008	74	680	S4 008							
1.9 D [FC./KC.]	10.97-12.07	70	760	S6 008	77	780	S5 008	60	540	S4 005	70	640	S3 008				
		70	760	S6 008	77	780	S5 008	74	680	S4 008	70	640	S3 007				
	01.98-12.07				77	780	S5 008	74	680	S4 008	70	640	S3 008				
		70	760	S6 008	77	780	S5 008	60	540	S4 005							
		SSJ	70	760	S6 008												
DCI [FC./KC.]	05.00-12.07	70	760	S6 008	77	780	S5 008	60	540	S4 005	70	640	S3 008				
DCI 4x4 [FC./KC.]	05.00-12.07	70	760	S6 008	77	780	S5 008	60	540	S4 005	70	640	S3 008				
DTI [FC./KC.]	09.98-12.07	70	760	S6 008	77	780	S5 008	60	540	S4 005	70	640	S3 008				
	02.00-12.07	70	760	S6 008	77	780	S5 008	60	540	S4 005							
DTI 4x4 [FC./KC.]	05.00-12.07	70	760	S6 008	77	780	S5 008	60	540	S4 005	70	640	S3 008				
Kangoo II																	
1.6 [FW/KW]	01.08→				63	610	S5 005	52	470	S4 002	45	400	S3 002				
16V [FW/KW]	01.08→				54	530	S5 002	52	470	S4 002							
					63	610	S5 005	52	470	S4 002	45	400	S3 002				
Diesel																	
1.5 dCi [FW/KW]	03.11→				85	800	S5 011	72	680	S4 007	70	640	S3 007				
DCI [FW/KW]	01.08→				63	610	S5 005	60	540	S4 005							
					77	780	S5 008										
		70	760	S6 008	77	780	S5 008	74	680	S4 008	70	640	S3 008				
		70	760	S6 008	85	800	S5 011	74	680	S4 008	70	640	S3 008				
Koleos																	
2.5 , 4x4 [HY]	09.08→								70	630	S4 026						
Diesel																	
2.0 dCi [HY]	09.08→				77	780	S5 008	74	680	S4 008	70	640	S3 008				
		70	760	S6 008	77	780	S5 008	74	680	S4 008	70	640	S3 008				
		SSJ	70	760	S6 008												
dCi 4x4 [HY]	09.08→				77	780	S5 008	74	680	S4 008	70	640	S3 008				
		70	760	S6 008	77	780	S5 008	74	680	S4 008	70	640	S3 008				
		SSJ	70	760	S6 008												

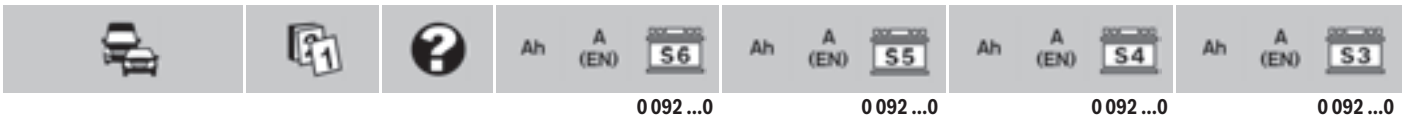

Laguna I													
1.6 i 16V [B56]	05.98-02.01	70	760	S6 008	77	780	S5 008	74	680	S4 008	53	500	S3 004
		70	760	S6 008	77	780	S5 008	74	680	S4 008	70	640	S3 007
1.8 GPL [B56]	09.95-02.01				63	610	S5 005	52	470	S4 002	45	400	S3 002
					63	610	S5 005	52	470	S4 002	53	500	S3 004
i [B56]	01.94-03.01				63	610	S5 005	52	470	S4 002	45	400	S3 002
i 16V [B56]	05.98-02.01	70	760	S6 008	77	780	S5 008	72	680	S4 007	53	500	S3 004
		70	760	S6 008	77	780	S5 008	72	680	S4 007	70	640	S3 007
2.0 i [B56]	01.94-02.01				63	610	S5 005	60	540	S4 005	53	500	S3 004
					63	610	S5 005	60	540	S4 005	56	480	S3 005
i 16V [B56]	09.95-02.01				63	610	S5 005	60	540	S4 005	53	500	S3 004
i 16V [556]	09.99-02.01				63	610	S5 005	60	540	S4 005	56	480	S3 005
					63	610	S5 005	60	540	S4 005	53	500	S3 004
3.0 i [B56]	01.94-02.01				63	610	S5 005	60	540	S4 005	56	480	S3 005
		i 24V [B56]	03.97-02.01				63	610	S5 005	60	540	S4 005	56
Diesel													
1.9 DCI, DTI [B56]	10.97-02.01	70	760	S6 008	77	780	S5 008	72	680	S4 007	70	640	S3 007
2.2 D, D Turbo [B56]	01.94-02.01	70	760	S6 008	77	780	S5 008	74	680	S4 008	70	640	S3 007
Laguna I Grandtour													
1.6 i 16V [K56]	05.98-02.01	70	760	S6 008	77	780	S5 008	74	680	S4 008	53	500	S3 004
		70	760	S6 008	77	780	S5 008	74	680	S4 008	70	640	S3 007
1.8 GPL [K56]	09.95-02.01	70	760	S6 008	77	780	S5 008	74	680	S4 008	53	500	S3 004
		70	760	S6 008	77	780	S5 008	74	680	S4 008	70	640	S3 007
i [K56]	09.95-02.01				63	610	S5 005	52	470	S4 002	45	400	S3 002
i 16V [K56]	05.98-02.01				63	610	S5 005	52	470	S4 002	45	400	S3 002
					63	610	S5 005	52	470	S4 002	53	500	S3 004
2.0 i [K56]	09.95-02.01				63	610	S5 005	60	540	S4 005	53	500	S3 004
					63	610	S5 005	60	540	S4 005	56	480	S3 005
i 16V [A56]	09.99-02.01				63	610	S5 005	60	540	S4 005	53	500	S3 004
i 16V [K56]	09.95-02.01				63	610	S5 005	60	540	S4 005	56	480	S3 005
					63	610	S5 005	60	540	S4 005	53	500	S3 004
3.0 i [K56]	03.96-02.01				63	610	S5 005	60	540	S4 005	56	480	S3 005
		i 24V [K56]	03.97-02.01				63	610	S5 005	60	540	S4 005	56
Diesel													
1.9 DCI, DTI [K56; S56]	10.97-02.01	70	760	S6 008	77	780	S5 008	72	680	S4 007	70	640	S3 007
2.2 D, D Turbo [K56; S56]	02.95-02.01	70	760	S6 008	77	780	S5 008	74	680	S4 008	70	640	S3 007
Laguna II													
1.6 16V [BG.]	03.01-09.07				74	750	S5 007	60	540	S4 004			
		XXX									53	470	S3 004
1.8 16V [BG.]	03.01-12.05				74	750	S5 007	60	540	S4 004	53	500	S3 004
					61	600	S5 004	60	540	S4 004			
					74	750	S5 007	60	540	S4 004			
		XXX									53	470	S3 004
2.0 T [BG.]	07.02-09.07				74	750	S5 007	60	540	S4 004			
											53	470	S3 004
		16V [BG.]	03.01-09.07				74	750	S5 007	60	540	S4 004	
		XXX									53	470	S3 004
16V IDE [BG.]	03.01-09.07				74	750	S5 007	60	540	S4 004			
					74	750	S5 007	60	540	S4 004	53	500	S3 004
		XXX									53	470	S3 004
3.0 V6 24V [BG.]	03.01-09.07				74	750	S5 007	72	680	S4 007			
Diesel													
1.9 DCI [BG.]	03.01-09.07				74	750	S5 007	72	680	S4 007			
					74	750	S5 007	72	680	S4 007	70	640	S3 007
2.0 DCI [BG.]	09.04-09.07				74	750	S5 007	72	680	S4 007			
2.2 DCI [BG.]	03.01-09.07				74	750	S5 007	72	680	S4 007			
					74	750	S5 007	72	680	S4 007	70	640	S3 007
		07.02-09.07	70	760	S6 008	77	780	S5 008	72	680	S4 007	70	640

			Ah A (EN) S6	Ah A (EN) S5	Ah A (EN) S4	Ah A (EN) S3
			0092 ...0	0092 ...0	0092 ...0	0092 ...0

◀ RENAULT

Laguna II Grandtour											
1.6 16V [KG.]	03.01-09.07				74	750	S5 007	60	540	S4 004	
		XXX									53 470 S3 004
1.8 16V [KG.]	03.01-12.05				74	750	S5 007	60	540	S4 004	53 500 S3 004
	03.01-09.07				74	750	S5 007	60	540	S4 004	
		XXX									53 470 S3 004
	12.01-09.07				61	600	S5 004	60	540	S4 004	
2.0 T [KG.]	07.02-09.07				74	750	S5 007	60	540	S4 004	
		XXX									53 470 S3 004
	01.05-09.07				74	750	S5 007	60	540	S4 004	53 500 S3 004
16V [KG.]	03.01-09.07				74	750	S5 007	60	540	S4 004	
		XXX									53 470 S3 004
16V IDE [KG.]	03.01-09.07				74	750	S5 007	60	540	S4 004	
					74	750	S5 007	60	540	S4 004	53 500 S3 004
		XXX									53 470 S3 004
3.0 V6 24V [KG.]	03.01-09.07				74	750	S5 007	72	680	S4 007	
Diesel											
1.9 DCi [KG.]	03.01-12.05				74	750	S5 007	72	680	S4 007	70 640 S3 007
	03.01-09.07				74	750	S5 007	72	680	S4 007	
2.0 DCi [KG.]	09.04-09.07				74	750	S5 007	72	680	S4 007	
2.2 DCi [KG.]	03.01-09.07				74	750	S5 007	72	680	S4 007	
					74	750	S5 007	72	680	S4 007	70 640 S3 007
Laguna III											
1.6/ 2.0/ 3.5 [BT]	10.07→				63	610	S5 005	60	540	S4 005	
2.0 TCe [BT]	10.07→				63	610	S5 005	60	540	S4 005	
	02.08→		70	760	S6 008	77	780	S5 008	74	680	S4 008
Diesel											
1.5 dCi [BT]	07.07→		70	760	S6 008	85	800	S5 010	80	740	S4 010
2.0 dCi [BT]	10.07→		70	760	S6 008	85	800	S5 010	80	740	S4 010
			70	760	S6 008	85	800	S5 011	74	680	S4 008
	02.08→		70	760	S6 008	77	780	S5 008	74	680	S4 008
3.0 dCi [BT]	02.08→		70	760	S6 008	85	800	S5 010	80	740	S4 010
Laguna III Coupé											
2.0 TCe [DT]	02.08→				63	610	S5 005	60	540	S4 005	
			70	760	S6 008	77	780	S5 008	74	680	S4 008
3.5 [DT]	02.08→				63	610	S5 005	60	540	S4 005	70 640 S3 008
Diesel											
2.0 dCi [DT]	02.08→		70	760	S6 008	77	780	S5 008	74	680	S4 008
			70	760	S6 008	85	800	S5 010	80	740	S4 010
3.0 dCi [DT]	02.08→		70	760	S6 008	85	800	S5 010	80	740	S4 010
Laguna III Grandtour											
1.6/ 2.0 [KT]	10.07→				63	610	S5 005	60	540	S4 005	
2.0 TCe [KT]	10.07→				63	610	S5 005	60	540	S4 005	
	02.08→		70	760	S6 008	77	780	S5 008	74	680	S4 008
3.5 [KT]	02.08→				77	780	S5 008	74	680	S4 008	
Diesel											
1.5 dCi [KT]	07.07→		70	760	S6 008	85	800	S5 010	80	740	S4 010
2.0 dCi [KT]	10.07→		70	760	S6 008	85	800	S5 010	80	740	S4 010
			70	760	S6 008	85	800	S5 011	74	680	S4 008
	02.08→		70	760	S6 008	77	780	S5 008	74	680	S4 008
3.0 dCi [KT]	02.08→		70	760	S6 008	85	800	S5 010	80	740	S4 010
Latitude											
2.0 [L7]	09.10→				63	610	S5 005	60	540	S4 005	
Diesel											
2.0 dCi [L7]	09.10→				77	780	S5 008	74	680	S4 008	
3.0 dCi [L7]	09.10→				85	800	S5 010	80	740	S4 010	
Logan											
1.4/ 1.6 , 16V, 16V Hi-Flex [LS; LSR2]	07.04→				63	610	S5 005	60	540	S4 005	
Diesel											
1.5 dCi [LS]	06.05→				63	610	S5 005	60	540	S4 005	
	10.05→				61	600	S5 004				
		XXX									53 470 S3 004

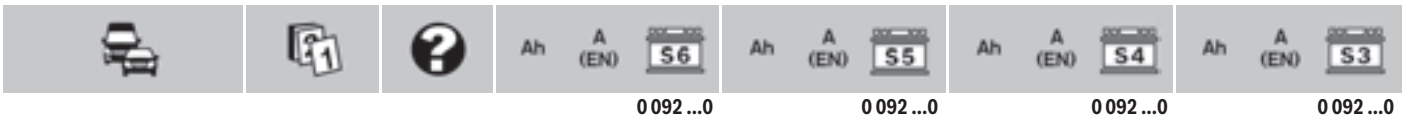

Logan MCV											
1.4 [KS/FS]	01.07→					54	530	S5 002	52	470	S4 002
1.6 , 16V [KS; KS/FS]	01.07→					63	610	S5 005	60	540	S4 005
Diesel											
1.5 dCi [KS]	01.07→					61	600	S5 004			
		XXX									
dCi [KS/FS]	01.07→		70	760	S6 008	77	780	S5 008	74	680	S4 008
									53	470	S3 004
Mascott											
Diesel											
90	01.99-06.04		95	850	S6 013				95	800	S4 013
			95	850	S6 013	100	830	S5 013	95	800	S4 013
110	01.99-06.04		95	850	S6 013				95	800	S4 013
			95	850	S6 013	100	830	S5 013	95	800	S4 013
.60	01.99-06.04		95	850	S6 013	100	830	S5 013	95	800	S4 013
130/ 140	01.99-06.04		95	850	S6 013	100	830	S5 013	95	800	S4 013
Master											
P28/ T28 -35	09.80-09.97					63	610	S5 005	60	540	S4 005
									56	480	S3 005
Diesel											
P28/ T28 -35, -35D	09.80-09.97		63	610	S5 005	60	540	S4 005	56	480	S3 005
1.9 dCi 80 [X70]	05.00-10.06		95	850	S6 013	100	830	S5 013	95	800	S4 013
	04.01-10.06					100	830	S5 013	74	680	S4 008
dTi 80 [X70]	01.00-09.03					100	830	S5 013	74	680	S4 008
2.2 dCi 90 [X70]	01.00-10.06					100	830	S5 013	74	680	S4 008
	05.00-10.06		95	850	S6 013	100	830	S5 013	95	800	S4 013
									90	720	S3 013
2.3 dCi	02.10→					100	830	S5 013	95	800	S4 013
			95	850	S6 013	100	830	S5 013	95	800	S4 013
2.5 dCi 16V [ADCU]	10.04-02.12					100	830	S5 013	74	680	S4 008
dCi 90 [X70]	05.00-09.03					100	830	S5 013	74	680	S4 008
			95	850	S6 013	100	830	S5 013	95	800	S4 013
									90	720	S3 013
dCi 100	11.06-04.10		95	850	S6 013	100	830	S5 013	95	800	S4 013
dCi 100 [X70]	10.03-10.06		95	850	S6 013	100	830	S5 013	95	800	S4 013
dCi 110 [X70]	10.03-10.06					100	830	S5 013	74	680	S4 008
dCi 120 [X70]	07.02-10.06		95	850	S6 013	100	830	S5 013	95	800	S4 013
	10.03-10.06					100	830	S5 013	74	680	S4 008
dCi 120, dCi 120 FAP, dCi 150 FAP	11.06-04.10					100	830	S5 013	74	680	S4 008
2.5/ 2.8 D [X70]	10.97-10.04					100	830	S5 013	74	680	S4 008
2.8 dTi 110 [X70]	10.97-09.03		95	850	S6 013	100	830	S5 013	95	800	S4 013
	01.98-09.03					100	830	S5 013	95	800	S4 013
dTi 120 [X70]	10.97-09.03					100	830	S5 013	95	800	S4 013
			95	850	S6 013	100	830	S5 013	95	800	S4 013
									90	720	S3 013
3.0 dCi 140 [X70]	10.03-10.06		95	850	S6 013	100	830	S5 013	95	800	S4 013
									90	720	S3 013
Megane											
1.6 i [BA10]	09.97-09.07					54	530	S5 002	52	470	S4 002
									45	400	S3 002
Megane I											
1.4 i [X64]	01.96-10.02					54	530	S5 002	52	470	S4 002
i 16V [X64]	06.98-10.02		61	600	S5 004	52	470	S4 002	45	400	S3 002
1.6 i [X64]	01.96-02.99					54	530	S5 002	52	470	S4 002
	01.01-10.02					54	530	S5 002	52	470	S4 002
i 16V [X64]	06.98-10.02		54	530	S5 002	52	470	S4 002	45	400	S3 002
1.8 i 16V [X64]	03.99-10.02					54	530	S5 002	52	470	S4 002
						61	600	S5 004	52	470	S4 002
									45	400	S3 002
2.0 i [X64]	01.96-10.02		63	610	S5 005	60	540	S4 005	56	480	S3 005
i 16V [X64]	01.96-10.02		63	610	S5 005	60	540	S4 005	56	480	S3 005
Diesel											
1.9 D, D Turbo [X64]	01.96-10.02		70	760	S6 008	77	780	S5 008	74	680	S4 008
DCI [X64]	03.99-10.02		70	760	S6 008	77	780	S5 008	74	680	S4 008
			70	760	S6 008	77	780	S5 008	74	680	S4 008
DTI [X64]	06.97-10.02		70	760	S6 008	77	780	S5 008	74	680	S4 008
	03.99-10.02		70	760	S6 008	77	780	S5 008	74	680	S4 008
Megane I Cabrio											
1.4 i 16V [X64]	03.99-09.03		61	600	S5 004	52	470	S4 002	45	400	S3 002
1.6 i [X64]	09.96-09.03		54	530	S5 002	52	470	S4 002	45	400	S3 002

			Ah A (EN) S6			Ah A (EN) S5			Ah A (EN) S4			Ah A (EN) S3		
			0 092 ...0			0 092 ...0			0 092 ...0			0 092 ...0		
◀ RENAULT														
1.6 i 16V [X64]	03.99-09.03		70	760	S6 008	77	780	S5 008	52	470	S4 002	45	400	S3 002
	05.00-09.03		70	760	S6 008	77	780	S5 008	74	680	S4 008	70	640	S3 007
2.0 i [X64]	09.96-09.03					63	610	S5 005	60	540	S4 005	56	480	S3 005
i 16V [X64]	09.96-09.03					63	610	S5 005	60	540	S4 005	56	480	S3 005
	01.01-09.03		70	760	S6 008	77	780	S5 008	60	540	S4 005	56	480	S3 005
i 16V IDE [X64]	03.99-09.03		70	760	S6 008	77	780	S5 008	60	540	S4 005	56	480	S3 005
Megane I Classic														
1.4 i [X64]	09.96-09.03					54	530	S5 002	52	470	S4 002	45	400	S3 002
	05.00-09.03					61	600	S5 004	52	470	S4 002	45	400	S3 002
i 16V [X64]	03.99-09.03					61	600	S5 004	52	470	S4 002	45	400	S3 002
1.6 i [X64]	09.96-09.03					54	530	S5 002	52	470	S4 002	45	400	S3 002
	10.99-09.03		70	760	S6 008	77	780	S5 008	72	680	S4 007	70	640	S3 007
	05.00-09.03		70	760	S6 008	77	780	S5 008	52	470	S4 002	45	400	S3 002
			70	760	S6 008	77	780	S5 008	72	680	S4 007			
i 16V [X64]	08.98-09.03		70	760	S6 008	77	780	S5 008	52	470	S4 002	45	400	S3 002
1.8 i [X64]	05.00-09.03		70	760	S6 008	77	780	S5 008	52	470	S4 002	45	400	S3 002
2.0 i [X64]	09.96-09.03					63	610	S5 005	60	540	S4 005	56	480	S3 005
Diesel														
1.9 D, D Turbo, DCI [X64]	09.96-09.03		70	760	S6 008	77	780	S5 008	74	680	S4 008	70	640	S3 007
DTI [X64]	08.97-09.03		70	760	S6 008	77	780	S5 008	74	680	S4 008	70	640	S3 007
	11.00-09.03		70	760	S6 008	77	780	S5 008	60	540	S4 004	70	640	S3 008
Megane I Coupé														
1.4 i 16V [X64]	03.99-10.02					61	600	S5 004	52	470	S4 002	45	400	S3 002
1.6 i [X64]	01.96-10.02					54	530	S5 002	52	470	S4 002	45	400	S3 002
i 16V [X64]	03.99-10.02		70	760	S6 008	77	780	S5 008	52	470	S4 002	45	400	S3 002
	05.00-10.02		70	760	S6 008	77	780	S5 008	74	680	S4 008	70	640	S3 007
2.0 i [X64]	01.96-10.02					63	610	S5 005	60	540	S4 005	56	480	S3 005
i 16V [X64]	01.96-10.02					63	610	S5 005	60	540	S4 005	56	480	S3 005
	09.01-10.02		70	760	S6 008	77	780	S5 008	60	540	S4 005	56	480	S3 005
i 16V IDE [X64]	03.99-10.02		70	760	S6 008	77	780	S5 008	60	540	S4 005	56	480	S3 005
Diesel														
1.9 DCI, DTI [X64]	06.97-10.02		70	760	S6 008	77	780	S5 008	74	680	S4 008	70	640	S3 007
Megane I Grandtour														
1.4 i 16V [X64]	03.99-09.03					61	600	S5 004	52	470	S4 002	45	400	S3 002
1.4/ 1.6 i [X64]	07.98-09.03					54	530	S5 002	52	470	S4 002	45	400	S3 002
1.6 i 16V [X64]	03.99-09.03		70	760	S6 008	77	780	S5 008	52	470	S4 002	45	400	S3 002
			70	760	S6 008	77	780	S5 008	74	680	S4 008	70	640	S3 007
1.8 i 16V [X64]	10.00-09.03		70	760	S6 008	77	780	S5 008	52	470	S4 002	45	400	S3 002
Diesel														
1.9 D [X64]	03.99-09.03		70	760	S6 008	77	780	S5 008	74	680	S4 008	70	640	S3 007
	01.01-09.03		70	760	S6 008	77	780	S5 008	60	540	S4 004	70	640	S3 008
DCI, DTI [X64]	07.98-09.03		70	760	S6 008	77	780	S5 008	74	680	S4 008	70	640	S3 007
Megane II														
1.4 [LM]	10.03-10.09					74	750	S5 007	44	440	S4 001			
		XXX										53	470	S3 004
1.6 16V [LM]	10.03-10.09					74	750	S5 007	60	540	S4 004			
		XXX										53	470	S3 004
	05.05-10.09					74	750	S5 007	60	540	S4 004	53	500	S3 004
2.0 16V [LM]	09.02-10.09					74	750	S5 007	60	540	S4 004			
		XXX										53	470	S3 004
Diesel														
1.5 DCI [LM]	11.02-10.09					74	750	S5 007	60	540	S4 004			
						74	750	S5 007	60	540	S4 004	70	640	S3 007
1.9 DCI [LM]	10.03-10.09					74	750	S5 007	60	540	S4 004			
2.0 DCI [LM]	09.04-10.09		70	760	S6 008	77	780	S5 008	72	680	S4 007	70	640	S3 008
Megane II Cabrio														
1.6 16V [EM]	10.03-03.10					74	750	S5 007	60	540	S4 004			
		XXX										53	470	S3 004
	05.05-03.10					74	750	S5 007	60	540	S4 004	53	500	S3 004
2.0 T [EM]	10.03-03.10					74	750	S5 007	60	540	S4 004			
		XXX										53	470	S3 004
16V [EM]	10.03-03.10					74	750	S5 007	60	540	S4 004			
		XXX										53	470	S3 004

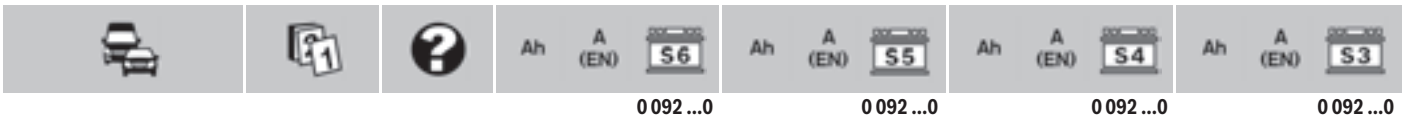

Diesel										
1.5/ 1.9/ 2.0 DCI [EM]	10.03-03.10				74	750	S5 007	60	540	S4 004
Megane II Grandtour										
1.4 16V [KM.]	10.03-05.09				74	750	S5 007	44	440	S4 001
		XXX							53	470
1.6 16V [KM.]	10.03-05.09				74	750	S5 007	44	440	S4 001
					74	750	S5 007	60	540	S4 004
		XXX							53	470
16V Flex-Fuel [KM.]	02.08-05.09				61	600	S5 004	44	440	S4 001
		XXX							53	470
2.0 16V [KM.]	10.03-05.09				74	750	S5 007	60	540	S4 004
		XXX							53	470
Diesel										
1.5/ 1.9/ 2.0 DCI [KM.]	10.03-05.09				74	750	S5 007	60	540	S4 004
Megane II Hatchback										
1.4 16V [BM./CM./GM./SM.]	11.02-10.08				74	750	S5 007	60	540	S4 004
		XXX							53	470
1.6 16V [BM./CM./GM./SM.]	11.02-10.08				74	750	S5 007	60	540	S4 004
					74	750	S5 007	60	540	S4 004
		XXX							53	500
									53	470
	10.05-10.08				61	600	S5 004	60	540	S4 004
16V Flex-Fuel [BM./CM./GM./SM.]	01.07-10.08				61	600	S5 004	60	540	S4 004
		XXX							53	470
2.0 T [BM./CM./GM./SM.]	05.04-10.08				74	750	S5 007	60	540	S4 004
		XXX							53	470
16V [BM./CM./GM./SM.]	11.02-10.08				74	750	S5 007	60	540	S4 004
					74	750	S5 007	60	540	S4 004
		XXX							53	500
									53	470
16V Sport [BM./CM./GM./SM.]	03.03-10.08				74	750	S5 007	60	540	S4 004
		XXX							53	470
Diesel										
1.5/ 1.9/ 2.0 DCI, DCI Sport [BM./CM./GM./SM.]	11.02-10.08				74	750	S5 007	60	540	S4 004
									70	640
Megane III CC										
1.4 [EZ]	10.10→				54	530	S5 002	52	470	S4 002
1.6/ 2.0 [EZ]	10.10→				63	610	S5 005	60	540	S4 005
2.0 TCe [EZ]	10.10→				63	610	S5 005	60	540	S4 005
Diesel										
1.5/ 1.9/ 2.0 dCi [EZ]	10.10→	70	760	S6 008	77	780	S5 008	74	680	S4 008
Megane III Coupé										
1.2/ 1.4/ 1.6 [DZ]	01.09→				52	520	S5 001	44	440	S4 001
2.0 [DZ]	01.09→				61	600	S5 004	60	540	S4 004
R.S. [DZ]	11.09→				63	610	S5 005	60	540	S4 005
	11.11→	70	760	S6 008						
TCe [DZ]	01.09→				61	600	S5 004	60	540	S4 004
Diesel										
1.5 dCi [DZ]	01.09→				61	600	S5 004	60	540	S4 004
					63	610	S5 005	60	540	S4 005
1.6 dCi [DZ]	01.12→	70	760	S6 008						
1.9/ 2.0 dCi [DZ]	01.09→				74	750	S5 007	72	680	S4 007
Megane III Grandtour										
1.2 [KZ]	01.12→	70	760	S6 008						
1.4/ 1.6 [KZ]	06.09→				52	520	S5 001	44	440	S4 001
2.0 [KZ]	06.09→				61	600	S5 004	60	540	S4 004
TCe [KZ]	06.09→				61	600	S5 004	60	540	S4 004
Diesel										
1.5 dCi [KZ]	06.09→				61	600	S5 004	60	540	S4 004
					63	610	S5 005	60	540	S4 005
1.6 dCi [KZ]	01.12→	70	760	S6 008						
1.9 dCi [KZ]	06.09→				74	750	S5 007	72	680	S4 007
2.0 dCi [KZ]	06.09→				74	750	S5 007	72	680	S4 007
	11.10→				77	780	S5 008	74	680	S4 008



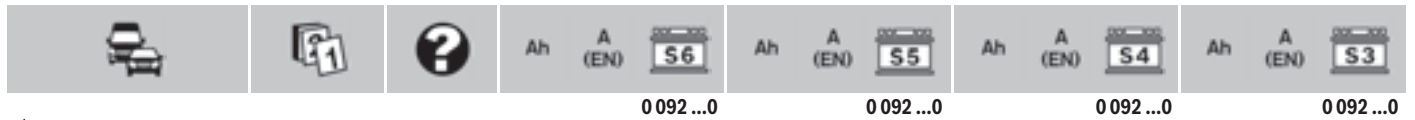

◀ RENAULT

Megane III Hatchback													
1.2 [BZ]	01.12→				74	750	S5 007						
1.4 [BZ]	11.08→				52	520	S5 001	44	440	S4 001			
1.6 [BZ]	11.08→				52	520	S5 001	44	440	S4 001			
					74	750	S5 007						
	11.11→				74	750	S5 007	72	680	S4 007			
					54	530	S5 002	52	470	S4 002			
2.0 [BZ]	11.08→				61	600	S5 004	60	540	S4 004			
TCe [BZ]	11.08→				74	750	S5 007	72	680	S4 007			
Diesel													
1.5 dCi [BZ]	11.08→				52	520	S5 001	44	440	S4 001			
					61	600	S5 004	60	540	S4 004			
					63	610	S5 005	60	540	S4 005			
					77	780	S5 008						
1.6 dCi [BZ]	01.12→	70	760	S6 008									
1.9 dCi [BZ]	11.08→				61	600	S5 004	60	540	S4 004			
					74	750	S5 007						
2.0 dCi [BZ]	11.08→				74	750	S5 007						
	11.10→				77	780	S5 008	74	680	S4 008			
Modus													
1.2 [FP/JP]	09.04→				61	600	S5 004	44	440	S4 001			
		XXX							53	470	S3 004		
	11.04→				61	600	S5 004	60	540	S4 004			
					53	500	S3 004						
TCe [FP/JP]	10.07→				61	600	S5 004	60	540	S4 004			
1.4 [FP/JP]	06.04-12.06				61	600	S5 004	44	440	S4 001			
		XXX							53	470	S3 004		
	07.05-12.06				61	600	S5 004	60	540	S4 004			
					53	500	S3 004						
1.6 [FP/JP]	09.04→				61	600	S5 004	60	540	S4 004			
		XXX							53	470	S3 004		
Diesel													
1.5 dCi [FP/JP]	09.04-12.06				74	750	S5 007	72	680	S4 007			
	09.04→				74	750	S5 007	60	540	S4 004			
	10.10→				61	600	S5 004						
XXX								53	470	S3 004			
Rodeo													
5	09.81-05.87								45	300	S3 016		
Safrane													
2.0 i [B54]	04.92-09.96				63	610	S5 005	60	540	S4 005			
2.0/ 2.5 i 16V, i 20V [B54]	10.96-12.00	70	760	S6 008	77	780	S5 008	60	540	S4 005			
2.2 i [B54]	04.92-09.96	70	760	S6 008	77	780	S5 008	60	540	S4 005			
3.0 i [B54]	04.92-09.96	70	760	S6 008	77	780	S5 008	74	680	S4 008			
	10.96-12.00				74	750	S5 007	72	680	S4 007			
i Biturbo [B54]	02.93-09.96	70	760	S6 008	77	780	S5 008	74	680	S4 008			
i 24V [B54]	03.99-12.00				74	750	S5 007	72	680	S4 007			
Diesel													
2.1 D Turbo [B54]	04.92-09.96	95	850	S6 013	100	830	S5 013	74	680	S4 008			
2.2 12V D Turbo [B54]	10.96-12.00	95	850	S6 013	100	830	S5 013	74	680	S4 008			
2.5 D Turbo [B54]	04.92-09.96	95	850	S6 013	100	830	S5 013	95	800	S4 013			
Sandero													
1.4 [BS]	12.09→				52	520	S5 001	44	440	S4 001			
1.6 [BS]	12.09→				61	600	S5 004	60	540	S4 004			
	11.10→				54	530	S5 002	52	470	S4 002			
16V [BS]	11.10→				54	530	S5 002	52	470	S4 002			
Scenic I													
1.4 i [JA.]	11.96-04.03	70	760	S6 008	77	780	S5 008	60	540	S4 004			
		XXX							53	470	S3 004		
					52	520	S5 001	44	440	S4 001	41	360	S3 001
	02.00-04.03	70	760	S6 008	77	780	S5 008	60	540	S4 004			
1.6 i [JA.]	01.96-04.03	JEA	70	760	S6 008								
					52	520	S5 001	44	440	S4 001	41	360	S3 001
					70	760	S6 008	77	780	S5 008	60	540	S4 004
	03.99-04.03	XXX							53	470	S3 004		

						Ah A (EN) S6		Ah A (EN) S5		Ah A (EN) S4		Ah A (EN) S3	
				0 092 ...0		0 092 ...0		0 092 ...0		0 092 ...0		0 092 ...0	
1.8 i [JA.]	09.00-04.03		70 760	S6 008	77 780	S5 008	60 540	S4 004					
		XXX										53 470	S3 004
2.0 i [JA.]	11.96-04.03		70 760	S6 008	77 780	S5 008	60 540	S4 004				53 500	S3 004
		XXX										53 470	S3 004
	03.99-04.03		70 760	S6 008	77 780	S5 008	60 540	S4 004					
iRX4 [JA.]	06.99-04.03		70 760	S6 008	77 780	S5 008	60 540	S4 004					
		XXX										53 470	S3 004
Diesel													
1.9 D [JA.]	11.96-09.99		70 760	S6 008									
	10.99-04.03				77 780	S5 008	60 540	S4 004					
D Turbo [JA.]	11.96-04.03		70 760	S6 008									
DCI [JA.]	06.97-04.03		70 760	S6 008	77 780	S5 008	60 540	S4 004					
	03.99-04.03		70 760	S6 008	77 780	S5 008	60 540	S4 004			70 640		S3 008
DCI RX4 [JA.]	06.97-04.03		70 760	S6 008	77 780	S5 008	60 540	S4 004					
	06.00-01.03		70 760	S6 008	77 780	S5 008	60 540	S4 004			70 640		S3 008
DTI [JA.]	06.97-02.99		70 760	S6 008	77 780	S5 008	60 540	S4 004					
	03.99-04.03		70 760	S6 008	77 780	S5 008	60 540	S4 004			70 640		S3 008
Scenic II													
1.4 16V [JM]	05.03-04.09				74 750	S5 007	60 540	S4 004					
		XXX										53 470	S3 004
1.6 16V [JM]	05.03-04.09				74 750	S5 007	60 540	S4 004					
		XXX			74 750	S5 007	60 540	S4 004				53 500	S3 004
		XXX										53 470	S3 004
	07.05-04.09				61 600	S5 004	60 540	S4 004					
2.0 16V [JM]	05.03-04.09				74 750	S5 007	60 540	S4 004					
		XXX										53 470	S3 004
16V Turbo [JM]	06.03-04.09				74 750	S5 007	60 540	S4 004					
		XXX										53 470	S3 004
Diesel													
1.5/1.9 DCI [JM]	05.03-04.09				74 750	S5 007	60 540	S4 004			70 640		S3 007
2.0 DCI [JM]	09.04-04.09				74 750	S5 007	60 540	S4 004			70 640		S3 007
			70 760	S6 008	77 780	S5 008	72 680	S4 007			70 640		S3 007
Scenic III													
1.2 [J95]	05.12→		70 760	S6 008									
1.4 [J95]	05.09→				61 600	S5 004	60 540	S4 004					
		XXX										53 470	S3 004
1.6 [J95]	05.09→				61 600	S5 004							
		XXX			61 600	S5 004	60 540	S4 004					
		XXX										53 470	S3 004
	05.12→				61 600	S5 004	60 540	S4 004			53 500		S3 004
2.0 [J95]	05.09→				74 750	S5 007	72 680	S4 007			70 640		S3 007
Diesel													
1.5 dCi [J95]	05.09→				61 600	S5 004	60 540	S4 004					
					63 610	S5 005	60 540	S4 005					
					74 750	S5 007							
					85 800	S5 011							
1.6 dCi [J95]	03.11→	SSJ	70 760	S6 008									
1.9/2.0 dCi [J95]	05.09→				74 750	S5 007	72 680	S4 007					
Sport Spider													
2.0	05.96-10.99				63 610	S5 005	60 540	S4 005			56 480		S3 005
Thalia													
1.0/1.2 i 16V [LB]	06.01-10.07				54 530	S5 002	52 470	S4 002					
1.2 i [LB]	06.01-10.07				54 530	S5 002	52 470	S4 002					
1.2/1.6 [LU]	10.08→				52 520	S5 001	44 440	S4 001					
1.4 [LU]	10.08→				63 610	S5 005	52 470	S4 002			45 400		S3 002
i [LB]	10.99-10.07				63 610	S5 005	52 470	S4 002			45 400		S3 002
i 16V [LB]	06.01-10.07				63 610	S5 005	52 470	S4 002			45 400		S3 002
	11.01-10.07				63 610	S5 005	52 470	S4 002					
1.6 i [LB]	10.99-10.07				63 610	S5 005	52 470	S4 002					
	06.01-10.07				63 610	S5 005	52 470	S4 002			45 400		S3 002
	01.04-10.07				54 530	S5 002	52 470	S4 002					



		Ah A (EN) S6			Ah A (EN) S5			Ah A (EN) S4			Ah A (EN) S3		
		0092 ...0			0092 ...0			0092 ...0			0092 ...0		
RENAULT													
Diesel													
1.5 dCi [LB]	06.01-10.07				61	600	S5 004	60	540	S4 004			
dCi [LU]	10.08→				74	750	S5 007	72	680	S4 007			
1.9 D [LB]	10.99-10.07	70	760	S6 008	77	780	S5 008	60	540	S4 005			
Trafic													
1.4/ 1.6/ 1.7/ 2.0/ 2.2 , i	09.80-12.02				63	610	S5 005	60	540	S4 005	56	480	S3 005
2.0 , 16V [EL./FL./JL.]	06.01→				85	800	S5 011	60	540	S4 004			
Diesel													
1.9/ 2.0 DCI [EL./FL./JL.]	05.01→	70	760	S6 008	85	800	S5 011	74	680	S4 008	70	640	S3 008
1.9/ 2.1/ 2.5 D, D 4x4	09.80-11.03				77	780	S5 008	74	680	S4 008	70	640	S3 008
2.5 DCI [EL./FL./JL.]	06.02-12.06				85	800	S5 011	80	740	S4 010			
	01.06→	70	760	S6 008	85	800	S5 011	74	680	S4 008	70	640	S3 008
Trafic Rodeo													
Diesel													
1.9/ 2.1 D	02.92-11.03				77	780	S5 008	74	680	S4 008	70	640	S3 008
Twingo I													
1.0 i [CO./SO.]	01.00-05.07				52	520	S5 001	44	440	S4 001			
i 16V [CO./SO.]	03.01-05.07				52	520	S5 001	44	440	S4 001			
1.2 i [CO./SO.]	03.93-08.97				54	530	S5 002	52	470	S4 002	45	400	S3 002
	01.96-05.07				52	520	S5 001	44	440	S4 001	45	400	S3 002
	05.98-05.07				54	530	S5 002	44	440	S4 001	41	360	S3 001
	09.98-05.07				52	520	S5 001	44	440	S4 001	41	360	S3 001
					54	530	S5 002	52	470	S4 002	45	400	S3 002
i 16V [CO./SO.]	09.00-05.07				54	530	S5 002	44	440	S4 001	41	360	S3 001
	10.03-05.07				54	530	S5 002	52	470	S4 002			
Twingo II													
1.2 , TCe, 16V [CN/GN]	04.07→				54	530	S5 002	52	470	S4 002			
1.6 R.S. [CN/GN]	07.07→				52	520	S5 001	44	440	S4 001	41	360	S3 001
Diesel													
1.5 dCi [CN/GN]	04.07→				63	610	S5 005	60	540	S4 005			
	04.10→				63	610	S5 005	60	540	S4 005	56	480	S3 005
Vel Satis													
2.0 [BJ]	04.02-12.06				85	800	S5 010	80	740	S4 011			
					85	800	S5 011	72	680	S4 007	70	640	S3 007
					85	800	S5 011	80	740	S4 010			
					85	800	S5 011	80	740	S4 011			
T [BJ]	07.05-12.09				85	800	S5 010	80	740	S4 011			
					85	800	S5 011	80	740	S4 010			
					85	800	S5 011	80	740	S4 011			
3.5 V6 [BJ]	04.02-12.09				85	800	S5 011	72	680	S4 007	70	640	S3 007
	06.05-12.09				85	800	S5 011	80	740	S4 010			
Diesel													
2.0 DCI [BJ]	08.05-12.09				85	800	S5 011	80	740	S4 010			
2.2 DCI [BJ]	04.02-12.09				85	800	S5 011	80	740	S4 010			
					85	800	S5 011	80	740	S4 010	70	640	S3 007
	07.05-12.09				85	800	S5 011	80	740	S4 011			
3.0 DCI V6 [BJ]	04.02-12.09				85	800	S5 011	80	740	S4 010			
Wind													
1.2/ 1.6 [E4]	04.10→				52	520	S5 001	44	440	S4 001			
Winnebago													
2.2 i	03.88-12.00				63	610	S5 005	60	540	S4 005	56	480	S3 005
Diesel													
2.1 D	03.83-06.87	70	760	S6 008	77	780	S5 008	74	680	S4 008	70	640	S3 008
4													
0.8/ 1.0/ 1.1	10.82-12.93										45	300	S3 016
4 (F4/F6)													
0.8/ 1.1 , Pick up [R2106-R2430]	10.76-12.93										45	300	S3 016
5													
1.0	10.79-12.85										45	300	S3 016
	10.84-12.96				54	530	S5 002	52	470	S4 002	45	400	S3 002
1.1	10.79-12.85										45	300	S3 016
	10.84-12.96				54	530	S5 002	52	470	S4 002	45	400	S3 002

		0 092 ...0			0 092 ...0			0 092 ...0			0 092 ...0					
1.2	10.84-12.96				54	530	\$5 002	52	470	\$4 002	45	400	\$3 002			
1.4	10.80-12.85										45	300	\$3 016			
	10.84-12.96				54	530	\$5 002	52	470	\$4 002	45	400	\$3 002			
Alpine Turbo, Turbo 2	12.79-12.85										45	300	\$3 016			
i	10.84-12.96				54	530	\$5 002	52	470	\$4 002	45	400	\$3 002			
Turbo	10.84-12.96				54	530	\$5 002	52	470	\$4 002	45	400	\$3 002			
1.7	06.87-12.96				63	610	\$5 005	52	470	\$4 002	45	400	\$3 002			
i	10.86-12.96				63	610	\$5 005	52	470	\$4 002	45	400	\$3 002			
Diesel																
1.6 D	10.84-12.96	70	760	\$6 008	77	780	\$5 008	74	680	\$4 008	70	640	\$3 007			
6																
1.1	09.80-03.86										45	300	\$3 016			
9																
1.1/1.2/1.4/1.7, i, Turbo	09.81-12.95				54	530	\$5 002	52	470	\$4 002	45	400	\$3 002			
[L42]																
Diesel																
1.6 D [L42]	09.82-12.92	70	760	\$6 008	77	780	\$5 008	74	680	\$4 008	70	640	\$3 007			
11																
1.1/1.2/1.4/1.7, i, Turbo	03.83-03.91				54	530	\$5 002	52	470	\$4 002	45	400	\$3 002			
1.4/1.7 [B37]	01.85-03.95				63	610	\$5 005	52	470	\$4 002	45	400	\$3 002			
Diesel																
1.6 D	03.83-03.91	70	760	\$6 008	77	780	\$5 008	74	680	\$4 008	70	640	\$3 007			
18																
1.6	04.78-02.86										45	300	\$3 016			
1.6/2.2 Injection, Turbo	05.82-02.86				54	530	\$5 002	52	470	\$4 002	45	400	\$3 002			
2.0	11.84-02.86				54	530	\$5 002	52	470	\$4 002	45	400	\$3 002			
Diesel																
2.1 D	11.81-02.86	70	760	\$6 008	77	780	\$5 008	74	680	\$4 008	70	640	\$3 007			
18 Berline																
1.4/1.6	04.78-02.86										45	300	\$3 016			
1.6 i Turbo, Turbo	10.82-09.85				54	530	\$5 002	52	470	\$4 002	45	400	\$3 002			
2.0	10.81-02.86				54	530	\$5 002	52	470	\$4 002	45	400	\$3 002			
Diesel																
2.1 D, D Turbo	10.80-02.86	70	760	\$6 008	77	780	\$5 008	74	680	\$4 008	70	640	\$3 007			
18 Break																
1.4/1.6	04.78-02.86										45	300	\$3 016			
1.6 4x2	04.78-02.86										45	300	\$3 016			
4x4	03.83-02.86										45	300	\$3 016			
1.6/2.2 i, i Turbo, Turbo	10.82-02.86				54	530	\$5 002	52	470	\$4 002	45	400	\$3 002			
2.0 4x2	10.81-02.86				54	530	\$5 002	52	470	\$4 002	45	400	\$3 002			
4x4	03.83-02.86				54	530	\$5 002	52	470	\$4 002	45	400	\$3 002			
Diesel																
2.1 D, D Turbo, D 4x2, D 4x4	10.80-02.86	70	760	\$6 008	77	780	\$5 008	74	680	\$4 008	70	640	\$3 007			
19																
1.2/1.4/1.7 [X53]	09.88-12.01				54	530	\$5 002	52	470	\$4 002	45	400	\$3 002			
i [X53]	09.88-12.01				54	530	\$5 002	52	470	\$4 002	45	400	\$3 002			
1.8 i [X53]	05.92-12.95				63	610	\$5 005	60	540	\$4 005	56	480	\$3 005			
i 16V [X53]	06.89-12.95				63	610	\$5 005	60	540	\$4 005	56	480	\$3 005			
Diesel																
1.9 D, D Turbo [X53]	09.88-12.01	70	760	\$6 008	77	780	\$5 008	74	680	\$4 008	70	640	\$3 007			
19 Cabrio																
1.7 i [X53]	09.88-12.95				54	530	\$5 002	52	470	\$4 002	45	400	\$3 002			
1.8 i [X53]	05.92-12.95				63	610	\$5 005	60	540	\$4 005	56	480	\$3 005			
i 16V [X53]	06.89-12.95				63	610	\$5 005	60	540	\$4 005	56	480	\$3 005			
19 Sedan																
1.8 i	02.93-04.98				54	530	\$5 002	52	470	\$4 002	45	400	\$3 002			
21																
1.4/1.7 [L48]	03.86-12.94				54	530	\$5 002	52	470	\$4 002	45	400	\$3 002			
1.7 i [L48]	03.86-12.94				54	530	\$5 002	52	470	\$4 002	45	400	\$3 002			
2.0 i Turbo [L48]	04.87-03.93				63	610	\$5 005	60	540	\$4 005	56	480	\$3 005			
2.0/2.2 [L48]	03.86-12.94				63	610	\$5 005	60	540	\$4 005	56	480	\$3 005			
i [L48]	07.86-12.94				63	610	\$5 005	60	540	\$4 005	56	480	\$3 005			

			Ah A (EN) S6		Ah A (EN) S5		Ah A (EN) S4		Ah A (EN) S3				
			0092 ...0		0092 ...0		0092 ...0		0092 ...0				
RENAULT													
Diesel													
1.9/2.1 D, D Turbo [L48]	03.86-12.94	70	760	S6 008	77	780	S5 008	74	680	S4 008	70	640	S3 007
21 Fastback													
1.4/1.7 [B48]	09.89-03.93				54	530	S5 002	52	470	S4 002	45	400	S3 002
1.7 i [B48]	09.89-12.93				54	530	S5 002	52	470	S4 002	45	400	S3 002
2.0 [B48]	09.89-12.91				63	610	S5 005	60	540	S4 005	56	480	S3 005
2.0/2.2 i [B48]	09.89-12.93				63	610	S5 005	60	540	S4 005	56	480	S3 005
Diesel													
1.9/2.1 D, D Turbo [B48]	09.89-12.93	70	760	S6 008	77	780	S5 008	74	680	S4 008	70	640	S3 007
21 Nevada													
1.4/1.7 [K48]	06.86-12.95				54	530	S5 002	52	470	S4 002	45	400	S3 002
1.7 i [K48]	06.86-12.95				54	530	S5 002	52	470	S4 002	45	400	S3 002
2.0/2.2 [K48]	06.86-12.95				63	610	S5 005	60	540	S4 005	56	480	S3 005
i [K48]	10.86-12.95				63	610	S5 005	60	540	S4 005	56	480	S3 005
Diesel													
1.9/2.1 D, D Turbo [K48]	10.86-12.95	70	760	S6 008	77	780	S5 008	74	680	S4 008	70	640	S3 007
25													
2.0	01.84-12.92				54	530	S5 002	52	470	S4 002	45	400	S3 002
2.0/2.2 i	01.84-12.92				54	530	S5 002	52	470	S4 002	45	400	S3 002
2.5 i Turbo	10.84-12.92				63	610	S5 005	60	540	S4 005	56	480	S3 005
2.7/2.9 i	01.84-12.92				63	610	S5 005	60	540	S4 005	56	480	S3 005
Diesel													
2.1 D, D Turbo	01.84-12.92	70	760	S6 008	77	780	S5 008	74	680	S4 008	70	640	S3 007

ROLLS-ROYCE

Camargue													
6.8	03.75-06.85							70	630	S4 027			
Corniche													
6.8	03.71-08.94							70	630	S4 027			
V8 Turbo	01.00-12.02							70	630	S4 027			
Ghost													
6.6 [RR4]	12.09→	95	850	S6 013	100	830	S5 013	95	800	S4 013			
Park Ward													
5.4 V12	03.00-12.02							70	630	S4 027			
Phantom													
6.8 [RR1]	03.03→				100	830	S5 013	95	800	S4 013			
Phantom Coupé													
6.8 [RR3]	09.08→				100	830	S5 013	95	800	S4 013			
Phantom Drophead													
6.8 [RR2]	06.07→				100	830	S5 013	95	800	S4 013			
Phantom VI													
6.8	10.78-12.99							70	630	S4 027			
Silver Dawn													
6.8	09.94-08.97							70	630	S4 027			
Silver Seraph													
5.4	03.98-12.02							70	630	S4 027			
Silver Spirit													
6.8	10.80-03.93							70	630	S4 027			
	03.94-05.98							70	630	S4 027			
Silver Spur													
6.8 , Turbo	10.80-12.98							70	630	S4 027			

ROVER

City Rover													
1.4	09.03-05.05				63	610	S5 005	60	540	S4 005			
Maestro													
1.3/1.6/2.0 , i	09.88-12.93				52	520	S5 001	44	440	S4 001	41	360	S3 001
Diesel													
2.0 D, D Turbo	09.88-12.93				52	520	S5 001	44	440	S4 001	41	360	S3 001

			Ah A (EN) S6	Ah A (EN) S5	Ah A (EN) S4	Ah A (EN) S3
			0 092 ...0	0 092 ...0	0 092 ...0	0 092 ...0

Maestro Estate											
Diesel											
2.0 D, D Turbo	09.88-12.93		52	520	S5 001	44	440	S4 001	41	360	S3 001
Mini											
1.0/ 1.3, i	09.88-09.00								45	300	S3 016
Mini Cabrio											
1.3, i	02.90-09.00								45	300	S3 016
Mini Cooper											
1.3, i	02.90-09.00								45	300	S3 016
Mini Cooper Cabrio											
1.3, i	02.90-09.00								45	300	S3 016
Mini De Ville											
1.3 i	09.94-09.96								45	300	S3 016
Mini De Ville Cabrio											
1.3 i	09.94-09.96								45	300	S3 016
Mini Margrave											
1.4 i	09.95-09.00								45	300	S3 016
Mini Retro Rally											
1.3 i	09.94-09.96								45	300	S3 016
Montego											
1.3	09.88-12.93		52	520	S5 001	44	440	S4 001	41	360	S3 001
1.6	09.88-12.93		52	520	S5 001	44	440	S4 001	41	360	S3 001
			52	520	S5 001	44	440	S4 001	53	500	S3 004
Estate	09.88-12.93		52	520	S5 001	44	440	S4 001	41	360	S3 001
			52	520	S5 001	44	440	S4 001	53	500	S3 004
2.0	09.88-12.93		61	600	S5 004	60	540	S4 004	53	500	S3 004
		XXX							53	470	S3 004
EFI	09.88-12.93								53	500	S3 004
i	09.88-12.93		61	600	S5 004	60	540	S4 004			
		XXX							53	470	S3 004
i Estate	09.88-12.93		61	600	S5 004	60	540	S4 004			
		XXX							53	470	S3 004
i Turbo	09.88-12.93		61	600	S5 004	60	540	S4 004			
		XXX							53	470	S3 004
Diesel											
2.0 D Turbo, D Turbo Estate	09.88-12.93		61	600	S5 004	60	540	S4 004			
Serie 200											
211 i	11.95-03.00		52	520	S5 001	44	440	S4 001	41	360	S3 001
213	03.85-09.89		54	530	S5 002	52	470	S4 002	45	400	S3 002
214 i	01.93-03.00		54	530	S5 002	52	470	S4 002	45	400	S3 002
214/ 216 Cabrio, GTi 16V	01.92-11.99		52	520	S5 001	44	440	S4 001	41	360	S3 001
Cabrio											
i 16V	10.89-02.96		54	530	S5 002	52	470	S4 002	45	400	S3 002
S, Si 16V, Vanden Plas EFI, Vanden Plas EFI Estate, Vitesse	03.85-02.96		54	530	S5 002	52	470	S4 002	45	400	S3 002
Si 16V Cabrio, 16V, 16V Coupé	10.92-03.00		52	520	S5 001	44	440	S4 001	41	360	S3 001
216 GTi 16V	09.90-02.96		54	530	S5 002	52	470	S4 002	45	400	S3 002
i 16V Cabrio	03.96-03.00		52	520	S5 001	44	440	S4 001	41	360	S3 001
i 16V Coupé	10.89-02.96		54	530	S5 002	52	470	S4 002	45	400	S3 002
	03.96-03.00		52	520	S5 001	44	440	S4 001	41	360	S3 001
218 i 16V	09.95-03.00		63	610	S5 005	60	540	S4 005	53	500	S3 004
			63	610	S5 005	60	540	S4 005	56	480	S3 005
i 16V Coupé	03.96-03.00		63	610	S5 005	60	540	S4 005	56	480	S3 005
220 GTi 16V	09.91-06.96		54	530	S5 002	52	470	S4 002	45	400	S3 002
			54	530	S5 002	52	470	S4 002	53	500	S3 004
GTi/GSi	10.92-06.96		54	530	S5 002	52	470	S4 002	45	400	S3 002
			54	530	S5 002	52	470	S4 002	53	500	S3 004
i Turbo	01.93-06.96		54	530	S5 002	52	470	S4 002	45	400	S3 002
			54	530	S5 002	52	470	S4 002	53	500	S3 004
i Turbo Coupé	01.93-06.96		54	530	S5 002	52	470	S4 002	45	400	S3 002
			54	530	S5 002	52	470	S4 002	53	500	S3 004

			Ah	A (EN)	S6	Ah	A (EN)	S5	Ah	A (EN)	S4	Ah	A (EN)	S3
			0092 ...0			0092 ...0			0092 ...0			0092 ...0		
ROVER														
Diesel														
218/220 D Turbo, SD, SDI, 1.9D	10.92-03.00		61	600	S5 004	60	540	S4 004	53	500	S3 004			
Serie 400														
414 16V	04.90-02.96		54	530	S5 002	52	470	S4 002	45	400	S3 002			
414/416 i 16V, Si 16V	05.95-03.00		52	520	S5 001	44	440	S4 001	41	360	S3 001			
416 GSi 16V, GTi 16V	04.90-02.96		54	530	S5 002	52	470	S4 002	45	400	S3 002			
420 i Turbo 16V	01.93-02.96		54	530	S5 002	52	470	S4 002	45	400	S3 002			
			54	530	S5 002	52	470	S4 002	53	500	S3 004			
16V	02.92-02.96		54	530	S5 002	52	470	S4 002	45	400	S3 002			
			54	530	S5 002	52	470	S4 002	53	500	S3 004			
	10.95-03.00		63	610	S5 005	60	540	S4 005	53	500	S3 004			
			63	610	S5 005	60	540	S4 005	56	480	S3 005			
Diesel														
418/420 D 1.9, SD, SDI, TD	09.91-03.00		61	600	S5 004	60	540	S4 004	53	500	S3 004			
Serie 400 Coupé														
418 GSi 16V	01.97-12.98		54	530	S5 002	52	470	S4 002	45	400	S3 002			
Serie 400 Tourer														
416 GSi 16V, GTi 16V	04.90-02.96		54	530	S5 002	52	470	S4 002	45	400	S3 002			
i 16V	02.96-03.00		52	520	S5 001	44	440	S4 001	41	360	S3 001			
418 i 16V	03.96-12.98		54	530	S5 002	52	470	S4 002	45	400	S3 002			
Diesel														
418 D 1.9	09.91-04.95		61	600	S5 004	60	540	S4 004	53	500	S3 004			
TD	02.96-03.00		61	600	S5 004	60	540	S4 004	53	500	S3 004			
Serie 600														
618/620/623 i 16V, i 16V Turbo	04.93-09.00		63	610	S5 005	60	540	S4 005	56	480	S3 005			
Diesel														
620 SDi	03.95-12.98		61	600	S5 004	60	540	S4 004						
Serie 800														
820	10.86-10.91		63	610	S5 005	60	540	S4 005	56	480	S3 005			
i	10.86-10.91		63	610	S5 005	60	540	S4 005	56	480	S3 005			
820/827 i 16V, i 16V Turbo, i 24V, i 24V Coupé	01.92-09.99		63	610	S5 005	60	540	S4 005	56	480	S3 005			
825 i	10.86-10.88		63	610	S5 005	60	540	S4 005	56	480	S3 005			
	01.96-12.98		63	610	S5 005	60	540	S4 005	56	480	S3 005			
i Coupé	01.96-12.98		63	610	S5 005	60	540	S4 005	56	480	S3 005			
825/827 i Si, i Sterling	10.86-10.91		63	610	S5 005	60	540	S4 005	56	480	S3 005			
Diesel														
825 TD	10.88-12.98	70	760	S6 008	77	780	S5 008	74	680	S4 008	70	640	S3 008	
Streetwise														
1.4/1.6/1.8	09.03-12.05		63	610	S5 005	60	540	S4 005						
Diesel														
2.0 TD	09.03-05.05	70	760	S6 008	77	780	S5 008	74	680	S4 008				
25														
1.1 i	07.01-05.04		52	520	S5 001	44	440	S4 001	41	360	S3 001			
i 16V	02.03-05.05		52	520	S5 001	44	440	S4 001	41	360	S3 001			
1.4/1.6 i 16V	02.00-05.05		63	610	S5 005	60	540	S4 001	41	360	S3 001			
1.8 i 16V	02.00-10.04		77	780	S5 008	60	540	S4 004						
		XXX							53	470	S3 004			
Diesel														
2.0 iDT	02.00-05.05		77	780	S5 008	72	680	S4 007	70	640	S3 007			
	02.03-05.05		74	750	S5 007	72	680	S4 007						
45														
1.4/1.6 16V	02.00-05.05		54	530	S5 002	44	440	S4 001	41	360	S3 001			
1.8 16V	02.00-05.05		63	610	S5 005	60	540	S4 004						
		XXX							53	470	S3 004			
2.0 V6	02.00-05.05		63	610	S5 005	60	540	S4 004						
		XXX							53	470	S3 004			
Diesel														
2.0 iDT	02.00-05.05		77	780	S5 008	60	540	S4 004						
		XXX							53	470	S3 004			
	02.03-05.05		74	750	S5 007	72	680	S4 007						

			Ah A (EN) S6	Ah A (EN) S5	Ah A (EN) S4	Ah A (EN) S3
			0 092 ...0	0 092 ...0	0 092 ...0	0 092 ...0

75											
1.8 iT 16V	09.02-05.05				63	610	S5 005	60	540	S4 005	
i 16V	01.99-05.05				63	610	S5 005	60	540	S4 005	56 480 S3 005
2.0/2.5 i 24V	01.99-05.05				77	780	S5 008	72	680	S4 007	70 640 S3 008
4.6 iPower	10.03-05.05				74	750	S5 007	72	680	S4 007	
Diesel											
2.0 CDT, CDTi	01.99-05.05				77	780	S5 008	72	680	S4 007	70 640 S3 008
75 Tourer											
1.8 iT 16V	09.02-05.05				63	610	S5 005	60	540	S4 005	56 480 S3 005
i 16V	01.01-05.05				63	610	S5 005	60	540	S4 005	
2.0 i 24V	01.01-05.05				63	610	S5 005	60	540	S4 005	
2.5 i 24V	01.01-05.05				77	780	S5 008	72	680	S4 007	70 640 S3 008
4.6 iPower	10.03-05.05				74	750	S5 007	72	680	S4 007	
Diesel											
2.0 CDT, CDTi	01.01-05.05				77	780	S5 008	72	680	S4 007	70 640 S3 008
100 Metro											
1.0/1.1/1.3/1.4, GTi 16V, i, i 16V	01.83-12.98				54	530	S5 002	52	470	S4 002	45 400 S3 002
Diesel											
1.4 D	01.93-12.94				61	600	S5 004	60	540	S4 004	53 500 S3 004
		XXX									53 470 S3 004
1.5 D	12.94-12.98				61	600	S5 004	60	540	S4 004	53 500 S3 004
		XXX									53 470 S3 004
100 Metro Cabrio											
1.1/1.4 i	09.90-03.98				54	530	S5 002	52	470	S4 002	45 400 S3 002
1.4 i 16V	04.97-10.98				54	530	S5 002	44	440	S4 001	41 360 S3 001
2000-3500											
2000/2300/2600/3500, Vitesse Inj.	10.82-10.86							70	630	S4 027	
Diesel											
2400 D Turbo	04.82-10.86	ZE						70	630	S4 027	

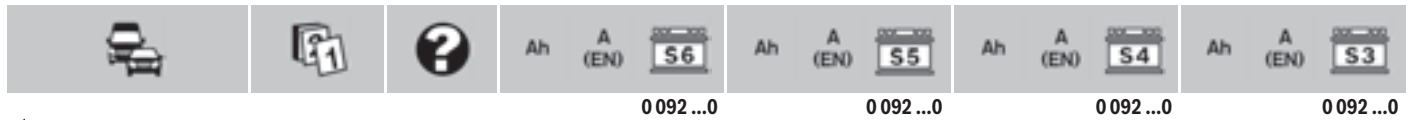

SAAB (SAAB AUTOMOBILE AB)

9-3											
1.8 i [9440]	09.04-09.10				63	610	S5 005	60	540	S4 005	
T [9440]	09.02-02.11				63	610	S5 005	60	540	S4 005	56 480 S3 005
T BioPower [9440]	05.09-02.11				63	610	S5 005	60	540	S4 005	
2.0 T [9440]	02.03-02.11				63	610	S5 005	60	540	S4 005	56 480 S3 005
	05.09-06.12				63	610	S5 005	60	540	S4 005	
	09.10-06.12				77	780	S5 008	74	680	S4 008	
T BioPower [9440]	09.02-06.12				63	610	S5 005	60	540	S4 005	
	09.10-12.11				77	780	S5 008	74	680	S4 008	
T BioPower XWD [9440]	07.09-06.12				77	780	S5 008	74	680	S4 008	
T Sport [9440]	09.02-02.11				63	610	S5 005	60	540	S4 005	56 480 S3 005
T XWD [9440]	09.08-06.12				63	610	S5 005	60	540	S4 005	
	09.10-12.11				77	780	S5 008	74	680	S4 008	
2.0/2.3 i 16V, i 16V Turbo [9400]	03.98-08.02				63	610	S5 005	60	540	S4 005	56 480 S3 005
2.8 T [9440]	09.05-06.12				63	610	S5 005	60	540	S4 005	56 480 S3 005
	04.08-06.12				63	610	S5 005	60	540	S4 005	
T XWD [9440]	05.08-06.12				63	610	S5 005	60	540	S4 005	
Diesel											
1.9 TiD [9440]	09.04-12.10		70	760	S6 008	85	800	S5 010	74	680	S4 008
TTiD [9440]	02.08-02.11		70	760	S6 008	85	800	S5 010	74	680	S4 008
	09.10-06.12					85	800	S5 010			
						85	800	S5 010	80	740	S4 010
2.2 TiD [9440]	10.02-08.04		70	760	S6 008	85	800	S5 010	74	680	S4 008 70 640 S3 008
16V D Turbo [9400]	03.98-10.00		95	850	S6 013	100	830	S5 013	95	800	S4 013 90 720 S3 013
	11.00-09.02					100	830	S5 013	95	800	S4 013



◀ SAAB

9-3 Cabriolet													
1.8 T [9440]	08.03-02.11				63	610	S5 005	60	540	S4 005	56	480	S3 005
T BioPower [9440]	01.07-06.12				63	610	S5 005	60	540	S4 005			
2.0 T [9440]	08.03-02.11				63	610	S5 005	60	540	S4 005	56	480	S3 005
	09.10-06.12				77	780	S5 008	74	680	S4 008			
T BioPower [9440]	07.07-06.12				63	610	S5 005	60	540	S4 005			
	09.10-06.12				77	780	S5 008	74	680	S4 008			
2.0/ 2.3 i 16V, i 16V Turbo, T [9400]	03.98-08.03				63	610	S5 005	60	540	S4 005	56	480	S3 005
2.8 T [9440]	09.05-02.11				77	780	S5 008	74	680	S4 008			
	09.08-06.12				63	610	S5 005	60	540	S4 005			
Diesel													
1.9 TiD [9440]	01.06-09.10				74	750	S5 007	72	680	S4 007			
TiD [9440]	02.08-02.11				74	750	S5 007	72	680	S4 007			
	09.10-06.12				85	800	S5 010						
9-3 Coupé													
2.0/ 2.3 i 16V, i 16V Turbo [9400]	03.98-08.03				63	610	S5 005	60	540	S4 005	56	480	S3 005
Diesel													
2.2 16V D Turbo [9400]	11.00-09.02	95	850	S6 013	100	830	S5 013	95	800	S4 013	90	720	S3 013
9-3 Kombi													
1.8 i [9440]	03.05->				63	610	S5 005	60	540	S4 005	56	480	S3 005
T [9440]	05.05-06.12				63	610	S5 005	60	540	S4 005			
T BioPower [9440]	01.07-06.12				63	610	S5 005	60	540	S4 005			
2.0 T [9440]	03.05-06.12				63	610	S5 005	60	540	S4 005	56	480	S3 005
	03.09-06.12				63	610	S5 005	60	540	S4 005			
	09.10-06.12				77	780	S5 008	74	680	S4 008			
T BioPower [9440]	07.07-06.12				63	610	S5 005	60	540	S4 005			
	09.10-06.12				77	780	S5 008	74	680	S4 008			
T BioPower XWD [9440]	07.07-06.12				77	780	S5 008	74	680	S4 008			
T XWD [9440]	09.08-06.12				63	610	S5 005	60	540	S4 005			
	09.10-06.12				77	780	S5 008	74	680	S4 008			
2.8 T [9440]	03.05-06.12				63	610	S5 005	60	540	S4 005	56	480	S3 005
	03.08-06.12				63	610	S5 005	60	540	S4 005			
T XWD [9440]	01.08-06.12				63	610	S5 005	60	540	S4 005			
Diesel													
1.9 TiD [9440]	03.05-09.10	70	760	S6 008	85	800	S5 010	74	680	S4 008	70	640	S3 008
TiD [9440]	02.08-02.11	70	760	S6 008	85	800	S5 010	74	680	S4 008			
	09.10-06.12				85	800	S5 010	80	740	S4 010			
9-3X													
2.0 T BioPower XWD [9440]	03.10-06.12				63	610	S5 005	60	540	S4 005			
	03.11-06.12				77	780	S5 008	74	680	S4 008			
T XWD [9440]	03.10-06.12				63	610	S5 005	60	540	S4 005			
Diesel													
1.9 TtiD [9440]	03.10-06.12	70	760	S6 008	85	800	S5 010	74	680	S4 008			
9-5													
1.6/ 2.0/ 2.8 BioPower, BioPower XWD, T, T XWD [650]	03.10-06.12				77	780	S5 008	74	680	S4 008			
2.0 t [9600]	06.97-08.09	70	760	S6 008	77	780	S5 008	74	680	S4 008	70	640	S3 008
T BioPower [9600]	01.05-02.10	70	760	S6 008	77	780	S5 008	74	680	S4 008			
	09.05-02.10	70	760	S6 008	77	780	S5 008	74	680	S4 008	70	640	S3 008
Turbo [9600]	09.06-02.10	70	760	S6 008	77	780	S5 008	74	680	S4 008	70	640	S3 008
2.0/ 2.3 [9600]	09.99-02.10	70	760	S6 008	77	780	S5 008	74	680	S4 008	70	640	S3 008
2.3 t [9600]	06.97-08.00	70	760	S6 008	77	780	S5 008	74	680	S4 008	70	640	S3 008
	09.00-02.10	70	760	S6 008	77	780	S5 008	74	680	S4 008			
T [9600]	09.03-02.10	70	760	S6 008	77	780	S5 008	74	680	S4 008	70	640	S3 008
T BioPower [9600]	01.07-02.10	70	760	S6 008	77	780	S5 008	74	680	S4 008			
Turbo [9600]	05.99-09.01	63	610	S5 005	60	540	S4 005	56	480	S3 005			
	09.01-02.10	70	760	S6 008	77	780	S5 008	74	680	S4 008	70	640	S3 008
	04.08-02.10	70	760	S6 008	77	780	S5 008	74	680	S4 008			
Turbo BioPower [9600]	11.06-02.10	70	760	S6 008	77	780	S5 008	74	680	S4 008			
3.0 t [9600]	06.97-08.03	70	760	S6 008	77	780	S5 008	74	680	S4 008	70	640	S3 008

			Ah A (EN) S6	Ah A (EN) S5	Ah A (EN) S4	Ah A (EN) S3
			0 092 ...0	0 092 ...0	0 092 ...0	0 092 ...0

Diesel													
1.9/ 2.2 TiD [9600]	03.02-02.10	70	760	S6 008	77	780	S5 008	74	680	S4 008	70	640	S3 008
2.0 TiD4, TTiD4, TTiD4 XWD [650]	03.10-06.12				85	800	S5 010						
3.0 TiD [9600]	09.01-08.05	70	760	S6 008	77	780	S5 008	74	680	S4 008			
9-5 Kombi													
2.0 T BioPower [9600]	01.06-02.10	70	760	S6 008	77	780	S5 008	74	680	S4 008	70	640	S3 008
Turbo [9600]	09.06-02.10	70	760	S6 008	77	780	S5 008	74	680	S4 008	70	640	S3 008
2.0/ 2.3/ 3.0 t, T [9600]	06.97-02.10	70	760	S6 008	77	780	S5 008	74	680	S4 008	70	640	S3 008
2.3 T BioPower [9600]	01.07-02.10	70	760	S6 008	77	780	S5 008	74	680	S4 008			
Turbo [9600]	05.99-02.10	70	760	S6 008	77	780	S5 008	74	680	S4 008	70	640	S3 008
	11.06-02.10	70	760	S6 008	77	780	S5 008	74	680	S4 008			
Diesel													
1.9 TiD [9600]	01.06-02.10	70	760	S6 008	85	800	S5 010	74	680	S4 008	70	640	S3 008
	01.07-02.10	70	760	S6 008	85	800	S5 010	74	680	S4 008			
2.2/ 3.0 TiD [9600]	09.01-08.05	70	760	S6 008	77	780	S5 008	74	680	S4 008	70	640	S3 008
90													
	08.84-08.87							60	540	S4 025			
900 I													
2.0/ 2.1, i, i Turbo, Turbo	09.83-08.93				63	610	S5 005	60	540	S4 005	56	480	S3 005
900 I Cabriolet													
2.0/ 2.1, i, Turbo	08.86-08.94				63	610	S5 005	60	540	S4 005	56	480	S3 005
900 II													
2.0 i Turbo	09.93-08.98	70	760	S6 008	77	780	S5 008	60	540	S4 005	56	480	S3 005
2.0/ 2.3 i	09.93-08.98	70	760	S6 008	77	780	S5 008	60	540	S4 005	56	480	S3 005
2.5 i	09.93-10.98	70	760	S6 008	77	780	S5 008	74	680	S4 008	70	640	S3 008
900 II Cabriolet													
2.0 i	03.94-08.98	70	760	S6 008	63	610	S5 005	60	540	S4 005	56	480	S3 005
	09.94-08.98	70	760	S6 008	77	780	S5 008	60	540	S4 005	56	480	S3 005
i Turbo	03.94-08.98	70	760	S6 008	77	780	S5 008	60	540	S4 005	56	480	S3 005
2.3 i	03.94-08.98	70	760	S6 008	77	780	S5 008	60	540	S4 005	56	480	S3 005
2.5 i	03.94-10.98	70	760	S6 008	77	780	S5 008	74	680	S4 008	70	640	S3 008
900 II Coupé													
2.0 i Turbo	03.94-08.98	70	760	S6 008	77	780	S5 008	60	540	S4 005	56	480	S3 005
2.0/ 2.3 i	03.94-08.98	70	760	S6 008	77	780	S5 008	60	540	S4 005	56	480	S3 005
2.5 i	03.94-10.98	70	760	S6 008	77	780	S5 008	74	680	S4 008	70	640	S3 008
9000													
2.0 CD Turbo	05.88-08.93				63	610	S5 005	60	540	S4 005	56	480	S3 005
CD Turbo 16V	09.92-12.98				63	610	S5 005	60	540	S4 005	56	480	S3 005
CD 16V	09.89-08.93				63	610	S5 005	60	540	S4 005	56	480	S3 005
CS	09.93-12.98				63	610	S5 005	60	540	S4 005	56	480	S3 005
CS Turbo	09.94-12.98				63	610	S5 005	60	540	S4 005	56	480	S3 005
i 16V	12.85-08.93				63	610	S5 005	60	540	S4 005	56	480	S3 005
Turbo 16V	09.84-08.93				63	610	S5 005	60	540	S4 005	56	480	S3 005
2.3 CD Turbo	09.90-08.93	70	760	S6 008	77	780	S5 008	74	680	S4 008	70	640	S3 008
CD Turbo Ecopow., CD Turbo S	09.90-12.98	70	760	S6 008	77	780	S5 008	74	680	S4 008	70	640	S3 008
CD 16V	09.89-12.98	70	760	S6 008	77	780	S5 008	74	680	S4 008	70	640	S3 008
CDE Turbo, CDE Turbo Ecopower	09.93-12.98	70	760	S6 008	77	780	S5 008	74	680	S4 008	70	640	S3 008
CS Aero Turbo	09.92-12.98	70	760	S6 008	77	780	S5 008	74	680	S4 008	70	640	S3 008
CS Turbo	09.91-08.93	70	760	S6 008	77	780	S5 008	74	680	S4 008	70	640	S3 008
i 16V	09.89-08.93	70	760	S6 008	77	780	S5 008	74	680	S4 008	70	640	S3 008
Turbo 16V	09.90-08.93	70	760	S6 008	77	780	S5 008	74	680	S4 008	70	640	S3 008
2.3/ 3.0 CS Turbo Ecopower, CS Turbo S, CS 16V, CSE Turbo, Griffin	09.91-12.98	70	760	S6 008	77	780	S5 008	74	680	S4 008	70	640	S3 008
3.0 CD	09.94-12.98	70	760	S6 008	77	780	S5 008	74	680	S4 008	70	640	S3 008
CS	09.94-12.98	70	760	S6 008	77	780	S5 008	74	680	S4 008	70	640	S3 008

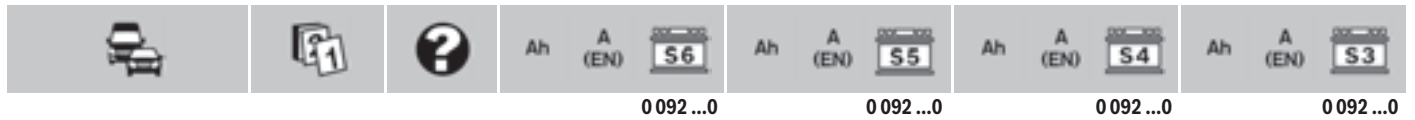

SANTANA

Land Rover
Diesel

2.8 TD PS-10, TD PS-10 4x4	03.03→					77	780	S5 008	74	680	S4 008		
----------------------------	--------	--	--	--	--	----	-----	---------------	----	-----	---------------	--	--

SEAT

Alhambra

1.4 TSI [710]	05.10-05.12	BWD	70	760	S6 008	54	530	S5 002	52	470	S4 002		
	06.11→		70	760	S6 008	54	530	S5 002	52	470	S4 002		
1.8 T [7V8]	05.98-02.00	VAD	70	760	S6 008	77	780	S5 008	60	540	S4 005	56	480
	06.00-03.10		70	760	S6 008	77	780	S5 008	60	540	S4 005	56	480
2.0 [7V8]	03.96-02.00	VAD				77	780	S5 008	60	540	S4 005	56	480
	06.00-03.10		70	760	S6 008	77	780	S5 008	60	540	S4 005	56	480
	06.00-03.10		70	760	S6 008	77	780	S5 008	60	540	S4 005	56	480
	12.10→	VAD				63	610	S5 005	60	540	S4 005		
2.8 [7V9]	06.00-03.10		70	760	S6 008	77	780	S5 008	74	680	S4 008	70	640
	06.00-03.10		70	760	S6 008	77	780	S5 008	74	680	S4 008	70	640

Diesel

1.9 TDI [7V8]	03.96-02.00	VAD				100	830	S5 013	95	800	S4 013	90	720
	05.97-02.00	VAD				100	830	S5 013	74	680	S4 008	90	720
	06.00-03.10		70	760	S6 008	100	830	S5 013	74	680	S4 008	70	640
			95	850	S6 013	85	800	S5 011	74	680	S4 008	70	640
	11.02-11.08		95	850	S6 013	85	800	S5 011	74	680	S4 008		
	06.00-03.10		95	850	S6 013	85	800	S5 011	80	740	S4 010	70	640
	06.05-11.08		95	850	S6 013	85	800	S5 011	80	740	S4 010		
	06.05-03.10					85	800	S5 011	80	740	S4 011		
2.0 TDI [7V9]	11.05-03.10		95	850	S6 013	85	800	S5 011	80	740	S4 010		
	05.10→	BWD				77	780	S5 008	74	680	S4 008	70	640
	05.11→	BWD				77	780	S5 008	74	680	S4 008		

Altea

1.2 TSI [5P1]	05.10→	BWD				77	780	S5 008	60	540	S4 005	45	400
		BWD,SSJ	70	760	S6 008								
1.4 [5P1]	05.06-05.10					54	530	S5 002	52	470	S4 002	45	400
	11.07→	BWD				54	530	S5 002	52	470	S4 002	45	400
1.6 [5P1]	03.04→		70	760	S6 008	77	780	S5 008	52	470	S4 002	45	400
	09.09→					63	610	S5 005	60	540	S4 005		
1.8 TSI [5P1]	01.07-06.07					63	610	S5 005	60	540	S4 005	56	480
	06.07→		70	760	S6 008	77	780	S5 008	60	540	S4 005	56	480
2.0 FSI [5P1]	05.04-03.09		70	760	S6 008	77	780	S5 008	74	680	S4 008	70	640
	05.06-03.09		70	760	S6 008	77	780	S5 008	60	540	S4 005	56	480

Diesel

1.6 TDI [5P1]	10.09→					77	780	S5 008	60	540	S4 005		
		SSJ	70	760	S6 008								
	05.10→					77	780	S5 008	74	680	S4 008		
1.9 TDI [5P1]	04.04-12.10		70	760	S6 008	77	780	S5 008	74	680	S4 008	70	640
	08.09-12.10					77	780	S5 008	74	680	S4 008		
2.0 TDI [5P1]	03.04→					77	780	S5 008	60	540	S4 005	70	640
		SSJ	70	760	S6 008								
	04.04-11.10		70	760	S6 008	77	780	S5 008	74	680	S4 008	70	640
	11.05-03.09					77	780	S5 008	60	540	S4 005	56	480
	11.05-05.10	BWD,SSJ	70	760	S6 008								
	03.09-05.10	BWD	70	760	S6 008	77	780	S5 008	60	540	S4 005		

Altea Freetrack

1.4 TSI [5P5/5P8]	05.10→					63	610	S5 005	52	470	S4 002	45	400
		BWD,SSJ	70	760	S6 008								
2.0 TFSI 4WD [5P5/5P8]	06.07-06.09		70	760	S6 008	77	780	S5 008	60	540	S4 005	56	480
	07.09→					63	610	S5 005	60	540	S4 005		

Diesel

1.6 TDI [5P5/5P8]	05.10→		70	760	S6 008	77	780	S5 008	74	680	S4 008	70	640
2.0 TDI [5P5/5P8]	06.07-10.10		70	760	S6 008	77	780	S5 008	60	540	S4 005	56	480

						Ah A (EN) S6		Ah A (EN) S5		Ah A (EN) S4		Ah A (EN) S3		
						0 092 ...0		0 092 ...0		0 092 ...0		0 092 ...0		
2.0 TDI 4WD [5P5/5P8]	06.07-06.09					77	780	S5 008	60	540	S4 005	56	480	S3 005
	06.07→	BWD,SSJ	70	760	S6 008									
	02.08→		70	760	S6 008	77	780	S5 008	74	680	S4 008	70	640	S3 008
	03.09-10.10	BWD	70	760	S6 008	77	780	S5 008	60	540	S4 005			
	09.10→					77	780	S5 008	60	540	S4 005	56	480	S3 005
Altea XL														
1.2 TSI [5P5]	04.10→	BWD				77	780	S5 008	60	540	S4 005	45	400	S3 002
		BWD,SSJ	70	760	S6 008									
1.4 [5P5]	10.06-05.10					54	530	S5 002	52	470	S4 002	45	400	S3 002
	TSI [5P5]	11.07→				63	610	S5 005	52	470	S4 002	45	400	S3 002
1.6 [5P5]	10.06→					63	610	S5 005	52	470	S4 002	45	400	S3 002
	12.07-11.10		70	760	S6 008	77	780	S5 008	52	470	S4 002	45	400	S3 002
	09.09→					63	610	S5 005	60	540	S4 005			
1.8 TSI [5P5]	01.07-06.07					63	610	S5 005	60	540	S4 005	56	480	S3 005
	06.07-03.09					54	530	S5 002	52	470	S4 002			
2.0 FSI [5P5]	10.06-03.09					63	610	S5 005	60	540	S4 005	56	480	S3 005
	TFSI [5P5]	10.06-03.09	70	760	S6 008	77	780	S5 008	74	680	S4 008			
Diesel														
1.6 TDI [5P5]	10.09→		70	760	S6 008	77	780	S5 008	74	680	S4 008	70	640	S3 008
	05.10→					77	780	S5 008	74	680	S4 008			
1.9 TDI [5P5]	10.06-12.10		70	760	S6 008	77	780	S5 008	60	540	S4 005	56	480	S3 005
	08.09-12.10					77	780	S5 008	74	680	S4 008			
2.0 TDI [5P5]	05.06→					77	780	S5 008	60	540	S4 005			
		SSJ	70	760	S6 008									
	10.06-03.09		70	760	S6 008	77	780	S5 008	74	680	S4 008	70	640	S3 008
	10.06-11.10		70	760	S6 008	77	780	S5 008	60	540	S4 005	56	480	S3 005
	03.09-05.10	BWD	70	760	S6 008	77	780	S5 008	60	540	S4 005			
		BWD,SSJ	70	760	S6 008									
Arosa														
1.0 [6H1]	02.97-06.04											40	340	S3 000
		XXX							42	390	S4 000			
	10.97-02.00								44	440	S4 001	41	360	S3 001
1.4 [6H1]	02.97-06.04					54	530	S5 002	52	470	S4 002	45	400	S3 002
	16V [6H1]	01.99-06.04				63	610	S5 005	60	540	S4 005	56	480	S3 005
Diesel														
1.4 TDI [6H1]	01.98-06.04					63	610	S5 005	60	540	S4 005	56	480	S3 005
1.7 SDI [6H1]	08.97-10.03	VAD				63	610	S5 005	60	540	S4 005	56	480	S3 005
Cordoba														
1.0 [6K2]	09.96-06.99	VAD				52	520	S5 001	44	440	S4 001	41	360	S3 001
	05.99-12.02					54	530	S5 002	52	470	S4 002	45	400	S3 002
1.2 [6L2]	10.02-04.04					54	530	S5 002	52	470	S4 002			
	11.04-06.06					54	530	S5 002	52	470	S4 002			
	05.06-11.09					54	530	S5 002	52	470	S4 002	45	400	S3 002
1.4 [6K2]	09.93-06.99	VAD				52	520	S5 001	44	440	S4 001	41	360	S3 001
	07.96-12.02	VAD				61	600	S5 004	60	540	S4 004			
		VAD,XXX										53	470	S3 004
	05.99-12.02					54	530	S5 002	52	470	S4 002	45	400	S3 002
[6L2]	09.02-11.06					63	610	S5 005	60	540	S4 005			
	05.04-11.09					63	610	S5 005	60	540	S4 005	56	480	S3 005
1.6 [6K2]	09.93-06.99	VAD				61	600	S5 004	60	540	S4 004			
		VAD,XXX										53	470	S3 004
	03.97-12.02					52	520	S5 001	44	440	S4 001	41	360	S3 001
	05.99-12.02					54	530	S5 002	52	470	S4 002	45	400	S3 002
						63	610	S5 005	52	470	S4 002	45	400	S3 002
[6L2]	04.03-11.09					63	610	S5 005	60	540	S4 005	56	480	S3 005
1.8 [6K2]	09.93-06.99	VAD				61	600	S5 004	60	540	S4 004			
		VAD,XXX										53	470	S3 004
T Cupra [6K2]	05.99-12.02					63	610	S5 005	60	540	S4 005	56	480	S3 005
2.0 [6K2]	09.93-12.02	VAD				61	600	S5 004	60	540	S4 004			
		VAD,XXX										53	470	S3 004
	[6L2]	09.02-04.05	70	760	S6 008	63	610	S5 005	60	540	S4 005			
	04.03-11.09					63	610	S5 005	60	540	S4 005	56	480	S3 005

			Ah A (EN) S6	Ah A (EN) S5	Ah A (EN) S4	Ah A (EN) S3
			0092 ...0	0092 ...0	0092 ...0	0092 ...0

◀ SEAT

Diesel													
1.4 TDI [6L2]	10.02-12.05		70	760	S6 008	77	780	S5 008	74	680	S4 008		
	05.05-11.09		70	760	S6 008	77	780	S5 008	74	680	S4 008	70 640 S3 008	
	06.06-11.09		70	760	S6 008	77	780	S5 008	74	680	S4 008		
1.9 D [6K2]	09.93-06.99	VAD				74	750	S5 007	72	680	S4 007	70 640 S3 007	
	07.99-12.02					74	750	S5 007	72	680	S4 007	70 640 S3 007	
SDI [6K2]	12.95-06.99	VAD				74	750	S5 007	72	680	S4 007	70 640 S3 007	
	05.99-08.02	VAD	70	760	S6 008	77	780	S5 008	74	680	S4 008	70 640 S3 008	
	06.99-08.02		70	760	S6 008	77	780	S5 008	74	680	S4 008	70 640 S3 008	
SDI [6L2]	09.02-12.05		70	760	S6 008	77	780	S5 008	74	680	S4 008		
TD [6K2]	09.93-08.97	VAD				74	750	S5 007	72	680	S4 007	70 640 S3 007	
TDI [6K2]	07.96-06.99	VAD				74	750	S5 007	72	680	S4 007	70 640 S3 007	
	05.99-12.02		70	760	S6 008	77	780	S5 008	74	680	S4 008	70 640 S3 008	
TDI [6L2]	09.02→		70	760	S6 008	77	780	S5 008	74	680	S4 008	70 640 S3 008	
	10.02-09.05		70	760	S6 008	77	780	S5 008	74	680	S4 008		
Cordoba Vario													
1.4 [6K5]	05.97-08.97					52	520	S5 001	44	440	S4 001	41 360 S3 001	
	09.97-06.99	VAD				52	520	S5 001	44	440	S4 001	41 360 S3 001	
	05.99-12.02					54	530	S5 002	52	470	S4 002	45 400 S3 002	
1.6 [6K5]	04.97-06.99					52	520	S5 001	44	440	S4 001	41 360 S3 001	
	09.97-12.02					54	530	S5 002	52	470	S4 002	45 400 S3 002	
1.8 [6K5]	07.96-06.99	VAD				52	520	S5 001	44	440	S4 001	41 360 S3 001	
Diesel													
1.9 SDI [6K5]	06.97-06.99	VAD				74	750	S5 007	72	680	S4 007	70 640 S3 007	
	06.99-08.02		70	760	S6 008	77	780	S5 008	74	680	S4 008	70 640 S3 008	
TDI [6K5]	06.97-06.99	VAD				74	750	S5 007	72	680	S4 007	70 640 S3 007	
	05.99-08.02		70	760	S6 008	77	780	S5 008	74	680	S4 008	70 640 S3 008	
Exeo													
1.6 [3R2]	03.09-09.10					63	610	S5 005	60	540	S4 005		
1.8 [3R2]	12.08-05.10		70	760	S6 008	77	780	S5 008	74	680	S4 008	70 640 S3 008	
1.8/ 2.0 TSI [3R2]	05.10→					77	780	S5 008	74	680	S4 008	70 640 S3 008	
2.0 TFSI [3R2]	03.09→		70	760	S6 008	77	780	S5 008	74	680	S4 008	70 640 S3 008	
Diesel													
2.0 TDI [3R2]	12.08→		70	760	S6 008	77	780	S5 008	74	680	S4 008	70 640 S3 008	
	02.09-12.11					85	800	S5 010	74	680	S4 008	70 640 S3 008	
Exeo ST													
1.6/ 1.8 [3R5]	06.09-09.10		70	760	S6 008	77	780	S5 008	74	680	S4 008	70 640 S3 008	
1.8 TSI [3R5]	05.10→					77	780	S5 008	74	680	S4 008	70 640 S3 008	
2.0 TSI [3R5]	06.09→		70	760	S6 008	77	780	S5 008	74	680	S4 008	70 640 S3 008	
	05.10→					77	780	S5 008	74	680	S4 008	70 640 S3 008	
Diesel													
2.0 TDI [3R5]	06.09→		70	760	S6 008	77	780	S5 008	74	680	S4 008	70 640 S3 008	
Fura													
0.9	01.82-12.85											45 400 S3 003	
Ibiza													
0.9/ 1.2/ 1.5/ 1.7 , i, Turbo [021A]	06.84-05.93					52	520	S5 001	44	440	S4 001	41 360 S3 001	
1.0 [6K1]	03.93-06.96								44	420	S4 000	40 340 S3 000	
		JEA,XXX							42	390	S4 000		
	09.96-10.99								44	420	S4 000	40 340 S3 000	
	09.96-05.02	JEA,XXX							42	390	S4 000		
	05.99-05.02			52	520	S5 001						40 340 S3 000	
		XXX								42	390	S4 000	
		10.99-05.02	JEA				61	600	S5 004				
	05.00-05.02	JEA				63	610	S5 005	44	440	S4 001	41 360 S3 001	
1.2 [6J5]	03.08→					54	530	S5 002	52	470	S4 002	45 400 S3 002	
	07.09→					54	530	S5 002	52	470	S4 002		
[6L1]	11.01-04.04	JEA				63	610	S5 005	44	440	S4 001	41 360 S3 001	
	11.04-06.06	JEA				63	610	S5 005	44	440	S4 001	41 360 S3 001	
	05.06-11.09					63	610	S5 005	52	470	S4 002	45 400 S3 002	
	06.07-05.08					63	610	S5 005	52	470	S4 002		
TSI [6J5]	09.10-09.12					61	600	S5 004	60	540	S4 004		
		BWD,SSJ	60	680	S6 005								

						Ah A (EN) S6		Ah A (EN) S5		Ah A (EN) S4		Ah A (EN) S3		
				0 092 ...0		0 092 ...0		0 092 ...0		0 092 ...0		0 092 ...0		
1.2 TSI [6J5]	08.12→			54	530			S5 002	52	470	S4 002			
1.3 [6K1]	03.93-07.94								44	420	S4 000	40	340	
		JEA,XXX							42	390	S4 000			
1.4 [6J5]	03.08→			63	610	S5 005			60	540	S4 005	56	480	
[6K1]	09.93-12.97	JEA		63	610	S5 005			52	470	S4 002	45	400	
	11.96-10.99	JEA		63	610	S5 005			60	540	S4 005	56	480	
	12.97-05.02	JEA		63	610	S5 005			44	440	S4 001	41	360	
	01.98-05.98	JEA		61	600	S5 004			52	470	S4 002	45	400	
[6L1]	09.01-11.09	JEA		63	610	S5 005			60	540	S4 005	56	480	
	01.02-12.07			63	610	S5 005			52	470	S4 002	45	400	
	05.06-11.09			63	610	S5 005			60	540	S4 005	56	480	
TSI [6J5]	03.09→			54	530	S5 002			52	470	S4 002	45	400	
1.6 [6J5]	05.08→			54	530	S5 002			52	470	S4 002	45	400	
[6K1]	03.93-10.99	JEA		63	610	S5 005			52	470	S4 002	45	400	
	03.97-05.02	JEA		63	610	S5 005			44	440	S4 001	41	360	
	05.99-05.02	JEA		63	610	S5 005			60	540	S4 005	56	480	
	07.00-05.02			63	610	S5 005			60	540	S4 005	56	480	
GLP [6J5]	05.11→			63	610	S5 005			60	540	S4 005			
1.6/2.0 [6L1]	07.02-11.09			63	610	S5 005			60	540	S4 005	56	480	
1.8 T [6L1]	12.03-11.09			63	610	S5 005			60	540	S4 005	56	480	
T Cupra [6K1]	10.99-10.00	JEA		63	610	S5 005			60	540	S4 005	56	480	
	09.00-05.02	JEA		63	610	S5 005			60	540	S4 005			
T Cupra R [6L1]	05.04-02.08			63	610	S5 005			60	540	S4 005	56	480	
	04.05-02.08			63	610	S5 005			60	540	S4 005			
1.8/2.0 [6K1]	03.93-10.99	JEA		63	610	S5 005			52	470	S4 002	45	400	
Diesel														
1.2 TDI [6J5]	06.10→			77	780	S5 008			60	540	S4 005			
		BWD,SSJ	60	680	S6 005									
1.4 TDI [6L1]	05.02-11.09			70	760	S6 008	77	780	S5 008	74	680	S4 008	70	640
1.4/1.6/1.9/2.0 TDI [6J5]	02.08→			70	760	S6 008	77	780	S5 008	74	680	S4 008	70	640
1.7 D [021A]	06.84-05.93			63	610	S5 006			60	540	S4 006	56	480	
1.9 D, TD [6K1]	03.93-10.99	JEA		63	610	S5 006			60	540	S4 006	56	480	
SDI [6K1]	12.95-10.99			63	610	S5 006			60	540	S4 006	56	480	
	05.99-05.02			70	760	S6 008	77	780	S5 008	74	680	S4 008	70	640
SDI [6L1]	01.02-12.05			70	760	S6 008	77	780	S5 008	74	680	S4 008	70	640
TDI [6K1]	07.96-06.99	VAD		63	610	S5 006			60	540	S4 006	56	480	
	03.97-06.99	VAD		77	780	S5 008			60	540	S4 006	56	480	
	05.99-05.02			70	760	S6 008	77	780	S5 008	74	680	S4 008	70	640
TDI [6L1]	09.01-11.09			70	760	S6 008	77	780	S5 008	74	680	S4 008	70	640
	05.05-11.09			70	760	S6 008	77	780	S5 008	74	680	S4 008		
TDI Cupra R [6L1]	03.04-11.05			70	760	S6 008	77	780	S5 008	74	680	S4 008	70	640
	11.05-02.08			70	760	S6 008	77	780	S5 008	74	680	S4 008		
Ibiza SC														
1.2 TSI [6J1]	09.10-09.12	BWD		61	600	S5 004								
		BWD,SSJ	70	760	S6 008									
1.2/1.4/1.6 [6J1]	07.08→			54	530	S5 002			52	470	S4 002	45	400	
1.4 TSI [6J1]	03.09→			54	530	S5 002			52	470	S4 002	45	400	
TSI Cupra [6J1]	03.09→			54	530	S5 002			52	470	S4 002	45	400	
1.6 GLP [6J1]	05.11→			63	610	S5 005			60	540	S4 005			
Diesel														
1.2 TDI [6J1]	05.10→			77	780	S5 008			60	540	S4 005			
		SSJ	70	760	S6 008									
1.4/1.6/1.9/2.0 TDI [6J1]	02.08→			70	760	S6 008	77	780	S5 008	74	680	S4 008	70	640
Ibiza ST														
1.2 TSI [6J8]	09.10→			61	600	S5 004			60	540	S4 004			
		BWD,SSJ	60	680	S6 005									
	08.12→			54	530	S5 002			52	470	S4 002			
1.2/1.4 [6J8]	04.10→			54	530	S5 002			52	470	S4 002			
Diesel														
1.2 TDI [6J8]	04.10→			77	780	S5 008			60	540	S4 005			
		BWD,SSJ	60	680	S6 005									

								Ah A (EN) S6		Ah A (EN) S5		Ah A (EN) S4		Ah A (EN) S3	
				0092 ...0		0092 ...0		0092 ...0		0092 ...0					
◀ SEAT															
1.6 TDI [6J8]	03.10→	BWD				77	780	S5 008	60	540	S4 005				
		BWD,SSJ	70	760	S6 008										
		SSJ	70	760	S6 008										
	05.10→					77	780	S5 008	60	540	S4 005				
Inca															
1.4 [6K9]	11.95-06.03					54	530	S5 002	52	470	S4 002	45	400	S3 002	
1.6 [6K9]	11.95-05.97	VAD										45	400	S3 003	
	06.97-09.00					63	610	S5 005	60	540	S4 005	56	480	S3 005	
Diesel															
1.7 D [6K9]	09.96-09.00		70	760	S6 008	61	600	S5 004	60	540	S4 004				
		XXX										53	470	S3 004	
1.9 D [6K9]	11.95-06.03		70	760	S6 008	74	750	S5 007	72	680	S4 007	70	640	S3 007	
SDI [6K9]	12.95-09.00		70	760	S6 008	74	750	S5 007	72	680	S4 007	70	640	S3 007	
	09.00-06.03	VAD				74	750	S5 007	60	540	S4 004				
		VAD,XXX										53	470	S3 004	
Leon															
1.2 TSI [1P1]	02.10-12.12	BWD				77	780	S5 008	60	540	S4 005	45	400	S3 002	
		BWD,SSJ	60	680	S6 005										
1.4 [1M1]	12.99-02.02	VAD				54	530	S5 002	52	470	S4 002				
	12.99-04.04					54	530	S5 002	52	470	S4 002	45	400	S3 002	
[1P1]	06.06-05.10					54	530	S5 002	52	470	S4 002				
TSI [1P1]	11.07-12.12	BWD				77	780	S5 008	60	540	S4 005	45	400	S3 002	
		BWD,SSJ	60	680	S6 005										
TSI [5F1]	09.12→		70	760	S6 008										
1.6 [1M1]	10.98-07.04	VAD				63	610	S5 005	60	540	S4 005	56	480	S3 005	
	04.02-06.06					63	610	S5 005	60	540	S4 005	56	480	S3 005	
	10.05-06.06					63	610	S5 005	60	540	S4 005				
[1P1]	07.05-12.12					63	610	S5 005	60	540	S4 005	56	480	S3 005	
	12.09-12.12					63	610	S5 005	60	540	S4 005				
1.8 [1M1]	10.98-12.03					63	610	S5 005	60	540	S4 005	56	480	S3 005	
	12.99-07.04	VAD				63	610	S5 005	60	540	S4 005				
T [1M1]	12.99-12.00					63	610	S5 005	60	540	S4 005	56	480	S3 005	
	09.00-04.04	VAD				63	610	S5 005	60	540	S4 005				
T Cupra R [1M1]	05.02-05.03	VAD				63	610	S5 005	60	540	S4 005				
	05.03-06.06					63	610	S5 005	60	540	S4 005	56	480	S3 005	
TSI [1P1]	06.07-03.09					63	610	S5 005	60	540	S4 005				
1.8/ 2.8 Cupra Syncro, T Syncro [1M1]	03.00-04.04					63	610	S5 005	60	540	S4 005				
2.0 FSI [1P1]	07.05-03.09					63	610	S5 005	60	540	S4 005	56	480	S3 005	
	05.09-12.12					63	610	S5 005	60	540	S4 005	56	480	S3 005	
TFSI [1P1]	05.05-05.09					63	610	S5 005	60	540	S4 005	56	480	S3 005	
	06.09-12.12					63	610	S5 005	60	540	S4 005				
TFSI Cupra [1P1]	09.09-12.12					63	610	S5 005	60	540	S4 005				
TFSI FR [1P1]	07.06→		70	760	S6 008	77	780	S5 008	60	540	S4 005				
2.8 [1M1]	10.00-07.01					63	610	S5 005	60	540	S4 005				
	05.02-04.04					63	610	S5 005	60	540	S4 005				
Diesel															
1.6 TDI [1P1]	02.10-12.12	BWD				77	780	S5 008	60	540	S4 005				
		SSJ	70	760	S6 008										
	11.10-12.12					77	780	S5 008	74	680	S4 008				
TDI [5F1]	09.12→		70	760	S6 008										
	11.12→					63	610	S5 005	60	540	S4 005				
1.9 SDI, TDI [1M1]	10.98-06.06		70	760	S6 008	77	780	S5 008	74	680	S4 008	70	640	S3 008	
TDI [1P1]	07.05-12.10		70	760	S6 008	77	780	S5 008	74	680	S4 008	70	640	S3 008	
	06.07-12.10		70	760	S6 008	77	780	S5 008	74	680	S4 008				
TDI Syncro [1M1]	09.00-07.04		70	760	S6 008	77	780	S5 008	74	680	S4 008				
2.0 TDI [1P1]	07.05-03.09		70	760	S6 008	77	780	S5 008	74	680	S4 008				
	07.05-12.12		70	760	S6 008	77	780	S5 008	74	680	S4 008	70	640	S3 008	
	03.09-12.12	BWD				77	780	S5 008	60	540	S4 005				
		BWD,SSJ	70	760	S6 008										
Malaga															
1.2/ 1.5/ 1.7, i	05.85-12.93					63	610	S5 006	60	540	S4 006	56	480	S3 006	

			Ah A (EN) S6	Ah A (EN) S5	Ah A (EN) S4	Ah A (EN) S3
			0 092 ...0	0 092 ...0	0 092 ...0	0 092 ...0



Diesel															
1.7 D	05.85-12.93			63	610	S5 006	60	540	S4 006	56	480	S3 006			
Marbella															
0.8/0.9, i	01.87-05.98									45	400	S3 003			
Mii															
1.0 [KF1]	10.11→	BWD								40	340	S3 000			
		BWD,XXX					42	390	S4 000						
	10.12→	XXX					42	390	S4 000						
Panda															
Trans	09.82-12.86						44	420	S4 000	40	340	S3 000			
		XXX					42	390	S4 000						
40	09.82-12.86						44	420	S4 000	40	340	S3 000			
		XXX					42	390	S4 000						
Ronda															
1.2/1.5	04.84-12.86			63	610	S5 006	60	540	S4 006	56	480	S3 006			
Diesel															
1.7 D	06.82-12.86						70	630	S4 027						
Terra															
0.9	01.87-12.94									45	400	S3 003			
Diesel															
1.3/1.4 D	03.90-12.94									45	400	S3 003			
Toledo															
1.2/1.4, TSI [KG3]	07.12→			54	530	S5 002	52	470	S4 002						
1.4 [1M2]	07.99-05.02	VAD		63	610	S5 005	60	540	S4 005	56	480	S3 005			
	[5P2]	05.06-05.09		63	610	S5 005	60	540	S4 005						
1.6 [1M2]	04.99-05.02	VAD		63	610	S5 005	60	540	S4 005	56	480	S3 005			
	04.02-07.04			63	610	S5 005	60	540	S4 005	56	480	S3 005			
	[5P2]	09.04-05.09	70	760	S6 008	77	780	S5 008	60	540	S4 005	70	640	S3 008	
1.6/1.8/2.0 [1L2]	05.91-03.99	VAD		61	600	S5 004	44	440	S4 001	41	360	S3 001			
1.8 [1M2]	04.99-12.03	VAD		63	610	S5 005	60	540	S4 005	56	480	S3 005			
	T [1M2]	09.00-07.04		63	610	S5 005	60	540	S4 005	56	480	S3 005			
	TSI [5P2]	01.07-05.09	70	760	S6 008	77	780	S5 008	74	680	S4 008	70	640	S3 008	
2.0 FSI [5P2]	09.04-03.09		70	760	S6 008	77	780	S5 008	74	680	S4 008	70	640	S3 008	
	11.05-03.09		70	760	S6 008	77	780	S5 008	74	680	S4 008				
	TFSI [5P2]	11.05-05.09	70	760	S6 008	77	780	S5 008	74	680	S4 008				
2.3 [1M2]	04.99-11.00	VAD		63	610	S5 005	60	540	S4 005	56	480	S3 005			
	09.00-11.03	VAD		63	610	S5 005	60	540	S4 005						
Diesel															
1.6 TDI [KG3]	07.12→			63	610	S5 005	60	540	S4 005						
1.9 D, TD, TDI [1L2]	05.91-03.99	VAD		74	750	S5 007	72	680	S4 007						
	TDI [1M2]	04.99-07.04	VAD	70	760	S6 008	77	780	S5 008	74	680	S4 008	70	640	S3 008
	TDI [5P2]	09.04-09.05	70	760	S6 008	77	780	S5 008	74	680	S4 008	70	640	S3 008	
		09.04-05.09	70	760	S6 008	77	780	S5 008	74	680	S4 008				
		02.06-05.09	70	760	S6 008	77	780	S5 008	74	680	S4 008	70	640	S3 008	
2.0 TDI [5P2]	09.04-05.09		70	760	S6 008	77	780	S5 008	74	680	S4 008				

SKODA

Citgo												
1.0 [NF1]	10.11→									40	340	S3 000
		XXX					42	390	S4 000			
Fabia												
1.2 [5J2]	12.06→			63	610	S5 005	52	470	S4 002	45	400	S3 002
	03.10→			63	610	S5 005	60	540	S4 005	45	400	S3 002
		SSJ		60	560	S5 E05						
	11.11→			54	530	S5 002	52	470	S4 002			
1.2/1.4/2.0 [6Y3]	09.99-12.07			63	610	S5 005	52	470	S4 002	45	400	S3 002
1.4 TSI RS [5J2]	05.10-05.12			54	530	S5 002	52	470	S4 002			
	05.12→			54	530	S5 002	52	470	S4 002	45	400	S3 002
1.4/1.6 [5J2]	01.07→			63	610	S5 005	52	470	S4 002	45	400	S3 002

						Ah A (EN) S6		Ah A (EN) S5		Ah A (EN) S4		Ah A (EN) S3		
						0092...0		0092...0		0092...0		0092...0		
SKODA														
Diesel														
1.2 TDI [5J2]	03.10→	BWD		63	610	S5 005		60	540	S4 005		45	400	S3 002
		BWD,SSJ		70	760	S6 008								
1.4 TDI [5J2]	01.07-03.10			70	760	S6 008		77	780	S5 008		74	680	S4 008
1.4/ 1.9 SDI, TDI [6Y3]	09.99-12.07			70	760	S6 008		77	780	S5 008		74	680	S4 008
1.6 TDI [5J2]	03.10→	BWD		77	780	S5 008		60	540	S4 005				
		BWD,SSJ		70	650	S5 E08								
1.9 TDI [5J2]	04.07-03.10			70	760	S6 008		77	780	S5 008		74	680	S4 008
				70	760	S6 008		77	780	S5 008		74	680	S4 008
												70	640	S3 008
Fabia Combi														
1.2 [5J5]	12.06-05.09			54	530	S5 002		52	470	S4 002		45	400	S3 002
	10.07→			63	610	S5 005		52	470	S4 002		45	400	S3 002
	03.09-11.11			70	760	S6 008		54	530	S5 002		74	680	S4 008
				70	760	S6 008		77	780	S5 008		52	470	S4 002
				70	760	S6 008		77	780	S5 008		74	680	S4 008
				77	780	S5 008		74	680	S4 008		45	400	S3 002
	03.10→			63	610	S5 005		60	540	S4 005		45	400	S3 002
		SSJ		60	560	S5 E05								
	11.11→			54	530	S5 002		52	470	S4 002				
1.2/ 1.4/ 2.0 [6Y5]	12.99-12.07			63	610	S5 005		52	470	S4 002		45	400	S3 002
1.4 TSI [5J5]	05.12→			54	530	S5 002		52	470	S4 002		45	400	S3 002
TSI RS [5J5]	05.10-05.12			54	530	S5 002		52	470	S4 002				
1.4/ 1.6 [5J5]	10.07→			63	610	S5 005		52	470	S4 002		45	400	S3 002
Diesel														
1.2 TDI [5J5]	03.10→	70	760	S6 008		77	780	S5 008		74	680	S4 008		
		BWD		63	610	S5 005		60	540	S4 005		45	400	S3 002
		BWD,SSJ		70	760	S6 008								
1.4 TDI [5J5]	10.07-03.10			70	760	S6 008		77	780	S5 008		74	680	S4 008
1.4/ 1.9 SDI, TDI [6Y5]	08.00-12.07			70	760	S6 008		77	780	S5 008		74	680	S4 008
1.6 TDI [5J5]	03.10→	BWD		77	780	S5 008		60	540	S4 005				
		BWD,SSJ		70	650	S5 E08								
1.9 TDI [5J5]	10.07-03.10			70	760	S6 008		77	780	S5 008		74	680	S4 008
				70	760	S6 008		77	780	S5 008		74	680	S4 008
												70	640	S3 008
Fabia Schrägheck														
1.0/ 1.2/ 1.4/ 2.0 [6Y2]	09.99-04.07			63	610	S5 005		52	470	S4 002		45	400	S3 002
Diesel														
1.4/ 1.9 SDI, TDI, TDI RS [6Y2]	09.99-03.08	70	760	S6 008		77	780	S5 008		74	680	S4 008		S3 008
Favorit														
135/ 136, i.e.	09.88-12.98			63	610	S5 005		60	540	S4 005		45	400	S3 002
Felicia														
1.3/ 1.6, i [6U1]	10.94-08.01			63	610	S5 005		52	470	S4 002		45	400	S3 002
Diesel														
1.9 D [6U1]	10.95-08.01			63	610	S5 005		60	540	S4 005		56	480	S3 005
Felicia Combi														
1.3/ 1.6, i [6U5]	10.94-08.01			63	610	S5 005		52	470	S4 002		45	400	S3 002
Diesel														
1.9 D [6U5]	10.95-08.01			63	610	S5 005		60	540	S4 005		56	480	S3 005
Felicia Fun														
1.3 [6UF]	08.96-03.01			54	530	S5 002		52	470	S4 002		45	400	S3 002
Forman														
1.1/ 1.3, i.e.	10.90-12.95			63	610	S5 005		60	540	S4 005		45	400	S3 002
Octavia														
1.2 TSI [1Z3]	02.10→			63	610	S5 005		60	540	S4 005				
1.4 [1U2]	06.99-12.10			63	610	S5 005		52	470	S4 002		45	400	S3 002
[1Z3]	05.04→			63	610	S5 005		52	470	S4 002		45	400	S3 002
TSI [1Z3]	11.08→			54	530	S5 002		52	470	S4 002		45	400	S3 002
1.6 [1U2]	09.96-09.04			63	610	S5 005		52	470	S4 002				
	08.00-12.10			63	610	S5 005		52	470	S4 002		45	400	S3 002
[1Z3]	05.04→			63	610	S5 005		52	470	S4 002		45	400	S3 002
	08.09→			63	610	S5 005		60	540	S4 005				
1.6/ 2.0 FSI [1Z3]	05.04-10.08			63	610	S5 005		60	540	S4 005		56	480	S3 005
1.8 [1U2]	09.96-04.99			63	610	S5 005		52	470	S4 002				
RS [1U2]	08.00-09.04			63	610	S5 005		60	540	S4 004		56	480	S3 005

											Ah A (EN) S6			Ah A (EN) S5			Ah A (EN) S4			Ah A (EN) S3		
		0 092 ...0			0 092 ...0			0 092 ...0			0 092 ...0											
1.8 T [1U2]	03.98-12.10				63	610	S5 005	52	470	S4 002	56	480	S3 005									
T 4x4 [1U2]	01.00-07.00				63	610	S5 005	52	470	S4 002												
	08.00-12.10				63	610	S5 005	52	470	S4 002	56	480	S3 005									
TSI [1Z3]	06.07→				63	610	S5 005	60	540	S4 005												
	03.09→				77	780	S5 008	74	680	S4 008												
2.0 [1U2]	06.99-05.07				63	610	S5 005	60	540	S4 005	56	480	S3 005									
	03.02-09.04				63	610	S5 005	60	540	S4 005												
FSI 4x4 [1Z3]	12.04-10.08				63	610	S5 005	60	540	S4 005												
i [1U2]	08.00-01.05				63	610	S5 005	60	540	S4 005	56	480	S3 005									
RS, TSI RS [1Z3]	10.05→	70	760	S6 008	77	780	S5 008	74	680	S4 008	70	640	S3 008									
4x4 [1U2]	08.00-09.04				63	610	S5 005	60	540	S4 005												
Diesel																						
1.6 TDI [1Z3]	06.09→				77	780	S5 008	74	680	S4 008												
		SSJ	70	760	S6 008																	
1.9 SDI, TDI [1U2]	09.96-12.10				70	760	S6 008	77	780	S5 008	74	680	S4 008	70	640	S3 008						
TDI [1Z3]	05.04-12.10				70	760	S6 008	77	780	S5 008	74	680	S4 008	70	640	S3 008						
	03.06→				70	760	S6 008	77	780	S5 008	74	680	S4 008									
1.9/ 2.0 TDI RS, TDI 4x4 [1Z3]	04.06→				70	760	S6 008	77	780	S5 008	74	680	S4 008									
2.0 TDI [1Z3]	05.04-05.10				70	760	S6 008	77	780	S5 008	74	680	S4 008									
	05.04→				70	760	S6 008	77	780	S5 008	74	680	S4 008	70	640	S3 008						
	03.10→				77	780	S5 008	74	680	S4 008												
Octavia Combi																						
1.2 TSI [1Z5]	02.10→				63	610	S5 005	60	540	S4 005												
1.4 [1Z5]	05.04-06.06				54	530	S5 002	52	470	S4 002												
	05.06→				63	610	S5 005	52	470	S4 002	45	400	S3 002									
TSI [1Z5]	11.08→				54	530	S5 002	52	470	S4 002	45	400	S3 002									
1.4/ 1.6 [1U5]	02.97-12.10				63	610	S5 005	52	470	S4 002	45	400	S3 002									
1.6 [1Z5]	05.04→				63	610	S5 005	52	470	S4 002												
	08.09→				63	610	S5 005	60	540	S4 005												
FSI [1Z5]	05.04-10.08				63	610	S5 005	52	470	S4 002												
1.8 [1U5]	10.96-04.99				63	610	S5 005	52	470	S4 002												
RS [1U5]	01.03-01.06				63	610	S5 005	60	540	S4 004	56	480	S3 005									
T [1U5]	03.98-12.10				63	610	S5 005	52	470	S4 002	56	480	S3 005									
T 4x4 [1U5]	01.00-07.00				63	610	S5 005	52	470	S4 002												
	08.00-12.10				63	610	S5 005	52	470	S4 002	56	480	S3 005									
TSI [1Z5]	06.07→	70	760	S6 008	77	780	S5 008	74	680	S4 008												
	05.09→				77	780	S5 008	74	680	S4 008												
TSI 4x4 [1Z5]	11.08→	70	760	S6 008	77	780	S5 008	74	680	S4 008												
	03.09→				63	610	S5 005	60	540	S4 005												
2.0 [1U5]	08.00-09.04				63	610	S5 005	60	540	S4 005												
	08.00-01.06				63	610	S5 005	60	540	S4 005	56	480	S3 005									
FSI [1Z5]	11.04-10.08				63	610	S5 005	60	540	S4 005	56	480	S3 005									
FSI 4x4 [1Z5]	11.04-10.08				63	610	S5 005	60	540	S4 005	56	480	S3 005									
RS, TSI RS [1Z5]	10.05→	70	760	S6 008	77	780	S5 008	74	680	S4 008	70	640	S3 008									
4x4 [1U5]	11.99-12.00				63	610	S5 005	60	540	S4 005	56	480	S3 005									
	08.00-01.05				63	610	S5 005	60	540	S4 005												
	03.02-01.06				63	610	S5 005	60	540	S4 005	56	480	S3 005									
Diesel																						
1.6 TDI [1Z5]	06.09→				77	780	S5 008	74	680	S4 008												
		SSJ	70	760	S6 008																	
TDI 4x4 [1Z5]	06.09→				63	610	S5 005	60	540	S4 005												
1.9 SDI [1U5]	05.97-12.03				70	760	S6 008	77	780	S5 008	74	680	S4 008	70	640	S3 008						
TDI [1U5]	08.97-12.10				70	760	S6 008	77	780	S5 008	74	680	S4 008	70	640	S3 008						
	08.00-03.10				70	760	S6 008	77	780	S5 008	74	680	S4 008									
TDI [1Z5]	05.04→				70	760	S6 008	77	780	S5 008	74	680	S4 008	70	640	S3 008						
TDI 4x4 [1U5]	08.00-12.09				70	760	S6 008	77	780	S5 008	74	680	S4 008	70	640	S3 008						
TDI 4x4 [1Z5]	11.04→				70	760	S6 008	77	780	S5 008	74	680	S4 008	70	640	S3 008						
	05.06-05.10				70	760	S6 008	77	780	S5 008	74	680	S4 008									
2.0 TDI [1Z5]	05.04-05.10				70	760	S6 008	77	780	S5 008	74	680	S4 008									
	05.04→				70	760	S6 008	77	780	S5 008	74	680	S4 008	70	640	S3 008						
	03.10→				77	780	S5 008	74	680	S4 008												
TDI RS [1Z5]	04.06→				70	760	S6 008	77	780	S5 008	74	680	S4 008									

				Ah A (EN) S6	Ah A (EN) S5	Ah A (EN) S4	Ah A (EN) S3	
				0092 ...0	0092 ...0	0092 ...0	0092 ...0	
◀ SKODA								
2.0 TDI 4x4 [1Z5]	12.05-05.10		70 760	S6 008	77 780	S5 008	74 680 S4 008	70 640 S3 008
	05.10→				77 780	S5 008	74 680 S4 008	
Pick-Up								
1.6 MPI [6U7]	10.95-03.01				63 610	S5 005	60 540 S4 005	
135/136, i.e. [6U7]	09.91-12.97				63 610	S5 005	60 540 S4 005	45 400 S3 002
MPI [6U7]	08.96-03.01				63 610	S5 005	60 540 S4 005	45 400 S3 002
Diesel								
1.9 D [6U7]	01.96-03.01				63 610	S5 005	60 540 S4 005	
Praktik								
1.2 TSI [5J7]	03.10→		70 760	S6 008	63 610	S5 005	60 540 S4 005	
1.2/1.4 [5J7]	03.07→				63 610	S5 005	52 470 S4 002	45 400 S3 002
Diesel								
1.2 TDI [5J7]	03.10→		70 760	S6 008	63 610	S5 005	60 540 S4 005	
1.4 TDI [5J7]	03.07-03.10		70 760	S6 008	77 780	S5 008	74 680 S4 008	70 640 S3 008
1.6 TDI [5J7]	03.10→				63 610	S5 005	60 540 S4 005	
Rapid								
1.2 [NH3]	07.12→				54 530	S5 002	52 470 S4 002	
TSI [NH3]	07.12→		70 760	S6 008	54 530	S5 002	52 470 S4 002	
1.4 TSI [NH3]	07.12→				54 530	S5 002	52 470 S4 002	
1.6 [NH3]	07.12→		70 760	S6 008	63 610	S5 005	60 540 S4 005	
120/130/135/136	09.84-12.90				52 520	S5 001	44 440 S4 001	41 360 S3 001
Diesel								
1.6 TDI [NH3]	07.12→		70 760	S6 008	63 610	S5 005	60 540 S4 005	
Roomster								
1.2 TSI [5J7]	03.10→				63 610	S5 005	60 540 S4 005	45 400 S3 002
		SSJ			60 560	S5 E05		
1.2/1.4/1.6 [5J7]	05.06→				63 610	S5 005	52 470 S4 002	45 400 S3 002
Diesel								
1.2 TDI [5J7]	03.10→	SSJ	70 760	S6 008				
1.4 TDI [5J7]	05.06-03.10		70 760	S6 008	63 610	S5 005	60 540 S4 005	56 480 S3 005
1.6 TDI [5J7]	03.10→				63 610	S5 005	60 540 S4 005	45 400 S3 002
		SSJ			60 560	S5 E05		
1.9 TDI [5J7]	03.06-05.06				77 780	S5 008	74 680 S4 008	
	05.06-03.10		70 760	S6 008	63 610	S5 005	60 540 S4 005	56 480 S3 005
Superb								
1.4 TSI [3T4]	04.08→				63 610	S5 005	60 540 S4 005	
1.8 T [3U4]	12.01-03.08		70 760	S6 008	77 780	S5 008	74 680 S4 008	70 640 S3 008
TSI [3T4]	03.08→				63 610	S5 005	60 540 S4 005	
	09.08→				63 610	S5 005	74 680 S4 008	
					77 780	S5 008	60 540 S4 005	
	03.09→				77 780	S5 008	74 680 S4 008	
TSI 4x4 [3T4]	11.08→		70 760	S6 008	77 780	S5 008	74 680 S4 008	
	03.09→				77 780	S5 008	74 680 S4 008	
2.0 [3U4]	12.01-03.08		70 760	S6 008	77 780	S5 008	60 540 S4 005	70 640 S3 008
TSI [3T4]	05.10→				77 780	S5 008	74 680 S4 008	
2.8 [3U4]	12.01-03.08		70 760	S6 008	85 800	S5 011	74 680 S4 008	70 640 S3 008
	02.02-03.08		70 760	S6 008	77 780	S5 008	74 680 S4 008	
3.6 V6 4x4 [3T4]	11.08→				85 800	S5 011	80 740 S4 010	
Diesel								
1.6 TDI [3T4]	09.10→	SSJ	80 800	S6 011				
1.9 TDI [3U4]	12.01-03.08		70 760	S6 008	77 780	S5 008	74 680 S4 008	70 640 S3 008
1.9/2.0 TDI [3T4]	03.08→		70 760	S6 008	85 800	S5 011	74 680 S4 008	
2.0 TDI [3U4]	10.05-03.08		70 760	S6 008	85 800	S5 011	74 680 S4 008	70 640 S3 008
	02.06-02.06		70 760	S6 008	77 780	S5 008	74 680 S4 008	
TDI 4x4 [3T4]	09.08→		70 760	S6 008	85 800	S5 011	74 680 S4 008	
	11.10→		70 760	S6 008	77 780	S5 008	74 680 S4 008	
2.5 TDI [3U4]	12.01-03.08		70 760	S6 008	85 800	S5 011	74 680 S4 008	70 640 S3 008
Superb Combi								
1.4 TSI [3T5]	09.09→				63 610	S5 005	60 540 S4 005	
1.8 TSI [3T5]	03.09→				77 780	S5 008	74 680 S4 008	
	09.09→				63 610	S5 005	60 540 S4 005	
TSI 4x4 [3T5]	03.09→				77 780	S5 008	74 680 S4 008	
	09.09→				63 610	S5 005	60 540 S4 005	



		0 092 ...0				0 092 ...0				0 092 ...0				0 092 ...0			
2.0 TSI [3T5]	05.10→					77	780	S5 008	74	680	S4 008						
3.6 V6 4x4 [3T5]	09.09→					63	610	S5 005	60	540	S4 005						
Diesel																	
1.6 TDI [3T5]	09.10→	SSJ	80	800	S6 011												
1.9 TDI [3T5]	09.09-09.10		70	760	S6 008	77	780	S5 008	74	680	S4 008						
	09.09-11.10					77	780	S5 008	74	680	S4 008						
2.0 TDI [3T5]	09.09-03.10					77	780	S5 008	74	680	S4 008						
	09.09→		70	760	S6 008	85	800	S5 011	74	680	S4 008						
	02.10→		70	760	S6 008	77	780	S5 008	74	680	S4 008						
TDI 4x4 [3T5]	09.09→		70	760	S6 008	85	800	S5 011	74	680	S4 008						
	11.10→					77	780	S5 008	74	680	S4 008						
Yeti																	
1.2 TSI [5L7]	09.09→					54	530	S5 002	52	470	S4 002	45	400	S3 002			
1.4 TSI [5L7]	06.10→	BWD				77	780	S5 008	60	540	S4 005						
		BWD,SSJ				70	650	S5 E08									
1.8 TSI 4x4 [5L7]	05.09→					77	780	S5 008	60	540	S4 005	56	480	S3 005			
	11.09→		70	760	S6 008	77	780	S5 008	74	680	S4 008						
Diesel																	
1.6 TDI [5L7]	11.10→	SSJ	70	760	S6 008												
2.0 TDI [5L7]	11.09→		70	760	S6 008	85	800	S5 011	74	680	S4 008						
	11.11→					77	780	S5 008	74	680	S4 008						
TDI 4x4 [5L7]	05.09→		70	760	S6 008	85	800	S5 011	74	680	S4 008						
105																	
, L, S	08.76-12.90					52	520	S5 001	44	440	S4 001	41	360	S3 001			
120																	
Coupé Rapid/ L/ LS, GLS	08.76-12.90					52	520	S5 001	44	440	S4 001	41	360	S3 001			
130																	
GL/ L, GL	09.84-12.90					52	520	S5 001	44	440	S4 001	41	360	S3 001			
135																	
L, GL	09.84-12.90					52	520	S5 001	44	440	S4 001	41	360	S3 001			
136																	
L, GL	09.84-12.90					52	520	S5 001	44	440	S4 001	41	360	S3 001			

SMART (MCC)

Forfour															
1.1/ 1.3/ 1.5 , Brabus, Sportstyle [454]	01.04-06.07					54	530	S5 002	52	470	S4 002	45	400	S3 002	
Diesel															
1.5 cdi [454]	09.04-06.07		70	760	S6 008	77	780	S5 008	74	680	S4 008	70	640	S3 008	
Fortwo Cabrio															
0.7 , Brabus [450]	02.04-03.07					54	530	S5 002	52	470	S4 002	45	400	S3 002	
1.0 [451]	04.07→					54	530	S5 002	52	470	S4 002	45	400	S3 002	
Brabus [451]	04.07→					54	530	S5 002	52	470	S4 002	45	400	S3 002	
	04.12→					54	530	S5 002	52	470	S4 002	45	400	S3 002	
mhd [451]	10.07→					54	530	S5 002	52	470	S4 002	45	400	S3 002	
Diesel															
0.8 [451]	04.07-07.09					63	610	S5 005	60	540	S4 005	56	480	S3 005	
	08.09→											45	400	S3 002	
		SSJ	60	680	S6 005										
cdi [450]	02.04-03.07					63	610	S5 005	60	540	S4 005	56	480	S3 005	
Fortwo Coupé															
0.7 , Brabus [450]	02.04-03.07					54	530	S5 002	52	470	S4 002	45	400	S3 002	
1.0 [451]	04.07-05.08	SSJ	60	680	S6 005										
	04.07→					54	530	S5 002	52	470	S4 002	45	400	S3 002	
Brabus, mhd [451]	04.07→					54	530	S5 002	52	470	S4 002	45	400	S3 002	
Diesel															
0.8 [451]	04.07-07.09					63	610	S5 005	60	540	S4 005				
	08.09→	SSJ	60	680	S6 005										
cdi [450]	02.04-03.07					63	610	S5 005	60	540	S4 005	56	480	S3 005	
Roadster															
0.7 , Brabus [452]	04.03-11.05					54	530	S5 002	52	470	S4 002	45	400	S3 002	



			Ah A (EN) S6 0092 ...0	Ah A (EN) S5 0092 ...0	Ah A (EN) S4 0092 ...0	Ah A (EN) S3 0092 ...0
--	--	--	------------------------	------------------------	------------------------	------------------------

◀ SMART

Roadster Coupé										
0.7 , Brabus [452]	04.03-11.05	54	530	S5 002	52	470	S4 002	45	400	S3 002
Smart Cabrio										
0.6 [450]	03.00-01.04	54	530	S5 002	52	470	S4 002			
	01.01-01.04	54	530	S5 002	52	470	S4 002	45	400	S3 002
0.7 [450]	01.03-01.04	54	530	S5 002	52	470	S4 002	45	400	S3 002
Brabus [450]	01.03-01.04	54	530	S5 002	52	470	S4 002	45	400	S3 002
Diesel										
0.8 cdi [450]	03.01-01.04	63	610	S5 005	60	540	S4 005			
Smart Coupé										
0.6/0.7 , Brabus [450]	07.98-01.04	54	530	S5 002	52	470	S4 002	45	400	S3 002
Diesel										
0.8 cdi [450]	11.99-01.04	63	610	S5 005	60	540	S4 005			
Smart Crossblade										
0.6 [450]	10.02-01.04	54	530	S5 002	52	470	S4 002			

SSANGYONG

Actyon										
2.3 i 4WD	11.06→				95	830	S4 029			
4WD	09.06→				70	630	S4 027			
Diesel										
2.0 CRDi, Xdi, Xdi 4WD	10.05→				95	830	S4 029			
Actyon Sports										
Diesel										
2.0 E-Xdi, E-Xdi 4WD	12.11→				95	830	S4 029			
Xdi 4WD	03.07-12.12				70	630	S4 027			
Chairman										
2.3 i	10.97-09.03	100	830	S5 013						
Chairman New										
2.8/3.2 i	09.03-01.08	100	830	S5 013						
Korando										
2.0 L, L AWD	06.12→				60	540	S4 025			
2.0/2.3/3.2 i, i 4WD, i 16V [KJ]	07.96-12.05				95	830	S4 029			
Diesel										
2.0 D, D AWD	07.10→				95	830	S4 029			
2.2/2.3/2.5/2.9 D, D 4WD, TD Intercooler 4WD [KJ; K4]	10.86-12.05				95	830	S4 029			
Kyron										
2.3 i	01.10→				60	540	S4 025			
i 4WD	11.05→				60	540	S4 025			
3.2 i 4WD	11.05→				95	830	S4 029			
Diesel										
2.0 Xdi	05.05→				60	540	S4 025			
					95	830	S4 029			
2.0/2.7 Xdi 4WD	05.05→				95	830	S4 029			
Musso										
2.0/2.3/3.2 i [MJ]	01.96-12.05				60	540	S4 024			
Diesel										
2.3/2.9 D, TD Intercooler [MJ]	07.93-12.05				95	830	S4 029			
Rexton										
2.3/3.2 i, i 4WD, RX230 4WD	09.01→				95	830	S4 029			
Diesel										
RX270/2.7/2.9 CRDi 4WD, TD, Xdi 4WD, XDI 4WD, XVT 4WD	09.02→				95	830	S4 029			



			Ah A (EN) S6 0 092 ...0	Ah A (EN) S5 0 092 ...0	Ah A (EN) S4 0 092 ...0	Ah A (EN) S3 0 092 ...0
--	--	--	----------------------------	----------------------------	----------------------------	----------------------------

Rodius							
3.2 , 4WD	11.06→				95	830	S4 029
Diesel							
2.7 Xdi, Xdi 4WD	05.05→				95	830	S4 029

STEYR (STEYR-DAIMLER-PUCH AG)

G													
320/ 500 , V8	01.98→	70	760	S6 008	77	780	S5 008	74	680	S4 008	70	640	S3 008
Diesel													
300 DT	01.98→	70	760	S6 008	77	780	S5 008	74	680	S4 008	70	640	S3 008

SUBARU

BRZ													
2.0 [Z10]	01.12→				60	540	S4 024						
Forester													
2.0 [S12]	12.07-12.10				60	540	S4 024						
	09.10-12.12				70	630	S4 026						
2.0/ 2.5 i S Turbo 4x4, i Turbo 4x4, i 4x4 [SF; SG]	01.97-11.07				60	540	S4 024						
2.5 [S12]	12.07-12.10				70	630	S4 026						
Turbo [S12]	12.07-12.12				60	540	S4 024						
Diesel													
2.0 D [S12]	12.07-12.12				95	830	S4 028						
Impreza													
1.5/ 1.6/ 1.8/ 2.0 i, i Turbo 4WD, i 4WD, R, R Crossover 4x4, R 4x4 [; G12]	11.92-12.11				60	540	S4 024						
Diesel													
2.0 D Crossover 4x4, D 4x4 [G12]	09.08-12.11				95	830	S4 028						
Impreza Coupé													
1.6/ 2.0 i, i 4WD	10.93-09.00				60	540	S4 024						
Impreza Kombi													
1.5/ 1.6/ 1.8/ 2.0/ 2.5 i, i 4WD, i 4WD Turbo [; GC, GF; GD, GG]	01.93-06.07				60	540	S4 024						
Impreza Outback													
2.0 i 4WD [GD, GG]	10.00-06.07				60	540	S4 024						
Impreza Sedan													
1.5 R, R 4x4 [G12]	03.08-09.11				60	540	S4 024						
1.6/ 1.8/ 2.0/ 2.5 i, i 4WD, i 4WD Turbo, i 4WD Turbo STI, i 4WD Turbo S202 STI [GC, GF; GD, GG]	01.93-06.07				60	540	S4 024						
Impreza WRX													
2.5 4x4 [G22]	09.10→				60	540	S4 024						
Impreza WRX Hatchback													
2.5 4x4 [G12; G22]	06.07→				60	540	S4 024						
Impreza WRX STI Hatchback													
2.5 [G22]	06.07→				60	540	S4 024						
Justy													
1.3/ 1.5 4x4 [G3X]	09.03-08.07			52	520	S5 001	44	440	S4 001	41	360	S3 001	
Legacy													
1.6/ 1.8/ 2.0/ 2.2/ 2.5/ 3.0 , i, i CNG 4WD, i Turbo 4WD, i 4WD, i 4WD Turbo, R 4WD, Turbo, 4WD [; BC/BF; BJ; BL/BP; B14]	01.89→				60	540	S4 024						

		Ah	A (EN)	S6	Ah	A (EN)	S5	Ah	A (EN)	S4	Ah	A (EN)	S3
				0092 ...0			0092 ...0			0092 ...0			0092 ...0
Subaru													
Diesel													
2.0 D, D 4WD [BL/BP; B14]	04.07→												
		95	830										S4 028
Legacy Kombi													
2.0/ 2.2/ 2.5 i, i 4WD [BD/BG]	01.94-08.98												
		60	540										S4 024
2.0/ 2.5/ 3.0, i 4WD, R 4WD, Turbo, 4WD [BE/BH; BL/BP; B14]	10.98→												
		60	540										S4 024
Diesel													
2.0 D, D 4WD [BL/BP; B14]	04.07→												
		95	830										S4 028
Legacy Outback													
2.5/ 3.0 i 4WD, 4WD [BD/BG; BE/BH; BL/BP]	06.96-05.09												
		60	540										S4 024
Diesel													
2.0 D 4WD [BL/BP]	04.07-05.09												
		60	540										S4 024
Legacy Sedan													
1.8/ 2.0/ 2.2/ 2.5 i, i Turbo 4WD, i 4WD [BD/BG; BE/BH]	01.94-06.03												
		60	540										S4 024
Leone Sedan													
1.3/ 1.6	11.84-09.91												
		60	540										S4 025
MV													
1.8	11.84-12.94												
		60	540										S4 025
Outback													
2.5/ 3.6 [B14]	06.09→												
		60	540										S4 024
Diesel													
2.0 D [B14]	06.09→												
		60	540										S4 024
Serie L													
1.6 [A]	11.84-12.90												
		60	540										S4 024
		60	540										S4 025
1.8 Automatic 4WD, i, i Turbo 4WD, 4WD [A]	11.84-12.90												
		60	540										S4 025
Serie L Coupé													
1.8 XT Turbo [A]	11.84-12.90												
	01.88-12.90												
		60	540										S4 024
		60	540										S4 025
	11.84-12.90												
		60	540										S4 025
Serie L Kombi													
1.3 [A]	11.84-12.90												
		45	330										S4 022
		45	330										S4 023
1.6 [A]	11.84-12.90												
		60	540										S4 024
		60	540										S4 025
4WD [A]	11.84-12.90												
		60	540										S4 024
		60	540										S4 025
1.8 [A]	11.84-12.90												
		60	540										S4 025
i Turbo 4WD, i Turbo 4WD Automatic [A]	11.84-12.90												
		60	540										S4 025
4WD [A]	11.84-02.92												
		60	540										S4 025
4WD Automatic [A]	11.84-12.90												
		60	540										S4 025
Serie L Pickup													
1.8 4WD [A]	08.80-10.87												
		60	540										S4 025
Serie L Sedan													
1.3 [A]	11.84-12.90												
		45	330										S4 022
		45	330										S4 023
Automatic [A]	11.84-12.90												
		45	330										S4 022
		45	330										S4 023
1.8 [A]	11.84-12.90												
		60	540										S4 025
Automatic [A]	11.84-12.90												
		60	540										S4 025
i 4WD [A]	01.88-09.91												
		60	540										S4 025
SVX													
3.3 i 4WD	09.92-12.96												
		60	540										S4 025
Trezia													
1.3 [NSP]	03.11→												
		60	560										S5 E05

			Ah A (EN) S6	Ah A (EN) S5	Ah A (EN) S4	Ah A (EN) S3
			0 092 ...0	0 092 ...0	0 092 ...0	0 092 ...0

Diesel						
1.4 D [NLP]	03.11→		63	610	S5 005	S4 005
Tribeca						
3.0/ 3.6 R, 4x4 [B9; W10]	04.06→					S4 024
Vivio						
660 i 4WD [R13]	08.93-06.98					S4 018
XV						
1.6/ 2.0 [G33]	09.11→					S4 024
Diesel						
2.0 D [G33]	08.11→					S4 026
700						
	10.83-12.93					S4 018

SUZUKI

Alto						
1.1 i 16V [MA]	02.02-12.06					S4 018
600/ 800 [SS]	06.82-12.85					S4 018
800 [EC]	01.86-11.93					S4 018
Alto Hatchback						
1.0 [AMF]	12.08→					S4 018
, i [EF]	10.94-02.02					S4 018
Baleno Hatchback						
1.3/ 1.6/ 1.8 i 16V, i 16V 4WD, 16V	04.95-09.06					S4 019
Diesel						
1.9 D Turbo	04.98-05.02					S4 026
Baleno Sedan						
1.3/ 1.6 i 16V 4WD, 16V	04.95-04.05					S4 019
1.3/ 1.6/ 1.8 i 16V	04.95-09.05					S4 019
1.5 i 16V	04.95-04.05					S4 018
Diesel						
1.9 D Turbo	12.98-05.02					S4 026
Baleno Wagon						
1.3/ 1.6/ 1.8 i 16V, i 16V 4WD	09.95-09.07					S4 019
Diesel						
1.9 D Turbo	12.98-05.02					S4 026
Cappuccino						
660 Turbo	08.93-08.03					S4 019
Carry						
1.0/ 1.3/ 800, 16V [ED; FD; ST]	11.80-03.09					S4 019
Carry Van						
1.0 [ED]	10.85-03.99					S4 019
Grand Vitara						
1.6/ 2.0/ 2.5/ 2.7 i XL-7 4WD, i 4WD, i 4x4, i 16V	03.98→					S4 024
2.0 4WD	10.05→					S4 024
2.4 4x4	09.08→					S4 024
2.7 XL-7	06.01-03.03					S4 024
	04.03→					S4 028
3.2 4x4	01.09→					S4 028
Diesel						
1.9/ 2.0 D Turbo, DDiS	03.98→					S4 028
Grand Vitara Cabrio						
1.6/ 2.0 i 16V	03.98-03.08					S4 024
Ignis Hatchback						
1.3 i 16V	10.00-09.03	52	520	S5 001	44	440 S4 001
		52	520	S5 001	44	440 S4 001 41 360 S3 001
	10.03-12.07				45	330 S4 021
i 16V 4WD	10.00-09.03	52	520	S5 001	44	440 S4 001 41 360 S3 001
	10.03-12.07				45	330 S4 021

				Ah A (EN) S6	Ah A (EN) S5	Ah A (EN) S4	Ah A (EN) S3					
				0092 ...0	0092 ...0	0092 ...0	0092 ...0					
◀ SUZUKI												
1.5 i 16V	10.03-12.07			52	520	S5 001	44	440	S4 001	41	360	S3 001
i 16V Sport	12.03-12.07			52	520	S5 001	44	440	S4 001	41	360	S3 001
i 16V 4WD	10.03-12.07			52	520	S5 001	44	440	S4 001	41	360	S3 001
Diesel												
1.3 DDiS Turbo	10.03-12.07			74	750	S5 007	44	440	S4 001	41	360	S3 001
Jimny												
1.3 i 16V [FJ]	10.98→						45	330	S4 022			
i 16V 4WD [FJ]	10.98-10.08	JEA					45	330	S4 022			
	10.00→						45	330	S4 022			
Diesel												
1.5 DDiS 4WD [FJ]	12.03→						60	540	S4 024			
Kizashi												
2.4 i, i 4WD	06.10→						70	630	S4 026			
Liana Hatchback												
Diesel												
1.4 D	03.05-12.07						40	330	S4 019			
Liana Sedan												
Diesel												
1.4 D	03.05-12.07						70	630	S4 026			
Samurai												
1.0/ 1.3 , i, i Commercial Luxe,	07.84→						40	330	S4 019			
i 4x4, LX, VX												
Diesel												
1.9 D Turbo 4x4	08.93-12.04						70	630	S4 026			
Samurai Cabrio												
1.3 , i	03.87-12.04						40	330	S4 019			
Diesel												
1.9 D Turbo 4x4	08.93-12.04						70	630	S4 026			
SJ 410												
1.0 , J, V	07.84-12.88						40	330	S4 019			
SJ 410 Cabrio												
1.0	09.80-12.88						40	330	S4 019			
SJ 410 Pickup												
1.0	09.81-12.88						40	330	S4 019			
SJ 413												
1.3 , 4x4	11.84-08.90						40	330	S4 019			
SJ 413 Cabrio												
1.3	11.84-12.88						40	330	S4 019			
Splash												
1.0 [A5B]	01.08→			52	520	S5 001	44	440	S4 001			
1.2 [A5B]	01.08→			52	520	S5 001	44	440	S4 001	41	360	S3 001
Diesel												
1.3 DDiS [A5B]	01.08→			74	750	S5 007	72	680	S4 007	70	640	S3 007
Swift												
1.0/ 1.3 i, i 16V [MA]	03.96-12.04						40	330	S4 019			
1.3 i	02.00-03.06						40	330	S4 019			
	11.04-09.10			52	520	S5 001	44	440	S4 001			
i 4WD	02.00-03.06						40	330	S4 019			
	11.04-09.10			52	520	S5 001	44	440	S4 001			
1.5 i	06.03-03.05						40	330	S4 019			
	11.04-09.10			52	520	S5 001	44	440	S4 001			
				52	520	S5 001	45	330	S4 022			
1.6 i	09.05-09.10			52	520	S5 001	44	440	S4 001			
i [Z]	12.11→			54	530	S5 002	52	470	S4 002			
Swift Cabrio												
1.3 [EA]	09.91-12.95						40	330	S4 019			
Swift Hatchback												
1.0 [EA]	10.89-04.95						40	330	S4 019			
i [EA]	10.89-09.95						40	330	S4 019			
i [MA]	03.96-12.04						40	330	S4 019			
1.0/ 1.3 , i 16V GTI, i 16V GXI,	10.84-03.89						40	330	S4 019			
Turbo [OA]												
1.2 , 4WD [AZG; AZH]	09.10→			54	530	S5 002	52	470	S4 002			

			Ah A (EN) S6			Ah A (EN) S5			Ah A (EN) S4			Ah A (EN) S3		
			0 092 ...0			0 092 ...0			0 092 ...0			0 092 ...0		
1.3 [EA]	10.89-12.91					40	330	S4 019						
						45	330	S4 022						
i [EA]	09.91-09.95					40	330	S4 019						
						45	330	S4 022						
i [MA]	06.96-03.01					40	330	S4 019						
						45	330	S4 022						
i 4WD, 4WD, 16V GTi [EA]	01.89-09.95					40	330	S4 019						
i 16V [MA]	04.01-12.04					40	330	S4 019						
1.3/1.5/1.6 , 4WD [MZ/EZ]	11.04→		52	520	S5 001	44	440	S4 001	41	360	S3 001			
Diesel														
1.3 DDiS [MZ/EZ]	02.08→		61	600	S5 004	60	540	S4 004						
		XXX							53	470	S3 004			
DDiS D Turbo [AZG]	09.10→		54	530	S5 002	52	470	S4 002						
			60	560	S5 E05	52	470	S4 002						
DDiS D Turbo [MZ/EZ]	08.05→		61	600	S5 004	60	540	S4 004						
		XXX							53	470	S3 004			
Swift Sedan														
1.3/1.6 , i, i 16V, i 16V 4WD, 16V, 16V 4WD [EA]	03.89-12.95					40	330	S4 019						
SX4														
1.6 VVT	12.07→		61	600	S5 004	60	540	S4 004						
		XXX							53	470	S3 004			
2.0 i, i 4x4	07.06→								53	500	S3 004			
SX4 Hatchback														
1.5	05.06→		61	600	S5 004	60	540	S4 004						
		XXX							53	470	S3 004			
1.6 VVT	05.06→		61	600	S5 004	60	540	S4 004						
		XXX							53	470	S3 004			
VVT 4WD	05.06→		61	600	S5 004	60	540	S4 004						
		XXX							53	470	S3 004			
Diesel														
1.6/1.9/2.0 DDiS, DDiS 4WD	05.06→	70	760	S6 008	77	780	S5 008	74	680	S4 008	70	640	S3 008	
Vitara														
1.6 [ET]	03.88-03.98					40	330	S4 019						
i [ET]	03.88-03.98		52	520	S5 001	40	330	S4 019						
			52	520	S5 001	44	440	S4 001						
			52	520	S5 001	45	330	S4 022						
	09.91-03.98					40	330	S4 019						
i 4x4	09.95-03.04					40	330	S4 019						
1.6/2.0/2.5 i 16V, i 24V [ET]	07.90-03.98					40	330	S4 019						
2.0/2.5 i 24V [SE; SV]	04.97-12.98					40	330	S4 019						
Diesel														
1.9/2.0 D, D Turbo [SE; SV]	08.96-12.98					70	630	S4 026						
D Turbo, D Turbo Interc., D 4x4 [ET]	12.94-12.98					70	630	S4 026						
2.0 HDi [ET]	03.02→		77	780	S5 008	74	680	S4 008						
Vitara Cabrio														
1.6/2.0 , i, i 16V [ET; OS]	03.88-03.98					40	330	S4 019						
Diesel														
1.9 D 4x4 [ET]	01.95-03.98					70	630	S4 026						
Wagon R+														
1.0 i 16V [MM]	05.00-08.03					40	330	S4 018						
i 16V Turbo [EM]	10.96-05.00					40	330	S4 018						
i 16V Turbo [MM]	05.00→					40	330	S4 018						
i 16V 4WD [EM]	10.96-05.00					40	330	S4 018						
1.0/1.2 i 16V [EM]	09.97-05.00		52	520	S5 001	44	440	S4 001	41	360	S3 001			
1.2 i 16V 4WD [EM]	07.98-05.00		52	520	S5 001	44	440	S4 001	41	360	S3 001			
1.3 i 16V [MM]	05.00-08.03		52	520	S5 001	44	440	S4 001	41	360	S3 001			
	09.03-03.06					40	330	S4 018	45	300	S3 016			
i 16V 4WD [MM]	10.01-03.06		52	520	S5 001	44	440	S4 001	41	360	S3 001			

			Ah A (EN) S6 0092 ...0	Ah A (EN) S5 0092 ...0	Ah A (EN) S4 0092 ...0	Ah A (EN) S3 0092 ...0
--	--	--	------------------------	------------------------	------------------------	------------------------

◀ SUZUKI

Diesel											
1.3	DDiS D Turbo [MM]	09.03-03.06				40	330	S4018	45	300	S3016
X-90											
1.6	i, i 4x4	09.95→				40	330	S4018			

TALBOT

Express											
1.8/2.0	[J5]	09.81-12.93							45	300	S3017
Diesel											
1.9/2.5	D, D Turbo [J5]	09.81-12.93							45	300	S3017
Horizon											
1.1/1.3/1.4/1.6		07.79-06.86							45	300	S3017
Diesel											
1.7/1.9	D	07.82-06.86	77	780	S5008	74	680	S4008	70	640	S3008
Samba											
1.0/1.1/1.2/1.4	, Rallye [51A]	01.81-12.87							45	300	S3017
Solara											
1.6		09.81-07.86							45	300	S3017
Diesel											
1.9	D	11.84-07.86							45	300	S3017
1100											
1.1	City Laster	07.79-06.85							45	300	S3017

TATA (TELCO)

Indica											
1.4	i	02.98→				60	540	S4024			
Indigo											
1.4	i, i Marina [; T4]	12.02-03.10				60	540	S4024			
Diesel											
1.4	D Turbo, TD Marina [; T4]	12.02-05.05				60	540	S4024			
Safari											
2.0	i 4x4	02.00→				70	630	S4027			
Diesel											
2.0	D Turbo 4x4	02.00→				70	630	S4027			
Sierra											
1.9		11.89→				95	830	S4029			
Telcoline											
Diesel											
2.0	TDi	10.03→				95	830	S4028			

TOYOTA

Auris											
1.3	VVT-i [E15, JTN]	09.08-10.09	SSJ			60	560	S5E05			
	VVT-i [E15, NMT, SB1]	11.08-10.12	SSJ			60	560	S5E05			
1.3/1.6	, VVT-i [E18]	10.12→				54	530	S5002	52	470	S4002
1.4	[E15, JTN; E15, NMT, SB1]	10.06-03.09				63	610	S5005	52	470	S4002
									45	400	S3002
1.6	[E15, JTN]	10.06-08.12				63	610	S5005	60	540	S4005
		12.08-10.09				63	610	S5005	60	540	S4005
	[E15, NMT, SB1]	02.07-10.12				63	610	S5005	52	470	S4002
		02.09-10.12				63	610	S5005	60	540	S4005
1.8	i [E15, JTN]	12.08-10.09				63	610	S5005	60	540	S4005
	i [E15, NMT, SB1]	02.09-10.12				63	610	S5005	60	540	S4005
	VVT-i HSD	06.10-10.12							40	330	S4030
	[E15, NMT, SB1]										
	VVT-i HSD [E18]	10.12→							40	330	S4018

						Ah A (EN) S6		Ah A (EN) S5		Ah A (EN) S4		Ah A (EN) S3	
				0 092 ...0		0 092 ...0		0 092 ...0		0 092 ...0		0 092 ...0	
Diesel													
1.4 D-4D [E18]	10.12→				63	610	S5 005	60	540	S4 005			
1.4/2.0 D-4D [E15, JTN; E15, NMT, SB1]	10.06-10.12	70	760	S6 008	85	800	S5 010	74	680	S4 008	70	640	S3 008
2.2 D-CAT [E15, NMT, SB1]	02.07-10.12	70	760	S6 008	85	800	S5 010	74	680	S4 008			
Avensis													
1.6/1.8/2.0 i 16V, i 16V 4WD [T25; T27]	01.03→				63	610	S5 005	60	540	S4 005			
i 16V [T22]	10.97-01.03				63	610	S5 005	52	470	S4 002	45	400	S3 002
2.4 i [T25]	09.03-11.08				63	610	S5 005	60	540	S4 005	56	480	S3 005
Diesel													
2.0 D Turbo [T22]	10.97-01.03	70	760	S6 008	77	780	S5 008	74	680	S4 008	70	640	S3 008
D Turbo [T25]	03.03-04.06	70	760	S6 008	77	780	S5 008	74	680	S4 008			
D-4D [T25]	04.06-11.08	70	760	S6 008	77	780	S5 008	74	680	S4 008	70	640	S3 008
D-4D [T27]	11.08→	70	760	S6 008	85	800	S5 010	74	680	S4 008			
2.2 D-CAT, D-4D [T25; T27]	04.05→				85	800	S5 010	80	740	S4 010			
Avensis Liftback													
1.6/1.8 i 16V [T22]	10.97-01.03				63	610	S5 005	52	470	S4 002	45	400	S3 002
1.6/1.8/2.0/2.4 i, i 16V [T25]	01.03-11.08				63	610	S5 005	60	540	S4 005			
2.0 i 16V [T22]	10.97-01.03				63	610	S5 005	52	470	S4 002			
	07.00-01.03				63	610	S5 005	52	470	S4 002	45	400	S3 002
Diesel													
2.0 D Turbo [T22]	10.97-01.03	70	760	S6 008	77	780	S5 008	74	680	S4 008	70	640	S3 008
D Turbo [T25]	03.03-04.06	70	760	S6 008	77	780	S5 008	74	680	S4 008			
D-4D [T25]	04.06-11.08	70	760	S6 008	77	780	S5 008	74	680	S4 008	70	640	S3 008
2.2 D-CAT [T25]	04.05-11.08				85	800	S5 010	80	740	S4 010			
D-4D [T25]	04.05-11.08				85	800	S5 010	80	740	S4 010			
Avensis Verso													
2.0/2.4 i 16V [M2]	05.01→							60	540	S4 024			
Diesel													
2.0 D Turbo [M2]	05.01-07.05	70	760	S6 008	77	780	S5 008	74	680	S4 008			
Avensis Wagon													
1.6/1.8 i 16V [T25]	01.03-11.08				63	610	S5 005	60	540	S4 005			
1.6/1.8/2.0 [T27]	11.08→				63	610	S5 005	60	540	S4 005			
i 16V [T22]	10.97-01.03				63	610	S5 005	52	470	S4 002	45	400	S3 002
2.0 i 16V [T25]	01.03-11.08				63	610	S5 005	60	540	S4 005			
					63	610	S5 005	60	540	S4 005	56	480	S3 005
i 16V 4WD [T25]	09.03-11.08				63	610	S5 005	60	540	S4 005			
2.4 i [T25]	09.03-11.08				63	610	S5 005	60	540	S4 005	56	480	S3 005
Diesel													
2.0 D Turbo [T22]	10.97-01.03	70	760	S6 008	77	780	S5 008	74	680	S4 008	70	640	S3 008
D Turbo, D-4D [T25]	03.03-11.08	70	760	S6 008	77	780	S5 008	74	680	S4 008	70	640	S3 008
D-4D [T27]	11.08→				77	780	S5 008	74	680	S4 008			
2.2 D-CAT, D-4D [T25; T27]	04.05→				85	800	S5 010	80	740	S4 010			
Aygo													
1.0	02.05→							44	420	S4 000	40	340	S3 000
				XXX				42	390	S4 000			
Diesel													
1.4	05.05-09.10				54	530	S5 002	52	470	S4 002			
Camry													
1.8 [V1]	10.82-10.86							60	540	S4 024			
[V2]	10.86-08.88							45	330	S4 021			
i [V2]	01.87-06.89							60	540	S4 024			
2.0 [V2]	07.89-06.91							60	540	S4 024			
i [V1]	08.83-07.86							60	540	S4 024			
i [V2]	10.86-11.92							45	330	S4 021			
i 4x4 [V2]	09.87-05.91							60	540	S4 024			
								70	630	S4 026			
2.0/2.4/3.0 i 16V, i 24V [V3]	08.99-01.06							70	630	S4 026			
2.2 i [V1]	02.93-04.98							60	540	S4 024			
i [V2]	05.98-02.02							60	540	S4 024			

		Ah A (EN) S6		Ah A (EN) S5		Ah A (EN) S4		Ah A (EN) S3	
		0092 ...0		0092 ...0		0092 ...0		0092 ...0	
◀ TOYOTA									
2.2/ 3.0 i 16V, i 24V [V1]	06.91-08.96					60	540	S4 024	
i 16V, i 24V [V2]	06.96-09.01					60	540	S4 024	
2.4 [V3]	08.02-08.09					70	630	S4 026	
i [V3]	08.01-01.06					70	630	S4 026	
	09.02-05.06					60	540	S4 024	
VVT-i [V4]	01.06-08.11					70	630	S4 026	
2.4/ 3.5 , i [V5; V40]	01.06→					70	630	S4 027	
2.5	09.87-08.91					60	540	S4 024	
i [V2]	02.88-02.93					60	540	S4 024	
3.0 i [V2]	07.97-08.02					60	540	S4 024	
i [V3]	09.02-06.06					60	540	S4 024	
3.5 [V4]	01.06-08.11					70	630	S4 027	
Diesel									
1.8 D Turbo [V1]	09.83-09.85					95	830	S4 028	
2.0 D Turbo [V2]	01.86-05.91					95	830	S4 028	
Camry Liftback									
1.8/ 2.0 , i [V1]	10.82-10.86					60	540	S4 024	
Diesel									
1.8/ 2.0 D Turbo [V1]	09.83-10.86					95	830	S4 028	
Camry Sedan									
2.4/ 3.0 i	03.03-12.05					70	630	S4 026	
Camry Vienta									
3.0 i [V1]	04.94-06.97					60	540	S4 024	
Camry Vienta Wagon									
3.0 i [V1]	04.94-06.95					60	540	S4 024	
Camry Wagon									
1.8/ 2.0 , i [V2]	10.86-11.92					45	330	S4 021	
2.2/ 2.5/ 3.0 i, i 16V, i 24V [V1; V2]	08.88-02.98					60	540	S4 024	
2.4 i [V3]	09.02-06.06					70	630	S4 026	
Diesel									
2.0 D Turbo [V2]	10.86-05.91					95	830	S4 028	
Carina E Liftback									
1.6 i 16V [T19]	02.92-01.96					60	540	S4 024	
	02.92-10.97					45	330	S4 021	
1.8/ 2.0 i 16V [T19]	02.92-10.97					45	330	S4 021	
Diesel									
2.0 D [T19]	02.92-01.96					95	830	S4 028	
	10.94-01.96	77	780	S5 008		74	680	S4 008	70 640 S3 008
D Turbo [T19]	01.96-10.97	77	780	S5 008		74	680	S4 008	70 640 S3 008
Carina E Sedan									
1.6 i 16V [T19]	02.92-01.96					60	540	S4 024	
	02.92-10.97					45	330	S4 021	
1.8/ 2.0 i 16V [T19]	02.92-10.97					45	330	S4 021	
Diesel									
2.0 D [T19]	02.92-09.94					95	830	S4 028	
	10.94-01.96	77	780	S5 008		74	680	S4 008	70 640 S3 008
D Turbo [T19]	01.96-10.97	77	780	S5 008		74	680	S4 008	70 640 S3 008
Carina E Wagon									
1.6 i 16V [T19]	11.92-10.97					45	330	S4 021	
1.8 i 16V [T19]	11.94-01.96					60	540	S4 024	
	05.95-10.97					45	330	S4 021	
2.0 i 16V [T19]	11.92-10.97					45	330	S4 021	
Diesel									
2.0 D, D Turbo [T19]	11.92-10.97	77	780	S5 008		74	680	S4 008	70 640 S3 008
Carina II Liftback									
1.6/ 1.8 , i [T15]	10.83-11.87					60	540	S4 024	
1.6/ 2.0 i 16V, 16V [T17]	12.87-01.92					45	330	S4 021	
Diesel									
2.0 D [T15; T17]	10.83-01.92					95	830	S4 028	
Carina II Sedan									
1.6/ 1.8/ 2.0 , i [T15]	10.83-11.87					60	540	S4 024	
1.6/ 2.0 i 16V, 16V [T17]	12.87-01.92					45	330	S4 021	

			Ah A (EN) S6	Ah A (EN) S5	Ah A (EN) S4	Ah A (EN) S3
			0 092 ...0	0 092 ...0	0 092 ...0	0 092 ...0

Diesel										
2.0 D [T15; T17]	10.83-01.92					95	830	S4 028		
Carina II Wagon										
1.6/2.0 i 16V, 16V [T17]	12.87-01.92					45	330	S4 021		
Diesel										
2.0 D [T17]	12.87-01.92					95	830	S4 028		
Celica Cabrio										
2.0 i 16V [T16]	08.85-08.89					45	330	S4 021		
i 16V [T18]	10.90-11.93					45	330	S4 021		
i 16V [T20]	08.94-05.99					45	330	S4 021		
Celica Coupé										
1.6/2.0, i 16V [T16; T18]	08.85-08.93					45	330	S4 021		
1.6/2.0/2.4, i, i 16V [A6]	08.81-08.85					60	540	S4 024		
1.8 i 16V [T23]	08.99-09.05					60	540	S4 024		
2.2 i 16V [T18]	10.89-09.97					60	540	S4 024		
Celica Liftback										
1.6/1.8/2.0/2.2/2.8, i, i 16V, i 16V Turbo, i 16V Turbo 4WD [A6; T16; T18; T20]	08.81-08.99					45	330	S4 021		
1.6/2.0/2.4, i, i 16V [A6]	08.81-08.85					60	540	S4 024		
1.6/2.2 i 16V [T18]	10.89-09.94					60	540	S4 024		
Corolla										
1.3, i 16V [E11]	09.96-08.99					45	330	S4 021		
i	04.97-07.01					60	540	S4 024		
	05.95-10.06					40	330	S4 018		
1.3/1.4/1.6 i 12V, i 16V, i 16V 4x4, 12V, 16V, 16V 4x4 [E9; E10]	05.87-04.97					45	330	S4 021		
1.3/1.6 VVT-i [E15]	11.06→	54	530	S5 002	52	470	S4 002	45	400	S3 002
1.4 i, i 16V [E12, JTD; E12, NMT] VVT-i [E15]	10.01-02.07	63	610	S5 005	52	470	S4 002	45	400	S3 002
	11.06-12.08	54	530	S5 002	52	470	S4 002			
1.5 i	08.00-12.04					45	330	S4 022		
	08.00-10.06	63	610	S5 005	60	540	S4 005	56	480	S3 005
1.6 [E15]	02.85-04.88					95	830	S4 029		
	12.08-04.10	54	530	S5 002	52	470	S4 002	45	400	S3 002
1.6/1.8, i, i 16V [E12; E12, JTD; E12, NMT; E15]	08.00-03.10	63	610	S5 005	60	540	S4 005	56	480	S3 005
Diesel										
1.4/2.0 D Turbo, D-4D [E12, JTD; E12, NMT; E15]	01.02→	70	760	S6 008	77	780	S5 008	74	680	S4 008
								70	640	S3 008
1.9 D [E11]	01.00-07.01					95	830	S4 028		
2.0 D [E11]	04.97-10.99					95	830	S4 028		
D Turbo [E11]	08.00-09.01					95	830	S4 028		
Corolla Coupé										
1.3/1.6, i 16V [E8]	05.83-07.87					45	330	S4 021		
Corolla Hatchback										
1.3 12V [E10]	05.92-05.95					45	330	S4 021		
1.3/1.4/1.6, i 12V, i 16V, 12V, 16V [E8; E9] i 16V [E11]	05.83-04.92					45	330	S4 021		
	05.97-07.01					60	540	S4 024		
1.3/1.6 i 16V [E10]	05.92-04.97					45	330	S4 021		
1.4 i 16V [E12]	11.01-12.07	63	610	S5 005	52	470	S4 002	45	400	S3 002
1.6 i 16V [E12]	11.01-02.07					60	540	S4 024	56	480
1.8 i [E10]	07.94-12.99					60	540	S4 024		
i 16V [E10]	11.92-04.97					60	540	S4 024		
i 16V [E12]	11.01-12.07	63	610	S5 005	60	540	S4 005			
Diesel										
1.4 D Turbo [E12]	09.02-12.07	70	760	S6 008	77	780	S5 008	74	680	S4 008
1.8 D [E8]	05.83-04.87					70	630	S4 026		
1.8/2.0 D [E9; E10]	05.87-04.97					95	830	S4 028		
1.9 D [E11]	01.00-07.01					95	830	S4 028		

			Ah A (EN) S6			Ah A (EN) S5			Ah A (EN) S4			Ah A (EN) S3		
			0092 ...0			0092 ...0			0092 ...0			0092 ...0		
◀ TOYOTA														
2.0 D [E11]	05.97-09.99							95	830					S4 028
D Turbo [E11]	08.00-07.01							95	830					S4 028
D Turbo [E12]	11.01-05.04	70	760	S6 008	77	780	S5 008	74	680	S4 008	70	640	S3 008	
Corolla II														
1.3 i	09.94-07.99							45	330					S4 022
Corolla Liftback														
FX 1.6/ 1.3/ 1.6 i, i 12V, i 16V, 12V, 16V [E8; E9]	05.83-04.92							45	330					S4 021
1.3 12V [E10]	05.92-05.95							45	330					S4 021
1.3/ 1.4/ 1.6 i 16V [E11/JT; E11/SB]	05.97-11.01							60	540					S4 024
1.3/ 1.6 i 16V [E10]	05.92-05.95							45	330					S4 021
1.8 i 16V [E10]	10.92-05.95							60	540					S4 024
Diesel														
1.8 D [E8]	05.83-04.87							70	630					S4 026
1.8/ 2.0 D [E9; E10]	05.87-05.95							95	830					S4 028
1.9 D [E11/JT]	12.99-11.01							95	830					S4 028
2.0 D [E11/JT]	05.97-09.99							95	830					S4 028
D [E11/SB]	12.99-11.01							95	830					S4 028
D Turbo [E11/JT]	08.00-09.01							95	830					S4 028
Corolla Sedan														
1.3 i 16V [E10]	05.92-04.97							45	330					S4 021
								60	540					S4 024
1.3/ 1.6 i 16V, 16V [E8; E9]	05.83-04.92							45	330					S4 021
1.4/ 1.6 i 16V [E11]	04.97-09.01							60	540					S4 024
Diesel														
1.8 D [E8]	05.83-04.87							70	630					S4 026
1.8/ 2.0 D [E9; E10]	05.87-04.97							95	830					S4 028
2.0 D Turbo	10.01-05.04	70	760	S6 008	77	780	S5 008	74	680	S4 008				
Corolla Verso														
1.6 i [R2]	02.09→				54	530	S5 002	52	470	S4 002				
1.6/ 1.8 i 16V [E12; R1]	09.01-02.09				63	610	S5 005	60	540	S4 005				
1.8 i 16V [E12]	09.01-01.04							60	540	S4 024	56	480	S3 005	
i 16V [R11]	02.04→				63	610	S5 005	60	540	S4 005	56	480	S3 005	
VWT-i [R2]	02.09→				63	610	S5 005	60	540	S4 005				
		SSJ			60	560	S5 E05							
Diesel														
2.0 D Turbo [E12; R1]	09.01-08.05	70	760	S6 008	77	780	S5 008	74	680	S4 008	70	640	S3 008	
2.0/ 2.2 D-CAT, D-4D [R2]	02.09→				77	780	S5 008							
2.2 D-CAT, D-4D [R1]	08.05-02.09				85	800	S5 010	80	740	S4 010				
Corolla Wagon														
1.3/ 1.4/ 1.6 i 12V, i 16V, i 16V 4WD, 12V, 16V, 16V 4WD [E7; E9]	08.79-08.95							45	330					S4 021
1.3/ 1.4/ 1.6/ 1.8 i 16V, i 16V 4x4 [E11]	04.97-09.01							60	540					S4 024
1.3/ 1.6/ 1.8 i 16V, 12V [E10]	05.92-04.97							45	330					S4 021
1.4 i [E12, JTD; E12, NMT]	08.02-02.07				63	610	S5 005	52	470	S4 002	45	400	S3 002	
i 16V [E12, JTD; E12, NMT]	10.01-11.06				63	610	S5 005	52	470	S4 002	45	400	S3 002	
1.6 i [E12, JTD; E12, NMT]	08.02-02.07				63	610	S5 005	60	540	S4 005	56	480	S3 005	
i 16V [E12, JTD; E12, NMT]	10.01-11.06				63	610	S5 005	60	540	S4 005	56	480	S3 005	
1.8 i 16V [E12]	08.00-12.06				63	610	S5 005	60	540	S4 005				
4x4 [E10]	05.95-04.97							60	540	S4 024				
Diesel														
1.4 D Turbo [E12, NMT]	04.04-02.07	70	760	S6 008	77	780	S5 008	74	680	S4 008				
1.8 D [E7]	05.83-07.87							70	630					S4 026
1.8/ 2.0 D [E9; E10]	08.87-04.97							95	830					S4 028
1.9 D [E11]	01.00-07.01							95	830					S4 028
D 4x4 [E11]	01.00-07.01							95	830					S4 028

						Ah A (EN) S6		Ah A (EN) S5		Ah A (EN) S4		Ah A (EN) S3	
				0 092 ...0		0 092 ...0		0 092 ...0		0 092 ...0		0 092 ...0	
2.0 D [E11]	04.97-10.99							95	830	S4 028			
D Turbo [E11]	08.00-09.01							95	830	S4 028			
D Turbo [E12, JTD; E12, NMT]	10.01-02.07	70	760	S6 008	77	780	S5 008	74	680	S4 008	70	640	S3 008
D 4x4 [E11]	04.97-10.99							95	830	S4 028			
Corona													
2.0	06.83-04.87							60	540	S4 024			
Corona Liftback													
1.6 [T15]	10.83-11.87							60	540	S4 024			
								70	630	S4 026			
1.8 [T15]	10.83-11.87							60	540	S4 024			
								70	630	S4 026			
GLi [T15]	08.85-11.87							60	540	S4 024			
								70	630	S4 026			
2.0 GLi [T15]	08.85-11.87							60	540	S4 024			
								70	630	S4 026			
Diesel													
2.0 D [T15]	10.83-11.87							70	630	S4 026			
								95	830	S4 028			
Corona Sedan													
1.8 [T14]	01.82-07.99							60	540	S4 024			
								70	630	S4 026			
2.0 [T14]	04.83-12.86							60	540	S4 024			
								70	630	S4 026			
16V [T17]	12.87-08.92							60	540	S4 024			
2.4 i [T14]	08.84-12.86							60	540	S4 024			
								70	630	S4 026			
Corona Wagon													
1.8 [T14]	01.82-12.86							60	540	S4 024			
								70	630	S4 026			
2.0 [T14]	04.83-12.86							60	540	S4 024			
								70	630	S4 026			
2.4 i [T14]	08.85-12.86							60	540	S4 024			
								70	630	S4 026			
Cressida Sedan													
2.0 [X6]	09.80-04.85							60	540	S4 024			
i [X6]	08.82-04.85							60	540	S4 024			
								70	630	S4 026			
2.0/2.8, i, i 24V [X8]	08.88-08.96							60	540	S4 024			
i [X7]	08.84-08.86							60	540	S4 024			
Diesel													
2.4 D [X8]	08.88-08.96							70	630	S4 026			
								95	830	S4 028			
2.5 D Turbo [X7]	08.84-08.86							70	630	S4 026			
								95	830	S4 028			
Cressida Wagon													
2.0/2.8, i [X6; X7]	09.80-08.86							60	540	S4 024			
Diesel													
2.5 D Turbo [X7]	11.84-08.86							70	630	S4 026			
								95	830	S4 028			
Crown													
2.8 i [S12]	08.83-09.85							70	630	S4 026			
Diesel													
2.4 D [S12]	08.83-08.87							70	630	S4 026			
Dyna													
2.0	09.84-08.86							60	540	S4 025			
Diesel													
2.5 D-4D	08.01-10.06							95	830	S4 028			
3.0 D	07.01→							95	830	S4 028			
3.4 D	09.84-08.87							95	830	S4 029			
Dyna 100													
1.8	08.87-05.95							60	540	S4 025			
								70	630	S4 027			

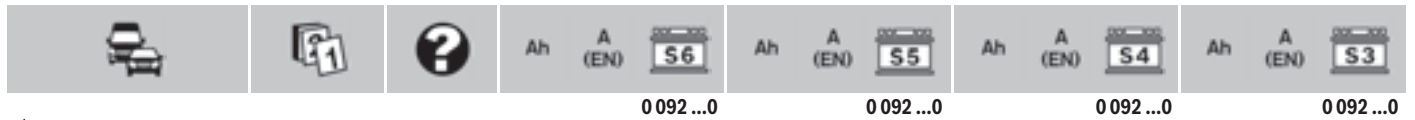

◀ TOYOTA

Diesel							
2.5 D	08.85-08.01		70	630		S4 027	
3.0 D-4D [Y2]	09.06→		95	830		S4 028	
Dyna 150							
2.0	08.85-08.87		60	540		S4 025	
Diesel							
2.5 D	08.85-07.87		95	830		S4 028	
	08.87-08.88		70	630		S4 027	
2.8 D	08.88-05.95		70	630		S4 027	
3.0 D	05.98-08.01		70	630		S4 027	
D-4D [Y2]	09.06→		95	830		S4 028	
Dyna 200							
Diesel							
3.0/ 3.4 D	08.87-08.88	ZE	70	630		S4 027	
Echo							
1.5 i 16V	09.99→		45	330		S4 023	45 400 S3 002
	06.03→		45	330		S4 022	
GT86							
2.0	04.12→		60	540		S4 024	
Hiace							
1.8/ 2.0/ 2.2 , 4WD [YH]	12.82-08.89		60	540		S4 025	
2.4 [RCH]	03.97-11.08		60	540		S4 025	
i [RCH]	08.95-11.08		60	540		S4 025	
2.4/ 2.7 i 4WD, 4x4 [RCH]	08.96-05.09		70	630		S4 027	
2.7 [RCH]	04.98-05.09		70	630		S4 027	
Diesel							
2.4 D, D Turbo, D Turbo 4WD [LXH]	08.95-08.01		95	830		S4 028	
D, D 4x4 [LH]	08.82-08.89		70	630		S4 027	
2.5 D Turbo	08.01→		60	540		S4 025	
D Turbo 4x4, D-4D [KLH]	08.01→		60	540		S4 025	
D-4D 4x4 [KLH]	08.01→		95	830		S4 028	
Hiace Pickup							
1.6	11.82-07.85		60	540		S4 024	45 300 S3 017
Diesel							
2.2 D	11.82-07.85		60	540		S4 024	
Hiace Van							
2.0/ 2.4 , i, i 4WD [ZH]	08.89-02.06		60	540		S4 025	
Diesel							
2.4 D [LH]	08.89-01.05		95	830		S4 029	
D Turbo [LXH]	08.96-08.01		95	830		S4 028	
D 4x4 [LH]	08.89-08.95		70	630		S4 027	
			95	830		S4 029	
2.8 D [LH]	08.89-08.00		70	630		S4 027	
Hiace Wagon							
2.4 i [ZH]	08.89-09.02		60	540		S4 025	
Diesel							
2.4 D [LH]	08.89-02.06		95	830		S4 029	
3.0 D [LH]	08.98-02.06		60	540		S4 025	
Hilux							
1.6 [N5/N6]	08.86-07.98		45	330		S4 023	
2.0 [N5/N6]	09.83-08.88		60	540		S4 025	
2.7 i VVTi 4x4 [Raider]	06.05→		70	630		S4 027	
Diesel							
2.4 D [N5/N6]	08.84-07.98		70	630		S4 026	
2.5 D-4D [N15]	07.05-08.11		70	630		S4 026	
			95	830		S4 028	
2.5/ 3.0 D-4D 4x4 [N25; N26]	07.05-08.11		95	830		S4 029	
Hilux Pickup							
1.8 [N8]	01.89-10.94		45	330		S4 023	
[N8...13]	08.88-08.94		45	330		S4 023	
2.2/ 2.4 i 4WD, 4WD [N8...13]	08.88-08.97		60	540		S4 025	

						Ah A (EN) S6		Ah A (EN) S5		Ah A (EN) S4		Ah A (EN) S3	
						0 092 ...0		0 092 ...0		0 092 ...0		0 092 ...0	
2.4 i [N14...19]	08.97-08.99												
						45	330					S4 023	
						70	630					S4 026	
i 4WD [N14...19]	11.97-08.01					60	540					S4 025	
i 4x4 [N8...13]	09.88-08.97					45	330					S4 023	
						70	630					S4 026	
Diesel													
2.4 D [N8...13]	08.88-08.97					70	630					S4 026	
						70	630					S4 027	
D [N14...19]	08.97-08.01					70	630					S4 026	
	11.97-08.01					70	630					S4 027	
D Turbo [N14...19]	08.97-08.01					70	630					S4 026	
	08.99-08.01					70	630					S4 027	
D 4x4 [N8...13]	09.88-12.97					70	630					S4 026	
2.5 D Turbo 4x4 [N14...19]	08.01-08.05					70	630					S4 026	
Hilux Surf													
2.7 i 4WD [N21]	08.04-07.09					70	630					S4 027	
Hilux Vigo													
Diesel													
2.5 D Turbo	07.02→					95	830					S4 028	
D Turbo 4x4	10.04→					70	630					S4 026	
Hilux Wagon													
Diesel													
2.4 D Turbo [N8...13]	01.90-11.95					70	630					S4 026	
						70	630					S4 027	
iQ													
1.0	11.08→					45	330					S4 023	
1.3 VVT-i	05.09→	BWD				45	330					S4 023	
		BWD,SSJ	60	680	S6 005	60	560	S5 E05					
Diesel													
1.4	11.08-05.12					70	630					S4 027	
Land Cruiser													
2.4 [J7]	10.85-05.93					70	630					S4 026	
i [J7]	12.88-04.96					95	830					S4 029	
3.4 i 24V [J9]	04.96-12.06					60	540					S4 024	
4.0 [J8]	01.90-08.92					95	830					S4 029	
, 4x4 [J6; J6/7]	11.84-12.92					95	830					S4 029	
i [J8]	09.87-08.92					70	630					S4 027	
	01.90-08.92					95	830					S4 029	
4.0/ 4.5/ 4.7 i 4x4, i 24V, i 32V 4x4, 4x4 [J6/7/10; J8; J10; J12; J15]	08.92→					95	830					S4 028	
4.2 [J4]	08.80-04.86					70	630					S4 027	
4.6/ 4.7, i 4x4 [J20]	09.07→					70	630					S4 026	
Diesel													
2.4/ 3.0 D, D Turbo [J7]	11.84-04.96					95	830					S4 029	
3.0 D-4D [J12]	09.02-08.09					95	830					S4 028	
		ASB				95	830					S4 028	
D-4D [J15]	08.09→					100	830	S5 013					
3.0/ 4.2 D, D Turbo, D Turbo Interc., D Turbo 4x4, 24V D Turbo [J8; J9; J10]	01.90-07.08					95	830					S4 028	
3.4/ 3.5/ 4.0/ 4.2 D, D Turbo, D Turbo 4x4 [J4; J6; J7]	08.80→					95	830					S4 028	
4.2 D 4x4 [J7/10]	03.98-10.07					95	830					S4 028	
						95	830					S4 029	
4.5 D-4D 4x4 [J20]	09.07→					95	830					S4 028	
4x4 [J7]	03.07→					70	630					S4 026	
						70	630					S4 027	
Land Cruiser Prado													
2.7 i 4x4 [J12]	08.04-09.09					95	830					S4 028	
3.4 i 24V [J9]	04.96-09.03					60	540					S4 024	

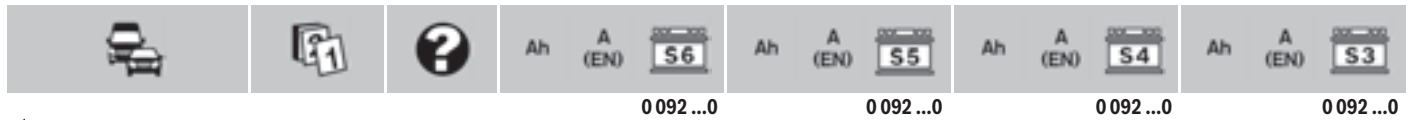

◀ TOYOTA

Diesel					
3.0 D Turbo 4x4 [J12]	11.02-07.07	ASB	95	830	S4 028
			95	830	S4 029
Liteace					
1.3/ 1.6/ 1.8 [M2]	10.79-08.85		45	330	S4 023
1.5 [M3]	10.85-08.88		45	330	S4 023
	10.85-01.92		40	330	S4 019
[R2]	01.92-05.94		40	330	S4 019
2.0 [M3]	01.86-08.88		45	330	S4 023
2.2 i [R2]	01.92-01.95		60	540	S4 025
Diesel					
1.8 D [M2]	10.82-08.85		45	330	S4 023
1.8/ 2.0 D [M3]	10.85-01.92		95	830	S4 029
2.0 D [R2]	01.92-01.95		70	630	S4 027
			95	830	S4 029
Model F					
2.0/ 2.2 , i , i 4x4	08.84-01.90		45	330	S4 023
Diesel					
2.0 D	05.83-07.88		95	830	S4 028
MR2 Cabrio					
1.6/ 2.0 i 16V, i 16V Turbo [W1; W2]	11.84-06.95		45	330	S4 021
1.8 16V [W3]	12.99-05.06		45	330	S4 021
MR2 Coupé					
1.6/ 2.0 i, i 16V [W1; W2]	11.84-08.99		45	330	S4 021
Paseo Cabrio					
1.5 i 16V [L5]	09.96-08.98		60	540	S4 025
Paseo Coupé					
1.5 i 16V [L5]	08.95-08.99		60	540	S4 025
Picnic					
2.0 i 16V	09.96-05.01		45	330	S4 021
Diesel					
2.2 D Turbo	09.97-05.01		95	830	S4 028
Previa					
2.4 i, i 16V, i 16V 4x4	05.90→		60	540	S4 024
Diesel					
2.0/ 2.2 D Turbo	01.92-01.06		60	540	S4 024
Prius					
1.5 i [W11]	09.00-08.03		45	330	S4 022
i [W20]	09.03-03.09	BWD	45	330	S4 022
1.8 i [W30]	04.09→		40	330	S4 030
Prius+					
1.8 i [W40]	03.12→		40	330	S4 030
Prius Alpha					
1.8 i	05.11→		40	330	S4 030
Quantum					
Diesel					
2.5 D-4D	03.05→		95	830	S4 029
RAV4					
1.8/ 2.0/ 2.4 i 4WD, i 4x4, i 16V, i 16V 4x4, WT-i 4x4 [; A1; A2]	04.94→		45	330	S4 021
2.0 [A3]	12.08-11.12		60	540	S4 024
2.0/ 2.4/ 3.5 4x4 [A3]	11.05→		45	330	S4 021
Diesel					
2.0 D Turbo [A2]	05.01-11.05		95	830	S4 028
2.2 D-CAT 4x4, D-4D 4x4 [A3]	11.05-11.12		95	830	S4 028
D-4D [A3]	11.05-11.12		100	830	S5 013
RAV4 Cabrio					
2.0 i 16V 4x4 [A1]	11.95-08.00		45	330	S4 021
Starlet					
1.0 [P8]	12.89-01.96		40	330	S4 019



						Ah A (EN) S6		Ah A (EN) S5		Ah A (EN) S4		Ah A (EN) S3	
				0 092 ...0		0 092 ...0		0 092 ...0		0 092 ...0		0 092 ...0	
1.0/ 1.3 [P7]	10.84-11.89					45	330			S4 023			
1.3 i 12V, 12V [P8]	12.89-01.96					45	330			S4 021			
i 16V [P8]	01.92-01.96					45	330			S4 023			
i 16V [P9]	01.96-07.99	JEA				40	330			S4 019			
						45	330			S4 023			
i 16V Turbo [P9]	01.96-07.99					60	540			S4 024			
12V [P9]	01.96-07.99					40	330			S4 019			
Diesel													
1.5 D [P7]	12.86-11.89					60	540			S4 025			
D [P8]	12.89-01.96					70	630			S4 026			
Supra													
3.0 i, i Turbo	01.86-04.93					70	630			S4 026			
i 24V	08.86-05.96					70	630			S4 026			
						95	830			S4 028			
i 24V Bi-Turbo	05.93-01.96					70	630			S4 026			
Tercel													
1.5 [L2]	08.81-08.88					45	330			S4 023			
Tercel Station Wagon													
1.5 4x4 [L2]	09.82-08.88					45	330			S4 023			
Tercel Wagon													
1.5 4x4 [L2]	10.82-01.88					45	330			S4 023			
Toyoace													
Diesel													
2.5 D [Y3]	08.83-07.85					70	630			S4 027			
Urban Cruiser													
1.3 VWT-i [P1]	01.09→	SSJ				60	560			S5 E05			
Diesel													
1.4 D-4D 4x4 [P1]	01.09→					60	540			S4 024			
Verso-S													
1.3 VWT-i	11.10→					60	560			S5 E05			
Diesel													
1.4 D-4D	11.10→					63	610	S5 005	60	540	S4 005		
Yaris													
1.0 [P13, VNK]	07.11→					54	530	S5 002	52	470	S4 002		
i 16V [P1]	01.99-12.02					45	330			S4 023			
	01.01-08.05					44	440			S4 001			
VWT-i [P9, JTD]	08.05-07.11					54	530	S5 002	52	470	S4 002	45	400
VWT-i [P9, VNK]	11.05-07.11					54	530	S5 002	52	470	S4 002	45	400
1.0/ 1.3 [P13, JTD]	08.11→					54	530	S5 002	52	470	S4 002		
1.3 [P13, VNK]	07.11→					54	530	S5 002	52	470	S4 002		
						60	560	S5 E05	52	470	S4 002		
i 16V [P1]	08.99-12.02					45	330			S4 023			
	05.02-08.05					52	520	S5 001	44	440	S4 001	41	360
VWT-i [P9]	01.06→					54	530	S5 002	52	470	S4 002		
VWT-i [P9, VNK]	11.05-10.08					54	530	S5 002	52	470	S4 002	45	400
	11.08-07.11	SSJ				60	680	S6 005	60	560	S5 E05		
1.5 HSD [P13, VNK]	04.12→					40	330			S4 018			
i 16V [P1]	01.01-08.05					45	330			S4 023			
Turbo [P1]	03.03-12.05					54	530	S5 002	52	470	S4 002	45	400
VWT-i [P9]	01.06→					52	520	S5 001	44	440	S4 001	41	360
1.8 VWT-i [P9, JTD]	11.06-07.11					63	610	S5 005	52	470	S4 002	45	400
Diesel													
1.4 D Turbo [P1]	10.01-08.06					63	610	S5 005	60	540	S4 005	56	480
D-4D [P9, VNK; P13, VNK]	11.05→					63	610	S5 005	60	540	S4 005		
Yaris Verso													
1.3 i 16V [P2]	08.99-09.05	JEA				45	330			S4 022			
						45	330			S4 023			
1.5 i 16V [P2]	08.99-09.05					45	330			S4 023			
Diesel													
1.4 D Turbo [P2]	08.01-09.05					60	540			S4 025			

			Ah A (EN) S6 0092...0	Ah A (EN) S5 0092...0	Ah A (EN) S4 0092...0	Ah A (EN) S3 0092...0
--	--	--	-----------------------	-----------------------	-----------------------	-----------------------

◀ TOYOTA

4-Runner						
2.4/ 3.0, i [; N13]	09.89-11.95			70	630	S4 027
2.7 [N18]	11.95-08.00			70	630	S4 027
i 16V [N18]	11.95-08.00			70	630	S4 027
3.4 i [N18]	11.95-08.02			70	630	S4 027
				95	830	S4 029
4.0/ 4.7 i, i 4x4 [N21]	09.02→			70	630	S4 027
Diesel						
2.4/ 3.0 D Turbo [; N13]	01.90-11.95			70	630	S4 027
3.0 D Turbo AWD [N18]	08.00→			70	630	S4 027
1000						
1.0	11.69-08.88			45	330	S4 021

TRABANT

601						
0.6/ 1.1, S	10.83-12.91		63 610	S5 005	60 540	S4 005 45 400 S3 002

TVR

Cerbera						
4.0	04.98-01.99		61 600	S5 004	60 540	S4 004
	01.99-12.04				70 630	S4 027
i	01.00-12.05		61 600	S5 004	60 540	S4 004
4.2/ 4.5 iV8, iV8 GT	01.96-12.01				70 630	S4 027
4.5 i	01.97-03.98		61 600	S5 004	60 540	S4 004
Chimaera						
3.9 iV8	03.92-12.96				70 630	S4 027
	04.98-01.99		61 600	S5 004	60 540	S4 004
4.3 iV8	01.93-12.93				70 630	S4 027
4.5 i	01.00-02.03		61 600	S5 004	60 540	S4 004
iV8	01.97-12.02				70 630	S4 027
5.0 iV8	03.92-12.96				70 630	S4 027
	04.98-03.02		61 600	S5 004	60 540	S4 004
Griffith						
4.0/ 4.3 iV8	01.90-12.93				70 630	S4 027
Griffith 500						
5.0 i, iV8	03.90-12.02				70 630	S4 027
Sagaris						
4.0	01.04-12.07				70 630	S4 026
Tamora						
3.6	01.02-12.07				74 680	S4 009
Tuscan						
3.6/ 4.0	01.98-12.07				74 680	S4 009

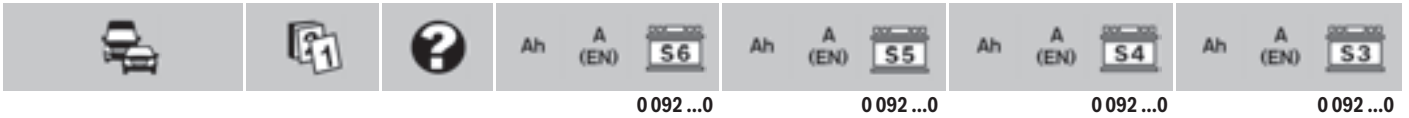

VAUXHALL

Agila						
1.0 i [A]	09.99-08.03		52 520	S5 001	44 440	S4 001 41 360 S3 001
Twinport [B]	03.08→		52 520	S5 001	44 440	S4 001
1.0/ 1.2 Twinport [A]	08.03-02.08		52 520	S5 001	44 440	S4 001 41 360 S3 001
1.2 i [A]	09.00-06.04		52 520	S5 001	44 440	S4 001
Twinport [B]	03.08→		52 520	S5 001	44 440	S4 001 41 360 S3 001
VVT [B]	03.08→		52 520	S5 001	44 440	S4 001
			60 560	S5 E05	44 440	S4 001
Diesel						
1.3 CDTI [B]	03.08→		61 600	S5 004	60 540	S4 004
Antara						
2.4	01.12→				70 630	S4 027
2.4/ 3.2 V6 4x4, 4x4	11.06→				74 680	S4 009



Diesel													
2.0 CDTI 4x4	11.06→								74	680	S4 009		
									95	830	S4 029		
2.2 CDTI	11.10→								95	830	S4 029		
CDTI 4x4	11.10→								95	830	S4 029		
Arena													
Diesel													
1.9/ 2.5 , D	03.98-08.01	70	760	S6 008	77	780	S5 008	74	680	S4 008	70	640	S3 008
Astra													
1.2 Twinport [H]	03.07-03.09				52	520	S5 001	44	440	S4 001			
1.2/ 1.3/ 1.4 [E]	09.84-08.91				61	600	S5 004	44	440	S4 001	41	360	S3 001
1.2/ 1.4 i [G]	09.97-08.05				61	600	S5 004	44	440	S4 001	41	360	S3 001
1.3 S [E]	09.84-08.87				61	600	S5 004	44	440	S4 001	41	360	S3 001
1.3/ 1.4/ 1.6 i [E]	09.84-12.91				61	600	S5 004	44	440	S4 001	41	360	S3 001
1.4 [F]	09.91-09.93				61	600	S5 004	44	440	S4 001	41	360	S3 001
i [H]	09.04-12.05				61	600	S5 004						
				XXX							53	470	S3 004
i [J]	09.09→				52	520	S5 001	44	440	S4 001			
Turbo [J]	09.09→				52	520	S5 001	44	440	S4 001			
	09.11→				61	600	S5 004						
				XXX							53	470	S3 004
Twinport [H]	03.04-03.10				61	600	S5 004	44	440	S4 001	41	360	S3 001
Twinport Dualfuel [H]	04.05-03.10				61	600	S5 004	44	440	S4 001			
1.4/ 1.6 i [F]	09.90-02.98				61	600	S5 004	44	440	S4 001	41	360	S3 001
1.6 [E]	09.84-12.91										53	500	S3 004
[H]	03.07-03.10				52	520	S5 001	44	440	S4 001	41	360	S3 001
	01.11→				61	600	S5 004	44	440	S4 001			
i [G]	09.97-08.05				61	600	S5 004	44	440	S4 001	41	360	S3 001
	09.98-08.05				61	600	S5 004	44	440	S4 001			
i [J]	09.09→				61	600	S5 004	60	540	S4 004			
i Dualfuel [G]	09.02-08.05				61	600	S5 004	44	440	S4 001	41	360	S3 001
i Turbo [J]	09.09→				61	600	S5 004	60	540	S4 004			
Turbo [H]	03.07-03.10				61	600	S5 004	60	540	S4 004			
	01.11→				61	600	S5 004	44	440	S4 001			
Twinport [H]	03.04-03.07				61	600	S5 004	44	440	S4 001	41	360	S3 001
	03.07-03.09				61	600	S5 004	44	440	S4 001			
1.8 i [E]	09.84-08.91				61	600	S5 004	44	440	S4 001	41	360	S3 001
					61	600	S5 004	44	440	S4 001	53	500	S3 004
i [F]	09.91-02.98				61	600	S5 004	44	440	S4 001	41	360	S3 001
					61	600	S5 004	44	440	S4 001	53	500	S3 004
i [G]	09.97-08.05				74	750	S5 007	60	540	S4 004			
				XXX							53	470	S3 004
i [H]	03.04-02.09				61	600	S5 004	44	440	S4 001	41	360	S3 001
	08.05-03.10				61	600	S5 004	60	540	S4 004			
i Dualfuel [G]	09.02-08.05				74	750	S5 007	60	540	S4 004			
				XXX							53	470	S3 004
2.0 GTC Turbo [J]													
	06.12→	70	760	S6 008									
i [E]	09.86-08.91				61	600	S5 004	44	440	S4 001	41	360	S3 001
					61	600	S5 004	44	440	S4 001	53	500	S3 004
i [F]	09.91-02.98				61	600	S5 004	44	440	S4 001	41	360	S3 001
i [G]	09.97-08.05				74	750	S5 007	60	540	S4 004			
				XXX							53	470	S3 004
	09.00-08.05				61	600	S5 004						
Turbo [G]	07.02-08.05				74	750	S5 007	60	540	S4 004			
				XXX							53	470	S3 004
Turbo [H]	03.04-03.10				74	750	S5 007	60	540	S4 004			
				XXX							53	470	S3 004
Turbo 16V [H]	03.04-03.10				74	750	S5 007	60	540	S4 004			
				XXX							53	470	S3 004
2.2 i [G]	09.00-08.05				74	750	S5 007	72	680	S4 007	70	640	S3 007
Diesel													
1.3 CDTI [H]	01.06-03.10				74	750	S5 007	60	540	S4 004			
1.3/ 1.7/ 2.0 CDTI [J]	09.09→				74	750	S5 007	72	680	S4 007			

				Ah A (EN) S6	Ah A (EN) S5	Ah A (EN) S4	Ah A (EN) S3
				0092...0	0092...0	0092...0	0092...0
VAUXHALL							
1.6 D [E]	09.84-12.89			74	750	S5 007	60 540 S4 004 53 500 S3 004
1.7 CDTI	01.12->	70	760	S6 008			
CDTI [H]	03.04-03.07			74	750	S5 007	60 540 S4 004 70 640 S3 007
	03.07-09.09			74	750	S5 007	72 680 S4 007 70 640 S3 007
	05.07-03.10			61	600	S5 004	
	XXX						53 470 S3 004
	03.10->			74	750	S5 007 60 540 S4 004	
CDTI 16V [G]	03.03-08.05			74	750	S5 007	72 680 S4 007 70 640 S3 007
D [E]	01.89-08.91			74	750	S5 007 60 540 S4 004	
D/DR, DTL, TD [F]	12.91-02.98			74	750	S5 007 60 540 S4 004	
DT [G]	03.98-08.00			74	750	S5 007	72 680 S4 007 70 640 S3 007
1.7/2.0 DTI [G]	09.00-08.05			74	750	S5 007	72 680 S4 007 70 640 S3 007
1.9 CDTI [H]	03.04-03.10			74	750	S5 007	60 540 S4 004 70 640 S3 007
	09.05-03.10			74	750	S5 007	72 680 S4 007
2.0 DTL [G]	03.98-08.05			74	750	S5 007	72 680 S4 007 70 640 S3 007
GTC [J]	08.12->	70	760	S6 008			
2.2 DTI [G]	09.01-08.05			74	750	S5 007	72 680 S4 007
Astra Convertible							
1.4 [F]	09.91-09.93			61	600	S5 004	44 440 S4 001 41 360 S3 001
1.6 i [F]	09.91-02.98			61	600	S5 004	44 440 S4 001 41 360 S3 001
i [G]	09.00-08.05			61	600	S5 004	44 440 S4 001 41 360 S3 001
i Twinport [G]	03.03-08.05			61	600	S5 004	
	XXX						53 470 S3 004
1.8 i [F]	09.94-02.98			61	600	S5 004	44 440 S4 001 41 360 S3 001
				61	600	S5 004	44 440 S4 001 53 500 S3 004
i [G]	09.00-08.05			74	750	S5 007	60 540 S4 004
	XXX						53 470 S3 004
2.0 i [F]	09.91-02.98			61	600	S5 004	44 440 S4 001 41 360 S3 001
i Turbo [G]	03.02-08.05			74	750	S5 007	60 540 S4 004
	XXX						53 470 S3 004
2.2 i [G]	09.00-08.05			74	750	S5 007	72 680 S4 007 70 640 S3 007
Astra Coupé							
1.6 i Twinport [G]	03.03-08.05			61	600	S5 004	
	XXX						53 470 S3 004
1.8 i [G]	09.97-08.05			74	750	S5 007	60 540 S4 004
	XXX						53 470 S3 004
	03.01-08.05			74	750	S5 007	60 540 S4 004 53 500 S3 004
i Dualfuel [G]	09.02-08.05			74	750	S5 007	60 540 S4 004
	XXX						53 470 S3 004
2.0 i Turbo [G]	09.00-08.05			74	750	S5 007	60 540 S4 004
	XXX						53 470 S3 004
2.2 i [G]	09.00-08.05			74	750	S5 007	72 680 S4 007 70 640 S3 007
Astra Estate							
1.2 Twinport [H]	03.07-03.09			52	520	S5 001	44 440 S4 001
1.2/1.4 i [G]	09.97-08.05			61	600	S5 004	44 440 S4 001 41 360 S3 001
1.4 [H]	09.04-12.05			61	600	S5 004	
	XXX						53 470 S3 004
Twinport [H]	08.04-03.10			61	600	S5 004	44 440 S4 001 41 360 S3 001
1.4/1.6 i [F]	09.90-02.98			61	600	S5 004	44 440 S4 001 41 360 S3 001
1.6 [H]	09.07-03.10			61	600	S5 004 44 440 S4 001	
i [G]	09.97-08.05			61	600	S5 004	44 440 S4 001 41 360 S3 001
	09.02-08.05			61	600	S5 004	
	XXX						53 470 S3 004
i Dualfuel [G]	09.02-08.05			61	600	S5 004	44 440 S4 001 41 360 S3 001
S [D]	02.82-08.86			61	600	S5 004	44 440 S4 001 41 360 S3 001
Turbo [H]	09.07-03.10			52	520	S5 001	44 440 S4 001 41 360 S3 001
Twinport [H]	08.04-03.07			61	600	S5 004	44 440 S4 001 41 360 S3 001
	09.07-03.09			52	520	S5 001	44 440 S4 001
1.8 i [F]	09.91-02.98			61	600	S5 004	44 440 S4 001 41 360 S3 001
				61	600	S5 004	44 440 S4 001 53 500 S3 004
i [G]	09.97-08.05			74	750	S5 007	60 540 S4 004
	XXX						53 470 S3 004

				Ah A (EN) S6	Ah A (EN) S5	Ah A (EN) S4	Ah A (EN) S3	
				0 092 ...0	0 092 ...0	0 092 ...0	0 092 ...0	
1.8 i [H]	08.04-02.09			61	600	S5 004	44 440 S4 001	41 360 S3 001
	08.05-03.10			61	600	S5 004	60 540 S4 004	
i Dualfuel [G]	09.02-08.05			74	750	S5 007	60 540 S4 004	
	XXX						53 470 S3 004	
2.0 i [F]	09.91-02.98			61	600	S5 004	44 440 S4 001	41 360 S3 001
i [G]	09.97-08.05			74	750	S5 007	60 540 S4 004	
	XXX						53 470 S3 004	
Turbo [G]	09.02-08.05			61	600	S5 004	60 540 S4 004	
	XXX						53 470 S3 004	
Turbo [H]	08.04-02.09	XXX					53 470 S3 004	
	08.04-03.10			74	750	S5 007	60 540 S4 004	
Turbo 16V [H]	08.04-03.10			74	750	S5 007	60 540 S4 004	
	XXX						53 470 S3 004	
2.2 i [G]	09.00-08.05			74	750	S5 007	72 680 S4 007	70 640 S3 007
Diesel								
1.3 CDTI [H]	06.05-03.10			74	750	S5 007	60 540 S4 004	
1.7 CDTI [H]	08.04-03.07			74	750	S5 007	60 540 S4 004	70 640 S3 007
	09.04-03.07			74	750	S5 007	72 680 S4 007	
	03.07-03.10			74	750	S5 007	72 680 S4 007	70 640 S3 007
	05.07-03.10			61	600	S5 004		
	XXX						53 470 S3 004	
	03.10→			74	750	S5 007	60 540 S4 004	
				74	750	S5 007	72 680 S4 007	
D/DR, DTL, TD [F]	12.91-02.98			74	750	S5 007	60 540 S4 004	
1.7/2.0 CDTI, DT, DTI, DTL [G]	03.98-08.05			74	750	S5 007	72 680 S4 007	70 640 S3 007
1.9 CDTI [H]	08.04-03.10			74	750	S5 007	60 540 S4 004	70 640 S3 007
	09.05-03.10			74	750	S5 007	60 540 S4 004	
Astra GTC								
1.4 Turbo [J]	09.11→			61	600	S5 004		
				70	760	S6 008		
	XXX						53 470 S3 004	
Twinport [H]	06.05-03.09			52	520	S5 001	44 440 S4 001	
	09.05-02.09			61	600	S5 004		
	XXX						53 470 S3 004	
1.6 Turbo [J]	09.11→			61	600	S5 004		
	XXX						53 470 S3 004	
Twinport [H]	09.05-03.08			61	600	S5 004	44 440 S4 001	41 360 S3 001
VVT [H]	12.06→			61	600	S5 004		
	XXX						53 470 S3 004	
1.6/1.8, i VVT [H]	01.11→			61	600	S5 004	44 440 S4 001	
1.8 i [H]	06.05-02.09			61	600	S5 004	44 440 S4 001	41 360 S3 001
2.0 Turbo [H]	06.05-02.09			74	750	S5 007	60 540 S4 004	
	XXX						53 470 S3 004	
Turbo 16V [H]	06.05-03.09			74	750	S5 007	72 680 S4 007	
	06.05-12.09			74	750	S5 007	60 540 S4 004	
Diesel								
1.7 [J]	11.11→			61	600	S5 004		
				70	650	S5 E08		
	XXX						53 470 S3 004	
CDTI [H]	06.05-03.07			74	750	S5 007	60 540 S4 004	
	09.05-12.09			74	750	S5 007	72 680 S4 007	
1.9 CDTI [H]	06.05-12.09			74	750	S5 007	60 540 S4 004	
2.0 [J]	09.11→			74	750	S5 007	72 680 S4 007	
Astra Sport Tourer								
Diesel								
1.7 CDTI	01.12→			70	760	S6 008		
Astra Sports Tourer								
1.4 i [J]	09.10→			61	600	S5 004		
	XXX						53 470 S3 004	
i Turbo [J]	09.10→			61	600	S5 004		
	XXX						53 470 S3 004	

			Ah	A (EN)	S6	Ah	A (EN)	S5	Ah	A (EN)	S4	Ah	A (EN)	S3
			0092 ...0			0092 ...0			0092 ...0			0092 ...0		
◀ VAUXHALL														
1.6 i [J]	09.10→		61	600	S5 004									
		XXX										53	470	S3 004
Diesel														
1.3 CDTi [J]	09.10→		60	560	S5 E05	72	680	S4 007						
			74	750	S5 007	72	680	S4 007						
1.7 CDTi	01.12→		70	760	S6 008									
1.7/2.0 CDTi [J]	09.10→		74	750	S5 007	72	680	S4 007						
Astra TwinTop														
1.6 i [H]	09.05-03.08		61	600	S5 004	44	440	S4 001	41	360	S3 001			
	03.07-12.09		61	600	S5 004	60	540	S4 004						
i Turbo [H]	03.07-12.09		61	600	S5 004	60	540	S4 004						
1.8 i [H]	03.06-03.09		61	600	S5 004	60	540	S4 004						
2.0 i Turbo [H]	09.05-12.09		74	750	S5 007	72	680	S4 007						
Diesel														
1.9 CDTi [H]	09.05-12.09		74	750	S5 007	72	680	S4 007						
Astra Van														
1.4/1.6 i [F; G]	09.90-08.05		61	600	S5 004	44	440	S4 001	41	360	S3 001			
Diesel														
1.7 D/DR, DTL [F]	12.91-02.98		74	750	S5 007	60	540	S4 004						
1.7/2.0 CDTi, DT, DTi, DTL [G]	03.98-08.05		74	750	S5 007	72	680	S4 007	70	640	S3 007			
Belmont														
1.3/1.4/1.6/1.8, i, S	09.85-09.93		61	600	S5 004	44	440	S4 001	41	360	S3 001			
Diesel														
1.6 D	09.85-09.93		74	750	S5 007	60	540	S4 004						
Brava Pick-Up														
2.3, i [TF0]	09.91-09.96		52	520	S5 001	44	440	S4 001						
Diesel														
2.2/2.5 D, TD [TF0]	02.89-12.96	95	850	S6 013	100	830	S5 013	95	800	S4 013	90	720	S3 013	
2.5/3.1 TD [TF1]	03.97-08.02	95	850	S6 013	100	830	S5 013	95	800	S4 013	90	720	S3 013	
Calibra														
2.0 i	03.90-03.98		74	750	S5 007	60	540	S4 004	53	500	S3 004			
		XXX										53	470	S3 004
i turbo	03.92-07.97		74	750	S5 007	60	540	S4 004	53	500	S3 004			
		XXX										53	470	S3 004
2.5 i V6	04.93-03.97		74	750	S5 007	60	540	S4 004	53	500	S3 004			
		XXX										53	470	S3 004
Carlton II														
1.8 S	12.82-08.86		61	600	S5 004	44	440	S4 001	41	360	S3 001			
			61	600	S5 004	44	440	S4 001	53	500	S3 004			
2.0 i	10.78-11.86		74	750	S5 007	60	540	S4 004	53	500	S3 004			
		XXX										53	470	S3 004
S	10.78-11.86		74	750	S5 007	60	540	S4 004	53	500	S3 004			
		XXX										53	470	S3 004
2.2 i	11.84-08.86		74	750	S5 007	60	540	S4 004	53	500	S3 004			
		XXX										53	470	S3 004
Diesel														
2.3 D	05.83-08.86		74	750	S5 007	72	680	S4 007	70	640	S3 007			
Carlton III														
1.8	09.86-10.94		61	600	S5 004	44	440	S4 001	41	360	S3 001			
			61	600	S5 004	44	440	S4 001	53	500	S3 004			
i	09.86-10.94		61	600	S5 004	44	440	S4 001	41	360	S3 001			
			61	600	S5 004	44	440	S4 001	53	500	S3 004			
2.0 i	09.86-10.94		74	750	S5 007	60	540	S4 004	53	500	S3 004			
		XXX										53	470	S3 004
2.4 i	09.86-10.94		74	750	S5 007	60	540	S4 004	53	500	S3 004			
		XXX										53	470	S3 004
2.6 i	09.90-10.94		74	750	S5 007	60	540	S4 004	53	500	S3 004			
		XXX										53	470	S3 004
3.0 i	03.87-10.94											53	500	S3 004
			74	750	S5 007	60	540	S4 004	53	500	S3 004			
		XXX										53	470	S3 004

		Ah A (EN) S6			Ah A (EN) S5			Ah A (EN) S4			Ah A (EN) S3		
		0 092 ...0			0 092 ...0			0 092 ...0			0 092 ...0		
3.6 i	01.90-03.94	74	750	S5 007	60	540	S4 004	53	500	S3 004			
	XXX							53	470	S3 004			
Diesel													
2.3 D, TD Interc., YTD	09.86-10.94	74	750	S5 007	72	680	S4 007	70	640	S3 007			
Cavalier II													
1.3/ 1.6/ 1.8/ 2.0, i	09.81-08.88	52	520	S5 001	44	440	S4 001	41	360	S3 001			
Diesel													
1.6 D	03.82-08.88	61	600	S5 004	44	440	S4 001	53	500	S3 004			
Cavalier III													
1.4/ 1.8	09.88-11.95	52	520	S5 001	44	440	S4 001	41	360	S3 001			
1.6 i KAT	09.88-11.95	52	520	S5 001	44	440	S4 001	41	360	S3 001			
1.6/ 1.8 i	09.88-11.95	52	520	S5 001	44	440	S4 001	41	360	S3 001			
S	09.88-08.95	52	520	S5 001	44	440	S4 001	41	360	S3 001			
2.0 i	09.88-11.95	52	520	S5 001	44	440	S4 001	41	360	S3 001			
		52	520	S5 001	44	440	S4 001	53	500	S3 004			
i 4x4	09.88-08.95	52	520	S5 001	44	440	S4 001	41	360	S3 001			
		52	520	S5 001	44	440	S4 001	53	500	S3 004			
i 16V	09.88-11.95	52	520	S5 001	44	440	S4 001	41	360	S3 001			
		52	520	S5 001	44	440	S4 001	53	500	S3 004			
i 16V 4x4	09.88-11.95	52	520	S5 001	44	440	S4 001	41	360	S3 001			
		52	520	S5 001	44	440	S4 001	53	500	S3 004			
2.5 i V6	02.93-11.95	52	520	S5 001	44	440	S4 001	41	360	S3 001			
		52	520	S5 001	44	440	S4 001	53	500	S3 004			
Diesel													
1.7 D, TD	09.88-11.95	61	600	S5 004	44	440	S4 001	53	500	S3 004			
Combo													
1.2/ 1.4 i	09.94-10.01	61	600	S5 004	44	440	S4 001	41	360	S3 001			
1.4 [D]	02.12→	61	600	S5 004									
	XXX							53	470	S3 004			
i Twinport [Tour]	01.04-01.12	52	520	S5 001	44	440	S4 001						
i Twinport Dualfuel [Tour]	09.04-01.12	61	600	S5 004	44	440	S4 001						
1.6 CNG [Tour]	04.05-01.12	61	600	S5 004									
	XXX							53	470	S3 004			
i [Tour]	10.01-08.04	61	600	S5 004	44	440	S4 001	41	360	S3 001			
Diesel													
1.3 [D]	02.12→	61	600	S5 004									
	XXX							53	470	S3 004			
CDTi [Tour]	09.04-01.12	61	600	S5 004									
	XXX							53	470	S3 004			
	03.06-01.12	74	750	S5 007	72	680	S4 007	70	640	S3 007			
1.6 [D]	02.12→	61	600	S5 004									
		74	750	S5 007	72	680	S4 007						
	XXX							53	470	S3 004			
1.7 CDTi [Tour]	09.04-01.12	74	750	S5 007	72	680	S4 007	70	640	S3 007			
D	09.94-10.01	74	750	S5 007	60	540	S4 004						
DI, DTi [Tour]	09.01-08.04	74	750	S5 007	60	540	S4 004	70	640	S3 007			
2.0 [D]	02.12→	74	750	S5 007	72	680	S4 007						
Corsa													
1.0 Twinport [D]	07.06-10.09	54	530	S5 002				40	340	S3 000			
	XXX							42	390	S4 000			
	12.09→	54	530	S5 002	52	470	S4 002						
1.0/ 1.2/ 1.4/ 1.6 GSi, i [B]	09.94-09.00	61	600	S5 004	44	440	S4 001	41	360	S3 001			
1.0/ 1.2/ 1.4/ 1.8 i 12V, i 16V, 16V Dualfuel [C]	09.00-08.05	61	600	S5 004	44	440	S4 001	41	360	S3 001			
1.0/ 1.4 Twinport [C]	09.03-08.05	52	520	S5 001	44	440	S4 001	41	360	S3 001			
1.2 i Twinport [D]	12.09→	54	530	S5 002	52	470	S4 002						
Twinport [C]	09.04-09.06	52	520	S5 001	44	440	S4 001						
Twinport [D]	07.06→	52	520	S5 001	44	440	S4 001						
	12.09→	54	530	S5 002	52	470	S4 002						
Twinport Dualfuel [C]	09.04-09.06	61	600	S5 004	44	440	S4 001						
1.2/ 1.4 i LPG, LPG [D]	12.09→	52	520	S5 001	44	440	S4 001						







			Ah	A (EN)	S6	Ah	A (EN)	S5	Ah	A (EN)	S4	Ah	A (EN)	S3
			0092 ...0			0092 ...0			0092 ...0			0092 ...0		
VAUXHALL														
1.4 Twinport [D]	07.06-11.10		63	610	S5 005	44	440	S4 001	41	360	S3 001			
	12.09→		52	520	S5 001	44	440	S4 001						
			54	530	S5 002	52	470	S4 002						
Twinport Turbo [D]	07.12→	70 760	S6 008											
1.6 i [C]	09.01-08.03		61	600	S5 004									
		XXX							53	470	S3 004			
i OPC Turbo [D]	02.07→		61	600	S5 004	60	540	S4 004						
		XXX							53	470	S3 004			
	01.11→		63	610	S5 005	52	470	S4 002	53	500	S3 004			
	10.11→		61	600	S5 004									
i Turbo [D]	10.07→		61	600	S5 004	60	540	S4 004						
Diesel														
1.3 CDTI [C]	09.03-09.06		74	750	S5 007	52	470	S4 002						
			74	750	S5 007	60	540	S4 004						
	09.05-09.06		61	600	S5 004									
		XXX							53	470	S3 004			
CDTI [D]	07.06-03.09		74	750	S5 007	72	680	S4 007						
	07.06-07.10		74	750	S5 007	52	470	S4 002	70	640	S3 007			
	12.09→		74	750	S5 007	72	680	S4 007						
1.5/1.7 D, TD, XTD [B]	09.94-08.00		74	750	S5 007	60	540	S4 004						
1.7 CDTI [C]	09.03-08.05		74	750	S5 007	60	540	S4 004	70	640	S3 007			
CDTI [D]	07.06-02.09		74	750	S5 007	72	680	S4 007	70	640	S3 007			
	07.06→		74	750	S5 007	72	680	S4 007						
DI, DTI [C]	09.00-08.03		74	750	S5 007	60	540	S4 004	70	640	S3 007			
Frontera														
2.0/2.2/2.4 i [A]	01.92-08.98	70 760	77	780	S5 008	74	680	S4 008	70	640	S3 008			
2.2 i [B]	09.98-09.04	70 760	77	780	S5 008	74	680	S4 008	70	640	S3 008			
3.2 i [B]	09.98-09.04	70 760	77	780	S5 008	70	630	S4 026	70	640	S3 008			
Diesel														
2.2 DTI [B]	09.98-09.04	70 760	77	780	S5 008	70	630	S4 026	70	640	S3 008			
2.3/2.5/2.8 TD, TDI Turbo, TDS Turbo [A]	01.92-08.98	70 760	77	780	S5 008	74	680	S4 008	70	640	S3 008			
Insignia														
1.4 Turbo [68; 69]	09.11→	70 760	S6 008											
1.6 [68]	11.08→		52	520	S5 001	44	440	S4 001						
			61	600	S5 004	60	540	S4 004						
[69]	11.08→		61	600	S5 004	60	540	S4 004						
1.8 [68]	11.08→		74	750	S5 007	72	680	S4 007						
[69]	11.08→		74	750	S5 007	72	680	S4 007						
2.0 Turbo [68]	11.08→		74	750	S5 007	72	680	S4 007						
Turbo [69]	11.08→		74	750	S5 007	72	680	S4 007						
Turbo 4x4 [68]	11.08→		74	750	S5 007	72	680	S4 007						
Turbo 4x4 [69]	11.08→		74	750	S5 007	72	680	S4 007						
2.8 Turbo 4x4 [68]	11.08→		85	800	S5 010	74	680	S4 008						
	09.09→		74	750	S5 007	72	680	S4 007						
Turbo 4x4 [69]	11.08→		85	800	S5 010	74	680	S4 008						
	09.09→		74	750	S5 007	72	680	S4 007						
Diesel														
2.0 CDTI [68]	11.08→		85	800	S5 010	74	680	S4 008						
			85	800	S5 010	80	740	S4 010						
	03.12→		74	750	S5 007	72	680	S4 007						
CDTI [69]	11.08→		74	750	S5 007	72	680	S4 007						
			85	800	S5 010	74	680	S4 008						
	03.12→		80	730	S5 E11	80	740	S4 010						
			85	800	S5 010	80	740	S4 010						
CDTI 4x4 [68]	07.09→		80	730	S5 E11	80	740	S4 010						
			85	800	S5 010	80	740	S4 010						
CDTI 4x4 [69]	07.09→		80	730	S5 E11	80	740	S4 010						
			85	800	S5 010	80	740	S4 010						
Insignia Sports Tourer														
1.4 [35]	09.11→	70 760	S6 008											
1.6 [35]	02.09→		52	520	S5 001	44	440	S4 001						
			61	600	S5 004	60	540	S4 004						

		Ah A (EN) S6			Ah A (EN) S5			Ah A (EN) S4			Ah A (EN) S3		
		0 092 ...0			0 092 ...0			0 092 ...0			0 092 ...0		
1.8 [35]	02.09→		74	750	S5 007	72	680	S4 007					
2.0 Turbo [35]	02.09→		74	750	S5 007	72	680	S4 007					
4x4 [35]	02.09→		74	750	S5 007	72	680	S4 007					
2.8 Turbo 4x4 [35]	02.09→		85	800	S5 010	74	680	S4 008					
	09.09→		74	750	S5 007	72	680	S4 007					
Diesel													
2.0 CDTI [35]	02.09→		85	800	S5 010	74	680	S4 008					
			85	800	S5 010	80	740	S4 010					
	03.12→		74	750	S5 007	72	680	S4 007					
CDTI 4x4 [35]	07.09→		74	750	S5 007	72	680	S4 007					
	06.10→		85	800	S5 010	80	740	S4 010					
Meriva													
1.4 ecoFLEX [B]	04.10→		61	600	S5 004								
		XXX							53	470	S3 004		
Ecotec [B]	04.10→		61	600	S5 004								
		XXX							53	470	S3 004		
16V Twinport [A]	07.04-03.10		74	750	S5 007	44	440	S4 001					
		XXX							53	470	S3 004		
1.6 i [A]	03.03-09.05		74	750	S5 007	44	440	S4 001					
		XXX							53	470	S3 004		
i OPC Turbo [A]	09.05-03.10		74	750	S5 007	44	440	S4 001					
		XXX							53	470	S3 004		
i 16V [A]	03.03-03.10		74	750	S5 007	44	440	S4 001					
		XXX							53	470	S3 004		
1.8 i 16V [A]	03.03-03.10		74	750	S5 007	60	540	S4 004					
		XXX							53	470	S3 004		
Diesel													
1.3 CDTI [A]	09.03-03.10		74	750	S5 007	60	540	S4 004					
		XXX							53	470	S3 004		
	09.05-03.10		61	600	S5 004								
CDTI [B]	06.10→		60	560	S5 E05								
		XXX							53	470	S3 004		
1.7 CDTI [A]	09.03-09.09		74	750	S5 007	72	680	S4 007	70	640	S3 007		
	09.06-03.10		74	750	S5 007	72	680	S4 007					
CDTI [B]	04.10→		74	750	S5 007	72	680	S4 007					
DTI [A]	03.03-09.05		74	750	S5 007	72	680	S4 007					
Mokka													
1.4/ 1.6 Turbo ecoFLEX, Turbo	09.12→		70	760	S6 008								
ecoFLEX 4x4													
Diesel													
1.7 CDTI ecoFLEX	09.12→		70	760	S6 008	61	600	S5 004					
		XXX							53	470	S3 004		
CDTI ecoFLEX 4x4	09.12→		70	760	S6 008								
Monaro Coupé													
5.7/ 6.0, i [V2 III]	08.02→		77	780	S5 008	74	680	S4 008					
Monterey													
3.2 i [A]	06.92-08.98					70	630	S4 026					
3.5 i V6 [B]	02.98-12.99					74	680	S4 009					
Diesel													
3.0 DTI [B]	02.98-12.99		70	760	S6 008	77	780	S5 008	74	680	S4 008	70	
									640		S3 008		
3.1 TD [A]	09.91-08.98					70	630	S4 026					
Movano													
Diesel													
1.9/ 2.2/ 2.5/ 2.8/ 3.0 D, DTI	06.98-03.10		95	850	S6 013	100	830	S5 013	95	800	S4 013	90	
[A]									720		S3 013		
2.3 CDTI FWD, CDTI RWD [B]	04.10→		100	830	S5 013	95	800	S4 013					
Nova													
1.0/ 1.2/ 1.3/ 1.4/ 1.6, i, S	05.83-08.94		61	600	S5 004	44	440	S4 001	41	360	S3 001		
Diesel													
1.5 D, TD	09.87-08.94		74	750	S5 007	60	540	S4 004					

			Ah A (EN) S6	Ah A (EN) S5	Ah A (EN) S4	Ah A (EN) S3
			0092 ...0	0092 ...0	0092 ...0	0092 ...0

◀ VAUXHALL

Omega														
2.0 i [B]	09.93-12.00			74	750	S5 007	60	540	S4 004	53	500	S3 004		
		XXX								53	470	S3 004		
2.2/ 2.5/ 3.0 i [B]	04.94-09.04			74	750	S5 007	72	680	S4 007	70	640	S3 007		
2.6/ 3.2 i [B]	09.00-09.04			74	750	S5 007	72	680	S4 007					
Diesel														
2.0 DTI [B]	09.97-08.00			85	800	S5 010	72	680	S4 007	70	640	S3 007		
2.2 DTI [B]	06.00-09.03			85	800	S5 010	72	680	S4 007					
2.5 TD, TDI [B]	04.94-09.04			85	800	S5 010	72	680	S4 007	70	640	S3 007		
Royale														
2.5	09.84-08.87			74	750	S5 007	60	540	S4 004	53	500	S3 004		
		XXX								53	470	S3 004		
3.0 i	10.78-08.87			74	750	S5 007	60	540	S4 004	53	500	S3 004		
		XXX								53	470	S3 004		
Senator														
2.5 i [B]	09.87-10.90			74	750	S5 007	60	540	S4 004	53	500	S3 004		
		XXX								53	470	S3 004		
2.6 i [B]	09.90-08.93			74	750	S5 007	60	540	S4 004	53	500	S3 004		
		XXX								53	470	S3 004		
3.0 i [A]	09.85-08.87			74	750	S5 007	60	540	S4 004					
		XXX								53	470	S3 004		
i [B]	01.88-08.93			74	750	S5 007	60	540	S4 004	53	500	S3 004		
		XXX								53	470	S3 004		
i 24V [B]	09.89-08.93			74	750	S5 007	60	540	S4 004	53	500	S3 004		
		XXX								53	470	S3 004		
Signum														
1.8 i	05.03-02.05			74	750	S5 007	72	680	S4 007	70	640	S3 007		
	03.06-09.08			74	750	S5 007	72	680	S4 007	70	640	S3 007		
2.0 Turbo	05.03-09.08			74	750	S5 007	72	680	S4 007	70	640	S3 007		
2.2 Direct	05.03-09.08			74	750	S5 007	72	680	S4 007	70	640	S3 007		
2.8 V6 Turbo	08.05-09.07			74	750	S5 007	72	680	S4 007	70	640	S3 007		
	09.05-09.08			74	750	S5 007	72	680	S4 007					
3.2 i	05.03-09.05			85	800	S5 010	72	680	S4 007	70	640	S3 007		
Diesel														
1.9 CDTI	04.04-09.08			74	750	S5 007	72	680	S4 007	70	640	S3 007		
	09.05-09.08			74	750	S5 007	72	680	S4 007					
2.0/ 2.2 DTI	05.03-09.08			74	750	S5 007	72	680	S4 007	70	640	S3 007		
3.0 CDTI	05.03-09.08			85	800	S5 010	74	680	S4 008	88	740	S3 012		
Sintra														
2.2 i 16V	09.96-09.99			61	600	S5 004	60	540	S4 004	53	500	S3 004		
		XXX								53	470	S3 004		
3.0 i V6 24V	09.96-09.99			61	600	S5 004	60	540	S4 004	53	500	S3 004		
		XXX								53	470	S3 004		
Diesel														
2.2 TD	09.97-09.99			74	750	S5 007	60	540	S4 004					
Tigra														
1.4/ 1.6 i [A]	09.94-08.99			61	600	S5 004	44	440	S4 001	41	360	S3 001		
Tigra TwinTop														
1.4 i [B]	06.04-12.09			74	750	S5 007	44	440	S4 001	41	360	S3 001		
1.8 i [B]	06.04-12.09			74	750	S5 007	60	540	S4 004					
		XXX								53	470	S3 004		
Diesel														
1.3 CDTI [B]	06.04-03.09			74	750	S5 007	60	540	S4 004					
Vectra														
1.6 i [B]	09.95-08.00			61	600	S5 004	44	440	S4 001	41	360	S3 001		
i [C]	09.01-07.05			77	780	S5 008	60	540	S4 004	56	480	S3 005		
i GTS [C]	01.06-10.08			77	780	S5 008	60	540	S4 004	56	480	S3 005		
i 16V [B]	09.95-08.01			61	600	S5 004	44	440	S4 001	41	360	S3 001		
1.8 Dualfuel [C]	04.02-08.06		70	760	S6 008	77	780	S5 008	60	540	S4 004	56	480	S3 005
i [C]	09.01-08.05		70	760	S6 008	77	780	S5 008	60	540	S4 004	56	480	S3 005
			70	760	S6 008	77	780	S5 008	60	540	S4 005			
	09.03-08.05			77	780	S5 008	60	540	S4 004	56	480	S3 005		
	01.06-10.08			77	780	S5 008	60	540	S4 004	56	480	S3 005		

											Ah A (EN)  S6			Ah A (EN)  S5			Ah A (EN)  S4			Ah A (EN)  S3		
					0 092 ...0			0 092 ...0			0 092 ...0			0 092 ...0								
1.8 i 16V [B]	09.95-08.99				61	600	S5 004	44	440	S4 001	41	360	S3 001									
	09.00-08.01				61	600	S5 004	44	440	S4 001	53	500	S3 004									
2.0 i [B]	09.95-09.02				74	750	S5 007	72	680	S4 007	70	640	S3 007									
	05.97-09.02				74	750	S5 007	72	680	S4 007	53	500	S3 004									
i 16V [B]	09.95-08.01				74	750	S5 007	72	680	S4 007	53	500	S3 004									
					74	750	S5 007	72	680	S4 007	70	640	S3 007									
Turbo [C]	03.03-10.08	70	760	S6 008	77	780	S5 008	74	680	S4 008	70	640	S3 008									
2.2 Direct [C]	09.03-10.08	70	760	S6 008	77	780	S5 008	74	680	S4 008	70	640	S3 008									
i [B]	10.99-08.01				74	750	S5 007	72	680	S4 007	70	640	S3 007									
i [C]	09.01-09.05	70	760	S6 008	77	780	S5 008	74	680	S4 008												
i 16V [B]	09.00-08.01				74	750	S5 007	72	680	S4 007	53	500	S3 004									
2.5 i V6 [B]	09.95-08.01				74	750	S5 007	72	680	S4 007	53	500	S3 004									
					74	750	S5 007	72	680	S4 007	70	640	S3 007									
2.6 V6 [B]	09.00-08.01				74	750	S5 007	72	680	S4 007												
					74	750	S5 007	72	680	S4 007												
2.8 GTS Turbo [C]	09.05-10.08				74	750	S5 007	72	680	S4 007	70	640	S3 007									
	09.06-10.08				77	780	S5 008	74	680	S4 008												
Turbo [C]	09.05-10.08				74	750	S5 007	72	680	S4 007	70	640	S3 007									
3.2 i [C]	08.02-09.05	70	760	S6 008	85	800	S5 010	74	680	S4 008	70	640	S3 008									
Diesel																						
1.7 TD [B]	09.95-08.01				74	750	S5 007	72	680	S4 007	70	640	S3 007									
1.9 CDTI [C]	04.04-10.08				85	800	S5 010	74	680	S4 008												
2.0 DI [B]	09.96-08.00				74	750	S5 007	72	680	S4 007	70	640	S3 007									
	DTI [B]	09.97-08.00				74	750	S5 007	72	680	S4 007	70	640	S3 007								
	09.00-08.01				74	750	S5 007	72	680	S4 007												
DTI [C]	04.02-09.05				85	800	S5 010	74	680	S4 008												
2.2 DTI [B]	09.00-08.01				74	750	S5 007	72	680	S4 007												
DTI [C]	04.02-09.05				85	800	S5 010	80	740	S4 010												
3.0 CDTI [C]	03.03-10.08				85	800	S5 010	74	680	S4 008	88	740	S3 012									
Vectra Estate																						
1.6 i [C]	09.03-05.04				61	600	S5 004	44	440	S4 001												
	07.04-10.08				77	780	S5 008	60	540	S4 004	56	480	S3 005									
i 16V [B]	09.95-08.01				61	600	S5 004	44	440	S4 001	41	360	S3 001									
1.8 i [C]	09.03-08.05				61	600	S5 004															
			70	760	S6 008	77	780	S5 008	60	540	S4 004	56	480	S3 005								
	XXX										53	470	S3 004									
	01.06-10.08				77	780	S5 008	60	540	S4 004	56	480	S3 005									
i 16V [B]	09.95-08.99				61	600	S5 004	44	440	S4 001	41	360	S3 001									
					61	600	S5 004	44	440	S4 001	53	500	S3 004									
	09.00-08.01				61	600	S5 004	44	440	S4 001	41	360	S3 001									
2.0 i 16V [B]	09.95-08.01				74	750	S5 007	72	680	S4 007	53	500	S3 004									
					74	750	S5 007	72	680	S4 007	70	640	S3 007									
Turbo [C]	09.03-10.08	70	760	S6 008	77	780	S5 008	74	680	S4 008	70	640	S3 008									
2.2 Direct [C]	09.03-10.08	70	760	S6 008	77	780	S5 008	74	680	S4 008	70	640	S3 008									
i [C]	09.03-09.05				74	750	S5 007	72	680	S4 007												
i 16V [B]	09.00-08.01				74	750	S5 007	72	680	S4 007	53	500	S3 004									
2.5 i V6 [B]	09.95-08.01				74	750	S5 007	72	680	S4 007	53	500	S3 004									
					74	750	S5 007	72	680	S4 007	70	640	S3 007									
2.6 V6 [B]	09.00-08.01				74	750	S5 007	72	680	S4 007												
					74	750	S5 007	72	680	S4 007												
2.8 GTS Turbo [C]	01.07-10.08				77	780	S5 008	74	680	S4 008												
					77	780	S5 008	74	680	S4 008												
Turbo [C]	09.05-10.08				74	750	S5 007	72	680	S4 007	70	640	S3 007									
3.2 i [C]	09.03-09.05	70	760	S6 008	85	800	S5 010	74	680	S4 008	70	640	S3 008									
Diesel																						
1.7 TD [B]	09.95-08.01				74	750	S5 007	72	680	S4 007	70	640	S3 007									
1.9 CDTI [C]	04.04-10.08				85	800	S5 010	74	680	S4 008												
2.0 DI [B]	09.96-08.00				74	750	S5 007	72	680	S4 007	70	640	S3 007									
	DTI [B]	09.97-08.00				74	750	S5 007	72	680	S4 007	70	640	S3 007								
	09.00-08.01				74	750	S5 007	72	680	S4 007												
2.0/ 2.2 DTI [C]	09.03-09.05				85	800	S5 010	74	680	S4 008												
2.2 DTI [B]	09.00-08.01				74	750	S5 007	72	680	S4 007												
3.0 CDTI [C]	09.03-10.08				85	800	S5 010	74	680	S4 008	88	740	S3 012									
Vivaro																						
2.0 16V	03.01→	70	760	S6 008	77	780	S5 008	72	680	S4 007	70	640	S3 007									

			Ah A (EN) S6	Ah A (EN) S5	Ah A (EN) S4	Ah A (EN) S3
			0092 ...0	0092 ...0	0092 ...0	0092 ...0



◀ VAUXHALL

Diesel											
1.9 DI	03.01-08.06				74	750	S5 007	72	680	S4 007	70 640 S3 007
DTI	03.01-08.06				74	750	S5 007	72	680	S4 007	70 640 S3 007
2.0 CDTI	08.06→	95	850	S6 013	100	830	S5 013	74	680	S4 008	
2.5 CDTI	08.06→				100	830	S5 013	80	740	S4 010	
	09.06-06.08	95	850	S6 013	100	830	S5 013	74	680	S4 008	70 640 S3 008
DTI	04.04-08.06				100	830	S5 013	80	740	S4 010	88 740 S3 012
VX 220											
2.0/2.2 i 16V, i 16V Turbo	09.00-09.05				52	520	S5 001	44	440	S4 001	41 360 S3 001
VXR8											
6.0/6.2 V8	02.07→				74	750	S5 007	72	680	S4 007	
Zafira											
1.4 Turbo [C]	01.12→				61	600	S5 004				
				XXX							53 470 S3 004
1.6 CNG [B]	09.05-03.10				61	600	S5 004				53 470 S3 004
				XXX							53 470 S3 004
CNG [C]	01.12→				61	600	S5 004				53 470 S3 004
				XXX							53 470 S3 004
CNG Turbo [B]	03.09→				61	600	S5 004				53 470 S3 004
				XXX							53 470 S3 004
i [A]	09.98-08.99				61	600	S5 004	44	440	S4 001	41 360 S3 001
	09.99-06.05				61	600	S5 004	44	440	S4 001	
i [B]	07.05→				61	600	S5 004	44	440	S4 001	41 360 S3 001
	03.06-02.09				61	600	S5 004	44	440	S4 001	
	01.11→				52	520	S5 001	44	440	S4 001	
i CNG [A]	09.01-06.05				61	600	S5 004	44	440	S4 001	
i Dualfuel [A]	09.99-06.05				74	750	S5 007	72	680	S4 007	
1.8 [C]	01.12→				61	600	S5 004				
				XXX							53 470 S3 004
i [A]	03.99-09.00				74	750	S5 007	60	540	S4 004	53 500 S3 004
				XXX							53 470 S3 004
	09.00-06.05				74	750	S5 007	60	540	S4 004	
i [B]	07.05-02.10				61	600	S5 004	44	440	S4 001	41 360 S3 001
	01.11→				61	600	S5 004	44	440	S4 001	53 500 S3 004
i Dualfuel [A]	09.00-06.05				61	600	S5 004				
				XXX							53 470 S3 004
LPG [B]	03.10→										53 500 S3 004
2.0 i Turbo [B]	07.05→				74	750	S5 007	72	680	S4 007	70 640 S3 007
Turbo [A]	09.01-06.05				74	750	S5 007	60	540	S4 004	
				XXX							53 470 S3 004
2.2 [A]	09.00-06.05				74	750	S5 007	72	680	S4 007	
i Direkt [B]	07.05→				74	750	S5 007	60	540	S4 004	
				XXX							53 470 S3 004
Diesel											
1.7 CDTI [B]	03.08→				63	610	S5 005	60	540	S4 005	
					74	750	S5 007	72	680	S4 007	70 640 S3 007
1.9 CDTI [B]	07.05-03.08				74	750	S5 007	72	680	S4 007	
	07.05→				74	750	S5 007	60	540	S4 004	70 640 S3 007
					74	750	S5 007	72	680	S4 007	70 640 S3 007
2.0 CDTI [C]	01.12→				74	750	S5 007	72	680	S4 007	
					70	760	S6 008				
DI [A]	03.99-08.00				74	750	S5 007	72	680	S4 007	70 640 S3 007
DTI [A]	04.99-06.05				74	750	S5 007	72	680	S4 007	70 640 S3 007
2.2 DTI [A]	03.02-06.05				74	750	S5 007	72	680	S4 007	

			Ah A (EN)  0 092 ...0	Ah A (EN)  0 092 ...0	Ah A (EN)  0 092 ...0	Ah A (EN)  0 092 ...0
---	---	---	--	---	--	--



VOLVO

C30												
1.6 [P14]	10.06→	BWD				74	750	S5 007	60	540	S4 004	
		BWD,XXX										53 470 S3 004
1.8 [P14]	10.06-07.10	BWD				74	750	S5 007	60	540	S4 004	
		BWD,XXX										53 470 S3 004
F Flexifuel [P14]	10.06-07.10	BWD				74	750	S5 007	60	540	S4 004	
		BWD,XXX										53 470 S3 004
2.0 [P14]	10.06→					74	750	S5 007	72	680	S4 007	
F Flexifuel [P14]	08.09→					74	750	S5 007	60	540	S4 004	
2.4/ 2.5 i, T5 [P14]	10.06→	BWD	70	760	S6 008	77	780	S5 008	74	680	S4 008	70 640 S3 008
Diesel												
1.6 D DRiVe [P14]	10.06-07.11	BWD				85	800	S5 010	80	740	S4 010	
		BWD,SSJ	70	760	S6 008							
D2 DRiVe [P14]	08.10→	BWD,SSJ	70	760	S6 008							
2.0 D [P14]	10.06-07.07					85	800	S5 010	80	740	S4 010	
	10.06-09.10	BWD				85	800	S5 010	80	740	S4 010	
2.0/ 2.4 D3, D4, D5 [P14]	10.06→	BWD				85	800	S5 010	80	740	S4 010	
C70 Coupé												
2.0/ 2.3/ 2.4/ 2.5 LPT, T, T5, 20V	01.97-07.02		70	760	S6 008	77	780	S5 008	60	540	S4 005	56 480 S3 005
C70 I Cabrio												
2.0 T	03.98-03.06		70	760	S6 008	77	780	S5 008	60	540	S4 005	56 480 S3 005
2.3 T5	02.98-07.02		70	760	S6 008	77	780	S5 008	60	540	S4 005	56 480 S3 005
	08.02-03.06		70	760	S6 008	77	780	S5 008	60	540	S4 005	
2.4	03.99-07.00		70	760	S6 008	77	780	S5 008	74	680	S4 008	56 480 S3 005
T	08.98-07.02		70	760	S6 008	77	780	S5 008	74	680	S4 008	56 480 S3 005
T5	08.02-03.06		70	760	S6 008	77	780	S5 008	74	680	S4 008	56 480 S3 005
C70 II Cabrio												
2.4	03.06-07.10		70	760	S6 008	77	780	S5 008	60	540	S4 005	56 480 S3 005
i	03.06-07.10	BWD	70	760	S6 008	77	780	S5 008	60	540	S4 005	56 480 S3 005
2.5 T5	03.06-07.07		70	760	S6 008	77	780	S5 008	60	540	S4 005	56 480 S3 005
	08.07→	BWD				77	780	S5 008	60	540	S4 005	56 480 S3 005
		BWD,SSJ	70	760	S6 008							
Diesel												
2.0 D	01.08-07.10	BWD				85	800	S5 010	80	740	S4 010	
		BWD,SSJ	70	760	S6 008							
D3	10.10→	BWD				85	800	S5 010	80	740	S4 010	
		BWD,SSJ	70	760	S6 008							
D4	10.10→	BWD				85	800	S5 010	80	740	S4 010	
		BWD,SSJ	70	760	S6 008							
2.4 D	08.06-07.10	BWD				85	800	S5 010	80	740	S4 010	
		BWD,SSJ	70	760	S6 008							
D5	08.06-07.10	BWD				85	800	S5 010	80	740	S4 010	
		BWD,SSJ	70	760	S6 008							
		SSJ	95	850	S6 013							
S40 I												
1.6/ 1.8/ 1.9/ 2.0 T, T 16V, T4, 16V	09.95-01.04		70	760	S6 008	77	780	S5 008	60	540	S4 005	56 480 S3 005
Diesel												
1.9 D	05.96-01.04		70	760	S6 008	77	780	S5 008	74	680	S4 008	70 640 S3 008
S40 II												
1.6 [P11]	11.04→	BWD				74	750	S5 007	60	540	S4 004	
		BWD,XXX										53 470 S3 004
1.8 [P11]	04.04-07.10	BWD				74	750	S5 007	60	540	S4 004	
		BWD,XXX										53 470 S3 004
F Flexifuel [P11]	04.06-07.10	BWD				74	750	S5 007	60	540	S4 004	
		BWD,XXX										53 470 S3 004
2.0 [P11]	10.06→	BWD				74	750	S5 007	72	680	S4 007	
F Flexifuel [P11]	08.09→	BWD				74	750	S5 007	72	680	S4 007	

				Ah A (EN) S6	Ah A (EN) S5	Ah A (EN) S4	Ah A (EN) S3
				0092 ...0	0092 ...0	0092 ...0	0092 ...0
◀ VOLVO							
2.4 [P11]	12.03-07.10	BWD		74 750 S5 007	72 680 S4 007		
				74 750 S5 007	72 680 S4 007	70 640 S3 007	
	12.03→			74 750 S5 007	72 680 S4 007		
2.5 T5 [P11]	12.03-07.07	BWD		74 750 S5 007	72 680 S4 007	70 640 S3 007	
	12.03→			74 750 S5 007	72 680 S4 007		
	08.07→	BWD		74 750 S5 007	72 680 S4 007		
T5 AWD [P11]	04.04-07.07	BWD		74 750 S5 007	72 680 S4 007	70 640 S3 007	
	08.07-07.10	BWD		74 750 S5 007	72 680 S4 007		
Diesel							
1.6 D DRiVe [P11]	11.04→	BWD		85 800 S5 010	80 740 S4 010		
		BWD,SSJ	70 760 S6 008				
D2 [P11]	08.11→	BWD,SSJ	70 760 S6 008				
2.0 D [P11]	01.04-07.10	BWD		85 800 S5 010	80 740 S4 010		
2.0/ 2.4 D3, D4, D5 [P11]	03.06→	BWD		85 800 S5 010	80 740 S4 010		
S60 I							
2.0 T	11.00-07.09	BWD	70 760 S6 008	77 780 S5 008	60 540 S4 005	56 480 S3 005	
2.3/ 2.4 T5	11.00-07.09	BWD	70 760 S6 008	77 780 S5 008	60 540 S4 005	56 480 S3 005	
2.4	11.00-07.09	BWD	70 760 S6 008	77 780 S5 008	60 540 S4 005	56 480 S3 005	
	11.02-08.06		70 760 S6 008	77 780 S5 008	60 540 S4 005		
T	11.00-07.03	BWD	70 760 S6 008	77 780 S5 008	60 540 S4 005	56 480 S3 005	
	08.03-07.06	BWD	70 760 S6 008	77 780 S5 008	60 540 S4 005		
T AWD	11.01-07.03	BWD	70 760 S6 008	77 780 S5 008	60 540 S4 005	56 480 S3 005	
	08.03-07.06	BWD	70 760 S6 008	77 780 S5 008	60 540 S4 005		
2.4/ 2.5 Bi-Fuel CNG, Bi-Fuel LPG, RAWD	06.02-07.08	BWD	70 760 S6 008	77 780 S5 008	60 540 S4 005	56 480 S3 005	
2.5 T	04.04-07.09	BWD	70 760 S6 008	77 780 S5 008	60 540 S4 005	56 480 S3 005	
T AWD	04.04-07.09	BWD	70 760 S6 008	77 780 S5 008	60 540 S4 005	56 480 S3 005	
Diesel							
2.4 D	08.01-07.06	BWD	95 850 S6 013	100 830 S5 013	95 800 S4 013	90 720 S3 013	
	08.03-07.09	BWD	95 850 S6 013	100 830 S5 013	95 800 S4 013		
	08.05-07.06			85 800 S5 010	80 740 S4 010		
	08.06-07.09	BWD	80 800 S6 011	85 800 S5 010	80 740 S4 010		
D5	08.05-07.09	BWD	95 850 S6 013	100 830 S5 013	95 800 S4 013	90 720 S3 013	
S60 II							
1.6 T3, T4	11.10→	BWD,SSJ	70 760 S6 008				
1.6/ 2.0/ 3.0 T4F, T5, T6 AWD	08.10→	BWD		77 780 S5 008	74 680 S4 008		
2.0 T	08.10-07.11	BWD		77 780 S5 008	74 680 S4 008	70 640 S3 008	
Diesel							
1.6 DRiVe	08.11→	BWD,SSJ	70 760 S6 008				
2.0 D3	08.10-07.11	BWD		85 800 S5 011	80 740 S4 011		
		BWD,SSJ	70 760 S6 008				
	08.12→			85 800 S5 010	80 740 S4 010		
D4	08.11→	BWD		85 800 S5 010	80 740 S4 010		
2.4 D5	08.10-07.11	BWD		85 800 S5 010	80 740 S4 010		
	08.11→	BWD,SSJ	70 760 S6 008				
D5 AWD	08.10→	BWD		85 800 S5 010	80 740 S4 010		
S70							
R 2.3/ 2.0/ 2.3/ 2.4/ 2.5 , AWD, Bifuel, T, T AWD, T 20V, T-5, 20V	01.97-07.00		70 760 S6 008	77 780 S5 008	60 540 S4 005	56 480 S3 005	
Diesel							
2.5 TDI	01.97-07.00		70 760 S6 008	77 780 S5 008	74 680 S4 008	70 640 S3 008	
S80 I							
2.0/ 2.3/ 2.4/ 2.5/ 2.9/ 3.0 , AWD, Bi-Fuel LPG, R, T, T AWD, T5 [TS]	06.98-07.06	BWD	70 760 S6 008	77 780 S5 008	60 540 S4 005	56 480 S3 005	
2.4 T4 Bi-Fuel CNG [TS]	08.01-07.06	BWD	70 760 S6 008	77 780 S5 008	60 540 S4 005		
2.8 T6 [TS]	05.98-07.01	BWD	70 760 S6 008	77 780 S5 008	74 680 S4 008	70 640 S3 008	
3.0 T6 [TS]	08.01-07.06	BWD	70 760 S6 008	77 780 S5 008	60 540 S4 005		
Diesel							
2.4 D, D5 [TS]	08.01-07.06	BWD	95 850 S6 013	100 830 S5 013	95 800 S4 013	90 720 S3 013	
2.5 TDI [TS]	08.98-07.01	BWD	70 760 S6 008	77 780 S5 008	60 540 S4 005	56 480 S3 005	

			Ah A (EN) 	Ah A (EN) 	Ah A (EN) 	Ah A (EN) 
			0 092 ...0	0 092 ...0	0 092 ...0	0 092 ...0

S80 II											
1.6 T4F [AS]	08.11→					77	780	S5 008	74	680	S4 008
1.6/2.0 T4, T5 [AS]	08.10→	BWD				77	780	S5 008	74	680	S4 008
2.0 B [AS]	01.08-07.12	BWD				77	780	S5 008	74	680	S4 008
F Flexifuel [AS]	01.08-07.12	BWD	70	760	S6 008	77	780	S5 008	74	680	S4 008
T [AS]	08.10→	BWD				77	780	S5 008	74	680	S4 008
2.5 FT Flexifuel [AS]	05.08-07.10	BWD	70	760	S6 008	77	780	S5 008	74	680	S4 008
	08.09-07.12	BWD				85	800	S5 010	74	680	S4 008
T [AS]	03.06-07.09		70	760	S6 008	77	780	S5 008	60	540	S4 005
	08.09-07.12	BWD				85	800	S5 010	74	680	S4 008
3.0 T6 AWD [AS]	01.07-07.10	BWD	70	760	S6 008	77	780	S5 008	74	680	S4 008
	08.10→	BWD				77	780	S5 008	74	680	S4 008
3.2 , AWD [AS]	08.06→	BWD	70	760	S6 008	77	780	S5 008	74	680	S4 008
4.4 V8 AWD [AS]	03.06-12.10		70	760	S6 008	77	780	S5 008	74	680	S4 008
Diesel											
1.6 D DRIVe [AS]	08.09-07.11	BWD	70	760	S6 008						
DRIVe [AS]	08.11→	SSJ	70	760	S6 008						
2.0 D [AS]	08.07-07.10	BWD	95	850	S6 013	100	830	S5 013	95	800	S4 013
D3 [AS]	08.10-07.12	BWD				85	800	S5 010	80	740	S4 010
2.4 D [AS]	08.06-07.09		95	850	S6 013	100	830	S5 013	95	800	S4 013
	08.09-07.10					100	830	S5 013	80	740	S4 010
		BWD				100	830	S5 013	80	740	S4 010
D5 [AS]	03.06-07.09					100	830	S5 013	80	740	S4 010
	11.08-07.11	BWD				100	830	S5 013	80	740	S4 010
	08.11→					100	830	S5 013	80	740	S4 010
D5 AWD [AS]	03.06-07.09		95	850	S6 013	100	830	S5 013	95	800	S4 013
	08.09-07.11					100	830	S5 013	80	740	S4 010
	08.11→	BWD				85	800	S5 010	80	740	S4 010
S90											
2.5/2.9 , Exekutive, Exekutive Plus	11.96-12.99		70	760	S6 008	77	780	S5 008	60	540	S4 005
V40 I											
1.6/1.8/1.9/2.0 , T4, 16V, 16VT	01.95-06.04		70	760	S6 008	77	780	S5 008	60	540	S4 005
2.0 T, T4 T	08.00-04.04		70	760	S6 008	77	780	S5 008	60	540	S4 005
Diesel											
1.9 D	01.96-04.04		70	760	S6 008	77	780	S5 008	74	680	S4 008
V40 II											
1.6 T3, T4	09.12→		70	760	S6 008						
Diesel											
1.6/2.0 D2, D3, D4	09.12→		70	760	S6 008						
V50											
1.6 [P12]	01.05-12.12	BWD				74	750	S5 007	60	540	S4 004
		BWD,XXX								53	470
1.8 [P12]	04.04-07.10	BWD				74	750	S5 007	60	540	S4 004
		BWD,XXX								53	470
F Flexifuel [P12]	04.06-07.10	BWD				74	750	S5 007	60	540	S4 004
		BWD,XXX								53	470
2.0 [P12]	10.06-12.12	BWD				74	750	S5 007	60	540	S4 004
F Flexifuel [P12]	08.09-12.12	BWD				74	750	S5 007	60	540	S4 004
2.4 [P12]	04.04-07.10	BWD	70	760	S6 008	74	750	S5 007	72	680	S4 007
i [P12]	04.04-07.10	BWD	70	760	S6 008	74	750	S5 007	72	680	S4 007
2.5 T5, T5 AWD [P12]	04.04-12.12	BWD	70	760	S6 008	74	750	S5 007	72	680	S4 007
Diesel											
1.6 D DRIVe [P12]	11.04-07.10	BWD				85	800	S5 010	80	740	S4 010
		BWD,SSJ	70	760	S6 008						
D2 DRIVe [P12]	08.11-12.12	BWD				85	800	S5 010	80	740	S4 010
		BWD,SSJ	70	760	S6 008						
2.0 D [P12]	04.04-07.10	BWD				85	800	S5 010	80	740	S4 010
2.0/2.4 D3, D4, D5 [P12]	04.06-12.12	BWD				85	800	S5 010	80	740	S4 010
V60											
1.6 T3, T4	09.10→	BWD,SSJ	70	760	S6 008						
T4F	09.11→	BWD				77	780	S5 008	74	680	S4 008

				Ah A (EN) S6	Ah A (EN) S5	Ah A (EN) S4	Ah A (EN) S3
				0092 ...0	0092 ...0	0092 ...0	0092 ...0
◀ VOLVO							
2.0/ 3.0 T, T5, T6 AWD	09.10→	BWD		77	780	\$5 008	74 680 \$4 008 70 640 \$3 008
Diesel							
1.6 DRIVE	09.11→	BWD,SSJ	70 760	\$6 008			
2.0 D3	09.10-08.11	BWD		85	800	\$5 010	80 740 \$4 010
		BWD,SSJ	70 760	\$6 008			
	09.12→			85	800	\$5 010	80 740 \$4 010
D4	09.11→	BWD		85	800	\$5 010	80 740 \$4 010
		BWD,SSJ	70 760	\$6 008			
2.4 D4 AWD	09.12→			85	800	\$5 010	80 740 \$4 010
D5	09.10-08.11	BWD		85	800	\$5 010	80 740 \$4 010
	09.11→	BWD,SSJ	70 760	\$6 008			
D5 AWD	09.10→	BWD		85	800	\$5 010	80 740 \$4 010
D5 Hybrid	11.12→		80 800	\$6 011			
V70							
2.3 i	07.98→		70 760	\$6 008	77 780	\$5 008	60 540 \$4 005 56 480 \$3 005
V70 I							
2.0/ 2.3/ 2.4/ 2.5 , AWD, AWD Turbo, BI-FUEL, R, R AWD, T, T AWD, T XC, T XC AWD, T 20V, Turbo, T-5, T-5 AWD, XC AWD, 20V	01.97-03.00		70 760	\$6 008	77 780	\$5 008	60 540 \$4 005 56 480 \$3 005
Diesel							
2.5 TDI	01.97-03.00		70 760	\$6 008	77 780	\$5 008	74 680 \$4 008 70 640 \$3 008
V70 II							
2.0 T	03.00-07.07	BWD	70 760	\$6 008	77 780	\$5 008	60 540 \$4 005
2.3/ 2.4 T5	03.00-07.07	BWD	70 760	\$6 008	77 780	\$5 008	60 540 \$4 005
2.3/ 2.4/ 2.5 , BI-FUEL CNG, BI-FUEL LPG	03.00-07.07	BWD	70 760	\$6 008	77 780	\$5 008	60 540 \$4 005
2.4 T	03.00-07.03	BWD	95 850	\$6 013	100 830	\$5 013	95 800 \$4 013
T AWD	09.00-07.03	BWD	70 760	\$6 008	77 780	\$5 008	60 540 \$4 005
XC AWD	09.00-07.02	BWD	70 760	\$6 008	77 780	\$5 008	74 680 \$4 008
2.5 T	04.04-07.07	BWD	95 850	\$6 013	100 830	\$5 013	95 800 \$4 013
T AWD	08.02-07.07	BWD	95 850	\$6 013	100 830	\$5 013	95 800 \$4 013
T AWD R	03.03-07.07	BWD	95 850	\$6 013	100 830	\$5 013	95 800 \$4 013
Diesel							
2.4 D	08.01-07.07	BWD	95 850	\$6 013	100 830	\$5 013	95 800 \$4 013 90 720 \$3 013
	08.06-07.07	BWD	95 850	\$6 013	100 830	\$5 013	95 800 \$4 013
D AWD	08.02-07.06	BWD	95 850	\$6 013	100 830	\$5 013	95 800 \$4 013 90 720 \$3 013
D5	12.05-07.06	BWD	95 850	\$6 013	100 830	\$5 013	95 800 \$4 013
	08.06-07.07	BWD	95 850	\$6 013	100 830	\$5 013	95 800 \$4 013 90 720 \$3 013
D5 AWD	12.05-07.07	BWD	95 850	\$6 013	100 830	\$5 013	95 800 \$4 013
2.5 D	03.00-07.01	BWD	95 850	\$6 013	100 830	\$5 013	95 800 \$4 013 90 720 \$3 013
V70 III							
1.6 T4	08.10→	BWD,SSJ	70 760	\$6 008			
T4F	08.11→	BWD		77	780	\$5 008	74 680 \$4 008
2.0 B, F Flexifuel	10.07-07.11	BWD		85	800	\$5 010	80 740 \$4 010
T	08.10-07.11	BWD		77	780	\$5 008	74 680 \$4 008
T5	08.10→	BWD	70 760	\$6 008	77 780	\$5 008	74 680 \$4 008
2.5 FT Flexifuel	05.08-07.09			85	800	\$5 010	80 740 \$4 010
	08.09-12.11	BWD		85	800	\$5 010	80 740 \$4 010
T	08.07-07.10			85	800	\$5 010	80 740 \$4 010
	08.09-07.12	BWD		85	800	\$5 010	80 740 \$4 010
3.0 T6 AWD	08.07-07.10			85	800	\$5 010	80 740 \$4 010
	08.10→	BWD		85	800	\$5 010	80 740 \$4 010
3.2	08.07-07.10			85	800	\$5 010	80 740 \$4 010
	08.10→	BWD		77	780	\$5 008	74 680 \$4 008
AWD	08.07-07.10			85	800	\$5 010	80 740 \$4 010
	08.10→	BWD		77	780	\$5 008	74 680 \$4 008
Diesel							
1.6 D DRIVE	01.10-07.11	BWD	70 760	\$6 008	74 750	\$5 007	72 680 \$4 007 70 640 \$3 007
	08.11→		70 760	\$6 008	74 750	\$5 007	72 680 \$4 007 70 640 \$3 007

						Ah A (EN) S6		Ah A (EN) S5		Ah A (EN) S4		Ah A (EN) S3		
				0 092 ...0		0 092 ...0		0 092 ...0		0 092 ...0		0 092 ...0		
2.0 D	10.07-07.10					85	800	S5 010	80	740	S4 010	88	740	S3 012
D3	08.10-07.11	BWD				85	800	S5 010	80	740	S4 010			
		BWD,SSJ	70	760	S6 008									
D4	08.11→	BWD,SSJ	70	760	S6 008									
2.4 D	08.07-07.09					85	800	S5 010	80	740	S4 010	88	740	S3 012
	08.09-07.10					85	800	S5 010	80	740	S4 010			
D5	08.07-07.09					85	800	S5 010	80	740	S4 010	88	740	S3 012
	08.09→	BWD				85	800	S5 010	80	740	S4 010			
D5 AWD	10.07-07.09					85	800	S5 010	80	740	S4 010			
	08.09→	BWD				85	800	S5 010	80	740	S4 010			
V90														
2.9	01.97-07.98		70	760	S6 008	77	780	S5 008	60	540	S4 005	56	480	S3 005
XC60														
2.0 T	08.10-07.11					77	780	S5 008	74	680	S4 008			
T5	08.10→	BWD				77	780	S5 008	74	680	S4 008			
3.0 T6 AWD	03.09-07.10		70	760	S6 008	77	780	S5 008	74	680	S4 008	70	640	S3 008
	08.10→	BWD				77	780	S5 008	74	680	S4 008			
3.2 AWD	08.09-07.10		70	760	S6 008	77	780	S5 008	74	680	S4 008	70	640	S3 008
	03.10→					74	750	S5 007						
Diesel														
2.0 D3 DRiVe	08.10-07.11	SSJ	70	760	S6 008									
2.4 D AWD	03.09-07.09		95	850	S6 013	100	830	S5 013	74	680	S4 008	90	720	S3 013
	08.09-07.11	BWD	95	850	S6 013	100	830	S5 013	74	680	S4 008	90	720	S3 013
D DRiVe	08.09-07.10		95	850	S6 013	100	830	S5 013	95	800	S4 013	90	720	S3 013
D3 AWD	08.11→	BWD	95	850	S6 013	100	830	S5 013	74	680	S4 008	90	720	S3 013
D5 AWD	03.09-07.09		70	760	S6 008	77	780	S5 008	74	680	S4 008	70	640	S3 008
	08.09-07.11	BWD	70	760	S6 008	77	780	S5 008	74	680	S4 008	70	640	S3 008
	08.11→	BWD,SSJ	70	760	S6 008									
XC70 I														
2.3/2.4 T	08.02-07.07	BWD	70	760	S6 008	77	780	S5 008	74	680	S4 008			
2.5 T	08.02-07.07	BWD	70	760	S6 008	77	780	S5 008	74	680	S4 008	70	640	S3 008
Diesel														
2.4 D, D5	08.02-07.07	BWD	95	850	S6 013	100	830	S5 013	95	800	S4 013	90	720	S3 013
XC70 II														
3.0/3.2 AWD, T6 AWD	08.07→	BWD				85	800	S5 010	80	740	S4 010			
3.2 2WD	08.10→	BWD				77	780	S5 008	74	680	S4 008			
						85	800	S5 010	80	740	S4 010			
Diesel														
2.0 D3 DRiVe	08.10-12.11	BWD,SSJ	70	760	S6 008									
	08.11→	BWD				85	800	S5 010	80	740	S4 010			
2.4 D AWD	08.07-07.09					85	800	S5 010	80	740	S4 010			
	08.09-07.11	BWD				85	800	S5 010	80	740	S4 010			
D DRiVe	08.09-07.10	BWD				85	800	S5 010	80	740	S4 010			
D3 AWD	08.11→	BWD				85	800	S5 010	80	740	S4 010			
D5 AWD	08.07-07.09					85	800	S5 010	80	740	S4 010	88	740	S3 012
	08.09→	BWD				85	800	S5 010	80	740	S4 010			
XC90														
2.5 T FWD	01.03-07.06		70	760	S6 008	77	780	S5 008	74	680	S4 008			
T5 AWD	08.12→		70	760	S6 008	77	780	S5 008	74	680	S4 008			
2.5/2.9/4.4 T AWD, T6 AWD, V8 AWD	10.02-10.12	BWD	70	760	S6 008	77	780	S5 008	74	680	S4 008	70	640	S3 008
3.2 AWD	08.06-07.10	BWD	70	760	S6 008	77	780	S5 008	74	680	S4 008	70	640	S3 008
	08.10→	BWD				77	780	S5 008	74	680	S4 008			
FWD	08.06-07.10		95	850	S6 013	100	830	S5 013	95	800	S4 013			
	08.10→	BWD	95	850	S6 013	100	830	S5 013	95	800	S4 013			
Diesel														
2.4 D5 AWD	01.03→	BWD	95	850	S6 013	100	830	S5 013	95	800	S4 013			
	10.07-07.11	BWD	95	850	S6 013	100	830	S5 013	95	800	S4 013	90	720	S3 013
240														
1.8	11.78-07.88								70	630	S4 027			
2.0	08.84-07.89					63	610	S5 005	60	540	S4 005	56	480	S3 005
i	08.84-07.92					63	610	S5 005	60	540	S4 005	56	480	S3 005
2.1 iT	08.80-07.86					63	610	S5 005	60	540	S4 005	56	480	S3 005

				Ah A (EN) S6	Ah A (EN) S5	Ah A (EN) S4	Ah A (EN) S3
				0092 ...0	0092 ...0	0092 ...0	0092 ...0
◀VOLVO							
2.3	08.84-07.90	JEA		63	610	\$5 005	60 540 \$4 005 56 480 \$3 005
i	08.84-07.93	JEA		63	610	\$5 005	60 540 \$4 005 56 480 \$3 005
Diesel							
2.4 D	04.79-07.93		70 760 \$6 008	77	780	\$5 008	74 680 \$4 008 70 640 \$3 008
340							
1.3	08.79-07.91		70 760 \$6 008	77	780	\$5 008	74 680 \$4 008 53 500 \$3 004
			70 760 \$6 008	77	780	\$5 008	74 680 \$4 008 56 480 \$3 005
1.4	08.79-07.91		70 760 \$6 008	77	780	\$5 008	74 680 \$4 008 53 500 \$3 004
			70 760 \$6 008	77	780	\$5 008	74 680 \$4 008 56 480 \$3 005
1.7	07.85-10.91		70 760 \$6 008	77	780	\$5 008	74 680 \$4 008 53 500 \$3 004
			70 760 \$6 008	77	780	\$5 008	74 680 \$4 008 70 640 \$3 008
2.0	08.84-07.88		70 760 \$6 008	77	780	\$5 008	74 680 \$4 008 53 500 \$3 004
			70 760 \$6 008	77	780	\$5 008	74 680 \$4 008 56 480 \$3 005
i	08.84-07.88		70 760 \$6 008	77	780	\$5 008	74 680 \$4 008 53 500 \$3 004
			70 760 \$6 008	77	780	\$5 008	74 680 \$4 008 56 480 \$3 005
Diesel							
1.6 D	09.84-07.91		70 760 \$6 008	77	780	\$5 008	74 680 \$4 008 70 640 \$3 008
360							
2.0	08.84-07.90		70 760 \$6 008	77	780	\$5 008	74 680 \$4 008 53 500 \$3 004
			70 760 \$6 008	77	780	\$5 008	74 680 \$4 008 56 480 \$3 005
i	08.84-07.90		70 760 \$6 008	77	780	\$5 008	74 680 \$4 008 53 500 \$3 004
			70 760 \$6 008	77	780	\$5 008	74 680 \$4 008 56 480 \$3 005
440							
1.6/1.7/1.8/2.0, i, T	09.88-07.97			63	610	\$5 005	60 540 \$4 005 56 480 \$3 005
Diesel							
1.9 DT	09.93-07.97		70 760 \$6 008	77	780	\$5 008	74 680 \$4 008 70 640 \$3 008
460							
1.6/1.7/1.8/2.0, i, iT	03.90-07.97			63	610	\$5 005	60 540 \$4 005 56 480 \$3 005
Diesel							
1.9 D	09.93-07.97		70 760 \$6 008	77	780	\$5 008	74 680 \$4 008 56 480 \$3 005
480							
1.7/2.0, iT	04.86-12.96			63	610	\$5 005	60 540 \$4 005 56 480 \$3 005
740							
2.0 iT	08.84-07.89		70 760 \$6 008	77	780	\$5 008	60 540 \$4 005 56 480 \$3 005
	08.90-07.92		70 760 \$6 008	77	780	\$5 008	60 540 \$4 005 56 480 \$3 005
i16VT	08.89-07.90		70 760 \$6 008	77	780	\$5 008	74 680 \$4 008 70 640 \$3 008
2.0/2.3, i	08.83-07.95		70 760 \$6 008	77	780	\$5 008	60 540 \$4 005 56 480 \$3 005
i16V	04.88-07.92		70 760 \$6 008	77	780	\$5 008	60 540 \$4 005 56 480 \$3 005
2.3 iT	08.84-10.91		70 760 \$6 008	77	780	\$5 008	74 680 \$4 008 70 640 \$3 008
Diesel							
2.4 D, TD	04.84-07.92		95 850 \$6 013	100	830	\$5 013	95 800 \$4 013 90 720 \$3 013
760							
2.0/2.3/2.8, i, iT	02.82-07.92		70 760 \$6 008	77	780	\$5 008	74 680 \$4 008 70 640 \$3 008
Diesel							
2.4 D, TD	01.82-07.92		70 760 \$6 008	77	780	\$5 008	74 680 \$4 008 70 640 \$3 008
780							
2.0/2.3/2.8, iT, i16VT	01.86-07.91		70 760 \$6 008	77	780	\$5 008	74 680 \$4 008 70 640 \$3 008
Diesel							
2.4 TD	08.85-07.91		70 760 \$6 008	77	780	\$5 008	74 680 \$4 008 70 640 \$3 008
850							
R/T-5/T-5R/2.0	09.91-07.97		70 760 \$6 008	77	780	\$5 008	60 540 \$4 005 56 480 \$3 005
2.0/2.3/2.5 AWD, GLE, GLT, Turbo	09.91-07.97		70 760 \$6 008	77	780	\$5 008	60 540 \$4 005 56 480 \$3 005
2.3	09.97-07.98		70 760 \$6 008	77	780	\$5 008	60 540 \$4 005 56 480 \$3 005
Diesel							
TDI	05.96-07.97		70 760 \$6 008	77	780	\$5 008	74 680 \$4 008 70 640 \$3 008
850 Kombi							
R/T-5/T-5R/2.0	03.92-07.97		70 760 \$6 008	77	780	\$5 008	60 540 \$4 005 56 480 \$3 005
2.0/2.5 AWD, GLE, GLT, Turbo	09.91-07.97		70 760 \$6 008	77	780	\$5 008	60 540 \$4 005 56 480 \$3 005
2.3	09.97-07.98		70 760 \$6 008	77	780	\$5 008	60 540 \$4 005 56 480 \$3 005
Diesel							
TDI	05.96-07.97		70 760 \$6 008	77	780	\$5 008	74 680 \$4 008 70 640 \$3 008



940														
2.0 Turbo	04.96-09.98		70	760	S6 008	77	780	S5 008	74	680	S4 008	70	640	S3 008
16V	09.90-07.91		70	760	S6 008	77	780	S5 008	60	540	S4 005	56	480	S3 005
2.0/ 2.3														
	09.90-07.95		70	760	S6 008	77	780	S5 008	60	540	S4 005	56	480	S3 005
Turbo Interc.	09.90-10.98		70	760	S6 008	77	780	S5 008	74	680	S4 008	70	640	S3 008
2.3 Turbo														
	09.94-07.98		70	760	S6 008	77	780	S5 008	60	540	S4 005	56	480	S3 005
16V	09.90-07.92		70	760	S6 008	77	780	S5 008	74	680	S4 008	70	640	S3 008
Diesel														
2.4 D, TD	09.90-07.97		70	760	S6 008	77	780	S5 008	74	680	S4 008	70	640	S3 008
960														
2.0/ 2.3/ 2.4/ 2.5/ 2.8/ 3.0	09.90-07.98		70	760	S6 008	77	780	S5 008	74	680	S4 008	70	640	S3 008
, T, T 16V														
Diesel														
2.4 TD	08.90-07.97		70	760	S6 008	77	780	S5 008	74	680	S4 008	70	640	S3 008

VW (VOLKSWAGEN)

Amarok														
2.0 TSI [2H]	12.10→					77	780	S5 008	74	680	S4 008			
Diesel														
2.0 BiTDI [2H]	09.10-05.12					100	830	S5 013	95	800	S4 013			
BiTDI 4Motion [2H]	09.10-05.12					100	830	S5 013						
		SSJ	95	850	S6 013									
TDI [2H]	09.10→					100	830	S5 013	95	800	S4 013			
	11.11→					77	780	S5 008	74	680	S4 008			
TDI 4Motion [2H]	09.10→					100	830	S5 013	95	800	S4 013			
	11.11→		95	850	S6 013	100	830	S5 013	95	800	S4 013			
Beetle														
1.2/ 1.4/ 2.0 TSI [5C1]	04.11→					63	610	S5 005	60	540	S4 005			
Diesel														
1.6/ 2.0 TDI [5C1]	10.11→					63	610	S5 005	60	540	S4 005			
Beetle Cabriolet														
1.2 TSI [5C7]	01.13→		70	760	S6 008	63	610	S5 005	60	540	S4 005			
1.4/ 2.0 TSI [5C7]	01.13→					63	610	S5 005	60	540	S4 005			
Diesel														
1.6 TDI [5C7]	01.13→		70	760	S6 008	63	610	S5 005	60	540	S4 005			
2.0 TDI [5C7]	01.13→					63	610	S5 005	60	540	S4 005			
Bora														
1.4/ 1.6 [1J2]	09.98-05.05					63	610	S5 005	52	470	S4 002	45	400	S3 002
1.6 FSI [1J2]	08.01-05.05					63	610	S5 005	52	470	S4 002	45	400	S3 002
1.8/ 2.0/ 2.3 [1J2]	09.98-05.05		70	760	S6 008	77	780	S5 008	60	540	S4 005	56	480	S3 005
1.8/ 2.0/ 2.3/ 2.8 T, 4Motion [1J2]	01.99-05.05		70	760	S6 008	77	780	S5 008	60	540	S4 005	56	480	S3 005
Diesel														
1.9 SDI, TDI, TDI 4Motion [1J2]	09.98-05.05		70	760	S6 008	85	800	S5 011	74	680	S4 008	70	640	S3 008
Bora Variant														
1.4/ 1.6 [1J6]	05.99-05.05					63	610	S5 005	52	470	S4 002	45	400	S3 002
1.6 FSI [1J6]	08.01-05.05					63	610	S5 005	52	470	S4 002	45	400	S3 002
1.8/ 2.0/ 2.3/ 2.8 T, 4Motion [1J6]	05.99-05.05		70	760	S6 008	77	780	S5 008	60	540	S4 005	56	480	S3 005
2.0/ 2.3 [1J6]	05.99-05.05		70	760	S6 008	77	780	S5 008	60	540	S4 005	56	480	S3 005
Diesel														
1.9 TDI, TDI 4Motion [1J6]	09.98-05.05		70	760	S6 008	85	800	S5 011	74	680	S4 008	70	640	S3 008
Bus														
1.9/ 2.1 [24, 25]	08.82-07.92	VAD				61	600	S5 004	44	440	S4 001	41	360	S3 001
Syncro [24, 25]	08.85-07.92	VAD	70	760	S6 008	100	830	S5 013	80	740	S4 010	70	640	S3 008
Diesel														
1.6/ 1.7 D, D Turbo, D Turbo Syncro [24, 25]	08.84-07.92	VAD							60	540	S4 004			
Caddy														
1.2 TSI [2C]	09.10→					54	530	S5 002	52	470	S4 002			

			Ah A (EN) S6			Ah A (EN) S5			Ah A (EN) S4			Ah A (EN) S3		
			0092...0			0092...0			0092...0			0092...0		
◀ VW														
1.4 [2K]	02.04-08.10					63	610	S5 005	52	470	S4 002	45	400	S3 002
[9K9]	11.95-09.00	VAD				63	610	S5 005	52	470	S4 002	45	400	S3 002
	12.97-06.03	VAD				54	530	S5 002	52	470	S4 002	45	400	S3 002
	09.00-06.03					63	610	S5 005	52	470	S4 002	45	400	S3 002
1.6 [2K]	04.04-08.10					63	610	S5 005	52	470	S4 002	45	400	S3 002
	06.04→					63	610	S5 005	52	470	S4 002			
[9K9]	11.95-09.00	VAD				63	610	S5 005	52	470	S4 002	45	400	S3 002
BiFuel [2C]	05.11→					63	610	S5 005	60	540	S4 005			
1.6/2.0, EcoFuel [2C]	10.10→					63	610	S5 005	52	470	S4 002	45	400	S3 002
2.0 EcoFuel [2K]	04.06-08.10					63	610	S5 005	52	470	S4 002	45	400	S3 002
Diesel														
1.6 TDI [2C]	08.10→					63	610	S5 005	60	540	S4 005	56	480	S3 005
			70	760	S6 008	63	610	S5 005	60	540	S4 005			
		SSJ	70	760	S6 008									
1.7 SDI [9K9]	07.96-08.98	VAD	70	760	S6 008	77	780	S5 008	60	540	S4 005			
1.9 D [9K9]	11.95-08.98	VAD	70	760	S6 008	77	780	S5 008	60	540	S4 005			
	09.98-06.03		70	760	S6 008	77	780	S5 008	60	540	S4 005			
SDI [9K9]	11.95-08.98	VAD	70	760	S6 008	77	780	S5 008	60	540	S4 005			
	09.00-06.03		70	760	S6 008	77	780	S5 008	60	540	S4 005	70	640	S3 008
TDI [2K]	02.04-08.10		70	760	S6 008	77	780	S5 008	60	540	S4 005	70	640	S3 008
TDI [9K9]	10.96-08.98	VAD	70	760	S6 008	77	780	S5 008	60	540	S4 005			
	09.97-09.00	VAD	70	760	S6 008	77	780	S5 008	60	540	S4 005	70	640	S3 008
	09.00-06.03		70	760	S6 008	77	780	S5 008	60	540	S4 005	70	640	S3 008
TDI 4Motion [2K]	11.08-08.10					77	780	S5 008	74	680	S4 008			
		SSJ	70	760	S6 008	70	650	S5 E08						
2.0 SDI [2K]	02.04-08.10		70	760	S6 008	77	780	S5 008	60	540	S4 005	70	640	S3 008
TDI [2C]	08.10→					63	610	S5 005	60	540	S4 005			
	11.10→					77	780	S5 008	74	680	S4 008			
TDI [2K]	09.07-08.10		70	760	S6 008	77	780	S5 008	74	680	S4 008	70	640	S3 008
TDI 4Motion [2C]	08.10→					77	780	S5 008	74	680	S4 008			
	11.10→					63	610	S5 005	60	540	S4 005			
Caddy Pickup														
1.6 [9U7]	06.96-12.00	VAD				63	610	S5 005	52	470	S4 002	45	400	S3 002
1.6/1.8 [14, 1A]	08.83-07.92	VAD				63	610	S5 005	52	470	S4 002	45	400	S3 002
Diesel														
1.6 D [14, 1A]	08.82-07.92	VAD	70	760	S6 008	77	780	S5 008	60	540	S4 005			
1.9 D [9U7]	06.96-08.98	VAD	70	760	S6 008	77	780	S5 008	60	540	S4 005			
California T4														
1.8 [70, 7D]	12.90-07.92	VAD				63	610	S5 005	52	470	S4 002	45	400	S3 002
2.0 [70, 7D]	09.90-06.03	VAD	70	760	S6 008	100	830	S5 013	80	740	S4 010	70	640	S3 008
2.5 [70, 7D]	11.90-12.93	VAD				63	610	S5 005	52	470	S4 002	45	400	S3 002
	07.94-06.03	VAD				63	610	S5 005	52	470	S4 002	45	400	S3 002
	05.99-06.03	VAD				100	830	S5 013	52	470	S4 002	45	400	S3 002
Sincro [70, 7D]	11.92-06.03	VAD				63	610	S5 005	52	470	S4 002	45	400	S3 002
	06.97-06.03	VAD				100	830	S5 013	74	680	S4 008	70	640	S3 008
2.8 [70, 7D]	05.96-05.00	VAD	70	760	S6 008	100	830	S5 013	80	740	S4 010	70	640	S3 008
	05.00-06.03	VAD				100	830	S5 013	74	680	S4 008	70	640	S3 008
Diesel														
1.9 D [70, 7D]	09.90-04.97	VAD	70	760	S6 008	100	830	S5 013	80	740	S4 010	70	640	S3 008
1.9/2.4 D Sincro, D Turbo [70, 7D]	10.92-06.03	VAD	70	760	S6 008	100	830	S5 013	80	740	S4 010	70	640	S3 008
2.4 D [70, 7D]	09.90-05.98	VAD				63	610	S5 005	52	470	S4 002	45	400	S3 002
	05.97-06.03	VAD	70	760	S6 008	100	830	S5 013	74	680	S4 008	70	640	S3 008
2.5 TDI [70, 7D]	01.95-06.03	VAD	70	760	S6 008	100	830	S5 013	80	740	S4 010	70	640	S3 008
	05.98-06.03	VAD	70	760	S6 008	100	830	S5 013	74	680	S4 008	70	640	S3 008
TDI Sincro [70, 7D]	03.98-06.03	VAD	70	760	S6 008	100	830	S5 013	74	680	S4 008	70	640	S3 008
California T5														
2.0 TSI [7E]	05.11→					63	610	S5 005	60	540	S4 005			
	07.12→		95	850	S6 013	100	830	S5 013	95	800	S4 013			
TSI 4Motion [7E]	07.11→					63	610	S5 005	60	540	S4 005			
2.0/3.2, 4Motion [7H]	02.03-11.09		95	850	S6 013	100	830	S5 013	60	540	S4 005	56	480	S3 005
Diesel														
1.9 TDI [7H]	04.03-11.09		95	850	S6 013	100	830	S5 013	80	740	S4 010			

						Ah A (EN) S6		Ah A (EN) S5		Ah A (EN) S4		Ah A (EN) S3		
						0 092 ...0		0 092 ...0		0 092 ...0		0 092 ...0		
2.0 TDI [7E]	09.09→		95	850	S6 013	100	830	S5 013	80	740	S4 010			
	06.10→						85	800	S5 010	80	740	S4 010		
	05.11→		70	760	S6 008									
TDI 4Motion [7E]	11.09→		95	850	S6 013	100	830	S5 013	80	740	S4 010			
	06.10→						85	800	S5 010	80	740	S4 010		
2.5 TDI [7H]	02.03-11.09		95	850	S6 013	100	830	S5 013	80	740	S4 010			
	11.03-11.09		95	850	S6 013	100	830	S5 013	60	540	S4 005	56	480	S3 005
TDI 4Motion [7H]	07.04-11.09		95	850	S6 013	100	830	S5 013	80	740	S4 010			
Caravelle T4														
1.8 [70, 7D]	12.90-07.92	VAD				63	610	S5 005	52	470	S4 002	45	400	S3 002
2.0 [70, 7D]	09.90-04.99	VAD				63	610	S5 005	52	470	S4 002	45	400	S3 002
	05.99-06.03					63	610	S5 005	52	470	S4 002			
2.5 [70, 7D]	11.90-12.93	VAD				63	610	S5 005	52	470	S4 002	45	400	S3 002
	07.94-06.03	VAD				63	610	S5 005	52	470	S4 002	45	400	S3 002
	05.99-06.03	VAD				100	830	S5 013	52	470	S4 002	45	400	S3 002
Syncro [70, 7D]	11.92-06.03	VAD				63	610	S5 005	52	470	S4 002	45	400	S3 002
	06.97-11.01	VAD				100	830	S5 013	74	680	S4 008	70	640	S3 008
	05.99-06.03	VAD				100	830	S5 013	52	470	S4 002	45	400	S3 002
2.8 [70, 7D]	01.96-05.00	VAD				63	610	S5 005	52	470	S4 002	45	400	S3 002
	05.00-06.03	VAD				100	830	S5 013	74	680	S4 008	70	640	S3 008
Diesel														
1.9 D [70, 7D]	10.90-04.97	VAD	70	760	S6 008	100	830	S5 013	80	740	S4 010	70	640	S3 008
1.9/ 2.4 D Syncro, D Turbo [70, 7D]	10.92-06.03	VAD	70	760	S6 008	100	830	S5 013	80	740	S4 010	70	640	S3 008
2.4 D [70, 7D]	09.90-05.98	VAD				63	610	S5 005	52	470	S4 002	45	400	S3 002
	05.97-06.03	VAD	70	760	S6 008	100	830	S5 013	74	680	S4 008	70	640	S3 008
2.5 TDI [70, 7D]	01.95-06.03		95	850	S6 013									
		VAD				63	610	S5 005	52	470	S4 002	45	400	S3 002
	05.98-06.03	VAD	70	760	S6 008	100	830	S5 013	74	680	S4 008	70	640	S3 008
TDI Syncro [70, 7D]	03.98-06.03	VAD	70	760	S6 008	100	830	S5 013	74	680	S4 008	70	640	S3 008
Caravelle T5														
2.0 [7E]	09.09→		95	850	S6 013	100	830	S5 013	60	540	S4 005	56	480	S3 005
TSI [7E]	05.11→					63	610	S5 005	60	540	S4 005			
	07.12→		95	850	S6 013	100	830	S5 013	95	800	S4 013			
TSI 4Motion [7E]	07.11→					63	610	S5 005	60	540	S4 005			
2.0/ 3.2, 4Motion [7H]	02.03-11.09		95	850	S6 013	100	830	S5 013	60	540	S4 005	56	480	S3 005
Diesel														
1.9 TDI [7H]	04.03-11.09		95	850	S6 013	100	830	S5 013	80	740	S4 010			
2.0 TDI [7E]	09.09→		95	850	S6 013	100	830	S5 013	80	740	S4 010			
	06.10→						85	800	S5 010	80	740	S4 010		
	05.11→		70	760	S6 008									
TDI 4Motion [7E]	09.09→		95	850	S6 013	100	830	S5 013	80	740	S4 010			
	06.10→						85	800	S5 010	80	740	S4 010		
2.5 TDI [7H]	02.03-11.09		95	850	S6 013	100	830	S5 013	80	740	S4 010			
	11.03-11.09		95	850	S6 013	100	830	S5 013	60	540	S4 005	56	480	S3 005
TDI 4Motion [7H]	07.04-11.09		95	850	S6 013	100	830	S5 013	80	740	S4 010			
CC														
1.4/ 1.8/ 2.0/ 3.6 FSI 4Motion, TSI [358]	11.11→		70	760	S6 008									
Diesel														
2.0 TDI [358]	11.11→		70	760	S6 008									
		SSJ	70	760	S6 008									
TDI 4Motion [358]	11.11→		70	760	S6 008									
Corrado														
1.8/ 2.0/ 2.8/ 2.9, G60, 16V [50]	09.88-07.95	VAD				61	600	S5 004	44	440	S4 001	41	360	S3 001
Crafter 30														
Diesel														
2.0 BiTDI [2E, 2F]	07.11→					77	780	S5 008	74	680	S4 008			
TDI [2E, 2F]	05.11→					77	780	S5 008	74	680	S4 008			
2.5 TDI [2E, 2F]	04.06→		95	850	S6 013	100	830	S5 013	74	680	S4 008	70	640	S3 008

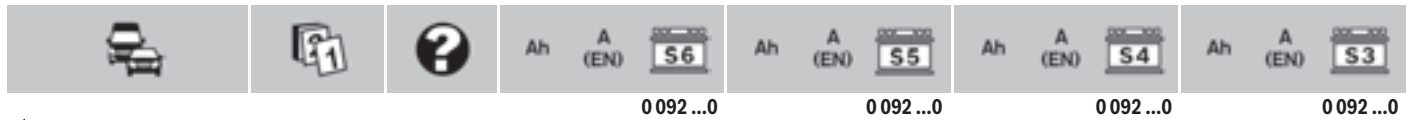

		0092...0				0092...0				0092...0				0092...0			
◀ VW																	
Crafter 35																	
Diesel																	
2.0	BiTDI [2E, 2F]	07.11→				77	780	S5 008	74	680	S4 008						
	TDI [2E, 2F]	05.11→				77	780	S5 008	74	680	S4 008						
2.5	TDI [2E, 2F]	04.06→	95	850	S6 013	100	830	S5 013	74	680	S4 008	70	640	S3 008			
Crafter 50																	
Diesel																	
2.0	BiTDI [2E, 2F]	07.11→	95	850	S6 013												
		10.11→				77	780	S5 008	74	680	S4 008						
	TDI [2E, 2F]	05.11→				77	780	S5 008	74	680	S4 008						
2.5	TDI [2E, 2F]	04.06→	95	850	S6 013	100	830	S5 013	74	680	S4 008	70	640	S3 008			
Eos																	
1.4	TSI [1F7]	11.07-11.10	SSJ	70	760	S6 008											
		05.08-11.10					54	530	S5 002	52	470	S4 002					
	TSI [1F8]	11.10→					54	530	S5 002	52	470	S4 002	45	400			
			BWD				77	780	S5 008	60	540	S4 005	45	400			
			BWD,SSJ	60	680	S6 005											
1.6	FSI [1F7]	05.06-05.08				63	610	S5 005	52	470	S4 002	45	400	S3 002			
2.0	FSI [1F7]	05.06-11.09		70	760	S6 008	77	780	S5 008	60	540	S4 005	56	480			
	TSI [1F7]	05.06-11.10		70	760	S6 008	77	780	S5 008	60	540	S4 005	56	480			
		11.09-11.10		70	760	S6 008	63	610	S5 005	60	540	S4 005	56	480			
	TSI [1F8]	11.10→		70	760	S6 008	63	610	S5 005	60	540	S4 005	56	480			
				70	760	S6 008	77	780	S5 008	60	540	S4 005	56	480			
3.2	[1F7]	05.06-11.10		70	760	S6 008				74	680	S4 008	70	640			
	FSI [1F7]	05.07-05.08		70	760	S6 008				74	680	S4 008	70	640			
3.6	[1F7]	05.09-11.10		70	760	S6 008	77	780	S5 008	74	680	S4 008	70	640			
Diesel																	
2.0	TDI [1F7]	05.06-05.08		70	760	S6 008	77	780	S5 008	60	540	S4 005					
		05.08-11.10	SSJ	70	760	S6 008											
	TDI [1F8]	11.10→					77	780	S5 008	60	540	S4 005					
			BWD														
			BWD,SSJ	70	760	S6 008											
Eurovan																	
2.8	[70]	05.96-06.03	VAD			63	610	S5 005	52	470	S4 002	45	400	S3 002			
Diesel																	
2.4	D [70]	10.92-08.98								95	800	S4 013	90	720			
Fox																	
1.0	[Fase I]	10.03-04.05					54	530	S5 002				40	340			
			XXX								42	390	S4 000				
1.2	[5Z1]	04.05-12.12				63	610	S5 005	52	470	S4 002	45	400	S3 002			
		09.10-12.12				54	530	S5 002	52	470	S4 002						
1.4	[5Z1]	04.05-12.12				63	610	S5 005	52	470	S4 002	45	400	S3 002			
Diesel																	
1.4	TDI [5Z1]	04.05-12.12				63	610	S5 005	52	470	S4 002	45	400	S3 002			
Golf																	
1.6	i	05.99→				63	610	S5 005									
1.8	[19]	08.84-07.87								72	680	S4 007	70	640			
Diesel																	
1.6	D [19]	08.84-07.88				74	750	S5 007	72	680	S4 007	70	640	S3 007			
Golf Cabriolet																	
2.0	[1E, 1V]	08.95-06.02	VAD			61	600	S5 004	44	440	S4 001						
Golf I Cabriolet																	
1.3/ 1.6/ 1.8	[15]	08.82-08.93	VAD							44	440	S4 001	41	360			
Golf II																	
1.0/ 1.3/ 1.6/ 1.8	, G60, G60 syncro, syncro [19, 1G]	08.83-11.92	VAD			61	600	S5 004	44	440	S4 001	41	360	S3 001			
Diesel																	
1.6	D, TD [19, 1G]	08.83-08.92								60	540	S4 004					
Golf III																	
1.4	[1H1]	11.91-12.97	VAD			63	610	S5 005	60	540	S4 005	45	400	S3 002			
1.6	[1H1]	09.92-12.97	VAD			63	610	S5 005	60	540	S4 005	45	400	S3 002			
		05.97-12.97	VAD			63	610	S5 005	60	540	S4 004	45	400	S3 002			
1.8	[1H1]	11.91-12.97	VAD			63	610	S5 005	60	540	S4 005	45	400	S3 002			
1.8/ 2.9	syncro [1H1]	01.93-12.97	VAD	70	760	S6 008	77	780	S5 008	60	540	S4 005	56	480			

				Ah A (EN) S6			Ah A (EN) S5			Ah A (EN) S4			Ah A (EN) S3		
				0 092 ...0			0 092 ...0			0 092 ...0			0 092 ...0		
2.0 [1H1]	11.91-12.97	VAD		63	610	S5 005	60	540	S4 005	45	400	S3 002			
	05.97-12.97	VAD		77	780	S5 008	60	540	S4 004						
		VAD,XXX									53	470	S3 004		
syncro [1H1]	07.95-12.97	VAD		63	610	S5 005	60	540	S4 005	45	400	S3 002			
2.8 [1H1]	01.92-12.97	VAD		63	610	S5 005	60	540	S4 005	45	400	S3 002			
iVR6	07.94-12.97	VAD	70	760	S6 008	77	780	S5 008	60	540	S4 005	56	480	S3 005	
Diesel															
1.9 D, SDI, TD [1H1]	11.91-12.97	VAD	70	760	S6 008	100	830	S5 013	80	740	S4 010	70	640	S3 008	
TDI [1H1]	09.93-12.97	VAD	70	760	S6 008	100	830	S5 013	80	740	S4 010	70	640	S3 008	
	05.97-12.97	VAD				85	800	S5 010	74	680	S4 008	70	640	S3 008	
TDI syncro [1H1]	03.95-12.97	VAD	70	760	S6 008	100	830	S5 013	80	740	S4 010	70	640	S3 008	
Golf III Cabriolet															
1.6 [1E7]	10.94-04.98	VAD				63	610	S5 005	60	540	S4 005	45	400	S3 002	
	07.97-04.98	VAD				63	610	S5 005	52	470	S4 002	45	400	S3 002	
1.8 [1E7]	09.93-04.98	VAD	70	760	S6 008	77	780	S5 008	60	540	S4 005	56	480	S3 005	
	01.98-03.98	VAD				77	780	S5 008	60	540	S4 004				
		VAD,XXX										53	470	S3 004	
2.0 [1E7]	09.93-04.98	VAD	70	760	S6 008	77	780	S5 008	60	540	S4 005	56	480	S3 005	
	04.97-04.98	VAD				77	780	S5 008	60	540	S4 005	56	480	S3 005	
Diesel															
1.9 TDI [1E7]	08.95-04.98	VAD	70	760	S6 008	100	830	S5 013	80	740	S4 010	70	640	S3 008	
	04.97-04.98	VAD				100	830	S5 013	74	680	S4 008	70	640	S3 008	
Golf III Variant															
1.4 [1H5]	07.93-02.99	VAD				63	610	S5 005	60	540	S4 005	45	400	S3 002	
	12.97-05.98	VAD				63	610	S5 005	44	440	S4 001	41	360	S3 001	
1.6 [1H5]	10.94-02.99	VAD				63	610	S5 005	60	540	S4 005	45	400	S3 002	
	05.97-02.99	VAD				63	610	S5 005	52	470	S4 002	45	400	S3 002	
1.8 [1H5]	07.93-02.99	VAD	70	760	S6 008	77	780	S5 008	60	540	S4 005	56	480	S3 005	
	12.97-02.99	VAD				77	780	S5 008	60	540	S4 004				
		VAD,XXX										53	470	S3 004	
1.8/ 2.0/ 2.9 syncro [1H5]	10.94-12.97	VAD	70	760	S6 008	77	780	S5 008	60	540	S4 005	56	480	S3 005	
2.0 [1H5]	07.93-02.99	VAD	70	760	S6 008	77	780	S5 008	60	540	S4 005	56	480	S3 005	
	05.97-02.99	VAD				77	780	S5 008	60	540	S4 005	56	480	S3 005	
Diesel															
1.9 D, SDI, TD [1H5]	07.93-02.99	VAD	70	760	S6 008	100	830	S5 013	80	740	S4 010	70	640	S3 008	
	07.93-02.99	VAD	70	760	S6 008	100	830	S5 013	80	740	S4 010	70	640	S3 008	
	05.97-02.99	VAD				85	800	S5 010	74	680	S4 008	70	640	S3 008	
	TDI syncro [1H5]	10.94-12.97	VAD	70	760	S6 008	100	830	S5 013	80	740	S4 010	70	640	S3 008
Golf IV															
1.4/ 1.6 [1J1]	10.97-05.04					63	610	S5 005	52	470	S4 002	45	400	S3 002	
1.6 FSI [1J1]	08.01-05.04					63	610	S5 005	52	470	S4 002	45	400	S3 002	
1.8 i	12.03→		70	760	S6 008	77	780	S5 008	60	540	S4 005	56	480	S3 005	
1.8/ 2.0 BiFuel, T [1J1]	10.97-05.04		70	760	S6 008	77	780	S5 008	60	540	S4 005	56	480	S3 005	
1.8/ 2.0/ 2.3 [1J1]	10.97-05.04		70	760	S6 008	77	780	S5 008	60	540	S4 005	56	480	S3 005	
	4Motion [1J1]	07.98-06.05				70	760	S6 008	77	780	S5 008	60	540	S4 005	56
2.8 [1J1]	12.98-08.02					85	800	S5 011	80	740	S4 011				
	4Motion [1J1]	05.99-06.05				70	760	S6 008	85	800	S5 011	60	540	S4 005	56
3.2 4Motion R32 [1J1]	06.02-05.04		70	760	S6 008	85	800	S5 011	60	540	S4 005	56	480	S3 005	
Diesel															
1.9 SDI, TDI, TDI 4Motion [; 1J1]	10.97-06.05		70	760	S6 008	85	800	S5 011	74	680	S4 008	70	640	S3 008	
Golf IV Cabriolet															
1.6 [1E7]	04.98-10.00	VAD				63	610	S5 005	52	470	S4 002	45	400	S3 002	
						63	610	S5 005	60	540	S4 005	56	480	S3 005	
1.8/ 2.0 [1E7]	04.98-06.02	VAD	70	760	S6 008	77	780	S5 008	60	540	S4 005	56	480	S3 005	
Diesel															
1.9 TDI [1E7]	04.98-10.00	VAD	70	760	S6 008	100	830	S5 013	80	740	S4 010	70	640	S3 008	
	04.98-12.01	VAD	70	760	S6 008	77	780	S5 008	74	680	S4 008	70	640	S3 008	
Golf IV Variant															
1.4/ 1.6 [1J5]	05.99-06.06					63	610	S5 005	52	470	S4 002	45	400	S3 002	
1.6 FSI [1J5]	08.01-06.06					63	610	S5 005	52	470	S4 002	45	400	S3 002	
1.8/ 2.0/ 2.3/ 2.8 BiFuel, T, 4Motion [1J5]	05.99-06.06		70	760	S6 008	77	780	S5 008	60	540	S4 005	56	480	S3 005	

				Ah A (EN) S6		Ah A (EN) S5		Ah A (EN) S4		Ah A (EN) S3				
				0092 ...0		0092 ...0		0092 ...0		0092 ...0				
◀ VW														
2.0/ 2.3 [1J5]	05.99-06.06	70	760	S6 008	77	780	S5 008	60	540	S4 005	56	480	S3 005	
Diesel														
1.9 SDI, TDI [1J5]	05.99-06.06	70	760	S6 008	85	800	S5 011	74	680	S4 008	70	640	S3 008	
TDI 4Motion [1J5]	05.99-06.06	70	760	S6 008	85	800	S5 011	74	680	S4 008	70	640	S3 008	
	01.00-07.01	70	760	S6 008	85	800	S5 011	80	740	S4 010	70	640	S3 008	
		70	760	S6 008	85	800	S5 011	80	740	S4 011	70	640	S3 008	
		70	760	S6 008	100	830	S5 013	80	740	S4 011	70	640	S3 008	
Golf Plus														
1.2 TSI [521]	08.09→	BWD,SSJ	60	680	S6 005									
	05.10→	BWD				54	530	S5 002	52	470	S4 002			
1.4 TSI [5M1]	05.06-12.08				63	610	S5 005	52	470	S4 002	45	400	S3 002	
	05.08-12.08				63	610	S5 005	52	470	S4 002	56	480	S3 005	
TSI [521]	01.09-09.12	BWD			63	610	S5 005	52	470	S4 002	56	480	S3 005	
	01.09→	BWD			63	610	S5 005	52	470	S4 002	45	400	S3 002	
	05.12→				63	610	S5 005	52	470	S4 002	56	480	S3 005	
1.4/ 1.6 [5M1]	01.05-12.08				63	610	S5 005	52	470	S4 002	45	400	S3 002	
,FSI [521]	01.09→	BWD			63	610	S5 005	52	470	S4 002	45	400	S3 002	
FSI [5M1]	01.05-01.09				63	610	S5 005	52	470	S4 002	45	400	S3 002	
1.6 BiFuel [521]	05.09→	BWD			54	530	S5 002	52	470	S4 002				
2.0 FSI [5M1]	05.05-06.08		70	760	S6 008	85	800	S5 011	60	540	S4 005	56	480	S3 005
Diesel														
1.6 TDI [521]	05.09→	BWD				63	610	S5 005	60	540	S4 005			
		SSJ	70	760	S6 008									
1.9/ 2.0 TDI [5M1]	01.05-05.09		70	760	S6 008	85	800	S5 011	74	680	S4 008	70	640	S3 008
2.0 TDI [521]	01.09→	BWD				85	800	S5 011	74	680	S4 008			
			70	760	S6 008	85	800	S5 011	74	680	S4 008	70	640	S3 008
		BWD,SSJ	70	760	S6 008									
Golf V														
1.4 [1K1]	10.03-11.08				63	610	S5 005	52	470	S4 002	45	400	S3 002	
TSI [1K1]	11.05-11.08				63	610	S5 005	52	470	S4 002	45	400	S3 002	
1.4/ 1.6 FSI [1K1]	10.03-07.08				63	610	S5 005	52	470	S4 002	45	400	S3 002	
1.6 [1K1]	01.04-11.08				63	610	S5 005	52	470	S4 002	45	400	S3 002	
	11.07-11.08				63	610	S5 005	52	470	S4 002				
2.0 FSI [1K1]	01.04-11.05	VAD	70	760	S6 008	77	780	S5 008	60	540	S4 005	56	480	S3 005
	01.05-11.08		70	760	S6 008	77	780	S5 008	60	540	S4 005	56	480	S3 005
FSI 4Motion [1K1]	08.04-10.08		70	760	S6 008	77	780	S5 008	60	540	S4 005	56	480	S3 005
GTI [1K1]	09.04-11.05	VAD	70	760	S6 008	77	780	S5 008	60	540	S4 005	56	480	S3 005
	11.05-11.08		70	760	S6 008	77	780	S5 008	60	540	S4 005	56	480	S3 005
2.5 [1K1]	02.06-07.07				85	800	S5 011	80	740	S4 011				
3.2 R32 [1K1]	05.05-07.07				85	800	S5 011	74	680	S4 008				
		SSJ	70	760	S6 008									
R32 4Motion [1K1]	11.05-11.08		70	760	S6 008	85	800	S5 011	74	680	S4 008			
Diesel														
1.9/ 2.0 SDI, TDI, TDI 4Motion [1K1]	10.03-11.08		70	760	S6 008	85	800	S5 011	74	680	S4 008	70	640	S3 008
Golf V Variant														
1.4/ 1.6, TSI [1K5]	05.07-07.09				63	610	S5 005	52	470	S4 002	45	400	S3 002	
2.0 GTI [1K5]	05.07-06.09				85	800	S5 011	52	470	S4 002	45	400	S3 002	
Diesel														
1.9 TDI [1K5]	05.07-11.08		70	760	S6 008	85	800	S5 011	74	680	S4 008	70	640	S3 008
TDI 4Motion [1K5]	12.07-06.09		70	760	S6 008	85	800	S5 011	74	680	S4 008	70	640	S3 008
2.0 TDI [1K5]	05.07-05.08		70	760	S6 008	85	800	S5 011	74	680	S4 008	70	640	S3 008
	07.08-07.09					85	800	S5 011	80	740	S4 011			
			70	760	S6 008	85	800	S5 011	74	680	S4 008	70	640	S3 008
TDI 4Motion [1K5]	05.07-06.09					77	780	S5 008	80	740	S4 011			
						85	800	S5 011	74	680	S4 008			
						85	800	S5 011	80	740	S4 011			
Golf VI														
1.2 TSI [5K1]	05.09-11.12	BWD,SSJ	70	760	S6 008	70	650	S5 E08						
	05.10-11.12	BWD				54	530	S5 002	52	470	S4 002			
1.4 [5K1]	10.08-11.12	BWD			63	610	S5 005	52	470	S4 002	56	480	S3 005	
TSI [5K1]	10.08-11.12	BWD			63	610	S5 005	52	470	S4 002	56	480	S3 005	
		SSJ	70	760	S6 008									

						Ah A (EN) S6		Ah A (EN) S5		Ah A (EN) S4		Ah A (EN) S3		
				0 092 ...0		0 092 ...0		0 092 ...0		0 092 ...0		0 092 ...0		
1.4 TSI [5K1]	09.12-11.12			63	610	S5 005		52	470	S4 002		56	480	S3 005
1.6 [5K1]	10.08-11.12	BWD		63	610	S5 005		52	470	S4 002		56	480	S3 005
				63	610	S5 005		52	470	S4 002		56	480	S3 005
BiFuel [5K1]	11.08-11.12	BWD		63	610	S5 005		52	470	S4 002		56	480	S3 005
1.8 TSI [5K1]	06.09-01.11	BWD		63	610	S5 005		60	540	S4 005				
2.0 GTI [5K1]	04.09-11.12	BWD		85	800	S5 011		74	680	S4 008				
		BWD,SSJ	70	760	S6 008									
	05.11-11.12	BWD		63	610	S5 005		60	540	S4 005				
TSI 4Motion [5K1]	11.09-11.12	BWD		63	610	S5 005		60	540	S4 005				
		BWD,SSJ	70	760	S6 008			74	680	S4 008				
Diesel														
1.6 TDI [5K1]	12.08-11.12	BWD,SSJ	70	760	S6 008									
	02.09-11.12	BWD		85	800	S5 011		74	680	S4 008				
TDI 4Motion [5K1]	12.08-11.12			77	780	S5 008		60	540	S4 005				
		SSJ	70	760	S6 008									
2.0 TDI [5K1]	10.08-11.12	BWD		85	800	S5 011		74	680	S4 008				
		BWD,SSJ	70	760	S6 008									
	04.09-05.10			77	780	S5 008		80	740	S4 011				
				85	800	S5 011		60	540	S4 005				
				85	800	S5 011		80	740	S4 011				
	04.09-11.12	SSJ	70	760	S6 008									
	09.09-11.12			85	800	S5 011		74	680	S4 008				
	11.09-11.12		70	760	S6 008			85	800	S5 010		74	680	S4 008
TDI 4Motion [5K1]	10.08-11.12	BWD		85	800	S5 011		74	680	S4 008				
		BWD,SSJ	70	760	S6 008									
Golf VI Cabrio														
1.2 TSI [517]	03.11→	BWD						52	470	S4 002				
		BWD,SSJ	70	760	S6 008									
1.4 TSI [517]	03.11→	BWD		77	780	S5 008								
		BWD,SSJ	70	760	S6 008									
2.0 TSI [517]	05.12→			77	780	S5 008								
		SSJ	70	760	S6 008									
Diesel														
1.6 TDI [517]	03.11→	BWD		77	780	S5 008								
		BWD,SSJ	70	760	S6 008									
2.0 TDI [517]	11.11→	BWD		77	780	S5 008								
		BWD,SSJ	70	760	S6 008									
Golf VI Cabriolet														
1.4 TSI [517]	09.12→			77	780	S5 008								
		SSJ	70	760	S6 008									
Golf VI Variant														
1.2 TSI [AJ5]	08.09→	SSJ	70	760	S6 008									
	07.10→	BWD		54	530	S5 002		52	470	S4 002				
		BWD,SSJ		60	560	S5 E05								
1.4 [AJ5]	07.09→	BWD		63	610	S5 005		52	470	S4 002		56	480	S3 005
TSI [AJ5]	06.09→	BWD		63	610	S5 005		52	470	S4 002		56	480	S3 005
	07.12→			63	610	S5 005		52	470	S4 002		56	480	S3 005
1.6 [AJ5]	07.09→	BWD		77	780	S5 008		60	540	S4 005		70	640	S3 008
		BWD,SSJ	70	760	S6 008									
	07.10→	BWD		63	610	S5 005		52	470	S4 002				
Diesel														
1.6 TDI [AJ5]	07.09→			85	800	S5 011		80	740	S4 011				
		SSJ	70	760	S6 008									
	12.09→	BWD,SSJ	70	760	S6 008									
TDI 4Motion [AJ5]	07.09→	BWD		85	800	S5 011		74	680	S4 008				
		BWD,SSJ	70	760	S6 008									
2.0 TDI [AJ5]	07.09→			85	800	S5 011		80	740	S4 011				
		BWD		77	780	S5 008		74	680	S4 008				
				85	800	S5 011		74	680	S4 008				
		BWD,SSJ	70	760	S6 008									
	09.10→	BWD		85	800	S5 011		80	740	S4 011				



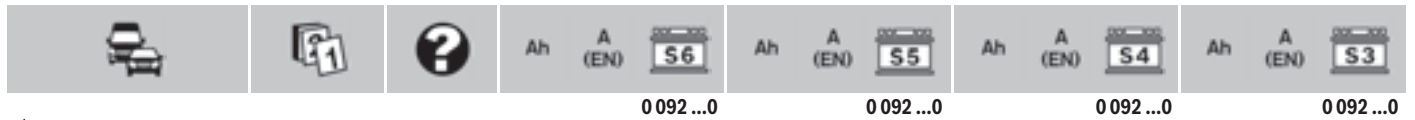

◀ VW

Golf VII												
1.2/ 1.4 TSI, TSI ACT, TSI MultiFuel [5G1]	08.12→		70	760	S6 008							
Diesel												
1.6/ 2.0 TDI, TDI 4Motion [5G1]	08.12→		70	760	S6 008							
Iltis												
1.7 [183]	01.79-12.88	VAD				52	520	S5 001	44	440	S4 001	41 360 S3 001
Diesel												
1.6 D [183]	08.87-12.88	VAD				52	520	S5 001	44	440	S4 001	41 360 S3 001
Jetta												
1.0/ 1.3/ 1.6/ 1.8 , syncro, 16V [1G2, 19E]	01.84-09.92	VAD				61	600	S5 004	44	440	S4 001	41 360 S3 001
1.2 TSI [162]	10.10→	SSJ	70	760	S6 008							
1.4 TSI [1K2]	07.06-10.10					63	610	S5 005	60	540	S4 005	56 480 S3 005
TSI [162]	04.11→		70	760	S6 008	54	530	S5 002	52	470	S4 002	
			70	760	S6 008	63	610	S5 005	60	540	S4 005	
1.4/ 1.6 , Hybrid [162]	12.11→					63	610	S5 005	60	540	S4 005	
1.6 [1K2]	10.05-10.10		70	760	S6 008	77	780	S5 008	60	540	S4 005	56 480 S3 005
FSI [1K2]	09.05-06.08		70	760	S6 008	77	780	S5 008	60	540	S4 005	56 480 S3 005
1.8 [1G2]	08.84-02.87					52	520	S5 001	44	440	S4 001	
2.0 [1G2]	08.89-07.92					52	520	S5 001	44	440	S4 001	
FSI [1K2]	08.05-06.08		70	760	S6 008	85	800	S5 011	60	540	S4 005	56 480 S3 005
TSI [1K2]	06.05-10.10		70	760	S6 008	85	800	S5 011	60	540	S4 005	56 480 S3 005
TSI [162]	10.10→		70	760	S6 008	54	530	S5 002	52	470	S4 002	
2.5 [1K2]	01.05-10.10		70	760	S6 008	85	800	S5 011	60	540	S4 005	56 480 S3 005
Diesel												
1.6 D, D Turbo [1G2, 19E]	01.84-09.92	VAD							60	540	S4 004	
TDI [1K2]	07.09-10.10		70	760	S6 008	77	780	S5 008	60	540	S4 005	56 480 S3 005
			70	760	S6 008	85	800	S5 011	60	540	S4 005	56 480 S3 005
	12.09-10.10		70	760	S6 008	63	610	S5 005	60	540	S4 005	
TDI [162]	10.10→	SSJ	70	760	S6 008							
1.9 TDI [1K2]	09.05-10.10		70	760	S6 008	85	800	S5 011	74	680	S4 008	70 640 S3 008
2.0 TDI [1K2]	08.05-10.10		70	760	S6 008	85	800	S5 011	74	680	S4 008	70 640 S3 008
	07.09→					85	800	S5 011	80	740	S4 011	
TDI [162]	10.10→					77	780	S5 008	74	680	S4 008	
Jetta IV												
1.6/ 2.0 i	09.99-12.05					77	780	S5 008	60	540	S4 005	
Käfer												
1200/ 1600 , i [1]	10.73-08.04	VAD				52	520	S5 001	44	440	S4 001	41 360 S3 001
Kombi												
2.5 i	07.93-05.05					85	800	S5 010				
LT												
28/ 31/ 35/ 40/ 45/ 50/ 55 2.4 [28, 29, 21]	12.82-04.96	VAD	70	760	S6 008	77	780	S5 008	60	540	S4 005	56 480 S3 005
28/ 35/ 46 2.3 [2D, 2H]	05.96-11.01		70	760	S6 008	100	830	S5 013	80	740	S4 010	70 640 S3 008
40/ 45 2.4 4x4 [29, 21]	09.85-07.92	VAD	70	760	S6 008	100	830	S5 013	80	740	S4 010	70 640 S3 008
Diesel												
28 2.5 TDI [2D, 2H]	05.96-05.99		70	760	S6 008	100	830	S5 013	80	740	S4 010	70 640 S3 008
	05.99-04.06		95	850	S6 013	100	830	S5 013	74	680	S4 008	70 640 S3 008
28/ 31/ 35/ 40/ 45/ 50/ 55 2.4 D, 2.4 D Turbo, 2.4 D Turbo 4x4, 2.4 D 4x4 [28, 29, 21; 29, 21]	12.82-04.96	VAD	70	760	S6 008	100	830	S5 013	80	740	S4 010	70 640 S3 008
28/ 35/ 46 2.5 SDI [2D, 2H]	05.96-04.01		70	760	S6 008	100	830	S5 013	80	740	S4 010	70 640 S3 008
2.8 D Turbo, 2.8 TDI [2D, 2H]	07.97-04.06		95	850	S6 013	100	830	S5 013	74	680	S4 008	70 640 S3 008
35 2.5 TDI [2D, 2H]	05.96-05.99		70	760	S6 008	100	830	S5 013	80	740	S4 010	70 640 S3 008
	05.99-04.06		95	850	S6 013	100	830	S5 013	74	680	S4 008	70 640 S3 008
46 2.5 TDI [2D, 2H]	05.96-05.99		70	760	S6 008	100	830	S5 013	80	740	S4 010	70 640 S3 008
	05.99-04.06		95	850	S6 013	100	830	S5 013	74	680	S4 008	70 640 S3 008
Lupo												
1.0/ 1.4 [6X1]	10.98-07.05					63	610	S5 005	52	470	S4 002	45 400 S3 002

											Ah A (EN) S6			Ah A (EN) S5			Ah A (EN) S4			Ah A (EN) S3		
		0 092 ...0			0 092 ...0			0 092 ...0			0 092 ...0											
1.4 FSI [6X1]	09.00-11.03	70	760	S6 008	77	780	S5 008	52	470	S4 002	56	480	S3 005									
1.6 GTI [6X1]	05.00-07.05	70	760	S6 008	77	780	S5 008	60	540	S4 005	56	480	S3 005									
Diesel																						
1.2 TDI 3L [6X1]	10.98-11.00				77	780	S5 008	74	680	S4 008												
	11.00-07.05	70	760	S6 008	77	780	S5 008	60	540	S4 005												
1.4/ 1.7 SDI, TDI [6X1]	06.98-07.05	70	760	S6 008	77	780	S5 008	60	540	S4 005	70	640	S3 008									
Multivan T4																						
1.8/ 2.0 [70, 7D]	09.90-04.99	VAD			63	610	S5 005	52	470	S4 002	45	400	S3 002									
2.5 [70, 7D]	11.90-06.03	VAD			63	610	S5 005	52	470	S4 002	45	400	S3 002									
	05.99-06.03	VAD			100	830	S5 013	52	470	S4 002	45	400	S3 002									
Syncro [70, 7D]	11.92-06.03	VAD			63	610	S5 005	52	470	S4 002	45	400	S3 002									
	06.97-11.01	VAD			100	830	S5 013	74	680	S4 008	70	640	S3 008									
	12.99-06.03	VAD			100	830	S5 013	52	470	S4 002	45	400	S3 002									
2.8 [70, 7D]	01.96-05.00	VAD			63	610	S5 005	52	470	S4 002	45	400	S3 002									
	05.00-06.03	VAD			100	830	S5 013	74	680	S4 008	70	640	S3 008									
Diesel																						
1.9 D [70, 7D]	09.90-04.97	VAD	70	760	S6 008	100	830	S5 013	80	740	S4 010	70	640	S3 008								
1.9/ 2.4 D Syncro, D Turbo [70, 7D]	10.92-04.99	VAD	70	760	S6 008	100	830	S5 013	80	740	S4 010	70	640	S3 008								
2.4 D [70, 7D]	09.90-05.98				63	610	S5 005	52	470	S4 002	45	400	S3 002									
	05.97-06.03		70	760	S6 008	100	830	S5 013	74	680	S4 008	70	640	S3 008								
2.5 TDI [70, 7D]	01.95-06.03	VAD			63	610	S5 005	52	470	S4 002	45	400	S3 002									
	05.98-06.03	VAD	70	760	S6 008	100	830	S5 013	74	680	S4 008	70	640	S3 008								
TDI Syncro [70, 7D]	03.98-06.03	VAD	70	760	S6 008	100	830	S5 013	74	680	S4 008	70	640	S3 008								
Multivan T5																						
2.0 [7E]	09.09→		70	760	S6 008	100	830	S5 013	74	680	S4 008	70	640	S3 008								
[7H]	06.03-11.09		70	760	S6 008	77	780	S5 008	74	680	S4 008	70	640	S3 008								
			70	760	S6 008	100	830	S5 013	60	540	S4 005	70	640	S3 008								
			70	760	S6 008	100	830	S5 013	74	680	S4 008	70	640	S3 008								
TSI [7E]	05.11→				85	800	S5 011	80	740	S4 011												
	07.12→		95	850	S6 013	100	830	S5 013	95	800	S4 013											
TSI 4Motion [7E]	07.11→				63	610	S5 005	60	540	S4 005												
3.2 [7H]	02.03-11.09		70	760	S6 008	77	780	S5 008	74	680	S4 008	70	640	S3 008								
			70	760	S6 008	100	830	S5 013	60	540	S4 005	70	640	S3 008								
			70	760	S6 008	100	830	S5 013	74	680	S4 008	70	640	S3 008								
	05.08-11.09				85	800	S5 011	80	740	S4 011												
4Motion [7H]	07.04-11.09		70	760	S6 008	77	780	S5 008	74	680	S4 008	70	640	S3 008								
			70	760	S6 008	100	830	S5 013	60	540	S4 005	70	640	S3 008								
			70	760	S6 008	100	830	S5 013	74	680	S4 008	70	640	S3 008								
Diesel																						
1.9 TDI [7H]	04.03-11.09		70	760	S6 008	85	800	S5 011	80	740	S4 010											
			70	760	S6 008	85	800	S5 011	80	740	S4 011											
			70	760	S6 008	100	830	S5 013	74	680	S4 008	70	640	S3 008								
			70	760	S6 008	100	830	S5 013	80	740	S4 011											
2.0 TDI [7E]	09.09→				85	800	S5 011	74	680	S4 008												
		SSJ	70	760	S6 008																	
	06.10→				85	800	S5 010	80	740	S4 010												
	05.11→		70	760	S6 008																	
TDI 4Motion [7E]	09.09→				85	800	S5 011	74	680	S4 008												
		SSJ	70	760	S6 008																	
	06.10→				85	800	S5 010	80	740	S4 010												
2.5 TDI [7H]	02.03-11.09		95	850	S6 013	100	830	S5 013	74	680	S4 008	70	640	S3 008								
TDI 4Motion [7H]	07.04-11.09		95	850	S6 013	100	830	S5 013	74	680	S4 008	70	640	S3 008								
New Beetle																						
1.4/ 1.6/ 1.8/ 2.0/ 2.3/ 2.5/ 3.2 , RSI 4x4, T [1C1/9C1]	01.98-12.10		70	760	S6 008	77	780	S5 008	60	540	S4 005	56	480	S3 005								
Diesel																						
1.9 TDI [1C1/9C1]	01.98-12.10		70	760	S6 008	77	780	S5 008	60	540	S4 005	70	640	S3 008								
New Beetle Cabriolet																						
1.4/ 1.6/ 1.8/ 2.0/ 2.5 , T [1Y7]	01.03-10.10		70	760	S6 008	77	780	S5 008	60	540	S4 005	56	480	S3 005								
Diesel																						
1.9 TDI [1Y7]	06.03-09.10		70	760	S6 008	77	780	S5 008	60	540	S4 005	70	640	S3 008								



0092 ...0 0092 ...0 0092 ...0 0092 ...0







◀ VW

Passat												
1.3/ 1.6/ 1.8/ 2.0/ 2.2 [32B]	01.83-03.88	VAD				61	600	S5 004	44	440	S4 001	41 360 S3 001
1.4 TSI [3C2]	05.07-07.10	SSJ	70	760	S6 008							
TSI [362]	08.10→	SSJ	70	760	S6 008							
	11.10→	BWD,SSJ	70	760	S6 008							
	11.12→		70	760	S6 008							
TSI EcoFuel [3C2]	11.08-07.10	BWD,SSJ	70	760	S6 008							
TSI EcoFuel [362]	09.10→	BWD,SSJ	70	760	S6 008							
1.6 [3B2]	10.96-11.00					63	610	S5 005	52	470	S4 002	45 400 S3 002
[3B3]	10.00-05.05					63	610	S5 005	52	470	S4 002	45 400 S3 002
[3C2]	03.05-07.10	BWD				77	780	S5 008	52	470	S4 002	45 400 S3 002
		BWD,SSJ	70	760	S6 008							
FSI [3C2]	03.05-06.08	BWD				77	780	S5 008	52	470	S4 002	45 400 S3 002
		BWD,SSJ	70	760	S6 008							
1.6/ 1.8 [312/351/3A2]	04.88-03.97	VAD				61	600	S5 004	44	440	S4 001	41 360 S3 001
1.8 [3B2]	12.96-11.00		70	760	S6 008	85	800	S5 010	80	740	S4 011	70 640 S3 008
			70	760	S6 008	85	800	S5 011	74	680	S4 008	70 640 S3 008
			70	760	S6 008	85	800	S5 011	80	740	S4 011	70 640 S3 008
	01.97-11.00		70	760	S6 008	85	800	S5 010	74	680	S4 008	70 640 S3 008
[3B3]	10.00-05.05		70	760	S6 008	77	780	S5 008	60	540	S4 005	56 480 S3 005
FSI [3C2]	11.09-07.10	BWD				77	780	S5 008	60	540	S4 005	70 640 S3 008
		BWD,SSJ	70	760	S6 008							
FSI [362]	08.10→	BWD,SSJ	70	760	S6 008							
syncro [3B2]	06.97-11.00		70	760	S6 008	85	800	S5 011	60	540	S4 005	56 480 S3 005
TSI [3C2]	05.08-07.10	BWD				77	780	S5 008	60	540	S4 005	70 640 S3 008
		BWD,SSJ	70	760	S6 008							
TSI [362]	02.11→	SSJ	70	760	S6 008							
Turbo [3B2]	10.96-11.00		70	760	S6 008	85	800	S5 010	80	740	S4 011	70 640 S3 008
			70	760	S6 008	85	800	S5 011	74	680	S4 008	70 640 S3 008
			70	760	S6 008	85	800	S5 011	80	740	S4 011	70 640 S3 008
1.8/ 2.0 G60, G60 syncro, syncro [312/351/3A2]	09.89-09.94	VAD				85	800	S5 010	72	680	S4 007	70 640 S3 007
2.0 [3B2]	01.00-08.00		70	760	S6 008	85	800	S5 010	80	740	S4 011	70 640 S3 008
			70	760	S6 008	85	800	S5 011	74	680	S4 008	70 640 S3 008
			70	760	S6 008	85	800	S5 011	80	740	S4 011	70 640 S3 008
[312/351/3A2]	08.88-03.97	VAD				85	800	S5 010	72	680	S4 007	70 640 S3 007
	03.95-03.97	VAD				61	600	S5 004	44	440	S4 001	41 360 S3 001
FSI [3C2]	03.05-07.10	BWD	70	760	S6 008	85	800	S5 011	60	540	S4 005	56 480 S3 005
FSI 4Motion [3C2]	09.05-07.10	BWD	70	760	S6 008	85	800	S5 011	60	540	S4 005	56 480 S3 005
TSI [3C2]	03.05-11.05		70	760	S6 008	85	800	S5 011	60	540	S4 005	56 480 S3 005
	08.05-12.07		70	760	S6 008	77	780	S5 008	60	540	S4 005	
	11.05-02.08	BWD	70	760	S6 008	85	800	S5 011	60	540	S4 005	56 480 S3 005
	05.08-07.10					85	800	S5 011	74	680	S4 008	
		BWD	70	760	S6 008	85	800	S5 011	60	540	S4 005	56 480 S3 005
		SSJ	70	760	S6 008							
	05.08-11.10		70	760	S6 008	85	800	S5 011	60	540	S4 005	56 480 S3 005
TSI [362]	11.10→	BWD,SSJ	70	760	S6 008							
2.0/ 2.3 [3B3]	10.00-05.05		70	760	S6 008	85	800	S5 011	60	540	S4 005	56 480 S3 005
2.0/ 2.3/ 2.8/ 4.0 4Motion [3B3]	10.00-05.05		70	760	S6 008	85	800	S5 011	60	540	S4 005	56 480 S3 005
2.3 [3B2]	10.96-11.00		70	760	S6 008	85	800	S5 010	80	740	S4 011	70 640 S3 008
			70	760	S6 008	85	800	S5 011	74	680	S4 008	70 640 S3 008
			70	760	S6 008	85	800	S5 011	80	740	S4 011	70 640 S3 008
2.3/ 2.8 syncro [3B2]	01.97-11.00		70	760	S6 008	85	800	S5 011	74	680	S4 008	70 640 S3 008
2.8 [3B2]	01.97-11.00		70	760	S6 008	85	800	S5 010	80	740	S4 011	70 640 S3 008
			70	760	S6 008	85	800	S5 011	74	680	S4 008	70 640 S3 008
			70	760	S6 008	85	800	S5 011	80	740	S4 011	70 640 S3 008
	01.98-10.02		70	760	S6 008	85	800	S5 010	74	680	S4 008	70 640 S3 008
[3B3]	10.00-05.05					85	800	S5 011	74	680	S4 008	
		SSJ	70	760	S6 008							
[312/351/3A2]	06.91-03.97	VAD				85	800	S5 010	72	680	S4 007	70 640 S3 007
3.2/ 3.6 FSI 4Motion [3C2]	09.05-07.10	BWD	95	850	S6 013	100	830	S5 013	74	680	S4 008	70 640 S3 008

			Ah A (EN) S6			Ah A (EN) S5			Ah A (EN) S4			Ah A (EN) S3		
			0 092 ...0			0 092 ...0			0 092 ...0			0 092 ...0		
3.6 FSI [3C2]	09.05-07.10	BWD				85	800	S5 011	74	680	S4 008			
		BWD,SSJ	70	760	S6 008									
FSI R36 4Motion [3C2]	04.07-07.10	BWD				85	800	S5 011	74	680	S4 008	70	640	S3 008
		BWD,SSJ	95	850	S6 013									
V6 4Motion [362]	01.11→	SSJ	80	800	S6 011									
4.0 [3B3]	05.02-09.04		70	760	S6 008	77	780	S5 008	80	740	S4 011			
			70	760	S6 008	85	800	S5 011	60	540	S4 005			
			70	760	S6 008	85	800	S5 011	80	740	S4 011			
Diesel														
1.6 D, TD [32B]	04.82-03.88	VAD							60	540	S4 004			
TDI [3C2]	08.09-07.10	SSJ	70	760	S6 008									
TDI [362]	08.10→	SSJ	70	760	S6 008									
1.6/1.9 D, TD, TDI [312/351/3A2]	08.88-03.97	VAD							60	540	S4 004			
1.9 TDI [3B2]	10.96-11.00		70	760	S6 008	85	800	S5 010	80	740	S4 011	70	640	S3 008
			70	760	S6 008	85	800	S5 011	74	680	S4 008	70	640	S3 008
			70	760	S6 008	85	800	S5 011	80	740	S4 011	70	640	S3 008
TDI [3B3]	10.00-05.05		70	760	S6 008	85	800	S5 011	74	680	S4 008	70	640	S3 008
TDI [3C2]	03.05-11.08	BWD				85	800	S5 011	74	680	S4 008	70	640	S3 008
		BWD,SSJ	70	760	S6 008									
1.9/2.5 TDI syncro [3B2]	06.97-11.00		70	760	S6 008	85	800	S5 011	74	680	S4 008	70	640	S3 008
TDI 4Motion [3B3]	10.00-05.05		70	760	S6 008	85	800	S5 011	74	680	S4 008	70	640	S3 008
2.0 TDI [3B3]	11.03-05.05		70	760	S6 008	77	780	S5 008	80	740	S4 011			
			70	760	S6 008	85	800	S5 011	60	540	S4 005			
			70	760	S6 008	85	800	S5 011	74	680	S4 008	70	640	S3 008
			70	760	S6 008	85	800	S5 011	80	740	S4 011			
TDI [3C2]	03.05-11.09	BWD	70	760	S6 008	85	800	S5 011	74	680	S4 008			
	03.05-07.10	BWD	70	760	S6 008	85	800	S5 011	74	680	S4 008	70	640	S3 008
	03.06-05.06	BWD				85	800	S5 011	74	680	S4 008			
		BWD,SSJ	70	760	S6 008									
	11.08-07.10	BWD				85	800	S5 011	74	680	S4 008			
		BWD,SSJ	70	760	S6 008									
	11.08-11.10					85	800	S5 011	80	740	S4 011			
		SSJ	80	800	S6 011									
TDI [362]	08.10→	BWD,SSJ	70	760	S6 008									
		SSJ	70	760	S6 008									
	12.12→		70	760	S6 008									
TDI 4Motion [3C2]	03.05-08.10	BWD	70	760	S6 008	85	800	S5 011	74	680	S4 008	70	640	S3 008
	05.09-07.10	BWD				85	800	S5 011	74	680	S4 008			
		BWD,SSJ	70	760	S6 008									
TDI 4Motion [362]	08.10→	SSJ	70	760	S6 008									
2.5 TDI [3B2]	08.98-11.00		70	760	S6 008	85	800	S5 010	80	740	S4 011	70	640	S3 008
			70	760	S6 008	85	800	S5 011	74	680	S4 008	70	640	S3 008
			70	760	S6 008	85	800	S5 011	80	740	S4 011	70	640	S3 008
TDI [3B3]	10.00-05.05		70	760	S6 008	85	800	S5 011	74	680	S4 008	70	640	S3 008
Passat Alltrack														
2.0 TSI 4Motion [365]	01.12→	SSJ	70	760	S6 008									
Diesel														
2.0 TDI, TDI 4Motion [365]	01.12→	SSJ	70	760	S6 008									
Passat CC														
1.4 TSI [357]	01.11-05.12	BWD	70	760	S6 008									
1.8 TSI [357]	05.08-05.10	BWD				63	610	S5 005	60	540	S4 005	56	480	S3 005
	11.08-01.12	BWD	70	760	S6 008									
	11.08-05.12					63	610	S5 005	60	540	S4 005	56	480	S3 005
2.0 TSI [357]	05.08-05.12	BWD				85	800	S5 011	74	680	S4 008			
		BWD,SSJ	70	760	S6 008									
	11.10-05.12	BWD	70	760	S6 008									
3.6 FSI 4Motion [357]	08.08-05.12	BWD	70	760	S6 008	77	780	S5 008	74	680	S4 008	70	640	S3 008
Diesel														
2.0 TDI [357]	05.08-05.12	BWD				85	800	S5 011	74	680	S4 008			
						85	800	S5 011	74	680	S4 008	70	640	S3 008
		BWD,SSJ	70	760	S6 008									









			Ah A (EN) S6			Ah A (EN) S5			Ah A (EN) S4			Ah A (EN) S3		
			0092 ...0			0092 ...0			0092 ...0			0092 ...0		
◀ VW														
2.0 TDI [357]	05.09-11.10					85	800	S5 011	80	740	S4 011			
		SSJ	80	800	S6 011									
TDI 4Motion [357]	11.09-05.12	BWD				85	800	S5 011	74	680	S4 008			
		BWD,SSJ	70	760	S6 008									
Passat Variant														
1.3/1.6/1.8/2.0/2.2 [32B]	01.83-03.88	VAD				61	600	S5 004	44	440	S4 001	41	360	
1.4 TSI [3C5]	05.07-11.10		70	760	S6 008	77	780	S5 008	60	540	S4 005			
		SSJ	95	850	S6 013									
TSI [365]	08.10→	SSJ	70	760	S6 008									
	11.10→	BWD,SSJ	70	760	S6 008									
	11.12→		70	760	S6 008									
TSI EcoFuel [3C5]	11.08-11.10	BWD				63	610	S5 005	52	470	S4 002	45	400	
TSI EcoFuel [365]	09.10→	BWD,SSJ	70	760	S6 008									
1.6 [3B5]	01.97-11.00					63	610	S5 005	52	470	S4 002	45	400	
[3B6]	10.00-05.05					63	610	S5 005	52	470	S4 002	45	400	
[3C5]	08.05-11.10	BWD				63	610	S5 005	52	470	S4 002	45	400	
FSI [3C5]	08.05-06.08	BWD				63	610	S5 005	52	470	S4 002	45	400	
1.6/1.8 [315/35I/3A5]	04.88-03.97	VAD				61	600	S5 004	44	440	S4 001	41	360	
1.8 [3B5]	05.97-11.00		70	760	S6 008	85	800	S5 010	74	680	S4 008	70	640	
			70	760	S6 008	85	800	S5 010	80	740	S4 011	70	640	
[3B6]	10.00-05.05					77	780	S5 008	60	540	S4 005	70	640	
			70	760	S6 008	77	780	S5 008	60	540	S4 005	56	480	
		VAD	70	760	S6 008									
FSI [3C5]	11.09-11.10					77	780	S5 008	74	680	S4 008			
FSI [365]	08.10→	BWD,SSJ	70	760	S6 008									
G60 syncro [315/35I/3A5]	09.89-07.93	VAD				85	800	S5 010	72	680	S4 007	70	640	
syncro [3B5]	08.97-08.00		70	760	S6 008	85	800	S5 011	60	540	S4 005	70	640	
TSI [3C5]	05.07-11.10					77	780	S5 008	74	680	S4 008			
Turbo [3B5]	05.97-11.00		70	760	S6 008	85	800	S5 010	80	740	S4 011	70	640	
			70	760	S6 008	85	800	S5 011	74	680	S4 008	70	640	
			70	760	S6 008	85	800	S5 011	80	740	S4 011	70	640	
1.8/2.0 TSI [365]	11.10→	BWD,SSJ	70	760	S6 008									
1.8/2.0/2.2 syncro [32B]	08.84-03.88	VAD				85	800	S5 010	72	680	S4 007	70	640	
2.0 FSI [3C5]	08.05-11.10	BWD	70	760	S6 008	85	800	S5 011	60	540	S4 005	56	480	
FSI 4Motion [3C5]	09.05-11.10	BWD	70	760	S6 008	85	800	S5 011	60	540	S4 005	56	480	
TSI [3C5]	08.05-12.07		70	760	S6 008	85	800	S5 011	60	540	S4 005	56	480	
	08.05-11.10	BWD	70	760	S6 008	85	800	S5 011	60	540	S4 005	56	480	
	05.08-11.10					85	800	S5 011	74	680	S4 008			
		SSJ	70	760	S6 008									
2.0/2.3 [3B6]	10.00-05.05		70	760	S6 008	85	800	S5 011	60	540	S4 005	56	480	
2.0/2.3/2.8/4.0 4Motion [3B6]	10.00-05.05		70	760	S6 008	85	800	S5 011	60	540	S4 005	56	480	
2.0/2.8 [315/35I/3A5]	08.88-03.97	VAD				85	800	S5 010	72	680	S4 007	70	640	
2.0/2.9 syncro [315/35I/3A5]	10.90-03.97	VAD				85	800	S5 010	72	680	S4 007	70	640	
2.3 [3B5]	09.97-11.00		70	760	S6 008	85	800	S5 010	80	740	S4 011	70	640	
			70	760	S6 008	85	800	S5 011	74	680	S4 008	70	640	
			70	760	S6 008	85	800	S5 011	80	740	S4 011	70	640	
2.3/2.8 syncro [3B5]	01.97-08.00		70	760	S6 008	85	800	S5 011	74	680	S4 008	70	640	
2.8 [3B5]	06.97-11.00		70	760	S6 008	85	800	S5 010	80	740	S4 011	70	640	
			70	760	S6 008	85	800	S5 011	74	680	S4 008	70	640	
			70	760	S6 008	85	800	S5 011	80	740	S4 011	70	640	
	09.97-08.00					85	800	S5 011	80	740	S4 011			
[3B6]	10.00-05.05					77	780	S5 008	74	680	S4 008			
						77	780	S5 008	80	740	S4 011			
						85	800	S5 011	74	680	S4 008			
						85	800	S5 011	80	740	S4 011			
syncro [315/35I/3A5]	10.94-12.95		70	760	S6 008	85	800	S5 010	74	680	S4 008	70	640	
3.2 FSI 4Motion [3C5]	11.05-11.10	BWD	95	850	S6 013	85	800	S5 011	74	680	S4 008			
3.6 FSI [3C5]	09.05-11.10	BWD	70	760	S6 008	85	800	S5 011	74	680	S4 008			
FSI R36 4Motion [3C5]	04.07-11.10	BWD	95	850	S6 013	85	800	S5 011	74	680	S4 008			
FSI 4Motion [3C5]	09.05-11.10	BWD	70	760	S6 008	85	800	S5 011	74	680	S4 008			

				Ah	A (EN)		Ah	A (EN)		Ah	A (EN)		Ah	A (EN)	
				0 092 ...0			0 092 ...0			0 092 ...0			0 092 ...0		
3.6 V6 4Motion [365]	01.11→	BWD,SSJ	95	850	S6 013										
4.0 [3B6]	05.02-09.04					77	780	S5 008	80	740	S4 011				
						85	800	S5 011	74	680	S4 008				
						85	800	S5 011	80	740	S4 011				
Diesel															
1.6 D, TD [32B]	04.82-03.88	VAD								60	540	S4 004			
TDI [3C5]	08.09-11.10		70	760	S6 008	77	780	S5 008	60	540	S4 005				
TDI [365]	08.10→	SSJ	70	760	S6 008										
1.6/1.9 D, TD, TDI [315/35I/3A5]	08.88-03.97	VAD								60	540	S4 004			
1.9 TDI [3B5]	05.97-11.00		70	760	S6 008	85	800	S5 010	80	740	S4 011	70	640	S3 008	
			70	760	S6 008	85	800	S5 011	74	680	S4 008	70	640	S3 008	
			70	760	S6 008	85	800	S5 011	80	740	S4 011	70	640	S3 008	
TDI [3C5]	08.05-11.08	BWD				85	800	S5 011	74	680	S4 008	70	640	S3 008	
		BWD,SSJ	70	760	S6 008										
1.9/2.0/2.5 TDI, TDI 4Motion [3B6]	10.00-05.05		70	760	S6 008	85	800	S5 011	74	680	S4 008	70	640	S3 008	
1.9/2.5 TDI syncro [3B5]	06.97-08.00		70	760	S6 008	85	800	S5 011	74	680	S4 008	70	640	S3 008	
2.0 TDI [3C5]	08.05-06.08	BWD				85	800	S5 011	74	680	S4 008				
		BWD,SSJ	70	760	S6 008										
	08.05-11.10	BWD	70	760	S6 008	85	800	S5 011	74	680	S4 008	70	640	S3 008	
	03.06-05.06	BWD				77	780	S5 008	74	680	S4 008				
	11.08-11.10					85	800	S5 011	80	740	S4 011				
		BWD				77	780	S5 008	60	540	S4 005				
		BWD,SSJ	70	760	S6 008										
TDI [365]	08.10→	BWD,SSJ	70	760	S6 008										
		SSJ	70	760	S6 008										
	12.12→		70	760	S6 008										
TDI 4Motion [3C5]	08.05-11.10	BWD	70	760	S6 008	85	800	S5 011	74	680	S4 008	70	640	S3 008	
	05.09-11.10	BWD				85	800	S5 011	74	680	S4 008				
		BWD,SSJ	70	760	S6 008										
TDI 4Motion [365]	08.10→	SSJ	70	760	S6 008										
2.5 TDI [3B5]	08.98-11.00		70	760	S6 008	85	800	S5 010	80	740	S4 011	70	640	S3 008	
			70	760	S6 008	85	800	S5 011	74	680	S4 008	70	640	S3 008	
			70	760	S6 008	85	800	S5 011	80	740	S4 011	70	640	S3 008	
Phaeton															
3.2 [3D]	05.02-05.05		70	760	S6 008	77	780	S5 008	60	540	S4 005	70	640	S3 008	
3.2/4.2 4Motion [3D]	05.03→		70	760	S6 008	77	780	S5 008	60	540	S4 005	70	640	S3 008	
3.6 4Motion [3D]	11.08-05.10		70	760	S6 008	63	610	S5 005	60	540	S4 005				
	05.10→					63	610	S5 005	60	540	S4 005				
		SSJ	70	760	S6 008										
6.0 4Motion [3D]	05.02→		95	850	S6 013	77	780	S5 008	60	540	S4 005	70	640	S3 008	
Diesel															
3.0 TDI 4Motion [3D]	09.04-05.07		70	760	S6 008	77	780	S5 008	60	540	S4 005	70	640	S3 008	
	03.07-06.07		70	760	S6 008	63	610	S5 005	60	540	S4 005				
	06.07-10.08					77	780	S5 008	74	680	S4 008				
	06.08→		70	760	S6 008	63	610	S5 005	60	540	S4 005				
5.0 TDI 4Motion [3D]	11.02-10.06		95	850	S6 013	77	780	S5 008	60	540	S4 005	70	640	S3 008	
Polo															
1.0/1.3 [80; 86,87]	10.81-09.94	VAD				61	600	S5 004	44	440	S4 001	41	360	S3 001	
1.0/1.3/1.4/1.6 [6N1]	10.94-12.99	VAD				54	530	S5 002	52	470	S4 002	45	400	S3 002	
1.0/1.4/1.6 , 16V [6N2]	07.98-09.01					54	530	S5 002	52	470	S4 002	45	400	S3 002	
1.2 [6R1]	06.09→					54	530	S5 002	52	470	S4 002				
						77	780	S5 008	60	540	S4 005	45	400	S3 002	
TSI [6R1]	06.09→	BWD				63	610	S5 005	52	470	S4 002				
	05.11→					54	530	S5 002	52	470	S4 002				
1.2/1.4/1.6 [9N3]	04.05-12.09					63	610	S5 005	52	470	S4 002	45	400	S3 002	
1.2/1.4/1.6/2.0 , FSI [; 9N1; 9N2]	09.01-05.07					63	610	S5 005	52	470	S4 002	45	400	S3 002	
1.4 [6R1]	06.09→	BWD				63	610	S5 005	52	470	S4 002				
	02.10→					63	610	S5 005	52	470	S4 002				
BiFuel [6R1]	03.10-01.11	BWD				54	530	S5 002	52	470	S4 002				
FSI [9N3]	04.05-07.06					63	610	S5 005	52	470	S4 002				

			Ah A (EN) S6			Ah A (EN) S5			Ah A (EN) S4			Ah A (EN) S3		
			0092 ...0			0092 ...0			0092 ...0			0092 ...0		
VW														
1.4 GTI [6R1]	05.10-09.12	BWD				63	610	\$5 005	60	540	\$4 005			
	09.12→					63	610	\$5 005	52	470	\$4 002			
TSI ACT [6R1]	10.12→					63	610	\$5 005	52	470	\$4 002			
1.6 BiFuel [6R1]	01.11→	BWD				63	610	\$5 005	60	540	\$4 005			
1.8 GTI [9N3]	09.05-11.09		70	760	\$6 008	77	780	\$5 008	60	540	\$4 005	70	640	\$3 008
Diesel														
1.2 TDI [6R1]	10.09→	BWD				63	610	\$5 005	52	470	\$4 002			
		BWD,KZO,SSJ	60	680	\$6 005									
		BWD,KZO,SSJ	70	760	\$6 008									
1.3 D [86,87]	08.86-08.90	VAD				61	600	\$5 004	44	440	\$4 001	41	360	\$3 001
1.4 D [80]	10.90-09.94	VAD				74	750	\$5 007	60	540	\$4 004			
		VAD,XXX										53	470	\$3 004
TDI [6N2]	10.99-09.01		70	760	\$6 008	77	780	\$5 008	60	540	\$4 005			
TDI [9N1; 9N2; 9N3]	09.01-12.09		70	760	\$6 008	77	780	\$5 008	60	540	\$4 005	70	640	\$3 008
1.6 TDI [6R1]	06.09→	BWD				77	780	\$5 008	60	540	\$4 005			
		BWD,KZO,SSJ	60	680	\$6 005									
		BWD,KZO,SSJ	70	760	\$6 008									
		BWD,SSJ	70	760	\$6 008									
		SSJ	70	760	\$6 008									
1.7 SDI [6N2]	10.99-09.01		70	760	\$6 008	77	780	\$5 008	74	680	\$4 008	70	640	\$3 008
1.7/ 1.9 D, SDI [6N1]	10.94-12.99	VAD	70	760	\$6 008	77	780	\$5 008	60	540	\$4 005			
1.9 D [6N2]	10.99-09.01		70	760	\$6 008	77	780	\$5 008	74	680	\$4 008	70	640	\$3 008
SDI [6N2]	10.99-09.01		70	760	\$6 008	77	780	\$5 008	60	540	\$4 005			
SDI [9N1]	09.01-05.05		70	760	\$6 008	77	780	\$5 008	74	680	\$4 008	70	640	\$3 008
SDI [9N2]	11.03-05.07		70	760	\$6 008	77	780	\$5 008	74	680	\$4 008	70	640	\$3 008
SDI [9N3]	04.05-12.09					77	780	\$5 008	74	680	\$4 008			
TDI [9N1]	09.01-05.05					77	780	\$5 008	74	680	\$4 008			
TDI [9N2]	07.03-05.07					77	780	\$5 008	74	680	\$4 008			
TDI [9N3]	04.05-12.09					77	780	\$5 008	74	680	\$4 008			
			70	760	\$6 008	77	780	\$5 008	74	680	\$4 008	70	640	\$3 008
Polo Classic														
1.0/ 1.3 [80]	10.90-09.94	VAD				61	600	\$5 004	44	440	\$4 001	41	360	\$3 001
[86,87]	10.81-08.90	VAD				61	600	\$5 004	44	440	\$4 001	41	360	\$3 001
1.4 [6V2]	05.96-08.99	VAD				54	530	\$5 002	52	470	\$4 002	45	400	\$3 002
	10.99-09.01	VAD				54	530	\$5 002	52	470	\$4 002	45	400	\$3 002
1.6 [6V2]	11.95-09.01	VAD				54	530	\$5 002	52	470	\$4 002	45	400	\$3 002
	10.99-09.01	VAD				54	530	\$5 002	44	440	\$4 001	41	360	\$3 001
1.8 [6V2]	03.98-09.01	VAD				54	530	\$5 002	52	470	\$4 002	45	400	\$3 002
2.0 [6V2]	08.99-09.01	SSJ,VAD	70	760	\$6 008									
		VAD				77	780	\$5 008	52	470	\$4 002	45	400	\$3 002
Diesel														
1.3 D [86,87]	08.86-08.90	VAD				61	600	\$5 004	44	440	\$4 001	41	360	\$3 001
1.4 D [80]	10.90-09.94	VAD				61	600	\$5 004	44	440	\$4 001	41	360	\$3 001
1.7 SDI [6V2]	11.97-08.99	VAD	70	760	\$6 008	77	780	\$5 008	60	540	\$4 005	70	640	\$3 008
1.9 D [6V2]	01.96-04.96	VAD	70	760	\$6 008	77	780	\$5 008	60	540	\$4 005			
SDI [6V2]	12.95-08.99	VAD	70	760	\$6 008	77	780	\$5 008	60	540	\$4 005			
	10.99-09.01	VAD	70	760	\$6 008	77	780	\$5 008	60	540	\$4 005	70	640	\$3 008
TDI [6V2]	07.96-08.99	VAD	70	760	\$6 008	77	780	\$5 008	60	540	\$4 005			
	11.97-08.99	VAD	70	760	\$6 008	77	780	\$5 008	60	540	\$4 005	70	640	\$3 008
	08.98-08.99	VAD	70	760	\$6 008	77	780	\$5 008	60	540	\$4 005	56	480	\$3 005
	10.99-09.01	VAD	70	760	\$6 008	77	780	\$5 008	60	540	\$4 005	56	480	\$3 005
			70	760	\$6 008	77	780	\$5 008	60	540	\$4 005	70	640	\$3 008
Polo Coupé														
1.0/ 1.3, G40 [80]	10.90-09.94	VAD				61	600	\$5 004	44	440	\$4 001	41	360	\$3 001
, G40 [86,87]	10.81-08.90	VAD				61	600	\$5 004	44	440	\$4 001	41	360	\$3 001
Diesel														
1.3 D [86,87]	08.86-08.90								60	540	\$4 004			
1.4 D [80]	10.90-09.94	VAD				74	750	\$5 007	60	540	\$4 004			
		VAD,XXX										53	470	\$3 004
Polo Hatchback														
1.4 i	04.02→					63	610	\$5 005	60	540	\$4 005			
Polo Sedan														
1.6 [612]	09.10→					54	530	\$5 002	52	470	\$4 002			



Diesel			0 092 ...0		0 092 ...0		0 092 ...0		0 092 ...0					
1.9 TDI	11.02-07.06		70	760	S6 008	77	780	S5 008	74	680	S4 008	70	640	S3 008
Polo Variant														
1.4 [6V5]	05.97-08.99					54	530	S5 002	52	470	S4 002	45	400	S3 002
	01.98-08.99					54	530	S5 002	52	470	S4 002			
	10.99-06.00					54	530	S5 002	52	470	S4 002	45	400	S3 002
	10.99-09.01					54	530	S5 002	52	470	S4 002			
1.6 [6V5]	05.97-08.99	VAD				63	610	S5 005	52	470	S4 002	45	400	S3 002
	09.97-09.01	VAD				54	530	S5 002	52	470	S4 002	45	400	S3 002
	10.99-09.01	VAD				63	610	S5 005	52	470	S4 002	45	400	S3 002
Diesel														
1.7 SDI [6V5]	11.97-08.99	VAD	70	760	S6 008	77	780	S5 008	60	540	S4 005	70	640	S3 008
1.9 SDI [6V5]	06.97-08.99	VAD	70	760	S6 008	77	780	S5 008	60	540	S4 005	70	640	S3 008
	10.99-09.01	VAD	70	760	S6 008	77	780	S5 008	60	540	S4 005	70	640	S3 008
TDI [6V5]	06.97-08.99	VAD	70	760	S6 008	77	780	S5 008	60	540	S4 005	70	640	S3 008
	10.99-09.01	VAD	70	760	S6 008	77	780	S5 008	60	540	S4 005	70	640	S3 008
Quantum														
2.2	08.84-03.88								72	680	S4 007	70	640	S3 007
Diesel														
1.6 D Turbo	07.82-07.85								72	680	S4 007	70	640	S3 007
Quantum Station Wagon														
1.8/ 2.2 , 4Motion	09.83-07.88								72	680	S4 007	70	640	S3 007
Santana														
1.8/ 2.0 [32]	06.85-03.88	VAD				61	600	S5 004	44	440	S4 001	41	360	S3 001
Diesel														
1.6 D, D Turbo [32]	06.85-03.88	VAD							60	540	S4 004			
Scirocco														
1.4 TSI [137]	08.08→					63	610	S5 005	60	540	S4 005			
	11.08→	SSJ	70	760	S6 008									
1.6/ 1.8 , 16V [53B]	08.82-07.92	VAD				61	600	S5 004	44	440	S4 001	41	360	S3 001
2.0 TSI [137]	08.08→					77	780	S5 008	74	680	S4 008			
	11.09→					63	610	S5 005	60	540	S4 005			
Diesel														
2.0 TDI [137]	10.08→	BWD				85	800	S5 011	74	680	S4 008			
	11.10→		70	760	S6 008	63	610	S5 005	60	540	S4 005			
Sharan														
1.4 TSI [7N1]	05.10-06.12	BWD,SSJ	70	760	S6 008									
			80	800	S6 011									
	10.11→	SSJ	70	760	S6 008									
	05.12→	SSJ	80	800	S6 011									
1.8 T [7M8]	11.97-02.00	VAD	70	760	S6 008	77	780	S5 008	60	540	S4 005	56	480	S3 005
T [7M9, 7M6]	05.00-03.10		70	760	S6 008	77	780	S5 008	60	540	S4 005	56	480	S3 005
2.0 [7M8]	09.95-02.00	VAD	70	760	S6 008	77	780	S5 008	60	540	S4 005	56	480	S3 005
[7M9, 7M6]	05.00-03.10		70	760	S6 008	77	780	S5 008	60	540	S4 005	56	480	S3 005
TSI [7N1]	11.10→	BWD				77	780	S5 008	60	540	S4 005			
2.8 [7M8]	09.95-02.00	VAD	70	760	S6 008	100	830	S5 013	80	740	S4 010	70	640	S3 008
[7M9, 7M6]	05.00-03.10		70	760	S6 008	77	780	S5 008	74	680	S4 008	70	640	S3 008
syncro [7M8]	07.96-02.00	VAD	70	760	S6 008	100	830	S5 013	80	740	S4 010	70	640	S3 008
4Motion [7M9, 7M6]	05.00-03.10		70	760	S6 008	77	780	S5 008	74	680	S4 008	70	640	S3 008
Diesel														
1.9 TDI [7M8]	09.95-02.00					85	800	S5 011	80	740	S4 011			
		VAD	70	760	S6 008	100	830	S5 013	74	680	S4 008			
	03.99-02.00		95	850	S6 013	100	830	S5 013	80	740	S4 010	90	720	S3 013
TDI [7M9, 7M6]	04.00-03.10		95	850	S6 013	100	830	S5 013	80	740	S4 010	90	720	S3 013
	05.00-03.10		95	850	S6 013	100	830	S5 013	80	740	S4 010	70	640	S3 008
TDI 4Motion [7M9, 7M6]	05.00-03.10		95	850	S6 013	100	830	S5 013	80	740	S4 010	70	640	S3 008
2.0 TDI [7M9, 7M6]	11.05-03.10		70	760	S6 008	85	800	S5 011	74	680	S4 008			
			70	760	S6 008	85	800	S5 011	80	740	S4 011			
			70	760	S6 008	100	830	S5 013	80	740	S4 011			
			95	850	S6 013	100	830	S5 013	80	740	S4 010	90	720	S3 013
TDI [7N1]	05.10→	BWD,SSJ	70	760	S6 008									
			80	800	S6 011									
	05.11→	SSJ	70	760	S6 008									

				Ah	A (EN)		Ah	A (EN)		Ah	A (EN)		Ah	A (EN)	
				0092 ...0			0092 ...0			0092 ...0			0092 ...0		
◀ VW															
2.0 TDI 4Motion [7N1]	05.10→	BWD,SSJ	70	760	S6 008										
Taro															
1.8/ 2.2/ 2.4 , 4x4 [7A]	04.89-03.97						60	540	S4 025						
Diesel															
2.4 D, D 4x4 [7A]	04.89-03.97						70	630	S4 027						
Tiguan															
1.4 TSI [5N1]	05.08-05.11	BWD,SSJ	70	760	S6 008										
	08.10-05.11	SSJ	70	760	S6 008										
TSI [5N2]	05.11→	BWD,SSJ	70	760	S6 008										
	09.12→	SSJ	70	760	S6 008										
TSI 4Motion [5N1]	11.07-11.08					63	610	S5 005	60	540	S4 005	56	480	S3 005	
	03.08-05.11	SSJ	70	760	S6 008										
TSI 4Motion [5N2]	05.11-09.12	BWD				63	610	S5 005	60	540	S4 005	56	480	S3 005	
			70	760	S6 008										
	09.12→					63	610	S5 005	60	540	S4 005	56	480	S3 005	
			70	760	S6 008										
2.0 FSI 4Motion [5N1]	11.07-05.11					63	610	S5 005	60	540	S4 005	56	480	S3 005	
TSI [5N1]	03.08-05.11					77	780	S5 008	74	680	S4 008				
TSI 4Motion [5N1]	11.07-05.11					63	610	S5 005	60	540	S4 005	56	480	S3 005	
TSI 4Motion [5N2]	05.11→	BWD				63	610	S5 005	60	540	S4 005	56	480	S3 005	
						63	610	S5 005	60	540	S4 005	56	480	S3 005	
Diesel															
2.0 TDI [5N1]	03.08-05.11	SSJ	70	760	S6 008										
			80	800	S6 011										
TDI [5N2]	05.11→	BWD,SSJ	70	760	S6 008										
			80	800	S6 011										
TDI 4Motion [5N1]	11.07-05.11					77	780	S5 008	74	680	S4 008	70	640	S3 008	
		SSJ	80	800	S6 011										
	03.08-05.11					77	780	S5 008	74	680	S4 008				
TDI 4Motion [5N2]	05.11→	BWD	70	760	S6 008	77	780	S5 008	74	680	S4 008	70	640	S3 008	
	11.12→		70	760	S6 008										
Touareg															
3.0 FSI Hybrid [7P5]	03.10→	BWD				77	780	S5 008							
3.2 [7LA]	11.02-11.06		70	760	S6 008	100	830	S5 013	74	680	S4 008				
	09.03-11.06		70	760	S6 008	77	780	S5 008	74	680	S4 008	70	640	S3 008	
3.6 FSI [7LA]	08.05-11.06		70	760	S6 008	100	830	S5 013	74	680	S4 008				
	10.05-11.06		70	760	S6 008	77	780	S5 008	74	680	S4 008	70	640	S3 008	
FSI [7L6]	12.06-05.10		70	760	S6 008	100	830	S5 013	74	680	S4 008				
FSI [7P5]	04.10→	BWD	95	850	S6 013										
	08.10→	BWD	95	850	S6 013	100	830	S5 013							
4.2 FSI [7LA]	06.06-11.06		95	850	S6 013	100	830	S5 013	95	800	S4 013	90	720	S3 013	
FSI [7L6]	12.06-05.10		95	850	S6 013	100	830	S5 013	95	800	S4 013	90	720	S3 013	
FSI [7P5]	01.11→	BWD	95	850	S6 013	100	830	S5 013							
4.2/ 6.0 [7LA]	12.02-11.06		95	850	S6 013	100	830	S5 013	95	800	S4 013				
6.0 [7L6]	12.06-05.10		95	850	S6 013	100	830	S5 013	95	800	S4 013				
Diesel															
2.5 TDI [7LA]	01.03-11.06		70	760	S6 008	100	830	S5 013	74	680	S4 008				
	07.03-11.06		70	760	S6 008	77	780	S5 008	74	680	S4 008	70	640	S3 008	
	01.06-11.06		95	850	S6 013	100	830	S5 013	74	680	S4 008				
TDI [7L6]	12.06-05.10		95	850	S6 013	100	830	S5 013	74	680	S4 008				
3.0 TDI [7LA]	11.04-11.06		70	760	S6 008	100	830	S5 013	74	680	S4 008				
	04.06-11.06		95	850	S6 013	100	830	S5 013	74	680	S4 008				
TDI [7L6]	12.06-05.08		70	760	S6 008	100	830	S5 013	74	680	S4 008				
	12.06-05.10		95	850	S6 013	100	830	S5 013	74	680	S4 008				
	11.07-05.10		70	760	S6 008	77	780	S5 008	74	680	S4 008	70	640	S3 008	
TDI [7P5]	01.10-05.11	BWD,SSJ	80	800	S6 011										
			95	850	S6 013										
			105	950	S6 015										
	11.10→	BWD	95	850	S6 013										
4.2 TDI [7P5]	01.10→	BWD				110	920	S5 015							
5.0 TDI [7LA; 7L6]	11.02-05.10		95	850	S6 013	100	830	S5 013	95	800	S4 013				
Touran															
1.2 TSI [1T3]	05.10→	SSJ	70	760	S6 008										

						Ah A (EN) S6		Ah A (EN) S5		Ah A (EN) S4		Ah A (EN) S3				
				0 092 ...0		0 092 ...0		0 092 ...0		0 092 ...0		0 092 ...0				
1.4 TSI [1T3]	05.10-09.12	BWD			54	530	S5 002	52	470	S4 002						
	09.12→				54	530	S5 002	52	470	S4 002						
	TSI EcoFuel [1T3]	05.10→	BWD		54	530	S5 002	52	470	S4 002						
TSI, TSI EcoFuel [1T1; 1T2]	02.06-05.10				63	610	S5 005	52	470	S4 002	45	400	S3 002			
1.6 [1T1; 1T2]	07.03-05.10				63	610	S5 005	52	470	S4 002	45	400	S3 002			
	FSI [1T1; 1T2]	02.03-01.07			63	610	S5 005	52	470	S4 002	45	400	S3 002			
2.0 EcoFuel [1T1; 1T2]	02.06-05.10				63	610	S5 005	60	540	S4 005						
	FSI [1T1; 1T2]	10.03-01.07			63	610	S5 005	60	540	S4 005						
Diesel																
1.6 TDI [1T3]	05.10→	BWD			63	610	S5 005	60	540	S4 005						
		SSJ	70	760	S6 008											
1.9 TDI [1T1]	02.03-11.06				70	760	S6 008	100	830	S5 013	74	680	S4 008			
1.9/2.0 TDI [1T2]	11.06-05.10				70	760	S6 008	100	830	S5 013	74	680	S4 008			
2.0 TDI [1T1]	02.03-11.06				70	760	S6 008	100	830	S5 013	74	680	S4 008			
	11.05-11.06				70	760	S6 008	77	780	S5 008	74	680	S4 008			
TDI [1T3]	05.10→	BWD			77	780	S5 008	74	680	S4 008						
Transporter T3																
1.9/2.1 [24, 25]	08.82-07.92	VAD			61	600	S5 004	44	440	S4 001	41	360	S3 001			
		Syncro [24, 25]	02.85-07.92	VAD	70	760	S6 008	100	830	S5 013	80	740	S4 010	70	640	S3 008
Diesel																
1.6/1.7 D, D Turbo, D Turbo Syncro [24, 25]	01.81-07.92	VAD						60	540	S4 004						
Transporter T4																
1.8 [70, 7D]	12.90-07.92	VAD			63	610	S5 005	52	470	S4 002	45	400	S3 002			
2.0 [70, 7D]	09.90-06.03				63	610	S5 005	52	470	S4 002	45	400	S3 002			
2.5 [70, 7D]	11.90-06.03	VAD			63	610	S5 005	52	470	S4 002	45	400	S3 002			
	05.99-12.99				100	830	S5 013	72	680	S4 007	70	640	S3 008			
	05.99-06.03				63	610	S5 005	52	470	S4 002	45	400	S3 002			
	12.99-06.03				100	830	S5 013	52	470	S4 002	45	400	S3 002			
	Syncro [70, 7D]	11.92-04.99	VAD			63	610	S5 005	52	470	S4 002	45	400	S3 002		
	06.97-06.03				100	830	S5 013	74	680	S4 008	70	640	S3 008			
	05.99-06.03				63	610	S5 005	52	470	S4 002	45	400	S3 002			
2.8 [70, 7D]	01.96-05.00	VAD			63	610	S5 005	52	470	S4 002	45	400	S3 002			
	05.00-06.03	VAD			100	830	S5 013	74	680	S4 008	70	640	S3 008			
Diesel																
1.9 D [70, 7D]	09.90-04.97	VAD	70	760	S6 008	100	830	S5 013	80	740	S4 010	70	640	S3 008		
	D Turbo [70, 7D]	10.92-04.99	VAD	70	760	S6 008	100	830	S5 013	80	740	S4 010	70	640	S3 008	
		05.99-06.03		70	760	S6 008	100	830	S5 013	74	680	S4 008				
2.4 D [70, 7D]	09.90-05.98				100	830	S5 013	74	680	S4 008	70	640	S3 007			
	05.97-06.03				100	830	S5 013	74	680	S4 008	70	640	S3 008			
	D Syncro [70, 7D]	11.92-09.98	VAD	70	760	S6 008	100	830	S5 013	80	740	S4 010	70	640	S3 008	
2.5 TDI [70, 7D]	01.95-06.03				85	800	S5 011	80	740	S4 011						
		VAD	95	850	S6 013	100	830	S5 013	80	740	S4 010					
	05.98-09.00	VAD	70	760	S6 008	100	830	S5 013	74	680	S4 008	70	640	S3 008		
	05.98-06.03		70	760	S6 008	100	830	S5 013	74	680	S4 008	70	640	S3 008		
	05.99-06.03	VAD				100	830	S5 013	74	680	S4 008	70	640	S3 008		
	04.01-06.03	VAD	70	760	S6 008	100	830	S5 013	74	680	S4 008	70	640	S3 008		
TDI Syncro [70, 7D]	03.98-06.03	VAD	70	760	S6 008	100	830	S5 013	74	680	S4 008	70	640	S3 008		
Transporter T5																
2.0 [7E]	09.09→		95	850	S6 013	100	830	S5 013	60	540	S4 005	56	480	S3 005		
	[7F]	09.09-05.13			95	850	S6 013	100	830	S5 013	60	540	S4 005	56	480	S3 005
	[7H]	06.03-11.09			95	850	S6 013	100	830	S5 013	60	540	S4 005	56	480	S3 005
	TSI [7E]	05.11→				63	610	S5 005	60	540	S4 005					
		07.12→		95	850	S6 013	100	830	S5 013	95	800	S4 013				
	TSI [7F]	07.12→		95	850	S6 013	100	830	S5 013	95	800	S4 013				
TSI 4Motion [7E]	07.11→				63	610	S5 005	60	540	S4 005						
2.0/3.2, 4Motion [7J]	06.03-11.09		95	850	S6 013	100	830	S5 013	60	540	S4 005	56	480	S3 005		
3.2 [7H]	02.03-11.09		95	850	S6 013	100	830	S5 013	60	540	S4 005	56	480	S3 005		
	05.08-11.09				85	800	S5 011	80	740	S4 011						
	4Motion [7H]	07.04-11.09		95	850	S6 013	100	830	S5 013	60	540	S4 005	56	480	S3 005	
Diesel																
1.9 TDI [7H]	04.03-11.09		95	850	S6 013	100	830	S5 013	80	740	S4 010					

			Ah A (EN) S6			Ah A (EN) S5			Ah A (EN) S4			Ah A (EN) S3		
			0092 ...0			0092 ...0			0092 ...0			0092 ...0		
◀ VW														
1.9/ 2.5 TDI, TDI 4Motion [7J]	04.03-11.09		95	850	S6 013	100	830	S5 013	80	740	S4 010			
2.0 TDI [7E]	09.09→		95	850	S6 013	100	830	S5 013	80	740	S4 010			
	06.10→					85	800	S5 011	80	740	S4 011			
	05.11→		70	760	S6 008									
TDI [7F]	09.09→		95	850	S6 013	100	830	S5 013	80	740	S4 010			
	06.10→					85	800	S5 011	80	740	S4 011			
TDI 4Motion [7E]	09.09→		95	850	S6 013	100	830	S5 013	80	740	S4 010			
	06.10→					85	800	S5 011	80	740	S4 011			
TDI 4Motion [7F]	09.09→		95	850	S6 013	100	830	S5 013	80	740	S4 010			
	06.10→					85	800	S5 011	80	740	S4 011			
2.5 TDI [7H]	02.03-11.09		95	850	S6 013	100	830	S5 013	80	740	S4 010			
	11.03-11.09		95	850	S6 013	100	830	S5 013	60	540	S4 005	56	480	S3 005
TDI 4Motion [7H]	07.04-11.09		95	850	S6 013	100	830	S5 013	80	740	S4 010			
up!														
1.0 [121]	12.11→	BWD										40	340	S3 000
		BWD,XXX							42	390	S4 000			
	11.12→											40	340	S3 000
		XXX							42	390	S4 000			
Vento														
1.4/ 1.6 [1H2]	11.91-12.97	VAD				63	610	S5 005	60	540	S4 005	45	400	S3 002
1.8/ 2.0/ 2.8 [1H2]	11.91-12.97	VAD	70	760	S6 008	77	780	S5 008	60	540	S4 005	56	480	S3 005
Diesel														
1.9 D, SDI, TD [1H2]	11.91-12.97	VAD	70	760	S6 008	100	830	S5 013	80	740	S4 010	70	640	S3 008
TDI [1H2]	09.93-12.97	VAD	70	760	S6 008	100	830	S5 013	80	740	S4 010	70	640	S3 008
	05.97-12.97	VAD				100	830	S5 013	74	680	S4 008	70	640	S3 008

WARTBURG

Wartburg														
1.3/ 353 , W, 1.3	07.71-05.91					52	520	S5 001	44	440	S4 001	41	360	S3 001

ZASTAVA (YUGO)

Florida														
1.3/ 1.4/ 1.6	10.88-06.95					63	610	S5 006	60	540	S4 006	56	480	S3 006
Yugo														
45/ 55/ 60/ 65 , i.e.	04.80-12.93					63	610	S5 006	60	540	S4 006	56	480	S3 006
Yugo Cabrio														
1.3 i.e.	07.89-12.93					63	610	S5 006	60	540	S4 006	56	480	S3 006
Yugo Koral														
1.1 iL	05.03-11.08								52	470	S4 002			
Yugo Van														
45	04.80-12.93					63	610	S5 006	60	540	S4 006	56	480	S3 006
101														
1100/ 1300	06.72-12.93					63	610	S5 006	60	540	S4 006	56	480	S3 006

ZAZ

Lanos														
1.4 i	01.07→					63	610	S5 006	60	540	S4 006			
Sens														
1.3 Si [TF698]	01.02→					63	610	S5 005	60	540	S4 006	56	480	S3 006
1102 Tawrija														
1.1/ 1.3 i	06.90→					63	610	S5 006	60	540	S4 006	45	400	S3 003

			Ah A (EN)	Ah A (EN)	Ah A (EN)
			0 092 ...0	0 092 ...0	0 092 ...0

AUWÄRTER (EA)

Eurostar								
SHD 0 404	01.80→	ZE	180	1000	T5 077	170	1000	T4 077
Teamstar								
City/ Kombi	01.80→	ZE	180	1000	T5 077	170	1000	T4 077
813								
-42	01.73→	ZE	180	1000	T5 077	170	1000	T4 077
913								
-47	01.73→	ZE	180	1000	T5 077	170	1000	T4 077

AWD

TL									
	01.88→	ZE					125	720	T3 040

BEDFORD

Serie CF									
2 /230, /250, /280, /350	05.84-07.87						90	540	T3 031
Serie T									
L 750, 860	08.80-11.86						125	720	T3 040

CITROEN

C									
25/ 35/ 45 1.9D, 1.9D Turbo, 2.5 D, 2.5 D Turbo	01.80-03.94						88	680	T3 013
Jumper									
1.9/ 2.5/ 2.8 D, D Turbo, TDi [23]	02.94-02.02						88	680	T3 013

DAF

CF											
65/ 75/ 85 .180, .220, .240, .250, .280, .290, .300, .310, .320, .340, .360, .380, .410, .430, .460, .510	10.97→	ZE	180	1000	T5 077	170	1000	T4 077			
F..											
600/ 1000 , CB	12.86-12.93	ZE					110	680	T3 035		
800 CBS, CN	12.86-08.91						110	680	T3 035		
900 DF	11.81-11.88						110	680	T3 035		
1100 DNTD	12.86-11.89		145	800	T5 075	140	800	T4 075	120	680	T3 075
1300/ 1500/ 1600 DF	01.70-08.91	ZE	145	800	T5 075	140	800	T4 075	120	680	T3 075
1300/ 1500/ 1600/ 1800 DT	01.70-08.91	ZE	145	800	T5 075	140	800	T4 075	120	680	T3 075
1300/ 1700 DNT	12.86-02.95	ZE	145	800	T5 075	140	800	T4 075	120	680	T3 075
DNTD	12.86-02.89	ZE	145	800	T5 075	140	800	T4 075	120	680	T3 075
1700 DNS	01.88-02.95	ZE	145	800	T5 075	140	800	T4 075	120	680	T3 075
1900 DNS	12.86-09.93	ZE	180	1000	T5 077	170	1000	T4 077			
DNT	12.86-09.93	ZE	180	1000	T5 077	170	1000	T4 077			





◀ DAF 0092 ...0 0092 ...0 0092 ...0

2100/ 2103/ 2105/ 2300/ 2303/ 2305/ 2500/ 2505/ 2525/ 2535/ 2800/ 2803/ 2805/ 3300/ 3305/ 3325/ 3600 DH, DHR, DHS, DHT, DHTD, DHU, DKS, DKSE, DKTD, DKV, DKX, DKX ATi, DKXE ATi, DKZ ATi	01.74-09.91	ZE	180	1000	T5 077	170	1000	T4 077		
---	-------------	----	-----	------	---------------	-----	------	---------------	--	--

2105 DF	07.78-08.91	ZE	180	1000	T5 077	170	1000	T4 077		
----------------	-------------	----	-----	------	---------------	-----	------	---------------	--	--

2300/ 2700/ 2900/ 3200 HS ATi, HT, KS ATi, KV ATi	01.90-12.93	ZE	180	1000	T5 077	170	1000	T4 077		
--	-------------	----	-----	------	---------------	-----	------	---------------	--	--

LF											
45 .150, .170	04.01-12.07	ZE							110	680	T3 035
.180	07.01-12.08	ZE							110	680	T3 035
.220	11.01-01.09	ZE							110	680	T3 035
55 .180	04.01-08.08	ZE							125	720	T3 040
.220	04.01-08.08	ZE							125	720	T3 040
.250	04.01-08.08	ZE							125	720	T3 040

MB											
200 DKDL	01.70-07.90	ZE	180	1000	T5 077	170	1000	T4 077	200	1050	T3 080

N..											
2826 DKA, DKS, DKTD	10.80-09.91	ZE	225	1150	T5 080	215	1150	T4 080	200	1050	T3 080

SB											
201/ 2005 DH, DKDL	01.74-12.93	ZE	225	1150	T5 080	215	1150	T4 080	200	1050	T3 080

XF										
95 .380	01.97-04.03	ZE	180	1000	T5 077	170	1000	T4 077		
.430	01.97-08.03	ZE	180	1000	T5 077	170	1000	T4 077		
.480	01.97-09.03	ZE	180	1000	T5 077	170	1000	T4 077		
.530	01.97-09.03	ZE	180	1000	T5 077	170	1000	T4 077		
105 .410	01.06→	ZE	180	1000	T5 077	170	1000	T4 077		
.460	01.06→	ZE	180	1000	T5 077	170	1000	T4 077		
.510	01.06→	ZE	180	1000	T5 077	170	1000	T4 077		

45											
.130/ .150/ .160/ .180/ .210 , Turbo	05.91-04.01	ZE							110	680	T3 035

55											
.180 Ti	11.95-12.97								125	720	T3 040
.180/ .210/ .230	08.95-12.02	ZE							125	720	T3 040
.210 Ti	11.95-12.97	ZE							125	720	T3 040

65											
.180 ATi	01.93-08.98	ZE	145	800	T5 075	140	800	T4 075	120	680	T3 075
.210 ATi	01.93-12.96	ZE	145	800	T5 075	140	800	T4 075	120	680	T3 075
	01.93-04.02	ZE	180	1000	T5 077	170	1000	T4 077			
.240 ATi	03.96-08.98	ZE	145	800	T5 075	140	800	T4 075	120	680	T3 075

75										
.240/ .270/ .300 ATi	01.92-04.02	ZE	180	1000	T5 077	140	800	T4 075		

85										
.330/ .360/ .400 ATi	02.90-12.99	ZE	180	1000	T5 077	170	1000	T4 077		

95										
.310/ .330/ .350/ .360/ .380/ .400/ .430/ .500 , ATi	01.87-12.98	ZE	180	1000	T5 077	170	1000	T4 077		

DODGE

50											
	04.79-10.86								125	720	T3 040

			Ah A (EN) T5	Ah A (EN) T4	Ah A (EN) T3
			0 092 ...0	0 092 ...0	0 092 ...0

EBRO (MISA)

L											
35/ 45/ 60/ 80 , , F, S, SF, .08, .09	07.79-06.90								125	720	T3 040
Trade											
2.0/ 2.8	09.84-02.87								66	510	T3 008
100											
/8 D	04.84-05.87	ZE							88	680	T3 013

ERF

C											
31 R 4	10.81-10.89	ZE							125	720	T3 041

FIAT

Ducato 11											
2.8 JTD, JTD EGR, TD, TD EGR [244..]	04.02-08.06								88	680	T3 013
Ducato 15											
2.8 JTD, JTD EGR, TD, TD EGR [244..]	04.02-08.06								88	680	T3 013
Ducato 18											
2.8 JTD, JTD CGV, JTD EGR, TD [244..]	04.02-08.06								88	680	T3 013
242											
E	11.79-05.85								88	680	T3 013

GINAF

Serie X											
X21../ X22../ X31../ X32../ X33../ X42../ X4345/ X4446/ X4449/ X5250/ X5350/ X5450/ X5460 , B, /S/B, TS, TS/TSV	07.99→	ZE	180	1000	T5 077	170	1000	T4 077	155	900	T3 077

HINO

FS											
/ 275 , KA	05.85→	ZE	180	1000	T5 077	170	1000	T4 077			

IFA

Multicar											
M 24	01.75-12.90	ZE	145	800	T5 075	140	800	T4 075	120	680	T3 075

IKARUS

Serie 400											
405	01.94→	ZE	225	1150	T5 080	170	1000	T4 077	155	900	T3 077



			Ah A (EN) T5	Ah A (EN) T4	Ah A (EN) T3
			0092 ...0	0092 ...0	0092 ...0

IVECO

A						
55 -13	12.79-12.88	ZE			66	510 T3 008
55/ 60/ 70 -10, -12	11.79-06.88	ZE			66	510 T3 008
55/ 70/ 79 -14	05.88-12.92	ZE			66	510 T3 008
60 -9	09.88-12.92	ZE			66	510 T3 008
90 -13	01.83-01.85	ZE			110	760 T3 038
-14	05.88-06.91	ZE			110	760 T3 038
AP 160						
	12.82-12.86	ZE	140	800 T4 076	110	760 T3 038
Daily						
A40/ A45/ A49/ 30/ 35/ 40/ 45/ 49/ 59 -8, -10, -10 Turbo, -10 Turbo I.D., -10 Turbo 4x4, -12 Turbo [; 96]	07.89-05.99				88	680 T3 013
29 L 9 [00]	05.99-09.02				110	680 T3 035
11 [00]	05.99-09.02				110	680 T3 035
29 L/ 35 C/ 35 S 10 [00]	09.02-03.06				110	680 T3 035
12 [00]	09.02-03.06				110	680 T3 035
29 L/ 35 C/ 35 S/ 40 C/ 45 C/ 50 C/ 55 S/ 60 C/ 65 C/ 70 C 10, 11, 12, 13, 14, 15, 17, 18 [06; 09]	04.06-12.11				110	680 T3 037
29 L/ 35 C/ 35 S/ 40 C/ 50 C/ 65 C 13, 14, 15, 17 [00]	05.99-03.06				110	680 T3 035
35 C 11 [00]	05.99-08.06				110	680 T3 035
	09.02-08.06				110	680 T3 037
35 C/ 35 S 9 [00]	05.99-03.06				110	680 T3 035
35 S 11 [00]	05.99-08.06				110	680 T3 035
	09.03-08.06				110	680 T3 037
50 C 11 [00]	05.99-08.06				110	680 T3 035
	09.02-08.06				110	680 T3 037
12 [00]	09.02-03.06				110	680 T3 035
						T3 037
Daily, Grinta						
30/ 35/ 40 -8, -8 Duty, -9, -10 Turbo, -10 Turbo 4x4	04.78-09.90				88	680 T3 013
EuroCargo						
60 E/ 65 E/ 75 E 10, 12, 14	01.91-08.00	ZE			110	680 T3 035
65 E 15	08.00-08.03	ZE			110	680 T3 037
65 E/ 75 E 13	08.00-08.03	ZE			110	680 T3 037
65 E/ 75 E/ 80 E 13, 14, 16 [03]	09.03→	ZE			110	680 T3 037
15 [03]	09.03-08.05	ZE			110	680 T3 035
75 E 15	01.91-08.00	ZE			110	680 T3 035
	09.00-08.03	ZE			110	680 T3 037
18	09.00-08.03	ZE			110	680 T3 037
18 [03]	09.03-08.05	ZE			110	680 T3 037
	09.05→	ZE			110	680 T3 035
75 E/ 80 E/ 90 E/ 100 E 17	09.00-08.03	ZE			110	680 T3 037
75 E/ 100 E 17 [03]	09.03-08.05	ZE			110	680 T3 035
80 E 15	01.91-08.00	ZE			110	680 T3 035
	09.00-08.03	ZE			110	680 T3 037
18	01.91-08.00	ZE			110	680 T3 035
	09.00-08.03	ZE			110	680 T3 037
18 [03]	09.03-08.05	ZE			110	680 T3 035
	09.05→	ZE			110	680 T3 037
21	01.91-08.00	ZE			110	680 T3 035
	09.00-08.03	ZE			110	680 T3 037

			Ah A (EN) T5			Ah A (EN) T4			Ah A (EN) T3		
			0 092 ...0			0 092 ...0			0 092 ...0		
80 E/ 90 E 17 [03]	09.03-09.05	ZE						110	680	T3 037	
80 E/ 90 E/ 100 E 21 [03]	09.03-08.05	ZE						110	680	T3 035	
80 E/ 90 E/ 100 E/ 110 E 22 [03]	09.05→	ZE						110	680	T3 037	
85 E 18	01.91-08.00	ZE						110	680	T3 035	
85 E/ 90 E/ 100 E 15	01.83-08.00	ZE						110	680	T3 035	
90 E 18	09.91-07.00	ZE						110	680	T3 035	
	09.00-08.03	ZE						110	680	T3 037	
18 [03]	09.03-09.05	ZE						110	680	T3 037	
	09.05→	ZE						110	680	T3 035	
21	01.91-12.00	ZE						110	680	T3 035	
	09.00-08.03	ZE						110	680	T3 037	
100 E 18	01.91-11.00	ZE						110	680	T3 035	
	09.00-08.03	ZE						110	680	T3 037	
18 [03]	09.03-08.05	ZE						110	680	T3 035	
	09.05→	ZE						110	680	T3 037	
21	01.91-11.00	ZE						110	680	T3 035	
	09.00-08.03	ZE						110	680	T3 037	
110 E 25 [03]	09.07→	ZE						110	680	T3 037	
120 E 17	09.00-08.03	ZE	180	1000	T5 077	170	1000	T4 077	110	680	T3 037
17 [03]	09.03-08.05	ZE	180	1000	T5 077	170	1000	T4 077	110	680	T3 035
18	09.91-07.00	ZE	180	1000	T5 077	170	1000	T4 077	110	680	T3 035
											T3 037
	09.00-08.03	ZE	180	1000	T5 077	170	1000	T4 077	110	680	T3 037
21	01.91-08.00	ZE	180	1000	T5 077	170	1000	T4 077	110	680	T3 035
	09.00-08.03	ZE	180	1000	T5 077	170	1000	T4 077	110	680	T3 037
120 E/ 130 E 28 [03]	09.03→	ZE	180	1000	T5 077	170	1000	T4 077	110	680	T3 037
120 E/ 130 E/ 135 E/ 150 E/ 170 E 23	10.91-08.00	ZE	180	1000	T5 077	170	1000	T4 077	110	680	T3 035
120 E/ 130 E/ 140 E/ 150 E/ 160 E 18 [03]	09.03→	ZE	180	1000	T5 077	170	1000	T4 077	110	680	T3 037
120 E/ 130 E/ 140 E/ 150 E/ 160 E/ 180 E 24 [03]	09.03-08.05	ZE	180	1000	T5 077	170	1000	T4 077	110	680	T3 037
25 [03]	09.05→	ZE	180	1000	T5 077	170	1000	T4 077	110	680	T3 037
120 E/ 130 E/ 140 E/ 150 E/ 180 E 24	09.00-08.03	ZE	180	1000	T5 077	170	1000	T4 077	110	680	T3 037
120 E/ 130 E/ 150 E/ 160 E/ 180 E 21 [03]	09.03-08.05	ZE	180	1000	T5 077	170	1000	T4 077	110	680	T3 037
120 E/ 130 E/ 150 E/ 170 E 15	12.91-07.00	ZE	180	1000	T5 077	170	1000	T4 077	110	680	T3 035
120 E/ 130 E/ 150 E/ 180 E 28	09.00-08.03	ZE	180	1000	T5 077	170	1000	T4 077	110	680	T3 037
120 E/ 140 E/ 150 E/ 160 E 22 [03]	09.05→	ZE	180	1000	T5 077	170	1000	T4 077	110	680	T3 037
120 EL 18 [03]	09.05→	ZE	180	1000	T5 077	170	1000	T4 077	110	680	T3 035
130 E 18	09.91-07.00	ZE	180	1000	T5 077	170	1000	T4 077	110	680	T3 035
	09.00-08.03	ZE	180	1000	T5 077	170	1000	T4 077	110	680	T3 037
21	09.01-08.03	ZE	180	1000	T5 077	170	1000	T4 077	110	680	T3 035
135 E 18	01.94-07.00	ZE	180	1000	T5 077	170	1000	T4 077	110	680	T3 035
140 E 18	09.00-08.03	ZE	180	1000	T5 077	170	1000	T4 077	110	680	T3 037
21	09.03-08.05	ZE	180	1000	T5 077	170	1000	T4 077	110	680	T3 037
28 [03]	09.03-08.05	ZE	180	1000	T5 077	170	1000	T4 077	110	680	T3 035
	09.05→	ZE	180	1000	T5 077	170	1000	T4 077	110	680	T3 037
150 E 18	09.91-07.00	ZE	180	1000	T5 077	170	1000	T4 077	110	680	T3 035
	09.00-08.03	ZE	180	1000	T5 077	170	1000	T4 077	110	680	T3 037
21	01.91-08.00	ZE	180	1000	T5 077	170	1000	T4 077	110	680	T3 035
	09.01→	ZE	180	1000	T5 077	170	1000	T4 077	110	680	T3 035
150 E/ 160 E/ 180 E 28 [03]	09.03→	ZE	180	1000	T5 077	170	1000	T4 077	110	680	T3 037
30 [03]	09.05→	ZE	180	1000	T5 077	170	1000	T4 077	110	680	T3 037



			Ah			A (EN) T5			Ah			A (EN) T4			Ah			A (EN) T3		
◀ IVECO			0092 ...0						0092 ...0						0092 ...0					
150 E/ 170 E 27	09.91-07.00	ZE	180	1000	T5 077	170	1000	T4 077	110	680	T3 035									
170 E 18	09.91-07.00	ZE	180	1000	T5 077	170	1000	T4 077	110	680	T3 035									
180 E 21	04.92-07.00	ZE	180	1000	T5 077	170	1000	T4 077	110	680	T3 035									
	09.00-08.03	ZE	180	1000	T5 077	170	1000	T4 077	110	680	T3 037									
260 E 23	12.91-07.00	ZE	180	1000	T5 077	170	1000	T4 077	155	900	T3 077									
27	09.91-07.00	ZE	180	1000	T5 077	170	1000	T4 077	155	900	T3 077									
28 [03]	09.03-08.05	ZE	180	1000	T5 077	170	1000	T4 077	110	680	T3 035									
280 E 23	12.91-11.00	ZE	180	1000	T5 077	170	1000	T4 077	155	900	T3 077									
320 E 27	10.91-08.00	ZE	180	1000	T5 077	170	1000	T4 077	155	900	T3 077									
28	09.00-08.03	ZE	180	1000	T5 077	170	1000	T4 077	155	900	T3 077									
EuroClass																				
380 .10.29, .10.35, .12.29, .12.35, .12.38	01.93-11.02	ZE	180	1000	T5 077	170	1000	T4 077												
EuroMover																				
190 E/ 260 E 24	08.00-03.06	ZE	180	1000	T5 077	170	1000	T4 077	155	900	T3 077									
EuroStar																				
180 E/ 190 E/ 240 E/ 260 E/ 400 E/ 440 E 38, 39, 40, 42, 43, 46, 47, 48, 52	04.92-09.04	ZE	225	1150	T5 080	170	1000	T4 077												
EuroTech																				
175 E/ 179 E 27	04.92-07.00	ZE	180	1000	T5 077	170	1000	T4 077	110	680	T3 035									
180 E/ 190 E 38	06.92-07.00	ZE	180	1000	T5 077	170	1000	T4 077	155	900	T3 077									
180 E/ 190 E/ 240 E/ 260 E 24, 25	07.92-08.03	ZE	180	1000	T5 077	170	1000	T4 077	155	900	T3 077									
180 E/ 190 E/ 240 E/ 260 E/ 400 E/ 440 E 30, 31, 34, 35	04.92-08.03	ZE	180	1000	T5 077	170	1000	T4 077	155	900	T3 077									
39, 40, 42	04.92-09.04	ZE	180	1000	T5 077	170	1000	T4 077	155	900	T3 077									
180 E/ 190 E/ 260 E 27	07.92-08.03	ZE	180	1000	T5 077	170	1000	T4 077	155	900	T3 077									
180 E/ 400 E 52	04.92-12.00	ZE	180	1000	T5 077	170	1000	T4 077	155	900	T3 077									
190 E/ 260 E/ 440 E 43	08.00-08.03	ZE	180	1000	T5 077	170	1000	T4 077	155	900	T3 077									
240 E 38	09.92-11.00	ZE	180	1000	T5 077	170	1000	T4 077	155	900	T3 077									
			225	1150	T5 080	170	1000	T4 077												
260 E 38	06.92-07.00	ZE	180	1000	T5 077	170	1000	T4 077	155	900	T3 077									
52	04.92-07.00	ZE	225	1150	T5 080	170	1000	T4 077												
325 E 27	07.92-07.00	ZE	180	1000	T5 077	170	1000	T4 077	155	900	T3 077									
400 E 38	09.92-11.00	ZE	180	1000	T5 077	170	1000	T4 077	155	900	T3 077									
			225	1150	T5 080	170	1000	T4 077												
440 E 38	04.93-11.00	ZE	180	1000	T5 077	170	1000	T4 077	155	900	T3 077									
440 E/S 43	04.02→		225	1150	T5 080				220	1150	T3 081									
EuroTrakker																				
180 E/ 190 E/ 260 E 24, 25, 27, 30, 31	07.92-08.04	ZE	180	1000	T5 077	170	1000	T4 077	155	900	T3 077									
190 E/ 260 E 34	04.92-07.00	ZE	180	1000	T5 077	170	1000	T4 077	155	900	T3 077									
37	04.93-12.01	ZE	180	1000	T5 077	170	1000	T4 077	155	900	T3 077									
38	08.00-08.04	ZE	180	1000	T5 077	170	1000	T4 077	155	900	T3 077									
42	04.92-12.00	ZE	180	1000	T5 077	170	1000	T4 077	155	900	T3 077									
44	08.00-08.04	ZE	180	1000	T5 077	170	1000	T4 077	155	900	T3 077									
190 E/ 260 E/ 400 E 35	08.00-08.04	ZE	180	1000	T5 077	170	1000	T4 077	155	900	T3 077									
260 E 47	06.92-12.00	ZE	180	1000	T5 077	170	1000	T4 077	155	900	T3 077									
48	08.00-08.04	ZE	180	1000	T5 077	170	1000	T4 077	155	900	T3 077									
330 E/ 340 E/ 380 E 34	04.92-07.00	ZE	225	1150	T5 080	170	1000	T4 077												
330 E/ 340 E/ 380 E/ 400 E/ 410 E/ 440 E/ 720 E 37	04.92-12.02	ZE	225	1150	T5 080	170	1000	T4 077												
340 E/ 380 E/ 400 E/ 410 E/ 440 E 38	08.00-08.04	ZE	225	1150	T5 080	170	1000	T4 077												
340 E/ 380 E/ 400 E/ 410 E/ 440 E/ 720 E 42	04.92-12.00	ZE	225	1150	T5 080	170	1000	T4 077												
44	08.00-08.04	ZE	225	1150	T5 080	170	1000	T4 077												

			Ah			A (EN)			Ah			A (EN)		
			T5			T4			T3					
			0 092 ...0			0 092 ...0			0 092 ...0					
340 E/ 380 E/ 410 E 35	08.00-08.04	ZE	225	1150	T5 080	170	1000	T4 077						
380 E/ 410 E/ 720 E 48	08.00-08.04	ZE	225	1150	T5 080	170	1000	T4 077						
380 E/ 720 E 47	04.92-12.00	ZE	225	1150	T5 080	170	1000	T4 077						
400 E 34	04.92-12.00	ZE	180	1000	T5 077	170	1000	T4 077	155	900	T3 077			
			225	1150	T5 080	170	1000	T4 077						
440 E 34	04.92-07.00	ZE	225	1150	T5 080	170	1000	T4 077						
39	08.00-08.04	ZE	180	1000	T5 077	170	1000	T4 077	155	900	T3 077			
Stralis														
N 440 S/ 440 S 31, 33, 35, 36, 40, 42, 43, 44, 45, 48, 50, 54, 56 [; 07]	08.02-12.12		225	1150	T5 080				220	1150	T3 081			
190 S/ 260 S 27, 30, 31, 33, 35, 36, 40, 42, 43, 44, 45, 48, 50, 54, 56	08.02-12.12	ZE	225	1150	T5 080	170	1000	T4 077						
Trakker														
N 190 T 41 [07]	07.07→		225	1150	T5 080	215	1150	T4 080	220	1150	T3 081			
N 190 T/ N 260 T/ N 340 T/ N 380 T/ N 400 T/ N 410 T/ N 440 T/ N 720 T 45, 50 [07]	07.07→	ZE	180	1000	T5 077	170	1000	T4 077	155	900	T3 077			
N 260 T/ N 340 T/ N 380 T/ N 400 T/ N 410 T/ N 440 T/ N 720 T 41 [07]	07.07→	ZE	180	1000	T5 077	170	1000	T4 077	155	900	T3 077			
180 T 24	09.04-03.06	ZE	180	1000	T5 077	170	1000	T4 077	155	900	T3 077			
27	09.04-03.06	ZE	180	1000	T5 077	170	1000	T4 077	155	900	T3 077			
31	09.04-03.06	ZE	180	1000	T5 077	170	1000	T4 077	155	900	T3 077			
190 T 27	09.04-03.06		225	1150	T5 080	215	1150	T4 080	220	1150	T3 081			
190 T/ 260 T 31	09.04-12.12		225	1150	T5 080	215	1150	T4 080	220	1150	T3 081			
33	04.06-12.12		225	1150	T5 080	215	1150	T4 080	220	1150	T3 081			
35	09.04-03.06		225	1150	T5 080	215	1150	T4 080	220	1150	T3 081			
36	04.06-12.12		225	1150	T5 080	215	1150	T4 080	220	1150	T3 081			
38	09.04-12.12		225	1150	T5 080	215	1150	T4 080	220	1150	T3 081			
41	04.06-12.12		225	1150	T5 080	215	1150	T4 080	220	1150	T3 081			
44	09.04-12.12		225	1150	T5 080	215	1150	T4 080	220	1150	T3 081			
45	04.06-12.12		225	1150	T5 080	215	1150	T4 080	220	1150	T3 081			
260 T 48	09.04-03.06		225	1150	T5 080	215	1150	T4 080	220	1150	T3 081			
50	04.06-12.12		225	1150	T5 080	215	1150	T4 080	220	1150	T3 081			
340 T/ 380 T/ 400 T/ 410 T 35	09.04-03.06	ZE	180	1000	T5 077	170	1000	T4 077	155	900	T3 077			
340 T/ 380 T/ 400 T/ 410 T/ 440 T/ 720 T 38	09.04-12.12	ZE	180	1000	T5 077	170	1000	T4 077	155	900	T3 077			
41	04.06-12.12	ZE	180	1000	T5 077	170	1000	T4 077	155	900	T3 077			
44	09.04-12.12	ZE	180	1000	T5 077	170	1000	T4 077	155	900	T3 077			
340 T/ 380 T/ 410 T/ 440 T/ 720 T 45	04.06-12.12	ZE	180	1000	T5 077	170	1000	T4 077	155	900	T3 077			
340 T/ 400 T 36	04.06-12.12	ZE	180	1000	T5 077	170	1000	T4 077	155	900	T3 077			
380 T/ 400 T/ 410 T/ 440 T/ 720 T 50	04.06-12.12	ZE	180	1000	T5 077	170	1000	T4 077	155	900	T3 077			
380 T/ 400 T/ 410 T/ 720 T 42	04.06-12.12	ZE	180	1000	T5 077	170	1000	T4 077	155	900	T3 077			
380 T/ 410 T/ 720 T 48	09.04-03.06	ZE	180	1000	T5 077	170	1000	T4 077	155	900	T3 077			
TurboStar														
190 -33, P	07.84-05.87	ZE	180	1000	T5 077	170	1000	T4 077						
-42, P	07.84-09.86	ZE	180	1000	T5 077	170	1000	T4 077						
190/ 240/ 260 -36, -36, P, -36 P, -38 PT	07.87-12.00	ZE	180	1000	T5 077	170	1000	T4 077						
-48, -48, P	03.89-11.00	ZE	180	1000	T5 077	170	1000	T4 077						
TurboTech														
190/ 220/ 240/ 260 -24, -26, -30 N, -32, -36, -36 P, -36 PT, -36 T	03.80-01.01	ZE	180	1000	T5 077	170	1000	T4 077						



			Ah A (EN) T5			Ah A (EN) T4			Ah A (EN) T3		
◀ IVECO			0092 ...0			0092 ...0			0092 ...0		
50											
50 -8, -9	01.83-06.91	ZE							66	510	T3 008
60											
60/65 -9, -9 A, -10, -11, -12, -14	05.82-12.92	ZE							66	510	T3 008
70											
75/79 -9 A..., -10, -12, -13 W, -14, -14 PM	01.83-12.92	ZE							110	760	T3 038
80											
80 -9 A., -13 A., -14 PM, -14 W, -16, -16 A., -17 W	01.83-02.86 02.82-06.94								110 110	760 760	T3 038 T3 038
90											
90 -9 A., 90/95 -13, -13 A., -14, -16 PM, -17 W	01.83-02.86 06.82-11.95								110 110	760 760	T3 038 T3 038
100											
100/109 -13, -14	11.78-06.91	ZE							110	760	T3 038
110											
110 NC, NR, NT, PC, -13 A..., -16 A..., -17 AW, -17 W	01.83-12.99	ZE							143	950	T3 047
115 -14, -17	09.83-12.99	ZE	180	1000	T5 077	170	1000	T4 077			
120											
120 -13, -16, -17	01.83-09.90	ZE	180	1000	T5 077	170	1000	T4 077			
130											
130 -13 A..., -16 A., -14, -17	01.83-10.91 09.83-08.92	ZE							143	950	T3 047
140											
145 -17	02.86-07.92	ZE	180	1000	T5 077	170	1000	T4 077			
150											
150/159 -16 AN..., -17, -18, -23	07.82-12.91	ZE	180	1000	T5 077	170	1000	T4 077			
160											
160 -17 AN...	07.89-07.96	ZE	180	1000	T5 077	170	1000	T4 077			
160 R 81	06.83-12.86	ZE				140	800	T4 076	110	760	T3 038
160/165 -23 AHW, -23 ANW, -24, T, -30 AH...	06.82-05.89	ZE	180	1000	T5 077	170	1000	T4 077			
170											
170 -18	09.83-02.86	ZE				140	800	T4 076	110	760	T3 038
170/175 -17, -23 AH, -23 AHW, -23 ANW, -24, P, -25 AH, -25 AHW, -34 AH, -34 AHW	09.86-07.96	ZE	180	1000	T5 077	170	1000	T4 077			
180											
180 -23 AH, -23 AHW, -24, -25 AH, -25 AHW, -26	07.91-07.00 12.82-10.86 07.91-07.00 06.82-10.86	ZE	180	1000	T5 077	170	1000	T4 077			
-34 AH, -34 AHW	07.91-07.00	ZE	180	1000	T5 077	170	1000	T4 077			
190											
190 -18, -20 N, -24, -25 AH..., -25 AN..., -26 N..., -29, -30 AHW, -30 H, N, -32 AH..., -32 P, -36 P, -38, P	07.80-11.98	ZE	180	1000	T5 077	170	1000	T4 077			
220											
220 -30 PT, -34 HTM, -38 PT	04.85-07.86 09.91-11.00 07.80-07.86	ZE	180	1000	T5 077	170	1000	T4 077			
240											
240 -25 ANW, -30 P, -35 ANW, -38 P...	07.91-12.00 07.80-04.89 07.91-12.00 07.80-07.86	ZE	180	1000	T5 077	170	1000	T4 077			

			Ah	A (EN)		Ah	A (EN)		Ah	A (EN)	
					0 092 ...0			0 092 ...0			0 092 ...0

260												
260	-23 AH, -25 AH..., -25 AHB, -25 AN..., -26 H..., -26 NW, -30 AH..., -30 H..., -32 AH..., -34 AH, -34 AHW	01.77-12.99	ZE	180	1000	T5 077	170	1000	T4 077			
300												
300	PC, PT, -25 AH..., -30 AH..., -32 AH..., -34 AH	01.77-12.99	ZE	180	1000	T5 077	170	1000	T4 077			
320												
320	-30 H, -32 AH...	01.84-07.96	ZE	180	1000	T5 077	170	1000	T4 077	155	900	T3 077
330												
330	-25 AH...	07.83-02.85	ZE	180	1000	T5 077	170	1000	T4 077	155	900	T3 077
	-25 AN	04.89-12.89	ZE	180	1000	T5 077	170	1000	T4 077	155	900	T3 077
	-26 H, -30 AH, -30 AN..., -30 H..., -30 N..., -32 ANW, -35 H, -36 AH..., -36 H, -36 HW	01.79-12.99	ZE	180	1000	T5 077	170	1000	T4 077			
340												
-34	AH	03.89-12.98	ZE	180	1000	T5 077	170	1000	T4 077			
370												
370	.10.24, .12.L.25, .12.24, .12.30, HD, .12.35	09.83-12.86	ZE				170	1000	T4 078			
619												
N, T		01.70-07.88	ZE							143	950	T3 047

KAROSA

C											
734	.1340	08.93→		180	1000	T5 077	170	1000	T4 077		
LC											
735/ 736/ 757	, .1022, .1024, .1030, .1031, .1060	01.91→	ZE	180	1000	T5 077	170	1000	T4 077		

KÄSSBOHRER

Setra											
S 210/ S 211/ S 213/ S 214/ S 215/ S 216/ S 228/ S 300/ S 309/ S 312/ SG 180	, DT..., H, H..., HD, HD..., HDH, HDH Intercontinental, HDS, HDS..., HR..., N, NC, NR, RL, SL, SL, UL	01.69-07.01	ZE	180	1000	T5 077	170	1000	T4 077		

KIA

K 2500												
TCi		09.01→								125	720	T3 042
K 2700												
[SD]		04.98-08.04								125	720	T3 042
Pregio												
2.5 TCi [TB]		08.01→								110	680	T3 035
										125	720	T3 042
2.7 D [TB]		02.97→								110	680	T3 035



			Ah	A (EN)		Ah	A (EN)		Ah	A (EN)	
			0092 ...0			0092 ...0			0092 ...0		

KRAZ

16t										
5133VE	01.00→	ZE	225	1150	T5 080					
17t										
5444	01.00→	ZE	225	1150	T5 080					
18t										
5133N2	01.00→	ZE	225	1150	T5 080					
23t										
6322/ 6446 , -02	01.00→	ZE	225	1150	T5 080					
26t										
6510/ 65101	01.00→	ZE	225	1150	T5 080					
27t										
64372/ 65032 , -02	01.00→	ZE	225	1150	T5 080					
28t										
6230C4/ 6233M6/ 6443/ 64431/ 65032/ 65053/ 65055 , -000, -02	01.00→	ZE	225	1150	T5 080					
29t										
7133C4/ 7133N4	01.00→	ZE	225	1150	T5 080					
32t										
6133C6	01.00→	ZE	225	1150	T5 080					
34t										
6446	01.00→	ZE	225	1150	T5 080					

LEYLAND

Constructor										
	01.81-10.99	ZE			125	720	T3 040			
Cruiser										
	01.83-10.90	ZE			125	720	T3 040			
Roadrunner										
6/ 8/ 10 .12, .13	09.84-10.96				110	680	T3 035			
Roadtrain										
/ 20 , .33	09.86-10.90	ZE			125	720	T3 040			

LEYLAND-DAF

45										
.120/ .130/ .150/ .160 , Turbo	05.90-12.01	ZE			110	680	T3 035			
50										
.160	01.90-12.01	ZE			110	680	T3 035			
60										
.180/ .210	01.90-12.01	ZE			110	680	T3 035			
80										
.330 ATi	01.90-12.01	ZE			125	720	T3 040			
95										
.310/ .350/ .380/ .400	04.89-12.01	ZE	180	1000	T5 077	170	1000	T4 077		

LIAZ (CZ)

Serie 18t-33,5t										
18.23/ 19.38/ 34.33 KB 05, SD/S3, TBV	01.88-12.00	ZE	180	1000	T5 077	170	1000	T4 077		
Serie 100-300										
100/ 110/ 230 , .55 p, .573 DD	03.87-09.03	ZE	180	1000	T5 077	170	1000	T4 077		

			Ah	A (EN)		Ah	A (EN)		Ah	A (EN)	
0 092 ...0					0 092 ...0				0 092 ...0		

MAN

Bus 8t											
8.136/ 8.150/ 8.160/	03.82-09.01	ZE	145	800	T5 075	140	800	T4 075	120	680	T3 075
8.170/ 8.220 FAE, FOC, FOCL											
Bus 9t											
9.136/ 9.150/ 9.170 FAE, FOC	03.82-05.95	ZE	145	800	T5 075	140	800	T4 075	120	680	T3 075
Bus 10t											
10.150/ 10.180 HOCL	01.88-05.92	ZE	145	800	T5 075	140	800	T4 075	120	680	T3 075
10.150/ 10.220 FOC, FOCL [L2000]	02.95-09.01	ZE	145	800	T5 075	140	800	T4 075	120	680	T3 075
Bus 11t											
11.150/ 11.190/ 11.220/ 11.230 HOCL	04.92-12.04	ZE	145	800	T5 075	140	800	T4 075			
Bus 12t											
12.170 FOC, FOCL	03.85-04.90	ZE	180	1000	T5 077	140	800	T4 075	120	680	T3 075
12.220 HOCL-NL, HOCL-SR [A76; A77]	07.98-09.06	ZE	180	1000	T5 077	140	800	T4 075	120	680	T3 075
12.280 HOCL-NL [A76]	01.01-09.02	ZE	225	1150	T5 080	215	1150	T4 080	200	1050	T3 080
Bus 13t											
13.220/ 13.230 HOCL	11.95-05.04	ZE	225	1150	T5 080	170	1000	T4 077	155	900	T3 077
Bus 14t											
14.170/ 14.192 FOC	04.85-04.90	ZE	180	1000	T5 077	140	800	T4 075	120	680	T3 075
14.220 HOCL-NL [A66]	07.98-09.06	ZE	180	1000	T5 077	140	800	T4 075	120	680	T3 075
Bus 16t											
16.280 HOC, HOCL	02.84-04.87	ZE	180	1000	T5 077	140	800	T4 075	120	680	T3 075
Bus 17t											
17.192/ 17.232/ 17.272 GM2	03.91-05.94	ZE	180	1000	T5 077	140	800	T4 075	120	680	T3 075
Bus 18t											
18.220/ 18.260/ 18.280 HOCL-NL [A69]	07.98-09.06	ZE	180	1000	T5 077	170	1000	T4 077	155	900	T3 077
18.310 HOCL-NL [A69]	07.98-09.06	ZE	180	1000	T5 077	170	1000	T4 077			
18.400 HOCL [A51]	09.96-12.00	ZE	180	1000	T5 077	170	1000	T4 077			
Bus 22t											
22.192 FVL-KO	07.81-09.90	ZE	180	1000	T5 077	140	800	T4 075	120	680	T3 075
22.280/ 22.330 HOCLN	05.85-09.89	ZE	225	1150	T5 080	215	1150	T4 080	200	1050	T3 080
22.331/ 22.361 HOCLN	09.89-04.92	ZE	225	1150	T5 080	170	1000	T4 077			
22.360 HOCLN	06.86-09.89	ZE	225	1150	T5 080	215	1150	T4 080	200	1050	T3 080
	02.93-04.93	ZE	225	1150	T5 080	215	1150	T4 080	200	1050	T3 080
22.370/ 22.400/ 22.420 HOCLN	04.93-12.00	ZE	225	1150	T5 080	215	1150	T4 080	200	1050	T3 080
Bus 24t											
24.360/ 24.400/ 24.410/ 24.460 HOCLLN, HOCLN [474]	07.96-09.06	ZE	225	1150	T5 080	215	1150	T4 080	200	1050	T3 080
Bus 26t											
26.240 DF-KO	12.81-08.88	ZE	180	1000	T5 077	140	800	T4 075	120	680	T3 075
EL / EM											
EL 202/ EL 222/ EL 262 , F [A12; A16, A17]	01.93-09.01	ZE	225	1150	T5 080						
EM 11.222/ EM 13.222/ EM 192/ EM 220 [A53; 469]	10.93-12.04	ZE	180	1000	T5 077	170	1000	T4 077	155	900	T3 077



			Ah A (EN)	Ah A (EN)	Ah A (EN)
			0092 ...0	0092 ...0	0092 ...0

◀ MAN

E2000

19.293/ 19.314/ 19.343/ 19.364/ 19.403/ 19.414/ 19.463/ 19.464/ 26.233/ 26.293/ 26.314/ 26.343/ 26.364/ 26.403/ 26.414/ 26.463/ 26.464/ 27.604/ 28.233/ 28.293/ 28.314/ 28.343/ 28.364/ 28.403/ 28.414/ 28.463/ 28.464/ 30.293/ 30.314/ 30.343/ 30.364/ 30.403/ 30.414/ 30.463/ 30.464/ 32.293/ 32.314/ 32.343/ 32.364/ 32.403/ 32.414/ 32.463/ 32.464/ 33.293/ 33.343/ 33.364/ 33.403/ 33.414/ 33.463/ 33.464/ 33.604/ 35.343/ 35.364/ 35.403/ 35.414/ 35.463/ 35.464/ 40.604/ 41.343/ 41.364/ 41.403/ 41.414/ 41.463/ 41.464/ 41.604/ 42.414/ 42.464/ 50.414/ 50.464/ 50.604 , DFAL, DFAS, DFAS, DFALS, DFL, DFLS, DFVL, DFVLS, F, FA, FALS/FALK, FANL, FANLC, FAV, FAVL, FL, FLS/FLK, FNL, FNLC, FV, VF, VFA, VFAK, VFAS, VFAVK, VFK, VFL, VFLLC, VFNL, VFVK	06.96-09.02	ZE	180	1000	T5 077	170	1000	T4 077	155	900	T3 077
---	-------------	----	-----	------	---------------	-----	------	---------------	-----	-----	---------------

E2000 Evol. (FE)

19.310/ 19.360/ 19.410/ 19.460/ 26.360/ 26.410/ 26.460/ 28.310/ 28.360/ 28.410/ 28.460/ 30.360/ 30.410/ 30.460/ 32.360/ 32.410/ 32.460/ 33.360/ 33.410/ 33.460/ 35.360/ 35.410/ 35.460/ 41.410/ 41.460/ 50.410/ 50.460/ 310A/ 360A/ 410A/ 460A DA, DF, F, FA, F, FL, FVA, FVF, FVN, VA, VF	01.00-12.03	ZE	180	1000	T5 077	170	1000	T4 077	155	900	T3 077
---	-------------	----	-----	------	---------------	-----	------	---------------	-----	-----	---------------

F / HF

292/ 332/ 362 F, HF [881; 883]	09.85-04.94	ZE	225	1150	T5 080						
-----------------------------------	-------------	----	-----	------	---------------	--	--	--	--	--	--

F/M/U 90

19.242/ 19.262/ 19.272/ 19.292/ 19.302/ 19.322/ 19.332/ 19.342/ 19.362/ 19.372/ 19.402/ 19.422/ 19.462/ 19.502 F, FA, FL, FLS	07.86-06.96	ZE	180	1000	T5 077	140	800	T4 075	120	680	T3 075
19.322/ 19.332/ 19.362/ 19.372/ 19.422 U, UL	07.86-05.94	ZE	145	800	T5 075	140	800	T4 075	120	680	T3 075

			Ah	A (EN)		Ah	A (EN)		Ah	A (EN)	
0 092 ...0						0 092 ...0			0 092 ...0		

22.292/ 22.332/ 22.362/ 24.192/ 24.222/ 24.232/ 24.242/ 24.262/ 24.272/ 24.292/ 24.302/ 24.322/ 24.332/ 24.342/ 24.362/ 24.372/ 24.402/ 24.422/ 24.462/ 24.502/ 25.272/ 25.302/ 25.322/ 25.372/ 25.422/ 25.502/ 26.242/ 26.262/ 26.272/ 26.292/ 26.302/ 26.322/ 26.332/ 26.342/ 26.362/ 26.372/ 26.402/ 26.422/ 26.462/ 26.502/ 33.242/ 33.262/ 33.272/ 33.292/ 33.322/ 33.332/ 33.342/ 33.362/ 33.372/ 33.402/ 33.422/ 33.462/ 33.502 DF, DFA, DFL, DFLS, FNL, FVL, FVLS	07.86-06.96	ZE	180	1000	T5 077	170	1000	T4 077	155	900	T3 077
22.332/ 22.362 UNL 24.322/ 24.332/ 24.362/ 24.372/ 24.422/ 25.322/ 25.372/ 25.422/ 26.322/ 26.372/ 26.422 UNL	07.86-10.86	ZE	180	1000	T5 077	170	1000	T4 077	155	900	T3 077
24.322/ 24.332/ 24.362/ 24.372/ 24.422/ 25.322/ 25.372/ 25.422/ 26.322/ 26.372/ 26.422 UNL	10.86-05.94	ZE	145	800	T5 075	140	800	T4 075	120	680	T3 075
32.272/ 32.322/ 32.342/ 32.372/ 32.402/ 32.422/ 35.262/ 35.292/ 35.322/ 35.332/ 35.342/ 35.362/ 35.372/ 35.402/ 35.422 VF, VFA, VFAK	10.88-06.96	ZE	180	1000	T5 077	170	1000	T4 077	155	900	T3 077
FR / FRH											
352/ 402 F [A33]	07.98-09.01	ZE	225	1150	T5 080						
FR-FRH											
292/ 362 [880; 882]	05.85-12.92	ZE	225	1150	T5 080						
352/ 402 [A03]	09.95-11.99	ZE	225	1150	T5 080						
F90											
32.262/ 32.272/ 32.292/ 32.302/ 32.322/ 32.332/ 32.362/ 32.372/ 32.422/ 35.272/ 35.302/ 35.322/ 35.372/ 35.422 VF, VFA	03.88-04.95	ZE	180	1000	T5 077	170	1000	T4 077	155	900	T3 077
F2000											
17.373 DF	01.94-12.00	ZE	180	1000	T5 077	170	1000	T4 077			
19.233/ 19.273/ 19.293/ 19.314/ 19.320/ 19.323/ 19.343/ 19.364/ 19.373/ 19.403/ 19.414/ 19.423/ 19.463/ 19.464/ 19.603/ 19.604/ 23.314/ 23.364/ 23.403/ 23.414/ 23.463/ 23.464 DFA, DFC, DFK, DFL, DFLS, DFS, DFS/DFK/DF-TM/ DFC, F, FA, FAS/FAC/FAK, FL, FLL, FLL-P, FLLR-P, FLLS/ FLLC/FLCW, FLS, FLS/FLK/ FLC, FNL, FNLC, FNLL, FNLLC, FNLLC/FNLLW, FNLLC/L, FNLLRC, FNLS/FNLC, FVL, K/L, VF, VF-TM	01.94→	ZE	180	1000	T5 077	170	1000	T4 077	155	900	T3 077













◀ MAN 0092 ...0 0092 ...0 0092 ...0







24.273/ 24.293/ 24.314/ 24.323/ 24.343/ 24.364/ 24.373/ 24.403/ 24.414/ 24.423/ 24.463/ 24.464/ 26.233/ 26.273/ 26.293/ 26.314/ 26.323/ 26.343/ 26.364/ 26.373/ 26.403/ 26.414/ 26.423/ 26.463/ 26.464/ 26.603/ 26.604/ 27.273/ 27.293/ 27.314/ 27.323/ 27.343/ 27.364/ 27.373/ 27.403/ 27.414/ 27.423/ 27.463/ 27.464/ 27.603/ 27.604/ 32.293/ 32.314/ 32.343/ 32.364/ 32.403/ 32.414/ 32.463/ 32.464/ 33.323/ 33.343/ 33.364/ 33.373/ 33.374/ 33.403/ 33.423/ 33.463/ 33.603/ 33.604/ 35.343/ 35.364/ 35.403/ 35.414/ 35.463/ 35.464/ 40.414/ 40.464/ 41.343/ 41.364/ 41.403/ 41.414/ 41.463	01.94→	ZE	180	1000	T5 077	170	1000	T4 077	155	900	T3 077
DFA, DFC, DFK, DFL, DFLS, DFS, DFS/DFK/DF-TM/ DFC, F, FA, FAS/FAC/FAK, FL, FLL, FLL-P, FLLR-P, FLLS/ FLLC/FLCW, FLS, FLS/FLK/ FLC, FNL, FNLC, FNLL, FNLLC, FNLLC/FNLLW, FNLLC/L, FNLLRC, FNLS/FNLC, FVL, K/L, VF, VF-TM											
23.293/ 23.343/ 33.373	01.94-12.00	ZE	180	1000	T5 077	170	1000	T4 077	155	900	T3 077
26.273/ 26.293/ 26.323/ 26.343/ 26.364/ 26.373/ 26.403/ 26.423/ 26.463/ 26.464/ 27.273/ 27.293/ 27.314/ 27.323/ 27.343/ 27.364/ 27.373/ 27.414/ 27.423/ 27.463/ 27.464/ 27.603/ 33.323/ 33.343/ 33.364/ 33.373/ 33.403/ 33.414/ 33.423/ 33.463/ 33.464/ 33.603 DF	01.94-12.01	ZE	180	1000	T5 077	170	1000	T4 077	155	900	T3 077
41.464 DFA, DFC, DFK, DFL, DFLS, DFS, DFS/DFK/ DF-TM/DFC, F, FA, FAS/ FAC/FAK, FL, FLL, FLL-P, FLLR-P, FLLS/FLLC/FLCW, FLS, FLS/FLK/FLC, FNL, FNLC, FNLL, FNLLC, FNLLC/FNLLW, FNLLC/L, FNLLRC, FNLS/FNLC, FVL, K/L, VF, VF-TM	07.99-09.01	ZE	180	1000	T5 077	170	1000	T4 077	155	900	T3 077
F2000 Evol. (FE)											
35.310/ 35.410/ 310A/ 360A/ 410A/ 460A DA, DF, F, FA, F, FL, VF	07.99-09.03	ZE	180	1000	T5 077	170	1000	T4 077			
Lion's City / NL											
/ NL 223/ NL 243/ NL 283/ NL 313 [A21; A37]	07.98-09.06	ZE	225	1150	T5 080						

			Ah	A (EN)		Ah	A (EN)		Ah	A (EN)	
			0 092 ...0			0 092 ...0			0 092 ...0		

Lion's City G / NG											
NG 243/ NG 263/ NG 313/ NG 353/ NG 363	07.98-09.06	ZE	225	1150	T5 080						
Lion's City LL / NL											
NL 263/ NL 313/ NL 353/ NL 363 [A26]	08.98-09.06	ZE	225	1150	T5 080						
Lion's City M / NM											
[A47]	04.04-09.06	ZE	225	1150	T5 080						
NM 11.222/ NM 11.223/ NM 182/ NM 192/ NM 222/ NM 223 , F [A35; 469]	05.90-09.06	ZE	180	1000	T5 077						
NM 152 [A05; 469]	05.90-05.96	ZE	145	800	T5 075	140	800	T4 075	135	1000	T3 045
NM 283 F [A35]	10.01-09.06	ZE	225	1150	T5 080	215	1150	T4 080			
Lion's City T / TÜ / EL											
[A78]	06.04-09.06	ZE	225	1150	T5 080						
Lion's City Ü / NÜ											
[A20]	06.04-09.06	ZE	225	1150	T5 080						
NÜ 233/ NÜ 283 [A20]	07.98 →	ZE	225	1150	T5 080	215	1150	T4 080			
NÜ 263 [A20]	09.96-09.01	ZE	180	1000	T5 077						
	01.01-09.06	ZE	225	1150	T5 080						
NÜ 313 [A20]	07.98-09.06	ZE	180	1000	T5 077						
Lion's City ÜLL / NÜ											
NÜ 313/ NÜ 353/ NÜ 363 [A25]	02.98-09.06	ZE	225	1150	T5 080						
Lion's Classic G / SG											
SG 263, 313	06.03-09.06	ZE	225	1150	T5 080	215	1150	T4 080	200	1050	T3 080
Lion's Classic SL											
SL 223/ SL 283 [A74]	06.03-10.06	ZE	225	1150	T5 080	215	1150	T4 080	200	1050	T3 080
Lion's Classic Ü / SÜ											
SÜ 223/ SÜ 283/ SÜ 313/ SÜ 363 [A72]	06.04-09.06	ZE	225	1150	T5 080	215	1150	T4 080	200	1050	T3 080
Lion's Coach L											
C, L [R07, R08, R09]	09.02-09.06	ZE	225	1150	T5 080						
Lion's Coach RHC											
RHC 414/ RHC 464 [R07, R08, R09]	09.02-09.06	ZE	225	1150	T5 080						
Lion's Comfort											
R 313 [A01, A04]	01.98-12.01	ZE	225	1150	T5 080						
Lion's Regio C											
[R12, R13, R14]	10.06-05.07	ZE	225	1150	T5 080						
Lion's Regio L											
[R12, R13, R14]	10.06-05.07	ZE	225	1150	T5 080						
Lion's Regio ÜL											
ÜL 314/ ÜL 364 [R12, R13, R14]	06.04-09.06	ZE	225	1150	T5 080						
Lion's Star											
FRH 422 [A03]	01.93-09.96	ZE	225	1150	T5 080						
RH/ RHS 352, 402, 414, 463, 464 [A03; R02, R03]	07.98-09.06	ZE	225	1150	T5 080						
Lion's Star L											
RHS 414, 464 [R02, R03]	10.01-09.06	ZE	225	1150	T5 080						
Lion's Top Coach											
RH 403, 463 [A32]	06.99-01.04	ZE	225	1150	T5 080						
Lion's Top Star											
RHS 414, 464 [R03]	01.02-09.06	ZE	225	1150	T5 080						
L2000											
8.103/ 8.113/ 8.153/ 8.163/ 8.185/ 8.223/ 8.224/ 9.153/ 9.163/ 9.185/ 9.223/ 9.224/ 10.145/ 10.153/ 10.163/ 10.223/ 10.224 L	08.94-08.02	ZE	145	800	T5 075	140	800	T4 075	120	680	T3 075



			Ah  			Ah  			Ah  		
◀ MAN			0092 ...0			0092 ...0			0092 ...0		
8.103/8.113/8.153/ 8.163/8.185/8.223/ 8.224/9.153/9.163/ 9.223/9.224/10.153/ 10.163 LL	01.95-08.02	ZE	145	800	T5 075	140	800	T4 075	120	680	T3 075
8.103/8.153/8.163/ 8.223/8.224/9.153/ 9.163/9.223/9.224/ 10.153/10.163/10.223/ 10.224 F	10.93-01.95	ZE	145	800	T5 075	140	800	T4 075	120	680	T3 075
F, FL, FL	10.93-09.01	ZE	145	800	T5 075	140	800	T4 075	120	680	T3 075
8.153/8.163/8.223/ 8.224/10.153/10.160/ 10.163/10.223/10.224 LA	01.95→	ZE	145	800	T5 075	140	800	T4 075	120	680	T3 075
8.224/9.224 LLC, LLS	07.94-03.01	ZE	145	800	T5 075	140	800	T4 075	120	680	T3 075
8.224/9.224/10.224 LC, LC, LK, LK-L, LK, L-KI, LK-LV	07.94-09.01	ZE	145	800	T5 075	140	800	T4 075	120	680	T3 075
12.153/12.163/12.224 L	01.95-08.01	ZE	180	1000	T5 077	140	800	T4 075	120	680	T3 075
12.163/12.224/14.163/ 14.224/14.264/15.163/ 15.224/15.264/18.224/ 18.264/20.224/20.264 LL	08.95-09.01	ZE	180	1000	T5 077	140	800	T4 075	120	680	T3 075
14.130 L	01.86-12.87	ZE	180	1000	T5 077	140	800	T4 075	120	680	T3 075
14.153/14.163 L	01.95-08.01	ZE	180	1000	T5 077	140	800	T4 075	120	680	T3 075
14.170/14.192 L	01.86-12.93	ZE	180	1000	T5 077	140	800	T4 075	120	680	T3 075
14.224/14.264/15.163/ 15.223/15.224/15.264/ 18.224/18.264/20.224/ 20.264 L	08.95→	ZE	180	1000	T5 077	140	800	T4 075	120	680	T3 075
14.224/14.264/18.224/ 18.264 LA	08.95-09.01	ZE	180	1000	T5 077	140	800	T4 075	120	680	T3 075
15.192 F	03.82-12.96	ZE	180	1000	T5 077	140	800	T4 075	120	680	T3 075
L2000 Evol. (LE)											
8.140/8.150/8.180/ 8.220/9.140/9.150/ 9.180/9.220/10.150/ 10.180/10.220/140C/ 160B/160C/180C/220C	09.00-12.06	ZE	145	800	T5 075	140	800	T4 075	120	680	T3 075
F, FA, F, FL											
M2000											
12.224/12.255/12.264/ 12.284/12.285/14.224/ 14.264/14.284/15.284/ 18.224/18.264/18.284/ 20.284/25.224/25.264/ 25.284 LA-AF, LAC, LAK, LAK-LV, LC, LC, LRC, LK, LRK, LK-LV, L-KO, LLC, LLK, LLLC, LNLC, LNLLC, M, MA, MAC, MAK, MAK-LV, MA-KO, MA-LF, MC, MK-LV, M-KO, ML, MLC, MLK, MLLC, MLS, MNLC, MNLLC, MVL, MVLC	08.95-08.02	ZE	180	1000	T5 077	140	800	T4 075	120	680	T3 075
26.225/26.255 DLK	01.99-06.02	ZE	180	1000	T5 077	140	800	T4 075	120	680	T3 075
26.284 DL	01.99-09.01	ZE	180	1000	T5 077	140	800	T4 075			
26.285 DLK	01.99-12.02	ZE	180	1000	T5 077	140	800	T4 075			
DL-TM	01.99-12.02	ZE	180	1000	T5 077	140	800	T4 075			
M2000 Evol. (LE)											
12.180/12.220/12.250/ 12.280/180C/220C F, FL	07.01-06.06	ZE	145	800	T5 075	140	800	T4 075	120	680	T3 075







				Ah	A (EN)		Ah	A (EN)		Ah	A (EN)	
	0 092 ...0						0 092 ...0			0 092 ...0		
14.220/ 14.250/ 14.280/ 15.180/ 15.220/ 15.250/ 15.280/ 18.220/ 18.250B/ 18.280/ 160B/ 180B/ 220B/ 250B/ 280B F, FL	08.00-09.06	ZE	180	1000	T5 077	140	800	T4 075	120	680	T3 075	
14.225/ 14.255/ 14.285/ 18.220/ 18.250B/ 18.280/ 20.220/ 20.250/ 20.280/ 160B/ 220B/ 250B/ 280B DF, F, FA	09.00-09.06	ZE	180	1000	T5 077	140	800	T4 075	120	680	T3 075	
M2000 Evol. (ME)												
12.220/ 12.250/ 12.280/ 14.220/ 14.250/ 14.280/ 18.220/ 18.250/ 18.280/ 25.250/ 25.280/ 220B/ 250B/ 280B DF, F, FA, F, FL	08.00-07.05	ZE	180	1000	T5 077	140	800	T4 075	120	680	T3 075	
NG												
232 [A18]	04.94-11.99	ZE				140	800	T4 076	110	760	T3 038	
262/ 263/ 272/ 312/ 313/ 363 , F [A11; A24; 896]	06.90-09.06	ZE	180	1000	T5 077							
NL												
NL 263/ 202/ 222/ 223/ 262/ 263/ 312/ 313 , F [A10; A21; A22; A30; 895; 898]	09.89-09.06	ZE	180	1000	T5 077							
232 [A15]	04.94-11.99	ZE				140	800	T4 076	110	760	T3 038	
233 , F [A21; A22]	07.98→	ZE	225	1150	T5 080	215	1150	T4 080				
R												
292	03.86-01.93	ZE	225	1150	T5 080							
RH												
352/ 402/ 403 , F [A13; A33]	07.98-09.01	ZE	225	1150	T5 080							
RN												
313/ 353 [A02]	09.96-03.98	ZE	225	1150	T5 080							
RÜ												
240/ 280 [597]	01.80-12.88	ZE				170	1000	T4 078				
SD												
200	06.79-12.86	ZE	180	1000	T5 077							
202	10.85-10.93	ZE	225	1150	T5 080							
F	01.87-04.94	ZE	225	1150	T5 080							
SG												
220/ 240/ 242/ 292/ 312/ 322 , F, H, H, HÜ, HÜ	05.80-06.97	ZE	180	1000	T5 077							
SL												
200 , F	05.80-04.87	ZE	180	1000	T5 077							
202 FR-SDK [A08]	04.96-01.98	ZE	180	1000	T5 077							
SL II												
202 , F	06.84-04.94	ZE	180	1000	T5 077							
SM												
152 MIDI	11.87-04.94	ZE	145	800	T5 075	140	800	T4 075	135	1000	T3 045	
182/ 192 MIDI	11.87-02.95	ZE	180	1000	T5 077							
SR												
280/ 321 H	01.77-11.86	ZE	180	1000	T5 077							
292 H	05.85-12.85	ZE							143	950	T3 047	
361 H	06.84-11.86	ZE	225	1150	T5 080	215	1150	T4 080	200	1050	T3 080	
362 H	09.85-12.85	ZE	225	1150	T5 080							
SÜ												
223 [A72]	11.99-09.01	ZE	225	1150	T5 080	215	1150	T4 080				
240/ 242/ 272/ 292/ 322 , F	02.77-06.97	ZE	180	1000	T5 077							
263/ 313 [A72]	11.99-09.01	ZE	180	1000	T5 077							
283/ 313/ 363 F [A91]	06.04-09.06	ZE	180	1000	T5 077							
TAG												
24.430 FN, FP	09.04-09.06	ZE	225	1150	T5 080	170	1000	T4 077	155	900	T3 077	











◀ MAN

TG												
310A/ 360A/ 410A/ 460A/ 510A	D, DF	03.99-08.02	ZE	225	1150	T5 080	170	1000	T4 077	155	900	T3 077
F, FL, F-, FL-WW		03.99-04.07	ZE	180	1000	T5 077	170	1000	T4 077	155	900	T3 077
TGA												
18.310/ 18.320/ 18.350/ 18.360/ 18.390/ 18.400/ 18.410/ 18.430/ 18.440/ 18.480/ 18.510/ 18.530/ 19.350/ 19.360/ 19.390/ 19.400/ 19.430/ 19.440/ 19.480	FA, FC, FH, FK, FL, FA, FC, FK, FL, FA, FH, FA, FL, FC, FK, FL, FL-, FC-, FK-WW	09.02-05.10	ZE	180	1000	T5 077	170	1000	T4 077	155	900	T3 077
18.310/ 18.360/ 18.410/ 18.480	F, FA	09.02-09.06	ZE	180	1000	T5 077	170	1000	T4 077	155	900	T3 077
18.320/ 18.360/ 18.400/ 18.440	F, FL	02.07-08.08	ZE	180	1000	T5 077	170	1000	T4 077	155	900	T3 077
18.460	F, FL	09.02-05.04	ZE	180	1000	T5 077	170	1000	T4 077	155	900	T3 077
18.480	F, FL	07.06-09.07	ZE	180	1000	T5 077	170	1000	T4 077	155	900	T3 077
		07.06-08.08	ZE	180	1000	T5 077	170	1000	T4 077	155	900	T3 077
		04.08-08.08	ZE	180	1000	T5 077	170	1000	T4 077	155	900	T3 077
18.530	F, FL	11.02-09.04	ZE	180	1000	T5 077	170	1000	T4 077	155	900	T3 077
18.540	F, FL	02.07-08.08	ZE	180	1000	T5 077	170	1000	T4 077	155	900	T3 077
24.350/ 24.360/ 24.390/ 24.400/ 24.430/ 24.440/ 24.480/ 24.530/ 26.310/ 26.320/ 26.350/ 26.360/ 26.390/ 26.400/ 26.410/ 26.430/ 26.440/ 26.460/ 26.480/ 26.510/ 26.530/ 26.540/ 28.310/ 28.320/ 28.350/ 28.360/ 28.390/ 28.400/ 28.430/ 28.440/ 28.480/ 28.540/ 32.310/ 32.350/ 32.360/ 32.390/ 32.400/ 32.410/ 32.430/ 32.440/ 32.460/ 32.480/ 33.310/ 33.350/ 33.360/ 33.390/ 33.400/ 33.430/ 33.440/ 33.460/ 33.480/ 35.310/ 35.350/ 35.360/ 35.390/ 35.400/ 35.410/ 35.430/ 35.440/ 35.460/ 35.480/ 35.530/ 37.350/ 37.360/ 37.390/ 37.400/ 37.410/ 37.430/ 37.440/ 37.460/ 37.480/ 37.530/ 39.390/ 39.400/ 39.430/ 39.440/ 39.480/ 40.390/ 40.400/ 40.410/ 40.430/ 40.440/ 40.480/ 41.350/ 41.360/ 41.390/ 41.400/ 41.410/ 41.430/ 41.440/ 41.460/ 41.480/ 41.530/ 41.540		06.02-05.10	ZE	225	1150	T5 080	170	1000	T4 077	155	900	T3 077
	FD, FD, FDA, FD-, FDA-WW, FD, FFD, FD, FFD, FV, FD, FH, FN, FV, FD, FV, FDA, FDA-WW, FD-WW, FFD, FFDC, FFDK, FFD-WW, FN, FN, FP, FN, FP, FV, FV, FV-WW, L, FL, VF											

			Ah	A (EN)		Ah	A (EN)		Ah	A (EN)	
0 092 ...0						0 092 ...0			0 092 ...0		
24.360/ 24.400/ 24.410/ 24.440/ 24.460/ 24.480/ 24.510/ 24.540/ 26.280/ 26.310/ 26.330/ 26.360/ 26.410/ 26.480/ 26.530/ 28.310/ 28.320/ 28.350/ 28.360/ 28.410/ 28.440/ 28.460/ 28.480/ 28.510/ 28.530/ 32.360/ 32.410/ 32.530/ 33.350/ 33.390/ 33.410/ 33.430/ 33.460/ 33.480/ 33.510/ 33.530/ 40.410/ 40.480 , DA, DF	09.02-08.08	ZE	225	1150	T5 080	170	1000	T4 077	155	900	T3 077
26.440 F, FL	02.07-09.07	ZE	225	1150	T5 080	170	1000	T4 077	155	900	T3 077
41.660 FD, FD, FDA, FD-, FDA-WW, FD, FFD, FD, FFD, FV, FD, FH, FN, FV, FD, FV, FDA, FDA-WW, FD-WW, FFD, FFDK, FFDK, FFD-WW, FN, FN, FP, FN, FP, FV, FV, FV-WW, L, FL, VF	04.03-09.06	ZE	225	1150	T5 080	170	1000	T4 077	155	900	T3 077
TGL											
7.150/ 7.180/ 8.150/ 8.180/ 8.210/ 8.240/ 10.180/ 10.210/ 10.240/ 12.180/ 12.210/ 12.240 , L	05.05→	ZE	145	800	T5 075	140	800	T4 075	120	680	T3 075
TGM											
12.240/ 12.280/ 13.240/ 13.280/ 15.240/ 15.280/ 15.330/ 18.240/ 18.280/ 18.330/ 26.280/ 26.330 , L	10.05→	ZE	180	1000	T5 077	140	800	T4 075	120	680	T3 075
TGS											
18.320/ 18.360/ 18.400/ 18.440/ 18.480/ 18.540	10.07→	ZE	180	1000	T5 077	170	1000	T4 077	155	900	T3 077
18.480 F, FL	04.08→	ZE	180	1000	T5 077	170	1000	T4 077	155	900	T3 077
24.320/ 24.360/ 24.400/ 24.440/ 24.480	10.07→	ZE	225	1150	T5 080	170	1000	T4 077	155	900	T3 077
24.480 DF	04.08→	ZE	225	1150	T5 080	170	1000	T4 077	155	900	T3 077
TGX											
18.360/ 18.400/ 18.440/ 18.480/ 18.540/ 18.680	10.07→	ZE	180	1000	T5 077	170	1000	T4 077	155	900	T3 077
18.480 F, FL	04.08→	ZE	180	1000	T5 077	170	1000	T4 077	155	900	T3 077
24.360/ 24.400/ 24.440/ 24.480/ 26.360/ 26.400/ 26.440/ 26.480/ 26.540/ 28.360/ 28.400/ 28.440/ 28.480/ 28.540/ 33.360/ 33.400/ 33.440/ 33.480/ 33.540/ 33.680	10.07→	ZE	225	1150	T5 080	170	1000	T4 077	155	900	T3 077
33.480 DF	04.08→	ZE	225	1150	T5 080	170	1000	T4 077	155	900	T3 077
ÜL											
242/ 272/ 292/ 312/ 313/ 322/ 353 [A01,A04; 893]	09.89-09.06	ZE	180	1000	T5 077						
363 [A01,A04]	01.01-09.06	ZE	225	1150	T5 080	215	1150	T4 080			
6t											
6.100/ 6.90 F	10.79-10.93	ZE	145	800	T5 075	140	800	T4 075	120	680	T3 075
8t											
8.100/ 8.136/ 8.150/ 8.90 F, FAE, FAKO, FL	10.79-05.95	ZE	145	800	T5 075	140	800	T4 075	120	680	T3 075
9t											
9.136/ 9.150 F, FAE, FAKO, FL	10.79-05.95	ZE	145	800	T5 075	140	800	T4 075	120	680	T3 075



			Ah A (EN) 				Ah A (EN) 				Ah A (EN) 			
◀ MAN			0092 ...0				0092 ...0				0092 ...0			
10t														
10.136/ 10.150 F, FL	09.81-10.93	ZE	145	800	T5 075	140	800	T4 075	120	680	T3 075			
12t														
12.136/ 12.152/ 12.162/ 12.170/ 12.192/ 12.222/ 12.232/ 12.262/ 12.272 F, FA, FL, FR	04.83-06.97	ZE	180	1000	T5 077	140	800	T4 075	120	680	T3 075			
14t														
14.136/ 14.152/ 14.162/ 14.170/ 14.192/ 14.220/ 14.222/ 14.232/ 14.262/ 14.272 F, FA, FL, FR, U, UL	06.75-06.97	ZE	180	1000	T5 077	140	800	T4 075	120	680	T3 075			
15t														
15.168/ 15.192/ 15.220/ 15.240 F, FL, H, HK, HS	11.76-02.89	ZE	180	1000	T5 077	140	800	T4 075	120	680	T3 075			
16t														
16.136/ 16.170 F	03.84-11.86	ZE	145	800	T5 075	140	800	T4 075	120	680	T3 075			
FL	09.84-11.86	ZE	145	800	T5 075	140	800	T4 075	120	680	T3 075			
16.168/ 16.192/ 16.220/ 16.240 F	11.76-12.86	ZE	180	1000	T5 077	140	800	T4 075	120	680	T3 075			
FL	11.76-12.86	ZE	180	1000	T5 077	140	800	T4 075	120	680	T3 075			
16.168/ 16.192/ 16.240/ 16.280 FR, FT, H, H, HK, HS, HA, HK, HS	01.77-06.89	ZE	180	1000	T5 077	140	800	T4 075	120	680	T3 075			
16.170 FA	02.85-11.86	ZE	145	800	T5 075	140	800	T4 075	120	680	T3 075			
16.192/ 16.220/ 16.240 FA	01.77-12.86	ZE	180	1000	T5 077	140	800	T4 075	120	680	T3 075			
17t														
17.136/ 17.170 F	11.86-08.88	ZE	145	800	T5 075	140	800	T4 075	120	680	T3 075			
FL	11.86-08.88	ZE	145	800	T5 075	140	800	T4 075	120	680	T3 075			
FR	11.86-08.88	ZE	145	800	T5 075	140	800	T4 075	120	680	T3 075			
FRL	11.86-08.88	ZE	145	800	T5 075	140	800	T4 075	120	680	T3 075			
17.170 FA	11.86-07.89	ZE	145	800	T5 075	140	800	T4 075	120	680	T3 075			
17.192/ 17.220/ 17.222/ 17.232/ 17.240 FA	11.86-06.96	ZE	180	1000	T5 077	140	800	T4 075	120	680	T3 075			
17.192/ 17.220/ 17.232/ 17.240 F	11.86-01.91	ZE	180	1000	T5 077	140	800	T4 075	120	680	T3 075			
FL	11.86-04.95	ZE	180	1000	T5 077	140	800	T4 075	120	680	T3 075			
17.192/ 17.240 FR	11.86-08.88	ZE	180	1000	T5 077	140	800	T4 075	120	680	T3 075			
17.240/ 17.241 H, HA	11.86-06.91	ZE	180	1000	T5 077	140	800	T4 075	120	680	T3 075			
17.272 FLS	09.91-05.95	ZE	180	1000	T5 077	140	800	T4 075	120	680	T3 075			
18t														
18.192/ 18.222/ 18.232/ 18.241/ 18.262/ 18.272 F, FL, HA	09.90-06.96	ZE	180	1000	T5 077	140	800	T4 075	120	680	T3 075			
19t														
19.240/ 19.281/ 19.291/ 19.321 F	11.76-08.88	ZE	180	1000	T5 077	140	800	T4 075	120	680	T3 075			
FA	11.76-02.89	ZE	180	1000	T5 077	140	800	T4 075	120	680	T3 075			
19.240/ 19.281/ 19.321 FLS, H, HA	06.77-01.88	ZE	180	1000	T5 077	140	800	T4 075	120	680	T3 075			
19.240/ 19.291 FL	08.77-08.88	ZE	180	1000	T5 077	140	800	T4 075	120	680	T3 075			
19.321 U	01.79-08.86	ZE	180	1000	T5 077	140	800	T4 075	120	680	T3 075			
UL	06.79-08.86	ZE	180	1000	T5 077	140	800	T4 075	120	680	T3 075			
19.331/ 19.361 FA	04.85-08.88	ZE	180	1000	T5 077	170	1000	T4 077	155	900	T3 077			
U	09.83-07.89	ZE	180	1000	T5 077	170	1000	T4 077	155	900	T3 077			
UL	09.83-07.89	ZE	180	1000	T5 077	170	1000	T4 077	155	900	T3 077			
19.331/ 19.361/ 19.390 F	12.82-12.87	ZE	180	1000	T5 077	170	1000	T4 077	155	900	T3 077			
FL	12.82-12.87	ZE	180	1000	T5 077	170	1000	T4 077	155	900	T3 077			
20t														
20.280 DFAEG	05.78-06.90	ZE	180	1000	T5 077	140	800	T4 075	120	680	T3 075			
20.281/ 20.291 FVLS	04.80-11.86	ZE	180	1000	T5 077	140	800	T4 075	120	680	T3 075			
20.321/ 20.331/ 20.361 FVLS	04.80-11.86	ZE	180	1000	T5 077	170	1000	T4 077	155	900	T3 077			

						Ah A (EN) T5		Ah A (EN) T4		Ah A (EN) T3		
						0 092 ...0		0 092 ...0		0 092 ...0		
22t												
22.220/ 22.240/ 22.281/ 22.291	FNL	11.76-11.86	ZE	180	1000	T5 077	140	800	T4 075	120	680	T3 075
22.240	FVL, H	06.77-12.88	ZE	180	1000	T5 077	140	800	T4 075	120	680	T3 075
22.281	FNLS	04.80-11.85	ZE	180	1000	T5 077	140	800	T4 075	120	680	T3 075
22.321	FNLS	04.80-11.85	ZE	180	1000	T5 077	170	1000	T4 077	155	900	T3 077
22.321/ 22.331/ 22.361	FNL	04.80-11.86	ZE	180	1000	T5 077	170	1000	T4 077	155	900	T3 077
	UNL, UNL, UNLW	06.79-11.86	ZE	180	1000	T5 077	170	1000	T4 077	155	900	T3 077
24t												
24.192	FVL-KO	05.87-12.90	ZE	180	1000	T5 077	140	800	T4 075	120	680	T3 075
24.192/ 24.240/ 24.291	FVL	11.86-08.88	ZE	180	1000	T5 077	140	800	T4 075	120	680	T3 075
24.220/ 24.240/ 24.291	FNL	11.86-08.88	ZE	180	1000	T5 077	140	800	T4 075	120	680	T3 075
24.331	FVL	11.86-08.88	ZE	180	1000	T5 077	170	1000	T4 077	155	900	T3 077
24.331/ 24.361	FNL	11.86-09.87	ZE	180	1000	T5 077	170	1000	T4 077	155	900	T3 077
	FVLS, UNL	11.86-07.89	ZE	180	1000	T5 077	170	1000	T4 077	155	900	T3 077
26t												
26.240	DF	01.77-08.88	ZE	180	1000	T5 077	140	800	T4 075	120	680	T3 075
	DFK, DF-TM	01.77-08.88	ZE	180	1000	T5 077	140	800	T4 075	120	680	T3 075
	DH	08.77-01.88	ZE	180	1000	T5 077	140	800	T4 075	120	680	T3 075
	DHA	08.77-01.88	ZE	180	1000	T5 077	140	800	T4 075	120	680	T3 075
26.281/ 26.291/ 26.321/ 26.331/ 26.361/ 26.365	DF, DFK, DFS, DFA, DFA, DFAK, DFAS, DFLS	02.80-02.89	ZE	180	1000	T5 077	170	1000	T4 077	155	900	T3 077
26.281/ 26.321	DH	03.80-01.88	ZE	180	1000	T5 077	170	1000	T4 077	155	900	T3 077
	DHA	03.80-01.88	ZE	180	1000	T5 077	170	1000	T4 077	155	900	T3 077
26.291/ 26.320/ 26.331/ 26.361/ 26.365	DF	07.72-08.88	ZE	180	1000	T5 077	170	1000	T4 077	155	900	T3 077
27t												
27.322	DF	01.93-06.96	ZE	180	1000	T5 077	170	1000	T4 077	155	900	T3 077
	DFA	01.93-06.96	ZE	180	1000	T5 077	170	1000	T4 077	155	900	T3 077
27.365	VFAEG	11.82-12.90	ZE	180	1000	T5 077	170	1000	T4 077	155	900	T3 077
27.372/ 27.502	DF	01.93-06.96	ZE	180	1000	T5 077	140	800	T4 075	120	680	T3 075
	DFA	01.93-06.96	ZE	180	1000	T5 077	140	800	T4 075	120	680	T3 075
30t												
30.281	VF	06.80-11.85	ZE	180	1000	T5 077	140	800	T4 075	120	680	T3 075
	VFA	05.82-11.85	ZE	180	1000	T5 077	140	800	T4 075	120	680	T3 075
30.291	VF, VF-TM	09.85-11.86	ZE	180	1000	T5 077	170	1000	T4 077	155	900	T3 077
30.291/ 30.321/ 30.331/ 30.361	VFA	05.82-11.86	ZE	180	1000	T5 077	170	1000	T4 077	155	900	T3 077
30.321/ 30.331/ 30.361	VF	06.80-11.86	ZE	180	1000	T5 077	170	1000	T4 077	155	900	T3 077
32t												
32.240	DF	01.77-08.88	ZE	180	1000	T5 077	140	800	T4 075	120	680	T3 075
	DH	08.77-01.88	ZE	180	1000	T5 077	140	800	T4 075	120	680	T3 075
	DHA	08.77-01.88	ZE	180	1000	T5 077	140	800	T4 075	120	680	T3 075
32.281/ 32.291/ 32.321/ 32.331/ 32.361/ 32.365	DF, DFK, DFS, DFA, DFA, DFAK, DFAS	02.80-08.88	ZE	180	1000	T5 077	170	1000	T4 077	155	900	T3 077
32.281/ 32.321	DH	03.80-01.88	ZE	180	1000	T5 077	170	1000	T4 077	155	900	T3 077
	DHA	03.80-01.88	ZE	180	1000	T5 077	170	1000	T4 077	155	900	T3 077
32.291/ 32.331/ 32.361	VF, VFAK	11.86-08.88	ZE	180	1000	T5 077	170	1000	T4 077	155	900	T3 077
32.291/ 32.331/ 32.361/ 32.365	DF	06.83-08.88	ZE	180	1000	T5 077	170	1000	T4 077	155	900	T3 077
33t												
33.321/ 33.331	VF	12.80-02.90	ZE	180	1000	T5 077	170	1000	T4 077	155	900	T3 077
40t												
40.365/ 40.372/ 40.402/ 40.422/ 40.440/ 40.462/ 40.502	DF, DFA	10.81-06.96	ZE	180	1000	T5 077	170	1000	T4 077	155	900	T3 077



			Ah	A (EN)		Ah	A (EN)		Ah	A (EN)	
0092 ...0						0092 ...0			0092 ...0		

◀ MAN

41t											
41.262/ 41.272/ 41.292/ 41.322/ 41.332/ 41.342/ 41.361/ 41.362/ 41.372/ 41.402/ 41.422 VF, VFA, VFS	01.85-06.96	ZE	180	1000	T5 077	170	1000	T4 077	155	900	T3 077
48t											
48.292/ 48.321/ 48.331/ 48.332/ 48.362/ 48.462 VF, VFAK	04.83-06.90	ZE	180	1000	T5 077	170	1000	T4 077	155	900	T3 077

MERCEDES-BENZ

Actros											
1831/ 1835/ 1840/ 1843/ 1848/ 1853/ 1857/ 2031/ 2035/ 2040/ 2043/ 2048/ 2053/ 2531/ 2535/ 2540/ 2543/ 2548/ 2553/ 2557/ 2631/ 2635/ 2640/ 2643/ 2648/ 2653/ 2657/ 3231/ 3235/ 3240/ 3243/ 3331/ 3335/ 3340/ 3343/ 3348/ 3353/ 3357/ 4140/ 4143/ 4148 , A, AK, AS, L [SKN]	09.96-09.03	ZE	225	1150	T5 080	170	1000	T4 077			
Actros II											
1832/ 1836/ 1841/ 1844/ 1846/ 1848/ 1850/ 1851/ 1854/ 1855/ 1858/ 1860/ 1861/ 2032/ 2036/ 2041/ 2044/ 2046/ 2048/ 2050/ 2051/ 2054/ 2055/ 2532/ 2536/ 2541/ 2544/ 2546/ 2548/ 2550/ 2551/ 2554/ 2555/ 2558/ 2560/ 2632/ 2636/ 2641/ 2644/ 2646/ 2648/ 2650/ 2651/ 2654/ 2655/ 2658/ 3232/ 3236/ 3241/ 3246/ 3248/ 3332/ 3336/ 3341/ 3344/ 3346/ 3348/ 3350/ 3351/ 3354/ 3355/ 3358/ 3360/ 4141/ 4144/ 4146/ 4148/ 4150/ 4151 , Black Edition, BlueTec [MP2]	04.03-12.08	ZE	225	1150	T5 080	170	1000	T4 077			
Actros III											
1832/ 1836/ 1841/ 1844/ 1846/ 1848/ 1851/ 1855/ 1860/ 2048/ 2051/ 2055/ 2532/ 2536/ 2541/ 2544/ 2546/ 2548/ 2551/ 2555/ 2560/ 2648/ 2651/ 2655/ 2660/ 3248/ 3332/ 3348/ 3351/ 3355/ 3360/ 4141 BlueTec [MP3]	06.08→	ZE	225	1150	T5 080	170	1000	T4 077			
2441/ 2444 LS BlueTec [MP3]	12.09→		225	1150	T5 080	170	1000	T4 077			
2441/ 2446/ 3244 BlueTec [MP3]	06.08→		225	1150	T5 080	170	1000	T4 077			
4144 BlueTec [MP3]	06.08→	ZE	225	1150	T5 080	170	1000	T4 077			
	12.09→		225	1150	T5 080	170	1000	T4 077			
4146/ 4148/ 4151/ 4155/ 4160 BlueTec [MP3]	06.08→	ZE	225	1150	T5 080	170	1000	T4 077			





Atego											
712/ 714/ 715/ 717/ 812/ 814/ 815/ 817/ 818/ 823/ 915/ 917/ 918/ 923/ 925/ 1015/ 1017/ 1018/ 1023/ 1214/ 1215/ 1217/ 1218/ 1223/ 1225/ 1228/ 1317/ 1318/ 1323/ 1325/ 1328/ 1517/ 1518/ 1523/ 1525/ 1528/ 1823/ 1828/ 1833/ 2523/ 2528/ 2533/ 2628/ 2633	01.98-10.04	ZE	180	1000	T5 077	140	800	T4 075	120	680	T3 075
, A, AF, AK, B, F, K, KO, L, LKO, LS [LKN]											
Atego II											
713/ 716/ 813/ 816/ 818/ 822/ 824/ 916/ 918/ 922/ 924/ 1016/ 1018/ 1022/ 1024/ 1216/ 1218/ 1222/ 1224/ 1226/ 1318/ 1322/ 1324/ 1326/ 1518/ 1522/ 1524/ 1526/ 1924/ 1926/ 1929/ 2224/ 2226/ 2229	10.04→	ZE	180	1000	T5 077	140	800	T4 075	120	680	T3 075
BlueTec, L BlueTec											
818	09.04→		180	1000	T5 077	140	800	T4 075	120	680	T3 075
822/ 922/ 1022/ 1222/ 1229/ 1322/ 1329/ 1522/ 1529	09.04→	ZE	180	1000	T5 077	140	800	T4 075	120	680	T3 075
Axor											
1823/ 1828/ 1835/ 1840/ 1843/ 2523/ 2528/ 2535/ 2540/ 2543/ 2628	01.02-08.06	ZE	225	1150	T5 080	170	1000	T4 077			
, LS											
Axor II											
1824/ 1826/ 1829/ 1833/ 1836/ 1840/ 1843/ 2529/ 2533/ 2536/ 2540/ 2543/ 2629/ 2633/ 2636/ 2640/ 2643/ 3236/ 3240/ 3243/ 3335/ 3340/ 3343	09.04→	ZE	225	1150	T5 080	170	1000	T4 077			
Citaro											
O 530 GNG3 UESTRA, GNUE3, GN3, GN3 UESTRA, N, GN 3, NUE3, N3, N3 UESTRA, N3/NUE3	01.98→	ZE	225	1150	T5 080						
Citaro L											
O 530 N3	01.99-09.06	ZE	225	1150	T5 080						
Cito											
O 520	01.99-09.03	ZE	225	1150	T5 080						
Conecto											
O 345	05.01-08.07	ZE	225	1150	T5 080						
Econic											
1823/ 1824/ 1828/ 1829/ 1833/ 2628/ 2629/ 2633/ 3233	03.98→	ZE	225	1150	T5 080	170	1000	T4 077			
, L, NGT											
O 301											
/F	02.86-02.01	ZE	145	800	T5 075	140	800	T4 075	120	680	T3 075
O 303											
	01.80-09.92	ZE				170	1000	T4 078			
O 305											
/G	11.76-05.87	ZE	225	1150	T5 080	170	1000	T4 077	155	900	T3 077
O 307											
	11.76-07.87	ZE	225	1150	T5 080	170	1000	T4 077	155	900	T3 077
O 309											
B	08.82-02.89								88	680	T3 013



				Ah A (EN) T5			Ah A (EN) T4			Ah A (EN) T3		
				0092 ...0			0092 ...0			0092 ...0		
◀ MERCEDES-BENZ												
D	01.70-02.89	ZE							88	680	T3 013	
O 402												
/F	02.86-02.01	ZE	180	1000	T5 077	140	800	T4 075	120	680	T3 075	
O 404												
	09.91-10.99	ZE	225	1150	T5 080	170	1000	T4 077				
O 405												
/E/G/GAS/GN/GNDE/ GN-G/GNTD/GT/GTD/GTZ/ N/N-G/N1	10.84-02.01	ZE	225	1150	T5 080	170	1000	T4 077				
O 407												
	03.87-02.01	ZE	225	1150	T5 080	170	1000	T4 077				
O 408												
	01.91-12.01	ZE				170	1000	T4 078				
Sprinter												
208/ 210/ 211/ 212/ 213/ 214/ 216/ 308/ 310/ 311/ 312/ 313/ 314/ 316/ 408/ 410/ 411/ 412/ 413/ 414/ 416/ 418/ 424/ 509/ 511/ 515/ 518/ 524/ 616 , CDI, CDI James Cook, CDI 4x4, D, D James Cook, James Cook, NGT [; NCV3; T1N]	02.95→								88	680	T3 013	
Tourino												
O 510	01.04→	ZE	225	1150	T5 080							
Tourismo												
O 350/ 15 , RHD/SHD	10.95-09.06	ZE	225	1150	T5 080							
Touro												
OC 500	10.02-08.08	ZE	225	1150	T5 080							
Travego												
O 580 , RH(D)-15, RHD-17	10.99→	ZE	225	1150	T5 080							
Unimog												
U 90/ U 110/ U 130/ U 140/ U 800/ U 900/ U 1000/ U 1100/ U 1150	01.77-09.01		145	800	T5 075	140	800	T4 075	120	680	T3 075	
U 100/ U 110/ U 140/ U 800/ U 1100/ U 1150/ U 1700 L	01.77-09.01		145	800	T5 075	140	800	T4 075	120	680	T3 075	
U 130/ U 140 T	07.92-09.98		145	800	T5 075	140	800	T4 075	120	680	T3 075	
U 300/ U 300/400/ U 400/ U 500	04.00→	ZE	145	800	T5 075	140	800	T4 075	120	680	T3 075	
U 600	01.77-05.88								100	600	T3 072	
	05.88-02.01								110	850	T3 073	
L	01.77-05.88								100	600	T3 072	
T	01.77-05.88								100	600	T3 072	
U 650	05.88-02.01								110	850	T3 073	
U 1100 T	01.77-05.88		145	800	T5 075	140	800	T4 075	120	680	T3 075	
	03.89-02.01		145	800	T5 075	140	800	T4 075	120	680	T3 075	
U 1200	02.82-05.88		145	800	T5 075	140	800	T4 075	120	680	T3 075	
	01.88-02.01	ZE	145	800	T5 075	140	800	T4 075	120	680	T3 075	
T	01.83-05.88		145	800	T5 075	140	800	T4 075	120	680	T3 075	
	01.88-02.01	ZE	145	800	T5 075	140	800	T4 075	120	680	T3 075	
U 1250	12.84-05.88		145	800	T5 075	140	800	T4 075	120	680	T3 075	
	01.88-02.01	ZE	145	800	T5 075	140	800	T4 075	120	680	T3 075	
U 1250/ U 1300/ U 1350/ U 1450/ U 1550/ U 1650/ U 1750/ U 1850/ U 2100/ U 2150 L	01.77-08.02	ZE	145	800	T5 075	140	800	T4 075	120	680	T3 075	
U 1400/ U 1450/ U 1600/ U 1650	01.88-09.02	ZE	145	800	T5 075	140	800	T4 075	120	680	T3 075	
U 1400/ U 1700/ U 1800 T	01.88-08.02	ZE	145	800	T5 075	140	800	T4 075	120	680	T3 075	
U 1500 T	01.77-05.88		145	800	T5 075	140	800	T4 075	120	680	T3 075	
U 1500/ U 1550	01.77-05.88		145	800	T5 075	140	800	T4 075	120	680	T3 075	
U 1700	05.78-09.88		145	800	T5 075	140	800	T4 075	120	680	T3 075	

			0 092 ...0			0 092 ...0			0 092 ...0		
			Ah	A (EN)	T5	Ah	A (EN)	T4	Ah	A (EN)	T3
U 1700	09.88-02.01	ZE	145	800	T5 075	140	800	T4 075	120	680	T3 075
U 1750/ U 1800/ U 1850/ U 2100/ U 2150/ U 2400/ U 2450	09.88-08.02	ZE	145	800	T5 075	140	800	T4 075	120	680	T3 075
U 2400 TG	07.93-08.02	ZE	145	800	T5 075	140	800	T4 075	120	680	T3 075
U 3000/ U 4000/ U 4000/ 5000/ U 5000	09.02→	ZE							100	600	T3 072
UX											
100	08.96→					140	800	T4 076			
Vario											
512/ 612/ 614/ 615/ 618/ 810/ 812/ 814/ 815/ 818	01.96-09.06	ZE							88	680	T3 013
, D, DA, DT [T2W]											
Vito											
113/ 114 [638 TON]	11.95-09.03								88	680	T3 013
2t											
207/ 208/ 209/ 210 , D [T1]	08.77-06.95								88	680	T3 013
3t											
307/ 308/ 309/ 310 , D [T1]	08.77-06.95								88	680	T3 013
4t											
407/ 408/ 409/ 410 , D [T1]	07.81-06.95								88	680	T3 013
5t											
L 508 DG	01.70-12.88	ZE							88	680	T3 013
507/ 508/ 510 , D	04.86-02.01		145	800	T5 075	140	800	T4 075	88	680	T3 013
6t											
L 608 D	01.70-12.88	ZE							88	680	T3 013
609/ 611 D	04.86-09.01	ZE	145	800	T5 075	140	800	T4 075	88	680	T3 013
7t											
709/ 711 [LK]	03.84-12.99	ZE				140	800	T4 076	88	680	T3 013
709/ 711/ 714 D	04.86-02.01	ZE	145	800	T5 075	140	800	T4 075	88	680	T3 013
8t											
809/ 810/ 811/ 814 D, DA, DT	04.86-02.01	ZE	145	800	T5 075	140	800	T4 075	88	680	T3 013
809/ 811/ 814/ 817 , F, KO, L, LO, O [LK]	03.84-12.99	ZE				140	800	T4 076	88	680	T3 013
9t											
L 911/ LA 911 B	10.68-02.01								100	600	T3 072
914/ 917 , AF, AK, Export, KO, O [LK]	03.84-12.99	ZE				140	800	T4 076	88	680	T3 013
10t											
1013/ 1017 , A, LS	11.75-02.91		180	1000	T5 077	140	800	T4 075	120	680	T3 075
11t											
L 1113/ LA 1113/ LKO 1113 B	10.69-02.01		145	800	T5 075	140	800	T4 075	120	680	T3 075
O 1114/ 1114/ 1117/ 1120/ 1124 , A, A Export, AF, AK, Export, F, L, LO, O [LK]	03.84-12.99	ZE				140	800	T4 076	88	680	T3 013
12t											
1213/ 1217 , A, K, AK, KO, KO, AKO, L, LS, S, AS	09.75-05.86		180	1000	T5 077	140	800	T4 075	120	680	T3 075
1217 KO [LK]	03.94-12.99					140	800	T4 076	88	680	T3 013
1222 , A, AF	05.82-12.91	ZE	180	1000	T5 077	140	800	T4 075	120	680	T3 075
1222/ 1224/ 1226/ 1227/ 1234 , A, AF, F [MK]	07.89→	ZE	180	1000	T5 077	140	800	T4 075	120	680	T3 075
13t											
L 1313/ LA 1313/ LF 1313	01.67-02.01								100	600	T3 072
1314/ 1317/ 1320/ 1324 , AK, K, KO, L [LK]	07.84→	ZE				140	800	T4 076	88	680	T3 013
1317	03.96-12.99	ZE				140	800	T4 076	88	680	T3 013
14t											
1414/ 1420/ 1422/ 1428	08.73-09.96	ZE	180	1000	T5 077	140	800	T4 075	120	680	T3 075
1417/ 1419/ 1422/ 1424 C, CA, CL, F	07.75-03.91	ZE	180	1000	T5 077	140	800	T4 075	120	680	T3 075



			Ah A (EN) T5			Ah A (EN) T4			Ah A (EN) T3		
◀ MERCEDES-BENZ			0092 ...0			0092 ...0			0092 ...0		
1417/ 1420/1422/ 1424/ 1426/ 1427/ 1431 , A, F, L, LS, S [MK]	12.87→	ZE	180	1000	T5 077	140	800	T4 075	120	680	T3 075
1419/ 1424 L	09.76-01.87		180	1000	T5 077	140	800	T4 075	120	680	T3 075
1420/ 1422 L	08.82-03.91	ZE	180	1000	T5 077	140	800	T4 075	120	680	T3 075
1424	07.75-01.87		180	1000	T5 077	140	800	T4 075	120	680	T3 075
1425 LS, S	11.82-03.91	ZE	180	1000	T5 077	140	800	T4 075	120	680	T3 075
15t											
L 1513/ LA 1513	10.69-02.01								100	600	T3 072
1514/ 1517/ 1520/ 1524 , L [LK]	10.88→	ZE				140	800	T4 076	88	680	T3 013
16t											
1614/ 1620/ 1622/ 1625/ 1628/ 1633/ 1635/ 1636/ 1638/ 1644	01.80-03.91	ZE	180	1000	T5 077	140	800	T4 075	120	680	T3 075
1617/ 1619	11.74-05.87		180	1000	T5 077	140	800	T4 075	120	680	T3 075
K, KA, KO	11.74-01.87		180	1000	T5 077	140	800	T4 075	120	680	T3 075
1617/ 1619/ 1622/ 1625 A, C, CA, CL	10.80-03.91	ZE	180	1000	T5 077	140	800	T4 075	120	680	T3 075
1617/ 1619/ 1624 L	02.77-01.87		180	1000	T5 077	140	800	T4 075	120	680	T3 075
1620/ 1622/ 1625/ 1628/ 1633/ 1635/ 1636 L	01.80-03.91	ZE	180	1000	T5 077	140	800	T4 075	120	680	T3 075
1624 [MK]	02.93-08.96	ZE	180	1000	T5 077	140	800	T4 075	120	680	T3 075
1638/ 1644 LS	06.81-08.89	ZE	180	1000	T5 077	140	800	T4 075	120	680	T3 075
17t											
1717/ 1720/ 1722/ 1726/ 1727/ 1729/ 1733/ 1734/ 1735/ 1748 , AK, K, L [MK; SK]	12.87-02.01	ZE	180	1000	T5 077	140	800	T4 075	120	680	T3 075
1720/ 1724 [LK]	01.84-02.01	ZE				140	800	T4 076	88	680	T3 013
18t											
1820/ 1824/ 1827/ 1831/ 1834/ 1838/ 1840/ 1844/ 1850/ 1853 , AK, K, L, LS [MK; SK]	12.90→	ZE	180	1000	T5 077	140	800	T4 075	120	680	T3 075
19t											
L 1924/ L 1928	05.79-02.01	ZE	145	800	T5 075	140	800	T4 075	120	680	T3 075
1922/ 1926/ 1929/ 1935/ 1948 , A, AK, K, L [MK; SK]	12.87-09.96	ZE	180	1000	T5 077	140	800	T4 075	120	680	T3 075
1922/ 1928/ 1933/ 1935/ 1936/ 1938/ 1944	01.80-03.91	ZE	180	1000	T5 077	140	800	T4 075	120	680	T3 075
1922/ 1928/ 1933/ 1935/ 1936/ 1944 A, L, LS	01.80-03.91	ZE	180	1000	T5 077	140	800	T4 075	120	680	T3 075
20t											
2020/ 2024 , L [LK]	01.84-02.01	ZE				140	800	T4 076	88	680	T3 013
2024/ 2025/ 2027/ 2028/ 2031/ 2033/ 2035/ 2036/ 2038/ 2044/ 2050/ 2055 , A, AK, AS, LS, S [; SK]	01.80-02.01	ZE	180	1000	T5 077	140	800	T4 075	120	680	T3 075
22t											
2219 A, K, KO	06.76-06.87		180	1000	T5 077	140	800	T4 075	120	680	T3 075
L	11.76-01.87		180	1000	T5 077	140	800	T4 075	120	680	T3 075
2219/ 2220/ 2222/ 2225/ 2228/ 2233/ 2235/ 2236/ 2238/ 2244 , B, C, CL	12.79-03.91	ZE	180	1000	T5 077	140	800	T4 075	120	680	T3 075
2220/ 2222/ 2228/ 2233/ 2235/ 2238/ 2244 L	12.79-03.91	ZE	180	1000	T5 077	140	800	T4 075	120	680	T3 075
23t											
2320/ 2327 [MK]	02.93-09.96	ZE	180	1000	T5 077	140	800	T4 075	120	680	T3 075
24t											
2420/ 2422/ 2425/ 2426/ 2427/ 2428/ 2429/ 2431/ 2433/ 2434/ 2435/ 2438/ 2444/ 2448 , B, K, L [; MK; SK]	12.79-09.96	ZE	180	1000	T5 077	140	800	T4 075	120	680	T3 075

			Ah	A (EN)		Ah	A (EN)		Ah	A (EN)	
0 092 ...0					0 092 ...0				0 092 ...0		

25t											
2522/ 2524/ 2527/ 2528/ 2531/ 2534/ 2536/ 2538/ 2544/ 2550/ 2553 , A, B, K, L [; MK; SK]	01.86→	ZE	180	1000	T5 077	140	800	T4 075	120	680	T3 075
26t											
L 2624/ L 2628	01.78-02.01	ZE	145	800	T5 075	140	800	T4 075	120	680	T3 075
2628/ 2633/ 2635/ 2636/ 2638/ 2644	02.80-03.91	ZE	180	1000	T5 077	140	800	T4 075	120	680	T3 075
2628/ 2635/ 2636 A, B	02.80-03.91	ZE	180	1000	T5 077	140	800	T4 075	120	680	T3 075
2629/ 2631/ 2634/ 2635/ 2638/ 2644/ 2648/ 2650/ 2653 , A, AK, AS, K, L, S [SK]	07.88-09.96	ZE	180	1000	T5 077	140	800	T4 075	120	680	T3 075
30t											
3025/ 3028/ 3033/ 3036/ 3038/ 3050 , B, K [; SK]	02.80-02.01	ZE	180	1000	T5 077	140	800	T4 075	120	680	T3 075
32t											
3225/ 3228/ 3229/ 3231/ 3233/ 3234/ 3235/ 3238/ 3244/ 3248/ 3250/ 3253 , A, B, K, K [; MK; SK]	09.85-02.01	ZE	180	1000	T5 077	140	800	T4 075	120	680	T3 075
33t											
3328/ 3333/ 3335/ 3336/ 3338 , A, B	01.81-11.91	ZE	180	1000	T5 077	140	800	T4 075	120	680	T3 075
35t											
3528/ 3529/ 3534/ 3535/ 3538/ 3544/ 3548/ 3550/ 3553 , A, AK, K, L, S [; SK]	07.82-09.96	ZE	180	1000	T5 077	140	800	T4 075	120	680	T3 075
38t											
3836/ 3850 , A	11.81-08.94	ZE	180	1000	T5 077	140	800	T4 075	120	680	T3 075
44t											
4435 K [SK]	10.89-02.01	ZE	180	1000	T5 077	140	800	T4 075	120	680	T3 075
48t											
4844/ 4850 , A [; SK]	07.87-09.96	ZE	180	1000	T5 077	140	800	T4 075	120	680	T3 075

MITSUBISHI

Canter											
2.8 D [FE]	10.96-04.98	ZE							110	680	T3 036
Canter 35											
2.8 D Turbo Interc. [FE]	05.98-10.00	ZE							110	680	T3 036
3.0 D Turbo [FB]	11.00-02.05								110	680	T3 036
D Turbo Interc. [FE]	11.00-02.05								110	680	T3 036
Canter 55											
3.0 D Turbo Interc. [FE]	11.00-02.05								110	680	T3 036
Canter 60											
3.3 D Turbo [FE]	01.86-09.96	ZE							110	680	T3 036
D Turbo [FH]	01.86-12.96	ZE							110	680	T3 036
3.9 D Turbo [FE]	05.96-02.05								110	680	T3 036
Canter 75											
3.9 D Turbo [FE]	06.97-02.05								110	680	T3 036
D Turbo [FH]	01.98→								110	680	T3 036
5.0 D Turbo [FH]	01.88-07.97	ZE							110	680	T3 036
D Turbo Interc. [FH]	07.88-07.97	ZE							110	680	T3 036

NEOPLAN

Cityliner											
HD/ HDC/ N 113/ N 116	09.73→	ZE	225	1150	T5 080	170	1000	T4 077			
N 116/3...	09.85→	ZE	225	1150	T5 080	170	1000	T4 077			
N 118/3...	09.98→	ZE	225	1150	T5 080						

			Ah	A (EN)		Ah	A (EN)		Ah	A (EN)		
					0 092 ...0				0 092 ...0			

◀ NEOPLAN

Clubliner											
N 122 /2	10.81-09.95	ZE	225	1150	T5 080	170	1000	T4 077			
Jetliner											
N 208/ N 212/ N 213/ N 214/ N 216/ N 218/ N 221	01.72-05.01	ZE	180	1000	T5 077	170	1000	T4 077			
..., H, SHD, /3, /3...											
Jumbocruiser											
N 138 /4	08.83-12.96	ZE	225	1150	T5 080						
Metroliner											
MIC 4008/ MIC 4012/ MIC 4016	04.90-12.00	ZE	225	1150	T5 080						
N											
4007/ 4009/ 4014/ 4016/ 4020/ 4021 , NF, NF, L NF	05.86-09.99	ZE	225	1150	T5 080						
Skyliner											
N 122/ N 128 , /3..., /4	09.82-05.10	ZE	225	1150	T5 080	215	1150	T4 080	220	1150	T3 081
SL II											
	01.81-12.96	ZE	225	1150	T5 080						
Spaceliner											
N 117/ N 119 , /2, /3..., /4	08.83-05.01	ZE	225	1150	T5 080	215	1150	T4 080	220	1150	T3 081
Starliner											
N516 ...	08.96→	ZE	225	1150	T5 080	215	1150	T4 080	220	1150	T3 081
Tourline											
2216/ 2216/3 SHD, SHD-L	11.03→	ZE	225	1150	T5 080	215	1150	T4 080	220	1150	T3 081
Transliner											
N 316/ N 321 H, K, Ü, /3 K	06.89→	ZE	225	1150	T5 080	170	1000	T4 077			

NISSAN

Atleon											
120	09.00-10.06								110	680	T3 035
											T3 037
140	09.00→	ZE							110	680	T3 035
											T3 037
165	09.00→	ZE							110	680	T3 035
											T3 037
L50											
4.0 D	02.93-12.04	ZE							88	680	T3 013
L60											
4.0 D	02.93-12.04	ZE							88	680	T3 013
M											
5.9 D	03.93-12.08								88	680	T3 013
Trade											
2.0/ 2.3/ 2.8/ 3.0 D, D Turbo	03.87-12.00								66	510	T3 008

OPEL

Bedford-Blitz											
2.3 D CF	09.80-07.87								88	680	T3 013

OTOMARSAN

O 302											
	12.75-12.89	ZE	145	800	T5 075	140	800	T4 075	120	680	T3 075



PEGASO (ENASA)

Serie 1200											
1210/ 1215 .6, .8, .9	01.87→	ZE							88	680	T3 013
1214	05.82-03.87	ZE							88	680	T3 013
1217	05.82-03.87	ZE							180	1100	T3 079
1223	05.82-03.87	ZE	180	1000	T5 077	170	1000	T4 077	155	900	T3 077
1234 R, T	10.85→	ZE	180	1000	T5 077	170	1000	T4 077	155	900	T3 077
1236 .38 R, T, Troner	04.87→	ZE							180	1100	T3 079
Serie 1300											
1331 , R	05.82-03.87	ZE							180	1100	T3 079
Serie 1400											
1431/ 1434/ 1436 , G, .38 G	10.85→	ZE							180	1100	T3 079
Serie 2300											
2323/ 2331/ 2334 K, R, T, .26 K, .38 K, T, .38 R, .38 T	05.82→	ZE	180	1000	T5 077	170	1000	T4 077	155	900	T3 077
Serie 2400											
2431 K	05.82-03.87	ZE	180	1000	T5 077	170	1000	T4 077	155	900	T3 077
Serie 5000											
5036/ 5064 , S/1, /1	05.75→	VE							150	760	T3 063
5064 A, B	01.86→	ZE							180	1100	T3 079
Serie 5100											
5117	01.84→	VE							150	760	T3 063
Serie 5300											
5317	01.86→	ZE							180	1100	T3 079
Serie 6000											
6031 A	10.84-11.89	ZE							88	680	T3 013
6038	01.80-06.86	ZE							88	680	T3 013
6046/ 6100 S, /1	01.76→	ZE							180	1100	T3 079
6420	01.86→	ZE							180	1100	T3 079



PEUGEOT

Boxer											
1.9/ 2.0/ 2.2/ 2.8 D, D Turbo, HDi [U3; U5]	07.98-05.06								88	680	T3 013
J 5											
1.9 D	11.87-12.93								88	680	T3 013

RENAULT

B											
70/ 90	01.83-06.94								88	680	T3 013
80 Messenger	08.90-06.99								88	680	T3 013
90/ 110/ 120 Messenger 4x2, Messenger 4x4, 4x2, 4x4	06.86-06.99		180	1000	T5 077	170	1000	T4 077	155	900	T3 077
120 Messenger	10.91-06.01		180	1000	T5 077	170	1000	T4 077	155	900	T3 077
C											
210/ 230/ 260/ 280/ 290/ 300/ 340 , T, ti [Ligne 3]	10.82-10.98	ZE				140	800	T4 076	135	1000	T3 045
CBH											
280/ 320/ 340/ 350/ 380/ 385 , 6x4, 6x4T, 6x6, 6x6T	04.86-10.98	ZE				140	800	T4 076	135	1000	T3 045
CCH											
300	12.90-12.92	ZE				140	800	T4 076	135	1000	T3 045
CLM											
280/ 320/ 340/ 350/ 380/ 385 , TR	04.86-10.98	ZE				140	800	T4 076	135	1000	T3 045
CLR											
220	05.86-05.91	ZE	180	1000	T5 077	170	1000	T4 077	155	900	T3 077



				Ah A (EN) T5			Ah A (EN) T4			Ah A (EN) T3		
				0092 ...0			0092 ...0			0092 ...0		
◀ RENAULT												
230	10.90-10.98	ZE				140	800	T4 076	135	1000	T3 045	
FR												
1 , -FRH	10.82-12.96	ZE	180	1000	T5 077	170	1000	T4 077	155	900	T3 077	
G												
170	04.83-02.90	ZE	145	800	T5 075	140	800	T4 075	120	680	T3 075	
200	05.90-06.93	ZE	180	1000	T5 077	170	1000	T4 077	155	900	T3 077	
210	11.83-02.90	ZE	180	1000	T5 077	140	800	T4 075	120	680	T3 075	
	01.90-10.96	ZE	180	1000	T5 077	170	1000	T4 077	155	900	T3 077	
220	03.91-04.93	ZE	180	1000	T5 077	140	800	T4 075	120	680	T3 075	
	05.93-10.96	ZE	180	1000	T5 077	170	1000	T4 077	155	900	T3 077	
230	03.84-06.93	ZE	180	1000	T5 077	140	800	T4 075	120	680	T3 075	
ti	01.90-10.96	ZE	180	1000	T5 077	140	800	T4 075	120	680	T3 075	
						170	1000	T4 077	155	900	T3 077	
235	05.95-10.96	ZE	180	1000	T5 077	140	800	T4 075	120	680	T3 075	
260	01.82-05.90	ZE	180	1000	T5 077	140	800	T4 075	120	680	T3 075	
	02.96-06.97	ZE	180	1000	T5 077	140	800	T4 075	120	680	T3 075	
270	11.92-10.96	ZE	180	1000	T5 077	170	1000	T4 077	155	900	T3 077	
	01.95-10.96	ZE	180	1000	T5 077	140	800	T4 075	120	680	T3 075	
280	10.82-06.93	ZE	180	1000	T5 077	140	800	T4 075	120	680	T3 075	
	01.90-06.93	ZE	180	1000	T5 077	170	1000	T4 077	155	900	T3 077	
290	05.85-12.89	ZE	180	1000	T5 077	140	800	T4 075	120	680	T3 075	
300	01.90-10.96	ZE	180	1000	T5 077	170	1000	T4 077	155	900	T3 077	
	10.92-06.97	ZE	180	1000	T5 077	140	800	T4 075	120	680	T3 075	
320	05.88-05.90	ZE	180	1000	T5 077	140	800	T4 075	120	680	T3 075	
330	02.90-03.93	ZE	180	1000	T5 077	170	1000	T4 077	155	900	T3 077	
ti	10.91-10.92	ZE	180	1000	T5 077	170	1000	T4 077	155	900	T3 077	
340 ti	01.90-10.96	ZE	180	1000	T5 077	170	1000	T4 077	155	900	T3 077	
	10.92-06.97	ZE	180	1000	T5 077	140	800	T4 075	120	680	T3 075	
GBH												
280 , , E, E [M 4]	06.80-06.91	ZE				140	800	T4 076	135	1000	T3 045	
GC												
231	06.80-12.85	ZE				140	800	T4 076	135	1000	T3 045	
GLM												
280 [M 4]	06.80-06.91	ZE							143	950	T3 047	
GLR												
190/ 210/ 230 , , 4x4	09.78-06.91	ZE	180	1000	T5 077	140	800	T4 075	120	680	T3 075	
JE												
13	01.83-04.91	ZE							143	950	T3 047	
15	10.86-06.91	ZE				140	800	T4 076	110	760	T3 038	
JK												
60/ 65/ 75 , B	10.79-01.86					140	800	T4 076	110	760	T3 038	
Kerax												
260/ 270/ 300/ 320/ 340/ 350/ 370/ 385/ 400/ 410/ 420/ 450/ 460/ 500	06.97-03.09	ZE	180	1000	T5 077	170	1000	T4 077	155	900	T3 077	
Magnum												
380/ 385/ 390/ 420/ 430/ 470/ 500/ 520/ 560 AE, ti AE	09.90-05.00	ZE	180	1000	T5 077	170	1000	T4 077	155	900	T3 077	
400/ 440/ 460/ 480/ 500 E, TECH, E, TECH	11.99-03.09	ZE	225	1150	T5 080	170	1000	T4 077	155	900	T3 077	
Mascott												
90	01.99-06.04								110	680	T3 035	
											T3 037	
110	01.99-06.04								110	680	T3 035	
											T3 037	
.60	01.99-06.04								110	680	T3 035	
120	05.04-05.07								110	680	T3 035	
130	01.99-06.04								110	680	T3 035	
	06.07-12.10								110	680	T3 035	
											T3 037	
140	01.01-06.04								110	680	T3 035	
150	10.01-06.04								110	680	T3 035	







		Ah		Ah		Ah		Ah			
		A (EN)		A (EN)		A (EN)		A (EN)			
		T5		T4		T3					
		0 092 ...0		0 092 ...0		0 092 ...0					
150	06.07-12.10							110	680	T3 035	
										T3 037	
160	05.04-05.07							110	680	T3 035	
Master											
P28/ T28 -35D	09.80-09.97							66	510	T3 008	
2.5 D [X70]	10.97-09.03							88	680	T3 013	
Midliner											
CE 160/ M 140/ M 150/ M 160/ M 180/ M 200/ M 210/ M 230/ M 250/ ME 160/ ME 180 , SP	10.86-12.01	ZE		140	800	T4 076		135	1000	T3 045	
Midlum											
135/ 150/ 180/ 210/ 220/ 250/ 260/ 270 , 4x2, 4x4	02.00-04.06	ZE	180	1000	T5 077	170	1000	T4 077	155	900	T3 077
Midlum II											
160/ 190/ 220/ 240/ 280	05.06-03.09	ZE	180	1000	T5 077	170	1000	T4 077	155	900	T3 077
PR											
10/ 12/ 14 S, SR	06.80-09.87	ZE						143	950	T3 047	
180	03.83→	ZE	180	1000	T5 077	170	1000	T4 077	155	900	T3 077
Premium											
210/ 220/ 250/ 260/ 270/ 300/ 320/ 340/ 370/ 385/ 400/ 420 Distribution, Lander, Route, SP	02.96-04.06	ZE	180	1000	T5 077	170	1000	T4 077	155	900	T3 077
Premium II											
280/ 320/ 370/ 410/ 440/ 450 Distribution, Route	09.05-03.09	ZE	180	1000	T5 077	170	1000	T4 077	155	900	T3 077
R											
TS 6x4 Major	01.93-05.96	ZE	180	1000	T5 077	170	1000	T4 077	155	900	T3 077
310/ 330	10.80-05.91	ZE						143	950	T3 047	
340	03.86-01.90	ZE						143	950	T3 047	
	01.90-01.96	ZE	180	1000	T5 077	170	1000	T4 077	155	900	T3 077
350/ 365/ 370/ 380/ 385/ 390/ 420	09.84-10.96	ZE	180	1000	T5 077	170	1000	T4 077	155	900	T3 077
S											
45/ 53 R, RX	06.80-12.94	ZE	180	1000	T5 077	170	1000	T4 077	155	900	T3 077
90	05.84-06.91	ZE						88	680	T3 013	
100/ 110/ 120/ 130/ 135/ 140/ 150/ 160/ 170/ 180/ 210/ 220 Midliner, TI Midliner	10.82-01.00	ZE				140	800	T4 076	135	1000	T3 045
130 Export	09.85-06.91					140	800	T4 076	135	1000	T3 045
	11.89-06.91	ZE				140	800	T4 076	135	1000	T3 045
150	05.83-07.86	ZE				140	800	T4 076	135	1000	T3 045
SG											
2/ 3/ 4	10.79-01.94							150	760	T3 063	
TBH											
280 D, E	06.80-06.91	ZE						143	950	T3 047	
TLM											
280	06.80-05.91	ZE						143	950	T3 047	
TP											
3	06.80-05.85	ZE	180	1000	T5 077	170	1000	T4 077	155	900	T3 077
75											
.130	06.80-05.91	ZE	180	1000	T5 077	140	800	T4 076	135	1000	T3 045
85											
.150 , ti	09.84-01.95	ZE	180	1000	T5 077	140	800	T4 076	135	1000	T3 045
95											
.130	06.80-05.91	ZE	180	1000	T5 077	140	800	T4 076	135	1000	T3 045
110											
.150/ .170 , ti	06.80-01.95	ZE	180	1000	T5 077	140	800	T4 076	135	1000	T3 045



			Ah A (EN) T5	Ah A (EN) T4	Ah A (EN) T3
			0092 ...0	0092 ...0	0092 ...0

SCANIA

G											
230	09.07→	ZE	180	1000	T5 077	170	1000	T4 077	155	900	T3 077
			225	1150	T5 080	215	1150	T4 080	200	1050	T3 080
270	09.07→	ZE	225	1150	T5 080	215	1150	T4 080	200	1050	T3 080
280/320	09.07→	ZE	180	1000	T5 077	170	1000	T4 077	155	900	T3 077
420	09.07→	ZE	225	1150	T5 080	170	1000	T4 077	155	900	T3 077
P											
230/270/280/310/320/340/360/380/400	09.04→	ZE	180	1000	T5 077	170	1000	T4 077	155	900	T3 077
420/470/480	09.04→	ZE	225	1150	T5 080	170	1000	T4 077	155	900	T3 077
R											
124 GA	04.05→	ZE	225	1150	T5 080	170	1000	T4 077			
230/270/310/340/380/400	03.04→	ZE	180	1000	T5 077	170	1000	T4 077	155	900	T3 077
420/470/480/500/560/580/620	02.04→	ZE	225	1150	T5 080	170	1000	T4 077	155	900	T3 077
Serie 82											
F/K/S CL, CR, HR [BUS]	10.81-12.95	ZE	180	1000	T5 077	170	1000	T4 077	155	900	T3 077
G/T	05.80-03.88	ZE				140	800	T4 076			
P	05.80-03.88	ZE	180	1000	T5 077	170	1000	T4 077	155	900	T3 077
Serie 86											
B/BF/BR, S [BUS]	05.75-01.99	ZE							135	680	T3 044
Serie 92											
G/K/P/R/T, CL, CR [; BUS]	05.82-12.94	ZE	180	1000	T5 077	170	1000	T4 077	155	900	T3 077
Serie 93											
F/G/K/P/R/T, CL, CLB, CR, CRB, HL/HR, L, R [; BUS]	11.87-12.01	ZE	180	1000	T5 077	140	800	T4 075	120	680	T3 075
Serie 94											
K/L/N E, IB, UB [BUS]	03.97→	ZE	225	1150	T5 080	170	1000	T4 077	155	900	T3 077
P,R/T 220, 230, 260, 300, 310	08.96-09.04	ZE	180	1000	T5 077	170	1000	T4 077	155	900	T3 077
Serie 111											
B/BF, CKD [BUS]	06.90-01.99	ZE	180	1000	T5 077	170	1000	T4 077	135	680	T3 044
Serie 112											
BK/K/N CLB, P [BUS]	04.82-12.00	ZE	180	1000	T5 077	170	1000	T4 077	155	900	T3 077
BR/CR/F [BUS]	09.78-01.95	ZE	180	1000	T5 077	170	1000	T4 077	135	1000	T3 045
CN/S [BUS]	10.81-10.91	ZE	180	1000	T5 077	170	1000	T4 077	155	900	T3 077
G,P,R 280	01.81-05.88	ZE	180	1000	T5 077	170	1000	T4 077	155	900	T3 077
305	01.81-05.88	ZE	180	1000	T5 077	170	1000	T4 077	155	900	T3 077
313	06.87-05.88	ZE	180	1000	T5 077	170	1000	T4 077	155	900	T3 077
316	06.87-05.88	ZE	180	1000	T5 077	170	1000	T4 077	155	900	T3 077
333	10.82-05.88	ZE	180	1000	T5 077	170	1000	T4 077	155	900	T3 077
345	06.87-05.88	ZE	180	1000	T5 077	170	1000	T4 077	155	900	T3 077
363	12.86-05.88	ZE	180	1000	T5 077	170	1000	T4 077	155	900	T3 077
P	05.85-05.88		180	1000	T5 077	170	1000	T4 077	120	680	T3 075
R	05.85-05.88	ZE	180	1000	T5 077	170	1000	T4 077	155	900	T3 077
T 215	05.80-05.88	ZE	180	1000	T5 077	170	1000	T4 077	120	680	T3 075
280	10.82-05.88	ZE	180	1000	T5 077	170	1000	T4 077	120	680	T3 075
290	05.80-05.88	ZE	180	1000	T5 077	170	1000	T4 077	120	680	T3 075
305	01.81-05.88	ZE	180	1000	T5 077	170	1000	T4 077	120	680	T3 075
313	06.87-05.88	ZE	180	1000	T5 077	170	1000	T4 077	120	680	T3 075
316	05.80-05.88	ZE	180	1000	T5 077	170	1000	T4 077	120	680	T3 075
333	10.82-05.88	ZE	180	1000	T5 077	170	1000	T4 077	120	680	T3 075
345	10.82-05.88	ZE	180	1000	T5 077	170	1000	T4 077	120	680	T3 075
Serie 113											
BN CLB [BUS]	05.90-08.98	ZE	180	1000	T5 077	170	1000	T4 077	155	900	T3 077
BN/CN/N, A, ALB [BUS]	01.90-08.98	ZE	180	1000	T5 077	170	1000	T4 077	155	900	T3 077
F/N CR, DRB, HL/HR [BUS]	12.88-08.98	ZE	180	1000	T5 077	170	1000	T4 077	155	900	T3 077
K CLA/CRA [BUS]	07.90-08.98	ZE	225	1150	T5 080	170	1000	T4 077	155	900	T3 077
320	11.90-12.94	ZE	180	1000	T5 077	140	800	T4 075	120	680	T3 075

				Ah	A (EN)		Ah	A (EN)		Ah	A (EN)	
	0 092 ...0						0 092 ...0			0 092 ...0		
K/L CLL, TLA/TRA, TLB [BUS]	01.90-08.98	ZE	225	1150	T5 080	170	1000	T4 077	155	900	T3 077	
K/L/N CLB [BUS]	05.82-08.98	ZE	225	1150	T5 080	170	1000	T4 077	155	900	T3 077	
K/T 203, 215	05.88-05.00	ZE	180	1000	T5 077	140	800	T4 075	120	680	T3 075	
N CLL/CRL [BUS]	04.91-08.98	ZE	180	1000	T5 077	140	800	T4 075	120	680	T3 075	
P/T	05.88-12.00	ZE	180	1000	T5 077	140	800	T4 075	120	680	T3 075	
P,R 310	06.88-05.97	ZE	180	1000	T5 077	170	1000	T4 077	155	900	T3 077	
313	05.88-02.95	ZE	180	1000	T5 077	170	1000	T4 077	155	900	T3 077	
P,R/T 320	05.88-05.00	ZE	180	1000	T5 077	170	1000	T4 077	155	900	T3 077	
340, 343, 350, 360, 360 AU, 384, 400	05.88-05.00	ZE	180	1000	T5 077	170	1000	T4 077	155	900	T3 077	
R	05.88-05.97	ZE	180	1000	T5 077	170	1000	T4 077	155	900	T3 077	
R/T H	06.95-12.98	ZE	180	1000	T5 077	170	1000	T4 077	155	900	T3 077	
T 310	06.88-05.97	ZE	180	1000	T5 077	140	800	T4 075	120	680	T3 075	
313	05.88-05.97	ZE	180	1000	T5 077	140	800	T4 075	120	680	T3 075	
Serie 114												
K EB, IB [BUS]	08.97→	ZE	225	1150	T5 080	170	1000	T4 077	155	900	T3 077	
P 260	02.01-09.04	ZE	225	1150	T5 080	170	1000	T4 077	155	900	T3 077	
P,R/T 320, 340, 360, 380	02.96-09.04	ZE	180	1000	T5 077	170	1000	T4 077	155	900	T3 077	
Serie 124												
K/P,R/T EB, IB, 360, 400, 420, 420 HPI, 440, 470 [; BUS]	03.95→	ZE	225	1150	T5 080	215	1150	T4 080	220	1150	T3 081	
Serie 142												
R/T 385, 388, 398, 405, 410, 420, 430	05.80-03.88	ZE	180	1000	T5 077	170	1000	T4 077	155	900	T3 077	
Serie 143												
R/T 405, 420, 450, 470, 500, 530	03.88-06.98	ZE	225	1150	T5 080	170	1000	T4 077	155	900	T3 077	
Serie 144												
R/T 460, 530	01.96-08.01	ZE	225	1150	T5 080	215	1150	T4 080	220	1150	T3 081	
Serie 164												
R/T 480, 580	04.00-09.04	ZE	225	1150	T5 080	215	1150	T4 080	220	1150	T3 081	
T												
470	09.04-10.05	ZE	225	1150	T5 080	170	1000	T4 077	155	900	T3 077	

SEDDON DIESEL

201	01.80→	ZE							90	540	T3 030
301	01.80→	ZE							125	720	T3 040
400	01.80→	ZE							125	720	T3 040

SETRA

ComfortClass 400												
S 415/S 416/S 417 GT, GT-HD, HD/HDH	02.03→		225	1150	T5 080	215	1150	T4 080	220	1150	T3 081	
Setra												
S 215/S 309/S 312/S 315	03.95-09.05	ZE	180	1000	T5 077	170	1000	T4 077				
TopClass 400												
S 411/S 415/S 416/S 417/ S 431 DT, HD, HDH	02.03→		225	1150	T5 080	215	1150	T4 080	220	1150	T3 081	



			Ah	A (EN)		Ah	A (EN)		Ah	A (EN)	
0092 ...0					0092 ...0				0092 ...0		

SISU

SM											
220/ 280/ 300	12.82-12.95	ZE	180	1000	T5 077	170	1000	T4 077	155	900	T3 077
SR											
220/ 280	04.82-12.95	ZE				170	1000	T4 078			
300	04.82-12.95	ZE	180	1000	T5 077	170	1000	T4 077	155	900	T3 077

STEYR (STEYR-DAIMLER-PUCH AG)

Pinzgauer											
2.4 D Turbo	10.86-12.96								88	680	T3 013
Serie 11-18 HU											
SFL/ SG/ SL/ SS 11 HU 200, 11 HU 250, 11 HUA 280, 18 HUA 280	01.84→	ZE	225	1150	T5 080	170	1000	T4 077	155	900	T3 077
8 S											
14/ 18	05.89→	ZE	145	800	T5 075	140	800	T4 075	110	760	T3 038
9 S											
14/ 18	04.86→	ZE				140	800	T4 076	135	1000	T3 045
10 S											
14/ 18	04.86→	ZE				140	800	T4 076	135	1000	T3 045
11 S											
14/ 18	07.89→	ZE							88	680	T3 013
12 M											
18/ 21	09.86→	ZE	145	800	T5 075	140	800	T4 075	120	680	T3 075
12 S											
14/ 18/ 21	04.86→	ZE				140	800	T4 076	135	1000	T3 045
13 S											
14/ 18/ 21/ 23	09.88→	ZE				140	800	T4 076	135	1000	T3 045
14 S											
14/ 18/ 21	04.86→	ZE				140	800	T4 076	135	1000	T3 045
15 S											
14/ 18/ 21/ 23	04.86→	ZE	145	800	T5 075	140	800	T4 075	120	680	T3 075
16 S											
18/ 21/ 23	04.86→	ZE	145	800	T5 075	140	800	T4 075	120	680	T3 075
17 S											
18/ 21/ 23	09.88→	ZE	145	800	T5 075	140	800	T4 075	120	680	T3 075
19 S											
24/ 28	01.88→	ZE	145	800	T5 075	140	800	T4 075	120	680	T3 075
31/ 34/ 37	10.87→	ZE	180	1000	T5 077	170	1000	T4 077	155	900	T3 077
39	05.90-06.96	ZE	180	1000	T5 077	140	800	T4 075	120	680	T3 075
22 S											
28	01.88→	ZE	145	800	T5 075	140	800	T4 075	120	680	T3 075
31/ 34/ 37	10.87→	ZE	180	1000	T5 077	170	1000	T4 077	155	900	T3 077
26 S											
28	01.88→	ZE	145	800	T5 075	140	800	T4 075	120	680	T3 075
31/ 34/ 37	10.87→	ZE	180	1000	T5 077	170	1000	T4 077	155	900	T3 077
32 S											
28	01.88→	ZE	145	800	T5 075	140	800	T4 075	120	680	T3 075
31/ 34/ 37	10.87→	ZE	180	1000	T5 077	170	1000	T4 077	155	900	T3 077
33 S											
31/ 34	10.87→	ZE	180	1000	T5 077	140	800	T4 075	120	680	T3 075
40 S											
31/ 34/ 37	01.88→	ZE	180	1000	T5 077	140	800	T4 075	120	680	T3 075
591											
.136	02.82-02.86								88	680	T3 013
691											
.136	02.82-02.86								88	680	T3 013
791											
.145/ .170/ .210	11.78-02.86	ZE	145	800	T5 075	140	800	T4 075	120	680	T3 075

			Ah	A (EN)		Ah	A (EN)		Ah	A (EN)	
					0 092 ...0				0 092 ...0		

891											
.170	11.78-02.86	ZE	145	800	T5 075	140	800	T4 075	120	680	T3 075
991											
.200	05.78-12.87	ZE	180	1000	T5 077	170	1000	T4 077	155	900	T3 077
1291											
.260/ .280/ .310/ .330	05.78-12.87	ZE	180	1000	T5 077	140	800	T4 075	120	680	T3 075
1391											
.170	11.78-09.87	ZE	145	800	T5 075	140	800	T4 075	120	680	T3 075
1491											
.260/ .280/ .310/ .330	05.78-12.87	ZE	180	1000	T5 077	140	800	T4 075	120	680	T3 075
1891											
.280/ .310/ .330	02.82-12.87	ZE	180	1000	T5 077	170	1000	T4 077	155	900	T3 077
2891											
.260/ .280/ .330	09.83-12.87	ZE	180	1000	T5 077	140	800	T4 075	120	680	T3 075

TALBOT

Express											
1.9/ 2.5 D [J 5]	09.81-12.93								88	680	T3 013

TATA (TELCO)

613											
LPT	10.04→	ZE							180	1100	T3 079

TATRA

Serie 815											
T 815 NT/NTH/P/TP/V, PJ 28	03.83→	ZE	225	1150	T5 080	215	1150	T4 080	200	1050	T3 080
170, S/P/PJ/PR/RN/VS, -2											
2 NT 4x4	01.92→	ZE				140	800	T4 076	110	760	T3 038

URAL AUTOMOBIL PLANT

11t											
32552	12.02→	ZE	180	1000	T5 077				200	1050	T3 080
12t											
43206	12.02→	ZE	180	1000	T5 077				200	1050	T3 080
13t											
43203/ 43206	12.02→	ZE	180	1000	T5 077				200	1050	T3 080
14t											
3255/ 325512, -41	12.02→	ZE	180	1000	T5 077				200	1050	T3 080
15t											
43202/ 43203	12.02→	ZE	180	1000	T5 077				200	1050	T3 080
16t											
5557 -10	12.02→	ZE	180	1000	T5 077				200	1050	T3 080
17t											
43203/ 55571, -10	12.02→	ZE	180	1000	T5 077				200	1050	T3 080
19t											
5557 -31	12.02→	ZE	180	1000	T5 077				200	1050	T3 080
20t											
4320/ 55571, -30	12.02→	ZE	180	1000	T5 077				200	1050	T3 080
21t											
4320/ 55571/ 532301	12.02→	ZE	180	1000	T5 077				200	1050	T3 080
25t											
632302	12.02→	ZE	180	1000	T5 077				200	1050	T3 080
26t											
53236	12.02→	ZE	180	1000	T5 077				200	1050	T3 080









			Ah	A (EN)		Ah	A (EN)		Ah	A (EN)	
0 092 ...0						0 092 ...0			0 092 ...0		

◀ URAL AUTOMOBIL PLANT

30t											
44202 , -03	12.02→	ZE	180	1000	T5 077				200	1050	T3 080
33t											
6329/ 6529/ 63621	12.02→	ZE	180	1000	T5 077				200	1050	T3 080
39t											
542301	12.02→	ZE	180	1000	T5 077				200	1050	T3 080
43t											
542362	12.02→	ZE	180	1000	T5 077				200	1050	T3 080
88t											
632911	01.03→	ZE	180	1000	T5 077				200	1050	T3 080

VOLVO

B											
7 L	05.99→	ZE	225	1150	T5 080	170	1000	T4 077			
7/ 10/ 12 F, F, FA, M	10.80→	ZE				140	800	T4 076	110	760	T3 038
10 L	05.94→	ZE	180	1000	T5 077	170	1000	T4 077			
R	11.83-01.96	ZE	180	1000	T5 077	170	1000	T4 077			
	01.02→	ZE				140	800	T4 076	110	760	T3 038
10/ 12 B, BLE, CH 5000-	01.92-09.11	ZE	180	1000	T5 077	170	1000	T4 077			
12	09.91-10.95	ZE	180	1000	T5 077	170	1000	T4 077			
B	06.01→	ZE	180	1000	T5 077	170	1000	T4 077			
	10.01→	ZE				140	800	T4 076	110	760	T3 038
BB											
57 , T	11.75-01.96	ZE							135	680	T3 044
F											
7/ 10/ 12	08.77-12.94	ZE	180	1000	T5 077	140	800	T4 075	120	680	T3 075
16	10.87-12.94	ZE	225	1150	T5 080	170	1000	T4 077			
406/ 407/ 408/ 409	09.75-02.86								90	540	T3 030
610/ 611/ 612/ 613/ 614	11.80-02.86	ZE							90	540	T3 030
616/ 617 S	12.78-02.86	ZE							90	540	T3 030
FE											
240/ 280/ 320	05.06→		225	1150	T5 080	170	1000	T4 077			
260	05.09→	ZE	225	1150	T5 080	170	1000	T4 077			
FH											
12/ 16 340, 380, 420, 460, 470, 500, 520, 540, 550, 610	08.93→	ZE	180	1000	T5 077	170	1000	T4 077			
16 660	01.06→		225	1150	T5 080	170	1000	T4 077	155	900	T3 077
400/ 440/ 480/ 500/ 520	09.06→	ZE	225	1150	T5 080	215	1150	T4 080	220	1150	T3 081
FL											
6 180, 220, 250	05.00-05.06	ZE	180	1000	T5 077	140	800	T4 076			
7/ 10	09.85-12.01	ZE	180	1000	T5 077	140	800	T4 075	120	680	T3 075
12 380, 420	09.95-12.01	ZE	180	1000	T5 077	140	800	T4 075	120	680	T3 075
240/ 280	05.06→	ZE	180	1000	T5 077	170	1000	T4 077			
408	02.86-12.95	ZE							110	680	T3 035
608/ 610/ 611/ 612/ 613/ 614/ 615/ 616/ 617/ 618/ 619	09.85-08.00	ZE	145	800	T5 075	140	800	T4 075	90	540	T3 030
FLC											
	09.96-09.00	ZE							110	680	T3 035
FM											
7/ 9 250, 260, 290, 300, 310	09.98-08.05	ZE	180	1000	T5 077	170	1000	T4 077			
9 340	03.02-08.05	ZE	180	1000	T5 077	170	1000	T4 077			
380	03.02-08.05	ZE	180	1000	T5 077	170	1000	T4 077			
10 320	04.99-12.01	ZE	225	1150	T5 080	170	1000	T4 077			
360	04.99-12.01	ZE	225	1150	T5 080	170	1000	T4 077			
12 340	09.98-09.05	ZE	225	1150	T5 080	170	1000	T4 077			
345	11.02-09.05	ZE	225	1150	T5 080	170	1000	T4 077			
380	09.98-09.05	ZE	225	1150	T5 080	170	1000	T4 077			
385, 420, 425, 460, 500	09.98-09.05	ZE	225	1150	T5 080	170	1000	T4 077			

			Ah	A (EN)		Ah	A (EN)		Ah	A (EN)	
			0 092 ...0			0 092 ...0			0 092 ...0		
300/ 340/ 360/ 380/ 400/ 440/ 480	09.05-09.09	ZE	225	1150	T5 080	170	1000	T4 077			
FS											
718	11.91-03.96	ZE	180	1000	T5 077	140	800	T4 075	120	680	T3 075
N											
7/ 10/ 12 , 260, 280, 290, 300, 315, 320, 330, 350, 370, 380	09.73-01.98	ZE	180	1000	T5 077	140	800	T4 076			
10 250	06.84-04.89		180	1000	T5 077	140	800	T4 076			
NH											
12 380, 420	05.99→	ZE	180	1000	T5 077	170	1000	T4 077			
NL											
10/ 12 275, 285, 320, 350, 360, 390, 400	05.91-09.01	ZE	180	1000	T5 077	170	1000	T4 077			
9700											
	04.01-09.06	ZE	225	1150	T5 080	215	1150	T4 080	220	1150	T3 081
9900											
	10.01-09.06	ZE	225	1150	T5 080	215	1150	T4 080	220	1150	T3 081

VW (VOLKSWAGEN)

LT											
28/ 35/ 46 2.3, 2.5 SDI, 2.5 TDI, 2.8 D Turbo, 2.8 TDI [2D, 2H]	05.96-04.06								88	680	T3 013
L80											
[2V]	01.95-12.99	ZE							88	680	T3 013
Transporter T4											
2.5 TDI [70, 7D]	01.95-06.03								90	540	T3 031





AHLMANN

AS					
12	06.72-06.87 ZE		135	1000	T3 045

ALLIS-CHALMERS

H					
3	→12.85			70	630 S4 027

ATLAS COPCO

Serie PR-PRH					
PR 365,600	12.71-12.86		110	680	T3 036
700	05.72-12.86 ZE		100	600	T3 072
Serie PT-PTS					
PT 900	12.74-12.89		100	600	T3 072
Serie ST-ST5					
ST/ST5 71,95	02.73-12.86		100	600	T3 072
Serie XA-XASS					
XA/XAS/XASS 40, 50,	→12.89			95	830 S4 028
60					
80	→12.89		135	1000	T3 045
120, 160	→12.89		100	600	T3 072

AVELING BARFORD

GN-Serie					
GN	01.77-12.88		150	760	T3 063
T-Serie					
TR 3	→12.87		150	760	T3 063

BARBER-GREENE

SA-Serie					
41	01.76-09.90		125	720	T3 040
SB-Serie					
111	01.76-09.90		125	720	T3 040
800-Serie					
873	→12.86		125	720	T3 041
879 A	→12.86			70	630 S4 027

BERTOLINI

Serie 300					
310 S	10.69-01.01			45	300 S3 017

BOMAG

BW					
200	01.73-06.86		180	1100	T3 079





BROOM AND WADE

CV-Serie						
125/ 160/ 250 S, SS	01.71-12.89		110	680		T3035

CASE

DH						
4	01.80-01.95		110	680		T3035
Serie 600						
680 E	09.74-03.88		110	680		T3036
Serie 800						
850 B	11.75-04.87		110	680		T3036
Serie 1000						
1194/ 1294/ 1394/ 1494/ 1694	01.84-06.89		125	720		T3041
1270	09.71-12.86		110	680		T3035
W						
7 E	04.71-04.87 ZE		110	680		T3036
14	01.72-12.85		110	680		T3036

CASE IH (CASE INTERNATIONAL)

Serie 100						
100 B	01.86-06.86		125	720		T3041
Serie 485-885						
585/ 685 L, XL	06.83-06.98		110	680		T3036
Serie 500						
531/ 541	01.86-06.86		150	760		T3063
Serie 700						
745 XL, A	01.86-01.01		135	1000		T3045
Serie 800						
844 XL, A	01.86-01.01		135	1000		T3045
Serie 900						
923/ 933/ 943/ 953	01.86-06.86		150	760		T3063
Serie 4000						
4300	01.86-06.86		110	680		T3035

CATERPILLAR

Serie 900						
916	02.93→ ZE		110	680		T3036

CLAAS

Dominator								
48	01.78-10.88		88	680	T3013	90	720	S3 013
66/ 76/ 85/ 86/ 96	10.74-10.85		135	1000	T3045			
108 SL Maxi	09.90-09.05	170	1000		T4078			
Jaguar								
675/ 680	10.74-10.87	170	1000		T4078			
685 SL	01.87-01.02	170	1000		T4078			
690	10.74-10.87 ZE		135	1000	T3045			
690/ 695 SL	10.74-06.02		135	1000	T3045			
Lexion								
405/ 410/ 420/ 430/ 440/ 450/ 460	01.97→		135	1000	T3045			





◀ CLAAS

Mega										
202/ 203/ 204/ 208/ 218	01.90-09.98							135	1000	T3 045

CLARK

RW										
140	01.72-12.89	145	800	T5 075	140	800	T4 075			
TV										
80	→12.87	145	800	T5 075	140	800	T4 075			

CLAYSON

8000-Serie											
8070	01.77-11.86								95	800	S4 013
									100	830	S5 013
8080	01.77-11.86								74	750	S5 007
									77	780	S5 008

DEMAG

SC-Serie										
10 D	→12.91	145	800	T5 075	140	800	T4 075	120	680	T3 075

DEUTZ-FAHR

D											
7007	06.86-06.01	145	800	T5 075	140	800	T4 075				
DX											
3	.10 A	06.86-06.01						88	680	T3 013	
	.30 A	06.86-06.01						88	680	T3 013	
	.50 A	06.86-06.01	145	800	T5 075	140	800	T4 075	120	680	T3 075
	.51, .60, .70 A, .90 A	06.86-06.01	145	800	T5 075	140	800	T4 075	120	680	T3 075
4	.10	06.86-06.01	145	800	T5 075	140	800	T4 075	120	680	T3 075
	.30 A	06.86-06.01	145	800	T5 075	140	800	T4 075	120	680	T3 075
	.50 A	06.86-06.01	145	800	T5 075	140	800	T4 075	120	680	T3 075
	.51, .60, .70 A, .90 A	06.86-06.01	145	800	T5 075	140	800	T4 075	120	680	T3 075
		06.86-01.05	145	800	T5 075	140	800	T4 075	120	680	T3 075
		01.90-01.05	145	800	T5 075	140	800	T4 075	120	680	T3 075
6	.30 A	06.86-06.01	145	800	T5 075	140	800	T4 075	120	680	T3 075
	.50 A	06.86-06.01	180	1000	T5 077	170	1000	T4 077			
7	.10 A	06.86-06.01	180	1000	T5 077	170	1000	T4 077			
Intrac											
6	.60 turbo	01.88-01.03	145	800	T5 075	140	800	T4 075			
2004		05.78-12.88						135	1000	T3 045	
M											
1080		01.81-01.96	145	800	T5 075	140	800	T4 075			
1202		01.80-01.95						88	680	T3 013	
2385		01.82-01.97	145	800	T5 075	140	800	T4 075			
3330/ 3360		03.87-03.02						135	1000	T3 045	
3570		03.87-03.02	145	800	T5 075	140	800	T4 075			
3580		03.87-03.02	145	800	T5 075	140	800	T4 075			
3610		03.87-03.02	145	800	T5 075	140	800	T4 075	120	680	T3 075
3630		03.87-03.02	145	800	T5 075	140	800	T4 075	120	680	T3 075
3640		03.87-03.02 ZE	145	800	T5 075	140	800	T4 075	120	680	T3 075



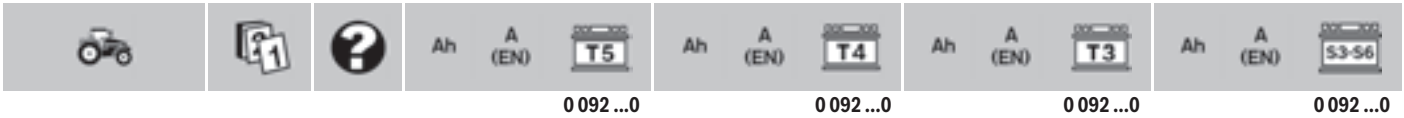

DYNAPAC

C-Serie								
CF/CH/ CH 33/44/46, 60/61	→12.86				135	680	T3044	

FENDT

F								
255 GT	02.77-02.92							100 830 S5 013
275 GT	02.76-02.91				135	1000	T3045	
Farmer 100-Serie								
102/ 103 S/FW 135, S/FW 138	02.77-02.92				135	1000	T3045	
105 S/FW 258	02.77-02.92	140	800	T4076	135	1000	T3045	
Farmer 200-Serie								
200 S	10.74-10.89							95 800 S4 013
								100 830 S5 013
200/ 203 V/FL 145, V/FL 155	02.74-02.89							100 830 S5 013
203/ 204/ 205 P, P/FL 156, P/FL 166	02.75-02.94							100 830 S5 013
Farmer 300-Serie								
305 LS/FW 162, LS/FW 168, LS/FW 178	02.80-02.95	140	800	T4076	135	1000	T3045	
306 LS/FW 162, LS/FW 168, LS/FW 178	02.80-02.95	140	800	T4076	135	1000	T3045	
308 LS/FW 162, LS/FW 168, LS/FW 178	02.80-02.95	140	800	T4076	135	1000	T3045	
310 LSA	09.84-08.90				135	1000	T3045	
Favorit								
600/ 610/ 611/ 612/ 614/ 615/ 626 FWA 285.260, LS, LS/FW 280, LS/FW 281, LS/FW 282, LS/FWA 283, LS/FWA 284, LS/FWA 285	02.76-02.97	170	1000	T4078				

FERRARI

Serie 70								
72 S	01.71→							45 400 S3 003
Serie 90								
94/ 95/ 96	06.80-09.04							45 400 S3 003
95 RS	11.88-11.03							45 400 S3 003
								70 630 S4 027
Serie 800								
	12.85-12.89							45 400 S3 003
Serie 900								
933	01.82-12.89							70 630 S4 027
Serie 1000								
1100	12.85-12.00							45 400 S3 003
T								
93	01.88-01.03							45 400 S3 003





FIAT

50-Serie										
55	.46, .65, .90	03.84-08.88					88	680	T3 013	90 720 S3 013
60-Serie										
60	.46, .65, .66, .90	09.84-08.88					88	680	T3 013	90 720 S3 013
65	.46, .65, .66, .90	04.85-08.88					88	680	T3 013	90 720 S3 013
70-Serie										
70	.65, .66, .90	03.84-08.88					88	680	T3 013	90 720 S3 013
80-Serie										
85	.55	10.84-08.88					88	680	T3 013	90 720 S3 013
90-Serie										
90/95	.55, .90	06.84-08.88					143	900	T3 046	
100-Serie										
100/130/140	.90	01.84-08.88					143	900	T3 046	
115.90		01.84-08.88					143	900	T3 046	
160	.90	01.84-04.88	180	1000	T5 077					
400-Serie										
400		01.68-12.85 ZE				140	800	T4 076	110 760	T3 038
420		01.77-12.85				140	800	T4 076	110 760	T3 038

FIAT-ALLIS







FE										
18		01.82-12.88 ZE					110	680	T3 036	
20/28		10.81-12.88 ZE					180	1100	T3 079	
FL										
9		01.78-07.85 ZE					110	680	T3 035	
20		05.79-10.92 ZE	170	1000	T4 078					
FR										
7/9B		09.87-12.90							74 680	S4 008
7/10/12/20		01.82-12.90 ZE					110	680	T3 035	
9/15		03.82-09.87 ZE					180	1100	T3 079	
10 B		12.85-12.90							95 800	S4 013
									100 830	S5 013
20 B		01.86-12.90							95 800	S4 013
									100 830	S5 013
35		01.85-12.91					88	680	T3 013	90 720 S3 013

FIAT-HITACHI (N.H.GEOTECH)

FH										
120/150		05.88-03.04							95 830	S4 028

FORD

Serie 3000										
3430/3930		06.90-06.05					110	680	T3 035	
3610		01.81-01.96					130	680	T3 043	100 830 S5 013
Serie 4000										
4130/4630/4830		06.90-06.05					110	680	T3 035	
Serie 5000										
5610		06.90-06.05					130	680	T3 043	
Serie 6000										
6410/6610/6810		01.81-06.05					130	680	T3 043	
Serie 7000										
7610/7810		06.90-06.05					130	680	T3 043	

			Ah A (EN) 	Ah A (EN) 	Ah A (EN) 	Ah A (EN) 
			0 092 ...0	0 092 ...0	0 092 ...0	0 092 ...0

Serie 8000

8210/ 8630/ 8730/ 8830	06.90-06.05		130	680	T3 043		
------------------------	-------------	--	-----	-----	---------------	--	--

FORD NEW HOLLAND**Serie 35**

3435	06.95-01.99					95	800	S4 013
						100	830	S5 013
3935	06.95-01.99					95	800	S4 013
						100	830	S5 013
4135	06.95-01.99					95	800	S4 013
						100	830	S5 013
4635/ 4835/ 5635/ 6635/ 7635	06.95-01.99		135	1000	T3 045			

Serie 55

555/ 655 C			130	680	T3 043			
------------	--	--	-----	-----	---------------	--	--	--

Serie 8000

8030	11.86-11.01		88	680	T3 013	90	720	S3 013
8050/ 8060/ 8070	01.85-12.01					74	680	S4 008
TF								
42	03.83-12.01					74	680	S4 008
44	03.83-03.98		88	680	T3 013	90	720	S3 013
46	06.85-06.00		88	680	T3 013	90	720	S3 013
TW								
15/ 25/ 35	01.86-01.01		130	680	T3 043			
TX								
34	06.86-04.02					74	680	S4 008

GALION**100-Serie**

118/ 160 A, C, L, B	→12.88		180	1100	T3 079			
---------------------	--------	--	-----	------	---------------	--	--	--

400-600 Serie

503	→12.88					70	630	S4 027
-----	--------	--	--	--	--	----	-----	---------------

GRADALL**G-Serie**

800	→12.88		125	720	T3 040			
-----	--------	--	-----	-----	---------------	--	--	--

HANOMAG GMBH**C**

44 C	02.80-07.92 ZE		140	800	T4 076	135	1000	T3 045
55 C	02.80-03.96 ZE		140	800	T4 076	135	1000	T3 045
66 C	02.80-03.96 ZE		140	800	T4 076	135	1000	T3 045

D

600 D	02.80-03.96 ZE					135	1000	T3 045
-------	----------------	--	--	--	--	-----	------	---------------

Serie 5-70

22/ 33 C	02.80-07.95 ZE					135	1000	T3 045
44 C	02.80-07.92 ZE		140	800	T4 076	135	1000	T3 045
	02.80-03.96 ZE		140	800	T4 076	135	1000	T3 045
	08.82-03.96 ZE		140	800	T4 076	135	1000	T3 045
55 C	02.80-03.96 ZE		140	800	T4 076	135	1000	T3 045
	01.81-03.96 ZE		140	800	T4 076	135	1000	T3 045
66 C	02.80-03.96 ZE		140	800	T4 076	135	1000	T3 045
77 C	02.80-03.96 ZE					143	950	T3 047





HOLDER

A					
40	07.79-12.88			60	540 S4 005
				63	610 S5 005
50	07.79-12.88			60	540 S4 005
				63	610 S5 005
60	10.78-07.85			95	800 S4 013
				100	830 S5 013
C					
500	05.81-02.97			95	800 S4 013
				100	830 S5 013

IH (INTERNATIONAL HARV.)

H										
90 E	01.72-12.85	225	1150	T5 080	215	1150	T4 080	200	1050	T3 080
Serie 400										
431	11.72-06.86							150	760	T3 063
433, V	06.73-12.85								100	830 S5 013
Serie 500										
531/541	01.72-12.85							150	760	T3 063
Serie 600										
644	01.74-12.85							135	1000	T3 045
Serie 700										
743	04.80-12.85							135	1000	T3 045
Serie 800										
844, A	01.74-12.85				140	800	T4 076	135	1000	T3 045
Serie 900										
923/933/943/953	03.76-12.85							135	1000	T3 045
956 XLA	09.82-12.85				140	800	T4 076	135	1000	T3 045
Serie 1000										
1255, XLA	07.79-12.85	180	1000	T5 077	170	1000	T4 077			
1455, XLA	07.79-12.85	180	1000	T5 077	170	1000	T4 077			

INGERSOLL-RAND

DR-Serie					
DR 125	01.76-12.88			125	720 T3 040
DRAF 125	→12.88			112	510 T3 061

JCB CHASESIDE

3-Serie					
3 CX, D	04.69-09.90			125	720 T3 040
400-Serie					
413	04.73-09.90			125	720 T3 040
800-Serie					
805/806/807/808, B	09.73-09.90			125	720 T3 040

JOHN DEERE

JD					
410	03.74→			143	950 T3 047
Serie 70-140					
140	01.73-12.87			45	400 S3 002
Serie 800					
840	09.79-10.86			55	420 T3 005
				56	480 S3 005

			Ah A (EN) 	Ah A (EN) 	Ah A (EN) 	Ah A (EN) 
			0 092 ...0	0 092 ...0	0 092 ...0	0 092 ...0

Serie 900									
940	09.79-10.86			55	420	T3 005	56	480	S3 005
Serie 1000									
1040	09.79-10.86						60	540	S4 005
							63	610	S5 005
1085	11.82-12.87						95	800	S4 013
							100	830	S5 013
Serie 1100									
1140	09.79-10.86						60	540	S4 005
							63	610	S5 005
1188	01.88-01.03						95	800	S4 013
							100	830	S5 013
Hydro 4	01.91-12.92						95	800	S4 013
							100	830	S5 013
Serie 1600									
1640	09.79-10.86						74	750	S5 007
							77	780	S5 008
Serie 2000									
2040	09.79-10.86						74	750	S5 007
							77	780	S5 008
Serie 2100									
2140	09.79-10.86						74	750	S5 007
							77	780	S5 008
Serie 2200									
2258	06.96→						95	800	S4 013
							100	830	S5 013
Serie 3000									
3040	05.82-10.86			88	680	T3 013	90	720	S3 013
Serie 3100									
3140	05.82-10.86						95	800	S4 013
							100	830	S5 013
Serie 4000									
4055/ 4255	01.89-06.92			100	600	T3 072			
4100/ 4200/ 4600	08.98→						45	300	S3 016
4450/ 4850	05.83-10.88			100	600	T3 072			
4650	03.85-10.88			100	600	T3 072			
4755	01.89-02.89			100	600	T3 072			
	03.89-06.91			100	600	T3 072			
	07.91-05.94			100	600	T3 072			
Serie 6000									
6100	01.92→	ZE		100	600	T3 072	100	830	S5 013
6200	01.92→	ZE		100	600	T3 072	100	830	S5 013
6300	01.92→	ZE		100	600	T3 072	100	830	S5 013
6400	01.92→	ZE		100	600	T3 072	100	830	S5 013
6600	01.92→	ZE	145	800	T5 075	140	800	T4 075	
6800	01.92→	ZE	145	800	T5 075	140	800	T4 075	
6810	08.91→		145	800	T5 075	140	800	T4 075	
6900	01.94→	ZE	145	800	T5 075	140	800	T4 075	
Serie 8000									
8100/ 8200/ 8300/ 8400	08.94→	ZE		110	680	T3 035			

KHD

DX-Serie											
85	05.78-10.85		145	800	T5 075	140	800	T4 075	120	680	T3 075
86	01.82-10.85		145	800	T5 075	140	800	T4 075	120	680	T3 075
	07.82-10.85		145	800	T5 075	140	800	T4 075	120	680	T3 075
90	05.78-10.85		145	800	T5 075	140	800	T4 075	120	680	T3 075
92	01.82-10.85		145	800	T5 075	140	800	T4 075	120	680	T3 075
110	05.78-10.85		145	800	T5 075	140	800	T4 075	120	680	T3 075
120	07.80-10.85		145	800	T5 075	140	800	T4 075	120	680	T3 075



			Ah A (EN) T5	Ah A (EN) T4	Ah A (EN) T3	Ah A (EN) S3-S6				
◀ KHD			0 092 ...0	0 092 ...0	0 092 ...0	0 092 ...0				
140	05.78-10.85	180	1000	T5 077	170	1000	T4 077			
145	07.80-10.85	180	1000	T5 077	170	1000	T4 077			
160	05.78-10.85	180	1000	T5 077	170	1000	T4 077			
250	01.82-10.85	145	800	T5 075	140	800	T4 075	120	680	T3 075
Intrac										
2004	05.78-06.87							135	1000	T3 045

KOMATSU

D										
85 A	02.91→	ZE						180	1100	T3 079

KUBOTA

Serie 6030-8030										
6030/ 7030	12.87-09.88							88	680	T3 013

LAMBORGHINI (S+L+H)

R											
754	01.82-12.85							135	1000	T3 045	
700-Serie											
700	03.89-12.99								95	830	S4 028
900-Serie											
956 DT	01.84-12.99				170	1000	T4 078				
1000-Serie											
1506 Turbo	01.84-12.99	225	1150	T5 080	215	1150	T4 080	200	1050	T3 080	
1706 Turbo	01.84-12.99	225	1150	T5 080	215	1150	T4 080	200	1050	T3 080	

LANDINI

4000-Serie										
4500	01.69-06.86							110	680	T3 035
5000-Serie										
5500	→06.86							110	680	T3 035
9500-Serie										
9500	01.73-06.86	145	800	T5 075	140	800	T4 075	120	680	T3 075

LAVERDA (FIATAGRI)

MX										
300	03.87-10.90	ZE	180	1000	T5 077					
Serie 3000										
3300/ 3350/ 3400/ 3500/ 3550/ 3600/ 3650/ 3700/ 3750/ 3790/ 3850/ 3890	01.83→		180	1000	T5 077					
3550 AL	03.86-03.01		180	1000	T5 077					
3900	01.83-12.85	ZE	180	1000	T5 077					

LIEBHERR

A										
902/ 922	01.79-01.02	ZE						135	1000	T3 045
R										
902/ 911/ 912/ 922	04.72-06.90							135	1000	T3 045

			Ah A (EN) 	Ah A (EN) 	Ah A (EN) 	Ah A (EN) 
			0 092 ...0	0 092 ...0	0 092 ...0	0 092 ...0

921 ,B	04.72-06.90		135	1000	T3 045
932/942	04.72-06.90 ZE		135	1000	T3 045

MASSEY-FERGUSON (MF)

30-Serie						
33	01.73-12.89		150	760	T3 063	
200-Serie						
203/ 205	01.70-12.88		125	720	T3 040	
244	01.70-12.88		110	680	T3 035	
400-Serie						
450	01.73-12.87					95 830 S4 028
2000-Serie						
2203, 2205	10.73-12.88		125	720	T3 040	
3000-Serie						
3303, 3305	10.73-12.88		125	720	T3 040	
3366	01.71-01.86		150	760	T3 063	

mitsubishi

FG						
20/ 25	06.77-12.87					45 300 S3 016

MUIR HILL

100-Serie						
121	01.73-12.86		130	680	T3 043	

NEW HOLLAND

Serie 8000						
8030	03.82-11.86					95 800 S4 013
						100 830 S5 013
8040	03.80-11.86					95 800 S4 013
						100 830 S5 013
8050	03.82-11.86					74 750 S5 007
						77 780 S5 008
8060	03.82-11.86					74 750 S5 007
						77 780 S5 008
8070	03.80-11.86					95 800 S4 013
						100 830 S5 013
TF						
44	03.83-11.86					95 800 S4 013
						100 830 S5 013

O & K (ORENSTEIN & KOPPEL)

G-Serie						
16	04.74-06.87 ZE		135	1000	T3 045	
L-Serie						
4	01.74-06.90					95 800 S4 013
						100 830 S5 013
6/ 35	01.69-06.90		135	1000	T3 045	
10/ 25	01.74-12.86 ZE		135	1000	T3 045	
15	01.74-12.86					95 800 S4 013
						100 830 S5 013





◀ O & K

MH-Serie										
3	01.76-12.85									74 750 S5 007
4/6	09.76-06.90 ZE					135	1000		T3 045	77 780 S5 008
RH-Serie										
4/6/9	01.72-06.90 ZE					135	1000		T3 045	
12	05.76-06.90	145	800	T5 075	140	800	T4 075			

POCLAIN

Serie 60										
60 C, CL, P	03.76-03.01 ZE					135	1000		T3 045	
Serie 70										
75 P	09.75-09.90 ZE					180	1100		T3 079	
Serie 90										
90 P	01.76-01.01 ZE					180	1100		T3 079	

REFORMWERKE BAUER

Metrac										
3000	01.79-06.87					88	680		T3 013	
Muli										
33/40/50/150	01.75-06.85					88	680		T3 013	

SAME (S+L+H)

Antares										
100	03.89-03.04									95 800 S4 013
										100 830 S5 013
Aster										
60	03.89-03.04									95 800 S4 013
										100 830 S5 013
70	03.89-03.04									95 800 S4 013
										100 830 S5 013
Condor										
55	07.82-10.87					143	900		T3 046	
Corsaro Frutteto										
70	10.81-03.88					143	900		T3 046	
Delfino										
35	01.72-01.86									74 680 S4 008
Drago										
120	01.78-05.86				170	1000	T4 078			
Explorer										
60 Special	06.86-06.01					88	680	T3 013	90	720 S3 013
70 Special	07.86-07.01					88	680	T3 013	90	720 S3 013
Falcon										
	07.75-10.87					112	510		T3 061	
Frutteto										
60	04.87-04.02					88	680	T3 013	90	720 S3 013
75	04.87-04.02					88	680	T3 013	90	720 S3 013
Laser										
110/130	03.83-04.98					180	1100	T3 079		
150	03.83-03.98				170	1000	T4 078			
Leopard										
C	06.80-12.85	145	800	T5 075	140	800	T4 075			
Ranger										
45	02.82-02.97									74 680 S4 008
Solar										
50	06.86-06.01									95 800 S4 013
										100 830 S5 013

			Ah A (EN) 	Ah A (EN) 	Ah A (EN) 	Ah A (EN) 
			0 092 ...0	0 092 ...0	0 092 ...0	0 092 ...0

60	06.86-06.01					95	800	S4 013
						100	830	S5 013
Vigneron								
50/62	02.82-03.03					74	680	S4 008
60/75	03.78-03.03					95	830	S4 028
70	06.82-02.88			120	760			T3039

STEINBOCK

Serie DFG									
1D/1.25/1.6 DA	→12.88			88	680	T3 013	90	720	S3 013
2.5 R	→12.88			88	680	T3 013	90	720	S3 013
2.5/2.5 SB/3.0/3.5/4 D	→12.88	180	1000	T5 077					
4 D	→12.88	180	1000	T5 077					

STEYR (STEYR-DAIMLER-PUCH AG)

Serie 8000									
8055	02.82-09.01						95	800	S4 013
							100	830	S5 013
8060	01.80-02.87		140	800	T4 076	130	680	T3 043	
,a	01.80-02.87		140	800	T4 076	130	680	T3 043	
8070 ,a	10.84-10.99		140	800	T4 076	130	680	T3 043	
8075 ,a	01.84-01.99		140	800	T4 076	135	1000	T3 045	
8080	01.80-06.85		140	800	T4 076	135	1000	T3 045	
,a	01.80-06.85		140	800	T4 076	130	680	T3 043	
	06.84-06.99		140	800	T4 076	130	680	T3 043	
8090 ,a	01.84-01.99		140	800	T4 076	135	1000	T3 045	
8100 ,a	12.78-12.88					130	680	T3 043	
8130 ,a	07.84-07.99		140	800	T4 076	135	1000	T3 045	
8180	04.87-04.02					110	680	T3 035	

VOLVO BM

A								
20	08.86-08.01	ZE	145	800	T5 075	140	800	T4 075
DR								
861	01.79-07.86					135	1000	T3 045
L								
50/70/90	11.91→					110	680	T3 035
120	01.87-01.02		145	800	T5 075	140	800	T4 075
160	01.87-01.02		145	800	T5 075	140	800	T4 075
LM								
1240	12.72-12.87	ZE				125	720	T3 040
Serie 4000								
4400	01.79-06.86	ZE				110	680	T3 035
4500	12.79-06.86	ZE				125	720	T3 040

ZETOR

Serie 5000								
5211	01.88-01.03		180	1000	T5 077	170	1000	T4 077
5245	01.88-01.03		180	1000	T5 077	170	1000	T4 077
Serie 6000								
6211	01.88-01.03		180	1000	T5 077	170	1000	T4 077
6245	01.88-01.03		180	1000	T5 077	170	1000	T4 077
Serie 7000								
7245	01.88-01.03		180	1000	T5 077	170	1000	T4 077
7745	01.88-01.03		180	1000	T5 077	170	1000	T4 077



			Ah A (EN) 	Ah A (EN) 	Ah A (EN) 	Ah A (EN) 
			0 092 ...0	0 092 ...0	0 092 ...0	0 092 ...0

◀ ZETOR

Serie 8000								
8045	01.75-06.85		88	680	T3 013	90	720	S3 013
8145	→07.87		88	680	T3 013	90	720	S3 013
Serie 10000								
10145	01.88-01.03		88	680	T3 013	90	720	S3 013
Serie 12000								
12045	01.75-06.85		88	680	T3 013	90	720	S3 013
12145	→07.87		88	680	T3 013	90	720	S3 013
Serie 16000								
16145	01.88-01.03		88	680	T3 013	90	720	S3 013
						95	800	S4 013
						100	830	S5 013

ZETTELMAYER

ZL-Serie								
501	09.79-12.89					95	800	S4 013
						100	830	S5 013
2000	04.76-12.89		135	1000	T3 045			





APRILIA

50 cc									
AF 1 Project 108	01.88-12.89					4	20	M4 F17'	YB4L-B
/90 REP	01.90-12.94					4	20	M4 F17'	YB4L-B
AF 1/ Amico/ Classic/ ET/ Europa/ F-1/ Gulliver/ Mojito/ Rally/ Red Rose/ RS/ RX/ Sconic/ SR , AC, AE/Fire/Tuareg, CD, Classic, Custom	01.83→					4	20	M4 F17'	YB4L-B
AF 1/ RS/ SR Esquire, Extrema Replica, Futura	01.92-12.99					4	20	M4 F17'	YB4L-B
Amico SL	01.95-12.00					4	20	M4 F17'	YB4L-B
Sport	01.91-12.97					4	20	M4 F17'	YB4L-B
Amico/ Gulliver/ Rally/ Sonic/ SR LC, LC Street, LX	01.93→					4	20	M4 F17'	YB4L-B
Area/ Habana 50, 51	01.98-12.03					4	20	M4 F17'	YB4L-B
Filo G 1 A, G 4 LNT	01.81-12.87					4	20	M4 F17'	YB4L-B
Partner RDL	01.80-12.85					4	20	M4 F17'	YB4L-B
Scarabeo 2T	01.93→					4	20	M4 F17'	YB4L-B
Scarabeo/ Sportcity One 4T, 4T 4V	01.02→					9	80	M4 F25'	12N9-4B-1; YB9-B
Scarabeo/ SR DiTech	01.00-12.05		4	30	M6 004			YTX5L-4; YTX5L-BS	
Sportcity One 2T	01.08-12.11					9	80	M4 F25'	12N9-4B-1; YB9-B
SR R	01.04→					9	80	M4 F25'	12N9-4B-1; YB9-B
Replica	01.95-12.00					4	20	M4 F17'	YB4L-B
Trial SC	01.83-12.88					4	20	M4 F17'	YB4L-B
SL	01.83-12.88					4	20	M4 F17'	YB4L-B
100 cc									
Scarabeo 2T	01.00-12.00		4	30	M6 004			YTX5L-4; YTX5L-BS	
4T	01.01→					9	80	M4 F25'	12N9-4B-1; YB9-B
125 cc									
AF 1/ AFI Replica	03.87-12.94					6	40	M4 F19'	12N5.5-3B
AF 1/ RS Extrema Replica, Futura, Futura/Sport/ RR/Sintesi	06.88-12.12					9	80	M4 F25'	12N9-4B-1; YB9-B
AFI Project 108	03.87-12.87					9	80	M4 F25'	12N9-4B-1; YB9-B
Sintesi	06.88-12.89					9	80	M4 F25'	12N9-4B-1; YB9-B
AS R	01.91→					6	40	M4 F19'	12N5.5-3B
Atlantic/ Leonardo/ Scarabeo	01.96-12.11					12	120	M4 F32'	YB12AL-A; YB12AL-A2
Classic/ ETX/ Pegaso/ Red Rose/ RS/ RS4/ RX/ Sportcity One/ STX/ Tuono	01.82→					9	80	M4 F25'	12N9-4B-1; YB9-B
Habana	01.99-12.02		8	80	M6 010			YTX9-4; YTX9-BS	
Leonardo ST	01.01-12.05					12	120	M4 F32'	YB12AL-A; YB12AL-A2
Mojito/ SR	01.99→		6	50	M6 006			YTX7L-4; YTX7L-BS	
Sportcity	01.02-12.08		12	190	M6 019			YT12B-4; YT12B-BS	
Sportcity Cube	01.08→		10	90	M6 014			YTX12-4; YTX12-BS	
ST	01.82→	MEK				9	80	M4 F25'	12N9-4B-1; YB9-B
		MKS				6	40	M4 F19'	12N5.5-3B
Tuareg	01.86-12.89	MEK				9	80	M4 F25'	12N9-4B-1; YB9-B
	01.86-12.94	MKS				6	40	M4 F19'	12N5.5-3B
Rally	06.89-12.94					9	80	M4 F25'	12N9-4B-1; YB9-B
Wind	07.88-12.94					9	80	M4 F25'	12N9-4B-1; YB9-B
150 cc									
Leonardo	01.97-12.04		8	80	M6 010			YTX9-4; YTX9-BS	
ST	01.02-12.04					12	120	M4 F32'	YB12AL-A; YB12AL-A2
Mojito	01.03-12.07		6	50	M6 006			YTX7L-4; YTX7L-BS	
Scarabeo	01.99-12.03					12	120	M4 F32'	YB12AL-A; YB12AL-A2
SR	01.99-12.01		6	50	M6 006			YTX7L-4; YTX7L-BS	





0 092 ...0

0 092 ...0

◀ APRILIA

200 cc							
Atlantic/ Scarabeo	01.99-12.08			12	120	M4 F32*	YB12AL-A; YB12AL-A2
Scarabeo ie	01.09→			12	120	M4 F32*	YB12AL-A; YB12AL-A2
Sportcity	01.05-12.10	12	190	M6 019			YT12B-4; YT12B-BS
250 cc							
Atlantic ie	01.06-12.08			12	120	M4 F32*	YB12AL-A; YB12AL-A2
Atlatic/ Leonardo	01.98-12.06			12	120	M4 F32*	YB12AL-A; YB12AL-A2
RS	01.94-12.02			4	20	M4 F17*	YB4L-B
300 cc							
Atlantic	01.10→			9	80	M4 F25*	12N9-4B-1; YB9-B
Leonardo	01.02-12.06			12	120	M4 F32*	YB12AL-A; YB12AL-A2
Scarabeo	01.09-12.10	10	90	M6 014			YTX12-4; YTX12-BS
350 cc							
ETX, AE	01.85-12.92			14	140	M4 F34*	12N14-3A; YB14L-A2
Tuareg Wind	01.87-12.93			9	80	M4 F25*	12N9-4B-1; YB9-B
400 cc							
Atlantic/ Scarabeo	01.05-12.08	10	90	M6 014			YTX12-4; YTX12-BS
450 cc							
RXV/ SXV	01.06→	8	150	M6 011			YTZ10S-4; YTZ10S-BS
500 cc							
Atlantic/ Scarabeo	01.01-12.08			14	140	M4 F34*	12N14-3A; YB14L-A2
550 cc							
RXV/ SXV	01.06→	8	150	M6 011			YTZ10S-4; YTZ10S-BS
600 cc							
ETX/ Pegaso/ Tuareg, Tuareg, Wind	01.85-12.94			14	140	M4 F34*	12N14-3A; YB14L-A2
650 cc							
Moto 6.5	01.95-12.03			12	120	M4 F32*	YB12AL-A; YB12AL-A2
Pegaso	04.92-12.00			12	120	M4 F32*	YB12AL-A; YB12AL-A2
	01.05-12.09	10	90	M6 014			YTX12-4; YTX12-BS
i.e.	01.01-12.04			12	120	M4 F32*	YB12AL-A; YB12AL-A2
750 cc							
SL Shiver	01.07→	12	100	M6 018			YTX14-4; YTX14-BS
850 cc							
NA Mana	01.07→	12	100	M6 018			YTX14-4; YTX14-BS
1000 cc							
ETV Caponord	01.01-12.07	12	100	M6 018			YTX14-4; YTX14-BS
RST/ Tuono Fighter/R, Futura	01.01-12.09	10	90	M6 014			YTX12-4; YTX12-BS
RSV Mille	09.98-08.00	12	100	M6 018			YTX14-4; YTX14-BS
Mille /R, Mille R, Mille R Factory, Mille SP	09.98-12.08	10	90	M6 014			YTX12-4; YTX12-BS
RSV4 Factory	01.09→			11	90	M4 F29*	12N10-3B; YB10L-B; YB10L-B2
SL Falco	09.99-12.04	12	100	M6 018			YTX14-4; YTX14-BS

ATALA

50 cc							
Byte/ Carosello/ Hacker/ Skeggia, 50	01.96→			4	20	M4 F17*	YB4L-B

BENELLI

50 cc							
Devil/ KB-X/ K2/ Naked/ Pepe/ Scooty/ Spring/ 491, AC, LC	09.91→			4	20	M4 F17*	YB4L-B
80 cc							
Devil/ KB-X	01.93→			4	20	M4 F17*	YB4L-B
100 cc							
K2	01.99-12.04			5	30	M4 F18*	12N5-3B; YB5L-B
Naked	01.97→			4	20	M4 F17*	YB4L-B

		Ah		A (EN)		M6		M4		M4		M4		M4	
		0 092 ...0		0 092 ...0											
Pepe LX	01.97→	3	30	M6 001	YT4L-4; YT4L-BS										
125 cc															
Adiva	01.01-12.06	12	100	M6 018	YTX14-4; YTX14-BS										
Jarno	01.88-12.93					9	80	M4 F25'	12N9-4B-1; YB9-B						
Scooter	06.95→					9	80	M4 F26'	12N9-3B; YB9L-B						
Sport Spezial	01.70-06.89					4	20	M4 F17'	YB4L-B						
Velvet	01.99-12.04	8	80	M6 010	YTX9-4; YTX9-BS										
124	09.82-06.89					12	80	M4 F12'	6N11A-3A						
125 Sport, Sport T	01.70-06.89					4	20	M4 F17'	YB4L-B						
150 cc															
Adiva	01.99-12.04	12	100	M6 018	YTX14-4; YTX14-BS										
Velvet	01.99-12.04	8	80	M6 010	YTX9-4; YTX9-BS										
250 cc															
Adiva	01.06→	8	80	M6 010	YTX9-4; YTX9-BS										
Velvet	01.99-12.04					12	120	M4 F30'	12N12A-4A-1; YB12A-A						
250 2C/2CE/Sport Speciale	01.74-01.87					12	80	M4 F12'	6N11A-3A						
350 cc															
354 Sport II, Sport II Turismo, T, Turismo	01.80-06.89					14	140	M4 F34'	12N14-3A; YB14L-A2						
400 cc															
Velvet Dusk	01.02-12.03	8	80	M6 010	YTX9-4; YTX9-BS										
600 cc															
654 , Sport T	01.80-06.89					14	140	M4 F34'	12N14-3A; YB14L-A2						
900 cc															
Tornado	01.00→	11	140	M6 016	YT12A-4; YT12A-BS										
Biposto, F1, Limited Edition	01.00→					30	300	M4 F54'	53030						
Tre RS/LE	01.03-12.06					30	300	M4 F54'	53030						
TreK 899	01.09→	11	230	M6 017	YTZ14S-4; YTZ14S-BS										
900 Sport	12.78-12.87					30	300	M4 F54'	53030						
1130 cc															
TnT/ TreK	01.04→	12	100	M6 018	YTX14-4; YTX14-BS										
Tornado Tre	01.06→	11	140	M6 016	YT12A-4; YT12A-BS										
TreK Amazonas	01.07→	11	230	M6 017	YTZ14S-4; YTZ14S-BS										

BETA-INTERMOTOR

50 cc															
Adventure/ Chrono	05.87-12.03					4	20	M4 F17'	YB4L-B						
Ark/ Chrono/ Enduro/ RR/ Tempo AC, Crono, LC, RK 6, Super Motard, 502	01.93-12.09					4	20	M4 F17'	YB4L-B						
Eikon	01.98-12.06	8	80	M6 010	YTX9-4; YTX9-BS	4	20	M4 F17'	YB4L-B						
Quadra/ REV/ RK6/ ST/ Super Trial/ Techno/ Tempo	01.92-12.08					4	20	M4 F17'	YB4L-B						
125 cc															
Alp/ RR	01.04→	4	30	M6 004	YTX5L-4; YTX5L-BS										
Eikon	01.99-12.05	8	80	M6 010	YTX9-4; YTX9-BS										
Techno	01.94-12.00					4	20	M4 F17'	YB4L-B						
125 RE, Urban	01.09→	4	30	M6 004	YTX5L-4; YTX5L-BS										
150 cc															
Eikon	01.00-12.06	8	80	M6 010	YTX9-4; YTX9-BS										
200 cc															
Alp 4T	01.99→	4	30	M6 004	YTX5L-4; YTX5L-BS										
250 cc															
REV 3/ RR	01.00-12.08	4	30	M6 004	YTX5L-4; YTX5L-BS										
350 cc															
Alp 4.0	01.04→	6	50	M6 006	YTX7L-4; YTX7L-BS										
Euro/ Jonathan	01.01→	8	80	M6 010	YTX9-4; YTX9-BS										
400 cc															
RR	01.05→	4	30	M6 004	YTX5L-4; YTX5L-BS										





◀ BETA-INTERMOTOR

0 092 ...0

0 092 ...0

450 cc					
RR	01.05→	4	30	M6 004	YTX5L-4; YTX5L-BS
500 cc					
RR 525	01.05→	4	30	M6 004	YTX5L-4; YTX5L-BS

BIMOTA

600 cc					
YB 9 SR, SRi	01.95-12.99				12 120 M4 F32' YB12AL-A; YB12AL-A2
900 cc					
DB 3 Mantra	01.95-12.98	6	50	M6 006	YTX7L-4; YTX7L-BS
1000 cc					
DB 5 Mille	01.05→	12	190	M6 019	YT12B-4; YT12B-BS
Tesi 2 D	01.04→				14 140 M4 F34' 12N14-3A; YB14L-A2
1100 cc					
DB 6 R	01.07→	12	190	M6 019	YT12B-4; YT12B-BS
SB 6 R	01.96-12.98	6	50	M6 006	YTX7L-4; YTX7L-BS

BMW

125 cc					
C 1	03.00-04.03				14 140 M4 F34' 12N14-3A; YB14L-A2
200 cc					
C 1	03.01-02.03				14 140 M4 F34' 12N14-3A; YB14L-A2
450 cc					
G 450 X	09.08-06.10	7	110	M6 009	YTZ7S-4; YTZ7S-BS
475 cc					
R 45	06.78-07.85				18 150 M4 F41' 51814
650 cc					
F 650 , CS	11.93-07.05				12 120 M4 F32' YB12AL-A; YB12AL-A2
GS	09.99-10.07				12 120 M4 F32' YB12AL-A; YB12AL-A2
	03.08-06.12	12	100	M6 018	YTX14-4; YTX14-BS
GS Dakar, ST	11.96-09.07				12 120 M4 F32' YB12AL-A; YB12AL-A2
R 65 GS	11.87-11.92	19	170	M6 045	- 18 150 M4 F41' 51814
800 cc					
F 800 GS	03.08→	12	100	M6 018	YTX14-4; YTX14-BS
R	04.09→	12	100	M6 018	YTX14-4; YTX14-BS
S, ST	05.06-07.12	12	100	M6 018	YTX14-4; YTX14-BS
R 80 R	01.91-12.94	19	170	M6 045	- 25 220 M4 F52' 52515; Y60-N24L-A
RT	01.84-12.95				30 300 M4 F54' 53030
850 cc					
R 850 C, GS, R, RT	10.94-07.07	19	170	M6 045	- 19 170 M4 F45' 51913
900 cc					
R 900 RT	09.06-09.09				18 150 M4 F41' 51814
980 cc					
R 100 GS Dakar, GS Dakar Classic, GS, PD, R, R Mystic, RS, RT, RT Classic	09.86-02.96				25 220 M4 F52' 52515; Y60-N24L-A
1000 cc					
K 1	09.88-09.93	19	170	M6 045	- 25 220 M4 F52' 52515; Y60-N24L-A
K 100	09.83-09.88	19	170	M6 045	- 30 300 M4 F54' 53030
LT	07.86-10.91	19	170	M6 045	- 30 300 M4 F54' 53030
RS, RT, /2	09.83-06.92	19	170	M6 045	- 30 300 M4 F54' 53030
S 1000 RR	09.09-08.11	8	150	M6 011	YTZ10S-4; YTZ10S-BS
1100 cc					
K 1100 LT	01.92-04.99	19	170	M6 045	- 18 150 M4 F41' 51814
LT High Line, LT Special Edition	01.94-04.99	19	170	M6 045	- 19 170 M4 F45' 51913
RS	01.93-12.96	19	170	M6 045	- 19 170 M4 F45' 51913
RS Sondermodell	01.95-12.96	19	170	M6 045	- 19 170 M4 F45' 51913



		0 092 ...0				0 092 ...0			
		Ah	A (EN)	M6	RS	Ah	A (EN)	M4	RS
R 1100 GS	08.93-12.99	19	170	M6 045	-	19	170	M4 F45'	51913
R	10.94-04.01	19	170	M6 045	-	18	150	M4 F41'	51814
RS	11.92-06.01	19	170	M6 045	-	18	150	M4 F41'	51814
RT	09.95-08.01	19	170	M6 045	-	18	150	M4 F41'	51814
S	01.98-07.05	19	170	M6 045	-				
1150 cc									
R 1150 GS	08.99-11.03	19	170	M6 045	-	18	150	M4 F41'	51814
GS Adventure, R, R Rockster	01.01-06.06	19	170	M6 045	-	19	170	M4 F45'	51913
RS, RT	03.01-12.02					18	150	M4 F41'	51814
	01.03-03.06					19	170	M4 F45'	51913
1200 cc									
K 1200 GT	09.02-07.05					19	170	M4 F45'	51913
	11.05-10.08					19	170	M4 F45'	51913
LT	09.98-07.08					19	170	M4 F45'	51913
RS	10.96-07.05	19	170	M6 045	-	19	170	M4 F45'	51913
K 1200/ R 1200 R, R Sport	06.05-10.10	12	100	M6 018	YTX14-4; YTX14-BS				
S, ST	09.04-09.08	12	100	M6 018	YTX14-4; YTX14-BS				
R 1200 C, C Independent, C Montauk, CL	10.97-10.04					19	170	M4 F45'	51913
GS, GS Adventure	03.04-09.09	12	100	M6 018	YTX14-4; YTX14-BS				
HP2 Sport	03.08-07.10	12	100	M6 018	YTX14-4; YTX14-BS				
RT	01.05-11.09					19	170	M4 F45'	51913
1300 cc									
K 1300 GT	01.09-10.10					19	170	M4 F45'	51913
R, S	01.09→	12	100	M6 018	YTX14-4; YTX14-BS				

BS VILLA

50 cc									
SP/ ZX/ Z5	01.93-12.00	3	30	M6 001	YT4L-4; YT4L-BS				

BUELL

1000 cc									
XB9R/ XB9S/ XB9SX Firebolt, Lightning, Lightning CityX	01.01→	12	100	M6 018	YTX14-4; YTX14-BS				
1200 cc									
M2 Cyclone	01.97-12.03	18	260	M6 023	YTX20L-4; YTX20L-BS				
S1 Lightning	01.96-12.99	12	100	M6 018	YTX14-4; YTX14-BS				
S3 Thunderbolt	01.97-12.02	18	260	M6 023	YTX20L-4; YTX20L-BS				
XB12R Firebolt	01.04→	12	100	M6 018	YTX14-4; YTX14-BS				
XB12S/ XB12Ss Lightning	01.04→	12	100	M6 018	YTX14-4; YTX14-BS				
XB12X Ulysses	01.05→	12	100	M6 018	YTX14-4; YTX14-BS				
X1 Lightning	01.99-12.02	18	260	M6 023	YTX20L-4; YTX20L-BS				

CAGIVA

50 cc									
City/ Mantis/ Progress/ Progress Corsa	07.95-12.01	3	30	M6 001	YT4L-4; YT4L-BS				
Coccis/ Prima	01.88-12.96					5	30	M4 F18'	12N5-3B; YB5L-B
Cucciolo	01.98-12.00					4	20	M4 F17'	YB4L-B
K 3	01.91-12.92					4	20	M4 F17'	YB4L-B
Mito	01.98-12.00					4	20	M4 F17'	YB4L-B
W 4	01.91-12.94					4	20	M4 F17'	YB4L-B
80 cc									
W 4	01.92-12.94					4	20	M4 F17'	YB4L-B
125 cc									
Aletta Electra/ Aletta Oro/ Blues	01.84-12.93	12	120	M4 F30'	12N12A-4A-1; YB12A-A				





◀ CAGIVA

0 092 ...0

0 092 ...0

Cruiser/ Freccia C9/ Mito/ N90/ Planet/ Raptor/ Super-City/ SuperCity/ Tamanaco	01.87→			9	80	M4 F25*	12N9-4B-1; YB9-B
Freccia C10/ Freccia C12/ Mito R, Racing, R/SP	01.87-12.93			9	80	M4 F25*	12N9-4B-1; YB9-B
K7/ Passing/ W 8	01.91-12.01			4	20	M4 F17*	YB4L-B
Mito SP 525	01.08→			9	80	M4 F25*	12N9-4B-1; YB9-B
Mito/ Mito II/ SuperCity Ev, Evolution, LE/Replica	01.92-12.01			9	80	M4 F25*	12N9-4B-1; YB9-B
Roadster 200 cc	01.94-12.00	8	80			M6 010	YTX9-4; YTX9-BS
Roadster 250 cc	01.96-12.97			9	80	M4 F25*	12N9-4B-1; YB9-B
SST 350 cc	01.83-12.85			7	40	M4 F21*	12N7-3B; YB7L-B
Elefant	01.85-12.89			14	140	M4 F34*	12N14-3A; YB14L-A2
SST	11.81-12.86			7	40	M4 F21*	12N7-3B; YB7L-B
T 4 E, R	10.86-12.93			3	10	M4 F15*	YB3L-A
W 12 450 cc	01.93-12.96			14	140	M4 F34*	12N14-3A; YB14L-A2
T 4 E, R 500 cc	01.87-12.90			14	140	M4 F34*	12N14-3A; YB14L-A2
Canyon/ River 600 cc	01.97-12.02	12	100			M6 018	YTX14-4; YTX14-BS
Canyon/ River/ W16 650 cc	01.94-12.01			14	140	M4 F34*	12N14-3A; YB14L-A2
Elefant	01.85-12.89			14	140	M4 F34*	12N14-3A; YB14L-A2
Raptor i.e.	01.05→	8	80			M6 010	YTX9-4; YTX9-BS
Raptor/ V-Raptor 750 cc	01.01-12.04	10	90			M6 014	YTX12-4; YTX12-BS
Elefant	01.87-12.90			19	190	M4 F44*	YB16-B
	01.94-12.97			19	190	M4 F44*	YB16-B
900 cc							
Canyon/ Elefant/ Gran Canyon AC, EFi, ie, i.E.	01.90-12.00			19	190	M4 F44*	YB16-B
1000 cc							
Navigator	01.00-12.05			19	190	M4 F44*	YB16-B
Raptor X 3	01.00-12.05	10	90			M6 014	YTX12-4; YTX12-BS
	01.04→	12	190			M6 019	YT12B-4; YT12B-BS
V-Raptor/ X-tra Raptor	01.00-12.06	12	190			M6 019	YT12B-4; YT12B-BS

CCM

600 cc

604 Roadster RS, R/RS/R30, Supermoto Dual Sport, Trial Dual Sport	01.99-12.02	8	80			M6 010	YTX9-4; YTX9-BS
--	-------------	---	----	--	--	---------------	------------------------

CPI

50 cc

Aragon/ ATV/ GTR/ GTS/ Hussar/ Oliver/ Popcorn 125 cc	01.00→	4	30			M6 004	YTX5L-4; YTX5L-BS
GTR/ GTS/ Sahel/ X-Large 200 cc	01.00→	4	30			M6 004	YTX5L-4; YTX5L-BS
GTR/ GTS/ X-Large 230 cc	01.00→	4	30			M6 004	YTX5L-4; YTX5L-BS
ATV	01.00→	4	30			M6 004	YTX5L-4; YTX5L-BS

Ah
A
(EN)

0 092 ...0

Ah
A
(EN)

0 092 ...0

DAELIM

50 cc										
Cordi/ E-Five/ Message/ S-Five	01.98→		3	30	M6 001	YT4L-4; YT4L-BS				
125 cc										
NS/ Otello	01.98→		6	50	M6 007	YTX7A-4; YTX7A-BS				
VC Advance	01.95-12.01						9	80	M4 F25'	12N9-4B-1; YB9-B
VS Evolution	01.02→						9	80	M4 F25'	12N9-4B-1; YB9-B
VT	01.98-12.01						9	80	M4 F25'	12N9-4B-1; YB9-B
Evolution	01.01→		6	50	M6 006	YTX7L-4; YTX7L-BS				

DERBI

50 cc										
Atlantis/ GPR/ Paddock/ Predator/ Senda LC, R	01.95-12.05						4	20	M4 F17'	YB4L-B
Atlantis/ Paddock/ Predator AC	01.96→						4	20	M4 F17'	YB4L-B
Aventura/ Easy/ Fenix/ Furax/ Hunter/ Senda/ Vamos	01.92-12.05						4	20	M4 F17'	YB4L-B
Boulevard 2T	01.09→						9	80	M4 F25'	12N9-4B-1; YB9-B
GP1	01.98-12.02		3	30	M6 001	YT4L-4; YT4L-BS				
Start DS	01.83-12.93						5	30	M4 F18'	12N5-3B; YB5L-B
Variant SLE America, Sport	01.86-12.90						4	20	M4 F17'	YB4L-B
100 cc										
Atlantis	01.01-12.06		8	80	M6 010	YTX9-4; YTX9-BS				
125 cc										
GPR Nude/Racing	01.04→						4	20	M4 F17'	YB4L-B
GP1/ Mulhacen	01.06→		6	50	M6 006	YTX7L-4; YTX7L-BS				
Rambla	01.09→		10	90	M6 014	YTX12-4; YTX12-BS				
Senda R/SM	01.02→		6	50	M6 006	YTX7L-4; YTX7L-BS				
250 cc										
Rambla	01.09→		10	90	M6 014	YTX12-4; YTX12-BS				

DUCATI

250 cc										
F3	01.86-12.89						14	140	M4 F34'	12N14-3A; YB14L-A2
350 cc										
Indiana	01.86-06.90						14	140	M4 F34'	12N14-3A; YB14L-A2
400 cc										
Monster	01.01-12.02						16	120	M4 F40'	YB16AL-A2
400 Supersport	03.92-12.94						16	120	M4 F40'	YB16AL-A2
600 cc										
Supersport Carenata, Nuda	08.93-12.99						16	120	M4 F40'	YB16AL-A2
TL	01.85-12.86						14	140	M4 F34'	12N14-3A; YB14L-A2
620 cc										
Monster/ Multistrada/ Supersport , i.e., S	01.02-12.06		12	190	M6 019	YT12B-4; YT12B-BS				
650 cc										
Indiana/ Pantah , Policeman, Replica, Vigili Urbani	06.86-12.93						14	140	M4 F34'	12N14-3A; YB14L-A2
700 cc										
Monster 695, 696	01.07→		12	190	M6 019	YT12B-4; YT12B-BS				
750 cc										
Indiana	01.87-12.90						14	140	M4 F34'	12N14-3A; YB14L-A2
Monster	01.95-12.01						16	120	M4 F40'	YB16AL-A2
i.e.	01.02-12.02						16	120	M4 F40'	YB16AL-A2
Superbike 749, 749 Dark, 749 R, 749 S	01.03-12.06		12	190	M6 019	YT12B-4; YT12B-BS				



		0 092 ...0		0 092 ...0		
		M6		M4		
		M6		M4		
◀ DUCATI						
Superbike/ 748/ 750 Sport , SP/SPS, SS, Supersport, 748 R, 748 /S/E	01.88-12.03			16	120	M4 F40* YB16AL-A2
Supersport	01.99-12.02	12	190	M6 019	YT12B-4; YT12B-BS	
750 F1 /Desmo /LS	01.85-12.88			14	140	M4 F34* 12N14-3A; YB14L-A2
Montijuich, Paso	01.86-12.92			14	140	M4 F34* 12N14-3A; YB14L-A2
800 cc						
Hypermotard/ Monster 796	01.10→	12	190	M6 019	YT12B-4; YT12B-BS	
Monster/ Sport/ Supersport , S/Dark, S2R	01.03-12.07	12	190	M6 019	YT12B-4; YT12B-BS	
850 cc						
Superbike 848 EVO	01.11→			16	120	M4 F40* YB16AL-A2
851 , Strada	03.88-12.93			16	120	M4 F40* YB16AL-A2
Superbike Strada	01.91-12.93			16	160	M4 F39* YB16B-A; YB16B-A1
S3	01.89-12.92			16	120	M4 F40* YB16AL-A2
890 cc						
851/ 888 S.P. , SP, SP IV, SP Racing, S.P.V., SP5, Strada	01.90-12.94			16	120	M4 F40* YB16AL-A2
900 cc						
Monster	01.93-12.98			16	120	M4 F40* YB16AL-A2
i.e.	01.99-12.02			16	120	M4 F40* YB16AL-A2
Supersport	01.98-12.02	12	190	M6 019	YT12B-4; YT12B-BS	
900 i.e. Sport	01.98-12.02	12	190	M6 019	YT12B-4; YT12B-BS	
SL, SS	01.91-12.03			16	120	M4 F40* YB16AL-A2
SS Hailwood Replica	01.80-12.85			25	220	M4 F52 52515; Y60-N24L-A
				30	300	M4 F54* 53030
SS Supersport	01.88-12.93			25	220	M4 F52 52515; Y60-N24L-A
				30	300	M4 F54* 53030
Supersport	01.90-12.98			16	120	M4 F40* YB16AL-A2
906/ 907 Paso , Paso I.E.	01.89-12.93			19	190	M4 F44* YB16-B
907 i.e.	01.90-12.94			19	190	M4 F44* YB16-B
916 cc						
Monster 916 S4/R	01.99-12.03	12	190	M6 019	YT12B-4; YT12B-BS	
ST 4	01.99-12.03			16	120	M4 F40* YB16AL-A2
S4 Fogarty	01.02-12.02	12	190	M6 019	YT12B-4; YT12B-BS	
916 Senna , SP, SS, Strada, Supersport	01.92-12.98			16	120	M4 F40* YB16AL-A2
950 cc						
ST2/ 916 , Corsa	01.95-12.03			16	120	M4 F40* YB16AL-A2
1000 cc						
Desmosedici/ Monster/ Superbike S4RS, 989 RR, 996 S4R, 998 S4R, 999, 999 R, 999 S	09.02-12.08	12	190	M6 019	YT12B-4; YT12B-BS	
GT/ Paul Smart/ Sport	01.06-12.10	12	190	M6 019	YT12B-4; YT12B-BS	
Monster/ ST 4 /S, S	01.01-12.05	12	190	M6 019	YT12B-4; YT12B-BS	
Multistrada/ Supersport/ 998 DS, DS /S, Final Edition	01.02-12.06	12	190	M6 019	YT12B-4; YT12B-BS	
Supersport/ 998	01.02-12.04	12	190	M6 019	YT12B-4; YT12B-BS	
916 Corsa	01.97-12.97			16	120	M4 F40* YB16AL-A2
916/ 996 SPS	01.97-12.01			16	120	M4 F40* YB16AL-A2
996	01.99-12.01			16	120	M4 F40* YB16AL-A2
Biposto	01.99-12.01			16	120	M4 F40* YB16AL-A2
R	01.01-12.01	12	190	M6 019	YT12B-4; YT12B-BS	
998 R	01.02-12.02	11	140	M6 016	YT12A-4; YT12A-BS	
1100 cc						
Hypermotard/ Monster/ Multistrada/ Streetfighter/ Superbike EVO, /S, S/SP, 1098 R, 1098 /S	01.07→	12	190	M6 019	YT12B-4; YT12B-BS	
1200 cc						
Multistrada /S	01.10→	12	190	M6 019	YT12B-4; YT12B-BS	



Ah
A
(EN)

0 092 ...0

Ah
A
(EN)

0 092 ...0

FANTIC

50 cc									
Big Wheel/ Koala/ Oasis/ Pony	03.86-12.99					4	20	M4 F17'	YB4L-B
Grinta/ Leader/ Queenie	01.95-12.99		3 30	M6 001	YT4L-4; YT4L-BS				
Pony SR	01.91-12.01					4	20	M4 F17'	YB4L-B
125 cc									
Raider 125 LC	10.84-12.85					3	10	M4 F15'	YB3L-A
250 cc									
Raider LC	08.84-12.86					3	10	M4 F15'	YB3L-A

GARELLI (AGRATI-GARELLI)

50 cc									
Bimatic/ NOI/ Pony/ Queenie/ Sahel/ Sahel 89/ Team/ Tiger/ Urka , AC, ES, LC, ES, matic, XLE	02.80-12.97					4	20	M4 F17'	YB4L-B
125 cc									
GTA	01.83-12.92	MEK				9	80	M4 F25'	12N9-4B-1; YB9-B
		MKS				5	30	M4 F18'	12N5-3B; YB5L-B
Tiger XLE	03.86-12.88					4	20	M4 F17'	YB4L-B
XR, XRD	01.84-12.88	MEK				9	80	M4 F25'	12N9-4B-1; YB9-B
		MKS				5	30	M4 F18'	12N5-3B; YB5L-B
XR	06.84-12.88	MEK				9	80	M4 F25'	12N9-4B-1; YB9-B
		MKS				5	30	M4 F18'	12N5-3B; YB5L-B

GAS-GAS

350 cc									
Pampera 320	01.98→		3 30	M6 001	YT4L-4; YT4L-BS				
450 cc									
FSE/ Wild	01.02→		7 110	M6 009	YTZ7S-4; YTZ7S-BS				

GILERA (PIAGGIO)

50 cc									
Bullit/ Eaglet/ Easy Moving/ GSM/ Sioux/ Stalker/ Storm	01.91-12.06					4	20	M4 F17'	YB4L-B
DNA/ Ice/ SKP	01.97-12.08		3 30	M6 001	YT4L-4; YT4L-BS				
GSA Lusso	03.82-12.93	MEK				4	20	M4 F17'	YB4L-B
Runner DD	01.97-12.02					4	20	M4 F17'	YB4L-B
PureJet	01.03→					9	80	M4 F25'	12N9-4B-1; YB9-B
Racing Replica	01.04-12.07					4	20	M4 F17'	YB4L-B
Typhoon	01.93-12.99					8	80	M4 F24'	YB7-A
125 cc									
Apache	01.91-12.93	MEK				9	80	M4 F25'	12N9-4B-1; YB9-B
		MKS				6	40	M4 F19'	12N5.5-3B
Arizona Hawk	11.85-12.86	MEK				9	80	M4 F25'	12N9-4B-1; YB9-B
		MKS				6	40	M4 F19'	12N5.5-3B
Coguar	01.99-12.03					9	80	M4 F25'	12N9-4B-1; YB9-B
Crono	01.91-12.93	MEK				9	80	M4 F25'	12N9-4B-1; YB9-B
		MKS				6	40	M4 F19'	12N5.5-3B
CX	03.91-12.93	MEK				9	80	M4 F25'	12N9-4B-1; YB9-B
		MKS				6	40	M4 F19'	12N5.5-3B
DNA	01.00-12.04					11	90	M4 F29'	12N10-3B; YB10L-B; YB10L-B2
Fast Bike	02.87-12.89	MEK				9	80	M4 F25'	12N9-4B-1; YB9-B
		MKS				6	40	M4 F19'	12N5.5-3B



			Ah		A (EN)		M6		JS		Ah		A (EN)		M4		JS	
◀ GILERA			0 092 ...0						0 092 ...0									
Freestyle	05.91-12.93	MEK	9	80								M4 F25'	12N9-4B-1; YB9-B					
		MKS	6	40								M4 F19'	12N5.5-3B					
GFR	01.93-12.93	MEK	9	80								M4 F25'	12N9-4B-1; YB9-B					
		MKS	6	40								M4 F19'	12N5.5-3B					
KK	09.86-12.89	MEK	9	80								M4 F25'	12N9-4B-1; YB9-B					
		MKS	6	40								M4 F19'	12N5.5-3B					
KZ	03.86-12.89	MEK	9	80								M4 F25'	12N9-4B-1; YB9-B					
		MKS	6	40								M4 F19'	12N5.5-3B					
MXR	09.88-12.93	MEK	9	80								M4 F25'	12N9-4B-1; YB9-B					
		MKS	6	40								M4 F19'	12N5.5-3B					
Nexus	01.07→		10	90			M6 014	YTX12-4; YTX12-BS										
RC Rally	04.87-12.88				11	90						M4 F29'	12N10-3B; YB10L-B; YB10L-B2					
RRT Nebraska	02.86-03.88	MEK	9	80								M4 F25'	12N9-4B-1; YB9-B					
		MKS	6	40								M4 F19'	12N5.5-3B					
RTX	02.86-12.86	MEK	9	80								M4 F25'	12N9-4B-1; YB9-B					
		MKS	6	40								M4 F19'	12N5.5-3B					
Runner FX	01.98-12.03		9	80								M4 F25'	12N9-4B-1; YB9-B					
ST	01.08→		10	90			M6 014	YTX12-4; YTX12-BS										
VX	01.01-12.07		9	80								M4 F25'	12N9-4B-1; YB9-B					
RV	05.84-12.86	MEK	9	80								M4 F25'	12N9-4B-1; YB9-B					
		MKS	6	40								M4 F19'	12N5.5-3B					
RX	01.84-06.85	MEK	9	80								M4 F25'	12N9-4B-1; YB9-B					
		MKS	6	40								M4 F19'	12N5.5-3B					
R1 S	12.87-12.89	MEK	9	80								M4 F25'	12N9-4B-1; YB9-B					
		MKS	6	40								M4 F19'	12N5.5-3B					
SP 01	03.89-12.89	MEK	9	80								M4 F25'	12N9-4B-1; YB9-B					
		MKS	6	40								M4 F19'	12N5.5-3B					
SP 02	01.90-12.90	MEK	9	80								M4 F25'	12N9-4B-1; YB9-B					
		MKS	6	40								M4 F19'	12N5.5-3B					
Typhoon	01.93-12.98		4	20								M4 F17'	YB4L-B					
XR 1	03.88-12.89	MEK	9	80								M4 F25'	12N9-4B-1; YB9-B					
		MKS	6	40								M4 F19'	12N5.5-3B					
XR 2	01.89-12.95	MEK	9	80								M4 F25'	12N9-4B-1; YB9-B					
		MKS	6	40								M4 F19'	12N5.5-3B					
180 cc																		
DNA	01.00-12.04				11	90						M4 F29'	12N10-3B; YB10L-B; YB10L-B2					
Runner FX-R	01.98-12.03		9	80								M4 F25'	12N9-4B-1; YB9-B					
VX-R	01.01-12.04		10	90			M6 014	YTX12-4; YTX12-BS										
200 cc																		
Arizona , Fast Bike, Hawk, RTX	11.85-12.88	MEK	9	80								M4 F25'	12N9-4B-1; YB9-B					
		MKS	6	40								M4 F19'	12N5.5-3B					
Runner VX-R	01.02-12.08				11	90						M4 F29'	12N10-3B; YB10L-B; YB10L-B2					
RV , Fast Bike, Hawk, RTX	01.85-12.86	MEK	9	80								M4 F25'	12N9-4B-1; YB9-B					
		MKS	6	40								M4 F19'	12N5.5-3B					
RX , Fast Bike, Hawk, RTX	01.85-12.88	MEK	9	80								M4 F25'	12N9-4B-1; YB9-B					
		MKS	6	40								M4 F19'	12N5.5-3B					
200 , Fast Bike, Hawk, RTX	02.86-12.86	MEK	9	80								M4 F25'	12N9-4B-1; YB9-B					
		MKS	6	40								M4 F19'	12N5.5-3B					
	02.87-12.93	MEK	9	80								M4 F25'	12N9-4B-1; YB9-B					
		MKS	6	40								M4 F19'	12N5.5-3B					
T4	01.79-12.85		6	40							M4 F19'	12N5.5-3B						
250 cc																		
Arizona/ Rally	11.85-12.86				11	90						M4 F29'	12N10-3B; YB10L-B; YB10L-B2					
NGR	05.85-12.89	MEK	11	90								M4 F29'	12N10-3B; YB10L-B; YB10L-B2					
		MKS	6	40								M4 F19'	12N5.5-3B					
300 cc																		
Nexus	01.09→		10	90			M6 014	YTX12-4; YTX12-BS										



			Ah A (EN) M6 JS	Ah A (EN) M4 JS
			0 092 ...0	0 092 ...0

350 cc							
Dakota ER	01.86-12.89	MEK			11	90	M4 F28' 12N10-3A; "-3A-1; "-3A-2; YB10L-A2
		MKS			6	40	M4 F19' 12N5.5-3B
XRT	05.88-12.89				14	140	M4 F34' 12N14-3A; YB14L-A2
500 cc							
Dakota ER	04.87-12.89	MEK			11	90	M4 F28' 12N10-3A; "-3A-1; "-3A-2; YB10L-A2
		MKS			6	40	M4 F19' 12N5.5-3B
550 cc							
Nordwest/ RC 600/ XRT 600 , C, R	05.88-12.00				14	140	M4 F34' 12N14-3A; YB14L-A2

HARLEY-DAVIDSON

500 cc							
MT	07.89-12.99				14	140	M4 F34' 12N14-3A; YB14L-A2
883 cc							
Sportster	01.86-12.87				19	190	M4 F44' YB16-B
	01.88-12.99	18	260	M6 023	YTX20L-4; YTX20L-BS		
Deluxe	01.86-12.87				19	190	M4 F44' YB16-B
	01.88-12.99	18	260	M6 023	YTX20L-4; YTX20L-BS		
Evolution, Evolution De Luxe	01.86-12.90				19	190	M4 F44' YB16-B
Hugger	01.88-12.99	18	260	M6 023	YTX20L-4; YTX20L-BS		
XL 53 C Sportster /Custom	01.98-12.05	18	260	M6 023	YTX20L-4; YTX20L-BS		
1000 cc							
Roadster/ XLX-61	08.78-08.85				19	190	M4 F44' YB16-B
VR	01.95-12.05	12	100	M6 018	YTX14-4; YTX14-BS		
1130 cc							
V-Rod	01.01-12.06	12	100	M6 018	YTX14-4; YTX14-BS		
XLH Sportster	01.86-12.90				19	190	M4 F44' YB16-B
1200 cc							
Electra Glide Sport	09.87-12.97				20	200	M4 F47' Y50-N18L-A; Y50N18L-A2
Sportster , Custom	01.87-12.92				19	190	M4 F44' YB16-B
	01.96-12.08	18	260	M6 023	YTX20L-4; YTX20L-BS		
Sportster/ XL R Sportster, Roadster	01.98-12.08	18	260	M6 023	YTX20L-4; YTX20L-BS		
1340 cc							
Bad Boy	09.84-12.89				19	190	M4 F44' YB16-B
	01.90-12.98				19	190	M4 F43' YB16L-B
Convertible/ Dyna Low Glide/ Dyna Low Rider/ Fat Boy	01.85-12.98				19	190	M4 F44' YB16-B
Dyna Glide Super	01.85-12.94				19	190	M4 F44' YB16-B
Wide	01.85-12.85				19	190	M4 F44' YB16-B
Dyna Low Rider Sport Edition	01.86-12.98				19	190	M4 F44' YB16-B
Dyna Low Rider/ Heritage Softail/ Softail Convertible, Custom, Nostalgia	01.85-12.98				19	190	M4 F44' YB16-B
Electra Glide	09.81-12.98				20	200	M4 F47' Y50-N18L-A; Y50N18L-A2
Advokat	01.92-12.98				20	200	M4 F47' Y50-N18L-A; Y50N18L-A2
Road King	01.92-12.98				20	200	M4 F47' Y50-N18L-A; Y50N18L-A2
Sport	01.88-12.98				20	200	M4 F47' Y50-N18L-A; Y50N18L-A2
Ultra Classic	01.88-12.98				20	200	M4 F47' Y50-N18L-A; Y50N18L-A2
Electra Glide/ Tour Glide Classic	01.85-12.98				20	200	M4 F47' Y50-N18L-A; Y50N18L-A2





0 092 ...0

0 092 ...0

◀ HARLEY-DAVIDSON

Heritage Softail	01.85-12.89					19	190	M4 F44*	YB16-B
	01.90-12.98					19	190	M4 F43*	YB16L-B
Classic	01.90-12.98					19	190	M4 F43*	YB16L-B
Special	01.90-12.98					19	190	M4 F44*	YB16-B
Softail Springer	01.90-12.98	18	260	M6 023	YTX20L-4; YTX20L-BS				
Softail/ Sport Glide	01.85-12.98					19	190	M4 F44*	YB16-B
Tour Glide Ultra Classic	09.88-12.98					19	190	M4 F44*	YB16-B
	01.91-12.98					20	200	M4 F47*	Y50-N18L-A; Y50N18L-A2

1450 cc

Dyna Glide/ Softail Springer, Super	01.99-12.06	18	260	M6 023	YTX20L-4; YTX20L-BS				
--	-------------	----	-----	---------------	----------------------------	--	--	--	--

1580 cc

Softail Rocker	01.08→	18	260	M6 023	YTX20L-4; YTX20L-BS				
-----------------------	--------	----	-----	---------------	----------------------------	--	--	--	--

HERCULES (SACHS)

50 cc

Fox	01.92-06.93					5	30	M4 F18*	12N5-3B; YB5L-B
Gipsy/ Limbo/ MX 1/ Swing/ ZX/ ZX 1	01.90→					4	20	M4 F17*	YB4L-B
Samba SR	01.92→					4	20	M4 F17*	YB4L-B

80 cc

RX 9 Replica	01.88-12.98					5	30	M4 F18*	12N5-3B; YB5L-B
Samba SR	01.94→					5	30	M4 F18*	12N5-3B; YB5L-B
Ultra 80 AC, Chopper	01.81-12.92					9	80	M4 F26*	12N9-3B; YB9L-B
RS AC	01.82-12.92					9	80	M4 F26*	12N9-3B; YB9L-B

125 cc

Samba SR	01.92-12.02					5	30	M4 F18*	12N5-3B; YB5L-B
-----------------	-------------	--	--	--	--	---	----	----------------	------------------------

HONDA

50 cc

AF 29/ PK/ SA Vision, Vision 50, Wallaroo	01.88-12.06	3	30	M6 001	YT4L-4; YT4L-BS				
C SW	01.94-12.00					4	20	M4 F17*	YB4L-B
MBX	01.83-12.86					3	10	M4 F15*	YB3L-A
SD	01.83-12.86					3	10	M4 F15*	YB3L-A
MTX S	01.83-12.97					3	10	M4 F15*	YB3L-A
NB/ NH/ PXL	01.80-12.94					4	20	M4 F17*	YB4L-B
ND Melody	01.82-12.85					4	20	M4 F17*	YB4L-B
NPS Zoomer	01.05-12.06	7	110	M6 009	YTZ7S-4; YTZ7S-BS				
NQ Spree	01.84-12.85					4	20	M4 F17*	YB4L-B
Spree Special	01.86-12.87	3	30	M6 001	YT4L-4; YT4L-BS				
NS F Aero	01.87-12.97					3	10	M4 F15*	YB3L-A
Melody	01.81-12.85					3	10	M4 F15*	YB3L-A
NSR	01.89-12.04					3	10	M4 F15*	YB3L-A
PX E	01.84-12.90					4	20	M4 F17*	YB4L-B
R	01.85-12.91					4	20	M4 F17*	YB4L-B
QR/ SFX	01.96-12.06	3	40	M6 003	YTR4A-BS				
SGX/ SRX	01.97-12.01	3	30	M6 001	YT4L-4; YT4L-BS				
Shadow, Sky	01.97-12.03	3	30	M6 001	YT4L-4; YT4L-BS				
SH City Express	01.84-12.03	7	110	M6 009	YTZ7S-4; YTZ7S-BS	4	20	M4 F17*	YB4L-B
Scoopy	01.95-12.04	7	110	M6 009	YTZ7S-4; YTZ7S-BS	4	20	M4 F17*	YB4L-B
Sky/ ST Dax, DX	01.88-12.02	3	30	M6 001	YT4L-4; YT4L-BS				
Tact	06.93-12.03	7	110	M6 009	YTZ7S-4; YTZ7S-BS				
XBR-S Super Sport	01.98→	3	40	M6 003	YTR4A-BS				

75 cc

CRM/ MBX/ MTX/ NSR	01.86-12.00					3	10	M4 F15*	YB3L-A
---------------------------	-------------	--	--	--	--	---	----	----------------	---------------

80 cc

MBX	01.82-12.87					3	10	M4 F15*	YB3L-A
------------	-------------	--	--	--	--	---	----	----------------	---------------

						Ah A (EN) M6 JS				Ah A (EN) M4 JS	
				0 092 ...0						0 092 ...0	
MTX R	01.83-12.87							3	10	M4 F15'	YB3L-A
NH	01.83-12.94	SAO						5	30	M4 F18'	12N5-3B; YB5L-B
Lead	01.82-12.96	SAO						5	30	M4 F18'	12N5-3B; YB5L-B
SH Scoopy	01.84-12.96							5	30	M4 F18'	12N5-3B; YB5L-B
90 cc											
C Cub	01.84-12.02							5	30	M4 F18'	12N5-3B; YB5L-B
EZ Cub	01.90-12.96			4	30	M6 004	YTX5L-4; YTX5L-BS				
100 cc											
Lead	01.03-12.07			4	30	M6 004	YTX5L-4; YTX5L-BS				
SH	01.96-12.01			4	30	M6 004	YTX5L-4; YTX5L-BS				
SJ EX	01.96-12.99			4	30	M6 004	YTX5L-4; YTX5L-BS				
125 cc											
CA 125 Rebel	01.95-12.99			6	50	M6 006	YTX7L-4; YTX7L-BS				
CB 125 T, TD Superdream	01.78-12.93							9	80	M4 F25'	12N9-4B-1; YB9-B
CBF 125 M	01.09→			6	50	M6 006	YTX7L-4; YTX7L-BS				
CG 125	01.86-12.08							3	10	M4 F15'	YB3L-A
CH Spacy	01.84-12.99			8	80	M6 010	YTX9-4; YTX9-BS				
CLR 125 City Fly	01.98-12.03			4	30	M6 004	YTX5L-4; YTX5L-BS				
CM 125 C	01.82-12.99							9	80	M4 F25'	12N9-4B-1; YB9-B
CR 125 R	01.84-12.01			7	110	M6 009	YTZ7S-4; YTZ7S-BS				
CRM 125 125	01.90-12.00			3	30	M6 001	YT4L-4; YT4L-BS				
FES Pantheon	01.03-12.06			8	80	M6 010	YTX9-4; YTX9-BS				
MBX 125/ NS 125 F	01.83-12.90							5	30	M4 F18'	12N5-3B; YB5L-B
MTX 125/ NS 125 R	01.83-12.95							5	30	M4 F18'	12N5-3B; YB5L-B
NH Lead	01.83-12.87							5	30	M4 F18'	12N5-3B; YB5L-B
NSR 125 F	05.89-12.98			4	30	M6 004	YTX5L-4; YTX5L-BS				
NX 125	01.89-12.99			6	50	M6 006	YTX7L-4; YTX7L-BS				
PCX/ PES	01.06→			6	50	M6 006	YTX7L-4; YTX7L-BS				
SES/ VT 125 C2 Shadow, Dylan	01.00-12.06			6	50	M6 006	YTX7L-4; YTX7L-BS				
SH i Scoopy	01.05→			6	50	M6 006	YTX7L-4; YTX7L-BS				
VT 125 C Shadow	01.99-12.08			7	110	M6 009	YTZ7S-4; YTZ7S-BS				
XL 125 R	01.79-12.00							9	80	M4 F25'	12N9-4B-1; YB9-B
Varadero	01.01→			7	110	M6 009	YTZ7S-4; YTZ7S-BS				
XLR 125 R	01.98-12.01			6	50	M6 007	YTX7A-4; YTX7A-BS				
150 cc											
NSR 150	12.95-02.01							3	10	M4 F15'	YB3L-A
SES Dylan	01.02-12.07			6	50	M6 006	YTX7L-4; YTX7L-BS				
200 cc											
MTX 200/ XL 200 R, RP, RW	01.79-12.98							3	10	M4 F15'	YB3L-A
TLR 200	01.85-12.95			3	30	M6 001	YT4L-4; YT4L-BS				
TR 200 Fat Cat	01.86-12.87			8	80	M6 010	YTX9-4; YTX9-BS				
XL 200 FM	01.79-12.89							9	80	M4 F25'	12N9-4B-1; YB9-B
250 cc											
CB 250 Clubman	01.84-12.94							12	120	M4 F30'	12N12A-4A-1; YB12A-A
G, N	01.75-12.87							12	120	M4 F30'	12N12A-4A-1; YB12A-A
N Two Fifty	01.92-12.02			6	50	M6 006	YTX7L-4; YTX7L-BS				
CB 250/ CBR 250/ NX 250	01.86-12.08			6	50	M6 006	YTX7L-4; YTX7L-BS				
CBR 250 R	06.88-12.92			6	50	M6 006	YTX7L-4; YTX7L-BS				
CBR 250/ CMX 250 Rebel, RR	01.93-12.03			6	50	M6 006	YTX7L-4; YTX7L-BS				
CBX 250 RS	01.83-12.86			8	80	M6 010	YTX9-4; YTX9-BS				
CD 250 U	01.88-12.93			8	80	M6 010	YTX9-4; YTX9-BS	9	80	M4 F25'	12N9-4B-1; YB9-B
CH/ CN/ Elite	01.85-12.99			10	90	M6 014	YTX12-4; YTX12-BS				
CM 250 C	01.82-12.85							9	80	M4 F25'	12N9-4B-1; YB9-B
CRF 250 R	01.04-12.09			4	30	M6 004	YTX5L-4; YTX5L-BS				
X	01.04-12.09			4	30	M6 004	YTX5L-4; YTX5L-BS				
				7	110	M6 009	YTZ7S-4; YTZ7S-BS				
FES Foresight	01.98-12.05			10	90	M6 014	YTX12-4; YTX12-BS				
FTR 250	01.86-12.96			4	30	M6 004	YTX5L-4; YTX5L-BS				
NSR 250	01.87-12.99							3	10	M4 F15'	YB3L-A
Rebel Special	08.88-12.98			6	50	M6 006	YTX7L-4; YTX7L-BS				
VT 250 F	01.83-12.97			6	50	M6 006	YTX7L-4; YTX7L-BS				
VTR 250 F	01.83-12.93							9	80	M4 F25'	12N9-4B-1; YB9-B
VTZ 250	01.87-12.98							9	80	M4 F25'	12N9-4B-1; YB9-B



		0 092 ...0				0 092 ...0			
		Ah	A (EN)	M6	JS	Ah	A (EN)	M4	JS
◀ HONDA									
XL 250/ XLR 250 R	01.82-12.95					3	10	M4 F15*	YB3L-A
XR 250 R	01.81-12.04	3	30	M6 001	YT4L-4; YT4L-BS				
300 cc									
SH i Scoopy	01.07→	9	200	M6 012	YTZ12S-4; YTZ12S-BS; TTZ12 S -BS				
350 cc									
XL 350 R	01.84-12.88					3	10	M4 F15*	YB3L-A
400 cc									
CB 1	01.89-12.90	8	80	M6 010	YTX9-4; YTX9-BS				
CB 400/ CBX 400	01.78-12.85					12	120	M4 F30*	12N12A-4A-1; YB12A-A
CBR 400 R	01.86-12.96	6	50	M6 006	YTX7L-4; YTX7L-BS				
RR	01.88-12.98	6	50	M6 006	YTX7L-4; YTX7L-BS				
NS 400 R	01.85-12.87					5	30	M4 F18*	12N5-3B; YB5L-B
TRX FW	01.95-12.02	12	100	M6 018	YTX14-4; YTX14-BS				
VFR 400 R	01.86-12.92	6	50	M6 007	YTX7A-4; YTX7A-BS				
450 cc									
CB 450 N	01.84-12.88					12	120	M4 F32*	YB12AL-A; YB12AL-A2
CMX 450 Rebel	01.86-12.87					12	120	M4 F30*	12N12A-4A-1; YB12A-A
CRF 450 R	01.02-12.08	7	110	M6 009	YTZ7S-4; YTZ7S-BS				
X	01.05-12.09	7	110	M6 009	YTZ7S-4; YTZ7S-BS				
500 cc									
CB 500	01.93-12.02	8	80	M6 010	YTX9-4; YTX9-BS				
T	01.76-12.87	8	80	M6 010	YTX9-4; YTX9-BS				
CBF 500 A	01.04-12.08	8	150	M6 011	YTZ10S-4; YTZ10S-BS				
CBR 500 F	01.87-12.90	8	80	M6 010	YTX9-4; YTX9-BS				
FT 500	01.82-12.85					14	140	M4 F34*	12N14-3A; YB14L-A2
VF 500/ VT 500	01.83-12.88					12	120	M4 F30*	12N12A-4A-1; YB12A-A
XBR 500 F	01.85-12.87					12	120	M4 F30*	12N12A-4A-1; YB12A-A
XL 500 R	01.82-08.85					3	10	M4 F15*	YB3L-A
600 cc									
CB 600 F Hornet	01.07→	8	150	M6 011	YTZ10S-4; YTZ10S-BS				
Hornet	01.98-12.99	6	50	M6 006	YTX7L-4; YTX7L-BS				
	01.00-12.06	8	150	M6 011	YTZ10S-4; YTZ10S-BS				
CBF 600	01.04-12.08	6	50	M6 006	YTX7L-4; YTX7L-BS				
CBR 600 F	01.87-12.00	8	80	M6 010	YTX9-4; YTX9-BS				
	01.01-12.08	8	150	M6 011	YTZ10S-4; YTZ10S-BS				
R	01.89-08.90	8	80	M6 010	YTX9-4; YTX9-BS				
RR	01.03→	8	150	M6 011	YTZ10S-4; YTZ10S-BS				
FJS Silver Wing	01.01-12.07	9	200	M6 012	YTZ12S-4; YTZ12S-BS; TTZ12 S -BS				
NTV 600 Revere	01.88-12.92	8	80	M6 010	YTX9-4; YTX9-BS				
VT 600 C Shadow	01.88-12.04	8	80	M6 010	YTX9-4; YTX9-BS				
XL 600 LM	01.85-12.87					14	140	M4 F34*	12N14-3A; YB14L-A2
R	01.83-12.87					3	10	M4 F15*	YB3L-A
RM	01.86-12.87					14	140	M4 F34*	12N14-3A; YB14L-A2
XR 600	01.85-12.00	8	80	M6 010	YTX9-4; YTX9-BS				
650 cc									
CB 650 SC Nighthawk	01.81-12.85					12	120	M4 F30*	12N12A-4A-1; YB12A-A
CBX 650	01.83-12.87					12	120	M4 F32*	YB12AL-A; YB12AL-A2
CX 650 Turbo	01.83-12.85					14	140	M4 F34*	12N14-3A; YB14L-A2
CX 650/ GL 650	01.83-12.86					14	140	M4 F34*	12N14-3A; YB14L-A2
FMX 650	01.05-12.06	8	80	M6 010	YTX9-4; YTX9-BS				
FX 650 Vigor	01.99-12.03	8	80	M6 010	YTX9-4; YTX9-BS				
NT 650/ NX 650/ XR 650	01.88-12.07	8	80	M6 010	YTX9-4; YTX9-BS				
Dominator, Hawk GT, R									
NT 650 V Deauville	01.98-12.05	8	150	M6 011	YTZ10S-4; YTZ10S-BS				
NTV 650	01.88-12.97	8	80	M6 010	YTX9-4; YTX9-BS				
TRX	01.03-12.05	12	100	M6 018	YTX14-4; YTX14-BS				
XL 650 V Transalp	01.00-12.06	9	200	M6 012	YTZ12S-4; YTZ12S-BS; TTZ12 S -BS				
680 cc									
DN-01	01.08→	11	230	M6 017	YTZ14S-4; YTZ14S-BS				
NT 700 V Deauville	01.06→	8	150	M6 011	YTZ10S-4; YTZ10S-BS				
750 cc									
CB 750/ CBX 750/ VF 750	01.82-12.03					14	140	M4 F34*	12N14-3A; YB14L-A2
NR 750	01.87-12.92	10	90	M6 014	YTX12-4; YTX12-BS				



0 092 ...0

0 092 ...0

RVF 750	01.94-12.98	8	80	M6 010	YTX9-4; YTX9-BS					
V 45 Magna	01.82-12.92					12	120	M4 F30'	12N12A-4A-1; YB12A-A	
VF 750 Custom	01.87-12.93					14	140	M4 F34'	12N14-3A; YB14L-A2	
VFR 750 F	01.86-12.97	10	90	M6 014	YTX12-4; YTX12-BS					
R	01.88-12.95	8	80	M6 010	YTX9-4; YTX9-BS					
VT 750 DC Black Widow	01.01-12.03	11	230	M6 017	YTZ14S-4; YTZ14S-BS					
Shadow	01.97→	12	100	M6 018	YTX14-4; YTX14-BS					
XRV 750 Africa Twin	01.93-12.00	12	100	M6 018	YTX14-4; YTX14-BS					
800 cc										
PC 800 Pacific Coast	01.88-12.98	10	90	M6 014	YTX12-4; YTX12-BS					
VFR 800	01.98-12.01	10	90	M6 014	YTX12-4; YTX12-BS					
	01.02→	8	150	M6 011	YTZ10S-4; YTZ10S-BS					
900 cc										
CB 900 Hornet	01.02-12.07	8	150	M6 011	YTZ10S-4; YTZ10S-BS					
CBR 900 RR Fireblade	01.92-12.99	8	80	M6 010	YTX9-4; YTX9-BS					
	01.00-12.01	8	150	M6 011	YTZ10S-4; YTZ10S-BS					
	01.02-12.03	8	80	M6 010	YTX9-4; YTX9-BS					
1000 cc										
CB 1000	01.93-12.96	10	90	M6 014	YTX12-4; YTX12-BS					
	01.09→	8	150	M6 011	YTZ10S-4; YTZ10S-BS					
C	01.82-12.91					14	140	M4 F34'	12N14-3A; YB14L-A2	
CBF 1000	01.06→	8	150	M6 011	YTZ10S-4; YTZ10S-BS					
CBR 1000	01.87-12.99					14	140	M4 F36'	YB14L-B2	
RR Fireblade	01.04→	8	150	M6 011	YTZ10S-4; YTZ10S-BS					
VF 1000 F	01.84-12.87					16	160	M4 F39'	YB16B-A; YB16B-A1	
F2, R	01.84-12.87					16	160	M4 F39'	YB16B-A; YB16B-A1	
VTR 1000 F Firestorm	01.97-12.06	9	200	M6 012	YTZ12S-4; YTZ12S-BS; TTZ12 S-BS					
SP-1, SP-2	01.00→	9	200	M6 012	YTZ12S-4; YTZ12S-BS; TTZ12 S-BS					
XL 1000 V Varadero	01.99-12.02	12	100	M6 018	YTX14-4; YTX14-BS					
1100 cc										
CB 1100 SF X-Eleven	01.99-12.03	10	90	M6 014	YTX12-4; YTX12-BS					
CBR 1100 XX Super Blackbird	01.97-12.98	10	90	M6 014	YTX12-4; YTX12-BS					
	01.99-12.06	9	200	M6 012	YTZ12S-4; YTZ12S-BS; TTZ12 S-BS					
ST 1100 Pan-European	01.90-12.02	12	100	M6 018	YTX14-4; YTX14-BS					
VF 1100	01.83-12.86	18	260	M6 023	YTX20L-4; YTX20L-BS					
VT 1100 C Shadow	01.87-12.98	12	100	M6 018	YTX14-4; YTX14-BS					
C2 Shadow ACE	01.95-12.05	11	230	M6 017	YTZ14S-4; YTZ14S-BS					
1200 cc										
GL 1200 Gold Wing	01.84-12.88					20	200	M4 F47'	Y50-N18L-A; Y50N18L-A2	
1300 cc										
CB 1300	01.03→	11	230	M6 017	YTZ14S-4; YTZ14S-BS					
ST 1300 Pan-European	01.02→	11	230	M6 017	YTZ14S-4; YTZ14S-BS					
VTX 1300	01.03→	12	100	M6 018	YTX14-4; YTX14-BS					
1500 cc										
GL 1500 C F6C	01.97-12.03	12	100	M6 018	YTX14-4; YTX14-BS					
Gold Wing, SE	01.88-12.00					20	200	M4 F47'	Y50-N18L-A; Y50N18L-A2	
1800 cc										
GL 1800/ VTX 1800 , Gold Wing	01.01→	18	260	M6 023	YTX20L-4; YTX20L-BS					

HUSABERG



350 cc										
FC 350/ FE 350/ MC 350/ TE 350	01.91→	7	110	M6 009	YTZ7S-4; YTZ7S-BS					
400 cc										
FC 400/ FE 400	01.96-12.99	7	110	M6 009	YTZ7S-4; YTZ7S-BS					
500 cc										
FC 500/ FE 501 , E	01.93-12.04	7	110	M6 009	YTZ7S-4; YTZ7S-BS					
550 cc										
FC 550	01.00-12.05	7	110	M6 009	YTZ7S-4; YTZ7S-BS					

			Ah	A (EN)			Ah	A (EN)		
--	--	--	----	--------	--	--	----	--------	--	--

0 092 ...0

0 092 ...0

◀ HUSABERG

600 cc										
FC 600/ FE 600/ FES 600 , E	01.92→	7	110	M6 009	YTZ7S-4; YTZ7S-BS					
650 cc										
FE 650/ FS 650 , E	01.00-12.08	7	110	M6 009	YTZ7S-4; YTZ7S-BS					

HUSQVARNA (CAGIVA)

125 cc										
CR/ SM/ WR/ WRE/ WRK	01.84→	3	30	M6 001	YT4L-4; YT4L-BS					
250 cc										
CR/ TC/ TE/ WR , GS	01.90→	7	110	M6 009	YTZ7S-4; YTZ7S-BS					
260 cc										
WRK	09.88→	7	110	M6 009	YTZ7S-4; YTZ7S-BS					
350 cc										
TE	01.95→	7	110	M6 009	YTZ7S-4; YTZ7S-BS					
360 cc										
WR	01.91→	7	110	M6 009	YTZ7S-4; YTZ7S-BS					
400 cc										
TE 400	01.01-12.02	12	100	M6 018	YTX14-4; YTX14-BS					
TE 410	01.95-12.00	3	30	M6 001	YT4L-4; YT4L-BS					
WR 400	01.85→	7	110	M6 009	YTZ7S-4; YTZ7S-BS					
450 cc										
SM/ TE , R	01.03→	3	30	M6 001	YT4L-4; YT4L-BS					
500 cc										
TE 510	01.83-12.90	12	100	M6 018	YTX14-4; YTX14-BS					
	01.03→	7	110	M6 009	YTZ7S-4; YTZ7S-BS					
580 cc										
SM 570/ TE 570 , R	01.93→	12	100	M6 018	YTX14-4; YTX14-BS					
610 cc										
SM	01.07→	3	30	M6 001	YT4L-4; YT4L-BS					
e	01.98-12.06	3	30	M6 001	YT4L-4; YT4L-BS					
TC	01.05→	12	100	M6 018	YTX14-4; YTX14-BS					
TE	01.91-12.02	3	30	M6 001	YT4L-4; YT4L-BS					

HYOSUNG

50 cc										
SB/ SD/ SF , Prima, Super Cab	01.99-12.08	3	30	M6 001	YT4L-4; YT4L-BS					
100 cc										
Cab/ EZ/ Supercab , Supercab	01.97→	3	30	M6 001	YT4L-4; YT4L-BS					
125 cc										
Cruise I/ Cruise II/ GF/ Grand Prix/ GT/ GV/ Hyper/ Karion/ MS1/ RX/XRX , Aquila/M Cruiser, Citytrail, Classic, Naked	01.96→	6	50	M6 007	YTX7A-4; YTX7A-BS					
250 cc										
GT/ GV , Aquila	01.00-12.07	12	100	M6 018	YTX14-4; YTX14-BS					
600 cc										
Comet/ Naked	01.00→	12	100	M6 018	YTX14-4; YTX14-BS					
650 cc										
GT/ GV , Aquila/Cruiser	01.04→	12	100	M6 018	YTX14-4; YTX14-BS					

ITALJET

50 cc										
Dragster/ Formula/ Torpedo/ Velocifero , AC, LC, Race	01.94-12.08	4	20	M4 F17'	YB4L-B					
100 cc										
Millenium	01.00-12.03	6	50	M6 007	YTX7A-4; YTX7A-BS					



125 cc							
Dragster	01.97-12.08	11	90	M4 F29'	12N10-3B; YB10L-B; YB10L-B2		
Formula/ Jack/ Jet-Set/ Jupiter/ Torpedo	09.96→	9	80	M4 F25'	12N9-4B-1; YB9-B		
Millenium	01.00-12.03	6	50	M6 007	YTX7A-4; YTX7A-BS		
150 cc							
Jet-Set/ Jupiter	01.01-12.08	9	80	M4 F25'	12N9-4B-1; YB9-B		
180 cc							
Dragster	01.98-12.04	12	100	M6 018	YTX14-4; YTX14-BS		

KAWASAKI

80 cc							
KFX 80 A	01.03-12.06	4	30	M6 004	YTX5L-4; YTX5L-BS		
125 cc							
AR 125	01.85-12.94	5	30	M4 F18'	12N5-3B; YB5L-B		
BN 125 A Eliminator	01.98-12.07	9	80	M4 F25'	12N9-4B-1; YB9-B		
KDX 125	01.90-12.94	3	10	M4 F15'	YB3L-A		
SR	01.90-12.94	3	10	M4 F15'	YB3L-A		
KLX 125	03.10→	6	50	M6 006	YTX7L-4; YTX7L-BS		
D	12.09→	6	50	M6 006	YTX7L-4; YTX7L-BS		
KMX 125	01.86-12.03	4	20	M4 F17'	YB4L-B		
200 cc							
KMX 200	01.87-12.92	4	20	M4 F17'	YB4L-B		
250 cc							
BJ 250 Estrella	01.93-12.99	8	80	M6 010	YTX9-4; YTX9-BS		
KLF 250	01.02-12.10	6	50	M6 006	YTX7L-4; YTX7L-BS		
KLR 250	01.84-12.88	4	20	M4 F17'	YB4L-B		
	01.90-12.00	4	20	M4 F17'	YB4L-B		
KLX 250	01.93-12.98	6	50	M6 006	YTX7L-4; YTX7L-BS		
	01.09→	6	50	M6 006	YTX7L-4; YTX7L-BS		
KR 250/ KR-1	01.85-12.95	4	20	M4 F17'	YB4L-B		
KR-1 R/S	01.89-12.92	4	20	M4 F17'	YB4L-B		
Z 250 P	01.85-12.89	11	90	M4 F28'	12N10-3A; "-3A-1; "-3A-2; YB10L-A2		
ZZ-R 250	07.90-12.93	6	50	M6 006	YTX7L-4; YTX7L-BS		
305 cc							
Z 305 LTD	01.85-12.90	11	90	M4 F28'	12N10-3A; "-3A-1; "-3A-2; YB10L-A2		
400 cc							
EN 400 Vulcan	01.85-12.92	12	120	M4 F30'	12N12A-4A-1; YB12A-A		
FX 400/ Z 400 F, R	01.83-12.96	12	120	M4 F30'	12N12A-4A-1; YB12A-A		
GPZ 400	01.84-12.90	14	140	M4 F34'	12N14-3A; YB14L-A2		
KLE 400	01.91-12.01	10	90	M6 014	YTX12-4; YTX12-BS		
VN 400 Vulcan	01.95-12.05	10	90	M6 014	YTX12-4; YTX12-BS		
ZR 400 Zephyr	01.89-12.96	10	90	M6 014	YTX12-4; YTX12-BS		
ZXR 400	01.89-12.03	8	80	M6 010	YTX9-4; YTX9-BS		
440 cc							
Z 440 , LTD Belt Drive	01.80-12.85	12	120	M4 F30'	12N12A-4A-1; YB12A-A		
450 cc							
EN 450/ Z 450 A, LTD	01.85-12.90	12	120	M4 F30'	12N12A-4A-1; YB12A-A		
500 cc							
EN 500	01.90-12.95	12	120	M4 F30'	12N12A-4A-1; YB12A-A		
	01.96-12.04	12	120	M4 F32'	YB12AL-A; YB12AL-A2		
Vulcan, LTD	01.95-12.98	12	120	M4 F32'	YB12AL-A; YB12AL-A2		
ER-5/ KLE 500	09.90-12.07	10	90	M6 014	YTX12-4; YTX12-BS		
GPZ 500 R, S	09.86-12.04	14	140	M4 F34'	12N14-3A; YB14L-A2		
ZL 500 Eliminator	01.86-12.94	12	120	M4 F30'	12N12A-4A-1; YB12A-A		
550 cc							
GPZ 550/ GT 550/ Z 550/ ZR 550 , Zephyr	01.80-12.01	12	120	M4 F30'	12N12A-4A-1; YB12A-A		





0 092 ...0

0 092 ...0

◀ KAWASAKI

600 cc									
GPX 600/ GPZ 600 R	01.84-12.90					12	120	M4 F30*	12N12A-4A-1; YB12A-A
KLR 600	01.83-12.90	44B				14	140	M4 F34*	12N14-3A; YB14L-A2
ZL 600 Eliminator	01.86-03.90					12	120	M4 F30*	12N12A-4A-1; YB12A-A
	01.95-12.98					12	120	M4 F30*	12N12A-4A-1; YB12A-A
ZX-6R	01.94-12.94		10	90	M6 014	YTX12-4; YTX12-BS			
Ninja	01.95-12.01		10	90	M6 014	YTX12-4; YTX12-BS			
	01.07→		10	90	M6 014	YTX12-4; YTX12-BS			
ZX-6RR Ninja	01.02-12.06		8	80	M6 010	YTX9-4; YTX9-BS			
ZZ-R 600	01.90-12.92					12	120	M4 F30*	12N12A-4A-1; YB12A-A
	01.93-12.09		10	90	M6 014	YTX12-4; YTX12-BS			
650 cc									
ER-6 F, N	01.06-12.08		10	90	M6 014	YTX12-4; YTX12-BS			
GPZ 650 R	01.92-12.92					12	120	M4 F30*	12N12A-4A-1; YB12A-A
KLR 650	09.86→					14	140	M4 F34*	12N14-3A; YB14L-A2
Tengai	09.88-12.93					14	140	M4 F34*	12N14-3A; YB14L-A2
KLX 650	01.92-12.96		8	80	M6 010	YTX9-4; YTX9-BS			
Versys	01.07→		10	90	M6 014	YTX12-4; YTX12-BS			
W 650	01.99-12.06		12	100	M6 018	YTX14-4; YTX14-BS			
ZX-6R Ninja	01.02-12.06		10	90	M6 014	YTX12-4; YTX12-BS			
ZX-6RR Ninja	01.03-12.03		8	80	M6 010	YTX9-4; YTX9-BS			
750 cc									
GPX 750/ GPZ 750 R	01.85-12.91					14	140	M4 F34*	12N14-3A; YB14L-A2
GPZ 750/ GT 750/ VN 750	01.82-12.96					14	140	M4 F34*	12N14-3A; YB14L-A2
VN 750/ Z 750 Turbo, Twin, Vulcan	01.73-12.03					14	140	M4 F34*	12N14-3A; YB14L-A2
Z 750	01.80-12.87					14	140	M4 F34*	12N14-3A; YB14L-A2
	01.04→		8	80	M6 010	YTX9-4; YTX9-BS			
ZR 750 Zephyr	01.91-12.99		10	90	M6 014	YTX12-4; YTX12-BS			
ZR-7	01.99-12.04		10	90	M6 014	YTX12-4; YTX12-BS			
S	01.01-12.04		10	90	M6 014	YTX12-4; YTX12-BS			
ZXR 750	09.85-12.90					14	140	M4 F34*	12N14-3A; YB14L-A2
R	01.91-12.95		8	80	M6 010	YTX9-4; YTX9-BS			
ZX-7R Ninja	01.96-12.03		10	90	M6 014	YTX12-4; YTX12-BS			
ZX-7RR Ninja	01.96-12.00		8	80	M6 010	YTX9-4; YTX9-BS			
800 cc									
VN 800 A, B, Drifter	01.95-12.06		12	100	M6 018	YTX14-4; YTX14-BS			
900 cc									
GPZ 900 R	01.84-12.96					14	140	M4 F34*	12N14-3A; YB14L-A2
VN 900	01.06→		10	90	M6 014	YTX12-4; YTX12-BS			
ZL 900 Eliminator	01.85-12.87					14	140	M4 F34*	12N14-3A; YB14L-A2
ZX-9R Ninja	09.93-12.97		10	90	M6 014	YTX12-4; YTX12-BS			
	01.98-12.03		8	80	M6 010	YTX9-4; YTX9-BS			
1000 cc									
GPZ 1000 R/RX	01.86-12.89					14	140	M4 F34*	12N14-3A; YB14L-A2
GTR 1000	01.86-12.01					18	180	M4 F42*	YB18L-A
KLV 1000	01.04-12.08		8	80	M6 010	YTX9-4; YTX9-BS			
Z 1000	01.03-12.06		8	80	M6 010	YTX9-4; YTX9-BS			
	01.10→		8	80	M6 010	YTX9-4; YTX9-BS			
C	01.07-12.09		8	80	M6 010	YTX9-4; YTX9-BS			
GTR, LTD, R	01.80-12.97					18	180	M4 F42*	YB18L-A
ZL 1000 Eliminator	09.86-12.90					14	140	M4 F34*	12N14-3A; YB14L-A2
ZX-10	01.88-12.90					14	140	M4 F34*	12N14-3A; YB14L-A2
R Ninja	01.04-12.10		12	190	M6 019	YT12B-4; YT12B-BS			
1100 cc									
GPZ 1100	01.81-12.88					19	190	M4 F43*	YB16L-B
	01.95-12.98		12	100	M6 018	YTX14-4; YTX14-BS			
Z 1100 ST	01.81-12.85					18	180	M4 F42*	YB18L-A
ZRX 1100	01.97-12.00		12	100	M6 018	YTX14-4; YTX14-BS			
ZX-11 Ninja	01.97-12.01		12	100	M6 018	YTX14-4; YTX14-BS			
ZZ-R 1100	01.90-08.93					14	140	M4 F34*	12N14-3A; YB14L-A2
	09.93-12.01		12	100	M6 018	YTX14-4; YTX14-BS			





0 092 ...0

0 092 ...0

1200 cc									
ZRX 1200/ ZX-12R/ ZZ-R 1200	01.00-12.06	12	100	M6 018	YTX14-4; YTX14-BS				
1300 cc									
Z 1300 DFI, G	01.80-12.90					20	200	M4 F47'	Y50-N18L-A; Y50N18L-A2
1400 cc									
ZZ-R 1400	01.06→	12	100	M6 018	YTX14-4; YTX14-BS				
1500 cc									
VN 1500 Classic/Vulcan, SE Vulcan	01.87-12.99					20	200	M4 F47'	Y50-N18L-A; Y50N18L-A2

KEEWAY

50 cc									
Focus 45/ Hurricane 45/ RY 8 45	01.05→	4	30	M6 004	YTX5L-4; YTX5L-BS				
125 cc									
Arn/ Focus/ Matrix/ Speed/ Superlight/ Viva , V1	01.05→	6	50	M6 007	YTX7A-4; YTX7A-BS				

KREIDLER

50 cc									
Florett/ Flory , XL 25/50, 25	01.96→	3	30	M6 001	YT4L-4; YT4L-BS				
125 cc									
Enduro/ Supermoto	01.00→	8	80	M6 010	YTX9-4; YTX9-BS				
Florett RMC	01.04→	8	80	M6 010	YTX9-4; YTX9-BS				
Mustang	01.85-12.95					7	40	M4 F21'	12N7-3B; YB7L-B

KTM

50 cc									
Chrono/ Go	01.94-12.99	3	30	M6 001	YT4L-4; YT4L-BS				
Cross	01.97-12.01					4	20	M4 F17'	YB4L-B
80 cc									
RLS	10.81-12.91					9	80	M4 F25'	12N9-4B-1; YB9-B
125 cc									
125 LC 2	01.96→	3	30	M6 001	YT4L-4; YT4L-BS				
250 cc									
250 EXC Enduro comp.	01.03→	4	30	M6 004	YTX5L-4; YTX5L-BS				
400 cc									
400 EXC	01.98-12.02	3	30	M6 001	YT4L-4; YT4L-BS				
		4	30	M6 004	YTX5L-4; YTX5L-BS				
LC4, LC4 Competition, LC4 Enduro, Super Competition	01.94→	8	80	M6 010	YTX9-4; YTX9-BS				
450 cc									
450 EXC Racing	01.03→	4	30	M6 004	YTX5L-4; YTX5L-BS				
500 cc									
500 EXC	01.00→	3	30	M6 001	YT4L-4; YT4L-BS				
550 LC4 Enduro	01.87-12.90					9	80	M4 F25'	12N9-4B-1; YB9-B
550 cc									
550 LC4 Enduro	01.91-12.01					9	80	M4 F25'	12N9-4B-1; YB9-B
600 E Cross Country	01.85-12.95					18	150	M4 F41'	51814
600 cc									
600 LC 4 Competition	01.95-12.99	3	30	M6 001	YT4L-4; YT4L-BS				
Enduro	01.87-12.93					9	80	M4 F25'	12N9-4B-1; YB9-B
	01.95-12.99	3	30	M6 001	YT4L-4; YT4L-BS				
620 Duke	01.96-12.98	8	80	M6 010	YTX9-4; YTX9-BS				





◀ KTM

0 092 ...0

0 092 ...0

620 LC 4	01.93-12.01	8	80	M6 010	YTX9-4; YTX9-BS
Competition	01.96-12.01	8	80	M6 010	YTX9-4; YTX9-BS
Enduro	01.96-12.99	8	80	M6 010	YTX9-4; YTX9-BS
Enduro Dakar, Rallye, Super Competition	01.95→	8	80	M6 010	YTX9-4; YTX9-BS
620 cc					
620 Duke, E Duke	01.93-12.98	8	80	M6 010	YTX9-4; YTX9-BS
625 cc					
640 Duke I	01.98→	3	30	M6 001	YT4L-4; YT4L-BS
640 LC 4 Adventure	01.01→	8	80	M6 010	YTX9-4; YTX9-BS
640/ 640 LC 4-E Duke II, Enduro, Supermoto	01.99→	8	80	M6 010	YTX9-4; YTX9-BS
990 cc					
990 Duke, Supermoto	09.04→	11	230	M6 017	YTZ14S-4; YTZ14S-BS
1000 cc					
990 Adventure, Superduke, Supermoto R	01.05→	11	230	M6 017	YTZ14S-4; YTZ14S-BS

KYMCO

50 cc					
Agility/ DJ/ Vitality Refined, 2T, 4T	01.03→	3	30	M6 001	YT4L-4; YT4L-BS
Cobra/ Dink/ Super 9 LC, Racer	01.95-12.05	4	30	M6 004	YTX5L-4; YTX5L-BS
Cobra/ Super 9 AC, Cross	01.95-12.05	4	30	M6 004	YTX5L-4; YTX5L-BS
Dink/ Fever/ Filly/ People/ Spacer/ Top Boy	01.95→	4	30	M6 004	YTX5L-4; YTX5L-BS
Heroism/ K 12/ Scout/ Super 8/ Yup	01.95→	3	30	M6 001	YT4L-4; YT4L-BS
ZX Fever	01.98-12.04	3	30	M6 001	YT4L-4; YT4L-BS
100 cc					
Cobra, Cross, Racer	01.95-12.05	4	30	M6 004	YTX5L-4; YTX5L-BS
125 cc					
Bet and Win/ Calypso/ Dink/ Grand Dink/ Heroism/ Movie XL/ Spacer/ Vivio	01.95-12.08	8	80	M6 010	YTX9-4; YTX9-BS
People	01.05→	6	50	M6 007	YTX7A-4; YTX7A-BS
Zing	01.95-12.03	6	50	M6 007	YTX7A-4; YTX7A-BS
150 cc					
Bet & Win/ Dink/ Grand Dink/ Heroism/ Movie/ Spacer/Yager	01.95→	8	80	M6 010	YTX9-4; YTX9-BS
Zing	01.95-12.03	6	50	M6 007	YTX7A-4; YTX7A-BS
250 cc					
Bet & Win/ Dink/ Grand Dink	01.99→	10	90	M6 014	YTX12-4; YTX12-BS
500 cc					
Xciting	01.04→	3	30	M6 001	YT4L-4; YT4L-BS

LAVERDA

125 cc					
CU/ GS/ LB/ LB 1 Custom, Lesmo, Ride, Sport, Standard, UNO	11.83-12.97	6	40	M4 F19'	12N5.5-3B
600 cc					
OR Atlas	06.86-12.88	14	140	M4 F34'	12N14-3A; YB14L-A2
660 cc					
668 Sport	01.95-12.98	14	140	M4 F34'	12N14-3A; YB14L-A2
750 cc					
Formula S/ Strike	01.97-12.02	14	140	M4 F34'	12N14-3A; YB14L-A2



0 092 ...0

0 092 ...0

1000 cc							
Jota/ RGS Corsa, Executiv, Jota, /2	05.83-12.95	42B			30	300	M4 F54' 53030
RGS	03.82-12.90	42B			30	300	M4 F54' 53030
SFC	06.85-12.95				30	300	M4 F54' 53030

MALAGUTI

50 cc							
Centro/ Crosser/ Evolution/ F-15/ RST/ Yesterday	01.87-12.08				4	20	M4 F17' YB4L-B
Ciak	01.98-12.08				5	30	M4 F18' 12N5-3B; YB5L-B
ET/ Fifty/ F-10/ F-12/ Grizzly Jetline, Jetline Wap, Phantom, RCX 10, RCX 12, Street, Top, Top 10	01.86→				4	20	M4 F17' YB4L-B
125 cc							
Blog	01.09→		6	50	M6 006		YTX7L-4; YTX7L-BS
Ciak/ Madison	01.98-12.08				9	80	M4 F25' 12N9-4B-1; YB9-B
F-12/ F-18 Phantom Max, Warrior	01.00→				9	80	M4 F25' 12N9-4B-1; YB9-B
150 cc							
Ciak/ F-18/ Madison K , Warrior	01.99→				9	80	M4 F25' 12N9-4B-1; YB9-B
180 cc							
Madison K	01.99→				9	80	M4 F25' 12N9-4B-1; YB9-B
200 cc							
Madison S	01.03→				9	80	M4 F25' 12N9-4B-1; YB9-B
250 cc							
F-12 Phantom Max	01.04→				9	80	M4 F25' 12N9-4B-1; YB9-B
Madison S	01.99-12.02				9	80	M4 F25' 12N9-4B-1; YB9-B
Password	01.06→		10	90	M6 014		YTX12-4; YTX12-BS
400 cc							
Madison K	01.02→				12	120	M4 F32' YB12AL-A; YB12AL-A2
450 cc							
Spidermax GT 500	01.04→				14	140	M4 F34' 12N14-3A; YB14L-A2

MALANCA

125 cc							
125 GTI Strada, GTI 80	01.80-12.92				12	80	M4 F12' 6N11A-3A

MBK

50 cc							
Active/ Fizz/ Flipper/ Nitro/ Ovetto/ Stunt	01.87→				4	20	M4 F17' YB4L-B
Booster Rocket	01.96-12.05				4	20	M4 F17' YB4L-B
Mach-G	01.00→		3	30	M6 001		YT4L-4; YT4L-BS
X-Limit	01.97-12.07				3	10	M4 F15' YB3L-A
100 cc							
Booster	01.00→		4	30	M6 004		YTX5L-4; YTX5L-BS
Nitro/ Ovetto	01.97-12.05		3	30	M6 001		YT4L-4; YT4L-BS
125 cc							
Doodo/ Skyliner/ Thunder	01.98→				7	40	M4 F21' 12N7-3B; YB7L-B
Flame	01.94→		6	50	M6 007		YTX7A-4; YTX7A-BS
X	01.04→		6	50	M6 007		YTX7A-4; YTX7A-BS
250 cc							
Skyliner	01.00→		7	120	M6 008		YT7B-4; YT7B-BS
265 cc							
Kilibri 300	01.03-12.05		8	80	M6 010		YTX9-4; YTX9-BS



			Ah A (EN) M6 JS	Ah A (EN) M4 JS
			0 092 ...0	0 092 ...0

MOTO GUZZI

125 cc					
125 C, Custom	01.84-12.94	9	80	M4 F25*	12N9-4B-1; YB9-B
TT	07.85-12.87	6	40	M4 F19*	12N5.5-3B
350 cc					
NTX	10.86-12.91	18	180	M4 F42*	YB18L-A
V 35 C	01.82-12.87	25	220	M4 F52	52515; Y60-N24L-A
		30	300	M4 F54*	53030
Florida	05.86-12.91	18	180	M4 F42*	YB18L-A
Il, III, Imola, Imola II	11.79-12.91	25	220	M4 F52	52515; Y60-N24L-A
		30	300	M4 F54*	53030
Polizia NT	05.91-12.01	25	220	M4 F52	52515; Y60-N24L-A
		30	300	M4 F54*	53030
TT	06.84-12.87	25	220	M4 F52	52515; Y60-N24L-A
		30	300	M4 F54*	53030
350 Nevada	01.90-12.94	18	180	M4 F42*	YB18L-A
500 cc					
V 50 C, III, Monza, Monza II	01.81-12.87	25	220	M4 F52	52515; Y60-N24L-A
		30	300	M4 F54*	53030
Polizia NT	05.91-12.01	25	220	M4 F52	52515; Y60-N24L-A
		30	300	M4 F54*	53030
750 cc					
Breva	01.03→	14	140	M4 F34*	12N14-3A; YB14L-A2
Nevada Classic i.e.	01.04→	14	140	M4 F34*	12N14-3A; YB14L-A2
V 75	07.85-12.91	25	220	M4 F52	52515; Y60-N24L-A
		30	300	M4 F54*	53030
SP	09.90-12.00	30	300	M4 F54*	53030
750 Nevada, Nevada Basic, Nevada Club, NTX, NTX Polizia	07.88→	18	180	M4 F42*	YB18L-A
PA	05.91-12.01	25	220	M4 F52	52515; Y60-N24L-A
		30	300	M4 F54*	53030
Targa	07.88-12.94	25	220	M4 F52	52515; Y60-N24L-A
		30	300	M4 F54*	53030
850 cc					
T 5/V 85, TS Polizia	06.83-12.00	30	300	M4 F54*	53030
950 cc					
Mille GT, California II, California III, CI, Le Mans, Le Mans IV, Quota IE, S, SP II, SP III	04.87-12.00	25	220	M4 F52	52515; Y60-N24L-A
		30	300	M4 F54*	53030
V 1000, California II, California III, CI, Le Mans, Le Mans IV, Quota IE, S, SP II, SP III	01.82-12.95	25	220	M4 F52	52515; Y60-N24L-A
		30	300	M4 F54*	53030
1000, California II, California III, CI, Le Mans, Le Mans IV, Quota IE, S, SP II, SP III	06.84-12.95	25	220	M4 F52	52515; Y60-N24L-A
		30	300	M4 F54*	53030
1000 cc					
V 10/ 1000 Centauro, Daytona, Daytona R	01.92-12.00	25	220	M4 F52*	52515; Y60-N24L-A
V 1000 Le Mans, Strada	01.93-12.95	25	220	M4 F52	52515; Y60-N24L-A
		30	300	M4 F54*	53030
1000 Daytona RS	01.97-12.00	12	190	M6 019	YT12B-4; YT12B-BS
Le Mans, Strada	09.84-12.94	25	220	M4 F52	52515; Y60-N24L-A
		30	300	M4 F54*	53030
1100 cc					
California	01.94→	30	300	M4 F54*	53030
V 11 Roso Mandello	01.01→	25	220	M4 F52*	52515; Y60-N24L-A
Sport	01.01→	25	220	M4 F52*	52515; Y60-N24L-A
1100 Sport	10.94-12.00	12	190	M6 019	YT12B-4; YT12B-BS
		25	220	M4 F52*	52515; Y60-N24L-A



Ah
A
(EN)

0 092 ...0

Ah
A
(EN)

0 092 ...0

MOTO MORINI

350 cc

350 Coguaro	01.88-12.98	18	180	M4 F42'	YB18L-A
Dart	03.88-12.91	14	140	M4 F34'	12N14-3A; YB14L-A2
Excalibur	01.86-12.93	18	180	M4 F42'	YB18L-A
K 2	12.84-01.88	12	120	M4 F30'	12N12A-4A-1; YB12A-A
New York	07.88-12.93	18	180	M4 F42'	YB18L-A
XE Kanguro	12.84-12.94	12	120	M4 F30'	12N12A-4A-1; YB12A-A

400 cc

400 Dart	01.91-12.94	14	140	M4 F34'	12N14-3A; YB14L-A2
----------	-------------	----	-----	---------	--------------------

500 cc

500/501 Camel, Coguaro, Excalibur, New York, Turbo, 2 Camel	01.82-12.98	18	180	M4 F42'	YB18L-A
---	-------------	----	-----	---------	---------

1200 cc

Corsaro/9 1/2	01.05→	14	140	M4 F34'	12N14-3A; YB14L-A2
---------------	--------	----	-----	---------	--------------------

MOTRON

50 cc

Spike/ Syncro/ Thunder	01.96→	4	20	M4 F17'	YB4L-B
------------------------	--------	---	----	---------	--------

MUENCH

2000 cc

2000 Mammut	01.01→	10	90	M6 014	YTX12-4; YTX12-BS
-------------	--------	----	----	--------	-------------------

MV AGUSTA

750 cc

F4 Agostini	01.03→	25	220	M4 F52'	52515; Y60-N24L-A
Brutale S, Brutale Serie Oro, S, S 1+1, Senna, SPR	01.99→	8	80	M6 010	YTX9-4; YTX9-BS

910 cc

Brutale R/S	01.06→	9	200	M6 012	YTZ12S-4; YTZ12S-BS; TTZ12 S-BS
-------------	--------	---	-----	--------	---------------------------------

1000 cc

F4 Ago, S, Senna, Tamburini, 1+1	01.04→	8	150	M6 011	YTZ10S-4; YTZ10S-BS
-------------------------------------	--------	---	-----	--------	---------------------

MZ (MOTORRADWERKE ZSCHOPAU)

125 cc

ETZ 125 Saxon Roadstar, Saxon Sportstar, Saxon Standard	01.91-12.98	5	30	M4 F18'	12N5-3B; YB5L-B
Moskito/ RT 125	01.00→	6	40	M4 F19'	12N5.5-3B
125 SX/SM	01.01-12.08	6	40	M4 F19'	12N5.5-3B

150 cc

ETZ 150	01.84-12.90	9	80	M4 F26'	12N9-3B; YB9L-B
Standard, OR	01.91-12.06	9	80	M4 F26'	12N9-3B; YB9L-B
TS 150	01.75-12.85	12	80	M4 F12'	6N11A-3A

250 cc

ETZ 250 Gespann	01.85-12.86	9	80	M4 F26'	12N9-3B; YB9L-B
ETZ 250/ ETZ 251	09.81-12.90	9	80	M4 F26'	12N9-3B; YB9L-B
ETZ 251 Gespann	01.91-12.97	5	30	M4 F18'	12N5-3B; YB5L-B
Saxon Fun, Saxon Tour	01.91-12.97	5	30	M4 F18'	12N5-3B; YB5L-B

300 cc

ETZ 301 Saxon Fun, Saxon Tour	08.90-12.98	5	30	M4 F18'	12N5-3B; YB5L-B
-------------------------------	-------------	---	----	---------	-----------------





0 092 ...0

0 092 ...0

◀ MZ

500 cc						
ETZ 500/ LS 500/ Red Star/ Silver Star/ SP 5/ 500 R Classic, Fun, Gespann, Roadster, Saxon Country, Saxon Fun, Saxon Tour, Saxon Voyager, Skorpion, Tour, 500	01.91-12.06	14	140	M4 F34'	12N14-3A; YB14L-A2	
600 cc						
LS 600 Skorpion	01.94-12.05	9	80	M4 F26'	12N9-3B; YB9L-B	
660 cc						
Baghira/ Mastiff/ Skorpion , Black Panther, Cup, Enduro, Forest, Gespann, Replica, Sport, Sport Replica, Streetmoto, Tour, Trail, Traveller	01.94→	9	80	M4 F26'	12N9-3B; YB9L-B	
1000 cc						
1000 SF, S/ST	01.02→	10	90	M6 014	YTX12-4; YTX12-BS	







PEGASUS

50 cc						
Corona/ R/ Sky X , 25, 50	01.00→	4	20	M4 F17'	YB4L-B	
125 cc						
Corona/ Sky	01.00-12.10	7	40	M4 F21'	12N7-3B; YB7L-B	

PEUGEOT

50 cc						
Buxy/ Elyseo/ Elystar/ Fox/ Looxor/ Ludix/ Metal-X/ SC/ Speedake/ Speedfight I/ Speedfight II/ Squab/ ST/ SV/ Trekker TKR/ Vivacity/ XP 6/ XR6/ Zenith , Advantage, i.e., Junior, L, LA, Offroad, Road, Supermotard, Trail, TSDI, Zenith L	01.87→	4	20	M4 F17'	YB4L-B	
80 cc						
SV	01.92-12.02	5	30	M4 F18'	12N5-3B; YB5L-B	
100 cc						
Elyseo	01.98-12.03	8	80	M4 F24'	YB7-A	
Looxor/ Speedfight/ Trekker TKR/ Vivacity	01.97-12.06	4	30	M6 004	YTX5L-4; YTX5L-BS	
SV	01.97-12.03	5	30	M4 F18'	12N5-3B; YB5L-B	
125 cc						
Elyseo/ Advantage	01.98→	4	30	M6 004	YTX5L-4; YTX5L-BS	
Elystar/ Advantage	01.03→	8	80	M4 F24'	YB7-A	
Jet Force ABS, Compressor	01.03→	8	80	M4 F24'	YB7-A	
SV	07.91-12.02	5	30	M4 F18'	12N5-3B; YB5L-B	
150 cc						
Elyseo	01.01-12.03	12	120	M4 F32'	YB12AL-A; YB12AL-A2	
Elystar	01.03-12.07	8	80	M4 F24'	YB7-A	
250 cc						
Satelis	01.06→	10	90	M6 014	YTX12-4; YTX12-BS	
SV	01.02-12.04	10	90	M6 014	YTX12-4; YTX12-BS	
400 cc						
Geopolis	01.07→	12	120	M4 F32'	YB12AL-A; YB12AL-A2	



			Ah A (EN)			Ah A (EN)		
0 092 ...0					0 092 ...0			

PGO

50 cc									
Big Max/ Star	01.93-12.03					4	20	M4 F17'	YB4L-B
Comet Junior, 2	01.93-12.05	3	30	M6 001	YT4L-4; YT4L-BS				
Comet/ Galaxy/ Mega	01.93-12.05	3	30	M6 001	YT4L-4; YT4L-BS				
80 cc									
Star	01.93-12.05	3	30	M6 001	YT4L-4; YT4L-BS				

PIAGGIO

APE									
50 FL2	01.91-12.05					9	80	M4 F25'	12N9-4B-1; YB9-B
50 cc									
Diesis/ Free/ NRG/ Quartz/ Sfera/ Typhoon TPH/ Velofax/ Zip/ Zip & Zip	01.90-12.05					4	20	M4 F17'	YB4L-B
Fly/ Vespa LX 2T	01.04→					9	80	M4 F25'	12N9-4B-1; YB9-B
Free Kat	01.93-12.99					4	20	M4 F17'	YB4L-B
Gilera Eaglet/ Vespa Eaglet, ET2, ET2 i	01.97-12.05					4	20	M4 F17'	YB4L-B
Liberty 2T	01.97-12.05					4	20	M4 F17'	YB4L-B
4T	01.00-12.03					9	80	M4 F25'	12N9-4B-1; YB9-B
NRG Extreme	01.96-12.00					4	20	M4 F17'	YB4L-B
Extreme LC	01.96-12.00	3	30	M6 001	YT4L-4; YT4L-BS	4	20	M4 F17'	YB4L-B
NRG/ Vespa mc2, Quartz	01.93-12.00					4	20	M4 F17'	YB4L-B
Storm	01.94-12.96					8	80	M4 F24'	YB7-A
Vespa ET4	01.02→					9	80	M4 F25'	12N9-4B-1; YB9-B
FL 2 AE	02.90-12.99					8	80	M4 F24'	YB7-A
LXV	01.06-12.08					9	80	M4 F25'	12N9-4B-1; YB9-B
S 2T, S 4T	01.07→					9	80	M4 F25'	12N9-4B-1; YB9-B
Scatto	01.90-12.99					4	20	M4 F17'	YB4L-B
Vespa LX 4T	01.05→					9	80	M4 F25'	12N9-4B-1; YB9-B
Vespa PK S	09.82-12.87					8	80	M4 F24'	YB7-A
SS/SE Elestar, XL, XL Cup, XL Plurimatic, XL Puch, XL 2	01.83-12.99					8	80	M4 F24'	YB7-A
Zip Cat	01.00-12.04	3	30	M6 001	YT4L-4; YT4L-BS				
SP	01.01→	3	30	M6 001	YT4L-4; YT4L-BS				
80 cc									
Sfera	01.91-12.98					5	30	M4 F18'	12N5-3B; YB5L-B
						8	80	M4 F24'	YB7-A
TPH	01.94-12.01					5	30	M4 F18'	12N5-3B; YB5L-B
						8	80	M4 F24'	YB7-A
Vespa P X	12.81-12.91					6	40	M4 F19'	12N5.5-3B
Vespa PK S	09.82-12.85					8	80	M4 F24'	YB7-A
Vespa PX	12.81-12.91					8	80	M4 F24'	YB7-A
E	12.81-12.91					8	80	M4 F24'	YB7-A
						9	80	M4 F25'	12N9-4B-1; YB9-B
E Lusso	01.88-12.98					8	80	M4 F24'	YB7-A
E Lusso Elestart	01.94→					9	80	M4 F25'	12N9-4B-1; YB9-B
100 cc									
Fly	01.06→					9	80	M4 F25'	12N9-4B-1; YB9-B
Vespa PK XL	01.86-12.96					8	80	M4 F24'	YB7-A
125 cc									
Beverly/ Fly/ Hexagon/ Liberty	01.94→					9	80	M4 F25'	12N9-4B-1; YB9-B
Carnaby/ Vespa	01.03-12.10					11	90	M4 F29'	12N10-3B; YB10L-B; YB10L-B2
Granturismo/ X7/ X8									
Liberty 4T	01.01→					9	80	M4 F25'	12N9-4B-1; YB9-B
Sfera	10.95-12.98					8	80	M4 F24'	YB7-A
Skipper 4T	01.00-12.02					8	80	M4 F24'	YB7-A
Skipper SKR LX	01.93-12.99					8	80	M4 F24'	YB7-A



		0 092 ...0				0 092 ...0			
		Ah	A (EN)	M6	JS	Ah	A (EN)	M4	JS
PIAGGIO									
Skipper/ Typhoon/ Vespa/ Vespa PK ST,TPH, T5, XL Automatik, XL 2	03.85-12.05					8	80	M4 F24*	YB7-A
Vespa ET4	01.96-12.04	8	80	M6 010	YTX9-4; YTX9-BS				
LX	01.05-12.09					9	80	M4 F25*	12N9-4B-1; YB9-B
LX ie	01.09→	10	90	M6 014	YTX12-4; YTX12-BS				
S ie	01.09-12.12	10	90	M6 014	YTX12-4; YTX12-BS				
Vespa Cosa AE	01.88-12.90					9	80	M4 F25*	12N9-4B-1; YB9-B
FL	01.91-12.95	8	80					M4 F24*	YB7-A
Vespa P ETS	01.83-12.85	8	80					M4 F24*	YB7-A
Vespa PK S	09.82-12.87	8	80					M4 F24*	YB7-A
Vespa PK/ Vespa PX E, E Arc AE, E Lusso	01.82-12.94	6	40					M4 F19*	12N5.5-3B
XEvo	01.07→	10	90	M6 014	YTX12-4; YTX12-BS				
Zip	01.00-12.05	8	80	M6 010	YTX9-4; YTX9-BS				
150 cc									
Hexagon/ Skipper SKR	01.94-12.00					9	80	M4 F25*	12N9-4B-1; YB9-B
Liberty/ Vespa ET 4, LE	01.00-12.05					9	80	M4 F25*	12N9-4B-1; YB9-B
Skipper SKR ST	01.00→					8	80	M4 F24*	YB7-A
Vespa P S	01.82-12.87					9	80	M4 F25*	12N9-4B-1; YB9-B
Vespa PX E	01.82-12.93					8	80	M4 F24*	YB7-A
E Lusso	01.88-12.93	6	40					M4 F19*	12N5.5-3B
180 cc									
Hexagon	01.98-12.03					9	80	M4 F25*	12N9-4B-1; YB9-B
Super Hexagon GTX	01.01-12.05					11	90	M4 F29*	12N10-3B; YB10L-B; YB10L-B2
X9	01.00-12.03					11	90	M4 F29*	12N10-3B; YB10L-B; YB10L-B2
200 cc									
Beverly/ Carnaby	01.01-12.08	10	90	M6 014	YTX12-4; YTX12-BS				
Vespa Cosa	01.88-12.98					9	80	M4 F25*	12N9-4B-1; YB9-B
Elestart, FL Elestart, Globe Rocket	01.91-12.02	9	80					M4 F25*	12N9-4B-1; YB9-B
Vespa PX E	01.84-12.90	6	40					M4 F19*	12N5.5-3B
E Grand Sport, E Grand Sport Elestart	01.84-12.99	9	80					M4 F25*	12N9-4B-1; YB9-B
E Lusso, E Lusso Grand Sport	01.84-12.98	8	80					M4 F24*	YB7-A
GS	01.85-12.95	9	80					M4 F25*	12N9-4B-1; YB9-B
		6	40					M4 F19*	12N5.5-3B
250 cc									
Beverly/ Vespa GTS, i.e	01.05→					11	90	M4 F29*	12N10-3B; YB10L-B; YB10L-B2
Beverly/ X8/ X9	01.00-12.08					11	90	M4 F29*	12N10-3B; YB10L-B; YB10L-B2
Carnaby/ X7	01.08-12.12	10	90	M6 014	YTX12-4; YTX12-BS				
Hexagon GT	01.98-12.03					11	90	M4 F29*	12N10-3B; YB10L-B; YB10L-B2
MP3	01.08-12.12	12	100	M6 018	YTX14-4; YTX14-BS				
Vespa GT	01.05-12.07					11	90	M4 F29*	12N10-3B; YB10L-B; YB10L-B2
300 cc									
Vespa GTS Super, GTV	01.08→	10	90	M6 014	YTX12-4; YTX12-BS				
500 cc									
Beverly	01.02-12.08					11	90	M4 F29*	12N10-3B; YB10L-B; YB10L-B2

PUCH (STEYR-DAIMLER-PUCH AG)

50 cc									
CB 50 Lido Vario	01.84-12.98	4	20					M4 F17*	YB4L-B
80 cc									
Lido SE	01.84-12.98	5	30					M4 F18*	12N5-3B; YB5L-B

			Ah A (EN) M6 JS	Ah A (EN) M4 JS
			0 092 ...0	0 092 ...0

125 cc				
Lido	01.84-12.98	8	80	M4 F24' YB7-A

RENAULT SPORT

125 cc				
Kouranos	01.01→	8	80	M6 010 YTX9-4; YTX9-BS

ROYAL ENFIELD

350 cc				
Bullet	01.55-12.07	12	120	M4 F30' 12N12A-4A-1; YB12A-A
500 cc				
Bullet/ 500GT/ 500S, Clubman	01.91→	14	140	M4 F34' 12N14-3A; YB14L-A2

SACHS (FICHTEL & SACHS AG)

125 cc				
MadAss/ Roadster/ X-Road/ XT.C/ ZX 125/ ZZ 125, V2, 2T, 4T	05.97→	6	40	M4 F19' 12N5.5-3B

SANGLAS

400 cc				
400 Y	01.78-12.88	12	120	M4 F30' 12N12A-4A-1; YB12A-A
500 cc				
500 S2 V5	12.77-12.87	14	140	M4 F34' 12N14-3A; YB14L-A2

SIMSON

50 cc				
Albatros/ Habicht 50/ SR 50/ SR 50/1/ SR 50/1-M/ SR 53 gamma XG, gamma XGE, OR, S, SD, XC	06.93-12.03	6	40	M4 F19' 12N5.5-3B
Habicht 25	01.96-12.02	6	40	M4 F19' 12N5.5-3B
S 51 B 2-4	01.82-12.90	12	80	M4 F12' 6N11A-3A
Enduro	01.81-12.90	12	80	M4 F12' 6N11A-3A
S 53	09.90-11.94	6	40	M4 F19' 12N5.5-3B
S 53/ SR 50/1 beta, C	09.90-12.02	6	40	M4 F19' 12N5.5-3B
S 53/ SR 50/1/ SR 53 M alpha B, B	09.90-12.02	6	40	M4 F19' 12N5.5-3B
Sperber 50/ Star 50	01.96-12.02	6	40	M4 F19' 12N5.5-3B
SR 50	01.85-12.90	12	80	M4 F12' 6N11A-3A
CC, CCE	01.93-12.03	5	30	M4 F18' 12N5-3B; YB5L-B
XCE	06.93-12.03	5	30	M4 F18' 12N5-3B; YB5L-B
XGE	01.94-12.04	6	40	M4 F19' 12N5.5-3B
	MEK	5	30	M4 F18' 12N5-3B; YB5L-B
SR 50/ SR 50/1 XG	06.93-12.03	6	40	M4 F19' 12N5.5-3B
SR 50/1 XCE	01.95-12.02	6	40	M4 F19' 12N5.5-3B
XGE	01.95-12.02	6	40	M4 F19' 12N5.5-3B
	MEK	5	30	M4 F18' 12N5-3B; YB5L-B
SR 50/1/ SR 53 CE, CX	09.90-12.02	6	40	M4 F19' 12N5.5-3B
70 cc				
Habicht 80/ S 80/1/ S 83 B, Basic	01.95-12.02	6	40	M4 F19' 12N5.5-3B
CX, OR, S, XCE	01.95-12.02	6	40	M4 F19' 12N5.5-3B
S 70	01.80-12.90	12	80	M4 F12' 6N11A-3A





◀ SIMSON

0 092 ...0

0 092 ...0

Sperber 80	01.96-12.02					6	40	M4 F19'	12N5.5-3B
SR 80	01.85-12.90					5	30	M4 F18'	12N5-3B; YB5L-B
	01.94-12.02					5	30	M4 F18'	12N5-3B; YB5L-B
CC, CCE	01.94-12.02					5	30	M4 F18'	12N5-3B; YB5L-B

STEYR (STEYR-DAIMLER-PUCH AG)**50 cc**

Lido Vario CB	01.88-12.98					4	20	M4 F17'	YB4L-B
----------------------	-------------	--	--	--	--	---	----	----------------	---------------

SUZUKI**50 cc**

AD/ AE/ AP	01.90-12.03					3	30	M6 001	YT4L-4; YT4L-BS
AE/ AH/ AY/ TS/ TS 50/ UX	08.87-12.06					3	30	M6 001	YT4L-4; YT4L-BS
Adress/GP, K, Katana, R, W Zillion, XA, XK									
CP	01.85-12.93					3	30	M6 001	YT4L-4; YT4L-BS
FB	01.89-12.89					3	30	M6 001	YT4L-4; YT4L-BS
	01.91-12.91					3	30	M6 001	YT4L-4; YT4L-BS
RG	01.89-12.89					4	20	M4 F17'	YB4L-B
80 cc									
CP/ CS/ FB	01.83-12.93					5	30	M4 F18'	12N5-3B; YB5L-B
FR	01.95-12.02					3	30	M6 001	YT4L-4; YT4L-BS
RG/ TS Gamma, WF, X	01.84-12.91					4	20	M4 F17'	YB4L-B
100 cc									
AH Adress	01.92-12.96					4	30	M6 004	YTX5L-4; YTX5L-BS
110 cc									
UG Hokuto	01.00-12.02					4	30	M6 004	YTX5L-4; YTX5L-BS
125 cc									
AN/ RG/ UE	01.85-12.01					6	50	M6 007	YTX7A-4; YTX7A-BS
DR S	01.87-12.94					4	20	M4 F17'	YB4L-B
DR/ RGT	08.90-12.02					6	50	M6 006	YTX7L-4; YTX7L-BS
DR/ RV SE, Van Van	01.95-12.06					6	50	M6 006	YTX7L-4; YTX7L-BS
GN/ GS	01.89-12.05					8	80	M4 F24'	YB7-A
GZ/ VL Intruder, Marauder	01.00-12.07					6	50	M6 006	YTX7L-4; YTX7L-BS
TS R	01.89-12.96					3	30	M6 001	YT4L-4; YT4L-BS
UC Epicuro	01.99-12.01					6	50	M6 007	YTX7A-4; YTX7A-BS
UH Burgman	01.02-12.06					8	80	M6 010	YTX9-4; YTX9-BS
150 cc									
UH Burgman	01.02-12.06					8	80	M6 010	YTX9-4; YTX9-BS
185 cc									
GT	01.73-12.85					11	90	M4 F28'	12N10-3A; "-3A-1; "-3A-2; YB10L-A2
200 cc									
SP	01.86-12.88					4	20	M4 F17'	YB4L-B
TS R, X	01.86-12.96					3	30	M6 001	YT4L-4; YT4L-BS
UH Burgman	01.07→					8	80	M6 010	YTX9-4; YTX9-BS
250 cc									
AN Burgman	01.98-12.06					11	140	M6 016	YT12A-4; YT12A-BS
DR S, SZ-H	01.82-12.89					4	20	M4 F17'	YB4L-B
GF/ NZ S	01.86-12.96					11	90	M4 F29'	12N10-3B; YB10L-B; YB10L-B2
GN	01.86-11.99					11	90	M4 F28'	12N10-3A; "-3A-1; "-3A-2; YB10L-A2
GZ/ VL Intruder, Marauder	01.99-12.07					6	50	M6 006	YTX7L-4; YTX7L-BS
RG	01.83-12.89					5	30	M4 F18'	12N5-3B; YB5L-B
RGV	01.89-12.93					3	30	M6 001	YT4L-4; YT4L-BS
TS X	01.86-12.89					4	20	M4 F17'	YB4L-B
TU X	01.97-12.01					11	90	M4 F28'	12N10-3A; "-3A-1; "-3A-2; YB10L-A2

				Ah A (EN) M6 JIS				Ah A (EN) M4 JIS	
				0 092 ...0				0 092 ...0	
350 cc									
DR , S, SH	01.90→	3	30	M6 001	YT4L-4; YT4L-BS				
SZ	01.95-12.99	6	50	M6 006	YTX7L-4; YTX7L-BS				
400 cc									
AN Burgman	01.99-12.02	8	80	M6 010	YTX9-4; YTX9-BS				
	01.03-12.03	11	140	M6 016	YT12A-4; YT12A-BS				
DR-Z	01.99-12.04	7	120	M6 008	YT7B-4; YT7B-BS				
S, SM, E	01.05-12.09	7	120	M6 008	YT7B-4; YT7B-BS				
GS T	01.81-12.87					11	90	M4 F28'	12N10-3A; "-3A-1; "-3A-2; YB10L-A2
GSF Bandit	01.88-12.95	8	80	M6 010	YTX9-4; YTX9-BS				
GSX-R	01.84-12.99	8	80	M6 010	YTX9-4; YTX9-BS				
LS	01.87-12.97					14	140	M4 F36'	YB14L-B2
450 cc									
GS TL	01.81-12.91					11	90	M4 F28'	12N10-3A; "-3A-1; "-3A-2; YB10L-A2
500 cc									
GS	01.01-12.07					11	90	M4 F28'	12N10-3A; "-3A-1; "-3A-2; YB10L-A2
E	01.89-12.00					11	90	M4 F28'	12N10-3A; "-3A-1; "-3A-2; YB10L-A2
								M4 F29'	12N10-3B; YB10L-B; YB10L-B2
RG Gamma	01.85-12.89	4	30	M6 004	YTX5L-4; YTX5L-BS				
RGV	01.89-12.00	4	30	M6 004	YTX5L-4; YTX5L-BS				
SP	01.92-12.00					4	20	M4 F17'	YB4L-B
550 cc									
GS E	01.83-01.86					11	90	M4 F29'	12N10-3B; YB10L-B; YB10L-B2
GSX E	01.85-12.87					11	90	M4 F29'	12N10-3B; YB10L-B; YB10L-B2
EF	01.85-12.88					11	90	M4 F29'	12N10-3B; YB10L-B; YB10L-B2
600 cc									
DR R Dakar, S	01.85-12.89					5	30	M4 F18'	12N5-3B; YB5L-B
GSF Bandit	01.95-12.04	8	80	M6 010	YTX9-4; YTX9-BS				
GSR	01.06-12.11	8	80	M6 010	YTX9-4; YTX9-BS				
GSX EF, F, FU, FU 2	08.87-12.06					11	90	M4 F29'	12N10-3B; YB10L-B; YB10L-B2
GSX-R	01.92-12.03	10	90	M6 014	YTX12-4; YTX12-BS				
	01.92-12.07	8	80	M6 010	YTX9-4; YTX9-BS				
RF R	01.93-12.97	8	80	M6 010	YTX9-4; YTX9-BS				
SP	01.85-12.95					5	30	M4 F18'	12N5-3B; YB5L-B
VS Intruder	01.95-12.98					16	160	M4 F39'	YB16B-A; YB16B-A1
650 cc									
AN Burgman	01.03→	12	100	M6 018	YTX14-4; YTX14-BS				
DL V-Strom	01.04→	10	90	M6 014	YTX12-4; YTX12-BS				
DR R	01.90-12.94	3	30	M6 001	YT4L-4; YT4L-BS				
R, Dakar, R, RE, Dakar	01.88-12.94					5	30	M4 F18'	12N5-3B; YB5L-B
RE	01.94-12.94	10	90	M6 014	YTX12-4; YTX12-BS				
RS	01.90-12.91					5	30	M4 F18'	12N5-3B; YB5L-B
RSE	01.91-12.91	12	100	M6 018	YTX14-4; YTX14-BS				
SE	01.96-12.97					11	90	M4 F29'	12N10-3B; YB10L-B; YB10L-B2
	01.98-12.99	8	80	M6 010	YTX9-4; YTX9-BS				
GR	01.83-12.89					14	140	M4 F34'	12N14-3A; YB14L-A2
X	01.85-12.95					14	140	M4 F34'	12N14-3A; YB14L-A2
GSF Bandit	01.05→	8	80	M6 010	YTX9-4; YTX9-BS				
GSX F	01.08→	8	80	M6 010	YTX9-4; YTX9-BS				
LS Savage	03.86-12.93					14	140	M4 F36'	YB14L-B2
SV	01.99-12.02	11	140	M6 016	YT12A-4; YT12A-BS				
XF Freewind	01.97-12.01	8	80	M6 010	YTX9-4; YTX9-BS				
XN 85 Turbo	01.82-12.87					14	140	M4 F34'	12N14-3A; YB14L-A2





0 092 ...0

0 092 ...0

◀ SUZUKI

700 cc									
GS	01.85-12.90					14	140	M4 F34*	12N14-3A; YB14L-A2
GV GL	01.86-12.96					14	140	M4 F36*	YB14L-B2
750 cc									
DR S Big Touring	01.88-12.89					14	140	M4 F36*	YB14L-B2
DR BIG	01.90-12.00					14	140	M4 F34*	12N14-3A; YB14L-A2
GSX	01.98-01.01	8	80	M6 010	YTX9-4; YTX9-BS				
E, EF	01.80-12.93					14	140	M4 F34*	12N14-3A; YB14L-A2
F	09.88-12.97					14	140	M4 F36*	YB14L-B2
	01.98-12.06	8	80	M6 010	YTX9-4; YTX9-BS				
GSX/ GSX-R RG, S	01.85-12.88					14	140	M4 F34*	12N14-3A; YB14L-A2
GSX-R	01.88-12.03					14	140	M4 F34*	12N14-3A; YB14L-A2
		11	140	M6 016	YT12A-4; YT12A-BS	14	140	M4 F34*	12N14-3A; YB14L-A2
	01.90-12.10	11	140	M6 016	YT12A-4; YT12A-BS				
						14	140	M4 F34*	12N14-3A; YB14L-A2
J- K, R	01.88-12.89	11	140	M6 016	YT12A-4; YT12A-BS	14	140	M4 F34*	12N14-3A; YB14L-A2
Spezial Edition	01.86-12.87	11	140	M6 016	YT12A-4; YT12A-BS	14	140	M4 F34*	12N14-3A; YB14L-A2
W	01.92-12.97	8	80	M6 010	YTX9-4; YTX9-BS				
		10	90	M6 014	YTX12-4; YTX12-BS				
	01.95-12.97	11	140	M6 016	YT12A-4; YT12A-BS				
Y	01.99-12.03	11	140	M6 016	YT12A-4; YT12A-BS				
VS Intruder	01.85-12.91					16	160	M4 F39*	YB16B-A; YB16B-A1
800 cc									
DR Big SU	01.91-12.99					14	140	M4 F36*	YB14L-B2
S, SU	01.90-12.99					14	140	M4 F36*	YB14L-B2
VL/ VZ C Intruder, Intruder	01.97→	10	90	M6 014	YTX12-4; YTX12-BS				
Volusia, M Intruder U, UE, UZ, Z, Marauder									
VS/ VX	01.90-12.00					16	160	M4 F39*	YB16B-A; YB16B-A1
VX U	01.90-12.97					16	160	M4 F39*	YB16B-A; YB16B-A1
850 cc									
GS G	01.79-12.88					14	140	M4 F34*	12N14-3A; YB14L-A2
900 cc									
RF R, RS 2	09.93-12.99	8	80	M6 010	YTX9-4; YTX9-BS				
1000 cc									
DL V-Strom	01.02-12.10	12	100	M6 018	YTX14-4; YTX14-BS				
GSX-R	01.01-12.04	10	90	M6 014	YTX12-4; YTX12-BS				
	01.05-12.06	11	140	M6 016	YT12A-4; YT12A-BS				
	01.07→	10	90	M6 014	YTX12-4; YTX12-BS				
SB 3 D	01.82-12.92					14	140	M4 F34*	12N14-3A; YB14L-A2
SV S	01.03-12.07	12	100	M6 018	YTX14-4; YTX14-BS				
TL R	01.98-12.00	11	140	M6 016	YT12A-4; YT12A-BS				
S	01.97-12.01	10	90	M6 014	YTX12-4; YTX12-BS				
1100 cc									
GS/ GSX G	01.82→	12	100	M6 018	YTX14-4; YTX14-BS				
GSX E	01.80-12.87					14	140	M4 F34*	12N14-3A; YB14L-A2
F	01.88-12.96					14	140	M4 F36*	YB14L-B2
GSX-R	01.86-12.88					14	140	M4 F34*	12N14-3A; YB14L-A2
	01.93-12.97	10	90	M6 014	YTX12-4; YTX12-BS				
Slingshot	01.93-12.94					14	140	M4 F34*	12N14-3A; YB14L-A2
W	01.92-12.98	10	90	M6 014	YTX12-4; YTX12-BS				
1200 cc									
GSF S Bandit	01.95-12.06	10	90	M6 014	YTX12-4; YTX12-BS				
GSX	01.99-12.01	10	90	M6 014	YTX12-4; YTX12-BS				
GV Madura	01.86-12.96					14	140	M4 F36*	YB14L-B2
1250 cc									
GSF Bandit	01.07→	11	140	M6 016	YT12A-4; YT12A-BS				
1300 cc									
B-King	01.08-12.10	11	140	M6 016	YT12A-4; YT12A-BS				
GSX-R Hayabusa	01.99-12.07	11	140	M6 016	YT12A-4; YT12A-BS				
	01.08→	10	90	M6 014	YTX12-4; YTX12-BS				





0 092 ...0

0 092 ...0

1400 cc					
GSX	01.02-12.07	12	100	M6 018	YTX14-4; YTX14-BS
1600 cc					
VZ Marauder	01.04-12.05	18	260	M6 023	YTX20L-4; YTX20L-BS

SWM

125 cc					
RS 125/ RZ 125/ TL 125 , GS TF 3, NW	01.80-12.92	5	30	M4 F18'	12N5-3B; YB5L-B

SYM

50 cc					
DD/ Fiddle/ Jet/ Jungle/ Mask/ Red Devil	01.97→	3	30	M6 001	YT4L-4; YT4L-BS
100 cc					
Jet	01.98→	3	30	M6 001	YT4L-4; YT4L-BS
125 cc					
Euro MX	01.05→	8	80	M6 010	YTX9-4; YTX9-BS
Husky	01.97-12.05	6	50	M6 006	YTX7L-4; YTX7L-BS
Joyride/ Shark	01.99→	8	80	M6 010	YTX9-4; YTX9-BS
Super Duke	01.96→	6	50	M6 007	YTX7A-4; YTX7A-BS
150 cc					
Joyride	01.02→	8	80	M6 010	YTX9-4; YTX9-BS

TRIUMPH

600 cc					
Daytona/ Speed Four	01.02→	8	80	M6 010	YTX9-4; YTX9-BS
TT	01.00-12.03	10	90	M6 014	YTX12-4; YTX12-BS
650 cc					
Daytona	01.05-12.06	8	80	M6 010	YTX9-4; YTX9-BS
675 cc					
Daytona	01.06→	7	120	M6 008	YT7B-4; YT7B-BS
RR	01.06→	7	120	M6 008	YT7B-4; YT7B-BS
Street Triple	01.07→	8	80	M6 010	YTX9-4; YTX9-BS
750 cc					
Bonneville	01.87-12.89	9	80	M4 F25'	12N9-4B-1; YB9-B
Bonneville/ Tiger Europa, TR7V	01.85-12.95	9	80	M4 F25'	12N9-4B-1; YB9-B
Daytona/ Speed Triple/ Trident	09.90→	14	140	M4 F34'	12N14-3A; YB14L-A2
790 cc					
Bonneville/ Speedmaster , America	01.00-12.04	10	90	M6 014	YTX12-4; YTX12-BS
865 cc					
Bonneville T100	01.04→	14	140	M4 F34'	12N14-3A; YB14L-A2
Bonneville/ Speedmaster , SE	01.03→	10	90	M6 014	YTX12-4; YTX12-BS
900/ Thruxton					
885 cc					
Daytona/ Daytona 900/ Legend/ Saxon/ Speed Triple T 509/ Speed Triple 900/ Sprint/ST 900/ Thunderbird/ Tiger/ Trident/ Trident 900/ Trophy 900 , Adventurer, Sport, Sprint, Super Three, Triumph, TT	09.90→	14	140	M4 F34'	12N14-3A; YB14L-A2
955 cc					
Daytona Centennial Edition	01.02→	12	100	M6 018	YTX14-4; YTX14-BS
i	01.99→	12	100	M6 018	YTX14-4; YTX14-BS
Daytona T595	01.97-12.98	14	140	M4 F34'	12N14-3A; YB14L-A2





◀ TRIUMPH

0 092 ...0

0 092 ...0

Speed Triple	01.99-12.03	12	100	M6 018	YTX14-4; YTX14-BS
Sprint RS, ST	01.99-12.04	12	100	M6 018	YTX14-4; YTX14-BS
Tiger i	01.01-12.06	10	90	M6 014	YTX12-4; YTX12-BS
1000 cc					
Daytona	09.90-12.93	14	140	M4 F34'	12N14-3A; YB14L-A2
1050 cc					
Speed Triple/ Sprint/ Tiger, ST	01.05→	10	90	M6 014	YTX12-4; YTX12-BS
1200 cc					
Daytona/Trophy	09.90-12.03	14	140	M4 F34'	12N14-3A; YB14L-A2
2300 cc					
Rocket III Classic Twinspark, Twinspark	05.04→	18	260	M6 023	YTX20L-4; YTX20L-BS

WINKING

Elektroscooter

Bunny E GO	01.97→	3	30	M6 001	YT4L-4; YT4L-BS
50 cc					
AS/ AT/ Bunny, AS, AT	01.91→	4	20	M4 F17'	YB4L-B

YAMAHA

50 cc

Aerox/ Breeze/ B-Whizz/ BW's/ CR/ CS/ CW/ Jog/ Zest	01.88→	4	20	M4 F17'	YB4L-B
Axis	01.97-12.07	3	30	M6 001	YT4L-4; YT4L-BS
BW's R	01.96→	4	20	M4 F17'	YB4L-B
BW's/ CA/ CG/ CY/ YE/ YM/ YN Breeze, Bump, Evolis, Jog, M Salient, Neo's, NG	09.82→	4	20	M4 F17'	YB4L-B
BW's/ EW/ YE/ YH Slider, Spy, Why, Zest	01.93→	4	20	M4 F17'	YB4L-B
DT R	01.89-12.02	3	10	M4 F15'	YB3L-A
YA R	01.92→	3	30	M6 001	YT4L-4; YT4L-BS
80 cc					
YE	01.94-12.97	4	20	M4 F17'	YB4L-B
90 cc					
YA Axis	01.91-12.98	3	30	M6 001	YT4L-4; YT4L-BS
100 cc					
YN/ YQ Aerox, Neo's	01.99-12.08	3	30	M6 001	YT4L-4; YT4L-BS
125 cc					
DT	01.99→	3	10	M4 F16'	YB3L-B
DT/ RD LC	01.82-12.89	5	30	M4 F18'	12N5-3B; YB5L-B
NXC CygnusX	01.04→	6	50	M6 007	YTX7A-4; YTX7A-BS
SR	01.93-12.03	7	40	M4 F21'	12N7-3B; YB7L-B
TDR	10.89-12.03	4	30	M6 004	YTX5L-4; YTX5L-BS
TT-R	01.00-12.08	3	30	M6 001	YT4L-4; YT4L-BS
TW/ YBR	01.99-12.06	6	50	M6 006	YTX7L-4; YTX7L-BS
TZ/ TZR	01.87→	5	30	M4 F18'	12N5-3B; YB5L-B
Vity	01.08→	8	80	M6 010	YTX9-4; YTX9-BS
XC Cygnus	01.94-12.03	6	50	M6 006	YTX7L-4; YTX7L-BS
XN Teo's	01.00-12.03	7	40	M4 F21'	12N7-3B; YB7L-B
XV Virago	01.97-12.01	11	90	M4 F28'	12N10-3A; "-3A-1; "-3A-2; YB10L-A2
XVS Dragstar	01.00-12.04	7	40	M4 F21'	12N7-3B; YB7L-B
YP R Majesty	01.95-12.02	8	80	M6 010	YTX9-4; YTX9-BS
YZF-R	01.08→	6	40	M4 F19'	12N5.5-3B
135 cc					
RX-Z	01.92→	5	30	M4 F18'	12N5-3B; YB5L-B
200 cc					
DT R, WR	01.84-12.00	3	10	M4 F16'	YB3L-B

		0 092 ...0				0 092 ...0					
		Ah		A (EN)	M6	M6	Ah		A (EN)	M4	M4
250 cc											
FZR	01.87-12.97						11	90		M4 F28'	12N10-3A; "-3A-1; "-3A-2; YB10L-A2
RD LC	01.81-12.86						6	40		M4 F19'	12N5.5-3B
SR	01.92-12.00						12	120		M4 F30'	12N12A-4A-1; YB12A-A
SRV	01.92-12.02	6	50		M6 007	YTX7A-4; YTX7A-BS					
TDR 250	01.88-12.92						5	30		M4 F18'	12N5-3B; YB5L-B
TT R	01.92-12.06						5	30		M4 F18'	12N5-3B; YB5L-B
TZR	01.86-12.92						5	30		M4 F18'	12N5-3B; YB5L-B
	01.91-12.96						12	120		M4 F30'	12N12A-4A-1; YB12A-A
WR F	01.01→	4	30		M6 004	YTX5L-4; YTX5L-BS					
XG Tricker	01.05-12.06	6	50		M6 006	YTX7L-4; YTX7L-BS					
X-Max	01.05-12.06	7	120		M6 008	YT7B-4; YT7B-BS					
XS	01.77-12.85						12	120		M4 F30'	12N12A-4A-1; YB12A-A
XV F	01.94-12.94						11	90		M4 F28'	12N10-3A; "-3A-1; "-3A-2; YB10L-A2
L	01.93-12.00						11	90		M4 F28'	12N10-3A; "-3A-1; "-3A-2; YB10L-A2
Route 66, S Virago	01.89-12.00						11	90		M4 F28'	12N10-3A; "-3A-1; "-3A-2; YB10L-A2
Virago	01.89-12.96						11	90		M4 F28'	12N10-3A; "-3A-1; "-3A-2; YB10L-A2
YP Majesty	01.95-12.03	7	120		M6 008	YT7B-4; YT7B-BS					
260 cc											
Versity 300	01.03-12.06	8	80		M6 010	YTX9-4; YTX9-BS					
350 cc											
RD 350	01.85-12.94						5	30		M4 F18'	12N5-3B; YB5L-B
F	01.85-12.95						5	30		M4 F18'	12N5-3B; YB5L-B
LC	01.80-12.85						6	40		M4 F19'	12N5.5-3B
R	01.85-12.95						5	30		M4 F18'	12N5-3B; YB5L-B
RZ 350	01.84-12.85						6	40		M4 F19'	12N5.5-3B
400 cc											
FZR	01.86-12.95	8	80		M6 010	YTX9-4; YTX9-BS					
SP	04.87-12.90	8	80		M6 010	YTX9-4; YTX9-BS					
	04.91-12.93	8	80		M6 010	YTX9-4; YTX9-BS					
SRX	01.86-12.96						5	30		M4 F18'	12N5-3B; YB5L-B
WR F	01.98-12.02	6	50		M6 006	YTX7L-4; YTX7L-BS					
XS DOHC	01.82-12.90						12	120		M4 F30'	12N12A-4A-1; YB12A-A
XV	01.83-12.91						12	120		M4 F32'	YB12AL-A; YB12AL-A2
450 cc											
WR 426 F	01.01-12.02	6	50		M6 006	YTX7L-4; YTX7L-BS					
WR 450 F	01.03→	4	30		M6 004	YTX5L-4; YTX5L-BS					
500 cc											
FZR	01.89-12.99						12	120		M4 F32'	YB12AL-A; YB12AL-A2
RD LC	01.84-12.87						6	40		M4 F19'	12N5.5-3B
SR	01.78-12.99						7	40		M4 F21'	12N7-3B; YB7L-B
T-Max	01.01-12.02	9	80		M6 013	YT9B-4; YT9B-BS					
XT	01.86-12.89	8	80		M6 010	YTX9-4; YTX9-BS					
XV SE, Virago	01.83-12.97						12	120		M4 F30'	12N12A-4A-1; YB12A-A
535 cc											
XV Virago	01.87-12.03						12	120		M4 F32'	YB12AL-A; YB12AL-A2
550 cc											
XZ Vision	01.82-12.85						14	140		M4 F34'	12N14-3A; YB14L-A2
600 cc											
FJ/FZ	01.85-12.89						12	120		M4 F30'	12N12A-4A-1; YB12A-A
FZ 6/ FZS Fazer, Fazer S2	01.98→	12	190		M6 019	YT12B-4; YT12B-BS					
FZR	01.89-12.99						12	120		M4 F32'	YB12AL-A; YB12AL-A2
FZR/ YZF R, R Thundercat	01.94-12.03	10	90		M6 014	YTX12-4; YTX12-BS					
SRX/ XT	01.86-12.95						5	30		M4 F18'	12N5-3B; YB5L-B
TT RE	01.03-12.07	9	80		M6 013	YT9B-4; YT9B-BS					
S	01.93-12.97	3	30		M6 001	YT4L-4; YT4L-BS					
TT/ XT E	01.93-12.05	8	80		M6 010	YTX9-4; YTX9-BS					



		0 092 ...0				0 092 ...0			
		Ah	A (EN)	M6	JS	Ah	A (EN)	M4	JS
◀ YAMAHA									
XJ	01.84-12.91					12	120	M4 F30*	12N12A-4A-1; YB12A-A
	01.92-12.03	8	80	M6 010	YTX9-4; YTX9-BS				
XJ6	01.09→	12	190	M6 019	YT12B-4; YT12B-BS				
XT K	01.91-12.95	8	80	M6 010	YTX9-4; YTX9-BS				
Z Tenere	01.85-12.91					12	120	M4 F32*	YB12AL-A; YB12AL-A2
YX Radian	01.86-12.90					12	120	M4 F30*	12N12A-4A-1; YB12A-A
YZF R6	01.99-12.02	9	80	M6 013	YT9B-4; YT9B-BS				
	01.08→	8	150	M6 011	YTZ10S-4; YTZ10S-BS				
650 cc									
XJ	01.80-12.85					12	120	M4 F30*	12N12A-4A-1; YB12A-A
XVS Drag Star	01.98-12.08	12	190	M6 019	YT12B-4; YT12B-BS				
660 cc									
MT-03/XT, 660	01.04→	9	80	M6 013	YT9B-4; YT9B-BS				
SZR/XTZ, 660	01.91-12.01	8	80	M6 010	YTX9-4; YTX9-BS				
700 cc									
XJ	01.85-12.88					14	140	M4 F34*	12N14-3A; YB14L-A2
750 cc									
FZ	01.85-12.94					14	140	M4 F34*	12N14-3A; YB14L-A2
FZR	01.88-12.92	8	80	M6 010	YTX9-4; YTX9-BS	14	140	M4 F34*	12N14-3A; YB14L-A2
FZX/XJ/XTZ	01.82-12.97					14	140	M4 F34*	12N14-3A; YB14L-A2
XJ Seca	01.82-12.85					14	140	M4 F34*	12N14-3A; YB14L-A2
XV	01.81-12.97					16	120	M4 F40*	YB16AL-A2
YZF	01.93-12.98	10	90	M6 014	YTX12-4; YTX12-BS				
R7	01.99-12.03	9	80	M6 013	YT9B-4; YT9B-BS				
800 cc									
FZ8 Fazer	01.10→	8	150	M6 011	YTZ10S-4; YTZ10S-BS				
850 cc									
TDM/TRX	01.91-12.03	10	90	M6 014	YTX12-4; YTX12-BS				
900 cc									
TDM	01.02→	12	190	M6 019	YT12B-4; YT12B-BS				
XJ	01.85-12.94					14	140	M4 F34*	12N14-3A; YB14L-A2
S Diversion	01.95-12.03	12	100	M6 018	YTX14-4; YTX14-BS				
950 cc									
XVS A Midnight Star	01.09→	11	230	M6 017	YTZ14S-4; YTZ14S-BS				
1000 cc									
FZR Exup	01.89-01.90					14	140	M4 F34*	12N14-3A; YB14L-A2
	01.91-12.95	12	100	M6 018	YTX14-4; YTX14-BS				
Genesis	01.87-12.88					14	140	M4 F34*	12N14-3A; YB14L-A2
FZR/ GTS	01.92-12.99	12	100	M6 018	YTX14-4; YTX14-BS				
FZS Fazer	01.01-12.07	12	130	M6 020	YT14B-4; YT14B-BS				
FZ1 Fazer	01.06→	11	230	M6 017	YTZ14S-4; YTZ14S-BS				
XV A2	01.81-12.89					20	200	M4 F47*	Y50-N18L-A; Y50N18L-
YZF R Thunderace	01.96-12.03	12	100	M6 018	YTX14-4; YTX14-BS				
YZF-R1	01.98-12.03	12	190	M6 019	YT12B-4; YT12B-BS				
	01.04→	8	150	M6 011	YTZ10S-4; YTZ10S-BS				
1100 cc									
BT Bulldog	01.02-12.06	12	130	M6 020	YT14B-4; YT14B-BS				
FJ	01.84-12.85					14	140	M4 F34*	12N14-3A; YB14L-A2
XVS	01.99-12.08	12	130	M6 020	YT14B-4; YT14B-BS				
1200 cc									
FJ	01.86-12.90					14	140	M4 F34*	12N14-3A; YB14L-A2
	01.91-12.97	12	100	M6 018	YTX14-4; YTX14-BS				
VMX V-Max	01.85-12.03					16	120	M4 F40*	YB16AL-A2
XJR	01.95-12.99	12	100	M6 018	YTX14-4; YTX14-BS				
XT Z Super Tenere	01.10→	11	230	M6 017	YTZ14S-4; YTZ14S-BS				
1300 cc									
FJR	01.01→	12	130	M6 020	YT14B-4; YT14B-BS				
XJR	01.99-12.06	12	130	M6 020	YT14B-4; YT14B-BS				
	01.07→	11	230	M6 017	YTZ14S-4; YTZ14S-BS				
XVS A Midnight Star	01.07→	18	260	M6 023	YTX20L-4; YTX20L-BS				
XVZ	01.89-12.98	18	260	M6 023	YTX20L-4; YTX20L-BS				
TF Royal Star Venture	01.99-12.01	18	260	M6 023	YTX20L-4; YTX20L-BS				

			Ah A (EN)			Ah A (EN)		
0 092 ...0					0 092 ...0			

1600 cc					
Road Star/ XV A Silverado, A	01.99→	18	260	M6 023	YTX20L-4; YTX20L-BS
Wild Star, Warrior					
1700 cc					
MT-01/ XV , Road Star Warrior	01.03→	12	130	M6 020	YT14B-4; YT14B-BS
VMX V-Max	01.09→	11	230	M6 017	YTZ14S-4; YTX14S-BS
1900 cc					
XV Midnight Star	01.06→	12	130	M6 020	YT14B-4; YT14B-BS



de

Gegenüberstellung

Benutzerhinweise

Im nachfolgenden Katalogteil sind Bestellnummern von Herstellern anderer Marken, für die es einbaugleiche Bosch-Erzeugnisse oder -Teile gibt, aufgeführt. Da die verschiedenartigsten Bezeichnungssysteme angewendet werden, konnten die fremden Bestellnummern nur in einer einheitlichen, alphanumerischen Sortierfolge geordnet werden. Sie weicht bei einigen Herstellern von der dort üblichen Sortierfolge ab.

„Werden Bosch-Teile mit Teilenummern versehen, sind aus wettbewerbsrechtlichen Gründen in jedem Fall die jeweiligen Bosch-Teilenummern zu verwenden und als solche kenntlich zu machen. Daneben können auch fremde Teilenummern verwendet werden, um die technische bzw. funktionale Gleichwertigkeit der jeweiligen Produkte zum Ausdruck zu bringen. Ggf. sollten nach Möglichkeit fremde Teilenummern sogleich mehrerer Hersteller aufgeführt werden.“

Eine fremde Teilenummer ist dabei eindeutig als solche eines anderen Herstellers kenntlich zu machen, wie insbesondere durch gleichzeitige Nennung des fremden Herstellers bzw. der fremden Marke sowie deren eindeutige Zuordnung zu der fremden Teilenummer.

Alle Angaben dürfen nur in Standard-Schrift erfolgen. Insbesondere dürfen keine Logos oder besondere Schriftzüge der fremden Hersteller verwendet und ihre Marken bzw. Namen auch sonst nicht besonders hervorgehoben werden.

Vielmehr sollte die Nennung fremder Namen, Marken und Teilenummern generell möglichst unauffällig erfolgen.“

en

Cross-reference

Notes for users

The following catalog section lists part numbers of non-Bosch equipment for which there are interchangeable Bosch products or components available. Since a wide range of different designation systems are used, we were forced to arrange the non-Bosch part numbers in a uniform alphanumerical order. This differs from the customary order employed by some manufacturers.

“If part numbers are assigned to Bosch parts, the corresponding Bosch part numbers are always to be used and clearly identified as such to satisfy the law on competition. Use can additionally be made of non-Bosch part numbers to express the equivalent technical and functional properties of the products concerned.

If applicable, the non-Bosch part numbers of several manufacturers should be listed wherever possible. When doing so, a non-Bosch part number is to be clearly identified as that of another manufacturer, in particular by naming the other manufacturer or the non-Bosch make and clearly assigning this to the non-Bosch part number.

All such information must always be given in standard typeface. In particular, use is not to be made of any logos or special emblems of other manufacturers and their brands and names are not to be specially highlighted in any other way.

On the contrary, mention should only be made of non-Bosch names, makes and part numbers as inconspicuously as possible.”

fr

Table de correspondance

A l'attention de l'utilisateur

Cette section du catalogue reprend les références des fabricants d'autres marques pour lesquelles il existe des produits ou des composants Bosch de montage identique. De multiples systèmes de codage étant utilisés, les références des produits d'autres marques ne peuvent être reprises que suivant un classement alphanumérique uniforme. Pour certains fabricants, ce classement peut différer de celui qu'ils utilisent habituellement.

«Si des pièces Bosch sont munies de références, pour des raisons liées à la législation sur la concurrence, les références Bosch correspondantes doivent être utilisées dans tous les cas et être rendues identifiables comme telles. Parallèlement, des références étrangères peuvent également être utilisées pour exprimer l'équivalence technique ou fonctionnelle des produits considérés.

Le cas échéant, indiquer si possible conjointement les références étrangères de plusieurs fabricants.

Une référence étrangère doit être identifiée clairement comme étant celle d'un autre fabricant, notamment par l'indication simultanée de l'autre fabricant ou de l'autre marque, de même que par leur correspondance claire à la référence étrangère.

Toutes les indications doivent être effectuées dans la police standard. Aucun logo ou monogramme particulier des fabricants étrangers ne doit en particulier être utilisé et leurs marques ou noms ne doivent être mis en valeur d'aucune autre façon.

Au contraire, les noms, marques et références étrangers doivent, d'une manière générale, être cités de façon aussi discrète que possible.»

it

Comparazione

Avvertenze per la consultazione

Nella seguente parte del catalogo vengono riportati i numeri di ordinazione di costruttori di prodotti d'altra marca, per i quali sono disponibili prodotti o parti di prodotti Bosch di corrispondente applicazione. Dato che vengono utilizzati i più diversi sistemi di denominazione, si è potuto ordinare i numeri di ordinazione di altra marca solo in una sequenza di classificazione unitaria ed alfanumerica. Per alcune case costruttrici si differenzia perciò dalla sequenza di classificazione normalmente usata. In questo confronto le sigle Bosch vanno considerate come dati indicativi.

«Qualora componenti Bosch vengano correati di codici, per motivi legati alle leggi che regolano la concorrenza si devono utilizzare in ogni caso i relativi codici Bosch evidenziandoli come tali. L'utilizzo di codici di altra marca è comunque possibile per esprimere una equivalenza tecnica o funzionale dei relativi prodotti.

Possibilmente è da privilegiare l'indicazione contemporanea di codici di diversi costruttori.

Un codice che non sia Bosch va evidenziato in modo univoco in tal senso, in particolare nominando contestualmente il costruttore o la marca di appartenenza. Tutte le indicazioni devono essere riportate ricorrendo a caratteri standard. In particolare non si devono utilizzare loghi o scritte particolari usati dai costruttori di prodotti di altra marca né si devono mettere in risalto i relativi marchi o nomi.

Al contrario, l'indicazione di nomi, marche e codici diversi da Bosch dovrebbe essere in genere quanto più discreta possibile.»

es

Equivalencias

Indicaciones para el usuario

A continuación se han relacionado números de pedido de fabricantes de otras marcas para los que existen productos o piezas Bosch de iguales características. Dado que se utilizan los más diversos sistemas de designación, los números de pedido ajenos han podido relacionarse tan sólo en un orden unificado, alfanumérico. En el caso de algunos fabricantes, el orden de esta clasificación difiere del que utilizan habitualmente.

«Si piezas Bosch se dotan de números de pieza, por motivos de índole legal relativos a la competencia se deben utilizar en cualquier caso los respectivos números de pieza Bosch, identificándolos como tales debidamente. Paralelamente se pueden usar también números de pieza ajenos para poner de manifiesto la equivalencia técnica o funcional de los respectivos productos.

En su caso y en la medida de lo posible, se deberían citar al mismo tiempo números de pieza ajenos de varios fabricantes. Un número de pieza ajeno se debe identificar en estos casos claramente como perteneciente a otro fabricante, por ejemplo citando simultáneamente al fabricante ajeno o la marca ajena así como estableciendo la correspondencia de éstos con el número de pieza ajeno.

Todos los datos se deben escribir solo con letra estándar. En particular, no se permite utilizar logotipos o caracteres gráficos propios de los fabricantes ajenos, ni tampoco destacar sus marcas y nombres de manera especial.

Por el contrario, los nombres, las marcas y los números de piezas de empresas ajenas se deberían citar, en general, de la forma más discreta posible.»

pt

Comparação

Instruções para o utilizador

Na parte do catálogo que se segue, apresentam-se os números de referência de fabricantes de outras marcas e, em alguns casos, de fabricantes de veículos, para as quais existem produtos ou peças equivalentes aos da Bosch.

Sendo os sistemas de designação dos mais variados tipos, os números de referência de fabricantes externos só puderam ser catalogados numa sequência alfanumérica única. Esta desvia-se da sequência de catalogação normalmente utilizada por alguns fabricantes.

«Se as peças Bosch estiverem identificadas com um número de peça, devem ser usados sempre os respectivos números de peça Bosch e ser identificados como tal, por motivos relacionados com a lei da concorrência. Podem ser usados adicionalmente números de peça de terceiros para destacar a equivalência técnica ou funcional dos respectivos produtos.

Se necessário, e consoante a possibilidade, deveriam ser indicados os números de peça de terceiros de vários fabricantes em simultâneo.

Contudo, um número de peça de terceiros deve ser claramente identificado como sendo de outro fabricante, nomeando tanto o outro fabricante ou a outra marca, como a respectiva atribuição inequívoca do número de peça de terceiros. Todas as indicações têm de ser expressas em letra standard. Não podem, sobretudo, ser usados quaisquer logótipos ou inscrições especiais de outros fabricantes, nem ser destacada, de modo algum, a marca ou o nome.

Por norma, é desejável que a menção de nomes, marcas e números de peça de terceiros seja feita da forma menos visível possível.»

sv

Jämförelse

Bruksanvisning

I efterföljande katalogdel ingår artikelnummer på de produkter av annan tillverkning, för vilka utbytbara Boschprodukter eller delar finns. Eftersom olika beteckningssystem används, har de främmande artikelnumren endast kunnat sorteras i en enhetlig, alfanumerisk följd, som avviker från sedvanlig sorteringsföljd när det gäller en del tillverkare.

»Om Bosch reservdelar förses med reservdelsnummer ska av konkurrensrättsliga skäl alltid respektive Bosch-reservdelsnummer användas och kännetecknas som sådant. Därutöver kan även främmande reservdelsnummer användas, för att markera att teknisk resp. funktionell likvärdighet består med respektive produkt. Om möjligt bör samtidigt främmande reservdelsnummer för flera tillverkare anges.

Därvid ska det entydigt framgå att det främmande reservdelsnumret härrör från en annan tillverkare, genom att framför allt den främmande tillverkaren eller det främmande märket samtidigt nämns samt dess entydiga allokering till det främmande reservdelsnumret.

Alla angivelser får bara göras med standardskrift. I synnerhet får inga logotypen eller speciella fonter från den främmande tillverkaren användas och inte heller dess märke eller namn speciellt framhållas. Tvärtom ska främmande namn, märke och reservdelsnummer generellt sett användas så diskret som möjligt.»

pl

Zamienniki

Wskazówki dla użytkownika

W następnej części katalogu podane są numery katalogowe producentów innych marek, dla których istnieją zamienniki produkty lub części firmy Bosch. Ponieważ stosowane są bardzo różne systemy nazewnictwa, numery katalogowe innych firm podane są jedynie w jednolitej kolejności alfanumerycznej. W przypadku niektórych producentów odbiega ona od stosowanej przez nich kolejności sortowania.

„Jeśli części Bosch będą miały numery katalogowe, to ze względu na przepisy dotyczące konkurencji, w każdym przypadku należy użyć poszczególnych numerów katalogowych Bosch i wyraźnie je tak oznaczyć. Ponadto można użyć obcych numerów katalogowych, aby zademonstrować techniczną lub funkcjonalną jednorodność z poszczególnymi produktami.

Ewentualnie w razie możliwości można wymienić jednocześnie obce numery katalogowe kilku innych producentów. Obcy numery katalogowych musi zostać wyraźnie oznaczony jako dotyczący innego producenta, a w szczególności poprzez jednoczesne wymienienie innego producenta lub innej marki oraz ich jednoznaczne przyporządkowanie do obcego numera katalogowego.

Wszystkie informacje muszą być sporządzone w standardowym sposobie zapisu. W szczególności nie można używać żadnych logotypów ani specjalnych napisów innych producentów, a ich marki lub nazwy nie mogą być wyróżnione w specjalny sposób.

Wymienienie obcych nazw, marek i numerów katalogowych powinno raczej zasadniczo nastąpić w sposób jak najmniej widoczny“.

cs

Převod

Pokyny pro uživatele

V následujícím dílu katalogu jsou uvedena objednávací čísla výrobců jiných značek, pro něž existují montážně shodné výrobky nebo díly Bosch. Protože se používají nejrozličnější systémy označování, mohou být cizí objednávací čísla uspořádána jen v jednotné, alfa-numerické posloupnosti třídění. U některých výrobců se mohou vyskytovat odchylky od zde používané běžné posloupnosti třídění.

„Jestliže jsou díly Bosch opatřeny číslem dílu, je z konkurenčně legálních důvodů v každém případě nutno používat čísla dílů Bosch a jako takové je označovat. Kromě toho mohou být používána také cizí čísla dílů, aby se vyjádřila technická popř. funkční ekvivalence příslušného produktu. Podle možnosti měla být případně uváděna cizí čísla dílů hned několika výrobců.

Cizí číslo dílu jiného výrobce je přitom jako takové třeba jednoznačně označit, zejména současným pojmenováním cizího výrobce popř. cizí značky a uvádět rovněž jejich jednoznačné přiřazení k cizímu číslu dílu. Všechny údaje smí být uváděny jen standardním písmem. Zejména se nesmí používat žádná loga nebo zvláštní nápisy cizích výrobců, a jejich značky popř. jména také nesmí nijak zvlášť zvýrazňovat. Spíše by měla být pojmenování cizími názvy, značkami a čísly dílů obecně pokud možno nenápadná.“

ru

Сопоставления

Вниманию пользователей

В следующей части каталога приводятся номера для заказов производителей других марок, для которых имеются идентичные изделия или запчасти компании Bosch. Поскольку используются различные системы обозначений, номера заказов других производителей располагаются в едином алфавитно-цифровом порядке. Для некоторых производителей они отличаются от используемого у них порядка классификации.

«Если изделия Bosch имеют номера деталей, то по причинам законодательных положений в области конкуренции в любом случае необходимо использовать соответствующие номера Bosch и показывать их. Кроме того, можно использовать также номера деталей других производителей, чтобы показать техническую и функциональную равноценность соответствующих изделий.

В отдельных случаях необходимо по возможности указывать номера деталей нескольких производителей.

Номер детали другого производителя явно показывать как таковой, например, одновременно называя другого производителя или другую марку, а также их однозначное отношение к номеру детали другого производителя. Все данные должны указываться стандартным шрифтом. В особенности, не разрешается использовать логотипы и специальные надписи других производителей и особым образом выделять их марки и названия.

Напротив, названия, марки и номера деталей других производителей всегда необходимо указывать по возможности неброско.»

AAA

132925	0 092 T30 610	T3 061
160920	0 092 T30 630	T3 063
3 P 8 S	0 092 T30 610	T3 061

320844 P	0 092 S40 050	S4 005
320844 P	0 092 S50 050	S5 005
450888 P	0 092 S40 080	S4 008
545847 L	0 092 S30 160	S3 016
545848 LG	0 092 S30 170	S3 017

545863 LNG	0 092 S40 220	S4 022
550838 L	0 092 S40 040	S4 004
550838 L	0 092 S50 010	S5 001
555881 LG	0 092 S30 030	S3 003
555892 L	0 092 S30 020	S3 002

560883 LG	0 092 S30 060	S3 006
560894 L	0 092 S30 050	S3 005
560896 LF	0 092 S50 040	S5 004
580822 LG	0 092 S40 270	S4 027
580860 L	0 092 S40 080	S4 008

6HP4S	0 092 S30 160	S3 016
6PE4PE	0 092 S40 270	S4 027
6PR4D	0 092 S30 160	S3 016
6PV5	0 092 S40 260	S4 026
6P4PE	0 092 S40 250	S4 025

6RP4	0 092 S30 170	S3 017
600922 S	0 092 S40 290	S4 029
600948 V	0 092 S40 280	S4 028
610931 V	0 092 T30 380	T3 038
620932 V	0 092 T30 390	T3 039

620935 V	0 092 T40 750	T4 075
620935 V	0 092 T50 750	T5 075
625952	0 092 T30 400	T3 040
632934 V	0 092 T30 460	T3 046
655927 V	0 092 T30 770	T3 077

655927 V	0 092 T40 770	T4 077
720937 V	0 092 T30 800	T3 080

AC DELCO

M100H3	0 092 S50 130	S5 013
M36T7	0 092 S30 010	S3 001
M44H3	0 092 S30 020	S3 002

M44H3R	0 092 S30 030	S3 003
M44T7	0 092 S40 010	S4 001
M50T7	0 092 S40 040	S4 004
M55H3	0 092 S30 050	S3 005
M55H3R	0 092 S30 060	S3 006

M55T3F	0 092 S40 040	S4 004
M55T7	0 092 S40 040	S4 004
M60H3	0 092 S40 050	S4 005
M60T7	0 092 S50 040	S5 004
M66H3	0 092 S40 080	S4 008

M66H3R	0 092 S40 090	S4 009
M66T7	0 092 S30 070	S3 007
M72H3	0 092 S40 080	S4 008
M85T7	0 092 S30 120	S3 012
M88H3	0 092 S30 130	S3 013

M92H3	0 092 S30 130	S3 013
100K1	0 092 S40 280	S4 028
102-D0	0 092 T30 350	T3 035
102-D0R	0 092 T30 360	T3 036
120-A0R	0 092 T30 750	T3 075

120-A0R	0 092 T40 750	T4 075
140-A0R	0 092 T40 750	T4 075
160-B0R	0 092 T30 770	T3 077
160-B3	0 092 T30 790	T3 079
180-B0R	0 092 T40 770	T4 077

180-B0R	0 092 T50 770	T5 077
180-B3	0 092 T30 790	T3 079
2055	0 092 S30 050	S3 005
2060V	0 092 S40 050	S4 005
2060V	0 092 S50 050	S5 005

2066	0 092 S40 080	S4 008
2066	0 092 T30 080	T3 008
2072	0 092 S40 080	S4 008
2088	0 092 S40 130	S4 013
2088	0 092 T30 130	T3 013

2090V	0 092 S40 130	S4 013
2092	0 092 S40 130	S4 013
210-C0R	0 092 T30 800	T3 080
210-C0R	0 092 T50 800	T5 080
2340	0 092 S30 160	S3 016

2345	0 092 S30 160	S3 016
24 110 N	0 092 T30 350	T3 035
2535J	0 092 S40 180	S4 018
2545	0 092 S40 210	S4 021
2665	0 092 S40 240	S4 024

2670	0 092 S40 260	S4 026
27100	0 092 S50 130	S5 013
2744	0 092 S40 010	S4 001
2760P	0 092 S50 040	S5 004
2764	0 092 S50 040	S5 004

2770P	0 092 S40 070	S4 007
2785	0 092 S30 120	S3 012
2790P	0 092 S30 120	S3 012
29 125 N	0 092 T30 400	T3 040
3060	0 092 S40 050	S4 005

3060	0 092 S50 050	S5 005
3066	0 092 S40 090	S4 009
3070V	0 092 S40 090	S4 009
3072	0 092 S40 090	S4 009
3345	0 092 S30 170	S3 017

3535J	0 092 S40 190	S4 019
3545	0 092 S40 230	S4 023
3545J	0 092 S40 220	S4 022
3665	0 092 S40 250	S4 025
3670	0 092 S40 270	S4 027

3680	0 092 S40 290	S4 029
45E1	0 092 S30 160	S3 016
45E1R	0 092 S30 170	S3 017
4750P	0 092 S40 040	S4 004
4755	0 092 S40 040	S4 004

4760P	0 092 S50 040	S5 004
4764	0 092 S50 040	S5 004
60G6R	0 092 S40 270	S4 027
70G6	0 092 S40 260	S4 026
70G6R	0 092 S40 270	S4 027

72 110	0 092 T30 380	T3 038
72 120	0 092 T30 380	T3 038
72 143	0 092 T30 470	T3 047
79 120 N	0 092 T30 750	T3 075
79 120 N	0 092 T40 750	T4 075

79 135 N	0 092 T50 750	T5 075
79 143 N	0 092 T30 770	T3 077
79 143 N	0 092 T40 770	T4 077
79 165 N	0 092 T40 770	T4 077
79 200 N	0 092 T30 800	T3 080

89 110	0 092 T30 390	T3 039
--------	---------------	---------------

AGRIA

029 560	0 092 M4F 100	M4 F10
029 560	0 092 M40 100	M4 010
558 67	0 092 M4F 540	M4 F54

558 67	0 092 M40 540	M4 054
--------	---------------	---------------

AKKUBAT

260038	0 092 S60 050	S6 005
270037	0 092 S60 080	S6 008
290035	0 092 S60 130	S6 013

535112	0 092 S40 180	S4 018
535136	0 092 S40 190	S4 019
536157	0 092 S30 010	S3 001
540215	0 092 S40 000	S4 000
545052	0 092 S30 160	S3 016

545076	0 092 S30 170	S3 017
545234	0 092 S40 210	S4 021
545258	0 092 S40 220	S4 022
545258	0 092 S40 230	S4 023
545593	0 092 S40 010	S4 001

545630	0 092 S30 020	S3 002
545654	0 092 S30 030	S3 003
550351	0 092 S50 010	S5 001
555257	0 092 S30 050	S3 005
555271	0 092 S30 060	S3 006

555419	0 092 S50 020	S5 002
560091	0 092 S40 240	S4 024
560114	0 092 S40 250	S4 025
560374	0 092 S50 040	S5 004
563115	0 092 S40 050	S4 005

566154	0 092 S30 070	S3 007
575194	0 092 S40 080	S4 008
575231	0 092 S40 090	S4 009
585018	0 092 S30 120	S3 012
588118	0 092 S30 130	S3 013

600315	0 092 S50 130	S5 013
620078	0 092 T30 390	T3 039
625059	0 092 T30 460	T3 046
645057	0 092 T30 770	T3 077
665017	0 092 T40 770	T4 077

665055	0 092 T40 780	T4 078
665079	0 092 T30 790	T3 079
700213	0 092 T30 800	T3 080
710014	0 092 T30 810	T3 081
730012	0 092 T50 800	T5 080

ALFA ROMEO

46214085	0 092 S30 020	S3 002
46227867	0 092 S40 050	S4 005
46227867	0 092 S50 050	S5 005

46227869	0 092 S40 080	S4 008
46227870	0 092 S40 090	S4 009
46227873	0 092 S40 080	S4 008
46227876	0 092 S30 020	S3 002
46227877	0 092 S40 070	S4 007

46227895	0 092 S50 130	S5 013
50500212	0 092 S40 020	S4 002

ASTON MARTIN

LRA1250AA	0 092 S50 130	S5 013
XR8310655AA	0 092 S50 130	S5 013
2R8310655AA	0 092 S50 130	S5 013

AUDI

YT12B-BS	0 092 M60 190	M6 019
000 915 105 AH	0 092 S50 130	S5 013
000 915 105 AK	0 092 S50 150	S5 015

000 915 105 CE	0 092 S60 020	S6 002
000 915 105 CE	0 092 S60 130	S6 013
1J0 915 105	0 092 S40 020	S4 002
1J0 915 105 A	0 092 S50 050	S5 005
1J0 915 105 AC	0 092 S50 050	S5 005

1J0 915 105 AG	0 092 S40 100	S4 010
1J0 915 105 D	0 092 S40 020	S4 002
3D0 915 105	0 092 S60 010	S6 001
3D0 915 105	0 092 S60 080	S6 008
3D0 915 105 A	0 092 S60 020	S6 002

3D0 915 105 A	0 092 S60 130	S6 013
3D0 915 105 C	0 092 S50 010	S5 001
4A0 915 105 A	0 092 S40 040	S4 004
4A0 915 105 B	0 092 S50 070	S5 007
4A0 915 105 C	0 092 S50 070	S5 007

4A0 915 105 D	0 092 S50 070	S5 007
4A0 915 105 E	0 092 S50 070	S5 007
4A0 915 105 F	0 092 S50 070	S5 007
4D0 915 105 C	0 092 S50 150	S5 015
4E0 915 105	0 092 S50 130	S5 013

4E0 915 105	0 092 S50 150	S5 015
4E0 915 105 A	0 092 S50 150	S5 015
4F0 915 105 A	0 092 S30 080	S3 008
4F0 915 105 A	0 092 S40 080	S4 008
4F0 915 105 B	0 092 S50 100	S5 010

4F0 915 105 C	0 092 S50 130	S5 013
4F0 915 105 D	0 092 S50 150	S5 015
4F0 915 105 E	0 092 S60 020	S6 002
4F0 915 105 E	0 092 S60 130	S6 013
441 915 105	0 092 S50 130	S5 013

441 915 105 A	0 092 S50 130	S5 013
8A0 915 105	0 092 S30 010	S3 001
8A0 915 105 A	0 092 S40 010	S4 001
8D0 915 105	0 092 S30 010	S3 001
8D0 915 105 A	0 092 S40 020	S4 002

8D0 915 105 B	0 092 S50 050	S5 005
8D0 915 105 C	0 092 S50 100	S5 010
8D0 915 105 D	0 092 S50 100	S5 010
8D0 915 105 F	0 092 S40 020	S4 002
8D0 915 105 G	0 092 S50 050	S5 005

8D0 915 105 H	0 092 S50 100	S5 010
8E0 915 105	0 092 S30 020	S3 002
8E0 915 105 A	0 092 S40 050	S4 005
8E0 915 105 A	0 092 S50 050	S5 005
8E0 915 105 B	0 092 S40 080	S4 008

8E0 915 105 D	0 092 S40 100	S4 010
8E0 915 105 D	0 092 S50 100	S5 010
8E0 915 105 D	0 092 S50 130	S5 013
8E0 915 105 G	0 092 S40 050	S4 005
8E0 915 105 G	0 092 S50 050	S5 005

8E0 915 105 H	0 092 S40 080	S4 008
8E0 915 105 K	0 092 S50 130	S5 013
8E0 915 105 L	0 092 S40 080	S4 008
8K0 915 105 C	0 092 S30 080	S3 008
8K0 915 105 C	0 092 S40 080	S4 008

8K0 915 105 D	0 092 S40 100	S4 010
8K0 915 105 D	0 092 S50 100	S5 010
8K0 915 105 E	0 092 S40 130	S4 013
8K0 915 105 E	0 092 S50 130	S5 013
8K0 915 105 E	0 092 S60 020	S6 002

8K0 915 105 E	0 092 S60 130	S6 013
8K0 915 105 F	0 092 S50 150	S5 015
8K0 915 105 G	0 092 S40 050	S4 005
8K0 915 105 G	0 092 S50 050	S5 005
8K0 915 105 H	0 092 S40 050	S4 005

8N7 915 105	0 092 S50 050	S5 005
8N7 915 105 A	0 092 S50 050	S5 005
8Z0 915 105	0 092 S50 050	S5 005
8Z0 915 105 D	0 092 S50 100	S5 010
8Z0 915 105	0 092 S40 050	S4 005

8Z0 915 105	0 092 S50 050	S5 005
-------------	---------------	---------------

AUTOPART

ARL045A-60-10C	0 092 S40 000	S4 000
ARL045G-60-10B	0 092 S40 010	S4 001
ARL048A-60-10C	0 092 S30 020	S3 002

ARL048A-61-10C	0 092 S30 030	S3 003
ARL050D-60-10C	0 092 S50 010	S5 001
ARL050G-60-10C	0 092 S40 020	S4 002
ARL055G-61-10B	0 092 S40 040	S4 004
ARL058A-60-10C	0 092 S30 050	S3 005

ARL058A-61-10C	0 092 S30 060	S3 006
ARL060D-60-10C	0 092 S40 050	S4 005
ARL060D-61-10C	0 092 S40 060	S4 006
ARL060G-60-10C	0 092 S40 050	S4 005
ARL060G-61-10C	0 092 S50 060	S5 006

ARL066A-60-10C	0 092 S50 050	S5 005
ARL075D-60-10B	0 092 S50 080	S5 008
ARL075G-60-10B	0 092 S50 080	S5 008
ARL098A-60-10C	0 092 S50 130	S5 013
ARL135A-61-10D	0 092 T30 380	T3 038

ARL145A-61-10D	0 092 T30 450	T3 045
----------------	---------------	---------------

BANNER

P40 26	0 092 S40 180	S4 018
P40 27	0 092 S40 190	S4 019
P44 09	0 092 S40 010	S4 001

P45 24	0 092 S40 220	S4 022
P50 03	0 092 S40 020	S4 002
P60 68	0 092 S40 240	S4 024
P60 69	0 092 S40 250	S4 025
P62 19	0 092 S40 040	S4 004

P70 24	0 092 S40 270	S4 027
P70 29	0 092 S40 260	S4 026
P72 09	0 092 S40 070	S4 007
P72 12	0 092 S40 080	S4 008
P80 14	0 092 S40 100	S4 010

P88 20	0 092 S30 120	S3 012
P95 04	0 092 S40 280	S4 028
P95 05	0 092 S40 290	S4 029
P95 33	0 092 S40 130	S4 013
SHD PRO 645 03	0 092 T50 750	T5 075



◀ BANNER

SHD PRO 680 08	0 092 T50 770	T5 077
SHD PRO 725 03	0 092 T50 800	T5 080
SHD 610 40	0 092 T30 380	T3 038
SHD 635 44	0 092 T30 450	T3 045
SHD 640 35	0 092 T40 750	T4 075

SHD 670 33	0 092 T30 470	T3 047
SHD 670 43	0 092 T40 770	T4 077
SHD 680 32	0 092 T50 770	T5 077
SHD 700 27	0 092 T40 800	T4 080
50 500	0 092 S50 080	S5 008

540 08	0 092 S40 000	S4 000
544 09	0 092 S30 010	S3 001
545 23	0 092 S40 210	S4 021
545 24	0 092 S40 230	S4 023
545 77	0 092 S30 160	S3 016

545 79	0 092 S30 170	S3 017
555 19	0 092 S30 040	S3 004
561 31 RF	0 092 S40 050	S4 005
570 01	0 092 S60 080	S6 008
572 09	0 092 S30 070	S3 007

572 31 RF	0 092 S30 080	S3 008
572 33	0 092 S40 090	S4 009
580 01	0 092 S60 110	S6 011
588 34 RF	0 092 S30 130	S3 013
592 01	0 092 S60 130	S6 013

600 26	0 092 T30 720	T3 072
600 35	0 092 T30 710	T3 071
610 42	0 092 S50 150	S5 015
620 34	0 092 T30 750	T3 075
625 11	0 092 T30 400	T3 040

625 13	0 092 T30 410	T3 041
670 43	0 092 T30 770	T3 077
700 27	0 092 T30 800	T3 080
725 11	0 092 T30 810	T3 081

BAROCLEM

BM 50	0 092 S40 040	S4 004
BM 50	0 092 S50 010	S5 001
BM 71	0 092 S40 070	S4 007

BM 85	0 092 S40 130	S4 013
BM 85	0 092 T30 130	T3 013
B1	0 092 S40 010	S4 001
B 101 D	0 092 S30 020	S3 002
B 101 DR	0 092 S30 020	S3 002

B 101 G	0 092 S30 030	S3 003
B 15 D	0 092 T30 430	T3 043
B 204 G	0 092 S30 030	S3 003
B 206 D	0 092 S30 050	S3 005
B 208 D	0 092 S40 050	S4 005

B 208 D	0 092 S50 050	S5 005
B 208 DR	0 092 S30 050	S3 005
B3	0 092 S30 030	S3 003
B 305 D	0 092 S40 080	S4 008
B 305 G	0 092 S40 090	S4 009

B 308 D	0 092 S40 080	S4 008
B 508 D	0 092 S40 130	S4 013
B 508 D	0 092 T30 130	T3 013
B 510 D	0 092 S50 130	S5 013
CM 11 D	0 092 S40 260	S4 026

CM 12 G	0 092 S40 290	S4 029
CM 13 D	0 092 S40 280	S4 028
C6	0 092 S40 040	S4 004
DU 10 DS	0 092 S30 020	S3 002
DU 11 FD	0 092 S30 050	S3 005

DU 11 FFD	0 092 S40 040	S4 004
DU 12 D	0 092 S40 080	S4 008
DU 12 D	0 092 T30 080	T3 008
DU 13 D	0 092 S40 130	S4 013
DU 13 D	0 092 T30 130	T3 013

DU 14 D	0 092 T30 380	T3 038
DU 14 S	0 092 T30 450	T3 045
DU 15 D	0 092 T30 470	T3 047
DU 55 D	0 092 S30 050	S3 005
DU 66 D	0 092 S40 080	S4 008

DU 66 D	0 092 T30 080	T3 008
D9	0 092 S40 050	S4 005
D9	0 092 S50 050	S5 005
E1	0 092 S40 270	S4 027
E3	0 092 S40 080	S4 008

E4	0 092 S40 070	S4 007
FD 55 D	0 092 S40 040	S4 004
FD 58 D	0 092 S50 040	S5 004
FD 60 D	0 092 S50 040	S5 004
F3	0 092 S40 130	S4 013

F3	0 092 T30 130	T3 013
H1	0 092 S50 130	S5 013
H 13 D	0 092 T30 400	T3 040
JD 4 DI	0 092 S40 180	S4 018
M 120 D	0 092 T30 300	T3 030

M 120 G	0 092 T30 310	T3 031
M 130 D	0 092 T30 350	T3 035
M 130 G	0 092 T30 360	T3 036
M 14 TG	0 092 T30 390	T3 039
M 15 D	0 092 T30 770	T3 077

M 15 D	0 092 T40 770	T4 077
M 16 D	0 092 T30 800	T3 080
M 4 D	0 092 T30 610	T3 061
M 5 D	0 092 T30 630	T3 063
NS 40 Z	0 092 S40 190	S4 019

NS 60	0 092 S40 220	S4 022
RN 103 D	0 092 S30 160	S3 016
RN 205 D	0 092 S30 160	S3 016
RN 205 G	0 092 S30 170	S3 017
RN 207 D	0 092 S30 160	S3 016

RN 207 G	0 092 S30 170	S3 017
SM 10 D	0 092 S40 260	S4 026
SM 10 G	0 092 S40 270	S4 027
SM 14 D	0 092 T30 460	T3 046
SV 14 D	0 092 T30 440	T3 044

TP 120 D	0 092 T30 750	T3 075
TP 120 D	0 092 T40 750	T4 075
TP 120 G	0 092 T30 390	T3 039
TP 135 SH	0 092 T50 750	T5 075
TP 140 D	0 092 T40 750	T4 075

TP 140 TD	0 092 T40 760	T4 076
TP 155 D	0 092 T30 770	T3 077
TP 155 D	0 092 T40 770	T4 077
TP 16 D	0 092 T30 800	T3 080
TP 170 D	0 092 T40 770	T4 077

TP 170 G	0 092 T30 790	T3 079
TP 200 D	0 092 T30 800	T3 080
55 D23 L	0 092 S40 240	S4 024
55 D23 R	0 092 S40 250	S4 025
6 TNB	0 092 T30 420	T3 042

BENTLEY

PM3 078 OPB	0 092 S50 040	S5 004
PM3 255 5PB	0 092 S50 070	S5 007
1J0 915 105 AD	0 092 S50 050	S5 005

3D0915105G	0 092 S60 020	S6 002
3D0915105G	0 092 S60 130	S6 013

BMW

61 21 1371 404	0 092 S30 020	S3 002
61 21 1371 404	0 092 S40 020	S4 002
61 21 1371 405	0 092 S30 050	S3 005

61 21 1371 405	0 092 S50 050	S5 005
61 21 1371 552	0 092 S40 040	S4 004
61 21 1371 552	0 092 S50 010	S5 001
61 21 1373 670	0 092 S40 040	S4 004
61 21 1373 670	0 092 S50 010	S5 001

61 21 1382 949	0 092 S30 120	S3 012
61 21 1459 014	0 092 M4F 410	M4 F41
61 21 1459 014	0 092 M40 410	M4 041
61 21 1459 400	0 092 M4F 540	M4 F54
61 21 1459 400	0 092 M40 540	M4 054

61 21 1459 650	0 092 M4F 520	M4 F52
61 21 1459 650	0 092 M40 520	M4 052
61 21 2306 626	0 092 M4F 450	M4 F45
61 21 2306 626	0 092 M40 450	M4 045
61 21 4141 568	0 092 S50 050	S5 005

61 21 4141 569	0 092 S50 080	S5 008
61 21 4141 570	0 092 S50 100	S5 010
61 21 6915 739	0 092 S50 130	S5 013
61 21 6915 741	0 092 S50 130	S5 013
61 21 6917 884	0 092 S50 080	S5 008

61 21 6919 342	0 092 S60 020	S6 002
61 21 6919 342	0 092 S60 130	S6 013
61 21 6924 021	0 092 S60 080	S6 008
61 21 6924 023	0 092 S60 130	S6 013
61 21 6927 452	0 092 S30 020	S3 002

61 21 6 927 453	0 092 S30 050	S3 005
61 21 6 927 453	0 092 S40 050	S4 005
61 21 6 927 453	0 092 S50 050	S5 005
61 21 6 927 454	0 092 S30 080	S3 008
61 21 6 927 454	0 092 S40 080	S4 008
61 21 7 555 285	0 092 S60 020	S6 002
61 21 7 555 285	0 092 S60 130	S6 013
61 21 7 555 719	0 092 S60 110	S6 011
61 21 7 567 386	0 092 S50 020	S5 002
61 21 7 567 388	0 092 S60 010	S6 001
61 21 7 567 388	0 092 S60 080	S6 008
61 21 7 567 390	0 092 S30 050	S3 005
61 21 7 567 391	0 092 S60 010	S6 001
61 21 7 567 391	0 092 S60 080	S6 008
61 21 7 570 682	0 092 S30 080	S3 008
61 21 7 570 682	0 092 S40 080	S4 008
61 21 7 604 809	0 092 S60 150	S6 015
61 21 8 361 186	0 092 S50 050	S5 005
61 21 8 361 187	0 092 S40 050	S4 005
61 21 8 361 187	0 092 S50 050	S5 005
61 21 8 361 192	0 092 S50 080	S5 008
61 21 8 361 193	0 092 S40 080	S4 008
61 21 8 361 193	0 092 S50 080	S5 008
61 21 8 361 194	0 092 S50 100	S5 010
61 21 8 361 195	0 092 S50 100	S5 010
61 21 8 361 199	0 092 S50 130	S5 013
61 21 8 361 200	0 092 S50 130	S5 013
61 21 8 361 201	0 092 S50 130	S5 013
61 21 8 363 889	0 092 S30 020	S3 002
61 21 8 363 890	0 092 S30 020	S3 002
61 21 8 363 890	0 092 S40 020	S4 002
61 21 8 363 893	0 092 S40 040	S4 004
61 21 8 363 893	0 092 S50 010	S5 001
61 21 8 363 894	0 092 S40 040	S4 004
61 21 8 363 894	0 092 S50 010	S5 001
61 21 8 363 895	0 092 S40 040	S4 004
61 21 8 363 895	0 092 S50 010	S5 001
61 21 8 363 895	0 092 S50 040	S5 004
61 21 8 363 896	0 092 S40 040	S4 004
61 21 8 363 896	0 092 S50 010	S5 001
61 21 8 363 896	0 092 S50 040	S5 004
61 21 8 363 901	0 092 S40 070	S4 007
61 21 8 363 902	0 092 S40 070	S4 007
61 21 8 363 903	0 092 S50 100	S5 010
61 21 8 363 904	0 092 S50 100	S5 010
61 21 8 363 905	0 092 S50 100	S5 010
61 21 8 363 906	0 092 S50 100	S5 010
61 21 8 363 909	0 092 S30 120	S3 012
61 21 8 363 910	0 092 S30 120	S3 012
61 21 8 363 911	0 092 S30 120	S3 012
61 21 8 363 912	0 092 S30 120	S3 012
61 21 8 363 913	0 092 S50 130	S5 013
61 21 8 363 914	0 092 S50 130	S5 013
61 21 8 368 536	0 092 S50 150	S5 015
61 21 8 368 537	0 092 S50 150	S5 015
61 21 8 368 554	0 092 S30 020	S3 002
61 21 8 368 555	0 092 S30 020	S3 002
61 21 8 376 036	0 092 S50 130	S5 013
61 21 8 376 380	0 092 S50 150	S5 015
61 21 8 376 383	0 092 S50 150	S5 015
61 21 8 376 384	0 092 S50 150	S5 015
61 21 8 376 449	0 092 S30 020	S3 002
61 21 8 376 449	0 092 S40 020	S4 002
61 21 8 376 450	0 092 S50 100	S5 010
61 21 8 376 451	0 092 S50 100	S5 010
61 21 8 376 453	0 092 S30 020	S3 002
61 21 8 376 453	0 092 S40 020	S4 002
61 21 8 376 456	0 092 S50 150	S5 015
61 21 8 377 034	0 092 S50 130	S5 013
61 21 8 377 036	0 092 S50 130	S5 013
61 21 8 377 120	0 092 S30 020	S3 002
61 21 8 377 120	0 092 S40 020	S4 002
61 21 8 377 121	0 092 S30 020	S3 002
61 21 8 377 123	0 092 S30 020	S3 002
61 21 8 377 123	0 092 S40 020	S4 002
61 21 8 377 127	0 092 S40 040	S4 004
61 21 8 377 127	0 092 S50 010	S5 001
61 21 8 377 127	0 092 S50 040	S5 004
61 21 8 377 128	0 092 S40 040	S4 004
61 21 8 377 128	0 092 S50 010	S5 001
61 21 8 377 131	0 092 S40 040	S4 004
61 21 8 377 131	0 092 S50 010	S5 001
61 21 8 377 131	0 092 S50 040	S5 004
61 21 8 377 132	0 092 S40 040	S4 004
61 21 8 377 132	0 092 S50 010	S5 001
61 21 8 377 135	0 092 S40 050	S4 005
61 21 8 377 135	0 092 S50 050	S5 005
61 21 8 377 136	0 092 S40 050	S4 005
61 21 8 377 136	0 092 S50 050	S5 005
61 21 8 377 139	0 092 S40 050	S4 005
61 21 8 377 139	0 092 S50 050	S5 005
61 21 8 377 140	0 092 S40 050	S4 005
61 21 8 377 140	0 092 S50 050	S5 005
61 21 8 381 708	0 092 S40 050	S4 005
61 21 8 381 708	0 092 S50 050	S5 005
61 21 8 381 709	0 092 S40 050	S4 005
61 21 8 381 709	0 092 S50 050	S5 005
61 21 8 381 711	0 092 S40 070	S4 007
61 21 8 381 714	0 092 S40 070	S4 007
61 21 8 381 717	0 092 S40 070	S4 007
61 21 8 381 726	0 092 S40 080	S4 008
61 21 8 381 726	0 092 S50 080	S5 008
61 21 8 381 727	0 092 S40 080	S4 008
61 21 8 381 730	0 092 S40 080	S4 008
61 21 8 381 731	0 092 S40 080	S4 008
61 21 8 381 734	0 092 S40 080	S4 008
61 21 8 381 734	0 092 S50 080	S5 008
61 21 8 381 735	0 092 S40 080	S4 008
61 21 8 381 740	0 092 S50 100	S5 010
61 21 8 381 741	0 092 S50 080	S5 008
61 21 8 381 742	0 092 S50 100	S5 010
61 21 8 381 743	0 092 S50 100	S5 010
61 21 8 381 744	0 092 S50 100	S5 010
61 21 8 381 745	0 092 S50 100	S5 010
61 21 8 381 746	0 092 S50 100	S5 010
61 21 8 381 747	0 092 S50 100	S5 010
61 21 8 381 748	0 092 S50 100	S5 010
61 21 8 381 751	0 092 S30 120	S3 012
61 21 8 381 752	0 092 S30 120	S3 012
61 21 8 381 754	0 092 S30 120	S3 012
61 21 8 381 755	0 092 S30 120	S3 012
61 21 8 381 757	0 092 S30 120	S3 012
61 21 8 381 764	0 092 S50 130	S5 013
61 21 8 381 765	0 092 S50 130	S5 013
61 21 8 381 768	0 092 S40 130	S4 013
61 21 8 381 769	0 092 S50 130	S5 013
61 21 8 381 772	0 092 S50 130	S5 013
61 21 8 381 773	0 092 S50 130	S5 013
61 21 8 381 775	0 092 S50 130	S5 013
61 21 8 381 776	0 092 S50 130	S5 013
61 21 8 381 777	0 092 S50 130	S5 013
61 21 8 381 780	0 092 S50 150	S5 015
61 21 8 381 782	0 092 S50 150	S5 015
61 21 8 381 785	0 092 S50 150	S5 015
61 21 9 062 491	0 092 M4F 520	M4 F52
61 21 9 062 491	0 092 M40 520	M4 052
61 21 9 069 234	0 092 S40 020	S4 002
61 21 9 069 235	0 092 S50 050	S5 005
61 21 9 069 476	0 092 S50 040	S5 004
61 21 9 069 480	0 092 S40 070	S4 007
61 21 9 069 482	0 092 S30 120	S3 012
BOSCH		
0 092 M40 040	0 092 M4F 040	M4 F04
0 092 M40 100	0 092 M4F 100	M4 F10
0 092 M40 120	0 092 M4F 120	M4 F12
0 092 M40 150	0 092 M4F 150	M4 F15
0 092 M40 160	0 092 M4F 160	M4 F16
0 092 M40 170	0 092 M4F 170	M4 F17
0 092 M40 180	0 092 M4F 180	M4 F18
0 092 M40 190	0 092 M4F 190	M4 F19
0 092 M40 200	0 092 M4F 200	M4 F20
0 092 M40 210	0 092 M4F 210	M4 F21
0 092 M40 220	0 092 M4F 220	M4 F22
0 092 M40 240	0 092 M4F 240	M4 F24
0 092 M40 250	0 092 M4F 250	M4 F25
0 092 M40 260	0 092 M4F 260	M4 F26
0 092 M40 270	0 092 M4F 270	M4 F27
0 092 M40 280	0 092 M4F 280	M4 F28
0 092 M40 290	0 092 M4F 290	M4 F29
0 092 M40 300	0 092 M4F 300	M4 F30



◀ BOSCH

0 092 M40 320	0 092 M4F 320	M4 F32
0 092 M40 330	0 092 M4F 330	M4 F33
0 092 M40 340	0 092 M4F 340	M4 F34
0 092 M40 350	0 092 M4F 350	M4 F35
0 092 M40 360	0 092 M4F 360	M4 F36

0 093 A54 0S1	0 092 S40 180	S4 018
0 093 A54 03J	0 092 S40 190	S4 019
0 093 A54 54C	0 092 S40 210	S4 021
0 093 A54 54D	0 092 S40 220	S4 022
0 093 A54 54E	0 092 S40 230	S4 023

0 093 A56 0S4	0 092 S40 240	S4 024
0 093 A56 04G	0 092 S40 260	S4 026
0 093 A56 04H	0 092 S40 270	S4 027
0 093 A56 04J	0 092 S40 250	S4 025
0 093 A57 03T	0 092 S40 260	S4 026

0 093 A57 03U	0 092 S40 270	S4 027
0 093 A59 52W	0 092 S40 280	S4 028
0 093 A59 52X	0 092 S40 290	S4 029
0 093 S53 6RV	0 092 S30 010	S3 001
0 093 S54 03K	0 092 S40 000	S4 000

0 093 S54 030	0 092 S40 000	S4 000
0 093 S54 05K	0 092 S30 010	S3 001
0 093 S54 30J	0 092 S40 010	S4 001
0 093 S54 30N	0 092 S40 010	S4 001
0 093 S54 41N	0 092 S30 020	S3 002

0 093 S54 41S	0 092 S30 030	S3 003
0 093 S54 41X	0 092 S40 010	S4 001
0 093 S54 50J	0 092 S40 010	S4 001
0 093 S54 52S	0 092 S30 160	S3 016
0 093 S54 52T	0 092 S30 170	S3 017

0 093 S54 54R	0 092 S40 010	S4 001
0 093 S54 54S	0 092 S40 010	S4 001
0 093 S54 54T	0 092 S40 010	S4 001
0 093 S55 01K	0 092 S30 040	S3 004
0 093 S55 01L	0 092 S30 040	S3 004

0 093 S55 01Y	0 092 S40 020	S4 002
0 093 S55 04A	0 092 S40 020	S4 002
0 093 S55 04B	0 092 S50 010	S5 001
0 093 S55 040	0 092 S40 020	S4 002
0 093 S55 51N	0 092 S30 050	S3 005

0 093 S55 51T	0 092 S30 060	S3 006
0 093 S55 54B	0 092 S40 040	S4 004
0 093 S55 54C	0 092 S40 040	S4 004
0 093 S56 0S0	0 092 S40 260	S4 026
0 093 S56 0S6	0 092 S50 040	S5 004

0 093 S56 02R	0 092 S40 270	S4 027
0 093 S56 02S	0 092 S50 040	S5 004
0 093 S56 2B4	0 092 S40 060	S4 006
0 093 S56 20J	0 092 S40 050	S4 005
0 093 S56 20L	0 092 S50 060	S5 006

0 093 S56 22V	0 092 S50 050	S5 005
0 093 S56 22W	0 092 S50 060	S5 006
0 093 S56 3RS	0 092 S30 070	S3 007
0 093 S56 40K	0 092 S30 070	S3 007
0 093 S56 61S	0 092 S30 080	S3 008

0 093 S57 020	0 092 S40 270	S4 027
0 093 S57 021	0 092 S40 260	S4 026
0 093 S57 040	0 092 S40 070	S4 007
0 093 S57 041	0 092 S40 070	S4 007
0 093 S57 042	0 092 S40 070	S4 007

0 093 S57 10D	0 092 S40 070	S4 007
0 093 S57 10E	0 092 S40 070	S4 007
0 093 S57 20U	0 092 S40 070	S4 007
0 093 S57 40C	0 092 S40 080	S4 008
0 093 S57 40D	0 092 S40 090	S4 009

0 093 S57 53D	0 092 S50 070	S5 007
0 093 S58 017	0 092 S40 100	S4 010
0 093 S58 03E	0 092 S40 100	S4 010
0 093 S58 50F	0 092 S30 120	S3 012
0 093 S58 55K	0 092 S50 100	S5 010

0 093 S58 80X	0 092 S30 130	S3 013
0 093 S59 03E	0 092 S30 130	S3 013
0 093 S59 03F	0 092 S30 130	S3 013
0 093 S59 2RU	0 092 S40 130	S4 013
0 093 S59 55K	0 092 S50 130	S5 013

0 093 S60 018	0 092 S50 130	S5 013
0 093 S60 03N	0 092 S50 130	S5 013
0 093 S61 05K	0 092 S50 150	S5 015
0 093 T54 32Z	0 092 S40 010	S4 001
0 093 T54 42X	0 092 S40 020	S4 002

0 093 T54 42Y	0 092 S30 030	S3 003
0 093 T54 52T	0 092 S40 010	S4 001
0 093 T55 52Z	0 092 S40 050	S4 005
0 093 T56 22V	0 092 S50 050	S5 005
0 093 T56 32U	0 092 S30 070	S3 007

0 093 T56 62T	0 092 S30 080	S3 008
0 093 T58 82Z	0 092 S40 130	S4 013
0 093 X64 0B4	0 092 T40 760	T4 076
0 093 X64 02V	0 092 T40 750	T4 075
0 093 X67 02V	0 092 T40 770	T4 077

0 093 X67 02W	0 092 T40 780	T4 078
0 093 X68 030	0 092 T50 770	T5 077
0 093 X72 52V	0 092 T50 800	T5 080
0 097 H57 0P1	0 092 S60 010	S6 001
0 097 H57 0P1	0 092 S60 080	S6 008

0 097 H59 5P1	0 092 S60 020	S6 002
0 097 H59 5P1	0 092 S60 130	S6 013
0 097 051 9P1	0 092 M60 450	M6 045
0 097 250 3P3	0 092 M60 030	M6 003
0 097 250 30E	0 092 M60 010	M6 001

0 097 250 40C	0 092 M60 040	M6 004
0 097 250 60E	0 092 M60 060	M6 006
0 097 250 60F	0 092 M60 070	M6 007
0 097 250 7P1	0 092 M60 080	M6 008
0 097 250 7P2	0 092 M60 090	M6 009

0 097 250 8P1	0 092 M60 110	M6 011
0 097 250 80C	0 092 M60 100	M6 010
0 097 250 9P1	0 092 M60 120	M6 012
0 097 250 9P2	0 092 M60 130	M6 013
0 097 251 00C	0 092 M60 140	M6 014

0 097 251 1P1	0 092 M60 160	M6 016
0 097 251 1P2	0 092 M60 170	M6 017
0 097 251 2P1	0 092 M60 190	M6 019
0 097 251 2P3	0 092 M60 200	M6 020
0 097 251 20E	0 092 M60 180	M6 018

0 097 251 4P1	0 092 M60 210	M6 021
0 097 251 4P2	0 092 M60 220	M6 022
0 097 251 8P1	0 092 M60 230	M6 023
0 097 251 8P2	0 092 M60 240	M6 024
0 180 000 40E	0 092 M4F 040	M4 F04

0 180 000 60C	0 092 M4F 070	M4 F07
0 180 000 80B	0 092 M4F 100	M4 F10
0 180 000 80B	0 092 M40 100	M4 010
0 180 001 20E	0 092 M4F 120	M4 F12
0 180 001 20E	0 092 M40 120	M4 012

0 180 050 30C	0 092 M4F 150	M4 F15
0 180 050 30C	0 092 M40 150	M4 015
0 180 050 30D	0 092 M4F 160	M4 F16
0 180 050 30D	0 092 M40 160	M4 016
0 180 050 40B	0 092 M4F 170	M4 F17

0 180 050 40B	0 092 M40 170	M4 017
0 180 050 50C	0 092 M4F 180	M4 F18
0 180 050 50C	0 092 M40 180	M4 018
0 180 050 60B	0 092 M4F 190	M4 F19
0 180 050 60B	0 092 M40 190	M4 019

0 180 050 60C	0 092 M4F 200	M4 F20
0 180 050 70C	0 092 M4F 210	M4 F21
0 180 050 70C	0 092 M40 210	M4 021
0 180 050 70D	0 092 M4F 220	M4 F22
0 180 050 70D	0 092 M40 220	M4 022

0 180 050 72T	0 092 M4F 230	M4 F23
0 180 050 72T	0 092 M40 230	M4 023
0 180 050 80D	0 092 M4F 240	M4 F24
0 180 050 80D	0 092 M40 240	M4 024
0 180 050 90E	0 092 M4F 250	M4 F25

0 180 050 90E	0 092 M40 250	M4 025
0 180 050 90F	0 092 M4F 260	M4 F26
0 180 050 90F	0 092 M40 260	M4 026
0 180 050 90G	0 092 M4F 270	M4 F27
0 180 051 10C	0 092 M4F 280	M4 F28

0 180 051 10C	0 092 M40 280	M4 028
0 180 051 10D	0 092 M4F 290	M4 F29
0 180 051 10D	0 092 M40 290	M4 029
0 180 051 20B	0 092 M4F 300	M4 F30
0 180 051 20B	0 092 M40 300	M4 030

0 180 051 20D	0 092 M4F 320	M4 F32
0 180 051 20D	0 092 M40 320	M4 032
0 180 051 20F	0 092 M4F 330	M4 F33
0 180 051 4B4	0 092 M4F 380	M4 F38
0 180 051 40B	0 092 M4F 340	M4 F34

0 180 051 40B	0 092 M40 340	M4 034
0 180 051 40C	0 092 M4F 350	M4 F35
0 180 051 40C	0 092 M40 350	M4 035
0 180 051 40D	0 092 M4F 360	M4 F36
0 180 051 40D	0 092 M40 360	M4 036



0 180 051 40E	0 092 M4F 370	M4 F37
0 180 051 60F	0 092 M4F 390	M4 F39
0 180 051 60F	0 092 M40 390	M4 039
0 180 051 60G	0 092 M4F 400	M4 F40
0 180 051 60G	0 092 M40 400	M4 040

0 180 051 80E	0 092 M4F 410	M4 F41
0 180 051 80E	0 092 M40 410	M4 041
0 180 051 80F	0 092 M4F 420	M4 F42
0 180 051 80F	0 092 M40 420	M4 042
0 180 051 90B	0 092 M4F 430	M4 F43

0 180 051 90B	0 092 M40 430	M4 043
0 180 051 90C	0 092 M4F 440	M4 F44
0 180 051 90C	0 092 M40 440	M4 044
0 180 051 90D	0 092 M4F 450	M4 F45
0 180 051 90D	0 092 M40 450	M4 045

0 180 051 90E	0 092 M4F 460	M4 F46
0 180 051 90E	0 092 M40 460	M4 046
0 180 052 00C	0 092 M4F 470	M4 F47
0 180 052 00C	0 092 M40 470	M4 047
0 180 052 00G	0 092 M4F 480	M4 F48

0 180 052 42T	0 092 M4F 510	M4 F51
0 180 052 42T	0 092 M40 510	M4 051
0 180 052 50F	0 092 M4F 520	M4 F52
0 180 052 50F	0 092 M40 520	M4 052
0 180 053 00U	0 092 M4F 540	M4 F54

0 180 053 00U	0 092 M40 540	M4 054
0 180 053 210	0 092 M40 550	M4 055
0 180 607 00B	0 092 T30 600	T3 060
0 180 611 20P	0 092 T30 610	T3 061
0 180 614 00N	0 092 T30 620	T3 062

0 180 615 00U	0 092 T30 630	T3 063
0 180 618 00R	0 092 T30 640	T3 064
0 180 620 00N	0 092 T30 640	T3 064
0 180 653 50K	0 092 S40 180	S4 018
0 180 653 50M	0 092 S40 190	S4 019

0 180 653 6RV	0 092 S30 010	S3 001
0 180 653 82U	0 092 S40 000	S4 000
0 180 654 3RT	0 092 S40 010	S4 001
0 180 654 30H	0 092 S40 010	S4 001
0 180 654 41N	0 092 S30 020	S3 002

0 180 654 41S	0 092 S30 030	S3 003
0 180 654 41X	0 092 S40 010	S4 001
0 180 654 50J	0 092 S40 010	S4 001
0 180 654 50N	0 092 S40 210	S4 021
0 180 654 50O	0 092 S40 230	S4 023

0 180 654 51F	0 092 S40 220	S4 022
0 180 654 52S	0 092 S30 160	S3 016
0 180 654 527	0 092 S30 170	S3 017
0 180 655 01I	0 092 S40 020	S4 002
0 180 655 01K	0 092 S30 040	S3 004

0 180 655 01L	0 092 S30 040	S3 004
0 180 655 01U	0 092 S40 020	S4 002
0 180 655 01S	0 092 S40 240	S4 024
0 180 655 016	0 092 S40 250	S4 025
0 180 655 51N	0 092 S30 050	S3 005

0 180 655 51S	0 092 T30 050	T3 005
0 180 655 51T	0 092 S30 060	S3 006
0 180 656 01C	0 092 S40 260	S4 026
0 180 656 01D	0 092 S40 270	S4 027
0 180 656 01W	0 092 S40 240	S4 024

0 180 656 01X	0 092 S40 250	S4 025
0 180 656 02S	0 092 S50 040	S5 004
0 180 656 20J	0 092 S40 050	S4 005
0 180 656 3RS	0 092 S30 070	S3 007
0 180 656 40K	0 092 S30 070	S3 007

0 180 656 50U	0 092 S30 070	S3 007
0 180 656 61B	0 092 T30 080	T3 008
0 180 657 0RT	0 092 S40 270	S4 027
0 180 657 00T	0 092 S40 260	S4 026
0 180 657 10D	0 092 S40 070	S4 007

0 180 657 10E	0 092 S40 070	S4 007
0 180 657 20U	0 092 S40 070	S4 007
0 180 657 40C	0 092 S40 080	S4 008
0 180 657 40D	0 092 S40 090	S4 009
0 180 657 513	0 092 S40 100	S4 010

0 180 658 017	0 092 S40 100	S4 010
0 180 658 50F	0 092 S30 120	S3 012
0 180 658 50L	0 092 S40 280	S4 028
0 180 658 50M	0 092 S40 290	S4 029
0 180 658 812	0 092 T30 130	T3 013

0 180 659 014	0 092 T30 300	T3 030
0 180 659 015	0 092 T30 310	T3 031
0 180 659 20Q	0 092 S40 130	S4 013
0 180 659 50I	0 092 S40 280	S4 028
0 180 659 50J	0 092 S40 290	S4 029

0 180 660 00Z	0 092 T30 710	T3 071
0 180 660 01B	0 092 T30 720	T3 072
0 180 660 018	0 092 S50 130	S5 013
0 180 660 22U	0 092 T30 330	T3 033
0 180 660 22V	0 092 T30 340	T3 034

0 180 661 00D	0 092 T30 380	T3 038
0 180 661 01B	0 092 T30 350	T3 035
0 180 661 01C	0 092 T30 360	T3 036
0 180 661 01D	0 092 T30 390	T3 039
0 180 661 01E	0 092 T30 730	T3 073

0 180 662 01A	0 092 T30 390	T3 039
0 180 662 019	0 092 T30 750	T3 075
0 180 662 031	0 092 T30 390	T3 039
0 180 662 50C	0 092 T30 400	T3 040
0 180 662 50E	0 092 T30 410	T3 041

0 180 662 50N	0 092 T30 420	T3 042
0 180 663 00E	0 092 T30 430	T3 043
0 180 663 20B	0 092 T30 460	T3 046
0 180 663 51G	0 092 T30 450	T3 045
0 180 663 516	0 092 T30 440	T3 044

0 180 663 519	0 092 T50 750	T5 075
0 180 664 00Y	0 092 T40 750	T4 075
0 180 664 00Z	0 092 T40 750	T4 075
0 180 664 010	0 092 T40 760	T4 076
0 180 664 30X	0 092 T30 470	T3 047

0 180 664 30Y	0 092 T30 480	T3 048
0 180 664 32Z	0 092 T30 460	T3 046
0 180 665 50D	0 092 T30 770	T3 077
0 180 665 52W	0 092 T30 480	T3 048
0 180 667 00N	0 092 T40 780	T4 078

0 180 667 01A	0 092 T30 790	T3 079
0 180 667 016	0 092 T40 770	T4 077
0 180 667 017	0 092 T40 770	T4 077
0 180 667 018	0 092 T30 790	T3 079
0 180 667 019	0 092 T40 780	T4 078

0 180 668 00W	0 092 T50 770	T5 077
0 180 668 00X	0 092 T30 790	T3 079
0 180 670 012	0 092 T30 800	T3 080
0 180 671 50E	0 092 T40 800	T4 080
0 180 672 00P	0 092 T30 810	T3 081

0 180 672 50C	0 092 T50 800	T5 080
0 180 755 51S	0 092 T30 050	T3 005
0 180 756 61B	0 092 T30 080	T3 008
0 180 758 812	0 092 T30 130	T3 013
0 180 760 03F	0 092 T30 320	T3 032

BOSCH SHORT CODE

05A	0 092 T30 050	T3 005
06A	0 092 T30 080	T3 008
08A	0 092 T30 130	T3 013

09A	0 092 T30 300	T3 030
09B	0 092 T30 310	T3 031
1A	0 092 S50 130	S5 013
1AN	0 092 S50 130	S5 013
1BN	0 092 S50 150	S5 015

10A	0 092 T30 720	T3 072
10AS	0 092 M60 140	M6 014
10B	0 092 T30 710	T3 071
10C	0 092 T30 330	T3 033
10D	0 092 T30 340	T3 034

11A	0 092 T30 390	T3 039
11B	0 092 T30 380	T3 038
11C	0 092 T30 350	T3 035
11D	0 092 T30 360	T3 036
11E	0 092 T30 730	T3 073

12A	0 092 T30 400	T3 040
12AS	0 092 M60 180	M6 018
12AS1	0 092 M60 190	M6 019
12B	0 092 T30 410	T3 041
12C	0 092 T30 750	T3 075

12D	0 092 T30 390	T3 039
12E	0 092 T30 420	T3 042
13A	0 092 T30 450	T3 045
13B	0 092 T30 440	T3 044
13C	0 092 T50 750	T5 075

13D	0 092 T30 430	T3 043
13E	0 092 T30 460	T3 046
14A	0 092 T40 750	T4 075
14AS1	0 092 M60 210	M6 021
14AS2	0 092 M60 220	M6 022



◀ BOSCH SHORT CODE

14B	0 092 T40 760	T4 076
14C	0 092 T30 470	T3 047
14D	0 092 T30 480	T3 048
14E	0 092 T40 750	T4 075
14T1	0 092 T40 750	T4 075
14T2	0 092 T40 760	T4 076
15A	0 092 T30 770	T3 077
16A	0 092 T30 790	T3 079
17A	0 092 T40 780	T4 078
17B	0 092 T40 770	T4 077
17C	0 092 T40 780	T4 078
17D	0 092 T30 790	T3 079
17T1	0 092 T40 770	T4 077
17T2	0 092 T40 780	T4 078
18A	0 092 T50 770	T5 077
18AS1	0 092 M60 230	M6 023
18AS2	0 092 M60 240	M6 024
18B	0 092 T30 790	T3 079
18T2	0 092 T50 770	T5 077
20A	0 092 T30 800	T3 080
21A	0 092 T40 800	T4 080
22A	0 092 T50 800	T5 080
22B	0 092 T30 810	T3 081
22T1	0 092 T50 800	T5 080
3AS	0 092 M60 010	M6 001
3F	0 092 S30 010	S3 001
4AS	0 092 M60 040	M6 004
4B	0 092 S40 010	S4 001
4BA	0 092 S40 180	S4 018
4BN	0 092 S40 010	S4 001
4C	0 092 S30 020	S3 002
4CA	0 092 S40 190	S4 019
4CN	0 092 S30 020	S3 002
4CT	0 092 S40 020	S4 002
4D	0 092 S30 030	S3 003
4DN	0 092 S30 030	S3 003
4DT	0 092 S30 030	S3 003
4E	0 092 S40 010	S4 001
4EA	0 092 S40 210	S4 021
4EN	0 092 S40 010	S4 001
4ET	0 092 S40 010	S4 001
4F	0 092 S40 000	S4 000
4FA	0 092 S40 220	S4 022
4FN	0 092 S40 000	S4 000
4GA	0 092 S40 230	S4 023
4HN	0 092 S30 010	S3 001
4K	0 092 S30 160	S3 016
4KN	0 092 S30 160	S3 016
4L	0 092 S30 170	S3 017
4LN	0 092 S30 170	S3 017
4P	0 092 S40 010	S4 001
4PN	0 092 S40 010	S4 001
4PT	0 092 S40 010	S4 001
4S	0 092 S40 010	S4 001
5B	0 092 S30 040	S3 004

5BN	0 092 S40 040	S4 004
5C	0 092 S30 040	S3 004
5CN	0 092 S40 040	S4 004
5D	0 092 S30 050	S3 005
5DN	0 092 S30 050	S3 005
5DT	0 092 S40 050	S4 005
5E	0 092 S30 060	S3 006
5EN	0 092 S30 060	S3 006
5H	0 092 S40 020	S4 002
5K	0 092 S40 020	S4 002
5KN	0 092 S40 020	S4 002
5LN	0 092 S50 010	S5 001
6A	0 092 S40 260	S4 026
6AA	0 092 S40 260	S4 026
6AS1	0 092 M60 060	M6 006
6AS2	0 092 M60 070	M6 007
6B	0 092 S40 270	S4 027
6BA	0 092 S40 270	S4 027
6C	0 092 S40 050	S4 005
6CN	0 092 S40 050	S4 005
6CT	0 092 S50 050	S5 005
6D	0 092 S30 070	S3 007
6DA	0 092 S40 240	S4 024
6DT	0 092 S30 070	S3 007
6E	0 092 S30 070	S3 007
6EA	0 092 S40 250	S4 025
6F	0 092 S30 080	S3 008
6FT	0 092 S30 080	S3 008
6H	0 092 S50 040	S5 004
6HN	0 092 S50 040	S5 004
6M	0 092 S50 060	S5 006
6MN	0 092 S50 060	S5 006
6NN	0 092 S40 060	S4 006
6PN	0 092 S50 050	S5 005
7A	0 092 S40 270	S4 027
7AA	0 092 S40 270	S4 027
7AS	0 092 M60 080	M6 008
7BA	0 092 S40 260	S4 026
7C	0 092 S40 080	S4 008
7CN	0 092 S40 080	S4 008
7D	0 092 S40 070	S4 007
7DN	0 092 S40 070	S4 007
7E	0 092 S40 070	S4 007
7EN	0 092 S40 070	S4 007
7F	0 092 S40 090	S4 009
7FN	0 092 S40 090	S4 009
7G	0 092 S40 070	S4 007
7GN	0 092 S40 070	S4 007
7HN	0 092 S50 070	S5 007
7OH	0 092 S60 010	S6 001
7OH	0 092 S60 080	S6 008
8A	0 092 S30 130	S3 013
8AS	0 092 M60 100	M6 010
8AT	0 092 S40 130	S4 013
8B	0 092 S30 120	S3 012

8BN	0 092 S30 120	S3 012
8C	0 092 S40 100	S4 010
8CN	0 092 S40 100	S4 010
8DN	0 092 S50 100	S5 010
9A	0 092 S40 130	S4 013
9AN	0 092 S30 130	S3 013
9BA	0 092 S40 280	S4 028
9BN	0 092 S30 130	S3 013
9CA	0 092 S40 290	S4 029
9CN	0 092 S50 130	S5 013
95H	0 092 S60 020	S6 002
95H	0 092 S60 130	S6 013
CHEVROLET		
EC0730008	0 092 S40 090	S4 009
CHRYSLER		
CID 1000 83 E	0 092 S40 080	S4 008
CITROEN		
ZC 98 652 82 U	0 092 S30 130	S3 013
ZC 98 652 82 U	0 092 S50 130	S5 013
ZC 98 652 82 U	0 092 T30 130	T3 013
ZC 98 653 20 U	0 092 S30 160	S3 016
ZC 98 653 85	0 092 S30 050	S3 005
ZC 98 654 76 U	0 092 S30 160	S3 016
ZC 98 654 82	0 092 S40 080	S4 008
ZC 98 654 82	0 092 T30 080	T3 008
5600 GR	0 092 S50 080	S5 008
5600 HR	0 092 S40 080	S4 008
5600 HS	0 092 S50 130	S5 013
5600 JT	0 092 S30 020	S3 002
5600 JW	0 092 S40 050	S4 005
5600 JW	0 092 S50 050	S5 005
5600 JX	0 092 S40 080	S4 008
5600 OR	0 092 S50 080	S5 008
5600 QA	0 092 S50 080	S5 008
5600 QN	0 092 S40 020	S4 002
5600 QN	0 092 S50 020	S5 002
5600 QP	0 092 S40 050	S4 005
5600 QP	0 092 S50 050	S5 005
5600 QR	0 092 S40 080	S4 008
5600 RC	0 092 S50 080	S5 008
5600 RY	0 092 S40 130	S4 013
5600 SK	0 092 S50 150	S5 015
5600 SL	0 092 S50 080	S5 008
5600 SR	0 092 S40 280	S4 028
5600 ST	0 092 S40 240	S4 024



5600 SX	0 092 S40 080	S4 008
5600 SX	0 092 S50 080	S5 008
5600 SZ	0 092 S50 050	S5 005
5600 13	0 092 S40 270	S4 027
5600 14	0 092 S30 160	S3 016

5600 15	0 092 S30 160	S3 016
5600 16	0 092 S30 050	S3 005
5600 16	0 092 S40 270	S4 027
5600 17	0 092 S40 270	S4 027
7905525547	0 092 S50 020	S5 002

7905525557	0 092 S50 050	S5 005
79 05 525 567	0 092 S50 080	S5 008
7905525747	0 092 S40 000	S4 000
7905525757	0 092 S40 000	S4 000
7905525767	0 092 S50 130	S5 013

7905525787	0 092 S50 130	S5 013
7905525797	0 092 S50 050	S5 005

CLAAS		
177 755 0	0 092 T30 130	T3 013
177 756 0	0 092 T30 380	T3 038
177 757 0	0 092 T30 470	T3 047

177 758 0	0 092 S30 020	S3 002
177 760 0	0 092 S30 050	S3 005
177 763 0	0 092 S40 080	S4 008
177 763 0	0 092 T30 080	T3 008
177 764 0	0 092 S40 080	S4 008

177 765 0	0 092 S50 130	S5 013
177 765 0	0 092 T30 130	T3 013
177 766 0	0 092 T30 750	T3 075
177 766 0	0 092 T40 750	T4 075
177 767 0	0 092 T40 750	T4 075

177 768 0	0 092 T30 450	T3 045
177 769 0	0 092 T40 750	T4 075
177 769 0	0 092 T40 760	T4 076
177 770 0	0 092 T30 770	T3 077
177 770 0	0 092 T40 770	T4 077

177 771 0	0 092 T40 770	T4 077
177 772 0	0 092 T50 770	T5 077
177 773 0	0 092 T50 800	T5 080
177 774 0	0 092 T50 800	T5 080
177 778 0	0 092 S40 040	S4 004

177 779 0	0 092 S40 050	S4 005
177 779 0	0 092 S50 050	S5 005
177 780 0	0 092 T30 350	T3 035
177 780 0	0 092 T30 360	T3 036
177 780 0	0 092 T30 370	T3 037

177 781 0	0 092 T30 800	T3 080
177 790 0	0 092 S40 010	S4 001
177 791 0	0 092 S40 040	S4 004
177 791 0	0 092 S50 010	S5 001
177 792 0	0 092 S50 040	S5 004

177 793 0	0 092 S40 070	S4 007
177 794 0	0 092 S30 120	S3 012
177 795 0	0 092 S50 130	S5 013

DACIA		
77 00 427 648	0 092 S40 050	S4 005
77 00 758 343	0 092 S30 020	S3 002

DAEWOO		
ZX01001	0 092 S30 050	S3 005
ZX01019	0 092 S30 060	S3 006
ZX01021	0 092 S40 190	S4 019

DAF		
AELD215	0 092 T30 400	T3 040
ALED214	0 092 T30 350	T3 035
ALED214	0 092 T30 370	T3 037

0067737	0 092 S40 270	S4 027
1295015	0 092 S40 270	S4 027
1314342	0 092 T30 750	T3 075
1314342	0 092 T40 750	T4 075
1314343	0 092 T40 750	T4 075

1314344	0 092 T40 770	T4 077
1314345	0 092 T30 800	T3 080
1314346	0 092 T50 800	T5 080
1315880	0 092 T30 400	T3 040
1316655	0 092 T30 750	T3 075

1316655	0 092 T40 750	T4 075
1316656	0 092 T40 750	T4 075
1316657	0 092 T40 770	T4 077
1316658	0 092 T30 800	T3 080
1316659	0 092 T50 800	T5 080

1316660	0 092 T30 350	T3 035
1316660	0 092 T30 370	T3 037
1316661	0 092 S50 040	S5 004
1320826	0 092 T30 350	T3 035
1320826	0 092 T30 370	T3 037

1320827	0 092 S50 040	S5 004
1398663	0 092 T30 400	T3 040
1427088	0 092 T30 400	T3 040
1427088	0 092 T40 750	T4 075
1427089	0 092 T50 770	T5 077

1440622	0 092 T40 750	T4 075
1440623	0 092 T50 770	T5 077
1677035	0 092 T40 750	T4 075
1677037	0 092 T40 770	T4 077
1689802	0 092 T40 750	T4 075

1689803	0 092 T50 770	T5 077
1689804	0 092 T50 800	T5 080

DAIHATSU		
28800 33060 000	0 092 S40 220	S4 022
28800 87106 000	0 092 S40 210	S4 021
28800 87107 000	0 092 S40 210	S4 021

28800 87327 000	0 092 S40 270	S4 027
28800 87329 000	0 092 S40 180	S4 018
28800 87335 000	0 092 S40 260	S4 026
28800 87719 000	0 092 S40 260	S4 026

DELPHI		
BE03627	0 092 S30 010	S3 001
BE03627H	0 092 S40 010	S4 001
BE03647	0 092 S40 010	S4 001

BE04020	0 092 S30 020	S3 002
BE04023	0 092 S30 160	S3 016
BE04027P	0 092 S40 010	S4 001
BE04033	0 092 S30 170	S3 017
BE04047P	0 092 S40 010	S4 001

BE04427	0 092 S40 010	S4 001
BE04523	0 092 S30 160	S3 016
BE04525	0 092 S40 210	S4 021
BE04527H	0 092 S40 010	S4 001
BE04533	0 092 S30 170	S3 017

BE04535	0 092 S40 230	S4 023
BE04535J	0 092 S40 220	S4 022
BE04547	0 092 S40 010	S4 001
BE05020	0 092 S40 020	S4 002
BE05027P	0 092 S40 040	S4 004

BE05047P	0 092 S40 040	S4 004
BE05520	0 092 S30 050	S3 005
BE05527	0 092 S50 040	S5 004
BE05530	0 092 S40 060	S4 006
BE05536	0 092 S40 270	S4 027

BE05547	0 092 S40 040	S4 004
BE06027P	0 092 S50 040	S5 004
BE06047P	0 092 S40 040	S4 004
BE06220	0 092 S50 050	S5 005
BE06327H	0 092 S40 070	S4 007

BE06427	0 092 S40 070	S4 007
BE06427H	0 092 S40 070	S4 007
BE06447	0 092 S40 070	S4 007
BE06620	0 092 S40 080	S4 008
BE06627	0 092 S40 070	S4 007

BE06630	0 092 S40 090	S4 009
BE06647	0 092 S40 070	S4 007
BE07026	0 092 S40 260	S4 026
BE07027P	0 092 S40 070	S4 007
BE07036	0 092 S40 270	S4 027

BE07220	0 092 S40 080	S4 008
BE07230	0 092 S40 090	S4 009
BE08220	0 092 S40 100	S4 010
BE08220	0 092 S50 100	S5 010
BE08527	0 092 S30 120	S3 012



◀ DELPHI

BE08820	0 092 S30 130	S3 013
BE09220	0 092 S40 130	S4 013
BE10020	0 092 S50 130	S5 013
BE11072	0 092 T30 380	T3 038
BE12079N	0 092 T30 750	T3 075
BE12079N	0 092 T40 750	T4 075
BE12529N	0 092 T30 400	T3 040
BE13579N	0 092 T40 750	T4 075
BE14372	0 092 T30 470	T3 047
BE14379N	0 092 T30 770	T3 077
BE16572	0 092 T40 780	T4 078
BE16579N	0 092 T40 770	T4 077
BE18079N	0 092 T40 770	T4 077
BE18079N	0 092 T50 770	T5 077
BE18089	0 092 T30 790	T3 079
BE20079N	0 092 T30 800	T3 080
BE22579N	0 092 T50 800	T5 080
BT10524N	0 092 T30 350	T3 035
BT10534N	0 092 T30 360	T3 036
BT11072	0 092 T30 380	T3 038
BT12079N	0 092 T30 750	T3 075
BT12079N	0 092 T40 750	T4 075
BT12529N	0 092 T30 400	T3 040
BT12534N	0 092 T30 410	T3 041
BT13079N	0 092 T30 430	T3 043
BT13579N	0 092 T40 750	T4 075
BT14372	0 092 T30 470	T3 047
BT16579N	0 092 T40 770	T4 077
BT16589N	0 092 T30 790	T3 079
BT18079N	0 092 T40 770	T4 077
BT18079N	0 092 T50 770	T5 077
BT18089N	0 092 T30 790	T3 079
BT20079N	0 092 T30 800	T3 080
BT23079N	0 092 T50 800	T5 080
S40AL	0 092 S30 010	S3 001
S40AT	0 092 S30 020	S3 002
S45AL	0 092 S40 010	S4 001
S45ALF	0 092 S40 010	S4 001
S45AT	0 092 S30 020	S3 002
S55ALF	0 092 S30 040	S3 004
S55ALF	0 092 S40 040	S4 004
S55AT	0 092 S30 050	S3 005
S55AT	0 092 S40 050	S4 005
S55BT	0 092 S30 060	S3 006
S68AL	0 092 S40 070	S4 007
S68AL	0 092 S50 070	S5 007
S68ALF	0 092 S40 070	S4 007
S68AT	0 092 S40 080	S4 008
S68BT	0 092 S40 090	S4 009
S75AL	0 092 S50 070	S5 007
S90AL	0 092 S30 120	S3 012

DETA		
DA1000	0 092 S50 130	S5 013
DA472	0 092 S50 010	S5 001
DA530	0 092 S50 020	S5 002
DA602	0 092 S50 040	S5 004
DA640	0 092 S50 050	S5 005
DA722	0 092 S50 070	S5 007
DA770	0 092 S50 080	S5 008
DA852	0 092 S50 100	S5 010
DB356	0 092 S40 180	S4 018
DB357	0 092 S40 190	S4 019
DB440	0 092 S40 000	S4 000
DB442	0 092 S40 010	S4 001
DB450	0 092 S30 160	S3 016
DB451	0 092 S30 170	S3 017
DB454	0 092 S40 210	S4 021
DB455	0 092 S40 230	S4 023
DB457	0 092 S40 220	S4 022
DB500	0 092 S40 020	S4 002
DB501	0 092 S30 030	S3 003
DB542	0 092 S40 040	S4 004
DB604	0 092 S40 240	S4 024
DB605	0 092 S40 250	S4 025
DB620	0 092 S40 050	S4 005
DB712	0 092 S40 070	S4 007
DB740	0 092 S40 080	S4 008
DB741	0 092 S40 090	S4 009
DB802	0 092 S40 100	S4 010
DB852	0 092 S30 120	S3 012
DB950	0 092 S40 130	S4 013
DC412	0 092 S30 010	S3 001
DC440	0 092 S30 020	S3 002
DC502	0 092 S30 040	S3 004
DC550	0 092 S30 050	S3 005
DC652	0 092 S30 070	S3 007
DC700	0 092 S30 080	S3 008
O117 4689	0 092 T40 770	T4 077
O117 7864	0 092 T30 750	T3 075
O117 7864	0 092 T40 750	T4 075
O117 8118	0 092 T30 770	T3 077
O117 8118	0 092 T40 770	T4 077
O117 8321	0 092 S30 130	S3 013
O117 8321	0 092 T30 130	T3 013
O117 9683	0 092 S50 130	S5 013
O294 0231	0 092 T40 760	T4 076
O439 7207	0 092 T30 790	T3 079

DEUTZ-FAHR		
O117 4689	0 092 T40 770	T4 077
O117 7864	0 092 T30 750	T3 075
O117 7864	0 092 T40 750	T4 075
O117 8118	0 092 T30 770	T3 077
O117 8118	0 092 T40 770	T4 077
O117 8321	0 092 S30 130	S3 013
O117 8321	0 092 T30 130	T3 013
O117 9683	0 092 S50 130	S5 013
O294 0231	0 092 T40 760	T4 076
O439 7207	0 092 T30 790	T3 079

DIN NORMBEZEICHNUNG		
518 14	0 092 M4F 410	M4 F41
518 14	0 092 M40 410	M4 041
519 13	0 092 M4F 450	M4 F45
519 13	0 092 M40 450	M4 045
525 15	0 092 M4F 520	M4 F52
525 15	0 092 M40 520	M4 052
530 30	0 092 M4F 540	M4 F54
530 30	0 092 M40 540	M4 054
532 28	0 092 S30 160	S3 016
532 32	0 092 S30 160	S3 016
533 33	0 092 S30 030	S3 003
535 15	0 092 S30 020	S3 002
535 16	0 092 S30 030	S3 003
535 20	0 092 S40 180	S4 018
535 22	0 092 S40 190	S4 019
535 23	0 092 S30 020	S3 002
535 24	0 092 S30 010	S3 001
535 28	0 092 S30 010	S3 001
535 29	0 092 S30 030	S3 003
535 30	0 092 S30 020	S3 002
535 31	0 092 S30 030	S3 003
535 32	0 092 S30 170	S3 017
535 33	0 092 S30 170	S3 017
536 24	0 092 S30 010	S3 001
536 25	0 092 S30 010	S3 001
536 30	0 092 S30 160	S3 016
536 31	0 092 S30 170	S3 017
536 38	0 092 S30 030	S3 003
536 47	0 092 S30 160	S3 016
536 53	0 092 S30 010	S3 001
536 54	0 092 S30 010	S3 001
538 56	0 092 S30 160	S3 016
538 57	0 092 S30 170	S3 017
538 90	0 092 S30 170	S3 017
540 19	0 092 S30 160	S3 016
540 20	0 092 S30 170	S3 017
540 38	0 092 S30 160	S3 016
540 39	0 092 S30 170	S3 017
540 45	0 092 S40 010	S4 001
540 50	0 092 S30 160	S3 016
540 53	0 092 S30 170	S3 017
543 12	0 092 S40 010	S4 001
543 16	0 092 S40 010	S4 001
543 17	0 092 S40 010	S4 001
543 19	0 092 S40 010	S4 001
543 21	0 092 S30 020	S3 002
543 22	0 092 S30 030	S3 003
543 23	0 092 S40 010	S4 001
543 24	0 092 S40 010	S4 001
544 34	0 092 S30 020	S3 002
544 49	0 092 S30 030	S3 003
544 58	0 092 S30 020	S3 002
544 59	0 092 S30 020	S3 002



544 64	0 092 S30 030	S3 003
544 65	0 092 S40 010	S4 001
544 69	0 092 S40 010	S4 001
544 72	0 092 S30 160	S3 016
544 73	0 092 S30 170	S3 017
545 19	0 092 S40 010	S4 001
545 23	0 092 S40 210	S4 021
545 24	0 092 S40 230	S4 023
545 33	0 092 S40 010	S4 001
545 49	0 092 S30 020	S3 002
545 51	0 092 S40 220	S4 022
545 77	0 092 S30 160	S3 016
545 79	0 092 S30 170	S3 017
545 91	0 092 S40 010	S4 001
547 18	0 092 S30 030	S3 003
547 19	0 092 S30 020	S3 002
548 27	0 092 S30 040	S3 004
550 40	0 092 S30 040	S3 004
550 41	0 092 S40 240	S4 024
550 42	0 092 S40 250	S4 025
550 46	0 092 S30 040	S3 004
550 52	0 092 S40 020	S4 002
550 55	0 092 S30 050	S3 005
550 56	0 092 S30 040	S3 004
550 57	0 092 S30 040	S3 004
550 59	0 092 S30 040	S3 004
550 63	0 092 S30 050	S3 005
550 65	0 092 S30 030	S3 003
550 66	0 092 S40 020	S4 002
550 70	0 092 S40 020	S4 002
552 18	0 092 S30 040	S3 004
552 19	0 092 S30 040	S3 004
552 21	0 092 S30 040	S3 004
554 14	0 092 S30 070	S3 007
554 15	0 092 S30 070	S3 007
554 23	0 092 S30 040	S3 004
554 27	0 092 S30 040	S3 004
555 19	0 092 S30 050	S3 005
555 30	0 092 S30 050	S3 005
555 31	0 092 S30 040	S3 004
555 42	0 092 S30 050	S3 005
555 48	0 092 S30 060	S3 006
555 59	0 092 S30 050	S3 005
555 64	0 092 T30 050	T3 005
555 65	0 092 S30 060	S3 006
555 70	0 092 S30 050	S3 005
555 71	0 092 S30 050	S3 005
555 77	0 092 S30 050	S3 005
555 77	0 092 S40 050	S4 005
556 51	0 092 S40 270	S4 027
560 13	0 092 S40 050	S4 005
560 48	0 092 S40 260	S4 026
560 49	0 092 S40 270	S4 027
560 68	0 092 S40 240	S4 024
560 69	0 092 S40 250	S4 025
560 70	0 092 S40 050	S4 005
560 72	0 092 S40 050	S4 005
560 75	0 092 S40 270	S4 027
560 77	0 092 S50 040	S5 004
560 78	0 092 S40 050	S4 005
560 90	0 092 S50 060	S5 006
560 92	0 092 S40 050	S4 005
560 98	0 092 S40 260	S4 026
560 99	0 092 S40 270	S4 027
562 18	0 092 S40 050	S4 005
562 19	0 092 S40 050	S4 005
562 21	0 092 S50 060	S5 006
563 16	0 092 S30 070	S3 007
563 18	0 092 S30 070	S3 007
563 20	0 092 S30 070	S3 007
563 22	0 092 S30 070	S3 007
563 23	0 092 S30 070	S3 007
563 26	0 092 S30 070	S3 007
563 28	0 092 S30 070	S3 007
563 30	0 092 S30 070	S3 007
564 20	0 092 S30 070	S3 007
565 30	0 092 S30 070	S3 007
565 37	0 092 S30 070	S3 007
565 38	0 092 S30 070	S3 007
566 13	0 092 S30 080	S3 008
566 18	0 092 S30 080	S3 008
566 19	0 092 S30 070	S3 007
566 27	0 092 S30 080	S3 008
566 37	0 092 S30 080	S3 008
566 38	0 092 S30 080	S3 008
566 41	0 092 S30 080	S3 008
566 44	0 092 S30 080	S3 008
566 47	0 092 S30 080	S3 008
566 47	0 092 T30 080	T3 008
566 48	0 092 S50 050	S5 005
568 18	0 092 S40 070	S4 007
568 21	0 092 S40 070	S4 007
568 23	0 092 S30 080	S3 008
570 24	0 092 S40 270	S4 027
570 29	0 092 S40 260	S4 026
570 33	0 092 S40 080	S4 008
570 58	0 092 S40 080	S4 008
570 64	0 092 S40 080	S4 008
570 69	0 092 S40 080	S4 008
571 13	0 092 S40 070	S4 007
571 14	0 092 S40 070	S4 007
572 17	0 092 S40 080	S4 008
572 18	0 092 S40 070	S4 007
572 20	0 092 S40 080	S4 008
572 21	0 092 S40 080	S4 008
572 22	0 092 S40 080	S4 008
572 23	0 092 S40 080	S4 008
572 24	0 092 S40 080	S4 008
572 27	0 092 S40 070	S4 007
572 29	0 092 S40 080	S4 008
572 30	0 092 S40 070	S4 007
574 12	0 092 S40 080	S4 008
574 13	0 092 S40 090	S4 009
575 31	0 092 S40 080	S4 008
575 33	0 092 S40 080	S4 008
575 39	0 092 S40 100	S4 010
575 40	0 092 S40 080	S4 008
576 11	0 092 S40 080	S4 008
580 43	0 092 S40 100	S4 010
585 15	0 092 S30 120	S3 012
585 21	0 092 S40 280	S4 028
585 22	0 092 S40 290	S4 029
588 12	0 092 S30 130	S3 013
588 15	0 092 S30 130	S3 013
588 20	0 092 S50 070	S5 007
588 23	0 092 S30 130	S3 013
588 27	0 092 S30 130	S3 013
588 33	0 092 S30 130	S3 013
588 37	0 092 S30 130	S3 013
588 38	0 092 S30 130	S3 013
588 38	0 092 T30 130	T3 013
588 39	0 092 S30 130	S3 013
590 36	0 092 S30 130	S3 013
590 36	0 092 S40 130	S4 013
590 37	0 092 S30 130	S3 013
590 37	0 092 S40 130	S4 013
590 40	0 092 T30 300	T3 030
590 42	0 092 S30 130	S3 013
590 50	0 092 S30 130	S3 013
590 50	0 092 S40 130	S4 013
592 17	0 092 S40 130	S4 013
592 18	0 092 S40 130	S4 013
592 19	0 092 S40 130	S4 013
592 20	0 092 S40 130	S4 013
592 26	0 092 S40 130	S4 013
592 27	0 092 S40 130	S4 013
593 12	0 092 S30 130	S3 013
593 12	0 092 S40 130	S4 013
595 18	0 092 S40 280	S4 028
595 19	0 092 S40 290	S4 029
595 23	0 092 S50 130	S5 013
595 41	0 092 T30 310	T3 031
600 35	0 092 T30 710	T3 071
600 38	0 092 S50 130	S5 013
600 42	0 092 S50 130	S5 013
600 44	0 092 S50 130	S5 013
600 47	0 092 T30 720	T3 072
604 11	0 092 S50 130	S5 013
604 12	0 092 S50 130	S5 013
610 13	0 092 T30 380	T3 038
610 32	0 092 S50 130	S5 013
610 47	0 092 T30 350	T3 035
610 48	0 092 T30 360	T3 036
610 49	0 092 T30 390	T3 039
610 50	0 092 T30 730	T3 073



◀ DIN NORMBEZEICHNUNG

620 45	0 092 T30 750	T3 075
620 46	0 092 T30 390	T3 039
625 12	0 092 T30 400	T3 040
625 14	0 092 T30 410	T3 041
625 23	0 092 T30 420	T3 042

630 14	0 092 T30 430	T3 043
632 11	0 092 T30 460	T3 046
635 42	0 092 T30 440	T3 044
635 45	0 092 T50 750	T5 075
635 52	0 092 T30 450	T3 045

640 34	0 092 T40 750	T4 075
640 35	0 092 T40 750	T4 075
640 36	0 092 T40 760	T4 076
643 33	0 092 T30 470	T3 047
643 34	0 092 T30 480	T3 048

655 13	0 092 T30 770	T3 077
670 23	0 092 T40 780	T4 078
670 42	0 092 T40 770	T4 077
670 43	0 092 T40 770	T4 077
670 44	0 092 T30 790	T3 079

670 45	0 092 T40 780	T4 078
670 46	0 092 T30 790	T3 079
680 32	0 092 T50 770	T5 077
680 33	0 092 T30 790	T3 079
700 38	0 092 T30 800	T3 080

715 14	0 092 T40 800	T4 080
720 25	0 092 T30 810	T3 081
725 12	0 092 T50 800	T5 080
812 31	0 092 S30 010	S3 001
812 33	0 092 S40 010	S4 001

812 36	0 092 S30 020	S3 002
812 37	0 092 S40 010	S4 001
812 38	0 092 S30 160	S3 016
812 40	0 092 S30 170	S3 017
812 42	0 092 S30 050	S3 005

812 44	0 092 S40 080	S4 008
812 45	0 092 S40 080	S4 008
812 46	0 092 S40 270	S4 027
812 52	0 092 S30 070	S3 007
812 58	0 092 S30 040	S3 004

812 59	0 092 S40 080	S4 008
--------	---------------	---------------

DUCELLIER (→ VALEO)

D 4 D	0 092 T30 610	T3 061
LE240D	0 092 S30 160	S3 016
LE240G	0 092 S30 170	S3 017

XB 14 D	0 092 T30 390	T3 039
XB 15	0 092 T30 770	T3 077
XB 15	0 092 T40 770	T4 077
XB 17	0 092 T30 720	T3 072
XC 13 D	0 092 T30 300	T3 030

XD 14	0 092 T30 380	T3 038
XD 15	0 092 T30 470	T3 047
XD 4	0 092 T30 610	T3 061
XEG45	0 092 S30 170	S3 017
XE1D30	0 092 S30 160	S3 016

XE1D35	0 092 S30 160	S3 016
XE2D40	0 092 S30 160	S3 016
XE2D45	0 092 S30 160	S3 016
XE 8	0 092 M4F 540	M4 F54
XE 8	0 092 M40 540	M4 054

XF10D	0 092 S40 260	S4 026
XF10D55	0 092 S30 050	S3 005
XF10D70	0 092 S30 050	S3 005
XF10E56	0 092 S40 040	S4 004
XF10G55	0 092 S40 270	S4 027

XF 15	0 092 T30 430	T3 043
XF 21	0 092 T30 440	T3 044
XG 11	0 092 S40 080	S4 008
XG 11	0 092 T30 080	T3 008
XH 13 D	0 092 T30 400	T3 040

XL1S38	0 092 S30 020	S3 002
XL2D55	0 092 S30 050	S3 005
XL2D60	0 092 S30 050	S3 005
XL2E	0 092 S40 040	S4 004
XL2G40	0 092 S30 030	S3 003

XL2G55	0 092 S40 270	S4 027
XL2S	0 092 S30 050	S3 005
XL3D65	0 092 S40 080	S4 008
XL3G65	0 092 S40 090	S4 009
XL3S75	0 092 S40 080	S4 008

XL5D	0 092 S40 130	S4 013
XL 5 D	0 092 T30 130	T3 013
XM10D65	0 092 S40 260	S4 026
XM10D70	0 092 S40 260	S4 026
XM10G55	0 092 S40 270	S4 027

XM10G65	0 092 S40 270	S4 027
XM 12 D	0 092 T30 300	T3 030
XM 13	0 092 S30 130	S3 013
XM 13	0 092 T30 130	T3 013
XM 13 P	0 092 T30 720	T3 072

XM 14 D	0 092 T30 390	T3 039
XM 15 B	0 092 T30 770	T3 077
XM 15 B	0 092 T40 770	T4 077
XM 15 G	0 092 T30 470	T3 047
XM 15 G	0 092 T30 770	T3 077

XM 15 G	0 092 T40 770	T4 077
XM 15 PD	0 092 T40 770	T4 077
XM 15 PG	0 092 T40 770	T4 077
XM 15 RG	0 092 T40 770	T4 077
XM 16 G	0 092 T30 800	T3 080

XM 16 PG	0 092 T30 800	T3 080
XM 4	0 092 T30 610	T3 061
XM 5	0 092 T30 630	T3 063
XM 5 P	0 092 T30 630	T3 063
XM 5 R	0 092 T30 630	T3 063

XN60G	0 092 S40 190	S4 019
XT12D	0 092 S40 080	S4 008
XT 12 D	0 092 T30 080	T3 008
XT 14 P	0 092 T40 750	T4 075
XT 15 P	0 092 T40 770	T4 077

XT9G	0 092 S30 170	S3 017
------	---------------	---------------

EUROPEAN TYPE NUMBER

004 014 001	0 092 M4F 040	M4 F04
006 012 003	0 092 M4F 070	M4 F07
008 011 004	0 092 M4F 100	M4 F10

008 011 004	0 092 M40 100	M4 010
012 014 008	0 092 M4F 120	M4 F12
012 014 008	0 092 M40 120	M4 012
180 027 100	0 092 T30 640	T3 064
503 012 001	0 092 M4F 150	M4 F15

503 012 001	0 092 M40 150	M4 015
503 013 001	0 092 M4F 160	M4 F16
503 013 001	0 092 M40 160	M4 016
503 014 003	0 092 M60 010	M6 001
503 903 004	0 092 M60 030	M6 003

504 011 002	0 092 M4F 170	M4 F17
504 011 002	0 092 M40 170	M4 017
504 012 003	0 092 M60 040	M6 004
505 012 003	0 092 M4F 180	M4 F18
505 012 003	0 092 M40 180	M4 018

506 011 004	0 092 M4F 190	M4 F19
506 011 004	0 092 M40 190	M4 019
506 012 004	0 092 M4F 200	M4 F20
506 014 005	0 092 M60 060	M6 006
506 015 005	0 092 M60 070	M6 007

507 012 004	0 092 M4F 210	M4 F21
507 012 004	0 092 M40 210	M4 021
507 013 004	0 092 M4F 220	M4 F22
507 013 004	0 092 M40 220	M4 022
507 101 008	0 092 M4F 230	M4 F23

507 101 008	0 092 M40 230	M4 023
507 901 012	0 092 M60 080	M6 008
507 902 011	0 092 M60 090	M6 009
508 012 008	0 092 M60 100	M6 010
508 013 008	0 092 M4F 240	M4 F24

508 013 008	0 092 M40 240	M4 024
508 901 015	0 092 M60 110	M6 011
509 014 008	0 092 M4F 250	M4 F25
509 014 008	0 092 M40 250	M4 025
509 015 008	0 092 M4F 260	M4 F26

509 015 008	0 092 M40 260	M4 026
509 016 008	0 092 M4F 270	M4 F27
509 901 020	0 092 M60 120	M6 012
509 902 008	0 092 M60 130	M6 013
510 012 009	0 092 M60 140	M6 014

511 012 009	0 092 M4F 280	M4 F28	536 054 030	0 092 S30 010	S3 001	560 163 042	0 092 S40 250	S4 025
511 012 009	0 092 M40 280	M4 028	538 102 030	0 092 S40 000	S4 000	560 170 064	0 092 S50 040	S5 004
511 013 009	0 092 M4F 290	M4 F29	540 108 033	0 092 S40 000	S4 000	562 019 048	0 092 S40 050	S4 005
511 013 009	0 092 M40 290	M4 029	540 126 033	0 092 S40 180	S4 018	562 021 048	0 092 S50 060	S5 006
511 901 014	0 092 M60 160	M6 016	540 127 033	0 092 S40 190	S4 019	562 103 060	0 092 S50 050	S5 005
511 902 023	0 092 M60 170	M6 017	540 128 036	0 092 S40 000	S4 000	562 104 060	0 092 S50 060	S5 006
512 011 012	0 092 M4F 300	M4 F30	540 200 036	0 092 S30 010	S3 001	563 018 051	0 092 S30 070	S3 007
512 011 012	0 092 M40 300	M4 030	543 017 033	0 092 S40 010	S4 001	563 102 060	0 092 S30 070	S3 007
512 013 012	0 092 M4F 320	M4 F32	543 019 039	0 092 S40 010	S4 001	564 020 064	0 092 S30 070	S3 007
512 013 012	0 092 M40 320	M4 032	543 023 039	0 092 S40 010	S4 001	565 030 054	0 092 S30 070	S3 007
512 014 010	0 092 M60 180	M6 018	543 024 033	0 092 S40 010	S4 001	566 041 051	0 092 T30 080	T3 008
512 015 012	0 092 M4F 330	M4 F33	543 107 048	0 092 S40 010	S4 001	566 101 064	0 092 S30 080	S3 008
512 901 019	0 092 M60 190	M6 019	544 059 036	0 092 S30 020	S3 002	570 024 054	0 092 S40 270	S4 027
512 903 013	0 092 M60 200	M6 020	544 064 036	0 092 S30 030	S3 003	570 029 054	0 092 S40 260	S4 026
514 011 014	0 092 M4F 340	M4 F34	544 069 036	0 092 S40 010	S4 001	570 072 051	0 092 S40 270	S4 027
514 011 014	0 092 M40 340	M4 034	544 105 045	0 092 S40 020	S4 002	570 073 051	0 092 S40 260	S4 026
514 012 014	0 092 M4F 350	M4 F35	544 106 045	0 092 S30 030	S3 003	570 137 057	0 092 S40 260	S4 026
514 012 014	0 092 M40 350	M4 035	545 019 036	0 092 S40 010	S4 001	570 138 057	0 092 S40 270	S4 027
514 013 014	0 092 M4F 360	M4 F36	545 023 030	0 092 S40 210	S4 021	570 144 064	0 092 S40 070	S4 007
514 013 014	0 092 M40 360	M4 036	545 024 030	0 092 S40 230	S4 023	570 145 064	0 092 S40 070	S4 007
514 014 014	0 092 M4F 370	M4 F37	545 051 030	0 092 S40 220	S4 022	570 146 064	0 092 S40 070	S4 007
514 400 019	0 092 M4F 380	M4 F38	545 077 030	0 092 S30 160	S3 016	570 901 076	0 092 S60 010	S6 001
514 901 022	0 092 M60 210	M6 021	545 079 030	0 092 S30 170	S3 017	570 901 076	0 092 S60 080	S6 008
514 902 022	0 092 M60 220	M6 022	545 101 048	0 092 S40 010	S4 001	571 013 068	0 092 S40 070	S4 007
516 015 016	0 092 M4F 390	M4 F39	545 156 033	0 092 S40 210	S4 021	571 014 068	0 092 S40 070	S4 007
516 015 016	0 092 M40 390	M4 039	545 157 033	0 092 S40 220	S4 022	572 030 064	0 092 S40 070	S4 007
516 016 012	0 092 M4F 400	M4 F40	545 158 033	0 092 S40 230	S4 023	574 012 068	0 092 S40 080	S4 008
516 016 012	0 092 M40 400	M4 040	545 171 042	0 092 S40 010	S4 001	574 013 068	0 092 S40 090	S4 009
518 014 015	0 092 M4F 410	M4 F41	545 172 042	0 092 S40 010	S4 001	575 039 064	0 092 S40 100	S4 010
518 014 015	0 092 M40 410	M4 041	545 173 042	0 092 S40 010	S4 001	575 121 072	0 092 S50 070	S5 007
518 015 018	0 092 M4F 420	M4 F42	550 041 036	0 092 S40 240	S4 024	580 043 064	0 092 S40 100	S4 010
518 015 018	0 092 M40 420	M4 042	550 042 036	0 092 S40 250	S4 025	580 122 072	0 092 S40 100	S4 010
518 901 026	0 092 M60 230	M6 023	550 054 039	0 092 S40 020	S4 002	585 015 076	0 092 S30 120	S3 012
518 902 026	0 092 M60 240	M6 024	550 056 054	0 092 S30 040	S3 004	585 021 054	0 092 S40 280	S4 028
519 011 019	0 092 M4F 430	M4 F43	550 057 054	0 092 S30 040	S3 004	585 022 054	0 092 S40 290	S4 029
519 011 019	0 092 M40 430	M4 043	550 066 033	0 092 S40 020	S4 002	585 200 080	0 092 S50 100	S5 010
519 012 019	0 092 M4F 440	M4 F44	550 070 033	0 092 S40 020	S4 002	588 033 064	0 092 S30 130	S3 013
519 012 019	0 092 M40 440	M4 044	550 144 039	0 092 S40 020	S4 002	588 107 085	0 092 S40 130	S4 013
519 013 017	0 092 M4F 450	M4 F45	550 154 042	0 092 S40 020	S4 002	590 122 072	0 092 S30 130	S3 013
519 013 017	0 092 M40 450	M4 045	550 155 054	0 092 S50 010	S5 001	590 123 072	0 092 S30 130	S3 013
519 014 018	0 092 M4F 460	M4 F46	555 059 042	0 092 S30 050	S3 005	592 026 076	0 092 S40 130	S4 013
519 014 018	0 092 M40 460	M4 046	555 065 042	0 092 S30 060	S3 006	595 018 064	0 092 S40 280	S4 028
519 901 017	0 092 M60 450	M6 045	555 107 054	0 092 S40 050	S4 005	595 019 064	0 092 S40 290	S4 029
520 012 020	0 092 M4F 470	M4 F47	555 155 054	0 092 S40 040	S4 004	595 104 068	0 092 S40 280	S4 028
520 012 020	0 092 M40 470	M4 047	555 156 054	0 092 S40 040	S4 004	595 105 068	0 092 S40 290	S4 029
520 016 020	0 092 M4F 480	M4 F48	560 048 028	0 092 S40 260	S4 026	595 200 085	0 092 S50 130	S5 013
524 101 020	0 092 M4F 510	M4 F51	560 049 028	0 092 S40 270	S4 027	595 901 085	0 092 S60 020	S6 002
524 101 020	0 092 M40 510	M4 051	560 068 039	0 092 S40 240	S4 024	595 901 085	0 092 S60 130	S6 013
525 015 022	0 092 M4F 520	M4 F52	560 069 039	0 092 S40 250	S4 025	600 044 076	0 092 S50 130	S5 013
525 015 022	0 092 M40 520	M4 052	560 077 060	0 092 S50 040	S5 004	600 131 080	0 092 S50 130	S5 013
530 030 030	0 092 M4F 540	M4 F54	560 098 028	0 092 S40 260	S4 026	610 049 068	0 092 T30 390	T3 039
530 030 030	0 092 M40 540	M4 054	560 099 028	0 092 S40 270	S4 027	610 200 085	0 092 S50 150	S5 015
532 036 024	0 092 M40 550	M4 055	560 160 042	0 092 S40 260	S4 026	620 046 068	0 092 T30 390	T3 039
535 020 024	0 092 S40 180	S4 018	560 161 042	0 092 S40 270	S4 027	632 011 085	0 092 T30 460	T3 046
535 022 024	0 092 S40 190	S4 019	560 162 042	0 092 S40 240	S4 024	635 045 068	0 092 T50 750	T5 075



◀ EUROPEAN TYPE NUMBER

640 034 095	0 092 T40 750	T4 075
640 035 076	0 092 T40 750	T4 075
640 036 076	0 092 T40 760	T4 076
643 033 095	0 092 T30 470	T3 047
643 034 090	0 092 T30 480	T3 048
670 023 080	0 092 T40 780	T4 078
670 042 115	0 092 T40 770	T4 077
670 043 100	0 092 T40 770	T4 077
670 044 100	0 092 T30 790	T3 079
670 045 100	0 092 T40 780	T4 078
670 046 110	0 092 T30 790	T3 079
680 032 100	0 092 T50 770	T5 077
680 033 110	0 092 T30 790	T3 079
715 014 115	0 092 T40 800	T4 080
720 025 145	0 092 T30 810	T3 081

725 012 115	0 092 T50 800	T5 080

EXIDE

EA1000	0 092 S50 130	S5 013
EA1004	0 092 S40 280	S4 028
EA1005	0 092 S40 290	S4 029

EA472	0 092 S50 010	S5 001
EA530	0 092 S50 020	S5 002
EA602	0 092 S50 040	S5 004
EA640	0 092 S50 050	S5 005
EA722	0 092 S50 070	S5 007

EA754	0 092 S40 260	S4 026
EA755	0 092 S40 270	S4 027
EA770	0 092 S50 080	S5 008
EA852	0 092 S50 100	S5 010
EB356	0 092 S40 180	S4 018

EB357	0 092 S40 190	S4 019
EB440	0 092 S40 000	S4 000
EB442	0 092 S40 010	S4 001
EB450	0 092 S30 160	S3 016
EB451	0 092 S30 170	S3 017

EB454	0 092 S40 210	S4 021
EB455	0 092 S40 230	S4 023
EB457	0 092 S40 220	S4 022
EB500	0 092 S40 020	S4 002
EB501	0 092 S30 030	S3 003

EB542	0 092 S40 040	S4 004
EB604	0 092 S40 240	S4 024
EB605	0 092 S40 250	S4 025
EB620	0 092 S40 050	S4 005
EB712	0 092 S40 070	S4 007

EB740	0 092 S40 080	S4 008
EB741	0 092 S40 090	S4 009
EB802	0 092 S40 100	S4 010
EB852	0 092 S30 120	S3 012
EB950	0 092 S40 130	S4 013

EC400	0 092 S40 000	S4 000
EC412	0 092 S30 010	S3 001
EC440	0 092 S30 020	S3 002
EC502	0 092 S30 040	S3 004
EC550	0 092 S30 050	S3 005

EC652	0 092 S30 070	S3 007
EC700	0 092 S30 080	S3 008
EK700	0 092 S60 080	S6 008
EK800	0 092 S60 110	S6 011
EK900	0 092 S60 130	S6 013

EL600	0 092 S5E 050	S5 E05
EL700	0 092 S5E 080	S5 E08
EL800	0 092 S5E 110	S5 E11
165 25	0 092 T30 630	T3 063
445 00	0 092 S40 010	S4 001

4502	0 092 M4F 220	M4 F22
4502	0 092 M40 220	M4 022
4503	0 092 M4F 250	M4 F25
4503	0 092 M40 250	M4 025
4504	0 092 M4F 040	M4 F04

4507	0 092 M4F 100	M4 F10
4507	0 092 M40 100	M4 010
451 00	0 092 S40 020	S4 002
4516	0 092 M4F 170	M4 F17
4516	0 092 M40 170	M4 017

4517	0 092 M4F 180	M4 F18
4517	0 092 M40 180	M4 018
4518	0 092 M4F 200	M4 F20
4520	0 092 M4F 300	M4 F30
4520	0 092 M40 300	M4 030

4521	0 092 M4F 340	M4 F34
4521	0 092 M40 340	M4 034
4522	0 092 M4F 540	M4 F54
4522	0 092 M40 540	M4 054
4525	0 092 M4F 300	M4 F30

4525	0 092 M40 300	M4 030
4526	0 092 M4F 280	M4 F28
4526	0 092 M40 280	M4 028
4527	0 092 M4F 350	M4 F35
4527	0 092 M40 350	M4 035

4528	0 092 M4F 470	M4 F47
4528	0 092 M40 470	M4 047
4529	0 092 M4F 340	M4 F34
4529	0 092 M40 340	M4 034
4530	0 092 M4F 400	M4 F40

4530	0 092 M40 400	M4 040
4531	0 092 M4F 420	M4 F42
4531	0 092 M40 420	M4 042
4532	0 092 M4F 390	M4 F39
4532	0 092 M40 390	M4 039

4533	0 092 M4F 440	M4 F44
4533	0 092 M40 440	M4 044
4534	0 092 M4F 430	M4 F43
4534	0 092 M40 430	M4 043
4535	0 092 M4F 450	M4 F45

4535	0 092 M40 450	M4 045
4538	0 092 M4F 520	M4 F52
4538	0 092 M40 520	M4 052
4542	0 092 M4F 120	M4 F12
4542	0 092 M40 120	M4 012

4543	0 092 M4F 150	M4 F15
4543	0 092 M40 150	M4 015
4545	0 092 M4F 160	M4 F16
4545	0 092 M40 160	M4 016
4546	0 092 M4F 180	M4 F18

4546	0 092 M40 180	M4 018
4555	0 092 M4F 410	M4 F41
4555	0 092 M40 410	M4 041
4559	0 092 M4F 190	M4 F19
4559	0 092 M40 190	M4 019

4560	0 092 M4F 210	M4 F21
4560	0 092 M40 210	M4 021
4562	0 092 M4F 290	M4 F29
4562	0 092 M40 290	M4 029
4563	0 092 M4F 330	M4 F33

4564	0 092 M4F 320	M4 F32
4564	0 092 M40 320	M4 032
4566	0 092 M4F 370	M4 F37
4567	0 092 M4F 360	M4 F36
4567	0 092 M40 360	M4 036

4572	0 092 M4F 480	M4 F48
4573	0 092 M4F 260	M4 F26
4573	0 092 M40 260	M4 026
4577	0 092 M4F 240	M4 F24
4577	0 092 M40 240	M4 024

4581	0 092 M4F 270	M4 F27
4582	0 092 M4F 540	M4 F54
4582	0 092 M40 540	M4 054
460 00	0 092 S40 040	S4 004
460 00	0 092 S50 040	S5 004

464 00	0 092 S50 050	S5 005
468 00	0 092 S30 070	S3 007
468 00	0 092 S40 070	S4 007
476 00	0 092 S40 080	S4 008
490 00	0 092 S50 130	S5 013

4988	0 092 M4F 480	M4 F48
535 22	0 092 S40 190	S4 019
540 56	0 092 S40 000	S4 000
543 17	0 092 S40 010	S4 001
543 20	0 092 S40 010	S4 001

544 64	0 092 S30 030	S3 003
544 69	0 092 S40 010	S4 001
545 19	0 092 S40 010	S4 001
545 23	0 092 S40 210	S4 021
545 24	0 092 S40 230	S4 023

545 77	0 092 S30 160	S3 016
545 79	0 092 S30 170	S3 017
550 00	0 092 S40 020	S4 002
555 59	0 092 S30 050	S3 005
555 65	0 092 S30 060	S3 006



560 48	0 092 S40 260	S4 026
560 49	0 092 S40 270	S4 027
560 68	0 092 S40 240	S4 024
560 69	0 092 S40 250	S4 025
560 77	0 092 S50 040	S5 004

562 19	0 092 S40 050	S4 005
562 19	0 092 S50 050	S5 005
565 30	0 092 S30 070	S3 007
566 36	0 092 S40 090	S4 009
566 38	0 092 S30 080	S3 008

566 38	0 092 T30 080	T3 008
570 24	0 092 S40 270	S4 027
570 29	0 092 S40 260	S4 026
571 13	0 092 S40 070	S4 007
571 14	0 092 S40 070	S4 007

574 12	0 092 S40 080	S4 008
580 35	0 092 S40 100	S4 010
585 15	0 092 S30 120	S3 012
588 27	0 092 S30 130	S3 013
592 26	0 092 S30 130	S3 013

592 26	0 092 S40 130	S4 013
595 18	0 092 S40 280	S4 028
595 19	0 092 S40 290	S4 029
600 27	0 092 T30 730	T3 073
600 38	0 092 S50 130	S5 013

605 027 068	0 092 T30 310	T3 031
610 04	0 092 T30 360	T3 036
610 040 076	0 092 T30 380	T3 038
610 40	0 092 T30 380	T3 038
615 01	0 092 T30 350	T3 035

620 034 068	0 092 T30 750	T3 075
625 011 064	0 092 T30 400	T3 040
625 11	0 092 T30 400	T3 040
625 13	0 092 T30 410	T3 041
625 23	0 092 T30 420	T3 042

635 030 068	0 092 T40 750	T4 075
635 031 068	0 092 T40 760	T4 076
635 042 068	0 092 T30 440	T3 044
635 043 100	0 092 T30 450	T3 045
640 03	0 092 T40 750	T4 075

640 09	0 092 T30 460	T3 046
640 21	0 092 T40 760	T4 076
643 027 095	0 092 T30 770	T3 077
643 029 095	0 092 T30 470	T3 047
643 089 090	0 092 T30 480	T3 048

643 29	0 092 T30 470	T3 047
645 00	0 092 T30 400	T3 040
645 01	0 092 T30 410	T3 041
645 07	0 092 T40 750	T4 075
665 014 090	0 092 T40 770	T4 077

680 032 100	0 092 T50 770	T5 077
680 19	0 092 T40 780	T4 078
680 32	0 092 T40 770	T4 077
680 32	0 092 T50 770	T5 077
685 07	0 092 T40 770	T4 077

685 07	0 092 T50 770	T5 077
700 038 105	0 092 T40 800	T4 080
720 18	0 092 T50 800	T5 080
725 012 115	0 092 T50 800	T5 080
730 15	0 092 T50 800	T5 080

735 07	0 092 T50 800	T5 080
810 00	0 092 S50 130	S5 013
855 00	0 092 S40 020	S4 002
860 00	0 092 S40 040	S4 004
866 00	0 092 S50 050	S5 005

870 00	0 092 S30 070	S3 007
877 00	0 092 S40 080	S4 008

FAAM

00L62	0 092 S50 150	S5 015
00X56	0 092 S50 130	S5 013
43L12	0 092 S40 010	S4 001

44L02	0 092 S40 000	S4 000
44L12	0 092 S30 020	S3 002
45E23	0 092 S30 160	S3 016
45E23	0 092 S30 170	S3 017
45L11	0 092 S30 030	S3 003

45NS3	0 092 S40 220	S4 022
45NS3	0 092 S40 230	S4 023
45NS4	0 092 S40 210	S4 021
52L12	0 092 S40 020	S4 002
54002	0 092 S30 010	S3 001

54402	0 092 S30 020	S3 002
55X12	0 092 S40 020	S4 002
55502	0 092 S40 020	S4 002
56002	0 092 S30 050	S3 005
57002	0 092 S30 080	S3 008

59202	0 092 S30 130	S3 013
60D21	0 092 S40 250	S4 025
60D22	0 092 S40 240	S4 024
60L20	0 092 S40 040	S4 004
60L21	0 092 S40 060	S4 006

62L22	0 092 S40 050	S4 005
620M2	0 092 T30 380	T3 038
62060	0 092 T40 750	T4 075
62061	0 092 T30 390	T3 039
63560	0 092 T50 750	T5 075

63572	0 092 T30 460	T3 046
65X22	0 092 S50 050	S5 005
650M3	0 092 T30 470	T3 047
66062	0 092 T40 770	T4 077
68062	0 092 T50 770	T5 077

69962	0 092 T40 780	T4 078
70L30	0 092 S30 070	S3 007
70L31	0 092 S40 090	S4 009
70104	0 092 T30 790	T3 079
72062	0 092 T30 810	T3 081

74L32	0 092 S40 080	S4 008
80L40	0 092 S40 100	S4 010
80X32	0 092 S50 080	S5 008
88L50	0 092 S30 120	S3 012
92L52	0 092 S40 130	S4 013

FB

FB10L-A2	0 092 M4F 280	M4 F28
FB10L-A2	0 092 M40 280	M4 028
FB10L-B2	0 092 M4F 290	M4 F29

FB10L-B2	0 092 M40 290	M4 029
FB12A-A	0 092 M4F 300	M4 F30
FB12A-A	0 092 M40 300	M4 030
FB14-A2	0 092 M4F 350	M4 F35
FB14-A2	0 092 M40 350	M4 035

FB14L-A2	0 092 M4F 340	M4 F34
FB14L-A2	0 092 M40 340	M4 034
FB14L-B2	0 092 M4F 360	M4 F36
FB14L-B2	0 092 M40 360	M4 036
FB16-B	0 092 M4F 440	M4 F44

FB16-B	0 092 M40 440	M4 044
FB16L-B	0 092 M4F 430	M4 F43
FB16L-B	0 092 M40 430	M4 043
FB3L-A	0 092 M4F 150	M4 F15
FB3L-A	0 092 M40 150	M4 015

FB3L-B	0 092 M4F 160	M4 F16
FB3L-B	0 092 M40 160	M4 016
FB4L-B	0 092 M4F 170	M4 F17
FB4L-B	0 092 M40 170	M4 017
FB5L-B	0 092 M4F 180	M4 F18

FB5L-B	0 092 M40 180	M4 018
FB50-N18L-A	0 092 M4F 470	M4 F47
FB50-N18L-A	0 092 M40 470	M4 047
FB7-A	0 092 M4F 240	M4 F24
FB7-A	0 092 M40 240	M4 024

FB9-B	0 092 M4F 250	M4 F25
FB9-B	0 092 M40 250	M4 025
FB9L-B	0 092 M4F 260	M4 F26
FB9L-B	0 092 M40 260	M4 026
FTX12-BS	0 092 M60 140	M6 014

FTX14-BS	0 092 M60 180	M6 018
FTX7A-BS	0 092 M60 070	M6 007
FT4L-BS	0 092 M60 010	M6 001

FEMSA

ACB 12Y-21	0 092 S30 160	S3 016
ACB 12Y-22	0 092 S30 170	S3 017
ACB 12Y-6	0 092 S30 160	S3 016

ACB 12Y-7	0 092 S30 170	S3 017
ACL 12Y-2	0 092 S40 270	S4 027
ACL 12Y-4	0 092 S40 270	S4 027
ACL 12Y-8	0 092 S40 270	S4 027
APF 12S-2	0 092 S30 070	S3 007



FENDT

G 198 900 901 010	0 092 T30 450	T3 045
G 345 900 901 010	0 092 T30 130	T3 013
G 524 900 050 010	0 092 T30 080	T3 008

G 718 901 050 010	0 092 T40 770	T4 077
X 830 020 081 000	0 092 T30 450	T3 045

FIAMM

ATX 100	0 092 T30 710	T3 071
AT 100	0 092 T30 720	T3 072
A 120	0 092 T40 750	T4 075

A 135 SHD	0 092 T40 750	T4 075
B 160	0 092 T30 770	T3 077
B 180	0 092 T30 770	T3 077
B 180 B03	0 092 T30 770	T3 077
B 180 SHD	0 092 T30 770	T3 077

B19JAK 35	0 092 S40 180	S4 018
B19JX 35	0 092 S40 190	S4 019
B19J 35	0 092 S40 180	S4 018
B24JX 45	0 092 S40 220	S4 022
B24X 45	0 092 S40 230	S4 023

B24 45	0 092 S40 210	S4 021
CBX 110	0 092 T30 360	T3 036
CB 110	0 092 T30 350	T3 035
CB 110 B01	0 092 T30 370	T3 037
CHX 125	0 092 T30 410	T3 041

CH 125	0 092 T30 400	T3 040
CX 200	0 092 T30 800	T3 080
CX 225 SHD	0 092 T30 810	T3 081
D11 110	0 092 T30 380	T3 038
D11 135	0 092 T30 450	T3 045

D14 148	0 092 T30 470	T3 047
D23X 60	0 092 S40 250	S4 025
D23 60	0 092 S40 240	S4 024
D26X 75	0 092 S40 270	S4 027
D26 75	0 092 S40 260	S4 026

D31X95	0 092 S40 290	S4 029
D31 95	0 092 S40 280	S4 028
E2X 45	0 092 S30 170	S3 017
E2 45	0 092 S30 160	S3 016
LO 40	0 092 S40 000	S4 000

LO 44+	0 092 S40 000	S4 000
L1B 36	0 092 S30 010	S3 001
L1B 44	0 092 S40 010	S4 001
L1B 50+	0 092 S40 020	S4 002
L1X 44	0 092 S30 030	S3 003

L1 44	0 092 S30 020	S3 002
L1 50	0 092 S40 020	S4 002
L1 54+	0 092 S50 020	S5 002
L2B 45	0 092 S30 040	S3 004
L2B 54	0 092 S40 040	S4 004

L2B 60+	0 092 S50 050	S5 005
L2X 60	0 092 S40 060	S4 006
L2 55	0 092 S30 050	S3 005
L2 60	0 092 S40 050	S4 005
L2 60	0 092 S50 050	S5 005

L2 64+	0 092 S50 050	S5 005
L3B 63	0 092 S30 070	S3 007
L3B 71	0 092 S40 070	S4 007
L3B 75+	0 092 S50 070	S5 007
L3X 70	0 092 S40 090	S4 009

L3 70	0 092 S30 080	S3 008
L3 70	0 092 S40 080	S4 008
L3 74	0 092 S40 080	S4 008
L3 80+	0 092 S50 080	S5 008
L4B 85+	0 092 S50 100	S5 010

L5B 85	0 092 S30 120	S3 012
L5 100+	0 092 S50 130	S5 013
L5 88	0 092 S30 130	S3 013
L5 90	0 092 S40 130	S4 013
L6 110	0 092 S50 150	S5 015

MC12 120	0 092 T30 390	T3 039
MC 130	0 092 T30 430	T3 043
MC15 160	0 092 T30 480	T3 048
MT 132	0 092 T30 460	T3 046
TR520	0 092 S5E 050	S5 E05

TR680	0 092 S5E 080	S5 E08
TR740	0 092 S5E 110	S5 E11
VR760	0 092 S60 080	S6 008
VR800	0 092 S60 110	S6 011
VR900	0 092 S60 130	S6 013

170 B 20 NX	0 092 S40 190	S4 019
180 E 2 D	0 092 S30 160	S3 016
210 B 24	0 092 S40 210	S4 021
210 B 24 NX	0 092 S40 220	S4 022
210 B 24 X	0 092 S40 230	S4 023

210 E 2	0 092 S30 160	S3 016
210 E 2 SM	0 092 S30 160	S3 016
210 E 2 X	0 092 S30 170	S3 017
210 L1	0 092 S30 020	S3 002
210 L1	0 092 S40 020	S4 002

210 L1 C	0 092 S30 020	S3 002
210 L1 C	0 092 S40 020	S4 002
210 L1 X	0 092 S30 030	S3 003
210 L1 XC	0 092 S30 030	S3 003
220 D 20	0 092 S40 240	S4 024

220 D 20 X	0 092 S40 250	S4 025
230 L 1 ST	0 092 S30 020	S3 002
230 L 1 ST	0 092 S40 020	S4 002
260 D 23	0 092 S40 240	S4 024
260 D 23 X	0 092 S40 250	S4 025

270 L 1	0 092 S30 020	S3 002
270 L 1	0 092 S40 020	S4 002
270 L1 C	0 092 S40 010	S4 001
270 L 1 X	0 092 S30 030	S3 003
270 L1 XC	0 092 S30 030	S3 003

3 B 11	0 092 T30 630	T3 063
3 B 7	0 092 T30 610	T3 061
3 B 8	0 092 T30 610	T3 061
3 B 8 S	0 092 T30 610	T3 061
3 R 2 PP	0 092 M4F 100	M4 F10

3 R 2 PP	0 092 M40 100	M4 010
3 S2 P	0 092 M4F 040	M4 F04
3 S4 P	0 092 M4F 120	M4 F12
3 S4 P	0 092 M40 120	M4 012
330 AVF	0 092 S30 040	S3 004

330 AVF	0 092 S40 040	S4 004
330 AVFC	0 092 S30 040	S3 004
330 AVFC	0 092 S40 040	S4 004
330 L 12	0 092 S30 050	S3 005
330 L 2	0 092 S30 050	S3 005

330 L 2	0 092 S40 050	S4 005
330 L 2 C	0 092 S40 050	S4 005
330 L 2 C	0 092 S50 050	S5 005
330 L 2 F	0 092 S50 040	S5 004
330 L 2 X	0 092 S30 060	S3 006

360 AV	0 092 S30 070	S3 007
380 AV	0 092 S50 040	S5 004
380 AVK	0 092 S30 070	S3 007
380 AVK	0 092 S40 070	S4 007
400 AV	0 092 S40 070	S4 007

400 AV	0 092 S50 070	S5 007
400 L3 C	0 092 S40 080	S4 008
400 L3 X	0 092 S40 090	S4 009
400 L3 XC	0 092 S40 090	S4 009
400 L5 C	0 092 S50 130	S5 013

420 AV	0 092 S40 100	S4 010
430 AVF	0 092 S40 070	S4 007
430 AVF	0 092 S50 070	S5 007
430 AVFC	0 092 S40 070	S4 007
430 AVFC	0 092 S50 070	S5 007

440 L3 C	0 092 S40 080	S4 008
440 L5	0 092 S50 130	S5 013
440 L5 C	0 092 S50 130	S5 013
440 L 5 SM	0 092 S30 130	S3 013
440 L 5 SM	0 092 S40 130	S4 013

440 L 5 SM	0 092 S50 130	S5 013
440 L 5 SM	0 092 T30 130	T3 013
450 L3 C	0 092 S40 080	S4 008
500 A	0 092 T30 750	T3 075
500 A	0 092 T40 750	T4 075

500 A	0 092 T50 750	T5 075
500 AV	0 092 S30 120	S3 012
500 AV	0 092 S40 100	S4 010
500 360 030	0 092 S40 010	S4 001
500 430 028	0 092 S30 020	S3 002

500 430 028	0 092 S40 020	S4 002
500 431 028	0 092 S30 030	S3 003
500 434 030	0 092 S40 010	S4 001
500 440 033	0 092 S30 020	S3 002
500 440 033	0 092 S40 020	S4 002

500 450 039	0 092 S40 010	S4 001
500 544 039	0 092 S30 040	S3 004
500 544 039	0 092 S40 040	S4 004
500 550 042	0 092 S30 050	S3 005
500 550 042	0 092 S40 050	S4 005
500 551 042	0 092 S30 060	S3 006
500 600 033	0 092 S40 260	S4 026
500 601 033	0 092 S40 270	S4 027
500 630 051	0 092 S30 070	S3 007
500 660 051	0 092 S30 080	S3 008
500 660 051	0 092 S40 080	S4 008
500 700 057	0 092 S40 080	S4 008
500 701 057	0 092 S40 090	S4 009
500 880 068	0 092 S30 130	S3 013
500 880 068	0 092 S40 130	S4 013
500 880 068	0 092 S50 130	S5 013
540 L 3	0 092 S40 080	S4 008
6 AC 4 P	0 092 S30 030	S3 003
6 AT 6	0 092 T30 720	T3 072
6 AT 6 TR	0 092 T30 720	T3 072
6 AV 4 P	0 092 S30 010	S3 001
6 AV 4 PFRM	0 092 S40 010	S4 001
6 AV 4 PW	0 092 S40 010	S4 001
6 AV 4 ST	0 092 S30 010	S3 001
6 AV 4 WC	0 092 S30 010	S3 001
6 AV 4 WK	0 092 S40 010	S4 001
6 AV 5 FC	0 092 S40 010	S4 001
6 AV 5 FST	0 092 S40 010	S4 001
6 AV 5 PRM	0 092 S40 010	S4 001
6 AV 5 PW	0 092 S40 010	S4 001
6 AV 5 WC	0 092 S40 010	S4 001
6 AV 7 C	0 092 S30 070	S3 007
6 AV 7 K	0 092 S30 070	S3 007
6 AV 7 K	0 092 S40 070	S4 007
6 AV 7 P	0 092 S30 070	S3 007
6 AV 7 PRM	0 092 S30 070	S3 007
6 BP 5	0 092 S40 270	S4 027
6 B 3 PS	0 092 M4F 210	M4 F21
6 B 3 PS	0 092 M40 210	M4 021
6 B 6	0 092 S40 270	S4 027
6 B 6 D	0 092 S40 260	S4 026
6 B 6 PRM	0 092 S40 270	S4 027
6 D 2 P	0 092 M4F 160	M4 F16
6 D 2 P	0 092 M40 160	M4 016
6 D 2 PS	0 092 M4F 150	M4 F15
6 D 2 PS	0 092 M40 150	M4 015
6 D 3 P	0 092 M4F 280	M4 F28
6 D 3 P	0 092 M40 280	M4 028
6 D 4 P	0 092 M4F 430	M4 F43
6 D 4 P	0 092 M40 430	M4 043
6 D 5 P	0 092 M4F 470	M4 F47
6 D 5 P	0 092 M40 470	M4 047
6 EP 450	0 092 S40 280	S4 028
6 EP 450 X	0 092 S40 290	S4 029
6 ER 6	0 092 T30 400	T3 040

6 E 12	0 092 M60 140	M6 014
6 E 14	0 092 M60 180	M6 018
6 E 4	0 092 M60 010	M6 001
6 E 5	0 092 M60 040	M6 004
6 E 9	0 092 M60 100	M6 010
6 FP 6	0 092 S40 260	S4 026
6 H 2 P	0 092 M4F 250	M4 F25
6 H 2 P	0 092 M40 250	M4 025
6 H 2 PS	0 092 M4F 260	M4 F26
6 H 2 PS	0 092 M40 260	M4 026
6 H 3 P	0 092 M4F 340	M4 F34
6 H 3 P	0 092 M40 340	M4 034
6 H 4 P	0 092 M4F 410	M4 F41
6 H 4 P	0 092 M40 410	M4 041
6 IF 130	0 092 M4F 520	M4 F52
6 IF 130	0 092 M40 520	M4 052
6 IF 200	0 092 M4F 540	M4 F54
6 IF 200	0 092 M40 540	M4 054
6 IF 5 P	0 092 M4F 540	M4 F54
6 IF 5 P	0 092 M40 540	M4 054
6 I 2 P	0 092 M4F 170	M4 F17
6 I 2 P	0 092 M40 170	M4 017
6 K 3 PS	0 092 M4F 190	M4 F19
6 K 3 PS	0 092 M40 190	M4 019
6 L 2 P	0 092 M4F 180	M4 F18
6 L 2 P	0 092 M40 180	M4 018
6 MC 4 RD	0 092 S40 260	S4 026
6 MC 4 RPV	0 092 S40 270	S4 027
6 MC 4 RV	0 092 S40 270	S4 027
6 MD 10	0 092 T30 380	T3 038
6 MD 10 P	0 092 T30 380	T3 038
6 MD 13	0 092 T30 470	T3 047
6 MD 13 P	0 092 T30 470	T3 047
6 ME 10	0 092 T30 390	T3 039
6 ME 12	0 092 T30 480	T3 048
6 ME 13	0 092 T30 480	T3 048
6 ME 15	0 092 T30 790	T3 079
6 ME 4 P	0 092 S30 020	S3 002
6 ME 4 P	0 092 S40 020	S4 002
6 ME 4 PR	0 092 S40 020	S4 002
6 ME 4 PRM	0 092 S30 020	S3 002
6 ME 4 PRM	0 092 S40 020	S4 002
6 ME 5	0 092 S30 050	S3 005
6 ME 5	0 092 S40 050	S4 005
6 ME 5 P	0 092 S30 050	S3 005
6 ME 5 P	0 092 S40 050	S4 005
6 ME 5 PF	0 092 S30 040	S3 004
6 ME 5 PF	0 092 S40 040	S4 004
6 ME 5 PRM	0 092 S30 050	S3 005
6 ME 5 PRM	0 092 S40 050	S4 005
6 ME 5 ST	0 092 S30 050	S3 005
6 ME 5 ST	0 092 S40 050	S4 005
6 ME 6	0 092 S30 080	S3 008
6 ME 6	0 092 S40 080	S4 008
6 ME 6	0 092 T30 080	T3 008

6 ME 6G	0 092 S30 080	S3 008
6 ME 6G	0 092 S40 080	S4 008
6 ME 6 PG	0 092 S30 080	S3 008
6 ME 6 PG	0 092 S40 080	S4 008
6 ME 6 PR	0 092 S30 070	S3 007
6 ME 8	0 092 S30 130	S3 013
6 ME 8	0 092 S40 130	S4 013
6 ME 8	0 092 S50 130	S5 013
6 ME 8	0 092 T30 130	T3 013
6 ME 8 C	0 092 S30 130	S3 013
6 ME 8 C	0 092 S40 130	S4 013
6 ME 8 C	0 092 S50 130	S5 013
6 ME 8 K	0 092 S30 130	S3 013
6 ME 8 K	0 092 S40 130	S4 013
6 ME 8 K	0 092 S50 130	S5 013
6 ME 8 K	0 092 T30 130	T3 013
6 ME 8 P	0 092 S30 130	S3 013
6 ME 8 P	0 092 S40 130	S4 013
6 ME 8 P	0 092 S50 130	S5 013
6 ME 8 P	0 092 T30 130	T3 013
6 ME 8 PL	0 092 S30 130	S3 013
6 ME 8 PL	0 092 S40 130	S4 013
6 ME 8 PL	0 092 S50 130	S5 013
6 ME 8 PL	0 092 T30 130	T3 013
6 ML 6 PGRM	0 092 S30 080	S3 008
6 ML 6 PGRM	0 092 S40 080	S4 008
6 ML 6 PGRM	0 092 T30 080	T3 008
6 MP 11	0 092 T30 460	T3 046
6 MP 4	0 092 S30 030	S3 003
6 MP 4 C	0 092 S30 010	S3 001
6 MP 5 RM	0 092 S30 060	S3 006
6 M 4 P	0 092 M4F 390	M4 F39
6 M 4 P	0 092 M40 390	M4 039
6 M 5 PS	0 092 M4F 420	M4 F42
6 M 5 PS	0 092 M40 420	M4 042
6 R 3	0 092 S30 160	S3 016
6 S 3 P	0 092 M4F 300	M4 F30
6 S 3 P	0 092 M40 300	M4 030
6 Y 2 P	0 092 M4F 200	M4 F20
6 Y 3 PS	0 092 M4F 320	M4 F32
6 Y 3 PS	0 092 M40 320	M4 032
6 Y 4 P	0 092 M4F 350	M4 F35
6 Y 4 P	0 092 M40 350	M4 035
6 Y 5 PS	0 092 M4F 360	M4 F36
6 Y 5 PS	0 092 M40 360	M4 036
660 B	0 092 T30 770	T3 077
660 B	0 092 T40 770	T4 077
800 B	0 092 T40 770	T4 077
850 B	0 092 T40 770	T4 077
900 C	0 092 T30 800	T3 080
FIAT		
1305436080	0 092 S50 130	S5 013
1320778080	0 092 S50 130	S5 013
1334384080	0 092 S50 080	S5 008



◀ FIAT

1334385080	0 092 S50 130	S5 013	46840940	0 092 S50 100	S5 010	5893765	0 092 S50 050	S5 005
1334386080	0 092 S50 130	S5 013	46840941	0 092 S40 000	S4 000	5894195	0 092 S40 000	S4 000
1340661080	0 092 S50 150	S5 015	50500212	0 092 S40 020	S4 002	5894412	0 092 S50 130	S5 013
1346948080	0 092 S50 130	S5 013	50500212	0 092 S50 020	S5 002	59068175	0 092 S40 000	S4 000
1346949080	0 092 S50 130	S5 013	50500230	0 092 S50 100	S5 010	59068176	0 092 S30 120	S3 012
4248779	0 092 S30 030	S3 003	50501113	0 092 S50 100	S5 010	60600097	0 092 S50 130	S5 013
46211709	0 092 S40 020	S4 002	50501114	0 092 S50 100	S5 010	60627457	0 092 S50 130	S5 013
46211710	0 092 S40 050	S4 005	50503179	0 092 S50 080	S5 008	60627931	0 092 S50 080	S5 008
46211710	0 092 S50 050	S5 005	50503180	0 092 S50 040	S5 004	60669159	0 092 S50 050	S5 005
46211823	0 092 S40 130	S4 013	50503181	0 092 S40 070	S4 007	60672124	0 092 S50 080	S5 008
46214085	0 092 S30 020	S3 002	50503182	0 092 S50 080	S5 008	60672125	0 092 S50 130	S5 013
46214087	0 092 S40 080	S4 008	50503183	0 092 S50 070	S5 007	60672126	0 092 S40 070	S4 007
46227863	0 092 S30 170	S3 017	50503188	0 092 S50 010	S5 001	60672128	0 092 S50 080	S5 008
46227866	0 092 S40 050	S4 005	50503188	0 092 S50 050	S5 005	60677703	0 092 S50 020	S5 002
46227866	0 092 S50 050	S5 005	50503189	0 092 S50 050	S5 005	60677704	0 092 S50 040	S5 004
46227867	0 092 S40 050	S4 005	51760192	0 092 S40 000	S4 000	60677705	0 092 S50 050	S5 005
46227867	0 092 S50 050	S5 005	51760193	0 092 S50 020	S5 002	60677706	0 092 S50 050	S5 005
46227868	0 092 S30 060	S3 006	51760307	0 092 S40 000	S4 000	60677707	0 092 S40 070	S4 007
46227869	0 092 S40 080	S4 008	51760308	0 092 S40 020	S4 002	60677708	0 092 S50 080	S5 008
46227870	0 092 S40 090	S4 009	51760308	0 092 S50 020	S5 002	60677709	0 092 S50 070	S5 007
46227871	0 092 S30 130	S3 013	51760309	0 092 S40 050	S4 005	60778721	0 092 S50 020	S5 002
46227871	0 092 S50 130	S5 013	51760309	0 092 S50 050	S5 005	60778722	0 092 S50 020	S5 002
46227872	0 092 S50 040	S5 004	51761145	0 092 S50 020	S5 002	60778723	0 092 S50 020	S5 002
46227873	0 092 S40 080	S4 008	51763094	0 092 S40 000	S4 000	60778724	0 092 S50 020	S5 002
46227875	0 092 S50 130	S5 013	51763095	0 092 S50 020	S5 002	60778725	0 092 S50 050	S5 005
46227876	0 092 S30 020	S3 002	51763097	0 092 S30 080	S3 008	60778726	0 092 S50 050	S5 005
46227877	0 092 S50 070	S5 007	51763097	0 092 S40 080	S4 008	60778729	0 092 T30 320	T3 032
46227895	0 092 S50 130	S5 013	517 6309 80	0 092 S50 100	S5 010	60779202	0 092 S50 080	S5 008
46413856	0 092 S50 080	S5 008	51763099	0 092 S50 100	S5 010	71714567	0 092 S50 130	S5 013
46516276	0 092 S50 050	S5 005	51767152	0 092 S40 020	S4 002	71716340	0 092 S40 070	S4 007
46750611	0 092 S50 050	S5 005	51767152	0 092 S50 020	S5 002	71716988	0 092 S50 080	S5 008
46756131	0 092 S50 020	S5 002	51767531	0 092 S50 050	S5 005	71718030	0 092 S50 050	S5 005
46756133	0 092 S30 050	S3 005	51767532	0 092 S50 050	S5 005	71718462	0 092 S50 100	S5 010
46756133	0 092 S40 050	S4 005	51773100	0 092 S40 000	S4 000	71719455	0 092 S50 050	S5 005
46756133	0 092 S50 050	S5 005	51773101	0 092 S40 020	S4 002	71719456	0 092 S50 080	S5 008
46756135	0 092 S50 050	S5 005	51773102	0 092 S40 050	S4 005	71719457	0 092 S50 130	S5 013
46756136	0 092 S50 020	S5 002	51778209	0 092 S50 050	S5 005	71719458	0 092 S50 130	S5 013
46766413	0 092 S50 050	S5 005	51778210	0 092 S40 000	S4 000	71730452	0 092 S40 000	S4 000
46766414	0 092 S50 050	S5 005	51778210	0 092 S50 050	S5 005	71730453	0 092 S50 020	S5 002
46810022	0 092 S50 020	S5 002	51778211	0 092 S50 020	S5 002	71730459	0 092 S40 000	S4 000
46810023	0 092 S50 050	S5 005	51778212	0 092 S40 000	S4 000	71730466	0 092 S50 020	S5 002
46810024	0 092 S50 050	S5 005	51778213	0 092 S50 080	S5 008	71730467	0 092 S50 050	S5 005
46810025	0 092 S50 080	S5 008	51779950	0 092 S50 130	S5 013	71730468	0 092 S50 080	S5 008
46810026	0 092 S50 130	S5 013	51779951	0 092 S50 130	S5 013	71731658	0 092 S50 020	S5 002
46820313	0 092 S40 000	S4 000	51779952	0 092 S50 150	S5 015	71731659	0 092 S50 080	S5 008
46832509	0 092 S50 020	S5 002	51780106	0 092 S50 020	S5 002	71736356	0 092 S50 080	S5 008
468325090	0 092 S50 020	S5 002	51780107	0 092 S50 020	S5 002	71740269	0 092 S50 100	S5 010
46832510	0 092 S30 050	S3 005	51780108	0 092 S50 020	S5 002	72002401	0 092 S30 030	S3 003
46832510	0 092 S40 050	S4 005	51784851	0 092 S40 000	S4 000	7571545	0 092 S40 000	S4 000
46832510	0 092 S50 050	S5 005	51784852	0 092 S50 020	S5 002	7571546	0 092 S50 020	S5 002
468325100	0 092 S50 050	S5 005	51810270	0 092 S50 020	S5 002	7571547	0 092 S50 080	S5 008
46832713	0 092 S40 000	S4 000	55700403	0 092 S40 020	S4 002	7571548	0 092 T30 320	T3 032
46832714	0 092 S50 020	S5 002	55700404	0 092 S40 050	S4 005	7571550	0 092 S40 000	S4 000
46836155	0 092 S50 050	S5 005	55700404	0 092 S50 050	S5 005	7571554	0 092 S50 050	S5 005
46840939	0 092 S40 000	S4 000	55700416	0 092 S40 000	S4 000	7571581	0 092 S50 020	S5 002

7699835	0 092 S50 020	S5 002

FODEN		
1623080	0 092 T50 750	T5 075
1623081	0 092 T50 800	T5 080
1623082	0 092 T50 770	T5 077

FORD		
A55SX 10655 C4A	0 092 S40 270	S4 027
A970X 10655 EA	0 092 S50 040	S5 004
A970X 10655 EA	0 092 S50 050	S5 005

A970X 10655 GA	0 092 S40 290	S4 029
A970X 10655 HA	0 092 S30 160	S3 016
A970X 10655 KA	0 092 S40 270	S4 027
ME8U2J 10655 DA	0 092 S40 280	S4 028
ME8U2J 10655 HA	0 092 S40 130	S4 013

ME8U2J 10655 HA	0 092 S50 130	S5 013
ME8U2J 10655 JA	0 092 S30 010	S3 001
ME8U2J 10655 JA	0 092 S40 010	S4 001
ME8U2J 10655 JA	0 092 S50 020	S5 002
VCY15 10655 AA	0 092 S50 080	S5 008

V3C15 10655 AA	0 092 S50 130	S5 013
YM2J 10655 A4A	0 092 S50 040	S5 004
YM211 0655 EA	0 092 S50 130	S5 013
YS6J 10655 B4A	0 092 S40 040	S4 004
YS6J 10655 C2A	0 092 S50 040	S5 004

YS6J 10655 C4A	0 092 S50 040	S5 004
YS7J 10655 C2A	0 092 S50 040	S5 004
YS7J 10655 C4A	0 092 S50 040	S5 004
YS7J 10655 D2A	0 092 S40 070	S4 007
YS7J 10655 D2A	0 092 S50 070	S5 007

YS7J 10655 D4A	0 092 S30 070	S3 007
YS7J 10655 D4A	0 092 S40 070	S4 007
YS7J 10655 D4A	0 092 S50 070	S5 007
YU2J 10655 A4A	0 092 S30 040	S3 004
YU2J 10655 C4A	0 092 S40 260	S4 026

YU2J 10655 D4A	0 092 S40 270	S4 027
YU2J 10655 E4A	0 092 S40 080	S4 008
YU2J 10655 E4A	0 092 S50 080	S5 008
YU2J 10655 F4A	0 092 S30 070	S3 007
YU2J 10655 G4A	0 092 S40 000	S4 000

YU2J 10655 JA4A	0 092 S40 240	S4 024
1U2J 10655 A4A	0 092 S30 020	S3 002
1U2J 10655 A4A	0 092 S40 020	S4 002
1U2J 10655 A4A	0 092 S50 020	S5 002
1U2J 10655 B4A	0 092 S30 010	S3 001

1U2J 10655 B4B	0 092 S30 040	S3 004
1U2J 10655 C4A	0 092 S40 050	S4 005
1U2J 10655 C4A	0 092 S40 070	S4 007
1U2J 10655 C4A	0 092 S50 050	S5 005
1U2J 10655 D4A	0 092 S30 070	S3 007

1U2J 10655 D4A	0 092 S50 080	S5 008
1U2J 10655 E4A	0 092 S30 080	S3 008
1U2J 10655 E4A	0 092 S40 080	S4 008
1U2J 10655 E4A	0 092 S50 080	S5 008
1U2J 10655 E4A	0 092 S50 130	S5 013

1U2J 10655 F4A	0 092 S3D 610	S3 D61
1U2J 10655 F4A	0 092 S50 130	S5 013
1U2J 10655 G4A	0 092 S30 040	S3 004
1U2J 10655 G4A	0 092 S40 010	S4 001
1053140	0 092 S40 040	S4 004

1053140	0 092 S50 010	S5 001
1053141	0 092 S50 040	S5 004
1060815	0 092 S30 160	S3 016
1060816	0 092 S40 260	S4 026
1062547	0 092 S40 010	S4 001

1062548	0 092 S40 070	S4 007
1072324	0 092 S40 010	S4 001
1072331	0 092 S40 040	S4 004
1072331	0 092 S50 010	S5 001
1072331	0 092 S50 040	S5 004

1072341	0 092 S50 040	S5 004
1072345	0 092 S40 070	S4 007
1072348	0 092 S40 070	S4 007
1072348	0 092 S50 070	S5 007
1108517	0 092 S40 290	S4 029

1130879	0 092 S50 040	S5 004
1130881	0 092 S50 040	S5 004
1130882	0 092 S40 070	S4 007
1130883	0 092 S40 010	S4 001
1130884	0 092 S40 040	S4 004

1130884	0 092 S50 040	S5 004
1130885	0 092 S50 040	S5 004
1130886	0 092 S50 070	S5 007
1130887	0 092 S50 040	S5 004
1130888	0 092 S40 070	S4 007

1130888	0 092 S50 070	S5 007
1133130	0 092 S50 080	S5 008
1135513	0 092 S50 040	S5 004
1135513	0 092 S50 050	S5 005
1135514	0 092 S30 120	S3 012

1139432	0 092 S30 020	S3 002
1139435	0 092 S40 050	S4 005
1139435	0 092 S50 050	S5 005
1139437	0 092 S40 080	S4 008
1139438	0 092 S50 130	S5 013

1347729	0 092 S40 010	S4 001
1347732	0 092 S30 070	S3 007
1347733	0 092 S40 010	S4 001
1347737	0 092 S30 070	S3 007
1426512	0 092 S40 010	S4 001

1426517	0 092 S30 040	S3 004
1426519	0 092 S40 040	S4 004
1426519	0 092 S50 040	S5 004
1426522	0 092 S40 100	S4 010
1426522	0 092 S50 100	S5 010

1445813	0 092 S30 040	S3 004
1445813	0 092 S40 040	S4 004
1445814	0 092 S30 040	S3 004
1445814	0 092 S40 040	S4 004
2S6T 10655 EA	0 092 S30 010	S3 001

2U2J1 0655 GA	0 092 S30 050	S3 005
3U2J1 0655 AA	0 092 S40 010	S4 001
3U2J 10655 AA	0 092 S50 020	S5 002
3U2J1 0655 BA	0 092 S30 040	S3 004
3U2J1 0655 BB	0 092 S30 040	S3 004

3U2J1 0655 BB	0 092 S40 040	S4 004
3U2J 10655 BB	0 092 S50 040	S5 004
3U2J 10655 BB	0 092 S50 050	S5 005
3U2J1 0655 CA	0 092 S40 040	S4 004
3U2J1 0655 CA	0 092 S50 040	S5 004

3U2J1 0655 DA	0 092 S30 070	S3 007
3U2J 10655 DA	0 092 S40 070	S4 007
3U2J 10655 DA	0 092 S50 070	S5 007
3U2J1 0655 EA	0 092 S40 010	S4 001
3U2J1 0655 FA	0 092 S30 040	S3 004

3U2J1 0655 FB	0 092 S30 040	S3 004
3U2J1 0655 FB	0 092 S40 040	S4 004
3U2J1 0655 GA	0 092 S40 040	S4 004
3U2J1 0655 GA	0 092 S50 040	S5 004
3U2J1 0655 HA	0 092 S30 070	S3 007

3U3J1 0655 AA	0 092 S30 170	S3 017
3U3J1 0655 BA	0 092 S40 020	S4 002
3U3J1 0655 CA	0 092 S30 130	S3 013
5CP1 10655 DA	0 092 S40 100	S4 010
5CP1 10655 DA	0 092 S50 100	S5 010

6G9N1 0655 LA	0 092 S40 010	S4 001
6G9N1 0655 MA	0 092 S30 040	S3 004
6G9N 10655 MA	0 092 S50 040	S5 004
6G9N 10655 NA	0 092 S30 070	S3 007
6G9N1 0655 NA	0 092 S40 040	S4 004

6G9N1 0655 NA	0 092 S50 040	S5 004
6G9N1 0655 PA	0 092 S40 100	S4 010
6G9N1 0655 PA	0 092 S50 100	S5 010
7M0 915 105	0 092 S40 010	S4 001
7M0 915 105 A	0 092 S50 040	S5 004

7M0 915 105 B	0 092 S50 040	S5 004
7M0 915 105 C	0 092 S30 120	S3 012
83BB 10657 AA	0 092 S40 040	S4 004
87BB 10655 BA	0 092 S40 040	S4 004
87BB 10655 CA	0 092 S50 040	S5 004

93BB 10655 CC	0 092 S40 070	S4 007
95GB 10655 AB	0 092 S50 040	S5 004
96FB 10655 AD	0 092 S40 010	S4 001
97FB 10655 AA	0 092 S30 010	S3 001
97FB 10655 CB	0 092 S50 040	S5 004

98AB 10655 AA	0 092 S40 010	S4 001
98AB 10655 AB	0 092 S30 040	S3 004
98AB 10655 AB	0 092 S40 040	S4 004
98AB 10655 BA	0 092 S40 040	S4 004
98AB 10655 BA	0 092 S50 010	S5 001



◀ FORD

98AB 10655 BA	0 092 S50 040	S5 004
98AB 10655 BC	0 092 S40 040	S4 004
98AB 10655 BC	0 092 S50 010	S5 001
98AB 10655 CA	0 092 S30 070	S3 007
98AB 10655 CA	0 092 S50 040	S5 004

98AB 10655 DA	0 092 S40 070	S4 007
98AB 10655 DA	0 092 S50 100	S5 010
98AX 10655 A4A	0 092 S40 010	S4 001
98AX 10655 B4A	0 092 S40 040	S4 004
98AX 10655 B4A	0 092 S50 010	S5 001

98AX 10655 B4A	0 092 S50 040	S5 004
98AX 10655 C4A	0 092 S30 070	S3 007
98AX 10655 C4A	0 092 S50 040	S5 004
98AX 10655 D2A	0 092 S40 070	S4 007
98AX 10655 D4A	0 092 S40 070	S4 007

98AX 10655 D4A	0 092 S50 100	S5 010
----------------	---------------	---------------

FULMEN

C	0 092 S40 000	S4 000
D	0 092 S30 160	S3 016
E	0 092 S30 170	S3 017

EQUIPA B	0 092 S30 020	S3 002
EQUIPA F	0 092 S40 020	S4 002
EQUIPA F1	0 092 S40 010	S4 001
EQUIPA F2	0 092 S40 010	S4 001
EQUIPA G	0 092 S30 030	S3 003

EQUIPA H	0 092 S40 050	S4 005
EQUIPA H	0 092 S50 050	S5 005
EQUIPA H1	0 092 S40 040	S4 004
EQUIPA H2	0 092 S40 040	S4 004
EQUIPA J	0 092 S40 080	S4 008

Equipa J1	0 092 S40 070	S4 007
Equipa J2	0 092 S40 070	S4 007
EQUIPA K	0 092 S40 090	S4 009
Equipa L	0 092 S50 130	S5 013
EQUIPA L1	0 092 S30 120	S3 012

EX-EB16B	0 092 M4F 440	M4 F44
EX-EB16B	0 092 M40 440	M4 044
EX-EB16CLB	0 092 M4F 460	M4 F46
EX-EB16CLB	0 092 M40 460	M4 046
EX-EB16LB	0 092 M4F 430	M4 F43

EX-EB16LB	0 092 M40 430	M4 043
EX-ETX20LBS	0 092 M60 230	M6 023
EX-12N14-3A	0 092 M4F 340	M4 F34
EX-12N14-3A	0 092 M40 340	M4 034
FA1000	0 092 S50 130	S5 013

FA1004	0 092 S40 280	S4 028
FA1005	0 092 S40 290	S4 029
FA387	0 092 S40 180	S4 018
FA456	0 092 S40 210	S4 021
FA472	0 092 S50 010	S5 001

FA530	0 092 S50 020	S5 002
FA602	0 092 S50 040	S5 004
FA640	0 092 S50 050	S5 005
FA654	0 092 S40 240	S4 024
FA655	0 092 S40 250	S4 025

FA722	0 092 S50 070	S5 007
FA770	0 092 S50 080	S5 008
FA852	0 092 S50 100	S5 010
FB1004	0 092 S40 280	S4 028
FB1005	0 092 S40 290	S4 029

FB 293 M	0 092 S40 270	S4 027
FB 299 M	0 092 S40 270	S4 027
FB356	0 092 S40 180	S4 018
FB357	0 092 S40 190	S4 019
FB440	0 092 S40 000	S4 000

FB442	0 092 S40 010	S4 001
FB450	0 092 S30 160	S3 016
FB451	0 092 S30 170	S3 017
FB454	0 092 S40 210	S4 021
FB455	0 092 S40 230	S4 023

FB457	0 092 S40 220	S4 022
FB500	0 092 S40 020	S4 002
FB501	0 092 S30 030	S3 003
FB542	0 092 S40 040	S4 004
FB604	0 092 S40 240	S4 024

FB605	0 092 S40 250	S4 025
FB620	0 092 S40 050	S4 005
FB712	0 092 S40 070	S4 007
FB740	0 092 S40 080	S4 008
FB741	0 092 S40 090	S4 009

FB802	0 092 S40 100	S4 010
FB852	0 092 S30 120	S3 012
FB950	0 092 S30 130	S3 013
FB950	0 092 S40 130	S4 013
FC412	0 092 S30 010	S3 001

FC440	0 092 S30 020	S3 002
FC502	0 092 S30 040	S3 004
FC550	0 092 S30 050	S3 005
FC652	0 092 S30 070	S3 007
FC700	0 092 S30 080	S3 008

FK	0 092 S30 020	S3 002
FL 299 M	0 092 S40 270	S4 027
FORMULA B	0 092 S30 020	S3 002
FORMULA F	0 092 S40 020	S4 002
FORMULA F1	0 092 S40 010	S4 001

FORMULA H	0 092 S40 050	S4 005
Formula H	0 092 S50 050	S5 005
FORMULA H1	0 092 S40 040	S4 004
FORMULA I	0 092 S50 060	S5 006
FORMULA J	0 092 S40 080	S4 008

Formula J1	0 092 S40 070	S4 007
Formula L	0 092 S50 130	S5 013
HK	0 092 S30 050	S3 005
JK	0 092 S40 080	S4 008
Lk	0 092 S50 130	S5 013

SMX10	0 092 M4F 170	M4 F17
SMX10	0 092 M40 170	M4 017
SMX100	0 092 M4F 340	M4 F34
SMX100	0 092 M40 340	M4 034
SMX110	0 092 M4F 360	M4 F36

SMX110	0 092 M40 360	M4 036
SMX120	0 092 M4F 470	M4 F47
SMX120	0 092 M40 470	M4 047
SMX130	0 092 M4F 540	M4 F54
SMX130	0 092 M40 540	M4 054

SMX20	0 092 M60 010	M6 001
SMX30	0 092 M4F 180	M4 F18
SMX30	0 092 M40 180	M4 018
SMX40	0 092 M4F 240	M4 F24
SMX40	0 092 M40 240	M4 024

SMX50	0 092 M60 100	M6 010
SMX60	0 092 M4F 250	M4 F25
SMX60	0 092 M40 250	M4 025
SMX70	0 092 M60 140	M6 014
SMX80	0 092 M4F 300	M4 F30

SMX80	0 092 M40 300	M4 030
SMX90	0 092 M60 180	M6 018
WK	0 092 S40 100	S4 010
Z1	0 092 S40 180	S4 018
Z10	0 092 S40 270	S4 027

Z11	0 092 S40 280	S4 028
Z12	0 092 S40 290	S4 029
Z2	0 092 S40 190	S4 019
Z4	0 092 S40 220	S4 022
Z7	0 092 S40 240	S4 024

Z8	0 092 S40 250	S4 025
Z9	0 092 S40 260	S4 026
035512-A	0 092 S40 180	S4 018
035513-A	0 092 S40 190	S4 019
038560-A	0 092 S40 000	S4 000

040422A-A	0 092 S30 020	S3 002
043418A-A	0 092 S40 010	S4 001
043420A-A	0 092 S40 010	S4 001
044612-A	0 092 S30 020	S3 002
045442-A	0 092 S30 160	S3 016

045443-A	0 092 S30 170	S3 017
045515-A	0 092 S40 220	S4 022
050422A-A	0 092 S40 020	S4 002
050423A-A	0 092 S30 030	S3 003
050 442	0 092 S30 160	S3 016

050 443	0 092 S30 170	S3 017
050568A-A	0 092 S40 040	S4 004
050600A-A	0 092 S40 040	S4 004
055 491	0 092 S40 270	S4 027
055614-A	0 092 S30 050	S3 005

060302-A	0 092 S40 240	S4 024
060303-A	0 092 S40 250	S4 025
060426A-A	0 092 S40 050	S4 005
060426A-A	0 092 S50 050	S5 005
063 270	0 092 S30 070	S3 007

065358A-A	0 092 S40 070	S4 007
065596A-A	0 092 S40 070	S4 007
070 293	0 092 S40 270	S4 027
070430A-A	0 092 S40 080	S4 008
070431A-A	0 092 S40 090	S4 009
070 490	0 092 S40 260	S4 026
070490-A	0 092 S40 260	S4 026
070 491	0 092 S40 270	S4 027
070491-A	0 092 S40 270	S4 027
074616-A	0 092 S40 080	S4 008
080 298	0 092 T30 300	T3 030
080658-A	0 092 S40 100	S4 010
085636A-A	0 092 S30 120	S3 012
095434HD	0 092 T30 130	T3 013
095454-A	0 092 S40 280	S4 028
095455-A	0 092 S40 290	S4 029
095626A-A	0 092 S50 130	S5 013
096 246	0 092 T30 300	T3 030
100286HD	0 092 T30 730	T3 073
100626-A	0 092 S50 130	S5 013
110246HD	0 092 T30 350	T3 035
110247HD	0 092 T30 360	T3 036
112 084	0 092 T30 610	T3 061
112084HD	0 092 T30 610	T3 061
125388HD	0 092 T30 400	T3 040
125389HD	0 092 T30 410	T3 041
135384HD	0 092 T30 450	T3 045
135396HD	0 092 T30 470	T3 047
135482HD	0 092 T40 750	T4 075
140084HD	0 092 T30 620	T3 062
140482SH STE	0 092 T40 750	T4 075
145394HD	0 092 T30 440	T3 044
160 038	0 092 T30 630	T3 063
165038HD	0 092 T30 630	T3 063
180484HD	0 092 T40 770	T4 077
180484HD	0 092 T50 770	T5 077
180554HD	0 092 T30 790	T3 079
190484SH STE	0 092 T40 770	T4 077
190484SH STE	0 092 T50 770	T5 077
200056HD	0 092 T30 640	T3 064
200416HD	0 092 T30 800	T3 080
220416SH STE	0 092 T50 800	T5 080
360 422	0 092 S30 020	S3 002
450 418	0 092 S40 010	S4 001
510 422	0 092 S40 020	S4 002
600 600	0 092 S40 040	S4 004
640 426	0 092 S50 050	S5 005
640 427	0 092 S50 060	S5 006
680 358	0 092 S40 070	S4 007
760 430	0 092 S40 080	S4 008
900 434	0 092 S50 130	S5 013

GS		
GM10Z-3A	0 092 M4F 280	M4 F28
GM10Z-3A	0 092 M40 280	M4 028
GM10Z-3A-2	0 092 M4F 280	M4 F28
GM10Z-3A-2	0 092 M40 280	M4 028
GM10Z-3B-2	0 092 M4F 290	M4 F29
GM10Z-3B-2	0 092 M40 290	M4 029
GM10-3B	0 092 M4F 290	M4 F29
GM10-3B	0 092 M40 290	M4 029
GM12AZ-3A-2	0 092 M4F 320	M4 F32
GM12AZ-3A-2	0 092 M40 320	M4 032
GM12AZ-4A-1	0 092 M4F 300	M4 F30
GM12AZ-4A-1	0 092 M40 300	M4 030
GM12AZ-4B-2	0 092 M4F 330	M4 F33
GM14Z-3A	0 092 M4F 340	M4 F34
GM14Z-3A	0 092 M40 340	M4 034
GM14Z-3A-1	0 092 M4F 340	M4 F34
GM14Z-3A-1	0 092 M40 340	M4 034
GM14Z-3B	0 092 M4F 360	M4 F36
GM14Z-3B	0 092 M40 360	M4 036
GM14Z-4A	0 092 M4F 350	M4 F35
GM14Z-4A	0 092 M40 350	M4 035
GM16A-3A	0 092 M4F 400	M4 F40
GM16A-3A	0 092 M40 400	M4 040
GM16B-4A	0 092 M4F 390	M4 F39
GM16B-4A	0 092 M40 390	M4 039
GM16Z-3B	0 092 M4F 430	M4 F43
GM16Z-3B	0 092 M40 430	M4 043
GM16Z-4B	0 092 M4F 440	M4 F44
GM16Z-4B	0 092 M40 440	M4 044
GM18A-3A	0 092 M4F 420	M4 F42
GM18A-3A	0 092 M40 420	M4 042
GM18Z-3A	0 092 M4F 470	M4 F47
GM18Z-3A	0 092 M40 470	M4 047
GM3-3A	0 092 M4F 150	M4 F15
GM3-3A	0 092 M40 150	M4 015
GM3-3B	0 092 M4F 160	M4 F16
GM3-3B	0 092 M40 160	M4 016
GM4-3B	0 092 M4F 170	M4 F17
GM4-3B	0 092 M40 170	M4 017
GM5Z-3B	0 092 M4F 180	M4 F18
GM5Z-3B	0 092 M40 180	M4 018
GM7Z-4A	0 092 M4F 240	M4 F24
GM7Z-4A	0 092 M40 240	M4 024
GM9Z-3B	0 092 M4F 260	M4 F26
GM9Z-3B	0 092 M40 260	M4 026
GM9Z-4B	0 092 M4F 250	M4 F25
GM9Z-4B	0 092 M40 250	M4 025
GTX12-BS	0 092 M60 140	M6 014
GTX14-BS	0 092 M60 180	M6 018
GTX7A-BS	0 092 M60 070	M6 007
GTX7L-BS	0 092 M60 060	M6 006
GTX9-BS	0 092 M60 100	M6 010
GT4L-BS	0 092 M60 010	M6 001

HONDA		
31500-SB2-731	0 092 S30 170	S3 017
31500-SB2-732	0 092 S30 170	S3 017
31500-SB2-733	0 092 S30 170	S3 017
31500-SF1-A41	0 092 S40 250	S4 025
31500-SH3-G01	0 092 S40 230	S4 023
31500-SH3-G03	0 092 S40 230	S4 023
914620	0 092 T40 750	T4 075
A 110 076 313	0 092 T40 760	T4 076
A 120 080 310	0 092 T40 750	T4 075
A 120 080 313	0 092 T40 760	T4 076
A 135 088 313	0 092 T40 760	T4 076
A 140 093 310	0 092 T40 750	T4 075
A 140 093 310	0 092 T50 750	T5 075
B 165 100 313	0 092 T40 780	T4 078
B 180 110 310	0 092 T50 770	T5 077
D20 050 041 013	0 092 S40 020	S4 002
D23 050 041 010	0 092 S40 240	S4 024
D23 050 041 110	0 092 S40 250	S4 025
D23 050 042 010	0 092 S40 240	S4 024
D23 050 042 110	0 092 S40 250	S4 025
D23 060 052 010	0 092 S40 240	S4 024
D23 060 052 110	0 092 S40 250	S4 025
D26 060 053 117	0 092 S40 270	S4 027
D26 070 063 017	0 092 S40 260	S4 026
D26 070 063 117	0 092 S40 270	S4 027
D31 070 060 011	0 092 S40 280	S4 028
D31 070 060 111	0 092 S40 290	S4 029
D31 080 069 011	0 092 S40 280	S4 028
D31 080 069 111	0 092 S40 290	S4 029
D31 090 072 011	0 092 S40 280	S4 028
D31 090 072 111	0 092 S40 290	S4 029
D31 100 085 011	0 092 S40 280	S4 028
D31 100 085 011	0 092 S40 290	S4 029
D31 100 085 111	0 092 S40 290	S4 029
LB1 036 030 013	0 092 S30 010	S3 001
LB1 040 036 013	0 092 S30 010	S3 001
LB1 044 036 013	0 092 S30 010	S3 001
LB1 044 040 013	0 092 S40 010	S4 001
LB1 050 042 013	0 092 S40 010	S4 001
LB1 050 049 013	0 092 S50 010	S5 001
LB2 050 046 013	0 092 S30 040	S3 004
LB2 055 046 013	0 092 S30 040	S3 004
LB2 060 049 013	0 092 S40 040	S4 004
LB2 060 054 013	0 092 S40 040	S4 004
LB2 060 060 013	0 092 S50 040	S5 004



◀ INCI

LB3 066 060 013	0 092 S30 070	S3 007
LB3 066 064 013	0 092 S30 070	S3 007
LB3 070 070 013	0 092 S40 070	S4 007
LB3 072 061 013	0 092 S30 070	S3 007
LB3 072 073 013	0 092 S50 070	S5 007

LB4 075 066 013	0 092 S40 100	S4 010
LB4 080 074 013	0 092 S50 100	S5 010
LB5 085 076 013	0 092 S30 120	S3 012
L0 040 033 013	0 092 S40 000	S4 000
L1 036 030 013	0 092 S30 020	S3 002

L1 036 036 013	0 092 S30 020	S3 002
L1 044 036 013	0 092 S30 020	S3 002
L1 044 036 113	0 092 S30 030	S3 003
L1 044 040 013	0 092 S30 020	S3 002
L1 045 040 013	0 092 S30 020	S3 002

L1 050 042 013	0 092 S40 020	S4 002
L1 050 046 013	0 092 S40 020	S4 002
L1 050 051 013	0 092 S50 020	S5 002
L2 050 042 013	0 092 S30 050	S3 005
L2 050 046 013	0 092 S30 050	S3 005

L2 050 046 113	0 092 S30 060	S3 006
L2 055 046 013	0 092 S30 050	S3 005
L2 055 046 113	0 092 S30 060	S3 006
L2 055 054 013	0 092 S40 050	S4 005
L2 055 054 113	0 092 S30 060	S3 006

L2 060 049 013	0 092 S30 050	S3 005
L2 060 049 113	0 092 S40 060	S4 006
L2 060 054 013	0 092 S40 050	S4 005
L2 060 054 113	0 092 S40 060	S4 006
L2 060 062 013	0 092 S50 050	S5 005

L3 066 060 013	0 092 S30 080	S3 008
L3 066 064 013	0 092 S40 080	S4 008
L3 072 064 013	0 092 S30 080	S3 008
L3 072 068 013	0 092 S40 080	S4 008
L3 072 760 013	0 092 S50 080	S5 008

L3 074 064 013	0 092 S30 080	S3 008
L3 074 064 113	0 092 S40 090	S4 009
L3 075 070 013	0 092 S40 080	S4 008
L3 075 070 113	0 092 S40 090	S4 009
L5 088 076 013	0 092 S30 130	S3 013

L5 090 076 013	0 092 S30 130	S3 013
L5 090 086 013	0 092 S40 130	S4 013
L5 092 076 013	0 092 S30 130	S3 013
L5 100 086 013	0 092 S50 130	S5 013
L5 100 096 013	0 092 S50 130	S5 013

NS40 035 024 030	0 092 S40 190	S4 019
NS40 042 033 030	0 092 S40 180	S4 018
NS60 045 038 010	0 092 S40 210	S4 021
NS60 045 038 110	0 092 S40 230	S4 023
NS60 045 038 130	0 092 S40 220	S4 022

TANK 100 072 210	0 092 T30 420	T3 042
TANK 125 080 210	0 092 T30 420	T3 042

IVECO

176548	0 092 T30 790	T3 079
2994558	0 092 S40 080	S4 008
2994558	0 092 S50 080	S5 008

2994559	0 092 S50 130	S5 013
2994560	0 092 T30 380	T3 038
2994561	0 092 T30 770	T3 077
2994562	0 092 T40 770	T4 077
2994563	0 092 T30 810	T3 081

2994565	0 092 T30 350	T3 035
2994566	0 092 T40 750	T4 075
2994567	0 092 T50 770	T5 077
2994568	0 092 T50 800	T5 080
500002138	0 092 T40 770	T4 077

500307471	0 092 T30 350	T3 035
500339942	0 092 T40 770	T4 077
93162326	0 092 S40 080	S4 008
93162327	0 092 T30 130	T3 013
93162328	0 092 S50 130	S5 013

93162328	0 092 T30 130	T3 013
93162329	0 092 T30 380	T3 038
93162330	0 092 T30 390	T3 039
93162331	0 092 T30 770	T3 077
93162331	0 092 T40 770	T4 077

93162332	0 092 T30 770	T3 077
93162332	0 092 T40 770	T4 077
93162333	0 092 T30 480	T3 048
93162334	0 092 T40 770	T4 077
93162335	0 092 T30 790	T3 079

93162336	0 092 T40 780	T4 078
93162337	0 092 T50 800	T5 080
93162455	0 092 S50 130	S5 013
93162465	0 092 T30 350	T3 035
93162741	0 092 T30 380	T3 038

99439381	0 092 T30 790	T3 079
----------	---------------	---------------

JAGUAR

DBC 6427	0 092 S40 040	S4 004
DBC 6427	0 092 S50 010	S5 001
JLM 10453	0 092 S40 040	S4 004

JLM 10453	0 092 S50 010	S5 001
LNA 1250BB	0 092 S40 080	S4 008
LNC 1250AA	0 092 S40 080	S4 008
LRA 1250AA	0 092 S50 130	S5 013
XR8 310655 AA	0 092 S50 130	S5 013

1X43 10655 BA	0 092 S50 130	S5 013
1X43 10655 BC	0 092 S40 100	S4 010
1X43 10655 BC	0 092 S50 100	S5 010
1X43 10655 BD	0 092 S40 100	S4 010
1X43 10655 BD	0 092 S50 100	S5 010

1X43 10655 CA	0 092 S40 080	S4 008
1X43 10655 DA	0 092 S40 050	S4 005
1X43 10655 DA	0 092 S50 050	S5 005
1X43 10655 DB	0 092 S40 050	S4 005
1X43 10655 DB	0 092 S50 050	S5 005

1X43 10655 DC	0 092 S40 050	S4 005
1X43 10655 DC	0 092 S50 050	S5 005
1X43 10655 DD	0 092 S40 050	S4 005
1X43 10655 DD	0 092 S50 050	S5 005
2R83 10655 AA	0 092 S50 130	S5 013

4R43 10655 AA	0 092 S50 130	S5 013
4R83 10655 BA	0 092 S30 130	S3 013
4R83 10655 BA	0 092 S40 130	S4 013
4R83 10655 BA	0 092 S50 130	S5 013
4R83 10655 CA	0 092 S40 130	S4 013

4R83 10655 CA	0 092 S50 130	S5 013
6W83 10655 AA	0 092 S30 120	S3 012
6W83 10655 BA	0 092 S50 130	S5 013

JOHN DEERE

AL 11 240 0	0 092 T30 050	T3 005
AL 11 240 1	0 092 T30 050	T3 005
AL 11 240 2	0 092 T30 080	T3 008

AL 11 240 3	0 092 T30 080	T3 008
AL 11 240 4	0 092 T30 130	T3 013
AL 11 240 5	0 092 T30 130	T3 013
AL119623	0 092 T40 760	T4 076
AL119623W	0 092 T40 760	T4 076

AL119625	0 092 T40 770	T4 077
AL119625W	0 092 T40 770	T4 077
AL 31 917	0 092 T30 470	T3 047
AL 75 644	0 092 T30 730	T3 073
AL75644W	0 092 T30 730	T3 073

AL 75 854	0 092 T30 730	T3 073
AZ 27 734	0 092 T30 380	T3 038
AZ 31 917	0 092 T30 470	T3 047
AZ 75 644	0 092 T30 730	T3 073
EPYP	0 092 S40 010	S4 001

EPYP001	0 092 T30 300	T3 030
EPYP 002	0 092 T30 750	T3 075
EPYP 002	0 092 T40 750	T4 075
EPYP 003	0 092 T30 400	T3 040
EPYP005	0 092 M4F 510	M4 F51

EPYP005	0 092 M40 510	M4 051
EPYP310013	0 092 T30 380	T3 038
EPYP519013	0 092 M4F 450	M4 F45
EPYP519013	0 092 M40 450	M4 045
EPYP541400	0 092 S30 010	S3 001

EP YP 544 59S	0 092 S30 020	S3 002
EPYP552401	0 092 S50 010	S5 001
EPYP560409	0 092 S30 040	S3 004
EPYP560409	0 092 S40 040	S4 004
EPYP570409	0 092 S30 080	S3 008

EPYP595402	0 092 S30 130	S3 013
EPYP595402	0 092 S40 130	S4 013

KÄSSBOHRER

7 471 048 105 0	0 092 T50 800	T5 080
-----------------	---------------	---------------

LAMBORGHINI (S+L+H)

1 J091 510 5AH	0 092 S50 130	S5 013
7L0915105	0 092 S50 080	S5 008

LANCIA

46 214 085	0 092 S30 020	S3 002
46227867	0 092 S40 050	S4 005
46227867	0 092 S50 050	S5 005

46227868	0 092 S30 060	S3 006
46227869	0 092 S40 080	S4 008
46227870	0 092 S40 090	S4 009
46 227 876	0 092 S30 020	S3 002
46 227 877	0 092 S40 070	S4 007

51767152	0 092 S40 020	S4 002
----------	---------------	---------------

LAND ROVER GROUP

YGD 000230	0 092 S50 130	S5 013
YGD 000250	0 092 S50 130	S5 013
YGD 000270	0 092 S50 150	S5 015

YGD 000271	0 092 S50 150	S5 015
YGD500050	0 092 S40 050	S4 005
YGD500050	0 092 S50 050	S5 005
YGD 500100	0 092 S50 080	S5 008
YGD500130	0 092 S50 130	S5 013

YGD500160	0 092 S40 130	S4 013
YGD500160	0 092 S50 130	S5 013
YGD500190	0 092 S40 100	S4 010
YGD500190	0 092 S50 100	S5 010
YGD500200	0 092 S40 050	S4 005

YGD 500200	0 092 S50 050	S5 005
------------	---------------	---------------

LEYLAND

AELD 214	0 092 T30 350	T3 035
AELD 215	0 092 T30 400	T3 040
1314346	0 092 T50 800	T5 080

1440622	0 092 T40 750	T4 075
1440623	0 092 T50 770	T5 077

LINDE

791 990 0223	0 092 S30 020	S3 002
791 990 0245	0 092 S30 130	S3 013
791 990 0245	0 092 T30 130	T3 013

LUCAS

532 28	0 092 S30 160	S3 016
532 32	0 092 S30 160	S3 016
533 33	0 092 S30 030	S3 003

535 15	0 092 S30 020	S3 002
535 16	0 092 S30 030	S3 003
535 23	0 092 S30 020	S3 002
535 24	0 092 S30 010	S3 001
535 28	0 092 S30 010	S3 001

535 29	0 092 S30 030	S3 003
535 30	0 092 S30 020	S3 002
535 31	0 092 S30 030	S3 003
535 32	0 092 S30 170	S3 017
535 33	0 092 S30 170	S3 017

536 24	0 092 S30 010	S3 001
536 25	0 092 S30 010	S3 001
536 30	0 092 S30 160	S3 016
536 31	0 092 S30 170	S3 017
536 38	0 092 S30 030	S3 003

536 47	0 092 S30 160	S3 016
536 53	0 092 S30 010	S3 001
536 54	0 092 S30 010	S3 001
538 56	0 092 S30 160	S3 016
538 57	0 092 S30 170	S3 017

538 90	0 092 S30 170	S3 017
540 19	0 092 S30 160	S3 016
540 20	0 092 S30 170	S3 017
540 38	0 092 S30 160	S3 016
540 39	0 092 S30 170	S3 017

540 45	0 092 S40 010	S4 001
540 50	0 092 S30 160	S3 016
540 53	0 092 S30 170	S3 017
543 12	0 092 S40 010	S4 001
543 16	0 092 S40 010	S4 001

543 17	0 092 S40 010	S4 001
543 19	0 092 S40 010	S4 001
543 21	0 092 S30 020	S3 002
543 22	0 092 S30 030	S3 003
543 23	0 092 S40 010	S4 001

543 24	0 092 S40 010	S4 001
544 34	0 092 S30 020	S3 002
544 49	0 092 S30 030	S3 003
544 58	0 092 S30 020	S3 002
544 65	0 092 S40 010	S4 001

544 72	0 092 S30 160	S3 016
544 73	0 092 S30 170	S3 017
545 33	0 092 S40 010	S4 001
545 49	0 092 S30 020	S3 002
545 51	0 092 S40 220	S4 022

545 91	0 092 S40 010	S4 001
547 18	0 092 S30 030	S3 003
547 19	0 092 S30 020	S3 002
548 27	0 092 S30 040	S3 004
550 40	0 092 S30 040	S3 004

550 41	0 092 S40 240	S4 024
550 42	0 092 S40 250	S4 025
550 46	0 092 S30 040	S3 004
550 52	0 092 S40 020	S4 002
550 55	0 092 S30 050	S3 005

550 56	0 092 S30 040	S3 004
550 57	0 092 S30 040	S3 004
550 59	0 092 S30 040	S3 004
550 63	0 092 S30 050	S3 005
550 65	0 092 S30 030	S3 003

550 66	0 092 S40 020	S4 002
550 70	0 092 S40 020	S4 002
552 18	0 092 S30 040	S3 004
552 19	0 092 S30 040	S3 004
552 21	0 092 S30 040	S3 004

554 15	0 092 S30 070	S3 007
554 23	0 092 S30 040	S3 004
554 27	0 092 S30 040	S3 004
555 19	0 092 S30 050	S3 005
555 30	0 092 S30 050	S3 005

555 31	0 092 S30 040	S3 004
555 42	0 092 S30 050	S3 005
555 48	0 092 S30 060	S3 006
555 64	0 092 T30 050	T3 005
555 70	0 092 S30 050	S3 005

555 71	0 092 S30 050	S3 005
555 77	0 092 S40 050	S4 005
556 51	0 092 S40 270	S4 027
560 13	0 092 S40 050	S4 005
560 70	0 092 S40 050	S4 005

560 72	0 092 S40 050	S4 005
560 75	0 092 S40 270	S4 027
560 78	0 092 S40 050	S4 005
560 90	0 092 S50 060	S5 006
560 92	0 092 S40 050	S4 005

560 98	0 092 S40 260	S4 026
560 99	0 092 S40 270	S4 027
562 18	0 092 S40 050	S4 005
562 21	0 092 S50 060	S5 006
563 16	0 092 S30 070	S3 007

563 18	0 092 S30 070	S3 007
563 20	0 092 S30 070	S3 007
563 22	0 092 S30 070	S3 007
563 23	0 092 S30 070	S3 007
563 26	0 092 S30 070	S3 007

◀ LUCAS

563 28	0 092 S30 070	S3 007
563 30	0 092 S30 070	S3 007
564 20	0 092 S30 070	S3 007
565 37	0 092 S30 070	S3 007
565 38	0 092 S30 070	S3 007
566 13	0 092 S30 080	S3 008
566 18	0 092 S30 080	S3 008
566 19	0 092 S30 070	S3 007
566 27	0 092 S30 080	S3 008
566 37	0 092 S30 080	S3 008
566 41	0 092 S30 080	S3 008
566 44	0 092 S30 080	S3 008
566 47	0 092 T30 080	T3 008
566 48	0 092 S50 050	S5 005
568 18	0 092 S40 070	S4 007
568 21	0 092 S40 070	S4 007
568 23	0 092 S30 080	S3 008
570 32	0 092 S40 270	S4 027
570 33	0 092 S40 080	S4 008
570 58	0 092 S40 080	S4 008
570 64	0 092 S40 080	S4 008
570 69	0 092 S40 080	S4 008
572 17	0 092 S40 080	S4 008
572 18	0 092 S40 070	S4 007
572 20	0 092 S40 080	S4 008
572 21	0 092 S40 080	S4 008
572 22	0 092 S40 080	S4 008
572 23	0 092 S40 080	S4 008
572 24	0 092 S40 080	S4 008
572 27	0 092 S40 070	S4 007
572 29	0 092 S40 080	S4 008
572 30	0 092 S40 070	S4 007
574 13	0 092 S40 090	S4 009
575 31	0 092 S40 080	S4 008
575 33	0 092 S40 080	S4 008
575 40	0 092 S40 080	S4 008
576 11	0 092 S40 080	S4 008
580 43	0 092 S40 100	S4 010
584 24	0 092 S30 120	S3 012
585 21	0 092 S40 280	S4 028
585 22	0 092 S40 290	S4 029
588 12	0 092 S30 130	S3 013
588 15	0 092 S30 130	S3 013
588 20	0 092 S50 070	S5 007
588 23	0 092 S30 130	S3 013
588 33	0 092 S30 130	S3 013
588 37	0 092 S30 130	S3 013
588 38	0 092 T30 130	T3 013
588 39	0 092 S30 130	S3 013
590 36	0 092 S40 130	S4 013
590 37	0 092 S40 130	S4 013
590 40	0 092 T30 300	T3 030
590 42	0 092 S30 130	S3 013
590 50	0 092 S40 130	S4 013
592 17	0 092 S40 130	S4 013

592 18	0 092 S40 130	S4 013
592 19	0 092 S40 130	S4 013
592 20	0 092 S40 130	S4 013
592 27	0 092 S40 130	S4 013
593 12	0 092 S40 130	S4 013
595 23	0 092 S50 130	S5 013
595 41	0 092 T30 310	T3 031
600 35	0 092 T30 710	T3 071
600 42	0 092 S50 130	S5 013
600 44	0 092 S50 130	S5 013
600 47	0 092 T30 720	T3 072
604 11	0 092 S50 130	S5 013
604 12	0 092 S50 130	S5 013
610 13	0 092 T30 380	T3 038
610 32	0 092 S50 130	S5 013
610 47	0 092 T30 350	T3 035
610 48	0 092 T30 360	T3 036
610 49	0 092 T30 390	T3 039
610 50	0 092 T30 730	T3 073
620 45	0 092 T30 750	T3 075
620 46	0 092 T30 390	T3 039
625 12	0 092 T30 400	T3 040
625 14	0 092 T30 410	T3 041
625 23	0 092 T30 420	T3 042
630 14	0 092 T30 430	T3 043
632 11	0 092 T30 460	T3 046
635 42	0 092 T30 440	T3 044
635 45	0 092 T50 750	T5 075
635 52	0 092 T30 450	T3 045
640 34	0 092 T40 750	T4 075
640 35	0 092 T40 750	T4 075
640 36	0 092 T40 760	T4 076
643 33	0 092 T30 470	T3 047
643 34	0 092 T30 480	T3 048
655 13	0 092 T30 770	T3 077
665 15	0 092 T40 780	T4 078
670 23	0 092 T40 780	T4 078
670 42	0 092 T40 770	T4 077
670 43	0 092 T40 770	T4 077
670 44	0 092 T30 790	T3 079
670 45	0 092 T40 780	T4 078
670 46	0 092 T30 790	T3 079
680 33	0 092 T30 790	T3 079
700 38	0 092 T30 800	T3 080
715 14	0 092 T40 800	T4 080
720 25	0 092 T30 810	T3 081
725 12	0 092 T50 800	T5 080
812 31	0 092 S30 010	S3 001
812 33	0 092 S40 010	S4 001
812 36	0 092 S30 020	S3 002
812 37	0 092 S40 010	S4 001
812 38	0 092 S30 160	S3 016
812 40	0 092 S30 170	S3 017
812 42	0 092 S30 050	S3 005
812 44	0 092 S40 080	S4 008

812 45	0 092 S40 080	S4 008
812 46	0 092 S40 270	S4 027
812 52	0 092 S30 070	S3 007
812 58	0 092 S30 040	S3 004
812 59	0 092 S40 080	S4 008
MAN		
07 97020 0880	0 092 S50 130	S5 013
07 97020 0880	0 092 T30 130	T3 013
07 97020 0885	0 092 T30 130	T3 013
07 97020 1550	0 092 T30 770	T3 077
07 97020 1550	0 092 T40 770	T4 077
07 97020 1555	0 092 T30 770	T3 077
07 97020 1555	0 092 T40 750	T4 075
07 97020 1555	0 092 T40 770	T4 077
07 97020 1556	0 092 T30 770	T3 077
07 97020 1556	0 092 T40 770	T4 077
07 97020 1750	0 092 T40 770	T4 077
07 97020 1750	0 092 T50 770	T5 077
07 97020 1755	0 092 T40 770	T4 077
07 97020 1755	0 092 T50 770	T5 077
07 97020 1756	0 092 T40 770	T4 077
07 97020 1756	0 092 T50 770	T5 077
07 97020 2250	0 092 T50 800	T5 080
07 97020 2255	0 092 T50 800	T5 080
07 97020 2256	0 092 T50 800	T5 080
81 26601 0005	0 092 T30 630	T3 063
81 26601 0029	0 092 T30 420	T3 042
81 26601 0035	0 092 T30 750	T3 075
81 26601 0035	0 092 T30 770	T3 077
81 26601 0035	0 092 T40 750	T4 075
81 26601 0035	0 092 T40 760	T4 076
81 26601 0079	0 092 T40 760	T4 076
81 26601 0091	0 092 T30 080	T3 008
81 26601 0117	0 092 T30 770	T3 077
81 26601 0117	0 092 T40 770	T4 077
81 26601 0118	0 092 T40 770	T4 077
81 26601 0118	0 092 T50 770	T5 077
81 26601 0119	0 092 T50 800	T5 080
81 26601 0129	0 092 T50 770	T5 077
81 26601 0133	0 092 T30 130	T3 013
81 26601 0134	0 092 T40 750	T4 075
81 26601 0134	0 092 T40 760	T4 076
81 26601 0135	0 092 T40 770	T4 077
81 26601 0137	0 092 T30 800	T3 080
81 26601 0137	0 092 T50 800	T5 080
81 26601 0141	0 092 T40 750	T4 075
81 26601 0141	0 092 T40 760	T4 076
81 26605 0005	0 092 T50 800	T5 080
84 26601 0005	0 092 T50 800	T5 080
88 26601 0005	0 092 T50 800	T5 080
88 26601 0017	0 092 T50 800	T5 080



MARELLI

ETS 100 D	0 092 S40 280	S4 028
ETS 45 D	0 092 S40 020	S4 002
ETS 65 D	0 092 S40 070	S4 007
ETS 65 D	0 092 S50 070	S5 007
ETS 70 D	0 092 S30 080	S3 008
ETS 70 D	0 092 S40 080	S4 008
ETS 70.1 D	0 092 S40 070	S4 007
ETS 70.1 D	0 092 S50 070	S5 007
ETS 85 D	0 092 S30 120	S3 012
ETS 90 D	0 092 S40 130	S4 013
ETS 92 D	0 092 S40 130	S4 013
R 105 D	0 092 S50 130	S5 013
R 55 D	0 092 S40 020	S4 002
R 55 S	0 092 S30 030	S3 003
R 65 D	0 092 S50 050	S5 005
R 80 D	0 092 S40 080	S4 008
02 84 40	0 092 T30 610	T3 061
26 02 40 F	0 092 S40 010	S4 001
27 03 00	0 092 S30 070	S3 007
27 04 00 K	0 092 S30 070	S3 007
27 04 40 ES	0 092 S40 070	S4 007
27 04 40 ES	0 092 S50 070	S5 007
29 03 00 F	0 092 S50 040	S5 004
29 63 30 B	0 092 S40 260	S4 026
29 72 55	0 092 S40 270	S4 027
29 73 00 ES	0 092 S40 270	S4 027
29 73 30	0 092 S40 270	S4 027
29 73 30 B	0 092 S40 270	S4 027
33 83 85	0 092 T30 720	T3 072
38 75 00	0 092 T30 390	T3 039
38 75 00 ES	0 092 T30 390	T3 039
38 75 00 LV	0 092 T30 390	T3 039
42 82 55	0 092 S30 040	S3 004
42 82 55	0 092 S40 040	S4 004
43 62 10 ES	0 092 S40 010	S4 001
43 62 40 ES	0 092 S40 020	S4 002
43 62 50	0 092 S30 020	S3 002
43 62 55 ES	0 092 S40 020	S4 002
43 72 10 ES	0 092 S30 030	S3 003
43 72 50	0 092 S30 030	S3 003
43 72 50 ES	0 092 S30 030	S3 003
43 72 55 ES	0 092 S30 030	S3 003
43 83 20	0 092 S30 050	S3 005
43 83 20	0 092 S40 050	S4 005
43 83 20 ES	0 092 S30 050	S3 005
43 83 20 ES	0 092 S40 050	S4 005
43 83 20 ES	0 092 S50 050	S5 005
43 83 20.1 ES	0 092 S30 050	S3 005
43 83 20.1 ES	0 092 S40 050	S4 005
43 93 20	0 092 S30 060	S3 006
43 93 20 ES	0 092 S30 060	S3 006
44 01 40	0 092 S30 160	S3 016
44 22 00.1 ES	0 092 S30 160	S3 016

44 25 04	0 092 S30 160	S3 016
44 32 00.1 ES	0 092 S30 170	S3 017
44 34 40	0 092 T30 130	T3 013
44 35 03	0 092 S30 170	S3 017
46 62 55	0 092 S30 080	S3 008
46 62 55	0 092 S40 080	S4 008
46 62 55	0 092 T30 080	T3 008
47 64 20 ES	0 092 S30 080	S3 008
47 64 20 ES	0 092 S40 080	S4 008
48 03 50 ES	0 092 S40 260	S4 026
48 13 50 ES	0 092 S40 270	S4 027
48 25 00 ES	0 092 T40 750	T4 075
48 25 00 ES	0 092 T50 750	T5 075
48 25 00 LV	0 092 T40 750	T4 075
48 25 00 LV	0 092 T50 750	T5 075
48 46 50 SS	0 092 T30 770	T3 077
48 46 50 SS	0 092 T40 770	T4 077
51 52 20	0 092 S40 220	S4 022
54 84 50.1 ES	0 092 S40 280	S4 028
54 94 50.1 ES	0 092 S40 290	S4 029
55 58 50	0 092 T30 790	T3 079
55 58 50 ES	0 092 T30 790	T3 079
55 58 50 LV	0 092 T30 790	T3 079
6 DATM 9 Y	0 092 S30 020	S3 002
6 DATM 9 Y	0 092 S40 020	S4 002
62 65 00 K	0 092 S40 100	S4 010

MAZDA

B3D3-18-520	0 092 S30 010	S3 001
E508-18-520	0 092 S40 180	S4 018
E515-18-520	0 092 S40 260	S4 026
FE05-18-520	0 092 S40 240	S4 024
N256-18-520	0 092 S40 240	S4 024
RF72-18-520A	0 092 S40 250	S4 025
R202-18-520	0 092 S40 260	S4 026
0605-18-520A	0 092 S40 190	S4 019
3922-18-520	0 092 S40 190	S4 019
3922-18-520A	0 092 S40 190	S4 019
4094-18-520	0 092 S40 270	S4 027
6051 85 20	0 092 S40 190	S4 019
8715-18-520	0 092 S40 250	S4 025

MERCEDES-BENZ

A 000 541 83 01	0 092 T30 720	T3 072
A 000 541 86 01	0 092 T30 720	T3 072
A 000 982 03 08	0 092 S40 050	S4 005
A 000 982 03 08	0 092 S50 050	S5 005
A 000 982 11 08	0 092 T30 750	T3 075
A 000 982 11 08	0 092 T40 750	T4 075
A 000 982 12 08	0 092 T40 770	T4 077
A 000 982 13 08	0 092 T50 800	T5 080

A 000 982 14 08	0 092 T40 770	T4 077
A 000 982 15 08	0 092 T30 750	T3 075
A 000 982 15 08	0 092 T40 750	T4 075
A 000 982 17 08	0 092 S50 100	S5 010
A 000 982 30 08	0 092 S40 050	S4 005
A 000 982 30 08	0 092 S50 050	S5 005
A 000 982 31 08	0 092 S40 080	S4 008
A 000 982 31 08	0 092 S50 080	S5 008
A 000 982 32 08	0 092 S50 100	S5 010
A 000 982 33 08	0 092 S50 130	S5 013
A 000 982 37 08	0 092 S40 080	S4 008
A 000 982 37 08	0 092 S50 080	S5 008
A 000 982 38 08	0 092 S40 130	S4 013
A 000 982 38 08	0 092 S50 130	S5 013
A 000 982 39 08	0 092 T40 760	T4 076
A 000 982 40 08	0 092 T40 760	T4 076
A 000 982 41 08	0 092 T40 770	T4 077
A 000 982 42 08	0 092 T50 770	T5 077
A 000 982 43 08	0 092 T50 800	T5 080
A 000 982 44 08	0 092 T50 800	T5 080
A 001 541 02 01	0 092 S40 130	S4 013
A 001 541 02 01	0 092 T30 130	T3 013
A 001 541 08 01	0 092 S30 050	S3 005
A 001 541 09 01	0 092 T30 080	T3 008
A 001 541 12 01	0 092 T30 720	T3 072
A 001 541 35 01	0 092 S30 050	S3 005
A 001 541 36 01	0 092 S40 080	S4 008
A 001 541 36 01	0 092 T30 080	T3 008
A 001 541 37 01	0 092 S40 130	S4 013
A 001 541 37 01	0 092 T30 130	T3 013
A 001 541 38 01	0 092 S30 050	S3 005
A 001 541 39 01	0 092 T30 080	T3 008
A 001 541 40 01	0 092 S40 130	S4 013
A 001 541 40 01	0 092 T30 130	T3 013
A 001 541 41 01	0 092 T30 080	T3 008
A 001 541 44 01	0 092 S30 050	S3 005
A 001 541 45 01	0 092 S40 130	S4 013
A 001 541 45 01	0 092 T30 130	T3 013
A 001 541 47 01	0 092 S30 020	S3 002
A 001 541 48 01	0 092 S30 020	S3 002
A 001 541 57 01	0 092 S30 020	S3 002
A 001 541 67 01	0 092 T30 420	T3 042
A 001 541 72 01	0 092 S40 130	S4 013
A 001 541 72 01	0 092 T30 130	T3 013
A 001 541 74 01	0 092 S30 050	S3 005
A 001 541 76 01	0 092 S40 130	S4 013
A 001 541 76 01	0 092 T30 130	T3 013
A 001 541 78 01	0 092 S30 050	S3 005
A 001 541 80 01	0 092 S40 130	S4 013
A 001 541 80 01	0 092 T30 130	T3 013
A 001 541 92 01	0 092 T30 380	T3 038
A 002 541 06 01	0 092 T30 750	T3 075
A 002 541 06 01	0 092 T40 750	T4 075
A 002 541 07 01	0 092 T30 750	T3 075
A 002 541 07 01	0 092 T40 750	T4 075



◀ MERCEDES-BENZ

A 002 541 08 01	0 092 T30 750	T3 075
A 002 541 08 01	0 092 T40 750	T4 075
A 002 541 09 01	0 092 T40 750	T4 075
A 002 541 10 01	0 092 T40 750	T4 075
A 002 541 11 01	0 092 T40 750	T4 075
A 002 541 11 01	0 092 T50 750	T5 075
A 002 541 15 01	0 092 T40 780	T4 078
A 002 541 16 01	0 092 T40 780	T4 078
A 002 541 17 01	0 092 T40 780	T4 078
A 002 541 17 01	0 092 T50 800	T5 080
A 002 541 21 01	0 092 T40 760	T4 076
A 002 541 23 01	0 092 T40 760	T4 076
A 002 541 27 01	0 092 T30 720	T3 072
A 002 541 28 01	0 092 T30 720	T3 072
A 002 541 29 01	0 092 T30 720	T3 072
A 002 541 30 01	0 092 T50 800	T5 080
A 002 541 35 01	0 092 T40 770	T4 077
A 002 541 37 01	0 092 T40 770	T4 077
A 002 541 40 01	0 092 T30 050	T3 005
A 002 541 41 01	0 092 S40 130	S4 013
A 002 541 41 01	0 092 T30 130	T3 013
A 002 541 43 01	0 092 T30 080	T3 008
A 002 541 49 01	0 092 T30 800	T3 080
A 002 541 50 01	0 092 T30 380	T3 038
A 002 541 53 01	0 092 T40 780	T4 078
A 002 541 64 01	0 092 T30 730	T3 073
A 002 541 68 01	0 092 S40 080	S4 008
A 002 541 70 01	0 092 S40 080	S4 008
A 002 541 72 01	0 092 S40 080	S4 008
A 002 541 73 01	0 092 S40 050	S4 005
A 002 541 73 01	0 092 S50 050	S5 005
A 002 541 76 01	0 092 S40 270	S4 027
A 002 541 78 01	0 092 S40 260	S4 026
A 002 541 79 01	0 092 S40 270	S4 027
A 002 541 80 01	0 092 T30 420	T3 042
A 002 541 87 01	0 092 S40 260	S4 026
A 002 541 92 01	0 092 T30 720	T3 072
A 002 541 93 01	0 092 T30 750	T3 075
A 002 541 93 01	0 092 T40 750	T4 075
A 002 541 94 01	0 092 T30 770	T3 077
A 002 541 94 01	0 092 T40 770	T4 077
A 002 541 96 01	0 092 T30 720	T3 072
A 002 541 97 01	0 092 T30 750	T3 075
A 002 541 97 01	0 092 T40 750	T4 075
A 003 541 00 01	0 092 T30 720	T3 072
A 003 541 01 01	0 092 T30 750	T3 075
A 003 541 01 01	0 092 T40 750	T4 075
A 003 541 05 01	0 092 T50 770	T5 077
A 003 541 07 01	0 092 T40 760	T4 076
A 003 541 33 01	0 092 S40 260	S4 026
A 003 541 64 01	0 092 S40 050	S4 005
A 003 541 64 01	0 092 S50 050	S5 005
A 003 541 65 01	0 092 S40 050	S4 005
A 003 541 65 01	0 092 S50 050	S5 005
A 003 541 66 01	0 092 S40 050	S4 005

A 003 541 66 01	0 092 S50 050	S5 005
A 003 541 73 01	0 092 S40 080	S4 008
A 003 541 73 01	0 092 S50 080	S5 008
A 003 541 88 01	0 092 T30 750	T3 075
A 003 541 88 01	0 092 T40 750	T4 075
A 003 541 89 01	0 092 T30 750	T3 075
A 003 541 89 01	0 092 T40 750	T4 075
A 004 541 13 01	0 092 S40 130	S4 013
A 004 541 13 01	0 092 T30 130	T3 013
A 004 541 17 01	0 092 T50 800	T5 080
A 004 541 20 01	0 092 T30 420	T3 042
A 004 541 23 01	0 092 S40 080	S4 008
A 004 541 23 01	0 092 T30 080	T3 008
A 004 541 28 01	0 092 T30 080	T3 008
A 004 541 29 01	0 092 T30 080	T3 008
A 004 541 30 01	0 092 T30 130	T3 013
A 004 541 31 01	0 092 T30 130	T3 013
A 004 541 33 01	0 092 S40 260	S4 026
A 004 541 42 01	0 092 S30 020	S3 002
A 004 541 44 01	0 092 T50 800	T5 080
A 004 541 45 01	0 092 S50 130	S5 013
A 004 541 46 01	0 092 S50 130	S5 013
A 004 541 48 01	0 092 T40 770	T4 077
A 004 541 49 01	0 092 T30 800	T3 080
A 004 541 49 01	0 092 T50 800	T5 080
A 004 541 51 01	0 092 T40 770	T4 077
A 004 541 52 01	0 092 T30 800	T3 080
A 004 541 71 01	0 092 S50 130	S5 013
A 004 541 75 01	0 092 T30 320	T3 032
A 004 541 89 01	0 092 T30 750	T3 075
A 004 541 89 01	0 092 T40 750	T4 075
A 004 541 90 01	0 092 T30 750	T3 075
A 004 541 90 01	0 092 T40 750	T4 075
A 004 541 91 01	0 092 T40 770	T4 077
A 004 541 92 01	0 092 T40 770	T4 077
A 004 541 93 01	0 092 T50 800	T5 080
A 004 541 94 01	0 092 T50 800	T5 080
A 005 541 19 01	0 092 S40 050	S4 005
A 005 541 19 01	0 092 S50 050	S5 005
A 005 541 20 01	0 092 S40 080	S4 008
A 005 541 21 01	0 092 S50 130	S5 013
A 005 541 23 01	0 092 S40 050	S4 005
A 005 541 23 01	0 092 S50 050	S5 005
A 005 541 24 01	0 092 S40 080	S4 008
A 005 541 24 01	0 092 S50 080	S5 008
A 005 541 25 01	0 092 S50 130	S5 013
A 193 982 00 08	0 092 S40 050	S4 005
A 193 982 00 08	0 092 S50 050	S5 005
A 304 540 03 01	0 092 T30 770	T3 077
A 304 540 03 01	0 092 T40 770	T4 077
A 335 540 00 01	0 092 T30 720	T3 072
A 335 540 01 01	0 092 T30 720	T3 072
A 454 541 03 02	0 092 S30 020	S3 002
A 454 541 04 02	0 092 S40 080	S4 008
A 454 541 04 02	0 092 S50 080	S5 008

HAA 193 54 1P 000	0 092 S40 080	S4 008
000 541 83 01	0 092 T30 720	T3 072
000 541 86 01	0 092 T30 720	T3 072
000 982 03 08	0 092 S40 050	S4 005
000 982 03 08	0 092 S50 050	S5 005
000 982 11 08	0 092 T30 750	T3 075
000 982 11 08	0 092 T40 750	T4 075
000 982 12 08	0 092 T40 770	T4 077
000 982 13 08	0 092 T50 800	T5 080
000 982 14 08	0 092 T40 770	T4 077
000 982 15 08	0 092 T30 750	T3 075
000 982 15 08	0 092 T40 750	T4 075
000 982 17 08	0 092 S50 100	S5 010
000 982 30 08	0 092 S40 050	S4 005
000 982 30 08	0 092 S50 050	S5 005
000 982 31 08	0 092 S40 080	S4 008
000 982 31 08	0 092 S50 080	S5 008
000 982 32 08	0 092 S50 100	S5 010
000 982 33 08	0 092 S50 130	S5 013
000 982 37 08	0 092 S40 080	S4 008
000 982 37 08	0 092 S50 080	S5 008
000 982 38 08	0 092 S40 130	S4 013
000 982 38 08	0 092 S50 130	S5 013
000 982 39 08	0 092 T40 760	T4 076
000 982 40 08	0 092 T40 760	T4 076
000 982 41 08	0 092 T40 770	T4 077
000 982 42 08	0 092 T50 770	T5 077
000 982 43 08	0 092 T50 800	T5 080
000 982 44 08	0 092 T50 800	T5 080
001 541 02 01	0 092 S40 130	S4 013
001 541 02 01	0 092 T30 130	T3 013
001 541 08 01	0 092 S30 050	S3 005
001 541 09 01	0 092 T30 080	T3 008
001 541 12 01	0 092 T30 720	T3 072
001 541 35 01	0 092 S30 050	S3 005
001 541 36 01	0 092 S40 080	S4 008
001 541 36 01	0 092 T30 080	T3 008
001 541 37 01	0 092 S40 130	S4 013
001 541 37 01	0 092 T30 130	T3 013
001 541 38 01	0 092 S30 050	S3 005
001 541 39 01	0 092 T30 080	T3 008
001 541 40 01	0 092 S40 130	S4 013
001 541 40 01	0 092 T30 130	T3 013
001 541 41 01	0 092 T30 080	T3 008
001 541 44 01	0 092 S30 050	S3 005
001 541 45 01	0 092 S40 130	S4 013
001 541 45 01	0 092 T30 130	T3 013
001 541 47 01	0 092 S30 020	S3 002
001 541 48 01	0 092 S30 020	S3 002
001 541 57 01	0 092 S30 020	S3 002
001 541 67 01	0 092 T30 420	T3 042
001 541 72 01	0 092 S40 130	S4 013
001 541 72 01	0 092 T30 130	T3 013
001 541 74 01	0 092 S30 050	S3 005
001 541 76 01	0 092 S40 130	S4 013



001 541 76 01	0 092 T30 130	T3 013
001 541 78 01	0 092 S30 050	S3 005
001 541 80 01	0 092 S40 130	S4 013
001 541 80 01	0 092 T30 130	T3 013
001 541 92 01	0 092 T30 380	T3 038

002 541 06 01	0 092 T30 750	T3 075
002 541 06 01	0 092 T40 750	T4 075
002 541 07 01	0 092 T30 750	T3 075
002 541 07 01	0 092 T40 750	T4 075
002 541 08 01	0 092 T30 750	T3 075

002 541 08 01	0 092 T40 750	T4 075
002 541 09 01	0 092 T40 750	T4 075
002 541 10 01	0 092 T40 750	T4 075
002 541 11 01	0 092 T40 750	T4 075
002 541 11 01	0 092 T50 750	T5 075

002 541 15 01	0 092 T40 780	T4 078
002 541 16 01	0 092 T40 780	T4 078
002 541 17 01	0 092 T40 780	T4 078
002 541 17 01	0 092 T50 800	T5 080
002 541 21 01	0 092 T40 760	T4 076

002 541 23 01	0 092 T40 760	T4 076
002 541 27 01	0 092 T30 720	T3 072
002 541 28 01	0 092 T30 720	T3 072
002 541 29 01	0 092 T30 720	T3 072
002 541 30 01	0 092 T50 800	T5 080

002 541 35 01	0 092 T40 770	T4 077
002 541 37 01	0 092 T40 770	T4 077
002 541 40 01	0 092 T30 050	T3 005
002 541 41 01	0 092 S40 130	S4 013
002 541 41 01	0 092 T30 130	T3 013

002 541 43 01	0 092 T30 080	T3 008
002 541 49 01	0 092 T30 800	T3 080
002 541 50 01	0 092 T30 380	T3 038
002 541 53 01	0 092 T40 780	T4 078
002 541 64 01	0 092 T30 730	T3 073

002 541 68 01	0 092 S40 080	S4 008
002 541 70 01	0 092 S40 080	S4 008
002 541 72 01	0 092 S40 080	S4 008
002 541 73 01	0 092 S40 050	S4 005
002 541 73 01	0 092 S50 050	S5 005

002 541 76 01	0 092 S40 270	S4 027
002 541 78 01	0 092 S40 260	S4 026
002 541 79 01	0 092 S40 270	S4 027
002 541 80 01	0 092 T30 420	T3 042
002 541 87 01	0 092 S40 260	S4 026

002 541 92 01	0 092 T30 720	T3 072
002 541 93 01	0 092 T30 750	T3 075
002 541 93 01	0 092 T40 750	T4 075
002 541 94 01	0 092 T30 770	T3 077
002 541 94 01	0 092 T40 770	T4 077

002 541 96 01	0 092 T30 720	T3 072
002 541 97 01	0 092 T30 750	T3 075
002 541 97 01	0 092 T40 750	T4 075
002600	0 092 T50 800	T5 080
003 541 00 01	0 092 T30 720	T3 072

003 541 01 01	0 092 T30 750	T3 075
003 541 01 01	0 092 T40 750	T4 075
003 541 05 01	0 092 T50 770	T5 077
003 541 07 01	0 092 T40 760	T4 076
003 541 33 01	0 092 S40 260	S4 026

003 541 64 01	0 092 S40 050	S4 005
003 541 64 01	0 092 S50 050	S5 005
003 541 65 01	0 092 S40 050	S4 005
003 541 65 01	0 092 S50 050	S5 005
003 541 66 01	0 092 S40 050	S4 005

003 541 66 01	0 092 S50 050	S5 005
003 541 73 01	0 092 S40 080	S4 008
003 541 73 01	0 092 S50 080	S5 008
003 541 88 01	0 092 T30 750	T3 075
003 541 88 01	0 092 T40 750	T4 075

003 541 89 01	0 092 T30 750	T3 075
003 541 89 01	0 092 T40 750	T4 075
004 541 13 01	0 092 S40 130	S4 013
004 541 13 01	0 092 T30 130	T3 013
004 541 17 01	0 092 T50 800	T5 080

004 541 20 01	0 092 T30 420	T3 042
004 541 23 01	0 092 S40 080	S4 008
004 541 23 01	0 092 T30 080	T3 008
004 541 28 01	0 092 T30 080	T3 008
004 541 29 01	0 092 T30 080	T3 008

004 541 30 01	0 092 T30 130	T3 013
004 541 31 01	0 092 T30 130	T3 013
004 541 33 01	0 092 S40 260	S4 026
004 541 42 01	0 092 S30 020	S3 002
004 541 44 01	0 092 T50 800	T5 080

004 541 45 01	0 092 S50 130	S5 013
004 541 46 01	0 092 S50 130	S5 013
004 541 48 01	0 092 T40 770	T4 077
004 541 49 01	0 092 T30 800	T3 080
004 541 49 01	0 092 T50 800	T5 080

004 541 51 01	0 092 T40 770	T4 077
004 541 52 01	0 092 T30 800	T3 080
004 541 71 01	0 092 S50 130	S5 013
004 541 75 01	0 092 T30 320	T3 032
004 541 89 01	0 092 T30 750	T3 075

004 541 89 01	0 092 T40 750	T4 075
004 541 90 01	0 092 T30 750	T3 075
004 541 90 01	0 092 T40 750	T4 075
004 541 91 01	0 092 T40 770	T4 077
004 541 92 01	0 092 T40 770	T4 077

004 541 93 01	0 092 T50 800	T5 080
004 541 94 01	0 092 T50 800	T5 080
005 541 19 01	0 092 S40 050	S4 005
005 541 19 01	0 092 S50 050	S5 005
005 541 20 01	0 092 S40 080	S4 008

005 541 21 01	0 092 S50 130	S5 013
005 541 23 01	0 092 S40 050	S4 005
005 541 23 01	0 092 S50 050	S5 005
005 541 24 01	0 092 S40 080	S4 008
005 541 24 01	0 092 S50 080	S5 008

005 541 25 01	0 092 S50 130	S5 013
193 982 00 08	0 092 S40 050	S4 005
193 982 00 08	0 092 S50 050	S5 005
304 540 03 01	0 092 T30 770	T3 077
304 540 03 01	0 092 T40 770	T4 077

335 540 00 01	0 092 T30 720	T3 072
335 540 01 01	0 092 T30 720	T3 072
454 541 03 02	0 092 S30 020	S3 002
454 541 04 02	0 092 S40 080	S4 008
454 541 04 02	0 092 S50 080	S5 008

MG

Z155565	0 092 S30 060	S3 006
Z255565	0 092 S30 060	S3 006

MINI (BMW)

118668 20DE	0 092 S60 010	S6 001
118668 20DE	0 092 S60 080	S6 008
61217 567 386	0 092 S50 050	S5 005

61217 567 388	0 092 S50 080	S5 008
61218 376 453	0 092 S40 020	S4 002

MITSUBISHI

MB097835	0 092 S40 270	S4 027
MN148848	0 092 S30 020	S3 002
MN148850	0 092 S40 050	S4 005

MN148850	0 092 S50 050	S5 005
MZ690077	0 092 S40 250	S4 025
MZ690082	0 092 S40 050	S4 005
MZ690082	0 092 S50 050	S5 005
MZ690092	0 092 S40 290	S4 029

Z2157070	0 092 S40 270	S4 027
Z2157101	0 092 T30 710	T3 071

MOLL

540 045 036	0 092 S30 010	S3 001
540 108 033	0 092 S40 000	S4 000
543 016 033	0 092 S30 010	S3 001

544 059 036	0 092 S30 020	S3 002
544 064 036	0 092 S30 030	S3 003
545 051 030	0 092 S40 220	S4 022
545 051 030	0 092 S40 230	S4 023
545 077 030	0 092 S30 160	S3 016

545 079 030	0 092 S30 170	S3 017
545 084 030	0 092 S40 210	S4 021
555 059 042	0 092 S30 050	S3 005
555 065 042	0 092 S40 060	S4 006
555 066 042	0 092 S30 040	S3 004



◀ MOLL

560 020 048	0 092 S30 050	S3 005
560 068 039	0 092 S40 240	S4 024
560 069 039	0 092 S40 250	S4 025
561 011 054	0 092 S40 050	S4 005
562 019 048	0 092 S50 050	S5 005

562 021 048	0 092 S30 060	S3 006
562 025 051	0 092 S50 040	S5 004
565 030 054	0 092 S30 070	S3 007
566 038 051	0 092 S30 080	S3 008
570 082 057	0 092 S30 080	S3 008

571 013 068	0 092 S30 070	S3 007
574 012 068	0 092 S40 080	S4 008
574 014 068	0 092 S40 090	S4 009
575 039 064	0 092 S40 100	S4 010
580 045 064	0 092 S5E 110	S5 E11

582 014 072	0 092 S5E 110	S5 E11
585 015 076	0 092 S30 120	S3 012
588 027 064	0 092 S30 130	S3 013
592 022 076	0 092 S30 130	S3 013
595 031 076	0 092 S40 130	S4 013

600 026 060	0 092 T30 720	T3 072
600 038 085	0 092 T30 130	T3 013
605 027 068	0 092 T30 360	T3 036
605 028 068	0 092 T30 370	T3 037
610 040 076	0 092 T30 450	T3 045

620 034 068	0 092 T50 750	T5 075
620 045 068	0 092 T40 750	T4 075
625 012 072	0 092 T30 400	T3 040
625 014 072	0 092 T30 410	T3 041
625 023 000	0 092 T30 420	T3 042

630 013 068	0 092 T30 430	T3 043
635 030 068	0 092 T30 750	T3 075
635 044 068	0 092 T30 380	T3 038
640 020 076	0 092 T40 760	T4 076
640 036 076	0 092 T40 760	T4 076

643 017 090	0 092 T30 770	T3 077
643 018 090	0 092 T30 770	T3 077
665 014 090	0 092 T40 770	T4 077
670 018 100	0 092 T40 770	T4 077
670 032 100	0 092 T40 780	T4 078

670 033 100	0 092 T30 470	T3 047
670 034 085	0 092 T30 470	T3 047
680 019 100	0 092 T50 770	T5 077
680 032 100	0 092 T50 770	T5 077
680 036 100	0 092 T30 790	T3 079

680 040 095	0 092 T40 800	T4 080
700 038 105	0 092 T30 800	T3 080
725 012 115	0 092 T50 800	T5 080
81070	0 092 S60 080	S6 008
81095	0 092 S60 130	S6 013

83046	0 092 S40 010	S4 001
83056	0 092 S40 040	S4 004
83058	0 092 S50 050	S5 005
83071	0 092 S40 070	S4 007
83075	0 092 S40 080	S4 008

83085	0 092 S5E 110	S5 E11
83091	0 092 S30 120	S3 012
83095	0 092 S50 130	S5 013
83110	0 092 S50 150	S5 015

MONBAT

544 059 041	0 092 S30 020	S3 002
544 065 041	0 092 S30 010	S3 001
545 077 036	0 092 S30 160	S3 016

545 079 036	0 092 S30 170	S3 017
550 154 047	0 092 S30 020	S3 002
550 154 048	0 092 S40 020	S4 002
550 155 047	0 092 S40 010	S4 001
550 155 048	0 092 S50 010	S5 001

555 059 051	0 092 S30 050	S3 005
555 066 051	0 092 S40 040	S4 004
560 068 046	0 092 S40 240	S4 024
560 069 046	0 092 S40 250	S4 025
560 901 068	0 092 S60 050	S6 005

562 019 055	0 092 S40 050	S4 005
562 025 055	0 092 S50 040	S5 004
565 108 056	0 092 S40 040	S4 004
565 108 057	0 092 S50 040	S5 004
565 115 056	0 092 S40 050	S4 005

565 115 057	0 092 S50 050	S5 005
566 047 060	0 092 S30 080	S3 008
566 049 060	0 092 S30 070	S3 007
570 901 076	0 092 S60 080	S6 008
575 012 071	0 092 S50 080	S5 008

575 046 071	0 092 S50 070	S5 007
575 119 074	0 092 S40 080	S4 008
575 119 075	0 092 S50 080	S5 008
575 121 074	0 092 S40 070	S4 007
575 121 075	0 092 S50 070	S5 007

580 045 071	0 092 S5E 110	S5 E11
580 103 071	0 092 S40 100	S4 010
580 901 081	0 092 S60 110	S6 011
585 107 078	0 092 S5E 110	S5 E11
585 122 078	0 092 S50 100	S5 010

588 027 077	0 092 S30 130	S3 013
588 112 077	0 092 S30 120	S3 012
595 901 085	0 092 S60 130	S6 013
600 032 070	0 092 S40 280	S4 028
600 033 070	0 092 S40 290	S4 029

600 048 087	0 092 S50 130	S5 013
600 048 088	0 092 S50 130	S5 013
610 040 076	0 092 T30 380	T3 038
610 043 076	0 092 T30 380	T3 038
625 012 072	0 092 T30 400	T3 040

625 014 072	0 092 T30 410	T3 041
625 103 086	0 092 T50 750	T5 075
635 039 095	0 092 T30 450	T3 045
635 044 095	0 092 T30 450	T3 045
640 034 098	0 092 T40 750	T4 075

643 022 100	0 092 T30 470	T3 047
654 101 105	0 092 T30 750	T3 075
665 015 110	0 092 T40 770	T4 077
680 102 120	0 092 T50 770	T5 077
710 038 130	0 092 T50 800	T5 080

730 026 140	0 092 T40 800	T4 080
-------------	---------------	---------------

MONZA

EMF 647	0 092 T30 400	T3 040
---------	---------------	---------------

MOTORCRAFT

EMF 015	0 092 S40 210	S4 021
1 060 815	0 092 S30 160	S3 016
1 060 817	0 092 S40 270	S4 027

1 112 312	0 092 S30 040	S3 004
1 112 614	0 092 S40 260	S4 026
1 112 615	0 092 S40 270	S4 027
1 112 616	0 092 S40 080	S4 008
1 112 616	0 092 S50 080	S5 008

1 112 621	0 092 S30 070	S3 007
1 112 629	0 092 S40 240	S4 024
1 139 432	0 092 S30 020	S3 002
1 139 435	0 092 S40 050	S4 005
1 139 435	0 092 S50 050	S5 005

1 139 436	0 092 S30 070	S3 007
1 139 437	0 092 S30 080	S3 008
1 139 438	0 092 S50 130	S5 013
1 140 049	0 092 S40 270	S4 027
1 151 998	0 092 S40 010	S4 001

1 337 232	0 092 S30 050	S3 005
1 347 729	0 092 S40 010	S4 001
1 347 730	0 092 S30 040	S3 004
1 347 731	0 092 S40 040	S4 004
1 347 731	0 092 S50 040	S5 004

1 347 732	0 092 S30 070	S3 007
1 347 733	0 092 S40 010	S4 001
1 347 735	0 092 S30 040	S3 004
1 347 736	0 092 S40 040	S4 004
1 347 736	0 092 S50 040	S5 004

1 347 737	0 092 S30 070	S3 007
1 347 739	0 092 S30 170	S3 017
1 347 741	0 092 S40 020	S4 002
1 347 742	0 092 S30 130	S3 013
1 377 909	0 092 S40 000	S4 000

1 445 813	0 092 S40 040	S4 004
1 445 814	0 092 S40 040	S4 004



NEOPLAN

07 97020 2250	0 092 T50 800	T5 080
834 226 001	0 092 T50 800	T5 080

NISSAN

KE240 LM150	0 092 T30 400	T3 040
KE240 60J00	0 092 S40 240	S4 024
KE240 89928	0 092 S40 240	S4 024

KE240 89940	0 092 S40 260	S4 026
KE240 89945	0 092 S40 270	S4 027
KE240 89955	0 092 S40 290	S4 029
KE240 89975	0 092 T30 710	T3 071
KE240 89983	0 092 T30 350	T3 035

KE240 89983	0 092 T30 370	T3 037
KE241 60J00	0 092 S40 240	S4 024
KE241 95J10	0 092 S40 290	S4 029
24410 AY60B	0 092 S40 010	S4 001
24410 AY60B	0 092 S50 010	S5 001

24410 AY60C	0 092 S40 040	S4 004
24410 AY60C	0 092 S50 040	S5 004
24410 D1514	0 092 S40 270	S4 027
24410 P8010	0 092 S40 270	S4 027
24410 06H73	0 092 S40 240	S4 024

24410 07H73	0 092 S40 260	S4 026
24410 2X101	0 092 S40 080	S4 008
24410 3X10A	0 092 S40 080	S4 008
24410 3X10A	0 092 S50 080	S5 008
24410 3X90A	0 092 S40 050	S4 005

24410 3X90A	0 092 S50 050	S5 005
24410 38301	0 092 S40 270	S4 027

OPEL

09159053	0 092 S40 100	S4 010
09175245EK	0 092 S30 120	S3 012
09194916EK	0 092 S30 120	S3 012

09201469EQ	0 092 S50 040	S5 004
09201470 ER	0 092 S40 070	S4 007
09201472ES	0 092 S30 120	S3 012
09201870ET	0 092 S50 040	S5 004
09201873 EU	0 092 S40 070	S4 007

1201030	0 092 S40 010	S4 001
1201101	0 092 S30 020	S3 002
1201106	0 092 S30 080	S3 008
1201200	0 092 S40 040	S4 004
1201200	0 092 S50 040	S5 004

1201201	0 092 S30 050	S3 005
1201202	0 092 S30 050	S3 005
1201204	0 092 S30 040	S3 004
1201204	0 092 S40 040	S4 004
1201210	0 092 S40 020	S4 002

1201210	0 092 S50 020	S5 002
1201212	0 092 S30 080	S3 008
1201212	0 092 S40 080	S4 008
1201252	0 092 S40 080	S4 008
1201256	0 092 S40 080	S4 008

1201261	0 092 S40 080	S4 008
1201264	0 092 S30 070	S3 007
1201264	0 092 S50 070	S5 007
1201269	0 092 S40 070	S4 007
1201274	0 092 S40 080	S4 008

1201279	0 092 S50 040	S5 004
1201280	0 092 S40 070	S4 007
1201283	0 092 S30 010	S3 001
1201284	0 092 S40 010	S4 001
1201299	0 092 S40 070	S4 007

1201301	0 092 S40 070	S4 007
1201302	0 092 S30 120	S3 012
1201303	0 092 S30 120	S3 012
1201304	0 092 S40 290	S4 029
1201305	0 092 S30 120	S3 012

1201308	0 092 S40 130	S4 013
1201308	0 092 S50 130	S5 013
1201330	0 092 S30 120	S3 012
1201331	0 092 S40 040	S4 004
1201331	0 092 S50 010	S5 001

13164410FG	0 092 S50 040	S5 004
13165235	0 092 S40 000	S4 000
13165236	0 092 S40 020	S4 002
13165237	0 092 S40 050	S4 005
13165238	0 092 S30 080	S3 008

13165238	0 092 S40 080	S4 008
13165239	0 092 S30 070	S3 007
13165239	0 092 S40 070	S4 007
13165240	0 092 S40 100	S4 010
1777871	0 092 S40 080	S4 008

19001646	0 092 S50 070	S5 007
19001884	0 092 S30 010	S3 001
19001885	0 092 S40 010	S4 001
19001888	0 092 S30 010	S3 001
19001889	0 092 S40 010	S4 001

19001893	0 092 S50 050	S5 005
19001894	0 092 S40 070	S4 007
19001895	0 092 S50 080	S5 008
19001898	0 092 S50 080	S5 008
19001900	0 092 S30 120	S3 012

19002969	0 092 S50 040	S5 004
19002974	0 092 S50 070	S5 007
19003129	0 092 S50 040	S5 004
19003130	0 092 S50 070	S5 007
19023197	0 092 S50 100	S5 010

19023517	0 092 S50 070	S5 007
19023518	0 092 S30 070	S3 007
19023519	0 092 S50 100	S5 010
19201470	0 092 S50 070	S5 007
19201873	0 092 S50 070	S5 007

24422574	0 092 S40 010	S4 001
24446351	0 092 S30 070	S3 007
24446351EQ	0 092 S50 040	S5 004
24446352	0 092 S30 070	S3 007
24446352	0 092 S40 070	S4 007

24446352	0 092 S50 070	S5 007
24446352 ER	0 092 S40 070	S4 007
24446353	0 092 S30 120	S3 012
24446353ES	0 092 S30 120	S3 012
24447232	0 092 S30 070	S3 007

24447232	0 092 S40 040	S4 004
24447232	0 092 S50 040	S5 004
24447233	0 092 S30 070	S3 007
24447233	0 092 S40 070	S4 007
24447233	0 092 S50 070	S5 007

24447233 EU	0 092 S40 070	S4 007
24447332ET	0 092 S50 040	S5 004
24456171	0 092 S50 100	S5 010
6201250	0 092 S30 070	S3 007
6201250	0 092 S40 040	S4 004

6201250	0 092 S50 040	S5 004
6201252	0 092 S30 070	S3 007
6201252	0 092 S40 040	S4 004
6201252	0 092 S50 040	S5 004
620127	0 092 S50 100	S5 010

6201271	0 092 S30 070	S3 007
6201271	0 092 S40 070	S4 007
6201271	0 092 S50 070	S5 007
6201272	0 092 S30 070	S3 007
6201272	0 092 S40 070	S4 007

6201272	0 092 S50 070	S5 007
6201273	0 092 S50 100	S5 010
6201305	0 092 S30 120	S3 012
6777172	0 092 S50 070	S5 007
90540295	0 092 S40 070	S4 007

90540473	0 092 S30 010	S3 001
90540474	0 092 S40 010	S4 001
90540476	0 092 S50 040	S5 004
90540477	0 092 S50 070	S5 007
90542072	0 092 S40 080	S4 008

90564961	0 092 S40 080	S4 008
90567354	0 092 S50 070	S5 007
9115185	0 092 S50 040	S5 004
9115186	0 092 S40 070	S4 007
91156435	0 092 S50 100	S5 010

91158371	0 092 S30 070	S3 007
91158372	0 092 S50 070	S5 007
91158373	0 092 S30 120	S3 012
91158375	0 092 S30 070	S3 007
91158376	0 092 S50 070	S5 007

9159053	0 092 S40 100	S4 010
9159074	0 092 S50 070	S5 007
9159075	0 092 S50 070	S5 007
9194929	0 092 S40 290	S4 029
9195675	0 092 S40 070	S4 007

◀ OPEL

9199053	0 092 S50 100	S5 010
9201469	0 092 S30 070	S3 007
9201470	0 092 S50 070	S5 007
9201472	0 092 S30 120	S3 012
9201871	0 092 S30 070	S3 007

9201872	0 092 S30 070	S3 007
9201872	0 092 S50 040	S5 004
9201873	0 092 S50 070	S5 007
93176704	0 092 S40 040	S4 004
93182214	0 092 S40 130	S4 013

93182214	0 092 S50 130	S5 013
----------	---------------	---------------

PEUGEOT

ZC 98 652 82 U	0 092 S40 130	S4 013
ZC 98 653 20 U	0 092 S30 160	S3 016
ZC 98 653 85	0 092 S30 050	S3 005

ZC 98 654 76 U	0 092 S30 160	S3 016
ZC 98 654 82	0 092 S40 080	S4 008
5600 CR	0 092 S30 020	S3 002
5600 CT	0 092 S30 050	S3 005
5600 CX	0 092 S40 080	S4 008

5600 GJ	0 092 S30 020	S3 002
5600 GR	0 092 S40 080	S4 008
5600 GR	0 092 S50 080	S5 008
5600 HR	0 092 S40 080	S4 008
5600 HS	0 092 S50 130	S5 013

5600 JT	0 092 S30 020	S3 002
5600 JW	0 092 S40 050	S4 005
5600 JW	0 092 S50 050	S5 005
5600 JX	0 092 S40 080	S4 008
5600 KH	0 092 S40 050	S4 005

5600 KH	0 092 S50 050	S5 005
5600 KJ	0 092 S40 020	S4 002
5600 KJ	0 092 S50 020	S5 002
5600 OR	0 092 S50 080	S5 008
5600 QA	0 092 S50 080	S5 008

5600 QN	0 092 S40 020	S4 002
5600 QP	0 092 S40 050	S4 005
5600 QP	0 092 S50 050	S5 005
5600 QR	0 092 S40 080	S4 008
5600 RC	0 092 S50 080	S5 008

5600 SH	0 092 S50 150	S5 015
5600 SL	0 092 S50 080	S5 008
5600 SQ	0 092 S40 280	S4 028
5600 SX	0 092 S50 080	S5 008
5600 SY	0 092 S50 050	S5 005

5600 13	0 092 S40 270	S4 027
5600 14	0 092 S30 160	S3 016
5600 15	0 092 S30 160	S3 016
5600 17	0 092 S40 270	S4 027
7905525547	0 092 S50 020	S5 002

7905525557	0 092 S50 050	S5 005
7905 525 567	0 092 S40 080	S4 008
7905 525 567	0 092 S50 080	S5 008
7905525747	0 092 S40 000	S4 000
7905525757	0 092 S40 000	S4 000

7905525767	0 092 S50 130	S5 013
7905525787	0 092 S50 130	S5 013
7905525797	0 092 S50 050	S5 005

PINGUELY

244 020 6240	0 092 S40 080	S4 008
244 020 6240	0 092 S50 080	S5 008
244 020 7920	0 092 S50 130	S5 013

PORSCHE

7PP 915 105	0 092 S60 020	S6 002
7PP 915 105	0 092 S60 130	S6 013
955 611 085 00	0 092 S60 020	S6 002

955 611 085 00	0 092 S60 130	S6 013
955 611 092 00	0 092 S60 020	S6 002
955 611 092 00	0 092 S60 130	S6 013
955 611 095 20	0 092 S50 130	S5 013
955 611 095 21	0 092 S50 130	S5 013

955 611 110 20	0 092 S50 150	S5 015
955 611 110 21	0 092 S50 150	S5 015
999 611 036 00	0 092 S30 010	S3 001
999 611 050 00	0 092 S30 070	S3 007
999 611 051 20	0 092 S50 040	S5 004

999 611 055 20	0 092 S50 070	S5 007
999 611 060 00	0 092 S40 050	S4 005
999 611 060 00	0 092 S50 050	S5 005
999 611 070 00	0 092 S40 080	S4 008
999 611 070 00	0 092 S50 080	S5 008

999 611 075 00	0 092 S40 080	S4 008
999 611 075 00	0 092 S50 080	S5 008
999 611 080 00	0 092 S50 100	S5 010
999 611 088 20	0 092 S40 130	S4 013
999 611 088 20	0 092 S50 130	S5 013

999 611 088 20	0 092 T30 130	T3 013
----------------	---------------	---------------

PRESTOLITE ELECTRIC

56048	0 092 S40 260	S4 026
56049	0 092 S40 270	S4 027

PSA (PEUGEOT S.A.)

79 055 25777	0 092 S50 080	S5 008
--------------	---------------	---------------

PUCH

(STEYR-DAIMLER-PUCH AG)

170 5601	0 092 M4F 100	M4 F10
170 5601	0 092 M40 100	M4 010

RENAULT

24 41 000 01R	0 092 S50 100	S5 010
24 41 000 02R	0 092 S50 100	S5 010
24 41 000 02R	0 092 S50 130	S5 013

24 41 000 03R	0 092 S40 050	S4 005
24 41 000 03R	0 092 S50 050	S5 005
24 41 000 04R	0 092 S40 080	S4 008
24 41 000 04R	0 092 S50 080	S5 008
24 41 000 05R	0 092 S50 150	S5 015

50 10 043 412	0 092 T30 420	T3 042
77 00 427 648	0 092 S40 050	S4 005
77 00 431 758	0 092 S30 010	S3 001
77 00 431 758	0 092 S30 020	S3 002
77 00 431 761	0 092 S30 070	S3 007

77 00 431 761	0 092 S40 070	S4 007
77 00 431 761	0 092 S50 070	S5 007
77 00 758 343	0 092 S30 020	S3 002
77 00 758 380	0 092 S40 080	S4 008
77 01 376 961	0 092 S50 050	S5 005

77 01 376 962	0 092 S30 020	S3 002
77 01 376 962	0 092 S40 010	S4 001
77 01 376 963	0 092 S40 020	S4 002
77 01 376 963	0 092 S50 020	S5 002
77 01 376 963	0 092 S50 100	S5 010

77 01 376 964	0 092 S40 050	S4 005
77 01 376 964	0 092 S50 050	S5 005
77 01 376 965	0 092 S30 080	S3 008
77 01 376 965	0 092 S40 080	S4 008
77 01 376 965	0 092 S50 080	S5 008

77 01 376 966	0 092 S50 100	S5 010
77 01 376 967	0 092 S40 130	S4 013
77 01 376 967	0 092 S50 130	S5 013
77 01 376 968	0 092 S40 010	S4 001
77 01 376 968	0 092 S50 010	S5 001

77 01 376 972	0 092 S30 040	S3 004
77 01 376 972	0 092 S40 040	S4 004
77 01 376 972	0 092 S50 040	S5 004
77 01 376 973	0 092 S30 070	S3 007
77 01 376 973	0 092 S40 070	S4 007

77 01 380 452	0 092 S30 020	S3 002
77 01 380 455	0 092 T30 130	T3 013
77 01 380 456	0 092 S40 050	S4 005
77 01 380 456	0 092 S50 050	S5 005
77 01 381 060	0 092 S30 020	S3 002

77 01 381 061	0 092 S40 020	S4 002
77 01 381 062	0 092 S40 050	S4 005
77 01 381 062	0 092 S50 050	S5 005
77 01 381 063	0 092 S40 080	S4 008
77 01 381 064	0 092 S40 080	S4 008

77 01 381 088	0 092 S40 130	S4 013
77 01 401 539	0 092 S30 050	S3 005
77 01 401 598	0 092 S30 160	S3 016
77 01 401 601	0 092 S30 160	S3 016
77 01 401 749	0 092 S30 160	S3 016

77 01 401 756	0 092 S30 160	S3 016
77 01 402 351	0 092 S30 160	S3 016
77 01 410 004	0 092 S40 000	S4 000
77 02 124 758	0 092 S30 160	S3 016
77 11 222 756	0 092 S30 020	S3 002

77 11 222 756	0 092 S40 020	S4 002
77 11 222 779	0 092 S40 020	S4 002
77 11 222 779	0 092 S50 020	S5 002
77 11 222 780	0 092 S40 050	S4 005
77 11 222 780	0 092 S50 040	S5 004

77 11 222 780	0 092 S50 050	S5 005
77 11 222 781	0 092 S30 080	S3 008
77 11 222 781	0 092 S40 080	S4 008
77 11 222 781	0 092 S50 080	S5 008
77 11 222 782	0 092 S50 100	S5 010

77 11 222 783	0 092 S40 130	S4 013
77 11 222 783	0 092 S50 130	S5 013
77 11 222 784	0 092 S30 010	S3 001
77 11 222 785	0 092 S40 010	S4 001
77 11 222 785	0 092 S50 010	S5 001

77 11 222 786	0 092 S30 040	S3 004
77 11 222 786	0 092 S40 040	S4 004
77 11 222 786	0 092 S50 010	S5 001
77 11 222 786	0 092 S50 040	S5 004
77 11 222 787	0 092 S30 070	S3 007

77 11 222 787	0 092 S40 070	S4 007
77 11 222 787	0 092 S50 070	S5 007
77 11 238 596	0 092 S40 020	S4 002
77 11 238 596	0 092 S50 020	S5 002
77 11 238 597	0 092 S50 050	S5 005

77 11 238 598	0 092 S50 080	S5 008
77 11 419 085	0 092 S50 100	S5 010
77 11 419 086	0 092 S50 130	S5 013
77 11 423 286	0 092 S50 130	S5 013
77 11 423 287	0 092 S50 150	S5 015

79 05 525 537	0 092 S30 020	S3 002
79 05 525 557	0 092 S40 050	S4 005
79 05 525 557	0 092 S50 050	S5 005
79 05 525 567	0 092 S40 080	S4 008
79 05 525 727	0 092 S30 050	S3 005

82 00 032 903	0 092 S40 100	S4 010
82 00 032 903	0 092 S50 100	S5 010
82 00 253 615	0 092 S40 040	S4 004
82 00 377 287	0 092 S40 080	S4 008
82 00 377 287	0 092 S50 080	S5 008

82 00 377 288	0 092 S40 080	S4 008
82 00 377 288	0 092 S50 080	S5 008
82 00 400 846	0 092 S50 100	S5 010
82 00 472 779	0 092 S50 080	S5 008
82 00 687 749	0 092 S40 130	S4 013

82 00 687 749	0 092 S50 130	S5 013
---------------	---------------	---------------

ROLLS-ROYCE

61210 147 397	0 092 S60 020	S6 002
61210 147 397	0 092 S60 130	S6 013
61210 147 399	0 092 S50 080	S5 008

ROVER

YGD 0001 10	0 092 S50 050	S5 005
YGD 0001 20	0 092 S40 080	S4 008
YGD 0001 20	0 092 S50 080	S5 008

YGD 0002 19	0 092 S50 050	S5 005
YGD 0002 30	0 092 S50 130	S5 013
YGD 5000 50	0 092 S40 050	S4 005
YGD 5000 50	0 092 S50 050	S5 005
YGD 5001 00	0 092 S30 080	S3 008

YGD 5001 30	0 092 S40 130	S4 013
YGD 5001 30	0 092 S50 130	S5 013
YGD 5001 60	0 092 S30 130	S3 013
YGD 5001 60	0 092 S40 130	S4 013
YGD 5001 90	0 092 S40 100	S4 010

YGD 5001 90	0 092 S50 100	S5 010
YGD 5002 00	0 092 S40 050	S4 005
Z15 4324	0 092 S40 010	S4 001
Z15 4459	0 092 S30 020	S3 002
Z15 4577	0 092 S30 160	S3 016

Z15 4579	0 092 S30 170	S3 017
Z15 5056	0 092 S40 040	S4 004
Z15 5056	0 092 S50 010	S5 001
Z15 5559	0 092 S30 050	S3 005
Z15 6092	0 092 S40 050	S4 005

Z15 6092	0 092 S50 050	S5 005
Z15 6219	0 092 S40 050	S4 005
Z15 6219	0 092 S50 050	S5 005
Z15 7024	0 092 S40 270	S4 027
Z15 8522	0 092 S40 290	S4 029

Z16 1048	0 092 T30 360	T3 036
Z25 4324	0 092 S40 010	S4 001
Z25 4459	0 092 S30 020	S3 002
Z25 4577	0 092 S30 160	S3 016
Z25 4579	0 092 S30 170	S3 017

Z25 5056	0 092 S40 040	S4 004
Z25 5056	0 092 S50 010	S5 001
Z25 5559	0 092 S30 050	S3 005
Z25 6092	0 092 S40 050	S4 005
Z25 6092	0 092 S50 050	S5 005

Z25 6219	0 092 S40 050	S4 005
Z25 6219	0 092 S50 050	S5 005
Z25 7024	0 092 S40 270	S4 027
Z25 8522	0 092 S40 290	S4 029
Z26 1048	0 092 T30 360	T3 036

61216915739	0 092 S50 130	S5 013
-------------	---------------	---------------

SAEM

3 CF 400	0 092 T30 610	T3 061
3 SE 700	0 092 T30 630	T3 063
6 AP 4A R	0 092 S30 160	S3 016

6 AP 4R	0 092 S30 160	S3 016
6 CM 10 P	0 092 T30 390	T3 039
6 CM 10 PX	0 092 T40 750	T4 075
6 CM 10 PX	0 092 T50 750	T5 075
6 CM 13 PK	0 092 T30 770	T3 077

6 CM 13 PK	0 092 T40 770	T4 077
6 CP 12	0 092 T30 460	T3 046
6 CP 5L	0 092 S40 270	S4 027
6 CS 5	0 092 S40 270	S4 027
6 GP 5F	0 092 S50 040	S5 004

6 GP 5K	0 092 S40 040	S4 004
6 GP 5K	0 092 S50 010	S5 001
6 MR 45 OC	0 092 S40 280	S4 028
6 MR 850	0 092 T30 790	T3 079
6 MR 850 X	0 092 T40 770	T4 077

6 MZ 33 0X	0 092 S40 270	S4 027
6 RF 570	0 092 T30 400	T3 040
6 RF 6	0 092 T30 400	T3 040
6 SP 500	0 092 T30 390	T3 039
6 SP 500 X	0 092 T50 750	T5 075

6 SP 850	0 092 T30 790	T3 079
6 SP 850 X	0 092 T40 770	T4 077
6 SP 900 X	0 092 T30 800	T3 080
6 ZP 25 0	0 092 S30 020	S3 002
6 ZP 250 X	0 092 S30 030	S3 003

6 ZP 30 0	0 092 S40 050	S4 005
6 ZP 30 0	0 092 S50 050	S5 005
6 ZP 32 0	0 092 S30 050	S3 005
6 ZP 32 0X	0 092 S30 060	S3 006

SCAINI

250 B2003	0 092 S40 180	S4 018
250 B2013	0 092 S40 190	S4 019
320 B2401	0 092 S40 210	S4 021

320 B2413	0 092 S40 220	S4 022
350 B2411	0 092 S40 230	S4 023
500 D2601	0 092 S40 260	S4 026
500 D2611	0 092 S40 270	S4 027
54 521	0 092 S30 030	S3 003

54 522	0 092 S30 020	S3 002
56 020	0 092 S30 050	S3 005
56 021	0 092 S30 060	S3 006
56 063	0 092 S40 270	S4 027
59 020	0 092 S40 130	S4 013



◀ SCAINI

59 020	0 092 T30 130	T3 013
70 020	0 092 T50 800	T5 080
720 E.41.01	0 092 T30 720	T3 072

SCANIA

12760020	0 092 S40 080	S4 008
12760020	0 092 S50 080	S5 008
12762420	0 092 S50 100	S5 010

1421128	0 092 T40 750	T4 075
1421129	0 092 T40 750	T4 075
1421131	0 092 T50 770	T5 077
1421132	0 092 T50 770	T5 077
1421134	0 092 T40 750	T4 075

1421135	0 092 T40 750	T4 075
1447567	0 092 T40 750	T4 075
1447568	0 092 T40 750	T4 075
1447570	0 092 T40 770	T4 077
1447570	0 092 T50 770	T5 077

1447571	0 092 T40 770	T4 077
1447571	0 092 T50 770	T5 077
1447572	0 092 T50 800	T5 080
1447574	0 092 T50 800	T5 080
1748913	0 092 T50 770	T5 077

1748914	0 092 T50 770	T5 077
1748917	0 092 T50 770	T5 077
1748918	0 092 T40 770	T4 077
1748918	0 092 T50 770	T5 077
1748921	0 092 T40 760	T4 076

1748922	0 092 T40 750	T4 075
1748925	0 092 T40 760	T4 076
1748926	0 092 T40 750	T4 075
1748929	0 092 T50 800	T5 080
1748930	0 092 T50 800	T5 080

1748933	0 092 T50 800	T5 080
1748934	0 092 T50 800	T5 080
4231775	0 092 S40 050	S4 005
4231775	0 092 S50 050	S5 005
489905	0 092 T50 800	T5 080

5106661	0 092 S40 050	S4 005
5106661	0 092 S50 050	S5 005
5241732	0 092 S40 080	S4 008
5355763	0 092 S40 080	S4 008
582713	0 092 T50 800	T5 080

SEAT

SZ21003	0 092 S30 030	S3 003
000 915 105 AH	0 092 S50 130	S5 013
000 915 105 AK	0 092 S50 130	S5 013

1J0 915 105	0 092 S40 020	S4 002
1J0 915 105 A	0 092 S50 050	S5 005
1J0 915 105 AB	0 092 S40 020	S4 002
1J0 915 105 AC	0 092 S50 050	S5 005
1J0 915 105 AD	0 092 S50 050	S5 005

1J0 915 105 AG	0 092 S50 100	S5 010
1J0 915 105 AH	0 092 S50 130	S5 013
1K0 915 105	0 092 S40 020	S4 002
1L0 915 105	0 092 S30 010	S3 001
1L0 915 105 A	0 092 S30 040	S3 004

1L0 915 105 B	0 092 S30 070	S3 007
1L0 915 105 C	0 092 S40 070	S4 007
1L0 915 105 D	0 092 S50 070	S5 007
4B0 915 105	0 092 S50 130	S5 013
4B0 915 105 J	0 092 S50 130	S5 013

4B0 915 105 L	0 092 S50 130	S5 013
4D0 915 105 C	0 092 S50 130	S5 013
4E0 915 105	0 092 S50 130	S5 013
4F0 915 105 A	0 092 S40 080	S4 008
4F0 915 105 C	0 092 S50 130	S5 013

4F0 915 105 E	0 092 S60 020	S6 002
4F0 915 105 E	0 092 S60 130	S6 013
441 915 105	0 092 S50 130	S5 013
8E0 915 105	0 092 S30 020	S3 002
8E0 915 105 A	0 092 S40 050	S4 005

8E0 915 105 A	0 092 S50 050	S5 005
8E0 915 105 B	0 092 S40 080	S4 008
8E0 915 105 D	0 092 S50 130	S5 013
8E0 915 105 G	0 092 S40 050	S4 005
8E0 915 105 G	0 092 S50 050	S5 005

8E0 915 105 H	0 092 S40 080	S4 008
8E0 915 105 L	0 092 S40 080	S4 008
8K0 915 105 C	0 092 S40 080	S4 008
8K0 915 105 D	0 092 S40 100	S4 010
8K0 915 105 D	0 092 S50 100	S5 010

8K0 915 105 F	0 092 S50 150	S5 015
8K0 915 105 G	0 092 S40 050	S4 005
8K0 915 105 H	0 092 S40 050	S4 005
8Z0 915 105	0 092 S40 050	S4 005
8Z0 915 105	0 092 S50 050	S5 005

SKODA

000 915 105 AH	0 092 S50 130	S5 013
000 915 105 AK	0 092 S50 130	S5 013
1J0 915 105 AD	0 092 S50 050	S5 005

1J0 915 105 AH	0 092 S50 130	S5 013
1K0 915 105	0 092 S40 020	S4 002
3B0 915 105	0 092 S50 100	S5 010
4B0 915 105	0 092 S50 130	S5 013
4B0 915 105 J	0 092 S50 130	S5 013

4B0 915 105 L	0 092 S50 130	S5 013
4D0 915 105 C	0 092 S50 130	S5 013
4E0 915 105	0 092 S50 130	S5 013
4F0 915 105 A	0 092 S40 080	S4 008
4F0 915 105 C	0 092 S50 130	S5 013

4F0 915 105 E	0 092 S60 020	S6 002
4F0 915 105 E	0 092 S60 130	S6 013
441040161506	0 092 S40 020	S4 002
441040161516	0 092 S50 050	S5 005
441 915 105	0 092 S50 130	S5 013

8E0 915 105	0 092 S30 020	S3 002
8E0 915 105	0 092 S40 020	S4 002
8E0 915 105	0 092 S50 050	S5 005
8E0 915 105 A	0 092 S40 050	S4 005
8E0 915 105 A	0 092 S50 050	S5 005

8E0 915 105 B	0 092 S40 080	S4 008
8E0 915 105 D	0 092 S50 130	S5 013
8E0 915 105 G	0 092 S40 050	S4 005
8E0 915 105 G	0 092 S50 050	S5 005
8E0 915 105 H	0 092 S40 080	S4 008

8E0 915 105 L	0 092 S40 080	S4 008
8K0 915 105 C	0 092 S40 080	S4 008
8K0 915 105 D	0 092 S40 100	S4 010
8K0 915 105 D	0 092 S50 100	S5 010
8K0 915 105 F	0 092 S50 150	S5 015

8K0 915 105 G	0 092 S40 050	S4 005
8K0 915 105 H	0 092 S40 050	S4 005
8Z0 915 105	0 092 S40 050	S4 005
8Z0 915 105	0 092 S50 050	S5 005
8Z0 915 105 D	0 092 S50 100	S5 010

SMART (MCC)

Q45400 21	0 092 S40 080	S4 008
451 541 0002	0 092 S30 020	S3 002
451 541 0002	0 092 S50 020	S5 002

451 541 0102	0 092 S30 050	S3 005
451 541 0102	0 092 S50 050	S5 005

SONNAK

SA1000	0 092 S50 130	S5 013
SA1004	0 092 S40 280	S4 028
SA1005	0 092 S40 290	S4 029

SA386	0 092 S40 180	S4 018
SA387	0 092 S40 190	S4 019
SA472	0 092 S50 010	S5 001
SA530	0 092 S50 020	S5 002
SA602	0 092 S50 040	S5 004

SA640	0 092 S50 050	S5 005
SA654	0 092 S40 240	S4 024
SA655	0 092 S40 250	S4 025
SA722	0 092 S50 070	S5 007
SA754	0 092 S40 260	S4 026

SA770	0 092 S50 080	S5 008
SA852	0 092 S50 100	S5 010
SB1004	0 092 S40 280	S4 028
SB1005	0 092 S40 290	S4 029
SB356	0 092 S40 180	S4 018

SB357	0 092 S40 190	S4 019
SB440	0 092 S40 000	S4 000
SB442	0 092 S40 010	S4 001
SB450	0 092 S30 160	S3 016
SB451	0 092 S30 170	S3 017

SB454	0 092 S40 210	S4 021
SB455	0 092 S40 230	S4 023
SB457	0 092 S40 220	S4 022
SB500	0 092 S40 020	S4 002
SB501	0 092 S30 030	S3 003

SB542	0 092 S40 040	S4 004
SB620	0 092 S40 050	S4 005
SB712	0 092 S40 070	S4 007
SB740	0 092 S40 080	S4 008
SB741	0 092 S40 090	S4 009

SB802	0 092 S40 100	S4 010
SB852	0 092 S30 120	S3 012
SB950	0 092 S40 130	S4 013
SC412	0 092 S30 010	S3 001
SC440	0 092 S30 020	S3 002

SC502	0 092 S30 040	S3 004
SC550	0 092 S30 050	S3 005
SC652	0 092 S30 070	S3 007
SC700	0 092 S30 080	S3 008

SPEED

0 188 S56 638	0 092 T30 080	T3 008
0 188 S58 827	0 092 T30 130	T3 013

STECO

B14G	0 092 T40 750	T4 075
B15G	0 092 T40 770	T4 077
B15G	0 092 T50 770	T5 077

B15TLD	0 092 T30 790	T3 079
B15TLG	0 092 T40 780	T4 078
C13D	0 092 T30 350	T3 035
C13G	0 092 T30 310	T3 031
D1D45	0 092 S40 010	S4 001

D1P55D	0 092 S50 010	S5 001
D14G	0 092 T30 380	T3 038
D2D60	0 092 S50 040	S5 004
D2E55	0 092 S40 040	S4 004
D2P65D	0 092 S50 040	S5 004

D23D	0 092 S40 240	S4 024
D23G	0 092 S40 250	S4 025
D3D70	0 092 S30 070	S3 007
D3P75D	0 092 S50 070	S5 007
D5D85	0 092 S30 120	S3 012

E2D45	0 092 S30 160	S3 016
E2G45	0 092 S30 170	S3 017
F21	0 092 T30 440	T3 044
H13D	0 092 T30 400	T3 040
L0D40	0 092 S40 000	S4 000

L1D40	0 092 S30 020	S3 002
L1D50	0 092 S40 020	S4 002
L1G50	0 092 S30 030	S3 003
L1P55D	0 092 S40 020	S4 002
L2D60	0 092 S50 050	S5 005

L2G60	0 092 S50 060	S5 006
L2P65D	0 092 S50 050	S5 005
L2P65G	0 092 S50 060	S5 006
L3D70	0 092 S40 080	S4 008
L3G70	0 092 S40 090	S4 009

L3P75D	0 092 S40 080	S4 008
L3P75G	0 092 S40 090	S4 009
L5D	0 092 T30 130	T3 013
L5D100	0 092 S50 130	S5 013
M10D70	0 092 S40 260	S4 026

M10G70	0 092 S40 270	S4 027
M13P	0 092 T30 730	T3 073
M16PG	0 092 T50 800	T5 080
M4-112	0 092 T30 610	T3 061
M4-140	0 092 T30 620	T3 062

M5	0 092 T30 630	T3 063
N45GBJ	0 092 S40 220	S4 022
T14P	0 092 T40 750	T4 075
T15P180	0 092 T40 770	T4 077
T15P180	0 092 T50 770	T5 077

1426SMT	0 092 T30 420	T3 042
1871LCD	0 092 T50 800	T5 080
1877LCD	0 092 T40 750	T4 075
1908LCD	0 092 T30 730	T3 073
2417STC	0 092 S40 180	S4 018

2420STC	0 092 S40 220	S4 022
2423STC	0 092 S40 240	S4 024
2424STC	0 092 S40 250	S4 025
2684LTC	0 092 S30 160	S3 016
2685LML	0 092 S30 170	S3 017

2685LTC	0 092 S30 170	S3 017
2697LTC	0 092 S40 260	S4 026
2738LTC	0 092 S40 000	S4 000
2754LTC	0 092 S30 120	S3 012
2773SMK	0 092 M60 060	M6 006

2780LMT	0 092 T30 350	T3 035
2782SMK	0 092 M4F 040	M4 F04
2786SMK	0 092 M4F 160	M4 F16
2786SMK	0 092 M40 160	M4 016
2787SMK	0 092 M60 010	M6 001

2788SMK	0 092 M4F 170	M4 F17
2788SMK	0 092 M40 170	M4 017
2789SMK	0 092 M4F 180	M4 F18
2789SMK	0 092 M40 180	M4 018
2791SMK	0 092 M60 100	M6 010

2792SMK	0 092 M4F 250	M4 F25
2792SMK	0 092 M40 250	M4 025
2792SML	0 092 M4F 250	M4 F25
2792SML	0 092 M40 250	M4 025
2793SMK	0 092 M60 140	M6 014

2795SMK	0 092 M4F 300	M4 F30
2795SMK	0 092 M40 300	M4 030
2795SML	0 092 M4F 300	M4 F30
2795SML	0 092 M40 300	M4 030
2796SMK	0 092 M60 180	M6 018

2797SMK	0 092 M4F 340	M4 F34
2797SMK	0 092 M40 340	M4 034
2800SMK	0 092 M4F 440	M4 F44
2800SMK	0 092 M40 440	M4 044
2801SMK	0 092 M4F 470	M4 F47

2801SMK	0 092 M40 470	M4 047
2802SMK	0 092 M4F 520	M4 F52
2802SMK	0 092 M40 520	M4 052
2802SML	0 092 M4F 520	M4 F52
2802SML	0 092 M40 520	M4 052

2803SMK	0 092 M4F 540	M4 F54
2803SMK	0 092 M40 540	M4 054
2803SML	0 092 M4F 540	M4 F54
2803SML	0 092 M40 540	M4 054
2978SMT	0 092 T30 440	T3 044

2985LTC	0 092 S30 030	S3 003
2986LTC	0 092 S50 060	S5 006
2987LTC	0 092 S40 090	S4 009
2995LTC	0 092 S40 040	S4 004
3005LTC	0 092 S40 270	S4 027

3037LMT	0 092 T30 610	T3 061
3040LMT	0 092 T30 630	T3 063
3075LMT	0 092 T40 750	T4 075
3156LMT	0 092 T30 380	T3 038
3246LMT	0 092 T40 770	T4 077

3246LMT	0 092 T50 770	T5 077
3450LTC	0 092 S40 020	S4 002
3452LTC	0 092 S50 050	S5 005
3453LTC	0 092 S50 060	S5 006
3454LTC	0 092 S40 080	S4 008

3455LTC	0 092 S40 090	S4 009
3456LTC	0 092 S50 010	S5 001
3457LTC	0 092 S50 040	S5 004
3458LTC	0 092 S50 070	S5 007
3459LTC	0 092 S30 020	S3 002

3460LTC	0 092 S40 020	S4 002
3461LTC	0 092 S50 050	S5 005
3462LTC	0 092 S40 080	S4 008
3463LMT	0 092 T30 130	T3 013
3463LTC	0 092 S50 130	S5 013

3464LTC	0 092 S40 010	S4 001
3465LTC	0 092 S50 040	S5 004
3466LTC	0 092 S30 070	S3 007
3468LCD	0 092 T50 800	T5 080
3471LMT	0 092 T30 790	T3 079

3472LMT	0 092 T40 780	T4 078
3490LMT	0 092 T30 400	T3 040
3552LCD	0 092 T40 770	T4 077
3552LCD	0 092 T50 770	T5 077
4005LMT	0 092 T30 310	T3 031

4014LMT	0 092 T30 620	T3 062
512D35BJ	0 092 S40 180	S4 018
6TN-B	0 092 T30 420	T3 042



SUZUKI		
PS610 004	0 092 S50 130	S5 013
33610-73010	0 092 S40 190	S4 019
33610-79J00	0 092 S30 080	S3 008
33610-79J00	0 092 S40 080	S4 008
33610 79J00 000	0 092 S30 080	S3 008
33610 79J00 000	0 092 S40 080	S4 008
33610-79220	0 092 S40 190	S4 019
33610-83E2	0 092 S30 010	S3 001
33610-83E2	0 092 S40 010	S4 001
33610-83E3	0 092 S40 010	S4 001
33610-83E4	0 092 S30 070	S3 007
33610-83E40	0 092 S40 040	S4 004
33610-83E40	0 092 S40 070	S4 007
33610-83E40	0 092 S50 040	S5 004
33610 83E40 000	0 092 S40 040	S4 004
33610 83E40 000	0 092 S40 070	S4 007
33610 83E40 000	0 092 S50 040	S5 004
33610-83011	0 092 S30 170	S3 017
33610-85C80	0 092 S30 160	S3 016
33610 85C80 000	0 092 S30 160	S3 016

SZNAJDER		
535 70	0 092 S40 180	S4 018
535 72	0 092 S40 190	S4 019
538 46	0 092 S30 030	S3 003
538 58	0 092 S30 010	S3 001
538 59	0 092 S30 020	S3 002
543 08	0 092 S40 000	S4 000
545 58	0 092 S40 010	S4 001
545 59	0 092 S30 020	S3 002
545 65	0 092 S30 030	S3 003
545 72	0 092 S40 220	S4 022
546 25	0 092 S50 010	S5 001
547 25	0 092 S30 020	S3 002
550 58	0 092 S50 010	S5 001
550 59	0 092 S50 020	S5 002
550 65	0 092 S30 030	S3 003
553 25	0 092 S50 010	S5 001
555 25	0 092 S40 020	S4 002
555 26	0 092 S30 030	S3 003
555 59	0 092 S50 020	S5 002
555 65	0 092 S30 060	S3 006
560 48	0 092 S40 260	S4 026
560 49	0 092 S40 270	S4 027
560 68	0 092 S40 240	S4 024
560 69	0 092 S40 250	S4 025
560 77	0 092 S40 040	S4 004
562 25	0 092 S40 050	S4 005
562 58	0 092 S30 040	S3 004
562 59	0 092 S40 050	S4 005

562 65	0 092 S40 060	S4 006
564 25	0 092 S50 040	S5 004
565 30	0 092 S30 070	S3 007
570 01	0 092 S60 080	S6 008
570 24	0 092 S40 270	S4 027
570 25	0 092 S50 050	S5 005
570 26	0 092 S50 060	S5 006
570 29	0 092 S40 260	S4 026
574 12	0 092 S40 080	S4 008
574 14	0 092 S40 090	S4 009
575 19	0 092 S40 090	S4 009
575 20	0 092 S50 080	S5 008
575 25	0 092 S40 070	S4 007
578 02	0 092 S40 100	S4 010
580 25	0 092 S30 080	S3 008
580 70	0 092 S40 260	S4 026
580 72	0 092 S40 270	S4 027
585 42	0 092 S5E 110	S5 E11
588 27	0 092 S30 130	S3 013
592 18	0 092 S40 130	S4 013
596 25	0 092 S40 130	S4 013
600 11	0 092 T30 370	T3 037
600 25	0 092 S50 130	S5 013
600 38	0 092 S50 130	S5 013
600 70	0 092 S40 280	S4 028
600 72	0 092 S40 290	S4 029
610 11	0 092 T30 350	T3 035
610 27	0 092 T30 360	T3 036
625 13	0 092 T30 750	T3 075
643 14	0 092 T30 770	T3 077
643 27	0 092 T30 770	T3 077
643 89	0 092 T30 790	T3 079
645 20	0 092 T40 750	T4 075
650 13	0 092 T40 760	T4 076
650 32	0 092 T50 750	T5 075
670 18	0 092 T40 770	T4 077
670 19	0 092 T40 770	T4 077
675 18	0 092 T40 770	T4 077
680 13	0 092 T40 770	T4 077
680 14	0 092 T40 770	T4 077
680 32	0 092 T50 770	T5 077
680 34	0 092 T50 770	T5 077
680 89	0 092 T30 790	T3 079
690 13	0 092 T50 770	T5 077
690 14	0 092 T50 770	T5 077
690 32	0 092 T50 770	T5 077
690 34	0 092 T50 770	T5 077
700 13	0 092 T50 770	T5 077
700 14	0 092 T50 770	T5 077
700 15	0 092 T30 800	T3 080
710 27	0 092 T40 800	T4 080
730 11	0 092 T30 810	T3 081
730 11	0 092 T50 800	T5 080

TAB		
100712	0 092 T30 420	T3 042
101712	0 092 T30 420	T3 042
116044	0 092 S40 180	S4 018
116144	0 092 S40 190	S4 019
116260	0 092 S40 240	S4 024
116360	0 092 S40 250	S4 025
116445	0 092 S30 170	S3 017
116545	0 092 S40 240	S4 024
116745	0 092 S40 220	S4 022
116745	0 092 S40 230	S4 023
116845	0 092 S40 210	S4 021
116870	0 092 S40 260	S4 026
116970	0 092 S40 270	S4 027
117036	0 092 S30 010	S3 001
117044	0 092 S40 010	S4 001
117045	0 092 S40 010	S4 001
117054	0 092 S30 040	S3 004
117055	0 092 S30 040	S3 004
117060	0 092 S40 050	S4 005
117066	0 092 S50 050	S5 005
117073	0 092 S40 070	S4 007
117074	0 092 S40 080	S4 008
117075	0 092 S40 080	S4 008
117080	0 092 S50 080	S5 008
117090	0 092 S30 120	S3 012
117092	0 092 S60 110	S6 011
117099	0 092 S50 130	S5 013
117100	0 092 S50 130	S5 013
117175	0 092 S40 090	S4 009
117240	0 092 S40 020	S4 002
117460	0 092 S30 050	S3 005
117845	0 092 S40 000	S4 000
173055	0 092 S60 050	S6 005
173065	0 092 S60 080	S6 008
173085	0 092 S60 130	S6 013
189045	0 092 S40 010	S4 001
189050	0 092 S50 010	S5 001
189055	0 092 S30 040	S3 004
189060	0 092 S40 040	S4 004
189066	0 092 S30 070	S3 007
189072	0 092 S50 070	S5 007
189082	0 092 S50 100	S5 010
189100	0 092 S50 130	S5 013
190 P	0 092 T50 800	T5 080
485912	0 092 T40 750	T4 075
486912	0 092 T50 750	T5 075
492912	0 092 T40 800	T4 080
493912	0 092 T50 800	T5 080
50 P	0 092 T30 050	T3 005
60 P	0 092 T30 080	T3 008
80 P	0 092 T30 130	T3 013
85 PL5	0 092 S50 130	S5 013

TALBOT

43 223 800	0 092 S30 050	S3 005
43 223 900	0 092 S30 050	S3 005
94 056 002 38	0 092 S30 170	S3 017

94 056 002 48	0 092 S30 170	S3 017
---------------	---------------	---------------

TOPLA-TAP

118050	0 092 S50 010	S5 001
118060	0 092 S50 040	S5 004
118072	0 092 S50 070	S5 007

118082	0 092 S40 100	S4 010
118082	0 092 S50 100	S5 010
118095	0 092 S50 130	S5 013
150400	0 092 S50 150	S5 015
150490	0 092 S30 120	S3 012

150845	0 092 S40 000	S4 000
158072	0 092 S40 040	S4 004
158091	0 092 S50 050	S5 005
158092	0 092 S40 050	S4 005
158098	0 092 S40 060	S4 006

158300	0 092 S40 080	S4 008
158350	0 092 S40 090	S4 009
159070	0 092 S30 070	S3 007
160644	0 092 S30 010	S3 001
160674	0 092 S30 080	S3 008

160699	0 092 S40 130	S4 013
161654	0 092 S30 040	S3 004
177260	0 092 S40 240	S4 024
177360	0 092 S40 250	S4 025
177445	0 092 S30 160	S3 016

177545	0 092 S30 170	S3 017
177845	0 092 S40 210	S4 021
177895	0 092 S40 280	S4 028
177945	0 092 S40 220	S4 022
177945	0 092 S40 230	S4 023

177995	0 092 S40 290	S4 029
611244	0 092 S40 010	S4 001

TOYOTA

BCI-025	0 092 S50 050	S5 005
BCI-096	0 092 S40 080	S4 008
28800-YZZAA	0 092 S40 210	S4 021

28800-YZZAB	0 092 S40 220	S4 022
28800-YZZAB	0 092 S40 230	S4 023
28800-YZZAC	0 092 S40 240	S4 024
28800-YZZAE	0 092 S40 240	S4 024
28800-YZZAF	0 092 S40 250	S4 025

28800-YZZAG	0 092 S40 260	S4 026
28800-YZZAH	0 092 S40 270	S4 027
28800-YZZAJ	0 092 S40 280	S4 028
28800-YZZAK	0 092 S40 290	S4 029
28800-YZZAM	0 092 S40 020	S4 002

28800-YZZAM	0 092 S50 020	S5 002
28800-YZZAN	0 092 S30 050	S3 005
28800-YZZAN	0 092 S40 050	S4 005
28800-YZZAP	0 092 S40 080	S4 008
28800-YZZAP	0 092 S50 080	S5 008

28800-YZZAQ	0 092 S50 100	S5 010
28800-YZZAR	0 092 S40 210	S4 021
28800-YZZAS	0 092 S40 260	S4 026
28800-YZZAT	0 092 S40 270	S4 027
28800-YZZAV	0 092 S30 010	S3 001

28800-YZZAW	0 092 S40 010	S4 001
28800-YZZAX	0 092 S40 060	S4 006
28800-YZZAY	0 092 S40 280	S4 028
28800-YZZAZ	0 092 S40 290	S4 029
28800-YZZBA	0 092 S40 080	S4 008

28800-YZZBA	0 092 S50 080	S5 008
28800-YZZBB	0 092 S40 090	S4 009
28800-YZZBC	0 092 S40 080	S4 008
28800-YZZBC	0 092 S50 080	S5 008
28800-YZZBD	0 092 S30 080	S3 008

28800-YZZBD	0 092 S40 080	S4 008
28800-YZZCA	0 092 S40 220	S4 022
28800-YZZDA	0 092 S40 280	S4 028
28800-YZZDB	0 092 S40 290	S4 029
28800-YZZIA	0 092 S30 010	S3 001

28800-YZZIB	0 092 S40 010	S4 001
28800-YZZIC	0 092 S40 040	S4 004
28800-YZZID	0 092 S30 070	S3 007
28800-YZZID	0 092 S40 070	S4 007
28800-YZZIE	0 092 S30 070	S3 007

28800-YZZIE	0 092 S40 070	S4 007
28800-YZZIF	0 092 S30 120	S3 012
28800-0D310	0 092 S30 020	S3 002
28800-0D340	0 092 S30 020	S3 002
28800-0D340	0 092 S40 020	S4 002

28800-0D350	0 092 S40 050	S4 005
28800-0D350	0 092 S50 050	S5 005
28800-0D380	0 092 S40 050	S4 005
28800-0G020	0 092 S40 080	S4 008
28800-0G020	0 092 S50 080	S5 008

28800-0G050	0 092 S50 080	S5 008
28800-0H160	0 092 S40 260	S4 026
28800-0J020	0 092 S40 250	S4 025
28800-0J030	0 092 S40 020	S4 002
28800-0J040	0 092 S30 020	S3 002

28800-0J040	0 092 S40 020	S4 002
28800-0N030	0 092 S40 050	S4 005
28800-0N030	0 092 S50 050	S5 005
28800-0N040	0 092 S30 080	S3 008
28800-0N040	0 092 S50 080	S5 008

28800-0N060	0 092 S30 080	S3 008
28800-0N060	0 092 S40 080	S4 008
28800-0N060	0 092 S50 080	S5 008
28800-0R040	0 092 S50 100	S5 010
28800-0R060	0 092 S50 100	S5 010

28800 12080	0 092 S40 220	S4 022
28800-130LS	0 092 S30 080	S3 008
28800-130LS	0 092 S40 080	S4 008
28800-130LT	0 092 S50 100	S5 010
28800 15050	0 092 S40 240	S4 024

28800 15060	0 092 S40 240	S4 024
28800 24030	0 092 S40 190	S4 019
28800 26040	0 092 S40 180	S4 018
28800 30082	0 092 S40 270	S4 027
28800 30131	0 092 S40 260	S4 026

28800 33111	0 092 S40 270	S4 027
28800 42030	0 092 S40 240	S4 024
28800-445L0	0 092 S50 100	S5 010
28800 46012	0 092 S40 290	S4 029
28800 54040	0 092 S40 290	S4 029

28800 54459 83	0 092 S30 020	S3 002
28800 54459 83	0 092 S40 020	S4 002
28800 54523 83	0 092 S40 210	S4 021
28800 54524 83	0 092 S40 230	S4 023
28800 54570 83	0 092 S30 160	S3 016

28800 54571 83	0 092 S30 170	S3 017
28800 55501 83	0 092 S40 250	S4 025
28800 55502 83	0 092 S40 240	S4 024
28800 56048 83	0 092 S40 260	S4 026
28800 56049 83	0 092 S40 270	S4 027

28800 56219 83	0 092 S40 050	S4 005
28800 56219 83	0 092 S50 050	S5 005
28800 56638 83	0 092 S40 080	S4 008
28800 57024 83	0 092 S40 270	S4 027
28800 57029 83	0 092 S40 260	S4 026

28800 57412 83	0 092 S40 080	S4 008
28800 58031 83	0 092 S40 290	S4 029
28800 64010	0 092 S40 240	S4 024

TUDOR

A 120.3	0 092 T40 750	T4 075
A 120.3	0 092 T40 760	T4 076
A 140.3	0 092 T40 750	T4 075

A 140.3	0 092 T40 760	T4 076
A 150.3	0 092 T30 770	T3 077
A 150.3	0 092 T40 770	T4 077
A 160.3	0 092 T30 770	T3 077
A 160.3	0 092 T40 770	T4 077

A 180.3	0 092 T50 770	T5 077
A 210.3	0 092 T30 800	T3 080
A450	0 092 S40 010	S4 001
A460	0 092 S30 160	S3 016
A461	0 092 S30 170	S3 017

◀ TUDOR

A471	0 092 S30 030	S3 003
A480	0 092 S40 040	S4 004
A480	0 092 S50 010	S5 001
A550	0 092 S30 050	S3 005
A551	0 092 S30 060	S3 006
A700	0 092 S40 080	S4 008
A701	0 092 S40 090	S4 009
A950	0 092 S50 130	S5 013
TA1000	0 092 S50 130	S5 013
TA1000	0 092 S50 150	S5 015
TA1004	0 092 S40 280	S4 028
TA1005	0 092 S40 290	S4 029
TA386	0 092 S40 180	S4 018
TA387	0 092 S40 190	S4 019
TA472	0 092 S50 010	S5 001
TA530	0 092 S50 020	S5 002
TA602	0 092 S50 040	S5 004
TA640	0 092 S50 050	S5 005
TA654	0 092 S40 240	S4 024
TA655	0 092 S40 250	S4 025
TA722	0 092 S50 070	S5 007
TA770	0 092 S50 080	S5 008
TA852	0 092 S50 100	S5 010
TB1004	0 092 S40 280	S4 028
TB1005	0 092 S40 290	S4 029
TB356	0 092 S40 180	S4 018
TB357	0 092 S40 190	S4 019
TB440	0 092 S40 000	S4 000
TB442	0 092 S40 010	S4 001
TB443	0 092 S30 010	S3 001
TB450	0 092 S30 160	S3 016
TB451	0 092 S30 170	S3 017
TB454	0 092 S40 210	S4 021
TB455	0 092 S40 230	S4 023
TB457	0 092 S40 220	S4 022
TB500	0 092 S40 020	S4 002
TB501	0 092 S30 030	S3 003
TB542	0 092 S40 040	S4 004
TB604	0 092 S40 240	S4 024
TB605	0 092 S40 250	S4 025
TB620	0 092 S40 050	S4 005
TB712	0 092 S40 070	S4 007
TB740	0 092 S40 080	S4 008
TB741	0 092 S40 090	S4 009
TB802	0 092 S40 100	S4 010
TB852	0 092 S30 120	S3 012
TB950	0 092 S40 130	S4 013
TST450	0 092 S40 010	S4 001
TST470	0 092 S30 020	S3 002
TST471	0 092 S30 030	S3 003
TST53F	0 092 S40 040	S4 004
TST530	0 092 S40 040	S4 004
TST530	0 092 S50 010	S5 001
TST550	0 092 S30 050	S3 005
TST551	0 092 S30 060	S3 006

TST660	0 092 S40 070	S4 007
TST700	0 092 S40 080	S4 008
TST701	0 092 S40 090	S4 009
TST920	0 092 S30 120	S3 012
TST950	0 092 S50 130	S5 013
14019	0 092 T30 620	T3 062
16525	0 092 T30 630	T3 063
20018	0 092 T30 640	T3 064
4205E2	0 092 S30 160	S3 016
4205E2X	0 092 S30 170	S3 017
4230L3B	0 092 S50 040	S5 004
4240L1	0 092 S30 020	S3 002
4240L1X	0 092 S30 030	S3 003
4270D23	0 092 S40 050	S4 005
4270D23	0 092 S50 050	S5 005
4300L2BF	0 092 S50 040	S5 004
4300L2BK	0 092 S40 040	S4 004
4300L2BK	0 092 S50 010	S5 001
439 24	0 092 S40 220	S4 022
445 00	0 092 S40 010	S4 001
4502	0 092 M4F 220	M4 F22
4502	0 092 M40 220	M4 022
4503	0 092 M4F 250	M4 F25
4503	0 092 M40 250	M4 025
4506	0 092 M4F 070	M4 F07
4507	0 092 M4F 100	M4 F10
4507	0 092 M40 100	M4 010
451 00	0 092 S40 020	S4 002
4516	0 092 M4F 170	M4 F17
4516	0 092 M40 170	M4 017
451 68	0 092 S40 240	S4 024
451 69	0 092 S40 250	S4 025
4517	0 092 M4F 180	M4 F18
4517	0 092 M40 180	M4 018
4518	0 092 M4F 200	M4 F20
4520	0 092 M4F 300	M4 F30
4520	0 092 M40 300	M4 030
4521	0 092 M4F 340	M4 F34
4521	0 092 M40 340	M4 034
4522	0 092 M4F 520	M4 F52
4522	0 092 M40 520	M4 052
4525	0 092 M4F 300	M4 F30
4525	0 092 M40 300	M4 030
4526	0 092 M4F 280	M4 F28
4526	0 092 M40 280	M4 028
4527	0 092 M4F 350	M4 F35
4527	0 092 M40 350	M4 035
4528	0 092 M4F 470	M4 F47
4528	0 092 M40 470	M4 047
4529	0 092 M4F 340	M4 F34
4529	0 092 M40 340	M4 034
4530	0 092 M4F 400	M4 F40
4530	0 092 M40 400	M4 040
4531	0 092 M4F 420	M4 F42
4531	0 092 M40 420	M4 042

4532	0 092 M4F 390	M4 F39
4532	0 092 M40 390	M4 039
4533	0 092 M4F 440	M4 F44
4533	0 092 M40 440	M4 044
4534	0 092 M4F 430	M4 F43
4534	0 092 M40 430	M4 043
4538	0 092 M4F 520	M4 F52
4538	0 092 M40 520	M4 052
4543	0 092 M4F 150	M4 F15
4543	0 092 M40 150	M4 015
4545	0 092 M4F 160	M4 F16
4545	0 092 M40 160	M4 016
4546	0 092 M4F 180	M4 F18
4546	0 092 M40 180	M4 018
4550AT	0 092 S40 280	S4 028
4554	0 092 M4F 260	M4 F26
4554	0 092 M40 260	M4 026
4556	0 092 M4F 040	M4 F04
4557	0 092 M4F 040	M4 F04
4559	0 092 M4F 190	M4 F19
4559	0 092 M40 190	M4 019
4560	0 092 M4F 210	M4 F21
4560	0 092 M40 210	M4 021
4562	0 092 M4F 290	M4 F29
4562	0 092 M40 290	M4 029
4563	0 092 M4F 330	M4 F33
4564	0 092 M4F 320	M4 F32
4564	0 092 M40 320	M4 032
4566	0 092 M4F 370	M4 F37
4567	0 092 M4F 360	M4 F36
4567	0 092 M40 360	M4 036
4572	0 092 M4F 480	M4 F48
4573	0 092 M4F 260	M4 F26
4573	0 092 M40 260	M4 026
4574	0 092 M4F 460	M4 F46
4574	0 092 M40 460	M4 046
4577	0 092 M4F 240	M4 F24
4577	0 092 M40 240	M4 024
4579	0 092 M4F 320	M4 F32
4579	0 092 M40 320	M4 032
4581	0 092 M4F 270	M4 F27
4583	0 092 M4F 210	M4 F21
4583	0 092 M40 210	M4 021
4589	0 092 M60 080	M6 008
4590	0 092 M60 010	M6 001
4591	0 092 M60 040	M6 004
4592	0 092 M60 040	M6 004
4593	0 092 M60 070	M6 007
4594	0 092 M60 060	M6 006
4595	0 092 M60 100	M6 010
4596	0 092 M60 140	M6 014
4597	0 092 M60 180	M6 018
4598	0 092 M60 240	M6 024
4599	0 092 M60 230	M6 023
460 00	0 092 S50 040	S5 004

460 24	0 092 S40 270	S4 027
460 29	0 092 S40 260	S4 026
464 00	0 092 S50 050	S5 005
464 65	0 092 S50 060	S5 006
468 00	0 092 S40 070	S4 007

476 00	0 092 S40 080	S4 008
485 18	0 092 S40 280	S4 028
485 19	0 092 S40 290	S4 029
490 00	0 092 S50 130	S5 013
4960	0 092 M4F 120	M4 F12

4960	0 092 M40 120	M4 012
4967	0 092 M4F 290	M4 F29
4967	0 092 M40 290	M4 029
4974	0 092 M60 220	M6 022
4980	0 092 M4F 250	M4 F25

4980	0 092 M40 250	M4 025
4985	0 092 M4F 390	M4 F39
4985	0 092 M40 390	M4 039
4988	0 092 M4F 480	M4 F48
535 20	0 092 S40 180	S4 018

535 22	0 092 S40 190	S4 019
53856S38	0 092 S30 160	S3 016
53857S38	0 092 S30 170	S3 017
540 34	0 092 S40 000	S4 000
542 28	0 092 S40 180	S4 018

543 17	0 092 S40 010	S4 001
543 20	0 092 S40 010	S4 001
54434S47	0 092 S30 020	S3 002
54449S47	0 092 S30 030	S3 003
544 59	0 092 S30 020	S3 002

54459S47	0 092 S30 020	S3 002
544 64	0 092 S30 030	S3 003
545 01	0 092 S40 220	S4 022
545 05	0 092 S40 010	S4 001
545 19	0 092 S40 010	S4 001

545 23	0 092 S40 210	S4 021
545 24	0 092 S40 230	S4 023
545 77	0 092 S30 160	S3 016
54577S46	0 092 S30 160	S3 016
545 79	0 092 S30 170	S3 017

54579S46	0 092 S30 170	S3 017
550 19	0 092 S40 040	S4 004
554 14	0 092 S30 070	S3 007
55530S55	0 092 S30 050	S3 005
55531S55	0 092 S40 040	S4 004

55548S60	0 092 S30 060	S3 006
555 59	0 092 S30 050	S3 005
55559S55	0 092 S30 050	S3 005
555 65	0 092 S30 060	S3 006
560 48	0 092 S40 260	S4 026

56048S60	0 092 S40 260	S4 026
560 49	0 092 S40 270	S4 027
56049S60	0 092 S40 270	S4 027
560 68	0 092 S40 240	S4 024
560 69	0 092 S40 250	S4 025

560 77	0 092 S50 040	S5 004
562 19	0 092 S40 050	S4 005
565 30	0 092 S30 070	S3 007
56618S70	0 092 S40 080	S4 008
566 36	0 092 S40 090	S4 009

566 38	0 092 S30 080	S3 008
568 01	0 092 S40 070	S4 007
568 02	0 092 S40 270	S4 027
570 24	0 092 S40 270	S4 027
570 29	0 092 S40 260	S4 026

57029S72	0 092 S40 260	S4 026
571 13	0 092 S40 070	S4 007
571 14	0 092 S40 070	S4 007
57217S75	0 092 S40 080	S4 008
57218S75	0 092 S40 090	S4 009

574 12	0 092 S40 080	S4 008
575 05	0 092 S40 270	S4 027
575 39	0 092 S40 100	S4 010
580 35	0 092 S40 100	S4 010
585 15	0 092 S30 120	S3 012

58815S95	0 092 S30 130	S3 013
588 27	0 092 S30 130	S3 013
59017-S-110	0 092 T30 300	T3 030
59018-S-110	0 092 T30 310	T3 031
592 26	0 092 S40 130	S4 013

595 18	0 092 S40 280	S4 028
595 19	0 092 S40 290	S4 029
60000	0 092 T30 350	T3 035
60027	0 092 T30 730	T3 073
600 38	0 092 S50 130	S5 013

61004	0 092 T30 360	T3 036
61040	0 092 T30 380	T3 038
610 52	0 092 S50 150	S5 015
61501	0 092 T30 350	T3 035
615 03	0 092 T30 350	T3 035

62034-S-120	0 092 T30 750	T3 075
62034-S-120	0 092 T40 750	T4 075
62035-S-120	0 092 T30 390	T3 039
62511	0 092 T30 400	T3 040
62513	0 092 T30 410	T3 041

6330GRX	0 092 S40 270	S4 027
63605	0 092 T30 390	T3 039
64003	0 092 T40 750	T4 075
64009	0 092 T30 460	T3 046
64020-S-140	0 092 T40 750	T4 075

64021	0 092 T40 760	T4 076
64317-S-150	0 092 T30 770	T3 077
64317-S-150	0 092 T40 770	T4 077
64329	0 092 T30 470	T3 047
64500	0 092 T30 400	T3 040

64501	0 092 T30 410	T3 041
64502	0 092 T30 440	T3 044
64507	0 092 T40 750	T4 075
6500 AX	0 092 T50 750	T5 075
6570 AB	0 092 T30 400	T3 040

6600 AM	0 092 T30 460	T3 046
66514-S-160	0 092 T40 770	T4 077
67018-S-180	0 092 T40 770	T4 077
67019-S-180	0 092 T30 790	T3 079
68001	0 092 T50 770	T5 077

68019	0 092 T40 780	T4 078
68022	0 092 T30 790	T3 079
68032	0 092 T40 770	T4 077
68032	0 092 T50 770	T5 077
6850 BX 2	0 092 T40 770	T4 077

6850 B2	0 092 T30 790	T3 079
68507	0 092 T40 770	T4 077
68507	0 092 T50 770	T5 077
70027-S-210	0 092 T30 800	T3 080
70027-S-210	0 092 T50 800	T5 080

702.2	0 092 T30 610	T3 061
718.2	0 092 T30 630	T3 063
72018	0 092 T50 800	T5 080
73015	0 092 T50 800	T5 080
73507	0 092 T50 800	T5 080

7450ATX	0 092 S40 290	S4 029
7500 AX	0 092 T50 750	T5 075
7850 BX 2	0 092 T40 770	T4 077
7850 B2	0 092 T30 790	T3 079
7900 CX	0 092 T30 800	T3 080

810 00	0 092 S50 130	S5 013
826 60	0 092 S30 020	S3 002
850 00	0 092 S40 010	S4 001
855 00	0 092 S40 020	S4 002
860 00	0 092 S50 040	S5 004

86035S	0 092 S30 060	S3 006
866 00	0 092 S50 050	S5 005
870 00	0 092 S40 070	S4 007
875 60	0 092 S40 070	S4 007
877 00	0 092 S40 080	S4 008

888 44	0 092 S30 130	S3 013
888.44	0 092 T30 130	T3 013

URANIO

6MC5B	0 092 S40 270	S4 027
6MC6H	0 092 S40 260	S4 026

VARTA

A14	0 092 S40 180	S4 018
A15	0 092 S40 190	S4 019
A17	0 092 S30 010	S3 001

B18	0 092 S40 010	S4 001
B19	0 092 S30 020	S3 002
B20	0 092 S30 030	S3 003
B23	0 092 S30 160	S3 016
B24	0 092 S30 170	S3 017

◀ VARTA

B32	0 092 S40 210	S4 021
B33	0 092 S40 220	S4 022
B34	0 092 S40 230	S4 023
B35	0 092 S40 000	S4 000
B39	0 092 T30 010	T3 001

B39W	0 092 T30 010	T3 001
C10	0 092 S30 040	S3 004
C14	0 092 S30 050	S3 005
C15	0 092 S30 060	S3 006
C20	0 092 T30 050	T3 005

C20W	0 092 T30 050	T3 005
C22	0 092 S40 020	S4 002
C30	0 092 S50 020	S5 002
C6	0 092 S50 010	S5 001
D15	0 092 S50 050	S5 005

D21	0 092 S50 040	S5 004
D24	0 092 S40 050	S4 005
D33	0 092 T30 080	T3 008
D39	0 092 S50 060	S5 006
D43	0 092 S40 060	S4 006

D47	0 092 S40 240	S4 024
D48	0 092 S40 250	S4 025
D52	0 092 S60 050	S6 005
D53	0 092 S5E 050	S5 E05
D54	0 092 S5E 070	S5 E07

D59	0 092 S40 040	S4 004
E11	0 092 S40 080	S4 008
E12	0 092 S40 090	S4 009
E13	0 092 S30 080	S3 008
E23	0 092 S40 260	S4 026

E24	0 092 S40 270	S4 027
E29	0 092 T30 600	T3 060
E38	0 092 S50 070	S5 007
E39	0 092 S60 080	S6 008
E43	0 092 S40 070	S4 007

E44	0 092 S50 080	S5 008
E45	0 092 S5E 080	S5 E08
E46	0 092 S5E 100	S5 E10
E9	0 092 S30 070	S3 007
F10	0 092 T30 130	T3 013

F17	0 092 S40 100	S4 010
F18	0 092 S50 100	S5 010
F21	0 092 S60 110	S6 011
F22	0 092 S5E 110	S5 E11
F5	0 092 S30 120	S3 012

F6	0 092 S30 130	S3 013
G1	0 092 T30 300	T3 030
G14	0 092 S60 130	S6 013
G2	0 092 T30 310	T3 031
G3	0 092 S40 130	S4 013

G7	0 092 S40 280	S4 028
G8	0 092 S40 290	S4 029
H13	0 092 T30 330	T3 033
H14	0 092 T30 340	T3 034
H15	0 092 S60 150	S6 015

H3	0 092 S50 130	S5 013
H4	0 092 T30 710	T3 071
H5	0 092 T30 720	T3 072
H9	0 092 T30 320	T3 032
I1	0 092 S50 150	S5 015

I11	0 092 T30 610	T3 061
I16	0 092 T30 390	T3 039
I18	0 092 T30 370	T3 037
I2	0 092 T30 380	T3 038
I4	0 092 T30 350	T3 035

I5	0 092 T30 360	T3 036
I6	0 092 T30 730	T3 073
I8	0 092 T30 750	T3 075
J1	0 092 T30 400	T3 040
J10	0 092 T30 450	T3 045

J2	0 092 T30 410	T3 041
J3	0 092 T30 420	T3 042
J5	0 092 T30 430	T3 043
J8	0 092 T30 440	T3 044
K10	0 092 T40 750	T4 075

K11	0 092 T30 460	T3 046
K13	0 092 T30 620	T3 062
K4	0 092 T30 470	T3 047
K7	0 092 T50 750	T5 075
K8	0 092 T40 760	T4 076

L14	0 092 T30 630	T3 063
L2	0 092 T30 770	T3 077
L5	0 092 T30 480	T3 048
M18	0 092 T50 770	T5 077
M7	0 092 T30 790	T3 079

M8	0 092 T40 770	T4 077
M9	0 092 T40 780	T4 078
N12	0 092 T30 640	T3 064
N2	0 092 T30 800	T3 080
N5	0 092 T30 810	T3 081

N7	0 092 T40 800	T4 080
N9	0 092 T50 800	T5 080
0004 14 334	0 092 M4F 040	M4 F04
0006 12 334	0 092 M4F 070	M4 F07
0008 11 334	0 092 M4F 100	M4 F10

0008 11 334	0 092 M40 100	M4 010
0012 14 334	0 092 M4F 120	M4 F12
0012 14 334	0 092 M40 120	M4 012
004 014 001 A510	0 092 M4F 040	M4 F04
004 014 001 3100	0 092 M4F 040	M4 F04

004 014 001 3101	0 092 M4F 040	M4 F04
006 012 003 A510	0 092 M4F 070	M4 F07
006 012 003 A514	0 092 M4F 070	M4 F07
006 012 003 3100	0 092 M4F 070	M4 F07
006 012 003 3101	0 092 M4F 070	M4 F07

008 011 004 A510	0 092 M4F 100	M4 F10
008 011 004 A510	0 092 M40 100	M4 010
008 011 004 3100	0 092 M4F 100	M4 F10
008 011 004 3100	0 092 M40 100	M4 010
008 011 004 3101	0 092 M4F 100	M4 F10

008 011 004 3101	0 092 M40 100	M4 010
0 112 25 310	0 092 T30 610	T3 061
012 014 008 A510	0 092 M4F 120	M4 F12
012 014 008 A510	0 092 M40 120	M4 012
012 014 008 A514	0 092 M4F 120	M4 F12

012 014 008 3100	0 092 M4F 120	M4 F12
012 014 008 3100	0 092 M40 120	M4 012
012 014 008 3101	0 092 M4F 120	M4 F12
012 014 008 3101	0 092 M40 120	M4 012
0 140 23 310	0 092 T30 620	T3 062

0 150 30 310	0 092 T30 630	T3 063
0 200 23 310	0 092 T30 640	T3 064
0 503 12 334	0 092 M4F 150	M4 F15
0 503 12 334	0 092 M40 150	M4 015
0 503 13 334	0 092 M4F 160	M4 F16

0 503 13 334	0 092 M40 160	M4 016
0 504 11 334	0 092 M4F 170	M4 F17
0 504 11 334	0 092 M40 170	M4 017
0 505 12 334	0 092 M4F 180	M4 F18
0 505 12 334	0 092 M40 180	M4 018

0 506 11 334	0 092 M4F 190	M4 F19
0 506 11 334	0 092 M40 190	M4 019
0 506 12 334	0 092 M4F 200	M4 F20
0 507 12 334	0 092 M4F 210	M4 F21
0 507 12 334	0 092 M40 210	M4 021

0 507 13 334	0 092 M4F 220	M4 F22
0 507 13 334	0 092 M40 220	M4 022
0 508 13 334	0 092 M4F 240	M4 F24
0 508 13 334	0 092 M40 240	M4 024
0 509 14 334	0 092 M4F 250	M4 F25

0 509 14 334	0 092 M40 250	M4 025
0 509 15 334	0 092 M4F 260	M4 F26
0 509 15 334	0 092 M40 260	M4 026
0 509 16 334	0 092 M4F 270	M4 F27
0 511 12 334	0 092 M4F 280	M4 F28

0 511 12 334	0 092 M40 280	M4 028
0 511 13 334	0 092 M4F 290	M4 F29
0 511 13 334	0 092 M40 290	M4 029
0 512 11 334	0 092 M4F 300	M4 F30
0 512 11 334	0 092 M40 300	M4 030

0 512 13 334	0 092 M4F 320	M4 F32
0 512 13 334	0 092 M40 320	M4 032
0 512 15 334	0 092 M4F 330	M4 F33
0 514 11 334	0 092 M4F 340	M4 F34
0 514 11 334	0 092 M40 340	M4 034

0 514 12 334	0 092 M4F 350	M4 F35
0 514 12 334	0 092 M40 350	M4 035
0 514 13 334	0 092 M4F 360	M4 F36
0 514 13 334	0 092 M40 360	M4 036
0 514 14 334	0 092 M4F 370	M4 F37

0 516 15 334	0 092 M4F 390	M4 F39
0 516 15 334	0 092 M40 390	M4 039
0 516 16 334	0 092 M4F 400	M4 F40
0 516 16 334	0 092 M40 400	M4 040
0 518 14 334	0 092 M4F 410	M4 F41

0 518 14 334	0 092 M40 410	M4 041
0 518 15 334	0 092 M4F 420	M4 F42
0 518 15 334	0 092 M40 420	M4 042
0 519 11 334	0 092 M4F 430	M4 F43
0 519 11 334	0 092 M40 430	M4 043
0 519 12 334	0 092 M4F 440	M4 F44
0 519 12 334	0 092 M40 440	M4 044
0 519 13 334	0 092 M4F 450	M4 F45
0 519 13 334	0 092 M40 450	M4 045
0 520 12 334	0 092 M4F 470	M4 F47
0 520 12 334	0 092 M40 470	M4 047
0 520 16 334	0 092 M4F 480	M4 F48
0 525 15 334	0 092 M4F 520	M4 F52
0 525 15 334	0 092 M40 520	M4 052
0 530 30 334	0 092 M4F 540	M4 F54
0 530 30 334	0 092 M40 540	M4 054
0 535 22 310	0 092 S40 190	S4 019
0 536 46 310	0 092 S40 010	S4 001
0 536 54 310	0 092 S30 010	S3 001
0 543 17 310	0 092 S40 010	S4 001
0 543 21 310	0 092 S30 020	S3 002
0 543 21 310	0 092 S40 020	S4 002
0 543 22 310	0 092 S30 030	S3 003
0 543 24 310	0 092 S40 010	S4 001
0 544 59 310	0 092 S30 020	S3 002
0 544 59 310	0 092 S40 020	S4 002
0 544 64 310	0 092 S30 030	S3 003
0 544 69 310	0 092 S40 010	S4 001
0 545 19 310	0 092 S40 010	S4 001
0 545 23 310	0 092 S40 210	S4 021
0 545 24 310	0 092 S40 230	S4 023
0 545 51 310	0 092 S40 220	S4 022
0 545 77 310	0 092 S30 160	S3 016
0 545 79 310	0 092 S30 170	S3 017
0 550 40 310	0 092 S30 040	S3 004
0 550 40 310	0 092 S40 040	S4 004
0 550 40 310	0 092 S50 010	S5 001
0 550 54 310	0 092 S40 020	S4 002
0 550 56 310	0 092 S30 040	S3 004
0 550 56 310	0 092 S40 040	S4 004
0 550 56 310	0 092 S50 010	S5 001
0 550 57 310	0 092 S30 040	S3 004
0 550 57 310	0 092 S40 040	S4 004
0 550 63 310	0 092 S30 050	S3 005
0 550 63 310	0 092 S40 050	S4 005
0 550 65 310	0 092 S30 030	S3 003
0 550 66 310	0 092 S40 020	S4 002
0 550 70 310	0 092 S40 020	S4 002
0 555 59 310	0 092 S30 050	S3 005
0 555 59 310	0 092 S40 050	S4 005
0 555 64 310	0 092 T30 050	T3 005
0 555 65 310	0 092 S30 060	S3 006
0 555 70 310	0 092 S30 050	S3 005
0 560 48 310	0 092 S40 260	S4 026
0 560 49 310	0 092 S40 270	S4 027

0 560 68 310	0 092 S40 240	S4 024
0 560 69 310	0 092 S40 250	S4 025
0 560 77 310	0 092 S50 040	S5 004
0 560 78 310	0 092 S40 050	S4 005
0 560 78 310	0 092 S50 050	S5 005
0 560 90 310	0 092 S50 060	S5 006
0 560 91 310	0 092 S50 040	S5 004
0 560 92 310	0 092 S40 050	S4 005
0 560 92 310	0 092 S50 050	S5 005
0 560 98 310	0 092 S40 260	S4 026
0 560 99 310	0 092 S40 270	S4 027
0 561 11 310	0 092 S50 040	S5 004
0 562 19 310	0 092 S40 050	S4 005
0 562 19 310	0 092 S50 050	S5 005
0 563 18 310	0 092 S30 070	S3 007
0 564 20 310	0 092 S30 070	S3 007
0 564 20 310	0 092 S40 070	S4 007
0 565 30 310	0 092 S30 070	S3 007
0 566 38 310	0 092 S30 080	S3 008
0 566 38 310	0 092 S40 080	S4 008
0 566 47 310	0 092 T30 080	T3 008
0 570 24 310	0 092 S40 270	S4 027
0 570 29 310	0 092 S40 260	S4 026
0 570 64 310	0 092 S40 080	S4 008
0 570 72 310	0 092 S40 270	S4 027
0 571 13 310	0 092 S30 070	S3 007
0 571 13 310	0 092 S40 070	S4 007
0 571 13 310	0 092 S50 070	S5 007
0 571 14 310	0 092 S40 070	S4 007
0 572 30 310	0 092 S40 070	S4 007
0 574 12 310	0 092 S40 080	S4 008
0 574 13 310	0 092 S40 090	S4 009
0 575 31 310	0 092 S40 080	S4 008
0 585 15 310	0 092 S30 120	S3 012
0 585 21 310	0 092 S40 280	S4 028
0 585 22 310	0 092 S40 290	S4 029
0 588 33 310	0 092 S30 130	S3 013
0 588 33 310	0 092 S40 130	S4 013
0 588 33 310	0 092 S50 130	S5 013
0 588 33 310	0 092 T30 130	T3 013
0 588 38 310	0 092 T30 130	T3 013
0 590 40 310	0 092 T30 300	T3 030
0 590 41 310	0 092 T30 310	T3 031
0 592 15 310	0 092 S40 130	S4 013
0 592 19 310	0 092 S50 130	S5 013
0 592 26 310	0 092 S40 130	S4 013
0 595 18 310	0 092 S40 280	S4 028
0 595 19 310	0 092 S40 290	S4 029
0 600 35 310	0 092 T30 710	T3 071
0 600 38 310	0 092 S50 130	S5 013
0 600 44 310	0 092 S50 130	S5 013
0 600 47 310	0 092 T30 720	T3 072
0 610 13 310	0 092 T30 380	T3 038
0 610 23 310	0 092 T30 380	T3 038
0 610 39 310	0 092 T30 730	T3 073

0 610 47 800	0 092 T30 350	T3 035
0 610 48 310	0 092 T30 360	T3 036
0 610 50 310	0 092 T30 730	T3 073
0 620 45 310	0 092 T30 750	T3 075
0 620 45 310	0 092 T40 750	T4 075
0 620 46 310	0 092 T30 390	T3 039
0 625 12 310	0 092 T30 400	T3 040
0 630 14 310	0 092 T30 430	T3 043
0 632 11 310	0 092 T30 460	T3 046
0 635 39 310	0 092 T30 450	T3 045
0 635 42 310	0 092 T30 440	T3 044
0 635 45 310	0 092 T50 750	T5 075
0 635 52 310	0 092 T30 450	T3 045
0 640 34 310	0 092 T40 750	T4 075
0 640 35 310	0 092 T40 750	T4 075
0 640 36 310	0 092 T40 760	T4 076
0 643 23 310	0 092 T30 470	T3 047
0 643 33 310	0 092 T30 470	T3 047
0 643 34 310	0 092 T30 480	T3 048
0 655 13 310	0 092 T30 770	T3 077
0 655 13 310	0 092 T40 770	T4 077
0 670 23 310	0 092 T40 780	T4 078
0 670 42 310	0 092 T40 770	T4 077
0 670 43 310	0 092 T40 770	T4 077
0 670 44 310	0 092 T30 790	T3 079
0 670 45 310	0 092 T40 780	T4 078
0 680 32 310	0 092 T50 770	T5 077
0 700 38 310	0 092 T30 800	T3 080
0 715 14 310	0 092 T40 800	T4 080
0 720 25 310	0 092 T30 810	T3 081
0 725 12 310	0 092 T50 800	T5 080
1 004 14 334	0 092 M4F 040	M4 F04
1 006 12 334	0 092 M4F 070	M4 F07
1 008 11 334	0 092 M4F 100	M4 F10
1 008 11 334	0 092 M40 100	M4 010
1 012 14 334	0 092 M4F 120	M4 F12
1 012 14 334	0 092 M40 120	M4 012
1 112 25 310	0 092 T30 610	T3 061
112 025 051 A742	0 092 T30 610	T3 061
112 025 051 3100	0 092 T30 610	T3 061
112 025 051 3101	0 092 T30 610	T3 061
1 150 30 310	0 092 T30 630	T3 063
140 023 072 A742	0 092 T30 620	T3 062
140 023 072 3100	0 092 T30 620	T3 062
150 030 076 A742	0 092 T30 630	T3 063
150 030 076 3100	0 092 T30 630	T3 063
150 030 076 3101	0 092 T30 630	T3 063
1 503 12 334	0 092 M4F 150	M4 F15
1 503 12 334	0 092 M40 150	M4 015
1 503 13 334	0 092 M4F 160	M4 F16
1 503 13 334	0 092 M40 160	M4 016
1 504 11 334	0 092 M4F 170	M4 F17
1 504 11 334	0 092 M40 170	M4 017
1 505 12 334	0 092 M4F 180	M4 F18
1 505 12 334	0 092 M40 180	M4 018



◀ VARTA

1506 11 334	0 092 M4F 190	M4 F19
1506 11 334	0 092 M40 190	M4 019
1506 12 334	0 092 M4F 200	M4 F20
1507 12 334	0 092 M4F 210	M4 F21
1507 12 334	0 092 M40 210	M4 021
1507 13 334	0 092 M4F 220	M4 F22
1507 13 334	0 092 M40 220	M4 022
1509 14 334	0 092 M4F 250	M4 F25
1509 14 334	0 092 M40 250	M4 025
1509 15 334	0 092 M4F 260	M4 F26
1509 15 334	0 092 M40 260	M4 026
1509 16 334	0 092 M4F 270	M4 F27
1511 12 334	0 092 M4F 280	M4 F28
1511 12 334	0 092 M40 280	M4 028
1511 13 334	0 092 M4F 290	M4 F29
1511 13 334	0 092 M40 290	M4 029
1512 11 334	0 092 M4F 300	M4 F30
1512 11 334	0 092 M40 300	M4 030
1512 13 334	0 092 M4F 320	M4 F32
1512 13 334	0 092 M40 320	M4 032
1514 11 334	0 092 M4F 340	M4 F34
1514 11 334	0 092 M40 340	M4 034
1514 12 334	0 092 M4F 350	M4 F35
1514 12 334	0 092 M40 350	M4 035
1514 13 334	0 092 M4F 360	M4 F36
1514 13 334	0 092 M40 360	M4 036
1514 14 334	0 092 M4F 370	M4 F37
1516 15 334	0 092 M4F 390	M4 F39
1516 15 334	0 092 M40 390	M4 039
1518 14 334	0 092 M4F 410	M4 F41
1518 14 334	0 092 M40 410	M4 041
1518 15 334	0 092 M4F 420	M4 F42
1518 15 334	0 092 M40 420	M4 042
1519 11 334	0 092 M4F 430	M4 F43
1519 11 334	0 092 M40 430	M4 043
1519 12 334	0 092 M4F 440	M4 F44
1519 12 334	0 092 M40 440	M4 044
1519 13 334	0 092 M4F 450	M4 F45
1519 13 334	0 092 M40 450	M4 045
1520 12 334	0 092 M4F 470	M4 F47
1520 12 334	0 092 M40 470	M4 047
1525 15 334	0 092 M4F 520	M4 F52
1525 15 334	0 092 M40 520	M4 052
1530 30 334	0 092 M4F 540	M4 F54
1530 30 334	0 092 M40 540	M4 054
1535 22 310	0 092 S40 190	S4 019
1536 46 310	0 092 S40 010	S4 001
1543 17 310	0 092 S40 010	S4 001
1543 21 310	0 092 S30 020	S3 002
1543 21 310	0 092 S40 020	S4 002
1543 22 310	0 092 S30 030	S3 003
1543 24 310	0 092 S40 010	S4 001
1544 59 310	0 092 S30 020	S3 002
1544 59 310	0 092 S40 020	S4 002
1544 64 310	0 092 S30 030	S3 003

1544 69 310	0 092 S40 010	S4 001
1545 19 310	0 092 S40 010	S4 001
1545 23 310	0 092 S40 210	S4 021
1545 24 310	0 092 S40 230	S4 023
1545 51 310	0 092 S40 220	S4 022
1545 77 310	0 092 S30 160	S3 016
1545 79 310	0 092 S30 170	S3 017
1550 40 310	0 092 S30 040	S3 004
1550 40 310	0 092 S40 040	S4 004
1550 40 310	0 092 S50 010	S5 001
1550 54 310	0 092 S40 020	S4 002
1550 56 310	0 092 S30 040	S3 004
1550 56 310	0 092 S40 040	S4 004
1550 56 310	0 092 S50 010	S5 001
1550 57 310	0 092 S30 040	S3 004
1550 57 310	0 092 S40 040	S4 004
1550 63 310	0 092 S30 050	S3 005
1550 63 310	0 092 S40 050	S4 005
1550 66 310	0 092 S40 020	S4 002
1550 70 310	0 092 S40 020	S4 002
1555 59 310	0 092 S30 050	S3 005
1555 59 310	0 092 S40 050	S4 005
1555 64 310	0 092 T30 050	T3 005
1555 65 310	0 092 S30 060	S3 006
1560 48 310	0 092 S40 260	S4 026
1560 49 310	0 092 S40 270	S4 027
1560 68 310	0 092 S40 240	S4 024
1560 69 310	0 092 S40 250	S4 025
1560 77 310	0 092 S50 040	S5 004
1560 78 310	0 092 S40 050	S4 005
1560 78 310	0 092 S50 050	S5 005
1560 91 310	0 092 S50 040	S5 004
1560 92 310	0 092 S40 050	S4 005
1560 92 310	0 092 S50 050	S5 005
1560 98 310	0 092 S40 260	S4 026
1560 99 310	0 092 S40 270	S4 027
1561 11 310	0 092 S50 040	S5 004
1562 19 310	0 092 S40 050	S4 005
1562 19 310	0 092 S50 050	S5 005
1563 18 310	0 092 S30 070	S3 007
1564 20 310	0 092 S30 070	S3 007
1564 20 310	0 092 S40 070	S4 007
1565 30 310	0 092 S30 070	S3 007
1566 38 310	0 092 S30 080	S3 008
1566 38 310	0 092 S40 080	S4 008
1566 47 310	0 092 T30 080	T3 008
1570 24 310	0 092 S40 270	S4 027
1570 29 310	0 092 S40 260	S4 026
1570 64 310	0 092 S40 080	S4 008
1570 72 310	0 092 S40 270	S4 027
1571 13 310	0 092 S30 070	S3 007
1571 13 310	0 092 S40 070	S4 007
1571 13 310	0 092 S50 070	S5 007
1571 14 310	0 092 S40 070	S4 007
1572 30 310	0 092 S40 070	S4 007

1574 12 310	0 092 S40 080	S4 008
1574 13 310	0 092 S40 090	S4 009
1575 31 310	0 092 S40 080	S4 008
1585 15 310	0 092 S30 120	S3 012
1585 21 310	0 092 S40 280	S4 028
1585 22 310	0 092 S40 290	S4 029
1588 33 310	0 092 S30 130	S3 013
1588 33 310	0 092 S40 130	S4 013
1588 33 310	0 092 S50 130	S5 013
1588 33 310	0 092 T30 130	T3 013
1588 38 310	0 092 T30 130	T3 013
1590 40 310	0 092 T30 300	T3 030
1590 41 310	0 092 T30 310	T3 031
1592 15 310	0 092 S40 130	S4 013
1592 19 310	0 092 S50 130	S5 013
1592 26 310	0 092 S40 130	S4 013
1595 18 310	0 092 S40 280	S4 028
1595 19 310	0 092 S40 290	S4 029
1600 38 310	0 092 S50 130	S5 013
1600 44 310	0 092 S50 130	S5 013
1600 47 310	0 092 T30 720	T3 072
1610 13 310	0 092 T30 380	T3 038
1610 23 310	0 092 T30 380	T3 038
1610 39 310	0 092 T30 730	T3 073
1610 47 310	0 092 T30 350	T3 035
1610 48 310	0 092 T30 360	T3 036
1610 50 310	0 092 T30 730	T3 073
1620 45 310	0 092 T30 750	T3 075
1620 45 310	0 092 T40 750	T4 075
1620 46 310	0 092 T30 390	T3 039
1625 12 310	0 092 T30 400	T3 040
1635 39 310	0 092 T30 450	T3 045
1635 42 310	0 092 T30 440	T3 044
1635 45 310	0 092 T50 750	T5 075
1635 52 310	0 092 T30 450	T3 045
1640 35 310	0 092 T40 750	T4 075
1640 36 310	0 092 T40 760	T4 076
1643 23 310	0 092 T30 470	T3 047
1643 33 310	0 092 T30 470	T3 047
1670 23 310	0 092 T40 780	T4 078
1670 43 310	0 092 T40 770	T4 077
1670 45 310	0 092 T40 780	T4 078
1680 32 310	0 092 T50 770	T5 077
1700 38 310	0 092 T30 800	T3 080
1715 14 310	0 092 T40 800	T4 080
1725 12 310	0 092 T50 800	T5 080
200 023 095 A742	0 092 T30 640	T3 064
200 023 095 3100	0 092 T30 640	T3 064
2 536 046 030 302	0 092 S40 010	S4 001
2 536 46 300	0 092 S40 010	S4 001
2 543 019 039 302	0 092 S40 010	S4 001
2 543 023 039 302	0 092 S40 010	S4 001
2 543 107 048 301	0 092 S40 010	S4 001
2 543 17 300	0 092 S40 010	S4 001
2 543 23 302	0 092 S40 010	S4 001



2 543 24 300	0 092 S40 010	S4 001
2 544 059 036 302	0 092 S30 020	S3 002
2 544 064 036 302	0 092 S30 030	S3 003
2 544 069 036 302	0 092 S40 010	S4 001
2 544 105 045 301	0 092 S40 020	S4 002
2 544 106 045 301	0 092 S30 030	S3 003
2 544 59 300	0 092 S30 020	S3 002
2 544 59 300	0 092 S40 020	S4 002
2 544 59 302	0 092 S40 020	S4 002
2 544 64 300	0 092 S30 030	S3 003
2 544 64 302	0 092 S30 030	S3 003
2 544 69 300	0 092 S40 010	S4 001
2 545 019 036 302	0 092 S40 010	S4 001
2 545 077 030 302	0 092 S30 160	S3 016
2 545 079 030 302	0 092 S30 170	S3 017
2 545 101 048 301	0 092 S40 010	S4 001
2 545 19 300	0 092 S40 010	S4 001
2 545 19 302	0 092 S40 010	S4 001
2 550 056 054 302	0 092 S30 040	S3 004
2 550 056 054 302	0 092 S40 040	S4 004
2 550 056 054 302	0 092 S50 010	S5 001
2 550 057 054 302	0 092 S30 040	S3 004
2 550 057 054 302	0 092 S40 040	S4 004
2 550 070 033 302	0 092 S40 020	S4 002
2 550 57 300	0 092 S30 040	S3 004
2 550 57 300	0 092 S40 040	S4 004
2 550 70 300	0 092 S40 020	S4 002
2 555 059 042 302	0 092 S30 050	S3 005
2 555 065 042 302	0 092 S30 060	S3 006
2 555 107 054 301	0 092 S40 050	S4 005
2 555 59 300	0 092 S30 050	S3 005
2 555 59 300	0 092 S40 050	S4 005
2 555 59 302	0 092 S40 050	S4 005
2 560 077 060 302	0 092 S50 040	S5 004
2 560 091 060 302	0 092 S50 040	S5 004
2 560 098 028 302	0 092 S40 260	S4 026
2 560 099 028 302	0 092 S40 270	S4 027
2 560 77 300	0 092 S50 040	S5 004
2 560 91 300	0 092 S50 040	S5 004
2 560 99 300	0 092 S40 270	S4 027
2 561 011 054 302	0 092 S50 040	S5 004
2 561 11 300	0 092 S50 040	S5 004
2 562 019 048 302	0 092 S40 050	S4 005
2 562 019 048 302	0 092 S50 050	S5 005
2 562 103 060 301	0 092 S50 050	S5 005
2 562 19 300	0 092 S40 050	S4 005
2 562 19 300	0 092 S50 050	S5 005
2 562 19 302	0 092 S50 050	S5 005
2 563 102 064 301	0 092 S30 070	S3 007
2 563 18 300	0 092 S30 070	S3 007
2 563 18 302	0 092 S30 070	S3 007
2 564 020 064 302	0 092 S30 070	S3 007
2 564 020 064 302	0 092 S40 070	S4 007
2 564 20 300	0 092 S30 070	S3 007
2 564 20 300	0 092 S40 070	S4 007

2 566 041 051 302	0 092 S30 080	S3 008
2 566 041 051 302	0 092 S40 080	S4 008
2 566 101 064 301	0 092 S30 080	S3 008
2 566 101 064 301	0 092 S40 080	S4 008
2 566 38 300	0 092 S30 080	S3 008
2 566 38 300	0 092 S40 080	S4 008
2 566 41 302	0 092 S30 080	S3 008
2 566 41 302	0 092 S40 080	S4 008
2 566 47 300	0 092 T30 080	T3 008
2 570 072 051 302	0 092 S40 270	S4 027
2 570 073 051 302	0 092 S40 260	S4 026
2 570 72 300	0 092 S40 270	S4 027
2 571 013 068 302	0 092 S40 070	S4 007
2 571 013 068 302	0 092 S50 070	S5 007
2 571 014 068 302	0 092 S40 070	S4 007
2 571 14 300	0 092 S40 070	S4 007
2 574 012 068 302	0 092 S40 080	S4 008
2 574 013 068 302	0 092 S40 090	S4 009
2 574 12 300	0 092 S40 080	S4 008
2 585 015 076 302	0 092 S30 120	S3 012
2 588 033 064 302	0 092 S40 130	S4 013
2 588 107 085 301	0 092 S40 130	S4 013
2 588 107 085 301	0 092 S50 130	S5 013
2 588 33 300	0 092 S30 130	S3 013
2 588 33 300	0 092 S40 130	S4 013
2 588 33 300	0 092 S50 130	S5 013
2 588 33 302	0 092 S40 130	S4 013
2 588 33 302	0 092 S50 130	S5 013
2 588 38 300	0 092 T30 130	T3 013
2 600 044 076 302	0 092 S50 130	S5 013
2 600 44 300	0 092 S50 130	S5 013
2 880 46 310	0 092 S40 010	S4 001
2 880 66 310	0 092 S30 070	S3 007
2 880 74 310	0 092 S40 080	S4 008
2 881 46 310	0 092 S40 010	S4 001
2 881 56 310	0 092 S30 040	S3 004
2 881 56 310	0 092 S40 040	S4 004
4 503 14 310	0 092 M60 010	M6 001
4 504 12 310	0 092 M60 040	M6 004
4 506 14 310	0 092 M60 060	M6 006
4 506 15 310	0 092 M60 070	M6 007
4 508 12 310	0 092 M60 100	M6 010
4 510 12 310	0 092 M60 140	M6 014
4 512 14 310	0 092 M60 180	M6 018
503 012 001 A510	0 092 M4F 150	M4 F15
503 012 001 A510	0 092 M40 150	M4 015
503 012 001 A514	0 092 M4F 150	M4 F15
503 012 001 3100	0 092 M4F 150	M4 F15
503 012 001 3100	0 092 M40 150	M4 015
503 012 001 3101	0 092 M4F 150	M4 F15
503 012 001 3101	0 092 M40 150	M4 015
503 013 001 A510	0 092 M4F 160	M4 F16
503 013 001 A510	0 092 M40 160	M4 016
503 013 001 A510	0 092 M40 160	M4 016
503 013 001 3100	0 092 M4F 160	M4 F16
503 013 001 3100	0 092 M40 160	M4 016

503 013 001 3101	0 092 M4F 160	M4 F16
503 013 001 3101	0 092 M40 160	M4 016
503 014 003 A514	0 092 M60 010	M6 001
503 014 003 3104	0 092 M60 010	M6 001
503 903 004 A514	0 092 M60 030	M6 003
503 903 004 3104	0 092 M60 030	M6 003
504 011 002 A510	0 092 M4F 170	M4 F17
504 011 002 A510	0 092 M40 170	M4 017
504 011 002 A514	0 092 M4F 170	M4 F17
504 011 002 3100	0 092 M4F 170	M4 F17
504 011 002 3100	0 092 M40 170	M4 017
504 011 002 3101	0 092 M4F 170	M4 F17
504 011 002 3101	0 092 M40 170	M4 017
504 011 002 3104	0 092 M4F 170	M4 F17
504 012 003 A514	0 092 M60 040	M6 004
504 012 003 3104	0 092 M60 040	M6 004
505 012 003 A510	0 092 M4F 180	M4 F18
505 012 003 A510	0 092 M40 180	M4 018
505 012 003 3100	0 092 M4F 180	M4 F18
505 012 003 3100	0 092 M40 180	M4 018
505 012 003 3101	0 092 M4F 180	M4 F18
505 012 003 3101	0 092 M40 180	M4 018
506 011 004 A510	0 092 M4F 190	M4 F19
506 011 004 A510	0 092 M40 190	M4 019
506 011 004 3100	0 092 M4F 190	M4 F19
506 011 004 3100	0 092 M40 190	M4 019
506 011 004 3101	0 092 M4F 190	M4 F19
506 011 004 3101	0 092 M40 190	M4 019
506 012 004 A510	0 092 M4F 200	M4 F20
506 012 004 A514	0 092 M4F 200	M4 F20
506 012 004 3100	0 092 M4F 200	M4 F20
506 012 004 3101	0 092 M4F 200	M4 F20
506 014 005 A514	0 092 M60 060	M6 006
506 014 005 3104	0 092 M60 060	M6 006
506 015 005 A514	0 092 M60 070	M6 007
506 015 005 3104	0 092 M60 070	M6 007
507 012 004 A510	0 092 M4F 210	M4 F21
507 012 004 A510	0 092 M40 210	M4 021
507 012 004 A514	0 092 M4F 210	M4 F21
507 012 004 3100	0 092 M4F 210	M4 F21
507 012 004 3100	0 092 M40 210	M4 021
507 012 004 3101	0 092 M4F 210	M4 F21
507 012 004 3101	0 092 M40 210	M4 021
507 013 004 A510	0 092 M4F 220	M4 F22
507 013 004 A510	0 092 M40 220	M4 022
507 013 004 A514	0 092 M4F 220	M4 F22
507 013 004 3100	0 092 M4F 220	M4 F22
507 013 004 3100	0 092 M40 220	M4 022
507 013 004 3101	0 092 M4F 220	M4 F22
507 013 004 3101	0 092 M40 220	M4 022
507 101 008 A510	0 092 M4F 230	M4 F23
507 101 008 A510	0 092 M40 230	M4 023
507 101 008 3100	0 092 M4F 230	M4 F23
507 101 008 3100	0 092 M40 230	M4 023
507 101 008 3101	0 092 M4F 230	M4 F23



◀ VARTA

507 101 008 3101	0 092 M40 230	M4 023
507 901 012 A514	0 092 M60 080	M6 008
507 901 012 3104	0 092 M60 080	M6 008
507 902 011 A514	0 092 M60 090	M6 009
507 902 011 3104	0 092 M60 090	M6 009
508 012 008 A514	0 092 M60 100	M6 010
508 012 008 3104	0 092 M60 100	M6 010
508 013 008 A510	0 092 M4F 240	M4 F24
508 013 008 A510	0 092 M40 240	M4 024
508 013 008 A514	0 092 M4F 240	M4 F24
508 013 008 3100	0 092 M4F 240	M4 F24
508 013 008 3100	0 092 M40 240	M4 024
508 013 008 3101	0 092 M4F 240	M4 F24
508 013 008 3101	0 092 M40 240	M4 024
508 901 015 A514	0 092 M60 110	M6 011
508 901 015 3104	0 092 M60 110	M6 011
509 014 008 A510	0 092 M4F 250	M4 F25
509 014 008 A510	0 092 M40 250	M4 025
509 014 008 A514	0 092 M4F 250	M4 F25
509 014 008 3100	0 092 M4F 250	M4 F25
509 014 008 3100	0 092 M40 250	M4 025
509 014 008 3101	0 092 M4F 250	M4 F25
509 014 008 3101	0 092 M40 250	M4 025
509 014 008 3104	0 092 M4F 250	M4 F25
509 015 008 A510	0 092 M4F 260	M4 F26
509 015 008 A510	0 092 M40 260	M4 026
509 015 008 A514	0 092 M4F 260	M4 F26
509 015 008 3100	0 092 M4F 260	M4 F26
509 015 008 3100	0 092 M40 260	M4 026
509 015 008 3101	0 092 M4F 260	M4 F26
509 015 008 3101	0 092 M40 260	M4 026
509 016 008 A510	0 092 M4F 270	M4 F27
509 016 008 A514	0 092 M4F 270	M4 F27
509 016 008 3100	0 092 M4F 270	M4 F27
509 016 008 3100	0 092 M40 270	M4 027
509 016 008 3101	0 092 M4F 270	M4 F27
509 901 020 A514	0 092 M60 120	M6 012
509 901 020 3104	0 092 M60 120	M6 012
509 902 008 A514	0 092 M60 130	M6 013
509 902 008 3104	0 092 M60 130	M6 013
510 012 009 A514	0 092 M60 140	M6 014
510 012 009 3104	0 092 M60 140	M6 014
511 012 009 A510	0 092 M4F 280	M4 F28
511 012 009 A510	0 092 M40 280	M4 028
511 012 009 A514	0 092 M4F 280	M4 F28
511 012 009 3100	0 092 M4F 280	M4 F28
511 012 009 3100	0 092 M40 280	M4 028
511 012 009 3101	0 092 M4F 280	M4 F28
511 012 009 3101	0 092 M40 280	M4 028
511 013 009 A510	0 092 M4F 290	M4 F29
511 013 009 A510	0 092 M40 290	M4 029
511 013 009 A514	0 092 M4F 290	M4 F29
511 013 009 3100	0 092 M4F 290	M4 F29
511 013 009 3100	0 092 M40 290	M4 029
511 013 009 3101	0 092 M4F 290	M4 F29
511 013 009 3101	0 092 M40 290	M4 029

511 901 014 A514	0 092 M60 160	M6 016
511 901 014 3104	0 092 M60 160	M6 016
511 902 023 A514	0 092 M60 170	M6 017
511 902 023 3104	0 092 M60 170	M6 017
512 011 012 A510	0 092 M4F 300	M4 F30
512 011 012 A510	0 092 M40 300	M4 030
512 011 012 A514	0 092 M4F 300	M4 F30
512 011 012 3100	0 092 M4F 300	M4 F30
512 011 012 3100	0 092 M40 300	M4 030
512 011 012 3101	0 092 M4F 300	M4 F30
512 011 012 3101	0 092 M40 300	M4 030
512 013 012 A510	0 092 M4F 320	M4 F32
512 013 012 A510	0 092 M40 320	M4 032
512 013 012 A514	0 092 M4F 320	M4 F32
512 013 012 3100	0 092 M4F 320	M4 F32
512 013 012 3100	0 092 M40 320	M4 032
512 013 012 3101	0 092 M4F 320	M4 F32
512 013 012 3101	0 092 M40 320	M4 032
512 013 012 3101	0 092 M40 320	M4 032
512 014 010 A514	0 092 M60 180	M6 018
512 014 010 3104	0 092 M60 180	M6 018
512 015 012 A510	0 092 M4F 330	M4 F33
512 015 012 A514	0 092 M4F 330	M4 F33
512 015 012 3100	0 092 M4F 330	M4 F33
512 015 012 3101	0 092 M4F 330	M4 F33
512 901 019 A514	0 092 M60 190	M6 019
512 901 019 3104	0 092 M60 190	M6 019
512 903 013 A514	0 092 M60 200	M6 020
512 903 013 3104	0 092 M60 200	M6 020
514 011 014 A510	0 092 M4F 340	M4 F34
514 011 014 A510	0 092 M40 340	M4 034
514 011 014 A514	0 092 M4F 340	M4 F34
514 011 014 3100	0 092 M4F 340	M4 F34
514 011 014 3100	0 092 M40 340	M4 034
514 011 014 3101	0 092 M4F 340	M4 F34
514 011 014 3101	0 092 M40 340	M4 034
514 011 014 3104	0 092 M4F 340	M4 F34
514 012 014 A510	0 092 M4F 350	M4 F35
514 012 014 A510	0 092 M40 350	M4 035
514 012 014 A514	0 092 M4F 350	M4 F35
514 012 014 3100	0 092 M4F 350	M4 F35
514 012 014 3100	0 092 M40 350	M4 035
514 012 014 3101	0 092 M4F 350	M4 F35
514 012 014 3101	0 092 M40 350	M4 035
514 013 014 A510	0 092 M4F 360	M4 F36
514 013 014 A510	0 092 M40 360	M4 036
514 013 014 A514	0 092 M4F 360	M4 F36
514 013 014 3100	0 092 M4F 360	M4 F36
514 013 014 3100	0 092 M40 360	M4 036
514 013 014 3101	0 092 M4F 360	M4 F36
514 013 014 3101	0 092 M40 360	M4 036
514 014 014 A510	0 092 M4F 370	M4 F37
514 014 014 3100	0 092 M4F 370	M4 F37
514 014 014 3101	0 092 M4F 370	M4 F37
514 400 014 3101	0 092 M4F 380	M4 F38
514 400 019 A510	0 092 M4F 380	M4 F38

514 400 019 3100	0 092 M4F 380	M4 F38
514 901 022 A514	0 092 M60 210	M6 021
514 901 022 3104	0 092 M60 210	M6 021
514 902 022 A514	0 092 M60 220	M6 022
514 902 022 3104	0 092 M60 220	M6 022
516 015 016 A510	0 092 M4F 390	M4 F39
516 015 016 A510	0 092 M40 390	M4 039
516 015 016 3100	0 092 M4F 390	M4 F39
516 015 016 3100	0 092 M40 390	M4 039
516 015 016 3101	0 092 M4F 390	M4 F39
516 015 016 3101	0 092 M40 390	M4 039
516 016 012 A510	0 092 M4F 400	M4 F40
516 016 012 A510	0 092 M40 400	M4 040
516 016 012 3100	0 092 M4F 400	M4 F40
516 016 012 3100	0 092 M40 400	M4 040
516 016 012 3101	0 092 M4F 400	M4 F40
516 016 012 3101	0 092 M40 400	M4 040
518 014 015 A510	0 092 M4F 410	M4 F41
518 014 015 A510	0 092 M40 410	M4 041
518 014 015 3100	0 092 M4F 410	M4 F41
518 014 015 3100	0 092 M40 410	M4 041
518 014 015 3101	0 092 M4F 410	M4 F41
518 014 015 3101	0 092 M40 410	M4 041
518 015 018 A510	0 092 M4F 420	M4 F42
518 015 018 A510	0 092 M40 420	M4 042
518 015 018 3100	0 092 M4F 420	M4 F42
518 015 018 3100	0 092 M40 420	M4 042
518 015 018 3101	0 092 M4F 420	M4 F42
518 015 018 3101	0 092 M40 420	M4 042
518 901 026 A514	0 092 M60 230	M6 023
518 901 026 3104	0 092 M60 230	M6 023
518 902 026 A514	0 092 M60 240	M6 024
518 902 026 3104	0 092 M60 240	M6 024
519 011 019 A510	0 092 M4F 430	M4 F43
519 011 019 A510	0 092 M40 430	M4 043
519 011 019 3100	0 092 M4F 430	M4 F43
519 011 019 3100	0 092 M40 430	M4 043
519 011 019 3101	0 092 M4F 430	M4 F43
519 011 019 3101	0 092 M40 430	M4 043
519 012 019 A510	0 092 M4F 440	M4 F44
519 012 019 A510	0 092 M40 440	M4 044
519 012 019 3100	0 092 M4F 440	M4 F44
519 012 019 3100	0 092 M40 440	M4 044
519 012 019 3101	0 092 M4F 440	M4 F44
519 012 019 3101	0 092 M40 440	M4 044
519 013 017 A510	0 092 M4F 450	M4 F45
519 013 017 A510	0 092 M40 450	M4 045
519 013 017 A514	0 092 M4F 450	M4 F45
519 013 017 3100	0 092 M4F 450	M4 F45
519 013 017 3100	0 092 M40 450	M4 045
519 013 017 3101	0 092 M4F 450	M4 F45
519 013 017 3101	0 092 M40 450	M4 045
519 013 017 3104	0 092 M4F 450	M4 F45
519 014 018 A510	0 092 M4F 460	M4 F46
519 014 018 A510	0 092 M40 460	M4 046



519 014 018 3100	0 092 M4F 460	M4 F46
519 014 018 3100	0 092 M40 460	M4 046
519 014 018 3101	0 092 M4F 460	M4 F46
519 014 018 3101	0 092 M40 460	M4 046
519 901 017 A512	0 092 M60 450	M6 045
519 901 017 3102	0 092 M60 450	M6 045
520 012 020 A510	0 092 M4F 470	M4 F47
520 012 020 A510	0 092 M40 470	M4 047
520 012 020 3100	0 092 M4F 470	M4 F47
520 012 020 3100	0 092 M40 470	M4 047
520 012 020 3101	0 092 M4F 470	M4 F47
520 012 020 3101	0 092 M40 470	M4 047
520 016 020 A510	0 092 M4F 480	M4 F48
520 016 020 3100	0 092 M4F 480	M4 F48
520 016 020 3101	0 092 M4F 480	M4 F48
524 101 020 A510	0 092 M4F 510	M4 F51
524 101 020 A510	0 092 M40 510	M4 051
524 101 020 3100	0 092 M4F 510	M4 F51
524 101 020 3100	0 092 M40 510	M4 051
524 101 020 3101	0 092 M4F 510	M4 F51
524 101 020 3101	0 092 M40 510	M4 051
525 015 022 A510	0 092 M4F 520	M4 F52
525 015 022 A510	0 092 M40 520	M4 052
525 015 022 3100	0 092 M4F 520	M4 F52
525 015 022 3100	0 092 M40 520	M4 052
525 015 022 3101	0 092 M4F 520	M4 F52
525 015 022 3101	0 092 M40 520	M4 052
530 030 030 A510	0 092 M4F 540	M4 F54
530 030 030 A510	0 092 M40 540	M4 054
530 030 030 A514	0 092 M4F 540	M4 F54
530 030 030 3100	0 092 M4F 540	M4 F54
530 030 030 3100	0 092 M40 540	M4 054
530 030 030 3101	0 092 M4F 540	M4 F54
530 030 030 3101	0 092 M40 540	M4 054
530 030 030 3104	0 092 M4F 540	M4 F54
532 011 024 A510	0 092 M40 570	M4 057
532 036 024 A510	0 092 M40 550	M4 055
532 036 024 3100	0 092 M40 550	M4 055
532 036 024 3101	0 092 M40 550	M4 055
535 020 024 3100	0 092 S40 180	S4 018
535 022 024 3100	0 092 S40 190	S4 019
536 046 030 3022	0 092 S40 010	S4 001
536 054 030 3100	0 092 S30 010	S3 001
536 115 039 3012	0 092 S40 010	S4 001
540 050 026 3022	0 092 S30 160	S3 016
540 126 033 2082	0 092 S40 180	S4 018
540 126 033 3132	0 092 S40 180	S4 018
540 127 033 2082	0 092 S40 190	S4 019
540 127 033 3132	0 092 S40 190	S4 019
540 128 036 3172	0 092 S40 000	S4 000
540 200 036 3172	0 092 S30 010	S3 001
541 400 036 3122	0 092 S30 010	S3 001
542 400 039 3132	0 092 S40 000	S4 000
543 017 033 3100	0 092 S40 010	S4 001
543 019 039 3022	0 092 S40 010	S4 001

543 023 039 3022	0 092 S40 010	S4 001
543 024 033 3100	0 092 S40 010	S4 001
543 107 048 3012	0 092 S40 010	S4 001
544 059 036 3022	0 092 S30 020	S3 002
544 059 036 3100	0 092 S30 020	S3 002
544 059 036 3172	0 092 S30 020	S3 002
544 064 036 3022	0 092 S30 030	S3 003
544 064 036 3100	0 092 S30 030	S3 003
544 064 036 3172	0 092 S30 030	S3 003
544 069 036 3022	0 092 S40 010	S4 001
544 069 036 3100	0 092 S40 010	S4 001
544 105 045 3012	0 092 S40 020	S4 002
544 402 044 3132	0 092 S40 010	S4 001
545 019 036 3022	0 092 S40 010	S4 001
545 019 036 3100	0 092 S40 010	S4 001
545 023 030 3100	0 092 S40 210	S4 021
545 024 030 3100	0 092 S40 230	S4 023
545 051 030 3100	0 092 S40 220	S4 022
545 077 030 3022	0 092 S30 160	S3 016
545 077 030 3122	0 092 S30 160	S3 016
545 077 030 3172	0 092 S30 160	S3 016
545 079 030 3022	0 092 S30 170	S3 017
545 079 030 3122	0 092 S30 170	S3 017
545 079 030 3172	0 092 S30 170	S3 017
545 101 048 3012	0 092 S40 010	S4 001
545 156 033 2082	0 092 S40 210	S4 021
545 156 033 3132	0 092 S40 210	S4 021
545 157 033 2082	0 092 S40 220	S4 022
545 157 033 3132	0 092 S40 220	S4 022
545 158 033 2082	0 092 S40 230	S4 023
545 158 033 3132	0 092 S40 230	S4 023
545 171 042 3172	0 092 S40 010	S4 001
545 172 042 3172	0 092 S40 010	S4 001
545 173 042 3172	0 092 S40 010	S4 001
545200030	0 092 T30 010	T3 001
545 200 030 A742	0 092 T30 010	T3 001
545 200 030 3102	0 092 T30 010	T3 001
545 412 040 3122	0 092 S30 020	S3 002
545 413 040 3122	0 092 S30 030	S3 003
546 012 042 3100	0 092 S30 020	S3 002
550 040 045 3100	0 092 S30 040	S3 004
550 054 039 3100	0 092 S40 020	S4 002
550 056 054 3022	0 092 S30 040	S3 004
550 056 054 3022	0 092 S40 040	S4 004
550 056 054 3022	0 092 S50 010	S5 001
550 056 054 3100	0 092 S30 040	S3 004
550 057 054 3022	0 092 S30 040	S3 004
550 057 054 3022	0 092 S40 040	S4 004
550 057 054 3100	0 092 S30 040	S3 004
550 065 033 3100	0 092 S30 030	S3 003
550 066 033 3100	0 092 S40 020	S4 002
550 070 033 3022	0 092 S40 020	S4 002
550 070 033 3100	0 092 S40 020	S4 002
550 154 042 3172	0 092 S40 020	S4 002
550 155 054 3172	0 092 S50 010	S5 001

552 400 047 3132	0 092 S40 020	S4 002
552 401 052 3162	0 092 S50 010	S5 001
553 400 047 3122	0 092 S30 040	S3 004
554 400 053 3162	0 092 S50 020	S5 002
555 059 042 3022	0 092 S30 050	S3 005
555 059 042 3100	0 092 S30 050	S3 005
555 059 042 3172	0 092 S30 050	S3 005
555 064 042 A742	0 092 T30 050	T3 005
555 064 042 3100	0 092 T30 050	T3 005
555 064 042 3101	0 092 T30 050	T3 005
555 065 042 3022	0 092 S30 060	S3 006
555 065 042 3100	0 092 S30 060	S3 006
555 065 042 3172	0 092 S30 060	S3 006
555 070 042 3100	0 092 S30 050	S3 005
555 107 054 3012	0 092 S40 050	S4 005
555 155 054 3172	0 092 S40 040	S4 004
555 156 054 3172	0 092 S40 040	S4 004
556 400 048 3122	0 092 S30 050	S3 005
556 401 048 3122	0 092 S30 060	S3 006
560 048 028 3100	0 092 S40 260	S4 026
560 049 028 3100	0 092 S40 270	S4 027
560 068 039 3100	0 092 S40 240	S4 024
560 069 039 3100	0 092 S40 250	S4 025
560 077 060 3022	0 092 S50 040	S5 004
560 090 045 3100	0 092 S50 060	S5 006
560 091 060 3022	0 092 S50 040	S5 004
560 092 045 3100	0 092 S40 050	S4 005
560 098 028 3022	0 092 S40 260	S4 026
560 099 028 3022	0 092 S40 270	S4 027
560 127 054 3132	0 092 S40 060	S4 006
560 160 042 2082	0 092 S40 260	S4 026
560 161 042 2082	0 092 S40 270	S4 027
560 162 042 2082	0 092 S40 240	S4 024
560 163 042 2082	0 092 S40 250	S4 025
560 170 064 3172	0 092 S50 040	S5 004
560 408 054 3132	0 092 S40 050	S4 005
560 409 054 3132	0 092 S40 040	S4 004
560 410 054 3132	0 092 S40 240	S4 024
560 411 054 3132	0 092 S40 250	S4 025
560 500 056 B602	0 092 S5E 050	S5 E05
560 901 068 B512	0 092 S60 050	S6 005
561 011 054 3022	0 092 S50 040	S5 004
561 400 060 3162	0 092 S50 040	S5 004
562 019 048 3022	0 092 S40 050	S4 005
562 019 048 3022	0 092 S50 050	S5 005
562 019 048 3100	0 092 S40 050	S4 005
562 019 048 3172	0 092 S40 050	S4 005
562 103 060 3012	0 092 S50 050	S5 005
562 103 060 3172	0 092 S50 050	S5 005
562 104 060 3172	0 092 S50 060	S5 006
562 400 048 3172	0 092 S40 060	S4 006
563 018 051 3100	0 092 S30 070	S3 007
563 102 064 3012	0 092 S30 070	S3 007
563 400 061 3162	0 092 S50 050	S5 005
563 401 061 3162	0 092 S50 060	S5 006



◀ VARTA

564 020 064 3022	0 092 S30 070	S3 007
564 020 064 3022	0 092 S40 070	S4 007
564 020 064 3100	0 092 S30 070	S3 007
565 030 054 3100	0 092 S30 070	S3 007
565 500 065 B602	0 092 S5E 070	S5 E07

566 041 051 3022	0 092 S30 080	S3 008
566 041 051 3022	0 092 S40 080	S4 008
566 047 051 A742	0 092 T30 080	T3 008
566 047 051 3100	0 092 T30 080	T3 008
566 047 051 3101	0 092 T30 080	T3 008

566 101 064 3012	0 092 S30 080	S3 008
566 101 064 3012	0 092 S40 080	S4 008
570 024 054 3100	0 092 S40 270	S4 027
570 029 054 3100	0 092 S40 260	S4 026
570 064 051 3100	0 092 S40 080	S4 008

570 072 051 3022	0 092 S40 270	S4 027
570 073 051 3022	0 092 S40 260	S4 026
570 137 057 2082	0 092 S40 260	S4 026
570 138 057 2082	0 092 S40 270	S4 027
570 144 064 3122	0 092 S30 070	S3 007

570 144 064 3172	0 092 S40 070	S4 007
570 145 064 3172	0 092 S40 070	S4 007
570 146 064 3172	0 092 S40 070	S4 007
570 409 064 3122	0 092 S30 080	S3 008
570 412 063 3132	0 092 S40 260	S4 026

570 413 063 3132	0 092 S40 270	S4 027
570 500 065 B602	0 092 S5E 080	S5 E08
570 901 076 B512	0 092 S60 080	S6 008
570 901 076 3122	0 092 S60 010	S6 001
570 901 076 3122	0 092 S60 080	S6 008

571 013 068 3022	0 092 S40 070	S4 007
571 013 068 3022	0 092 S50 070	S5 007
571 013 068 3100	0 092 S40 070	S4 007
571 014 068 3022	0 092 S40 070	S4 007
571 014 068 3100	0 092 S40 070	S4 007

572 030 064 3100	0 092 S40 070	S4 007
572 409 068 3132	0 092 S40 070	S4 007
574 012 068 3022	0 092 S40 080	S4 008
574 012 068 3100	0 092 S40 080	S4 008
574 012 068 3132	0 092 S40 080	S4 008

574 012 068 3172	0 092 S40 080	S4 008
574 013 068 3022	0 092 S40 090	S4 009
574 013 068 3100	0 092 S40 090	S4 009
574 013 068 3132	0 092 S40 090	S4 009
574 013 068 3172	0 092 S40 090	S4 009

574 402 075 3162	0 092 S50 070	S5 007
575 031 057 3100	0 092 S40 080	S4 008
575 121 072 3172	0 092 S50 070	S5 007
575 500 073 B602	0 092 S5E 100	S5 E10
577 400 078 3162	0 092 S50 080	S5 008

580 122 072 3172	0 092 S40 100	S4 010
580 406 074 3132	0 092 S40 100	S4 010
580 500 073 B602	0 092 S5E 110	S5 E11
580 901 080 B512	0 092 S60 110	S6 011
585 015 076 3022	0 092 S30 120	S3 012

585 015 076 3100	0 092 S30 120	S3 012
585 015 076 3172	0 092 S30 120	S3 012
585 021 054 3100	0 092 S40 280	S4 028
585 022 054 3100	0 092 S40 290	S4 029
585 200 080 3162	0 092 S50 100	S5 010

585 200 080 3172	0 092 S50 100	S5 010
588 027 064 3100	0 092 T30 130	T3 013
588 033 064 3022	0 092 S30 130	S3 013
588 033 064 3022	0 092 S50 130	S5 013
588 033 064 3100	0 092 T30 130	T3 013

588 038 068 A742	0 092 T30 130	T3 013
588 038 068 3100	0 092 T30 130	T3 013
588 038 068 3101	0 092 T30 130	T3 013
588 107 085 3012	0 092 S40 130	S4 013
588 107 085 3012	0 092 S50 130	S5 013

588 403 074 3122	0 092 S30 120	S3 012
590 040 048 A742	0 092 T30 300	T3 030
590 040 048 3100	0 092 T30 300	T3 030
590 040 048 3101	0 092 T30 300	T3 030
590 040 048 3102	0 092 T30 300	T3 030

590 041 048 A742	0 092 T30 310	T3 031
590 041 048 3100	0 092 T30 310	T3 031
590 041 048 3101	0 092 T30 310	T3 031
590 041 048 3102	0 092 T30 310	T3 031
590 122 072 3122	0 092 S30 130	S3 013

590 123 072 3172	0 092 S30 130	S3 013
592 026 076 3100	0 092 S40 130	S4 013
595 014 054 3100	0 092 T30 720	T3 072
595 018 064 3100	0 092 S40 280	S4 028
595 019 064 3100	0 092 S40 290	S4 029

595 104 068 2082	0 092 S40 280	S4 028
595 105 068 2082	0 092 S40 290	S4 029
595 200 085 3172	0 092 S50 130	S5 013
595 402 080 3132	0 092 S40 130	S4 013
595 404 083 3132	0 092 S40 280	S4 028

595 405 083 3132	0 092 S40 290	S4 029
595 901 085 B512	0 092 S60 130	S6 013
595 901 085 3122	0 092 S60 020	S6 002
595 901 085 3122	0 092 S60 130	S6 013
600 026 060 3100	0 092 T30 720	T3 072

600 035 060 A742	0 092 T30 710	T3 071
600 035 060 3100	0 092 T30 710	T3 071
600 035 060 3101	0 092 T30 710	T3 071
600 044 076 3022	0 092 S50 130	S5 013
600 047 060 A742	0 092 T30 720	T3 072

600 047 060 3100	0 092 T30 720	T3 072
600 047 060 3101	0 092 T30 720	T3 072
600 123 072 A742	0 092 T30 320	T3 032
600 123 072 3102	0 092 T30 320	T3 032
600 131 080 3172	0 092 S50 130	S5 013

600 402 083 3162	0 092 S50 130	S5 013
602 102 068 A742	0 092 T30 330	T3 033
602 103 068 A742	0 092 T30 340	T3 034
605 901 095 B512	0 092 S60 150	S6 015
610 013 076 A742	0 092 T30 380	T3 038

610 013 076 3100	0 092 T30 380	T3 038
610 013 076 3101	0 092 T30 380	T3 038
610 042 080 3100	0 092 S50 150	S5 015
610 047 068 A742	0 092 T30 350	T3 035
610 047 068 3100	0 092 T30 350	T3 035

610 047 068 3101	0 092 T30 350	T3 035
610 047 068 3102	0 092 T30 350	T3 035
610 048 068 A742	0 092 T30 360	T3 036
610 048 068 3100	0 092 T30 360	T3 036
610 048 068 3101	0 092 T30 360	T3 036

610 048 068 3102	0 092 T30 360	T3 036
610 049 068 3100	0 092 T30 390	T3 039
610 049 068 3102	0 092 T30 390	T3 039
610 050 085 A742	0 092 T30 730	T3 073
610 050 085 3100	0 092 T30 730	T3 073

610 050 085 3101	0 092 T30 730	T3 073
610 087 068 3100	0 092 T30 390	T3 039
610 200 085 3172	0 092 S50 150	S5 015
610 402 092 3162	0 092 S50 150	S5 015
610 404 068 A742	0 092 T30 370	T3 037

620 045 068 A742	0 092 T30 750	T3 075
620 045 068 3100	0 092 T30 750	T3 075
620 045 068 3100	0 092 T40 750	T4 075
620 045 068 3101	0 092 T30 750	T3 075
620 046 068 3100	0 092 T30 390	T3 039

620 046 068 3101	0 092 T30 390	T3 039
620 109 076 A742	0 092 T30 390	T3 039
625 012 072 A742	0 092 T30 400	T3 040
625 012 072 3100	0 092 T30 400	T3 040
625 012 072 3101	0 092 T30 400	T3 040

625 012 072 3102	0 092 T30 400	T3 040
625 014 072 A742	0 092 T30 410	T3 041
625 014 072 3100	0 092 T30 410	T3 041
625 014 072 3101	0 092 T30 410	T3 041
625 014 072 3102	0 092 T30 410	T3 041

625 023 000 A742	0 092 T30 420	T3 042
625 023 000 3100	0 092 T30 420	T3 042
625 023 000 3101	0 092 T30 420	T3 042
630 013 068 3100	0 092 T30 430	T3 043
630 014 068 A742	0 092 T30 430	T3 043

630 014 068 3100	0 092 T30 430	T3 043
630 014 068 3101	0 092 T30 430	T3 043
632 011 085 3100	0 092 T30 460	T3 046
635 039 100 3100	0 092 T30 450	T3 045
635 042 068 A742	0 092 T30 440	T3 044

635 042 068 3100	0 092 T30 440	T3 044
635 042 068 3101	0 092 T30 440	T3 044
635 042 068 3102	0 092 T30 440	T3 044
635 045 068 3100	0 092 T50 750	T5 075
635 045 068 3101	0 092 T50 750	T5 075

635 052 100 A742	0 092 T30 450	T3 045
635 052 100 3100	0 092 T30 450	T3 045
635 052 100 3101	0 092 T30 450	T3 045
635 052 100 3102	0 092 T30 450	T3 045
640 034 095 3100	0 092 T40 750	T4 075

640 034 095 3101	0 092 T40 750	T4 075
640 035 076 3100	0 092 T40 750	T4 075
640 035 076 3101	0 092 T40 750	T4 075
640 035 076 3102	0 092 T40 750	T4 075
640 036 076 3100	0 092 T40 760	T4 076

640 036 076 3101	0 092 T40 760	T4 076
640 103 080 A732	0 092 T40 750	T4 075
640 103 080 3412	0 092 T40 750	T4 075
640 400 080 A732	0 092 T40 760	T4 076
640 400 080 3412	0 092 T40 760	T4 076

643 033 095 A742	0 092 T30 470	T3 047
643 033 095 3100	0 092 T30 470	T3 047
643 033 095 3101	0 092 T30 470	T3 047
643 034 090 3100	0 092 T30 480	T3 048
643 034 090 3101	0 092 T30 480	T3 048

643 089 090 3100	0 092 T30 480	T3 048
643 107 090 A742	0 092 T30 460	T3 046
645 400 080 A722	0 092 T50 750	T5 075
655 013 090 A742	0 092 T30 770	T3 077
655 013 090 3100	0 092 T30 770	T3 077

655 013 090 3100	0 092 T40 770	T4 077
655 013 090 3101	0 092 T30 770	T3 077
655 013 090 3102	0 092 T30 770	T3 077
655 104 090 A742	0 092 T30 480	T3 048
670 023 080 3100	0 092 T40 780	T4 078

670 023 080 3101	0 092 T40 780	T4 078
670 042 115 3100	0 092 T40 770	T4 077
670 043 100 3100	0 092 T40 770	T4 077
670 043 100 3101	0 092 T40 770	T4 077
670 044 100 3100	0 092 T30 790	T3 079

670 044 100 3101	0 092 T30 790	T3 079
670 045 100 3100	0 092 T40 780	T4 078
670 045 100 3101	0 092 T40 780	T4 078
670 045 100 3102	0 092 T40 780	T4 078
670 046 110 3100	0 092 T30 790	T3 079

670 046 110 3101	0 092 T30 790	T3 079
670 103 100 A732	0 092 T40 770	T4 077
670 103 100 3412	0 092 T40 770	T4 077
670 104 100 A732	0 092 T40 780	T4 078
670 104 100 3412	0 092 T40 780	T4 078

680 032 100 3100	0 092 T50 770	T5 077
680 032 100 3101	0 092 T50 770	T5 077
680 033 110 A742	0 092 T30 790	T3 079
680 033 110 3100	0 092 T30 790	T3 079
680 033 110 3101	0 092 T30 790	T3 079

680 108 100 A722	0 092 T50 770	T5 077
680 108 100 3412	0 092 T50 770	T5 077
700 027 105 3100	0 092 T50 800	T5 080
700 038 105 A742	0 092 T30 800	T3 080
700 038 105 3100	0 092 T30 800	T3 080

700 038 105 3101	0 092 T30 800	T3 080
700 110 30A A742	0 092 T30 600	T3 060
715 014 115 3100	0 092 T40 800	T4 080
715 400 115 A732	0 092 T40 800	T4 080
720 018 115 A742	0 092 T30 810	T3 081

720 025 145 3100	0 092 T30 810	T3 081
720 025 145 3101	0 092 T30 810	T3 081
725 012 115 3100	0 092 T50 800	T5 080
725 012 115 3101	0 092 T50 800	T5 080
725 103 115 A722	0 092 T50 800	T5 080

725 103 115 3412	0 092 T50 800	T5 080
------------------	---------------	---------------

VAUXHALL

91128942	0 092 S50 040	S5 004
91128943	0 092 S40 070	S4 007
91131978	0 092 S30 120	S3 012

91153990	0 092 S40 070	S4 007
91157120	0 092 S30 120	S3 012
91 158 371 EQ	0 092 S50 040	S5 004
91 158 372 ER	0 092 S40 070	S4 007
91 158 373 ES	0 092 S30 120	S3 012

91 158 375 ET	0 092 S50 040	S5 004
91 158 376 EU	0 092 S40 070	S4 007
93179170	0 092 S40 040	S4 004
93179170	0 092 S50 040	S5 004

VOLVO

MAC0006	0 092 T30 710	T3 071
11308464	0 092 S30 130	S3 013
11308464	0 092 S40 130	S4 013

11308464	0 092 S50 130	S5 013
11714689	0 092 S40 260	S4 026
11807951	0 092 S40 020	S4 002
11807951	0 092 S50 020	S5 002
1235132	0 092 S40 270	S4 027

1235272	0 092 S40 270	S4 027
1235719	0 092 S40 270	S4 027
1235780	0 092 S40 270	S4 027
1277399	0 092 S40 270	S4 027
1696588	0 092 T30 440	T3 044

1696734	0 092 T30 440	T3 044
20007057445	0 092 T30 130	T3 013
20393420	0 092 T30 350	T3 035
20393420	0 092 T30 370	T3 037
20393421	0 092 T30 350	T3 035

20393421	0 092 T30 370	T3 037
20393422	0 092 T40 750	T4 075
20393422	0 092 T40 760	T4 076
20393423	0 092 T40 750	T4 075
20393424	0 092 T40 770	T4 077

20393424	0 092 T50 770	T5 077
20393425	0 092 T40 770	T4 077
20393425	0 092 T50 770	T5 077
20393426	0 092 T50 800	T5 080
20393427	0 092 T30 810	T3 081

20393427	0 092 T50 800	T5 080
20774108	0 092 T50 800	T5 080
20774109	0 092 T50 800	T5 080
20935640	0 092 T50 800	T5 080
20935641	0 092 T50 800	T5 080

30658161	0 092 S40 050	S4 005
30658161	0 092 S50 050	S5 005
30658162	0 092 S40 080	S4 008
30695118	0 092 S60 020	S6 002
30695118	0 092 S60 130	S6 013

30695142	0 092 S60 020	S6 002
30695142	0 092 S60 130	S6 013
30696118	0 092 S60 020	S6 002
30696118	0 092 S60 130	S6 013
307445773	0 092 S30 120	S3 012

30745772	0 092 S50 100	S5 010
30745773	0 092 S60 020	S6 002
30745773	0 092 S60 130	S6 013
30745774	0 092 S40 050	S4 005
30745774	0 092 S50 050	S5 005

30745775	0 092 S30 080	S3 008
30745775	0 092 S40 080	S4 008
30745775	0 092 S50 080	S5 008
30745776	0 092 S40 100	S4 010
30745776	0 092 S50 100	S5 010

30745777	0 092 S30 130	S3 013
30745777	0 092 S40 130	S4 013
30745777	0 092 S60 020	S6 002
30745777	0 092 S60 130	S6 013
30745778	0 092 S60 020	S6 002

30745778	0 092 S60 130	S6 013
30772209	0 092 S50 050	S5 005
30772210	0 092 S50 050	S5 005
30772213	0 092 S50 050	S5 005
30772214	0 092 S50 050	S5 005

30772215	0 092 S50 050	S5 005
30772218	0 092 S50 050	S5 005
30772219	0 092 S50 080	S5 008
30772220	0 092 S50 080	S5 008
30772223	0 092 S50 080	S5 008

30772224	0 092 S50 100	S5 010
30772225	0 092 S50 100	S5 010
30772228	0 092 S50 100	S5 010
30772229	0 092 S60 020	S6 002
30772229	0 092 S60 130	S6 013

30772230	0 092 S60 020	S6 002
30772230	0 092 S60 130	S6 013
30772233	0 092 S60 020	S6 002
30772233	0 092 S60 130	S6 013
30772234	0 092 S50 100	S5 010

30772235	0 092 S50 100	S5 010
30772238	0 092 S50 100	S5 010
30772239	0 092 S60 020	S6 002
30772239	0 092 S60 130	S6 013
30772240	0 092 S60 020	S6 002

◀ VOLVO

30772240	0 092 S60 130	S6 013
30772243	0 092 S60 020	S6 002
30772243	0 092 S60 130	S6 013
31255132	0 092 S50 080	S5 008
31255132	0 092 S60 010	S6 001

31255132	0 092 S60 080	S6 008
31255361	0 092 S50 080	S5 008
31255362	0 092 S50 080	S5 008
31255363	0 092 S50 080	S5 008
3199172	0 092 T40 750	T4 075

3199173	0 092 T40 750	T4 075
3199174	0 092 T40 770	T4 077
3199175	0 092 T40 770	T4 077
3199176	0 092 T30 810	T3 081
3199177	0 092 T30 810	T3 081

8158060	0 092 T30 350	T3 035
8158060	0 092 T30 370	T3 037
8158061	0 092 T30 350	T3 035
8158062	0 092 T40 750	T4 075
8158063	0 092 T40 750	T4 075

8158064	0 092 T40 770	T4 077
8158065	0 092 T40 770	T4 077
8158066	0 092 T30 810	T3 081
8158067	0 092 T30 810	T3 081
862311	0 092 S40 270	S4 027

862312	0 092 T30 130	T3 013
862313	0 092 T30 350	T3 035
862314	0 092 T40 750	T4 075
8645083	0 092 S50 130	S5 013
8666095	0 092 S50 040	S5 004

8688665	0 092 S50 040	S5 004
9139291	0 092 S30 050	S3 005
9139292	0 092 S40 080	S4 008
9139293	0 092 S50 130	S5 013
9139347	0 092 S30 050	S3 005

9139348	0 092 S40 080	S4 008
9139349	0 092 S50 130	S5 013
9139350	0 092 S40 040	S4 004
9139350	0 092 S50 010	S5 001
9139351	0 092 S40 270	S4 027

9139588	0 092 S40 050	S4 005
9139588	0 092 S50 050	S5 005
9139589	0 092 S40 080	S4 008
93139720	0 092 S50 130	S5 013
9438598	0 092 S40 280	S4 028

9438607	0 092 S40 280	S4 028
9438785	0 092 S50 130	S5 013
9472329	0 092 S30 050	S3 005
9472330	0 092 S40 080	S4 008
9487608	0 092 S40 280	S4 028

95038086	0 092 S40 050	S4 005
95038086	0 092 S50 050	S5 005
95038087	0 092 S40 080	S4 008
95038094	0 092 S50 040	S5 004
95038110	0 092 S50 130	S5 013

95039347	0 092 S30 050	S3 005
95039348	0 092 S40 080	S4 008
95039349	0 092 S50 130	S5 013
95039350	0 092 S50 130	S5 013

VOTEX

000 056 030 H 138	0 092 S40 260	S4 026
000 056 030 P 138	0 092 S40 260	S4 026

VW (VOLKSWAGEN)

J0 915 105 AC	0 092 S50 050	S5 005
J28 800 040 10	0 092 S40 230	S4 023
J28 800 040 20	0 092 S40 250	S4 025

J28 800 040 30	0 092 S40 270	S4 027
J28 800 040 40	0 092 S40 260	S4 026
J7A ZZZ 900 15	0 092 S40 230	S4 023
J7A ZZZ 900 16	0 092 S40 250	S4 025
J7A ZZZ 900 17	0 092 S40 270	S4 027

J7A ZZZ 900 18	0 092 S40 260	S4 026
000 915 105 AA	0 092 S30 010	S3 001
000 915 105 AB	0 092 S30 020	S3 002
000 915 105 AB	0 092 S40 020	S4 002
000 915 105 AC	0 092 S40 050	S4 005

000 915 105 AC	0 092 S50 040	S5 004
000 915 105 AC	0 092 S50 050	S5 005
000 915 105 AD	0 092 S40 050	S4 005
000 915 105 AD	0 092 S50 050	S5 005
000 915 105 AE	0 092 S40 080	S4 008

000 915 105 AE	0 092 S50 080	S5 008
000 915 105 AF	0 092 S40 080	S4 008
000 915 105 AF	0 092 S50 080	S5 008
000 915 105 AG	0 092 S50 100	S5 010
000 915 105 AH	0 092 S30 120	S3 012

000 915 105 AH	0 092 S50 130	S5 013
000 915 105 AH	0 092 S60 020	S6 002
000 915 105 AH	0 092 S60 130	S6 013
000 915 105 AJ	0 092 S50 100	S5 010
000 915 105 AK	0 092 S50 130	S5 013

000 915 105 AK	0 092 S50 150	S5 015
000 915 105 CC	0 092 S60 010	S6 001
000 915 105 CC	0 092 S60 080	S6 008
000 915 105 CD	0 092 S60 010	S6 001
000 915 105 CD	0 092 S60 080	S6 008

000 915 105 CE	0 092 S60 020	S6 002
000 915 105 CE	0 092 S60 130	S6 013
1E0 915 105	0 092 S50 040	S5 004
1E0 915 105	0 092 S50 050	S5 005
1H0 915 105	0 092 S40 020	S4 002

1H0 915 105 A	0 092 S50 080	S5 008
1H0 915 105 B	0 092 S40 020	S4 002
1H0 915 105 C	0 092 S50 080	S5 008
1H0 915 105 E	0 092 M4F 270	M4 F27
1H0 915 105 F	0 092 S40 020	S4 002

1H0 915 105 G	0 092 S50 040	S5 004
1H0 915 105 G	0 092 S50 050	S5 005
1J0 915 105	0 092 S30 020	S3 002
1J0 915 105	0 092 S40 020	S4 002
1J0 915 105 A	0 092 S40 050	S4 005

1J0 915 105 A	0 092 S50 050	S5 005
1J0 915 105 AA	0 092 S30 010	S3 001
1J0 915 105 AB	0 092 S30 020	S3 002
1J0 915 105 AB	0 092 S40 020	S4 002
1J0 915 105 AC	0 092 S40 050	S4 005

1J0 915 105 AC	0 092 S50 050	S5 005
1J0 915 105 AD	0 092 S40 050	S4 005
1J0 915 105 AD	0 092 S50 050	S5 005
1J0 915 105 AE	0 092 S30 080	S3 008
1J0 915 105 AE	0 092 S40 080	S4 008

1J0 915 105 AE	0 092 S50 080	S5 008
1J0 915 105 AF	0 092 S40 080	S4 008
1J0 915 105 AF	0 092 S50 080	S5 008
1J0 915 10 5AG	0 092 S50 100	S5 010
1J0 915 105 AH	0 092 S40 130	S4 013

1J0 915 105 AH	0 092 S50 130	S5 013
1J0 915 105 AJ	0 092 S50 150	S5 015
1J0 915 105 AK	0 092 S50 150	S5 015
1J0 915 105 AL	0 092 S40 000	S4 000
1J0 915 105 B	0 092 S40 050	S4 005

1J0 915 105 B	0 092 S50 050	S5 005
1J0 915 105 C	0 092 S40 080	S4 008
1J0 915 105 C	0 092 S50 080	S5 008
1J0 915 105 D	0 092 S30 020	S3 002
1J0 915 105 D	0 092 S40 020	S4 002

1J0 915 105 E	0 092 S40 050	S4 005
1J0 915 105 E	0 092 S50 050	S5 005
1J0 915 105 F	0 092 S40 050	S4 005
1J0 915 105 F	0 092 S50 050	S5 005
1J0 915 105 G	0 092 S50 080	S5 008

1J0 915 105 H	0 092 S50 130	S5 013
1J0 915 105 J	0 092 S50 130	S5 013
1J0 915 105 K	0 092 S30 010	S3 001
1J0 915 105 L	0 092 S30 010	S3 001
1J0 915 105 M	0 092 S40 080	S4 008

1J0 915 105 M	0 092 S50 080	S5 008
1J0 915 105 N	0 092 S40 080	S4 008
1J0 915 105 N	0 092 S50 080	S5 008
1J0 915 105 P	0 092 S50 100	S5 010
1J0 915 105 Q	0 092 S50 100	S5 010

1J0 915 15 AK	0 092 S50 150	S5 015
1K0 915 105	0 092 S30 020	S3 002
1K0 915 105	0 092 S40 020	S4 002
1K0 915 418	0 092 S30 020	S3 002
1L0 915 105 E	0 092 S50 080	S5 008

191 915 105	0 092 S30 010	S3 001
191 915 105 A	0 092 S30 010	S3 001
191 915 105 AA	0 092 S30 040	S3 004
191 915 105 AB	0 092 S50 070	S5 007
191 915 105 B	0 092 S30 040	S3 004

191 915 105 C	0 092 S30 040	S3 004
191 915 105 D	0 092 S30 040	S3 004
191 915 105 E	0 092 S30 010	S3 001
191 915 105 F	0 092 S50 040	S5 004
191 915 105 G	0 092 S50 040	S5 004

191 915 105 H	0 092 S50 040	S5 004
191 915 105 K	0 092 S40 070	S4 007
191 915 105 L	0 092 S40 070	S4 007
191 915 105 M	0 092 S40 070	S4 007
191 915 105 M	0 092 S50 070	S5 007

191 915 105 N	0 092 S40 070	S4 007
191 915 105 P	0 092 S40 070	S4 007
191 915 105 Q	0 092 S40 070	S4 007
191 915 105 Q	0 092 S50 070	S5 007
2D0 915 105	0 092 S50 080	S5 008

2D0 915 105 B	0 092 S50 130	S5 013
2D0 915 105 C	0 092 S40 130	S4 013
2D0 915 105 C	0 092 S50 130	S5 013
2D0 915 105 C	0 092 T30 130	T3 013
2E0 915 105 C	0 092 S50 130	S5 013

282 915 105	0 092 S50 010	S5 001
3B0 915 105	0 092 S50 100	S5 010
3B0 915 105 B	0 092 S40 080	S4 008
3B0 915 105 B	0 092 S50 080	S5 008
3D0 915 105	0 092 S50 080	S5 008

3D0 915 105 A	0 092 S60 020	S6 002
3D0 915 105 A	0 092 S60 130	S6 013
3D0 915 105 C	0 092 S50 010	S5 001
3D0 915 105 G	0 092 S60 020	S6 002
3D0 915 105 G	0 092 S60 130	S6 013

3D0 915 105 H	0 092 S50 100	S5 010
3D0 915 105 H	0 092 S60 010	S6 001
3D0 915 105 H	0 092 S60 080	S6 008
357 915 105 A	0 092 S50 130	S5 013
4B0 915 105	0 092 S50 130	S5 013

4B0 915 105 H	0 092 S50 100	S5 010
4B0 915 105 J	0 092 S50 130	S5 013
4B0 915 105 L	0 092 S50 130	S5 013
4D0 915 105	0 092 S50 080	S5 008
4D0 915 105 A	0 092 S40 080	S4 008

4D0 915 105 A	0 092 S50 080	S5 008
4D0 915 105 C	0 092 S50 130	S5 013
4D0 915 105 C	0 092 S50 150	S5 015
4E0 915 105	0 092 S50 130	S5 013
4E0 915 105	0 092 S50 150	S5 015

4F0 915 105 A	0 092 S40 080	S4 008
4F0 915 105 A	0 092 S50 080	S5 008
4F0 915 105 B	0 092 S40 100	S4 010
4F0 915 105 B	0 092 S50 100	S5 010
4F0 915 105 C	0 092 S50 130	S5 013

4F0 915 105 D	0 092 S50 150	S5 015
4F0 915 105 E	0 092 S50 130	S5 013
4F0 915 105 E	0 092 S60 020	S6 002
4F0 915 105 E	0 092 S60 130	S6 013
441 915 105	0 092 S50 130	S5 013

441 915 105 A	0 092 S50 130	S5 013
535 915 105	0 092 S50 040	S5 004
535 915 105	0 092 S50 050	S5 005
535 915 105 A	0 092 S50 050	S5 005
6E0 915 105	0 092 S50 050	S5 005

6E0 915 105 A	0 092 S50 050	S5 005
6E0 915 105	0 092 S50 050	S5 005
6E0 915 105 A	0 092 S50 050	S5 005
6N0 915 105	0 092 S50 050	S5 005
6N0 915 105 A	0 092 S50 050	S5 005

7D0 915 105	0 092 S50 130	S5 013
7D0 915 105 A	0 092 S50 130	S5 013
7D0 915 105 B	0 092 S50 080	S5 008
7D0 915 105 C	0 092 S50 080	S5 008
7L0 915 105	0 092 S50 080	S5 008

7M0 915 105 E	0 092 S50 050	S5 005
7N0 915 105	0 092 S50 020	S5 002
7N0 915 105 A	0 092 S50 100	S5 010
8A0 915 105 E	0 092 S50 050	S5 005
8D0 915 105	0 092 S30 010	S3 001

8D0 915 105 A	0 092 S40 020	S4 002
8D0 915 105 AF	0 092 S40 020	S4 002
8D0 915 105 B	0 092 S50 050	S5 005
8D0 915 105 BG	0 092 S50 050	S5 005
8D0 915 105 C	0 092 S50 100	S5 010

8D0 915 105 CH	0 092 S50 100	S5 010
8D0 915 105 D	0 092 S50 100	S5 010
8D0 915 105 DJ	0 092 S50 100	S5 010
8D0 915 105 E	0 092 S30 010	S3 001
8D0 915 105 F	0 092 S30 020	S3 002

8D0 915 105 F	0 092 S40 020	S4 002
8D0 915 105 G	0 092 S40 050	S4 005
8D0 915 105 G	0 092 S50 050	S5 005
8D0 915 105 H	0 092 S50 100	S5 010
8D0 915 105 J	0 092 S30 120	S3 012

8D0 915 105 J	0 092 S50 100	S5 010
8E0 915 105	0 092 S30 020	S3 002
8E0 915 105	0 092 S40 020	S4 002
8E0 915 105 A	0 092 S40 050	S4 005
8E0 915 105 A	0 092 S50 050	S5 005

8E0 915 105 B	0 092 S40 080	S4 008
8E0 915 105 B	0 092 S50 080	S5 008
8E0 915 105 B	0 092 S60 010	S6 001
8E0 915 105 B	0 092 S60 080	S6 008
8E0 915 105 C	0 092 S50 100	S5 010

8E0 915 105 D	0 092 S50 130	S5 013
8E0 915 105 G	0 092 S40 050	S4 005
8E0 915 105 G	0 092 S50 050	S5 005
8E0 915 105 H	0 092 S40 080	S4 008
8E0 915 105 L	0 092 S40 080	S4 008

8E0 915 105 Z	0 092 S50 100	S5 010
8K0 915 105 C	0 092 S40 080	S4 008
8K0 915 105 D	0 092 S40 100	S4 010
8K0 915 105 D	0 092 S50 100	S5 010
8K0 915 105 F	0 092 S50 150	S5 015

8K0 915 105 G	0 092 S40 050	S4 005
8K0 915 105 H	0 092 S40 050	S4 005
8K0 915 105 H	0 092 S50 080	S5 008
8N7 915 105	0 092 S50 050	S5 005
8N7 915 105 A	0 092 S50 050	S5 005

8Z0 915 105	0 092 S40 050	S4 005
8Z0 915 105	0 092 S50 050	S5 005
8Z0 915 105 D	0 092 S50 100	S5 010
867 915 105	0 092 S40 040	S4 004
867 915 105 A	0 092 S50 040	S5 004

867 915 105 A	0 092 S50 050	S5 005
867 915 105 B	0 092 S50 050	S5 005
867 915 105 C	0 092 S50 040	S5 004
867 915 105 C	0 092 S50 050	S5 005

YORK

6YE5P	0 092 S40 270	S4 027
-------	---------------	---------------

YUASA

B49-6	0 092 M4F 100	M4 F10
B49-6	0 092 M40 100	M4 010
GM7CZ-3D	0 092 M4F 230	M4 F23

GM7CZ-3D	0 092 M40 230	M4 023
HJ-S46B24R	0 092 S40 220	S4 022
NS40	0 092 S40 190	S4 019
NS40L	0 092 S40 180	S4 018
NS40S	0 092 S40 190	S4 019

NS40Z	0 092 S40 190	S4 019
NS40ZA	0 092 S40 190	S4 019
NS40ZAL	0 092 S40 180	S4 018
NS40ZL	0 092 S40 180	S4 018
NS60	0 092 S40 220	S4 022

NS60LS	0 092 S40 210	S4 021
NS60S	0 092 S40 230	S4 023
NS70	0 092 S40 270	S4 027
NS70L	0 092 S40 260	S4 026
NT60S4	0 092 S40 190	S4 019

NT60S4L	0 092 S40 180	S4 018
NT80S6	0 092 S40 220	S4 022
NT80S6LS	0 092 S40 210	S4 021
NT80S6S	0 092 S40 230	S4 023
NX100S6	0 092 S40 220	S4 022

NX100S6LS	0 092 S40 210	S4 021
NX100S6S	0 092 S40 230	S4 023
NX1105	0 092 S40 270	S4 027
NX1105L	0 092 S40 260	S4 026
N40	0 092 S40 230	S4 023

N50	0 092 S40 270	S4 027
N50L	0 092 S40 260	S4 026
N50Z	0 092 S40 270	S4 027
N50ZL	0 092 S40 260	S4 026
SY50-N18L-AT	0 092 M4F 480	M4 F48











































◀ YUASA

YB10L-A2	0 092 M4F 280	M4 F28
YB10L-A2	0 092 M40 280	M4 028
YB10L-B	0 092 M4F 290	M4 F29
YB10L-B	0 092 M40 290	M4 029
YB10L-B2	0 092 M4F 290	M4 F29
YB10L-B2	0 092 M40 290	M4 029
YB12A-A	0 092 M4F 300	M4 F30
YB12A-A	0 092 M40 300	M4 030
YB12A-B	0 092 M4F 330	M4 F33
YB12AL-A	0 092 M4F 320	M4 F32
YB12AL-A	0 092 M40 320	M4 032
YB12AL-A2	0 092 M4F 320	M4 F32
YB12AL-A2	0 092 M40 320	M4 032
YB14-A2	0 092 M4F 350	M4 F35
YB14-A2	0 092 M40 350	M4 035
YB14-B2	0 092 M4F 370	M4 F37
YB14L-A1	0 092 M4F 380	M4 F38
YB14L-A2	0 092 M4F 340	M4 F34
YB14L-A2	0 092 M40 340	M4 034
YB14L-B2	0 092 M4F 360	M4 F36
YB14L-B2	0 092 M40 360	M4 036
YB16AL-A2	0 092 M4F 400	M4 F40
YB16AL-A2	0 092 M40 400	M4 040
YB16-B	0 092 M4F 440	M4 F44
YB16-B	0 092 M40 440	M4 044
YB16B-A	0 092 M4F 390	M4 F39
YB16B-A	0 092 M40 390	M4 039
YB16B-A1	0 092 M4F 390	M4 F39
YB16B-A1	0 092 M40 390	M4 039
YB16CL-B	0 092 M4F 460	M4 F46
YB16CL-B	0 092 M40 460	M4 046
YB16L-B	0 092 M4F 430	M4 F43
YB16L-B	0 092 M40 430	M4 043
YB18L-A	0 092 M4F 420	M4 F42
YB18L-A	0 092 M40 420	M4 042
YB3L-A	0 092 M4F 150	M4 F15
YB3L-A	0 092 M40 150	M4 015
YB3L-B	0 092 M4F 160	M4 F16
YB3L-B	0 092 M40 160	M4 016
YB4L-B	0 092 M4F 170	M4 F17
YB4L-B	0 092 M40 170	M4 017
YB5L-B	0 092 M4F 180	M4 F18
YB5L-B	0 092 M40 180	M4 018
YB7-A	0 092 M4F 240	M4 F24
YB7-A	0 092 M40 240	M4 024
YB7C-A	0 092 M4F 230	M4 F23
YB7C-A	0 092 M40 230	M4 023
YB7L-B	0 092 M4F 210	M4 F21
YB7L-B	0 092 M40 210	M4 021
YB9-B	0 092 M4F 250	M4 F25
YB9-B	0 092 M40 250	M4 025
YB9L-A2	0 092 M4F 270	M4 F27
YB9L-B	0 092 M4F 260	M4 F26
YB9L-B	0 092 M40 260	M4 026
YHD-12	0 092 M40 550	M4 055

YTR4A-BS	0 092 M60 030	M6 003
YTX12-BS	0 092 M60 140	M6 014
YTX12-4	0 092 M60 140	M6 014
YTX14-BS	0 092 M60 180	M6 018
YTX14-4	0 092 M60 180	M6 018
YTX16-BS	0 092 M60 220	M6 022
YTX16-BS-1	0 092 M60 210	M6 021
YTX16-4	0 092 M60 220	M6 022
YTX16-4-1	0 092 M60 210	M6 021
YTX20-BS	0 092 M60 240	M6 024
YTX20L-BS	0 092 M60 230	M6 023
YTX20L-4	0 092 M60 230	M6 023
YTX20-4	0 092 M60 240	M6 024
YTX5L-BS	0 092 M60 040	M6 004
YTX5L-4	0 092 M60 040	M6 004
YTX7A-BS	0 092 M60 070	M6 007
YTX7A-4	0 092 M60 070	M6 007
YTX7L-BS	0 092 M60 060	M6 006
YTX7L-4	0 092 M60 060	M6 006
YTX9-BS	0 092 M60 100	M6 010
YTX9-4	0 092 M60 100	M6 010
YTZ10S-BS	0 092 M60 110	M6 011
YTZ10S-4	0 092 M60 110	M6 011
YTZ12S-BS	0 092 M60 120	M6 012
YTZ12S-4	0 092 M60 120	M6 012
YTZ14S-BS	0 092 M60 170	M6 017
YTZ14S-4	0 092 M60 170	M6 017
YTZ7S-BS	0 092 M60 090	M6 009
YTZ7S-4	0 092 M60 090	M6 009
YT12A-BS	0 092 M60 160	M6 016
YT12A-4	0 092 M60 160	M6 016
YT12B-BS	0 092 M60 190	M6 019
YT12B-4	0 092 M60 190	M6 019
YT14B-BS	0 092 M60 200	M6 020
YT14B-4	0 092 M60 200	M6 020
YT4L-BS	0 092 M60 010	M6 001
YT4L-4	0 092 M60 010	M6 001
YT7B-BS	0 092 M60 080	M6 008
YT7B-4	0 092 M60 080	M6 008
YT9B-BS	0 092 M60 130	M6 013
YT9B-4	0 092 M60 130	M6 013
Y50-N18L-A	0 092 M4F 470	M4 F47
Y50-N18L-A	0 092 M40 470	M4 047
Y50N18L-A2	0 092 M4F 470	M4 F47
Y50N18L-A2	0 092 M40 470	M4 047
Y60-N24L-A	0 092 M4F 520	M4 F52
Y60-N24L-A	0 092 M40 520	M4 052
005	0 092 S40 240	S4 024
012	0 092 S30 020	S3 002
012T	0 092 S40 020	S4 002
014	0 092 S40 250	S4 025
017	0 092 S30 130	S3 013
019	0 092 S40 130	S4 013
019AGM	0 092 S60 130	S6 013
019T	0 092 S50 130	S5 013





020	0 092 S50 150	S5 015
024	0 092 S30 120	S3 012
027	0 092 S40 050	S4 005
027AGM	0 092 S60 050	S6 005
027T	0 092 S50 050	S5 005
030	0 092 S40 260	S4 026
031	0 092 S40 270	S4 027
048	0 092 S30 160	S3 016
049	0 092 S30 170	S3 017
053	0 092 S40 210	S4 021
054	0 092 S40 180	S4 018
055	0 092 S40 190	S4 019
057	0 092 S40 230	S4 023
063	0 092 S30 010	S3 001
063T	0 092 S40 010	S4 001
065	0 092 S30 040	S3 004
075	0 092 S40 040	S4 004
075T	0 092 S40 040	S4 004
075T	0 092 S50 040	S5 004
077	0 092 S30 030	S3 003
078	0 092 S30 060	S3 006
085	0 092 S50 010	S5 001
086	0 092 S40 090	S4 009
093	0 092 S50 010	S5 001
095	0 092 S30 070	S3 007
096	0 092 S30 080	S3 008
096AGM	0 092 S60 080	S6 008
096T	0 092 S40 080	S4 008
100	0 092 S40 070	S4 007
100T	0 092 S30 070	S3 007
100T	0 092 S50 070	S5 007
110	0 092 S40 100	S4 010
110T	0 092 S40 100	S4 010
110T	0 092 S50 100	S5 010
115AGM	0 092 S60 110	S6 011
12N10-3A	0 092 M4F 280	M4 F28
12N10-3A	0 092 M40 280	M4 028
12N10-3A-1	0 092 M4F 280	M4 F28
12N10-3A-1	0 092 M40 280	M4 028
12N10-3A-2	0 092 M4F 280	M4 F28
12N10-3A-2	0 092 M40 280	M4 028
12N10-3B	0 092 M4F 290	M4 F29
12N10-3B	0 092 M40 290	M4 029
12N12A-4A-1	0 092 M4F 300	M4 F30
12N12A-4A-1	0 092 M40 300	M4 030
12N14-3A	0 092 M4F 340	M4 F34
12N14-3A	0 092 M40 340	M4 034
12N24-4	0 092 M4F 510	M4 F51
12N24-4	0 092 M40 510	M4 051
12N5-3B	0 092 M4F 180	M4 F18
12N5-3B	0 092 M40 180	M4 018
12N5.5A-3B	0 092 M4F 200	M4 F20
12N5.5-3B	0 092 M4F 190	M4 F19
12N5.5-3B	0 092 M40 190	M4 019
12N7-3B	0 092 M4F 210	M4 F21

42B	Abmessungen weichen geringfügig von der Erstausrüstertyp ab	ASB	Anschluss beachten	MKS	Kickstarter
44B	Batterie hat Gasableitung rechts statt links, bei Einbau bitte beachten	BAW	Bei Einbau der Alternativtype, Batteriewanne austauschen	SAO	Batterie hat Schaltung 0 statt 1; Bei Einbau bitte beachten
AGM	Für dieses Fahrzeug nur AGM (Absorbent Glass Mat) - Batterie verwenden	BWD	Achtung: Batteriewechsel muss mit Diagnosetester, z.B. KTS Serie, am Steuergerät angemeldet werden	SSJ	Für Fahrzeuge mit Start-Stopp-Funktion
AHB	Achtung: Keine abweichende Kapazität (Ah) zur vorher verwendeten Batterie verbauen. Sonst reicht das Anmelden am Steuergerät nicht aus, sondern es wird ein Flashen des Steuergerätes notwendig	FAD	Ford Pol-Adapter 0 189 999 021 erforderlich	VAD	VW-Bodenleistenadapter Nr. 0 189 999 020 erforderlich
		JEA	Je nach Erstausrüstungs-Bestückung	VE	Vier erforderlich
		KZO	Kalte Zonen	XXX	Lieferung nur solange Vorrat
		KZO	Nicht für kalte Zonen	ZE	Zwei erforderlich
		MEK	Mit Elektrostarter	*	mit Säurepack und Einfüllhilfe (Fresh Pack)

	Pkw		Batterie S3 - S6		Kapazität Batterie
	Pkw / Kleintransporter		Bosch-Batterie T3		EAN Code
	Nkw		Bosch-Batterie T4		Europ. Typnummer
	Nkw / Kleintransporter		Bosch-Batterie T5		Bestellnummer
	Land- oder Baumaschine		Bosch-Batterie M4		Suchnummer
	Motorrad		Bosch-Batterie M6		Größtmaß der Batterie
	Wohnmobil		JIS Japanische Batterie		Circa Gewicht der Batterie unbefüllt
	Caddy		Information / Erläuterung		Batteriegewicht
	Bootsmotor		Sonderfälle		Circa Batteriesäuremenge in kg
	Batterie Reservekapazität		Datum / Einbauzeitraum		Batterien, max. Stückzahl pro Palette
	Prüfstrom bei -18°C		Exportland		
	Bosch-Batterie S3		Batterie-Schaltung		
	Bosch-Batterie S4		Batterie-Endpole		
	Bosch-Batterie S5		Batterie-Bodenbefestigung		
	Bosch-Batterie S6		Kälteprüfstrom Batterie		



42B	Dimensions differ slightly from original equipment type	ASB	Note connection	MEK	With electric starter
44B	When fitting battery, note that gas discharge is on right instead on left	BAW	On installation of alternative type, replace battery tray	MKS	Kick-starter
AGM	Only use AGM (Absorbent Glass Mat) battery for this vehicle	BWD	Attention: Battery replacement must be entered in control unit with diagnostic tester, e.g. KTS Series.	SAO	Battery has circuit 0 instead of 1; note when installing
AHB	Attention: Do not use different battery capacity (Ah) than installed before. Otherwise registration at control unit not sufficient and reprogramming of control unit necessary	FAD	Ford pole adapter 0 189 999 021 required	SSJ	For vehicles with Start-Stop function
		JEA	Depending on original equipment fitted	VAD	VW bottom rail adapter 0 189 999 020 required
		KZO	Cold climates	VE	Four required
		KZO	Not for cold climates	XXX	Available while stocks last
				ZE	Two required
				*	with electrolyte pack and filling aid (Fresh Pack)









































	Passenger cars		Bosch battery T3		European type number
	Passenger cars/Small vans		Bosch battery T4		Part number
	Commercial vehicles		Bosch battery T5		Search number
	Commercial vehicle / small transporter		Bosch battery M4		Maximum battery dimension
	Agricultural machine / construction machine		Bosch battery M6		Approximate weight of empty battery
	Motorcycle		JIS Japanese battery		Battery weight
	Mobile home		Information/Explanations		Approximate electrolyte quantity in kg
	Caddy		Special case		Batteries, max. qty. per pallet
	Marine engine		Date/ Production period		
	Battery reserve capacity		Export market		
	Test current at -18°C		Battery circuit		
	Bosch battery S3		Battery terminal posts		
	Bosch battery S4		Battery bottom attachment		
	Bosch battery S5		Battery low-temperature test current		
	Bosch battery S6		Battery capacity		
	Battery S3 - S6		EAN code		

42B	Les dimensions sont légèrement différentes de celles du type pour équipements de première monte	ASB	Vérifier les connexions	SAO	La batterie a le circuit 0 (au lieu du 1) ; en tenir compte lors du montage
44B	L'évacuation des gaz de la batterie est à droite, pas à gauche, en tenir compte lors du montage	BAW	Pour montage de l'autre type, remplacer le bac de batterie	SSJ	Pour véhicules avec fonction démarrage-arrêt
AGM	Utiliser uniquement une batterie AGM (Absorbent Glass Mat) pour ce véhicule	BWD	Attention: Un changement de batterie doit être signalé sur la centrale de cde avec un testeur de diagnostic, par ex. de la série KTS.	VAD	Adaptateur rebord de fixation VW n° 0 189 999 020 nécessaire
AHB	Attention: Ne pas monter de capacité (Ah) différente de la batterie précédente. Sinon, l'enregistrement dans la centrale de commande ne suffit pas, mais il est nécessaire de flasher la centrale de commande.	FAD	Adaptateur Ford 0 189 999 021 nécessaire	VE	Quatre nécessaires
		JEA	Selon équipement de première monte	XXX	Dans la limite des stocks disponibles
		KZO	Zones froides	ZE	2 nécessaires
		KZO	Pas pour zones froides	*	avec pack acide et outil de remplissage (Fresh Pack)
		MEK	Avec démarreur électrique		
		MKS	Démarreur au pied		

	Voiture particulière		Batterie S3 - S6	Ah	Capacité de la batterie
	Voiture particulière / véhicule utilitaire léger		Batterie Bosch T3	EAN	Code EAN
	Véhicule utilitaire		Batterie Bosch T4	ETN	Numéro de type Europ.
	Véhicule utilitaire / Fourgonnette		Batterie Bosch T5		Référence
	Machine agricole ou machine de travaux publics		Batterie Bosch M4		Code d'identification
	Moto		Batterie Bosch M6		Cote maximale de la batterie
	Camping-car		JIS batterie japonaise		Poids approximatif de la batterie vide
	Caddy		Information / explication		Poids de la batterie
	Moteur pour bateau		Cas spécial		Quantité approximative d'électrolyte en kg
	Batterie capacité de réserve		Date/période de montage		Batteries, nombre max. par palette
	Courant de contrôle à -18°C		Pays d'exportation		
	Batterie Bosch S3	L	Commande de la batterie		
	Batterie Bosch S4	T	Pôles terminaux de la batterie		
	Batterie Bosch S5	B	Fixation au plancher de la batterie		
	Batterie Bosch S6	A (EN)	Courant de contrôle à froid de la batterie		









































42B	Le dimensioni possono essere leggermente diverse rispetto a quelle del tipo fornito nel primo equipaggiamento	ASB	Prestare attenzione alla connessione	MKS	Con avviamento a pedale
44B	Batteria con scarico gas a destra anziché a sinistra; da considerare durante il montaggio	BAW	Se si monta il tipo alternativo, sostituire il vano batteria	SAO	La batteria presenta il comando 0 anziché 1; fare attenzione durante il montaggio
AGM	Per questo veicolo utilizzare solo batteria AGM (Absorbent Glass Mat)	BWD	Attenzione: la sostituzione della batteria deve essere segnalata preliminarmente con il tester di diagnosi, ad es. serie KTS, alla centralina	SSJ	Per veicoli con funzione di avviamento/arresto
AHB	Attenzione: non montare una capacità diversa (Ah) rispetto alla batteria montata in precedenza. In caso contrario non è sufficiente la registrazione nella centralina ma si rende necessaria la programmazione Flash della centralina	FAD	Necessario adattatore poli Ford 0 189 999 021	VAD	Necessario adattatore listello pavimento VW n. 0 189 999 020
		JEA	A seconda della dotazione di primo equipaggiamento	VE	Quattro necessari
		KZO	Per zone fredde	XXX	Consegna solo fino ad esaurimento scorte
		KZO	Non per zone fredde	ZE	Sono necessari due pezzi
		MEK	Con motorino d'avviamento elettrico	*	con pacchetto acido e ausilio di riempimento (Fresh Pack)

	Autovettura		Batteria S3 - S6		Capacità batteria
	Autovettura / furgone		Batteria Bosch T3		Codice EAN
	Veicolo commerciale		Batteria Bosch T4		N. tipo europ.
	Veicoli commerciali / camioncini		Batteria Bosch T5		Numero di ordinazione
	Trattore o macchina per l'edilizia		Batteria Bosch M4		Numero ricerca
	Motociclo		Batteria Bosch M6		Dimensione massima della batteria
	Camper		JIS batteria giapponese		Peso approssimativo della batteria non riempita
	Caddy		Informazione / dichiarazione		Peso batteria
	Motore nautico		Caso specifico		Quantità approssimativa di acido batteria in kg
	Batteria capacità di riserva		Data/Periodo di montaggio		Batterie, max. numero di pezzi per pallet
	Corrente di prova a -18°C		Paese d'esportazione		
	Batteria Bosch S3		Circuito batteria		
	Batteria Bosch S4		Poli terminali batteria		
	Batteria Bosch S5		Fissaggio sul fondo batteria		
	Batteria Bosch S6		Corrente di prova a freddo batteria		

42B	Las dimensiones difieren ligeramente del tipo del primer equipamiento
44B	La batería tiene la salida de gas a la derecha en lugar de a la izquierda, tener en cuenta a la hora de instalar
AGM	Para este vehículo, sólo utilizar batería AGM (Absorbent Glass Mat)
AHB	Atención: No montar una capacidad (Ah) divergente a la batería previamente montada. En caso contrario, no alcanza el registro en la unidad de mando, sino es necesaria una programación flash de la unidad de mando







































ASB	Observar la conexión
BAW	En caso de montaje de los tipos alternativos, cambiar la bandeja de la batería
BWD	Atención: El cambio de batería se debe registrar en la unidad de mando con el comprobador de diagnóstico, p. ej. serie KTS
FAD	Adaptador de polos Ford 0 189 999 021 necesario
JEA	Según equipamiento original
KZO	Para zonas frías
KZO	No para zonas frías
MEK	Con arrancador eléctrico

MKS	Con pedal de arranque
SAO	La batería tiene conmutación 0 en lugar de 1; por favor, prestar atención durante en el montaje
SSJ	Para vehículos con función de arranque/parada
VAD	Adaptador de regleta de piso VW Núm. 0 189 999 020 necesario
VE	Cuatro necesarios
XXX	Suministro mientras duren las reservas
ZE	2 necesarios
*	con ácido y ayuda de llenado (Fresh Pack)









































	Turismo		Batería S3 - S6		Capacidad de la batería
	Turismo / furgoneta		Batería Bosch T3		Código EAN
	Vehículo industrial		Batería Bosch T4		Norma Europea
	Vehículos industriales / de transporte pequeño		Batería Bosch T5		Número de referencia
	Maquinaria agrícola o de construcción		Batería Bosch M4		Referencia comercial
	Motocicletas		Batería Bosch M6		Medida máxima de batería
	autocaravana		JIS batería japonesa		Peso aprox. de la batería vacía
	Caddy		Información / explicación		Peso de la batería
	Motor náutico		Caso especial		Cantidad aprox. de ácido de batería en kg
	Capacidad de reserva de batería		Fecha/periodo de fabricación		Baterías; máx. número de piezas por palet
	Corriente de comprobación a -18°C		País de exportación		
	batería Bosch S3		Conmutación de baterías		
	batería Bosch S4		Polos finales de batería		
	batería Bosch S5		Fijación de piso de batería		
	batería Bosch S6		corriente de ensayo en frío de la batería		



42B	As dimensões diferem ligeiramente dos modelos do fabricante do equipamento original	ASB	Observar a conexão	SAO	A bateria tem circuito 0 em vez de 1; respeitar aquando da montagem
44B	A evacuação dos gases da bateria faz-se pela direita em vez de pela esquerda, atenção ao montar	BAW	Aquando da montagem do modelo alternativo, substituir o alojamento da bateria	SSJ	Para veículos com função de arranque/paragem
AGM	Para este veículo utilizar apenas bateria AGM (Absorbent Glass Mat)	BWD	Atenção: A troca de bateria tem de ser registrada na unidade de comando com o aparelho de teste de diagnose, p. ex. série KTS	VAD	Necessário adaptador VW n.º 0 189 999 020
AHB	Atenção: não instalar uma capacidade diferente (Ah) da bateria utilizada anteriormente. Caso contrário, não bastará fazer o login na unidade de comando, sendo necessário atualizar a unidade de comando por flash	FAD	Necessário adaptador Ford 0 189 999 021	VE	Necessários quatro
		JEA	Consoante equipamento original/equipamento	XXX	Disponível para entrega enquanto existir estoque
		KZO	Regiões frias	ZE	Necessários dois
		KZO	Não adequado para regiões frias		Com pacote de ácido e ajuda para enchimento (Fresh Pack)
		MEK	Com motor de partida elétrico		
		MKS	Pedal de partida		





































	Veículo ligeiro		Bateria S3 - S6		Capacidade bateria
	Veículo ligeiro / Furgão		Bateria Bosch T3		Código EAN
	Veículos pesados		Bateria Bosch T4		Norma europeia
	Veículo utilitário/furgão		Bateria Bosch T5		Número de pedido
	Máquinas agrícolas / de construção		Bateria Bosch M4		Número de consulta
	Motocicleta		Bateria Bosch M6		Dimensões máximas da bateria
	Caravana		Bateria japonesa JIS		Peso aproximado da bateria vazia
	Caddy		Informação / explicação		Peso da bateria
	Motor de barco		Caso especial		Quantidade aproximada de ácido para baterias em kg
	capacidade de reserva da bateria		Data/Período de instalação		Baterias, n.º máx. de unidades por paleta
	Corrente de teste com -18°C		País de exportação		
	Bateria Bosch S3		Circuito de bateria		
	Bateria Bosch S4		Terminais da bateria		
	Bateria Bosch S5		Fixação da base da bateria		
	Bateria Bosch S6		Corrente de teste a frio bateria		

42B	Mitat poikkeavat vähäisessä määrin ensivarustelumallista	ASB	Huomioi liitäntä	MKS	polkukäynnistin
44B	Asennuksen yhteydessä huomattava: akun kaasunpoisto on oikealla (ei vasemmalla)	BAW	Vaihtoehtotyypin asennuksen yhteydessä, vaihda akun alusta	SAO	Akussa on 0-kytkentä kytkennän 1 sijaan: Huomio asennuksen yhteydessä
AGM	Käytä vain AGM-akkaa (Absorbent Glass Mat) tässä ajoneuvossa	BWD	Huomio: Akun vaihto täytyy ilmoittaa ohjainlaitteessa vianmäärittäjätesterillä, esim. KTS-sarjalla	SSJ	Ajoneuvoihin, joissa on Start-/Stop-toiminto
AHB	Huomio: Uuden akun varauskäynnin (kapasiteetti Ah) on oltava sama kuin vanhan. Muutoin se ei riitä ohjainlaitteen ohjelmointiin, vaan ohjainlaitteen muisti on tyhjennettävä (flash-ohjelmointi).	FAD	Ford-napa-adapteri 0 189 999 021 on tarpeen	VAD	VW-lattialistasovitin n:o 0 189 999 020 on tarpeen
		JEA	Ensiasennuksen varustuksesta riippuen	VE	Tarvittava määrä = 4
		KZO	kylmä ilmastovyöhyke	XXX	Toimitetaan niin kauan kuin varastoa riittää
		KZO	Ei kylmiin ilmastovyöhykkeisiin	ZE	Tarvittava määrä: 2
		MEK	varust. sähkötoiminen käynnistin	*	happopakkaus ja täyttöapu (Fresh Pack)

	HA		Akku S3 - S6		Akkukapasiteetti
	HA / pienkuljetusauto		Bosch-akku T3		EAN-koodi
	HYA		Bosch-akku T4		Tyyppinumero Eurooppa
	Hyötyajoneuvo/kevytpakettiauto		Bosch-akku T5		Tilausnumero
	Maatalouskone tai työkone		Bosch-akku M4		Hakunumero
	Moottoripyörä		Bosch-akku M6		Akun suurin koko
	Matkailuauto		JIS Japani -akku		Akun suurinpiirteinen tyhjäpaino
	Caddy		Informaatio / selitys		Akun paino
	Venemoottori		Erytystapaus		Akkuhapon määrä n. kg
	Akun varakapasiteetti		Päiväys/asennusaikaväli		Akut, suurin kappalemäärä/suurpakkaus
	Koestusvirta -18°C lämpötilassa		Vientimaa		
	Bosch-akku S3		Akun kytkentä		
	Bosch-akku S4		Akun päätenapa		
	Bosch-akku S5		Akun pohjakiinnitys		
	Bosch-akku S6		Akun kylmäkäynnistysvirta		



42B	Wymiary różnią się nieznacznie od pierwotnego wyposażenia fabrycznego	ASB	Zwrócić uwagę na przyłącze	SAO	Akumulator ma włączenie 0 zamiast 1; zwrócić uwagę podczas montażu
44B	Akumulator ma odprowadzenie gazu z prawej strony zamiast z lewej; zwrócić uwagę podczas montażu	BAW	W przypadku zamontowania typu alternatywnego, wymienić miskę akumulatora	SSJ	Dla pojazdów z funkcją start/stop
AGM	W tym pojeździe stosować wyłącznie akumulatory AGM (Absorbent Glass Mat)	BWD	Uwaga: Wymiana akumulatora musi zostać zgłoszona przez tester diagnostyczny w sterowniku, np. serii KTS	VAD	Wymagana przejściówka listwy podłogowej VW nr 0 189 999 020
AHB	Uwaga: Nie montować akumulatora o pojemności (Ah) innej niż akumulatora stosowanego poprzednio. W takim wypadku nie wystarczy zalogowanie do sterownika, lecz będzie konieczna edycja flasha sterownika.	FAD	Wymagana przejściówka Ford 0 189 999 021	VE	Konieczne cztery
		JEA	Zależnie od pierwszego wyposażenia	XXX	Dostawa tylko do wyczerpania zapasu
		KZO	Zimne strefy	ZE	Konieczne dwa * z kwasem i przyrządem do napełniania (Fresh Pack)
		KZO	Nie do zimnych stref klimatycznych		
		MEK	Z elektrozrusznikiem		
		MKS	Rozrusznik nożny		

	Samochody osobowe		Akumulator S3 - S6		Pojemność akumulatora
	Sam. osobowy / mała furgonetka		Akumulator Bosch T3		Kod EAN
	Samochody użytkowe		Akumulator Bosch T4		Kod EAN
	Pojazd użytkowy / mała furgonetka		Akumulator Bosch T5		Nr katalogowy
	Maszyny rolnicze / budowlane		Akumulator Bosch M4		Nr referencyjny
	Motocykle		Akumulator Bosch M6		Największy rozmiar akumulatora
	Pojazd mieszkalny		JIS akumulator japoński		Przybliżony ciężar pustego akumulatora
	Caddy		Informacja / objaśnienie		Ciężar akumulatora
	Silniki do łodzi		Informacje dodatkowe		Przybliżona ilość kwasu w akumulatorze w kg
	Pojemność rezerwowa akumulatora		Data produkcji		Akumulatory, maks. ilość na palecie
	Prąd próbny przy -18°C		Kraj eksportu		
	Akumulator Bosch S3		Obwód akumulatora		
	Akumulator Bosch S4		Bieguny akumulatora		
	Akumulator Bosch S5		Mocowanie akumulatora		
	Akumulator Bosch S6		Prąd kontroli akumulatora na zimno		

42B	Rozměry se nepatrně liší od typu použitého v originální výbavě
44B	Akumulátor má odvod plynů vpravo namísto vlevo, dejte pozor při montáži
AGM	Pro toto vozidlo používejte pouze akumulátor AGM (Absorbent Glass Mat)
AHB	Pozor: Nemontujte odlišnou kapacitu (Ah) vzhledem k předtím použitému akumulátoru. Jinak nebude stačit přihlášení u řídicí jednotky, ale bude nutná inicializace paměti flash řídicí jednotky.

ASB	Dbejte na přípojku
BAW	Při zabudování alternativního typu vyměňte vanu akumulátoru
BWD	Pozor: Výměna akumulátoru musí být pomocí diagnostického testeru, např. řady KTS, ohlášena řídicí jednotce
FAD	Je nezbytný pól. adaptér Ford 0 189 999 021
JEA	Podle originální výbavy vozidla
KZO	Chladné oblasti
KZO	Ne pro chladné oblasti
MEK	S elektrickým spouštěčem

MKS	Nožní startér
SAO	Akumulátor má zapojení 0 místo 1. Dejte pozor při montáži
SSJ	Pro vozidla s funkcí Start-Stop
VAD	Je nezbytný adaptér pro podlah. lištu č. 0 189 999 020
VE	Jsou nutné čtyři
XXX	Dodávky jen v rámci zásob
ZE	Jsou nutné dva * s balením kyseliny a plnicí pomůckou (Fresh Pack)

	Osobní vozidlo
	Osobní vozidlo/malá dodávka
	Užitkové vozidlo
	Užitk. vozy / malé dodávky
	Zemědělský nebo stavební stroj
	Motocykl
	Obytné vozidlo
	Caddy
	Lodní motor
	Akumulátor, rezervní kapacita
	Zkušební proud při -18 °C
	Akumulátor Bosch S3
	Akumulátor Bosch S4
	Akumulátor Bosch S5
	Akumulátor Bosch S6

	Akumulátor S3 - S6
	Akumulátor Bosch T3
	Akumulátor Bosch T4
	Akumulátor Bosch T5
	Akumulátor Bosch M4
	Akumulátor Bosch M6
	Jap. akum. JIS
	Informace/vysvětlení
	Zvláštní případ
	Datum/období montáže
	Vyvázející země
	Zapojení akumulátoru
	Koncové póly akumulátoru
	Uchycení akumulátoru k podložce
	Proud zk. chlad. akum.

	Kapacita akum.
	Kód EAN
	Evrop. typ. číslo
	Objednací číslo
	Vyhledávací číslo
	Horní mez. rozměr akumulátoru
	Přibližná hmotnost prázdného akumulátoru
	Hmotn. akum.
	Přibližné množství kyseliny v akumulátoru v kg
	Akumul., max. počet ks v paletě







42B	Размеры незначительно отклоняются от типа завода-изготовителя
44B	Аккумуляторная батарея имеет газоотвод справа, а не слева, учитывать при установке
AGM	Для этого автомоб.используется только аккумулял.AGM (Absorbent Glass Mat)
AHB	Внимание: Не устанавливать аккумулятор другой емкости (Ач) по сравнению с используемым до этого аккумулятором. В противном случае недостаточно регистрации в блоке управления, а требуется "прошивка" блока управления.

ASB	обратить внимание на соединение
BAW	При монтаже альтернативного типа заменить поддон аккумуляторной батареи
BWD	Внимание: замена аккумулятора должна быть зарегистрирована в блоке управления с помощью диагностического тестера, например, серии KTS.
FAD	Необходим адаптер Ford 0 189 999 021
JEA	В зависимости от первичной комплектации
KZO	Холодные зоны
KZO	Не для холодных зон
MEK	С электростартером

MKS	педальный пусковой механизм
SAO	Аккумуляторная батарея имеет соединение 0 вместо 1; пожалуйста, соблюдать при монтаже.
SSJ	Для автомобилей с функцией пуск-останов
VAD	Необходим адаптер отбортовки VW Nr. 0 189 999 020
VE	необходимо четыре
XXX	Поставка, пока есть на складе
ZE	необходимо два
*	с кислотами и помощью в заправке (Fresh Pack)

	Легковой автомобиль
	Легковой автомобиль / малый автомобиль-фургон
	Грузовой автомобиль
	Грузовик/автомобиль-фургон
	Сельскохозяйственная или строительная машина
	Мотоцикл
	Жилой автомобиль
	Caddy
	Лодочный мотор
	Резервная емкость аккумулятора
	Испытательный ток при -18°C
	Аккумулял. Bosch S3
	Аккумулял. Bosch S4
	Аккумулял. Bosch S5
	Аккумулял. Bosch S6

	Аккумулятор S3 - S6
	Аккумулятор Bosch T3
	Аккумулятор Bosch T4
	Аккумулятор Bosch T5
	Аккумулятор Bosch M4
	Аккумулятор Bosch M6
	Японский аккумулятор, стандарт JIS
	Информация / Пояснение
	Особый случай
	Дата / Период сборки
	Страна-экспортер
	Подключение аккумуляторов
	Полюсные выводы аккумуляторов
	Крепление аккумуляторов
	Испытательный ток аккумулятора на морозе

	Ёмкость аккумулятора
	EAN-код
	Европейский типовой номер
	Номер для заказа
	Поисковый номер
	Максим.размер аккумулятора
	Прибл.вес аккумулятора не заполнен
	Вес аккумулятора
	Прибл.количество электролита, кг
	Аккумуляторы, макс.кол-во в контейнере

