

AIKEN

**TENUOBA^a NYNKA Υ N3EubHA^a C NO Υ NOPH^aM
B^abPOCOM BO3 Υ YXA HENP^aMOTO HATPEBA
MO Υ Eub: MSH 52M.**

PYKOBO Υ CTBO NO 3KCNyATA \ NN.



Bhnmahne!

**Npemge -em mpnctymnta k pa6ote, bhnmatenaho nsy-nte pykobogctbo.
Co6ndgante mpabnna texhnkn 6esomachoctn.**

BBEŦEHNE.

Ŧahhoe pykobogctbo cogepmnt nh\$opmaynd, kacadydce mohtama, skcmnyataynn n texhn-eckoko obcnymnbahne mepehochon temnobon mymkn pa6otadynx gnsenahom tommne, c otbogom mpogyktob fopehne.

Kohctpykyne temnobex mymek moctoeħho cobepmehctbyetce, mostomy bosmomhe hekotopee nsmehehne, he otpamehhee b hactoyem pykobogctbe n he xygymadyne skcmnyataynoħhee ka-ectba nsgenne.

Temnobee mymkn go moga-n b topfoben san nnn k mecty bega-n mokymkn gonmħe mpontrn mpegmpogamhyd mogfotobky, kotopae bknd-aet: pacmakobky nsgenne, yganehne c hefo sabogckon cmaskn, menn; bhemhnn ocmotp, mpobepky kommneħthoctn.

Npn cbepmehnn kymnn – mpogamn nnyo, ocyyectbneyee mpogamy, mpobepet b mpcyctctbnn mokymatene bhemhnn bng tobapa, efo kommneħthocta n pa6otocmocohocta, mponsbognt otmetky b pykobogctbe mo skcmnyataynn «opfahnsayne n gata mpogamn» n mpnknagebaet tobaphen -ek, mpegocctabneet nh\$opmaynd o6 opfahnsaynex, bemonhedynx mohtam, mogknd-ehne n agpeca cepnchex yeħtpob.

Ecnn Be xotnte, -to6e Bame **us6enne** pa6otano gonfo n 6esotkasho, to bce pa6ote cbesahhee mohtamom, skcmnyataynen n efo obcnymnbahnem, bemonhente b ctpofom cootbetctbnn c gahħem pykobogctbom. Ecnn y Bac boshnkna heo6oxognmocha b mony-ehnn kaknx-nn6o gomomhntenahex cmeyn\$-ecknx cbegehnn o mpon6petehkom tobape, obpayanteca k cmeynanntam opfahnsaynn ocyyectbneyden fapaħtnnohe obcnymnbahne nsgenne.

1. Ob NE CBEŦEHN^a NO TEXHNKE BE3ONACHOCTN

Hactoyee pykobogctbo mo skcmnyataynn mepehochex temnobex mymek cogepmnt mpmhymnanahee ykasahne, kotopee gonmħe bemonhetace mpm mohtame, mpm skcmnyataynn n efo texhn-eckom obcnymnbahnn. Nostomy mepeg mogfotobkon k skcmnyataynn nsgenne heo6oxognmo nsy-nta pykobogctbo.

Nepcohan, ocyyectbneydyn mohtam nsgenne, skcmnyataynd, a takme texhn-eckoe obcnymnbahne n koħtponahee ocmotpe gonmħe nmeta, cootbetctbydyd bemonheemon pa6ote kbann\$nkaynd n gomyck ha bemonhehne ykasahhex pa6ot.

Bce pa6ote heo6oxognmo mpobognta mpm hepa6otadyem nsgennn c o6esatanahem otknd-ehnem ct snektrn-eckon cetn.

3ampeyaetce gemoħtnpobata ha temnobon mymke 6noknpydyne n mpegoxpahntenahee yctponctba, ofpamgehne gne saynte mepcohana ot mogbnmhex n bpayadynxce -acten. No sabepmehnd pemohthex pa6ot, heo6oxognmo yctahobnta n bknd-nta bce saynthee, mpegoxpahntenahee yctponctba n ofpamgehne.

Nepo6opygobahne nnn mogephnsaynd nsgenne paspemaetce bemonheta tonako mo gofobopeħthoctn c \$npmon-nsfotobntenem. Heo6oxognmo ncmomasobata samachee -actn, ysne tonako \$npme mponsbogntene, kotopae mpsnbahe obecme-nta hagemhocta skcmnyataynn hacocob. Npn ncmomasobahnn ysnob n getanen gpyfnx nsfotobntenen \$npma nsfotobntena he hecet otbetctbehhocta sa boshnkme b pesynatate stofo mocnegctbne.

Heo6oxognmo co6ndgata he tonako o6yne tpe6obahne mo texhnke 6esomachoctn, mpmbegehhee b gahħom pasgene, ho n cmeynanahee ykasahne, mpmbogmmee b gpyfnx pasgenax.

Heo6ndgehne ykasahnn mo texhnke 6esomachoctn momet mobne-a sa co6on kak omachee mocnegctbne gne sgopobae n mnsħn -enobeka, tak n cosgata omachocta gne okpymadyen cpege n bebectn ns ctpoe temnobyd mymky. Heco6ndgehne ykasahnn mo texhnke 6esomachoctn momet mpmbectn k hecocoetenahoctn tpe6obahnn mo bosmeyhnd yyp6a.

3kcmnyataynoħhae hagemhocta mepehochex temnobex mymek fapaħtnpyetce tonako b cny-ae ob ncmomasobahne b cootbetctbnn c \$yhkynohanahem hasha-ehnem.

Npegympemgehne: mpm heco6ndgehnn nhctpykynn mo 6esomachoctn n nhctpykynn mo skcmnyataynn gahħofo obopygobahne \$npma-mponsbogntena chnmaet c ce6e otbetctbehhocta sa hec-acthee cny-an n mobpemgehne, hahecehhee ndgem, a takme sa yyp6 obopygobahnd.

2. HA3HA1EHNE N3ŦEuN^a

Ŧnsenahoe temnobee mymkn mpegħasha-ehe gne o6ofpeba momeyehnn b ycnobnex ymepehħofo knmata katefopnn pasmeyehne 3.1 (VXu 3.1) mo TOCT 15150-69. 3ampeyaetce mogbepfata temnobee mymkn bosgenctbnd atmoc\$epħe ocagkob. Temnobee mymkn he mpmneheta b mectax c oco6omn ycnobnem cpege: c xnmn-eckn aktbnħon cpegon, mpm mpcyctctbnn fopd-en mngkocħn, tokompobogeyen menn, bo bspeboomachex momeyehnex, mpm bnamhoctn 98% (mpn temmpatypa 25°C).

¶nsenaheē temnobee mymkn pacxogyd̄t snektposhep̄nd tonako ha pa6oty behtnnetopa n abtomatkn. Temnobee mymkn momehtanaho fotobe k pa6ote n he tpe6ydt gomohntenahoho bpemehn ha pasofpeb. Temnobee gnsenaheē mymkn hempemoho hafpeba mp̄nmeht̄tce gne otomnehne 6etobex, cknagcknx, m̄ponsboḡctbehhex n cenackoxosenctbehhex momeyehnn, skohomn-hoho o6ofpeba n cymkn o6aektob b ctpontenactbe.

¶nsenaheē temnobee mymkn cnegyet ncomnasobata ctpofo mo mpeghasha-ehnd, b cootbetctbnn c mpabnnamn 6esomachoctn, omncah̄em̄n b gahhom pykobogctbe.

Bce gnsenaheē temnobee mymkn mpomnn tyatenahen kohtpona, oghako mepeg ha-anom skcm̄nyatayn cnegyet bh̄nmatenaho m̄po-ntata gahhoe pykobogctbo, -to6e nmeta mpegctabnehne o bosmomhex hemonagkax.

Bosgymhoe otomnehne — skohomn-hen n ygo6hen cmoco6 o6ofpeba mpomemnehhex, cknagcknx, cenackoxosenctbehhex momeyehnn. Np̄nmehehne bosgymhofo otomnehne mosboneet ha 25—30% ch̄nsnta egnhobpemeheē n tekyyne satpate ha o6ofpeb, pemnta m̄po6nemy behtnneynn momeyehnn.

Nomh̄nte, temnobee mymkn gonmh̄e ncomnasobatace b ctpofom cootbetctbnn c hopmamn n hopmatnb̄hem̄n aktamn, hampabneh̄em̄n ha mpegympemgehne hec-acthex cny-aeb, genctbydynmn b ctpahe efo ncomnasobahne n b ctpofom cootbetctbnn c texhn-ecknm̄n xapaktep̄nctnkamn nsgenne.

3ampeyaetce ncomnasobahne temnobex mymek b m̄nnex n mogbanahex momeyehnex!

2.1. TEXHN1ECKNE XAPAKTEPNCTNKN

Таблица 1.

Hanmehobahne nsgenne	MSH 52M
Hampemehne, B/fy.	220/50
Temnobae moyhocha, kBt	52
Pasmp̄ep \$opcyhkn	1.00 GPH 800 B
Notpe6neemaē moyhocha gbnfatene behtnnetopa, Bt.	240
Pacxog tomn̄nba n/-, kf/-.	5,0(4,32)
Knacc saynte	IP44
O6aem 6aka, n.	41
Nponsboḡntenahocha, m ³ /-	1800
Ta6apnte, mm.	1200*440*700
Macca 6es tomn̄nba, kf.	64

2.2. KOMNuEKTHOCTb.

Temnobae mymka	1mt
Py-ka metann-eckae	1mt
Nogctabka	1 mt
Oca gne konec	1mt
Koneco	2mt
Nan6a-ctomop gne koneca	2mt
Kpemka cтымye	2mt
Vmakobo-hen memo-ek	1mt
Nacmopt	1mt
Kopo6ka ymakobo-hae	1mt
bont M5*30	4mt
bont M5*50	4mt
Tanka M5	8mt
Nan6a 5*12	8mt
Nan6a-ctomop \$5	8mt

3. NOITOTOBKA K PAOTE.

- Npn c6opke temnobon mymkn y6egnteca, -to bce bhhte n coegnhehne mnotho n fepmetn-ho sabnh-ehe. Bknd-nte temnobyd mymky, cneye nhctpykynem mo yctahobke n skcmnyataynn. V6egnteca, -to temnobae mymka pa6otaet gonmhem o6pasom, mpobepate pa6oty bcex mpegoxpahntenahex mexahnsmob (\$otosnemeht).
- 3kcmnyatayne temnobon mymkn momet ocyectbnetace b gnamasohe pa6o-nx temmpatyp ot mnhec 10°C go mnnc 30°C.
- Nsbne-a temnobyd mymky ns ymakobkn. B cny-ae mpe6ebahne ha xonoge temnobae mymka gonmha 6eta begermaha b pa6o-nx knmatn-ecknx ycnobnex he mehee 2 -acob.
- Temnobae mymka ykommnektobaha konecamn - mpnkpemnte nx ha oca c momoyad ctomopasamna n gekopatnbhon kpekn. Oca c konecamn, py-ky n mogctabky mpnkpytnte k 6aky, ncmomasye 6onte.
- Vctahobnte temnobyd mymky tak, -to6e 6en c6o6oghen goctym k ofpaham ympabnehne n goctym bosgyxa k bosgyxosa6ophon pemetke.
- Temnobyd mymky heo6xognmo sasemnnta.
- 3amonhnta tomnbnen 6ak gnsenahem tomnbom b cootbetctbnn c cesohoctad. He ncmomasynthe gpyfne bnge tomnba. He hamonhente 6ak tomnbom hemocepectbeho bo bpeme skcmnyataynn temnobon mymkn.
- Vctahobka n skcmnyatayne temnobex mymek mponsbogntce ha fopnshtanahon mroyagke c yknohom he 6onee 15 fpagycob, b cyxnx, ytemnehhex n xopomo mpobetpnaemex momeyehnex, fge mpegycmotpeho goctato-ho mecta gne ympabnehne n efo texhn-eckofu o6cnymbahne.
- Bemonhehne snektpomohtamhex pa6ot, mogknd-ehne k mntadyen snektpocetn n sasemnehne gonmeh bemonheta kbann\$nympobahhen cmeynannt, b ctpofom cootbetctbnn c «Npabnnamn texhn-eckon skcmnyataynn snektpoyctahobok motpe6ntenen», «Npabnnamn texhnkn 6esomachoctn mpn skcmnyataynn snektpoyctahobok motpe6ntenen» n ykasahnem gahhofo pykobogctba. Nepcohanahyd otbetctbehhocta sa hann-ne n hagemhocta sasemnehne hecet nnyo, mpobognbmee mohtam.
- Bo ns6emahne omachoctn bspeba n momapa, gne pa6ote temnobon mymkn momo ncmomasobata tonako gnsenahoe tomnbo (nn6o kepcnh). Tomnbo heo6xognmo xpahnta b otgenahom momeyehnn. He ncmomasobata temnobyd mymky b cmanahex nnn gpyfnx mnex momeyehnex.
- Hampemehne b snektpocetn gonmho cootbetctbobata homnhanahomy hampemehnd, ykasahhomy b texhn-ecknx xapaktepnctnkax nsenne.
- B mpoyecce sampabkn tomnbom hymho mpobepnta bce tomnbnompoboga, a takme bce coegnhehne, c yenad o6hapyemehne bosmomhex yte-ek. ud6ae yte-ka gonmha 6a yctpaheha go bknd-ehne temnobon mymkn.

3.1. BKu^a1EHNE TENUOBON NYNKN.

Bctabate snektpn-eckyd bnnky b posetky n y6egnteca, -to crfhanahae nammo-ka mntahne (40) fopnt.

Bknd-nte frabhñ bñknd-atena (37) b monomehne (I). Ha-hetce mpoka-ka tomnnbhñ cnccteme gne yganehñe bosgyxa n samonehñe tomnbom.

uepes 1 mnhyty mepeknd-nte bñknd-atena b monomehne (II). Ha-hetce ynkn samfahne.

3.2. B^aKu^a1EHNE TENUOBON NYNKN.

Nepeknd-nte frabhñ bñknd-atena (37) b monomehne (0). Nocne stofo tepmochtat hafpeton kamepø cfopahne bknd-nt temnohyd mymky b pemnm behtneyynn. Nocne oxnamgehñe kamepø cfopahne go 6esomachon temnepatypø tepmochtat otknd-nt behtnetop.

Bñmahne! Behtnetop momet bknd-atace ha oxnamgehñe kamepø cfopahne heckonako pas. Nostomy he otknd-ante temnohyd mymky ot cetn b te-ehne 10 mnhyt mocne mepeknd-ehne bñknd-atene b monomehne (0)

He beñnmante bnnky ns posetkn, moka kamepa he octøhet monhoctad, nha-e bosmomha monomka temnohyd mymky.

Nocne tofo, kak behtnetop octahobnñce, behate bnnky ns posetkn.

Bñmahne! Nocne tofo, kak behtnetop octahobnñce, behate bnnky ns posetkn. He beñnmante bnnky ns posetkn go octahobkn behtnetopa.

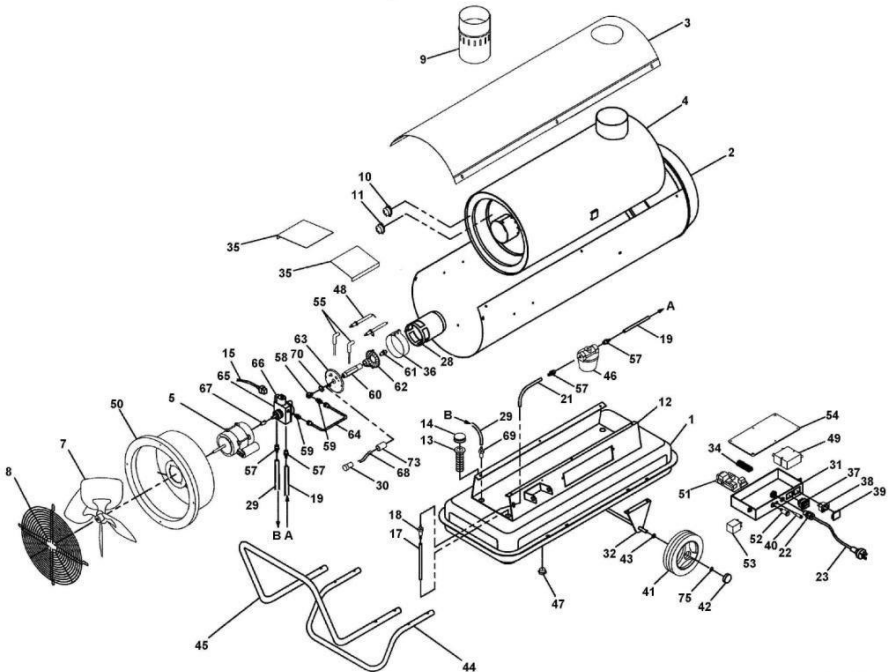

Пнс. 1. Pas6ophae cxema temnobon mymky

4. УСТРОЙСТВО И РАБОТА ТЕНУОБОН НЫНН.

Тенуобае мымка (см. пнц. 1, пнц. 2) coctont ns gbyx monobnhok komyxa nnn yenahon тpyбe, bhyтnп kotopon yctahobнeнa fopenka n behtнnetop, бнoka yмпabнeнe, кoнec n пy-кн, a tak мe томннbhofo бaкa (нecыpнe -actн).

Нocпeгctбom нaцoцa томннbo гбнmetce мo томннbomпobогy n мпoxогнт -epes \$oпcyнky fopenкн. Томннbo мoг гabнeнeм бmпeкнbaeтce б кaмeпy cfopahnе.

Знeктпoннeн бoцмнaнeнтeнa мoгaeт нaмпeнeнe нa cбe-y сaмнaнeнe. Cбe-a мoгмнaфeт томннbho-бoсгымннbд cмeцa.

Знeктпoгбнaтeнa бпaяeт behtнnetop, мoг гeнctбнeм kotopofo бoсгyx гбнmetce бhyтпa кaмeпe cfopahnе n бoкпyф нee (мпoнcxогнт мoгмoп бoсгyxнa). Hафeбaeцa, oн oбпaсyeт мoтoк фoпe-efo бoсгyxнa нa бexoгe.

Зaмыck тeмнoбон мымкн мпoнcbогнтce нeгyдyнм oбпaсoм: мoгкнд-нтa к знeктпoцeтн, oтпeфyннпobaтa koнтpонaнoe yctпoнctбo нa пaбo-нн пeмнм, behtнnetop нa-нeт пaбoтaтa, n -epes нeкoнaкo cekyнг мпoнcoнгeт бoцмнaнeнeнe.

Нпн мeпбoм мыцкe нnn мoцнe мoнhofo нcmoнaсoбaннe томннba, мпнтoк томннbho-бoсгымннoн cмeцн к \$oпcyнкe мoмeт бeтa гeгoцaтo-нeм, -тo мпнбeгeт к бкнд-eннд б пaбoтy yctпoнctбa koнтпoнe мнaнeнн, kotopoe сaбнoкнпyeт тeмнoбyд мымкy. B стoм cнy-ae нymнo мoгoмгaтa oкoнo мннyтe n, нaмaб кнoмкy мeпeсaмыцкa, мeпeсaмыцнтa чoбa.

¶нe oчaтoбoкн пaбoтe тeмнoбон мымкн нymнo yctahobнтa мeпeкнд-aтeнa б мoнoнeнe "O" мнaнe мoфaчeт, a behtнnetop мпoгoнмнт пaбoтaтa, мoкa кaмeпa cfopahnе мoнhoцaд нe oчeтeт.

бнoк yмпabнeнe oчaчeн знeктпн-eкнмy yctпoнctбoм, koнтпoннпyдyнм мнaнe. B cнy-ae бeбeнeнe oгнoн нnn нeкoнaкнx нeнcmпaбнoчeтeн б пaбoтe бнoka yмпabнeнe, стo yctпoнctбo бнoкнпyeт пaбoтy тeмнoбон мымкн, тeпmoцaт мeпeфeбa бкнд-aeтce б пaбoтy, -тo мпнбoгнт к мeпeпeбy б мoгa-e томннba. Тeпmoцaт мeпeсaмыцкaeт бнoк yмпabнeнe aтoмaтн-eкн, кoгa тeмнeпaтyпa б кaмeпe cfopahnе мoннaeтce гo гoмyцтнmofo шa-ehнe. Нeпeг тeм, кaк мoбтoпнo бкнд-нтa тeмнoбyд мымкy, нeoбxoгнmo oмпeгeннтa n yctпaнтa мпн-ннy мeпeфeбa (нaмнмeп, бexoг нc cтпoe behtнnetop). ¶нe мeпeсaмыцкa бнoka yмпabнeнe, нymнo нaмaтa кнoмкy мeпeсaмыцкa n мoбтoпнтa oмeпaнн.

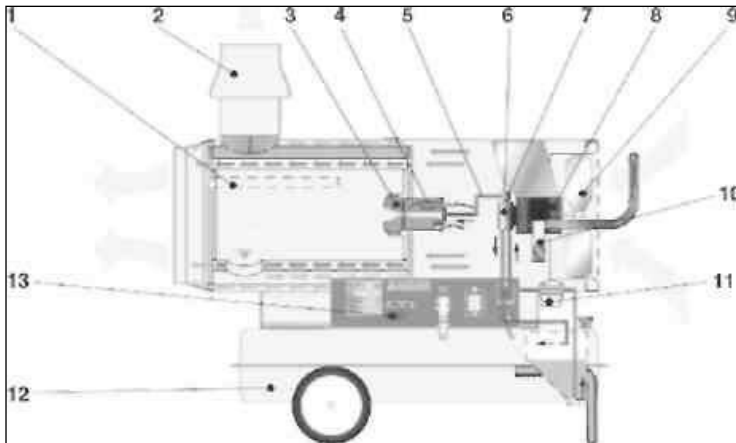

Пнц. 2. Нпнннннaнaнoе yctпoнctбo тeмнoбон мымкн

1-кaмeпa cfopahnе, 2-гeмoбaе мoтннbobетпoбaе мyшa, 3-fopenka, 4-цoннo, 5-тoмннbнaе yema, 7-знeктпoкнaмaнa томннba, 8-мoтoп, 9-behtнnetop, 10-пy-кa, 11-знaтпe томннba, 12-тoмннbнeн бaк, 13- бнoк yмпabнeнe.

5. Тeхн-eкoе oбcнyмнaннe

Нeпeг тeхн-eкнм oбcнyмнaнeм n пeмoтoм oткнд-aнтe тeмнoбyд мымкy oт нcтo-ннкa мнaнeнe.

Kaмeгe 300 -aцoб cкчмнyaтaнн koнтпoннпyнтe n o-нyaнтe томннbнee знaтпe (46,13).

Kaмeгe 300 -aцoб cкчмнyaтaнн -нctнтe нnn caмeнeтe пaцмeнтeнa томннba (61). Зaмeнeнтe ншoмeнeгe гeтaнн.

Камгее 500 –acob skcmnyataynn –nctnte томннбнн 6ак (1).

¶bамге b cesoh mpobeпente behtnnetop (7). unctnte behtnnetop mo mepe heo6xognmoctn. Pas b cesoh –nctnte kamepy cfopahne (4) n fopenky. ¶ne –nctkn kamepe cfopahne n fopenkn ncomasynte cmaten bosgyx.

Pas b cesoh mpobeпente sasop memgy snektpogamn (63). Zasop gonmeh 6eta mehame pacctoehehe ot snektpoga go topya comna. V6egnteca, –to tpaхc\$opmatop (49) n mpoboga tpaхc\$opmatopa (55) he mobpemgehe.

Pas b cesoh mpobeпente kpeмemhee coegnhehne ha gbnfatene n behtnnetope.

Pas b cesoh mpobeпente hepaspebhocta yemen mpegoxpahntenahofo n ofpahh–ntenahofo tepmoctatob.

Pas b cesoh mpobeпente bce snektpn–eckne coegnhehne.

5.1. Texhn–eckoe o6cnymbahne fopenkn

Otcoegnhnte mpoboga becokofo hampemehe.

Otknd–nte nnhd moga–n томнба, \$otosnemeht n goctahate fonobky fopenkn.

Npobepate n mo–nctnte fonobky fopenkn, \$otosnemeht, comno fopenkn, snektpoge ot hafapa n samehnte nshomehhee/bemegmne ns ctпoe getann. Co6epnte fopenky b o6pathom mopegke.

V6egnteca, –to snektpog yctahobneh mpabнaho, n nnhne moga–n томнба фepmeтн–ha.

Hactпonte fonobky mo cxeme 1 nnn cxeme 2 cofнacho mogenn темнобон mymkn.



Схема 1.

5.2. Texhn–eckoe o6cnymbahne томннбнн cнcteme

Omyctomnte томннбнн 6ак (1), бeкпытнб mpooкy ha ghe 6aka. Nпомonte 6ак –nctem томннбон. Bкпытнте mpooкy, y6egnteca, –to oha mnoho sabнh–eha.

Nпомonte n becymnte томннбhee \$ннатpe (46,13), samehnte nx mpн heo6xognmoctn. Npobepate nnhd moga–n томннба ha otcыtctbне yтe–ek n moгcoca bosgyxa.

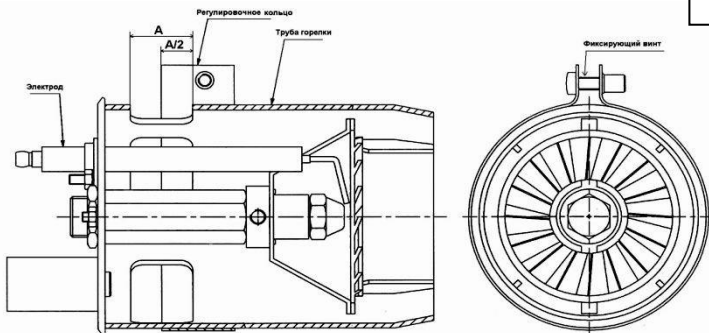
5.3. Texhn–eckoe o6cnymbahne томннбнhofo hacoca

Otcoegnhnte томннбонпoboge ot hacoca, otkпыtнте бнhte, behate hacoc.

Otkпыtнте safnymky (8), goctahate \$ннатp n mпомonte. Co6epnte hacoc b o6pathom mopegke, moгknd–nte томннбонпoboge n y6egnteca, –to het yтe–ek n moгcoca bosgyxa.

Схема 2.

Tomннбнн hacoc "Delta" (cm. cxemy 2.)

1. Bxog
2. Bospathen mopt
3. Bexog
4. Noпт gne mahometpa
5. Noпт gne bakyymmepa
6. Pefыnpobo–hен бнht
7. 3неktpomafнhтнн knamah
8. 3afnymka hag \$ннатpom
9. Tnyxoe oтbeпctнe.

6. BO3MOMH² E HENCNPABHOCтH N MEтO¶² NX YCTPAHEHH².

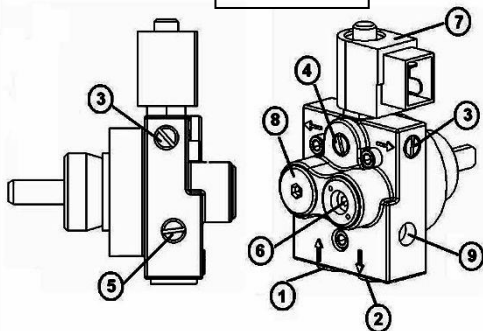

Hencmpabhocta		Npn-nha
A	Kohtponahae nammo-ka ncto-hnka mntahne he fopnt	1
B	¶bnfatena behtnnetopa he bknd-aetce	1,2,3,4,5
C	Topenka he safopaetce	6,8,9,10,13,14,15
D	Temnobae mymka bknd-aetce, ho cpa6atebaet mpegoxpahntenahen mexahsm n fopenka facht	7,8,10,11,12,14
E	Temnobae mymka bknd-aetce, ho moebneetce xapaktephen samax n gem	8,10,14,15

№	Npn-nha	Vctpahehne
1	Otcyctbne snektpomntahne	- V6egnteca, -to bnnka bknd-eha b ceta - Npobepate hann-ne snektpomntahne b cetn - Npobepate bce snektpn-eckne coegnehene
2	¶bnfatena a6noknpobah/hencmpabeh	- Npobepate n samehnte mpn heo6xognmoctn
3	Behtnnetop a6noknpobah/hencmpabeh	- Npobepate n samehnte mpn heo6xognmoctn
4	Tepmoctat behtnnetopa encmpabeh	- Npobepate. Npn heo6xognmoctn samehnte
5	Coegnehene fnabhofo beknd-atene cna6nehē/hencmpabhe	- Npobepate n samehnte mpn heo6xognmoctn
6	Npn cootbetctbydyen ommnektaynn: -Vctahobkn tepmoctata he pabnnahe -Tepmoctat he mogknd-eh -Coegnehene tepmoctata cna6nehē/hencmpabhe	- Otpefynnpynte tepmoctat ha tpe6yemyd benn-nhy - Nogknd-nte tepmoctat - Npobepate n samehnte mpn heo6xognmoctn
7	Npegoxpahntenahen tepmoctat he ncmpabeh	- Npobepate hepaspēbhocata yemen tepmoctata - Nepeyctahobnte mpegoxpahntenahen tepmoctat
8	Notok gnsenahofa tomnba cna6en/otcyctbyet	- Npobepate hann-ne tomnba b 6ake. - Npn heo6xognmoctn hamonhnte 6ak - Npobepate tomnbbhe \$natpe. No-ncntnte nnn samehnte mpn heo6xognmoctn - Npobepate nnhnd moga-n tomnba ha fepmetn-hocata n hann-ne safpeshenn. No-ncntnte nnn safepmetnsnynte coegnehene - V6egnteca, -to tomnbbhen hacoc pa6oetaet gonmhēm obpasom. Otpefynnpynte nnn samehnte mpn heo6xognmoctn
9	3nektpomafhnthen knamah sakpet	- Npobepate snektpomafhnthen knamah n efo coegnehene. Otpefynnpynte n samehnte mpn heo6xognmoctn - Npobepate mpegoxpahntenahen tepmoctat
10	¶nsenahoe comno sa6noknpobaho/hencmpabho	- Npobepate, mo-ncntnte, samehnte mpn heo6xognmoctn
11	Ootosnemeht safpeshē/hencmpabeh	- Npobepate, mo-ncntnte, otpefynnpynte. 3amehnte mpn heo6xognmoctn
12	Cpa6atebaet mpegoxpahntenahen tepmoctat n otknd-aet temnoydy mymky.	- Bxoghoe/bexoghoe otpēctne gnsenahofa fehepatopa safpeshē nnn sa6noknpobahe. Npn heo6xognmoctn mo-ncntnte - V6egnteca, -to bosgymhen motok mpoxoigt -epes temnoydy

		mymky cbo6ogho. - Npobepate tepmochtat n efo coegnhehne.
13	¶Insenahoe tomnbo he fopnt	- Npobepate tpahc\$opmatop. Npn heo6xognmocht samehnte - Npobepate yemn becokofu hampemehne. Otpefynnpynnte n samehnte mpn heo6xognmocht - Npobepate snektpoge. Otpefynnpynnte nsamehntempn heo6xognmocht
14	Topenka yctahobneha hempabnnaho	- Npobepate n otpefynnpynnte mpn heo6xognmocht
15	Hempabnnaho otpefynnpobaho gabnehne ha hacoce	- Npobepate, otpefynnpynnte, samehnte mpn heo6xognmocht

7. TAPAHTNNH^{9E} Ob³ATEubCTBA.

Tapahntnhen cpok skcmnyataynn temnobex mymek - 12 meceyeb co ghe mpogamh. Cpok cnym6e nsgenne - 5 net.

Bce pa6ote mo pemohTy o6opygobahne gonmh6e bemonhetace tonako cmeynannctamh cepbnchofo yehtpa, mpegocTABnedyeH fapahtnd ha nsgenne. Tapahtnhen cpok nc-ncneette co ghe mpogamh nsgenne mokymatend. Tapahtne pacmpoctpaheetce ha bce bnge mponcbogctbehhex n kohctpyktnbhex ge\$ektob.

¶ahhae fapahtne he pacmpoctpaheetce ha mobpemgehne, boshnkme b pesynatate heco6ndgehne mpabnn skcmnyataynn, ygapa nnn magehne, camoctoetenahofu pemohTa, nsmehehne bhytpehhefo yctponctba, pefynnpobkn hempabnnahofu mogknd-ehne, otyctbtbne sahynehne (sasemnehne) nsgenne.

7.1. CuY1AN YTPAT⁹ TAPAHTNNH^{9X} Ob³ATEubCTB.

- He mpabnnaho samonhehe cbngetenactbo o mpogame n fapahtnh6e tanoh6e.
- Otyctbtbne macmopta nsgenne, fapahtnhofo tanoha.
- Npn ncmnasobahnn nsgenne he mo hasha-ehnd nnn c hapymehnemh mpabnn skcmnyataynn.
- Npn hann-nn mexahn-ecknx mobpemgehnn (tpeynhe, ckone, cnege ygapob n magehnn, ge\$opmaynn kopmyca nnn nd6ex gpyfnx snemehtob kohctpykynn).
- Npn hann-nn bhytpn nsgenne moctpophnx mpegmetob.
- Npn hann-nn mpnshakob camoctoetenahofu pemohTa.
- Npn hann-nn nsmehehnn kohctpykynn.
- 3afpesh6ehne nsgenne, kak bhytpehhee, tak n bh6emhee - pmab-nha, kpacka n t.g.
- ¶e\$ekte, ebnedynce pesynatatom hempabnnahon nnn he6pemhon skcmnyataynn, tpahcmoptnpo6kn, xpahehne, nnn ebnedtce cnegctbnem heco6ndgehne pemhma mntahne, ctnxnnhofo 6egctbne, abapnn n t.m.
- Tapahtne he pacmpoctpaheetce ha pacxogh6e matepnane, habechoe o6opygobahne cmehh6e hacagkn, atakme nd6ee gpyfne -actn nsgenne, nmedyne ectectbehhon ofpahh-ehhon cpok cnym6e.
- Vcnobne fapahtn he mpegycmatnbadt mpo\$nnaktky n -nctky nsgenne, a takme beesg mactepa k mecty yctahobkn nsgenne c yenad efo mogknd-ehne, hactponkn, pemohTa, kohcynataynn.
- Tpahtnopthee pacxoge he bxoget b o6aem fapahtnhofo o6cnymbahne.

Npn hapymehnn tpe6obahnn hactoeeyefo pykobogctba fapahtnhen cpok skcmnyataynn, a takme pefnamehtnpo6ahhen cpok cnym6e nsgenne ahhytnpydctce, n mpetehsnn \$nmon nsfotobntenem he mpnhnmadctce.

No ncte-ehnn cpoka cnym6e, heo6xognmo o6patntace b cepbnch6en yehtp sa kohcynataynen moganahenmen skcmnyataynn kanopn\$epa. B mpotnbhom cny-ae ganahenmae skcmnyatayne momet mobne-a hebosmohchoTa hopmanahofu ncmnasobahne gahhofu nsgenne.

8. NPABNuA XPAHEHN⁹ N TPAHCNOPTNPOBKN.

Xpahnta temnobyd mymky heo6xognmo b sakpetex nnn gpyfnx momeyehnex c ectectbehhon behtnneyen, fge kone6ahne temmpataye n bnamhocta bosgyxa cyyeectbehho mehame, -em ha otkpetom bosgyxe b panohax c ymepehhem n xonogh6em knnmatom, mpn temmpataye he beme +40°C n he hnme -50°C, othocntenahon bnamhoctn he 6onee 80% mpn +25°C.

Npn gnntenahom xpahehnn nsgenne heo6xognmo ognh pas b 6 meceyeb mponsbognta mpobepky coctoehe sakohcepbnpobahhex mobexhocten n getanen. Npn o6hapymehnn ge\$ektob mobexhoctn nnn hapymehne ymakobkn heo6xognmo mponsbectn mepekohcepbaynd.

Спок xpahehne nsgennn – he 6onee 3 net.

Temnobee mymkn momho tpahcmoptnpobata nd6em bngom sakpetofo tpahcmopta b ymakobkn mponsbogntene nnn 6es hee c coxpahehнем nsgenne ot mexahn-ecknx mobpemgehnn, atmoc\$ephex ocagkob, bosgenctbne xnmn-ecknx aktbnhex beyectb n obesatenahem co6ndgehнем mep mpegocropomhoctn mрn mepeboske xpmknx fпyсob, –to cootbetctbyet ycnobnem mepeboskn 8 mo TOCT 15150-89.

9. CBEŋEHN^a O COOTBETCTBNN N NPHEMKE.

Temnobae mymka c mogmophem бe6pocom bosgyxa mpemofa hafpeba: AIKEN MSH 52M

Cootbetctbydt tpe6obahнем TV-150103.07, TV-150103.07, TOCT P 1029-2-1-95, TOCT 12.2.037-78, TOCT 12.2.007.10-87, TOCT 10280-83, TOCT12.2.013.0-91(M3K 745-1-82), TOCT P 50614-93 (M3K745-2-84), TOCT17770-86, TOCT12.2.030-2000, TOCT P 51318.14.1-99, TOCT50735-55, hopmam EN60335, EN50366, EN55014, EN61029, EN61000, EN1596, o6ecme-nbadыnm 6esomachocta mnshn, sgopobae motpe6нтeneн oxpahы okpымadyeн cpege n mpnshaxe foghemn k skcmnyataynn o6ecme-nbadыnm 6esomachocta mnshn, sgopobae motpe6нтeneн n oxpahы okpымadyeн cpege.

10. PEKBN3NT^a N3TOTOBNTEu^a.

No sakasy OOO «MEPNTuNHK PYC» Mockobckae o6nacta, f.Xnmkn, yn.uehnhfпagckae q.29

Nponsbogntena: OOO «ТemноТpeng», 453503, bamkoptoctah, f. benopeyk,

yn. C.Tdnehhа, 14, t. (34792) 5-42-62

