

**MEISTER**

**Flooring  
Installation and  
Care Instructions**



Longlife parquet | Alpine flame planks | Lindura® wood flooring | Design flooring  
Nadura® | Laminate flooring | Skirting | Care and Accessories

# MEISTER Flooring Installation and Care Instructions

## Contents

|  |    |
|--|----|
| Laying instructions  | 4  |
| Preparatory measures, substrates and general instructions  | 4  |
| Laying instructions for Longlife parquet and Lindura wood flooring   | 6  |
| Longlife parquet and Lindura wood flooring with Mastercllic Plus technology  | 6  |
| Longlife parquet PS 500 and PS 400 with UniZip technology  | 8  |
| Alpine flame planks with Maxiclic technology   | 10 |
| Laying instructions for Longlife parquet and Lindura wood flooring on walls  | 12 |
| Longlife parquet PD 450, PD 400, PS 300, PC 400, PC 200, PD 200, and Lindura wood flooring HD 400 with Mastercllic Plus technology | 12 |
| Laying instructions for design, Nadura and laminate flooring   | 14 |
| Design, Nadura and laminate flooring with Mastercllic Plus technology  | 14 |
| Laminate flooring with Multiclic technology  | 16 |
| MeisterDesign. flex with Multiclic technology  | 18 |
| MeisterDesign. rigid with Multiclic technology   | 20 |
| MeisterDesign. life with Maxiclic technology   | 22 |
| Laying instructions for humid rooms  | 24 |
| Laying instructions for home conservatories  | 25 |
| Mouldings and accessories  | 26 |
| Flooring profiles  | 26 |
| Wall transitions   mouldings   | 28 |
| Underlay materials   | 29 |
| Installation on hot-water underfloor heating structure   | 30 |
| Longlife parquet   | 30 |
| Alpine flame planks  | 31 |
| Lindura wood flooring  | 32 |
| Design flooring  | 33 |
| Nadura flooring  | 34 |
| Laminate flooring  | 35 |
| Installation on hot-water underfloor heating structure with cooling function   | 36 |
| Installation over electrical underfloor heating systems  | 37 |
| Full surface bonding   | 38 |
| Longlife parquet, Lindura wood flooring and Nadura flooring  | 38 |
| Alpine flame planks  | 39 |
| Design flooring MeisterDesign. life  | 40 |
| Design flooring MeisterDesign. pro   | 41 |
| Cleaning and care instructions   | 42 |
| Warranty conditions  | 47 |

# Preparatory measures, substrates and general instructions

**The packages must be acclimatised before you open them. Store them unopened and lying flat on the ground for approx. 48 hours (in winter 3–4 days) (Fig. 1) / MeisterDesign. life, MeisterDesign. rigid and MeisterDesign. pro for approx. 24 hours (in winter 2 days) (Fig. 1.1) in the centre of the room you want to work in.** Do not store the packages in front of damp or freshly wallpapered walls. Before you install the flooring, outer doors and windows must be installed and all painting and decorating work must be finished. The room temperature must be approx. 20°C (at least 15°C), and the relative humidity must be approx. 30–65 per cent.

Parquet, Lindura and Nadura floorings are natural products. Therefore, possible differences in colour and structure are an expression of its authenticity. Bleaching may occur with all flooring with direct sunlight or intense, artificial lighting. As a natural product, wood has hygroscopic properties. Dry cracks can appear as the wood expands/contracts, and are not due to faulty quality. In contrast to standard parquet floors, our Longlife parquet PC 400 in a planked look has deliberately been produced at the factory with open joints and slits that underline its special character. Before installation, check all planks in daylight for recognisable faults and damages, as well as colour and structure (Fig. 13). Arrange the planks before laying so that you achieve the floor pattern and colour you want (Fig. 14). You cannot make a claim for any products you have already installed.

The substrates must be considered as ready-to-lay in accordance with the generally accepted rules of the trade, taking into account VOB (German Construction Contract Procedures), Part C, DIN 18 356 »Parquetry« or DIN 18 365 »Floorcovering work« respectively. Therefore, they must be dry, even, solid and clean. The residual humidity, measured using the CM method, of mineral substrates must be no more than 2 per cent (1.8 per cent for underfloor heating) and that of anhydrite screeds must be a maximum of 0.5 per cent (0.3 per cent for underfloor heating) (Fig. 4). For installation over underfloor heating systems or underfloor heating systems with cooling function, separate information sheets are available from page 30 onwards. Any substrate unevenness of three or more millimetres for each initial metre and two or more millimetres for each subsequent continuous metre must be evened out according to DIN 18 202, table 3, line 4 (Fig. 2). We recommend consulting technical information sheet O2 from the Zentralverband für Parkett und Fußbodentechnik (Central

Association for Parquet Flooring and Flooring Technology) and the BEB (German Federal Association of Screed and Floor Covering). For MeisterDesign. life, joints in old ceramic sub-floors wider than 7 mm and more than 2 mm deep (Fig. 3), must be levelled using suitable filler materials. For MeisterDesign. rigid, this applies to joints wider than 10 mm and deeper than 2 mm (Fig. 3.1). 0.2 mm thick PE film (SD value  $\geq 75$  m) must be laid out on all mineral substrates (except poured asphalt screed) as a vapour barrier (Fig. 5). The strip edges must overlap by at least 20 cm and the overlapping edges must be masked off at the sides. Alternatively, you can use MEISTER insulating underlay with an integrated moisture-resistant barrier. A vapour barrier is not required for waterproof MeisterDesign. life or MeisterDesign. rigid. In rooms that are not above a cellar and foundations, the currently valid building conditions require that the owner of the building provide a barrier against damage to the base plate due to moisture from the ground, in accordance with the DIN 18 195 directive.

MEISTER flooring can be laid on existing surfaces, such as ceramic tiles and boards or stone floors, so long as the old flooring is firmly bonded and there are no loose areas. You should also spread out a PE film (SD value  $\geq 75$  m) on these subfloors as a separating layer (Fig. 6). On existing PVC, wooden planks, wood-based boards, OSB boards, drywall elements etc., no vapour barrier must be used (Fig. 6.1). Textile flooring such as carpet or needle fleece must be removed not only for technical reasons, but for hygiene reasons, too (Fig. 6.2).

**MEISTER flooring is not suitable for installation in humid rooms/wet areas (bathrooms, saunas, swimming pool etc.). The MeisterDesign. flex, MeisterDesign. comfort and Nadura design floorings, the LC 150, LD 150, LB 150, LL 150, LD 250, LL 250 laminate floorings, and the MeisterDesign. life, MeisterDesign. rigid and MeisterDesign. pro waterproof design floorings can all be installed in humid rooms (Class W0-I, e.g. bathrooms; Class W1-I for life and pro). They are not suitable for installation in outdoor areas or wet rooms such as showers, saunas, public washrooms or rooms with a floor drain (Fig. 9) – separate briefing note, see page 24.**

All MEISTER floorings are suitable for installation in home conservatories (Fig. 10). Shading and ventilation systems must be used to avoid strong sunlight and prevent the flooring from heating up. It is important to maintain a suitably consistent temperature for the living space all year round. The surface temperature of the floor must not permanently exceed 29°C –

separate briefing note, see page 25. With MeisterDesign. rigid, we recommend installing any heavy objects or fitted furniture (such as kitchens or kitchen islands) prior to laying the flooring and only laying it up to just below the skirting (Fig. 11).

The flooring is installed as a floating structure without glue. MeisterDesign. pro flooring is exclusively intended for full-surface bonding. Some other types of flooring can also be installed with full surface bonding using an approved adhesive as an alternative to floating installation (Fig. 12) – separate briefing note, see pages 38–41.

If the floor area is longer or wider than 10 m (Fig. 7) (or longer or wider than 12 m for Nadura, LL 250 and LD 250 laminate (Fig. 7.1), or longer or wider than 15 m for MeisterDesign. life and MeisterDesign. rigid (Fig. 7.2)) then you must provide an expansion joint. Cover this with a transition profile. It is also important to provide these joints between two adjacent rooms, in doorways (Fig. 8), passageways and rooms with a lot of angles (MeisterDesign. rigid can be installed in doorways without transition profiles).

Always use a jointing profile for clean transitions to adjacent, lower areas or floor coverings and an end profile next to higher adjacent thresholds, tiles or the like. Give stairs a clean finish with the stair edge profile (see pages 26–27).

To protect the wood from dirt, a sufficiently large entrance covering must always be laid (such as a doormat or carpet) (Fig. 15). Do not use any rubber-coated mats, since prolonged contact can lead to permanent discolouration, especially in design flooring. In addition, you should also fit chair and furniture feet with felt sliders; office chairs, mobile containers, etc., on castors must be equipped with soft, standard running surfaces (type W) (Fig. 16). Coloured rubber, natural rubber or plastic glides and castors as well as dark car, bike or equipment tyres may possibly cause discolouration on design flooring. Please only use light, non-migrating furniture glides, castors or tyres, if possible. We recommend protecting MeisterParquet. longlife and Lindura wood flooring in these heavy-wear areas with appropriate floor protection mats (e.g. polycarbonate mats) (Fig. 16.1).

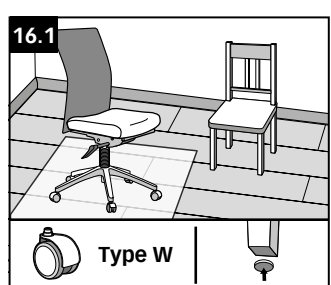
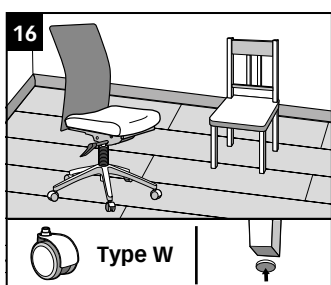
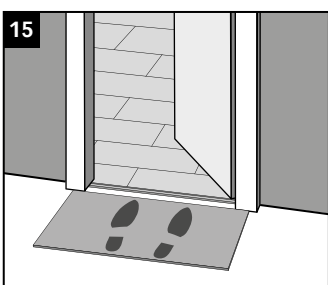
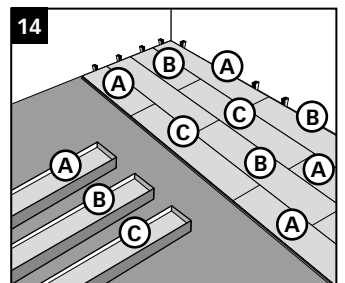
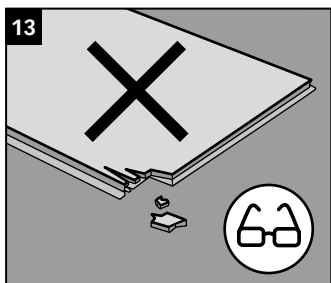
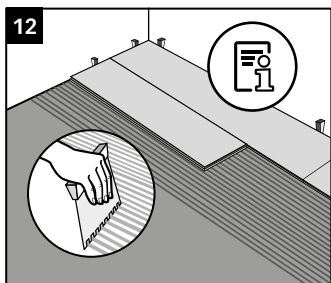
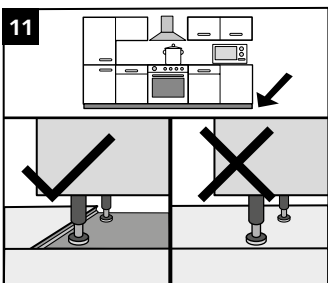
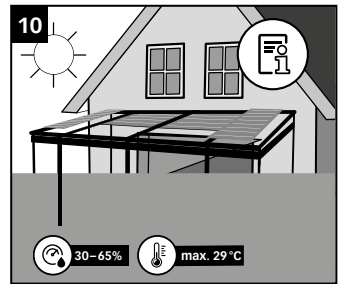
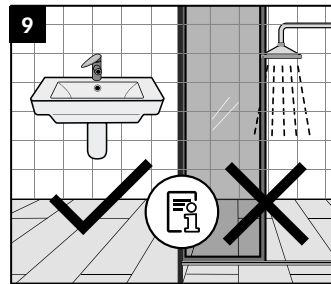
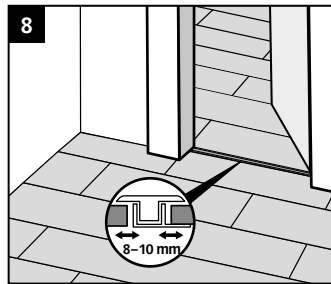
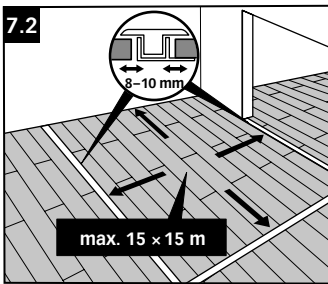
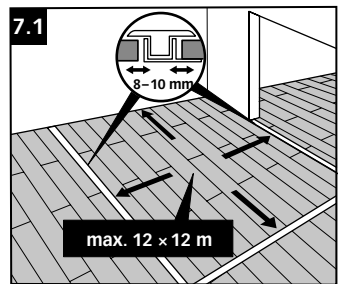
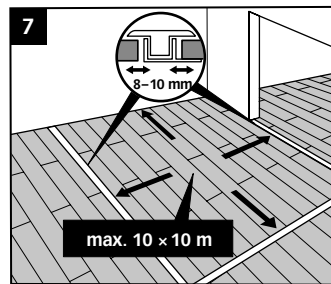
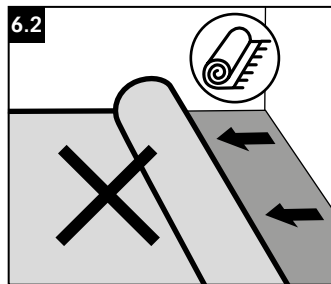
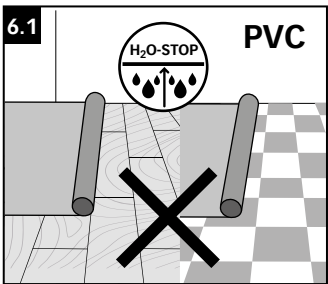
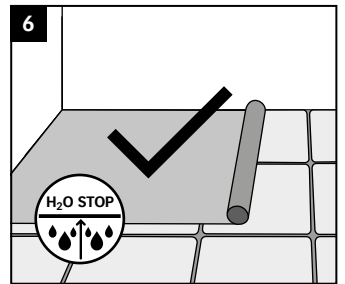
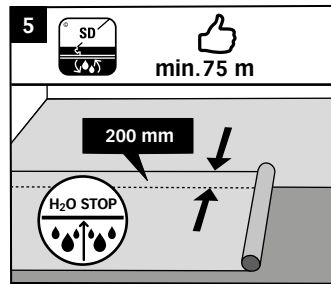
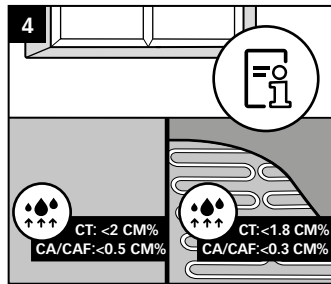
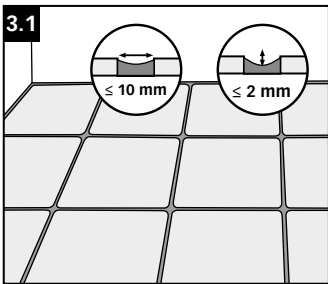
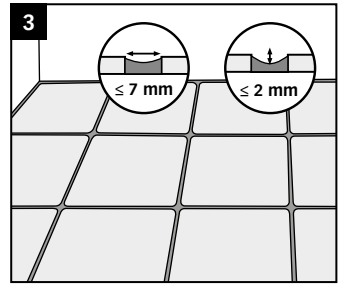
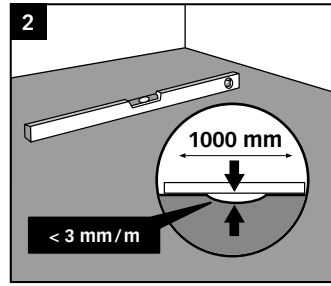
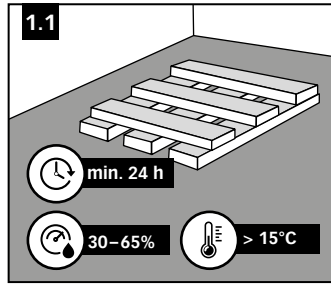
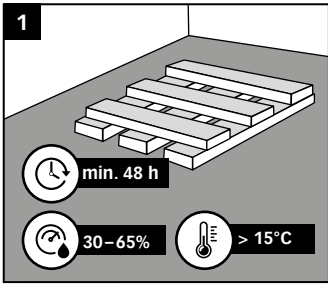

# MEISTER Longlife parquet and Lindura wood flooring with Mastercllic Plus technology

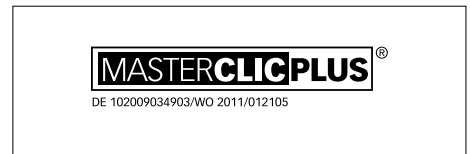

**Fig. 1**

You need the following tools and aids to install MEISTER Longlife parquet and Lindura wood flooring with Mastercllic Plus technology. Hammer, keyhole or electric saw (**for Lindura wood flooring: hard metal saw blades or diamond tipped saw blades**), possibly power drill, folding metre rule, pencil, wedges (spacer wedges), heel bar, angle or adjustable bevel, possibly PE film (0.2 mm). Furthermore, if you are using products without a sound-absorbing Silence cushion, use the system-bound MEISTER insulating underlay. Any other insulating underlay must have a suitable pressure stability (CS value  $\geq 15$  kPa).

**Fig. A1 + A2**

The flooring is installed as a floating structure without glue. The Mastercllic Plus connection system makes it possible to install the flooring quickly and easily. The end interlocking occurs when the next row is laid. In addition, it is a valuable installation aid, as the planks can be aligned against each other in this way. To do this, you should lift the plank slightly and simply square it with the tongue in the groove of the plank that has already been laid.

**Fig. 2**

Remove any dirt, small stones, etc. from the surface prior to installation.

**Fig. 3**

PE film 0.2 mm thick must be laid out to form a "bath" on all mineral substrates (except poured asphalt screed) as a vapour barrier. The strip edges must overlap by at least 20 cm and the overlapping edges must be masked off. Alternatively, the option is available to use MEISTER insulating underlay with integrated vapour barrier.

**Fig. 4**

Lay the corresponding MEISTER insulating underlay with a pressure resistance of  $> 15$  kPa.

**Fig. 5**

Before installation, check all planks in daylight for recognisable faults in colour and structure. Goods already installed cannot be claimed for later.

**Fig. 6**

Install a mixture of planks from different packages.

**Fig. 7**

When sawing the elements, make sure you work from the correct side: if you use a bench saw, keep the decorative side facing up, if you use a keyhole or portable circular saw, keep the decorative side down.

Start by laying the first complete plank in the left-hand corner of the room with the tongue sides facing the wall. Remove only the tongues on the long sides of all the other planks you want to lay in the first row. Using wedges, you can easily keep a gap of at least 15 mm from the wall.

**Fig. 8**

Insert the head end of the next complete plank into plank 1. Install the other planks in this row in exactly the same way across the entire width of the room.

**Fig. 9**

The last planks in each row are cut to size so that a gap of 15 mm to the wall is taken into account. You can use cut-off pieces of planks to start subsequent rows.

**Fig. 10**

Make sure that the planks in the first row are straight. Cut the first plank of the second row down to approx. 80 cm. Fix this plank upright with the tongue as far as possible into the groove on the groove side of the previous row of planks and press the plank down slowly using a forward and downward turning motion. The plank has to click into the previously installed row.

**Fig. 11**

Similarly, the next complete plank is turned into the click connection on the long side and the head end pushed tight against the previous plank before it is lowered. Then press the plank down slowly using a forward and downward turning motion. The plank has to click into the previously installed row and the end joint with the previous plank has to be closed.

**Fig. 12**

Continue installing the panels row by row in this way. Remember that the end joints must always be offset by at least 30–40 cm.

**Fig. 13 + Fig. 14**

Cut the last plank in each row so that you leave a gap of at least 15 mm to the wall. Lay the plank with the tongue side facing the wall to mark the remaining plank width.

**Fig. 15**

Taking the plank marked for width, push the plastic end tongue forward out of the end groove using the spare piece of plank.

**Fig. 16**

Begin cutting the plank to size at the end of the plastic tongue.

**Fig. 17**

After the plank has been cut to size, push the plastic tongue on the end back into the end groove. Start by laying the last row in the right-hand corner of the room (leaving at least a 15 mm gap to the wall) and angle the long side of the plank into the second-last row. The next plank is angled in the same way and lowered down at the end.

**Fig. 18**

Push the plastic tongue that is pointing out towards the wall back into the end connection using a heel bar, scraper, screw driver or similar.

**Fig. 22**

Next, remove the wooden wedges from around the walls.

**Fig. 23**

Screw the skirting board clips to the wall at intervals of 40–50 cm. To ensure that the skirting board fits tightly, do not position it on an uneven wall.

**Fig. 24**

The skirting board is placed on the clip from above and pressed down. For the length joints of the skirting boards, the clip is placed on the joint with a half overlap to ensure a good hold. Please avoid bringing any silicone products into contact with the skirting boards.

**Fig. 19 – Fig. 21**

**To take a plank row back out again**, lift the entire row, levering it at the side out of the last row. You can then slide the planks apart at the ends. Should you wish to reuse the disassembled planks, you should first push the end plastic tongue back into the top groove so it sits flush.

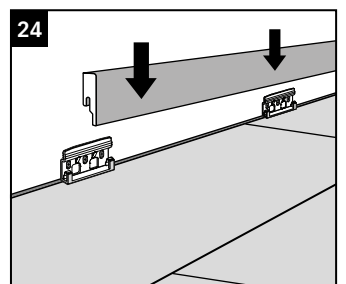
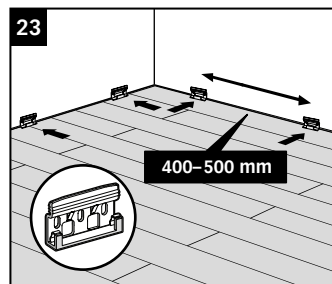
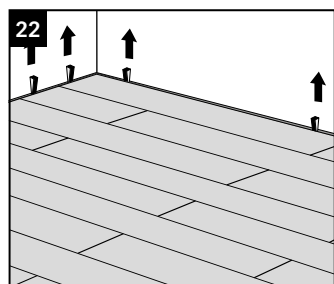
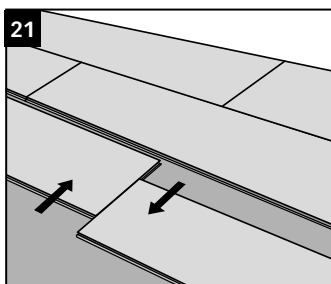
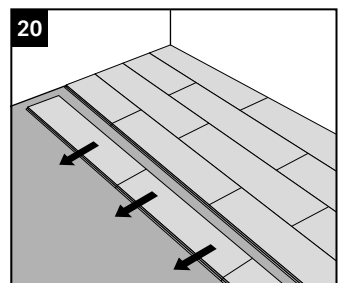
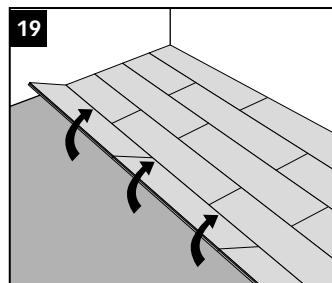
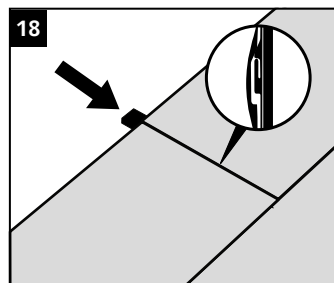
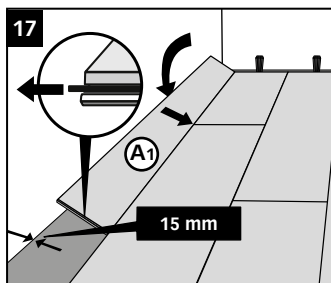
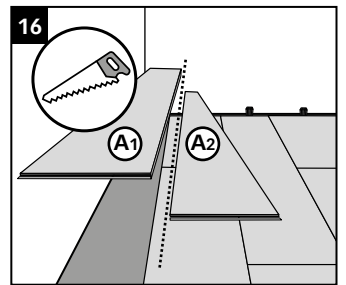
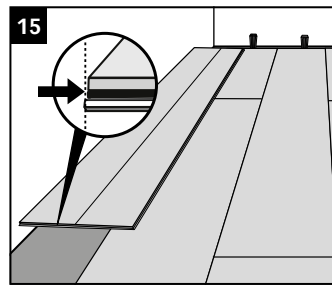
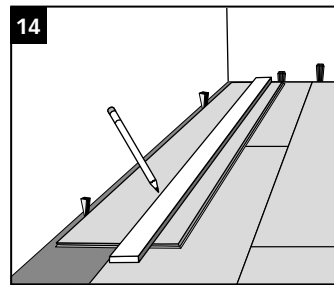
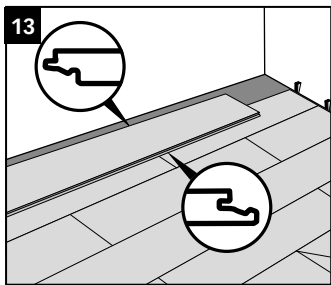
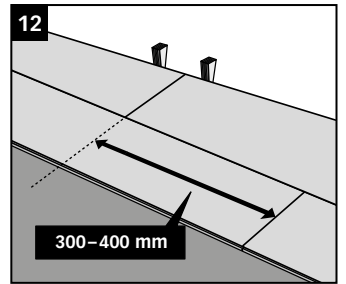
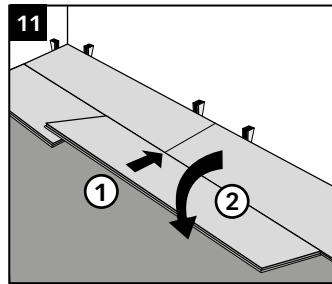
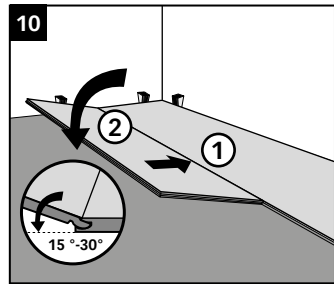
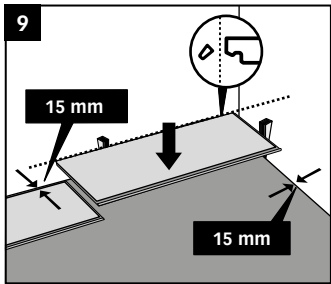
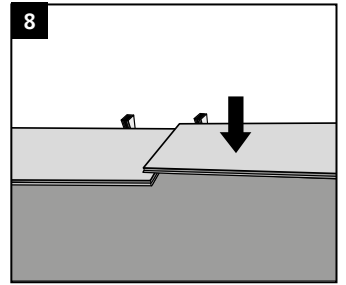
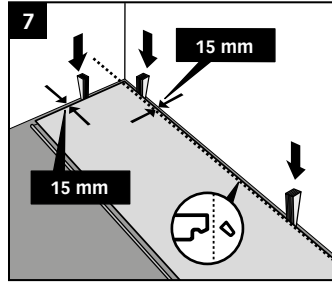
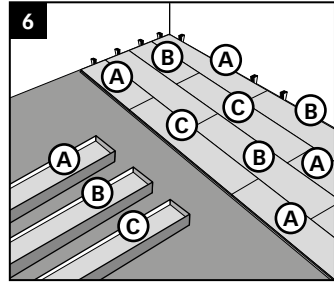
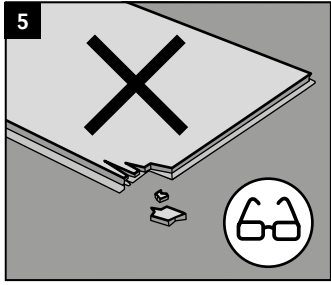
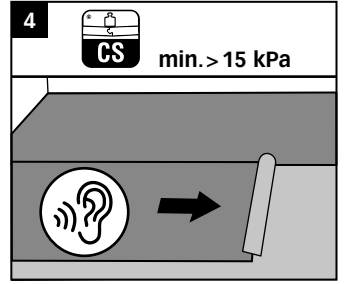
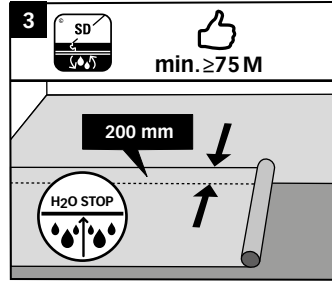
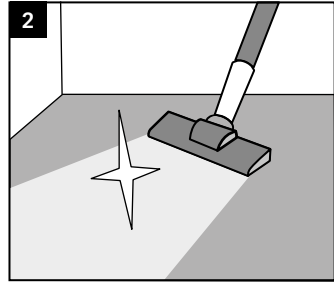
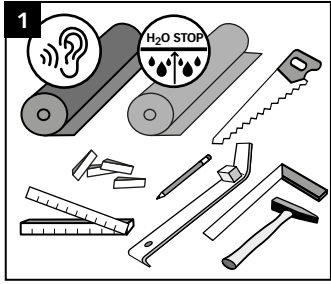
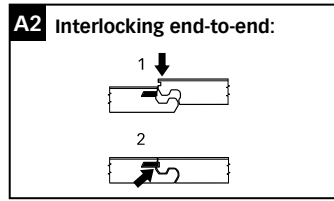
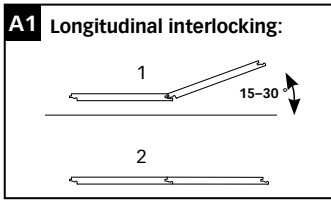

# MEISTER Longlife parquet PS 500 and PS 400 with UniZip technology



**Fig. 1**

You need the following tools and aids to install MeisterParquet. longlife PS 500 and PS 400 with UniZip technology: Hammer, keyhole or electric saw, possibly power drill, folding metre rule, pencil, MEISTER tapping block, wedges (spacer wedges), heel bar, angle or adjustable bevel, possibly PE film (0.2 mm). Furthermore, if you are using products without a sound-absorbing Silence cushion, use the system-bound MEISTER insulating underlay. Any other insulating underlay must have a suitable pressure stability (CS value  $\geq 15$  kPa).

**Fig. 2**

Remove any dirt, small stones, etc. from the surface prior to installation.

**Fig. 3**

PE film 0.2 mm thick must be laid out to form a "bath" on all mineral substrates (except poured asphalt screed) as a vapour barrier. The strip edges must overlap by at least 20 cm and the overlapping edges must be masked off. Alternatively, the option is available to use MEISTER insulating underlay with integrated vapour barrier.

**Fig. 4**

Lay the corresponding MEISTER insulating underlay with a pressure resistance of  $> 15$  kPa.

**Fig. 5**

Before installation, check all planks in daylight for recognisable faults in colour and structure. Goods already installed cannot be claimed for later.

**Fig. 6**

Install a mixture of planks from different packages.

**Diagonal herringbone pattern (option 1)**

**Fig. 14**

In order to obtain a uniform distance to all walls, draw a guide line using a chalk line.

**Fig. 7**

Start the laying process in a corner of the room. Saw the tongues off the first plank, both on the short and the long side.

**Fig. 8**

Using wedges, you can easily keep a gap of 10–15 mm from the wall. On the second plank, only the tongue on the long side has to be cut off.

**Fig. 9**

Now angle the head end of the second plank into the long side of the first plank.

**Fig. 10 + Fig. 11**

Then angle the long side of the third plank into the first plank. Now interlock the short side of the third plank into the second plank using the MEISTER tapping block.

**Fig. 12 – Fig. 14**

Follow this process to continue laying. Make sure that the long sides of the boards are angled in first before interlocking the planks on their short sides.

**Fig. 15**

Lay the first braid as far as the wall/corner of the room. The left over pieces of planks there can possibly be used at the start of the next row. The first braid has to be fixed with wedges so that the braid does not slide during the subsequent laying process.

**Fig. 16 + Fig. 17**

Before starting with the next row, check if there are any leftover pieces that could be used. While continuing with the laying, ensure that the long sides of the planks are angled in first and only then interlock the head ends. In certain situations, it is not possible to angle in the long side first before interlocking the head end. The special connection technique allows the plank to be interlocked in any conceivable direction, meaning the head end can be angled in first and the element can be interlocked via the long side, for example.

Following this sequence, lay the surface up to the end of the room. The planks that end at the wall are cut to size so that a gap of 10–15 mm to the wall is taken into account.

**Parallel herringbone pattern (option 2)**

**Fig. 18**

In order to obtain a uniform distance to all walls, draw a guide line using a chalk line. Start the laying process in the middle of the room facing a wall. To ensure symmetrical laying, the laying line must be shifted by  $\frac{1}{4}$  of the mitre width (PS 500: 50.2 mm; PS 400: 35.4 mm) from the centre of the room.

**Fig. 9**

Angle the head end of the second plank into the long side of the first plank.

**Fig. 10 + Fig. 11**

Then angle the long side of the third plank into the first plank. Now interlock the short side of the third plank into the second plank using the MEISTER tapping block.

**Fig. 18**

Follow this process to continue laying as far as the sixth plank. Align the planks with the laying line and cut them parallel to the wall. You can now align what is known as the head (in the shape of a triangle) at an even distance of 10–15 mm from the wall along the laying line and fix it in place with wedges. Make sure that the long sides of the planks are angled in first before interlocking the planks on their short sides.

**Fig. 19**

Lay the first braid as far as the opposite wall. The leftover pieces of planks there can possibly be used at the start of the next row. The first braid has to be fixed with wedges so that the braid does not slide during the subsequent laying process.

**Fig. 20 + Fig. 21**

Before starting with the next row, check if there are any leftover pieces that could be used. While continuing with the laying, ensure that the long sides of the planks are angled in first and only then interlock the head ends. In certain situations, it is not possible to angle in the long side first before interlocking the head end. The special connection technique allows the plank to be interlocked in any conceivable direction, meaning the head end can be angled in first and the element can be interlocked via the long side, for example. Following this sequence, lay the surface up to the end of the room. The planks that end at the wall are cut to size so that a gap of 10–15 mm to the wall is taken into account.

**Fig. 22**

Next, remove the wooden wedges from around the walls.

**Fig. 23**

Screw the skirting board clips to the wall at intervals of 40–50 cm. To ensure that the skirting board fits tightly, do not position it on an uneven wall.

**Fig. 24**

The skirting board is placed on the clip from above and pressed down. For the length joints of the skirting boards, the clip is placed on the joint with a half overlap to ensure a good hold.

Please avoid bringing any silicone products into contact with the skirting boards.



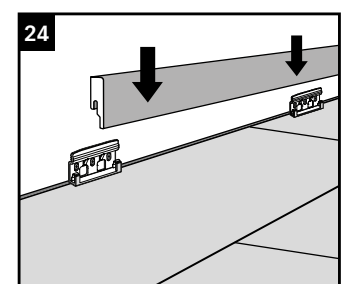
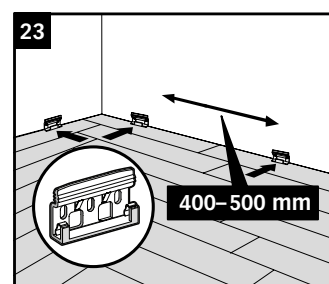
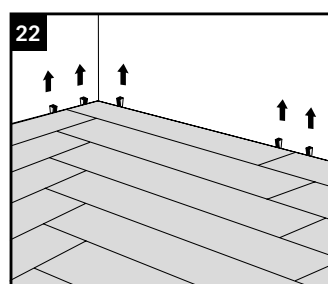
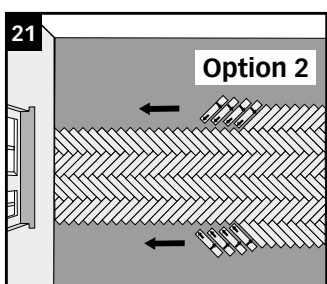
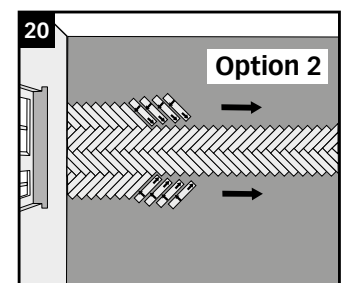
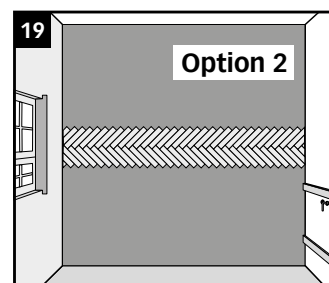
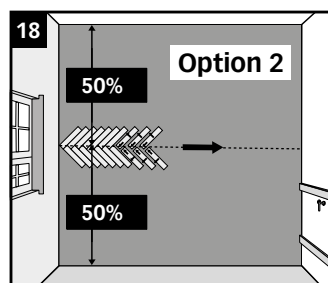
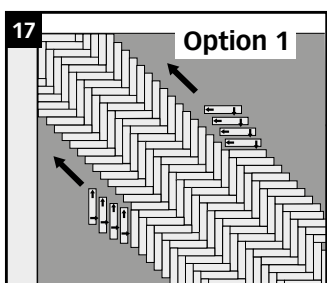
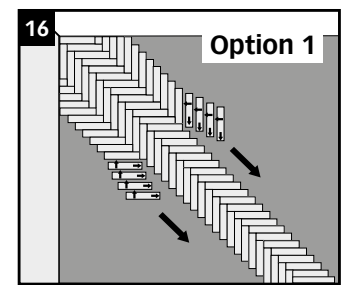
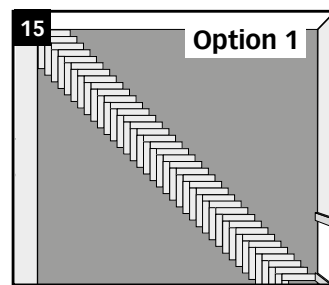
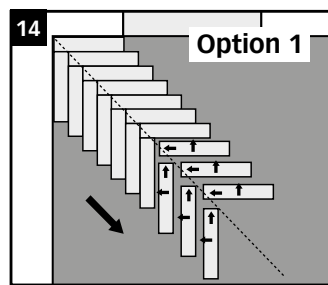
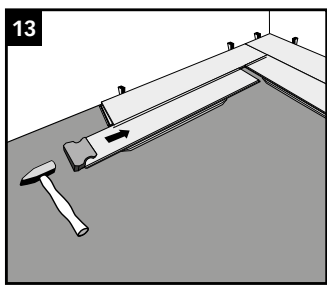
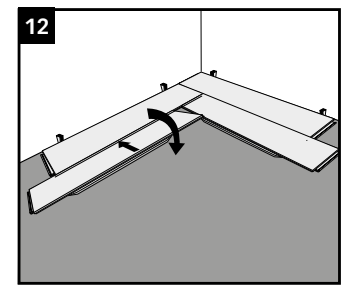
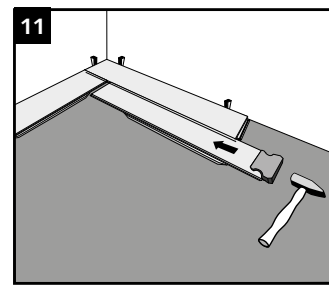
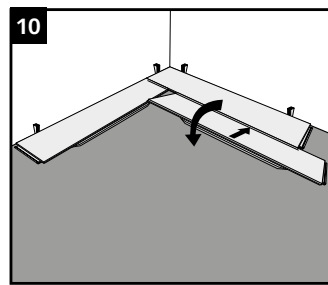
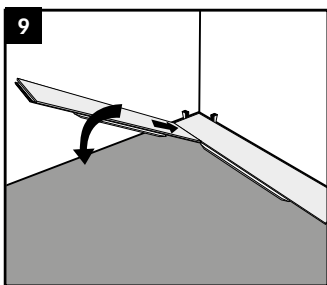
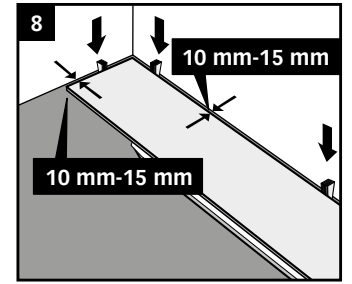
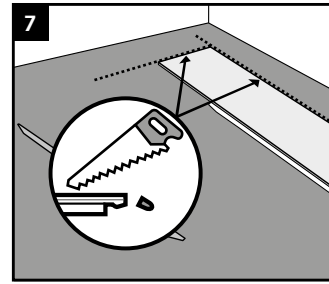
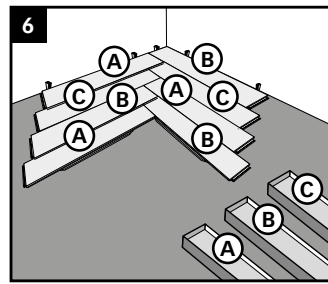
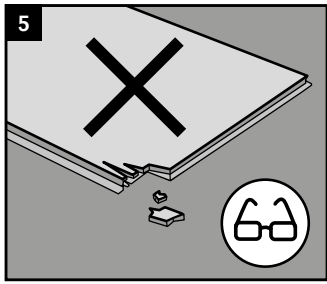
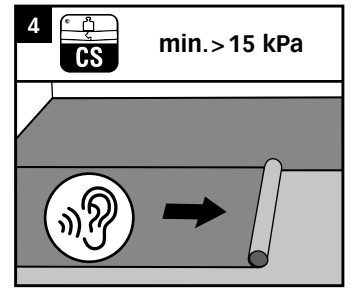
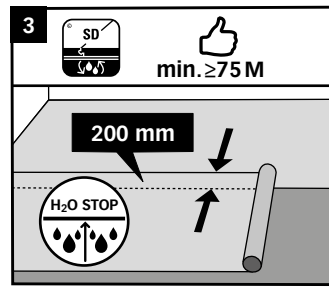
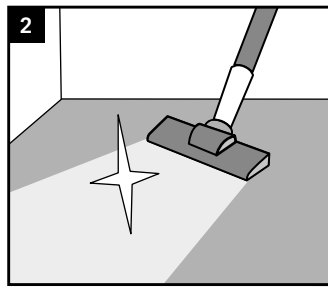
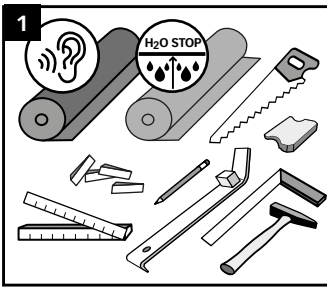

# Alpine flame planks with Maxiclic technology



**Fig. 1**

You need the following tools and aids to install Alpine flame planks with Maxiclic technology: Rubber hammer with a white head or hammer with tapping block, keyhole or electric saw, possibly power drill, folding metre rule, pencil, wedges, angle or adjustable bevel, possibly PE film (0.2 mm).

Furthermore, if you are using products without a sound-absorbing Silence cushion, use the system-bound MEISTER insulating underlay. Any other insulating underlay used must have a suitable pressure stability (CS value  $\geq 15$  kPa).

**Fig. A1 + A2**

The flooring is installed as a floating structure without glue. The specially designed click connection Maxiclic (fold-down system) allows quick and easy installation. The long side of the plank is angled with the tongue side into the groove of the previous row and lowered into the previous plank at the end. The Maxiclic connection at the end is then locked by tapping it into place with a white rubber hammer or a hammer in combination with a tapping block.

**Fig. 2**

Remove any dirt, small stones, etc. from the surface prior to installation.

**Fig. 3**

PE film 0.2 mm thick must be laid out to form a "bath" on all mineral substrates (except poured asphalt screed) as a vapour barrier. The strip edges must overlap by at least 20 cm and the overlapping edges must be masked off. Alternatively, the option is available to use MEISTER insulating underlay with integrated vapour barrier.

**Fig. 4**

Lay the corresponding MEISTER insulating underlay with a pressure resistance of  $> 15$  kPa.

**Fig. 5**

Before installation, check all planks in daylight for recognisable faults in colour and structure. Goods already installed cannot be claimed for later.

**Fig. 6**

Install a mixture of planks from different packages.

**Fig. 7**

When sawing the elements, make sure you work from the correct side: if you use a bench saw, keep the wear layer side facing up; if you use a keyhole or portable circular saw, keep the wear layer side down. Start by laying the first complete plank in the left-hand corner

of the room with the tongue sides facing the wall. Remove only the tongues on the long sides of all the other planks you want to lay in the first row. Using wedges, you can easily keep a gap of approx. 15 mm to the wall.

**Fig. 8**

Insert the next complete plank into the head end of plank 1 and lock them in place by tapping them in with a white rubber hammer. Install the other planks in this row in exactly the same way across the entire width of the room.

**Fig. 9**

The last planks in each row are cut to size so that a gap of at least 15 mm to the wall is taken into account. You can use cut-off pieces of planks to start subsequent rows.

**Fig. 10**

Make sure that the planks in the first row are straight. Cut the first plank of the second row down to approx. 80cm. Angle this plank with the tongue into the groove side of the previous row of planks and press the plank down slowly using a forward and downward turning motion. If appropriate, use a tapping block to help establish an optimum connection by tapping lightly along the length of the plank.

**Fig. 11**

Again, angle the next complete plank of the second row first on its long edge against the previously laid row and press it tight to the head end of the previous plank before lowering it. Then press the plank down slowly using a forward and downward turning motion. If appropriate, use a tapping block to help establish an optimum connection by tapping lightly along the length of the plank.

**Fig. 12**

The head end connection is established by tapping it into place with a white rubber hammer.

**Fig. 13**

Continue installing the panels row by row in this way. Remember that the end joints must always be offset by at least 30–40 cm.

**Fig. 14 – Fig. 16**

Cut the last plank in each row so that you leave a gap of at least 15 millimetres to the wall. Lay the plank with the tongue side facing the wall to mark the remaining plank width.

**Fig. 17**

Start by laying the last row in the right-hand corner of the room and angle the long side of the plank into the second-last row. The next plank is turned in on the long side as before and lowered at the head end into the previous plank.

**Fig. 18**

Locking at the head end is again through blows with the rubber hammer.

**Fig. 22**

Finally, remove the spacer wedges from around the walls.

**Fig. 23**

Screw the skirting board clips to the wall at intervals of 40–50 cm. To ensure that the skirting board fits tightly, do not position it on an uneven wall.

**Fig. 24**

The skirting board is placed on the clip from above and pressed down. For the length joints of the skirting boards, the clip is placed on the joint with a half overlap to ensure a good hold. Please avoid any silicon products coming into contact with the mouldings.

**Fig. 19 – Fig. 21**

**To take a plank row back out again**, lift the entire row, levering it at the side out of the last row. You can then slide the planks apart at the ends. This way, the locking system remains intact and the planks can be refitted.

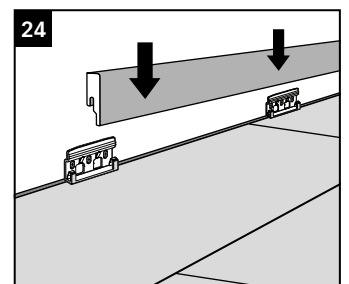
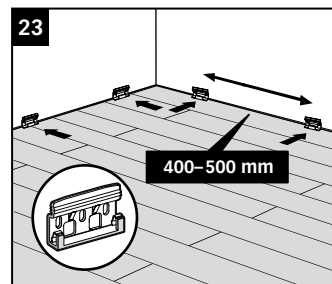
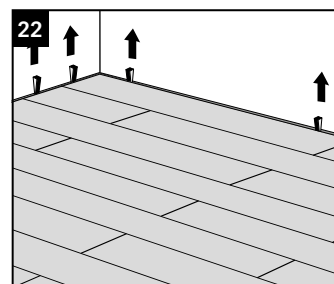
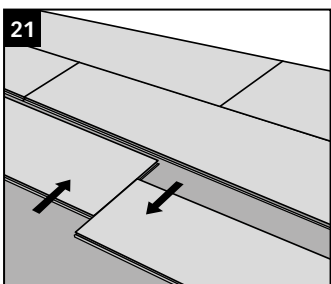
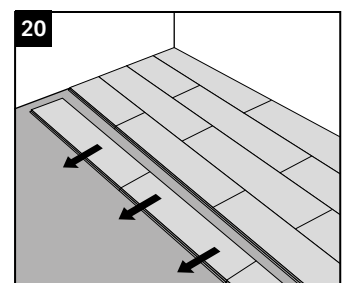
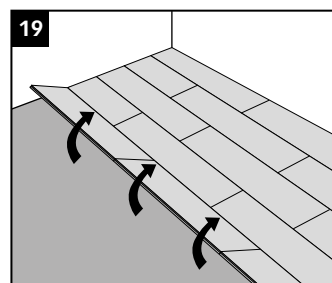
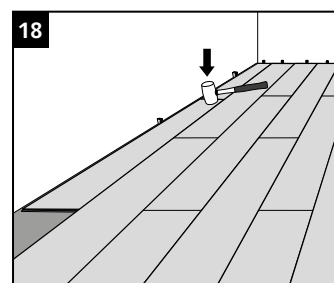
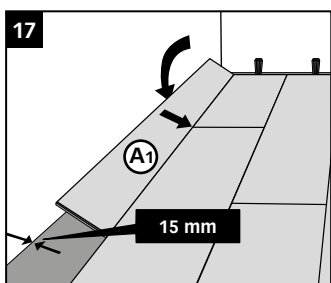
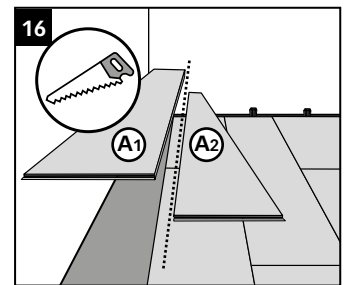
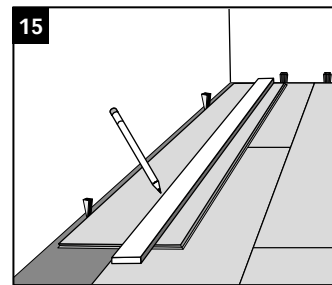
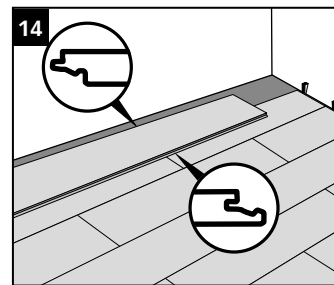
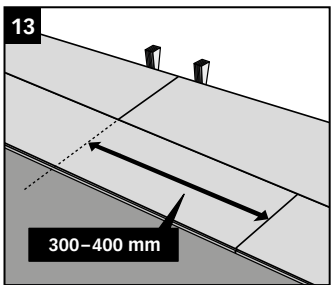
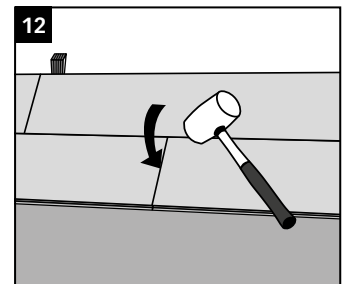
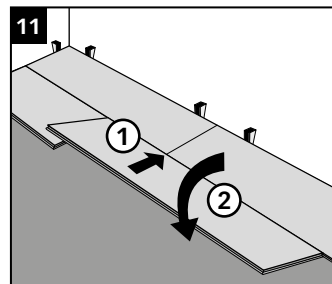
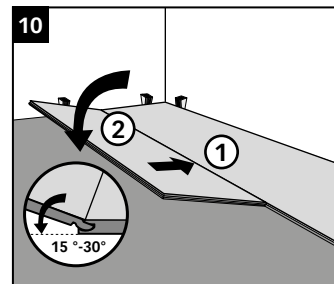
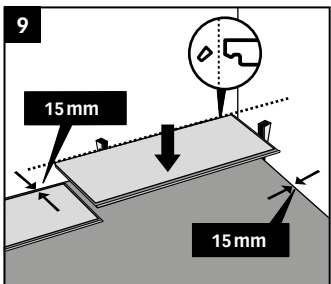
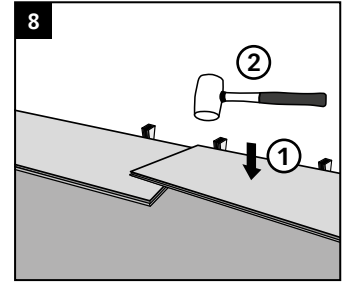
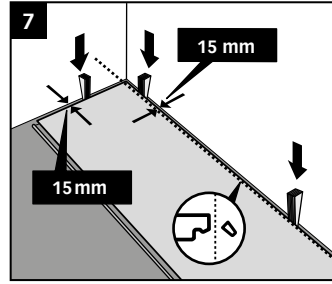
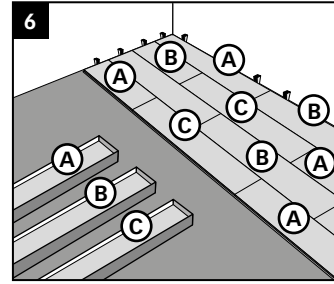
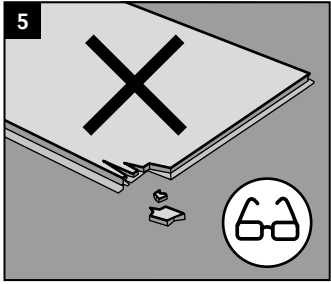
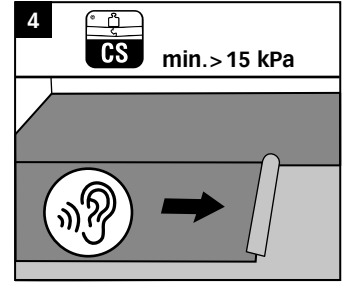
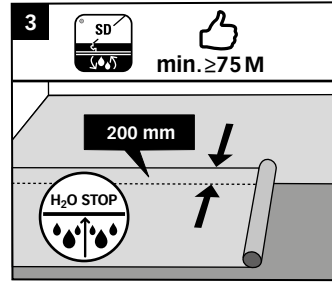
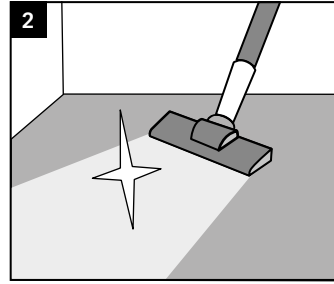
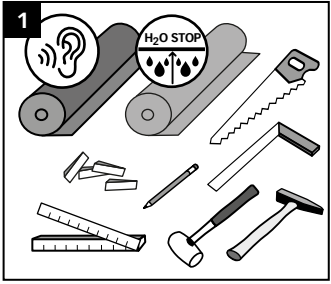
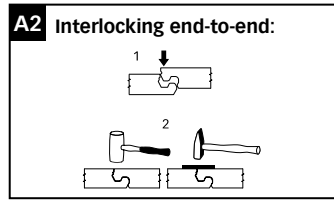
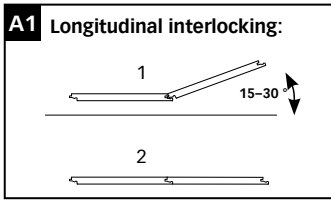

# Laying instructions for fastening Longlife parquet PD 450, PD 400, PD 200, PC 200, PS 300, PC 400 (staple TOP 13) and Lindura® wood flooring HD 400 (staple TOP 11) to the wall

---

### Preparatory measures:

The packages must be acclimatised before you open them. Store them for approx. 48 hours (3-4 days in winter) flat on the floor in the centre of the room you want to work in. Do not store the packages in front of damp or freshly wallpapered walls. Before you install the planks, the conditions must comply with the general requirements for the installation of wooden materials in interior rooms. Make sure that the walls are dry, i.e. contain a maximum residual moisture of 5 per cent. All windows and doors must also have been installed and a room temperature of approx. 20°C and approx. 30 – 65 percent relative humidity must prevail.

During installation, make sure that air can also circulate behind the wood panelling (possibly provide lath backing structure). You must avoid trapped air. It is also important during installation that you allow a gap of at least 10 – 15 mm next to all walls and other fixed elements. You need an expansion joint if your installation surface is longer or wider than 10 metres.

### Sub-structure with batten profile type 8

Place the batten profile type 8 at maximum intervals of 40 centimetres apart (fig. 1). Please use suitable plugs or screws to screw the sub-structure to the wall at intervals of 50 cm. Correct any slight unevenness in the wall by placing spacers or wooden wedges underneath the laths. Use a standard metal hacksaw or one-hand angle grinder with metal cutting disc to trim the profile. A minimum gap of 20 mm is required when installing MEISTER recessed lights. This must be guaranteed by fixing the batten profile to the wall using a space of at least 12 mm.

### Installation

As a result of the Masterclip Plus system the planks are installed from right to left (fig. 9). Start by laying the first complete plank with the tongue side facing the floor. With all the planks in the first row remove the tongues along the long edges.

To install the first row use the start/end clip. To fix these, mark the profile's position on the back of the plank. The middle of the rail is marked using a pencil (fig. 2) and the start/end clip is fixed using the supplied screws (fig. 3). Tighten the screws but do not over tighten them. Then simply clip the plank into the batten profile (fig. 4). If the clip does not slot in correctly then the profile may have been pressed together during trimming. In this case please bend open the profile to its original dimensions again. Use the TOP 13|TOP 11 clip to fix the planks for the rest of the installation. For this simply screw the clip onto the batten profile (fig. 5) and push it onto the plank groove (fig. 6 + 7). Make sure that the planks in the first row are straight.

Angle the tongue of the first plank in the second row into the groove of the previous row of planks (fig. 8) and slowly press the planks onto the batten profile. Use the TOP 13|TOP 11 clip to fix the planks for the rest of the installation (fig. 7). Continue installing the planks row by row in this way (fig. 10). To cut the last row to size, use a spare piece of plank and draw the remaining plank width on it (leaving a gap of 10-15 mm to the ceiling).

Taking the plank marked for width, push the plastic end tongue forward out of the end groove using the spare piece of plank (fig. 11). Begin cutting the plank to size at the end of the plastic tongue. After the plank has been cut to size, push the plastic tongue on the end back into the end groove (fig. 12 + 13).

To install the start/end clips on the last row mark the position of the batten profile using a piece of adhesive tape (fig. 14) and transfer the position of the profile onto the back of the plank (fig. 15 + 16). Now the clip is fixed on the plank in the first row (fig. 17) and inserted into the plank (fig. 18). Afterwards the plastic tongue in the last row must be fixed using a screwdriver (fig. 19).

Use the MEISTER angled cover moulding for example to cover the all-round expansion joints (fig. 20 + 22).



Fig. 1



Fig. 2



Fig. 3



Fig. 4



Fig. 5



Fig. 6

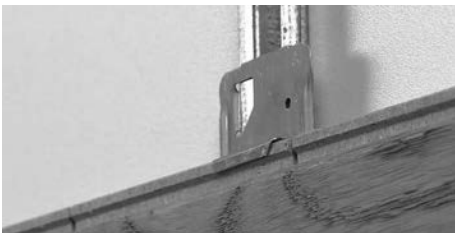

Fig. 7



Fig. 8



Fig. 9



Fig. 10



Fig. 11



Fig. 12



Fig. 13



Fig. 14



Fig. 15

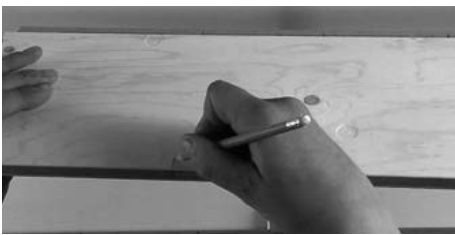

Fig. 16



Fig. 17



Fig. 18

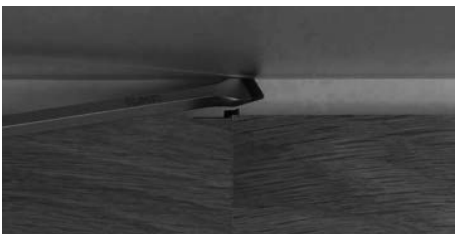

Fig. 19



Fig. 20



Fig. 21



Fig. 22

# MEISTER design, Nadura and laminate flooring with Mastercllic Plus technology



**Fig. 1**

You need the following tools and aids to install MEISTER laminate, Nadura and design flooring with Mastercllic Plus technology: Hammer, keyhole or electric saw (**for Nadura: hard metal saw blades or diamond tipped saw blades**), possibly power drill, folding metre rule, pencil, wedges (spacer wedges), heel bar, angle or adjustable bevel, possibly PE film (0.2 mm). Furthermore, if you are using products without a sound-absorbing Silence cushion, use the system-bound MEISTER insulating underlay. Any other insulating underlay must have a suitable pressure stability (CS value  $\geq 15$  kPa).

**Fig. A1 + A2**

The flooring is installed as a floating structure without glue. The Mastercllic Plus connection system makes it possible to install the flooring quickly and easily. The end interlocking occurs when the next row is laid. In addition, it is a valuable installation aid, as the planks can be aligned against each other in this way. To do this, you should lift the plank slightly and simply square it with the tongue in the groove of the plank that has already been laid.

**Fig. 2**

Remove any dirt, small stones, etc. from the surface prior to installation.

**Fig. 3**

PE film 0.2 mm thick must be laid out to form a "bath" on all mineral substrates (except poured asphalt screed) as a vapour barrier. The strip edges must overlap by at least 20 cm and the overlapping edges must be masked off. Alternatively, the option is available to use MEISTER insulating underlay with integrated vapour barrier.

**Fig. 4**

Lay the corresponding MEISTER insulating underlay with a pressure resistance of  $> 15$  kPa in the private residential sector or  $> 60$  kPa in the commercial sector.

**Fig. 5**

Before installation, check all planks in daylight for recognisable faults in colour and structure. Goods already installed cannot be claimed for later.

**Fig. 6**

Install a mixture of planks from different packages.

**Fig. 7**

When sawing the elements, make sure you work from the correct side: if you use a bench saw, keep the decorative side facing up, if you

use a keyhole or portable circular saw, keep the decorative side down.

Start by laying the first complete plank in the left-hand corner of the room with the tongue sides facing the wall. Remove only the tongues on the long sides of all the other planks you want to lay in the first row. Using wedges, you can easily keep a gap of at least 10 mm from the wall.

**Fig. 8**

Insert the head end of the next complete plank into plank 1. Install the other planks in this row in exactly the same way across the entire width of the room.

**Fig. 9**

The last planks in each row are cut to size so that a gap of 10 mm to the wall is taken into account. You can use cut-off pieces of planks to start subsequent rows.

**Fig. 10**

Make sure that the planks in the first row are straight. Cut the first plank of the second row down to approx. 80 cm (50–60 cm for LB 150, Nadura NB 400 and MeisterDesign. comfort DB 600 S).

Fix this plank upright with the tongue as far as possible into the groove on the groove side of the previous row of planks and press the plank down slowly using a forward and downward turning motion. The plank has to click into the previously installed row.

**Fig. 11**

Similarly, the next complete plank is turned into the click connection on the long side and the head end pushed tight against the previous plank before it is lowered. Then press the plank down slowly using a forward and downward turning motion. The plank has to click into the previously installed row and the end joint with the previous plank has to be closed.

**Fig. 12**

Continue installing the panels row by row in this way. Remember that the end joints must always be offset by at least 30–40 cm (25 cm for LB 150, Nadura NB 400 and MeisterDesign. comfort DB 600 S).

**Fig. 13 + Fig. 14**

Cut the last plank in each row so that you leave a gap of approx. 10 mm to the wall. Lay the plank with the tongue side facing the wall to mark the remaining plank width.

**Fig. 15**

Taking the plank marked for width, push the plastic end tongue forward out of the end groove using the spare piece of plank.

**Fig. 16**

Begin cutting the plank to size at the end of the plastic tongue.

**Fig. 17**

After the plank has been cut to size, push the plastic tongue on the end back into the end groove. Start by laying the last row in the right-hand corner of the room (leaving at least a 10 mm gap to the wall) and angle the long side of the plank into the second-last row. The next plank is angled in the same way and lowered down at the end.

**Fig. 18**

Push the plastic tongue that is pointing out towards the wall back into the end connection using a heel bar, scraper, screw driver or similar.

**Fig. 22**

Next, remove the wooden wedges from around the walls.

**Fig. 23**

Screw the skirting board clips to the wall at intervals of 40–50 cm. To ensure that the skirting board fits tightly, do not position it on an uneven wall.

**Fig. 24**

The skirting board is placed on the clip from above and pressed down. For the length joints of the skirting boards, the clip is placed on the joint with a half overlap to ensure a good hold.

Please avoid bringing any silicone products into contact with the skirting boards.

**Fig. 19 – Fig. 21**

**To take a plank row back out again**, lift the entire row, levering it at the side out of the last row. You can then slide the planks apart at the ends. Should you wish to reuse the disassembled planks, you should first push the end plastic tongue back into the top groove so it sits flush.

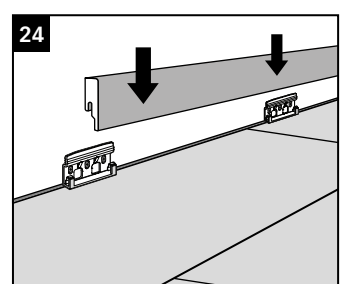
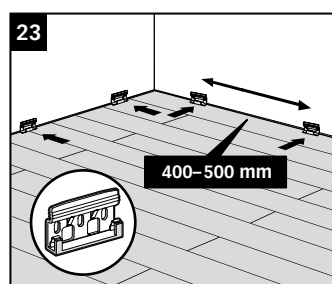
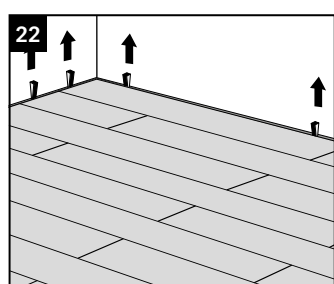
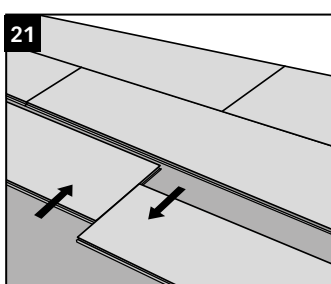
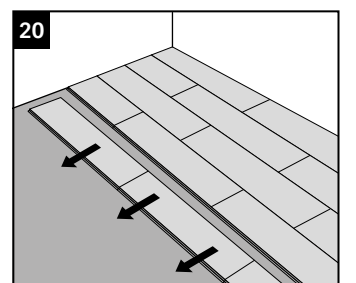
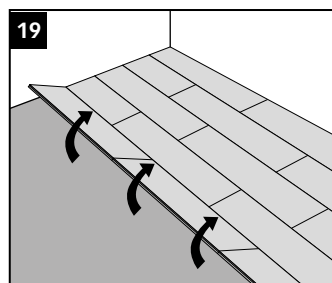
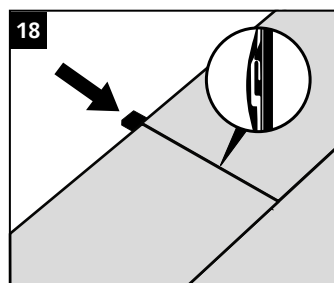
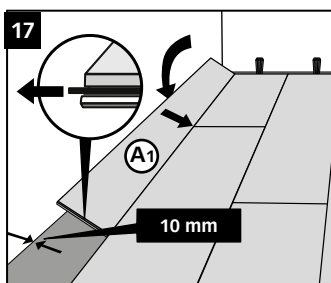
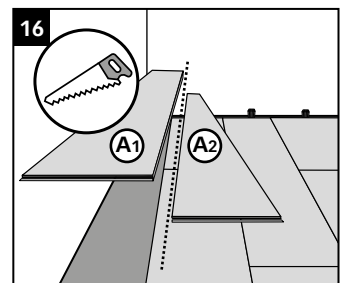
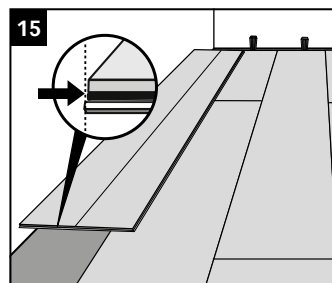
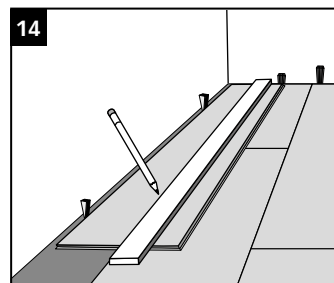
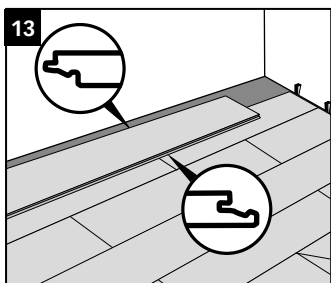
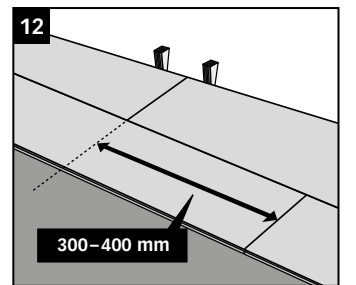
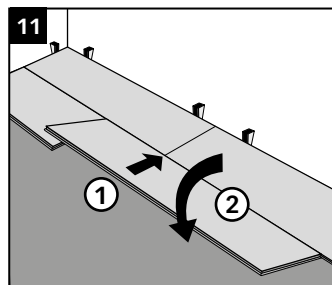
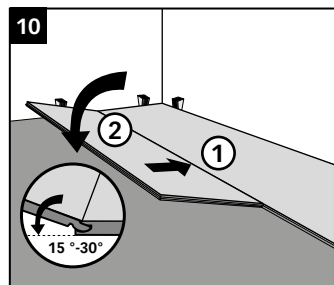
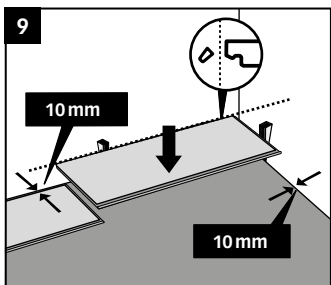
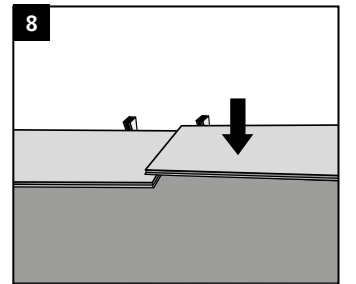
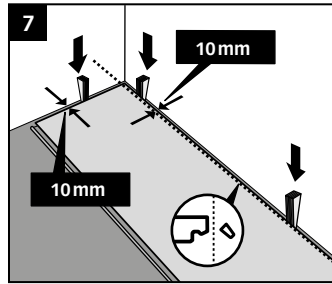
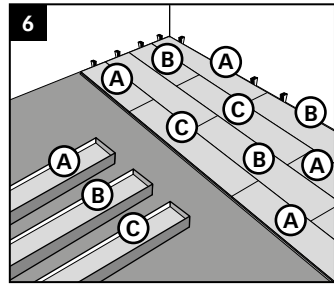
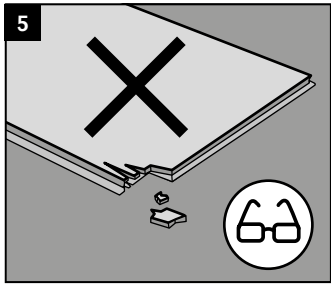
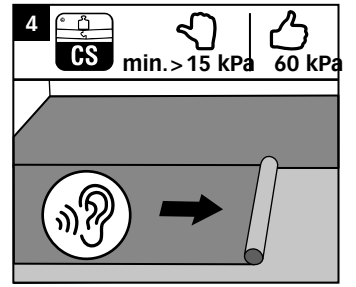
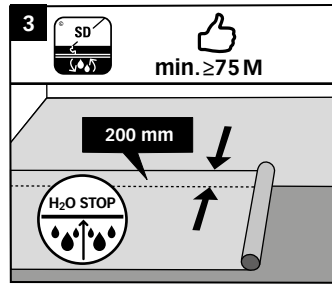
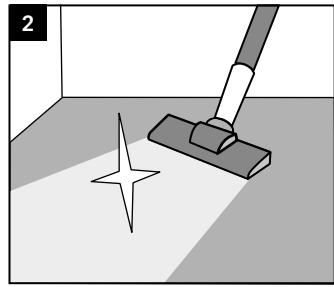
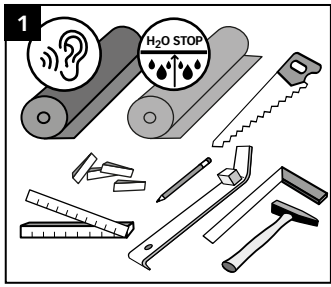
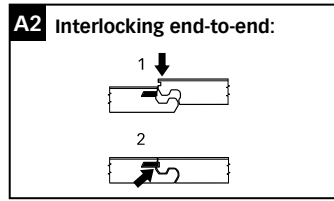
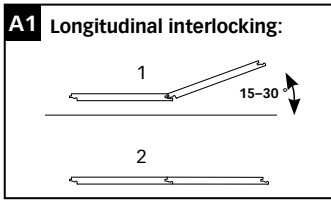

# MEISTER laminate flooring with Multiclic technology

**Fig. 1**

You need the following tools and aids to install MEISTER laminate flooring with Multiclic technology.

Hammer, keyhole or electric saw, possibly power drill, folding metre rule, pencil, wedges (spacer wedges), heel bar, angle or adjustable bevel, MEISTER tapping block, possibly PE film (0.2 mm).

Furthermore, if you are using products without a sound-absorbing Silence cushion, use the system-bound MEISTER insulating underlay. Any other insulating underlay must have a suitable pressure stability (CS value  $\geq 15$  kPa).

The flooring is installed as a floating structure without glue. The specially designed click connection allows quick and easy installation. Two different installation options are available to choose from. Option 1: Angle in the head end and long side; Option 2: Angle in the long side and join the head end using the MEISTER tapping block and several light taps with the hammer.

**Fig. 2**

Remove any dirt, small stones, etc. from the surface prior to installation.

**Fig. 3**

PE film 0.2 mm thick must be laid out to form a "bath" on all mineral substrates (except poured asphalt screed) as a vapour barrier. The strip edges must overlap by at least 20 cm and the overlapping edges must be masked off. Alternatively, the option is available to use MEISTER insulating underlay with integrated vapour barrier.

**Fig. 4**

Lay the corresponding MEISTER insulating underlay with a pressure resistance of  $> 15$  kPa in the private residential sector or  $> 60$  kPa in the commercial sector.

**Fig. 5**

Before installation, check all planks in daylight for recognisable faults in colour and structure. Goods already installed cannot be claimed for later.

**Fig. 6**

Install a mixture of planks from different packages.

**Fig. 7**

When sawing the elements, make sure you work from the correct side: if you use a bench saw, keep the decorative side facing up, if you use a keyhole or portable circular saw, keep the decorative side down.

Start by laying the first complete plank in the

left-hand corner of the room with the tongue sides facing the wall. Saw the tongues off the first plank, both on the short and the long side. Remove only the tongues on the long sides of all the other planks you want to lay in the first row.

**Fig. 8**

Using wedges, you can easily keep a gap of at least 10 mm from the wall.

**Fig. 9**

Angle the end of the next complete plank into the end of plank 1. Install the other planks in this row in exactly the same way across the entire width of the room.

**Fig. 10 + Fig. 14**

The last planks in each row are cut to size so that a gap of 10 mm to the wall is taken into account. You can use cut-off pieces of planks to start subsequent rows.

**Option 1**

Make sure that the planks in the first row are straight. Cut the first plank of the second row down to approx. 80 cm.

**Fig. 11**

Angle the head end of the next complete plank into the end of the previous plank.

**Fig. 12 + Fig. 13**

Once you have angled in all of the planks in a row, angle them into the previously laid row and press them down slowly using a forward and downward turning motion. The row of planks has to click into the previously installed row. Alternatively, you can angle in the head end of each individual plank first and then connect the long side by slightly raising it and angling it into the previous row. Continue installing the panels row by row in this way.

**Option 2****Fig. 15**

Cut the first plank of the second row down to approx. 80 cm. Angle this plank with the tongue into the groove side of the previous row of planks and press the plank down slowly using a forward and downward turning motion. The plank has to click into the previously installed row.

Again, angle the next complete plank of the second row first on its long edge against the previously laid row. Make sure the long joint is always tight.

**Fig. 16**

Once you have angled in the plank so it lies flat on the subfloor, click the head ends together using the MEISTER tapping block and light taps with the hammer. Continue installing the panels row by row in this way.

**Fig. 17**

Remember that the end joints must always be offset by at least 30–40 cm.

**Fig. 18 + Fig. 19**

The last planks in each row are cut to size so that a gap of 10 mm to the wall is taken into account. Lay the plank with the tongue side facing the wall to mark the remaining plank width.

**Fig. 20**

Start by laying the last row in the right-hand corner of the room and angle the long side of the plank into the second-last row.

**Fig. 21**

The next plank is angled in along the long side and lowered down in the same way. The head-end connection is then established with the help of a heel bar and several light taps with the hammer.

**Fig. 25**

Next, remove the wooden wedges from around the walls.

**Fig. 26**

Screw the skirting board clips to the wall at intervals of 40–50 cm. To ensure that the skirting board fits tightly, do not position it on an uneven wall.

**Fig. 27**

The skirting board is placed on the clip from above and pressed down. For the length joints of the skirting boards, the clip is placed on the joint with a half overlap to ensure a good hold.

Please avoid bringing any silicone products into contact with the skirting boards.

**Fig. 22 – Fig. 24**

**To take a plank row back out again,** lift the entire row, levering it at the side out of the last row. Then you can separate the head ends of the planks by angling them. This way, the locking system remains intact and the planks can be refitted.



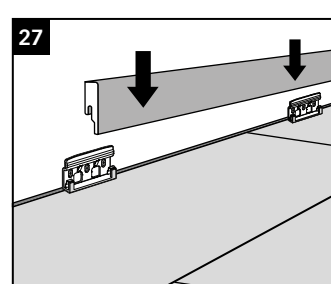
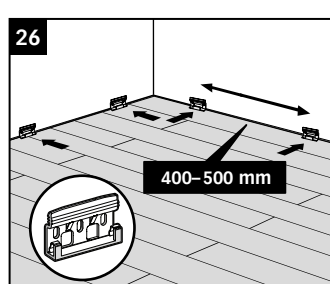
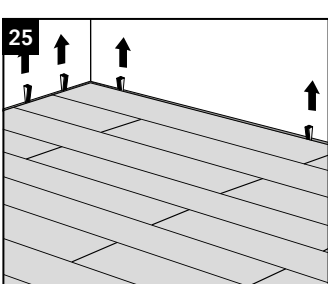
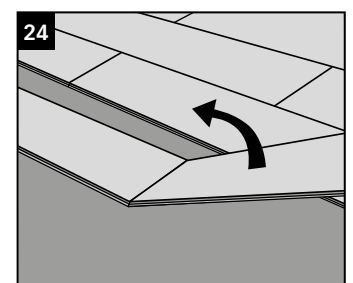
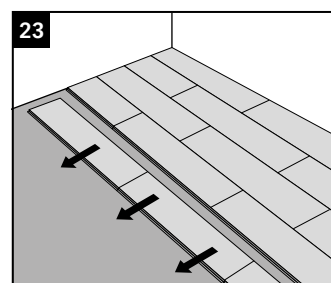
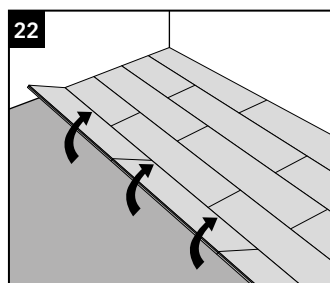
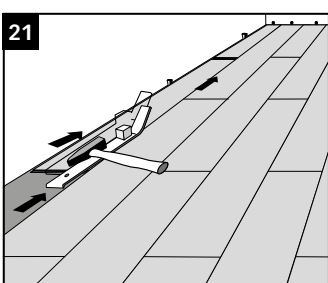
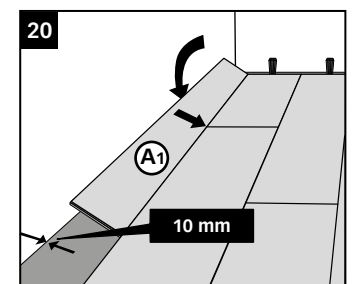
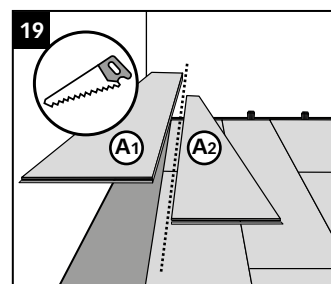
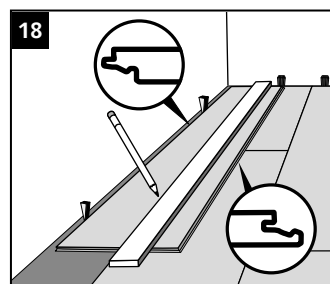
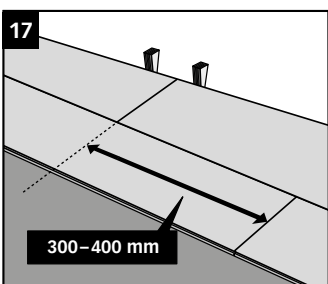
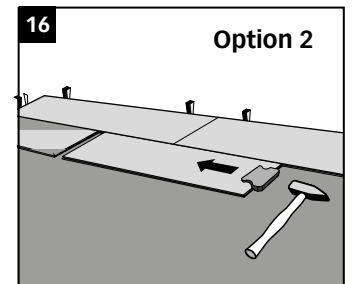
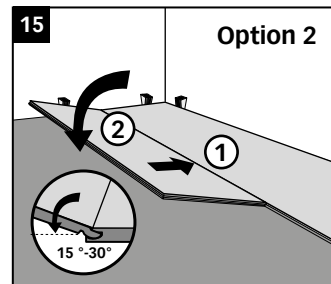
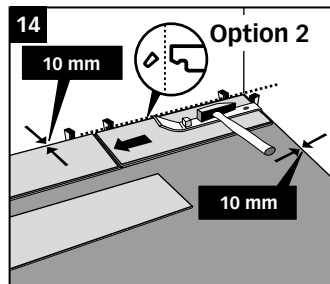
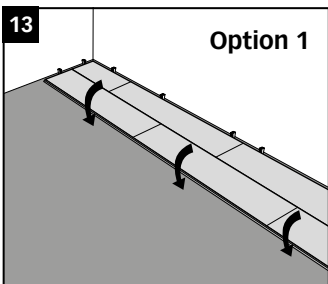
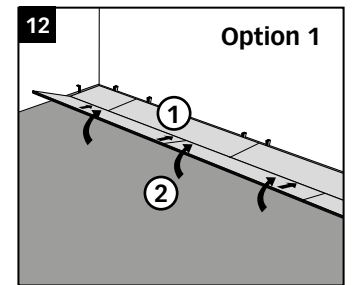
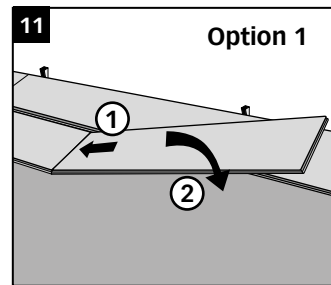
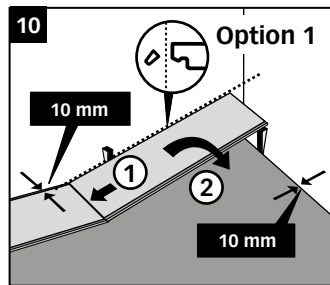
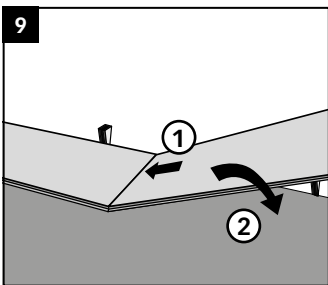
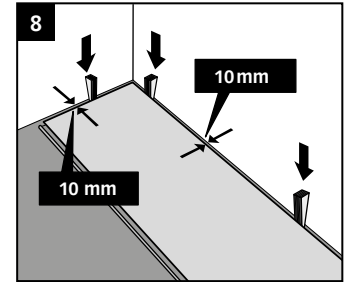
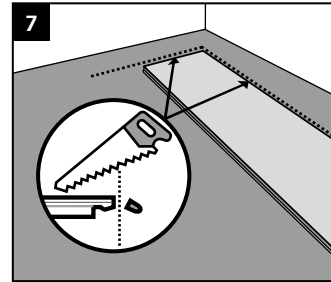
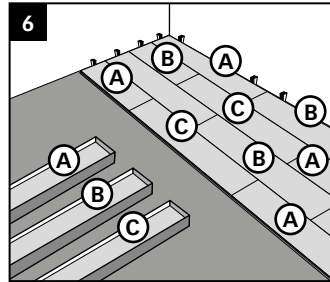
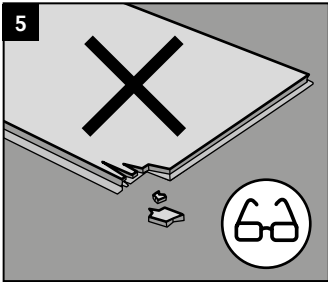
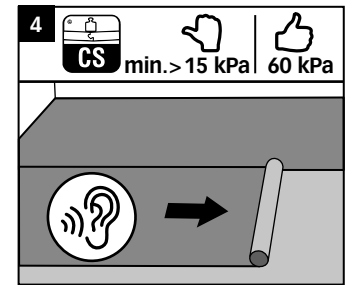
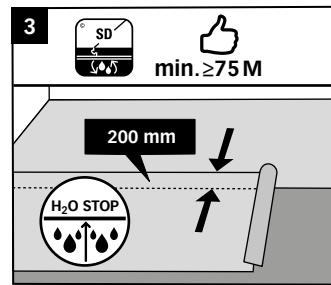
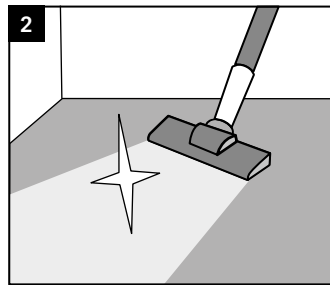
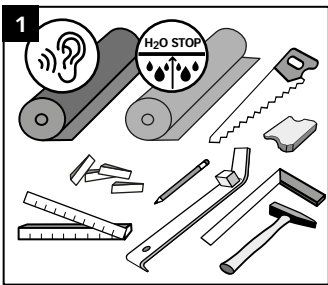

# MEISTER design flooring MeisterDesign. flex with Multiclic technology

**Fig. 1**

You need the following tools and aids for installing MEISTER design flooring with Multiclic technology:

Hammer, keyhole or electric saw, possibly power drill, folding metre rule, pencil, wedges (spacer wedges), heel bar, angle or adjustable bevel, MEISTER 5 mm tapping block, possibly PE film (0.2 mm).

Furthermore, if you are using products without a sound-absorbing Silence cushion, use the system-bound MEISTER insulating underlay. Any other insulating underlay must have a suitable pressure stability (CS value  $\geq 60$  kPa).

The flooring is installed as a floating structure without glue. The specially designed click connection allows quick and easy installation. Two different installation options are available to choose from. Option 1: Angle in the head end and long side; Option 2: Angle in the long side and join the head end using the MEISTER 5 mm tapping block and several light taps with the hammer.

**Fig. 2**

Remove any dirt, small stones, etc. from the surface prior to installation.

**Fig. 3**

PE film 0.2 mm thick must be laid out to form a "bath" on all mineral substrates (except poured asphalt screed) as a vapour barrier. The strip edges must overlap by at least 20 cm and the overlapping edges must be masked off. Alternatively, the option is available to use MEISTER insulating underlay with integrated vapour barrier.

**Fig. 4**

Lay the corresponding MEISTER insulating underlay with a pressure resistance of  $> 60$  kPa.

**Fig. 5**

Before installation, check all planks in daylight for recognisable faults in colour and structure. Goods already installed cannot be claimed for later.

**Fig. 6**

Install a mixture of planks from different packages.

**Fig. 7**

When sawing the elements, make sure you work from the correct side: if you use a bench saw, keep the decorative side facing up, if you use a keyhole or portable circular saw, keep the decorative side down. Start by laying the first complete plank in the left-hand corner of the room with the tongue sides facing the wall. Saw the tongues off the first plank, both on the short and the long side. Remove only the tongues on the long

sides of all the other planks you want to lay in the first row.

**Fig. 8**

Using wedges, you can easily keep a gap of at least 10 mm from the wall.

**Fig. 9**

Angle the end of the next complete plank into the end of plank 1. Install the other planks in this row in exactly the same way across the entire width of the room.

**Fig. 10 + Fig. 14**

The last planks in each row are cut to size so that a gap of 10 mm to the wall is taken into account. You can use cut-off pieces of planks to start subsequent rows.

**Option 1**

Make sure that the planks in the first row are straight. Cut the first plank of the second row down to approx. 80 cm (50–60 cm for MeisterDesign. flex DB 400).

**Fig. 11**

Angle the head end of the next complete plank into the end of the previous plank.

**Fig. 12 + Fig. 13**

Once you have angled in all of the planks in a row, angle them into the previously laid row and press them down slowly using a forward and downward turning motion. The row of planks has to click into the previously installed row. Alternatively, you can angle in the head end of each individual plank first and then connect the long side by slightly raising it and angling it into the previous row. Continue installing the panels row by row in this way.

**Option 2****Fig. 15**

Cut the first plank of the second row down to approx. 80 cm. Angle this plank with the tongue into the groove side of the previous row of planks and press the plank down slowly using a forward and downward turning motion. The plank has to click into the previously installed row.

Again, angle the next complete plank of the second row first on its long edge against the previously laid row. Make sure the long joint is always tight.

**Fig. 16**

Once you have angled in the plank so it lies flat on the subfloor, click the head ends together using the MEISTER 5 mm tapping block and light taps with the hammer. Continue installing the panels row by row in this way.

**Fig. 17**

Remember that the end joints must always be offset by at least 30–40 cm (25 cm for MeisterDesign. flex DB 400).

**Fig. 18 + Fig. 19**

The last planks in each row are cut to size so that a gap of 10 mm to the wall is taken into account. Lay the plank with the tongue side facing the wall to mark the remaining plank width.

**Fig. 20**

Start by laying the last row in the right-hand corner of the room and angle the long side of the plank into the second-last row.

**Fig. 21**

The next plank is angled in along the long side and lowered down in the same way. The head-end connection is then established with the help of a heel bar and several light taps with the hammer.

**Fig. 25**

Next, remove the wooden wedges from around the walls.

**Fig. 26**

Screw the skirting board clips to the wall at intervals of 40–50 cm. To ensure that the skirting board fits tightly, do not position it on an uneven wall.

**Fig. 27**

The skirting board is placed on the clip from above and pressed down. For the length joints of the skirting boards, the clip is placed on the joint with a half overlap to ensure a good hold.

Please avoid bringing any silicone products into contact with the skirting boards.

**Fig. 22 – Fig. 24**

**To take a plank row back out again,** lift the entire row, levering it at the side out of the last row. Then you can separate the head ends of the planks by angling them. This way, the locking system remains intact and the planks can be refitted.

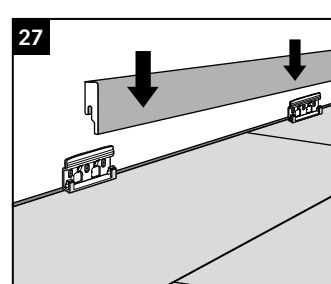
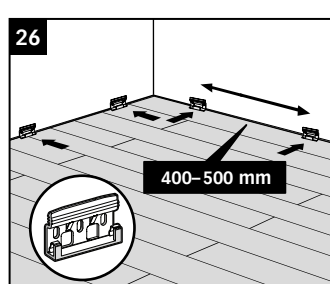
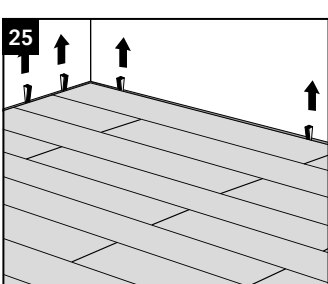
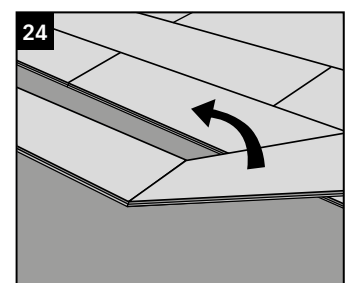
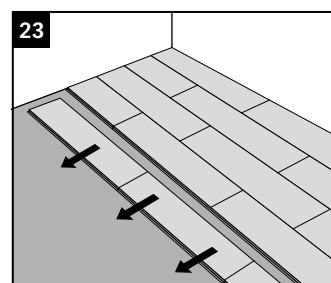
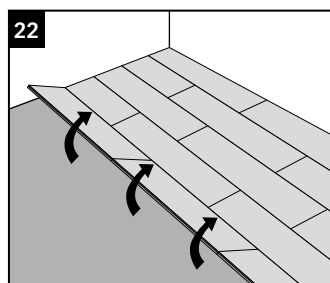
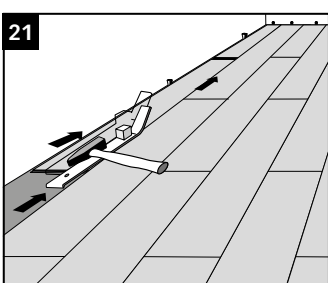
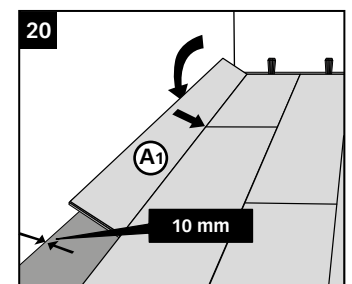
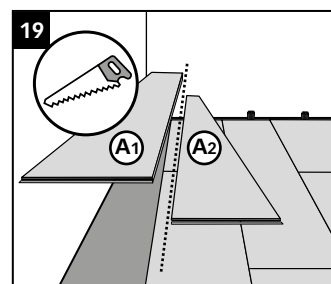
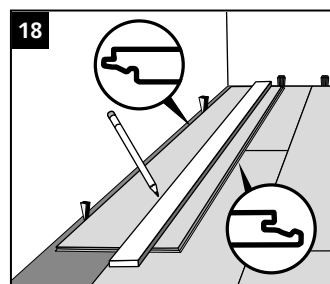
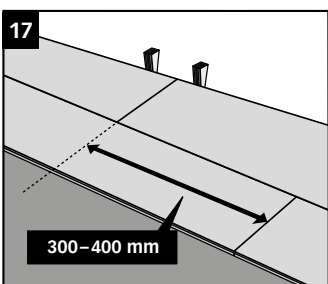
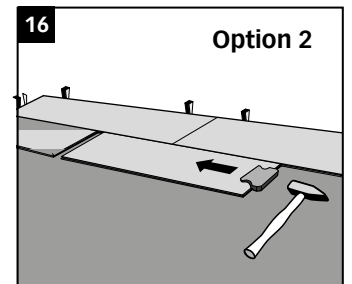
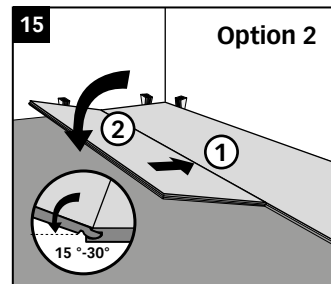
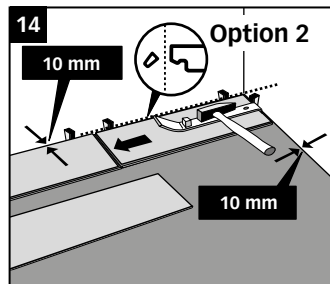
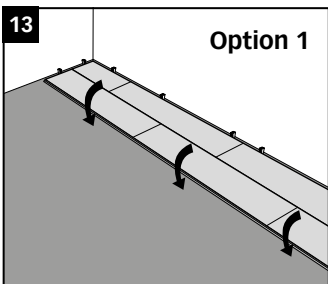
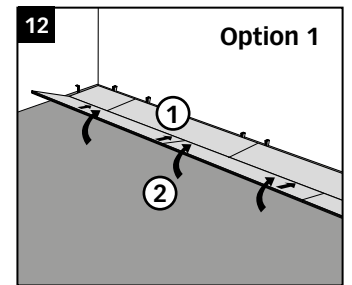
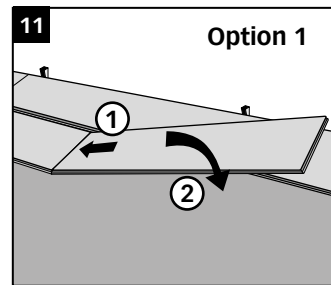
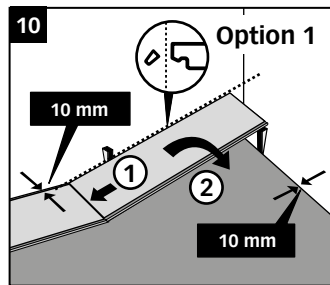
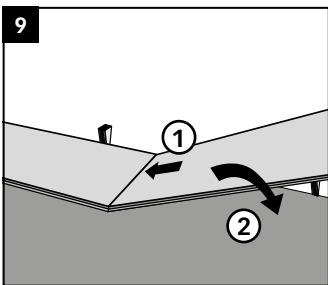
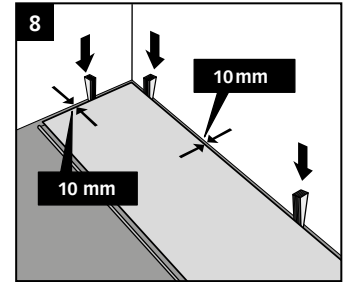
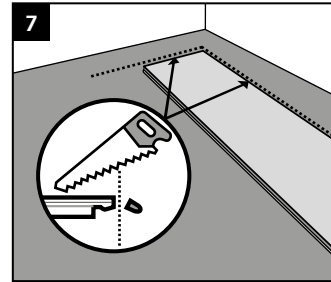
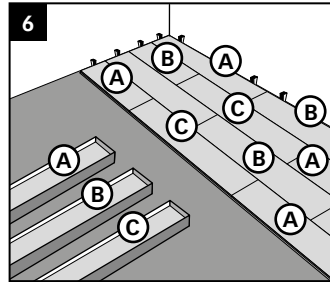
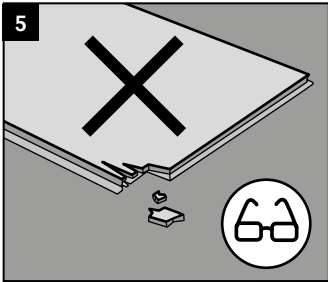
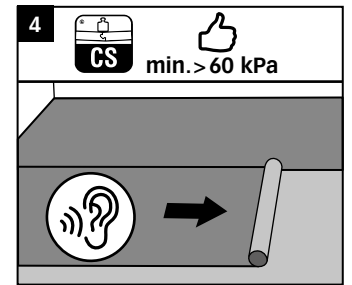
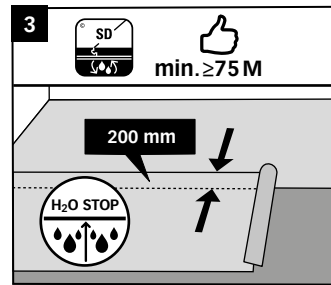
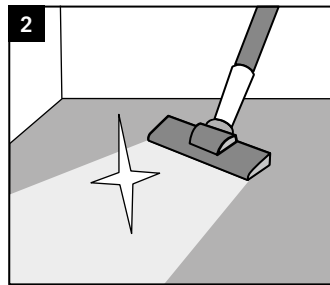
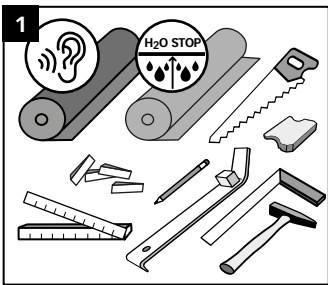

# MEISTER design flooring MeisterDesign. rigid with Multiclic technology



**Fig. 1**

You need the following tools and aids for installing MEISTER design flooring MeisterDesign. rigid with Multiclic technology:

Hammer, installation knife with trapezoidal blade, keyhole or electric saw, possibly power drill, folding metre rule, pencil, wedges (spacer wedges), heel bar, angle or adjustable bevel, MEISTER 5 mm tapping block.

If the product does not already feature a Silence backing, you must use the system-oriented MEISTER insulating underlay Silence-Compact (CS value > 400 kPa) as a cushioning layer. Other types of insulating underlay must meet the increased requirements in accordance with the technical bulletin "TM 1" from MMFA for Class 2 (polymer) floor coverings.

The flooring is installed as a floating structure without glue. The specially designed click connection allows quick and easy installation. Two different installation options are available to choose from. Option 1: Angle in the head end and long side; Option 2: Angle in the long side and join the head end using the MEISTER 5 mm tapping block and several light taps with the hammer.

**Fig. 2**

Remove any dirt, small stones, etc. from the surface prior to installation.

**Fig. 3**

Before installation, check all planks in daylight for recognisable faults in colour and structure. Goods already installed cannot be claimed for later.

**Fig. 4**

Install a mixture of planks from different packages.

You can score the planks with an installation knife (trapezoidal blade) once or twice and then fold them down. Sawing with a jig saw or portable circular saw or snapping with a guillotine cutter are also possible. When sawing the elements, make sure you work from the correct side: if you use a bench saw, keep the decorative side facing up, if you use a keyhole or portable circular saw, keep the decorative side down.

**Fig. 5**

Start by laying the first complete plank in the left-hand corner of the room with the tongue sides facing the wall. Saw the tongues off the first plank, both on the short and the long side. Remove only the tongues on the long sides of all the other planks you want to lay in the first row.

**Fig. 6**

Using wedges, you can easily keep a gap of at least 10 mm from the wall.

**Fig. 7**

Angle the end of the next complete plank into the end of plank 1. Install the other planks in this row in exactly the same way across the entire width of the room.

**Fig. 8 – Fig. 10**

Cut the last plank in each row so that you leave a gap of at least 5mm to the wall. You can score the planks with an installation knife (trapezoidal blade) once or twice and then fold them down. You can use cut-off pieces of planks to start subsequent rows.

**Option 1**

Make sure that the planks in the first row are straight. Cut the first plank of the second row down to approx. 80 cm (50–60 cm for MeisterDesign. rigid RB 400 S).

**Fig. 11**

Angle the head end of the next complete plank into the end of the previous plank.

**Fig. 12 + Fig. 13**

Once you have angled in all of the planks in a row, angle them into the previously laid row and press them down slowly using a forward and downward turning motion. The row of planks has to click into the previously installed row. Alternatively, you can angle in the head end of each individual plank first and then connect the long side by slightly raising it and angling it into the previous row. Continue installing the panels row by row in this way.

**Option 2**

**Fig. 15**

Cut the first plank of the second row down to approx. 80 cm. Angle this plank with the tongue into the groove side of the previous row of planks and press the plank down slowly using a forward and downward turning motion. The plank has to click into the previously installed row.

**Fig. 16**

Again, angle the next complete plank of the second row first on its long edge against the previously laid row. Make sure the long joint is always tight.

**Fig. 17**

Once you have angled in the plank so it lies flat on the subfloor, click the head ends together using the MEISTER 5 mm tapping block and light taps with the hammer. Continue installing the panels row by row in this way.

**Fig. 18**

Remember that the end joints must always be offset by at least 30–40 cm (25 cm for MeisterDesign. rigid RB 400 S).

**Fig. 19 + Fig. 20**

The last planks in each row are cut to size so that a gap of 10 mm to the wall is taken into account. Lay the plank with the tongue side facing the wall to mark the remaining plank width.

**Fig. 21**

Start by laying the last row in the right-hand corner of the room and angle the long side of the plank into the second-last row.

**Fig. 22**

The next plank is angled in along the long side and lowered down in the same way. The head-end connection is then established with the help of a heel bar and several light taps with the hammer.

**Fig. 26**

Next, remove the wooden wedges from around the walls.

**Fig. 27**

Screw the skirting board clips to the wall at intervals of 40–50 cm. To ensure that the skirting board fits tightly, do not position it on an uneven wall.

**Fig. 28**

The skirting board is placed on the clip from above and pressed down. For the length joints of the skirting boards, the clip is placed on the joint with a half overlap to ensure a good hold.

Please avoid bringing any silicone products into contact with the skirting boards.

**Fig. 23 – Fig. 25**

**To take a plank row back out again,** lift the entire row, levering it at the side out of the last row. Then you can separate the head ends of the planks by angling them. This way, the locking system remains intact and the planks can be refitted.

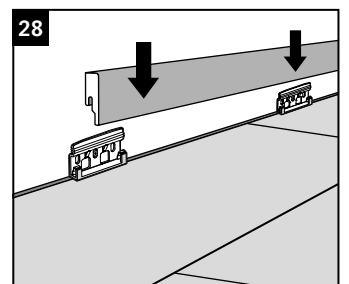
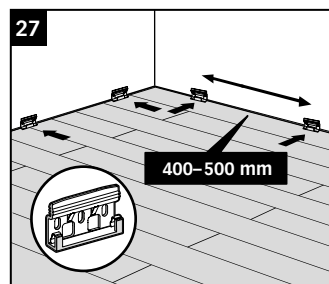
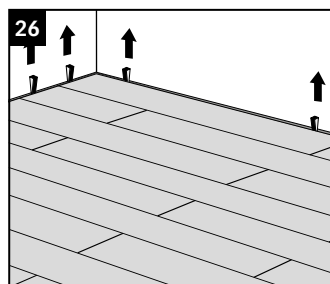
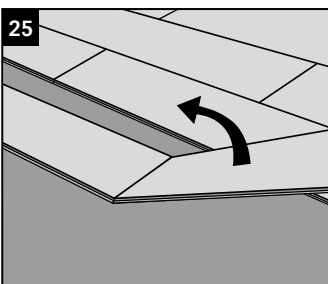
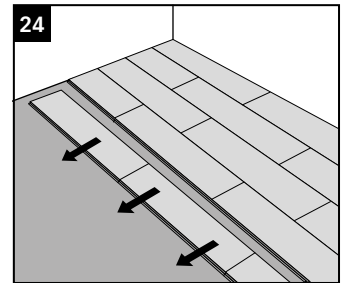
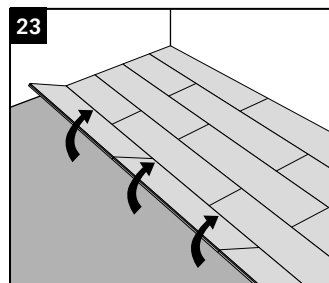
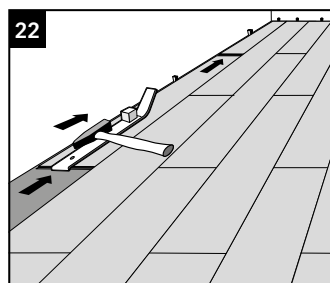
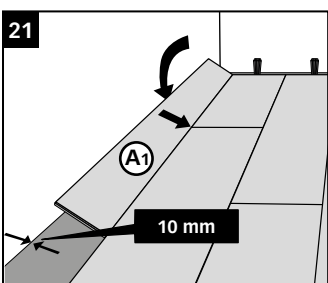
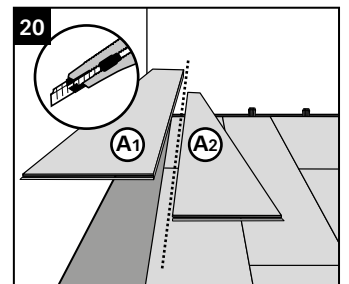
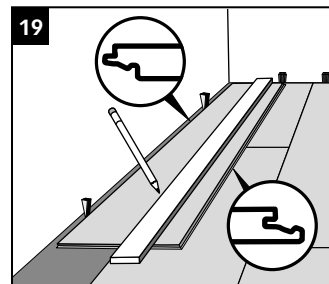
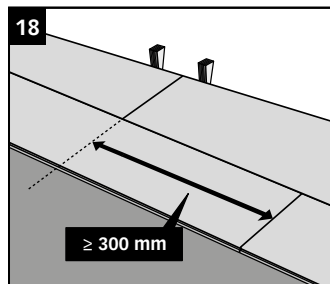
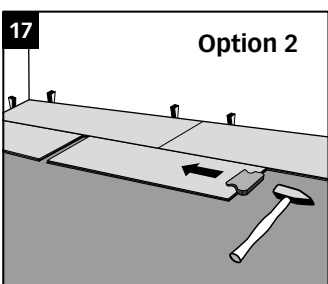
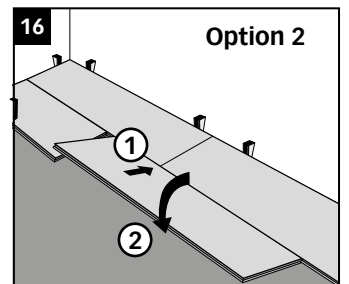
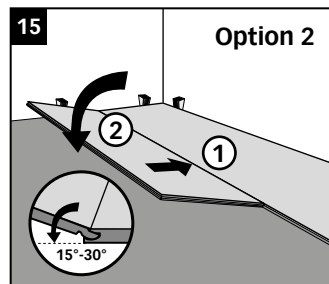
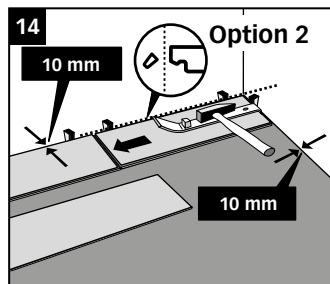
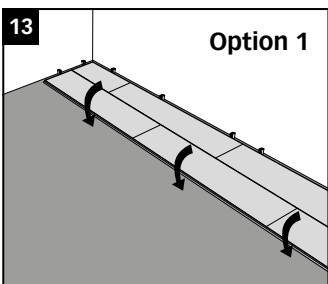
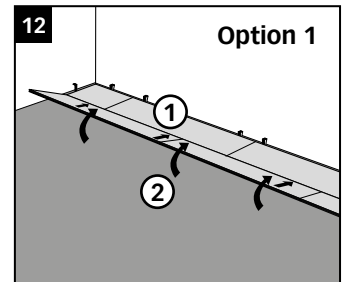
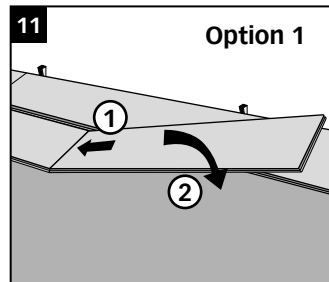
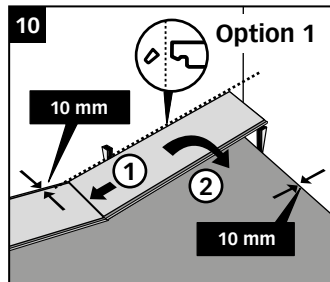
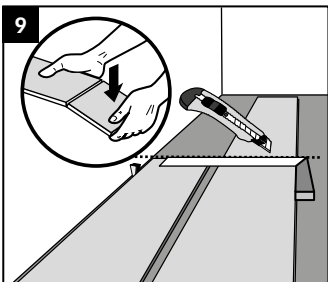
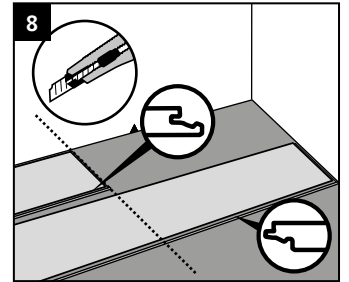
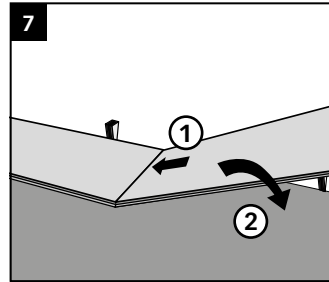
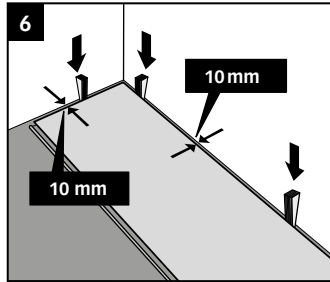
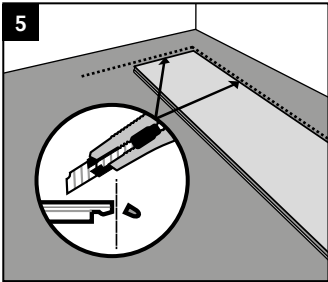
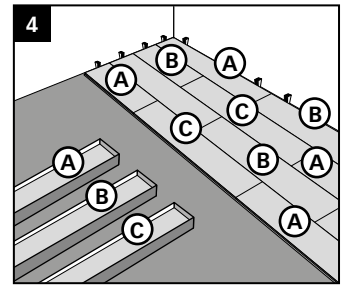
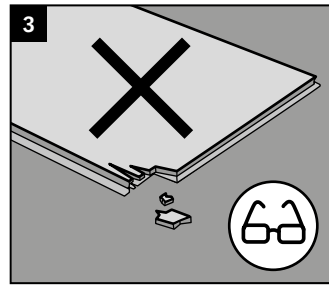
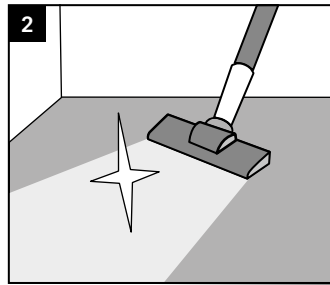
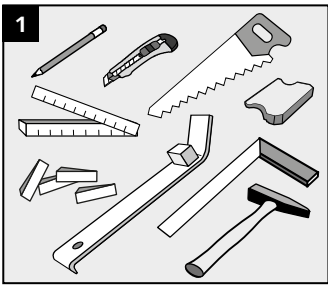

# MEISTER Design flooring MeisterDesign. life with Maxiclic technology



DE 102005012827

**Fig. 1**

You need the following tools and aids for installing MEISTER design flooring with Maxiclic technology: Rubber hammer with a white head (non-marking), installation knife with trapezoidal blade, jig saw or electric saw, folding metre rule, pencil, spacer wedges, angle or adjustable bevel. If the product does not already feature a Silence backing, you must use the system-oriented MEISTER insulating underlay SilenceCompact (CS value > 400 kPa) as a cushioning layer. Other types of insulating underlay must meet the increased requirements in accordance with the technical bulletin "TM 1" from MMFA for Class 2 (polymer) floor coverings.

**Fig. A1 + A2**

The flooring is installed as a floating structure without glue. The specially designed click connection Maxiclic (fold-down system) allows quick and easy installation. The long side of the plank is angled with the tongue side into the groove of the previous row and lowered into the previous plank at the end. The Maxiclic connection at the head end is then locked by tapping it into place with a white rubber hammer.

**Fig. 2**

Remove any dirt, small stones, etc. from the surface prior to installation.

**Fig. 3**

Lay the corresponding MEISTER insulating underlay with a pressure resistance of > 400 kPa.

**Fig. 4**

Before installation, check all planks in daylight for recognisable faults in colour and structure. Goods already installed cannot be claimed for later.

**Fig. 5**

Install a mixture of planks from different packages.

You can score the planks with an installation knife (trapezoidal blade) once or twice and then fold them down. Sawing with a jig saw or portable circular saw or snapping with a guillotine cutter are also possible. When sawing the elements, make sure you work from the correct side: if you use a bench saw, keep the decorative side facing up, if you use a keyhole or portable circular saw, keep the decorative side down.

**Fig. 6 + Fig. 7**

Start by laying the first complete plank in the left-hand corner of the room with the tongue sides facing the wall. Remove only the tongues on the long sides of all the other planks you want to lay in the first row. Using wedges, you can easily keep a gap of at least 5 mm from the wall.

**Fig. 8**

Insert the next complete plank into the head end of plank 1 and lock them in place by tapping them in with a white rubber hammer. Install the other planks in this row in exactly the same way across the entire width of the room.

**Fig. 9 – Fig. 11**

Cut the last plank in each row so that you leave a gap of at least 5mm to the wall. You can score the planks with an installation knife (trapezoidal blade) once or twice and then fold them down. You can use cut-off pieces of planks to start subsequent rows.

**Fig. 12**

Make sure that the planks in the first row are straight. Cut the first plank of the second row down to approx. 80cm (in the case of DB 800 to approx. 50-60 cm). Angle this plank with the tongue into the groove side of the previous row of planks and press the plank down slowly using a forward and downward turning motion.

**Fig. 13**

Again, angle the next complete plank of the second row first on its long edge against the previously laid row and press it tight to the head end of the previous plank before lowering it. Then press the plank down slowly using a forward and downward turning motion.

**Fig. 14**

The head end connection is established by tapping it into place with a white rubber hammer.

**Fig. 15**

Continue installing the panels row by row in this way. Remember that the end joints must be offset by at least 30 cm (approx. 20 cm for DB 800).

**Fig. 16 + Fig. 17**

Cut the last plank in each row so that you leave a gap of at least 5mm to the wall. Lay the plank with the tongue side facing the wall to mark the remaining plank width.

**Fig. 18**

Start by laying the last row in the right-hand corner of the room and angle the long side of the plank into the second-last row. The next plank is turned in on the long side as before and lowered at the head end into the previous plank.

**Fig. 19**

Locking at the head end is again through blows with the rubber hammer.

**Fig. 23**

Finally, remove the spacer wedges from around the walls.

**Fig. 24**

Screw the skirting board clips to the wall at intervals of 40–50 cm. To ensure that the skirting board fits tightly, do not position it on an uneven wall.

**Fig. 25**

The skirting board is placed on the clip from above and pressed down. For the length joints of the skirting boards, the clip is placed on the joint with a half overlap to ensure a good hold. Please avoid any silicon products coming into contact with the mouldings.

**Fig. 20 – Fig. 22**

To take a plank row back out again, lift the entire row, levering it at the side out of the last row. Afterwards you can slide the ends of the planks apart. This way, the locking system remains intact and the planks can be refitted.

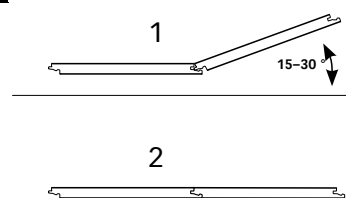
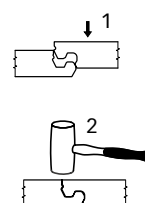
**A1 Longitudinal interlocking:****A2 Interlocking end-to-end:**

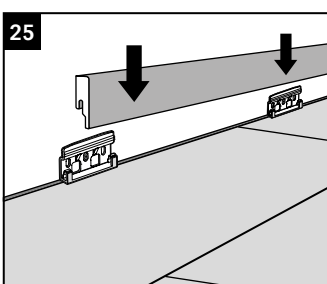
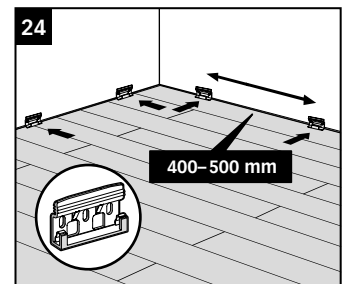
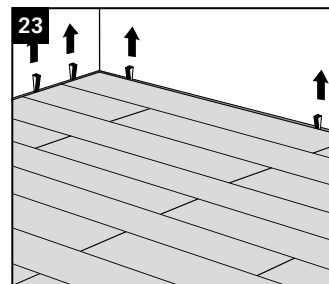
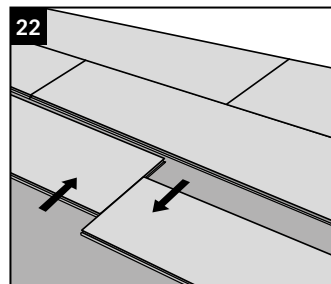
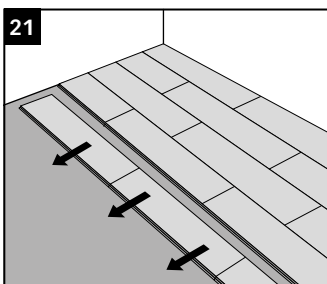
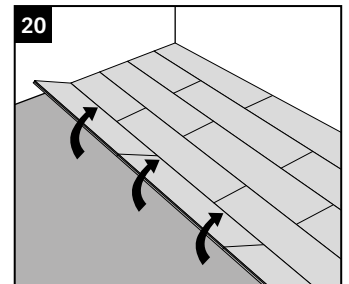
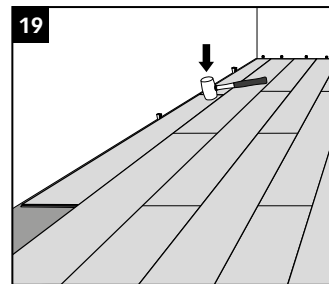
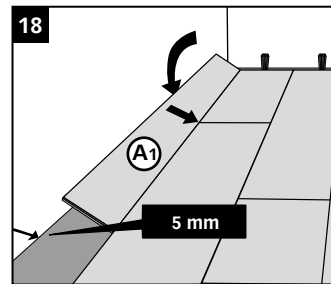
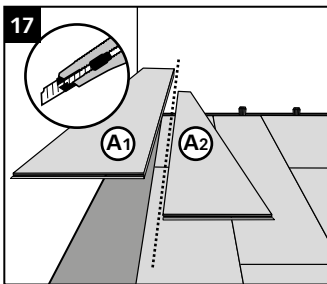
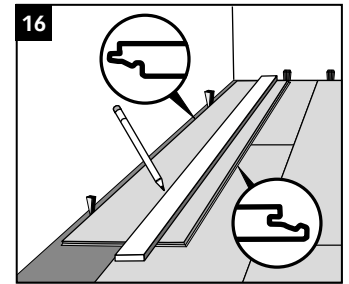
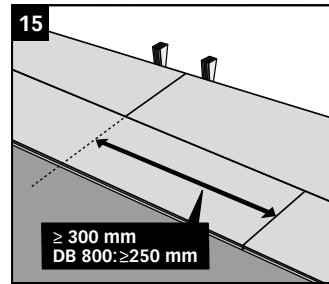
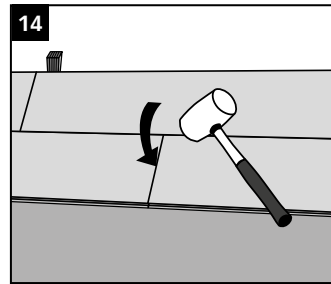
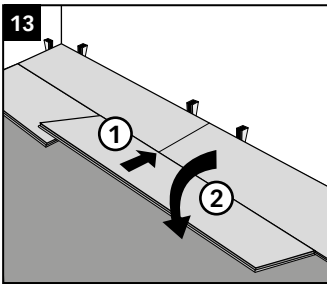
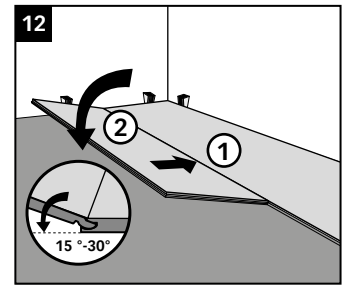
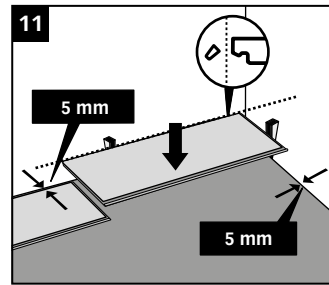
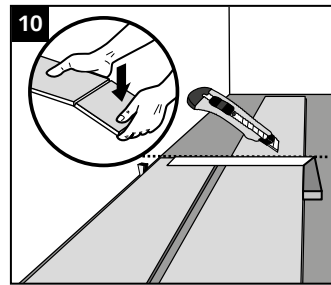
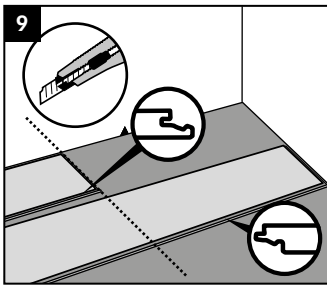
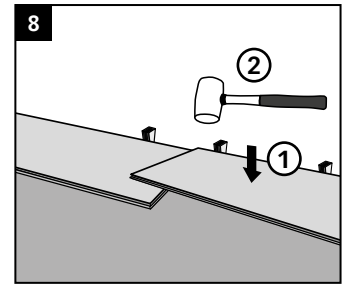
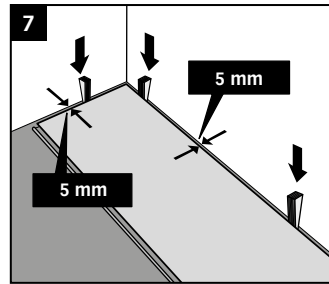
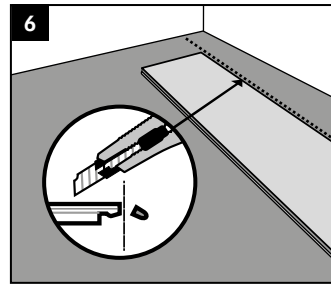
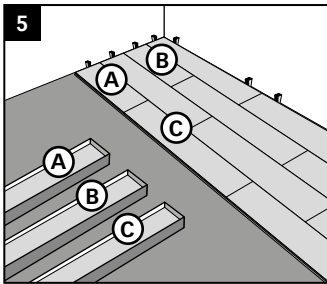
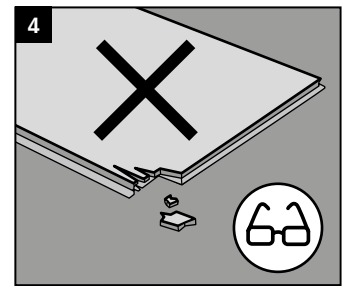
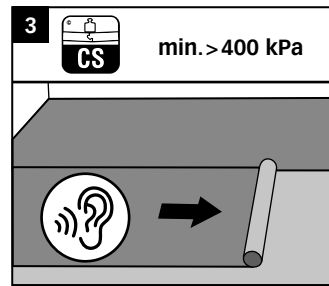
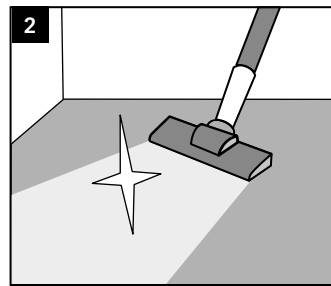
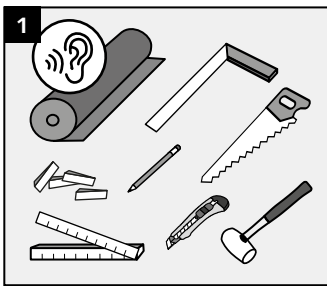

# MeisterDesign. life, MeisterDesign. pro, MeisterDesign. rigid, MeisterDesign. flex, MeisterDesign. comfort, Nadura® and laminate (except LC 55 | LD 55) in humid rooms

The laying instructions for Masterclac Plus, Maxiclic or Multiclic technology (see pages 14 to 23) and the general notes and preparatory measures must be observed.

**The term "humid rooms" (Class W0-I) refers to all rooms with higher but not permanent moisture and/or with periodically high humidity, e.g. bathrooms. This does not include outdoor areas and wet rooms, e.g. saunas, shower cubicles, steam rooms and rooms with a floor drain.**

**Please note: Do not leave puddles of water/spills to dry on the surface; wipe up and wipe dry immediately (within 4 hours – or within 24 hours for Nadura flooring and laminate LL 250/LD 250).**

In addition, any parts of the flooring which come into contact with sanitary cleaners, chemicals etc. must be wiped with clear water without delay.

Care must always be taken that no humidity gets under the flooring. **In the case of Nadura flooring and MeisterDesign. life, we recommend using full surface bonding**, in which case the wall ends and edge areas must be sealed with plasticiser-free silicone or natural stone silicone, for example. Structural measurements also have to be taken for floating installations. Edge joints are generally necessary to guarantee the flooring can expand, particularly in rooms with high humidity.

Wall ends and edge areas should preferably be fitted with suitable end, transition or joining profiles made of aluminium. To ensure the necessary seal against liquids, a pre-compressed PE sealing tape without plasticisers can be used, for example. This tape is glued under the cover profile. Once this has been screwed to the base profile, the result is a sealed finish with the flooring. The bottom profile must be glued to the adhesive and sealing tape of the respective sound-absorbing cushion.

Joints between the profile and the wall must be sealed water-impermeably using a permanently flexible sealing compound (plasticiser-free silicone). This also applies to the wall and edge areas where none of the above-mentioned aluminium profiles can be used. In such areas, a PE joint filler cord (plasticiser-free) must be used as to finish off. These expansion joints must also be sealed with sealing compound to prevent humidity penetration. Joints in the edge and wall area must always have a width of 10 mm to fixed building structures.

**This is a maintenance joint which, as a flexible joint, requires permanent maintenance and care. The term maintenance joint is used for all those joints which are exposed to heavy chemical and/or physical influences and whose sealants must be checked at regular intervals and renewed if necessary in order to avoid consequential damage.**

## With end profile

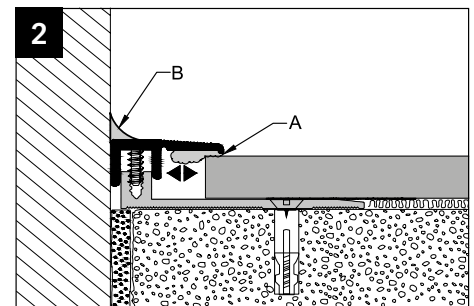
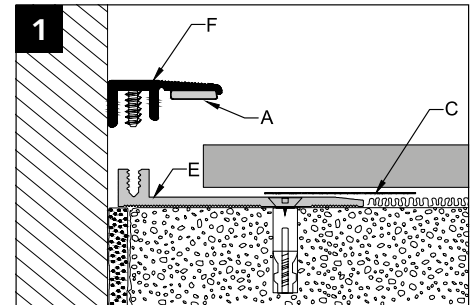

## Without end profile

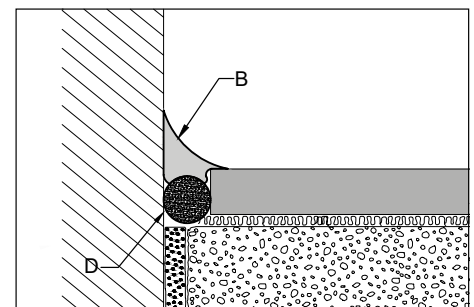

## With waterproof skirting board 20 PK Aqua profile

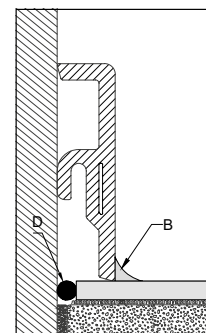

- A – Pre-compressed and plasticiser-free PE sealing tape
- B – Maintenance joint, permanently flexible, plasticiser-free silicone
- C – Adhesive tape for sound-absorbing cushion
- D – PE joint filler cord, plasticiser-free
- E – Bottom profile
- F – Cover profile



# Briefing note

## Home conservatories

Home conservatories are conservatories designed for year-round use as a recreation room, meaning they have to be capable of being heated to comfortable temperatures (more than 19°C). This means that, even in winter, the temperature must not fall below 15°C.

Solar heating in summer is limited by natural shading and/or structural measures such as ventilation, suitable glazing and sun protection depending on the local conditions and orientation of the home conservatory to avoid excessive temperature fluctuations in the floor.

The climatic conditions in the room also have to be taken into account:

- | Climate during installation: The room air temperature should be 20°C (at least 15°C) with a relative humidity of 30–65%
- | Permanent indoor climate: Room air temperature 18–22°C, relative humidity of 30–65%

The surface temperature of the floor must not permanently exceed 29°C.

The flooring may only be installed on a sub-floor that complies with the specifications of DIN 18356 "Parquet works" and DIN 18365 "Flooring works".

- | The sub-structure is permanently protected against rising damp from the ground.
- | The sub-structure is insulated in a way that precludes damage due to temperature differences or condensation.
- | In the case of screeds, the residual moisture values must be checked and maintained by taking CM measurements prior to laying:
  - | Heated/unheated cement screed: 1.8 CM% / 2.0 CM%,
  - | Heated/unheated calcium sulphate screed: 0.3 CM% / 0.5 CM%
- | The subfloor must be checked to ensure it is ready for laying. Above all, this must be smooth, dry, clean, free of cracks and release agents, and able to withstand lifting and pressing force.

If a levelling compound is applied to the subfloor then it is essential to observe the prescribed climatic conditions for the room, the necessary subfloor preparation (sanding, priming, etc.) and the drying times.

The packages must be acclimatised before you open them. Store them for approx. 48 hours (approx. 3–4 days in winter) unopened and flat on the floor in the centre of the room you want to work in.

For full surface bonding, it is essential to observe the manufacturer's requirements (regarding climatic conditions for the room, open time, sufficient quantity of the suitable adhesive, etc.).

The lightfastness of MEISTER flooring (with the exception of parquet and Lindura wood flooring) has been tested according to test standard EN ISO 105-B02 and meets the highest requirements. Nevertheless, the possibility of colour changes due to strong and persistent solar radiation cannot be excluded.

The product-specific installation instructions must be observed.

# Flooring profiles

If the floor area is longer or wider than 10 m (or longer or wider than 15 m for MeisterDesign. life and MeisterDesign. rigid) then you must provide an expansion joint. This is covered with a transition profile. Please also be aware of this in doorways, passageways and rooms with

many angles (MeisterDesign. rigid can be laid in door areas without a transition profile). In general, two adjacent rooms must be separated by a transition profile. Use the joining profile to adjust to adjacent, lower lying areas or floor coverings.

The clip-on end profile is ideal for clean transitions to adjacent, higher thresholds, tiles or the like. Stairs that are laid with MEISTER flooring have a clean finish with the stair edge profile.

## Joining, end and transition profiles, anodised aluminium, matching all MEISTER design flooring (except for: Design flooring MeisterDesign. rigid, MeisterDesign. flex and MeisterDesign. life)

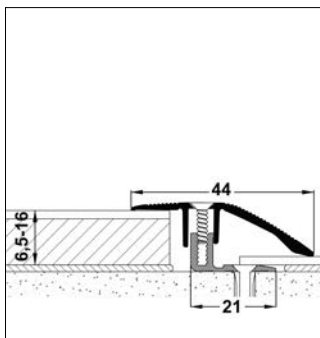

**Joining profile type 200 (6.5 to 16mm)**  
Acts as a crossover between adjacent, lower-lying areas or floor coverings (e.g. carpet or linoleum)

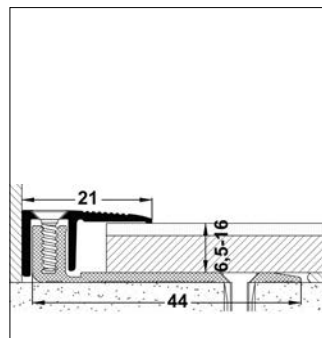

**End profile type 201 B (6.5 to 16mm)**  
Broad bottom profile allows better fixing to substrate.

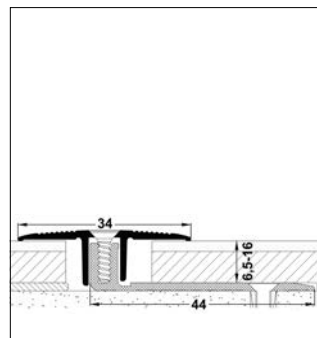

**Transition profile type 202 B (6.5 to 16mm)**  
Broad bottom profile allows better fixing to substrate. For expansion joints: Height differences of up to 3 mm can be overcome.

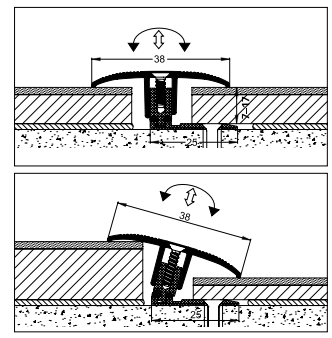

**Transition profile Flexo type 302 (7 to 17mm)**  
For expansion joints: Suited for floor coverings between 7 and 17 mm (at equal covering height). Bridges height differences of up to 12 mm (e. g. from 23 mm to 8 mm or from 15 mm to 3 mm).

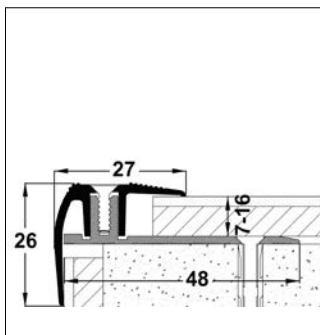

**Stair profile type 203 (7 to 16mm)**  
Supplied as a 2-part profile system (cover and base element). Screws are provided.

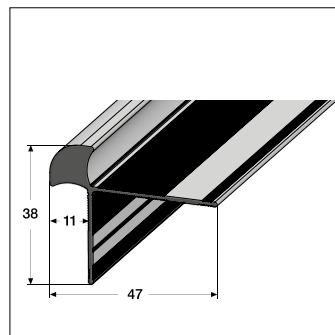

**Stair profile type 11 (10 to 11mm)**  
Two-sided; discreet, visible edge; drilled countersunk, with grooves.

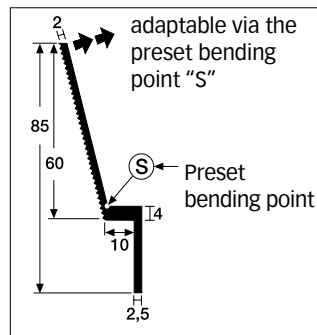

**Sloping angle 3402**  
With adhesive grooves; natural-coloured aluminium; with countersunk drill holes; 20mm x 3.5mm Ø wood screws with cross-slot head are provided. Toughness: approx. 75N/sq.mm<sup>2</sup>. Length: 100 cm

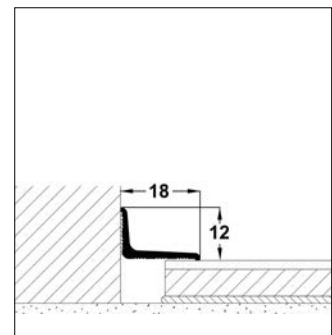

**End profile type 300 SK (self-adhesive)**  
For clean finishes with patio doors and floor-to-ceiling windows.

**Joining, end and transition profiles, anodised aluminium, matching all MEISTER design flooring  
MeisterDesign. flex, MeisterDesign. rigid and MeisterDesign. life**

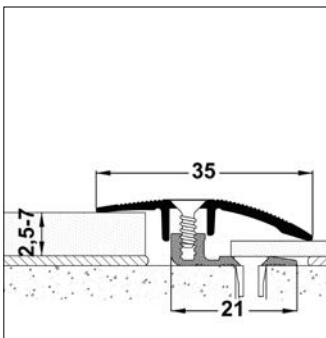

**Joining profile type 100  
(2.5 to 7mm)**  
Acts as a crossover between adjacent, lower-lying areas or floor coverings (e.g. carpet or linoleum)

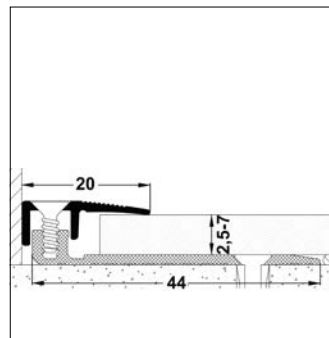

**End profile type 101  
(2.5 to 7mm)**  
The clip-on end profile is ideal for clean transitions to adjacent, higher thresholds, tiles or the like.

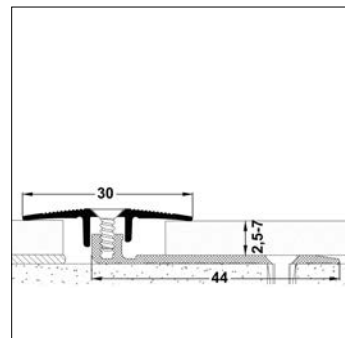

**Transition profile type 102  
(2.5 to 7mm)**  
For expansion joints. Bridges height differences of up to 3mm.

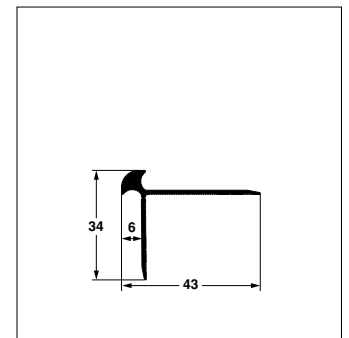

**Stair profile type 5  
(5 to 6 mm)**  
Two-sided; discreet, visible edge; drilled countersunk, with grooves.

**Transition profile type 335 SK (self-adhesive) covered in specially coated laminate film or anodised aluminium,  
matching all MEISTER flooring**

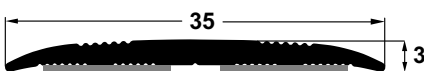

# Wall transitions

To cover the expansion joints around the edges of MEISTER laminate flooring, use MEISTER skirting board 3 PK and 5 PK profiles. For LB 150, we recommend MEISTER skirting board 8 PK profiles with colour-matching decorative surface. When installing MEISTER Longlife parquet and MEISTER Lindura wood flooring, we offer matching real wood veneered MEISTER skirting board profiles 3 PK.

When installing MEISTER Nadura flooring, use the MEISTER skirting board 8 PK profile. When installing MEISTER design flooring, use the MEISTER skirting board 20 PK and 8 PK profiles with colour-matching decorative surface. The MEISTER skirting board profiles are a clean and sophisticated floor connector and can be fitted with a clip, glued (with silicone-free assembly adhesive), nailed or

screwed. A hollow space inside the attachment clips (PK) makes it possible to lay concealed cables through it. Please avoid any silicon products coming into contact with the mouldings.

## Skirting board – a perfect finish

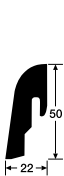

Skirting board Profile 2 PK



Skirting board 3 PK profile

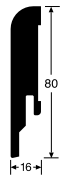

Skirting board 5 PK profile

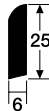

Skirting board Profile 6



Quarter round 7 profile

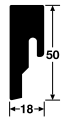

Skirting board 8 PK profile



Skirting board 9 PK profile

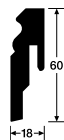

Skirting board 10 PK profile  
10 F MK profile



Skirting board 11 PK profile  
11 F MK profile

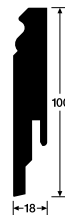

Skirting board 12 PK profile  
12 F MK profile



Skirting board 13 PK profile

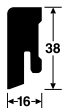

Skirting board 14 MK profile  
14 F MK profile

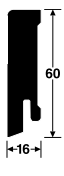

Skirting board 15 MK profile



Skirting board 16 MK profile

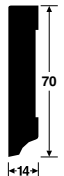

Skirting board 17 profile



Skirting board 18 PK profile



Skirting board 19 PK profile



Skirting board 20 PK profile

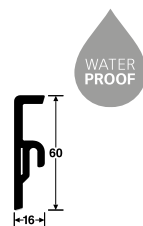

Skirting board 20 PK Aqua profile



Skirting board 21 F MK profile

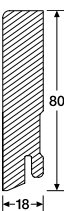

Skirting board 22 F MK profile

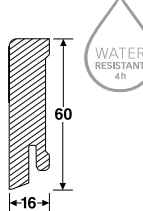

Skirting board 23 F MK profile

**PK|MK profiles:**  
MDF base material  
(PK Aqua: ABS base material)

**F MK profile:**  
Spruce base material

# Underlay materials

Thanks to the special PUR mineral blend, MEISTER Silence 25 DB, MEISTER-Silence 20 or MEISTER-Silence 15 DB are the ideal insulating underlay for effective room and footfall noise protection. The high self-weight of the products also has a positive effect on the sound-absorbing properties. In the case of Silence 25 DB and 15 DB the vapour barrier is already integrated, which means the laying of an additional PE-film is no longer necessary on mineral substrates.

The MEISTER SilenceGrip (with non-slip properties) and MEISTER Silence Compact insulating underlays are 1.5 mm thick underlays made of a PUR mineral blend and have been especially developed for floor coverings with a solid, elastic and synthetic core with click system. These underlays fulfil the increased requirements of the technical bulletin issued by the MMFA (Multilayer Modular Flooring Association) for Class 2 floor coverings.

All MEISTER underlay materials can be installed on underfloor heating. They comply with the technical bulletin provided by the European Producers of Laminate Flooring (EPLF) based on CEN/TS 16354. The Silence products also meet the requirements of the technical bulletin issued by the Multilayer Modular Flooring Association (MMFA): "Underlay Materials under Multilayer Modular Floor Coverings (MMF) – Test Standards and Performance Indicators" for Class 1 (with HDF core).

## Product properties – underlay materials

| Summary                         | Silence 25 DB           | Silence 20              | Silence 15 DB         | SilenceGrip           | Silence Compact          | Twin Control          | Foam film             | Plastic film |
|---------------------------------|-------------------------|-------------------------|-----------------------|-----------------------|--------------------------|-----------------------|-----------------------|--------------|
| Material thickness approx.      | 3 mm                    | 2.5 mm                  | 2 mm                  | 1.5 mm                | 1.5 mm                   | 2 mm                  | 2 mm                  | 0.2 mm       |
| Weight approx.                  | 2,6 kg/m <sup>2</sup>   | 2 kg/m <sup>2</sup>     | 1,6 kg/m <sup>2</sup> | 1,5 kg/m <sup>2</sup> | 1,5 kg/m <sup>2</sup>    | 0,3 kg/m <sup>2</sup> | 0,2 kg/m <sup>2</sup> |              |
| Pressure resistance             | approx. 130 kPa<br>•••• | approx. 150 kPa<br>•••• | ca. 220 kPa<br>•••••  | ca. 450 kPa<br>•••••  | approx. 450 kPa<br>••••• | approx. 50 kPa<br>••• | approx. 45 kPa<br>••• | –            |
| Room noise improvement          | •••••                   | ••••                    | •••                   | •••                   | •••                      | ••                    | ••                    | –            |
| Footfall noise improvement      | ••••                    | ••••                    | •••                   | •••                   | •••                      | •••                   | •••                   | –            |
| Suitable for underfloor heating | ••••                    | ••••                    | ••••                  | ••••                  | ••••                     | ••                    | ••                    | •••••        |
| Suitable for underfloor cooling | ••••                    | ••••                    | ••••                  | ••••                  | ••••                     | –                     | –                     | •••••        |
| Correction of unevenness        | ••••                    | ••••                    | •••                   | ••                    | ••                       | •••                   | •••                   | –            |
| Humidity protection             | ✓                       | No                      | ✓                     | No                    | No                       | ✓                     | No                    | ✓            |

## Recommendations for use

| Summary  | Silence 25 DB         | Silence 20               | Silence 15 DB         | SilenceGrip              | Silence Compact          | Twin Control          | Foam film                | Plastic film |
|--|-----------------------|--------------------------|-----------------------|--------------------------|--------------------------|-----------------------|--------------------------|--------------|
| Weight approx.   | 2,6 kg/m <sup>2</sup> | 2 kg/m <sup>2</sup>      | 1,6 kg/m <sup>2</sup> | 1,5 kg/m <sup>2</sup>    | 1,5 kg/m <sup>2</sup>    | 0,3 kg/m <sup>2</sup> | 0,2 kg/m <sup>2</sup>    |              |
| Wooden planks  | –                     | ×                        | –                     | ×                        | ×                        | –                     | ×                        | –            |
| Wood based boards, OSB boards, drywall elements                            | –                     | ×                        | –                     | ×                        | ×                        | –                     | ×                        | –            |
| Mineral subfloors (e.g. cement screed, anhydride screed)                   | ×                     | × with plastic (PE) film | ×                     | × with plastic (PE) film | × with plastic (PE) film | ×                     | × with plastic (PE) film | ×            |
| Mastic asphalt screed  | –                     | ×                        | –                     | ×                        | ×                        | –                     | ×                        | –            |
| Existing coverings (e.g. ceramic tiles and boards, natural stone, plastic) | ×                     | × with plastic (PE) film | ×                     | × with plastic (PE) film | × with plastic (PE) film | ×                     | × with plastic (PE) film | ×            |

Properties:

••••• Ideally suited •••• Very well suited ••• Well suited •• Suited • Suited to a certain extent ✓ Available × Suited – Not suited

# MEISTER Longlife parquet flooring on hot-water underfloor heating structures

The entire MEISTER Longlife parquet range is suitable for installation on hot-water underfloor heating.

**Please follow the instructions below:**

The PD 450, PD 400, PD 200, PS 500, PS 400, PS 300, PC 400 and PC 200 collections have a thermal resistance on MEISTER Silence 25 DB of 0.118m<sup>2</sup> K/W. Due to the natural warmth of the flooring, the underfloor heating can be switched off more often during moderately cold weather compared to heating under tiled floors. MEISTER flooring on underfloor heating reaches an even surface temperature all over. All types of wood are suitable for installation on hot-water underfloor heating – due to the natural swelling and shrinking properties of natural woods, open joints may appear. Especially maple and beech are more sensitive. The floors must not be covered with any coverings, e.g. carpets, runners, mats or any other overlays as this may cause an accumulation of heat. These types of flooring react with deformations and warping. When laying on hot water underfloor heating in commercial areas, we recommend the installation of a fidbox® (measuring device from floorprotector).

**Preparatory measures:**

Any room heated over a large area requires planning and coordination of the heating system, the screed and the various coverings, taking into account the type of use, in order to ensure optimum and fault-free functioning over the long term. When these special floor constructions are installed, professional standards are correspondingly important. Supplies and processing steps must correspond with the latest technology, the available information sheets from the central association of the German construction trade and the assembly and installation guidelines of the relevant system suppliers and manufacturers.

**Caution!** In case of underfloor heating, the bottom profiles of the transition profiles etc. are fixed with mounting adhesive.

**Screed – Checking moisture – Readiness for laying**

After completion and a corresponding lying time, the screed can be heated. Complete drying out (readiness for laying) is an absolute prerequisite for the preparation and installation steps for MEISTER Longlife parquet flooring and is therefore essential. The reason for this is that the moisture measurements to be carried out as part of subfloor checking cannot be reliably performed on heated constructions due to the risk of damage. This means that heated screed must be dried out by means of heating up and cooling down with a heating break before installation of any type of covering. To be ready for the installation of MEISTER flooring, the moisture content (according to DIN 4725, part 4 – measured with CM devices) of cement screed should be a maximum of 1.8 CM% and of anhydrite screed it should be a maximum of 0.3 CM%. The moisture content limits also apply to fast-hardening cement and screed with screed additives – TKB technical briefing note 14.

**Special measures**

(heating up and cooling down)  
The client must observe the following instructions and/or have them performed by the persons responsible:

- | The screed with underfloor heating must be heated up after its respective holding time in accordance with its specific data sheet.
- | During heating up, the initial temperature should be increased daily up to the full (maximum) heating power.
- | The pattern of the heating measure and the heating break must be carried out in accordance with the measure protocol.
- | The time plan indicates the minimum period of heating up – each additional day is of further benefit and provides extra security.
- | MEISTER Longlife parquet must be installed in accordance with DIN 18 356, 18 365 and 18 367 at a screed surface temperature of at least 15°C and a relative humidity of 30–65% (max.).
- | After installation of the flooring (completion), this climate must be maintained for one week (adhering and hardening time of adhesives and other material layers used).
- | After installation of MEISTER Longlife parquet, the maximum surface temperature of 29°C must not be exceeded.

**Important note:** The above points must be carried out according to the relevant rules and/or confirmed by specialists (architect, heating specialist etc.)

**Structure of floating installation**

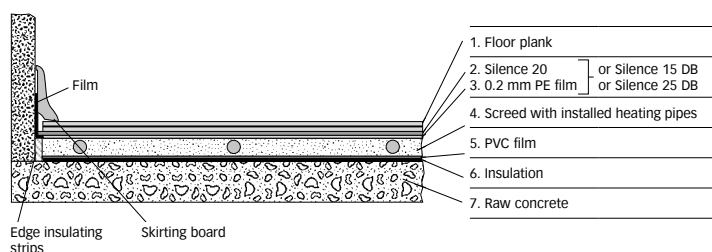

**Structure of surface bonding**

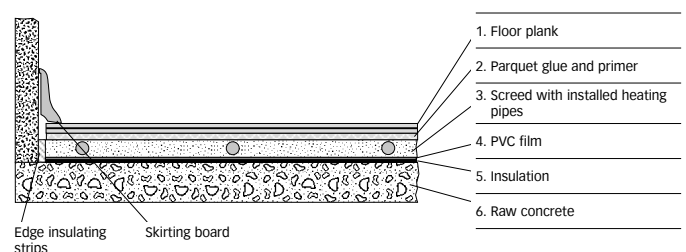

**Note:** Full surface bonding must be carried out by a professional.

# Alpine flame planks on hot-water underfloor heating structures

All Alpine flame planks are suitable for installation over controlled hot-water underfloor heating systems.

**Please follow the instructions below:**

The Alpine flame planks have a thermal resistance on MEISTER Silence 15 DB of 0.152 m<sup>2</sup> K/W. Due to the natural warmth of the flooring, the underfloor heating can be switched off more often during moderately cold weather compared to heating under tiled floors. Alpine flame planks used over underfloor heating achieve an even surface temperature all over. All types of wood are suitable for installation on hot-water underfloor heating – due to the natural swelling and shrinking properties of natural woods, open joints may appear. Especially maple and beech are more sensitive. The floors must not be covered with any coverings, e.g. carpets, runners, mats or any other overlays as this may cause an accumulation of heat. These types of flooring react with deformations and warping. When laying on hot water underfloor heating in commercial areas, we recommend the installation of a fidbox® (measuring device from floorprotector).

**Preparatory measures:**

Any room heated over a large area requires planning and coordination of the heating system, the screed and the various coverings, taking into account the type of use, in order to ensure optimum and fault-free functioning over the long term. When these special floor constructions are installed, professional standards are correspondingly important. Supplies and processing steps must correspond with the latest technology, the available information sheets from the central association of the German construction trade and the assembly and installation guidelines of the relevant system suppliers and manufacturers.

**Caution!** In case of underfloor heating, the bottom profiles of the transition profiles etc. are fixed with mounting adhesive.

**Screed – Checking moisture – Readiness for laying**

After completion and a corresponding lying time, the screed can be heated. Complete drying out (readiness for laying) is an absolute prerequisite for the preparation and installation steps for Alpine flame planks and is therefore essential. The reason for this is that the moisture measurements to be carried out as part of subfloor checking cannot be reliably performed on heated constructions due to the risk of damage. This means that heated screed must be dried out by means of heating up and cooling down with a heating break before installation of any type of covering. To be ready for the installation of the flooring, the moisture content (according to DIN 4725, part 4 – measured with CM devices) of cement screed should be a maximum of 1.8 CM% and of anhydrite screed it should be a maximum of 0.3 CM%. The moisture content limits also apply to fast-hardening cement and screed with screed additives – TKB technical briefing note 14.

**Special measures**

(heating up and cooling down)  
The client must observe the following instructions and/or have them performed by the persons responsible:

- | The screed with underfloor heating must be heated up after its respective holding time in accordance with its specific data sheet.
- | During heating up, the initial temperature should be increased daily up to the full (maximum) heating power.
- | The pattern of the heating measure and the heating break must be carried out in accordance with the measure protocol.
- | The time plan indicates the minimum period of heating up – each additional day is of further benefit and provides extra security.
- | Alpine flame planks must be installed in accordance with DIN 18 356, 18 365 and 18 367 at a screed surface temperature of at least 15°C and a relative humidity of 30–65% (max.).
- | After installation of the flooring (completion), this climate must be maintained for one week (adhering and hardening time of adhesives and other material layers used).
- | After installation of the Alpine flame planks, the maximum surface temperature of 29°C must not be exceeded.

**Important note:** The above points must be carried out according to the relevant rules and/or confirmed by specialists (architect, heating specialist etc.)

**Structure of floating installation**

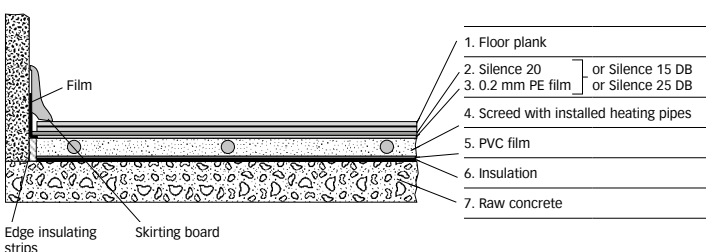

**Structure of surface bonding**

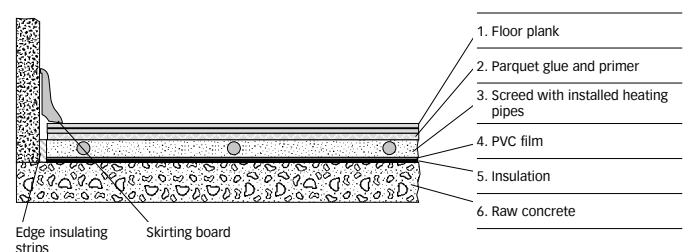

**Note:** Full surface bonding must be carried out by a professional.

# MEISTER Lindura wood flooring on hot-water underfloor heating structures

The MEISTER Lindura wood flooring is suitable for installation on hot-water underfloor heating.

**Please follow the instructions below:**

When installed with MEISTER-Silence 25 DB, MEISTER Lindura wood flooring has a thermal resistance of 0.084m<sup>2</sup> K/W.

Due to the natural warmth of the flooring, the heating can be switched off more often during moderately cold weather compared to heating under tiled floors. MEISTER flooring on underfloor heating reaches an even surface temperature all over. The floors must not be covered with any coverings, e.g. carpets, runners, mats or any other overlays, as this may cause an accumulation of heat. These types of flooring react with deformations and warping. When laying on hot water underfloor heating in commercial areas, we recommend the installation of a fidbox® (measuring device from floorprotector).

**Preparatory measures:**

Any room heated over a large area requires planning and coordination of the heating system, the screed and the various coverings, taking into account the type of use, in order to ensure optimum and fault-free functioning over the long term. When these special floor constructions are installed, professional standards are correspondingly important. Supplies and processing steps must correspond with the latest technology, the available information sheets from the central association of the German construction trade and the assembly and installation guidelines of the relevant system suppliers and manufacturers.

**Caution!** In case of underfloor heating, the bottom profiles of the transition profiles etc. are fixed with mounting adhesive.

**Screed – Checking moisture – Readiness for laying**

After completion and a corresponding lying time, the screed can be heated. Complete drying out (readiness for laying) is an absolute prerequisite for the preparation and installation steps for MEISTER Lindura wood floor and is therefore essential. The reason for this is that the moisture measurements to be carried out as part of subfloor checking cannot be reliably performed on heated constructions due to the risk of damage.

This means that heated screed must be dried out by means of heating up and cooling down with a heating break before installation of any type of covering. To be ready for the installation of MEISTER flooring, the moisture content (according to DIN 4725, part 4 – measured with CM devices) of cement screed should be a maximum of 1.8 CM% and of anhydrite screed it should be a maximum of 0.3 CM%. The moisture content limits also apply to fast-hardening cement and screed with screed additives – TKB technical briefing note 14.

**Special measures**

(heating up and cooling down)

The client must observe the following instructions and/or have them performed by the persons responsible:

- | The screed with underfloor heating must be heated up after its respective holding time in accordance with its specific data sheet.
- | While heating up, the initial temperature should be increased daily up to the full (maximum) heating power.
- | The pattern of the heating measure and the heating break must be carried out in accordance with the measure protocol.
- | The time plan indicates the minimum period of heating up – each additional day is of further benefit and provides extra security.
- | MEISTER Lindura wood flooring must be installed in accordance with DIN 18 356, 18 365 and 18 367 at a screed surface temperature of at least 15°C and a relative humidity of 30–65% (max.).
- | After installation of the flooring (completion), this climate must be maintained for one week (adhering and hardening time of adhesives and other material layers used).
- | After installation of MEISTER Lindura wood flooring, the maximum surface temperature of 29°C must not be exceeded.

**Important note:** The above points must be carried out according to the relevant rules and/or confirmed by specialists (architect, heating specialist etc.).

**Structure of floating installation**

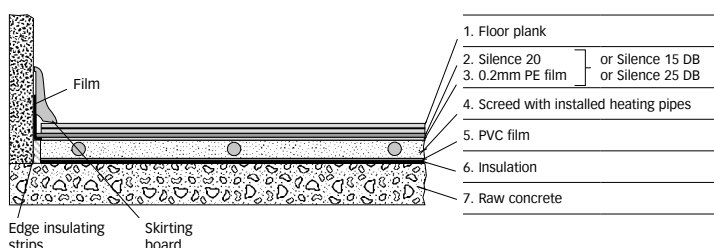

**Structure of surface bonding**

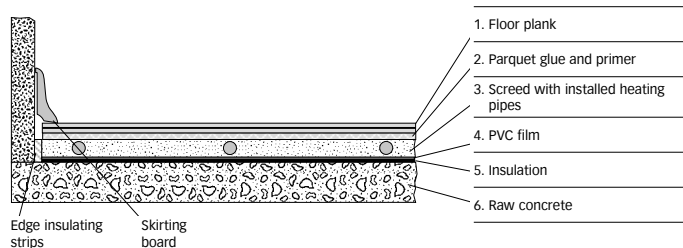

**Note:** Full surface bonding must be carried out by a professional.



# MEISTER design flooring on hot-water underfloor heating structures

The MEISTER design flooring is suitable for installation on hot-water underfloor heating.

**Please follow the instructions below:**

When installed with MEISTER PE film (0.2 mm), MEISTER flooring from the DD 350 S collection has a thermal resistance of 0.10 m<sup>2</sup> K/W, while flooring from the DL 600 S, DD 600 S and DB 600 S collections has a value of 0.09 m<sup>2</sup> K/W. The DL 400, DD 400 and DB 400 collections have a thermal resistance of 0.05 m<sup>2</sup> K/W when laid on MEISTER Silence 15 DB. The DL 800, DD 800 and DB 800 collections have a thermal resistance of 0.02 m<sup>2</sup> K/W when installed on Meister SilenceGrip. The RL 400 S and RB 400 S collections have a thermal resistance of 0.05 m<sup>2</sup> K/W, while that of the RD 300 S collection is 0.064 m<sup>2</sup> K/W. Due to the natural warmth of the flooring, the heating can be switched off more often during moderately cold weather compared to heating under tiled floors. MEISTER flooring on underfloor heating reaches an even surface temperature all over.

The floors must not be covered with any coverings, e.g. carpets, runners, mats or any other overlays as this may cause an accumulation of heat. These types of flooring react with deformations and warping.

When laying on hot water underfloor heating in commercial areas, we recommend the installation of a fidbox® (measuring device from floorprotector).

**Preparatory measures:**

Any room heated over a large area requires planning and coordination of the heating system, the screed and the various coverings, taking into account the type of use, in order to ensure optimum and fault-free functioning over the long term.

When these special floor constructions are installed, professional standards are correspondingly important.

Supplies and processing steps must correspond with the latest technology, the available information sheets from the central association of the German construction trade and the assembly and installation guidelines of the relevant system suppliers and manufacturers.

**Caution!** In case of underfloor heating, the bottom profiles of the transition profiles etc. are fixed with mounting adhesive.

**Screed – Checking moisture – Readiness for laying**

After completion and a corresponding lying time, the screed can be heated. Complete drying out (readiness for laying) is an absolute prerequisite for the preparation and installation steps for MEISTER design flooring and is therefore essential. The reason for this is that the moisture measurements to be carried out as part of subfloor checking cannot be reliably performed on heated constructions due to the risk of damage. This means that heated screed must be dried out by means of heating up and cooling down with a heating break before installation of any type of covering. To be ready for the installation of MEISTER flooring, the moisture content (according to DIN 4725, part 4 – measured with CM devices) of cement screed should be a maximum of 1.8 CM% and of anhydrite screed it should be a maximum of 0.3 CM%.

The moisture content limits also apply to fast-hardening cement and screed with screed additives – TKB technical briefing note 14.

**Special measures**

(heating up and cooling down)

The client must observe the following instructions and/or have them performed by the persons responsible:

- | The screed with underfloor heating must be heated up after its respective holding time in accordance with its specific data sheet.
- | During heating up, the initial temperature should be increased daily up to the full (maximum) heating power.
- | The pattern of the heating measure and the heating break must be carried out in accordance with the measure protocol.
- | The time plan indicates the minimum period of heating up – each additional day is of further benefit and provides extra security.
- | MEISTER design flooring must be installed in accordance with DIN 18 356, 18 365 and 18 367 at a screed surface temperature of at least 15°C and a relative humidity of 30 to max. 65%.
- | After installation of the flooring (completion), this climate must be maintained for one week (adhering and hardening time of adhesives and other material layers used).
- | After installation of the MEISTER design flooring, the maximum surface temperature of 29°C must not be exceeded.

**Important note:** The above points must be carried out according to the relevant rules and/or confirmed by specialists (architect, heating specialist etc.).

**Structure of floating installation**

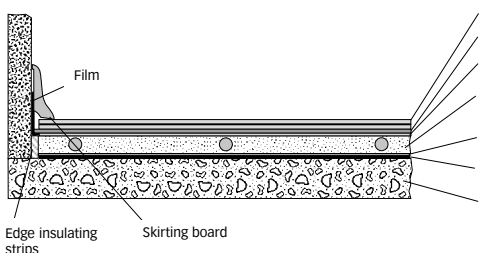

| Collections:<br>DL 400, DD 400, DB 400, | DL 600 S, DD 350 S,<br>DD 600 S, DB 600 S | DD 800, DB 800,<br>DL 800           | RL 400 S, RB 400 S,<br>RD 300 S          |
|---|---|-------------------------------------|--|
| 1. Floor plank                          | Floor plank with sound-absorbing cushion  | Floor plank                         | Floor plank with sound-absorbing cushion |
| 2. Silence 20<br>3. 0.2 mm PE film      | ] or Silence 15 DB<br>or Silence 25 DB    | 0.2 mm PE film                      | SilenceGrip or SilenceCompact            |
| 4. Screed with installed heating pipes  |   | Screed with installed heating pipes | Screed with installed heating pipes      |
| 5. PVC film                             | PVC film                                  | PVC film                            | PVC film                                 |
| 6. Insulation                           | Insulation                                | Insulation                          | Insulation                               |
| 7. Raw concrete                         | Raw concrete                              | Raw concrete                        | Raw concrete                             |

# MEISTER Nadura flooring on hot-water underfloor heating structures

All MEISTER Nadura flooring is suitable for installation on hot-water underfloor heating.

**Please follow the instructions below:**

When installed with MEISTER Silence 25 DB, MEISTER flooring from the NB 400 collection has a thermal resistance of 0.09 m<sup>2</sup> K/W. Due to the natural warmth of the flooring, the heating can be switched off more often during moderately cold weather compared to heating under tiled floors. MEISTER flooring on underfloor heating reaches an even surface temperature all over. The floors must not be covered with any coverings, e.g. carpets, runners, mats or any other overlays as this may cause an accumulation of heat. These types of flooring react with deformations and warping. When laying on hot water underfloor heating in commercial areas, we recommend the installation of a fidbox® (measuring device from floorprotector).

**Preparatory measures:**

Any room heated over a large area requires planning and coordination of the heating system, the screed and the various coverings, taking into account the type of use, in order to ensure optimum and fault-free functioning over the long term. When these special floor constructions are installed, professional standards are correspondingly important. Supplies and processing steps must correspond with the latest technology, the available information sheets from the central association of the German construction trade and the assembly and installation guidelines of the relevant system suppliers and manufacturers.

**Caution!** In case of underfloor heating, the bottom profiles of the transition profiles etc. are fixed with mounting adhesive.

**Screed – Checking moisture – Readiness for laying**

After completion and a corresponding lying time, the screed can be heated. Complete drying out (readiness for laying) is an absolute prerequisite for the preparation and installation steps for MEISTER Nadura flooring and is therefore essential. The reason for this is that the moisture measurements to be carried out as part of subfloor checking cannot be reliably performed on heated constructions due to the risk of damage. This means that heated screed must be dried out by means of heating up and cooling down with a heating break before installation of any type of covering. To be ready for the installation of MEISTER flooring, the moisture content (according to DIN 4725, part 4 – measured with CM devices) of cement screed should be a maximum of 1.8 CM% and of anhydrite screed it should be a maximum of 0.3 CM%.

The moisture content limits also apply to fast-hardening cement and screed with screed additives – TKB technical briefing note 14.

**Special measures**

(heating up and cooling down)

The client must observe the following instructions and/or have them performed by the persons responsible:

- | The screed with underfloor heating must be heated up after its respective holding time in accordance with its specific data sheet.
- | While heating up, the initial temperature should be increased daily up to the full (maximum) heating power.
- | The pattern of the heating measure and the heating break must be carried out in accordance with the measure protocol.
- | The time plan indicates the minimum period of heating up – each additional day is of further benefit and provides extra security.
- | MEISTER Nadura flooring must be installed in accordance with DIN 18 356, 18 365 and 18 367 at a screed surface temperature of at least 15°C and a relative humidity of 30–65% (max.).
- | After installation of the flooring (completion), this climate must be maintained for one week (adhering and hardening time of adhesives and other material layers used).
- | After installation of the MEISTER Nadura flooring, the maximum surface temperature of 29°C must not be exceeded.

**Important note:** The above points must be carried out according to the relevant rules and/or confirmed by specialists (architect, heating specialist etc.).

**Structure of floating installation**

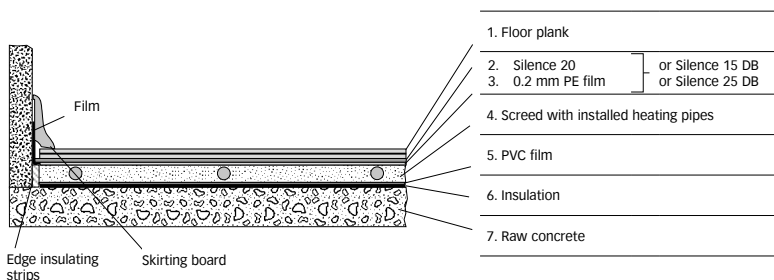

**Structure of surface bonding**

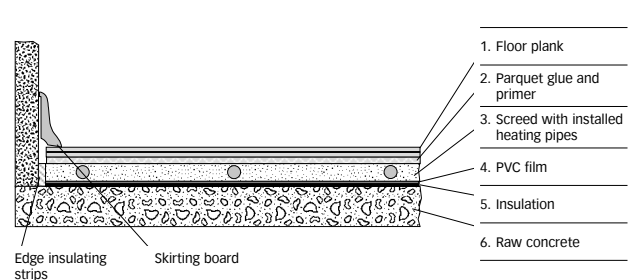

**Note:** Full surface bonding must be carried out by a professional.

# MEISTER laminate flooring on hot-water underfloor heating structures

All MEISTER laminate flooring is suitable for installation on hot-water underfloor heating.

**Preparatory measures:**

Any room heated over a large area requires planning and coordination of the heating system, the screed and the various coverings, taking into account the type of use, in order to ensure optimum and fault-free functioning over the long term. When these special floor constructions are installed, professional standards are correspondingly important. Supplies and processing steps must correspond with the latest technology, the available information sheets from the central association of the German construction trade and the assembly and installation guidelines of the relevant system suppliers and manufacturers. The floors must not be covered with any coverings, e.g. carpets, runners, mats or any other overlays as this may cause an accumulation of heat. These types of flooring react with deformations and warping.

**Caution!** In case of underfloor heating, the bottom profiles of the transition profiles etc. are fixed with mounting adhesive.

**Screed – Checking moisture – Readiness for laying**

After completion and a corresponding lying time, the screed can be heated. Complete drying out (readiness for laying) is an absolute prerequisite for the preparation and installation steps for MEISTER laminate flooring and is therefore essential. The reason for this is that the moisture measurements to be carried out as part of subfloor checking cannot be reliably performed on heated constructions due to the risk of damage. This means that heated screed must be dried out by means of heating up and cooling down with a heating break before instal-

lation of any type of covering. To be ready for the installation of MEISTER flooring, the moisture content (according to DIN 4725, part 4 – measured with CM devices) of cement screed should be a maximum of 1.8 CM% and of anhydrite screed it should be a maximum of 0.3 CM%.

The moisture content limits also apply to fast-hardening cement and screed with screed additives – TKB technical briefing note 14.

**Special measures**

(heating up and cooling down)  
The client must observe the following instructions and/or have them performed by the persons responsible:

- | The screed with underfloor heating must be heated up after its respective holding time in accordance with its specific data sheet.
- | While heating up, the initial temperature should be increased daily up to the full (maximum) heating power.

- | The pattern of the heating measure and the heating break must be carried out in accordance with the measure protocol.
- | The time plan indicates the minimum period of heating up – each additional day is of further benefit and provides extra security.
- | MEISTER laminate flooring must be installed in accordance with DIN 18 356, 18 365 and 18 367 at a screed surface temperature of at least 15°C and a relative humidity of 30–65% (max.).
- | After installation of the flooring (completion), this climate must be maintained for one week (adhering and hardening time of adhesives and other material layers used).
- | After installation of the MEISTER laminate flooring, the maximum surface temperature of 29°C must not be exceeded.

**Important note:** The above points must be carried out according to the relevant rules and/or confirmed by specialists (architect, heating specialist etc.).

**Laminate flooring heat transmitting resistance**  
MEISTER laminate flooring on insulating underlays

|                                    | Installation on<br>MEISTER Twin Control m <sup>2</sup> K/W | Installation on<br>MEISTER-Silence 25 DB m <sup>2</sup> K/W |
|------------------------------------|--|---|
| LL 250   LD 250                    | –  | 0.071   |
| LC 150   LD 150<br>LB 150   LL 150 | 0.115  | 0.07  |
| LC 55   LD 55                      | 0.104  | –   |

Laminate flooring with integrated sound-absorbing lining

|                   | Installation on<br>MEISTER Twin Control m <sup>2</sup> K/W | Installation with 0.2 mm<br>MEISTER-PE film m <sup>2</sup> K/W |
|-------------------|--|--|
| LL 250 S          | –  | 0.085  |
| LL 150 S          | –  | 0.075  |
| LC 55 S   LD 55 S | –  | 0.07   |

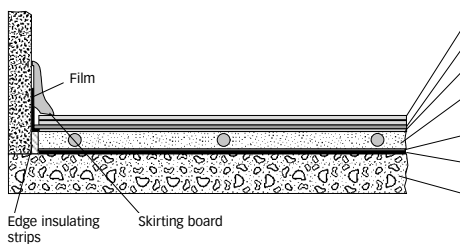

**Collections:**

Laminate LC 55, LD 55, LC 150, LD 150, LB 150, LL 150, LL 250, LD 250

Laminate LC 55 S, LD 55 S, LL 150 S, LL 250 S

|  |  |
|--|--|
| 1. Floor plank                         | Floor plank with sound-absorbing cushion                               |
| 2. Silence 20<br>3. 0.2 mm PE film     | or Twin Control or Silence 15 DB<br>or Silence 25 DB<br>0.2 mm PE film |
| 4. Screed with installed heating pipes | Screed with installed heating pipes                                    |
| 5. PVC film                            | PVC film   |
| 6. Insulation                          | Insulation   |
| 7. Raw concrete                        | Raw concrete   |

# MEISTER flooring on controlled hot-water underfloor heating with cooling function

The entire MEISTER flooring range is suitable for installation on controlled hot-water underfloor heating with cooling function.

**The following measures and features must be observed for hot water under-floor heating with cooling function:**

- | The cooling function should only be active at a room temperature > 26°C.
- | The cooling temperature may not be more than 2 to 3°C below the room temperature and thus not fall below 23°C.
- | The relative humidity at the cooled floor surface must not exceed 75%.
- | For unhindered cooling transfer, floor surfaces should not be covered with carpets or similar items.
- | MEISTER parquet, Nadura and Lindura floorings should be completely glued in order to optimise the passage of heat. Other MEISTER floorings can also be installed as floating floors according to their installation instructions.
- | To keep the seasonal differences in relative humidity as low as possible, the relative humidity should also be > 40% during the heating period. The use of a humidifier to maintain an optimum relative humidity is recommended.
- | For checking and controlling the current climatic conditions, the installation of a temperature and humidity data logger (e. g. fidbox®) is recommended. These parameters can also be checked manually using an infrared thermometer and hygrometer. A room temperature of approx. 18–22°C and a relative humidity of approx. 30–65% are the basis for a healthy room climate.

- | Experts in flooring and parquet laying recommend not carrying out active cooling for more than 14 days at a time (followed by an inactive phase of at least 14 days). For longer cooling phases or an operating period > 21 days/year, other types of room cooling (air conditioning) should be used.
- | The respective cleaning and care instructions must always be followed.

**Possible risks and damage if the above points are not observed:**

- | Deformation and cupping of the individual planks
- | Formation of joints between the plank rows and in the area of the head joints
- | Delamination/detachment of the covering layers
- | Dew point / condensation water formation and thus damage to the subsurface as well (screed)

Any room heated over a large area requires planning and coordination of the heating system, the screed and the various coverings, taking into account the type of use, in order to ensure optimum and fault-free functioning over the long term. When these special floor constructions are installed, professional standards are correspondingly important. Supplies and processing steps must correspond with the latest technology, the available information sheets from the central association of the German construction trade and the assembly and installation guidelines of the relevant system suppliers and manufacturers. Corresponding information is provided by the interface coordination of the German Federal Association of Surface Heating and Surface Cooling e. V. (BVF).

**Important note:** The above points must be carried out according to the relevant rules and/or confirmed by specialists (architect, heating specialist etc.). Further information can be found in the standards DIN EN 1264, DIN EN 15377 and DIN EN 12831 as well as in the interface coordination at the German Federal Association of Surface Heating and Surface Cooling e. V. (BVF).

# MEISTER flooring over electrical underfloor heating

---

All MEISTER floors can be laid over electrical auxiliary heating and surface heating systems with a performance of 125 W/m<sup>2</sup>. These heating systems have to be able to deliver this performance evenly over the entire surface. Heating systems such as these are not suitable for installation in humid rooms.

The products' technical briefing notes from both MEISTER and the respective surface heating manufacturer – as well as the current applicable standards and regulations – must be followed carefully. If the heating mats are approved by the manufacturer for full-surface bonding, the installation and adhesive recommendations of the adhesive manufacturer must also be observed.

The floor must be installed in accordance with the manufacturer's specifications and adapted for the application. The requirements in accordance with VOB Section C DIN 18356 parquet and DIN 18365 flooring installation work, and current technology apply.

The MEISTER flooring requires a permanent living climate of approx. 30–65 per cent relative humidity at a room temperature of approximately 20°C. If you notice or expect a much lower level of humidity, we recommend the use of a humidifier (vaporiser). This will prevent the MEISTER floor from drying out excessively.

A thermostat and temperature sensor must be installed according to the manufacturer's instructions to ensure the surface temperature of 29°C is not exceeded.

All types of wood are suitable; however, significant natural swelling and shrinking can occur depending on the climatic conditions within the room.

The floors must not be covered with any coverings, e.g. carpets, runners, mats or any other overlays as this may cause an accumulation of heat.

## **fidbox®**

Humidity and fluctuations in temperature can influence how long a floor lasts and retains its value.

We therefore recommend using a fidbox® (a measuring device from floorprotector), which can take long-term data recordings for temperature (°C) and relative humidity (%) in the immediate vicinity of the floor, which can be read using a reading device. In the event of a claim for damage, this can be clarified quickly using the results to prevent any protracted research into the causes.

## Full surface bonding

# MeisterParquet. longlife, Lindura® wood flooring and Nadura®

The parquet flooring MeisterParquet. longlife, Lindura wood flooring and Nadura can also be installed with full surface bonding using an approved adhesive as an alternative to floating installation.

Please note that all installation instructions for Masterclik Plus and Unizip connections must be followed carefully at all times as well as the general recommendations / Technical Commission on Construction Adhesives (Technische Kommission Bauklebstoffe - TKB) technical briefing notes and preparatory measures explained in the installation instructions when installing flooring with full surface bonding.

MeisterWerke recommends a water-free, shear-resistant adhesive released by the adhesive manufacturer ("Hard" according to ISO 17178).

**If you require more information, please contact the corresponding adhesive manufacturer.**

### Information on adhesives:

The recommendations for adhesives are based on extensive tests conducted by the manufacturers. Due to the variability of on-site conditions, it is not possible to establish warranty claims based on the information provided. We cannot assume liability for any losses incurred in using the adhesive system. For that reason, we recommend that you test the adhesive yourself thoroughly before installing flooring or contact the adhesive manufacturer's technical customer service.

### Installation method:

With the floors mentioned lay each plank individually in the fresh adhesive bed. Then

press them down well so that the backs of the planks are moistened as thoroughly as possible. To avoid hollow spots, extra weight can also be applied to the planks using a suitable material. Please note all of the adhesive manufacturer's instructions such as those on hardening and working time.

According to DIN 18365 and 18356, the subsurface for flooring or parquet must always be smooth, dry, clean, free of cracks and release agents, and able to withstand lifting and pressing force.

CM moisture content with screed:

Cement screed: 2.0 CM% (with underfloor heating: 1.8 CM%)

Anhydrite screed: 0.5 CM-% (with underfloor heating: 0.3 CM-%)

(The moisture content limits also apply to fast-hardening cement and screed with screed additives – TKB technical briefing note 14.)

The contractor responsible for laying the flooring/parquet must ensure that subfloor material is inspected for technical suitability. This inspection must be in accordance with the recognised rules of the trade and current technology, and in compliance with the German Construction Contract Procedures (Vergabe- und Vertragsordnung für Bauleistungen – VOB). If the subsurface reveals deficiencies or there is a risk of damage occurring to the construction of the flooring, the contractor must report these concerns in writing, particularly in the following cases:

- | Serious unevenness
- | Cracks in the subfloor
- | Insufficiently dry subfloor
- | Insufficiently firm subfloor
- | Contaminated subfloor, e.g. oil, wax, lacquer, paint residues
- | Subfloor not being level with adjoining structures

- | Unsuitable subfloor temperature
- | Unsuitable room climate
- | No documentation on heating characteristics for heated flooring constructions
- | Required secure locking of expansion joints in the subfloor
- | No edging strip projection
- | No marking of measurement points for heated flooring constructions
- | No joint layout (if necessary)

### fidbox®

Humidity and fluctuations in temperature can influence how long a floor lasts and retains its value. We therefore recommend using a fidbox® (a measuring device from floor-protector), which can take long-term data recordings for temperature (°C) and relative humidity (%) in the immediate vicinity of the floor, which can be read using a reading device. In the event of a claim for damage, this can be clarified quickly using the results to prevent any protracted research into the causes. You can obtain more information from MeisterWerke.

# Full surface bonding

## Alpine flame plank parquet flooring

The Alpine flame planks parquet flooring by MEISTER can also be installed with full surface bonding using an approved adhesive as an alternative to floating installation.

Please note that all installation instructions concerning the click connection must be followed carefully at all times as well as the general recommendations / Technical Commission on Construction Adhesives (Technische Kommission Bauklebstoffe - TKB) technical briefing notes and preparatory measures explained in the installation instructions when installing flooring with full surface bonding. With regard to the required level of subsurface evenness, we recommend consulting technical information sheet no.02 from the Zentralverband für Parkett und Fußbodentechnik (Central Association for Parquet Flooring and Flooring Technology) and the BEB (Federal Association of Screed and Floor Covering).

MeisterWerke recommends a water- and solvent-free adhesive released by the adhesive manufacturer. The adhesive used should comply with the DIN ISO 17178 definitions of hard or hard elastic. Ask the respective adhesive manufacturer how the subfloor should be prepared for this particular system.

**If you require more information, please contact the corresponding adhesive manufacturer.**

### Information on adhesives:

The recommendations for adhesives are based on extensive tests conducted by the manufacturers. Due to the variability of on-site conditions, it is not possible to establish warranty claims based on the

information provided. We cannot assume liability for any losses incurred in using the adhesive system. For that reason, we recommend that you test the adhesive yourself thoroughly before installing flooring or contact the adhesive manufacturer's technical customer service.

### Installation method:

With the floors mentioned lay each plank individually in the fresh adhesive bed. Then press them down well so that the backs of the planks are moistened as thoroughly as possible. To avoid hollow spots, extra weight can also be applied to the planks using a suitable material. Please note all of the adhesive manufacturer's instructions such as those on hardening and working time.

According to DIN 18365 and 18356, the subsurface for flooring or parquet must always be smooth, dry, clean, free of cracks and release agents, and able to withstand lifting and pressing force.

CM moisture content with screed:

Cement screed: 2.0 CM% (with underfloor heating: 1.8 CM%) anhydrite screed: 0.5 CM% (with underfloor heating: 0.3 CM%)

The moisture content limits also apply to fast-hardening cement and screed with screed additives – TKB technical briefing note 14.

The contractor responsible for laying the flooring/parquet must ensure that subsurface material is inspected for technical suitability. This inspection must be in accordance with the recognised rules of the trade and current technology, and in compliance with the German Construction Contract Procedures (Vergabe- und Vertragsordnung für Bauleistungen – VOB). If the subfloor reveals

deficiencies or there is a risk of damage occurring to the construction of the flooring, the contractor must report these concerns in writing, particularly in the following cases:

- | Serious unevenness
- | Cracks in the subfloor
- | Insufficiently dry subfloor
- | Insufficiently firm subfloor
- | Contaminated subfloors, e.g. oil, wax, lacquer, paint residues
- | Subfloor not being level with adjoining structures
- | Unsuitable subfloor temperature
- | Unsuitable room climate
- | No documentation on heating characteristics for heated flooring constructions
- | Required secure locking of expansion joints in the subfloor
- | No edging strip projection
- | No marking of measurement points for heated flooring constructions
- | No joint layout (if necessary)

### fidbox®

Humidity and fluctuations in temperature can influence how long a floor lasts and retains its value. We therefore recommend using a fidbox® (a measuring device from floor-protector), which can take long-term data recordings for temperature (°C) and relative humidity (%) in the immediate vicinity of the floor, which can be read using a reading device. In the event of a claim for damage, this can be clarified quickly using the results to prevent any protracted research into the causes. You can obtain more information from MeisterWerke.

# Full surface bonding

## Design flooring MeisterDesign. life

The design flooring MeisterDesign. life can also be installed with full surface bonding using an approved adhesive as an alternative to floating installation.

Please note that all installation instructions concerning the click connection must be followed carefully at all times as well as the general recommendations / Technical Commission on Construction Adhesives (Technische Kommission Bauklebstoffe - TKB) technical briefing notes and preparatory measures explained in the installation instructions when installing flooring with full surface bonding. With regard to the required level of subsurface evenness, we recommend consulting technical information sheet no.02 from the Zentralverband für Parkett und Fußbodentechnik (Central Association for Parquet Flooring and Flooring Technology) and the BEB (Federal Association of Screed and Floor Covering).

MeisterWerke recommends a water- and solvent-free adhesive released by the adhesive manufacturer. The adhesive used should comply with the DIN ISO 17178 definitions of hard or hard elastic.

Ask the respective adhesive manufacturer how the subfloor should be prepared for this particular system.

**If you require more information, please contact the corresponding adhesive manufacturer.**

### Information on adhesives:

The recommendations for adhesives are based on extensive tests conducted by the manufacturers. Due to the variability of on-site conditions, it is not possible to establish warranty claims based on the information provided. We cannot assume liability for any losses incurred in using the adhesive system. For that reason, we recommend that you test the adhesive yourself thoroughly before installing flooring or contact the adhesive manufacturer's technical customer service.

### Installation method:

With the floors mentioned lay each plank individually in the fresh adhesive bed. Then press them down well so that the backs of the planks are moistened as thoroughly as possible. To avoid hollow spots, extra weight can also be applied to the planks using a suitable material. Please note all of the adhesive manufacturer's instructions such as those on hardening and working time.

According to DIN 18365 and 18356, the subsurface for flooring or parquet must always be smooth, dry, clean, free of cracks and release agents, and able to withstand lifting and pressing force.

CM moisture content with screed:

Cement screed: 2.0 CM% (with underfloor heating: 1.8 CM%)

Anhydrite screed: 0.5 CM-% (with underfloor heating: 0.3 CM-%)

The moisture content limits also apply to fast-hardening cement and screed with screed additives – TKB technical briefing note 14.

The contractor responsible for laying the flooring/parquet must ensure that subsurface material is inspected for technical suitability. This inspection must be in accordance with the recognised rules of the trade and current technology, and in compliance with the German Construction Contract Procedures (Vergabe- und Vertragsordnung für Bauleistungen – VOB). If the subfloor reveals deficiencies or there is a risk of damage occurring to the construction of the flooring, the contractor must report these concerns in writing, particularly in the following cases:

- | Serious unevenness
- | Cracks in the subfloor
- | Insufficiently dry subfloor
- | Insufficiently firm subfloor
- | Contaminated subfloors, e.g. oil, wax, lacquer, paint residues
- | Subfloor not being level with adjoining structures
- | Unsuitable subfloor temperature
- | Unsuitable room climate
- | No documentation on heating characteristics for heated flooring constructions
- | Required secure locking of expansion joints in the subfloor
- | No edging strip projection
- | No marking of measurement points for heated flooring constructions
- | No joint layout (if necessary)



# Full surface bonding

## Design flooring MeisterDesign. pro

MeisterDesign. pro is a high-quality design flooring for full surface bonding. Workmanship skills and product-specific knowledge is required for installation.

### General information:

Substrate preparation must be carried out in accordance with VOB DIN 18365. The relevant information sheets such as TKB information sheet no. 8 "Beurteilen und Vorbereiten von Untergründen für Bodenbelag- und Parkettarbeiten" (Evaluation and preparation of subfloors for flooring and parquet work) must be heeded. With regard to the required level of subsurface evenness, we recommend consulting technical information sheet no. 02 from the Zentralverband für Parkett und Fußbodentechnik (Central Association for Parquet Flooring and Flooring Technology) and the BEB (Federal Association of Screed and Floor Covering).

MeisterWerke recommends a low-emission and solvent-free adhesive (RAL - Blue Angel or EC1), used with a system-oriented substrate preparation.

In order to achieve optimal wetting of the back and secure adherence, it is vital that you follow the instructions provided by the adhesive manufacturer regarding processing requirements, notched adhesive comb, application amounts and working times. Special approval from the adhesive manufacturer is required when using contact adhesive or reaction resin adhesive.

After laying the covering in the adhesive bed, every plank must be pressed down with a scraping cork/handle scraper, and rolled with a heavy roller (min. 50 kg).

**If you require more information, please contact the corresponding adhesive manufacturer.**

### Information on adhesives:

The recommendations for adhesives are based on extensive tests conducted by the manufacturers. Due to the variability of on-site conditions, it is not possible to establish warranty claims based on the information provided. We cannot assume liability for any losses incurred in using the adhesive system. For that reason, we recommend that you test the adhesive yourself thoroughly before installing flooring or contact the adhesive manufacturer's technical customer service.

According to DIN 18365 and 18356, the subsurface for flooring must always be smooth, dry, clean, free of cracks and release agents, and able to withstand lifting and pressing force.

CM moisture content with screed:

Cement screed: 2.0 CM% (with underfloor heating: 1.8 CM%)

Anhydrite screed: 0.5 CM-% (with underfloor heating: 0.3 CM-%)

The moisture content limits also apply to fast-hardening cement and screed with screed additives – TKB technical briefing note 14.

The contractor responsible for laying the flooring/parquet must ensure that subsurface material is inspected for technical suitability. This inspection must be in accordance with the recognised rules of the trade and current technology, and in compliance with the German Construction Contract Procedures (Vergabe- und Vertragsordnung für Bauleistungen – VOB). If the subsurface reveals deficiencies or there is a risk of damage occurring to the construction of the flooring, the contractor must report these concerns in writing, particularly in the following cases:

- | Serious unevenness
- | Cracks in the subfloor
- | Insufficiently dry subfloor
- | Insufficiently firm subfloor
- | Contaminated subfloors, e.g. oil, wax, lacquer, paint residues
- | Subfloor not being level with adjoining structures
- | Unsuitable subfloor temperature
- | Unsuitable room climate
- | No documentation on heating characteristics for heated flooring constructions
- | Required secure locking of expansion joints in the subfloor
- | No edging strip projection
- | No marking of measurement points for heated flooring constructions
- | No joint layout (if necessary)

# Cleaning and protective care agents

## Overview of the use of the care products

|  |                 |                 |
|--|-----------------|-----------------|
| Cleaning after completion<br>of construction work<br>Day-to-day cleaning | Freshening care | Special cleaner |
|--|-----------------|-----------------|

### MEISTER parquet flooring and Lindura wood flooring

|                 |  |  |   |
|-----------------|--|--|---|
| naturally oiled | Dr. Schutz Premium Wood Soap<br>MR: 1:200  | Dr. Schutz Premium Care Oil<br>MR: undiluted | Dr. Schutz Deep Clean for hard floors<br>MR: 1:1 to 1:3 |
|                 | In areas with heavy wear/<br>commercial areas:<br>First cleaning<br>Dr. Schutz Premium Care Oil<br>MR: undiluted |  |   |

|                               |  |  |  |
|-------------------------------|--|--|--|
| lacquered  <br>matt lacquered | Dr. Schutz Wood and Cork Floor<br>Cleaner<br>MR: 1:200 | Dr. Schutz Wood and Cork Floor<br>Polish Matt<br>MR: undiluted | Dr. Schutz Deep Clean for hard floors<br>MR: undiluted |
|-------------------------------|--|--|--|

### Alpine flame planks

|                 |  |   |   |
|-----------------|--|---|---|
| naturally oiled | Hain Special Soap, colourless<br>MR: 1:200 | Hain Care Balm, colourless<br>MR: undiluted | Dr. Schutz Deep Clean for hard floors<br>MR: 1:1 to 1:3 |
|-----------------|--|---|---|

### MEISTER design flooring

|  |  |  |
|--|--|--|
| <ol style="list-style-type: none"> <li>1. Cleaning after completion of<br/>construction work:<br/>Dr. Schutz PU Cleaner<br/>MR: 1:10</li> <li>2. Day-to-day cleaning:<br/>Dr. Schutz PU Cleaner<br/>MR: 1:200</li> </ol> | Dr. Schutz Full Care Matt<br>MR: undiluted | Dr. Schutz Deep Clean for hard floors<br>MR: undiluted |
|--|--|--|

### MEISTER Nadura® flooring

|  |   |
|--|---|
| Dr. Schutz Laminate Cleaner<br>MR: 1:200 | Dr. Schutz Deep Clean for hard floors<br>MR: 1:1 to 1:3 |
|--|---|

### MEISTER laminate flooring

|  |  |
|--|--|
| Dr. Schutz Laminate Cleaner<br>MR: 1:200 | Dr. Schutz Elatex Stain Remover<br>MR: undiluted |
|--|--|

MR = mixing ratio

# Cleaning and protective care agents

## **The quality does not stop with the installation.**

You have bought a quality product "made in Germany". These cleaning and care instructions will provide you with all the information important to ensuring a long period of value preservation and a beautiful appearance of your flooring. With a bit of time and effort, you can contribute to ensuring that you are able to enjoy your new MEISTER flooring for a long time to come.

MEISTER products are based on selected materials, which are processed by experienced experts with state-of-the-art technology to create a quality product "made in Germany". The premium quality includes substantiated consultation and excellent service. For this reason, you will only find MEISTER products in selected specialist shops.

## **1. The right care**

Your dream floor also needs the right care. MEISTER complements its product range with a high-quality series of care products from Dr. Schutz. Cleaners and care products, tailored for the floorings, ensure that your floor looks good in the long term. Even if you only need to run the vacuum round for day-to-day care (to remove loose dust), the surfaces should be cleaned and cared for regularly with Dr. Schutz care products to preserve the value of your floor.

When cleaning, please be aware that the floor must only ever be slightly moistened. In the ideal case, the film of water should be a thin mist, so that it dries out after about a minute. Some types of wood, such as beech or maple, are particularly sensitive to moisture. You should not use any abrasive cleaners, even in case of more severe stains. Even for stubborn stains and dirt, the Dr. Schutz Elatex Stain Remover\* will help.

Scratches on the floor not only affect the overall appearance. They will also make the floor more prone to dirt and moisture. The Dr. Schutz care products are designed to ensure that the floor is considerably more resistant to signs of wear and tear in heavy wear areas. Your qualified specialist shops will also be able to provide you with more tips on how to care for your MEISTER floor in the best possible way.

## **2. Preservation of value | Precautionary measures**

A room temperature of approx. 18–22°C and a relative air humidity of approx. 30–65 per cent will contribute to your personal well-being and are the basis for a healthy room climate. With such a room climate, you will also help your MEISTER floor obtain the optimal conditions, as it reacts to its climatic surroundings like any other wooden material. Low air humidity with a high temperature will lead to a contracting process in the wood, which dries the floor out. If you determine an air humidity which is considerably lower than 30 percent in the long term, we recommend the use of air humidifiers (vaporizers). This will prevent your MEISTER floor drying out excessively. As with all wooden products, very high air humidity will cause absorption of humidity, which can lead to the length and thickness increasing.

### **The introduction of dirt onto the floor:**

Most dirt is brought into your home from the outside and transferred onto the flooring. For this reason, we recommend installing a sufficiently large entrance covering (e.g. a doormat) in the entrance. Do not use any rubber-coated mats since prolonged contact can lead to permanent discolouration. Please consider that dirt, such as sand or small stones, will act like sandpaper on all floorings and can lead to unsightly scratches. To protect the wood from scratches, you should also fit chair and furniture feet with felt sliders; office chairs, mobile containers, etc., on castors must be equipped with soft, standard running surfaces (type w). Coloured rubber, natural rubber or plastic glides and castors as well as dark car, bike or equipment tyres may possibly cause discolouration on design flooring. Please only use light, non-migrating furniture glides, castors or tyres, if possible. We recommend protecting the floor in these heavy wear areas with appropriate floor protection mats (e.g. polycarbonate mats).

# Cleaning and protective care agents

### 3. Cleaning after completion of construction work

Newly laid MEISTER floors must be cleaned after completion of construction work and before first use in order to completely remove any dirt or glue residue which has arisen during the course of the installation.

You should clean **MEISTER laminate flooring** after completion of construction work with Dr. Schutz Laminate Cleaner\*, diluted with water in a ratio of 1:200.

You should clean **MEISTER Nadura flooring** after completion of construction work with Dr. Schutz Laminate Cleaner\*, diluted with water in a ratio of 1:200.

You should clean **lacquered and matt-lacquered MEISTER Longlife parquet and MEISTER Lindura wood flooring** after completion of construction work with Dr. Schutz Wood and Cork Floor Cleaner\*, diluted with water in a ratio of 1:200.

You should clean **naturally oiled MEISTER Longlife parquet and naturally oiled MEISTER Lindura wood flooring** after completion of construction work with Dr. Schutz Premium Wood Care\*, diluted with water in a ratio of 1:200. The flooring has been treated ready for residential use. For **commercial areas and areas which are particularly highly frequented** (such as hallways, kitchens, dining rooms and open living areas with direct exit), subsequent treatment with Dr. Schutz Premium Care Oil is necessary. Apply the care oil in accordance with the manufacturer's instructions. After drying (at least 12 hours), the floor can be used again and can be cleaned using a thin mist of water again after allowing it to completely harden for 7 days.

You should clean **naturally oiled HAIN Alpine flame planks** after completion of construction work with HAIN Special Soap, diluted with water in a ratio of 1:200. **Tip:** Use 2 buckets: one for the cleaning solution and one with clear water to rinse the cloth. The flooring has been treated ready for residential use. For **commercial areas and areas which are particularly highly frequented**, subsequent treatment with HAIN Parquet Care Balm is necessary.

You should clean **MEISTER design flooring** after completion of construction work with Dr. Schutz PU Cleaner\*, diluted with water in a ratio of 1:10.

Clean the floor using a well wrung out mop and then neutralise with clear water.

The floor is washed with a mist of water using the relevant cleaning solution and a **non-lint** mop.

*\* Water-based care products (e.g. polymer dispersions) or Dr. Schutz Elatex Stain Remover can penetrate the seams of the planks in the case of improper adhesion or incomplete jointing, leading to swelling of the base material.*

### 4. Day-to-day cleaning MEISTER laminate flooring

To remove daily dirt, vacuuming or sweeping is sufficient. For conventional mopping, Dr. Schutz Laminate Cleaner\*, diluted with water in a ratio of 1:200, can be used occasionally. The floor should be wiped with a thin mist of water using a non-lint cloth, which has been dipped in this solution and wrung out well. Remove stains, smears and other bonded dirt with Dr. Schutz Elatex Stain Remover\* or undiluted Dr. Schutz Laminate Cleaner\* and a non-scratch, white pad. Then, wipe with a thin mist of water, until the dirt and cleaning agent residue is completely removed.

#### MEISTER Nadura flooring

To remove daily dirt, vacuuming or sweeping is sufficient. For conventional mopping, Dr. Schutz Laminate Cleaner\*, diluted with water in a ratio of 1:200, can be used. The floor should be wiped with a thin mist of water using a non-lint cloth, which has been dipped in this solution and wrung out well. If necessary, use a scrubbing brush.

To remove stubborn stains dilute the Wood Floor Deep Clean with water in a ratio of 1:1 to 1:3 and spray the floor (using a hand spray or similar). Leave it to take effect for 5 minutes maximum, depending on the stubbornness of the stains. Then scrub the floor using a scrubbing brush. Remove the loosened dirt using a well pressed cloth and neutralise the floor using clean, if possible warm water until any residue dirt or cleaning products have been completely removed.

Remove stains and heel marks with Dr. Schutz Elatex Stain Remover\*, undiluted Dr. Schutz Laminate Cleaner\* or Dr. Schutz Deep Clean\*

and a non-scratch, white pad. Then, wipe with a thin mist of water, until the dirt and cleaning agent residue is completely removed.

In **commercial properties** cleaning should always be possible using a cleaning machine or spray cleaning process with a disk buffing machine. For this, dilute Dr. Schutz Deep Clean\* with water in a ratio of 1:1. Please contact our technical customer services in case of application.

### Lacquered and matt lacquered MEISTER Longlife parquet and Lindura wood flooring

To remove daily dirt, vacuuming or sweeping is sufficient. Depending on the frequency and level of dirt, dilute Dr. Schutz Wood and Cork Floor Cleaner\* with water in a ratio of 1:200. The floor should be wiped with a thin mist of water using a non-lint cloth, which has been dipped in this solution and wrung out well. Remove fatty stains and other bonded dirt with undiluted Dr. Schutz Wood and Cork Floor Cleaner\* and a non-scratch, white pad. Then, wipe with a thin mist of water, until the dirt and cleaning agent residue is completely removed. Problem stains can be removed with Dr. Schutz Deep Clean\*.

We recommend refreshing the floor with Dr. Schutz Wood and Cork Floor Polish Matt\* to preserve its quality and at the first sign of wear. In areas subject to heavier levels of dirt or to build up resistance to wear, first carry out a deep clean with undiluted Dr. Schutz Deep Clean and a green pad. After the floor has dried completely, apply undiluted Dr. Schutz Wood and Cork Floor Polish Matt\* very thinly and evenly with a non-lint mop. Leave the floor to dry for at least 12 hours before use. For the aforementioned deep clean, use the Dr. Schutz Deep Clean\* undiluted. Distribute the cleaning solution over the floor in sections using a cloth and then immediately remove any residue of the care product by scrubbing. Make sure that no puddles form. For larger surfaces, use a disk buffing machine with a green pad. Immediately absorb any dirty water completely with absorbent, dry cloths. Then wipe with a thin mist of clean water using a cloth. If possible carry out the cleaning in pairs so that one person removes the dirt and the other person immediately absorbs any dirty water.

## Cleaning and protective care agents

### **Naturally oiled MEISTER Longlife parquet flooring and naturally oiled MEISTER Lindura wood flooring**

To remove daily dirt, vacuuming or sweeping is sufficient. For regular cleaning and care, use Dr. Schutz Premium Wood Care\* diluted with water in a ratio of 1:200. The floor should be wiped with a thin mist of water using a non-lint cloth, which has been dipped in this solution and wrung out well. The floor is cleaned and polished in one work step. We recommend refreshing the floor with Dr. Schutz Premium Care Oil\* to preserve its quality and at the first sign of wear. With normal levels of dirt, clean the floor first using Dr. Schutz Premium Wood Care\* diluted with water in a ratio of 1:200 and a green pad. In cases of heavy soiling or care product build-up, carry out intensive cleaning first using Dr. Schutz Deep Clean\* diluted with water in a ratio of 1:1 to 1:3 and a green pad. Distribute the cleaning solution over the floor in sections using a cloth and then immediately remove any residue of the care product by scrubbing. Make sure that no puddles form. For larger surfaces, use a disk buffing machine with a green pad. Immediately absorb any dirty water completely with absorbent, dry cloths. Then wipe with a thin mist of clean water using a cloth. If possible carry out the cleaning in pairs so that one person removes the dirt and the other person immediately absorbs any dirty water.

**Subsequently, the flooring must always be re-oiled using Dr. Schutz Premium Care Oil in accordance with the manufacturer's instructions.** After drying (at least 12 hours), the floor can be used again and can be cleaned using a thin mist of water again after allowing it to completely harden for 7 days.

Osmo products can be used to clean and care for naturally oiled MEISTER Longlife parquet flooring and Lindura wood flooring.

For regular cleaning and care, we recommend Osmo Wisch-Fix, diluted with water. The floor should be washed with a thin mist of water using a non-lint mop. Then wipe dry. With regular use, the surface becomes resistant to new occurrences of dirt and signs of wear-and-tear.

To remove particularly stubborn stains and for occasional, intensive refreshing or maintenance, we recommend Osmo Wax Care and Cleaning Agent. First, the floor must be cleaned thoroughly with Osmo-Wisch-Fix. Immediately absorb any dirty water completely with an absorbent, dry mop. Apply Osmo Wax Care and Cleaning Agent thinly and evenly with a non-lint cloth. For larger surfaces, use a disk buffing machine with a white pad. Remove any surplus immediately with a dry cloth. After drying, the surface can be polished if required.

For heavier signs of wear-and-tear and for renovations, the floor should be treated afterwards with Osmo Hard Wax Oil 3062 matt.

### **Naturally oiled HAIN Alpine flame planks**

To remove daily dirt, vacuuming or sweeping is sufficient. For regular cleaning and care, use HAIN Parquet Special Soap diluted with water in a ratio of 1:200. The floor should be washed with a thin mist of water using a non-lint cloth. The floor is cleaned and polished in one work step. **Tip:** Use 2 buckets: one for the cleaning solution and one with clear water to rinse the cloth.

We recommend refreshing the floor with HAIN Parquet Care Balm to preserve its quality and at the first sign of wear. With normal levels of dirt, clean the floor first using HAIN Parquet Special Soap diluted with water in a ratio of 1:100 or 1:200 depending on the level of dirt. After the floor has dried completely, apply undiluted HAIN Parquet Care Balm very thinly and evenly using a spray bottle or a non-lint mop. Then polish with a soft cotton cloth or a disk buffing machine and a white pad. After polishing, the surface must feel dry to the touch, as residues can remain sticky and shiny. It is therefore essential for all residues to be cleaned up or polished in. After drying (approx. 12–24 hours), the floor can be used again and can be wiped using a thin mist of water again after allowing it to completely harden for 10 days.

In cases of heavy soiling or care product build-up, carry out intensive cleaning first using Dr. Schutz Deep Clean\* diluted with water in a ratio of 1:1 to 1:3 and a green pad. Distribute the cleaning solution over the floor in sections using a cloth and then immediately remove any residue of the care product by scrubbing. Make sure that no puddles form. For larger surfaces, use a disk buffing machine with a green pad. Immediately absorb any dirty water completely with absorbent, dry cloths.

Then wipe with a thin mist of clean water using a cloth. If possible, carry out the cleaning in pairs so that one person removes the dirt and the other person immediately absorbs any dirty water. **Subsequently, the flooring must always be re-oiled using HAIN Parquet Care Oil.** After drying (approx. 12–24 hours), the floor can be used again and can be cleaned using a thin mist of water again after allowing it to completely harden for 10 days.

# Cleaning and protective care agents

## MEISTER design flooring

Loose dust and dirt is removed by vacuuming or sweeping.

Depending on the frequency and degree of dirt, the removal of bonded dirt should be carried out with Dr. Schutz PU Cleaner\*, which is diluted with water at a ratio of 1:200. The floor should be wiped with a thin mist of water using a mop, which has been dipped in this solution and wrung out well. Remove stubborn stains and heel marks with undiluted Dr. Schutz PU Cleaner\* and a cloth or non-scratch, white pad. Then wipe the floor with clear water. A thorough clean of the floor is required to remove particularly stubborn dirt and residues and to prepare the floor for treatment with a care product in case of visible signs of wear. For this, evenly spray Dr. Schutz Deep Clean\* undiluted on the floor and after allowing it to take effect for a short while (max. 5 minutes), scrub with a green pad or scrubbing brush. Wipe away loosened dirt using a cloth and wipe over again using clear water until all dirt and cleaner residue has been completely removed.

**Note:** If the flooring is not to receive a care treatment afterwards, only use scrubbing brushes instead of green pads.

If there are signs of wear on the surface after long or intensive use, this can be refreshed with intensive maintenance after thoroughly cleaning the floor with (Dr. Schutz Deep Clean\*). To do this, apply undiluted Dr. Schutz Full Care Matt\* thinly and evenly in a lengthwise direction with a lint-free mop rinsed in clear water and wrung out well. When the protective film can be walked on (after 45 minutes), apply a second coating in the crossways direction. Use: 750ml for approx. 25–35m<sup>2</sup> per application.

If the protective film is worn away over the course of time, this can be refreshed with intensive maintenance after thoroughly cleaning the floor with Dr. Schutz Deep Clean\*.

In **commercial properties** cleaning should always be possible using a cleaning machine or spray cleaning process with a disk buffing machine as well as separate value conservation measures. Please contact our technical customer services in case of application.

## 5. General information about cleaning and care

Never leave MEISTER flooring moist or wet over a long period of time. When cleaning, always try to use a dry method if possible (using a mop, hair broom, vacuum cleaner), or only wipe with a thin mist of water (with wrung out cloths) and do not leave any "puddles" on the floor. Steam cleaners are not suitable for the flooring. Do not use any cream cleaners or scouring powders as these agents can attack the surface of the floor.

Please only use suitable cleaners. Problem stains on laminate and Nadura flooring, as well as lacquered parquet and wood flooring, can be removed with Dr. Schutz Elatex Stain Remover. Please be aware that you may increase the gloss level on the laminate/ Nadura surface by removing the stain with increased pressure with a white pad. For this reason, try this out in an inconspicuous place or left-over plank first.

All kinds of chemicals, such as solvents, antiseptics and disinfectants, hair dye, fats, nail varnish remover, acetone, felt pen or ballpoint ink, many cause permanent stains.

*\* Water-based care products (e.g. polymer dispersions) or Dr. Schutz Elatex Stain Remover can penetrate the seams of the planks in the case of improper adhesion or incomplete jointing, leading to swelling of the base material.*

# Longlife warranty on MeisterWerke parquet

---

**I. Warranty cover:** MeisterWerke Schulte GmbH, Johannes-Schulte-Allee 5, 59602 Rüthen-Meiste, provides a warranty, over and beyond statutory rights under § 437 of the German Civil Code (replacement, cancellation of contract, reduction of purchase price and compensation), under the following warranty conditions. With the triple-layer parquet coating (fine wood wear layer, middle layer and backing) the parquet's special durability is achieved by using a special middle layer made from high density fibre board (HDF). Provided the product is properly used as intended in living areas, MeisterWerke warrants the durability of the three-layer glued structure of the product. The warranty does not cover any damage caused by incorrect treatment and use. In particular, any load or wear on the flooring that is not the purpose for which the flooring was intended, mechanical damage caused by furniture, pets etc. such as dents and scratches, for example. Optical faults such as joints, colour changes due to the effects of light or seasonal, climatic warping of individual planks are also not covered. Also excluded is damage due to an infestation of insects, incorrect care, cleaning or maintenance of the surface and the surface coating, especially chemical damage and/or damage due to the effects of moisture. The warranty applies exclusively to first choice products and use in private living areas subject to normal wear, with the exception of humid rooms, such as bathrooms or saunas. Special warranty conditions apply for the USA and Canada. This warranty does not apply in said regions.

**II. Warranty period:** The warranty period for MEISTER parquet flooring is 35 years after the appropriate date of purchase.

**III. Warranty conditions:** The flooring must have been fitted in accordance with the installation instructions enclosed in every third product package, in the permitted areas of use named within the instructions. In particular the instructions relating to checking moisture in the substrate and the instructions for installation over underfloor heating must be observed. The floor must also be maintained and cleaned according to the care instructions enclosed with the product. If these installation and care instructions are missing and/or incomplete, the claimant must request these instructions from a specialist retailer or directly from MeisterWerke before starting the fitting. It should also be noted that the surface coating is a protective coating for the wear layer of wood underneath and is subject to normal wear. Therefore, the warranty does not cover wearing down of this coating. When signs of wear appear, a specialist company must be engaged to expertly renew the surface in good time and to the extent necessary. Therefore, the warranty does not cover damage resulting from incorrect installation, incorrect care or cleaning or a failure to expertly renew the surface coating in good time.

**IV. Reporting a warranty claim:** Any complaint must be made in text form (e.g. as a letter sent via the postal system, a fax, or an e-mail), enclosing a copy of the original invoice from the specialist retailer, which serves as a certificate of warranty. If it is not possible to present the original retailer's invoice, any claim under the warranty is excluded. Following receipt of the claim, MeisterWerke must notify the customer within four weeks of whether a warranty claim has been acknowledged. If no notification is given within this period, the warranty claim is deemed to have been rejected. During this period, MeisterWerke or a third party employed by them must be granted access to the product that is the subject of the complaint on site in order to investigate whether the claim is justified.

**V. Scope of the warranty:** When a warranty claim is acknowledged, MeisterWerke will at their discretion repair the faulty floor element or alternatively provide replacement material of the same quality, if at all possible from the same range, for the entire room in which the problem has occurred. The customer can collect the replacement material free of charge from the original sales outlet stated in the original invoice, excluding any further claims over and beyond this, including but not limited to compensation claims for the removal or fitting of the flooring or for consequential damage that has occurred other than in the product supplied itself.

**VI. Limitation of warranty:** The warranty period is not extended by a warranty claim. Claims under the warranty expire six months from the date of MeisterWerke's receipt of the customer's written complaint (see IV.), but no earlier than the expiry of the warranty period.

**VII. Choice of law:** This warranty is subject to German law, to the exclusion of the United Nations Treaty governing contracts for the international sale of goods. However, this does not affect the legal provisions regarding the limitation of the choice of law; in particular and in accordance with Art. 6 (2) of EC Regulation (EC) No. 593/2008 (the "Rome I Regulation"), the beneficiary of the warranty can, irrespective of the choice of law and in accordance with Section 1, invoke the mandatory protection of the law that would apply in the absence of this choice of law.

# Warranty on MeisterWerke parquet flooring for Alpine flame planks

**I. Warranty cover:** MeisterWerke Schulte GmbH, Johannes-Schulte-Allee 5, 59602 Rütten-Meiste, provides a warranty, over and beyond statutory rights under § 437 of the German Civil Code (replacement, cancellation of contract, reduction of purchase price and compensation), under the following warranty conditions. Provided the product is properly used as intended in living areas, MeisterWerke warrants the durability of the three-layer glued structure of the product. The warranty does not cover any damage caused by incorrect treatment and use. In particular, any load or wear on the flooring that is not the purpose for which the flooring was intended, mechanical damage caused by furniture, pets etc. such as dents and scratches, for example. Optical faults such as joints, colour changes due to the effects of light or seasonal, climatic warping of individual planks are also not covered. Also excluded is damage due to an infestation of insects, incorrect care, cleaning or maintenance of the surface and the surface coating, especially chemical damage and/or damage due to the effects of moisture. The warranty applies exclusively to first choice products and use in private living areas subject to normal wear, with the exception of humid rooms, such as bathrooms or saunas. Special warranty conditions apply for the USA and Canada. This warranty does not apply in said regions.

**II. Warranty period:** The warranty period is in accordance with the warranty time stated for each individual product and for the concrete type of use described, after the appropriate date of purchase respectively.

**III. Warranty conditions:** The flooring must have been fitted in accordance with the installation instructions enclosed in every third product package, in the permitted areas of use named within the instructions.

In particular the instructions relating to checking moisture in the substrate and the instructions for installation over underfloor heating must be observed. The floor must also be maintained and cleaned according to the care instructions enclosed with the product. If these installation and care instructions are missing and/or incomplete, the claimant must request these instructions from a specialist retailer or directly from MeisterWerke before starting the fitting. It should also be noted that the surface coating is a protective coating for the wear layer of wood underneath and is subject to normal wear. Therefore, the warranty does not cover wearing down of this coating. When signs of wear appear, a specialist company must be engaged to expertly renew the surface in good time and to the extent necessary. Therefore, the warranty does not cover damage resulting from incorrect installation, incorrect care or cleaning or a failure to expertly renew the surface coating in good time.

**IV. Reporting a warranty claim:** Any complaint must be made in text form (e.g. as a letter sent via the postal system, a fax, or an e-mail), enclosing a copy of the original invoice from the specialist retailer, which serves as a certificate of warranty. If it is not possible to present the original retailer's invoice, any claim under the warranty is excluded. Following receipt of the claim, MeisterWerke must notify the customer within four weeks of whether a warranty claim has been acknowledged. If no notification is given within this period, the warranty claim is deemed to have been rejected. During this period, MeisterWerke or a third party employed by them must be granted access to the product that is the subject of the complaint on site in order to investigate whether the claim is justified.

**V. Scope of the warranty:** When a warranty claim is acknowledged, MeisterWerke will at their discretion repair the faulty floor element or alternatively provide replacement material of the same quality, if at all possible from the same range, for the entire room in which the problem has occurred. The customer can collect the replacement material free of charge from the original sales outlet stated in the original invoice, excluding any further claims over and beyond this, including but not limited to compensation claims for the removal or fitting of the flooring or for consequential damage that has occurred other than in the product supplied itself.

**VI. Limitation of warranty:** The warranty period is not extended by a warranty claim. Claims under the warranty expire six months from the date of MeisterWerke's receipt of the customer's written complaint (see IV.), but no earlier than the expiry of the warranty period.

**VII. Choice of law:** This warranty is subject to German law, to the exclusion of the United Nations Treaty governing contracts for the international sale of goods. However, this does not affect the legal provisions regarding the limitation of the choice of law; in particular and in accordance with Art. 6 (2) of EC Regulation (EC) No. 593/2008 (the "Rome I Regulation"), the beneficiary of the warranty can, irrespective of the choice of law and in accordance with Section 1, invoke the mandatory protection of the law that would apply in the absence of this choice of law.



# Warranty on MeisterWerke Lindura wood flooring

---

**I. Warranty cover:** MeisterWerke Schulte GmbH, Johannes-Schulte-Allee 5, 59602 Rütten-Meiste, provides a warranty, over and beyond statutory rights under § 437 of the German Civil Code (replacement, cancellation of contract, reduction of purchase price and compensation), under the following warranty conditions. MeisterWerke warrants the durability of the multilayer product structure relating to pressing and fusing the single layers with one another. The warranty does not cover any damage caused by incorrect treatment and use. In particular, any load or wear on the flooring that is not the purpose for which the flooring was intended, mechanical damage caused by furniture, pets etc. such as dents and scratches, for example. Optical faults such as joints, colour changes due to the effects of light or seasonal, climatic warping of individual planks are also not covered. Also excluded is damage due to an infestation of insects, incorrect care, cleaning or maintenance of the surface and the surface coating, especially chemical damage and/or damage due to the effects of moisture. The warranty applies exclusively to first choice products and use in private living areas subject to normal wear up to heavy-wear areas, with the exception of humid rooms, such as bathrooms or saunas, or use in commercial areas with normal wear, such as offices, waiting rooms and boutiques (corresponds to the range of application of wear class 32).

Special warranty conditions apply for the USA and Canada. This warranty does not apply in said regions.

**II. Warranty period:** The warranty period is in accordance with the warranty time stated for each individual product and for the concrete type of use described, after the appropriate date of purchase respectively.

**III. Warranty conditions:** The flooring must have been fitted in accordance with the installation instructions enclosed in every third product package, in the permitted areas of use named within the instructions. In particular, information in the installation instructions about checking the humidity of subsurfaces and the installation on underfloor heating must be observed. The floor must also be maintained and cleaned according to the care instructions enclosed with the product. If these installation and care instructions are missing and/or incomplete, the claimant must request these instructions from a specialist retailer or directly from MeisterWerke before starting the fitting. In addition, it should be noted that the surface coating is a protective layer for the wooden wear layer underneath it and is subject to normal wear. Therefore, the warranty does not cover wearing down of this coating. When signs of wear appear, a specialist company must be engaged to expertly renew the surface in good time and to the extent necessary. Therefore, the warranty does not cover damage resulting from incorrect installation, incorrect care or cleaning or a failure to expertly renew the surface coating in good time.

**IV. Reporting a warranty claim:** Any complaint must be made in text form (e.g. as a letter sent via the postal system, a fax, or an e-mail), enclosing a copy of the original invoice from the specialist retailer, which serves as a certificate of warranty. If it is not possible to present the original retailer's invoice, any claim under the warranty is excluded. Following receipt of the claim, MeisterWerke must notify the customer within four weeks of whether a warranty claim has been acknowledged. If no notification is given within this period, the warranty claim is deemed to have been rejected. During this period, MeisterWerke or a third party employed by them must be granted access to the product that is the subject of the complaint on site in order to investigate whether the claim is justified.

**V. Scope of the warranty:** When a warranty claim is acknowledged, MeisterWerke will repair the defective floor element or alternatively provide replacement material of the same quality – if at all possible from the same range – for the entire contiguous area in which the problem has occurred. The customer can collect the replacement material free of charge from the original sales outlet stated in the original invoice, excluding any further claims over and beyond this, including but not limited to compensation claims for the removal or fitting of the flooring or for consequential damage that has occurred other than in the product supplied itself.

**VI. Limitation of warranty:** The warranty period is not extended by a warranty claim. Claims under the warranty expire six months from the date of MeisterWerke's receipt of the customer's written complaint (see IV.), but no earlier than the expiry of the warranty period.

**VII. Choice of law:** This warranty is subject to German law, to the exclusion of the United Nations Treaty governing contracts for the international sale of goods. However, this does not affect the legal provisions regarding the limitation of the choice of law; in particular and in accordance with Art. 6 (2) of EC Regulation (EC) No. 593/2008 (the "Rome I Regulation"), the beneficiary of the warranty can, irrespective of the choice of law and in accordance with Section 1, invoke the mandatory protection of the law that would apply in the absence of this choice of law.

# Warranty of wear resistance for MeisterWerke design, Nadura and laminate flooring

**I. Warranty cover:** MeisterWerke Schulte GmbH, Johannes-Schulte-Allee 5, 59602 Rùthen-Meiste, provides a warranty, over and beyond statutory rights under § 437 of the German Civil Code (replacement, cancellation of contract, reduction of purchase price and compensation) that the decorative/veneer layer on the purchased product will not wear away within the warranty period provided the product is used properly for the purpose intended, according to the following warranty conditions. Any spot on which the decorative/veneer layer has been removed down to the substrate material over an area of at least 1 cm<sup>2</sup> is regarded as having worn away, though signs of wear on the edge area of an individual floor element are excluded from this warranty. Any improper use of the floor for a purpose for which it is not intended, as well as mechanical damage and non-compliance with the MeisterWerke care instructions for the respective floor exclude this warranty.

The warranty applies exclusively to first choice products and use in private living areas or commercial areas depending on the wear class specified, with the exception of humid rooms, such as bathrooms or saunas. The warranty also applies to use in humid rooms such as bathrooms with MeisterDesign. life, MeisterDesign. pro, MeisterDesign. comfort, MeisterDesign. flex, MeisterDesign. rigid, MeisterDesign. laminate LL 250, LL 250 S, LD 250, LL 150, LL 150 S, LB 150, LD 150, LC 150 and Nadura NB 400. Use in wet rooms, such as showers, public washrooms and saunas, is not permitted. Special warranty conditions apply for the USA and Canada. This warranty does not apply in said regions.

**II. Warranty period:** The warranty period is in accordance with the warranty time stated for each individual product and for the concrete type of use described, after the appropriate date of purchase respectively.

**III. Warranty conditions:** The flooring must be fitted professionally and especially in accordance with the fitting instructions accompanying every third product packaging, in the permitted areas of use stated therein. In particular the instructions relating to checking moisture in the substrate and the instructions for installation over underfloor heating must be observed. The floor must also be maintained and cleaned according to the care instructions enclosed with the product. If these installation and care instructions are missing and/or incomplete, the claimant must request these instructions from a specialist retailer or directly from MeisterWerke before starting the fitting.

**IV. Reporting a warranty claim:** Any complaint must be made in text form (e.g. as a letter sent via the postal system, a fax, or an e-mail), enclosing a copy of the original invoice from the specialist retailer, which serves as a certificate of warranty. If it is not possible to present the original retailer's invoice, any claim under the warranty is excluded. Following receipt of the claim, MeisterWerke must notify the customer within four weeks of whether a warranty claim has been acknowledged. If no notification is given within this period, the warranty claim is deemed to have been rejected. During this period, MeisterWerke or a third party employed by them must be granted access to the product that is the subject of the complaint on site in order to investigate whether the claim is justified.

**V. Scope of the warranty:** When a warranty claim is acknowledged, MeisterWerke will repair the defective floor element or alternatively provide replacement material of the same quality – if at all possible from the same range – for the entire contiguous area in which the problem has occurred. The customer can collect the replacement material free of charge from the original sales outlet stated in the original invoice, excluding any further claims over and beyond this, including but not limited to compensation claims for the removal or fitting of the flooring or for consequential damage that has occurred other than in the product supplied itself.

**VI. Limitation of warranty:** The warranty period is not extended by a warranty claim. Claims under the warranty expire six months from the date of MeisterWerke's receipt of the customer's written complaint (see IV.), but no earlier than the expiry of the warranty period.

**VII. Choice of law:** This warranty is subject to German law, to the exclusion of the United Nations Treaty governing contracts for the international sale of goods. However, this does not affect the legal provisions regarding the limitation of the choice of law; in particular and in accordance with Art. 6 (2) of EC Regulation (EC) No. 593/2008 (the "Rome I Regulation"), the beneficiary of the warranty can, irrespective of the choice of law and in accordance with Section 1, invoke the mandatory protection of the law that would apply in the absence of this choice of law.



© 2020 by MeisterWerke Schulte GmbH

For reasons of printing technology, colours and structures may vary from the reproductions shown here.

We reserve the right to make changes. No responsibility is assumed for errors.

MEISTER – a trademark of MeisterWerke Schulte GmbH

Johannes-Schulte-Allee 5 | 59602 Rùthen-Meiste | GERMANY

Phone: +49 2952 816-0 | Fax +49 2952 816-66 | [www.meister.com](http://www.meister.com)

GB