



STEAB_{sp.a}

Via Ugo Corti, 18 - 00141 FIRENZE - ITALIA - Tel. 055-419988 r.a. - Fax: 055-419989 - www.steab.it

ALLEGATO TECNICO Technical data sheet

Codice documento:

SC-ALLT Rev.0

Rif./des.

Paguro® 5664/20

DISPOSITIVO DI CONNESSIONE IP-68

JUNCTION DEVICE IP-68

A3

Per cavi tondi multi-conduttori : ϕ est. min 4.5+max 8.5

For round multi-conductors : ϕ ext. min 4.5 + max 8.5

Schema sguainatura cavo

Wire stripping

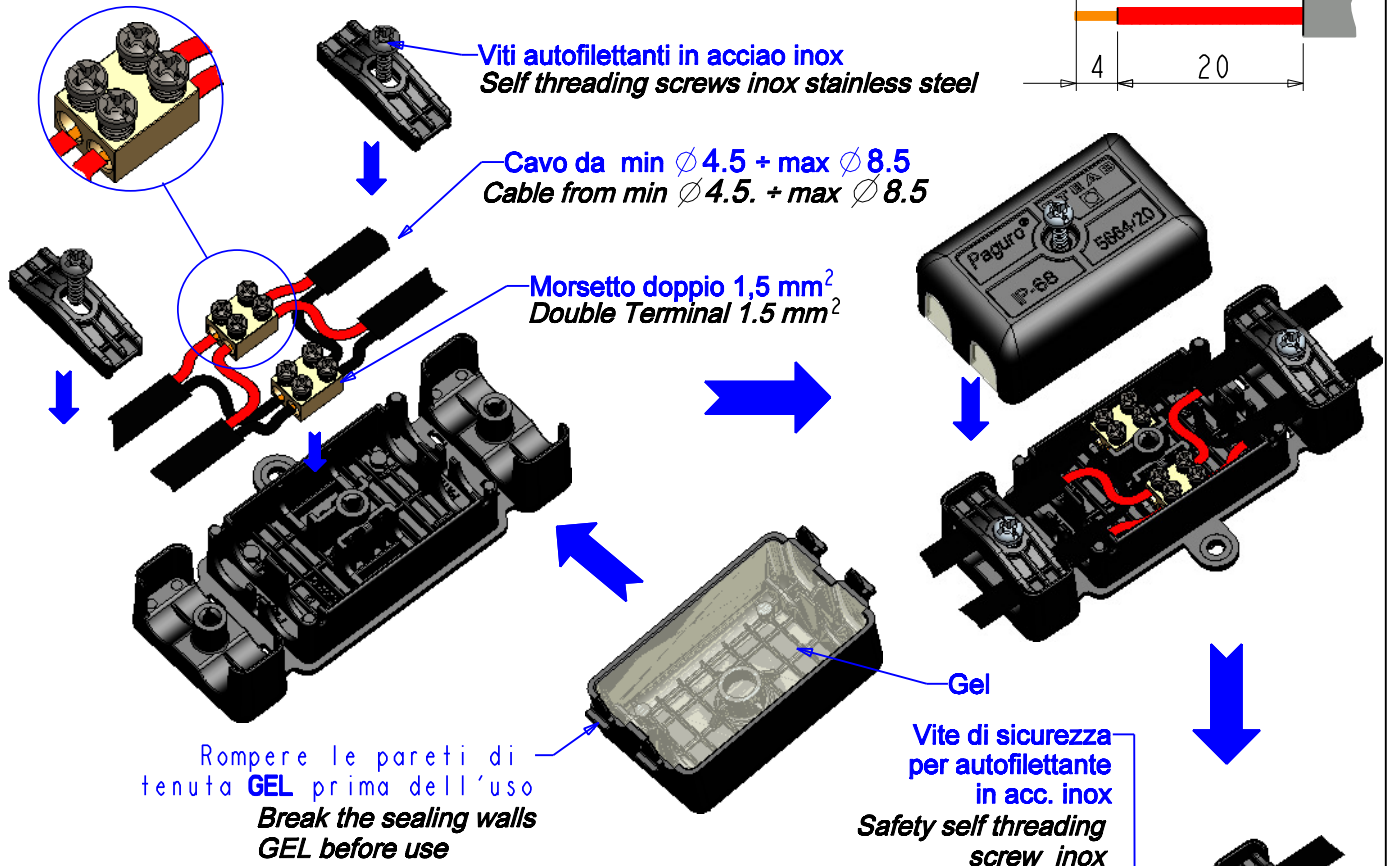
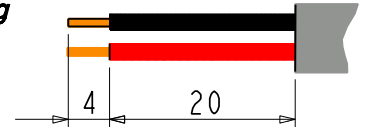

Viti autofilettanti in acciaio inox
Self threading screws inox stainless steel

Cavo da min ϕ 4.5 + max ϕ 8.5
Cable from min ϕ 4.5. + max ϕ 8.5

Morsetto doppio 1,5 mm²
Double Terminal 1.5 mm²

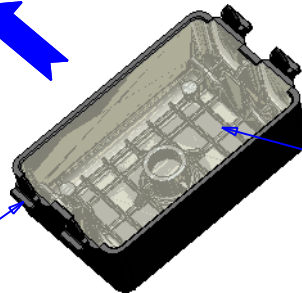
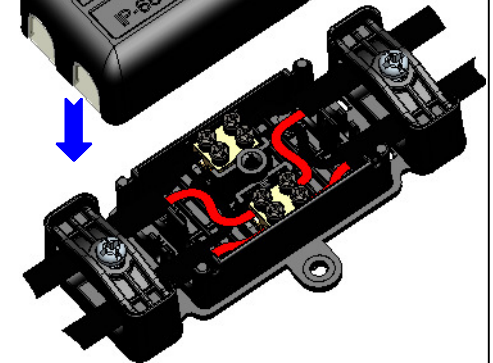
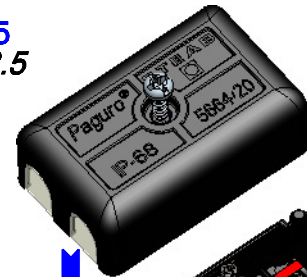

Rompe le pareti di tenuta GEL prima dell'uso
Break the sealing walls GEL before use

Vite di sicurezza per autofilettante in acc. inox
Safety self threading screw inox stainless steel

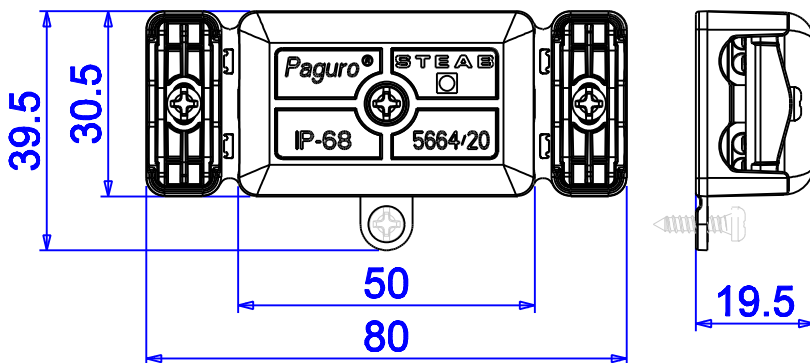

Schema di collegamento in parallelo

Wiring diagram parallel connections

Occhiello d'ancoraggio
Anchorage loop

