



STEAB_{sp.a}

Via Ugo Corti, 18 - 00141 FIRENZE - ITALIA - Tel. 055-419988 r.a. - Fax. 055-419989 - www.steab.it

ALLEGATO TECNICO Technical data sheet

Codice documento:

SC-ALLT Rev.0

Rif./des.

Paguro® 5664

DISPOSITIVO DI CONNESSIONE IP-68 JUNCTION DEVICE IP-68

A3

Per cavi tondi multi-conduttori : \varnothing est. min 4.5+max 8.5
For round multi-conductors : \varnothing ext. min 4.5 + max 8.5

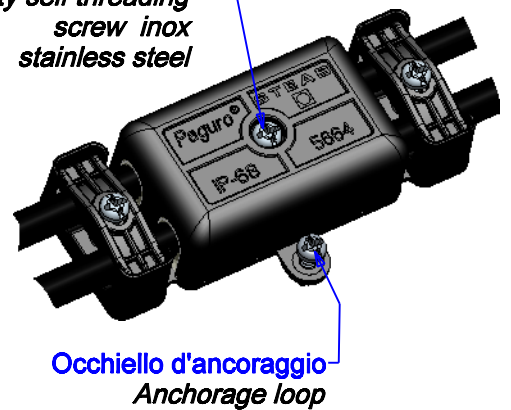
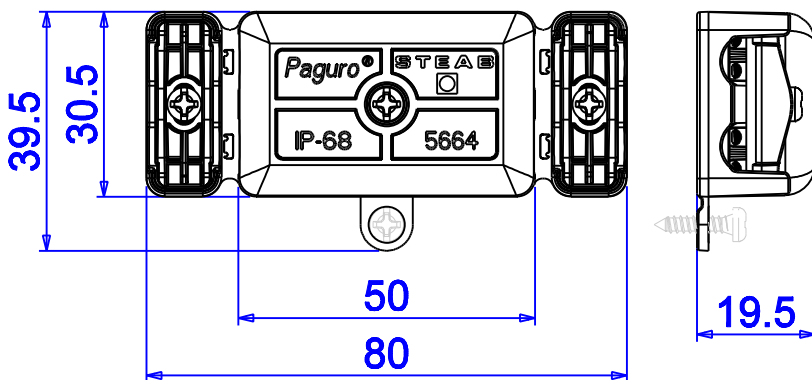
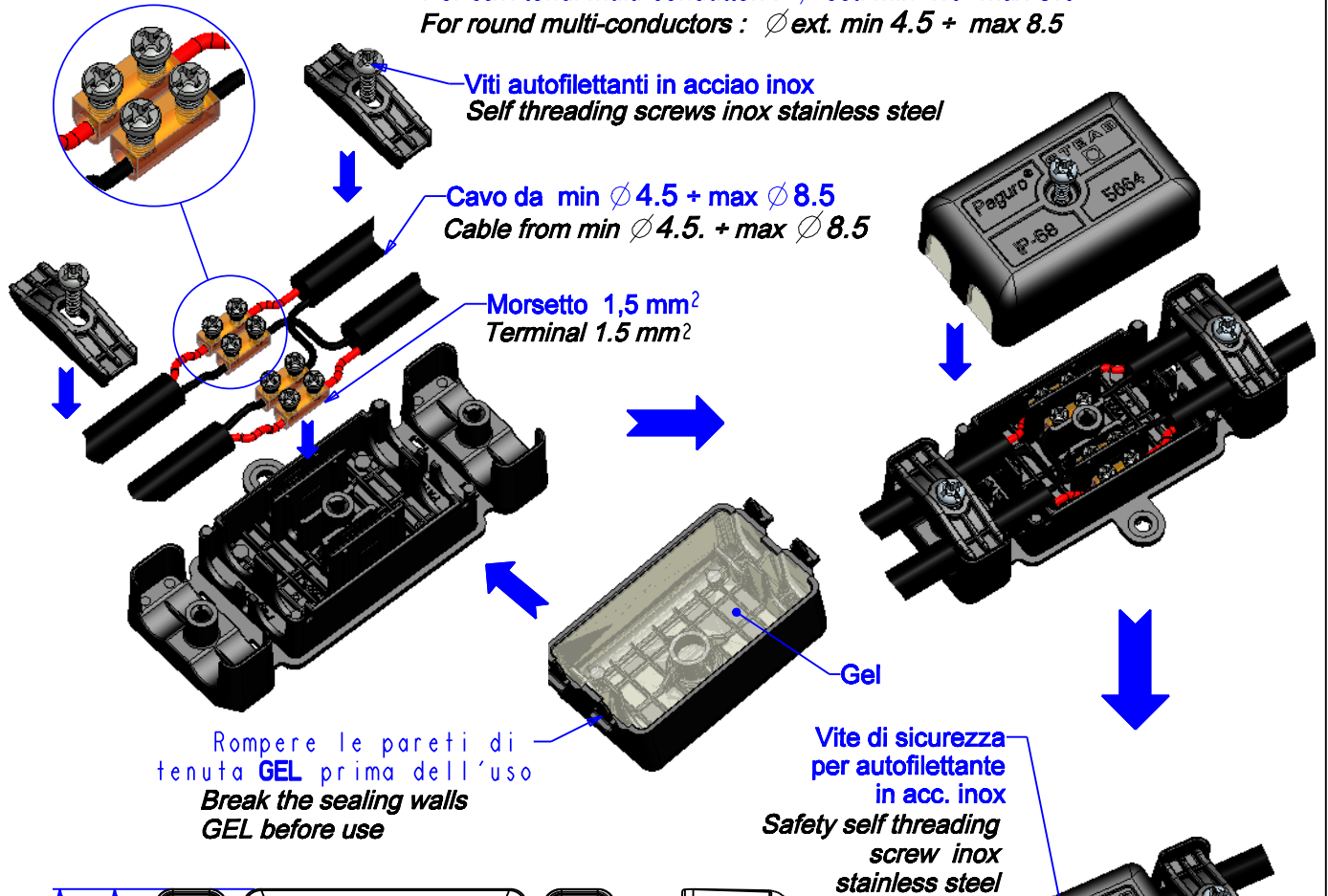

Schema sguainatura cavo
Wire stripping

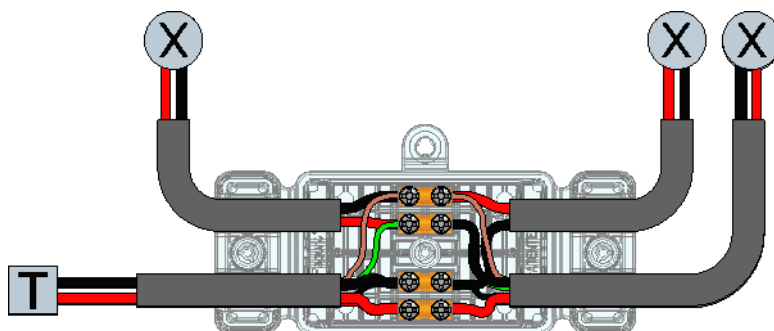
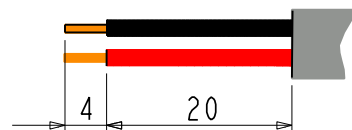

Schema di collegamento in serie
Wiring diagram serial connection