

LX 16/25

DESIGNED FOR TOP PERFORMANCE



The LX II edition is a strong and reliable partner which bridges the gap between low-duty and heavy duty material handling daily operations. Due to its durability, low maintenance LX is suitable for environments as logistic centers, terminals, production and manufacturing areas. Also the new tiller arm equipped with fork lifting and lowering proportional control improves user-friendliness and maneuverability of the truck.

1600kg Capacity

The strong LX structure, the powerful electric motors and the two lateral cylinders allow a nominal load capacity of 1600 kg with a high residual capacity



ZAPI CONTROLLER

AC technology guarantees more energy efficiency and longer battery charging duration, thus reducing maintenance cost. Furthermore the absence of brushes in the motor and the simpler motor structure increase system reliability.



TILLER EVOLUTION

Fully integrated ergonomic technopolymer tiller system including finger tip throttle and proportional fork controls, safety pushbutton, horn, turtle button, hourmeter, battery status indicator as standard equipment.



МАНЕВРЕННОСТЬ

Ширина, такая же как и у стандартной европаллеты (800 мм) позволяет свободно маневрировать в узких местах и коридорах, увеличивает маневренность и снижает радиус разворота



ОБЗОРНОСТЬ

Широкая мачта и управление по центру обеспечивают хорошую обзорность



BATTERY COMPARTMENTx

The separate battery compartment allow the installation of high capacity battery (225Ah - 300Ah). The battery inspection is easy and comfortable trough the battery cover with hinges. As option automatic battery refilling system can be supplied as the external high frequency battery charger that can be easilly plugged trough Anderson connector.

-



EASY MANTENANCE

Removing the strong cover allow to have the access to electric and hydraulic system as to the motorwheel and stabilizing wheels.



OPERATOR PLATFORM

The LX stacker can be equipped with cushioned stand-on foldable platform very useful for covering medium-sized distances and for intensive application.



Description

1.1 Изготовитель		PR INDUSTRIAL
1.3 ТИП УПРАВЛЕНИЯ		ELECTRIC
1.4 ТИП УПРАВЛЕНИЯ		Ручной
1.5 Грузоподъемность	Q Kg	1600
1.6 РАССТОЯНИЕ ДО ЦЕНТРА ТЯЖЕСТИ ГРУЗА	c mm	600
1.8 Load distance, center or drive axle to fork	x mm	820
1.9 КОЛЕСНАЯ БАЗА	y mm	1436

Weights

2.1 Вес Штабелера С Аккумулятором (Без Груза)	Kg	1025
2.1 Вес Штабелера С Аккумулятором (Без Груза)	Kg	1065
2.2 НАГРУЗКА НА ОСИ ПОД ГРУЗОМ, ЗАДНЯЯ ОСЬ	Kg	1665
2.2 НАГРУЗКА НА ОСИ ПОД ГРУЗОМ, ПЕРЕДНЯЯ	Kg	960
2.3 НАГРУЗКА НА ОСИ БЕЗ ГРУЗА, ПЕРЕДНЯЯ	Kg	706
2.3 НАГРУЗКА НА ОСИ БЕЗ ГРУЗА, ЗАДНЯЯ ОСЬ	Kg	319

Tyres/Chassis

3.1 Переднее Колесо		RUBBER
3.1 Tyres: stabilizers wheels - front		POLY.C.
3.1 Задние Колеса		POLY.C.
3.2 Размеры Передних Колес (Ширина)	mm	101
3.2 Размеры Передних Колес (Ø)	mm	250
3.3 Размеры Задних Колес (Ø)	mm	82
3.3 Размеры Задних Колес (Ширина)	mm	70
3.4 Боковые Колеса (Ø)	mm	100
3.4 Боковые Колеса (ширина)	mm	38
3.5 Размер шины: задние колеса	nr	4
3.5 Размер шины: передние колеса	nr	1x
3.6 Колея, Передние Колеса	b10 mm	586
3.7 Колея, Задние Колеса	b11 mm	390

Dimensions

4.2 Height, mast lowered	h1 mm	1765
4.4 Высота Подъема	h3 mm	2410
4.5 Height, mast extended	h4 mm	2970
4.9 Height of tiller in drive position min	h14 mm	990
4.9 Высота Рукоятки При Движении Тележки Макс	h14 mm	1390
4.15 Высота Вил В Опущенном Положении	h13 mm	90
4.19 Общая Длина Тележки	l1 mm	1944
4.19 Overall length with lowered platform	l1 mm	2528
4.19 Overall length with raised platform	l1 mm	2068
4.20 Расстояние До Основания Вил	l2 mm	795
4.20 Length to face of forks with lowered platform	l2 mm	1378
4.20 Length to face of forks with raised platform	l2 mm	919
4.21 Общая Ширина Тележки	b1 mm	800
4.22 Размеры Вил	s mm	70
4.22 Размеры Вил	e mm	170
4.22 Размеры Вил	l mm	1150
4.24 Fork carriage width	b3 mm	644
4.25 Расстояние Между Вилами (По Наружному Краю)	b5 mm	560
4.32 Клиренс, В Центре Колесной Базы	m2 mm	20
4.34 Расстояние между пролетами стеллажей Для свободной работы с паллетой 800x1200 (продольная установка паллеты)	Ast mm	2365
4.34 Aisle width with lowered platform	Ast mm	2948
4.34 Aisle width with raised platform	Ast mm	2494
4.35 Радиус Поворота Тележки	Wa mm	1613
4.35 Turning radius with lowered platform	Wa mm	2196
4.35 Turning radius with raised platform	Wa mm	1742

Performances

5.1 Travel speed laden	Km/h	6.0
5.1 Travel speed unladen	Km/h	6.0
5.1 Travel speed laden with platform in lowered position	Km/h	6.0
5.1 Travel speed unladen with platform in lowered position	Km/h	6.0
5.1 Travel speed laden with platform in raised position or with raised forks	Km/h	6.0
5.1 Travel speed unladen with platform in raised position or with raised forks	Km/h	6.0
5.2 Скорость Подъема Тележки, С Нагрузкой	m/s	0.13
5.2 Скорость Подъема Тележки, С Без Груза	m/s	0.25
5.3 Lowering speed laden	m/s	0.31
5.3 Lowering speed unladen	m/s	0.38
5.8 Max gradeability laden	%	5
5.8 Max gradeability unladen	%	10
5.10 Тормоз	REVERSE CURRENT BRAKING	

Electric motors

6.1 Drive motor power	kW	1.2
6.2 Lift motor power	kW	3.2
Тип батареи	Тип	Traction (C5)
6.4 Battery voltage	V	24
6.4 Battery capacity, Min	Ah	225
6.4 Battery capacity, Max	Ah	300
6.5 Battery weight, Min	Kg	270
6.5 Battery weight, Max	Kg	270
6.6 Energy consumption according to VDI cycle	kWh/h	1.17
8.4 Sound level at driver's ear	dB(A)	67

остаточной грузоподъемности

Полная высота подъема (H3) 2500 mm	Kg	1600
------------------------------------	----	------

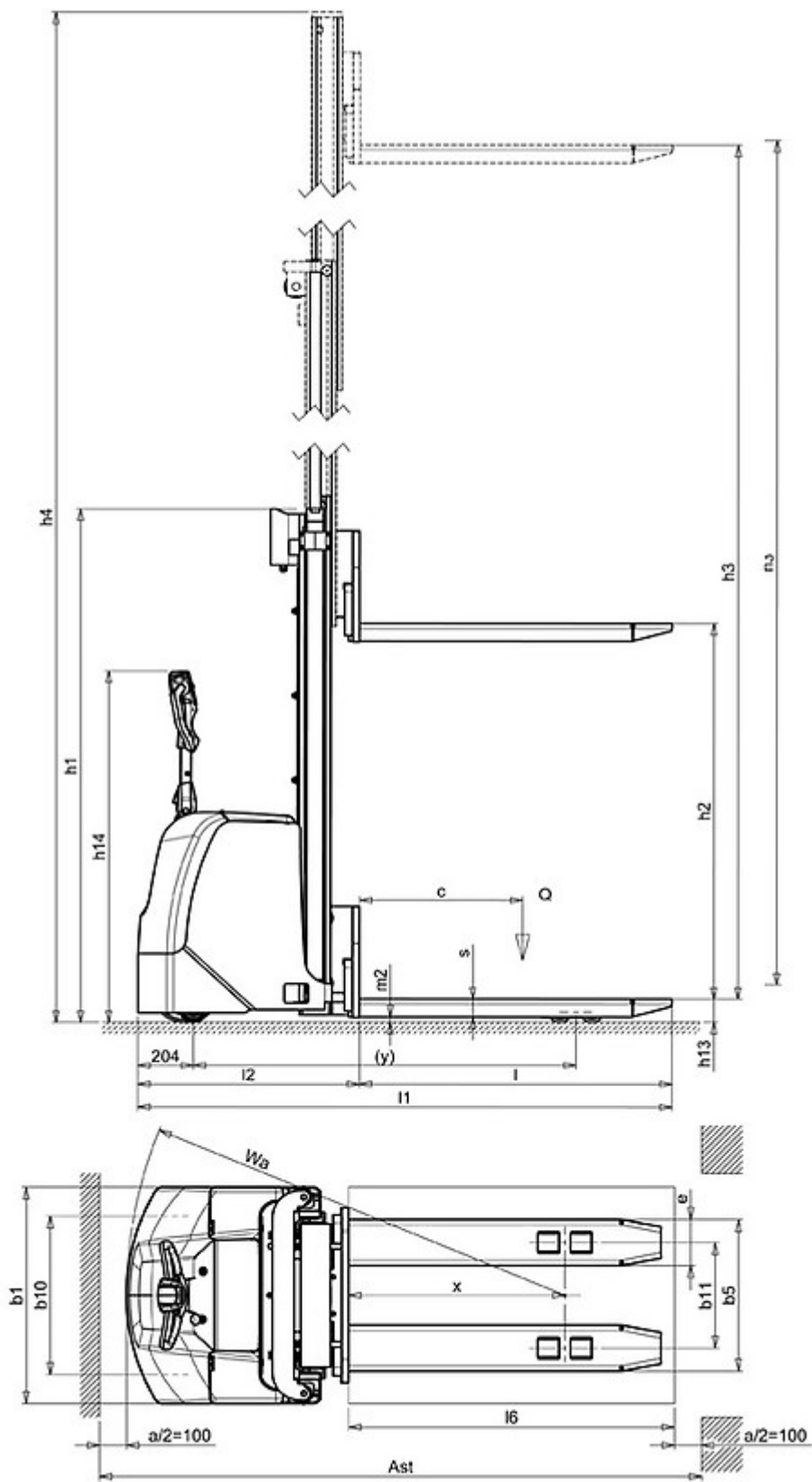

The information is aligned with the Data file at the time of download. Printed on 02/07/2019 (ID 3109)

©2019 | PR INDUSTRIAL s.r.l. | All rights reserved | Image shown may not reflect actual package. Specifications subject to change without notice

