

GX 12/29 BASIC PLUS AGM

THE COMPACT STACKER WITH LONG AUTONOMY



This compact, powerful and robust stacker is the ideal solution for working in confined spaces.

The reduced width (800 mm), the lateral driving system and the wide mast positioning allow great manoeuvrability, stability and visibility.

Built-in battery charger with integrated cable and plug make it a plug and play unit!

GX BASIC PLUS AGM

The BASIC PLUS AGM version is equipped with AGM Deep cycle batteries, a tiller made with metal tube and ergonomic controls.

This configuration is the best value for money choice and grants long endurance type batteries.

MANOEUVRABILITY

The overall width has the same size than the EuroPallet (800mm) allow the unit to work in narrow spaces and corridors, increase maneuverability and reducing the turning radius.

The combination of the lateral drive, the wide mast and the low carter offer outstanding visibility.

TILLER BASIC

Fully integrated hergonomic tiller system including finger tip throttle and fork controls, safety pushbutton, horn, and turtle button is the standard equipment of the GX BASIC

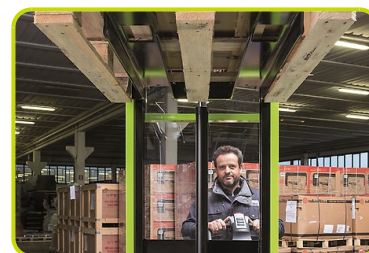

TURTLE MODE SWITCH

Offered as standard, this function enables operating the truck in confined spaces: it allows the unit to travel with the tiller in upright position.

This function is activated by pressing the turtle button on the tiller and rotating the drive control throttle. The truck travels at limited speed.

Release the button to disable this function.



COVER

Strong ABS carter/cover with storage compartments on top, easily removable to speed up maintenance operations. The bottom access opening allows an immediate disassembly of motor wheel, portal and tiller without lifting the machine. Schuko plug with spiral cable for an easy battery charging.



BATTERY PACK AGM

A separate compartment is the housing of AGM deep cycle batteries. Such batteries are powerful (110Ah), allow 3 hours endurance and don't need maintenance. GEL batteries available on demand.



Description

1.1 Изготовитель		PR INDUSTRIAL
1.3 ТИП УПРАВЛЕНИЯ		Электрический
1.4 ТИП УПРАВЛЕНИЯ		Ручной
1.5 Грузоподъемность	Q Kg	1200
1.6 РАССТОЯНИЕ ДО ЦЕНТРА ТЯЖЕСТИ ГРУЗА	c mm	600
1.8 Load distance, center or drive axle to fork	x mm	780
1.9 КОЛЕСНАЯ БАЗА	y mm	1234

Weights

2.1 Вес Штабелера С Аккумулятором (Без Груза)	Kg	585
2.2 НАГРУЗКА НА ОСИ ПОД ГРУЗОМ, ЗАДНЯЯ ОСЬ	Kg	1187
2.2 НАГРУЗКА НА ОСИ ПОД ГРУЗОМ, ПЕРЕДНЯЯ	Kg	598
2.3 НАГРУЗКА НА ОСИ БЕЗ ГРУЗА, ПЕРЕДНЯЯ	Kg	423
2.3 НАГРУЗКА НА ОСИ БЕЗ ГРУЗА, ЗАДНЯЯ ОСЬ	Kg	162

Tyres/Chassis

3.1 Переднее Колесо		RUBBER
3.1 Tyres: stabilizers wheels - front		POLY.C.
3.1 Задние Колеса		POLY.C.
3.2 Размеры Передних Колес (Ширина)	mm	76
3.2 Размеры Передних Колес (Ø)	mm	250
3.3 Размеры Задних Колес (Ø)	mm	82
3.3 Размеры Задних Колес (Ширина)	mm	70
3.4 Боковые Колеса (Ø)	mm	100
3.4 Боковые Колеса (ширина)	mm	38
3.5 Размер шины: задние колеса	nr	2
3.5 Размер шины: передние колеса	nr	1x+1
3.6 Колея, Передние Колеса	b10 mm	565
3.7 Колея, Задние Колеса	b11 mm	410

Dimensions

4.2 Height, mast lowered	h1 mm	1987
4.4 Высота Подъема	h3 mm	2810
4.5 Height, mast extended	h4 mm	3392
4.9 Высота Рукоятки При Движении Тележки Макс	h14 mm	1310
4.9 Height of tiller in drive position min	h14 mm	915
4.15 Высота Вил В Опущенном Положении	h13 mm	90
4.19 Общая Длина Тележки	l1 mm	1760
4.20 Расстояние До Основания Вил	l2 mm	609
4.21 Общая Ширина Тележки	b1 mm	800
4.22 Размеры Вил	s mm	70
4.22 Размеры Вил	e mm	150
4.22 Размеры Вил	l mm	1150
4.24 Fork carriage width	b3 mm	650
4.25 Расстояние Между Вилами (По Наружному Краю)	b5 mm	560
4.32 Клиренс, В Центре Колесной Базы	m2 mm	20
4.34 Расстояние между пролетами стеллажей Для свободной работы с паллетой 800x1200 (продольная установка паллеты)	Ast mm	2210
4.35 Радиус Поворота Тележки	Wa mm	1430

Performances

5.1 Travel speed laden	Km/h	4.7
5.1 Travel speed unladen	Km/h	5.2
5.2 Скорость Подъема Тележки, С Нагрузкой	m/s	0.11
5.2 Скорость Подъема Тележки, С Без Груза	m/s	0.19
5.3 Lowering speed laden	m/s	0.12
5.3 Lowering speed unladen	m/s	0.15
5.8 Max gradeability laden	%	5
5.8 Max gradeability unladen	%	10
5.10 Тормоз	Электрический	

Electric motors

6.1 Drive motor power	kW	0.7
6.2 Lift motor power	kW	2.2
Тип батареи	Тип	AGM
6.4 Battery voltage	V	24
6.4 Battery capacity, Min	Ah	110
6.4 Battery capacity, Max	Ah	110
6.5 Battery weight, Min	Kg	76
6.5 Battery weight, Max	Kg	80
6.6 Energy consumption according to VDI cycle	kWh/h	0.9
8.4 Sound level at driver's ear	dB(A)	62

остаточной грузоподъемности

Полная высота подъема (H3) 2500 mm	Kg	1200
Полная высота подъема (H3) 2900 mm	Kg	800

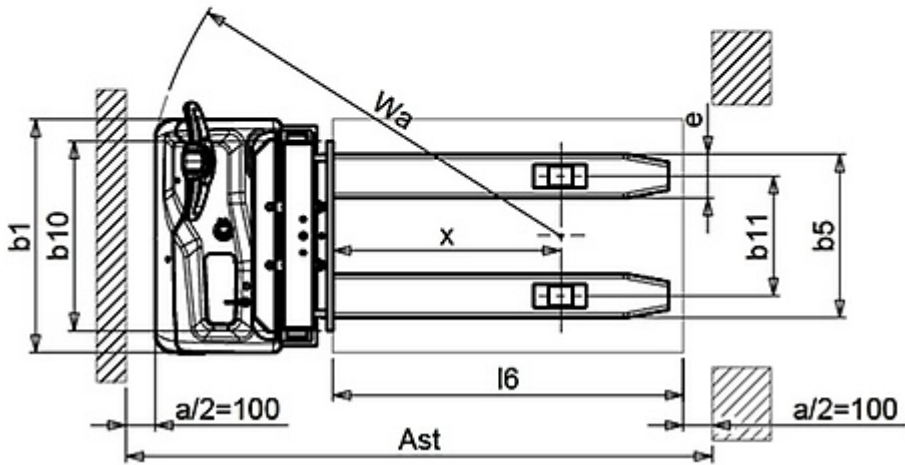
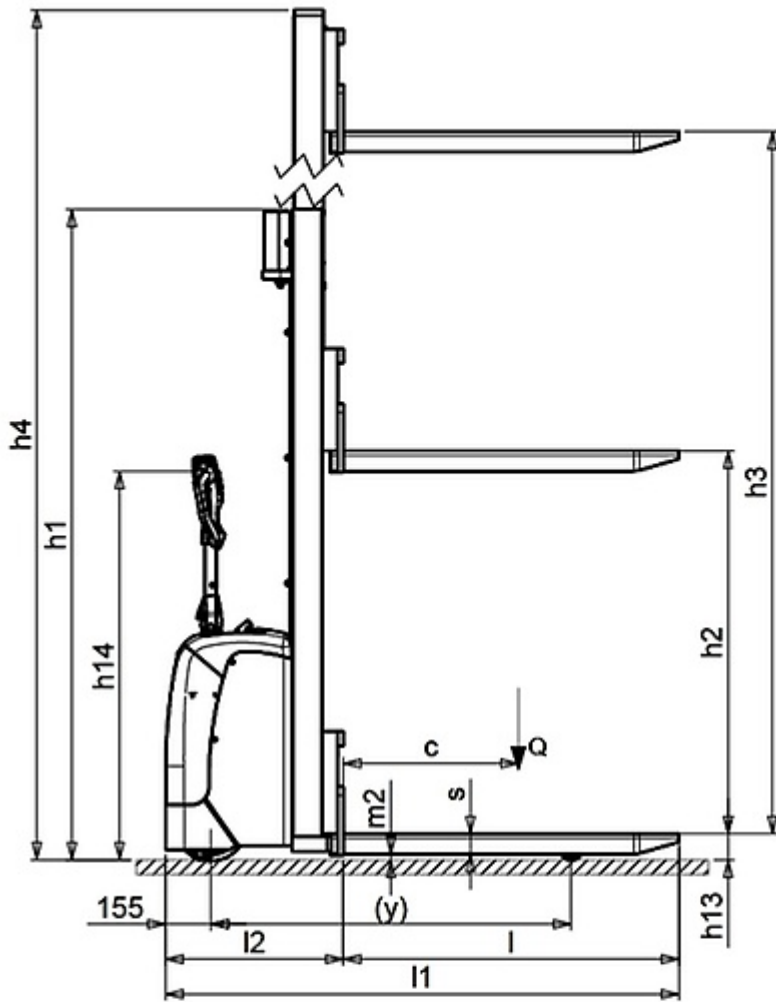

The information is aligned with the Data file at the time of download. Printed on 20/06/2019 (ID 10069)

©2019 | PR INDUSTRIAL s.r.l. | All rights reserved | Image shown may not reflect actual package. Specifications subject to change without notice