



Craftsman
MARINE

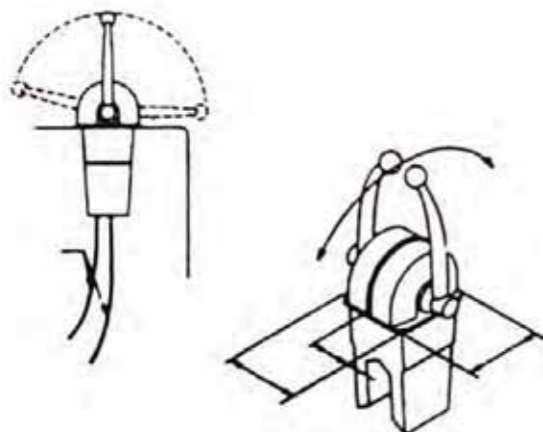
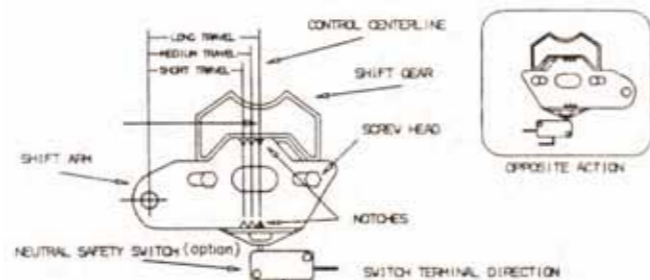

FIG. 1 CONTROL BOX CLEARANCES



TOTAL SHIFT CABLE TRAVEL (AT THE CONTROL)

SHORTEST = 2.70 Inches (68.5mm)
MEDIUM = 2.96 Inches (75.12mm)
LONGEST = 3.22 Inches (81.72mm)

FIG. 2 SHIFT CABLE TRAVEL SETTING

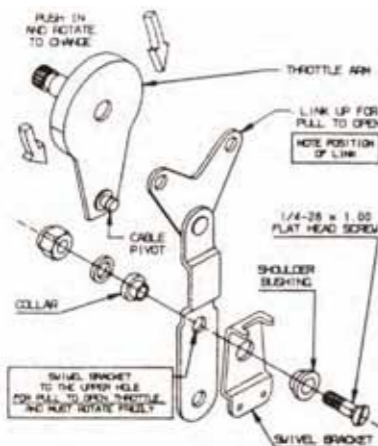

FIG. 3 "PULL TO OPEN" SETTING

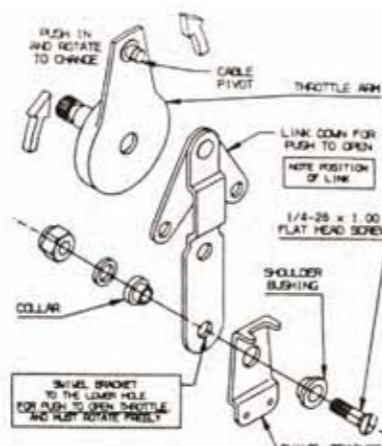

FIG. 4 "PUSH TO OPEN" SETTING

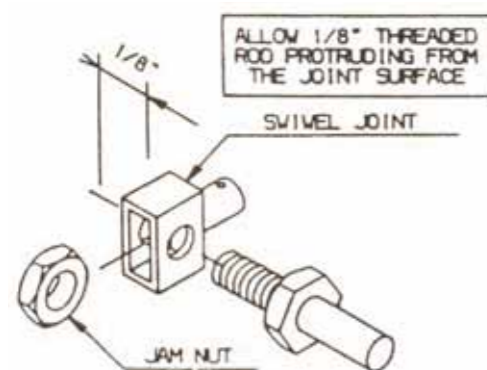

FIG. 5 SHIFT CABLE SWIVEL CONNECTION

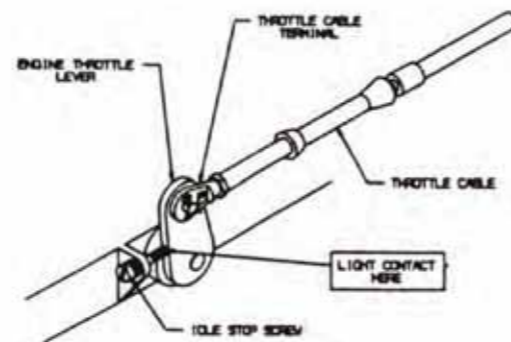

FIG. 6 ENGINE THROTTLE CONNECTION

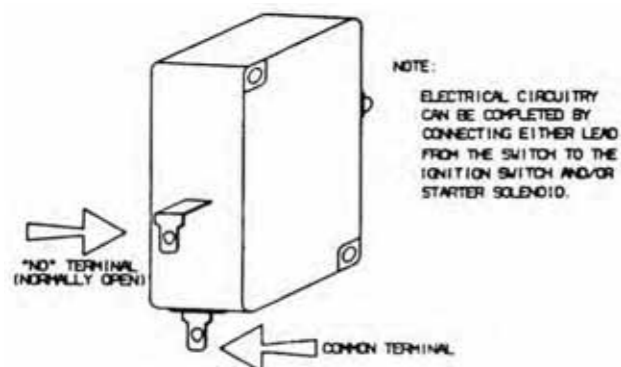

FIG. 7 NEUTRAL SAFETY SWITCH (OPTION)



FIG. 10 NEUTRAL WARM-UP



VECTRA

MANUAL

Single engine control VECTRA and Dual engine control VECTRA allows throttle and shift operations for either Single or Twin Engines in Inboard / Outboard / Inboard-Outboard configuration. These levers also have a feature to allow the control of the throttle while the gear is in neutral position. (Usually this operation is used for Engine Warm up).

Craftsman Marine push-pull cables can be used directly on the Lever.

1) INSTALLATION PREREQUISITES

1.1) Before you install a Control Lever: (Ref. Fig. 1)

- Define the mounting location depending upon the space required for installation (refer templates in Fig. 9 for Double Control Lever and Fig. 10 for Single Control Lever)
- Once the mounting location is defined, ensure that the Handle movements for extreme throttle positions are not restricted.
- Ensure that the Cable routing allows long bending radius.

1.2) Before you install the Control Cables:

- Ensure that no bending radius is less than 200mm while routing a cable.
- Use of cable hangers or routing through segments of conduit for long straight runs is recommended.
- Do not use fittings which may compress or damage the cable casing.
- For installing Control Cable on a Boat with outboard engine, add 4 feet length to the original length measured while routing.

2) INSTALLING CONTROL CABLES:

2.1) Choosing mode of operation:

Using Table-A, determine the correct operating mode of throttle and shift cable for your engine.

ENGINE	SHIFT CABLE ACTION	THROTTLE CABLE ACTION
Honda, Suzuki, Tohatsu, Mercruiser, Johnson, Evinrude, Omc, Volvo Inboard/Outboard	"PULL" TO GO FORWARD	"PUSH" TO OPEN THROTTLE
Yamaha 90 H.P. & Higher, Yamaha 70 H.P. & Below, Yamaha Inboard/Outboard		
Mercury 18, 25 HP & Outboards and Mariner Outboards		
Inboards (Diesel, Gas)	MOST TRANSMISSIONS "PULL" TO GO FORWARD	MOST THROTTLES "PULL" TO OPEN

Table-A: Cross-reference of throttle and shift cable action with Engine type.

2.2) Installing a shift cable

- Referring Table-A, verify whether the shift cable action is Push or Pull.
- Depending upon the shift cable action, reverse the Shift Arm and Neutral Safety Switch Mounting if required.
- Insert the Jam Nut in BLACK Plastic Swivel Joint (Ref. Fig. 5) and Screw it on Cable Rod end completely.
- Using Cotter Pin, fasten the Swivel Joint on Shift Arm (Select the desired Travel Length, Refer instruction "2.3")
- In order to restrict cable dislocation, fasten the cable on lever body using clamp.

2.3) Selecting a shift cable travel length (Ref. Fig. 2)

The Engine Control Lever allows following travel lengths for a shift cable:

1.	Short	68 mm
2.	Medium	75 mm (Recommended Travel Length)
3.	Long	82 mm

2.4) Installing a throttle cable

2.4.1) Control Lever End

- Referring Table-A, verify whether the throttle cable action is Push or Pull.
- Dismantle the Handle and Side Cover from the Control Lever.
- Depending on the requirement of throttle cable action, check the settings for Throttle Arm, Link Assembly arrangement and Swivel Bracket Position (Ref. Fig. 3 and 4) (For reversing the cable action settings, refer to the instruction "2.4.2")
- Screw the RED Plastic Eye terminal on Throttle Cable.
- Using Circlip, affix this eye terminal on pivot on Throttle arm.
- In order to restrict cable dislocation, fasten the cable on swivel bracket using clamp.

2.4.2) Settings for reversing the cable action (Push to Pull / Pull to Push) (Ref. Fig. 3 and 4)

- Remove the swivel bracket from the link assembly.
- Dismantle the link assembly carefully from Shift Gear without disturbing any other spares of the Lever.
- Press and rotate the throttle arm to around 180 degrees until it is locked again. (Ensure the handle is removed)
- Rearrange and screw the link assembly as in the diagram.
- Verify whether the swivel bracket rotates freely.

2.4.3) Engine End

- While installing the Control System, make sure that the engine is in neutral position.
 - Throttle Cable must be in light contact with idle stop screw (Ref. Fig. 6)
- NOTE: Disconnect the throttle cable before rigging the engine idle. Failure of this precaution may damage cable and/or engine.*

2.4.4) Engine Warm-Up

- Pull the Handle Lever Hub in the direction marked in Fig. 8
- Rotate the Handle (clockwise/counterclockwise) for throttling. Accelerate the throttle to the desired level.
- Engage the handle back to neutral. The spring will automatically adjust the neutral position of Handle.

3) NEUTRAL SAFETY SWITCH (OPTIONAL)

The neutral safety switch prevents the engine start while the gear engaged. (Ref. Fig. 7)

- Set the control lever to the neutral detent.
- Check the neutral safety switch for continuity.

3.1) Continuity Test (Ref. Fig. 7)

An electric circuit of lamp and battery connected in series can be used for this test:

- Connect one end of this circuit to COMMON terminal and the other to NO (Normally Open) terminal of the switch. As the circuit is completed, the test lamp must glow.
- Now disengage the handle from neutral position.

The test lamp will be switched off as the circuit remains incomplete.

3.2) Connecting the Neutral Safety Switch with the engine:

- Connect one terminal of the neutral safety switch to the ignition switch (start lead) and the other to starter solenoid.
- Terminals and Insulators provided with this product are to be used in order to avoid short-circuits.

